



Scanned from the collections of
The Library of Congress



Packard Campus
for Audio Visual Conservation
www.loc.gov/avconservation

Motion Picture and Television Reading Room
www.loc.gov/rr/mopic

Recorded Sound Reference Center
www.loc.gov/rr/record

The TALKING MACHINE WORLD

For the
makers &
sellers of
talking
machines

Published Each Month by Edward Lyman Bill, Inc., at 373 Fourth Ave., New York, January 15, 1918



Victrola XVI, \$215
Victrola XVI, electric, \$270
Mahogany or oak

The instrument by which the value of
all musical instruments is measured



The Highest Class Talking Machine in the World

THE INSTRUMENT OF QUALITY

Sonora

CLEAR AS A BELL



From the New York Globe

**CANNED MUSIC
MAKES ROUNDS**

Plays the Whole Day Through
for Our Men and the Wounded
French.

By JUNIUS B. WOOD.

(Cable to the New York Globe and Chicago Daily News. Copyright, 1917.)

THE AMERICAN ARMY IN FRANCE, Dec. 11.—In a certain unnamed spot a few miles back of the French front are the long one-story frame barracks of a regiment of American railroad engineers. These buildings, with those of a French hospital, near which is a cemetery that is daily growing larger, form a mushroomlike military city. Day and night the Americans take trains up under fire and return to sleep and rest in the barracks.

Every morning, and sometimes oftener, according to how the fighting goes, they bring in a long train which stops at an equally long platform, while its load of helpless, suffering, and bandaged humanity is carried into the wards of the adjoining hospital. Each one who is more seriously wounded is taken farther to more comfortable and better equipped permanent hospitals in southern France. The wounds have been bandaged in the temporary field dressing stations, but only in a few cases has there been an opportunity to wash off the dirt of the trenches before the patients are hurried to this evacuated hospital. Then starts the fight to fan back the flickering flame of life.

In that war born city is one phonograph. Grand opera singers, amusing actors, and entertaining speakers do not come to that hospital in the war zone. A single box of "canned music" is all they have to relieve the monotony of the puffing locomotives, the stifled groans of their fellow wounded and their own gnawing pain. Occasionally German bomb dropping machines seem reluctant even to permit these fragiles of humanity escape.

It is Never Silent.

One thoughtful New York mother sent this ray of brightness to her son, a captain in a railroad regiment. He turned it over, records and all, to the hospital so that all might use it. Now it is never silent day or night until taps sounds. Early in the morning it starts on its rounds through the

hospital wards and by evening it reaches the Y. M. C. A. hut and finishes the night on a rough pine board table in the officers' quarters grinding out the old, familiar home-sick tunes.

Occasionally when work is slack the owner goes himself to run the machine. Here is his description of a Sunday afternoon in that strange city sight:

"I spent an hour and a half playing the machine in a ward where two men carried in the records. There were from sixty-five to seventy-five men in the ward. Some were suffering from pneumonia and still others were terribly burned by mustard gas. Nearly half of the remainder had not seen daylight for a long time. All eyes seemed to be bandaged and there was an everlasting coughing.

"I started off with the "Marsellaise" and every last man who had an ounce of strength left in his system sat up on his cot at salute and tried to raise a bandaged hand if one was left. After that we had some American marching songs, comic opera, grand opera, and everything left on the worn out records.

Records Nearly Worn Out.

"We have used these records until they sound like the proverbial tin can. I wrote to America a couple of months ago for more, but they never materialized. The machine works all day in the hospital and we use it only when the patients have gone to sleep. It would be a calamity if they were deprived of its solace."

For military reasons I am not permitted to give the name or location of this American regiment which, in addition to its war work of carrying forward ammunition and supplies and bringing back the wounded and dying is also spreading the good samaritanism of music. However, anybody who wishes to answer the appeal can send them to me and the American post-office here will see that they are delivered. Anything in the line of music is a balm in the ears of the wounded, even of the French Polu, who does not understand English. Send them in care of Junius B. Wood, war correspondent American Expeditionary Force in France.

IN the trenches and battle zone of Europe 25,000 Sonora Portable Style Phonographs, distributed by our London representatives, are with the British army.

In thousands of American homes the beautiful Sonora is cheering those left behind, while the pride of the household is serving in training camp, cantonment, or over seas.

The man leaving for war should buy a Sonora for his family because, especially for the women and children, it is *needed* for the maintenance of confidence and optimism, for entertainment and restful pleasure, and as a conqueror of loneliness, worry, and "the blues."

\$50	\$55	\$60	\$85	\$105
\$110	\$140	\$160	\$180	\$200
\$275	\$375	\$500	\$1000	

The above are stock models.

Art Models made to
Special Order.

1917 was the greatest in the history of Sonora. Each New Year finds this wonderful phonograph established more firmly in the public's esteem.

The Sonora is of unequalled quality. It is easily sold and offers to you the opportunity for splendid profit and the development of a substantial valuable business.

Some territories are still open. Write us for details.



Elite \$180

Sonora Phonograph Sales Company, Inc.

GEORGE E. BRIGHTSON, President

Executive Offices: 279 Broadway, NEW YORK

Sonora operates and is licensed under BASIC PATENTS of the phonograph industry

The Talking Machine World

Vol. 14. No. 1

New York, January 15, 1918

Price Twenty Cents

LIMIT FREE DELIVERY OF RECORDS

Dealers Inclined to Fix a Limit on Number of Records That Will Be Delivered Without Extra Charge to the Customer—Cuts Into Profits

Retail stores throughout the country, particularly the big department stores, have at the suggestion of the Federal authorities, and as a result of the labor shortage, been making every effort to cut down the volume of free delivery of goods, and at the same time much of the expense of the system by educating the public to carry away with them all small parcels. A number of talking machine men have fallen in line with the campaign, with a view to cutting down the volume of record deliveries. In St. Louis, for instance, the talking machine retailers have entered into an agreement to refuse to deliver free less than six records. In other words, a customer buying five records must carry them home himself or pay additional delivery charges. It would seem to be a move in the right direction. Taking all factors into consideration, the net profit on an individual record, particularly of the popular type, is comparatively small, and to pay out as much as 50 per cent. or more of that profit to cover delivery doesn't smack of good business. The practice has been carried on in the past under the broad term of service, it being felt that the customer would carry away enough records personally to balance it, but a definite rule on deliveries, and the minimum set on the number of records that will be delivered without charge, eliminates the element of chance. It gives the dealer what is due him as profit. It is just one of the trade improvements that can be laid directly to wartime conditions.

WOULD MAGNETIZE NEEDLES

One Writer Believes That It Would Prove Convenience to Talking Machine Owner

A writer in "System" makes the following suggestion regarding the handling of needles that might prove of interest to some members of the trade. He says: "I would magnetize my steel reproducing needles so that instead of lying flat in a tray and scattering all over its surface they would bunch together. This would make them much easier to pick up and would prevent them from rolling out of the tray at every jar.

"When any of them fell into the top of the phonograph, instead of being compelled to pick them out one by one, my customers could easily brush them into a corner and remove them all at once. The same would be true should the tray containing them be upset."

ON "GOING AFTER BUSINESS"

"Only about one sale in ten is a floor sale—the other nine are accomplished almost entirely by outside effort, by carrying the instruments out for home demonstration," remarks W. H. Stoakes, Edison dealer at Grinnell, Iowa.

"There is more than a grain of truth in what Mr. Stoakes writes," says the Editor of Edison Diamond Points. "There are many of them. We have long preached home demonstrations and outside canvassing. The man who stands behind a counter all day and waits for customers to come to him will wait a long time. You should leave your counter and go after business.

"Time was when the dealer did not find it necessary to go after business. Times have changed.

"I hauled out eleven instruments into the country and sold nine of them inside of two weeks," writes Chris Verwers, of Keota, Iowa.

"If you have a Ford all the better. As George Silzer puts it 'Crank her up and hit the highway for those sales that won't come to you.'" This suggestion is well worth considering.

BERLINER'S LATEST INVENTION

Canadian Talking Machine Man Produces Flying Dirigible Torpedo Usable on Land or Sea Which Has Attracted Considerable Attention

Emile Berliner, widely known through his inventions in the talking machine trade, and whose improvements in the telephone made long-distance talking over a wire practicable, is now the inventor of a flying "dirigible torpedo," utilizable on land as well as on sea.

Dr. Berliner's contrivance is in effect a small aeroplane—a monoplane in miniature—run by a little gasoline engine and motor and carrying a propeller and a rudder that is set before launching. It has other means of automatic control, with a gyroscope to keep it level.

The machine is nothing more nor less than an artificial bird that holds a torpedo in its beak. More definitely speaking, the torpedo, carrying a heavy charge of high explosive, is held by spring arms in front of the little aeroplane, so as to be set off on striking the target.

For use on the sea, the flying torpedo may be modified by attaching beneath it a small plane set at such an angle that the machine on striking the water will skip along over the waves toward an enemy ship, the difficulty of hitting it with gunfire being thereby greatly increased.

Dr. Berliner's latest invention has been the subject of considerable notice in leading papers.

MAKING THE TELEPHONE AID SELLING

Proper Use of Telephone Frequently Means Time and Money Saved for the Talking Machine Dealer Who Uses Some Originality in Work

With the price of printed matter still soaring skyward and with mailing costs materially advanced by the war tax, the telephone may come into more general use as a means of selling records. Merchants in a great many lines of trade outside of the talking machine field have been steadily placing greater dependence on the telephone as a means of keeping in intimate touch with their patrons. In fact, it seems logical to presume these merchants in other fields have broken the ice, so that the increased use of the 'phone by talking machine merchants will be cordially received.

A certain talking machine dealer has adopted the plan of mailing out the new record lists each month and then instead of following up his customer by mail, he calls each one by 'phone, runs over the list somewhat after the manner of a grocer enumerating household necessities, and, where the customer evinces interest, he places that record on the group to be sent up on approval. When the records are delivered on approval, a personal letter accompanies them, outlining the individual beauty of each record. Thus the dealer introduces a maximum of the personal element at a minimum cost.

SOLDIERS WHO ARE REAL ARTISTS AS WELL AS ARTISANS

Members of Company B, 306th Infantry, Make Special Case for Popular Priced Talking Machine Which They Find the Keenest Source of Pleasure and Entertainment in the Camp

The talking machine is undoubtedly the greatest comfort to the men in the camps, as it is to the men in the trenches at the front. No other musical instrument affords them such pleasure, because it brings into their lives the

placed it in a case which they specially built and decorated themselves, with the result that they have now something very unique in an outfit.

The outside of the cabinet shows as a decoration the great seal of the United States, and



© 1917, Underwood & Underwood, N. Y.

best in song and music, and enables them, when they are so inclined, to dance to its inspiring music. The men in the camps, however, are just as inclined to the good-looking talking machine as are their folks at home, and the picture herewith is of unusual interest in this connection. It shows how the members of Company B, 306th Infantry took a popular-priced talking machine,

Company B, 306th Infantry Enjoying Themselves

other decorations which emphasize that the men of this company are not only artisans but artists. Around this talking machine the members of Company B gather in the evening and spend hours listening to the music of the day, including very often music of the better type, for the men who are in camp do not leave their musical taste and inclinations at home.

Why 1918 Holds Great Possibilities For Every One In The Talking Machine Trade

FROM almost every angle 1917 has proven a most unusual year in the talking machine industry. It has been a year to test the stability and permanence of the trade and be it said that the trade has not been found wanting under the test. War has brought with it many problems for both talking machine manufacturers and dealers. Its effect has been first of all to curtail supplies and labor, and to hinder the transportation of peace products to an alarming degree. But, on the other hand, it has brought with it a wide recognition of talking machines and records as genuine essentials in the equipment of military units. The coming of the New Year sees the talking machine more firmly entrenched than ever in the hearts of the people, and as a result the future looks bright indeed.

Review of Holiday Business in Machines and Records

Despite the war and despite the high cost of living and other factors connected therewith, the holiday business in talking machines and records reached proportions that swamped the facilities of both producers and retailers. Conditions made it impossible for many of the manufacturers to keep their output up to a point reached the previous year. Transportation problems likewise have had their effect, and there really seemed to be something the matter with the dealer who could say he went through the month of December without suffering serious loss of sales in some manner and through no fault of his own.

It was a noteworthy fact that the big demand was for machines selling in the neighborhood of \$100, and therefore, the most serious shortage was in that type of machines. Machines retailing at from \$20 to \$40 were not such good sellers, and both jobbers and dealers had the experience of seeing these machines lie on their shelves without moving while at the same time they were turning down orders for the more expensive models, or at least endeavoring to install temporary substitutes.

Factories Couldn't Turn Out Records Fast Enough

The record situation was similarly embarrassing. Aside from the call for standard vocal and instrumental numbers, it seemed that everyone who owned a talking machine or expected to own one, wanted records of "Over There," "Goodbye Broadway, Hello France" and the other hits of the day, and the result was that the record supply in no sense met the demand. Of course there were plenty of records, but while they were frequently accepted as substitutes, they were not just what the public were crying for. The factories could not simply turn out the required records fast enough. It was impossible, and the result was embarrassing.

In order to relieve the record situation and help clear up the jobbers' and dealers' shelves and to enable the factories to catch up with orders, several of the companies have shown an inclination to cut down on their monthly lists of new records. The Victor Co. has taken the first step in this direction, by including only fourteen new selections in its January record supplement, and it is stated that the same plan will be followed out for several months to come at least. Several other companies have arranged to adopt the same method, or are contemplating some such action, in an effort to clear the decks for the coming year.

The Industry on a More Permanent Basis

During the past year or so the industry may be said to have settled into more or less permanent channels, and this fact also augurs well for the future. In 1915, it will be remembered, there was a great influx of new concerns into the trade. Hardly a day passed without its group of new corporations setting forth their

intention of making machines or records. They apparently felt that there was great wealth simply waiting to be grasped. There were also many new concerns in 1916, but the number had dropped off materially from the previous year.

It is quite evident that many of these corporations were of the fly-by-night variety. Their object was to sell stock and plenty of it and to offer machines at retail far under established prices and for that matter far below established quality. Many of these concerns dropped by the wayside without delay; 1917 has seen the clearing out of others, while the companies properly organized, and with the correct appreciation of the status of the trade, have survived and established what may be looked upon as permanent positions in the industry.

That the trade condition in this particular is more or less settled is a matter of congratulation for both the trade itself and the public, for it acts as a protection to both sides.

Must Have Courage to Plan Ahead

From present prospects it is safe to assume that 1918 holds great possibilities for everyone in the talking machine trade, but to take advantage of the opportunity, the trade members must have faith in the future and the courage to plan ahead. If early ordering was ever necessary, it should be doubly necessary during the months to come. It is going to be harder than ever for the factories to keep up production to a high pitch, and with the war demands on the railroads, harder than ever for the wholesalers and retailers to get the goods within a reasonable time after they are shipped. It is only by working far ahead that even a fair measure of protection can be assured. In other words, the retailer who does not place his orders for holiday stocks in the spring at least, is simply taking big chances on the future of his business. It will mean tying up some capital, and perhaps a little financial strain, but the sacrifice will be worth while, if the trade members plan to stay in business.

Why the Talking Machine Is a Necessity

The big banking interests and some Government officials are preaching the doctrine of rigid economy by the general public, advising them to discontinue the purchase of anything not ranking as a necessity of life. This doctrine in itself should revert to the benefit of the talking machine trade. The fact that the Army and Navy have already absorbed thousands of talking machines of various types and thousands, if not millions, of records, and are at the same time appealing for more with the full endorsement of the officials, is the best indication that the talking machine is a recognized wartime essential. From the viewpoint of economy, it can also be viewed in a favorable light for it requires a minimum of outlay in proportion to what it has to offer. The machines themselves are comparatively low priced, and record libraries can be built up by the expenditure of only a few cents weekly. In fact, it can safely be asserted that the talking machine is one of the real "essentials" to the nation in war times.

New Year Going to Mark Important Era

From every viewpoint, it would seem that 1918 is going to mark a new era in the progress of the talking machine, as well as genuine prosperity for those members of the industry who have the courage to take full advantage of the opportunity that is there. Certain it is that the manufacturers are not letting the grass grow under their feet. While frankly able to meet only a percentage of the demand for their products, they have kept up their advertising to the full limit, and in some instances a

little stronger than ordinary, and plan to do so in the months to come in order that the public may be kept in close touch with talking machines and records until such time as the industry can take full advantage of all the selling opportunities that exist or will exist. It is this spirit of building for the future that is responsible for the present strong position of the talking machine.

Talking Machine Hardware

We manufacture hardware for all styles of cabinets

Lid Supports
Needle Cups
Needle Rests

Door Catches
Sliding Casters
Continuous Hinges

Sockets
Tone Rods
Knobs, etc.

BEST QUALITY

LOWEST PRICES

WEBER-KNAPP COMPANY

- Jamestown, N. Y.

Victrola VI-A, \$30
Oak



Victrola IX-A, \$57.50
Mahogany or oak



Victrola XI-A, \$110
Mahogany or oak

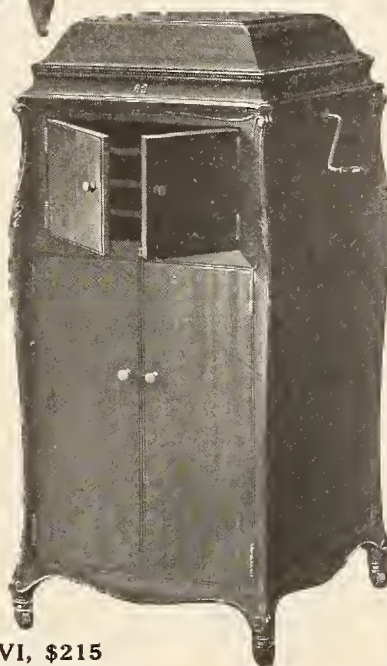
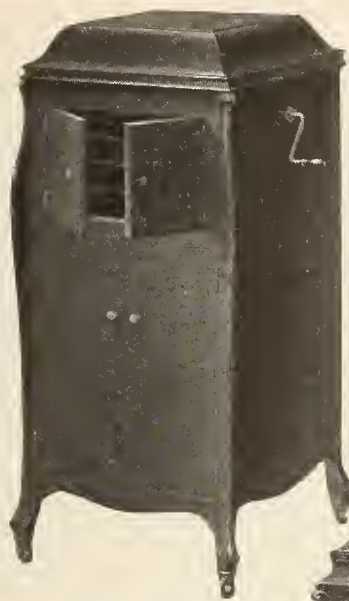

Victrola XVI, \$215
Victrola XVI, Electric, \$270
Mahogany or oak

Victor Supremacy

Victor supremacy is a real asset for every music retailer.

Just how much of an asset depends upon the retailer himself—with no limit to the measure of his success.

Victor Talking Machine Co. Camden, N. J., U. S. A.

Berliner Gramophone Co., Montreal, Canadian Wholesalers

“Victrola” is the Registered Trade-mark of the Victor Talking Machine Company designating the products of this Company only.

Warning: The use of the word **Victrola** upon or in the promotion or sale of any other Talking Machine or Phonograph products is misleading and illegal.

Important Notice. Victor Records and Victor Machines are scientifically co-ordinated and synchronized by our special processes of manufacture, and their use, one with the other, is absolutely essential to a perfect Victor reproduction.



Victor Wholesalers

- Albany, N. Y.... Gately-Haire Co., Inc.
- Atlanta, Ga..... Elyea-Austell Co.
Phillips & Crew Co.
- Austin, Tex..... The Talking Machine Co., of
Texas.
- Baltimore, Md.... Cohen & Hughes.
E. F. Droop & Sons Co.
H. R. Eisenbrandt Sons, Inc.
- Bangor, Me..... Andrews Music House Co.
- Birmingham, Ala. Talking Machine Co.
- Boston, Mass..... Oliver Ditson Co.
The Eastern Talking Machine
Co.
The M. Steinert & Sons Co.
- Brooklyn, N. Y... American Talking Mch. Co.
G. T. Williams.
- Buffalo, N. Y..... W. D. & C. N. Andrews.
Neal, Clark & Neal Co.
- Burlington, Vt.... American Phonograph Co.
- Butte, Mont..... Orton Bros.
- Chicago, Ill..... Lyon & Healy.
The Rudolph Wurlitzer Co.
Chicago Talking Machine Co.
- Cincinnati, O.... The Rudolph Wurlitzer Co.
- Cleveland, O..... The W. H. Buescher & Sons
Co.
The Collister & Sayle Co.
The Eclipse Musical Co.
- Columbus, O..... The Perry B. Whitsit Co.
- Dallas, Tex..... Sanger Bros.
- Denver, Colo..... The Hext Music Co.
The Knight-Campbell Music
Co.

- Des Moines, Ia.... Mickel Bros. Co.
- Detroit, Mich..... Grinnell Bros.
- Elmira, N. Y..... Elmira Arms Co.
- El Paso, Tex.... W. G. Walz Co.
- Honolulu, T. H.... Bergstrom Music Co., Ltd.
- Houston, Tex.... Thos. Goggan & Bro.
- Indianapolis, Ind. Stewart Talking Machine Co.
- Jacksonville, Fla. Florida Talking Machine Co.
- Kansas City, Mo.. J. W. Jenkins Sons Music Co.
Schmelzer Arms Co.
- Lincoln, Nebr.... Ross P. Curtice Co.
- Little Rock, Ark.. O. K. Houck Piano Co.
- Los Angeles, Cal. Sherman, Clay & Co.
- Memphis, Tenn... O. K. Houck Piano Co.
- Milwaukee, Wis... Badger Talking Machine Co.
- Minneapolis, Minn. Beckwith, O'Neill Co.
- Mobile, Ala..... Wm. H. Reynolds.
- Montreal, Can.... Berliner Gramophone Co.,
Ltd.
- Nashville, Tenn... O. K. Houck Piano Co.
- Newark, N. J.... Price Talking Machine Co.
- New Haven, Conn. Henry Horton.
- New Orleans, La.. Philip Werlein, Ltd.
- New York, N. Y... Blackman Talking Mach. Co.
Emanuel Blout.
C. Bruno & Son, Inc.
I. Davega, Jr., Inc.
S. B. Davega Co.
Charles H. Ditson & Co.
Landay Bros., Inc.
New York Talking Mach. Co.
Ormes, Inc.
Silas E. Pearsall Co.

- Omaha, Nebr..... A. Hospe Co.
Nebraska Cycle Co.
- Peoria, Ill..... Putnam-Page Co., Inc.
- Philadelphia, Pa. Louis Buehn Co., Inc.
C. J. Heppe.
Penn Phonograph Co., Inc.
The Talking Machine Co.
H. A. Weymann & Son, Inc.
- Pittsburgh, Pa.... W. F. Frederick Piano Co.
C. C. Mellor Co., Ltd.
Standard Talking Machine Co.
- Portland, Me..... Cressey & Allen, Inc.
- Portland, Ore.... Sherman, Clay & Co.
- Providence, R. I.. J. Samuels & Bro., Inc.
- Richmond, Va.... The Corley Co., Inc.
W. D. Moses & Co.
- Rochester, N. Y... E. J. Chapman.
The Talking Machine Co.
- Salt Lake City, U. Consolidated Music Co.
The John Elliott Clark Co.
- San Antonio, Tex. Thos. Goggan & Bros.
- San Francisco, Cal. Sherman, Clay & Co.
- Seattle, Wash.... Sherman, Clay & Co.
- Sioux Falls, S. D.. Talking Machine Exchange.
- Spokane, Wash.... Sherman, Clay & Co.
- St. Louis, Mo.... Koerber-Brenner Music Co.
- St. Paul, Minn.... W. J. Dyer & Bro.
- Syracuse, N. Y.... W. D. Andrews Co.
- Toledo, O..... The Whitney & Currier.
- Washington, D. C. Cohen & Hughes.
E. F. Droop & Sons Co.
Robt. C. Rogers Co.

AN IMPORTANT ACCESSORY—ALBUMS FOR FILING DISC RECORDS

The enormous demand for "National" Record Albums keeps pace with the ever increasing demand for machines and records, and our output capacity has been enlarged to meet the greater needed supply. Record Albums have proven themselves to be the best and most convenient, as well as economic, method of filing and keeping disc records.

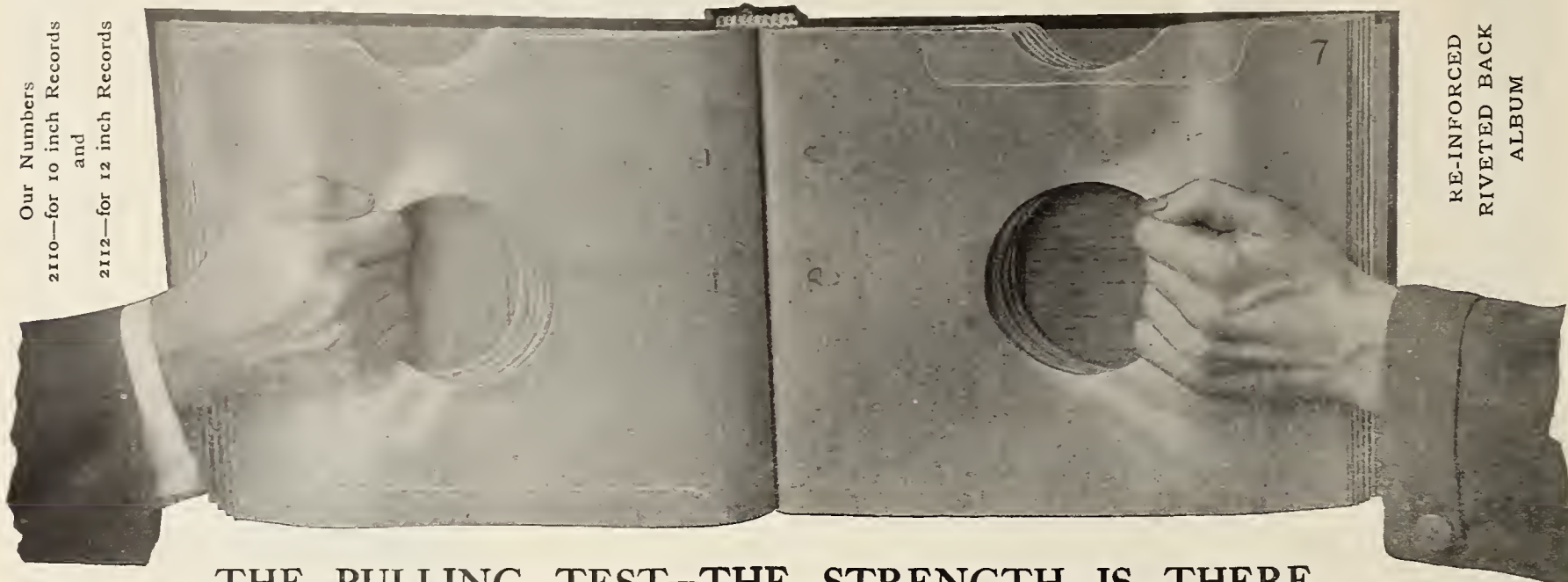

THE PULLING TEST—THE STRENGTH IS THERE

STRENGTH AT THE STRESS AND STRAIN POINT

PRACTICALLY UNBREAKABLE FOR REGULAR USAGE

Albums are an **Indispensable Requisite** in the talking machine business and wherever records are sold. An accessory that is necessary and worth while. Practical and handy. Save time and records. A **profitable adjunct** to the business. All owners of machines and records want Albums to file and preserve their records.

We manufacture disc Record Albums containing 12 pockets to fit cabinets of all sizes and styles. We also make Albums containing 17 pockets. With the indexes they are a complete system for filing all disc records.

For durability, finish and artistic design, our Albums are unsurpassed. We have unexcelled manufacturing facilities, and considering quality our prices are the lowest. Write us giving quantity you may desire, and we will quote prices.

OUR ALBUMS ARE MADE TO CONTAIN VICTOR, COLUMBIA, EDISON, PATHÉ, AND ALL OTHER DISC RECORDS

NATIONAL PUBLISHING CO., 239 S. American Street, PHILADELPHIA, PA.

WIDDICOMB PHONOGRAPH CATALOG

DEDICATES TOAST TO FIGHTING MEN

BARTLETT MUSIC CO.'S DISPLAY

Handsome Publication Illustrating and Describing New Products of This Company

Dr. M. Goldstein, of Boston Book Co., Writes Some Patriotic Verse

In Window Dressing Contest Conducted by Los Angeles Express and Tribune

The Widdicomb Furniture Co., of Grand Rapids, Mich., have just published their first phonograph catalog entitled "The Widdicomb, a Finished Product." It has been prepared in a very attractive manner and thoroughly describes and illustrates the eight Period models constituting this attractive line. They embrace examples of the Chippendale, Colonial, Adam, Queen Anne and Early American Schools. Fine coated paper is used throughout and perfectly prepared half-tone work reproduces in detail the fine architectural points of each model, which are most distinctive. On each page the slogan of the company appears. "Play it Yourself."

Herewith is reproduced a little New Year's toast dedicated to our soldiers and sailors, the work of Dr. M. Goldstein, who is connected with the Boston Book Co., the prominent New York manufacturers of record albums:

A Toast to our Boys in Khaki,
A Toast to our Boys in Blue,
A Toast to our Brave and Plucky.
A Toast to our Red, White and Blue.

A Toast to our Allies on Land,
A Toast to our Allies on Sea,
A Toast to those Heroes in Command,
A Toast to the Brave and the Free.

REFRAIN

Hurrah for our Boys in Khaki,
Hurrah for our Boys in Blue,
Hurrah for the Brave and the Plucky.
Hurrah for our Red, White and Blue.

JORDAN CABINET WORKS ORGANIZED

The Jordan Cabinet Works, of Brooklyn, was recently incorporated with a capital stock of \$25,000. Those interested are E. E. and E. B. Jordan, Jr., and A. B. Wilson.

The Phonograph Clearing House, Inc., of Manhattan, has been incorporated.

LOS ANGELES, CAL., January 6.—The Los Angeles Express and Tribune recently conducted a window dressing contest which was unique in



Bartlett Music Co.'s Window Display

many particulars, and which scored an emphatic success. The contest embraced many industries, and each house participating presented its display in the window of the Los Angeles Express and Tribune. Herewith is shown the window display prepared by the Bartlett Music Co., Columbia dealers. During the week of this display a number of people called at the offices of the newspaper to inquire on what floor the phonograph department was located, as they wished to buy a Grafonola and records. These inquiries were directed to the nearest Columbia dealer, and the display thereby served a dual purpose.

We hear a lot of "necessary evils," but did you ever hear of an unnecessary good?

Announcing

"Music in the Home"

By ANNE SHAW FAULKNER, Author of "What We Hear in Music"

A book of the utmost importance to the trade at this time

Retail Price, \$1.25

Dealer's Price, 65 cents

ASK YOUR DISTRIBUTOR REGARDING IT!

RALPH FLETCHER SEYMOUR, Publisher, Fine Arts Bldg., CHICAGO

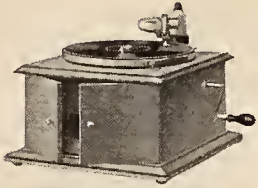

Victrola IV-A, \$20
Oak

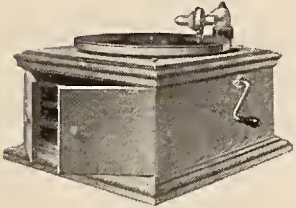

Victrola VI-A, \$30
Oak

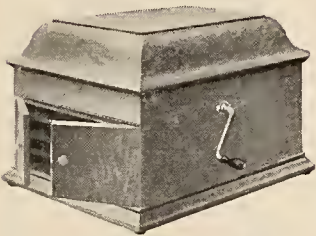

Victrola VIII-A, \$45
Oak



Victrola IX-A, \$57.50
Mahogany or oak



Victrola X-A, \$85
Mahogany or oak

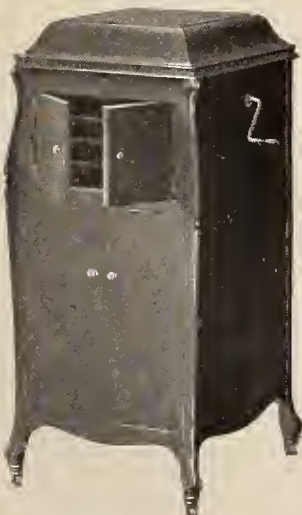

Victrola XI-A, \$110
Mahogany or oak

Victor Supremacy is lasting

It is built on the solid foundation of great things actually accomplished.

And the success of every Victor retailer increases with every new development of this wonderful instrument.

Victor Talking Machine Co.
Camden, N. J., U. S. A.

Berliner Gramophone Co., Montreal, Canadian Wholesalers

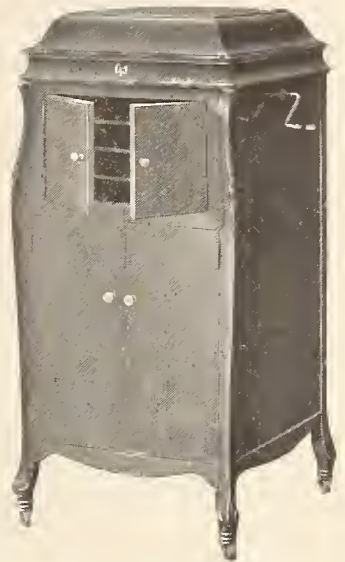

Victrola XIV, \$165
Mahogany or oak

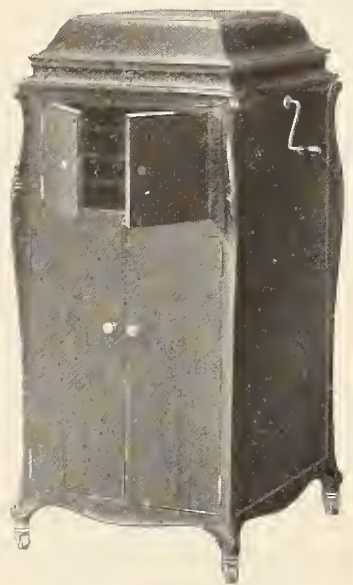

Victrola XVI, \$215
Victrola XVI, electric, \$270
Mahogany or oak



Victrola XVII, \$265
Victrola XVII, electric, \$325
Mahogany or oak

"Victrola" is the Registered Trade-mark of the Victor Talking Machine Company designating the products of this Company only.

Warning: The use of the word Victrola upon or in the promotion or sale of any other Talking Machine or Phonograph products is misleading and illegal

Important Notice. Victor Records and Victor Machines are scientifically co-ordinated and synchronized by our special processes of manufacture, and their use, one with the other, is absolutely essential to a perfect Victor reproduction.



"HIS MASTER'S VOICE"
REG. U.S. PAT. OFF.

The TALKING MACHINE WORLD

For the makers & sellers of talking machines

PUBLISHED BY EDWARD LYMAN BILL, Inc.

President, C. L. Bill, 373 Fourth Ave., New York; Vice-President, J. B. Spillane, 373 Fourth Ave., New York; Second Vice-President, J. Raymond Bill, 373 Fourth Ave., New York; Secretary and Treasurer, August J. Timpe, 373 Fourth Ave., New York.

J. B. SPILLANE, Editor

J. RAYMOND BILL, Associate Editor

AUGUST J. TIMPE, Business Manager

Trade Representatives: B. BRITTAIN WILSON, L. M. ROBINSON, WILSON D. BUSH, C. CHACE, E. B. MUNCH, L. E. BOWERS, A. J. NICKLIN, V. D. WALSH

Boston: JOHN H. WILSON, 324 Washington Street

Chicago Office: E. P. VAN HARLINGEN, Republic Building, 209 South State Street. H. SCOTT KINGWILL, Assistant Manager. Telephone, Wabash 5774

London, Eng., Office: 2 Gresham Buildings, Basinghall St. W. LIONEL STURDY, Mgr. The Talking Machine World has regular correspondents located in all of the principal cities throughout America.

Published the 15th of every month at 373 Fourth Ave., New York.

SUBSCRIPTION (including postage): United States, Mexico, \$1.00 per Year; Canada, \$1.25; all other countries, \$1.75. Single copies, 20 cents.

ADVERTISEMENTS: \$4.50 per inch, single column, per insertion. On quarterly or yearly contracts a special discount is allowed. Advertising pages, \$125.00.

REMITTANCES should be made payable to Edward Lyman Bill, Inc., by check or Post Office Money Order.

NOTICE TO ADVERTISERS.—Advertising copy should reach this office by the first of each month. By following this rule clients will greatly facilitate work at the publication headquarters.

Long Distance Telephones—Numbers 5982-5983 Madison Sq.
Cable Address: "Elbill," New York.

NEW YORK, JANUARY 15, 1918

BUSINESS during the holiday season so recently closed more than exceeded the prognostications indulged in the early part of December. Christmas trade opened up slowly, but the closing days showed tremendous activity in the demand for machines and records. Reports from correspondents in different parts of the country vary considerably as to the volume of trade, for it was most uneven in many respects. Some States showed an activity that equaled the same period of last year, while others had quite an increased trade in records but a falling off in the sales of talking machines due to local conditions and the lack of stock. But taking the holiday business of the Nation as a whole, it was, in the face of war conditions, in the main satisfactory.

Record business has assumed formidable dimensions, and this was demonstrated not only during the holidays, but during the first weeks of the New Year. While the demand for popular numbers, and particularly patriotic numbers of all kinds was large, yet there is no question but that the demands for records of standard vocal and instrumental numbers, especially the standard operas, is becoming an increasingly important feature of the record business.

Leading jobbers and dealers inform The World that this aspect of the business is as marked as it is pleasing. The growth in popularity of records of high class instrumental and vocal numbers can be greatly aided if the dealers or salesmen concentrate on bringing these records to the attention of their customers. In this way they can help to move what is usually a slow moving section of their record stock and help to elevate the musical taste of the owners of talking machines. They can do this more effectively if they know something about these high-class songs or instrumental numbers themselves—if they know the composers and the character of their compositions and impart this knowledge to the buyers of these records. In this way they give these records an interest that would be lacking were the customer induced to buy one of the records without giving it the consideration which it would receive if the buyer was properly interested in the selection and its composer.

THERE is a big field to be developed here—one that unquestionably means much for the musical advancement of America, and one that will help in a trade way as well. The popular and patriotic records will always sell, because they are

seasonable, but the standard compositions, the classics so to speak, do not sell in as large numbers as they should, largely because of the lack of attention given them by a large army of salesmen. This neglect is entirely due to their lack of real knowledge of these numbers.

While the leading manufacturers of records tell something about the high-class records in their bulletins every month, yet the salesman should have a wider knowledge of the composers and of their compositions if he desires to appeal to high-class trade.

This is well worth while, for there is no question but that the artistic and musical merits of the talking machine are being more widely recognized to-day than ever before. Evidence of this fact is to be found in the records now on the market of the great symphony orchestras and of leading artists both instrumental and vocal, who are known and esteemed throughout the world.

The dealer and salesman should make a resolution this first month of the year to give more attention to their record departments—to learn more about the goods they are handling, not merely in a commercial way, but also to know the composers and their works. In this way they will be able to meet the requirements of their particular customers, and help educate a large number of people who are ambitious to expand their record library by including records of distinct and enduring musical merit.

AT no time in trade history was it so necessary to cultivate an optimistic viewpoint as far as business is concerned as to-day. The abnormal conditions brought about through the war have a tendency to bring about a hysterical state of mind that is as harmful to the individual as it is to an industry and to the nation. Now is the time to cultivate that desirable quality in the world of business which we call confidence, and which is also as great an essential in the winning of the war.

We must not give credence to every rumor that is put out portending to calamity or trouble, for there is nothing that weakens the morale of our business forces quicker than the insidious annoying little rumors that incline one to pessimism and indifference to necessities whether of war or business.

One thing that we must keep in mind is that the Government of the United States is not wilfully or willingly desirous of bringing disaster to the business men of this country despite the constant flow of "non-essential industry" news which is reaching the daily newspapers throughout the country from correspondents in Washington.

WE may be in the position of an industry that is not entirely essential to the military conduct of war, but our industry is one that is wholly essential to civilization. We need not become panic stricken because one man in the U. S. A. might do without musical instruments. They said in England, when war came, that no one must dream of buying anything new, whether motor cars, pianos, talking machines, or clothes. But the folks went on buying just the same; and yet the war loans have been floated over there with complete regularity and success. Why? Because the people have found they need music almost as much as they need food; and a good deal more than they need rich, expensive food and drink.

Despite the enormous sums which the Liberty Loan Campaigns, past and future, will bring into the national treasury, the Government will still depend principally upon taxation to raise money for the purpose of financing the extraordinary expenditures of war. Unless the industries of the country are kept going on a profit-making basis, the Government will not be able to levy taxes. The more profit an industry makes, the greater will be its tax returns to the Government, and the larger will the war-chest become. Therefore no sensible man will believe for an instant that the Federal authorities are going to hinder any line of business arbitrarily, or will place stultifying restrictions around a business that otherwise would be able to contribute a quota towards keeping the war-funds at high-water mark.

COME what may, we are in war, and in it to win. To obtain our purpose, we shall keep business going all the time; but that does not mean that everything must go on just as it did be-

fore the war. That is impossible; and so much the better. Whatever comes in the future, every bit of brains, nerve and skill in our industry will be needed.

We must continue to make talking machines and records, and continue to sell them and sell more of them than ever before to a people who will be working, planning, organized and organizing; to a cheerful, to a purposeful, to a victory-making people. We must inaugurate and maintain a campaign of publicity that will awaken the people of America to the value of music as a necessity—as a companion that will bring comfort and cheer in days of sorrow as well as victory.

Music by means of the talking machine is a necessity. It supplies the fighting forces as well as those who are working at home for the success of the Nation with that force that replenishes and freshens. For it is hard to define the mysterious power of music in a great crisis such as we are now going through. It is the food that nurtures the Nation's soul, that stimulates brave deeds, and that increases the determination to surmount all difficulties.

THE development of export trade not only during the war, but after peace is declared, is considered by every student of the nation's needs to be absolutely essential to the progress of our country. A forward step in this direction was the passage recently by the Senate of the Webb Export Combination Bill, which it is expected will be enacted into law at an early date. This measure is a highly desirable recognition of the principle of co-operation in foreign trade which has had the support not only of the National Foreign Trade Council but of the leaders in all branches of industry. American exporters have long been greatly hampered in their efforts to compete with foreign exporters in the markets of the world by their apprehension that the Sherman Act forbade combined effort, including even the organization of joint selling agencies. The Webb Bill removes such disadvantages as may now be imposed by our anti-trust laws to the end that American exporters may be free to utilize all the advantages of co-operative action in coping with combinations of foreign rivals united to resist American competition and a combination of foreign buyers equipped to depress the prices of American goods.

The passage of the Webb Bill will mean the definite recognition by Congress of the principle of co-operation, and it should prove a very substantial benefit to the nation's export trade.

DURING the past year talking machine dealers in various sections of the country through local organizations have taken steps to eliminate entirely or at least control within reasonable bounds the practice of sending out records on approval, and it is to be hoped that the elimination of this practice or at least its curtailment to a negligible point will become general throughout

the country during the present year. As a matter of fact present conditions offer to the dealer an excellent opportunity for taking the bull by the horns and eliminating bad business practices that have grown up with competition. Stock is going to be short both in records and machines, and with such a situation the retailer can come pretty near to picking his trade. If he has the record the customer wants make the customer buy it outright. If the records don't suit, the approval plan is not going to sell them. At the same time under that plan the records may be out of the store when somebody else is ready to buy them. Taken from every angle this is the time to clean house without facing the danger of serious loss of business to competitors.

JUST at this time the presentation by the Musical League of Philadelphia of detailed figures showing that nearly \$102,000,000 are spent annually in that city and vicinity in various forms of musical activity, should serve to interest every member of the trade, no matter in what part of the country he is located.

The additional fact that there is a permanent investment of approximately \$20,500,000 in musical establishments and musical instruments in that one city alone must also not be overlooked. Figures of this sort go far to emphasize the necessity of music and the part it plays in civic life. The citizens of a city the size of Philadelphia, whose population is approximately 1,700,000, do not spend an average of \$60 apiece annually on a mere fad or hobby, but demand value for their money.

Talking machine men could do good work for the industry by compiling, or assisting to compile, similar figures for their respective cities or towns. The aggregate amount spent for music annually, as compiled by such means, would undoubtedly impress the country to a staggering degree. A few authentic figures are better than hours of wild conversation in securing public recognition for music and the things that make music.

AT least 50 per cent. of the war rumors that are abroad these days should be summarily dissolved into thin air. Among those rumors which should receive scant attention are those purporting that this or that plant has been anywhere from 60 to 100 per cent. commandeered by the United States Government. The Washington policy as expressed by such men as Willard, Gifford and Garfield does not include drastic action against any industry. Where individual plants are utilized for war work, moreover, the manufacturer will have no reason for concealing the facts. When his plant has been taken over a manufacturer will immediately inform his clients with respect to his inability to supply them with goods, because there would be nothing to gain in a business way by holding back the truth and there is good will to lose. Therefore, unless direct word is given out by the manufacturer in person, rumors bearing on commandeering should be discountenanced.

HAPPY NEW YEAR!



This big calendar pad has over 300 sheets of record profits. As you start to tear them off, day by day, keep

*Pearsall Service
for Victor Records*

in mind. Every day in 1918 means more business; improved methods and greater profits because the efficient dealer is specializing on record sales as THE business foundation.

Full of hope, ambition and prosperity—1918. Full of pep—*Pearsall Service*.

SILAS E. PEARSALL CO.

VICTOR DISTRIBUTORS

18 West 46th Street

New York

Edison Message No. 15

WHERE MUSIC STANDS

The merchants in your street who sell food, clothing and fuel are selling essentials to the body. You who sell music sell an essential to the mind *and* body.

From Confucius down through the ages practically every philosopher of note has declared that music is a human essential.

When you meet a man or woman who thinks a phonograph is an extravagance ask that man or woman if good books are an extravagance. There is scarcely anyone who would dare say that books are an extravagance, yet books have limitations that music does not have. Music, next to religion, is the world's greatest solace.

Thomas A. Edison, Inc.
Orange, New Jersey

Don't be afraid to stick
up for music.

War Problems in the Field of Salesmanship and How Best to Meet Them :: :: By G. D. Crain, Jr.

"The worst thing about having to employ so many new clerks," said a tired talking machine dealer, as he looked about at a number of "new beginners" attempting to wait on the trade in his store during the holiday rush, "is training them. It's a job that I haven't much time for, and one that takes a lot of steam."

Yet, without question, the new clerk who is not given the advantage of sympathetic coaching is sure to make a lot of mistakes, and will fail to render the sort of service customers of the store are demanding.

The soldiers who go to France are given several months of intensive training before they get on the firing line. They receive instruction in the methods of warfare which are being used in the world conflict, so that when they take their places in the trenches they are prepared for all developments.

The new salesman, especially the one just starting out in selling work, is green timber. He needs coaching and instruction. He needs to have confidence instilled into him, so that he will not lose his nerve when a tough proposition is presented.

The best way to improve work in the store is to have a weekly conference or "round table." This can be made so interesting and enjoyable that the clerks, instead of dodging the meeting, will welcome it. It should be accompanied by "eats" of some sort, so that the social spirit will be developed, and bashful clerks encouraged to speak their minds.

The boss can be the chairman of the meeting, and can outline subjects for discussion, but it is a good idea for him not to attempt to monopolize the conversation.

Let salesmen, especially those who are experienced enough to be able to give good advice, discuss the problems of their everyday work, because such discussions will give the newcomers an idea of what they may expect.

The merchant can devote some of the time to the description of new models of machines and the new records, comment on changing prices, etc., and he should also explain the policy which is back of the store, so that customers will get from sales people an expression in line with the actual policy of the establishment.

Just now, when most prices have been increased, explanations of high prices should be made intelligently, and advances not simply excused "on account of the war." There is a good reason for the advance in price of every commodity which is carrying an increase, particularly talking machines, and it is a good idea to inform the sales people on this subject. Customers frequently inquire about these things, and they should be given an intelligent answer.

In the smaller store, where there are only a

few clerks, the proprietor can put in odd moments to good advantage in explaining to the new employes the methods which it is intended they shall use and something about the features of the line handled.

In this connection it is well to note that with new sales people having to be trained, now is a good time to study the arrangement and marking of record stock. Obsolete methods in this respect, which were tolerable when experienced salesmen, familiar with all of the retails

*"To Improve Work
in the Store Have a
Weekly Conference
Round Table"*

of the business, were in charge, make the work of new employes doubly difficult.

The arrangement of record stock in some logical way (there are several good systems in use) will enable the rawest recruit in the sales army to take care of his own work without having constantly to ask questions of the dealer or one of his assistants.

The dealer who is training his help should be possessed of lots of patience. He must expect mistakes to be made, and be ready to correct them without animosity. In the case of employes who are just being broken into business harness, reproofs are often taken keenly to heart, and the dealer can afford to be generous in his attitude on this subject.

If he shows that he does not demand infallibility, but only earnest intelligent effort, he will win confidence and loyalty that will go far to keep the mistakes from being repeated.

The new clerk who is made to feel that committing an error is not fatal, but that making the same mistake twice is a capital offense, will develop a spirit of determination to do things right, and will soon display ability that will mean less need for supervision.

One mighty good way to improve the work of new clerks is by enlisting the aid of traveling salesmen representing both the jobbers and the manufacturers.

The travelers are often just as good retail merchants as those who have stores, because they are constantly calling on the dealers, and

they know good methods when they see them.

Furthermore, they are nearly always more than willing to co-operate with their customers in every possible way, and if they are asked to help in coaching a new hand, they will be glad to do so.

Many of these old-timers have seen service behind a counter themselves, and their suggestions are based on practical experience, and consequently are worth more than a lot of fine-spun theories.

Sometimes a traveling man will jump in and do a little sales work himself, if there happens to be a lot doing on a busy day. An ounce of demonstration is worth a pound of argument, and this is especially true of sales work.

After the new clerk has seen how his friend Bill, the traveling man, handles a difficult customer, and how quickly he gets under the hide of the grouchy individual whose bark is usually worse than his bite, he perks up considerably.

Use the traveling man in the clerk's training school, but don't forget that, no matter how informal, there should be a training school.

(Copyright, 1917)

COLUMBIA AUDITORS MEET

Second Convention of Auditing Department of Columbia Co. at Hotel McAlpin a Great Success—Important Matters Were Considered

The second annual convention of the auditing department of the Columbia Graphophone Co. was held at the Hotel McAlpin, New York, on December 28 and 29. The two-day session was devoted exclusively to a discussion of problems, methods and systems of branch auditing, accounting, stock keeping and inventorying.

Henry C. Cox, comptroller of the company, brought to the attention of the conference a new manual of instructions for the guidance of the company's bookkeepers, which will shortly be ready for distribution to the branches, and explained such of its provisions as are new. The discussion of these new features and of branch accounting generally was highly interesting and beneficial to everyone in attendance.

At the conclusion of the dinner at the hotel on December 28 the entire party were the guests of the company at the Century Theatre.

The convention adjourned late in the afternoon of the 29th, every one expressing appreciation of the benefit derived from the free discussion of so many topics of special interest.

Those present and assisting were: M. Dorian, chief auditor, and E. O. Rockwood, T. Allan Laurie, Homer Reid, H. L. Moorey, F. S. Binger, W. G. Wustefeld, W. E. C. Heym, F. M. Snell, S. S. Gilroy, R. A. Grant, C. Klebart and Harry P. Victor. Hayward Cleveland, one of the veterans, was not able to be present, owing to his detention on the Pacific Coast, but he sent a helpful telegram which was read to his associates, and his place at the conference table as well as at the banquet was marked by a vacant chair.

A most gratifying and highly appreciated incident of the conference was the reading of a letter from H. L. Willson, general manager of the company, congratulating the auditing department on its fine work during the year and wishing each member of the staff continued success and a Happy New Year.

TAKES CHARGE OF DEPARTMENT

H. V. Boswell, formerly with the Rudolph Wurlitzer Co., of Louisville, Ky., has taken charge of the Kaufman-Straus Co.'s talking machine department in that city. He succeeds Robert Duffy, who is now with the Columbia Graphophone Co., of Indianapolis.

Record Cleaners

The "Standard" Circular Cleaner grips the surface and clings as if on rails. A cleaner that has "made good."

PRICE, 50 CENTS, LIST

We also manufacture the "Simplex" Record Cleaner, 15 cents list price.

SEND 10 CENTS FOR A SAMPLE CLEANER

Automatic Stops



A u t o m a t i c

Stops are in use everywhere. They give excellent service, are easily installed and are absolutely guaranteed.

SEND 50c FOR SAMPLE STOP

KIRKMAN ENGINEERING CORPORATION, 237 Lafayette St., New York



 BRILLIANTONE
NEEDLES

ANNOUNCEMENT

To Talking-Machine Trade

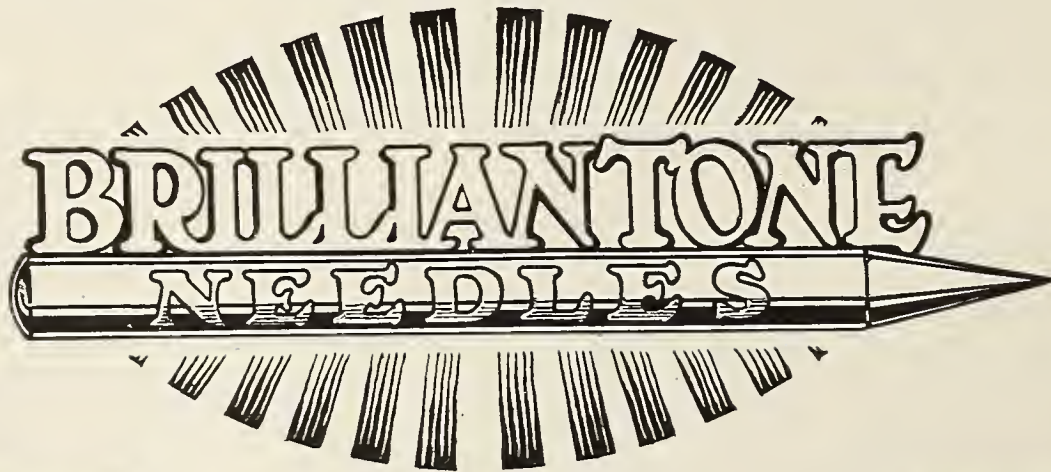

WE take great pleasure in announcing the opening of our offices. To our New York friends we extend a cordial invitation to call upon us, and to our out of town friends an invitation to make our offices their headquarters when in the city. We are now booking orders for the highest quality uniform pointed steel talking machine needles manufactured.



MADE IN AMERICA
By AMERICAN LABOR



Deliveries Begin Feb. 1st, 1918
Soft, Half-Tone, Loud & Extra Loud

PRICES AND SAMPLES ON REQUEST

Brilliantone Steel Needle Co. of America
INC.

B. R. FORSTER, President

Marbridge Bldg., Broadway at 34th Street, New York

ROOMS 657-659

Columbia advertising recognizes the importance of the dealer. To make people test a Grafonola in your store—that is the focus of Columbia advertising.

**Columbia Graphophone Co.
Woolworth Building, New York**



INDIANAPOLIS REPORTS A PROSPEROUS HOLIDAY SEASON

Large Percentage Did Cash Business—Dealers and Jobbers Report Trade Increases as Compared With Last Year—Optimistic Regarding New Year—Interesting News Budget of the Month

INDIANAPOLIS, IND., January 5.—The holiday business came up to the expectations of most of the local talking machine dealers and apparently is keeping up. The retailers are still busy selling records and machines and the wholesale men report that orders from dealers have come in almost as steadily as before Christmas.

A noticeable feature of the business was the large percentage of cash business and the size of the down payments. Nearly all the dealers comment on this.

Ben Brown, manager of the Columbia store, said that the total increase in business over December of last year would run nearly 50 per cent. Increases in the business of dealers in the smaller towns in his territory were especially noticed by Mr. Brown. Mr. Brown is making arrangements to go to New York to attend the conference of the Columbia managers.

At the Stewart Talking Machine Co., distributors of the Victor line, business was reported as far ahead of last year. Emerson Knight, advertising manager, said that he believed the Victor Co.'s advertising on the ground that music was more essential during war than in peace had proved effective in stimulating the business.

Jewell Cartmill, secretary of the Kipp Phonograph Co., said that business was not only bigger than last year before Christmas, but that it was keeping up and that dealers throughout their territory continued to send in orders after Christmas. The demand for a few styles caused a shortage, but the company was able to handle its Christmas orders nicely.

R. S. Goldsbury, of the Pathé department of the Mooney-Mueller-Ward Co., said the demand for records had almost depleted the stock. The new art models of the Pathé have proved popular and many orders are coming in for these, Mr. Goldsbury said. The entire supply of electric Pathés was sold out.

O. C. Maurer, in charge of the talking machine department of the Kiefer-Stewart Co., said there appeared to be a strong demand for the oak finish cabinets in the Sonora machines. Business in the Stewart phonograph, which the company also distributes, was remarkably good, Mr. Maurer said. Dealers also made heavy demands for the Emerson records. Mr. Maurer said the outlook for business in the coming year was exceptionally good.

A. H. Snyder, manager of the Edison Shop, said that there was an increase in total business over last year, and that from December 15 the daily sales record showed a marked increase over any previous ones for the same period with larger down payments and a trend toward the higher-priced machines.

Mr. Snyder used an especially attractive window display just before Christmas. He had the window fitted out like a living room and had a woman and a five-year-old girl knitting while two small children played on the floor

near an Edison machine. The Christmas spirit and the showing of the place of the talking machine in the home were well brought out. Newspaper advertising featured a similar idea.

George Standke, manager of the Brunswick Shop, is highly pleased with the first holiday business of his store, which ran above his expectations. Mr. Standke said he was pleasantly surprised at the size of the cash payments and added that he believed in selling goods and not terms. Prospects for a good year look bright to Mr. Standke.

"I did not run short of machines because I have been in the talking machine business long enough to know how to get around that," said Mr. Standke. "I did my buying early. I have never been able to understand why experienced talking machine men should ever complain of any shortage. They know what the demand for machines is during the holiday season and they ought to get their orders in early. Let them start ordering in the spring for their Christmas business. They should not expect a factory to be able to turn out their orders at the last minute."

Mr. Standke has a number of the new DeLuxe models of the Brunswick on the way and already he has sold the first sample model he got.

H. A. W. Smith, manager of the Pathé Shop, said that nearly one-third of the large Christmas business was cash, and that the record business was unusually good. The new Pathé art models which Mr. Smith has on display are attracting much favorable comment, and indications are that they will prove popular sellers. The Pathé Shop has been using animated picture advertising in local theatres, showing people dancing to a Pathé machine and this advertising is proving worthwhile, Mr. Smith said.

H. E. Whitman, manager of the talking machine department of the Pearson Piano Co., said that the holiday business showed a demand for the larger Edisons and Victrolas. The record business was so large the clerks were worked overtime in caring for the customers.

A. E. Pfeiffer, manager of the Starr Piano Co., said that the Starr machine enjoyed a good sale during the holidays. The fact that it plays all records made it popular with the public, Mr. Pfeiffer added.

Serge Hallman, manager of the Aeolian store, said that the Vocalion department enjoyed a good holiday trade, and that business was holding up nicely.

C. P. Herdman, manager of the Columbia department of the Baldwin Piano Co. store, said that his stock of machines had been so selected in advance that he was able to get through the holiday season without the usual trouble of running short of particular styles. A large part of the business was from out-of-town buyers, and this was nearly all cash.



SCHUBERT PHONOGRAPH



Dealers sold 10 times more SCHUBERT Phonographs this year than a year ago.

Because 10 times more people wanted the SCHUBERT after hearing all other machines.

Five Models, \$60 Up

Every dealer was pleased with the way we handled his holiday orders, and with our local newspaper advertising with his name attached.

We'd be glad to hear from you—maybe we have something of interest to you.



The BELL TALKING MACHINE CORPORATION

Offices and Show Rooms, 44 W. 37th St., New York Factory, 1 to 7 West 139th St.

LOCAL TERRITORIAL DISTRIBUTORS

Schubert Phonograph Distributing Co., 308 Lyceum Bldg., Pittsburgh, Pa.

J. A. Ryan, 3231 Troost Ave., Kansas City, Mo. Smith-Woodward Piano Co., 1018 Capitol Ave., Houston, Tex.

Give Them What They Want!



The tremendous demand for PATHE PATHEPHONES during the past year is UNQUESTIONABLE PROOF that the people are no longer satisfied with a ONE-RECORD machine.

The people have been educated regarding Records—They know that there are good Pathe Records—They know that there are good Victor Records—that there are good Columbia Records and good Edison Records—

The people want to hear ALL makes of records and they must have a talking machine THAT WILL PLAY all makes of records—

The *Pathe* Pathephone

Is the Only Standard Talking Machine That Gives You This Great Selling Advantage

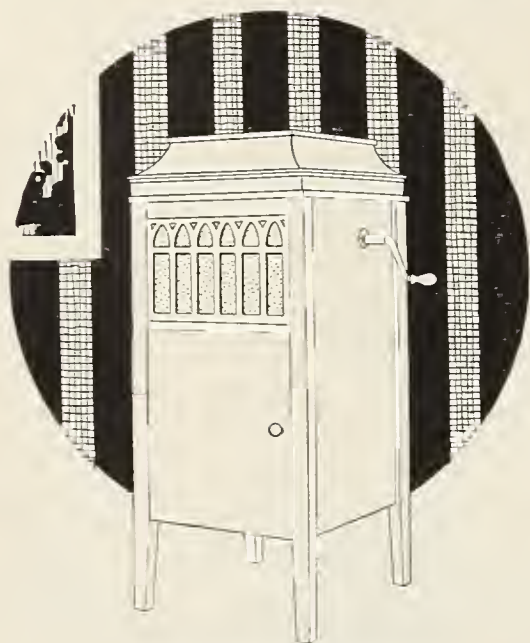

Pathephone \$75 Model

This and other grand features—the **Pathe Sapphire Ball** and **Pathe Everlasting Records**—make Pathe the greatest of all phonograph propositions.

*Hook Up With the
Pittsburgh Pathephone Co.
for Real Pathe Service!*

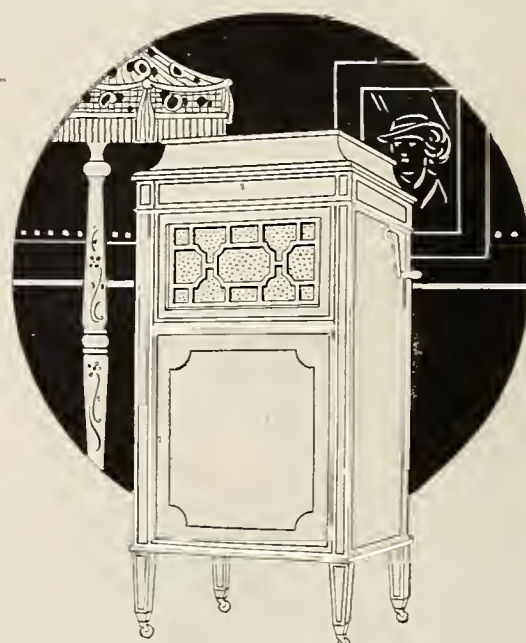

Pathephone \$225 Model

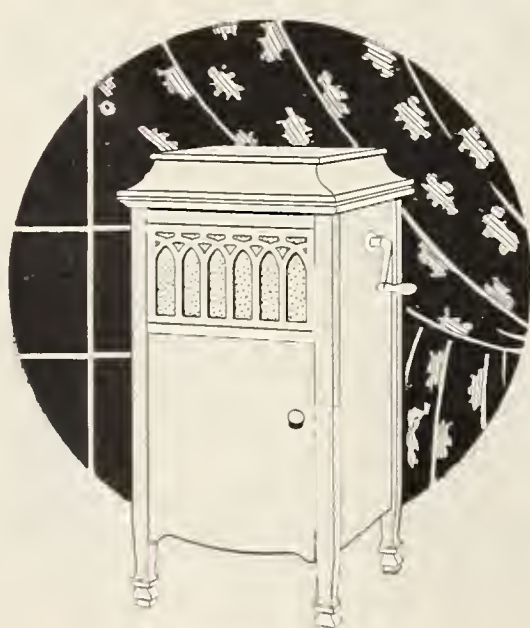

Pathephone \$100 Model

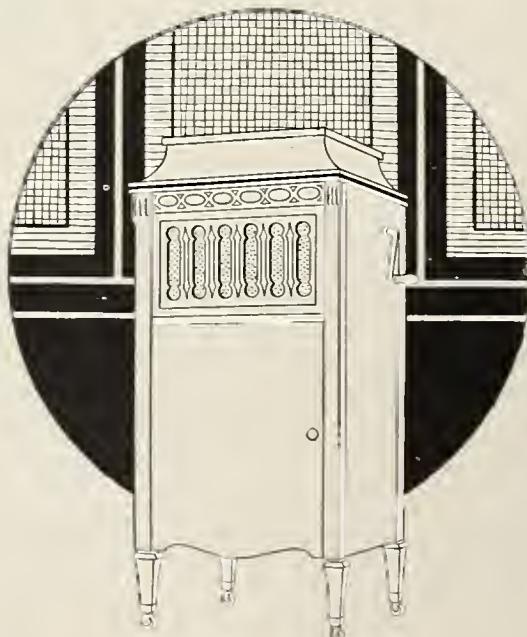

Pathephone \$110 Model

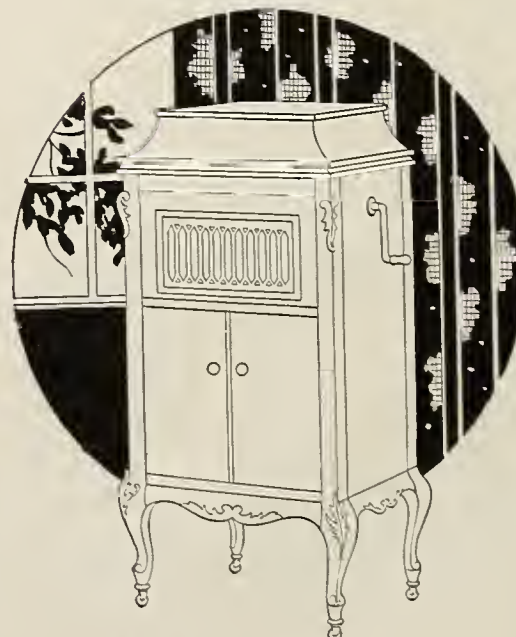

Pathephone \$175 Model

PITTSBURGH PATHEPHONE CO.

963 LIBERTY AVENUE, PITTSBURGH, PENNSYLVANIA

DOEHLER DIE-CASTINGS

SHEER MERIT has attained for Doehler Die-Castings their prominence as LEADERS in their class in the talking machine and kindred trades as it has throughout the various branches of the metal working industries. The consistent use of Doehler Die-Cast tone-arms and sound boxes by the leading manufacturers and supply houses in the trade is the direct result of the undisputed quality of our products and the efficient service our extensive resources make possible.

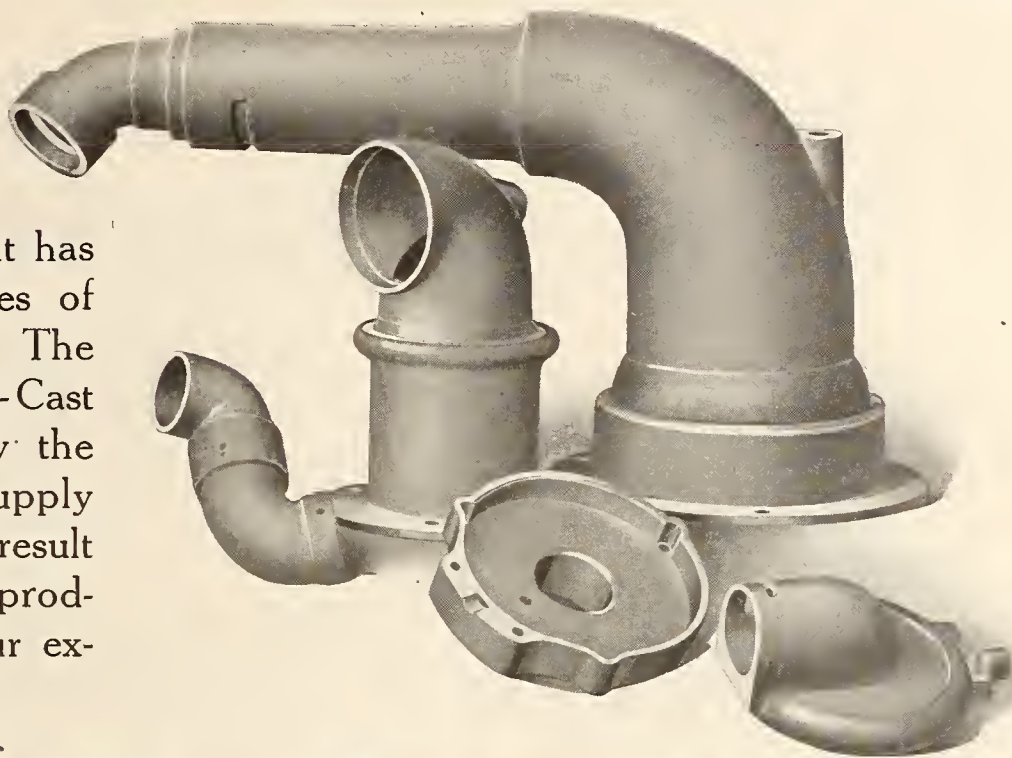

DOEHLER DIE-CASTING CO.

BROOKLYN. N.Y.
NEWARK. N.J. **TOLEDO. OHIO.**

SALES OFFICES

CHICAGO
4414 No. Campbell Ave.

DETROIT
914 Ford Building

ROCHESTER
159 St. Paul Street

BOSTON
723 Oliver Building

MUSIC FOR U. S. SOLDIERS IN CUBA

How Uncle Sam's Boys Have Been Cared for in This Important Essential, Thanks to Courtesy of R. C. Ackerman and Otto Heineman

R. C. Ackerman, export manager of the Otto Heineman Phonograph Supply Co., New York, who returned recently from a trip through Central America and Cuba, brought with him the accompanying photograph which depicts a body of American soldiers in camp near Camaguey listening to a Vanophone machine playing Emerson records. The Otto Heineman Phonograph Supply Co. handles both of these products in the foreign field, and the company owes this picture to the courtesy of Major Halford, commanding officer of the First Battalion, Seventh Regiment, U. S. Marines.

Mr. Ackerman made Major Halford's acquaintance in Camaguey on the occasion of one of the concerts American Marines Near Camaguey, Cuba, Enjoy Talking Machine Music which Mr. Ackerman gave the guests of the hotel. Major Halford has had long experience in Latin countries, having been in the Philippines as well as Cuba. As members of Mr. Ackerman's family have fought in every U. S. war from 1776 down to the service of Lieut. Ackerman on Admiral Dewey's flagship in the Philippines, Major Halford was pleased to accept Mr. Ackerman's offer of a gift for the United States soldiers of a Vanophone and a collection of Emerson records.

Otto Heineman, president of the Otto Heineman Phonograph Supply Co., has amplified this by making an equivalent present to each of the

posts of United States soldiers in Cuba. "Our boys" are down in that country at the present time co-operating with the Cuban forces to prevent any tampering with the sugar crops, and the importance of this vigilance will be readily realized by all who feel the scarcity of this all important commodity.

SOUTH AMERICA LIKES THE 'TALKER'

There is said to be an increasingly good market in South America for talking machines made



in this country, particularly for those made to sell at wholesale for from \$4.50 to \$25 each, says the New York Times. Several large commission houses in this city with connections in the Southern markets report having done an extremely good business this fall in these lines. It is pointed out by the head of one of these houses that South Americans are a music-loving people, and that the popular-priced talking machine of good reproduction and tone qualities is a great favorite with them. Also it is said that this country is getting a large part of the business in these lines which formerly went to Europe, which it will hold after the war is over.

UTILIZING VACANT WINDOW SPACE

Placing Record Posters in Vacant Store Windows Opens a New Avenue of Publicity for the Progressive Talking Machine Retailer

The United States Government in the exploitation of the various Liberty Bond issues has seen fit to put posters in the windows of every available vacant store. This is an idea which if not immediately opportune for the talking machine dealer may be of value at a later date. Record posters could undoubtedly be placed in the windows of many vacant stores at a very slight expense, and if it is advisable to spend thousands of dollars in order to have one window front on a prominent street, it is probably good business to have as many window fronts speak for your business as is possible, especially when the cost of the additional ground street windows is very small.

DISPLAY SERVICE CO. MOVES

The Display Service Co., formerly located at 16 West Nineteenth street, has moved to 114 West Seventeenth street, New York. This company specializes on original and artistic window displays and has lately been catering to the wants of the talking trade. It is now sending out catalogs describing its products.

DEALERS EVERYWHERE ARE SELLING QUANTITIES OF OUR

HANAIEI BANJUKES

(Ukuleles in Banjo Form)

A bigger hit than the Ukulele because much louder and more pleasing in tone, and of more substantial construction. Perfect two octave scales. A thoroughly practical instrument for both solo playing and club work. Send for illustrated catalogue and price list today, as

The Banjoke Is One of the Biggest Sellers in the Musical Instrument Line.

SHERMAN, CLAY & CO.

Sole Manufacturers

163 Kearny Street

San Francisco

Your Customers Will Be Hungry for the 37 Columbia February Hits

IT'S easy to sell people what they're hungry for—whether it's fun, marshmallows or music.

That's why the records in the Columbia February List will not gather any dust on dealers' shelves.

9 popular hits; 6 dance favorites; 2 comedy selections; 12 vocal successes; 6 stirring instrumental numbers; and 5 Burgess bedtime stories. A powerful list.

A corking War Song Medley; Handy's Orchestra Jazz Dance "Blues"; Bert Williams' best fun; Boy Choir recordings; a 90 Instrument Symphonic Masterpiece; Vocal gems by Barrientos, Tamaki Miura, Vernon Stiles, Oscar Seagle, Charles Harrison and other popular artists.

For real live novelty, interest, surprise and the right kind of SALES VALUE the February List can't be beat.

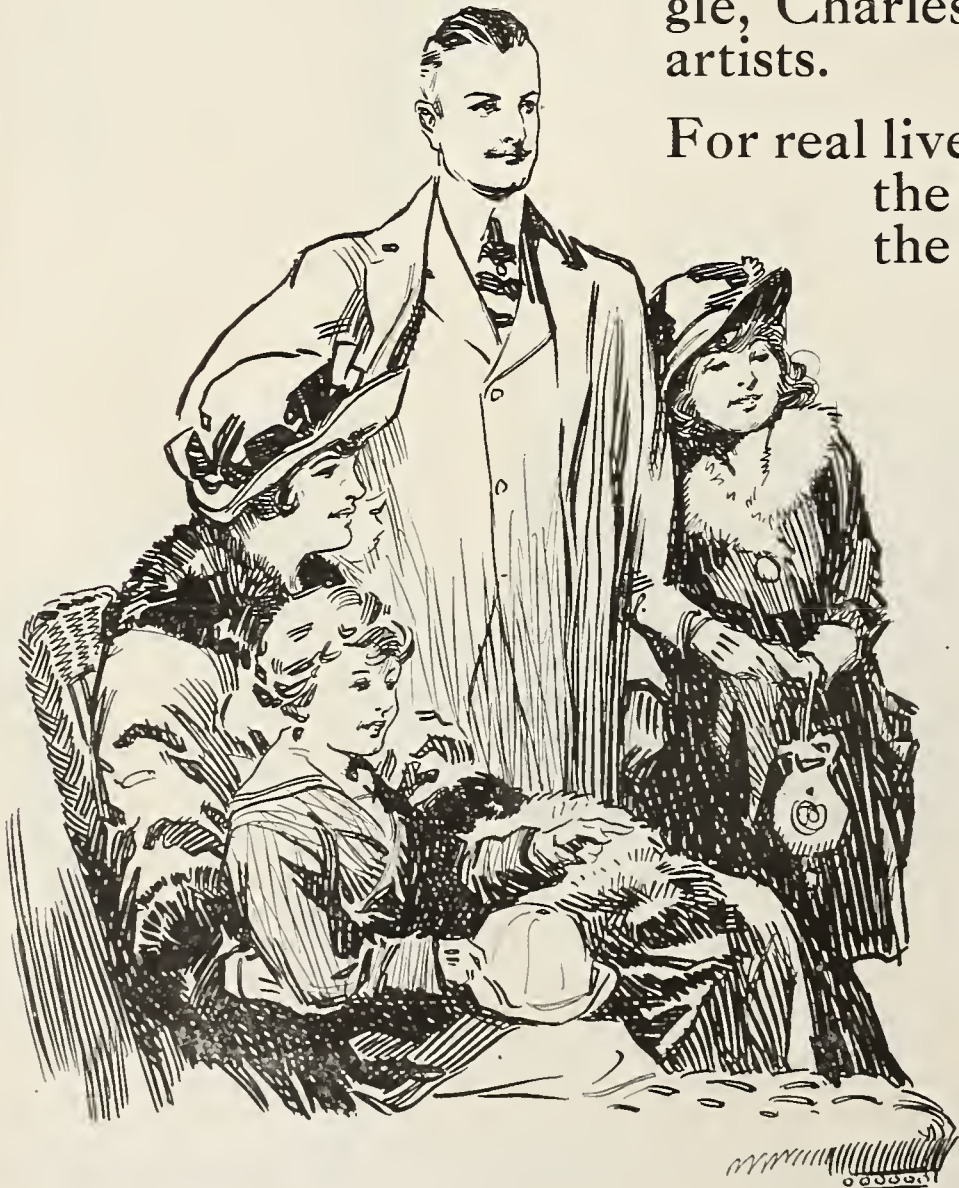

COLUMBIA GRA
Woolworth

Colu
Gra

The Dollars Received at Christmas Will Go to Buy Thousands of Columbia Grafonolas

MANY a Christmas check, or Christmas "bonus," will find its way soon into the hands of Columbia dealers.

Don't slack up your drive on the higher priced Grafonola models for a single moment.

Display in your windows, store and advertising the beautiful, popular, *de luxe* Grafonola 200 model. When people hear the clearness, brilliance and mellowness of this aristocratic model they will say, "That's the instrument we want."

Remember that there is a Columbia model to fit every purse.

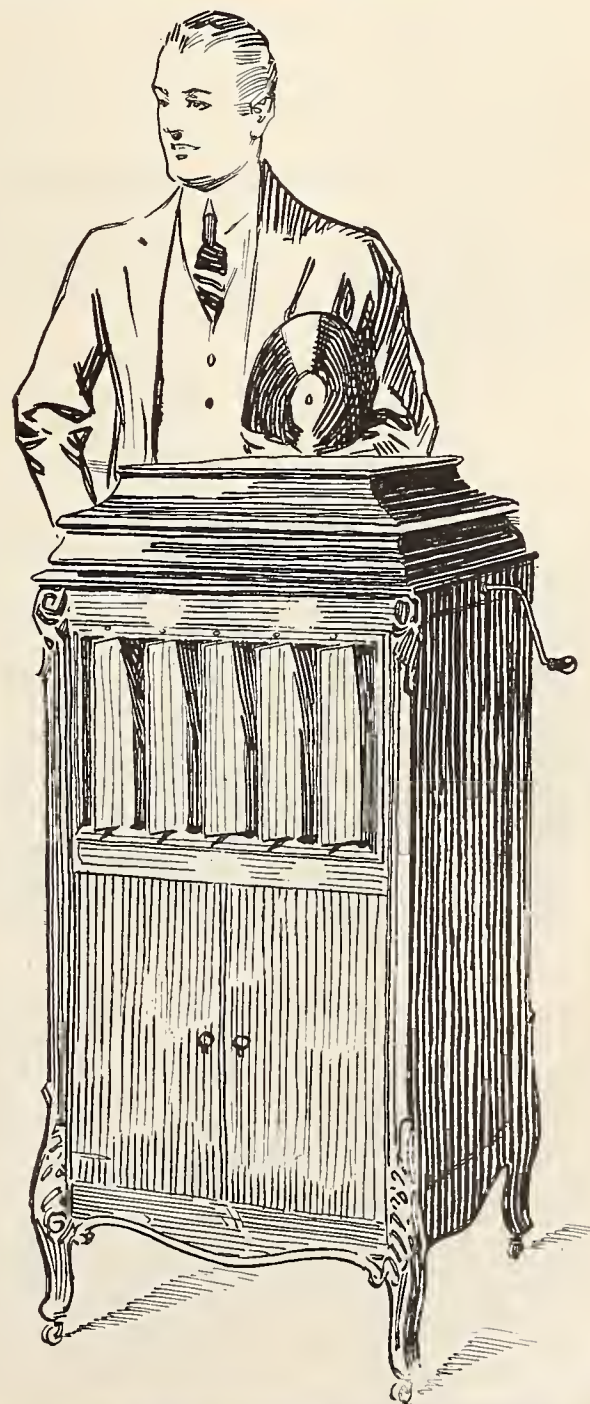

COLUMBIA COMPANY
 Building, New York

Columbia Grafonolas



INCREASING DELIVERY WAGON VALUE

Posters Advertising Special Records Can Readily Be Attached to Sides of Vehicles

The idea has recently been advanced of advertising records by the use of poster cards prominently displayed on the sides of the dealer's delivery wagons or delivery cars. A good many of the posters which feature individual records or general types of records such as the Hawaiian are of a standard size. This makes it easy to attach a frame moulding on the side of the car with a slit in the top to permit removing old posters and inserting new ones. A car or wagon moving down the street invariably attracts the attention of pedestrians, and it seems quite likely that the brilliant record posters will implant the idea in the minds of a good many to drop in to buy this or that particular record. The children, or the people in the street, are also likely to be attracted and their comment is also apt to produce sales.

PATENTS CLEVER WINDING DEVICE

Emile Kaliski Invents System for Winding Machine by Raising and Lowering Cover

Emile Kaliski, president of the Kaliski Music Co., Ltd., Monroe, La., has just secured a patent on a clever winding device for talking machines. In Mr. Kaliski's invention the raising and lowering of the lid of the machine serve to operate the ratchet wheel connected with the motor and thereby winds up the spring without further attention. The advantage claimed for the new winding device is that it obviates the necessity of marring the side of the talking machine case to provide an opening for the usual winding key.

The big things of life are the unexpected ones. The little things, the courtesies, the right hand of fellowship, the smile, all pave the way to the Big Opportunity. Be courteous to every man, give him your best service, no matter what his clothes, no matter where his home.

MAKING THE WINDOW PAY THE RENT

How the Sonora Phonograph Agency in Atlantic City Has Built Up a Successful Trade

ATLANTIC CITY, N. J., January 5.—When the Sonora Phonograph Agency was established at 711 Boardwalk, this city, about three years ago, it was predicted that it would never succeed, because people on that thoroughfare were there for pleasure rather than business, moreover, others had tried but had failed. Good-natured ones deemed it might be possible to make both ends meet were several different makes han-

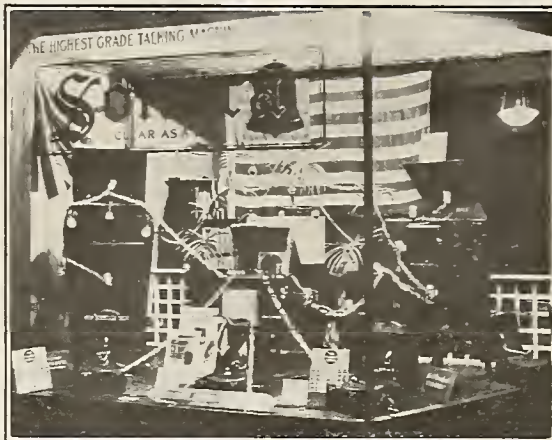

Window of Sonora Phonograph Agency

dled, but with one instrument—most assuredly not!

Nevertheless, A. E. Jordan, of the Sonora Phonograph Agency, has proven how unwise it is to prophesy, for he has made good in his venture, thanks to his original methods of attracting the attention of the millions who pass his store in a year. The keynote of his success may be discovered in his clever window displays, which never fail to attract, and the line he handles. He believes that a good window should pay the rent, and this means much, for rents are high on the Boardwalk.

With this end in view the Sonora Phonograph Agency has made a practice of changing its

windows constantly. This has proven a splendid trade attracter, and emphasizes also the value of the window-dressing department, published in *The World* each month, to talking machine dealers throughout the country. The picture herewith is rather a poor representation of one of the many methods used in window display by Mr. Jordan. He has made it a point to arrange a proper window for the special seasons of the year as well as for special days. By this means he has increased Sonora sales beyond expectations, and this despite financial conditions and the high cost of living, due to war times.

TALKER HELPS THE ORDER CLERK

A talking machine of the dictating type has been put to new and excellent use by a prominent Eastern concern. It had been the practice for the telephone order clerk to write out the order in longhand as it was received over the wire and then repeat it to the customer for verification. Now a talking machine has been installed and the order clerk repeats the order over the telephone and into the transmitter of the dictating machine at the same time. When a cylinder is full it is taken to a typist to be transcribed. The saving of time is considerable, and it is declared that mistakes have also been cut to a minimum.

FEATURE RECORD SELLING CABINET

Emerson dealers throughout the country are utilizing to excellent advantage a record selling cabinet which is well calculated to produce and stimulate sales. This cabinet, which is designated as "Emerson Record Selling Cabinet No. 4," is of all steel construction and holds 100 records. It has ten separate compartments or pockets, each holding about ten records in envelopes, ten titles visible. All parts and joints of the cabinet are electrically welded into one solid fixture, and it presents a very attractive appearance.



DAYTON MOTORS

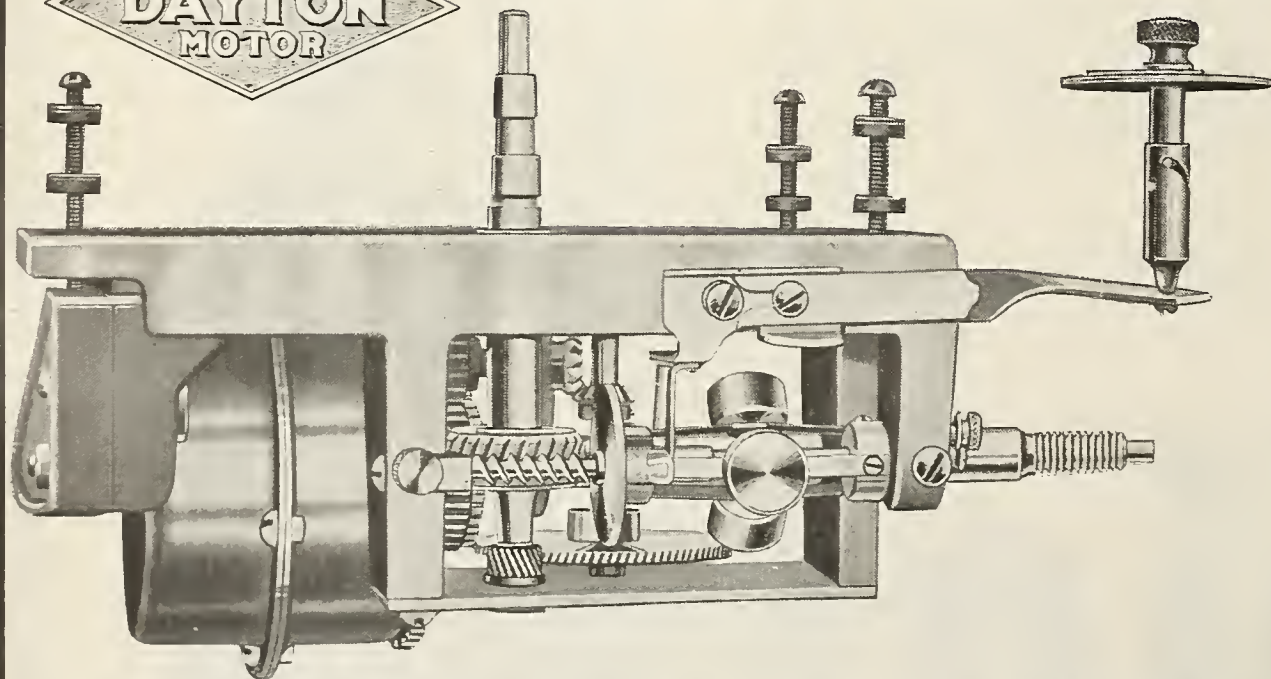

Stand for Excellence of Motor Construction.

They

1. Run Silently.
2. Run Evenly.
3. Run without Vibration.
4. Stand up and give long service.
5. Please users and build business.

Your success as a phonograph builder depends upon the success your instruments enjoy in the home. That success will be short lived if the instruments are built of other than the best parts obtainable. Therefore, the best motor must be used—the best tone arm, the best sound box.

In the Dayton Motor we have that best motor. Because it is simple of construction. Because it is noiseless and will not mingle a single discordant sound with the strains of artist or opera record. Because it runs evenly and without vibration.

Those are the reasons why the Dayton Motor excels. Those are the reasons why an avalanche of business from builders of phonographs who know a super-grade motor has forced us to reincorporate our Company on a larger scale in order to handle the business.

You, Mr. Builder, are striving for success in phonograph building. Be sure you build upon a foundation of excellence and permanence rather than upon one of sand. Use Dayton Motors, Dayton Tone Arms, and Dayton Sound Boxes.

Please the user by placing in your instruments parts that will satisfy—To do so is to build a customer business that will redound to your credit in a bigger and a better business.

Dayton Tone Arms and Dayton Sound Boxes—like Dayton Motors—come in several sizes. All are built scientifically and at prices that will interest you.

Write today for complete information. Investigation is always worth while and we invite it.

The Thomas Manufacturing Company, Dayton, Ohio

322 BOLT STREET : : : : : MAKERS OF

DAYTON MOTORS—TONE ARMS—SOUND BOXES

Building Up Record Sales By Bringing the Hidden Records to the Attention of Buyers

To say that there is a serious shortage of records most in demand is to reiterate a fact that has been most painfully impressed upon the average jobber and retailer during the past few weeks who has seen hundreds of dollars in potential sales lost because certain types of records could not be delivered rapidly enough. At the same time the jobber or retailer saw on his shelves hundreds of records that under ordinary circumstances might be considered fair sellers, but in no sense "hits," and insofar as the present was concerned simply represented tied-up capital.

With holiday business past, it would seem that this phase of the situation should receive more than casual consideration. Any man who knows anything at all about records will realize that the really worth-while selections in the record catalog are not in any sense confined to the half-dozen or so numbers that are featured strongly each month with special placards or by other means. He knows as a matter of fact that there are real gems on his shelves that require only proper exploitation to insure their sale. Knowing these facts it is up to him to get busy.

Educational work in the talking machine store is too often accepted as meaning the work of interesting school authorities and school children in records included in special educational lists. In short, educational work is taken to mean school work, when as a matter of fact the term should be applied with equal strength to the education of the grown-up in what the record lists as a whole have to offer.

The average owner of a talking machine, unless he is unusually enthusiastic, does not take the trouble to delve deeply into the mysteries of the record catalog in an effort to discover hidden numbers that may appeal to him. For the most part the talking machine owner follows the current supplements with more or less regularity and finds therein a sufficient number of records to meet his requirements without considering the records that have gone before.

In this particular he requires educating just as much as the child in order that he may realize the good things that are hidden away among the thousands of records listed in the ordi-

nary catalog, and thereby keep the retailer's stock moving by purchasing such records occasionally. He is not going to do the delving himself. He is not going to select a dozen records by their names only and spend an hour having them tested only to find that none meets with his particular requirements. The dealer will have to do this work for him.

It is a known fact in good salesmanship that the customer can be handled much more satisfactorily and quickly if he is limited in his

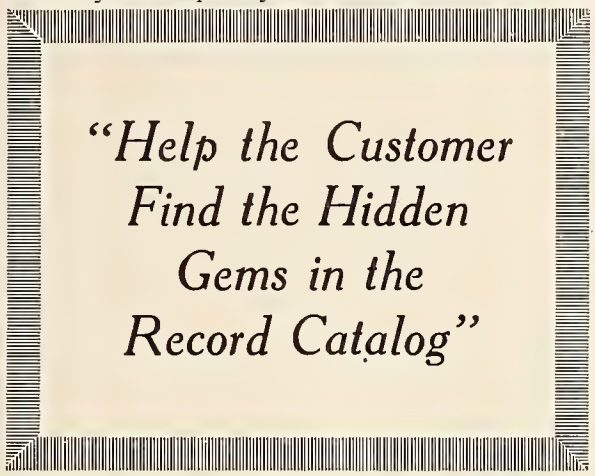

selections. In buying a cravat, for instance, a man will pick out one from half a dozen shown him and be satisfied much more easily than if he tries to make a selection from a rack containing a hundred or more cravats of varied designs. The same rule applies to record selling and the answer is this:

In addition to featuring the new records monthly, the dealer should also make it a point to play for each customer from the catalog numbers two or three records of various types that he knows to be good. In a surprising number of cases the customer will take at least one of these records, of which he previously knew nothing and probably cared less, because it has been hidden from him in a mass of other records.

It must be remembered that the companies do not record selections on the spur of the moment. There is always some point, either in the character of the music itself or in connection with the recording artists, that is calculated to

make that record of special interest. The retailer, if he is alive, will recognize and emphasize this point, and give the customer some idea of why that particular record is worthy of attention.

These hidden records may also be featured profitably with the newer releases in window displays. One record thus shown alone with the proper sign attached to it is bound to attract attention, and likewise result in some sales if the selection is a good one. Displayed alone it cannot but help stand out prominently, and this system of display will be found more effective than to group a dozen or more catalog records in one display on a chance that one or two may be selected. In other words, limit the range of choice, and the customer makes a selection with that much greater readiness.

The featuring of catalog records in special ways is not in any sense a theory. Dealers in various sections have been doing just that thing for years and, be it said, doing it most successfully, with the result that their entire stock of records has kept turning over in a way that has made it an asset instead of a liability.

It is a very fine thing to announce and advertise that a dealer has on hand every record in a certain catalog, but it does not pay to have every record simply as a talking point. Every record in the catalog is intended to sell, and with very few exceptions will sell if given the proper attention.

This fact is proven by the special holiday lists on which appear records that have been issued years before. Ordinarily they could lie on the shelf and disintegrate into dust before being asked for by a customer, but by properly exploiting certain selections as being most appropriate for the Yuletide, they attract attention that means sales.

Giving talking machine owners the records they come in and demand is not salesmanship. It is simply order taking. To take a record out of stock and convince them that it is the record they want, means selling goods, and that is what the average talking machine dealer will have to do during 1918 if he wants to keep on doing business and make a profit while waiting for the delayed delivery of the self-selling hits.

OPEN NEW RECORDING LABORATORY

Emerson Phonograph Co. Has Special Quarters in the Columbia Trust Co. Building, 362 Fifth Avenue, New York, for Recording Purposes

The Emerson Phonograph Co., New York, manufacturer of Emerson records, has announced the opening of a new recording laboratory, which is up-to-date in every detail and acoustically perfect. This laboratory is located on the fourth floor of the Columbia Trust Co.'s Building at 362 Fifth avenue, on the corner of Thirty-fourth street, and easily accessible.

The floor has been equipped throughout with the most modern and approved types of recording mechanism, and Arthur Bergh, musical director of the Emerson Phonograph Co., personally supervised the installation of the machinery and the lay-out of the different rooms and offices. There are two large-sized recording rooms, with two orchestras, and nothing has been spared to facilitate the work of the artists and the recording experts.

For some time past the Emerson Phonograph Co. has been looking for a new recording laboratory, for it had outgrown its first laboratory a few months after placing on the market its seven-inch universal cut record, and with the advent of its new nine-inch record new recording quarters were absolutely imperative. The present laboratory will give the company an opportunity to adequately handle both its seven-inch and nine-inch recordings.

Phon d'Amour
THE TONE MASTERPIECE

To truly appreciate the Phon d'Amour it must be seen, heard and compared. One must see and have explained the Fritsch inventions—the marvelous wooden diaphragm, the ingenious reproducer and sound amplifier.

One must hear a favorite record played, first on another instrument, and then on the Phon d'Amour.

Then will come the realization that here indeed is a wonder phonograph—a marvelous, artistic instrument that plays any record of whatever style or make, that glorifies the best made records and filters the imperfections from less worthy ones, a phonograph that establishes a new and higher standard of artistry and craftsmanship. See it, hear it play, compare it.

The FRITZSCH PHONOGRAPH COMPANY
228-230 West 7th Street, Cincinnati, O.

Trade-Mark. Copyright 1917 by The Fritsch Phonograph Company

THE TRADE IN BOSTON AND NEW ENGLAND

JOHN H. WILSON, MANAGER, 324 WASHINGTON STREET, BOSTON, MASS.

BOSTON, MASS., January 3.—The aftermath of Christmas is not exactly pleasant to consider. It is not due to trade exactly that there is a depressing feeling abroad, but to the weather, which has been so excessively cold as to hamper trade of pretty nearly every description. Boston along with other parts of New England and the East has been in the grip of a frigid wave, which has continued for a number of days. At this writing a snowstorm is setting in which may add to the difficulties and during such weather as is now being experienced here people will not go out unless for the most urgent reasons. At the cantonments—one here may speak specifically for Camp Devens at Ayer—the weather has been colder than here, but the soldiers have been able to keep comfortable, and it has been a godsend that they have had so many Victors, Columbias, Edisons and the like to keep them entertained. During the past several weeks a number of machines have been sent to the camp largely through the thoughtfulness of friends. Added to the general cold situation there is the fuel problem, which is getting more acute every day, and a few of the talking machine warerooms have barely escaped closing because of empty bins. But in such cases a load of coal arrived at the eleventh hour and saved the situation.

Christmas Business Late But Strong

Now to go back to the Christmas business. It did not begin as early in December as it should, but almost in every case the really busy period started on the 15th. From then on all the warerooms were filled, and on the Saturday and Monday before the holiday there were crowds of people besieging the retail establishments. Take it all in all, the business done in Boston was surprisingly good considering the general conditions. Several places were heard from where a bigger business could have been done if the requisite amount of goods could have been secured from the factory. One interesting feature of the Victor business was the heavy demand for the records of the Boston Symphony Orchestra, which were first announced in the December catalog. Toward the end of the month there was scarcely a dealer who had a single one in stock.

Busy Times at Steinert's

The business of M. Steinert & Sons Co. for December was a surprisingly good one. Both the company's warerooms in Boylston street

and in Arch street, which latter place is so convenient to the downtown business section, had a busy time of it from the first part of the month. Russell Steinert, manager of the Victor business of the company, told your correspondent that there were times when the eleven booths on the second floor and all of those on the ground floor were occupied by patrons, and so great was the crowd that records had to be tried out even in the foyer and the corridors.

Planning New Columbia Stores

At the warerooms of the Grafonola Co., of New England, Manager Arthur C. Erisman reports a good business also. The total sales in machines and records were of an exceedingly gratifying character. Since the return of Norman Mason as sales manager for this house there has been a betterment of conditions, for he, through his previous association with Manager Erisman, knows exactly what is demanded by the store's customers. For a week or so before the holidays Manager Erisman established a store in Federal street close to the South Station and quite a number of machines were sold. Plans are under way to locate several stores throughout the city.

Many New Sonora Dealers

Manager Richard Nelson, of the Sonora, has in the past four weeks placed this equipment with thirteen good dealers in Boston and the suburbs, and he plans in the very near future to increase this number to twenty-four. Six agencies have been placed in Providence, all of them high-grade places. Among the latest dealers to take on the Sonora are the United Talking Machine Co., of Brockton, and the C. F. Wing Co., of New Bedford. Manager Nelson says the holiday business was way ahead of what had been looked for, and this was especially true of the Jordan Marsh Co., the largest department store dealers in Boston, which had taken on the Sonora only a few weeks before.

Ditson Business Only Limited by Supplies

The Victor business at the Oliver Ditson Co. was excellent during the holidays. According to Manager Henry A. Winkelman it would have been better if the factory could have sent the goods as fast as they were needed. While speaking enthusiastically of the holiday business Mr. Winkelman qualifies the statement by saying that had the general conditions been as in former years the demand for goods would have been phenomenal. Two of Manager Winkel-

man's good men who are in the nation's service, Joseph Carlson and John Carnivan, have dropped in to pay their respects, which helped to brighten up things up a bit. Carlson is in the Signal Corps at Camp Devens, and he has more than one object in calling around as often as he can. Carnivan, who had a furlough at the Christmas season, is with the rifle range at Annapolis, Md.

Attending Meeting of Columbia Managers

Manager Fred E. Mann, of the Columbia Co., is in New York to remain for the rest of the week. He went over especially for an important meeting. M. C. Perkins has arrived in town from Springfield, to become assistant to Manager Mann. Mr. Perkins was the manager of the Springfield branch which was discontinued, as mentioned in this department last month. The business at the Columbia headquarters was extremely heavy, and it is a notable fact that the heaviest call was for the high-priced machines.

New Vocalion Period Styles

Manager R. S. Hibshman, of the Vocalion Co., is telling his patrons of the new period styles which the company has lately put out. There are sixteen of them and they are magnificent examples of the cabinet-maker's art. Several of these are already in Manager Hibshman's Boylston street warerooms.

Increase in Emerson Record Prices

Local Manager Oscar W. Ray, of the Emerson Phonograph Co., is making known to the dealers in his territory news of the advance in the price of Emerson records beginning January 15, the new price to be 35 cents. Those dealers with whom he has come in such personal touch so as to discuss the situation are more than satisfied with the new arrangement, as it gives them a wider margin of profit, and will give them more of an opportunity to develop their territories. Under this new plan dealers will get their first shipment of goods direct from the factory, and subsequent shipments will be delivered from the Boston headquarters. Mr. Ray says he plans to give dealers the quickest kind of service, and he is looking for a most prosperous year ahead. The dealers are now getting the new foreign catalog of records, and those that have been tried out are adjudged as good records as have appeared on the market in a long time, especially with regard to the band numbers.

Eastern Victor Service

is based on the principle that
a Victor dealer wants what
he wants when he wants it.

EASTERN TALKING MACHINE CO.

177 TREMONT STREET

BOSTON, MASS.

Old Department Store Closes Doors

The W. & A. Bacon Co., one of the oldest established department stores in the city, has finally closed its doors. It met with financial difficulties back in August, and the business was placed in the hands of receivers, but the general business conditions have been such that the company has not been able to weather the storm, much to the regret of its many friends. The Victor, Columbia, as well as the Emerson Cos., were represented in the talking machine department, which, under the management of George J. Krumscheid, has been doing a very good business, this being one of the best paying departments in the whole store.

Greetings From W. S. Parks

W. S. Parks, the new manager of the Baltimore Columbia warerooms, did not forget his Boston friends during the holidays, as many of them received holiday greetings, showing that he had not forgotten the happy days spent in Boston as assistant to Manager Fred E. Mann. Mr. Parks sends word that he is now quite his old self again.

Interesting Personal Items

Manager Richard Nelson, of the Sonora Co., and his family spent Christmas with his father's family in Albany. The senior Mr. Nelson is the Episcopal Bishop of the Albany diocese.

Interesting letters continue to be received from John Alsen, who is with the 101st Regiment somewhere in France. Several of these letters come from Alsen's old associates in George Lincoln Parker's Victor and Edison department, of which he was manager before leaving to join the army.

One of the latest of the salesmen to join Manager Arthur Erisman's staff at the ware-rooms of the Grafonola Co., of New England, is Louis Besserer, who comes into the business with a wide knowledge of music, as he is an accomplished violinist. For some time he was leading violinist in the orchestra of the Boston Opera House. He is proving an able salesman and a genial, affable manner serves him well in dealing with customers.

Brunswick Expansion in Boston Territory

The Brunswick phonograph is steadily growing in popularity throughout the New England territory, thanks to the indefatigable labors of R. H. Booth, manager of the local office. The instrument is not only well represented in this city just now, but agencies are being closed in every city of importance throughout the East. The tone quality of the Brunswick, thanks to individual constructive features, has made a strong appeal to purchasers, and the general character of the case design is always artistic, and the



STEINERT'S

35 ARCH ST. BOSTON.

Victor Distributors

Many talking machine owners are forming their record buying habits now. Be sure they find what they want when they come to your store. Keep your VICTOR record stocks complete.

We can help you for we have

The Largest and Most Complete Stock of Records in New England

Write, or Telephone Beach 1330

M. STEINERT & SONS CO., 35 Arch St., BOSTON

finish excellent. Mr. Booth has a capable road staff who are doing good work. Mr. Walter is now visiting a number of points in the New England territory and is making some very excellent connections for the Brunswick. The general trade outlook as far as this house is concerned is most gratifying, and 1918 promises to be a record-breaker.

H. L. Royer Adds the Sonora

Herbert L. Royer found very little time to himself during the holidays, and with his Victor outfits he showed his patrons the Sonora, which he now carries in stock. Royer's place around

the corner from Summer street was found by many persons to be a very convenient place.

Manager Longfellow, of the Edison and Victor department of Chickering & Sons, lost the services of L. C. Christensen, his repair man, a fortnight ago, he having gone into the naval reserve, and is stationed at Hingham.

Ricardo Constantino, son of the famous singer, who is attached to the staff at the Grafonola Co., of New England, is going over Saturday to New York and Bridgeport, where he plans to study the late models of the Columbia machines,

(Continued on page 22)

BAGSHAW STEEL NEEDLES

THE honest quality incorporated in all Bagshaw steel needles is responsible for their dominance.

W. H. BAGSHAW CO., Inc.
LOWELL, MASS.

TRADE IN BOSTON AND NEW ENGLAND

(Continued from page 21)

both at the warerooms and the factory. He also will visit his brother, Antonio Constantino, who is in charge of the record department of the Columbia's Fifth avenue store.

William Ellsler returned a few days ago from New York, where he went to spend the holiday with his aged mother. Ellsler is one of the valued employes of the Grafonola Co. of New England.

Taking an Inventory

Manager Silliman, of the Pardee, Ellenberger Co., has been extremely busy since the holidays taking an inventory of the stock of the Edison equipment, and in this he has been assisted by his staff of traveling men, who have not as yet started off into their respective territories. Manager Silliman reports a very good December business throughout New England, and the indications look good, he says, for a brisk business from now on. Mr. Pardee, head of the house, who was in town a few days ago, is well pleased at the business done during the past year.

Activity With Talking Machine Co.

The Eastern Talking Machine Co. found its convenient location in Tremont street of the greatest advantage during the Christmas season, and throughout most of the month of December the warerooms, with their comfortable booths were filled with buyers, who were bent on purchasing the more expensive outfits. The Eastern had a very heavy call for the records of the Boston Symphony Orchestra, and its large supply, laid in very early, was soon exhausted.

Handsomely Decorated Warerooms

Among the handsomely decorated Victor and Edison warerooms during the Christmas season those of the C. C. Harvey Co. in Boylston street were among the more artistic, largely because an artist and professional decorator takes care of the scheme each season. Manager White and his staff of clerks had a busy time of it attending to customers for the past several weeks.

Kept Busy on Deliveries

Warren Batchelder, manager of the Victor department of the A. M. Hume Co., had such a busy season that for several nights toward Christmas teams were delivering Victor outfits way into the early morning.

R. A. Young, who took charge of the Victrola department of the H. Batterman Co., the large department store at Broadway and Flushing avenue, Brooklyn, N. Y., last October, reports having closed a very satisfactory holiday business. Mr. Young was formerly with the Lion store in Toledo, O.

FEBRUARY WINDOW DISPLAY

Attractive Window Prepared by New Dealers' Service Department of Columbia Co. Should Stimulate the Trade of Dealers

The new dealer service department of the Columbia Graphophone Co., New York, which is under the management of H. L. Tuers, has prepared a February window display that is even more effective than the one which was introduced to Columbia dealers last month. This latter display was accorded a welcome reception from Columbia representatives throughout the country, who state that it proved a powerful stimulant to record and machine sales.

The February display, which is shown here-

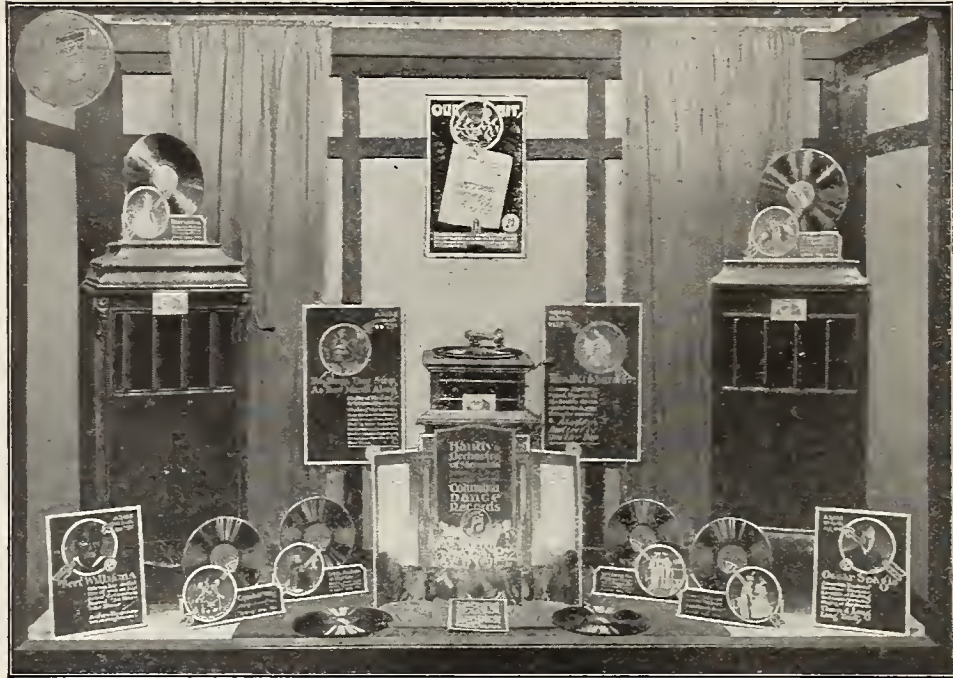

Columbia Window Display for February

with, consists of a Handy Orchestra cut-out, three half-sheet cards featuring new Columbia records, two quarter-sheet cards announcing new records by Oscar Seagle and Bert Williams, six small cut-outs and a series of price tickets. This display well reflects the determination of the new department to furnish Columbia dealers with a series of highly artistic window displays which will act as an impetus to sales.

The February window display is lithographed in eight colors, and the display is furnished to the dealers at actual manufacturing cost, which is exceedingly small, compared with the value of the material supplied. This low cost is made possible by the fact that the Columbia dealer service department is in a position to order very large quantities, which lowers the cost per unit.



Read the Trade Mark carefully, hear the machine, and you'll agree that it is truly

The World's Musical Instrument
Improves All Records

Send for our Special Proposition

HOFFAY TALKING MACHINE Co., Inc.
3 West 29th Street New York City

A. M. STEWART PLAYS SANTA CLAUS

President of Stewart Talking Machine Co., Indianapolis, Makes Substantial Christmas Gift to Every Employee of the Company

INDIANAPOLIS, IND., January 5.—Santa Claus, through the medium of Alexander M. Stewart, president of the Stewart Talking Machine Co.,

well-known Victor distributors of this city, was very good to the employes of that company. Mr. Stewart personally visited each of the many employes of the company on Christmas Eve, and in addition to extending the usual greetings of the season presented each member of the staff with a substantial gift as a mark of appreciation for loyal services rendered during the year. 1917,

by the way, has proved the record year in the history of the Stewart Co., and this means much when the business record of this enterprising Indianapolis house is considered.

SETS HIGH MARK IN RECORD SALES

PORTLAND, ORE., January 3.—Miss A. Bennett, of Eilers Music House, this city, has the reputation of being the best record seller in Portland. She sold over \$2,000 worth of records during December. Miss Bennett says there is a constant demand for the "Missouri Waltz," and they can not get enough records of "There's a Long, Long Trail," for which there is a big demand. Many machines are being sold by this house.

The Eclipse Outlook



ECLIPSE

The 1918 outlook is extremely bright for the Victor dealer who goes about his business, spurred by the knowledge that the war chiefs are placing increasingly heavy emphasis on the war value of music in general and of the Victrola in particular. During 1918 patriotic inspiration will add increased ginger to "Eclipse Victor Service". 'Nuf said!

ECLIPSE MUSICAL COMPANY
CLEVELAND OHIO



Otto Heineman Phonograph Supply Co.

INCORPORATED

25 WEST 45th STREET, NEW YORK
FACTORIES, ELYRIA, O.—NEWARK, N. J.—PUTNAM, CONN.



CHICAGO

ATLANTA

SEATTLE

CINCINNATI

TORONTO

Try These Combinations

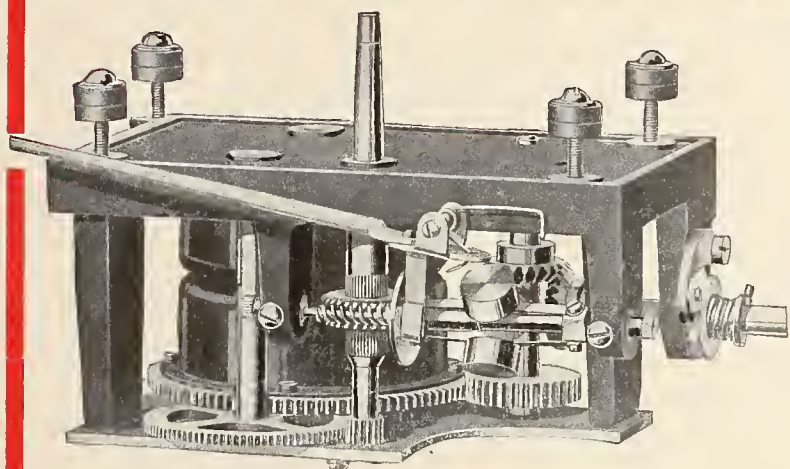

Heineman Motor No. 77

Heineman Motor No. 77
Heineman Tone Arm No. 11
Heineman Ideal Sound Box
No. 2

The Ideal Combination
for Your **\$85** Machine

Meisselbach

Motor No. 18

Meisselbach

Tone Arm No. 98

Meisselbach

Sound Box No. 2C

The Ideal Combination
For Your **\$165** Machine

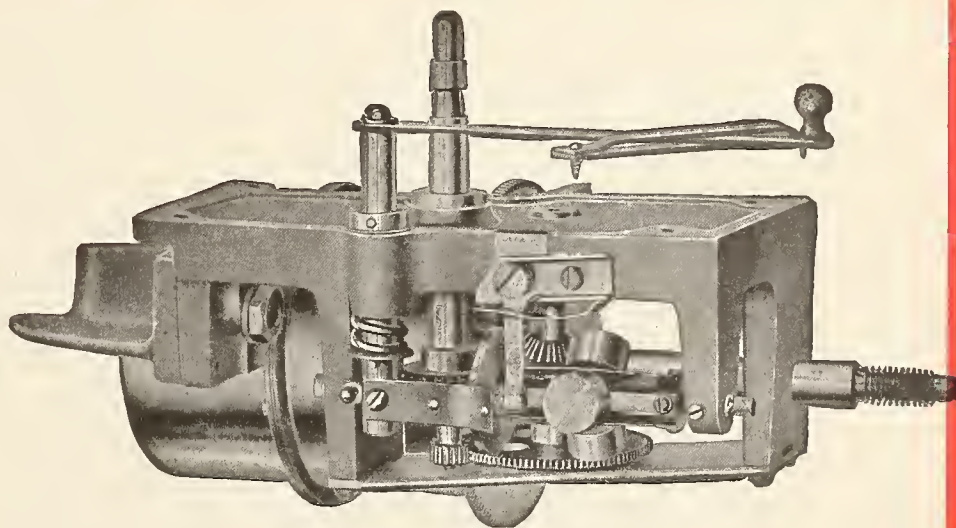

Meisselbach Motor No. 18

All prices F. O. B. New York or nearest branch office

Our branch offices are under the direction of competent talking machine men

We are at your service

Otto Heineman
President

	MEISSELBACH	
TONE ARMS	MOTORS	SOUND BOXES

EDISON DEALERS IN WISCONSIN TERRITORY CONVENE

Very Successful Gathering of Edison Dealers Held in Milwaukee—Tone Test Given at the Pabst Theatre a Feature of the Convention—Many Interesting Papers Read—Officials Present

MILWAUKEE, Wis., January 5.—One of the recent successful conventions of Edison dealers was that held at the Hotel Wisconsin, this city, recently and which was attended by approximately 150 dealers in the Wisconsin zone, many of them accompanied by their wives. F. K. Babson and C. E. Goodwin, of the Phonograph Co., of Chicago; T. J. Leonard, general sales manager of the musical phonograph division of Thomas A. Edison, Inc.; L. A. Zollner, supervisor for Thomas A. Edison, Inc., in the Milwaukee zone; and A. E. Schiller, mechanical instructor for Thomas A. Edison, Inc., in the Milwaukee zone, also were present.

One of the features of the convention was a tone test at the Pabst Theatre, given by Julia Heinrich, formerly of the Metropolitan Opera Co.; the lecturer representing the Edison laboratories was Miss Huldah Voedisch. This tone test was given to a capacity house and aroused much enthusiasm.

Another feature of the convention was the banquet at the Hotel Wisconsin, which was attended by most of the dealers and their wives who attended the convention.

As is the rule at all the dealers' conventions the addresses of company officials were supplemented by business papers read by the dealers themselves. One of the most interesting of these was that of W. E. Bosshard, of Tomah, Wis., on the subject of "How I Make Tone Tests Pay." Mr. Bosshard described in detail how he had gone about arousing interest in tone tests and sent out invitations to 600 people and had succeeded in packing the local armory to the doors, although its seating capacity was 600. He told of the work done by the artists and how he had followed up the tone tests by keeping in touch with those who had attended. One of the immediate results of the test was two cash sales of C-250 instruments. Mr. Bosshard concluded by saying that he had been repaid many times for the expense connected with the tone tests by the interest it aroused locally in the New Edison and the actual business booked as a result.

Another particularly interesting paper was that on "Window Displays," read by Geo. Eicholz, of Milwaukee, who said in part:

"When you first look for a location for your store you take into consideration three things—floor space for selling your goods; your window space; and how many people pass the location of your selection. The value of your location is judged by the latter two things and from your window and the passer-by you must get your money back. As the speaker before me said, you must create a desire before you can sell, so your window display must be staged in such a manner as to create a desire to own in the passer-by.

"If you advertise in a newspaper (which is considered the best form of advertising) and you get 15 per cent. of its readers to see your ad, you certainly get returns; but with a good window display you can stop 50 per cent. of the people passing; therefore, I say your window is the best form of advertising, with the newspaper second.

"You may say, 'I have often tried to stage a good window but failed.' I say try until you get one or two good displays and they will suggest other good displays, and after once succeeding you will wonder why you ever failed in displaying your goods to the best possible advantage.

"You will ask, What do you consider a good window or what constitutes a good window? Your record catalog will give you many ideas as to a good display; almost each selection listed therein is a good title for a window display; for instance:

"Your Hawaiian records suggest a Hawaiian window and that interests people who have a machine in Hawaiian records, also it interests

people that love Hawaiian music in a machine. 'Old Folks at Home,' 'My Old Kentucky Home,' 'Dixie' and other Southern melodies suggest a display of Southern folk songs. Such a window sells Southern melody records as well as machines to people that like the old songs of the South. Patriotic music suggests a patriotic display.

"I find that the most attractive displays can always be made by a combination of machines

VICTOR CO. SUES FOR INFRINGEMENT

Brings Action Against Brodegaard Bros. Co., for Featuring Machine Named "Victoria"

OMAHA, NEB., January 4.—The Victor Talking Machine Co., of Camden, N. J., filed suit in Federal Court last week against Brodegaard Bros. Co., operating a jewelry store at Sixteenth and Douglas streets. The plaintiff alleges that the defendant is infringing the plaintiff's trade mark and trade name and misleading the public.

The complaint states that Brodegaard Bros. Co. is selling the "Victoria"; that the name "Victoria" is placed on the machine in the same position as the name "Victor" on the plaintiff's well-known machine and that folders are printed in such a way as to mislead the public into believing that the "Victoria" talking machine is the "Victor."

Samples of the folders advertising the machine are appended to the complaint. It is pointed out that one of these folders shows a picture of a man standing beside the "Victoria" machine and holding in his hands a "Victor" record, all of which, it is alleged, is part of an intention to mislead and deceive the public. A photograph of the window at Sixteenth and Douglas streets containing the display of the machines is also appended, with a sign reading "Victoria talking machine, \$45." The advertising folders are printed in foreign languages.

The petition is signed by Charles K. Haddon, vice-president of the Victor Talking Machine Co. It states also that the trade name, good will, etc., of the Victor Co. "are worth far more than \$1,000,000."

Damages are asked from the defendant and an injunction preventing the defendant from continuing to offer the "Victoria" machine for sale under that name.

and records. Opera music suggests an operatic window. There are many scenes from operas that can easily be incorporated in your window displays. Instrumental solo records, dance music, music for special occasions such as Easter, the Fourth of July, Christmas, Washington's Birthday, all suggest good ideas for window trimming.

"And now I am going to tell you what we do if we want to make an especially good display. We call all the boys together in the store and tell them to suggest something for a good display. Each makes a suggestion and then we work it out together, so that our best windows have never been a one man's idea."

CONCENTRATE ON WINDOW DISPLAYS

How the Haverty Furniture Co. Brings the Columbia Line to Public Attention

HOUSTON, TEX., January 7.—The Haverty Furniture Co., of this city, has always made it a point to pay particular attention to its window displays, recognizing that the proper dressing of a window very often yields handsome dividends in actual sales, in addition to furnishing



Artistic Display of Haverty Co.

invaluable publicity for the house and the products that are featured.

The Haverty Furniture Co. handles the line of Columbia Grafonolas and Columbia records manufactured by the Columbia Graphophone Co., New York, and these products have formed the basis for many effective displays. House furnishings and talking machines lend themselves admirably to combined display, and the accompanying illustration will give a fair idea of the attractiveness of some of the Haverty Furniture Co.'s windows. This is only one of several recent artistic efforts.

THIS ALBUM MADE US FAMOUS
by selling it. Why don't you try?



Buy Your Albums Direct From the Manufacturer

43-51 W. Fourth St.
New York, N. Y.

THE BOSTON BOOK CO., Inc.

The only exclusive Record Album Factory in the world.

Chicago Office:
1470 So. Michigan Ave

THE SALESMAN WITHOUT THE POLISH

How One Young Man Managed to Handle the High-Class Trade on Sheer Nerve—Was so Rough and Nervy That He Proved Most Entertaining to the Bright Lights of Society

In practically every treatise on salesmanship one reads that the salesman must of necessity cultivate a most refined bearing, that he must learn to place himself apparently in the social position of his prospect. If he is dealing with a plebeian he must act as the plebeian, but when he deals with a society queen he should have that in his manner which conveys that he is of an equal, if not a little superior, social plane.

As is the case with all rules, the foregoing has its exceptions, and one of the exceptions was brought to light recently in an Eastern city.

The young salesman in question has plenty of ambition and pep, and, as the manager expressed it, the gall of a brass monkey, but unquestionably lacks polish. He rarely lets a prospect get away. He can enjoy the experience of being thrown out almost bodily following a definite refusal of the prospect to buy the machine he offers and then call up in the morning and explain that he has reserved a special model, and then ask shipping directions. Putting it over in that manner is almost his daily habit.

The real gem of his work, however, cropped out recently when, being the only salesman left on the floor, the manager was reluctantly compelled to send him out in answer to an inquiry from a prominent society woman. The best the manager hoped for was to hold the prospect until a polished salesman could get on the job. The young man in question called on the lady,

spent the greater part of the evening entertaining her in his own crude way, and solemnly assured her that she was indeed fortunate in being able to command his time, inasmuch as his special work with the talking machine company was to take care of the higher class trade, leaving the ordinary salesman to handle the usual run of things. He actually convinced the woman that she needed a model costing several hundred dollars and closed the sale on that basis.

The manager reached the store the next morning prepared to inquire where the good salesman should start on the case, when he received a message from the society matron asking, with an ill-concealed laugh in her voice, for "the young man reserved for the high-class trade."

It developed later that several of the most polished salesmen in town had called on that particular prospect, but that the rough boy with an exhibition of nerve that would have abashed anyone more polished had simply galloped away with the prize. The lady explained that he was the funniest and most entertaining salesman she had dealt with for some time. She simply couldn't turn him down without an order.

WHY CASH TRADE IS ADVISABLE

George E. Brightson, President of the Sonora Phonograph Sales Corp., Inc., Speaks With Approval of Credit Men's Resolutions

George E. Brightson, president of Sonora Phonograph Sales Corp., Inc., recently spoke with the utmost approval of the resolutions adopted by the New York Credit Men's Association. The resolutions ran:

"Recognizing that the credit granted by the retail merchant to the consumer, known technically as the individual credit, is one of the most rigid forms of credit, and that it is neither wise nor economic to tie up large amounts of capital in such forms of credit, it is sincerely recommended both to the retail merchant and to the consumer that all forms of supplies be purchased and sold on terms of payment the first of the month following the date of purchase, or in no event beyond thirty days from the date of purchase."

It was a further belief of the conference that foodstuffs and the daily necessities of the home be purchased and sold on a cash basis alone.

"Carrying beyond a short period individual credits should neither be asked nor granted under the unusual conditions of to-day," said a second resolution, "and it is sincerely urged that this recommendation govern the credit granting of retail merchants, and its reasonableness be so presented to the consumer that no dispute may arise regarding its absolute necessity. Observance of this plan will keep at a minimum the total sum of individual credits and release capital that may be required for the national defense.

"This is precisely what I have been advocating for a long time," said Mr. Brightson, "and it is a pleasure to learn that the undesirability of unnecessary long credits is now becoming apparent to many. The easy-payment plan I have long regarded as a growing evil.

"'Nothing down and \$1 a week' is demoralizing to any business, and is not the right way to put an organization on a sound and substantial foundation."

AUSTRALIAN VISITOR IN NEW YORK

Charles Tait, managing director of Allan & Co. Pty., Ltd., Melbourne, Australia, was a recent visitor to the trade in New York. Mr. Tait has been in the United States for over eight weeks and does not contemplate returning home until he has thoroughly visited the American music trade centers. Allan & Co. handle in their chain of stores many well-known American pianos. They are also Victor talking machine jobbers and control a large business.

The K. & E. Phonograph Exchange, of Manhattan, has been incorporated with a capitalization of \$1,000 by Irving Kesner, Hyman Edelstein and Solomon Manheimer.

Delpheon
the
Incomparable

Just such an instrument as the aggressive dealer has been awaiting

"We are well pleased with Delpheon and think you have made a great improvement by the use of two reproducers and the improved horn. Delpheon sells on its merit . . . We are only sorry that we did not get in touch with you before, so that we could have spent some of our advertising money and energy on Delpheon instead of other makes in the past two years."

(Name and address on request.)

Delpheon is not an ordinary phonograph. Its reproduction cannot be distinguished from the original. It has more points of superiority than any other. One ordered on trial will prove beyond doubt all that is claimed for it.

Dealers and Distributors write today

The DELPHEON COMPANY
BAY CITY MICHIGAN

100,000 FOR A NAME

EVERY good product desires a good name. We want the Talking Machine trade to supply us with a good name for our product, needles made right to play right.

To the person or persons who suggest what we deem to be the most satisfactory name for our needles we will offer as a reward 100,000 needles. None are barred from participation. We prefer the suggestion of some coined word that can be copyrighted.

To assist in selecting the proper name we wish to state that we will manufacture the best steel needles that can be put on the market.

Needles should be changed for each record played. Our process of manufacture will be such as to insure the reproduction of every delicate shading and tone. Continued use of our needles by your customers will mean contented patrons at all times.

We are desirous of hearing from distributors of needles who wish to establish a source of supply which can be depended upon at all times for quality, price and real service.

We hope to be able to announce the name chosen for our quality needles in the March issue of this periodical. In the event that more than one person suggest the same name, the first suggestion mailed, as indicated by the postmark on the envelope, will be given the credit for the suggestion. Anyone interested in the Talking Machine industry is invited to participate. All we ask is prompt action and to indicate at the same time the name of machine handled and firm with which you are connected.

Record Needle & Manufacturing Co.
Manhattan Bldg., Milwaukee, Wis.



The only come back on Columbia Records
is the come back for MORE.

Columbia Graphophone Co.
Woolworth Building, New York

TALKING MACHINES FOR THE CAMPS

Soldiers of Motor Supply Co. No. 317 Solicit Records From Indianapolisites—Leading Dealers Experiencing Profitable Soldiers' Trade

INDIANAPOLIS, IND., January 5.—The soldiers in the Motor Supply Co., No. 317, who are expecting to leave Fort Benjamin Harrison soon, have made a request of the people of Indianapolis asking for their used talking machine records. They have a small Victrola which they say helps them greatly in passing away the time and in driving away the blues and they are desirous of stocking up on records before they leave.

Women at the Red Cross Shop, in the L. S. Ayres & Co. store, are receiving the records for the soldiers. The soldiers made their plea for records through the local newspapers.

Although most of the soldiers who were stationed at Fort Harrison have left, local talking machine dealers are getting reports from Camp Shelby and Camp Taylor of the great enjoyment the Indiana soldiers are getting from the few talking machines they selected and now have in their camps.

H. A. W. Smith, manager of the Pathé Shop, made a special proposition on a Pathé to the members of the 139th Field Artillery, which is now at Camp Shelby, Miss. The soldiers took the Pathé and a large number of Pathé records to the camp with them. Hardly a day goes by but what some mother or friend of the soldiers of this company comes into the shop and tells Mr. Smith of the pleasures the boys are getting out of the Pathé.

Their barracks have proved popular with soldiers who are not quite so fortunate in owning a Pathé. Mr. Smith said that he had sold several \$25 Pathés to be shipped as Christmas presents to local boys in Camp Shelby.

The Starr Piano Co. is now displaying in its window a Starr machine in its special trunk to be used as an army or navy model. Mr. Pfeiffer says that already he has received many inquiries from soldiers and from friends of soldiers regarding this outfit, which sells complete at \$75.

Ben Brown, manager of the Columbia store, said that the talking machine in his opinion will play a big factor in the war, not only at the front but back at home.

A CLEVER ADVERTISING STUNT

Home Music Co., Lancaster, Pa., Reproduces Words of Songs in Local Advertising to Call Attention to the New Columbia Records

The Home Music Co., Lancaster, Pa., who handle the Columbia line of Grafonolas and records, have hit upon an original method for advertising the new Columbia records in the local newspapers. The company takes a generous space and then reproduces the words of the choruses of the various songs, with the number of the Columbia record on which the song appears shown plainly at the bottom, together with the name of the company. According to reports the original method of advertising is getting excellent results.

"One pound of learning requires ten pounds of common sense to apply it." There is a lot in that old Persian proverb.

BUYS VICTOR AGENCY IN SCRANTON

Scranton Talking Machine Co., Columbia Dealers, Now Have Victor Department

SCRANTON, PA., January 3.—The Scranton Talking Machine Co., 215 Lackawanna avenue, this city, has purchased the Victor agency and a substantial stock of Victrolas and records from the E. A. Fenstermacher Co., of 215 Wyoming avenue. The stock was removed to the Scranton Co.'s store, where a large Victor department has been opened in addition to the Columbia department operated successfully by the company for several years.

MAGNIFYING TELEGRAPH CLICKS

A diaphragm and horn similar to that used in connection with talking machines has been utilized to advantage by two Western inventors to amplify and make more audible the weak relay clicks of telegraph instruments. The weak clicks are transmitted to the diaphragm, whose vibrations act upon the air and shoot the corresponding sounds out through the horn in greatly increased volume. The new invention is believed to be especially valuable in connection with long telegraph lines.

NEW QUARTERS IN SAN FRANCISCO

The California Phonograph Co., San Francisco, Cal., has moved from 975 Market street to much larger quarters at 1009 Market street, that city, where two floors are occupied and an equipment of fifteen soundproof booths has been installed.



WESER PHONOGRAPHS

For 39 years the piano trade has recognized in Weser instruments the highest piano and player piano value. It always has been our delight to invite comparison of the Weser products with those of other makers. Many of our best dealers have been acquired by such comparisons.

Weser Phonographs are making rapid headway in the same manner. Compare them with the world's most expensive makes—in tone quality—in appearance—in reliability, and solidity of construction, and we are content to abide by your decision.

The **Weser Phonograph** will play any record. Made in satin finish mahogany. Other woods on special order. Electric motor will be furnished if desired. Write for catalog.

WESER BROS., Inc.

520-530 West 43rd Street

NEW YORK



MILWAUKEE DEALERS REPORT BIG TRADE INCREASES

Business of Unusual Proportions Transacted During Holidays—Co-operative Publicity a Great Help—Optimism Prevails Regarding the General Trade Outlook for the New Year—Trade News

MILWAUKEE, WIS., January 5.—Fresh from a successful holiday selling season, the results of which probably never before were equaled in Milwaukee, talking machine and phonograph dealers of this city are leaving no stone unturned to make the early months of the New Year exceed previous corresponding periods in volume of sales. They have become imbued, and justly so, with the idea that conditions which ordinarily would be considered wholly unfavorable are by no means deterrents if the will is there to do. That was proven during the holiday season recently closed. There is not a single dealer in Milwaukee who did not show a very appreciable increase in sales, compared with a year ago, which had been the high-water mark up to that time.

Local dealers probably were more fortunate than those in some other large cities because they had behind them the full power and influence of a co-operative advertising campaign, conducted by the Milwaukee Association of Music Industries, at a cost of about \$3,000. The stirring appeal of the series of full-page advertisements could not be denied. The spirit of the war was combined with the spirit of music, and the result was that many homes that never before knew the appeal of the talking machine now are equipped with it.

Jobbers as well as retailers have but one report to make relative to Christmas business in 1917, and that may be summed up in the phrase, "Just fine." It is a fact that at the beginning of the holiday buying season the feeling in the trade was that if dealers could reach the record of sales of 1916 they would consider themselves fortunate. Now that increases of from 25 to 50 and in a few instances 75 per cent. were shown there is ample cause for elation. Only a shortage of machines, records, needles and other supplies kept business to the limits it did reach.

Members of the Badger Talking Machine Co., Victor jobbers, were weak from exhaustion when Christmas came. Never before did the house experience so great and urgent a rush of business. Up to the last minute on Christmas eve retailers were imploring the company to help them out.

In some instances relief was given by picking up machines of certain styles which did not sell as well as others in certain districts and turning them over to dealers in other districts. In this manner quite a few disappointments were overcome and stocks were rather nicely readjusted.

Miss Blanche Brewster, of the Victor department of the J. B. Bradford Piano Co., showed herself to be a true patriot and an exponent of the essentiality of music among soldiers in camps by raising a fund for the purchase of a Victrola for Company H, 340th U. S. Infantry, Camp Custer, Mich. All of the boys of Company H are from Milwaukee and letters from the camp indicate that Miss Brewster's gift was one of the most welcome surprises the boys had ever experienced.

The Yahr & Lange Co., wholesalers of the Sonora in Wisconsin and Upper Michigan, entertained its thirty-five traveling representatives and department heads at a banquet in the Calumet Club on December 27. The company has been distributing the Sonora for less than a year,

but made a most remarkable record, and the banquet was more of a Sonora love feast than anything else. Arthur Roelke, manager of the Sonora department, was one of the principal speakers and congratulated the travelers for their splendid efforts in behalf of the Sonora line, which, he said, is destined to make a new and greater record of expansion during 1918 in Wisconsin and upper Michigan, because of its great merits.

The Kroeger Bros. Co., which opened Pathephone departments in its three big department stores on December 1, is delighted with the early success of the innovation. The company acquired a fourth store on January 1 and a Pathephone department was installed immediately.

The Wisconsin Chair Co., Port Washington, Wis., a large manufacturer of fine office furniture, has entered the ranks of producers of talking machines. The machine is being marketed under the trade name of "Vista" and has a universal reproducer. The branch plant at Grafton, Wis., is making records and supplies.

A boxed Victor machine destined for the L. M. DeVaud Co., Marion, Wis., disappeared mysteriously from the depot platform a few minutes after it had been unloaded and has not been heard of since. The theft took place in broad daylight.

A. G. Kunde, distributor of the Columbia, reports that holiday business exceeded his highest expectations and that the reports he has received from his dealers bear a similar cheery tone. The number of Columbia retailers in Milwaukee county now has grown to twenty-five, but all seem to thrive on competition.

Edward R. Sweeney has joined the Badger Talking Machine Co., and is assisting in covering the Wisconsin territory.

The Wisconsin Cabinet & Panel Co., New London, Wis., one of the largest of the wood-working plants of the Thomas A. Edison group, henceforth will furnish all of the box shooks and shipping cases required by the various Edison cabinet factories throughout the country. There is a large and well equipped box factory in connection with the plant and this will be enlarged and become a more important division of the New London works. Several more nailing, sticker and printing machines will be installed at once and the force increased from twenty to at least fifty more.

ONE SMALL TOWN DEALER'S RECORD

PORTLAND, ORE., January 3.—Eastern Oregon is strong for the New Edison. In Baker, with a population of about 7,000, Carl Adler is the only licensed Edison dealer in the town, and he sold 112 machines to the people of Baker and the adjacent country for the Christmas trade. A big advertisement in the Baker Herald gives the names of the 112 "music lovers who have been made happy and contented by the possession of the New Edison phonograph purchased at Adler's." Incidentally, Mr. Adler is an enthusiastic reader of *The Talking Machine World*, which may be one explanation of his success.

Aug. D. Volkman & Sons, Iron Ridge, Wis., have been appointed Columbia retailers in that city.

Have You Set Your
1918 Profit
Stakes?



Set them high — then sell
READY-FILE.

There is no reason why, if you sell **READY-FILE**, your accessories business should not double this year. Every owner of a Victrola is a prospect for **READY-FILE**.

Every Victrola X and XI you sell in 1918 means an extra profit to you — and **READY-FILE** sells itself.

Why not get this extra profit? We'll help you.

To our accessories line we have added the **READY NEEDLE POINTER** — the newest and simplest fibre needle pointer on the market. Send for a sample. If you don't say it's the best pointer made we'll refund your money. Fill in the coupon — it means more profit to you.

COUPON — MAIL THIS TODAY

READY FILE CO.,
Indianapolis, Ind.

I enclose { 75 cents for sample Ready
Needle Pointer.
\$4.25 for sample set Ready
File.

Please ship to the following address:

Name _____
Street No. _____
City _____ State _____
My Favorite Distributor _____

Ready File Co., Inc.
Indianapolis, Ind.



PERSONAL SERVICE

The members of our Company are always available and will gladly see you personally or write you at any time we can possibly serve you.

Why not communicate at once with us?

BADGER TALKING MACHINE CO. 135 Second Street
MILWAUKEE, WIS.
VICTOR DISTRIBUTORS.



Victor Wholesalers

Complete Stock of

VICTOR RECORDS

IN EVERY LANGUAGE

Victor Victrolas

Victor Tungs-tone Needles

FULL TONE HALF TONE



Try us on records you are unable to obtain from your local wholesaler.

Orders received by us are filled the same day.

Our Trade News Service, compiled by some of the ablest sales managers in the country, assists you in selling your merchandise.

YOU CANNOT afford to be without us as one of your wholesalers.

STEEL NEEDLES

ALL TALKING MACHINE SPECIALTIES

Cabinets to Match Victrolas

- 100 in paper envelope
- 200 in paper envelope
- 200 in metal boxes
- 300 in metal boxes

I. DAVEGA JR. INC.
 VICTOR FACTORY WHOLESALERS
 125 West 125th St. NEW YORK
The House of Service

- 4 and 4-a, \$5.10
- 6 and 6-a, 6.75
- 8 and 8-a, 8.25
- 9 and 9-a, 10.75

Write us for our price quotations on quantities

F. O. B. New York
Prices subject to immediate acceptance

Superior Steel
BRILLIANTONE
NEEDLES

Punch thru circle with thumb nail -

Victor
Tungs-tone Stylus
Full Tone 4 for 10¢

Victor FIBRE NEEDLES

100 for 40¢

NEW HONOR FOR JOHN F. DITZELL

Manager of Talking Machine Department of Famous & Barr Store Takes Charge of Piano Department—Has Made Fine Record

St. Louis, Mo., January 4.—John F. Ditzell's amazing success in promoting the Famous & Barr Department Store's Victrola department from a four-demonstration room affair to one of thirty-two rooms since last February has brought him unusual honor and much hard work. He has been made manager of the piano department, which is housed with his department in the wide aisle on the sixth floor of the building.

Mr. Ditzell is not a piano man and says that he never has been. He came here from Kansas



John F. Ditzell

City last February as a Victrola manager when the two departments divided the space about equally, with the odds rather in favor of the pianos. It has been the prediction of observers recently that the piano department would have to get out of the way very soon. Perhaps that is what the heads of the store thought, and to save it they made Mr. Ditzell manager.

"I hardly know what to say about the piano department," says Mr. Ditzell. "The management of that department came to me entirely as a surprise. But I regard the talking machine as so much of a musical instrument, and have built my campaigns on it with that opinion uppermost, so I think they will fit the piano department. I, of course, will select only well-tried pianos and players and will apply talking machine sales and advertising methods to them, and I believe that these methods will win.

"The Christmas season has been a splendid one for us. We did more than double the business of any previous year with ease and satisfaction to all concerned. I was complimented by the Victor Co. on the Victor ads with which we prepared the way for our Christmas selling campaign. The keynote to our advertising here has been to put a touch of human nature into all advertising, and we find it pays. Most of our advertising texts are the perplexities of the actual customers.

"The business this year has been remarkable for the proportion of cash sales and the short credit asked."

ATTRACTIVE PATHE HANGERS

The Pathé Frères Phonograph Co., Brooklyn, N. Y., has mailed to its dealers three very attractive hangers which can be displayed to excellent advantage by Pathé representatives. One of these hangers features new Pathé records made by Rube Goldberg, famous cartoonist, who sings his popular hit "Father Was Right." There are also presented on this hanger other popular hits from the Pathé catalog.

Another hanger gives a list of new Pathé dance records, which are meeting with a ready sale throughout the country, and the third hanger features the new monthly supplement of Pathé records. This supplement contains a splendid group of operatic records, the latest dance numbers and popular song successes.

LANSING OFFICE IN SAN FRANCISCO

Walter S. Gray in Charge and Will Handle a Full Line of Lansing Talking Machine Covers

BOSTON, MASS., January 5.—E. H. Lansing, of this city, whose khaki covers for talking machines have attained national fame by reason of their reliability and excellent construction, has just closed arrangements with Walter S. Gray, of San Francisco, Cal., whereby he will have on hand a goodly stock of Lansing covers. This will give Mr. Lansing's many friends in the Western part of the country more prompt service than is possible at the present time. The headquarters for Lansing khaki covers in San Francisco will be room 422 Chronicle Building. In view of freight conditions, this particularly timely step will enable the trade in the Far West to get quick deliveries of Lansing covers just when they need them.

PROOF OF SERVICE RENDERED

"I am looking for the store where there is less talk of service waiting and more proof of service rendered," remarked a buyer the other day. "I shall be able to recognize that store without difficulty, for its advertising will be truthful, its windows attractive and its merchandise of obviously superior standards. And when I have found it I shall not hesitate because of the prices I am asked to pay. For the record of service performed is the best proof of its own equable value."

NEW STORE IN GRAND RAPIDS, MICH.

W. F. Graham, Antigo, Wis., has opened a talking machine and music store at Grand Rapids, Wis., in the MacKinnon Building. Mr. Graham is an expert at sewing machines, and the music business is an outgrowth of his sales and repair business in that line. He expects to do particularly well in the exploitation of talking machines.

VISUALIZATION OF THE PRODUCT

Basis of Attractive Window Display of the Home Furnishing Co., Columbus, O.

COLUMBUS, O., January 5.—The Home Furnishing Co., of this city, which handles the products of the Columbia Graphophone Co., New York, recently presented one of the most artistic window displays that have been prepared by a local talking machine dealer for some time past. This display is shown in the accompanying illustration.



An Unusual Window Display

tion, although a photograph hardly does justice to the many distinctive features of this window. In preparing this display the company took cognizance of the fact that the success of any window setting depends in a large measure upon the visualization of the product that is featured. It was decided to present a Columbia Grafonola No. 110 as the keynote of this window, and in order to keep the instrument in the center of the display an ingenious decorating arrangement was used. How well the company's idea was carried out may be seen in the photograph. This window attracted considerable attention in local talking machine circles, and the principle of visualization will probably be used as the basis of other window displays along similar lines.

H. J. Luethy, Random Lake, Wis., is a new Sonora retailer in southeastern Wisconsin, who is building up a good business.

Manufacturers—Jobbers—Dealers

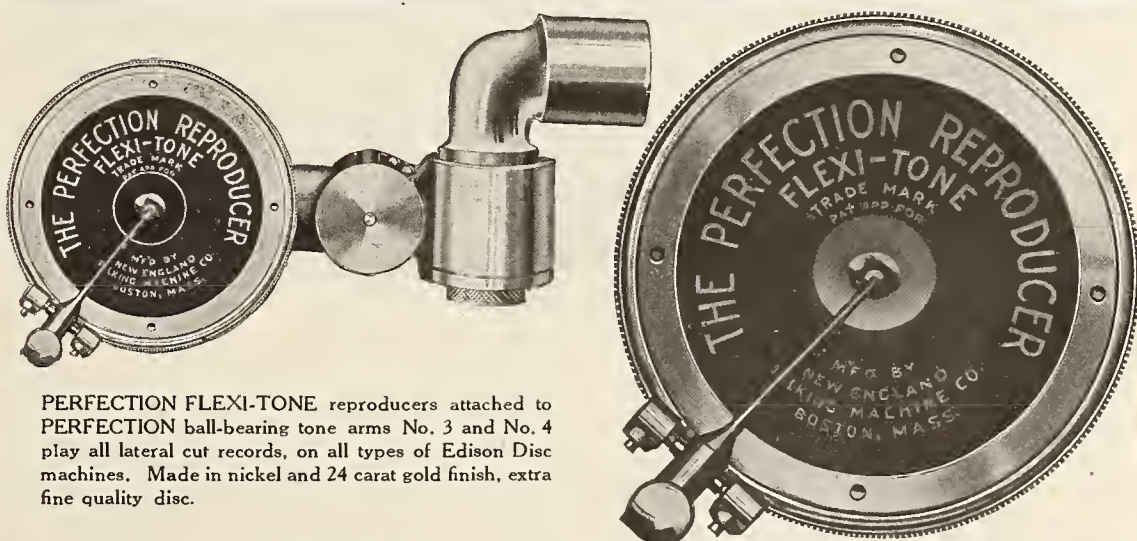

PERFECTION FLEXI-TONE reproducers attached to PERFECTION ball-bearing tone arms No. 3 and No. 4 play all lateral cut records, on all types of Edison Disc machines. Made in nickel and 24 carat gold finish, extra fine quality disc.

Tone arms fitted to Edison machines only

PERFECTION FLEXI-TONE reproducers No. 3, No. 6 and No. 7 fit all types of Victor and Columbia machines. Made in nickel and 24 carat gold finish, extra fine quality.

These reproducers and arms are the very finest made mechanically. The PERFECTION FLEXI-TONE reproducers are the most perfect phonograph reproducers built, reproducing all lateral cut records, from highest pitched soprano, to lowest pitched bass, as perfectly as the records were recorded in the recording room. Wonderful clarity of sound, as well as great volume. Extra fine quality of finish guaranteed. Manufacturers, jobbers and dealers will find in this line of reproducers just what they have been looking for, as they are assembled by skilled workmen especially adapted to this kind of work, producing a product built with watchlike precision.

All accessories in stock ready for immediate shipment. Phonograph manufacturers can have PERFECTION FLEXI-TONE reproducers fitted to their machines. Write for prices, information, etc.

NEW ENGLAND TALKING MACHINE CO.

16-18 Beach Street

BOSTON, MASS.



The NEW YEAR

“Win the War” and “More Business for Every Columbia Dealer” is our double-disc record Wish for 1918.

**Columbia Graphophone Co.
Woolworth Building, New York**

BUILDERS OF THE DAYTON MOTOR RECAPITALIZE

Thomas Mfg. Co. Increase Capital to \$300,000 in Order to Handle Avalanche of Motor Business—Something of the “Live Wires” Interested in This Enterprise

DAYTON, O., January 8.—Brief reference was made in The World last month to the increase in capital stock of the Thomas Mfg. Co., makers of Dayton motors, tone arms and sound boxes, of this city, to \$300,000. Of this \$200,000 is preferred, and it has been underwritten by the United Security Co., of Canton, O., one of the largest bonding concerns in the United States. The \$100,000 common stock issue has been taken up by the old stockholders.

This \$300,000 increase in capital stock of the company has been brought about by the growth

ton inventive genius and Dayton manufacturing skill that made the Dayton motor.

M. H. Mathews, founder of the Thomas Mfg. Co., retains the presidency and general management of the company, being the heaviest owner of the common stock. G. M. Mathews is vice-president. W. R. Funk, business manager of the U. B. Publishing House, one of the largest in Ohio, is secretary. F. B. Jennings, connected with the Thomas Co. since its inception, is treasurer.

Associated with these men on the board of



Plant of the Thomas Mfg. Co., Dayton, O.

in popularity of Dayton motors, tone arms and sound boxes—also other articles of manufacture turned out by the Thomas plant.

This increased demand is due to the general excellence of the Dayton product. In fact, the aim of the Thomas plant from the very start has been quality of material and workmanship, feeling sure that the trade would appreciate a high-grade motor, tone arm and sound box. That belief has been justified by the big volume of business booked and now rapidly being cared for by this concern.

The Thomas Co. has long been one of Dayton's leading industrial units. The Dayton motor is the prime motive force behind this wonderful industrial expansion. It is the result of scientific experiment on the part of Dayton inventors and mechanics. Dayton inventors brought out the Wright Aeroplane, the Omar Fare Register for street cars, the National Cash Register, the Delco Electric Starter, the Dayton Computing Scale and a host of other well-known specialties. Dayton, the home of 1,000 factories, is known as the “City of Precision” because its mechanics are accustomed to the building of exact machinery. And it was Day-

ton directors are Hon. E. E. Burkhardt, twice Mayor of Dayton and now one of the firm of Burkhardt, Heald & Pickrel, a leading firm of attorneys in Dayton; A. C. Jackson, formerly cashier of the Dayton Savings Bank, now assistant secretary of the United Security Co., Canton, Ohio, and Chas. W. Slagle, president of the Merchants' National Bank, Dayton, Ohio.

Mr. Mathews informed our representative that offices of the company have been located in Chicago, Toronto and New York. The New York office is operated under the name “The Thomas Phonograph Parts Co.,” and is located at 18 West Twentieth street, in charge of C. J. Kronberg, J. J. Freund and H. Germain. The Chicago office is located at 1330 Otis Building, 10 South LaSalle street, and is in charge of F. E. Reid, for many years in the phonograph business in Minneapolis. The Toronto office is in charge of Paul K. Wood, a very well known figure in the phonograph motor industry; also Frank J. Foley, formerly a leading attorney of Toronto, also at one time connected with a leading phonograph company of Canada.

During the interview President Mathews said

that business during the past months had exceeded his fondest expectations. He told of five orders which alone aggregated nearly \$300,000, and of a score of smaller orders also rapidly being filled. President Mathews smilingly referred to the future of the Dayton motor as something tremendous, if indications were borne out. And, judging by the hum of machinery, modern and ably handled, and the general bustle about the plant, it certainly looks like even the most optimistic dreams ought to come true—so far as Dayton motors, tone arms and sound boxes are concerned.

This article shows a view of the main plant of the Thomas Mfg. Co. It is located in the heart of Dayton, just a half block from the Union Station. It occupies 300,000 feet of floor space. Another factory building stands two blocks east, near the Miami-Erie Canal, and it has floor space aggregating 55,000 feet.

Mr. Mathews stated that for the present there would be no building operations, but that the entire increase of capital would be devoted to the expansion of equipment and the refining still further the products produced.

The local papers have devoted considerable space recently to the growth of the business of the Thomas Mfg. Co., and the Journal particularly had a full-page story giving illustrations of the various departments of this establishment, and telling in detail of the success of the motor, sound box and tone arms turned out by this establishment, and emphasizing that the business has been built on the basis of quality. In fact, the Thomas Mfg. Co. is right on the map these days.

NEW VICTOR REPAIR PART CATALOGS

The Victor Talking Machine Co. has just issued for the use of its dealers a new repair part catalog for Victrolas VIII-A and IX-A, and also for the latest type Victrola XXV. Owing to change in the mechanical equipment of the new model as compared with the old type, the new repair part catalogs are very necessary to the dealer and should be filed carefully. The Victor Co.'s suggestion that the repair part catalogs be preserved in the new style patent spring binder, supplied at cost by the company, is a good one. It will keep the catalogs all together and available whenever required.

Extensive improvements have been made in the music store of Harold N. Stillwell, talking machine dealer on East Main street, Freehold, N. J.

“NICHOLSON” New Catalog Showing New Styles RECORD CABINETS

strictly high-grade construction at prices
BELOW COMPETITION

Write for a copy of the catalog and our
special free advertising help for dealers.

K. NICHOLSON FURNITURE CO. Chase City,
Virginia
Sectional Bookcases and Record Cabinets

How to Make the Instalment Department of a Talking Machine Business Successful

By Marion Dorian

[During the past two months we have had a number of inquiries from dealers, particularly from the smaller towns, in regard to making the instalment accounts profitable, and we take the liberty of printing below an article written some time ago for The World by Marion Dorian, chief auditor of the Columbia Graphophone Co., which is so pertinent that it will undoubtedly be read with interest and profit.—Editor.]

We hear about the difficulties incident to instalment business. If dealers have had losses with this class of business it is largely because they have not gone about it in the right way.

There are five cardinal rules for the successful handling of instalment accounts. These have been thoroughly tested, and a fair try-out will prove them powerful aids in making instalment business what it ought to be.

There are exceptions to all rules, and circumstances will arise when it is wise to suspend the rule temporarily. In such cases the sensible dealer will act accordingly.

The five rules follow:

1. Investigate the customer in advance of delivery of goods.
2. Sell him no more than he can pay for comfortably.
3. Let terms be simple and clear-cut. Make sure the customer understands and accepts them.
4. Enforce those terms.
5. Do not allow arrears to accumulate.

Three-fourths of the trouble dealers have with instalment accounts is due to anxiety to secure a good sale. Insufficient or no investigation is made as to the responsibility, reputation, or antecedents of the customer. The sale is hurriedly consummated, the goods delivered and shortly thereafter the dealer learns to his sorrow that the customer is not what he represented himself to be. In many instances both customer and goods disappear.

It is easy to ascertain all it is necessary to know about the customer. His resources and income; his reputation for prompt payment and his general standing in the community. This should be done before the goods are delivered and will insure you against surprises.

Rule 2 is equally important. The advance investigation informs you as to the prospect's income; how permanent it is and what demands are made upon it by his family. With this information in your possession you can determine what it is safe to sell him. Suppose a prospect receives a salary of \$20 per week, and has a family of four. If he has been receiving this salary for some time and his reputation is good, you are justified in assuming he can safely pay \$2 or \$3 per week. More than that is dangerous, because allowance must be made for possible sickness of some of his family, which will make greater than ordinary demands upon his income. Eight to twelve months is the period within which an outfit should be entirely paid for. Allowing for a \$2 a week payment spread over eight months a customer could in that time pay for an outfit costing \$64. That would be the limit which the wise dealer would sell him. Many dealers make the mistake of selling a customer double the amount he can pay for comfortably, with the result that the payments become harder as they multiply and each payment day the customer feels he is carrying a burden. Consequently his attitude becomes one of antagonism and he pays grudgingly; whereas, if sold a bill he can pay for comfortably, he does it cheerfully.

Many customers who buy goods on the instalment plan are of limited business experience. A complicated instalment lease is to them an incomprehensible thing. Your lease should be as simple and clear-cut as is consistent with adequate protection. The terms of the contract should be made clear, and customer should accept them in all particulars. Salesmen should be prohibited from making

verbal agreements with customer. If special terms are made these should be written into the contract itself. If this is not done disputes are apt to arise which are destructive of the mutual confidence which must exist to insure a continuance of patronage. The customer should be furnished a copy of the contract, so that he can refer to it at any time. In this way you gain the customer's confidence and he will not only give you his own future business, but induce his friends to do likewise.

Terms should be made as reasonable as you

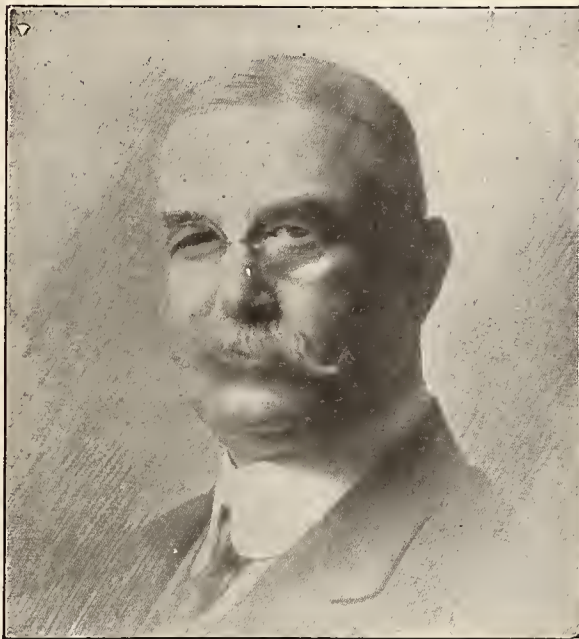

Marion Dorian

can afford, but once these have been agreed upon and accepted they should be enforced rigidly. There is no easier way to spoil good customers than by giving the impression that terms are mere formalities. There is no surer way of getting a list of accounts in bad condition than by ignoring the regular date when an instalment is to be paid. If the customer has agreed to pay on Monday train him to make the payment on that day and not on some other day. If his payment is not made on Monday notify him immediately to bring in the payment or make it to your collector without further

delay. The moment the first lapse occurs, get right after him and remind him that the goods were sold on definite and accepted terms and that you expect him to perform his promise. If his payment has not been made by the close of business on Monday have the collector at his place of business or residence on Tuesday morning and you will save money. Even the most obdurate customer will respond to this kind of treatment, especially if the call is made promptly.

If you enforce the terms and train the customer to make payments regularly no arrears will accumulate. If you allow two or three payments to lapse it is like drawing eye teeth to get a customer to make up the arrears. You may secure subsequent payments regularly, but lapsed payments hang fire until the end. Instead of getting your account settled within the contract period, it runs over some months, and persistent dunning, which often results in the loss of a good customer, is necessary, to say nothing of the added expense to which the dealer is put.

These rules may not be new or presented in a novel way, but if followed they will result in better and more profitable instalment accounts. They may be summarized as: Selecting a customer wisely; selling him judiciously; starting him correctly; keeping him in the straight and narrow path, and, finally, making him an asset, because you have sold him an article which has afforded him and his family unlimited pleasure and made it possible for him to pay for it without discomfort. In so doing you have made a lasting friend.

EMERSON MEN "DOING THEIR BIT"

At the executive offices of the Emerson Phonograph Co., 3 West Thirty-fifth street, New York, a service flag with four stars testifies to the fact that four members of the company's forces are now enlisted in Uncle Sam's forces in the fight for democracy. These boys who are "doing their bit" include C. D. MacKinnon, of the sales staff; Frank Hennigs and Jack Lawrence, of the recording department, and Joseph Greenwald, the competent and popular head of the Emerson shipping department.

STRADIVARA

"KNOWN FOR TONE"

You, as a dealer, know that the chief selling feature of any phonograph is TONE.

And comparison of STRADIVARA tone with the tone of all other phonographs will **prove** to you that TONE is the supreme selling feature of the STRADIVARA.

A tone of exquisite clarity and violin-like resonance—free from needle or motor vibration—a tone as peculiar to the STRADIVARA as the time-mellowed purity of a genuine Stradivarius is peculiar to the genius of Stradivari himself.

A tone that is **largely** due to the fact that the STRADIVARA is the only phonograph in the world that embodies a **spruce sound board**, built on the principle of the violin and piano.

Hear STRADIVARA tone and you will be quick to realize that you have at last found the tone that **SPEAKS** for itself and for **your profit!**

The Stradivara Plays EVERY Kind of Record

Each Stradivara is equipped with the Stradivara Automatic Stop Device.

7 Models—from \$45 to \$225

Progressive Dealers: Stradivara sales are going strong in the trade. And that their strength is rapidly increasing is attested by good reports from our dealers.

Get in line for a share of Stradivara profits **today**. Write for the most liberal discount proposition ever offered.

Distributors of Lyric Records—Write for Proposition.

SCHILLING PIANO CO., Inc.

Wholesale Distributors

112 WEST 23d STREET, NEW YORK

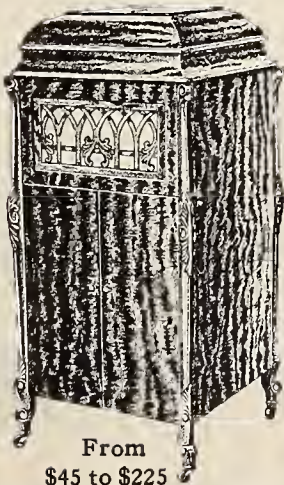

From \$45 to \$225

On January 15th, 1918
The Retail Price of
Emerson Records

will be **3** for **\$1.00** or **35c**
each

From the very first, we have made Emerson Records, the biggest, fullest values in the phonograph field. We have been continually improving everything that went into their manufacture—from the raw materials to the kind of artists and selections, but up to now we have never found it necessary to raise the retail price.

The war has affected our costs. Raw materials and labor have gone up by leaps and bounds; taxes have been imposed. It is necessary to raise the selling price to keep profits normal.

For example, shellac, the basis of all phonographic records, has gone up in price 200% since the war began—all other materials have gone up in like proportion.

Your Profits Will Be Increased

We know that the cost of retailing has increased in the same proportion as the cost of manufacturing, and we have arranged our new prices to allow you a more liberal profit also.

January and February are the two biggest record months of the year—this opportunity therefore comes to you at a time when you can do the largest volume of Emerson Record business.

Emerson Records at the new price are a remarkable value—for with the many new improvements you are giving an exceptional record at an unusually low price.

The public has become accustomed to increased prices in every commodity of merit it buys. We know that you will sell more Emerson Records at the new price than you did at the old. You can push them harder. It will pay you well to do so.

We want the Emerson Record to continue its rapid progress—we want you to make even a more liberal profit than formerly. We want to make Emerson Records a line of even more importance to you.

By raising the price we are making your stock on hand worth more!

Emerson Phonograph Company^{INC.}

3 WEST 35th STREET

--

--

--

NEW YORK, N. Y.

CONDITIONS IN THE TALKING MACHINE TRADE IN INDIA

United States Consul Lucien Memminger, of Madras, Makes a Report Which Throws an Interesting Light on the General Situation in That Country—Trade Is Largely Undeveloped

WASHINGTON, D. C., January 4.—United States Consul Lucien Memminger, stationed at Madras, India, has sent to the Bureau of Foreign and Domestic Commerce the following report regarding India's trade in talking machines:

"A firm in Bombay which deals in talking machines has branches at Madras, Calcutta, Rangoon, Delhi, and other cities. A representative of this firm states that it has been dealing more largely in the Swiss machines than in others, because it is able to sell them at a much lower price. The Swiss machines, for example, retail at \$9.08 to \$48.67, whereas the lowest price he is able to quote on certain American machines is \$22.71, and they run as high as \$84.35. Before the war the Madras firm had agencies in all towns of any importance in the Madras Presidency, such as Madura, 134,130 inhabitants; Tanjore, 60,341; Trichinopoly, 123,512; Rajahmundry, 48,417; Bezwada, 32,867; Guntur, 40,529; and Negapatam, 60,168. These agencies have been closed, as the business fell off during the war on account of the difficulty of obtaining supplies regularly, and the higher cost of manufacturing, transportation, insurance rates, etc., which necessitated higher retail prices locally. There has been also a certain tightness of money, causing a reduced demand for such articles as might be considered luxuries.

"The dealer mentioned states that talking machines are very largely in use in Madras among those who have means to buy, beyond the bare necessities, certain comforts or luxuries which cost only a moderate amount. In the wealthier homes of the zamindars, rajahs, etc., a certain number of such instruments is found, but not to the same extent. Of the total population of Madras, 518,660, the merchant said about 6 per cent. might be considered as possible users or purchasers of talking machines.

"A large proportion of the poorer people, he said, is not unfamiliar with these instruments, even though they do not possess any, as it is a common practice for companies or individuals to tour the country, giving concerts with the machines, and taking up collections from the villagers or country people who gather to hear them. In this way the machines have penetrated into the most remote districts.

"It is said that the greater number of records sold here, except among the European community, are in Indian languages—Tamil, Telugu, Marathi, Kanarese, Hindustani, etc. Of these the first two are the most generally in use in this district, Hindustani not being commonly employed in Southern India. For Europeans, however, of whom there are about 4,000 in Madras and 14,000 in the Presidency, nearly all English people, records are in English. A fair number of talking machines is found in homes of the Europeans, but probably not in as great a proportion as among the moderately well-to-do East Indians.

"The merchant who has been quoted states that his firm now gets records in English from London, these being made either there or in America; while some in Hindustani are obtained by him from Bombay. He is of the opinion that Calcutta is the only place in India where records in native languages are actually being manufactured. Formerly many such records were made in Germany, as firms there sent representatives to India to record the songs or recitations of the leading Indian artists, and afterwards reproduced these on discs which were then offered for sale in India.

"Several Indian dramatic or musical artists have a reputation throughout parts or in all of India, and records reproducing their best-known pieces are popular. Instrumental music, comical songs, etc., also make popular records.

"A list of department stores is forwarded. They not only sell at Madras, but also have branches at other points in Southern India, as for example Ootacamund, summer capital of

the Presidency; Bangalore, principal city of Mysore; and Secunderabad, in Hyderabad State. Usually it is well to address the branches direct.

"There are few here who deal exclusively in music and musical instruments. One music dealer, however, has an establishment of considerable extent."

PLAN TO CORRECT TALKER TONES

New York Inventor Designs New Machine for Equalizing Tones of Talking Machine and Giving Each Its Proper Value

A talking machine cabinet designed to sift, correct and beautify sound before it is thrown to the atmosphere, has been invented by Henry C. Miller of Saratoga, N. Y. The inventor's idea, as set forth, is to correct defects in some of the tones which are unduly magnified by the horn or other amplifying device.

The principle of the invention is better understood when it is made clear just how and where a tone is changed from true to false on some talking machines, before it reaches the ears of the listener. Assuming all sound vibrations recorded in the grooves of the disk to be true it is noted that in passing through the reproducer and into the horn a certain tone is unduly magnified. If a horn of a different volume is substituted, this defective tone can be made to assume its proper value. This is due to the fact that the horn which serves to magnify the sound is in itself tuned to a certain key by virtue of its size, shape and weight, and naturally responds to vibrations of a tone to which it is keyed.

The same idea is set forth in the case of the

piano, where it frequently happens that when a certain note is struck some object in the room will rattle in sympathy. In the talking machine this sympathetic connection generally results in undue amplification of a particular tone.

In the new cabinet the sound, instead of being

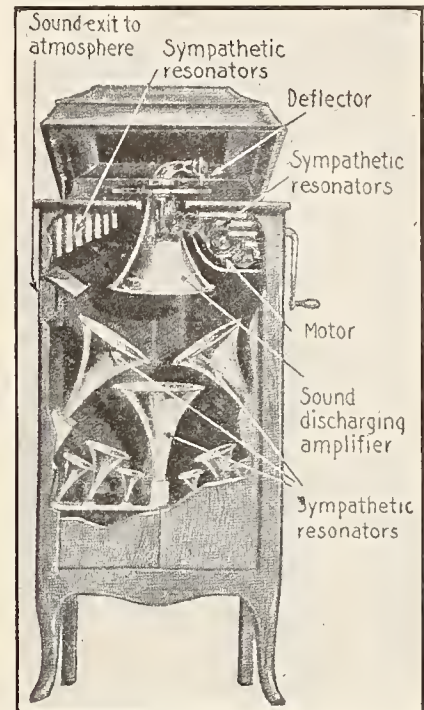

H. C. Miller's Plan of Equalizing Tones

directed from the horn to the atmosphere, is thrown downward into the open ends of a series of "sympathizers" and resonators, each carefully keyed to vibrate in sympathy with a different tone. To accomplish this result, it is necessary to provide a sympathizer to correspond with every tone in the musical scale. When a record is played on the new machine, each tone will set into vibration the particular amplifier which has been tuned to correspond with it. Thus every tone will receive equal amplification before it is thrown on the air.



PERFECT LIGHT

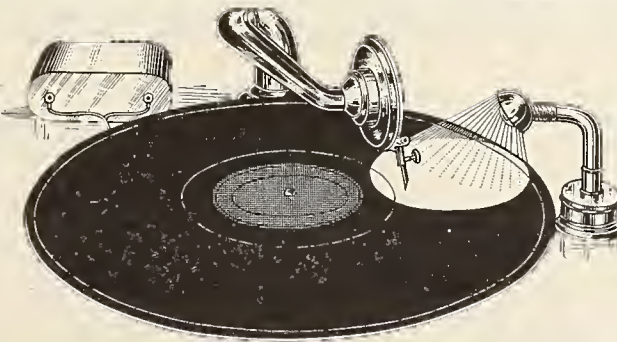

PROTECTS RECORDS

THE DEPENDABLE LIGHT THAT STAYS RIGHT

Gives the Right Light, at the Right Place, at the Right Time, All the Time

RELIABILITY Hundreds of Disk-Lites Sold and Not One Returned Because of Faulty Construction

Your Salespeople and Customers Will Not Lose Confidence in the Disk-Lite

SERVICE The Disk-Lite is Made To Serve as well as to Sell. One Style—One Price—Everlasting Satisfaction

Repeat Orders from Leading Dealers are Proving Disk-Lite Success

JOBBER AND DEALERS—Continue your Holiday prosperity by stocking the Disk-Lite. Send for samples. Prove to yourself the superiority of the Disk-Lite, the Perfect Phonograph Light.

RETAIL PRICES: \$3 Nickel Finish; \$3.50 Gold Finish. Liberal Discounts

DISK-LITE MFG. CO.

Washington, D. C.

LUCKY 13 PHONOGRAPH CO.

3 East 12th Street, New York City, N. Y.

Bargains

Bargains

Bargains

Floor Cabinet Machines, Cut-out Numbers, at Exceptionally Low Prices **\$13.00 UP**

We beg to announce that we have recently purchased twenty-five hundred floor cabinet machines, cut-out numbers, equipped with double spring motors, reversible tone-arms and reproducers, and can offer same at the following prices.

- Type A, fumed oak floor cabinet machine, 35 in. high - - - \$13.00
- Type B, mahogany finish floor cabinet machine, 39½-in. high - 18.50
- Type C, mahogany finish floor cabinet machine, 42½-in. high - 20.50
- No. 45, mahogany finish floor cabinet machine, 36-in. high - 15.50
- Table cabinet with cover quartered oak, D. S. motor - - - 10.75
- Table cabinet, larger size with cover quartered oak, D. S. motor 11.25

If you are interested in high class machines at real low prices get in touch with us for samples at once, as we cannot tell how long this lot will last.

STEEL NEEDLES
65c per thousand. Immediate Delivery.

MOTORS

No. 01— 8-in. turntable	\$1.25	10-in. turntable.....	\$1.40
No. 1—10-in. turntable	2.65	12-in. turntable	2.95
No. 6—10-in. turntable, double spring...	3.50	12-in. turntable.....	3.85
No. 3—12-in. turntable, double spring			6.75
No. 7—12-in. turntable, double spring			7.50
No. 4—12-in. turntable, double spring			9.50

MAIN SPRINGS

No. 0—¾ in. 20 gauge 8 ft. 6 in.	25c ea.	100 lots 20c ea.	1000 lots 19c ea.
No. 1—¾ in. 25 gauge 10 ft.	39c ea.	100 lots 35c ea.	1000 lots 33c ea.
No. 2—13/16 in. 25 gauge 10 ft.	39c ea.	100 lots 35c ea.	1000 lots 33c ea.
No. 3—7/8 in. 25 gauge 11 ft.	49c ea.	100 lots 44c ea.	1000 lots 42c ea.
No. 4—1 in. 23 gauge 10 ft.	49c ea.	100 lots 44c ea.	1000 lots 42c ea.
No. 5—1 3/16 in. 27 gauge 18 ft.	90c ea.	100 lots 85c ea.	1000 lots 80c ea.

GOVERNOR SPRINGS

\$1.00 per hundred. Special price on large quantities for motor manufacturers.

SAPPHIRE POINTS AND BALLS

Sapphire Points	13c each in 100 lots	12c each in 1000 lots
Sapphire Balls	15c each in 100 lots	14c each in 1000 lots

NEEDLE CUPS

\$20.00 per thousand, \$17.50 per thousand in 5,000 lots. Larger quantities still lower.

TONE ARMS AND REPRODUCERS

Baby, to play 7-in. records only.....	\$.60
No. 1—Tone Arm and Reproducer90
No. 2—Tone Arm and Reproducer, for playing all records.....	1.25
No. 6—Tone Arm and Reproducer, for playing all records high grade.	2.25
No. 7—Tone Arm and Reproducer, for playing all records high grade.	2.25
No. 8—Tone Arm and Reproducer, for playing all records high grade.	2.25

NEEDLE CUP COVERS

\$10.00 per thousand, \$9.00 per thousand in 5,000 lots. Larger quantities still lower.

RECORDS

The "Popular" Brand, 10-in. double face, lateral cut, all instrumental:

32c in lots of 100
30c in lots of 1000
29c in lots of 5000

We also manufacture special machine parts such as worm gears, stampings, or any screw machine parts for motor manufacturers.

Special quotations given for Canada and all other export points. Merchandise delivered with custom duty, war tax and freight paid by us.

Write for our 84 page catalogue, the only one of its kind in America. Illustrating 33 different styles talking machine and over 500 different phonographic parts, also gives description of our efficient repair department.

LUCKY 13 PHONOGRAPH CO., 3 East 12th Street, New York

CO-OPERATIVE ADVERTISING CAMPAIGN SCORES SUCCESS

How the Milwaukee Talking Machine and Piano Dealers Got Increased Business Stimulus and Satisfactory Results Through Association Effort in the Domain of Publicity

MILWAUKEE, Wis., January 5.—Although the holiday season is over, the Milwaukee Association of Music Industries is going right along with its co-operative advertising campaign, believing that business can be very favorably influenced, especially at a time when it usually is rather slack, by keeping before the public. The campaign was undertaken at the middle of November and covers a period of ten weeks. It undoubtedly was responsible to a considerable degree for the splendid business which talking machine and phonograph dealers of Milwaukee enjoyed during that period, and by continuing its influence the association is keeping business good. There will be no appreciable slack season in this city this year if the efforts of the dealers count for anything.

Advertisements were published once a week, on Friday evenings, in the daily newspaper of the largest circulation, The Journal. Usually the advertisements were framed so that both the piano, player and grand and the talking machine and phonograph received the joint benefit. But during the week between Christmas and

New Year's the association published an exclusive phonograph advertisement for the benefit of that division of the industry. The word

TO ALL HUMAN-KIND IT WAS GIVEN— ENCLOSED WITHIN IT IS ALL THE MUSIC OF THE AGES— The PHONOGRAPH



IT SEEMS only an exquisite bit of cabinet work. A piece of furniture almost too beautiful to be placed in an ordinary setting.

But at the press of a tiny lever it places all the music of the world at your command. It's a musical instrument, yet it is infinitely more than any musical instrument. It has tapped the fountain heads of music. Its call has reached the greatest artists of the age. Their voices and instrumental creations have been contributed to its treasure-troves. Yet no melody is too simple, no instrument too humble to have escaped the magic touch of its rendition.

Music is priceless—its value cannot be computed in cold terms of dollars and cents. A world without music would be a dreary world indeed. And dreary, chill, and uninviting is a home without music.

Consider what a phonograph would mean in your home. Long winter evenings brightened by its rich floods of melody. Amusement a plenty for restless children. Happy dance records for the older boys and girls. The "old-time" songs and favorite comedians for Dad. And for mother, a day-time companion, an inexhaustible source of comfort during the long hours when she is alone.

Consider again the children—their musical education is a constant problem for parents. No instrument can give them a finer, broader appreciation of good music. Their training will be aided, their creative powers quickened by the music of the world's greatest artists.

There is no member of the family who will not be benefited by a phonograph in the home—no home that will not be made cheerier, more inviting—a better home.

You are pausing on the threshold of a new year. The happiness it will bring to your family depends largely on yourself. Resolve NOW that the New Year shall bring Music into your home. ALL the Music of ALL the World—A PHONOGRAPH!

HERE is listed the members of the Milwaukee Association of Music Industries—those Music Houses where you may be sure of always receiving QUALITY PRODUCTS backed by GENUINE SERVICE and sold at HONEST PRICES.

BINDER SHOP 111 N. 1st St. Phone 1-1111	LETTER PRESS CO. 111 N. 1st St. Phone 1-1111	BRISTLE PIANO CO. 111 N. 1st St. Phone 1-1111	MOORE'S 111 N. 1st St. Phone 1-1111	C. C. WALKER 111 N. 1st St. Phone 1-1111
NEWTON-HOOD 111 N. 1st St. Phone 1-1111	JOE GOLDMAN 111 N. 1st St. Phone 1-1111	MILWAUKEE PIANO CO. 111 N. 1st St. Phone 1-1111	MILWAUKEE PIANO CO. 111 N. 1st St. Phone 1-1111	MILWAUKEE PIANO CO. 111 N. 1st St. Phone 1-1111
J. A. BRADSHAW PIANO CO. 111 N. 1st St. Phone 1-1111	W. H. BISHOP 111 N. 1st St. Phone 1-1111	W. H. BISHOP 111 N. 1st St. Phone 1-1111	W. H. BISHOP 111 N. 1st St. Phone 1-1111	W. H. BISHOP 111 N. 1st St. Phone 1-1111
W. H. BISHOP 111 N. 1st St. Phone 1-1111	W. H. BISHOP 111 N. 1st St. Phone 1-1111	W. H. BISHOP 111 N. 1st St. Phone 1-1111	W. H. BISHOP 111 N. 1st St. Phone 1-1111	W. H. BISHOP 111 N. 1st St. Phone 1-1111

**MILWAUKEE ASSOCIATION
OF MUSIC INDUSTRIES**

Milwaukee Association Advertisement Bearing on the Talking Machine "phonograph" was officially introduced as the designation of all makes of instruments producing sounds from records.

ALWAYS THINK OF THE NEXT SALE

In Dealing With Customers it Will Be Always Well to Keep in Mind the Sales to Come—Some Pointers on the Danger of Overselling

If you are looking for an idea to give to your dealers and their salesmen which will make them the pride of the service, here is the message for your next call, says the "Peptimist."

Never make a sale without thinking of the next one. Always have in mind the sales to come. This will make you more conservative in your statements and more careful in your analyses of your prospects and what you sell them. Moreover, you will always aim to send your customer away with a "I-want-some-more" feeling. This is the secret of sales success.

It is well known a first sale seldom pays for itself—your profits lie in repeats. The next sale, and the next and the next are where Columbia dealers make money.

There are just two thoughts to keep in mind in selling for the next sale:

(a) **Study your customer's wants.** Fill those, not yours. Satisfy him, not yourself. Even if the first purchase is small, better have it satisfactory in every particular than unsatisfactory in one. Never force a man to buy what he is not willing to buy. This does not mean to limit your sales. Offer him ideas. Introduce him to new records he does not know of, but do this in a manner of giving him the benefit of your greater knowledge of Columbia product, not in the manner of a man simply trying to sell records. Every succeeding sale depends on the pleasure the customer finds in the preceding one.

(b) **Do not oversell.** Use judgment. This is an intricate problem and one by which the

real salesman can always be known. Realize it is better to sell a man ten records in two instalments than to crowd the ten into the first sale. Always keep in mind, the ten, twenty, thirty, fifty records you know you can sell a

man, but use judgment in selling them. Keep his interest going. Do not smother it. "A bird in the hand" may be worth "two on the bush," but if you have strings on the two on the bush, you can keep all three. Never let a customer leave your store without some string of interest or desire to pull him back. A sale is valuable just in proportion to the surety you have that there will be another.

SERIOUS FIRE IN MILWAUKEE

Flames Break Out in Building Occupied by the Phonograph Co. of Milwaukee on Christmas Morning and Cause Loss Estimated at \$20,000—Orders Filled From Chicago

MILWAUKEE, Wis., January 5.—The Phonograph Co. of Milwaukee, jobber, and the Edison Shop, retailer of the Edison, encountered a rather exciting experience at the close of the holiday season. Early on the morning of Christmas fire was discovered in the three-story building, the first floor and part basement of which is occupied by the Edison dealers, and the remainder of which is a furniture repair and refinishing shop. The wholesale department and stockrooms were badly damaged, while the retail salesrooms were scorched but not rendered unfit for continuing business. Fortunately the fire came at a time when the stockrooms were fairly depleted by the holiday rush or the loss would have mounted into many thousands of dollars. Four firemen were injured in the effort to save the building and contents. The loss is estimated at \$20,000 to \$25,000, fairly well covered by insurance. The record stocks were relatively much less damaged than machines. Wholesale orders have been filled from Chicago while repairs are being made and new stocks provided. The retail department was open for business as usual on December 26, and while little evidence of fire could be seen in the retail warerooms, the smell of smoke filled the air and told a mute story of a narrow escape. The Edison Shop is one of the handsomest of its kind in the country. William A. Schmidt, general manager, was undaunted by the loss and within a few days' time was ready for both wholesale and retail business as usual.

The World is in receipt of Christmas and New Year's greetings from Thomas Edens Osborne, the enterprising talking machine man of Belfast, Ireland. The kindly sentiments expressed are most cordially reciprocated.

Lansing Khaki Moving Covers

PROTECT VARNISH IN THE COLD WEATHER

and enable you to deliver your phonograph free of blemishes of all kinds.

These covers are made of Government Khaki, interlined with heavy felt or cotton, fleece-lined, quilted and properly manufactured. Perfect protection in all weather.

GRADE B

\$5.00

GRADE A

\$7.50

Carrying Straps Extra

Use the Lansing Khaki Moving Cover and your delivery troubles will be over.

Write for booklet

E. H. LANSING

611 Washington St., BOSTON

SAN FRANCISCO OFFICE, Room 422 CHRONICLE BLDG.
WALTER S. GRAY, Manager



THE TRADE IN PHILADELPHIA AND LOCALITY

PHILADELPHIA, PA., January 8.—The Philadelphia jobbers and dealers in talking machines have just seen through the greatest year in the history of the industry. It has been a profitable year for all concerned. Both lines of the trade have come through the year with a good balance to their credit. What they might have done is a question that could only be answered through the amount of business that they have been compelled to divert from them on account of not being able to supply the goods. There was a shortage that was considerable, but probably not more than the previous year.

Just what the new year is going to bring forth I have not found one dealer who is willing to make a prophecy. The general trend is for carefulness. As one dealer said to me the past week, "I think nothing better could be done for the trade than to have the sign 'Be Cautious' printed and placed on every desk." This it is not to be inferred to mean that there is going to be a big slump in the business, but that the dealer will be wise who does not take too much of a plunge until he sees the way the wind will blow.

Closed a Great Sonora Business

F. D. W. Connelly, the Philadelphia manager of the Sonora Co., went to New York the day after New Year to transact some business at the company offices. He reports an elegant business on the Sonora all during and previous to the holiday season, and while it was not necessary to do so, this statement was confirmed by other dealers, who made emphatic the big December demand for the Sonora. The Sonora Co. advertised quite liberally, and big business was the result. Manager Connelly is arranging for a concert to be given on the second floor of the Sonora Building on the 11th of January. Frank J. Coupe, the general advertising and retail sales manager of the Sonora Co., was in Philadelphia recently.

Blake & Burkhart Closed Big Year's Business

Blake & Burkhart report that they have had a wonderful Christmas business in Edisons, and it went considerably beyond their expectation. The last week before Christmas was phenomenal, and Christmas Eve they had the biggest record demand they have ever experienced in any one day. They report that they are certainly well



VICTOR DEALERS

Appreciate

WEYMANN SERVICE

We urge all Victor Dealers to try our "Short Service," that is—

1. We fill the largest percentage of all orders received for records on which dealers are short.
2. We have the shortest and quickest delivery after orders are received.

WEYMANN

Victor Wholesalers

1108 Chestnut Street PHILADELPHIA, PA.

pleased with their year's business. Among their recent visitors was Charles Gardiner, the supervisor of the Edison zone.

New Sonora Agencies

The Sonora Co. has, at present, nine agencies in this city, and the most recent firm to take the handling of this machine was James Bellak's Sons, who also handle the Victor.

William Keech, formerly a salesman at the Sonora store, has opened a Sonora warerooms at 2808 North Broad street, and is meeting with very good success.

Louis Buehn Co. Ahead of Last Year

Louis Buehn, of the Louis Buehn Co., says: "Business for December was quite satisfactory,

so far as sales were concerned, but very unsatisfactory in other ways." Their inability to get records held down their total sales considerably for the month. Lack of machines also curtailed the month's business. "The demand apparently was just as strong as ever," says Mr. Buehn, "and for the intermediate grades, Nos. 9, 10 and 11, it was excessively large. One year's business closed slightly ahead of last year. This was brought about through the considerably increased record business, and in spite of the reduction in the machine business."

Penn Co. Reports Enormous Record Trade

The Penn Phonograph Co. also report that they had a very good December business; it was exceptionally large in records, with which they were very well stocked. Their record stock, says Mr. Barnhill, has practically been "shot to pieces," and the present supply from the factory is practically "nil." They are simply living now on their reserve. They have only a few machines left. In the new year they expect to carry a very much larger stock than heretofore and will rearrange the upper floors of their building to handle it, and to make the work easier.

Columbia Co. Rearrangement of Quarters

The Pennsylvania Talking Machine Co., whose name has been changed to the Columbia Graphophone Co., the big jobbing establishment in this city of the Columbia on North Broad street, have been making a considerable rearrangement of their offices and other departments. All the offices of the "big men" have been moved from the fifth to the fourth floor, including those of W. C. Fuhri and A. J. Heath. Both men are in New York this week for several days. The Dictaphone department of the company has been taken from their Broad street establishment, and has been removed to the second floor of 924 Chestnut street, where they have suitable quarters and are more in the heart of the business section of the city.

Establish Fifty Pathé Agencies

Your correspondent found Mr. Eckhardt, the head of the Pathé Shop in Philadelphia, at his warerooms Tuesday, slightly cold and anxious, awaiting the additional installation of more radiation, but warm and complacent inside and

(Continued on page 38)

It is the morning of a new year. The sword has been unsheathed and it is the morning of our country's greatest war.

May God strengthen us in our task of spreading broadcast the deep comfort and the true inspiration offered by that mightiest of musical instruments—the Victrola.

Distributors for the Ready File
for Victrola X's and XI's.

Penn Phonograph Co.

17 S. NINTH STREET

(VICTOR
JOBBER)

PHILADELPHIA

*She asked to hear 8 records.
She heard 3. She pur-
chased TWO.*

She wanted to spend MORE money for Victor Records—enough to add NINE \$\$\$\$\$\$\$\$\$\$

If this were YOUR STORE, you know that this profit is lost FOREVER, but you can't blame the SALESMAN.

BUHEHN SERVICE on VICTOR RECORDS

minimizes your TROUBLES and maximizes your PROFITS. It enables you to play records ASKED FOR and to SUGGEST additional numbers. It is constant, co-operative and constructive.

Now for a tip. There are over 1200 Victor Opera Records. A customer who likes opera can be developed into a steady record buying unit, so the result of your record sales is only limited to your selling energy. Put your "worry" of deliveries up to Buehn Service.

The Louis Buehn Company

Victor Distributors Exclusively Wholesale

PHILADELPHIA



We Recommend This Month	High Grade Needles, Full Tone	55^c per m
	Royal Crown Needles, Loud Tone Our Special Brands	

THE TRADE IN PHILADELPHIA

(Continued from page 36)

highly elated over the business that the Pathé Shop did during the holiday period. The Pathé Shop did not open until November 30.

Mr. Eckhardt says: "Our business was all that I had hoped it would be. Not getting open until November 30 we had not the time to apprise the people of the wonderful proposition we had to present to them. There were, however, a goodly number of them who found out for themselves. We had an extraordinary business for the time that we were open. And much of it was a cash business and especially large first payments. The line commends itself to the higher element of music lovers."

Prepare to Start the Spring Drive

Mr. Eckhardt has already been able to establish upward of fifty dealers to handle the Pathé. Arrangements are being made to start the spring drive, which, with the experience of the last month, will enable the company to present the Pathé more forcibly. A series of concerts will

AN IMPORTANT ACCESSORY

Growth of the Record Album Business of the National Publishing Co. of Philadelphia

PHILADELPHIA, PA., January 9.—How one enterprise develops another is well illustrated in the enormous demand for albums for holding disc records. These albums are made in book form. The interiors consist of numbered envelopes or pockets of strong fibre paper for containing the records, and are securely fastened to the back for giving the necessary strength. Each album is made to hold usually twelve records, and there are index pages inside of the front and back covers, on which the title of each record and the envelope number may be written. This affords a complete and handy system for filing records and keeping them in excellent condition. The albums are generally put in cabinets, and frequently in book cases, and when a record is desired an album is placed upon a table or the lap, which avoids the strain of stooping or getting on the knees to search for some particular record in an old filing device. For convenience and practicability record albums have surpassed any other filing system ever tried or tested.

Any man of middle age can well remember when the talking machine business was in its infancy and see the wonderful growth within the past ten or twelve years and the tremendous output of records, which are bought continually long after a machine has been purchased. Thus it will be seen that record albums are a most important accessory, for they have solved the problem of keeping and preserving records.

The National Publishing Co., of this city, report that their large and well-equipped factory for manufacturing albums is kept full of orders all the time. There has been such a large increase in the demand each year that they have

be inaugurated about the middle of January which it is expected will startle the music lovers of this city. The dealers will be invited to attend.

Harry Weymann Is Optimistic Anent New Year

Harry Weymann, of H. A. Weymann & Son, Inc., says: "As usual at this time of the year, a quantity of machines was delivered the day before Christmas, and quite a few of our out-of-town dealers sent their trucks to avoid the express and freight embargoes, and in order to make their delivery to their customers in time for Christmas. Our entire wholesale and shipping departments worked until 9.30 on Christmas Eve, until the last machine was shipped out.

"Our record orders in December have exceeded any December since we have been in the Victor talking machine business." Mr. Weymann is quite optimistic as to the coming year, and believes that the war is not going to affect the trade, and that the Victor Co. are going to be able to supply a big percentage of the demand for talking machines and records that will assuredly be placed upon them.

enlarged their output facilities to keep step with the growth. Knowing that The Talking Machine World is distributed among practically all of the talking machine manufacturers and dealers in this country and abroad, they take this means of thanking their many hundreds of customers for the orders they have received, and to state that they will always be ready to serve the trade in the future.

EFFICIENCY IN DEALERS' PUBLICITY

O. J. Dreyer Suggests Charging Dealers for Printed Matter so as to Avoid Waste—Would Impress Its Value More Effectively

In a symposium which recently appeared in "Advertising and Selling," a well-known advertising magazine, relative to the desirability of charging dealers for publicity matter, O. J. Dreyer, advertising manager of the Globe-Wernicke Co., Cincinnati O., contributed a very interesting article. This company, which manufactures the Brown disc record cabinet and sectional record files, is also the world's leading manufacturer of office filing cabinets and sectional bookcases, and is a national advertiser of considerable renown.

Mr. Dreyer's article, which is entitled "Charge Dealers for Matter," reads as follows:

"There are many kinds of advertising, and there is much waste in every kind, but by far the greatest waste is in the distribution of catalogs and printed matter to dealers for their use, and this includes envelope enclosures, circulars, booklets, pamphlets, and, in fact, anything which they receive from an advertiser free and send to their customers and prospects.

"In the case of printed matter being sent direct to consumers by the advertiser: If the mailing list is strictly up to date, there is no waste and in this case the advertiser has full control of the printed matter.

TALKING MACHINE DEALERS

—READ THIS—

"The finest and most delicate pieces of mechanism do not prove efficient unless properly lubricated. Skill, Genius, Invention and Workmanship must have the proper Oil. Stop and consider this when you have to buy an Oil for household use."

NYOIL
IS BEST

FOR ANY TALKING MACHINE



Being made in our Watch Oil Dep't, the same care given in refining as in our "Watch Oil," as all gums and impurities are extracted, leaving it Colorless, Odorless and Stainless.

BEWARE OF SCENTED OILS

Machines will not clog if oiled with NYOIL. NYOIL is used by the U. S. Gov't in Army and Navy. A trial order will make a permanent customer of you.

Ladies use NYOIL for Sewing Machines, for it is stainless.

Sportsmen find NYOIL best for Guns, for it keeps them from rusting.

NYOIL is put up in 1oz., 3/4 oz. and 8 oz. Bottles, and in Pint, Quart and Gallon Cans.

For Sale by all Talking Machine Supplies Dealers

WILLIAM F. NYE, New Bedford, Mass., U. S. A.

"Where the advertiser sends the printed matter to the dealer to be distributed by him, the advertiser loses all control of it. The dealer has the best of intentions, usually, to send out all printed matter which the advertiser will send him. If the dealer requests the advertising matter from the advertiser the chances are he will send it out, but then, he is human like the rest of us, and it is often overlooked, neglected and finally goes to the furnace or paper baler. If he does not request it there is still a greater percentage of waste.

"Investigations by the traveling salesmen of an advertiser will prove that most dealers have printed matter piled up in basements and warehouses, which they intend to use but never get around to the point where it is actually used. Of course, some of that which comes in at a psychological moment is sent out, but most of the printed matter is received, placed to one side and then neglected.

"There is just one way to remedy this trouble and eliminate this enormous waste, and that is for every advertiser in the country to make a nominal charge for all advertising material supplied to dealers. Ten per cent. of the cost will undoubtedly solve the problem. Thus, if a catalog costs 10 cents a dealer should be willing to spend 1 cent for it. If booklets cost \$50 per thousand a dealer should be willing to pay \$5 for each thousand he desires to use. The dealer then has a monetary value in the advertising material and will not waste it."

Walter J. Staats, auditor of the Victor Talking Machine Co., Camden, N. J., has been appointed Federal Fuel Administrator for Camden and Gloucester Counties, N. J.

PRESTO UNIVERSAL TONE-ARM



In Position for Playing Lateral Cut Records

This tone-arm has been designed to play all makes and types of records, whether of vertical or lateral cut. No change or adjustment becomes necessary. By merely turning a swivel joint, the change from one system to the other is made quickly.

THE PRESTO PERFECTED SOUND BOX is in no small measure responsible for the success of the Tone-Arm. The "triangle" Needle Holder permits the use of all types of needles, including the fibre needle. This is a feature not generally found in other makes of sound boxes. The use of new and especially designed machinery enables us to produce work that is of exceptional precision and refinement.

Prices and Samples Upon Request

Let us figure on your other phono parts requirements

PRESTO PHONO. PARTS CORP.

124-130 PEARL STREET,

BROOKLYN, N. Y.



Otto Heineman Phonograph Supply Co.

INCORPORATED

25 WEST 45th STREET, NEW YORK

FACTORIES, ELYRIA, O.—NEWARK, N. J.—PUTNAM, CONN.



CHICAGO

ATLANTA

SEATTLE

CINCINNATI

TORONTO

Dean Steel Needles

*The Quality
Needle
of the World*

We are Ready NOW for 1918 Contracts

Pathe Sapphires—Full Tone

Pathe Sapphires—Half Tone

Edison Sapphires

Edison Genuine Diamond Points

**We handle only
Quality Jewels**

*Deliveries from New York or nearest
branch office. All Jewels in stock.*

MEISSELBACH
MOTORS

AF Meisselbach & Bro. Newark N.J.

AF Meisselbach & Bro. Newark N.J.

TONE ARMS MOTORS SOUND BOXES

Happenings in the Dominion of Canada

CONTINUAL ROUND OF ACTIVITY IN TORONTO TRADE

After Record-Breaking Holiday Season Talking Machine Men Plunge Into Plans for New Year—Geo. W. Hopkins Addresses Toronto Ad Club—Travelers Make Good Report—New Ventures

TORONTO, CAN., January 9.—A full house greeted Geo. W. Hopkins, sales manager, Columbia Graphophone Co., who made a special trip from New York to address the Toronto Ad Club, at the Board of Trade, December 11. Mr. Hopkins is recognized as one of the leading sales managers in the United States, and his talk here met with enthusiastic approval, delivered, as it was, with punch and pep, and the result of an intimate knowledge of the selling field.

The J. Coulter Co., Ltd., are putting on the market the Harmonola, a new cabinet phonograph, to be sold through the jewelry trade in three models.

C. W. Lindsay, Ltd., Ottawa branch, during the month of December gave noon hour recitals which were entirely informal and included popular and classic, secular and sacred music. This firm handles Columbia, Pathé and Sonora lines.

The Music Supply Co., Columbia distributors, are running some strong advertising in conjunction with their dealers.

"A carload of phonographs is just being unloaded this morning, so we are feeling more contented," remarked W. D. Stevenson, of the Canadian Phonograph Supply Co., London, Canadian distributors of Starr lines, when *The World* called. "We had practically cleared our stock prior to receiving this delivery, and this enables us to continue giving our dealers the same prompt service that we gave when the demand was not quite so heavy."

R. W. Burgess, of the Pathé Co., has just returned from a successful seven weeks' trip to the West, where he went as far as Saskatoon. While there Mr. Burgess opened up a great many valuable accounts for the Pathé western distributors, Messrs. R. J. Whitla & Co., Ltd., amongst which were Cross, Goulding & Skinner; Furnishers, Ltd., and Ashdown's of Winnipeg, as well as Campbell & Campbell, of Brandon, Man. Mr. Burgess personally had charge of the big opening at Ashdown's, and demonstrated the Pathéphone to a very large and appreciative audience. To demonstrate how easily it could be done he proceeded to sell for cash on the opening night one of the superb new Louis XVI Pathéphones, and a large assortment of Pathé records, a total cash sale approaching \$400.

A. F. Meisselbach, of the Meisselbach division of the Otto Heineman Phonograph Supply Co., Newark, N. J., and one of America's pioneer motor manufacturers, recently paid his initial visit to this city. On a former occasion Mr. Meisselbach had seen something of Western Canada while on his way from the Western States to Vancouver. He expressed himself quite pleased with Toronto. Mr. Meisselbach is much impressed with the rapid growth of the phonograph industry, and to him the number of homes without a phonograph is but an indication that the industry is only in its infancy.

Ralph Cabanas, for over two years manager of the Columbia Graphophone Co.'s business, with headquarters in Toronto, resigned from that position on December 31 and in a short time proposes visiting Mexico to look into business conditions there. On coming to Canada in 1915, Mr. Cabanas expected to remain until matters became normal and required his return, to again give personal attention to his business interests in Mexico. During his stay in Canada Mr. Cabanas has thoroughly familiarized himself with methods of doing business here and leaves with the satisfaction of having seen Columbia trade develop to the extent of this year's volume, being a little more than treble that of his first year. On a recent visit to New York he was congratulated by officials of the com-

pany on his record here. He has made many warm personal friends in and out of the trade who will regret his departure, but at the same time extend very best wishes for a complete revival of his former business success in Mexico.

Thomas C. Watkins, "The Right House," of Hamilton, Ont., have taken on the agency for Brunswick phonographs and records.

R. R. Gauvin, a leading furniture dealer of Smith Falls, Ont., has opened a new phonograph department and has secured the agency for Pathéphones and Pathé records.

F. A. Girdwood, proprietor of the Rexall Drug Store, Perth, Ont., has added the Pathé line of phonographs and records. D. J. Ritza, another eastern Ontario druggist, has likewise taken on the Pathé.

R. S. Mason, formerly with the J. M. Greene Music Co., Peterboro, and son of the manager of that firm's Lindsay branch, has leased a store in Orillia, where he will handle Brunswick phonographs and records.

Among recent trade visitors to Toronto were M. H. Matthews, president, and L. A. Baxter, vice-president and superintendent of the Thomas Mfg. Co., Dayton, O. This firm has opened up a Canadian branch in Toronto in the Kent Building, which is in charge of P. K. Wood and F. J. Foley. At the Canadian branch it is the purpose to carry for immediate shipment a large stock of each of their five types of motors and of the four designs of tone arms and sound boxes together with all necessary parts.

At the Stanley Piano warerooms, Yonge street, the Brunswick phonograph line is now being strongly featured.

S. E. Lumdsen, a well-known piano dealer of Arnprior, Ont., has secured the agency for Pathéphones and Pathé records for his district.

M. E. Standfield has started on the road wholesaling Starr phonographs and records for the Canadian distributors, the Canadian Phonograph Supply Co., London, Ont.

D. R. Doctorow, credit and sales manager for Leonard Markels, the New York motor manufacturer, spent a few days in Canada early this month, during which he closed some substantial

orders. Mr. Doctorow informed your correspondent that he was arranging at the factory to have a service man come to Toronto for two or three weeks in the interests of Markels motors and parts.

New Victor dealers in Toronto are High Park Music Store, Roncesvalles avenue, and the St. Clair Music Store, St. Clair avenue.

The Phonograph Shop, 310 Yonge street, Toronto, is featuring the Solophone.

A recital was recently given to a number of invited guests by Manager C. R. Coleman, of Thos. Claxton, Ltd., this city, to demonstrate the playing of various makes of records with the Bliss reproducer. The faithful reproduction was enthusiastically commented upon.

Whether or not talking machines should be displayed in the piano booths at the Canadian National Exhibition provoked a spirited discussion at the recent annual meeting held in Toronto, Ont., of the Canadian Piano and Organ Manufacturers' Association, resulting in the decision that they may be shown, but that the exhibition committee shall have power to enforce the rule that talking machines and player-pianos shall be demonstrated only in the soundproof rooms behind closed doors. It is proposed to interview the exhibition authorities with respect to suitable accommodation for the manufacturers of talking machines wishing to exhibit.

The Hudson Bay Co., following the concert of the Hawaiian players and singers in costume with the Bird of Paradise Co., who were filling an engagement here for a week, had a thirty-minutes' recital of Bird of Paradise Hawaiian Music through the medium of the Starr phonograph.

Arthur Middleton appeared on December 27-28 with the Winnipeg Oratorio Society. He is well known through his connection with the Edison Co., and Edison dealers made capital out of his appearance by featuring his records.

Reed & Robinson, Edmonton, Alta, are handling a large volume of business with the Aeolian-Vocalion line.

Lucy Gates, the Columbia artist, delighted large Winnipeg audiences in that city lately in a song recital.

The Mason & Risch Co., Ltd., local Victrola representatives, stated that the buying of Victrola records for Christmas giving was unusually large.

MONTREAL'S PROSPERITY REFLECTED IN HOLIDAY SALES

Big Run on Higher-Priced Models—Some Generous Advertising Campaigns—Many New Agencies Announced for Prominent Lines—Stores Enlarged and Remodeled to Take Care of Future Demands

MONTREAL, ONT., January 4.—The local talking machine trade were all unanimous in stating that the holiday trade of 1917 goes down on record as one of the best in their history and are all agreed that the talking machine has certainly come into its own. Several reasons are advanced for the large increase. First, the large amount of money in circulation, the demand this year being practically for the more expensive machines, and this was forcibly brought to the attention of your correspondent by nearly

every dealer called upon. Secondly, the manufacturers have spent large sums of money in printers' ink using full pages exploiting their products and educating the people to the advantages of music in the home, especially in war time. Thirdly, the dealers themselves in addition to the appropriation allowed them by the manufacturers for advertising supplemented this largely by running good-sized copy. Fourthly, the Christmas Club idea had a stimulating ef-

(Continued on page 42)

Talking Machine Supplies and Repair Parts

SPRINGS, SOUND BOX PARTS, NEEDLES

THE RENÉ MANUFACTURING CO.

MONTVALE, NEW JERSEY



Unico
Construct

THE UNICO SYSTEM



Eastern Talking Machine Co., Boston, Mass.



Neal, Clark & Neal Co., Buffalo, N. Y.



Cohen & Hughes, Inc., Washington, D. C.

Record Sales Will

Install
Unico
Demonstrating
Rooms
Now

FRANCE, GREAT BRITAIN and Canada have during the past three years experienced the greatest industrial activity. Their leading retail Establishments have increased their volume of sales to the maximum. The United States is entering upon similar prosperity. Music is now a Patriotic Necessity. Record sales in 1918 will surpass all previous demands. Prepare *NOW* to secure your share of the business by installing

THE UNICO SYSTEM

THE UNIT CONSTRUCTION CO.

RAYBURN CLARK

121-131 South Thirty-first Street

Send today dimensions of your available space

UN

THE SALES BUILDER

Predominate in 1918

Install
Unico
Record Racks
Record Counters
Now



M. Steinert & Sons Co., Boston, Mass.



F. L. Steers Co., New York City, N. Y.



S. B. Davega Co., New York City, N. Y.

**U
N
I
C
O** DEMONSTRATING ROOMS
RECORD RACKS
RECORD COUNTERS
WALL DECORATIONS
COMPLETE INTERIORS

(Patented as to design and construction)

In six standard styles and in special period design such as Adam, Louis XVI, Colonial, Modern French, etc.

- Offer 1. Individuality and Class.
- 2. Highest Sales Efficiency.
- 3. Most Economical Investment.

Follow the lead of the leaders. Double Sales and Profits through

THE UNICO SYSTEM

DUCTION COMPANY

SMITH, President

, PHILADELPHIA, U. S. A.

Plans for a complete department will reach you promptly

CO

TRADE CONDITIONS IN THE DOMINION OF CANADA—(Continued from page 39)

fect in disposing of a large number of machines on the instalment principle, although from various interviews cash business predominated. There are many more reasons that could be advanced, but these are the principal ones. Record Gift Certificates were never as popular as this year and promise for its future big business in this respect. Why not extend this and make a birthday certificate?

D. S. Cluff, representing the Canadian Phonograph Supply Co., London, Ont., Canadian distributors for the Starr machine and records, has just returned from a highly successful trip in the Maritime Provinces, where he opened a large number of new accounts.

J. G. Bradt, manager of the Columbia Graphophone Co., Toronto, was a recent visitor to the trade in Montreal.

Local Brunswick Shops handling Brunswick talkers include Berlin Phonograph Co., Ltd., 153 St. Catherine street, East, who are East End representatives; Geo. A. Peate, 584 St. Catherine street, West, representatives for Eastern Ontario and Quebec, and the Cowan Piano & Music Co., 633 St. Catherine street, West, West End representatives.

H. P. Labelle & Co., Ltd., are now featuring the Starr line in addition to other makes handled.

Some of the local branch stores of the United Cigar Stores are featuring Emerson records.

The members of the Montreal Publicity Association at a special luncheon at the Rose Room of the Windsor Hotel recently heard an appeal from Mrs. F. W. Stewart on behalf of the Superfluity Shop and the toys made by the returned soldiers.

An address was given by G. W. Hopkins, general sales manager of the Columbia Graphophone Co., New York, one of the four men chosen by the United States to handle Government publicity, who spoke on the little things that make big business. Mr. Hopkins was full of valuable hints for salesmen and advertising men as to the best ways of promoting business.

S. H. Brown, retail manager of the Berliner Gramophone Co., Ltd., and P. Decker, manager of the 417 store, sent a substantial supply of smokes to Messrs. Dewar and Reece, who recently enlisted in the United States Marine Corps.

Eighty-nine Columbia Grafonolas constituted a unique showing in the window of Layton Bros. and was the largest number of talking machines ever displayed in a Montreal store window. The publicity thus gained brought most wonderful results.

Henderson & Richardson, Board of Trade Building, handle the Stewart, and the day before Christmas had sold their complete stock. They report an increasing interest in Operaphone records.

The Edwards Furniture Co., Sherbrooke, Que., are now stocking a line of phonographs.

J. A. Hurteau & Co., Ltd., have completed alterations to the interior of their store, adding a number of soundproof booths and new lighting effects throughout. It presents a most attractive appearance. Pathé and Sonora business has never been as good before in December, said this firm.

W. J. Whiteside experienced his first Christmas business with the Victor as his leader. He reports being sold out of every model in the store with the exception of one machine which he uses for demonstration purposes. As regards his supply of records it was sadly depleted. The majority of Victors sold were for spot cash and included the higher-priced styles, very little call being noticeable for the smaller types.

The Berliner Gram-O-Phone Co., Ltd., evidenced a large demand for the first records of the Boston Symphony Orchestra.

The Canadian Graphophone Co. report both wholesale and retail Columbia business away in excess of last year as regards the month of December and are well satisfied with the number of Grafonolas and Columbia records disposed

of sold as Christmas gifts, the popularity of which is steadily increasing every year.

Lieut. "Gitz" Rice has just recorded for the Berliner Gramophone Co. two Victor records, ten-inch, as follows: "Fun in Flanders" (Parts I and II), 18405; "Honey, Will You Miss Me?" and "Take Me Back to the Land of Promise," 216016.

Lieut. "Gitz" Rice needs no introduction to Canadians. His fame as an entertainer reaches far beyond his native Montreal. When the call of the Motherland was heard he went overseas with the First Canadian Contingent, and saw action at Neuve Chapelle, Ypres, Festubert, Givnechy, Loos, the Somme and Vimy Ridge. Then he was badly gassed and sent to a hospital in England, and is now in Montreal on sick leave.

His ability as an entertainer led to his being detailed to organize entertainments for the men at the front, and he was awarded a commission in order to make his efforts fully effective. Lieut. Rice took charge of all musical entertainments within the Canadian lines, and, with the aid of the various concert and musical troops organized from different regiments, was able to entertain 70,000 soldiers every week.

The authenticity of the songs and jokes on these records is vouched for as true to life in the trenches. Other records by Lieut. Rice will be issued in the near future.

The Berliner Gram-O-Phone Co., Ltd., have enlarged considerably their two St. Catherine street, West, stores, thus giving them a larger number of demonstration rooms and even with the additional rooms at their disposal customers had to wait their turn in line during Christmas and New Year's week.

The report of Charles Culross, Sonora and Aeolian Vocalion representative, is to the effect that the demand was confined largely to the most expensive styles of both makes and which he stated sold with much less effort than the smaller machines.

A. Comtois, 1473 Notre Dame street, West, is handling His Master's Voice products.

The Berliner Gram-O-Phone Co., Ltd., report a holiday business equal to the record volume established in December of previous year. The rush came in the last three days preceding Christmas and kept up continuously until New Year's Eve.

Goodwin's, Ltd., report a good steady flow of trade for Edison Diamond Discs and Amberolas.

"We are not so eager for trade that we take all talking machine sales that are offered us," said Manager Henry Hamlet, of Wm. Lee, Ltd., who do an extensive business in Edison Amberolas and Columbia Grafonolas. "We are daily turning down sales that are offered us, as we only want business that is absolutely of a high class nature."

Geo. A. Peate, who is handling the Brunswick phonograph in Eastern Ontario and the Province of Quebec, is very optimistic over the future possibilities of this make and predicts a great future for the Brunswick. He has already sold a large number to leading local musicians of national repute, who he states are in a position to judge and compare. Two traveling representatives will start out on the road the first of the year.

Sales Manager W. W. O'Hara, of Layton Bros., told your correspondent that on Christmas Eve they were left practically without an Edison machine on the floor, and were cleared out of everything above \$200. Columbia Grafonolas and records also shared in the prosperity. "Months ago we placed what we believed sufficient orders to fill all our wants," he said, "but we never anticipated the onslaught which came as an avalanche and cleaned us out."

According to Norman F. Rowell, manager of the phonograph department of C. W. Lindsay, Ltd., holiday business this year was unprecedented, and Columbia, Pathé and Sonora machines were the gainers.

That the music loving public are being edu-

cated to the advantages of owning a phonograph was amply demonstrated at the warerooms of J. W. Shaw & Co., where Columbia Grafonolas were sold in large numbers as well as Columbia records.

Pathéphones and Pathé records enjoyed a brisk demand at the store of G. A. Holland & Son Co.

Wm. Lee, Ltd., are handling the new Golden-tone needle, which they state is selling freely.

NEWS FROM NORTHERN PROVINCES

Talking Machine Trade Most Active in Provinces of Saskatchewan and Alberta

Wm. H. Field, manager, Saskatoon Piano Co., who features "His Master's Voice" lines, is adding a number of sound-proof rooms on the ground floor. The firm is also planning an addition to the rear of the building occupied by them. The Victrola department, at present located in the basement, has been outgrown, and to meet the need of more rooms it was decided to locate these on the ground floor.

A Columbia distributing agency has been opened up in Calgary, Alta, by James E. Williams.

Nipper, the famous Victor dog, was a prominent and attractive feature in a recent display of Heintzman & Co.'s Moose Jaw store. The Victrolas shown were all of satin finish, and with an attractive arrangement of "His Master's Voice" records the window presented a striking appeal. A later window by reason of its artistic simplicity was particularly good. A cabinet machine and one of table size were shown against a background of denim.

The Victrola department of Heintzman & Co., Ltd., at Calgary, is now in charge of B. Gillespie, formerly manager of Western Gramophones Co.'s branch in that city. Mr. Gillespie is a thorough and consistent Victrola enthusiast, and finds a ready response to his enterprise in giving service to the public. Four years ago Mr. Gillespie commenced his Victrola experience with His Master's Voice, Ltd., Toronto, later transferred to Western Gramophone Co., Winnipeg, and then to that firm's branch at Calgary.

The Child & Gower Piano Co., Regina, Sas., are handling a large number of Vocalion phonographs and Columbia Grafonolas.

Jos. M. Tees, formerly of Winnipeg, where he was one of the pioneers in the music business, is now a citizen of Calgary. Mr. Tees is manager of the Imperial Phonograph Co., which firm is featuring Columbia lines.

The Hudson Bay Co., at Calgary, have taken on the Columbia line. The formal announcement of this event took the form of a series of four recitals in their "Temple of Music" on the fifth floor, but which is being removed to the fourth floor. The recital attracted audiences that crowded every available inch of floor space. The programs were of such artistic value and so well rendered as to win from this department's competitors most generous compliments to the work of J. F. Fisher, manager of this branch of the Hudson Bay Co.'s business. Mr. Fisher came west a few months ago from Toronto, where he was on the staff of the Nordheimer Co. The influence of his knowledge of his business, his friendly personality and broad appreciation of the place of music in the lives of the people, is daily reflected in the improved service of his department and appreciation of his patrons.

The "no records exchanged" sign is hung conspicuously in the store of Mason & Risch, Regina, Sas. Asked as to the difficulty of enforcing the rule, Mr. Polson, manager, replied that he found it of considerable advantage not to exchange records, as customers naturally preferred unused stock. He told of a Scotsman and his wife who had transferred their record trade to his Victrola department, their explanation being that by doing so they were assured of the records purchased being all new.

The Most Memorable Motor Event in a Generation!

The Appearance on the Scene of the

BUTTERFLY MOTOR

Leonard Markels
Jewel-Bearing

The motor that knows
no peer!

Read and note these specifications word for word, and you will realize that a new chapter in the history of the phonograph has been opened by the final completion of the

SILENT BUTTERFLY MOTOR *Jewel Bearing*

Specifications

- Beveled gear, noiseless winding.
- New ratchet device that prevents clicking.
- Bakelite intermediate gear—absolutely silent.
- Plays seven to eight 10-inch or five and a half 12-inch records at one winding.
- Cast iron nickeled frame.
- Powerful, durable, compact, accessible.
- Built especially for the highest-grade machines.
- Guaranteed in every minutest detail.
- The perfection of mechanical genius as applied to the phonograph motor.

Write today for Butterfly Folder

LEONARD MARKELS, 165 William Street, NEW YORK

Made in its entirety, from first to last, under the direct personal supervision and vigorous exacting standards of the recognized Phonograph-Motor Genius of America, Leonard Markels

Every Butterfly Motor tested thoroughly, in every practical way, before it leaves our Factory with our Unqualified Guarantee

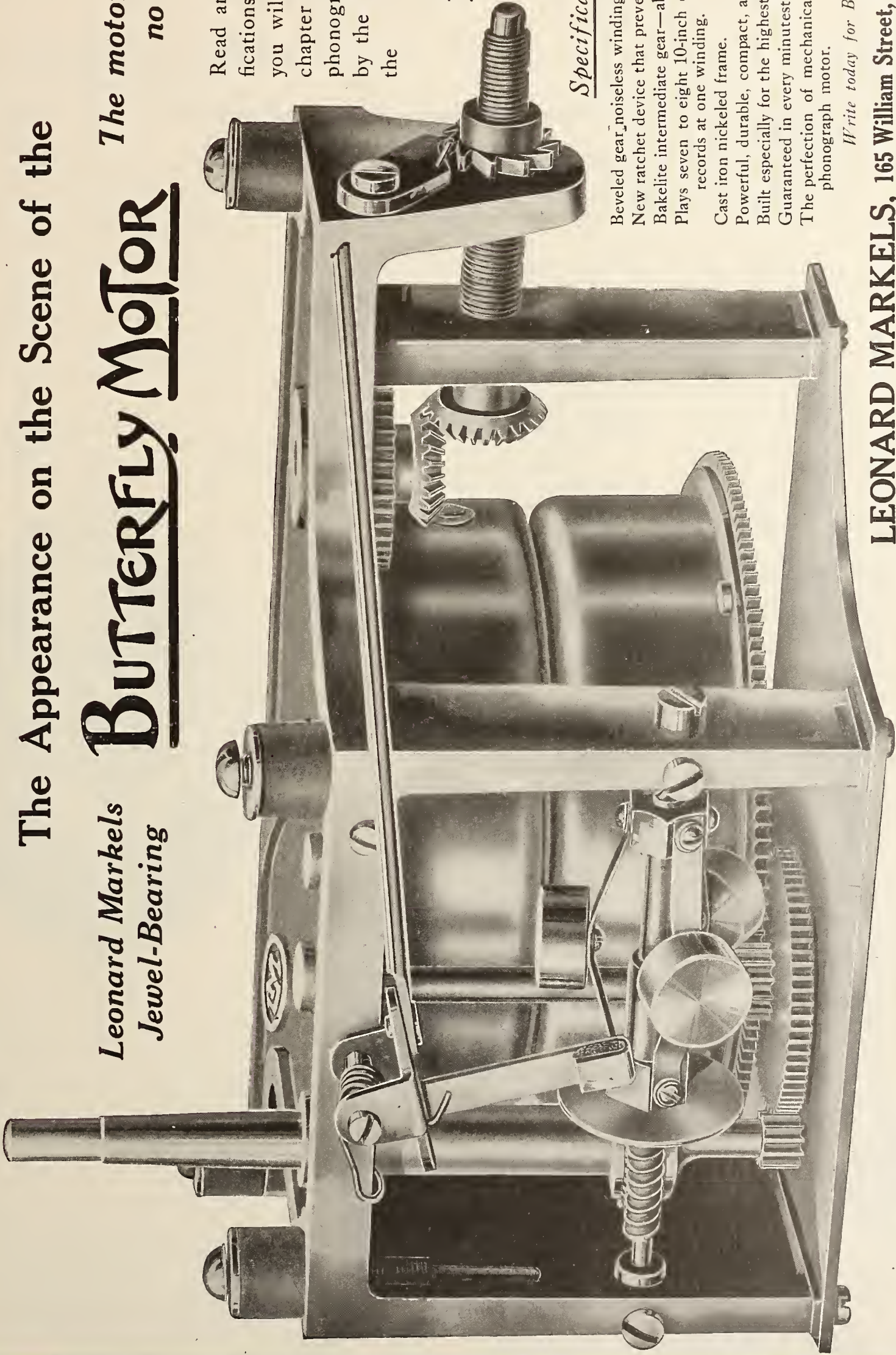



There isn't an angle on local advertising, bill boards, store equipment and fixtures that the Columbia Dealer Service Department won't solve for you *gladly*.

**Columbia Graphophone Co.
Woolworth Building, New York**

RECENT DEVELOPMENTS IN THE TRADE IN PORTLAND, ORE.

As Is Usually the Case the Holiday Demand Cleans Out Available Stocks—Patriotic and Semi-Patriotic Records Have the Call—Machines in Period Styles Make a Hit

PORTLAND, ORE., January 3.—The volume of talking machine business throughout Oregon, and particularly this city and vicinity, is practically limited by the available supply of machines and records, and the demand is spread over all the leading lines of instruments. In other words, conditions existing at Portland are as a rule those which, according to reports, exist in practically every other section of the country. From present indications there will be no let-up in business for the coming months at least.

The G. F. Johnson Piano Co., by selling "It's a Long, Long Way to Berlin, but We'll Get There" and "Send Me Away With a Smile," is not losing any friends. R. F. Callahan, the genial talking machine salesman, delights in patriotic records, which he says sell like hotcakes. But he also has the fine taste to recommend the best classic reproductions to discriminating buyers. He says the Boston Symphony Orchestra records sell immediately after being heard. He considers them the most wonderful reproductions of orchestra music ever made.

The William and Mary model of the New Edison machine is being sold at the Meier & Frank store at the old price, with only a nominal sum added for war tax. January 1st the prices on all Edisons were advanced and Portland people took advantage last month of the opportunity to buy these beautiful instruments at the old figures and sales during the Christmas holidays were numerous.

Louis Older, formerly with the Columbia Graphophone Co. there, and now in the Canadian army, stationed at Vancouver, B. C., got a six-day leave of absence last week and celebrated it by coming down to Portland and marrying Miss Suzanne Glen, stenographer of the Columbia Graphophone Co.

The Cowan Classique, one of the most beautiful talking machines ever brought to this city, is having a fine sale. These beautiful instruments have been sold to owners of some of Portland's handsomest homes. The case is not its only recommendation, as the tone is unusually full and sweet.

Miss Emma Reynolds, of the Hyatt Talking Machine Co., reports many good sales. Many

machines were sold for Christmas gifts. The sale of records is constantly increasing. Those of Galli-Curci are very popular. The Hyatt Co. handles the Victor, Columbia and Edison machines.

P. Murphy, of the Jackson Furniture Co. of Oakland, Cal., is now salesman at Bush & Lane's Piano Co. here. Mr. Murphy sold a thousand-dollar Sonora machine immediately after join-

TRADE OPTIMISTIC AND CONFIDENT

D. Bartelstone Tells of Conditions and Prospects Experienced on Recent Trip—Closed Many Contracts With Manufacturers of Standing

D. Bartelstone, head of the Lucky 13 Phonograph Co., New York, returned recently from an extended Western and Northeastern trip, which included a visit to a number of the company's clients. In addition to securing good-sized orders for the coming year Mr. Bartelstone closed contracts whereby his company will be in a position to offer manufacturers and dealers maximum service during 1918.

In a chat with *The World* Mr. Bartelstone commented upon the fact that the great majority of the members of the talking machine industry seem to be imbued with optimism and confidence in the future. The manufacturers report the closing of a satisfactory year, and, judging from their plans for 1918, the question of service to their clients will be a most important factor in the coming year's developments.

The Lucky 13 Phonograph Co. now numbers among its patrons some of the best-known members of the trade, who have been taking advantage of the company's offer to keep them supplied with all phonograph parts immediately upon receipt of their orders. The company carries large stocks on hand, and Mr. Bartelstone has been in a position to take advantage of several important contracts during 1917. For the new year this service will be even more intensive than in the past, and a number of new lines will be announced in the near future.

D. Bartelstone has been associated with the talking machine industry for a number of years,

ing the Portland house. The Sonora is selling rapidly. A carload has just arrived for Bush & Lane and is being quickly disposed of.

Wm. Gadsby & Sons, the large furniture house, have just stocked up with a complete line of Columbia Grafonolas and handle these machines exclusively.

Miss Ethel Brown has taken charge of the talking machine department of H. Jennings & Sons. This house sells Columbia Grafonolas and Windsor machines.

Miss H. Perry, formerly with Byron Mauzy, of San Francisco, is now saleswoman with the Bush & Lane Co. here.

and in addition to being a competent executive and merchandising man also possesses an invaluable technical knowledge of the talking machine business, a knowledge which has contrib-



D. Bartelstone

uted materially to his company's success. He is well known in local trade circles, and according to his present plans will visit the trade throughout the country at frequent intervals this year.

A CONVENIENT BLACKMAN SOUVENIR

Combined Desk Rule and Blotting Device Carries Holiday Greetings to Trade

The Blackman Talking Machine Co., New York, the prominent Victor wholesalers, remembered their friends in the trade with a most attractive and useful holiday souvenir in the form of an eight-inch celluloid ruler on one side of which appears monthly calendars for 1918, and to the reverse side of which are attached several strips of blotting paper that should prove a great convenience in blotting signatures on letters. The Blackman souvenir will find a permanent place on many desks.



Announces

A NEW RECORD ALBUM

Each album has a system of interlocking which makes each envelope an individual container. Riveted at the back so that the strain cannot weaken the envelopes. Ends are brass finished.

Indestructible and guaranteed to be the strongest album on the market

Metal-back and other grades also manufactured as heretofore.

NEW YORK ALBUM & CARD CO., 23-25 Lispenard St., NEW YORK

Featuring the Musical Possibilities of the Talking Machine

By William Braid White

[Note.—This is the eleventh in a series of articles on the general subject of the musical possibilities of the talking machine. The aim of the series is to develop these possibilities from all angles, thus opening up fields for sales expansion oftentimes neglected wholly or in part.—Editor.]

SCHUBERT UNFINISHED SYMPHONY

The other day I was listening to some Columbia records at a friend's house and, in looking over his collection, the title "Symphony in B minor (Unfinished)" caught my eye. What memories that name brings back! How I remembered that very young fellow whose pennies were few and far between, but who scraped up each week enough to buy a gallery seat at the St. Nicholas Garden, in New York, so that he might hear Franz Kaltenborn's orchestra on Tuesday nights. This was way back twenty years ago, or very nearly that long. Kaltenborn made a brave attempt to popularize orchestral music in New York during the summer by giving it in a place where you could sit and drink beer while drinking in metaphorically the music from a very good band. His players were nearly all Philharmonic men and they made a pretty large hit that first season. Every Tuesday night was symphony night, and I shall never forget that it was on one of these Tuesdays that I first heard the Unfinished Symphony of Schubert.

The Talking Machine Route

You talking machine fellows, do you know what you might be giving the great American public in these serious times if you would but help them to get acquainted with some of your really fine records of symphonic music? It is such a pity that the people have been taught, by newspaper jokes and by general indifference, to sneer at everything which dares to call itself "artistic." But, thank heaven, those days are passing and we are coming to better understanding. Still, there is much progress yet to be made, and in no direction can it be made more surely and rapidly than via the talking machine route. The talking machine is the best musical educator the people ever will have, and in these days, when we are entered on a great and trying task, we need the encouragement and the strength that come from great music; need it as we never needed it before.

It is up to the salesman to encourage with all their hearts whatever will tend to bring about a better popular understanding of, and demand for, high-class records. The people's heart is right. They want good music, but they don't know what to ask for. They don't know what to listen to. It is up to you to tell them. And how can you tell them if you know no more than they do?

That is why these articles are written; not to instruct you in a superior way, but to furnish ideas that may lead you to take a more definite interest in these things and to make yourself better acquainted with them.

The home folks will not be wanting fox-trots and jazz when the brothers, husbands and sons are at the front. It is up to the talking machine man to decide what they shall have in place of the appalling drivel that once suited everybody.

Franz Peter Schubert

Will you listen, then, while I tell you something about this record: Columbia A5748, the Unfinished Symphony of Franz Schubert, in two parts, one on each side of the disc? It is worth while hearing.

Franz Peter Schubert was one of the world's neglected geniuses. You often hear of such, but seldom know of a real specimen. Schubert's case was genuine. All his life was passed in poverty and disappointment. He died at the early age of thirty-one, in something very like the weakness of an improperly nourished body. In his short life he managed to compose ten

symphonies, operas, piano compositions galore, quartets and quintets for strings, and no less than 600 songs, many of which, such as the "Erl-King," "Gretchen at the Spinning Wheel," the "Serenade," "Hark, Hark the Lark," "Who Is Sylvia," are well known through records to every talking machine man.

Schubert was born in 1797 near Vienna and died the year after the great Beethoven. His father was a poor school teacher and the boy was educated at the school maintained for the choir boys of the Imperial Chapel, a place amongst whom had been secured for him at the age of eleven, on account of his beautiful voice. The fare was scanty, the discipline severe and the child suffered under it. But he was already, although he had no formal musical education, beginning experiments in composition. When he was sixteen his voice broke, and he was dismissed from the school and choir. Three years followed of miserable attempts to teach in his father's school. This finally had to be abandoned altogether, but Schubert nevertheless found time, during the year 1815, when he was but eighteen years old, to compose two symphonies, five operas and one hundred and thirty-seven songs! Some of these songs have since been sung all over the world and are still included in the program of every song recital.

An obscure musical appointment was, at this time, refused to him on the grounds that he was "imperfectly qualified!" Poor Schubert!

Schubert at The Inn

The rest of his life was passed quietly and obscurely. He lived sometimes at home, sometimes in rooms elsewhere. His songs sold fairly well after a time, but often for miserably insufficient prices. For his larger works, however,

he could not obtain a hearing at all. Even his songs he had to give away, almost. Franz Lachner, many years later, once related how he and Schubert had a mind one day to go to the country for an excursion, but neither of them had any money. So Schubert hunted up a bundle of songs he had recently written down and gave them to Lachner, asking him to take them to the publisher, as Schubert himself was too shy to present himself there again. After much hesitation, the publisher consented to pay five Austrian florins (about one dollar) for the bundle of manuscript! The two took this money and went off, happy as kings. At lunch time they stopped at a little inn. While waiting for their meal, Schubert found an old cracked spinet, at which he sat down and began to play over ideas for new songs that had occurred to him on the road. Soon the landlady and all the other guests had stolen silently into the room and sat listening entranced! Some of these songs, says Lachner, were among Schubert's greatest.

The Unfinished Symphony

As I said before, poor Schubert could get no hearing for his larger works, and that is the very reason why the unfinished symphony is really "unfinished," having only the first and second movements. The circumstances were somewhat as follows:

In the year 1821 the Musical Society of Gratz in Austria elected Schubert to honorary membership. The obscure composer was delighted at the recognition and announced that he would compose a symphony for the society as a mark of his thanks. He at once set to work and finished the first two movements. He had just be-

(Continued on page 47)

THE 1918 TRIO

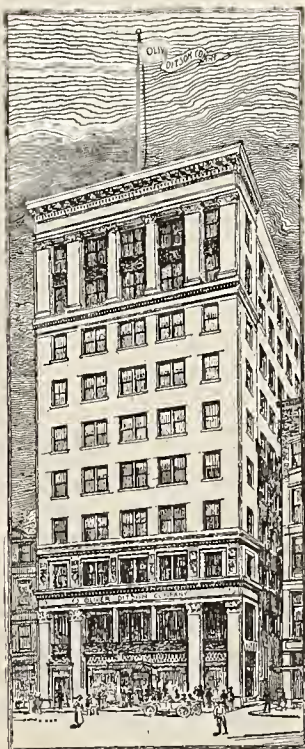

NEW HOME OF OLIVER DITSON CO.

DITSON

VICTOR

BOSTON

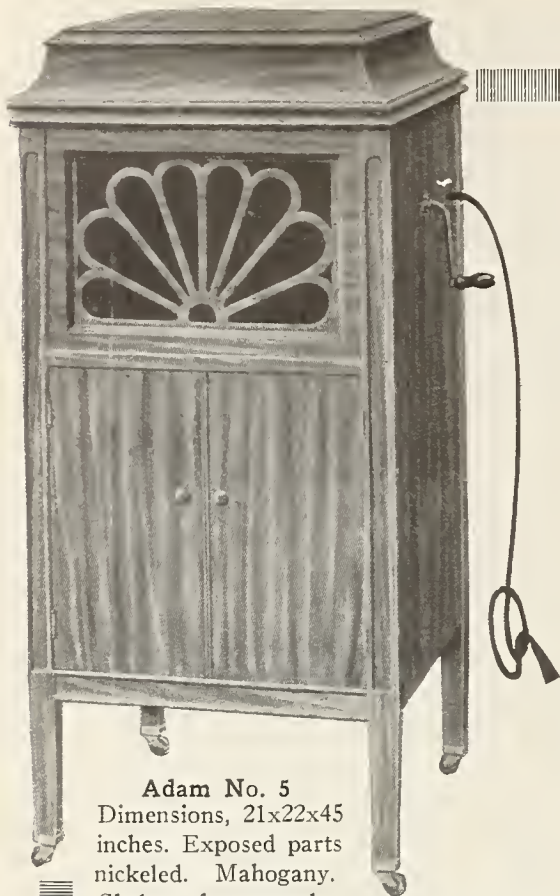

Adam No. 5
Dimensions, 21x22x45 inches. Exposed parts nicked. Mahogany. Shelves for records.
Price \$100—with electric motor \$125.
"Play It Yourself"

BUT WE DON'T—

We could cheapen our factory cost in many ways as by using gum and birch and finishing to resemble mahogany—but we don't.

We use mahogany and walnut.

We could use two coatings and rub by machine—but we don't.

We use three and rub by hand.

We could save money by using motors that wind with a grind and run with a rumble, with a wabbling turn table—but we don't.

We use a precision motor—as silent to wind and run as your watch.

We could use a poorly constructed tone arm and reproducer with a rattle and a scratch at every turn—but we don't.

We use an acoustically correct and properly constructed tone arm and a brilliant reproducer that conforms to the perfection of the rest of the machine—Great volume—little surface noise.

We could save by using a 10 or 15-lb. iron casting for the concealed horn—but we don't.

We use a machined and carved round neck conforming perfectly to the shape of the tone arm.

We could save by using albums or racks in our higher priced machines—but we don't.

We have built in containers that conform with our beautifully designed cabinets.

We could save by using the usual cheap slide or damper as a tone control—but we don't.

Our modulating device is exceptionally fine and is controlled to any degree by the operator, from a distance if desired, without muffling in the least.

We could have a cheap man assemble many machines a day—but we don't.

We assemble so carefully and accurately that four machines are a day's work for a well paid mechanic.

The
Slogan of

The Widdicomb

A Finished Product

Is "Not How Cheaply But How Well"

We realize the prestige of the older concerns and know that to make a success we must build carefully and pay every attention to the details of construction and equipment. Our facilities allow us to produce a perfect machine, at a moderate price and with a better discount for the dealer.

The dealer with the Widdicomb line is not only selling the phonograph but complete satisfaction as well.

Apply at once for particulars and territory. Catalog and discounts now ready and orders piling up fast.

Prospective jobbers will be amply repaid by a visit to our factory.

PHONOGRAPH DIVISION

The Widdicomb Furniture Co.

Established 1865

Grand Rapids

Michigan



Chippendale Console No. 4

Dimensions, 23x36x40 inches. Exposed parts gold plated. Mahogany or Walnut. Capacity, 150 records. Price \$200—with electric motor \$225.

"Play It Yourself"

Make two sales grow in place of one—that is the purpose of the Columbia Sales Department.

**Columbia Graphophone Co.
Woolworth Building, New York**



THE MUSICAL POSSIBILITIES OF THE TALKING MACHINE

(Continued from page 45)

gun the Scherzo when some misunderstanding arose, apparently, between him and the Gratz musicians. The work was laid aside, and although, according to Sir George Grove, whose authority is final, it did come into the hands of the Musical Society, it was never performed, but remained forgotten until 1865, when it was disinterred and performed for the first time at one of the concerts of the Vienna Gesellschaft der Musikfreunde in the same year. Since then it has been played constantly, and is now given at least once a year by every important symphony orchestra in the world.

Allegro Moderato

Schubert certainly never heard his manuscript performed, and yet it stands as a model of euphony and delicate perfection. It contains many novel ideas in the way of orchestration and general treatment and is of a captivating beauty that appeals to the musically unlearned as quickly as to the professed musician. Let us look into it a little more closely.

The first movement (Part I on the record) allegro moderato is agitated and stressful. It opens with a solemn theme intoned by the stringed-basses. After nine bars of this, the first and second violin take up a rippling accompaniment, which, a little later, is interrupted by a secondary tune from the oboe. This is joined by other reed instruments, with the dancing violins continuing underneath. Suddenly horns and bassoons break in with a challenging chord. A few notes of preparation follow, and then emerges in the 'cellos what is perhaps the sweetest bit of melody in all the literature of the symphony, the famous second theme of the movement; gracious, charming and tender.

As the strains of the 'cellos die away, the violins take up the tune an octave higher and play with it lovingly. But a change impends. A sudden pause comes. Then, without warning, the entire orchestra crashes into a series of ascending chords which lead higher and higher until there modulates out from them the second theme again, tossed around between violins and 'cellos until the first theme returns and is repeated as in the beginning.

A second section of the movement now opens, with a third tune taken from the original oboe melody of the opening. It mounts onward and upward, until the whole set of subjects is hurled together into another maelstrom of orchestral color, to emerge at last in gentle alternate repetitions, drawing to a lovely and thrilling close, with unison chords and a roll of the drums.

Andante con moto

As the first part is stormy and stressful, so the second is heavenly in its peace and harmony. Three little melodies are voiced together at the opening, in stringed, brass and reed instruments, respectively. After some little working out of these in canonic form (that is to say, by one voice following the other in imitation first on strings, then in reeds and so on) there comes out a second melody all by itself, in the shape

of a solo for the clarinet, accompanied by a syncopated running figure in the strings and oboes. This works up to a sort of climax, and then dies down again into the melodies of the opening. These are repeated and finally develop to a close, the little canonic imitation frisking around from one set of instruments to another, till, quietly, almost dreamily, the movement draws to its gentle end.

Schubert left some two dozen bars of a third movement written out. There is no trace of any sketch for a finale.

It will not be doubted by any one who will calmly sit down in a quiet room to listen to this symphony that Schubert has here touched heights of beauty which few have reached. The storm and stress of the first movement are everywhere concealed in the velvet glove of sweet melody and graceful treatment of the instrumental work. The pure appealing loveliness of the second movement comes to one like a breath from heaven. Schubert, poor, obscure and neglected, Schubert, that ugly little man with the thick spectacles, whom the sweet Fanny Vogel could not make up her mind to marry, who was too shy to approach the bedside of dying Beethoven, whose best friends thought him a bit unpractical and stupid; this Schubert touched immortal heights of inspiration, dreamed immortal dreams of beauty, such as few others, either before or since, have been

permitted to conceive in the great realm of music.

You who may have thought that the music of the masters is obscure, recondite, hard to understand, listen to the sweet loveliness of Schubert, and know that the immortal language is always simple, always easy, always clear to those who listen to it with open ears and minds ready to be taught. Study, let me urge you ever more earnestly, the great treasures of musical beauty that forever have been stored up through the genius and skill of the men who have made the talking machine what it is. Make up your minds definitely that the immortal inspiration of the great souls who have expressed themselves in great music is going to be wanted by the great American people during the strenuous days of the war. Do your part in making it easier for the people to get the consolation, the strength and the encouragement which lie buried in these splendid records on your shelves. You will never regret any trouble to which you go in this connection.

C. A. WOODS PIANO CO. IN NEW HOME

The C. A. Woods Piano Co., formerly located at 1323 St. Nicholas avenue, New York, has moved to new and larger quarters at 1327 St. Nicholas avenue, where special attention will be given to the talking machine department. The company features the Schubert phonograph with a gratifying degree of success in the Washington Heights section.

Ward's Khaki Moving Covers



Grade "D" Cover with No. 3 Straps.

PROTECT YOUR MACHINES FROM ALL KINDS OF WEATHER

and will enable you to deliver them free from dust, scratches, bruises and all other finish destroyers

Our covers are faced with Standard Khaki, lined with a heavy grade flannel, interlined with an exceptionally good grade of heavy cotton or felt, diagonally and closely quilted, and manufactured according to the usual superior "WARD New London" quality.

Grade "D" \$5.00 Grade "K" \$7.50

Carrying Straps: No. 1 \$1.00; No. 2 \$2.00; No. 3 \$3.50

ORDER SAMPLE COVER ON APPROVAL

With Name of Machine silk embroidery on any Cover; extra, 25c.
With Dealer's Name and Address, first Cover; extra, \$1.00
Same on additional Covers, each extra, 50c.

Write for booklet

THE C. E. WARD CO.

(Well-known Lodge Regalia House)

101 William St., New London, Ohio

Also Manufacturers of Rubberized Covers and Dust Covers for the Wareroom

A New Motif in Phonographs

And an additional source of phonograph profit

The Art Period Pathé Phonograph

In three designs—William and Mary, Sheraton and Jacobean

It is the right thing at the right time—the timely answer to the demand for an Art Phonograph that will fit into the modern scheme of period interiors.

And it's of *double* significance to the dealer because of its astonishingly low retailing price of

\$190

and because of an attractive discount.

There isn't a vestige of doubt about it. In the Art Period Pathé Phonograph you've got something tremendous to offer, at a low price. You will be handsomely repaid for your selling efforts.

This new "phonograph *motif*" embodies all of the five star Pathé Phonograph selling features:

No Needles to Change!

THE PATHÉ SAPPHIRE BALL takes the place of needles. And it is permanent. It never wears out.

Pathé Records Won't Wear Out

We guarantee every Pathé Record to play at least a thousand times with the Pathé Sapphire Ball without impairing the unexcelled beauty of tone.

The Pathé Phonograph Plays All Makes of Records

Each Pathé Phonograph, at any price, plays not only Pathé Records, but all other makes of records.

The Pathé "Controla"

With the Pathé "Controla" you may increase or decrease the tonal volume of the Pathé Phonograph at will.

Write now for details and tie up early with the ever-growing trend toward Art Period furniture.

Pathé



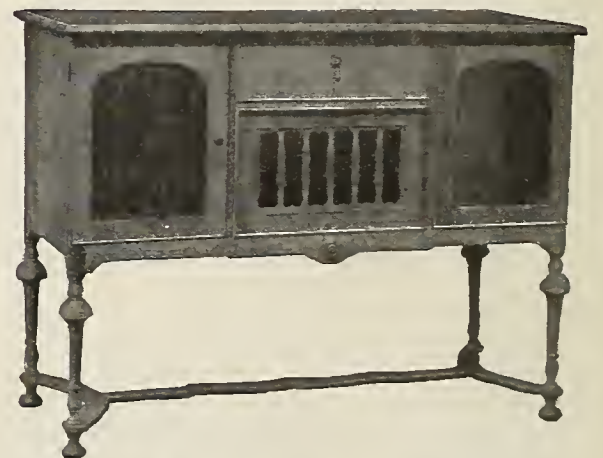

Sheraton Design—in Satin Finish Mahogany. With Spring Motor \$190, and \$200 electrically equipped.



William and Mary Design—in American Walnut Finish. With Spring Motor \$190, and \$200 electrically equipped.

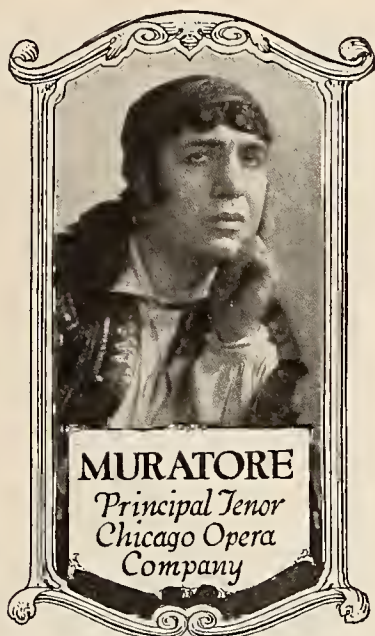

Jacobean Design—in Fumed Oak. With Spring Motor \$190, and \$200 electrically equipped.



The Endless Profit of Pathé Records!

Profit based on the largest record repertoire in the world!

Profit based upon the world-wide reputation of the Pathe artist personnel:

Muratore, Muzio, Ober, Cavalieri, Didur, Thibaud, Ganz, Bispham, Grace Hoffman, Slezak, Urlus, Weil, Fitziu, Sammarco, Ruffo, DeCisneros and others—most of them *exclusively* Pathe artists.

Profit based on the Pathé monthly list of records: the latest patriotic, popular, musical comedy and sentimental song and dance successes, at the moment they become successes.

Profit based on the vast new world of melody unfolded by that repertoire: Europe's best songs, sung in practically every foreign language, by native artists of renown; quaint folk songs and melodies; romantic gypsy instrumental ensembles, favorite Court artists and famed military bands.

Profit based on the genuine satisfaction embodied in the Pathé record guarantee:

PATHÉ RECORDS WON'T WEAR OUT

We guarantee every Pathé record to play at least one thousand times with the Pathé Sapphire Ball without impairing the unexcelled beauty of tone.

Profit based on Pathé TONE—it sells itself!

Profit based upon the international prestige that revolves around the name "Pathé."

Profit based upon a genuinely liberal dealer-discount.

And Pathé Record prices enable you to meet all other record prices.

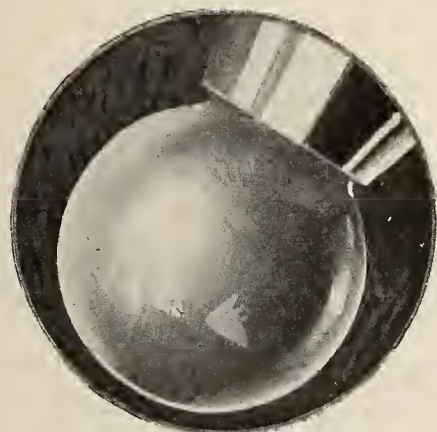

The Pathé Sapphire Ball
Enlarged many times

PATHÉ FRÈRES PHONOGRAPH COMPANY

20 GRAND AVENUE, BROOKLYN, N. Y.

Pathé Frères Phonograph Company of Canada, Ltd., 6 Clifford Street, Toronto

PITTSBURGH TRADE CLOSES ONE OF ITS BEST YEARS

General Conditions Throughout This Territory Most Promising—S. H. Nichols Succeeds Kenneth Mills as Columbia Manager—J. C. Roush Visiting the East—Wheeling Music Co. Incorporated

PITTSBURGH, PA., January 9.—The Pittsburgh talking machine trade reports having closed one of the most successful years in the history of the business, despite the shortage of both machines and records. The holiday season passed former marks by a good margin, and dealers are only wondering how large their sales might have been if it were not for the scarcity of goods. Stocks in most instances were depleted, but are gradually being replenished to meet the steady demand that continues. One of the most serious obstacles confronting local talking machine distributors at this writing is an embargo placed by the Government on all classes of incoming and outgoing freight. It is understood that this measure is only a temporary one, and it is expected that some improvement in shipping conditions will result from the Government control of the railroads. General conditions throughout this territory are extremely promising, and the trade is quite optimistic as to the outlook for 1918. From reliable sources it is learned that it is the intention of the United States Government to place a total of \$110,000,000 worth of war orders here within the next six months. Orders exceeding \$55,000,000 were placed with local plants during a recent week.

S. H. Nichols, formerly for a number of years district manager of the Columbia Graphophone Co. in this territory, comprising Pittsburgh, Cincinnati, Detroit, Buffalo and other points, has been appointed manager of the Pittsburgh branch of the company, succeeding Kenneth Mills. Mr. Mills has been transferred to the Columbia branch at 55 Warren street, New York City, as assistant to Manager Lambert Friedl. Last June Mr. Mills succeeded Mr. Friedl as manager here, and it is interesting to note that they are again associated in the same organization. Mr. Mills is followed by the well wishes of a host of friends in the local trade.

The Buehn Phonograph Co., local Edison jobbers, tendered a dinner to their employes on Thursday, December 27, at the Fort Pitt Hotel. Covers were laid for eighteen. After the dinner the party attended the theatre.

Among visitors who called on the Buehn Phonograph Co. recently were the following: Harvey Howard, Cameron, W. Va.; L. R. Cope, Lisbon, O.; S. G. Patterson, New Brighton, Pa.;

Howard Ross, of the Ross Furniture Co., Fairmont, W. Va.; H. H. Findt, Steubenville, O.; W. B. Pflughardt, Charleroi, Pa.

Edward Crede, auditor of a local bank, has been announced winner of the second prize in the Edison contest started "Edison Week" in October.

J. C. Roush, president of the Standard Talking Machine Co., local Victor distributors, is spending a week or ten days in the East on business. He will visit the Victor factory.

J. C. McGinnity, of the road staff of the Standard Talking Machine Co., has joined the colors with the field artillery, and is stationed at Camp Sam Houston, San Antonio, Tex. Corp. Don Morrow, of the Standard inside force, returned from Camp Lee, Va., over the holidays.

The Wheeling Music Co., Wheeling, W. Va., has been incorporated to deal in talking machines and other musical instruments, with a capital stock of \$10,000. The incorporators are Joseph N. Johnson, Frank Sweitzer, Frank Porterfield, Jr., S. Porterfield and G. Bowman, all are residents of Wheeling.

50% SALES INCREASE IN ATLANTA

Excellent Report by Grafonola Department of Haverty Furniture Co.—Other Prominent Lines Also in Strong Demand

ATLANTA, GA., January 4.—Manager Thornton, of the Grafonola department, Haverty Furniture Co., this city, reports the holiday trade very active. The business of the Haverty Co. was 50 per cent. larger than 1916, which, up to that time, was the largest month in the firm's history.

The Cable Piano Co., Victor dealers, are reported as having done the largest business in their Victrola department since the department was organized. All other Victor dealers enjoyed a very greatly increased business.

Phonographs Inc., the Edison dealers and the Diamond Disc Shop, also Edison retailers, had a most satisfactory business, their best sellers being the \$200 and \$250 types. The New Edison has been well received in Atlanta.

All dealers in the trade are anticipating the largest year's business that has ever been done. The various army camps near Atlanta have contributed materially to the success of the trade.

PATENTS MULTIPLE PHONOGRAPH

Yonkers, N. Y., Inventor Designs Machine for Playing a Half Dozen or More Disc Records in Succession and Automatically

A new phonograph designed to play a number of disc records in succession, and without the attention of the operator after he has started the machine, has been invented by Lucien M. Flagg, of Yonkers, N. Y., who is at present enlisted in the United States, Naval Reserve. Mr. Flagg has just been granted a patent on his invention, which is illustrated herewith.

The invention is cleverly conceived, and is pro-

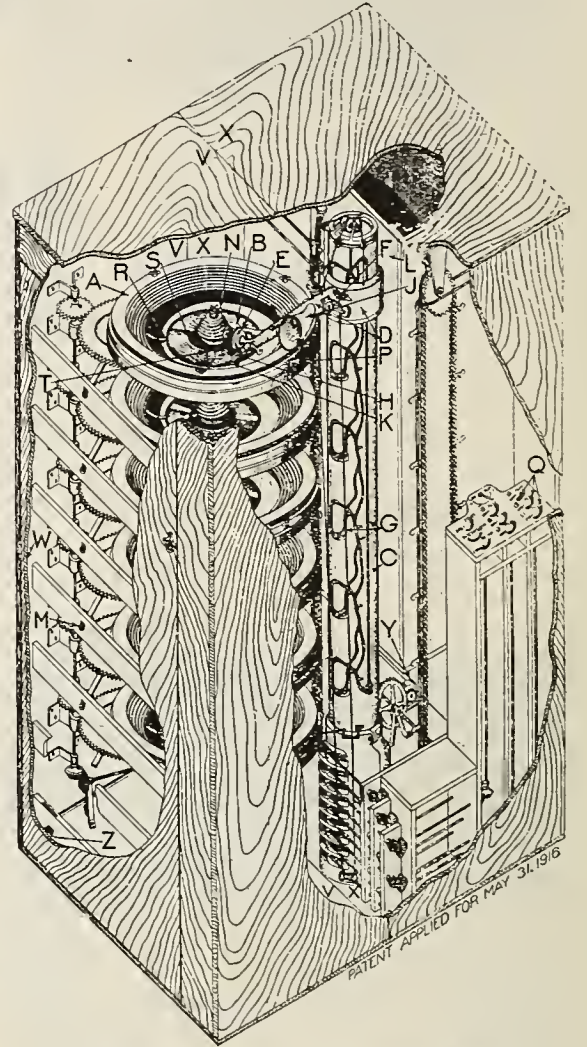

L. M. Flagg's Multiple Phonograph

vided with a series of turntables bearing records. The tone arm is placed in position at the top, and as each record is played, the sound box and tone arm are lifted therefrom by a mechanical arrangement lowered and placed in playing position on the record below. After the bottom record has been played, the tone arm and sound box are automatically lifted and placed in position above the top record. Means are provided whereby the operator may omit any record in the series or repeat the playing of a record if desired. The mechanism may also be regulated to stop playing automatically after any record. The mechanism is designed particularly for electric operation. Special attention has been given to the means for making the mechanism as fool proof as possible. The use of a semi-permanent needle obviates the necessity of frequent needle changing and permits of the playing of a series of records several times without any attention to that detail from the operator.

The first model of the new instrument is about five feet high, three feet six inches wide, and two feet eight inches deep, and is designed to accommodate six records.

ARKANSAS CITY DEALER PROGRESSES

K. Weller Daniels, of Arkansas City, Kan., has installed new equipment for his rearranged department where Edisons will be handled. And he is going at the business aggressively. He has been using pages in the local papers, effective copy prepared by himself, that is getting the trade.

No "guesser" ever won shoulder straps in a contest with a "knower."

A Quick, Easy, Profitable Seller!

The Elmbrola is a beautiful machine—a sweet, clear-toned phonograph—one you would surely buy for yourself if you wanted one for your own home. Compare it with any other—it compares with the best. Note the Elmbrola's woodwork, the finish, and then put on a record. There are so many exclusive features in the

PERFECTION
Elmbrola
ST. PAUL, MINN.

"Sounds Clear — Made Sound"

that we can't tell you about them here. Get our Illustrated Folder and see for yourself. But there's one big reason why you should get this folder—PROFITS. Unless you send for this folder, you'll never know what big profits you can make. We have a good surprise in store for you. Don't delay, but write us at once.



Model B Elmbrola

ELMBROLA TALKING MACHINE CO.

Dept. A.

ST. PAUL, MINN.

How Judgment of Human Nature Helps in Closing Sales of Talking Machines

What is salesmanship? What will bring a salesman closer to his point of selling a talking machine than judgment of human nature? Nothing, absolutely nothing, for when a man enters a talking machine store and the salesman approaches him in the wrong manner, the salesman is pushing him away and will be unable to obtain his confidence. No matter how attractively arranged a store may be, and no matter how inviting its atmosphere, if the salesman does not approach his prospect properly half of the otherwise good impression made by the store is lost.

The talking machine salesman should always make it a point to show his prospect around the entire store, meanwhile listening to what the prospect has to say, noticing his actions, and, by watching his eyes, learning what attracts him the most.

A talking machine salesman never goes wrong if he endeavors to find out what the hobby of his prospect may happen to be. No matter what the hobby is, whether it is hunting, or fishing, or billiards, or even stamp collecting, the salesman will find that the hobby offers him an easy medium through which he can gain the confidence of the prospect.

The salesman who knocks his competitor is in reality boosting him instead. It never pays to knock a competitor or any other make of talking machine. There are many good talking machines made, and the salesman who is willing to admit that there are other good lines besides the ones he is handling will make an impression on the prospect, and will cause the prospect to have greater confidence in all of the statements made by the salesman concerning his own line.

In demonstrating a talking machine the salesman should always play something which, in his judgment at least, will find a responsive chord in the prospect's heart. When selling a middle-aged customer a piece like "Silver Threads" or "Annie Laurie" is bound to be pleasing. When dealing with a prospect who believes he knows a great deal about music other tactics are necessary. Say to this kind of a customer, "You, of course, are familiar with this selection from 'Aida.'" Then proceed to play a selection from that or some other opera which you have named. While this is mere flattery, it leads the prospect to believe that you have a good opinion of his knowledge of music and it helps to place him in a pleasant frame of mind and one in which he will more readily respond to the ideas and suggestions you advance in your selling talk.

When explaining the construction of the talking machine the salesman should spare neither time nor effort to make the customer understand anything that he wants to know about the instrument. The wise salesman will "tear the talking machine to pieces" if necessary to make clear any point the customer wishes to know concerning the way the talking machine is made.

One of the strongest selling arguments any talking machine salesman can offer is the fact that he works for a one-price house, which every talking machine house should be. If a customer knows that the price marked on the tag is the one which he will have to pay and that all customers are treated alike so far as prices are concerned, he will have a great deal more confidence in both the house and the line of instruments being handled than he will if he knows that by haggling the price will be brought down.

It is impossible to judge a sale, absolutely until the salesman has spent a little time with the customer, and as each prospect is different from every other each deal must be handled a little bit differently in some points at least. The

expert salesman is the one who can think faster than his customer and who can direct his thoughts and his questions along lines which will make the sale easier. This can be done only if the salesman has right ideas concerning

human nature, and therefore judgment of human nature and getting the confidence of the customer are the two big things which constitute the foundation of real talking machine salesmanship.

WANAMAKER TO SHARE PROFITS

Department Store Owner, With Large Retail Talking Machine Interests, Announces Plan Whereby Employees Will Participate in Profits

According to a recent announcement employees of the John Wanamaker stores in New York and Philadelphia are to be classified according to their importance during the coming year and their sales are to be averaged. A fund of

\$400,000 is virtually to be set aside to be distributed in extra commissions.

The plan is ostensibly a method of sharing profits, but under the signature of John Wanamaker the explanation is made that if the profits do not permit the withdrawal of \$400,000 the balance lacking will be taken "out of the pockets" of the firm. Nor will \$400,000 be the maximum amount, for if conversely profits are large the extra compensation will be increased. This is an important move.



Attendez Citoyens!

DO YOUR BIT

Help our boys who are
"Going Over" to learn French.

The new VICTOR Records

"First Aid"
French
for American
Soldiers

will be invaluable to them.

C. BRUNO & SON, Inc.

(Established 1834)

Victor Distributors to the Dealer Only

351-353 Fourth Avenue

NEW YORK

We Do Not Retail

HIS MASTER'S VOICE

ALMA GLUCK

ENRICO CARUSO

ADELINA PATTI

JOHN MCCORMACK

AMELITA GALLI-CURCI

FRITZ KREISLER

ERNESTINE SCHUMANN-HEINK

Pictures for Victor Customers

A NEW AND ARTISTIC FIELD OF PROFIT OPEN TO VICTOR RECORD RETAILERS

Appeal to the *eye* as well as to the *ear*! Your customers delight in the music of Alma Gluck, Caruso, Schumann-Heink, Galli-Curci, Kreisler, Patti, McCormack. Let them, also, *see* these Victor artists.

The pictures reproduced here are the only **HAND-COLORED PHOTOGRAVURES** of these seven artists on the market. They were made for us by a New York firm of lithographers. They are eleven by fourteen inches in measurement, just the right size for the demonstrating booth or home.

35c TO RETAILERS

Thirty-five cents each is the price to retailers, two dollars and twenty-five cents a set. The retail price should be strictly held at sixty-cents. This allows a fair profit, although each one might easily bring a dollar. To every retailer ordering six or more sets another complete set will be given **FREE**. Order now by postal card.

"Although I listen to thy voice,
Thy face I never see"—*Moore*

**Stewart Talking
Machine Company**
Victor Jobbers
Indianapolis

A "SELLING BOOK" FOR NEW EDISON

M. M. Blackman Produces a Volume of Information That Is Invaluable for the Salesman Concerned in New Edison Exploitation

KANSAS CITY, Mo., January 4.—A year ago M. M. Blackman, manager of the Phonograph Co., distributors of Edisons in Kansas City territory, told members of the Edison Diamond Disc Jobbers' Association at the convention in New York of a new plan he had conceived for assisting salesmen to perfect themselves in their job of selling Edisons. Last September this plan, worked out by Mr. Blackman and the Gundlach Advertising Agency of Chicago, was put into effect, with the issuance of a magnificent volume, with sixteen pages 12 by 15½ inches, the "last word" in de luxe printing of original drawings, photographs and text—and yet far from being merely ornamental. The volume tells the whole Edison story, of the conception, the painstaking evolution, the production, and the performance of the "music recreating" equipment. The work is a marvel of conciseness—for this whole story is told in less than 3,000 words, including description of construction features, of Mr. Edison's search for best ways of doing things, of the re-creation tone tests, of the music that is the soul of man, and even comments of critics of well-known publications, who attended tests.

Five thousand copies of the book were published. And last September they were distributed to jobbers, who passed them along to dealers. Perhaps the most important result from the book is right there with the dealers, who through it have gained a new conception of marketing Edisons, and think and talk of them with a higher enthusiasm.

Dealers have studied the book, imbibed its spirit, and kept it where customers could see it. But in addition to using it as the keynote and guide to their store selling, they have supplied their salesmen with copies. The salesmen have taken these books on their sales visits and there have fulfilled the original function for which the book was intended.

It is in reality a "selling guide." The salesman, opening the book when he begins his sales talk, can if he desires—or if he has not learned the contents thoroughly—merely read the pages to the customer, displaying the pictures at the same time. This sales talk is logical—developed—even to the last paragraph in the book, which is designed to "get the name on the dotted line."

The salesmen have usually been importuned to leave the book so that some absent member of the family might see it; but since it is the only one each has, the request usually had to be denied—the salesman could come again.

But the enthusiasm of the prospect over the book, and its impressive way of presenting the subject, was anticipated in the plan of Mr. Blackman. There was to be a miniature of the large volume, six by eight inches, an exact duplicate, which the salesman could leave—and which, of course, the members of the family would later use on others, backed by the enthusiasm they had gained from the salesman's talk and the view of the handsomer edition. These miniatures were distributed just before Christmas, and salesmen have therefore had a few weeks' use of them.

The book—both the large one and the miniature—might be called a catalog; yet it is far more than a catalog, in design—and principally in function. It never gets into the hands of anybody except a real prospect, who has had the Edison presented to him by a salesman, and who has had his interest in every page aroused by that salesman. And anybody except the owner of one of the miniatures who sees it, must nearly always see it while the owner is telling about the excellencies of the Edison.

The Numm Electric Co., of Amarillo, Tex., have opened a branch house in Wichita Falls, and have been fortunate in securing the Victor agency, formerly held by Harrison & Everton, at that place.

ACCESSORIES BUSINESS ACTIVE

President Wilking, of the Ready-File Co., Tells of Trade Expansion—Important Jobbers Fall in Line—Big Foreign and Domestic Orders

INDIANAPOLIS, IND., December 29.—In spite of the war the talking machine accessories business is looming bright for 1918. Although raw materials are higher and freight shipments more or less delayed, yet the outlook is excellent, according to F. O. Wilking, president of the Ready-File Co., of this city. This company, manufacturing a filing system for Victrolas and a fibre needle pointer, has done a tremendously big business the last year.

President Wilking recently returned from an extended trip to the East and reports business flourishing. He put in Ready-File in most of the important Eastern houses, including the Penn Phonograph Co., H. A. Weymann and Louis Buehn, Philadelphia; Blackman Talking Machine Co., and S. B. Davega, New York; American Talking Machine Co., Brooklyn; Henry Horton, New Haven; J. Samuels & Bro., Providence; the Oliver Ditson Co., M. Steinert & Sons, Eastern Talking Machine Co., Boston; Cressey & Allen, Portland, Me., and Gately-Haire, Albany, N. Y.

The Ready-File Co. recently received an order for 2,000 sets of Ready-File from J. W. Jenkins' Sons Music Co., of Kansas City. This concern writes that 90 per cent. of the Victrolas X and XI it sells are equipped with this filing system. The company recently filled orders from Cuba, Australia and England, which indicates that the war is not stopping business altogether in these countries.

President Wilking announces that the recent delay experienced by the company in filling orders for Ready Needle Pointers has been obviated and this new accessory is now being manufactured on schedule. The company already has a big lot of orders from the trade throughout the country awaiting shipment.

The Ready-File Co. expects to have an ex-

hibit at the National Music Show in New York and will have a few surprises for the trade the coming year.

STATUS OF JANUARY RECORD LISTS

Victor Co. Calls Attention to Importance of the First Supplement of the New Year to Those Who Have Secured Machines at Christmas

An important fact regarding the January record supplements that is not generally appreciated by the usual run of talking machine dealers is the relation it bears to the new talking machine owners—those who have just received their machines the previous Christmas. In a letter accompanying the January Supplement of Victor Records, the Victor Co. says most pertinently:

"The most important supplement Victor retailers receive during the year is that for January. It is the most important because it is the first supplement which comes to the attention of thousands of new customers. A copy of the supplement for January, 1918, is handed you herewith.

"Can you get a mental picture of all the thousands of people who, for the first time in their lives, are now enjoying all the delights that a Victrola brings into the home? Can you get a mental picture of their unbounded enthusiasm? If so, you will realize very clearly that the January supplement is, and will always be, the most important of the year.

"When you put their first supplement into the hands of these new customers, they will fully expect that you will be able to supply them with any record listed therein, and for your own individual good, for the reputation of your own business, it is of the utmost importance that you should not disappoint these people who will inevitably become regular customers of the store that gives them the best service."

Fame is no snob. She weighs merit from behind a bandage.

**Manufacturers—
Jobbers—Retailers**

If you are ready to take advantage of the enormous demand for good talking machines, we can serve you two ways.



Harponola

We are in the position to sell you the finest looking and scientifically constructed cabinets at reasonable prices.

We can sell you fully equipped machines under your own trade mark or ours, in carload lots at jobbing discounts.

If you are a dealer, please bear in mind that we manufacture only high grade cases and are installing the best mechanical equipment that money can buy. A postal will bring you our catalogue with full details.

Our prices and discounts are fair to the manufacturer, liberal to the jobber, right to the dealer and just to the public.

Write us today as we are now placing orders for raw material for our 1918 requirements.

THE CELINA FURNITURE CO.
CELINA OHIO

OUR THREE BIG LEADERS

Compare our prices, our undisputed qualities with any other type. NEVER before in the history of phonographs have such unusual, high-grade, low-priced MACHINES been offered.

IMPORTANT

We urge dealers to inquire **AT ONCE** for our **BIG DISCOUNTS** and order our literature in regard to all of our product.

Our prices and our qualities are our success. Hundreds of dealers are enjoying this success with us.

"LIVE" Agents Wanted Everywhere

Our Famous Leader MODEL "MASTER"

Of our Model "Master" we feel we have a right to be justly proud. Never before has the public been offered an opportunity to buy a large, strictly high class phonograph at anything like the price for which we offer this model. Our Model "Master" is of such unusual value that it has created a sensation throughout the entire phonograph world, for there is not a single machine in the market today which can favorably compare with it in value. No finer looking machine made for the low price we offer.



Retail Price
\$75.00

SPECIFICATIONS:
48 inches high; 20½ inches wide; 20½ inches deep



Model X

RETAIL PRICES:

Electric Outfit, - \$75.00

Spring Motor, - \$60.00

SPECIFICATIONS:

43 inches high; 19 inches deep and 17 inches wide

The above model is manufactured in TWO other types, namely:

OPEROLLO XV

Electric Outfit, - \$100

Spring Motor, - \$75

SPECIFICATIONS:

45 in. high, 21 in. deep and 19 in. wide

OPEROLLO De Luxe

Electric Outfit, - \$125

Spring Motor, - \$110

SPECIFICATIONS:

52 in. high, 23 in. deep and 22 in. wide

The Phonograph of the Future

will invariably be

EQUIPPED WITH ELECTRIC MOTOR

Be prepared! More and more the public is demanding the electrically-operated phonograph that does away with the constant necessity of winding. Connect with a line that has already "electrified."

Electric operation is only ONE of the exceptionally fine features of our 1918 models. Every feature has been refined and perfected. All of our 1918 models are supplied with double spring motors, instead of the electric motor, if desired.



Model F

An unlimited market for our Model "F," the only **perfect, inexpensive, floor-cabinet** machine in the country.

Sells ALL the Time



Retail Price

\$40.00

SPECIFICATIONS:

40 inches high; 18 inches deep; 15 inches wide

We are Distributers of LYRIC Records

OPEROLLO PHONOGRAPH CO. INC.
Detroit, Mich.

There's a Columbia Grafonola in every Y. M. C. A. and Knights of Columbus Army Hut. Who says Columbia isn't doing its bit to Win the War?

**Columbia Graphophone Co.
Woolworth Building, New York**



RECORD DEMAND TURNED SCALES IN BALTIMORE TRADE

Business for 1917 Exceeded Last Year—Holiday Trade Closed With Fine Record—Larger Prices Demanded and Paid—Liberal Advertising Brings Results—News of the Trade

BALTIMORE, MD., January 8.—A prosperous year was closed by the talking machine dealers and distributors when the month of December passed. Shortage of machines and shortage of records at various times during the year apparently did not interfere with the gross business when the final tabulation was made, for without exception business showed a substantial increase over the year of 1916.

December closed with a fine rush. Buying was of a class that pleased the dealers without exception, for a great deal of cash business was gathered in by all of the dealers. Larger payments were demanded and obtained by the dealers. The increased prices of machines did not affect the business in any way.

Unlike previous years the machines that had the big call were those above \$50; many dealers found it difficult to get a sufficient number of machines of the higher grade, while all of them still retained their cheap machines after the holiday rush had concluded. Business continued after Christmas with a fine class of buying.

Heavy sales of records is what, in many instances, made possible the increased business over last year. Yet the supply of records was at no time equal to the demand made upon the jobbers and dealers. There is still a shortage of records and machines, but dealers are hoping to have this cleared up now that the rush has concluded.

Dealers advertised liberally throughout December both in the newspapers and other mediums and used mail matter, leaving no stone unturned to build up a real month's business. The dealers were aided in their big advertising drive by the ads of the various factories.

Stormy weather during the close of the month held back some buying. W. C. Roberts, of the E. F. Droop & Sons Co., Victor distributors, stated that December was a most remarkable month for business. Cash sales in particular exceeded expectations. The big business was in records as well as machines. The year closed about 25 per cent. in excess of the previous year, and it was due to the extraordinarily large sale of records, while the machine business was under that of 1916. Looking toward 1918 the firm feel that this is going to be a good year for business and they plan to increase their sales force with experienced and trained men.

S. C. Cook, assistant manager of the Baltimore branch of the Columbia Graphophone Co., says: "Business was simply great in December and for the year 1917 was enormous. That's the best thing I can say. We were so far ahead of 1916—and that was a great year—that I would not give out the increased figures. Records and machines are both coming along every day, and we have managed to keep all of our dealers satisfied, which was some job."

W. S. Parks, the Baltimore manager for the Columbia Co., is out of the hospital after be-

ing a patient for more than six weeks. He was able to be at his desk in final days of the Christmas branch and was pleased beyond measure. He left on New Year's day to attend the convention of Columbia managers in New York City.

Jesse Rosenstein, for the National Piano Co., Pathé distributors, reports business fine for December with a general increase for 1917 over the months of the previous year that the firm handled the line. The firm was handicapped in some measure by the delay in shipments, due to freight congestion.

I. Son Cohen, of Cohen & Hughes, Victor distributors, reports business satisfactory for December, but not much of an increase over the previous year. The business for the year has not been figured up as yet, but will show an increase. Machine and record shortage from time to time kept business back. Mr. Cohen left on Wednesday for New York to stir up more machines and records for Baltimore and during the month of December he also made a number of trips to both the Victor factory and the Victor offices.

Department stores having talking machine departments, as well as furniture houses with talking machine departments, did exceptionally good business during December and closed the

year in good shape. Record business with these firms was what helped business immensely, for there were times when they were without machines other than those they had in their demonstrating booths.

The Brunswick is being handled by the local Brunswick Co. and also by the music department of Brager's Department Store. The Kimball talking machine is being handled here by the H. D. French Piano Co., the W. W. Kimball Co.'s representatives, and the firm has been able to sell all that have been shipped here.

VICTROLA OUTFITS FOR SOLDIERS

Automobile Club of Delaware County Presents Outfit of Victrola and Records to Each of Five Regiments From That District

PHILADELPHIA, PA., January 5.—The Automobile Club of Delaware County recently purchased and presented to each of five regiments from this section now in active service a complete Victrola outfit, including records and needles. Each outfit consisted of a Victrola VIII with six record albums containing in all 102 double-faced Victor records; 10,000 needles were included in each outfit and both machines and records were packed in specially constructed pine boxes for transportation, the boxes being fitted with handles so that the outfits could be carried easily by two men. Deep appreciation from both officers and men was the reward of the club members for their thoughtfulness and generosity.

Anticipate Your 1918 Requirements Now

by investigating at once the merits of our improved Veeco Electric Motor and Vitraloid Turntable for electrically equipping your higher grade machines.

The Veeco motor runs on either A. C. or D. C. of 100-125 volts without any adjustment, and can be supplied to run on any voltage from 6 to 250.

To dealers we supply the motor mounted on either 12" or 12½" square mahogany boards, all ready to install.

Send for a sample and try it out.

Orders for 1918 should be placed at once.

THE VEECO COMPANY

248 Boylston St.

Boston, Mass.

The Original Producers of a Complete Electric Drive for the Talking Machine Manufacturer's Use

"B & H" REPOINTER

For "B & H" Fibre Needles

This little device is as perfect for its purpose as time, study and money can make it.

It does its work properly and just as it should be done. With one motion of the lever it planes the point side of the needle and sharpens it as you would a pencil with a penknife. It does not break or crack the cortex or shell of the bamboo.

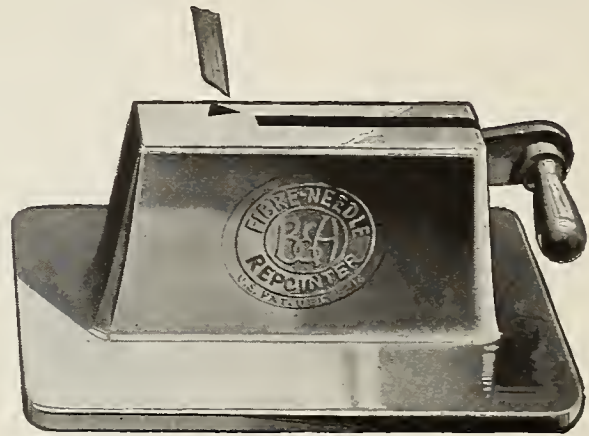

U. S. Patent December 5, 1916

It perfects and repoints a needle from seven to nine times. For efficiency, workmanship and general appearance, the "B & H" Repointer cannot be excelled. It is a high-grade tool, (handsomely nickel-plated), easy to operate, practical and fool-proof; put up in an attractive leatherette box, with tray to receive shavings.

An imperfect needle may be instantly perfected and repointed some eight or nine times with this device.

Every user of fibre needles will want a "B & H" Repointer and Perfecter.

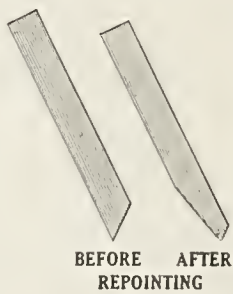

As it is our earnest desire that every user of "B & H" Fibre Needles should have the proper instrument wherewith to repoint his needles *correctly*, we strongly recommend that jobbers and dealers keep this device in stock for the benefit and accommodation of their customers.

GUARANTEED IN EVERY RESPECT

RETAIL PRICE \$2.00 EACH

Sample mailed to jobbers on approval

B & H FIBRE MANUFACTURING CO.

33-35 West Kinzie Street,

CHICAGO, ILL.

There's something mighty tempting in the Columbia February List for every musical appetite.

Columbia Graphophone Co.
Woolworth Building, New York



NEW BUYING ELEMENT CROPS UP IN BUFFALO TRADE

Mechanics and Laborers Put Extra Earnings Into Talking Machines and Records During Holiday Season—Heavy Increase in Population Presages Live Business for 1918—The Month's News

BUFFALO, N. Y., January 5.—According to the reports of holiday business coming from local dealers, the public generally has been talking machine crazy. Practically all of the stocks have been cleaned out or greatly depleted, and many more machines and records could have been sold had supplies been available. Mechanics and laborers made up a large proportion of the buyers, for this class of workmen are making more money than they ever made before, and are ready and willing to spend it for talking machines. It is estimated that the Christmas trade just passed was 25 per cent. greater than that of a year ago.

The prospects are that prosperous conditions will continue throughout 1918. Buffalo's population is increasing by leaps and bounds and it is estimated that there are now 530,000 people, with the people still pouring in. With a big suburban territory to work, the dealers have every confidence in future business.

"There was an unprecedented demand for machines and records and there was not a dealer in our territory whose 1917 business did not surpass that of 1916," said V. W. Moody, manager of the Neal, Clark & Neal Co. "It was necessary, however, to make a few substitutions of special-finish Victrolas. Our method of distribution was such that none of these dealers lost business, and few, if any, carried any unsold stock after December 25." The business done at the attractively arranged new retail store of the Neal, Clark & Neal Co. fully met with the estimated forecast of the firm. While not able to advertise machines as extensively as in other years on account of the shortage, the store made a special drive on records and did approximately fifty per cent. more record business in December than was forecasted for the month.

O. M. Kiess, manager of the Buffalo branch

of the Columbia Graphophone Co., attended a meeting of the company's branch managers of the United States and Canada in New York City this week.

"Our Edison stock moved very fast," was the holiday report of Charles J. Hereth.

The King Furniture Co. is featuring Columbia Grafonolas. The manager of this section is Harry S. Cohen.

The Adams-Koenig Co. handles the Solophone, manufactured by the Hallet & Davis Piano Co.

In their large ads in the newspapers every day during the holidays Victor & Co. played up the Pathéphone strongly. The window displays of Christmas goods at this store were changed frequently. A demonstration was made daily by a live Santa Claus and a big business was booked.

"We are satisfied with our holiday trade," said C. H. Heineke, manager of the Victrola department of Denton, Cottier & Daniels. "We were practically sold out and didn't have enough machines to meet the demand. We found our two new extra demonstrating rooms a big necessity."

W. D. Andrews, of W. D. & C. N. Andrews, spent New Year's in Buffalo. "Our holiday trade was limited by the goods received," was the report of this firm. "We had the biggest record business in our history. We were short of records." This store featured window displays of \$20 and \$30 Victrolas as suitable gifts for soldiers and others.

"Every machine of every other type, which we received, was shipped immediately to dealers," said Mr. Andrews.

Charles Wright, employed for eleven years by W. D. & C. N. Andrews, was a holiday visitor. He is now at Camp Dix. Fred P. Besser, for-

merly with this firm, is at Spartanburg. Major H. H. Noyes, who traveled for W. D. & C. N. Andrews in the Buffalo territory for five years, is serving his country in France. He is with Pershing's army.

E. O. Hock, Victrola salesman at Robert L. Loud's store, expects to go to Camp Dix February 15.

Lingard Loud, son of Robert L. Loud, has passed an examination for the aviation corps, and is awaiting a call from the War Department.

A new show window has been completed at the Buffalo branch of the Rudolph Wurlitzer Co. A service flag bearing forty-three stars supplies a striking background for the window. W. P. Tanney is manager of this branch, and R. E. Harrington is a member of the sales force.

Teck Theatre audiences attending performances by Harry Lauder and other stars are accustomed to view the display of Columbia Grafonolas in the show windows of Winegar, Lindsay & Seales, located in the Teck Building.

HOLIDAY GREETINGS ACKNOWLEDGED

The World takes pleasure in acknowledging and reciprocating greetings of the season from many of its friends in the trade. Cards have been received from H. A. Weymann & Son, Inc., Harger & Blish, J. C. Roush, of the Standard Talking Machine Co.; Lester Burchfield, of Sanger Bros.; E. P. Hamilton, of Frederick Loeser & Co.; Mickel Bros. Co., W. D. & C. N. Andrews, and many others.

E. M. BAKER'S NEW POST

Edward M. Baker, formerly advertising manager of the Columbia Graphophone Co., has been appointed advertising manager of the Borden's Condensed Milk Co., New York.

The F. G. and A. Howald Furniture Co., of Columbus, O., have secured the agency for the Brunswick phonograph.



A Logical Profit

in excess of regular business will accrue to Victor dealers who are wide awake. The secret for success in 1918 consists simply in having adequate stocks of the right records at the right time, and in this respect "The House of Service" is your best insurance.

The Year
With a
Lucky Eight

1918

W. D. & C. N. ANDREWS, Buffalo, N. Y.

IMPORTANT

HANOVER, PA., November 20, 1917

To Our Customers and the Trade:

You have probably been notified by Clement Beecroft, of Philadelphia, Pa., or his attorneys, Wiedersheim & Fairbanks, of Philadelphia, Pa., of an alleged infringement of letters patent No. 1,244,944, dated October 30, 1917.

We wish to say that we have an irrevocable license to manufacture and sell this cabinet, and the patentee has no claim, either in law or equity, against this Company, or any of its customers.

We therefore notify you that we will stand back of you in any dealings with this Company, and that we will defend any suit for infringement which may be brought against you.

If further intimidation by the patentee is resorted to, we wish you would notify us, and we will take legal action to have the patentee enjoined.

Very truly yours,

THE GEO. A. LONG CABINET COMPANY

LONG CABINETS



No. 83

In all finishes. Specially adapted for use with Columbia 50. Front posts made to follow lines of posts on Columbia 75.

FIRST and FOREMOST

In the cabinet field.

Why? Because we've *specialized* in

CONSTRUCTION FINISH and ADAPTABILITY

Our supremacy in these essentials warrants your handling *the perfect line*.

That's why you should anticipate your wants NOW, *when the season's at its height*.



No. 79

In all finishes. Shown with top moulding and shelves. Specially adapted for use with Victrola IX.

Prompt deliveries on all orders. Write for Illustrated Catalogue of complete line

THE GEO. A. LONG CABINET COMPANY
HANOVER, PA.

FRIEDA HEMPEL NOW EDISON ARTIST

Famous Metropolitan Prima Donna Latest Addition to the Edison Family of Musical Celebrities—Scores New Triumph in Opera

Frieda Hempel, noted Metropolitan Opera prima donna, is now an Edison artist. The Musical Phonograph Division of Thomas A. Edison, Inc., has just announced the acquisition of Madame Hempel to its present galaxy of Met-



Frieda Hempel

ropolitan artists. Madame Hempel is one of the shining lights of Mr. Gatti-Casazza's stronghold on Broadway.

Madame Hempel's joining the Edison organization occurs at a time when the name of Hempel is on the tip of every opera-lover's tongue, as a result of her brilliant debut in "The Daughter of the Regiment."

The music critics of the New York newspapers have been lavish in their praise of Madame Hempel's performance in "The Daughter of the Regiment," and have not hesitated to assert that she surpasses even the famous Sembrich, who was the last artist to appear in the same role at the Metropolitan, some ten years ago. Madame Hempel herself considers "The Daughter of the Regiment" to be one of her best roles.

Madame Hempel's vocal and histrionic accomplishments so impressed the critic of the Musical Leader that he declared her to be one of the greatest favorites heard in

years at the Metropolitan . . ." The Musical Courier pays tribute as follows: ". . . Her popularity has rapidly and steadily increased until she has become one of the foremost among the favorites of the public . . ." These opinions are confirmed by the Chicago Courier, which says: "Frieda Hempel, who has been heralded throughout this country as one of the greatest artists ever appearing at the Metropolitan . . . has won a place . . . which no one, not even Sembrich, could fill."

Madame Hempel comes of a music-loving family. After three years of thorough and conscientious study she made her debut at one of the smaller European court theatres. It was a great triumph. Subsequently she was summoned to Bayreuth—an honor said to have never before been accorded to so young and so inexperienced a singer. From that time on her career has been one of brilliant success. She has sung in most of the great European opera houses and has the distinction of being the only woman in the world upon whom the Belgian Officer's Cross of the Order of Leopold has been bestowed. This is only one of many honors.

Madame Hempel's view on music's place in war-time takes on an especial interest at this time. In a recent interview she made the statement that "the musical reaction of the war is very evident. People instinctively turn to music to ease the terrible strain for a little while."

INTRODUCE NEW SIZE OF RECORD

Emerson Phonograph Co. to Place a Nine-Inch Double-Disc Record on the Market

The Emerson Phonograph Co., New York, is now ready to place on the market a new nine-inch double-disc record, which will retail at 65 cents. The first list of these new records will be ready on the 15th of the month, and, judging from the enthusiastic comments of Emerson dealers, this record will be accorded a hearty welcome from the trade in all parts of the country.

The new Emerson nine-inch record is a universal cut record, similar to the Emerson seven-inch records which have been on the market for some time past. These records can be played on all makes of machines (with one exception) without any attachment, this feature being the paramount factor in their signal success.

Monthly lists of new selections will be issued for the new nine-inch records, and some of the most popular artists now before the public will be included in this library. The company is planning to inaugurate an extensive merchandising and advertising campaign in behalf of its nine-inch record, as it believes that a universal cut double-disc record, retailing at 65 cents, will meet with a ready sale everywhere.

The Columbia Graphophone Mfg. Co. has been incorporated under the laws of Delaware with a capital stock of \$30,000,000, to engage in the manufacture and sale of graphophones and other sound reproducing instrumentalities.

OFFER PHOTOGRAVURES OF ARTISTS

Stewart Talking Machine Co. Issues Series of Artistic Prints of Noted Victor Stars for Sale to Talking Machine Owners

INDIANAPOLIS, IND., January 4.—"Although thy voice I have often heard, thy face I have never seen." Using this well-known and popular quotation from the genial poet Moore as a selling text, the Stewart Talking Machine Co., Victor jobbers at Indianapolis, are offering to the trade hand colored photogravures of seven noted Victor artists, the artists being Galli-Curci, Caruso, McCormack, Schumann-Heink, Alma Gluck, Patti and Kreisler. They were made from unusual photographs. These photogravures measure eleven by fourteen inches—an appropriate size for framing—and were hand-colored in delicate tints by a firm of New York artists. They sell for 35 cents apiece to the dealer and allow a clear profit of 15 to 50 cents on each one. These photogravures are being marketed on the theory that every one who hears a record of any of the seven artists is a ready prospect for an artistic print.

NEW BRUNSWICK AGENTS DOWN EAST

Important Houses Take the Representation of This Well Known Line in Their Territory

BOSTON, MASS., January 9.—The Boston headquarters of the Brunswick-Balke-Collender Co., the phonograph department of which is under the capable management of R. H. Booth, at 94 Washington street, has, as reported in the Boston letter elsewhere, closed an excellent volume of business within the past few months, and excellent reports are being received from the traveling representatives. For instance, F. H. Walter, who has been covering Maine, New Hampshire, Vermont, Massachusetts and Rhode Island, for the past ten weeks, has closed some very important accounts and reports a growing interest in the Brunswick phonograph in his territory.

Among dealers who have been recently booked by Mr. Walter are the Wentworth Music Co., prominent music dealers, who have stores in Waterville, Pittsfield and Madison, Me.; Chas. F. Wing & Co., prominent talking machine dealers, New Bedford, Mass.; J. L. Chalifoux, the large department store of Lowell, Mass.; Kneuper-Dimmick Co., piano dealers, Lawrence, Mass.; R. P. Marble, Attleboro, Mass. All these establishments have placed substantial orders for the Brunswick line, and are bringing its merits to the attention of the public. Naturally Manager Booth is pleased with the substantial advance of the Brunswick in his territory.

The Peoria Phonograph Co., 418 South Adam street, Peoria, Ill., was damaged to the extent of over \$8,000 by fire recently. Four thousand dollars insurance was carried on the stock in the possession of this company.



Mr. Dealer:

Don't make your New Year's Resolutions until you have made investigation of the

GABELOLA

The Home Entertainer Supreme

You don't have to change needles or records. No winding, magazine contains 24 records and 600 needles. Just push the button.

START THE NEW YEAR RIGHT

Send for Catalog

GABEL'S ENTERTAINER COMPANY

210 N. ANN STREET — General Offices and Factory — CHICAGO, ILL.

GABEL'S ENTERTAINER SALES CO., Suite 512, No. 117 N. Dearborn St., Chicago

HEIFETZ "RECORDED" IN HUMAN INTEREST INTERVIEW

By Wm. H. Nolan, New York Talking Machine Co., New York

"Heifetz telephoned for some more records," the boy said to me the other day as I stepped into my office.

"Heifetz?" I queried, my mind on other things.

"Yes—Jascha Heifetz, the violinist. He got one of the new Victrola XVI electrics the other day. What kind of records do you suppose he wants?"



W. H. Nolan

Though we do not sell records to retail purchasers, the opportunity to secure worthwhile experience seemed to present itself, so I responded to the Heifetz inquiry with a personal call. But when it came to picking out records for Jascha Heifetz, I confess I was not entirely sure.

It was the morning after the third concert of the young Russian violinist who had become the rage of America—hundreds had been turned away from Carnegie Hall unable to secure admission. The papers were carrying big headlines about "The Musical Marvel of the Age," "The Wizard of the Bow," "The Genius of the Violin," "The Reincarnated Paganini." The most conservative critics piled superlatives upon superlatives trying to describe his greatness. And in the end they were all compelled to resort to the frail apology, that "words could not express his genius."

I gave up trying to figure out the musical wants of such a youth, and decided to ask

Heifetz to name them himself, selecting some of the famous records of Elman, Zimbalist and Kreisler, and, adding a couple of the new records of the Boston Symphony for variety, and along with a few of the most unusual records in the catalog, I started for the apartment of the Heifetz's at St. James Court.

In a separate package I carefully carried a bundle of records which I thought might interest the nineteen-year-old boy. They were nothing more or less than the first four records Jascha Heifetz had recorded for the Victor Co.—the first records, in fact, he had ever made.

In response to my ringing of the bell, the door was opened by a short, dignified man of middle age—quite Russian in type. From a room, but one adjoining, came the wonderful tones of a violin, in a Paganini "Caprice." I explained that I had called to see Jascha Heifetz. "In a few moments, please," he answered in rather hesitating but good English. "My son has not yet finished his practicing. He began so late today."

"Perhaps the concert last night is the reason for that," I ventured.

"Concert . . . No! No!" explained the father, brushing the idea aside with the wave of a Russian cigarette. "It is the Victrola that he would spend all his time on. He got up an hour earlier than usual—and he has played all the records he has over and over again. I could not get him to begin his practicing—and it should always be done in the morning."

The "practicing" sounded like a concert performance, to one listener at least, and just as he had crashed down the scale in thrilling thirds, his father called his name and spoke a short phrase to him in Russian—the passage was repeated on the violin. The father spoke a brief word—evidently of approval—and the playing went on. Once again he interrupted the player

at the end of a difficult passage—at least it sounded difficult—and again the passage was repeated until it won the word of approval. Shortly thereafter there came a finale that would have aroused any audience to a frenzy of enthusiasm. Mr. Heifetz rose and led the way to the music room.

There stood the tall, slender young wizard—in a gray tweed suit, the coat of which had been replaced by a fresh white linen jacket, his round, boyish face flushed, his light brown hair ruffled, and his black slippered feet headed straight toward the Victrola. He greeted me enthusiastically—or perhaps it is nearer the truth to say he greeted the records enthusiastically—then suddenly seeming to remember, he turned to his father and said:

"Did it go all right the last time?"

There came the anxiously awaited nod of approval—and the priceless instrument that lay on the piano was forgotten in the wonderful mahogany instrument that graced the corner of the room.

I always thought I had a good talking knowledge of the Victrola—but by the time Jascha Heifetz had put the Victrola through its paces for me I had a much greater one. No boy with a new drum or a new engine had ever been any happier. It is the first talking machine Jascha Heifetz had ever had, and he fairly took it to pieces to see how the wheels went round.

He discovered how to attach the motor to an electric plug in the wall, but he didn't take any chances until he made sure the electric lights in the apartment were 110 volts. He found the voltage instructions in the back of the machine. We got to talking about electricity, and I learned some more facts from the young Russian.

He played the violin records of Elman, Zimbalist and Kreisler and his eyes grew bright and he nodded his head in acclaim as the records of the brilliant artists of the violin revealed the beauties of their playing. Again and again he exchanged understanding glances of enjoyment



"Pathé Records"

Their Significance to the Dealer:

They signify not only the largest record collection in the world, but they signify the only records that bear the Pathé Record Guarantee:

Pathé Records Won't Wear Out

We guarantee every Pathé Record to play at least one thousand times with the Pathé Sapphire Ball without impairing the unexcelled beauty of TONE.

They signify:

No Needles to Change

THE PATHÉ SAPPHIRE BALL takes the place of needles. And it is permanent. It never wears out.

They signify the world-wide Pathé Record Repertoire: Music new to America—vocal and instrumental celebrities of European fame.

And the Pathé monthly list of patriotic, popular, musical comedy and sentimental songs and dance hits—

Plus the brilliant Pathé artist personnel:

Muratore, Muzio, Ober, Cavalieri, Didur, Thibaud, Ganz, Bispham, Grace Hoffman, Slezak, Urlus, Weil, Fitzu, Sammarco, Ruffo, De-Cisneros and others.

Of further significance is the fact that Pathé Records, despite their unique guarantee, cost no more than other makes of records—

And the fact that they are subject to a dealer's discount so generous it will well repay you to investigate—to-day.

FISCHER COMPANY

940 Chestnut Avenue

CLEVELAND, OHIO

No Needles to Change

THE SAPPHIRE BALL takes the place of needles. And it is permanent. It never wears out.

Pathé Records Won't Wear Out

We guarantee every Pathé Record to play at least one thousand times with the Pathé Sapphire Ball without impairing the unexcelled beauty of tone.

The Pathé Phonograph Plays All Makes of Records

Each Pathé Phonograph, at any price, plays not only Pathé Records, but all other makes of records.

The Pathé "Controla"

With the Pathé "Controla" you may increase or decrease the tonal volume of the Pathé Phonograph at will.

Bert Williams' record A2438 means side-splitting fun for customers, and the music of dollars to Columbia dealers.

**Columbia Graphophone Co.
Woolworth Building, New York**



with his father as test passages for the violin were reproduced on the disc.

Then he tried out the different needles, expressing great interest in the Victor tungs-tone needle which reproduced brilliantly the violin music. He was also delighted with the fibre needle, which produced such a soft, mellow tone. He wanted to know what the needle was made of—and where the bamboo grew—and couldn't the material be obtained anywhere but in Japan. The records of the Boston Symphony Orchestra seemed almost uncanny to him—and he left the room for a moment to bring back his mother—a gentle, sweet woman, to hear the Tschaikowsky Fourth Symphony.

The comradeship between the boy and his parents was a pleasure to see. If he enjoyed anything, they must enjoy it too. And always there was the air of respectful obedience of looking up to his father and his mother for suggestions and advice. Jascha Heifetz is wonderful—but Mr. and Mrs. Heifetz are even more wonderful, for never once, by manner or speech, did they convey the impression that they were the parents of a genius. At last I undid the smaller bundle of records and slipping one out of its envelope handed it to the young violinist with the remark that "here was a record he might like to hear."

The music began. Young Heifetz came a little closer to the instrument and suddenly stopped short—it was the "Valse Bluette," the first record he had ever made.

"Listen, mother," he said as he reached out his hand and drew her nearer, and he looked up into his father's face and smiled. With intent, wondering eyes he watched the black whirling disc, his lips puckered, then parted in a smile. He blushed like a school-girl. When the record was finished, he reached out for the second—the Schubert "Ave Maria"—one of the most beautiful "Ave Marias" ever written. Then came the "Chorus of the Dervishes" from the Beethoven "Ruin of Athens," and last of all the "Scherzo Tarantella" of Wienawaski. This number perhaps more than any other shows Heifetz's absolute command over the seemingly impossible in technique.

The wonder of it all—this mere boy standing before me, a youth of nineteen, a genius. Since he was nine years of age he has been thrilling thousands with his violin. He has played in all the cities of Russia and all through Denmark, Norway and Sweden. He has traveled across the barren plains of Siberia and now he has braved the perils of the ocean and brought his art to America.

In spite of the hundreds of skilled violinists, and the present recognition of the great artists, Jascha Heifetz sprang into fame in New York in one night, and his four months' tour throughout the country has only deepened the first marvelous impressions. Now he has recorded his greatest numbers, and the thousands of persons who may not have an opportunity to hear the great violinist in concert, in person, may hear him as many times as they wish in their own homes through the medium of his marvelous Victor records. His art, which is thrilling the musical

world, comes to the Victor owners with absolute reproduction.

Heifetz's records show the marvelous purity



Jascha Heifetz

of technique and tone that can only come from a youth touched by the divine spark. A youth whose art, though perfect, will deepen with the experience that years only can bring.

"How do you like the records?" I asked young Heifetz as the last note of his own record faded away.

Jascha Heifetz grinned—a plain boyish grin.

"Say, father," he said, evading my question, "was I all right on that?"

As I was waiting for the elevator I had the feeling that those records would be played again and again—that Jascha Heifetz might get acquainted with himself. And even as I was pondering over genius and the youth upon whom it had been bestowed—the door opened, and the reincarnated Paganini, forgetting all about genius and its solemn responsibilities, called out abruptly:

"Say, do you suppose I could have that record of Harry Lauder's—'Stop Your Ticklin,' Jock'?"

PLAN TO ENLARGE DEPARTMENTS

GRAND RAPIDS, MICH., January 7.—At the annual meeting of the Friedrich Music House, of this city, to be held this month, plans will be discussed for enlarging several departments in the company's store. Special attention will be given to the talking machine department, which is fast outgrowing its facilities.

A PAIR OF HOLIDAY SOUVENIRS

The American Talking Machine Co., Brooklyn, N. Y., presented to their friends in the trade a clever holiday reminder in the form of a small hand mirror bearing on the back the company's advertisement with the catch line: "We want to do business with the man on the other side." The company also distributed a second souvenir in the form of a magazine pencil.

Room 73

65 Nassau Street

Clifford A. Wolf
MANUFACTURER OF
Diamond and Sapphire
Phonograph Points

New York City

Phone, 2124 Cortlandt

Globe-Wernicke

(BUILT-TO-ENDURE)

Sectional Cabinets For Disc Records

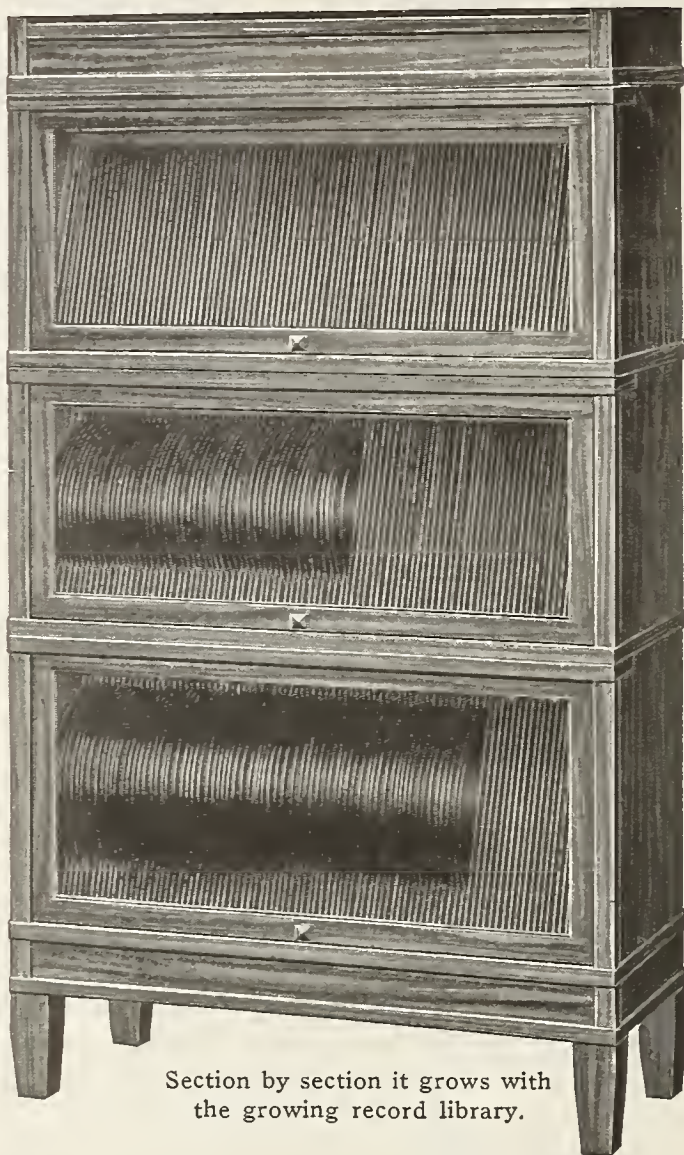

← No. 351 Art-Mission Top.

← No. 0328 Art-Mission Disc Record Section for ten-inch records.

← No. 0328 Art-Mission Disc Record Section for ten-inch records.

← No. 0329 Art-Mission Disc Record Section for ten- and twelve-inch records.

← No. 357 Art-Mission Base.

Section by section it grows with the growing record library.

The better the facilities you furnish your customers for housing records the greater the quantity of records you will sell.

Look carefully at the cabinet.

It invites you to fill it, in fact, you cannot resist the temptation to fill it. No matter how many sections are bought there will be empty compartments and these are always in sight, and the records too are always in sight. Any record is so easily found and quickly replaced that this cabinet adds an extra charm and fascination to the playing of records.

Suppose each of your customers had this cabinet and you had a sample on your salesroom floor to remind them to buy additional sections. Not only would the sale of the cabinets increase but what a tremendous increase in the sale of records would result and there is excellent profit in the sale of both.

Each section has 90 compartments numbered consecutively from 1 up. Globe-Wernicke Catalogue No. 317 T W describes and illustrates these goods fully.

Brown Disc Record Cabinet

For every small talking machine given as a Christmas present

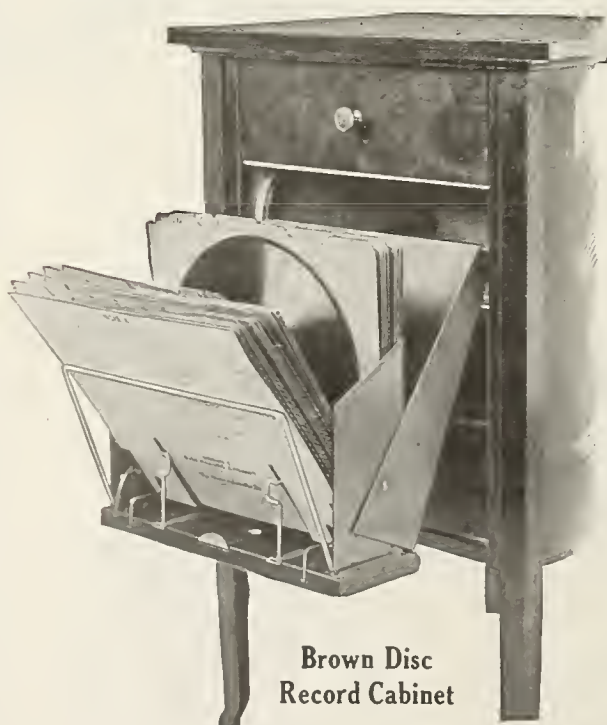

Brown Disc Record Cabinet

Every record right in front of you always.

No searching—No confusion.

Records lie flat when drawer is closed—No warping.

Records are vertical when drawer is open. Every record at your fingers' ends.

A separate compartment for every record.

No Scratching—Rubbing—Cracking or Breaking.

The Brown Disc Record Cabinet was devised to preserve a record perfectly and thereby insure Perfect Reproduction of Sound.



BROWN DISC RECORD CABINET No. 4-T FOUR DRAWER

Same as No. 4 but with Table Top. For use with Victrola VIII and IX, Columbia Grafonola 15, 25, 35 and 50, Aeolian Vocalion D and E. 32½ inches high. Top 18¾ inches wide by 22¼ inches deep.

Ask for Catalogue No. 317 T W

The Globe-Wernicke Co.
CINCINNATI

FINE BOOK FOR THE RETAILER

"Music in the Home," a New Volume by Anne Shaw Faulkner, of Special Value in Training Parent and Child in a Proper Appreciation of the Sort of Music for the Home

One of the latest additions to the literature that will aid the talking machine dealer in developing a more general interest in music, and particularly talking machine music, in the child mind and in the home with a resultant increased demand for both talking machines and records, is a new volume entitled "Music in the Home." The author is Anne Shaw Faulkner, a writer of recognized standing in musical circles and who possesses a thorough knowledge of educa-



Anne Shaw Faulkner

tional work in connection with the development of interest in the talking machine.

In the first place, "Music in the Home" is a book that gets away from the stilted text-book style, and, yet avoids the technical. The message which it carries is presented in plain, ordinary language, readily understandable and likewise distinctly interesting. It is planned as an aid to parents and teachers "in the cause of better listening," which brought down to plain terms means an aid to training the child to get the most out of the music which it hears. It is intended more for the home than for the school, more for the mother than for the teacher, and thereby makes an appeal to parents that is of the strongest sort.

An idea of the character of the contents may be gleaned from the various chapter headings which include: "The Home Education of the Listener," "The Language of Music," "What Music Tells Us," "The Architecture or Form of Music," "The Importance of Nationality in Music," "The Characteristic of Folk Music," "The Message That Music Brings," "The Stories That Music Tells," "The Correlation of Music in the Home With the Studies of School," "Music in Its Relation to Geography," "Music and the History of the World," "The Literary Sources of Music" and "Music Every Home Should Know."

Miss Faulkner has succeeded in linking up music with history and geography and in giving it an interest beyond that which is confined to itself; in other words, by getting away from the usual practice of treating music as a thing apart.

The musical selections suggested in the various chapters are of the standard variety, and without exception found in the leading record lists. This is particularly evident in the chapter devoted to "Music Every Home Should Know," wherein several hundred songs and instrumental numbers are carefully classified under a variety of headings.

"Music in the Home" has already been purchased in considerable quantities by prominent talking machine companies who are utilizing it in their work of exploitation in the belief that

the sale of the volume to their customers will, in the future, make for greater sales of records of the standard sort, thereby building up record libraries in the home that will become permanent and insure continued interest in the talking machine. The book has also been adopted and endorsed by the National Bureau for the Advancement of Music and by a number of schools. It has also been featured successfully by various talking machine wholesalers and dealers, particularly in the West.

Anne Shaw Faulkner (Mrs. Oberndorfer) is as well known as a lecturer on musical subjects, as she is as a writer, and has appeared before many of the largest clubs, schools and colleges in America. She is the authoress of "What We Hear in Music," used by many high schools and colleges as a text book.

"Music in the Home" is published by Ralph Fletcher Seymour, 410 South Michigan avenue, Chicago, Ill. The price is \$1.25 net.

KEEPING THE STOCK IN ORDER

Why the Neatly Kept, Orderly Talking Machine Wareroom Invites Customers and Holds Trade—Some Points Worth Noting

The old saying has it that the "apparel oft proclaims the man," and this is just as true in the matter of looking after your stock or your store front as it is of your person. The dusty windows and the ill-kept store are a serious deterrence to business progress and dealers should keep these facts in mind. The neatly kept, orderly establishment is always inviting to purchasers, and it will be found that the majority of them gravitate to talking machine establishments that are so arranged.

In this connection the following excerpt from "Peptimist" is timely and the application to the Columbia product is just as applicable to every other line of instruments which the dealer handles:

"The wise dealer knows that the public will

never hold his product in any higher esteem than he himself holds it. That is why an inviting store front; neat, tidy and ample demonstration space, and artistic surroundings always count. This idea can be pushed a little further. The way that a dealer's salesmen handle Grafonolas and records has a big indirect effect on the customer. If records are left lying around loose, out of their jackets, or if Grafonolas are allowed to become dusty and parts taken off, an impression is given that the machines and records in that shop are not valuable enough to receive special care.

"Put it up to the dealer. Point out his own impressions, say, buying a necktie. If he goes into a store and finds a pile of neckties on a counter jumbled together in chaotic confusion, if the salesman picks one out here and there, breaking loose the main mass, like a dish of spaghetti—it may be a good tie but impressions are against it. If he goes into a store where the salesman carefully takes out boxes and selects ties from individual packages it may be no better a tie, but impressions are decidedly in its favor.

"Your friend dealer will see the point. A few suggestions regarding the careful handling of records—for effect as well as efficiency—will create an impression well worth while. Taking care of the instruments is equally, if not more, important. The Columbia Grafonola is not a box—it is a musical instrument. You never find a piano minus a pedal or half a dozen keys. You find piano salesmen treating pianos with respect. The dealer who treats his Columbia with the same respect commands an equal regard for Columbia products from his customers."

SECURE THE SONORA AGENCY

The Hessig-Ellis Drug Co., Memphis, Tenn., have secured the agency for the Sonora phonograph throughout that territory, and have opened a substantial talking machine department.

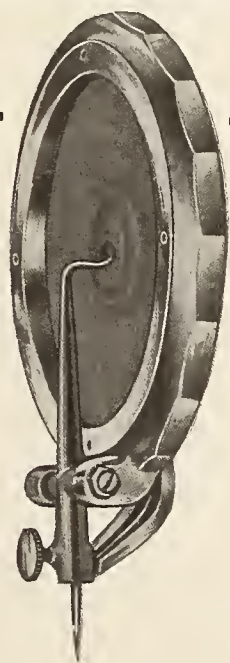

Tone—the vital thing

If you, as a manufacturer, can talk and prove *tone superiority* in your product, you have a selling argument to overshadow all the "talking points" of cabinets, and designs and accessory features.

And you *can* talk tone superiority. You can put out a product that will be a revelation in tone-purity, tone-quality, tone-volume. When you realize what vivid, lifelike, colorful tone can be produced and sustained by the talking machine equipped with

**Parr Magnetic Reproducer
fitted with the
Vibratone Patented Diaphragm**

These two dominating and proven inventions open up wonderful possibilities for manufacturers eager to put their product at the top-notch of class and character.

You want your product to be RIGHT!

If you want your product worthy of your name, you certainly want that product to be right in its most *vital feature*. And it will be right if it is equipped with the Parr Magnetic Reproducer—the reproducer for those who seek *perfection*.

The indestructible, non-crystallizing, always resilient

VIBRATONE PATENTED DIAPHRAGM

Possessing all the good points of mica diaphragms, it overcomes all mica's had features. Guaranteed uniform in quality, free from bubbles, blisters and waves, the Vibratone Patented Diaphragm is non-porous, non-absorbent.

It has a definite function and it performs it. It improves tone; in fact it creates new tone possibilities for every reproducer of other types.

PARR MANUFACTURING CORPORATION
1 UNION SQUARE At Fourteenth St. NEW YORK

**Take the Parr
Magnetic Reproducer—**

The most sensitive of reproducers. The permanent magnetic device, an integral part of the reproducer, acts on the stylus box. Its possibilities in giving warmth and delicacy in the tonal reproduction of quiet passages make old-style sound boxes seem obsolete. And in fortissimo passages where ordinary reproducers create unpleasant, music destroying blasts, caused by the needle jumping and losing its grip, the Parr Magnetic Reproducer, with its marvelous flexibility, follows every wave and vibration in the record and takes everything the record holds.

PERHAPS no higher ideals than those of the Edison organization exist in the commercial world. It has been the ambition of the Edison organization to incorporate their ideals of surpassing design, materials and execution into every product that goes forth from the Edison Laboratories.

In strict conformity and highly expressive of these ideals is the Official Laboratory Model of the New Edison in the William and Mary Cabinet, recently announced. The spirit of Edison dominance is revealed in every line.

THOMAS A. EDISON, Inc.
ORANGE NEW JERSEY

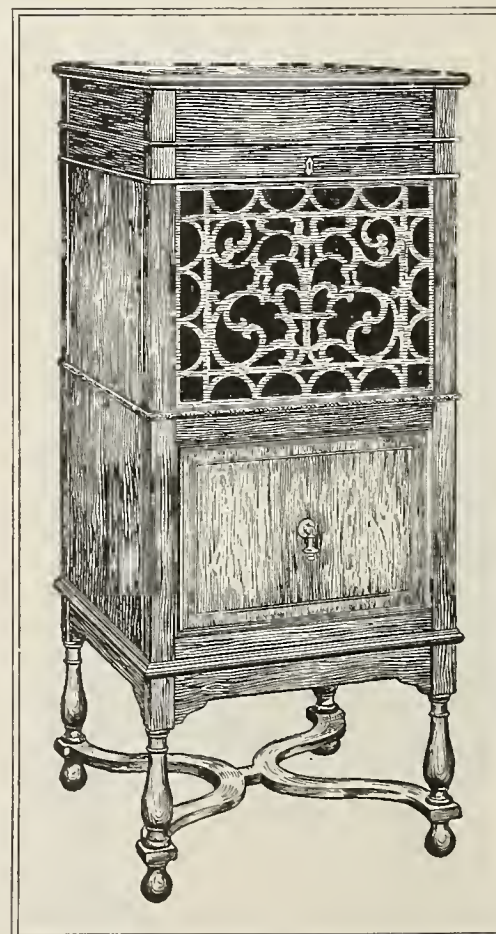

Official Laboratory Model New Edison—William and Mary Cabinet, executed in American Walnut.

EARLY ORDERING IS SALVATION OF SAN FRANCISCO TRADE

Planning for Holiday Stocks Early in Year Saves the Day in Christmas Rush—W. S. Gray Opens Jobbers' Distributing Agency—Columbia Men Visit Headquarters—General News

SAN FRANCISCO, CAL., January 1.—While business was hardly up to expectations at some of the local talking machine departments during the early part of December, it picked up about the middle of the month and the rush from then until Christmas more than made up for the comparative quietness of the preceding two weeks. As a matter of fact, the trade reports the closing of a banner holiday season, both in machines and records, and especially in the higher-priced machines and patriotic records. Notwithstanding the freight congestion and consequent slow deliveries on late orders, most of the local houses, at least, were very well supplied with stock with the exception of a few certain models, having placed their orders for holiday goods early in the year in anticipation of increasing difficulty in getting goods from the Eastern factories as the year advanced. In some instances holiday stock had been stored here for several months prior to the time it was needed.

Reports from other sections of the Pacific Coast received by local jobbers indicate the closing of a very successful year not only in the San Francisco Bay district, but for the Western territory as a whole. In a few isolated spots business was hardly so good as might have been desired, depending upon local conditions, but it was sufficiently active in other vicinities to bring the total volume up to a very satisfactory showing.

Opens Jobbers' Distributing Agency

Walter S. Gray announces the opening of a jobbers' distributing agency in this city. It is his intention to supply the talking machine dealers of the Pacific Coast with all trade accessories, such as Lansing delivery covers, record delivery envelopes, steel needles, etc. Mr. Gray has been Pacific Coast sales agent for the Domestic Talking Machine Corp. for some time and will continue in that capacity, with headquarters at the same location on the fourth floor of the Chronicle Building.

Closed by Holiday Trade

James J. Black reports the closing of an exceptionally fine holiday business in the talking machine department of the Wiley B. Allen Co. Business was a little late developing, he says, but the week before Christmas was sufficiently active to bring the month's business up to a very satisfactory figure. The strong demand for high-grade machines was most noticeable and record sales were the best in the history of the business. Not only did December business show a substantial increase over the corresponding month of 1916, but the year 1917 was

better all through than the preceding one, according to Mr. Black. In checking over holiday business he was gratified to find that first payments ran larger than at any other time in the history of the firm's business, which, he says, was probably due to the fact that practically all workers are getting increased remuneration for their services nowadays. The Wiley B. Allen Co.'s store in Oakland, Cal., did an exceptionally heavy business in December, the end of the holiday season finding very little stock on hand there. The Saturday before Christmas was a banner day at the Oakland store. Very good reports are also coming in from other branches of the firm's business, especially from the Northwest.

Only Difficulty Was Getting Stock

In regard to holiday business, Andrew G. McCarthy, of Sherman, Clay & Co., says the demand for Victor goods left no possible ground for complaint—the only difficulty was to get sufficient stock to supply the needs of the Western trade. The shortage was particularly noticeable on the large styles of machines. Record sales far exceeded expectations. Taking the year as a whole, Mr. McCarthy says Sherman, Clay & Co.'s Victor business showed a substantial increase over the preceding one. They do a wholesale business only in southern California, and the reports from that section are very gratifying. In the Northwest both wholesale and retail business has been active, according to the reports coming in from Seattle, Portland and Tacoma. Spokane, however, seems to be a little slower.

Columbia Men Off for New York

Just before leaving for New York, after Christmas, Fred A. Denison, district manager for the Columbia Graphophone Co., reported a banner holiday business on Columbia products in his territory. The object of Mr. Denison's trip was to attend a convention of the company's managers from all over the country. Others to go from the Western territory included C. V. H. Jones, P. F. West and T. O. Moore, of San Francisco; W. F. Stidham and Mr. Mathews, of Los Angeles, Cal.; G. H. Williams, of Seattle, Wash., and L. D. Heater, of Portland, Ore. Mr. Denison and the San Francisco delegation are expected back at headquarters about the middle of January.

W. E. Henry, who represents the foreign record department of the Columbia Graphophone Co. on the Pacific Coast, has been successful in interesting a great many Western dealers in this branch of the business. In several instances large stocks have been installed, and Mr. Henry is getting very satisfactory reports from all along the line. He plans to leave shortly on an extended trip through the Southwest.

Higher-Priced Machines in Demand

At the Edison Shop, opposite Union Square, holiday business was well up to expectations, according to W. J. Carson, who was particularly well pleased over the large number of high-priced machines sold the last few days before Christmas—even on the Christmas Eve—which brought the month's business up to a much higher figure than was anticipated early in the month.

Edw. Humphrey Goes to Byron Mauzy

Edw. Humphrey has resigned as manager of the Victrola department at Hale Bros., one of the large department stores of this city, to go with Byron Mauzy as manager of his talking machine department. Mr. Mauzy was very well pleased with holiday business in that part of his establishment. In fact, 1917 was a very good

\$15 Retail
Shelton Electric Talking Machine Motor

FULLY GUARANTEED FOR ONE YEAR

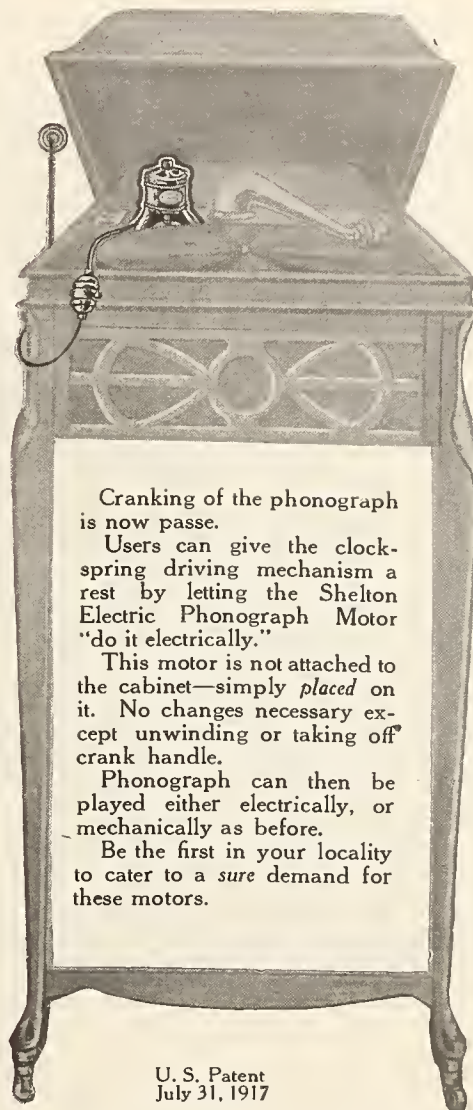

Cranking of the phonograph is now passe.

Users can give the clock-spring driving mechanism a rest by letting the Shelton Electric Phonograph Motor "do it electrically."

This motor is not attached to the cabinet—simply placed on it. No changes necessary except unwinding or taking off crank handle.

Phonograph can then be played either electrically, or mechanically as before.

Be the first in your locality to cater to a sure demand for these motors.

U. S. Patent
July 31, 1917

SHELTON ELECTRIC CO.

NEW YORK—30 East 42nd Street
CHICAGO—30 East Randolph Street
BOSTON—101 Tremont Street
SAN FRANCISCO—62 Post Street

year throughout, everything considered, he says.

Clark Wise, of Clark Wise & Co., reports an unprecedented demand for records during December, and machine sales were fairly active also, although not so good in proportion as record business.

Geo. T. Hively, manager of the talking machine department of the Eastern Outfitting Co., which handles Columbia products exclusively, is very well satisfied with holiday business, and he considers prospects good for 1918, providing stock can be obtained the same as usual.

Jas. D. Moore, who has been manager of the Victor department of the Lion Department Store in Toledo, O., for the past five years, is receiving valuable assistance from Wallace Currier, who recently assumed the position of assistant manager of that department. Holiday business with this house has been excellent.

A good question for a retailer new to the business to ask himself: Is your stock of goods such that your customers want and does it suit the conditions of your locality?

The Mutual
PLACE YOUR 1918 ORDERS TO-DAY for Mutual TONE ARMS AND SOUND BOXES

Mutual Talking Machine Co., Inc.
145 West 45th Street, New York

PHILADELPHIA PA. CHICAGO, ILL. (Insulation Dept.) AMELIA CO. VA. MONTREAL CAN. WEST PHILADELPHIA PA.

INTERNATIONAL MICA COMPANY
MICA DIAPHRAGMS

Let our Diaphragm Department take care of your Diaphragm Difficulties and be covered on this essential part for the future. Quotations and samples promptly forwarded upon request.

Offices and Factory, 37th and Brandywine Streets, WEST PHILADELPHIA, PA.



A New Record Repertoire and Greater Record Sales for the New Year!

NOT only do Pathé Records represent the largest and most unique record repertoire in the world: music of which America still knows little—the great voices of all Europe; romantic instrumental ensembles of the Old World's Bohemia; the famed military bands, the songs and melodies of lands that *live* romance; the brilliance and beauty of a world of art so far a closed book to most Americans—

To say nothing of the regular monthly list of up-to-date patriotic, sentimental, musical comedy and popular song successes and dance novelties—

But they represent *continuous* sales

And increased "record dividends" to the dealer—

because there is a fast-growing demand for records that play without needles. And Pathé Records mean:

No Needles to Change

THE SAPPHIRE BALL takes the place of needles. And it is permanent. It never wears out.

Pathé Records Won't Wear Out

We guarantee every Pathé Record to play at least one thousand times with the Pathé Sapphire Ball without impairing the unexcelled beauty of tone.

The Pathé Phonograph Plays All Makes of Records

Each Pathéphone, at any price, plays not only Pathé Records, but all other makes of records.

The Pathé "Controla"

With the Pathé "Controla" you may increase or decrease the tonal volume of the Pathé Phonograph at will.

No Needles to Change

THE PATHE SAPPHIRE BALL takes the place of needles. And it is permanent. It never wears out.

Pathe Records Won't Wear Out

Here's the Pathé Record Guarantee: "We guarantee every Pathé Record to play at least a thousand times with the Pathé Sapphire Ball without impairing the unexcelled beauty of tone."

Pathé recordings are not merely phonographed recordings of such world-famed artists as Muratore, Muzio, Cavalieri, DeCisneros, Grace Hoffman, Ober, Slezak, Urlus, Bispham, Sammarco, Ruffo, Weil and others. They are the *realism* of those voices.

Pathé Records cost no more than other records and because they offer the dealer an unusually generous discount.

Write for details TO-DAY.

Williams-Davis-Brooks & Hinchman Sons

26 East Congress Street
DETROIT, MICHIGAN



The Pathé Sapphire Ball
Enlarged many times

Washington Birthday Window Suggestion for Talking Machine World Readers :: :: By Ellis Hansen

"If you put a little lovin' into all the work you do,
And a little bit of gladness, and a little bit of you,
And a little bit of sweetness, and a little bit of song
Not a day will seem too toilsome; not a day will seem too
long;
And your work will be attractive, and the world will stop
to look,
And the world will see a sweetness, like the tinklin' of a
brook,
In the finished job; and then the world will turn to look
at you
With a world's appreciation of the thing you've found to
do."
The Winning Way—From Houston Post.

Every live talking machine dealer is continually studying over the important problem of creating the best impression. He likes to have his efforts stand out, way ahead of those of his competitors.

Department stores depend largely upon bargain sales. This, of course, is out of the question with the talking machine dealer. There is, however, one other means used to a great extent by department stores which should also appeal to talking machine dealers, and that is the show window. By using taste, brains and a certain amount of effort the progressive dealer can impress his customers through his show windows and in the creation of impressions most dealers realize that it is the first glance that really counts. If a window is attractive, clean and interesting it appeals irresistibly to the many pedestrians who pass it daily. People are quick to notice interesting displays and few things help more to get a store that valuable business asset—good will. Encouraged by the editor of this journal, I shall design a number of inexpensive displays in this and succeeding issues suitable for small show windows and not only describe them with illustrations and diagrams, but I will actually make up a limited quantity of the display parts that cannot easily be obtained by retail dealers. These parts can be obtained from me at a very reasonable price and thereby enable dealers to get the full effect of the illustrations. The woodwork and easily made parts will be described in full so anybody at all handy with tools will be able to make them.

Before explaining the making of the display



Detail of Scrola

here shown I want to advise every dealer interested in the plan to select some one handy with tools in their employ to have full charge of the show window. Most of the large stores have realized the need of a window trimmer and have either a special trimmer or a clerk who puts in part time for display work. But even the small dealer with only one window and a few clerks ought to have one person and one person only to take care of the show window, and to be held responsible for the appearance of that window. It does not necessarily have to be a man. I know of several stores where women clerks are doing very well indeed as window trimmers. Dealers, however, should realize that it takes time and money to make attractive displays. The would-be window trimmer can no more invent or construct without mental equipment than he can without material with which to work. I know of dealers that do not consider the trimming of their windows as work, but rather as a pleasant pastime, a mental rest from the daily humdrum of every day toil, a labor of love, which, though added to the regular daily duties, should make the person elected to do it thankful and happy! And then dealers wonder why their show windows don't bring results. Any dealer that wants to get results from his windows must first of all recognize window trimming as work—tedious, exacting work, work that not only re-

quires gray matter, but imagination, elbow grease and good judgment besides. If anyone of your force can make your window stand out and appeal, as is the true mission of a show window, he should be rewarded not only financially, but by your confidence and trust. Faith in business is really quite as important as faith in religion. When we give a man that we know can be trusted our confidence and express our faith in him and his work, we make easier all his tasks and remove, or help to remove, the greatest obstacle on his road to success.

Don't think this is mere talk, because it is not; it is my own experience, as I shall presently relate. When L. F. Geissler engaged me about seventeen years ago to take charge of the Sherman-Clay windows in San Francisco I had never trimmed a music window before. Somehow Mr. Geissler had faith in me and never hampered me with restrictions, neither did he allow anyone to tell me how to do my work. He trusted me to do the right thing. Consequently, I planned and worked as never before and as a result made a success of it. The other distinguished houses that I have been with have treated me very much the same way and especially my last employer, E. H. Uhl, manager for the Rudolph Wurlitzer Co.'s Chicago branch. In the three years that I worked for Mr. Uhl I cannot recall one instance of being told what to do or called down in regard to my work. During that period I made a most complete fiasco in building a float at considerable expense to be used for the advertising men's street parade. The float almost collapsed before it was one block on its way. Of course, I felt very humiliated and unhappy and expected to get what I thought was coming to me. Mr. Uhl was in Cincinnati during the accident and upon his return I told him frankly that nobody but myself was to blame for the failure. Instead of calling me

importance of making the window trimmers' job worth while. Give due credit to the trimmer and don't let some one higher up swipe the glory if glory is due. Allow a reasonable amount of money for display material and other expenses as you would for any other branch of

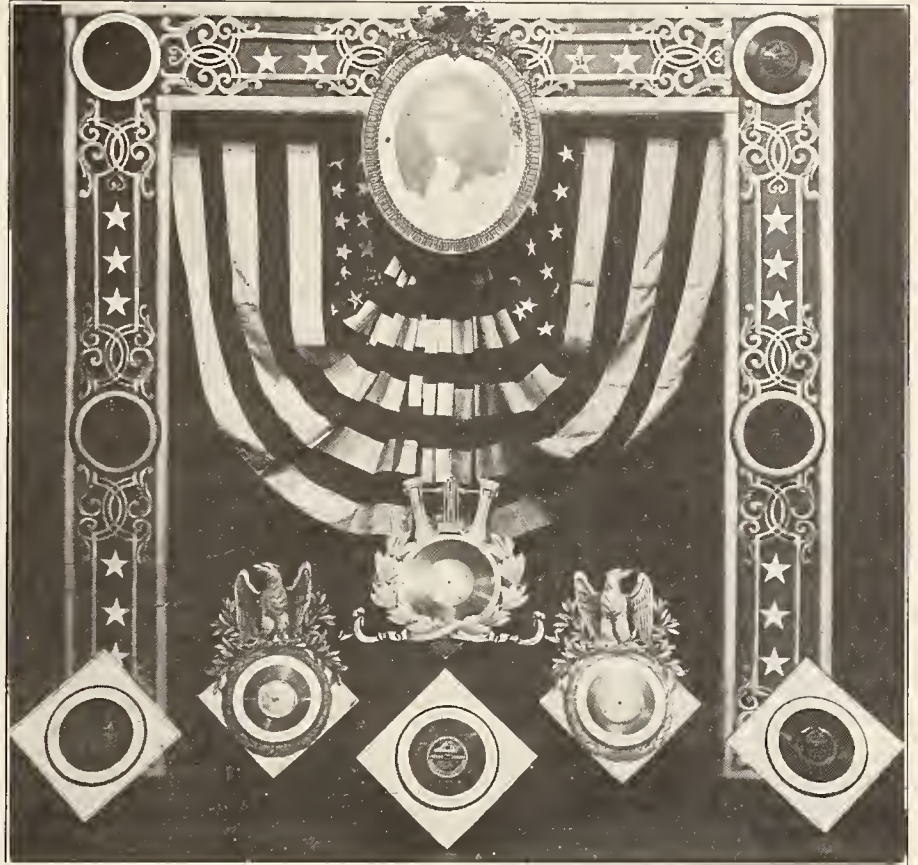

Washington Birthday Window Designed Especially by Ellis Hansen for The Talking Machine World

advertising. Arrange for a place to store all used display material and if you hold the trimmer responsible let it be under lock and key.

Now for the display. It should not appear until the month of February, but by changing the picture in the center the rest of the display would always be appropriate for a patriotic window.

How to Make Display

First make three simple frames or panels; two uprights (see diagram A) and one top frame (B). Use basswood strips one inch square, which can be obtained at your nearest lumber yard. Make the uprights six feet ten inches long by eleven and one-half inches wide. Put two crosspieces (D) as shown in diagram four inches from top, the other thirty-six inches from bottom. Drill quarter-inch holes in center of crosspieces. Next make top panel (B). Length four feet ten and one-half inches, width, eleven and one-half inches, with a crosspiece in center. Now cut two pieces of one-fourth inch wood

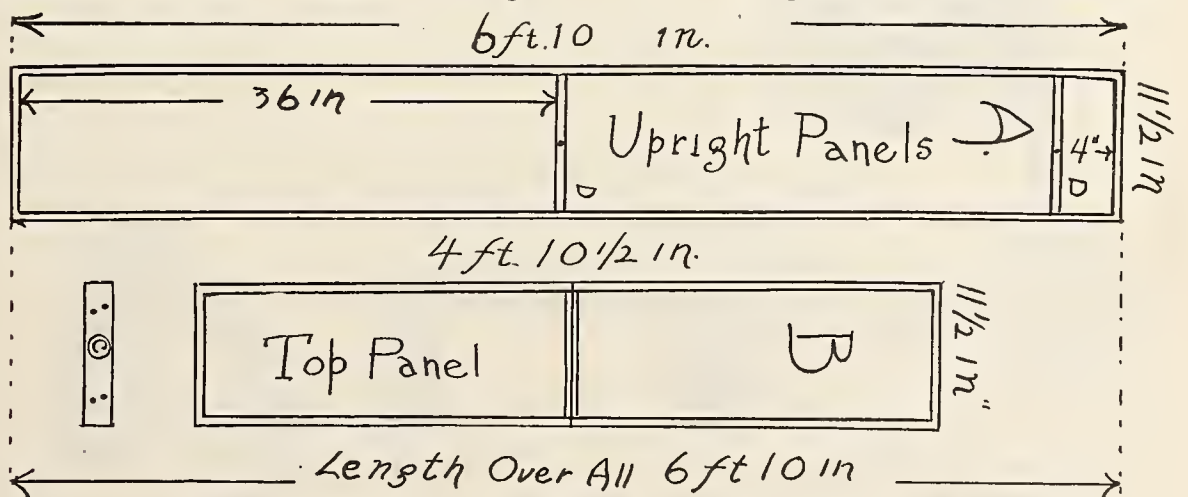

Key to Arrangement of Washington Birthday Window Display

down he put his arm around my shoulder and told me not to worry but forget all about it as he would forget it. No wonder, I could do good work for a man of that calibre.

These remarks are intended to emphasize the

two inches wide by eleven inches long (C). These pieces are used to fasten the top piece (B) to the two side panels (A). Four one-inch screws will hold the panels together securely.

(Continued on page 68)

WASHINGTON BIRTHDAY WINDOW

(Continued from page 67)

Make the three frames rigid and secure. Then proceed to tack on the scrola. "Scrola" is the name that I have selected for this new decorative material. It stands out in strong relief, being made of heavy cardboard, machine cut and colored by one of the most expert air brush artists in America. After the scrola has been tacked on turn the frames and tack blue crepe paper on the back. Sixteen five-pointed stars, three inches in diameter, should be cut out of white paper and pasted on the crepe paper back of the scrola as indicated in the picture. By using three incandescent lamps back of the frames a very beautiful effect can be produced. Pictures of Washington can be had from ten cents up. Any frame of suitable size will do, but an oval frame is to be preferred. The two American flags used are four by eight feet in size and can be obtained in most stores at \$1.50 each. The folds in the drape are three inches wide and the arrangement is so simple that anyone who tries can duplicate the effect by studying the photograph. The record stands at the bottom of the display were fully described in last month's World. The placing of the phonograph is, of course, up to the trimmer and depends on the number of instruments to be used. Three-sixteenth inch by one and one-fourth inches round-headed stove bolts are used to bolt the four records on uprights. The ten records used should, of course, be patriotic selections. The smallest size window used should be seven feet square. The scrola all ready to be tacked on frames can be obtained all complete for \$5 money with order or C. O. D. by writing to Ellis Hansen, 600 South Harvey avenue, Oak Park, Ill. This simply covers the cost of production, with a very slight additional charge for handling.

P. C. Peuser, who recently entered the retail field at Franklin, Pa., with a store at 139 Adams avenue, has secured the agency for the Sonora.

TALKING MACHINE EXPORTS

The Figures for September Presented—Exports Show Machines Decrease and Records Increase

WASHINGTON, D. C., December 30.—In the summary of the exports and imports of the commerce of the United States for the month of September, 1917 (the latest period for which it has been compiled), which has just been issued by the Bureau of Statistics of the Department of Commerce and Labor, the following figures regarding talking machines and supplies appear:

Talking machines to the number of 6,437, valued at \$191,157, were exported in September, 1917, as compared with 7,955 talking machines, valued at \$181,847, sent abroad in the same month of 1916. The total exports of records and supplies for September, 1917, were valued at \$150,554, as compared with \$106,054 in September, 1916. For the nine months 63,659 talking machines were exported, valued at \$1,606,555, in September, 1917, and 45,210, valued at \$1,128,602, in 1916, while records and supplies valued at \$1,330,759 were sent abroad during 1917, as against \$823,858 in 1916.

GENEROUS CHRISTMAS BONUS

For Employes of Otto Heineman Phonograph Co.—Get War Saving Certificates in Addition

The Otto Heineman Phonograph Supply Co., New York, presented its force of employes with a handsome Christmas bonus in recognition of the fact that they had contributed materially to the closing of the company's biggest year.

In addition to this Christmas bonus, every employe in the Heineman executive and sales offices throughout the country was presented by Mr. Heineman with a \$5 war saving certificate, and accompanying this certificate was a suggestion from Mr. Heineman that the employes recognize the Government's splendid thrift plan embodied in this war saving stamp plan.

VICTOR FRENCH COURSE IN DEMAND

Represents a Timely Contribution to the War Needs of the Country From the Talking Machine Trade—Being Strongly Featured

Victor wholesalers and retailers generally are evincing more than usual interest in the new Victor course in practical French for the American soldiers, which, as has been announced in The World, is contained complete in three double sided records, accompanied by explanatory text books and selling retail at \$2.50 for the course.

The Victor Co. has issued for use and distribution by the retailers a most attractive folder explaining the idea back of the preparation of the course and some facts regarding it. The folder is illustrated by interesting photographs of the American soldiers in France and a sec-



Victor Poster Design of French Course

tion of the first lesson is also reproduced to give an idea of its character.

The new course, as it stands, represents a most notable contribution to the war needs of the country from the talking machine trade, and in announcing the course in the booklet the Victor Co. says:

"The directors of the Victor Talking Machine Co., desirous of contributing to the comfort, the welfare and the safety of our gallant troops, ordered the preparation of a practical course in French which would take care of the soldier's immediate needs, serve as a working basis for further development, and be put on the market at a small fraction of the usual cost.

"To accomplish any such ambition it was necessary to make sweeping departures from precedent. It meant endless study, endless consultations with recognized authorities, endless elimination of nonessentials. This finally has been achieved and a practical, comprehensive system has been devised through which a working knowledge of French may be obtained quickly. Instead of costing \$40 or \$50, it costs \$2.50."

The point is made that the course is in no sense intended to be a grammatical treatise on the French language, but is designed to enable the American fighting man to make his needs known directly and in idiom if necessary.

It is expected that many thousand sets of the records will be sold in the near future to follow the thousands of sets that have already been ordered.

EXTRA VICTOR CO. DIVIDEND

The Victor Talking Machine Co. has declared the regular quarterly dividend of 1 3/4 per cent. on the preferred and 5 per cent. on the common stocks; and an extra dividend of 15 per cent. on the common. The extra dividend was payable December 15.

The Columbus Stradivara Co., of Columbus, O., has been incorporated with a capitalization of \$100,000 for the purpose of manufacturing musical instruments, William J. Shaver being one of the principals.

KOCH-O-PHONE
\$24.50



No. 23

The KOCH-O-PHONE is the FORD of the Phonograph world. There is no charge for the name or expensive advertising added to the cost. Most people would rather pay \$48 (resale price) than \$100 for the same amount of pleasure. Plays all makes of disc records. No disconnecting needed in exchanging from one make of record to another. Simply turn the sound box and change needle to suit make of record. This machine for tonal quality and volume is not excelled by any \$100 machine on the market.

No. 23—Height 43 in., width 19 1/2 in., depth 22 in.; double spring worm driven motor; 12 in. turntable, all metal trimmings are nickel plated; made in mahogany finish. With tone modifier; weight about 125 lbs. \$24.50

Cabinet alone, complete with needle cups . . . \$15.00
Equipped with tone modifier . . . 50 cents extra

Tone Arms and Sound Boxes
(Genuine Mica)

Our new universal tone arm and sound box, No. 3, has proven a big success. Has all the desired requisites in the way of producing a clear, rich and musical tone.

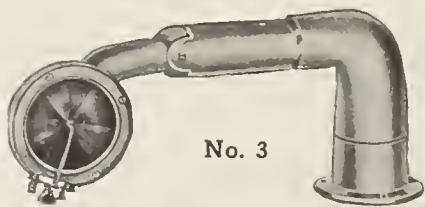

No. 3

Price \$1.50
In Lots of One Thousand

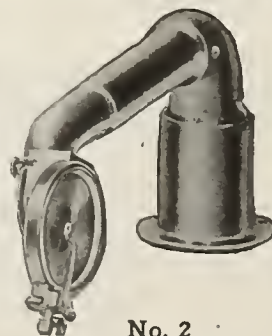

No. 2

Real Mica, 95c
in 100 Lots
Imitation Mica, 85c

ANDS KOCH, Manufacturer

296 Broadway

NEW YORK

Are you taking advantage of the services of the experts in the Columbia Dealer Service Department? Their hobby is More Sales—Quicker Sales!

Columbia Graphophone Co.
Woolworth Building, New York



GROWTH IN THE DEMAND FOR TALKING MACHINE PARTS DISCUSS PLANS FOR THE NEW YEAR

Illustrated in the Development of the Business of the Doehler Die-Casting Co., of Brooklyn—New Fireproof Building Recently Occupied by This Company Most Completely Equipped

The Doehler Die-Casting Co. are completing a year of great advancement. Not only is the

increase shown in volume of business but in the actual size of their Brooklyn plant. During the year a seven-story glass and concrete addition was added to their already large plant, running through and facing on the next street. This new building at Court and Ninth streets, Brooklyn, is already filled and contains the general and executive offices of the company.

This building is entirely fireproof and offers the best of working conditions to the many employes. It is modernly equipped and contains among its features a "First Aid" room and employes' restaurant. During the year the aluminum die castings of phonograph parts, perfected by the Doehler Co., have become very popular in the trade.

The remarkable growth of this firm is shown by the fact that ten years ago they employed twenty men and now they operate four factories

Branch Managers of Otto Heineman Phonograph Supply Co. Visit Headquarters in New York to Talk Over Future Campaign

Otto Heineman, president of the Otto Heineman Phonograph Supply Co., was the host during the New Year holidays to several of his branch managers who visited New York to talk over plans for the new year. Among these visitors were S. A. Ribolla, manager of the branch in Chicago, and C. T. Pott, manager of the Canadian branch at Toronto.

Both visitors spoke enthusiastically of the business outlook in their respective territories for 1918 and substantiated this optimism by bringing with them good sized orders to be filled immediately. Their sales totals for 1917 indicated that the Heineman business in their sections had far exceeded expectations, but they expressed the belief that 1918 will far out-distance these figures.

While here, Messrs. Ribolla and Pott conferred with Mr. Heineman regarding the important new plans to be announced in the near future and made arrangements whereby the manufacturers in their territories will be afforded excellent service during the coming year. Both of these visitors, in addition to the other Heineman branch managers, will spend some time in New York the end of this month, when the annual conference of the Heineman sales staff will be held.



Main Entrance Doehler Die-Casting Co.



Executive Offices of the Company



Section Devoted to Casting of Phonograph Parts



Where Estimates and Costs Are Figured situated at various points throughout the country and employ well over one thousand men.

The Doehler Die-Casting Co. are very optimistic over the new year, which so recently made its debut, and are making plans accordingly.

BUYS BETHLEHEM T. M. CO.

Penn House Furnishing Co. Buy Assets and Good Will of Company Formerly Owned by E. J. Delfraisse—Business in Good Shape

BETHLEHEM, PA., January 14.—The assets, stock, fixtures, leases and good will of the Bethlehem Talking Machine Co. of this city was purchased last week by the Penn House Furnishing Co., of Allentown, Pa., Max Chanoch, president.

The Bethlehem Talking Machine Co. has been conducted for the last two years by E. J. Delfraisse, who has become Western representative of Jacob Doll & Sons, of New York. The company had no liabilities, which speaks well for a talking machine business, as seldom, when changes of this kind are made, are there nothing but assets to figure on. A. F. Jones, who has been connected with Mr. Delfraisse, will remain under the new management.

PARAGON MFG. CO. INCORPORATED

HICKORY, N. C., January 7.—The Paragon Mfg. Co., of this city, has been capitalized at \$30,000 for the manufacture of talking machines. The company is planning to produce three styles of cabinet machines and will merchandise through the dealers.

FACTS ABOUT THE KENT ATTACHMENT NO. 1

To Play Lateral Cut Records on the Edison Diamond Disc Phonograph

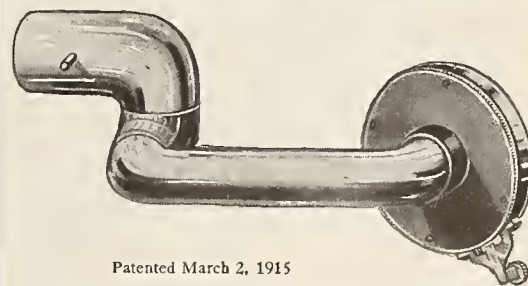

Patented March 2, 1915

It has been recognized by experts the most perfect device of its kind on the market. It has been on the market ever since the Edison Diamond Disc made its appearance. It can be had with or without reproducer and is made in two lengths. It is guaranteed by the Manufacturer in every way.

F. C. KENT & CO.
Manufacturer of Phonograph Accessories
24 Scott Street Newark, N. J.

Mozart Dealers Are Mozart Boosters!

Every dealer handling the *Mozart* line not only sells it, but believes in *Mozart* product. We have gained their confidence by giving them machines that sell readily, prompt service and a fair profit.

Let Us Show You Why the *Mozart* Is a "Money-Maker"



STYLE A
Height, 45½"
Width, 17"
Depth, 21"
Retail Price \$55



STYLE B
Height, 47"
Width, 23"
Depth, 24"
Retail Price \$100



STYLE C
Height, 47"
Width, 23"
Depth, 24"
Retail Price \$100

Mozart 10 in. and 12 in. records are increasing dealers' sales fourfold. January supplement ready to be mailed.



WRITE TODAY FOR
OPEN TERRITORY

Mozart Merits

Seven Models, Retailing from
\$15 to \$100

Unsurpassed factory facilities

A Record line that will add to
your profits

An established product that has
been on the market
two years

THE MOZART TALKING MACHINE COMPANY

J. P. FITZGERALD, *President*

2608-2618 NORTH 15th STREET

ST. LOUIS, MO.

BEARING OF FREIGHT SITUATION ON CINCINNATI TRADE

Western Manufacturers Watching Situation Carefully in Expectation of Increased Demand for Local Products—Deliveries by Motor Trucks—R. J. Whelan Resigns—Review of the Trade

CINCINNATI, O., January 5.—Talking machine manufacturers of the Middle West believe that a continuation of the present freight and express conditions in the United States will create markets for their output right in their own centers, thereby completely changing the situation of this important industry.

As is generally known, the larger manufacturers are located in the Eastern markets and the factories about Cincinnati believe that if these are to be handicapped in the future in the delivery of the finished product it will cause dealers to turn to producers nearer home. That is the way the present condition of traffic is being figured out. In the meantime, talking machine manufacturers as well as the piano industry of the Middle West is looking about for some one to institute a truck system between the larger centers in the Ohio Valley, which method of transportation will be relied upon by "home" manufacturers as an outlet for their energies.

Richard J. Whelan has retired as manager of the Cincinnati branch of the Columbia Graphophone Co., the change taking place this week. His successor has not been appointed. The branch is temporarily in charge of F. F. Dawson, of the New York office. Mr. Whelan's plans for the future have not materialized. He has had charge of the Cincinnati district slightly over seven years.

There was a falling off in the holiday business in the Middle West and Manager Greulich, of the Cable Piano Co., who is an enthusiastic Victor dealer, believes this may have been due to the appearance of the Government's questionnaire, which reached the homes of prospective selectives the week before Christmas. That appears to be the only excuse that can be given for the decrease. The trade generally found the

buyers wanted medium-priced machines and the average payment was higher than was the custom during the holiday rush of a year ago.

Chas. L. Byars, manager of the Vocalion department of the local Aeolian store, in commenting on the December trade, said that while the volume of Vocalion business was not as big as hoped for, yet the quality of accounts opened could not have been better. He remarked:

"The dealers and merchants of the country can do considerable toward allaying the apprehensions of the people by talking and acting in an optimistic manner concerning business conditions. If a dealer himself will be convinced that there is no shortage of money in the land, a very small percentage of unemployed, a higher average wage than ever before, he will have no trouble in taking an optimistic view of conditions."

Manager Dittrich, of the Victor department of the Rudolph Wurlitzer Co., said:

"The New Year has started off with a rush, especially in record business, and record stocks are disappearing rapidly. Most of the dealers report that it is absolutely impossible to keep their record stock complete, owing to the tremendous demand, which exceeds anything previously known in the talking machine line.

"In reviewing the holiday business, we find that December started off in good shape, but that towards the middle of the month business began to fall behind that of last year. Last week, however, proved to be the busiest week that Cincinnati merchants ever remember having experienced.

"While machine sales came up splendidly during the latter part of December, the record business was the one big surprise of the season, and as most dealers were well prepared, splendid results were secured.

"With conditions rapidly becoming normal, and many problems being solved, there is no reason to expect anything else but a most successful talking machine year during 1918. The big question will be stock, and it will be necessary for the progressive dealer to look far ahead in placing orders for his requirements for the year."

New models are to be produced about February 1 by the Crystola Co. One will sell for less than \$110. The style and details of the other have not been formally adopted. Ben Schwenger, the Cleveland district representative, was in town this week, arranging for his year's supply of Crystolas.

Mr. Neumeister, of the Otto Heineman Phonograph Supply Co., is getting through a satisfactory amount of his required supplies and generally speaking is well satisfied, considering conditions.

The Fritzsche Phonograph Co. will enter the South American field, having arranged to be represented there by the North Brazil Machinery Syndicate, with headquarters at Fortaleza Ceara, Brazil. The South American firm represents some thirty-eight American concerns. The Fritzsche house, launched less than a year ago, has twenty dealers to its credit, including a firm in Australia, and is doing a splendid business. Their products are winning much genuine appreciation.

The All-Ohio Singing Contest, as conducted by the Columbia Graphophone Co., in connection with the Scripps newspapers, came to a close last month, at Columbus, O., when Miss Ruth Stein, of Akron, and E. C. Mulholland, of Toledo, O., were selected as winners. H. A. Herrick, the Columbia's special representative, personally escorted the winners to New York, where they will have their voices recorded in the Columbia's laboratory. It is expected now that the records will be ready for the market the latter part of January, and all are anxiously looking forward to hearing the records of the successful contestants.

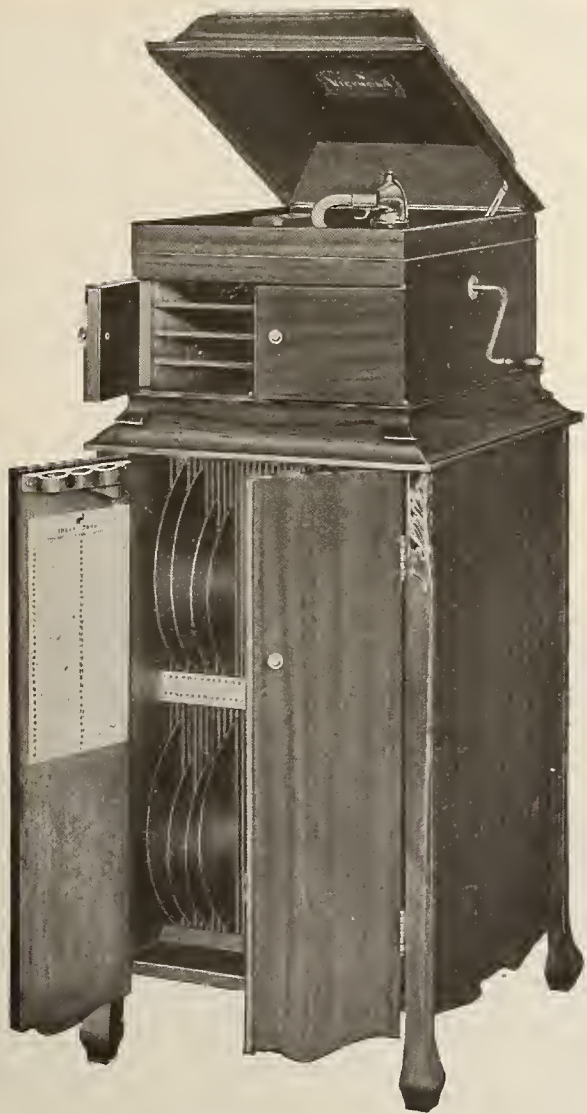

No. 19. Cabinet
(DOUBLE DOOR FRONT)

Made especially to hold the Victor-Victrola, No. IX

Trade Winning Holiday Outfits

Salter Cabinets, made to harmonize with portable models of standard machines, enable you to offer your trade outfits which serve to land customers who would otherwise escape.

The felt-lined compartments of which we are the originators are a feature of all Salter Cabinets. Each record has a compartment to itself, is thus protected against scratching, breakage and dust, and is instantly accessible.

SEND FOR CATALOGS

We also make a beautiful line of sheet music and music roll cabinets.

SALTER MFG. CO.

337-49 N. Oakley Boulevard
CHICAGO, ILL.



No. 111. Cabinet (Opened)
For Columbia \$50.00 Machine
33½ inches high. Top, 23 x 19½ inches

BRILLIANTONE STEEL NEEDLE CO.

New Company Organized in New York With B. R. Forster as President to Specialize in Steel Needles—Offices in the Marbridge Building

The new year has ushered in a new needle house into the talking machine industry. It is entitled the Brilliantone Steel Needle Co., of



B. R. Forster

New York. Although the firm is new, the "men behind the guns" are not new to the trade.

B. R. Forster, the president and treasurer of this new concern, has been connected for some years as the general manager with I. Davega, Jr., Inc., and in that position developed an enormous needle business for that house.

H. Ettinger, vice-president, has had a large experience and acquaintance throughout the trade through his former connection as the

manager of the talking machine department of Kranich & Bach.

H. A. Acton, another experienced man, is appointed as secretary.

The Brilliantone Steel Needle Co. opened offices on January 2 in the Marbridge Building, Broadway and Thirty-fourth street, suites 657 and 658, and Mr. Forster extends a cordial invitation to members of the trade to visit them



H. A. Acton

at the above address and to his out-of-town friends to make their offices their headquarters while in town.

This company will specialize entirely in steel needles, in medium, half-tone, loud and extra loud grades, and have selected for their slogan the following line, "Highest quality uniformly pointed steel talking machine needles made in America by American labor." They plan to begin deliveries of needles on February 1.

SAFETY HINTS FOR EDISON WORKERS

Pertinent Suggestions As to Means for Avoiding Factory Accidents Offered by John D. Otis and M. M. Jones at Recent Committee Dinner

Safety suggestions of value to workers were given by John D. Otis, of the American Museum of Safety, and by M. M. Jones, personnel department of Thomas A. Edison, Inc., following a dinner of the Workmen's Committee of the Edison Phonograph Works, in the clubhouse of the Thomas A. Edison Association, Orange, N. J., recently. The speakers gave an outline of what safety committees can accomplish and advised the men to specialize their investigations so as to become experts in eliminating dangerous hazards, and to secure the greatest possible benefits from their study of conditions in the plant. The need of teaching workers to anticipate and avoid dangers which naturally follow carelessness and lack of caution was pointed out and the speakers urged the men to at all times "think safety," as well as to act safely, when going about their daily work. Co-operation between men on the safety committees with foremen was pointed out as an excellent method of securing good results.

The human element, Mr. Otis pointed out, is the biggest factor in plant accidents. All the guards in the world, in his opinion, will not save a man from injury unless that man keeps his mind fixed on his tasks and at all times pays strict attention to the operation he is engaged in. He paid a compliment to the safety committees and declared that, owing to the interest taken by them in their work, the co-operation of other workers is being secured, and the men are disposed to listen to suggestions made from time to time for their safety.

Motion pictures were also shown, illustrating accidents of various kinds, each film presenting a different lesson.

Costs No More Than a Good Stand!

Purchasers of small Victrolas want a Converto Cabinet the minute they see one—because: it takes the place of a stand, covers the machine, converts it into a handsome cabinet type, provides dust-proof record compartment—all at a cost no higher than for simply a good stand that has none of these features.

Lundstrom
CONVERTO
PATENT APPLIED FOR

**Talking Machine
Cabinet**

It appeals likewise to present owners of small Victrolas. At little additional cost it gives them a cabinet machine. It revives interest in their machines and in buying new records.

Front doors of machine open through upper doors of cabinet and combine to make a continuation of the horn. The Converto is broadly protected by patent. Two sizes, retailing for \$20 and \$25—allowing a good profit to dealers.

This is a substantial proposition attested to by many of the country's leading dealers.

Write for Prices and Particulars

The C. J. Lundstrom Mfg. Co.
LITTLE FALLS, N. Y.

Branch Office: Flatiron Bldg.

New York City



Setting Victrola into Cabinet



Sound Doors Open for Playing



Completely Closed

MORE USE FOR THE PHONOGRAPH

Cortina Academy of Languages Using That Argument as Basis for Campaign

The Cortina Academy of Languages are carrying on a campaign along the lines of getting more use out of the phonograph. It is their contention that the phonograph in the home is too often reserved for purely entertaining purposes. Through various forms of advertising literature and car cards, the owner of a machine is advised of the possibilities in their phonograph for acquiring the knowledge of one or two additional languages. Through the use



Cortina Illustrative Idea

of attractive "home" photographs, one of which is here reproduced, the ease and comfort of self-education in the home is attractively portrayed.

The necessity of acquiring a knowledge of military French was anticipated by the Cortina Academy and the result was a set of military French records that are proving very popular throughout the country.

While this campaign is, of course, primarily intended for the increased sales of Cortina records, the effect is bound to be felt by the trade in general through supply sales as well as instruments, and to the dealers carrying the Cortina line the campaign should prove especially helpful.

TO INCREASE OUTPUT OF NEEDLES

Factory Making the Wall-Kane Steel Needles Enlarged to Meet Growing Demands

"It is a sound business principle that in order to succeed any merchant must give the public the greatest value for its money," said D. F. Tauber, president of the Progressive Phonographic Supply Co., New York, sole distributor of the Wall-Kane steel needles. "This principle certainly applies to the needle business and our dealers tell us that they have been able to give their patrons splendid service and value in the Wall-Kane needle. This needle, through the use of chemical processes, plays ten records perfectly, and these same processes give the point of the Wall-Kane a coating that benefits the record and adds to its longevity.

"At the present time our needle is being handled by progressive jobbers throughout the country and our recent factory enlargements will enable us to increase our output materially during the coming year. I may add further that we have received quite a number of letters from dealers, referring to the excellent tone quality of the Wall-Kane needle and the satisfaction it is giving all users."

The Daniels Music Co. recently opened elaborate Edison parlors at 106-108 East Fifth avenue, Arkansas City, Kansas, where they are featuring a full line of Edison Diamond Disc phonographs and records.

JOE SCHWETZ GENERAL MANAGER

Placed in Charge of Wholesale Victor Department of I. Davega, Jr., Inc.—Company Reports Excellent Business Record for 1917

I. Davega, Jr., Inc., Victor distributors, 125 West One Hundred and Twenty-fifth street, announce that Joe Schwetz, who has been connected with the firm for years, has been appointed general manager of the wholesale department. Mr. Schwetz succeeds B. R. Forster, who recently resigned and is now in business for himself. Mr. Schwetz has been Mr. Forster's assistant for some time and is thoroughly conversant with the work.

Mr. Schwetz has a wide acquaintance in the field and his efficient management, together with that of Abram Davega, who has general supervision over all affairs of the company, gives great promise of a fine year ahead for that company.

Records show that I. Davega, Jr., Inc., have just concluded one of the best years in the history of the firm. During the coming year it is announced that they will handle Victor products exclusively. As a further aid to dealers, they have obtained a supply of record cabinets for 4's and 6's, of which they have a large stock on hand.

SOLDIERS LIKE WESER PHONOGRAPH

Members of 21st Company, 153rd Depot Brigade, Send Letter of Appreciation to Weser Bros.

A Weser phonograph has been a source of entertainment for many of the soldiers at Camp Dix, Wrightstown, N. J. The machine was presented to the Twenty-first Company, Sixth Battalion, 153rd Depot Brigade, who have expressed their appreciation in a letter to Weser Bros., 520-530 West Forty-third street, New York, which was signed by every man in the company, as well as Capt. W. H. England. A number of records were also sent with the machine.

MME. MUZIO VISITS PATHE SHOP

Prominent Pathé Artist Inspects New Retail Quarters Opened in Philadelphia

PHILADELPHIA, PA., January 7.—One of the recent visitors at the new Pathé Shop, recently opened by the Philadelphia Pathephone Co., at 1026 Chestnut street, was Mme. Claudia Muzio, the prominent operatic soprano, who is a member of the Metropolitan Opera Company, and an exclusive Pathé artist.

Mme. Muzio has made several Pathé records which have been very well received by the dealers, and when she visited the Pathé Shop she expressed her keen appreciation of the handsome warerooms which the Philadelphia Pathe-



Mme. Muzio and the Pathé

phone Co. have established, congratulating Mr. Eckhardt upon the progress he is making and upon the exquisite decorations in his retail shop.

INCORPORATED

The National Phonograph Co., Chicago, has been incorporated with a capital stock of \$10,000. The incorporators are Martin Rasmussen, Harry Rasmussen, and Frank Cummings.

The Trade Is Advised

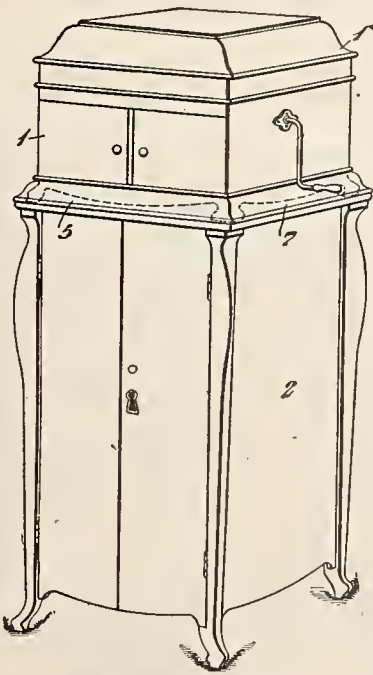

DESIGN OF CABINET

That I have been granted United States Letters Patent No. 1,244,944, dated October 30th, 1917, on a cabinet for Talking Machines (the design of which is shown herewith) and for which the following claims are made:

1. A cabinet for a talking machine having a top on which the casing of the machine is adapted to be supported, an inclosure rising from said top, and formed of cleats which are adapted to engage the sides of the base, certain of the cleats being fixed to said top and another cleat forming a gate for entrance into the space of the inclosure, and means for holding the gate in closed position and permitting its opening.

2. A cabinet for a talking machine having a top on which the casing of the machine is adapted to be supported, cleats rising from said top forming an inclosure for the sides of the base of said machine and adapted to interlock therewith, one of said cleats being separate from the other cleats and movable forming a gate for the insertion of said base into the space of said inclosure, the inner sides of the cleats overhanging so as to form interlocking joints with said base.

I am prepared to protect my interests under said patent to the fullest extent and all infringers will be prosecuted vigorously.

(Signed) CLEMENT BEECROFT

PLACE ORDERS NOW FOR

- Record Delivery Envelopes
- Record Stock Envelopes
- Catalog Supplement Envelopes
- Record Cabinets
- Talking Machine Needles
- Peerless Locking Plates

CLEMENT BEECROFT, 309 West Susquehanna Ave. Philadelphia, Pa.

HANDSOME NEW DELPHEON MODELS

New Hepplewhite Model Table Machine and William and Mary Model Cabinet Machine Recently Added to This Comprehensive Line

The Delpheon Co., Bay City, Mich., has just placed on the market two handsome art models which are shown in the accompanying illustrations. The table machine will be known as the Hepplewhite model and the cabinet machine as the William and Mary model. The latter will retail at \$200 and the former at \$400. The William and Mary model will be equipped with all

The Hepplewhite model measures fifty-six inches long, thirty-six and one-half inches high and twenty-five and one-half inches deep. It is made of the very high grade mottled mahogany and the experience and knowledge of the Delpheon finishing department is used to excellent advantage in giving this instrument a most beautiful finish. It has a beautifully carved grille and the posts are also carved. A heavy plank top is used. The center front section curves outwards, while the two end sections curve inwards.

On each side of the grille are the standard Delpheon individual compartment record files

An electric motor will be used. The reproducing equipment is the same as on the other models, with the exception of the resounding chamber,

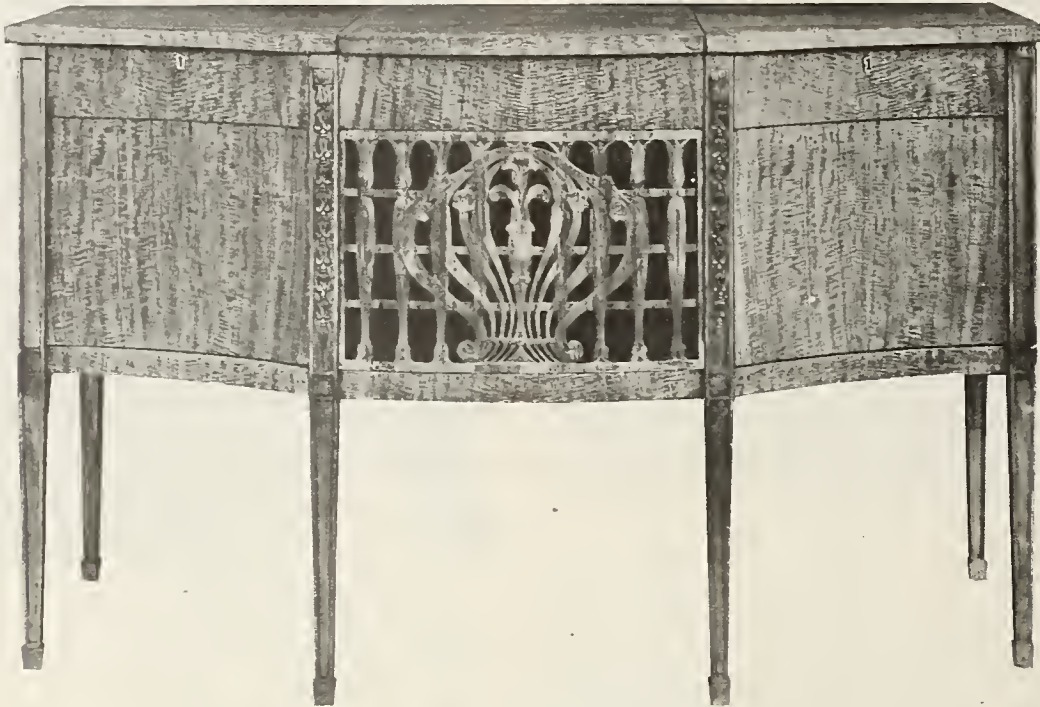

Hepplewhite Model Delpheon

Delpheon features, including the three spring motor playing seven ten-inch records. Only the very choicest five-ply mottled mahogany is used throughout.

working on slides and giving a total capacity of 210 records. This model will be equipped with gold hardware with the exception of the drawer pulls, which will be finished to match the wood.



William and Mary Model Delpheon which is of unusual size and gives a remarkable tone quality.

In spite of the fact that the Delpheon Co. has not yet sent out photographs or descriptive literature featuring these two art models, the first order on each model given to the factory has been sold out. From all indications these two instruments will be very successful and the factory is planning to devote considerable time to the production of these art designs.

ACTION ON STEPHENS BILL COMING

Predicted That Congress Will Take Up the Discussion of Measure Early This Year

WASHINGTON, D. C., December 30.—Congressional action on the Stephens Standard Price bill early in the coming year was confidently predicted to-day by E. A. Whittier, secretary-treasurer of the American Fair Trade League, who is in Washington following the opening session of Congress. Mr. Whittier has kept in close touch with the progress of the measure and his prophecy, therefore, carries some weight. Mr. Whittier also took occasion to reply in no

uncertain terms to the statement issued by the National Retail Drygoods Association concerning the recent complaints filed by the Federal Trade Commission against Mishawaka Woolen Mfg. Co. and the Cudahy Packing Co., and charged that the statement was issued without any real knowledge of the facts in the case.

"Mr. Howe is quoted as saying," declared Mr. Whittier, "that 'the fact that advocates of price maintenance are seeking a new law is in itself evidence that the present law (the Clayton Act) prevents their doing what they would like to do without laying themselves open to prosecution.' This certainly indicts Mr. Howe's intelligence, or his sincerity, for everybody else

knows, even if he does not, that the Stephens bill was introduced and actively supported in Congress a year before the Clayton Act was drawn. Moreover, it will be difficult for Mr. Howe to find anything in the Clayton Act which even remotely involves the Stephens bill stabilization principle for the prevention of predatory price cutting. Rather, its whole theory supports that principle and eliminates cut-throat competition and unfair discrimination."

It has been said we don't succeed so much on our own acts as we profit by the mistakes of others. And there's a lot of truth in the statement.

A

AMERICAN

A

Clear in Tone, Beautiful in Design, Smooth Running Motors

The American phonograph, which embodies all the good qualities and special features that the buying public demands, has no equal as to price, beauty and tone. You cannot afford to be without this popular line for your holiday business. The American line has many fine features, beautiful in design, finest of material and workmanship, and the right quality of motor for each particular model, making a well-balanced line at popular prices and a ready seller.

Mr. Dealer: Whether you are at the present time handling any other line of phonographs or are yet undecided as to what line you will have, ask us for the full particulars and you will find that this line will increase your profits and add materially to the volume of your business

PRICES QUOTED ARE WHOLESALE



No. 3—\$18.50



No. 5—\$23.50



No. 6—\$29.00



No. 10—\$47.50



No. 13—\$61.00



No. 22—\$85.00

We stand back of every American

AMERICAN PHONOGRAPH COMPANY

Main Office and Factory, 111 Lyon St., GRAND RAPIDS, MICH.

503 Cable Bldg., CHICAGO

A

A

HOW NEW YORK TALKING MACHINE CO. STAFF CELEBRATED

Executives Prepare a Very Pleasing Surprise for Entire Force at Christmas Time—Substantial Evidence of Appreciation of the Work of the Men—Entertained Also at Travers Island

On Christmas Eve, as a surprise to the office and sales force of the New York Talking Machine Co., the executives had set up, trimmed and brilliantly lighted, a beautiful Christmas tree, which seemed to symbolize the spirit pervading the whole organization.

As the members of the New York Talking Machine Co. gathered around this tree singing

more tangible form than mere words the company's sincere appreciation of the loyal services rendered throughout the year.

The week following, on New Year's Eve, part of this group, composed of the sales and office force with their wives and sweethearts, were the guests of Vice-President R. J. Keith at the Travers Island Club House of the New York



Christmas Party of New York Talking Machine Co. (Sales and Office Forces Shown in Picture) the beautiful old Christmas carols and wishing one another a "Merry, Merry Christmas," a spirit of good-will, fellowship and loyalty to one another was evident on all sides. Christmas to the employes of the New York Talking Machine Co. meant more than long hours and the handling of a tremendous volume of business.

Piled high underneath the tree were gifts and packages for everyone. A. D. Geissler, president, after distributing the many gift boxes, surprised each of the group with a Christmas envelope, which, as he stated, expressed in a

Athletic Club. Gathered about the table, which was artistically and gayly appointed for this occasion, were a happy group of people. The dinner, dancing, and merrymaking made New Year's Eve a memorable one for Mr. Keith's guests, one of whom was Miss Marie Morrisey, the attractive and talented concert contralto.

At 12 o'clock Mr. Keith wished to the group, and to each one individually, a New Year filled with health, happiness and prosperity, and the return toast to him voiced the feeling of fellowship, good-will and co-operative spirit that

is a very noticeable feature in the New York Talking Machine Co. organization.

335 STARS IN EDISON SERVICE FLAG

Service Banner Measuring 20 by 12 Feet Now Hangs at Entrance to Laboratories

At the entrance of the Edison Laboratories in Orange, N. J., hangs the great Edison service flag, twenty feet long and twelve feet wide, and bearing 335 stars, each one representing an employe who has gone from the Edison plants to render active service to his country in this present emergency. The flag not only serves to eulogize those who have entered the service, but likewise acts as an inspiration to those who are still following their peaceful pursuits while awaiting their turn to serve.

SOME NEW CORPORATIONS

The Superior Mfg. Co., Wilmington, has been incorporated under the laws of Delaware with a capital stock of \$350,000 to engage in the manufacture of talking machines.

The Electrone Co., Inc., Dover, has been chartered under the laws of Delaware with a capital stock of \$100,000 to engage in the registration of vocal and instrumental sounds on discs, etc., in other words, to make talking machine records.

The Uniset Reproducer Co., Chicago, has been incorporated with a capital stock of \$25,000 to manufacture mechanical devices for phonographs and musical instruments.

Articles of incorporation have been filed by the Melodious Reproducer Co., of Milwaukee. The capital stock is \$25,000, and the promoters are Clarence M. Ustick, Everard H. Grove and D. C. Van Dyke.

The National Phonograph Co., Chicago, has been incorporated with a capital stock of \$10,000. The incorporators are Martin Rasmussen, Harry Rasmussen and Frank Cummings.

GRINNELL'S RECORD SERVICE

A GOOD FEATURE TO PUSH—

Victor Records of

**"FIRST AID"
FRENCH**

FOR AMERICAN SOLDIERS

There's a vast field here for business—an already present demand.

Have the French course in stock. It is in a sense a patriotic duty—and insures added profits.

Send Us Your Order Today

Glad to place you on our list to receive our advance announcement of best selling Records regularly each month.

You'll find it of value. To have us mail this doesn't obligate you in the least.

—Through its promptness; the vast extent and completeness of our stock; the care with which every order is filled; the transportation facilities at our command and the unswerving aim to be of definite assistance to the dealer in building a greater Record business—

Affords for you a most satisfactory means of, at all times, keeping your stock at highest point of completeness—and best serving your record buying public.

A constantly increasing number of aggressive dealers are taking advantage of our superior service. You'll find it not only pleasing but helpful. *Try us on your next order!*

Grinnell Bros

Distributors, Victrolas and Records

First and State Streets, Detroit

Run your busin

Make them carry the burden, then your profits on the Machines will be NET! Don't say "It can't be done." Others are doing it.

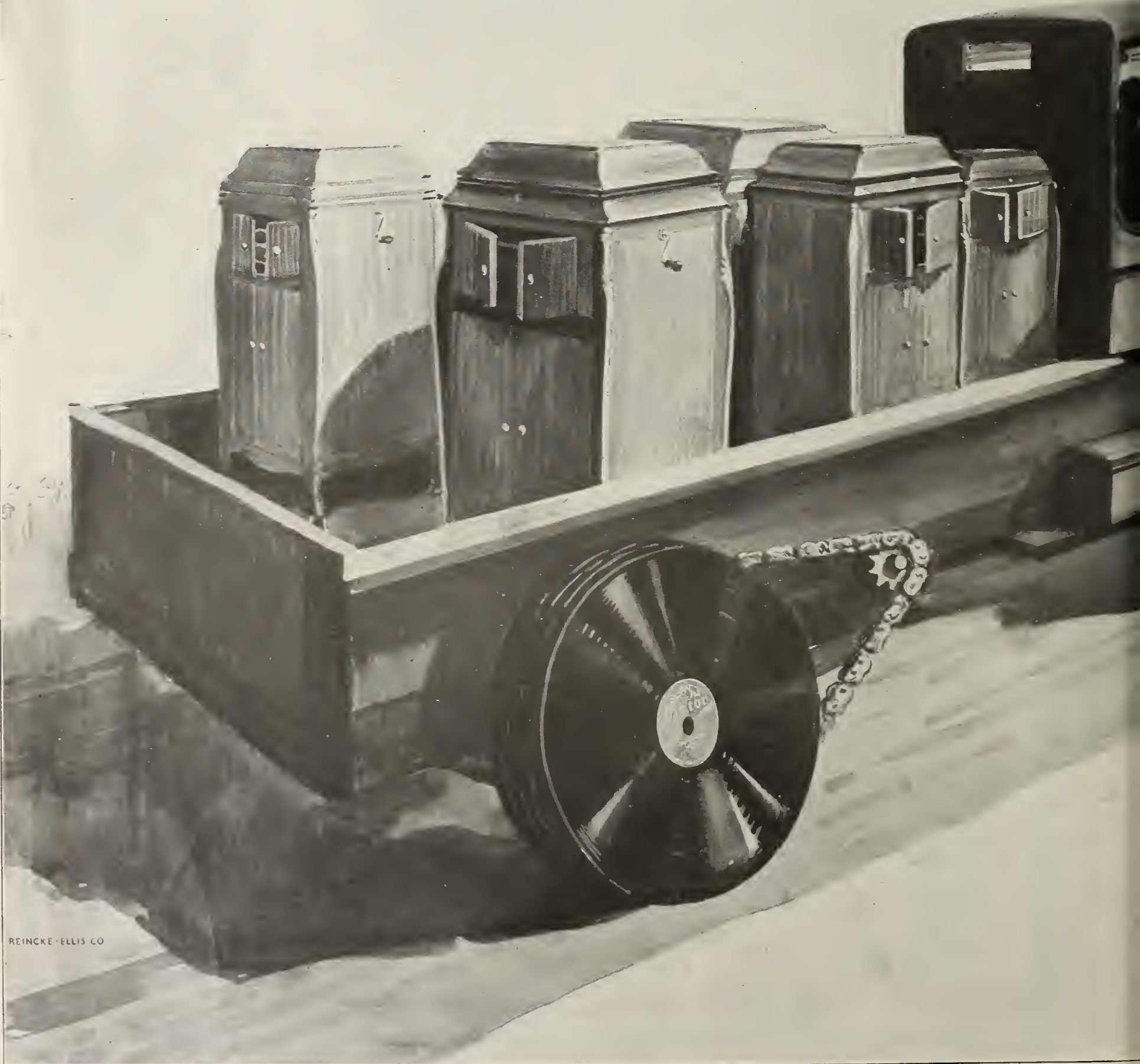

ess on Records!

Push Records and push them hard.
Nearly every Victor owner can be
made a regular purchaser of Records
instead of an occasional purchaser.

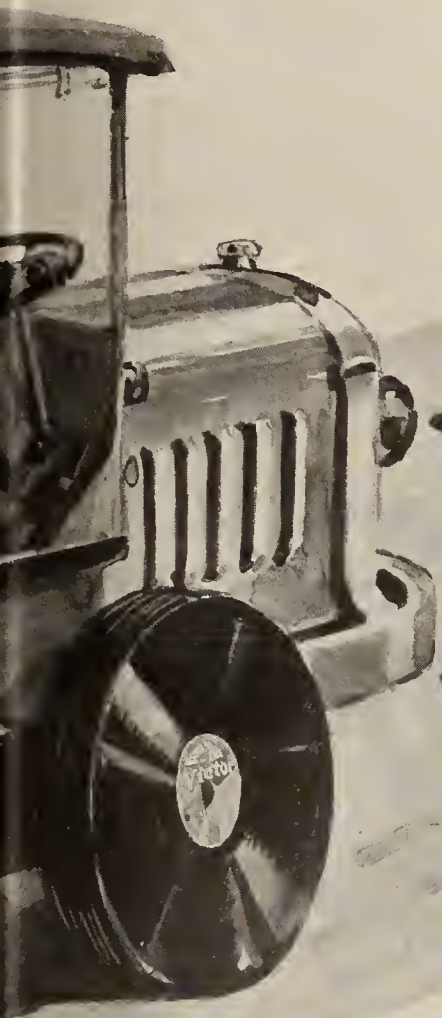

MAKE 1918
RECORD YEAR

Largest Stock of
Victor Records
in the Two Largest Cities

Victor Wholesalers

Chicago Talking Machine Co.
12 N. Michigan Ave., Chicago

New York Talking Machine Co.
119 W. 40th Street, New York

BRUNSWICK PROGRESS IN THE EAST

Exceptional Holiday Demand for Brunswick Phonograph—Sales Conference in New York—New Representatives Announced—Anxiously Awaiting the New \$1,500 Art Model

The New York offices of the Brunswick-Balke-Collender Co. have concluded an exceptionally fine holiday season, exceeding in volume of business the same period of the year previous.

During the last week of December a sales conference of twenty-five representatives of the company was held at Thum's, on Broadway, after which all "did their bit" at a banquet which was served. At this meeting plans were made for the coming year and new policies were adopted increasing the already high facilities of the organization.

It is announced that the following new salesmen have joined the Brunswick staff: F. H. Walter, E. S. Campbell, J. H. Wengrovius and Chester Abelowitz, men who are well known in the field and experienced.

All members of the sales staff are awaiting eagerly the coming of the new \$1,500 model of the Brunswick, which is expected to arrive almost any day. Advance information states that this new model will be finished both in English brown mahogany and American walnut and equipped with the universal electric motor. As no advance photographs of the new machine have as yet been received there is a great amount of interest in its arrival.

The New York office have been very busy opening new accounts during the past month. Among them might be mentioned, Edward Strauss, 94 Court street, Brooklyn; the Flatbush Music Co., 932 Flatbush avenue, Brooklyn; the Riley-Hogan Co., 125th street, and a department in the large department store of H. C. F. Koch & Co., 125th street. In the last case the New York office of the Brunswick-Balke-Collender Co. operate the department themselves. Reports already received from these new dealers indicate the popularity of the Brunswick machine in their locality.

NEW COMPANY FORMED IN TEXAS

Verhalen-Delphoon Sales Co., of Texas, to Distribute Products of Delphoon Co., Bay City

DALLAS, TEX., January 8.—A company has been organized in this city for the purpose of distributing the products of the Delphoon Co., Bay City, Mich., in Texas, Oklahoma and the Southwest. This company will probably be known as the Verhalen-Delphoon Sales Co. Walter Verhalen, of Dallas, is at the head of this organization, and is now making plans whereby the dealers in this territory will receive efficient service and co-operation. Mr. Verhalen made a trip to Chicago some time ago to look over high-grade lines of talking machines. While there he saw and heard the Delphoon, and was so favorably impressed with this instrument that he visited Bay City and closed the deal for distributing rights in his territory.

NEW REPRODUCERS ANNOUNCED

New England Talking Machine Co. Calls Attention to New Line of Perfection Flexi-tone Reproducers and Points Out Their Advantages

BOSTON, MASS., January 5.—The New England Talking Machine Co., of 16 Beach street, this city, announce their new Perfection Flexi-tone reproducers to the trade. These new reproducers allow for great interchangeability of records among the various talking machines. A very attractive circular is being sent to the trade calling the attention of the dealer not only to the many merits of the reproducer, but also the great sales help it affords the dealer. Perfection Flexi-tone reproducers attached to Perfection ball bearing tone arms Nos. 3 and 4 play all lateral cut records on all types of Edison disc machines and Perfection Flexi-tone reproducers Nos. 3, 6 and 7 are designed to fit all types of Victor and Columbia machines. It is claimed for these reproducers that they have a wonderful clarity of sound and will reproduce the sounds as perfectly as the recording at the laboratories, from the highest to the low-

est sounds. The New England Talking Machine Co. and its president, Chas. P. Trundy, are well and favorably known to the trade and their new product will, no doubt, receive the high popularity that it deserves.

PLAN TO SIMPLIFY BUSINESS

Credit Men Suggest Rules After Studying Office Procedure That Are Worthy Consideration

In order to co-operate to the greatest possible extent in supplying the nation's need of men for war service, the National Association of Credit Men recently made a study of office procedure, with a view to economizing labor there by simplifying processes. As a consequence J. H. Tregoe, secretary and treasurer of the association, was provided with three rules, copies of which he has sent out to all members of the association, with the statement that they were drawn up by the Committee on Commercial War Economy, and the request that they be observed. The rules are:

"1. That checks received in the course of merchandising, and unimportant letters and communications, be not acknowledged.

"2. That every dispensable and non-productive office or business device or system that can be released without decreasing the real abilities of the business be suspended during the war.

"3. That credit departments shall not inquire of other departments in unimportant cases, and that promiscuous and merely general inquiries be discontinued."

Mr. Tregoe, in the letter accompanying these rules, points out that even small economies of this description in office procedure may not only, in the aggregate, prove of value in conserving the working resources of the nation, but may also be vitally important in enabling the individual business to weather the hard times of the war period. These suggestions are well worth adoption by talking machine dealers who are seeking efficient methods of transacting their business.

DIE CASTINGS

Our greatly increased
plant enables us to ac-
cept orders for

Immediate Delivery

NATIONAL LEAD CO.

111 Broadway

New York City

LOS ANGELES BREAKS ALL PREVIOUS TRADE RECORDS

Every One Pleased With Volume of Business for 1917—Uneasiness Regarding the Securing of Stock in View of Transportation Conditions—Window Displays Receiving Much Consideration

LOS ANGELES, CAL., January 5.—In spite of the shortage of stocks and the slowness with which freight has been moving during the fall months, all previous records were broken in the talking machine business during the month of December. The demand for the medium-priced machines was noticeable, but a great many more than usual were disposed of during the holidays. Not that the large models were entirely overlooked, as a good many nice sales were made by the local dealers in the more costly designs, but the mass of the people seemed to be interested in machines from \$100 to \$150. Both record and machine stocks are very low at present and there are probably fewer machines and records in Los Angeles to-day than ever before at this time of the year. The outlook is not good for a replenishment at present, as the jobbing houses are not holding out any hopes for any shipments in the very near future. Just what the outcome will be is problematical, and in the meantime dealers are talking up the models they have in stock.

Just what effect the taking over of the railroads and steamship lines by the Government will have on our transportation facilities is a question at present. However, all local dealers are hoping for the best, as they figure that unless freights are entirely stopped they cannot be any worse off than they have been for the past six months. All indications point to a good business during January, as great activity is being shown in all lines of business. This part of the country is badly in need of rain, and although no damage has been done so far some of the crops will be much shorter than usual if we do not get some rain in the very near future.

Barker Bros. had a banner holiday trade and C. B. Boothe, their manager, says that all past records for December were broken. Barker's had the usual trouble in getting records and certain models of machines, many of which were entirely out of stock before Christmas. Mr. Boothe reports the sale of one of their own make period models. This was a very handsome machine and was so constructed that either the Edison Disc, Victor or Columbia interior could be installed. Price, \$1,250. The volume of business was so great that Mr. Boothe was compelled to close the talking machine department at 5.30 on Monday, the 24th, in order that the force could catch up with their orders.

C. S. Ruggles, manager for Sherman, Clay & Co., local Victor jobbers, says that he is thinking seriously of taking a vacation unless he is able to get some goods in the near future. Victor dealers all over Southern California are clamoring for machines and records and the Sherman, Clay & Co. stock is, of course, getting perilously low.

The Diamond Disc Distributing Co., local Edison jobbers, report a tremendous business in both Edison disc and cylinder machines and records. The C 250 and C 150 models were the best sellers during the holidays and Mr. Lovejoy, the manager, says they are running short on these two models and future shipments from the factory are uncertain. There was a big demand for the new Edison period model, the William and Mary, and all the dealers were sold out before Christmas. This is bound to be a popular machine and a ready sale for it is assured when the jobbers receive a new shipment.

The Southern California Music Co. just closed a most prosperous holiday business and many more machines and records were sold than ever before at this season. A large number of standard models were sold, but the medium-priced machines were mostly in demand.

The Columbia Graphophone Co., wholesale, report a fine business during December, and were in a better position to supply their dealers than the other jobbers, as they had an extra large stock on hand before the demand became so heavy. The Columbia Co. has put in quite

a number of new licensed dealers in Los Angeles during the last year, and report that they are all doing well and steadily increasing their business.

All local dealers are paying more attention to their windows than ever before and during Christmas week some very unique and beauti-

ful window displays were on exhibition, and attracted an unusual amount of interest and comment. This city has long been famous for its fine show windows, and during the last two or three semi-annual Fashion Shows the music stores and window displays have compared favorably with some of those of the smartest shops on Broadway. The people of this city are great "window shoppers," and the talking machine dealers are awaking to the fact that their windows can be dressed in such a way that they will greatly increase their business.

THE VALUE OF GOOD ADVICE

A New York business man relates that an employe of his, after being in business about eighteen months, found it difficult to meet his obligations. He said, in commenting on the case:

"As it not infrequently is found to occur in such cases, he was fairly beside himself and requested me to call on him. After giving me a résumé of his affairs his first impulse was to consult a lawyer. Instead of doing this I advised him to see his creditors, be open and

above-board with them, and explain affairs as they actually existed. At first he remonstrated, but when I demonstrated to him that no possible harm could result in doing this he finally decided to adopt my idea, and he called a meeting of his creditors.

"His creditors, almost without exception, acted splendidly toward him, with the result that he is still in business and gradually getting on his feet again.

"I am strongly of the belief that if more and wider publicity were given to this method it would be an advantage to debtors and creditors."



Accessories

FOR THE

VICTOR

WE

Carry Them All

- Record Cabinets
- The Ready File
- Record Albums
- Dealers' Stock Envelopes
- Record Delivery Bags
- Fibre Needles
- Fibre Needle Cutters
- Playrite Steel Needles
- The Record Lite
- Victrola Cabinet Polish
- Three-In-One Oil
- Oil Cans
- Supplement Mailing Envelopes
- Victrola Price Cards
- Record Carrying Cases
- Record Easels for Window Display
- and
- Many Others

WE CAN SUPPLY YOU WITH ANYTHING IN THE WAY OF ACCESSORIES

If your Distributor is unable to give you this service send your order to





Blackman

TALKING MACHINE CO.

97 CHAMBERS ST. NEAR CHURCH ST. NEW YORK

VICTOR DISTRIBUTORS

Why the Century Phonograph Needs No Introduction

Two Popular Century Models

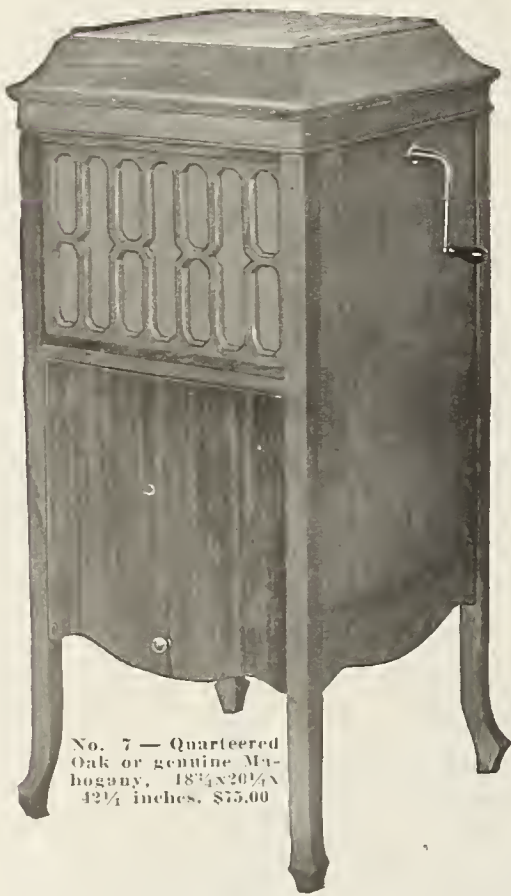

No. 7 — Quartered
Oak or genuine Mahogany. 18 3/4 x 20 1/2 x
42 1/4 inches. \$75.00



No. 3—Oak or Imitation Mahogany.
17 x 18 1/2 x 13 inches high, \$30.00

☞ The Century Phonograph is built and guaranteed by the Century Cabinet Co., for many years the leading manufacturer of talking machine cabinets.

☞ The cabinets are the best that the market affords; the tone quality is the result of actual laboratory experiments; the constructional equipment includes the best "Universal" Tone Arm on the market and the recognized leaders in other equipment.

Century Phonographs

Can be sold by
the dealer with

Confidence!

☞ The Century line is complete, and our dealer proposition insures your success.

WRITE TODAY FOR
OPEN TERRITORY

Century Cabinet Company

25 West 45th Street, New York

Factory—Utica, N.Y.

DETROIT TRADE STARTS THE NEW YEAR IN BUOYANT MOOD

Closed Most Satisfactory Business in 1917—Freight Congestion and Shortage of Stock Badly Felt—Detroiters Without Exception All Optimistic—Good Work of the Local Association

DETROIT, MICH., January 7.—Well, one more year has passed and it is indeed gratifying to know that the talking machine industry has prospered during the preceding twelve months and that the coming twelve months are very encouraging for good business. With very few exceptions every dealer in Detroit says he enjoyed a very good trade during 1917—better than the year before—and that the new year has started off excellently. The holiday business in December was very brisk, even if it did come in the ten days before Christmas! The early part of the month was just fair, but it brightened up considerably right after the 15th. The shortage of some particular models did not seem to make much difference because dealers were able to sell the customers something else. The announcement by many dealers that prices would advance January 1 had a lot to do no doubt with getting people to buy in December. December was a good month, and January will be a good month as compared with a year ago.

Record business is excellent even right now and has been. Patriotic popular numbers, such as "Over There," are in demand and are selling fast, as are also good dance numbers.

Now that the old year has elapsed some of the dealers are planning an early departure south for recreation and rest. C. A. Grinnell, of Grinnell Bros., will leave any day for his winter home at Sea Breeze, Fla., while Max Strasburg is planning to go golfing at Pinehurst. Others will take short vacations, feeling that they have earned the same after the strenuous December.

The coal situation is proving somewhat of a setback to business, many families doubling up, and not buying machines as they had previously intended. However, this condition is not interfering with the record business, which, as before stated, is just as brisk as ever.

The Edison Shop, according to R. B. Alling,

had a dandy year in 1917, many good dealers having been added to the list. Retail business in Detroit and throughout the entire territory has been on the increase.

Frank Bayley, Edison dealer on Broadway, says that his Edison business ran far ahead of expectations. He and the Edison Shop comprise the only downtown dealers and naturally their business would be good. The Edison Shop used many half and full pages in the local papers during December, which helped all Edison dealers.

Ed Andrew, manager of the talking machine department of the J. L. Hudson Co., says: "We more than reached our quota for December, also for the twelve months of 1917—so that we haven't the least complaint to make. We have been very careful in our credit department so that our collections have been unusually good. You know it's not always how much goods you can sell as how much you can actually collect each month." The Hudson store is now selling both the Victrola and the Sonora, and has been boosting both of them very strong.

Wallace Brown, now dealer for Brunswick phonographs, said he had a dandy holiday business, selling a great many more machines than he had really planned for. He is determined that 1918 shall be even better. Frankly, Mr. Brown did not expect a big business during 1917 on Brunswicks, feeling that it would take six or seven months properly to introduce the phonograph to the Detroit public.

The Detroit Talking Machine Dealers' Association has accomplished excellent results during the year just passed. Some very bad trade evils have been eliminated, partially or wholly, and only by proper co-operation. The organization has been working harmoniously and every member feels that he has received more than his "money's worth" for his dues. During 1918

even greater results will be accomplished, if the plans in contemplation do not go amiss.

Generally speaking, Detroit looks mighty good for 1918. Its industries are staple; war orders for trucks, munitions and shells, running into millions and millions of dollars have already been let, and a number of new million-dollar factories are being erected to handle nothing but war orders. In addition, it is expected to make Detroit the center of the manufacture of airplane motors and parts, and already several big orders in Detroit have been placed by the Government. Detroit business men are all optimistic and really believe that 1918 will be one of the greatest years in the history of the town.

Keenan & Jahn did a nice December business with the Aeolian-Vocalion. It was really their first month with this line. John D. Angeli, manager of the new department, says that a great many people have been in "looking" with promises that they would buy later.

Sam Lind, Columbia manager, says he has had a very big year, with more and better dealers than ever before.

Williams, Davis, Brooks & Hinchman Sons, Michigan Pathé jobbers, had more business in 1917 than they thought it possible to secure, and are exceedingly well pleased with their affiliation with Pathé. They have disposed of more machines and records than they originally planned on, and have surprised the factory several times with telegrams for more goods. They now have a big stock and are in excellent condition to fill orders from their dealers.

LOCATED IN NEW QUARTERS

The M. A. Barker Music Co., Poplar Bluff, Mo., is now located in new quarters in the Greer Block, that town, where they are featuring Columbia Graphophones, Starr phonographs and other musical goods.

The Browne-Wolf Drug Co., of Healdsburg, Cal., with headquarters on West street, has taken the agency for the Victor talking machine.

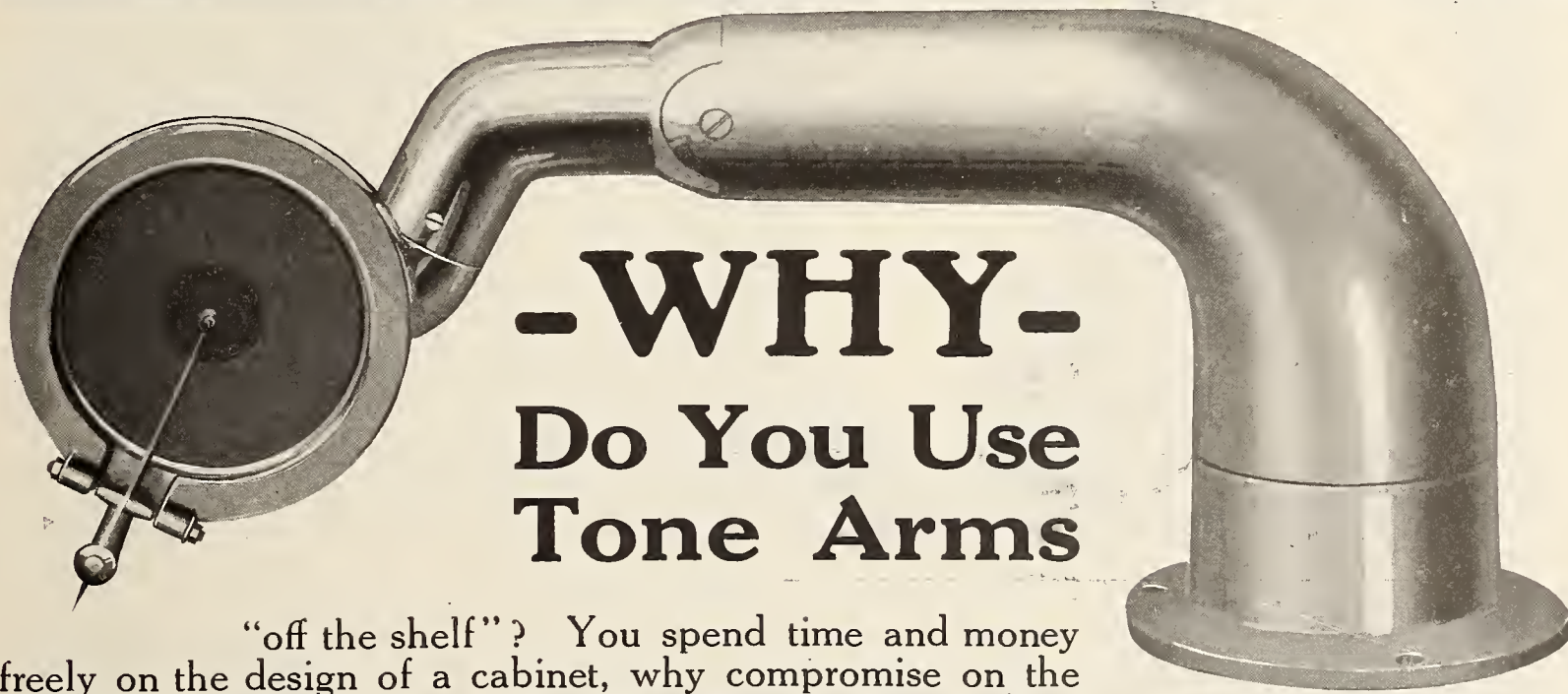

"off the shelf"? You spend time and money freely on the design of a cabinet, why compromise on the tone arm? Why don't you put the same thought into the tone arm? Make it at least as distinctive as the cabinet.

We have experts who are specialists in designing tone arms that will blend with your cabinet in quality and appearance—that will continue quality unbroken from sound chamber connection to stylus groove.

These men are ready to serve and prove to you by sketches and figures that "INDIANA" made tone arms will increase the value of your machine and make it a better selling proposition.

Bear in mind that acceptance of this service does not obligate you in any way and anything developed for you is for you exclusively, and is not sold or sampled to your competitors.

WE ESTIMATE FROM SAMPLE OR BLUE PRINT

"INDIANA" DIE CASTING COMPANY

East 11th Street at Cornell Ave.

INDIANAPOLIS, IND.

SAFETY UNDERNEATH

You'd naturally expect to find the most advanced shop methods and equipment used by the plant that produces phonographs so well and widely known as those which bear the name of

TRADE MARK
Thomas A Edison

If these large manufacturers consider it advisable to use

Faultless Pivot-Bearing Casters

on their product, that's a safe lead for you to follow.

A word from you puts all our caster experience at your service—brings you samples and a copy of FAULTLESS Catalog "G."

Faultless Caster Company
Evansville, Indiana

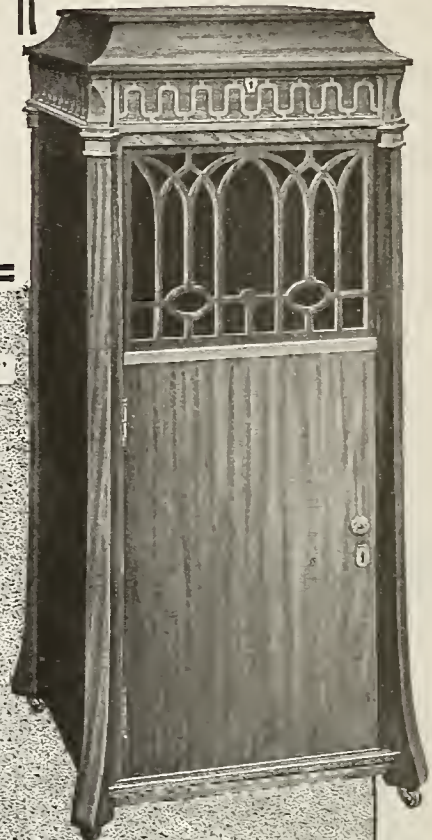

"It Moves the FAULTLESS Way"

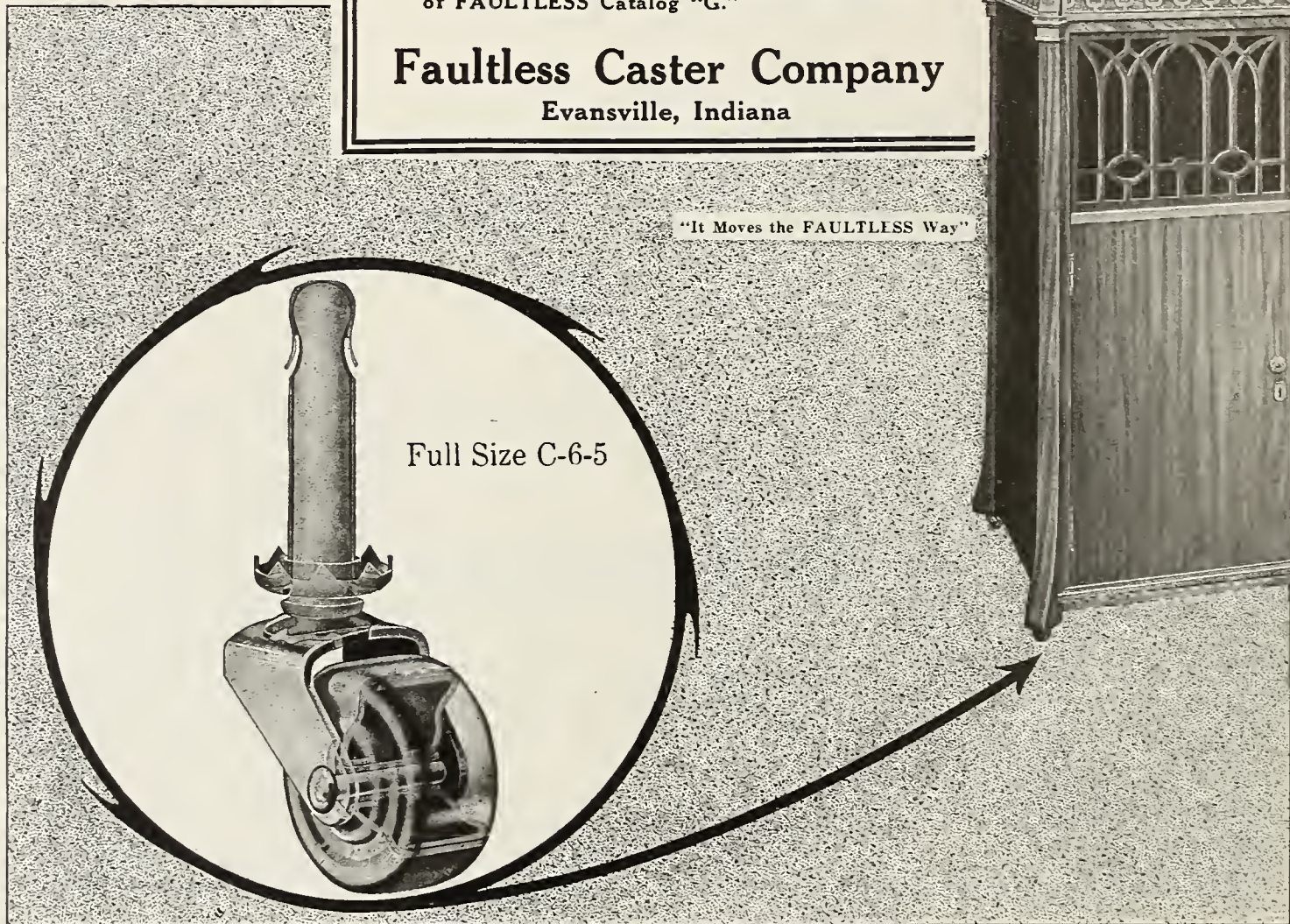

OVER 500 VICTOR MEN IN SERVICE

Roll of Honor, Bearing Names of All Those Now in Armed Service of Country, Now Installed in Hall of Administration Building

In paying tribute to the hundreds of their employes who have entered the military service of the country, the Victor Talking Machine Co. has departed from the service flag idea and as a result there now appears in the main hall of the Administration Building in Camden a tall mahogany pedestal, surmounted by a silken American flag and bearing, on swinging panels, the names of the Victor employes to the number of over five hundred who have entered the service of Uncle Sam, together with the department in which they had been employed. Surmounting the roll of honor is a placard on which appears the following: "In appreciation of the splendid display of loyalty by members of all departments, the directors of the Victor Co.

have ordered that this roll of honor, containing the names of the employes who are known to have gone direct from this plant to join the armed forces of the country, be posted and maintained during the period of the war."

ENTERS THE FIELD IN MILWAUKEE

Triumph Phonograph Co., Organized in That City, to Manufacture Machines of New Type

MILWAUKEE, WIS., January 7.—As the result of years of study of the reproduction of the human voice by mechanical means, Albert C. Ehlmann, a well-known singer and musician, has evolved a new phonograph which will be manufactured and marketed under the name of the "Triumph." Mr. Ehlmann has organized the Triumph Phonograph Co. with a capital stock of \$25,000 for this purpose, and with him are associated Julius E. Kiefer and Robert A. Kiefer. Offices have recently been opened in this city.

The Triumph Co. has decided for the present to contract for the manufacture of its product. It has made connections with concerns specializing in such work so that the machine will be constructed strictly in accordance with the plans of the designer and under his direct supervision. Mr. Ehlmann has been elected secretary-treasurer and general manager of the new company. Julius E. Kiefer is president and Robert A. Kiefer is vice-president. An active selling campaign is now being planned.

GRAND RAPIDS DEALERS TO MEET

GRAND RAPIDS, MICH., January 7.—The annual meeting of the Grand Rapids Retail Music Dealers' Association will be held on January 17. An elaborate program is now being worked out for the occasion. Otto Friedrich, of the Friedrich Music House, and Clayton Hoffman, of the Herrick Piano Co., are in charge of the arrangements.

HELPS MUSICAL APPRECIATION

The Important Part Played by the Talking Machine in Stimulating a Love for Music Forms Subject of Editorial in Munsey's Magazine

In the December issue of Munsey's there was an excellent editorial in which the importance of the talking machine and the player-piano as factors in musical development and appreciation was dwelt upon in a very sympathetic way. These two instruments were estimated as among the most notable inventions of the age, and it was pointed out that the true musical artist neither feels nor affects contempt for the talking machine or the player-piano. In this connection the writer says:

"He (the artist) knows that the roll of perforated paper can sound chords which the fingers of Paderewski cannot compass; that the earliest appreciation of musical timbre and orchestral coloring may be derived from half a dozen black discs.

"In music, as in every other art, the first requisite to the development of a sound and cultivated taste is frequent contact with the work of artists. A person of sufficiently acute mind, hearing music and more music and more music of all kinds, could conceivably end by deducing for himself every principle on which music is based. A person of merely average intelligence who will use it as he listens will, if opportunity to hear music comes often, arrive eventually at a fair understanding of what constitutes good music. More than that, he will have some inkling why it is good, and will appreciate what he hears at somewhat near its actual worth.

"The case for vocal music is even stronger. We shall have an unusual lot of it this winter, and the reference is not to concert platforms, but to chorus-singing in the home, in the church, in the camp. The chorus is a community enterprise hitherto undeveloped in America, but less likely to suffer neglect in the future. Interest in choral singing has been powerfully stimulated by the plans of Major-General Franklin Bell and others to make the American soldier a singing soldier because, as General Bell rightly declares, a singing soldier makes a fighting soldier. Choral singing is capable of developing more enthusiasm than any other form of the musical art. It can progress to the heights of Parnassus, and it carries the singer with it.

"The secret does not lie in the artistic knowledge and appreciation acquired, but in the kindling of generous emotions, their liberation or 'motor discharge,' as psychologists would say;

above all in the creation of that contagious fellowship and general good-will which are vital to the success of an army and richly profitable to the life of each single human soul."

COLUMBIA MANAGERIAL CHANGES

Geo. W. Hopkins, General Sales Manager of the Columbia Co., Makes Important Announcement

Geo. W. Hopkins, general sales manager of the Columbia Graphophone Co., New York, has announced the following organization changes effective as of January 1:

R. J. Whelen, manager, Cincinnati branch, resigned.

F. F. Dawson, of the general sales department, temporarily in charge of the Cincinnati branch, as acting manager.

F. A. Denison has been appointed manager of the San Francisco branch.

K. Mills has been appointed assistant manager of the New York branch.

S. H. Nichols, at his own request, has been appointed manager of the Pittsburgh branch.

H. A. Yerkes has been appointed field sales manager, and, as the title indicates, will actively represent the general sales department in the field.

CATALOG OF THOMAS PHONOPARTS

Details of the Dayton Motor and Other Talking Machine Accessories Made by Thomas Mfg. Co. Set Forth in Elaborate Manner—New and More Comprehensive Catalog Now in Work

A booklet that should prove of interest to talking machine manufacturers or those who contemplate entering that field is the elaborately designed illustrated catalog of phonoparts issued by the Thomas Mfg. Co., of Dayton, O., recognized as among the largest manufacturers of motors, tone arms, sound boxes and talking machine parts for the trade. The present catalog of the company serves to show various models of the Dayton motor complete and ready for installation, and with the various excellent features clearly indicated.

Facing the pictures of the motors there appear plates showing the various parts disassembled. Each part is carefully numbered, and the name of each appears in a list printed underneath the plates.

The second section of the catalog is used to illustrate and describe the various models of tone arm and sound box combinations, with the specifications of each detail carefully set forth. Special attention is given to descriptive matter regarding the Dayton sound boxes. Turntables and other Thomas Co. products also receive attention in the catalog.

Of general interest are excellent views of the exterior and interior of the great Thomas Mfg. Co. plant, illustrating the actual work of making phonograph parts, and two pages given over to a semi-editorial on building business and emphasizing the qualities of the service idea.

The Thomas Mfg. Co. announce that they have now in preparation a new and more elaborate catalog which will be ready for publication in a few weeks.

OVERENTHUSIASM UNWISE

Many advertisements are made misleading, not through any deliberate intention of being dishonest, but because of the overenthusiasm of the advertising man who somehow seems to think that the goods and values his store has to offer are far better than those of any other store. He feels that each item advertised has to be lauded to the skies, although, as a matter of fact, it is just an ordinary piece of merchandise at a fair price. That is the reason many old established stores prefer to print advertisements with little descriptive matter.

The Wasech Phonograph Co., Salt Lake City, Utah, has changed its name to the Ashworth-O'Loughlin Co.



No. 1410. Rim Table for Victrola IX or IXA Mahogany Holds 5 Victor Albums

During 1918

you want to hit the bull's-eye of prosperity. The dealer who handles the Udell line of cabinets is certain to increase his profits in a handsome way, because Udell cabinets are quality-famous throughout the entire country and because Udell products bear a well-known trademark toward which both the trade and the consumer public have learned to look with confidence.

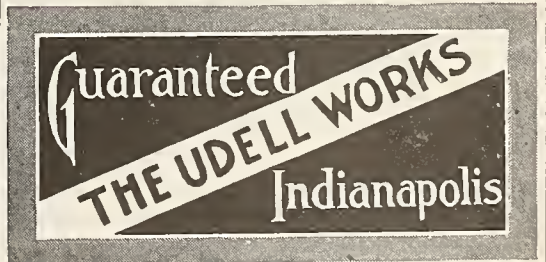

TRADE MARK

Start the new year by writing for our catalog.

THE UDELL WORKS

1205 WEST 28th STREET

INDIANAPOLIS, IND.

A BIG DEMAND

Throughout the Country for

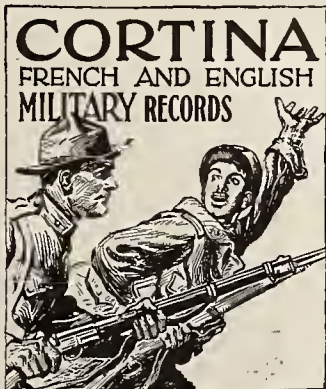

Get your share of this business. An ideal gift for the boys in training or the trenches. It often sells a machine with it.

The course consists of an authoritative Military Manual containing a foreword by Major-Gen. Leonard Wood.

WITH TWENTY PHONOGRAPH RECORDS (10-12" double face discs). Send for full information. Advertising matter, military poster-hangers free.

Also Spanish, Italian, German, and English and French for Spaniards

CORTINA ACADEMY OF LANGUAGE
12 East 46th Street, New York

Why the WALL-KANE STEEL NEEDLE

is superior to any ordinary steel needle and why it plays 10 records perfectly

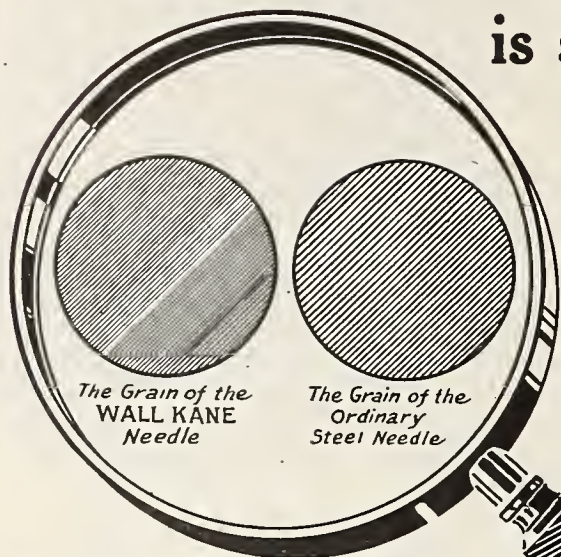

No. 1

No. 2

The Wall-Kane Steel Needle is the finest grade of ordinary domestic steel needle, wonderfully improved by chemical processes, which, briefly described, are as follows:

The highest grade of steel needle of domestic manufacture, and playing one record only, is first subjected to chemical processes by which the grain of the needle is made very much finer (see illustration under magnifying glass).

After this process the needle looks all black, like illustration No. 1. Considerable quantity of the charcoal in the original needle is now eliminated, and the needle greatly strengthened by the finer grains and the elimination of the charcoal.

The needle is then subjected to various chemical processes, which result in softening the point so that the grooves of the record are very much benefited. While in this process the needle looks like illustration No. 2.

Three different coats of certain chemical solutions are then placed on the point of the needle, so that, by the protection afforded by these coatings, the needle will positively play at least ten records before the friction with the grooves reaches the original grain of the point.

BEWARE OF IMITATIONS

This handsome metal enamel display stand holds 60 packages, 2 doz. extra loud, 1 doz. medium and 2 doz. loud; each package containing 50 WALL-KANE NEEDLES, retailing for 10c. Price of stand to dealers, \$4.00. Single packages, 6½c.



Jobbing Territory
Open for
Progressive Houses

PROGRESSIVE PHONOGRAPHIC SUPPLY CO.

145 West 45th Street

NEW YORK

WORKING IN CAMP FUNSTON ZONE

The Schmelzer Arms Co., of Kansas City, Are Catering to Needs of Uncle Sam's Boys—Handle Great Volume of Holiday Business

KANSAS CITY, Mo., January 3.—The Schmelzer Arms Co., prominent Victor wholesalers and dealers, who have as their slogan: "The most interesting store in Kansas City," report an unusually active holiday season, despite the fact that they saw real money getting away from them owing to a serious shortage of Victor goods. The Schmelzer Arms Co., however, in addition to being talking machine jobbers, are also one of the largest sporting goods houses in the world, and have a building with a 125-foot frontage, devoted to sporting goods of all kinds. There is even an entire floor devoted to toys which is a mighty active place just before Christmas.

The talking machine business during the holidays was notable for the demand for the higher priced machines, although there were quite a few medium priced outfits purchased for the boys in the military camps.

The Schmelzer Arms Co. recently opened a completely stocked store in the zone established just inside the reservation at Camp Funston, Kansas, which is one of the largest camps in the country. The space in the zone is leased to concessioners by the Government and each concessioner must erect his own building, although all must be of uniform design. In the zone are to be found three theatres, a billiard and pool hall, and stores of all sorts, the idea being to meet the demands of the soldiers without requiring them to leave the reservation and meet the temptations in the various towns nearby. The prices in the zone are practically governed by the general managing, and are in every case to the advantage of the soldiers. The Schmelzer Arms Co. building there is fifty feet square, and two stories high, and contains about practically everything in the sporting goods line from

clothes to fishing tackle. There are also talking machines and records on hand.

The company has closed the banner year in its history, due largely to the untiring efforts of the officers, who are Chas. J. Schmelzer, president and treasurer; Harvey J. Schmelzer, vice-president and secretary; Arthur A. Trostler, assistant secretary, and Stanford S. Madden, assistant treasurer.

ENLARGES ITS BOOTH EQUIPMENT

The Delpheon Sales Co., of New York, Augments Its Conveniences for Dealers

The Delpheon Sales Co., 25 Church street, New York, local distributors for the products of the Delpheon Co., Bay City, Mich., recently added a number of booths to the equipment of its New York ware-rooms in order that out-of-town dealers and interested music lovers might have maximum convenience at their disposal when listening to this successful phonograph. These booths are furnished attractively and comfortably, the furnishings and decorations being in complete accord with the musical qualities of the Delpheon and the success which it has achieved throughout the country.

J. D. Manton, head of the Delpheon Sales Co., is a firm believer in the value

of attractively decorated warerooms, and his stores are models in this respect. Well lighted and ideally arranged, his establishments have won the enthusiastic approval of all visitors. The Delpheon line is completely "at home" in New York, and the Delpheon Sales Co. is preparing to handle an extensive wholesale business in this territory during the coming year.

MISS TRUSSLER JOINS NAVY

Miss E. A. Trussler, a member of the Columbia Co.'s advertising department, has been appointed a yeoman in the U. S. Navy, and on January 1 assumed her new duties at the Brooklyn Navy Yard. Miss Trussler leaves for this patriotic work with the good wishes of all her associates, with whom she has been very popular for several years past.



The Attractive Quarters of the Delpheon Sales Co.

FROM OUR CHICAGO HEADQUARTERS

E. P. VAN HARLINGEN, Manager
H. SCOTT KINGWILL, Ass't. Mgr.

World Office
Republic Bldg., 209 South State St., Chicago
Telephone: Wabash 5774

CHICAGO, ILL., January 10.—What is the use of trying to do a thing yourself when you can get others much more competent to do it for you? The proper thing to do at the present time is to review the talking machine business for the last year and to make a forecast regarding the future. With this idea in mind the Chicago representative of The World asked a number of leading men in the talking machine trade of Chicago to do this very reviewing and prophesying. Of course, this is a very busy time. Inventories are in progress and plans are in the making for the new year. By no means all of the men who were written letters on this subject responded, but those who did accomplished the task to the entire satisfaction of the inquirer, who is very sure that the trade at large will read with great interest these communications. Here they are:

Griffith P. Ellis' Interesting Views

Griffith P. Ellis, sales manager of the Chicago Mfg. Machine Co., in discussing the business situation, said:

"After closing our books with the most successful month of the largest year in our history, I can't feel anything but pleased over general conditions in the talking machine business for 1917.

"The year was one that brought its alarms to the talking machine industry, just as it did to all others. It was a period of mental readjustment to wartime conditions, with no precedent to guide the trade, as in previous wartime periods the talking machine industry was not of any substantial proportions.

"When war was first declared there was a feeling of anxiety as to the future, but as the first few weeks passed after the declaration of war and retail sales remained about normal, the feeling of confidence returned.

"The two offerings of Liberty Loan Bonds also proved upsetting for perhaps three or four weeks around the period when the strong drive was on; but the lull in business was only temporary and was subsequently offset by increased purchases by the public shortly after the close of the bond selling campaign.

"Had these various economic disturbances been predicted at the start of 1917, it is quite possible it would have had a psychological effect on the campaigns of retailers, and it is

quite likely the results would not have been nearly so satisfactory. As nothing of this kind could be guessed at with any degree of accuracy early in the year, the trade naturally laid plans as in previous years and set out with the full determination to surpass 1916—the banner year in the talking machine industry.

"So well formed were these plans that practically without exception retailers were able to meet the emergencies arising out of our entrance into the war and pull through with a highly satisfactory year's business. Most retailers showed a splendid increase over the previous year's business, and I think I can say that without exception every account on our books showed an increase in record sales.

"Probably the most gratifying feature of the year's business just closed is the effort that was made by the more aggressive retailers to concentrate their efforts toward the increase of their record sales. Quite a few retailers showed the wisdom of devoting as much as 75 per cent. of their total annual advertising appropriation to featuring records.

"Many novel ideas were devised throughout the year, and the result was a very largely increased record business. In fact, this was the general condition with most of our accounts, and I think I am safe in saying that practically 98 per cent. of the accounts on our books showed record increases anywhere from 30 per cent. up to 200 per cent.

"It is a great satisfaction to feel that the retailers have come to a realization of the possibilities of this vitally important and profitable end of their business.

"The wholesaler had burdens to bear in the way of increased corporation income taxes and war taxes on floor stocks of machines and records that were not passed on to the retailer, and which made serious inroads in the net profits of the wholesalers. Our company, for instance, had to pay thousands of dollars in war taxes to cover our floor stocks—not one cent of which was passed on to the retailer or to the public.

"The Victor Co.'s action in absorbing the entire war tax on records gives splendid and praiseworthy evidence of their willingness to carry, in so far as they were able to do so, the increased burdens brought on us by the war.

"The reports of our traveling representatives

indicate there are no stocks in dealers' stores, and such machines as they are receiving from time to time are going right out immediately to take care of sales already made. The demand seems insatiable and there appears little likelihood that retailers will be able to accumulate any considerable quantity of machines during this year. The goods are sold before they reach the dealer's floor.

"With twenty billions of dollars being spent by the Government—with labor fully employed at higher wages than ever before—and with savings deposits for 1917 showing an increase of millions and millions of dollars (in spite of all the money that was invested in Liberty Loan Bonds, Red Cross, Y. M. C. A. and other wartime contributions) I can't see anything but a wonderful year ahead of us in 1918.

"I am, first of all, an optimist; but in view of the fact that the Victor Co. have orders for machines and records which will more than take their entire output for months to come, I can't see anything but hopeful signs for our business; and I believe that even the calamities of the world's greatest war will not bring about anything but continued good business, limited only by factory production."

Why Business Will Stand Under Stress

Lester E. Noble, manager wholesale talking machine department of Chicago branch of the Rudolph Wurlitzer Co., said:

"In going over the talking machine business for the year 1917, the most striking feature to my mind is that the business has proven itself to be one which will stand up under stress, such as has pervaded the country during that period. That fact signifies that the talking machine business is a standard line of endeavor and also signifies that the talking machine itself is a necessity. This latter point is proven by the fact that businesses consisting of the handling of articles that are not necessities have suffered terrifically during the last year, while the talking machine business has not only held its own, but has gone ahead of last year, in demand at least. Difficulties that manufacturers have encountered have tended to diminish the normal supply of merchandise, or at least to eliminate or cut down the usual increase in supply, but this fact, while appearing to be a handicap in the face of

(Continued on page 89)

THE "WADE" FIBRE NEEDLE CUTTER Is a Consistent Performer

The Wade

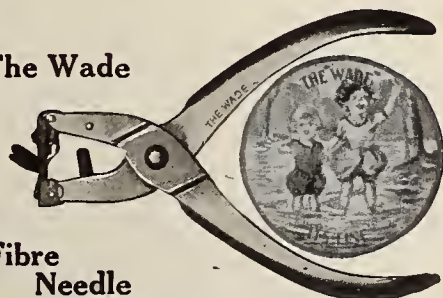

Fibre Needle Cutter No. 1
Price \$1.50

An Athlete or Race Horse is said to be a "consistent performer" when past performances are regularly repeated.

This is particularly true of the Wade Fibre Needle Cutter. It is now more than nine years ago that the "plier handle" fibre needle cutter was invented and patented by Samuel O. Wade and at no time since then has it failed in "consistent performance."

Nothing has yet equaled the simplicity and ease of operation of this plier principle—it gives 18 or 20 new, perfect points to a fibre needle even in the hands of a child—it is strong and durable and its material and workmanship are guaranteed.

"Consistent performance" is the secret of its large sales.

ARE YOU GETTING YOUR SHARE OF THIS BUSINESS BY CARRYING A SUFFICIENT STOCK AT ALL TIMES?

The Wade

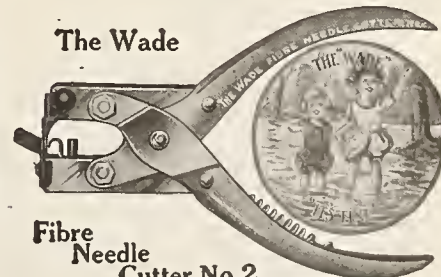

Fibre Needle Cutter No. 2
Price \$2.00

WADE & WADE, 3807 Lake Park Ave., Chicago, Ill.



Advertising is all right if you advertise all right



The meaning of the word Advertise is
"To cause a turning toward."

If printed announcements fail in this
respect they are, properly speaking,
not advertisements at all.



Subscribe to our Advertising Services
and get striking cuts for a purely nom-
inal price.



Victrola Advertising Service
52 Cuts a Year

Victrola Half Service
26 Cuts a Year

Victor Folder Service

Featuring Records. They Replace Envelopes for
Mailing Supplements

Victor Window Display Cards
They Help Popularize New Records

Small Goods Advertising Service
36 Cuts a Year

Piano Advertising Service

Free to Dealers Who Represent America's Popular
High Grade Piano

Samples and Prices Free—Write for Them
The cuts shown on this page are miniature reproductions



Copyright 1917

EVERYTHING KNOWN IN MUSIC

Lyon & Healy

VICTOR DISTRIBUTORS
CHICAGO



FROM OUR CHICAGO HEADQUARTERS—(Continued from page 87)

increased demand, has proven to be a benefit to the talking machine trade generally. It has proven a very great benefit from the standpoint of credit. The talking machine retailers have taken the instalment and record approval features of their business so much for granted that in a great many cases this feature of their business, which normally may be very good features, have become detriments to the business generally through loose manipulation. The shortage of incoming stock has tended generally to make them handle credits more conservatively as regards initial payments and length of terms, and logical limits with regard to approval sales, and in a great many cases which have come to the writer's notice, retailers have discovered that these features were not being properly handled heretofore. Another very good feature, brought about not entirely by the shortage of merchandise, but also by general conditions throughout the country, is that the buying of talking machines is being done more logically by the different classes of people. That is, people are buying talking machines of a price that is within their means, thereby making the business generally more healthy from the financial standpoint than has been the case heretofore.

"From the writer's viewpoint, the prospects for 1918 are very bright. The demand will, without doubt, be normal, and there is strong indication at the present time that the supply will be very nearly normal, and that there will be no radical interruption of manufacture."

The Government Should Encourage Business

Charles F. Baer, manager Chicago office Columbia Graphophone Co.:

"The year opened with a rush. Business was excellent, showing a substantial increase month by month over the previous year, notwithstanding that war was declared the early part of the year—the flotation of two issues of Liberty Bonds—which money would have under natural circumstances gone into the purchase of talking machines, musical instruments, automobiles, and what not.

"The public had just about survived the first bond issue and business was again commencing to get back into a normal state, when the second bond issue was floated and we are now recovering from that.

"The press and the public speeches of some of our bigger men have not been conducive to the proper advancement of business as a whole, for instead of dealing out encouragement, they have dealt out discouragement and yet with all this our business has been better than it was last year.

"There is no question but that the civic morale of our people in this country is bound to right itself, for in that respect we are the greatest nation in the world, and with all classes of labor in demand, with money flowing back and forth throughout the country, there can be only one answer for the year 1918—and that is: It will be substantially satisfactory from a business point of view."

Lyon & Healy Service

"Advertising is all right if you advertise all right" is the fundamental principle on which the service department of Lyon & Healy are working, and for that reason they are offering to their dealers printed announcements and cuts of every description in order to further the idea and instruct their numerous dealers as to the proper methods to employ in getting business. Not only is this department offering printed announcements to their dealers, but subscribers for their advertising service are given cuts to use along with their advertising "copy" that are very original and artistic in every detail. The price of this service is very nominal, and an idea of what this company is offering may be had from the following:

For Victrola advertising service they submit fifty-two cuts a year, or one each week, and for the Victrola half service twenty-six cuts a year or one cut every second week. For featuring records they have replaced the old style envelopes for mailing supplements and have gotten out a very interesting Victor folder for the dealer to send to his customers. Records are also popularized by Victor display cards which are gotten up under the personal supervision of a highly trained and specialized advertising manager, who has under his personal jurisdiction not only a large and highly competent force of copy writers, but also a staff of commercial artists, whose work is considered as being among the best in the city. The drawings that these artists turn out have all the simplicity of composition and line at their command that it is possible for artists to have. The figures used in these cuts, whether they be of line drawing, crayon or color, contain the necessary action and proportion that is necessary to make a drawing that will pass the eye of the most critical observer. Piano advertising is also handled by this service department and is offered to the dealers who represent the Lyon & Healy line of pianos. Circulars and prices are furnished upon application and a good idea of the draftsmanship that is rendered by the art department may be seen on the full-page advertisement of Lyon & Healy in this issue.

C. L. Davidson Recuperating

C. L. Davidson, president of the Talking Machine Shop, who was mentioned in the columns of *The World* last month as being confined to the hospital suffering with an attack of appendicitis and gall-stones, has improved very favorably since his operation and is now resting up at his home in Park Ridge.

Returned From New York Convention

Chas. F. Baer, general manager of the Chicago branch of the Columbia Graphophone Co., returned last week from New York, where he attended the annual convention held by that company on January 1, 2 and 3. They had three days and one night of solid session of interesting and enthusiastic business talks and much valuable information pertaining to plans and propaganda for the sales for 1918 were discussed. The information gained by Mr. Baer

was conveyed by him to his sales force at a banquet, which was held at the Palmer House, Chicago, on Monday of this week. There was a very interesting and enthusiastic meeting held after the banquet during which Mr. Baer conveyed the information he had obtained at the convention in New York. Every man in the sales force went away with a determination that he would "go over the top" in 1918.

G. I. Stanton Improving

G. I. Stanton, advertising manager of the Columbia Graphophone Co., has for the past two weeks been confined to the German Deaconess Hospital, where he is suffering with an attack of bladder trouble. Whether an operation is imminent is uncertain at this time, but it is thought by the physicians in charge that this will not be necessary as he has been improving greatly within the past few days.

Not Books, Why Music?

"Our business has stood the shock of diving into war with remarkable steadfastness, in spite of a great shrinkage in the market value of nearly all the gilt-edge securities, and in the face of a propaganda of retrenchment apparently backed by the Government the public does not see fit to lay aside the music of the phonograph," said C. E. Goodwin, manager of the Phonograph Co., Chicago.

"I quote a paragraph from a letter from Mr. Maxwell, vice-president of Thomas A. Edison, Inc., for the benefit of those in the trade who may at times have misgivings or qualms of conscience about keeping this trade in the front right now when there is so much strife and suffering in the world. Mr. Maxwell says: 'When you meet a man or woman who thinks a phonograph is an extravagance ask that man or woman if good books are an extravagance. There is scarcely anyone who would dare say that books are an extravagance, yet books have limitations that music does not have. Music, next to religion, is the world's greatest solace. Don't be afraid to stick up for music.'"

Sales Increased 100 Per Cent.

Messrs. Schiff, who control the destinies of the Vitanola Talking Machine Co., state that the sales of 1917 showed an increase of 100 per cent. over those of 1916. This is due in a large measure, no doubt, to the attractive new models that they have recently adopted. Vitanolas are good machines inside and out; so are the Schiffs, or they could not have accomplished what they have accomplished.

Made Life of Boys More Happy

The Armstrong Drug Co., Pontiac, Ill., recently opened a new Brunswick Shop. Dave C. Miller, manager of the new store, with the assistance of E. S. Bristol, special representative of the talking machine department of the Brunswick-Balke-Collender Co., formerly opened the affair, and nightly concerts were held for a week and were attended by great numbers of the townspeople. One of the most interesting happenings of the event was made possible through the courtesy of D. T. Trumbo, assistant super-

(Continued on page 91)

TRANSFER NAME-PLATES

We make the Transfer Name-Plates and Trade-Marks for the largest talking machine manufacturers in this country and for dealers in every state.

YOUR NAME, Mr. Dealer, on every machine brings the owner back to you for records and his friends to you for a machine.

Samples, Suggestions and Sketches Furnished Free

THE MEYERCORD COMPANY, CHICAGO

Largest Manufacturers of **DECALCOMANIA** Transfer Name-Plates

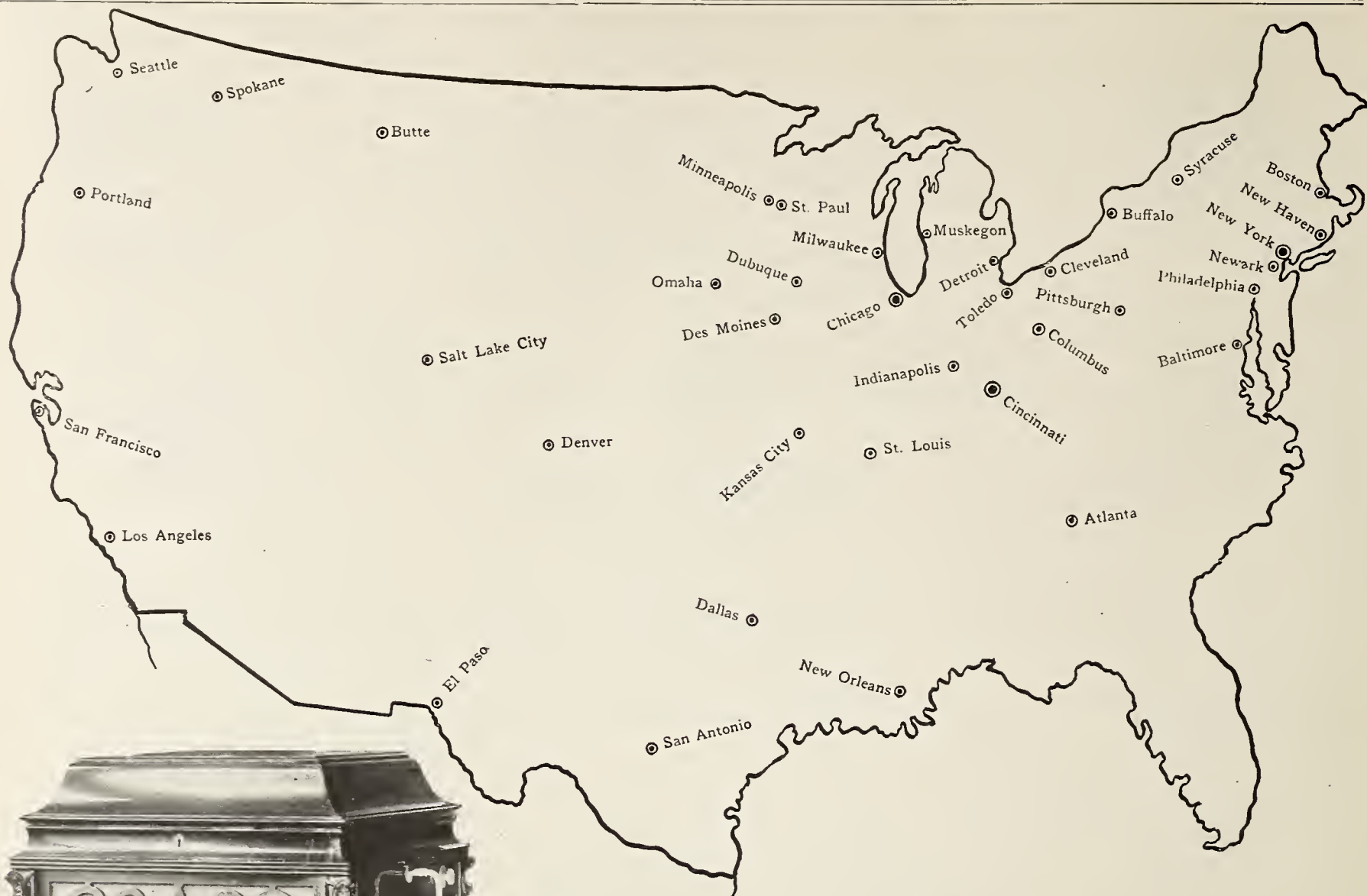

Prices, \$32.50 to \$180.00

Prompt Deliveries

—as wanted

—when wanted

(The second of a series of advertisements giving reasons why you should sell The Brunswick.)

With direct factory branches in the 36 leading trade centers, we are always in a position to make prompt deliveries to meet your requirements. This means your order will be shipped when you want it, as you want it. Disappointments are avoided. Our manufacturing conditions are such that we are able at all times to supply all models in all finishes promptly.

This enables the dealer in small towns and remote places to have the same advantages as the dealers in the large cities. A service enabling them to be in a position to make almost immediate delivery of any model listed. An advantage that means much in these days of close competition.

The Brunswick Proposition

tells in detail, the other advantages of an affiliation with The House of Brunswick. It points the way to more and bigger profits. It also describes the many points of Brunswick superiority and exclusive selling features. Write or wire for this proposition. There is still some open territory.

THE BRUNSWICK-BALKE-COLLENDER CO.
CHICAGO SAN FRANCISCO NEW YORK CINCINNATI

Branch Houses in Principal Cities of the United States, Mexico, France

623 South Wabash Ave., Chicago

29 West 42nd St., New York

7th and Main Sts., Cincinnati

Canadian Distributors
 Musical Merchandise Sales Co., Excelsior Life Building, Toronto

The Brunswick

ALL PHONOGRAPHS IN ONE

Illustrated is Model 175 which retails at \$180. Height, 49½ in. Width, 23½ in. Depth, 24½ in.

Plays all records, including the famous Pathé for which a special sound box is furnished.

Has wooden-walled sound chamber and 9 other exclusive Brunswick features.

Other models \$32.50 upward.

FROM OUR CHICAGO HEADQUARTERS—(Continued from page 89)

intendent of the Pontiac Reformatory, who gave permission for Mr. Bristol to give a benefit concert for the boys of the institution. Mr. Bristol took one of the large-sized Brunswick machines over to the cell house on Sunday evening and played numerous Pathé records on the machine. The cells of the institution are arranged in five tiers in rows about 320 feet long. There are four of these blocks of cells altogether, each separated by a fire wall, and it was, therefore, necessary for Mr. Bristol to give four individual performances in order that all the boys of the institution could hear the music. Mr. Trumbo, the assistant superintendent, was very pleased over the success of the affair and said that that was the first time anything of this kind had ever been attempted in the institution and stated that any time a talking machine man came to town he would be more than pleased to have him give a concert for the boys. On Monday, the day after the concert, Mr. Bristol, the Brunswick representative, paid a visit to the institution's work shops and with the permission of Mr. Trumbo interviewed many of the boys regarding what they thought of the idea. All interviewed showed their appreciation of the event and hoped that Mr. Bristol would return soon and give them another concert. There is in this institution a band composed of the boys, which frequently gives concerts, but this idea was new to them, and the McCormack records, patriotic songs, band pieces and cornet solos that were rendered on the machine were something that they do not frequently hear, and they were, therefore, very enthusiastic to have Mr. Bristol play for them again.

He Went Broke

The Chicago Talking Machine Co. recently received a letter containing a check and the following information: "The paying teller at the First National Bank of Chicago refuses to honor this check. Therefore, I am returning it to you asking that you straighten out this matter,

as the above bank informs me that they no longer carry this checking account." The check in question caused a great deal of wonderment as to what kind of a fellow it was who could hold on to a dollar, the amount the check called for, for such a long time, as it was dated February 24, 1899! One of the officials of the company remarked: "It certainly took a long time for that gink to go broke, but 'Sherman was right, this war sure is ——."

Some Record on Deliveries

In order to help make Christmas deliveries on time both A. B. Stoll, manager of the Brunswick Shop, and C. V. Yates, of the sales department, came down to the warerooms the Sunday before Christmas and each donned a pair of overalls and worked all days as "Hikers" on one of the delivery trucks. This was necessary, owing to the fact that there was a shortage of delivery men and over seventy-nine machines were promised for delivery that day. Five auto trucks were employed to take care of the work, but only eight helpers showed up instead of ten.

"Two Aces Change Places"

C. L. Egner and W. F. Fries, both travelers for the Victor Co., have recently been changed from their old territories and new districts have been allotted to them. Mr. Egner formerly traveled throughout the State of Missouri, but is now transferred to the territory embracing Illinois and Wisconsin. Mr. Fries formerly looked after the company's interests through Michigan, but will now look after the Iowa territory.

Record-Lite Attachment Popular

"Music in the Home," by Anna Shaw Faulkner, author of the popular work entitled, "What We Hear in Music," is now on sale at the Edison Shop and has created quite a demand and is receiving much favorable comment. The accessory department has also been having quite a demand for the "Record-Lite" attachment for phonographs for the past month. The demand

for these lights has increased to such an extent that it has become necessary to lay in a larger stock than was the custom heretofore.

Hold Educational Convention

Mrs. Frances E. Clark, head of the educational department of the Victor Co., with headquarters at Camden, N. J., presided at an educational convention which was held in the Congress Hotel on January 2, 3 and 4. Fourteen traveling representatives of the Victor Co.'s educational department attended and various means and methods applicable to this department were discussed.

The Six Best Sellers

The six best sellers in the Victor library for the month are: "Somewhere in France Is the Lily," and on the reverse side "My Sweetheart Is Somewhere in France"; "Missouri Waltz"—"Danny Boy" (vocal selection by Schumann-Heink); "I'd Love to Be a Sailor" (a new Lauder selection); "There's a Green Hill Out in Flanders," and reversed, "Say a Prayer for the Boys Over There"; "The Rainbow of Love."

The six best Columbia sellers for the past month are: "Over There," and on the reverse side "I May Be Gone for a Long, Long Time"; "From Me to Mandy Lee," reversed, "All Bound Round With the Mason Dixon Line"; "Send Me Away With a Smile," and reversed side "My Sweetheart Is Somewhere in France"; "Life in a Trench in Belgium" (parts one and two) "Poet and Peasant" (parts one and two, overture); "Livery Stable Blues," fox-trot, and reversed "That Jazz Band."

The six best Edison sellers for the past month are: "Battle Hymn of the Republic" (Old plantation melody) "Explanatory Talk for La fatal pietra" (The Fatal Stone); "Aida," and reversed "La Fatal Pietra"; "Awakening of Spring" and "Pirouette"; "New York Blues," and reversed "Saxophone Sobs"; "Ellis March," and reversed "One, Two Three, Four Medley Waltz"; "It's Nice to Get Up in the Mornin'."

(Continued on page 93)

It Is Not Too Late to Make the Best New Year's Resolution You Ever Made



THAT is, to investigate the Empire Dealer's proposition, and to apply for the exclusive agency in case same is still open for your City.

Empire dealers all look back on 1917 as their most prosperous year, and forward to 1918 as being still more prosperous. Not in the actual money profits alone, but in the more permanent profits that come from a clientele of satisfied customers. They are all Empire boosters, and are glad to pass the good word for Empire products and policies along to other Dealers. This has been evidenced in numerous instances recently, where good sized orders were placed by dealers that we had never even quoted, who took the Empire agency on the recommendation of an Empire dealer.

Write today for our complete catalogs of Empire Machines and Empire Records, and full information regarding our Splendid Dealer Helps :-



The Empire, Model B, conceded to be the greatest value ever offered in a high grade talking machine.

Empire Talking Machine Co.

JOHN H. STEINMETZ, President

429 South Wabash Avenue,

Chicago, Ill.

A REVOLUTION IN THE TALKING MACHINE WORLD!!

Of Greatest Importance to **Manufacturers**
Assemblers
Jobbers
Dealers

"UNISSET REPRODUCER"

Plays ALL MAKES of Records (VICTOR, COLUMBIA, PATHE, EDISON, ETC.)
in ONE and the SAME POSITION and PLAYS THEM PERFECTLY!! Nothing
to twist or change except needle.

GREATEST
INVENTION



OF MANY
YEARS!

Mr. Manufacturer: At last you can employ a perfectly straight one piece tone arm, thus improving the tone and appearance of your Talking Machine. We supply straight tone arms for use with the UNISSET REPRODUCER.

Mr. Jobber and Mr. Dealer: An enormous and profitable business is waiting for you. The UNISSET REPRODUCER can be slipped on all tone arms of standard talking machines. No talking machine owner cares to be limited to one class of record only. The UNISSET REPRODUCER means simplicity, no twisting, no changes, no second parts. It has a rich, natural tone, no piercing, wiry quality to offend sensitive ears.

Retails at \$5.00 nickel plated. (\$6.00 for Edison Machine) Price includes Edison jewel and one Pathe jewel. Usual trade discounts.

Samples C. O. D. or check with order, otherwise please state references.

When ordering state for which type of machine.

We are open to connect with responsible jobbers.

This reproducer is just what everybody has been looking for.

Deliveries begin early in February.

ORDER YOUR SAMPLES NOW.

UNISSET REPRODUCER CO.

Cable Bldg., Jackson Blvd. and Wabash Ave.

CHICAGO, ILL.

FROM OUR CHICAGO HEADQUARTERS—(Continued from page 91)

and reversed "When the Bonnie, Bonnie Heather Is Blooming, I'll Return Annie Laurie to You."

The six best sellers for the month in the Pathé library are: "Within the Garden of My Heart" and "Love, Here Is My Heart"; "Arrival of the U. S. Troops in France," and reverse side, "Hail, Hail, the Gang's All Here!"; "It's a Long Way to Berlin," and on other side "That's What Ireland Means to Me"; "Till the Clouds Roll By," and reversed "Just You Watch My Step"; "Allah's Holiday," from Katinka, and reversed "Merry Widow Waltz"; "When the Boys Come Home," and on the other side "Danny Deever."

The six best Emerson's for the month are: "My Sweetie," and reversed "Good-bye Dollie Gray"; "I Don't Want to Get Well," and reversed "Cocoanut Dance"; "Joan of Arc," reversed "Hands Across the Sea"; "The Dixie Volunteers," and on other side "Washington Post March"; "Hail! Hail! the Gang's All Here!" and "Cold Turkey"; "Hello, My Dearie," and on the other side "Chü Chin Chow."

New Hiawatha Line

The Ottawa Pianophone Co. recently presented to the trade their new Hiawatha phonograph, which they feel marks the attainment of an ideal, being the result of a definite intention to produce a musical instrument that will incidentally be accepted as a standard of perfection. The new machine is an expression of quality and refinement in every detail and is indeed a masterpiece in mechanical perfection. The design is neat and the dignified lines lend grace and charm to the beautiful furnishings. A feature of this machine is that the modifier is built in and is a part of the machine and not an attachment. The machine plays all records with the same attachment. At present they are offering six cabinet machines ranging in price from \$50 to \$100 and one table machine which comes in mahogany and oak, high polish or dull finish. They are equipped with double springs, powerful and silent motors, automatic stops, tone modifier, speed regulator, etc. The new

factory at Ottawa, Ill., has splendid railroad facilities, being situated directly on the side of the Rock Island Railroad. This factory is equipped with modern machinery and is operated by skilled workmen under the supervision of a man who has had many years of experience. The plant is up-to-date in every particular, operating its own power plant seasoning rooms, which guarantee against warping, and this wood after getting out of the season room is guaranteed to pass a most rigid inspection. The capacity is 300 machines a day, thereby enabling the company to render prompt and efficient service.

Empire Talking Machine Co. Improvements

The Empire Talking Machine Co. report that they have had an exceptionally good start for the new year, and that the business of 1917 succeeded the biggest year in the history of that company. Not only does this apply to talking machines but also to records, and from present indications January will be a very good month. This company has just issued a sixty-four-page record catalog which includes their January and February supplements. This catalog contains sixteen more pages than any they have issued previously and is very beautifully illustrated. Many new artists have been added to the Empire list and the new records just being issued by that company are far superior to any they have previously put on the market. The surface noise has been eliminated to a minimum and in some records it is absolutely undiscernible. The Empire machine has been steadily proving its worth and is receiving favorable comment throughout the trade. The new motor this company is installing in its machine is guaranteed to play five twelve-inch records with one winding and the style and finish of the cabinet is very beautiful. This company is now in splendid shape to take care of their dealers' needs and has added several expert and experienced shipping clerks to its already large shipping department, which in itself is an assurance

that the dealers' needs will be taken care of immediately.

Wade & Wade Cutters

About nine years ago, when the late Samuel O. Wade introduced his first needle cutter on the market, there was much speculation as to whether it would prove successful or not. A great many maintained that it was a very simple contrivance, but that, being operated on the "plier" principle the same as a plier used by an electrical worker, that there could, therefore, be no precision made in the cut as there was bound to be a certain kind of spring to the jaws when the tension was put on the handle. Nevertheless Mr. Wade "nursed his invention" and kept plugging away with the dog determination for which he was characteristic and shortly before his death a few months ago put upon the market the cutter that worked on the "plier" principle, an instrument that was perfect in every detail. It is said by many in the trade that nothing as yet has equaled the simplicity and ease of operation of this "plier" principle. The little workshop in which the present Wade & Wade fibre needle cutter was founded has grown in the nine years it has been in existence to wonderful proportions and this institution has now attained a point where it can turn out thousands and thousands of these "pliers" in a year. The material of which these "pliers" are made is strong and durable and the workmanship is positively guaranteed. Each cutter is also guaranteed to be foolproof and constant in operation.

New Repair Company

After careful investigation as to the wants of the dealers in the trade, E. O. Chapman and J. J. Elwart discovered that dealers in the phonograph business in general were without proper repair service and for that reason they put their heads together and inaugurated the Mid-West Phonograph Repair Co. They are prepared to handle all kinds of repair business

(Continued on page 95)

All of Our Dealers Are Making Greater Profits

FOR OUR SALES IN 1917 SHOW AN INCREASE OF

100% OVER 1916

and 1916 was a Banner Year for us. Notwithstanding the fact that our country is now in war we have made this tremendous increase in 1917 and we have made preparations for

A STILL GREATER INCREASE FOR 1918

No doubt we owe this great increase to the new models that we have recently adopted. Have you seen them?

The **VITANOLA** Talking Machines

Embody: Expert workmanship—carefully selected woods—excellent finishes—unexcelled tone. Reliable motors and reasonable prices. Above all we offer our organization that is expressly adapted to serve you and your requirements.

Write for our Free Trial Offer and Agency Proposition

VITANOLA TALKING MACHINE COMPANY

501-509 West 35th Street

CHICAGO, ILL.

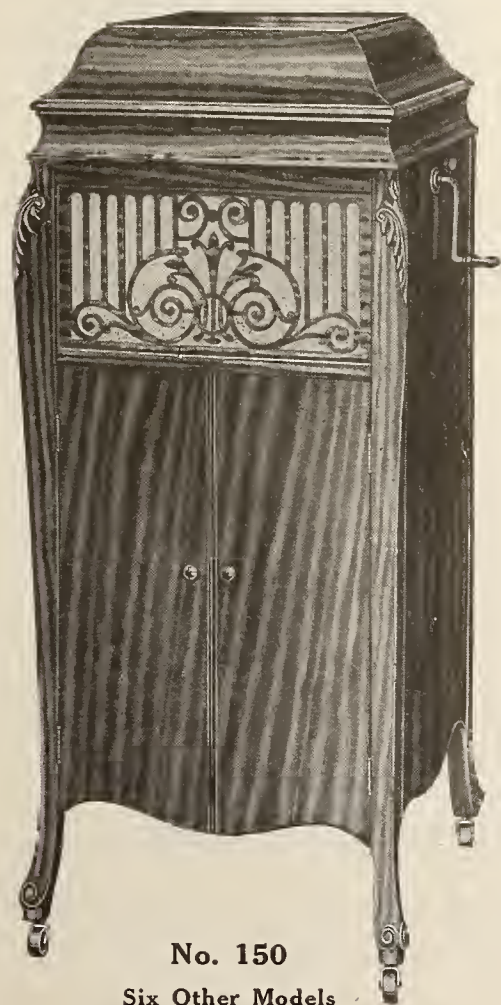

No. 150

Six Other Models
retailing at \$25 to \$175

A NEW LINE

Automatic RECORD CONTAINER

PATENT PENDING

100% efficient, convenient, accessible and durable.

The most practical filing device ever placed on the market.

The difficulty of taking care of and filing talking machine records solved at last.



Holds 200 Records



Holds 200 Records



Holds 100 Records

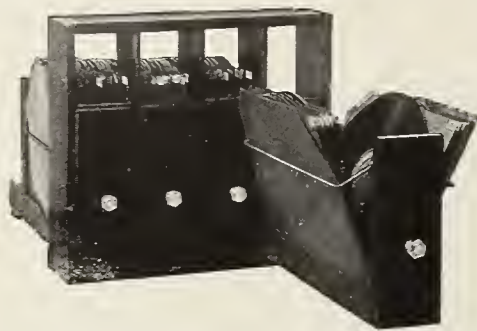

This Automatic Record Container Insert is made in two sizes—80 and 100 record capacities. Can be placed in any cabinet.

The individual cabinets illustrated here are equipped with Automatic Record Containers, giving them double the filing capacity over all other cabinets of the same size. Isn't this worth while?



Holds 100 Records



Holds 100 Records



Mr. Dealer: You will find this a most convenient carrying case for your salesmen. It holds 25 records, either 10 in. or 12 in. It is equipped with numbered guide cards and index book.

Write us today for full particulars about our line of individual filing cabinets, equipped with the most economical record filing device, which is protected by U. S. Patent.

Manufacturers: Write us for our proposition on shop rights to equip your line of talking machines with Automatic Record Containers



Holds 100 Records

AUTOMATIC CONTAINER CO.

303 Tacoma Building

CHICAGO, ILLINOIS

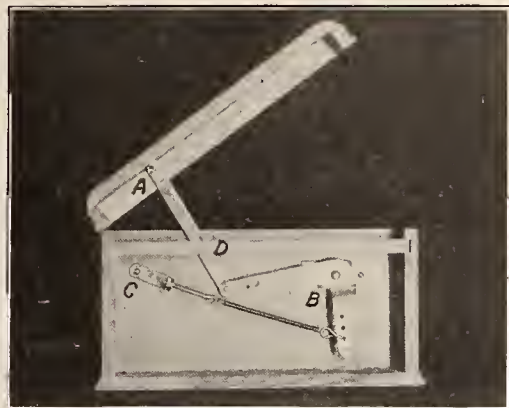

CHICAGO COVER BALANCE NO. 1

Others—Why Not You?

Most of the new talking machines of real merit are equipped with the

CHICAGO COVER BALANCE

It is not merely a Talking point; it's a Positive point of vantage. Don't take our word for it. Ask the users. Investigate.

WE MAKE NO CHARGE FOR SAMPLES TO BONA-FIDE MANUFACTURERS

CHICAGO HINGED COVER SUPPORT AND BALANCE CO.

2242 WEST 69th STREET, CHICAGO, ILL.

FROM OUR CHICAGO HEADQUARTERS—(Continued from page 93)

in general and are lining up numerous dealers whose business is not large enough to have a repair department of their own. Both of these gentlemen have been in the motor manufacturing business for a number of years and are thoroughly experienced along this line, thereby being able to guarantee absolute satisfaction.

Salter Holiday Outfit

The Salter "trade winning holiday outfits" which were especially put out in combination with the regular Salter line to take care of the holiday trade were in far greater demand during the holiday season than had been anticipated. These cabinets were made to harmonize with the portable models of standard machines and enabled the dealer to offer to his trade outfits which served to land customers who would otherwise escape. A feature of these particular Salter cabinets was the felt-lined compartments of which this company were the originators. Each record has an individual compartment for itself and is thus protected from scratching, breakage and dust, and is instantly accessible. The many Salter dealers in order to insure delivery in time for the spring trade are placing their orders now. They are doing this as a precautionary means, as from present indications there will, no doubt, be more business done in the next few months than ever before.

Personals and Visitors

Recent visitors to the city were: H. T. Smith, Cable Piano Co., and G. Herman, J. L. Hudson Co., both of Detroit; Miss Minnie Springer, Pearson Piano Co., Indianapolis, Ind.; Ed. Winger, Winger Furniture Co., Grand Rapids, Mich.; H. G. Power, Taylor Carpet Co., Indianapolis, Ind.; F. W. Clement, of the Chas. Roat Music Co., Battle Creek, Mich.; E. H. Jackson, Talking Machine Shop, Rockford, Ill.

The Monarch Talking Machine Co., Inc., Philadelphia, Pa., has increased its capital stock from \$5,000 to \$100,000.

TONE ARMS from \$1.25 to \$4.25
MOTORS from \$1.65 to \$11.50
JOHNSON ELECTRIC MOTORS \$17.50
EDISON IMPORTED SAPPHIRE POINTS
PATHE IMPORTED SAPPHIRE BALLS
EDISON IMPORTED DIAMOND POINTS
 Continuous Hinges Phonograph Hardware
Lakeside Supply Co.
 220 So. Clark St., CHICAGO, ILL.
 Phone, Harrison 3840

NEW DEVICE FOR FILING RECORDS

Interesting Details Bearing Upon Latest Device Placed on the Market by the Automatic Container Co., of Chicago

CHICAGO, ILL., January 10.—Manufacturers, as well as dealers, will be interested in the new device for filing talking machine records, which is being marketed by the Automatic Container Co., 301-303 Tacoma building, this city. Their full page "ad" appears in this issue, featuring

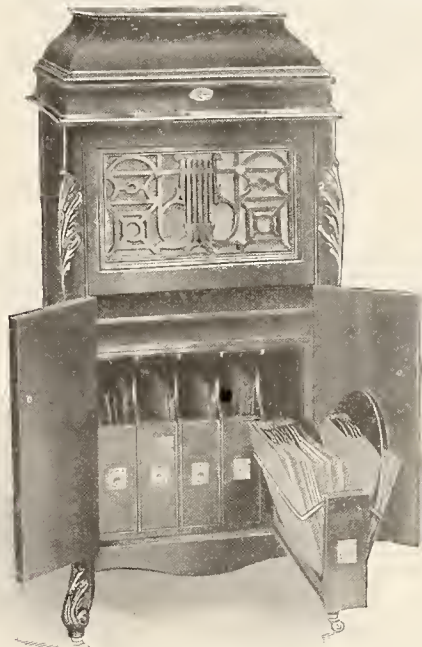

The Automatic Container

a new line of individual filing cabinets in which dealers will be especially interested. Manufacturers, however, will be particularly interested in the "Automatic" filing device as applied to the standard talking machine cabinet. The cut accompanying this article illustrates the practicability of the new automatic container built into a standard cabinet.

This "automatic" record container, which is a patented article, is beyond a doubt one of the most attractive devices for record filing which have yet appeared on the market. When the containers are filled to their capacity, the cabinet contains a solid mass of records separated by thin guides, only. The space usually taken up by shelves, racks, partitions and albums is eliminated. Maximum filing capacity is therefore afforded; actually from 50 per cent. to 100 per cent. more records can be filed in a given space than by albums, racks, or other device.

When the container is drawn from its place in the cabinet, the weight of the records automatically throws the side rods of the container outward, thus giving the necessary expansion and making each record immediately accessible. The opened file-pocket remains open until the record has been returned to its proper place. The simplicity and convenience of this device should appeal to manufacturers and dealers.

The Automatic Container Co., marketing this device, is a new corporation which has purchased, and is enlarging, the business formerly carried on by Frank P. Read, the inventor, of Chicago. Mr. Read is president and general manager of the new company, and Fred M. Sargent, of Evanston, Ill., is secretary and treasurer. The company enters the field with bright prospects for a good business.

MUSIC A REAL WAR NEED

Some Timely Reading Matter Being Sent Out With Lyon & Healy Letters

A new and very tasty envelope stuffer is now being sent out on an extensive scale by Lyon & Healy. It is included in practically every letter sent out by this great Chicago institution and is entitled "Music Serves a Very Real Need in War Time." It is printed on an antique stock in blue ink, and contains pertinent quotations from a number of sources. The quotation from the Chicago Tribune is as follows:

"It may not be amiss to bring out the fact that in war time music is an essential. It is a necessity in the ranks of the fighting men, for it instills the firmness of morale necessary to success in war; it is important in the lives of civilians, because it strengthens moral fiber and dissipates depression. Whether it be the stirring strains of the sonorous band, or the sounds of a soothing symphony, it is a tonic in war time; it is the mental exhilaration that engenders physical recuperation."

There is also a pithy bit of comment by Lyon & Healy which is worthy of consideration:

"And if music is a powerful aid to men of action, its importance to those who can do little but 'stand and wait' is even greater. Every old person and every child who can have recourse to music for an hour a day is thrice blessed.

"There is no magic about music. Every man or woman who works intensely for a long period finally lowers the nerve force and the result is an irritable and excited condition.

"Listening to sweet music, preferably melodies that awaken pleasant recollections, slows down the nerves and in a short time makes almost a rebirth of the individual."

Sapphire Needles
 FOR PATHE and EDISON RECORDS
 These needles are made in Switzerland of Asiatic Sapphires, which are recognized as the best.
 Price **\$3.00** per dozen
 Send check with order or goods will be sent C. O. D.
 Quotations given on larger quantities.
CHARLES J. WOODARD
 Room 503 Cable Bldg. 57 E. Jackson Blvd., CHICAGO

FROM OUR CHICAGO HEADQUARTERS—(Continued from page 95)

THE PAST, PRESENT AND FUTURE

Discussed by L. C. Wiswell, Manager of the Victor Dept. of Lyon & Healy, for The World

CHICAGO, ILL., January 11.—L. C. Wiswell, manager of the Victrola department of the house of Lyon & Healy, when interviewed by a representative of The World this month, said:

"The retail trade in general during the past year was very fortunate indeed and did a bigger business than they had ever dreamed of or dared anticipate. The one factor that kept the trade down and which exerted a major influence in keeping it from reaching greater proportion was the shortage of machines as is well known. This shortage did not apply to one particular line only, but existed in all the well known makes, which was very unfortunate indeed. With the records, however, the situation that prevailed throughout the year was exceptionally favorable and during the holiday season the dealers in general sure went "over the top" for once in their life anyway.

"I have talked with the heads of various other houses and have been assured by them that the situation was absolutely satisfactory in every detail with the possible exception of the aforesaid shortage of machines. The year of 1918 is bound to be an excellent one and can only be measured by the amount of energy and pep that the dealers exert. There has, within the past few months, been a great number of new machines placed in homes. It therefore naturally remains that the record departments will benefit greatly by this. The pace set by various wholesale dealers and jobbers in the trade during the latter part of the year was amazing. Some said it was only a spurt and that they were merely trying to unload for the holiday season. This, however, has proved untrue as these very same wholesalers and jobbers are today working just as hard as they were before the holiday season began and are shipping in as

great quantities as they did during the holiday season and the tendency is, as may be judged from the way orders are coming in, that they will keep right at it indefinitely.

"Another thing that is worthy of mention is the amount and quality of publicity that was given to the various makes of machines in the local papers for the past few months. These newspapers have been commenting upon this fact themselves. Never in their history have they had a like amount of space devoted in their papers to talking machines and the art work contained in some of these advertisements are really masterpieces in themselves. This condition still prevails in the papers, and for that reason I base my opinion that this young new year will go down in the history before the new one comes along as being the greatest ever known in the talking machine trade."

A CHANGE IN CHICAGO

CHICAGO, ILL., January 11.—The Hallet & Davis Piano Co., of Boston, discontinued on January 1 their Pathé jobbing agency in this city, which was located in the Shops Building on Wabash avenue. This does not mean that the Hallet & Davis Co. are going out of Pathé distribution by any manner of means. It simply means that they are going to cultivate more thoroughly than ever before the New England and Eastern States. Hallet & Davis have transferred their accounts in this territory to the Fuller-Morrison Co., the great wholesale drug house which has recently taken on Pathé distribution in this territory. B. O. Ainsley, who is manager of the Hallet & Davis talking machine branch here, will go East about the middle of January. J. C. Tidmarsh, who has been associated with him, is now traveling for the Fuller-Morrison Co., and helping in getting the Pathé department organized and in good running order.

The Fuller-Morrison Co. is the largest establishment of its kind in the world and keeps a

force of over fifty salesmen on the road constantly. M. P. Mears, sales manager of the company, says that they have the situation well in hand at present, and that this section of the country will be covered thoroughly is assured.

LET THE PUBLIC KNOW

The Chicago Talking Machine Co. have prepared and are sending out to their dealers a very handsomely illustrated Victor window card featuring the "Missouri Waltz" and "Kiss Me Again Waltz." This card is mounted on very heavy material and portrays in the foreground a couple waltzing and also an illustration of a large Victor cabinet machine. In the background are several more couples, the interior of a ballroom being suggested. This display is a beautifully colored hand-lithographed window sign 22-inch by 28-inch and was prepared especially to increase the sales of Victor dealers.

ADD TO CHICAGO MOTROLA OFFICES

Ernest Horcher is now in charge of the service department of the Chicago offices of the Jones Motrola Co. Mr. Horcher was formerly connected with the New York branch of this company, but came on to Chicago last week. Robert E. Rae, sales manager, and Harry E. Merrian, electrical expert, both of the same company, with headquarters in New York, spent the last week visiting Manager Hey, of the Chicago office of the company, and attending to details.

ANGELUS TRADE-MARK INJUNCTION

Judge Manton in the Federal Court last week granted a temporary injunction to the Wilcox & White Co., manufacturers of the Angelus piano players, against Frank J. Leiser, doing business as the Angelus Phonograph Co. Infringement of trade-mark and unfair competition was charged.

The Standard of Perfection



STYLE 100

Other styles

Indicating Retail Price, \$35, \$50, \$75

HIAWATHA

FINISHES

Walnut and mahogany, in the dull or high polish. Oak in high polish or fumed. Every cabinet built in a thorough manner. *Hiawatha* construction is guaranteed to last indefinitely, not merely glued together but dove-tailed.

TONE QUALITY

The tone of the *Hiawatha* can best be described in one word, "natural," reproducing the artist's voice or selection in the full rich natural tone.

MOTORS AND EQUIPMENTS

Our motors are made of the highest grade material obtainable, using double spring in all hand power machines, are silent and powerful, equipped with automatic stop and speed control. Electric Motors \$25.00 extra, every motor guaranteed fully for the period of one year.

PLAYS ALL RECORDS

Your selections are not limited to records of any single make, as the *Hiawatha* plays all makes of records with the same attachment.

CABINETS

Made of five ply stock of genuine Veneer, given five coats of finish and each cabinet hand rubbed, which gives to *Hiawatha* cabinets the wonderful polish such as is found only in the most expensive furnishings.

TONE CHAMBER

Made of genuine spruce, is known as the straight way type, extending from the mouth of the tone arm, with no obstructions to break the sound waves. The use of spruce wood in the Tone Chamber has the same effect in reproducing the tone as it has in all high priced violins.

TONE MODIFIER

(Patent applied for)

Built in on top of motor board as part of the machine, not an attachment, modifying the tone to suit every taste.



Capacity 300 Machines per Day

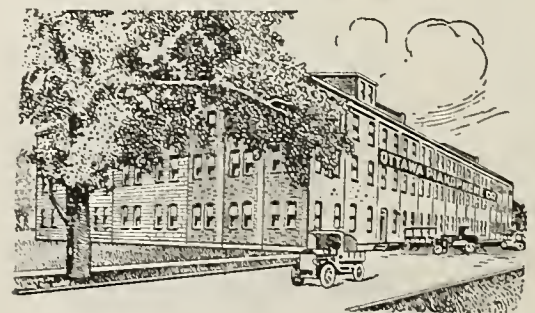

The Home of Hiawatha

OTTAWA PIANOPHONE COMPANY City Address: 802 Republic Building
Factory: Ottawa, Illinois

"ALL ORDERS F. O. B. FACTORY"

UNISSET REPRODUCER INTRODUCED

This New Reproducer Is Said to Be an Absolute Departure From Other Sound Boxes on the Market—Will Play All Kinds of Records—The Men Behind the Company

CHICAGO, ILL., January 10.—The Uniset Reproducer Co., Cable building, this city, which has just incorporated, is putting a new reproducer on the market, which many term one of the greatest inventions that have appeared in the talking machine field for many years.

This reproducer is an absolute departure from all the other sound boxes which are now on the market. It will play all records, of no matter which make or description, such as the Victor, Columbia, Edison, Pathé and Gennett records, etc., in one and the same position, without any change of any kind.

We understand that this reproducer can easily be slipped on all the tone arms of the standard made machines, and once it is put on, it will remain in one and the same position, reproducing all the different records equally well. In consequence the possibilities of this Uniset Reproducer are tremendous.

Manufacturers and assemblers of phonographs will be able in the future to employ a perfectly straight tone arm and thus do away with all the disadvantages which are common to tone arms that have joints, bents and kinks, which very often work loose, rattle and create other unpleasant noises when playing the record. Another vast field for the Uniset Reproducer is amongst jobbers, dealers and the individual owners of machines.

There is no question but that the average talking machine owner does not care to be confined to one particular make of records; there are many beautiful records and titles in other catalogs which he may not be able to enjoy, but his sound box will not reproduce such records.

Although, of course, there are arrangements in the market that make it possible to play different makes of records on a phonograph, it is reasonable to assume that the Uniset Reproducer will receive special consideration, as it is simplicity in itself, and as it is not necessary to change the position, which means more or less trouble, to the user of the phonograph. The Uniset sound box will sell at \$5.00, n. p. retail; \$6.00 for the Edison machines, and the gold plated sound boxes will possibly be \$1.00 more. We understand that the Uniset Reproducer will be ready for delivery about the first week of February, and orders are now being accepted.

The president of the Uniset Reproducer Co. is James B. Orth, prominent business man of Chicago. W. Hadert, the vice-president and general manager, is a man of twenty-two years' experience in talking machine trade. He knows all branches from factory and recording to selling. He has traveled for important concerns all over the world and is by virtue of all this experience well equipped for managing a concern of this kind and for marketing the product in a most efficient manner. Joseph Juttler, secretary and treasurer, is a gentleman of wide experience in the business field, a man with a personality and is to be considered as a distinct acquisition to the company. The board of directors is constituted of the above, together with Richard Bauer, of the well-known Chicago piano manufacturing house of Julius Bauer & Co., and Wm. Meissner, the inventor of the Uniset reproducer.

SPECIALIZES IN PLATING

Joseph Musante, electro-plater and silvermith, 168 Centre street, New York, has recently entered the trade, specializing in the plating of phonograph parts. His special process of finishing in gold which prevents turning black has already strongly appealed to a number of houses in the trade. The other finishes used are silver, nickel and antique.

It ain't the individual nor the city as a whole, But the everlastin' team work of every hloom-in' soul.—Adapted from Kipling.

FRENCH RECORD POSTER

Victor Talking Machine Co. Issues Attractive Poster Featuring French Records

The Victor Talking Machine Co. has just issued a large three-color poster featuring its series of French language records. There are three records in this series, the records containing those French words that will be found of greatest use to the American who finds himself "somewhere in France," and the French words and their English equivalents can be learned more readily through the medium of a talking machine than through almost any other way. The poster itself represents an American soldier talking to a French soldier and a pretty little peasant girl. The poster is not only artistic in every sense, but should prove a valuable aid towards popularizing this very practical series of records issued by the Victor Co.

No use talking, the individual who makes a habit of looking efficient is cultivating the habit of being efficient.

RED CROSS QUILT BRINGS \$700

Embroidered With Names of President Wilson and Thos. A. Edison and Is Auctioned Off

One might think that a quilt which would bring \$700 would be embroidered in gold, but such was not the case with the Red Cross quilt auctioned off December 29 at the Edison Laboratories at Orange, N. J. This particular quilt had embroidered on it the names of President Wilson and Thomas A. Edison, both being contributors. The quilt consisted of many small squares with red crosses in each, the name of the contributor being embroidered in each square around the cross. The quilt was made by Mrs. A. Q. Almquist, of West Orange. After much spirited bidding the quilt went for \$700, which goes to the West Orange Community Unit of the Orange Chapter of the Red Cross.

If at times you find embarrassment in meeting customers, make it a point to study the manners and methods of successful people and see how they meet strangers.

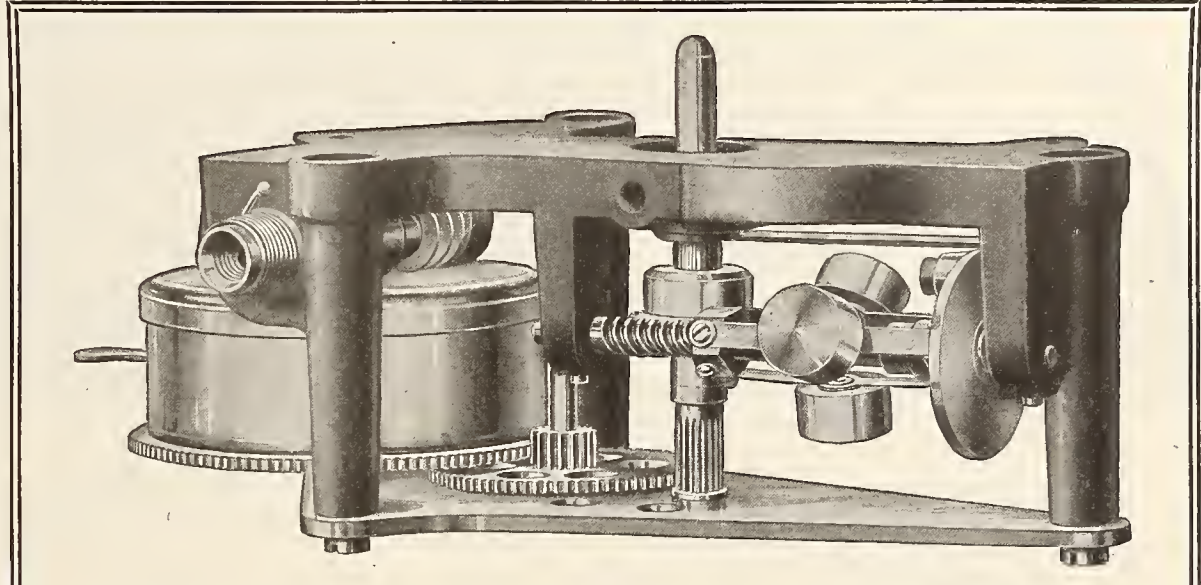

Stewart Single Spring Motor

Rigid cast frame. Simple design. Hobbed gears. Powerful and silent. Plays one 12" or two 10" records. Furnished with side or top speed regulator control.

We are furnishing this remarkable Stewart Motor to some of the large phonograph manufacturers. It will pay you to get our prices.

Our large plant, equipped with special machinery for economical production in large quantities, places us in a position to offer phonograph manufacturers parts of quality at exceedingly attractive figures.

It will pay you to use Stewart parts. Our facilities enable us to handle large orders promptly. Write for detailed information and prices.



Stewart Tone Arm and Universal Reproducer Plays All Records

STEWART PHONOGRAPH CORPORATION

Manufacturers of Phonograph Motors and Parts

CHICAGO

327 Wells Street

ILLINOIS

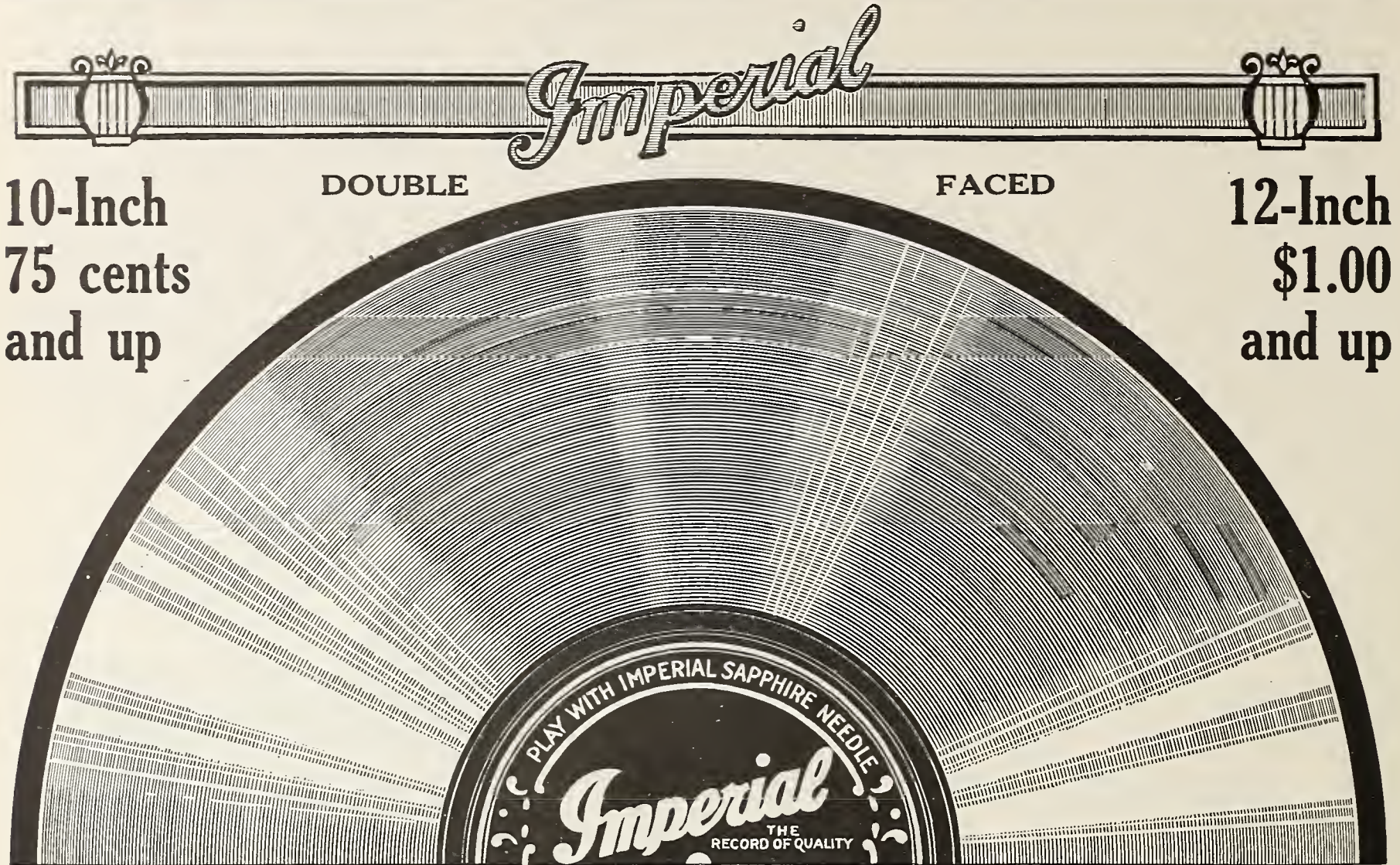

10-Inch
75 cents
and up

DOUBLE

FACED

12-Inch
\$1.00
and up

“The Road to Profits”

Stock the Records that bring back satisfied customers

IMPERIAL RECORDS

Recorded in our own laboratory and made in our own factory, faithfully reproduce the **World's most famous** Instrumental, Operatic and Popular Music.

The **Imperial Records** can be played on all makes of Talking Machines and are backed by our catalog of over Two Thousand numbers, containing among them a galaxy of Artists known the World over.

Supplements listing new attractive and varied additions to our repertoire published every month.

You will make no mistake in writing us for further details and our very liberal discounts.

IMPERIAL TALKING MACHINE COMPANY, Main Office and Factory: No. 9 Vandever Avenue, Wilmington, Del.

Recording Laboratory and Showrooms: 35 West 31st Street, New York City

Pacific Coast Distributors: The Stern Talking Machine Corporation, 1085 Market Street, San Francisco, Cal.



REPAIRS

TALKING MACHINE TROUBLES AND HOW TO REMEDY THEM

Conducted by Andrew H. Dodin

[This department of The Talking Machine World is designed for the service of all classes of our dealers, including those who make, and those who sell, talking machines. Andrew H. Dodin, who conducts this department, has a wide and enviable reputation as a repairer of talking machines and conducts an exclusive talking machine repair shop at 176 Sixth Avenue, New York. Tell him your troubles through The World and he will help you if possible. The service is free.—Editor.]

EQUIPMENT FOR MAKING REPAIRS

There are many dealers who are driven away from the idea of making small repairs and adjustments by the fact that they think the tools and equipment necessary for the work would cost more than the benefit derived from immediate adjustments.

On the contrary the cost of the necessary tools is surprisingly low and I am going to give a list and the approximate cost price of those needed for making small repairs and adjustments and also a list of the average repair parts which a dealer should always carry in stock.

In the first place a suitable space should be set aside for the placing of a work bench. In the absence of suitable lumber for its making use can be made of machine cases. It is possible to get from four or five of these packing cases sufficient suitable material to make an ample sized and strong enough work bench.

The first purchase in the tool outfit is the bench vise, and in selecting it you should be careful to get one which will open far enough to hold the largest sized spring cage. A suitable sized vise can be obtained for from \$3.50 to \$6.00.

The following list of bench tools are all that are necessary for making small repairs on motors, to which can be added those special tools made and sold by the several talking machine companies for use in adjusting their particular makes of motors, and which can be obtained from the distributors of these companies:

- 1 riveting hammer.....\$.50
- 1 ball hammer60
- 3 sizes of screwdrivers.....each, .30
- 1 round file20
- 1 flat file20
- 1 three-cornered file25
- 1 nail set10
- 1 oil can15
- 1 jackknife45
- 1 pair round nose pliers..... .85
- 1 iron bench block..... .50

For sound box adjustments it is almost imperative, for good results, to have those tools supplied by the respective companies and aside from these it is only necessary to have a small alcohol lamp, small screw driver, and a very light hammer. A 1x56 tap for threading thumb screw hole in Victor needle bars and a 2x56 tap for the same purpose for Columbia sound boxes are necessary. These are obtainable at about 25 cents each.

Lubricant for springs can be obtained from the various companies, or if you prefer to mix it yourself use Dixon's No. 633 graphite mixed with heavy oil to about the consistency of molasses. For heavy springs like the Columbia a better mixture is Dixon's Graphitoleo. It is also necessary to have a small can of good oil, and vaseline for use on gears and governor spirals. Some gasoline for cleaning purposes, a small bottle of white shellac for glueing mica to gaskets in sound boxes, and some emery cloth constitute the balance of supplies.

If you are a Victor dealer the following parts will be found to be in almost daily demand by the repairman.

	Catalog No.
Main springs	3014A. 2141A.
Winding ratchets	3017A. 1949P.F.
Pawls	183P.F. 2512C.P.
Winding shafts	3041A. 2510A.
Turntable spindle gears.....	2758B. 3029B.
Governor spindles	3275P.F. 963P.F.
Governor springs	282P.F. 1729P.F.
Governor spring screws.....	3075P.F.
Governor spring screw washers...	3066P.F.
Automatic brake springs.....	2810P.F.
Brake leather	1057P.F.
Rubber washers	883P.F.
Turntable felts	393P.F. 750P.F.

For Victor sound boxes the following are always in demand:

	Catalog No.
Needle set screw.....	1228Bl.
Rubber insulators	304P.F.
Mica diaphragms	414P.F.
Needle bar tension springs.....	487Bl.
Diaphragm screw	471P.F.
Diaphragm screw washer.....	1030P.F.

The Columbia dealer will find the following parts very necessary: main springs, governor springs, spring cage tab screws, winding ratchet and gear assembled, pawls, winding shafts of

various lengths, main drive gears, turntable spindle gear, governor spindles, mica diaphragms, gaskets and needle thumb screws.

The dealer who equips his repair man with the tools, supplies and repair parts as I have outlined above will find that he will be able to handle nine out of ten repairs.

Overcoming Noise in Motor

"A. H. Dodin,

"Care of Talking Machine World.

"I am stuck on a Heineman No. 7 motor. If it is wound just a little it runs very nicely, but if it is more than half wound it is very noisy. I find that touching the turntable just a little will stop the noise. The turntable must be touched several times during the playing of the record to insure quietness. It is just like applying a light brake. It must be a very simple adjustment and I do not like to bother the maker of the machine or the motor with it.

"SCOTT LANE."

The trouble is without doubt in the adjustment of the governor—either the governor spindle is too tight in its bearings or the spiral worm of governor sets too far into the fibre gear cuts. Try adjusting at these points but do not attempt it until you are sure the motor is entirely run down.—Andrew Dodin.

MICKEL BROS. CO.'S GOOD REPORT

Victor Wholesalers in Omaha Pleased With Results for 1917 and Prospects for Future

OMAHA, NEB., January 5.—Geo. E. Mickel, general manager of the Mickel Bros. Co., Victor wholesalers of this city, reports that 1917 was a very good year for his company, despite the problem of getting stock, and that they are looking forward to 1918 to be even better than the year just passed even though they have the problem of transportation and shortage of goods to meet. Mr. Mickel has been on a visit to dealers in the territory and finds the majority of them in a most satisfactory condition.

ALL FOREIGN MAIL CENSORED

Government Policy in This Respect Announced by Postmaster-General

WASHINGTON, D. C., January 7.—Postmaster-General Burleson recently made formal announcement that a censorship of all mail entering or leaving the United States is being conducted at New York as well as the Canal Zone, Porto Rico and larger seaports of this country. The announcement reads:

"Censorship of international mail has been inaugurated pursuant to Section 3 of the Trading With the Enemy Act and Sections 14, 15 and 16 of the executive order of October 12, 1917."

AN OPPORTUNITY

to secure a TALKING MACHINE at a very low cost



We have left over from a large contract a number of cabinets, all of which we have equipped with mechanisms, making a complete Talking Machine, as illustrated. While they last, we offer them at **\$6.50 each**, net cash, F.O.B. our factory. Orders for less than five machines will not be accepted.

Specifications

Oak or Mahogany Cabinet, 15 in. wide, 17 in. deep, 8 in. high. Nickel-plated Tone Arm and Soundbox. Single Spring Motor. 10 in. Turntable.

THE GEORGE A. LONG CABINET COMPANY
HANOVER, PA.

WAREROOMS THAT ARE "DIFFERENT"

New Establishment of the Silverstone Music Co. the Center of Interest During the Holiday Season—Initial Recital Held—Formal Opening Will Occur Some Time This Month

ST. LOUIS, Mo., January 4.—The new warerooms of the Silverstone Music Co., Edison jobber, which will be formally opened at a date this month as yet unset, are different from any other in this city, and Mr. Silverstone says that he has carried out many ideas that are entirely original with him.

The first floor fixtures, which consist of a recital hall and three demonstration rooms, are built entirely of quartered oak, finished in what is known as silver gray. The entire floor side-walls are paneled in oak. The windows and doors have the small, long glass, the effect in the recital hall being that of a small chapel.

The decorations are carried out with specially made lighting fixtures, small busts of musicians and specially designed and stained desks and chairs. The recital hall, although smaller than the old one, seats more because of a different adjustment of the space. On the blank wall side of the recital hall a door was put in to relieve the effect there. It is a real door with open panels and back of it to lend space idea is a looking glass.

The third floor is the machine sales floor, and as the customer steps into a small hallway, for all the world like the hallway in an old-fashioned house, he finds in front of him a room that duplicates a formal parlor, slightly stiff in furnishings, and in front of him a phonograph. The salesman sees the customer seated and asks to be excused to get some records. In an alcove, well curtained off, he starts another machine. So entirely unexpectedly the prospect hears a machine play. In some instances this has been taken for real music and in all trials the effect has been good.

This entire floor is finished with ceiling-high partitions and the various rooms are decorated and furnished as the different rooms of a flat. The effect is very good.

The second floor, finished in white and gold, is a record sales floor. It is frankly a business floor with everything for the convenience and comfort of the customer, with no space wasted.

The warerooms include two shops, one for the mechanical parts and another for the wood-working department. There are storage floors, a large shipping room. Mr. Silverstone has a private office on the second floor and the cashier's force and the sales offices are on a balcony over the shipping department.

The initial recital in the warerooms, which

the Silverstone Co. occupied before the Christmas rush, was by Marie Alcock, who came here to sing solo parts with the Pageant Choral Club in the "Messiah." The affair was entirely informal but very successful.

The best test of the new Edison quarters was during the holiday trade when, with the second floor not yet finished, the largest retail trade of any similar period was handled without serious trouble. It is true that the recital hall was used for record demonstrations, and that the areaway on the first floor was used, but everybody was waited on.

TRADE PERIL IN ENGLISH BILL

Proposed Law Would Remove From Register Trademark Used as Name of Article

A despatch from London states that representatives of American manufacturers in England are much alarmed over a bill pending in Parliament providing that if the proprietor of a word or trademark so uses his mark as to lead the public to regard it as the name of an article it shall be removed from the register of trademarks. If the bill is passed many American articles which have become popularized through name trademarks will probably be imitated under the same name and Americans will have no redress, thus entailing untold loss to them financially if not the ruin of their business in England.

Americans here say that cargo space for England is now so restricted that the trade in many articles has already become greatly affected, and that if the bill becomes a law imitators may be successful in getting control of all the business before the cargo space is increased and normal conditions are resumed between the United States and England commercially.

The attention of the American Consul-General, Robert P. Skinner, has been called to the seriousness of the situation, and if the representations of American representatives and officials here are unavailing, Washington will probably be asked to intercede with the British Government for the removal of certain objectionable features of the bill.

EXPANSION WITH OGDEN CO.

The sectional record cabinet and sales system manufactured by J. B. Ogden, of the Ogden Sectional Cabinet Co., Lynchburg, Va., continues to grow in popularity throughout the country. Since moving to the new factory they are much better equipped to supply the needs of the trade, and this business promises to be a very important one during 1918.

DEMAND FOR MELOPHONE LINE

Advance Orders for the Products of This Company Indicate Continued Prosperity for 1918

Henry Sobel, president of the Melophone Talking Machine Co., in a recent statement to a representative of The World, stated that the new dealers handling the company's line of machines are steadily increasing. He says the outlook for the present year is exceptionally bright, as the number of advance orders for shipments for the first few months of the year has been quite heavy. While the Melophone Co. have been featuring their expensive machines during the past few months, the demand for the popular-priced machines has by no means been small, all of which made the year 1917 one of great prosperity for the company.

"BUBBLE BOOKS" POPULAR

CHICAGO, ILL., January 11.—The local branch of the Columbia Graphophone Co. has recently received an exceptionally large stock of "Bubble Books." This was made necessary owing to the great demand which has sprung up for these books within the past few weeks. The book is devoted exclusively to childhood songs and stories, such as "Tom, Tom the Piper's Son," "Mary Had a Little Lamb," etc. It was illustrated by Rhoda Chase and is gotten out by the Columbia Graphophone Co. in conjunction with Harper & Bros., publishers. The book contains a printed text of these little childhood songs and stories on pages which are made in the form of an envelope, each envelope containing a six-inch Columbia record. When the record is put on the machine and is started off one may read the words that are being sung or spoken on the pages, and on the opposite page is a picture illustrating the song or story. The book has a hard cover and is printed in four colors. It contains three records and retails at \$1 per book.

ANENT EXPORTS TO LATIN-AMERICA

Since the war began American exports to Latin-America have increased 100 per cent. in value, while those of Germany have disappeared entirely, declares the American Exporter, New York, in its current issue. In 1913 we shipped to Latin-America merchandise values at \$323,775,885. In 1917 we shipped merchandise to the same market valued at over \$650,000,000. Our exports to-day to Latin-America actually exceed in value Germany's annual exports before the war to the combined markets of Canada, the United States, Mexico, the West Indies, Central and South America, plus those to Russia.

No. 100

Our factory leader. Simple in design; priced within reach of all, yet artistic enough for the most discriminating.



No. 200

Heavily gold plated on all exposed metal parts. Sound chamber has special carved doors opening out from it.

No. 150

Needle receptacles set in tandem in sliding disappearing receptacles. Heavily nickel plated on all exposed metal parts.



These instruments are made of genuine mahogany of exquisite workmanship and design, and compare favorably with the most expensive standard machines now upon the market. They are unapproachable in their priced class anywhere.

The prices of all standard makes of Phonographs have been increased. We have determined to keep ours the same until after the Holiday Season. Write us for our agency proposition TODAY.

JUST TEAR THIS OFF

Put it in an envelope with your business card or letter head and we will send you immediately free of charge a beautiful illustrated catalog of high-grade cabinet machines.

MELOPHONE TALKING MACHINE CO., Inc.
378 Lafayette St., N. Y.
27 E. Madison St., Chicago

WHY MUSICAL INSTRUMENTS ARE ABSOLUTELY ESSENTIAL

Will Payne Handles This Subject in a Masterly Way in the Current Issue of the Saturday Evening Post—Believes in Winning the War Without Destroying Industry

As has been said before, some of those in authority in Washington and other parts of the country, and the general public at large, will not be convinced of the fact that musical instruments are absolutely essential by the emphasis that has been laid upon that fact by manufacturers and dealers in musical instruments or by trade publications. The really convincing argument must come from those on the outside, and with no mercenary interests in the music industry.

It is particularly gratifying, therefore, to note the manner in which Will Payne, the noted writer, in an exceptionally able article on "Business That Isn't Necessary," in the Saturday Evening Post last week, upholds the cause of music and of the making and selling of musical instruments from the practical, rather than the theoretical, standpoint. Mr. Payne emphasizes the great economic danger that lies in shutting down any industry no matter how non-essential it may appear, suddenly and without warning, and how it is absolutely necessary to provide for the resumption of all industry on a basis as near normal as possible immediately upon the declaration of peace. His conclusions are understandable and sensible.

"Shutting down the factory is quite simple," he says. "All you need do is lock the door and walk away. Anybody can do that. But starting it up again after a long period of idleness, repairing the deterioration, assembling the materials and labor force, and so on, is much more difficult. It isn't merely the factory. There's no use starting up a factory unless you have an outlet for its product. These particular factories have an elaborately organized outlet covering the entire country—their agents and dealers in every considerable town. Except the youngest of them, those agents and dealers were doing something else before they went into the business. They have put their skill and energy and capital into that. If the business were shut down a good many of them would be broke; most of them would be out of a job. Mainly they would, of course, begin seeking something else to do. The whole extensive organization of the business would begin to fall apart and vanish. No scratch of the pen could build it up again out of hand."

He touches right on the music trade when he says:

"The music shop on the corner looks non-essential enough; nothing in it that you can eat, wear, throw at an enemy or raise the winter temperature with for more than a few minutes. It represents also consumption of materials and labor. If you look over the materials you will find they consist largely of expensive woods that are of very little utility except for an ornamental purpose. So far as waging war or down-to-brass-tacks subsistence is concerned the lumber used in building a small reviewing stand from which the mayor inspects a parade would be worth many times all the wood in the shop. Aside from wood, there is perhaps a hundred pounds of wire. But all the material in the shop, for war or hardpan subsistence, would hardly be worth carrying away.

"And if you sorted out all the labor you would probably find that much of it was not very useful for military purposes or hardpan subsistence. It is largely labor that is especially skilled and valuable for that particular kind of work.

"Nowhere has the war strain been more severe than in France; but the luxury shops of Paris have by no means been cut out. Many of them are open and doing business as usual. They are woven into the business fabric of the country. To cut them out would start a raveling that would probably weaken the business fabric even for war purposes. They produce war taxes and bond subscriptions. A good many people subsist by them. True, it is not

absolutely necessary that those people should subsist. They could just go and jump into the river, thereby decreasing the consumption of food. But France doesn't wish them to do that.

"Our music shop contains nothing to eat, wear, hurl or raise the temperature. But the hardest-pressed belligerent finds it advisable to maintain military bands. I am told that the German Government—whose rigorous efficiency for war is daily held up for our emulation—expends a good deal of money, labor and precious materials for the purpose of keeping a supply of talking machines in the rest and concentration camps all along behind the battle front, because it finds that popular music played on these machines invigorates the men's mind and makes better fighters of them. The military critics are always talking about the morale of the different troops—that is, about the state of their minds. By the common judgment of experts nothing is more essential in this war than those

imponderable things which keep men in a high, resolute state of mind. To that crucial end music contributes as well as canned beef."

Then, again, says the writer:

"Cutting out is simple enough, but building up is another matter. The vital thing in any business is its organization—the human associations by which it is carried on. Shut it down and the organization immediately begins to disintegrate. Building it up again takes time and effort. No business organization whatever should be destroyed. Cut down where necessary but never cut out. Prune but leave roots and trunk.

"Say it is a talking machine business. If there is war work—time fuses, small shells, uniform buttons, or what else—that it can do to advantage, turn some of its capacity over to that—gradually so as not to disorganize the factory—and preserve the business organization. We want it now to pay taxes and buy Liberty Bonds. Sure as sure can be we shall decidedly want it to help take up the slack when war production ceases and the millions of hands now engaged therein must turn to other employment."

WINDOWS AS TRADE ATTRACTORS

How the Goldberg Co. Emphasize the Value of the Talking Machine as a Solace and Entertainment in Military Hospitals

The Goldberg Furniture & Carpet Co., 161st street and Third avenue, New York, one of the most successful furniture houses in the upper



The Goldberg Co.'s Attractive Window part of the city, recently utilized its large show windows for a very attractive Columbia display, shown in the accompanying illustration.

This display is particularly interesting at this time in view of the fact that it is intended to depict the solace and entertainment provided in military hospitals by the Grafonola and Co-

lumbia records. Incidentally it may be mentioned that this display is built around the material prepared by the new Columbia dealer service department.

The Goldberg Furniture & Carpet Co. has built up an extensive Columbia following in its section of the city, and Manager Gall has made it a point to offer his patrons efficient Grafonola and record service. The Columbia department is growing rapidly, and a portion of this success may be attributed to the up-to-date and progressive sales and merchandising methods which are utilized at all times.

GEORGE W. LYLE LEAVES FOR WEST

George W. Lyle, assistant to President Widmann of the Pathé Freres Phonograph Co., Brooklyn, N. Y., left last week for a month's trip to the Pacific Coast. Mr. Lyle will visit the Pathé jobbers throughout the country, and will also call upon many of the Pathé dealers. There are a number of important deals for Pathé representation now pending, which will be closed by Mr. Lyle while he is away on this initial trip of the new year.

Enthusiasm is a habit, belief is a habit, persistency is a habit, politeness is a habit, salesmanship is a habit.

NOW IS THE TIME TO REPLENISH YOUR STOCK

Records prove that the next three months are the best in the year for selling the

VICSONIA

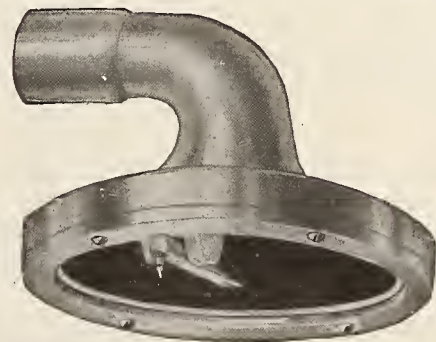

Mr. Dealer:

Don't miss sales by being out of stock. Order NOW.

If you are not familiar with the "best reproducer for playing EDISON RECORDS," send us \$3.50 and we will send you one on 10 days' approval. Money refunded if not satisfactory.

State Make of Machine

Vicsonia Manufacturing Company, Inc.
313 East 134th Street (Bronx) NEW YORK, N. Y.



Columbia Records—patriotic, dance, vocal, orchestra—sell *a tempo accelerando*. Less time selling records; more time taking in profits.

**Columbia Graphophone Co.
Woolworth Building, New York**

C. K. BENNETT REVIEWS CONDITIONS

General Manager of Eclipse Musical Co. Reports 1917 as a Most Successful Year in Cleveland Territory—Thoroughly Optimistic Regarding Outlook for Future

CLEVELAND, O., January 7.—In discussing business conditions during the year just closed and the future prospects of the talking machine business in this section, Chas. K. Bennett, general manager of the Eclipse Musical Co., prominent Victor distributors of this city, remarked: "I am pleased to say from a personal observation that this section of the Middle West has just passed through a most successful year, in fact, the most successful one in the history of the talking machine business. Even though a great many dealers were constantly calling for more goods, every dealer's business will show a splendid increase over 1916, in fact the percentage will amount to a great deal more than that which the factory produced.

"I have talked personally with a great many dealers in the last few days and without an exception each one has told me personally the same story with regard to the quality of business done, and more particularly the fact that cash sales during December were three and four times as great as during the same period in 1916.

"The record end of the business comes in for a big share of the credit for increased sales, this applying not only to the large exclusive shops and department stores in the larger cities, but to the little fellows in the small towns. I had a verbal report from one small dealer whose purchases during the year of 1917 will not exceed \$800 and whose record sales during the month of December amounted to over \$342. Success such as this reflects great credit on the Victor Co. for the publicity given the line and the demand which they are helping to create, to say nothing of the wonderful qualities placed in the goods.

"Another very conspicuous item that I have observed was the fact that a great many more high-priced machines were sold during the past two or three months than during the same period of 1916, indicating beyond question of doubt that the prosperity in our country is now being enjoyed by a different class of people than heretofore, who, like the wealthy man, enjoy the good things of life equally well.

"Business since Christmas has kept up at a very pleasing gait, in fact most of the large stores have retained the extra help taken on for Christmas, and the demand indicates that this rush is going to continue for some little time.

"The success of the dealers above mentioned during the holidays was so pronounced and their surprise so great that this has inspired them to continue the active campaign and thus reap the full benefits.

"The talking machine business has never been in a more healthy condition, nor has the demand been greater, and with every dealer fully

realizing this condition the clamor for goods is just as pronounced as it was before Christmas, and with every other condition equal I predict that 1918 will show up even more prosperous than any year in the history of the business."

BETTER BUSINESS BUREAU REPORTS

Secretary C. L. Dennis Issues Comprehensive Statement of the Activities of the Bureau During November—Eight New Cases Taken Care of and Many Complaints Investigated

MILWAUKEE, Wis., January 5.—C. L. Dennis, secretary of the Better Business Bureau of the National Association of Piano Merchants, has just issued a most exhaustive report of the activities of that bureau during the month of November.

During the month the bureau gave direct attention to eight new cases, and two old cases, growing out of charges of misleading advertising and also investigated a number of miscellaneous complaints. The work was carried on where possible in co-operation with the secretaries of local Vigilance Committees. Of the eight new cases handled two were due to overpricing, two to "explosive" advertising of special sales, one to "factory prices" advertised by a "gyp" dealer, one to questionable special sale, and one to the efforts of the manufacturer to protect his rights against encroachment by a dealer. Price comparisons were the cause of the trouble in most cases.

The report emphasized particularly the activities of "gyp" dealers in many cities, and it was found that the present situation in the country is being taken full advantage of in forwarding this class of operation. It is suggested that complaints regarding "gyp" dealers be forwarded to the bureau as soon as possible with full information in order that prompt action may be taken.

Of the eight new cases taken up by the bureau during November two were in Indianapolis, one in Chicago, two in Davenport, Ia., one in Peoria, Ill., one in St. Louis, Mo., and one in Stroudsburg, Pa. The miscellaneous complaints taken care of came from a score or more cities.

The trade has been much interested in the report of the bureau's work being sent out by Secretary Dennis, and the members have expressed themselves in complimentary terms. A full report of the bureau and its work will be made at the meeting of the executive board, committees, and State Commissioners of the National Association of Piano Merchants, to be held at the Biltmore Hotel, New York, January 30 and 31, 1918.

UNCLE SAM'S MEN HEARD FROM

Roy J. Keith Gets Interesting Letters From W. G. Porter and Morris Owens

Roy J. Keith, vice-president of the New York Talking Machine Co., received a few days ago a very interesting letter from W. G. Porter, who was formerly one of Mr. Keith's "right-hand men", in the executive offices, and who resigned to become a member of the Ambulance Service in the U. S. Army.

Mr. Porter, who has a host of friends in the local talking machine trade, is now serving his country "somewhere in France," and his letter reflects the good cheer and optimism which made him one of the most popular members of the local wholesale fraternity. Mr. Porter is serving in the same company as Joe Swan, another member of the New York Talking Machine Co.'s staff.

Mr. Keith also received in his New Year's mail an interesting communication from Morris Owens, who was formerly a member of the company's sales staff, and who is now with the 104th Field Artillery at Camp Wadsworth, Spartanburg, N. C. In his letter Mr. Owens expresses only one regret, namely, that his former associates—Messrs. Porter and Swan—managed to reach the firing line in France before he did. In other words, his letter emphasized the spirit of patriotism and unselfishness which is going to be an important factor in the conflict "over there."

L. W. Essex, secretary of the Manophone Corp., Adrian, Mich., has resigned his position with this company. His plans for the future have not as yet been announced.

We have a
Splendid
Proposition for
Live Dealers

Delpheon
the
Incomparable

Six Models
Retailing From
\$75 to \$175

DELPHEON SALES COMPANY

Distributors

25 CHURCH STREET, NEW YORK

Telephone—Cortland 4744



H. L. WILLSON'S MESSAGE TO TRADE

General Manager of Columbia Graphophone Co. Extends New Year Greetings to Columbia Dealers Through Columns of The World

H. L. Willson, general manager of the Columbia Graphophone Co., sends the following message to Columbia dealers, through the columns of The World:

"By the courtesy of The Talking Machine World, I am able to send a New Year greeting



H. L. Willson

to Columbia dealers, through the news columns of a trade paper which for years has stood staunch and true to musical instrument manufacturers and dealers.

"Nineteen hundred and seventeen has closed with a bigger year, bigger prospects, and greater satisfaction to the Columbia Graphophone Co.

and we believe to Columbia dealers than any previous year. We are entering the New Year full of confidence in our dealers, in our product, and in our policies, and in 1918 we hope to give you heartier co-operation and better service, and exert a little more effort in every direction in order that you may reap bigger sales, bigger profits and greater satisfaction in your representation of our company.

"We take the opportunity of thanking all Columbia dealers for their splendid loyalty and co-operation in 1917, and wishing them a happy and satisfactory New Year in the efforts we know they will make in 1918 in their own and our behalf."

BAKER JOINS TRAVELING STAFF

George A. Baker, connected with the local wholesale branch of the Columbia Graphophone Co., for many years has been appointed a member of the company's traveling staff, and will visit the Columbia dealers in Brooklyn. Mr. Baker assumed his new duties the first of the year, and from all indications will achieve very pleasing success.

During the past few years Mr. Baker has been in close touch with Columbia dealers in this territory, and his intimate knowledge of the details of talking machine merchandising well equips him to fill his present post. He understands the dealers' problems, and is in a position to render them efficient service and co-operation.

SOMEWHAT PERSONAL!

For a store salesman, especially, the habit of shaving every morning, for example, is a good habit. No man can shave himself without following it up with clean linen, brushed clothes, a shine, and a smile which begins at his heart and spreads out. Omit the morning shave, and you have not only discounted your appearance for the day, but you have discounted your efficiency for the day.

IT WAS TO BE EXPECTED

Ready File Co. Tells of the Results Secured Through Advertising in The World—Many Orders Received From Foreign Countries

C. Stanley Garrison, advertising manager of the Ready File Co., Indianapolis, Ind., writes as follows to The World regarding the results secured by that company through its advertisements carried in the columns of this paper. He says:

"You will be interested in knowing of some of our advertising experiences in The Talking Machine World.

"As a result of our double-page spread and our page spreads, we have received orders from Canada, Cuba and England and several fat ones from here at 'home.' While we expected results from local circulation, we will admit our surprise at the way The World pulls abroad."

NOW LOCATED IN MEMPHIS

John A. Hofheimer, who was formerly connected with the Maison-Blanche Co., New Orleans, La., is now associated with B. Lowenstein & Bros., Memphis, Tenn., where he is making an excellent record in the talking machine department of that business. Mr. Hofheimer is a practical, progressive man, who has given much consideration to the problems of the industry and their solution.

VALUE OF CO-OPERATION

Every one of us needs the very closest co-operation of the other fellow. If you are selling, try to know your merchandise better, be enthusiastic about it, be agreeable to your customers, look neat—in a word, sell better than you ever sold before; or, if you are in the executive end of the business, do your work in such a way as to be satisfactory to your department and to yourself. Remember, you are the final judge of the honesty of your labor.

"MICKEL"

A Great Name in the Victor Game

How Many of Those MILLIONS of Victor Records are YOU Going to Sell During 1918?

It's a big game. So big, in fact, that one cannot sit down and realize it all at one sitting. But if you are properly set for it you know you are going to get *your share*. A little hustle, "punch," vim and energy will sell you far *more* than your share. Let's get together on the *Victor Record* question *now*; there are many things we can tell you about the game. Will you meet us half way by writing us, *Now?*

Mickel Bros. Co.

15th and Harney Streets
411 Court Avenue

OMAHA, NEBRASKA
DES MOINES, IOWA

Those "Lively" Westerners.

PAYS TRIBUTE TO TALKING MACHINE

Bishop Mitchell, of St. Paul, Tells People of Toronto the Blessings of the Talking Machine in the Home and in the War

Bishop Mitchell, of St. Paul, Minn., recently preached in a Toronto church on the importance of education because of its effect in enlarging the vision of the soul. In illustrating his thought he said: "Unfortunately I myself had not the early advantage of a thorough musical education and for many years my ear was dull to the concord of sweet sounds. Thanks to the player-piano and the talking machine I have gained an understanding of some of the great music of the world and my power of appreciation is wonderfully enlarged. To that extent my life has been made fuller and more interesting. Some musicians, generally those whose performances are only indifferent, affect to look with contempt upon what they are pleased to call 'canned music.' They are surely wrong. Not long ago a young woman assured me that she could not endure a player-piano, it was so mechanical. If it were half as mechanical as the playing of this very young woman the inventor would not be proud of it.

"I come home after a hard day. I ask one of the greatest artists in all the world to sing to me. If I do not like his song I can stop it in the middle without discourtesy. If I like it, I say 'Sing it again,' and he sings it again in the same glorious and fervent tone. I may even cry 'Sing it again,' and he sings. To me the talking machine and the player-piano have opened a new world of beauty and discovered a very universe of splendor."

The eloquence of the bishop was not ill-placed. Beyond the shade of a doubt, the public appreciation of the best music has advanced more since the invention of the phonograph than in a hundred years previous to its appearance. On the remote prairies of Alberta, Scotti and Destinn and Rappold and Caruso are singing every evening. In the miner's cabin, on the frontiers of civilization, on the widespread seas as well as in the luxurious city home men and women are gaining an insight into the glories of an art formerly obscured by clouds and darkness. Even on the battle front the art of the greatest living musicians may be appreciated. Many significant stories have come to us from the war zone, but one thinks most frequently, perhaps, of the request of the unlucky Townshend force captured by the Turks in Mesopotamia more than a year ago. While besieged at Kut el Amara and cut off from the relieving force proceeding up the river they got a message through the enemy's lines. "Send us some phonograph needles." The needles were delivered by aeroplane.

VICTOR NUMERICAL CATALOG

The Victor Co. has just issued its new numerical catalog listing all records up to and including the November supplement for use in combination with the November record catalog.

In this numerical catalog extra pages are provided for adding to the catalog the new records issued every month.

The suggestions made on the inside of the front cover are particularly valuable. Properly used, this catalog will insure efficiency in ordering and handling records. This is particularly true in meeting the requirements of the smaller stores.

The six divided spaces before each record number afford a most convenient method for keeping track of the demand for each particular record—a most important essential in the successful conduct of a business and one which should be taken advantage of.

JOSEPH MUSANTE

Electro-plater and Silversmith
Gold, Silver, Nickel and Antique Finishes
Specializing in phonograph parts and musical instruments
168 CENTRE ST. NEW YORK
Telephone, Franklin 3053

You need this Record System

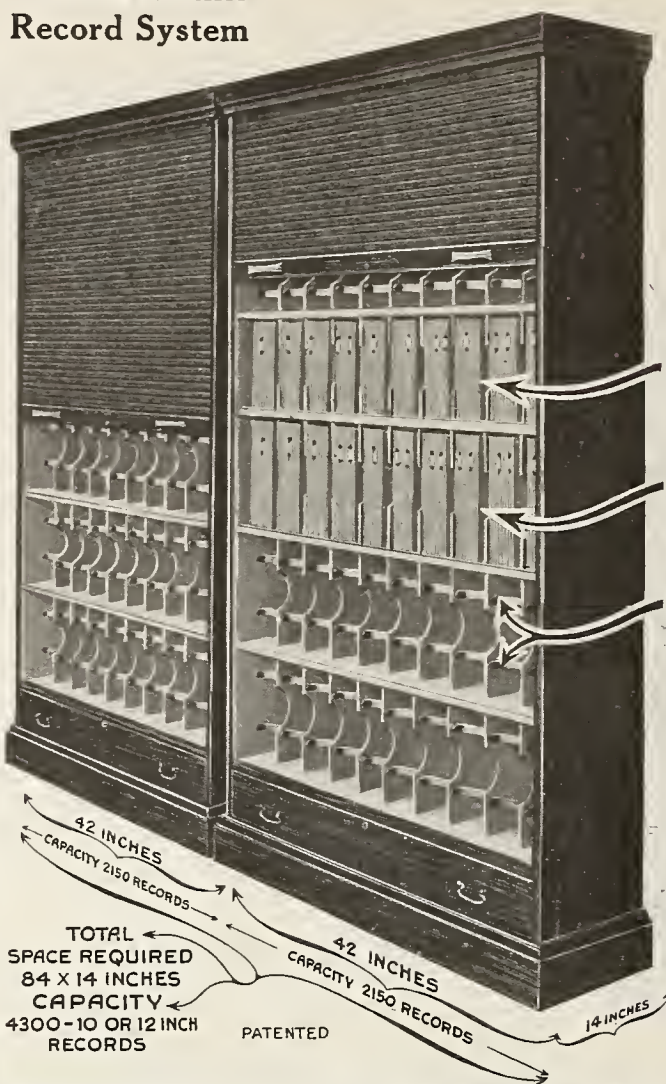

New Model No. 2150 DD

Improved in design and construction.
UNITS fit flat together on the end.
DOUBLE drawers in the Base.
SOLID Oak and Birch in all standard finishes.

Write for Our Manual of Filing Dept. K.

350-10 inch Records

350-12 inch Records
Patented Adjuster for Using 10 inch Records

Soft, Flat Springs Hold Records Upright And Prevent Warping.

Capacity 2150 thin records, 1075 Edisons.

Every record at your finger tips as simple as 1-2-3.

Built to fit your needs.

Prices { Oak \$55
 { Birch \$60

UNCONDITIONALLY GUARANTEED

Ogden's Patented Cabinets Protect against Dust, Warping and Theft. Save Time, Space, Money. : : Prices Subject to Change : :

OGDEN SECTIONAL CABINET CO., Inc., Lynchburg, Va.

"A NEGLECTED WAR ASSET"

President Bird, of Manufacturers' Association of New Jersey, Tells of the Service That Trade Organizations Can Render the Government by Giving Accurate Information

Under the heading of "A Neglected War Asset," J. Philip Bird, president of the Manufacturers' Association of New Jersey, has emphasized the value of existing trade associations in assisting the Government in its war work, by providing the authorities with accurate information regarding capacity, equipment and organizations of various manufacturing plants that might be utilized for Government work. The suggestions of Mr. Bird are fully in accord with what has been done, and is being done, by the Music Industries Chamber of Commerce and are therefore of interest to the music trade men. He says:

"In the possession of our long established national craft organizations is practically all the information needed by our Government officials for the prosecution of the war as to location of plants, number of men employed, capacity, etc. These American craft bodies have at their fingers' ends concrete, definite and up-to-the-minute information on the ability of every industrial plant in their respective and correlated lines. They know every minute of the day where labor is scarce and where it is adequate or plentiful. They have authentic knowledge as to supply and demand for important raw materials.

"If this highly perfected machinery and organization were taken advantage of by the Government, it would unquestionably save our officials the expenditure of considerable time, energy and money now being devoted to the gathering and usage of such necessary information on our economic and industrial resources.

"The patriotic co-operation of the thousand and one craft organizations ought to be availed of. The Government would be most willingly served with trustworthy trade data by the steel men, rubber men, live stock men, hardware men,

implement makers, engineers, garment producers, paint manufacturers, etc., through their well established trade associations.

"An arrangement of this kind would, with proper authority behind it, almost automatically avoid the evil of any district shortage of labor or raw materials causing delay in placing or delivery of important rush orders for badly needed supplies. It would place the industries of the nation under the practical and most effective control of a patriotic, voluntary and co-operative dictatorship, similar to the present voluntary censorship which our American newspapers are working under so satisfactorily. A properly drawn up set of rules, fixed by official promulgation as a supplementary method, would likewise solve the much mooted problem of essential and non-essential industries.

"Each craft association being a specialist in its own line, it is evident that no single national chamber of commerce, manufacturers' association, or even a State chamber or association, has the necessary facilities for doing what trade or craft bodies can do. This machinery for the carrying on of America's most gigantic enterprise—winning the war—should not be neglected.

"Let us cease encouraging 'Manufacturers' War Congresses,' etc., etc., who pass resolutions and go home, and turn our efforts to the utilization of this neglected war asset. The present instrumentalities are adequate to the present demand."

CLOSED SATISFACTORY BUSINESS

The Phonograph Clearing House, Inc., New York, which carried its first announcement to the trade in last month's World, reports the closing of a very satisfactory business during the past few weeks. S. N. Rosenstein, president of the company, states that his concern found one hundred items for as many manufacturers and dealers, and that he had received inquiries from all parts of the country and more are coming in every day.

TALKING MACHINE RECORDS FOR SOLDIERS AND SAILORS

New York Evening Journal, in Cartoon and Poem, Urges Public to Send Disc Records to Men Now in Training for Military Service—The Value of Music in Preserving Morale

The important part that the talking machine plays in the life of the soldier or sailor has the Y. M. C. A., who so far as possible will see that they are distributed in accordance with the



©Star Publishing Co., 1917.

OVER HERE--AND OVER THERE

It is only a half-worn record
Of an old, familiar air,
And you hardly know that you hear it
As you doze in your Morris chair.

The sleet on the window rattles,
While the blasts of Winter blow,
But what do you care for Winter
By your fireside's cheery glow?

What is a half-worn record
And a ditty of other days—
It is Just a Song at Twilight,
Heard through a dreamy haze.

Cheer up our boys in camp or aboard ship by sending them any disc talking machine records you can spare. They will keep our soldier and sailor lads in good spirits these long Winter evenings. Any Army or Navy agency will gladly forward whatever records you may turn in.

N. Y. Evening Journal Cartoon and Poem Urging Gifts of Records to the Boys in Service

been strongly emphasized recently through the energetic campaign being carried on by the New York Evening Journal to have talking machine owners contribute new and old records for the use of the men in camps or on ships. Several days recently the Journal ran special front-page stories emphasizing the desirability of talking machines for the fighting men and publishing letters from soldiers and sailors asking for records or telling of their appreciation of gifts of records received.

On one evening the Evening Journal covered four columns of its editorial page with the cartoon and accompanying bit of poetry reproduced herewith, and it is reported that the effect of the campaign has been immediately apparent, with the result that practically every camp and a great majority of the ships had new supplies of records for the Christmas season. The contributions of records are being collected by

It is only a half-worn record
Of some old, familiar air,
Yet it makes of the dreary dugout
A bit of home over there.

Gone are the shivering trenches
And the stretch of bloody loam;
Every heart with the music's turning
Back to the Old Folks at Home.

And each for his Annie Laurie
Would lay him down and die—
Strange how a half-worn record
Brings a tear to the soldier's eye!

C. B. Q.

expressed desires of the donor. The campaign carried on by the Evening Journal demonstrates that the value of the talking machine is being universally recognized.

COLUMBIA MEN IN U. S. SERVICE

Imposing List of Officers, Directors and Employes of Columbia Graphophone Co. in Service of the Government in Various Capacities

The accompanying list of the officers, directors and employes of the Columbia Graphophone Co., New York, who have entered the service of the Government, is a remarkable tribute to the patriotism and unselfishness of the members of the Columbia organization. President Whitten is devoting almost all of his time to the U. S. Navy, and every Columbia employe who has entered the service of the Government is proud of the fact that the head of the company is sacrificing all of his personal interests to assist the United States in its fight for democracy.

The Columbia factories at Bridgeport, Conn., can also boast of a service flag that is a tribute to the whole-hearted patriotism of the employes at this plant. At the present time 285 members of the Columbia factory staff are "doing their bit" for the Government, constituting a splendid body of well trained men:

List of Enlisted Men

Officers and Directors—F. S. Whitten, president, lieutenant in navy; Capt. John J. Phelps, director, navy.

Executive Office Employes—M. D. Easton, army; J. E. Barry, army; E. L. Manning, army; E. C. Nelson, navy; Edw. Shannon, navy; Edw. Prink, army; C. C. Couper, army.

Baltimore Branch—Jos. Heilman, navy.
Boston Branch—Eugene Martin, army; D. E. Ballou, army; Wm. Townsend, army; F. L. Dickinson, army; F. D. McCutcheon, army.

Chicago Branch—Vincent Farnham, merchant marine; Gregory Dorian, navy; A. B. Russell, signal corps; M. C. Master, radio division navy; Wm. Finger, mechanical staff, ordnance department.

Dallas Branch—E. B. Shiddell, army; Fred Winkle, navy.
Kansas City Branch—Walter Hoag, army; Marco Randazzo, aviation.

Los Angeles Branch—W. O. Ryle, army; Lawrence Powers, army.

New Haven Branch—W. W. Knott, army; Harold Wilson, navy.

New Orleans Branch—A. F. Fortier, army; E. J. Hymel, army.

Warren St. Branch, New York—J. A. Sieber, navy; J. A. Johnson, navy; W. E. Guthrie, army; J. D. MacDonald, army; R. Wagner, army; Wm. Strohmeyer, army; Joseph Jones, army; Edw. Flanagan, army; Walter Gaffney, army; J. Turbidity, army; C. R. Rhodes, army; A. Vernon, army; D. S. Barr, army.

Philadelphia Branch—Joseph Callahan, army; John Kelly, army; Chas. Glasgow, army; Benj. Thomas, army; Jos. Mollick, navy; Albert Lancaster, army; Wm. Page, army; W. H. Appleby, navy; Wm. Wagner, army.

Pittsburgh Branch—B. D. McCampbell, army.
Portland, Me., Branch—Clyde Skinner, navy.

San Francisco Branch—Andrew C. Love, army; Kirk Kuhn, army; Quinton Worthington, army.

St. Louis Branch—Clyde Roos, army.

List of Drafted Men

Executive Office—D. V. B. Allen.

Baltimore Branch—William Freeman.

Chicago Branch—F. Lindgren, J. Peterson, L. Batchelor, G. Simpson.

Indianapolis Branch—Bynum C. Fletcher.

Warren St. (N. Y.) Branch—T. Mulligan.

Philadelphia Branch—Louis Dickinson.

San Francisco Branch—Lou Batchelor, Jack Bates.

NOW MAKING PHONOGRAPHS

The Coops & Sons' Piano Co., which moved its factory to Pasadena from the East about four years ago, has begun the manufacture of phonographs in addition to its piano line. The new machine is described as a first-class model, retailing in the neighborhood of \$100.

CRYSTAL EDGE MICA DIAPHRAGMS

**M
I
C
A**

Let us send you samples *today* of our diaphragms and you will readily understand why the best talking machines are equipped with *Crystal Edge Mica* diaphragms exclusively.

We use only the very finest selected mica, the best diaphragm material in the world. To insure a supply for the holiday trade place your orders immediately.

PHONOGRAPH APPLIANCE CO., 109 West Broadway, NEW YORK

FINANCIERS SAY BUSINESS WILL BREAK RECORDS IN 1918

Leaders in Important Lines Predict That the Industrial Activity of the Nation Will Be on a Tremendous Scale During the Year Just Beginning—Optimistic Viewpoint Heartens All

Industrial and financial activity on a tremendous scale is foretold for 1918 by representative men in various important lines, whose views have been gathered for the January number of *System*, the "magazine of business." Demands of the war will, of course, be of chief importance and will engage general attention. Income of supply agencies will be greatly augmented, but the outlook in other directions is also for prosperity because business of every character will adjust itself to the war situation, and the experience of 1917, in which unprecedented Government requirements were met without disturbance of business, will be continued, according to the best opinion. High wages will be coincident with widespread economies.

Following are some of the views sent to the magazine:

Nation's Aim Is to Win War

W. P. G. HARDING, Governor of the Federal Reserve Board—The paramount business of the United States at this time is the winning of the war, and the activities of the American people are directed to this end. The production, manufacture and transportation of those articles which are necessary for the maintenance of the population of a nation engaged in war and for the support of its armies in the field must be stimulated in every possible way. The Government is the largest purchaser of supplies, the chief customer of business, and its financial requirements will be very heavy. The people are fast learning habits of thrift, of industry and of economy. Over 10,000,000 of them are holders of Government obligations in which they have invested their savings and for which many have themselves gone into debt, thus pledging their future earnings and economies for the support of the Government.

ELBERT H. GARY, chairman of the board of directors of the United States Steel Corp.—It is up to us to prove our continued loyalty to the Government; but, more than that, our loyalty to ourselves in the performance of duty. If our country is defeated in the pending military conflict your property and business and mine will be of little value. We shall have retraced our national steps a century and a half. The wealth of the country will be seized and retained as prize money by other nations. We have been forced into the war and we are com-

pelled to fight in defense of our persons, our property and our sacred honor. There is no escape. We are in the war to the end, however costly and bitter the struggle. No man, no country, was ever engaged in a more righteous or a more compulsory defense.

Business Dominated by War

FRANK A. VANDERLIP, president of the National City Bank—The business situation in 1918 will be dominated by the war, and the energies of this country must be concentrated as fully as possible upon winning the war. In the aggregate the production of the industries both in quantities and values will be enormous; they will be greater than ever before, employment will be complete and the aggregate of payments in wages will be far ahead of any previous year. The income of our farmers will be larger than ever before. There will be an unusual distribution of income among the masses of the people, and this purchasing power will make a large market for necessities and essentials, not to speak of what may be classed as luxuries. There is a great resource as yet hardly touched in the army of women who have never gone into industry but who will respond now to our appeal to their patriotism. The problem of America is to speed up its productive machinery to the highest possible limit.

Schwab Is Bullish

CHARLES M. SCHWAB, chairman of the board of directors of the Bethlehem Steel Corp.—I have always been bullish on the United States. I can see nothing ahead to make me modify my attitude; a tremendous significance attaches to how squarely we meet the problems, apparent or not yet apparent, which lie before us. We can think only of the successful prosecution of the war—in its every phase—for the end of the war is nowhere in sight. We shall be successful in the measure that we put business before pleasure.

CHARLES H. SABIN, president of the Guaranty Trust Co.—Demand for additional capital is greater than ever because of general business activity, but the Government's demand for money also is unprecedented, so the bankers must bear the double strain of colossal loan flotations and the financing of unexampled trade activities. In addition, a considerable volume of maturing obligations must be provided for. Fortunately, the machinery for relieving much

of the pressure exists in our strong, centralized banking system and its great credit resources.

GEORGE E. SMITH, president of the Manufacturers' Export Association—We must buy from neutral countries in order to carry on our own war preparations; if we buy from them we must also sell to them or we shall not be able to pay for what we buy. Therefore, I think that it is a very high duty to develop our export trade in the most intensive fashion and with the highest possible efficiency. We may not—probably we shall not—have goods enough for both the home and the foreign markets; that which is sold in foreign markets helps us to pay our way in the war, and hence I should give the foreign markets the preference over the domestic.

B. D. CALDWELL, president of Wells, Fargo & Co.—I do not believe there will be any let-up in the business of this country during the coming year or, indeed, during the war, the end of which does not appear to be in sight. The performance of our part in the successful prosecution of the war is the greatest business we have ever undertaken, and will require that every enterprise which can help in the least degree shall strive for the high-water mark in activity and efficiency.

Demand Exceeds Supply

ALBA B. JOHNSON, president of the Baldwin Locomotive Works—War involves prodigious expenditures and these produce business activity. Therefore, as long as the present conditions of war exist, there must continue to be a demand exceeding the supply, resulting in strongly sustained prices.

CHARLES E. MITCHELL, president of the National City Co.—When the exigencies of the times have come home to all, then will America awake. She will bear taxation without grumbling. She will treat her railroads fairly, that they may wax strong for her needs. She will stamp out sedition, which now flames about her very skirts. She will lend every assistance to her corporations that they may produce in abundance. She will, while demanding fair play for her laborer, insist that he toil unremittingly for the common good.

EXHIBIT AT AUTOMOBILE SHOW

The Doehler Die-Casting Co., Brooklyn, exhibited at the National Automobile Show held at the Grand Central Palace from January 5 to 12. Although the exhibit was naturally devoted in a larger way to automobile die-castings, there was shown a very fine exhibit of die-castings of talking machine parts. The display was varied and wide in scope and contained die-castings of sound boxes, tone arms, tone arm necks, in fact, every possible part of a talking machine that could be die-casted. The exhibit was well visited by the thousands attending the show.

MUSIC FOR "OUR BOYS"

"Music for Our Boys in the Service" is the heading of a timely and effective poster mailed to Columbia dealers this week. The text of this poster reads as follows: "Send some Columbia records to your soldier. There's a Columbia Grafonola in his Y. M. C. A. or Knights of Columbus Army Hut. Bring your records to us and we will deliver them for you." It is interesting to note that a Columbia Grafonola may be found in the army huts mentioned, as it indicates the remarkable popularity of this instrument.

LEAVES ON WESTERN TRIP

Leonard Markels, well-known motor manufacturer, left New York Sunday for a Western trip, and according to his present plans will visit Chicago, Milwaukee, St. Paul and Minneapolis. During the past few months Mr. Markels has received letters from many Western manufacturers regarding contracts for 1918, and will close these contracts while away on his present trip.

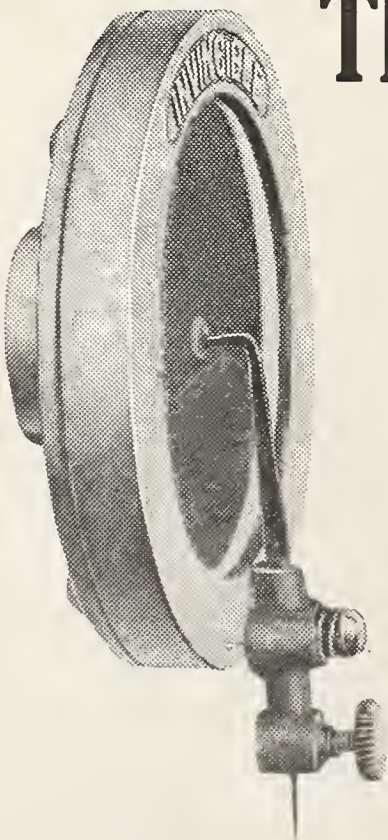

The "INVINCIBLE"

A New and Better Sound-Box

- ☐ Plays all makes of records.
- ☐ Pure, clear and sweet tone.
- ☐ Constructed to give service and absolutely guaranteed.
- ☐ No superfluous parts, and production uniform—no seconds.
- ☐ Supplied with mica or composition diaphragms.
- ☐ Our composition diaphragm is a staple product and is guaranteed to be the best for all sound box purposes, has stood the test equivalent to 200 years' wear and still in service, thousands of them in use in homes throughout the U. S. and Canada.

WRITE TODAY FOR SAMPLES AND PRICES

New Jersey Reproducer Co.
10 Oliver Street NEWARK, N. J.

VAN VEEN "BED-SET" BOOTHS

Increase Your Record Sales

Write for a copy of our
NEW CATALOG

Van Veen "Bed-Set" Sectional Booths can be erected as easily as a bed (no skilled labor required). Booths shipped on short notice *anywhere*. Room sizes any multiple of 3 feet. High grade finish, will match your sample if desired. Sound-proof construction. We design and build complete interiors. We also build record racks, which are described in our new catalog.

Prepare for a Machine Shortage
by Developing Record Sales



Demonstration Booths Mean
Additional Record Business

If a special feature is desired, different from regular catalog design, we will build it to suit. Illustration shows special design of front for booth. This can be varied to suit owner.

Van Veen Booths Will Pay for
Themselves by Increasing
Your Record Sales

ARTHUR L. VAN VEEN & CO., Telephone Greeley 4749 Marbridge Bldg., 47 West 34th St., New York

TALKING MACHINE ARTISTS TO TOUR

Collins, Harlan, Campbell, Burr, Meyers, Murray and Others in Group Giving Concerts in the East—Of Particular Interest to Talking Machine Owners and Retailers Everywhere

As is announced on another page of The World this month, the Popular Talking Machine Artists, the men who have made records of the popular kind for so many years that their names are known and esteemed in the majority of homes, and who are represented in all the leading monthly lists, are now preparing for their spring concert tour.

At intervals during a year or more, these artists, including Henry Burr, Arthur Collins, George H. Meyers, Albert Campbell, Byron G. Harlan, Fred Van Eps and Billy Murray, with Theodore Morse, the noted composer, at the piano, have given concerts in various cities in the East and have met with unqualified success, through co-operation with local talking machine dealers.

The voices of Collins and Harlan, Albert Campbell, Billy Murray and the rest of them, have long been familiar in the homes of the country through the talking machine, and the public generally, especially in the smaller cities and environs, have shown a surprising interest in the opportunity to hear these artists in person on the stage, and to see them at close range. Whether they appear on the records as members of the Peerless Quartette, the Sterling Trio, or as individuals, the interest has been the same, and it has been a rare occasion when the artists have not played to capacity audiences. Instances are cited where talking machine enthusiasts have traveled from fifty to seventy-five miles each way just to see and hear their favorite record artists in the flesh.

The concerts given by the artists are made up of solos, and chorus numbers, and comedy bits, which, with a generous number of encores, run somewhat over two hours. Where practical the concerts are held with the co-operation of the local newspapers and talking machine dealers of the various lines, for, as the artists without exception sing for at least two record companies, and in some cases for a half a dozen or more companies, practically every dealer in town has some direct interest in their work and stands to benefit by their appearance before his customers. In some cases one dealer will arrange for the concert by himself, and more often dealers will co-operate to bring the feature to their city. Instances are on record where newspapers have printed two and four-page supplements featuring the concert, the artists and talking machines generally, and carrying a substantial amount of advertising from local retailers to make the venture pay and to give it impressiveness.

As one newspaper puts it in a review of the concert: "It is something unusually interesting to hear a coterie of the men who, taken together, have made more talking machine records than

any other people on earth." Another says: "It is particularly pleasing to see and hear this aggregation—to gaze directly at persons who have been announced on the printed covers for years." Still another paper says: "This is an event of special interest to owners of talking machines, as it affords them the rare opportunity of seeing these artists in person and watching the manner in which they 'put across' the various songs and instrumental numbers that have become so popular the world over."

Among dates scheduled by the Popular Talking Machine Artists for next month are: February 6, Syracuse; 7, Buffalo; and 8, Rochester, all the dates being made through the co-operation of local talking machine wholesalers and dealers.

GROWING IN POPULARITY

The Widdicomb Line of Phonographs Has Won Favor Among Lovers of Artistic Creations in Phonograph Making and Designing

GRAND RAPIDS, MICH., January 9.—The Widdicomb line of phonographs recently introduced to the trade is meeting with a very cordial re-



Widdicomb Queen Anne Model

ception. The experience of the Widdicomb Furniture Co. in catering to the furniture trade has enabled them to offer a line of phonographs whose cabinets have achieved instantaneous popularity even before the fine tone of the phonograph is heard. The accompanying illustration shows one of their console models in the Queen Anne style. Their years of furniture experience had taught them that the Queen Anne style ranks high among the various period styles. The other popular periods are all represented in the various artistic models in the line made by this company. It is their contention that as phonographs are essentially pieces of living room furniture great care must necessarily be given to the cabinet and its harmonious relation to the other furniture in the room.

The Widdicomb Furniture Co. have also seen to it that every other part of the machine matches in perfection to the cabinet that contains it. This is notably evident in the remarkable reproducing qualities of the instrument which contains so many distinctive features, among which is the modulator which is featured in the phrase "Play it yourself."

TO PRESERVE GREAT SPEECHES

Society Formed to Make Talking Machine Records of Speeches in Congress

St. Louis, Mo., January 10.—Guy Colterman, a prominent attorney of this city, has founded a society to be known as The Nation's Forum, which will make the talking machine aid in winning the war. The society plans to use records of speeches by American leaders in Liberty Loan campaigns and other patriotic activities all over the country. It is also planned to make permanent records of great speeches and messages in Congress and elsewhere, so that posterity may listen to the voices of the war leaders of 1918.

ADVANCE RECORD PRICE

On January 15 Emerson records heretofore retailing at 25 cents will be advanced to 35 cents retail, thus affording a much larger profit for retailers and jobbers. In addition, the company is beginning to shift its new 65-cent records which, from all indications, will meet with an active demand from dealers handling machines that do not include record lines.

The company states that, by the use of more economical methods in manufacturing and selling, it succeeded in reducing its expenses considerably during the past few months. This saving, added to the increased profits derived from a larger volume of business, enabled the company to close a very satisfactory year.

War service and business service should and can go hand in hand these days.

Phonograph Clearing House, Inc.

Found 100 items for 100 manufacturers and dealers last month.

Phonograph Clearing House, Inc.

Disposed of an equal number of items for an equal number of manufacturers and dealers during the same period.

What Do You Want?
What Have You to Sell?

Get It or Sell It
Through Us

Phonograph Clearing
House, Inc.

51 East 42nd Street NEW YORK

You Ought to Know

In case you are contemplating expanding the sphere of your business to include departments devoted to Pianos, Player-Pianos, Musical Merchandise or Sheet Music, that you'll find news and comments about them all in



ESTABLISHED 1876

The oldest and leading music trade weekly, which covers every branch of the industry.

It Contains

instructive and educational articles. Hints on salesmanship and advertising. Editorials that are timely and authoritative. Facts about the new things in the trade. Trade happenings in all parts of the United States.

“Review the Music Trade With Us”

Send your \$2 now for a full year's subscription to

THE MUSIC TRADE REVIEW
373 FOURTH AVENUE NEW YORK

A. D. GEISSLER CHATS OF WAR, BUSINESS AND PROSPECTS

President of New York Talking Machine Co. Discourses in His Usual Interesting Way on Business Conditions and Prospects—Lessons Learned in 1917

The representative of The World was thinking of business conditions more than world-wide conditions when he visited recently the offices of Arthur D. Geissler, president of the New York Talking Machine Co.

The first question asked Mr. Geissler was worded "A lot happened last year, didn't it?" the aim of this question being to get Mr. Geissler's ideas on the different changes in organization, methods of distribution, etc., which had transpired during 1917.

In answer to this question Mr. Geissler said: "Yes, not only last year but the year before that and the year before that. But now, what a different atmosphere seems to pervade, that we have the first inklings of peace and that we can, for a moment, stop and consider all the dreadful debauchery and waste of homes, lives and treasure since this war began.

"And now that we are in it, how fortunate it was that France was ready—that Great Britain was ready with her navy—that little Belgium was able to throw herself into the breach until France could gather herself together and hold the onrushing tide—and then Britain was able to sustain that support!

"What must be the feeling to have them 'over there' now to know that we, too, are really 'in it!' The months of recruiting and enlistment—the filling up of officers' instruction camps—the draft bill—the shipping and food regulation—the huge appropriations—and finally, for them to realize the glow of heart with which we greeted their Joffre, their Balfour and their Italian Mission—'Vive L'Italia,' I say. She understands and must—sore beset as she has been.

"We have had our drives for money—it has been a year of preparation. Our resources—our resolutions—are the things now that must count this year.

"You ask me to predicate business condi-

tions. How can anyone say what is to be?

"The largest industries in the country have offered their entire resources to the Government. I understand the Victor Talking Machine Co. was amongst the first to do so. If labor, material, fuel and transportation conditions permit the Victor Co. to make even as much merchandise as they made last year, then the business of the retailer and the wholesaler will be as large as last year.

"We are selling Victrolas and Victor records, that is true, but essentially what we sell is music—a product no longer considered a luxury, but a necessity—shown by the liberal ap-

DEMAND FOR FIBRE NEEDLES

Continues to Grow, Judging From the Increased Activity With the B. & H. Fibre Needle Co., Chicago—A Chat With President F. D. Hall

CHICAGO, ILL., January 10.—"From present indications," said F. D. Hall, of the B. & H. Fibre Mfg. Co., when called upon by a representative of the World this month, "it looks as though the trade in general is threatened with another avalanche of business for the coming year. Not only in this country has business been exceptionally good, but there has been an enormous increase in the export trade lately. Shipments to Central and South America and Australia are being handled in a more expeditious manner than for some time past, and now that the Government has taken over the rail situation, the trade can rest assured that all freight in transit hereafter will be sent over the quickest possible routes and that there will be no delay at the point of destination. This will have an effect upon the dealers to whom the goods are being shipped of giving them the necessary stimuli to get out and do more business than they have

propriations made by the Government for provision of music to its soldiers and sailors, realizing that mental and physical strength comes not through food alone. And through the Victrola, we are furnishing to the people the most *inexpensive* medium, of relaxation, pleasure and inspiration.

"You ask me what was the greatest lesson learned in 1917? I feel that through the Liberty Loan issues we have learned that huge sums of money can be raised by the Government without disturbing business seriously. Through the placing of these funds in the hands of the best consumer that business has ever known—the Government—we have a consequent speeding up of industries which has caused the country at large to look upon Washington with confidence, and feel that big business, small business and the laborer will be treated fairly."

done, knowing that their orders will be taken care of promptly. The freight situation prevailing towards the latter part of the old year was a major factor in keeping a great many dealers from taking in all the business that was possible for them to do.

"The raw material which we use for the manufacture of fibre needles is of better grade and quality than we have ever had before, and the Porto Rican fibre, samples of which the Government sent us some time ago, has proved its merit and is equal, if not superior, to the material that we have been receiving from the Orient.

"We have installed many new and improved machines for the manufacture of our needles and are turning out a product that is far superior both in quality and workmanship than ever before. Of course, this necessitated a large increase of our forces and we have made all preparations to take care of the trade for the coming year, which, no doubt, will be a banner one. We have also made many improvements and have added several new features to our latest needle cutter and are also prepared to take care of the demand that has been increasing so rapidly."

TALKING MACHINE MEN TO MEET

New Applications for Membership and Annual Reports to Be Acted on at Coming Meeting

The next meeting of the Talking Machine Men, Inc., will be held in the directors' room of the Merchants' Association, on the ninth floor of the Woolworth Building, at 2 p. m. on January 16. Many important matters will come up for discussion at this meeting, and all members are urged to attend. Arrangements for the annual dinner will be submitted, and the reports of the various standing committees will be read. Among recent applications for membership, to be acted upon at this meeting, are those of the Berlin Department Store, 1013 Broadway, Brooklyn, and Schmuckler & Singer, Inc., 133 Canal street, New York City.

NEW QUARTERS IN MINNEAPOLIS

Nye's Brunswick Shop Now Located in the New LaSalle Building, That City

MINNEAPOLIS, MINN., January 5.—One of the first business concerns to move into the recently completed LaSalle Building, this city, is Nye's Brunswick Shop, conducted by Ex-Mayor Wallace G. Nye and Geo. M. Nye, and in which the Brunswick phonograph is featured, together with Pathé records. The new quarters are most elaborately furnished. In addition to a full line of phonographs, the Shop also has on display a big assortment of billiard outfits which are also manufactured by the Brunswick-Balke-Collender Co. With the opening of the new shop, Wallace G. Nye remarked: "I find the harmony of the Brunswick Shop most agreeable in contrast with the discord of public life."

Miss Frieda Hempel, the Metropolitan opera soprano, will start on an extended concert tour early in February.

To Our Clientele

¶ During this period of unusual conditions we are doubling our efforts in order to maintain our service and assist you in every possible way in marketing Victrolas and Victor records, which have won recognition as an *essential product* in the camp as well as in the home.

¶ As a Victor retailer you are therefore "doing your bit" to provide the necessary entertainment and relaxation for the public and the "boys" in camp, in addition to helping the Government carry its economic burden.

G. T. WILLIAMS CO., Inc.

VICTOR WHOLESALE EXCLUSIVELY

217 Duffield Street

BROOKLYN, N. Y.



37 hits! 37 sales winners! That's how we have kept our promise with Columbia dealers. The February List is a corker.

**Columbia Graphophone Co.
Woolworth Building, New York**

WM. MAXWELL OPTIMISTIC OVER THE TRADE OUTLOOK

Vice-President of Thos. A. Edison, Inc., Tells of Great Business in 1917 and Gives Reasons Why There Should Be a Large Purchasing Power This Year

Reviewing the business situation at the request of The Talking Machine World William Maxwell, vice-president of Thos. A. Edison, Inc., writes:

"Our phonograph business in 1917 was the largest in our history, and was 20 per cent. ahead of 1916. The present indications are that our orders for 1918 will be considerably in excess of 1917, but we may not be able to manufacture as many phonographs as we made last year. We expect our record production to be materially larger than last year.

"Among a certain class of bankers, particularly the smaller bankers who absorb their opinions on broad financial questions from the public statements of large bankers, it has become quite the fashion to speak with gloomy foreboding of what the future holds in store for the musical instrument industry. It has been reported to me that various small bankers have said in effect that under present conditions they can't conceive of anyone buying pianos or phonographs.

"The pleasing fact remains, however, that people are buying phonographs and pianos in very large quantities—particularly phonographs.

REARRANGE SUPERVISORS' DISTRICTS

New Schedule for Edison Phonograph Supervisors Became Effective on January 1—Visit Factory for Get-Together Conference

The following rearrangement of Edison phonograph supervisors' territories has been announced by the musical phonograph division of Thos. A. Edison, Inc., as having become effective on January 1. The supervisors and the territories which they will cover are as follows: H. R. Skelton, with E. F. Bedford, as mechanical instructor for the territory embracing Boston, New Haven, Albany and Syracuse; C. S. Gardner, with J. C. Knipper, as mechanical instructor, for New York, Philadelphia, Williamsport, Pa., Pittsburgh and Richmond; N. Johnstone, with J. Finlayson, as mechanical instructor for Cleveland, Cincinnati, Detroit, Indianapolis and Chicago; L. A. Zollner, with A. E. Schiller, as mechanical instructor for Milwaukee, Minneapolis, Des Moines and Sioux City; C. W. Burgess, with D. Lawson, as mechanical instructor for El Paso, Kansas City, Omaha, Denver, Ogden, Utah, and Helena; J. A. Shearman, with C. A. Harrington, as mechanical instructor for Dallas, Atlanta, New Orleans and St. Louis; D. M. Martin, with H. D. Gumaer, as mechanical instructor for all of Canada.

Over the Christmas holidays Supervisors Skelton, Gardner, Johnstone and Martin, and the entire staff of mechanical instructors, were at Orange to participate in a get-together conference, during the course of which they were entertained at dinner by the company.

These bankers make the not uncommon error of ascribing to everyone else their own state of mind, or that which they observe in their immediate associates. The class of people with whom a banker comes most frequently in contact is not the class from which the phonograph dealer will get his business in 1918. The workingman and the farmer are the people who will make the phonograph business good in 1918. There are literally millions of families in the United States who heretofore have felt that they could not afford phonographs, but who, in 1918, because of increased earning capacity, will (despite the high cost of living) feel both able and inclined to make their homes better places to live in by purchasing phonographs. These people will not feel that they are committing an extravagance when they purchase a phonograph. On the contrary, they will feel, and feel rightly, that they are making an investment for the benefit of every member of the family circle.

"The thing that worries me now in connection with our phonograph business is the possibility that the increased purchasing power of these millions of families will find our dealers and ourselves unprepared to meet the demand."

MOST APPRECIATIVE OF OFFER

Otto Heineman, president of the Otto Heineman Supply Co., has received a letter from Major General George Barnett, Commandant, Headquarter U. S. Marine Corps, Washington, D. C., acknowledging Mr. Heineman's offer to furnish each of the U. S. Marine Corps stationed in Cuba and at other points with a Vanophone and collection of Emerson records, for which this company acts as export agents in the Latin-American field.

In a chat with The World Mr. Heineman expressed great pleasure at having an opportunity to provide some amusement for "our boys." Mr. Ackerman, export manager of the company, states that the U. S. Marine boys are anxious to be sent "over there." Their enthusiasm can be readily appreciated, for outside of the patriotic spirit involved the Marine Corps is as fine a body of men as ever have fought for Uncle Sam, and this division offers special attractions to the young American with red blood in his veins. Service on land, at sea, or in the air is open to him, and the fact that the Marine Corps contains no conscripted men appeals to many young Americans who desire to offer their services to the Government, in preference to waiting for the draft.

From F. W. Woolworth: "There are plenty of opportunities for young men today. Many fail because they are not willing to sacrifice. No one ever got far who was in bondage to the body." This is especially true to-day when a great war is facing us.

A POPULAR COLUMBIA MAN

Frank K. Pennington, Assistant General Sales Manager of the Columbia Graphophone Co.

We take pleasure in presenting herewith Frank K. Pennington, assistant general sales manager of the Columbia Graphophone Co., New York, and one of the most popular members of the Columbia organization.

Although he has been connected with the Columbia for less than a year, Mr. Pennington



Frank K. Pennington

has already won the esteem, friendship and admiration of every one of his co-workers. His door is always open for visitors to the executive officers, and his many years of practical sales experience, combined with his magnetic personality, has given Mr. Pennington an entree into the heart of every Columbia man. He is proving an invaluable assistant to George W. Hopkins, general sales manager of the company, and it is Mr. Pennington's earnest hope and ambition that he will soon find time to visit every Columbia branch and become personally acquainted with all his co-workers.

EDISON MAN GIVES LIFE TO COUNTRY

The first man of the Edison organization to give his life for his country was Leslie Parker Colton, of the record stock department, Edison Phonograph Works, Orange, N. J. He was a sailor on the Battleship "Missouri." His death occurred the day following the date originally set for his marriage. Mr. Colton had been three years with the Edison organization.



L. P. Colton

He enlisted in the navy and had seen but two weeks' service.

No man can help an organization to become greater, better, more successful and more efficient without making himself the same.

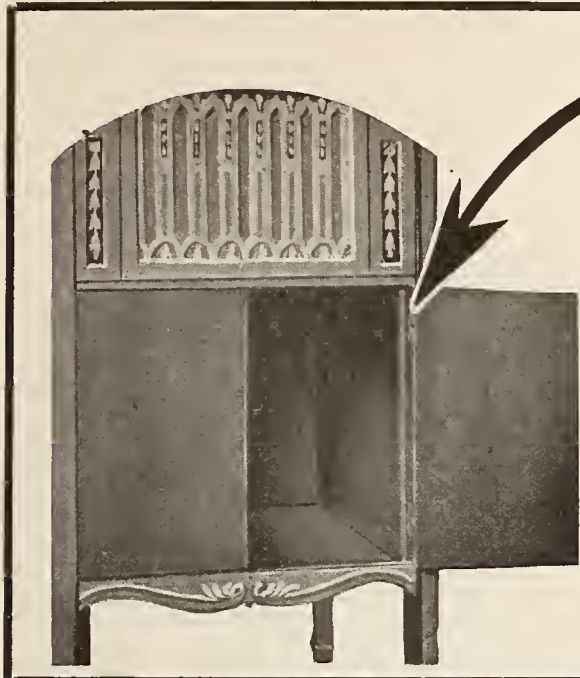

SOSS

INVISIBLE HINGES

Preserve Beauty

In many beautifully designed, finely finished Talking Machines, Pianos, Music Cabinets, Piano Players, and Benches, the elimination of the unsightly protruding Hinge is essential to preserve the beauty of the design.

Design and Construction

The fine cabinet work which is required in many instances to preserve the disguise of the instrument requires that the hinges be as inconspicuous as possible. SOSS Hinges are *Invisible*.

Write for catalogue "T"

SOSS MANUFACTURING COMPANY

435 ATLANTIC AVENUE

LOS ANGELES, 224 Central Bldg.

Branch Offices

SAN FRANCISCO...164 Hansford Bldg.

DETROIT—922 David Whitney Bldg.

Canadian Representatives—J. E. Beauchamp & Co., Montreal, Can.

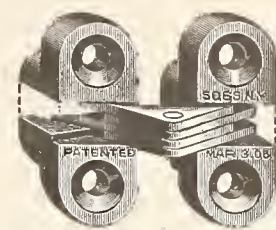

AN IMMENSE CABINET FACTORY

Plant of Globe-Wernicke Co. in Cincinnati Has Over Twenty Acres of Floor Space

The accompanying picture will give some idea of the magnitude of the Globe-Wernicke fac-

the Globe-Wernicke Co. is accustomed to handling carload or trainload orders with ease and convenience, so that prompt shipments to its clientele are the rule and not the exception in the trade.

The Globe-Wernicke Co. is recognized everywhere as the leading manufacturer of sectional

ELECTRICALLY EQUIPPED OPEROLLOS

All Models in 1918 Line to Be Provided With Electric Motors, It Is Announced

DETROIT, MICH., January 7.—Simultaneously with the new year comes the announcement of the

Operollo Phonograph Co., Inc., of this city, that the 1918 models of the Operollo phonograph will all be equipped with electric motors. They announce that their motive in bringing out an electrically operated phonograph is in response to the numerous and repeated demands of the buying public to which they have ever lent an attentive ear. The choice in the matter is still left to the buyer, however, as these models will be equipped with double spring motors if desired. Electric motors are only one of the many fine features to be found in

the new models, it is also reported by the firm.



The Great Plant of the Globe-Wernicke Co. at Cincinnati, O., Where the Brown Record Cabinets Are Made

tory at Cincinnati, O., where the Brown disc record cabinets are manufactured. This plant has a ground area of fifteen acres, with a floor area of over twenty acres, and is considered the largest plant of its kind in the world. The resources of this factory are so enormous that

office files and sectional bookcases, and the company's policy provides for maximum service to its dealers and the public. The Globe-Wernicke Co. has attained very pleasing success with the Brown disc record cabinet, which is carried in stock by progressive dealers from coast to coast.

THE ANSWER SHOULD BE "YES"

Geo. W. Pound, counsel and general manager of the Music Industries Chamber of Commerce, calls attention to the fact that on the second page of the questionnaire, which registrants under the draft are required to fill out, are these questions:

"Is your business essential to the conduct of the war?" to which it is urged that all men from this industry answer "Yes."

"What is your business?" to which the answer should be "Music."

There are many thousand men employed in the various branches in the industry who will be called upon to fill out the questionnaires, and it is pointed out that the answers outlined as above will do no harm and will perhaps set those with whom they come in contact to thinking of the importance of the music trade.

PROMPT SETTLEMENTS NECESSARY

Credit Men Should Remember That Present Conditions Should Discourage the Carrying of Long-Standing Open Accounts

In line with its advice to credit men that "the nation is at war, and it is time to put your house in order," the December letter of the National Association of Credit Men points out that the carrying of a large number of open accounts results in an expensive waste that ought not to be permitted under present conditions.

In the opinion of the association, prompt settlements should be expected, and asked for where they are not made voluntarily. The merchants who are slow by habit or custom should be pulled up and shown that they cannot expect credit favors unless they arrange to take proper and reasonable care of their accounts. The merchant disposed to be a little shrewd in his practices, taking advantage of unearned discounts, returning merchandise freely, or doing those little tricks which add to the burdens of

the credit man, it is felt, should be shown without hesitation that the days for the indulgence of these practices are past, and that, if he expects the best in treatment and prices, he must give his best.

"This is no time," continues the letter, "for the credit man to be flabby in his treatment of accounts, to be a jellyfish in the hands of his debtors. Rather he must remember that prudence, skill and fearlessness can do a world of good in credits generally, and put his own house in a position that will make it solid, no matter what may happen, and give it ability to contribute its part to the national defense."

LIMIT FIFTH AVENUE SIGNS

Ordinances Just Passed Bar Signs of All Kinds Which Overhang More Than One Foot

Another step toward the conservation of Fifth avenue has been taken by the Board of Estimate in the adoption of two ordinances regulating the placing of signs on buildings on the avenue between Washington Square and 110th street. The Fifth Avenue Association has been working for these ordinances for some time. They prohibit business signs or signs of any nature being carried out over the building line more than one foot. Illuminated signs are not permitted to extend at all over the building line.

REPAIRS

All Makes of Talking Machines Repaired Promptly and Efficiently

TALKING MACHINE REPAIR AND SALES CORPORATION

ANDREW H. DODIN, President
176 Sixth Avenue New York

TELEPHONE, CHELSEA 8437

Wall-Kane Needles

60 packages without stand, \$3.90; 60 packages with stand, \$4; 100 packages without stand, \$6.50; single packages, 6 1/2c, any quantity.

ORDER NOW

RICHMOND NEEDLE CO., 2014 Fifth Ave., New York

SOLVE THE FREIGHT PROBLEM IN MISSOURI TERRITORY

Shipments by Express so Slow That Many Dealers Use Their Own Cars—St. Louis Trade Surpassed Expectations as a Whole—Interesting News Items From the Saintly City

St. Louis, Mo., January 8.—In the main, the talking machine business in St. Louis this year undoubtedly surpassed expectations and expectations were for a larger business than last year, despite conditions. The stocks of machines were very heavy at the beginning of the holiday season and they held out well. Practically all lines were broken as to certain styles, but there were enough machines of every kind to supply needs if the person insisted on a certain make and was not exacting as to style.

Several heretofore exclusive dealers added machines to meet the holiday demand, taking on lines that do not demand the carrying of record stocks. In this manner the Smith-Reis Piano Co. and the Vandervoort Music Salon added the Brunswick and the Grand Leader Department Store added the Sonora. These firms made liberal window displays of these types of machines before the holiday season closed.

One unexpected condition put a number of country dealers at a disadvantage. That was the complete congestion of the express companies as to outgoing freight. Several dealers located fifty miles or so from St. Louis declined to accept the explanation of no shipments from local wholesalers and came to town to see about it. The machines ordered were loaded again and taken to the station and seldom did the dealers succeed in getting them shipped.

Manager Staffleback, of the Pathé line, turned a new deal in this connection. He got his drivers out at 4 a. m. and loaded his shipments onto trucks and applied at the express offices for shipments this early in the day. As a rule, he found the outgoing cars not loaded at that time and his shipments were accepted, but when the available cars were loaded, all later offers were refused. Some dealers twenty miles from the city sent their own trucks to obtain goods.

The Aeolian Vocalion had a very merry Christmas, according to Manager Guttenberger, of the talking machine department at Aeolian Hall. Business far exceeded previous records, it is reported, with a big call for higher priced machines.

This recalls that every sales manager in town is remarking on the high percentage of cash on sales and the short term credits asked. The record made this year never has been equaled, so say all of them. But, strange to

say, the advertising for long terms was never more noticeable. Several of the large dealers published offers of terms that allow eighteen months on machines at \$100 and less and twenty-four months on machines at \$200.

C. R. Salmon, of the Columbia wholesale department, is again in possession of the Columbia sales cup for record distribution. He was the first winner and also he is the first salesman to win the cup the second time. He may not realize on his ambition to win the cup enough times to gain ownership, as on the day the cup arrived Mr. Salmon filed his National Army questionnaire and waived all claim for exemption. He expects to be called for service in the spring, but is hoping in vain, he thinks, that he will have time enough to cinch the cup ownership.

Record sales were extremely heavy this year and the dealers have noted with great pleasure the number of persons, even those not owning machines, who have adopted the rule of giving records as gifts. It is notable that a good many of these gifts were high priced records, those which machine owners had expressed a desire to own, but did not feel they could afford. This note in the sales is reported often by the Victrola dealers.

The Silverstone Music Co. is trying the effect of talking machine music on egg production, having loaned an Edison Disc machine to a local newspaper for use in the paper's booth at the poultry show, which is running at this writing.

TRADE CONDITIONS IN VANCOUVER

Kent Piano Co. Tone Tests—Pathéphone Advance in Vancouver—British Columbia Talking Machine Co. Incorporated

VANCOUVER, B. C., January 8.—During the early part of the month the Kent Piano Co., Ltd., of this city, conducted a series of tone tests at Vancouver, Victoria, Grand Forks and Trail. These were by Hardy Williamson, of the Edison list of artists and well known in Ontario through his recitals with the Edison Diamond Disc. In Vancouver the Kent Piano Co. issued invitations for a recital in the ballroom of the leading hotel. W. E. Townsend, of the Hudson Bay Co.,

was recently in Toronto and reported splendid sales of Pathéphones in Vancouver. The Hudson Bay Co. are strongly featuring the Pathéphone and are putting splendid selling effort behind it, which is bound to bring good results.

Walter F. Evans, Ltd., recently devoted considerable space in the daily newspapers, comprising a series of Victrola advertisements pertaining to construction, educational in character, illustrated and cleverly written.

The Hudson Bay Co., since adding the Columbia line a few months ago, through the efforts of Manager E. Gowan have created a wide and profitable clientele for this department of the firm's business.

The British Columbia Talking Machine Co., Ltd., have incorporated at Vancouver, B. C., with a capitalization of \$10,000.

Informal Friday evening recitals in the store of Fletcher Bros., Victoria, have been found very profitable by the house. These recitals are held on the ground floor, where there is a large phonograph and piano display floor, into which the main entrance opens. Many sales are attributable to these Columbia recitals.

PRAISE FOR STARR PHONOGRAPH

Son of Starr Co. Retail Manager Tells of Value of Starr Phonograph Trench Kit

RICHMOND, IND., January 1.—Charles Curtis, First Class Private, Field Hospital No. 149, Third Division, Camp Shelby, Miss., son of E. S. Curtis, manager of the Richmond retail wareroom of the Starr Piano Co., spent his Christmas vacation with his parents in this city. While here he was a visitor at the Starr store and also at the Starr Piano Co. factory. He was very much interested in the new Starr phonograph trench kit now being manufactured by the Starr Co., and said that music was one of the most enjoyable luxuries of camp life. "In the evening, after our day of hard work, we always have songs and the boys play on their guitars, banjos or mandolins, and we never get tired of it," young Curtis said.

"The boys of the training camps will certainly enjoy these phonograph trench kits, as they are just the thing to furnish a good supply of fun."

Henry Gennett, president of the Starr Piano Co., in behalf of the company, presented Private Curtis with a complete Starr phonograph trench outfit for his division, and also a good supply of Gennett records.

The company officials were assured that the gift was very much appreciated and that nothing could have pleased the men more.

NEW FORM FOR EXPORTERS

War Trade Board Prepares New Form of Agreement Which Is of Interest to Manufacturers of Musical Instruments Who Are Exporting

WASHINGTON, D. C., January 5.—The War Trade Board has prepared a new form of agreement for shippers exporting goods to their own branches or agencies abroad to supersede all previous forms. In issuing the form the board warns shippers that the mere signing thereof does not necessarily mean that licenses will be granted. Heretofore when the War Trade Board granted a license to the shipper to ship to his own branch it exercised no control over what the branch might do with the goods on their receipt. The branch might sell such goods to an enemy house.

It is therefore to make the bureau more effective and at the same time not to work hardships to reputable shippers who have branch houses in foreign countries that the new form has been prepared.

Why is it that the man who prepares for good business usually finds it? Because, subconsciously he fights to live up to his own expectations.

Chas. H. Mumby, 226 Broadway, Bayonne, N. J., has secured the agency for the Sonora phonograph.

Melophone Single Spring Motor

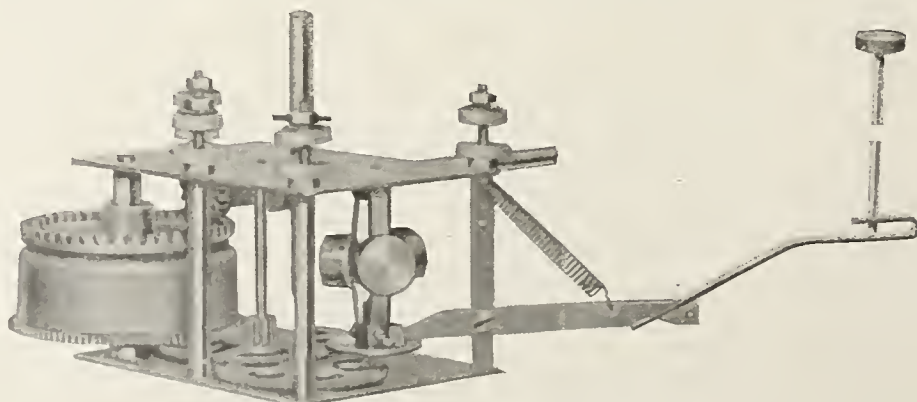

COMPLETE WITH 10-INCH TURNTABLE

Simple in construction, the most satisfactory and durable of all small motors.

Plays 2 ten-inch records with one winding.

Three years' successful record as the best single spring motor manufactured.

PRE-WAR PRICES

IMMEDIATE DELIVERIES

Melophone Talking Machine Co.

380 Lafayette Street, New York

29 E. Madison Street, Chicago

CONFERENCE OF COLUMBIA MANAGERS A DECIDED SUCCESS

Managers of Columbia Branches Visit New York for First Conference—The Many Interesting Practical Talks and Visit to Factories Thoroughly Enjoyed—Banquet at Hotel McAlpin a Fitting Finale—Geo. W. Hopkins, General Sales Manager, in Charge of Arrangements

The first conference of the branch managers of the Columbia Graphophone Co. was held in New York the week of January 2, and was a

get better acquainted before the real work of the conference started.

On Thursday the visitors were tendered a re-

of unusually valuable addresses were delivered, included in which were the following: "Executive Co-operation," H. L. Willson, vice-president and general manager; "Factory Support," C. A. Hanson, general works manager; "Motors," E. L. Tanner; "Traffic Problems," R. L. French, traffic manager; "Tone and Tone Reproduction," John J. Scully; "Our New Cabinets," N. T. Moore; "Record Stock in the Factory," Chas.



Conference of Columbia Managers at Recital Hall in Fifth Avenue Shop

success far beyond the expectations of Geo. W. Hopkins, general sales manager of the company, who was responsible for the introduction of the conference, and who handled the many incidental details that made the conference of practical value and of benefit to everyone in attendance.

ception at the Columbia Co.'s executive offices in the Woolworth Building, and at 11 a. m. left for Bridgeport, Conn., to spend the day in that city and to visit the immense Columbia factories. At noontime the managers, together with the executives of the company, and the

Morison, superintendent record stock; "What Our Laboratory Means to You," Geo. W. Beadle, consulting engineer. After luncheon the visitors attended a demonstration of the new designs, which was given under the supervision of John J. Scully, and the remainder of the



Banquet of Executive and Sales Organization of the Columbia Graphophone Co. at the Hotel McAlpin, January 5

The managers arrived in New York January 2, and on that evening were entertained at dinner at the City Club of New York, where an informal pow-wow gave them an opportunity to

department heads from the executive offices, assembled for luncheon at the Hotel Stratfield, Bridgeport, Conn.

During the course of the luncheon a number

afternoon was spent in a visit to the East and West plants. On Thursday evening, the managers, executives and executive department heads

(Continued on page 114)



It's easy to sell people what they're hungry for. People are hungry for Columbia Records.

**Columbia Graphophone Co.
Woolworth Building, New York**

CONFERENCE OF COLUMBIA MANAGERS A DECIDED SUCCESS

(Continued from page 113)

were entertained at dinner at Little Hungary.

Papers Read on Friday

On Friday morning the real work of the conference started, and the managers assembled at the recital hall of the Columbia Co.'s Fifth Avenue Shop. With Mr. Hopkins as chairman of



Geo. W. Hopkins

the conference, and President Whitten as the first speaker of the day, the conference was launched auspiciously, the following vital talks being given: "The Big Vision," Francis S. Whitten, president; "Drifting," G. W. Hopkins, general sales manager; "Reports—What They Mean to You and to Us," O. F. Benz; "Supplements," Paul Hayden; "Ordering of Records," A. R. Harris; "Dealer Service Department," H. L. Tuers; "Team Work," F. K. Pennington, assistant general sales manager; "Educational Department and How it Helps You," Frederic Goodwin, educational manager; "International Record Department and 'E' Series Records," Louis E. Rosenfield, sales manager, international record department; (Anton Heindl, manager of this department, was confined to his home with a serious attack of grippe); "Recording Laboratory," E. N. Burns, vice-president; "Export Sales," E. F. Sause, manager export department; "Artists," Theodore H. Bauer, concert and operatic director and adviser; "Artists' Follow Up," Lester L. Leverich; "Outstanding Points of This Day's Conference," G. W. Hopkins; "Period Design Grafonolas and the Fifth Avenue Shop," H. E. Speare, manager Fifth Avenue Shop.

Theatre Party Friday Evening

On Friday evening a theatre party at the Hippodrome served to act as a balance to the serious work which the managers and department heads had accomplished during the day.

Saturday's Conference Subjects

On Saturday morning the conference was resumed, and the following addresses were enthusiastically received: "Advertising Plans for 1918," W. H. Johns, vice-president, George Batten Co.; "What This Advertising Means to Salesmen and Dealers," R. W. Knox, advertising manager; "Co-operation Between Sales and Advertising," G. W. Hopkins, general sales manager; "How You Can Help the Dictaphone," Frank Dorian, general manager, the Dictaphone; "Technical Work We Are Doing for You," C. M. Goldstein, manager, research department; "Musical Menus," A. R. Harris; "What an Audit Means to You," Marion Dorian, auditor; "Retail Merchandising," G. W. Hopkins; "Representation," F. K. Pennington; "Question Box,"

Before adjourning, the visiting managers expressed their keen appreciation of the splendid program of business talks which had been prepared by the sales department. Mr. Hopkins and Mr. Pennington were congratulated upon the careful thought and consideration which they had bestowed upon every detail of the program, and the managers were unanimous in stating that the conference would enable them to greatly enhance the efficiency of their individual organizations in 1918.

Banquet at the Hotel McAlpin

On Saturday evening the managers, executives, members of the executive departments in the Woolworth Building and the members of the Dictaphone selling organization were the guests of the officials of the company at a banquet held at the Hotel McAlpin, which was a most enjoyable affair in every way. The Dictaphone division had also held its annual conference the week of January 2, and had succeeded in making their conference of practical value in every respect.

At the banquet on Saturday evening N. F. Milnor, general sales manager of the Dictaphone division, presided as toastmaster, and filled this important post with his customary good cheer and ability. He prefaced his introductions of the speakers of the evening with the remark that all of the addresses would be informal, and that each speaker would talk for only a few minutes.

Francis S. Whitten, president of the Columbia Co., was the first speaker of the evening, being accorded an enthusiastic reception from the members of his organization. Mr. Whitten paid a tribute to the men with whom he is associated, and smilingly told the guests that they should all feel the company was "their company," giving them some idea of the expectations of the Columbia executives for the new year.

Mr. Whitten was followed by several members of the Columbia executive organization, all of whom spoke pertinently and in a manner which won the hearty enthusiasm of every Columbia man present: H. L. Willson, vice-president and general manager; Frank Dorian, general manager of the Dictaphone division; Edward N. Burns, vice-president; George W. Hopkins, general sales manager; Frank K. Pennington, assistant general sales manager; Marion Dorian, chief auditor; C. A. Hanson, general manager of the Columbia factories. George Edward Smith, president of the Royal Type-writer Co., and prominent in industrial and financial circles, was another speaker at this dinner who earned the hearty applause of the diners.

Musical Entertainment on the Program

One of the surprises of the evening was the introduction of Licut. Gitz-Rice, of the Canadian Army, who had returned only a few days previous from the battle front abroad. Mr. Gitz-Rice proved to be an entertainer of exceptional ability, and his rendition of topical patriotic songs, as sung by the boys in the trenches, together

with his fund of timely stories, evoked encore after encore.

The musical program at the banquet called for the appearance of many popular Columbia artists, whose records have achieved phenomenal success in all parts of the country. Theodore H. Bauer, concert and operatic director of the Columbia Co., was in charge of the musical entertainment, and well deserved the hearty congratulations he received at the close of the banquet.

Prince's Orchestra, which is an exclusive Columbia organization, accompanied the artists, with Chas. A. Prince, director of the orchestra, at the piano. Among the artists who appeared during the course of the evening were the following: George Barrere, Henry Burr, Collins and Harlan, Frank Croxton, Miss Amperita Farrar, Arthur Fields, Chas. Harrison, José Mardones, Theodore Morse, Van and Schenck, Miss Genevieve Zielinska and the Peerless and Stellar Quartets. All of these artists were obliged to render many encores and were the recipients of congratulations from everyone.

Prizes Awarded Dictaphone Men

One of the pleasant events of the evening was the presentation of prizes and medals to the members of the Dictaphone selling organization who had made their quotas in 1917 and in previous years. N. F. Milnor officiated as the donor of these gifts and complimented each member of the organization upon his splendid work in 1917, which had enabled the Dictaphone division to close the biggest year in its history.

E. N. Price, of the Pittsburgh branch of the Dictaphone division, who had won fifteen prizes during the year, on behalf of the Dictaphone Sales Club presented Frank Dorian and Mr. Milnor with diamond studded gold fobs, as a mark of appreciation and personal esteem.

"Columbia Convention Camouflage"

One of the features of the banquet was the appearance of an attractive booklet entitled "Columbia Convention Camouflage." This booklet was also prepared in the shape of a record which was presented to everyone in attendance at the banquet. Arthur Fields sang the record, which was composed by Howard Johnson. This booklet, under the heading, "Columbia Medley," read as follows:

It costs some dough, as we all know, to buy a phonograph.
I tried to buy one just last week, and couldn't help but laugh,

The agony a man goes through selecting a machine;
They try to grab your coin so hard they make the eagle scream.

I looked at different makes till nearly dead:
At last I met a gentleman who said:

The Columbia's a gem when in motion,
Won't you come to our offices and see?
It's famous from ocean to ocean,
Come down and look it over, please, with me.
So I thought it over and said I'll go along,
When we hit the office, I could see I stood in strong.
Everyone I saw there had a smile upon his face,
I was introduced to everyone around the place.

There was Mr. Hopkins, he's the fellow, don't you know,
Put the Pep in Pepsin gum so many years ago.
Try and get away from him, you'll get it in the neck;
He can sell you stuff until your bankroll is a wreck.

CONFERENCE OF COLUMBIA MANAGERS A DECIDED SUCCESS

(Continued from page 114)

Next was Mr. Hanson; he's the factory support;
When I looked him over, I could see he was a sport.
He gets all complaints, and puts them all upon the shelf;
He just says forget it, boys and then forgets himself.

There was Mr. Willson, tho' he's quite severe he's nice,
Tho' they call him the big boss, he's not without a "Vice."
When the day is over, he is never through his toil,
Business is so rushing that he burns the midnight oil.

Next was Mr. Hayden, and I noticed by his hair
That he was a genius who had missed the barber's chair.
In his eyes he had a look as wild as it could be,
Maybe some wild women gave it to him, don't you see.

There was Mr. Tuers, quite the nicest little thing—
These remarks are all in fun, so don't mind what I sing—
When I looked him over, there were two things that I missed:
Flower in his buttonhole and watch upon his wrist.

I saw Mr. Pennington, he's bigger than an ox;
Everybody says that he's as crazy as a fox.
Tho' his hair is redder than the blush of any quince,
All the boys agreed and told me that he was a "prince."

Next was Mr. Heindl, he's a man of many tricks,
Speaks a lot of languages—I think it's thirty-six.
When I talked a bit with him, he took me by the hand,
English was the only thing he didn't understand.

Next was Mr. Benz, the man who's never known to shirk,
When I looked at him I knew he was a bear for work.
All day long he dictates, many letters he will write;
He dictates all day, but still his wife dictates at night.

Next I met a fellow, who is known as Mr. Jell,
If I didn't mention him he'd be as sore as—well
If I had my way I'd like to put him on the pan;
All that I can say is that he's just a married man.

Mr. Knox was on the job, I shook his hand with ease;
Knox was pasted in his hat, and Kno(cks) were on his knees.
As the advertising man friend Knox was introduced,
So you see that goes to prove that ever Kno(ck's) a boost.

There was Mr. Burns, the man who picks the records out,
When it comes to picking he is there beyond a doubt.
If the records turn out good that don't increase his fame;
If they're bad, it's always Mr. Burns who gets the blame.

Next comes Mr. Sause, the man who makes the foreign sales,
When you speak of traveling he'll tell you many tales.
My advice to Mr. Sause is really not the worst:
Speaking of America, why don't he see it first?

Then came Mr. Bauer. Talk of Oscar Hammerstein,
Bauer makes old Oscar look as tho' he were a shine.
What I'm going to tell you now is worse than any crime:
Harris says that Bauer has a temper all the time.

When I mention Harris, then I mean a friend of mine,
Also of each jazz band that you meet along the line.
He played me a record that he values more than pearls—
You all know the one I mean, made by the Watson girls.

Next was Mr. Dorian, who sells the Dictaphone,
Friend of all stenographers who like to work alone.
Wives of all the business men declare that he is great;
Hubby cannot alibi, "I'm at the office late."

I saw Mr. Goodwin; he's an educated chap;
He's a "highbrow"—I could tell by looking at his "map."
I must give him credit in these simple little terms:
He's the guy that puts it over on the other firms.

I saw Mr. Milnor, also of the "Dictaphone."
Milnor is a name that has a meaning all of its own;
He can trim you when you buy, you'll all agree to that,
But he is one (Milliner) who has never trimmed a hat.

Next was Lester Leverich, the marvel of the age,
Faster in the office than the boy they call the "page."
Ninety miles a minute is his record, so they say;
Don't know where he's going, but he knows he's on his way.

Now my little tale's nearly all over, all over,
But there's one man who's a Rover.
We wish the battle was all over, so he'd be here as of yore.
"Big Vision" Whitten, our president, I mean,
He's in the navy, and here he's seldom seen.
So pray for the day when it's all over
He'll come back to us once more.

At the start of the banquet a silent toast was drunk to the memory of Edward D. Easton, former president of the company; F. K. Warburton, former vice-president, and Andrew Devine, former director.

A toast was also given in honor of Lieut. Mortimer D. Easton, a director of the company, who is now serving his country with credit "somewhere in France."

Those Who Were Present

Among the managers who attended the con-

ference were the following: Westervelt Terhune, Atlanta; W. S. Parks, Baltimore; Fred E. Mann, Boston; O. M. Kiess, Buffalo; C. F. Baer, Chicago; A. W. Roos, Cleveland; F. R. Erisman, Dallas; S. E. Lind, Detroit; Ben L. Brown, Indianapolis; E. A. McMurtry, Kansas City; W. F. Stidham, Los Angeles; W. L. Sprague, Minneapolis; H. M. Blakeborough, New Haven; W. F. Standke, New Orleans; Lambert Friedl, New York; A. J. Heath, Philadelphia; K. Mills, Pittsburgh; G. P. Donnelly, Portland, Me.; L. D. Heater, Portland, Ore.; C. V. H. Jones, San Francisco; G. H. Williams, Seattle; I. W. Reid, St. Louis; James P. Bradt, Toronto, Ont., Canada; W. C. Fuhri, F. A. Denison, H. A. Yerkes, R. F. Bolton and S. H. Nichols.

SITUATION IN THE TWIN CITIES

General Shortage of Stock Felt in That Section—Working Hard to Catch Up on Orders—Business Totals for Year Show Big Increase

ST. PAUL and MINNEAPOLIS, MINN., January 7.—The talking machine business in the Twin Cities of St. Paul and Minneapolis is chugging along like an automobile full of gasoline. Before Christmas the dealers, both retail and wholesale, had all they could do to supply the machines, and after the holidays they had all that they could do to supply records. This does not imply that no machines are being sold. On the contrary, the dealers still have considerable difficulty in supplying machines.

W. J. Dyer & Bro., the St. Paul jobbing house, has not yet caught up on orders and despite the best efforts of Mr. Dyer and George Mairs, head of the talking machine department, they are unable to ship certain styles of machines. Beckwith-O'Neill Co., the Victor jobbers in Minneapolis, substantially relate the same story. The situation is somewhat less restrained than it was two months ago, but the house is short of many popular styles. The record demand is something tremendous, and an extra force has been organized to fill the calls from every part of their territory.

Likewise the Edison business was at a feverish pace. President Laurence H. Lucker, of the Minnesota Phonograph Co., the Edison jobber in this territory, reports that the volume of sales for December, 1917, equaled the grand total for

ILSLEY'S GRAPHITE PHONO SPRING LUBRICANT

Ilsley's Lubricant makes the Motor make good
Is prepared in the proper consistency, will not run out, dry up, or become sticky or rancid. Remains in its original form indefinitely.

Write for special proposition to Jobbers.

MANUFACTURED BY
ILSLEY-DOUBLEDAY & CO., 229-231 Front St., New York
Established 1853

the year 1913. Numerous new accounts were opened within the territory and the entire organization is riding at high tide, as there has been but little diminution in sales after the holiday season. There still is a shortage of goods in the more popular styles, but the want is being supplied rapidly and normal conditions soon will prevail.

The Columbia concern has had a remarkable record in this territory. Manager Sprague at present is in New York to reap the rewards of his success, in which are included a silver cup and many high praises. His record includes a 100 per cent. increase in December over the best previous December in this territory, a 100 per cent. increase for the year 1917 over 1916, and the opening of scores of new accounts. In December alone he opened thirty-one new accounts with substantial houses in South Dakota and introduced the Columbia machines in some of the best stores in the Twin Cities. According to all reports, he earned the silver cup and then some.

Minneapolis is making a new talking machine. It is called the Munola and is financed by Minneapolis capital. It was advertised rather extensively during the holiday rush.

F. J. Pellegrini, associated with the Columbia Co. for seven years, leaves the concern this week to enter a new line of business in Chicago.

In general it may be stated that the talking machine trade in the territory tributary to the Twin Cities is in a most satisfying condition. A holiday activity is observable in all the houses, whether wholesale or retail, and there is every indication that everything will be moving in good style for weeks to come.

GEORGE E. BRIGHTSON A GUEST

George E. Brightson, president of the Sonora Phonograph Corp., New York, was a guest last Wednesday evening at the dinner of the first panel of the Sheriff's Jury, held at Delmonico's. This dinner was attended by several hundred of the most prominent members of the industrial, financial and legal circles of New York City.

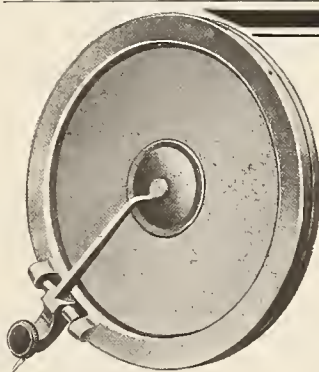

The Bliss Reproducer

Will Play All Records

A new superior and scientifically constructed sound box—no mica, rubber or cork used.

Beautiful full, rich tone quality, clear articulation. It individualizes each voice and instrument in the record. Greater volume with lighter needles, thus minimizing wear on records.

A demonstration of the Bliss reproducer means a sale—each sale brings another, for every music lover who hears the Bliss reproducer wants one.

Comparative tests solicited. Write today for dealer proposition.

WILSON LAIRD PHONOGRAPH CO., Inc.
29 West 34th Street, New York City

Canadian Distributors: HAWTHORN MFG. CO., 145 Yonge St., Toronto, Can.

WINNERS OF EDISON PATCHWORK ADVERTISEMENT CONTEST

Thos. A. Edison, Inc., Announce Decision in the Interesting Contest Inaugurated During Edison Week—First Prize of \$1,000 Won by Earle Insley—Interesting Compilation

Owing to the enormous number of entries in the Edison Week Patchwork Advertisement Contest conducted by Thomas A. Edison, Inc., Orange, N. J., from October 20 to 27, 1917, inclusive, the announcement of winners has just been made. The sales and advertising forces at

narrowed the advertisements down to one hundred, which selections were presented for the final consideration of Edison officials. It was from this hundred that the winners were selected after many readings and re-readings by the officials charged with the responsibility of selecting the winners, who emerged in the persons of the following:

Phil. Inquirer Dispatch

N.Y. Evening Mail — The most marvelous machine can never be a person, but Thomas A. Edison, the inventive wizard, has at last mastered (a human voice) reproducing instrument that does not betray itself in the very presence of the artist. *Phil. Inquirer Dispatch*

St. Louis Republic — It is a wonderful thing to see and hear an instrument re-creating a human voice that is right there beside it. *St. Louis Republic*

St. Francisco Examiner — the singer thrilled by the consciousness of a second personality. *St. Louis Republic*

St. Louis Dispatch — The problem "to hear ourselves as others hear us" has been solved by the Edison Diamond Disc Phonograph. *Phil. Inquirer*

The Boston Herald — Miss Christine Miller, the noted concert contralto, demonstrated in a recital at Symphony Hall, Boston, how thoroughly Edison has made it possible to reproduce all shades of tone and sweetness of the human voice. *Waco Times Herald*

Cleveland Press — standing beside one of the Phonographs, sang in unison with her self, it being impossible to distinguish between the singer's living voice and its Re-Creation. *The Boston Herald*

The Boston Herald — She sang a few bars and the instrument blended perfectly with her voice. *St. Louis Globe Democrat*

Waco Times Herald — She ceased and the instrument continued the air with the same beautiful tonal quality. Had Miss Miller attempted such a concert in Salem, in the early days of this country, she would have been hanged for a witch. *St. Louis Globe Democrat*

St. Louis Globe Democrat — The large audience of music-lovers sat enthralled under the spell of the wizardry which reproduced a human voice, the most delicate violin tones and the blare of a brass band with such fidelity that no one hearing also the same music at first hand, could tell which was the real. *Brooklyn Daily Eagle*

St. Louis Globe Democrat — The instrument was a stock phonograph intended solely for the home. *Germania Herald*

Phil. Inquirer — Perhaps the artistic merit of Mr. Edison's invention can in no way so well be attested as by the fact that 600 members of the Handel and Haydn Society of Boston were present. *The Boston Herald*

The Winning Edison Advertisement Prepared by Earle Insley

Orange had expected to make all readings of the advertisements from the preliminary to the final reading, but the quantity of advertisements was so far in excess of what had been expected that the task was beyond the capacity of even the extensive organization at the Edison laboratories. When it was realized that the force at Orange could not cope with the situation alone, it was decided to turn over to the senior class of the School of Journalism at Columbia University the preliminary readings. These readings

Fifth prize, \$50—Won by Gordon Roper Diver, 88a Girouard avenue, N. D. G., Montreal, Canada.

Ten prizes, each \$10—Won by Mrs. Florence Bassett, 430 N. Beaudry avenue, Los Angeles, Cal.; J. G. Bourns, 513 Washington street, Olympia, Wash.; Miss Katherine Gest, 1203 Second avenue, Rock Island, Ill.; Harold H. Hertel, 56 Loomis street, Naperville, Ill.; Mrs. Ray Keegan, 407 Gore boulevard, Lawton, Okla.; Alphonse Kirschner, 234 East Third street, Brooklyn, N. Y.; Miss Vida Laughrey, 44 North Mar-

ket street, Oskaloosa, Ia.; Mrs. A. E. Peterman, Theodore, Ala.; Miss Katharine Sartelle, 419 Sterling place, Madison, Wis.; Josephine A. Sheehan, 33 Gage street, Fitchburg, Mass.

The details of the Edison Week Patchwork Advertisement Contest were announced in full-page advertisements in a list of national publications appearing in September. The principal requirement of the contest was that advertisements submitted must be made up in their entirety of excerpts taken from the booklet, "What the Critics Say," a compendium of the criticisms of the famous Edison Tone Tests taken from approximately 1,500 newspapers throughout the country.

Prospective entrants were furnished an entry blank, together with a specimen patchwork advertisement, either by the local Edison dealer or direct from the company at Orange.

The final decisions in the contest were made the week preceding the Christmas week. Telegrams were sent to the winners, advising them of the fact, so as to reach them Christmas morning.

Professional advertisement writers and all employees of the Edison Co. or connected with the organization in any way, or members of their families or households, were barred from the contest, in order to put the contest on as fair a basis as possible.

The advertisement that won the first prize will be reproduced in a forthcoming advertisement of the Edison Co., which will appear in a list of weeklies and monthlies of national circulation.

First prize, \$1,000—Won by Earle Insley, Nanuet, N. Y. This prize-winning advertisement was made up of words, phrases and sentences clipped from tone test notices appearing in twenty-eight of the leading papers of the country, and was arranged in the most effective manner to so join the different sections as to make the strongest kind of endorsement of the Edison product and its reproductive qualities and of the performance of the Edison artists.

Second prize, \$500—Won by Edward Crede, 337 Fourth avenue, Pittsburgh, Pa.

Third prize, \$250—Won by Miss Jane P. Kelly, 318 South Water street, Crawfordsville, Ind.

Fourth prize, \$100—Won by Miss Leta Worrall, 1034 West Seventeenth street, Des Moines, Ia.

SAYS COLLECTIONS ARE REMARKABLE

The credit manager for one of the largest wholesale houses of its kind in the country is authority for the statement that there is nothing in the present condition of collections that could be taken to confirm reports heard in various quarters of poor business on the part of the retail trade. "Taken as a whole," he said to the New York Times, "collections were never better in the history of this house. The way the Southern trade is paying up is really remarkable, and high-priced cotton is the answer. While other sections of the country can hardly be said to be settling up as rapidly as the South, there is absolutely no fault to find with the way remittances are coming in generally. December, as a rule, is not a big month for collections, and yet we can already see evidences that the money which will come in this month will not be a great deal less than the amount received during November."

Most people don't turn over a new leaf until the old one is full.

"STERLING" Tone Quality



Style 501



Style 900

STERLING phonographs have been specially designed throughout for the true reproduction of the original music.

Let us show you why the **STERLING** has "made good".

Every **STERLING** phonograph is equipped with our specially designed durable spring worm gear motor, playing *five ten-inch records* with one winding, a motor that is used regularly in machines retailing at \$100. All models are equipped with our Universal Tone-Arm.

Your request for samples will have immediate attention. Write Today,

STERLING PHONOGRAPH CO., 285-287 No. 6th St., Brooklyn, N. Y.

ESTABLISHED 1914



Style 1700

Wholesale Prices

- 501—\$8.75 in quantities
- 900—\$13.50 in quantities
- 1700—\$22.50 in quantities

FROM OUR EUROPEAN HEADQUARTERS

2 GRESHAM BUILDING, BASINGHALL STREET E. C., LONDON, W. LIONEL STURDY, MANAGER.

LONDON, ENGLAND, E. C., January 3.—At this period with this harrowing war still proceeding, and the prospects of its end seemingly as remote as ever, it is not so easy to offer the usual New Year's greetings, or indulge in prognostications regarding business for the New Year. It goes without saying that manufacturers, factors and dealers are determined to make the gramophone business as live an issue during 1918 as it is possible with conditions as they are to-day. We enter the New Year with the peoples of the world at death's grip—battling to-day as never before in living history, to achieve a permanent peace, for enemy people as much as for the people of the allies. To that sentiment—to its early achievement—must we dedicate our thoughts and wishes on this, the opening of the New Year. Our New Year's wishes must be for an early triumph over the common enemy of mankind, at the same time registering a silent vow to act his or her best in a spirit of determination to "carry on" until to all men are secured those inalienable rights that are essential to civilization and to the world's progress.

To Soothe the Savage Breast

One is somehow reminded that music hath charms to soothe the savage breast, and though perhaps the connection is not too close, it is a relief to switch over one's mind from the all-absorbing horror of war to the charm and consolation of good music. Its dissemination by means of gramophone records has brought untold comfort to thousands of sorely stricken and nerve-wrecked people, and it is not too much to say that this concentrated value of music is recognized, even officially, as a national tonic of incalculable worth. The gramophone trade can therefore justly regard its existence

with a certain amount of pride, and "carry on" in the knowledge that as an industry it is in reality less a luxury than a national necessity, for by no other means is music so widely and usefully distributed. As the music channel of the masses, our trade is more justified in its existence than is the pianoforte, organ, sheet music, or other section. To my mind, it is too obvious for argument, and I have the satisfaction of knowing that in the circumstances of this painful war, not alone at home, but in the trenches, the first thing the soldier, sailor, or munition worker turns to for relief and nerve-soothing effect, is the glorious, the invincible, gramophone! It is a logical sequence, then, to find that the demand for machines and records is more insistent than ever. The instruments have to be rationed when possible, so as to secure as wide a distribution among dealers everywhere as is compatible with output. But when it comes to records—well, output is nothing short of gigantic. Manufacturers are working at high pressure all day, and night where labor is available. In like measure is the situation from the retail viewpoint, and altogether this season bids fair to create a wartime sales record!

Price of Needles Up—Reuse of Old Needles

The correspondence published in these columns the last few issues anent the subject of utilizing waste steel needles by the simple method of re-pointing them, continues to meet with the support of the trade, and certainly has aroused a degree of interest generally, all of which is most encouraging. From recent inquiries and reports I am more than ever convinced that the scheme is a practical one. More important still, and this is becoming widely rec-

ognized, is the absolute necessity for immediate experiments along the lines suggested, in view of the war demands for all available supplies of high-grade steel.

This fact brings to mind that the price of new needles is steadily on the increase. From time to time announcements are made by this or that firm to this effect, the most recent being an intimation from "His Master's Voice" Co. increasing the retail price of their needles to eighteenpence per box of 200, 7/6 per thousand, subject to the usual trade discount. This in itself indicates, and indeed confirms more than anything else, the need for steel economy. Let us not try to balk this solid fact; it has to be faced, and the sooner the better. Individually, a few members of the trade have shown sufficient foresight to plan ahead. They are making experiments with a view to discovering the best possible method for re-pointing old needles, and in one case at least resharpened needles are actually on sale. I am not going to say that they are, ipso facto, as good as new, being slightly more scratchy, but I assert, after experiment, that these needles offer good results, and excellent prospects of complete success.

To my mind, it is a sufficiently important matter for an official trade investigation. I am not satisfied to leave the matter to individual effort; I want to see action taken by a committee expressly convened by the whole trade for that purpose. The faults of one experiment might easily be remedied by another, and this is considerably less difficult to achieve by co-ordinated effort than it is by uncontrolled individual attempts to solve the problem.

The secretary of the British music trade de-

(Continued on page 118)



"His Master's Voice"

Copyright

This intensely human picture stands for all that is best in music

—it is the "His Master's Voice" trade-mark, and it brings to you, no matter where you are, the very best music of every kind, sung and played by the world's greatest artists—the greatest singers, pianists, violinists, orchestras and bands—all enshrined in the unequalled "His Master's Voice" records

'His Master's Voice'

—the trade-mark that is recognized throughout the world as the

HALL-MARK OF QUALITY

Branches

DENMARK: Skandnavisk Grammophon-Akti-
eselskab, Frihavnen, Copenhagen.

FRANCE: Cie. Française du Gramophone, 115
Boulevard Richard Lenoir, Place de la Répub-
lique, Paris.

SPAIN: Compañía del Gramófono, 56-58 Balmes,
Barcelona.

SWEDEN: Skandnaviska Grammophon-Akte-
bolaget, Drottning Gatan No. 47, Stockholm.

RUSSIA: The Gramophone Co., Ltd., 45, Nevsky
Prospect, Petrograd (Petersburg); No. 1
Solyanka, Solyanol Dvor, Moscow; 9, Golovinsky
Prospect, Tiflis; Nowy-Swiat 30, Warsaw; 33,
Alexandrowskaya Ulitsa, Riga; 11 Michallovskaya
Ulitsa, Baku.

INDIA: The Gramophone Co., Ltd., 139, Bal-
lughatta Road, Calcutta; 7, Bell Lane, Fort,
Bombay.

Great Britain:

The Gramophone Company, Ltd.

HAYES - MIDDLESEX - ENGLAND

Agencies

AUSTRALIA: S. Hoffnung & Co., Ltd., Sole
Concessionaries of The Gramophone Company,
Limited, 163, Pitt Street, Sydney.

NEW ZEALAND: Gramophonum, Ltd., 118-120
Victoria Street, Wellington.

SOUTH AFRICA: Darter & Sons, Post Box 174,
Capetown; Mackay Bros., Post Box 251, Johannes-
burg; Mackay Bros. & McMahon, Post Box 419,
Durban; Ivan H. Haarburger, Post Box 105,
Bloemfontein; Franz Moeller, Post Box 108, East
London; B. J. Ewins & Co., Post Box 86, Queens-
town; Handel House, Kimberley; Laurence &
Cope, Post Box 132, Buluwayo; The Argus Co.,
Salisbury.

EAST AFRICA: Bayley & Co., Lourenço
Marques.

HOLLAND: American Import Co., 22a, Amsterd
Veerkade, The Hague.

ITALY: A. Bossi & Co., Via Orefici 2, Milan.

**EGYPT (Also for the Soudan, Greece and the
Ottoman Empire):** K. Fr. Vogel, Post Box 414,
Alexandria.

FROM OUR LONDON HEADQUARTERS—(Continued from page 117)

fense committee has again been approached with a view to securing his co-operation and advice. By our next issue I shall hope to be in a position to report progress in this direction, as obviously the music trade committee is in the best possible position to raise discussion on the subject among its members with a view to arranging the terms of reference upon which to commence official investigation.

The First Resharpening of Used Needles

Meanwhile, of especial interest is the sub-joined letter from L. H. Mealey, of Seacombe, who may justly pride himself upon being the first to take up in a practical way the question of resharpening used needles:

"DEAR SIR—I hope you will give me an opportunity of explaining my process of sharpening gramophone needles. During the summer months finding that it was almost impossible to obtain needles from factors, I decided to try and sharpen used needles. My first attempt was with foot power, and later I had a small electric motor installed. I obtained the correct grade of wheel for sharpening and had an automatic machine made by which it was possible to repoint many thousand needles per hour. All went well until I received my first order to sharpen 5,000. Amongst these were about twenty different sizes and shapes of needles, and I found that the automatic arrangement would take one size of needle all right, but would not take various sizes and shapes. I then had to resort to hand tools, and although this process was slow at first, I found that a little practice was all to the good. I am now able to turn out a very good number of needles per hour. I had window hills printed, and also packets for packing needles. One window hill which I exhibited brought in 100 needles in the first fortnight, but we are collecting now from shop customers alone on an average 8,000 needles a week. On July 29 I wrote to Johnson Talking Machine Co., Ltd., Liverpool. They were delighted with the idea of resharpening needles, and I have sharpened several thousands for them since. I supplied posters to two other Liverpool factors and several dealers who made good use of them, and I also wrote to J. E. Hough, Ltd., as well as to the Columbia Graphophone Co., Ltd.

"I find there is no difficulty in collecting needles and none in sharpening, and I think if factors and dealers will only wake up to the fact that there is almost a famine in needles, and start collecting used needles, they will find that the present shortage can be got over.

"Personally I have not bought any new needles for three months, and I have sold quite a few thousand to factors and dealers. Yours faithfully L. H. MEALEY."

A Home Needle Repointing Apparatus

I am now able to offer an illustration of the extremely clever device for resharpening used needles, about to be marketed by the Johnson Talking Machine Co. This attachment is easily fitted to any make of gramophone, and is described as follows:

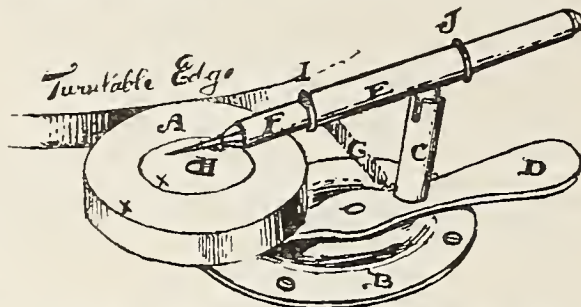

A.—Wheel composed of carborundum and polished material, is fitted on the outside with a band. This wheel revolves when put in action against the turntable.

B.—Base which holds lever D. Under this base is fitted a spring to cause pressure on the turntable of the wheel.

C.—Standard to hold needle clip, fitted with swivel at top to allow tube which holds needle clip to move up and down.

D.—Lever which allows wheel to engage or disengage on the turntable.

E.—Tube fitted with standard C, through which needle holder fits.

F.—Needle holder, which pushes through tube E. This holder clips needle and is held in position in tube E by rings 1—1. The needle holder can be made for various ways of holding needle.

G.—Tension spring. This can be made to fit any position, so that it will cause the needle to bear with pressure on the sharpening wheel.

H.—Screw which holds wheel on to rod D. 1—1. Rings which are fixed to keep needle holder in position.

"Everybody who has seen this device," writes Mr. Johnson, "prophesies a big sale for it, but unfortunately it is almost as difficult to get labor and material to make the apparatus as it is for us to buy needles. But I hope, if I have any luck, within the next month to have some of them ready for the market."

The Hertford Record Co. Makes Its Debut

Though within the knowledge of, so to say, the inner circle of the trade for the last few months, it will be news to many that the London and Hertford businesses of the Carl Lindstrom and Fonotipia Cos. have been bought out

by a new concern styling itself the Hertford Record Co., Ltd., of which Sir George Croydon Marks, M.P., is chairman, and H. M. Lemoine, one of the first directors.

This sale at last finally disposes of the sole remaining enemy tainted concern, though in saying this we take the opportunity of recognizing the proper conduct consistently displayed throughout a trying period by its then British directors.

The new company is thoroughly all British throughout its personnel and capital. The sub-joined letter issued to the trade this month is in itself sufficiently explanatory, and we cannot do better than quote it at length. It is issued by the Hertford Record Co., Ltd., from their London office, 62 Oxford street, West 1, and reads as follows: "We beg to inform you that we have now completed the purchase from the controller appointed by the Board of Trade under the Trading With the Enemy Amendment Act, 1916, of the business heretofore carried on under the names of Carl Lindstrom (London), Ltd., Fonotipia, Ltd., and others, and that this company is now in possession of the works, premises and stock alike at Hertford and at City road, E. C. We shall continue the chief business of manufacturing records as heretofore, but everything will be under the sole and direct personal control of the directors of this newly-formed British company, which has been registered with the express sanction of the Board of Trade and His Majesty's Treasury. We hereby give you notice that all prices and conditions of sale relating to the orders that are in hand at the works will be withdrawn as and from Monday, November 19, and that all orders executed as and from that date will be the subject of an increased price concerning which we will write you early next week, giving you the new prices and the new conditions of sale.

"While we have had the responsibility in connection with these works so far as the purchase is concerned as and from the day the deposit was paid on May 12 last, we have not been able

Established in the Talking Machine
Business 1886

DON'T MISS THIS TALK

WE can save you about 50% on exports of Gramophones in either Horn, Hornless or Trench Types. Also in Motors, Tone Arms, Sound Boxes, Needles, etc. Our factory's capacity (with full supply of metal) is 500 motors per day.

We have had years of experience in the invention and manufacture of Talking Machine goods and can guarantee satisfaction.

Write right now for catalogue and terms, and to save time mention your requirements.

MARKS:

"Ajax"

"Magnophone"

"Fibrolase," etc., etc.

LOUIS YOUNG & CO. (Reg'd)

54, City Road,

Telephone
Central, 1812

London, E. C., England

FROM OUR LONDON HEADQUARTERS—(Continued from page 118)

to take over the control until now. We, therefore, take this opportunity of thanking you for the consideration that you have given to the controller, the staff, and all those concerned with the manufacture and supply of the goods in connection with the orders that you have favored the controller with during the extremely difficult period that is now closing, and we look forward to the continuance of the friendly relations with perhaps a closer connection than has heretofore been possible, as we are desirous of serving you in the future to the fullest extent in our power. The chairman of this company is Sir George Croydon Marks, M.P., well known for many years as chairman of the National Phonograph Co., Ltd., and of other companies in which T. A. Edison was interested, while H. M. Lemoine, formerly assistant manager of the National Phonograph Co., Ltd., and latterly manager of Associated Copyrights, Ltd., will be actively and personally concerned as a director of the company. The whole of the existing members of the staff and others engaged at the Hertford Works, also the recording experts, are being retained by this company. Yours faithfully, Geo. Croydon Marks, chairman."

It only remains to record our welcome to the new company, and this we do right heartily, feeling assured that with such men at the helm as Sir Geo. Croydon Marks and H. M. Lemoine, its future commercial progress will be crowned with complete success. Apart from its experienced personnel, the company possesses a very fine up-to-date factory at Hertford, admirably planned and equipped for handling a large output of quality records expeditiously. It will be interesting to know under what name the records will be christened, as presumably new names will be adopted, and, as stated in the company's letter to the trade, whether or not the price increase foreshadowed will be in conformity with the alterations recently made by the leading record manufacturers, i. e., from 1/6 to 2/—.

Opening of Pathé Frères' English Factory

As announced in these columns several months back, the great French house of Pathé had planned to open up on British soil a suitable record and machine factory for the purpose of insuring complete and prompt deliveries of their goods to the British trade. In pre-war days most of the Pathé goods were made in the great Paris factory. Difficulties of manufacture and transport were then unknown, but since the outbreak of war great and increasing trouble in this respect has been experienced. I need not elaborate the reasons; they are all too obvious. It is sufficient to say that matters had reached such a pass during the last few months as to render the establishment of an output independent of Paris vitally necessary. Hence, with characteristic common sense, plans were prepared to the desired end. This in itself was a task of no mean magnitude, bearing in mind the official mobilization of industries, labor, idle factories,

machinery, etc., all over the country. Nothing daunted, the company's British manager, A. E. Beckett, set about his task. District after district was scoured, most to no purpose from the results viewpoint, until at last his persistence and energy were rewarded by the discovery of a likely place at West Drayton, Middlesex, a few miles from the great "His Master's Voice" factories. Having come to terms with the powers that be, Mr. Beckett was next met with the difficulty of putting into effect the necessary alterations and improvements to the existing buildings. Resources were none too easily available for the purpose; labor and material were scarce; time was pressing. All things came to "them as wait," and it may be added, to "them as are determined." And so, in due time the factory was ready for its new occupants.

Here then, at West Drayton, is established for the first time in the history of our trade, the foundation of a large and progressive French enterprise, which, it may be confidently predicted, is but the forerunner of a great expansion, to take effect as and when circumstances permit.

With these new facilities of quick output at their disposal Pathé are on the high road to remove the handicap under which they operated commercially in the past, in relation to the prompt marketing of current music.

The situation of the factory for water power, rail and road transport, could not be better, as every such facility exists in close proximity thereto. An up-to-date record-pressing plant has been installed, and suitable arrangements made for machine, sound box and other assembling shops. The present buildings occupy but a portion of the land available for new shops. This land will eventually be covered, as circumstances not unconnected with wartime exigencies permit, with new buildings, record and cabinet plant, etc. It only remains to heartily congratulate the Pathé people upon their excellent start this side of the channel.

First Records by Granados, the "Sussex" Victim

Invested with a special interest, therefore, are the records of Granados' Spanish dances, which have been recorded specially by Sir Henry J. Wood and his orchestra for Columbia, the first two of which are announced this month. These are the "Villanesca" (or Rustic Dance) and the "Andantino quasi Allegretto." It was on his return voyage from New York, in 1916, where he had scored a huge success with these dances, that the gifted composer fell a victim to German "Kultur" in the ill-fated "Sussex."

The Gramophone Trade Roll of Honor

Apropos the suggestion made in our last issue anent the above I have received from the Columbia Graphophone Co. the following list of gallant gentlemen, formerly members of the Columbia Wandsworth factory staff, who have given their lives in the service of their king and country: Tom Woods, Sixteenth Middlesex; R. Nye, London Rifle Brigade; B. Robertson, W.

Soundboxes

IF you are after a genuine offer of soundboxes, you'll do well to communicate with us immediately. We have tens of thousands of perfect soundboxes, fitted with the best quality mica. Confidently recommended for cheaper machines, absolutely reliable and give excellent reproduction. Price to clear \$50 per gross, F. O. B. London.

Orders for less than gross lots not accepted

Wire "Knotaslepe, London".

W. H. Reynolds (1915) Ltd.
45, City Road, London, E. C.

Write for new illustrated Complete Catalogue

E. Anderson, Buffs; Sidney Plumbridge, Rifle Brigade; James Maloney, W. Yates, Oxford and Bucks Light Infantry; F. Doughty, Alfred Goodman, E. Surrey Regiment; Arthur Goodman, East Surrey Regiment; A. Gillman, Welsh Fusiliers, and T. Green.

Popularity of "Guardsman" Records

The Invicta Record Co. has just issued a most attractive supplement; it is full of good things, so good that it seems invidious to make a selection.

I was not surprised to hear that, despite almost overwhelming difficulties incidental to the critical time in which we now live and that business men have to face in every direction, the export trade of this enterprising company steadily increases. The extraordinary foresight with which they appear to be gifted enables them to anticipate the popular demand in a way that can only be described as telepathic. We strongly advise our readers to get into touch with the Invicta Record Co., Ltd., by sending immediately a request for their complete catalogue and latest supplements.

The Man of Many Parts

Such is the slogan adopted by W. H. Reynolds, Ltd., of City road, London. Its immediate success has inspired competitors to imitation, the best possible compliment. What it means is that Reynolds' stock of machine parts and accessories, if not as multifarious as in pre-war days, is nevertheless still amazingly big, circumstances considered. Practically every line is cataloged, and a copy of this diverse and useful price-list may be obtained by any bona fide trades upon written application to the firm.

(Continued on page 120)

GUARDSMAN RECORDS

REGISTERED

10 inch and 12 inch Lateral Cut



TRADE MARK

We can ship you *immediately, any quantity* of Records:
BANDS ORCHESTRAS INSTRUMENTAL SOLOS VOCAL

SELECTION OF AMERICAN AIRS

including, "Marching Through Georgia"—"Dixie"—"Arkansas Traveller"—"Red, White and Blue"—"Star Spangled Banner," etc., etc., Recorded by Full Regimental Band of H. M. SCOTS GUARDS. Get Ready Now for the Big Trade coming and have

THE FINEST RECORDS of THE FINEST TITLES at THE FINEST PRICES

Apply for Lists and Prices to INVICTA RECORD COMPANY, Ltd.

Cables: Duarrab, London

1 New Inn Yard, London, E. C., England

FROM OUR LONDON HEADQUARTERS—(Continued from page 119)

In addition to this side of the business, Messrs. Reynolds factor high-class disc records, and carry their own lines of machines, of which their specialty at the moment is the "Bijouphone," a compact portable model which wants a lot of beating. It is of remarkably sweet tone quality, is equipped with reliable motor and fittings, and has compartment room for about twelve records. A really wonderful instrument, is the general verdict!

Unmusical Warfare

Apropos the occasional complaints ventilated in the press by suburban sufferers anent the abuse of gramophone playing, usually by a near neighbor, a highly amusing article recently appeared in the London Star newspaper, as a comment upon an advertisement in the Times. The article in question bears the startling caption: "Advertiser who is arming for record reprisals," and proceeds: "If you have one of those great three horse-power gramophones that your neighbors are tired of, here is a chance to dispose of it. An anguished advertiser in the Times is looking for a loud (second-hand) gramophone wanted for reprisals. No delicatoned drawing-room instruments need apply. What the advertiser wants is a brazen-lunged, bellowing contraption, a six-cylinder machine with a funnel like a tunnel, and an effective range of about two miles. The sort of thing that Hammersmith people buy to amuse the folk of Kew. There ought to be brave doings when that gramophone comes home. Shortly after dawn this morning the enemy opened fire with their ten-inch records, 'Ipecacuanha,' 'They're Wearing Them Higher in Hawaii,' and 'Hicky-Wicky-Yaka-Hoola.' Our twelve-inch batteries replied, and put in some effective fortissimo work with 'The Cellar Door by Moonlight,' 'Drinking,' and the 'Soldiers' Chorus.' Reinforcements in the shape of a dust-bin lid obligato were brought into action, and by breakfast time the enemy batteries were silenced, and the man next door was heard to go out for more oil and records. Except for a few bricks and a summons the rest of the neighborhood has so far preserved its neutrality.

"It would be interesting to know in what suburb this harmonious warfare is being waged. House property ought to be cheap there in a day or two."

Thos. Edens Osborne Keeps It Up!

War or no war, the value of advertising does not diminish. Politically, there are many adverse elements to good business existent in Ireland to-day, but the natives, whatever their political outlook may be, never fail of their homage to good music. Hence, our Belfast friend, Mr. Osborne, keeps up his interesting editorial advertisements in the local press to good advantage. Business, I learn, is excellent, the demand being almost beyond the limits of supply. This is as it should be. Nevertheless, a meed of praise is due to Mr. Osborne for his consistent methods in the face of not altogether favorable conditions.

Grand Opera in English

A new artistic and sales field of endeavor has been opened up by the enterprise of His Master's Voice Co. During the last few years grand opera in English has become increasingly popular, and will be all the more appreciated by the music-loving public now that this company has embarked upon the issue of a large number of records carrying the best songs from most of the popular operas sung in English by the leading British operatic artists. The first list was issued in August, with additions during the succeeding months. The result from a sales point of view is eminently satisfactory, for, with succeeding monthly issues, the November returns have shown a sales advance of well over 1,000 per cent, compared to the August figures. Of course, the Gramophone Co. know how to do things in the way of smart advertising, but without depreciation of this expenditure, the enormous sales advance indicates of itself that there exists a rich and wide field for commercial cultivation. Dealers have been quick to recognize this by stocking up on these records to the fullest possible extent.

More Records Increased in Price

As foreshadowed in this department, other record manufacturers have followed the price-increase example set by the leading companies. The further price changes in question apply to "The Popular" series of records, which are now up to 1/8, the "Clarion" disc, now 2/—, the "Clarion" cylinder record—to 1/4, the "Cameo" record—to 1/3, and the "Bull-dog" record to 1/8. With the exception of the "Clarion" ten-inch double disc, the price increases are very small, but it is sufficient to confirm that which I have all along maintained—the absolute necessity for higher charges in view of the rapid advance of all manufacturing, carriage, labor and other costs.

Some H. M. V. Statistics

The latest issue of "The Voice" to hand contains many interesting tips, of value to all dealers, apart from other pithy items pertinent to "His Master's Voice" service. Of the latter, subjoined are a few instances. A little lubricating oil goes a long way, and yet the company use in their factory no less than twelve thousand gallons per year, in addition to two hundred thousand gallons of cutting and cooling solution for automatic machines!

To give some idea of the extent of the H. M. V. works it may be mentioned that the length of leather belting used to drive the machinery—if put end to end, would measure close upon fifteen miles.

The machine factory is a building of six floors, having a total floor area of 140,000 square feet. This is stated to be only about one-quarter of the ultimate buildings it is expected will be erected at some future date. The window area of this building is as much as 42,000 square feet, so that it is obvious the maximum of natural light is secured.

Another little item tells us of the great in-

REX GRAMOPHONE CO.*are making a Specialty of***EXPORT***in***Horn, Hornless & Portable Disc Machines****REX GRAMOPHONE CO. 2 Elizabeth Place
Rivington Street, LONDON, E.C. 2**

Cable Address "Lyrecodisc, London"

Enquiries Solicited

terest the war staff takes in doing its little bit towards the provision of solace for the troops. The collection box is sent round weekly, and so well is it supported that since June, 1915, a grand total of 750,000 cigarettes and 360 pounds of tobacco has been sent to men on active service.

Lauder's £1,000,000 Scheme for Disabled Soldiers

"If it comes to pass that after the war disabled soldiers are found selling matches or bootlaces at street corners, then I wish to God that my son had not laid down his life for his country." Such were the moving words addressed by Harry Lauder to a great audience at the St. Andrew's Hall, Glasgow, in his appeal for £1,000,000 to be devoted to keeping in comfort disabled Scottish soldiers and sailors. To aid this scheme the Gramophone Co. have published a record by Mr. Lauder, one side of which carries his appeal for help, and the other his famous song, "Shoulder to Shoulder." A proportion of the profits from the sale of this record will benefit the fund, and this generous action on the part of the company will doubtless infuse all dealers with the desire to support the fund by putting forward their best efforts in the sale of the record. In addition to this dealers might well co-operate in assisting Harry Lauder to collect as large a sum as possible, not only to swell the gramophone trade contribution, but to secure the required total as speedily as possible. We have no doubt that the Gramophone Co., Ltd., Hayes, Middlesex, would willingly acknowledge on behalf of the organizer any contributions their dealers and other members of the trade might feel disposed to make.

New Record Issues of the Winner Co.

A champion list of records is that issued recently by the Winner Co. The titles itemized make a wide appeal by reason of their diversity. They are entirely in keeping with the high character of the previous list which includes records of Captain Bruce Bainsfather's successful musical production, "The Better 'Ole," of which are recorded Selections I and II, introducing most of the local hits of the piece. It is a record of "some" merit, the recording and rendition thereof by the Royal Court Orchestra being of extreme quality. This same orchestra is also responsible for some diverting selections from the two popular revues.

The handsome fifty-page catalog, No. 91, introduced by the company last month includes all records issued up to and including last October, and should be in the hands of every member of the trade.

EDISON BELL**WINNER**
TRADE MARK
GRAMOPHONE RECORDSCABLE
"PHONOKINO,
LONDON"**ARE THE GREATEST VALUE FOR MONEY PRODUCED IN GREAT BRITAIN**

TEN INCH

DOUBLE SIDED

NEEDLE CUT

PLAY ON ALL GRAMOPHONES**Catalogue contains 4000 Titles by the Premier Artistes, Instrumentalists, Orchestras and Bands
of the British Empire**

DEALERS PREPARED TO DO BUSINESS ARE INVITED TO COMMUNICATE WITH

Proprietors and Manufacturers, J. E. HOUGH, Ltd., 62 Glengall Road, London, S. E. 15, England

WORLD'S CLASSIFIED ADVERTISING

Any member of the trade may forward to this office a "Situation" advertisement intended for this Department to occupy a space of four lines, agate measure, and it will be inserted free. Replies will also be forwarded without cost. Additional space will be at the rate of 25c. per line. If bold faced type is desired the cost of same will be 25c. per line.

WOULD you pay not less than \$7,000 yearly? I am a sales creator! Do you want a high-class sales manager as well as a thorough advertising manager? Do you want a man who will increase your business; who will create a large number of new customers—and originate selling ideas—and keep those customers everlastingly plugging for your product? In other words, are you willing to pay not less than \$7,000 yearly (or \$5,000 yearly and interest in business) at the start to the man who will walk into your office, sit down at his desk, and do business "right off the reel?" Will you pay for brains, ability and experience? But last and best of all, do you want a man who will bring the business to your office with letters, reading like this: "Gentlemen: find enclosed, check and order, etc., etc." Cash with order business direct from dealers? I am the man who can put this over, provided you have honest goods, goods that will stand up to every honest statement I make in my correspondence. You must have a high-class product, I don't care whether it be phonographs (or other line of merchandise), I will make good. Twenty-seven years of successful salesmanship through the mails, advertising and with a sales force is worth to any high-grade concern not less than \$7,000 yearly. If my "ad" interests you let's get acquainted. Address me "Box 484," care The Talking Machine World, 373 Fourth Ave., New York.

POSITION WANTED—A thorough experienced Edison jobbers' traveler and also manager with all the constructive dynamic attributes of character, a live wire and hustler. Can hold and build up trade, enthusiastic and convincing. Highest references from headquarters. Address "Box 485," care The Talking Machine World, 373 Fourth Ave., New York.

RECORD EXPERT with fifteen years' experience wants position as **RECORDING—LABORATORY**—or **MANUFACTURING** man. References. Please write "O. H. W. 15," care The Talking Machine World, 373 Fourth Ave., New York.

SITUATION WANTED—Middle-aged man with fifteen years' experience in phonograph construction, would like to become associated with honorable concern desiring to build or building talking machines. I have several valuable inventions to offer along with my knowledge of the art for the right concern. Address "Box 486," care The Talking Machine World, 373 Fourth Ave., New York.

MANAGER OF VICTROLA DEPARTMENT—Doing one hundred thousand dollars, desires a change January 1 or thereabouts. The vicinity of New York City preferred. Age 27, salary \$3,000. Further particulars by letter. Address "Box 479," care The Talking Machine World, 373 Fourth Ave., New York.

WANTED—A small outfit for recording lateral ten-inch records with a complete outfit for manufacturing records. Address, with full details, "Box R. M.," care The Talking Machine World, 373 Fourth Ave., New York.

POSITION WANTED by expert mechanic with thorough knowledge of motors, assembling, cabinets and inspection of finished production. Competent to take full charge. Address "Box 487," care The Talking Machine World, 373 Fourth Ave., New York.

SALESMAN—Calling on talking machine and piano dealers, to handle a profitable side-line that may be developed. Territory open. Proposition one that most dealers will not refuse. Steady return on repeat business. Address "Box 488," care The Talking Machine World, 373 Fourth Ave., New York.

WANTED—Experienced salesmen in the talking machine and piano trade (having a slight knowledge of wood finishing will be an asset), to sell a meritorious article as a side line. Write for particulars at once, as territory is going rapidly. Our offer to the trade gets the business for the salesman. Address Master Mfg. Co., Box 96, Camden, N. J.

FOR SALE
A talking machine business in a city of over 300,000, established over ten years, doing over \$50,000 per year, will sell stock, fixtures, lease and Victrola contract. Will take from \$15,000 to \$20,000 to swing. A golden opportunity. Reason for selling, owner has made enough to retire. Address Golden Opportunity, care The Talking Machine World, 373 Fourth Ave., New York.

FOR SALE
Long established furniture factory, well and favorably known and successful—factory well equipped—150,000 square feet floor space—has had considerable experience in making high grade cabinets—labor conditions good, no unions or labor troubles—cheap labor—good reasons for selling. Correspondence confidential. Address "Phonograph," care The Talking Machine World, 373 Fourth Ave., New York.

SPOT CASH PAID—WANTED
Any amount of records in all languages, Talking Machines, Horn or Hornless, also parts of all makes. Address Phonograph and Record Exchange, 2104 Third Ave., New York. Telephone 7848 Harlem.

STEEL NEEDLES
Loud tone. 200 in envelope. A few million to close out at \$5.25 per million or 55c per thousand, in hundred-thousand lots. Bargains in motors, tone arms, parts, and complete machines.
FULTON TALKING MACHINE CO.
640 BROADWAY NEW YORK CITY

TRAVELERS visiting talking machine trade can make \$50.00 per week easily, selling our sensational novelty for talking machines as a sideline. Pocket samples. Excellent proposition. Only first class men need apply. State particulars, and district you cover. Address Uniset Reproducer Co., Wabash avenue and Jackson boulevard, Chicago, Ill.

POSITION WANTED—Would like to work in phonograph store or anywhere else in phonograph line. Address "Box 489," care The Talking Machine World, 373 Fourth Ave., New York.

SITUATION WANTED—Experienced Edison salesman and manager open to offer. Hold similar position now. Age 33, married. Address "Box 490," care The Talking Machine World, 373 Fourth Ave., New York.

WANTED—By a New York manufacturer, an expert man to develop a phonograph motor. Answer in detail by letter only, state experience and salary expected. Address M. Weingarten, 286 Fifth Ave., New York.

SITUATION WANTED—Superintendent at present employed, thoroughly familiar with every angle of the phonograph business, desires to make a change. Address "Box 491," care The Talking Machine World, 373 Fourth Ave., New York.

SITUATION WANTED—By high grade finishing foreman. Have had several years' experience on talking machines. Will be open for position February first. Want to connect up with a good, live, growing concern, one that would appreciate first class finishing, production and efficiency in every respect. State amount of men in finishing room, the output whether table or floor cases, the salary you would pay for an A1 man. Address "J. D.," 306 East South Grand Ave., Springfield, Ill.

SITUATION—Mechanical engineer thoroughly understanding the manufacturing of phonograph parts, complete machine assembling or machine work, is open for a position as superintendent or production manager. Highest credentials as to ability. Address "Box 473," care The Talking Machine World, 373 Fourth Ave., New York.

ENERGETIC—Young man with clerical, order and executive experience, familiar with the phonograph record line, desires position in any part of the country. Address Philip Greenberg, 2325 East Sixty-third St., Cleveland, Ohio.

WANTED—Capable, experienced, reliable person to take charge of disc manufacturing department. Address "Box 480," care The Talking Machine World, 373 Fourth Ave., New York.

WANTED—An experienced salesman for outside work on Edison phonographs and records. Position of manager is open for the right party. Please give references and state salary required. Address "Box 481," care The Talking Machine World, 373 Fourth Ave., New York.

SITUATION WANTED—If it were possible to secure a sales manager who has sold over \$21,000 worth of phonographs, personally, in one year, to manage your department, would you consider him? Have good position now. Will explain reasons for wanting to make a change. Will furnish signed statement of business done. Strictly confidential. Address "Box 472," care The Talking Machine World, 373 Fourth Ave., New York City.

STEEL NEEDLES
FULL TONE MADE OF THE BEST CARBON STEEL WIRE
100 in elegant envelopes, \$6.50
Per 1000 needles, - - -
MAIN SPRINGS
Columbia Size, 1" x 0.28 x 11' long, - - Each, \$0.60
" " 7/8" x 0.23 x 10' " - - " 0.35
" " 3/4" x 0.22 x 8 1/2' " - - " 0.24
Mica diaphragms for Columbia soundboxes, Each, \$0.30
" " " Victor " " 0.15
" " " all standard " " 0.20
FAVORITE PHONOGRAPH ACCESSORY CO.
1491 DeKalb Avenue Brooklyn, N. Y.

FOR SALE
Four-minute indestructible records, all new clean stock 10 cents each in 100 lots. Denninger Cycle Co., Rochester, N. Y.

FOR SALE
A phonograph and photograph business doing over \$30,000 per annum. Will sell at once. Reasons—Account of other business. Location in New Jersey, 45 minutes from Broadway. Address R. U. Wide-awake, care The Talking Machine World, 373 Fourth Ave., New York.

DIAPHRAGMS
Made from chemically treated fibre. Better than mica and cost one-half. Will stand immersion in water. Have wonderful musical qualities. Made in all sizes, flat and convex. Prompt deliveries in any quantity.
KAROLA LABORATORY,
Bloomfield, N. J.

WANTED—An expert talking machine assembler by a manufacturer in New York City. Permanent position for a man who thoroughly understands the assembling of popular priced machines. Address "Expert," care The Talking Machine World, 373 Fourth Ave., New York.

WANTED—A superintendent for a talking machine plant who is a capable executive and who can organize an efficient working class. We want a progressive and thoroughly efficient man who can take complete charge of the plant, which is one of the most complete in the country. Give full details as to past experience, training, etc. All replies held strictly confidential. Address "Box 476," care The Talking Machine World, 373 Fourth Ave., New York.

WANTED—Experienced talking machine salesmen who are familiar with the wholesale trade, and who are capable of handling a first class line of machines and records. There is an excellent opportunity for the right men, with unlimited earning possibilities. Give full particulars in first letter. This is a proposition that will place the right men with one of the best equipped manufacturers in the trade. Address "Box 477," care The Talking Machine World, 373 Fourth Ave., New York.

WANTED—By a New York distributor an assistant repair man. Salary to start \$14. Address "Repairs," Box 478, care The Talking Machine World, 373 Fourth Ave., New York.

SITUATION WANTED—Experienced Edison manager and salesman open to offer January 10. Hold similar position now. Broader field wanted. Address "Box 482," care The Talking Machine World, 373 Fourth Ave., New York.

SITUATION WANTED—After first of year by experienced Grafonola salesman. Texas or California territory. Warrant department will positively get results. Address H. Burdge, 4207 Oak, Kansas City, Mo.

POSITION WANTED—By two experts in manufacture of disc records. Thoroughly familiar with latest and best method of recording, electrotyping, pressing and equipments. Address "Box 378," care The Talking Machine World, 373 Fourth Ave., New York.

WANTED—First-class finishing-room foreman for high-grade cabinet work; also several cabinetmakers. Address "Cabinetmaker," care The Talking Machine World, 373 Fourth Ave., New York.

POSITION WANTED—Experienced talking machine repair man desires position. Chicago preferred. Address "N. O. 2," care The Talking Machine World, 209 South State St., Chicago, Ill.

WANTED—By an established New York manufacturer, an experienced salesman to visit the dealers. Excellent proposition for the right man and a side-line arrangement will also be considered. Address "Opportunity," care The Talking Machine World, 373 Fourth Ave., New York.

"MAGNET" DECALCOMANIE NAMEPLATES
FOR TALKING MACHINE CABINETS Etc.

Pamphlets with fac-simile illustrations and prices mailed on request.

SMITH-SCHIFFLIN CO.
126 Liberty Street New York City

FROM THE DORAN CO.
45 MICHIGAN AVE
DETROIT

SOLD BY HURTEAU, WILLIAMS & CO. LTD.
MONTREAL — OTTAWA

Kunkel Piano Co.
BALTIMORE

FROM THE PHONOGRAPH CO.
1240 HURON ROAD (Interway Floor)
PHONES - PROSPECT 2140 - CENT 1408
CLEVELAND

SOLD BY WALTER D. MOSES & CO.
Oldest Music House in VA and N.C.
103 E BROAD STREET
RICHMOND, VA.

SOLD BY J.E. STRATFORD
AUGUSTA, GA.

INSTALL COLUMBIA DISPLAY IN LOBBY OF HAVANA THEATRE

The Frank G. Robins Co., Columbia Representatives in Havana, Cuba, Now Carrying Complete Line of Grafonolas on Display in the Lobby of the National Theatre of Cuba

The Columbia Graphophone Co., New York, was recently advised by its representatives in Havana, Cuba, the Frank G. Robins Co., that they had leased the lobby of the National Theatre of Cuba, and in that famous and magnificent opera house would carry a complete line of

ments to be found in any part of the world.

For a number of years past the Frank G. Robins Co. has handled the products of the Columbia Co. as exclusive representatives in that country, and it has built up a business which has reached phenomenal sales totals. The line

ilege to occupy this valuable space was keenly contested for by the leading merchandising houses in Havana, the Frank G. Robins Co. emerged successful, and now occupies the entire lobby with its Grafonola display.

In addition to this artistic display the Columbia line will also be shown in Havana in the new ten-story building now being erected by the Frank G. Robins Co. for their exclusive use on Obispo and Havana streets. This building, with the exception of the edifice occupied by the National Bank of Cuba, will be the finest commercial building in Havana.

The illustrations of the Columbia display pre-



Views of the Columbia Grafonola Display in the Lobby of the National Theatre of Cuba, in Havana

Columbia product. The significance of this location may be gleaned from the illustrations herewith, for the space occupied by the Frank G. Robins Co. in the lobby of the National Theatre of Cuba constitutes one of the finest and most artistic talking machine establish-

has been displayed at retail in a store on San Rafael street, the principal business street in Havana, but the sales of Columbia product grew so rapidly that the company was obliged to look for new quarters. It finally secured them in the National Theatre's lobby, and although the priv-

sented by the Frank G. Robins Co. as shown herewith, following closely on the recent opening of the magnificent Columbia Shop in New York, indicate that the artistic possibilities of the Columbia line are now being recognized the world over.

AMERICAN GRAPHOPHONE CO. PLANS

Reorganization of Concern Under Way—New Title to Be Columbia Graphophone Mfg. Co.—Exchange of Stock to Be Made

Arrangements have been made by the American Graphophone Co. for a plan of reorganization and exchange of stock, and a circular signed by President Francis H. Whitten, outlining the details of the plan, has just been mailed to the stockholders. It involves the incorporation of a new company, the Columbia Graphophone Manufacturing Co. of Delaware, to succeed the present American Graphophone Co. of West Virginia, and stockholders are asked to exchange their present holdings for shares in the new company. The present company has outstanding \$2,500,000 non-cumulative preferred and \$7,500,000 common stock, both of \$100 par value. The new company is to have \$15,000,000 7 per cent. cumulative preferred, of \$100 par, and 150,000 shares of common stock without par value. This capitalization is considered sufficient to meet the financial needs of the business for some years.

Stockholders are offered four options under which they may exchange their holdings, the options expiring on May 1 next, with the provision that President Francis S. Whitten may terminate it any time between February 1 and May 1, 1918.

The holder of 100 shares of preferred can exchange his stock for 100 shares of preferred and 25 shares of common of the new company; or he can exchange it for 110 shares of new common. If the holder wishes to divide his option he can get 50 shares of new preferred for 50 old preferred and 67½ shares of new common for the other 50 shares of preferred.

The holder of 100 shares of common stock can take 100 shares of new preferred and 20 shares of new common, or he can take 105 shares of new common in exchange. If he desires to divide his option he can use 50 shares for a like amount of new preferred and the other 50 shares can be exchanged for 62½ shares of new common.

There will be considerable of the capitalization of the new company remaining after the exchange is completed and this stock will be kept for future needs. The change of the name from the American Graphophone Co. to the Columbia Graphophone Manufacturing Co. is for the purpose of associating the name of the company with the name of its product—the Columbia Graphophone.

It is asserted that the business increased considerably this year and sales for the eleven months, both in America and Europe, were between 25 and 30 per cent. ahead of the same period of 1916. Each month's sales last year showed an appreciable increase over the same month of 1916.

NEW HOFFAY CATALOG ISSUED

Volume Intended, Primarily, to Prove Source of Information for Dealers and Salesmen—Features of Hoffay Instruments Described

The Hoffay Talking Machine Co., Inc., recently issued a new catalog which is intended, among other things, to be a source of information to the dealers and salesmen of Hoffay instruments. All the patented features of the Hoffay talking machine are described minutely and are accompanied by illustrations showing the parts from several angles. The Hoffay "Airtight" sound box and the "Resurrectone" diaphragm are shown to particularly good advantage, and the qualities of these parts are minutely described. The several models of the Hoffay machines are shown and the new retail prices accompany the illustrations. The book is artistic from every standpoint.

CHANGE NAME OF BRANCH

The Columbia Graphophone Co., New York, announced recently that the name of its Philadelphia branch had been changed from the Pennsylvania Talking Machine Co. to the Columbia Graphophone Co. This branch, which handles the Columbia products exclusively at wholesale, is under the management of A. J. Heath, and is one of the branches in the territory of W. C. Fuhri, district manager.

Do You Collect Your Accounts?

FOR some time past we have been using a follow up system of collecting both our installment and open accounts that has brought us wonderful results. 90% of the work done right in your office. Saves attorneys' fees and keeps the good will and patronage of your customer.

The complete layout, simply explained, sent for \$5.00. Cash with order. We refer you to any Victor, Edison or Columbia Jobber in our section as to our reliability.

HYATT TALKING MACHINE CO., Portland, Oregon

Lufranc Quality



RECORD DELIVERY ENVELOPES

START THE NEW YEAR
WITH A GOOD SUPPLY
by Placing Your Order Now

Samples and Prices Furnished Cheerfully

Write Today Get the Best Always

LEWIS C. FRANK

654 Book Building

DETROIT, MICH.

T.M.W. 1217

LATEST PATENTS RELATING TO TALKING MACHINES AND RECORDS

WASHINGTON, D. C., January 8.—PHONOGRAPH.—Edward Rogers, Rosedale, N. Y., assignor of one-half to William A. Courtland, Brooklyn, N. Y. Patent No. 1,243,980.

This invention relates to phonographs and has for its primary object to provide an improved construction, combination and arrangement of parts in an instrument of this character whereby a plurality of disc records can be played thereon in succession without the intervention of an operator. One of the objects of the present invention is to provide improved means which will automatically remove a record from the turntable of the phonograph as soon as such record has been completed and replace it with the next record in order. A subsidiary object of the invention is to provide record holders of improved construction which are adapted to automatically start the reproducing needle at the beginning of the records and control the removal of said records from the turntable.

Figure 1 is a plan view of a phonograph constructed in accordance with the principles of the invention; Fig. 2 is a side elevation of the same; Fig. 3 is a side elevation at right angles to Fig. 2, parts being removed and parts shown in section; Fig. 4 is a sectional view of one of the record holders; Fig. 5 is a detail section on the line V—V, Fig. 1; Fig. 6 is a detail section on the line VI—VI, Fig. 1; Fig. 7 is a frag-

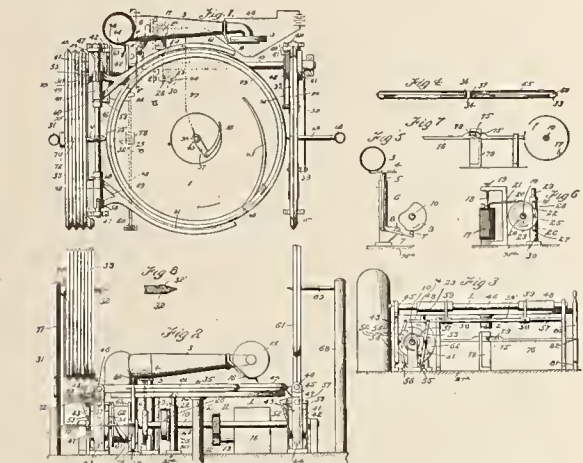

mentary detail in elevation; Fig. 8 is a fragmentary detail on an enlarged scale.

PHONOGRAPH.—Lewis Cole, Chicago, Ill., assignor to the Talk-Sing Co., same place. Patent No. 1,244,588.

This invention relates to phonographs suitably arranged for use in toys and other devices, such as cigar cutters, clocks, dolls, savings banks, etc.

The objects of the invention are to provide simplified and improved means for starting, stopping and governing the speed of devices of this class; to provide improved means for automatically disengaging the stylus at the end of operations of the device and restoring the stylus carrying arm to its initial position, ready to repeat operations and to provide improved means for causing the stylus to resiliently engage a record.

Figure 1 is a front elevation of a phonograph constructed according to this invention. Fig. 2

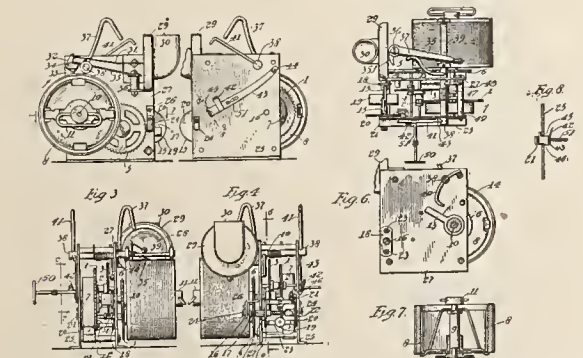

is a rear view. Fig. 3 is a left side view. Fig. 4 is a right side view. Fig. 5 is a plan view. Fig. 6 is a sectional elevation taken on the

line 6—6 of Fig. 4. Fig. 7 is a detail in section showing the record support. Fig. 8 is a sectional detail taken on the line 8—8 of Fig. 2, and shows part of the starting and stopping spring lever.

TOY PHONOGRAPH.—Lee A. Collins, Louisville, Ky. Patent No. 1,245,568.

This invention relates to an improved phonograph and has as its primary object to provide

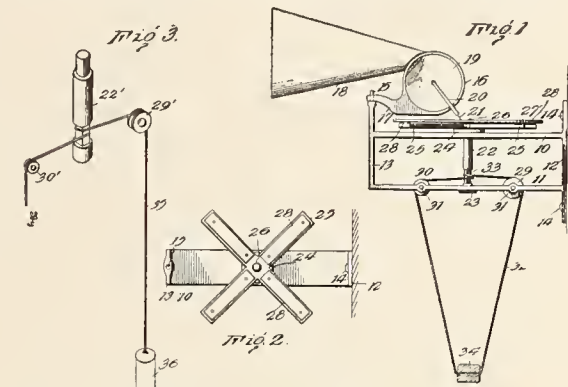

a device of this character which will constitute an attractive toy.

The invention has as a further object to provide a toy phonograph designed for attachment to a wall or other support and which may be easily mounted in position to be operated. And the invention has as a still further object to provide an improved and simple means for manually operating the phonograph.

Figure 1 is a side elevation of the improved phonograph showing the manner in which the device may be connected to a wall or other support and particularly illustrating the mechanism employed for manually rotating the record carriage of the phonograph. Fig. 2 is a top plan view of the device with the sound box removed, and Fig. 3 is a fragmentary perspective view showing a slightly modified form of operating mechanism for the device.

DRIVE MECHANISM FOR COMBINED PHONOGRAPHS AND PLAYER-PIANOS.—Melville Clark, Chicago, Ill., assignor to the Melville Clark Piano Co., same place. Patent No. 1,246,053.

The purpose of this invention is to combine in a single casing a phonograph mechanism and a player-piano mechanism, and to arrange for driving the phonograph from the same motor which drives the take-up roll of the player mechanism. The invention consists in the features and elements of construction contributing to this result and their combinations described and shown in the drawings: Figure 1 is a perspective view of a player-piano having a phonograph mechanism embodied in its casing in ac-

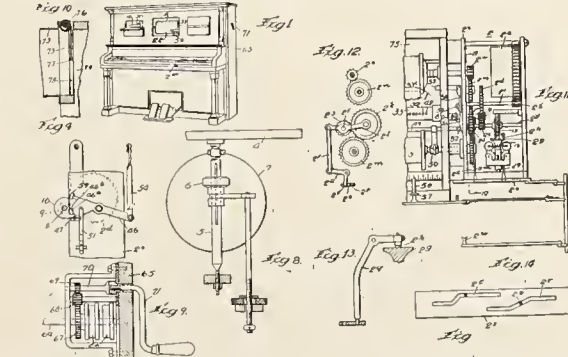

cordance with this invention. Fig. 2 is a plan sectional view of most of the drive gearing for the take-up roll and the phonograph. Fig. 3 is a detail elevation of certain portions of the drive gearing shown in Fig. 2. Fig. 4 is a detail elevation of a gear shifting device. Fig. 5 is a detail view of a clutch shifting device for the take-up roll. Fig. 6 is a diagrammatic view of the pneumatic connections between the tracker board and certain pneumatics adapted for automatic control of the two mechanisms. Fig. 7 is a detail view of a disengageable connection in a tempo-controlling means. Fig. 8 is a detail elevation of speed-varying means for the ro-

tary table of the phonograph. Fig. 9 is a detail section showing a manually operable winding gear for the motor. Fig. 10 is a detail section of a sound-controlling curtain for the phonograph amplifier. Fig. 11 is a front detail

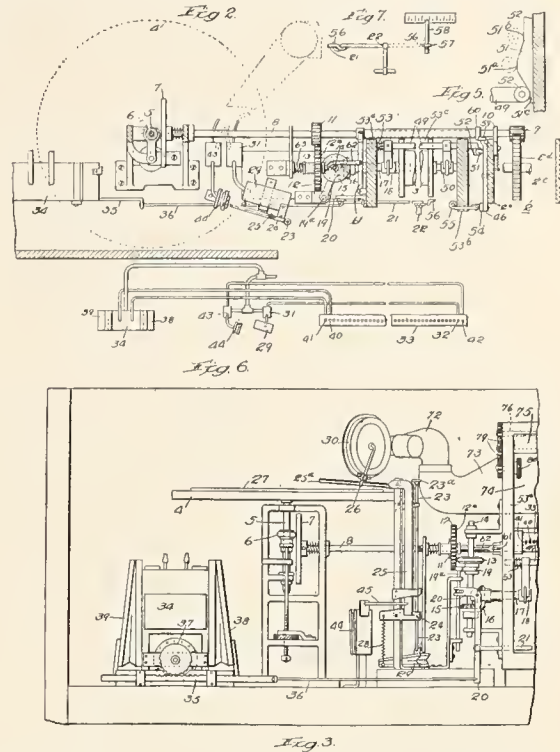

elevation of a spring motor for driving the mechanism associated with this invention. Fig. 12 is a diagrammatic side elevation of certain gear trains of the motor shown in Fig. 11. Fig. 13 is a detail of the motor brake. Fig. 14 is a detail view of the speed-controlling cam for actuating the brake and the reversing train.

TALKING MACHINE.—Louis Lumiere, Lyon, France, assignor to the Victor Talking Machine Co., Camden, N. J. Patent No. 1,246,763.

The main objects of this invention are to provide an improved talking machine including a cabinet, sound reproducing means including a comparatively large vibratory diaphragm

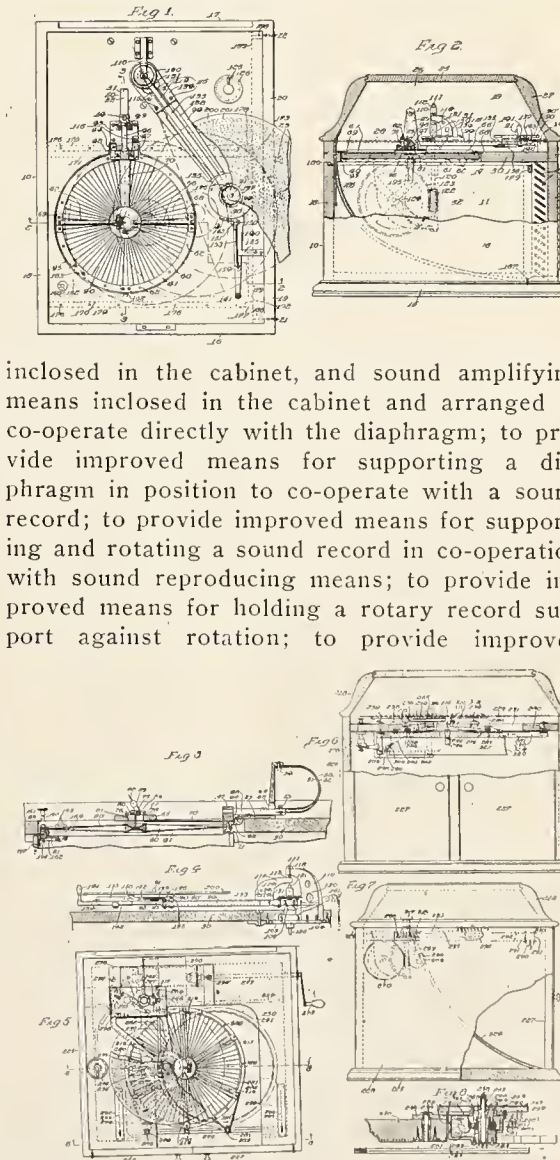

included in the cabinet, and sound amplifying means included in the cabinet and arranged to co-operate directly with the diaphragm; to provide improved means for supporting a diaphragm in position to co-operate with a sound record; to provide improved means for supporting and rotating a sound record in co-operation with sound reproducing means; to provide improved means for holding a rotary record support against rotation; to provide improved sound reproducing means and other improvements. In the drawings herewith Figure 1 is a fragmentary top plan view of a talking machine constructed in accordance with this invention; (Continued on page 124)

LATEST PATENTS RELATING TO TALKING MACHINES AND RECORDS—(Continued from page 123)

Fig. 2 a fragmentary end elevation partly in vertical transverse section on line 2—2 of Fig. 1; Fig. 3 a fragmentary vertical section on line 3—3 of Fig. 1; Fig. 4 a fragmentary side elevation of a portion of the machine shown in Fig. 1; Fig. 5 a fragmentary top plan view of a modified form of this invention; Fig. 6 a fragmentary front elevation partly in vertical transverse section on line 6—6 of Fig. 5; Fig. 7 a fragmentary side elevation partly in vertical section of the machine shown in Figs. 5 and 6; and Fig. 8 an enlarged fragmentary vertical section on line 8—8 of Fig. 5.

PHONOGRAPH NEEDLE.—Frederick L. Wood, Meriden, Conn. assignor to the Aeolian Co., New York. Patent No. 1,246,694.

The present invention relates to a novel phonograph needle for use in reproducing sound from sound records. The advantages of said needle will be apparent to those skilled in the

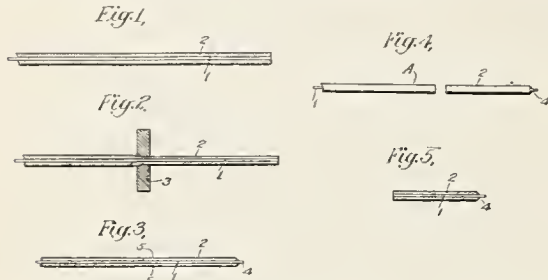

art from an understanding of the drawings. In the latter, Figures 1 to 4 inclusive are more or less diagrammatic representations of different stages in the process; and Fig. 5 is a mid-longitudinal section of the finished needle shown in Fig. 4.

RECORD FOR TALKING MACHINES.—Ademor N. Petit (deceased), Orange, N. J., assignor to John L. Lotsch, Brooklyn, N. Y. Patent No. 1,246,651.

This invention relates to records of the type wherein a sinuous groove of substantially uniform depth is cut into a tablet which is caused to rotate beneath a cutting tool of the proper shape and configuration, and its object is to produce an improved record groove, the walls of which are so proportioned and shaped as to reproduce the sounds which were employed to produce the original record with more clearness and distinctness than has been possible from records heretofore devised.

Another object is to produce a record groove which will retain its shape and reproduce the recorded sounds with fidelity and without false tones.

A further object is to produce a record groove wherein the reproducing tool will always properly engage the record surface notwithstanding the wear to which the tool may be subjected.

Figure 1 is a sectional view of a portion of a talking machine showing a recording tool in

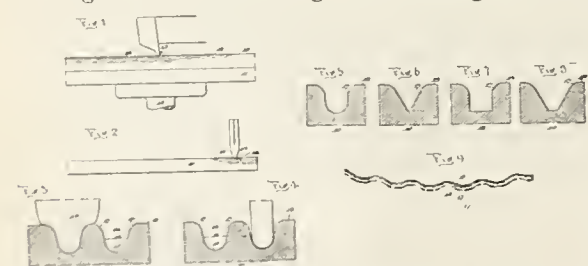

operative relation thereto. Fig. 2 is a sectional view of the same, taken at right angles to Fig. 1. Fig. 3 is an enlarged sectional view of a record groove and cutting tool. Fig. 4 is a similar view of the groove showing a reproducing stylus of ordinary construction engaging with the groove. Figs. 5, 6, 7 and 8 are sectional views of modified forms of groove. Fig. 9 is an enlarged plan view of a portion of the record groove.

REPRODUCER.—William Troupe Lakin, Cumberland, Md. Patent No. 1,246,616.

This invention is an improvement in reproducers, and has for its object to provide a device of the character specified, wherein the stylus bar is mounted parallel with the diaphragm, and is supported in knife edge bearings and points, to give it the greatest possible freedom of movement, which influences the diaphragm.

In the drawing: Figure 1 is a front view of the reproducer. Fig. 2 is a section on the line 2—2 of Fig. 1. Fig. 3 is a partial rear view. Fig. 4 is a section on the line 4—4 of Fig. 3. Fig. 5 is a perspective view, looking from below, of the stylus bar. Fig. 6 is a similar view

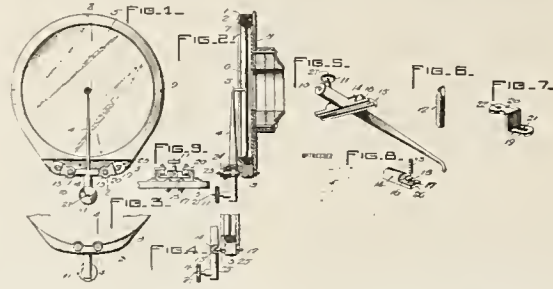

of one of the supporting pins for the stylus bar. Fig. 7 is a perspective view of one of the mounting brackets for the bar. Fig. 8 is a perspective view of one end of the fulcrum of the stylus bar looking from above, and Fig. 9 is a partial edge view of the reproducer.

SOUND BOX ADAPTER.—Anthony Vasselli, Newark, N. J., assignor by Mesne assignments to Otto Heineman Phonograph Supply Co., Inc., New York. Patent No. 1,246,506.

This invention relates to devices whereby the talking machine may be adapted to play records of the laterally undulating type or records of the "hill and dale" type and it consists primarily in the tone arm of the usual construction having at its free extremity a peculiarly shaped connection to which the sound box may be attached and by which the sound box may be shifted from a position in which a diaphragm lies in the vertical plane to a position in which the plane of the diaphragm will be at an angle of about 60 degrees to the plane of the record and this without removing the sound box in any way or changing the radial distance between the center of the tone arm pivot and the point of the needle.

In the patent to Catucci No. 1,156,130, dated October 12, 1915, an adapter is disclosed which

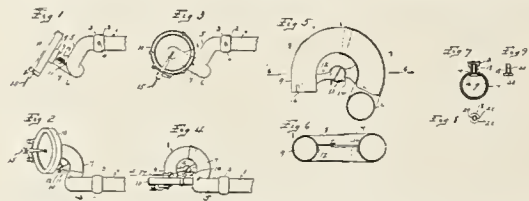

is designed as an attachment for one of the well-known types of talking machines now on the market so that when in use records of the "hill and dale" type may be played, or by removing the adapter and fastening the sound box to the tone arm in the usual manner records of the laterally undulating type may be played. In the present invention none of the parts are removed, and it is only necessary to swing the sound box from one position to the other and vice versa to play all styles of records now on the market.

Figure 1 is a side elevation of the improvement with a well-known sound box attached thereto and so much of a tone arm as is necessary to illustrate the invention arranged to reproduce records of the "hill and dale" type. Fig. 2 is a plan view of the same. Fig. 3 is a side elevation similar to Fig. 1 but showing the sound box arrangement to play records of the lateral undulating type. Fig. 4 is a plan view of the same. Fig. 5 is a fractional view partly in section of the improvement. Fig. 6 is a cross section of line 6—6 of Fig. 5. Fig. 7 is a cross section of line 7—7 of Fig. 4, and illustrates an improved sound box connection with the tone arm, or adapter. Fig. 8 is a plan view of the screw used in such connection. Fig. 9 is a side elevation of said screw showing one of its flattened sides.

A further object is to provide improved means embodying a joint, whereby the sound box is adapted for vertical adjustment and improved means whereby any wear on the parts of the joints may be readily taken up and the joint maintained tight.

Figure 1 is a side elevation of a tone arm em-

bodying this invention and showing the sound box in position to play one type of record. Fig. 2 is a top plan view of the parts shown in Fig. 1. Fig. 3 is a view similar to Fig. 1 showing the sound box in position to play another type of record. Fig. 4 is an elevation of the sound box and the adjacent portion of the tone arm as taken from the opposite side of Fig. 1. Fig. 5 is a detail sectional view taken on line 5—5, Fig. 1. Fig. 6 is a detail sectional view taken through the tone arm and fastening means for the sound box.

PHONOGRAPH SOUND BOX CONNECTION.—Charles S. Burton, Oak Park, Ill. Patent No. 1,247,219.

The purpose of this invention is to provide an improved connection between the sound box and the tone arm of a phonograph, adapted to permit swiveling of the two connected parts for adjustment of the sound box to two positions, and particularly adapted to permit such adjustment for adapting to zigzag and hill-and-dale records, the specific purpose being to insure the adjustment from one position to the other being made completely and not halted with the parts at an intermediate position.

In the drawings: Figure 1 is a side elevation of a portion of the tone arm and sound box em-

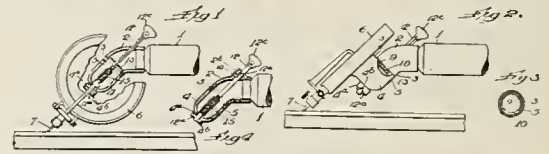

bodying this invention in one of its forms. Fig. 2 is a section axial with respect to the two inter-telescoping and swiveled members. Fig. 3 is a detail side elevation showing the two parts at a different adjustment from that shown in Fig. 1. Fig. 4 is a side elevation of a modified form, the parts being broken away and shown in axial section. Fig. 5 is a detail section at the line 5—5 on Fig. 4. Fig. 6 is a detail section at the line 6—6 on Fig. 4. Fig. 7 is a view similar to Fig. 3, showing a modified form.

CIRCLE LINE WAVE DOUBLE-DISC RECORD FOR SOUND PRODUCING MACHINES.—John A. Sowell, Sacramento, Cal., assignor of one-half to E. E. Sowell, same place. Patent No. 1,247,163.

This invention relates to improvements in double-disc records for sound producing machines, the object of the invention being to produce a record which will carry a greater number of impression lines to a given diameter than the discs now commonly used.

A further aim of the invention is to so construct the record that it will allow of a better reproduction especially as the needle of the sound producing machine moves toward the center of the record.

The invention embodies a record formed in radial waves with a slight inclination upward from the outer edges of the valleys between the waves to the inner edges thereof so that as the needle travels toward the center of the record it will move on a slight inclination upward, caus-

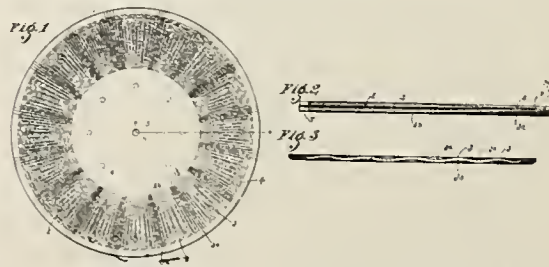

ing it to maintain a slight frictional action which will greatly increase the efficiency of the sound production. Also by reason of these waves the impression lines are relatively longer than they would be on flat surface, and hence a greater number can be placed on a record of a given diameter than on the now commonly used flat records.

In the drawings similar characters of reference indicate corresponding parts in the several views.

Figure 1 is a top plan view of the improved record. Fig. 2 is a sectional view taken on a line N—X of Fig. 1 and twice enlarged. Fig. 3 is an edge view of the record as shown in Fig. 1.

RECORD BULLETINS FOR FEBRUARY, 1918

VICTOR TALKING MACHINE CO.

- POPULAR SONGS
18410 The Land Where the Good Songs Go.
Give Me the Moonlight, Give Me the Girl,
18415 When the Great Red Dawn Is Shining,
When You Come Home.....Elizabeth Spencer
18424 Any Time's Kissing Time.....Elizabeth Spencer
At Siesta Time.....Anna Howard
18428 There's a Vacant Chair in Every Home To-night,
Shannon Four
The Dream of a Soldier Boy.....Charles Hart
18429 The Dixie Volunteers.....American Quartet
I Miss the Old Folks Now.....Van and Schenck
DANCE RECORDS
18407 My Sweetie—One-step,
Joseph C. Smith and His Orchestra
Some Sunday Morning—Medley Fox-trot,
Joseph C. Smith and His Orchestra
VOCAL RECORDS
45147 Serenade (Sing, Smile, Slumber) (Gounod),
Olive Kline
In an Old-Fashioned Town.....Elsie Baker
35664 Cinderella (Fairy Tale).....Sally Hamlin
Jack and the Beanstalk (Fairy Tale),
Sally Hamlin
RED SEAL RECORDS
FRANCES ALDA, Soprano
64692 Rule, Britannia!.....Thomas Arne
SOPHIE BRASLAU, Contralto
64747 I'm A-Longin' fo' You,
Karl Fuhrmann-Jane Hathaway
MABEL GARRISON, Soprano—In French
(Flute obb. by Clement Barone)
74542 La Perle du Brésil—Charmant Oiseau (Thou
Brilliant Bird).....Félicien David
PHILADELPHIA ORCHESTRA
(Leopold Stokowski, Conductor)
74560 A Midsummer Night's Dream—Scherzo,
Mendelssohn
CLARENCE WHITEHILL, Baritone
74556 The Two Grenadiers.....Heine-Schumann
ERNESTINE SCHUMANN-HEINK, Contralto
87282 Just Before the Battle, Mother....Geo. F. Root
EVAN WILLIAMS, Tenor
64761 Tim Rooney's at the Fightin'.....Nora Flynn
35663 Missouri Waltz,
Joseph C. Smith and His Orchestra
Kiss Me Again—Waltz,
Joseph C. Smith and His Orchestra

COLUMBIA GRAPHOPHONE CO.

- POPULAR HITS OF THE MONTH
A2451 Take Me Back to Dear Old Blighty,
Arthur Fields
When Yankee Doodle Learns to Parlez Vous
Francais.....Arthur Fields
A2443 We'll Knock the Heligo into Heligo Out of
Heligo Land!.....Arthur Fields
Hail! Hail! The Gang's All Here,
Irving Kaufman and Columbia Quartet
A2442 One Day in June.....Campbell and Burr
Rock-a-Bye Land.....Henry Burr
A2445 I Want to Go to the County Mayo,
M. J. O'Connell
Over in Erin.....J. Malachy White
A2444 I'm Coming Back to You, Poor Butterfly,
Hugh Donovan
Chimes of Normandy.....Robert Lewis
A2447 The Dixie Volunteers.....Peerless Quartet
Don't Try to Steal the Sweetheart of a Soldier,
Sterling Trio
DANCE RECORDS OF THE MONTH
A2419 Livery Stable Blues—Fox-trot,
Handy's Orchestra
That "Jazz" Dance—One-step,
Handy's Orchestra
A2420 The Hooking Cow Blues—Fox-trot,
Handy's Orchestra
Ole Miss Rag—Fox-trot.....Handy's Orchestra
A2448 Somewhere in France Is the Lily—One-step,
Introducing (1) "That's a Mother's Liberty
Loan," (2) "Don't Worry, Dearie,"
Prince's Band
Wait Till the Cows Come Home—Fox-trot,
Introducing (1) "A Sweetheart of My Own,"
(2) "Along Came Another Little Girl,"
Prince's Band
A6008 Chin-Chin-Chinaman—Fox-trot, Introducing (1)
"One Day in June," (2) "Oh! Papa, Oh!
Papa," (3) "Our Wedding Day,"
Prince's Band
Doing His Bit for the Girls—One-step, Intro-
ducing (1) "Just as Your Mother Was," (2)
"It's a Long, Long Way to the U. S. A.," (3)
"Down Where the Sweet Potatoes Grow,"
Prince's Band
A6009 Over the Top—One-step, Introducing (1) "Dixie
Volunteers," (2) "Nephews of Uncle Sam,"
Prince's Band
Since I First Knew You—Fox-trot, Introducing
(1) "There It Goes Again" (2) "You're My
Little Indiana Rose," (3) "In the Land of
Wedding Bells".....Prince's Band
A6010 Riviera Girl Waltzes, Introducing (1) "Just a
Voice to Call Me Dear," (2) "Will You For-
get?" (3) "Man, Man," (4) "Life's a Tale,"
Prince's Orchestra
Dodola Waltz.....Prince's Orchestra
COMEDY SELECTIONS OF THE MONTH
A2438 No Place Like Home.....Bert Williams
Twenty Years.....Bert Williams
A2430 Climbing Up the Golden Stairs,
Harry C. Browne
Johnny Get Your Gun.....Harry C. Browne
VOCAL SELECTIONS OF THE MONTH
48651 Nozze Di Figaro "Deh Vieni Non Tardar,"
Maria Barrientos
49260 Madam Butterfly "Un Bel Di Vedremo,"
Tamaki Miura
49259 Rigoletto—"Bella Figlia Del' Amore,"
Boston National Grand Opera Co. Quartet
A2449 Veni Jesu.....Paulist Choristers of Chicago
Alleluia Haec Dies,
Paulist Choristers of Chicago
A2446 Little Mother of Mine.....Charles Harrison
God Bring You Safely to Our Arms Again,
Charles Harrison
A2432 Cradle Song 1915.....Charles Harrison
The Old Refrain.....Charles Harrison
A2452 There's a Long, Long Trail,
Oscar Seagle and Columbia Stellar Quartet
Calling Me Home to You.....Oscar Seagle
A2435 Then You'll Remember Me.....Vernon Stiles
The Minstrel Boy.....Vernon Stiles
A2427 Way Down Yonder in the Cornfield,
Columbia Stellar Quartet

- S. R. Henry's Barn Dance,
Columbia Stellar Quartet
OLD "WAR TIME" MELODIES
A2436 Break the News to Mother,
Henry Burr and Columbia Stellar Quartet
Just as the Sun Went Down.....Peerless Quartet
FAVORITE HYMNS
A2431 Just As I Am.....Henry Burr
Lead, Kindly Light.....Henry Burr
INSTRUMENTAL NUMBERS OF THE MONTH
A6006 Rienzi Overture—Part I,
Columbia Symphony Orchestra
Rienzi Overture—Part II,
Columbia Symphony Orchestra
A6004 The Lost Chord.....Gatty Sellars
Largo.....Gatty Sellars
A2434 Butterfly (Papillon).....Josef Hofmann
Spinning Song.....Josef Hofmann
A2426 Anvil Chorus, from Il Trovatore.....Prince's Band
Royal Italian March.....Prince's Band
NOVELTY TROMBONE NUMBER
A2429 Slidus Trombonus.....Leo Zimmerman
The Four Stars.....Brass Quartet
TWO HAWAIIAN TRIOS
A2450 The Missouri Waltz,
Louise, Ferera and Greenus
Little Alabama Coon,
Louise, Ferera and Greenus
SPECIAL MENTION IN FEBRUARY SUPPLEMENT
A2124 Someone Else May Be There While I'm Gone,
Al Jolson
I Ain't Prepared for That....George O'Connor
COLUMBIA BEDTIME STORY RECORDS
A7525 Peter Rabbit Plays a Joke,
Thornton W. Burgess
Little Joe Otter's Slippery Slide,
Thornton W. Burgess
A7526 How Old Mr. Toad Won a Race,
Thornton W. Burgess
How Old Mr. Toad Happened to Dine With
Buster Bear.....Thornton W. Burgess
A7527 When Old Mr. Toad Was Puffed Up,
Thornton W. Burgess
Buster Bear Gets a Good Breakfast,
Thornton W. Burgess
A7528 Little Joe Otter Tries to Get Even,
Thornton W. Burgess
The Teaching of Reddy Fox,
Thornton W. Burgess
A7524 The Joy of the Beautiful Pine,
Thornton W. Burgess
Johnnie Chuck Finds the Best Thing in the
World.....Thornton W. Burgess

EDISON BLUE AMBEROL RECORDS

- CONCERT LIST
28278 Amore o grillo—Madame Butterfly (Puccini).
Tenor and Baritone, in Italian, orch. accomp.,
Guido Ciccolini and Thomas Chalmers
28279 Battle Hymn of the Republic (Howe). Baritone,
orch. accomp.....Thomas Chalmers and Chorus
WAR-TIME HITS
3402 Camp Songs, U. S. Army—No. 1,
Chorus of Male Voices
3403 Camp Songs, U. S. Army—No. 2,
Chorus of Male Voices
3387 Naval Reserve March (Sousa),
New York Military Band
3398 So Long, Mother! (Van Alstyne). Tenor, orch.
accomp.....George Wilton Ballard and Male Chorus
NEW YORK'S LATEST
3411 All I Need Is Just a Girl Like You (Burkhardt-
Olman). Soprano and Tenor, orch. accomp.,
Rachael Grant and Billy Murray
3391 Bungalow in Quogue—"The Riviera Girl"
(Kern). Soprano and Tenor,
Rachael Grant and Billy Murray
3399 I'm All Bound 'Round With the Mason-Dixon
Line (Schwartz). Tenor, orch. accomp.,
Vernon Dalhart
3406 Knit, Knit, Knit!—"Jack O'Lantern" (Caryll).
Soprano, Contralto and Contralto, orch. ac-
comp.,
Gladys Rice, Helen Clark and Marion Evelyn Cox
3397 Musical Sam from Alabam' (Thomas). Male
voices, orch. accomp.....Premier Quartet
3401 My Hawaii, You're Calling Me (Lewis). Soprano
and Tenor, orch. accomp.,
Gladys Rice and Vernon Dalhart
3388 Sweet Emalina, My Gal (Creamer-Layton).
Tenor, orch. accomp.....Vernon Dalhart
DANCE RECORDS
3390 All I Need Is Just a Girl Like You (Olman).
One-step.....Frisco Jazz Band
3404 More Candy (Kaufman). One-step,
Jaudas' Society Orchestra
3389 Paddle-Addle (Synder). Fox-trot,
Jaudas' Society Orchestra
3408 Waltz Memories (Ford).....Jaudas' Society Orchestra
SONGS AND BALLADS
3407 Best Things in Life Are Free (Johnson-Tracey).
Tenor, orch. accomp.....George Wilton Ballard
3394 Is It Nothing to You? (Edgar-Trevor). Soprano,
orch. accomp.....Betsy Lane Shepherd
3396 Two Roses (Gilberte). Contralto, orch. accomp.,
Caroline Lazzari
3392 When the Lights Are Low (Lane). Contralto,
orch. accomp.....Helen Clark
INSTRUMENTAL
3395 Ballet Egyptian, Nos. 1 and 2 (Luigini),
American Symphony Orchestra
3405 Ballet Egyptian, No. 3 (Luigini),
American Symphony Orchestra
3409 Love, Here Is My Heart (Silestu). Violin,
piano accomp. by John F. Burkhardt,
Herbert Soman
3410 Offertoire—Op. 12 (Donjon). Flute, orch. ac-
comp.....Weyert A. Moor
3400 Spanish Fandango (Schwartz),
New York Military Band
3393 Valse Illewellyn (Wiedoeft) (Saxophone, orch.
accomp.....Rudy Wiedoeft
3386 Vampire—Dance Characteristic (Losey),
Sodero's Band

EDISON DIAMOND DISC RE-CREATIONS

- 82133 Battle Hymn of the Republic (Old Plantation
Melody) Recessional (de Koven). Baritone
and Chorus.....Thomas Chalmers
83035 Explanatory Talk for La fatal pietra (The Fatal
Stone)—Aida (Verdi).
La fatal pietra (The Fatal Stone)—Aida (Verdi).
In Italian. Soprano and Tenor,
Marie Rappold and Giovanni Zenatello
80371 My Heart at Thy Sweet Voice
Samson and Dalilah (Saint-Saens). Cornet
Louis Katzman
80372 Triumphant March—Aida (Verdi).....Sodero's Band
Loin du Bal (Gillet).....Creator and His Band
Marche Lorraine (Ganne)....Creator and His Band

- 80373 Awakening of Spring (Bach)....Peerless Orchestra
Pirouette—Intermezzo (Finck)....Peerless Orchestra
50454 New York Blues (Rag Classical) (Frosini). Ac-
cordion.....P. Frosini
Saxophone Sobs (Erdman). Saxophone,
Rudy Wiedoeft
50455 Ellis March—Instrumental Duet....Ford Hawaiians
One, Two, Three, Four Medley—Waltz,
Waikiki Hawaiian Orchestra
50403 It's Nice to Get Up in the Mornin' (Lauder).
Baritone.....Glen Ellison
When the Bonnie, Bonnie Heather Is Blooming
I'll Return, Annie Laurie, to You (Ellis).
Baritone.....Glen Ellison

PATHE FRERES PHONOGRAPH CO.

- NEW OPERATIC GEMS
63019 La Gioconda (Ponchielli) "Suicidio" (Suicide
Remains), in Italian.....Claudia Muzio
Otello (Verdi) "Ave Maria," in Italian,
Claudia Muzio
NEW OPERATIC AND CLASSIC VOCAL RECORDS
60070 Aida (Verdi) "O patria mia" (My Native Land),
in Italian.....Rosa Raisa
Il Trovatore (Verdi) "D'Amor sull' ali rosee"
(Love, Fly on Rosy Pinions), in Italian,
Rosa Raisa
27505 Hymn Polski (Pozaraw) "Polish National
Hymn," in Polish.....Adamo Didur
O Matko Moja (Prusinowski) ("O Mother
Mine"), in Polish.....Adamo Didur
27006 Le Père la Victoire (Ganne), in French,
Auguste Bouilliez
Hymne de Mameli (Novaro) "Fratelli d'Italia"
(Brothers of Italy), in Italian,
Auguste Bouilliez
59051 Manon (Massenet) "Le Réve" (The Dream), in
French.....Edmond Clement
L'Adieu du Matin (Chizat) (Farewell of the
Morning), in French.....Edmond Clement
NEW POPULAR-PRICED OPERATIC RECORDS
51002 Zaza (Leoncavallo) "Zaza, piccola zingara"
(Zaza, Little Gypsy), in Italian, Baritone,
Alfred Costa
Il Trovatore (Verdi) "Racconta di Azucena"
(Tale of Azucena), in Italian, Mezzo-Soprano,
Maria Passeri
26008 Carmen (Bizet) "La fleur que tu m'avais jetée,"
in French, Tenor.....Leon Beyle
Le Barbier de Seville (Rossini) "Air de la Calom-
nie" (Slander's Whisper), in French, Bass,
M. Dupré
60068 Humoresque (Dvorak), Violin Solo, Piano acc.,
Jacques Thibaud
Romance (Svendsen), Violin Solo, Piano acc.,
Jacques Thibaud
NEW STANDARD BALLADS
25007 Carmena (Wilson) "Vocal Waltz," Soprano,
Grace Hoffman
Carissima (Penn), Soprano.....Grace Hoffman
52027 A Little Love, a Little Kiss (Silesu), Tenor,
Craig Campbell
Believe Me, if All Those Endearing Young
Charms (Page), Tenor.....Craig Campbell
40114 Comin' Thro' the Rye (Old Scottish Melody,
Soprano.....Rosina Buckman
The Land of Long Ago (Ray), Soprano,
Rosina Buckman
25005 Flow Gently, Sweet Afton (Spilman), Baritone,
Hugh Allan
There's Nobody Just Like You (Penn), Baritone,
Hugh Allan
20268 All Through the Night (Boulton), Baritone,
Gordon MacHughes
Absence Makes the Heart Grow Fonder (Dillea),
Tenor.....Milton Bernard
NEW RECORDINGS BY THE HAWAIIANS
20272 The Honeysuckle and the Bee (Penn),
Louise & Ferera Waikiki Orchestra
Pansy Faces (Penn),
Louise & Ferera Waikiki Orchestra
20285 Ninijso (Kilima),
Louise & Ferera Waikiki Orchestra
One, Two, Three, Four (Alau)....Irene Greenus,
with Louise & Ferera Hawaiian Orchestra
NEW BAND AND ORCHESTRA RECORDS
70154 Midsummer Night's Dream (Mendelssohn)
"Wedding March".....Gille Orchestra
Le Prophete (Meyerbeer) "Coronation March,"
Gille Orchestra
20273 Liberty Loan March (Sousa),
American Regimental Band
The Invincible Eagle (Sousa), March,
American Regimental Band
29194 Duncan Gray (arr. by Shipley Douglas), Humo-
rous Paraphrase.....Lndon Military Band
The Two Gendarmes (arr. by Shipley Douglas),
Humorous Paraphrase...London Military Band
29196 Le Dernier Baiser (Tosti),
Tzigane Orchestra of Budapest
Kis Grof (Renyi)...Tzigane Orchestra of Budapest
40106 Harry Lauder's Favorite Songs (Lauder), Med-
ley Selection.....American Regimental Band
Scottish Country Dances "Petronella,"
Highland Orchestra
20279 Father Was Right (Goldberg) "Humorous Song,"
Piano acc.....Rube Goldberg
Blame it on Poor Old Father (Williams)
"Humorous Song," Comedian, Orch. accomp.,
Billy Williams
POPULAR HITS OF THE MONTH
Somewhere in France Is the Lily (Howard),
Baritone.....Thomas Conkley
Daddy Found You Down Beside the Garden Wall
(Olman), Tenor.....Harry McClaskey
20278 When You Come Home (Squire), Contralto,
Jean Sterling, with Lyric Trio
Your Flag and Country Want You (Rubens),
Contralto.....Jean Sterling
20280 That's the Kind of a Baby for Me, from "Zieg-
feld Follies of 1917" (Egan), Tenor,
Noble Sissle
He's Always Hanging Around (Blake), Tenor,
Noble Sissle
NEW PATHE DE LUXE DANCE RECORDS
20281 Gold and Silver Waltz (Lehar),
Pathé Dance Orchestra
Jack o' Lantern (Caryll), Medley Fox-trot,
American Republic Band
20282 The Darktown Strutter's Ball (Brooks), Fox-
trot.....American Republic Band
Homeward Bound (Meyer-Jentes), Medley One-
step.....American Republic Band
20283 We're Going Over (Lange), Medley One-step,
American Republic Band
Paddle Addle (Synder), Fox-trot,
American Republic Band
20284 Leave it to Jane (Wodehouse-Kern), Medley Fox-
trot.....American Republic Band
Umbrellas to Mend (Kaufman), One-step,
American Republic Band
NEW SACRED VOCAL RECORDS
60069 But the Lord Is Mindful of His Own (Mendels-
sohn), Contralto.....Kathleen Howard
O Rest in the Lord (Mendelssohn), Contralto,
Kathleen Howard

(Continued on page 126)

- 20286 O Dry Those Tears! Contralto, Violin Obligato. Marian Crawford 10
- My Faith Looks Up to Thee (Mason), Contralto, Marian Crawford 10
- 20275 One Sweetly Solemn Thought (Ambrose), Contralto, Rose Bryant 10
- I Need Thee Every Hour (Lowry), Tenor William Wheeler 10
- UNIVERSITY QUARTET SINGS OLD FAVORITE
- 20250 Bright College Years (Yale Song), unaccom., University Quartet 10
- Funiculi-Funicula (Denza), unaccom., University Quartet 10
- NEW INSTRUMENTAL OFFERINGS
- 27007 Scherzo in E Minor (Mendelssohn), Piano Solo, Rudolph Ganz 10
- Spinning Song (Mendelssohn), Piano Solo, Rudolph Ganz 10
- 20244 Sylvia Ballet (Delibes) "Pizzicato," Violin Solo, Piano acc., Jan Rubini 10
- Serenata (Moskowski), Violin Solo, Piano acc., Jan Rubini 10
- 20270 Napoli la Bella (Cocq) "Beautiful Naples," Accordeon Solo, A. de Benedetto 10
- Bout-en-train (de Benedetto), Accordeon Solo, A. de Benedetto 10
- 20271 Pigtales and Chopsticks (Hesse), Xylophone Solo, R. Humphries 10
- Concert Polka (Steele), Xylophone Solo, R. Humphries 10

EMPIRE TALKING MACHINE CO.

- 5522 Aloba Oe (Farewell)—Soprano Solo, orch. acc., Rose Drehan 10
- My Sunshine Jane (Brennan-Ball)—Tenor Solo, orch. acc., Manuel Romain 10
- 5523 Will You Remember (from "Maytime") (Romberg)—Tenor Solo, orch. acc., James Harrod 10
- Somebody's Boy (Esrom-Morse)—Tenor Solo, orch. acc., Charles Ryan 10
- 5524 Mother, Dixie and You (Johnson-Santley)—Tenor Solo, orch. acc., Irving Kaufman 10
- I'll Be a Long, Long Way From Home (Miller)—Tenor Solo, orch. acc., Henry Burr 10
- 5525 Hail! Hail! the Gang's All Here (Esrom-Morse-Sullivan)—Quartet, orch. acc., Empire Four 10
- It's a Long Way Back to Mother's Knee (Sterling-Grossman-Lange)—Tenor Solo, orch. acc., Harvey Hindermeyer 10
- 5526 She's Back Among the Pots and Pans Again (Jerome-Hanlon-Further)—Comic selection, orch. acc., Ada Jones 10
- Long Boy (Herschell-Walker)—Comic selection, orch. acc., Byron G. Harlan 10
- 5527 Mine, Mine, Mine—Comic Dialogue, Golden-Heins 10
- The Cannibal King (Dorothy Fyfe)—Comic Duet, orch. acc., Collins-Harlan 10
- 5529 Aloba Land—Hawaiian Duet, Louise-Ferara 10
- Moana Girl—Hawaiian Trio (Miss Irene Greenis singing), Ferara-Greenis 10
- 5531 Some Jazz Blues (Lake)—Fox-trot, Empire Band 10
- Set Aside Your Tears (Till the Boys Come Marching Home)—One-step (Gilbert-Franklin-Friedland), Empire Band 10
- 5532 Alabama Slide (Johnson)—Fox-trot, Empire Band 10
- Some Day Somebody's Gonna Get You (Gilbert-Morgan)—One-step (Intro.: Jazbo Johnson's Hokum Band), Empire Band 10
- 1070 Caprice Viennois (Fritz Kreisler)—Violin Solo, Piano acc., Eugene DuBois 12
- Caprice de Concert (Perlet)—Concert Polka, Empire Band 12
- 1071 Carmen Selection No. 1 (Bizet)... Empire Band 12
- Light Cavalry (Suppe)—Overture... Empire Band 12

GENNETT RECORDS

- VOCAL RECORDS OF SPECIAL MERIT
- 10031 Mary of Argyle (Old Scotch Ballad) (Jefferys-Nelson)—Tenor with orch. acc., James Harrod 10
- Eileen Allanna (Marble-Thomas)—Tenor with orch. acc., James Harrod 10
- 7634 I Hear You Calling Me (Harford-Marshall)—Tenor with orch. acc., Harry McClaskey 10
- Sing Me Love's Lullaby (Terriss-Morse)—Tenor with orch. acc., Harry McClaskey 10
- 7632 Before the World Began (Sterling-Solman)—Tenor with orch. acc., Harry Ellis 10
- Sunny Sue (Wood)—Tenor with orch. acc., Harry Ellis 10
- DANCE RECORDS
- 7633 The Spinning Top—Waltz (Knecht), Gennett Dance Orchestra 10
- Valse Fascination—Waltz (Gray), Gennett Dance Orchestra 10
- 7630 Go to It—Fox-trot (Ossman), Vess Ossman's Banjo Orchestra 10
- Rag—A Minor—One-step (Lenzberg), Vess Ossman's Banjo Orchestra 10
- HUNGARIAN BAND MUSIC
- 7631 Hungarian Folk Song (Rácz) (1) Rácz Laczi Nótája; (2) Nem loptam én életemben, Original Hungarian Gypsy Band 10
- Hungarian Folk Songs (Huhay Béla) (1) Ha ki megyek a temető árákába; (2) Vörös bort ittam az éjjel; (3) Hejre Kati, Original Hungarian Gypsy Band 10
- TYPICAL HAWAIIAN MELODIES
- 7636 Honolulu March (Guitar Duet), Louise-Ferera 10
- Kilima Waltz (Hawaiian Steel Guitar with Guitar and Ukulele acc.), Louise-Ferera-Greenus Trio 10
- 7600 Hapa Haole Hula Girl (My Hawaiian Maid) (Cunka)—Instrumental Duet, Louise-Ferera 10
- Kawaihau Waltz—Hawaiian Medley—Instrumental Duet, Louise-Ferera 10

- POPULAR BAND RECORDS
- 10028 La Marseillaise—Marcia Reale (National Airs of France and Italy), Gennett Military Band 10
- God Save the King—Rule Britannia (English National Airs), Gennett Military Band 10
- 10014 March Patriotic (Rosey), Gennett Military Band 10
- National Emblem March (Bagley), Gennett Military Band 10
- 10022 Culver Black Horse Troop—March (Gillespie), Gennett Military Band 10
- For the Freedom of the World—March (Zamecnik), Gennett Military Band 10
- 7556 Marche Militaire, Op. 51, No. 1 (Schubert), Weber's Prize Band 10
- Marche Militaire, Op. 51, No. 2 (Schubert), Weber's Prize Band 10

- POPULAR WAR SONGS
- 7618 Good-bye Broadway, Hello France (Reisner-Davis-Baskette)—Tenor with orch. acc., Rolland Ball 10
- The Ragtime Volunteers Are Off to War (McDonald-Hanley)—Tenor with orch. acc., Frank Perry 10
- 7627 Somewhere in France Is the Lily (Johnson-Howard)—Tenor with orch. acc., Arthur Hall 10
- When Yankee Doodle Learns to Parlez Vous Francais (Hart-Nelson)—Tenor with orch. acc., Arthur Hall 10
- 7623 It's a Long Way to Berlin, But We'll Get There (Fields-Flatow)—Tenor with orch. acc., Arthur Hall 10
- Over There (Cohan)—Baritone with orch. acc., Jack Kimbal 10
- 7629 Hail! Hail! the Gang's All Here (Esrom-Morse-Sullivan)—Vocal Quartet with orch., Peerless Quartet 10
- I Don't Want to Get Well (Pease-Johnson-Jentes)—Tenor with orch. acc., Arthur Hall 10
- 7624 Send Me Away With a Smile (Weslyn-Piantadosi)—Baritone with orch. acc., Jack Kimbal 10
- I May Be Gone for a Long, Long Time (Brown-Von-Tilzer)—Tenor with orch. acc., Harry Ellis 10

EMERSON PHONOGRAPH CO.

- (January List)
- 7292 My Sweetie (Berlin), Tenor solo, orch. accomp., George Beaver 10
- Good-Bye, Dolly Gray (Barnes), Patriotic solo, orch. accomp., Harry Evans 10
- 7299 I Don't Want to Get Well (Johnson-Pease-Jentes) Character song, Eddie Nelson 10
- Cocoanut Dance (A. Hermann), Piano, banjo and saxophone, Van Eps Banta Trio 10
- 7301 Joan of Arc (Bryan-Weston-Wells), Patriotic solo, orch. accomp., Artbur Burdin 10
- Hands Across the Sea (Sousa), March, Emerson Military Band 10
- 7293 Sentimental Oriental Nights (Gilbert-Friedland), Tenor solo, orch. accomp., Wm. Sloane 10
- Popularity (Cohan)—One-step, Piano, banjo and saxophone, Van Eps Banta Trio 10
- 7300 The Dixie Volunteers (Leslie-Ruby), Character patriotic song, orch. accomp., Eddie Nelson 10
- Washington Post March (J. Philip Sousa), Emerson Military Band 10
- 7302 Hail! Hail! The Gang's All Here! What the Deuce Do We Care, (Esrom-Morse-Sullivan), Character song, orch. accomp., George L. Thompson 10
- Cold Turkey (Donaldson)—One-step, Emerson Dance Orchestra 10
- 7295 Indianola (Henry-Onivas)—Fox-trot, Van Eps Banta Trio 10
- Yah De Dah (Kaufman)—Jazz fox-trot, Emerson Military Band 10
- 7296 Wait Till the Cows Come Home (Caryll-Caldwell), Baritone solo, orch. accomp., Jack Warner 10
- I Want What I Want When I Want It (Blossom-Herbert), Baritone solo, orch. accomp., Arthur Burdin 10
- 7297 Some Sunday Morning (Kahn-Egan-Whiting), Soprano and tenor duet, orch. accomp., Ada Jones and Robert Grant 10
- On the Dixie Highway (Friedman)—One-step, Piano, banjo and saxophone, Van Eps Banta Trio 10
- 7266 Slidus Trombonus (M. L. Lake), Trombone comedy, Orch. accomp., Burt Smith 10
- The Mice and the Trap (O. Köhler), Scherzo, Emerson Symphony Orchestra 10
- 7298 Old Grey Mare (Frank Panella), Comic duet, orch. accomp., Collins and Harlan 10
- I'm Old Enough for a Little Lovin'—Mamma Told Me So Last Night (Skidmore-Walker), Character song, orch. accomp., Ada Jones 10
- 7273 Just You (Con Barth), Tenor solo, orch. accomp., Frank Woods 10
- I Love You Truly (Carrie Jacobs-Bond), Contralto solo, piano and violin accomp., Alice Louise Mertens 10
- 7276 A Broken Doll (Tate), Soprano solo, orch. accomp., Rosalie Zeamons 10
- The Blush Rose (O'Hara-Greene), Baritone solo, orch. accomp., Jack Warner 10
- 7294 Hello, My Dearie (Buck-Stamper), Soprano solo, orch. accomp., Marion Wilson 10
- Chu Chin Chow (Buck-Stamper), Tenor solo, orch. accomp., George Beaver 10

IMPERIAL TALKING MACHINE CO.

- (January List)
- POPULAR HITS OF THE DAY
- 5522 Oloha Oe (Farewell), Rose Drehan 10
- My Sunshine Jane (Brennan-Ball), Manuel Romain 10
- 5523 Will You Remember (from "Maytime") (Romberg), James Harrod 10
- Somebody's Boy (Esrom-Morse), Charles Ryan 10

- 5524 Mother, Dixie and You (Johnson-Santley), Irving Kaufman 10
- I'll Be a Long, Long, Way From Home (Miller), Henry Burr 10
- 5525 Hail! Hail! the Gang's All Here (Esrom-Morse-Sullivan), Imperial Four 10
- It's a Long Way Back to Mother's Knee (Sterling-Grossman-Lange), Harvey Hindermeyer 10
- COMIC SELECTIONS
- 5526 She's Back Among the Pots and Pans Again (Jerome-Hanlon-Further), Ada Jones 10
- Long Boy (Herschell-Walker), Byron G. Harlan 10
- 5527 Mine, Mine, Mine, The Cannibal King (Fyfe), Golden-Heins 10
- Collins-Harlan 10
- NEAPOLITAN SELECTIONS
- 5528 I m'arricordo 'e te (I Will Remember) (E. DeCurtis), Dominick Pacifico 10
- Adriana (Naldini-Mario), Les Iris-Palange 10
- OPERATIC SELECTIONS—VOCAL
- 3119 Carmen—Il fior che avevi a me (Flower Song) (Bizet), Salvatore Giordano 10
- Manon—Il sogno (The Dream) (Massenet), Salvatore Giordano 10
- 3120 Barbiere Di Siviglia—La Calunnia (Slander's Whisper) (Rossini), Enzo Bozano 10
- Roberto Il Diavolo—Evocation (Meyerbeer), Enzo Bozano 10

- INSTRUMENTAL SELECTIONS
- 1070 Caprice Viennois (Fritz Kreisler)—Violin solo, Eugene DuBois 10
- Polka Caprice De Concert (Perlet), Imperial Band 10
- 1071 Carmen Selection No. 1 (Bizet), Imperial Band 10
- Light Cavalry (Suppe), Imperial Band 10
- DANCE SELECTIONS
- 5530 You Don't Have to Come From Ireland to Be Irish—One-step, Imperial Orchestra 10
- Give Me the Moonlight, Give Me the Girl and Leave the Rest to Me—Fox-trot, Imperial Orchestra 10
- 5531 Some Jazz Blues—Fox-trot, Imperial Band 10
- Set Aside Your Tears (Till the Boys Come Home)—One-step, Imperial Band 10
- 5532 Alabama Slide—Fox-trot, Imperial Band 10
- Some Day Somebody's Gonna Get You—One-step, Imperial Band 10

\$3,000,000,000 TRADE BALANCE

Figures Show Economic Resources of U. S. to Wage Winning War

WASHINGTON, D. C., January 2.—America's exports were estimated to-day at the Department of Commerce to have passed the \$6,000,000,000 mark in 1917, a new high record. Imports were below \$3,000,000,000, and the trade balance in favor of the United States probably will be more than \$3,150,000,000, when final statistics are computed.

The country's gold supply showed less increase than last year because of the substitution of credits for cash in handling allied purchases after the United States entered the war. Imports of gold in March amounted to \$139,000,000, but in November were less than \$3,000,000. The total for the year was estimated at \$537,000,000, compared with \$686,000,000 in 1915.

Exports of gold showed a heavy increase over the preceding twelve months, due chiefly to the large movement to Japan, Spain and South American countries. The total was estimated at \$374,000,000, compared with \$155,000,000 last year.

The trade balance of more than \$3,000,000,000 with the country at war was regarded by officials as the best evidence that this country has the economic resources necessary to defeat Germany.

A NEW INCORPORATION

The Automobile Record Container Co. has been incorporated under the laws of the State of Delaware for the purpose of manufacturing talking machines and parts. The capitalization of the concern is \$50,000, the incorporators being Frank P. Read, of Chicago, Ill.; Fred M. Sargent, of Evanston, Ill., and Harry G. Chamberlain, of Glencot, Ill.

READY REFERENCE OF GENERAL SUPPLIES

DEALERS

Send for our "Trial Proposition" on the Regina Hexaphone—the latest and best paying popular priced coin-operated instrument for use in public places.



211 Marbridge Bldg., 34th St. and Broadway, New York City
Manufacturers of Regina Music Boxes; Reginaphones; Coin-operated Mandolin Orchestrions; Vacuum Cleaners and other specialties.

NEEDLES

WE MANUFACTURE

Diamond needles for Edison
Sapphire needles for Edison
Sapphire needles for Pathe
in stock ready for delivery

MERMOD & CO., 505 5th Ave., N. Y.

Keep Your Record Stock with



Costs about \$2.00 for 250 records for 50 years
Send for 20-page catalog

THE SYRACUSE WIRE WORKS,
SYRACUSE NEW YORK

Some of the Leading Jobbers of Talking Machines in America

1856 **WURLITZER** 1916

VICTOR
DISTRIBUTORS
VICTORS EXCLUSIVELY

*We make a specialty of getting the order
out on time—every time.*

The Rudolph Wurlitzer Co.
CINCINNATI AND CHICAGO

Two points of supply; order from the nearer

TEST IT. 

OUR VICTOR

Record Service

has a reputation for efficiency.
Suppose you try it.

E. F. DROOP & SONS CO.
1300 G. STREET, WASHINGTON, D. C.
231 N. HOWARD STREET, BALTIMORE, MD

Smith, Kline & French Co.
PHILADELPHIA

Wholesale Distributors for

THE INSTRUMENT OF QUALITY
Sonora
CLEAR AS A BELL 

In PENNSYLVANIA, NEW JERSEY
and DELAWARE

This Refers To

You, Mr. Jobber

Every talking machine jobber in this country should be represented in this department, no matter what line he handles or where he is located. The cost is slight and the advantage is great. Be sure to have your card in this department of *The Talking Machine World* each month. It will pay you a big profit on the investment.



Where Dealers May Secure

COLUMBIA

Product

Ready, Full Stocks, and Prompt Deliveries
from Convenient Shipping Centers
all over the United States.

Distributors

Atlanta, Ga., Columbia Graphophone Co., 63 N. Pryor St.
Baltimore, Md., Columbia Graphophone Co., 111 West German St.
Boston, Columbia Graphophone Co., 137 Federal St.
Buffalo, N. Y., Columbia Graphophone Co., 622 Main St.
Chicago, Ill., Columbia Graphophone Co., 14 N. Michigan Ave.
Cincinnati, O., Columbia Graphophone Co., 117-119 W. Fourth Ave.
Cleveland, O., Columbia Graphophone Co., 1375 Euclid Ave.
Dallas, Tex., Columbia Graphophone Co., 1011 Elm St.
Denver, Colo., Columbia Stores Co., 1608 Glenarm Place.
Detroit, Mich., Columbia Graphophone Co., 401 Woodward Ave.
Indianapolis, Ind., Columbia Graphophone Co., 44 N. Pennsylvania St.
Kansas City, Mo., Columbia Graphophone Co., 1112 Grand Ave.
Los Angeles, Cal., Columbia Graphophone Co., 745 S. Broadway.
Minneapolis, Minn., Columbia Graphophone Co., 412-414 Nicollet Ave.
New Haven, Conn., Columbia Graphophone Co., 206 Meadow St.
New Orleans, La., Columbia Graphophone Co., 517-525 Canal St.
New York City, Columbia Graphophone Co., 55 Warren St.
Omaha, Neb., Schmoller & Mueller Piano Co.
Philadelphia, Pa., Columbia Graphophone Co., 210 N. Broad St.
Pittsburgh, Columbia Graphophone Co., 101 Sixth St.
Portland, Me., Columbia Graphophone Co., 43 Exchange St.
Portland, Ore., Columbia Graphophone Co., 429-431 Washington St.
Salt Lake City, Utah, Columbia Stores Co., 221 South West Temple.
San Francisco, Cal., Columbia Graphophone Co., 334 Sutter St.
Seattle, Wash., Columbia Graphophone Co., 911 Western Ave.
Spokane, Wash., Columbia Stores Co., 818 Sprague Ave.
St. Louis, Mo., Columbia Graphophone Co., 1127 Pine St.
Tampa, Fla., Tampa Hardware Co.

DEALERS WANTED—Exclusive selling rights given where we are not actively represented.

Write for particulars to the Columbia Graphophone Co., Wholesale Department, Woolworth Building New York.

Headquarters for Canada:
Columbia Graphophone Co., 363-5-7 Sorauren Ave
Toronto, Ont.

SERVICE FIRST

EXCLUSIVE VICTOR JOBBERS
WHOLESALE ONLY

Standard Talking Machine Co.
PITTSBURGH, PA.

Victor Exclusively
EASTERN TALKING MACHINE CO.
177 Tremont Street, Boston
VICTOR DISTRIBUTORS

Sherman, Clay & Co.

San Francisco, Los Angeles, Portland, Seattle, Spokane
PACIFIC COAST DISTRIBUTORS OF
VICTOR PRODUCTS

W. J. DYER & BRO.
Saint Paul, Minn.

VICTOR & EDISON
Distributors

*Quick Service for all points in the North-
west. Machines, Records, Supplies.*

The PERRY B. WHITSIT CO.
Distributors of
Victrolas and Victor Records
COLUMBUS, OHIO

Southern Victor Dealers
Largest Stock VICTROLAS and RECORDS.
Prompt Shipment and Low Freight Rates.
WALTER D. MOSES & CO.
Oldest Music House in Virginia or North Carolina.
RICHMOND, VA.

**OLIVER
DITSON
COMPANY**
BOSTON

Largest VICTOR Talking
Machine Distributors East of
Chicago.

Creators of "The Fastest Victor
Service." Let us tell you more
about our service.



The New Edison

Official Laboratory
Model—William and
Mary Cabinet
Developed in Walnut.

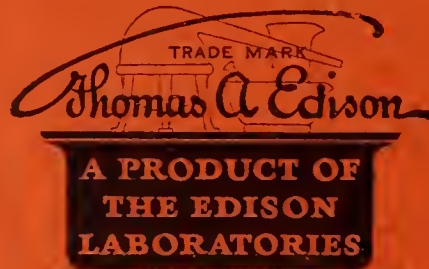

JOBBER'S OF THE NEW EDISON, EDISON RE-CREATIONS,
THE NEW EDISON DIAMOND AMBEROLA AND BLUE AMBEROL RECORDS

CALIFORNIA Los Angeles—Diamond Disc Distributing Co. San Francisco—Edison Phonographs, Ltd.	LOUISIANA New Orleans—Diamond Music Co., Inc.	New York—The Phonograph Corp. of Manhattan. Syracuse—Frank E. Bolway & Son, Inc. W. D. Andrews Co. (Amberola only.) Buffalo—W. D. & C. N. Andrews Co. (Amberola only.)	El Paso—El Paso Phonograph Co., Inc.
COLORADO Denver—Denver Dry Goods Co.	MASSACHUSETTS Boston—Pardee-Ellenberger Co.	OHIO Cincinnati—The Phonograph Co. Cleveland—The Phonograph Co.	UTAH Ogden—Proudfit Sporting Goods Co.
CONNECTICUT New Haven—Pardee-Ellenberger Co., Inc.	MICHIGAN Detroit—Phonograph Co., of Detroit	OREGON Portland—Edison Phonographs, Ltd.	VIRGINIA Richmond—C. B. Haynes & Co.
GEORGIA Atlanta—Phonographs, Inc.	MINNESOTA Minneapolis—Laurence H. Lucker.	PENNSYLVANIA Philadelphia—Girard Phonograph Co. Pittsburgh—Buehn Phonograph Co. Williamsport—W. A. Myers.	WISCONSIN Milwaukee—The Phonograph Co. of Milwaukee.
ILLINOIS Chicago—The Phonograph Co. James I. Lyons. (Amberola only.)	MISSOURI Kansas City—The Phonograph Co. of Kansas City. St. Louis—Silverstone Music Co.	RHODE ISLAND Providence—J. A. Foster Co. (Amberola only.)	CANADA Montreal—R. S. Williams & Sons Co., Ltd. St. John—W. H. Thorne & Co., Ltd. Toronto—R. S. Williams & Sons Co., Ltd. Vancouver—Kent Piano Co., Ltd. Winnipeg—R. S. Williams & Sons Co., Ltd. Calgary—R. S. Williams & Sons Co., Ltd.
INDIANA Indianapolis—Kipp Phonograph Co.	MONTANA Helena—Montana Phonograph Co.	TEXAS Dallas—Texas-Oklahoma Phonograph Co.	
IOWA Des Moines—Harger & Blish. Sioux City—Harger & Blish.	NEBRASKA Omaha—Schultz Bros.		
	NEW YORK Albany—American Phonograph Co.		

The TALKING MACHINE WORLD

For the
makers &
sellers of
talking
machines

Published Each Month by Edward Lyman Bill, Inc., at 373 Fourth Ave., New York, February 15, 1918



The best-known trade mark in the world

"The Victor talking machine's design, 'His Master's Voice,' has become a household word, and the quaint little fox terrier at attention before the horn is familiar to more Americans than any of the world's great masterpieces"—*Collier's Weekly*.

The Highest Class Talking Machine in the World

THE INSTRUMENT OF QUALITY



CLEAR AS A BELL

SONORA
PORTABLE

\$60

THIS, the highest grade Portable, is a big seller. It has the characteristic rich Sonora tone and appeals instantly to automobilists, vacationists, students, soldiers, and all who have use for a small, *quality* phonograph. Plays all makes of disc records, all sizes. *Weight only 15 pounds complete.*



LAST year Sonora's sales were over one hundred times what they were four years ago.

Only a phonograph of extraordinary excellence, you realize, could make such a phenomenal record. *Sonora dealers make money.*

Sonora's big sales are the result of Sonora's exceptional merit, Sonora's liberal, progressive selling policy, and Sonora's original, forceful advertising. *Now*—(not six months from now when you may be troubled because of delayed deliv-

eries owing to the filling of previous orders of more foresighted dealers)—*now*—investigate the remarkable opportunities which are offered to you through the sale of this superb instrument which, point for point, is *unequaled*.

At the Panama-Pacific Exposition Sonora won highest score for tone quality

\$50	\$55	\$60	\$85	\$105	\$110	\$140	\$160
\$180	\$200	\$275	\$375	\$500	\$1000		

Art models made to special order
Write today regarding selling Sonoras in 1918

Sonora Phonograph Sales Company, Inc.

GEORGE E. BRIGHTSON, President

Executive Offices: 279 Broadway, New York City

DISTRIBUTORS IN CONVENIENT CENTERS THROUGHOUT THE COUNTRY

Sonora operates and is licensed under BASIC PATENTS of the phonograph industry

The Talking Machine World

Vol. 14. No. 2

New York, February 15, 1918

Price Twenty Cents

IMPORTANT CHANGE IN TACOMA

Shaw Supply Co. Takes Over the Eilers Talking Machine Co. and Now Handles Three Leading Lines of Machines and Records

TACOMA, WASH., February 1.—John Ramaker, manager of the phonograph supply department of the Shaw Supply Co., 1015 Pacific avenue, announces that his company has taken over the Eilers Talking Machine Co.

"We have been handling the Edison and Columbia machines," said Mr. Ramaker, "and with the addition of the Victor machine we will now be carrying the three standard makes of talking machines. We are enlarging our space to accommodate our new stock and will have three new record rooms, making a total of eight record rooms."

Mr. Ramaker also announced that with the addition of stock the Shaw Supply Co. will introduce a novelty into Tacoma in the form of daily talking machine recitals. The artistically and comfortably furnished record room at the front of the Shaw Supply Co. will be used for these recitals, which will be given daily from 10 a. m. until 5 p. m.

"When I was East recently," said Mr. Ramaker, "these novelty recitals given daily by the various music houses were very successful. Some of the houses even served tea during the afternoon. Women down town shopping would drop in and listen to the music for a few minutes. We will commence these recitals at once and invite all Tacomans to attend."

W. M. RANDOLPH WITH B. H. ROTH

Takes Charge of Victrola and Sporting Goods Departments in Big Stores in West New York, N. J.—Expects to Increase Business

William M. Randolph, formerly connected with Landay Bros., New York, is now associated with B. H. Roth, of West New York, N. J., one of the largest exclusive Victrola dealers in Hudson County. Mr. Roth has enlarged his parlors and taken the two adjoining stores, adding large and well stocked sporting goods, kodak and toy departments. Mr. Randolph will have full charge of the Victor and sporting goods departments and expects to increase the business materially. The sporting goods line is not new to Mr. Randolph, for he was formerly buyer of sporting goods for a large New York house. He also has had wide experience in the talking machine field.

TALKING MACHINES FOR HAITIANS

Natives of West Indian Island Show Strong Desire for American Products

Since the occupation of Haiti by the United States there is said to have developed throughout the island a strong demand for merchandise made in this country, says the New York Times. The latest manifestation of this development is a number of orders for low and medium priced phonographs which exporters in this city have received during the last few weeks from Haitian importers to replace goods formerly obtained in Europe. Some of the higher-priced machines have also been sought, though in more or less limited quantities. The South American trade in American phonographs seems to be continuing strong in spite of high freight rates and the difficulties of transportation.

The advertising of your store is a reflection of its personality! You are as much a part of the store's advertisement as the printed daily store news! You are part of the "inside adv.," the daily paper and auxiliaries represents the "cover and trimmings!"

GALLI-CURCI SCORES IN NEW YORK

Noted Victor Artist Heard With Chicago Grand Opera Co. in New York—Her Remarkable Career—Puts Royalties Into Liberty Bonds

One of the stars who are making history with the Chicago Opera Company, which has attracted large audiences at the Lexington avenue Opera House, New York, the past few weeks, is Amelita Galli-Curci. This distinguished soprano was not entirely unknown, either here or in the West, for her voice, through the Victor records, has long been appreciated. Naturally the desire to hear this artist was strong, and there was much uneasiness when it was rumored



Mme. Amelita Galli-Curci, Soprano

that owing to a needed rest she would not be able to sing in this city, but this newest of prima donnas, unknown in this country a year and a half ago, appeared in New York and conquered. As a matter of fact she swept musical New York off its feet.

Mme. Galli-Curci's career is an interesting one, and it appears that she has never had a singing lesson in her life, that as a girl she heard all the operas at La Scala; that Mascagni, her piano teacher (she was a professional pianist before she became a singer), told her singers were born, not made; and, having found she was so born, she had taught herself. And never would she let any one, not even her husband, hear her practice (if practice is the right word for what coloratura sopranos do when in training). She locked all the doors, she said, and made her piano her only intimate.

The Italian soprano confesses that in an incredibly short time she has collected royalties from 450,000 talking machine records and put this money into Liberty Bonds—practical and patriotic, isn't it? Mme. Galli-Curci and her painter husband, Luigi Curci, who is a marquis but doesn't mention it, who are "at home" at 27 West Sixty-seventh street, have expressed themselves as delighted with New York and its people.

Next spring Mme. Galli-Curci expects to visit California. One fact stands forth, that no matter where she goes her voice and her ability will be known in advance by reason of her Victor records—among the greatest aids to public appreciation existing to-day.

INTERESTING THE CHILDREN

The children of to-day are the men and women of to-morrow. Build for the future of your store by cultivating the children to-day. Impressions are easily made. It will not be hard for a talking machine dealer to win their friendship, he has such a fascinating line to interest and entertain them. And they'll not forsake you later, when they grow up.

AFTER MISLEADING ADVERTISERS

Talking Machine Trade Should Be Interested in Efforts of Music Industries—Better Business Bureau to Protect Legitimate Business

The Music Industries Better Business Bureau, which has headquarters at 432 Broadway, Milwaukee, Wis., with C. L. Dennis as secretary, is doing good work in checking fraudulent advertising of musical instruments in various sections of the country.

As has been stated before in *The World*, the bureau makes a monthly report of its activities and the report for December recently issued is particularly interesting. Although the bureau was organized under the direction of the National Association of Piano Merchants, Secretary Dennis has also directed his attention to advertising of all types of musical instruments, including talking machines. Among the cases handled by the bureau during December were two in Chicago, Ill., both concerning the advertising of talking machines in a misleading manner.

One dealer used the name of a prominent machine as the basis for selling his own instruments, and the other made most extravagant statements regarding the capacity of the factory producing his machines and the profits that could be made by selling them. In the first case several papers were persuaded to refuse the advertising, and similar action is expected in the second instance.

Talking machine dealers throughout the country who are suffering at the hands of unscrupulous advertisers and "gyp" dealers, would do well to acquaint the Better Business Bureau with the facts.

PRICE CUTTING A MENACE

Damaging to the Manufacturer and Inimical to the Public Welfare—Points Worth Considering

Price cutting is not only damaging to the manufacturer but also inimical to public welfare. Careful buyers do not care to deal with the price-cutter. They rightly question his good faith, suspect he has a different price for different buyers, and are convinced that when he loses on a standard article this sacrifice is made up on other articles. The person who never buys unless he can get a bargain, the haggler over prices, is the advocate of the price-cutting practice. Fixed prices have stabilized business and given a fair field to the small dealer, who is hardest hit by the price-cutting practice. We are glad, therefore, remarks *Leslie's Weekly*, that one of the leading makers of an advertised commodity has determined to fight in the courts the Government indictment that the company's refusal to sell its products to dealers who persistently cut prices is in violation of the Sherman law. We agree with Mr. Sidney Colgate that a "great ethical principle" is here involved that affects vitally the entire manufacturing industry, that every manufacturer has "the moral and legal right to protect his good will and his good name."

HOW JARDINE IS "DOING HIS BIT"

A. E. Jardine, who conducts the Sonora Phonograph Agency at 711 Boardwalk, Atlantic City, N. J., has just lost his best demonstrator in the person of Fairfax A. Jones, who has joined the Aviation Service. Last April Mr. Jardine's son, who was acting as sales manager of this establishment, joined the Naval Service, and is now a commissioned officer on the U. S. S. "Wisconsin" "somewhere at sea." Meanwhile, Mr. Jardine is not only loyally contributing to the forces of Uncle Sam on land and sea, but he is "doing business as usual," and thus helping to stabilize industrial conditions.

Why the Salesman Who Oversells His Customer Is Not Exercising Good Business Judgment

The average talking machine salesman if he can induce the prospective purchaser of a \$50 machine to take one worth three or four times as much feels that he has done a good piece of work, that he has justified the term salesman as applied to himself and is looking out for the interests of his house. In a great many cases the salesman is right, but there are some cases where to induce a customer to invest several times the amount originally intended shows bad business judgment, and may lead to embarrassment later.

It frequently happens that a man feels that he has \$50 or \$60 to spend for a talking machine and starts out to buy one at that price, with the intention of paying cash for it. He is also prepared to buy a few records, and with his machine payment out of the way at one time may be expected to keep on buying records, possibly in small quantities, at regular intervals. If the salesman gets hold of such a man and persuades him to invest in a \$150 instrument, for instance, the customer, finding that he cannot pay in cash, grabs eagerly at the regular terms of the house which may be as low as \$10 down and \$10 a month. The result is that fourteen months are taken in paying off the obligation, the house has to wait for its money and the customer, meeting his payment every month, has little left to buy records, and the whole deal is indeed most unsatisfactory to both parties. If this same man had been permitted to buy his \$50 machine and a few records each month, the total sales during the fourteen months would have approximately equaled in amount the price of the \$150 machine, and the few records bought with it. Meanwhile, the dealer would have had the use of the cash he received from the customer.

There are, of course, many instances, on the other hand, where people inquire about cheaper models who could well afford the more expensive styles. The salesman owes it to himself to be able to judge in some manner the customer's buying power and govern himself accordingly. The salesman who oversells the customer, however, is not only placing on his customer a burden he should not bear, but is adding to the dealer's troubles, by giving him a new account to fret over, for the customer who has not contracted to pay more than he really feels he can afford to pay is going to be slow in meet-

ing his obligations, and will keep the collection department hustling to see that the payments are met.

In closing any kind of a sale, too, the salesman would do well to look at the cash side, and to endeavor to close on that basis if possible. There are too many salesmen who at the first sign of hesitancy on the part of their customer immediately emphasize the point that the machine can be bought on very low terms. In other words, they place all their cards on the table at once. It is just as easy to concentrate on the sale of the machine first and talk

*"Selling the
Customer What He
Can Afford to Buy
Is Good Business"*

terms afterward. If the demonstration is so effective that the customer feels that he really wants to buy the machine and certain records, he is much more easy to handle than if he is sold on the question of terms alone.

When the customer feels favorably impressed with the machine but hesitates to buy with the explanation that he is in doubt if he can afford it just then, that is the opportunity for the salesman to announce that the instrument can be purchased on time if desired, and suggest that 20 per cent. down and 20 per cent. a month would prove satisfactory. He will find that just as many machines will be sold on that basis as when he rushes to put forth the minimum terms of 10 per cent. down and 5 per cent. or 10 per cent. a month.

There are some salesmen who are so anxious to sell records, for instance, that where the customer is paying for a machine they will insist adding the price of half a dozen records to his account, to be paid for on a monthly basis, rather than be satisfied with the sale of three records

for cash. They forget that if the customer really wants the records and does not feel like paying for them at the time, he will most likely come back and get them a little later, and that if he once finds out that his record purchases may be added to his account without argument, he will be inclined to overstep the bounds and keep his account on the books for an indefinite period. Credit is a mighty valuable thing, whether it is individual credit or business credit, and it should not be handled carelessly.

It is cash business that helps men to pay the rent and discount bills, and the salesman who leaves it to the customer to ask for credit and to suggest terms will find that his volume of cash business will show a most satisfactory increase.

MISS MORRISEY'S 35,000-MILE TOUR

Popular Young Contralto Gave 74 Concerts on Recent Tour—Visited Many Military Camps

Miss Marie Morrisey, contralto, the brilliant young Edison artist, who is recognized as one of the foremost concert singers of the day, is a true American musically as well as patriotically. Her programs show her loyalty to American composers, and she featured American songs in a recent record-breaking three months' tour on which she traveled 35,000 miles and gave seventy-four concerts—ten of the concerts just "doing her bit" singing for the soldiers in the camps.

"Just a-Wearying for You" and "Last Night When You Said Good-bye," well known to Diamond Disc owners, and "Happy Days," which is soon to be recorded, found a much-encored place on her program.

"American audiences love American songs," declared Miss Morrisey the other day, "and they are going to have a chance to hear many of them. One good effect of the war will be the bringing forth of American composers. This country is not lacking in composers, but heretofore there has been rather listless encouragement for them, and very little opportunity to be heard. Now, with many foreign composers left off our programs, there is a great cry for American composers, musicians of great talent, who have been patiently waiting, and who successfully are answering the cry."

SINCERITY

That's the slogan back of every factor in

Ditson Service

It means much just now

Oliver Ditson Co.
BOSTON

VICTOR
Exclusively

Chas. H. Ditson & Co.
NEW YORK

AN IMPORTANT ACCESSORY—ALBUMS FOR FILING DISC RECORDS

The enormous demand for "National" Record Albums keeps pace with the ever increasing demand for machines and records, and our output capacity has been enlarged to meet the greater needed supply. Record Albums have proven themselves to be the best and most convenient, as well as economic, method of filing and keeping disc records.

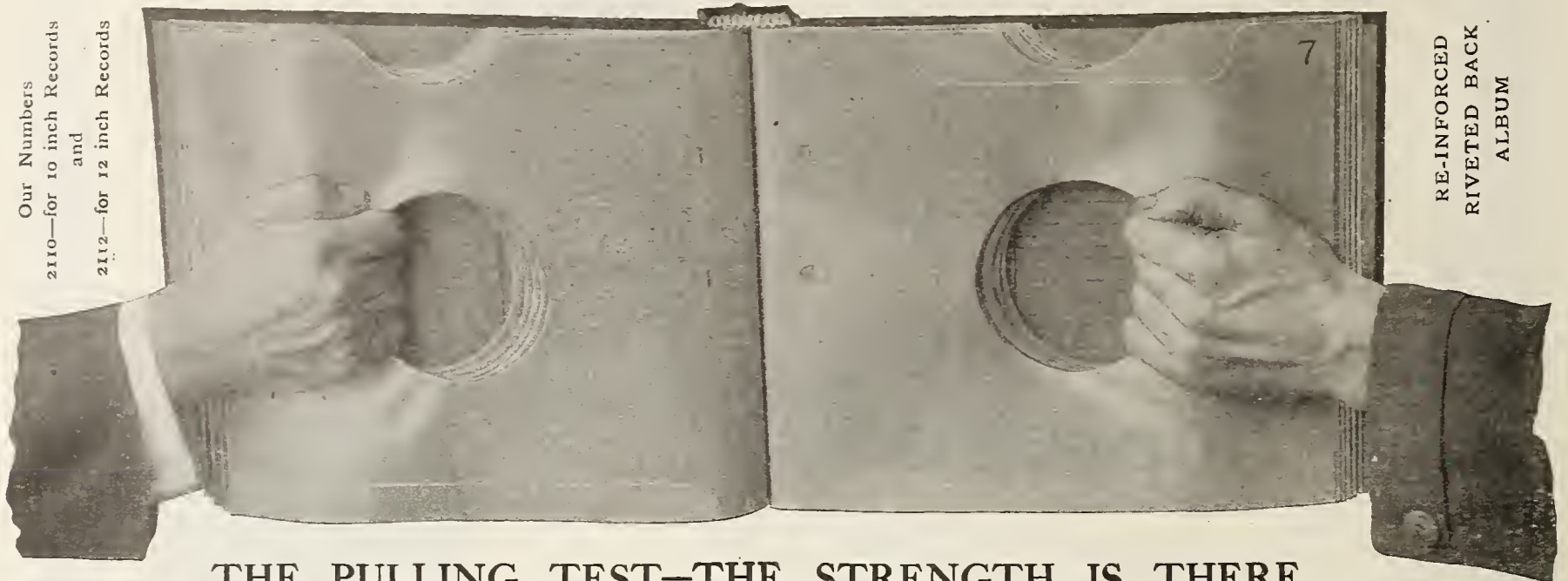

THE PULLING TEST—THE STRENGTH IS THERE

STRENGTH AT THE STRESS AND STRAIN POINT

PRACTICALLY UNBREAKABLE FOR REGULAR USAGE

Albums are an **Indispensable Requisite** in the talking machine business and wherever records are sold. An accessory that is necessary and worth while. Practical and handy. Save time and records. A **profitable adjunct** to the business. All owners of machines and records want Albums to file and preserve their records.

We manufacture disc Record Albums containing 12 pockets to fit cabinets of all sizes and styles. We also make Albums containing 17 pockets. With the indexes they are a complete system for filing all disc records.

For durability, finish and artistic design, our Albums are unsurpassed. We have unexcelled manufacturing facilities, and considering quality our prices are the lowest. Write us giving quantity you may desire, and we will quote prices.

OUR ALBUMS ARE MADE TO CONTAIN VICTOR, COLUMBIA, EDISON, PATHÉ, AND ALL OTHER DISC RECORDS

NATIONAL PUBLISHING CO., 239 S. American Street, PHILADELPHIA, PA.

CHANGING WINDOW DISPLAYS PAY

Butler's Music House, Marion, Ind., Believes in This Policy—Patriotic Records Featured

MARION, IND., February 8.—Despite the severe winter weather and the abundance of snow that kept many people off the streets, Butler's Music House of this city, of which Edwin Butler is the head, followed its usual practice of changing



Butler Bros.' Record Window Display

the window display each week, and even under the most unfavorable weather conditions the efforts put into this work were more than repaid by the sales registered.

The company has been paying particular attention to featuring patriotic records, and the accompanying illustration shows one of their recent windows devoted to that purpose. As will be seen, the Victor French Course for Soldiers, embodied in three records, is strongly advertised in the center of the display, while on the right appears the company's service flag with

its five stars. The background for the display consisted of large-sized flags of our Allies with the Stars and Stripes in the center. Opportunity was also found for showing the popular models of the Victrola and the Edison Diamond Disc phonograph, for the company handles both lines. The display of records about the floor served to facilitate the making of selections by those who stopped to look.

That the entire display was effective was proved by the increased volume of record sales.

DEATH OF BENTON M. HARGER

Harger & Blish, Inc., Des Moines, Ia., have sent out memoriam cards announcing the death of Benton Merritt Harger, president of that corporation, who died recently at his home in Hollywood, Cal., where he had resided for some years past. Mr. Harger had not been prominent in the trade of late years, merely retaining a financial interest in the corporation which bears his name. Following the death of his wife two months ago, Mr. Harger suffered an epileptic stroke from which he rallied, but a second stroke proved fatal. Mr. Harger was born in Syracuse, N. Y., April 12, 1839, and during his long, active life had been one of the foremost citizens of Dubuque.

The man who attracts attention is the man who is thinking all the time, and expressing himself in little ways. It is not the man who tries to dazzle his employer by doing the theatrical and spectacular.

MAKE BIG RECORD IN SMALL CITY

Huntley-Stockton-Hill Co., Greensboro, N. C., Sell 178 Edison Phonographs in a Six Weeks' Holiday Drive—Good Team Work

The Huntley-Stockton-Hill Co., of Greensboro, N. C., who handle the Edison line of phonographs and records, report an unusually active demand for those goods, a demand stimulated considerably by the energetic efforts of the company's staff.

During the six weeks' holiday drive, ending January 1, the company disposed of 178 machines as a result of competition developed by two selling teams.

In a letter to C. B. Haynes & Co., Edison jobbers, of Richmond, Va., the company says regarding its holiday drive:

"On about the 17th of November we divided our sales force into two teams and told them that the team that sold the most machines would receive a fine dinner and twenty-five dollars (\$25.00) in gold. There were only three or four machines sold until the first of December, when they began to get busy, and by the first of January one team had sold eighty-seven and the other ninety-one, making a total of one hundred and seventy-eight machines, which we feel is a very good showing for a town of this size, and also taking into consideration that we have only had the Edison line for a little over one and one-half years.

"We feel that if you could have supplied us with all the machines that we wanted we could easily have sold two hundred and fifty. We want to thank you, as well as the Edison factory, for the co-operation you have given us in the way of advertising matter, and we expect to sell twice as many machines in 1918 as we did in 1917."

The company's record of business is particularly good when it is considered that Greensboro has a population of approximately 30,000, of which about a third are negroes.

Talking Machine Hardware

We manufacture hardware for all styles of cabinets

Lid Supports
Needle Cups
Needle Rests

Door Catches
Sliding Casters
Continuous Hinges

Sockets
Tone Rods
Knobs, etc.

BEST QUALITY

LOWEST PRICES

WEBER-KNAPP COMPANY

Jamestown, N. Y.



Victrola IV-A, \$20
Oak

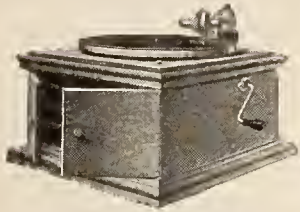

Victrola VI-A, \$30
Oak

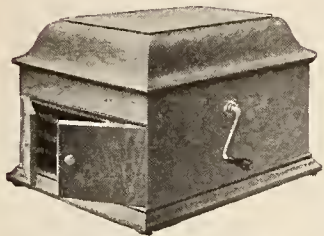

Victrola VIII-A, \$45
Oak



Victrola IX-A, \$57.50
Mahogany or oak



Victrola X-A, \$85
Mahogany or oak



Victrola XI-A, \$110
Mahogany or oak

Victor Supremacy

The supremacy of the Victrola is linked with the world's greatest artists.

The prosperity of the music trade, the success of Victor retailers, are the natural result of this overwhelming supremacy.

Victor Talking Machine Co.
Camden, N. J., U. S. A.

Berliner Gramophone Co., Montreal, Canadian Wholesalers



Victrola XIV, \$165
Mahogany or oak



Victrola XVI, \$215
Victrola XVI, electric, \$270
Mahogany or oak

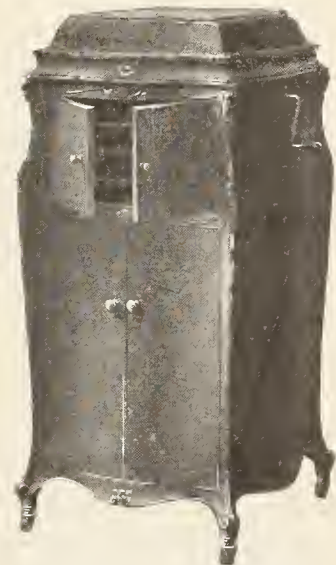

Victrola XVII, \$265
Victrola XVII, electric, \$325
Mahogany or oak

"Victrola" is the Registered Trade-mark of the Victor Talking Machine Company designating the products of this Company only.

Warning: The use of the word Victrola upon or in the promotion or sale of any other Talking Machine or Phonograph products is misleading and illegal

Important Notice. Victor Records and Victor Machines are scientifically co-ordinated and synchronized by our special processes of manufacture, and their use, one with the other, is absolutely essential to a perfect Victor reproduction.



REG. U.S. PAT. OFF.

The **TALKING**
MACHINE
WORLD

*For the
makers &
sellers of
talking
machines*

PUBLISHED BY EDWARD LYMAN BILL, Inc.

President, C. L. Bill, 373 Fourth Ave., New York; Vice-President, J. B. Spillane, 373 Fourth Ave., New York; Second Vice-President, J. Raymond Bill, 373 Fourth Ave., New York; Secretary and Treasurer, August J. Timpe, 373 Fourth Ave., New York.

J. B. SPILLANE, Editor

J. RAYMOND BILL, Associate Editor

AUGUST J. TIMPE, Business Manager

Trade Representatives: B. BRITAIN WILSON, L. M. ROBINSON, WILSON D. BUSH,
C. CHACE, E. B. MUNCH, L. E. BOWERS, A. J. NICKLIN, V. D. WALSH

Boston: JOHN H. WILSON, 324 Washington Street

Chicago Office: E. P. VAN HARLINGEN, Republic Building, 209 South State Street.
Telephone, Wabash 5774

London, Eng., Office: 2 Gresham Buildings, Basinghall St. W. LIONEL STURDY, Mgr.
The Talking Machine World has regular correspondents located in all of the principal cities throughout America.

Published the 15th of every month at 373 Fourth Ave., New York.

SUBSCRIPTION (including postage): United States, Mexico, \$1.00 per Year; Canada, \$1.25; all other countries, \$1.75. Single copies, 20 cents.

ADVERTISEMENTS: \$4.50 per inch, single column, per insertion. On quarterly or yearly contracts a special discount is allowed. Advertising pages, \$125.00.

REMITTANCES should be made payable to Edward Lyman Bill, Inc., by check or Post Office Money Order.

NOTICE TO ADVERTISERS.—Advertising copy should reach this office by the first of each month. By following this rule clients will greatly facilitate work at the publication headquarters.

Long Distance Telephones—Numbers 5982-5983 Madison Sq.
Cable Address: "Elbill," New York.

NEW YORK, FEBRUARY 15, 1918

ORDER well in advance, and order up to the hilt, is the advice that should be followed by the talking machine wholesaler and retailer just at the present time. For, remember, placing orders and getting the goods are two widely separated and distinct things at present.

The freight situation continues serious. With fuel, foodstuffs and munitions having the right of way on the railroads, and with the Government in control of the transportation systems to see that this priority order is enforced, the shippers and consignees of freight not coming within those favored classes must take their chances of delivery, and they are long chances.

Until weather conditions improve, there are only certain days when freight of certain classes will be received by the railroads, and then only in limited quantities. Moreover, there have been tight embargoes placed on the bulk of freight by several Eastern railroads, and there probably will be more embargoes in the future. The wise and logical thing to do, therefore, is to get the jump on the situation wherever possible by having goods on order and ready to ship at every opportunity.

Freight received by the jobber and dealer in normal times within a week or so after shipment—now takes anywhere from six weeks to three months en route. That means that the jobber and retailer must work at least that far ahead.

There has been much talk of the curtailment of the manufacture of "non-essentials," or all those goods not required to provide the necessities of life. Such curtailment would depend upon the point of view of the men issuing the order, and who might or might not have full appreciation of what music means in the present crisis. Assurances from Washington, however, are to the effect that no such discrimination will be practiced by the authorities, that any curtailment order will apply broadly to all manufacturers, and no one group of industries will be singled out for special attention.

The Garfield order can be accepted as proof of this attitude, and with assurances of a square deal from Washington the trade can go ahead and by foresight and the exercise of the proper spirit keep at least even with the game.

IT may interest talking machine men to know that there is a strong movement among piano merchants in the East, backed by the National Piano Merchants' Association, to eliminate the advertising of instalment terms, and to leave that question for

adjustment between the customer and the salesman as circumstances warrant.

It has been proven to be a fact that where minimum terms are quoted in an advertisement, such as \$1 down and \$1 a week, or \$5 down and \$5 per month on the various models, simply as a bait, the prospect comes into the store filled with the idea that those amounts are all he is expected to pay on the instrument he selects, and consequently most of the business is done on that basis, although in many cases the customer is in a position to pay either cash or substantial amounts each month. Where it is advertised that the terms may be arranged to suit the customer's convenience, provided they are within reason, the average amounts received as first payments and the instalments arranged for each month are much higher than the average.

The ordinary business man in making a \$200 purchase, for instance, would hesitate to offer \$5 or \$10 to bind the bargain and agree to pay a similar sum monthly. He realizes the amount of the investment and generally offers an initial payment averaging at least 20 per cent. of the amount of the purchase. Advertising of terms does not affect the talking machine dealer as much as it does the piano dealer, but while in the former case the average value of an individual purchase is smaller, there is at the same time an equal tendency to cheapen the products. A \$200 machine for which the dealer will accept \$5 or \$10 as first payment does not seem nearly as valuable to the purchaser as would be the case if he had to pay \$25 or \$50 down.

Advertising that the dealer will accept the customer's own terms, if in reason, appears to the ordinary reader to be a most generous proposition. The customer feels that he is safe to make a purchase because he can pay for it any way he sees fit, and his terms, ninety-nine times out of one hundred, will be better than the minimum terms that the retailer has been in the practice of asking. Just now every dollar in cash has an added value, and if by adopting this idea of the piano man the talking machine dealers can bring in the cash on their sales in larger quantities and with greater rapidity, then it certainly is worth trying.

THE drastic orders of Fuel Administrator Garfield closing down practically all of the industries located east of the Mississippi River for the five-day period from January 18 to 22 inclusive, and for each of the nine Mondays following, naturally hit the talking machine trade hard, although probably no worse than it hit hundreds of other industries.

Wherein the talking machine trade suffered, and will suffer, particularly, is that the majority of the larger factories are far behind in the production and delivery of orders booked for machines and records, and had relied on uninterrupted work during January and February to catch up in some measure with the demand so as to fill the holes in the retail stocks left by the holiday rush.

The spirit of the trade, however, was admirably shown in the observation of the Fuel Administrator's order to the letter. In practically every instance the factories shut down tight on the days named, keeping only a portion of the office force on hand to look after the mail.

Certain manufacturers in many industries apparently found a loophole in the order permitting the heating of plants and offices sufficiently to prevent damage to stock and the freezing of sprinkler systems. The heating thus deemed necessary ranged from 35 to 50 degrees, and it was found that employes could do certain work in that temperature without discomfort. In view of the fact that the greater part of the work in talking machine and record manufacturing is done by machinery, even to the varnishing of the cabinets, and that the use of machinery was absolutely prohibited on the "fuelless" days, however, put the bars up against any manufacturing activities.

Although there was naturally a strong protest immediately the order was issued, the talking machine men, manufacturers, jobbers and dealers fell in line with other business interests and accepted the order as a war necessity, and made the best of a bad situation.

According to reports from Washington, it seems, as this is written, that the effect of the five-day closing down and the subsequent workless Mondays has not been as satisfactory as hoped for in effecting a saving in coal, and in permitting of trans-

portation of fuel in increased quantities on those days. Therefore, instead of the order being rescinded in part, it is not improbable that it may be, in some manner or other, extended.

Meanwhile indications are that the trade has adapted itself to the changed conditions and is working along lines that will overcome in a considerable measure the effect of the shut-down, by increased efforts during the five working days, and overtime occasionally, when feasible. There are still many who grumble against the severity of the Garfield order and who are not yet thoroughly convinced regarding its necessity, but these are war times, and the great majority of the people of the United States comprehend that there must be fire where there is smoke and have set themselves to grin and bear it, regardless of personal opinions—in other words, to use a familiar advertising slogan, "there's a reason."

A little extra effort, a closer attention to details, and the go-ahead spirit will enable the trade to overcome these and other obstacles and, barring unforeseen conditions, make 1918 just as good a year for the talking machine industry as has been predicted.

THE merchant and his salesman should bear one fact in mind, that the first impressions are the most lasting, and if you give a man a good impression of your place when he enters you have accomplished half the battle of separating him from his money. A quick walk forward, a pleasant greeting and close attention are not hard things to give, but they will make sales where a glum dyspeptic countenance, with mouth drooping at the corners and a general look of having liver trouble, will put a customer in an antagonistic mood that will mean a hard fight to win his trade.

THE desirability of applying the trade acceptance to all classes of transactions in buying and selling merchandise is becoming more generally understood in all the leading industries of the country. Leading trade associations are recognizing the value of this plan of putting credits into available liquid form, in this way expanding the use of commercial paper.

There is no doubt but that the war, through its related activities, has done much in forcing developments which formerly and for some time recently had appeared disposed to hang fire. For instance, the trade acceptance, an institution whose merit is obvious, and which for years has been included among the fundamentals of commercial systems in practically every other civilized business country of the world, was up to a year ago understood but by a small number of people in this country, while a greater number considered the matter hardly worth their time or effort. What a change, however! Today every merchant and business organization is giving this subject the closest consideration.

The matter of credits has been much in the public mind since the United States entered the war, and business men in particular have become alive to the beneficial results of the use of trade acceptances, with the result that this subject is before the country in a new light. People are getting a better comprehension of how it will broaden industry by liquidizing credits, and thus give the merchant greater opportunities for trade expansion.

MANUFACTURERS and jobbers are giving considerable attention these days to the subject of advertising. Every live man to-day concedes that advertising is a necessity, one that returns good dividends on the investment when space is properly utilized. In this connection it is well to bear in mind that every advertising medium has two costs—space cost and service cost. One gives use; the other gives results. Space cost is fixed. Service cost varies. The amount this varies determines the amount of results—that is, the amount of value received. But this varies always in proportion to the circulation of the medium. The more representative the circulation the higher the service. Since you purchase advertising space to put it to use and secure results, it is false and momentary economy to consider any but the medium of greatest representative circulation. Results, through use, soon offset any initial saving in cost of space. Service includes safety. It protects your reputation and guarantees your sales. Let "Service First" be your motto; it is ours—it is a winning policy.

And, talking about advertising, there are many concerns in this and other industries which, through lack of courage or for other reasons, during the war, have set about curtailing expenses by cutting down, or eliminating their advertising appropriations, and thus undermining the value of their sales departments.

Economy along these lines is not sound nor sensible. The concerns that will reap the harvest when the harvest time of peace comes will be those which have had the courage to push their businesses in the face of war, and the foresight to maintain their advertising campaigns, and keep their sales organizations just as close to normal as conditions will permit.

Money spent along this line is not money thrown away by any means. It is money definitely invested for future dividends. It insures a permanence of name value and develops a cumulative effect that cannot be extinguished—one that will bring most satisfactory returns.

The business men who lose courage and plan to hibernate during the period of the war are, unless peace comes unexpectedly, going to find themselves and their advertising forgotten and their names but distant memories. The time the live ones spend in going ahead the others must spend in starting up again—a handicap which no successful business man desires to have placed upon him.

WASHINGTON'S POLICY



in taking the worst night for crossing the Delaware helped him to succeed. It's easy to sell machines, but the fact that so few dealers specialize on selling Victor Records is a BIG reason why you would make more money by devoting more energy to the work.

You will celebrate a year of unusual record profits by beginning right now to SELL MORE RECORDS, and to use

Pearsall Service

TO HELP YOU TO DO IT

SILAS E. PEARSALL CO.

VICTOR DISTRIBUTORS

18 West 46th Street

New York

Edison MessageNo. 16

The Need for Music

Food, raiment and shelter are absolutely essential to existence. But it is not these necessities that make life worth living, they merely make existence possible. In order to sustain the highly developed life of today the individual requires something more than physical sustenance.

In striving for a better, a higher, a more ideal existence, the absolute necessities bear no part but the sustaining of physical life. Life, without many things which are often misnamed "luxuries," would not be "living" at all, it would be mere existence.

Who but the most narrow-minded could possibly call music a luxury. A luxury is anything that can be taken out of our lives without actual suffering. Music could not be taken out of our lives without real suffering. It is honey to the soul. It speaks in all tongues and all ears understand. It brings man into closer touch with his Creator and with his fellow-man than any other medium. It speaks to the souls of men, and

men respond with the noblest and purest deeds of heroism. Inspired by it they make the sublimest sacrifices with a smile on their lips. They go into battle—they go down on ships at sea singing songs.

People buy food, clothing and shelter simply because they *must* have them. We are very proud to feel that they invest in the instrument of Music's Re-Creation because they *want* it; not because it is *absolutely* essential to *existence* but because they very deeply feel that they *need* it to round out their lives, to help make living worth while, to brighten leisure hours and to bind the home ties closer.

Music's Re-Creation is helping to sweeten the bitter cup that the world now holds to its lips, and every loyal member of the Edison organization is doing his part to make the influence of Mr. Edison's new art felt in every American home.

What a privilege—what a satisfaction it is to be associated with such a wonderful factor in the life of today!

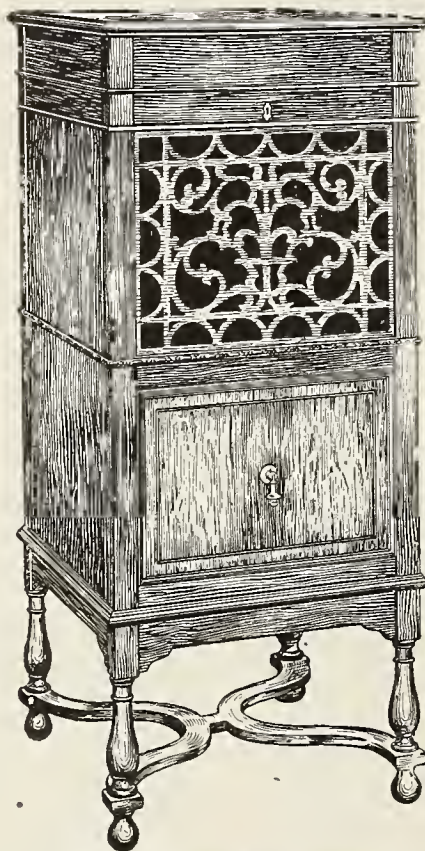

Official Laboratory Model
New Edison
William and Mary Cabinet
Executed in American Walnut

THOMAS A. EDISON, Inc.

Orange, N. J.

It Doesn't Pay for the Salesman to Laugh at the Mistakes of His Customers

It is not difficult for the average talking machine salesman to recount the humorous instances that occur in the course of his experience in the store, of the people who have come in without any knowledge of what they wanted or with the wrong name for the desired record, and people who have been confused as to artists and makes of machines, and brought their troubles to the salesman. These instances for the most part are really funny, but the time to laugh at them is when the customer has left the store, and when there are no outsiders to hear.

We all know of the story of the brawny Irishman who entered a talking machine store and demanded a record by "Al. McGluck." The incident is related as a story, but the average salesman has to meet demands equally as ridiculous every day in the week. Every customer is not well versed in the names of musical compositions, nor can everyone pronounce correctly the names of foreign artists. In fact, there are many salesmen, supposed to be authorities, who have weird methods of pronouncing some of the artists' names.

When a customer enters the store and asks, as did the colored woman, for the record "Human Rest," it is up to the salesman to inquire casually if the record wanted is not "Humoresque," and to act as though the customer had simply made a slip of the tongue. No matter how peculiar may sound some of the demands of customers, to the salesman who knows his line of records there is always a possibility of associating the customer's demand with some record in stock. The words may be different, but there is a phonetic similarity that cannot be mistaken. To grasp that similarity upon the instant and to save the customer embarrassment by bringing the desired record forward without delay is one of the traits of the salesman who knows his business.

We have seen incidents where the salesman has smiled in a superior way at the demand of a customer, and taken long enough to explain to that customer just where he, or she, was in error in pronouncing the name or indicating the desired selection. We have seen these customers flush with embarrassment, or more frequently with anger, and hurry out of the store before completing a purchase. Even when the customers did stay after being corrected, they acted as though their feelings were hurt and only bought the one record asked for to prevent the further embarrassment of having the salesman sneer as they went out empty handed. We have seen occasions where salesmen have smiled and actually laughed at the mistakes of a customer. It doesn't require statistics to prove

that the customer once laughed at is a customer lost.

One of the great problems of the talking machine has been to bring into the lives of the musically uneducated the greatest works of the masters. The man or woman who formerly depended for his music upon the vaudeville theatre or even the hand organ can now play at home and by means of the talking machine the great arias and symphonies that under ordinary conditions would be as foreign to him as Chinese. It is but natural that the average mortal cannot delve into this new musical world

*"Take the Customer
Seriously—Laugh
With Him,
But Not at Him"*

without making some mistakes, and every mistake thus recorded in the talking machine store may be accepted as proof positive that another convert has been won over to the cause of good music.

The man or woman who comes in and pronounces the name of some foreign composition or some foreign artist casually and without hesitation generally has much experience with the higher types of music, but the person who comes in and stumbles is exploring a new realm, and the salesman who is looking towards the future of the business should make a special effort to make that exploration pleasant and to remove the stumbling blocks of almost unpronounceable names with courtesy and tact. Then the customer leaves the store with the feeling that he has been well treated and will come again, rather than with the feeling that he has been laughed at and that his trade is not wanted.

Moreover, if after the exit of the customer making the humorous mistakes the salesman sees fit to laugh by himself, or in company with his fellows, that fact is noticed by other customers who happen to be present, and we may be sure, if any among them is not quite sure of his ground, he is going to think awhile about coming into that store again, unless for a record that is perfectly familiar to him. Of

course if the salesman's sense of humor is strong enough to overcome his sense of business and he can only control himself sufficiently to let the customer get out of the store, why, there is generally a stockroom in the basement or in the rear of the talking machine store to which he can repair and roll on the floor in glee for a few moments to relieve his feelings.

When he is selling records the salesman is not paying for and should not expect free entertainment. The customer comes into the store not in the role of a comedian but in the role of a purchaser and should be treated as such. The adage "Laugh and grow fat" is all right under certain circumstances, but the salesman who laughs at customers' mistakes is going to grow thin through lack of nourishment and the wherewithal to purchase same.

NEW WAR USE FOR THE TALKER

Kansas Cattleman Finds That Cows Fatten Quicker Under Influence of Music—Should Help Increase Meat Production of Country

KANSAS CITY, Mo., February 5.—Now comes Arnold Berns, of Peabody, Kan., pioneer cattleman, one who has seen the Texas longhorn give way to the grade Hereford and Shorthorn in the cattle industry, and declares that the phonograph can be made a great factor in fattening cattle. At the meeting of the Kansas State Board of Agriculture at Topeka, Kan., Mr. Berns said that the phonograph will serve to quiet the nerves of cattle in the fattening stalls and make them more susceptible to the grains and feeds given them and that they will take on fat faster by being quiet and less nervous.

"Many of the cattle in our Western feed lots and stalls," said Mr. Berns, "have been raised on the ranges of the West where the howl of the coyote has been the music of the range. These cattle taken off the range and confined in close quarters naturally become restive and nervous and miss the sounds and music of the ranges.

"Two bunches of cattle fed under identically the same conditions near Peabody, Kan., differed in weight and price when marketed. The man who sold the higher priced bunch of cattle was asked for an explanation by his less successful neighbor and was told that the seller of the higher priced bunch of cattle had arisen from his bed when he heard the cattle running around in nervous excitement in the feed lot at night and had gone down and talked soothingly to them until they became passive and their fright had passed away.

"Not many of us would care to get up of nights and go to the feed yard to talk or sing to a restive nervous bunch of cattle that were not taking on fat because of their nervousness,

"The phonograph could be employed to take the place of the human voice under such circumstances. We could start with a coyote record that would cause the range cattle to forget their homesickness and the longing for the freedom of the open prairie ranges and then we could educate them up to some of Caruso's or Melba's wonderful arias or the "Marseillaise" or some of the patriotic airs. Think of how undefeatable an army of soldiers would be if fed on beef that had been fattened to the music of such soul-stirring war airs as we are all hearing these days."

Mr. Berns spoke on "Cattle Feeding as a Business" and his introductory remarks were in relation to phonographic music as a feature of cattle feeding. His address was easily the leading feature of the Topeka meeting.

The Brunswick Shop, Dallas, Tex., has installed a stock of Columbia Grafonolas and records.

Record Cleaners

The "Standard" Circular Cleaner grips the surface and clings as if on rails. A cleaner that has "made good."

PRICE, 50 CENTS, LIST

We also manufacture the "Simplex" Record Cleaner, 15 cents list price.

SEND 10 CENTS FOR A SAMPLE CLEANER

Automatic Stops



Automatic

Stops are in use everywhere. They give excellent service, are easily installed and are absolutely guaranteed.

SEND 50c FOR SAMPLE STOP

KIRKMAN ENGINEERING CORPORATION, 237 Lafayette St., New York

To the Talking Machine Dealer: HAVE YOU CATALOGUE No. 317 T W?

Globe-Wernicke

(BUILT-TO-ENDURE)

Sectional Cabinets For Disc Records

The better the facilities you furnish your customers for housing records the greater the quantity of records you will sell.

Look carefully at the cabinet.

It invites you to fill it, in fact, you cannot resist the temptation to fill it. No matter how many sections are bought there will be empty compartments and these are always in sight, inviting you to fill them, and the records too are always in sight, inviting you to play them. Any record is so easily found and quickly replaced that this cabinet adds an extra charm and fascination to the playing of records.

Suppose each of your customers had this cabinet and you had a sample on your salesroom floor to remind them to buy additional sections. Not only would the sale of the cabinets increase but what a tremendous increase in the sale of records would result and there is excellent profit in the sale of both.

Each section has 90 compartments numbered consecutively from 1 up. Globe-Wernicke Catalogue No. 317 T W describes and illustrates these goods fully.

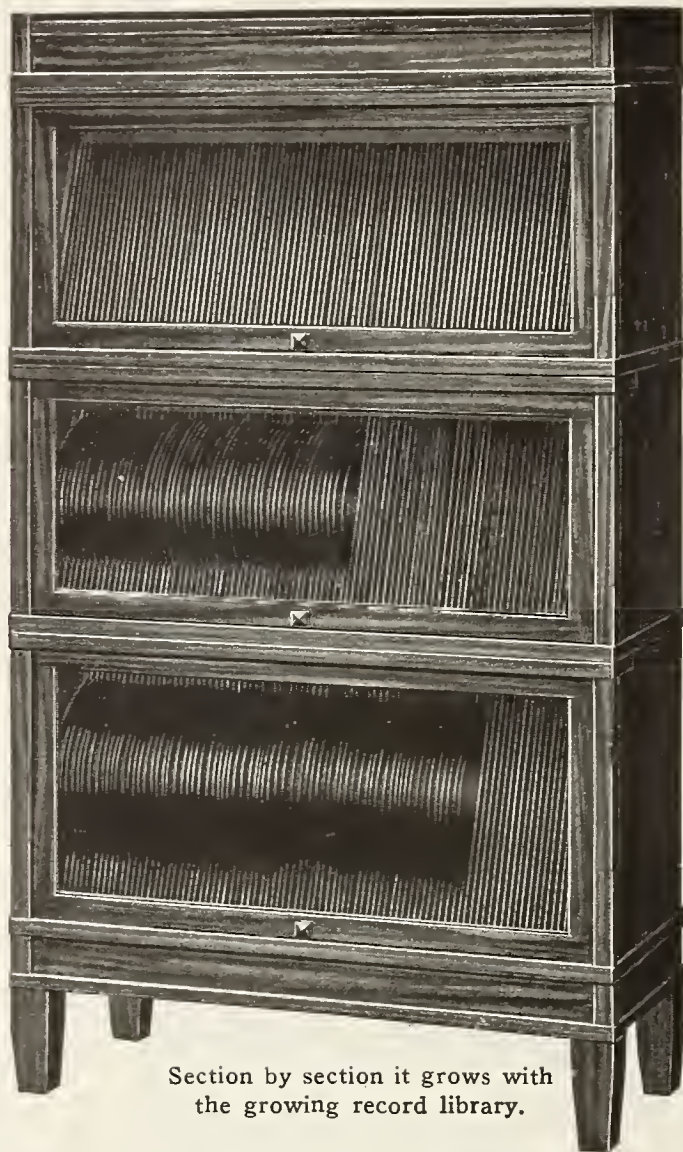

← No. 351 Art-Mission Top.

← No. 0328 Art-Mission Disc Record Section for ten-inch records.

← No. 0328 Art-Mission Disc Record Section for ten-inch records.

← No. 0329 Art-Mission Disc Record Section for ten- and twelve-inch records.

← No. 357 Art-Mission Base.

Section by section it grows with the growing record library.

Brown Disc Record Cabinet

For every talking machine made

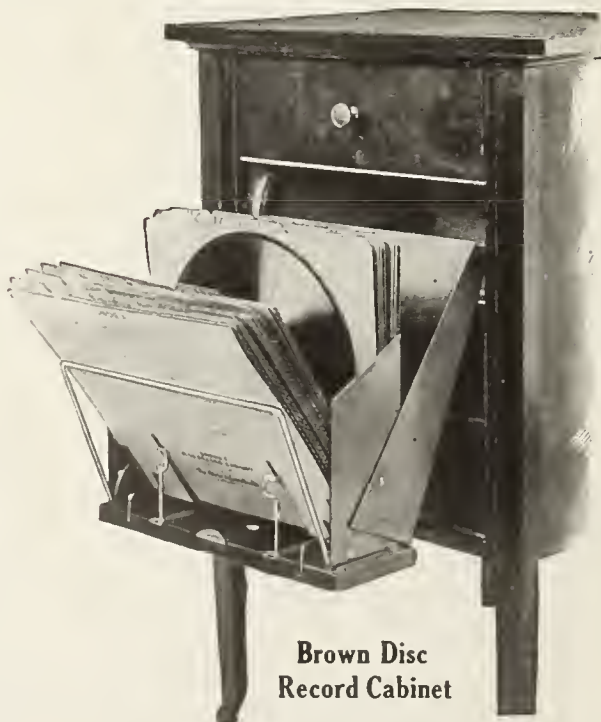

Brown Disc Record Cabinet

Every record right in front of you always.

No searching—No confusion.

Records lie flat when drawer is closed—No warping.

Records are vertical when drawer is open. Every record at your fingers' ends.

A separate compartment for every record.

No Scratching—Rubbing—Cracking or Breaking.

The Brown Disc Record Cabinet was devised to preserve a record perfectly and thereby insure Perfect Reproduction of Sound.

Ask for Catalogue No. 317 T W



No. 4 T with Table Top. For use with Victrola VIII and IX, Columbia Grafonola 15, 25, 35 and 50, Aeolian Vocalion D and E. 32½ inches high, Top 18¾ inches wide by 22¼ inches deep.

BROWN DISC RECORD CABINET No. 4-T FOUR DRAWER

The Globe-Wernicke Co.
CINCINNATI

"Over There!"

Arthur Fields.

Columbia.

A Knock-out!!

**Columbia Graphophone Co.
Woolworth Building, New York**



C. K. BENNETT HEADS OHIO ASS'N

Manager of Eclipse Musical Co. Elected President of Talking Machine Dealers' Association of Northern Ohio—Annual Banquet of That Organization to Be Held on February 20

CLEVELAND, O., February 2.—At the recent annual meeting of the Talking Machine Dealers' Association of Northern Ohio, held in this city, Charles K. Bennett, manager of the Eclipse



Charles K. Bennett

Musical Co., Victor distributor, was elected president for the year 1918, with H. E. Roos, of the Columbia Graphophone Co., vice-president; James Card, of the Lakeside Music Co., secretary; A. L. Maresh, of the Maresh Piano Co., treasurer, and E. B. Lyons, of the Eclipse Musical Co., recording secretary.

The annual banquet of the association will be held at the new Hotel Winton on February 20, and the program on that occasion will be an elaborate one. Among the speakers will be Henry C. Brown, assistant to the general manager of the Victor Talking Machine Co.; J. Raymond Bill, associate editor of The Talking Machine World, and a representative of the Columbia Graphophone Co. An autographic message from Thomas A. Edison is also looked for.

KEEPING SHOW WINDOWS CLEAN

Those who are located in regions where the illuminating medium is natural or artificial gas have experienced considerable difficulty with a peculiar greasy deposit on plate glass windows, which gives to them a bluish appearance regardless of the amount of energy expended in the cleaning. If after having followed the ordinary procedure of cleaning a piece of glass, a small sack be made of coarse cheese cloth and filled with lamp black and the glass thoroughly polished with this and then polished with a clean cloth, it will assume a brilliancy unobtainable by any other means.

TALKING MACHINE AT THE FRONT

Major H. H. Noyes, Who Formerly Traveled for W. D. & C. N. Andrews, Buffalo, Writes of Experiences With Pershing's Army in France —Asks About the War Sentiment Here

BUFFALO, N. Y., January 21.—"The Frenchman warms himself by suggestion. He builds a fire in the fireplace and so long as he can see a small blaze he is content."

This was one of the many interesting comments of life in France by Major H. H. Noyes, who traveled in the Buffalo territory for W. D. & C. N. Andrews of this city for five years. Major Noyes is now serving his country in France. He is with Pershing's army and an interesting letter from him was recently received by Mr. and Mrs. C. N. Andrews.

Referring to the subject of heat Major Noyes said: "We are different. We build a fire and put in a good-sized chunk of wood for a back log and really get some heat. We bought wood at about \$14 a cord. Coal is a luxury. If one has a piece of hard coal he wears it on his finger in place of a diamond. The houses here are cold and have no furnaces.

"The weather here is so rotten that I cannot wax very eloquent over the scenery. There are wonderful roads and lots of woods, which are mostly planted. Conservation is a religion here. They plant trees which they are not allowed to cut for thirty years or more.

"We eat, sleep and work war, but still you

folks know more about the war than we do," continued Major Noyes. "We are concerned with our own particular little world and have our hands full. Would be glad to learn the mental attitude of the people in the United States. Are they taking this war seriously or not? They should and the pacifist and slacker should not be allowed to sport and exhibit their views, for they are a menace. The pacifist is the worst enemy we have—worse, in fact, than the boche, and that is beyond one's comprehension. I have personally seen things over here on my trips to the British and French fronts that make one wonder whether or not civilization is more or less of a myth.

"One group of German prisoners wouldn't believe the American army was here. They thought we were British dressed in the uniform of the U. S. A., just to impress and mislead the Germans. A German prisoner, who had lived in America for several years, said to one of our men that the entrance of America in the war would make no difference. He also said that although we might get a few men over casually, a U. S. troop ship would never reach Europe. The funny part of this is that while he was talking a big fleet of transports was steaming in and he hadn't noticed them. When his attention was called to the fleet and he was told it was one of several already landed, he looked dazed for a minute and then turned away—licked."

Do your bit—but don't talk of it beforehand!



The ADVERTISING

of the

SCHUBERT

PHONOGRAPH



is concentrated right in the newspapers of the dealer's own home town, hitting hard the only people to whom he can expect to sell a machine.

The dealer's own name is in every ad.

We shall be glad to tell you all about our plans.

Five Models, \$60 Up

The BELL TALKING MACHINE CORPORATION

Offices and Show Rooms, 44 W. 37th St., New York Factory, 1 to 7 West 139th St.

LOCAL TERRITORIAL DISTRIBUTORS

Schubert Phonograph Distributing Co., 308 Lyceum Bldg., Pittsburgh, Pa.
 J. A. Ryan, 3231 Troost Ave., Kansas City, Mo. Smith-Woodward Piano Co., 1018 Capitol Ave., Houston, Tex.



Give Them What They Want!



The tremendous demand for PATHE PATHEPHONES during the past year is UNQUESTIONABLE PROOF that the people are no longer satisfied with a ONE-RECORD machine.

The people have been educated regarding Records—They know that there are good Pathe Records—They know that there are good Victor Records—that there are good Columbia Records and good Edison Records—

The people want to hear ALL makes of records and they must have a talking machine THAT WILL PLAY all makes of records—

The *Pathe* Pathephone

Is the Only Standard Talking Machine That Gives You This Great Selling Advantage



Pathephone \$75 Model

This and other grand features—the **Pathe Sapphire Ball** and **Pathe Everlasting Records**—make Pathe the greatest of all phonograph propositions.

Hook Up With the Pittsburgh Pathephone Co. for Real Pathe Service!

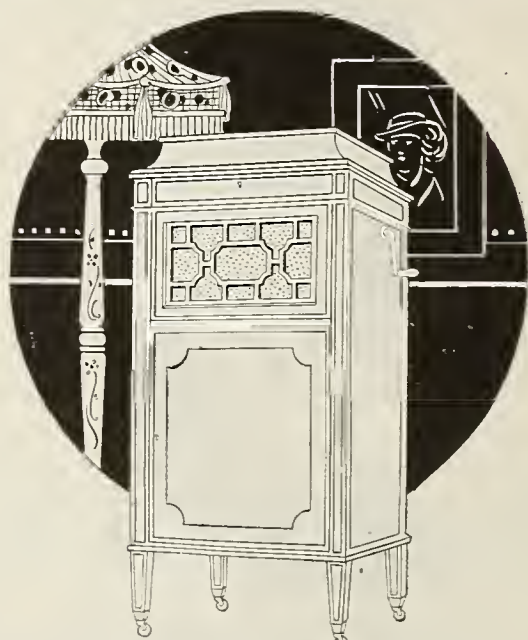

Pathephone \$225 Model

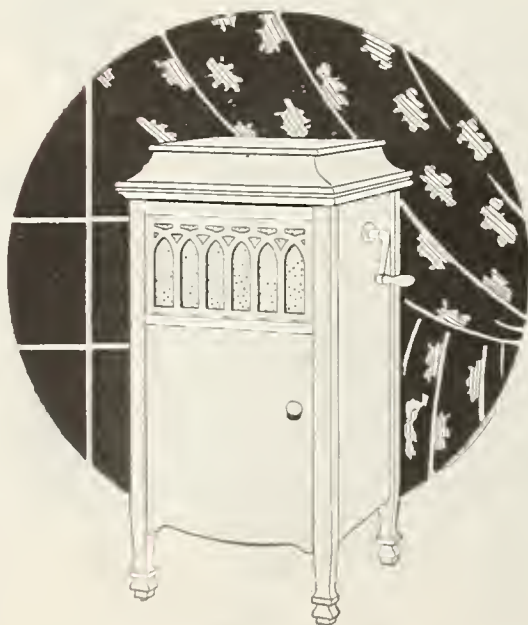

Pathephone \$100 Model

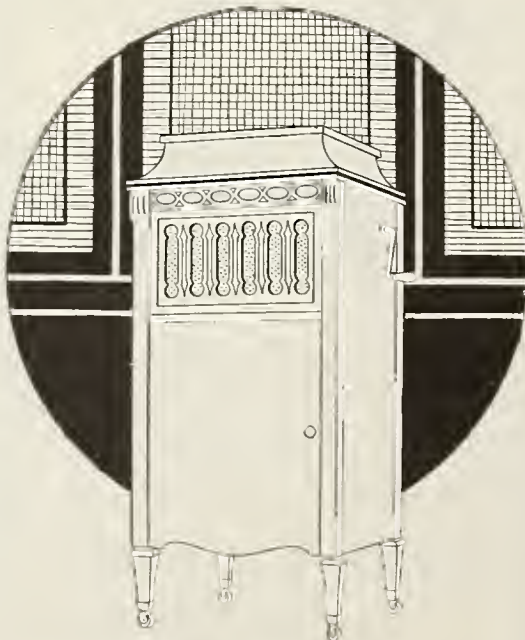

Pathephone \$110 Model

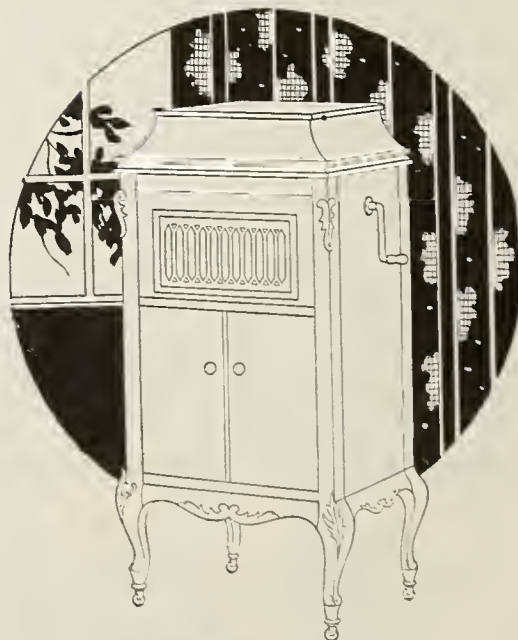

Pathephone \$175 Model

PITTSBURGH PATHEPHONE CO.

963 LIBERTY AVENUE, PITTSBURGH, PENNSYLVANIA

Talking Machine Aids Piano Technicians In the Study of Tone Composition

There is in Chicago a group of technicians in the piano trade who meet at regular intervals and discuss scientific matters relating to the designing and construction of pianos and the development of tone with a view to finding some means for improving their product where possible. A recent meeting of the technicians was devoted to the study of tone composition, and of particular interest from the viewpoint of this industry was the consideration which was given the talking machine, which helped to illustrate many points in the discussion.

In his opening remarks F. E. Morton, acoustic engineer of the American Steel & Wire Co., the chairman, said: "A knowledge of acoustics may be had by any one who can hear. In instruments and voices we learn to recognize certain combinations of those partial tones making up the entire tone and without specific analysis we hear a sound and say: 'That is the sound of a cornet or the sound of John's voice.' When we understand why we can tell one sound from another the pleasure of hearing and comprehending is multiplied. There is not a sound that you hear during the day that is not interesting from a scientific viewpoint. The fact that a sound may be reproduced, whether the characteristics are quite the same or not, is a matter of tremendous interest from the days of the little cylinder with the tin-foil around it up to the present day when the sound and reproduction are so nearly identical. That it is not exactly the same in quality as recorded is obvious to the listener. I have more respect for the talking machine now that I know its limitations than I had before I learned them. I also know more of its possibilities. I want to explain briefly for your direction in listening that first we will hear the natural voice and then the reproduction of that voice on this talking machine. The recording studio is a factor. Any room is a reverberating chamber and hence there are echoes.

"The diaphragm of the recording instrument possibly has a better ear than we have and the echo is recorded. The better the reproduction the more obvious the echo. The voice energy enters a receiver—a horn. That horn has a certain number of cubic inches of air which determines its pitch. The column of air vibrates more intensely in response to its own keynote than to any other. The horn material also responds with a greater degree of intensity to its own keynote, which may or may not be the same as the column of air contained. The diaphragm also has its keynote to which it responds with a quality peculiar to flat bodies. It responds to odd numbered high partials with greater intensity than to other partials. In the reproducing the process is reversed and the same conditions obtain. If the reproductions were made by the same diaphragm through the same horn and into the same room as that in which the record was made each augmented partial would be doubled. If reproduced through another instrument having another horn of different cubical content, a different keynote of horn material, a different keynote of diaphragm, other odd numbered higher partials would be augmented as would also the reverberation in the room. And so it is that we have a number of sounds foreign to the one to be recorded.

After very many repeated experiments there is no doubt in my mind that a talking machine record of a banjo number gives a better banjo tone than the banjo itself. The same is true of the xylophone. Those partial tones characteristic of the banjo and xylophone are the ones augmented. There are certain voice qualities which are improved by recording and reproduction. There are other voices and instruments which are not improved, but all are changed.

With a knowledge of that change we have no difficulty in appreciating all.

"You recognize another's voice but it is doubtful if you would recognize your own voice recorded and reproduced. Let us go back to our accepted piano tone composition, having a relative intensity of 50 per cent. in the fundamental and the other six partials in sequentially decreasing intensity until only a trace of the seventh is audible. A heavy stroke on a piano key brings out partials to or above the twenty-

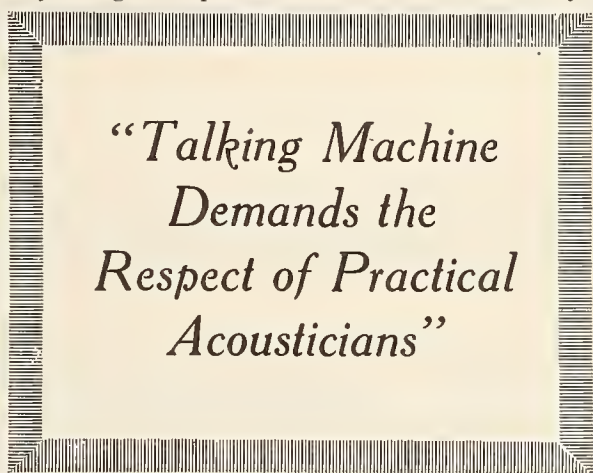

"Talking Machine Demands the Respect of Practical Acousticians"

fourth. By means of the resonators they may be heard.

"The horn material and the diaphragm are loads carried by the talking machine and constitute its limitations. If these loads were eliminated a true reproduction would remain. Break a talking machine record and with a microscope observe the track of the needle and you will find there truly recorded all the tone it was given and more, because it recorded the vibrations of part of its own material."

"It is not a limitation of failure to record but of faithfulness. If a horse hauls a wagon weighing a ton and the contents weighing one-half ton the limitation cause of hauling capacity is the weight of the wagon, or one ton. The horse hauls both. I am not criticizing the talking machine. It is a wonderful instrument. E. H. Rose will now sing for us, alternating with his own record on the talking machine as a demonstration."

Mr. Rose (Prince Lei Lani, Hawaiian tenor)

sang "Pua Sabinia," "Aloha Oe" and the "Rosary" (Schumann-Heink), taking one period with his voice, the next with the record and so on throughout the number.

"Applying the same theory to the reproduction of piano tone," remarked Mr. Morton, "I confess I spent many hours trying to find the cause of some apparent distortions. I couldn't understand why a piano record sounded so much like a cross between a banjo and a xylophone. The limitations are not failure to record or reproduce, but are caused by other partials, other tones. In volume I think we could approach very closely the volume of the original instrument. The augmented partials would become more obvious than in the talking machine of smaller tone chamber, or horn. We can't magnify the good without magnifying the evil. The relative intensity of partials contained in a tone determines its quality. If that relative intensity is disturbed the quality is changed. The mere increase in intensity of one partial above its normal degree would change its quality and this factor, as I have already mentioned, would account for its distortion. It is wonderful that we get as true an effect as we do with that handicap. If you have a nasal-toned piano, with odd numbered high partials, you put your tone regulator on the job, expecting him to make a perfect-toned piano. When such tones appear on a talking machine record we are apt to condemn the talking machine. By the collaboration of the piano manufacturer and the talking machine manufacturer that fault may be eliminated. We are fortunate in having the assistance of Mr. Harold Triggs, who will play for us. We will then have the reproduction of this number on the piano itself—an instrument not yet on the market, a Brambach electric player grand—and reproduced by the autograph roll, then reproduced on the talking machine." Mr. Triggs played "The Polonaise Militaire," which was then reproduced on electric player grand.

Mr. Morton (at talking machine): "I am playing a certain sustained portion of the composition over where the echo occurs. It is in effect not unlike a 'shake' which follows what

(Continued on page 18)

Phon d'Amour

THE TONE MASTERPIECE

TO realize the wonders of the Phon d'Amour you must see it, examine it, hear it play and compare it. To read a list of adjectives about it is not enough. Come to our showrooms. Let us explain the remarkable Fritzsches inventions, the reproducer, the wooden diaphragm, the sound amplifier. Then inspect the Fritzsches craftsmanship that has given to every Phon d'Amour the enduring value of a fine violin.

And last of all hear the Phon d'Amour play—any record of any style or make. Listen to its glorious tone production. Note how it exalts the finest records and eliminates imperfections from less worthy ones. Compare the Phon d'Amour with any other phonograph. Then you will appreciate that here indeed is an epoch-making instrument and that to be satisfied with any other phonograph is to be content with something less than the final, ultimate achievement in phonograph making.

You are invited to see and hear the marvelous new phonograph that has set a new milestone in musical progress

—Manufactured By—
The Fritzsches Phonograph Co., Cincinnati, Ohio

Trade-Mark. Copyright 1917 by
The Fritzsches Phonograph Company



“What would you like to hear?”

No matter what musical taste may be expressed in the customer's reply, the Columbia salesman can meet it.

Popular and patriotic songs, opera, plenty of Columbia's own unequaled dance music, sparkling gems of violin and piano, the grand harmonies of a great symphony orchestra, brass band music—all are to be found in Columbia's offerings for March.

Artists? The assemblage includes Stracciari, Lucy Gates, Godowsky, Eddy Brown, Vernon Stiles, Oscar Seagle, Mme. Miura, Al Jolson, Samuel Ash, Gene Green, Brice and King, Greek Evans, Henry Burr, Arthur Fields, Malachy White, Charles Harrison, Collins and Harlan.

As for the new and novel—there are two splendid features. The first of the Thornton Burgess Bedtime Stories, told for Columbia kiddies, in the author's own voice, are “Johnny Chuck Finds the Best Thing in the World” and “The Christmas Joy of the Beautiful Pine.” Lacalle's Spanish Orchestra makes its Columbia debut with “Alegrias” and “Los Crotalos,” two mad dances from the sensational New York musical success “The Land of Joy.”

We've given you just an idea of the good things in this March list. Examine it in detail, and you will realize its surpassing excellence.

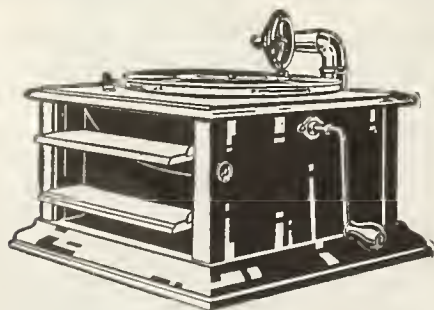

Columbia Grafonola
\$18

Columbia
Records

Let one Grafonola sell another



Columbia music is always good music, whether the Grafonola on which it is played costs \$18 or \$250.

People buy Columbia Grafonolas in order to enjoy Columbia music. The wise dealer's first aim, in making a sale, is to sell Columbia music. He is not over-anxious that the Grafonola purchased be an expensive model.

He knows that many a home hungry for good music is not yet ready to purchase a Grafonola of the more costly type. But such a home has a place, today, for the model at \$18, or \$30.

The dealer who sees that this want is met has made two sales. The inexpensive instrument will establish the enjoyment of Columbia music, and some day there will be an exchange for a higher-priced model—with a second profit.



Columbia Graphophone Co.

Woolworth Building, New York

Columbia Grafonolas

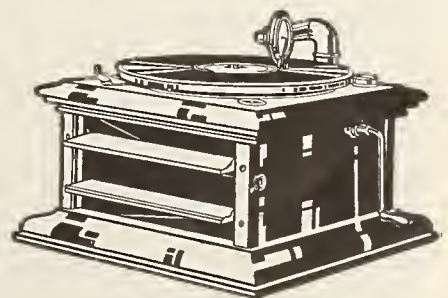

Columbia Grafonola
\$30

HOW THE TALKING MACHINE AIDS PIANO TECHNICIANS

(Continued from page 15)

sounds like a 'plucked' tone. It is not improbable that this results from the reflection of energy by the walls of the studio, and that this 'shake' is really an echo. You could build on the tone of a piano almost any combination by addition. The upper part of the register is much better than the lower."

"Now note particularly the difference in the lower and upper registers (demonstrating). From about middle C up the tone more nearly approaches the tone of the piano. From middle C, the farther down the less fundamental is observed. Mr. White has expressed just what I wanted to bring out and with that this point: Analyses have been made of the tone of the various parts of the piano scale. By means of the phonodeik it was determined with whatever degree of correctness the instrument might show, that the low notes—wound strings—had very little fundamental. If I recall, down in the next to the last octave there was barely a trace of the fundamental. That seemed unreasonable to me because we can determine the pitch of those notes, and it is the fundamental which determines the pitch. A possible explanation might be that the 'taps' on the atmosphere are less frequent at a point where there are only sixty-four vibrations per second than two octaves higher when there are 256. When the rate is only sixty-four per second the intensity, or rather carrying power, is not so great as in the upper register. At the same time I have a strong impression that, given a piano of such size that bass strings of correctly proportioned length and pliability may be used, the recording diaphragm will respond with sufficient intensity to influence favorably the reproduction. If we get a stronger fundamental with a long pliable bass string than we do with a short stiff one, it would be fair to assume that a balance of tone would result, and also that any company making records would be glad to pay the price for a piano that would improve the reproduction."

After considerable discussion on the question of piano tone, and the necessity of having a long string in order to produce the desired fundamental tones in the lower register, the question of reproducing music on the talking machine again came up, and it was agreed that much of the trouble lay in the diaphragm, as it is difficult if not impossible to design a diaphragm that would be suitable for reproducing very rapid vibrations or very slow ones with

equal faithfulness. For the diaphragm would respond to its own keynote with a greater intensity than it would to that of another pitch.

In the course of his discussion Mr. Morton offered some interesting suggestions regarding the recording of voices. "I suggest to those making records of male quartets," he said, "that the second bass be placed closer to the horn, the first bass a little farther, etc. It would rid us of the predominant tenor and give us the grateful fundamental.

"I feel that the public will be much more interested in all records having full strong fundamentals, however produced, than they will in the average present records, both orchestral and vocal. If those in charge of studios will understand that when the public says: 'This is a good and this is a poor tone' and we analyze both it will be found that the one which the public says is good has a dominant fundamental and the one which the public says is poor has little fundamental, they will effect a grateful change."

"I would like to ask what instrument records sell most readily to the public," asked one piano man, to which E. H. Rose replied: "'Cello, violin and harp records."

"There are some very excellent tones reproduced," declared Mr. Morton, "but their relationship is distorted. Take two violins, viola and 'cello. The 'cello is usually too light. We glory in a passage where it comes out strong. We like to hear a male quartet with a good substantial second bass. To determine in a flat vibrating body the true pitch—the fundamental—you can use this instrument known as a phenendoscope. You can locate sounds foreign to the desired tone in your piano, vibration of case, plate, etc. When you get through with it you can put it on your car and locate engine trouble. It is an aid to listening and any aid to listening is very well worth while. And now, to return to the talking machine, the diaphragm being flat and vibrating in odd-numbered segments, the attempt has been made to crown it. Just as soon as you near the arch you approach the unresponsive. It has too much resistance. It is not practical. Some day we will get away from the diaphragm entirely. The horn idea will never be entirely satisfactory as a true recorder or reproducer. The horn idea, or tone chamber, is distorting.

"In the meantime we have records to-day that couldn't be replaced by any other means. Think



Read the Trade Mark carefully—
hear the machine, and you'll agree
that it is truly

The World's Musical Instrument

Improves All Records
Send for our Special Proposition

HOFFAY TALKING MACHINE CO., Inc.
3 West 29th Street New York City

what the record of ancient history would mean in our talking machine studios to-day. Think of some of the great speeches by Roman senators handed down for us to-day as phonograph records. If there is anything on earth that should be encouraged it is the talking machine industry and everything pertaining to it. Give it its proper place. It has a big place and is one which will redound to our glory if we back it up strongly. The talking machine doesn't take the place of the piano. It never will and never can. The reproducing piano probably is the closest we can come to-day to a reproduction of an artist's work. The gradations are not as fine as we would like to have them, but we are progressing."

SOME GOOD PUBLICITY IN DENVER

C. B. Wells, Publicity Manager of Knight-Campbell Music Co., Gets Interesting Story on Music on Farm in Representative Papers

DENVER, COLO., January 19.—C. B. Wells, manager of publicity for the Knight-Campbell Music Co., is doing some excellent work in the interests of music and musical instruments generally. Only last week he succeeded in having printed in the Weekly Rocky Mountain News an interesting story on "Music Greatest Asset of the Country Home," the writer being Burt Wells himself, lover of music, cowman by experience and inclination, farmer by pre-natal instinct, by the grace of God a penpusher. The story told of the lonesome hours spent by women on farms and ranches far from the center of things and how music provides enjoyment in the evening for all hands. Of course the Victrola and the player-piano were referred to particularly. In addition to having the story in the Weekly News, which reaches about 25,000 country homes, it also appeared in the annual stock show souvenir edition of the Record Stockman, which circulates in a vast territory in the West. The story was accepted at its face value and cost the Knight-Campbell Co. nothing, although in fairness be it said that the company's name did not appear throughout the article. Mr. Wells is of the opinion that the same idea could be worked out profitably by piano and talking machine men in other sections of the country.

ASSOCIATION DUES NOT TAXABLE

War Tax Law Held to Apply Only to Social and Athletic Organizations

WASHINGTON, D. C., February 5.—Commercial organizations, even though they have social features, are not subject to the war tax, according to a ruling just issued by the Commissioner of Internal Revenue. The Commissioner ruled:

"Particular attention is called to the fact that the tax is imposed only upon dues or membership fees, including initiation fees, paid to any social, athletic or sporting club or organization, where such dues or fees are in excess of \$12 per year. The tax does not attach upon dues paid to chambers of commerce or other business organizations primarily organized and maintained for the furtherance of business interests. Such organizations may have social features without incurring liability to tax, provided such social features are entirely subordinated to the predominant purpose of the organization."

NEW INCORPORATION

The Audion Phonograph Co., New York, has been incorporated, with a capital stock of \$5,000, by A. LaGattuta, V. Himmer, Jr., and W. L. Sawyer.

The successful venture anchors to an achieved success, no matter how minor or humdrum the job was.

Ward's Khaki Moving Covers



Grade "D" Cover with No. 3 Straps.

PROTECT YOUR MACHINES FROM ALL KINDS OF WEATHER

and will enable you to deliver them free from dust, scratches, bruises and all other finish destroyers

Our covers are faced with Standard Khaki, lined with a heavy grade flannel, interlined with an exceptionally good grade of heavy cotton or felt, diagonally and closely quilted, and manufactured according to the usual superior "WARD New London" quality.

Grade "D" \$5.00 Grade "K" \$7.50

Carrying Straps: No. 1 \$1.00; No. 2 \$2.00; No. 3 \$3.50

ORDER SAMPLE COVER ON APPROVAL

With Name of Machine silk embroidery on any Cover; extra... 25c.
With Dealer's Name and Address, first Cover; extra... \$1.00
Same on additional Covers, each extra... 50c.

Write for booklet

THE C. E. WARD CO.

(Well-known Lodge Regalia House)

101 William St., New London, Ohio

Also Manufacturers of Rubberized Covers and Dust Covers for the Wareroom



Otto Heineman Phonograph Supply Co.

INCORPORATED

25 WEST 45th STREET, NEW YORK

FACTORIES, ELYRIA, O.—NEWARK, N. J.—PUTNAM, CONN.



CHICAGO

ATLANTA

SEATTLE

CINCINNATI

TORONTO

NEEDLES

NEEDLES

DEAN QUALITY

combined with

HEINEMAN EFFICIENCY

Our new needle factories in Putnam, Conn., and Newark, N. J., will soon be completed. Our output will then be tripled

Watch Our Deliveries

We use only the finest grade of steel in the production of Dean Needles

Otto Heineman
President



MEISSELBACH



TONE ARMS

MOTORS

SOUND BOXES

TALKING MACHINES VALUED BY SOLDIERS AT THE FRONT

Some Interesting Facts in This Connection Set Forth by Junius B. Wood, a War Correspondent Who Tells of the Joy They Bring in the Hospital and in the Camp

What a talking machine and even a limited supply of records means to the soldiers at the front, and particularly in the military hospitals, was set forth recently in a graphic manner by Junius B. Wood, who, writing for the New York Globe, said:

"In a certain unnamed spot a few miles back of the French front are the long one-story frame barracks of a regiment of American railroad engineers. These buildings, with those of a French hospital, near which is a cemetery that is daily growing larger, form a mushroomlike military city. Day and night the Americans take trains up under fire and return to sleep and rest in the barracks.

"Every morning, and sometimes oftener, according to how the fighting goes, they bring in a long train which stops at an equally long platform, while its load of helpless, suffering and bandaged humanity is carried into the wards of the adjoining hospital. Each one who is more seriously wounded is taken farther to more comfortable and better equipped permanent hospitals in Southern France. The wounds have been bandaged in the temporary field dressing stations, but only in a few cases has there been an opportunity to wash off the dirt of the trenches before the patients are hurried to this evacuated hospital. Then starts the fight to fan back the flickering flame of life.

"In that war-born city is one phonograph. Grand-opera singers, amusing actors and entertaining speakers do not come to that hospital in the war zone. A single box of "canned music" is all they have to relieve the monotony of the puffing locomotives, the stifled groans of their fellow wounded and their own gnawing pain. Occasionally German bomb-dropping machines seem reluctant even to permit these fragiles of humanity to escape.

It Is Never Silent

"One thoughtful New York mother sent this ray of brightness to her son, a captain in a railroad regiment. He turned it over, records and all, to the hospital so that all might use it. Now it is never silent day or night until taps sounds. Early in the morning it starts on its rounds through the hospital wards and by evening it reaches the Y. M. C. A. hut and finishes the night on a rough pine board table in the officers' quarters grinding out the old, familiar homesick tunes.

"Occasionally when work is slack the owner goes himself to run the machine. Here is his description of a Sunday afternoon in that strange city of the ill:

"I spent an hour and a half playing the machine in a ward where two men carried in the records. There were from sixty-five to seventy-five men in the ward. Some were suffering from pneumonia and still others were terribly burned by mustard gas. Nearly half of the remainder had not seen daylight for a long time. All eyes seemed to be bandaged and there was an everlasting coughing.

"I started off with the "Marseillaise" and every last man who had an ounce of strength left in his system sat up on his cot at salute and tried to raise a bandaged hand if one was left. After that we had some American marching songs, comic opera, grand opera, and everything left on the worn-out records.

Records Nearly Worn Out

"We have used these records until they sound like the proverbial tin can. I wrote to America a couple of months ago for more, but they never materialized. The machine works all day in the hospital and we use it only when the patients have gone to sleep. It would be a calamity if they were deprived of its solace."

"For military reasons I am not permitted to give the name or location of this American regiment which, in addition to its war work of carrying forward ammunition and supplies and bringing back the wounded and dying, is also spreading the Good Samaritanism of music. How-

ever, anybody who wishes to answer the appeal can send records to me and the American post-

GRAFONOLA IN MOTION PICTURES

Release to Be Made Shortly Will Feature Mae Murray and the Columbia Grafonola

The Universal Film Mfg. Co. will shortly present a new picture entitled "The Eternal Columbine." The star in this film will be Miss Mae Murray, one of the most popular and successful motion picture actresses now appearing



Miss Mae Murray and the Grafonola

before the public. A Columbia Grafonola plays quite a part in this new picture, and the accompanying photograph presents a scene in which Miss Murray and the Grafonola occupy the center of the stage.

C. F. Paige & Co., Athol, Mass., have fitted up a special room in their store to house the Victrola department, the business of which is increasing steadily.

office here will see that they are delivered. Anything in the line of music is a balm in the ears of the wounded, even of the French Poilu, who does not understand English. Send all you can and what you can in care of Junius B. Wood, war correspondent, American Expeditionary Force in France."

IMPORTANT FACTOR IN CREDIT WORK

How Good Correspondence Can Be Utilized Effectively in Cleaning Up Bad Accounts

Is the art of letter writing lost—an art than which there is none more important for effective credit work? We must lead men to understand that there can be no more expensive neglect than failure to appreciate the value of good correspondence.

The question arises, what is a good letter? This is a question difficult to answer. Surely, a letter should be neither too brief nor too long, yet thorough so that all points are covered. No important part of the subject under consideration should be neglected. The letter should be courteous, yet, as was expressed by a thoughtful credit man in a recent state conference, it should not "slop over." Fulsomeness is bad and creates a strong suspicion; but the proper expression of courtesy is one of the strongest features of good correspondence.

The letter should aim to accomplish its purpose without offense, leading rather than driving men, and yet sometimes it may happen that the best purpose of a letter may be accomplished if the party addressed is offended temporarily, because, as the editor of The Credit Man points out, some men never awake to a serious situation unless first made angry.

The unnecessary letter should never be written—the necessary letter never neglected—there should be careful thought given to each communication, for merely setting down in a moment of heat without digesting the real purpose and necessities of correspondence will fail of its purpose in the majority of instances. By the digestive process, the exercise of careful thought, the holding in mind of the purposes that are to be accomplished, a letter can perform a wonderful service, be a driving power and bind men together who otherwise would have no points of contact.

Letter writing is a neglected art, yet, by restoring it and making correspondence the subject of careful study and thought, we shall have accomplished much in making this work effective.

Lansing Khaki Moving Covers

PROTECT VARNISH IN THE COLD WEATHER

and enable you to deliver your phonograph free of blemishes of all kinds.

These covers are made of Government Khaki, interlined with heavy felt or cotton, fleecelined, quilted and properly manufactured. Perfect protection in all weather.



No. 3 Carrying Strap Shown in Cut, \$1.15

GRADE B
\$5.00

GRADE A
\$7.50

Carrying Straps Extra

Use the Lansing Khaki Moving Cover and your delivery troubles will be over.

Write for booklet

E. H. LANSING
611 Washington St., BOSTON

SAN FRANCISCO OFFICE, Room 530 CHRONICLE BLDG.
WALTER S. GRAY, Manager

THE TRADE IN BOSTON AND NEW ENGLAND

JOHN H. WILSON, MANAGER, 324 WASHINGTON STREET, BOSTON, MASS.

BOSTON, Mass., February 6.—It is of special interest that, despite general conditions, the month of January proved to be a far better month for most of the dealers than they had looked for. Most of them were able to show a business fully up to that of a year ago, while others went considerably ahead of January of 1917. This is doubly interesting in view of the fact that the business day is now shorter by one hour and there is a whole day, Monday, taken out of each week in deference to the request of the fuel administrator, which for the month has considerably shortened the hours, although the Monday closing did not really begin until the middle of the month. For the current month the situation will be worse, for there will be four Monday shut-downs and Washington's birthday, and all in the shortest month of the year. It will be interesting to see how the period will show up.

One good business asset just now is the demand for machines and records that comes from the Navy Yard, the forts down the harbor, Camp Devens at Ayer, and other places where soldiers and sailors may be stationed. The immense quantities of second-hand records that are sent away of course do not affect the dealers, but there are in addition a large number of records that are bought and sent away by friends. This is a most appreciable aid to business.

Oppose Instalment Plan of Doing Business

The trade is interested in the position lately taken by the Retail Credit Men's Association at a meeting held at a Boston hotel, when a resolution was passed abolishing the instalment plan of doing business. The reasons given for taking this attitude were that conservation is the watchword in the present crisis; that with the increase in the cost of merchandise a proportionate increase in capital becomes necessary; that it is neither wise nor economic to tie up large sums of capital in this form of credit; that it is essential to the national welfare to keep capital liquid, and therefore that all goods sold on credit be paid for on the first of the month following the date of purchase and in no case beyond thirty days from the date of purchase. A copy of this resolution was submitted to the Boston Chamber of Commerce for action by that body.

Fifty Victor Machines for Camp Devens

Herbert L. Royer, who has a well-appointed

Victor and Sonora shop in Chauncy street, a few feet from Summer street, is being congratulated by his friends on having successfully completed a deal whereby more than fifty Victor machines are soon to be sent to Camp Devens at Ayer. The purchase was made by a committee headed by Francis H. Spalding, which is interested in supplying music for the boys in camp. The money was largely secured by sums being raised from the proceeds of the sale of a large flag, which was made by Mrs. Martha Pierce Chute of Cambridge and Manchester. With these machines Mr. Royer was able to sell nearly 300 records. The outfits are to be distributed among different companies at the camp.

Dealers' Co-operation Service

Earl J. Silliman, who was transferred a while ago from the Vermont territory of the Columbia to the Boston wholesale headquarters, has been put in charge of the new record demonstration room where dealers, especially those from out of town, who are not familiar with all the details of good selling, may be coached. It is what might be called dealers' co-operation service.

Magnificent Display of Brunswick Phonographs

The dealer not acquainted with the line of phonographs carried by the Brunswick-Balke-Collender Co., at 94 Washington street, will be really surprised at the display which is on the second floor of the building. R. H. Booth is in charge of this phonograph department, and he has two men constantly in the field presenting the merits of the Brunswick machine, F. H. Walter and E. S. Campbell, who have between them all of New England with the exception of Connecticut, which is handled from the New York end. There is A. J. Kendrick besides, who is the district manager, with headquarters in Boston, and between these three live wires the Brunswick is getting a good showing in this field. There are several new styles of Brunswick machines soon to be put on the market which are sure to interest present and prospective agents.

Branching Out Into Larger Fields

R. S. Hibshman, manager of the Aeolian Vocalion, says that the business during January was good, all things considered. This house has begun to branch out into larger fields and to establish wholesale accounts around the city. The large department store of Magrane-Hous-

ton Co. in the downtown retail section has contracted for the Vocalions, and at the present time there is a good display in one of the large Washington street windows. This wholesale end of the business has been placed in charge of C. C. Westervelt, who has been with the Emerson Phonograph Co. J. F. Meade, the treasurer of the concern, who makes his headquarters in New York, was a Boston caller a short time ago.

Takes Charges of Victor Department

The Victor department of the Henry F. Miller Co. is now in charge of P. R. Smith, who has lately assumed the position. Mr. Smith has had a good experience in the phonograph business, for he was Thomas A. Edison's personal representative for some time and as such was called upon to go into many territories to straighten out knotty business problems facing the Edison dealers. Lately he has been in the employ of the United States Government.

Generous Action of A. M. Hume Co.

A space in the A. M. Hume Music Co.'s Victor warerooms has been generously donated to the Greater Boston Women's Committee, and authorized by the National War Work Council of the Y. M. C. A., whose purpose is to provide music and other forms of entertainment for the soldiers and sailors. Members of this committee are at the Hume warerooms for three hours each day and the Victor proposition is one that especially appeals to them as a desirable form of music.

Reports an Excellent January Business

Manager Fred E. Mann of the Columbia Graphophone Co. makes a most encouraging report of the January business just closed and says that while the demand for goods was naturally light at the beginning of the month, there was considerable speeding up as the days wore on, so that the sum total was considerably in advance of the January business last year. Manager Mann was over in Springfield a while ago looking over the territory and arranging to give that field as good service from the Boston end as it formerly had when there was a local headquarters in that city.

M. C. Perkins, who is now assistant to Mr. Mann, since the closing of the Springfield quarters, is rapidly making good in his new line and he is fast familiarizing himself with his new work, which for the time consists

Habits Have to Grow

For several years past Eastern Victor Service has made a specialty of speeding up the record end of the Victor business.

We have therefore contracted the *good habit* of giving the Victor dealer efficient record service.

EASTERN TALKING MACHINE CO.

177 TREMONT STREET

BOSTON, MASS.

THE TRADE IN BOSTON AND NEW ENGLAND—(Continued from page 20)

largely in perfecting the service stock department where several new men have had to be taken on owing to the demands which the draft has made upon the local Columbia employes.

Pleasant Surprise for Billy Fitzgerald

Wholesale Manager Billy Fitzgerald of the Eastern Talking Machine Co. got a pleasant surprise a few days ago, when he received a package which, upon being opened, brought back vividly to his memory an incident which happened back last summer when he played the part of lifesaver. A woman was crossing Tremont street almost in front of the Eastern establishment when she got mixed up between several teams and she was in danger of being crushed when gallant Bill rushed to the scene and dragged the frightened woman to a place of safety on the sidewalk. The gift was accompanied by a card which spoke the appreciation of the woman.

Tells Story of Progress

Business throughout the Edison territory handled by the Pardee, Ellenberger Co., Inc., is reported as excellent by Manager Frederick H. Silliman, but the staff of traveling men who have Northern Massachusetts, Maine, New Hampshire and Vermont as their fields have interesting stories of the amount of snow to be found in that territory these days.

Announce New Sonora Agencies

Joseph H. Burke, who is associated with Richard Nelson in the local management of the Sonora Phonograph Co. has been doing some telling work lately, and one of the good-sized deals which he lately put through was the placing of the Sonora agency with three of the Blake Co.'s large piano houses at Lynn, Attleboro and Pawtucket, R. I. The local management also reports that the large Springfield house of Forbes & Wallace has lately taken on the Sonora line. Both Mr. Nelson and Mr. Burke were in Hartford, Conn., lately in attendance on the salesmen's convention, when plans for the current year's business were considered from every angle.

Franz-Yahn Service Tells of Progress

The wholesale department of the Columbia Graphophone Co. is highly gratified over the volume of business which is being done by F. E. Yahn, who is head of the newly organized concern known as the Franz-Yahn Service, which maintains departments in the Poole Dry Goods Co. in Springfield, the Steiger-Cox Co. at Fall River and the Steiger-Dudgeon Co. at New Bedford. Mr. Yahn maintains an exclusive Columbia department in the Springfield establishment, and in arrangement and volume of goods displayed it makes one of the best show-

ings to be found anywhere about. Mr. Yahn has been in the talking machine business for several years and at one time was connected with the Springfield warerooms of the Columbia, and he is well informed with every phase of the business.

Doing Good Business in Lowell

Thomas Wardell, a Lowell dealer in Victor and Edison outfits, was a caller on Boston dealers a few days ago, in fact he comes up here frequently to buy goods. Mr. Wardell bought out the Ring Piano Co. in Lowell a couple of months ago, and has been meeting with good

success especially in his talking machine line. Mr. Wardell has had considerable experience on the stage and is full of interesting reminiscences. He is a veteran in the talking machine business, having been one of the early dealers in the days when the cylinder records were the only thing to be had.

Some of Our Distinguished Visitors

Visitors on the Boston dealers lately have included H. L. Tuers, manager of the Columbia's national dealers' service department, who came to Boston to take his examinations for the

(Continued on page 22)

STEINERT'S

35 ARCH ST.  BOSTON.

Victor Distributors

Many talking machine owners are forming their record buying habits now. Be sure they find what they want when they come to your store. Keep your VICTOR record stocks complete.

We can help you for we have

**The Largest and Most
Complete Stock of
Records in New England**

Write, or Telephone Beach 1330

M. STEINERT & SONS CO., 35 Arch St., BOSTON

The discerning wholesale buyer has learned to

SPECIFY BAGSHAW STEEL NEEDLES

Because of their quality, supremacy and reputation

W. H. BAGSHAW CO.

Lowell, Mass.

TRADE IN BOSTON AND NEW ENGLAND

(Continued from page 21)

aviation unit, which by the by he passed most successfully. Another caller was L. L. Spencer of the Silas Pearsall Co., a Victor jobber in New York, and H. M. Blakeborough, manager of the New Haven branch, who was in town for two days.

Joins the Nation's Service

The Eastern Talking Machine Co. has lately lost three more of its men, who have gone into the nation's service. They are John Maguire, who is in the Naval Reserve and is stationed at Hingham; Bernard Finnegan and Byron Corcoran, who are with the railroad engineers at Camp Devens.

Patriotic Atmosphere at Steinert's

The windows of the Arch street store of the M. Steinert & Sons Co., are full of a patriotic atmosphere for February, which month is so full of reminders of the two great men of the nation, Lincoln and Washington, whose birthday anniversaries come within these four weeks. In one of the windows, which is the happy conception of Robert Steinert, the manager of the talking machine department, is a liberal display of red, white and blue. In the center on a pedestal is a large bronze eagle from whose beak radiate streamers of the national colors.

PORTSMOUTH BUSY TALKER CENTER

J. M. Hassett Getting a Good Share of Trade From the Sailor Boys

PORTSMOUTH, N. H., February 2.—Joe M. Hassett has one of the busiest places, at 115 Congress street, that there is in the city. His establishment is one that formerly was operated by Fred W. Peabody, who conducts a chain of successful stores. The one in this city Mr. Hassett purchased some time ago and he has made a marked success of it from the start.

Just now he is getting a good share of business from the boys at the Navy Yard, where many men are coming and going all the time. Mr. Hassett carries the Victor, Edison and Columbia lines of machines and of these he keeps a large stock always on hand. He has a large number of friends in the business who never pass through the city without making a stop at his place for a handshake.

The object of advertising being to make public one's goods with the view of effecting sales, a dealer must first decide if he has the goods the people want, and then, how to apprise them of the fact.

There are standards of colors and President Wilson's picture finds a place in the arrangement, together with likenesses of Washington and Lincoln. Several high-priced Victrolas are in the window. The opposite window is more largely given over to a display of records and this, too, carries out the patriotic idea.

R. O. Ainslee Remains in Boston

When R. O. Ainslee came to Boston to attend the wholesale men's convention of the Hallet & Davis Co.'s Boston local warerooms it was to remain here, and make his home permanently in our midst. Mr. Ainslee came from Chicago, where he was in charge of the phonograph department of the Hallet & Davis house in that city; and coming here he is now occupying the same post. He will give all his attention to the wholesale end of this branch of the business, and as a man of considerable experience he promises to make good. The department will now be built up considerably, for Mr. Ainslee is a man of ideas and understands the art of developing business.

Joins the Naval Reserve

William McAuliffe, of the record department of the Columbia Co., is the latest of the staff to join the colors. A few days ago he reported at Hingham as a member of the Naval Reserve. He is the fifth one from that Columbia department to enter the service.

EDISON THRIFT STAMP CLUB FORMED

Employees of Edison Laboratories Form Organization for the Purpose of Encouraging Sale of Thrift Stamps to Help the Nation

The Edison Thrift Stamp Club was organized at the Edison Laboratories, Orange, N. J., late last month. The meeting was presided over by Charles Edison, who briefly outlined the purposes of the club, and was followed by Mr. Durand, manager of the Ediphone division, who explained the plan of the sale of Thrift Stamps to employes in full detail. Mr. Mambert, vice-president and financial executive; Mr. Wilson, vice-president and general manager, of Thomas A. Edison, Inc.; Mr. Philips, credit manager, also of the Thomas A. Edison interests, and Mr. Bachman, vice-president and manager of Edison storage battery, assisted in the organization work.

The object of the meeting was to bring together all captains and stamp station attendants for the purpose of outlining the plan and scope of the club.

A captain has been appointed from each department of the organization for the purpose of selling stamps direct to employes. The captains secure stamps and thrift cards from the

stamp stations and turn in all pledges, money and surplus stamps to the stations every night, the attendants of which in turn send all returns to the treasury service department, presided over by Harry Miller, treasurer of Thomas A. Edison, Inc. Upwards of one hundred captains and stamp station attendants were at the organization meeting.

The method of operation is as follows: The captains present a pledge card to the employes on which they pledge themselves to purchase at least one 25-cent thrift stamp per week. The captain sells the stamps direct to the employe



Mr. Edison With Thrift Card

and takes the money for them, which he turns over to the station attendant. The employe then receives a United States Government Thrift Card on which the stamps are pasted.

An effort is being made to have 100 per cent. of the employes purchasing thrift stamps regularly every week. In spite of the fact that many Edison employes are still paying on Liberty Bonds, the Thrift Stamps have very readily been purchased by the large army of Edison employes. Herewith is shown a picture of Thomas A. Edison holding in his hand a Thrift Card with the first Thrift Stamp purchased through the Edison Thrift Stamp Club attached.

Tie the new to the old. Capitalize your tried-out knowledge rather than fancy's rainbow pots.

The Eclipse Outlook

ECLIPSE

The 1918 outlook is extremely bright for the Victor dealer who goes about his business, spurred by the knowledge that the war chiefs are placing increasingly heavy emphasis on the war value of music in general and of the Victrola in particular. During 1918 patriotic inspiration will add increased ginger to "Eclipse Victor Service". 'Nuf said!

ECLIPSE MUSICAL COMPANY
CLEVELAND OHIO

FIXED PRICE ARGUMENTS BEFORE U. S. SUPREME COURT

Trade Interested in Arguments Made Before U. S. Supreme Court in Appeal of the Boston Store, Chicago, From Injunction Enjoining It From Selling Columbia Records at Cut Prices

The appeal of the Boston Store of Chicago from the injunction granted by the United States District Court in Chicago in September, 1915, enjoining it from selling Columbia records at cut prices was argued before the United States Supreme Court recently. The case came before the Supreme Court upon a certificate from the United States Circuit Court of Appeals in and for the Seventh Circuit.

It appears from the certificate that the appellant, the Boston Store of Chicago, entered into an agreement in writing on October 15, 1912, with the Columbia Graphophone Co., acting as the agent for the patentee, the American Graphophone Co., under the terms of which, among other things, the Boston Store agreed to maintain prices on the Columbia product. Subsequent to entering into the contract the Boston Store secured a stock of Columbia records and prior to the filing of the suit had sold at retail to the public the records which it had thus obtained, at prices less than the Columbia Co.'s official retail list prices. The records in suit were covered by United States Letters-Patent.

It was contended on behalf of the Graphophone Cos. that a patentee may, while exercising any of his three co-ordinate monopoly rights of making, using and selling, reserve, by proper agreement, such portion thereof as he may see fit, and that such a proper reservation was made upon the monopoly right to resell by a contract directly with the Boston Store, which was entered into at the very instant of the transaction. It was also contended on behalf of the Graphophone Cos. that the grant of the patent gave the article a status which enabled monopolistic bargaining and that the rules respecting ordinary sales did not apply.

Counsel for the Graphophone Cos. pointed out that the Columbia price maintenance system was based upon a contract—a direct contract

between patentee's agent and its immediate vendee, the Boston Store. No attempt was made to go beyond this, or by a mere "notice" to enforce its price system against any concern which was not a party (or privy) to a contract as in the Victor-Macy and Sanatogen cases recently decided by the Supreme Court.

It was further contended on behalf of the Graphophone Cos. that inasmuch as competitive conditions existed to protect the consumer, the contract between the Graphophone Cos. and the Boston Store, which imposed a resale price upon the latter, was valid as being a reasonable restraint of trade, and that the question as to the validity and legality of such a contract was not foreclosed by the decision of the Supreme Court in the Dr. Miles case.

The Boston Store claimed that under the recent Supreme Court decisions it had the right to sell the patented articles at any price it saw fit notwithstanding the fact that it had agreed by contract to maintain prices on them.

The questions certified to the Supreme Court were the following:

1. Does jurisdiction attach under the patent laws of the United States?
2. If so, do the recited facts disclose that some right or privilege granted by the patent laws has been violated?
3. Can a patentee, in connection with the act of delivering his patented article to another for a gross consideration then received, lawfully reserve by contract a part of his monopoly right to sell?
4. If jurisdiction attaches solely by reason of diversity of citizenship, do the recited facts constitute a cause of action?

The case was argued by Elisha K. Camp, general counsel for the Graphophone Cos., and Daniel N. Kirby and James M. Beck. Walter Bachrach and Hamilton Moses made the argument for the Boston Store.

knocked off him, the creases ironed out of him and he will become an accommodating diplomat with everybody's confidence and good-will. He will be known as a man with a "personality" or "character"—call it which you will—and he may view his future with confidence and serenity.

At the time Woodrow Wilson made the above remark he probably had no thought of becoming President of the United States. He had

enough to think about steering Princeton University with the finances of the institution tugging in one direction, the faculty in another and the students and their needs in a third. It hardened and toughened him into the kind of a man who could steer calmly through the midst of the most appalling state of international affairs any American statesman has ever had to face. The salesman who sinks his identity into the needs of a small country store need not be surprised if he finds that he has unconsciously developed in himself the kind of personality capable of heading the sales department of a big business.

TALKING MACHINE TRADE IN NORWAY

Figures on the Extent of the Industry in That Country—Prices at Which Talking Machines and Records Are Sold—Methods Used

WASHINGTON, D. C., February 5.—United States Consul Charles Forman has recently sent to the Bureau of Foreign and Domestic Commerce some interesting figures regarding the talking machine trade in Norway. The value of talking machines imported in the kingdom annually averages about \$100,000. They are received from Germany, France and the United States, but figures showing the exact amount from each country are not available.

Most of the talking machines sold in Bergen are imported by agents at Christiania. The most popular machines retail at \$26.80 (100 crowns); other and better machines range from 300 to 400 crowns. The retail prices of records vary from 80 cents to \$4.34.

Talking machines pay an import duty of 0.50 crown per kilo net weight (6 cents per pound). The rate of duty is applicable to talking machines from all countries entitled to most favored nation treatment.

The usual method of selling talking machines and discs is through agents in Christiania, who have a sole agency for Norway. Newcomers into the field may adopt this method, or if they prefer, may appoint an agent for Bergen, who should have a certain well-defined territory, and prices preferably should be quoted c. i. f. destination in dollars.

The usual terms of sale are 2 per cent. for cash, but credit of three months is extended, if desired. Dealers make a profit of 50 per cent. on machines and 33 per cent. on disc records.

A list of dealers has been forwarded to the Bureau of Foreign and Domestic Commerce, which may be procured from the department by referring to File No. 78,596.

CHARACTER—THE BASIS OF SUCCESS

What the Development of Character Means to the Salesman Most Interestingly Set Forth in an Article in "The Voice of the Victor"

"Character is a by-product," as Woodrow Wilson in one of his illuminating talks once told a group of college boys. Everybody knows that a salesman's success is largely determined by his power of impressing his "character" on his customers. For this reason many salesmen go after character much as though it were money—something they could put in their pocket and forget about until needed, says "The Voice of the Victor." What they get when they do this is not character, but another by-product, a sort of self-consciousness that is more of a liability than an asset.

If a man attends simply to his duty he will unconsciously develop the kind of character best calculated to help him carry on his work. Take the policeman, for instance. He probably never thinks about his "character" or "personality." The uniform, the discipline, the nature of his work all combine to harden and toughen him until he is fit to cope with criminals and to view with alertness a world that to him is always more or less under suspicion. Unconsciously he develops a "cop" mind, and becomes one of Squashville's "bravest." Precisely the same thing will happen to the salesman who attends to his work. His plain duty is to consider his customer's interests and his employer's interests and to make the two fit in with each other. He must be tactful and yielding over things that are open to discussion, and gracefully firm over things that are not. He must be equally as courteous to the bargain hunter, the fidget, the suspicious buyer, the nervous old lady who fears she is going to spend too much, as to the most accommodating customer on his list. If he does this, he may be assured that one by one the corners will be

THIS ALBUM MADE US FAMOUS
by selling it. Why don't you try?

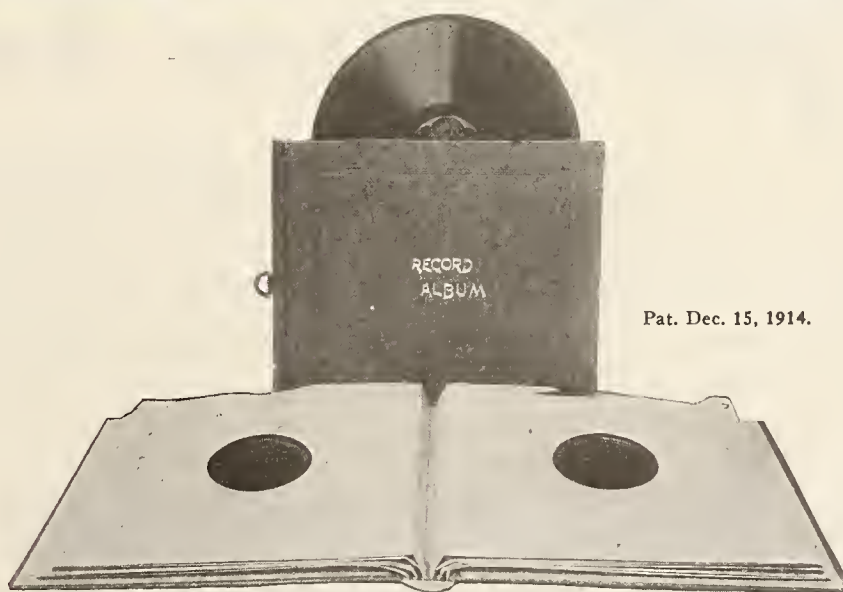

Buy Your Albums Direct From the Manufacturer

43-51 W. Fourth St.
New York, N. Y.

THE BOSTON BOOK CO., Inc.

The only exclusive Record Album Factory in the world.

Chicago Office:
1470 So. Michigan Ave

INDISPENSABLE TO DEALERS

What a Prominent Canadian Merchant Has to Say of The Talking Machine World—Believes in Getting as Near as Possible to a Cash Basis

Day after day The Talking Machine World receives communications from dealers located in all parts of the world, expressing words of appreciation for the merits of this publication, and the great value it is to them in the conduct of their business. For example, one which came to hand last week from Wm. Lee, Ltd., 618-622 St. Catherine St. West, Montreal, is interesting in this connection. It reads:

"We are very much alive to the benefits received through your very excellent magazine, The Talking Machine World. It is very interesting to hear the views of America's successful merchants from a financial standpoint. Finance in the musical instrument business means credit, and the advanced ideas of getting this talking machine business on a nearer cash basis is a very excellent move, as we are all beginning to recognize that the talking machine is to-day a necessity in every household, and when the general public gets educated to the cash basis, or short term payments, there will be just as many machines sold, and the dealer's risks will be at a minimum. Enclosed find check for the following year's subscription to your publication, which no talking machine dealer to-day can afford to be without."

WILL A. WATKIN CO. EXPANSION

The Will A. Watkin Co., Dallas, Tex., are doing an excellent business with the Columbia and recently installed several new demonstration rooms. They are carrying on a very forceful campaign of publicity in the local papers, in which the Columbia records are featured in a very striking and effective way. James I. Cruse, of the talking machine department of this house, is making a specialty of adjusting and repairing, and is building up quite a clientele.

EXPORTS OF TALKING MACHINES

The Figures for November Presented—Exports Show Machines and Records Both Increase

WASHINGTON, D. C., February 5.—In the summary of exports and imports of the commerce of the United States for the month of November, 1917 (the latest period for which it has been compiled), which has just been issued by the Bureau of Statistics of the Department of Commerce and Labor, the following figures regarding talking machines and supplies appear:

Talking machines to the number of 4,523, valued at \$164,762, were exported in November, 1917, as compared with 6,039 talking machines, valued at \$163,111, sent abroad in the same period of 1916. The total exports of records and supplies for November, 1917, were valued at \$173,159, as compared with \$169,224 in November, 1916. For the eleven months 79,117 talking machines were exported, valued at \$2,000,371 in November, 1917, and 56,009, valued at \$1,414,631 in 1916, while records and supplies valued at \$1,663,196, were sent abroad during 1917, as against \$1,121,885 in 1916.

NEW DELPHEON DEALERS IN TEXAS

DALLAS, TEX., February 4.—The Verhalen-Delphoeon Co., of this city, which was recently formed to act as distributor for the products of the Delphoeon Co., Bay City, Mich., has been closing a very satisfactory business. Walter Verhalen, head of the company, recently made a trip through the territory and closed a number of important deals. One of the new dealers which he appointed is the firm of Knight & Pevoto, of Sherman, Tex. This house is a very successful furniture concern and is making plans for an aggressive Delphoeon campaign in its locality.

There is rarely ever much work for the chemical engines and hose carriages when a man starts out to set the world on fire.

ISSUE A CLEVER CIRCULAR

Schmidt Music Co., Davenport, Ia., Utilizes Briggs Cartoon in Calling Attention to the Desirability of the Aeolian-Vocalion

DAVENPORT, IA., February 3.—In featuring the Aeolian-Vocalion, the Schmidt Music Co., of this city, recently conceived a very clever announcement for direct-by-mail advertising. The keynote of the circular was a reproduction of a cartoon by Briggs, showing the staid head of the family off his guard and jiggling delightedly to the music issuing from a phonograph. The caption was "It Happens in the Best Regulated Families." The caption appeared immediately under the name "Aeolian-Vocalion" in large letters at the top, thus making a very striking combination. The circular also bore a reproduction of a poem by Augusta Kortrecht, entitled "Since Father Bought the Phonograph," which appeared originally in "The Aeolian" magazine.

The Schmidt Co. states that the circular attracted widespread attention and comment, and judging from results apparently served to stimulate machine and record sales to a certain extent at least.

W. C. BETZER RESIGNS

Wm. C. Betzer, who for the past five months has had the management of the Victrola department of the James Black Dry Goods Co., Waterloo, Iowa, has tendered his resignation, which became effective February 1. Mr. Betzer has been connected with some of the largest talking machine departments in the country, both wholesale and retail, and his loss to the retail trade in Iowa will be deeply felt. The ill health of Mrs. Betzer is the cause attributed for the change being made.

Build on the thing that's yours. The eye that tags opportunity lets the horizon alone; it focuses on the foreground chance—briefly put, a bird in hand is worth two in the bush.



-WHY- Do You Use Tone Arms



"off the shelf"? You spend time and money freely on the design of a cabinet, why compromise on the tone arm? Why don't you put the same thought into the tone arm? Make it at least as distinctive as the cabinet.

We have experts who are specialists in designing tone arms that will blend with your cabinet in quality and appearance—that will continue quality unbroken from sound chamber connection to stylus groove.

These men are ready to serve and prove to you by sketches and figures that "INDIANA" made tone arms will increase the value of your machine and make it a better selling proposition.

Bear in mind that acceptance of this service does not obligate you in any way and anything developed for you is for you exclusively, and is not sold or sampled to your competitors.

WE ESTIMATE FROM SAMPLE OR BLUE PRINT

"INDIANA" DIE CASTING COMPANY

East 11th Street at Cornell Ave.

INDIANAPOLIS, IND.

100,000 FOR A NAME

NOTICE

Attention is called to the following changes in the conditions of our name contest, which were not included in the announcement of the contest made in the January issue of The Talking Machine World:

The contest closes at noon on March first, 1918. In the event that more than one person submits the name which is regarded as the best or most appropriate, the full prize of 100,000 needles will be given to each person submitting such name.

EVERY good product desires a good name. We want the Talking Machine trade to supply us with a good name for our product, needles made right to play right.

To the person or persons who suggest the most appropriate name for our needles we will offer as a reward 100,000 needles. None is barred from participation. We prefer the suggestion of some coined word that can be copyrighted.

To assist in selecting the proper name we wish to state that we will manufacture the best steel needles that can be put on the market.

Needles should be changed for each record played. Our process of manufacture will be such as to insure the reproduction of every delicate shading and tone. Continued use of our needles by your customers will mean contented patrons at all times.

We are desirous of hearing from distributors of needles who wish to establish a source of supply which can be depended upon at all times for quality, price and real service.

The contest will close at noon on March first, and the name chosen for our quality needles will be announced in the March issue of this periodical. In the event that more than one person suggests the prize-winning name, the full reward of 100,000 needles will be given to every one who submits said name. Anyone interested in the Talking Machine industry is invited to participate. All we ask is prompt action and to indicate at the same time the name of machine handled and firm with which you are connected.

Record Needle & Manufacturing Co.
Manhattan Bldg., Milwaukee, Wis.



Dollar bait! Al Jolson has sung the great Dixie hit, "I'm All Bound Round with the Mason Dixon Line." A Columbia headliner for March.

**Columbia Graphophone Co.
Woolworth Building, New York**

PORTLAND A BUSY TRADE CENTER

Some Record Sales During Holidays and January—Furniture Stores Taking on Talkers—Manufacturing Activity Gives Labor Greater Increased Buying Power—Some Big Brunswick Sales—News of Month Worth Recording

PORTLAND, ORE., February 4.—The sale of talking machines in Portland during the holidays and the month of January far exceeded all sales of previous years. Eilers Music House had a tremendous trade. H. A. Rayner, manager of the talking machine department, and his assistants had more business than they could handle. One day's sales amounted to \$7,000 and records were sold by the hundred. Such records as "Long Boy," "Joan of Arc," "Lil' Liza Jane" and other popular "Rags" or "Jazz" music were also sold out quickly, and the higher-class records were sold in large quantities.

The beautiful demonstration rooms of the G. F. Johnson Piano Co. were thronged with Victrola buyers during the month and the trade is excellent.

James Loder, manager of the Victrola department of the Wiley B. Allen Co., says they were practically sold out of Victrolas at Christmas and the sale of records by this house is unprecedented.

The Bush & Lane Co. report a big trade. The Sonora continues to gain in popularity among Portlanders. Several very high-priced Sonoras were sold by this firm.

The Wakefield Music Co. sold twenty-two Brunswick phonographs during the last month. These phonographs are now carried by a number of Portland houses and are selling rapidly.

The Hyatt Talking Machine Co., which carries the Columbia, the Edison and the Victrola machines, is one of the busiest places in Portland. E. B. Hyatt, manager of the company, says the business during the last two or three months exceeded that of any former year.

C. Collins, head of the talking machine department of the Reed-French Co., says that the holiday trade was exceptionally good. Edison and Columbia machines went like hot cakes. H. G. Reed, head of the Reed-French Co., is well satisfied with the business outlook of Portland and the surrounding country. This house will devote much of its attention to rural trade.

Meier & Frank's big department store carries Victrola, Edison and Columbia machines and has one of the largest stocks on the Pacific Coast. The trade of this house for December and January was immense.

The Lipman & Wolfe department store handles the Victrola, and Miss F. Isaacs in charge reports big sales during the past two months. This department has been moved to the ninth floor and in connection with the piano department makes a very handsome display.

A number of the principal furniture stores in Portland are selling talking machines. The Powers Furniture Co. had a big sale of Victrolas during the holidays. The Edwards Furniture Co. are selling the Brunswick and Unola phonographs and H. Jennings & Sons Furniture Co. sell the Grafonola and Windsor.

Shops, ship yards and lumber yards are all busy and giving work to both men and women of Portland and vicinity. This puts much money in circulation and the music dealers are reaping the benefit with the others. Many schools are being supplied with phonographs and the edu-

cational value of the machines is daily becoming more evident.

That the Victor is a favorite talking machine is evident from the fact that A. D. Hulburd, of Umatilla Co., Ore., came into the G. F. Johnson Piano House here and bought a Victor school machine, paying for it out of his own pocket, being convinced that the school directors of his district would approve of the purchase and buy it for the school. These school machines are very popular in Oregon and are materially assisting in the musical education of the children.

Nat Dumphy, of the Bush & Lane Co., accompanied by Thos. Wilkinson, manager of the firm, went to Seattle, Wash., recently to attend the annual banquet given by the Bush & Lane people. Mr. Dumphy was kept so busy selling Sonora, Victor and Columbia machines that a little relaxation was greatly appreciated.

The Stradivara machine, which is carried by a number of houses in this city, is becoming more and more popular. Eilers Music House had a big trade in these instruments during the holidays. The Remick Song Shop carries this machine and reports an increasing demand for it. The Hudson Arms Co., one of the most important sporting goods houses in Oregon, have added the Stradivara to their stock and are extensively advertising it.

Taylor C. White, manager of the phonograph department of Sherman, Clay & Co. here, after an unusually busy month got a three days' vacation which he spent in Seattle, Wash. Mr. White reports big sales of Victor machines.

A. R. Palmer, manager of the talking machine department of Olds, Wortman & King, this month visited Saginaw, Mich., to purchase Brooks talking machines for the firm.



WESER PHONOGRAPHS

For 39 years the piano trade has recognized in Weser instruments the highest piano and player piano value. It always has been our delight to invite comparison of the Weser products with those of other makers. Many of our best dealers have been acquired by such comparisons.

Weser Phonographs are making rapid headway in the same manner. Compare them with the world's most expensive makes—in tone quality—in appearance—in reliability, and solidity of construction, and we are content to abide by your decision.

The **Weser Phonograph** will play any record. Made in satin finish mahogany. Other woods on special order. Electric motor will be furnished if desired. Write for catalog.

WESER BROS., Inc.

520-530 West 43rd Street

NEW YORK



Necessity—The Mother of Invention

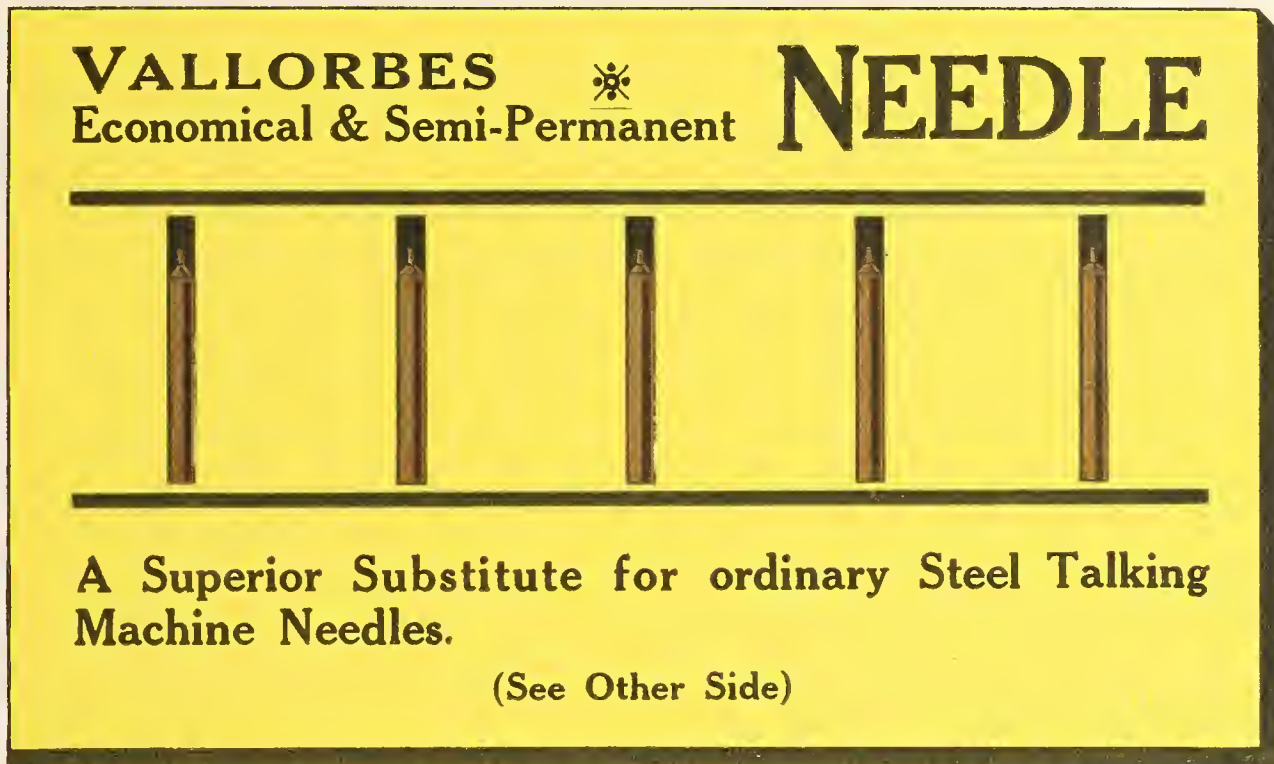

(Enlarged facsimile of package)

The Great World War has taxed the resources of the human mind, both lay and professional, to produce substitutes for articles made scarce.

Humanity has benefited by this, for in experimenting many new substitutes have been brought to light that are an improvement on the original articles.

These are here to stay.

We are now offering the trade a new needle—the Vallorbes Semi-Permanent Needle for playing lateral cut records.

At present, they retail for 15c per package of five and will return far more reproductions than 15c worth of the ordinary changeable steel needles will. They will not damage records. The points are parallel and as they wear down do not enlarge the lateral surface as do the tapered steel needles, thus conserving the life of the record.



Reverse side of package—Actual size.

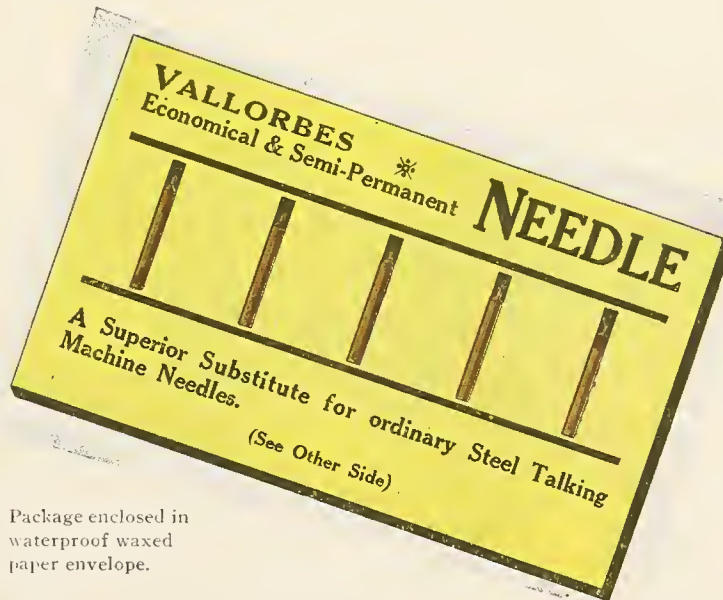

Package enclosed in waterproof waxed paper envelope.

Send 25c in stamps for a sample package. We will also send you dealer's discounts, etc.

Originators and Largest Manufacturers of DIAMOND POINTS



LANCASTER, PA., U. S. A.

"Vallorbes Semi-Permanent Needles" are made in Soft, Medium and Loud Tone. They are packed 100 packages to a carton.

SAPPHIRE BALL JEWELS Loud and Halftone

WHY ONE PRICE POLICY IS RIGHT

The Right Price for the Right Product Insures Satisfaction and Makes Better Business for the Salesman and Satisfies the Customer

The desire is born in the majority of people to purchase an article a little bit lower than the quoted price. Even though the original price may not be so high, a feeling of elation pervades the being of the person who has succeeded in beating the shopkeeper down. It flatters his vanity, and after a successful deal he considers himself an excellent business man. But does he ever take into consideration the fact that if a man lowers a price on his goods it really wasn't worth the first price, anyway, and probably isn't even worth the second price? How disappointing it is to a man who purchases an overcoat after beating down the salesman to see a duplicate of his coat in the window the following week tagged at least \$5 cheaper!

The one-price house eliminates all the dissatisfaction that arises from the thought that the lapse of a week or so will probably see the lowering of the price of a purchased article. Those people who are unable to buy anything without haggling over the price need not trade with a one-price house. But the person who desires real satisfaction will find it in that house and in that house only.

Another advantage of this system is that it makes it easier for both the salesman and the customer. If the price quoted is too high, the buyer is privileged to look at other goods not quite so expensive. No friction arises between the two; no argument is possible when the goods are permanently priced. The manager of the department is left in peace and is not called to make an article any cents cheaper than it is marked; he is enabled to carry on his end of the business without any unnecessary interference.

Of course, it takes time to educate some people to this system. It takes some time to impress upon them the desirability of a process in which it is impossible for human nature to enter and prove that the "Survival of the Fittest" is the winning law. This great system is a time saver and an energy saver. It does not leave the salesman utterly exhausted, so that he is cross and uncivil to the next customer he waits upon. It does not make his day one constant battle of wits. But what it does is to give him more time to display his goods and explain their value to each customer as he comes along.

And what does it do for the customer? It gives him more time to go from shop to shop and get exactly what he desires. He does not have to buy in the first shop he enters because

he can beat the salesman down lower there. It does not leave him so weary after the long struggle that he is incapable of making another purchase that day.

But this deplorable state of affairs will not exist when every retail firm in the country adopts the only system that really gives satisfaction to both the customer and the shopkeeper.

PATHE ARTISTS IN GRAND OPERA

Artists of the Chicago Opera Co., Who Have Made Pathé Records Were Featured During the Season Recently Opened in New York

The advertising department of the Pathé Frères Phonograph Co., New York, has called the attention of Pathé dealers to the fact that a number of famous artists, who are members of the Chicago Opera Co., record exclusively for the Pathé library. As the Chicago Opera Co. began recently a four weeks' stay at the Lexington Avenue Opera House, Fifty-first street and Lexington avenue, these Pathé artists are being featured extensively by the Pathé Frères Co., in the local newspapers.

The members of the Chicago Opera Co. who are exclusive Pathé artists are the following: Lucien Muratore, world-famous tenor; Anna Fitziu, Rosa Raisa, Rimini, Maguenat, Marcel Journet and Chenal.

These artists are appearing during the company's New York season, and the Pathé dealers are taking advantage of their appearances by featuring their records in every possible way.

GEORGE DEACON BECOMES MANAGER

George Deacon, former traveling representative for the New York Talking Machine Co., Victor wholesalers in Pennsylvania territory, has been appointed manager of the Economy Music Co., Scranton, Pa., well known Victor retailers. During his association with the New York Talking Machine Co., Mr. Deacon won the esteem and friendship of the Victor representatives in his territory and his intimate knowledge of dealers' problems will doubtless enable him to achieve pleasing success in his new post.

A QUESTION WORTH CONSIDERING

"What have I personally done the last year to help increase profits?" is a pretty good straight forward question to put to ourselves. Each one knows in his heart what the answer shall be; whether he has put his shoulder to the wheel, or let the other fellow take care of profits. That is not the point, however. The past is gone, but it can help us to take stock and plan for the future.

EDISON DISC JOBBERS TO MEET

Annual Convention of Association to Be Held at Hotel Knickerbocker on February 18 and 19—An Interesting Program Planned

The annual convention of the Edison Disc Jobbers' Association will be held at the Hotel Knickerbocker, New York, on February 18-19.

As is usually the case, an elaborate program is being arranged for the affair. There will be papers on important business subjects read by members of the association, talks by factory officials and comprehensive discussions of business conditions. Although nothing official has been announced it is believed that the factory will provide the usual entertainment for the visiting jobbers, which generally includes a dinner and theatre party.

The present officers of the association are: Walter Kipp, of Indianapolis, president; L. N. Bloom, of Cleveland, vice-president; F. E. Bolway, Syracuse, N. Y., secretary; and H. H. Blish, Des Moines, Ia., treasurer.

OPTIMISTIC REGARDING BUSINESS

R. W. Gresser Finds Delpheon Jobbers in Atlanta and Dallas Steadily Expanding Their Agencies Throughout an Important Territory

BAY CITY, MICH., February 6.—R. W. Gresser, sales manager of the Delpheon Co., in this city, returned from a trip to Atlanta and Dallas, where he visited the Delpheon jobbers who established headquarters in these cities during the past few months. Mr. Gresser states that these jobbers are very optimistic regarding business for the new year, and he was pleased to learn that they had established a number of important agencies in their respective territories, which means enlarged sales.

Mr. Gresser states that the greatest difficulty of the Delpheon Co. at the present time is in getting machines to these jobbers soon enough to meet the demand. He states that the Delpheon product is being accepted enthusiastically, and that it is being sold with push and earnestness. He is quite optimistic regarding the way in which the Delpheon is being received and contracts already closed will triple the factory output for 1918.

AL WILLIAMS TAKES CHARGE

SCRANTON, PA., February 8.—Jack Davis has resigned as manager of the Victor establishment of Stoehr & Fister, of this city. He is succeeded by Al Williams, who formerly occupied this position and is well known in the local Victor trade.



NYOIL

is the last word in the refining of high-grade oils, for every impurity is taken from it, leaving nothing but what is required to keep machines in perfect condition, being combined of four oils perfectly blended.

Will not Gum, Chill or become rancid; is free from acid. It is colorless and has no sickening smell, being absolutely odorless.

"The finest and most delicate pieces of mechanism do not prove efficient unless properly lubricated. Skill, Genius, Invention and Workmanship must have the proper Oil. Stop and consider this when you have to buy an Oil for household use."

Hundreds of satisfied customers have written us that they would never use anything else for **TALKING MACHINES, GRAPHOPHONES, PHONOGRAPHS AND SEWING MACHINES**

NYOIL will lubricate the machinery and polish all woodwork

and can be obtained of any "Up-to-date" Talking Machine Dealer in the world, and is manufactured by Wm. F. Nye, who for 50 years has made 80% of all the Watch, Clock and Chronometer Oil that is used in America.

WM. F. NYE, NEW BEDFORD, MASS., U. S. A.



NYOIL is put up in the following sizes:

- No. 1 Bottle 1 ounce
- No. 4 " 3 ounces
- No. 8 " 8 ounces

NYOIL is put up in the following sizes:

- No. 16 (Cans) 1 Pint
- No. 32 " 1 Quart
- No. 128 " 1 Gallon
- No. 540 " 5 Gallon

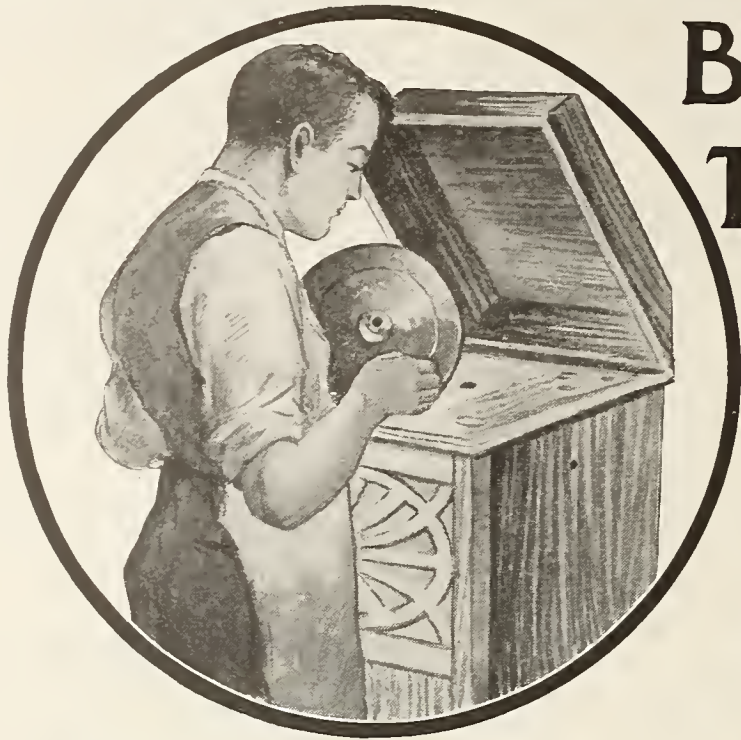

BUILDING UP or TEARING DOWN?



Which are you
doing in your

Talking Machine Business?

Just remember that unless you are putting real quality—super merit—into the working parts of every Talking Machine you make, you are tearing down instead of building up. Every poor machine sent out hurts you, hurts the dealer and displeases the customer. The success of your business depends on your motor.

Build quality into your product. Use the one best motor, because it is the life of your machine.

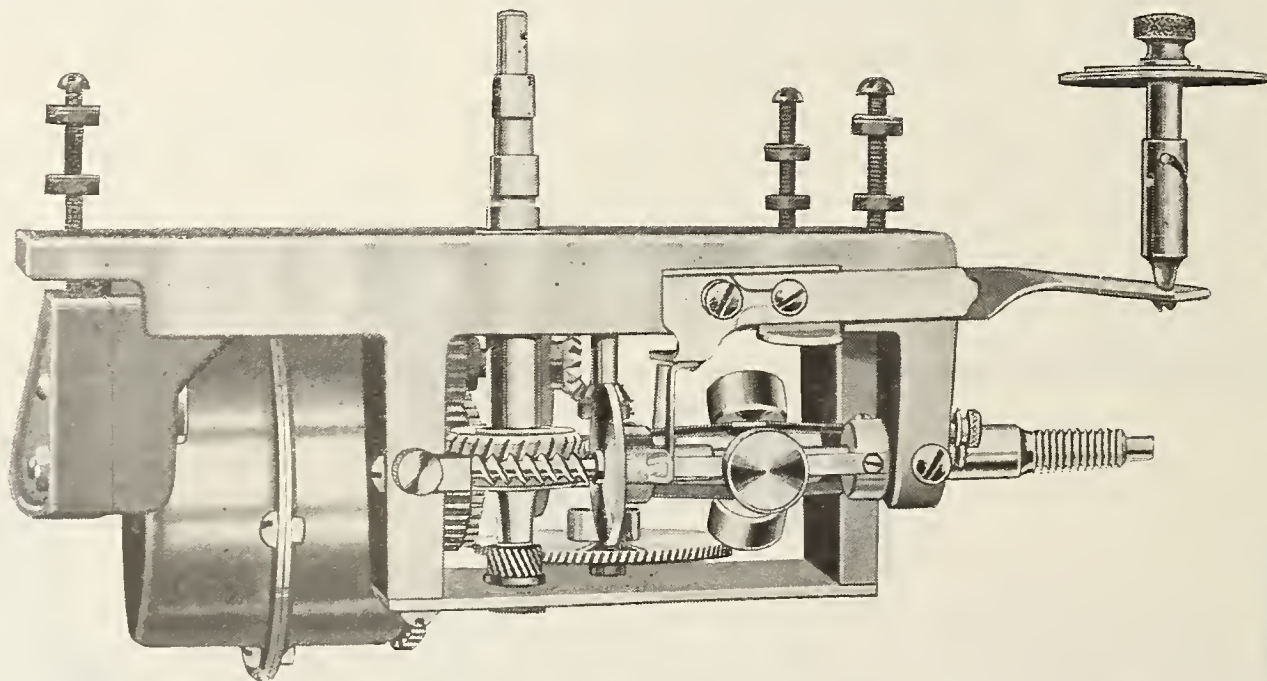

The Dayton Motor

is considered
by manufacturers
as being the

Best Motor in the World

The highest engineering skill was appealed to, and responded with designs for the "Dayton." The machine is built by careful workmen, trained in such enterprises as National Cash Register, Delco, Computing Scale, Wright Airplanes, and others which have given Dayton the title, "The City of Precision." Its workmanship had to be the highest to equal the merit of the design. It has made good wonderfully in thousands of machines.

You will gain reputation and re-orders if you equip your Talking Machines with it, and you will have no motor troubles. Why take chances on other makes when the "Dayton" means satisfaction?

Dayton Tone Arms are universal, playing any disc record. Five styles.

Dayton Reproducers are scientifically correct, and thoroughly practical. Two styles.

Write and let us tell you how to enhance the value of your machines at no more cost. Get our new phono-parts catalogue.

The Thomas Manufacturing Co.

322 BOLT STREET

DAYTON, OHIO

THE WORLD PROMINENT IN EXHIBIT

This Publication, Together With The Music Trade Review, Featured as Representative Organs of Two Leading Divisions of Music Trade at Trade Journal Display in Newark

Two of the outstanding features at the Trade Journals' Exhibit now being held in the Library Art Gallery in Newark, N. J., under the auspices of the Newark Free Public Library and the Newark Museum Association are The Talking Machine World and The Music Trade Review, which have been given a prominent place as the representative organs of the two divisions of the industry which they cover.

The World and The Review are placed in conspicuous positions on sloping screens near the entrance of the exhibit, so that they may be readily seen and examined by those who attend. Altogether there are about one thousand trade journals covering all branches of business in the industry, many of them little known by the laymen. The exhibit, however, serves to emphasize the importance of strictly business publications, for there is hardly a trade that has not at least one representative publication in the group.

The Newark Library has a business branch which makes a specialty of "Prints for Business Men." Over 250 trade journals, 350 house organs, and hundreds of publications along other and similar lines are on file at all times and the library subscribes for about \$3,000 of such publications annually.

The library officials have long been urging the use of trade publications in the schools, and literature recently issued says:

"Why does the teacher teach children to read and give them practice in reading fiction, poetry, essay, drama, literary description, and give them to read so little of directly informational material? Children ask for facts, Heaven knows; and we give them only fancies. Why does the teacher teach children to write friendly letters, anecdotes, descriptions of natural scenery, biographic sketches, moral homilies, yea, even poems, and fail to practice them on clear narratives of How the Clothes Wringer Works, and What to do to a Squeaking Hinge, or descriptions of the Purse I Lost, or Jack's Bob-sled? Why do librarians act as though their buildings were constructed and their salaries paid for lending light literature to be lightly read by light heads? And, for that matter, why do business men fail to demand that the existence of things written for the business world be recognized in libraries, and finally, why does not the business man read what the libraries do have of material that would be of value to his life and his business?"

"This exhibition stimulates one to the asking of these questions. If they will come to see it, it will doubtless stimulate some members of the community to answer them."

COLUMBIA EXPANSION IN CANADA

Mervin E. Lyle, of the executive office staff of the Columbia Graphophone Co., has been appointed to the Canadian division of the company for the time being as assistant to James P. Bradt, general manager of the Columbia, in the installation and organization of a new Columbia factory in Canada. Mr. Lyle's many years of experience in the manufacturing division of the Columbia Co.'s activities ideally equip him to render Mr. Bradt invaluable assistance in the establishment of the new plant.

FILE SCHEDULES IN BANKRUPTCY

Phonograph Specialties Mfg. Co., of 120 Walker street, New York, has filed schedules in bankruptcy with liabilities of \$11,091, of which \$3,337 are secured claims. The assets of the concern are listed at \$4,891.

The Peyer Music Co. has opened showrooms at 415 Cedar street, St. Paul, Minn., where they are featuring Columbia Grafonolas and Sonora phonographs. W. H. Simpson is manager.

TRADE SITUATION IN SWITZERLAND

U. S. Consul at Berne Tells of Class of Talking Machines in Demand in That Country

WASHINGTON, D. C., February 7.—United States Consul at Berne reports that there are some very strong concerns producing talking machines in Switzerland, but German products have a very large sale. Talking machine parts are manufactured extensively in and near Geneva. The greatest concern is the Deutsche Gramophon Gesellschaft at Berlin, represented in this district by Kaiser & Co., Markt-gasse, Berne. No talking machine discs are manufactured in Switzerland. Mostly all of them are imported from France and Germany.

Current prices are: German (American) makes, from \$32 to \$350; German, \$8 to \$120; Swiss, \$7 to \$100; French, \$10 to \$110. German, French and Belgian discs are on the market at \$0.40 to \$1.50. Since the war started prices have increased 15 per cent.

The German Gramophon Co. of Berlin and Pathé of Paris have the largest share of the trade. The German imports, including German-made American machines, amounted in 1914 to \$47,828, and French imports to \$15,488, while the direct American imports were valued at \$1,752.

Talking machines without horns have the widest sale, but the demand has been reduced by the war. Orders are regularly executed by Germany, however. Twenty to 35 per cent. is granted to dealers on talking machines and discs. France is a keen competitor in discs.

The exports of talking machines, cinematographs and similar machines in 1914 amounted to \$384,573; the imports, to \$70,755. The duty on phonographs, according to the Swiss customs tariff No. 955, is \$3.86 per 220 pounds.

The Victor Talking Machine Co. contributed \$2,500 to the \$50,000 fund being raised by the Knights of Columbus, of Camden, N. J., for work in the army cantonments.

BAYONNE, N. J., DEALERS ORGANIZE

Talking Machine Men Form Association for Purpose of Bettering Business Conditions

The talking machine dealers of Bayonne, N. J., which is not far from New York City, have organized a local association and adopted for it the name of "The Talking Machine Men of Bayonne," with Louis Gurans, president; E. G. Brown, secretary, and S. Wolfson, treasurer.

The association was organized at a meeting held recently in the store of the Bayonne Talking Machine Co., under the direction of Mr. Gurans, and it was believed that by getting together the dealers it might aid in eliminating the various trade abuses, and otherwise improve trade practices.

E. G. Brown was named a committee of one to draft and submit a constitution and by-laws for the new association, the charter members of which are Mr. Brown, S. Feldman, Louis Gurans, Harry Gleich, T. H. Kefer, S. Wolfson, J. H. Marshall and E. F. Mumby.

FEATURING HEIFETZ RECORDS

Victor Co. Issues Handsome Posters for the Use of Talking Machine Retailers

The four new Victor records by Jascha Heifetz represent the latest sensation in the Victor catalog, for this young violinist has taken the musical world by storm. The Victor Co. has planned its advertising to give full prominence to the Heifetz records and has sent to dealers most artistic posters bearing a life-size portrait of the violinist, together with an announcement of his exclusive contract with the Victor Co. and the production of his first records. Special advertising electros are also provided.

The Mid-West Phonograph Co., Chicago, has been incorporated with a capital stock of \$2,500 by Marion Luce, Anna Thustrup and H. A. Boissat.

Manufacturers—Jobbers—Dealers

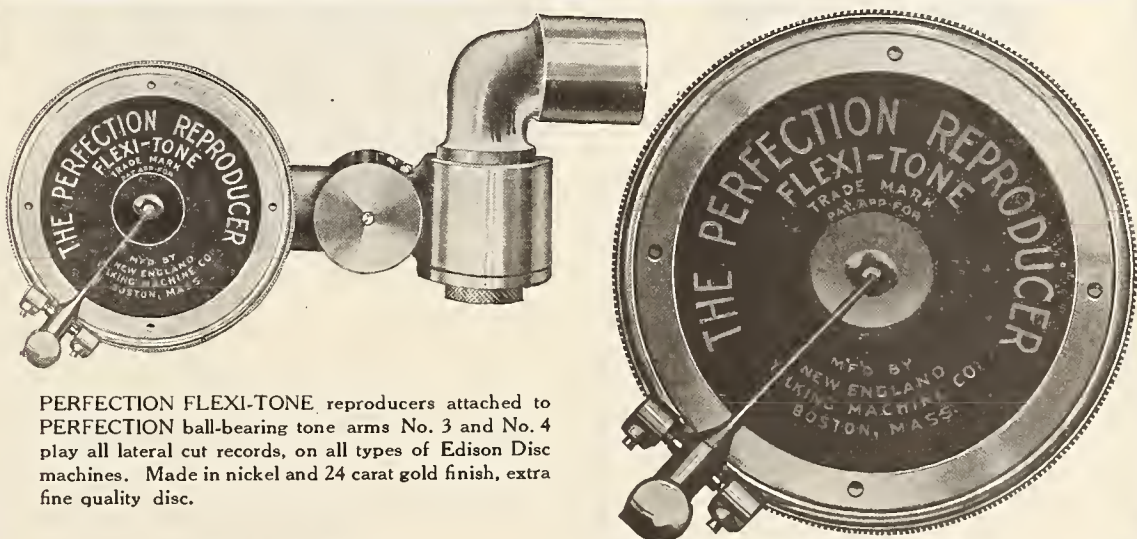

PERFECTION FLEXI-TONE reproducers attached to PERFECTION ball-bearing tone arms No. 3 and No. 4 play all lateral cut records, on all types of Edison Disc machines. Made in nickel and 24 carat gold finish, extra fine quality disc.

Tone arms fitted to Edison machines only

PERFECTION FLEXI-TONE reproducers No. 3, No. 6 and No. 7 fit all types of Victor and Columbia machines. Made in nickel and 24 carat gold finish, extra fine quality.

These reproducers and arms are the very finest made mechanically. The PERFECTIO FLEXI-TONE reproducers are the most perfect phonograph reproducers built, reproducing all lateral cut records, from highest pitched soprano, to lowest pitched bass, as perfectly as the records were recorded in the recording room. Wonderful clarity of sound, as well as great volume. Extra fine quality of finish guaranteed. Manufacturers, jobbers and dealers will find in this line of reproducers just what they have been looking for, as they are assembled by skilled workmen especially adapted to this kind of work, producing a product built with watchlike precision.

All accessories in stock ready for immediate shipment. Phonograph manufacturers can have PERFECTIO FLEXI-TONE reproducers fitted to their machines Write for prices, information, etc.

NEW ENGLAND TALKING MACHINE CO.

16-18 Beach Street

BOSTON, MASS.

Lucky 13 Phonograph Co., 3 East 12th St. NEW YORK



Type B—39 in. high. \$18.50 Wholesale
Double Spring Motor Plays all Records

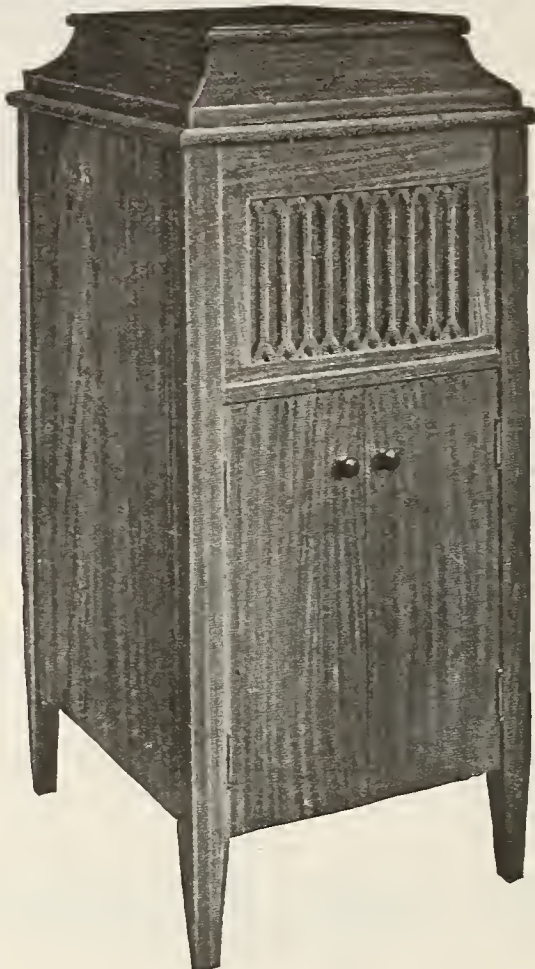

Type C—42 1/2 in. high. \$20.50 Wholesale
Double Spring Motor Plays all Records



Type D—46 in. high. \$26 Wholesale
Double Spring Motor Plays all Records

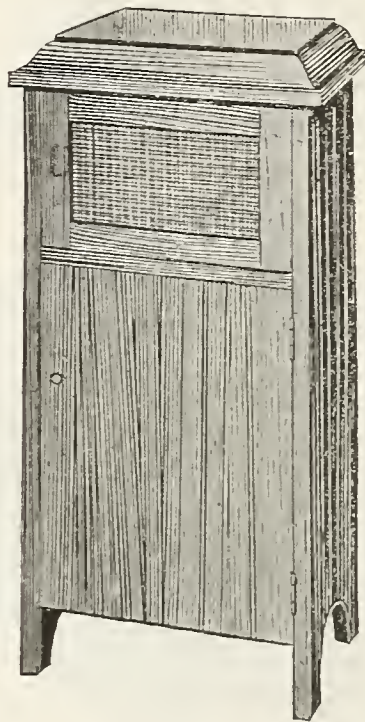

Type A, in Oak—35 in. high. \$13 Wholesale
Double Spring Motor Plays all Records

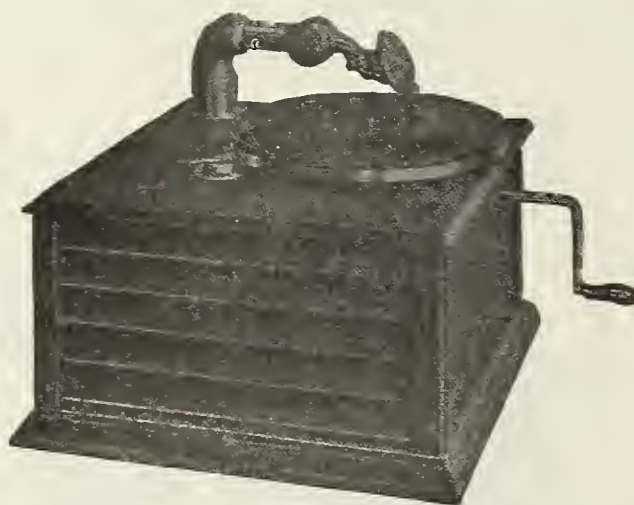

Type 15 \$8 Wholesale
Double Spring Motor Plays all Records

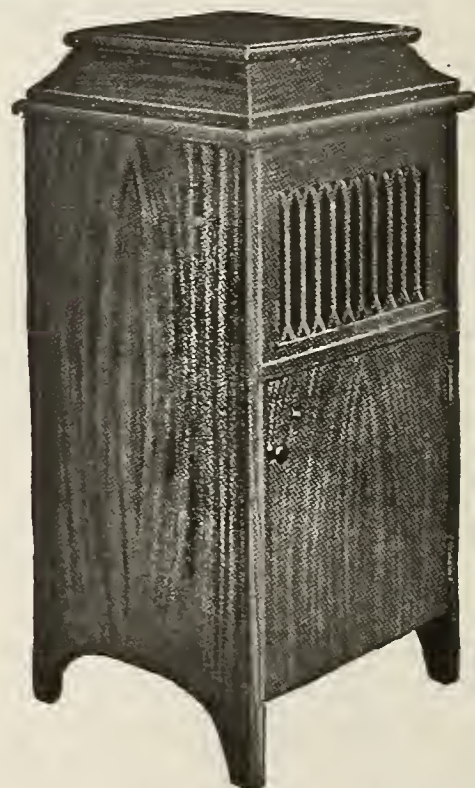

Type A, in Mahogany Finish—35 in. high
\$15 Wholesale
Double Spring Motor Plays all Records

STEEL NEEDLES

65c per thousand. Immediate Delivery.

RECORDS

The "Popular" Brand, 10-in. double face, lateral cut, all instrumental:

32c in lots of 100
30c in lots of 1000
29c in lots of 5000

MOTORS

No. 0—8-in. turntable\$1.25	10-in. turntable\$1.40
No. 1—10-in. turntable 2.65	12-in. turntable 2.95
No. 6—10-in. turntable, double spring	... 3.50	12-in. turntable 3.85
No. 8—12-in. turntable, double spring, plays 3 records 4.75		
No. 9—12-in. turntable, double spring, plays 3 records 5.75		
No. 10—12-in. turntable, double spring, plays 4 records 6.75		
No. 11—12-in. turntable, double spring, plays 7 records 8.50		

MAIN SPRINGS

No. 0—3/4 in. 20 gauge 8 ft. 6 in.	25c ea. 100 lots 20c ea. 1000 lots 19c ea.
No. 1—3/4 in. 25 gauge 10 ft.	39c ea. 100 lots 35c ea. 1000 lots 33c ea.
No. 2—13/16 in. 25 gauge 10 ft.	39c ea. 100 lots 35c ea. 1000 lots 33c ea.
No. 3—7/8 in. 25 gauge 11 ft.	49c ea. 100 lots 44c ea. 1000 lots 42c ea.
No. 4—1 in. 23 gauge 10 ft.	49c ea. 100 lots 44c ea. 1000 lots 42c ea.
No. 5—1 3/16 in. 27 gauge 18 ft.	90c ea. 100 lots 85c ea. 1000 lots 80c ea.

GOVERNOR SPRINGS

\$1.00 per hundred. Special price on large quantities for motor manufacturers.

SAPPHIRE POINTS AND BALLS

Sapphire Points13c each in 100 lots	12c each in 1000 lots
Sapphire Balls15c each in 100 lots	14c each in 1000 lots

NEEDLE CUPS

\$20.00 per thousand, \$17.50 per thousand in 5,000 lots. Larger quantities still lower.

NEEDLE CUP COVERS

Baby, to play 7-in. records only \$.60
No. 1—Tone Arm and Reproducer90
No. 2—Tone Arm and Reproducer, for playing all records 1.25
No. 6—Tone Arm and Reproducer, for playing all records 2.25
No. 7—Tone Arm and Reproducer, for playing all records 2.25
No. 8—Tone Arm and Reproducer, for playing all records 2.25
No. 4—Tone Arm and Reproducer, for playing all records 2.65

\$10.00 per thousand, \$9.00 per thousand in 5,000 lots. Larger quantities still lower.

We also manufacture special machine parts such as worm gears, stampings, or any screw machine parts for motor manufacturers. Special quotations given for Canada and all other export points. Merchandise delivered with custom duty, war tax and freight paid by us. Write for our 84 page catalogue, the only one of its kind in America. Illustrating 33 different styles talking machine and over 500 different phonographic parts, also gives description of our efficient repair department.

SAN FRANCISCANS OPTIMISTIC ANENT TRADE OUTLOOK

Believe Action of Government Has Done Much to Help Freight Conditions—Considerable Stock on Way From East—California Phonograph Co. Takes Over Kohler & Chase Department

SAN FRANCISCO, CAL., February 5.—The demand for talking machines of all grades continues very good in this city and at all the Bay points. Shipments are slow in coming in and the stocks of some of the more expensive machines, especially those in art cases, are practically exhausted. The Eastern blizzard and consequent tie-up of freight and the subsequent order of Fuel Administrator Garfield shutting down industrial plants for a period of five days caused some despondency at first. But when realization came that the order was for the purpose of relieving the freight situation a more optimistic spirit prevailed. Last year's business was so satisfactory and this year's demand has kept up so well that the dealers feel that they will get enough stock to keep them going, even if it is not just the kind that they want. The public is beginning to understand the situation as it applies to phonographs, much better, and in most instances the would-be purchasers are selecting some other case when they cannot get just what they wanted. This keeps the stocks moving, and notwithstanding the clouds of doubt in the sky for the present business is good.

Enthusiastic Over the Convention

F. A. Dennison, formerly district manager for the Columbia Graphophone Co. and newly appointed local manager of the San Francisco office, accompanied by C. V. H. Jones, the former San Francisco manager, together with T. O. Moore and Paul West, of the dictaphone department, have just returned from the company's convention in New York. They are all enthusiastic over the convention and the prospects for the coming year. During the absence of the district and local manager A. G. Farquharson had charge of the business. Both managers speak in high terms of his efficient management while serving in the dual capacity of district and local manager. W. F. Stidham, local manager of the Columbia at Los Angeles, returned with the San Francisco boys, and spent several days in this city before returning to his duties in the South. W. W. Weaver has joined the local sales force.

Buys Stock of Fox Piano Co.

The Jackson Furniture Co., of Oakland, which was negotiating for the talking machine department and stock of the Oakland branch of Kohler & Chase, could not reach an agreement with the latter and broke off negotiations. This week the Jackson Co. bought the stock of the Fox Piano Co., and with the purchase secured a Victor sales agency.

California Phonograph Co.'s Important Move

Kohler & Chase, of this city, have sold their entire stock of talking machines to the California Phonograph Co. and gone out of that end of the music business. As yet they have not sold their stock in the Oakland store, although it is understood there are several dealers negotiating for it.

The California Phonograph Co. by the purchase of the stock of talking machines formerly handled by Kohler & Chase, secured the Victor agency to add to the Columbia and Edison, which they already possessed. This company started as a branch of Eilers music house and later became independent. It moved to its present quarters just before Christmas, retain-

ing display on the ground floor of Eilers until the middle of this month when it moved the balance of its stock and the last thread binding it to the parent house was severed.

Plans an Active Campaign

The Steger talking machine, made by the Steger piano people, is said to be attracting some favorable attention on the Coast. George Heidinger, who represents the company, says he is going to make an active sales campaign with the machine this year.

Stern Talking Machine Corp. Branching Out

Frederick Stern, of the Stern Talking Machine Corp., is looking for openings in several Coast cities. This company was formed only a couple of years ago and now has stores in Oakland, Los Angeles and Richmond as well as San Francisco. Mr. Stern says his only difficulty is in getting stock. He finds the easiest part of business is to raise money to finance new stores and to sell machines.

Progress of Brunswick Phonograph

The Brunswick-Balke-Collender Co., with headquarters in this city, has established an agency in every city of any size in the State, and is planning a big campaign for 1918. The local manager is a "live wire."

Geo. W. Lyle Enthusiastic Over Pathé Prospects

George W. Lyle, general manager of the Pathé Co., is making a tour of Western cities with San Francisco as his temporary headquarters. While here he went over the situation with the managers of the Western Phonograph Co., who act as agents for the Pathé machine. Mr. Lyle is enthusiastic over the outlook for the present year, and says that his machine is constantly growing in popularity.

Sells Carload Quickly

George T. Hively, manager of the phonograph department of the Eastern Outfitting Co., says that he received a carload of Columbia phonographs shortly after the first of the year, and nearly all of them were sold before they arrived. The rest, he says, were quickly snapped up and now he is trying to get some more rushed through.

Anxiously Awaiting Victrola Shipments

Sherman, Clay & Co. have received notice that a shipment of Victrolas has been started to them, and A. G. McCarthy, the manager of the department, says that their arrival will be very welcome, as his stock is very much depleted. Under normal freight conditions they ought to arrive in about twenty days, but under present conditions he cannot predict when the machines will get through.

Developing Pacific Coast Trade

The senior member of the firm of Passow & Sons, of Chicago, who make the Musicrola, has been in San Francisco for some time assisting in making their talking machine better known on this Coast. The Century Co., which has two stores in this city under the management of Miss Field, is the agent for the Musicrola, and during his stay Mr. Passow makes his headquarters at these stores.

Featuring Lansing Khaki Covers

W. S. Gray, Coast manager of the Domestic talking machine, has moved his office to 530 Chronicle Building, where he is planning to open up a general manufacturers' agency for lines used by talking machine dealers. He is now representing the Lansing khaki moving covers made by E. H. Lansing, of Boston, and should be able to place these necessary supplies with every live dealer on the Pacific Coast.

Edison Shop Pleased With January Trade

The Edison Shop in this city reports that its last year's business was more than gratifying, and that the way business opened up in January it looks as if this would be a banner year unless something unforeseen happens.

Joins the Baldwin Sales Force

William Lawrence, who for a long time was with the phonograph department of the Em-

porium department store, and more recently in the same department at Kohler & Chase, has, since the latter discontinued its talking machine department, made connections with the Baldwin Co., in this city.

Making Machines in Pasadena

Coops & Sons, who have been manufacturing talking machines in Pasadena, are said to have improved their machine so that it will now play all makes of disc records. The company is establishing agencies all over the Pacific Coast.

MEXAPHONE CO. INCORPORATED

The General Mexaphone Co. of West New York, N. J., has been incorporated for the purpose of manufacturing mexaphones with a capital stock of \$500,000. The interested parties are: Henry T. Crapo, Boston; Willis A. Farnsworth, Winthrop, Mass.; James H. McClellan, Brookline, Mass.; William Walser, West New York.

An Open Letter to Every Live DEALER in the Trade

We want more dealers to know about STRADIVARA, and the quickest way we know how to do so is to "deliver the goods," and here's how we intend to do it:

WE WILL SHIP
from our regular stock

200

STRADIVARA
"KNOWN FOR TONE"

Machines

AS DEALERS' SAMPLES

If you consider yourself a "Live Dealer" be one of the "200" to join us in forcing the issue for our big Spring drive for business. Write today for a sample machine while the 200 allotment lasts.

Join this list of Live Dealers who have sold hundreds of our machines and are making REAL PROFITS:

- | | |
|--|---|
| Pickering,
Pittsburgh, Pa. | Robt. T. Everhart,
Norfolk, Va. |
| Wm. Beagle,
Johnstown, Pa. | Geo. L. Schuyler,
Watertown, N. Y. |
| Russell & Rigg,
Altoona, Pa. | Howell Bros.,
Hoboken, N. J. |
| F. P. Weaver,
Meadville, Pa. | Nat'l Furn. Co.,
Newark, N. J. |
| J. Stearns Wyman,
Boston, Mass. | Cannon Furn. Co.,
Newark, N. J. |
| S. Da. Boll,
Rochester, N. Y. | Hoffman Furn. Co.,
Newark, N. J. |
| B. E. Pudney,
Owego & Sidney, N. Y. | S. E. Lee Piano Co.,
Bridgeport, Conn. |
| L. B. Van Wageningen Co.,
Kingston, N. Y. | O. W. McVrell,
Winsted, Conn. |
| Larkin Piano Co.,
Yonkers, N. Y. | Walter Andrews,
Jamestown, N. Y. |
| Lindner Piano Co.,
Buffalo, N. Y. | Geo. A. Fellows,
Gloversville, N. Y. |
| Selmorc Piano Co.,
Brooklyn, N. Y. | |

Space prohibits us from mentioning several hundred

After all the supreme selling test is quality—by comparison; and STRADIVARA has all the features of other machines, with the REAL Norwegian spruce sound board tone feature added.

7 Models — from \$45 to \$225

SCHILLING PIANO CO., Inc.
Wholesale Distributors
112 WEST 23d ST., NEW YORK

DEALERS EVERYWHERE ARE SELLING
QUANTITIES OF OUR

HANAIEI BANJUKES

(Ukuleles in Banjo Form)

A bigger hit than the Ukulele because much louder and more pleasing in tone, and of more substantial construction. Perfect two octave scales. A thoroughly practical instrument for both solo playing and club work. Send for illustrated catalogue and price list today, as

The Banjuka Is One of the Biggest Sellers
in the Musical Instrument Line.

SHERMAN, CLAY & CO.
Sole Manufacturers

163 Kearny Street San Francisco

Why Not Feature
The Century Phonograph
as Your 1918 Leader?

No. 2 of a
Series

**A Popular
Century
Style**



No. 20—Quartered Oak
or Genuine Mahogany,
24 x 24 x 49½, \$200.00

What the Century Represents

The dealer who handles the **Century Phonograph** is not handling an experiment or a fly-by-night product, but a substantial, established and **guaranteed** phonograph.

Why the Century Leads

The Cabinets are manufactured by the largest talking machine cabinet manufacturers in the world, the Century Cabinet Co. The tone quality is pronounced by experts as unsurpassed and every part is a distinctive **Century** product. The Universal tone arm on the Century phonograph is the best on the market and an established success—every part on this phonograph except the motor is a Century guaranteed product, and the motor is the best obtainable.

What We Offer the Dealer

We offer progressive dealers a **complete** line of machines and a liberal proposition, backed up by a company that is in business to stay—not for a few weeks or months.

WRITE TODAY FOR
OPEN TERRITORY

Century Cabinet Company

25 West 45th Street, New York

Factory—Utica, N.Y.

What Amount Should A Dealer Spend to Make Publicity Profitable :: :: By W. Denville Simons

The talking machine dealer who avoids advertising bids fair to become as extinct as the dodo before very long. Here and there may be found firms or individual traders who, by virtue of a good position contiguous to some more enterprising rival, are able to "reap where they have not sown," and benefit by efforts to increase trade to which they have contributed nothing.

Such firms nowadays are, however, in the exception, and the item of advertising looms more or less largely among the expenses which have to be watched warily so as to attain the greatest possible results for the outlay.

In the face of competition, which grows keener every day, advertising is absolutely imperative and necessary if a respectable profit would be shown.

Certain expenses are incidental of course to every business, and it is a well-known axiom that "one must spend money to make money," and this cannot be avoided.

The money for rent, light, taxes, delivery charges, and salaries, all has to be spent before money can be earned to constitute a profit, and in the same way advertising is coming to be regarded more and more as an inevitable charge.

There is no experimental work in advertising nowadays, as it has been conclusively proved to be a profitable investment, but the question is, what is the right amount to devote to this indispensable item? In this article it is proposed to endeavor to fix a standard of advertising cost whereby individual cases of advertising may be tested and a more or less satisfactory working basis arrived at.

Many traders working under different conditions in different localities have given the writer the benefit of their experience, with the result of such information imparted being of considerable value.

Broadly the trade must be classed as national and local, each having its own distinct problems to solve. It is not proposed to deal with the national advertising problem, though doubtless investigation here would demonstrate that advertising nationally is even more costly than the local. The reason to be borne in mind is that the large city stores making any State their field of operations are considered general advertisers to a degree that would never pay a local store to emulate. Consequently we are here concerned only with the traders with a definite circumscribed sphere of influence.

The average local trader who sometimes runs several departments finds his advertising a distinct problem and therefore this is the object of our consideration.

After making every inquiry and giving careful thought to the whole subject the writer believes the average figure to be somewhere about four per cent. on the gross turnover, which should cover all work and mailing charges on your mailing list and whatever press advertising is done. This may be rather a generous estimate to some, though many successful traders place it higher.

Below this figure is just enough to make advertising an irritating expense, but not sufficient to make the expenditure an investment. No man can advertise a business of this kind scientifically and profitably on less than four per cent., although it ought to be nearer the five per cent. mark.

A dealer advertising to a better class clientele at slightly under this figure obtains a small measure of results, while the aggressive dealer or store out for the trade of the Tom, Dick and Harry type, to supply everything that brings in a profit at all, must be prepared to come nearer the five per cent. of his gross turnover towards his advertising expenditure. The above

figures are arrived at by actual experience of men who regularly advertise and who should know. Furthermore, the firms who have given the writer the above information are now successful and progressive, and not likely to continue spending money without being perfectly assured it is for their own benefit and profit.

For the benefit of the doubters as to the advantage of spending so much money, a few words as to what advertising really means to a business man would not be out of place.

Far too many business men consider advertising a bugbear—they feel they ought to ad-

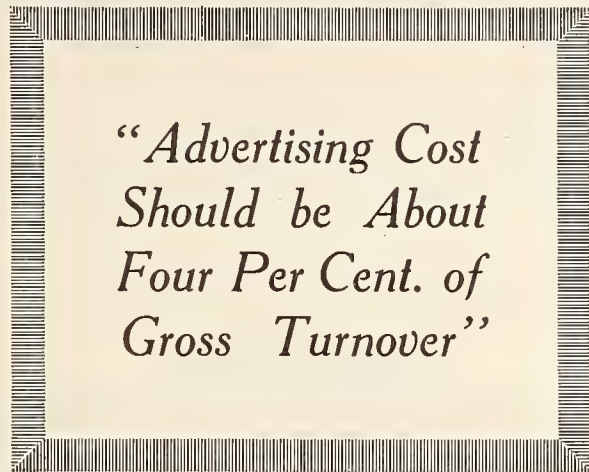

vertise, and when they make a spasmodic attempt, it has the experience of a nightmare, and is a constant worry until it is safely handed over to the postal authorities for distribution.

Can you wonder why such men doubt if it pays? Then again, that class of advertiser expects too much for his advertising, as should his announcement fail to produce an immediate return of orders the whole system is put down as being no good, money thrown away, etc. That is the fetish of "direct results" which has a deterrent effect on many a man who could advertise to his own great advantage, but fails to grasp the real significance of what advertising can do for him.

One of our cleverest American copywriters once said: "The essence of advertising is reputation that is indispensable to any considerable advance being made." That is a solid

truth and nothing will create reputation quicker than smart and careful advertising. It goes without saying that the written word must be backed up by the performed action, otherwise it were best that it were not written.

The greatest value of any advertisement, in the writer's opinion, however, lies in the power of suggestion. It is now well recognized that people do not always buy merely the things they want in a strict sense of the word. If that were so many talking machine houses would find, like Othello, their occupation gone.

It's the things people believe they want after reading a carefully drawn out advertisement that increase the turnover, and the fellow who draws up the advertisement helps the "almost persuaded" to make up their minds. A salesman must have his customer in front of him before he can do anything, whereas the work of the advertisement can be done anywhere, and this is its chief value.

Any particular line advertised may not be asked for at once if the talking machine is used as a side line in the business, but they have stimulated interest and brought the folks into the store to spend. That is what you pay the 4 per cent. for and it is worth it every time. Don't let it be believed that the writer has no belief in the possibility of direct sales from advertising. Such is far from the case, but the contention is that the ordinary retail business must look for more or less indirect results, in fact, will find it more satisfactory to proceed on such lines and be guided by the collective effort.

Advertising is but one link in the chain of business. One wheel in the machine set up to attract custom. Do not expect one wheel or that one link to work alone and do not expect an undue share of work from other parts by omitting it.

The consideration of one other aspect of the case must suffice for the present time. The favorite cry of one who never advertises is, "we give too good a value to be able to afford to advertise." In reality it is the advertising firm that gives good value every time, because, un-

(Continued on page 34)

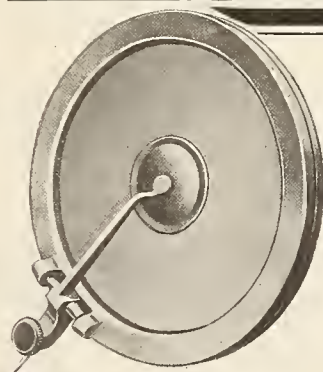

The Bliss Reproducer Will Play All Records

A new superior and scientifically constructed sound box—no mica, rubber or cork used.

Beautiful full, rich tone quality, clear articulation. It individualizes each voice and instrument in the record. Greater volume with lighter needles, thus minimizing wear on records.

A demonstration of the Bliss reproducer means a sale—each sale brings another, for every music lover who hears the Bliss reproducer wants one.

Comparative tests solicited. Write today for dealer proposition.

WILSON LAIRD PHONOGRAPH CO., Inc.

29 West 34th Street, New York City

Canadian Distributors: HAWTHORN MFG. CO., 145 Yonge St., Toronto, Can.



A window display that will bring people into your store—you want it. The Columbia Dealer Service Department will give it to you.

**Columbia Graphophone Co.
Woolworth Building, New York**

TO MAKE PUBLICITY PROFITABLE
(Continued from page 33)

like the man who does not advertise, they have promises to live up to. Such a claim of non-advertisers is farcical as a deeper examination will prove. Take two of the most common prices in the trade, namely, 75c. and \$1. In one case it is three cents, and in the other case a consideration of four cents on each record sold. Surely it is worth such an additional outlay to increase your trade.

To pursue this argument further would soon demonstrate what a very little extra business has to be expected before the advertising pays directly for itself, but that is not a part of the purpose of this article, which has been written with a view to rendering some assistance to the man who feels the necessity of deciding the important question (what ought I spend on advertising?).

It may not be out of place to mention in conclusion of the subject having been dealt with from the point of view of an established business, although a newly started dealer would find it necessary to spend a little more.

JOS. C. ROUSH NOW IN FLORIDA

The Heatless Days in the North Will Not Bother Talking Machine Man for Some Time

Joseph C. Roush, president of the Standard Talking Machine Co., of Pittsburgh, Pa., and secretary of the National Association of Talking Machine Jobbers, spent a day or two in New York recently to confer with President Blackman of the association before leaving for his annual winter vacation with his family in Florida. Mr. Roush stated that he planned to visit all the principal resorts and would return to the North when the birds told him it was time to migrate.

JOINS VICTOR EDUCATIONAL FORCE

Miss Frances E. Ryan, formerly supervisor of music in the public schools of Escabana, Mich., is a recent acquisition to the Victor educational forces and is covering the schools in New Jersey, demonstrating the advantage of the school Victrola. Mrs. Frances E. Clark, manager of the educational department of the Victor Talking Machine Co., has outlined a splendid program that will mark a distinct advance in Victor educational work throughout the country this spring.

"NICHOLSON"
New Catalog Showing New Styles
RECORD CABINETS
strictly high-grade construction at prices
BELOW COMPETITION
Write for a copy of the catalog and our
special free advertising help for dealers.
K. NICHOLSON FURNITURE CO., Chase City,
Virginia
Sectional Bookcases and Record Cabinets

PUBLICITY THAT AIDS PRESTIGE

An Illustration of How Ads With a Strong Amount of Newsy Personal Flavor Help to Interest Public in a Talking Machine Store

The recent newspaper advertising of the Martin Bros. Piano Co., of Springfield, Mo., offers

MARTIN'S
DOUBLE GROUND FLOOR SPACE
HERE'S CONVINCING PROOF THAT
Martin's Music Service Is Superior
Owing to the unprecedented growth of our Victrola and Edison departments, we are forced to double our ground floor space. An inquiry has been cut to the vacant store room adjoining, thus adding 2000 square feet of floor space.
When we moved into our new building on M. Daniel Avenue in June, we thought we had provided adequate floor space to care for the wants of our customers for some time to come. The holiday rush proved our calculations wrong. It became a common occurrence for us to have every one of the half dozen world-famous Victor and Edison demonstration booths filled with customers, while others stood outside waiting to take their place.
And the Holiday Rush Has Continued—The American People Are Realizing That
Music Is a Real Necessity—Now
IN WAR-TIME MORE THAN EVER.
Our business since Christmas has proved that the rush was not just a seasonal activity, but a constantly increasing demand for music.
HENCE THE DECISION TO DOUBLE OUR FLOOR SPACE
In order to maintain our music service at the highest point of efficiency, we are adding new booths and improving our facilities, which were already the best in the Southwest.
EVERYTHING IN THE MUSIC LINE
PIANOS THE NEW EDISON DIAMOND DISC PLAYER ROLLS
PLAYER PIANOS VICTROLAS EDISON AND VICTOR RECORDS
ORGANS STRINGED INSTRUMENTS SHEET MUSIC
EASY PAYMENT PLAN
PLAN CANNOT CREDIT FOR THREE MONTHS WHEN INTEREST IS PAID MONTHLY IN SMALL PAYMENTS.
MARTIN BROS. PIANO CO.
"Springfield's Largest and Best Music House"
MARTIN BLDG. M. DANIEL AVE.

Newsy, Personal Ad That Interests some rather unique examples of talking machine publicity. The first piece of "copy" reproduced herewith illustrates an excellent way in which to make capital of an increase in the size of a

We're Mighty Proud
Our Service Flag Has Seventeen Stars
WE are justly proud of these seventeen men who have put aside their personal ambitions and hopes to help make the world safe for democracy.
We hear from "our boys" every now and then, but we don't hear one word of complaint. Undoubtedly conditions are trying, as the life is new to them. But they have pitched in like all good Americans are doing.
We predict that they will all be men of whom Uncle Sam will be proud.
When it's all over, and the boys come home, they will find good positions awaiting them here.
Any man who leaves the Martin Bros. Piano Co. to fight for Uncle Sam is going to get his position back when he returns. That's the least we can do for him.
And we're proud of the patriotic spirit of our employees who are still with us. They are ALL doing their bit and helping to "keep the home fires burning."
They have made it possible for us to say that
Martin Employees Are
100% Liberty Bond holders
100% Red Cross and shell stamp holders
100% Red Cross members and subscribers
100% Y. M. C. A. fund contributors
With Such a Spirit, It Is Any Wonder That
Martin's Music Service Superior
MARTIN BUILDING **Martin Bros. Piano Co.** M. DANIEL AVENUE
"Springfield's Largest and Best Music House"

How Martin Bros. Help Uncle Sam

retail talking machine department. The second piece of "copy" is a very striking way of letting the local community know about "the boys who have joined Uncle Sam's fighting forces." Particularly in the smaller-sized cities this latter type of advertisement must have a strong amount of newsy personal interest.

SUCCESS FOR THE PRESENT YEAR

The Peptimist, Issued by the Columbia Graphophone Co., Contains Interesting Forecast of Possibilities for Success This Year

Under the heading of "Success in 1918" the following timely and interesting article appears in the current issue of The Peptimist, the successful house organ published by the Columbia Graphophone Co. for and about Columbia men:

"The new year finds our world among events without historic precedent. Nations, commerce, industry, the lives of every man and woman in the civilized lands of the earth are changed. Business has changed—you must change to meet the new front.

"Success will be made of sterner stuff in 1918 than in the year past. The keynote of the world's life to-day is sacrifice. Not a home in America but gladly bears its share of the burden. At the threshold of a year which holds within its palm unguessed lines of fate and fortune we Columbia men stand, earnestly willing and solemnly prepared to do the best in our power for our country, our homes and our neighbors.

"Success is still our aim but a new one. Where is the secret of the new success?

"Success in 1918 will follow and come, and only come and follow Service. The sacrifices of millions of homes must be met with service to millions of homes.

"It is with implicit faith in its truth we state the Columbia has its share, a true and big one, in serving its country. Already from our factory, sales branches and executive offices over four hundred Columbia men have joined the colors of the greater Columbia. And those at home have a duty as well—a duty to cheer, inspire and comfort not only our boys at the front but the homes behind the boys on the firing line.

"Music is a gift to man which few can count in words but all have felt in spirit.

"A singing nation and a singing army can conquer all the powers of darkness and silence. Music serves the spirits which serve their country. Music rests the weary body, soothes the worried mind. Our highest patriotisms are expressed in song. 'Give me a singing army,' once exclaimed a great general. 'Keep on singing,' Lloyd George has exhorted his countrymen.

"And the Columbia recognizes its privilege in having a share in keeping America a singing nation. It is a service. It is this service Columbia men will keep in mind in this new year. You are not selling for the gold you can get but for the good you can do. Sell to serve.

"You are dealing with homes and hearts. 'The success in 1918 is in service. 'May your share be large.'"



Otto Heineman Phonograph Supply Co.

INCORPORATED

25 WEST 45th STREET, NEW YORK

FACTORIES, ELYRIA, O.—NEWARK, N. J.—PUTNAM, CONN.



CHICAGO

ATLANTA

SEATTLE

CINCINNATI

TORONTO

YOU ARE NOT EXPERIMENTING

When You Use

HEINEMAN and **MEISSELBACH** Products

These Motors, Tone Arms and Sound Boxes are produced by the largest manufacturers of phonograph parts in the world, and are in use everywhere

Here are two outfits we recommend and guarantee

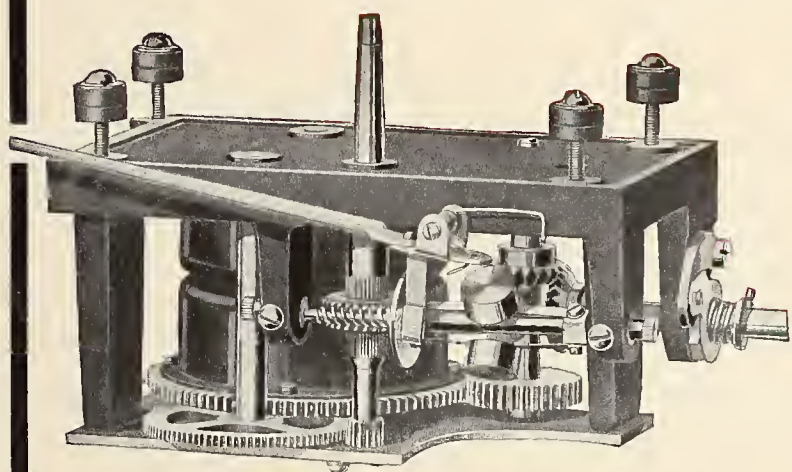

Heineman Motor No. 77

Heineman Motor No. 77

Heineman Tone Arm No. 11

Heineman Ideal Sound Box No. 2

The Ideal Outfit for Your \$85 Machine

Meisselbach

Motor No. 18

Meisselbach

Tone Arm No. 98

Meisselbach

Sound Box No. 2C

The Ideal Outfit for Your \$165 Machine

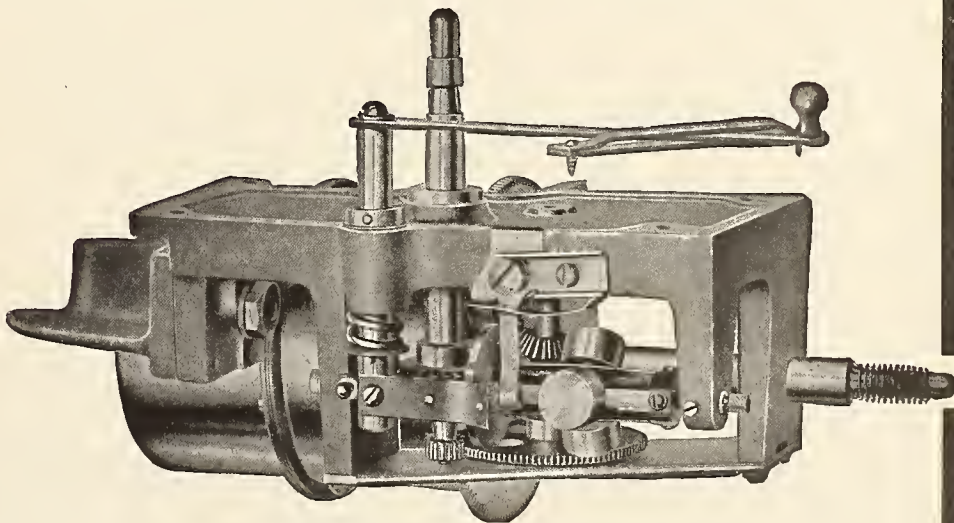

Meisselbach Motor No. 18

All prices F. O. B. New York or nearest branch office



MEISSELBACH



TONE ARMS

MOTORS

SOUND BOXES

ORIGINAL IDEAS ALWAYS IMPRESS

How W. G. Fulghum Told of Victrola Owners in Richmond—A Sales Developing Idea

Business is certainly humming down in Richmond, Ind., where Walter G. Fulghum is now engaged in the retailing of Victor talking machines and records. Mr. Fulghum the latter part

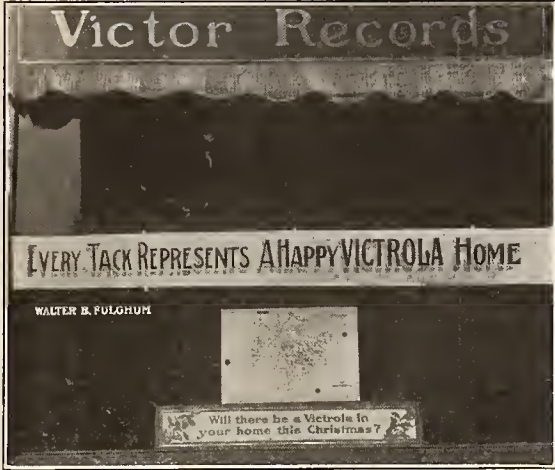

A Window Display With a Purpose of January informed The World regarding several of the new plans he is trying out.

One of the especially commendable ideas Mr. Fulghum introduced during the holiday season consisted in a window display, the central feature of which was a large map of the city of



Mr. Fulghum and Car in Front of Store Richmond. On this map tacks had been set in to represent every Richmond home in which a Victrola was already resident. This unique tabulation not only offered concrete evidence of the great popularity of the Victrola in Richmond homes, but also aroused considerable interest among the local inhabitants, who frequently gathered before the window in order to pick out their own personal friends in town who owned a Victrola. The size of the map made it easily possible to tell exactly what home each individual tack stood for.

Another idea, apparently simple and yet full of value, that Mr. Fulghum is now employing is what for lack of an official title may be called a score-card calendar. This presents on each sheet the days for just one month. As soon as the first machine sale is made a cross is marked through the first day of the month. Each machine that is sold thereafter means the crossing off of another day on the calendar. The goal is to sell one machine for every day in the year and at the present time the crosses have already been registered several days ahead of the actual date. This plan has developed a remarkable "esprit de corps" among the salesmen as every one in the organization watches the calendar with keen interest and fights to keep the sales right up to scratch.

Two Fords comprise Mr. Fulghum's motor fleet. One of these is a delivery car and the other, a picture of which is herewith shown, is utilized for direct personal solicitation.

TRAVELERS' LICENSE IN CHILI

The United States Consul General L. J. Keena at Valparaiso, Chili, reports that importers in that country are urging enforcement of the law of December 22, 1916, imposing a license tax of 1,000 pesos (about \$240) on foreign commercial travelers. The importers threaten to refuse to do business with any salesman who has not obtained the necessary license.

EDISON PHOTOGRAPHED IN TYPE

Wm. Maxwell Presents a Masterly Review of Edison's Ideas and Ideals in American Magazine

In a five-page article captioned "Edison—the 'Original Man From Missouri,'" William Maxwell, vice-president and general manager of Thomas A. Edison, Inc., and who enjoys a wide reputation as a writer, has set forth in the American Magazine for February a most interesting analysis of Thomas A. Edison, written from the viewpoint of one who has been closely associated with him and knows what he demands of his associates and of himself, as well as something of his ideas and ideals.

Mr. Maxwell emphasizes particularly Mr. Edison's wonderful capacity for work and his ability to get at the bottom of a problem. He mentions that there are few golfers in the Edison organization, because the men are kept so busy that they do not find time for that particular sport. Mr. Edison, their boss, demands that a thing be done thoroughly, that an employe must not skim the surface, but must dig into the fundamentals of his work.

Of the kind of men Mr. Edison has associated with him Mr. Maxwell says: "Mr. Edison likes men who will dig down to the roots of every problem they encounter. He has small patience with the man who is content to look superficially at a problem and theorize concerning the number and character of its roots. That is why he likes industrious men.

"You, perhaps, have a 10 per cent. greater brain equipment than I, but if I work twelve hours a day and you work only eight, Edison would prefer me to you. He recognizes, of course, that some men are smarter than others; but in his estimation there is no degree of ability that will outweigh laziness or lack of application. The nonchalant genius of business fiction has no place in the Edison organization. No man can last or, at least, no man can achieve importance in Mr. Edison's eyes, unless he is a tireless worker."

Mr. Maxwell has succeeded in drawing a word picture of Mr. Edison that will prove a revelation even to those privileged to have a business acquaintance with the great inventor. He has brought out facts often overlooked in the average biography, and portrays Mr. Edison not as a man apart but as a man among men. He points out that there are two Edisons—"one is the Edison of coldly scientific mind, who reasons ruthlessly and relentlessly to a conclusion far beyond the average man's foresight. The other is an Edison vividly human, intensely sympathetic, extremely generous and incessantly active in the interests of mankind. Edison can be the lion that he resembles, he can even be unjust; but he is never avaricious, and he is unfailingly generous."

A full-page photograph showing Mr. Edison in a characteristic pose accompanies this vivid and interesting human interest article.

FINE BUSINESS RECORD IN LOUISVILLE

The talking machine department of the Kaufman-Straus Co., Inc., Louisville, Ky., of which H. V. Boswell is manager, has been moved to the second floor, a much better location than heretofore, where a good stock of Edisons and Columbias is being shown. Business last month showed an increase of 25 per cent. over the same month last year, while an idea of the holiday business may be gleaned from the fact that the day before Christmas the department sent out thirty machines, all sold for cash.

SOME PERTINENT POINTERS

Customers are guests, and more, they are guests that pay. Be sociable with your customers; they like it. The more people you know personally, the greater can be your hold upon your trade. If people talk about your store, if it becomes noted, you will do business. Get all your store improvements commented upon in the news columns of your papers. It costs you nothing and it all counts.

Delpheon
the
Incomparable

Your nearest distributor will give you prompt service and the fullest co-operation.

DELPHEON plus DELPHEON SERVICE brings SUCCESS

The Delpheon Shop
117-119 Peachtree Arcade
Atlanta, Georgia

Delpheon Sales Company
25 Church Street
New York City

Walter Verhalen
Busch Building
Dallas, Texas

Verbeck Musical Sales Co.
435 William Street
Buffalo, New York

Chicago Display
Sixth Floor, Republic Building

Or write direct to

The DELPHEON COMPANY
BAY CITY MICHIGAN

THE TRADE IN PHILADELPHIA AND LOCALITY

PHILADELPHIA, PA., February 4.—The month of January was a profitable one for talking machine dealers in this city, despite conditions that served to keep the trade guessing most of the time. The poor transportation facilities handicapped the jobbers considerably in the shipment of their machines, but the fact that it was hard to ship machines out of the city worked to the advantage of local dealers in carting distance of the jobbers warehouses.

Although there was considerable improvement in the Victor machine situation during the month, both jobbers and dealers were only able to get a percentage of their record orders filled from the factory. Due, it is believed, to various conditions, including labor, governing record production. Dealers in Columbia and Edison lines also reported stock shortage, due to delayed shipments from the factory. The trade, however, is keeping up courage, and for the most part is optimistic regarding the future.

New Columbia Dealers' Service Pleases

The Columbia Graphophone Co. (formerly the Pennsylvania Co.) report that their business in January was quite satisfactory, and especially so considering the circumstances. Their new dealers' service has been meeting with hearty approval, and the latter appreciate the assistance the Philadelphia office is giving them in the exploiting of the Columbia, both machines and records. They had an enormous record business in January, and having had the foresight to order heavily, they felt little the inconvenience in the delay of shipping, caused by the weather and the freight embargo.

W. C. Fuhri, formerly the district manager here, has gone on a trip to Florida for a rest, and will not return until the end of the month. The Dictaphone office of the company, now at 924 Chestnut street, has changed managers, C

J. Welford being replaced by Clifford Malliet.

O. F. Jester, formerly connected with the Baltimore store of the Columbia, has joined the Philadelphia offices as salesman. The local manager says that he is very optimistic over the business this year and adds: "I feel that if we get some relief from this transportation condition, it will be the greatest year in the talking machine business."

Business Good With Buehn Co.

Louis Buehn, of the Louis Buehn Co., says that their business has been very good, considering the situation. "We were tremendously handicapped by the lack of goods, especially records, and by shipping difficulties, but in spite of all these troubles we have had a very good month. Our machine shipments this month have been about on a par with last year."

Gillies Co. Buys Connor & O'Neill Stock

The James B. Gillies Co., talking machine dealers at Broad and Susquehanna avenue, have purchased the stock of Connor & O'Neill, and has removed it to his store. The Connor & O'Neill firm have been located, for a number of years, on Fifteenth street, below Chestnut. Mr. Gillies has one of the finest stores up town, and is constantly being compelled to enlarge it.

Increase Prices

G. Dunbar Shewell, who is the eastern representative of the Cheney talking machine, has announced in the papers the past week that the Cheney will be raised in price from \$15 to \$25 beginning the first of February.

Dictaphones for Large Companies

The Dictaphone Co. report that their business was very fair in January, and they believe it will be very good from this on. Owing to the great scarcity of stenographers and typists they have just placed a complete outfit of the Dictaphone in "The Grit" office at Williamsport;

with George Wharton Pepper; the Lehigh Portland Cement Co., of Allentown; and the Atwater-Kent Mfg. Co. have added a large complement of machines during the month.

Penn Co. Stocking Up

Manager Barnhill, of the Penn Co., says that "In January our business was about as good as could be expected under the weather conditions, the freight embargo, and the impossibility to move stock promptly. Records have been very scarce and especially in the better grades." Mr. Barnhill, however, believes that business is going to be first rate this spring and summer, when transportation again becomes normal, and they are getting in a stock that will assure them the ability to fill all orders, and with promptness. J. Fisher, of C. C. Mellor Co., Pittsburgh, Pa., was one of the recent visitors to the Penn Co.

Weymann's War Music Display

H. A. Weymann & Son have this week a very attractive window, in which they show how the Victor talking machine is an absolute necessity in war times. They have the machines and records done up in non-destructible packages, and about these packages are war relics picked up in many sections, and especially from the war front in France. They report that their Victor business in January was very good, and believe that the remainder of the winter and spring is going to make an excellent showing, for Mr. Weymann says that music, he believes, has become a war time necessity.

Pathé Shop Getting Results

The Pathé Shop has been having a most excellent business in January. While there were only nineteen working days in the month, they have put forth their best efforts and have made every minute count. Their business was not

(Continued on page 38)



OPPORTUNITY

To increase the profit of every Talking Machine Dealer

The Weymann "Keystone State" Musical Instruments and Strings have a national reputation.

Leading dealers feature the Weymann make exclusively in conjunction with their Talking Machine and Record line, to attract the musical buying public to their stores. Thousands of "Weymann" "Keystone State" Mandolutes, Ukuleles, Mandolin-Banjoes, etc., are in daily use creating a continually increasing demand for "Keystone State" Strings. Here is an opportunity to supply these demands. Send us your initial order for our special assortment of

"Keystone State" Strings, their retail selling value	\$38.35
Cost to dealer net	18.00
	Profit, \$20.35

We will furnish free of cost a show case string display cabinet.

The various strings may thereafter be re-ordered in quantities of one dozen or more to at all times maintain the complete assortment. Mail your order today to:

H. A. WEYMANN & SON, Inc.

MANUFACTURERS

OFFICES:
1108 Chestnut Street

PHILADELPHIA, PA.

FACTORY:
1109 Sansom Street

Victor Wholesalers

Established Since 1864

BUEHN SERVICE

AGGRESSIVE Victor Record selling is the key-note of 1918 work. You cannot exhaust the record sales mine. Doubling of record aggressiveness this month actually increases your sales for March, too.

And so it goes—an endless chain of profits.

A stimulated record buying sustains its own buying power if you maintain the momentum with suggestions.

BUEHN SERVICE sees that the records you recommend are in your store to DELIVER. It is the deliveries of sales that prove the value of your record work and Buehn Service is most vital to record sales success.

Buehn Service does only one thing—"delivers the goods." And with the deliveries goes the co-operation that is helpful because it represents the nucleus of the information on problems solved by other dealers.

Buehn Service means a great deal to you in 1918.

The Louis Buehn Co., Philadelphia

ENVELOPES

The modern way of "wrapping" and delivering records. Made with string and Button Flap.

10 in , - - \$10 per M

12 " - - 12 " "

Your imprint, \$2 per M extra

on **VICTOR**
RECORDS

From a patriotic standpoint.

the Victor dealer can't jam more pleasure into the leisure hours of men-of-war and men-of-peace than to dole out, in ever-increasing quantities, the comfort and inspiration that characterize Victor talking machine records.

From a service standpoint

Penn service at all times is consistent with factory production and delivery.

Distributors for the Ready File
for Victrola X's and XI's.

Penn Phonograph Co.

17 S. NINTH STREET

(VICTOR
JOBBER)

PHILADELPHIA

THE TRADE IN PHILADELPHIA

(Continued from page 36)

quite as good as in December, but of this they have no cause to complain. They are finding considerable difficulty in making shipments to their dealers, but through judicious management they have been able to keep all their dealers and have added a number to their already long list during January. They report that business looks very promising for February. Walter Eckhardt, the head of the Pathé Shop, was in New York on Wednesday of this week. They expect, in February, to make quite a publicity campaign, and are arranging some extensive recitals to be given at their warerooms.

The Pathé Shop must be seen to be appreciated. It is one of the show places of the city. It is most artistic in its color effect and the arrangement for business, and customers cannot go away without a most pronounced impression of everything about the place, whether it is the Pathé machines and records, or the fine accommodations that Mr. Eckhardt has made for their comfort and convenience.

Closed Great January Business

Herbert Blake, of Blake & Burkhart, reports that their business was very good in January. It was the biggest January they have ever had with the exception of 1916, when their sales were extraordinary for that month. This month, Mr. Blake says, has started off very good, and that it looks very promising. He is especially pleased with the February list of Edison records, which contains many Broadway hits.

Gathering of Edison Dealers

On Tuesday night next at the monthly meeting of the Edison dealers here, which will be held at the Bingham House, T. J. Leonard, the sales manager of the Edison Co., will address

the association. Charles Gardner, the district superintendent for this district, will also be present and is expected to make a speech. They expect to have present about twenty-eight to thirty dealers.

DOMESTIC CORP. CHANGES

Horace Sheble Resigns as President and General Manager—George Anderson, Treasurer of Company, Now in Charge of Business

George Anderson, recently elected treasurer of the Domestic Talking Machine Corp., of Philadelphia, became acting head of that concern on January 26. Mr. Anderson succeeds Horace Sheble, the former president and general manager. Mr. Sheble's retirement is entirely voluntary and it is rumored he is to take up Government war work. He carries with him the best wishes and hearty good will of his associates and the board of directors.

DEATH OF MRS. D. K. WENDHEISER

Mrs. Delia Kivel Wendheiser, widow of the late Peter Wendheiser, founder of the Wendheiser Music Store at Rockville, Conn., and mother of George P. Wendheiser, at present a well-known piano and talking machine dealer in that city, died recently at the family homestead.

PLANT DESTROYED BY FIRE

The plant of the Carolina Veneer Co., Columbus, S. C., was totally destroyed by fire last week with a loss of \$100,000. Among the stock destroyed was much cabinet veneer intended for talking machine manufacturing, the shipment of which had been held up by traffic conditions.

TALKING MACHINE MEN MEET

First Session of New Year Held on Wednesday—Amendments to By-Laws Passed—To Determine Membership Status of Jobbers

The first meeting of the new year held by the Talking Machine Men, Inc., took place on Wednesday, January 23, in the rooms of the Merchants' Association in the Woolworth Building, New York. President J. T. Coughlin, of the association, presided, and one of the most successful meetings held in some time resulted.

The action of the executive committee at a recent meeting making an amendment to the by-laws to require seven days' notice of intention to propose a new member, was adopted and the amendment will provide two days for the membership committee to investigate the candidate and allow the secretary to give the usual five days' notice by mail to every member of the organization.

The committees appointed several meetings ago to solicit new members and also try and persuade the larger stores to charge 6 per cent. interest on instalment sales reported progress and a new committee was appointed to assist them in their endeavors. It is thought that with a campaign along these lines during the next few months the association will be able to announce that every dealer in the Greater City is charging 6 per cent. interest on time sales. Already a number of local dealers have put the interest clause into effect and this has also been done by dealers who are located in the New Jersey district.

The executive committee also sent out a letter a number of days ago to the leading jobbers to find out the consensus of opinion in regards to whether they wish to continue as active or associate members. This is a question that has come up many times during the past year, and the letters from a number of jobbers show the majority of them feel they can be of more value to the organization as associate members than otherwise. This includes the opinion of Chas. H. Ditson & Co., S. B. Davega & Co., Ormes, Inc., American Talking Machine Co., Emmanuel Blout, and I. Davega, Jr. A letter from J. Newcomb Blackman, of the Blackman Talking Machine Co., who has been interested in the Talking Machine Men, Inc., since the birth of the organization, gave it as his opinion that the jobber and distributor can be of more assistance as non-member. A letter from him stating his views was read and made a distinct impression upon the meeting.

The law committee was instructed to draft an amendment to the constitution which will embody the ideas of the distributors as well as the association in regard to their activities as members. This will be done after an amicable agreement is reached with the distributors as to the fee they should pay for membership. The constitution will be amended to take in the distributors as associate members at a somewhat larger fee than is now in force, which is \$3.

The secretary was instructed to address a communication to every member to find out their views in regard to the suggestion to close all talking machine stores at 9 p. m. If it is not feasible to close in every district at that time it may be found a good idea in certain localities, and, with the expressed opinion of all the members, agreements in different sections can be made.

TRADE CONVENTION POSTPONED

Fifth National Foreign Trade Convention to Be Held April 18, 19 and 20

The executive committee of the National Foreign Trade Council announced this week that, owing to the railroad congestion and the desire of the Council to co-operate with the Government in the relief of the situation due to the war, the dates of the fifth national foreign trade convention, to be held at Cincinnati, O., have been changed from February 7, 8 and 9 to April 18, 19 and 20.

THE VICTOR TALKING MACHINE COMPANY, in recognition of his twenty years of active service as Manager of the Traveling Department, has appointed
Mr. GEORGE D. ORNSTEIN

a Wholesaler of Victor Products in the city of Philadelphia and the neighboring territory. In order that the retailers of that district may enjoy the benefit of Mr. Ornstein's unique experience, the undersigned company has been incorporated to carry on an exclusively wholesale business, with temporary quarters at **9 North Eleventh Street, Philadelphia**, for the purpose of providing the retail trade with the most direct, efficient and satisfactory service.

Very sincerely yours,

THE GEO. D. ORNSTEIN COMPANY.

Leonard Markels

BUTTERFLY MOTOR

Jewel-Bearing

This is the MOTOR whose phenomenal success made it necessary for us to double our factory capacity.

The "Butterfly Motor" has won the endorsement of leading talking machine manufacturers everywhere. It is giving excellent service under exacting conditions, and is a motor that is *guaranteed* in every detail. Read its specifications and you can readily understand why the Butterfly Motor is accepted as a standard in its field.

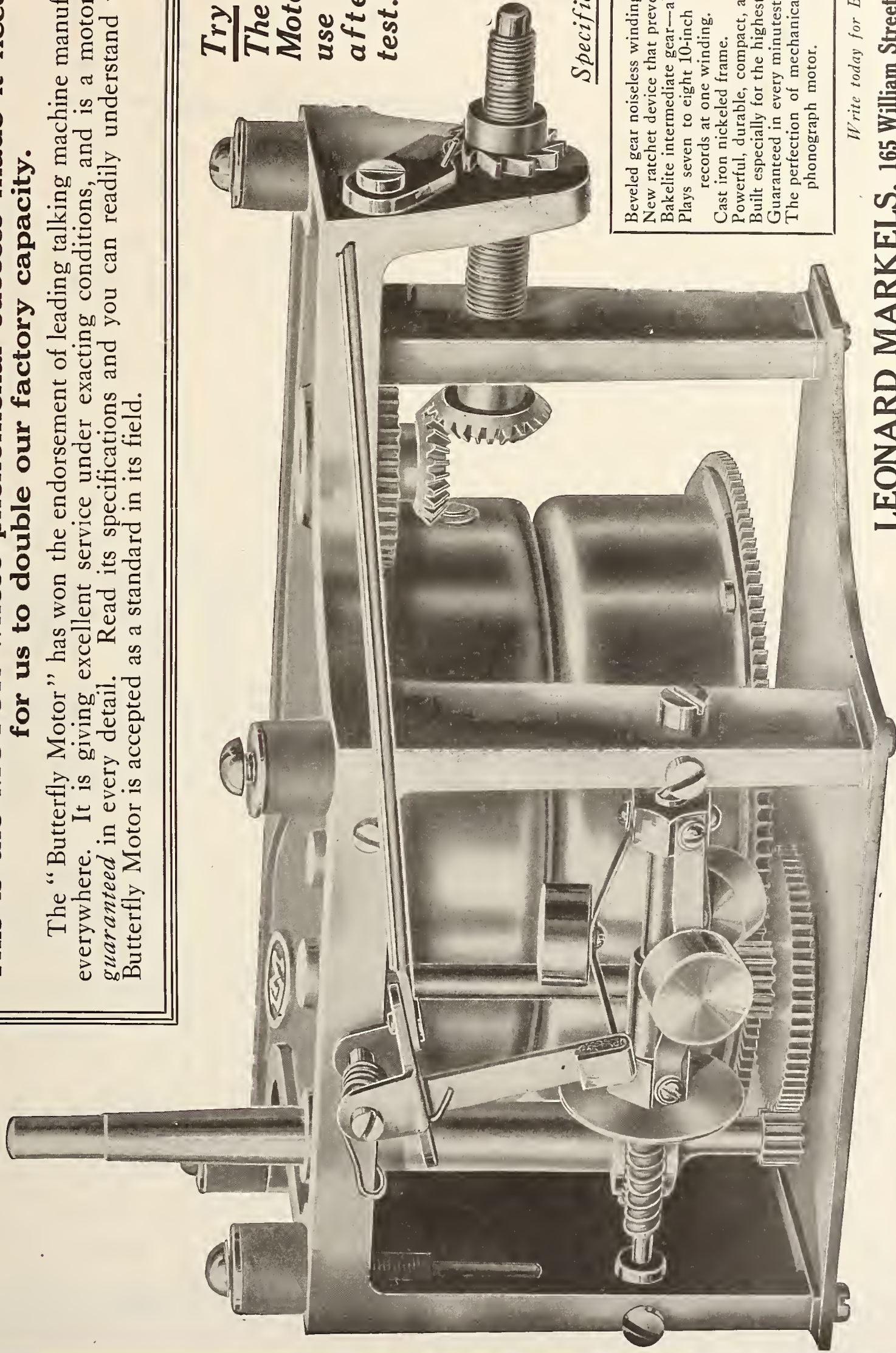

*Try a Sample of
The **BUTTERFLY**
Motor. You will
use it exclusively
after a thorough
test.*

SILENT BUTTERFLY MOTOR

Jewel Bearing

Specifications

Beveled gear noiseless winding.
New ratchet device that prevents clicking.
Bakelite intermediate gear—absolutely silent.
Plays seven to eight 10-inch or five and a half 12-inch records at one winding.
Cast iron nickeled frame.
Powerful, durable, compact, accessible.
Built especially for the highest-grade machines.
Guaranteed in every minutest detail.
The perfection of mechanical genius as applied to the phonograph motor.

Write today for Butterfly Folder

LEONARD MARKELS, 165 William Street, NEW YORK



One evening a week with theatres and movies closed means just so much more demand for those never-off-the-job entertainers, Columbia Grafonolas and Columbia Records.

**Columbia Graphophone Co.
Woolworth Building, New York**

INDIANAPOLIS DEALERS REPORT LARGE JANUARY TRADE

Record Business Has Been Exceptional—People Staying More at Home Has Helped Sales—How Victor Publicity Helps—Good Demand for Talking Machines But Difficult to Get Them

INDIANAPOLIS, IND., February 5.—Although the month of January was the coldest in the history of the local weather bureau and in spite of the closing orders of the national Fuel Administrator, the local talking machine dealers generally report that they did better business during the month than they had expected.

All of the dealers said the record business was exceptional and they attributed this to the fact that the closing of theatres on Tuesdays, together with the extremely cold weather, indicated that people were staying at home and enjoying their talking machines.

The weather moderated considerably during the last few days and this had the effect of stimulating the sale of machines. Most of the dealers express the opinion that the Monday-closing order simply makes Saturday or Tuesday a bigger day in sales and that the loss of Monday does not figure to any extent on the week's business.

"Our record business increased during the month and the sale of eight machines on the first Tuesday after the first Monday holiday indicates that we are making up for the lost Monday business on Tuesdays," said A. H. Snyder, manager of the Edison Shop. The total January business was ahead of last year in the same month, he added. Mr. Snyder is working his outside salesmen in zones and his plan is panning out well.

H. A. W. Smith, manager of the Pathé Shop, said that Tuesday business was showing up well, but he doubted whether it was offsetting the loss of Monday. The January business as a whole was good, he said.

H. E. Whitman, manager of the talking machine department of the Pearson Piano Co., reported that the record sales were far ahead of January of last year. Both the Edison and Victor machines were in steady demand, but a shortage of stock has been the worst problem, Mr. Whitman said.

This Christmas the Pearson Co. did not send out larger machines to be exchanged later for the smaller models when they arrived and as a result it was able to sell most of the largest machines.

C. P. Herdman, manager of the Columbia department of the Baldwin Piano Co., said that while the weather had naturally affected business it had held up well and that with a change in weather conditions he believed it would soon be back to normal.

A. E. Pfeiffer, manager of the Starr Piano Co. store, said that the Starr records and machines had enjoyed a good business in spite of the weather, although the Monday holiday closing was affecting business to some extent.

George Standke, manager of the Brunswick Shop, ran an ad on optimism on the first Monday closing holiday and he received congratulations from many persons on its timely appeal.

He was in Chicago this week conferring with the factory managers and company officials. The art model, No. 1500, of the Brunswick has attracted considerable attention on display in the shop.

Among the wholesalers the chief complaint has not been a lack of demand for talking machines but the shortage most of them have to worry with due to transportation.

R.-B. Goldsbury, of the Pathé department of the Mooney-Mueller-Ward Co., said that January had been better than anticipated, the record business being exceptionally brisk. A number of new contracts have been signed with dealers.

Edgar Eskew, formerly manager of the department, has resigned.

The People's Outfitting Co. has had an exceptional run on Pathé machines. During the last six months only one-half of one per cent. of the records shipped to dealers have been returned, Manager Goldsbury said, adding that this indicates the strong demand for records throughout the State.

At the Stewart Talking Machine Co., Victor jobbers, it was said that the demand for machines was much heavier this January than in 1917, but that transportation difficulties had kept the business down.

The national advertising done by the Victor Co. is bringing practical results, according to the Stewart Co. From fifteen to twenty inquiry cards sent to the Victor Co. by prospective buyers have been reaching the Stewart Co. every day. These cards are in turn sent to the nearest Victor dealer.

The local Victor dealers are expecting a large demand for the records of Jascha Heifetz, the Russian violin marvel, who will play in Indianapolis February 14.

The appearance here last week of Victor Herbert with the Cincinnati Symphony Orchestra boosted the sale of the Herbert records. A large number of the latest musical comedies are scheduled to appear here in the next few weeks and the record song hits of these shows will be in demand.

O. C. Maurer, in charge of the Sonora department of the Kiefer-Stewart Co., was a guest at the convention of Sonora dealers held under the auspices of the Yahr & Lange Drug Co., of Milwaukee, Wis., recently. Mr. Maurer said that the enthusiasm evinced by the Wisconsin dealers in spite of the cold weather that prevailed was notable and he added that he obtained a number of good points from the meeting.

Walter E. Kipp, of the Kipp Phonograph Co., Edison distributors, said that there was no complaint to make about the demand for Edisons.

H. A. Verkes, field sales manager of the Columbia Co., and Ben Brown, manager of the local branch, went to Louisville, Ky., last Mon-

day. The Grafonola Co., of Louisville, enjoyed an unusually big January business, the chief difficulty being in getting the machines, Mr. Brown said.

KEEPING UP ORDER DELIVERIES

Boston Book Co. Makes Good Shipping Progress Despite Handicaps—Pays Employees in Full for Time Lost on "Workless" Days

The Boston Book Co., manufacturer of record albums, has been making reasonable progress in the shipping of its orders despite the condition now affecting the railroads. The company has been in a nice position in regard to the materials entering into its products as it has large quantities on hand and in storage for now and future use. J. M. Alter, president of the company, in speaking of trade conditions recently, said: "The demand for our albums is greatly on the increase and from the indication of the orders arriving in every mail the talking machine industry is preparing for a year of great prosperity." The Boston Book Co., in following out its plans of keeping its labor standards on the highest plane, paid its employees in full during the recent five-day closing period and will continue to pay them for the lost Monday of each week. During the period when coal was scarce the company bought oil heaters to supplement the low pressure in the steam pipes, thereby keeping the temperature of the plant up to normal.

We are all inclined to kick when difficulties come our way, and it is a well-established fact that some of the keenest pleasures of life come from successfully overcoming difficulties.

The Mutual
TONE ARMS & SOUND BOXES

**Place Your 1918 Orders
TO-DAY**
for

Mutual

**TONE ARMS AND
SOUND BOXES**

"Mutual Products Have Made Good"

Mutual Talking Machine Co., Inc.
145 West 45th Street, New York

SHORTAGE OF STOCK IN CLEVELAND A SERIOUS PROBLEM

Matters of Interest to Be Discussed at Coming Banquet of Talking Machine Dealers' Association of Northern Ohio—Displaying Records at Food Show—Fischer Co. Doing Fine Pathé Business

CLEVELAND, O., February 6.—Shortage of stock, for which the responsibility is divided between the factories and the railroads, workless days, as prescribed by the Fuel Administrator, and other conditions similar to those affecting business throughout the East, serve to put a slight damper on the talking machine trade in this city, although the jobbers and dealers are going right ahead endeavoring to get the best results possible in the face of the handicaps.

C. K. Bennett, general manager of the Eclipse Musical Co., and the new president of the Talking Machine Dealers' Association of Northern Ohio, states that at the annual banquet of the association, to be held on February 20, an effort will be made to thresh out the problems for the benefit of the dealer. He states that one particular point will be emphasized, the necessity of pushing stock records that do not have the call under ordinary conditions. He says this is the time for the real salesman and not for the fellow that travels along the line of least resistance.

At the annual Cleveland food show this week a practical demonstration of how phonograph records are made is being given by C. A. Johnson in the booth of an exhibitor. He explains in detail how records are turned out so they may furnish pleasing music in cafes and dining rooms while diners enjoy their meals. This feature of the show has greatly excited the interest of the thousands of visitors.

The annual meeting of the Cleveland Music Trades' Association will be held February 14 at the Hotel Winton. Several talking machine dealers are members and out of town guests are expected.

This association recently expelled one of its members, who, it was declared, resorted to unfair methods in advertising. It was declared he

advertised second-hand instruments without using the word "used" in his ads.

Not for months has Cleveland seen a bigger campaign of publicity for any talking machine than that launched January 27 by the Young Furniture Co. This concern operates two immense stores in Cleveland, one in the swell shopping center of the upper Euclid avenue section, and another in West Side. Full newspaper page advertisements pointed out the merits of the phonographs handled by this house.

The Muehlhauser Brothers Piano Co., organized last October, opened a modest sized store at 1613 Euclid avenue, somewhat out of the lower shopping district, and began an active fight for business. It came right off the reel, in Hallet & Davis pianos and Sonora phonographs. The firm of four brothers did not have to make its name known, for the brothers had already established their reputation with the Cleveland trade. Since opening an additional storeroom has been found necessary, so the firm's future is assured, despite the handicaps met at the start in getting stock.

The Fischer Co., 25 Taylor Arcade, Ohio distributors for Pathé phonographs and records, is doing a splendid business despite war conditions.

Buescher's, 1016 Euclid avenue, still glories in the sale of Victrola outfits and Victor records. This firm carries a large stock of records and machines.

Gennett records reproducing Helen Ware's violin music are features widely advertised by the Starr Piano Co. The firm carries a complete library of Gennett records.

The Clifton Furniture Co., Madison avenue and West Ninety-ninth street, has joined others using phonographs to attract patrons.

The McMillin Music Co., 2053 East Ninth

street, continues to champion Victor records accompanied by their slogan, "Cleveland's Leading Music Store."

John McCormack, great tenor, is coming to sing for the Red Cross in Keith's big Hippodrome, March 3. As soon as McCormack's coming was scheduled dealers handling McCormack's songs and records reproducing them got busy with window displays and catchy ads. Meanwhile everybody is trying to get educated to McCormack's wonderful songs which the talking machine has popularized in every music-loving home in Cleveland.

The Fischer Co. declares the Edison record, "On the Banks of the Brandywine," is one of the winter's best sellers, while Harry Lauder's "Wee Hoose 'Mang the Heather" is another of the Victor records having a phenomenal run since Lauder appeared here in person.

The Eclipse Musical Co. has been having a run on Victor records reproducing the music of Jascha Heifetz, the new Russian violinist, who will appear in person in Gray's Armory tomorrow night. Cleveland violinists pronounce the new Russian a wonder with "his fiddle."

A Pathé record that is a winner here is the "Arrival of the U. S. A. Troops in France." Fred Fairbanks' "It's a Long Way to Berlin," another Pathé record, is also a big seller at stores handling these favorites.

Song hits which carry inspiration for the boys in military camps and "over there" characterize the offerings of most of the talking machine dealers. "La Marseillaise," by the Gennett Military Band, is a Starr hit among the latest records. "The Royal Hymn of the Republic" is another Starr catch.

The New Edison is attracting attention and selling rapidly at the two establishments of the Phonograph Co., whose main emporium is the entire third floor of the building, 1240 Huron road.

The Dictaphone Co., 1375 Euclid avenue, reports a good January business, particularly the latter half of the month.

"MICKEL"

A Great Name in the Victor Game

YOUR Part of the Country Is No Different Than Any **OTHER** Part of the Country, and Victor Record Sales Are Increasing Daily, Hourly, in **EVERY** Part of the Country!

The point we want to make, is THIS—Are you making the most of the situation? Are you making the most of our superior sized stocks? Are you making the most of the "SERVICE" we offer? There are so MANY things to be gained if you will make an immediate contract with—

Mickel Bros. Co.

15th and Harney Streets
411 Court Avenue

OMAHA, NEBRASKA
DES MOINES, IOWA



Those "Lively" Westerners.



**QUEEN ANNE No. 6**

Dimensions, 21x22x46 in.
Exposed parts nickeled.
Mahogany only. Capacity
80 records with album
space.

Price \$150—with electric
motor \$175.

"Play It Yourself"

Quality Wins Again

The talking machine trade has shown its enthusiastic appreciation of a high grade product by ordering liberally. So liberally that the initial cutting of the Widdicomb Phonograph was not sufficient to supply the insistent demand.

But during March we will be able to ship to all buyers.

*The
Widdicomb*

A Finished Product

The most expensively constructed and intelligently assembled phonograph in the world in its respective class is now ready for those dealers who believe in "quality first" last and all the time.

THE WIDDICOMB PHONOGRAPH IS MADE

*For the dealer who wants to offer better value for the money
For the dealer who wants a better profit than usual
Do you come under this classification?*

If so send for our catalogue *now*, and secure a Widdicomb agency or still better—send for a sample instrument and "*Play It Yourself.*" Compare it point by point with the machine that you consider the best.

Aside from the beautiful case, noiseless precision motor, efficient filing device, and great attention to all details, you will be greatly impressed with the perfectly natural tone reproduction of the Widdicomb and will enjoy the sensation of controlling that sound from a distance by the medium of our sound modulator with which each Widdicomb is equipped.

These good points all mean sales for the Widdicomb dealer.

**Aggressive jobbers will do
well to connect with this line**

PHONOGRAPH DIVISION

The Widdicomb Furniture Co.

Established 1865

Grand Rapids,

Michigan

**ADAM CONSOLE No. 2**

Dimensions, 22x36x39 in. Exposed parts nick-
eled. Mahogany and Walnut. Capacity, 150
records.

Price \$150—with electric motor \$175.

"Play It Yourself"

Columbia's national advertising has just one big aim and purpose—to make people buy Columbia Records through hearing them played on the Columbia Grafonola in Columbia stores.

**Columbia Graphophone Co.
Woolworth Building, New York**



MILWAUKEE DEALERS ARE TOO PATRIOTIC TO COMPLAIN

Believe in Carrying Out Instructions of Government—Dealers Had Excellent January—Jobbers Short of Stock—Sonora Dealers in Convention—Entertained by Yahr & Lange—News of Month

MILWAUKEE, Wis., February 10.—Milwaukee talking machine dealers are just a bit too patriotic to make serious complaint over the effect of the Federal Fuel Administration order which restricted business to five days a week during the last half of January and early part of February. Nevertheless, it is a fact that the curtailment has cost all of them a considerable volume of business and the only compensating feature is that every other line of business suffered, too.

Under the circumstances, local talking machine dealers have been doing mighty well since the holiday season passed. Although one full business day has been taken away from them, they have made the best of an unfavorable situation and worked so hard on the other five days of the week that most of them have been able to equal or even improve upon the volume of business for the corresponding period of 1917. It can be imagined how it would have been possible to show good gains if the "fuelless Monday" order had not been promulgated.

Local jobbers state that they still are not able to procure all of the stocks that are required to fill the demands upon their retail dealers, and they express the opinion that under existing conditions in manufacturing, traffic, and other phases of the situation, it is not likely that a surplus can be accumulated for some time to come. It is felt, however, that it is better to have a shortage than a considerable surplus, and by this token existing conditions are better than those of the reverse.

Harry A. Goldsmith, secretary of the Badger Talking Machine Co., Victor jobber in Wisconsin and Upper Michigan, says that the business situation in the territory served by the house is unusually favorable, considering war-time conditions. While the Badger Co. is in a somewhat better position to fill orders than in recent months, including the holiday rush, there is still a large shortage of numerous styles. Records, needles and other supplies are not to be had in the volume demanded by the state of business. As a matter of fact, the shortage of supplies and accessories is relatively greater than that of machines.

A. G. Kunde, Columbia jobber and retailer, expressed the opinion that business is being maintained at a level that is rather surprising under the conditions. While trade could hardly be expected to be as brisk during the first month and a half of the new year as it was during the last two months of the old year, it is better than anticipated.

At the Edison Shop, Edison jobber and retailer, much time in recent weeks has been devoted to overcoming the effects of the big fire which caused a heavy loss early on Christmas morning and wiped out a considerable part of the wholesale stock. Shipments have been coming in fairly good volume and while stocks are not yet what they should be the Edison dis-

tributors are much gratified over the situation.

Paul A. Seeger, manager of the talking machine department of the Edmund Gram Music House, representing the Aeolian-Vocalion and Columbia, is very much pleased with the condition of business. It has been Mr. Seeger's experience that the higher-priced styles have been selling relatively better than others. This does not mean that medium and low-priced styles are not moving, for many excellent sales of these are being made right along. Yet the tendency has been toward the costlier machine, due probably to the better financial position of buyers who patronize the Gram house.

Yahr & Lange, Sonora jobbers for Wisconsin and Upper Michigan, recently entertained more than one hundred of its retail representatives at a first annual sales convention and banquet at the New Plankinton House in Milwaukee. Fred E. Yahr presided as toastmaster at the dinner, and among the principal speakers were F. D. Andrews, Minneapolis, and O. C. Mauer, Indianapolis. Since taking the wholesale representation of the Sonora a year ago, Yahr & Lange have built up a remarkable organization

ARRANGE TO MEET ALL DEMANDS

Vice-President Ravis, of the New York Album & Card Co., Tells of Increased Facilities—New Representative for New England

In a chat this week with *The World*, Philip A. Ravis, vice-president of the New York Album & Card Co., 23-25 Lispenard street, New York, commented as follows regarding general conditions:

"With the additional facilities that we are now utilizing in the production of our albums we have every reason to believe that we will be in a position to supply our clientele promptly with albums the coming season. However, I would suggest that the dealers anticipate their requirements wherever possible in view of shipping difficulties at the present time and in order to make sure that the albums will be on hand when they need them. With the additional space which we now occupy we have also increased our facilities for printing delivery envelopes, and this branch of our business is steadily growing.

and given the Sonora one of the finest introductions ever enjoyed by a talking machine line in this territory.

George F. Ruez, president of the Badger Talking Machine Co., Victor jobber, and interested in numerous other concerns of note in the talking machine world, has been elected a director of the Merchants' and Manufacturers' Bank of Milwaukee.

A fourth store has been opened at Thirty-second street and North avenue by Kroeger Bros. Co., operating department stores at First and National avenues, Fifth avenue and Mitchell street, and Eighteenth street and Fond du Lac avenue. The Pathé departments establishment on December 1 in the three stores have been extended to the fourth store.

Edward Quick, 180 Villard avenue, North Milwaukee, is a new retail representative of the World phonograph.

H. L. Sorenson, Neenah, Wis., has recently enlarged his store and added a complete display and stock room, with demonstrating booths, to accommodate his rapidly growing Victor department.

Miss Gertrude Louise Gram, daughter of Edmund Gram, Steinway and Aeolian-Vocalion representative at Milwaukee, was married Saturday, February 9, to Frank W. Magin, a well-known manufacturer of Milwaukee.

"Our new No. 1012 album is meeting with a ready sale throughout the country and the dealers are greatly pleased with the distinctive features embodied in this album. Our metal-back album continues to be a prime favorite with our clientele and is giving excellent service everywhere."

L. W. Hough, well known in the New England talking machine trade, has been appointed New England representative for the New York Album & Card Co., with headquarters at 20 Sudbury street, Boston, Mass. Mr. Hough will carry a complete line of the company's albums in stock at all times and will also carry a stock of delivery and stock envelopes.

NOW SOLE PATHE DISTRIBUTORS

The Pathephone Sales Co. of New York, Inc., 111 East Fourteenth street, New York, is now the sole distributor for the Pathé products in the metropolitan territory, having taken over the interests of the Pathephone Distributors Co. and the Stilwell Co.



PERSONAL SERVICE

The members of our Company are always available and will gladly see you personally or write you at any time we can possibly serve you.

Why not communicate at once with us?

BADGER TALKING MACHINE CO. 135 Second Street
MILWAUKEE, WIS.
VICTOR DISTRIBUTORS



The Quality Phonograph

THE wise ones know that the phonograph business doesn't hold still a minute.

It's too healthy.

Maybe you know all the latest moves. And maybe you don't.

We warrant there's something Pathé can tell you which will strike a bright, white light in your mind, and get you busy.

PATHÉ FRÈRES PHONOGRAPH CO.
20 GRAND AVE. BROOKLYN, N. Y.

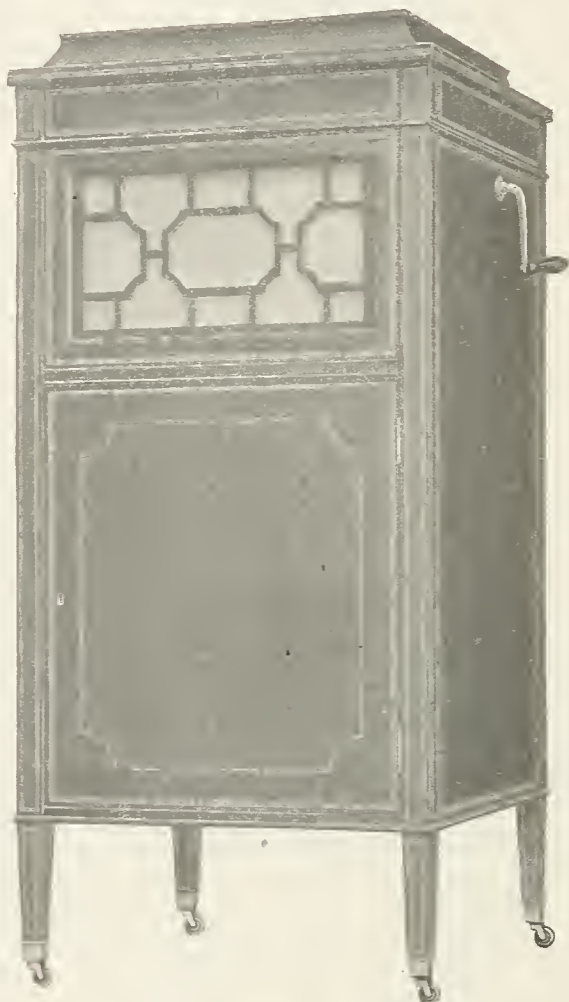

Pathé Phonograph, \$225

No Needles to Change

The Pathé Sapphire Ball takes the place of needles. It need not be changed.

Records Don't Wear Out

We guarantee every Pathé Record to play at least one thousand times with the Pathé Sapphire Ball without impairing the unexcelled beauty of tone.

The Pathé Controla

With the Pathé Controla you may increase or decrease the tonal volume of the Pathé Phonograph at will.

Each Pathé Phonograph

plays not only Pathé Records, but all other makes of records, and plays them perfectly.



The Quality Phonograph

IT isn't altogether a question of retail price, either — though *that's* important.

And it isn't altogether a question of better tone and longer-lasting records — though they're mighty important.

No, it's a number of things and they mean money *you can't get otherwise.*

Write

PATHÉ FRÈRES PHONOGRAPH CO.
20 GRAND AVE. BROOKLYN, N. Y.



ROSA RAISA

Recording for Pathé, and most of them *exclusively*

Muratore, Muzio, Thibaud, Ganz, Grace Hoffman, Rimini, Ober, Cavalieri, Bispham, Slezak, Urlus, Weil, Fitziu, Sammarco, Ruffo, De Cisneros, Journet, Chenal and Maguenat.



© Mishkin

ADAMO DIDUR

INVENTS NEW RECORDING METHOD

New York Engineer Applies for Patent on Multiple Diaphragm Phonograph—Each Instrument of Orchestra Recorded Separately on Film—Reproduced in Synchrony

H. Hartman, electrical engineer of New York, has invented and applied for patents on a multiple diaphragm phonograph, or electric orchestra, which offers a brand new idea in the recording and reproduction of musical sounds. It is claimed by Mr. Hartman that recording for talking machine records as at present conducted is limited in its possibilities, owing to the fact that a single diaphragm must take and record the tones of a great variety of instruments at one and the same time. He points out that as the musical vibrations produced by a violin and contrabasso are widely different, as are the vibrations produced by other orchestral instruments, it is not scientifically possible to record perfectly all the instruments at one time, because the diaphragm cannot respond simultaneously with the great variety of vibrations.

In recording for Mr. Hartman's electric orchestra he uses, in place of the usual records, a special film on which the tones of every instrument in the orchestra, to the number of forty-eight, if desired, are recorded in a separate track. By recording the music of each instrument separately the diaphragm can confine its action to the particular vibration of the one instrument and therefore there is no confusion or distortion of sound.

For the purpose of reproduction the film is wound on a reel and is led from a special compartment over guide rollers to a long, narrow and horizontally arranged department which contains as many sound boxes as there are record lines on the film. The sound boxes are separated as far as possible, and each is provided with a separate trumpet, the various trumpets being arranged in rows facing the audience. In order to regulate the movement of the film it is taken up over a sprocket wheel or on a drum at the opposite side of the cabinet. It is stated that a film of 1,500 feet in length will play continuously for more than an hour, and when the end is reached can be readily replaced by another film bearing other music. The sound boxes are fixed in position, welded to one another and rest freely upon the film, with the needle in a certain sound line. Sapphire and diamond needles are used to avoid the necessity of changing needles. It is claimed by the inventor that the device has been so perfected that perfect synchronization is obtained between the various instruments in the reproduction of the record.

Mr. Hartman is also the inventor of the "speaking clock," which also uses a flexible film, two inches wide, in place of the usual type of record. Operation of the clock is so arranged that the exact time is announced every fifteen minutes. A continuous film is used that runs twelve hours before regulating.

MICA

Diaphragms

Quotations and samples promptly forwarded upon request
Send us your requirements
No obligation incurred

INTERNATIONAL MICA COMPANY

Offices and Factory, 37th and Brandywine Streets, WEST PHILADELPHIA, PA.

PHILADELPHIA
PA.

CHICAGO, ILL.
(Insulation Dept.)

AMELIA CO.
VA.

MONTREAL
CAN.

WEST PHILADELPHIA
PA.

ONE PLAN FOR SAVING SALES

John F. Ditzell, of the Famous & Barr Store, Takes Advance Orders for Machines and Has Customer Make Payments Until Machine Is Delivered—Follows Automobile System

ST. LOUIS, Mo., February 6.—Several models of Victrolas have been very scarce in this market since the holidays, notably those formerly sold for \$100, \$125 and \$75. It was impossible for most if not all of the dealers to make deliveries of these machines in popular finish. John F. Ditzell, of the Famous & Barr talking machine department, solved the selling problem and it was not the old-time solution of putting in another make machine.

Mr. Ditzell's solution was the selling of ownership certificates. He explained it to the customer in this way:

"There are many popular articles of merchandise that you must wait your turn for. For years buyers of Ford automobiles have paid their money to get their names on the delivery program of that company. They cannot be insured delivery without paying a part or all of the money. Victrolas are like the Fords, the demand at present exceeds the supply.

"We do not know just when we can deliver this machine to you, but if you begin paying now you will get the first machine of this model that we receive. We will deliver it just as soon as we can."

It is surprising to many folk that the plan has succeeded and some of the most surprised persons are on Mr. Ditzell's force. They predicted that the plan would not sell any machines, but it has. In one case the buyer not only paid in full for the machine, but he has visited the store several times to hear records and make his selection and these are paid for and have been put aside to be delivered to him when the machine arrives. This many, and the others who have not paid as much, are content because they are going to get exactly what they want as soon as it is possible.

Mr. Ditzell tells rather an amusing story in this connection, which illustrates the point. E. C. Rauth, the Victor wholesale distributor here, had ordered a Buick car of a certain model. The company did not have that car, so Mr. Rauth made a payment and was assigned to a place on the delivery list. Some time later Mr. Ditzell decided to buy a Buick car, but he picked another model and this sort was ready for delivery, so, despite the fact that he started later than Mr. Rauth, he was driving a Buick first. This fact, he said, rather surprised Mr. Rauth, but he told him that it was exactly the

same proposition as the Victrola situation. Those who selected the models in stock got immediate delivery, while those who selected other models had to pay their money and wait.

BUILDING UP SUCCESSFUL BUSINESS

The Faultless Caster Co. Closes Many Contracts With Talking Machine Manufacturers

The Faultless Caster Co., Evansville, Ind., one of the most successful manufacturing concerns in the Middle West, has closed a number of contracts with prominent talking machine manufacturers whereby the company's casters will be used exclusively on 1918 product. The Faultless Caster Co. manufactures a complete line of high-grade casters, suitable for all kinds of furniture, and has perfected a special caster for talking machines designated as C-6-5 which has won the endorsement of well-known manufacturers, including Thomas A. Edison, Inc., the Sonora Phonograph Corp. and the Aeolian Co.

The C-6-5 caster is a nickel-plated, steel wheel caster, and as the company guarantees all of its casters against imperfection of workmanship and material, talking machine manufacturers using this caster have called the attention of their dealers to its merits and the fact that it is absolutely guaranteed.

The Faultless caster was awarded a gold medal at the Panama-Pacific International Exposition, and in fact this caster has won recognition from the most successful furniture manufacturers as a product which embodies all the necessary requirements for use on the most expensive manufacture. The Faultless Caster Co. manufactures 500 styles of casters for different uses.

A recent circular issued by the company featuring the C-6-5 caster for talking machines emphasized the following points of superiority as compared with the ordinary caster: (1) All the weight rests on a round-headed pivot stem; only one point of contact in each caster—friction reduced to a minimum. (2) Springs fitting into the neck of the stem never allow the caster to drop out of the socket. The caster, however, can be pulled out at will. (3) A washer fitting around the track plate strengthens and gives long life to the socket. (4) The steel wheel is made of two shells, one fitting inside the other. The outside shell being rimmed leaves the edge smooth and this evenly corresponds with the other side of the wheel. (5) A reinforcement around the bushing holds it tight and gives the wheel double strength and long life. (6) Stem made of screw stock steel is tapered so the caster will be held in true alignment—always ready for maximum service with minimum effort.



Salesman
Carrying
Case.
Holds 25
Records.

Automatic RECORD CONTAINER

Files All Records

The Automatic is the most practical record filing device on the market. Files all records with equal ease—Victor, Edison, Pathe, Columbia, etc.—and renders them immediately accessible.

Write for catalog and dealer or manufacturer's proposition.

AUTOMATIC CONTAINER CO.

301-303 Tacoma Building, CHICAGO, ILL.



Holds 100 records.

HEAVY RECORD DEMAND A FEATURE OF BUFFALO TRADE

Dealers Building Up Great Business—Remarkable Industrial Activity in Buffalo Helping Trade—Goold Bros. Enlarge Capital—Slow Deliveries Hurt Machine Trade—Delays in Shipments Hurt

BUFFALO, N. Y., February 7.—A heavy demand for records is the dominating feature of the talking machine trade this month. The booths are crowded, the demonstrators being kept busy from morning to night in taking care of the customers. Machines, however, are as scarce as sugar, coal and other staple articles. Added to the shortage reported at the factories are the delayed shipments on account of railroad embargoes. The dealers are closing their stores on the "heatless Mondays" and are trying to crowd six days' business into five and most of the dealers are satisfied with their receipts during the short weeks.

One great source of hope for plenty of trade during the coming year is Buffalo's remarkable industrial activity. According to the State Industrial Commission, the total amount paid wage-earners here in 1917 was 168 per cent. more than the total in 1914. The number of wage-earners in Buffalo was increased 70 per cent. in the past three years. There is not likely to be a let-up of this activity for many months.

Goold Bros., Inc., has filed a certificate of incorporation, with a capital stock of \$150,000. This firm handles the Victor line at its store at Main and Utica streets. The directors are George A. Goold, T. Amesbury Goold, Fred L. Armstrong, Gertrude A. Armstrong and William Goold.

"Our business stands practically as before," said T. Amesbury Goold. "My brother and I hold 95 per cent. of the stock in the company. There will be no change in policy. Our trade is in an excellent condition."

By means of vigorous advertising and extra good values the store of Victor & Co., Pathéphone jobbers, is crowded these days. The Pathéphone is always well represented in the firm's advertising and window displays and superior results are attained.

The Adam, Meldrum & Anderson Co. is conducting a series of Pathéphone recitals.

"The train service is slow and all the dealers are crying for goods," said C. M. Logan, traveling representative of W. D. & C. N. Andrews. On account of slow trains Mr. Logan has experienced many delays in covering his territory.

"We have a pretty good supply of the New Edisons," said Charles J. Hereth. "We were afraid of embargoes some time ago and played safe by laying in a good stock. This was before the advance in prices. We made no mistake in stocking up because the demand for the New Edison is steady even during this severe weather."

"You can see that our booths are always crowded, so we are doing a wonderful record business," said W. R. Gardner, manager of J. N. Adam & Co.'s Victrola department. "The cold weather seems to create a desire on the part of people to stay at home and enjoy their selections."

"We are supplying a heavy demand for the Heifetz records," said C. H. Heineke, manager of Denton, Cottier & Daniels' Victrola department. "This demand shows that he is one of the most popular of the Victor artists." Heifetz will give a recital in Buffalo on the evening of March 22.

Harold E. Kuhn, of Kuhn Bros., talking machine dealers, has been engaged temporarily as organist and chorister at St. Paul's Church, this city.

Trying to have "the bad check" law enacted in New York State is engaging the attention of the Buffalo Association of Credit Men, of which some of the talking machine dealers are members. The proposed law would make the issuing of a bad check prima facie evidence of intent to defraud and subject the maker to fine and imprisonment.

H. A. Brennan, manager of the William Hengerer Co.'s Victrola department, has returned from New York City, where he looked over the trade and received some new ideas for the coming season. Another purpose of his trip was to try to overcome the machine shortage in his department.

Howard W. Webb, talking machine dealer at 150 East Genesee street, is a member of the Jackson Glee Club of this city.

"The Missouri Waltz records are in great demand," said H. G. Towne, manager of Robert L. Loud's Victrola department. "The heaviest demand for records at this store is on Saturdays from 2 o'clock in the afternoon until 10 o'clock at night."

GEO. L. SCHUETZ THE FINAL WINNER

George L. Schuetz, of the Indianapolis branch of the Columbia Graphophone Co., is the final winner in the Pittsburgh district of the individual salesman cup donated by President Whitten for each district, his third victory in November giving him permanent possession of the trophy. He now enters the Columbia "Hall of Fame," along with L. C. Ackley, of the Los Angeles branch, who won the cup offered in the Pacific Coast district. The contests in Philadelphia, New York and Chicago territories are still undecided, a three-time winner in these districts having not yet been registered.

VICTROLA SPEEDS UP TYPISTS

PORTLAND, ORE., February 4.—The High School of Eugene, Ore., has adopted an original and effective method for speeding up the typewriting classes of the commercial department. A Victrola is used and at each beat of music a letter must be struck on the typewriter. As the typists develop speed the class strike two letters to each beat. Not only is speed acquired, but a smooth, steady movement is obtained.

They don't give rain checks for the Seats of the Mighty.

Victor Records

GALLI-CURCI RECORDS !!

They Are Profit-Makers For You. Order From Us NOW

The appearance of this greatest operatic soprano in the Chicago Opera Company's engagement NOW running in New York—the big musical event of the year—makes her records the most active in the list.

JASCHA HEIFETZ RECORDS

Another artist enjoying well merited popularity throughout the country and whose records are correspondingly in great demand.

We also recommend the Missouri Waltz 35663, a record for which there are heavy demands.

In view of the prevailing shortage of Records you want to get the good sellers when the opportunity presents itself. We have some of the best records of which we have a limited supply. Anticipate and stock up while the picking is good. Try us on any records, foreign or domestic, you are unable to obtain from your local distributors. ORDER NOW.

Galli-Curci Records

- | | |
|-------|-------|
| 74499 | 74532 |
| 500 | 536 |
| 509 | 538 |
| 510 | 552 |
| 511 | 557 |
| 522 | |

Jascha Heifetz Records

- | |
|-------|
| 64758 |
| 759 |
| 74562 |
| 563 |



I. DAVEGA JR INC

VICTOR FACTORY WHOLESALERS
125 West 125th St. NEW YORK
The House of Service



VICTROLAS—SUPPLIES—NEEDLES

Mr. Dealer:

Do you know that if you seat your prospect in a comfortable chair before the

GABELOLA

and "*Just Push the Button*"

that it will sell itself?

You can say with perfect frankness and without fear of contradiction that—

"This super-talking machine is winning its way in the thousands of homes where something more than a mere talking machine is desired."

It is self-operating—you don't have to change needles, records, or wind it up because these things are taken care of automatically.



STYLE 1

THE GABELOLA

Circassian Walnut—Height 66 inches, width 43 inches,
depth 20 inches

Price, \$600.00



STYLE 3

THE GABELOLA

Oak Finish—Height 66 inches, width 43 inches, depth 22 inches

Price, \$550.00

The Needle magazine contains 600 needles, and a new one drops into place each and every time a selection is played.

The record container (which contains a repertoire of 24 selections) automatically changes the record just as soon as a selection is played.

The motor is electrically driven and controlled.

It is ideal for the home, dancing school and restaurant.

A personification of pleasure and entertainment "with all the bother left out."

You can say all this and more, but it would be unnecessary.

"Just push the button" and then have your order blank ready.

GABEL'S ENTERTAINER CO.

GENERAL OFFICES AND FACTORY

210 N. ANN ST.

CHICAGO, ILL.

GABEL'S ENTERTAINER SALES CO.
Suite 512 No. 117 N. Dearborn St.

TALKING MACHINE SHORTAGE BADLY FELT IN NORTHWEST

Dealers Complain That Manufacturers, Transportation Officials, Federal Government and Weather Man Are Making Life Miserable These Days—Sonora Men Meet in Minneapolis—News of Month

ST. PAUL and MINNEAPOLIS, MINN., February 5.—Talking machine men in the Northwest, whether they be in the retailing branch or the jobbing branches, have distinct and adequate cause for complaint against almost everybody except the ultimate consumers. The manufacturers, the transportation officials, the Federal Government and even the weather man are combining to make life miserable for the trade men by hampering and limiting shipments of talking machine goods while the people are clamoring for instruments and records.

Yet one will travel far to hear any talking machine man offer a direct criticism. They realize full well that no complaint and no agitation that they make will aid them one iota and the best that they can expect is that fate will be as kind as possible.

The general Northwestern situation for the entire business is well stated by Eugene F. O'Neill, of the Beckwith-O'Neill Co.

"The machine receipts in this territory during January virtually amounted to nothing as the factories centered more on Eastern points as the holidays approached. The early January shipments have not come through and hardly can be expected before the middle of February on account of the uncertain traffic conditions. In the meantime the record situation has become fully as complicated as the machine situation and our afflictions instead of disappearing after the holidays only are increasing. I speak only for the Victrola situation as my information concerning other machines naturally is very limited.

"The dealers in what might be considered non-essentials will receive an awful jolt some day if they do not realize that war-time conditions now prevail and will govern every angle of the business from the production of the raw materials, through the factories and jobbers to the retail dealers.

"We must face every new cross with the best grace possible and trust that the future will bring a marked improvement in our affairs, but, to tell the truth, the labor situation, the difficulty in obtaining raw materials, and the transportation problems hardly warrant one in bubbling over with enthusiasm."

Sonora dealers from all over the Northwest will gather at the West Hotel, Minneapolis, February 6, for their annual convention and banquet. The Minneapolis Drug Co., distributor of the Sonora products, will do the honors, with Sewall D. Andrews as the chief steward. President Brightson, of the Sonora Co., was heralded as one of the headliners with some of the leading Eastern distributors in his supporting company.

W. L. Sprague, manager of the Minneapolis branch of the Columbia Graphophone Co., is back with the fine trophy he won at the Columbia convention. Having won the honor three times in succession the trophy becomes the permanent property of his branch. Although greatly hampered by various conditions, the branch increased its business for January, 1918, by 100 per cent. It could have shown much better results had certain matters been more favorable.

E. F. O'Neill, of the Beckwith-O'Neill Co., returned Friday from Boston, after an absence of two weeks. He was summoned to his old home by the death of a sister.

Several of the dealers in musical instruments are exhibiting in the Industrial Exposition, which is a winter fair and the outgrowth of the annual automobile shows. The exposition is conducted in the immense assembling plant of the Willys-Overland Co. The Minnesota Phonograph Co., in conjunction with Bostwick & Brown, Ediphone distributors, have four booths for the display and demonstration of products of the Edison laboratories. Laurence H. Lucker personally supervised the arrangement of the Edison display.

Columbia Grafonolas and Dictaphones were shown in a suite of four booths, with W. C. Hubbard, Dictaphone expert, and W. L. Sprague in charge. The show, opening February 2, will close late February 9, and is drawing thousands of visitors, mainly from St. Paul and Minneapolis, but also from the rural districts. Included among the latter were the Sonora dealers.

R. E. RAY NOW SALES MANAGER

Takes Important Post With Jones-Motrola, Inc.,—G. K. Stickle Returns to Canada

R. E. Ray has been appointed sales manager of the Jones-Motrola, Inc., New York, the manufacturers of the Jones-Motrola. Mr. Ray has already taken up his new duties and will organize the sales force of the company along most efficient lines. He is now making a short trip.

G. K. Stickle, sales manager of the company since its organization, has resigned to enter another line of business in Canada, while C. E. Reiss will continue in charge of the New York office.

The Jones-Motrola has steadily gained ground and has been endorsed by various prominent talking machine companies, among the latest being the Brunswick-Balke-Collender Co., manufacturers of the Brunswick phonograph, having recommended the Motrola to their dealers.

THE PATHE IN PORTLAND, ORE.

PORTLAND, ORE., February 4.—Ten days before Christmas Calef Bros., of Portland, Ore., began selling Pathé machines. The Calef Bros. have a big furniture store and never handled talking machines before. They have the exclusive sale of Pathé for furniture houses in Portland and are amazed at the success they are having.

SILVERSTONE MUSIC CO.'S OPENING

Handsome New Warerooms in St. Louis Open to Public With Special Ceremonies During Week of February 4—Tone Tests Given

St. Louis, Mo., February 6.—The Silverstone Music Co. held the formal opening of their new warerooms this week. There was no formal program, but there were daily tone test recitals all week by Prof. Chas. Kaub, a violinist of the St. Louis Symphony Orchestra, and Mme. Blanche Skrainka, a local soprano. As an added attraction, a band of Hawaiian stringed instrument players were brought on for the week and proved to be a popular attraction.

Despite the fact that this opening was first planned to be in December, there was much work to be done at the last moment. Working men to put on the finishing touches to the interior were scarce and materials hard to get and even the removal of the eight booths from the old warerooms to the new, where they were installed on the second floor as record demonstration booths, proved to be a work of weeks, instead of days. It required a grand rush to get all of the reserve stock out of boxes and into the new bins before the opening day came.

There are those who accuse Mr. Silverstone of second sight in the renting of an additional five-story building across the street and stocking it with machines several weeks ago in anticipation of the present conditions. That is what he did and it is this stock that is supplying the means for the present trade.

In his opening advertising, Mr. Silverstone featured a letter from Mr. Edison explaining that he was unable to attend the opening because of his work "for Uncle Sam" and he invited people to come and see the first Edison machine, the massive iron affair that was fashioned in 1878.

Asking a customer to call again helps some, but the thing that counts for most is to treat him so well that he will come without asking.

Manufacturers— Jobbers—Retailers

If you are ready to take advantage of the enormous demand for *good* talking machines, we can serve you two ways.



Harponola

We are in the position to sell you the finest looking and scientifically constructed cabinets at reasonable prices.

We can sell you fully equipped machines under your own trade mark or ours, in carload lots at jobbing discounts.

If you are a dealer, please bear in mind that we manufacture only high grade cases and are installing the best mechanical equipment that money can buy. A postal will bring you our catalogue with full details.

Our prices and discounts are fair to the manufacturer, liberal to the *jobber*, right to the dealer and just to the public.

Write us today as we are now placing orders for raw material for our 1918 requirements.

THE CELINA FURNITURE CO.
CELINA OHIO

NEW COLUMBIA HOME IN BALTIMORE

Local Branch of Columbia Graphophone Co. Plans to Occupy Handsome New Five-Story Building on South Howard Street on March 1

BALTIMORE, MD., February 4.—Announcement is made by W. S. Parks, the local manager for the Columbia Graphophone Co., that the local branch will shortly prepare to move to larger and more commodious quarters at 16 South Howard street. There they will have a five-story building with an entrance on German street as well as Howard.

The new Columbia headquarters will have three times the floor space of the present home and it is planned to occupy it on March 1. The first floor will be devoted to handling incoming records on the Howard street side and they, together with machines, will be shipped out of the German street side of the building. A model show window will always be kept trimmed as a suggestion to dealers how to properly display their machines and records, with the aim of increasing business. The first floor will show display rooms as models, after which dealers who want to improve their business may easily pattern. The second floor will be used principally for general offices. Mr. Parks plans to spend most of his time outside on the firing line looking after the sales and the headquarters will be practically taken care of by S. C. Cooke, the assistant manager, who did such fine work for the company during Mr. Parks' illness. The Baltimore headquarters looks after business in Maryland, Virginia, West Virginia, North Carolina and the District of Columbia. Business at this branch is gone away ahead of many of the branches and is now in good position with only New York, Philadelphia, Chicago and Pittsburgh leading in sales.

Mr. Parks has just returned from a tour of Virginia and among the places he visited were Richmond, Norfolk and Petersburg, Va., and also Washington. Mr. Parks says he found all of the merchants happy and confident that business would show from 50 to 100 per cent. increase this year over the past year. The trip was in part taken for the purpose of introducing A. C. Creal, the new district salesman, to the trade in that territory. Mr. Creal has joined the Columbia forces and will be in charge of the selling end in eastern Virginia and District of

Columbia. He was formerly advertising manager of the Eagle Furniture Co., of Memphis, Tenn. William Korhammer will be in charge of sales in the western part of Virginia. W. B. Sibbet, formerly in charge of the Dictaphone end of the business here, has become city and State salesman for the talking machine line and is succeeded in that branch by C. F. Smythe, formerly of the A. B. Dick Co., of Boston. A. Hoffman has been added to the Dictaphone department sales force.

THE TRADE SITUATION IN ATLANTA

January Business Very Good Considering Conditions—Future Prospects Unusually Bright—What the Dealers Are Doing

ATLANTA, GA., February 4.—Everything considered, talking machine business for the month of January in this section was quite satisfactory. The South, in common with the whole country, having recently come through the most severe weather in years, has been affected in a business way, but with the advent of better weather and the fact that cotton, the South's great staple, is bringing the highest price in years, the phonograph business at present is large and broadening.

I. M. & R. D. Bame, Victor dealers, have added the Sonora to their line, and are enjoying a fine business on same.

The Haverly Furniture Co. have taken on the full line of Pathéphones and Pathé records, in addition to their leading line, the Columbia Grafonola.

Phonographs, Inc., local Edison jobbers and retailers, have been enlivening their store with tone tests and recitals. At the time of this writing Miss Anna Case is due in the city for a concert at the Auditorium and will doubtless be favored with an enormous crowd.

The record business with all phonograph stores is quite active, the late patriotic and war hits being in great demand.

A. J. Endres has purchased the entire interests of the Bruett Piano Co., Gay Building, Madison, Wis., and will continue to feature the Kimball piano and phonograph line. A. J. Bruett, founder of the company, has returned to Milwaukee and will engage in the piano and talking machine business in that city.

NEW BRUNSWICK SALES MANAGER

Edward Strauss Takes Charge of Wholesale Phonograph Department of Brunswick-Balke-Collender Co. in New York—Other Changes Among the Salesmen—Trade Good

Edward Strauss, long connected with the Brunswick-Balke-Collender Co., manufacturers of the Brunswick phonograph, at their offices in Chicago, has come to New York as manager of the wholesale phonograph department here, with headquarters at 29 West Thirty-second street. Mr. Strauss has made a thorough study of the phonograph field and comes to his new post well equipped to develop business for the Brunswick phonograph in the East.

The sales organization of the company is being strengthened constantly. J. J. Brophy, formerly with the New York office, will in future travel through New England, with headquarters in New Haven.

A. J. Kendrick is returning to the West to continue his promotion work in establishing exclusive Brunswick shops. This work was temporarily suspended on account of readjusting the Eastern situation. The work now being resumed, it is planned to enlarge its scope and several Eastern cities may be included in this campaign.

These specialized shops, now fourteen in number and established throughout the Middle West, are based upon an idea of diversified merchandising carrying several of the Brunswick products. The Brunswick phonograph is, however, the prime factor in each case.

The Brunswick phonograph has recently been exhibited in the various furniture shows held in New York, Grand Rapids and Chicago. In every case the Brunswick booth was well visited and the results from each exhibit were gratifying.

Among the recent visitors at the New York headquarters of the house were J. F. Ditzell, of Famous & Barr, D. J. Nolan, of the May Co., enthusiastic Cleveland Brunswick dealers, and O. A. Field, of Field-Lippman, St. Louis, who are Brunswick dealers in that city. Mr. Field reports that the holiday business transacted in Brunswick phonographs was particularly fine.

The progress of the Brunswick phonograph in and about New York has been most satisfactory and the outlook for the year is declared to be excellent.

A

AMERICAN

A



No. 22—\$175.00



No. 13—\$135.00

Clear in Tone, Beautiful in Design, Smooth Running Motors

AMERICAN embodies all the good qualities and special features of phonographs and you cannot afford to be without this popular line. The finest of materials used, workmanship that cannot be surpassed, and a line designed and made from a dealer's standpoint. With this line many dealers are increasing their profit and adding materially to their volume of business.



No. 4—\$40.00



No. 5—\$50.00



No. 8—\$65.00



No. 9—\$80.00



No. 10—\$100.00



No. 11—\$115.00

We stand back of every American

AMERICAN PHONOGRAPH COMPANY

Main Office, 39 Fountain St., N. W., GRAND RAPIDS, MICH.

Branch Office, 503 Cable Bldg., CHICAGO, ILL.

A

A

Thousands of homes will welcome the Columbia Records of Father Finn's Paulist Choristers. "Agnus Dei" and "Salve, Regina" are the newest.

**Columbia Graphophone Co.
Woolworth Building, New York**



GOOD RESULTS FROM MILWAUKEE ADVERTISING CAMPAIGN

Talking Machine Men Enthusiastic Over Co-operative Publicity Plan of Milwaukee Association of Music Industries—Standards of Practice Adopted by the Trade

MILWAUKEE, Wis., February 6.—No members of the Milwaukee Association of Music Industries are more pleased with the results of the co-operative advertising campaign conducted by the association at a cost of \$3,000 for ten weeks ending in the middle of January than the talking machine men. For direct results, as shown by the talks with patrons, the campaign did wonders for the men of this industry. They have been able to trace a large volume of business to the publication of ten full-page advertisements, one of which was devoted exclusively to the talking machine and the others being combinations of sales effort directed at all types of pianos and talking machines.

A result of the advertising campaign has been the adoption by the association of a code of ethics, or standards of practice, which place the Milwaukee dealers in a most commanding position as a progressive organization, and one which has ventured perhaps further ahead than any similar body in the United States. The code consists of ten articles and has been aptly styled "The Ten Condemn-ments." It reads as follows:

**Standards of Practice
(Ten Condemn-ments)**

1. This association condemns advertising of, or otherwise offering by any dealer, instruments not regularly carried in stock by such dealer with the consent of the manufacturer, unless the instrument or instruments so advertised or offered shall first have been offered to the manufacturer thereof or to the nearest regularly authorized agent at cost.
2. This association condemns the practice of advertising instruments not regularly carried, unless the advertiser offers them in good faith and stands ready to sell said instruments at once to any buyer.
3. This association condemns the breaking of sales or malicious criticism of any instrument by a dealer or salesman for the purpose of dissatisfying the buyer after the sale of such instrument has been consummated.
4. This association condemns the advertising of used instruments stating the prices originally asked for the instruments when new.
5. This association condemns the breaking of offering of instruments at prices higher than the standard market value as represented by prices fixed in a majority of sales actually made.
6. This association condemns the advertising of private sales at residence addresses and places not recognized as regular trade locations.
7. This association condemns advertising as "Free" those articles included in the purchase price of the instrument, such as bench, scarf, etc.
8. This association condemns advertising of "Manufacturers' Sales," and the offering of instruments at "Factory Prices," and the advertising of "Special Sales" in which instruments

"Must Be Sold Regardless of Cost or Value."

9. This association condemns "Puzzle Contests" and "Guessing Contests," as the result of which "Purchase Coupons," orders or vouchers are given.

10. This association condemns advertising in which high-grade instruments and cheaper grades are listed indiscriminately, with the lowest prices and terms quoted to appear to apply to all.

The Milwaukee association, which was organized in February, 1917, has been incorporated under the laws of Wisconsin, and at its first annual meeting as a corporation elected the following officers: President, Henry M. Steussy, general manager Steussy-Schulz Piano Co., representing the Magnola and Pathéphone; vice-president, Paul F. Netzow, secretary-treasurer Milwaukee Piano Mfg. Co., representing the Imperial; secretary, Richard H. Zinke, general manager Badger Talking Machine Shop, Victor dealers; treasurer, William R. Winter, president Winter Piano Co., representing the Columbia; directors, Edmund Gram, representing the Aeolian-Vocalion; Fred B. Bradford, Victor dealer, and Leslie C. Parker, manager of the Victor department of Gimbel Bros.

Edmund Gram was president during the first year of the association's existence and Mr.

Steussy was secretary. The latter's splendid work in that position made him the unanimous choice for president when Mr. Gram announced his determination to retire because of the extraordinary demands upon his time by the presidency of the National Association of Piano Merchants of America and his private business affairs. In electing Mr. Zinke as secretary, the association gave deserved recognition to one of the most prominent and influential talking machine men of the Middle West. The association has a total of forty-one members, embracing practically every reputable music house in Milwaukee, and has made a splendid record since its inception.

SECURES THE EDISON AGENCY

The Lund Jewelry Co., Seymour, Conn., has been appointed representative for the Edison Diamond Disc Phonograph and Edison Re-Creation, and the establishment will be known in the future as The Edison Shop. The store has been remodeled, to admit of the installation of demonstration rooms and a large reception room.

MULTUM IN PARVO

Take all the men who have failed since Creation; take all the causes of their failure; and, though there be ten, or ten million, not one is proof of your failure. Every man is master of his own destiny.

Anticipate Your 1918 Requirements Now

by investigating at once the merits of our improved Veeco Electric Motor and Vitraloid Turntable for electrically equipping your higher grade machines.

The Veeco motor runs on either A. C. or D. C. of 100-125 volts without any adjustment, and can be supplied to run on any voltage from 6 to 250.

To dealers we supply the motor mounted on either 12" or 12½" square mahogany boards, all ready to install.

*Send for a sample and try it out.
Orders for 1918 should be placed at once.*

THE VEECO COMPANY
248 Boylston St. Boston, Mass.
The Original Producers of a Complete Electric Drive for the Talking Machine Manufacturer's Use

TRANSPORTATION THE BIG PROBLEM IN ST. LOUIS TRADE

Talking Machine Men More Interested in Getting Stock Than in Making Sales at Present—Fire Destroys Mozart Talking Machine Co. Factory—General Trade Conditions Reviewed

St. Louis, Mo., February 6.—Local talking machine dealers are talking transportation more than sales at present. It is their belief that the talking machine dealer who has an ample stock in this section is the one who will reap the harvest this spring. Stocks of certain styles of machines are exceedingly short and with other companies records are the difficult point. The Columbia Co. was considerably embarrassed for a time because the after Christmas shipments of records expected for the first of the year were lost in transit. The Victrola line of machines has been short of the styles selling for \$110 and the styles priced above and below this have been entirely out of stock.

Robert Cone, of the Artophone Co., said that the freight question had become a very serious one with that company. They had a large number of machines almost ready for use but that the minor parts were several weeks past due and machines that were to be shipped on after Christmas shipments were still held. "Some of our working men have shown considerable ingenuity in getting by the scarcity of certain parts," he said, "and we have kept up fairly

well with the most acute demands, but we are much farther behind than we like to be. As to cabinets, we are well fortified by reason of precautions taken last summer and recent tracers have shown that our most needed shipments are making progress."

One of the unfortunate happenings of the month was the burning of the Mozart Talking Machine Co. plant the second day after it had begun operations. The plant was formerly known as the Colonial Cabinet Co. and was bought by the Mozart Co. after a fire. It had required six months to re-equip the plant, chiefly because of the delay in obtaining motors and certain machinery. The plant had been in operation only two days when it was again destroyed by fire. The plant was well covered by insurance and so the heaviest part of the loss will be in the disarrangements of plans and the necessary wait to get a new plant equipped under the war conditions. In the meantime President Fitzgerald expects to find means of continuing the production of the Mozart machines.

Despite the handicaps of the shipping, trade has been very good, according to all reports.

Of course, it could be better with the full stocks of records and machines, but some of the houses will show an increase over any previous January, they assert. The jobbing trade has been excellent, counting by orders filed. Not so good if counted by orders delivered.

Manager Irby W. Reid, of the Columbia Co., spent a busy month-end after his return from the New York conference of branch managers, which he termed "the greatest sales meeting ever held." He was anxious to get his wholesale staff together and pass on some of the ideas and enthusiasm brought back from the East, but was unable to call this meeting until February 4 because of the pressure of business.

The new Columbia records made by Handy's jazz band at Memphis has proved a winner in the St. Louis district, where that band was well-known and its fame is secure for the present kind of music. The records have proven to be wonderful sellers in the country districts and especially in that section nearer Memphis.

TO ISSUE "TRADE NEWS SERVICE"

I. Davega, Jr., Inc., to Render Practical Cooperation to Dealers—Important Move

I. Davega, Jr., Inc., Victor factory distributors, 125 West 125th street, New York, are compiling a "News Service" for Victor dealers. This publication will be named "Trade News Service" and will be full of live news and timely helps for the dealers. It will be compiled and edited by Abram Davega and Joe Schwetz, who have a wide and varied experience in the merchandising of Victrolas and supplies. It will prove a very valuable assistant to the dealer and numerous requests have already been received to have their names placed upon the list. The initial issue is expected to make its appearance within about one month.

TO AID TRADE ACCEPTANCES

Council Asks War Credits Board to Insist on Their Use by Manufacturers

With the view of hastening the more general adoption of the use of trade acceptances, the American Trade Acceptance Council has suggested to the authorities in Washington that the War Credits Board, which looks after the granting of advances to manufacturers and contractors doing Government work, should adopt the policy of refusing to approve advance payments until the applicant has availed himself of his own credit by resort to trade acceptances in the purchase of goods. It is felt that, while the Government cannot itself pay for goods on the trade acceptance plan, by reason of certain legal obstacles, there is no valid reason why the contractor should not reduce the financial burdens of the Government by using trade acceptances to the widest possible degree. It is believed by bankers that these manufacturers and contractors should receive advances only after they have entirely exhausted their own credit facilities.

TRAVELING MEN'S TROUBLES

They Are Multitudinous in These Days of Disrupted Train Schedules

The troubles of traveling salesmen these days are not confined to paying taxes and enforced idleness on Mondays, says the New York Times. One traveling man who just recently returned from a trip through the South relates that, due to the curtailed passenger service on the railroads, he was delayed for three days in one town, and that in order to pay his swollen hotel bill he had to pawn his watch. He explained that, while his expense checks had been mailed by his firm on the prescribed dates to various points along his route, it had taken him so much longer to get from one point to another that it was frequently impossible to make his last check cover his expenses until he reached the town at which the next one would be waiting.

Big Profits—Quick Sales

DEALERS who are selling the Elmbrola are making big profits because the machine is right and the price is exceptionally low. The handsome appearance of the beautiful Elmbrola, together with its clear, distinct tone, makes it one of the easiest phonographs to sell you ever saw. Space prevents us from telling you about the many exclusive features of the



Model B Elmbrola



"Sounds Clear — Made Sound"



Model D Elmbrola

but a postcard or letter will bring you full particulars and some beautiful pictures.

We Guarantee Prompt Deliveries

When you take on the Elmbrola, your orders will be shipped to you promptly the same day we receive them. But the big reason why you should find out all about the Elmbrola is the exceptional profits you can make.

The Elmbrola is really a beautiful machine—its clear sweet tone wins all who hear it. Compare it with any other. See the handsome woodwork, the finish—and then put on a record.

Get full particulars right away—send us a postal or a letter now

ELMBROLA TALKING MACHINE CO., Dept. A, ST. PAUL, MINN.

Featuring the Musical Possibilities of the Talking Machine

By William Braid White

[Note.—This is the twelfth in a series of articles on the general subject of the musical possibilities of the talking machine. The aim of the series is to develop these possibilities from all angles, thus opening up fields for sales expansion oftentimes neglected wholly or in part.—Editor.]

RECORDS OF STRING MUSIC

The other day, at one of the meetings of the Chicago Piano Technicians' Conference, the statement was made that the most popular type of instrumental talking machine record is that of violin, harp and flute trio. The assertion was made by very high professional authority, and all the information I have seems to confirm it, generally speaking. The point is interesting and important, and involves certain considerations which ought, I think, to be clearly understood by all to whom the musical possibilities of the talking machine are rightly sensed.

It is hardly necessary for me to repeat what already is a hackneyed saying about the need for greater musical knowledge on the part of those who sell talking machines, in the light of the rapidly advancing musical taste of the public. Nor should it be—though it is—needful to point out that as this taste continues to grow, that which is expected and demanded of the talking machine in the way of mechanical and musical excellence becomes ever more clearly conceived and definitely formulated.

In brief, the talking machine has to satisfy a more refined public taste. The salesman must therefore know what a refined taste is, and must possess something of the same himself. More than all else he should be thoroughly well posted on the powers and the limitations of the talking machine and should know its strongest and its weakest musical points thoroughly.

The necessity to know of these things constitutes the *raison d'être* of articles like this one. The particular musical point which I am now bringing up is of enormous importance, and a thorough knowledge of it cannot fail to improve the selling ability of any man who deals with the public at retail.

The Popular Trio

To begin at the beginning, why is the violin, flute and harp trio so popular? To answer this question, get a record of, say, Schubert's *Serenade*, played by this combination of instruments, take it into a quiet place, where you won't be disturbed, put on the machine a soft-tone needle and listen critically. The effect is undoubtedly pleasing, but I think you will agree with me that the pleasure is, as it were, not evenly divided between the three instruments. Whenever I listen to a trio like this on the talking machine, I always notice clearly the modifications of tone-quality which so clearly come out. The harp, for instance, is certainly good, for it seems that plucked tones, as harp, mandolin or banjo, come out very well; but even so it sounds more like a mandolin at one end and a guitar at the other than like a true harp. No! it is not the harp that merely gives the pleasing effect.

On the other hand, the smooth and clear beauty of the flute, without any emotion or brilliant color in it, carries something soothing and superficially most attractive. Yet its tone is not of lasting attractiveness, for one tires of it too soon; it is too monotonous. The violin's tones, on the other hand, possess just the color that the flute lacks, have just the sustained quality which the harp has not, and seem to attract any and every kind of musical taste from lowest to highest alike.

Yet it is a fact that, in the upper part of the scale, the talking machine reproductions of flute and of violin are almost indistinguishable. The low tones of the violin can be distinguished readily from those of the flute, but the higher tones of both instruments seem to melt into each other, each losing something of its true

quality while gaining nothing worth while in exchange.

The Quartet of Strings

These facts have more than an academic interest. The violin and its big sisters, the violoncello and viola, are, beyond doubt, the loveliest and most generally attractive of all instruments to the ear, taking into consideration all possible advantages and disadvantages, and balancing one against the other. It is, however, a well-known fact that violin records do not sell so well, on the whole, as those of the 'cello, while the viola is hardly known. But what is more important still is that none of these instruments is as popular among buyers of records as its qualities would make one expect it to be.

To what extent, now, should one suppose that the peculiar modification of the violin tone in the upper registers, which makes it sound like a flute in these regions, is responsible for the relative slowness of sale, of which I have spoken? Candidly, I don't think we should put too much importance upon this fact, although it is one that ought to be mentioned and taken into consideration. As I said above, when you listen to a trio of violin, flute and harp, you undoubtedly like the violin tones best. Why then should not the records of solo violin playing be even more popular

The Source of Trouble

To tell the plain truth, I am pretty well convinced that the whole trouble is to be found in the retail stores. I think it would, in fact, be wrong to blame on the record or on the instrument itself what is really not of enough importance. I felt sure that someone would speak of the well-known facts regarding the reproduction of high violin tones; so I also spoke of them. But, while this is all true, it is also true that a trio of violin, flute and harp, where two of the three instruments sound almost wholly alike in certain registers, is a very popular form of instrumental music with record buyers. Then there must be some other reason for the slowness of which I complain.

In fact, we come back to the old facts. The violin is not appreciated by record buyers as it should be, any more than great violin playing is appreciated as it should be when it comes

out before the public in the person of an Ysaye, a Powell or a Heifetz. Of course, the musicians rave over it; but the musicians are only a small minority. Now, I believe that one of the undeveloped fields in record selling is right here in solo violin and solo 'cello reproductions; and I feel sure that if intelligent and well-informed work is put into promoting these, any salesman can reap a rich reward in his community, and among those who habitually visit him to buy.

The Great Players

The list of great artists who have made and are making records of their violin playing for the various talking machine record makers is formidable in quantity and dazzling in quality. Fritz Kreisler, Eugene Ysaye, who shall choose between them? Maud Powell and Kathleen Parlow; are they not the greatest women players of the world, unsurpassed since Norman-Neruda herself? Albert Spalding, Francis Mac-Millen and Eddy Brown, are they not making patriotic Americans proud of their country? Indeed, there are plenty of great violin players from whose records the best of violin music can be chosen at one's own sweet will anywhere and at any time.

But I shall perhaps be excused for remarking that here, as elsewhere in the record game, one finds a narrow-mindedness on the part of the retailers which can only be put down to want of familiarity with the contents of the catalogs. It is simply incredible that any man who has once heard the lovely playing of Kathleen Parlow in that exquisite slow movement of Mendelssohn's violin concerto could fail to recommend the record to his customers. Of course, you cannot expect the latter to know for themselves; the very word "concerto" will frighten most of them. But the salesman owes it to himself to know at least the sound of every record made by a well-advertised artist; simply because, in the first place, the Victor, Columbia, Edison and Pathé people do not promote and exploit an artist unless he or she is really *Al*, and because, in the second place, these manufacturers have a right to expect that the labor they and the artists expend, not to mention the money and time, in getting out fine records,

(Continued on page 54)

7th Floor

229 Fulton Street

Clifford A. Wolf

MANUFACTURER OF

Diamond and Sapphire

Phonograph Points

New York City

Phone, 1678 Cortlandt

Note New Address

THE MUSICAL POSSIBILITIES OF THE TALKING MACHINE

(Continued from page 53)

shall not go in vain even to the smallest degree. When I add that the violin and 'cello records are all eminently worth while and that they are suitable to every kind of decent taste—to every kind of taste that is not actually degraded—I have said all that need be said to recommend them. It only remains to point out that records as good as these can and should be made hot-cake sellers.

Taste!

In this respect may I say just a word on that very much discussed subject, public taste? Nothing is easier than to argue from one's own standpoint about other persons' ideas; and nothing is more fallacious. When a sensational, salacious newspaper is accused of degrading public taste, it always replies that it gives the public what it wants. The truth is that it gives the public what its own vulgarity wants; and the public responds to the suggestion in numbers always large enough to look superficially impressive, yet never really representative. The same thing is true with music; the vulgar mind wants only trash, when it does not actually want filth; and instinctively says that this is what the public want, too. Yet it is a serious mistake all the time! The taste of the public is always better than it is supposed to be. That does not mean that the plain people are all educated in the latest musical ideas and fads; but that the public taste is always towards the sane, the healthy and the clean in art, when it has a chance to go in its own direction to suit its own ideas.

That is why it is always much easier to sell high-grade instrumental records than it seems to be; when the salesman himself knows what he is selling and cares for it.

Getting Acquainted

Now, then, what is easier than to make a sort of at-home study of the stringed-instrument records during the next few weeks, with a view

to becoming acquainted with them more completely and definitely? I am convinced that there exists a great and almost undeveloped field for exploitation in this particular department of record selling, and I know, from observation, from talks with owners of talking machines and the statements of men in the business who know how to look for themselves at facts, that ignorance and not indifference or dislike is at the bottom of any public slowness to take up the reproduction of violin and 'cello music.

Some of Them

Just a word must follow about some of the violinists and 'cellists and about some of their records.

It is always safe to introduce a prospect to Kreisler or to MacMillen. Kreisler is manly, energetic and tonally lovely in his playing. His interpretation of the Dvorak Humoresque has sold well, but his other pieces have been badly neglected. I should like to have every one listen to his records of his own adaptation of Viennese dance tunes, to his Tambour in Chinois, and to some of the lighter music he has recently played. MacMillen is charming, gentler and less energetic. He has as yet done too little, but the two or three light bits he has recorded will tickle the ear and fancy of even an untrained music lover.

For clear, virile calmness, commend me to Spalding. He, too, is an American and a fine one; and now I believe is in the service. Get some of his Edison records and try them. You will enjoy them and him.

Pure glory of tone and pure serenity of thought are Kathleen Parlow's. Her playing of that lovely Andante of the Mendelssohn violin concerto is the best thing she has yet done. Its title is against it, but if you don't want to be out of date in heaven's name get out that record and listen to it. Then go and sell it.

Maud Powell might almost be called—apolo-

gies to a charming lady—a "veteran" of the concert stage. Her very fine violin and her super-fine playing have been exhibited through Victor records for some time, but she is yet to be spared to us, let us hope. She has done the Dvorak Humoresque, a Chopin valse arrangement, and, I think, the finale of Mendelssohn's violin concerto. She is a woman without "nerves," but all "nerve," a woman whose musical thought reflects her true self, in its pure clarity and perfect cleanness, in its classic beauty of outline and abstract beauty of tone. She is a wonder. Don't neglect her.

Pablo the Bald!

Just a line about the 'cellists. Casals! Kreisler calls him "the greatest artist that ever drew a bow." I heard that little bald-headed Spaniard play a set of variations for 'cello and orchestra with the Chicago Symphony Orchestra; and he drew tears to the eyes. And I, for one, don't care for 'cello concertos and show-pieces. His 'cello recordings are marvelous. Listen to his playing of the Adagio (slow movement) from that charming concerto in D minor by Papa Haydn, a little thing more than a century old; and know something of what lovely tone really is. Try his air for the G string by old Bach, still more aged, and learn for yourself that the sometimes whining 'cello may be a glorious baritone voice sending its harmonies rapturously heavenward.

There are other 'cellists, good old Kronold, Kindler, Kefer, and a number of others. But of them I must talk some other day.

Perhaps some one will feel like taking a bit, anyway, of this advice, humbly and sincerely offered by one who believes in the talking machine and in its wonderful mission.

BRILLIANTONE NEEDLE SHIPMENTS

Ship Needles Far in Advance of Advertised Date
—Eugene Latham Joins Force

The Brilliantone Steel Needle Co. are now well established in their new offices in the Marbridge Building at Sixth avenue and Broadway, New York. B. R. Forster, president of this new company, reports exceptionally fine business, the sales of the first month having far exceeded the amount anticipated. He says that in spite of this unexpected heavy demand all orders have been promptly filled. In this respect the company have even gone ahead of their plans.

It was originally announced that deliveries of this new needle would commence on February 1. Orders were accepted on this basis. Mr. Forster announces that large quantities of the needles were shipped during January, far in advance of the advertised date.

The Brilliantone Steel Needle Co. announce that Eugene Latham, well known in the talking machine field, having been connected for a number of years with the Silas E. Pearsall Co., has joined their sales staff. Through ill health Mr. Latham severed his connection with that organization and for almost a year has been in Atlantic City regaining his strength. Now fully recovered, Mr. Latham comes to this new organization, ready for the big work ahead of him.

Through an error last month it was stated that H. Ettinger, vice-president of this company, had been connected with the Victor department of Kranich & Bach. The credit for these years of service in this capacity should be given to H. W. Acton, secretary of the company, although Mr. Ettinger is also well known to the trade.

WHY NOT? SAY WE

Says a merchant who has done it himself: If your individuality and personality do not attract sufficient business or if you be weak in that respect, why not hire a good manager who has the qualifications that you are lacking? Your time and efforts may be profitably employed in the accounting department of your store, instead of the managing and sales department.

KOCH-O-PHONE

\$24.50



No. 23

The KOCH-O-PHONE is the FORD of the Phonograph world. There is no charge for the name or expensive advertising added to the cost. Most people would rather pay \$48 (resale price) than \$100 for the same amount of pleasure. Plays all makes of disc records. No disconnecting needed in exchanging from one make of record to another. Simply turn the sound box and change needle to suit make of record. This machine for tonal quality and volume is not excelled by any \$100 machine on the market.

No. 23—Height 43 in., width 19½ in., depth 22 in.; double spring worm driven motor; 12 in. turntable, all metal trimmings are nickel plated; made in mahogany finish. With tone modifier; weight about 125 lbs.\$24.50

Cabinet alone, complete with needle cups . . \$15.00
Equipped with tone modifier . . . 50 cents extra

Tone Arms and Sound Boxes
(Genuine Mica)

Our new universal tone arm and sound box, No. 3, has proven a big success. Has all the desired requisites in the way of producing a clear, rich and musical tone.

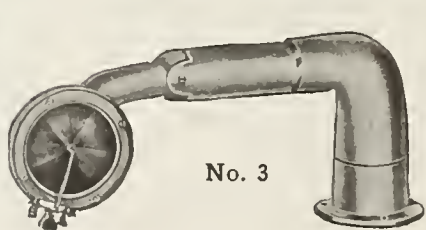

No. 3

Price\$1.50
In Lots of One Thousand

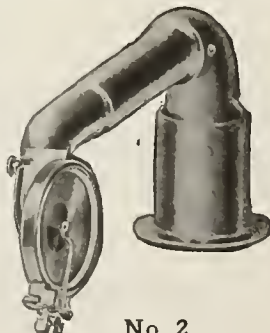

No. 2

Real Mica, \$1.00
in 100 Lots
Imitation Mica, 85c

AND'S KOCH, Manufacturer

296 Broadway

NEW YORK

FEATURING EDUCATIONAL SIDE OF THE VICTROLA

What Dealers in Various Sections of the Country Are Doing to Impress Upon the People in Their Communities the Value of the Victor in the Schools—Original Ideas Set Forth

PHILADELPHIA, PA., February 4.—One of the important forces operating for the advancement of music lies in the work being done by the educational department of the Victor Talking Machine Co. Within the last few years such remarkable headway has been made in introducing talking machines into the schools, as a means of educating young America, that today the list of public and private institutions of learning equipped with Victrolas includes several thousand cities in the United States alone.

The possibilities of the Victrola along strictly educational lines are, of course, being empha-

display utilizes the blackboard and desks, but in addition has introduced dummies to represent the children and the teacher, thereby add-

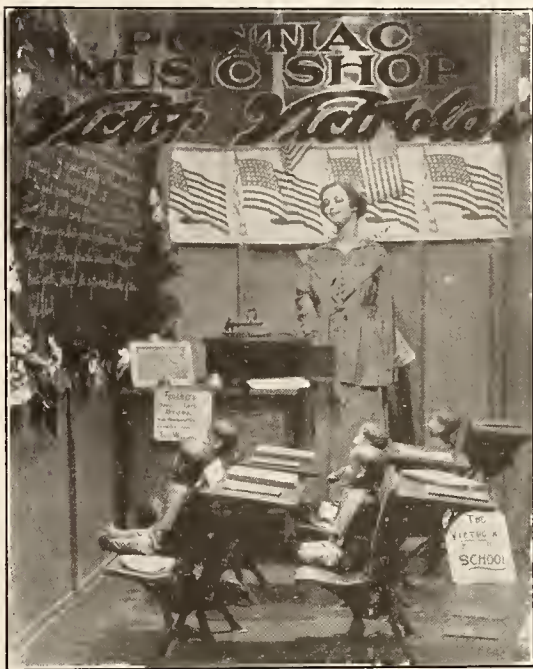

An Illinois Conception

ing a human element that is decidedly attractive. The Calder window features the school model Victrola and shows several very interesting pictures of the Victrola being put to use for educational purposes.

NEW STORE OPENED

The Munn-Brunswick Phonograph Co. has leased the Boehmler business block at 209 Main street, Cedar Falls, Ia., and has installed a complete line of phonographs and other musical instruments.

OPEN NEW BRUNSWICK SHOPS

Handsome Establishments Opened in Boston and Quincy by Arthur Koerner

BOSTON, MASS., February 6.—Arthur Koerner, prominent in the affairs of this city and an officer in the American Bankers' Association, is interested in two specialized Brunswick phonograph shops, one in this city and one in Quincy. It is announced that he has made arrangements to open up additional departments and stores to be conducted as exclusive Brunswick shops. He will devote his entire time to these establishments. It is reported that these will probably number eight or ten. The addition of these stores is a direct result of the success of the two stores mentioned above, which were only opened last September. A. J. Kendrick, of the Brunswick-Balke-Collender Co., who consummated this deal, left the early part of the week for New York.

LYRIC RECORDS ARE POPULAR

The Lyraphone Co. of America, manufacturers of the Lyric records, report that the sales of their records during the past two months have exceeded the expectations of the management. The February releases have met instant response from the dealers, who seemed to be especially pleased with the concert and operatic numbers. Both the February and the March lists contain a goodly number of the late popular songs.

LOCATED IN NEW QUARTERS

Clifford A. Wolf, manufacturer of diamond and sapphire phonograph points, is now situated in new quarters at 229 Fulton street, New York. The new offices greatly exceed the space formerly occupied and are combined with the manufacturing end of the business. Mr. Wolf reports the continuance of good business and is optimistic over the future.



A Connecticut Window

sized in many constructive ways by the educational department of the Victor Co. But it is not a single-handed crusade, for many of the prominent Victor jobbers have within the last year or two created educational departments of their own, and the movement has also been



A Pennsylvania Display

taken up in earnest by leading Victor dealers throughout the country. In most cases the educational departments of the retail establishments are headed by women, who have been previously trained to understand the psychology of children and how best to please and interest and at the same time teach them.

The accompanying pictures show window designs which have been presented by H. A. Weymann & Sons, of Philadelphia, John W. Calder & Co. of New Haven, Conn., and the Pontiac Music Shop of Pontiac, Ill. Each of these window displays has been built around an educational theme, and typifies to a nicety the way Victor dealers are co-operating in helping the public to appreciate the educational mission of the talking machine.

The Weymann window utilizes the school desks and a blackboard for "color." On the blackboard is written "The Victrola in the School for Drills, Games, Marching, Dancing, Singing Games, Physical Education, Stories and Games, Band Accompaniments and Chorus Singing." The mounted pictures shown in the window illustrate the Victor being used for each of these different purposes. The Pontiac window

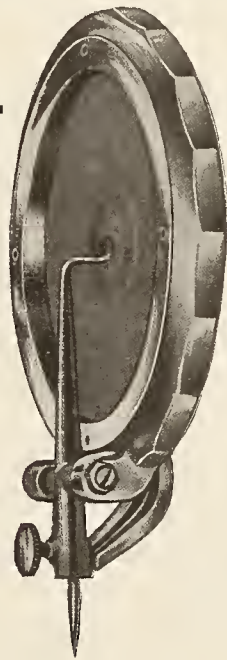

Tone—the vital thing

If you, as a manufacturer, can talk and prove *tone superiority* in your product, you have a selling argument to overshadow all the "talking points" of cabinets, and designs and accessory features.

And you can talk tone superiority. You can put out a product that will be a revelation in tone-purity, tone-quality, tone-volume. When you realize what vivid, lifelike, colorful tone can be produced and sustained by the talking machine equipped with

Parr Magnetic Reproducer fitted with the Vibratone Patented Diaphragm

These two dominating and proven inventions open up wonderful possibilities for manufacturers eager to put their product at the top-notch of class and character.

You want your product to be RIGHT!

If you want your product worthy of your name, you certainly want that product to be right in its most *vital feature*. And it will be right if it is equipped with the Parr Magnetic Reproducer—the reproducer for those who seek perfection.

The indestructible, non-crystallizing, always resilient VIBRATONE PATENTED DIAPHRAGM

Possessing all the good points of mica diaphragms, it overcomes all mica's bad features. Guaranteed uniform in quality, free from bubbles, blisters and waves, the Vibratone Patented Diaphragm is non-porous, non-absorbent.

It has a definite function and it performs it. It improves tone; in fact it creates new tone possibilities for every reproducer of other types.

PARR MANUFACTURING CORPORATION 1 UNION SQUARE At Fourteenth St. NEW YORK

Take the Parr Magnetic Reproducer—

The most sensitive of reproducers. The permanent magnetic device, an integral part of the reproducer, acts on the stylus box. Its possibilities in giving warmth and delicacy in the tonal reproduction of quiet passages make old-style sound boxes seem obsolete. And in fortissimo passages where ordinary reproducers create unpleasant, music destroying blasts, caused by the needle jumping and losing its grip, the Parr Magnetic Reproducer, with its marvelous flexibility, follows every wave and vibration in the record and takes everything the record holds.

Quality and Economy—Plus



The New Edison
Diamond Amberola
Model 75

FOR highest quality at a low price we do not know of any line of merchandise that compares with the New Edison Diamond Amberola and Edison Blue Amberol Records.

¶ The New Edison Diamond Amberola repeatedly has defeated the best known makes of talking machines costing from two to four times as much in side-by-side "tone" comparisons before unbiased, uninfluenced audiences of phonograph experts.

¶ Incidentally—no needles are required to play the Amberola because it has a permanent stylus (reproducer point) made from a genuine diamond, beautifully rounded and polished, and Edison Blue Amberol Records are practically unwearable and unbreakable.

¶ If you would know the "reasons why" the New Edison Diamond Amberola is so much superior musically to talking machines costing several times as much, and if you are interested in the profits being made by Amberola dealers, address :

THOMAS A. EDISON, Inc.

AMBEROLA DEPARTMENT

Orange, N. J.

INCREASED MACHINE DEMAND EXPECTED IN KANSAS CITY

Prospective Prosperity in Agricultural Sections Encourages Talking Machine Men—Working Hard to Prepare for Demand—Excellent Reports From Both Jobbers and Dealers

KANSAS CITY, Mo., February 6.—The present prospects indicate that a much larger number of persons will want talking machines than bought them last year, and local dealers generally are laying their plans for a substantial increase this summer, and for a good trade in the fall and winter. The statement is made advisedly that they are thus laying plans considerably in advance, since many of them realize the possibility that freight conditions might hamper shipments, and that war conditions may interfere with the production of machines. The distributors at Kansas City have made an even more careful survey than usual of the conditions, and have been closely in touch with their dealers. The recent extremely cold weather in this territory has been stimulating to optimism among business men and farmers; chiefly because it was accompanied by heavy snows, which provided needed moisture for planted wheat, and for the soil which will bear corn and other crops in the spring.

The spirit of co-operation has not been exemplified any more interestingly in Kansas City territory than at a "convention" of Edison dealers at Coffeyville, Kan., Tuesday, January 29. A score of Edison dealers gathered from eastern Oklahoma and eastern Kansas for a conference, the meeting resulting in the effecting of a definite organization. M. M. Blackman, manager of the Phonograph Co., Edison distributor in Kansas City territory, and C. L. Smith, of the same office, were among the "outsiders" present, Mr. Blackman especially joining in the discussions of sales methods and of trade matters. The dealers present reported a great deal of benefit from the discussions, and also much pleasure from the extension of acquaintance to other members of the Edison family.

F. J. Mortboy, formerly with the Manhattan Furniture Co., Manhattan, Kan., is now traveling for the Edison Co. in western Missouri, eastern Kansas and Oklahoma. This territory was formerly covered by C. L. Smith, who now has duties in the sales department of the Kansas City distributing headquarters.

Kansas City business men are up against the same problem that business men in other cities are with reference to office help. While there seems to be a bountiful supply, the turnover is extraordinarily fast. The Dictaphone, naturally, is helping with this problem. The branch office in Kansas City probably received more voluntary inquiries with reference to Dictaphones in the last two or three months than at any other time in its history.

The Henley-Waite Music Co. is taking time by the forelock and anticipating any possible inconvenience with reference to freight shipment by ordering six months' supplies in advance, and designating shipment. This company, like most of the others, is not afraid for the business that will develop this year. It looks like a big trade during the summer and of course next fall a repetition of the increases of the past year.

Mrs. Nellie Williams, manager of the Victrola department of the Jones Store Co., stated that their business for January was the biggest January the department had ever had, in fact, that the sales went way over those of last year. She added that were it not for the shortage of machines, thousands of dollars' worth more of goods could easily have been sold—in fact, many sales were lost outright for this reason while in others substitutions were made. Mrs. Williams stated also that the record business had been especially good, especially the sale of out-of-town records, which has increased 200 per cent. John McCormack's concert on January 31, as usual, greatly stimulated the sale of his records. Before the opening of the store on the morning of February 1, people were calling up and asking for the records of the songs McCormack had sung the night before.

Burton J. Pearce, manager of the talking machine department of the J. W. Jenkins' Sons Music Co., stated that a tremendous volume of business has been done, ever since the holidays, both in the wholesale and retail departments, the only handicap being the insufficient supply of goods.

Miss Patsy Ann Epperson, head of the record department, says that the sale of records continues to be wonderfully good. The firm's extensive advertising to the effect that the war spirit of sadness should be counteracted by lots of music in the home seems to have a direct effect on the sale of records.

A. A. Trostler, manager of the talking machine department of the Schmelzer Arms Co., is in the East where he will stop off at the Victor factory.

The Junkins-Riley Co., Pathé jobbers, report business having slowed down considerably since Christmas but say that collections are holding up splendidly. This great plentitude of money on the part of the people is particularly true in Oklahoma. Business has never been better there, especially right in the heart of the oil district. Here the new art models are a great favorite.

F. G. Abernathy, Highland, Kan., a Pathé dealer, recently died following a short illness.

Baily Bros., Greencastle, Mo., recently took the agency for the Pathé machine and say the initial business has been really excellent.

Otto D. Standke, manager of the talking machine department of the Geo. B. Peck Dry Goods Co., stated that business was better than ever before—the department having made a very substantial increase over last year's volume. Like every one else, however, Mr. Standke lamented the shortage but said that it was only recently that he had been seriously handicapped, as he had been fortunate enough to have had a fair supply on hand.

The Wunderlich Piano Co. has been having its usual steady business in Victrolas. Of course, it has felt the lack of machines and is, in fact, practically cleaned up on almost all models.

Miss M. E. Tower is the new assistant to Mr. Hall in the Hall Music Co.

The Edison Shop recently put on another stunt which, like its Hawaiian players, drew the crowd. In a series of recitals, Spalding records and other violin records were used in conjunction with the playing of Gilbert Jaffy, the "Boy Wonder" of Kansas City. This boy, who at fifteen is considered an embryo genius, was recently "discovered" in the city's Little Italy quarter.

Miss M. Ellis, Architects' and Engineers' Supply Co., Pathé and Sonora dealers, is a new assistant in that department. She was formerly with the J. W. Jenkins' Sons Music Co.

The Kansas City Photo Supply Co., which is in the center of the shopping district, installed on October 15 the Columbia line. It was an experiment, but it has developed in less than four months into a big retail distributing point. Practically one-half of the floor space of the company has been turned over to its use. Three additional rooms for demonstrating machines and record stocks in addition to a beautiful rest room are now in the course of construction. H. P. Laseter is in charge.

The Brunswick Shop, 923 Walnut street, which has not yet been in existence a year, has had a steadily increasing volume of sales until the owners now feel that they can well hold their own with some of their oldest competitors. Their most popular model has been the \$180 in Adam brown. The more expensive records have not been as popular as formerly but collections are holding up fine on all sales of machines.

AN INVALUABLE ASSET

Courtesy is a good thing that any man can use, because the only thing he has to spend to acquire it is a little thought and care.

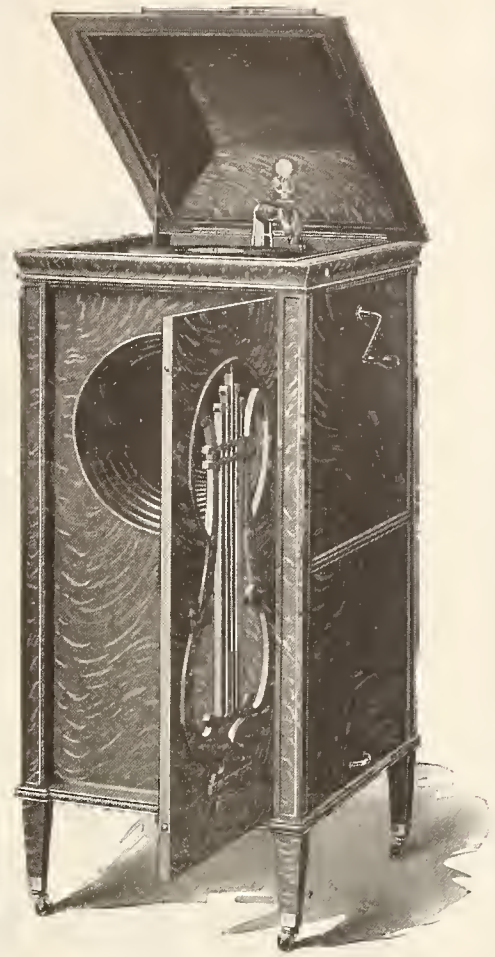

Style A

Price, \$225.00

Size 49½ x 21 x 25

In Fumed Oak or Satin Mahogany

Triple Spring, Spiral Gear, Nickeled Motor, Tone Modifier, Plush-covered Turntable, Automatic Stop, Lock Needle-cups and Rests, Leg Sockets and Casters.

Record compartment opening on side through a rising and falling balanced door, fitted with five ten-inch and four twelve-inch high-grade albums, capacity 108 records.

All exposed metal parts heavily gold-plated.

The patented spun vibratory horn is finished in Roman Gold.

Send for Catalogue

Not Sold Through Jobbers

FULTON-ALDEN CO
INC.

WAUKEGAN, ILLINOIS

A Mighty Strong Argument

*FOR THE DEALER TO PUT
BEFORE HIS CUSTOMERS*

The **B & H** FIBRE NEEDLE and
Needle REPOINTER

is a combination hard to beat—

*The one Saves the Record and the
other Saves the Needle*

The two together Save you Money

B & H FIBRE MANUFACTURING CO.

33-35 W. Kinzie Street, Chicago, Ill.

Two Artistic Window Suggestions Described for Talking Machine Dealers

By Ellis Hansen

The hearty response from dealers all over the country to the small but effective Washington that would be astonishing only a few years ago. Such beautiful instruments deserve artistic set-

tings and real skill in decoration to make the picture of the window harmonious and attractive.

An ideal setting for a fine period cabinet would be a music room furnished in the same historic design as the instrument. This is being done by at least one big store in Chicago (Lyon & Healy) and the result is very beautiful. But the average store has not the space nor does the expense justify such a realistic window display. There is, however, some well-defined and specific decorations used for music rooms that could be applied to the average show window and which would make that sympathetic and appropriate environment that adds its charm to the tastefully decorated music salon. Music suggests allegory and symbolism. Nowhere is the power of symbolism more attractively manifest. The musical instruments pictured in allegorical decorations lend themselves beautifully to decorative effects. The accepted meanings of some of the symbols most useful for music dealers (in window as well as printed advertising) are here recorded.

Pan Pipes: Music.

Lyre or Harp: Heavenly music.

Mask: Dramatic art, light or grand opera according to expression of mask.

Lamp or Torch: Learning, education, wisdom.



An Interesting and Idea-Suggesting Edison Grand Opera Window—No. 1

Birthday display, illustrated and described in last month's World, and of which all of the ready-made display material was disposed of, not only to the Eastern dealers but as far west as Fresno, Cal., has proved without a doubt that dealers are very much alive to the importance of good talker trims.

Going over my file of letters received during the last year (this being the twelfth article on window displays) I find that some of the most effective displays have been criticized and complained about on account of being too large, too costly and too difficult to make to be practical for the average dealer. Among the dozen or more described the two finest are to my mind, undoubtedly, the silhouette display in the May, 1917, issue and the Edison prize display published in the November issue. In this article I have simplified these very fine displays and, in doing so, I have reduced the size about one-half, which will enable the great majority of stores to make use of them.

The tendency in the making of musical instruments, and particularly so in talking machines, is to produce the artistic and beautiful. Just look at the improvement in the appearance of talking machines the last few years! Some of the fine period cases now on the market are veritable works of art. But even the inexpensive instruments are in many cases convincing proofs of the skill of the designer, with a dignity of line

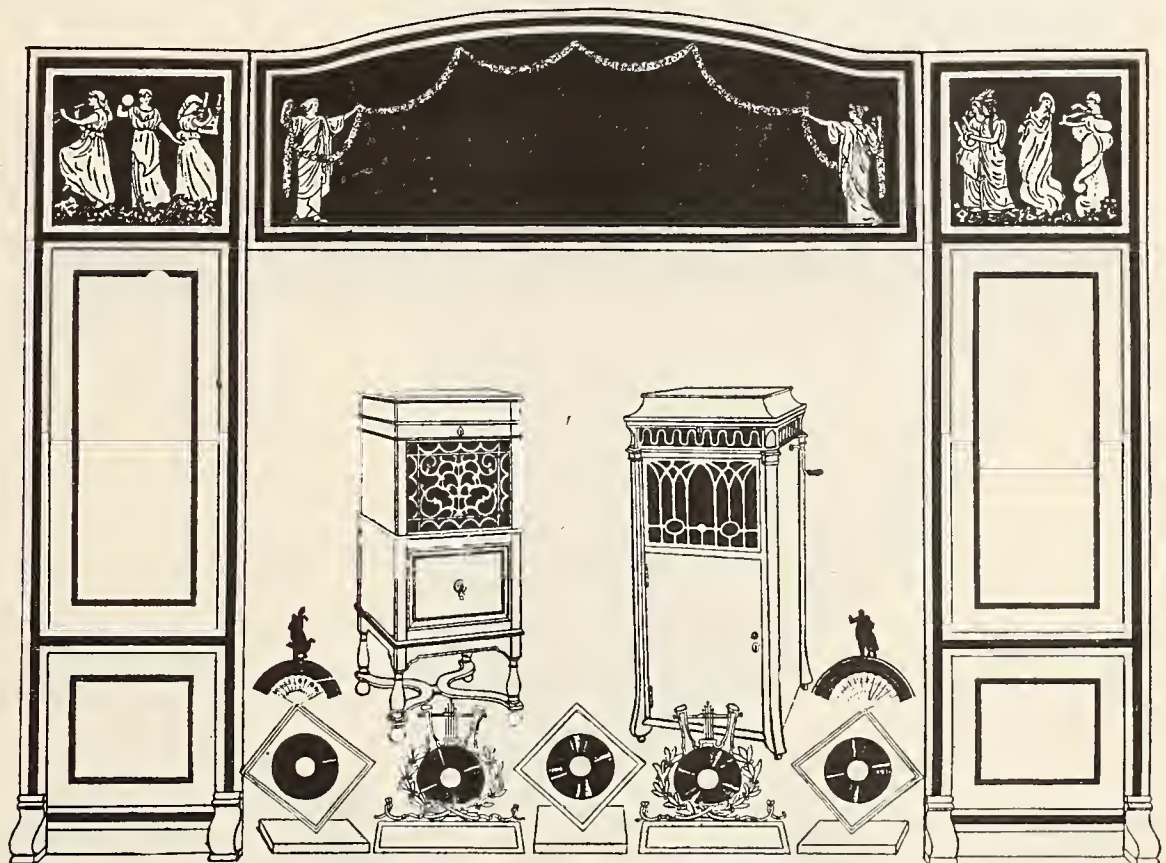

Details of a Simplified Arrangement of the Above Window—No. 1

Bell: Joy, earthly music, call to worship, invitation.

Candle: Study, information, attribute of Christmas (with holly wreath).

Trumpet: A message, a warning.

Scroll: Poetry, ancient learning.

Laurel: Victory, earthly success, reward.

But the richest field for the decoration for music windows are the thousands and thousands of paintings and panels on musical subjects from which the thoughtful decorator can choose the motif that is suitable for his purpose.

The most attractive features of the two displays herewith illustrated are the symbolic pieces.

In the Edison grand opera window, No. 1, and in the silhouette display, the joyous and triumphant groups of dancing and playing children tell the true story of the joy and happiness that music adds to life.

All the several features that made the two original displays so successful have been retained, as will readily be noticed by comparison.

(Continued on page 60)

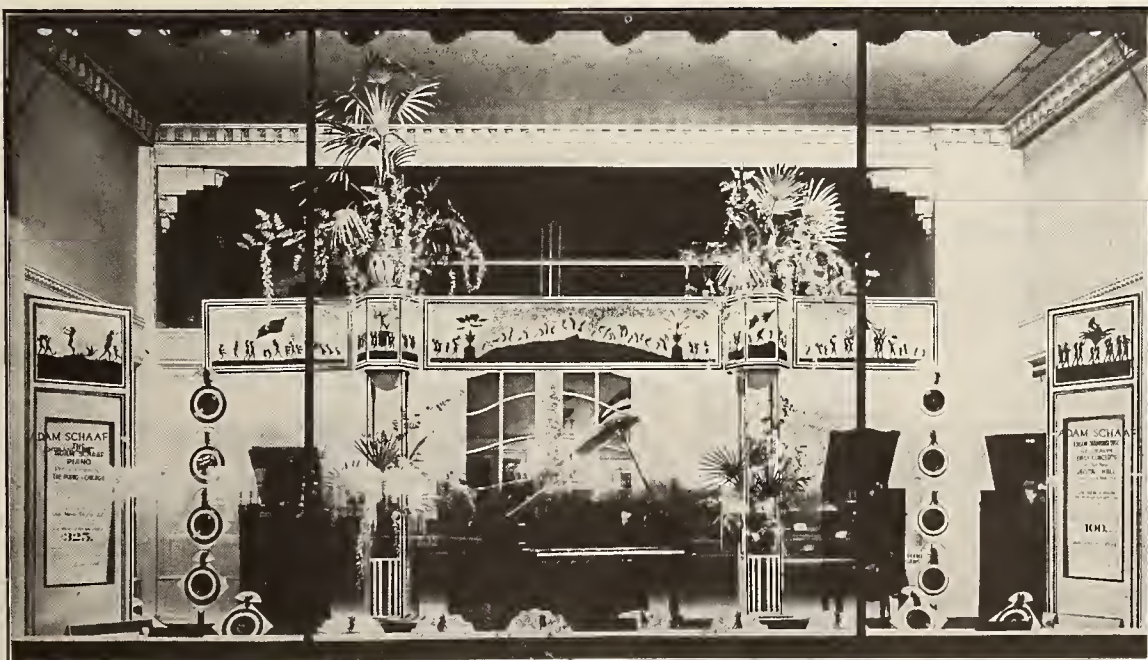

Relief Art Utilized Most Effectively in This Window Display—No. 2



Here's the kind of record that makes the customer's eyes sparkle, and makes him reach for his pocketbook. It's A2475, the Columbia debut of Lacalle's Spanish Orchestra!

**Columbia Graphophone Co.
Woolworth Building, New York**

TWO ARTISTIC WINDOW DISPLAYS FOR "TALKER" DEALERS

(Continued from page 59)

Every one and all of the other twelve displays pictured the time this series of articles appeared can be simplified and reduced in size and cost the same way.

Dealers should be able to adapt for their

Description of Silhouette Display No. 2

The frame work is identical with the Edison display except the circle on top, which is intended for the trade-mark, monogram or any other effect wanted. The silhouettes are hand-

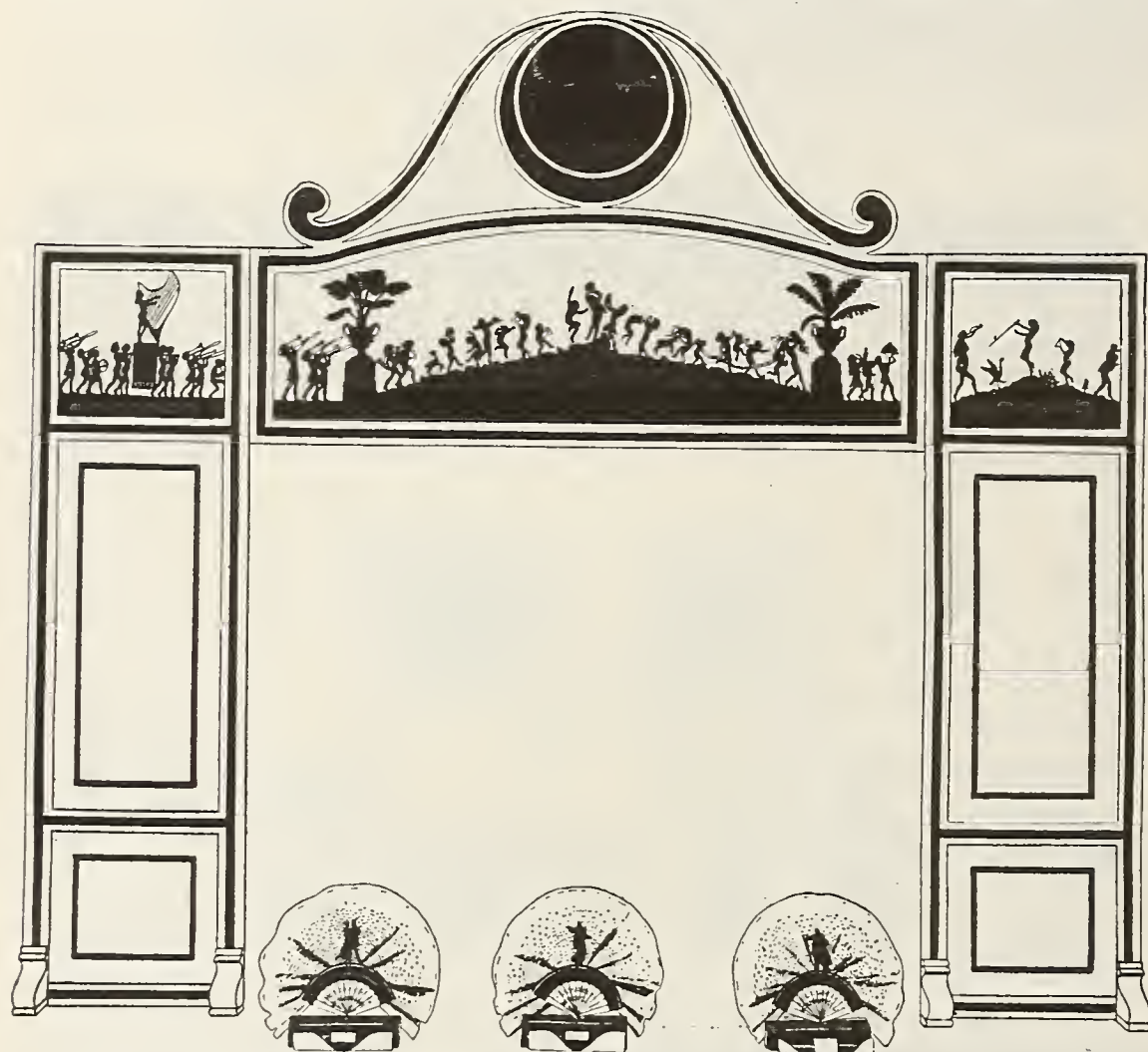

Details of Simplified Relief Art Window (No. 2) Shown at Bottom of Page 59

own needs the most important display features in any display described in this journal suitable for their own particular clientele and their own particular location. No other people on the face of the earth appreciates "Yankee ingenuity" more than the people in the land of its birth, and Yankee ingenuity is only another word for originality, and this applies equally to window trims as well as to Ingersoll dollar watches and other distinctive American inventions.

Display Adapted From Edison Window No. 1

This display consists of three frames made of wood and enameled ivory ornamented with one-inch black velour strips, as plainly seen in picture. Four ornamental wood supports serve to keep the side frames securely fastened to bottom of floor. The art panels consist of hand-colored figures mounted on black velour, which makes a very rich and striking contrast. The open space with the flower wreaths is intended for the name of the phonograph that is to be featured.

cut from black reinforced velour and mounted on white silk. The large center panels in the two uprights are intended for showcard and poster work.

STEINBACH & CO. EXPANDS

ASBURY PARK, N. J., February 7.—Steinbach & Co., of this city, one of the leading department stores in this section of the State, has purchased the Victor business of the Zacharias Co. Steinbach & Co. have opened up a very attractive Victor department on the fourth floor of their building, and according to their present plans will give the Victor products an aggressive representation, fully in accord with their prestige and quality.

Sometimes we feel that the ultra-progressive stores are to-day suffering from over-management as much as some of the old-timers have been suffering from neglect.

STILL JOINING THE SERVICE

Ernest Fontan, of the Traveling Staff of the New York Talking Machine Co., to Serve Uncle Sam—This Company Now Has Twenty-Three Stars on Its Service Flag

Ernest Fontan, one of the most popular members of the traveling staff of the New York Talking Machine Co., New York, Victor wholesaler, who has been covering New Jersey territory, was accepted this week as a member of the new National Army and according to present plans will enter the service of Uncle Sam the end of the month.

With Mr. Fontan's entry into the Government's service the New York Talking Machine Co. now has twenty-three stars in its service flag and this number is considered one of the finest records proportionately that has been attained by any commercial organization, in view of the fact that the company's staff is comparatively limited. At the present time several of the former members of the sales force are "somewhere in France" while others are in camps getting ready to leave for "over there" in order to do "their bit" in the war for democracy.

It is also understood that five members of the shipping force will soon be called for duty in the second draft giving the company's service flag a grand total of twenty-eight stars.

WM. L. GARBER RETURNS

William L. Garber, who was formerly associated with the New York Talking Machine's executive offices for several years and who enlisted as a member of the artillery corps some months ago, has just returned to New York and has rejoined the company's sales staff.

Mr. Garber was ready and willing to serve his country, but after spending several months in camp the medical examiners found that he was suffering from an "athletic heart" and this ailment necessitated his return home.

"I'm going to break a record one of these days," remarked the athletically inclined youngster.

"Fine," said his dad. "What record?"

"One of the phonograph records," replied the boy.

SCHUBERT PHONOGRAPH RECORDS

The greatest series of 75c. records ever made.

**10-INCH DOUBLE SIDED
ALL STARS ALL SELLERS**

New list by 15th monthly.
Dealers, write for list and prices

**BELL TALKING MACHINE COMPANY
41 WEST 37th STREET, NEW YORK**

The New 9 inch Emerson Records

Emerson Record
 INDIANOLA
 Instrumental
 Novelty and Fox Trot
 65c
 In U. S. A. No. 903

THE latest achievement of the Emerson Phonograph Co. —a 9 inch double disc, the unquestioned artistic equivalent of any record on the market. Plays as long as the average 10 inch record, and sells at 65c retail.

¶ It opens a completely new field for those who have hitherto been restricted from selling other large records, besides offering an exceptional merchandising opportunity to phonograph manufacturers.

¶ For some time at least it will be our policy to confine the production of these records to quick selling, popular, dance, vocal and patriotic selections.

¶ Applications for exclusive agencies in certain territories will be considered in the order of their receipt.

Emerson Phonograph Company INC.

3 West 35th Street, New York City

**A 9 inch Universal
Cut Record. Music
both sides. Plays
on all phonographs
with sound box in
either position.**

Retails at

65c

**At a liberal
profit to you**

DOEHLER DIE-CASTINGS

for tone arms, sound boxes and talking machine attachments are STANDARD throughout the industry.

Of the many instruments produced to-day from the most prominent makes down, the greater number, by far, are equipped with Doehler die-cast tone arm and sound box.

The enormous output of our three large plants permits of advantages to the users of die-castings, as regards prices and deliveries, not otherwise possible.

DOEHLER DIE-CASTING CO.

MAIN OFFICE AND EASTERN PLANT
BROOKLYN, N. Y. NEW JERSEY PLANT
NEWARK, N. J.
WESTERN PLANT
TOLEDO, OHIO.



VALLORBES JEWEL CO.'S NEW NEEDLE

Manufacturers Well Known in the Sapphire Trade Introducing New Semi-Permanent Needle for Talking Machine Records

LANCASTER, Pa., February 6.—The Vallorbes Jewel Co., of this city, have recently perfected a new needle for the talking machine, playing lateral cut records. It is to be known as the "Vallorbes Semi-Permanent Needle," and is attractively carded in sets of five and then placed in a moistureproof waxed envelope.

The Vallorbes Jewel Co. have been engaged in the needle business for some time, and claim to be the originators of the diamond point. As their name would imply they have hitherto restricted their output to the Vallorbes sapphire ball needle, which has made quite a name for itself in the trade, and diamond points. W. F. Meiskey, president of the company, realizing the demand for needles and their scarcity, due to the great worldwide war and its prior claims on the steel industry, set about to produce a needle which would be semi-permanent in form. The Vallorbes semi-permanent needle, he announces, is not only a "conservation" needle but a great improvement as well. Necessity has brought forth many new inventions during these wartimes that have proved a great boon to industry. The Vallorbes semi-permanent needle, it is claimed, is one of these and is here to stay. These needles are made in soft, medium and loud tones.

A BIG DEMAND

Throughout the Country for

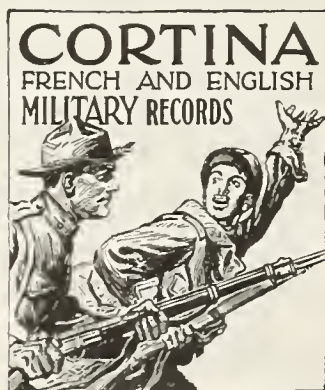

Get your share of this business. An ideal gift for the boys in training or the trenches. It often sells a machine with it.

The course consists of an authoritative Military Manual containing a foreword by Major-Gen. Leonard Wood.

WITH TWENTY PHONOGRAPH RECORDS (10-12" double face discs). Send for full information. Advertising matter, military poster-hangers free.

Also Spanish, Italian, German, and English and French for Spurlards

CORTINA ACADEMY OF LANGUAGE
12 East 46th Street, New York

EFFECTIVE COLUMBIA PUBLICITY

A Timely and Attractively Arranged Advertisement in the Saturday Evening Post Has Come in for Considerable Notice and Much Praise

The Columbia Graphophone Co., New York, used a very attractive advertisement last week in the Saturday Evening Post featuring a picture that was recently shown in the Talking Machine World which portrayed a family in England seeking shelter from the bombs dropped by German air raiders and taking along with them a Columbia Graphophone to relieve the wait until the "all clear" signal was given. It is said that this photograph pictures a scene very usual in the London district.

Under the heading "What Would You Have Taken With You?" the text of this interesting advertisement reads as follows:

"The people in this picture are seeking shelter from the bombs dropped by German air raiders. When the 'Take Cover' siren sounded they hustled to the dugout. You will notice that there are seven people here, and a Columbia Graphophone (as the English prefer to call it) is the only thing they are taking along.

"You who have never been bombed, and you who have never owned a phonograph may think this a queer choice. Some might have taken bed clothing, others food, others silverware and valuables, others a card-table and a lamp.

"But this family, owners of a phonograph, do not appear to have hesitated.

"Only the people who are actually feeling the horrors and dangers of war can completely appreciate the necessity for music.

"Music allows you to forget the discomforts of the present hour—it helps you to remember happier things and to dream of still happier seasons.

"The Columbia Grafonola, by virtue of the diversity of records, songs, dances, and instrumental selections that it will play, represents the greatest relief from boredom or oppression that is known.

"Incidentally, for the benefit of the curious, we will state that this is a Columbia instrument shown in the photograph. Any good phonograph would have been desirable in the dugout, but this happens to have been a horn type of Columbia Grafonola. They are very popular in Great Britain and all her colonies.

"In the United States the most popular Grafonola is the standard type, with the horn enclosed in the cabinet."

SOME WARTIME SUGGESTIONS

If yer want ter get ter somewheres,

Walk ahead!

Don't yer loiter by de roadside

Playin' dead.

Walk, an' whistle when yer walkin'!

Smile, an' do some friendly talkin'!

An' you'll get there without balkin'!

Walk ahead!

MAKING SONA-TONE PHONOGRAPHS

The Sona-Tone Phonograph Co., Inc., Organized With Men of National Prominence Interested to Manufacture This Instrument—Some Prominent Purchasers of the Sona-Tone

Thomas Dixon, author of "The Birth of a Nation," recently wrote the following letter to the Sona-Tone Phonograph Co., Inc., referring to a Sona-Tone phonograph which he had purchased for his New York home from E. W. Ladd, inventor of this instrument: "I am enclosing you my check for the Sona-Tone phonograph which we have played almost continuously in our home for the past week. I find it the clearest and sweetest toned musical instrument I have ever heard."

Two years ago Mr. Ladd, who holds patents on several successful and widely used mechanical devices, became interested in phonographic reproduction, and particularly along the lines of greater resonance. He worked to produce an instrument that would practically eliminate the noises due to accidental imperfections or the ordinary wear of the record, and as a result of his experiments the Sona-Tone was placed on the market and soon won considerable praise.

The commercial success of the line attracted the attention of a group of local business men, and a company was formed with Mr. Ladd as head of the production department, and controlled by interests identified with the United States Steamship Co. and its subsidiaries. The following are the officers of the Sona-Tone Phonograph Co., Inc.: President, B. G. Higley, vice-president and general counsel of the United States Steamship Co.; vice-president, H. F. Morse, president of the Hudson Navigation Co. and vice-president of the Groton Iron Works; secretary and treasurer, T. A. Sherman, counsel for the United States Steamship Co.

It is planned to manufacture a complete line of instruments, and among the recent purchasers of Sona-Tone phonographs are the following: Mrs. John F. Yawger, president of the New York City Federation of Women's Club; I. H. Griswold, president of the Bell Telephone Co., Plattsburgh, N. Y.; Stuart Gibboney, member of the law firm of Barker, Watson & Gibboney; George Hodgson, prominent in Buffalo social and religious circles; H. C. Hequemburg, president of the Dunkirk Iron Works, Dunkirk, N. Y.

BROAD IN CHARGE AT SCHIRMER'S

Henry Broad, well known in the Victor trade, is now in charge of the Victor department of G. Schirmer, Inc., 4 East Forty-third street, New York. This department will be under the general supervision of Mr. Andrews, the manager of the various retail departments of G. Schirmer, Inc. Mr. Broad succeeds H. O. Hunter, who resigned as manager of the Victor department last week.

Don't waste 24 valuable hours by waiting until tomorrow to put your individual sales problem up to Columbia's Dealer Service Department. Write today.

**Columbia Graphophone Co.
Woolworth Building, New York**



DISTRICT MANAGERS' CUP TO YERKES

Field Sales Manager, Making His Headquarters in Chicago, Wins President Whitten's Sterling Silver Trophy Offered to District Managers

George W. Hopkins, general sales manager of the Columbia Graphophone Co., New York, announced recently that H. A. Yerkes, field sales manager of the company, had won the President



Cup Won by H. A. Yerkes

Whitten district managers' cup, a handsome sterling silver trophy, which had been donated by Mr. Whitten, and which had been keenly contested for among the district managers throughout the country. The terms of this contest provided that permanent possession of the trophy rested with the district manager who won the cup for three months, and notwithstanding the fact that he did not register his first victory until October, Mr. Yerkes won the cup with three consecutive victories.

Mr. Yerkes won the President Whitten district managers' cup as district manager of the Middle West territory, and W. L. Sprague, manager of the Minneapolis branch, is also being congratulated upon this victory, for his branch was a most important factor in bringing the trophy to the Chicago division. The final result of the contest was in doubt until the last moment, for several of the district managers had been winners for two months, and needed only one more victory to clinch their right to permanent possession of the cup.

H. A. Yerkes is one of the most popular members of the Columbia sales organization, and was recently appointed field sales manager. He is at present making his headquarters in Chicago.

PRESSER CO. TO HANDLE VICTROLAS

Philadelphia Music House to Inaugurate New Talking Machine Department on March 1 With A. D. Proudfit in Charge as Manager

PHILADELPHIA, PA., February 8.—It has been announced that the Theodore Presser Co., prominent music publishers and dealers of this city, have arranged to open a new Victrola department with a store at 1710 Chestnut street, adjoining their present quarters, on March 1. The new store is being fitted up in a most elaborate manner with a full equipment of sound-proof demonstrating booths. Passageways will be cut from the present store of the company into the new Victrola section. The Victrola department will be under the management of A. D. Proudfit, at present manager of the retail piano store of the Estey Piano Co., New York, and formerly connected with the piano and Victrola department of Frederick Loeser & Co., Brooklyn, N. Y., as assistant manager. Mr. Proudfit has had much experience in handling Victrolas with the Loeser house and is considered well qualified for his new post.

TO ISSUE "EMERSON SPOTLIGHT"

Emerson Phonograph Co. Bringing Out House Organ for Its Dealers

The Emerson Phonograph Co., New York, manufacturer of the Emerson records, has announced the publication of a new house organ which will be known as the "Emerson Spotlight." The company decided to publish this house organ in order to keep its dealers posted on the latest developments of the Emerson business. The first issue of the house organ is now in the hands of the printers and will be in the mail by the end of the week. The "Emerson Spotlight" is essentially a practical publication and aims to tell the dealers how to increase the sale of Emerson records. If the first issue is any indication of the future numbers, this new periodical will be helpful, entertaining and useful to every storekeeper handling Emerson records.

Success is an easy thing to understand after it has been attained. The great problem is to understand in advance how to acquire it.

GRAFONOLAS POPULAR IN OREGON

M. E. Everitt, of North Bend, Selling Many of These Instruments in His Territory

PORTLAND, ORE., February 4.—The local branch of the Columbia Graphophone Co. recently received an interesting photograph from M. E. Everitt, North Bend, Ore., who owns one of the finest drug stores in the State. Mr. Everitt handles the complete Columbia line and is an enthusiastic "booster" of all of the Columbia products.

The accompanying photograph shows a shipment of Grafonolas recently received by Mr.



Big Columbia Shipment for M. E. Everitt

Everitt, this shipment of machines being the third shipment sent to Mr. Everitt during the last few months. Up to about six months ago there were no railroads in the town where Mr. Everitt is located and most of the machines which he sold were taken out from this town with either a rowboat or a gasoline launch, up the various rivers to the dairy farms and logging camps.

PATHE WINDOW HANGER FOR MARCH

The Pathé Frères Phonograph Corp., New York, has sent to its dealers a very attractive hanger featuring the new Pathé March records. This hanger contains a splendid picture of Grace Hoffman, a prominent coloratura soprano who records for the Pathé library exclusively. Miss Hoffman has a new record in this March list which will doubtless meet with a ready and extensive sale.

The March supplement of Pathé records also contains a number of well-known popular hits, dance records, Hawaiian numbers, standard vocal records, instrumental solos, band and orchestra records and a specially selected list of Irish records.

CRYSTAL EDGE MICA DIAPHRAGMS

**M
I
C
A**

Let us send you samples *today* of our diaphragms and you will readily understand why the best talking machines are equipped with *Crystal Edge Mica* diaphragms exclusively.

We use only the very finest selected mica, the best diaphragm material in the world.

PHONOGRAPH APPLIANCE CO., 109 West Broadway, NEW YORK

MADE IN AMERICA

MADE IN AMERICA



BY AMERICAN LABOR

BY AMERICAN LABOR

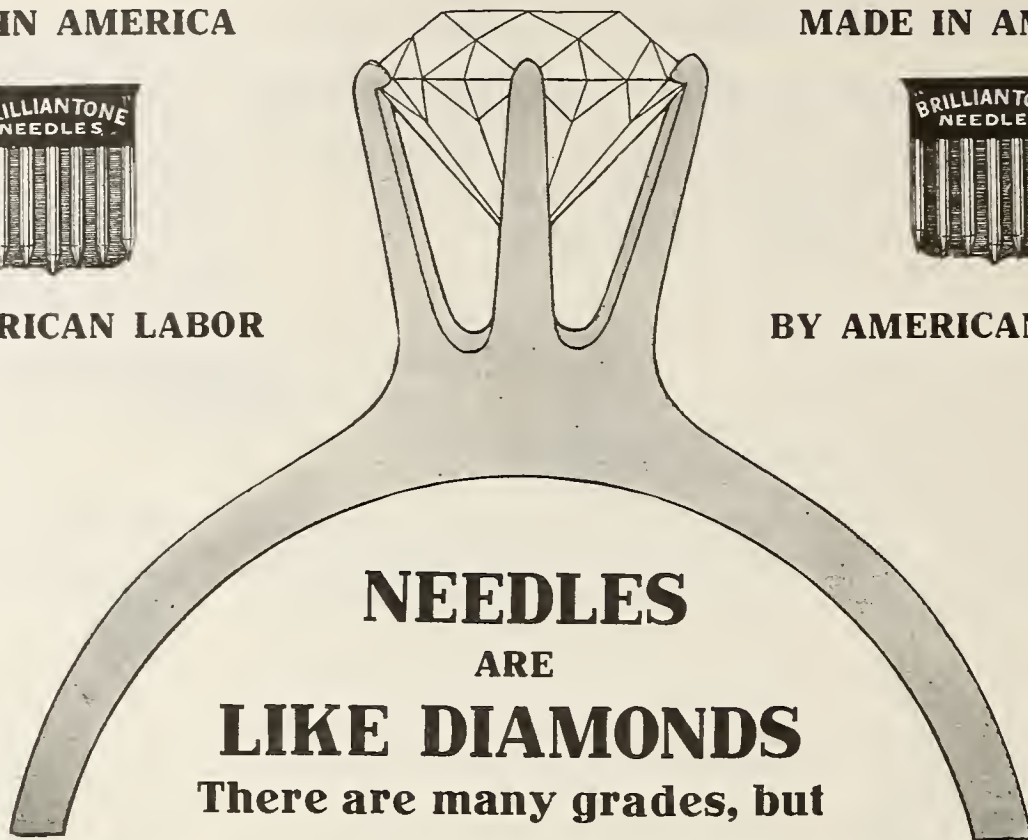

NEEDLES
ARE
LIKE DIAMONDS
There are many grades, but

YOU WANT ONLY THE BEST

Get the needles that prove they are the best because they are of uniform length, have uniform points and have uniform hardness. They are standard and reliable

ORDER

Half-tone
Loud
Extra
Loud

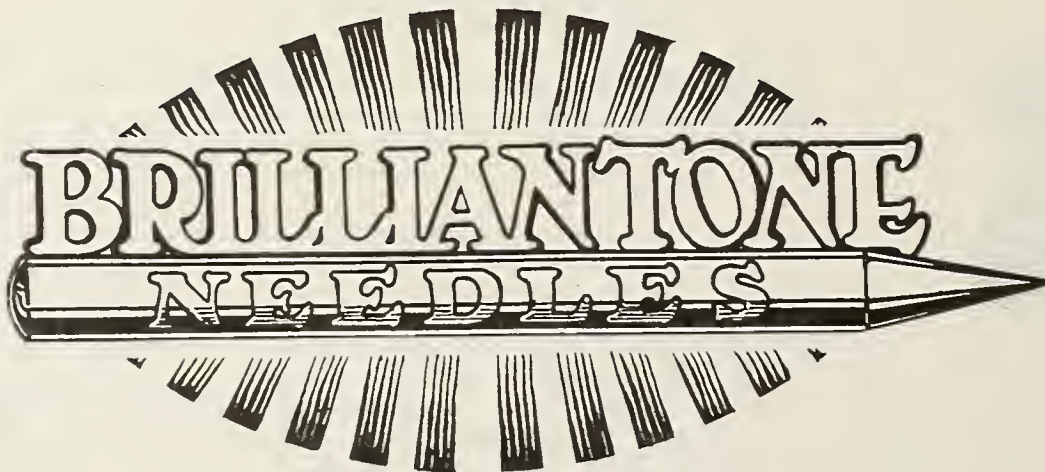

Prices
and
Samples
on
request

They Assure Customer Satisfaction

BRILLIANTONE STEEL NEEDLE CO.

of America, Inc.

B. R. FORSTER, President

Marbridge Bldg., Broadway at 34th Street, New York

ROOMS 657-659

RECENT HEINEMAN EXPANSION

Otto Heineman Phonograph Supply Co., Inc., Takes Over Portion of Second Floor in Present Building in Order to Accommodate the Steadily Growing Volume of Business

In order to accommodate its fast growing business and in order to provide its employes with maximum convenience and comfort the Otto Heineman Phonograph Supply Co., Inc., manufacturer of the Heineman products, Meisselbach products and the Dean steel needle, has materially increased the floor space that it occupies in the Central Building at 25 West Forty-fifth street, New York. In addition to occupying the greater part of the sixteenth floor at this address the company has made arrangements to also occupy a considerable portion of the second floor of this building.



Otto Heineman

According to the plans of Otto Heineman, president of the company, the executive and general offices will be located on the sixteenth floor and will be given over exclusively to the shipping department. This arrangement will enable the company to augment its office staff in various directions and give the shipping department sufficient room to meet the requirements of the Heineman business.

For several months past the Otto Heineman Co. has been seriously handicapped by the fact that the executive officers were obliged to work in cramped quarters and the office force could not be enlarged in view of the limited space available. This condition has been relieved by the leasing of space on the second floor which is ideally suited for the Heineman shipping department.

The offices on the sixteenth floor will include the private office of Otto Heineman, president and general manager of the company; Adolph Heineman, assistant to Mr. Heineman and in charge of the John M. Dean division; W. C. Pilgrim, assistant general manager; F. Aufrichtig, treasurer; Paul L. Baerwald, Eastern sales manager.

The export department which has steadily increased in importance during the past year will also occupy several rooms on the sixteenth floor, and R. C. Ackerman, manager of the Heineman export department, will have ample opportunity to adequately take care of this important and active division of the Heineman business.

The shipping department in its new home on the second floor will be in a position to render efficient service to the Heineman clientele and will leave nothing undone to co-operate with the users of these products in expediting shipments of goods that can be handled from New York.

CORLEY CO. EXECUTIVES IN TOWN

John G. Corley and Frank Corley Bring Good Business Reports From Richmond

Among the recent visitors to New York was John G. Corley, head of the Corley Co., Victor distributors and piano merchants of Richmond, Va. Mr. Corley was accompanied by his son, Frank Corley, who is in charge of the wholesale and retail Victor departments of the company. Mr. Corley, Sr., attended the meetings of the Board of Control of the National Association of Piano Merchants, of which he is an ex-president. He stated that business in Richmond was thoroughly satisfactory during the holidays, and that judging from results in January there was a good year ahead of the talking machine dealers in his section of the country.

LIQUID MUSIC IN PORTLAND, ORE.

Phonograph Cases Found to Contain Imitation Machines Lined With Five-Gallon Kegs of Whiskey—Columbia Co. Manager Through Error Aids in Foiling the Smugglers

PORTLAND, ORE., February 4.—Phony phonographs they proved to be, all done up in Sonora boxes and billed to the Columbia Graphophone Co., this city. Liquid music indeed it was which was sent from San Francisco to Portland. When Deputy Sheriff Christofferson opened the cases at the county jail he found instead of phonographs five five-gallon kegs of perfectly good jazz whiskey which hadn't any business in dry Oregon.

The shipment was consigned to an unknown person, but the boxes bore the address and name of the Columbia Graphophone Co. They came up on the steamer "Beaver" from San Francisco, and were lying round in everybody's way waiting for somebody to come and take them away. Finally, in order to relieve the

congestion the dock officials telephoned to S. D. Heater, of the Columbia Co., to send for the boxes. This he did, and when the boxes arrived at the house wonderment was expressed that they should be Sonora cases. Down into the basement the janitor moved them. Mr. Heater went down shortly afterward and found the janitor trying hard to shove something quickly back into the cases. Examination showed a five-gallon keg of liquor.

Mr. Heater promptly notified the sheriff's office and the offending cases were removed. Inside the cases were tall fir boxes painted a mahogany red to imitate the conventional talking machine. Inside each box, securely fastened, was snugly resting a five-gallon keg of liquid music.

The person to whom the shipment really belonged appeared at the dock with a bill of lading covering the shipment after it had gone and demanded his goods. Upon being informed what had become of it he disappeared abruptly and has not been seen since, although the sheriff is looking for him.

The Hit of
'Chu Chin Chow'

'AT SIESTA TIME'

Victor Record
18424

A Display Card Series of Value

The cards are 14" x 22", each individual card painted by an artist, and presenting a striking sales appeal for Victor Records.

Designed especially for Bruno Service and are "exclusive." The service consists of two cards monthly.

Send us your order for March Service and give it a month's trial.

C. BRUNO & SON, Inc.
351-353 Fourth Avenue NEW YORK

We Do Not Retail

How Best to Weld the War Spirit and the Sales End Advantageously :: :: :: By Warfield Webb

The only way to sell talking machines and to increase the sale of records is the method that will attract customers to your store. You want to get a legitimate trade and you want to increase the sales in a manner that will not smack too much of side-show methods. You want to line up the customers with a novel method that will give you an opportunity for real business getting. Why not make your talking machine department a feature? Why not make it appeal with something of a novelty that will attract without undue publicity?

In this way there is possible the sales that would not otherwise come to you. The war and its many phases and its appeals now to the people has brought about a newer meaning for the talking machine. Feature a window display with a soldier camp and a talking machine that has real human interest in it.

Make a display that will really appeal and then show the desirability of getting some records for the boys and sending them to the camp for the enjoyment of the soldiers.

Have a feature in your store and give a

prominent part to the playing of national anthems of all the allied countries. Have these played on frequent occasions and in this way familiarize the people with the various national hymns of those countries. Create in this way a little more patriotism, and at the same time give your talking machine an opportunity to help you make your sales larger. Get the people to seek you and have frequent concerts that will attract the people to your store. Getting the people inside will be a big help. The sales will often follow as a natural course.

TRADE NEWS FROM BALTIMORE

Dealers Complain of Shortage of Machines and Records—Bad Weather Delaying Shipments and Hurting Trade—New Pathé Dealers Established—Reports From Leading Dealers

BALTIMORE, Md., February 5.—With a general cry of shortage of machines and records from most of the firms, business went ahead in January of the previous year, despite the difficulties faced by all dealers. The most severe January that the retail trade has had to face from the standpoint of weather in the history of the industry was the lot of these merchants in this city and this section. One snowstorm followed another in rapid succession, and even with a vigilant street cleaning department it was not possible to keep the streets clear of snow in the retail shopping centers.

Stores having talking machine departments away from the main centers improved their business until the shortage of records of the late numbers stopped them. The freight congestion is the most serious phase of the situation, and even goods shipped by express are just as

hopelessly delayed as those sent by the freight route. Some of the Baltimore jobbers are now taking up the question of bringing in goods by motor trucks from New York and Philadelphia, a motor truck line being in course of organization at this time. This will take care of the freight problem in a measure, for Victor goods will be brought down over the line from Camden.

W. C. Roberts, manager of E. F. Droop & Son, Inc., is in anything but a pleasant frame of mind. He says January business went back considerably over last year, not because of business conditions, but because of lack of instruments and records. It would have been easy to have increased business had he been able to get goods. There was a demand for 10 per cent. more records and 20 per cent. more machines than could be taken care of. "I am in conference with a motor truck company," said Mr. Roberts, "and plan to have shipments brought in on five-ton trucks. This will help to relieve the situation, but the difficulty we are facing in this plan is that we have to get shipments up to New York or Philadelphia because there is more tonnage in New York to come here than

can at present be handled. I am hoping that this congestion will improve because the business is here and we ought to be able to get hold of it."

Jesse Rosenstein, for the National Piano Co., Pathé distributors, says that business went ahead last month, but not very much, owing to the shortage of records and instruments. He looks forward to showing big improvement in business just as soon as the goods that have been in transit for a long time arrive. A. Sindler & Son, furniture dealers of this city, have signed up a Pathé contract and will handle the line in a new music department to be established by them.

C. H. Eisenbrandt, of H. R. Eisenbrandt, Victor distributors, says that business showed an increase in January despite the shortage of instruments. He expects to see further improvement if only shipments of goods reach him.

HIGHER PRICED MODELS IN DEMAND

Victor Department of Ludwig Baumann & Co., New York, Tells of Increasing Demand for the More Expensive Types of Victrolas

In a chat this week with a representative of The World, F. J. Conn, manager of the Victor department of Ludwig Baumann & Co., Thirty-sixth street and Eighth avenue, New York, commented upon the fact that business the past month or so had been marked by an increased demand for the higher priced models of Victrolas. This is particularly gratifying in view of the fact that Mr. Conn's department during the past year has been the largest consumer of the smaller models of Victrolas in the city, and it is pleasing to learn that a new class of buyers is now in the market for cabinet Victrolas with an evident appreciation of the true musical qualities of the Victrola. Mr. Conn states that business has kept up very well so far this year, and judging from all indications these activities will continue for some time to come in the talking machine trade.

D. A. CREED A NEW YORK VISITOR

D. A. Creed, vice-president and general manager of the Chicago Talking Machine Co., Victor wholesalers, was a visitor to New York last week. Mr. Creed left Chicago for this city in company with A. D. Geissler, president of the New York Talking Machine Co., and the Chicago Talking Machine Co. Mr. Geissler had planned to spend a week or more in Chicago, but was called home suddenly owing to the illness of his little daughter, Martha. Mr. Geissler's many friends will be glad to know that this little lady has fully recovered from her recent operation and has now regained her usual good health and spirits.

YOU'VE GOT TO KEEP SHOVING

Graspin' opportunity ain't the only thing. You've gotta put your shoulder to it and shove and keep shovin'. When you get a big thing movin' it's easier to keep it movin' than to stop and rest.

"Lundstrom"
IT GROWS WITH YOUR BUSINESS

Standard Sectional Record Cabinet

A practical, inexpensive, convenient cabinet for dealers; made on the sectional principle, affording the following advantages:

It grows with your requirements: You first purchase just the number of sections you actually need for your present requirements; as you need more space, add more sections.

Adapted to any space: As many sections as desired may be placed in a stack; as many stacks may be used side by side as wall space will permit. Each section or shelf is indexed by a letter and each compartment by a number, forming a system of filing unsurpassed for simplicity and convenience.

Neat in appearance: No empty shelves; no overcrowding. Case always complete, yet always capable of additional expansion.

Carefully made and beautifully finished in plain and quartered oak, and in imitation and genuine mahogany.

Made in two sizes; to hold 10-inch and 12-inch records. Each section holds 200 records (100 Edison records). Stack may be made up with all sections of the same size; or sections for 10-inch records may be used above sections for 12-inch records by means of a reducing section as shown in accompanying illustration. Record sections furnished with or without doors.

Price for section \$3.00 and up

Cases shipped on approval direct from factory at considerable saving to you; on orders amounting to \$10.00 and over we pay freight to all points East of Montana, Wyoming, Colorado and New Mexico. To points in and West of these states, we equalize freight charges. For further particulars and full list of prices for the different sections in the different grades, write for illustrated circular No. 80.

The C. J. Lundstrom Mfg. Co.
LITTLE FALLS, N. Y.

Branch Office, Flatiron Bldg., New York City

Fifteen Years' Experience Making High Grade Filing Cabinets and Bookcases



RECORD MAKERS APPEAR IN BUFFALO

Favorite Recording Artists Draw Capacity Audience at Concert Given in That City on February 7 Under Auspices of Dealers

BUFFALO, N. Y., February 7.—Buffalonians of all classes who own talking machines thronged Elmwood Music Hall to-night to see in the flesh, and to hear at close range, the artists who have made records for years and with whom they have been long acquainted through that medium. The occasion was the concert given by the Peerless Record Makers, a group of favorite recording artists brought to this city by the Talking Machine Dealers' Association of Buffalo, and the event proved successful beyond all expectations.

Those who appeared with the Peerless Record Makers included Henry Burr, Billy Murray, Arthur Collins, Byron G. Harlan, J. H. Meyers, Albert Campbell, Peerless Quartet, Theodore Morse, Fred Van Epps and Sterling Trio.

The dealers threw plenty of human interest in their advance notices to the public regarding the program. Everything was done to herald the importance of the unique concert. This was one of the typical announcements of the dealers: "Recognizing the popular desire to hear the famous Record Makers, we have arranged this concert at great trouble and expense and through special arrangements with the recording laboratories. This is Buffalo's first and probably only opportunity of hearing these artists. Your record library contains selections by one or more of these artists and you will welcome this opportunity of hearing them sing and play just as they do when making records for their millions of admirers. A varied program, which will include many standard and up-to-the-minute numbers as well as old-time favorites, will make an appeal to every taste. Knowing these artists as you do, you can appreciate that their personal appearance in a concert will be an unusual treat."

The plan of bringing the Peerless Record

Makers to Buffalo was presented to the local association by C. N. Andrews about a year ago. Mr. Andrews did considerable correspondence in the matter, but arrangements for the Buffalo appearance could not be made at that time. When the present concert was recently considered Mr. Andrews, O. L. Neal and C. H. Heineke were appointed a committee to make the arrangements.

President T. A. Goold also appointed the following committee on advertising and tickets: V. W. Moody, Neal, Clark & Neal; F. G. Hohm, Bricka & Enos; John G. Schuler, Schuler Piano Co.; O. M. Kiess, Columbia Phonograph Co.; banquet committee, W. J. Bruehl, Neal, Clark & Neal; H. A. Brennan, William Hengerer Co., and H. G. Towne, of Robert L. Loud's store.

Thousands of circulars advertising the concert were furnished free to the dealers and were enclosed with their monthly lists. The dealers all sold tickets and everyone was appointed a booster. This personal canvassing of friends by the dealers helped greatly in swelling the attendance. No details were overlooked in the use of window signs and billboard and newspaper advertising. Many reading notices of the event appeared in the local press.

H. G. Towne, secretary of the Talking Machine Dealers' Association, sent to each member a comprehensive notice regarding the entertainment.

It is believed this concert will be a powerful impetus to the sale of records in this section.

At the conclusion of the concert the record makers were entertained at a special banquet by the local dealers and were heartily congratulated on the success of the entertainment. W. J. Bruehl paid tribute to the singers in several original parodies.

Last night the Peerless Record Makers gave a very successful concert in Syracuse under the auspices of the local talking machine dealers and have also arranged to offer their two hours of welcome entertainment in other cities in the East in co-operation with the members of the trade.

MEETING OF COLUMBIA DEALERS

To Be Held at Columbia Shop on Fifth Avenue on February 15 Under the Auspices of the Local Wholesale Branch of Columbia Co.

An informal meeting of the Columbia dealers in the metropolitan district will be held to-day, February 15, in the recital hall of the Columbia Shop, 411 Fifth avenue, New York, under the auspices of the local wholesale branch of the Columbia Graphophone Co. Lambert Friedl, manager of this branch, is responsible for this meeting and, according to his present plans, Columbia representatives in this territory will have an opportunity to discuss practical problems and hold a general "pow-wow" regarding merchandising and sales activities.

Mr. Friedl has prepared a program that includes many topics of vital interest to the dealers and he has planned to balance the serious part of the program by arranging for the appearance of several well-known Columbia artists, who will render a number of selections during the course of the afternoon.

In a chat this week with *The World* Mr. Friedl stated that business had kept up splendidly during the past few weeks and commented upon the fact that the Columbia Co. is leaving nothing undone to co-operate with the dealers in this territory. Referring to the difficulties incidental to securing goods at the present time, Mr. Friedl said: "We are going to almost unreasonable expenses in order to co-operate with the Government as well as our customers. In other words, we are making the Columbia Co. the third consideration in our business activities."

"The other day we paid express charges totaling several hundred dollars in order to secure some machines from the factory, and our dealers can therefore readily understand that the cost of doing business has increased tremendously during the past few months. However, we are charging this increased expense to patriotism and loyalty to our dealers."

RECORDS

—Try Us on Your Next Order

In giving us the opportunity to care for your needs, you can expect promptness and care in the very greatest degree.

First, a complete stock as a basis for our serving the Victrola dealer—then service in which the utmost dispatch and conscientious attention to

every detail of your order, are prominent features always—make the Grinnell Victor distributing organization of very great assistance to you in serving your Victrola and Record buying public.

It's to our own interest to help you to a greater business. We leave nothing undone!

RIGHT NOW get your stock of Records of "First Aid" Course in French

A big new field for business is open to you through these Records. Thousands of the boys liable to call will welcome the opportunity to acquire a working knowledge of French. Don't be without the "First Aid" course.

FREE

—Each Month

—an advance list of the Records which our committee of twelve decide will be the most popular among those to be issued. You'll find this of great help to you in ordering. Write us to send it—no obligation whatever.

Grinnell Bros

Distributors, Victrolas and Records

First and State Streets, Detroit

Happenings in Dominion of Canada

TORONTO CONTINUES TO BE VERY ACTIVE TRADE CENTER

Leading Makes of Talking Machines and Records in Demand—Steady Expansion in Stores and New Concerns Indicate That 1918 Will Be a Big Year in This Progressive City

TORONTO, ONT., February 6.—The Robert Simpson Co., Ltd., the well-known department store, is the newest addition to the local list of "His Master's Voice" dealers. The company's "Music Studio" is located on the sixth floor, where they have no less than eight demonstration rooms. It is in charge of Mr. Brown, formerly manager of the Mason & Risch Victrola department in Vancouver, and more recently on that firm's selling staff in this city.

The Canadian Symphonola Co., Ltd., have just received at their factory an interesting souvenir of the Halifax disaster. A couple of their De Luxe Symphonolas that had not yet been opened by W. H. Phinney & Co., Ltd., the Nova Scotia distributors of these lines, came back for repairs, the cabinets being badly used up by fire and water, and the packing cases being broken, scorched and soaked.

"No records exchanged" is the policy of the Toronto Grafonola Co. A notice to this effect is displayed in each of the twelve demonstration rooms. In discussing this policy H. Ritz, manager of the company, stated that he could credit increased record business to it.

"A very good January trade," report A. R. Blackburn & Co., "in both the piano and Victrola departments." The same report was made by R. F. Wilks & Co., who handle Columbia Grafonolas.

The branch store opened up at 1657 Dufferin street, this city, last fall, by Toronto Grafonola Co., is reported by H. Ritz to have proven a good addition to their business.

"We are well satisfied with the amount of business developed during 1917," said I. Montagnes, referring to the Canadian distribution of Sonora phonographs, for which line his firm have the Canadian representation. E. Van Gelder of this firm has just recently returned from New York, where he visited the Sonora factory to arrange for 1918 deliveries. In their retail department they report good success in closing cash sales for the higher priced makes, a number of Toronto's best-known citizens being among recent purchasers. Harry R. Braid, manager of this department, said that the Christmas and New Year's business arising out of the December campaign was very gratifying.

The R. S. Williams & Sons Co., Ltd., are now running a newspaper series of lists of Edison re-creations.

Domestic records are now being distributed in Canada by the Pollock Mfg. Co., Ltd., who maintain factories in Kitchener and Elmira, Ont.

H. L. Willson, New York, and C. A. Hanson, Bridgeport, vice-president and general works manager, respectively, of the Columbia Graphophone Co., visited the Canadian branch during the past month. This was Mr. Willson's first visit to Canada and was the coldest day ever experienced by him until his return to New York.

Patrons and friends of the Music Supply Co., Columbia distributors, were pleased to receive with that firm's good wishes for Christmas and New Year's a neat little vest pocket tickler. This with renewable fill came in a fine quality of seal with the Columbia trade-mark in gold.

With the calendar year Pathé Frères Phonograph Co. of Canada, Ltd., have started out on their second year. "The first year's results exceeded our anticipations," remarked Otis C. Dorrian, general manager of that firm.

Arthur M. Tanney, general manager J. A. Banfield of Winnipeg, Man., was among the January visitors to the Columbia factory in this city. The Banfield house has a Columbia department in which Mr. Tanney stated more business had been done in the last six months than they had thought could be done in a year.

Messrs. Wettlings and Dupont, Welland, Ont.; Mr. Britton, Grand Valley, Ont.; Mr. McKibbon, Wingham, Ont.; Alex. E. Creemore and H. Judson Smith, Brantford, Ont., have secured the agency of the Brunswick phonograph and records of this make.

"Music in the Home" ideas are incorporated in some Columbia Grafonola copy being run in the local newspaper by A. & H. Wideman of Markham, Ont.

George Dodds, who opened up on Danforth avenue, this city, a couple of years ago with His Master's Voice lines, has lately improved his selling facilities by adding a new demonstration room.

Frank Stanley is making extensive alterations for the equipping of what appears to be one of the most beautiful recital halls, to be used almost entirely for the sale of phonographs.

In the Edison Week Patchwork Advertisement Contest, from October 20 to 27 last, Gordon R. Diver, Montreal, won fifth prize.

J. C. Pott, Canadian sales manager of the Otto Heineman Phonograph Supply Co., Inc., accompanied by Mrs. Pott, spent the Christmas and New Year's holidays in New York. Mr. Pott is of the opinion that 1918 will see great developments in the Canadian phonograph business.

P. K. Wood, of the local branch of the Thomas Mfg. Co., makers of Dayton motors, recently spent a week at the firm's factory in Dayton, Ohio. Mr. Wood reports that the management are installing additional machinery to double their capacity.

Mr. Burgess' place on the road in Ontario with the Pathé Co., Toronto, will be taken by C. Le Voi, an experienced and successful talking machine salesman, whose apprenticeship was passed with the Columbia Co. During the last three months Mr. Le Voi has been in charge of the talking machine departments of Messrs. Jury & Lovell in Oshawa and Bowmanville. During that time he established a record for sales which will be difficult to beat in towns of this size.

The Pathé Co. have just received the first examples of some new art designs in Pathephones. They are in the shape of console tables, and include examples of Jacobean, William and Mary, and Sheraton. They retail for \$350. A fine display of these machines was made in one of the Yonge street windows of the Robert Simpson Co.

E. C. Pelton, formerly of Kentville, Ont., who moved into Ottawa a couple of months ago, taking with him Sherlock-Manning representation, has added the Starr line of phonographs and records. Until taking on the Starr Mr. Pelton had never connected up with the talking machine business.

John A. Croden of the Canadian Phonograph Supply Co., London, Ont., who are distributors in Canada of Starr phonographs and records, paid a visit to the factory at Richmond, Ind., recently.

New firms handling Brunswick phonographs and records include Alex Earle Creemore and H. Judson Smith & Co., Brantford, Ont.

J. P. Bradt, general manager of Columbia Graphophone Co.'s Canadian division, with headquarters at Toronto, attended the convention in New York of Columbia division managers and executive heads. At the same time the division salesmen and the district managers of the Dictaphone Co. had their convention.

Harry E. Wimperly, who is making a success of upstairs piano salesrooms, in the Ryrie Building at Yonge and Shuter streets, has added "His Master's Voice" line of talking machines.

Gerhard Heintzman, Ltd., are now listed among His Master's Voice dealers, having stocked Victor lines in their stores at Toronto, Hamilton and Kitchener. "The New Home of the Victrola" is the slogan featured in recent advertising of this department.

New premises at 864 Bloor Street, West, this city, have been purchased by J. H. MacMillan, suburban piano and talking machine man dealer. At present Mr. MacMillan is handling with good success the Aeolian-Vocalion phonograph.

The John Raper Piano Co., Ottawa, Ont., report the showing in their Victrola department for 1917 as remarkable. They trebled the 1916 sales of Victrolas and Victor records.

The Great War Veterans' Association, Toronto, Ont., in a recent letter from the secretary, W. E. Turley, to the R. S. Williams & Sons Co., Ltd., expressed himself as follows with regard to the new Edison Diamond Disc machine:

"The Edison is much appreciated by the members of this association. During the several months we have had the use of it at the clubhouse headquarters it has been the means of providing splendid entertainment for the members of this association. We have never had the slightest difficulty with it during that time and it has proved itself to be of sound construction, giving splendid reproductions of musical and vocal numbers. We believe it will provide fine entertainment for returned soldiers for many years to come."

Previous to the appearance in Toronto of Louise Homer, Mason & Risch, Ltd., ran a complete list of Homer Victor records preceded by a photo of this popular Victor artiste. The results from this particular piece of newspaper copy were splendid.

The Treadgold Sporting Goods Co., Kingston, Ont., has taken the agency for the Brunswick.

Mahood Bros. report good Victor business in Kingston, Ont.

New talking machine firms recently registering in Toronto, Ont., include The Phonograph Shop and the Concertola Mfg. Co.

In the Columbia Graphophone Co.'s newspaper advertising of recent date they say: There is a Columbia Grafonola in every Y. M. C. A. and Knights of Columbus Army hut. Following their name and address of the company, they finish up as follows:

"Food will win the war. Don't waste it."
James Malcom, president of Pathé Frères Phonograph Co. of Canada, Limited, has been elected mayor of the town of Kincardine, Ont.

Talking Machine Supplies and Repair Parts

SPRINGS, SOUND BOX PARTS, NEEDLES

THE RENÉ MANUFACTURING CO.
MONTVALE, NEW JERSEY

UNICO SYSTEM



THE SALES BUILDER

UNICO RECORD DEPARTMENTS

are the
Standard of Service and
Sales Efficiency



THE PURCHASING Public quickly discriminates. Look for the busiest Record Department in your community and you will usually find The Unico System of Demonstrating Rooms, Record Racks and Record Counters

MAXIMUM CAPACITY
MINIMUM SPACE
MODERATE COST

Record Sales in 1918 will surpass all previous demands. Prepare *now* to secure your share of this business by installing

THE UNICO SYSTEM

Patriotic Records will help
win the War



U N I C O DEMONSTRATING ROOMS
RECORD RACKS
RECORD COUNTERS
WALL DECORATIONS
COMPLETE INTERIORS

(Patented as to design and construction)

In six standard styles and in special period design such as Adam, Louis XVI, Colonial, Modern French, etc.

- Offer 1—Individuality and Class
- 2—Highest Sales Efficiency
- 3—Most Economical Investment

Follow the lead of the leaders.
Double sales and profits through

THE UNICO SYSTEM



THE UNIT CONSTRUCTION COMPANY

RAYBURN CLARK SMITH, President

Fifty-eighth Street and Grays Avenue, PHILADELPHIA, U. S. A.

Send today dimensions of your
available space

Plans for a complete department
will reach you promptly

TRADE CONDITIONS IN THE DOMINION OF CANADA—(Continued from page 68)

TO OPEN PATHE DISTRIBUTING BRANCH IN MONTREAL

Move Necessary to Take Care of Growing Business—Talking Machine Men Have Successful Meeting and Dinner—Berliner Gramophone Co., Ltd., Enlarge Quarters—General News

MONTREAL, QUE., February 5.—Owing to the rapidity with which their business is growing in the Province of Quebec, the Pathe Co. have decided to open a branch in this city to take care of that province. This branch will be under the management of R. W. Burgess, who has been so successful in handling the wholesale business in Ontario. Mr. Burgess' promotion is a well-earned one, and will cause great satisfaction to his friends in the trade. His territory will be a large one, but with his long experience and natural ability he should have no difficulty in handling it successfully.

The Talking Machine Men's night out entertainment and dinner, this is the way the tickets read, will take place at Cooper's February 8, when it is expected a large assemblage of talking machine, piano and musical men will be present. The purpose of the gathering is to foster and stimulate an interest outside of business amongst the members of the trade, and no doubt this informal gathering will be the nucleus of an association for social enjoyment, to create better fellowship and have the members of the trade become better acquainted. The idea is not to form a business association but to confine it strictly for social purposes.

In conformity with their policy of service, the Berliner Gramophone Co., Ltd., are making material enlargements to their record output and facilities for carrying larger stocks. An entire new building, with a private siding on the Grand Trunk Railway, has just recently been leased for a term of years.

The entire stock of Victrolas will be stored in this building along with materials for record manufacture, so that the parent factories and warehouses will be devoted entirely to the record branch of the business, head offices and sales department.

The building just leased and of which possession has already been taken, gives the firm an additional 23,000 feet of floor space or an increase of 50 per cent. It is being fitted up to the requirements of the company, while extensive alterations in the record storage warehouses in the way of additions are being made. Not only is the factory output increased and the storage facilities enlarged, but even greater stocks of records will be carried at the company's distributing houses in Toronto, Winnipeg and Calgary, making possible quick deliveries, so essential in record retailing.

A particularly interesting feature of the Berliner plant in Montreal is the recording department. Experiments and research work carried on by H. S. Berliner, vice-president of the company, personally, and with a staff of expert assistants for a number of years, has made recording in Canada possible. His Master's Voice dealers have been able to stock many hits, while still hits, through the efficiency of this recording department, which has also made possible records of special value in this country and specials by Canadian artists, as events made recordings of particular titles desirable.

Henry Burr recently made a special trip to Montreal to record two songs.

The Pratte Piano Co., Ltd., manufacturers of the Pratte piano, have registered their manufacturing phonograph department under the name of the Prattephone Co.

Almy's, Ltd., report an exceedingly heavy volume of business in January for Columbia Grafonolas and Columbia records, and Miss Vezina, who has charge of this department, is very much pleased that there has been no apparent falling off after the record business established by her department in December last. The amount of business already done in February promises a good outlook for its continuance.

The Berliner Gramophone Co., Ltd., report no falling off in sales of Victor machines and records as compared with their record Decem-

ber business of Victor machines and records, and state that it is wonderful the way business is keeping up, their various stores presenting an appearance of holiday times.

AFTER MISLEADING ADS IN CANADA

Amendments to the Criminal Code Advocated As a Means for Checking That Evil—Text of Proposed Law—Grafonolas in Army Camps

TORONTO, ONT., February 2.—The subject of fraudulent advertising has been a vexed question for some time past. Many parties have been accused of advertising in such a way, but owing to the loopholes existing in the present law many cases that seemed to present fraudulent methods have been allowed to escape through technical difficulties in its enforcement.

To meet these difficulties, amendments of the criminal code have been suggested and will come up for consideration in the near future. The original act, passed on June 12, 1914, is reproduced herewith, with the inclusion of the proposed amendments:

"His Majesty, by and with the advice and consent of the Senate and House of Commons of Canada, enacts as follows:

"I. The Criminal Code, chapter 146 of the Revised Statutes, 1906, is amended by inserting the following section immediately after the section 406 thereof:

"a. Every person who either himself or by his agent, servant, employe, or anyone on his behalf, knowingly publishes or causes to be published any advertisement for either directly or indirectly promoting the sale or disposal of any real or personal, movable or immovable property, or any interest therein, containing false or misleading statement, or false representation which is of a character likely to or is intended to enhance the price or value of such property or any interest therein, or to promote the sale or disposal thereof, or is liable to mislead anyone as to the true value of such property, shall be liable upon summary conviction to a fine not exceeding two hundred dollars or to six months' imprisonment, or to both fine and imprisonment, or in the case of a corporation to a fine not exceeding five hundred dollars.

"The production by the informant of any advertisements containing any statement alleged to be false or misleading shall be prima facie evidence that the same was knowingly published by the person whose name shall be mentioned therein, as the advertiser, or proprietor, owner, agent, manager, as the case may be, of the business referred to in said advertisement. The word person shall include an individual or partnership company or corporation."

WITH THE TRADE IN WINNIPEG

Stocks Coming Along in Better Shape and Dealers Find Business Active—Robert Shaw to Make Eastern Trip—Some Records That Are in Strong Demand at the Present Time

WINNIPEG, MAN., February 4.—Columbia Grafonolas and records are now coming along more freely to the Western Fancy Goods Co., who are the Western distributors for the company. January is reported as being one of the biggest months in this firm's history. There is a decided increase in the call for the higher priced machines.

Robt. Shaw, Western manager of the Columbia Grafonola Co., will shortly leave for a visit to the Columbia factory in Toronto.

Babson Bros. report satisfactory January trade in New Edison Diamond Disc machines and Edison records—a decided increase in sales being shown for the months of December and January.

Mason & Risch, Ltd., are handling a large

Miss Perrault, saleslady of the Berliner Gramophone Co., Ltd. (East End store), was married on January 22, as was also Miss Beau regard, cashier of the company's new store, on January 28.

Harold Dewar, late of the Berliner Gramophone Co.'s retail selling staff, and to whom has been made at various times in these columns, has gone overseas. H. M. Reece is at Key West, Fla.

volume of Victrola business both in machines and for His Master's Voice records.

Campbell & Campbell, of Brandon, are active in the retail talking machine field with the Pathe and Brunswick lines.

The Western Gramophone Co. report an enormous Christmas and January trade in Victor machines and records, "Somewhere in France" and "Missouri" waltz records being tremendous sellers.

Cross, Goulding & Skinner report a remarkably good talking machine business during the month of January. Heintzman & Co., Edmonton, Alta., report the most popular Victor selling records of the past week as follows: "Wait Till the Boys Come Home," sung by Green-MacDonough; "My Sweetheart Is Somewhere in France," sung by Elizabeth Spencer; "Say a Prayer for the Boys Out There," sung by Peerless Quartet; "When We Wind Up the Watch on the Rhine," sung by Henry Burr; "I Love to Be a Sailor," sung by Harry Lauder; Hungarian Dance, No. 5, played by Philadelphia Orchestra; "She Wandered Down the Mountain Side," sung by Alma Gluck.

Mr. Hood, who was until recently in charge of the phonograph department of Stanwoods, Ltd., has severed his connection with this firm, his position being filled by Mr. Roberts of the Brunswick Co., Toronto.

Ralph & Limon, Ltd., Calgary, Alta., are handling the Veolian and the Playola, both cabinet phonographs.

J. W. Kelly, president of the J. J. H. McLean Co., Ltd., His Master's Voice dealer here, recently visited Toronto and Eastern points.

SELLS AUTOS AND PHONOGRAPHS

Dohan's, Ltd., of Quebec, Adds Pianos and Edison Phonographs to Line of Automobiles—Makes Profits During the Winter

QUEBEC, QUE., February 5.—Dohan's, Ltd., Palace Hill, who handles several makes of automobiles, recently took on the agency of the Martin-Orme line of pianos and players and the Edison Diamond Disc phonograph and Edison records. These lines are side by side in this firm, showrooms. When asked if the lines conflicted in any way with his automobile business he replied that they did not, in fact one often helps out the sale of the other he remarked. Mr. Dohan also conducts an exclusive phonograph and piano warerooms in another part of the city, and was at one time actively connected with the piano business, but having a good opportunity of renting his premises at that time took advantage of the situation and vacated, going into the automobile business. In winter especially, when business in automobiles is quiet, Mr. Dohan finds the piano and phonograph business a desirable one, especially during the months of December and January. Mr. Dohan is to the best of our knowledge the only automobile dealer in Canada exploiting motor cars, pianos, phonographs and records, and his example might be easily followed by other aggressive merchants who could turn their idle minutes (during the winter) into profits. Mr. Dohan has not gone into the phonograph business half heartedly, as he has had several demonstration booths built for the purpose of demonstrating machines, records, pianos and players. His showrooms for an automobile buyer present a most up-to-date appearance, the floors nicely carpeted, easy chairs, splendidly lighted with up-to-the-minute electric fixtures, etc. Mr. Dohan is well satisfied with his recent idea of combining these lines.

CINCINNATI TRADE OPTIMISTIC

Excellent Business for January Gives Rosy Tint to Future—Many New Dealers Enter the Field—Freight Embargoes Handicap the Trade

CINCINNATI, O., February 4.—Fair deliveries of records and a good demand for this phase of the talking machine business resulted in the trade accumulating a good record for the first month of the year.

It can be stated without question that the volume of disc sales in January was considerably above the anticipation of the trade. Much of this may be attributed to the prolonged cold spell and the heavy snows during the month, which caused a decline in the amount of street travel and forced people to remain at home and entertain themselves with concerts. Constant playing brought about a demand for additional records and the trade benefited accordingly.

The Fritsch Phonograph Co. is looking forward to a decided increase in its business this year. Many new openings have been established and the officers expect to continue this work for several months. Among the agencies established in January were the Roberts Jewelry Co., Augusta, Ky.; Phonograph Record Exchange Co., Huntington, W. Va.; Smith Music Store, Parkersburg, W. Va.; Burgen Music Co., Charlestown, W. Va., and the Intermont Drug Co., Appalachia, Va.

The Phonograph Co., Edison dealers, according to O. A. Peterson, manager, is daily expecting a decided increase to its depleted storage department. His assistants have spotted several cars and an opening of the weather, now apparently under way, is expected to enable the railroads to rid themselves of many "dead" cars. These have been on sidings for weeks, no attempt being made to haul these while the Middle West was suffering from lack of coal.

F. F. Dawson, acting manager of the Graphophone Co., is still on the job at the Cincinnati branch and is not likely to be relieved until March 1. His assistant, Herbert Schmiedeke,

has joined the colors, the vacancy not being filled.

The Crystola Co. is handicapped by embargoes placed against outgoing shipments. Dr. A. J. Swing, of the company, reports many inquiries and looks for a big year.

A LIVE NORFOLK, VA., INSTITUTION

Columbia Co., Inc., Doing Very Well in That City With Columbia Line Exclusively

NORFOLK, VA., February 6.—One of the most successful retail establishments in this city is the talking machine store conducted by the Columbia Co., Inc. This store handles the products of the Columbia Graphophone Co. exclusively



Store of Columbia Co., Inc., Norfolk, Va. and through the use of aggressive sales methods has built up a substantial demand for that line.

T. J. Carey, president of the company, is a firm believer in the value of efficient merchandising, and during the eight years that the Columbia Co., Inc., has been in business has left nothing undone to render service and co-operation to the store's patrons. Mr. Carey attributes the success of the company largely to the fact that it carries a complete stock of everything listed in the Columbia catalog, both Grafonolas and records. It also maintains an expert repair department which proves of great advantage.

CLOSE MANY IMPORTANT DEALS

Century Cabinet Co. Steadily Expanding Its Line of Phonograph Representatives Throughout All Sections of the Country

The Century Cabinet Co., New York, manufacturer of the Century phonograph, has closed a number of important deals the past few months whereby this high-class instrument will be handled by representative dealers in different sections of the country. Some of these new Century dealers are leaders in mercantile activities in their respective cities, and are in a position to give this line splendid representation.

The Century Cabinet Co. is recognized as the largest manufacturer of talking machine cabinets in the country and the Century phonograph is therefore the product of a concern which has already won the confidence of the talking machine trade. James T. Lee, president of the company, is personally supervising the production and merchandising of the Century phonograph and is keenly interested and gratified in the fact that these products are being well received by the dealers.

PRAISE BRUNO DISPLAY CARDS

This Enterprising Firm of Victor Wholesalers Issue Most Artistic Announcements

C. Bruno & Son, Inc., Victor wholesalers, have received several letters from Victor retailers praising the display cards which this company is issuing monthly. These cards, which are 14 by 22 inches, are painted by a well-known artist and contain a sales appeal that acts as a stimulant to the sales of the records that are featured. One of the attractive cards in this month's series presents the hit of "Chu Chin Chow," entitled "At Siesta Time," and if this card is displayed properly it is certain to increase the sales of this particular record.

Pettiness in money matters encourages pettiness in many matters.

LONG CABINETS



No. 83

In all finishes. Specially adapted for use with Columbia 50. Front posts made to follow lines of posts on Columbia 75.

FIRST and FOREMOST

In the cabinet field.

Why? Because we've *specialized* in

**CONSTRUCTION
FINISH and
ADAPTABILITY**

Our supremacy in these essentials warrants your handling *the perfect line.*

That's why you should anticipate your wants **NOW, when the season's at its height.**

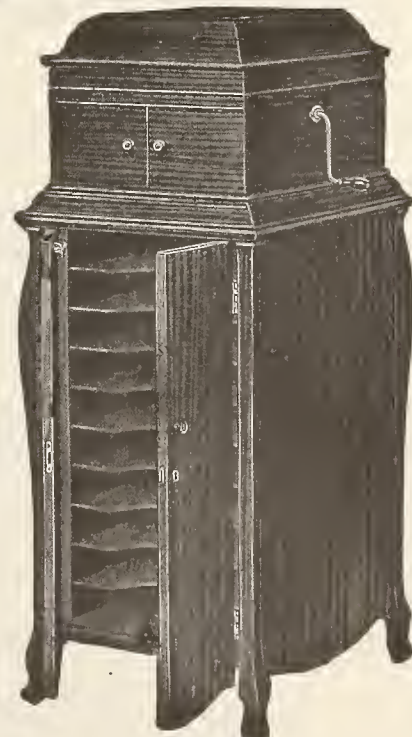

No. 79

In all finishes. Shown with top moulding and shelves. Specially adapted for use with Victrola IX.

Prompt deliveries on all orders. Write for Illustrated Catalogue of complete line

**THE GEO. A. LONG CABINET COMPANY
HANOVER, PA.**



10-Inch
75 cents
and up

DOUBLE

FACED;

12-Inch
\$1.00
and up



“The Road to Profits”

Stock the Records that bring back satisfied customers

IMPERIAL RECORDS

Recorded in our own laboratory and made in our own factory, faithfully reproduce the **World's most famous** Instrumental, Operatic and Popular Music.

The **Imperial Records** can be played on all makes of Talking Machines and are backed by our catalog of over Two Thousand numbers, containing among them a galaxy of Artists known the World over.

Supplements listing new attractive and varied additions to our repertoire published every month.

You will make no mistake in writing us for further details and our very liberal discounts.

IMPERIAL TALKING MACHINE COMPANY, Main Office and Factory: No. 9 Vandever Avenue, Wilmington, Del.

Recording Laboratory and Showrooms: 35 West 31st Street, New York City

Pacific Coast Distributors: The Stern Talking Machine Corporation, 1085 Market Street, San Francisco, Cal.



REPAIRS

TALKING MACHINE TROUBLES AND HOW TO REMEDY THEM

Conducted by Andrew H. Dodin

[This department of The Talking Machine World is designed for the service of all classes of our dealers, including those who make, and those who sell, talking machines. Andrew H. Dodin, who conducts this department, has a wide and enviable reputation as a repairer of talking machines and conducts an exclusive talking machine repair shop at 176 Sixth avenue, New York. Tell him your troubles through The World and he will help you if possible. The service is free.—Editor.]

SOME INQUIRIES ANSWERED

WEST ALLIS, WIS., January 31, 1918.

Editor, The Talking Machine World:

I would like advice on the following items, as I find phonograph people do not seem to agree on these points:

What is the correct playing weights of points on records of various standard makes of machines?

Is there a definite angle at which to place the needle or jewel point when in playing position on the record? If so, what determines this angle?
H. H. R.

ANSWER—The weight or pressure at the needle point of the Edison Diamond Disc sound box is between three and four ounces, and at the needle point for sound boxes playing lateral cut records, should be about six ounces. A diamond point needle should track the groove of the record at an angle of about 50 degrees to the surface of the record, steel needles at about 45 degrees. In some cases a little more or less degrees of angle will give better results.

The angle is determined by setting the sound box in the position giving the least blast. For instance, a sound box might play satisfactorily at the angle of 45 degrees, but would blast at an angle of 50 degrees, etc.

NEW YORK, N. Y., January 30, 1918.

Repair Department,

The Talking Machine World:

Some time ago one of the governor springs in a machine in my store was broken, and I was forced to substitute a spring not quite so long, but carrying a governor ball of about the same weight as the two that remained. Although the motor apparently runs at proper speed, there is a peculiar grinding noise coming from the governor, although it seems to revolve all right. Could the shorter spring have that result?
M. M.

ANSWER—If there is one short spring and two long ones in the governor it will naturally be thrown out of balance and is most likely to cause grinding or knocking noise. I would suggest that you write to the manufacturer of your motor for a complete set of springs and governor balls of the same size and attach them to the governor.

BOSTON, MASS., February 2, 1918.

A. H. Dodin,

care The Talking Machine World:

Is it possible to sharpen steel talking machines needles so that they may be used again without damage to the record? I understand that the shortage of needles has resulted in the placing on the market of machines for sharpening them. Can these machines be used safely?
J. H. W.

ANSWER—Steel needles of the usual type are generally hardened at the point by some special process, and if this hardened surface is not entirely worn away by use it should be possible to repoint them successfully. The point and sides of the needle, however, will have to be ground smoothly, and then polished until no roughness is discernible. There have been needle-sharpening devices on the market here, but they have met with indifferent success, owing to the plentiful supply of needles up to this time. It may be that if there is a genuine needle shortage an improved sharpening machine may make its appearance.

NEW JOBBER IN PHILADELPHIA

The George D. Ornstein Co. Appointed Victor Jobber With Quarters at 9 N. Eleventh Street

PHILADELPHIA, PA., February 4.—George D. Ornstein, who recently severed his connection as manager of the traveling department of the Victor Talking Machine Co., and in direct charge of the company's traveling representatives throughout the country, after over twenty years in the Victor service, is president of the new George D. Ornstein Co., which has been appointed wholesaler of Victrolas and Victor records in this city, and opened quarters at 9 North Eleventh street on February 1. Associated with Mr. Ornstein in the new venture is George A. Lyon, who for several years past



George D. Ornstein

was his assistant in the traveling department of the Victor Co.

It is doubtful if a single man in the talking machine trade is as well known among Victor wholesalers and dealers as Mr. Ornstein, for he has covered the country thoroughly and has kept in close personal touch with all developments from coast to coast. He has a keen knowledge of the talking machine business in all its phases, and has the ability of training new material to become effective in the field.

As a Victor wholesaler, Mr. Ornstein is particularly well equipped to win success. He is in a position to render distinct service to the dealers in the matter of giving advice, and his company is planning some original things in the matter of general service.

The company will confine itself to wholesale business exclusively, and starts with a floor space of nearly 10,000 square feet in the business center of Philadelphia, a location most convenient in every respect.

INCREASED WIDDICOMB DEMAND

This Artistic Phonograph Grows in Favor With the Trade, Judging From Orders Placed

GRAND RAPIDS, MICH., February 9.—The Widdicomb Furniture Co., of this city, report that the demand for the Widdicomb phonograph has far exceeded their expectations, and appreciative words regarding this meritorious product are heard on all sides.

The Widdicomb phonograph was the object of much interest at its debut at the Furniture Show held in Grand Rapids during the month of January. The full line was exhibited, four upright models and four console types. The popularity of the line was attested to by the fact that they were entirely cleaned out of a number of the models. It is announced that they are now able, however, to resume uninterrupted deliveries. With the immense facilities of the Widdicomb Furniture Co. at its back the phonograph division will be enabled to expand to take care of all business.

With such an auspicious start, H. C. Howard, manager of the phonograph division, looks for great things during the coming year. It is his opinion that a large part of the success the Widdicomb line has built up for itself has been through the prospective jobber or dealer following their suggestion to "Play It Yourself."

ISSUE FRIEDA HEMPEL FOLDER

Thomas A. Edison, Inc., have just issued an artistic and impressive folder calling attention to the fact that Frieda Hempel, the noted Metropolitan opera prima donna, has been added to the already extensive list of Edison artists, as announced in The World last month.

The folder, which is produced in two colors, contains an excellent portrait of Miss Hempel, together with something about her career in opera, and the announcement that the Edison Re-Creation of her voice will soon be available.

NOW IS THE TIME TO REPLENISH YOUR STOCK

Records prove that the next three months are the best in the year for selling the

VICSONIA



Mr. Dealer:

Don't miss sales by being out of stock. Order NOW.

If you are not familiar with the "best reproducer for playing EDISON RECORDS," send us \$3.50 and we will send you one on 10 days' approval. Money refunded if not satisfactory.

State Make of Machine

Vicsonia Manufacturing Company, Inc.
313 East 134th Street (Bronx) NEW YORK, N. Y.

A WAR POLICY

Being an Announcement from
Stephenson, Inc., New York

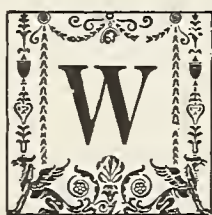

WE have entered this war to see it through to a deadly finish; an end that will insure for always the homes of civilized peoples against unbelievable ravage..... Stephenson Precision Made Motors are manufactured by DeCamp & Sloan, Incorporated, of Newark, N. J., whose enviable reputation for the manufacture of precision machinery has brought to them much work for the Government..... tools and dies of infinite accuracy..... parts for munitions, for aeroplanes. Thus, it has been their duty to apply their skill to things that wound and maim and kill; and, in the strange way of Fate, to apply the same skill to parts that gladden the heart..... the phonograph in the home, where a service flag means a son at the front..... and phonographs in the camps of the boys "over there."

And their war policy is to do their bit in every way. To apply their skill on Government work..... and always to apply the same skill on our work—the manufacture of the Stephenson Precision Made Motor. For, surely, music as well as shrapnel, has its part in war..... and who shall say it has a lesser part?

Frank V. Nutze

Vice-President

STEPHENSON, INC., One West 34th St., New York

DETROIT TALKING MACHINE DEALERS ELECT OFFICERS

S. E. Lind Heads Organization as President—Annual Convention of Grinnell Forces Tells of Progress—Busy Pathé Jobbers—Edison Shop Looks for Big Trade—The Business Outlook

DETROIT, MICH., February 7.—We have had many adverse conditions confronting us for the past thirty days owing to the coal situation. People in almost every section of the State have been without coal, and so serious has been the lack of coal and fuel that numerous cities have had to shut down their retail stores and industries almost completely. Railroad traffic has been tied up, and freight and express shipments have been the worst in their history. Notwithstanding this condition of affairs, it is really remarkable the encouraging reports one hears from dealers of talking machines and records. We don't mean to infer from this that all dealers are reporting a brisk business, but it is true that most of them report that business is entirely satisfactory. There are complaints by some dealers of their inability to get certain popular-priced models of machines, while others report a shortage of records. The wholesalers attribute the shortage to poor railroad shipments. Several dealers who ordered talking machines from outside jobbers had them sent by express and even then it took nearly thirty days to get them through to destination.

The Detroit Talking Machine Dealers' Association held its annual meeting in January at the Hotel Charlevoix with a very good attendance, the meeting itself being one of unusual interest and enthusiasm. The election of officers resulted as follows: President, S. E. Lind, Columbia Graphophone Co.; first vice-president, George W. Smith, Detroit Music Co.; second vice-president, Wallace Brown, Brunswick dealer; secretary, W. D. Trump, Jr., Max Strasburg Shops; executive committee, A. A. Grinnell, Sidney J. Guest, Phil B. Lang and Edward Andrew, Jr. The association passed resolutions to render unanimous and hearty support to the city and State fuel administrators; also to put on the proposed concert some time around Easter, the money for tickets sold to be turned over to one of the patriotic funds. Reports of the various past officers and committees showed the association had prospered, and that with a larger membership than ever the new year gives promise of great things.

Grinnell Bros., operating twenty-four branch retail stores, held their fifteenth annual convention at Detroit from January 29 to 31. It was the greatest meeting of its kind in the history of the company. C. A. Grinnell, vice-president of the company, presided at the business sessions. Among the numerous subjects discussed were the Victrola retail and wholesale departments. Reports showed that these departments enjoyed splendid business during 1917—probably the best of any in the Detroit or branch stores. A. A. Grinnell, vice-president and treasurer of the company, and C. H. Grinnell look after the Victrola departments both as to buying and distribution.

Max Strasburg, of the Max Strasburg Shops, who had planned to leave early in January for the South, has postponed his trip until some time in February. He will probably be "chasing the white ball on the green" under balmy skies ere this issue of The Talking Machine World is off the press.

Williams, Davis, Brooks & Hinchman Co., Michigan distributors for the Pathé line, are very well pleased with their sales the past year on Pathé machines and records, and both Mr. Chambers and Mr. Saunders, of this department, report that 1918 is going to be much better. In their building at Bates and Congress streets they have fixed up a very attractive room of what can be termed a "perfect Pathé Shop." It is of special interest to those who are already in business or who contemplate entering the talking machine business. The room shows just how a modern Pathé Shop should look as to decoration, booths and display as well as stock-keeping.

The East Detroit Music House and the J. L.

Hudson Co. are doing a good business with the Sonora phonograph.

R. B. Alling, of the Edison Shop, is confident that 1918 is going to be a big year for all Edison dealers in his respective territory. The Phonograph Co., of Detroit, which is the job-



S. E. Lind, President T. M. D. Association member for Edison phonographs, and of which Mr. Alling is also manager, is taking on new accounts right along, but they are the kind that produce results and this means profits to the dealer. Daily recitals are given at the Edison Shop, and too much praise cannot be given the two young ladies who have charge of these recitals. Both are high-class artists themselves and the in-

creasing attendance shows that they are worthwhile and worth the effort. The Edison Shop is the only phonograph store in Detroit that actually boasts of a recital hall—and it is right on the main floor.

S. E. Lind, local Columbia manager, was in New York during the early part of January, to attend the convention of Columbia branch managers. He is still effervescing over the convention, and he is determined that regardless of adverse conditions his books shall show an increase over the great record he made in 1917.

W. F. Huttie, sales manager of the Starr Piano Co.'s branch in this city, assisted by five other branch managers, were in Grand Rapids most of January in connection with the midwinter exhibition of furniture manufacturers. Their purpose in spending so much time in Grand Rapids was to sign up furniture dealers for the Starr line of phonographs and records. Mr. Huttie had splendid success, as did the other men there.

J. Henry Ling, Columbia dealer, Detroit, was hurt February 1 in a motor car accident, but is now on the road to recovery.

H. L. TUERS IN AVIATION SERVICE

Manager of Dealer Service Department of Columbia Graphophone Co. Joins Aviation Section of the Signal Officers' Reserve Corps

H. L. Tuers, manager of the dealer service department of the Columbia Graphophone Co., New York, has been accepted as a member of the Aviation Section of the Signal Officers' Reserve Corps and expects to be assigned to his new duties in the near future. Mr. Tuers is in line for an officer's commission at the end of the technical ground school course and the usual flying examinations. His successor has not yet been appointed.

A bluff is good (when you have enough reserve power to protect yourself should the bluff be called).

22 BEE CROFT YEARS

Connected With The Talking Machine Business

Advertisement for Clement Beecroft records, featuring a list of 30 records and a small illustration of a record player.

Record Cabinets Record Envelopes Needles

CLEMENT BEECROFT 309 W. Susquehanna Avenue Philadelphia

Build Up the Record end of your Business!

It ought to be bigger than the machine end—but is it?

You can sell a machine to a family but once, but there are dozens of new records every month and thousands of old favorites that will sell if brought to the attention of your machine owners.

**New York Talking
Machine Co.**
119 W. 40th St., New York

During the present shortage on Victor Records, retailers in all sections of the United States have found it profitable to forward record orders to the two largest exclusive wholesalers.

**Chicago Talking
Machine Co.**
12 N. Michigan Ave. Chicago



FROM OUR CHICAGO HEADQUARTERS

E. P. VAN HARLINGEN,
Manager

World Office
Republic Bldg., 209 South State St., Chicago
Telephone: Wabash 5774

CHICAGO, ILL., February 11.—While the manufacturing end of the Chicago trade has been materially handicapped by the recent five-day shut-down and the "heatless Monday" edict, there is no grumbling among the dealers from this source, their only means of complaint at present being the poor shipping facilities throughout the country. They are having a great deal of trouble in securing the necessary cars to make deliveries and when they are fortunate enough to secure some of the railroad rolling stock and place their product aboard they are out of the woods by no means, as then begins the real trouble. Owing to the fact that the railroads have discontinued the use of their car tracers, many consignments are miscarried while in transit, as there is a likelihood that a shipment consigned to New York may turn up in New Mexico or vice versa.

A great many of the manufacturers were also inconvenienced somewhat by the recent coal shortage, which was brought about by the big blizzards during the middle of January, but the fuel administration proved its worth in the emergency by literally commandeering numerous train loads of coal throughout the South and heading them off to Chicago. The railroad situation is bad throughout the entire country at present, as is well known; and for this reason jobbers as well as the retail dealers handling the products of the old-established concerns located in various parts of the country have suffered from a shortage of goods. The medium-priced machine has created such a strong demand throughout the trade that the stocks of the dealers have been rapidly depleted.

While the "heatless Monday" edict has been a means of curtailing the retail business to a certain extent so far as the sale of instruments is concerned it has had a tendency to cause impetus in the record business. Those of the people who already owned machines are at present coming down on Saturdays and loading up with records that will tide them over the "double holiday." There is also quite a demand for records on Tuesdays, owing to the fact that theatres and moving picture houses are compelled to close that day and people are prepared, therefore, to spend the evening at home. The dealers who keep their fingers on the public's pulse by watching the bookings of the big

shows that are billed for Chicago are the ones reaping the harvest in the record business at present. For example, the demand for popular music such as is being used by the Ziegfeld Follies at present in Chicago is very brisk. The wiser dealers have got in their supplies of these songs months ago, and are therefore, able to take care of the demand. There are musical shows that will reach Chicago in the near future which will also create a demand for other selections, and those dealers who have been farsighted enough to watch the bookings of these big shows have a plentiful supply of records on hand to care for the demand as it arises. There is still the shortage of steel needles, but not so great as during the holiday period, as shipments of these are coming in in fair shape at present, having been ordered several months ago.

Discusses Conditions Exhaustively

H. P. Ellis, of the Chicago Talking Machine Co., reports that they are still inconvenienced by the bad shipping conditions. "We have," said Mr. Ellis, "deliveries on the way that had been shipped from the factory on December 12. They are some place between here and the Victor factory, but just where we don't know. As the railroad companies are using their car tracers for other purposes, the shipper has to look out for himself. We have, therefore, employed a man who does nothing else but tear up and down the railroad tracks trying to locate our shipments for us. The only way we are receiving the goods from the Victor factories at present is through a very roundabout route. The city of Camden seems to be entirely tied up so far as the railroads are concerned, and for this reason shipments are being sent by boat through either Norfolk or Newport News, and then placed upon the cars and shipped to their destination over the B. & O. and C. & O. We can trace our cars, up to the time they are loaded on the trains at these points, but after that it takes a veritable Sherlock Holmes to find them.

"Records are coming in by express and this is increasing our overhead expenses materially. The record situation so far as popular selections are concerned is very grave at present. The demand is exceedingly strong, and the factories are working to capacity. Nevertheless shipments are a bugbear in this instance also. A

great many of our dealers who profited by our advice and ordered ahead way back in October and November are profiting. There are also a great many dealers who have a large supply on hand of records other than the popular ones, but they never took the trouble to use their salesmanship ability in selling these records. They just merely put them in stock and took a chance on their being called for, as they devoted their time to selling the popular numbers. These dealers are now having a demand for popular stuff, but are unable to fill them. They have, therefore, taken the trouble to go over their stock and are finding numerous selections that can be sold with little effort, as they are selections that give satisfactory returns to the purchaser. All that these records needed was a little energy behind them, and now that they are being pushed they are selling in the majority of cases better than the popular ones. We have a plentiful supply of these records on hand, and, therefore, can take care of the demand, as they are all good sellers and are liked by the purchaser if he is given the opportunity to hear them. By pushing these records the dealer cannot only relieve the situation materially, but can continue to do a good business as well if he will just expend a little energy towards pushing these numbers. In machines, the demand for elevens and fourteens got beyond the control of the dealers and the demand for these instruments grew to such proportions that the dealers' stock was rapidly depleted in many instances early in the season. The wise ones, therefore, began pushing the tens and sixteens, and these models have proved very satisfactory in taking care of the demand."

New Repeating Device

The Repeat-o-graph Co., of Illinois, is being incorporated with a capital stock of \$100,000 for the manufacture of a new device for a repeater and stop for talking machines. The attorney for the company says that their clients do not wish to make any announcement at present, although they will furnish details regarding their organization and product in the near future.

Exhibitors at the Furniture Show

The January furniture show in Chicago was a big success notwithstanding trade conditions that were not considered altogether favorable.

(Continued on page 79)

THE "WADE" FIBRE NEEDLE CUTTER

The "Original" Repointer Which Gives 20 or More "Original" Repoints

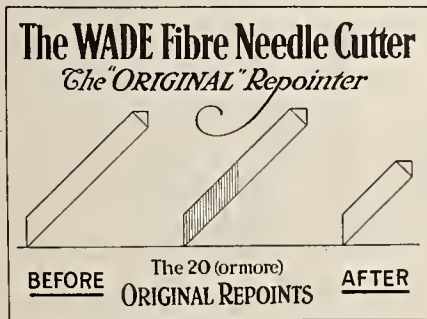

The term "Original" applies to the Wade Fibre Needle Cutter in several interesting and important ways.

The Plier-handle principle (protected by patent) of the "original" Wade Fibre Needle Cutter was the "original" idea of the "original" Mr. Samuel O. Wade, an inventive genius and skilled mechanic of great ability and wide experience.

The "original" intention of Mr. Wade to make the very best, most economical and durable Fibre Needle Cutter on the market has long since been fulfilled.

The "original" Wade Fibre Needle Cutter is simple in operation, strong and durable,

AND BEST OF ALL, IT GIVES 20 OR MORE "ORIGINAL" REPOINTS as shown by accompanying illustration.

YOU'LL SELL MORE "WADES" BECAUSE THEY GIVE MORE FOR THE MONEY

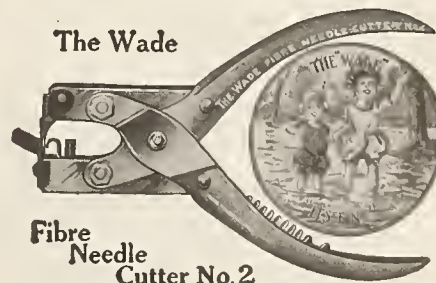

Price \$2.00

WADE & WADE, 3807 Lake Park Ave., Chicago, Ill.



SERVICE

Your customers will enjoy improved service at lower cost if you sell them fibre needles and a L. & H. Fibre Needle Cutter.

* * * *

Also Advertising Services to aid you in making yours the best known talking machine name in your locality are offered by us.

Subscribe to our Advertising Services and get striking cuts for a purely nominal price.



Victrola Advertising Service
52 Cuts a Year

Victrola Half Service
26 Cuts a Year

Victrola Folder Service

For Holding the Monthly Supplements in Place of Envelopes

Victrola Window Display Cards
Featuring the New Records

Small Instrument Advertising Service
36 Cuts a Year

Piano Advertising Service

Free to Dealers Who Represent America's Most Popular High Grade Piano

Samples and Prices Free—Write for Them



Lyon & Healy

Victor Distributors
CHICAGO

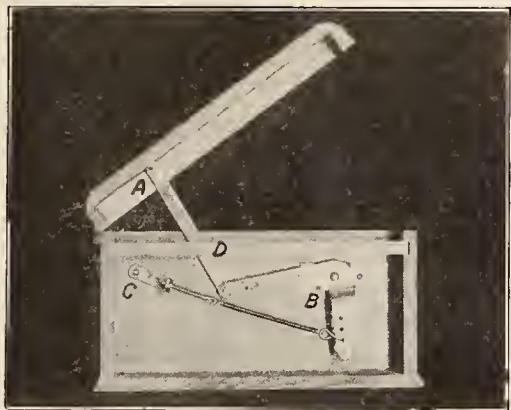

CHICAGO COVER BALANCE NO. 1

Others—Why Not You?

Most of the new talking machines of real merit are equipped with the

CHICAGO COVER BALANCE

It is not merely a Talking point; it's a Positive point of vantage. Don't take our word for it. Ask the users. Investigate.

WE MAKE NO CHARGE FOR SAMPLES TO BONA-FIDE MANUFACTURERS

CHICAGO HINGED COVER SUPPORT AND BALANCE CO.

2242 WEST 69th STREET, CHICAGO, ILL.

FROM OUR CHICAGO HEADQUARTERS—(Continued from page 77)

In the various buildings on Wabash avenue devoted to exhibits there were a number of displays of talking machines, and the exhibitors all seemed to be satisfied with the amount of business done. Among those having displays were the Brunswick-Balke-Collender Co., Elmbrola Talking Machine Co., Vitanola Talking Machine Co., Mandel Mfg. Co., and the United Phonographs Corp.

B. & H. Fibre Co. Preparedness

"Notwithstanding existing conditions," said F. D. Hall, president of the B. & H. Fibre Co., "there seems to be no let-up in the amount of orders coming in for our product. These orders are not coming in from any particular part of the country in excess to other parts, but it is general all over the country, and for this reason I am inclined to believe that the only thing that will interfere with the trade in general this year will be transportation. While several of my most expert and valuable employes have been called to the colors there has been no interruption to our progress. It is, of course, a hard matter to get workers to make fibre needles, as it takes from four to five months to drill them properly. Nevertheless, I was prepared in a measure for the loss of some of my most valued employes, because I always keep several in training prepared for any emergency that may arise. The absentees who have been called to the colors have been assured by me that whenever they return their same positions will be waiting for them, and not only that, but I think that I will have a mighty pleasant little surprise awaiting each one just as soon as he returns, as I am keeping their names on the salary list, and every payday I put their salary into a savings account which was taken out under their name. Therefore, should any of them come home and be physically unfit for work they will have a little nest egg waiting for them which they don't expect.

"I have been receiving a great number of testi-

monials from people all over the country who have purchased the B. & H. fibre needle pointer. Some of these letters are very amusing and others are written by intelligent, keen thinkers, and the prevailing statement which seems to appear in all of them is "best I have ever used." In making this statement, perhaps one is apt to be skeptical and accuse me of braggadocio; nevertheless I make this statement in all fairness. It is only the quotation contained in a great number of these testimonials which have been received recently, and, therefore, is not original on my part."

Gets Responsible Position

Miss H. McCormack, formerly with the talking machine section of the Hillman department store, is now connected with the Wade Talking Machine Shop, and is in charge of the record department. Miss McCormack is a very capable young lady and, although having been in the talking machine business for a little over a year, has proven her worth in this short space of time and is considered a valuable asset to the Wade Shop.

Acquire Canadian Patents

The Orilla Furniture Co., of Orilla, Canada, have recently made arrangements with the Automatic Container Co., of Chicago, whereby they have acquired the Canadian patent rights to manufacture the automatic filing devices that are produced by the latter company. A. V. Taylor, superintendent of the company, has written a letter to Mr. Read, president of the Automatic Container Co., in which he states that there is a very big demand for this product throughout Canada. The holiday trade reached proportions far beyond their expectations, nevertheless with their completely equipped factory and their unlimited stock on hand they were able to take care of the demand.

Mr. Read states that the business of the Automatic Container Co. has progressed steadily of late and had grown to such proportions that

it has become necessary to enlarge their factory facilities. For this reason he has made arrangements with a cabinet manufacturer located in Buffalo to make the necessary cabinets in that city and handle the Eastern trade from the Buffalo factory.

Arthur D. Geissler a Visitor

A. D. Geissler, president of both the Chicago Talking Machine Co. and the New York Talking Machine Co., spent last week in Chicago looking after the business interests of both companies.

New Victor Store

The Pearson Piano Co., of Anderson, Ind., a branch of the Pearson Piano Co., of Indianapolis, have acquired the Victor stock of the Meyer Bros. Drug House, of Anderson. The Pearson Piano Co. have a well-established warehouse in Anderson, and are better able to take care of the talking machine business, being a piano house, than were the Meyer Bros. Drug House. They have been located in their present premises for the past year and a half and have a very fine trade established. They have fitted up their wareroom with the necessary demonstration booths and have a competent sales force to handle this business.

Brunswick Doings

"The year of 1917 surpassed our expectations and the new year has started off with a rush," said H. B. Bibb, sales manager of the phonograph division of the Brunswick-Balke-Collender Co. "The number of new contracts coming in daily is very gratifying indeed. We are very fortunate in having our factory located in Dubuque, Iowa, as it is west of the Mississippi river and does not come under the Garfield fuel saving order. Our plant is working overtime and while some difficulty is being experienced in moving freight to the Eastern territory, we are able to keep our different branches supplied with stock by making express shipments.

(Continued on page 81)

TRANSFER NAME-PLATES

We make the Transfer Name-Plates and Trade-Marks for the largest talking machine manufacturers in this country and for dealers in every state.

YOUR NAME, Mr. Dealer, on every machine brings the owner back to you for records and his friends to you for a machine.

Samples, Suggestions and Sketches Furnished Free

THE MEYERCORD COMPANY, CHICAGO

Largest Manufacturers of **DECALCOMANIA** Transfer Name-Plates

Are One-Record Phonographs Doomed?

A Frank Discussion of a Situation Which Faces Every Dealer

HERE are two kinds of fine phonographs now, the one-record instruments and the all-record Brunswick. Many dealers, noting the welcome of this new, final-type phonograph, are wondering about the future.

And they may well spend time in studying the trend of public demand the changing attitude.

Up to now, the music lovers have had to content themselves with one-record instruments. They have been compelled to take one certain line of records, barring all the others. This has meant a limited selection and the uncomfortable feeling that they were deprived of many favorites.

No One-Record Maker Offers All the Great Singers and Musical Selections

Indications point strongly to the fact that music lovers prefer to make up their selection of records by names of singers of musical organizations instead of by name of record makers.

The Brunswick plays *all* records.

This includes Pathe Records.

An alliance between Brunswick and Pathe gives each Brunswick dealer the right to handle Pathe Records. This includes one of the largest musical collections in the world—all the latest hits, all the great operas, all the instrumental and band selections.

The Brunswick is the premier instrument with the *all*-record feature. All Brunswick dealers unite in the belief that this new-day phonograph is destined to dominate the entire musical world.

Nine customers out of ten, once they hear The Brunswick and compare it with others, prefer it. And no Brunswick owner would ever go back to an old-type machine.

Dealers with a vision of tomorrow's trade, men who want to know more about the tendency of the times, are invited to write to us so that we may present further interesting and important facts. For those who are looking ahead, we have a very interesting proposition.

THE BRUNSWICK-BALKE-COLLENDER CO.
CHICAGO SAN FRANCISCO NEW YORK CINCINNATI

Branch Houses in Principal Cities of the United States, Mexico, France

623-633 South Wabash Avenue, Chicago

29 West 42nd St., New York 7th and Main Sts., Cincinnati

Canadian Distributors
Musical Merchandise Sales Co., Excelsior Life Building, Toronto



Prices
\$32.50 to \$1500

The
Brunswick
ALL PHONOGRAPHS IN ONE

"A large contract has been closed with Martin Bros. Piano Co. by our representative, K. McInnis, who travels out of a St. Louis office. C. W. Kalder, who was in charge of our exhibit at the recent Grand Rapids furniture show, closed a number of contracts with some of the largest furniture dealers in the U. S."

G. F. Gamble is the new Brunswick representative in the New Orleans territory.

The large wall map of the United States hanging in Mr. Bibb's office, which designated by means of small tacks the location of Brunswick dealers throughout the country, is beginning to look like a forest. The central States are completely covered and the Western States as well as the Pacific Coast States are filling up rapidly.

A. G. Kendrick, in charge of the Brunswick's Eastern territory, is showing some speed in securing new accounts.

Edward Strauss, formerly connected with the Chicago office of the Brunswick Co., has been transferred to their New York office, of which he will be general manager.

Wallace Brown, the live wire Brunswick dealer of Detroit, hopped into Chicago on a visit one day last week, stirred things up a bit and then hopped back to Detroit.

Among other Brunswick visitors to Chicago within the past week were J. Lane, of the Brunswick Shop, Toledo, and G. F. Standke, manager of the Brunswick Shop, Indianapolis.

E. S. Bristol, who covers in a most intensive way thirty-six counties in northern and central Illinois, has been spending a week or so in Chicago attending the furniture show. Mr. Bristol has had remarkable success in the restricted but populous territory covered by him.

The New F. & W. Sound Box

The F. & W. Mfg. Co., of this city, is about to place on the market a new and distinctive sound box. It is constructed on new lines, inasmuch as the sound waves have no direct communication with the tone arm, but are passed through a separating partition into an acoustic

or tone chamber, then through proper channels, into the tone arm. The stylus bar or needle holder is suspended in an entirely new manner, making perfect connection, yet without friction, thus the sound is amplified with excellent results in point of tone and detail. Its reproduction of both vocal and instrumental music is decidedly realistic.

With this sound box, it is claimed that one can use the fibre needle and get better detail, and in most cases a volume of tone equal to the ordinary box with the steel needle, thus saving wear and tear on records.

The sound box was invented and perfected by Elmar Fletcher, of Chicago, an old-time phonograph man, having been in the business both in the making and reproducing of records, before the molded record was known. The box will be marketed by Roscoe L. Wickes, a well-known business man of Chicago, and Mr. Fletcher under the firm name of the F. & W. Mfg. Co., 6 East Lake street. The trade will be duly notified when the box will be ready for the market.

H. A. Yerkes' New Post

H. A. Yerkes has been appointed field sales manager of the Columbia Graphophone Co. and will shortly leave his present office in Chicago to take up his new duties at the Columbia headquarters in New York. He has just returned from a successful tour of the Central States, having visited Indianapolis, St. Louis, Kansas City, Omaha and Minneapolis and reports that the business throughout the sections of the country he had just visited is in fine shape and the dealers he visited are very optimistic. Mr. Yerkes has just received an announcement from the New York headquarters that he has won the President Whitten district manager's cup, a handsome sterling silver trophy, which had been donated by Mr. Whitten, and which had been keenly contested for among the district managers throughout the country. The terms of this contest provided that permanent possession of the trophy rested with the district man-

ager who won the cup for three months, and notwithstanding the fact that he did not register his first victory until October, Mr. Yerkes won the cup with three consecutive victories.

Mr. Yerkes won the President Whitten district managers' cup as district manager of the Middle West territory, and W. L. Sprague, manager of the Minneapolis branch, is also being congratulated upon this victory, for his branch was a most important factor in bringing the trophy to the Chicago division. The final result of the contest was in doubt until the last moment, for several of the district managers had been winners for two months, and needed only one more victory to clinch their right to permanent possession of the cup.

"All Through the Night"

Mr. Griffith, in charge of the stockroom of the Chicago Talking Machine Co., came down to work the other day wearing a big grin on his face, said good morning to everyone in the office, and then began to pass cigars around to the boys. When asked the reason of his generosity he replied: "The stork brought a new baby girl to our house last night, so I have a sneaking suspicion it is up to me to receive congratulations." After giving everyone in the office a cigar he tipped his hat over one eye and sauntered majestically to his desk in the stockroom. Soon after, strange and various well-known lullabies issued from a Victrola in the stockroom.

Talking Machine Shop News

C. L. Davidson, of the Talking Machine Shop, reports that they are still doing a nice business regardless of weather conditions and "heatless Mondays." "Our business for the past month compares very favorably with the January of last year," said Mr. Davidson, "and we therefore have no reason to kick. We have a good supply of records on hand, just exactly the stuff that people want at present. We are, therefore, able to fill 90 per cent. of our orders. The trade so

(Continued on page 83)

Convincing Proof of Merit

are the unsolicited testimonial letters which come to us from  dealers and owners in every day's mail:

A characteristic letter from an Empire owner sent to us by the dealer who sold him the machine:

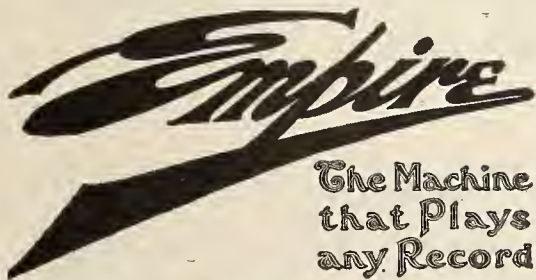

"The Model B Talking Machine I bought of you reached me last Saturday in splendid condition.

"This machine was my choice among a number of different ones which I looked at and heard play. I heard 8 other leading machines and none of them came up to the Empire. A friend of mine here also has a Model B. The Empire records are all good, some of them very good. The machine in appearance is as good as any \$200 cabinet I have seen and the quality of tone and the simplicity of operating are superior to anything I have seen for the price."

Our files contain many letters from dealers similar to this:

*"We are in receipt of the Model B Empire Phonograph and must say that it is all you claim it to be, and for that reason we are mailing you order for four models today. Please ship these out **at once** as we have only one machine on the floor at this time."*

Write today for our complete catalogs of Empire Machines and Empire Records, and full information regarding our Splendid Dealer Helps



Model B.

Price \$110

The Empire, Model B, conceded to be the greatest value ever offered in a high grade talking machine.

Empire Talking Machine Co.

JOHN H. STEINMETZ, President

429 South Wabash Avenue

Chicago, Ill.

The
**“Uniset
 Reproducer”**

does
 absolutely
 what
 we
 claim
 for
 it.

It
 plays
 all



Records,
 lateral
 and
 hill and dale
 cut
 in
 one

position,
 in
 rich, sweet
 natural
 tone.

Absolutely
 no
 parts
 to
 change
 except
 needle

Simple!

Perfect!

Our first announcement has brought us an enormous number of enquiries and orders from Manufacturers, Assemblers, Jobbers and Dealers all over the country.

“Uniset Reproducer” with **Straight Tonearm**, of all absorbing interest to Manufacturers and Assemblers, large and small.

“Uniset Reproducer” for Victor, Columbia, Edison, Pathe, etc. Machines—the **Dealer’s best side line**. Stimulates record business in *all* makes of records. Prevents losing sales of Machines.

“Uniset Reproducer”—greatest progress in Phonography

UNISET REPRODUCER CO.

Cable Building, Jackson Boul. & Wabash Ave.

Telephone, Harrison 1166

CHICAGO, ILL.

FROM OUR CHICAGO HEADQUARTERS—(Continued from page 81)

far this month has been steadily picking up, and at present is far ahead of the first two weeks in February, 1917. I think that trade in general has a good year before it, as we are now settling down to business, and the people are not as flighty as they formerly were when they read a newspaper, but are taking a more philosophical view of the situation."

Miss Ruth Lundgren, formerly with the Wade Shop, is now connected with the sales force of the Talking Machine Shop, having taken the place of Mrs. Myrtle Frame, who has joined the forces of the Davis Phonograph Co. on Adams and State streets.

Eddie Cantor, with the Ziegfeld Follies Co., who plays the part of the son of the character taken by Bert Williams, just returned from college, came tearing down the street the other day and dashing into the Talking Machine Shop, approached Miss Pauline Tishler and whispered savagely, "I must have them at once!" "What?" stuttered Pauline. "The four new Heifetz records—oh, boy, some music—I must have them."

To Handle Paroquet Record

C. J. Woodward, 57 East Jackson boulevard, has secured the representation for Chicago and Cook County of the Paroquet record, made in New York. He plans an active campaign in his territory for these products.

Mandel Mfg. Co. Plans Big Things

The Mandel Mfg. Co., Inc., with headquarters at 501-511 South Laflin street, have consummated arrangements whereby they will bring their full line of talking machines to the attention of the trade in this country in a most prominent way during the present year. They have concentrated considerable attention on this branch of their business and are turning out a very attractive line which shows extreme taste in designing, and better still, a most careful attention to details, as far as tone reproduction is concerned. The Mandel phonographs of 1918 represent the combination and concentration of

some of the keenest minds in the industry, to the end that their products may be of a standard to win the approbation of the most critical purchasers. That this enviable position has been attained is evident from the fact that the output last year far exceeded expectations, while the volume of orders which have been reaching this company since the first of the year, is of such magnitude as to demonstrate that the Mandel phonographs are constructed along lines that please the critical purchaser.

Open New Victor Department

Elbe Bros., South Bend, Ind., will formally open their new Victor department this month. The new department is beautifully decorated and is situated on the ground floor of the building. They have installed twelve beautiful soundproof record demonstrating booths, and this, together with their large record department, gives them the largest Victor department in the State of Indiana.

New Hillman Manager

Forrest Edwards, formerly connected with the Rhinehart Piano Co. at Sixty-third and Halsted streets, is now manager of the Victor department of Hillman's department store. This department is operated by the National Talking Machines Sales Corp. of Boston.

New Wilson Manager

W. E. Cotter is now in charge of the retail phonograph department of the Thos. E. Wilson & Co. warerooms on the corner of Monroe and Wabash avenue. Mr. Cotter is very well known throughout the trade, having been for the past twelve years connected with the firm of the W. W. Kimball Co. as wholesale traveler, representing them as salesman for pianos and talking machines. He has for his assistant Miss Margaret Campbell, a very pleasing and charming young woman, who is an experienced "Columbian" girl, having been connected with many of the largest talking machine departments throughout the city. Mr. Cotter stated that they contemplate enlarging their phonograph depart-

ment and adding four new soundproof demonstrating booths, as well as a new series of record bins. "Our business has shown a decided improvement for the past month," he stated, "and is rapidly increasing, due to our extensive advertising throughout the local daily papers as well as from the combined efforts of twenty-four women we have working for us on the outside. These women are bringing in great numbers of prospects and as a result we are making some very satisfactory sales. We are handling both Columbia and Sonora machines as well as the Wilson talking machine, which is manufactured by ourselves, and, therefore, have an exceptionally good line that will please the most exacting purchaser."

New Company Formed

There has just been organized in this city a new firm which has been incorporated in Illinois for \$10,000 and is known as the National Phonograph Co., Inc. They are located at 2713 West Twelfth street and occupy the three-story building which was formerly the plant of the Elkin & Seidel Mfg. Co. They are equipped with the most modern machinery both steam and electrical and have the capacity of turning out 1,500 cabinets a month. Their specialty is to produce a complete machine for the trade. Frank Cummings, an experienced and capable man, is the manager of the company, he was formerly connected with the World Phonograph Co., and had had charge of the finishing, machine shop, cabinet and assembling departments. The new company at present has two beautiful and original models prepared for the general trade and already over 200 machines are on the floor awaiting delivery.

Maurice Hebert represents the new company as chief designer. He is well known to the trade as one of the most capable artistic and original draftsmen in the country. He is known not only for his work in the talking machine industry which is in itself remarkable but also as

(Continued on page 85)

EMPIRE PHONO PARTS

Appeal to Manufacturers and Dealers in many ways

FIRST: In quality of tone production.

SECOND: In attractiveness of design (Patent applied for).

THIRD: In quality of material and workmanship.

FOURTH: In moderate cost, considering quality and utility.

They are the product of many years' experiment and experience, and are of proven worth and excellence



Universal Tone Arms and Reproducers No. 9

as illustrated, will add distinction to the highest grade machines.



Prices on samples and quantities quoted on request. We are in position to make prompt shipments.

THE EMPIRE PHONO PARTS COMPANY

W. J. McNAMARA, President

JOHN H. STEINMETZ, Sec. and Treas.

FACTORY:

1102 West 9th St., Cleveland, Ohio

SALES OFFICES:

427 South Wabash Ave., Chicago, Ill.

Bigger Things for 1918

Bigger for You — Bigger for Us

We have planned and prepared for BOTH a larger output — insuring better services, prompt deliveries, and even a better product than in 1917

THE Mandel line of talking machines, varying in retail price from \$35 to \$250 and meeting the price demands of every class of trade, has been improved in many details which means in the aggregate a considerable increase in intrinsic value.

This is a line which has proved a distinct satisfaction giver from the start.

Every part of every Mandel—Case, Motor, Tone Arm, Sound Box, Horn, Tone Chamber not only is distinctive but made in the Mandel factories, thus securing standardization and uniformity of output.

Do you want to handle just this type of machine?

It costs you nothing to investigate.

Let us send you model No. 3, illustrated here on FREE TRIAL.

Write today for full information and descriptive literature.

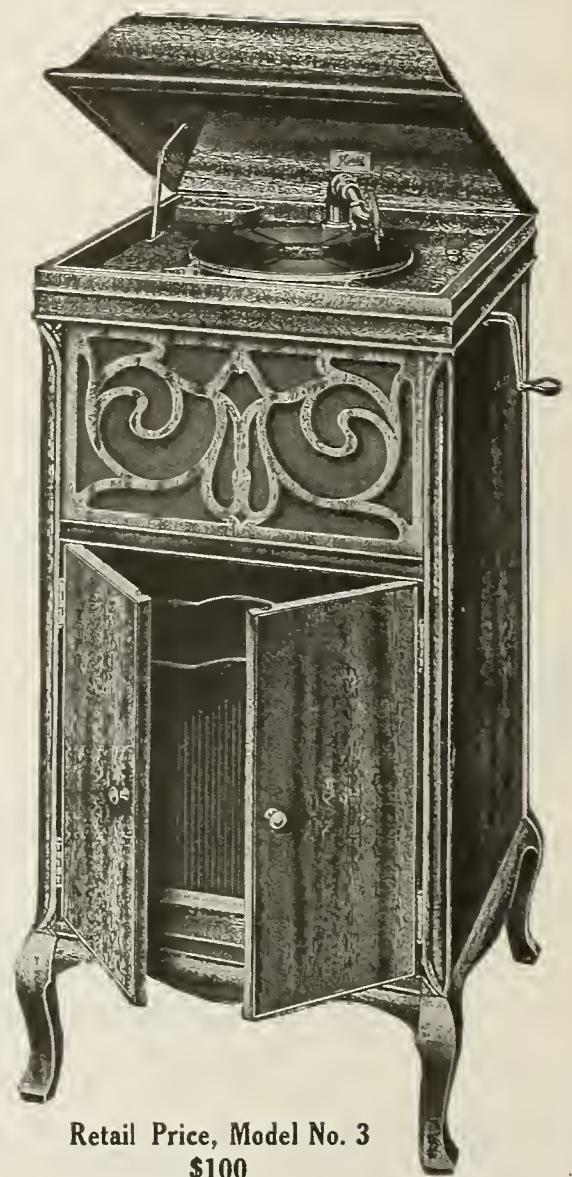

Retail Price, Model No. 3
\$100

No bigger value for the money exists today. This is the machine we will send on FREE TRIAL just to prove that we have confidence in our product

Mandel Manufacturing Co., Inc.

General Offices :
501-511 S. LAFLIN STREET
CHICAGO, ILL.

New York Display Rooms :
41 UNION SQUARE

New Lakeside No. 4 JUMBO TONE ARM

Only foolproof arm on the market, as *all* adjustments are *permanent* and *user* has *no* adjustments to make.

- Best mica used so fastened to the stylus to prevent same from pulling out.
- All parts machined to make a perfect mechanical fit.
- No adjustments when shifting from Victor to Edison.
- Heavy massive design best for correct reproduction.
- Permanent adjustment for all records except Pathé, when a weight is applied (see cut), which makes it just exactly right for playing Pathé. This weight also serves as a retainer for Edison and Pathé needles, which usually are mixed with the steel needles or lost.
- Arm fitted with long telescopic neck to make longer or shorter.
- Punched sound box clamping ring has a curvature preventing rubber gasket from working out.

ALL NEW FEATURE PATENTS APPLIED FOR

We also supply hardware, cabinets, motors and accessories for talking machines. Ask for our Bulletin.
We maintain an expert motor repair department.

LAKESIDE SUPPLY CO., Inc.

Tel. Harrison 3840

202 South Clark Street

CHICAGO, ILL.

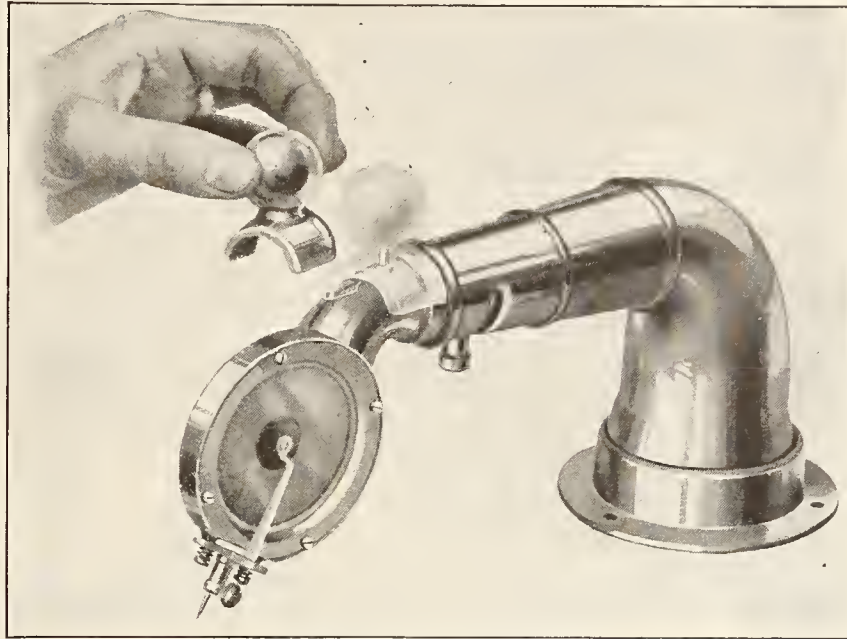

RETAIL PRICE \$7.50 EACH

Prices to Bona Fide Dealers
 Sample\$4.00 each Lots of 12 to 49.....\$3.50 each
 Lots of 6 to 11..... 3.75 each Lots of 50 to 100..... 3.25 each
 A further slight reduction on yearly contracts in 100 minimum lot shipments.

FROM OUR CHICAGO HEADQUARTERS—(Continued from page 83)

the designer of palatial residences. He is the man who designed the million-dollar residence of Charles M. Schwab, the steel magnate, and is a man of international reputation.

Organize New Company

The Empire Phono Parts Co. was organized at Cleveland, O., on February 2, and the officers elected were J. MacNamara, president, and John H. Steinmetz, secretary and treasurer. Mr. MacNamara is a pioneer manufacturer of tone arms, sound boxes, and accessories and was until recently president of the Union Phonograph Supply Co., of Cleveland, which succeeded the Union Specialty and Plating Co. He is well known to the trade as a producer of these products. Mr. Steinmetz is president of the Empire Talking Machine Co., of Chicago, and as is well known is an exponent of quality in any of the products that he offers to the trade, and in identifying the Empire trade-mark with the product of the Empire Phono Parts Co. the trade is assured that the product of this new company will conform with standard of quality that appeals to those seeking excellence and dependability rather than "price" alone.

The Empire Phono Parts Co. occupies the factory located at 1008 West Main street, Cleveland, which is directly opposite the Union Depot. This factory is equipped with the most modern machinery and is capable of turning out accurate products, and also includes as part of its assets what is considered to be one of the best plating plants in the State of Ohio, and is under the personal supervision of Mr. MacNamara. They are already turning out a considerable quantity of their products and manufacturers who have

seen and tested these products are enthusiastic about them. They have also applied for design patents on their new tone arm, thus protecting not only themselves but their patrons. They will cater to the phonograph manufacturers by producing standard goods of recognized merit. The sales offices are located at 427 South Wabash avenue, Chicago, and are in charge of Mr. Steinmetz. All inquiries relative to samples, etc., may be addressed in his care. They have prepared other attractive specialties which will be announced later. The illustration shown herewith is their number nine tone arm shown with connections and motor board equipment. The sound box is turned back permitting inser-

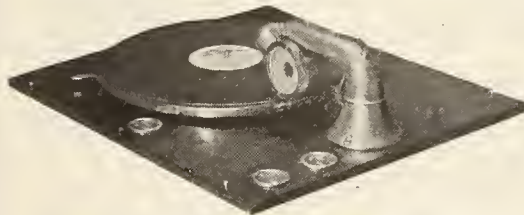

Empire Tone Arm and Sound Box No. 9

tion of the needle. This feature appeals to the consumer, as there is no possibility for the needle or jewel point to be set at an improper angle. The Empire equipment allows no chance, therefore, to injure the record while changing needles and all movable joints connecting with the sound box are screwed joints, which assure no looseness of parts.

Some Recent Visitors

Among the visiting dealers to Chicago this month were: H. E. Whitman, manager Pearson Piano Co., Indianapolis, Ind.; John F. Ditzell, manager Famous-Barr Co., St. Louis, Mo.; Thor Norberg, proprietor Norberg Music House, Moline, Ill.; Miss Mary E. Carroll, manager J. C. Baxter Piano Co., Davenport, Ia.

Magnola Progress

The Magnola Talking Machine Co., which, as everyone now knows, is backed by the same capital and the great experience of the M. Schulz Co., one of the largest piano manufacturers in the world, is having wonderful success with the Magnola talking machine. Representing years of experience in the acoustic field and also in the production of high-grade cabinet work these people have just naturally produced a talking machine in the Magnola that is distinctive and right. Furthermore, it has been a comparatively easy thing for them to build up a large trade, because they have the confidence of piano dealers everywhere. In the first stage of their existence the Magnola was sold largely in the piano trade. All they had to do was simply tell dealers they had a talking machine, and the dealers said

to themselves, "A product made by a company of which Otto Schulz is president," and ordered without seeing the machines. They have had no occasion to regret their action as steadily increasing repeat orders has clearly shown.

Ribolla's Interesting Comment on Trade

"Reports coming in from our Canadian office show a striking gain in business for the past year. This increase tends to progress steadily, and from present indications the talking machine business of Canada will be bigger than ever this year," said S. A. Ribolla, sales manager of the Chicago office of the Otto Heine-man Motor Co. "Similar conditions existing to-day in this country now existed in Canada at the beginning of the war. Up there they were disorganized to a great extent and business in general was demoralized when the war broke out, but conditions have adjusted themselves to such an extent that at present they are running on in a normal manner and business is nearly back to its normal condition. The war had a tendency in that country to stimulate the music industry and this is steadily gaining from day to day.

"This situation in Canada is the fact upon which I base my convictions that war conditions in the United States will ultimately make business better," continued Mr. Ribolla, "and for that reason I see a good year ahead of us. The Canadian Government has practically stamped music as a necessity. We know that the big limited companies who make a specialty of talking machines throughout Great Britain and her possessions show a more material increase in their business than they have for many years. There would be a greater increase if their capacity were not limited by the war departments as they are compelled to do a certain amount of governmental work. The little slump experienced in this country for the few months preceding the holidays has passed. A great many

(Continued on page 86)

!!! ATTENTION !!!

Manufacturers of High Class Talking Machines

The new "Orotund" tone-arm and reproducer are now ready.

Universally correct. You can play all records perfectly and safely with this new tone-arm outfit.

Artistic in design. Workmanship perfect. Tone quality exquisite. Acoustically correct.

Two styles—No. 3-A and No. 3-B.

No. 3-A—With mild tone sound-box.

No. 3-B—With loud tone sound-box.

We also make the most perfect universal attachments for the Victor, Edison and Columbia machines.

Send for circular and prices.

COMBINATION ATTACHMENT CO.

324 Republic Bldg.

CHICAGO

Sapphire Needles

FOR PATHE and EDISON RECORDS

These needles are made in Switzerland of Asiatic Sapphires, which are recognized as the best.

Price **\$3.00** per dozen

Send check with order or goods will be sent C. O. D.
Quotations given on larger quantities.

CHARLES J. WOODARD

Room 503 Cable Bldg. 57 E. Jackson Blvd., CHICAGO

FROM OUR CHICAGO HEADQUARTERS—(Continued from page 85)

dealers are carrying over a large amount of business. With more women wage earners than we ever had before, combined with the wonderful crops we had all over the country in the past year, which necessarily brought with them better wages than ever before, there is bound to be a notable improvement in business in the near future."

Returns From Eastern Trip

L. E. Noble, manager of the wholesale Victrola department of the Rudolph Wurlitzer Co., returned last week from a trip through the East, where he visited several of the large Eastern cities, as well as the Rudolph Wurlitzer headquarters at Cincinnati. "I received quite a shake-up on January 23," said Mr. Noble. "While aboard the Manhattan Limited, running through Philadelphia about three miles outside of North Philadelphia, something happened and all the coaches piled up. One man was killed and eight men were injured severely, but I managed to escape unscathed. The visit I paid to the Victor factory left me full of optimism, as

they certainly are doing things down there. Many of our dealers have reported that their business has increased materially in the past year and that the holiday trade was very satisfactory."

The Six Best Record Sellers

The Columbia library announce the six best sellers for the month as follows. "Alleluia Haec Dies" and "Veni Jesu" (Paulist Choristers of Chicago); "Barbiere Di Sivighia," "Largo Al Factotum" (Make Way for the Factotus); "Battle Hymn of the Republic" and "Star Spangled Banner"; "The Best Things in Life Are Free" and "For You a Rose"; "Calling Me Home to You" and "There's a Long, Long Trail"; "Caprice Viennois" (Opus No. 2) and Thais "Meditation," a violin solo.

The six best sellers for Pathé for the past month are: "The Honeysuckle and the Bee" and "Pansy Faces"; "Liberty Loan March" (Sousa) and "The Invincible Eagle" (Sousa); "Gold and Silver Waltz" and "Jack o' Lantern" (Medley Fox Trot); "The Darktown Strutter's

The Perfect Automatic Brake



New Styles
To Fit
All Makes of
Tone-Arms.
Now Ready
for Shipment.

Patented Aug. 28, '17

Simple construction. Easily attached. No Talking Machine complete without it.

Samples \$1.00 each, cash with order.
State make of tone-arm used.

Write for attractive quantity prices.

PERFECT AUTOMATIC BRAKE CO.
Room 400, 425 S. Wabash Ave., Chicago

Hiawatha Phonographs

MEAN

Quality Assured



STYLE 100

Quality of Tone
Quality of Construction
Quality of Finish

Models \$35, \$50, \$75 and \$100 retail. A complete line of Quality Phonographs. Quality is the keynote of the success of the Hiawatha.

Highest standard of equipment. Every Hiawatha Phonograph guaranteed fully. You owe it to yourself to investigate.

Hiawatha means success.

We can prove it.

Capacity 300 Machines per Day

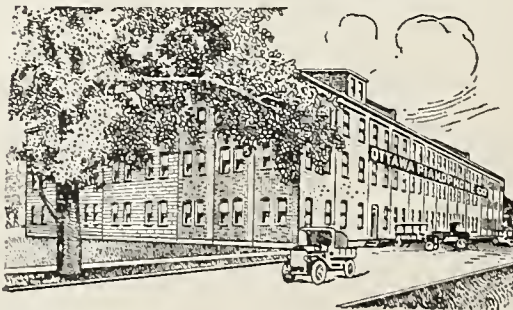

The Home of Hiawatha
OTTAWA ILLINOIS
"All Orders F. O. B. Factory"

Tone chamber made of genuine Spruce. No metal.
Cabinets made of 5-ply stock.
Construction guaranteed.
Motors and equipments, using double spring motors, highest standard of Quality.
Electric motor \$25.00 extra.
Tone modifier, built in as part of the machine, not an attachment. Patent applied for.
Plays all records with the same attachment.

OTTAWA PIANOPHONE COMPANY

City Address: 802 Republic Building, Chicago, Ill.

Ball" (Fox Trot) and "Homeward Bound" (Medley One Step); "Leave It to Jane" (Medley Fox Trot) and "Umbrellas to Mend" (One Step); "Pigtails and Chopsticks" (Xylophone Solo) and "Concert Polka" (Xylophone Solo).

Edison's six best sellers for the month are: "Battle Hymn of the Republic" (Old Plantation Melody); "My Heart at Thy Sweet Voice—Samson and Dalilah" and "Triumphal March—Aida"; "Loin du Bal" and "Marché Lorraine"; "New York Blues (Rag Classical)" and "Saxophone Sobs"; "Ellis March (Instrumental Duet)" and "One, Two, Three, Four Medley (Waltz)"; "It's Nice to Get Up in the Mornin'" and "When the Bonnie, Bonnie Heather is Blooming (I'll Return, Annie Laurie to You)."

Victor six best sellers for the month are as follows: "My Sweetie" and "Some Sunday Morning"; "Midsummer Night's Dream" (Orchestral); "Over There" and "Laddie Boy"; "Stars and Stripes Forever" and "Fairest of the Fair" (Sousa); "Somewhere in France is the Lily" and "My Sweetheart is Somewhere in France"; "Modern Maiden's Prayer" and "That's the Kind of a Baby for Me."

Big Order for Uniset Reproducer

The Uniset Reproducer Co., which is located in the Cable Building, Jackson boulevard and Wabash avenue, expect to make deliveries of the "Uniset Reproducer" the second week in February. Manufacturers who have tested this reproducer are enthusiastic over its great possibilities.

W. Hadart, vice-president and general manager of the company, has just closed contracts with a large phonograph company in the Middle West, which manufactures 75,000 machines a year. This is only one of several important deals that emphasizes how the "Uniset Reproducer" will play a prominent part in the industry this year.

As was mentioned in this department last month this reproducer is an absolute departure from all other sound boxes that are now on the market. It will play all records no matter of what make or description, including Victor, Columbia, Edison, Pathé and Gennett, etc., in one and the same position without change of any kind.

Charles H. Green Coming

Charles H. Green, who will be the manager of the National Music Show at the Grand Central Palace, New York, during the piano convention in June, will be in Chicago this month. He will be prepared to outline in detail the plans for the show to the local manufacturers. Mr. Green was very successful in his conduct, not only of the previous piano exhibitions, but also of shows in other lines, consequently the Music Trade Exhibitors' Association is to be congratulated on having secured him for this year's event.

Talking machines will be featured at this year's show on an elaborate scale, as they were last year in this city.

FROM OUR CHICAGO HEADQUARTERS (Continued from page 86)

A PROGRESSIVE CHICAGO MAN

Wm. Tures, of Combination Attachment Co., Has Built Up an Excellent Business With the "Orotund" Universal Tone Arm and Sound Box

CHICAGO, ILL., Feb. 10.—Wm. Tures of the Combination Attachment Co. with headquarters in the Republic Building is a man who conducts



Wm. Tures

his own business in such good shape that the men observing him want to avail themselves of the same intelligence and energy. Mr. Tures has recently been made a director of the Republic Merchants' Association, who conduct the wonderful service system in the great building in

which the Combination Attachment Co. is located. He is also a member of the publicity committee of the same organization. The Republic Item, a sprightly little monthly published in the interests of the Merchants' Association, recently told the history of his life and also printed the photo cut of him. Mr. Tures in a recent talk with The World described the latest introductions in the line of "Orotund" universal tone arms and sound boxes—combinations which give an excellent tone and also are adapted to both hill and dale records. Talking about the combinations represented by either number 3A or number 3B tone arms and sound boxes, Mr. Tures said:

"Is mechanically correct as it can be adjusted to any condition so that the proper angle is obtained, regardless of the height of the turn table or the size of the sound box. It is the only tone arm in which such adjustments can be obtained. The special adjusting sleeve construction and the continuous tapering elbow enables the arm to be lowered or raised, also the tone is carried unobstructed down into the throat of the tone chamber.

"The graduated or tapering effect is correct to produce perfect acoustic conditions.

"The tone produced by the sound box is conveyed to the tone chamber in such a way as to produce rich, clear, musical tones.

"The base of the arm is mounted to swing on ball bearings, a patent construction not found in any other tone arm and the only ball bearing arrangement where all bearings are in contact at all times, and have a perfect rolling action.

"A perfect turn back joint which also can be adjusted, is the most convenient method for changing needles.

"The universal sound box centers perfectly when changing from the hill and dale jewel record to the lateral cut record position.

"The weight is correct so that any record can be played safely and the fibre needle can be used universally on all records. This cannot be said of any other tone arm construction.

"The 'Orotund' universal tone arm and sound box is a work of art, as it is symmetrical and very attractive in appearance. It is an ornament on any talking machine. It was not the idea of the designer to see how cheap it could be made, but to embody all the best and important features to make it the highest grade tone arm on the market and to produce it at a fair price."

TO EXHIBIT AT NATIONAL MUSIC SHOW

Among the leading talking machine companies in the East who have reserved space at the National Music Show, to be held at the Grand Central Palace, New York, in June, and of which Charles H. Green is manager, are Thos. A. Edison, Inc., the Columbia Graphophone Co. and the Pathé Frères Co.

NEW EMPIRE RECORD CATALOG

Attractive Volume Just Issued Includes All Records Up to January, 1918—It Is Carefully Indexed and Interestingly Prepared

The Empire Talking Machine Co., Chicago, has just issued a comprehensive record catalog which lists in convenient form all Empire records issued up to and including January, 1918. For the convenience of machine owners the records are first listed in alphabetical order, and then, according to the type of selection whether concert music, dance music, etc. For the further convenience of the reader there is also a list provided in the back showing the pages upon which records of a certain price and size may be found.

The volume is carefully indexed, and makes a most impressive showing. It also indicates the substantial progress that has been made by the Empire Talking Machine Co. to date in the production of records.

CHRISTINE MILLER MARRIED

Popular Edison Artist Married to Daniel M. Clemon, of Pittsburgh—Spending Their Honeymoon in Chicago, Many Congratulations

CHICAGO, ILL., February 12.—The many friends in this city of Miss Christine Miller, the distinguished contralto, who is widely known in the talking machine trade through her Edison tone tests and her large repertoire of Edison records, were somewhat surprised to-day to learn of her marriage. The happy man is Daniel M. Clemon, formerly one of Carnegie's partners, and one of the big magnates of Pittsburgh, where it is stated he has prepared a \$500,000 home for his beautiful and talented wife. Mr. and Mrs. Clemon are spending their honeymoon in Chicago to-day, and are receiving the most cordial felicitations of a host of friends in the talking machine trade, for there are few artists who have such an army of admirers in and outside the industry.



VITA-NOLA
"The Quality Goes Clear Through"

Hooverize



Model No. 100

Utilize



Model No. 125

Economize



Model No. 150



Model No. 75



Trade Mark Registered

Make Every Dollar Count

And remember—Vita-Nola Talking Machines work in perfect accord with the spirit of the times—the spirit that demands efficiency without waste.

While good to look at, thoroughly dependable and wonderful tone qualities, not one unnecessary dollar goes into the maintenance of a Vita-Nola.

Thousands of people have seen the VITA-NOLA TALKING MACHINES last month at the furniture exposition. Hundreds of them have commented upon them. And what they all say is this:

"We had no idea that the VITA-NOLA was such an extraordinarily good phonograph."

That's our fault. We have been modest. We still are. We believe it is good business in the long run to give our buyers more than they have been led to expect.

But we know we are selling "MORE PHONOGRAPH" for the money than any other manufacturer.

To prove this write for our FREE TRIAL OFFER and you will be the judge. Also write for catalog and surprisingly low prices.

Vitanola Talking Machine Company

501-509 West 35th Street **CHICAGO, ILL.**

DISTRIBUTORS:

J. Pritzlaff Hdwe. Co., Milwaukee, Wis.
Standard Phonograph & Accessory Co., 1005 Commerce St., Dallas, Texas.
New England Vitanola Talking Machine Co., Boston, Mass.
Geo. C. Wetherbee & Co., Detroit, Mich.
The Chesterman Co., Sioux City, Ia.

Moore-Handley Hdwe. Co., Birmingham, Ala.
F. W. Hanpeter Furn. Co., St. Louis, Mo.
A. C. McClurg Co., Chicago, Ill.
Vitanola Distributors Co., Philadelphia, Pa.
Carpenter Paper Co., Omaha, Nebr.
Landauer & Co., Milwaukee, Wis.
J. M. Bennett Co., Minneapolis, Minn.

FROM OUR CHICAGO HEADQUARTERS—(Continued from page 87)

WANTS TO SEE THE TRAINS MOVE

Just a Little Sunshine and Rain Needed, Says L. C. Wiswell—Lyon & Healy Resume Concerts—Bartlett Markets Die Castings—New Morenus Phonograph—Other Timely Topics

CHICAGO, ILL., February 11.—“All we want is just a little sunshine, just a little rain, That will melt the snow—so the trains can go, And the trade will smile again,” mused L. C. Wiswell, manager of the Victor department of Lyon & Healy, when called upon by *The World* this month. “But,” he continued, “that’s getting to be an old story now, sad but true. Too much snow and not enough trains. If the train service of the country had been normal through the past month, I don’t believe there is a dealer in the country who would not be doing an enormous business to-day, more even than he would have dared anticipate. It is really surprising, when one stops to consider, how great the demand for talking machines is to-day.”

“A great many dealers ask me this question,” continued Mr. Wiswell. “If the factories are working to capacity how is it that there are not more machines produced than formerly?” “Now that is a very simple question to answer,” he continued, “if one stops to think. In normal times there is an average of twenty-six working days during the month. But take January of this year for example. To begin with there was the usual New Year’s holiday, four Sundays and four half-day holidays on Saturday making the average of sevendays that the factories were idle that month. But added to this we have had packed on a five-day shutdown on account of conserving fuel, as well as two heatless Mondays, which makes a total of fourteen days that were lost out of the thirty-one. For the month of February we have before us, counting Sundays, Saturday half days, Lincoln’s and Washington’s birthdays as well as the four heatless Mondays a total of twelve full days out of the

month that will be lost. Taking these facts into consideration, in spite of the factories working at full capacity, how can anyone wonder why they are not producing the same amount as formerly? That is a concrete example of the situation at present, but just as soon as the railroads are in good working order again and there are no more added holidays there is certainly going to be a busy season ahead.”

A Good Sales Puller

Lyon & Healy have resumed their concert season and attracting large numbers of people daily with their three afternoon performances. One of the features of these recitals are two very talented and entertaining young ladies who appear during each performance. Miss Olive June Lacy, one of the pleasing entertainers, demonstrates to the audience the applicability of the Victrola to the student of vocal culture by singing duets, accompanied by the instrument, while the other young lady, Miss Edna Baum, is accompanied by various instrumental selections in presenting classic and fancy dances. Many inquiries from prospective purchasers of machines are resulting from these concerts and numerous sales have already been made.

They Market Die Castings

E. P. Bartlett & Co., jobbers and manufacturers’ agents of steel copper products, 15 North Jefferson street, this city, represent the Indiana Die Casting Co. of Indianapolis, in Minnesota, Michigan, Indiana and Illinois. They not only take orders for die castings, but also market the company’s complete tone arms, sound boxes and stylus bars. They are in a position to manufacture to order practically all parts for talking machines. They report excellent business.

New Morenus Phonograph

The Morenus Piano Co., well-known manufacturers of pianos and player-pianos on West Superior street, corner of Orleans street, Chicago, have entered the talking machine trade with a line which is well worthy of the attention of dealers everywhere. R. F. Morenus, presi-

dent of the company, himself a practical piano manufacturer of many years’ experience, naturally turned his attention to the acoustic proposition at the start. The horn of the Morenus machine is shaped like a saxophone and enters the tone chamber from the bottom instead of the top. It is made entirely of wood and the tone, which is big and vibrant although large in volume, is in no way unpleasant. Play the machine with a fibre needle and you get the fine result. It is equipped with a unique graduating tone modifier, which Mr. Morenus himself designed. The machine has a high-grade reproducing tone arm and many little conveniences which are calculated to please the consumer. It is equipped with a Chicago hinged cover support. The Morenus is made in three attractive styles, retailing respectively at \$110, \$125 and \$150.

Ottawa Pianophone Co. Progress

The Ottawa Pianophone Co., with general sales offices at 802 Republic Building, Chicago, states that the factory at Ottawa, notwithstanding the deterrence caused by the “fuelless Mondays” and difficulty in making their shipments, is now rapidly heading towards the desirable state of being able to make shipments of Hiawatha talking machines with some degree of promptness. They also show some very fine letters from dealers who have been selling these excellent machines in direct competition with other machines, all of which goes to show that the merits of the Hiawatha are being widely recognized.

Death of Mr. Ryde, Sr.

James Ryde, father of J. B. Ryde, assistant manager of the Victrola department of Lyon & Healy, died at his home, 7239 Princeton avenue, Wednesday, January 30. He is survived by his widow, two sons and one daughter. Albert Ryde, one of the sons, is at present in training at the Great Lakes Naval Station, Great Lakes, Ill. The funeral was a private affair, the services being conducted at the family home and interment was at the Oakwoods Cemetery.

Different—But Practical

The MORENUS Phonograph is a Distinct Departure from a Tonal Viewpoint.

The horn, which is entirely of wood, is built on the principle of the saxophone and enters the tone chamber at the *bottom*, not the top. The tone is big and full but mellow, and the reproduction of the artist’s voice or instrument is faithful to an unusual degree.

Among the other features is a unique tone moderator which actually graduates: an exceptionally high grade and acoustically correct tone arm and reproducer, and a cover support which makes handling the lid a delight.

The case designs are *right* and the cabinet work and finish unexcelled.

The MORENUS is in 3 STYLES

A. OAK,	48 inches high.	Retail price	\$110
B. MAHOGANY,	“ “	“	125
C. OAK and MAHOGANY,	50 “	“	150

Very liberal discounts to the trade Send for our new descriptive catalog

The MORENUS PIANO CO.
341-371 West Superior Street CHICAGO, ILL.



Style B

**The greatest Children's Records ever made
—Thornton Burgess' Bedtime Stories, told
in the author's own voice. A Columbia gold
mine for live dealers.**



**Columbia Graphophone Co.
Woolworth Building, New York**

PATRIOTISM ON RECORDS

**Words of Leaders Will Be Heard All Over the
Country—Campaign to Start Soon**

The Four-Minute Men, who now make speeches to audiences on the war work of the country, will soon have their rivals in the addresses of leaders of America and her allies, which will be taken on the talking machine and delivered far and wide to public meetings throughout the country. The new idea was conceived by Guy Golterman, a St. Louis attorney, who is now in the East in the interest of the Nation's Forum, the organization which he has founded to push the work. He is indorsed by the Committee on Public Information, which sees in this new method the possibility of getting the war speeches of America's leaders, not only in their own words, but in their own voices, before the entire country.

Among the American leaders who have already made five-minute records for the movement are Secretaries McAdoo, Daniels, Baker and Lane; Frank A. Vanderlip, Samuel Gompers, Senators Harding and Lewis, Champ Clark, James W. Gerard and Otto H. Kahn. Mr. Golterman expects to add to this list General Pershing and the leaders of the armies, navies, and civil governments of Great Britain, France, Italy and Belgium. The master records on which the speeches have been recorded are on plates of steel and will be preserved in the Government archives at Washington. For use at public meetings, in moving picture theatres, lodge rooms, assembly halls, Y. M. C. A. auditoriums, and similar gathering places, other records will be manufactured in great numbers, and on the reverse of each record will be a

selection of patriotic music. These records will be spoken by especially manufactured talking machines, which will project the voice for a distance much further than usual.

"The idea came to me," said Mr. Golterman,

"as I looked at the facsimile of Washington's farewell, and the original of Lincoln's Gettysburg address, in the Congressional Library. I profoundly wished that the vitality of their voices could have been preserved."

LIVE PUBLICITY OF WALLACE BROWN PHONOGRAPH SHOP

DETROIT, MICH., February 12.—Wallace Brown, the well-known talking machine man of this city, is a hustler, and especially so when it comes to concentrating the attention of the public on the Brunswick Shop, which he controls, and the Brunswick phonograph, which he handles. The illustrations herewith give a very impressive idea of his activity in this direction. One shows two different sign boards which are used by Mr. Brown on the roads leading to Detroit, and the second illustration shows Wallace Brown's Brunswick Shop ad, which he is using in this city. This is advertising of a result-producing kind.



Two Signboards Used by Mr. Brown on Roads Leading to Detroit



Sign Used by Mr. Brown in the City of Detroit

**TEST offered to dealers to
prove the superiority of
Wall-Kane Steel Needles**

Take two standard disc records of the same selection, play one ten times with the same WALL-KANE loud needle; play the other record, the same selection, ten times, but with ten, new, full tone steel needles.

You will find that the record played ten times with the same WALL-KANE needle will sound clearer, will have less surface noise, and that under the magnifying glass the grooves of the record played ten times with the ten steel needles will seem to be more disturbed.

Beware of Imitations

Package of 50 WALL-KANE needles. Loud, Extra Loud and Medium, greater value than 500 ordinary steel needles, retails for 10c, costs the dealer 6 1/2c. Jobbing territories open.

**Progressive Phonographic Supply Co.
145 West 45th Street, New York**

FORM MILLION DOLLAR CORPORATION

The Aluminum Ware Mfg. Co., of Elmira, to Take Over Toyphone & Woodware Co.

ELMIRA, N. Y., February 8.—A new million dollar corporation, with its plant and home offices in this city, has been formed recently under the name of the Aluminum Ware Mfg. Co., of Elmira. The consolidation effected absorbs the National Aluminum Works of this city, the Toyphone and Woodware Mfrs. Corp., of New York City, and the Aluminum Distributing Co., of New York. The latter is a sales company headed by James H. Opp and this company undertakes to sell the whole production of the three plants.

The Aluminum Ware Mfg. Co., in taking over the Toyphone and Woodware Co., New York, secures the patents for a talking machine which this company has made and exploited during the past year. This machine has met with considerable success and all of the parts will be manufactured at the new company's plant in Elmira.

The Mirrorphone Co., of Troy, O., has been incorporated with a capital of \$10,000 to take over the output of the Lorimer-Hicks Co., manufacturers of the Lorophones.

"COMBINATION" PLAN INTERESTS

Trade Well Pleased With "Combination" Plan of Otto Heineman Phonograph Supply Co.

In a chat with The World this week, Otto Heineman, president of the Otto Heineman Phonograph Supply Co., Inc., New York, commented upon the fact that the manufacturers throughout the country are very well pleased with the "combination" plan that the company featured in last month's issue of The World.

In this plan Mr. Heineman called attention to an ideal combination for an \$85 machine; this combination including the Heineman motor No. 77, tone arm No. 11 and Ideal sound box No. 2. An ideal combination for a \$165 machine was featured as the Meisselbach motor No. 18, tone arm No. 98 and sound box No. 20.

These two combinations are being used to excellent advantage by talking machine manufacturers who state that the motors, tone arms and sound boxes featured are ideally adapted for the different types of machines presented in this combination plan. The Heineman motor No. 77 and Meisselbach motor No. 18 are recognized as two of the most popular motors on the market and talking machine manufacturers state that they are giving excellent service.

THE TELEPHONE AS A SALESMAN

How Eugene E. Hardie Has Increased Columbia Sales by Demonstrating Records Over the Phone—His Plan of Operation Interesting

BUTTE, MONT., February 11.—A novel idea has been introduced by Eugene E. Hardie, who has charge of the Columbia Graphophone department of the Newbro Drug Co., of this city, for increasing the sales, by demonstrating records over the telephone. He has had a telephone installed specially for this purpose and has fixed up a separate booth and apparatus which allows any person to hear any record over the phone just as clear as if they were standing by the machine. And from the success that the Newbro Drug Co. has had there is no doubt it would be to the advantage of any dealer to try Mr. Hardie's plan. He says that during the cold and wet weather they had to have a demonstrator specially to take the calls and demonstrate the records, and, if the calls increase, that they will have to install more telephones and special booths. If you don't think this works call

up No. 162 Butte, Mont., and Mr. Hardie will demonstrate personally and to your satisfaction.

MORE TIME FOR INCOME TAX RETURN

Time Limit Moved From March 1 to April 1 by Internal Revenue Commissioner Roper

WASHINGTON, D. C., February 11.—Internal Revenue Commissioner Roper announced to-day that the time for filing income and excess profits returns had been extended from March 1 to April 1. The ruling applies also to reports on payments of more than \$800 a year to be made by employers and business enterprises, and covers incomes both above and below \$3,000 and corporation incomes.

Delay in the preparation of blank forms and regulations was the principal cause of the postponement.

J. C. Fulton has arranged to carry a line of phonographs and records in his sewing machine store at 231 South Broad street, Middletown, Pa.

WM. A. SCHREINER GETS NEW POST

Is Appointed Manager of Sales Promotion Department at Local Wholesale Branch of Columbia Co.—Well Known in the Trade

William A. Schreiner has been appointed manager of the sales promotion department of the wholesale branch of the Columbia Graphophone



Wm. A. Schreiner

Co., at 55 Warren street, New York. This department is a division of the local branch which devotes its entire time to co-operating with the Columbia dealers in the development of Columbia Grafonola and record business. This department carries out the activities of the executive dealer service department, which plans and prepares all such material for the Columbia dealers throughout the country.

Mr. Schreiner is well known in the local trade, having formerly been a member of the Columbia Co.'s sales organization and also occupying important posts in various retail talking machine establishments. He is therefore splendidly equipped to render the dealers efficient service in his new position, as he thoroughly understands their problems and can handle their requirements adequately.

RAISE PRICE OF SCHUBERT MACHINES

Bell Talking Machine Corp. Will Assume War Tax, However—Also Introduce New Style—Extra Charge for Walnut Machine and Electric Motor—Mr. Rummell Discusses Situation

The Bell Talking Machine Corp., 44 West Thirty-seventh street, New York, has announced an increase in prices of the Schubert phonographs, and the introduction of one new style, to be known as Standard No. 75. The increase in the price averages about \$15.00 per machine, and the company assumes the war tax, while an extra charge is made for machines of walnut, the regular styles including mahogany and oak. A charge of \$30.00 is to be made where it is desired to have a machine equipped with electric motor. The new prices, which will go into effect on April 1, are as follows: Unity, Style 60, \$60; Standard, No. 75, \$75; Opera, No. 100, \$100; Melody, No. 115, \$115; Concert, No. 165, \$165; Grand, No. 215, \$215.

L. Rummel, speaking to a representative of The World this week, said: "We have taken great care to see that our regular customers are provided for, and during the last year, even through the holiday season, we made this our policy, not taking on new customers until our regular trade had been well taken care of. Owing to the increase and cost of material we have been forced to increase our prices, and are laying plans for a greater increase in facilities, so that we may give even better service than we have in the past."

Frank T. Nutze, vice-president and sales manager of Stephenson, Inc., New York, manufacturers of the Stephenson Precision motor, who has been visiting the Western trade, going as far as the Pacific Coast, has booked some large orders.

At Last

we are able to accept additional orders and will make

Immediate Delivery

of

Playrite

and

Melotone Needles

If ordered at once

This is your CHANCE to get a stock ON HAND
Don't delay, for we cannot promise
Continued IMMEDIATE delivery

Samples and Price List Mailed on Request



Blackman
TALKING MACHINE CO.

97 CHAMBERS ST. NEAR CHURCH ST. NEW YORK

Factory Distributors Victor Talking Machines





Help Us Bring the Best Youngsters of Your City to Your Store

The week of February 25th to March 2d is to be "*Thornton Burgess Week.*" There will be a full page advertisement in the Saturday Evening Post and Youth's Companion appearing February 28th. And in a large list of newspapers there will appear three advertisements—all featuring Thornton Burgess Bed Time Stories on Columbia Records. The readers will be urged to visit their Columbia Dealers and hear these records played.



Columbia Grafonola
Price \$215
With electric motor \$240

Your Chance to "Cash-In"

Use our special window-display material, counter cards, leaflets, etc., and have your own "*Thornton Burgess Week.*" Your branch will supply gladly all your needs. Do some special advertising yourself. Circularize homes and schools. This is a real opportunity you ought to take advantage of. Cash in on it.

COLUMBIA GRAPHOPHONE COMPANY, NEW YORK



Columbia Grafonola

SOUTHERN CALIFORNIA TRADE NEWS

January Proved a Better Month Than Was Predicted—C. S. Ruggles Visits New York—Fitzgerald Music Co. Recitals—Other News

LOS ANGELES, CAL., February 6.—January proved a better month than was predicted by most of the local dealers. Scarcity of stock has, of course, been a great handicap to the merchants, and now it is not a case of ordering from your jobber, but take what he can give you and be satisfied.

The demand for the large models continues brisk, and most of the dealers are entirely out of them by now, with little hopes for future deliveries.

Southern California is experiencing the driest winter season in years, and this year's rainfall is far below normal. Not much damage has been done so far, but if the rains do not come soon some of the crops are bound to suffer. The new draft will take a number of salesmen who were exempted before, and at the present writing a number are already on the way to American Lake.

C. S. Ruggles, manager for Sherman, Clay & Co., Victor jobbers, has left for New York to see his youngest son, Wesley Ruggles, who is due to sail for France in the near future. Mr. Ruggles will be gone three or four weeks, and will visit the Victor factory before returning to the coast. R. B. Bird, from Sherman, Clay & Co., San Francisco, is taking charge of the local branch during the absence of Mr. Ruggles.

The Wiley B. Allen Co. have lost two of their boys this week, Robert P. Raygust having already been called to the colors, and Walter Allee expecting to leave in the near future.

The Andrews Music Co. report a fine business during the month of January, and expects to also have a good February trade, providing the stock holds out that long.

Mis Juanita Brown, of the talking machine department of Barker Bros., was married on Monday, January 21, to Walter Mack, who left the next day for the Aviation Training Camp

at Atlanta, Ga., preparatory to service in France. The bride remains in the employ of Barker Bros.

The Fitzgerald Music Co., which in its phonograph department handles the Edison exclusively, recently gave two Glen Ellison and Edison tone-test recitals. The first was held on Tuesday of last week and the second on the Friday following. Both were attended by crowds that packed the company's recital rooms to their full capacity, about 500 persons. They were naturally made the most of in an advertising way. Mr. Ellison left Los Angeles after the second recital for Des Moines, Ia.

THOS. A. EDISON NOW 71 YEARS OLD

Well-Known Inventor Passes a New Milestone in Life—At Present in Florida—No Formal Celebration at West Orange Factories

Thomas A. Edison, head of the Edison interests in Orange, N. J., and honorary president of the Naval Consulting Board, celebrated his seventy-first birthday anniversary on February 11.

Owing to his absence there was no formal celebration at the West Orange plants as has been the custom for several years past, but his associates and employes did not let the occasion go by unnoticed. Since the declaration of war Mr. Edison has been working for the Government in an effort to solve the U-boat problem and has taken only one short vacation. He is at present in Florida with Mrs. Edison.

The "Edison Pioneers," an organization composed of the old associates of Thomas A. Edison, gave a luncheon at the Lawyers' Club on Monday in celebration of the inventor's birthday, there being forty-five present, and they took the occasion to send the inventor the following message:

"We, the Edison Pioneers, assembled at our first annual luncheon to celebrate your birthday, express our pride in your present patriotic occupation and send you our warmest love and hearty congratulations on this anniversary."

Secretary Daniels also sent the following telegram to Mr. Edison:

"Congratulations upon your birthday. Your friends rejoice in your youthful optimism and clear vision of national needs. It has been a privilege to be a co-worker with you."

CONDITION OF INTERNATIONAL TRADE

Secretary Redfield Discusses on the Likely Course of Foreign Trade—Declares Present Condition Is Deliberately Abnormal

That the current condition of international trade is deliberately abnormal is the opinion expressed by Secretary of Commerce Redfield in a statement addressed to the Bureau of Foreign and Domestic Commerce on the subject of foreign trade organization by industries after the close of the war.

"It seems to me," he writes, "there are two abnormal stages through which we must go before what we may call the normal ebb and flow on international trade will, after the war, resume its movement.

"First, the current condition is deliberately abnormal. All the great exporting nations are directly interfering with the progress of their export and import trade and treating it as a war measure on a strictly and avowedly different basis from that of peace.

"Second, another abnormal state must follow immediately after the war, which may be described as like the process of settlement to rest of particles suspended in a fluid in order that the fluid may become clear. In other words, there will be a long period of international reconstruction. It will take the form, at the beginning, of excessive demands for raw materials of many kinds, and probably for finished lumber and machinery and certain kinds of equipment. The whole object during this time will be restoration toward a normal economic manufacturing and productive basis. This period must be gone through fully before the third period, which I speak of as the normal condition, shall arise."



"Pathé Records"

Their Significance to the Dealer:

They signify not only the largest record collection in the world, but they signify the only records that bear the Pathé Record Guarantee:

Pathé Records Won't Wear Out

We guarantee every Pathé Record to play at least one thousand times with the Pathé Sapphire Ball without impairing the unexcelled beauty of TONE.

They signify:

No Needles to Change

THE PATHÉ SAPPHIRE BALL takes the place of needles. And it is permanent. It never wears out.

They signify the world-wide Pathé Record Repertoire: Music new to America—vocal and instrumental celebrities of European fame.

And the Pathé monthly list of patriotic, popular, musical comedy and sentimental songs and dance hits—

Plus the brilliant Pathé artist personnel:

Muratore, Muzio, Ober, Cavaleri, Didur, Thibaud, Ganz, Bispham, Grace Hoffman, Slczak, Urlus, Weil, Fitziu, Sammarco, Ruffo, De-Cisneros and others.

Of further significance is the fact that Pathé Records, despite their unique guarantee, cost no more than other makes of records—

And the fact that they are subject to a dealer's discount so generous it will well repay you to investigate—*to-day*.

FISCHER COMPANY

940 Chestnut Avenue

CLEVELAND, OHIO

No Needles to Change

THE SAPPHIRE BALL takes the place of needles. And it is permanent. It never wears out.

Pathé Records Won't Wear Out

We guarantee every Pathé Record to play at least one thousand times with the Pathé Sapphire Ball without impairing the unexcelled beauty of tone.

The Pathé Phonograph Plays All Makes of Records

Each Pathé Phonograph, at any price, plays not only Pathé Records, but all other makes of records.

The Pathé "Controla"

With the Pathé "Controla" you may increase or decrease the tonal volume of the Pathé Phonograph at will.

EXHIBITION OF COLOR PICTURES

The New Process of Producing Motion Pictures of Color of Nature Invented by Leon F. Douglass Is Demonstrated in New York

Under the direction of Thomas Boyd, of San Rafael, Cal., a private exhibition was given on February 12 and 13 in Wurlitzer Hall, New York City, of the new process for producing motion pictures of the colors of nature invented by Leon F. Douglass. Mr. Douglass is well known in the trade as the chairman of the board of directors of the Victor Talking Machine Co. In discussing Mr. Douglass' latest invention Mr. Boyd said to The World:

"Mr. Douglass for many years devoted his time to inventing processes which would bring superior tone qualities to the talking machine, and it was due in part to his efforts that the Victrola has been brought to the high standard of excellence as a sound reproducer which it enjoys to-day. Having mastered the laws of sound, he took up, at San Rafael, Cal., the problem of reproducing pictures in their natural colors, and for many years made a most exhaustive experiment to develop a theory which he had formulated when he first began this work. Success has been attained, and the pictures show how faithfully the invention is able to reproduce every hue, shade and tint of the colors of nature.

"The process is not only practicable, but is comparatively inexpensive. By means of a small and not costly device that may be attached to any motion picture camera, several color values of the image photographed are given to the negative, from which positive films are printed by a chemical process which I am not at liberty at this time to divulge. A film is thus produced which contains a series of images so colored as to give, when projected, a moving picture in natural colors, without the use at all of the rotary colored shutter which is usually required.

By this contrivance the brilliancy and intensity of the projected colored picture is increased and a stereoscopic effect is obtained, impossible in black and white. There is no more light required than is used in projecting black and white, and a speed of only twenty-four to the second is required, and through certain experiments being made this speed will be reduced. The cost of producing pictures by this process is slightly more than that for making black and white, while the advance in the art of producing motion pictures is considerable.

"The effects obtained are marvelously true to nature. The range of tint and hues unlimited. The presence of grays and neutral tints which are always present in nature, and which soften and tone down the harsh colors, are plentiful in these pictures. Thus, in addition to showing the vivid colors, all of the delicate shades and hues of flesh tints, of clothings and draperies, of the gradually changing sky tints of sunrise and sunset are reproduced with magical subtlety.

"The art of producing motion pictures of great brilliancy, showing every slight difference of the various shades of color, by a practicable and inexpensive process, has been accomplished."

INCREASES LINES HANDLED

S. N. Rosenstein, of the Phonograph Clearing House, New York, announced this week that he is now handling a number of well-known lines in addition to those that he has represented during the past few months. The latest additions to Mr. Rosenstein's line are the products manufactured by the Automatic Record Container Co., Chicago; the Scotsford line of phonograph accessories manufactured by the Barnhart Bros. & Spindler Co., Chicago; the lines made by the Weber, Knapp Co., Jamestown, N. Y., and the Crescent Talking Machine Co., New York. Mr. Rosenstein is planning to give these lines aggressive representation in New York, and judging from his activities the past few months the success of his company is assured.

You need this Record System



New Model No. 2150 DD

Improved in design and construction. **UNITS** fit flat together on the end. **DOUBLE** drawers in the Base. **SOLID** Oak and Birch in all standard finishes.

Write for Our Manual of Filing Dept. K.

350-10 inch Records

350-12 inch Records Patented Adjuster for Using 10 inch Records

Soft, Flat Springs Hold Records Upright And Prevent Warping.

Capacity 2150 thin records, 1075 Edisons.

Every record at your finger tips as simple as 1 — 2 — 3.

Built to fit your needs.

Prices { Oak \$55
 { Birch \$60

UNCONDITIONALLY GUARANTEED

Ogden's Patented Cabinets

Protect against Dust, Warping and Theft. Save Time, Space, Money. : : Prices Subject to Change : :

OGDEN SECTIONAL CABINET CO., Inc., Lynchburg, Va.

TO INTEREST SHORTHAND WRITERS

How Talking Machine Records May Be Utilized by Students in the Taking Down of Actual Dictation—Some Pointers of Interest

It is herewith suggested that talking machine dealers investigate the possibilities of selling records to the students who are learning shorthand. After a student has mastered the symbols of stenography there is a period of several weeks' duration during which the student must practice taking down actual dictation. At first the student cannot keep up with the speed of ordinary conversation, and it is only by continued practice that he or she learns to work fast with shorthand. While the student is learning to write fast he is often hard put to get somebody to read or dictate to him, as the occupation is exceedingly boring for the person lending the "helping hand." This is just where the talking machine can fit in, for there are many records in the catalog of recitations, speeches, poems, etc., which the student could play to his heart's content and at any desired rate of speed. While the record was playing he could take down what was said in shorthand and then afterwards be able to verify the accuracy of his stenographic effort. In this way the student would not have to bother any one else while he was going through the "practice makes perfect" stage.

In a great many cities located throughout the country there are commercial colleges teaching shorthand. The talking machine dealer can interest the instructors in these institutions to introduce the idea of listening to records for dictation as part of the course. Shorthand is also taught in the majority of the public high schools and arrangements could be made with the local teachers to suggest that their pupils practice by listening to prose talking machine records. The many people learning shorthand by correspondence would also be excellent prospects for the progressive talking machine dealer to consider.

PUTNAM, PAGE CO. DOING THEIR BIT

The Putnam, Page Co., Victor wholesalers, Peoria, Ill., are certainly doing their bit for the country. Roy Page, junior member of the firm, enlisted when war was declared with Germany, and is now a First Lieutenant in the U. S. A. Next in line to volunteer was Arthur Graham, who is in the Aviation Corps, and last week William Dane joined the Radio Electrical Corps and will doubtless be sent to Chicago, after which he will obtain a six months' course at Harvard University.

A SIGNIFICANT LETTER

Fred A. Girdwood, druggist and stationer, Perth, Ont., Canada, a Talking Machine World subscriber, writes as follows: "We are now handling Victor records and Victrolas, and find them the best paying side line we ever introduced, in fact, if we are not careful, the drug business will soon be the side line." This letter is a significant tribute to the growing popularity of the talking machine throughout Canada, and the prospects are for a wider appreciation as time goes on.

MCCORMACK'S POPULARITY GROWS

John McCormack, the famous Irish tenor, whose Victor records are so widely popular, has been scoring a great success with the Metropolitan Opera Co.'s forces in New York this season. His splendid aid toward raising funds for the Red Cross has also come in for a large measure of public recognition. Next summer he plans to visit France and sing to "our boys" who are "over there."

JOSEPH MUSANTE

Electro-plater and Silversmith
Gold, Silver, Nickel and Antique Finishes
Specializing in phonograph parts and musical instruments
168 CENTRE ST. NEW YORK
Telephone, Franklin 3053



A New Record Repertoire and Greater Record Sales for the New Year!

NOT only do Pathé Records represent the largest and most unique record repertoire in the world: music of which America still knows little—the great voices of all Europe; romantic instrumental ensembles of the Old World's Bohemia; the famed military bands, the songs and melodies of lands that *live* romance; the brilliance and beauty of a world of art so far a closed book to most Americans—

To say nothing of the regular monthly list of up-to-date patriotic, sentimental, musical comedy and popular song successes and dance novelties—

But they represent *continuous* sales

And increased "record dividends" to the dealer—

because there is a fast-growing demand for records that play without needles. And Pathé Records mean:

No Needles to Change

THE SAPHIRE BALL takes the place of needles. And it is permanent. It never wears out.

Pathé Records Won't Wear Out

We guarantee every Pathé Record to play at least one thousand times with the Pathé Sapphire Ball without impairing the unexcelled beauty of tone.

The Pathé Phonograph Plays All Makes of Records

Each Pathéphone, at any price, plays not only Pathé Records, but all other makes of records.

The Pathé "Controla"

With the Pathé "Controla" you may increase or decrease the tonal volume of the Pathé Phonograph at will.

No Needles to Change

THE PATHE SAPHIRE BALL takes the place of needles. And it is permanent. It never wears out.

Pathe Records Won't Wear Out

Here's the Pathé Record Guarantee: "We guarantee every Pathé Record to play at least a thousand times with the Pathé Sapphire Ball without impairing the unexcelled beauty of tone."

Pathé recordings are not merely phonographed recordings of such world-famed artists as Muratore, Muzio, Cavaliere, DeCisneros, Grace Hoffman, Ober, Slezak, Urlus, Bispham, Sammarco, Ruffo, Weil and others. They are the *realism* of those voices.

Pathé Records cost no more than other records and because they offer the dealer an unusually generous discount.

Write for details TO-DAY.

Williams-Davis-Brooks & Hinchman Sons

26 East Congress Street
DETROIT, MICHIGAN



The Pathé Sapphire Ball
Enlarged many times

DEALERS' ASSOCIATION IN LOS ANGELES JUST ORGANIZED

Herman Beck Elected President of Organization at Recent Meeting—Association to Try for Trade Betterment—To Take Up Question of Approvals and Time Sales

LOS ANGELES, CAL., February 7.—One of the most important happenings that has taken place in the talking machine business in Los Angeles for some time was the organization recently of the Retail Talking Machine Dealers' Association of Southern California. The meeting was called at the Hotel Clark and was attended by twenty-six dealers, or their representatives. The following stores were represented: The Vernon Music Co., Mr. Hollands, proprietor; the Hollywood Music Co., Messrs. Chamberlin and Tilden; Southern California Music Co., George Marygold, vice-president, and William Hobbs Richardson, manager, talking machine department; Zellner Music Co., Mr. Patten; George J. Birkel Music Co., Messrs. Geissler and Beck; Colyear's Furniture Co., Curtis Colyear; Bartlett Music Co., Frank Salyer, manager; Glockner Music Co., Mr. Glockner, proprietor; Platt Music Co., Mr. Gallagher; Overell's Furniture Co., Mr. Stoll; Eastern Outfitting Co., Mr. Brown; Lyon-McKinney-Smith Co., Howard Brown; Shireson Bros., Mr. Shireson; Holmes Supply Co., Mr. Gibson; Fitzgerald Music Co., Mr. Earl Dibble, manager; Barker Bros., Mr. Boothe; Wiley B. Allen Co., Mr. Tucker; Andrews Talking Machine Co., Irving Andrews; Barnes Music Co., George Barnes.

The following officers were elected for the ensuing year: Herman Beck, president; Curtis Colyear, first vice-president; C. B. Boothe, second vice-president; Earl Dibble, secretary; George Barnes, treasurer.

The object of the association is for the betterment of the trade in general and to try to regulate the approval system on records, and also fix a limit to the time for contracts to run. This is to be strictly a business organization

to meet once every month at the different stores. It is the intention of the officers to have three or four open meetings during the year when all employes in the trade will be welcome and a special program is to be provided for their benefit.

SEEK SPY EVIDENCE ON RECORDS

U. S. Secret Service Operatives to Examine Many Discs Brought in by "Nieuw Amsterdam" for Dangerous Messages From Enemy

One thousand phonograph records brought to an Atlantic port last week aboard the Holland-American liner "Nieuw Amsterdam" are to be tested by United States Secret Service operatives, who believe the discs may bear code messages for German spies.

The records are in several languages, and none will be passed until it has been translated, read backwards and forwards and sidewise, tested for acrostics and musical note alphabets and examined microscopically for marks that might be messages.

Many messages have been cleverly concealed among the words and the apparently meaningless "tra-la-las" of song records. And frequently messages have been hidden under the labels of discs.

MARCH VICTOR RECORD SUPPLEMENT

Little Volume Is as Usual Full of Interesting Text and Illustrations

The Victor record supplement for March is a most interesting volume gotten up in the usual elaborate form and with pictures of unusual

character. The cover design illustrates the Barcarolle from "Tales of Hoffman," with descriptive text on the first inside cover. Then there is a full-page portrait of Jascha Heifetz, the latest Victor acquisition, pictures of DeLuca engaged in the popular pastime of knitting, a view of John Philip Sousa leading the band of the Great Lakes Naval Station, and a picture of Lieut. Gitz-Rice in the trenches leading a group in song. The two center pages tell of the Victrola's service to the nation, and quotes from the comments of Walter R. Creighton, son of the late Lord Bishop of London, on the value of talking machine music in the trenches.

TALKING MACHINES FOR SOLDIERS

Talking Machine and Record Committee for Army and Navy Base Hospitals Doing Good Work in Getting Outfits for Sick Soldiers

An important war work is now being conducted by the Talking Machine and Record Committee for Army and Navy Base Hospitals, which is headed by Arthur L. Lawrason, of the Nevada Apartments, Broadway and Sixty-ninth street, New York. The object of the committee is to get talking machines of all makes with disc records and needles to provide for the amusement and diversion of our soldiers when they return wounded or invalided, as well as for the sick already in camps and hospitals. Mr. Lawrason is a Canadian who is unable to serve in the army, but has done excellent work both in that country and the United States for the comfort and welfare of the fighting men. Those who have no machines or records to donate are appealed to for cash donations for the purchase of same.

Stracciari, the baritone and Columbia artist, scored a big success with the Chicago Opera Co. at his debut last week.

Standard Stock With Leading "Victor" Dealers

The Lundstrom Patented "Converto" Cabinet, now in its second year, has experienced an unusually rapid growth in sales and popularity. Convertos are now carried as standard stock by a large number of the leading Victor dealers and distributors. In spite of the increased facilities it is and always

has been difficult to keep supply up to demand. This is due to the distinct advantages of the Converto for user, dealer and distributor. It houses a small Victrola—converts it into a handsome cabinet type, completely encloses the machine, takes the place of a stand, provides dust-proof record rack; it revives interest in records, helps dealers meet low-priced competition in cabinet machines; it costs no more than a good stand and gives dealers a good profit.

Lundstrom
CONVERTO
Patented Dec. 11, 1917

Talking Machine Cabinet

Prices and Particulars on Request

The C. J. Lundstrom Mfg. Co.
LITTLE FALLS, N. Y.

Branch Offices: Flatiron Bldg.

New York City



Setting Victrola into Cabinet



Sound Doors Open for Playing

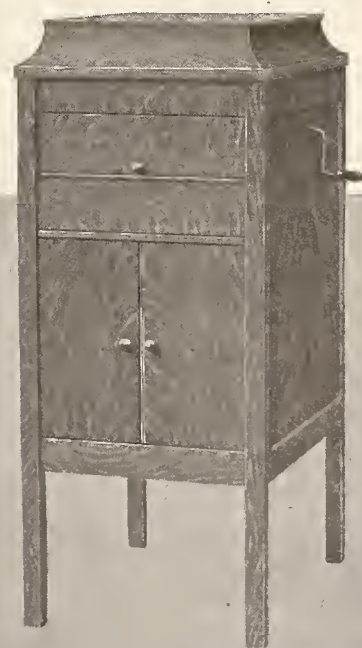

Completely Closed

You Ought to Know

In case you are contemplating expanding the sphere of your business to include departments devoted to Pianos, Player-Pianos, Musical Merchandise or Sheet Music, that you'll find news and comments about them all in



ESTABLISHED 1876

The oldest and leading music trade weekly, which covers every branch of the industry.

It Contains

instructive and educational articles. Hints on salesmanship and advertising. Editorials that are timely and authoritative. Facts about the new things in the trade. Trade happenings in all parts of the United States.

“Review the Music Trade With Us”

Send your \$2 now for a full year's subscription to

THE MUSIC TRADE REVIEW
373 FOURTH AVENUE NEW YORK

VAN VEEN "BED-SET" BOOTHS

Increase Your Record Sales

Write for a copy of our
NEW CATALOG

Van Veen "Bed-Set" Sectional Booths can be erected as easily as a bed (no skilled labor required). Booths shipped on short notice *anywhere*. Room sizes any multiple of 3 feet. High grade finish, will match your sample if desired. Sound-proof construction. We design and build complete interiors. We also build record racks, which are described in our new catalog.

Prepare for a Machine Shortage
by Developing Record Sales



Demonstration Booths Mean
Additional Record Business

Illustration shows a recent installation for the Winterroth Piano Co., on West 42d Street, New York.

Van Veen Booths Will Pay for
Themselves by Increasing
Your Record Sales

ARTHUR L. VAN VEEN & CO., Telephone Greeley 4749 Marbridge Bldg., 47 West 34th St., New York

LIEUT. J. H. GILES A VISITOR

Former Member of the Blackman Traveling Staff "Doing His Bit" for Uncle Sam—A. D. Robbins Has Joined the Aviation Corps

A visitor this week to the offices of the Blackman Talking Machine Co., New York, Victor wholesalers, was Lieut. James H. Giles of the 104th Field Artillery, now stationed at Spartanburg, S. C., and preparing to leave for "over



Lieut. James H. Giles

there" in the very near future. Lieut. Giles, who is now an acting captain, was formerly a member of the company's traveling staff, resigning to "do his bit" for Uncle Sam.

A. D. Robbins, who has been a member of the Blackman Talking Machine Co.'s sales staff for several years, and who has been visiting the Victor dealers in this territory for the past year, has enlisted as a member of the Aviation Corps, and is now stationed in Texas, preliminary to sailing for the other side.

George W. Lyle, assistant to the president of the Pathé Frères Phonograph Co., Brooklyn, N. Y., is at his desk again after a month's visit to the Pathé jobbers throughout the country, including the Pacific Coast.

ATTENTION OF MANUFACTURERS AND ASSEMBLERS

I have just completed a new kind of talking machine motor, and have a perfect model ready for demonstration. The motor can be used for machines retailing from \$20.00 upward. Would manufacture the same for the exclusive use of one large assembling house that can use a substantial quantity, or turn it over to a responsible manufacturer on a royalty basis. Address "Box 498," care The Talking Machine World, 373 Fourth Ave., New York.

1917 FOREIGN TRADE RECORD

Total of \$9,178,000,000 Reported; \$1,300,000,000 Over 1916

WASHINGTON, D. C., February 5.—America's foreign trade surpassed all records in 1917, amounting to \$9,178,000,000. Official figures just issued by the Department of Commerce showed that there was a gain of nearly \$1,300,000,000 over the preceding year. December exports of \$589,000,000, an increase of \$100,000,000 over November, caused the big increase. The year's exports amounted to \$6,226,000,000, and imports to \$2,952,000,000. Free imports formed 72 per cent. of the total.

The balance of trade in favor of the United States has nearly doubled in the last two years, amounting to \$3,274,000,000 in 1917, compared with \$1,776,000,000 in 1915.

Gold imports amounted to \$538,000,000, against \$686,000,000 in 1916, the decrease being due largely to the fact that since the United States entered the war purchases by the Allies have been financed by credits. Exports of gold totaled \$372,000,000, compared with \$156,000,000 in 1916.

Silver imports were \$53,000,000, against \$32,000,000 in 1916, and exports \$84,000,000, against \$71,000,000.

The general outlook as far as foreign trade is concerned is certainly improving.

TRIBUTE TO THE TALKING MACHINE

It is silent when you're weary
And therefore, unlike your friend,
It never bores nor gossips,
Never borrows, never lends.

It is always waiting for you
With the thing your mood most wants,
Whether raggy, jaggy music
Or the dreamy kind that haunts.

You sit back in a corner
With the shadows all about
And the music sets you dreaming,
And your pipe goes out.

Fairies gather round you,
Sometimes whispering in your ear,
Sometimes kissing shut your eyelids,
Leaving on your cheek a tear.

Ghosts of long ago peer at you,
Bringing back forgotten things,
When the record on your graphophone
Plays melodies or sings.

There's the tinkle of a cow bell
Or the gurgling of a brook,
Then a strain recalls to memory
Some sweet line from a loved book.

There's the scent of apple blossoms
And the murmur of the sea;
And a cupid comes a-whispering,
"Won't you listen, Love, to me?"

And he throws a few love kisses
From the record where he stands
And he dances to the music
While he waves his chubby hands.

Then comes a strain that makes you hear
A voice that's long been still;
And you see the grass and withered flowers
On a narrow slab-marked hill.

Then the fairies came back laughing,
(Music must give joy or pain);
Begging you to cease your sighing
And to light your pipe again.

All your heart is with the phantoms
As they dance about your chair
Ah! But when you try to touch them—
They're but music in the air.

SUPPLY MUSIC TO THE SOLDIERS

Company K at Camp Logan Proud of Their New Edison Phonograph

KEWANEE, ILL., February 10.—W. A. Bowen & Son, who handle Edison phonographs and records in this city, recently supplied an Army and



Company B and Its Edison Phonograph

Navy Edison phonograph to Company K, at Camp Logan, one of Uncle Sam's virile fighting forces. This firm have built up a very excellent business for the Edison in this territory.

CONGRATULATIONS FOR F. P. OLIVER

Fred P. Oliver, vice-president of the Blackman Talking Machine Co., New York, Victor wholesalers, is receiving congratulations from his many friends in the trade upon the arrival on Sunday morning of a baby girl. Miss Oliver has been christened Virginia, and, if early signs are any indication of the future, her career as a vocal star is almost assured.

The Mickel Bros. Co., Victor wholesalers in Omaha, Neb., and Des Moines, Ia., closed a large volume of business the past month.

Phonograph Clearing House, Inc.

Found 100 items for 100
manufacturers and dealers
in one month.

Phonograph Clearing House, Inc.

Disposed of an equal
number of items for an
equal number of manu-
facturers and dealers dur-
ing the same period.

What Do You Want?
What Have You to Sell?

Get It or Sell It
Through Us

Phonograph Clearing
House, Inc.

51 East 42nd Street NEW YORK



War does not lessen the demand or the need for good music—it increases it. There was never a better day than today to sell Columbia Grafonolas. It just depends on the dealer.

Columbia Graphophone Co.
Woolworth Building, New York

THE DELPHEON IN THE SOUTH

Delpheon Co., Inc., in Atlanta to Distribute Delpheon Phonographs in Georgia, North Carolina, South Carolina, Florida and Alabama

ATLANTA, GA., February 7.—The Delpheon Co., Inc., of this city, which was recently organized to distribute the products of the Delpheon Co., Bay City, Mich., in the States of Georgia, North Carolina, South Carolina, Florida and Alabama, has opened a very attractive store known as the

paper articles, and judging from all indications this instrument will soon be favorably known throughout Atlanta and the adjacent sections.

JASCHA HEIFETZ IN PITTSBURGH

The Standard Co. Makes Capital of Coming Appearance of Popular Violinist in That City

PITTSBURGH, PA., February 12.—The appearance in this city of Jascha Heifetz, the latest wonder violinist, whose first Victor records have created

ADVERTISING AND SELLING PRACTICE

Excellent New Book, Treating of This Subject in a Most Comprehensive Manner, Written by John B. Updycke and Published by A. W. Shaw Co.—Thoroughly Practical

"Advertising and Selling Practice" is the title of a most interesting and valuable volume of information for the advertising man and salesman, written by John B. Updycke, specialist in advertising training in the New York City schools, and published by the A. W. Shaw Co., Chicago and New York. Price, \$1.25 net.

The book explains the origin of advertising and shows just how modern advertising and selling developed. It shows how to study the specimens of early advertisements which are reproduced, and to compare them with advertisements in the papers and magazines to-day.

But the book is not limited to the history and theory of advertising and selling. It also gives specific plans and knacks which distinguish the superior from the mediocre merchandiser, and the well-selected illustrations will help greatly in quickening the interest of the employes.

The preparation of copy, the style of copy that builds business, how to judge the effectiveness of advertisements, what mediums to use, methods for checking returns, the advertising morgue, etc.

Mr. Updycke also takes up some principles of selling and explains the policies and methods that pay best in merchandising, giving a careful analysis of the fields and kinds of advertising and salesmanship.

All the way through the book he guides the beginner in a practical, helpful manner with problems at the end of each chapter to cover the text matter and require the reader to think for himself. Here is a problem selected at random: "Make a chart of the advertising you find in your community, in all mediums, and account for the mediums selected by certain advertisers for certain commodities."

In addition the book includes a most comprehensive bibliography on advertising and selling.

WANTS UNIFORM CITY POSTAGE

Senator Calder's Bill Would Abolish Increased Rates Between the Five Boroughs

To establish a uniform rate on first-class mail matter within the confines of Greater New York, Senator Calder has introduced the following amendment to the pending Post Office Appropriation bill:

"Provided, that the rate of postage on drop letters of the first-class, mailed in the City of New York for delivery within the confines of that city, shall be 2 cents an ounce or fraction thereof."

The effect of this amendment will be to provide a 2-cent rate on all first-class matter mailed in any of the five boroughs of Greater New York, a most necessary move.



One of the Display Rooms of the Delpheon Co., Inc., Atlanta

Delpheon Shop, a photograph of which is shown herewith. This store is considered one of the finest talking machine establishments in this State, and the company is planning to conduct it on a basis which will impress music lovers with the quality of the Delpheon phonograph.

D. G. Sunderland, who is the head of the Delpheon Co., Inc., of Atlanta, is leaving nothing undone to give the Delpheon aggressive representation in this territory. The Delpheon Shop has already been the subject of several news-

such a sensation, is not to go unnoticed by the local dealers if the Standard Talking Machine Co. can prevent it. The Standard Co. has sent out elaborate notices of Mr. Heifetz's concert at the Shriners' Mosque on March 11, with the Philadelphia Orchestra, and has made arrangements to receive subscriptions from dealers for tickets to the concert. The special slips supplied by the company for the ticket orders are coming in at a rapid rate and indicate that there will be a large attendance.

AUDION

A New Reproducer; Composition Diaphragm

Plays more pleasing to the public than any other; fits all standard phonographs. Retail at \$3.00, and dealers should stock these reproducers and sell them to the public on a money-back guarantee.

WRITE FOR TRIAL OFFER

AUDION PHONOGRAPH CO., 77 Reade Street, New York



SOSS



INVISIBLE HINGES

Preserve Beauty
In many beautifully designed, finely finished Talking Machines, Pianos, Music Cabinets, Piano Players, and Benches, the elimination of the unsightly protruding Hinge is essential to preserve the beauty of the design.

Design and Construction
The fine cabinet work which is required in many instances to preserve the disguise of the instrument requires that the hinges be as inconspicuous as possible. SOSS Hinges are *Invisible*.

Write for catalogue "T"

SOSS MANUFACTURING COMPANY

435 ATLANTIC AVENUE BROOKLYN, N. Y.
 LOS ANGELES, 224 Central Bldg. } **Branch Offices** { SAN FRANCISCO...164 Hansford Bldg.
 Canadian Representatives—J. E. Beauchamp & Co., Montreal, Can. } DETROIT—922 David Whitney Bldg.

CLOSE IMPORTANT CONTRACTS

Leonard Markels During His Recent Trip West Closed a Number of Deals Whereby the Markels Motor Will Be in Demand This Year

Leonard Markels, well-known motor manufacturer, recently visited the manufacturers throughout the West and closed a number of important contracts whereby Markels products will be used exclusively by these manufacturers during 1918. These contracts include both the customers who used the Markels motor in 1917 and manufacturers who were so impressed with the samples of Markels motors that they re-

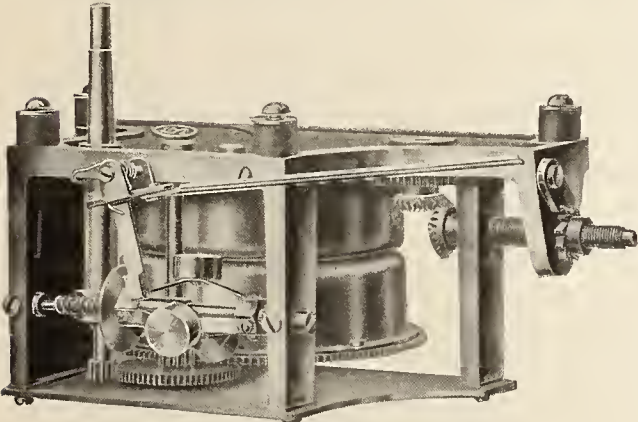

The Markels "Butterfly" Motor

ceived recently that they desired to place good sized orders for the coming year.

Mr. Markels states that the demand for the "Butterfly" motor is exceeding all expectations and that in order to keep pace with the orders which he is receiving for this motor, he has been obliged to materially increase his factory output. This motor has won the enthusiastic praise of manufacturers throughout the country, who state that it embodies the necessary requisites for a successful silent running motor. According to present plans, the Markels factory will produce in 1918 a motor output considerably ahead of last year, and the "Butterfly" will be one of the leaders in this production.

D. R. Doctorow, credit and sales manager for Leonard Markels, will leave for Canada during the next few days in response to several requests that have been received at the executive offices from well known Canadian manufacturers who contemplate using the Markels' products in 1918.

JOIN COLUMBIA SALES FORCE

A. B. Creal, formerly a member of the sales staff of a prominent Memphis furniture house has been appointed a member of the sales force of the Baltimore branch of the Columbia Graphophone Co., W. S. Parks, manager.

A. E. Landon has been appointed a member of the sales staff of the Columbia Co.'s Cleveland branch, A. W. Roose, manager. Both Mr. Creal and Mr. Landon have been spending some time in New York, prior to assuming their new duties.

HOFFAY CO. MARKETS SPECIALTIES

Decide to Put the "Resurrectone" and New "Half Fork-Tone" on the Market in Response to Numerous Requests for Those Products

The Hoffay Talking Machine Co., Inc., manufacturers of the Hoffay "Airtightphone" and the "Resurrectone," the special Hoffay sound box and diaphragm, have decided to place the "Resurrectone" and a new "Half Fork-Tone" sound box and diaphragm on the market. Joseph Hoffay, president of the company, decided on this move some time ago in answer to many requests the company has received throughout the past year. In speaking of the release of these products Mr. Hoffay said: "I owe a lot of apologies to those to whom in the past we refused our products to, owing to the policy of the company in force up to this time."

The Hoffay announcement appears on another page of this issue of The World, and among other things of interest to the trade is technical description of the action of vibrations on the diaphragm.

The Hoffay Co. will shortly inaugurate a campaign of publicity in behalf of their product. The various specialties will be illustrated and every feature will be numbered in accordance with an accompanying description.

SOLDIERS AND THE VICTROLA

Squad in New York Transports Machines and Records Very Carefully Through Streets

A convincing illustration of the part played by the talking machine in the life of the soldier was seen on one of the principal streets in New York recently. A squad of twelve or fourteen men in charge of a corporal was parading alongside the sidewalk in the column of twos, the first two men carrying between them a Victrola IX and one of the men in the rear transporting a sizable bundle of records. The Victrola was fully exposed so the public could gaze and be impressed with the instrument and the guard of honor that accompanied it, just to show, as it were, how essential is music.

"THORNTON BURGESS" WEEK

February 25 to March 2 Designated by the Columbia Co. as "Thornton Burgess" Week—Under Auspices of Educational Department

The week of February 25-March 2 has been designated by the Columbia Graphophone Co. as "Thornton Burgess" week, and under the auspices of the company's education department, an interesting and practical campaign will be instituted to stimulate the public's interest in the Thornton Burgess Columbia records during this week.

As announced recently in The World, Thornton Burgess, creator of the famous "Bed-Time" stories for children has made a series of these famous stories for the Columbia Co., exclusively. These records have already met with a remarkable sale throughout the country, and Columbia dealers are unanimous in acclaiming them as the best selling children's records that have yet been introduced.

According to its present plans "Thornton Burgess" week will be observed by the use of full-page advertisements in the Saturday Evening Post and the Youth's Companion featuring these records. These pages will appear in the issue of February 28, and three other advertisements will appear in the long list of newspapers that are included on the Columbia advertising schedule. The value of this publicity is tremendous, and this advertising, together with the special window display, counter-cards, leaflets, etc., prepared by the Columbia advertising division cannot fail to arouse the public's interest in these "Bed-time Stories."



Thornton Burgess

We have a
Splendid
Proposition for
Live Dealers

Delpheon

The
Incomparable

Six Models
Retailing From
\$75 to \$175

DELPHEON SALES COMPANY

Distributors
25 CHURCH STREET, NEW YORK
Telephone—Cortland 4744



\$15 Retail

Shelton Electric Talking Machine Motor

FULLY GUARANTEED FOR ONE YEAR

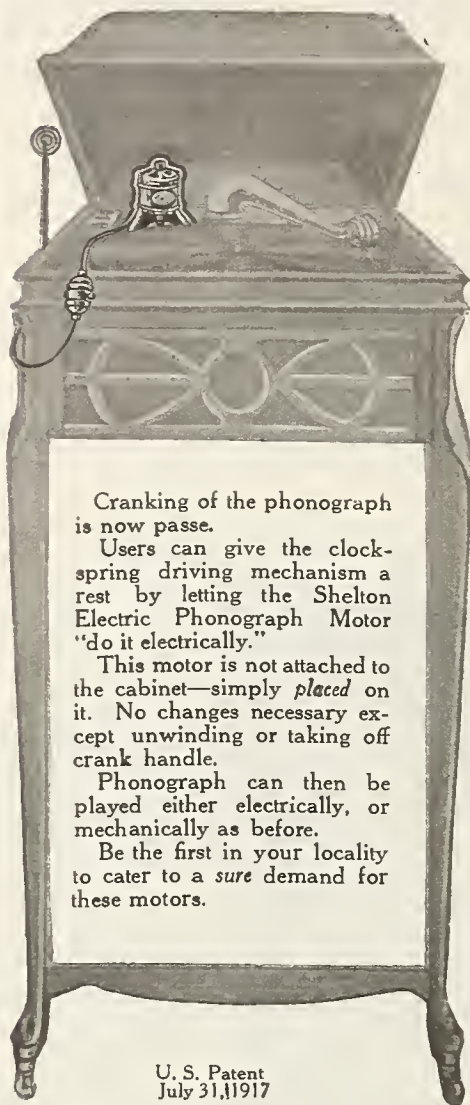

Cranking of the phonograph is now passe.

Users can give the clock-spring driving mechanism a rest by letting the Shelton Electric Phonograph Motor "do it electrically."

This motor is not attached to the cabinet—simply placed on it. No changes necessary except unwinding or taking off crank handle.

Phonograph can then be played either electrically, or mechanically as before.

Be the first in your locality to cater to a sure demand for these motors.

U. S. Patent July 31, 1917

SHELTON ELECTRIC CO.

NEW YORK—30 East 42nd Street
CHICAGO—30 East Randolph Street
BOSTON—101 Tremont Street
SAN FRANCISCO—62 Post Street

TALKS BY GEORGE W. HOPKINS

Will Give Series of Advertising Talks at Ad Men's Club—Arthur C. Erisman in Town

George W. Hopkins, general sales manager of the Columbia Graphophone Co., New York, will make a series of advertising talks on alternate Fridays at the headquarters of the Advertising Men's Club of New York. Mr. Hopkins gave the first talk in this series last Friday, his subject being "Practical Application of Business Psychology," and the interest which was accorded his address is indicated by the fact that there was a larger attendance at the clubhouse to hear Mr. Hopkins than at any similar event in the history of the club.

Arthur C. Erisman, president of the Grafonola Co., of New England, exclusive Columbia dealer, was a visitor last week at the executive offices of the Columbia Co., in the Woolworth Building, New York. Mr. Erisman spoke optimistically of the business situation in his territory, stating that his company's sales for the past six weeks had been far ahead of expectations, and indicative of a gratifying industrial outlook for the new year.

Other visitors this week at the Columbia executive offices were Messrs. White, representing the Southern Furniture Co., Richmond, Va.; Mr. Koteen, representing the Virginia Mercantile Corp., Norfolk, Va., and Mr. Kades, of Miller & Kades, Harrisburg, Pa.

EXPEDITING FREIGHT DELIVERY

A. J. Marshall, an Authority on Electric Vehicles, Proposes Means for Eliminating Confusion Now Existing in Trucking

Interesting suggestions for remedying inefficiencies at railroad terminals and in the present methods of hauling goods to and from such terminals have been submitted by A. Jackson Marshall, secretary of the Electric Vehicle Section of the National Electric Light Association. The subject is of immediate interest to members of the talking machine industry.

To emphasize the need of improvements Mr. Marshall makes the statement that where the cost of transporting freight from Philadelphia to New York by rail is 27 cents a ton, the terminal charges amount to no less than \$3.65. Even for the long haul between Chicago and New York the terminal charges are 65 cents more per ton than the rail charge.

Considerable delay and consequent confusion result from uneven demands on terminals for service. Trucks deliver freight at the terminals and call for freight at the same time, the result being that long lines of vehicles wait for service. This lack of schedule, and the inability to serve trucks properly, owing to inadequate facilities at the terminals, not only block the streets but entail considerable monetary loss due to idle investments represented by the waiting trucks.

Mr. Marshall suggests that a more reasonably uniform demand on terminals would reduce congestion, make possible the use of fewer trucks and drivers, and improve traffic conditions in the streets. He thinks that co-operation of individual trucking interests, resulting possibly in an arrangement whereby a few well-organized truck concerns would handle the bulk of the freight, would tend to expedite freight handling. Co-operation with experienced concerns such as the express companies is also urged. Another suggestion is that a plan could be worked out whereby the railroads themselves, or operating through a co-operative truck concern, could handle freight directly from shipper to consignee, thus minimizing confusion and effecting many economies.

The interesting proposal is made that much of the freight could be handled at night by noiseless trucks, with trailers if necessary. These trucks would not have to contend with the usual daytime congestion in the streets, and would in fact help to reduce such congestion. The railroads work on a 24-hour schedule, and it is expecting too much of the terminals to hold up their end with only a ten or twelve hour day.

The Commercial Economy Board, Council of National Defense, has been investigating the subject of co-operative deliveries, and has found that when such systems are properly organized and managed savings of no mean proportions have been effected. Mr. Marshall thinks that the country is likely to witness extensions of co-operative delivery systems in the not-far-distant future, especially if the war continues for any length of time.

Make your store a receiving headquarters for talking machine outfits donated to the fighting men—it will help.

BUILDING UP GOOD BUSINESS

How the Armstrong Drug Co. Is Featuring the Brunswick Phonograph and Pathé Records in Pontiac, Ill., to Good Purpose

PONTIAC, ILL., February 9.—The photograph of the store of the Armstrong Drug Co., of this city, illustrates the manner in which talking machines can be carried and displayed effectually in connection with other lines and where the space is limited. The Armstrong Drug Co. handles a full line of Brunswick phonographs



Armstrong Drug Co.'s Brunswick Display

and Pathé records and is pushing this end of the business vigorously. Mr. Armstrong has the able assistance of Dave C. Miller and Mr. Horn, and the results of the holiday trade made them very enthusiastic regarding Brunswick phonographs as an annex to the drug business. They are not only getting a good business from the town, but are going aggressively after the country trade and are getting it. The Armstrong deal was engineered by E. S. Bristol, who travels the northern Illinois territory for the Brunswick people. He is a man who believes in service of a constructive kind as the dealers he calls on can justify.

THE BRONX EXPOSITION

Governors of Several States and Others Associated in an Advisory Capacity

The management of the New York Permanent International Industrial Exposition, which opens in the Bronx next Memorial Day, has announced the association with the project in an honorary advisory capacity of the Governors of a score of States, United States Senators, members of Congress, Mayors of many large cities, and men prominent in financial and commercial affairs throughout the country. The chairman of the committee is Governor Charles S. Whitman, of New York.

Invitations to join the committee and to assist in the effort of the Exposition management to establish in New York a permanent nation-wide market place have been extended to the Governors of additional States and the Mayors of the larger municipalities. It is hoped that in this manner the manufacturing interests throughout the entire country will be interested in joining in a concerted effort to expand American trade in foreign lands, especially South America, and in the education of the masses of the people along lines of thrift and economy.

Now is the time to push those "slow-selling" records.

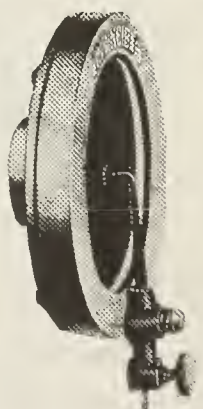

The "INVINCIBLE"

A New and Better Sound-Box

- ☑ Plays all makes of records.
- ☑ Pure, clear and sweet tone.
- ☑ Constructed to give service and absolutely guaranteed.
- ☑ No superfluous parts, and production uniform—no seconds
- ☑ Supplied with mica or composition diaphragms.

WRITE TODAY FOR SAMPLES AND PRICES

NEW JERSEY REPRODUCER CO.

847 Broad Street NEWARK, N. J.

ILSLEY'S GRAPHITE PHONO SPRING LUBRICANT
 Ilsley's Lubricant makes the Motor make good
 Is prepared in the proper consistency, will not run out, dry up, or become sticky or rancid. Remains in its original form indefinitely.
 Write for special proposition to Jobbers.
 MANUFACTURED BY
ILSLEY-DOUBLEDAY & CO., 229-231 Front St., New York
 Established 1853

ENLARGE CAPACITY OF DEAN PLANT

Demand for Dean Needles Necessitates This Important Move—Doing Phenomenal Business—Looks Like 1918 Will Be Biggest Year

Adolph Heineman of the Otto Heineman Phonograph Supply Co., Inc., who is in charge of the John M. Dean division of the company, states this week that arrangements are now being made whereby the capacity of the Dean needle factories will soon be tripled. Mr. Heineman and his associates are working indefatigably to co-operate with the Dean clientele, and it now seems as though these efforts will be productive of gratifying results.

Mr. Heineman states that the company has closed a phenomenal business the past few weeks, the total business being limited only by the factory capacity. The Dean steel needle is winning new friends day by day and Mr. Heineman has expressed his appreciation of the broad-minded spirit of the company's patrons, which has taken into consideration the many obstacles and handicaps that have confronted manufacturers since the first of the new year.

REMOVE EXECUTIVE OFFICES

The New Jersey Reproducer Co., Now Located at 847 Broad Street, Newark, Has Considerably Larger Floor Space—Business Excellent

The New Jersey Reproducer Co., manufacturer of the "Invincible" sound box has removed its executive offices from 10 Oliver street to 847 Broad street, Newark, N. J. In its new quarters the company has considerably more floor space than in its old home, and moreover, the present offices are in the heart of the business section of the city, easily accessible to all modes of travel.

Hector Pocaroba, sales manager of the New Jersey Reproducer Co., is now away on a Western and Canadian trip, and to date has been very successful in interesting the trade in the company's sound box. He states that in his opinion it does not require an expert salesman to sell the "Invincible," for a demonstration of its tone quality invariably results in the placing of an order.

Mr. Pocaroba recently returned from a trip through the New England States, where he closed several deals with prominent houses, and made arrangements whereby the "Invincible" will be included in the equipment of a number of successful machines. He states that the fact that the "Invincible" plays all types of records has helped materially in the introduction of this new sound box.

DON'T LIKE SLOW ACCOUNTS

How credit conditions are viewed in other industries is of interest to members of the music trade industry. For instance, the New York Times says: "There is a retail credit man in this city who takes issue with those of his profession who insist that certain accounts are good even if they are slow. His contention is that no account which is always slow can ultimately be good, and in addition to this it is a very hard account to handle. 'Suppose an account is slow sixty days,' he said yesterday. 'That makes an actual loss of 1 per cent. for the store. Even if interest is paid on an account of this kind, there is still a question of loss through the creditor's not being able to use his money in the meantime for earning discounts on merchandise he buys, etc. For this reason, if no other, it must be conceded that a slow account cannot be profitable in the long run and should be avoided.'"

RECORD VERSUS SHEET MUSIC SALES

One Publisher Sells Only 40,000 Copies of a Certain Song But Receives Royalties on Over 70,000 Records From a Single Company

When the present copyright law, that of 1909, first went into effect with its provision that the owner of the copyright receive 2 cents per copy for the mechanical reproduction of his music, there was considerable unfavorable comment from music publishers and song writers regarding that phase of the measure. With checks for hundreds or thousands of dollars received regularly from talking machine companies in settlement of royalty statements, these complaints have dropped off to practically nothing.

Just what the talking machine records do towards increasing the income of the copyright owner, who is most generally the publisher of the music, was brought to light in a recent case in New York, where one talking machine company made a return of 2 cents each for 71,000 records of a certain number, while the sale of the number in sheet music form totaled only slightly over 40,000 copies. In other words, there were nearly two records sold for every copy of the music itself.

AN INTERESTING LETTER

Recording Department of Columbia Co. Receives a Letter in Spanish From Would-be Recording Artist Who Admits He Is a Wonder

The recording department of the Columbia Graphophone Co., New York, received the other day a letter which brought a smile to the most confirmed pessimist in the building, for if self-valuation can be considered as a recommendation the writer of this letter is destined to become one of the world's greatest singers.

In this letter which is written in Spanish, the sender makes a request to be enrolled as a Columbia artist, and in part says:

"In this community my name has obtained so much fame that I am considered one of the best singers in the northern section of my State, and if you will consider me as such on the strength of my word, I will be ready to give you entire satisfaction, because I have always won fame which was practically impossible of attainment.

"I am voluntarily demonstrating the gift with which God endowed me. I should like to show the public in general the little success that I have obtained in my profession. It doesn't make any difference, I can even sing songs in English, and I hope to the omnipotent God that some day I will be one of the greatest singers in history.

"While it is true that up to the present I have not taken any lessons to sing for phonographic recordings, judging from my ability I figure that it would not take me even one-quarter of the time that it takes others, and I am only twenty-nine years of age.

"If you don't avail yourselves of my services after I have given you the first chance, and wherefor I shall wait until I receive your answer to see whether I can secure a place with you, I shall be obliged to communicate with the _____ Co., to whom, I believe, I have already been recommended."

R. B. CALDWELL AT HIS DESK

The many friends in the trade of R. B. Caldwell, sales manager of the Pathéphone Sales Co. of New York, Pathé distributors, will be glad to learn that this popular "veteran" of the talking machine industry is now on the road to permanent recovery, after being confined to his home for fourteen weeks. On election night Mr. Caldwell was waylaid by highwaymen on Eighteenth street, New York, and injured to such an extent that his condition was considered critical for several weeks. He suffered two relapses in December and January, but is now back at his desk, and visiting the Pathé dealers in his territory.



**THE WONDERFUL
 "RESURRECTONE"
 and the
 "HALF-FORK-TONE"**

Here are illustrated and described the two supreme reproducers, which are now sold to fit machines of other makes, to show what is the minimum tone that can be expected from the "HOFFAY"—the unusual "Airtight-phone."

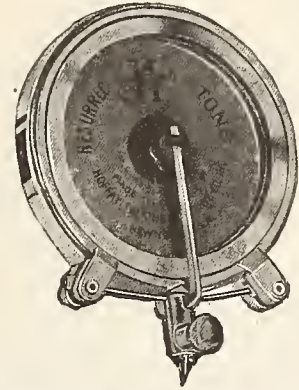

PRICE: Nickel-plated \$10. 22 karat gold plated \$12.50. To fit Victors, Sonoras, and attachments for Edison machines, etc. Money refunded if reproducer returned within 5 days from receipt.

Naturalness of sound requires accuracy of diaphragm vibration, which varies according to pitch. For instance, when the Bass strikes "E," there are 160 vibrations per second; when the Tenor strikes "C," there are 512 vibrations; and when the Soprano strikes "C" (high C) 2048 musical vibrations are transmitted to diaphragm every second of time. The terrific rapidity of vibration bends the one arm lever which moves the diaphragm to the extent of the resiliency of the lever, each bending adding additional superfluous vibrations (on account of the "reaction" of the one arm lever) thus making sounds higher in pitch and "strident"—in fact, artificial.

In the "RESURRECTONE," the diaphragm is vibrated by a "tuning-fork" working on both sides, the resiliency of the two arms being automatically "taken up," accuracy of vibration and "naturalness" of sound being therefore accomplished facts.

In the "RESURRECTONE," the connection of the two arms to the diaphragm is of the HOFFAY flexible kind, which is another exclusive feature making this reproducer absolutely superior to all others. In the "HALF-FORK-TONE" a one-arm lever rigidly connected vibrates the diaphragm, instead of the "tuning-fork."

The "HALF-FORK-TONE" is still much better than reproducers of other makes because the lever is supported by the other remarkable exclusive features of the "RESURRECTONE"—including the "flexed" Piano Wire Mounting which "tunes-up" the sound, and which has the additional great value of being "insulated" from the casing of the reproducer.

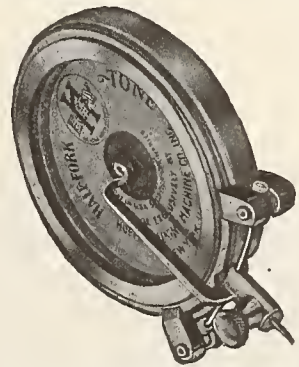

PRICE: Nickel-plated \$6. 22 karat gold plated \$7.50. To fit standard machines and attachments for Edisons. Money refunded if reproducer returned within five days from receipt.

Order a sample; improve your machine; increase the value of your records, and learn by actual test how much better the complete "HOFFAY" instrument must be than most other machines. "Tone" requires "airtightness" and the "RESURRECTONE," "HALF-FORK-TONE," as well as the "HOFFAY" are absolutely "airtight."

**Hoffay Talking Machine Co.
 INCORPORATED
 3 West 29th Street NEW YORK**





Are you selling your share of the **Columbia Records** which the folks at home are buying for their soldier boys? Remember there's a **Columbia Grafonola** in every **Y. M. C. A.** and **Knights of Columbus Army Hut.**

Columbia Graphophone Co.
Woolworth Building, New York

READY TO DELIVER NEEDLES

Blackman Talking Machine Co. Reports That Supplies Are Now More Plentiful

The Blackman Talking Machine Co., New York, has frequently called the attention of its dealers to the fact that the needle situation has been so uncertain the past few months that it has been unable to do other than try to fill the very urgent orders. J. Newcomb Blackman, president of the company, has just advised the trade, however, that the company is now able to see a little "daylight," and is ready to make reasonably prompt needle deliveries.

The Blackman Talking Machine Co. is sole distributor for the "Playrite" and "Melotone" brands of steel needles, both of which have attained considerable popularity throughout the country. A timely suggestion from the company advises the dealers to anticipate their needle orders wherever possible in order to take advantage of the slight improvement in the general situation.

HOW SELFRIDGE MET CONDITIONS

Famous English Merchant Tells How He Re-adjusted His Business to Meet War Needs—Some Lessons for American Business Men

The pressure brought about through war demands in the United States has resulted in no small degree of pessimism among certain manufacturers and business men, who professedly are patriotic, but who apparently suffer from "cold feet." To those people who feel like dropping their advertising, laying off their force and closing up shop, metaphorically speaking, we commend the attitude of Gordon Selfridge, the prominent London merchant, who was one merchant in England who refused to lose his head when the war broke out; who refused to cut salaries, or slash expenses; who refused to

OHIO EDISON DEALER GIVES PROOF OF GOOD BUSINESS

The excellent volume of holiday business handled by N. E. Olin & Son, Edison phonograph dealers at Kent, O., and particularly the

some of the cases were occupied by machines so they could sell them over again, and thereby take care of the steadily growing demand.



Each Empty Case Represents an Edison Phonograph Sold by N. E. Olin & Son

number of machines sold, is indicated by the array of empty cases which contained machines disposed of during Christmas time. Now the members of the company wish at times that

Olin & Son report that business for January has opened up most satisfactorily and they are exceedingly optimistic over the business outlook for 1918.

believe that the end of the world had come. That merchant happens to be an American, and last year his store paid the English Government an excess profits tax of \$200,000.

"When the war broke out," Mr. Selfridge told George T. Bye, of The Nation's Business, "it was the general opinion that the end had come for business. Many merchants reduced staffs and cut wages. The second or third day of the war I was waited upon by a committee of our buyers, who informed me that they were sure of heavy losses, and that they wished to see it through with me on a half-salary basis.

"But I wasn't sure business was going to be bad, and, with thanks for their loyalty and good spirit, I told every one in the house that Self-

ridge's would make no changes for the present. To that stand we owe something of our present prosperity. By keeping on our brightest face, spending more money for advertising, and serving our patrons with greater attention, we have increased our business to a volume of over \$15,000,000—a gain of \$2,500,000 in one year."

Mr. Selfridge took advantage of every twist in the war situation. He advertised that every person in his store during any German aeroplane attack was insured free, without preliminary registration, to the amount of \$5,000 for death resulting directly from the raid. The result was to make every woman turn to his store as a safe place to shop and lunch; and to direct public attention to its solid concrete construction. He has consistently sold "war bread" a cent or two cents a loaf lower than any one else in London—another great trade attracter.

But most important has been the maintenance of his personnel, and the adaptation of his line of goods to meet the changed conditions.

As fast as men have been called away, he has substituted women workers; and many of these, he says, will never be replaced by men. And he has foreseen each shift in the public demand, and provided for it. The luxuries of the rich early ceased to be a factor in his trade, as social life in London quickly diminished; but the luxuries of the poor—inexpensive pianos and jewelry and the like—have rapidly grown more important as the wages of workers have risen.

His advice to the American merchant is:

"Keep your business going at high pressure. Watch with the greatest care your organization, and your ability to fill with women or men above enlistment age the posts vacated by men called away. Watch the market, and keep your stock as full and up-to-date as you can."



THE LATEST



ALBUM

No. 1012

This album has heavy green envelopes, interlocked so that each envelope forms an individual record container. Both ends are finished with brass metal tops as shown in illustration.

Best Value on the Market for the Money

NYACCO METAL BACK ALBUMS

The Only Metal Back Album Manufactured.

A Leader in the Album Field

Write for Samples and Prices

NEW YORK ALBUM & CARD CO.

23-25 Lispenard St., New York

R. F. BOLTON IN NEW POST

Appointed This Week as Sales Manager of the International Record Department of the Columbia Graphophone Co.

George W. Hopkins, general sales manager of the Columbia Graphophone Co., New York, announced this week the appointment of R. F. Bolton as sales manager of the Columbia international record department. Mr. Bolton has already assumed his new duties, with headquarters at 104 West Thirty-eighth street, New York.



R. F. Bolton

R. F. Bolton is one of the most popular and best-posted members of the talking machine industry, having been associated with the Columbia Co. for twenty years. During this time he has occupied posts of importance and responsibility, and has always been in close touch with the Columbia dealers. He enters his new work with the determination to co-operate with Columbia representatives in every possible way, with the idea of materially increasing their foreign record sales.

The success of the Columbia Co.'s international record department has been one of the salient factors in the company's remarkable growth the past few years. Anton Heindl, manager of this department, is thoroughly versed in all the intimate details of this important branch of the business, and as one Columbia dealer remarked the other day: "The combination of Heindl and Bolton will doubtless mean big things for the Columbia international record department."

HONOR EDISON ON BIRTHDAY

Edison Disc Jobbers' Association Pay Strong Tribute to the Patriotic Work of Thomas A. Edison on Occasion of 71st Birthday

The Edison Disc Jobbers' Association, made up of the jobbers of Edison phonographs and records throughout the United States and Canada, recently sent the following letter to Thomas A. Edison upon the occasion of his seventy-first birthday anniversary on February 11.

Indianapolis, Ind., Feb. 11, 1918.

Mr. Thomas Alva Edison:

Greetings and congratulations to you on your seventy-first birthday. The Edison Disc Jobbers' Association, representing the entire body of distributors of the Amberola and Edison Disc phonograph products in the United States of America and the Dominion of Canada, unite in extending to you a warm greeting on this, your seventy-first birthday.

Our association with the name of Edison is always the source of great personal satisfaction to each and every one of us, but as we extend our greetings to you, sir, on this, your seventy-first birthday, we bring with them a deep sense of gratitude for your untiring devotion to your country and the cause of democracy throughout the world.

We are proud of you, Mr. Edison, and while you are throwing your great energy into the fight against the brutal autocracy that threatens the future of every liberty-loving people of the earth, please accept our pledge of unswerving loyalty to you and yours, through each trying hour of the task you have so nobly and cheerfully undertaken for mankind. We will try to profit by your splendid example and courage and we wish you many, many happy returns of this day.

Very obediently yours,

WALTER E. KIPP, President,
L. N. BLOOM, Vice-President,
FRANK E. BOLWAY, Secretary,
H. HARGER BLISH, JR., Treasurer,
A. H. CURRY, Executive Committee,
W. L. F. ROSENBLATT,
E. BOWMAN.

A PHILADELPHIA INCORPORATION

The North Philadelphia Talking Machine Co., Philadelphia, Pa., has been incorporated, with a capital stock of \$10,000, by Henry A. Gautschi and others.

Pudney & Howland, a new firm which will open a music store at 18 Broad street, Ossining, N. Y., on March 1 will feature Victrolas as well as pianos.

MURATORE WINS IN NEW YORK

Leading Tenor of Chicago Opera Co. Accorded Great Reception in Metropolis—Pathé Records of His Voice in Great Demand These Days

One of the outstanding factors in the remarkable success achieved by the Chicago Opera Co. in its New York season which recently started at the Lexington Theatre has been the individual honors accorded Lucien Muratore, leading tenor of the company, and one of the greatest artists of the present generation. Mr. Muratore has appeared at a number of performances at the Lexington Theatre, and every



Lucien Muratore

role in which he has been presented has served to enhance his fame and renown. Not since the days of Jean de Reszke has any tenor won such public acclaim.

Although Muratore had been accorded the most enthusiastic praise by Chicago musical critics, and his appearance with the Chicago Opera Co. in this city had been heralded as one of the "star" events of this company's local season, the New York music-loving public was hardly prepared for the superb brilliancy of Muratore's voice. Every local critic referred to his New York debut as an epoch-making event in operatic history, and each succeeding performance helped to augment this spontaneous praise and acclaim.

Muratore is an exclusive Pathé artist, and his Pathé records have been sold in large quantities by Pathé dealers everywhere. The Pathé Frères Co. has been congratulated upon their acquisition of Muratore as one of their artists, and this company's local representatives have taken advantage of the New York season of the Chicago Opera Co. to feature Muratore's records to excellent advantage.

AN OPPORTUNITY

to secure a TALKING MACHINE at a very low cost



We have left over from a large contract a number of cabinets, all of which we have equipped with mechanisms, making a complete Talking Machine, as illustrated. While they last, we offer them at **\$6.50 each**, net cash, F.O.B. our factory. Orders for less than five machines will not be accepted.

Specifications

Oak or Mahogany Cabinet, 15 in. wide, 17 in. deep, 8 in. high. Nickel-plated Tone Arm and Soundbox. Single Spring Motor. 10 in. Turntable.

THE GEORGE A. LONG CABINET COMPANY
HANOVER, PA.

PRIZES AWARDED FOR EDISON WEEK WINDOW DISPLAYS

Adam Schaaf, Chicago, Wins First Prize, With Capwell's Department Store, Oakland, Cal., Second, and A. D. Elster, Meriden, Conn., Third—Great Interest in Contest

Winners of the three grand prizes of \$300 for first prize, \$125 for second prize and \$75 for third prize in the Edison Week (1917) Dealers' Window Display Contest have just been announced. They are: First, Adam Schaaf, Chicago; second, Capwell's Department Store, Oakland, Cal.; third, A. D. Elster, Meriden, Conn.

This contest was entirely in the hands of Edison jobbers with the exception that the Edison Laboratories offered to give three prizes to the best three photographs submitted in the United States and Canada. Each jobber conducted a contest in his zone in accordance with rules laid down by him and gave from three to seven prizes, winners of first and second prizes being eligible for the grand prizes. This method necessitated a considerable length of time to eliminate non-winners in the various zones, to forward all of the photographs to Orange and have the non-winners in the grand prize contest eliminated.

An unusually large number of attractive displays were entered in the contest which is indicated by the three prize winners illustrated on this page. A considerable improvement over the previous year's display was readily noticeable, not only from a purely decorative standpoint but from the success of the dealers in telling the story of Mr. Edison's new art—Music's Re-Creation—by means of their displays. Many displays

a clever illusion, was in continuous movement. In front of the Faust scene were arranged six

Edison Re-Creations from "Faust" and the same number of Gioconda selections in front of the other scene.

CARD No. 1

Faust Re-Created on the New Edison
Gounod's opera "Faust" is recognized as one of the world's greatest operatic masterpieces. To every voice is allotted a superb aria—each one in itself sufficient to make Faust famous.



Adam Schaaf Store, Chicago, Winner of First Prize

The Jewel Song—soprano solo, Alice Verlet. Edison Re-Creation No. 82086.

The Flower Song—contralto solo, Eleanora de Cisneros. Edison Re-Creation No. 82519.

All Hail Thou Dwelling Lowly—tenor solo, Paul Alt-house. Edison Re-Creation No. 82096.

Even Bravest Heart—haritone solo, Thomas Chalmers. Edison Re-Creation No. 82060.

In addition to these magnificent solos, there is the great swelling Soldiers' Chorus—Edison Re-Creation No. 80121, and the graceful, melodious Faust Waltzes No. 80353. With the New Edison you can Re-Creat "Faust" right in your own home and by artists noted for their exquisite interpretation.

Another interesting feature was the ten news clippings from such well-known papers as the New York Tribune, Philadelphia Ledger, Detroit Free Press, San Francisco Chronicle and other famous newspapers. The heading of each paper was obtained and posted on the showcards and the wording was arranged as on the front page of the newspaper with cuts of the different Edison artists as they appeared in the concerts described.

CARD No. 2

A Musical Triumph in the Life of Edison
The ten news clippings here reproduced contain extracts from articles written by musical critics of five hundred of America's principal newspapers, after hearing artists sing in direct comparison with Edison Re-Creations of their work. Two thousand five hundred different materials and compositions had to be tried and discarded, and more than one million dollars expended in research work, before Mr. Edison obtained his desired result.



Capwell's Department Store, Oakland, Cal., Second Prize Winner

included life-size figures standing beside the laboratory model of the New Edison to represent Edison artists as they sing in direct comparison with the New Edison at the tone tests, which have been witnessed by upwards of 2,000,000 music lovers and music critics on approximately 1,500 different occasions, with the result that the auditors failed to distinguish the faintest difference between the actual voice and the New Edison's Re-Creation of it. Thirty noted Edison artists have participated in these tests, which have taken place in all parts of the United States and most of Canada.

The first prize winning display in the Grand Prize Contest was truly a masterpiece in the art of window dressing, as one glance at the reproduction on this page will readily confirm. The following description of this window will help to visualize its attractiveness:

Several novel ideas were introduced in this display, among which the most noteworthy were the two stage pictures—the garden scene from "Faust," portraying Alice Verlet singing the Jewel aria, and the very beautiful ship scene from "La Gioconda." These scenes were painted by artists and arranged exactly like stage settings, lighted by twenty incandescent concealed lights, and made a very realistic appearance. Even the moon appeared in one of the scenes and the moonrays were playing on the water, which, by



Display of A. D. Elster, Meriden, Conn., Which Won Third Prize

Joseph C. Smith and his famous dance orchestra are now making records for Columbia. Like all Columbia Dance Records, they sell themselves.

**Columbia Graphophone Co.
Woolworth Building, New York**



The color scheme of the display was pink, black and gold, and the friezes representing grand opera were painted in light water colors and mounted on black velvet which made a very beautiful and strong contrast. Five New Edisons and twenty Edison Re-Creations were displayed.

AN INTERESTING ANNOUNCEMENT

Name Desired for the New Steel Needles of the Record Needle & Mfg. Co., Milwaukee

The Record Needle & Mfg. Co., of Milwaukee, Wis., have a very interesting announcement in another part of The World, in which they ask the co-operation of the trade in selecting a fitting name for their new steel needles. H. A. Goldsmith, who is actively interested in this enterprise, is a practical talking machine man, who is fully acquainted with the needs of the trade, and it goes without saying that whatever he and those associated with him place on the market will be most reliable and satisfactory. The company are planning to conduct a large volume of business during 1918, and they have already booked some very large orders.

O. K. HOUCK AIDS HOSPITAL FUND

Well-Known Piano Man of Memphis Works Hard to Corner the Dollars

MEMPHIS, TENN., February 5.—O. K. Houck, of the O. K. Houck Piano Co., is one of the most active workers in raising a fund of \$200,000 for the Baptist Memorial Hospital in this city. Mr. Houck has not only worked hard in getting actual subscriptions, but has been one of the principal speakers at the various meetings held to stimulate the work. Mr. Houck's well-known fund of humor has in many cases gotten more results than some of the more serious discussions of other business men.

E. L. THOMPSON A WINNER

E. L. Thompson, a member of the local wholesale branch of the Columbia Graphophone Co., 55 Warren street, was the winner of the President Whitten individual salesman's cup for the month of December in this district. This was Mr. Thompson's first victory, and the contest for permanent possession of the trophy continues to be "fast and furious."

TWO COLUMBIA ARTISTS SCORE

Mme. Barrientos and Hipolito Lazaro Win Triumph at Metropolitan Opera House

Two famous Columbia artists, Hipolito Lazaro and Mme. Maria Barrientos, figured prominently in New York's operatic news this month, for both made their initial 1918 appearance with the Metropolitan Opera Co. Mme. Barrientos had made her debut with this opera company in the season of 1915-1916, but Lazaro's performance in "Rigoletto" last week marked his initial appearance at the Metropolitan Opera House.

Both of these artists won the enthusiastic praise of the musical critics, their performance in the leading roles in "Rigoletto" being re-

debut with the Metropolitan Opera Co. was one of the sensations of that season.

Hipolito Lazaro is considered one of the greatest tenors of recent times, and his appearance in Spain, Italy, Buenos Aires, London



Mme. Maria Barrientos

ferred to as one of the finest renditions of this popular opera that has been heard in recent years. These artists are scheduled for a number of performances this season at the Metropolitan Opera House, and their 1918 debut augurs well for their continued success at America's celebrated opera house.

Mme. Maria Barrientos and Hipolito Lazaro are both exclusive Columbia artists, and their Columbia records have already met with a very favorable reception throughout the country. Mme. Barrientos is a coloratura soprano who has achieved fame here and abroad, and her



Hipolito Lazaro

and Havana has given him international renown. He has won praise from distinguished critics for the remarkable range and power of his voice, and his Columbia records have served to add to his laurels as a tenor who will be an invaluable contributor to the history of operatic music.

MICKEL BROS. CO. HANDLING PIANOS

The Prominent Victor Jobbers of Omaha Are Now Handling Pianos and Players

OMAHA, NEB., January 28.—The Mickel Bros. Co., jobbers of Victor talking machines and records, with headquarters at Fifteenth and Harney streets, this city, who also carry other specialties, are now handling pianos and are working up a nice and satisfactory trade with the Packard and Hobart M. Cable pianos and player-pianos. The Mickel Bros. Co. are widely known throughout the State of Nebraska and have a big trade following.

Do You Collect Your Accounts?

FOR some time past we have been using a follow up system of collecting both our installment and open accounts that has brought us wonderful results. 90% of the work done right in your office. Saves attorneys' fees and keeps the good will and patronage of your customer.

The complete layout, simply explained, sent for \$5.00. Cash with order. We refer you to any Victor, Edison or Columbia Jobber in our section as to our reliability.

HYATT TALKING MACHINE CO., Portland, Oregon

Lufranc Quality



THE SAFEST ENVELOPES MADE

RECORD DELIVERY ENVELOPES

START THE NEW YEAR WITH A GOOD SUPPLY by Placing Your Order Now

Samples and Prices Furnished Cheerfully

Write Today Get the Best Always

LEWIS C. FRANK

654 Book Building

DETROIT, MICH.

T. M. W. 1217

WORLD'S CLASSIFIED ADVERTISING

Any member of the trade may forward to this office a "Situation" advertisement intended for this Department to occupy a space of four lines, agree measure, and it will be inserted free. Replies will also be forwarded without cost. Additional space will be at the rate of 25c. per line. If bold faced type is desired the cost of same will be 25c. per line.

POSITION WANTED—9 years' experience in Victor business, at present connected with large retail store in New York City. Am desirous of making a change and would consider taking charge of Victrola department with reliable firm. Capable of showing results. Know the Victor catalog thoroughly, and previous experience in handling salesmen, and have had several years' experience in charge of Victor department. Can furnish highest references from previous and present employers. Address "Box 492," care The Talking Machine World, 373 Fourth Ave., New York.

WANTED—To get in touch with some one with about \$25,000 to take half interest in an A1 talking machine manufacturing, paying, business. Plenty of cash customers and over \$40,000 worth of assets. A big chance for man with money. Entire plant, machinery, etc., can be moved to any location if desired. If you are interested address "Big Chance," care The Talking Machine World, 373 Fourth Ave., New York.

WANTED—Salesman on commission basis to sell high grade up-to-date talking machines, 3 salesmen for Southern territory and 2 for Eastern. Only those showing capable results need apply. Address Premier Cabinet Co., Williamsport, Pa.

SITUATION WANTED—Middle-aged man with fifteen years' experience in phonograph construction, would like to become associated with honorable concern desiring to build or building talking machines. I have several valuable inventions to offer along with my knowledge of the art for the right concern. Address "Box 486," care The Talking Machine World, 373 Fourth Ave., New York.

POSITION WANTED—A thorough experienced Edison jobbers' traveler and also manager with all the constructive dynamic attributes of character, a live wire and hustler. Can hold and build up trade, enthusiastic and convincing. Highest references from headquarters. Address "Box 485," care The Talking Machine World, 373 Fourth Ave., New York.

WANTED—Large Gramophone company in London is anxious to procure spring motors, tone arms and sound boxes of the highest grade to assemble their machines. At present using 90 per cent. Swiss and the balance British parts, but would like to get hold of good American parts if they can import them. Manufacturers of these parts are requested to communicate with "Box British," care The Talking Machine World, 373 Fourth Ave., New York.

WANTED—A thoroughly experienced Edison Diamond Disc salesman. In applying state age, experience, and give as references names of former employers. A good opening for a high class man. Address "Box 493," care The Talking Machine World, 373 Fourth Ave., New York.

WHOLESALE SALESMAN desires to make change. Well known and has built up successful record. Can furnish best of references from present connection. Victor line preferred. Address "Box 497," care The Talking Machine World, 373 Fourth Ave., New York.

SITUATION WANTED—Man of 12 years' talking machine experience desires a road position, can produce. Make me a proposition. Address "Lyb," care The Talking Machine World, 373 Fourth Ave., New York.

POSITION WANTED—Cabinet superintendent and designer wishes to connect with live concern March 1. Familiar with up-to-date methods. Good executive and knows how to obtain results. Now employed in New York City. Highest references. Forty years old. Address "Box 494," care The Talking Machine World, 373 Fourth Ave., New York.

POSITION WANTED—Manager or superintendent of phonograph factory will be open for position March 1. Now with a firm manufacturing high grade commercial phonographs. Output 125 a day. Am in a position to show how your production can be increased and your merchandise improved without increasing your cost. Specialize on designing period and modern styles, general construction, cost, elimination of waste. Executive ability in handling labor and labor problems. If it's production you need, address "Box 495," care The Talking Machine World, 373 Fourth Ave., New York.

SITUATION WANTED—Experienced Edison salesman and manager desires to make connection with live Edison dealer. Hold similar position now. Address "Box 496," care The Talking Machine World, 373 Fourth Ave., New York.

WANTED—Capable, experienced, reliable person to take charge of disc manufacturing department. Address "Box 480," care The Talking Machine World, 373 Fourth Ave., New York.

WANTED—A position as manager of talking machine store or department. Young, married man of long, practical experience. A1 references. Middle West preferred. Address "E. B. 6," care Talking Machine World, 209 S. State Street, Chicago, Ill.

TRAVELERS visiting talking machine trade can make \$50.00 per week easily, selling our sensational novelty for talking machines as a sideline. Pocket samples. Excellent proposition. Only first class men need apply. State particulars, and district you cover. Address Uniset Reproducer Co., Wabash avenue and Jackson boulevard, Chicago, Ill.

POSITION WANTED—Would like to work in phonograph store or anywhere else in phonograph line. Address "Box 489," care The Talking Machine World, 373 Fourth Ave., New York.

SITUATION WANTED—Experienced Edison salesman and manager open to offer. Hold similar position now. Age 33, married. Address "Box 490," care The Talking Machine World, 373 Fourth Ave., New York.

WANTED—By a New York manufacturer, an expert man to develop a phonograph motor. Answer in detail by letter only, state experience and salary expected. Address M. Weingarten, 286 Fifth Ave., New York.

SITUATION WANTED—Superintendent at present employed, thoroughly familiar with every angle of the phonograph business, desires to make a change. Address "Box 491," care The Talking Machine World, 373 Fourth Ave., New York.

SITUATION WANTED—By high grade finishing foreman. Have had several years' experience on talking machines. Will be open for position February first. Want to connect up with a good, live, growing concern, one that would appreciate first class finishing, production and efficiency in every respect. State amount of men in finishing room, the output whether table or floor cases, the salary you would pay for an A1 man. Address "J. D.," 306 East South Grand Ave., Springfield, Ill.

SITUATION—Mechanical engineer thoroughly understanding the manufacturing of phonograph parts, complete machine assembling or machine work, is open for a position as superintendent or production manager. Highest credentials as to ability. Address "Box 473," care The Talking Machine World, 373 Fourth Ave., New York.

ENERGETIC—Young man with clerical, order and executive experience, familiar with the phonograph record line, desires position in any part of the country. Address Philip Greenberg, 2325 East Sixty-third St., Cleveland, Ohio.

SITUATION WANTED—If it were possible to secure a sales manager who has sold over \$21,000 worth of phonographs, personally, in one year, to manage your department, would you consider him? Have good position now. Will explain reasons for wanting to make a change. Will furnish signed statement of business done. Strictly confidential. Address "Box 472," care The Talking Machine World, 373 Fourth Ave., New York City.

POSITION WANTED by expert mechanic with thorough knowledge of motors, assembling, cabinets and inspection of finished production. Competent to take full charge. Address "Box 487," care The Talking Machine World, 373 Fourth Ave., New York.

SALESMAN—Calling on talking machine and piano dealers, to handle a profitable side-line that may be developed. Territory open. Proposition one that most dealers will not refuse. Steady return on repeat business. Address "Box 488," care The Talking Machine World, 373 Fourth Ave., New York.

WANTED—Experienced salesmen in the talking machine and piano trade (having a slight knowledge of wood finishing will be an asset), to sell a meritorious article as a side line. Write for particulars at once, as territory is going rapidly. Our offer to the trade gets the business for the salesman. Address Master Mfg. Co., Box 96, Camden, N. J.

WANTED—An expert talking machine assembler by a manufacturer in New York City. Permanent position for a man who thoroughly understands the assembling of popular priced machines. Address "Expert," care The Talking Machine World, 373 Fourth Ave., New York.

WANTED—A superintendent for a talking machine plant who is a capable executive and who can organize an efficient working class. We want a progressive and thoroughly efficient man who can take complete charge of the plant, which is one of the most complete in the country. Give full details as to past experience, training, etc. All replies held strictly confidential. Address "Box 476," care The Talking Machine World, 373 Fourth Ave., New York.

WANTED—Experienced talking machine salesmen who are familiar with the wholesale trade, and who are capable of handling a first class line of machines and records. There is an excellent opportunity for the right men, with unlimited earning possibilities. Give full particulars in first letter. This is a proposition that will place the right men with one of the best equipped manufacturers in the trade. Address "Box 477," care The Talking Machine World, 373 Fourth Ave., New York.

WANTED—By a New York distributor an assistant repair man. Salary to start \$14. Address "Repairs," Box 478, care The Talking Machine World, 373 Fourth Ave., New York.

Wall-Kane Needles

60 packages without stand, \$3.90; 60 packages with stand, \$4; 100 packages without stand, \$6.50; single packages, 6 1/2c, any quantity.

ORDER NOW RICHMOND NEEDLE CO., 2014 Fifth Ave., New York Side-Line Salesmen Wanted

FOR SALE

at a very attractive price—6 handsome Unico Music Booths, model No. 2, finished in two tones of French gray enamel. These booths are of double construction throughout, making them as nearly sound proof as possible. Upper panels are of leaded glass. We are moving shortly and these booths must be sacrificed immediately. Write us for full particulars. Neal, Clark & Neal Company, 643 Main Street, Buffalo, N. Y.

STEEL NEEDLES (Extra Loud)

Made in America, of the best Carbon steel wire, 100 needles, in elegant black envelopes, per 1,000 needles \$6.50

Table listing prices for MAIN SPRINGS, GOVERNOR SPRINGS, THUMB SCREWS FOR STYLUS BARS, and MICA DIAPHRAGMS. Includes items like Columbia Motors, Victor Motors, and various needle cups.

FAVORITE PHONOGRAPH ACCESSORY CO. 1491 DeKalb Avenue Brooklyn, N. Y.

FOR SALE

Long established furniture factory, well and favorably known and successful—factory well equipped—150,000 square feet floor space—has had considerable experience in making high grade cabinets—labor conditions good, no unions or labor troubles—cheap labor—good reasons for selling. Correspondence confidential. Address "Phonograph," care The Talking Machine World, 373 Fourth Ave., New York.

SPOT CASH PAID—WANTED

Any amount of records in all languages, Talking Machines, Horn or Hornless, also parts of all makes. Address Phonograph and Record Exchange, 2104 Third Ave., New York. Telephone 7848 Harlem.

STEEL NEEDLES

Loud tone. 200 in envelope. A few million to close out at \$525 per million or 55c per thousand, in hundred-thousand lots. Bargains in motors, tone arms, parts, and complete machines.

FULTON TALKING MACHINE CO. 640 BROADWAY NEW YORK CITY

FOR SALE

Four-minute indestructible records, all new clean stock 10 cents each in 100 lots. Denninger Cycle Co., Rochester, N. Y.

SALESMAN WANTED—Experienced traveling phonograph salesman calling on the retail trade to carry as a side line an exceptional popular priced record. Address "Box F. B. 6," care The Talking Machine World, 209 South State St., Chicago, Ill.

MAGNET DECALCOMANIE NAMEPLATES FOR TALKING MACHINE CABINETS ETC. Includes logos for Doran Co., Hurteau Williams & Co., Kunkel Piano Co., and Smith-Schiffelin Co. with contact information for pamphlets and prices.

FROM OUR EUROPEAN HEADQUARTERS

2 GRESHAM BUILDING, BASINGHALL STREET E. C., LONDON, W. LIONEL STURDY, MANAGER.

Trade Making Slow Recovery After Post-Holiday Reaction—With a Few Notable Exceptions the Dealers Appear to Lack Realization of Publicity Possibilities—Improved Conditions in Machine Market—The Handling of Resharpened Needles—Steel Wire for Needle Making—Handling Accounts in Enemy Countries—W. H. Reynolds, Ltd., in New Home—What the New Record Lists Offer—The Copyright Question Discussed—Invicta Record Co. Recovering From Effects of Fire—Photographing the Voice—Bars Removed Against Dispatch of Catalogs—Other Trade News

announcements of manufacturers, though unfortunately the average dealer this side fails to grasp the value of coupling up his activities and publicity propaganda therewith. One day, I suppose, dealers will come to realize that, as the link between supply and demand, it is up to them to work in close association with the manufacturer, and thus double the value of the latter's expenditure. As it is, the enterprise is all on one side, with the result that a percentage of its selling power—how much it is impossible to estimate these times—is absolutely lost. Now and again one hears of a few real live dealers, like Jake Graham, of Liverpool; Thos. Edens Osborne, of Belfast; Paskell, of London, apart from the big stores, who actively co-operate with manufacturers, but taking the average dealer his apathy in this regard is very disappointing. Indeed, it is fair to say, of at least 50 per cent. of retailers, that they do not sell gramophones and records; people come in and buy them. That is a basic truth, notwithstanding the great difficulties which surround us.

war German monopoly. If this is to be achieved, however, I would suggest that the trade co-ordinate its plans so as to embrace a definite offer of encouragement of any and all legitimate efforts to secure to British interests alone the British gramophone market. This co-ordination should take the solidly practical form of financial support, if possible, and certainly the actual placement of a good order, after a satisfactory demonstration of the motor. Such action would materially assist the manufacturer, enabling him to plan a definite post-war campaign in the interests of British Empire trade. I am not aware that this matter has yet received the attention it deserves at the hands of our trade as a body, though individual support along the lines suggested has not been, and is not, wanting. In this connection, however, there is need for the establishment of a central authority for the encouragement and introduction of a settled plan of campaign along lines of more or less general agreement in conformity with the trade's aims and ambitions, based upon an intimate knowledge of the situation. A "prepared" policy is much preferable to any hasty or haphazard plan evolved at the last minute. The trade should know in advance of peace what it is hoped to accomplish. The best incentive to the success of those aims is to enthuse individuals with the thought that it depends largely upon personal effort of an active, not a passive, nature. Let us try and get each member of the trade to realize this.

LONDON, ENGLAND, E. C., January 30.—As in most countries, the period immediately succeeding Christmas tide is somewhat slack from the viewpoint of talking machine sales. In normal times the British market quickly recovers, and indeed the volume of trade often surpasses the ephemeral pre-holiday rush. To-day all this is changed. The trade recovery is considerably slower, the demand for records and machines being non-progressive. From inquiries around the trade and in conversation with retailers I learn that sales, of records especially, are only just picking up again after a period of somnolence, and now that the pantomimes are in full swing there is every prospect of increasing business. Every gramophone concern has published a list of records bearing the catchy numbers from the chief pantos, which, by the way, are very well patronized; aerial and other wartime exigencies considered. The lure of the theatres directly reflects itself in favor of the dealer; every theatregoer possessing a gramophone being a potential buyer of records. This fact is utilized to good advantage in the publicity

In the machine domain trade conditions are somewhat better than when last I wrote. Motors are coming along in larger quantities from Switzerland, at least for a period, and deliveries are more prompt. The British output of motors is still poor. There is, I am told, not much hope of improvement while the war is on, as it continues to absorb all available labor and material. Nevertheless, it is a matter of satisfaction to the trade that experiments are progressing along lines which should insure a big output immediately the situation permits, and, in any case, render it unnecessary for any Britisher to entertain the thought that we need ever again allow to be re-established the pre-

Second-hand Needles—Sales Policy

The sales policy in connection with the marketing of resharpened needles is causing a cer-

(Continued on page 108)



"His Master's Voice"

Copyright

'His Master's Voice'

—the trade-mark that is recognized throughout the world as the

HALL-MARK OF QUALITY

Branches

DENMARK: Skandinavisk Grammophon-Akti-
eselskab, Frihavnen, Copenhagen.

FRANCE: Cie. Française du Gramophone, 115
Boulevard Richard Lenoir, Place de la Répub-
lique, Paris.

SPAIN: Compañía del Gramófono, 56-58 Balmes,
Barcelona.

SWEDEN: Skandinaviska Grammophon-Akte-
bolaget, Drottning Gatan No. 47, Stockholm.

RUSSIA: The Gramophone Co., Ltd., 45, Nevsky
Prospect, Petrograd (Petersburg); No. 1
Solyanka, Solyanoi Dvor, Moscow; 9, Golevinsky
Prospect, Tiflis; Nowy-Swiat 30, Warsaw; 33,
Alexandrowskaya Ulitsa, Riga; 11 Michallovskaya
Ulitsa, Baku.

INDIA: The Gramophone Co., Ltd., 139, Bal-
laghatta Road, Calcutta; 7, Bell Lane, Fort,
Bombay.

Agencies

AUSTRALIA: S. Hoffnung & Co., Ltd., Sole
Concessionaries of The Gramophone Company,
Limited, 163, Pitt Street, Sydney.

NEW ZEALAND: Gramophontum, Ltd., 118-120
Victoria Street, Wellington.

SOUTH AFRICA: Darter & Sons, Post Box 174,
Capetown; Mackay Bros., Post Box 251, Johannes-
burg; Mackay Bros. & McMahon, Post Box 419,
Durban; Ivan H. Haarbarger, Post Box 105,
Bloemfontein; Franz Moeller, Post Box 108, East
London; B. J. Ewins & Co., Post Box 86, Queens-
town; Handel House, Kimberley; Laurence &
Cope, Post Box 132, Buluwayo; The Argus Co.,
Salisbury.

EAST AFRICA: Bayley & Co., Lourenso
Marques.

HOLLAND: American Import Co., 22a, Amsterd
Veerkade, The Hague.

ITALY: A. Bossi & Co., Via Orseolo 2, Milan.

**EGYPT (Also for the Soudan, Greece and the
Ottoman Empire):** K. Fr. Vogel, Post Box 414,
Alexandria.

Great Britain :

The Gramophone Company, Ltd.

HAYES - MIDDLESEX - ENGLAND

This intensely human pic-
ture stands for all that is
best in music

—it is the "His Master's Voice"
trade-mark, and it brings to you,
no matter where you are, the
very best music of every kind,
sung and played by the world's
greatest artists—the greatest
singers, pianists, violinists, or-
chestras and bands—all enshrined
in the unequalled "His
Master's Voice"
records

FROM OUR LONDON HEADQUARTERS—(Continued from page 107)

tain amount of interest this side, in view of the increasing quantities of used needles which are collected and dispatched for re-pointing. This class of business has developed considerably of late and one of the most important questions involved is, whether these needles should be re-sold as new.

The re-pointing process is in the main pretty good, though it falls a little short of being rightly considered equal to the fine, smooth, evenly-tapered points of new needles. Were it otherwise, the question would lose much of its value. As it is, if these re-pointed needles are sold without any notification that they are other than new, one could not avoid the feeling that an unintentional departure is made from equity. This very question was noted in a previous article devoted to an encouragement of re-pointing of old needles, and I then took the opportunity of stating that in my opinion every box of these needles should carry a clear indication that they were "resharpened needles." The position is a well-defined one, which, to my mind, permits of no quibbling. Unless he is informed to the contrary, the purchaser of a box of needles is rightly entitled to assume that they are new ones. That being so, to continue the sale of resharpener needles, except as such, is committing a pious fraud on the public. I honestly believe that this aspect of the case has not occurred to those who are developing this new field of economizing steel, but now that it has received publicity I think any of our friends whom this subject may affect will respond to the justice of the case, and adopt a policy which in itself will answer in the negative the question raised herein.

How They Do Things in the Navy

Warships which possessed a harmonium and a competent musician to operate it have in the past received an official grant of two shillings weekly. A new order endeavors to make it clear that the harmonium player need not really exist, the instrument itself being sufficient justification for the payment. It takes a column of close print in the London Gazette to explain this simple fact in official language, though nothing is said of the more modern and diverse musical instrument—the gramophone, or whether, as a contemporary puts it, the naval harmoniums are to be fitted with an automatic player attachment which will operate upon insertion of the Admiralty grant in the slot.

Steel Wire for Gramophone Needles

The first official action having for its object the rationing of steel for needles terminated on November 28 last. In the present ration of twenty-five tons of steel-wire is an official renewal which expires on February 28. It is expected that from this latter date permission will be given for the same amount of steel-wire to be allocated for the purpose named, each quarter, or otherwise as supplies permit. The ministry stipulate that the whole of the needles made from this ration, in which, by the way, all firms are entitled to participate, shall be utilized

for army and navy demands, and for no other purpose. The needle manufacturers must distribute supplies proportionate to their customers' previous ratio. We look like getting down to business at last.

Anent Branches in Enemy Countries

At the recent annual general meeting of the "His Master's Voice" shareholders, the chairman made interesting reference to the position of the company's branches in enemy countries and allied continental territory in enemy occupation. The statement is self-explanatory, and is just now of particular interest. He said: "In other parts of the world where business has been possible, sales have also been good. Our branch managers and agents have done everything humanly possible, steadfastly and loyally keeping up our trade and good name under circumstances of exile, hardship, privation and even personal danger. We thank them all most heartily and sincerely. Those of you who are acquainted with our history and have followed from time to time what I have been able to tell you at our annual meetings will know that our German branch is a separate German company, all the shares being owned by this company. We have been informed that our shareholding or ownership has, under orders from the German Government authorities, been sold by public venter to the highest bidder. Our information is meagre, and I merely mention the bald fact so that it may be within your knowledge. We have lodged a claim with the controller here as to our assets in enemy territories, and as it is understood that the balance of accounts between Great Britain and Germany is largely in Great Britain's favor it is open to hope that we shall not eventually be losers in respect to the reported sale. You will also know that we have, or had, a large record factory at Riga, which seaport town has recently passed into enemy hands. In July, 1915, when the Germans previously threatened Riga, the whole of our plant, machinery, and effects of every description, including boilers and plant, were moved to new premises in Moscow, where they have since been utilized for our purposes. Our total loss in Riga is therefore confined to the value of the land and the stripped building."

W. H. Reynolds, Ltd., in New Quarters

A recent call at W. H. Reynolds (1915), Ltd., revealed the interesting fact that a wartime removal is in progress. Their present location, 45 City road, is a building of many historic associations. For the past decade it has been occupied by successive firms, though I cannot say the place has proved over lucky from the viewpoint of enterprising occupants. The present tenants, Messrs. Reynolds, may certainly be considered an exception, as witness their need of the more commodious building they have now been forced to acquire, owing to trade expansion. The new home is almost opposite—22 City road, and removal thereto is now in course of operation. Upon visiting the new

REX GRAMOPHONE CO.

are making a Specialty of

EXPORT

in

Horn, Hornless & Portable Disc Machines**REX GRAMOPHONE CO. 2 Elizabeth Place
Rivington Street, LONDON, E.C. 2**

Cable Address "Lyrecodisc, London"

Enquiries Solicited

place, I am of opinion that it is in every way more suitable for our class of business than is No. 45. It is a large airy warehouse of five floors, not counting the basement; plenty of natural light; steam heated throughout, and so equipped as to insure prompt handling of gramophone repairs, the hundred-and-one parts and accessories stocked, packing and dispatch of complete machines, etc. In the basement there was to be seen a pleasing sight in the shape of several cases of Swiss motors, of which, I was assured by the director, there would be reasonable supplies for some time ahead. This enterprising firm evidently mean to maintain output on the highest possible level, quality being the declared keynote of their future policy. That is as it should be; the British trade has had enough of the cheap and nasty. We progress!

New Supplies of "Guardsman" Records Ready

The recent fire at the factory of the Invicta Record Co., which caused damage sufficient to disorganize output, is being made good as quickly as possible. At the time of writing the best possible report is to hand anent the progress of the rebuilding operations, and I learn that the pressing of records has again commenced in earnest. It will, of course, be some time before conditions can permit of normal output, but the company are sanguine, given a continuance of the present rate of progress, that rebuilding operations will be completed within the near future.

New "Winners" for 1918

The first new year Winner program of records is, in quality and value, an excellent augury of the company's 1918 service. Last year's sales are rumored to have reached unexpected proportions, and by the list under mention it certainly looks as though J. E. Hough, Ltd., are out on the right road to an eclipse of all previous records. The new list embodies vocal, band, orchestral and descriptive numbers galore, recorded by first-class artists. I don't hesitate to say that every title is a "cinch." There is a goodly leavening of panto "hits" amongst them, and some real tongue twisters, as for instance—"Sammy Salter Salted Sausages in Salter's Shop." Say it quickly, if you can! Altogether a fine sales list.

The Murdoch Trading Co.

Owing to the recent disastrous fire which entirely destroyed their large London warehouse, John G. Murdoch & Co., Ltd., are now carrying on their business at 59 Clerkenwell road, London, E. C., under, be it noted, a new title—The Murdoch Trading Co. The business has nat-

EDISON BELL**WINNER**
TRADE MARK
GRAMOPHONE RECORDSCABLE
"PHONOKINO,
LONDON"**ARE THE GREATEST VALUE FOR MONEY PRODUCED IN GREAT BRITAIN**

TEN INCH

DOUBLE SIDED

NEEDLE CUT

PLAY ON ALL GRAMOPHONES**Catalogue contains 4000 Titles by the Premier Artistes, Instrumentalists, Orchestras and Bands of the British Empire**

DEALERS PREPARED TO DO BUSINESS ARE INVITED TO COMMUNICATE WITH

Proprietors and Manufacturers, J. E. HOUGH, Ltd., 62 Glengall Road, London, S. E. 15, England

FROM OUR LONDON HEADQUARTERS—(Continued from page 108)

urally been very considerably disorganized, and though every effort is being made to satisfactorily straighten things out, the indulgence of the trade at such a time will be much appreciated. It is perhaps scarcely necessary to mention this, in view of the general sympathy of the trade already expressed to Messrs. Murdoch. A sad feature of the disaster is that while endeavoring to combat the outbreak of fire one of the oldest employes lost his life. He did his duty, and more, under circumstances that one day shall be told in full. The World begs to tender to the firm its sincere sympathy.

"Over There," the American war song which has achieved among the "Sammies" a rage only to be likened to our own "Tipperary," has just been announced by the Columbia Co. as a special issue. The song was brought over to this country by Albert de Courville and introduced by that astute producer into "Zig-Zag" at the London Hippodrome, sung by Shirley Kellogg.

Marie Corelli Buys a Compactophone

Miss Marie Corelli, the world-famed novelist, has just purchased a Regal Compactophone for sending to the soldiers. The famous writer has largely suspended her fiction writing activities and is devoting great energy to matters of war interest, of which this purchase of a Regal Compactophone is striking evidence. The sale of the instrument was effected by Keys Phono Depot, of John Bright street, Birmingham.

Not From the States This Time

Those who keep in touch with the taste of the public in popular songs will know that for some seasons past the big song of the year has been of the coon type. Thus we have had "Down Home in Tennessee" and "Down Where the Swanee River Flows," to quote the most recent examples. This year, again, the fashion reigns, but while those mentioned are airs that came to us from the U. S. A., it is interesting to note that this season's newcomer is by English authors and an English composer, A. J. Mills, Fred Godfrey and Bennett Scott, to wit. The song is "Down Texas Way," and even in advance of pantomime its merry catchy melody had already established a unique niche for itself. The song is issued on Columbia this month, sung by the Unity Quartet and Geo. F. Murray, tenor.

"Almost Uncanny"

Unquestionably the surprise of the present season have been the Columbia records of "Daddy" and "Love's Old Sweet Song," sung by Madame Clara Butt. The divinely gifted contralto has been responsible for many remarkable records since her association with Columbia, but, in all her glorious career she has never made records that compare with these.

"Rigoletto" Sells "Aida"

It is an accepted axiom of business that one good line sells another, but the Columbia Co. say they were not altogether prepared for the new "boom" which has suddenly set in for their complete opera of "Aida." It can only be

due, they say, to the favorable reception accorded to the newest issue of the complete "Rigoletto."

Alleged Injustice of a Copyright Society's Policy

Some interesting correspondence has recently been published by The Times newspaper from eminent composers relative to the methods of working the provisions of the Copyright Act, 1911, by the Performing Rights Society. The initial letter, which is signed by such eminent men as Sir Joseph Beecham, Sir Frederick Cowen, Dr. Walford Davies, Sir Edward Elgar, W. Landon, E. Ronald, Dr. Ethel Smyth and others, complains of the injustice which the policy of the Performing Rights Society inflicts alike on the public and the composer, and continues—"unless and until the Performing Rights Society produce and make available, at a reasonable inspection charge, to those interested, a full list of the works they claim to control, stating the prices they mean to charge for performing rights, composers of Allied and British nationality will continue to suffer by the inference that expensive legal consequences will result from the performance of their recent works, and those interested will be compelled to avoid their music and confine themselves to undoubted out-of-copyright or enemy works."

In his reply to this letter William Boosey, the president of the society, stated "that the society's composers and authors were perfectly satisfied with the manner in which their business was conducted and with the financial results of the same, and claimed for the society freedom to conduct their own business in their own way."

Whether or not this is a reasonable claim we leave to the good sense of our readers. There can be no doubt, however, that concert managers feel a grievance in this matter, and while "that lasts the position must remain exactly as set forth by the complainants.. We do not know what the Performing Rights Society imagines it has to lose by the publication of the names of the composers, etc., whom they represent, and a little light on this dark subject would doubtless give all concerned the key to a better understanding.

The Photographic Light of the Voice

In one of his lectures at the Royal Institution, Professor J. A. Fleming explained to his juvenile audience that by an invention of his own the vibration of the human voice upon the diaphragm of a telephone receiver, or on a phonograph record, could be visually reproduced, and shown on the lantern screen. By an apparatus connected with the motor of a gramophone he could cause the voice to make rays of light which by being reflected upon a circulating mirror were shown on the screen as a circle of light vibrating in accordance with the "waves" of the voice. Proceeding to the experiment he placed a record on his gramophone and played the national anthem, and the voice circle on the screen aroused considerable interest among the audience. "My invention," said the lecturer,

Soundboxes

If you are after a genuine offer of soundboxes, you'll do well to communicate with us immediately. We have tens of thousands of perfect soundboxes, fitted with the best quality mica. Confidently recommended for cheaper machines, absolutely reliable and give excellent reproduction. Price to clear \$50 per gross, F. O. B. London.

Orders for less than gross lots not accepted

Wire "Knotaslepe, London".

W. H. Reynolds (1915) Ltd.

45, City Road, London, E. C.

Write for new illustrated Complete Catalogue

"makes it possible to photograph the waves of the human voice."

Industrial Fairs Postponed

It is announced that the new accommodation for the British Industries Fair (Glasgow), 1918, may not be entirely completed by February 25, and as it is of great importance that the British Industries Fair in London and Glasgow should be held simultaneously, the Board of Trade have decided to postpone the opening of both fairs for two weeks. Accordingly, the period for which the British Industries Fairs in London and Glasgow open, will be March 11 to March 22.

Prohibited Exports From Sweden

The news is published by the Swedish Chamber of Commerce for the United Kingdom that plates and cylinders for gramophones, phonographs, and like instruments, also worn out plates and cylinders, have been added to the list of goods which are now prohibited for exportation from Sweden to all countries.

Of Special Interest to Advertisers

A recent official announcement makes known that "The unrestricted dispatch of trade catalogs and price lists from traders to traders is permitted up to January 31, 1919. Other classes of advertising circulars may be distributed up to the same date on the basis of one-third of the total weight of such matter distributed between February 1, 1916, and January 31, 1917. Annual reports of companies or societies issued to their own members, auctioneers' and surveyors' catalogs and price lists, prospectuses and application forms dispatched by insurance companies in response to requests in writing are definitely excluded from the order.

(Continued on page 110)

GUARDSMAN RECORDS

REGISTERED

10 inch and 12 inch Lateral Cut



TRADE MARK

We can ship you immediately, any quantity of Records:

BANDS ORCHESTRAS INSTRUMENTAL SOLOS VOCAL

SELECTION OF AMERICAN AIRS

including, "Marching Through Georgia"—"Dixie"—"Arkansas Traveller"—"Red, White and Blue"—"Star Spangled Banner," etc., etc., Recorded by Full Regimental Band of H. M. SCOTS GUARDS. Get Ready Now for the Big Trade coming and have

THE FINEST RECORDS of THE FINEST TITLES at THE FINEST PRICES

Apply for Lists and Prices to INVICTA RECORD COMPANY, Ltd.

Cables: Duarrab, London

1 New Inn Yard, London, E. C., England

FROM OUR LONDON HEADQUARTERS—(Continued from page 109)

Makes an Excellent Financial Showing

At the recent general meeting of the Gramophone Co., Ltd., E. T. L. Williams, the chairman, stated that the company became a controlled firm under the Munitions Act in September, 1915, and since then it had been impossible until now for the directors to submit any accounts. It was only during the first week of last month that the accounts for the year ended June, 1916, were finally settled. The adjustment of the 1917 accounts was also then possible. The balance was one upon which they might well congratulate themselves. The position was given in a nutshell by that paragraph of the report which dealt with the net assets. These net assets, after deducting debenture stock and all other liabilities, amounted on June 30 last to £1,148,539 3s. 6d., this being more

J. Stead & Co., Ltd.
Manor Needle Works
SHEFFIELD, ENGLAND
 MANUFACTURERS OF
Talking Machine
Main Springs
Best Prices—Best Quality
Inquiries Solicited

than double their ordinary share issue capital, and being in excess of the net assets shown in the previous balance sheet by £257,079. This

splendid financial showing met with the hearty approval of the stockholders of this enterprising and patriotic company.

No January List of Records

Owing to the great and continuous rush of orders, and to permit factory record stocks to be brought up-to-date, the Gramophone Co. announced that the usual monthly supplementary list would not be issued in January. Something good may be expected in February, though, and I should advise oversea dealers to keep well in touch with events. Some fine classics have lately been issued, and the grand opera in English records are all the rage. For the latter, especially, sales are progressive beyond all expectations, and there are more of these records to come! This appreciation of opera records in English is a healthy sign.

NEW JERSEY REGIMENTS EQUIPPED WITH ARMY AND NAVY MODEL EDISON PHONOGRAPH

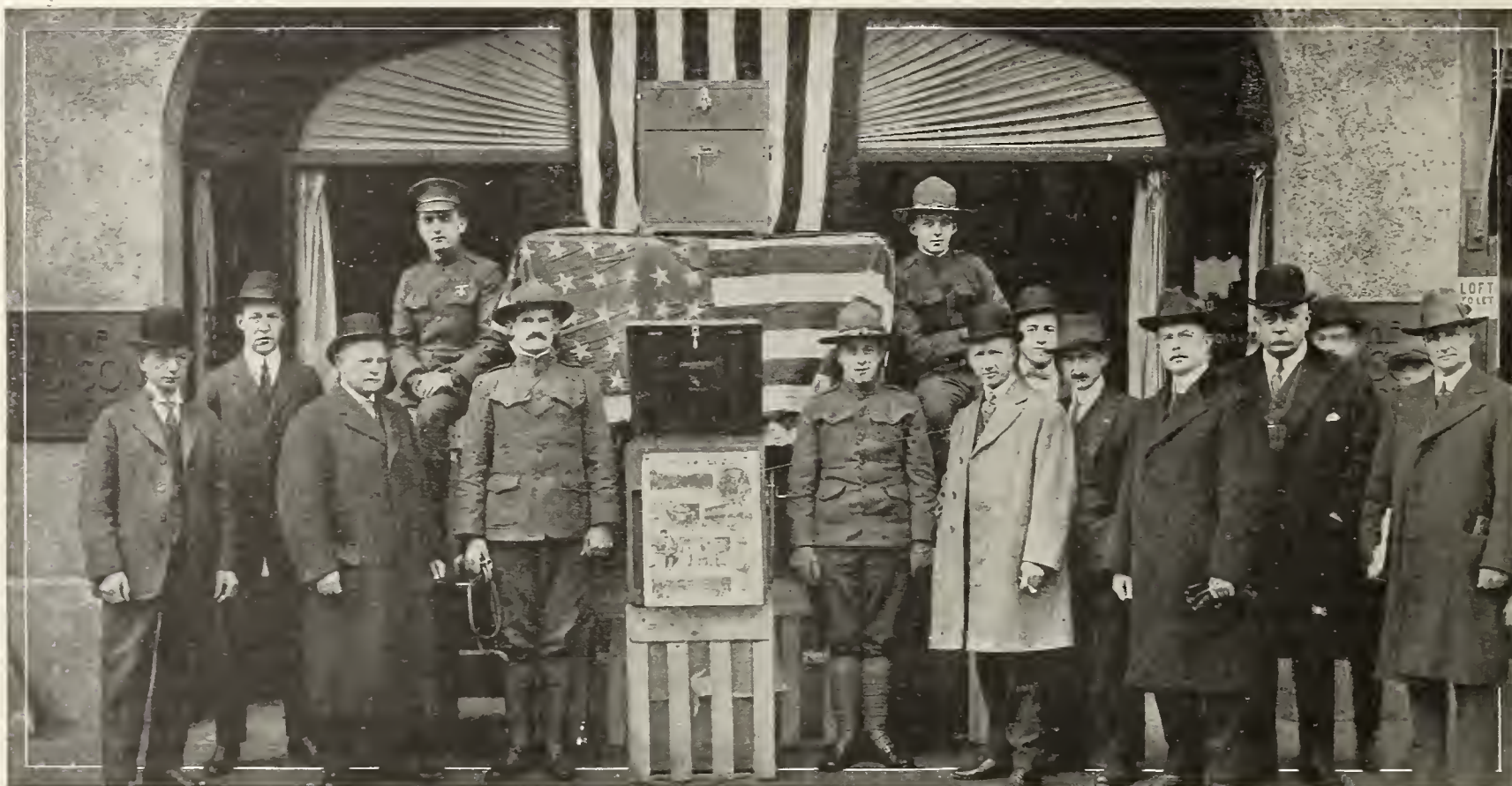

This photograph, taken in front of Phonographs, Ltd., Newark, N. J., shows a few of the Army and Navy Model New Edison Phonographs Recently given to the New Jersey Regiments, the purchases being made with a fund raised by the Newark Call at a Benefit Recital given by Edison Artists at the Broad Street Theatre, Newark

TWO SALESWOMEN GO WEST

PORTLAND, ORE., February 4.—The talking machine trade in the East has contributed several members to local sales staffs recently, among them being Miss Alma Hartman, formerly with Lyon & Healy, Chicago, and now with the rec-

ord department of the G. F. Johnson Music House, and Miss Helen Zedell, of New York, who has taken charge of the record department of the Graves Music Store. Evidently the familiar slogan embodying the advice to the male sex to journey west must now include the fair sex—a tribute to woman's new place in the commercial world.

(4) It is said on good authority that our enemies are now registering United States trademarks in countries mentioned in clause (1) through "dummies." The result is obvious; manufacturers who anticipate exporting trademarked products will find themselves blocked in their effort to do so.

More and effective business would result, says this institution, if American merchants and exporters would state exactly who their representatives are in Argentina. By making this information more public, the local Argentine buyer, when in the market for goods, would then not need to write the head office, and thus much time would be saved.

The decided drop in freight rates from \$1 per cubic foot to 70 cents in the past few months for shipments to South America is very encouraging.

FACTS ABOUT THE KENT ATTACHMENT NO. 1

To Play Lateral Cut Records on the Edison Diamond Disc Phonograph

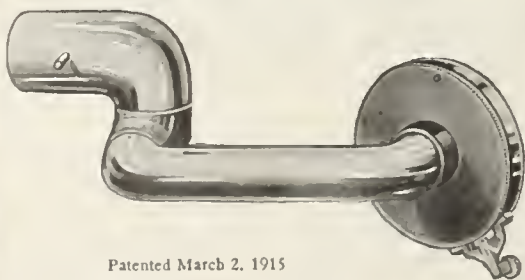

Patented March 2, 1915

It has been recognized by experts the most perfect device of its kind on the market. It has been on the market ever since the Edison Diamond Disc made its appearance. It can be had with or without reproducer, and is made in two lengths. It is guaranteed by the Manufacturer in every way.

F. C. KENT & CO.
 Manufacturer of Phonograph Accessories
 24 Scott Street Newark, N. J.

SOUTH AMERICAN IMPORT FACTS

Some Important Data Which Exporters to South America Should Remember

Manufacturers and exporters selling trademarked goods in foreign countries, particularly South America, may be interested in these few vitally important facts as set forth by the First National Bank of Boston:

- (1) In Argentina, Bolivia, Chili, Costa Rica, Cuba, Guatemala, Paraguay, Peru and Venezuela, trade-mark titles absolutely depend upon priority of registration. Furthermore, any one may lawfully register a United States trademark (registered or unregistered) and thus prevent entry of the goods into the country.
- (2) In Brazil, Cuba, Guatemala and Panama the trade-mark must be registered in the United States Patent Office before it can be registered in these countries.
- (3) In Ecuador, Mexico and Nicaragua no suit may be brought for infringement of a trademark without registration.

B. H. WOLFMAN APPOINTED MANAGER

Bernard H. Wolfman has been appointed a member of the traveling staff of the local wholesale branch of the Columbia Graphophone Co., 55 Warren street. Mr. Wolfman will cover the territory in the southern part of New York State and, although he is a newcomer in the talking machine industry, his previous experience with several prominent organizations well equips him to work in close co-operation with the Columbia dealers in his territory.

LATEST PATENTS RELATING TO TALKING MACHINES AND RECORDS

WASHINGTON, D. C., February 8.—PHONOGRAPH SOUND BOX CONNECTION.—Charles S. Burton, Oak Park, Ill. Patent No. 1,247,220.

The purpose of this invention is to provide an improved connection between the sound box and the tone arm of a phonograph, adapted to permit swiveling of the two connected parts for adjustment of the sound box to two positions, and particularly adapted to permit such adjustment for zigzag and hill-and-valley records, the specific purpose being to insure the adjustment from one position to the other being made completely and not halted with the parts at an intermediate position.

In the drawings: Figure 1 is a side elevation of a portion of the tone arm and sound box embodying this invention, a portion of the sound box being broken away to show other parts which are in section with respect to telescoping and swiveled members. Fig. 2 is a similar view

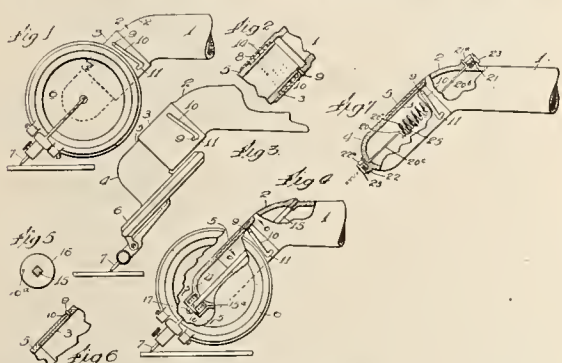

with the sound box in the other of the two positions to which it is adjustable for adaptation to the different types of records. Fig. 3 is a section at the line 3-3 on Fig. 2. Fig. 4 is a section similar to the sectional part of Fig. 1, showing a modification in certain details.

ATTACHMENT FOR TALKING MACHINES.—Lester Moroney, Manhattan Beach, Ore. Patent No. 1,247,441.

This invention relates to a means adapted to be attached to a talking machine of the Edison type, whereby to cause the raising and lowering of the cover to perform various detail operation now required to be performed manually and which usually are found more or less irksome. The invention provides a means whereby the horn is automatically swung to bring the sound box over the record, and then lowered, the operations being performed in proper sequence by the lowering of the cover, and the reverse operations taking place by the raising of the cover. The attachment includes means to automatically stop and release the turntable with the swinging of the horn, and a means automatically adjustable to the size of the record to govern the movement of the horn-actuating means.

Figure 1 is a perspective view of the attachment and indicating the cabinet of the talking machine in dotted lines, the view showing the position of the parts when the cover is in the raised position. Fig. 2 is a fragmentary plan view. Figure 3 is a view similar to Fig. 1 with

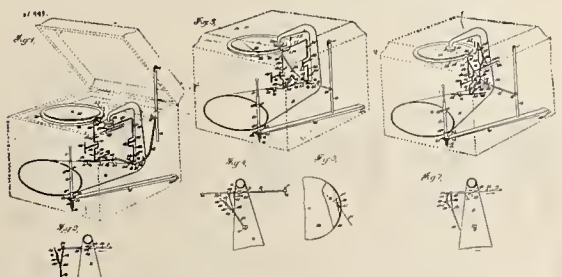

the cabinet cover lowered, certain trip elements being indicated in the positions they assume just as the cover reaches its lowermost position before the final movement of the said trip devices; Figs. 4 and 7 are views similar to Fig. 2 but showing the parts in different positions; Fig. 5 is a fragmentary plan view with parts broken away and in section, the view being

given to show the relation of the brake device to the depending brake flange of the turntable. Fig. 6 is a perspective view similar to Figs. 1 and 3 with the parts in the position after the sound box has moved to the center of the record and which results in the automatic stop being brought against the turntable.

LUBRICATING AND POLISHING PAD FOR TALKING MACHINE RECORDS.—Patrick B. Delany, South Orange, N. J. Patent No. 1,247,232.

This invention comprises a pad of peculiar construction and make-up for treatment of talking machine records for the purpose of incidentally removing dust but primarily to polish or smooth and lubricate the surface of the record and lubricate the needle which traverses it.

Figure 1 is an elementary form of this device that experience has demonstrated to be highly efficient; and Fig. 2, shows a modification. The device comprises a pad of appropriate soft materials adapted to be superficially coated or

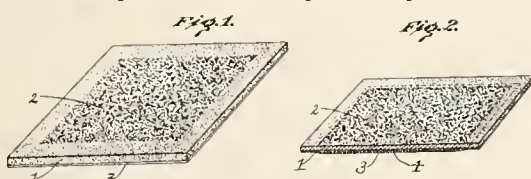

impregnated with graphite. The pad shown in the drawing may be a piece of felt, plush, corduroy, fustian or other fabric, all of good quality.

SOUND BOX.—Herman L. Berger and Francis C. Knochel, New York. Patent No. 1,248,062.

This invention relates to sound boxes for talking machines, and has for an object the provision of an improved construction whereby the vibration of the sound box will not be transmitted to the stylus.

Another object in view is to provide a separate support for a stylus formed independent of the parts forming the sound box proper, in order that none of the vibration or movement of the stylus caused by the grooves in a record shall be transmitted to the diaphragm.

In the accompanying drawing: Figure 1 is a rear view of a sound box disclosing an em-

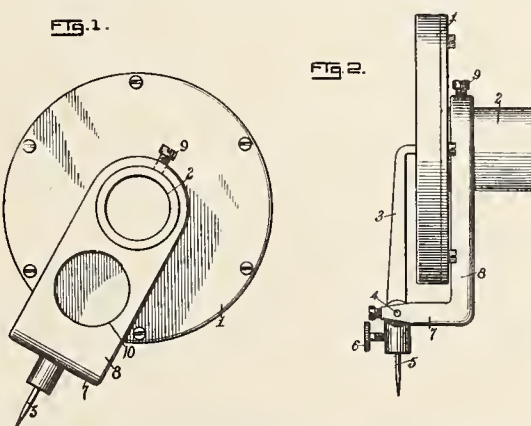

bodiment of the invention. Fig. 2 is an edge view of the sound box shown in Fig. 1.

RECORD CLEANER FOR SOUND REPRODUCING MACHINES.—Jos. Newcomb Blackman, New York. Patent No. 1,248,064.

This invention relates to record cleaners for sound reproducing machines of the type described and claimed generically in United States patent to Henry A. Place, dated September 25, 1906, No. 831,987, and shown in United States patent to C. E. Tackman, dated November 28, 1916, No. 1,206,168, in each of which a brush-holding arm is fixed to an attaching clamp having opposite spring fingers to clasp the sound box, sound tube, or other part of the reproducer, which moves over the record, so that the cleaner can be attached to or detached from the movable member, and will brush and clean the record in front of the following stylus.

In the specific examples of said invention illustrated in said patent to Place, the brush-holding arm is made integral with and fixed directly to the reproducer clasp.

In the present improvement, the inventor makes the adjustable reproducer clasp of elastic or resilient metal or material to embrace yieldingly the sound tube and bend and extend the elastic material thereof almost horizontally toward the stylus so as to form a light vertically surring arm, to the free end of which the brush clamp is attached. By this construction the brush can be adjusted on the sound tube both radially and vertically with respect to the record, and when properly adjusted will bear yieldingly and lightly on the record in front of the stylus, so as to accommodate itself to all variations in the record or reproducer mechanism, while bearing at all times with uniform light pressure on the record.

Figure 1 represents a record cleaner embodying the present invention applied to an ordi-

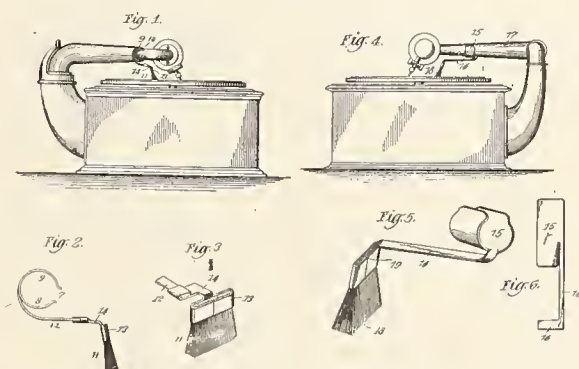

nary phonograph of the Victor type. Figs. 2 and 3 are enlarged detail views of the said cleaner embodying the present invention, applied to a phonograph of the Columbia type. Figs. 5 and 6 are enlarged detail views of the latter cleaner.

RECORD CLEANER FOR SOUND REPRODUCING MACHINES.—Jos. Newcomb Blackman, New York. Patent No. 1,248,063.

This invention relates to record cleaners for sound reproducing machines of the type described and claimed generically in United States patent to Henry A. Place, dated September 25, 1906, No. 831,987, and in which a brush-holding arm is fixed to an attaching clamp having opposite spring fingers to clasp the sound box, sound tube or member which moves over the record, so that the cleaner can be quickly attached to or detached from the movable member, and can be adjusted thereon so as to bear at the proper point and with the proper amount of pressure on the record directly in front of the following stylus.

In Letters Patent No. 865,674, issued September 10, 1907, is described a specific improvement on said generic invention, in which the spring fingered reproducer clasp is formed integrally with the brush holding clamp and arm. The specific examples of the invention shown in the said Place patent are also made in this way.

The disadvantage of this specific construction is that whereas the material of the brush-holding clamp should be soft and pliable properly to bind the brush bristles when set thereon, and the reproducer clasp should be of elastic material so as properly to grip the reproducer, the integral construction of the brush clamp and reproducer clasp does not permit such a divergent construction.

The present specific improvement on the said Place invention, therefore, consists of a pli-

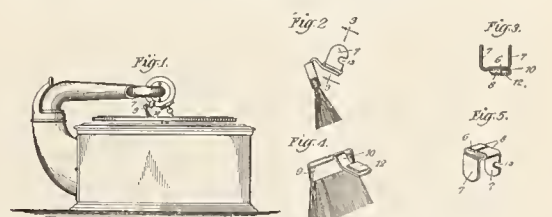

able brush clamp permanently attached to an elastic reproducer clasp.

Figure 1 represents a record cleaner embodying the present invention, attached to the sound box of an ordinary Victor talking machine. Figs. 2, 3, 4 and 5 are enlarged detail views showing the novel construction of the said record cleaner.

SOUND REPRODUCING APPARATUS.—Samuel D. (Continued on page 112)

LATEST PATENTS RELATING TO TALKING MACHINES AND RECORDS—(Continued from page 111)

Mott, Passaic, N. J., assignor of one-half to Arthur B. Sullivan, Allendale, N. J. Patent No. 1,247,861.

This invention relates to sound reproducing apparatus known as a "disc machine."

Among the objects of the invention is to attain a sound reproducing machine using a disc record in which the stylus will maintain the same relation to each record groove in which it is traveling without the provision of special compensation devices and attachments for varying the position of the stylus needle as it travels in the record groove. The most advantageous relation for the reproduction of sound is to position the stylus or needle so that it will be tangent to the record groove in which the stylus is engaged. By maintaining this position for all grooves of the record, increased life is given to the record and a more perfect reproduction of the sound is attained, as when the position of the stylus varies from tangency, the needle breaks or chips the walls of the grooves and destroys the record as well as failing in accurately reproducing all the sounds registered in the groove. It has been heretofore proposed, especially in machines in which the record disc rotates on a fixed support and the sound box travels across it, to vary the relation of the sound box to the record as it moves across it by mechanical compensating devices of various designs, but such expedients have failed to come into commercial practice owing to the undesirability of increasing and complicating the mechanism of sound reproducing machines with the attendant unreliability. By this invention the sound box is maintained in a stationary position and causes the rotating record disc to travel with relation to it in such manner that tangency of the stylus with the groove in which it is traveling is maintained.

By this invention it is also possible to successfully employ records of almost any diameter without providing the special compensating devices above referred to and which permits the reproduction of compositions heretofore not practical.

Other objects will be apparent from the subjoined description, among which might be mentioned the reduction of the number of movable joints or connections in the reproducing arm to which the sound box carrying the stylus is attached whereby the liability to loose connections owing to continued use and the consequent imperfect operation of the arm is practically overcome.

In the accompanying drawings Fig. 1 illustrates in plan view the mechanism, in accordance with this invention, for rotating the record and for causing it to travel bodily, the balance

tion is to provide a device which can be quickly and easily attached to a talking machine and which will efficiently operate to effect the movement of the reproducing elements of the talking machine to repeat the record.

Another object is to so construct the invention that it will not injure any of the several parts of the talking machine or record.

Another object is to so design the invention that it will be durable and of comparatively simple construction.

Figure 1 is a top plan view of the improved repeating device. Fig. 2 is a section on the line 2—2 of Fig. 1. Fig. 3 is a section on the line 3—3 of Fig. 1. Fig. 4 is a section on the line 4—4 of Fig. 1. Fig. 5 is a section on the line 5—5 of Fig. 1. Fig. 6 is a section on the line 6—6 of Fig. 1. Fig. 7 is a fragmentary sectional elevation showing certain of the elements of the invention. Fig. 8 is a section on the line 8—8 of Fig. 7. Fig. 9 is a fragmentary plan view showing a modification of certain of the parts

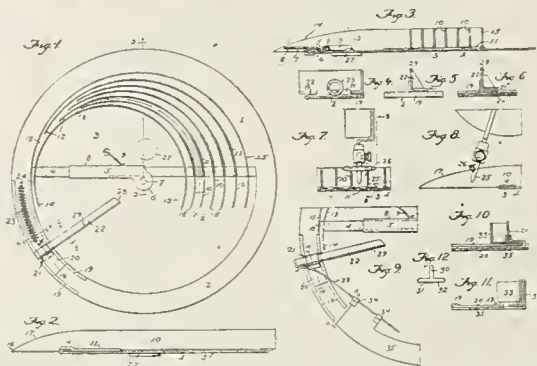

illustrated in Fig. 1. Fig. 10 is a section on the line 10—10 of Fig. 9. Fig. 11 is a section on the line 11—11 of Fig. 9, and Fig. 12 is a view of a cross arm employed in combination with the ordinary form of phonograph needle and instead of the specially constructed needle shown in Figs. 7 and 8.

PHONOGRAPH.—Magnus W. Turnquist, Chicago, Ill. Patent No. 1,249,251.

This invention relates to phonographs, and its principal object is to provide improved means for returning the tone arm and therewith the reproducer and needle to their starting place, whereby the musical selection or other sound produced may be repeated automatically without any further attention on the part of the attendant. Another object is to provide a simple, comparatively cheap, efficient and practical mechanism for accomplishing this result. Another object is to provide a repeating mechanism for phonographs, actuated by the turntable or disc which supports the record. Another object is to produce a repeating mechanism for phonographs, having adjustment means to accommodate various sizes of record discs.

Figure 1 is a plan of a fragment of a phonograph, showing a simple embodiment of the present invention applied thereto; Fig. 2 is a view partly in side elevation and partly in ver-

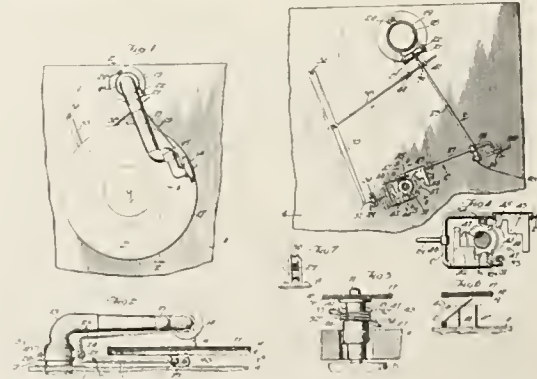

tical section of the parts seen in Fig. 1, the line of section being indicated at 2—2 in Fig. 1; Fig. 3 is a view partly in plan and partly in horizontal section, the line of section being taken at 3—3 in Fig. 2; Fig. 4 is a detail plan of a fragment of a certain oscillatory and reciprocatory frame; Fig. 5 is a detail vertical section taken on the line 5—5 of Fig. 3; Fig. 6 is a detail, vertical section taken on the line 6—6 of Fig. 3; and Fig. 7 is a detail end view of certain anti-friction bearing rollers.

PHONOGRAPH AND THE LIKE.—Henry B. Tremaine, Westfield, and E. S. Votey, Summit, N. J., assignors to the Aeolian Co., New York. Patent No. 1,248,757.

This invention relates to improvements in phonographs and the like and more particularly to means which readily permits the instrument to be used with any one of a plurality of sound boxes. This permits the ready interchange between sound boxes of both the hill and dale and lateral cut record types and between different sizes and qualities of sound boxes of the same type, also the same ready interchange between tone arms appropriate to the several sound boxes.

In the drawings, Figure 1 is a fragmentary vertical section of a phonograph showing the improvements in side elevation, the section being

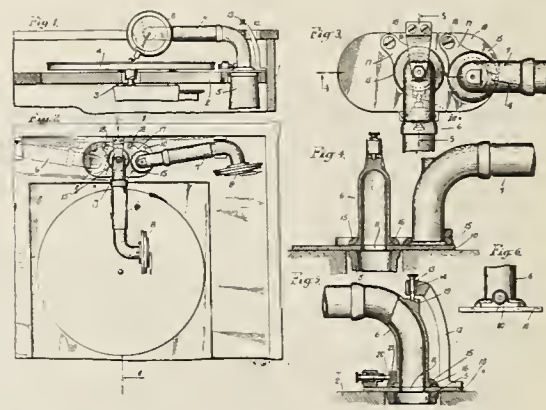

taken on the line 1—1 in Fig. 2 looking in the direction of the arrows; Fig. 2 is a plan view of the same; Fig. 3 is an enlarged detail of Fig. 2; Fig. 4 is a vertical section partly in elevation on line 4—4 in Fig. 3 looking in direction of the arrows; Fig. 5 is a vertical section partly in elevation on line 5—5 in Fig. 3 looking in direction of the arrows; and Fig. 6 is a detail view of the lower portion of Fig. 5 seen from the left.

PHONOGRAPH.—Leslie McArthur, Kenilworth, Ill., assignor to the Stewart Phonograph Corp., Chicago, Ill. Patent No. 1,249,791.

The purpose of this invention is to provide an improved construction in several details of a phonograph, or talking machine, so-called.

In the drawings: Figure 1 is a side elevation of a phonograph embodying the features of this invention. Fig. 2 is a plan view of a tone arm and sound box. Fig. 3 is a section at the

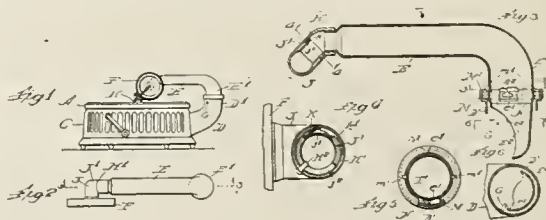

line, 3—3, on Fig. 2. Fig. 4 is a detail section at the line, 4—4, on Fig. 3. Fig. 5 is a detail section at the line, 5—5, on Fig. 3. Fig. 6 is a section at the line, 6—6, on Fig. 3.

Mrs. Frank J. Herms, of Quaker Ridge, New Rochelle, N. Y., last week donated a Victrola and a goodly number of records for the soldier boys in response to an advertisement of Mrs. Wm. E. Ogden, who is making a very strenuous campaign to supply the soldiers with music as a means of entertainment.

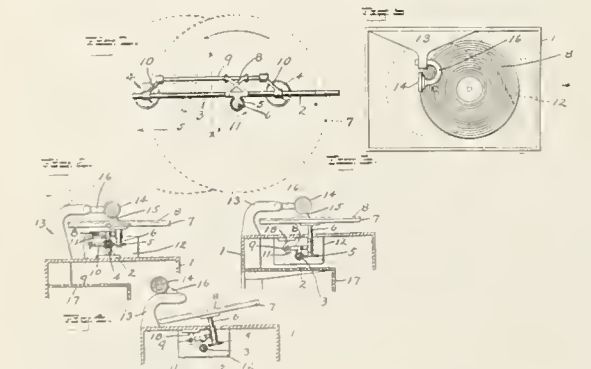

of the apparatus being removed. Fig. 2 is a side elevation and partial cross-section through a sound reproducing apparatus constructed in accordance with this invention, the cabinet containing the amplifying horn being broken away. Fig. 3 is a similar view illustrating a slight modification in the disposition of the disc driving mechanism. Fig. 4 is a similar view to Fig. 3 showing the parts as shifted to position to return the turntable to its original position. Fig. 5 is a plan view of the apparatus.

REPEATING DEVICE FOR TALKING MACHINES.—George F. Voith, Philadelphia, Pa. Patent No. 1,248,041.

This invention consists of a repeating device for talking machines. One object of the inven-

REPAIRS

All Makes of Talking Machines Repaired Promptly and Efficiently

TALKING MACHINE REPAIR AND SALES CORPORATION

ANDREW H. DODIN, President
176 Sixth Avenue New York
TELEPHONE, CHELSEA 8437

RECORD BULLETINS FOR MARCH, 1918

COLUMBIA GRAPHOPHONE CO.

- POPULAR HITS OF THE MONTH
A2477 Sweet Little Buttercup.....Henry Burr 10
A2470 Over There.....Arthur Fields 10
A2478 I'm All Bound 'Round with the Mason-Dixon Line.....Al Jolson 10
A2458 Sailing Around.....Samuel Ash 10
A2453 There's Another Angel Now in Old Killarney, That's Why I Love You and Call You Machree, J. Malachy White 10
DANCE RECORDS OF THE MONTH
A2417 The Old Town Pump—Fox-trot, Handy's Orchestra of Memphis 10
A2418 A Bunch of Blues—Fox-trot, Handy's Orchestra of Memphis 10
A2456 Sing Me Love's Lullaby—Waltz, Introducing "Celeste Aida".....Prince's Orchestra 10
A6017 I'm Going to Follow the Boys—Medley One-step, Introducing (1) Come on Over Mary to Old Father John, (2) I've Heard About the Knights of Columbus, (3) The Army's Full of Irish.....Prince's Band 12
A6018 Indianola—Fox-trot.....Prince's Band 12
A6014 Jewels of the Madonna—Act III, Chicago Symphony Orchestra 12
A6012 Orientale.....Eddy Brown 12
A6013 (a) Etude No. 2 in F Minor, Opus 25, (b) Arabesque No. 1 in A Flat, Opus 45, Leopold Godowsky 12
A2475 Alegrias (Table Dance) from "The Land of Joy".....Lacalle's Spanish Orchestra 10
A6011 Tosca—Selections—Part I, Columbia Symphony Orchestra 12
A2454 The Mocking Bird.....George Stehl 10
A2463 Whispering Hope.....Taylor Trio 10
A2457 Mahina Malamalama Waltz.....Kalani and Kalei Hawaiian Medley, Introducing (1) Moanalua Hula, (2) Maunawili, (3) Meleana, Louise and Ferera 10
A2455 Columbia Graphophone Company March, Prince's Band 10
VOCAL NUMBERS
A2465 Home, Sweet Home.....Columbia Stellar Quartet 10
A2464 There Is a Green Hill Far Away.....Henry Burr 10
A6007 I'll Sing Thee Songs of Araby.....Vernon Stiles 12
A2462 The Sunshine of Your Smile.....Charles Harrison 10
A2469 Nobody Knows De Trouble I've Seen, Oscar Seagle 10
A2466 Madam Butterfly—Love Duet, Tamaki Miura and Theodore Kittay 12
A2466 Agnus Dei.....Paulist Choristers 10
A7524 Johnny Chuck Finds the Best Thing in the World.....Thornton W. Burgess 12
COMEDY SKETCHES OF THE MONTH
A2461 In a Bird Store.....Golden and Heins 10
Towser Is Dead.....Golden and Heins 10

VICTOR TALKING MACHINE CO.

- POPULAR SONGS
18427 Sweet Little Buttercup, Elizabeth Spencer with Shannon Four 10
18433 The Further It Is From Tipperary, Billy Murray 10
18434 Liberty Bell (It's Time to Ring Again), Peerless Quartet 10
There's a Service Flay Flying at Our House, Shannon Four 10
VOCAL AND INSTRUMENTAL RECORDS
45148 Lorraine.....Reinold Werrenrath 10
35666 Gems from "Jack O' Lantern," Victor Light Opera Co. 12
18405 Fun in Flanders—Part I, Lieut. Gitz Rice and Henry Burr 10
18430 U. S. Field Artillery March.....Sousa's Band 10
18432 Maytime Waltz (Will You Remember?), Waldorf-Astoria Dance Orchestra 10
RED SEAL RECORDS
64722 Thou Art Near Me, Margarita, Barnett-Meyer-Helmund 10
64686 Pastorale.....S. di Giacomo-E. de Leva 10
64760 La Capricieuse (Op. 17).....Edward Elgar 10

AMELITA GALLI-CURCI, Soprano—In Italian
64748 Nozze di Figaro—Non so piu cosa son (Marriage of Figaro—I Know Not What I'm Doing), Mozart 10

PATHE FRERES PHONOGRAPH CO.

- POPULAR "HITS" OF THE MONTH
20277 Wait Till the Cows Come Home, from "Jack o' Lantern" (Caryll).....Campbell and Burr 10
Any Time's Kissing Time, from "Chu-Chin-Chow" (Norton), Jean Sterling, Contralto; Henry Burr, Tenor 10
20296 My Sweetie (Berlin).....Arthur Fields, Tenor 10
20294 There's a Green Hill Out in Flanders (Flynn), Harry McClaskey, Tenor 10
Chimes of Normandy (Wells), Jean Sterling, Contralto 10
20295 "Sweetness" (Honeysuckle of Mine) (Stern), Arthur Fields, Tenor 10
20292 Mandy Lou (Cook).....Noble Sissle, Tenor 10
Give Me the Moonlight, Give Me the Girl (Von Tilzer).....Peerless Quartet 10
Hello! I've Been Looking for You, from "The Big Show," N. Y. Hippodrome (Golden-Hubbell).....Louis Winsch, Baritone 10
20293 Hush-a-bye, Ma Baby (Missouri Waltz) (Knight-Logan-Eppel).....Campbell and Burr 10
They Needed an Angel in Heaven (Morecaldi), Henry Burr, Tenor 10
NEW STANDARD BALLADS SUNG IN ENGLISH
25008 Solvejg's Lied (Sunshine Song) (Grieg). Violin, flute and piano accomp., Grace Hoffman, Soprano 10
Swiss Echo Song (None He Loves But Me) (Eckert). Soprano, violin, flute and piano accomp., Grace Hoffman 10
27008 Lady Moon (Bruhns).....David Bispham, Baritone 10
A Warrior Bold (Adams), David Bispham, Baritone 10
40117 Sweet Genevieve (Cooper-Tucker), James Stanley, Basso 12
Mother o' Mine (Tours), Gordon MacHughes, Baritone 12
20287 When You and I Were Young, Maggie (Butterfield).....Harry McClaskey, Tenor 10
John Anderson, My Jo (Robert Burns), Louise Brentwood, Contralto 10
20291 The Bridge (Carew), University Quartet 10
How Can I Leave Thee? (Cramer), Isabelle Cannon, Mezzo-Soprano 10
NEW PATHE "DE LUXE" DANCE RECORDS
20298 "Miss 1917"—Medley fox-trot (Wodehouse-Kern). Intro.: "The Land Where the Good Songs Go" and "The Picture I Want to See," American Republic Band 10
Twilight Waltz (Savino), Pathe Dance Orchestra 10
20299 Smile and Show Your Dimple—Medley fox-trot (Berlin-Ruby). Intro.: "The Dixie Volunteers".....American Republic Band 10
The Wild, Wild Women—Medley one-step (Pierce-Glogau). Intro.: "Look Me Up When You're in Dixie".....American Republic Band 10
20300 I'm Coming Back to You, Poor Butterfly—Medley fox-trot (Donnelly-Golden-Hubbell). Intro.: "Geel! What a Wonderful Mate You'll Be," American Republic Band 10
Dance With Me—From "The Grass Widow"—Medley one-step (Pollock-Wolf-Hirsch). Intro.: "Just You and Me".....American Republic Band 10
NEW INSTRUMENTAL RECORDS
27009 Spring Song (Mendelssohn). Piano solo, Rudolph Ganz 10
Maiden's Wish (Chopin-Liszt). Piano solo, Rudolph Ganz 10
40118 Tambourin Chinois (Kreisler). Violin solo, Mischa Violin 12
Minuet in G, No. 2 (Beethoven). Violin solo, piano accomp., Mischa Violin 12
40116 Nocturne No. 2 (Chopin). Violoncello solo, piano accomp., Josef Hollman 12
Romance sans paroles (Faure). Violoncello solo, piano accomp., Josef Hollman 12
20302 Softly Awakes My Heart—From "Samson and Delilah" (Saint-Saens). Cornet solo, Sergeant Leggett 10
Until (Sanderson). Cornet solo, Sergeant Leggett 10
20288 Souvenir (Drdla). Violin solo, piano accomp., Jan Rubini 10
The Blush Rose (O'Hara). Violin solo, piano accomp., Jan Rubini 10
NEW BAND AND ORCHESTRA RECORDS
20289 Up the Street (Morse)—March, American Republic Band 10
Washington Grays (Grafulla)—March, American Republic Band 10
20254 Dutch Doll Dance (Rich). Pathe Salon Orchestra 10
Ma Belle Charmante (My Lady Fair) (Roberts)—Waltz.....Pathe Salon Orchestra 10
40115 Maynada (Morera).....Sardinian Orchestra 12
Lo Can del Pastoret (Vicens), Sardinian Orchestra 12
NEW RECORDINGS BY THE HAWAIIANS
20297 Hello, Aloha, Hello! (Meyer). Hawaiian Orchestra accomp., Harry McClaskey, Tenor 10
Aloha Land (Herzer)—"Waltz," Louise and Ferera Waikiki Orchestra 10
NEW STANDARD CLASSIC RECORDINGS
63020 Garibaldi Hymn (Italian National Air), "Inno de Guerra dei Cacciatori," in Italian, Claudia Muzio, Soprano 12
Canzone Guerresca (Giordano), "Italian War Song," in Italian.....Claudia Muzio, Soprano 12

EDISON BLUE AMBEROL RECORDS

- 3433 Are You From Heaven? (Gilbert-Friedland), Tenor Solo, orch. accomp., Vernon Dalhart 10
3423 For You and Tennessee (Bernard E. Fay), Male Quartet, orch. accomp., Harmony Four 10
3437 Someone Is Waiting for You (Al Piantadosi), Male voices, orch. accomp., Shannon Quartet 10
3428 Somewhere in France Is the Lily (Joseph E. Howard), Baritone Solo, orch. accomp., Edward Allen and Chorus 10
3426 They Go Wild, Simply Wild, Over Me! (Fred Fisher), Tenor Solo, orch. accomp., Billy Murray and Chorus of Girls 10
3424 When You Hear That Raggy Refrain (Herman Darewski), Tenor Solo, orch. accomp., Billy Murray and Male Chorus 10
ST. PATRICK'S DAY SPECIALS
3434 Blackthorn-Stick Medley of Jigs, Violin, orch. accomp., Charles D'Almaine 10
3435 Katy Mahone (Chauncey Olcott), Male Voices, orch. accomp., Shannon Quartet 10
3417 Medley of Irish Reels, Accordion, Piano accomp. by Denis L. Smith, Patrick J. Scanlon 10
3430 Tho' I had a Bit o' the Divil In Me (Harry Von Tilzer), Tenor Solo, orch. accomp., George McFadden 10
3429 Victory!—Easter Carol (R. M. Neal), Mixed

- Voices, orch. accomp., Carol Singers
3436 Break the News to Mother (Chas. K. Harris), Tenor Solo, orch. accomp., George Wilton Ballard and Chorus
CONCERT LIST
28281 Azt mondjak Szenes de la Csarda—No. 8 (Jeny Hubay). Op. 60. Violin, Piano accomp. by Jacques Grunberg.....Mary Zentay
28280 Three Fishers (John Hullah). Baritone Solo, orch. accomp., Arthur Middleton
REGULAR LIST—SONGS AND BALLADS
3412 Dixieland Memories—No. 1. Orch. accomp., Orpheus Male Chorus
3413 Dixieland Memories—No. 2. Orch. accomp., Orpheus Male Chorus
3425 Lullaby (E. W. Hanscom). Contralto and Male Voices, orch. accomp., Helen Clark and Shannon Quartet
3422 Suki San (Where the Cherry Blossoms Fall) (Walter Donaldson), Tenor Solo, Vernon Dalhart

- INSTRUMENTAL
3414 Impassioned Dream Waltz (J. Rosas), Peerless Orchestra
3415 Love's Message—Morceau Characteristic (F. H. Losey).....Sodero's Band
3420 Ma Belle Charmante—Concert Waltz (Chas. J. Roberts).....Peerless Orchestra
3432 Nightingale and the Frog (Rich. Eilenberg). Op. 119, No. 2. Piccolo and Bassoon, orch. accomp., Weyert A. Moor and Benjamin Kohon
3421 Saxophone Sobs (Ernie Erdman). Saxophone, orch. accomp., Rudy Wiedoeft

- TOE-TICKLING DANCES
3416 Hy-Sine—One-step (Morgan-Chapi), For Dancing.....Jaudas' Society Orchestra
3419 Jack O'Lantern Fox-trot (Ivan Caryll), For Dancing.....Jaudas' Society Orchestra
3418 That's It—Fox-trot (Creamer-Layton), For Dancing.....Frisco Jazz Band
3431 Favorite Hymns of Fanny Crosby—No. 1. Mixed Voices, orch. accomp., Calvary Choir
3427 Laughing Song, Orch. accomp., Ed Meeker and Empire Vaudeville Company
TWO FRENCH RECORDS
27181 Elle était vendeuse (Serpieri), Baritone Solo, in French, orch. accomp., Hector Pellerin
27180 La Cocarde de Mimi Pinson (Marinier et Heintz), Baritone Solo, in French, orch. accomp., Hector Pellerin

GENNETT RECORDS

- TYPICAL HAWAIIAN MELODIES
7638 Hilo March (Hawaiian Steel Guitar with Guitar and Ukulele).....Louise, Ferera and Greenus Trio
(1) Aloha Oe (Farewell to Thee) (Liliuokalani); (2) Ua Like No a Like (Sweet Constancy) (Hawaiian steel guitar with guitar and ukulele).....Louise, Ferera and Greenus Trio
7636 Honolulu March (Hawaiian Guitar Duet, Louise and Ferera
Kilima Waltz (Hawaiian steel guitar with guitar and ukulele).....Louise, Ferera and Greenus Trio
7600 Hapa Haele Hula Girl (My Hawaiian Maid) (Cunka) (Hawaiian Guitar Duet), Louise and Ferera
Kawaihau Waltz (Hawaiian Guitar Duet), Louise and Ferera
7524 Hula Medley—Intro.: "Moanulua-Manunawile-Meleana" (Hawaiian Guitar Duet), Louise and Ferera
Hawaii Waltz—Intro.: "Song from Hawaii-Sweet Lei Mona" (Hawaiian Guitar Duet), Louise and Ferera

- VOCAL RECORDS OF SPECIAL MERIT
10033 Danny Deever (Kipling-Damrosch), Baritone with orch. accomp., Royal Dadmun
The Pauper's Drive (Noel-Homer), Baritone with orch. accomp., Royal Dadmun
10032 Some Day (Wellings), Baritone with orch. accomp., Albert Wiederhold
Love's Sorrow (Shelley), Baritone with orch. accomp., Albert Wiederhold
10034 Bonnie, Sweet Bessie (Root-Gilbert), Tenor with orch. accomp., James Harrod
I'll Take You Home Again, Kathleen (Westendorf), Tenor with orch. accomp., James Harrod
(Recorded under personal supervision of Pietro Florida)
INSTRUMENTAL RECORDINGS OF OLD FAVORITES
7640 (1) A Perfect Day; (2) A Soldier's Farewell, Brass Quartet
(1) Absence; (2) Annie Laurie, Brass Quartet
7639 (1) Believe Me if All Those Endearing Young Charms; (2) Drink to Me Only With Thine Eyes; (3) Auld Lang Syne.....Brass Quartet
(1) The Rosary (Nevin); (2) Sweet and Low (Barnby).....Brass Quartet
7635 Oh, Promise Me—From "Robin Hood" (De-Koven), Cornet with orch. accomp., Chester W. Smith
Answer (Robyn), Cornet with orch. accomp., Chester W. Smith

- LATEST SONG SENSATIONS
7641 Hello! I've Been Looking for You (Golden-Hubbell), Tenor with orch. accomp., Arthur Hall
Liberty Bell (It's Time to Ring Again) (Goodwin-Mohr), Tenor with orch. accomp., Arthur Hall
7637 Says I to Myself, Says I (Morn-Von Tilzer), Soprano with orch. accomp., Ada Jones
I'm Old Enough for a Little Lovin' (Mama Told Me So Last Night) (Walker-Skidmore), Soprano with orch. accomp., Ada Jones
7629 I Don't Want to Get Well (Pease and Johnson-Jent), Tenor with orch. accomp., Arthur Hall
Hail! Hail! The Gang's All Here (Esrom-Morse-Sullivan), Vocal quartet with orch., Peerless Quartet

- ART TONE RECORDS
12502 Humoresque (Dvorak), Violin with piano accomp. by Francis Moore.....Helen Ware
Ave Maria (Schubert), Violin with piano accomp. by Francis Moore.....Helen Ware
10030 When the Bell in the Lighthouse Rings (Lamb-Solman), Bass with orch. accomp., Frederic Martin
Rocked in the Cradle of the Deep (Knight), Bass with orch. accomp., Frederic Martin
10019 Vulcan's Song—"Philemon et Baucis" (Gounod), Bass with orch. accomp., Frederic Martin
Gipsy John (Clay), Bass with orch. accomp., Frederic Martin
12501 Largo (Handel), Violin with piano accomp. by Francis Moore.....Helen Ware
Meditation—"Thais (Intermezzo Religieuse) (Massenet), Violin with piano accomp. by Francis Moore.....Helen Ware

EMERSON PHONOGRAPH CO.

- FEBRUARY LIST
HITS OF THE MONTH
7312 The Wild, Wild Women Are Making a Wild Man of Me (Piantadosi-Wilson-Lewis), Char-

(Continued on page 114)

RECORD BULLETINS FOR MARCH
(Continued from page 113)

- acter song, orch. accomp.....Henry Lewis
Oh! You Wonderful Girls! (Wm. B. Friedlan-
der). Character song, orch. accomp.....Henry Lewis
7310 Liberty Bell, It's Time to Ring Again (Good-
win-Mohr). Patriotic solo, orch. accomp.,
Arthur Burdin
Send Back Dear Daddy to Me (Sullivan-Tenney-
Maslof). Baritone solo, orch. accomp.,
Harry Lawrence
7311 Sweet Emalina, My Gal (Creamer-Layton). Bari-
tone solo, orch. accomp.....Henry Lewis
When the Moon Is Shining Somewhere in
France (Private Frederick Ratb). Patriotic
solo, orch. accomp.....Harry Evans
7305 Homeward Bound (Johnson-Goetz-Meyer). Patri-
otic solo, orch. accomp.....Jack Warner
Give My Regards to Broadway (George M.
Cohan). Patriotic solo, orch. accomp.,
Arthur Burdin
7307 Somebody's Done Me Wrong (Will E. Skid-
more). Character song, orch. accomp.,
Eddie Nelson
Hello, Aloha, Hello (Johnson-Meyer). Baritone
solo, orch. accomp.....George Beaver
7303 The Crickets Are Calling (Wodehouse-Kern).
Baritone solo, orch. accomp.....Jack Warner
March of the Toys (Victor Herbert),
Emerson Military Band
7304 Leave it to Jane (Wodehouse-Kern). Baritone
solo, orch. accomp.....Jack Warner
Al Fresco—Intermezzo (Victor Herbert),
Emerson Military Band
7309 Meet Me at the Station. Dear (Lewis-Young-
Snyder). Character song, orch. accomp.,
Eddie Nelson
One Day in June—It Might Have Been You
(Goodwin-Hanley). Baritone solo, orch. ac-
comp.....Harry Lawrence
7308 We're Going to Hang the Kaiser Under the
Linden Tree (Kendis-Brockman). Patriotic
solo, orch. accomp.....Harry Evans
There's a Green Hill Out in Flanders, There's
a Green Hill Up in Maine (Allan J. Flynn).
Patriotic solo, orch. accomp.....Jack Warner
7313 My Sweetie (Berlin)—Fox-trot,
Emerson Military Band
So Long Mother (Egan-Kahn-Van Alstyne)—
One-step.....Emerson Military Band
7314 Any Time Is Kissing Time (Frederick Norton).
One-step.....Emerson Military Band
That's the Kind of a Baby for Me (Harriman-
Egan). Baritone solo, orch. accomp.,
George Beaver
7306 Battle Hymn of the Republic (Julia Ward
Howe). Patriotic solo, orch. accomp.,
Harry Evans
Under the Double Eagle (J. F. Wagner)—March
and one-step.....Emerson Military Band

PLAN TO RELIEVE FREIGHT JAM

**Merchants' Association of New York Devises
Pick-up System Which Should Help Restore
Transportation Facilities to Normal**

In order to relieve the congestion at the freight terminals in New York City, both in the handling of incoming and outgoing freight, the Merchants' Association of New York has evolved a "store door delivery" and "pick-up" system to free the railroads from the accumulation of freight and likewise to serve the interests of the consignees.

As conditions now stand, a truck may stay in line all day in order to reach an unloading pier, and carry away a single case of goods. Under the proposed plan, as fast as the freight is received it will be placed in charge of a trucking company controlled by a carrier, according to the zone in which the consignee is located, and immediately delivered to him. By this system one truck could handle as much incoming freight in a day as a dozen trucks do under present conditions. The association urges that the carriers be permitted to form trucking companies or that present trucking companies be permitted to consolidate under Government supervision for the purpose of following out the system.

For outgoing freight the "pick-up" method would be followed, the trucks on their way back to the piers stopping at various points and gathering up freight intended for shipment.

BEAUTIFUL NEW HOME OF THE PHONOGRAPHS, LTD.

Reference has been made in The World before to the beautiful new home of Phonographs, Ltd., at 871 Madison street, San Francisco, Cal. A further idea of their comprehensiveness may be had from the picture herewith. The four views show the general office,

"Many of us know Mr. Ireton as the former general sales manager of Thomas A. Edison, Inc. We are more than glad to make his acquaintance as a jobber. We hope to see him in New York at the Jobbers' Convention in February. And you, Mr. Dealer in the San

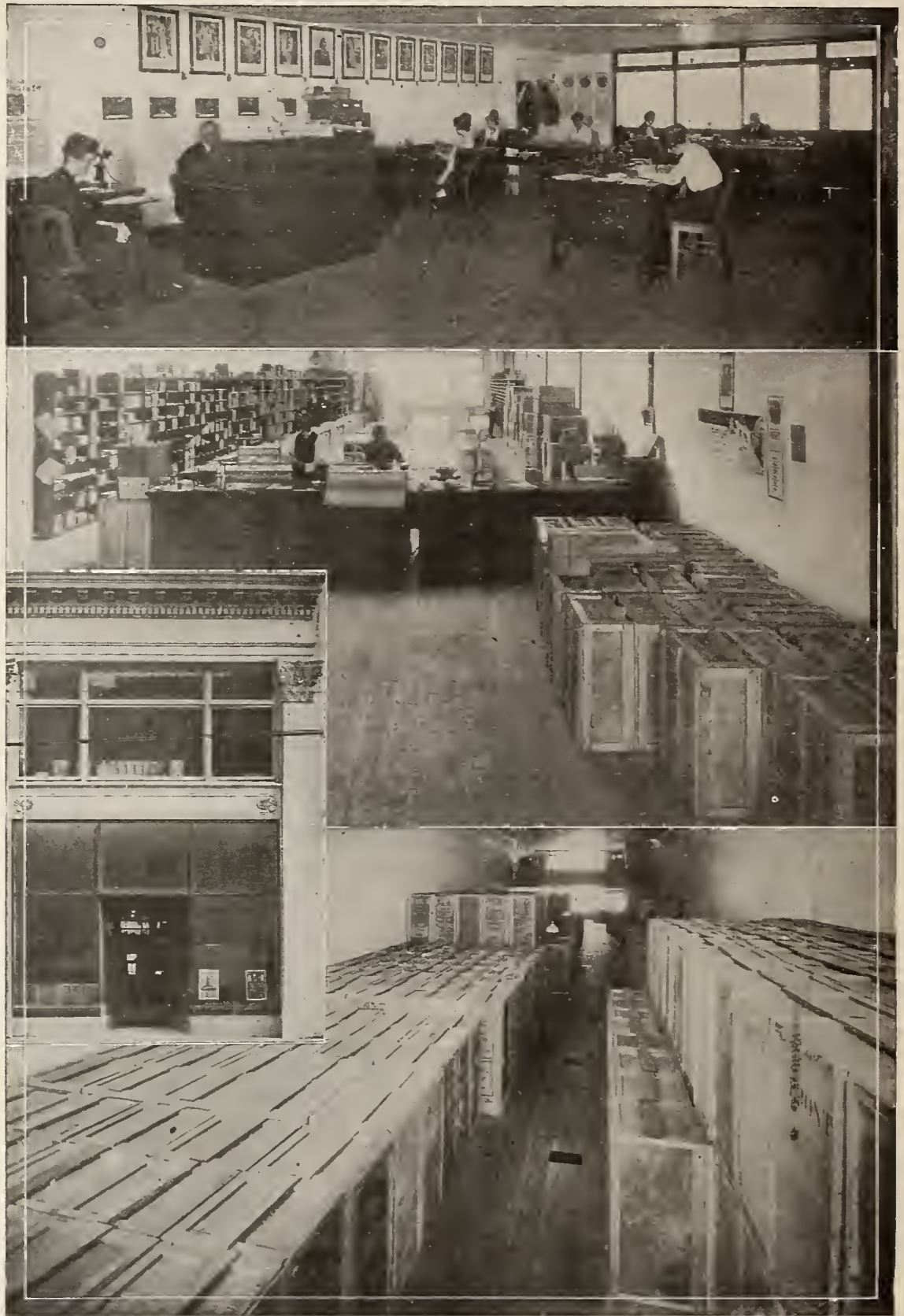

Views of Phonographs, Ltd., New Home in San Francisco with A. C. Ireton glancing over his desk; the store front; the ground floor with disc instrument stock, and the record stock department and shipping department. In using these views in Edison Diamond Points, the editor says: Francisco zone, will find it well worth your while to pay A. C. Ireton a visit. We know him. We know what he did for our Edison education. We know what he can do for yours." A pretty nice tribute.

READY REFERENCE OF GENERAL SUPPLIES

DEALERS

Send for our "Trial Proposition" on the Regina Hexaphone—the latest and best paying popular priced coin-operated instrument for use in public places.



211 Marbridge Bldg., 34th St. and Broadway, New York City
Manufacturers of Regina Music Boxes; Reginaphones;
Coin-operated Mandolin Orchestrions; Vacuum
Cleaners and other specialties.

NEEDLES
WE MANUFACTURE

Diamond needles for Edison
Sapphire needles for Edison
Sapphire needles for Pathe
in stock ready for delivery
MERMOD & CO., 505 5th Ave., N. Y.

Keep Your Record Stock with



Costs about \$2.00 for 250 records for 50 years
Send for 20-page catalog
THE SYRACUSE WIRE WORKS.
SYRACUSE NEW YORK

Some of the Leading Jobbers of Talking Machines in America

1856 **WURLITZER** 1916

VICTOR
DISTRIBUTORS
VICTORS EXCLUSIVELY

We make a specialty of getting the order out on time—every time.

The Rudolph Wurlitzer Co.
CINCINNATI AND CHICAGO

Two points of supply; order from the nearer

TEST IT. 

OUR VICTOR

Record Service

has a reputation for efficiency.
Suppose you try it.

E. F. DROOP & SONS CO.
1300 G. STREET, WASHINGTON, D. C.
231 N. HOWARD STREET, BALTIMORE, MD

Smith, Kline & French Co.
PHILADELPHIA

Wholesale Distributors for

THE INSTRUMENT OF QUALITY
Sonora
CLEAR AS A BELL 

In PENNSYLVANIA, NEW JERSEY
and DELAWARE

This Refers To

You, Mr. Jobber

Every talking machine jobber in this country should be represented in this department, no matter what line he handles or where he is located. The cost is slight and the advantage is great. Be sure to have your card in this department of *The Talking Machine World* each month. It will pay you a big profit on the investment.



Where Dealers May Secure

COLUMBIA

Product

Ready, Full Stocks, and Prompt Deliveries from Convenient Shipping Centers all over the United States.

Distributors

Atlanta, Ga., Columbia Graphophone Co., 63 N. Pryor St.
Baltimore, Md., Columbia Graphophone Co., 111 West German St.
Boston, Columbia Graphophone Co., 137 Federal St.
Buffalo, N. Y., Columbia Graphophone Co., 622 Main St.
Chicago, Ill., Columbia Graphophone Co., 14 N. Michigan Ave.
Cincinnati, O., Columbia Graphophone Co., 117-119 W. Fourth Ave.
Cleveland, O., Columbia Graphophone Co., 1375 Euclid Ave.
Dallas, Tex., Columbia Graphophone Co., 1011 Elm St.
Denver, Colo., Columbia Stores Co., 1608 Glenarm Place.
Detroit, Mich., Columbia Graphophone Co., 401 Woodward Ave.
Indianapolis, Ind., Columbia Graphophone Co., 44 N. Pennsylvania St.
Kansas City, Mo., Columbia Graphophone Co., 1112 Grand Ave.
Los Angeles, Cal., Columbia Graphophone Co., 745 S. Broadway.
Minneapolis, Minn., Columbia Graphophone Co., 412-414 Nicollet Ave.
New Haven, Conn., Columbia Graphophone Co., 206 Meadow St.
New Orleans, La., Columbia Graphophone Co., 517-525 Canal St.
New York City, Columbia Graphophone Co., 55 Warren St.
Omaha, Neb., Schmoller & Mueller Piano Co.
Philadelphia, Pa., Columbia Graphophone Co., 210 N. Broad St.
Pittsburgh, Columbia Graphophone Co., 101 Sixth St.
Portland, Me., Columbia Graphophone Co., 43 Exchange St.
Portland, Ore., Columbia Graphophone Co., 429-431 Washington St.
Salt Lake City, Utah, Columbia Stores Co., 221 South West Temple.
San Francisco, Cal., Columbia Graphophone Co., 334 Sutter St.
Seattle, Wash., Columbia Graphophone Co., 911 Western Ave.
Spokane, Wash., Columbia Stores Co., 818 Sprague Ave.
St. Louis, Mo., Columbia Graphophone Co., 1127 Plue St.
Tampa, Fla., Tampa Hardware Co.

DEALERS WANTED—Exclusive selling rights given where we are not actively represented.

Write for particulars to the Columbia Graphophone Co., Wholesale Department, Woolworth Building, New York.

Headquarters for Canada:
Columbia Graphophone Co., 363-5-7 Sorauren Ave.
Toronto, Ont.

SERVICE FIRST

EXCLUSIVE VICTOR JOBBERS
WHOLESALE ONLY

Standard Talking Machine Co.
PITTSBURGH, PA.

Victor Exclusively
EASTERN TALKING MACHINE CO.
177 Tremont Street, Boston
VICTOR DISTRIBUTORS

**Sherman, Clay & Co.**

San Francisco, Los Angeles, Portland, Seattle, Spokane
PACIFIC COAST DISTRIBUTORS OF
VICTOR PRODUCTS

W. J. DYER & BRO.
NORTHWESTERN DISTRIBUTORS
OF THE

**VICTOR**
Machines, Records and Supplies

Shipped Promptly to all
Points in the Northwest

The PERRY B. WHITSIT CO.
Distributors of
Victrolas and Victor Records
COLUMBUS, OHIO

Southern Victor Dealers
Largest Stock VICTROLAS and RECORDS.
Prompt Shipment and Low Freight Rates.
WALTER D. MOSES & CO.
Oldest Music House in Virginia or North Carolina.
RICHMOND, VA.

**OLIVER
DITSON
COMPANY**
BOSTON

Largest VICTOR Talking
Machine Distributors East of
Chicago.

Creators of "The Fastest Victor
Service." Let us tell you more
about our service.



The New Edison

Official Laboratory
Model—William and
Mary Cabinet
Developed in Walnut.

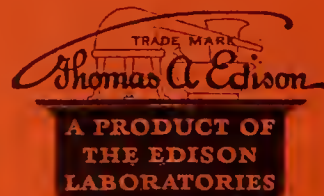

JOBBERS OF THE NEW EDISON, EDISON RE-CREATIONS,
THE NEW EDISON DIAMOND AMBEROLA AND BLUE AMBEROL RECORDS

CALIFORNIA Los Angeles—Diamond Disc Distributing Co. San Francisco—Edison Phonographs, Ltd.	LOUISIANA New Orleans—Diamond Music Co., Inc.	New York—The Phonograph Corp. of Manhattan. Syracuse—Frank E. Bolway & Son, Inc. W. D. Andrews Co. (Amberola only.) Buffalo—W. D. & C. N. Andrews Co. (Amberola only.)	El Paso—El Paso Phonograph Co., Inc.
COLORADO Denver—Denver Dry Goods Co.	MASSACHUSETTS Boston—Pardee-Ellenberger Co.	MICHIGAN Detroit—Phonograph Co., of Detroit	UTAH Ogden—Proudfit Sporting Goods Co.
CONNECTICUT New Haven—Pardee-Ellenberger Co., Inc.	MINNESOTA Minneapolis—Laurence H. Lucker.	MISSOURI Kansas City—The Phonograph Co. of Kansas City. St. Louis—Silverstone Music Co.	VIRGINIA Richmond—C. B. Haynes & Co.
GEORGIA Atlanta—Phonographs Inc.	MONTANA Helena—Montana Phonograph Co.	NEBRASKA Omaha—Stultz Bros.	WISCONSIN Milwaukee—The Phonograph Co. of Milwaukee.
ILLINOIS Chicago—The Phonograph Co. James I. Lyons. (Amberola only.)	NEW YORK Albany—American Phonograph Co.	NEW YORK Albany—American Phonograph Co.	CANADA Montreal—R. S. Williams & Sons Co., Ltd. St. John—W. H. Thorne & Co., Ltd. Toronto—R. S. Williams & Sons Co., Ltd. Vancouver—Kent Piano Co., Ltd. Winnipeg—R. S. Williams & Sons Co., Ltd. Calgary—R. S. Williams & Sons Co., Ltd.
INDIANA Indianapolis—Kipp Phonograph Co.		OREGON Portland—Edison Phonographs, Ltd.	
IOWA Des Moines—Harger & Blish. Sioux City—Harger & Blish.		PENNSYLVANIA Philadelphia—Girard Phonograph Co. Pittsburgh—Buehn Phonograph Co. Williamsport—W. A. Myers.	
		RHODE ISLAND Providence—J. A. Foster Co. (Amberola only.)	
		TEXAS Dallas—Texas Oklahoma Phonograph Co.	

The TALKING MACHINE WORLD

For the
makers &
sellers of
talking
machines

Published Each Month by Edward Lyman Bill, Inc., at 373 Fourth Ave., New York, March 15, 1918



Victrola XVI, \$215
Victrola XVI, electric, \$270
Mahogany or oak

The instrument by which the value of
all musical instruments is measured



The Highest Class Talking Machine in the World

THE INSTRUMENT OF QUALITY

Sonora

CLEAR AS A BELL



the talking machine taught Galli-Curci!!

from an interview with Amelita Galli-Curci in New York Times

"I HAD no training such as most opera singers have. I learned all I know about the voice while studying the role I was to sing. . . . When I tried to sing in New York several years ago there were in my voice faults that worked against me, and now I know that these imperfections sent me away from the wonderful city. To get rid of them I turned to the talking machine. I knew that I could correct them if I could hear them myself. I used many, many records, each time listening for the faults and the next time trying to correct them. I may say that my most painstaking teacher was the talking machine."

FOR the instruction of singers, for the learning of foreign languages, for the entertainment of family and friends, for delightful dance music, for cheering up the boys in camp and those left behind, nothing can equal the phonograph.

1918 sales will break the 1917 big records.

The preference of the public is for the highest class instrument. The Sonora with its superb tone which won highest score for quality at the Panama Pacific Exposition, its many superior and exclusive design and constructional features, and its unequalled prestige, is the phonograph for *you* to handle.

Sonoras sell with astonishing ease, they delight the purchasers and make splendid money for the dealer.

Write *today* regarding *your* agency!



Invincible
\$375

\$50	\$55	\$60	\$90	\$115	\$150	\$180
\$200	\$215	\$300	\$375	\$500	\$1000	

Art models made to special order to suit any taste.

Sonora Phonograph Sales Company, Inc.

GEORGE E. BRIGHTSON, President

Executive Offices: 279 Broadway, NEW YORK

Sonora operates and is licensed under BASIC PATENTS of the phonograph industry

The Talking Machine World

Vol. 14. No. 3

New York, March 15, 1918

Price Twenty Cents

VOCALION PROGRESS IN ST. LOUIS

Distributing Center for That Line Established by the Aeolian Co. on March 1

St. Louis, Mo., March 5.—Aeolian Hall, here, became a wholesale station for the Aeolian-Vocalion March 1. Arrangements for the establishment of the jobbing agency here were completed during a visit of General Wholesale Manager Alfring, of New York, last month. Assistant Manager Stevenson, of the Famous & Barr Co., Victrola department, has gone on the road to establish retail dealers. The territory is southern Illinois, Missouri, eastern Kentucky and eastern Tennessee.

"This was, of course, very good news to us," said Manager Guttenberger, of the Aeolian Hall Vocalion department, "for it means that an increased supply of machines is assured. No such step would be taken without assurance of machines to meet the greatly increased demand.

"We believe that this territory is ripe for this move. For a long time we have been having numbers of out-of-town customers come in and inquire for our instrument. Some of these had heard of it from owners, others had been impressed by our advertising and others had learned of it through the gradual spread of the fame of the machine. While we have been working in the local field, we have created a demand throughout a good-sized trade district, and we have on file a number of requests from

merchants who are anxious to undertake the distribution."

Shipping conditions have been the bane of Manager Guttenberger's existence recently. At Christmas time he sold a number of machines for which he had bills showing that the shipment had been started several days before. These machines reached him late in February and two others that he needs to settle all debts were still missing the first of the month.

ENTIRE PLAY NOW ON RECORDS

Entire Production on "Why Marry?" Recorded in Order to Facilitate the Presentation of the Play in Other Countries—An Important Move

The members of the "Why Marry?" company, playing at the Astor Theatre recently, completed the recording of the entire play on talking machine records. One set of the records is to be preserved in the offices of Selwyn & Co., managers of the piece, and the other sets are to be used later when the play is produced in England, Australia, South Africa and other countries. It is believed that the records will greatly facilitate the training of the various foreign companies, and will save considerable expense in sending over special directors, particularly in view of the upset condition of overseas transportation. It is believed to be the first time that a complete play has thus been recorded, although various actors have recorded their particular parts before.

MME. GALLI-CURCI'S TRIBUTE

Noted Soprano, in Interview, Declares That Talking Machine Enabled Her to Learn of and Remedy the Faults in Her Singing

Mme. Galli-Curci, of the Chicago Opera Co., and who made a sensational debut in New York recently, is one of the noted artists who pays high tribute to the talking machine as a medium for voice training. Mme. Galli-Curci, as is well known, is under contract to make records exclusively for the Victor Co., and her records have been in tremendous demand.

In an interview in the New York Times following her appearance in opera, Mme. Galli-Curci declared that the talking machine had enabled her to correct various faults in her singing, and was, therefore, largely responsible for her success. She said in part:

"I had no training such as most opera singers have. I learned all I know about the voice while studying the roles I was to sing. The master, Mascagni, helped me very much, but I did not go through the long hours of vocal labor that are the bane of most artistes. Always to me singing was a joy. It was never work. Perhaps that is why I was able to win New York.

"My friends have always helped me. Of them, Mr. Thorner, of the Chicago Opera Association, has always been so kind. He heard me in Catania, Italy, five years ago and told me I had a voice. When I tried to sing in New York several years ago there were in my voice faults that worked against me, and now I know that these imperfections sent me away from the wonderful city. To get rid of them I turned to the talking machine. I knew that I could correct them if I could hear them myself. I used many, many records, each time listening for the faults and the next time trying to correct them. I may say that my most painstaking teacher was the talking machine. I hope to go on improving, and shall work to do so, but I do not think I shall ever have the perfect voice. For eight years I have sung in public, and they have been eight years of the most joyful work ever done. Perhaps when I have sung eight years more I shall have been able to improve! Who knows? But no matter how long and where I sing, never do I expect to have the thrill of that first New York night in 'Dinorah,' when I knew that the New York which had once refused to hear me had taken me to its heart."

STUDYING FRENCH WITH THE TALKER

Uncle Sam's Forces at Spartanburg, S. C., Making Good Progress in This Direction

It is interesting to note that in the recent news from the camps at Spartanburg, S. C., special attention is paid to the fact that the members of several regiments are studying French with the aid of talking machine records. Notices to this effect have been published in the local newspapers, and have attracted considerable attention. The use of records for the study of French is another significant indication of the importance of the talking machine in war times, and the fact that it can be considered as a first-line essential in the true meaning of the term.

IMPORTANT PURCHASE IN DALLAS

DALLAS, TEX., March 2.—The Phonograph Shop, at 1300 Elm street, this city, recently purchased from the Western Automatic Music Co. that concern's entire stock of phonographs and records. The deal places the Phonograph Shop in the position of controlling exclusive selling rights for Edison phonographs in this city and vicinity.

This war should teach us to do without many things—except real loyalty.

A "TALKING" MECHANISM DEVELOPED OVER 160 YEARS AGO

According to John Wesley Mr. Miller, of Lurgan, Ireland, Anticipated Dr. Erasmus Darwin in Producing a Device Which Formulated Articulate Sounds—Some Interesting Data Presented

In a recent issue of The Talking Machine World reference was made to a letter written by Dr. Erasmus Darwin, grandfather of Chas. Darwin, to Benjamin Franklin in 1772, in which he said: "I have heard of somebody who attempted to make a speaking machine. Pray is there any truth in such reports?" Dr. Darwin was interested, it seems, because he himself had given considerable attention to the formation of articulate sounds and was working on a mechanism which, with the aid of pneumatics, would pronounce some short words somewhat like the human voice.

Meanwhile a correspondent informs us that Dr. Darwin should have directed his inquiries to Ireland, not America, for it appears that something in the form of a talking machine was known in Ireland in 1758 (many years before Darwin was interested), according to no less authority than John Wesley, who, like our Washington, "couldn't tell a lie." Writing in his journal under date of Monday, April 26, 1762, he said: "In the evening I preached to a large congregation in the market house at Lurgan, Ireland. I now embraced the opportunity, which I had long desired, of talking with Mr. Miller, the contriver of that statue, which was in Lurgan when I was there before (May 16, 1758). It was the figure of an old man, standing in a case, with a curtain drawn before him, over against a clock which stood on the other side of the room. Every time the clock struck he opened the door with one hand, drew back the curtain with the other, turned his head, as if looking round on the company and then said, with a clear, loud, articulate voice, 'Past one, two, three,' and so on. But so many came to see this (the like of which all allowed was not to be seen in Europe), that Mr. Miller was in danger of being ruined, not having time to attend to his own business. So, as none offered to purchase it, or to reward him for his pains, he took the whole machine to pieces."

Under date of Monday, June 14, 1773, a further entry occurs: "After preaching at Lurgan, I inquired of Mr. Miller whether he had any

thoughts of perfecting his speaking statue, which had so long lain by. He said he had altered his design; that he intended, if he had life and health, to make two, which would not only speak but sing hymns alternately with an articulate voice; that he had made a trial and it answered well. But he could not tell when he should finish it, as he had much business of other kinds to attend to, and could only give his leisure hours to this. How amazing it is that no man of fortune enables him to give all his time to the work."

The above data is certainly interesting and emphasizes afresh that there is "nothing new under the sun." Of Mr. Miller little is known, but Dr. Darwin, who was a sort of prophet in his own way, having crudely anticipated the possibilities of many of our more modern developments, had undoubtedly given considerable attention to the creation of some form of predecessor of the phonograph. In a note on his poem, "The Temple of Nature," which was published in 1803, the year after his death, the following appears:

"I have treated with greater confidence on the formation of articulate sounds, as I many years ago gave considerable attention to this subject for the purpose of improving shorthand; at that time I contrived a wooden mouth with lips of soft leather, and with a valve over the back part of it for nostrils, both of which could be quickly opened or closed by the pressure of the fingers, the vocality was given by a silk ribbon about an inch long and a quarter of an inch wide stretched between two bits of smooth wood a little hollowed; so that when a gentle current of air from bellows was blown on the edge of the ribbon it gave an agreeable tone, as it vibrated between the wooden sides, much like a human voice. This head pronounced p, b, m and the vowel a with so great nicety as to deceive all who heard it unseen, when it pronounced mamma, papa, map and pam; and had a most plaintive tone when the lips were gradually closed."

We present these interesting facts for further consideration and enlightenment.

How Recognition of the Pride of Race Will Increase Record Sales

By Frank E. Parsons

Pride of race is something that will not be downed even in these abnormal times, and the existence of that fact should provide many opportunities for the talking machine dealer to realize at least more than ordinary results from his record-selling campaign.

We all realize that it is the Italian to whom Italian records most appeal, or the Swede who takes most interest in Swedish records, and so on, but there are many records in the catalog proper, records of the popular, or standard, type sung in English, that will make a special appeal to certain classes—something connected with them, either the title of the piece, or the name and nationality of the singer.

This fact has been emphasized particularly by a live talking machine dealer in an Eastern city, who has practically doubled his sales of McCormack records. There is a large natural demand for McCormack records from musical people of all classes, but this particular dealer realized that the voice of McCormack sounded particularly sweet to the Irishman. He, therefore, sees to it that announcements regarding the new McCormack records as they appear find a place in the Irish and Catholic weekly papers and in the bulletins issued by the Catholic churches in his section. The success of the plan is demonstrated by the fact that the sales of McCormack records, even though good before, have practically doubled with this dealer as a result of this special publicity. The same plan was followed in connection with the publications of the various Knights of Columbus Councils, and with the same gratifying results.

Take the case of Caruso records, for instance. Practically everybody who buys records buys one or more of the recordings of this famous tenor, but even the lowliest Italian, unacquainted with English to any extent, can nevertheless be appealed to in his native tongue through special publications reaching him by the fact that the great tenor himself is an Italian.

There is a certain Polish singer who has recorded the songs of his native land for one of the prominent companies, and who has stimulated his royalty receipts tremendously by bringing his records personally to the attention of his compatriots. Not only that, but he has increased the sale of several of his records in English by that same direct means.

There are in the leading catalogs, and not all

in the foreign sections by any means, records that lend themselves particularly to exploitation in certain fields. There are, for instance, records that are designed particularly for use in the ceremonies of various fraternal orders—records that find a place in the ritualistic workings of the Masons, Elks, Odd Fellows, etc. Just simply to have these records on the shelf and to call attention to them in a desultory way, is not enough. All of these orders have special

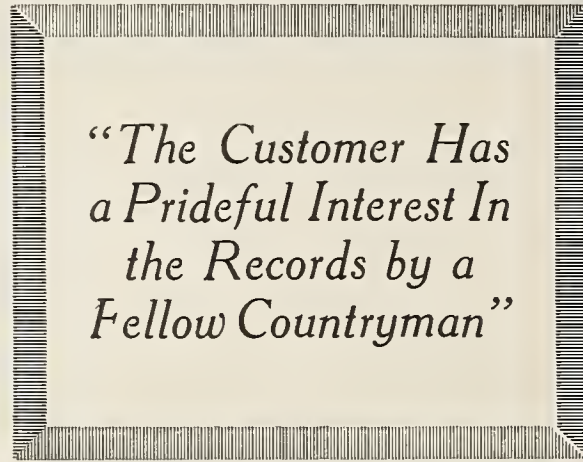

publications issued at regular intervals and devoted to their interests. These publications offer the logical mediums through which the talking machine dealers can call attention to special records of the fraternal-order type.

By advertising in mediums that go direct to the people most interested, there is a saving of wasted circulation, and consequently of considerable money. It is the same principle that influences manufacturers to advertise in trade journals. They might advertise to the dealer in national publications with circulations running into the millions, but of all that circulation only 1 per cent. would be interested in the proposition, and the 99 per cent. remaining would be wasted, even though paid for. In the trade journal the manufacturer appeals directly to those whom he desires to reach, and thus gets the benefit, at a restricted cost, of 100 per cent. circulation.

The talking machine dealer who studies racial sympathies, and in his publicity makes a special drive along that line, studying his records, what they offer, who the singer is, and whom he is most likely to appeal to, is going to get results that count.

There are almost as many people who will buy records because they are sung by artists of their own nationality, and through pride of that fact, as well, buy the records solely for their musical value. It is the ability to appeal directly to those people on a logical basis that will save exploitation expense and effort, and produce maximum sales.

There are a great many dealers to-day who have on their shelves, and classed as slow-selling records, selections that, if presented to a special class of buyers and in a special way, would move with a very satisfactory rapidity. The question is worth thinking about and studying.

MOZART PHONOGRAPH CO. RESUMING Overcoming Effects of Recent Fire and Will Be Working at Capacity Soon

St. Louis, Mo., March 4.—The Mozart Phonograph Co. will be working to full capacity again this month, according to a recent statement by President Fitzgerald. One of the buildings of the former Colonial Cabinet Co., which were acquired for Mozart production, is now working full time following the fire in January, and the second and more seriously damaged building will be entirely repaired and restocked soon. "We are taking care of the orders now coming in," said Mr. Fitzgerald, "but business threatens to get too good."

CAN RECORD READINGS FROM NOVELS

Apparently the American law does not prevent talking machine companies from making records of readings taken from novels. It does protect plays against such reproduction.

The question arose recently when records were made of chapters from "Pollyanna," the reciter merely cutting out descriptive paragraphs. The secretary of the American Publishers' Copyright League, after examining the law, gave it as his opinion that there had been no infringement of copyright.

SUFFERS HEAVY FIRE LOSS

The building occupied by the Emil Granberg Mfg. Co., manufacturers of talking machines and furniture, was the scene of a fire recently causing damage to building and stock of about \$8,000.

SINCERITY

That's the slogan back of every factor in

Ditson Service

It means much just now

Oliver Ditson Co.
B O S T O N

VICTOR
Exclusively

Chas. H. Ditson & Co.
N E W Y O R K

Victrola VI-A, \$30
Oak



Victrola IX-A, \$57.50
Mahogany or oak



Victrola XI-A, \$110
Mahogany or oak



Victrola XVI, \$215
Victrola XVI, electric, \$270
Mahogany or oak

Victor Supremacy is overwhelming

Musically, artistically, commercially, Victor supremacy is always, everywhere, in evidence.

Its universal recognition makes success easy for every Victor retailer.

Victor Talking Machine Co.
Camden, N. J., U. S. A.

Berliner Gramophone Co., Montreal, Canadian Wholesalers

"Victrola" is the Registered Trade-mark of the Victor Talking Machine Company designating the products of this Company only.

Warning: The use of the word Victrola upon or in the promotion or sale of any other Talking Machine or Phonograph products is misleading and illegal.

Important Notice. Victor Records and Victor Machines are scientifically co-ordinated and synchronized in the processes of manufacture, and their use, one with the other, is absolutely essential to a perfect reproduction.



Victor Wholesalers

- Albany, N. Y.... Gately-Haire Co., Inc.
- Atlanta, Ga..... Elyea-Austell Co.
Phillips & Crew Co.
- Austin, Tex..... The Talking Machine Co., of
Texas.
- Baltimore, Md.... Cohen & Hughes.
E. F. Droop & Sons Co.
H. R. Eisenbrandt Sons, Inc.
- Bangor, Me..... Andrews Music House Co.
- Birmingham, Ala. Talking Machine Co.
- Boston, Mass..... Oliver Ditson Co.
The Eastern Talking Machine
Co.
The M. Steinert & Sons Co.
- Brooklyn, N. Y... American Talking Mch. Co.
G. T. Williams.
- Buffalo, N. Y..... W. D. & C. N. Andrews.
Neal, Clark & Neal Co.
- Burlington, Vt.... American Phonograph Co.
- Butte, Mont..... Orton Bros.
- Chicago, Ill..... Lyon & Healy.
The Rudolph Wurlitzer Co.
Chicago Talking Machine Co.
- Cincinnati, O..... The Rudolph Wurlitzer Co.
- Cleveland, O..... The W. H. Buescher & Sons
Co.
The Collister & Sayle Co.
The Eclipse Musical Co.
- Columbus, O..... The Perry B. Whitsit Co.
- Dallas, Tex..... Sanger Bros.
- Denver, Colo..... The Hext Music Co.
The Knight-Campbell Music
Co.

- Des Moines, Ia.... Mickel Bros. Co.
- Detroit, Mich..... Grinnell Bros.
- Elmira, N. Y..... Elmira Arms Co.
- El Paso, Tex..... W. G. Walz Co.
- Honolulu, T. H.... Bergstrom Music Co., Ltd.
- Houston, Tex..... Thos. Goggan & Bro.
- Indianapolis, Ind.. Stewart Talking Machine Co.
- Jacksonville, Fla.. Florida Talking Machine Co.
- Kansas City, Mo.. J. W. Jenkins Sons Music Co.
Schmelzer Arms Co.
- Lincoln, Nebr.... Ross P. Curtice Co.
- Little Rock, Ark.. O. K. Houck Piano Co.
- Los Angeles, Cal.. Sherman, Clay & Co.
- Memphis, Tenn.... O. K. Houck Piano Co.
- Milwaukee, Wis... Badger Talking Machine Co.
- Minneapolis, Minn. Beckwith, O'Neill Co.
- Mobile, Ala..... Wm. H. Reynalds.
- Montreal, Can.... Berliner Gramophone Co.,
Ltd.
- Nashville, Tenn.... O. K. Houck Piano Co.
- Newark, N. J..... Price Talking Machine Co.
- New Haven, Conn. Henry Horton.
- New Orleans, La... Philip Werlein, Ltd.
- New York, N. Y... Blackman Talking Mach. Co.
Emanuel Blout.
C. Bruno & Son, Inc.
I. Davega, Jr., Inc.
S. B. Davega Co.
Charles H. Ditson & Co.
Landay Bros., Inc.
New York Talking Mach. Co.
Ormes, Inc.
Silas E. Pearsall Co.

- Omaha, Nebr..... A. Hospe Co.
Mickel Bros. Co.
- Peoria, Ill..... Putnam-Page Co., Inc.
- Philadelphia, Pa.. Louis Buchn Co., Inc.
C. J. Heppe.
The George D. Ornstein Co.
Penn Phonograph Co., Inc.
The Talking Machine Co.
H. A. Weymann & Son, Inc.
- Pittsburgh, Pa.... W. F. Frederick Piano Co.
C. C. Mellor Co., Ltd.
Standard Talking Machine Co.
- Portland, Me..... Cressey & Allen, Inc.
- Portland, Ore.... Sherman, Clay & Co.
- Providence, R. I... J. Samuels & Bro., Inc.
- Richmond, Va..... The Corley Co., Inc.
W. D. Moses & Co.
- Rochester, N. Y... E. J. Chapman.
The Talking Machine Co.
- Salt Lake City, U. Consolidated Music Co.
The John Elliott Clark Co.
- San Antonio, Tex. Thos. Goggan & Bros.
- San Francisco, Cal. Sherman, Clay & Co.
- Seattle, Wash..... Sherman, Clay & Co.
- Sioux Falls, S. D.. Talking Machine Exchange.
- Spokane, Wash.... Sherman, Clay & Co.
- St. Louis, Mo..... Koerber-Brenner Music Co.
- St. Paul, Minn.... W. J. Dyer & Bro.
- Syracuse, N. Y.... W. D. Andrews Co.
- Toledo, O..... The Whitney & Currier Co.
- Washington, D. C. Cohen & Hughes.
E. F. Droop & Sons Co.
Robt. C. Rogers Co.

AN IMPORTANT ACCESSORY—ALBUMS FOR FILING DISC RECORDS

The enormous demand for "National" Record Albums keeps apace with the ever increasing demand for machines and records, and our output capacity has been enlarged to meet the greater needed supply. Record Albums have proven themselves to be the best and most convenient, as well as economic, method of filing and keeping disc records.



MAKING THEIR SELECTION

Illustrating the daily actual usage of the Album, the most convenient and satisfactory record filing system extant.



THE ALBUM

soon pays for itself in time-saving and preserving records. The initial cost is really an investment which comes back fourfold.

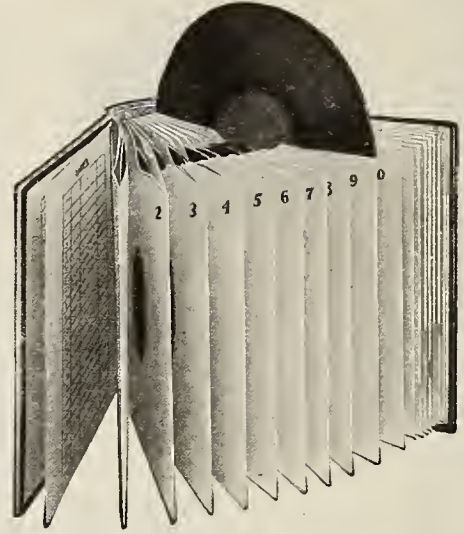

THE PERFECT PLAN

The pockets holding the records are substantially made from strong fibre stock, firmly joined together and bound in attractive covers.

A PLACE FOR EVERY RECORD AND EVERY RECORD IN ITS PLACE

Albums are an **Indispensable Requisite** in the talking machine business and wherever records are sold. An accessory that is necessary and worth while. Practical and handy. Save time and records. A **profitable adjunct** to the business. All owners of machines and records want Albums to file and preserve their records.

We manufacture disc Record Albums containing 12 pockets to fit cabinets of all sizes and styles. We also make Albums containing 17 pockets. With the indexes they are a complete system for filing all disc records.

For durability, finish and artistic design, our Albums are unsurpassed. We have unexcelled manufacturing facilities, and considering quality our prices are the lowest. Write us, giving quantity you may desire, and we will quote prices.

OUR ALBUMS ARE MADE TO CONTAIN VICTOR, COLUMBIA, EDISON, PATHÉ AND ALL OTHER DISC RECORDS

NATIONAL PUBLISHING CO. : 239 S. American Street : PHILADELPHIA, PA.

PROSPEROUS TIMES IN ATLANTA

Leading Establishments Make Cheery Reports Regarding February Trade and Are Optimistic About Outlook for March—News of Month

ATLANTA, GA., March 8.—The talking machine business in this city was very active during February, and the outlook for March would indicate that we are entering on a very prosperous era in this section.

The Diamond Disc Shop, Edison retailers, report that their February business was larger than that of December, 1917, which is unusual, as December is everywhere recognized as the banner month in the talking machine business. The Edison dealers, however, have been advertising consistently and the results are now becoming apparent in their increased business. The Edison from \$165 up, including the \$215 and \$265 models, has certainly taken the market in a larger proportion than ever.

The Delpheon Shop, dealers in the Delpheon phonograph, are meeting with fine success in Atlanta, and they have qualified recently as Columbia dealers, having had such insistent demand for Columbia product, as to necessitate their taking on this old and popular line.

The Atlanta Talking Machine Co., Columbia and Vocalion dealers, report a \$200 cash sale of records, this being one of the nicest sales of the kind that your correspondent has heard of in this city, for some time.

The Aeolian-Vocalion records which have now been on the market for some weeks are marvels

in respect to their smooth finish and beautiful appearance.

The Cable Piano Co., large Victor dealers, are enjoying a very satisfactory business. In many cases sales are only limited by the ability of the dealer to get the stock.

Mischa Elman, Victor artist, was recently in the city, and entertained a very large audience at the local auditorium.

Phillips & Crew, the oldest Victor dealers in Georgia, report a large and growing business. Some time since H. Phillips completely reorganized this business and injected new life into it.

The Haverty Furniture Co., Columbia and Pathé dealers, state that their February business

TALKING MACHINES FOR THE NAVY

Navy League Desires to Secure Machines and Records for Uncle Sam's Boys Who Go to Sea—They Help to Entertain and Instruct

The Navy League of the United States is making a special appeal for talking machines of all kinds and records for the men who are going to sea, and in this connection Mrs. W. H. Hamilton, publicity chairman, has sent out the following letter:

"The men are subject to times of great dependency, and one of the surest ways to fight these spells of ennui is to place a musical reproducing machine of some kind on board all ships.

"Several weeks ago a ship loaded with ammunition for France was held up five weeks in

this year is about 25 per cent. larger than in 1917. Their initial payments are larger and their monthly terms better. The cash record business with them is at least three times larger than during 1917.

The Columbia Graphophone Co., wholesale distributing headquarters for several Southern States adjacent to Atlanta, report that their business is far ahead of anything they have ever known, and is growing by leaps and bounds. An interesting feature has recently developed with them, in that they have employed a number of young women in their wholesale record department.

All talking machine dealers in Atlanta anticipate a very large March business.

our harbor for lack of coal. No one could leave the ship but the captain, according to regulations. So there in sight of land an entire crew stayed cold and idle. 'We would have gone mad if it had not been for the Victrola you gave us,' one of the men said.

"A submarine chaser about to start has just become the proud possessor of a Victrola given it by the Navy Club, and among the records is a set of French ones made by the Victor Talking Machine Co., so the men can study French on the way over.

"Another ship carrying many men goes over in the near future. 'We have no Victrola on board. Do you think you could get us one?' said one of the men. It means cheer and hominess, and gives a comfort where otherwise the boys might grow homesick and discouraged for lack of entertainment.

"You use your Victrolas but seldom; they will use them constantly. There are three ships waiting for a response to this notice; and the response has always been so wonderful I feel that many may be willing to make the sacrifice to brighten up the days in crossing which are so monotonous—those first days, the hardest for the troops and the crews of the ships. Donations are received at the headquarters of the Navy Club, 509 Fifth avenue."

Talking Machine Hardware

We manufacture hardware for all styles of cabinets

Lid Supports
Needle Cups
Needle Rests

Door Catches
Sliding Casters
Continuous Hinges

Sockets
Tone Rods
Knobs, etc.

BEST QUALITY

LOWEST PRICES

WEBER-KNAPP COMPANY

Jamestown, N. Y.

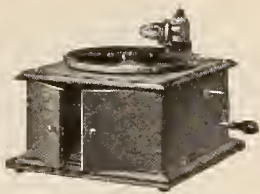

Victrola IV-A, \$20
Oak



Victrola VI-A, \$30
Oak

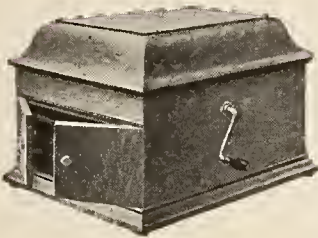

Victrola VIII-A, \$45
Oak



Victrola IX-A, \$57.50
Mahogany or oak



Victrola X-A, \$85
Mahogany or oak



Victrola XI-A, \$110
Mahogany or oak

Victor Supremacy is universally acknowledged

The Victrola has time and time again demonstrated its supremacy in the great things it has actually accomplished.

And with genuine Victrolas from \$20 to \$400 it is easy for every Victor retailer to reap all the advantages that come with such supremacy.

Victor Talking Machine Co.

Camden, N. J., U. S. A.

Berliner Gramophone Co., Montreal, Canadian Wholesalers

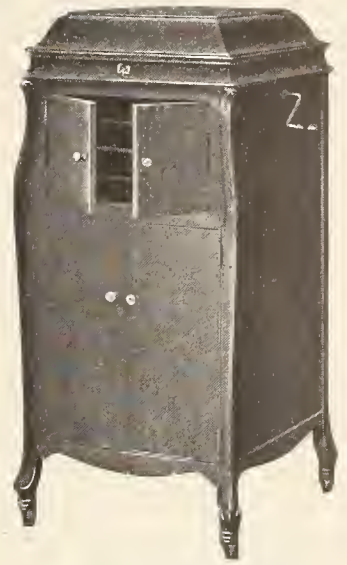

Victrola XIV, \$165
Mahogany or oak



Victrola XVI, \$215
Victrola XVI, electric, \$270
Mahogany or oak



Victrola XVII, \$265
Victrola XVII, electric, \$325
Mahogany or oak

"Victrola" is the Registered Trade-mark of the Victor Talking Machine Company designating the products of this Company only.

Warning: The use of the word Victrola upon or in the promotion or sale of any other Talking Machine or Phonograph products is misleading and illegal

Important Notice. Victor Records and Victor Machines are scientifically co-ordinated and synchronized in the processes of manufacture, and their use, one with the other, is absolutely essential to a perfect reproduction.



"HIS MASTER'S VOICE"
REG. U.S. PAT. OFF.

The TALKING MACHINE WORLD

For the makers & sellers of talking machines

PUBLISHED BY EDWARD LYMAN BILL, Inc.

President, C. L. Bill, 373 Fourth Ave., New York; Vice-President, J. B. Spillane, 373 Fourth Ave., New York; Second Vice-President, J. Raymond Bill, 373 Fourth Ave., New York; Secretary and Treasurer, August J. Timpe, 373 Fourth Ave., New York.

J. B. SPILLANE, Editor

J. RAYMOND BILL, Associate Editor

AUGUST J. TIMPE, Business Manager

Trade Representatives: B. BRITAIN WILSON, L. M. ROBINSON, WILSON D. BUSH, C. CHACE, E. B. MUNCH, L. E. BOWERS, A. J. NICKLIN, V. D. WALSH

Boston: JOHN H. WILSON, 324 Washington Street

Chicago Office: E. P. VAN HARLINGEN, Republic Building, 209 South State Street. Telephone, Wabash 5774

London, Eng., Office: 2 Gresham Buildings, Basinghall St. W. LIONEL STURDY, Mgr. The Talking Machine World has regular correspondents located in all of the principal cities throughout America.

Published the 15th of every month at 373 Fourth Ave., New York.

SUBSCRIPTION (including postage): United States, Mexico, \$1.00 per Year; Canada, \$1.25; all other countries, \$1.75. Single copies, 20 cents.

ADVERTISEMENTS: \$4.50 per inch, single column, per insertion. On quarterly or yearly contracts a special discount is allowed. Advertising pages, \$125.00.

REMITTANCES should be made payable to Edward Lyman Bill, Inc., by check or Post Office Money Order.

NOTICE TO ADVERTISERS.—Advertising copy should reach this office by the first of each month. By following this rule clients will greatly facilitate work at the publication headquarters.

**Long Distance Telephones—Numbers 5982-5983 Madison Sq.
Cable Address: "Elbill," New York.**

NEW YORK, MARCH 15, 1918

ANOTHER month has gone by and still the talking machine trade, every branch of it, continues to be faced with many problems involving both manufacturing and distributing. The bright spot in the situation during the past month has been the withdrawal of the fuelless Monday order, thereby giving back to the industry several days in which to endeavor to meet demands. It is steadily becoming more apparent that the question facing the trade is one of adjustment, and quick adjustment, to conditions that promise to continue for an indefinite period and which will most likely become worse before they get better. In other words, the companies, or individuals, in the trade, who sit still and decry the situation in general and wait for times to change for the better, are simply stirring up trouble for themselves.

Conditions are real. They must be faced, and every endeavor should be made to so regulate existing business demands and practices that a minimum of inconvenience may be occasioned. If stocks of machines and records are scarce, and there is every indication that they will be scarce for a long time, the problem resolves itself into doing the largest amount of business, and the best class of business, with the stocks now on hand, or that can be obtained. If the popular hits of the day cannot be secured from the factories, feature the records lying on the shelves, those selling at higher prices. If the leading styles of machines are unobtainable, develop some salesmanship and sell the styles that are in stock or can be secured from the factories, those machines that will bring in more money to the house.

Shorten terms of credit and get after the cash business, for there is plenty of it for the seeking. In fact, now is the time, as old Omar Khayyam would say, to "take the cash, and let the credit go."

One genuine consolation is, if we may accept assurances from Washington, that the talking machine trade, or for that matter the music industry generally, will suffer no more than hundreds of other industries in any action taken to conserve fuel and metal supplies, clear up the transportation tangle, or curtail production. Forceful arguments presented at Washington have convinced the administration that there is really no such thing as a "non-essential" industry, the hysterical economy talk of prominent bankers and others to the contrary notwithstanding. It has been found that one industry depends so much upon the other, and plays such a prominent part in

the business and social fabric of the country that to cripple a single line of trade would threaten wide disaster.

War conditions are not pleasant. We are getting abundant proof of that fact, but with the assurance of a square deal from the Government, the trade is in a position to grin and bear it, to make the most of the opportunities that are offered, and to bring about an adjustment that will reduce possible loss to a minimum.

ON and after May 1, 1918, the subscription price of The Talking Machine World will be \$2 per year. For a period of twelve years, since 1906, to be exact, the subscription price has been \$1 per year, and has been maintained in the face of increasing production costs, meaning a steadily growing loss on every subscription. Pre-eminent in its field, and the representative organ of the talking machine trade at large, it is but natural that the circulation of The World should increase by thousands each year. The size of the paper, too, has increased tremendously, reflecting as it does the great development of the industry as a whole, and the confidence of our advertisers based on profitable returns. The steady rise in the cost of paper, of printing and of all the elements that go to make a newspaper has placed a burden on the publishers of The World that can no longer be borne and still observe good business practice.

For several years past members of the trade, as well as other publishers, have marveled that we could produce and offer a publication of the size and scope of The World at such a small subscription price. Up to now, however, we have given to our readers the full fruits of The World's development at the subscription charge fixed over a decade ago. At the new price of \$2 we promise to our subscribers, who have so loyally supported us, still further development and greater value. An announcement in another section of The World tells how the present subscription rate can be enjoyed for some years to come. It is worth reading and acting upon.

THE value of the talking machine as an entertaining factor and gloom dispeller in the great army and naval camps in this country, and in the American military headquarters and trenches in France, is emphasized by the numerous letters sent by the soldiers to their folks at home and by the correspondents to the magazines and to the daily papers. Week after week pictures appear showing how the talking machine is utilized in the great social centers which are fathered by the Y. M. C. A. and the Knights of Columbus, and high tributes are paid to its power to bring joy and pleasure into the lives of these men who are serving Uncle Sam, and who are preparing to battle for the rights of man against the rights of might in the great field of war in Europe.

While the piano and the player have aroused enthusiasm among the soldiers, yet the talking machine, through its ability to bring into the camp the voice and personalities of the great operatic and concert artists, as well as the music of the symphony orchestras and the great bands of the nation, give a variety of music that has made the strongest kind of appeal to the soldiers, because of its educational influence. Moreover, in connection with popular army songs, the "talker" has proven a veritable song leader, for "the boys" have taken up these songs and joined forces with the talking machine in making them still more popular.

Music in war times is truly a necessity, and not only in the camps, but in the homes, the talking machine and its music appeals to the emotions and stimulates the imagination. In these days of stress and strife the people who can weld music into their daily affairs are blessed, for what can compare with the talking machine in this respect? Through its medium even the very poorest home can afford to have the best of music as well as the palaces of the rich.

THE average business man cannot but view the provisions of the income tax and excess profits tax sections of the War Revenue Act, which he will be called upon to meet very shortly, with more or less misgivings. No matter how anxious a business man is to bear his fair share of the country's war expense, he is bound to be troubled by the complexities of the law in determining just what he should pay and how he should pay it.

Out of the darkness, however, comes one bright light, and

that is the fact that in obeying the law and making his tax returns even the most indifferent merchant will be compelled to take an accurate inventory of his business for the inspection of the Government. He will have to give the matter thought, and is more than likely to come across facts that surprise him.

Taking an inventory for the purpose of making a good showing for the year's business is quite different from compiling an inventory that will mean the basis for tax assessment. Facts and not alone pretty figures will be demanded, and in the long run perhaps it is a good thing that some merchants in our own trade, for instance, will be compelled to find out just where they stand financially and what their business amounted to during 1917.

IN an interview in the New York newspapers, following her sensational debut in New York with the Chicago Opera Company last month, Mme. Galli-Curci gave full credit to the talking machine for aiding her in training her voice properly. The noted soprano emphasized the point that it was by means of talking machine records that she learned of the various faults in her singing and was enabled to correct them.

The statement of Mme. Galli-Curci is important as coming from an artist of recognized standing, and is practically in line with the claims that have been made for the talking machine as something more than a simple entertainer. Leading artists have long ago learned that the talking machine record presents their voice exactly as it is, with imperfections and all. Before an audience, and on the concert stage, personality may be made to counteract existing faults in singing, but on the talking machine record personality does not count. It is the singing itself that must pass the test. When the artists reach the point where they can, without prejudice, study the recordings of their voices and profit thereby, then is the full value of the talking machine realized.

IT may be a difficult task to convince the average manufacturer or dealer that when business is slow it is oftentimes advisable to increase his advertising. Too many overlook the importance of publicity as a prestige builder and as an educational factor in bringing directly to the attention of the purchasing public the fact that the house that keeps its name before the public is the house that can supply the goods they require most promptly and most completely. And even when a shortage prevails in certain products, as now, the public expects from the "live" houses that advertise, the best and quickest service when the opportunity affords.

The accepted rule among a great many institutions is to reduce the advertising appropriation when trade quiets down a bit. No greater mistake can be made. Experts in advertising who study the game from a cold, scientific standpoint—that is for pro-

TO OUR SUBSCRIBERS

If your copy of The Talking Machine World does not reach you on publication date, or a few days thereafter, do not assume that it has gone astray. The existing railway congestion has had a serious effect on the handling of mail, particularly second class matter, and brought about unusual delays. Kindly wait a few days longer than usual before writing to us, as the paper will probably arrive safely.

ducing results—are a unit on the proposition that a lull should mean increased advertising if anything.

With the professional advertising man such ways and means are the best to adopt that have "pulling" power; they therefore advise no curtailment of the publicity campaign when business is slow. Then is the time to make still further efforts. Where this plan has been followed success has always crowned the endeavors of the advertiser. Quite a few talking machine men are wise enough to pursue this course and are reaping the reward. Would that there were more, and these observations apply with equal force and cogency to every branch of the trade.

AMOST praiseworthy tendency to feature in an unusually energetic manner the better class of records is noted among talking machine dealers in many sections of the country. In their advertising they call particular attention to the records by the noted artists—records that retail at \$1 up, and at least one dealer has gone so far as to publish in his advertising special articles on the desirability of a library of records of the better sort. We all know that records are scarce, and that it is the proper thing to make the most of the records on hand, and the limited number that can be obtained, by featuring them in an unusual way. The logic of paying particular attention to the high-priced records is that the gross amount received for their sale is much larger and, therefore, serves to measure up with the total sales volume of popular types of records in normal times from a monetary standpoint. In other words, if a normal business cannot be done on accumulated profits, the condition can be offset to a certain degree by doing a smaller business on large profits.

IF a bill before the New York State Legislature becomes a law, it seems as though merchants in all industries in this State will be compelled to observe a one-price policy regardless of their personal desires. The bill seeks to amend the personal property law in order to make it compulsory upon the merchant offering goods on contract, or conditional sale, to place upon the article both the cash price and the conditional sale price. If the bill becomes a law it should prove of material aid to merchants who are already observing the one-price policy, and it should likewise serve to increase the number of cash sales by presenting to the customer the saving he can effect by buying for cash.

Chase the Delay-Snakes Out of Recordland



It is the delays in record deliveries that prevent you from rolling up the big record business that you are planning to do every month. Start right now and be free from "delay-snakes" by getting your

Victor Records thru PEARSALL SERVICE

This service is operated FOR your requirements. The definite purpose of getting records promptly is all the "magic" there is to it. March your record orders right in now.

SILAS E. PEARSALL CO.

VICTOR DISTRIBUTORS

18 West 46th Street

New York, N. Y.

Edison Message No. 18



To take music out of the world would be a calamity. To withhold music from the home would be a tragedy.

¶ Today music is doing its part, a tremendously effective part, in feeding the soul of America and vitalizing the spirit of her sons and daughters—in soothing tensed nerves—in sustaining the pitch of efficient living and doing—in keeping the world from falling below present standards and keying it up to higher standards—in helping to save the world for democracy.

¶ The Edison dealer who comprehends that, in Music's Re-Creation, he has in his hands a power for great good in his community, and who exercises that power, is a true citizen and a valuable member of the Edison Organization.

THOMAS A. EDISON, Inc.
Orange New Jersey

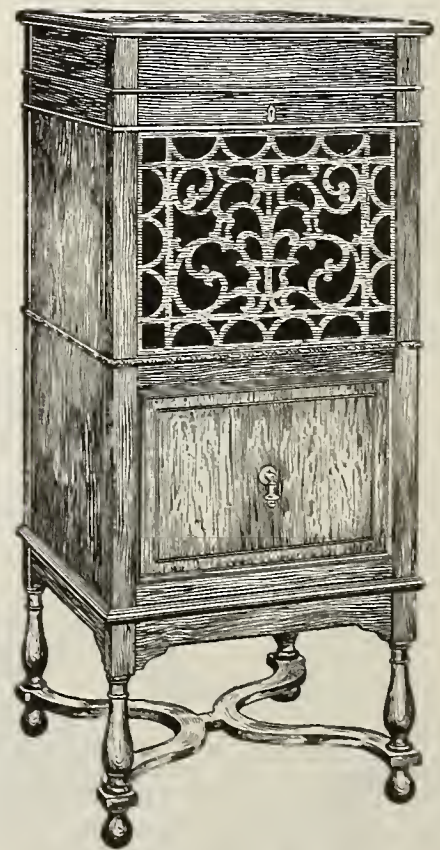

Official Laboratory Model New Edison—William and Mary Cabinet, executed in American Walnut.

Why the Sales of High Priced Records Should Be Featured Just Now

The present record shortage is not a thing to be dismissed in the belief that it is solely a manufacturing problem and therefore impossible of solution outside of the record factory.

As far as the present shortage affects the dealer's profits, the real solution lies right with the dealer himself. Here is what The World recommends, and our suggestion is based on the premise that it is as easy to press operatic records as to press records devoted to ragtime.

We recommend that every dealer get down to brass tacks and utilize every possible idea that is practical that will boom the sale of high-priced records. In this way, it will be possible for both wholesalers and retailers to do a greater cash turnover than last year, but on a numerically smaller record stock.

In the past dealers have relied pretty much on national advertising and other outside influences to sell both talking machines and records for them. The public has acquired the habit of coming in, making its own choice, and taking home whatever it pleases. Because of this practice there has been comparatively little hard pan selling—selling that convinces the buyer he wants what you want him to select.

Without doubt the national advertising of the record manufacturers, the record bulletins, and the numerous attractive store posters have gone a long way toward creating a demand for specific records. But there are few dealers who have taken up the problem in earnest where the manufacturer is forced to leave off. Examples are not over frequent where retailers are conscientiously engaged in devising ways and means for increasing the sale of high-priced records. There remains, therefore, a very broad field for expansion along this line. It is folly to think aggressive work on the part of the dealer and his staff of salesmen will not materially augment the sale of high-priced records. The personal element and the "home town" element can certainly be made to produce more sales for high-priced records than is now the case.

If the dealer will inject into his entire sales force the fact that every \$3 record sold is equivalent to selling three \$1 records or four 75-cent records, it is reasonable to suppose his sales force will soon be offering good practical suggestions for increasing the sale of the high-priced stock.

At this writing we will not discuss in detail, plans for selling high-priced records. Broadly speaking, however, there are five excellent channels to work through, five channels the possibilities of which have to date been developed by the dealer to a small degree only. They are: one, newspaper advertising; two, window display; three, direct mail communications; four, featuring of selected records after the customer enters the store and the booth; five, conversation engaged in by the salesmen and saleswomen. Considered in a general way here is

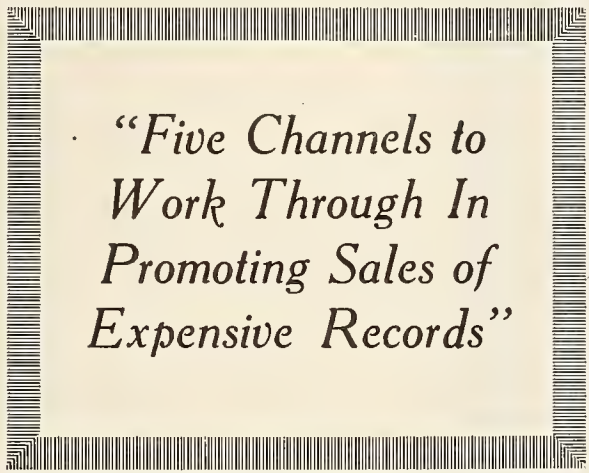

"Five Channels to Work Through In Promoting Sales of Expensive Records"

what these five different ways and means of selling high-priced records offer:

1. Newspaper advertising offers an opportunity to introduce the pictures of famous artists. Individual selections can be featured, and it would not seem advisable to run a list longer than ten records in any one advertisement. The playing up of specific pieces and of popular artists will introduce a very newsy element into retail advertising, and it will therefore be possible to use small-sized space very effectively.

2. Window display offers the opportunity for originality on an extended scale, with an option between simplicity and extravagance. Just as Hawaiian windows have, for instance, been built around Hawaiian dance records, just so can window displays be built around famous opera scenes, etc.

3. In direct mail communications to regular and prospective customers, feature circulars, etc., can be built around individual records of the high-priced class, thereby helping the public to select from the current record bulletins in favor of the high-priced records and thereby offer-

ing the chance of bringing back to mind some of the high-priced records of an earlier date.

4. Many plans may be devised for featuring records inside the store and in the demonstration booth. Special racks, special posters, special records left apparently carelessly on the machine in the booth, special display tables in the middle of the store, etc., etc., add the limit of human ingenuity.

5. Great things can be accomplished by having the salesman carefully study the nature of each client, so that he can suggest in an artful and diplomatic way certain high-priced records. Weekly meetings of the sales staff will help bring out the effective ways of working along this line.

All in all, the present is a time when the talking machine man who sits back and says "records are short" and lets it go at that is a slacker. The present is a time when men of action are needed, men with ideas to promote the sale of high-priced records. Every wholesale and retail record department will profit by bearing this thought firmly in mind, and the industry will have the satisfaction of knowing it is making good in spite of a numerical shortage and at the same time will be definitely advancing public appreciation for music of the better sort.

MME. GALLI-CURCI IN CONCERT

Amelita Galli-Curci, the great operatic soprano and Victor artist, whose records are so much in demand these days, gave her first song recital in New York on Monday, March 4, at Carnegie Hall, under the auspices of the Rubinstein Club, of which Mrs. W. R. Chapman is president. The club bought the entire floor platform seats and lower boxes, and had as its guests 150 presidents of women's clubs in Manhattan and Brooklyn. Mme. Galli-Curci will give one other concert, her last this season, on Sunday, March 17, at the Hippodrome.

JOINS MERCHANTS' ASSOCIATION

The Blackman Talking Machine Co., Inc., the well-known talking machine distributor of 97 Chambers street, New York, has been elected to membership in the Merchants' Association of New York. Several other talking machine houses are also enrolled in the association.



THE BROOKS Automatic Repeating Phonograph

Plays Any Kind of Record—Any Desired Number of Times and Then Stops Automatically—The Phonograph Sensation of the Age

MR. DEALER:—

You cannot duplicate the value we offer for twice the price. In size and appearance the "Brooks" compares favorably with Instruments retailing for \$300.00 and up.

In tone qualities it is unexcelled by any talking machine on earth! In mechanical equipment and automatic features it is years in advance of its nearest competitor. We have been building talking machines for three years—last year our sales doubled every four months. The BROOKS DEALER has no competition. The machine creates interest and discussion—it is self-advertising. Send for particulars, terms, prices. Do it Now.

BROOKS MANUFACTURING COMPANY
Talking Machine Dept. - SAGINAW, MICH., U. S. A.



View of Controlling Dial

This dial sets, starts and stops the machine. Will play any desired number up to nine or continuous.

Simplest Machine to Operate

Instructions

Set the needle at the inner edge of record cutting and then move pointer to the figure designating the number of times you wish record played.

That is all. You can now forget the machine. When the record has been played as many times as set for, the machine will stop automatically with the tone arm suspended in the air above record.

HEIGHT OF CABINET 50 INCHES
FURNISHED IN OAK OR MAHOGANY
SPRING OR ELECTRIC MOTOR

To the Talking Machine Dealer: HAVE YOU CATALOGUE No. 317 T W ?

Globe-Wernicke

(BUILT-TO-ENDURE)

Sectional Cabinets FOR DISC RECORDS

The better the facilities you furnish your customers for housing records the greater the quantity of records you will sell. Look carefully at the cabinet.

It invites you to fill it, in fact, you cannot resist the temptation to fill it. No matter how many sections are bought there will be empty compartments and these are always in sight, inviting you to fill them, and the records too are always in sight, inviting you to play them. Any record is so easily found and quickly replaced that this cabinet adds an extra charm and fascination to the playing of records.

Suppose each of your customers had this cabinet and you had a sample on your salesroom floor to remind them to buy additional sections. Not only would the sale of the cabinets increase but what a tremendous increase in the sale of records would result and there is excellent profit in the sale of both.

Each section has 90 compartments numbered consecutively from 1 up. Globe-Wernicke Catalogue No. 317 T W describes and illustrates these goods fully.

THE UNIT IDEA

of sectional construction was originated and brought to the highest state of mechanical and artistic perfection by the Globe-Wernicke Co. It applies equally to Bookcases and Disc Record Cabinets for the home, and to Filing Equipment of every kind for the office.

The Value of G/W Sectional Construction

Service is the keynote of this idea. You buy only what you need to-day—knowing that you can add to your purchase to meet the growth of your record library.

The important thing is to start right—get the first section or unit to match your furniture or furnishings—of a style that will be permanently artistic and useful—and one that you know you can duplicate at any future time.

The name Globe-Wernicke on any section is a guarantee that you can duplicate it exactly this year or the next generation. This assurance of permanent service is inherently a Globe-Wernicke attribute.

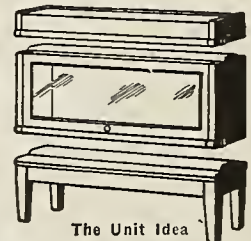

The Unit Idea

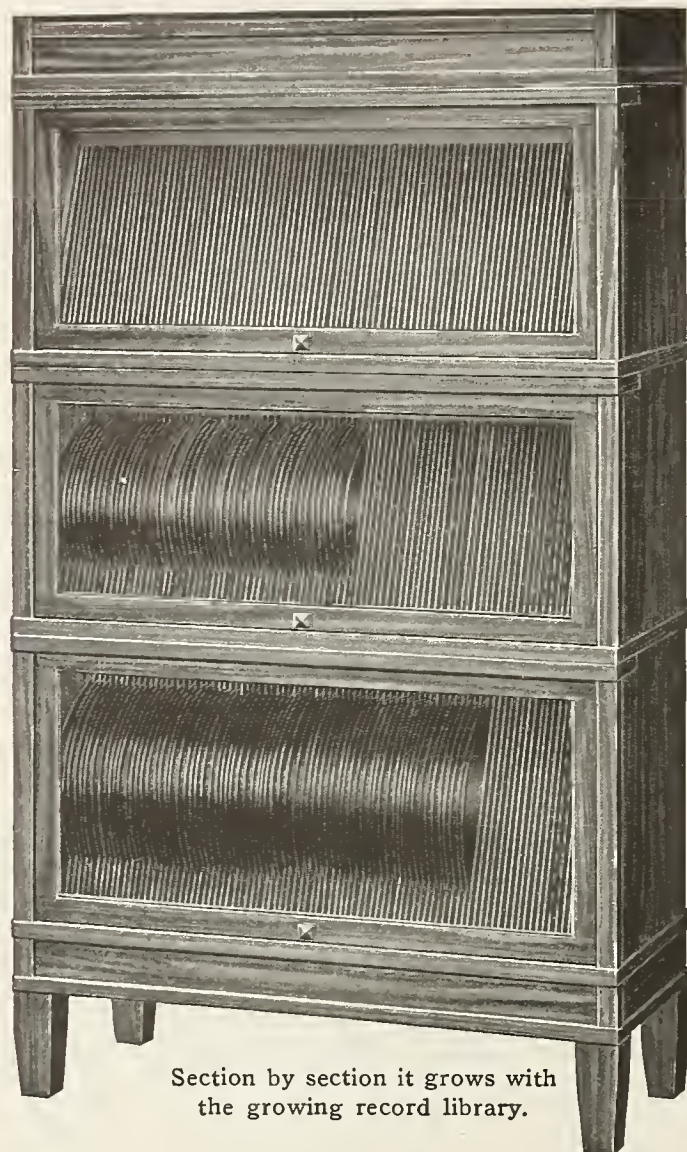

← No. 351 Art-Mission Top.

← No. 0328 Art-Mission Disc Record Section for ten-inch records.

← No. 0328 Art-Mission Disc Record Section for ten-inch records.

← No. 0329 Art-Mission Disc Record Section for ten- and twelve-inch records.

← No. 357 Art-Mission Base.

Section by section it grows with the growing record library.

Brown Disc Record Cabinet

For every talking machine made

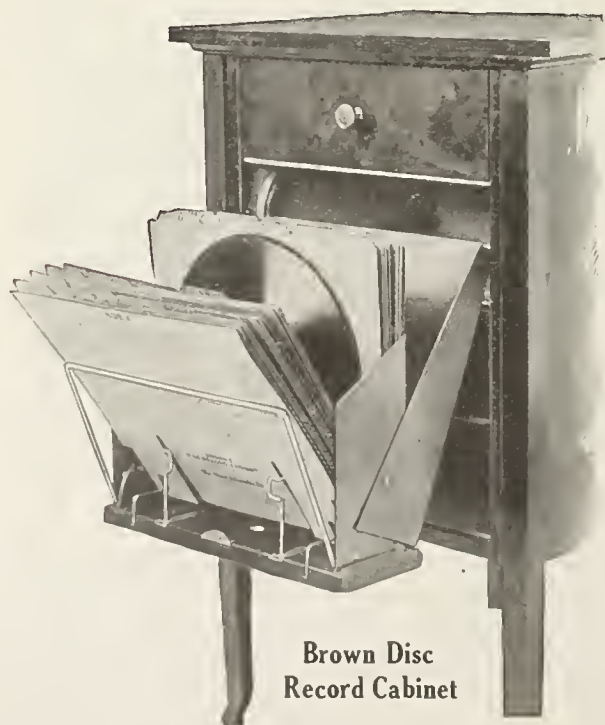

Brown Disc Record Cabinet

Every record right in front of you always.

No searching—No confusion.

Records lie flat when drawer is closed—No warping.

Records are vertical when drawer is open. Every record at your fingers' ends.

A separate compartment for every record.

No Scratching—Rubbing—Cracking or Breaking.

The Brown Disc Record Cabinet was devised to preserve a record perfectly and thereby insure Perfect Reproduction of Sound.

Ask for Catalogue No. 317 T W



BROWN DISC RECORD CABINET No. 4-T FOUR DRAWER

No. 4 T with Table Top. For use with Victrola VIII and IX. Columbia Grafonola 15, 25, 35 and 50. Aeolian Vocalion D and E. 32 1/2 inches high. Top 18 3/4 inches wide by 22 1/4 inches deep.

The Globe-Wernicke Co. CINCINNATI

Manufacturers of Steel Filing Cabinets, Wood Filing Cabinets, Sectional Bookcases and Disc Record Cabinets, Globe Steel Portable Safes

“Over There,” “Keep the Home Fires Burning” and six other great big war song hits on one Columbia dance record—A 6024, “War Song Medley One Step.” An April bell-ringer.

**Columbia Graphophone Co.
Woolworth Building, New York**



TRI-STATE VICTROLA DEALERS' PLANS

Officers of New Association Elected at Recent Meeting in St. Louis—Will Assist Dealers in Reaching Adequate Understanding of All the Important Phases of Their Business

St. Louis, Mo., March 4.—The Tri-State Victrola Dealers' Association, which effected a temporary organization here November 21, has been permanently organized and the temporary officers continued. They are: President, Arthur M. Magoon, Kieselhorst Piano Co.; secretary, C. F. Lippman, Field-Lippman Piano Stores; treasurer, E. H. Lehman Music Co., East St. Louis. These three, with Val Reis, of the Smith-Reis Piano Co., and John A. Ditzell, of the Famous & Barr Co., are directors.

President Magoon, following the permanent organization meeting, said that he believed that the Exchange Bureau, under the management of John A. Ditzell, would be the big feature of the organization, judging from the comment of new members and the dealers in the district that have inquired as to memberships. This bureau, undertaken at the suggestion of Mr. Ditzell, is modeled after the similar bureau of the Victor jobbers. Any member dealer having a surplus of records or machines can file an inventory with Mr. Ditzell, and these will be reprinted and distributed to all members, who will then arrange an exchange among themselves. Mr. Ditzell will have nothing to do with the actual exchange. His part is completed with attending to the prompt distribution of the lists. It also has been decided that the bureau will not attempt to pass on credits. Prospective exchangers, wishing credit information, can get such data by applying to the jobber. The association rule is that all exchanges must be settled by cash for the balance due within thirty days. Preliminary reports are that there is much dead stock on certain shelves that will prove very live stock on other shelves. Informal arrangements were made for extensive exchanges at the last meeting.

The prime object of the association is to assist the Victor Co. and Victor dealers in reaching an adequate understanding of their business. The territory originally contemplated was Missouri, southern Illinois and Arkansas. But the membership will extend beyond these lines, as applications are coming in from eastern Tennessee and the southeastern part of Kansas. It may reach into Iowa, it is said.

Charles I. Taylor, an advertising counselor who has had much experience with Victor advertising, spoke at the last meeting on the benefits of organization and his co-operation with the association is assured.

An employment bureau for experienced talking machine help will be organized under the direction of Secretary Lippman. Blanks will be drawn for the job seeker to fill out and these will be open to members seeking experienced help. The association has been incorporated. Salesmen and other staff members will be admitted as associate members. Some of the dealers elected to membership at the recent

meeting are: Highfill & Neifind Furniture Co., Caruthersville, Mo.; Vandervoort Music Salon, St. Louis; F. S. Gravenhorst, Effingham, Ill.; J. F. Lechridge, Mayfield, Ky.; Boveris Store Co., Ste. Genevieve, Mo.; Meach & Son, Mansfield, Mo.; R. V. Johnson, Memphis, Tenn.; W. C. Daumueller, Lebanon, Ill.; H. A. Arsularis, Neisha, Mo.; Walter H. Rhiem, Belleville, Ill., and Frank H. Ferand, Granite City, Ill.

TACOMA A BUSY TRADE CENTER

Rhodes Brothers Department Store Doing Big Victor Business

TACOMA, WASH., March 7.—Business of all kinds in Tacoma is active these days, and the talking machine people are getting their share of it. One of the lively Victor departments is that conducted by the Rhodes Brothers Department Store, with P. H. Seva as manager. The volume of business transacted has been growing so rapidly that it is planned to enlarge the department, moving into a better floor location and making it three times as large as it is at present.

The great complaint with this concern, as with all the Victor stores, is the shortage of goods, but it is expected that with the improvement in the weather, and the quicker railroad shipments from the East, this condition will be overcome to some extent.

A recent acquisition to the sales force of Rhodes Brothers is B. L. Miller, who was formerly with Sherman, Clay & Co. in Seattle. He is making a good record.

RECORDS FOR “BOYS” IN TRENCHES

Emerson Phonograph Co. Sends 10,000 Disc Records to the Y. M. C. A. for Entertainment of Uncle Sam's Boys at the Front

The Emerson Phonograph Co., New York, manufacturer of Emerson records, has sent out to the Y. M. C. A. 10,000 Emerson disc records to be forwarded to the boys in the trenches. Forty of the most popular selections have been selected for this purpose; the kind that the boys in camp will like—catchy song hits, dance, instrumental, humorous—the kind of music that will keep them in joyful spirits. Two hundred and fifty sets made up of these fifty selections are on their way, and will be distributed from the headquarters of the Y. M. C. A. Needless to say they will be welcome.

In a chat with The World the secretary of the Emerson Phonograph Co. said: “This is just the first of a series of contributions which we anticipate making to the boys. We feel that it is only our patriotic duty to do this, and that every phonograph company, whether manufacturer or retailer, should send as many records as possible to the boys in camp and in the trenches. This should also apply to the music-roll houses, to the sheet music companies, and, in fact, to everyone whose product can afford entertainment for the boys who are ‘doing their bit’ for their country.”

When you “take time by the forelock,” be sure it is your own time you're taking!



SCHUBERT PHONOGRAPH



FOR 1918

There will be some slight changes in the cabinets of some of the models for 1918, not very material, however, because the Schubert cabinets have always out-classed other phonographs in attractiveness, materials and workmanship.

Cuts are being made and as soon as sheets are printed we will notify dealers.

Five Models, \$60 Up



The BELL TALKING MACHINE CORPORATION

Offices and Show Rooms, 44 W. 37th St., New York Factory, 1 to 7 West 139th St.

LOCAL TERRITORIAL DISTRIBUTORS

Schubert Phonograph Distributing Co., 308 Lyceum Bldg., Pittsburgh, Pa.
J. A. Ryan, 3231 Troost Ave., Kansas City, Mo. Smith-Woodward Piano Co., 1018 Capitol Ave., Houston, Tex.

Give Them What They Want!



The tremendous demand for PATHE PATHEPHONES during the past year is UNQUESTIONABLE PROOF that the people are no longer satisfied with a ONE-RECORD machine.

The people have been educated regarding Records—They know that there are good Pathe Records—They know that there are good Victor Records—that there are good Columbia Records and good Edison Records—

The people want to hear ALL makes of records and they must have a talking machine THAT WILL PLAY all makes of records—

The *Pathe* Pathephone

Is the Only Standard Talking Machine That Gives You This Great Selling Advantage

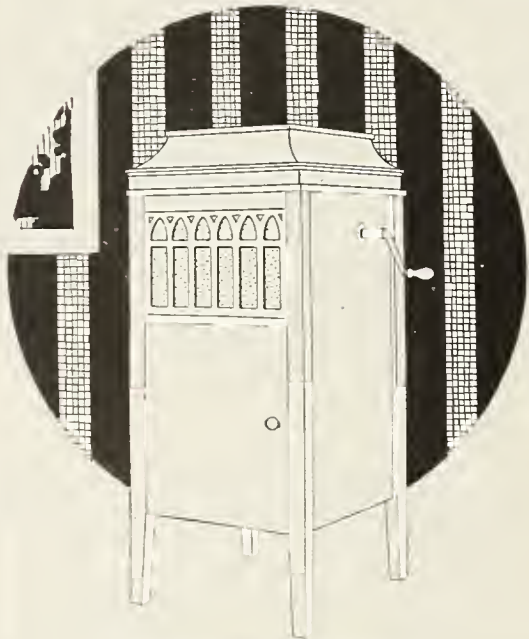

Pathephone \$75 Model

This and other grand features—the **Pathe Sapphire Ball** and **Pathe Everlasting Records**—make Pathe the greatest of all phonograph propositions.

*Hook Up With the
Pittsburgh Pathephone Co.
for Real Pathe Service!*

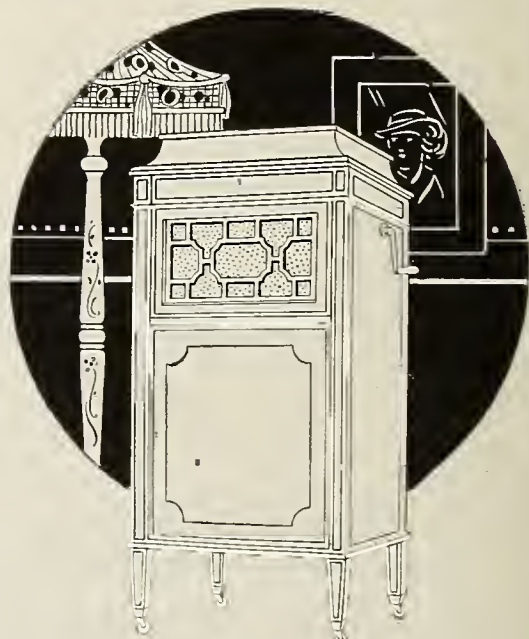

Pathephone \$225 Model



Pathephone \$100 Model

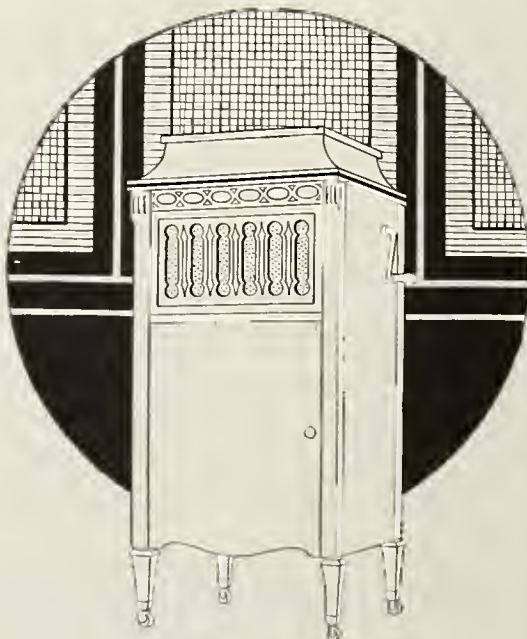

Pathephone \$110 Model

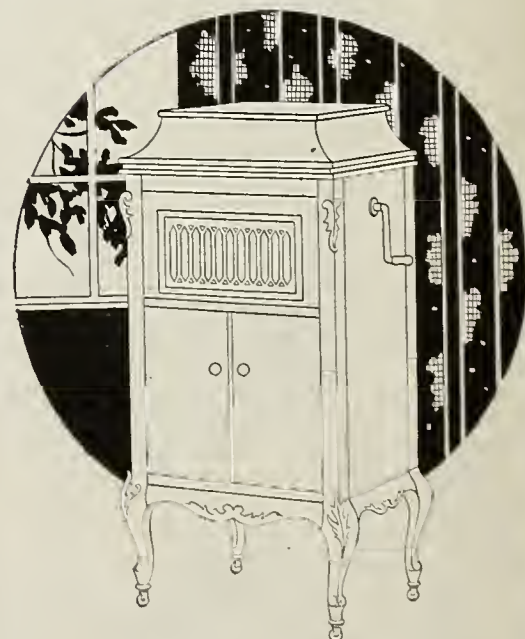

Pathephone \$175 Model

PITTSBURGH PATHEPHONE CO.

963 LIBERTY AVENUE, PITTSBURGH, PENNSYLVANIA

It Isn't Wise to Judge Prospective Purchasers by Their Outward Appearance

By Alfred Parsons

In the business of selling talking machines, or in the music trade field as a whole, the outward appearance of prospective purchasers is not always a safe guide to judge of their purchasing ability. There is a time-worn story in the piano trade of a rural gentleman who entered a fine piano wareroom, was side-stepped and joshed by all the star salesmen, and finally was turned over to a "rookie" for final consideration. The old gentleman tried out the piano with fingers knotted by earnest toil, and with finger nails in deep mourning. The final outcome was that he bought a magnificent grand and paid cash for it, taking the money out of a greasy old wallet dragged from the depths of one of his overall pockets. The illustration is one that draws deep laughter from the all-wise salesman.

One of the first pieces of advice which capable managers give to salesmen is to treat every customer with equal courtesy and consideration, regardless of their apparent circumstances. That this should be the natural attitude without suggestion goes without saying, but it doesn't require a psychologist to note how fine clothes and a suave, cultured manner win the immediate attention of talking machine salesmen, as compared with the indifference shown the ill-dressed, uncultured visitor. An excellent illustration of how this attitude works in another branch of the industry is pointed out in the experience of a man who related it to *The World* in this wise:

Some years ago a salesman entered the employ of an up-State piano house and worked hard to make a record. It was when player-pianos were new and the selling of them was hard work. This salesman was lolling about the warerooms hoping for the best, when late one afternoon an old chap, who would have been better off for a good scrubbing, and whose clothes were not only unkempt but had the fragrance of the stable about them, entered the wareroom. The salesman sized the visitor up either as a poor farmer or a stable hand. He was about to pass some bright and witty remark when there flashed through his brain the story of the old farmer. He said to himself, "Well, I have nothing else to do this afternoon, I might as well talk to this man."

"I want to see one of these here piano players," said the visitor. The salesman looked him over, and finally decided that it wouldn't do any harm to let him look at them, so he conducted him to the upper floor where the player-pianos were displayed and proceeded to demonstrate. As he played, the old gentleman's feet began to quiver, and finally ended by beating time to the music.

"Pretty fine piano," he said, "how much?"

"Seven hundred dollars," answered the salesman.

"That so? Got any better ones?"

"Sure," said the salesman, and conducted him to a large and massive instrument.

"This sells for \$850."

"How much for cash?" asked the visitor while the salesman's brain began to reel.

"Seven hundred and sixty-five dollars for cash," was the answer.

"All right, deliver it to-morrow" said the customer, and proceeded to draw from the inner recesses of his coat a long black stocking, simply full of money of all kinds, small change, bank notes and checks. The \$765 was counted out, a receipt given and the sale closed.

The salesman was naturally curious, and at the first opportunity stopped at a nearby town where the player was delivered, ostensibly to see if it had given satisfaction, and found that the man was a prosperous farmer and well off. Moreover, he had come to the store direct from the court house where he had settled an estate

for his niece amounting to something over \$100,000—hence the stocking full of change.

"After that," declared this salesman, who, by the way, is now a successful executive of a talking machine concern, "the rougher they looked the better I treated them."

During Christmas time in a town not far from New York, two of the most expensive styles of talking machines were purchased by customers whose outward appearance would not indicate that they could afford to buy a \$15 ma-

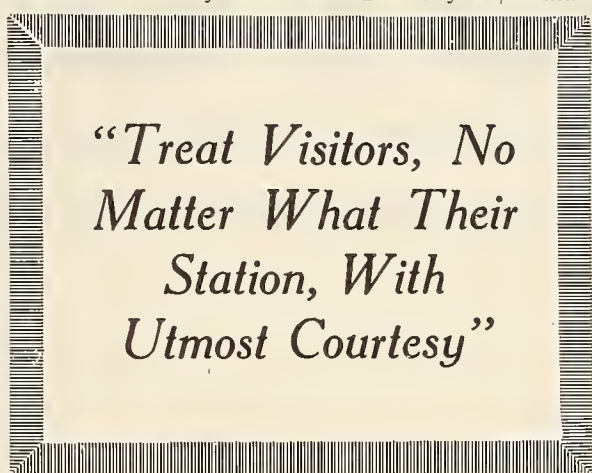

chine. The salesman was so unimpressed with the appearance and supposed financial inadequacy of his visitors that the head of the business, who happened to be around at the time, was forced to the opinion that these people were not being handled discreetly. He took them in hand himself and sold each of them a \$200 machine, much to the amazement of the salesman who first dickered with them when they entered the store. As a matter of fact, clothing doesn't always proclaim the size of the pocket-book.

Needless to say that circumstances like these

are unusual, for there are few businesses where the salesmen are so efficient, so courteous, and so attentive as in the talking machine trade.

But there are exceptions in this as in every other trade, and these remarks are meant for the "exceptions"—the men who sometimes fail to keep in mind the initial, elementary advice to salesmen to treat visitors to the store, no matter what their station in life may be, with equal consideration. There are many rough diamonds among talking machine buyers in this great country of ours.

PROSPERITY PROOFS IN LOUISVILLE

LOUISVILLE, Ky., March 4.—H. V. Boswell, manager of the Edison and Columbia department of the Kaufman-Straus Co., Inc., this city, reports that business for February showed an increase of 100 per cent. as compared with the same month last year. In fact, at the present time this house is doing the largest talking machine business in its history, and judging from the outlook at present it expects an increase of 120 per cent. in March. The demand is for high-class instruments, and 75 per cent. of the sales made are for cash. Mr. Boswell is a hustler, and believes that business can be secured if it is gone after properly. A handsome new motor truck has been purchased exclusively for the use of the talking machine department.

WANTS PHONOGRAPHS FOR CUBA

S. Sarmiento, of Manzanillo, Cuba, has notified the Foreign Trade Bureau of the Commercial Museum, Philadelphia, that his concern is in the market for phonographs and disc records to be marketed in Cuba. It is stated that correspondence should be in Spanish.

VICE-CONSULADO DEL PARAGUAY
WILMINGTON, DELAWARE
E. E. U. U. DE A.

January 28, 1918

New England Talking Machine Co.
16-18 Beach Street,
Boston, Mass.

Gentlemen:

I am indeed pleased with the PERFECTION FLEXI-TONE Reproducer that you sent me for use on my phonograph. It does all that you claim for it--and a lot more. It makes certain lateral-cut records that seemed thin before, full and rich when played with your reproducer.

I tried it on --- records, using an "elbow" attachment that is adjustable, and by centering the stylus properly to the --- record grooves, obtained with your reproducer a very rich and beautiful tone, and of course, all necessary volume. It also plays the ----- records very clearly and beautifully.

I congratulate you on a most remarkable product.

Very truly yours,

N.B.—This is only one of many letters we have received praising the **NEW PERFECTION FLEXI-TONE REPRODUCER**. You can see and hear for yourself by sending for a sample to

NEW ENGLAND TALKING MACHINE CO., 16 Beach St., Boston, Mass.

Columbia Records



Wonderful Choral Records Feature Widely Varied April Program

Father Finn's Paulist Choristers took New York by storm; their tour is a triumphal success. These famous boy singers, who make records exclusively for Columbia, have two splendid numbers in the April list—Tchaikowsky's "Legend" and Bach's "Sing Ye to the Lord."

Stracciari, who won new laurels in his recent appearance with the Chicago Opera Company, sings with tremendous power and fervor for the Columbia April program the heart-touching song to the courtiers from "Rigoletto."

Al Jolson revels in melodious ecstasy over a priceless gem—his "Lump of Sugar Down in Dixie."

A pair of song hits from Chu Chin Chow—swirling, coaxing, compelling dance records by Handy Jazzers; Jazarimba Orchestra; Jockers Brothers and Prince's Band—the very newest war songs—Cohen at the Telephone Again—these give just an idea of the straight-through superlativeness of Columbia's April offerings.

Give them half a chance, and they'll sell themselves. Order early.

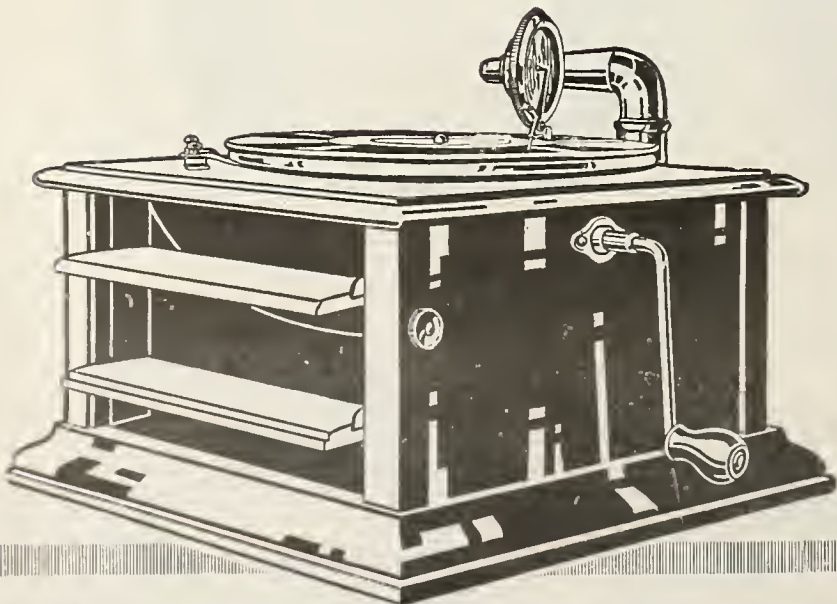

Columbia
Grafonola
\$18

Columbia Gra

Woolworth Buil

Columbia Grafonolas



Sell the Joy of Good Music—Let the Price Fix Itself

No matter how little money a customer can afford to pay for good music, there's a Columbia Grafonola to suit his purse.

The one he can afford to buy is the one to sell him. For, though it is the instrument that is delivered at his home, what he is really buying is the joy and comfort of music.

The low-priced model, at \$18 or \$30, will give him his desire. A moderate expenditure for an instrument will enable him to buy more records than if he puts nearly all his available purchase money into a higher-priced Grafonola.

Acquaintance with the Grafonola, increasing enjoyment of the wide variety and splendid quality of Columbia music, will make your customer a regular purchaser of Columbia Records, and an advertiser of his Grafonola among his friends.

Some day he will buy a higher priced instrument. That day will take care of itself, if you take care of his present desire in the right way.

Columbia superiority is as marked in the lowest priced instrument as in the Grafonola de luxe.

hophone Co.
ng, New York

Columbia
Grafonola
\$30





THE LATEST ALBUM



No. 1012

This album has heavy green envelopes, interlocked so that each envelope forms an individual record container. Both ends are finished with brass metal tops as shown in illustration.

Best Value on the Market for the Money

NYACCO METAL BACK ALBUMS

The Only Metal Back Album Manufactured.

A Leader in the Album Field

Write for Samples and Prices

NEW YORK ALBUM & CARD CO.

23-25 Lispenard St., New York

JAN RUBINI AND THE PATHE

Famous Pathé Artist Gives Informal Recital in Curtis-Colyear Warerooms

LOS ANGELES, CAL., March 1.—Jan Rubini, the famous violinist, who records for the Pathé Frères Phonograph Co.'s library, was a recent visitor to this city, and gave an informal recital in the establishment of the Curtis-Colyear Co., the prominent Pathé dealer in this city.



Jan Rubini's Recital in Curtis-Colyear Co.'s Phonograph Department

Mr. Rubini, who is internationally prominent, has made a number of Pathé records which have

been very successful. His concert at the Curtis-Colyear store was commented upon very favorably in the local papers, and this progressive Pathé representative took advantage of the opportunity to use some effective publicity in behalf of their Pathé department.

KNOWING THE RECORD NUMBERS

Persons who buy talking machine records probably have noticed that most of the dealers possess the faculty of remembering the numbers and do not have to refer to the catalogs when a record is asked for by the title and not the number, remarks a writer in the New York World. It's all a matter of practice, according to a Chambers street dealer, who said: "It's all in the day's work. You see, remembering the numbers of records is just about the same as remembering telephone numbers. Some are good at it and some are not, but the average dealer in records usually has the numbers of the records at his finger tips."

Ward's Khaki Moving Covers



PROTECT YOUR MACHINES FROM ALL KINDS OF WEATHER

and will enable you to deliver them free from dust, scratches, bruises and all other finish destroyers

Our covers are faced with Standard Khaki, lined with a heavy grade flannel, interlined with an exceptionally good grade of heavy cotton or felt, diagonally and closely quilted, and manufactured according to the usual superior "WARD New London" quality.

Grade "D" \$5.00 Grade "K" \$7.50

Carrying Straps: No. 1 \$1.00; No. 2 \$2.00; No. 3 \$3.50

ORDER SAMPLE COVER ON APPROVAL

With Name of Machine silk embroidery on any Cover; extra, 25c.
With Dealer's Name and Address, first Cover; extra, \$1.00
Same on additional Covers, each extra, 50c.

Write for booklet

THE C. E. WARD CO.

(Well-known Lodge Regalia House)

101 William St., New London, Ohio

Also Manufacturers of Rubberized Covers and Dust Covers for the Wareroom

Grade "D" Cover with No. 3 Straps.

VICTOR WIRELESS COURSE READY

Instruction in Wireless Telegraphy by Means of Records and Instruction Books Heralded as a Distinct Aid to the Government

The Victor Talking Machine Co. has just announced a special course of instruction in wireless telegraph by means of records and accompanying books of instruction. In announcing the course the company says in part:

"Higher pay and better rating are two benefits which the Victor retailer may now help our soldiers to obtain. He may also assist the nation in overcoming a critical need.

"In co-operation with the Marconi Institute in New York, we have prepared a course in wireless telegraphy with that object in view.

"The United States Army and Navy are in need of thousands of skilled wireless operators and a complete course of study may be carried on by means of these records, in camp and at home, at a very small fraction of the expense that is ordinarily involved.

"The course consists of six ten-inch double-faced records with book of instructions, all securely packed in a special container in which they may be transported readily. Our retail price is \$5.00 per set.

"Here again the Victor retailer is in position to assist solving one of the big national problems and enable the individual soldier to promote himself from the ranks.

"A special poster and descriptive folders will be used to feature this new product, and to give these records the widest circulation is a patriotic duty no less than a business proposition."

Special posters and descriptive folders will be issued for the use of the dealers in featuring this latest Victor product, which should meet with a ready demand.

Arrangements have recently been made with the Marconi Institute in New York to accept orders through Victor dealers for the books on wireless, "Practical Wireless Telegraphy," and "Military Signal Corps Manual," as well as subscriptions for the magazine, "The Wireless Age." A discount will be allowed on the orders.

L. L. LEVERICH AS A WRITER

Assistant Advertising Manager of the Columbia Co. Clever With His Pen—New Cohen Record

In the April list of new Columbia records will be featured a record to be added to the already popular "Cohen" series. This record will be designated as A2488, and will contain two recordings: "Cohen at the Real Estate Office" and "Cohen Calls His Tailor on the 'Phone.'" It is interesting to note that the former selection was written by Lester L. Leverich, assistant advertising manager of the Columbia Co. Mr. Leverich has achieved signal success as a writer and composer of witty song and verse, and a number of his compositions have been published in magazines and newspapers. It is said that his "Cohen" record is well calculated to compare in popularity with the original "Cohen" selection, the sales of which have reached phenomenal totals. Both sides of this new record are recorded by Joe Hayman, who has made all the "Cohen" records to date.

FIRE IN ALBANY STORE

The stock of the Standard Phonograph Co., 618 Broadway, Albany, N. Y., was badly damaged by fire last week. After the blaze it was found that several talking machines had been stripped of their electric motors and an investigation is being made.

AIDING WAR STAMP CAMPAIGN

Charles K. Haddon, vice-president of the Victor Talking Machine Co., is directing the War Stamp sale movement in Camden County, where it is expected \$3,500,000 will be raised by the sale of the stamps.

\$1,000,000 IN SONORA ORDERS

Frank J. Coupe Returns From Whirlwind Trip in Which He Booked Big Orders for 1918—Big Selling Campaign Now Being Planned

Swinging out from the executive offices in New York, Frank J. Coupe, sales and advertising director of the Sonora Phonograph Sales Co., Inc., jumped from city to city visiting the trade, and after a two weeks' whirlwind trip (with fourteen nights on sleepers), returned recently with over a million dollars' worth of 1918 orders for Sonoras. The first stop was Indianapolis, the next Chicago. Business in phonographs in the Windy City is excellent, Mr. Coupe reports, the local representatives, C. J. Van Houten & Zoon, ordering very heavily for the coming year's business.

At Milwaukee Yahr & Lange, Sonora distributors, were the hosts at a banquet given to the Wisconsin Sonora dealers. In this section everyone has money, is spending it for talking



Frank J. Coupe

machines, and the prospects are splendid. Two of the out-of-town guests at the Milwaukee meeting were Sewall Andrews, of the Minneapolis Drug Co., and Oscar Maurer, of the Kiefer-Stewart Co., of Indianapolis, two important Sonora distributors. Many new dealers were signed up, Sonora 1917 sales having been so extensive that it was clearly apparent to every prospective dealer that the Sonora is an extremely easy instrument to sell, decidedly popular, and in strong demand. Many dealers were almost completely sold out and rush orders for immediate delivery by express were commonplace.

At St. Joseph, Mo., a salesman's meeting was being held by C. D. Smith & Co., and Mr. Coupe outlined the policies of the Sonora Co. for 1918 with reference to the plans for extensive and unique dealer co-operation and assistance which the Sonora advertising department now has in preparation.

Business in Salt Lake has been phenomenal and the Strevell-Patterson Co. were found to be highly enthusiastic over the merits of the Sonora and are preparing for a great year.

That the farmers are cashing in on wheat, corn and other high-priced food products and are buying Sonoras was attested by the Southwestern Drug Co. of Wichita, Kansas, who expect that the coming twelve months will establish new high-selling records. Dealers everywhere were urged by Mr. Coupe to order early this year because of extraordinary transportation and manufacturing conditions.

The results of this short trip of Mr. Coupe's were highly gratifying to George E. Brightson, president of the company, who also visited some of the dealers during this period.

The distributors all along the line were at stations to welcome "Frank J," as he is popu-

"TALKING MACHINE IS THINKING MACHINE" SAYS LAUDER

Well-Known Singer Points Out That the Thoughts It Inspires in the Soldiers at the Front Are Pleasant Thoughts of Home and the Dear Ones Left Behind

"When I was across in France seeing the boys," said Harry Lauder, "I often thanked the inventor of the talking machine for not having lived in vain. A record out yonder, where the mud is much deeper than even in the streets of dear auld Glasca on the worst winter day, a record brings back the sniff o' the hills, the wee ingle neuk, and the days o' auld lang syne. It's graun, I'm tellin' ye! What an invention! Voices o' loved ones always wi' you; sangs o' the hameland, the mountain and glen to inspire you, to fill your heart and strengthen your arm. Aye, the talking machine is a thinking machine, and the thoughts that it inspires are pleasant thoughts—thoughts o' hame and the dear ones left behind."

Such is Harry Lauder's description of music among the men at the front in an interview with the London Phono-Record shortly after his return from his recent visit to the Western front. "I'll tell you a wee story," he proceeded in his own pawky and inimitable way, "an' it's no' a madeup yin, min, I'm telling ye! This is a story of how a gramophone backed up the gallant soldiers o' a gallant Scottish Regiment. The day's duties had been long and arduous, and for hours and hours the Jocks had been

under a fierce bombardment—without a rest and without a halt. Then day gave way to night. Shells were continually bursting; Lazy Lizzies, Whistling Willies and a' the rest o' the devil's messengers. Now the rain came on. Sheets and sheets o' it—rain that looked as if it never would stop, and made one wonder where it all came from. Even the trenches were flooded. That night passed and at dawn the Germans were scattered and new positions were taken. But still it rained."

Harry at this stage quietly chuckled, puffed away at his pipe, and went on. "Several hours later the boys were relieved, and tramped miles back to their rest camp—amid mud to the knees all the road, and with the water streaming down their necks and squelching in their boots. It was evening before they arrived at the place where warm tea, warm clothing, and a good dry bed awaited them, but, man, even before a helmet was doffed one o' the Jocks made for the company gramophones. He slipped on a record, wound up the machine, and started it agoin'. And the discomforts of the past thirty-six hours were sent into oblivion when the machine calmly churned out, 'When You Come to the End of a Perfect Day.'"

larly known, and when this cheerful sales manager told of the coming period models and outlined the new plans for aiding the dealers in increasing sales (which for the present must remain confidential), the Sonora dealers were a unit in declaring that in selling methods the 1918 Sonora program is bound to prove an eye-opener to those who do not realize that the phonograph industry is one of the fastest growing and most progressive lines in the country, and that despite all pessimistic talk the war is bound to increase and not decrease sales.

Mr. Coupe stated that the more expensive models from \$150 up are in surprisingly good demand, and the Sonora officials are all gratified that the Sonora idea of making the "Highest Class Talking Machine in the World" rather than the largest number of the lowest-priced talking machines, is being emphatically approved by the public.

It requires as much courage to go over the top of a rut as to go over the top of a trench.

ADDRESS GRAND RAPIDS DEALERS

L. C. Wiswell and C. B. Gilbert Principal Speakers at Recent Annual Meeting of Retail Music Dealers' Association in Grand Rapids

GRAND RAPIDS, MICH., March 2.—Among those who attended and spoke at the recent annual meeting of the Grand Rapids Retail Music Dealers' Association were Leslie C. Wiswell, manager of the wholesale Victrola department of Lyon & Healy, Chicago, and C. B. Gilbert, representing the Victor Talking Machine Co., Camden, N. J.

Mr. Wiswell dwelt at length upon present existing conditions in the trade and their effect on the distribution of both machines and records and stated that now was the time for the development of closer co-operation between the merchants in the various cities. Mr. Gilbert also reviewed the present trade situation from the standpoint of the factory man, and gave the retailers some valuable information.

Lansing Khaki Moving Covers

PROTECT VARNISH IN THE COLD WEATHER

and enable you to deliver your phonograph free of blemishes of all kinds.

These covers are made of Government Khaki, interlined with heavy felt or cotton, fleece-lined, quilted and properly manufactured. Perfect protection in all weather.



GRADE B
\$5.00

GRADE A
\$7.50

Carrying Straps Extra

Use the Lansing Khaki Moving Cover and your delivery troubles will be over.

Write for booklet

E. H. LANSING
611 Washington St., BOSTON

SAN FRANCISCO OFFICE, Room 530 CHRONICLE BLDG.
WALTER S. GRAY, Manager

THE TRADE IN BOSTON AND NEW ENGLAND

JOHN H. WILSON, MANAGER, 324 WASHINGTON STREET, BOSTON, MASS.

BOSTON, MASS., March 5.—As emphasized a month ago February was a very short month, the shortest one on record, because of the coal shortage which closed up tight three successive Mondays so far as business was concerned. As to the advantages of this Monday closing, which all told continued for five successive weeks, there is much difference of opinion. Spring is approaching, the weather is milder, the days longer, and all this means the use of less fuel for which the business interests certainly are most grateful. It is not surprising, therefore, that business has been rather light, but the one thing that has acted as a welcome stimulus has been the visit of the Chicago Opera Co., which is treated at more length in the succeeding paragraph. One thing that the talking machine men must be given credit for: they have uniformly accepted the unpleasant conditions gracefully; there have been no murmurings, no complaints, and they have come forward generously in response to every appeal for assistance, and there is not a week going by that some new campaign is not inaugurated. Two forthcoming whirlwind campaigns are to be the second drive for the Red Cross and the third Liberty Loan, and the trade may be depended on in advance to do its share. All honor to the patriotic stand which the trade is taking.

Chicago Opera Co. Stimulates Trade

With the appearance of the Chicago Opera Co. in Boston for two weeks, its season at the Boston Opera House ending on March 2, the various talking machine houses in Boston were keenly alive to the importance of exploiting the records of the various artists. Incidentally the company made a great success, a far greater one than had been expected, and the publicity manager, Rufus Dewey, showed himself an adept in giving proper prominence to the company and in working in effective unison with the talking machine headquarters managers. At all of the Victor distributing centers, notably the Oliver Ditson Co., the Eastern Talking Machine Co., M. Steinert & Sons, C. C. Harvey Co., George Lincoln Parker and A. M. Hume Music Co., there was a great call for the Galli-Curci records, for this artist made as pronounced a hit in Boston as in New York. The Columbia stores featured Stracciari, Baklanoff and Mary Garden, all exclusive Columbia artists. The Pathé, which does the recording for Muratore, Fitziu, Chenal, Rimini and Raisa (the latter won new laurels

for her work here) featured these singers in their advertisements.

In the opera program there were advertisements by the Vocalion Co., the Pathé Phonograph Co. with Hallet & Davis Co. mentioned as one of the dealers; the Brunswick-Balke-Collender Co., which used a picture of Muratore in calling attention to the Brunswick machine; M. Steinert & Sons Co., the Oliver Ditson Co., the Grafonola Co. of New England, the C. C. Harvey Co. and the Victor Co. itself, which had the whole of the back page.

Increases Executive Force

Oscar W. Ray, the New England manager of the Emerson Phonograph Co., is rapidly filling in his field with a staff of competent men, and there is growing evidence of the value of the school for salesmen which the parent company has started over in New York. One of Manager Ray's new men is H. L. Coombs, who comes from New York and will handle Connecticut and western Massachusetts. The local headquarters also have lately connected up with several important stores in the western part of the State through which such cities as Fall River and New Bedford and others will handle the Emerson line. Copies of the first issue of the "Emerson Spotlight" have reached this city and dealers are delighted with its appearance. Mr. Schwartz, who is in charge of the Emerson foreign department, was a visitor in Boston the latter part of February, making his headquarters with Manager Ray. Mr. Ray, by the way, was up in Montreal a while ago looking over the Emerson business there. On his way he encountered severe storms and cold and saw no less than eight engines stalled between Rouse's Point and Montreal.

L. W. Hough Increases Line Handled

L. W. Hough, of 20 Sudbury street, who is well known as the representative of the George A. Long Cabinet Co., manufacturers of disc record cabinets, has added a general line of albums for records which are manufactured by the New York Album & Card Co., in whose line of goods discriminating representatives of the trade are interested. Mr. Hough is ready at all times to give prompt attention and service to his customers, for whose inspection there will always be a full line of goods.

Steinert Co.'s Patriotic Records

M. Steinert & Sons Co., Victor wholesalers, have issued two booklets of a patriotic nature.

One is a little song book with words and music of seven patriotic numbers; the other is an essay on "Your Flag and Mine," with reproductions of famous pictures and colored facsimiles of the various flags of American history. The Victor warerooms of the Steinert Co. at Arch street and at the Boylston street stores have been experiencing very good business these past few weeks, despite the comparatively few business days.

About Will Ellsler

Townsend Walsh, dramatic critic for the Boston Traveler, thus writes in his paper of a well-known salesman at Arthur C. Erisman's establishment in Tremont street, one, it may be added, who has a great many friends in the business:

"I ran across Will Ellsler on Washington street the other afternoon. No more road-touring for him, he sagely said; at least not till theatrical conditions regain their normal equilibrium. Mr. Ellsler is the son of John A. Ellsler, one of the pioneer managers of the Middle West who was responsible for launching Abraham L. Erlanger in the business. Effie Ellsler, the one-time favorite, is Will's sister. Mr. Ellsler is now located here in a trustworthy position with the Grafonola Co. of New England."

Some Grafonola Co.'s News

Louis Besserer, who has been a valued member of Arthur C. Erisman's staff in the Grafonola Co. of New England, is in service, and is attached to the Charlestown Navy Yard, where, as he is an experienced musician, the violin being his specialty, he has been placed in charge of the orchestra.

Stanley B. Bowman, who left the Grafonola Co. of New England some time ago to associate himself with the Columbia distributor at Portland, Me., has returned to his first love, where his old associates are glad to again have him with them.

Lillian Dunnigan has severed her connection with the Grafonola Co. of New England after having served as cashier for five years.

Makes "Hit" at Pilgrim Publicity Dinner

George W. Hopkins, general sales manager of the Columbia Co., arrived in Boston on the first of the month especially to be present at the dinner that night of the Pilgrim Publicity Association. Mr. Hopkins came here from Chicago and at the conclusion of the dinner took the midnight train back to New York, which

Habits Have to Grow

For several years past Eastern Victor Service has made a specialty of speeding up the record end of the Victor business.

We have therefore contracted the *good habit* of giving the Victor dealer efficient record service.

EASTERN TALKING MACHINE CO.

177 TREMONT STREET

BOSTON, MASS.

made his visit here with Manager Fred E. Mann a very short one. The topic of his address at the advertising men's dinner was "The Psychology of Merchandise." Mr. Hopkins got a big reception from his Boston friends, who are legion here, and he has fond memories of the days he lived in this city.

Books Good Brunswick Phonograph Orders

F. H. Walter, of the Brunswick-Balke-Collender Co.'s staff, has just returned from a very successful trip taken to Providence, Fall River and New Bedford, in all of which places he was able to quicken the spirit of dealers as to the merits of the Brunswick line of machines. Just now the Boston headquarters are pushing the sale of Pathé records as well as Brunswick phonographs and the demand throughout New England is rapidly growing. Mr. Walters has the sympathy of his friends in the loss of his mother, which occurred three weeks ago in New York.

Recovered From Indisposition

A. M. Hume, head of the A. M. Hume Music Co., Victor dealers, was confined to his home in Melrose for a few days lately with a severe cold. He is now back at the warerooms, we are glad to say. Herman Baker, also of this house, is back from a trip taken to Philadelphia a while ago.

Perfects New Flexi-Tone Reproducer

The New England Talking Machine Co., with which Charles Trundy is closely identified, has finally perfected its new Perfection Flexi-Tone reproducer, on which Mr. Trundy has been diligently at work for some time. Demonstrations are being given at the factory, and a number of talking machine experts are dropping in to study this reproducer at close range.

Composite Victor Retail Publicity

The Eastern Talking Machine Co., Victor wholesalers, has just worked out a scheme of local advertising which is finding immediate favor with those directly interested in the plan. It is a sort of composite advertising in which sixty or seventy Victor dealers are co-operating. The advertisement, which is two columns wide, is to appear weekly throughout the year in one or more of the Boston dailies, and each week there is some special artist featured at the top.

Visiting Columbia Artists

R. F. Bolton, who has lately been made sales manager of the Columbia international record department, was in Boston for a short time toward the end of February. Another local caller at the Columbia wholesale quarters was L. L. Leverich, the company's assistant advertising manager, who came here largely in the interests



STEINERT'S
35 ARCH ST. BOSTON.

Victor Distributors

Many talking machine owners are forming their record buying habits now. Be sure they find what they want when they come to your store. Keep your VICTOR record stocks complete.

We can help you for we have

The Largest and Most Complete Stock of Records in New England

Write, or Telephone Beach 1330

M. STEINERT & SONS CO., 35 Arch St., BOSTON

of some of the Columbia artists who at the time were appearing with the Chicago Opera Co. at the Boston Opera House. S. J. Pabske, a salesman of the international sales department, is spending some time in this territory just now looking over the local field.

Good Reason for His Pride

Wholesale Manager Billy Fitzgerald, of the Eastern Co., is proud of the fact that he now has three nephews in the service of the country. The last one to ally himself with the great cause is now a lieutenant of engineers in the 101st Regiment. Another nephew is a lieu-

tenant in the Regulars, and the third one is a radio inspector.

Good Showing for Shortest Month

R. S. Hibshman, manager of the Aeolian-Vocalion, says that despite the short month business made a good showing in the machines which his house handles. Mr. Hibshman is regretting the anticipated loss of one of his good men, Albert Feldman, who is expecting to be called any day now to enter the service. He is to be connected for a time with the army and expects to go to Dartmouth College for a course
(Continued on page 22)

The discerning wholesale buyer has learned to

SPECIFY BAGSHAW STEEL NEEDLES

Because of their quality, supremacy and reputation

W. H. BAGSHAW CO. Lowell, Mass.

TRADE CONDITIONS IN BOSTON

(Continued from page 21)

of training. Mr. Feldman has made a marked success in selling Vocalion machines.

Closed an Excellent Month

The Pardee-Ellenberger Co., Inc., reported having had a very good month in Edison phonographs and records despite the brevity of the working days in February. Manager Silliman says that March has made an excellent start, all the traveling men are out and sending home encouraging reports of trade conditions, which are rapidly improving, and the prospects, generally speaking, are rosy for a good spring business. He states, also, that little difficulty was experienced from the coal shortage, that there were only a few hours on one day when when the

DEATH OF GEO. A. WALDRON

Old-Time Talking Machine Man Who Has Been Closely Associated With Its Mechanical Development Passes Away in Quincy, Mass.

BOSTON, MASS., March 8.—The talking machine world will be sorry to learn of the death of George A. Waldron, familiarly known as "Pop" Waldron, which occurred recently at his home in Quincy following an operation, which was the first illness he had had in many years. His relation to the talking machine business covered a period of twenty-seven years, he having entered it in 1891 as master mechanic for the New England Phonograph Co., then located in the Boylston Building at the corner of Washington and Boylston streets. He was one of the original talking machine men in the country, and invented many devices for cylinder machines which he never had the good fortune to get patented, and these he held closely to himself to the time of his death. In those early days he was associated with Carl G. Childs, who to-day is manager of the Victor recording laboratory at Camden, N. J.

Mr. Waldron was the originator of the first dictating machine, which he installed in the Boston police department and in the offices of several local lawyers, and from this beginning came the more complete machines of to-day that are in widespread use. The Eastern Talking Machine Co. possesses two of these original dictating machines.

Mr. Waldron used the old wax cylinder record and he used to shave these in a back room at his home in Quincy. He had been associated with the Eastern Co. for the last thirteen years as master mechanic. He was a native of Quincy, and is survived by his widow and two daughters, both school teachers. He was fond of hunting and duck shooting, and he often could be found sailing his craft in the waters of Quincy Bay.

The man with money may succeed, but he must have more than money; he must have brains to handle the business in which that money is invested.

steam got down to a point where inside work was uncomfortable.

To Form a Victor Dealers' Association

A Boston visitor, welcomed among the Victor trade, has been J. A. Frye, a representative from the home office who makes periodic trips to this city. He is here at this time in the interests of forming a Victor dealers' association, a plan which has met with considerable encouragement, and of which there will be more to report in a subsequent issue of The World.

Well Satisfied with Results

The C. C. Harvey Co. feel well satisfied at the business done in both Edison and Victor outfits in February. The early closing had some effect on trade conditions but there always seemed much to do in Manager White's department from morning till closing time.

ATTRACTIVE PATRIOTIC WINDOW

Buffham & Co., of Idaho Falls, Idaho, Make Timely Display of Grafonolas

IDAHO FALLS, IDAHO, March 2.—The patriotic window display of Grafonolas made by Buffham & Co., of this city, has attracted a great deal of



Buffham & Co.'s Window Display

attention and praise. The general scheme of coloring is carried out in the National colors, the central design being two Columbia machines. The ribbon crepe paper is alternating red, white and blue, and the floor is covered with red, white and blue crepe paper. Records of a patriotic nature are displayed to good advantage. The window is not an expensive one, but is very attractive and effective, as may be judged from the illustration herewith.

OFFERS PRIZE FOR WINDOW FEATURE

In a recent issue of "Printers' Ink" there was published over the signature of the Emerson Phonograph Co. an announcement offering a \$50 prize for the best suggestion with sketch or drawing and color scheme submitted before March 15 which would provide something permanent for the windows of the dealers selling Emerson records. It is suggested that this suggestion be something unique and telling which Emerson dealers can utilize to stimulate and increase sales.

ILSLEY'S GRAPHITE PHONO SPRING LUBRICANT

Ilsey's Lubricant makes the Motor make good
Is prepared in the proper consistency, will not run out, dry up, or become sticky or rancid. Remains in its original form indefinitely.

Write for special proposition to Jobbers.

MANUFACTURED BY

ILSLEY-DOUBLEDAY & CO., 229-231 Front St., New York
Established 1853

FEATURING BROOKS PHONOGRAPH

Some Interesting and Informative Literature Bearing Upon the Phonograph Made by the Brooks Mfg. Co., Saginaw, Mich., Recently Sent Out to the Trade—Tells of New Model

The Brooks Mfg. Co., Saginaw, Mich., has issued a very attractive large-sized circular devoted to a detailed description of the 1918 model of the Brooks phonograph. This model embodies a number of distinctive improvements over the 1917 design, and in its present form is one of the most attractive instruments that has been offered the dealers during the past six months.

The Brooks phonograph has won considerable comment from talking machine dealers throughout the country, owing to the fact that it is the only machine on the market that is equipped with an automatic repeater that plays and repeats any size and any make of disc records any number of times and then stops automatically at the will of the operator. This is all controlled by means of a small dial which sets, starts and stops the machine, and which will play any desired number up to nine or continuous. The dial is a model of simplicity, and when a record has been played as many times as set for, the machine will stop automatically with the tone-arm suspended in the air above the record. There is no necessity of lifting the needle off the record to change records, as this is done automatically. In operation the needle is lifted from the inner edge of the record, and gently deposited at the outer edge of the record cutting, accurately and perfectly.

Other improvements in the 1918 model include a counter-balanced lid support. Large nickel or gold-plated casters replace the smaller ones formerly used. The greatest improvement of the 1918 model, however, is a lever that may be moved with the finger which throws the repeater on or off. When this lever is placed in the off position the phonograph operates the same as the ordinary phonograph, thereby allowing the user to utilize the repeater at will.

The Brooks Mfg. Co., which is one of the country's leading high-grade furniture manufacturers, has a fifteen-acre plant at Saginaw. It has been manufacturing the Brooks phonograph for three years, and during 1917 its sales doubled every four months. It manufactures only one size of phonograph, retailing at \$165 with the repeater nickel-plated, and \$200, with the repeater gold-plated.

A salesman's indifference will discourage the most eager customer.



Salesman's Carrying Case.
Holds 25 Records.

Automatic RECORD CONTAINER

Makes Records Instantly Accessible

Opens automatically—remains open at the right place—every record in plain sight—closes easily and quickly.

No weight to handle—no more broken or misplaced records.

Files all records—simple—practical—durable.

Manufacturers get shop rights—to equip your Talking Machines.

AUTOMATIC CONTAINER CO.
5 NORTH LA SALLE STREET CHICAGO



Holds 100 records.

Pleases your customer—sells quickly—satisfactory in Parlor or Library.

Dealers, get prices on sample line.



Otto Heineman Phonograph Supply Co.

INCORPORATED

25 WEST 45th STREET, NEW YORK

FACTORIES, ELYRIA, O.—NEWARK, N. J.—PUTNAM, CONN.



CHICAGO

ATLANTA

SEATTLE

CINCINNATI

TORONTO

DEAN STEEL NEEDLES

DEAN QUALITY

combined with

HEINEMAN EFFICIENCY

If you are *not pleased*
with the

Quality

and

**Quantity
Deliveries**

of

**DEAN
Needles,**

kindly tell us

"We are at your service"

The Dean Steel Needle is
the standard needle of
the phonograph industry

Otto Heineman
President

If you are *pleased*
with the

Quality
and

**Quantity
Deliveries**
of

**DEAN
Needles,**

kindly tell others

*"Service is our
watchword"*

AF Meisselbach & Bro. Newark, N.J.

MEISSELBACH

TONE ARMS MOTORS SOUND BOXES

AF Meisselbach & Bro. Newark, N.J.

TALKING MACHINE BUSINESS MOST ACTIVE IN ST. LOUIS

Great Record and Machine Demand—Educating Brunswick Dealers—Value of Window Displays Emphasized by Columbia Co.—Victor French Course Admirably Featured—Art Models Popular

St. Louis, Mo., March 5.—The talking machine business in this community is as good as the traffic can bear. Both records and machines are making high-water marks of sales where the dealers, jobbers or retailers, have the stock to meet the demands. Even the used-machine dealers report unusually good business. Collections are reported very good from a retail standpoint, although some of the jobbers and manufacturers report that country dealers in some instances are a trifle slow.

Manager Jackson, of the Brunswick agency, is changing the method somewhat of introducing his machines to the dealers. Traveling Representative McGinnis will, hereafter, spend a longer time with each dealer to better equip him to meet the problems that arise. A good many of the Brunswick dealers now being signed are new to the talking machine business and the idea is to prepare them to give service from the start. The Brunswick distribution in this district has exceeded expectations, but the only embarrassment in meeting demands has been the freight traffic situation.

One of the recent successes in retailing has been the window displays distributed by the Columbia Co. These have scored a decided success in bringing to the front the records named and dealers without exception note instant increase in sales. C. R. Salmon, of the Columbia wholesale department, says that while there was much trouble in getting dealers to order the displays at first, now they are signing contracts for an entire year. Mr. Salmon, by the way, has finished with the draft board. After waiving all exemption and going in Class 1A, he has been set back to Class 5 because he is too light for his height.

The effort to push the Victor French course created a good deal of interest. The Famous & Barr Co. rather scored on this feature. Manager Ditzell had obtained the approval of the French Consul on the records before he began his advertising campaign, and when the special days came he had present at the record rooms the consul and a visiting French airman, both of whom added to the attractions of the sale and gave their best efforts at showing the people that they were good records. An adequate number of records were in stock but later demand cleaned up even what was regarded as reserve stock, but more arrived by the time it was planned to make a second drive on them.

Ben Phillips, for two years retail sales manager for the Columbia Co., has been transferred to the wholesale department and will travel in north Missouri. His early reports indicate that he is taking hold on his new job. L. Tippen, who came to St. Louis from Pittsburgh, where he has been in the employ of Columbia dealers, is in charge of the wholesale store at present. The Columbia Co. is planning a rather energetic advertising campaign on behalf of records by Helen Stanley, Bert Williams and Eddie Brown, who are to be attractions here shortly.

Guy Golterman, the former manager of the St. Louis Symphony Orchestra, whose plan for reproducing the addresses by President Wilson and other notables by talking machine records, returned from the East a few days ago and brought some of his records with him. These will be produced through "The People's Forum." Soon after his return he called a meeting of the local committee, consisting of Homer Bassford, a local newspaper man, A. L. Condon, of the Baldwin Piano Co. staff, and himself to try out the records in the public buildings here. Manager Irby W. Reid and C. R. Salmon, of the Columbia Co., were called upon to accompany the committee and they went to the Coliseum to try the records in his hall, the largest in the city and in which something like 20,000 persons can be seated. A \$60 horn machine was placed in the middle of the main floor and the records could be plainly heard in all the galleries. Those

privileged to hear the records declared that they were a most pronounced success.

President Silverstone, of the Silverstone Music Co., Edison jobbers, has gone to French Lick Springs, Ind., for an extended vacation. He was ordered away from his business by his physician, who declared that he was on the verge of a nervous breakdown. Mr. Silverstone had been working exceedingly hard since he began his plans to remove his store to the newly opened warerooms and the delays pertaining to building at present, the constant changing of plans to make the new warerooms more distinct and the trouble of moving and the subsequent opening plans were too much for him and he was unable to attend any of the opening festivities. When he left here he planned to leave the health resort long enough to go to New York to the Edison jobbers' meeting and then return there. Before going Mr. Silverstone installed Myron Goldberg, of Philadelphia, as vice-president and general manager of the Silverstone Music Co.

The Artophone Co. reports an excellent retail trade and that the jobbing trade is all that the firm can handle. Among the recent notable shipments was one that went to Chile, putting this comparatively new institution in the ranks of exporters.

The last week in February the talking machine trade in the four department stores was seriously disturbed by a strike of many of the clerks in those stores, who sought recognition of a clerks' union. While none of the sales folk in the talking machine departments "went out," the trade conditions in the stores were very seriously disturbed and trade was more or less slack all week, especially the record trade. Many persons would not go into the stores for small purchases while pickets were on duty. The machine trade was less affected as persons seeking to make larger purchases braved the

pickets and the ill will of organized labor. The strike did not reach the violence stage.

Late in February considerable interest attached to the window displays on Olive street of high art models. The Silverstone Music Co. displayed a \$1,600 Edison machine, the Field-Lippman Piano Stores the Brunswick Italian Renaissance model and the Columbia Co. the \$600 model. One of these machines was put into the window without signs and with all doors closed, and it was amusing to stand outside the window during the period that it was so exhibited and hear the speculations as to what it was.

A. H. Curry, an Edison jobber at Dallas, was a recent visitor. He wished to see the local stores with a view of getting suggestions.

A recent peculiar circumstance was that Miss Rose Marshal and Miss Bessie Platt, experienced and efficient saleswomen with the Thiebes Piano Co. talking machine department, resigned to go into the millinery business. It has been very seldom that the talking machine folk have quit the game to go into something else here. Usually, the talking machine trade draws from other lines.

MAKING IMPROVEMENTS IN STORE

WILKES-BARRE, PA., March 4.—The Landau music and jewelry firm at 70 South Main street, this city, are making important changes and improvements in their store which will cost several thousand dollars. Recently they closed a new lease of the building for ten years, and plan to install several elaborate Victrola salons on the second floor, and also enlarge their sales and display rooms throughout the building. The Landau firm, which is one of the oldest and most progressive in the State, having been located on South Main street since they began business in 1893, is composed of S. Landau, H. Landau and H. M. Michlosky.

Never mind about the regular way of doing things if you have a better way.

To the Talking Machine Man Who
Is Not Selling Pianos—Why?

When Piano Dealers started to sell Talking Machines with so much success, did they do so at the expense of their piano business? NO—the combination proved to be an instantaneous success—each has helped the other.

Your business, selling talking machines only, is probably as big as an exclusive business as you can make it. Why not branch out? You can do with Pianos what the piano man did with Talking Machines.

With little additional investment and the same overhead expense, you can sell Pianos and Player Pianos profitably. Your piano business will help your talking machine business, and you will make more money. For particulars address

KOHLER & CAMPBELL, Inc.

11th Avenue and 50th Street
NEW YORK CITY

The most successful manufacturers of Pianos, Player Pianos and Grand Pianos in America.

Kohler & Campbell, Inc.
11th AVE. and 50th ST.
NEW YORK

Dear Sirs: Kindly send us full particulars of your plan to combine profitable Piano and Player Piano selling with our present business.

.....
.....
.....

TEAR OFF THIS COUPON AND MAIL

BUFFALONIANS ARE CROWDING THE RECORD DEPARTMENTS

Impossible to Supply Demands for Grand Opera Records—H. A. Brennan With Victor Co.—New Brunswick Dealers—Some Changes in Sales Staff—New Pathé Dealers—Sonora Line With Goold

BUFFALO, N. Y., March 5.—Buffalonians are crowding the record departments of the local stores these days and are clamoring for the latest records. Their enthusiasm is unbounded and their purchasing power seems to fall little short of this standard, but everywhere the oft-recurring report is made: "The supply of records, like the machines, is far less than the demand." Jobbers and dealers say that unless factory output and railroad conditions prove an insurmountable handicap this will be a banner year in the trade. Expanding business in machines and records has caused one concern to seek larger quarters. New dealers are being appointed in the Buffalo territory and the list is to be augmented as the year advances.

It is reported that the recent performance of the Peerless Record Makers in this city has helped the local sale of records materially.

O. M. Kiess, manager of the local branch of the Columbia Graphophone Co., has let contracts for new Columbia quarters at 733-737 Main street. There will be two floors, with 10,000 square feet of space. The place will be ready for occupancy by May 1.

C. M. Wall, assistant manager of the Columbia, is spending the greater part of his time on the road. G. B. Stacey, in charge of the Dictaphone, reports that that branch of the business is increasing rapidly, and that he has equipped some of the largest business houses in Buffalo.

Charles Powers, of Neal, Clark & Neal's shipping department, and O. H. Williams, traveling representative of that firm, have joined the colors.

H. A. Brennan has resigned as manager of the Victrola department of the William Hengerer Co. to go with the Victor Talking Machine Co. Mr. Brennan successfully reorganized the Hengerer Co.'s Victrola business, which in 1917 was the largest in the history of the firm.

J. R. Flynn is manager of the Buffalo branch of the Brunswick-Balke-Collender Co., and Fred G. Eigenbrod is in charge of the Brunswick phonograph department of this branch. These firms were recently appointed Brunswick dealers: J. G. Seeger & Sons, Buffalo; E. W. Edwards & Son, Rochester, and the Kane Furniture Co., Kane, Pa. These concerns, as well as Froess Bros. and Stafford & McArdle, both of Erie, Pa., and the H. H. Roberts Trading Co., Blossburg, Pa., all report good business on the Brunswick.

Arthur Gesser has been appointed a salesman in J. N. Adam & Co.'s Victrola department. W. R. Gardner, manager of this department, will conduct shortly a spring Victrola week. He will be backed by plenty of newspaper advertising and window displays.

In the windows of Denton, Cottier & Daniels are military posters advertising "new Victor records of popular patriotic selections."

Victor & Co., Pathéphone jobbers, have appointed McNamara & Sharro Pathéphone dealers. This last-named concern is opening an exclusive Pathéphone shop at 335 Elk street, Buffalo.

C. N. Andrews, O. L. Neal, V. W. Moody, O. M. Kiess and T. A. Goold recently attended a Cleveland meeting of the Talking Machine Dealers' Association of Northern Ohio.

Albert Schwegler, of Schwegler Bros., Victrola dealers at 219 Genesee street, is building an attractive bungalow in Butler avenue.

W. D. Andrews, of Syracuse, a member of the firm of W. D. & C. N. Andrews, was a recent visitor.

The H. D. Taylor Co., 99-115 Oak street, is jobbing the Perfectrola talking machine in Buffalo and vicinity.

John G. Schuler, Sonora dealer, who received considerable publicity last fall by taking a sen-

TALKING MACHINE DEALERS —READ THIS—

"The finest and most delicate pieces of mechanism do not prove efficient unless properly lubricated. Skill, Genius, Invention and Workmanship must have the proper Oil. Stop and consider this when you have to buy an Oil for household use."

NYOIL
IS BEST

FOR ANY TALKING MACHINE



Being made in our Watch Oil Dep't, the same care given in refining as in our "Watch Oil," as all gums and impurities are extracted, leaving it Colorless, Odorless and Stainless.

BEWARE OF SCENTED OILS

Machines will not clog if oiled with NYOIL. NYOIL is used by the U. S. Gov't in Army and Navy. A trial order will make a permanent customer of you.

Ladies use NYOIL for Sewing Machines, for it is stainless.

Sportsmen find NYOIL best for Guns, for it keeps them from rusting.

NYOIL is put up in 1oz., 3¼ oz. and 8 oz. Bottles, and in Pint, Quart and Gallon Cans.

For Sale by all Talking Machine Supplies Dealers

WILLIAM F. NYE, New Bedford, Mass., U. S. A.

sational ride in a Curtiss aeroplane, says he intends to repeat the performance "as soon as the frost is out of the ground this spring."

The Hoffman Piano Co., Sonora dealer, reports that embargoes have somewhat lifted and that shipments are coming through more promptly.

J. H. Hackenheimer, of C. Kurtzmann & Co., has returned from a Western trip. Roy S. Dunn, representing that firm, is in the South.

Lawrence H. Montague, Columbia dealer, has written a new "America," which is being used at the various military camps and by Billy Sunday choruses.

The Ediphone is being widely advertised in the Buffalo newspapers. This machine is being handled by the Roach-Reid Co., 316 Mutual Life Building, Buffalo.

Goold Bros., Inc., have taken on the Sonora line. This is in addition to the Victor line, which they have handled for some time.

The Boston Music Co., of 218 Genesee street, features the Columbia. Harry Fairbanks, proprietor of this store, has been a violin instructor in this city for several years.

The Verbeck Musical Sales Co. reports active spring business on the Columbia and Delpheon.

MUSIC FOR FORESTRY REGIMENT

Thirty-eight Grafonolas Ordered for Great U. S. Regiment of Engineers Now in France

The Columbia Graphophone Co., New York, received recently an order from P. S. Risdale, editor-in-chief of the "American Forestry" magazine, Washington, D. C., for thirty-eight Grafonolas No. 15, enclosed in regular army trunks for the members of the Twentieth Engineers (Forest). These instruments were donated by the Welfare Committee for Lumbermen and Foresters in War Work, and the American Forestry Association. The Grafonolas were shipped to Chaplain Smith, headquarters, Twentieth Engineers (Forest), Washington, D. C., and will subsequently leave for France, where the regiment will be stationed.

These Grafonolas are for the use of thirty-eight separate companies of the Twentieth Engineers (Forest), the largest regiment in the world. This regiment is composed of the country's leading forestry experts, who are equipped to render invaluable service to the armies of Uncle Sam and the Allies abroad. Some of the companies in this regiment have already reached the "other side," and their reports home are typical of the cheery, optimistic spirit which is characteristic of America's fighting forces. These forestry engineers are welded together in an efficient, result-productive organization which is giving tremendous assistance to the "boys" in the trenches.

Delpheon
the
Incomparable

Your nearest distributor will give you prompt service and the fullest co-operation.

DELPHEON plus DELPHEON SERVICE brings SUCCESS

The Delpheon Shop
117-119 Peachtree Arcade
Atlanta, Georgia

Walter Verhalen
Busch Building
Dallas, Texas

Delpheon Sales Company
25 Church Street
New York City

Verbeck Musical Sales Co.
435 William Street
Buffalo, New York

Chicago Display
Sixth Floor, Republic Building

Or write direct to

The DELPHEON COMPANY

BAY CITY

MICHIGAN

THE STANDARD AUTHORITY



OF THE INDUSTRY IT SERVES

A Price Announcement

For over twelve years, the size of The Talking Machine World has steadily increased.

For over twelve years the editorial scope of The Talking Machine World has steadily grown.

For over twelve years the circulation of The Talking Machine World has steadily expanded.

To-day The Talking Machine World is triply dominant—in circulation, in prestige of editorial columns, and in the amount of advertising carried.

For over twelve years there has been no increase in the subscription price, but

With the May, 1918, issue the subscription price of "The World" will become \$2 a year

A Chance to Save Money

Subscriptions will be accepted at the existing rate of \$1 a year for one, two, or three years in advance, providing the remittance is in the mail prior to May 15, 1918. Every dollar spent now means a dollar saved. Act now if you want to economize.

EDWARD LYMAN BILL, Inc.

Publisher of
 THE TALKING MACHINE WORLD
 THE MUSIC TRADE REVIEW
 E. L. B. TECHNICAL LIBRARY

373 FOURTH AVENUE
 NEW YORK CITY



With every regiment that goes to the front, war songs become more popular. Ten of them, splendidly sung, in the Columbia April list. A2493, "There's a Service Flag Flying at Our House," sung by the Sterling Trio, will go straight to thousands of hearts.

Columbia Graphophone Co.
Woolworth Building, New York

INDIANAPOLIS TRADE COMPLAIN OF STOCK SHORTAGE

Business, Both Wholesale and Retail, Very Active—Conference of Pathé Dealers—Stewart Co.'s Big Victor Business—Standke Boosts Brunswick—Ready-File Co.'s Expanding Trade

INDIANAPOLIS, IND., March 5.—Business for local talking machine dealers picked up briskly during the closing days of February and rounded out a good month for most of them.

The wholesale dealers report their business as exceedingly good with the chief difficulty being in getting sufficient machines and records from the factories to supply the demand.

W. E. Pearce, of the phonograph department of the Brunswick-Balke-Collender Co.'s branch here, reports that the Brunswick business has been exceptionally good since the first of the year. George McCarty, of Fortville, Ind., is making a record on the number of the higher-priced Brunswick models he is selling.

J. E. Nash & Son, of Franklin, Ind., who also do business in Greenwood and Edinburgh, are

showing good results with the Brunswick. Jensen Brothers, who run the Brunswick Shop of Terre Haute, Ind., are figuring on opening a larger store soon.

T. H. Bracken, manager of the Starr Piano Co.'s branch, said that he is looking for a big year for talking machines. Mr. Bracken is planning to push this end of the Starr business this year.

The Stewart Talking Machine Co., distributor of the Victor line, reports that the dealers have been doing a phenomenal record business, and Emerson Knight, advertising manager for the company, says that the national advertising done by the Victor Co. continues to "pull like a team of oxen."

Miss Agnes Fryeberger, of Minneapolis, will

come to Indianapolis soon to talk to Indianapolis school teachers on the use of Victor machines in the schools. The Stewart Co. is planning on calling a meeting of its dealers to have Miss Fryeberger, who has written several texts on this subject, address them.

A. H. Snyder, manager of the Edison Shop, does not believe in letting conditions control his business.

"The business is here to be got, just the same as it was before the war," said Mr. Snyder. "But we have different conditions to meet and must adjust our tactics to meet them.

"The dealer who sits in his store and expects the buyers to come in might as well close up his shop. You've got to get out to the homes and take your proposition to the homes to do the business." Mr. Snyder has been very successful in working his salesmen in zones in which he has divided the city.

George Standke, manager of the local Brunswick Shop, gave the Brunswick a big boost before the American Club in the Chamber of Commerce. This club is composed of about sixty business men who meet every Monday and each member is allowed a day to boost whatever business he is in. Mr. Standke brought a Brunswick machine to the meeting on his boosting day and the machine did the work in great style. He also gave souvenir calendars away.

M. C. Rosner, manager of the Vocalion department of the Aeolian store, said that business picked up during the last days of February, and that the record business had been exceptionally good since the holidays.

The Mooney-Mueller-Ward Co., distributors of the Pathé, are planning to invite their dealers to a conference to be held within the next two weeks. R. B. Goldsbury, in charge of the company's Pathé department, reports that many contracts have been signed in the last month, and that business for 1918 is looking fine. Lambert Bertha, of La Fayette, Ind., has been engaged to assist Mr. Goldsbury.

H. A. W. Smith, manager of Pathéphone Shop, reports that February business was normal, and that indications are for a good business.

H. E. Whitman, manager of the Victor and Edison department of the Pearson Piano Co., says that the record business continues unusually brisk while the sale of machines runs only fair during January.

Officials of the Ready-File Co. are highly pleased with the way Edison dealers in convention at New York recently took to the Edison machine ready-files which will be ready for the market soon. The company has been unusually successful with its file for Victor machines.

Ben Brown, manager of the Columbia store, reports that February business was satisfactory. George W. Hopkins, general sales manager of the Columbia Co., visited the store Tuesday.

The Ideal Phonograph Co., Rockford, Ill., has been incorporated with capital stock of \$5,000 by B. J. Swanson, John Kinge and M. H. Gustafson.

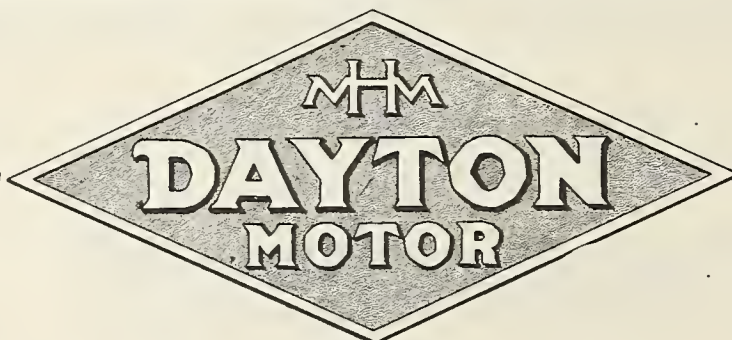

Three
Styles

Four
Sizes

Every manufacturer building talking machines knows that the success of his business depends wholly upon the satisfaction his products give to the dealer and the user. Therefore he realizes that only the best parts are good enough to put into his machine. That's the reason thousands of Dayton Motors are being sold. Their Superiority makes them

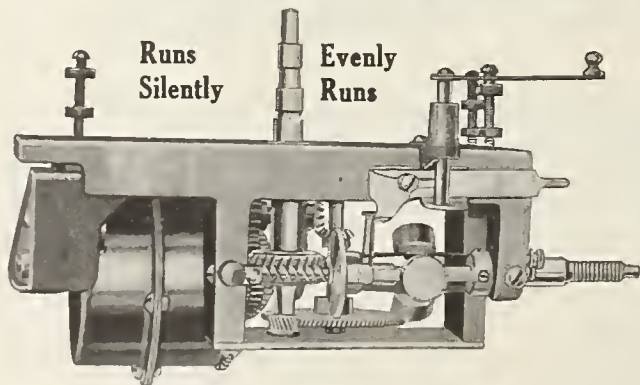

Runs
Silently

Evenly
Runs

"The Best Motor
In the World"

Let us prove it's the best for
you too—in quality, price and
service.

Dayton Tone Arms are universal, playing any disc record. Five styles—all good.

Dayton Reproducers are scientifically correct and thoroughly practical. Two styles.

Build satisfaction into your products by using the quality line—Dayton Motors, Dayton Tone Arms, Dayton Reproducers. They will bring you more business and satisfy the most exacting customers.

THE THOMAS MFG. CO., 322 Bolt Street, Dayton, Ohio

STEELCRAFT NEEDLES

“MADE RIGHT TO PLAY RIGHT”

Harry R. Leithold, of the Fred Leithold Piano Co., La Crosse, Wis., wins 100,000 Needles for sending us the “first choice” name for talking machine needles of

“STEELCRAFT”

What influenced Mr. Leithold in submitting the name “STEELCRAFT” was our recent announcement in this publication in which we said:

“To assist in selecting the proper name we wish to state that we will manufacture the best steel needles that can be put on the market. Our process of manufacture will be such as to insure the reproduction of every delicate shading and tone. Continued use of our needles by your customers will mean contented patrons at all times.”

“STEELCRAFT” means PERFECTION. This name emphasizes that the Steelcraft Needle is the supreme achievement of modern craftsmanship.

Remember the name **“STEELCRAFT”** when ordering needles from your wholesale distributors for Steelcraft Needles are **“Made Right to Play Right.”**

RECORD NEEDLE & MFG. CO.

MANHATTAN BLDG.

MILWAUKEE, WIS.

Lucky 13 Phonograph Co., 3 East 12th St. NEW YORK



Type B—40 in. high. \$18.50 Wholesale
Double Spring Motor Plays all Records

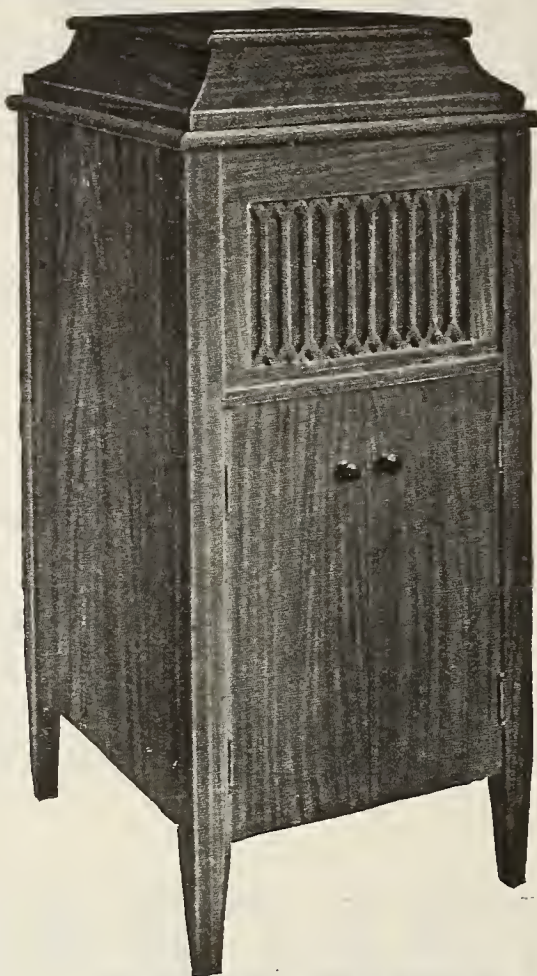

Type C—43 in. high. \$20.50 Wholesale
Double Spring Motor Plays all Records



Type D—46 in. high. \$26 Wholesale
Double Spring Motor Plays all Records

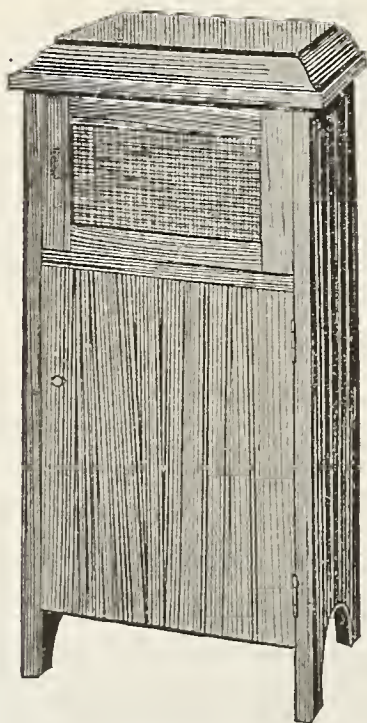

Type A, in Oak—35 in. high. \$13 Wholesale
Double Spring Motor Plays all Records

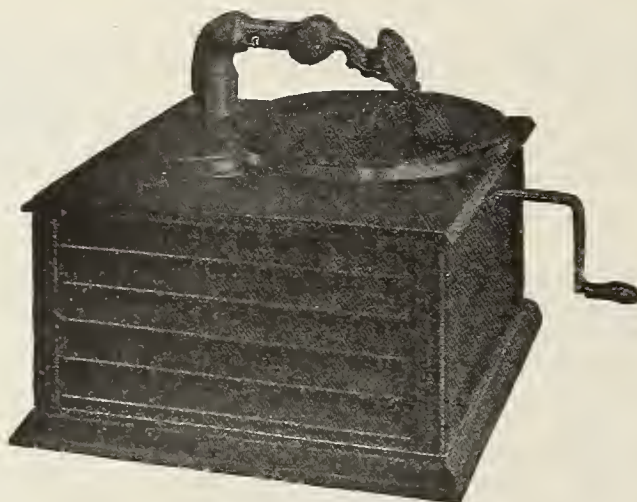

Type 15 \$8 Wholesale
Double Spring Motor Plays all Records

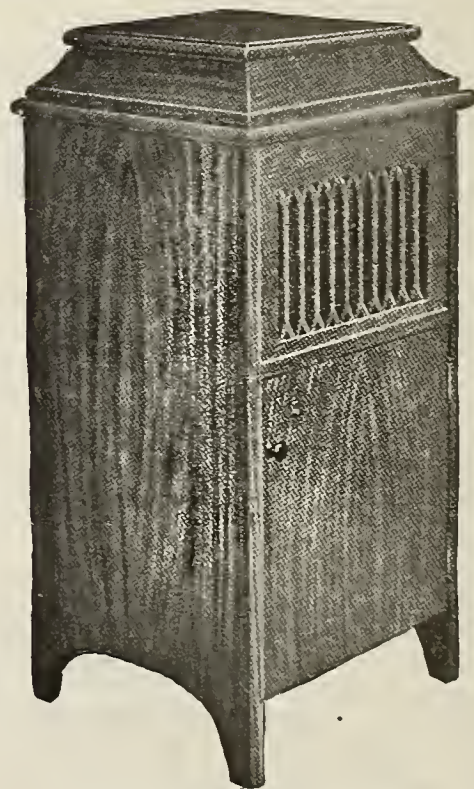

Type A, in Mahogany Finish—35 in. high
\$15 Wholesale
Double Spring Motor Plays all Records

STEEL NEEDLES

65c per thousand. Immediate Delivery.

RECORDS

The "Popular" Brand, 10-in. double face, lateral cut, all instrumental:

32c in lots of 100
30c in lots of 1000
29c in lots of 5000

MOTORS

No. 01—8-in. turntable\$1.25	10-in. turntable\$1.40
No. 1—10-in. turntable 2.65	12-in. turntable 2.95
No. 5—10-in. turntable, double spring, plays 2 records 2.75		
No. 6—10-in. turntable, double spring	...\$3.50	12-in. turntable 3.85
No. 8—12-in. turntable, double spring, plays 3 records 4.75		
No. 9—12-in. turntable, double spring, plays 3 records 5.75		
No. 10—12-in. turntable, double spring, plays 4 records 6.75		
No. 11—12-in. turntable, double spring, plays 7 records 8.50		

MAIN SPRINGS

No. 01—1-in. 22 gauge 7 ft.	20c ea.	100 lots 18c ea.	1000 lots 16c ea.
No. 0—3/4 in. 20 gauge 8 ft. 6 in.	25c ea.	100 lots 20c ea.	1000 lots 19c ea.
No. 1—3/4 in. 25 gauge 10 ft.	39c ea.	100 lots 35c ea.	1000 lots 33c ea.
No. 2—13/16 in. 25 gauge 10 ft.	39c ea.	100 lots 35c ea.	1000 lots 33c ea.
No. 3—7/8 in. 25 gauge 11 ft.	49c ea.	100 lots 44c ea.	1000 lots 42c ea.
No. 4—1 in. 23 gauge 10 ft.	49c ea.	100 lots 44c ea.	1000 lots 42c ea.
No. 5—1 1/4 in. 25 gauge 11 ft.	90c ea.	100 lots 85c ea.	1000 lots 80c ea.

GOVERNOR SPRINGS

\$1.00 per hundred. Special price on large quantities for motor manufacturers.

SAPPHIRE POINTS AND BALLS

Sapphire Points13c each in 100 lots	12c each in 1000 lots
Sapphire Balls15c each in 100 lots	14c each in 1000 lots

TONE ARMS AND REPRODUCERS

No. 1—Tone Arm and Reproducer \$.90
No. 2—Tone Arm and Reproducer, for playing all records 1.25
No. 6—Tone Arm and Reproducer, for playing all records 2.25
No. 7—Tone Arm and Reproducer, for playing all records 2.25
No. 8—Tone Arm and Reproducer, for playing all records 2.25
No. 4—Tone Arm and Reproducer, for playing all records 2.65

NEEDLE CUPS

\$20.00 per thousand, \$17.50 per thousand in 5,000 lots. Larger quantities still lower.

NEEDLE CUP COVERS

\$10.00 per thousand, \$9.00 per thousand in 5,000 lots. Larger quantities still lower.

We also manufacture special machine parts such as worm gears, stampings, or any screw machine parts for motor manufacturers. Special quotations given for Canada and all other export points. Merchandise delivered with custom duty, war tax and freight paid by us. Write for our 84 page catalogue, the only one of its kind in America. Illustrating 33 different styles talking machine and over 500 different phonographic parts, also gives description of our efficient repair department.

Why Grand Opera Artists Are Heard at Their Best Through Talking Machine Records

No greater tribute to the perfection of talking machine record making can be conceived than the remarks of critical purchasers these days when selecting records of noted opera artists whom they have heard in New York, Chicago and Boston, that their records are not only equal to their voices, but in some respects the numbers are sung with a perfection and artistry that even transcends the work of the artists in person on the operatic stage.

This is not surprising, for it is a well-known fact that almost without exception many grand opera stars would rather sing before the most critical audience than before a talking machine. The latter is a critic that records every imperfection, and when the test comes it often tells the story of slipshod work. The grand opera singer must sing 100 per cent. perfect in making a record, and this is oftentimes impossible on the opera stage. Hence it is that talking machine records of the grand opera artists are so absolutely perfect.

One would think that it is the simplest thing in the world to stand up before a talking machine and sing, and it might be if the singers did not have to use any more care than they do before an audience.

In the first place it is rather uncanny, standing in a big empty room before a mammoth horn protruding from between curtains, with the conductor away up high where he will not interrupt the sound waves, and the orchestra made up in number and instrumental quality especially for this work.

The singer stands on a wooden platform at the mouth of the receiving trumpet. A few hurried directions are given, and then strict silence is the rule. No human voice or sound

but that of the singer and the music must now disturb the atmosphere, for the machine behind the curtain relentlessly records every little sound wave.

A red light is flashed, and the orchestra gets to work. Then at the crucial moment the artist has to sing to this strange little assembly with the same zest he would under the inspiration of brilliant lights, beautiful clothes, splendid settings and an applauding audience. It is an ordeal, because he has to sing with far greater care in front of the talking machine than is required when an audience is to be pleased. The slightest variation means a start-over, a slight clearing of a throat, a deep breath or slight shuffle of the feet—and the revolving discs record every one of these faults—and the record is spoiled. But these faults are all criticized by an experienced record-director, and it is his business to see that nothing short of the perfect records are produced—because from these first moulds are made all of the thousands of records that go into so many homes.

When the artist has finished, the record is played over and the imperfections criticized. The weak spots are rehearsed, and the whole trying business commenced over again.

And so it is acknowledged by many of the operatic, concert and music-hall stars that to produce a record of pure and distinct tone is far harder than to make their way successfully through a whole operatic score. It is a tremendous task to get a set of the perfect records from the opera favorites. It has been said that Caruso has been forced to spend over four hours of untiring work before he was able to perfect his "Ridi Pagliacci" in the opera of "I Pagliacci," and in that time was forced to

make over thirty fresh starts before a disc of pure and distinct tone was obtained. This may be fiction, or extravagance of statement, but every operatic artist, whether Caruso or Mme. Galli-Curci, knows that when they make records they are singing to millions rather than to the thousands in the opera house, and the most particular pains are taken to have them right—absolutely perfect.

EXPANSION OF DELPHEON BUSINESS

Sales Manager R. W. Gresser Says That the Business of the Delpheon Co. Has Tripled in Volume During the Past Two Months

BAY CITY, MICH., March 5.—The Delpheon Co., of this city, manufacturer of the Delpheon phonograph, is making rapid progress in all parts of the country, and R. W. Gresser, sales manager of the company, states that the Delpheon business has practically tripled itself in the past two months. It has grown so rapidly that the company is only able to barely keep up with the demand, and it seems as though immediate preparations to provide for adequate expansion are imperative.

Mr. Gresser states that the company is in a better position to do this now than a year or even six months ago, as the work in the factory is now thoroughly systematized, and it is possible to turn out the completed Delpheon phonograph with far less work than before, and on a far more efficient basis.

Orders are being received daily from the Delpheon distributors in the South, and, judging from their reports, there is an era of stability and prosperity in this section of the country.

Foreign Records, too, —at Grinnell's

WE HAVE A LARGE STOCK OF ALL
THE FOREIGN RECORDS

Those of foreign birth, irrespective of country, are, almost without exception, music-lovers, and if there are such in your territory you are missing a fruitful source of added business and profits if you are not provided with vocal selections in their own tongue or instrumental music characteristic of the country from which they came.

Glad to go into this matter with you further and give you fullest information regarding any and all details.

Grinnell Bros

Distributors Victrolas and Records

First and State Streets, Detroit

We are of course splendidly equipped to supply you with any of the other Records issued by the Victor Company.

You Should Have a Stock of the Marconi-Victor Wireless Telegraph Records.

They meet a present, and very great demand—they provide a service that is not only unique but of definite value to the country—they demonstrate your progressiveness and up-to-dateness—they afford another source of profit for you.

No better time to order them than TODAY!

Let us add your name to those receiving our advance list of Records likely to be the best sellers. The service is free—and you'll find it of great value.



Will you spend three cents to get rid of that vexing sales problem? That's all the expense necessary—a letter to the Columbia Dealer Service Department will bring you the answer you need.

Columbia Graphophone Co.
Woolworth Building, New York

MAKING TOUR OF WHOLESALERS

W. P. White, Manager of Wholesale Victor Department of Thomas Goggan & Bro., Houston, Tex., Making a Most Interesting Trip

A recent visitor to New York was W. P. White, manager of the wholesale Victor department of Thomas Goggan & Bro., Houston, Tex., who is at present on a tour that is taking in the principal cities east of the Mississippi. Mr. White is devoting his efforts to calling on Victor wholesalers, and negotiating the purchase, sale or exchange of surplus stocks, and is meeting with an excellent measure of success. On the way to New York he called on a number of Southern jobbers and also visited the Victor factory. He also called on the trade in New England, and on his way home will visit Pittsburgh, Cleveland, Detroit and nearby cities.

Mr. White, who took charge of the Goggan department about a year ago, was before that time connected for some months with the trav-

eling sales department of the Victor Talking Machine Co., covering New England, and thus has an excellent knowledge of the problems of both the Victor wholesaler and the Victor dealer.

TO AMEND PERSONAL PROPERTY LAW

Bill Now Before State Legislature Provides for Cash and Instalment Prices Being Shown

A bill has been introduced in the New York State Legislature by Assemblyman H. W. Smith to amend the Personal Property Law in relation to displaying the selling price on goods sold under contract or conditional sale. The bill (Assem. Int. No. 537, Pr. 580) adds new Section 68 to the Personal Property Law providing that a conditional vendor who displays or exhibits goods to be sold under conditional sale, shall attach to such goods or chattels, sample or samples, in a conspicuous place, a statement of the selling price for cash and under conditional sale. Violation is a misdemeanor.

L. M. COLE WITH GIBSON-SNOW CO.

Appointed Eastern Representative for New York State Distributors of Sonora Line

L. M. Cole, the "Sonora Man," whose well-prepared booklet on phonograph merchandising



L. M. Cole

received favorable comment from the trade some months ago when Mr. Cole was manager for John G. Schuler, Buffalo, N. Y., prominent Sonora dealer, has been recently appointed Eastern representative for the Gibson-Snow Co., Inc., New York State distributors for the Sonora line.

Mr. Cole's thorough knowledge of the Sonora line ideally equips him to render valuable and efficient service to the Sonora dealers in the territory he will visit, and there is no doubt but that his previous retail experience will stand him in good stead in his present post. The Gibson-Snow Co. is planning an aggressive wholesale campaign, and judging from their business to date, it will be productive of excellent results.

INCORPORATED

The Bolway Co., Inc., Syracuse, was incorporated in Albany, N. Y., last week with a capital stock of \$40,000 for the purpose of dealing in sporting and athletic goods. Those interested are F. E. Bolway, the well-known phonograph jobber, of Syracuse; A. W. Fielder, New York, and E. V. Powell, Chicago.

Manufacturers—Jobbers—Dealers

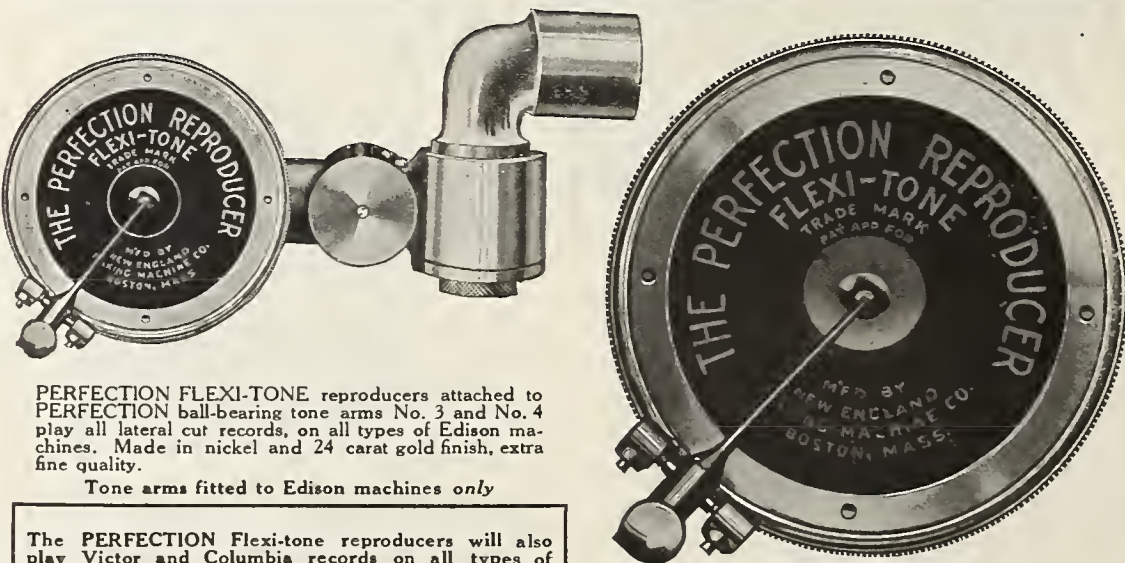

PERFECTION FLEXI-TONE reproducers attached to PERFECTION ball-bearing tone arms No. 3 and No. 4 play all lateral cut records, on all types of Edison machines. Made in nickel and 24 carat gold finish, extra fine quality.

Tone arms fitted to Edison machines only

The PERFECTION Flexi-tone reproducers will also play Victor and Columbia records on all types of Pathe machines, as they can be attached to the joint that is being sold with the machine for playing these records.

PERFECTION FLEXI-TONE reproducers No. 3, No. 6 and No. 7 fit all types of Victor and Columbia machines. Made in nickel and 24 carat gold finish, extra fine quality.

These reproducers and arms are the very finest made mechanically. The PERFECTION FLEXI-TONE reproducers are the most perfect phonograph reproducers built, reproducing all lateral cut records, from highest pitched soprano, to lowest pitched bass, as perfectly as the records were recorded in the recording room. Wonderful clarity of sound, as well as great volume. Extra fine quality of finish guaranteed. Manufacturers, jobbers and dealers will find in this line of reproducers just what they have been looking for, as they are assembled by skilled workmen especially adapted to this kind of work, producing a product built with watchlike precision.

All accessories in stock ready for immediate shipment. Phonograph manufacturers can have PERFECTION FLEXI-TONE reproducers fitted to their machines. Write for prices, information, etc.

NEW ENGLAND TALKING MACHINE CO.
16-18 Beach Street BOSTON, MASS.

Ohio Talking Machine Dealers Hold First Annual Banquet

CLEVELAND, O., March 4.—The first annual banquet of the Talking Machine Dealers' Association of Northern Ohio, Hotel Winton, the evening of February 20, marked a new era for the members of the organization.

The spirit of the meeting reflected the determination of everybody present to make 1918 a banner year despite handicaps imposed by the European war. The attendance was representative, several out-of-town men prominent in the talking machine business being guests.

The "messages" from the Victor, Columbia and Edison factories delivered by representatives of these big producing plants were stimulating and assured retailers that the manufacturers are not discouraged but will drive straight ahead turning out machines and records as fast as physical conditions will permit.

Charles K. Bennett, general manager of the Eclipse Musical Co., qualified as president and acted as toastmaster. The other officers installed are: First vice-president, A. W. Roos, of the Columbia Graphophone Co.; second vice-president, Elsie E. Baer, of the M. O'Neil Co., Akron, O.; secretary, James G. Card, of the Lakewood Music Co.; treasurer, A. L. Maresh, of the Maresh Piano Co.; assistant secretary, E. B. Lyon, of the Eclipse Musical Co.

Mr. Bennett will not announce his standing committees until the March meeting of the association—the third Wednesday of the month.

There was a splendid menu of eatables and popular and patriotic songs, in which the diners joined, helped to put every one in good humor.

President Bennett Reviews Conditions

President Bennett started the speech-making with an excellent address, during the course of which he said:

"I cannot help but feel that we all have been well repaid for our efforts in organizing this association, and which I am quite sure will develop into one of the strongest and largest organizations in the country; first, because we have represented here merchants from all over this State showing the spirit and desire to cooperate for the good of the business, and secondly, because we have a great number of large cities and all within a comparatively short distance of each other, thus making it possible to have these get-to-together meetings frequently.

"I am firmly convinced that it is the intention of each individual member of our organization to keep his shoulder to this wheel of progress and do his and her part to uphold the policies and principles looking towards the uplift of the business, and as President Hart, of the local Music Trades Association, said the other evening, 'the more open frankness and the better acquaintance we have with one another the more satisfactory will be our business,' and I wish to urge that we adopt this slogan ourselves and carry it out with a view of becoming intimately acquainted with each other.

Many Changes Due to War

"It has been necessary for us to make a great many changes in our business as well as our social life during the past year, and undoubtedly it will be necessary for us to make others in the future, but in no case has the Government interfered with our business, because Mr. Wilson has no intention of so doing. If anything, the President has made our business better because he fully realizes that music is one of the most, if not the most, essential in developing and keeping up the morale of this army and navy that we are now building. Music is, therefore, in more demand to-day than ever before, and that in a measure accounts for the scarcity of machines and records, and with but few exceptions every dealer here to-night showed an increase in his business over 1916. However, he did not come anywhere near supplying the demand that was made upon him.

"The war has opened up a world of new machine and record prospects, as we read in the papers that nine billions of dollars are to be distributed among the working people in the United States this year in return for their labors. These same workers in the past never hoped to be able to earn more than \$15 or \$20 per week, but are now earning \$35 and upwards. These same



laborers never even dreamed of such a condition and so shaped their lives to live within the \$15 limit. To-day, with the prosperity they are enjoying, they do not know as a matter of fact just how to spend this money, and saving is almost beyond their imagination. They do not enjoy the fine luxuries, such as fine homes and fine clothing, and outside of the larger cities they find it difficult to secure amusements such as theatres, and the 'booze' question is being curtailed to a most marked degree. The conclusion, therefore, is a very plain one.

"This new field open to us now is that section in the mill and factory districts. These work-



President Charles K. Bennett

ing people, like you and I, love music, and in the past have been contented with the 10-cent record and the \$5 machine, and besides did not feel that they were welcome in the exclusive shops, and grand opera music was beyond their comprehension. I had a personal experience this last Christmas with an individual coming into our retail store, dressed very poorly and without even a collar on, smoking a big black cigar, and his hat tilted on one side of his head. He stated that he was looking for a Victrola, something very good, and further explained that they now owned a small \$50 machine. 'You see I am making more money now,' he stated, 'and am traveling in better society, and we really need a big machine.' That describes my thought very clearly, and I want to ask if it is not a fact that there are a great many more just such characters in this city, and in fact, throughout the entire country. They are plentiful, and like my

Important addresses made by President Bennett, Geo. W. Hopkins, Henry C. Brown, J. Raymond Bill, C. H. Grinnell, an Interesting Letter from Wm. Maxwell

old boss used to tell us boys on the road, 'the proposition is just like gold mining, you have got to dig it out'—and so it is you must dig out these fellows who are making good salaries, and you will flatter them, offering them the popular-priced machines as well as to offer the service of your up-to-date store. I could keep on enumerating a lot of other ideas that could be worked and given serious thought; however, just take this little tip and go after the working class as you will find them ready buyers and quite liberal spenders."

Thos. H. Davies' Pertinent Poem

Following Mr. Bennett, Thomas H. Davies made a short address flavored with lots of good humor along the line of existing machine and record shortages. He closed with this poem:

Another year has now passed by,
The future greets us with a sigh.
When e'er machines we try to buy,
The shortage reaches to the sky.
It stares at us as we pass by,
All we can say is, me, oh my.

The jobbers use their old excuse,
And make us all feel like the deuce.
They tell us all there is no use
To pester them, they don't produce
They say they try to do their best
But that machines keep going West.

They told us this a year ago,
And we all thought that it was so.
We dealers do not want to crow
We all have made a lot of dough.
Machines came slow but fast they go,
Let's hope it will be ever so.

And as we get down to facts,
I'm sure we'll all agree
We're lucky that we're living
And in a land that's free.
Our business has been very fine,
Let every one keep this in mind.

We've all made money in the past,
Now is the time we must hold fast.
Our ship is in a heavy storm
Our duties we must all perform.
Let's help each other this year through,
That is the least we all can do.

A. W. Roos was the next speaker and he dwelt briefly on the efforts to be made during the coming year along the line of preserving the present high merchandising ethics of the talking machine retail business.

A "Message From the Victor Factory"

Henry C. Brown, in his "Message From the Victor Factory," declared the ladies are largely responsible for the great demand for talking machines and music. He drew a picture of the early days of talking machines and said the Victor Co. will continue to do what it has done from the start—aid dealers in building up business and placing it on a high basis.

"There is no limit to our business," said he. "Talking machines have added much to the life of our people; they have added both pleasure and profit to the world. Before the advent of talking machines the voices of the world's great singers died when they passed away. We have no way of comparing the voices of artists now dead with those of the great living singers, but the talking machine and its records have made it possible to preserve the human voice, so that when its owner dies posterity will be able to make comparisons between the singing and playing of living and dead artists.

"Before the coming of the talking machine the great artist was silent forever after his or her life was done. Now their efforts are preserved to posterity, like the sculptor's or the painter's."

"Our business is one of the greatest in the world. We should look at it from a high viewpoint. There is no place in our ranks for the fellow who gets discouraged.

"The Victor Co. is probably the largest advertiser."
(Continued on page 32)



Father Finn's Paulist Choristers are taking the country by storm; their New York appearance was a triumph. Are you among the many dealers who are sending in repeat orders for their exclusive Columbia records? A new one in April that will go big.

**Columbia Graphophone Co.
Woolworth Building, New York**

OHIO TALKING MACHINE DEALERS HOLD ANNUAL BANQUET

(Continued from page 31)

tiser in the world and we expended on publicity much more than \$2,000,000 last year and are going to keep right on spending in 1918. I believe in uplift advertising. We are doing it and we are going to keep on doing it. We are optimistic at our headquarters and are trying to spread this optimism all over the country. We are apportioning as much money for publicity in 1918 as we expended in 1917. We are going to give you the same support we did last year and want your co-operation.

"We gave you more goods in 1917 than you got in 1916," said he. "We are going to keep right ahead giving you goods as long as it is physically possible to produce machines. No man can foretell the future cost of goods. Labor, raw material—everything—has advanced and is going higher. The price of some articles has jumped 1,600 per cent. We have solved problems as they came before us and will continue to do so." He cited an instance where representatives of the Victor went to a big brass center to get materials with which to build machines. They were able to get the materials but could not get them accepted by the railroads. Trunks were bought, automobiles hired, and the goods transported 250 miles in this manner to the Camden factories.

In referring to current shortages Mr. Brown said:

"The higher ups set the pace for the buying of talking machines, and naturally when the better classes buy machines the lower classes fall into line. The Victor people could vastly increase their output and their sales if they allowed inferior workmanship and put forth an inferior grade of products, but we will not do this. Every machine that leaves our factories is tested. We invite honest competition, but we have no use for the thief in the dark. It is up to you to defend and stand by the merchandising principles which have made your business what it is to-day. We will protect dealers and the trade as far as we can, if the Federal Government will aid us."

Mr. Brown also explained the needle shortage, and described the Tungs-tone stylus and its particular merits. He explained that the taper point of the ordinary steel needle wears away so that it does not fit down into the groove, while the point of the stylus is of the same diameter its entire length, and wears away evenly and thus always fits into the groove. He recommended the use of the Tungs-tone stylus as it will help relieve the needle shortage.

George W. Hopkins Talks on Salesmanship

George W. Hopkins, general sales manager of the Columbia Graphophone Co., who was scheduled to deliver a "message from the Columbia Factory," really delivered a most inspiring address on salesmanship, in which line he ranks as an expert. In opening his remarks Mr. Hopkins declared that the heart of Columbia employes, each and every one of them, is in the company they serve.

"I went to accept the resignation of a certain man," said Mr. Hopkins, "but when I saw a card in his office reading, 'To hell with yesterday—what's doing to-day?' I did not ask for the resignation, believing that this employe was determined to overcome everything in his path. This typifies the new spirit in the hearts of Columbia employes. We are seeking to put the buyer in the picture with Columbia Grafonolas. If a buyer is in a snap shot with a machine the buyer is in the picture.

"A retailer can start two ways—right or wrong. The phonograph business is different from other lines. Retailers, or many of them, must learn how to merchandise their wares properly in an honest-to-God way.

"It is unfair not to charge interest on instalments. The cash buyer should have a discount equal to the interest on instalment payments.

"The human eye is a finance committee in seeking selling goods. In too many stores goods are not changed about. You find the same old thing in the same old place from day to day and the result is that no attention is paid to such displays. The ways of our grandfathers get us nowhere in business to-day. We must learn to look out—not in. We should get out and talk business methods with other men to get their viewpoint and to swap ideas. When two men swap dollars each has what he had before the trade, but when two men each swap an idea each has two ideas instead of one.

"We are apt to look too much at big sales—and not to watch the small affairs in our business. The man behind the counter should have his chance. The best advertised line of goods in the world can easily be damned by clerks and salesmen who have been offended.

"I would make the clerks of a retail store responsible for the store. Place these men on their merits and their mettle. I would impress upon this class of help why I engaged in business and endeavor to have them look at the results through my eyes and with my ambition to succeed.

"If Tom, Dick and Harry were my clerks I would give each one of them an opportunity to run the store. Each would vie with the other in seeking new ideas, new ways to dress shop windows, etc. In a short time this trio of clerks would be exchanging views with clerks all over the city and gaining ideas to build up my business. It pays to make thinkers and originators out of mere clerks behind the counter.

"I would pass from clerk to clerk when patrons were in my store and offer suggestions which would make the clerks know that I was personally interested in pushing their sales. I would impress my personality on every patron when I could.

"Don't play your game the way the other fellow plays it, for he will beat you; play it a new way, one of your own. Six months is the usual life of a talking machine, so it is up to us to find a way to prolong this life—that is, give the

machine a new lease on life by offering buyers records which reproduce the proper music—melodies that are wanted. The better-grade music, if reproduced at the psychological moment in trying to make a sale, will start a phonograph on a new lease of life.

"Soldiers want music, yet wherever I go I hear pleas for cigarettes for our boys—but seldom a plea for music.

"We will have more failures than ever this year. The rich will buy less, but there is another class making war wages that must be taught how to buy. The fellow who up to now has never had spare cash does not know really how to buy. The two great themes for our educational propaganda are "What to buy" and "How to buy." By advertising the advantages of buying a talking machine we will educate the greatly enriched laboring class to long to own a talking machine. In other words, teach them what to buy. By advertising how to buy a talking machine we will reach that class whose income has been cut down by the war and who therefore are now interested in spending judiciously and with good reason, where heretofore they spent freely and without special thought."

William Maxwell Discusses Non-Essentials

Owing to the fact that he was called upon to attend the annual convention of the Edison Disc Jobbers' Association in New York, William Maxwell, vice-president of Thomas A. Edison, Inc., was unable to be present at the local banquet as expected, but sent a paper, which was read by President Bennett. After a characteristic introduction Mr. Maxwell, in his paper, launched into the discussion of the question of non-essentials and said in part:

"A while back there was quite a number of prominent gentlemen who were pulling long faces and urging that the manufacture and sale of non-essentials be discontinued. A great deal of time was devoted to the preparation of a list of non-essentials. Finally, however, it was discovered that nobody knew what a non-essential really is. I understand that one gentleman said the only non-essential he could think of was lager beer. I do not know why he did not include Bourbon whiskey. Perhaps he is a man who packs a flask on his hip. Another gentleman thought that maybe perfume was a non-essential, but we married men who are familiar with the secrets of feminine toilettes know that perfume is regarded in certain quarters as quite essential.

"The dollar-a-year man and others who were railing against so-called non-essentials apparently did not get very much encouragement from President Wilson. Mr. Wilson intends to

"NICHOLSON"
New Catalog Showing New Styles
RECORD CABINETS
strictly high-grade construction at prices
BELOW COMPETITION
Write for a copy of the catalog and our
special free advertising help for dealers.
K. NICHOLSON FURNITURE CO., Chase City,
Virginia
Sectional Bookcases and Record Cabinets

OHIO TALKING MACHINE DEALERS HOLD ANNUAL BANQUET

(Continued from page 32)

win the war and will go to any necessary lengths to accomplish that result, but it is very evident he does not intend to hamstring business. I cannot understand what ails some of the men who have aired their views as to the proper way to win the war. Take the following for example:

"First, cut out the production of luxuries and non-essentials. Second, cut down the additions to permanent improvements and equipment, restricting them to such only as will aid in carrying on the war and essential industries. Third, keep enough people employed upon the necessities to support the country and the army and put the others to war work. Fourth, turn into the treasury, through taxes and loans, the money

"The spirit of cheery confidence," in spite of what all the preachers of melancholy from Frank Vanderlip down may say, has been our great national asset during the war.

"Happily for the nation, many of the 'preachers of melancholy,' if that is the name to call them, have experienced a change of heart. It is no longer quite so popular as it was to preach the wrecking of business as an aid in winning the war, and I do not think the national instrument trade needs to fear any drastic action on the part of the Government. The musical instrument industry, as an act of patriotism, stands in readiness to take a back seat to war industry whenever it is necessary. As soon as the freight tangle is straightened out I believe we can look

up to the retailer to get in touch with his share of the 9,000,000 families to compensate for his share of the several hundred thousand families.

"Retail business depends upon the earnings of money makers. The 1910 census showed that at that time there were 30,000,000 male money makers in this country and that there were 8,000,000 female money makers. Of these 33 per cent. were engaged in farming; 2 per cent. in mining; 28 per cent. in manufacturing and mechanical industries; 7 per cent. in transportation. In other words, about 70 per cent. of the money makers in this country are making more money than they ever made before, and, when I say making more money, I am taking in full account our old enemy—the high cost of living.

"I do not think I am naturally an optimist. But I can say to you gentlemen that, in my opinion, nothing short of some great calamity



Annual Banquet Talking Machine Dealers' Association of Northern Ohio, Hotel Winton, Cleveland

At Speakers' Table, Left to Right: C. H. Grinnell, A. W. Roos, G. W. Hopkins, Louis Meier, Retiring President of Association; Charles K. Bennett, New President of Association; Henry C. Brown, Leo. Hall, President Pittsburgh Talking Machine Dealers' Association; Thomas H. Davies and J. Raymond Bill.

released which was previously paid to these people now released from private service to war work.'

"I could scarcely believe my eyes when I read the foregoing expression of an opinion. Is not that fourth proposition a corker? Let us assume that a manufacturer of so-called non-essentials has a pay roll of \$100,000 a week. He discharges all of his men, tells them to go out and get work in the shipyards and munition factories. True, he no longer has to meet his pay roll, but, on the other hand, he would have in a very short time no money to meet it with, or to pay his taxes or to contribute in any other way to the support of the Government. His employees, even if they did find other employment, would be put to great expense in changing their place of residence. All the distributors who sell the manufacturer's products would be put out of business or seriously crippled. For every dollar thus 'released from private service to war work,' \$5 would be rendered unavailable. The particular banker who expressed this opinion overlooks an economic principle, which I once heard tersely expressed by a man who was running a drop case layout on a country fair ground. The gambler kept shouting, 'come on, boys, money won't grow in your pockets like the hair on your head.' We need to grow money, otherwise new wealth, in this country, and I am very thankful to say that I believe the President and his trusted advisers realize this necessity. There has been a great deal of exaggeration in regard to the scarcity of labor. Of course, there is a scarcity of labor in certain quarters, but when you think of what Canada has done, you will realize that if we do anywhere near as well, we can do all that our Allies expect us to do and still keep business getting better than usual.

"A great many consider Mark Sullivan, editor of Collier's Weekly, the best magazine editor in the country. Certainly he has a clear grasp of national affairs. Recently he said:

forward with absolute confidence to a year of unusual prosperity. We must not forget, however, that conditions are somewhat changed. The purchasing power of the country has been shifted around considerably. At least 9,000,000 families are better able to purchase phonographs this year than they were last year. Opposed to these are several hundred thousand families whose purchasing power has been reduced. It is

to the nation can prevent 1918 from being an exceedingly prosperous year for every live merchant in the musical instrument trade. Music is not a non-essential any more than literature. Accordingly, musical instruments are just as essential as books. There are certain levels of civilization where food and drink are the only essentials, but thank goodness that is not the

(Continued on page 34)

THIS ALBUM MADE US FAMOUS
by selling it. Why don't you try?



Buy Your Albums Direct From the Manufacturer

43-51 W. Fourth St.
New York, N. Y.

THE BOSTON BOOK CO., Inc.

The only exclusive Record Album Factory in the world.

Chicago Office:
1470 So. Michigan Ave

OHIO TALKING MACHINE DEALERS HOLD ANNUAL BANQUET

(Continued from page 33)

kind of civilization we have in this country. In America food for the body is only a little more important than food for the mind. Next to religion music is the greatest mental solace. Everyone of you members of the association ought to be proud you are in the musical instrument business and you ought to be insulted if anybody hints that music is a non-essential. We are going to win the war and we are going to make every necessary sacrifice, but the President of the United States, in my opinion, will do his best to see that no unnecessary sacrifice is made. I have confidence in his wisdom and the sincere belief that he possesses the courage of his convictions at all times. I am not a Democrat, but I take off my hat to Woodrow Wilson, the greatest of all Democrats and perhaps the greatest of all American statesmen."

J. Raymond Bill's Address

J. Raymond Bill, associate editor of *The Talking Machine World*, spoke in part as follows:

"My sole message is to enter a plea that we music men of America bend every effort toward making our nation intensely optimistic. No doubt mistakes have been made at Washington, but many of the errors have already been rectified and if the next six months are characterized by as much forward progress as the last six months have been, Uncle Sam will be in line for hearty congratulation.

"These days it is important to look at things from the very broadest viewpoint possible, if we would not have our enthusiasm sapped by that worst of parasites, pessimism. Viewed with regard to the immediate present, the fuel shortage, the rail congestion and the non-essential bugaboo might have offered grounds for alarm. And yet we all know mild weather is the certain solution of the fuel and transportation problems. During the last two months, moreover, those in close touch with Washington have seen a definite knockout delivered to the non-essential bugaboo. Banker Vanderlip, chief

exponent of what I choose to term irrational economy, has subsided to California where, let's hope, history will repeat itself in that California will not be heard from for some time. Along the same line, I would call attention to two articles appearing in the February issue of *The Nation's Business*, the official organ of the United States Chamber of Commerce. One article is by Dr. Garfield and the other by Mr. Noyes. Both are important figures in the National Fuel Administration and both in their articles directly refute the idea that there is any such thing as a non-essential. It, therefore, remains for us of the music industry to convey to the consumer public the common sense attitude that now prevails in official Washington.

"There are many other signs of a highly encouraging nature. Take, for instance, the practice of the modern army. It has been definitely established that the soldiers cannot and will not endure the fearful waiting periods of modern warfare without relaxation. The generals have found that army morale seriously deteriorates when the men are favored with only the so-called essentials of life—food, raiment, lodging. The military experts have found the modern man is not a savage and that his list of essentials is somewhat longer. To-day we, therefore, find theatres, reading matter of all kinds and music have joined the colors both with the American Expeditionary Force abroad and with our troops in the national cantonments at home. Three things, which one not versed in human psychology might imagine unnecessary, have proven to be in fact bulwarks of army morale. And if the fighting forces can't do without these things, it is folly to imagine the great civilian populace will dispense with such obvious life-essentials.

"I do not hesitate to predict that the music industry will come sooner or later to be recognized as a war industry proper. In the meantime, as I see it, our slogan might well be 'Cheer Up, America' and our purpose, if the

ladies will pardon the reference to Sherman, might well be to show Germany that Uncle Sam can fight to victory and at the same time endure the hell of war with a smile on his face."

What Pittsburgh Dealers Have Done

French Nestor, scheduled to tell about what has been accomplished in Pittsburgh by the dealer association in that city, could not attend, and Leo. Half, president of the Pittsburgh Dealers' Association, spoke in part as follows:

"First of all we got together and got acquainted—both with each other and with each other's problems. We learned to call ourselves and our mistaken methods by their right names. We canned the spirit of antagonism and retaliation and instituted instead a real honest-to-God desire to help each other in trade matters, to build up clean methods of advertising, etc.

"All that we have accomplished or hope to accomplish we attribute solely to getting started right and to maintaining the closest possible friendly relations, to frank discussions in open meetings, and genuine desire on the part of all members to keep conditions and competition clean. Do we believe in competition? We do. We believe in more business just as strongly as in better business and we have religiously avoided from the start any ruling or policy that would limit members. We favor complete freedom to formulate and carry out one's own sales policies and to advertise them in his own way—so long as the essential principles of fair play and trade betterment are observed.

"It is our policy to encourage initiative and 'pep' of whatever variety or kind.

"True, we believe in co-operation for trade building, but we realize success of the individual merchant depends solely on his own individual effort, energy and foresight. We do not jolly ourselves into believing that our association guarantees us continued prosperity, unless each member puts the right amount of effort and energy into conducting his particular business.

"We believe in music as a prime human necessity. We believe absolutely in the future of the talking machine industry, because the talking ma-



-WHY- Do You Use Tone Arms



“off the shelf”? You spend time and money freely on the design of a cabinet, why compromise on the tone arm? Why don't you put the same thought into the tone arm? Make it at least as distinctive as the cabinet.

We have experts who are specialists in designing tone arms that will blend with your cabinet in quality and appearance—that will continue quality unbroken from sound chamber connection to stylus groove.

These men are ready to serve and prove to you by sketches and figures that “INDIANA” made tone arms will increase the value of your machine and make it a better selling proposition.

Bear in mind that acceptance of this service does not obligate you in any way and anything developed for you is for you exclusively, and is not sold or sampled to your competitors.

WE ESTIMATE FROM SAMPLE OR BLUE PRINT

“INDIANA” DIE CASTING COMPANY

East 11th Street at Cornell Ave.

INDIANAPOLIS, IND.

OHIO TALKING MACHINE DEALERS HOLD ANNUAL BANQUET

(Continued from page 34)

chine and records to-day are the most convenient and satisfactory form of music for the average American home. Talk about industry having reached the peak is all 'bunk.' More talking machines and records will be sold this year than ever before provided only they can be produced and distributed under present conditions. The dealer who lies down is on the wrong track. If certain machines or records cannot be procured, he should push other types that can be procured.

"An important change coming out of the war conditions is the development of higher service standards. In the future the retail merchant must give closer and more studied attention to the actual helping and assisting of his patrons—to rendering a distinct service value wholly beyond and outside the article of merchandise delivered. The customer is rightfully entitled to this form of helpfulness in return for money spent through the dealer.

"We believe co-operation should not be confined to separate districts. We believe districts should co-operate. For example, there should be closer co-operation in trade matters between Pittsburgh, Cleveland, Buffalo, etc.

"We believe trade organizations in important centers should encourage the formation of smaller local associations to co-operate with the central association."

C. H. Grinnell Talks on "Value of Co-operation"

The next speaker on the program was C. H. Grinnell who made a special trip from Detroit, and who discussed "The Value of Co-operation" in the following interesting manner:

"The Detroit Talking Machine Association was organized February 7, 1916, with a membership made up of forty-two of the leading dealers of talking machines in the city of Detroit and Highland Park.

"To say that the association has been a tremendous influence for good among the talking machine dealers would be putting it mildly. In my judgment the one great cardinal feature which it has accomplished above all others has been the personal element which has been injected into the business.

"Previous to the organization of the association the various dealers, located at their several stations throughout the city, were practically unknown to one another and as a consequence irritation was very common among them and it was with reluctance that they fraternized with one another. After a period of two years this heretofore disturbing element has been entirely corrected. By the monthly meetings friendships have been cultivated between the various dealers and in many instances the prefixes of Mr. have been entirely disposed of and John meets Frank and Frank meets Bill.

"Much more could be said on this point, but why should I continue lest I be called presumptuous?"

"In passing I wish to mention some of the special things which the dealers of Detroit feel have been accomplished through the efforts of the association. There has been a noticeable shortening of time of the life of contracts which are now secured upon talking machines. The approval business has been helped tremendously. Previous to the organization of the association it was not uncommon for records to be out for at least seventy-two hours. Through the concerted efforts of the association at the present time twenty-four hours is a maximum and practically one-third of the records taken are kept by the various people who avail themselves of the approval privilege.

"Further, the association has encouraged the carrying of packages which are small and the returning of small record orders, thus co-operating with the United States Government in this world-wide war for democracy's safety.

"The sending of records upon a Saturday and days preceding holidays has been entirely dispensed with and the ten days preceding Christmas of the year 1917 no records whatsoever were sent out on approval.

"A departure from the old-established precedent previous to the organization of the talking machine association would have been impossible to have accomplished—the upholding of the interests upon contracts has been generally complied with. Previous to the organization of the association it was found that department stores failed to recognize the import of the interest loss. Since the advent of the association they have refrained entirely from newspaper advertising, bills, cards, etc.

"In conclusion, the one great thing that has been accomplished by bringing the different dealers together is an extremely kindly feeling for one another. Honest differences that were practically impossible to adjust previous to the organization of the association are now adjusted to the satisfaction of all concerned."

Send Protest to President Wilson

V. W. Moody was called on for an impromptu report on what the dealers' association in Buffalo has accomplished, and following this a telegram was sent to Woodrow Wilson as follows:

"Cleveland, O., February 20, 1918.

"To His Excellency Woodrow Wilson,

"President of the United States.

"The Talking Machine Dealers' Association of Northern Ohio, assembled at their annual meeting at the Hotel Winton, raises a voice of protest against the ruling of the Justice Court, prohibiting the recording of Bohemian, Polish and Slavish airs, on the grounds that the above-mentioned peoples are an alien enemy.

"These unfortunate countries, especially Bohemia, have sent thousands of volunteers to the Allied armies to join in the fight for freedom, from the tyranny of the Hapsburg dynasty, so that the whole world will have everlasting peace.

"The Slavs in America, as records show, are the most law-abiding and peaceful citizens. This law may create unrest and bitter feeling if enforced.

"Therefore be it resolved, that the Talking Machine Dealers' Association of Northern Ohio plead with Your Excellency to rescind this order and proclaim and place these peoples upon an equal footing with all other true and loyal Americans."

Those Who Attended

Among those present at the banquet were: Mr. and Mrs. T. H. Towell, Mr. and Mrs. P. J. Towell, Mr. and Mrs. C. K. Bennett, Mr. and Mrs. E. B. Lyons, Mr. and Mrs. Jack Kennedy, Mr. and Mrs. Norman H. Cook, Arthur Donaldson and Earle Poling, Eclipse Musical Co., Cleveland; Mr. and Mrs. Dan J. Nolan, May Co., Cleveland; C. J. Duncan, Massillon, O.; Sol Goldsmith, Goldsmith Music Store, Columbus, O.; F. E. Reinhardt, May Co., Cleveland; J. O. Raeder, Caldwell Piano Co., Cleveland; G. W.

Hopkins, Columbia Graphophone Co., New York; H. C. Brown, Victor Talking Machine Co., Camden; J. Raymond Bill, The Talking Machine World, New York; Mr. and Mrs. Louise Meier, L. Meier & Sons, Cleveland; R. B. Carnahan, Carnahan Music Co., Ravenna, O.; T. A. Davies, William Taylor Sons' Co., Cleveland; William Bowie, and the Misses House, Terry and Wilcox, B. Dreher's Sons Co., Cleveland; George C. Willie, George C. Willie Co., Canton, O.; Jerry Fraiberg, H. Fraiberg & Son, Cleveland; J. A. Bartholomew, Ashtabula Phonograph Co., Ashtabula, O.; W. E. Shay, Elyria, O.; John Drake, Drake & Moninger, Alliance, O.; E. F. Hunt, Alliance, O.; Miss Elise Baer, M. O'Neill Co., Akron, O.; Mr. and Mrs. Hubert Day, Hubert Day & Son, Elyria, O.; N. Borowitz, Akron, O.; J. H. Gunn, Columbia Graphophone Co., Cleveland; Mr. and Mrs. Arthur Leopold, Leopold Furniture Co., Cleveland; W. Buescher, and Ed. Buescher, W. H. Buescher & Son, Cleveland; Frank Cerne, Cleveland; J. J. Fedderman and Mr. Zinner, Clifton Furniture Co., Cleveland; C. A. Yates, Cleveland; R. E. Herschberger, Cleveland; J. A. Tucker, Phonograph Co., Cleveland; James Card, Lakewood Music Co., Cleveland; Grant Smith, Euclid Music Co., Cleveland; Mr. and Mrs. A. L. Maresh and Charles Maresh, Maresh Piano Co., Cleveland; Philip Dorn, Collier & Sayle Co., Cleveland; C. C. Lipstru, Cleveland; F. C. Enoch, Carey, Jackson & Enoch, Parkersburg, W. Va.; W. L. Kellogg, Whitney & Currier Co., Toledo; A. Smerda and Frank Smerda, Smerda's Music House, Cleveland; Miss Johnson, Taylor Co., Cleveland; Mr. and Mrs. George Robinson, Steubenville; Miss Verna Schaefer, Steubenville; Miss Kittenger and Miss Wornell, William Taylor Sons, Co., Cleveland; Mr. and Mrs. Curry, Hilliard & Curry, Wadsworth, O.; Mr. and Mrs. Norton, Wadsworth, O.; Miss Deshler; V. W. Moody and O. L. Neal, Neal, Clark & Neal Co., Buffalo; Mr. Switzer, Caldwell Piano Co., Cleveland; Joseph Phillips, Mr. Shriner and Mr. Dent, the Bailey Co., Cleveland; Frank Weigand, Barberton, O.; Miss Groth, the Bailey Co., Mr. and Mrs. C. H. Kennedy, Columbia Graphophone Co., Cleveland; Mr. and Mrs. Svehla, Cleveland; Leslie King, Morehouse-Martens Co., Columbus; C. N. Andrews, W. D. & C. N. Andrews, Buffalo, N. Y.; Leo. Half, president, Pittsburgh Talking Machine Dealers' Association, Pittsburgh, Pa.; C. H. Grinnell, Grinnell Bros., Detroit; F. W. Roos, Columbia Graphophone Co., Cleveland; Miss Marie Hutton, Fairmont, W. Va.

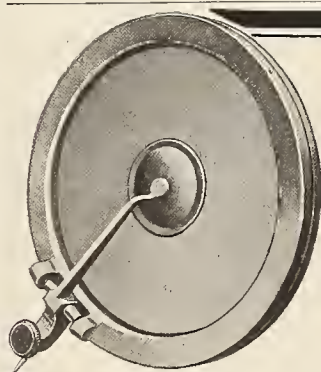

The Bliss Reproducer

Will Play All Records

A new superior and scientifically constructed sound box—no mica, rubber or cork used.

Beautiful full, rich tone quality, clear articulation. It individualizes each voice and instrument in the record. Greater volume with lighter needles, thus minimizing wear on records.

A demonstration of the Bliss reproducer means a sale—each sale brings another, for every music lover who hears the Bliss reproducer wants one.

Comparative tests solicited. Write today for dealer proposition.

WILSON LAIRD PHONOGRAPH CO., Inc.

29 West 34th Street, New York City

Canadian Distributors: HAWTHORN MFG. CO., 145 Yonge St., Toronto, Can.

THE TRADE IN PHILADELPHIA AND LOCALITY

PHILADELPHIA, PA., March 6.—The talking machine business in Philadelphia during the month of February has been as good as could reasonably be expected, from the general condition of affairs. It was hardly as good as February a year ago, but then this country had not entered the war, and the February of 1917 was an exceptionally good month, and the question of meeting war demands did not enter into the situation, tending to curtail the output.

During February the Victor Co. have delivered a fair percentage of the machines ordered, but they have been shy on records, and many of the most popular sellers have been hard to obtain, and therefore the amount of business has been somewhat curtailed. The freight situation has eased up a bit and the jobbers and dealers are getting out their goods very much more satisfactorily.

Larger Quarters for Geo. D. Ornstein & Co.

George D. Ornstein & Co., recent retailers and jobbers of the Victor talking machine, who for a brief period were located at 9 North Eleventh street, have taken very large and commodious quarters at the southeast corner of Eleventh and Chestnut streets, where they will occupy the second, third and fourth floors of that large and spacious building. They began to move in the past week, and are having the place shelved and will have as much floor space for the handling of machines and records as any firm in this city. The offices of the firm are on the second floor, and they will have fine elevator service.

Two new Victor dealers in this city are Theodore Presser, the big music publisher, and the Estey Piano Co. at Seventeenth and Walnut streets.

Busy Times With Columbia Co.

The Columbia Graphophone Co., at 210 North Broad street, report that their business has been remarkably good for the past month. During the early part of the month they were pretty well tied up with freight embargo, but this was lifted, thereby enabling them to get records from the factory in sufficient quantities to keep the dealers supplied, especially with the popular sellers. Machines from the Columbia factory have been coming through in fairly good volume. Among the visitors at the company's offices the

past week was F. K. Pennington, assistant general sales manager of the Columbia Co.; W. A. Quint, of the office force, has enlisted in the navy and has been sent to Fort Trumbull, New London, Conn.

Solving the Freight Problem

J. E. and W. H. Nace, Columbia dealers at Hanover, Pa., took the freight troubles by the horns the past week. They came to Philadelphia with four automobile trucks, loaded them with Columbia machines and records and returned home. The only trouble they experienced being the running short of gasoline, one puncture and one blowout. The drivers of the trucks were W. H. Nace, Allen G. Nace, George T. Adams and C. B. Myers.



WEYMANN SERVICE

GIVES THE VICTOR DEALER WHAT HE WANTS WHEN HE WANTS IT.

Let our organization furnish you the goods to make you the dominating Victor Dealer in your territory.

We can do it.

WEYMANN

Victor Wholesalers

1108 Chestnut Street

PHILADELPHIA, PA.

Good Report From the Louis Buehn Co.

Louis Buehn, of the Louis Buehn Co., Inc., states that his business in February was very satisfactory on the whole, but showed a loss against February of 1916, due entirely to their inability to secure goods from the factory. "The record supply question," Mr. Buehn says, "is very serious at present, and it has been almost impossible to secure the most popular of the records. Machines in February came through on a par with last year." Mr. Buehn does not believe that conditions will improve to any great extent during the spring and summer, owing to the supply and manufacturing situation.

Among the Buehn visitors the past week were Leon Wittich, of Reading, and Mr. Kleinhaus, representing the Werner Co., of Easton, Pa. Edward J. Bliss, of the Buehn sales force, who recently enlisted in the navy radio service, has been transferred from the Navy Yard here to the Marcus Hook station, where he will be in charge of the wireless plant.

Good February for Penn Co.

February was the best month the Penn Phonograph Co. has ever had, "strange as this statement may seem to the trade," said Mr. Barnhill, but it was due to a condition, the stating of which would reveal a trade secret. Mr. Barnhill states that business looks very promising for March.

Charles A. Reed, who has a large talking machine store at 3718 North Fifth street, has put in two new hearing rooms, and otherwise improved his store.

Minnie M. Hart, of Chester, Pa., has just opened a new store and fixed it up with new booths, and had a very satisfactory opening a few days.

At "The Home of the New Edison"

Blake & Burkart, "The Home of the New Edison" in Philadelphia, are very much elated over the business they done in February. "We are going at it strong this month," says Mr. Blake. "Machines and records are coming through very well, except the delay in shipments." If the delay should continue they are contemplating bringing the goods here by auto trucks. They have placed an attachment on the Edison machine in their store which is called the C and E

(Continued on page 38)

SELL RECORDS



JASCHA HEIFETZ

If Victor dealers will adapt themselves to war conditions by pushing the sale of the higher priced records, it will be possible to do the same cash turnover with a numerically smaller stock.

PENN PHONOGRAPH CO.
17 S. NINTH STREET PHILADELPHIA

Four words only of the English language end in CION.

But EVERY sale of a Victor Record ends in COIN.

So we can create "Record-coin," which is most essential for your business vocabulary.

Make this new word your slogan for Spring record sales. Buehn Service has been telling you for years about selling more records and has been backing it up with such efficient record co-operation that altho it operates locally in one sense, its reputation has become National.

You would be surprised to know about the many record orders received by Buehn Service from all over the country; it does make deliveries if we have a surplus, but our main efforts are exclusively for the Victor dealers of Philadelphia territory.

The Victor factory sends you many good points on HOW to sell more records and Buehn Service delivers the records when you want them.

Create a prestige as "the record house" of your city.

THE LOUIS BUEHN CO.
P H I L A D E L P H I A

BUEHN SERVICE

on VICTOR RECORDS

BUEHN SERVICE
ON THE
RECORD-LITE
REGISTERED U.S. PAT. OFF.

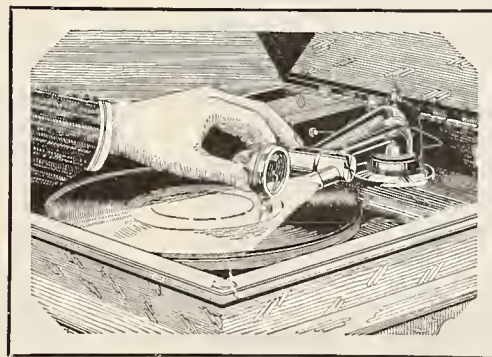

Every Victrola in your city should have a Record-Lite. It corresponds to searchlight on an automobile. It gives more light where the Victrola owner needs it and nets you a good profit for your interest in his behalf.

THE TRADE IN PHILADELPHIA

(Continued from page 36)

Repeater. It is a very useful device for its purposes, the attachment lifting up the arm of the machine and carrying it back and placing it in the proper starting position on the record, making possible the playing of a record over and over until the machine runs down.

Blake & Burkart have begun the issuing of a little magazine of information, which is entitled "Re-Created Notes." It is attractive in appearance, is utilized for the advertising of every part of their business, as well as the exploiting of the Edison machines and records. They are preparing an elaborate celebration for their Anniversary Week, which occurs April 14-20.

Pathé Shop Starts Publicity Campaign

The Pathé Shop here has started an advertising campaign in the local papers and with telling effect. In February Mr. Eckhardt says there was a constantly increasing interest and sale for the Pathé products, and notwithstanding the limited number of days they were able to do business in February, the month ended with a most satisfactory finish. Mr. Eckhardt says: "The finish was even beyond our most sanguine expectations, the month's business having exceeded somewhat the quota that had been established. It is quite evident that the local trade and patrons in this vicinity are becoming aroused to the advantages of the Pathé line, and we have made some very valuable and high-class connections."

A new addition to the Pathé Shop sales force is Louis Winch, the well-known singer. He has been making records for other companies for some time. H. H. Smith, a former Columbia employe, has joined the sales force at the Pathé Shop. The Pathé is represented in this city and vicinity by seventy dealers at present, and others are being constantly added.

George W. Lyle, of the Pathé Co., spent a day in Philadelphia recently, his first visit to the Pathé Shop. He was more than well impressed with the institution and organization.

The New Pathé Recordings

Manager Eckhardt says that he has only the highest compliment for the Pathé Co. in its record offerings, the April list representing a number of records which they have been permitted to put on special sale, and he says they are of the class that cannot help but make a deep impression for the artistic interpretation as shown in the recording.

Lively Demand for Dictaphones

C. A. Malliet, manager of the Philadelphia Dictaphone Co., reports that they have had a very good February in spite of the short num-

ber of working days. March looks fine to him. They have at length gotten their school in thorough operation, and it is in charge of Miss Belle R. Kinsloe. Among the recent visitors was William Kobin, of the executive offices of the company. They have added several new men to their selling force.

The Dictaphone Co. had a very interesting exhibit of the machine at the Atlantic City convention the past week of the National Educational Association. C. P. Hanson was in charge.

Cheney Machines Forging Ahead

The Cheney talking machine has been rapidly forging to the front in this city. A number of new agencies for the machine were created in February. G. D. Shewell, who represents the machine in this city, spent nearly a week at the Chicago factory recently. One of the most substantial of the dealers who started the handling of the machine in February was the Mather Brothers of New Castle, Pa. Marion

Cheney, a son of the inventor, whose home is in Philadelphia, and who is a sergeant in the army, was in Philadelphia on a ten days' furlough.

Victor Display at Weymann's

The Weymann firm is this week making a very fine window display of the Victor. They have a miniature British tank with military surroundings which is attracting a great deal of attention. The Weymann business in February was very satisfactory. They succeeded in securing large orders for the Marvel Victor Record Display Holders from firms who have come to recognize in this the best device on the market for the attractive display of records. The dealers who have used it find that it materially increases the sales of Victor records. The firm have placed in their Victrola department the past week Freda Robson and Leo Sandman to take the place of their men who have gone into the Government service.

ONE OF H. A. WEYMANN & SONS' PATRIOTIC WINDOWS

PHILADELPHIA, PA., March 4.—There are a thousand and one ways in which American business has adjusted itself to war times. Among others is the introduction of the war motive into window display, and along this line a recent window of H. A. Weymann & Sons, Inc., of this city, challenges all comers for attracting the attention of passers-by.

The display shown in the accompanying picture was made possible through the cooperation of a Philadelphian who recently returned from active service in France. A typical fighting trench has been built up by the use of sand bags and a foliage screen. Behind the sand-bag wall a dummy man clad in a British officer's uniform is shown listening to a portable model Victrola. Several close-up war photographs are shown in the foreground and numerous war trophies are appropriately placed in the trench scene. The war trophies are all genuine and

include gas masks, the knives of the African Chasseurs, a rifle, a ukulele, shell noses, steel helmets, and other paraphernalia of the battle-



Window That Attracted a Large Measure of Interest

field. The effect is striking, so much so that a photograph is inadequate to convey an idea of its merits.



WESER PHONOGRAPHS

For 39 years the piano trade has recognized in Weser instruments the highest piano and player piano value. It always has been our delight to invite comparison of the Weser products with those of other makers. Many of our best dealers have been acquired by such comparisons.

Weser Phonographs are making rapid headway in the same manner. Compare them with the world's most expensive makes—in tone quality—in appearance—in reliability, and solidity of construction, and we are content to abide by your decision.

The **Weser Phonograph** will play any record. Made in satin finish mahogany. Other woods on special order. Electric motor will be furnished if desired. Write for catalog.

WESER BROS., Inc.
520-530 West 43rd Street NEW YORK





Otto Heineman Phonograph Supply Co.

INCORPORATED

25 WEST 45th STREET, NEW YORK

FACTORIES, ELYRIA, O.—NEWARK, N. J.—PUTNAM, CONN.



CHICAGO

ATLANTA

SEATTLE

CINCINNATI

TORONTO

MOTOR PERFECTION

The achievements and progress in phonograph motor manufacturing in recent years are emphasized in the latest designs of

HEINEMAN and MEISSELBACH MOTORS

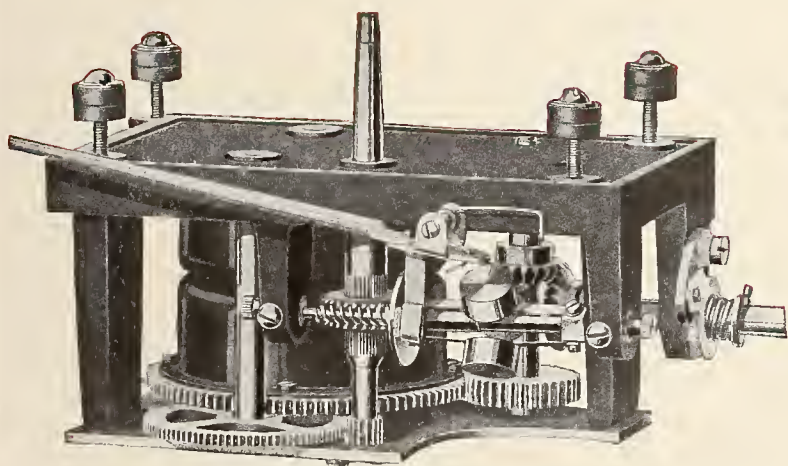

Heineman Motor No. 77

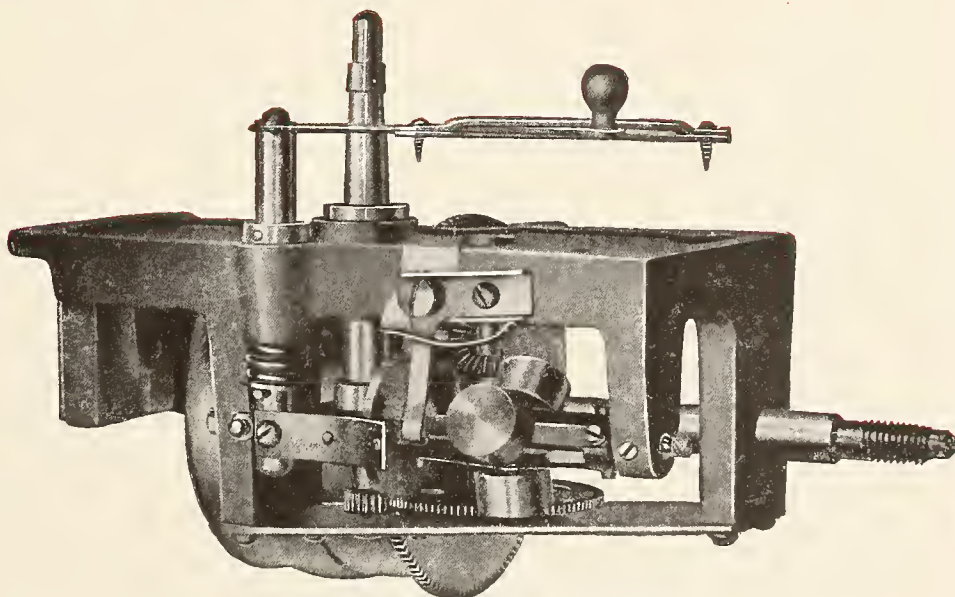

Meisselbach Motor No. 16

- HEINEMAN and MEISSELBACH Motors are recognized the world over as the *best* horizontal and vertical spring motors that are produced.
- They are offered to the trade with an iron-clad guarantee from the world's largest manufacturers of phonograph motors.

"We are at Your Service"

Otto Heineman
President



MEISSELBACH



TONE ARMS

MOTORS

SOUND BOXES

Winter is gone, and people begin to linger in front of the shop windows. Is your Columbia display one that will bring them into your store? Let the Columbia Dealer Service Department help you. Write today.

Columbia Graphophone Co.
Woolworth Building, New York



BUSINESS VOLUME BREAKS ALL RECORDS IN MILWAUKEE

Comparative Figures That Are Most Impressive—Another Co-operative Advertising Campaign—New Brunswick Dealers—Badger Co.'s Big Victor Business—Edison Popularity—News of Month

MILWAUKEE, Wis., March 12.—One of the most remarkable things in these remarkable times is the fact that talking machine business in Milwaukee during the first two and one-half months of 1918 has been much greater in volume than the transactions for the same period of any previous year. The situation is described as remarkable because not a single talking machine man in this city had looked for or even dared to hope that 1918 would bring a business as good as that of former years—probably because of the general feeling that one must expect poor business under conditions such as the trade is contending with. But Milwaukee dealers started out the new year with a firm determination to throw off that feeling, and the results speak for themselves.

January, 1918, showed a fine gain over the same month of 1917 on the books of most dealers. February showed up even better, and the tone of business so far in March indicates that the same will be true of the third month. Trade is being accelerated in a really surprising manner, and if local dealers are given the benefit of ample stocks for the remainder of the year, there seems to be no question that 1918 will prove most satisfactory.

The co-operative advertising campaign conducted from the middle of November until the middle of January has stimulated business to a remarkable extent. As a matter of fact, the influence of the campaign really is only beginning to be felt. It takes time to absorb such things. The absorption period has ended and the results are now becoming evident.

To keep the public mind alive to the meaning of the campaign, and to follow up the advantage already gained, the association has put into definite shape a plan to undertake a second campaign, which it is hoped to start next week. It will not be so expensive or elaborate a publicity drive as the first, but it is predicated thereon and doubtless will serve to even improve the present fine state of business.

About the most interesting item of news that has developed in the local trade during the last few days is the appointment of Charles J. Orth, 504 Grand avenue, as distributor for Wisconsin and Upper Michigan of the Puritan line, manufactured by the United Phonograph Corp., of Port Washington, Wis., and New York. During the last two years Mr. Orth has earned a place among the largest and most progressive talking machine dealers by his success in retailing the Sonora in Milwaukee and suburbs.

The Puritan already is widely known throughout the country, and particularly Wisconsin, where it is manufactured. The United Phonograph Corp. maintains large factories in Port Washington, Sheboygan and Grafton, Wis., and studios and recording rooms in New York City and at Grafton. They make the entire machine and the records as well.

The success of the Pathéphone departments established December 1 in the four stores of Kroeger Bros. Co., Milwaukee, has induced the company to open piano departments in connection with each store. A. J. Bruett is manager of the new departments and co-operating closely with the Pathéphone.

The Brunswick-Balke-Collender Co.'s Milwaukee branch at 275-279 West Water street, of which Thomas I. Kidd is manager, has increased the number of its retail dealers in the city of Milwaukee to nine, and is enlisting new dealers throughout the State almost every day. Manager Kidd says that business is so good that the demand for Brunswick rights in Wisconsin and Upper Michigan at this time is even greater than during the recent holiday season, which is considered excellent testimony that the Brunswick is growing in popularity at a rapid pace. Retail jewelers of Wisconsin are especially anxious to represent the line, and Manager Kidd oftentimes encounters many perplexing problems in deciding which of numerous applications from a single community shall be accepted.

At the Badger Talking Machine Co., Victor jobber, The World representative found that the same old problem—the question of obtaining adequate stocks—continues to be the most perplexing. In fact, the problem is more acute now than three months ago, when the retail trade was swinging into the last lap of holiday trade. Although practically as many machines are being provided now as then, the demand is much greater from all points in Badger territory. The situation is such that incoming stocks rarely reach the wareroom floor, but are marked up for the dealers practically on board freight cars. Harry A. Goldsmith, secretary of the Badger Co., says he has never experienced so overwhelming a rush for goods as during February and so far in March.

Yahr & Lange, Sonora jobbers for Wisconsin and Upper Michigan, report that they are meeting with a constantly increasing degree of success in wholesaling the line throughout the territory. The retail drug trade is taking a particular interest in the Sonora and, in addition, retailers in many other lines are applying for local dealerships in large numbers.

The New Edison is passing through the most

remarkable period since the first Edison machine was marketed in Wisconsin. The Edison Shop, Edison jobber and retailer, is getting further and further behind on its orders, although it is getting practically the largest supply of machines since its establishment. William A. Schmidt, manager of the house, virtually has been swamped with business for sixty days—and the end is not yet.

H. B. Gibbs, traveling representative of the Rudolph Wurlitzer Co., Chicago, recently spent several very busy days in the local retail Victor trade.

Richard H. Zinke, manager of the Badger Talking Machine Shop, Victor retailers, is back at his desk after a siege with pneumonia, which almost cost him his life. Mr. Zinke was taken with an attack of the grip early in February but insisted upon going about his duties as usual. The result was that he was sent to the hospital and for more than two weeks hovered between life and death. His robust constitution pulled him through, however, and while still weak, he attends to his duties every day.

Theodore J. Mueller, proprietor of the Central Drug Co., 6324 Greenfield avenue, West Allis, is remodeling and enlarging his store to accommodate a full-fledged Sonora department being established along "big city" lines. Mr. Mueller owns probably the largest pharmacy in West Allis, the big manufacturing suburb of Milwaukee, and is the first retailer in the city to open a complete and distinct talking machine store.

Henry Clusen, Victor dealer and jeweler, Manitowoc, Wis., suffered a considerable loss by fire and water on the night of February 21.

The Apollophone, the new creation of the Melville Clark interests, made its formal bow to the public during the week of February 18, when it was exhibited and demonstrated in a public display of the Artapallo under the direction of Miss Ursula Dietrich, New York, at the Hotel Wisconsin, who was brought to Milwaukee by the J. B. Bradford Piano Co., 411 Broadway.

Mrs. Anne Shaw Faulkner, of the Bureau for the Advancement of Music, New York, spent several days in Milwaukee late in February and arranged with the National League for Women's Service to undertake the collection of talking machine records for distribution among army cantonments.

Frank F. Koch, manager of the photographic department of the Voigt Drug Co., Appleton, Wis., has been appointed a Sonora dealer.



PERSONAL SERVICE

The members of our Company are always available and will gladly see you personally or write you at any time we can possibly serve you.

Why not communicate at once with us?

BADGER TALKING MACHINE CO. 135 Second Street
MILWAUKEE, WIS.
VICTOR DISTRIBUTORS



UNICO SYSTEM

THE SALES BUILDER

UNICO RECORD DEPARTMENTS

are the
Standard of Service and
Sales Efficiency

THE PURCHASING Public quickly discriminates. Look for the busiest Record Department in your community and you will usually find The Unico System of Demonstrating Rooms, Record Racks and Record Counters

**MAXIMUM CAPACITY
MINIMUM SPACE
MODERATE COST**

Record Sales in 1918 will surpass all previous demands. Prepare *now* to secure your share of this business by installing

THE UNICO SYSTEM

**Patriotic Records will help
win the War**

UNICO DEMONSTRATING ROOMS
RECORD RACKS
RECORD COUNTERS
WALL DECORATIONS
COMPLETE INTERIORS
(Patented as to design and construction)

In six standard styles and in special period design such as Adam, Louis XVI, Colonial, Modern French, etc.

- Offer 1—Individuality and Class
- 2—Highest Sales Efficiency
- 3—Most Economical Investment

Follow the lead of the leaders.
Double sales and profits through
THE UNICO SYSTEM



THE UNIT CONSTRUCTION COMPANY

RAYBURN CLARK SMITH, President

Fifty-eighth Street and Grays Avenue, PHILADELPHIA, U. S. A.

Send today dimensions of your
available space

Plans for a complete department
will reach you promptly.

IMPORTANT COLUMBIA CHANGES IN PITTSBURGH DISTRICT

J. F. Henk Forms Columbia Music Co.—Wholesale Division Moves to Larger Quarters—Dealers Connect Publicity With Noted Artists' Appearances—Pittsburgh Association's Advertising Plans

PITTSBURGH, PA., March 6.—The Columbia Graphophone Co., Sixth street and Duquesne way, has announced an important change involving both the wholesale and retail departments of this branch, whereby the two departments will be operated separately. The new arrangement became effective March 6. Following out the policy adopted in other cities, the retail agency has been sold to the Columbia Music Co., which concern is continuing that end of the business at the present location. The Columbia Music Co. is owned and managed by J. F. Henk, formerly assistant manager of the Columbia Graphophone Co.

The wholesale department of the Columbia Graphophone Co. is moving to new and larger quarters at 632-642 Duquesne way, where it will have greatly improved facilities for handling its trade. Manager E. H. Nichols states that the change has been made necessary by the vast increase in the business of this distributing agency and to permit a still greater expansion. The spacious building leased by the Columbia Graphophone Co. is well adapted to the needs of the business, and will be one of the finest wholesale talking machine establishments in the country. Further announcements of the reorganization and rearrangement of the Columbia wholesale branch are to be made in the near future, Manager Nichols states.

The Pittsburgh Talking Machine Dealers' Association is now carrying on a very aggressive newspaper publicity campaign, in which the idea is being effectively developed that music is a vital wartime necessity. The seven leading newspapers in the city, and over forty nearby out-of-town newspapers are being used in this campaign.

Leo Half, of Half Bros., Homestead, Pa., president of the Pittsburgh Talking Machine

Dealers' Association, delivered an address before the Cleveland Talking Machine Dealers' Association on February 20 on the subject of "The Value of Association Work and Dealer Co-operation," in which he outlined in a graphic manner the evidences of the successful furthering of this work from the history of the Pittsburgh Association. Mr. Half also outlined the "wartime" campaign now under way here.

The Standard Talking Machine Co., local Victor wholesale distributors, aided the Victor dealers of Pittsburgh and vicinity in the work of connecting up their advertising with the appearance here of two of the foremost Victor artists the week of March 4. One of these events commanding wide attention is the appearance of Galli-Curci, the famous coloratura soprano, at Syria Mosque, March 8. The other is the appearance of Jascha Heifetz, the noted young Russian violinist, at Syria Mosque, March 11; and at the Nixon Theatre, March 12. The Standard Talking Machine Co. supplied the dealers with printed matter, cards, etc., and with seats to sell to record patrons to still further connect up their stores with these Victor artists.

John O'Melia, manager of the Standard Talking Machine Co.'s record department for several years past, left on February 23 for Chicago, where he enters a course of instruction in preparation for Y. M. C. A. war work. Mr. O'Melia is the fourth member of the Standard organization to take up some line of war work, three others having enlisted in various branches of the service.

J. C. Roush, president of the Standard Talking Machine Co., is spending several weeks' vacation at Sea Breeze, Fla., accompanied by Mrs. Roush and their two children.

Manager Brennan, of the Pittsburgh Pathéphone Co., reports continued active trade in this

territory, and the dealers in the midst of an aggressive drive for spring business. The following additions have been made recently to the list of live Pathé retailers in western Pennsylvania: Gross & Rosenblatt, Beaver Falls; W. F. Beck & Son, 36 Belfont avenue, Lock Haven; and A. D. Ritz, Falls Creek.

Manager George Meyer, Jr., of the Brunswick-Balke-Collender Co., First avenue and Wood street, reports business quite active, the only handicap being the shortage of machines and delays in transportation. The Brunswick-Balke-Collender dealers in this territory continue to show a nice increase in sales over last year, Mr. Meyer states, and the outlook is quite favorable.

J. A. Endres, of the talking machine department of the Brunswick-Balke-Collender Co., is visiting for a week at his home in Buffalo, N. Y.

Cooper Bros., New Kensington, Pa., have just completed an addition of six handsome demonstration booths to care for their rapidly increasing trade. The Victor line is handled exclusively.

EDYTHE GLADYS EPSTEIN ARRIVES

Louis Epstein, Well-Known Victor Dealer, Proud Father of Bouncing Girl

Louis Epstein, big Victor dealer of 2976 Third avenue, New York, could hardly give his attention to business the past couple of weeks, owing to his excitement over a new arrival in his household in the person of a bouncing baby girl. The young lady is named Edythe Gladys Epstein, and was born early in the morning of February 17 at Mr. Epstein's home, 827 Cauldwell avenue, the Bronx. Both mother and daughter are in fine shape, and Mr. Epstein has again come so close to normal that he feels safe in having the various buttons replaced on his vest.

The greatest master is master of yourself.

"MICKEL"

A Great Name in the Victor Game

TWO Representative Stocks of Victor Records
In TWO Hustling Western Centres of Commerce!

Omaha and Des Moines! Spots of Action on the U. S. Map. If you are nearer Omaha or Des Moines than to some other point, why shouldn't you serve your own interests by putting the "Source of Supply" question up to the Mickels? Better look into this today—You'll gain nothing by staving the matter off!

Mickel Bros. Co.

15th and Harney Streets
411 Court Avenue

OMAHA, NEBRASKA DES MOINES, IOWA



Those "Lively" Westerners.



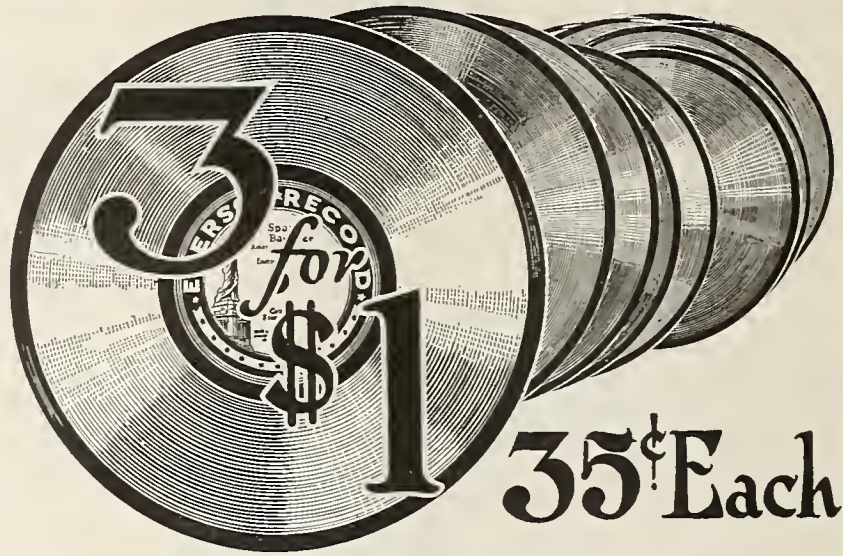

“The Greatest Move You Ever Made WE’RE SELLING MORE and MAKING MORE”

These are the words expressed just as definitely and even more enthusiastically by dealers all over the country.

“At first we thought that the increase in price might temporarily reduce our Emerson sales volume,” said one of these dealers last week, “but it has had quite the opposite effect.

“There must be something about human nature which makes people readier to buy something for which they pay 35c or 3 for \$1.00.

“We have sold more people 3 records than previously we had sold only one.

“The number of people buying Emerson Records hasn’t decreased, but the quantity purchased by each buyer has gone up.”

This is the report sent in from all parts of the country concerning

Emerson Records

Retail 3 for \$1.00 or 35c Each

But this is only one-half the advantages of the new scale of prices. The new fact about Emerson Records now is that you make more on every Record that you sell than you did before.

Emerson Records now cost you 21c in unbroken packages, and 22c in broken packages of less than 25 records of a selection,

The new list is the best we have ever issued. Included in it are most eminent stars; backing it is some of the finest display material we have ever printed.

Emerson Phonograph Company^{INC.}

3 West 35th Street

New York

The Columbia Grafonola was "First in France" with our boys, and more of them are going over with every transport. Call the attention of your customers to the jolly, rollicking songs of Al Jolson, George O'Connor, Arthur Fields and others, in the April list. They'll want to send them to the camps in France. There's a Columbia Grafonola in every Y. M. C. A. and K. of C. Army Hut.

Columbia Graphophone Co.
Woolworth Building, New York



FLAG RAISING DAY AT EDISON LABORATORY, ORANGE, N. J.

Ceremonies Also Included the Flinging to the Breeze of a Service Flag Containing 362 Stars—Stirring Address by General Sales Manager Leonard a Feature of the Celebration

Flag raising was the order of the day February 22 at the Edison Laboratories, Orange, N. J. Following the annual custom Old Glory was raised to the top of the flagpole on the roof of Mr. Edison's laboratory. An added feature of this year's ceremony was the flinging to the breeze of a service flag containing 362 stars, each star representing a man from the Edison organization who has gone into the service of Uncle Sam. The service flag hangs out of one of the top windows of Mr. Edison's laboratory and faces Valley road, where it is in full view of all passersby.

The Edison Employees' Band participated in the exercises by marching from their headquarters in one of the buildings around to the front of Mr. Edison's laboratory and into the laboratory yard where they played the "Star Spangled Banner" while Old Glory was raised on the top of the laboratory, and "America" when the service flag was run out of the window, all in the midst of a lively snowstorm. Thomas J. Leonard, general sales manager of the musical phonograph division, was master of ceremonies and made a most appropriate and splendidly delivered address following the raising of Old Glory and preceding the breaking out of the service flag. Mr. Leonard said in part:

"At the call of their country in its hour of need and inspired by the example of their employer, serving the Government devotedly and as modestly as the humblest soldier in the ranks, 362 Edison men stepped into the service of Uncle Sam. This is a magnificent showing, but probably not more than might be expected from the organization which set a standard for all other manufacturing organizations in its response to the Liberty Loan appeals and which, through its individual employes, has contributed with corresponding generosity to the successive forms of wartime demands.

"We gather to-day to pay a simple honor to our comrades and associates who have joined the colors. The day is especially well selected, for the principles for which the father of his country fought the good fight are the same principles that are to-day imperiled by the false doctrine of Prussianism."

After some eloquent comments regarding the origin of the service flag and what it is intended to typify, Mr. Leonard continued:

"There is another significance to the service flag. It is a reminder of our duty to the boys who are going to the front. Nothing is too good for our boys in the service. These boys, the chosen defenders of our flag, are willing to suffer hardship and every inconvenience that you and I may be permitted to live in peace and security. Remember that they are no more under obligation to risk their lives than you and I are. It is our country as well as their country—our responsibility as well as their responsibility. Yet these boys—our boys—are willing

to make the supreme sacrifice to protect our homes and our wives and children—yes, they are willing to go through hell itself that this great

of that duty. Let it have this additional significance. Let it inspire you to subscribe to the necessary things which will help win the war and make the task of our boys easier.

"All these will call for a sacrifice on your part, but this is the season of sacrifice and sacrifice is the least duty you and I can perform. Let the service flag on the old 'Lab' wall be a



Raising the Service Flag at the Edison Plant on Washington's Birthday

Large Picture Shows the Edison Employees and the Band Gathered for the Ceremonies. Upper Left Picture, Thos. J. Leonard Delivering the Principal Address. Upper Right, the Service Flag in Position.

nation of ours may remain great and secure for those who remain after them. It is our obligation, therefore, to do our duty at home; and let the service flag always be a reminder to you

silent reminder then of your duty to the boys at the front who are fighting for the honor of the flag that has never been unfurled save in a righteous cause—your flag and my flag."



The Quality Phonograph

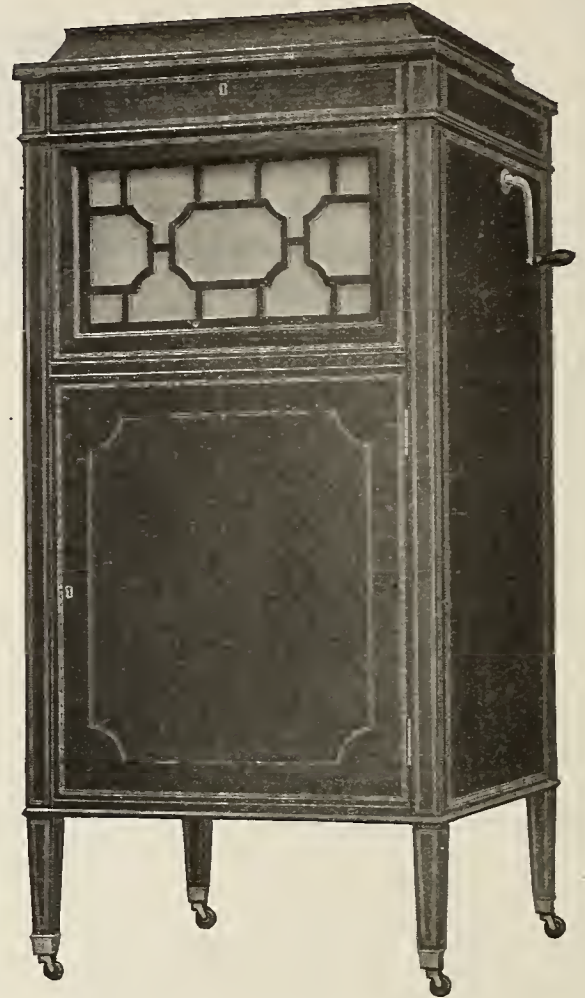

Pathé Phonograph \$225
Other Models \$25 to \$225

SOMETIMES the phonograph procession changes over night.

Not like a Bolshevik policy, but some new impulse is injected into a company's plans.

Right now, any dealer can profitably look into what Pathé has to offer.

PATHÉ FRÈRES PHONOGRAPH CO.

20 Grand Avenue

Brooklyn, N. Y.

No Needles to Change

The Pathé Sapphire Ball takes the place of needles. It need not be changed.

Records Don't Wear Out

We guarantee every Pathé Record to play at least one thousand times with the Pathé Sapphire Ball without impairing the unexcelled beauty of tone.

The Pathé Controla

With the Pathé Controla you can increase or decrease the tonal volume of the Pathé Phonograph at will.

Each Pathé Phonograph

Plays not only Pathé Records, but all other makes of records, and plays them perfectly.



Recording for Pathé,
and most of them
exclusively

Muratore, Muzio, Didur, Thi-
baud, Ganz, Grace Hoffman,
Rimini, Ober, Cavalieri, Bis-
pham, Slezak, Urlus, Weil,
Fitziu, Sammarco, Ruffo, De
Cisneros, Journet, Chenal, Ma-
guenat and others.



The Quality Phonograph

THE retail sale is the
final objective point.

And the ultimate user
of a phonograph is inclined
to buy the machine where
he need not change the
needle.

That's only one Pathé
advantage.

Write—we'll give you
the others.

PATHÉ FRÈRES PHONOGRAPH CO.

20 Grand Avenue

Brooklyn, N. Y.

A \$9000 ADVERTISEMENT SHOWING "VAN VEEN BED-SET" BOOTHS



In a recent issue of the Saturday Evening Post the Columbia Graphophone Co. used a back cover in colors; an advertisement which cost \$9000. In this copy, the above photograph was featured, showing the interior of Hardman, Peck & Co.'s store in Brooklyn, N. Y., where Van Veen booths are installed.

This store with its "Van Veen Bed-Set" installation was selected from thousands of installations as sufficiently attractive to call to the attention of 10,000,000 people. Let us prove how Van Veen Bed Set Booths will increase your record sales and pay for themselves in a short time.

WRITE FOR A COPY OF OUR NEW CATALOG

A. L. VAN VEEN & CO., Marbridge Bldg., 47 West 34th Street, NEW YORK

TALKING MACHINES AND PIANOS

Herbert Simpson, Vice-President of Kohler & Campbell, Inc., Formerly in Talking Machine Industry, Knows Requirements of Dealers—Is Ready to Aid Dealers Who Can Handle Pianos

The results of harmony between the talking machine and piano industries have been force-



Herbert Simpson

fully manifested during the last few years in many instances where piano dealers have found

it profitable to handle talking machines in connection with their piano business. There have been many men who, previously connected with the piano industry, have been very successful in merchandising talking machines.

Believing that a greater harmony between the two industries will promote even greater success to both Kohler & Campbell, Inc., Fiftieth street and Eleventh avenue, New York, one of the largest and most progressive piano manufacturers in the country, have been carefully studying the requirements of the talking machine industry, and have developed a department for meeting the requirements of the retail talking machine trade, so far as pianos are concerned. Their familiarity with the talking machine trade has been greatly augmented by the fact that Herbert Simpson, vice-president of this concern, was at one time assistant advertising manager of the Victor Talking Machine Co. Upon leaving this organization he became advertising manager for Kohler & Campbell, and through his success in the field of merchandising he has gradually worked his way up the ladder to his present capacity. During his affiliation with the talking machine industry, Mr. Simpson made many fast friends, who appreciate his capabilities and who realize that he has a thorough knowledge of the requirements of the talking machine dealer.

The tremendous manufacturing facilities of Kohler & Campbell, Inc., places them in a position not only to give the trade pianos and play-pianos of highest quality, but also an unexcelled service both in deliveries and merchandising aids.

The Jersey City Talking Machine Co., Jersey City, N. J., was incorporated this week with a capitalization of \$10,000.

PRIZES FOR BEST WINDOW DISPLAYS

Emerson Phonograph Co. Make Announcement Regarding Sales-Producing Record Displays

Prizes to the value of \$200 in Emerson records are offered to dealers in a new store and window display contest just inaugurated by the Emerson Phonograph Co. These prizes will be given for the most original and best sales-producing displays in either the interior or in the window of the dealer's store.

The dealers are asked to send photographs of the displays to the offices of the Emerson Phonograph Co. before April 15, and in order to assist the dealers in every possible way the company's advertising department has prepared a special package of hangers, announcements, etc., which the dealer can secure upon request.

It is planned to print the various winning photographs in early issues of the "Emerson Spotlight," the company's house organ. The first prize is \$75 worth of Emerson records, the second prize, \$50 worth; third prize, \$25 worth, and five prizes of \$10 worth of Emerson records each. Only those records that dealers had on hand before March 1 may be used in their displays.

WANT RECORDS IN NAVAL CAMPS

Phonograph records to be sent to the aviation training camps throughout the country are greatly needed, says the aeronautic committee of the Woman's Naval Service, and its members make an earnest appeal to the public to aid in supplying them. Several thousand are required. They may be sent to the Woman's Naval Service, 289 Madison avenue, in care of Mrs. Charles A. Van Rensselaer, chairman of the aeronautic committee.

TWIN CITY DEALERS ENDEAVORING TO MAKE ENDS MEET

Make a Strenuous Effort to Meet Demands Pending Improvement in Transportation and Receipt of New Stocks—Machines Being Brought in by Express—General Trade Very Satisfactory

MINNEAPOLIS and ST. PAUL, MINN.; March 6.—Between the shortage reported by manufacturers and transportation delays the local talking machine trade are much upset owing to their inability to supply their customers with machines as rapidly as they sell them. They are hopeful, however, that with better weather things will mend.

F. M. Hoyt, of the Beckwith-O'Neill Co., showed the writer twenty-six contracts on which he had taken first payments, but has been unable to deliver Victrolas that the contracts called for.

"It cost me \$2,000 extra expense for express charges in February alone," remarked W. L. Sprague, manager for the Columbia Co. in this district. "With improved weather conditions we are hoping for better service, but are somewhat consoled because of a growth of 80 per cent. in the volume of business for February as compared with the same month of 1917, and also because we have become the permanent owners of the \$400 silver trophy which this branch won in three successive months."

"Six carloads of Edison machines, ordered sent by express are being held up somewhere in America," said Laurence H. Lucker, president of the Minnesota Phonograph Co. "Virtually the entire shipment will be transhipped the moment it arrives. Express is slower than slow freight was a short time ago and we are ready to become Bolsheviks or almost anything else if it will help the industrial and railway situation. The carload of records I obtained on my visit to headquarters in January is all gone and not as much is obtainable as we had hoped."

"I just dread it when we run out of a line and must give the factory an order," complained Jay H. Wheeler, who manages the Pathé department for G. Sommers & Co. "It takes from six to eight weeks to get an order through by freight and fully twenty days by express, at greatly additional expense. We hope for a better showing now that the weather has improved."

The only jobber in the Twin Cities who is not complaining is R. L. Kern, manager of the Brunswick-Balke-Collender Co., manufacturers and distributors of the Brunswick phonographs. He has started four travelers through the Northwest and is opening new accounts almost daily. Incidentally, although a recent arrival in the field, he hopes to make some of his veteran competitors move very lively.

Thirty Sonora dealers in this territory, which includes Minnesota, North Dakota, South Dakota and Montana, attended the first annual Northwest Sonora Dealers' convention and banquet at the Hotel Rogers, Minneapolis, last month, as guests of the Minneapolis Drug Company, Sonora distributors. Sewell D. Andrews did the honors as representative of the house and made the dealers acquainted with the Sonora officials. Those attending the convention and banquet were George E. Brightson, president of the company; Frank J. Coupe, general sales manager; Superintendent Fahr, of the Saginaw factory; Fred E. Yahr, of the Yahr & Lange Drug Co., Milwaukee, and Walter J. Hamlin, of C. J. Van Houten Zoon Co., Chicago. Sonora distributors also attended the convention and made themselves generally amiable to the dealers. The latter returned to homes enthusiastic Sonora boosters.

The Minnesota Phonograph Co. announces a gross increase of 25 per cent in the volume of the Edison sales in the Northwest for the year 1917 as compared with 1916. It may be said that the company officials are contented with the showing and hope that they will be able to repeat.

Miss Salome Batton is to change her name via the marriage route this week, but will not retire from business at once, as she had expected. The lady selected to become her suc-

cessor as manager of the Victrola department of the Cable Piano Co.'s St. Paul branch was taken seriously ill just before the time for her departure and Miss Batton consented to remain until a successor was obtained.

Thirty-five salesmen are talking Pathé machines throughout the Northwest for G. Som-

mers & Co. Thirty are general salesmen and also talk other articles, but four give their entire time to Pathé products. The growth of the business has quite exceeded expectations, according to Manager Wheeler. The latter will leave soon for the East to order stock for the coming season.

F. M. Hoyt, with the Beckwith-O'Neill Co., returned last week from an Eastern tour, during which he visited Victrola jobbers in Chicago, Buffalo and New York and also the Victor headquarters in Camden.

FINDS CANNED PROPAGANDA

Chicago Official Discovers Praise of Kaiser on Phonograph Record

A dispatch from Chicago says that United States District Attorney Clyne is investigating what he believes to be active pro-German propaganda conducted through phonograph records.

The text of one of the German language records seized by Federal officials, which was given

out yesterday without comment by the district attorney, lauded the Kaiser and war lords of Germany. The record in question, according to the district attorney, was made for the Mozart Lodge of New York.

Joseph Fische, of 1442 Third Avenue, president of the Mozart Lodge, New York, when seen said that while the lodge had purchased such records a long time before the war, the practice had been discontinued as soon as the United States entered the world conflict.

BUY LIBERTY BONDS and THRIFT STAMPS

And then make your patriotism complete by stocking and pushing

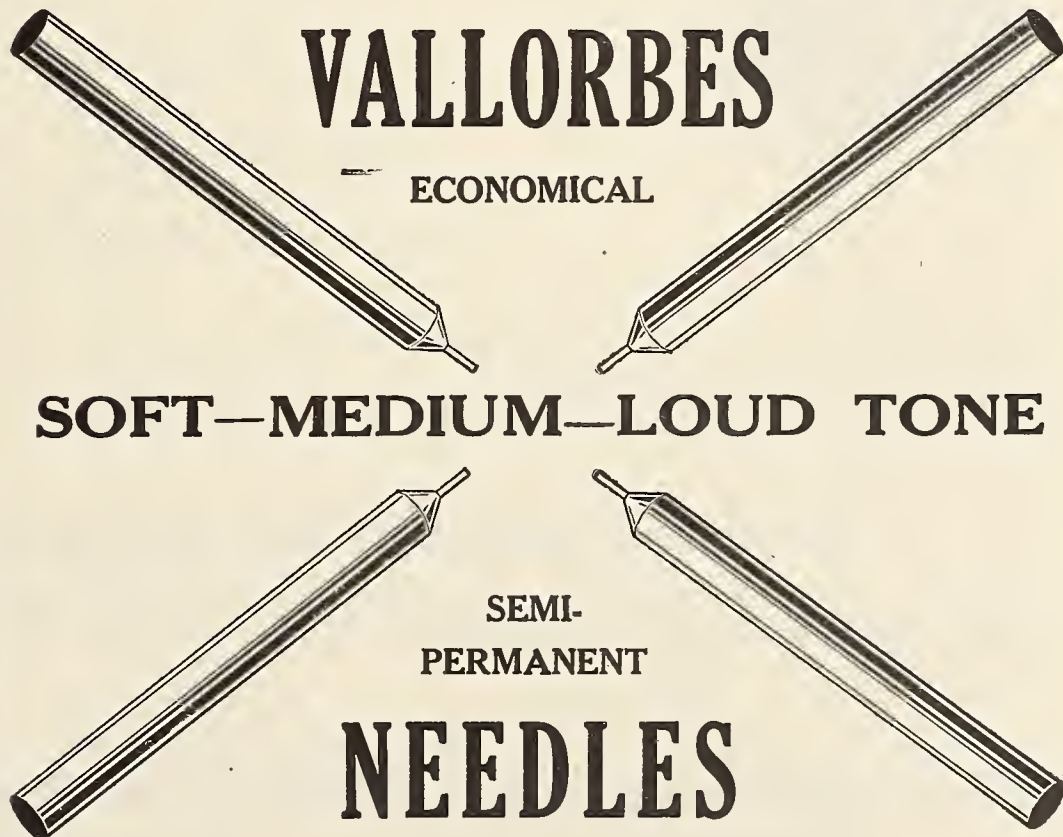

For their use conserves steel for Uncle Sam, democracy and civilization, and they are a real convenience and spell the beginning of the end of the old style steel needle.

SEND 30c. IN STAMPS FOR THREE SAMPLE PACKAGES (ONE SOFT, ONE MEDIUM, ONE LOUD), DEALERS' DISCOUNTS, ETC.

Originators and Largest Manufacturers of Diamond Points



Sapphire Ball Jewels Loud and Half-tone

LANCASTER, PA., U. S. A.

These 4 Beautiful Models Make The Elmbrola Easy To Sell



Model A Elmbrola

There's an Elmbrola Model for everyone—a low priced machine, a reasonably low priced machine, a medium priced machine, and a very fine machine at a price way below what you would expect to pay for it. This is what makes the Elmbrola so easy for dealers to sell—but there are still more exceptional selling features to the Elmbrola.



Model B Elmbrola

Handsomely Finished In Beautiful Woods

There's a distinctive, high class appearance to every Elmbrola. The appearance is so out of the ordinary and the finish is so beautiful that your customers are surprised when you tell them the remarkably low price. You feel proud to display these wonderful Elmbrolas, because your customers are bound to be pleased.

Sweet And Clear In Tone

Sit down for a minute and listen to the Elmbrola play. Its clear, sweet tone is so delightful that you want to hear it play for hours. Never before have you heard a tone that surpasses the tone of the Elmbrola. Thousands of people say that nothing can equal it, but judge the machine for yourself.



"Sounds Clear — Made Sound"

The dealers who are selling the Elmbrola are making big profits because the machine is right and the price is right. You should be handling the Elmbrola right NOW, and you certainly will handle it if you get our special low dealer prices.

Wonderful Improved Tone Regulator

This big feature enables you to get all the delicate shades of tone so necessary in the perfect reproduction of sound. You can play loud or soft as you wish by simply turning the button.



Model C Elmbrola

We Guarantee Prompt Deliveries

When you handle the Elmbrola, your orders will be shipped to you promptly the same day we receive them. There's no waiting—no delay. Our factory turns out the machines as fast as you can sell them.

This Is Your Opportunity To Cash In

Now is the time to sell the Elmbrola. Get our special proposition to dealers and see what big profits you can make. We have a Sales Plan for you that is a winner. Write us at once for full particulars—there's no obligation whatsoever.



Model D Elmbrola

Write for our proposition to dealers NOW

ELMBROLA TALKING MACHINE CO.

Dept. A

ST. PAUL, MINN.

SAN FRANCISCO BUYERS MEETING DEALERS HALF WAY

Show Willingness to Accept Available Styles of Machines or to Place Orders for Future Delivery
—More Commodious Quarters for Columbia Co.—General Trade News of Interest

SAN FRANCISCO, CAL., March 4.—The talking machine dealers are well satisfied with their February business. While there has been a shortage in some makes and styles the dealers say that their customers are accepting the situation good naturedly, and either ordering the machine they want, to be delivered when it arrives or accepting a substitute that is nearest to the machine desired. During the past ten days of the month several cars of machines, some of them shipped almost sixty days ago, arrived, and the dealers feel that the worst of the shortage is now over. Of course, in those factories where sufficient help cannot be obtained the shortage will continue. That is the manufacturers' problem and one that must be solved by each manufacturer for himself. The demand is here and the people have the money. Now, if the manufacturing end can be solved and the transportation end improved 1918 will prove a banner year in San Francisco. From the viewpoint of the local merchant the number of traveling salesmen who have been sent into this territory during the past month is an indication that the manufacturer is not worrying to any great extent over his output, and San Francisco rejoices accordingly.

Receives Records by Express

George T. Hively, manager of the talking machine department of the Eastern Outfitting Co., says that he has kept up his stock of records during the period of the worst freight congestion by having them sent by express. These additions to the heavy stock he had on hand have prevented him from feeling any serious shortage. Mr. Hively says that he placed heavy orders for future shipments nearly a year ago, and he does not anticipate any shortage during the present year.

Lease New Columbia Quarters

The Columbia Graphophone Co. has taken a lease on more commodious quarters in the Halliday Building at 130 Sutter street. The company will move by the first of April to its new quarters, where nearly twice as much space will be available as was provided in the old location. The Halliday Building is a new structure erected by the regents of the University of California, and is locally known as the "Daylight" building. The entire front is of glass and excellent light is provided everywhere without recourse to electricity. The first floor of the building is occupied by a clothing house and a large office furniture store. The Columbia Co.

will occupy the portion of the second floor over the clothier. The location is more desirable than the old one and the additional space makes the move one for congratulation.

Victor Business Exceptional

The California Phonograph Co. reports that its business for February was exceptional. The company does not complain of a shortage of machines or records except of Victors. As it was only recently that the company took over the Victor agency, with the purchase of the talking machine business of Kohler & Chase, this shortage is easily explained.

Andrew G. McCarthy's Views

Andrew G. McCarthy, of the talking machine department of Sherman, Clay & Co., says that there is plenty of demand for talking machines, but comparatively few are arriving. He has placed enormous orders for Victors at the factory, but as his company are jobbing the Victor as well as selling it at retail in their several stores the business of the Victor on the Coast passes through their hands. With such a demand he finds it impossible to keep everyone well supplied.

Humphrey Making a Fine Record

Edward Humphrey, who was recently put in charge of the talking machine department of Byron Mauzy, is making a splendid record in his department. Chas. Mauzy, the general manager of the company, says that his department is far ahead of the previous year despite the fact that a real shortage of Victor records and Victor higher-priced machines exists in the store. Mr. Humphrey has had his department redecorated and fitted up for the greater convenience of his customers, and the results are showing themselves in the record of the sales.

Kohler & Chase Sell Stock in Oakland

Kohler & Chase have sold their Oakland stock of talking machines to the John Breuner Co., a furniture dealer of that city, and they have now retired definitely from the talking machine business in both cities. By this purchase the furniture company acquires the agencies of both the Victor and Columbia machines.

Salesman Badly Injured

F. A. Smith, of the Brunswick-Balke Phonograph, says that his business for February was very satisfactory. He has just received information that James F. Mahoney, salesman for the company, met with a painful accident at Fresno on February 27, which may incapacitate

him for some time. According to the information in Mr. Smith's hands Mahoney slipped while boarding a train at Fresno and either sprained or broke his ankle. An X-ray will be necessary to ascertain the extent of the injury.

Noted Artists Coming

The announcement that McCormack and Gallucurci will sing in this city at early dates has already stimulated the demand for Victor record of their voices. It is expected that the sale will increase still more and continue for some time after their appearance.

Dealers to Hold Dance

The talking machine dealers of San Francisco are making ready for their second annual dance to be given at St. Francis Hotel on April 2. William Morton, of Sherman, Clay & Co., will have charge of the dance as chairman of the committee appointed for the purpose.

Some Trade Brieflets

F. B. Travers, of the Sonora Phonograph Co., has just returned from a trip through the southern part of the State. While there he covered the territory in company with E. M. Bonnell, the company's regular representative.

E. N. Clintsman, one time manager of the wholesale talking machine department of Kohler & Chase, and at another time in the general talking machine business in the Northwest, has recently been appointed deputy assessor of Alameda.

Charles S. Ruggles, who has charge of the wholesale Victor sales for Sherman, Clay & Co. at Los Angeles, has returned from a trip East, where he visited with his son, Wesley, who recently finished his military course and is leaving for France.

The San Diego branch of the Wiley B. Allen Co. has greatly enlarged the floor space of the talking machine department.

G. E. Morton, recently with the Columbia Graphophone Co. in New York, has been appointed manager of the talking machine department of the Emporium.

Serious Question of Labor

A. G. McCarthy, of Sherman, Clay & Co., says that one of the difficult problems which the dealers in talking machines have to solve is the question of labor. The number of young men wishing to go into the business in the past has always been ample. Now, however, so many have gone into the service of Uncle Sam that the dealers have been taking on younger boys. The call of the shipyards with pay of \$5 or \$6 a day is now depleting this supply and many are having recourse to girls. Girls with any experience are now scarce, and many dealers are really short-handed because they do not feel that they can take the time to train green girls.

On Selling Records



There are many excellent ideas the Victor Dealer can use to stimulate the sale of slow moving stocks. Some of these ideas have already been put into practice, others have not yet been discovered. We urge Victor dealers to encourage their salesmen in originating new plans for selling records, and along the same line our travelling representatives will be glad to offer several good suggestions.

ECLIPSE MUSICAL COMPANY
CLEVELAND OHIO

DROOP'S EDUCATIONAL PUBLICITY

E. H. Droop's Campaign to Inculcate a Better Appreciation of High-Class Music Excites Commendation—Helps Industry as a Whole

WASHINGTON, D. C., March 8.—E. F. Droop & Sons Co., Victor wholesalers and dealers, have been carrying on an original and most effective advertising campaign in the local newspapers in the interests of high-class Victor records. The advertisements are in the form of articles credited to E. H. Droop, head of the company, and give Victrola owners some new angles from which to regard their record libraries. In one of the articles, for instance, Mr. Droop says:

In our previous article we dwelt on the lack of knowledge possessed by the average Victrola user of the higher and better forms of music known as "classic" or "semi-classic" compositions.

It is not surprising that this condition should exist, and it must be said in justice to the great masses of our people that it is of comparatively recent date that they have had made available to them a medium through which every form of music could be brought right into the home—the Victrola—and then quite naturally they took up with the more catchy and trivial things in music, because these amused and entertained them; little thought has been given to the more serious forms of music—which are not only far more beautiful and lasting than the catch-penny airs that are whistled to-day and forgotten tomorrow—but they have an educational value which proves a great help as progress is made in the study and understanding of music.

Again we make the statement that if we can interest you to listen attentively for a little while to a few good selections chosen from the lighter classics—explaining what the composer had in mind when he wrote his tone picture, and helping you to clearly understand its rhythm and "phraseology," as it were—you will, if you persist in hearing similar selections, rapidly grow into appreciation of the masterpieces with which the great minds in music have endowed the world, and a realm of melody will be opened which you will never cease exploring—

Music is a vital force and from the cradle to the grave plays an important part in our lives; it entertains, refines, educates, soothes, comforts, and inspires, and now that the Victrola records have made it available, the best music by the best artists and musical organizations of the world should find a place in every heart and home.

We are at your service to help in building up a library of choice records of which you will not tire and which will always reflect credit upon the owner's taste.

Whether you want to buy or not—our Victrola booths are at your disposal and we invite you to call and try out the suggestion we have made. Suppose you hear some or all of the latest records.

It may be said that the articles have been effective in bringing about increased sales of the higher class Victor records, and it is planned to continue the series of talks for some time to come.

No matter how perfect a locomotive may be, it takes steam to drive it. No matter how clever a man may be, he will get nowhere without hustle.

FAULTLESS PIVOT BEARING CASTERS

Casters that roll easily across the floor—and smoothly. No chatter—no unsteadiness.

Simple construction—no complicated parts to get out of order, nothing to retard easy movement. Strong—plenty of metal in required places to resist strains.

Silent—neat appearing—a real necessity to YOUR talking machine, these FAULTLESS CASTERS.

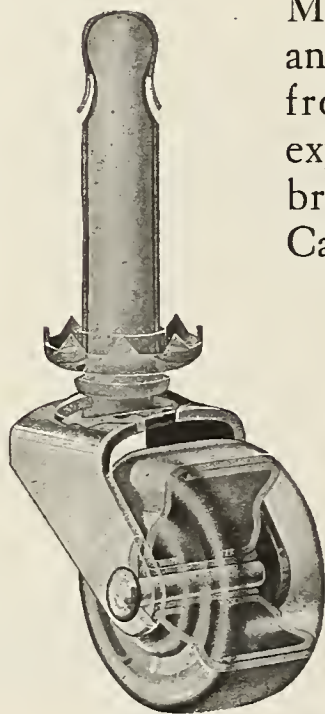

Full Size—C-65

Made with leather, fibre, felt, steel and lignum-vitae wheels. A word from you puts all our caster experience at your service and brings you a copy of Faultless Catalog "G."

**FAULTLESS
CASTER COMPANY**
EVANSVILLE, INDIANA

“Move the FAULTLESS Way”

GIVES TALKER TO JAPANESE SCHOOL

PORTLAND, ORE., March 5.—Away off in far-away Japan will be felt the generosity of a music dealer of Portland, Ore., Harold S. Gilbert, of the Harold S. Gilbert Piano Co., who has presented a Columbia graphophone to the Doshisha Girls' School of Kyoto, Japan. Mr. and Mrs. Gilbert have had as their guest Miss Denton, a missionary from the school at Kyoto,

which is a school supported by the Congregational Church. The interest which Mr. and Mrs. Gilbert felt in the school after hearing Miss Denton's description of conditions resulted in the handsome gift.

SECURES ORDERS FOR VEECO MOTOR

H. A. Robbins Has Most Successful Trip in the Interests of His Product

One of the recent visitors to New York was H. A. Robbins, treasurer of the Veeco Co., Boston, Mass., manufacturers of the Veeco electric motor for talking machines. Mr. Robbins had just completed a tour of the West, spending some time in Chicago, and succeeded in securing orders from a goodly number of representative manufacturers. He also garnered a substantial bundle of orders in New York before leaving for his Boston headquarters. Mr. Robbins had with him the new model Veeco motor, which embodies many improvements over the older models.

Lufranc Quality



THE
SAFEST
ENVELOPES MADE

RECORD DELIVERY ENVELOPES

START THE NEW YEAR
WITH A GOOD SUPPLY
by Placing Your Order Now

Samples and Prices Furnished Cheerfully

Write Today Get the Best Always

LEWIS C. FRANK

654 Book Building

DETROIT, MICH.

T.M.W.1217

Are you reaching the kiddies with Thornton Burgess' stories for children, told in the author's own voice for Columbia records exclusively? "Peter Rabbit Plays a Joke" and "Little Joe Otter's Slippery Slide" are the latest. Parents enjoy them just as much as the little folks.

Columbia Graphophone Co.
Woolworth Building, New York



IMPROVED TRANSPORTATION HELPS CINCINNATI TRADE

Although Conditions Are Far From Normal Retailers Can Get a Fair Amount of Stock—Automobile Deliveries Are Popular—Demand for Both Machines and Records Very Strong

CINCINNATI, O., March 8.—An opening of the lanes of transportation in and out of Cincinnati, which took place to a fair degree towards the close of February, put pep into the trade and exhilarated the retail situation. While certain of the lines are still in the embargo class, enough territory is open to enable the talking machine merchants to do some shipping.

So crying is the need of Edison machines around Bellefontaine, O., over 100 miles from Cincinnati, that J. C. Smucker, of Smucker Bros., representatives of the Phonograph Co., this city, travelled with a truck to the Queen City Friday to secure what goods he could get. It was Smucker's idea, and he benefited. Two weeks ago Manager Peterson's house secured goods from New York City which had been in transit since early in November. E. J. Stevens, Middletown, likewise came to the city in a machine during the past week and secured Edison goods.

Carload shipments are coming through to the Columbia house. It has been doing some shipping by express, and the breakage out of Cincinnati has been so great in recent months that R. L. French, traffic manager, came here last week from the Bridgeport, Conn., factory to get a line on the situation. F. F. Dawson, who took charge of the Cincinnati branch in December, expects to remain here several more months. He reports having an increase of almost 100 per cent last month over February of a year ago. J. L. Dubriel, of the general sales department, arrived in the city Saturday to temporarily fill the position of assistant manager. G. W. Hopkins, general sales manager, passed through earlier in the week, en route to St. Louis. Another of Mr. Dawson's visitors was W. C. Fuhri, of the Chicago branch, en route home from a Florida vacation.

C. W. Neumeister, local representative of the Heineman Phonograph Supply Co., is spending the week in New York City, attending a convention of the outside agents. Just before leaving he reported quite a boom in business in his territory.

A. J. Swing, of the Crystola Co., is in the East on several important matters in connection with the local factory.

J. M. Dolby, manager of the Dictating Machine Co., left to-day for Nashville, where he will open a branch office for the Ediphone.

Mr. Byars, Vocalion manager of the local Aeolian store, reports a very gratifying volume of Vocalion business for the month of February, just closed. He reports that a number of the new period designs have been received, and several were sold in the last few weeks. One of the largest and most elegant of these models is being shipped to one of Louisville's most prominent citizens. It is the Hepplewhite design, with the hand-painted front and inlaid front and top. This instrument is going into

one of the elegant new homes in Louisville, and will unquestionably create considerable interest in that locality among the members of Louisville's elite society.

Mr. Byars has just organized a new sales force, and now has four new recruits in his selling department in training. These men are all very promising, and from every indication the Vocalion forces are going to keep up a red-hot campaign this spring and summer in spite of the war and other handicaps. This is the spirit that spells success.

Wm. J. O'Neil, formerly on the Vocalion sales staff, is now in the Quartermaster's department of the U. S. Army, stationed at Camp Meigs, Washington, D. C. Robert Casey, for two years connected with the Vocalion sales staff, is now taking orders for Buick automobiles with the Leyman-Buick Co. of this city.

"The tremendous demand for Victrolas and records," said Manager Rudolph Dietrich, of the talking machine department of the Rudolph Wurlitzer Co., "continues without any diminution, and the demand, in fact, has been greatly strengthened by the shortage existing during the past sixty days. Better conditions, however, are in sight, as the transportation companies will undoubtedly recover to very great extent and this will bring a corresponding increase

in delivery as well as less delay in shipments.

"Inasmuch as during the past year it has been a question of supply rather than demand, we can only hope for the future and trust that the factory output will in a measure take care of the requirements of the dealers.

"We find that the demand for the March records was exceptionally heavy and, as this list is a very good one, the demand will undoubtedly be lasting. The appearance of Jascha Heifetz in Cincinnati caused a tremendous demand for records of this order. His appearance here about the time the records were released was a very happy coincidence and the demand was undoubtedly taken advantage of to its fullest extent by all of the local dealers."

NEW CONCERN IN TROY, O.

The Mirrophone Co., Troy, O., has been incorporated with capital stock of \$10,000 by George M. Jackson and others, and it is stated that the company has been formed to take over the output of the Lorimer-Hicks Co., manufacturers of the Lorophone, which company is at present in the hands of a receiver.

BUILD ON ROCK OF SOUND VALUES

Thy business is not built upon the sands of speech, be it ever so well spoken; it is built upon the rock of sound values. If ye have not sought and found that foundation, seek it for the good of thy house.

The NEW VEECO

THE ELECTRIC MOTOR WITHOUT A FAULT

The improved Veeco Electric Motor for Talking Machines represents the last word in scientific development with special regard for the purpose for which it is intended.

Runs on either A. C. or D. C., 100-125 volts without adjustment. Can be supplied to run on any voltage from 6 to 250.

Supplied mounted on 12" or 12½" square mahogany boards, all ready to install.

SEND FOR A SAMPLE AT ONCE

Then, after testing it thoroughly, place orders at once to insure delivery.

THE VEECO motor and the VITRALOID turntable make a complete motor unit for high-class machines.

THE VEECO COMPANY

248 BOYLSTON STREET

BOSTON, MASS.

The Original Producers of a Complete Electric Drive for Talking Machine Manufacturers' Use

A Mighty Strong Argument

*FOR THE DEALER TO PUT
BEFORE HIS CUSTOMERS*

The **B & H** FIBRE NEEDLE and
Needle REPOINTER

is a combination hard to beat—

*The one Saves the Record and the
other Saves the Needle*

The two together Save you Money

B & H FIBRE MANUFACTURING CO.

33-35 W. Kinzie Street, Chicago, Ill.

PROTECTION OF TRADE NAME

Recent Decision in Favor of the Aeolian Co. of General Trade Interest

The Aeolian Co., New York, was successful recently in a trade-mark case which should prove interesting to the talking machine industry as indicative of the value of trade names. This decision in the Aeolian Co.'s favor was handed down by the Circuit Court of Appeals, from whose decisions there is possible no further appeal.

Some time ago a talking machine company made application for the registration of the trade-mark "Orchestrola" for a talking machine. The Aeolian Co. filed a claim in opposition to the granting of this trade-mark in behalf of its well-known instrument the "Orchestrelle," an automatic pipe organ which has been on the market for many years.

After the case had passed through the usual trade-mark channels it reached the highest court in the land, which handed down an opinion denying the talking machine company the right to use the name "Orchestrola." This decision is clear and concise, one section, which gives the most important factor influencing the opinion, reading as follows:

"Assume that a person who had a good opinion derived from use or otherwise of an automatically-operated organ produced by the Aeolian Co. and marked 'Orchestrelle' desired to purchase a phonograph (the Aeolian Co., as we have seen, now produces phonographs), and is shown one marked 'Orchestrola,' would he not be likely to think it was produced by the same company as produced the organ and buy it on that account?"

"Perhaps if the two instruments were placed side by side, one marked 'Orchestrelle' and the other 'Orchestrola,' he would be able to detect the difference between the marks; but where

they were not so placed, and he was compelled to rely upon his memory only, unless he possessed one remarkably accurate in its impressions—the law considers the ordinary, not the extraordinary in cases like this—we believe he would not distinguish the one from the other. To be sure, they have points of difference, but the points of resemblance dominate and give character to the terms.

"We entirely agree with the Assistant Commissioner that the two words are 'confusingly similar' and would be likely to mislead not only as to the goods themselves but also as to their source of manufacture, and hence his decision is affirmed."

DEBUT OF "EMERSON SPOTLIGHT"

The first issue of the "Emerson Spotlight," the new house-organ published by the Emerson Phonograph Co. for benefit of Emerson record dealers, made its appearance a fortnight since, and has already won the enthusiastic approval of the Emerson selling organization and Emerson representatives throughout the country. It is planned to publish this house-organ monthly, and there is good reason to believe that it will be a pronounced success.

The first issue contains a number of practical suggestions to Emerson dealers how to boost Emerson record sales; these suggestions appearing under the headings "Phone Customers," "Attractive Packages," "Special Bulletins," "Newspapers Free," "Dance Programs," etc. There are some timely hints as to ad. helps, and the dealers are acquainted with the likenesses of some of the most popular artists in the Emerson record library.

When Service and Quality keep house together, Satisfaction hangs up its hat for a long stay.

THE "TALKER" AT THE FRONT

Uncle Sam's Forces Rapidly Learning French Through the Talking Machine

The talking machine as an educator is proving quite a favorite with Uncle Sam's forces who are now in France "doing their bit" to make the world safe for democracy. As a means of learning the French language they find the talking machine invaluable. In a recent letter from the front we read:

"The American soldiers attend a class in French every day at the Y. M. C. A. or at the Soldiers' and Sailors' Home, where an American volunteer or French professor gives lessons. The boys know a few set phrases when they land, but they are adding to their vocabulary all the while. Professors are rather scarce at the camps, but lessons are given by the talking machine. The Americans have found that a deep knowledge of French is not necessary for the short time they are here, in Paris, and especially so since they trade only in shops where at least one of the clerks speaks enough English to carry through a deal. Some of the college fellows have carried on their reputation of slang making, and they have invented funny phrases both in English and French.

"The Americans like the talking machine method. Its voice may be metallic and the tone monotonous, but the machine is a patient teacher and the pupils make it go over the words till they are satisfied. It is effective for pronunciation, for it does not vary, and the constant call on it for phrases does not wear on its voice. No living teacher could be put through such stunts.

To make this year one of the best you've ever had in "making good"—is a good resolution to make!

IT HOUSES A SMALL VICTROLA

The Lundstrom "Converto" Cabinet converts the small "Victrola" into a handsome cabinet type, completely enclosing the machine. It takes the place of a stand and

provides a dust-proof record rack for 60 records. It revives interest in records. It helps you meet low-price competition in cabinet machines and gives you a *good profit*. It costs the customer no more than a good stand! It has proven very successful for many of the country's leading Victor dealers.



Talking Machine Cabinet

Prices and Particulars on Request

The C. J. Lundstrom Mfg. Co.
LITTLE FALLS, N. Y.

Branch Offices: Flatiron Bldg.

New York City



Setting Victrola into Cabinet



Sound Doors Open for Playing



Completely Closed

DETROIT TRADE BUOYANT REGARDING GENERAL OUTLOOK

Removal of Restrictions Helps Business Expansion—A. A. Grinnell's Interesting Views—Burton Collver With Cheney Co.—Pathé Jobbers Pleased with Outlook—Some Noted Visitors

DETROIT, MICH., March 9.—The worst is over so far as adverse conditions are concerned in the talking machine business in Detroit. We do not mean by this that business has been dull, but simply that certain conditions have prevented sales being much greater. During the months of January and February dealers were up against the crisis in the coal situation—the extreme cold weather, freight congestion, and the after-effects of December holidays. On top of this came the restrictions on business hours and workless Mondays. Now, however, all this is over—there are no restrictions on business hours, the crisis in the coal situation is passed, and freight shipments are improving. It's a positive fact that of all the lines of business investigated recently by The Talking Machine World correspondent, except those devoted to war orders, the retail talking machine business is the very best.

A distinguished visitor was in Detroit the last day in February—being none other than H. C. Brown (and wife), of the Victor Talking Machine Co., of Camden, N. J. The visit of Mr. Brown was a combination of business and pleasure. He spent a few minutes with A. A. Grinnell and C. H. Grinnell, of Grinnell Bros., who are Victor jobbers, and E. P. Andrew, general manager of the J. L. Hudson music store. A part of his time was spent with Mrs. Brown in motoring about the city.

At 247 East Jefferson avenue, Detroit, is the wholesale branch of the Brunswick-Balke Co., State jobbers for the Brunswick phonograph. F. S. Kratzet is in full charge. While the company handles the full line of Brunswick products, the window is invariably given over to the display of Brunswick phonographs, the displays being changed very frequently so as to show off the different models. In Detroit the principal Brunswick dealer is Wallace Brown, 33 East Grand River avenue,

who has a national reputation for hustling. But Mr. Kratzet has other live dealers throughout the state, and is gradually developing good accounts in every town of 10,000 population or over. A large stock is always carried at the Detroit branch, so that dealers can always feel assured that their orders will be filled promptly.

C. H. Grinnell, manager of Grinnell Bros., wholesale Victrola department, was in Cleveland the last of February to address the Northern Ohio Talking Machine Dealers at their first annual convention. The address was devoted to the accomplishments of the Detroit talking machine dealers' association during its two years' existence.

A. A. Grinnell, treasurer of Grinnell Bros. and who devotes a great deal of his time to looking after the talking machine department, says that "1918 looks mighty good." Mr. Grinnell feels that it may be a while before the business is booming, still he feels that 1918 will be one of the best years the industry has ever seen. He continues that it is not a question of seeking orders but that his company could more than double the business now on its books if it could only get the merchandise. "Collections are very good," he said. "Our stock is large, although not quite as large as we would like to see it."

Ed Andrew, manager of the talking machine department of the J. L. Hudson store, spent the last week in February in Cleveland and Philadelphia. He plans to visit quite a number of other cities during March just to get a line on local conditions in various sections and to see where there is room for improvement at the Hudson store. "It is a paying proposition to the manager and to the department to get out occasionally and go to some other city and see what the dealers there are doing," he said. Mr. Andrew, by the way, has been elected sec-

retary of the Detroit Music Trades Association. That dealers believe that this is no time to be pessimistic is proven by the increasing amount of talking machine advertising in the daily newspapers. There is hardly a live dealer—yes, we don't know of a single one—that is not using space either in the dailies, the street cars, billboards or theatre programs. And the space per dealer is larger than it has ever been at this season of the year. The new concerns that have entered the retail field are also going after business by advertising so that the talking machine is brought forcibly to the attention of the public, no matter where the people look.

Burton Collver, one of the leading salesmen with the player-piano department of Grinnell Bros., resigned sometime ago to become sales manager of the Cheney Talking Machine Co., of Chicago. He has given up his residence in Detroit to be near the home office. He spent the month of February in Grand Rapids and Detroit attending furniture expositions and conferences.

The Detroit Talking Machine Dealers are perfecting plans for the coming recital which is scheduled for sometime in April or after Easter. We previously reported that the proceeds of the recital will be turned over to some patriotic fund. President Sam Lind is working hard to offer a program that will draw crowded houses.

Williams, Davis, Brooks & Hinchman Sons, wholesale jobbers in Michigan for Pathé, report very good business, larger stocks than ever and more orders than ever before. "Yes, business is coming along just splendidly," said Mr. Chamberlain, in charge of the sales of this department. "Our business the first two months under the adverse conditions has been far beyond what we had expected and we have every reason to feel that 1918 is going to be a good year, with business improving each month." The miniature Pathé store in the company's building is attracting unusual attention and it is proving of great help to dealers who are taking on the line. It shows them just how a modern, up-to-date shop should be laid out.

Max Strasburg, of the Strasburg Shops, judging from letters received, is having a very enjoyable time in the South playing golf at every opportunity. He expects to return to Detroit the last of March.

A. F. Noble Piano Co., Woodward avenue near Warren, is now retailing the Cheney talking machine.

Keenan & Jahn, who are retailing the Aeolian-Vocalion, are going after business harder than ever—even exceeding their efforts at Christmas time. Sales have been growing in numbers, and the new records that are coming in are proving very popular. John DeAngeli is in charge of this department.

Wallace Brown, Brunswick dealer, says this is no time to sit back and wait for business, but this is the time when the dealer must awaken interest in the talking machine business by judicious advertising, publicity and salesmanship. He is giving his attention to all three phases of business and is getting results.

The Edison Shop celebrated Thomas A. Edison's birthday in February by special recitals, special vocalists and giving away gratis a book containing the biography of Mr. Edison. The year 1918 is going to be a big one for the Edison Shop, judging from sales the first two months and the number of prospects now in view. The same statement can apply to the Phonograph Co., of Detroit, state jobbers for the Edison. Both firms are managed by R. B. Alling.

The number of international artists from a musical standpoint who have been in Detroit for recitals the past sixty days has proven a splendid stimulant to the record business. In fact, there is no better stimulant to the sale of records than the noted artists who come for recitals. Before and after their coming record sales are big.

The Majorana Graphophone Co., Louisville, Ky., has been incorporated with capital stock of \$50,000 to engage in the manufacture and merchandising of talking machines. The incorporators are G. B. Shumate, Peppino Majorana and S. M. Raffo.

KOCH-O-PHONE

\$18.00

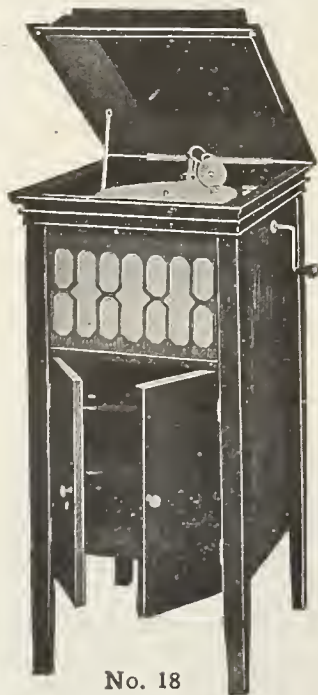

No. 18

The KOCH-O-PHONE is the FORD of the Phonograph world. There is no charge for the name or expensive advertising added to the cost. Most people would rather pay \$36 (resale price) than \$75 for the same amount of pleasure. Plays all makes of disc records. No disconnecting needed in exchanging from one make of record to another. Simply turn the sound box and change needle to suit make of record. This machine for tonal quality and volume is not excelled by any \$75 machine on the market.

No. 18—Height 40 in., width 18 in., depth 18 in.; double spring worm driven motor; 12 in. turntable, all metal trimmings are nickel plated; made in mahogany finish. Weight about 100 lbs.....\$18.00

Cabinet alone, complete with needle cups . \$10.00

Tone Arms and Sound Boxes

(Genuine Mica)

Our new universal tone arm and sound box, No. 3, has proven a big success. Has all the desired requisites in the way of producing a clear, rich and musical tone.

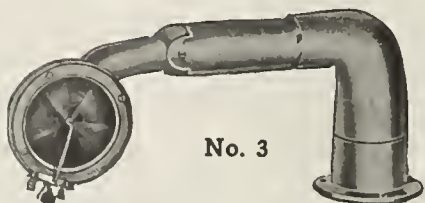

No. 3

Price\$1.50

In Lots of One Thousand



No. 2

Real Mica, \$1.00

in 100 Lots

Imitation Mica, 85c

ANDS KOCH, Manufacturer

296 Broadway

NEW YORK

BRUNSWICK OUTFIT FOR HOSPITAL

"Red Cross" Brunswick Machine and 400 Records Donated to Lilly Base Hospital in France by Brunswick Shop and the Public

INDIANAPOLIS, IND., March 5.—The base hospital unit in France equipped by the Eli Lilly Chemical Co., of Indianapolis, and known locally as



Brunswick for Lilly Base Hospital, France the Lilly Base Hospital, will soon be enjoying a "Red Cross" Brunswick machine with about 400 records.

George Standke, manager of the Brunswick Shop, decided the Indiana men and women who have patriotically donated their services to the Government by joining the hospital unit company, were deserving of anything that could be done for them. The owners of the shop heartily endorsed Mr. Standke's idea of sending the unit a "Red Cross" machine. The 400 records representing all kinds and makes were donations from Indianapolis people who saw the machine in the window of the Brunswick Shop.

The machine is ready for shipment and will soon be cheering the Indianaians who are toiling behind the battle lines of France.

CLOSE IMPORTANT CONTRACTS

Southwestern Distributor of Delpheon Phonograph Tells of Company's Progress—M. C. Collier Joins Traveling Sales Staff

DALLAS, TEX., March 5.—Walter Verhalen, of this city, Southwestern distributor for the Delpheon phonograph, has announced the appointment of H. C. Collier as a member of his traveling sales staff. Mr. Collier is visiting the dealers in this territory, and has already closed a number of important contracts, among which are the Durham Dry Goods Co. at Waxahachie, and Ray Royell, of Waco.

Mr. Collier has had an extensive experience in the musical business for the past twenty-five years, having been State agent and wholesale representative of one of the largest piano companies in the country. He has also had several years' experience selling phonographs at wholesale and expressed himself recently as most enthusiastic regarding the musical qualities of the Delpheon phonograph, which he states is certain to meet with success throughout this territory and in all parts of the country as well.

A DEFINITION OF ECONOMY

A good definition of economy is that it is good management. Economy carries with it the idea of saving, of careful spending, but talking machine men should bear in mind that it does not mean niggardliness. It relates as much to what you get as to what you spend. In advertising it is possible to spend a million dollars as economically as it is to spend ten dollars. Many times the expenditure of a small sum will prove to be more extravagant than the expenditure of a much larger sum, since the larger sum may bring better proportionate results than the smaller.

NINETY-TWO VICTROLAS IN ONE CAMP

Rhodes-Mahoney Furniture Co., Chattanooga, Does Nearly \$8,500 Worth of Machine and Record Business at Camp Near That City

CHATTANOOGA, TENN., March 4.—The important position held by the talking machine as a means of entertainment at the various military encampments is strongly emphasized in the record just hung up by the Rhodes-Mahoney Furniture Co., this city. Through the efforts of H. G. Ray, manager of the Victrola department of the company, there were sold to various individuals and organizations at the army camp here ninety-two Victrolas valued in all at \$5,448.65, together with over \$3,000 worth of records. The machines were bought in some cases by officers, and in other cases by company units, and Victrolas IX, X, XI and 14, were surprisingly frequent in the list. The figures, as offered, were compiled up to and including February 26, and several outfits sold since that time are not included.

Mr. Ray has made a complete list of sales to the camp, including the name of the purchaser, style of machine, and the price, and it makes a most impressive showing, one of which the company can feel proud.

PUT ON YOUR DEDUCTION CAP

When a goose lays an egg, she just waddles off as if she was ashamed of it—because she is a goose. When a hen lays an egg—ah, she calls heaven and earth to witness it! The hen is a natural-born advertiser. Hence the demand for hens' eggs exceeds the demand for goose eggs, and the hen has all the business she can attend to.—Andrew Lang.

Arthur F. Odell, a jeweler of Quincy, Ill., has bought out the Quincy Phonograph Co., at 411 Hampshire street, that city, and has placed Theo. Arnold in charge as manager.

Victor Records

How Scarce Records May Be Obtained

TO VICTOR RETAILERS

Instruct us what records you desire us to hold on order and to ship whenever received from the factory. We will thus be able to fill in your stock on the good numbers.

Very often good numbers arrive after your order has been filled and unless we have instructions to back order, the opportunity of getting them is lost.

The retailer who places his order in this manner has the advantage over the one who doesn't.

Get the advantage—Order NOW.

Magic-Tone
TRADE MARK
Needles

For Immediate Delivery

We are in a position to make immediate deliveries on loud Magic Tone steel needles packed in envelopes of 100.

PRICES

In lots of 10,000 and up 65c per thousand.
In lots of 100,000 and up 60c per thousand.

We will also furnish them, if you desire, in tin boxes, packed three hundred to the box, at the following prices:

In lots of 10,000 and up 75c per thousand.
In lots of 100,000 and up 65c per thousand.
In lots of 500,000 and up 60c per thousand.

Owing to the scarcity of needles, it would be to your advantage to anticipate your requirements and send us your order by return mail.

VICTOR RETAILERS—WRITE FOR OUR TRADE NEWS SERVICE



I. DAVEGA JR INC.

VICTOR FACTORY WHOLESALERS
125 West 125th St. NEW YORK

The House of Service



VICTROLAS—SUPPLIES—NEEDLES

Mr. Dealer:

Do you know that if you seat your prospect in a comfortable chair before the

GABELOLA

and "*Just Push the Button*"

that it will sell itself?

You can say with perfect frankness and without fear of contradiction that—

"This super-talking machine is winning its way in the thousands of homes where something more than a mere talking machine is desired."

It is self-operating—you *don't have to change needles*, records, or wind it up because these things are taken care of automatically.



STYLE 3

THE GABELOLA

Oak Finish—Height 66 inches, width 43 inches, depth 22 inches

Price, \$550.00



STYLE 1

THE GABELOLA

Circassian Walnut—Height 66 inches, width 43 inches, depth 20 inches

Price, \$600.00

The Needle magazine contains 600 needles, and a new one drops into place each and every time a selection is played.

The record container (which contains a repertoire of 24 selections) automatically changes the record just as soon as a selection is played.

The motor is electrically driven and controlled.

It is ideal for the home, dancing school and restaurant.

A personification of pleasure and entertainment "with all the bother left out."

You can say all this and more, but it would be unnecessary.

"Just push the button" and then have your order blank ready.

GABEL'S ENTERTAINER CO.

GENERAL OFFICES AND FACTORY

210 N. ANN ST.

CHICAGO, ILL.

GABEL'S ENTERTAINER SALES CO.
Suite 512

No. 117 N. Dearborn St.

The customer who is not asked to buy a more expensive Columbia Grafonola than he can afford will come back for a higher-priced model, some day. And he will spend more for records, in the meantime, because he will have more to spend.

**Columbia Graphophone Co.
Woolworth Building, New York**



MANY NEW DEALERS ENTER THE FIELD IN BALTIMORE

Retailers Generally Have Fair Supplies of Goods Though Jobbers Are Kept on the Jump—Columbia Co. Occupy New Headquarters—Motor Truck Service Proves Big Aid

BALTIMORE, Md., March 5.—Talking machine business with the retailers is in fine shape in this territory, but the jobbers are not as well off, owing principally to the lack of goods to meet the demand of their trade. As the month closed, however, goods began to arrive in better shape, but not quite sufficient to meet the demand of the orders the firms have on hand. While some of the wholesale houses went behind on their shipments of goods the orders they have, if they could have been filled, would have run up a staggering total for increased business. At the same time there is a strong current of optimism among the dealers, who are looking forward to better shipping conditions and finally additional consignments of records, which have been coming in very poorly.

During the month the Columbia Co. ran a series of advertisements in one of the local papers featuring the Burgess Bed-time Stories for Children, which they have put on records. This paper carries the Burgess feature and the advertisements appeared on the same page. The local Columbia headquarters expects some good business from this plan, which was given but an experimental trial.

Several talking machine dealers also took advantage of the new music page, which is being conducted in The Star and appeared with the other piano houses offering pianos and players. The ads were attractive and all music dealers believe the page will make an increased music public and bring about business.

The Columbia Co. moved into its new headquarters at 16 South Howard street this week and are just getting things in shape to handle business for the coming season. W. S. Parks, the local manager, is delighted with the new home and is looking forward to big business, which will be handled with more facility and dispatch. Mr. Parks expects to devote most of his time on the road, and the general office work will be in the hands of S. Clifford Cooke, the assistant manager. Mr. Cooke just now is devoting most of his efforts to watching the shipping department and making every effort to get goods out. During the month A. B. Creel, W. T. Sibbett and P. W. Peck, of the sales force, were sent to the New York headquarters of the Columbia Co. to take a special selling course.

The Columbia Co. is using motor trucks to ship machines and records to Washington and points along the line. Many dealers in the outlying section are driving to the Columbia headquarters in their motor cars and obtaining their supplies of machines and records. Mr. Carlisle, of Gaithersburg, Md., who recently became a Columbia dealer, grew impatient in not getting his goods quickly and motored to Baltimore and obtained his supply. Mr. Bullock, of the Bullock Furniture Co., of South Carolina, was a visitor to local Columbia headquarters

during the week. February business with the city trade showed an increase for the Columbia Co., but the territory did not go ahead, owing to shipping conditions, and not the lack of orders. For the past three weeks Mr. Parks and Mr. Cooke have been getting on the job at daylight, and working until late in the evening with the force getting things in shape.

The Brunswick phonograph is now getting established in this territory, according to Mr. Loesch, of the local headquarters of the Brunswick-Balke-Collender Co. In Baltimore Bragers' department store is handling the line exclusively and showing good results. The following dealers have just been signed up to handle the Brunswick: Ira Wright, Seaford, Del.; York Record Exchange, York, Pa.; Hodnett-Chism Furniture Co., Danville, Va. Mr. Loesch is well satisfied with conditions and expects to announce additional dealers next month, there being several contracts in the making at this time.

W. C. Roberts, of E. F. Droop & Sons Co., Victor distributors, reports that business in the retail department showed up very well, but the wholesale end fell back 33 per cent. over the same month, shortage of goods and inability to ship being the cause. Mr. Roberts was made happy to-day, for while The World representative was speaking with him his shipping department reported the arrival of a shipment of goods, but the amount received will not begin to fill the orders.

Jesse Rosenstein, for the National Piano Co., the Pathé distributor, reports business fairly good, but held back for the lack of goods. George W. Lyle, vice-president of the Pathé Frères Phonograph Co., was a visitor to him during the month.

H. D. French, of the H. D. French Piano Co., W. W. Kimball representatives, is still handling all of the Kimball machines that are sent to him. He has not been able to properly introduce them to the Baltimore public because of the inability to obtain a sufficient number of machines to make a big drive.

H. M. Little, in charge of the retail depart-

ment for Cohen & Hughes, Victor distributors, reports a wonderful business in his department, despite the lack of back number records. The wholesale business of this firm was also held back because of lack of goods. During the month I. Son Cohen, of the firm, made weekly trips to the Victor headquarters in an effort to obtain more goods.

Retail business with H. R. Eisenbrandt & Sons Co., Victor distributors, was also good, and the firm managed to do fairly well in its wholesale department, being able to get out some shipments. This firm could also use more goods.

William M. Mueller, the largest music dealer in Highlandtown, and who handles the Victor line, has been doing a good business, but has not been able to meet the demands for either records or machines. He has curtailed his sales force about 50 per cent. and is thus able to handle the business at a good profit.

Joseph Fink, of the Kranz-Fink Talking Machine Co., Victor dealers, is well satisfied with business, and is planning to improve his department by installing three additional booths and a new record room.

The jobbers received many orders from Southern merchants during the past month, for this is the season that the Merchants' & Manufacturers' Association of Baltimore provides its rebates to visitors. More than 600 merchants from the South have registered with the bureau up to this time, the influx of merchant buyers to the city showing an increase of more than 100 per cent. over the same period for several years past.

C. H. HOPPER VISITS NEW YORK

C. H. Hopper, president of Hopper, Kelly Co., Seattle, Wash., was a visitor recently at the executive offices of the Columbia Graphophone Co., New York. Mr. Hopper, who is recognized as one of the most progressive talking machine men on the Pacific Coast, spoke optimistically of the business situation in his territory, and commented upon the fact that Columbia business is increasing by leaps and bounds. Mr. Hopper was gratified to learn that the Columbia Co. is making plans for a banner 1918, and was particularly impressed with the plans which the company is making for a record-breaking Columbia record business.

CRYSTAL EDGE MICA DIAPHRAGMS

**M
I
C
A**

Let us send you samples *today* of our diaphragms and you will readily understand why the best talking machines are equipped with *Crystal Edge Mica* diaphragms exclusively.

We use only the very finest selected mica, the best diaphragm material in the world.

PHONOGRAPH APPLIANCE CO., 109 West Broadway, NEW YORK

THREE YEARS PROGRESS

The last report of our Board of Directors to our Stockholders states that the increase of sales of "HOFFAY" products during 1917 was 1,808 per cent over those in 1916.



WHY?



Because we manufacture the perfect instrument. Because we manufacture the reproducer which has led the World for the last four years—the "RESURRECTONE," with its exclusive "Tuning-fork." Because we have the next best reproducer—the "Half-fork-tone." Because we manufacture the unique "Air-tight" mechanism from the Reproducer to the grill of the cabinet, which preserves the beauty of the "HOFFAY" tone.

If to a "wind" instrument you add or change the position of a hole or "key," the tone changes.

If a "string" instrument gets cracked the tone is lost.

If a "singer" loses a front tooth his tone is lost.

If a "cigar" gets broken the flavor is gone.

The same applies to a talking machine—that is why the "HOFFAY," although playing Victor and Edison types of records, is "Air-tight."

Spring (1) supports full weight of Tone-arm (2) and is insulated by felt padding A. Part of weight of Reproducer (18) is allowed to bear on Victor records, and this weight is just what it should be for this type of record. Edison records require more weight than Victors and this is automatically given by the "HOFFAY" because Edison records are thicker, and the principle of this form of spring is that the thicker the record, the more weight there is upon it.

Tone-arm (2) is supported by revolving base (3) at pivots (4). The Tone-arm is straight, there being no curves or joints hindering the sounds. Joint (13) is cemented and consequently air-tight.

Stationary base (5) carries balls (6) upon which revolving base (3) turns around for the horizontal movement of Tone-arm. Revolving base (3) is held by balls (7), the adjustment of which is made by ring (8), the weight of which is taken up by washer (9), leaving the balls free; thus a remarkable anti-friction mounting is obtained.

Flange (10) suspending from revolving base (3) goes into groove (11) in stationary base (5) without contacting with said groove, which is filled with lubricating material, and is continually lubricated mainly by capillarity; thus a permanent air-tight and anti-friction joint being provided.

Balls (6) and (7) are oiled through space (12) and as the end of revolving base touching the balls is sunk into lubricating material, the air-tight mechanism described above is reinforced.

Space (14) between Tone-arm (2) and revolving base (3) permits the up and down movement of Tone-arm. This space is absolutely closed by means of flexible washer (15) supported by ring (16) and by end (16) of Tone-arm, where it is fastened. This washer (15) leaves Tone-arm absolutely free to move, and is guaranteed to last for several years—also, it may easily be replaced. An ideal flexible and vertical air-tight device is exclusively provided by the "HOFFAY."

Equality of distance between stylus (20) and vertical axis (21) of Tone-arm (2) when Reproducer (18) is in position to play Edison records as shown in photograph 2, or in position to play Victor records shown in photograph 1, is essential for good reproduction of sound and for lengthening the life of records. This is afforded by the "HOFFAY" automatically, no screws to fasten nor detaching of Reproducer being necessary.

To obtain good tone it is essential that the diaphragm corresponds in line with the vertical axis of horizontal movement of Tone-arm. Photograph 3 shows a dotted line from axis (21) of Tone-arm (2) to diaphragm (25) inside of Reproducer (18), thus demonstrating that this essential requirement is fulfilled.

It is equally essential that stylus (20) be in line with axis (21) when playing Edison records and in photograph 5 will be seen that this requirement is also fulfilled.

Perfect air-tightness is given by padding (26) in Tone-arm (2), and by padding (27) in Reproducer (18). See photograph 3. These paddings contact with flat surfaces (29) and (30) of elbow (31), respectively, when playing Victor records. The two paddings contact with one another when playing Edison records.

To play Edison records loosen up screw (40) and press clip (35), which releases elbow (31). This elbow swings out of the way on steel pivots (32) supported by steel braces (33), thus permitting Reproducer (18) to be swung on steel pivots (34) into the Edison position. Spring (17) locks up Reproducer (18) by engaging with the steel screw-head (19), and in this way a fixed position for Edison records is obtained.

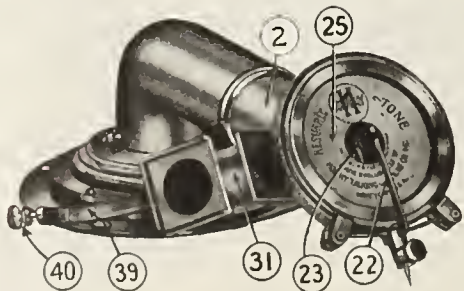
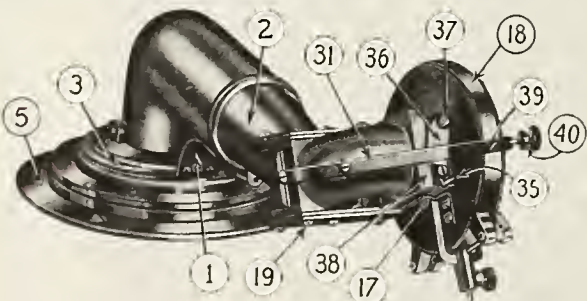
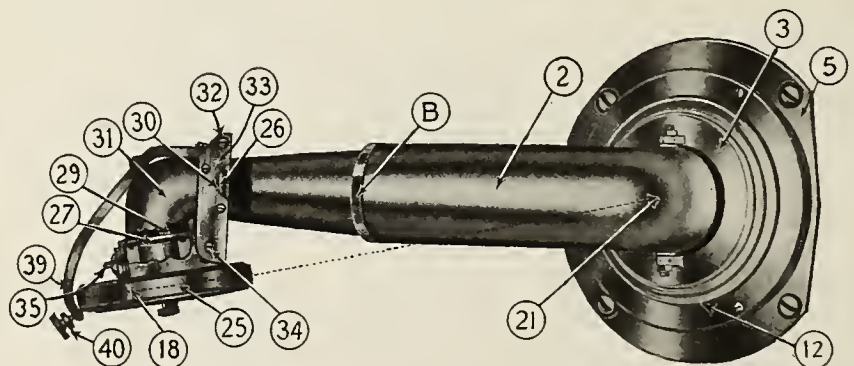
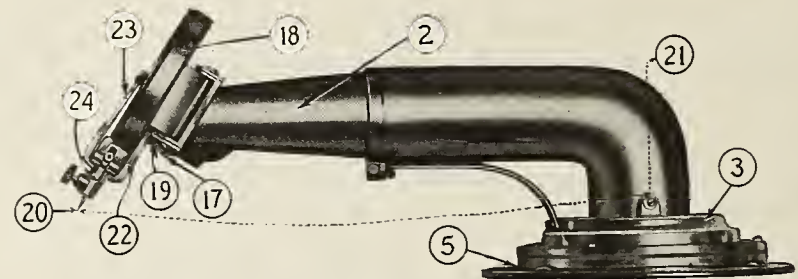
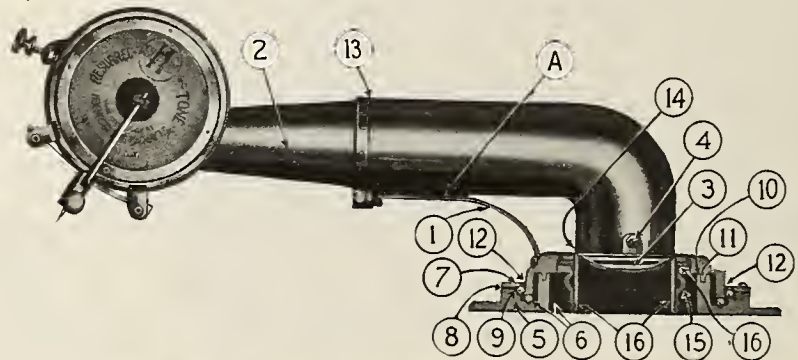

To change from Edison position (see photograph No. 5) swing Reproducer (18) to position shown in photograph No. 4 and press elbow (31) against Reproducer until plate (36) springs by itself over part (38) of said elbow. Then tighten up screw (40) so as to hold more firmly Reproducer (18) against elbow (31). In this way a fixed position is furnished by the "HOFFAY" for playing Victor records, and you know it's right because you hear it click. The braced construction is such that nothing but perfection is attained.

Either in "fixed" positions which the "HOFFAY" gives (and which prevent mistakes being made by the user of the machine); or in proper weights (for playing Victor and Edison records) given automatically by the "HOFFAY"; or in an absolutely air-tight construction (free from rotary joints, which in time loosen up, rattle and permit air to escape); or in an absolutely straight and air-tight Tone-arm; or in the most remarkable anti-friction and air-tight horizontal mounting for the Tone-arm, the "HOFFAY" fills all and every requirement for attaining perfection of sound and for fool-proof operation of the machine by the user.

Our new cabinets are beautiful and distinctive, befitting the perfect instrument they enclose.

SEND US A TRIAL ORDER TODAY

HOFFAY TALKING MACHINE CO., INC., 3 W. 29th Street, N. Y. City

Hoffay products are protected by patents granted and pending. Infringements will be prosecuted



THE WONDERFUL
"RESURRECTONE"
 and the
"HALF-FORK-TONE"

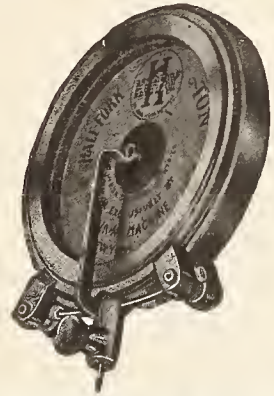
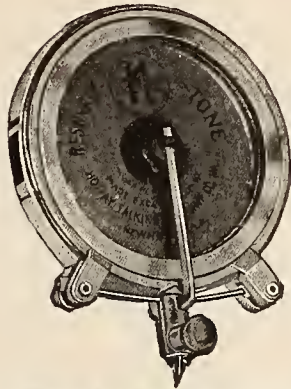

PRICE: Nickel-plated \$10. 22 karat gold plated \$12.50. To fit Victors, Sonoras, and attachments for Edison machines, etc. Money refunded if reproducer returned within 5 days from receipt.

PRICE: Nickel-plated \$6. 22 karat gold plated \$7.50. To fit standard machines and attachments for Edisons. Money refunded if reproducer returned within five days from receipt.

Naturalness of sound requires accuracy of diaphragm vibration, which varies according to pitch. For instance, when the Bass strikes "E," there are 160 vibrations per second; when the Tenor strikes "C," there are 512 vibrations; and when the Soprano strikes "C" (high C) 2048 musical vibrations are transmitted to diaphragm every second of time. The terrific rapidity of vibration bends the one arm lever which moves the diaphragm to the extent of the resiliency of the lever, each bending adding additional superfluous vibrations (on account of the "reaction" of the one arm lever) thus making sounds higher in pitch and "strident"—in fact, artificial.

Here are illustrated and described the two supreme reproducers, which are now sold to fit machines of other makes, to show what is the minimum tone that can be expected from the "HOFFAY"—the unusual "Airtight-phonograph."

In the "RESURRECTONE," the diaphragm is vibrated by a "tuning-fork" working on both sides, the resiliency of the two arms being automatically "taken up," accuracy of vibration and "naturalness" of sound being therefore accomplished facts.

In the "RESURRECTONE," the connection of the two arms to the diaphragm is of the HOFFAY flexible kind, which is another exclusive feature making this reproducer absolutely superior to all others.

The "HALF-FORK-TONE" is still much better than reproducers of other makes because the lever is supported by the other remarkable exclusive features of the "RESURRECTONE"—including the "flexed" Piano Wire Mounting which "tunes-up" the sound, and which has the additional great value of being "insulated" from the casing of the reproducer.

Order a sample; improve your machine; increase the value of your records, and learn by actual test how much better the complete "HOFFAY" instrument must be than any other machine. "Tone" requires "airtightness" and the "RESURRECTONE," "HALF-FORK-TONE," as well as the "HOFFAY" are absolutely "airtight."

Hoffay Talking Machine Co. Inc., 3 West 29th Street, New York City

RETURNS FROM SOUTHERN TRIP

Abram Davega, general manager of I. Davega, Jr., Inc., 125 West 125th street, returned around the first of the month from a pleasure trip through the South. He was well pleased with the business transacted during his absence and has come back with great plans for the future.

I. Davega, Jr., president of the company, and Mrs. Davega have left on a four months' tour through the South.

RATHER PARTICULAR IN BOSTON

BOSTON, MASS., March 5.—Henry Schultz, a talking machine dealer of 435 Broadway, South Boston, and his clerk, Robert Prohska, were fined \$10 each in the South Boston Court on Saturday on a charge of causing an obstruction on the sidewalk by operating a talking machine in the door of their store for advertising purposes. Both men have appealed from the decision.

VALLORBES NEEDLES IN DEMAND

The Vallorbes semi-permanent needle, which was recently announced to the trade, has jumped into instant popularity. The Vallorbes Jewel Co., producers of this new needle, and who are located at Lancaster, Pa., are in receipt of orders from practically every section of the country and are industriously tending to their filling.

ROY MARSHALL AGAIN AT DESK

The many friends in the trade of Roy Marshall will learn with pleasure that he has recently returned to his duties in the advertising department of the Victor Talking Machine Co. Mr. Marshall has just recovered from a severe siege of pneumonia.

The Brunswick-Munn Music Co., of Waterloo, Ia., has opened a new branch at Cedar Falls, Ia., making the third store now operated by that concern. The new store will handle the Brunswick phonograph and Pathé records.

T. McCREEDY NEW VICTOR TRAVELER

Thomas McCreedy has been appointed successor to Roger N. Lagow, on the traveling staff of the Victor Talking Machine Co. Mr. McCreedy will travel in the Middle West, concentrating his energies as a business ambassador in the State of Ohio.

JOINS THE NATIONAL ARMY

M. P. Fitzpatrick, who was formerly a member of the traveling sales staff of the Silas E. Pearsall Co., New York, Victor wholesalers, is now a member of the National Army, stationed at Camp Meade. Mr. Fitzpatrick is well known in the Victor trade, having visited the Victor dealers in the West before joining the staff of the S. E. Pearsall Co.

Edward Quick, of North Milwaukee, Wis., has been appointed distributor for the State of Wisconsin for the World phonograph, manufactured by the World Phonograph Co.

IMPROVES ALL RECORDS



Reg. U. S.

Pat. Off.

Our Dealer Proposition

We will send you this machine on receipt of \$54.00, or satisfactory references. It comes in either Oak or Mahogany, with space for five albums, and will play five ten-inch records on one winding. Accurate Automatic Stop. Machine mounted on Casters. First grade throughout. Try it out for five days, and if you don't feel that it is the ideal machine and the best you ever handled, return it at our expense, and we will refund the money at once.

Banking references furnished and required

A HOFFAY AGENCY

means Profit and Prestige for you. Not only profit on the phonographs you sell, but on the continuous profits you make on all records, for the Hoffay "Improves all Records," and as has been said, "Brings out of a record all that was put in." In being associated with the Hoffay you immediately attain Prestige.

One has only to listen to and examine the Hoffay to appreciate that the supremacy claimed is that supremacy accomplished. The Hoffay Air-tight Reproducer, Hoffay Air-tight Adapter, Hoffay Air-tight Tone Arm and Hoffay Air-tight Anti-friction tone-arm mounting are four of the most important exclusive features which make for the supremacy of the Hoffay

For Domestic and Foreign Business Address:

HOFFAY TALKING MACHINE COMPANY, Inc.

3 West 29th St. New York City



Other Models \$140, \$190, \$250



New York gave Stracciari an ovation. Stracciari has given the Columbia April program a splendid record—the song to the courtiers, from “Rigoletto.” Every opera lover will enthuse when he hears this one.

**Columbia Graphophone Co.
Woolworth Building, New York**

FREIGHT CONGESTION CHIEF DIFFICULTY IN PORTLAND

Volume of Business Only Limited by Ability to Meet Demands—Dealers in Every Line Under Stock Handicap—Early Relief Expected—Reserve Supplies Help Out

PORTLAND, ORE., March 4.—When the freight congestion is relieved Portland, Ore., will have talking machines in nearly every home—at least it so appears from the demand. This demand, by the way, is almost too great for the supply. Talking machines and records are short in stock in nearly every music house in Portland. Wheeler Dodds, head of the Victrola department of the Ira F. Powers department store, says it is impossible to get records enough to satisfy customers. The Gadsby Furniture Co., which has recently added the Columbia machine to its stock, while pleased with the success of the new department, regrets the freight conditions which seriously handicap the business. C. E. Moore is in charge of this department and its success is largely due to him.

All the music houses that carry the Victor, Columbia, Edison, Sonora, Brunswick and Stradivara are feeling the effect of the railroad difficulty. Eilers Piano House, which has one of the largest talking machine departments here, is selling the machines and records so fast that a new supply will be imperative in a short time. H. A. Raynor, manager of the phonograph department of this company, is cheerful in spite of a growing shortage of goods and predicts a good spring trade with plenty of goods coming.

Sherman, Clay & Co.'s immense stock of Victrolas is well looked after, but business is so good that even this big stock must be exhausted unless more Victrolas and records are received.

P. B. Norris, of the Wiley B. Allen Co., is also selling machines and records much faster than they are coming in.

Business men, in other lines as well as in the talking machine trade, believe, however, that there will soon be a great improvement in the transportation problems for the Pacific Northwest. The car shortage in Oregon on the Southern Pacific lines has been entirely wiped out in the last few weeks and a slight surplus recorded. A few months ago there was a shortage of more than 2,000 cars on this one line. The Oregon Washington Railroad & Navigation Co. has almost wiped out its car shortage and the Northern Pacific and Great Northern promise to have a surplus in a short time.

The Hyatt Talking Machine Co. has a big supply of Victors, Columbias and Edisons, but they are selling fast. Records are plentiful in the various houses, but there are certain popular records that are impossible to obtain.

The Harold S. Gilbert Piano Co., which is also carrying the Columbia, is running short of machines.

Bush & Lane is eagerly awaiting the arrival of a carload of Sonoras which are on the way.

The G. F. Johnson Co., which carries the Victrola, is looking for more goods, as is the Wakefield Music Co., which is doing such a big business with the Brunswick machine that the sup-

ply will have to be renewed in a very short time or there will be a lot of disappointed customers. The Edwards Furniture Co. has a big supply of Brunswick and Unola machines, but these cannot last all spring.

James Loder, formerly manager of the talking machine department of the Wiley B. Allen store at Portland, Ore., is now manager of the talking machine department for the Bush & Lane house here. Mr. Loder is so well known by Portland people and has such a big following that his customers depend very much upon his opinion. The Bush & Lane people consider themselves singularly fortunate in securing him. Mr. Loder is very much interested in the Sonora talking machine, which is sold exclusively in Portland by Bush & Lane. Mr. Loder says the Victrola, the Sonora and the Columbia make a splendid combination and satisfy the tastes of all customers.

Taylor C. White, manager of the local Victrola department of Sherman, Clay & Co., has made this department of the well-known music house one of the most efficient on the Pacific Coast. Maud Powell, the famous violinist, has been a Portland visitor for several weeks, giving a concert late last month. She visited the Sherman, Clay store and expressed her delight at the beauty and excellent service shown in the talking machine department.

Miss Powell said it was the most beautiful Victrola department she had seen on the Pacific Coast and she congratulated Mr. White on the attractive surroundings. Miss Powell, who makes records exclusively for the Victrola, may well be pleased with the appreciation shown her by Portland people whose demand for her records, which has always been great, has enormously increased since her concert.

Harry Lauder visited Portland, Ore., February 13 and gave a talk to the soldiers and gave two concerts, one a matinee and the other in the evening. Since then the demand for Lauder records has been enormous. Even before Lauder came to Portland the news of his approaching visit, which was announced as a final one, caused a rush for records.

A handsome Victrola has been purchased from Sherman, Clay & Co., Portland, Ore., by the Jewish women of the B'nai B'rith Society and sent to the Soldiers' Club at Tacoma, Wash., a club established by this society for soldiers and sailors of all creeds and denominations.

I. W. Lane, manager of the phonograph department of the Graves Music Store, Portland, Ore., is visiting friends in Waco and San Antonio, Tex. Mr. Lane will return in April.

Henry Schmidke, who has been traveling representative of the local branch of the Columbia Graphophone Co., has been promoted to the position of assistant manager. Charles V. Jones, former manager of the San Francisco branch, has been made factory traveling repre-

sentative covering the territories of the Portland and Seattle branches. Mr. Jones has been meeting with success in his first trip out of the Portland branch. R. C. Coltart, former assistant manager of the Portland branch, now becomes assistant manager of the San Francisco branch.

The Calif Bros. Furniture Store sold out all except one of its Pathé machines. A carload is reported on the way, due to arrive any day. Calls have been greatest for the \$75 and \$100 oak machines.

An attractive window display at the Edwards Furniture Co. has done much to enhance sales of the Brunswick machine. J. E. Allen, manager of the department, has succeeded in making it one of the best in the city.

A. R. Palmer, manager of the Olds, Wortman & King talking machine department, says that the Brooks machines have been finding a ready sale.

Good sales of the Stradivara machine are reported by the Hudson Arms Co. and the Remick Song Shop.

Visitors at the talking machine department of the G. F. Johnson Piano Co. are disposed to linger there because of the comfortable, well-ventilated, attractive demonstration rooms. The new house, which has been in business only four months, has many well-satisfied Victrola customers, due largely to the courtesy, efficiency and salesmanship of Mr. Johnson and his splendid corps of assistants.

The Wiley B. Allen Co. reports an unusual big business in the Victrola department. G. V. Taylor, head of the piano department, says that Paul B. Norris, the new Victrola manager, is making a wonderful record and that this indefatigable work is bringing results.

The Wakefield Music House reports large sales of Brunswick machines and records. February trade was a record-breaker and March has started off even better than February. Spring trade promises to be the greatest in the history of Portland.

Lack of records is one of the big features noted in the Portland trade. Miss Olga Binder, of the record department of the Wiley B. Allen Co., is almost dismayed at the lack of popular records in stock. While the Wiley B. Allen Co. has an enormous stock of records, the demand for patriotic and popular records has been so insistent that the immense supply is rapidly becoming exhausted.

SCHUBERT PHONOGRAPH RECORDS

The greatest series of 75c. records ever made.

10-INCH DOUBLE SIDED

ALL STARS

ALL SELLERS

New list by 15th monthly.

Dealers, write for list and prices

BELL TALKING MACHINE COMPANY
44 WEST 37th STREET, NEW YORK

Jewel-Bearing

BUTTERFLY MOTOR

Leonard Markels

This is the MOTOR whose phenomenal success made it necessary for us to double our factory capacity.

The "Butterfly Motor" has won the endorsement of leading talking machine manufacturers everywhere. It is giving excellent service under exacting conditions, and is a motor that is *guaranteed* in every detail. Read its specifications and you can readily understand why the Butterfly Motor is accepted as a standard in its field.

Try a Sample of The BUTTERFLY Motor. You will use it exclusively after a thorough test.

SILENT BUTTERFLY MOTOR

Jewel Bearing

Specifications

Beveled gear noiseless winding.
 New ratchet device that prevents clicking.
 Bakelite intermediate gear—absolutely silent.
 Plays seven to eight 10-inch or five and a half 12-inch records at one winding.
 Cast iron nickeled frame.
 Powerful, durable, compact, accessible.
 Built especially for the highest-grade machines.
 Guaranteed in every minutest detail.
 The perfection of mechanical genius as applied to the phonograph motor.

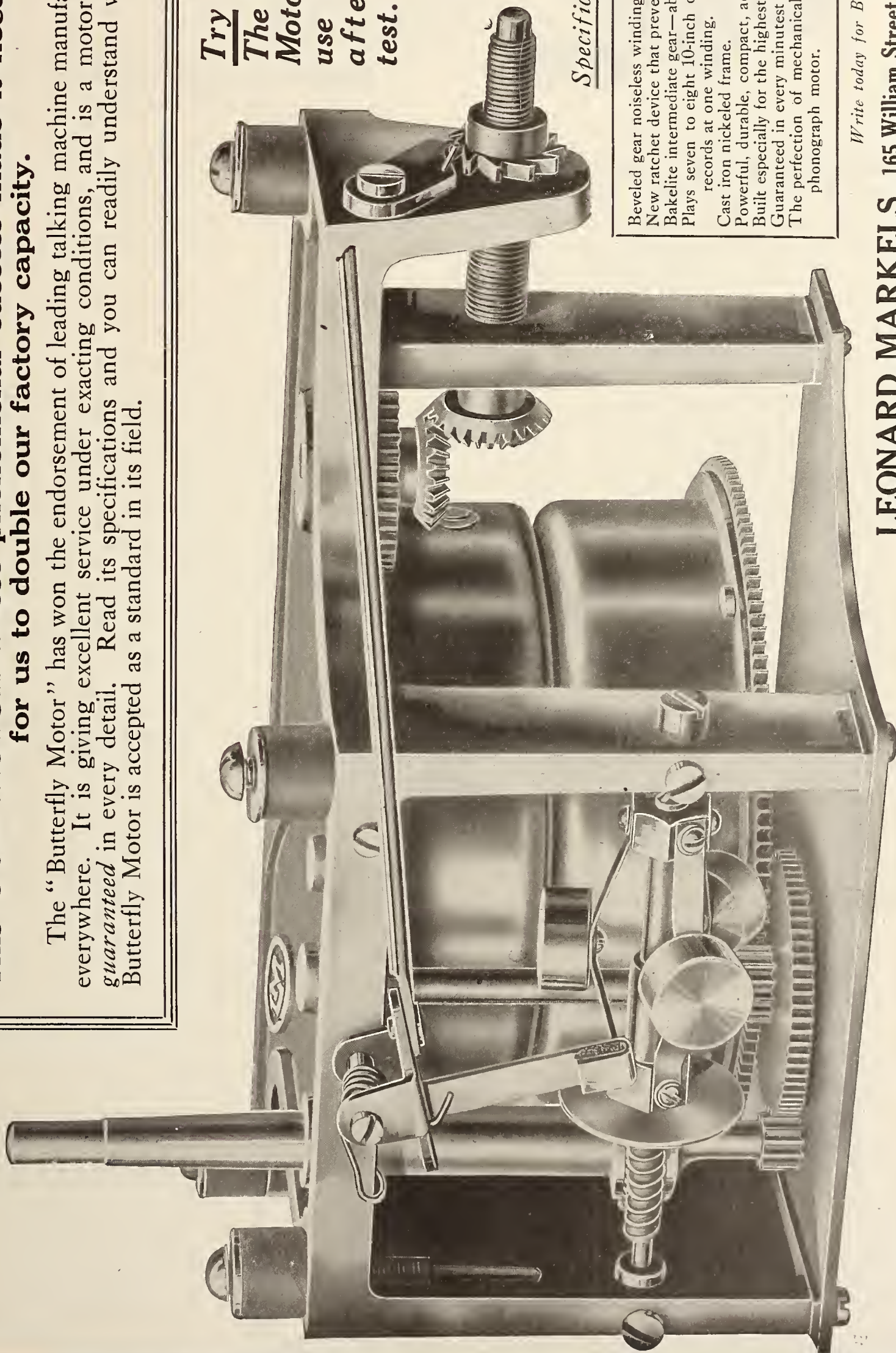

Write today for Butterfly Folder

LEONARD MARKELS, 165 William Street, NEW YORK

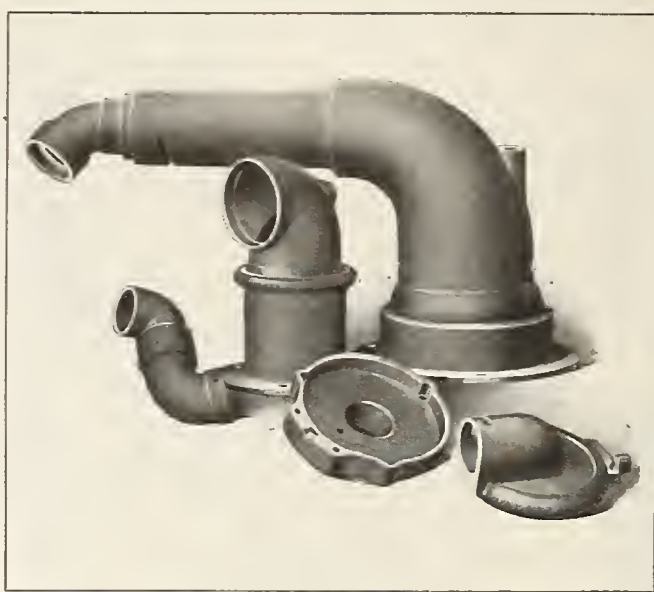

DOEHLER DIE-CASTINGS

for tone arms, sound boxes and talking machine attachments are STANDARD throughout the industry.

Of the many instruments produced to-day from the most prominent makes down, the greater number, by far, are equipped with Doehler die-cast tone arm and sound box.

The enormous output of our three large plants permits of advantages to the users of die-castings, as regards prices and deliveries, not otherwise possible.

DOEHLER DIE-CASTING CO.

MAIN OFFICE AND EASTERN PLANT
BROOKLYN, N. Y. NEW JERSEY PLANT
NEWARK, N. J.
WESTERN PLANT
TOLEDO, OHIO.

KANSAS CITY DEALERS ARE STRONG AFTER BUSINESS

Despite Shortage of Stock They Are Carrying on Strong Campaigns With the Goods on Hand—Junkins-Riley Co., Pathé Jobber, Turns Over Dealers to Wm. Volker—Other News

KANSAS CITY, Mo., March 5.—Despite shortage of stock, and the problems brought about thereby, talking machine dealers in this city and vicinity are not in any sense marking time. Although some of the more popular models of machines and the most desirable records are practically impossible to get, they are, nevertheless, carrying on strong campaigns to dispose of the goods already in their stores and to build for the future when conditions get back to normal. There is a lot of missionary work being done that cannot, and is not expected to, bring results for some time to come.

An interesting development of business in this section is found in the demand from the oil district. Fortunes are being made in oil over night, and the mechanic, or laborer, who yesterday was a prospect for a \$20 machine may to-day be in a position to buy one costing several hundred dollars. The pleasing part of the situation is that most of the deals with the oil men are for cash.

The Junkins-Riley Co., who have been Pathé jobbers for the Kansas City territory for a number of years, have sold a large part of their stock and turned over their dealers to the Wm. Volker Co., jobber of household furnishings. The Wm. Volker Co. is now the sole Pathé jobber of this territory.

The Junkins-Riley Co. will open an exclusive Pathé Shop (retail) in one of the best retail locations in the city. The shop will be designed by well-known architects and will be one of the best in this part of the country. Nothing definite has been done yet.

The Architects and Engineers Supply Co., Sonora dealers, report a big gain over last month and a bigger one over this time last year. They say that the demand for Sonoras is growing tremendously. Their record exchange department is also keeping up its big volume of business.

A. Einstein, of the Manophone Corporation, was a visitor among the trade recently.

"Our business continues to be simply wonderful," said S. G. Loewenthal, of the Henley-Waite Music Co. "The whole general line of Columbias seems to be in demand. We can't get enough of them. And our record business continues to be very, very good."

The Hall Music Co. management stated that the sale of Victors continues to be splendid and that, were it not for the shortage, business would be at the point of perfection. In records, the "Missouri Waltz" continues to be a leader.

Manager Lasseter at the Columbia department of the Kansas City Photo Supply Co. says that business is steadily on the increase. The additional record rooms, so recently built in, were only finished just in time—so fast has business increased. This company is a strong believer in the efficacy of advertising and has been doing extensive advertising both in the newspapers and on the street cars, the latter being particularly attractive.

The Brunswick-Balke-Collender Co., Brunswick jobbers in Kansas City, say that business all through this territory is on the boom, particularly in Missouri. As fast as the machines are shipped in to the dealers there comes a "big howl" for more and then more. The new Brunswick tone arm is making a big hit.

The Victrola department of the Jones Store Co. continues to have a very fine business. Of course they are handicapped by the shortage and sometimes so many substitutions have to be made that it requires the acme of diplomacy to put the deals across. "When we do get in some machines they are fumed oaks when the demand is for mahogany, etc.," said one of the salesmen. "However, we continue to take in the coin, so we should worry! Our business was far greater this month than a year ago."

The Brunswick Shop, which has not yet been established a year, now has a splendid business and verifies the belief of the management that just such an exclusive Brunswick Shop was needed in Kansas City. Sales continue to grow and the only difficulty is to supply the demand.

If the store dancing of the Edison company was merely a success at Peoria, at Clinton, and at East Orange, it took Kansas City by storm. On March 2, the end of the second week, the enrolment was up to 600 and more coming. And it was in Kansas City that, for the first time, the clumsy male insisted on coming to learn to dance. The first boys' classes were organized because the demand was so insistent. Those over eight years are not enrolled. But a large number between four and eight (garbed in gnome costumes of cheesecloth) put in a regular appearance and seem to enjoy it as much and more than baseball.

Miss Baldwin says that never before have the lessons been such a success. Hundreds of the little people come daily for registration while the mothers of many others register them over the phone. The lessons are being given in the basement of the Edison Shop (which has been fitted up splendidly for the purpose) and the mothers wait for the children in the concert room above and listen to the machines.

A unique feature at Kansas City is the large class of children from the city's slum district. They come every Saturday morning with a teacher from their ward school and to them that hour of dancing is a brief stay in Paradise. Many of them are Russians and the art of the dance is born in them.

STRONG DEMAND FOR PHONOGRAPHS

In a review of general business conditions, the New York Times had the following to say regarding the market for phonographs at the present time:

"The demand for phonographs continues strong, according to reports from several manufacturers with offices in this city. Though the hundred-dollar article seems to be the most sought, there is said also to be a good many of the more expensive lines selling, as well as a large number of the cheaper grades. The table cabinet continues in the lead among the higher grades. It is predicted that its sale this Spring and Summer will be unusually large, due to its being particularly well suited for the Summer cottage. It was explained that besides being a musical instrument of rare qualities it combines practical utility with beauty in a manner that is very pleasing."

DEALERS EVERYWHERE ARE SELLING
QUANTITIES OF OUR

HANAIE BANJUKES

(Ukuleles in Banjo Form)

A bigger hit than the Ukulele because much louder and more pleasing in tone, and of more substantial construction. Perfect two octave scales. A thoroughly practical instrument for both solo playing and club work. Send for illustrated catalogue and price list today, as

The Banjoke Is One of the Biggest Sellers
in the Musical Instrument Line.

SHERMAN, CLAY & CO.

Sole Manufacturers

163 Kearny Street San Francisco

A BIG DEMAND

Throughout the Country for

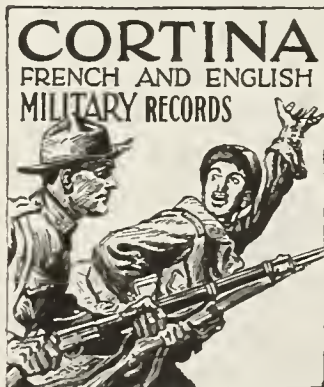

Get your share of this business. An ideal gift for the boys in training or the trenches. It often sells a machine with it.

The course consists of an authoritative Military Manual containing a foreword by Major-Gen. Leonard Wood.

WITH TWENTY PHONOGRAPH RECORDS (10-12" double face discs). Send for full information. Advertising matter, military poster-hangers free.

Also Spanish, Italian, German, and English
and French for Spaniards

CORTINA ACADEMY OF LANGUAGE
12 East 46th Street, New York

Featuring the Musical Possibilities of the Talking Machine

By William Braid White

[Note.—This is the thirteenth in a series of articles on the general subject of the musical possibilities of the talking machine. The aim of the series is to develop these possibilities from all angles, thus opening up fields for sales expansion oftentimes neglected wholly or in part.—Editor.]

RECORDS OF PIANO SOLOS

At the present moment the world finds itself very much in a state of flux. Everywhere new ideas are being tried out with an enthusiasm which a few short years ago would have been thought almost inconceivable. Old notions are being revaluated and whatever does not seem to weigh up to standard is being thrown on the dust heap. Every business, whether directly or indirectly interested in the great war which is now engaging our energies, is feeling the impulse of new and fresh ideas. The business to which the energies of this paper are devoted is one which, before the war, could rightly have been called new, fresh and untrammèd, yet even in this hustling industry we find the signs of a still newer and quickening spirit. We live in great times.

It is my especial business to discuss with those who sell talking machines ways and means for improving and stimulating the retail interest, by showing how the musical possibilities of the talking machine may be turned to best advantage. In so doing I am forcibly reminded from time to time, by observing the current of events, how much in these days our business must be kept abreast of new ideas and new criticisms by a better understanding on our parts of its strengths and virtues.

The fact is not to be concealed that the public is learning to-day more quickly than it ever learned before. Its feelings are sharper, its perceptions quicker, its criticisms more pungent. Wartime is bringing increase in efficiency and corresponding increase in demand for the best of everything. The shoddy and the cheap look shoddier and cheaper than ever. The good is becoming more and more thoroughly appreciated and understood. All this is well. And it all has its moral for ourselves.

Records

In the retail selling of talking machines the record is, of course, the dominating feature. I mean that it is the record which excites the interest in the beginning, and mainly sustains it during the process of selling. The machine itself is, of course, complementary and essential; but the record is the interest-producer primarily. A fine set of records may be sold with a relatively cheap machine, but the finest machine cannot be sold without records. That much being plain, it becomes our duty in these days of wartime prices, keen public criticism, intense competition and smaller margin of profit, to develop intensively every branch of the business which shows good profit and helps to produce more business.

Piano Records

It is a fact that certain branches of the record business, which normally should be good sellers, have not been developed by retailers with quite the intensity to which their advertising value would properly entitle them. When we consider that violin records by Kreisler and voice records by Galli-Curci (to mention only two names that come to mind) sell extremely well, while piano records by Paderewski and Godowsky (again choosing at random) sell only moderately well, we must ask ourselves what can be the reason for such a contrast in demand. It certainly is not that the violin or the voice is necessarily more popular than the piano, of itself. Indeed, it is well known that the piano is by all means the most popular of musical instruments and that piano music is the most popular of all music. How is it that piano records do not sell as they ought to (that is to say, in

enormous quantities) and what can we do about the matter?

I need make no apology for choosing such a topic, since quite obviously high-class piano records are profitable to make and sell; and therefore any defect in the public demand for them should be investigated and if possible corrected. The task is harder than it sounds, perhaps, but while I must decidedly disclaim any ability or inclination to teach the manufacturers or retailers what they know better than I do, I must nevertheless be allowed to say some things which come to mind through long-continued observation, and which are without doubt useful in affording some gleams of light in a rather dark corner.

Two Reasons

There can only be two possible reasons for any lack of public demand for piano records, or for any slowness, even, of such demand. These reasons may be (1) some possible defect in the composition of the record, or (2) some lack of interest in the product on the part of the retailer. Let me briefly examine both of these ideas for our mutual benefit.

Ear vs. Record

Those who have watched the progress of recording are well aware that, until about ten years ago, scarcely any attempts to record solo piano music had been seriously made. The piano had been from the first used as an accompanying instrument in voice recording, but the support it affords in this respect is of only the slightest weight, being perceptible and no more. The art of recording solo piano work has progressed quite slowly, meanwhile, and it has gradually come to be seen that much technical refinement has yet to be brought about before the marvelous fidelity and power of the vocal records are approached. The piano record does not show the slightest defect in respect of its "hearing." Certainly the record takes up all the sounds that proceed from the piano. The only trouble is that the record picks up and fixes permanently a certain varying number of fugitive incidental sounds that accompany all playing of the piano, and reproduces these with complete fidelity. Indeed it reproduces them with more than complete fidelity, for it tends to

give us these incidental sounds in forms not indeed really exaggerated but in their actual right proportionate powers; something which our ear, when listening to piano playing, naturally and instinctively rejects.

Reverberation

In a word, we hear selectively. The playing of a piano in a small room produces a multitude of reverberations or echoes, from the reflection of the sound waves back from walls and floor. These echoes the ear rejects or ignores. But the record does not. Hence the record gives us certain incidental additional sounds mixed up with the intended sounds, in such a manner that an effect of "blurring" and of something that can only be described as an imitation of the jangle of a cymbal after it is struck sticks out from the sounds of the piano and perceptibly modifies them. It need hardly be added that the modification does not make for improvement.

Now, some of these matters have been discussed briefly at some recent piano technicians' meetings. A report of one of these appeared in the February number of this paper. I was glad to observe at this meeting evidences of respect for, and interest in, the talking machine and especially the plain indications that the piano itself is recognized by these practical piano men to be responsible for a good deal of whatever criticism may be leveled at records of piano music. Although it could not be said that any specially conclusive results were obtained, it is fair to say that all present were able to perceive that the piano, as played and built for ordinary playing, is not an ideal instrument for recording of sound.

Defects of the Piano

The defects of the piano may be briefly summed up. In the first place, the sounds which proceed from this instrument are too widely diffused over the field of sound-wave operation. In the second place, the sounds which proceed from struck strings begin with a great intensity which rapidly subsides, and so tend to reflection from the walls of a small room, thus producing reverberations and echoes which are picked up by the record and interfere

(Continued on page 65)

7th Floor

229 Fulton Street

Clifford A. Wolf

MANUFACTURER OF

Diamond and Sapphire

Phonograph Points

New York City

Phone, 1678 Cortlandt

Note New Address

"BRILLIANTONE" NEEDLES

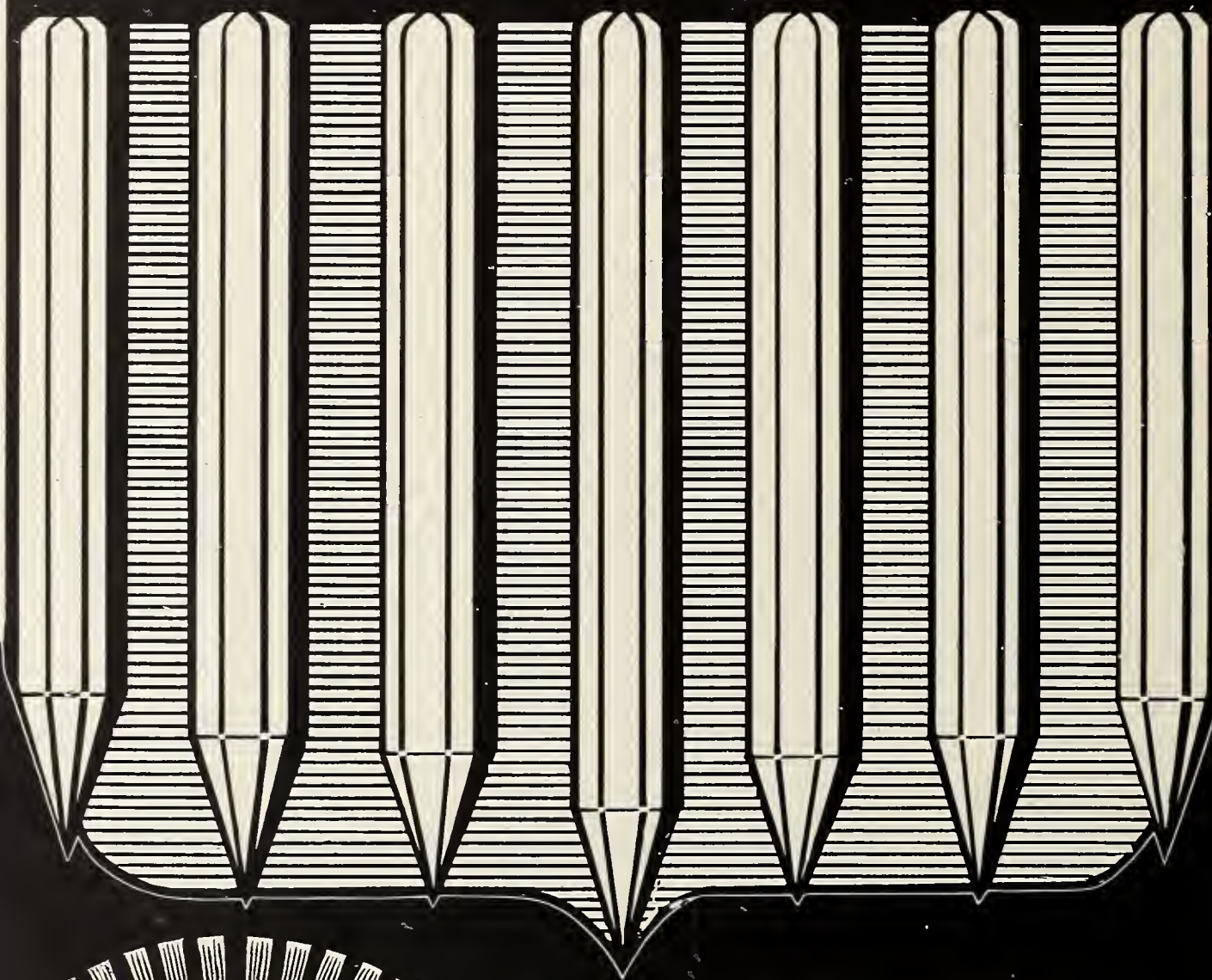

HALF-TONE
LOUD
EXTRA-LOUD

Prices and Samples for
IMMEDIATE DELIVERIES ONLY
Sent Upon Request

MADE IN AMERICA BY
AMERICAN LABOR

the best steel needles manufactured
because—

- (1) they are of uniform length
- (2) they have uniform points and
- (3) they are of uniform hardness
- (4) they are standard and reliable
- (5) they Assure Customer Satisfaction—

BRILLIANTONE STEEL NEEDLE CO.
of America, Inc.

B. R. FORSTER, President, Suite 657-659
Marbridge Building, B'way at 34th St., N. Y.

THE MUSICAL POSSIBILITIES OF THE TALKING MACHINE

(Continued from page 63)

with the clarity of the reproduction. In the third place, the bass strings vibrate in such a manner that the strong fundamental sounds which would best carry the tones of the piano to the record are swallowed up in a mass of incidental partial tones. In the fourth place, the vibration of the case and metal framing of the piano is sufficiently violent to produce additional reverberations which likewise interfere with clarity.

Remedies

The remedies are not entirely simple. Some of them may, however, be considered immediately practicable. The first is that piano recording should be done in large rectangular rooms, the walls lined with non-conducting material such as felt, with all re-entrant angles and elliptical concave corners eliminated. This will tend to reduce, if not eliminate entirely, reflection from walls, floor and roof. Secondly, such construction of the piano's case as will tend to deliver its sound waves in one given direction is highly desirable. This might be done by enclosing the piano, save only the keyboard, in a concrete box, having a tapered end with an opening to the talking machine horn, which also should be of concrete or similar non-conducting neutral material. Solid glass would be as good but more expensive.

The perfect piano for recording purposes will have to be built specially, I think. Such a piano must be above all longer, so as to permit of longer bass strings. I should like to see a twelve or even fifteen-foot grand built for the special purpose of talking machine recording. Many of the present difficulties would then vanish. The technical reason I have only been able to state briefly and inadequately; but so far as they go they are thoroughly valid.

Selling

So much for the recording side; but now what about the selling? After all, the facts that I have pointed out have not operated to prevent the sale of talking machine records of piano music, nor is there any particular reason why they should have. I have stated what any one can perceive for himself, but I have not failed to show likewise that the art of recording for the piano is in a state of progression. Why then wait for some imagined further improvement—which will come in good time—when we can have so much that is good already, and moreover can do our part towards educating the public into the desire for piano music records now? As the manufacturers solve, one by one, the problems of recording, they will increase the number thereof and will go after piano music more and more persistently. They will do this because the piano is the one most popular musical instrument; and because the player-piano and the hand-played player-piano record have awakened a new and vital interest in all that pertains to piano playing. All the ideas set forth above tend to show, in the aggregate, that the art of producing piano records relatively as perfect as those which the voice permits is a matter only of adjustment to certain conditions. Let the conditions be recognized and especially let the piano trade show a willingness to co-operate. The problem will then very soon solve itself.

"Push Them"

Therefore, it should be the aim of every wise retailer to push the sale of piano records with all his might. He should remember that, in the first place, many eminent pianists, with all the reputation and prestige of their names, have been willing to make records of their act. He will then realize that these men plainly see the possibilities in front of them and are not ashamed to associate themselves with a movement entitled to the highest respect and encouragement. He will likewise realize that any line of merchandise to which is attached the prestige of a great name is worthy of all encouragement and at the same time possesses an advertising value that does not pertain to any

which is not in the same position as to name. He will realize, in short, that he can sell talking machine records of piano playing, and make them profitable in every way.

Choices

Space does not allow me to do more than merely mention the names of a few records which might especially be studied by those who would sell piano music for the talking machine. But a word of suggestion may be useful. Numbers which involve brilliant runs, glittering scales and ornamental playing generally, but which do not call for heavy basses, deep sustained tones and the tragic side of the piano, as it might be called, sound best and will be the most popular. Such records as the Chopin study in G minor (double notes) by Bachaus, the Liszt Gnomenreigen by the same, Godowsky's record of the Chopin Valse in E minor

PLAN TO FINANCE EDISON DEALERS

Thos. A. Edison, Inc., Makes Arrangements Whereby Dealers May Utilize Instalment Contracts in Payment of Their Accounts With Distributors—Details of the Plan

Thomas A. Edison, Inc., have recently completed a plan for the financing of their dealers' deferred payment contracts. Under this plan, which is operated in conjunction with the Commercial Investment Trust, of 61 Broadway, New York, Edison dealers may utilize their retail instalment contracts in payment of their account with the distributors. The charges for the accommodation are within the amount now collected as interest from the retail purchaser of the phonograph.

In a recent interview Mr. Harrison Durant, financial supervisor of the Edison Co., had the following to say regarding the new plan:

"The financial plan formulated by the Commercial Investment Trust is a broad one, and decidedly advantageous. The charges are considerably less than those previously quoted by any of the regular discounting companies offering the same accommodation. The plan includes the insurance against loss or damage by fire, without additional cost, of all instruments in a purchaser's possession for an amount equal to the unpaid balance of the amount advanced. The plan is based on the well-known trade acceptance—in this case termed a 'collateral ac-

ceptance.' A dealer attaches his customer's paper to the acceptance, and receives credit for an amount not exceeding 84 per cent. of the unpaid balance of instalments. "The plan has our entire approval, and no doubt will be of great advantage and assistance to Edison dealers throughout this country and Canada. It is the only plan of its kind which the Thomas A. Edison, Inc., recommends to its dealers, and is the result of very sincere efforts on our part to relieve our dealers of some of the burden of their financing. The fact is that Edison instalment paper has terms which up to the present date have not been available to phonograph dealers."

The salesman can find many others of the same sort which a study of the catalog will suggest to him. This is a case where wisdom and discretion are desirable in every sense.

I believe in the piano record for the talking machine and in its future development. I want to see the public educated to it. It is a fine wide field. Let us get at it now with plough and harrow.

ceptance.' A dealer attaches his customer's paper to the acceptance, and receives credit for an amount not exceeding 84 per cent. of the unpaid balance of instalments.

"The plan has our entire approval, and no doubt will be of great advantage and assistance to Edison dealers throughout this country and Canada. It is the only plan of its kind which the Thomas A. Edison, Inc., recommends to its dealers, and is the result of very sincere efforts on our part to relieve our dealers of some of the burden of their financing. The fact is that Edison instalment paper has terms which up to the present date have not been available to phonograph dealers."

CONGRATULATION FOR W. H. BISHOP

W. H. Bishop, manager of the Trinity Talking Machine Co., 52 Broadway, New York, is receiving the congratulations of his many friends in the trade, upon the arrival at his home recently of Shirley Frances Bishop. This young lady is already taking a keen interest in Red Seal Victor records, and endeavoring to emulate the examples set by some of the famous Victor operatic sopranos.

The Trinity Talking Machine Co. is one of the most successful Victor retail establishments in the lower part of New York City, and Mr. Bishop has been an instrumental factor in developing the company's business to its present satisfactory totals.



Diaphragm



Amplifier



Reproducer

The
Phon d'Amour

Must Be Heard To Be Appreciated.

Fritzsch patents have given to music lovers a triumph of artistry and craftsmanship. To be satisfied with a phonograph other than the *Phon d'Amour* is to be content with something less than the final achievement in phonographs. You should see the *Phon d'Amour* and have its wonderful patented features explained to you. Hear it play, then compare it. Plays records of whatever make.

THE FRITZSCH PHONOGRAPH COMPANY

228-230 W. Seventh St.
CINCINNATI, OHIO

EDISON DIAMOND DISC JOBBERS HOLD ANNUAL CONVENTION

Only Three Members of Jobbers' Association Fail to Attend—Important Trade Topics Discussed—All Officers Re-elected—Edison Officials Make Addresses—Banquet at Sherry's

The Edison Diamond Disc Jobbers' Association held its annual convention at the Hotel Knickerbocker, New York, on Monday and

close to those of other years, and included special papers read by various members of the association, talks on important topics delivered

All officers were re-elected for another year, they being: Walter Kipp, Kipp Phonograph Co., Indianapolis, president; L. N. Bloom, Phonograph Co., Cleveland, vice-president; F. E. Bolway, Bolway & Son., Inc., Syracuse, secretary, and H. H. Blish, Harger & Blish, Des Moines, Ia., treasurer. The advisory committee for the coming year will consist of A. H. Curry, Dallas,



Members of Edison Disc Jobbers' Association Tuesday, February 18-19, and, despite the unusual travel conditions prevailing, only three members were missing when the roll was called, the jobbers coming from all sections of the United States and Canada to attend the gathering.

The convention program in the main followed

Who Held Their First Wartime Convention at Knickerbocker Hotel, New York, February 18-19

by factory officials, and general discussions at an open forum.

The first business session was held on Monday, at which time various officers and committees made their reports for the year. The reports for the most part were very encouraging.

Tex.; Albert Buehn, Pittsburgh, Pa., and George Babson, of New York.

Tuesday's sessions were given over to the reading of special papers and addresses by members of the Association and by factory officials, the latter including William E. Maxwell, vice-



Banquet Tendered the Visiting Jobbers by Thos. A. Edison, Inc., at Sherry's, on Evening of February 19

president of Thomas A. Edison, Inc.; L. C. McChesney, advertising manager; Thomas J. Leonard, sales manager; Harrison Durant, the financial supervisor; Verdi E. B. Fuller, general supervisor of the Edison Co., and some others. Mr. Maxwell opened the morning session with an interesting talk on the present business situation, and what the future appeared to hold forth for the Edison line and those interested in it. He also told something of what the factory planned in the matter of future developments.

M. M. Blackman, of the Phonograph Co., Inc., next brought before the jobbers his recent book



Walter E. Kipp, President

on the Edison phonograph, which was discoursed upon to considerable extent. F. E. Bolway read a paper on "Retail Selling Plans," and H. H. Blish, Jr., read a paper on "Tone Tests."

The session broke up at 1 o'clock when the factory officials and supervisors were the guests of the jobbers at a special luncheon at the Knickerbocker.

The afternoon session was opened by Harrison Durant, who presented a new and interesting financial plan to the jobbers, following which A. H. Curry read a paper on "Wholesale Selling Plans," W. B. Eddy read a paper on "Accounting and Collecting," and B. A. Trestrail, Toronto, led a discussion of war and business in Canada and the United States.

At the conclusion of the regular program, an open forum was announced, and a number of interesting informal discussions were indulged in.

On Tuesday evening the jobbers were the guests of Thomas A. Edison, Inc., at an elab-

orate banquet at Sherry's, where addresses were made by William E. Maxwell, vice-president of the Edison Co.; Walter Kipp, president of the Jobbers' Association, and others. A number of cabaret artists provided entertainment for the occasion.

Wednesday morning the jobbers went to the Edison factory at West Orange, N. J., for an informal get-together and were served a special luncheon in the Edison restaurant, after which several of the newest Frieda Hempel Re-Creations were presented for their entertainment and information.

Among those who attended the convention were D. W. Schultz, Schultz Bros., Omaha, Neb.; Robert L. Proudfit, Proudfit Sporting Goods Co., Ogdun, Utah; A. H. Curry and F. C. Beattie, of the Texas-Oklahoma Phonograph Co., Dallas, Tex.; L. A. Walker, Montana Phonograph Co., Helena, Mont.; W. L. F. Rosenblatt, Phonographs, Inc., Atlanta, Ga.; R. B. Cope, Girard Phonograph Co., Philadelphia; H. H. Blish, Jr., Harger & Blish, Des Moines, Ia.; J. G. Harrison, W. H. Thorne & Co., Ltd., St. John, N. B.; W. O. Pardee and H. L. Ellenberger, Pardee-Ellenberger Co., New Haven, Conn.; F. H. Silliman, Pardee-Ellenberger Co., Boston, Mass.; M. M. Blackman, the Phonograph Co., Inc., Kansas City; Albert Buehn, Buehn Phonograph Co., Pittsburgh, Pa.; C. R. Lee, George Babson and F. O. Faul, Phonograph Corp., of Manhattan, New York; C. E. Goodwin, the Phonograph Co., Chicago; R. S. Williams, H. G. Stanton, G. B. Petch, T. A. Dillon and Miss Punton, R. S. Williams & Sons Co., Ltd., Toronto, Ont.; R. B. Alling, the Phonograph Co., Detroit; F. S. Hemingway, the Diamond Music Co., Inc., New Orleans, La.; Walter Kipp, Kipp-Link Phonograph Co., Indianapolis, Ind.; F. E. Bolway, W. P. Eddy, J. G. Brown and A. W. Fiedler, F. E. Bolway & Sons, Inc., Syracuse, N. Y.; W. B. Smith and L. N. Bloom, the Phonograph Co., Cleveland, O.; R. E. Oldman, the Phonograph Co., Cincinnati; W. A. Meyers, Williamsport, Pa.; W. C. Wyatt and H. Richards, the Denver Drygoods Co., Denver, Colo.; W. A. Schmidt, the Phonograph Co., Milwaukee, Wis.; N. D. Griffith and P. R. Hanley, American Phonograph Co., Albany, N. Y.; C. B. Haynes and E. Bowman, C. B. Haynes & Co., Richmond, Va.; Mark Silverstone, Silverstone Music Co., St. Louis, Mo., and Laurence H. Lucker, Minneapolis, Minn.

THE VICTOR "VOICE" FOR FEBRUARY

Interesting Series of Pictures Show How Victrolas Provide Comfort and Entertainment for Fighting Men on Land and Sea

The February number of "The Voice of the Victor" might well be termed a war or military number, for most of the illustrations are calculated to show the interest in music, and particularly Victrola music, displayed by the fighting men of the nation.

The cover design of the February "Voice" consists of over 500 service stars representative of the number of Victor employes who have entered the service of Uncle Sam to date. The big feature, however, is the reproduction of a yard in length of a photograph of something like 40,000 soldiers in camp at Tacoma, Wash., listening to the singing of Alma Gluck. The point is emphasized that the soldiers asked for the selections they had heard on the Victrola.

The center spread is made up of a group of eleven photographs taken on land and sea, and showing how Victrolas are utilized to provide comfort and entertainment for the soldiers and sailors. One photograph depicts the use of a Victrola in a hospital where its music serves to soothe the patient while he is undergoing an operation.

If you hustle so eternally that your system demands a vacation, you have gotten where you cannot do good work. If you have reached a point where you cannot do good work, you cannot enjoy a vacation.

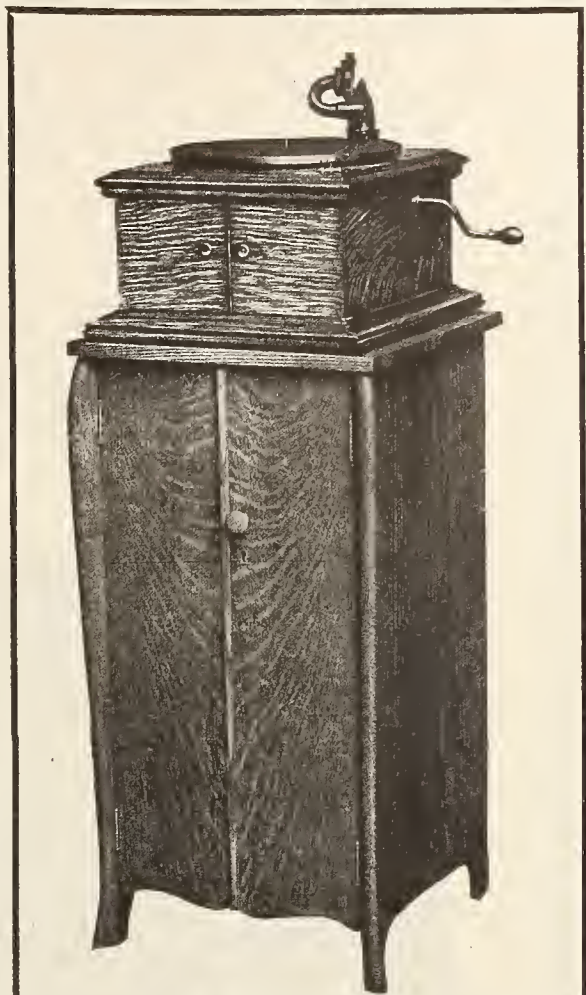

No. 404 UDELL CABINET

For filing Victor or Columbia Records. Capacity 208 Records. It is 32 inches high and the top is 17 inches square. You can use Victrola IV A or VI A or Columbia Grafonola 25 or 35 with this Cabinet and make a most attractive combination.

Either Quartered Oak or Mahogany, the price is \$7.50.

There is one factor, but little advertised, that helps account for the ever-increasing popularity and self-selling ability of Udell record cabinets. That factor is the intimate knowledge concerning what the American homes are buying, which the Udell organization gleans through its extensive activity in the furniture field proper.

Our large interests in the manufacture of furniture for elite homes gives us an up-to-the-minute realization of just what woods, just what period styles, just what kinds of finish and just what shades of finish are most sought for by the American public.

All this valuable knowledge is utilized in the designing of the celebrated and trade-marked line of Udell record cabinets. Catalog on request.



TRADE MARK

Start the new year by writing for our catalog.

THE UDELL WORKS

1205 WEST 28th STREET

INDIANAPOLIS, IND.

The BEST TALKING MACHINE NEEDLE

On the Market—Packed in Counter Salesman



50 Needles to a box and they retail at 10c. per Box.

60 Boxes to a package \$6.00.

This package costs you \$3.90 net.

Your profit is \$2.10 and your customer gets a needle that will give satisfaction.

The Fred. Gretsch Mfg. Co. 60 Broadway Brooklyn, N.Y. Manufacturers of Musical Instruments

CABINET

SUPREMACY



A Century Model

¶ In every industry there is a *leader* and this Company has conducted its business with the one thought in mind of being the *leader* in the talking machine cabinet industry.

¶ How well we have succeeded is indicated by the fact that

CENTURY CABINETS

are being used exclusively by the majority of the leading talking machine manufacturers. **Century Cabinets** are giving absolute satisfaction to every user, and every cabinet is guaranteed by the *world's largest manufacturer* of talking machine cabinets.

We are ready to quote on your 1918 contracts

CENTURY CABINET CO., 25 West 45th St., N. Y.

FACTORY: UTICA, N. Y.

Happenings in Dominion of Canada

TRADE CONTINUING ACTIVE IN TORONTO AND VICINITY

W. C. Willson Joins Pathé Organization—J. P. Bradt Tells of Columbia Progress—Canadian Phonograph Supply Co. Opens Local Starr Branch—Heintzman Opens Victor Store

TORONTO, ONT., March 8.—W. C. Willson, for the past fourteen years secretary-treasurer and manager of the Meadford Mfg. Co., Ltd., of Meadford, Ont., has joined the Pathé Frères phonograph organization in this city. He comes in the capacity of assistant manager of Pathé Frères Phonograph Co., of Canada, Ltd., and will have charge of the firm's internal organization. Mr. Willson brings to the Pathé organization not only a wide manufacturing experience, but also the energy and enthusiasm of a young man who has boundless faith in Canada's future and the part that Pathé Pathéphones and records will play in building up a musical and therefore a successful nation.

The R. S. Williams & Sons Co., Ltd., on March 12 will close an essay prize contest which they have been conducting for the best essay on Mr. Edison—his life and inventions—particularly his personal favorite among all his many inventions. The contest is open to the girls and boys of Toronto, and prizes of from \$2.50 to \$25—in all, \$100—are offered. This firm are now having daily Edison recitals for school children from 4 until 6 each afternoon, and all day on Saturdays.

J. P. Bradt, general manager of Canada for the Columbia Graphophone Co., has been planning ever since 1917 closed with a business with reports of a business 100 per cent. larger than 1916, how to keep pace with growing demands. Two things he found necessary—largely increased factory facilities, and an enlarged staff. The filling of the latter need is now announced, and factory negotiations are in progress. To aid in the direction of the greatly enlarged manufacture and growing business, Mervin E. Lyle has been transferred to Canada. Mr. Lyle comes from the head offices in New York. His experience of over fourteen years embraces every phase of the business. With such an experience Mr. Lyle will be of great aid to Mr. Bradt in upbuilding manufacture; in taking care of sales and the general development of the business to the benefit of dealers in Columbia products.

That music is being demanded more and more by Canadians, and that they have developed musically in the past three or four years is the experience of I. Montagnes & Co., distributors in Canada of Sonora phonographs. "Business increases every day," reports Mr. Montagnes. Shipments are now coming from New York by express as a result of the freight congestion, and stocks that they thought were ample for some months have been cleaned out.

"Specialists in Victor records," is the way Harry E. Wimperly describes the Victrola Service Co. recently opened up by him in the new Ryrie Building, this city. Having proved his theories right concerning upstairs piano salesrooms, Mr. Wimperly was encouraged to take on "His Master's Voice" lines, in which he is strongly specializing, being thoroughly familiar and enthusiastic as a result of his experience with the line when manager of the Bell piano salesrooms in Toronto. Mr. Wimperly has many original ideas that he is putting into effect, resulting in quite an extensive list of patrons for Victor records being built up in a very short time. By the way, Lieutenant Claude C. Wimperly, a son of Mr. Wimperly, is among the returned officers from the war front, attached for duty with the First Depot Battalion 1st C. O. R.

F. A. Trestrail, general manager of the Musical Merchandise Sales Co., who are Canadian distributors of Brunswick phonographs and records, has returned from a trip to Chicago, where he visited the immense factories of the Brun-

wick-Balke Co. The Musical Merchandise Sales Co. has started on its campaign of outdoor advertising, with a handpainted sign "at the Dom," Toronto, which is not apt to leave any passerby's mind unimpressed with the name "Brunswick."

Among the newest additions to "His Master's Voice" stores in this city is one opened up by Armand Heintzman, at the northwest corner of College street and Ossington avenue. Mr. Heintzman is vice-president of Gerhard Heintzman, Ltd., and superintendent of that company's factories. The retail Victor store is a personal venture "on the side," being an outcome of Mr. Heintzman's enthusiasm in connection with talking machine business in general, and Victor lines in particular.

The following is from a letter sent Columbia distributors in Canada by James P. Bradt, general manager of Columbia interests here:

"While we have for many months restricted our manufacture and sales of German, Austrian, Hungarian, Bulgarian and Turkish records, it has now been decided to withhold from the market every selection which could possibly arouse or foster hostile national sentiment among people of enemy-country origin resident in Canada. A list is being prepared and will go to you in a few days, showing what records we are suppressing. Upon receipt thereof you please immediately withdraw the prohibited selections from sale and advise us of your stock of each selection, if any.

"We also request that you send a copy of our list to every dealer on your list who may have in stock any of the prohibited records, with instructions to withdraw them at once. Please secure information as to your dealers' stocks and inform us. We do not intend to withdraw the records of standard composers, or other selections which are without objectional flavor."

To meet the convenience of their outside dealers visiting Toronto, the Canadian Phonograph Supply Co., of London, Ont., distributors of Starr phonographs and records in Canada, have arranged for a local branch. Samples of the various types will be on display. M. E. Stanfield, on the firm's selling staff, will look after this branch, in addition to handling his Ontario territory.

P. K. Wood, of the Thomas Mfg. Co.'s local branch, has returned from a visit to the firm's headquarters in Dayton, O.

Thomas Nash, the well-known "His Master's Voice" enthusiast, who is manager of "His Master's Voice," Ltd., Toronto, when not developing new ideas from which dealers can sell still more records, was a recent visitor to New York.

Mme. Barrientos, the eminent coloratura-soprano, exclusive Columbia artist, gave a song recital recently in Toronto and a large sale of records of her recordings is reported.

G. P. Sharkey, who is well known to the Canadian trade, has started business for himself under the name of Sharkey Novelty Co., and is offering the trade etched brass nameplates for pianos and talking machines.

Mr. Ruse is opening up with "His Master's Voice" lines. The store equipment will include a number of demonstration booths for the Victrola department.

CASSIDY'S, LTD., COLUMBIA DISTRIBUTORS IN WINNIPEG

Robert Shaw Continues as Manager—Grand Opera Season Helps Season of Record Sales—Trench Gramophone Appears—Berliner Gramophone Co. Enlarges Its Business—Other News

WINNIPEG, MAN., March 6.—The Western Fancy Goods Co., distributors of Columbia lines in the West, have now been taken over by Cassidy's, Ltd., and have moved into very much larger quarters. Robt. Shaw has been retained as manager, and Gordon Stark has been engaged as assistant manager. Mr. Shaw reports goods coming in considerable quantities—record shipments from factory, but there are thousands of orders for records still unfilled.

During the appearance of the San Carlo Opera Co. in Winnipeg the local phonograph dealers (Victor, Columbia, Edison and Pathé) took advantage of the occasion and used a whole page in the Winnipeg Tribune featuring each day a list of records of the opera playing that night.

A Winnipeg officer has just sent to his wife in Winnipeg one of the new trench gramophones, which are sold by a London firm. Small in construction, this little machine fits into a compact leather case and is most portable. Its most remarkable feature is the tone it produces. This is effected from a copper reflector which is fixed at the rear of the sound shutter, which resembles those shown in the new electric cir-

cular heaters. The great Harry Lauder, the soldiers' hero, was heard to great advantage on this wonderful little instrument which takes any sized record. Above the cannon's roar and the constant bursting of shells the lads in the trenches are able to enjoy the dulcet tones of Melba or the rollicking ballads of McCormack.

Cross, Goulding & Skinner, who are featuring the Columbia and Brunswick machines with great success, give favorable reports of activities in this department since the beginning of the year. The continued development of the talking machine business impresses this firm that the desire of the public for music in the home continues to grow.

The White House (the largest departmental store in St. Boniface) has taken up the Columbia line and is specializing in the French records on the Columbia list.

Stanwood's, Ltd., announce a big sale of the new Columbia record "Blighty." In connection with this record Mr. Shaw says the output was phenomenal, over one thousand being sold in the first day and a half.

(Continued on page 70)

Talking Machine Supplies and Repair Parts

SPRINGS, SOUND BOX PARTS, NEEDLES

THE RENÉ MANUFACTURING CO.
MONTVALE, NEW JERSEY

TRADE CONDITIONS IN THE DOMINION OF CANADA—(Continued from page 69)

All Columbia dealers have lately shared in a good distribution of Godowsky records, due to this artist's appearing in the leading centers of Western Canada and British Columbia.

The announcement of enlarged manufacturing facilities by the Berliner Gramophone Co., Ltd., Montreal, has been received with considerable elation by the management of the Western Gramophone Co., Western distributors of "His Master's Voice" lines.

Ashdown's have built new mahogany and glass

tone rooms and have very materially enlarged the Grafonola department, putting Chas. White in immediate charge under the direction of Ralph Patterson. Business is reported as brisk.

Babson Bros. report conditions and prospects good for immediate future trade in the Edison lines.

The Western Gramophone Co. say there has been a big demand for Victor records, and are looking forward to big times when Harry Lauder comes to Winnipeg.

cate of one recently purchased by Dr. Boyle, president of King's College, of that place.

The Black Diamond Needle Co. has been organized by Arthur Kempton, of Montreal, who is featuring a semi-permanent talking machine needle called the Black Diamond.

Pablo Casals records were featured by all Columbia dealers in the newspaper advertising both previous to and after his recital in Montreal and a large volume of sales is reported.

"We only wish we had taken on the representation of the Brunswick long ago," is the way the Cowan Piano & Music Co. expressed themselves to your correspondent. This firm are devoting considerable more space to the talking machine end of their business and purpose utilizing their upstairs studios for demonstrating parlors.

All the talking machine and piano dealers observed the recent heatless term of three days' duration.

Among the congratulations which have poured in upon Thomas A. Edison on the occasion of his seventy-first birthday were many from friends in Canada. Some of these messages are from men who recall the time when the electrical wizard sold papers and candy on the Grand Trunk trains.

RECENT DINNER OF MONTREAL TALKING MACHINE MEN

About Thirty-five Members of the Trade Have Most Enjoyable Reunion at Cooper's—Black Diamond Needle Co. Organized—Brunswick Phonograph Popular—Congratulations for Edison

MONTREAL, CAN., March 5.—A dinner free from long-drawn-out cut-and-dried speeches was that of the Montreal talking machine men held recently at Cooper's. The entertainment furnished by professional talent was given hearty applause and numbers of encores. Covers were laid for thirty-five and the dinner was of the high standard for which Cooper's is famed and was heartily enjoyed, of course. S. H. Brown, the versatile linguist and retail sales manager of the Berliner Gramophone Co., Ltd., who is excep-

tionally and most favorably known to the trade on the other side of the line, demonstrated that he could manage and conduct a dinner and entertainment of this nature as well as he conducts business. Those contributing to the program included Thomas Cowan, Lieutenant B. C. Hillium, S. R. Adamson, T. L. Rettie, Sergeant Harry Pearson, et al.

At a recital given in aid of the Red Cross at Windsor, N. S., a Starr phonograph contributed to the program. The phonograph was a dupli-

VALUE OF PERSISTENT PUBLICITY

Kirkman Engineering Corp. Tell of the Progress of Their Products—Advertising for Six Years in The World—Have Built Big Business

The Kirkman Engineering Corp., New York, manufacturer of automatic stops and other successful phonograph accessories, has been making rapid progress the past year, and in a chat with The World Thomas W. Kirkman, president and general manager of the company, stated as follows:

"We have been advertising our accessories in your paper for the past six years, and at the present time have a steadily increasing list of patrons, which includes manufacturers and dealers from coast to coast. As an indication of the value of persistent merchandising and advertising, it is interesting to note that the demand for our K-E automatic stops is far ahead of our expectations, and in advance of our manufacturing facilities.

"When we started to produce our automatic stops, the manufacturers of talking machines did not accept the idea with unanimous favor. Some argued that it was an added expense, and an unnecessary innovation, but our persistent campaign to the trade and the success of our device

has 'sold' the idea of an automatic stop to manufacturers and dealers everywhere.

"To-day we are selling the K-E automatic stops to many different talking machine manufacturers, including some of the leaders of the industry. From a new accessory, handled by the dealer only, it has progressed until it is now recognized as a part of the standard equipment of the high-grade, successful talking machine. We have weathered many storms in manufacturing and merchandising these stops, and as we look back upon our six years' experience in this field, we are inclined to believe that the practical merit of our device has enabled us to overcome all the obstacles which confronted us during the first few years, and gained for our product country-wide recognition."

CLAIMS PATENTS ARE INFRINGED

Mutual Talking Machine Co. Announces That it Plans to Prosecute Several Concerns for Imitating Its Ball Bearing Tone Arm

"During the past few weeks," said Wm. Phillips, president of the Mutual Talking Machine Co., New York, "my attention has been called to the fact that several concerns in the trade are infringing on the Mutual ball bearing

tone arm. Some of these infringements are sufficiently flagrant to warrant our attention, especially in view of the fact that this tone arm is a patented product, and patent claims have been granted on all of its distinctive features.

"It is our intention to prosecute vigorously all infringers of this ball bearing tone arm, and I have just placed in the hands of our attorneys proofs against two concerns whose infringements have been so serious that our customers have called our attention to their duplication of our product.

"We do not sell the Mutual ball bearing tone arm to motor manufacturers, but market it direct to the talking machine manufacturers or dealers, thereby eliminating the middleman, and enabling us to give maximum service to our clients. We, therefore, feel that the talking machine industry should be conversant of the infringers of our tone arm, particularly as this ball bearing tone arm is an original product, which is fully covered by patents. I may add that we intend to prosecute not only under the patent laws, but under the laws covering unfair competition."

Frank M. Elmer, talking machine dealer of Watertown, N. Y., has purchased a controlling interest in the Watertown News Co. here.

AMERICAN



No. 22—\$175.00



No. 13—\$135.00



No. 5—\$50.00



No. 4—\$40.00

AMERICANS embody all the good qualities and special features of phonographs, clear in tone, beautiful in design, finest finish, smooth running motors.

We stand back of every American



No. 8—\$65.00



No. 9—\$80.00



No. 10—\$100.00



No. 11—\$115.00

**American
Phonograph Co.**

39 Fountain Street, N. W.
GRAND RAPIDS MICH.

An Artistic Easter Window Suggestion Described for Talking Machine Dealers

By Ellis Hansen

This is the thirteenth of a series of articles on window display written by Ellis Hansen, who is recognized as one of the most practical designers of talking machine window displays in the United States.

Easter has come to be looked upon as the occasion for elaborate window displays.

Department stores, to which the world undoubtedly is indebted for the high standard of commercial art in the show windows of this country, generally make the Easter season the time for the "spring openings" and to-day—more than ever before—the success of any "opening" depends to a great extent on window displays. Years ago it was considered good form during the Easter season to use religious emblems, such as a giant cross made up of artificial flowers or wax figures made to represent angels with flapping wings, mammoth eggs with big dolls inside. Stuffed rabbits and live chicks were also noticed in many windows, all to signify Easter and jolly the crowds into the spirit of Easter shopping.

To-day such an appeal from the show windows of any self-respecting store would be considered coarse and poor in taste and, therefore, bad business. The idea to-day of a successful Easter display is rather to carry the spirit of spring, the rebirth of Mother Earth with the flowers, trees and all the living things so dear to all of us after the long cold winter sleep.



Detail of Card for Reproduction by Card Writer Put that spirit into the display. This is best accomplished by the discriminating use of flowers. The graceful Easter lily is very popular and justly so, but I would advise against lilies or other white flowers exclusively, for they might give a funereal air to the entire display and that, of course, by all means must be avoided. Lilies and roses, with the latter predominating, with plenty of vines and leaves make a good combination.

Another reason for talking machine dealers not to emphasize Easter too strongly is the short life of such a display. Easter comes unusually early this year, to be exact on March 31. It would be illogical to keep an exclusive Easter display in a dealer's window more than about a week or ten days after this date. On the other hand, a spring display could very nicely give four or six weeks' service. This would encourage dealers to spend more time and money on such a setting on account of the greater length of time it would serve.

Manufacturers have been in the habit of sending out circulars, hangers and show cards advertising Easter records. These, of course, should be made use of for the proper length of time and would, no doubt, add to the sale of Easter records. But such cards and other Easter advertising should be taken out of the windows before they have grown stale. Nothing is more out of place than a Christmas dis-

play in February and that same principle applies just as well to other holiday seasons.

The fixtures illustrated and described in this article should be made substantially and of good material and finish. This will increase the cost somewhat, but when it is taken into consideration that such fixtures can be used over and over again for the different seasons by changing

writer is able to make such a transparent sign, but, of course, an ordinary and less expensive card could be substituted. The size of the card should be twenty-five inches in diameter to give plenty of space to fasten at the back. The center opening is twenty-one inches, which would leave two inches all around. The floral decorations used consist of two potted palms for

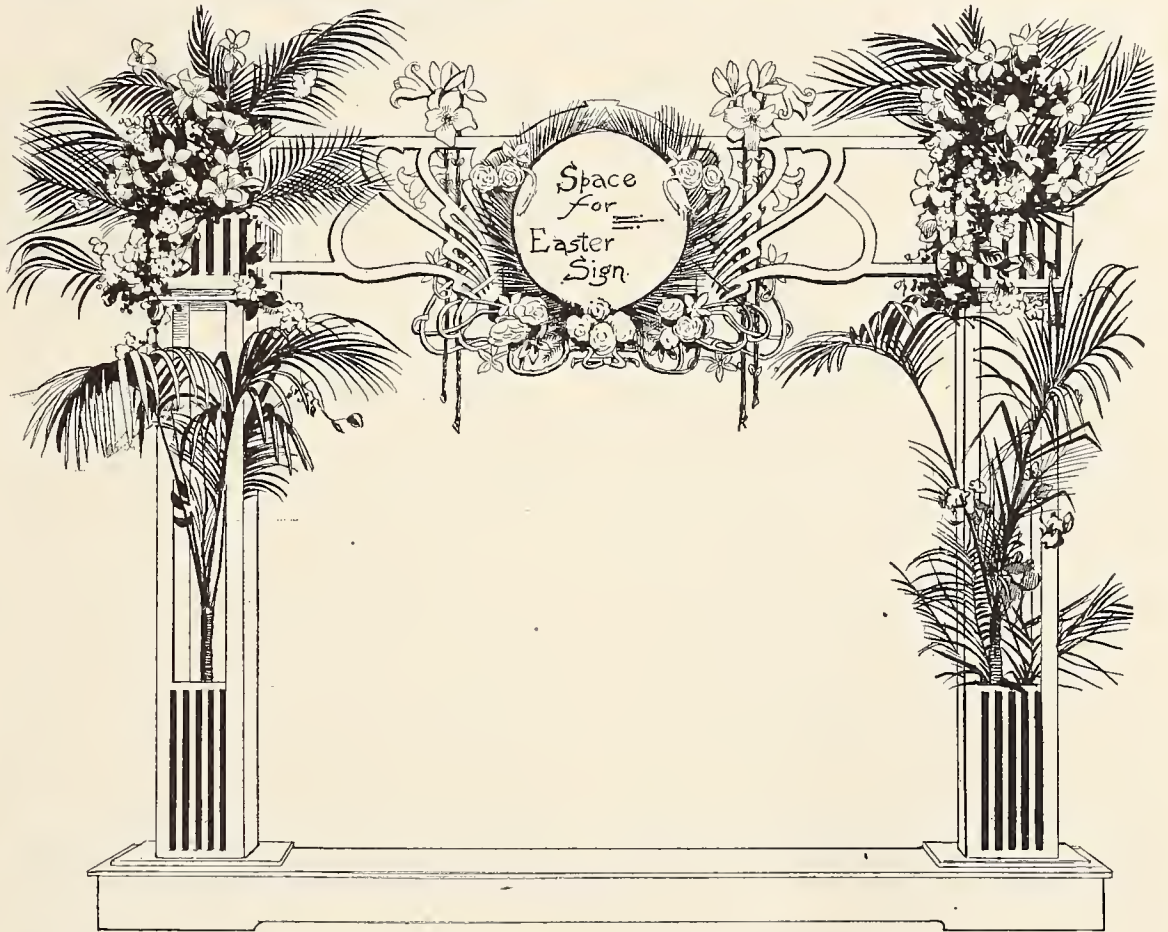

Easter Window Display Suggestion for Talking Machine Dealers

the floral decorations and show cards the additional first cost will pay in the long run. The fixtures consist of two tall flower stands built on simple straight lines. The lower parts are intended for palms or other graceful leaf plants. The upper parts are made into a kind of flower basket not only intended for holding flowers and foliage, but also serving to support the center

the lower part of the stands, Easter lilies, tea roses, and foliage and separate palm leaves. These can be furnished by any dealer in artificial flowers.

Such decorations can be used again and again, but care should be taken in storing them away when not in use. The making of artificial flowers has reached a high degree of perfec-

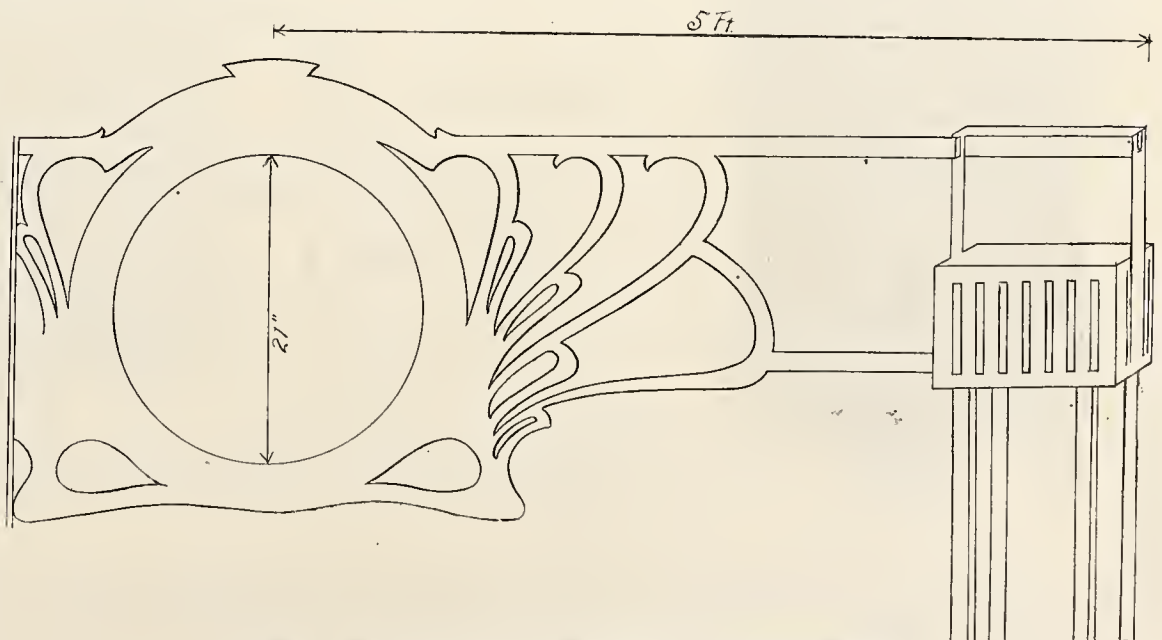

Detail of Section of Above Easter Window Display

tion. Nearly all the high-class stores make extensive use of them in all kinds of displays. Dealers, however, must be careful not to use the flowers in the shape in which they are sent from the manufacturers, which is in a stiff and unnatural way. This is done to take up as little space as possible in shipping. The stems, flowers and leaves should be blended and arranged as they appear in their natural state. If

(Continued on page 72)

AN ARTISTIC EASTER WINDOW SUGGESTION FOR DEALERS

(Continued from page 71)

this is done some very effective results can be obtained.

Now for the making of the fixtures. The easiest way would be to have a carpenter give an estimate as to the cost, and if satisfactory let him make all of the woodwork.

But for those who can spare the time and want the fun of making it themselves, I shall try to describe the material needed and how to go about the job.

Basswood $\frac{5}{8}$ -inch thick should be used throughout the display except for the square strips as stated. The base should be made 6 inches high, 30 inches wide and 10 feet in length. The height of the two flower stands is 7 feet 6 inches, which added to the 6-inch base makes these 8 feet high. Four strips, $1\frac{1}{2}$ -inch by $1\frac{1}{2}$ -inch, is needed for each stand; the length of these should be 6 feet 3 inches. Now mark each corner of the base in the shape of a square $10\frac{1}{2}$ inches, saw out four square holes $1\frac{1}{2}$ -inch by $1\frac{1}{2}$ -inch, into which the four $1\frac{1}{2}$ -inch strips should fit snugly. It is best to lower them to the bottom of the base as they are the main support of the entire fixture. The stands are $10\frac{1}{2}$ inches square, which leaves $7\frac{1}{2}$ inches between the uprights on all sides. The lower part of the stands intended for the palms is 21 inches high and contains $1\frac{7}{8}$ -inch by $\frac{7}{8}$ -inch strips four on each side, divided up between the $1\frac{1}{2}$ -inch uprights. These should be $19\frac{1}{4}$ inches in length. The distance between the strips must be exact. The two baskets on top of the supporting uprights overlap the uprights $1\frac{1}{2}$ inches on all four sides, which makes the bottom of the baskets $13\frac{1}{2}$ inches square. These are made of strips like the lower part of the stand, but instead of four strips $1\frac{7}{8}$ -inch by $\frac{7}{8}$ -inch six pieces are divided up between the corner pieces. The height of the baskets is 9 inches, which makes the length of the $\frac{7}{8}$ -inch strips $7\frac{1}{4}$ inches. The "handles" of the baskets

are made of $\frac{7}{8}$ -inch basswood, $2\frac{1}{2}$ inches wide by $16\frac{1}{2}$ inches long. Four such pieces are needed for the two baskets. Four square holes $1\frac{1}{2}$ -inch by $1\frac{1}{2}$ -inch are sawed out in the bottom of the baskets to hold the four uprights in place.

Now for the center piece. First make the pattern. Get a piece of fairly heavy paper (wrapping paper will do) size 32 inches by 60 inches, which will make one-half of the pattern. First enlarge the working diagram to the proper size, make the inside circle 21 inches in diameter and use this as a basis. The distance between the upper and lower bars in the center piece is $13\frac{1}{2}$ inches; the bars are $1\frac{1}{2}$ inches wide, which makes the size over all correspond to the size of the basket, handles $16\frac{1}{2}$ inches. Copy and enlarge the outlines as nearly as possible. Then take the pattern to a mill and have it band sawed. The wood should be $\frac{5}{8}$ -inch bass wood as said before, and the size required for the center piece would be 32 inches wide by 10 feet long. Finish the woodwork in ivory enamel or any other color you might desire.

BOSTON BOOK CO.'S NEW HOME

Have Spacious and Central Quarters at Southeast Corner of Washington Square, New York

Herewith is shown a photograph of the new home of the Boston Book Co. This building, which is a daylight plant, is equipped with the latest time and labor saving machines. The building is situated at the southeast corner of Washington Square, New York, and overlooks the park, thus giving the workers a view of nature both winter and summer. J. M. Alter, president of the above company, is very solicitous after his employes' welfare, and the new home of the company was selected with the view

of having one of the most efficient factories, and at the same time, by the installation of every convenience, make the work of the employes a



New Home of the Boston Book Co. pleasure. While the Boston Book Co.'s plant is quite large the necessity of carrying large reserve supplies of paper stock has compelled the firm to negotiate for other space in which to store such material.

MAKES IMPROVEMENTS IN STORE

Since taking over the management of the Rudolph Wurlitzer Co. store in Hamilton, O., H. J. Lee has made a number of improvements in the arrangement of the various departments, special attention being paid to the display and demonstration of Victrolas and player-pianos.

LONG CABINETS



No. 83

In all finishes. Specially adapted for use with Columbia 50. Front posts made to follow lines of posts on Columbia 75.

FIRST and FOREMOST

In the cabinet field.

Why? Because we've *specialized* in

CONSTRUCTION FINISH and ADAPTABILITY

Our supremacy in these essentials warrants your handling *the perfect line*.

That's why you should anticipate your wants NOW.



No. 79

In all finishes. Shown with top moulding and shelves. Specially adapted for use with Victrola IX.

Prompt deliveries on all orders. Write for Illustrated Catalogue of complete line

THE GEO. A. LONG CABINET COMPANY
HANOVER, PA.

TWO MILITARY GRAFONOLA TRUNKS

Now Ready for Styles 15 and 25—Have Tray for Records, Needles and Accessories

The dealer service department of the Columbia Graphophone Co. has just issued an attractive circular calling the attention of the Columbia dealers to the fact that there are now ready for distribution, two military Grafonola trunks, which hold Grafonolas Nos. 15 and 25.



Military Grafonola Outfit No. 25

These trunks were designed to meet the steadily increasing demand for such an article, and those dealers who have visited the Columbia headquarters are enthusiastic in their praise.

The trunks are equipped with a tray to hold a quantity of records, needles and accessories, and are especially built to hold Grafonolas securely at the bottom—the tone arm secured so as to permit no swinging, the winding crank fastens to the record tray. The whole, when locked, will adequately protect a Grafonola out-

fit from the most severe handling. Grafonola trunks are finished in olive drab, with brass and black-japanned fittings, locked with two keys, and leather grab handles provided for ease in handling.

This circular calls attention to the fact that Grafonolas are playing an important part in the life of American soldiers and sailors, being recognized as practical necessities in every military unit.

The Columbia Co.'s dealer service department suggests that the local dealers introduce Grafonola military outfits into the camps, and interest the local civic bodies and country organizations in the desirability of presenting these outfits to the boys who have joined the service from their communities.

By reason of the fact that the Columbia Co. has placed an order for a very large number of these trunks, Columbia dealers are enabled to purchase them at a very low price, and there is no doubt but that they can be featured by the dealer profitably and advantageously.



No. 25 Outfit, Ready for Shipping Tag or Quartermaster's Wagon

TAKES CHARGE IN DAYTON, O.

DAYTON, O., March 5.—Dovillo Gebhart, who has been engaged in the piano business in this city for the past few years, has become manager of the phonograph and record department of the Starr Piano Co. at 27 South Ludlow street, that city. Mr. Gebhart is very enthusiastic regarding the Starr phonograph and Gennett records, and has planned a strong campaign in that line.

UDELL WORKS ARE BUSY

Sales Manager Griffith Tells of the Active Conditions Prevalent at This Establishment

Tom Griffith, the well-known and popular sales manager of the Udell Works, Indianapolis, has recently joined the Indiana State Militia. Mr. Griffith does not come within the military service age, but very evidently is one of those practical Americans who, during wartimes, want to do their "bit" in a concrete fashion.

In a recent chat to The World Mr. Griffith remarked: "The Udell Works of Indianapolis, specialists in the building of cabinets for records and rolls, find themselves at this time with the biggest volume of business on their books that they have ever before enjoyed at this time of the year. In fact, the problem that we confront is getting men to make the cabinets and then getting them shipped. It is very evident from the demand for Udell cabinets that the talking machine business and the piano and player business is unusually good. It simply emphasizes the fact that in wartime people must have music to get their minds off the more serious side of this proposition.

"The Udell people take the position that the dealer is not rounding out a complete service unless he sells a cabinet, and from the good business standpoint he should sell the cabinet because he can make a profit on it and make a pleasing account. There is another angle on the cabinet sale which a dealer must not overlook, namely, that beyond any possible doubt the cabinet owner is a better buyer of new rolls. In this connection we recently received a letter from a prominent talking machine dealer in which he said:

"We found that the always satisfied owner of a Udell cabinet bought more records and rolls to start his library, and was a better repeat customer of the selfish desire to have a generous showing when he swung open the door of that well designed, properly constructed and beautifully finished Udell cabinet."

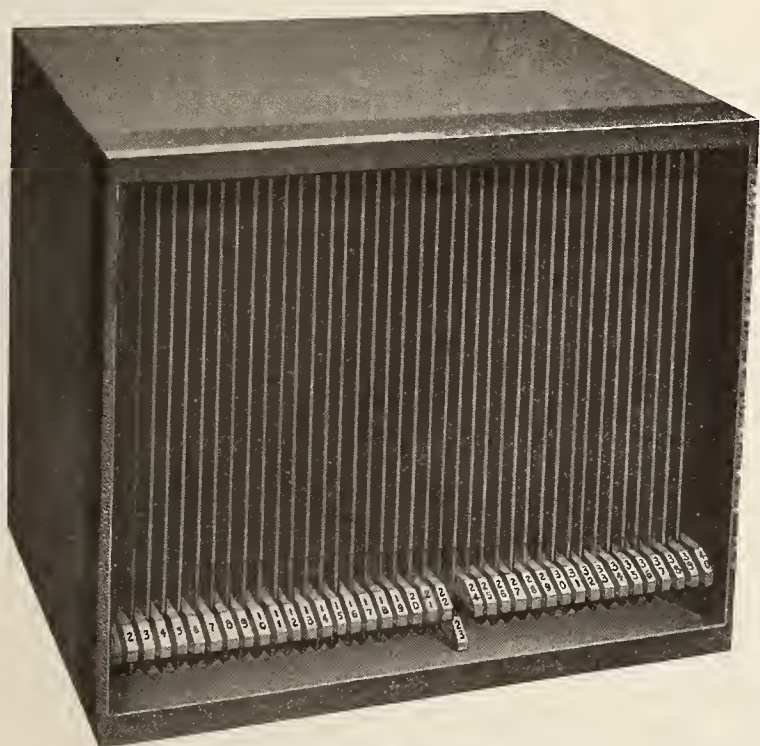

Style 150-E Retail \$10.00 Fits Edison C-150

Mr. Edison has given great thought and study to the tone of his truly marvelous instrument.

We have given untold thought and study to a device to simplify and facilitate the handling of the disc record.

The Eject-o-file Model 150-E

Has been designed and "BUILT TO FIT" the record compartment of the Edison Style C-150

Constructed with individual non-abrasive record compartments, filing and finding records is a pleasure when your machine is equipped with Eject-o-file.

Mr. DEALER, imagine it, you can now offer to your customer this device which embraces all the pleasure and joy of filing and finding you records at will. It greatly adds to the life and aids care of records. Just touch the button and the desired record is gently rolled into the hand.

Special files to fit any style or make talking machine, also auxiliary files. Order today

PEABODY PIANO COMPANY

JOHN STENGEL, Jr., President

Distributors of Eject-o-files

BALTIMORE, MARYLAND



ANNOUNCING

Ready File

FOR

THE NEW EDISON

MODELS A-100 AND C-150

ENDORSED BY

EDISON JOBBERS'
CONVENTION

NEW YORK, FEB. 18, 1918



Ready File means an extra profit of \$7 on practically every A-100 you sell—\$6 on practically every C-150.

Let us send complete details about this remarkable money-maker. A postal request will bring them at once.

The Ready File Co., Inc.

INDIANAPOLIS, IND.

Some Official Facts Regarding the Foreign Markets for Talking Machines

The development of the export business of this country in talking machines as a result of war conditions, and the shutting off of foreign manufacturing markets, is naturally a matter of much interest. More important perhaps than the present foreign demand is the question of securing a foothold in foreign countries in preparation for commercial activities after the war. The following review of the foreign market for talking machines, recently issued by the Bureau of Foreign and Domestic Commerce, is naturally of great interest, therefore, as indicating conditions as they exist at the present time, and offering a guide for American manufacturers seeking foreign outlet for their products. Reports issued by the Bureau follow:

French Indo-China

(Consul Horace Remillard, Saigon)

Talking machines are common in this district, and a good share of those sold here are of American make. American records are not so common, because of the small English-speaking population. Imports of talking machines and records for the period from January 1 to December 1, 1917, at Saigon, by countries, in kilos of 22 pounds were: From France, 219 kilos; America, 136 kilos; China, 110 kilos; Singapore, 23 kilos; Hongkong, 16 kilos; total 504 kilos. Most of the machines and records from "China" come from Shanghai, and many of them, as well as a great number of those from Hongkong and Singapore, are of American origin.

America pays the maximum duty on articles of this class. These duties, in francs per 100 kilos, are: Phonographs, gramophones, and similar machines, 90; cylinders or discs, not registered, 45; records registered on one side, 68; records registered on both sides, 90.

The prices obtained for talking machines and records are 40 to 50 per cent. higher than in the United States. Because of the distance and the slowness of transportation, machines and records, particularly the latter, should be carefully packed. As the chief towns are on or near the sea, there is no difficult inland transportation, and no conditions requiring special packing or preparation are to be encountered here.

France

(Consul William H. Hunt, St. Etienne)

Talking machines are classified under No. 604 of the French import tariff and pay an import duty of 90 francs per 100 kilos net weight (\$7.88 per 100 pounds). The rate of duty applicable to talking machines imported from countries having conventional or preferential tariff agreements is 60 francs per 100 kilos, but this rate does not apply to goods imported from the United States.

In order to obtain a footing in this market, it will be necessary for an American manufacturer either to open a branch in France or to grant an exclusive agency to some established firm. American phonograph companies now doing business here have successfully pursued both methods. If a branch or agency is established, it should be located in Lyons, Paris or Marseilles. St. Etienne is not sufficiently a center to serve as the seat of a general agency.

As the knowledge of English in French provincial business circles is not extensive, it is preferable that correspondence should be in French.

Manchuria

(Consul A. A. Williamson, Dairen)

The most popular talking machine in the Manchurian market, and one commanding by far the largest Japanese and Chinese patronage, is the "Nipponophone," made by the Nipponophone Co., of Japan. It is, distinctly a cheap machine, not to be compared with good machines of foreign manufacture, but its cheapness and the fact that it serves its purpose for two or three years is its greatest sales feature, and

one that American manufacturers who desire to sell to the masses here will find it hard to overcome. In fact, this firm once claimed that it had eliminated the competition of American manufacturers. Several well-known American makes, however, are on the market, and some business is done with them.

This class of goods is sold almost entirely by music stores or by stores handling them exclusively, although occasionally a jewelry store will carry them as a side line.

Records are on sale here, but they are almost entirely Japanese and Chinese music and pieces. The production of these records is a large business in the Far East. European music is seldom stocked locally, and those foreigners who have machines usually get their supplies of new records from Shanghai. Nipponophone needles are commonly used. An electric motor winder was imported some time ago, but apparently the importer has been able to do much with it.

Algeria

(Consul Arthur C. Frost, Algiers)

Phonographs, gramophones, etc., their accessories, separate parts, cases, and horns pay a duty of 90 francs per 100 kilos (\$7.88 per 100 pounds at the normal rate of exchange) when imported into Algeria. Freight and insurance rates at present are very high.

It is the custom of local houses to buy as largely as possible in France. This applies even to foreign merchandise, the local house preferring trade with a French agency to dealing directly with the foreign manufacturer. The French agency simplifies the negotiations, since the local house is familiar with French business methods and is able to obtain in France the quotations to which it is accustomed. It also simplifies customs formalities, as goods imported from France are admitted free of duty.

On account of the war the tendency is universal to dispense with luxuries. For this reason and because of high freight and insurance rates and the difficulties of transportation local houses are giving serious attention, with a view to immediate purchase, only to those American products for which there is an urgent present demand, and which can not readily be obtained in a nearer and more convenient market.

Considerable interest is being manifested in after-the-war trade with the United States, and business men are studying American products of all kinds with a view to deciding as to their suitability to the needs of the local market. To this end they appreciate receiving catalogs and advertising matter in French.

Switzerland

(Consul William P. Kent, Berne)

Talking machines do not yet have as impor-

tant a sale in Switzerland as in some other countries, but are being introduced slowly with great effort by German, French and Swiss manufacturers. Prior to the war Swiss manufacturers supplied about 20 per cent. of the market, but now their share amounts at least to 50 per cent. Cheap German products and German-made American machines are sold.

Current prices are: German (American) makes, \$30 to \$400; German, \$8 to \$120; Swiss, \$7 to \$100; French, \$10 to \$110. There are German, French and Belgian discs on the market at prices ranging from 40 cents to \$2. Since the beginning of the war prices have increased 60 per cent.

Import and Export Figures

The German imports, including German-made American machines, amount to \$47,828, and the French to \$15,488, while the direct American imports in 1914 were valued at \$1,752. In 1916 Switzerland exported \$330,000 worth of talking machines and cinematographs (the statistics include both classes of goods, but the figures represent chiefly exports of talking machines) to the United States. The increasing output of Swiss factories is clearly shown.

The talking machines that are sold here are chiefly those without horns. Commissions of 20 to 35 per cent. are granted to dealers on both machines and discs. France is a keen competitor in musical discs.

The total imports and exports of talking machines in 1915 and 1916 were:

Years	Imports		Exports	
	Pounds	Value	Pounds	Value
1915.....	153,000	\$55,285	2,152,813	\$680,383
1916.....	189,597	73,195	2,304,470	854,523

The duty on talking machines, according to the Swiss customs tariff, is \$3.86 per 220 pounds gross weight.

The chief Swiss manufacturers are Paillard & Co., Mermod Frères & Co., and Carl Lindström, all of Ste. Croix. A large credit house, with headquarters in Paris and branches in Geneva and La Chaux-de-Fonds, Switzerland, sells the French Pathé talking machines and discs by means of newspaper and magazine advertisements.

Requirements of Basel Market

(Consul Philip Holland, Basel)

American records for the most part are not satisfactory in Basel. There is practically no demand for voice records in English, and the European renditions of instrumental music appear to be as well done as those from the United States. There seems to be little, if any, interest in the high-priced voice records such as one commonly sees advertised in the American magazines.

Record Cleaners

The "Standard" Circular Cleaner grips the surface and clings as if on rails. A cleaner that has "made good."

PRICE, 50 CENTS, LIST

We also manufacture the "Simplex" Record Cleaner, 15 cents list price.

SEND 10 CENTS FOR A SAMPLE CLEANER

Automatic Stops



Automatic

Stops are in use everywhere. They give excellent service, are easily installed and are absolutely guaranteed.

SEND 50c FOR SAMPLE STOP

KIRKMAN ENGINEERING CORPORATION, 237 Lafayette St., New York

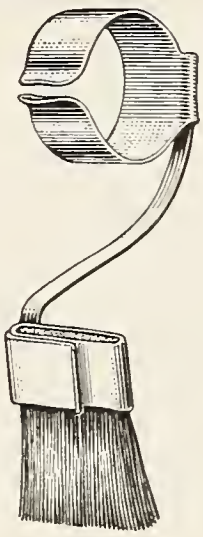

The IMPROVED No. 10

Cleanrite

TRADE MARK

RECORD BRUSH

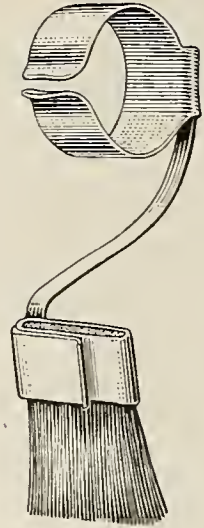

FOR VICTOR VICTROLAS

Price, Nickel Plated, 35c, Gold Plated, 75c

THE YIELDING SPRING IS THE BIG NEW THING

It Insures
Smooth
Surface
and
Preserves
Tone

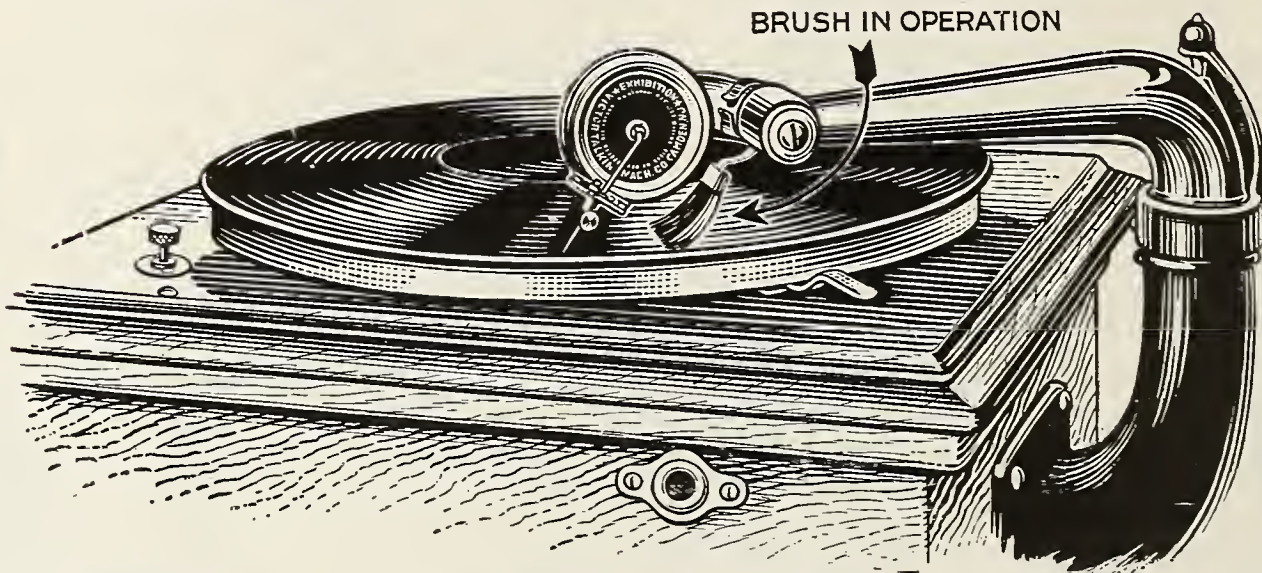

Best Selling
and Most
Indispensable
Accessory
for Victrolas
on
the Market

NO VICTROLA COMPLETE WITHOUT IT

No. 1



Is easily attached. Simply clamp Spring Clips (see No. 1) on goose neck as illustrated (see No. 2).

No. 2

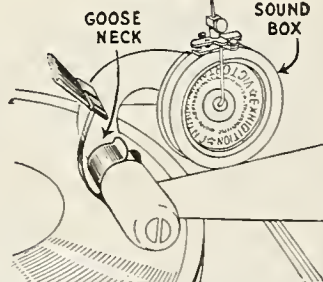

Once correctly adjusted (see No. 3) it does the work automatically.

The yielding spring insures correct Brush pressure regardless of Needle used.

No. 3

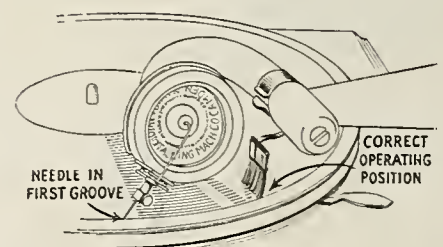

Write for Sample and Wholesale Price List

SPECIAL PRICE
SAMPLE BRUSH, POST PAID, 10c
 As this only covers cost of postage, packing, etc., we will supply only to bona-fide Dealers or Jobbers.

Regular Stock can be ordered from any VICTOR DISTRIBUTER or



Blackman

TALKING MACHINE Co.

97 CHAMBERS ST. NEAR CHURCH ST. NEW YORK
 VICTOR DISTRIBUTERS



REPAIRS

TALKING MACHINE TROUBLES AND HOW TO REMEDY THEM

Conducted by Andrew H. Dodin

[This department of The Talking Machine World is designed for the service of all classes of our readers, including those who make, and those who sell, talking machines. Andrew H. Dodin, who conducts this department, has a wide and enviable reputation as a repairer of talking machines and conducts an exclusive talking machine repair shop at 176 Sixth Avenue, New York. Tell him your troubles through The World and he will help you if possible. The service is free.—Editor.]

THE NEW VICTOR MOTOR

During the past two or three months about every Victor dealer that I have met has asked me the following question: "Have you had much trouble with the new Victor motors?" Inasmuch as the average Victor dealer is more concerned with trying to get enough machines than he is for retaining in his memory answers to casual questions, I am going to outline the construction and give you my idea of the adjusting and repair of the new Victrola X. A. motor.

The spring barrel attracts our attention at our first sight of this new motor. Made of one piece of steel and containing the two main springs it is so entirely different from the usual Victor spring barrel that it stands out as the most important change in the method of construction.

Removing the sleeve screw (Part No. 5486 C. P.) permits us to push the spring barrel arbor (Part No. 5429 C. P.) through the casting bearings and so take the cage out of the motor. Place the cage on a bench—ratchet end down—then take hold of the main drive gear (Part No. 5428 A. C. P.) and pull straight up and we find that the sleeve slips out of the center of the main spring. We also find that, unlike the old style models, the spring center has no hole for the customary rivet but instead, the sleeve has a slot cut in its side, into which a V shape bend in the end of the main spring slides. On winding, the first turn of the spring presses this V part into the groove in the sleeve and the tighter the spring is wound the tighter the V part holds. This method of fastening the spring at its center does away with the old troubles of hooking the spring on the sleeve rivet and also prevents a lot of breakage of springs as the rivet head caused an uneven surface in the spring coil and had a tendency to cause springs to break a few inches from the center. Next the winding ratchet and gear (Part No. 5336 A. C. P.) are pulled out in the same manner as the

main drive gear and we are ready to remove the retaining ring (Part No. 3692 W. N.), take out spring barrel cap (Part No. 5363 A. W. N.) and take a look at the main springs. It is now necessary to take out the top main spring in order to get to the second one, and also the separating plate (Part No. 5334 P. F.) which will be found between the two main springs. In replacing the main springs care must be used to get them coiled back in the right direction, the one in the bottom of the cage is coiled to the right and the one at the top to the left.

Care must also be used in the handling of the main driving gear—that it is not bent out of true and that the teeth are not nicked or bent. The arrangement of the teeth of the top plate winding gear (Part No. 3861 A. C. P.) and the winding gear and ratchet (Part No. 5336 A.) makes this type of motor one of the easiest winding machines on the market to-day.

The balance of the motor is practically the same as the previous type Victor with the ex-

ception that the governor drive gear (Part No. 5357 B.) is larger in diameter than the old governor gear (Part No. 2757 B.) and the same is true of the governor spindle (Part No. 5354 P. F.) as compared to Part No. 3275 P. F. in the older type.

The long sleeve on the governor friction (1595 D. P. F.) will prevent the breakage of governor springs, for it will strike against the governor collar (Part No. 3299 A.) before the springs have spread enough to break. Another guard against governor spring breakage is the little pin in the casting frame which engages the screw on part No. 5331 A. and prevents the improper movement of the regulating shaft (Part No. 5358 W. N.).

Outside of a few minor adjustments I have very little trouble with this type of motor, and if it is carefully adjusted, properly graphited, oiled and greased there is no reason why it should not outlast and stay in adjustment longer than any other motor on the market to-day.

McCORMACK'S \$75,000 INCOME TAX

Noted Irish Tenor's Contribution to the Government Exceeds That of Caruso—Great Work for the Red Cross—Big Royalties on Records

John McCormack, the noted Irish tenor and Victor artist, put into the hands of Mark Eisner, Collector of Internal Revenue for the Third New York District, a check for \$75,000, a sum equal to the annual salary of the President, which represented Mr. McCormack's income tax for the year. This exceeds by \$16,000 the income tax paid by Enrico Caruso three weeks ago, and is believed to represent an income of approximately \$300,000 a year.

Accompanied by D. F. McSweeney, his associate manager; M. F. Doyle, his attorney; United States Marshal Thomas D. McCarthy, a friend of the singer, Mr. McCormack went to 1150 Broadway, one day last week. News that he was coming had spread among the employes in the office, and the singer was the object of much interest when he arrived. He was introduced to Mr. Eisner by Marshal McCarthy, and the necessary papers were drawn in about half an hour. After Mr. McCormack had signed the form he made out a check for \$75,000 and was photographed handing it to Mr. Eisner.

After leaving Mr. Eisner's private room, Mr. McCormack rejoined Marshal McCarthy and Mr. Sweeney, and remarked, as a broad grin overspread his face: "If my father ever found out what I paid inside he would curse the Germans more than he does."

Asked how he felt about giving up so large a sum to the Government, Mr. McCormack re-

plied: "It makes me feel happy to do my bit for the country that made possible my success. It certainly makes a man feel great when he knows he is doing his duty. You know the Bible says 'The Lord giveth and the Lord taketh away. Blessed be the name of the Lord.' Well, with me it has been a case of America giveth and America taketh away. Blessed be the name of America."

McCormack's income is derived from his public appearances and from royalties on talking machine records. His associates say his income the last year from the records alone amounts to more than \$180,000. This is said to be greater than any two other singers living. Caruso's income from talking machine records is said to be \$125,000, with an equal amount from his operatic work, making \$250,000 in all.

McCormack started this week on his trans-continental tour to raise \$100,000 for the Red Cross. He has already taken in \$28,000 toward this sum from performances in Washington, Philadelphia, Boston and Cleveland. The largest amount contributed to the Red Cross at any concert was \$12,000, in Cleveland, but the singer received a telegram yesterday that San Francisco is out to make a record of \$20,000.

When his obligations to the Red Cross are canceled, Mr. McCormack expects to appear at a series of concerts in behalf of the Knights of Columbus War Camp Fund. It would not be surprising if at the end of his last tour in May he went to France to sing for the soldiers. He was quoted as saying that if it was thought he could contribute to the success of the war by going to France he would be glad to do so.

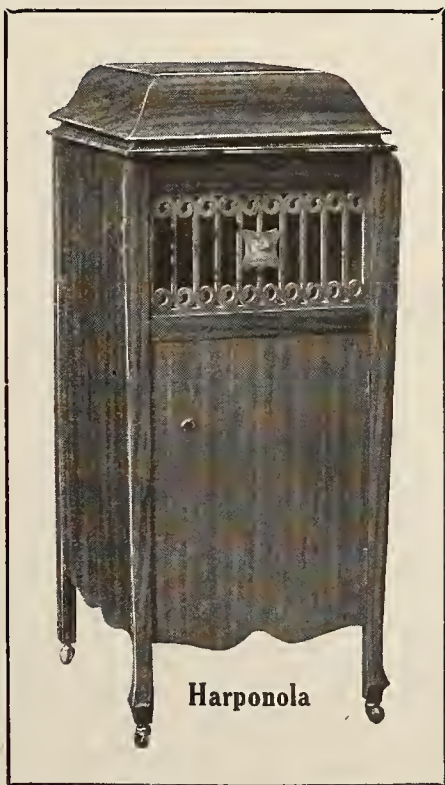

Harponola

Equipped—CABINETS—Unequipped

Our long experience as master builders of artistic cabinets enables us to produce a talking machine cabinet of exceptional merit. We offer

TO THE MANUFACTURER—These cabinets.

TO THE DEALER—High-class cabinets in which is installed the best mechanical equipment that money can buy. Send for catalogue.

TO THE JOBBER—Fully equipped machines under your trade mark or ours, in carload lots at jobbing discounts.

Prices that are right in each case. Send for particulars

THE CELINA FURNITURE CO.
CELINA OHIO

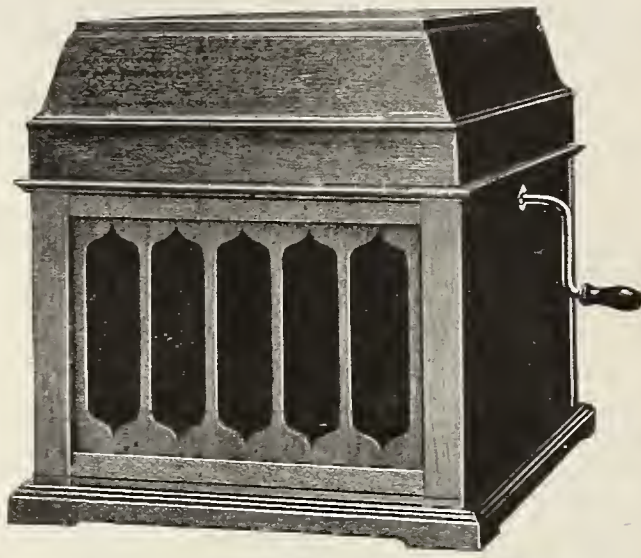

THE NEW EDISON DIAMOND AMBEROLA
MODEL 50

NO MERCHANDISE represents more remarkable value than the New Edison Diamond Amberola and Edison Blue Amberol Records.

The famous Edison curtain tests prove this. In these tests talking machines costing from two to five times as much have been completely outclassed by the Amberola.

To the best of our knowledge and belief Amberola sales are increasing faster than the sales of any other musical instrument on the market.

THOMAS A. EDISON, Inc.

Amberola Department

ORANGE, N. J.

ROGER N. LAGOW'S NEW POST

Victor Traveler and Foreign Trade Expert Now With Lightner & Leon, Wholesale Representatives of Victor Co. in South America

The resignation of Roger N. Lagow was accepted by the Victor Talking Machine Co. the first of this month. Mr. Lagow has for several years been an energetic member of the Victor Co.'s traveling staff, and in this capacity he has done much in the way of creating and applying



Roger N. Lagow

new and original sales and advertising plans for Victor dealers. Mr. Lagow, it should be added, has recently allied himself with the organization of Lightner & Leon, which firm is the South American wholesale representative of the Victor Co. His new position will mean an analytical study of the problems pertaining to wholesale export and import trade, for which work his past experience will stand him in good stead. Mr. Lagow, after graduating from Indiana University, took his Master's Degree at Harvard, and then for two years studied the romance languages in Paris, Madrid and Spanish America. At the conclusion of his foreign study he taught the romance languages at the University of Minnesota.

PLAN FOR BIG PRODUCTION

The Munzer Mfg. Corp. Have Produced Double the Number of Instruments Originally Planned for Their First Year—Big Plans Ahead

MINNEAPOLIS, MINN., March 9.—The Munzer Mfg. Corp., of this city, has now started its second year manufacturing Munola phonographs, and its success has been remarkable considering the short period of its business.

W. W. Munzer, director of sales, in an interview, states that their company have produced double the number of instruments originally planned during their first year. The most satisfying feature of their business has been the large number of repeat orders received from their various dealers. In fact, they are receiving repeat orders from approximately 85 per cent. of the active dealers in their organization. While they are hampered in selling machines through the Eastern part of the country on account of the transportation difficulties, they are overcoming this by the tremendous amount of business received from the Mississippi Valley and the Western United States.

While conditions are uncertain the Munzer Mfg. Corp. are planning a production for 1918 of 75,000 Munolas, and they claim they will sell double this amount if they can secure the material. While they have been specializing on the production of an instrument retailing at \$44.50, they state that they will turn out possibly one or two more models in addition to the original Munola.

DEATH OF JOHN C. ENGLISH

Prominent Talking Machine Inventor and Experimenter Passes Away in Texas

CAMDEN, N. J., March 4.—Word has been received from San Antonio, Tex., of the sudden death of John Clifford English, well known in New York and Philadelphia as a physicist, chemist and expert in acoustics. Mr. English had devoted the last eighteen years to the development of the art of sound reproducing, and was one of the men whose labors have done much to bring the product of the Victor Talking Machine Co. to its present state of perfection. Mr. English was in San Antonio for the benefit of his health, having on previous occasions found the climate there helpful. He leaves a widow.

MANY SWEATERS FOR SPALDING

Edison Artist in No Danger of Freezing or Starving to Death in France

The esteem in which Lieutenant Spalding, the Edison artist, is held by his many friends, is indicated by the fact that up-to-date he is reported to have received over eighty sweaters, and a great bulk of other knitted material since his arrival in France, to say nothing of huge quantities of tobacco, chocolates, books, etc. Mr. Spalding's present address in France is "Somewhere."

SERVICE FLAG ON LETTER HEADS

A clever adaptation of the service flag idea comes from the Standard Talking Machine Co., Victor wholesalers in Pittsburgh, Pa., who have printed in the lower corner of all their letter sheets, in colors, a service flag with four stars. The bright red border and blue stars show up most effectively and carry to every correspondent of the house the message that four Standard men are serving in the cause of democracy.

NEW BRILLIANTONE NEEDLE

Brilliantone Steel Needle Co. Announce New Long Tapered Steel Half-Toned Needle to Meet Demands—To Feature Export Trade

The Brilliantone Steel Needle Co., Marbridge Building, New York City, announce the addition of a new needle to their line. This new needle is a long tapered steel half-toned needle and was produced in response to insistent demands for this style.

B. R. Forster, president of the company, reports that the Brilliantone steel needle is not only immensely popular in this country but in foreign lands as well. Arrangements have just been concluded whereby one of the largest exporting houses in this country will represent this company in Shanghai, China. The Brilliantone steel needle is also enjoying popularity in points as far distant as Buenos Aires and Rio de Janeiro.

Eugene Latham, who was connected with this organization, has joined the United States Aviation Service and will devote the same energy he faithfully used in the selling of the Brilliantone steel needle to the services of his country.

SONORA DAILY PAPER PUBLICITY

The Sonora Phonograph Sales Co., Inc., has been using attractive advertising in the local newspapers, calling attention to the company's policy of selling its instruments without offering "easy" payments as the leading attraction. This copy has won favorable commendation from the company's dealers, who appreciate the fact that this publicity is helping them materially in developing Sonora business. The text states that "the Sonora is sold on a quality basis only, and you always get full value. When you buy a Sonora, you buy it for its quality, the terms being only secondary conditions."

"Is your daughter fond of the needle?"
"Very, if you refer to the gramophone needle."

"Lundstrom"
IT GROWS WITH YOUR BUSINESS

Standard Sectional Record Cabinet

A practical, inexpensive, convenient cabinet for dealers; made on the sectional principle, affording the following advantages:

It grows with your requirements: You first purchase just the number of sections you actually need for your present requirements; as you need more space, add more sections.

Adapted to any space: As many sections as desired may be placed in a stack; as many stacks may be used side by side as wall space will permit. Each section or shelf is indexed by a letter and each compartment by a number, forming a system of filing unsurpassed for simplicity and convenience.

Neat in appearance: No empty shelves; no overcrowding. Case always complete, yet always capable of additional expansion.

Carefully made and beautifully finished in plain and quartered oak, and in imitation and genuine mahogany.

Made in two sizes; to hold 10-inch and 12-inch records. Each section holds 200 records (100 Edison records). Stack may be made up with all sections of the same size; or sections for 10-inch records may be used above sections for 12-inch records by means of a reducing section as shown in accompanying illustration. Record sections furnished with or without doors.

Price for section \$3.00 and up

Cases shipped on approval direct from factory at considerable saving to you; on orders amounting to \$10.00 and over we pay freight to all points East of Montana, Wyoming, Colorado and New Mexico. To points in and West of these states, we equalize freight charges. For further particulars and full list of prices for the different sections in the different grades, write for illustrated circular No. 80.

The C. J. Lundstrom Mfg. Co.
LITTLE FALLS, N. Y.
Branch Office, Flatiron Bldg., New York City
Fifteen Years' Experience Making High Grade Filing Cabinets and Bookcases

"Over the Top" with Victor Records

Let this be your slogan for 1918



Victor
 Price 75¢
 Just a Baby's Prayer at Twilight
 Henry Burr
 18439

Victor Wholesalers

New York Talking Machine Co.
 119 W. 40th Street
 New York

Chicago Talking Machine Co.
 12 N. Michigan Ave.
 Chicago

FROM OUR CHICAGO HEADQUARTERS

E. P. VAN HARLINGEN,
Manager

World Office
Republic Bldg., 209 South State St., Chicago
Telephone: Wabash 5774

CHICAGO, ILL., March 12.—Both the wholesale and the retail trade of Chicago are feeling the effects of the loosening up of the recent freight congestion throughout the East. The record situation, while still acute, is in better condition than it has been for several weeks, due to the fact that manufacturers have been making use of the express service to send in their supplies. This, of course, adds somewhat to the expense of forwarding these records; nevertheless, the freight situation warranted this increased expenditure in order to relieve the situation. Another thing that the retail dealers are up against is how to appease the public demand for the popular song records, as the supply of these coming in is very limited. To meet the situation the dealers have been telling what they believe is true because, owing to the fact that experts in the record pressing departments have been drafted, they are working short-handed. It is further said that the process of pressing the record is not a "fly-by-night" proposition, but that it takes at least a year's training before a man can become proficient in the art of running one of these hydraulic presses and that it is estimated that at the end of that time his efficiency amounts to one-third, as two-thirds of the work he turns out will not pass inspection. These statements are being generally made by dealers who know the situation pretty thoroughly and bears considerable weight with their customers.

The wholesale dealers are facing a big situation in that they are getting a great many more orders than they have ever before received. This is brought about by the fact that the retail dealers are sending in their orders not to one place but to several places and in that manner making up their new stock lists; that is, the wholesaler is filling as much of the order as he can, making the shipment to the retailer, and the retailer is then taking the unfilled part of his order, returning it to some other wholesaler to see if he can add any more to the list. In this way the retailer is calling upon the resources not only of one but of several supply houses.

With the disappearance of the great snow blanket which covered the country last month, the railroads were enabled to relieve the shipping situation to a very great extent, and for this reason the wholesale dealers are getting in their machine shipments in a greater quantity

than heretofore. Where it formerly took at least six weeks for a shipment to go through, especially from the East, the same shipments are now coming in in from three to four weeks. The manufacturing plants are working to capacity and are turning out and shipping more machines than they have ever done.

While there is still a shortage of the medium-priced machines it is not so great as last month and the situation along this line is slowly coming back to normal. A great many of the manufacturers are preparing for the big "spring drive" which they anticipate will be launched in a short time, and for that reason have been putting on more employes and purchasing more materials so as to take care of the demand.

Ryde Enters Business

J. P. L. Ryde, who for the past twenty years was connected with the firm of Lyon & Healy, and for the last four years assistant manager of the Victor department, has resigned his position and is now located in Indianapolis, where he has purchased an interest in the firm of Fuller-Wagner Music Co. His new connection is a partnership with the firm and this company will now be known as the Fuller-Ryde Music Co. His successor at the Lyon & Healy establishment is H. J. Fidelke. Mr. Fidelke was formerly manager of the retail city credit department of that house.

The formal resignation took place on the evening of February 21, and on the previous evening Mr. Ryde was given a farewell dinner and theatre party by his former associates. The members of the firm who participated in the affair presented him with a silk umbrella and an engraved fountain pen, the presentation being made by L. C. Wiswell, manager of the Victor department of Lyon & Healy. There were fifteen members of the staff present at the party and dinner, one of the guests being W. Roche, who was in Chicago at the time on leave of absence. Mr. Roche was a former member of the firm of Lyon & Healy, but is now serving in the U. S. navy on the Battleship "Vermont," which is stationed somewhere at an "Atlantic port."

Six Best Sellers

Columbia Graphophone Co. announce for the past month the following six best sellers: "Long Boy" and "For You a Rose"; "Darktown Strutters' Ball" and "I'm All Bound Round With the

Mason-Dixon Line"; "Wait 'Til the Cows Come Home" and "Somewhere in France Is the Lily"; "Do Something" and "Liberty Bell"; "Hello, My Dearie" and "Ching Chong."

Six best sellers for the Victor Co. for the past month are: "Capricieuse" (Jascha Heifetz); "Gems From Leave it to Jane" and "Jack o' Lantern"; "Sweet Little Buttercup" and "Homeward Bound"; "Liberty Loan March" and "U. S. Field Artillery March" (Sousa's Band); "Maytime Waltz" and "American Serenade"; "Lorraine" and "Chimes of Normandy."

Pathé best sellers for the past month are as follows: "My Sweetie" and "Yock-A-Hilo Town"; "Give Me the Moonlight, Give Me the Girl" and "Hello! I've Been Looking for You"; "Homeward Bound" and "When the Boys From Dixie Eat the Melon on the Rhine"; "A Baby's Prayer at Twilight" and "Valley Rose"; "Liberty Bell" and "There's a Million Heroes in Each Corner of the U. S. A."; "Goulash" and "My Dough Boy."

Six best sellers from the Edison list for the past month are: "Leave it to Jane" and "Siren's Song" (Leave it to Jane); "Knit, Knit, Knit" (Jack o' Lantern) and "Jack o' Lantern Fox-Trot"; "Sweet, Emalina, My Gal" and "There it Goes Again"; "I Don't Want to Get Well" and "I'm All Bound Round With the Mason-Dixon Line"; "Naval Reserve March" and "Spirit of America."

The six best sellers for the Gennett records during the past month were as follows: "Largo" and "Meditation—Thais," violin solos (art tone record); "Hail! Hail! the Gang's All Here" and "I Don't Want to Get Well"; "Honolulu March" and "Kilima Waltz" (Hawaiian Instrumental Trio); "Over There" (one-step) and "Birds and the Brook"; "Paddle-Addle" (fox-trot) and "He's Just Like You" (one-step); "When the Bell in the Lighthouse Rings" and "Rocked in the Cradle of the Deep" (art tone record).

Perfects "Container" Distribution

F. P. Read, head of the Automatic Container Co., returned this week from Buffalo, where he had been making preparations with a large cabinet manufacturing company for the handling of their Eastern business. Mr. Read stated that he has also made arrangements with various manufacturing companies located in different

(Continued on page 83)

THE "WADE" FIBRE NEEDLE CUTTER

Service Feature Is of Immense Importance

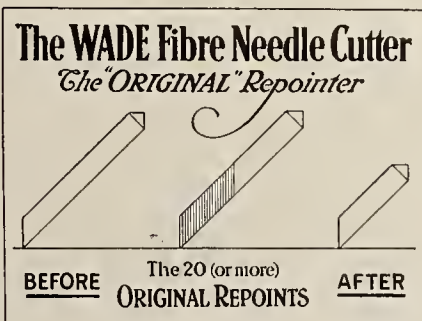

Your greatest revenue, Mr. Dealer, is from record sales.

The average customer seldom buys more than one talking machine in a lifetime, but may be readily educated to systematically accumulate a record library and thereby become a constant source of revenue to you.

The Wade Fibre Needle Cutter Is the Connecting Link

It permits the use of Fibre Needles, with all their acknowledged advantages, at the minimum expense, with its 20 or more original re-points to each fibre needle, and is very cheap insurance on the life of their records.

Instruct your salespersons to use these sales arguments and you will soon have a Wade Cutter and Fibre Needle in every customer's home, which, will naturally result in increased record sales.

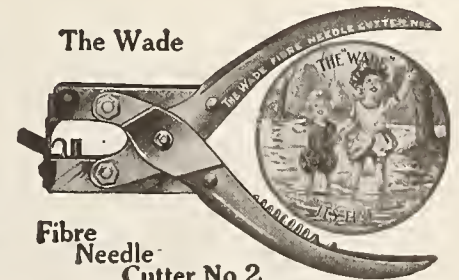

Price \$2.00

WADE & WADE, 3807 Lake Park Ave., Chicago, Ill.

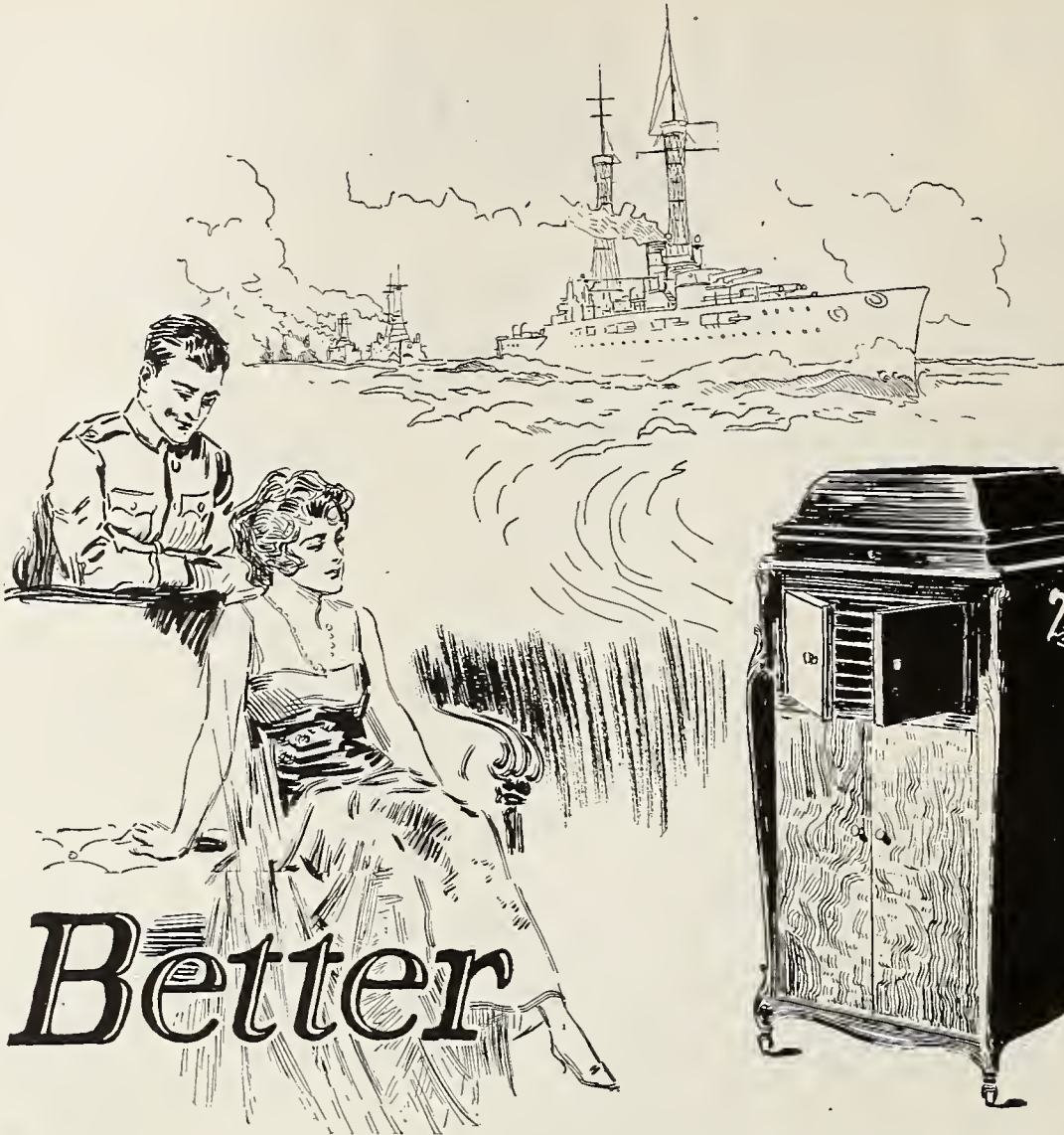

Better

SERVICE

Since the founding of this house in 1864 our ideal has been "to improve the service." War conditions now make this a patriotic duty. Orders placed with us are shipped without delay and as complete as possible from our large stock of over a half million records.

BUSINESS BUILDERS

Victrola Newspaper Advertising Service
52 Cuts a Year—\$8.33 per month

Victrola Newspaper Half Service
26 Cuts a Year—\$4.17 per month

Victrola Folder Service
For Mailing the Monthly Supplements in Place of Envelopes

Victrola Window Display Cards
Featuring the New Records

Small Instrument Newspaper Advertising Service
36 Cuts a Year—\$4.17 per month

Piano Advertising Service
Free to Dealers Who Represent America's Most Popular
High Grade Piano

Samples and Prices Free—Write for Them

Fibre needles are an economy for your customers. They give satisfaction and prolong the life of the records.

Send us a trial order and be sure to include a liberal supply of the efficient L & H Fibre Needle Cutters.

LYON & HEALY

VICTOR
DISTRIBUTORS

CHICAGO

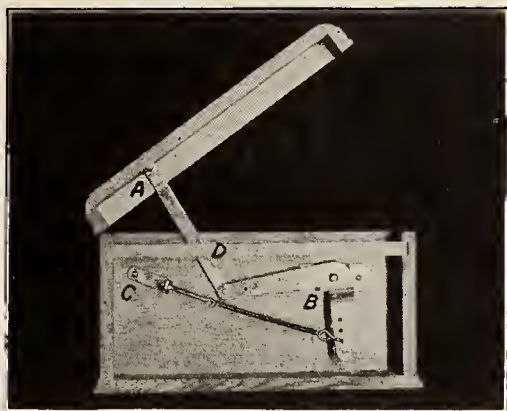

CHICAGO COVER BALANCE NO. 1

ISN'T IT TRUE?

You look for and insist upon style—finish and tone. Then again you insist upon a well-regulated motor, invisible hinges, and the best models of sound boxes and tone arms obtainable. Why not use the same judgment when selecting your cover support?

THE CHICAGO COVER BALANCE No. 1

is an absolute essential to the manufacturer who "produces the goods" instead of "talking quality."

CHICAGO HINGED COVER SUPPORT AND BALANCE CO.

2242 WEST 69th STREET, CHICAGO, ILL.

FROM OUR CHICAGO HEADQUARTERS—(Continued from page 81)

parts of the country to make their automatic record containers, the idea being that if orders are received from certain sections to turn them over to a manufacturer located in that particular territory, and thereby assuring their various dealers of prompt attention.

Mr. Read stated that the latest addition to their already large line, the salesman sample case, has met with much favor with the trade. This is a small compact leatherette case which consists of a simple automatic filing device and will carry twenty-four records. The case is small, light of weight and neat in appearance. It should prove popular.

New Assistant Manager

Miss Vera B. Jones, formerly connected with the Davis Phonograph Co. and for over six years associated with the J. Palmer Music Co., of Monfort, Wis., is now assistant to W. E. Cotter, retail sales manager of the phonograph department of the Thos. E. Wilson Co.

Hold Directors' Meeting

Among the prominent visitors to the trade this week was A. D. Geissler, of the New York Talking Machine Co., who was in town to attend a directors' meeting of the combined forces of the New York Talking Machine Co. and the Chicago Talking Machine Co. After the meeting Mr. Geissler, accompanied by R. J. Keith, D. A. Creed, H. P. Ellis and W. C. Griffith, spent a delightful evening at the Garrick Theatre.

What Is the Price?

One of the large drug concerns in Chicago have the agency for a small table talking machine which they advertised recently in their 1-cent sales. The method of advertising this machine has aroused much interest in the trade and is causing much wonderment as regards its actual retail price. The sale price of this machine varies in a way that would cause one to think that the quoted price was suggested by the weather bureau. The reason is this: One

day there is a special sale announcing, "This marvelous phonograph now on sale. Price \$15. Two for \$15.01." The next day or so the sign in the window is changed and reads, "This marvelous phonograph \$8.95." Then again the price changes to \$9.95. As the same machine is always shown it is little wonder that the trade in general is guessing as to its actual value.

Have Remarkable Sales

G. Harry Bent, manager of the retail piano department and the Victor department of the well-known firm of Geo. P. Bent, said that their sales of talking machines and records for the months of December, January and February were larger than the corresponding period of last year. While their sales of machines have increased somewhat the record sales are far beyond those of this time last year. The medium-priced machines were, of course, the best sellers, but they have been pushing the higher-priced machines more than ever for the past few months and have been getting good results. "Of course, the recent shortage held us back somewhat," said Mr. Bent, "but in taking inventory we discovered that we had a lot of good records on hand that would satisfy the trade if a little salesmanship were used; therefore, we started out and began pushing these records and soon discovered that our trade was satisfied, the result being that we increased our record materially."

Hold Patriotic Test

Under the auspices of C. E. Goodwin, general manager of the Phonograph Co., a patriotic contest and Edison tone test was held at Orchestra Hall on the evening of February 28. The price of admission was 10 cents, and the entire proceeds were used in purchasing Army and Navy model Edison phonographs for the various military and naval organizations. The Edison Shop, a subsidiary of the Phonograph Co., furnished the outfits at actual cost. The outfit consisted

of an Edison Army and Navy phonograph and \$30 worth of records. A special feature of the test was Glen Ellison, baritone, who sang in direct comparison with the Army and Navy model. The audience was well pleased by his masterly rendition of various Scotch songs, and his intimate knowledge and understanding of the Scotch and quaint whimsicalities enabled him to render the famous Harry Lauder songs with a fervor and vim that immediately places him in a class with that famed artist himself. The rent of Orchestra Hall, together with advertising and all other expenses, were borne by the Edison Shop. Each one in the audience was given a little ballot with which to vote for his favorite army or navy regiment. When these tickets were collected they were sorted out and the organizations receiving the greatest number of votes were awarded the machines. There was enough money taken in the box office to purchase two of these outfits, and one outfit went to Camp Grant. As no particular company was designated, Colonel Heistand was given charge of the machine and the records with the understanding that he make an investigation of the various barracks at the big cantonment at Rockford and determine which company was without a talking machine and donate it to that particular company. The other machine was won by Company E, 131st Infantry, at Camp Logan, Houston, Tex. As there were a great many of the jackies from the Great Lakes Naval Training Station present in the audience, one patriotic citizen suggested that there be a collection taken up and another machine purchased for the benefit of the boys at Great Lakes. This was done and enough was collected to buy the outfit for the jackies. The phonograph and the records were awarded to Company H, Third Regiment, at Camp Dewey.

Raffle Brunswick for Red Cross

At the recent Country Fair, which was held

(Continued on page 85)

TRANSFER NAME-PLATES

We make the Transfer Name-Plates and Trade-Marks for the largest talking machine manufacturers in this country and for dealers in every state.

YOUR NAME, Mr. Dealer, on every machine brings the owner back to you for records and his friends to you for a machine.

Samples, Suggestions and Sketches Furnished Free

THE MEYERCORD COMPANY, CHICAGO

Largest Manufacturers of **DECALCOMANIA** Transfer Name-Plates

What Happened at the Naval Training Station

A Phonograph Story That Points the Way for Every Phonograph Dealer

At the Great Lakes Naval Training Station are several club houses for the Jackies. In fitting up these camp homes, friends sent phonograph records, books, pictures and the like. The records were all DIFFERENT makes. Some were from one company, some from another. No single phonograph would have played them all—that is, none of the ONE-record type—so, naturally, a Brunswick was chosen.

THE Brunswick plays *all* records, whatever make. All the different kinds contributed were playable. None had to be laid away. This story could probably be told for many army and navy camps. Unless the all-record Brunswick is selected, many of the contributed records must be shelved. So this is a lesson in Brunswick superiority. It answers a question, a very serious one, in the minds of many dealers as to the future of phonographs. "Are *one*-record instruments doomed?"

Brunswick popularity indicates the readiness and eagerness of music-lovers to turn to the *all*-record type. Yet this feature alone does not sell all prospects. Brunswick tone is a paramount attraction. The absence of metallic and nasal noises is apparent.

Then The Brunswick has a dozen other new-day features that win. Not the least is its somewhat lower price. Every Brunswick Dealer has an opportunity to handle Pathe Records. The public likes Pathe operatic stars, late musical hits, band and instrumental selections. The offering each month is large.

Dealers who have not yet gone over the very profitable Brunswick proposition should write to us at once. A situation exists in the phonograph world which should cause every dealer to plan for the future. So write today.

THE BRUNSWICK-BALKE-COLLENDER CO.
CHICAGO SAN FRANCISCO NEW YORK CINCINNATI
BRANCH HOUSES IN PRINCIPAL CITIES OF UNITED STATES, CANADA, MEXICO, FRANCE

623-633 South Wabash Ave., Chicago
29 W. 42nd St., New York 7th and Main Sts., Cincinnati
Canadian Distributors
Musical Merchandise Sales Co., Excelsior Life Bldg., Toronto

Brunswick
ALL PHONOGRAPHS IN ONE



Retail Prices
\$32.50 to \$1500

FROM OUR CHICAGO HEADQUARTERS—(Continued from page 83)

in the banquet room of the Auditorium Hotel for the benefit of the Red Cross Society, one of the prizes which was raffled off consisted of a \$115 model Brunswick phonograph. This machine was donated by the Brunswick Shop and was won by a young lady who is a stenographer employed in one of the big theatrical booking agencies of Chicago.

Imitate Victor Trade-Mark

Federal Judge Carpenter, of the U. S. District Court of Chicago, last week entered an order under the "unfair competition act" restraining Garrett W. Woodward and Charles E. Gaven, of the Victor Inking Machine Co., from placing imitations of the Victor dog trade-mark on machines they manufacture. The label shown in court bore the familiar picture of the Victor dog, but the words "His Master's Voice" were omitted and "His Master's Ink" used instead. The firm name "Victor Inking Machine" also appeared on the label, and it was stated in some instances that the letter "I" was crossed so that it appeared to be the letter "T" and the following letter "N" being obliterated there appeared to be an abbreviation "T'king" for talking.

Henry C. Brown a Visitor

Henry C. Brown, assistant general manager of the Victor Co., accompanied by Mrs. Brown, visited Chicago this week. They stopped here en route to their home after paying a visit to their son Harry, who is a member of the British Royal Flying Corps stationed in Texas.

He's in the Army Now

George Derrig, assistant credit manager for the Chicago Talking Machine Co., recently left for Ft. Dodge, Des Moines, Ia., where now he is a member of Hospital Unit No. 11, stationed at that cantonment.

"Thumbs Down"

H. P. Ellis, of the Chicago Talking Machine Co., received a summons on Monday of this week to serve as a juror on cases now being tried in the Criminal Court. His numerous

friends in the trade are wondering what will happen if the man responsible for the recent freight congestion appears before said jury!

Place Orders for Cabinets Now

John F. Mortensen, president of the Salter Mfg. Co., in a chat with The World called attention to the fact that dealers would do well to place their orders for record cabinets at once in order to anticipate important advances in prices which are inevitable. "There have been further advances the last two or three months in practically everything entering into the construction of record cabinets," said Hr. Mortensen. "This not only includes lumber, veneers, but also hardware, shellac, varnish and even the felts with which the famous Salter felt-lined shelves are covered. For a limited period we will protect our customers at the old prices, in spite of the fact that we should have made material advances the first of the year.

Sachs & Co., the piano bench and talking machine house at 425 South Wabash avenue, have made arrangements for the Chicago city representation of the Salter lines of talking machine record and music and music roll cabinets. Both Sidney I. Sachs and G. C. Clifford are experienced men with a large following in the trade, and, no doubt, will do an excellent business on the well-known Salter lines.

Empire Activities

John H. Steinmetz, president of the Empire Talking Machine Co., reports that quite a number of new agencies have been taken on during the past month, and that these new dealers state that they are well satisfied with the results obtained through the medium of the Empire machines. During the past week the Empire Co. increased the proportions of its shipping room more than 50 per cent. by removing a wall in the rear of their building and occupying the space which was formerly used as a store room by another company. Mr. Steinmetz states that his company is now in better position than heretofore to render prompt serv-

ice to its customers, owing to these increased shipping facilities.

New Brunswick Travelers

C. J. Carroll, who for the past seven years has traveled for the Kipp Phonograph Co., of Indianapolis, Edison distributors, is now associated with the Brunswick-Balke-Collender Co., and has been assigned to the Denver field.

G. F. Gamble, who formerly covered the New Orleans territory representing the Brunswick, has been transferred to Minneapolis. He started the ball rolling by placing several large contracts in his new territory.

Doing Excellent Business

The Empire Phonoparts Co., which made its initial bow to the trade last month, has, in the short time of its existence, built up a trade that reaches in proportions far beyond its anticipations. It is the aim of this company to cater to a high-class trade and to supply its dealers with phonoparts of its own manufacture which embrace, besides the best material obtainable, essential features that cannot be obtained elsewhere. In this the company has been rather successful, and its clientele are enthusiastic over the products already turned out by the new company, especially the new tone arms and sound boxes.

Sell Entire Stock

The Hughes Music Co., of Oshkosh, Wis., recently sold out their entire Victor stock to the Wilson Music Co., of that city.

New Cheney Models

Many of the interesting features embodied in the Cheney talking machine have been greatly improved, as may be seen in the instrument that the Cheney Talking Machine Co. are offering to the trade this month. As already well known, the tone development and control are accomplished by a series of scientifically designed air chambers in the tone arm, throat and orchestral sections of the instrument. A tonal system such as this offered a large field for experimentation

(Continued on page 87)



**EXCELS IN QUALITY
EXCEEDS IN VALUE**

Sells Because It Excels

THE excellent values we are able to show in our extensive line of nine models of EMPIRE TALKING MACHINES are not confined to the higher priced machines.

☐ The Model F Empire shown herewith is our cheapest model and yet it is equipped with the same high grade tone arm and reproducer as our highest priced machines.

☐ It also carries the same type of noiseless, smooth running, double spring motor that is used in every other EMPIRE TALKING MACHINE.

☐ It is also fitted with the "PERFECT" Automatic Brake. In fact this little machine has every improvement that any talking machine has, and at a price that is easily within reach of any of your customers.

☐ Write to-day for our Dealer's proposition on Empire machines and records.



Model F
\$27.50

EMPIRE TALKING MACHINE COMPANY

JOHN H. STEINMETZ, President

429 SOUTH WABASH AVE.

CHICAGO, ILL.

Bigger Things for 1918

Bigger for You — Bigger for Us

We have planned and prepared for BOTH a larger output — insuring better services, prompt deliveries, and even a better product than in 1917

THE Mandel line of talking machines, varying in retail price from \$35 to \$250 and meeting the price demands of every class of trade, has been improved in many details which means in the aggregate a considerable increase in intrinsic value.

This is a line which has proved a distinct satisfaction giver from the start.

Every part of every Mandel—Case, Motor, Tone Arm, Sound Box, Horn, Tone Chamber not only is distinctive but made in the Mandel factories, thus securing standardization and uniformity of output.

Do you want to handle just this type of machine?

It costs you nothing to investigate.

Let us send you model No. 3, illustrated here on FREE TRIAL.

Write today for full information and descriptive literature.

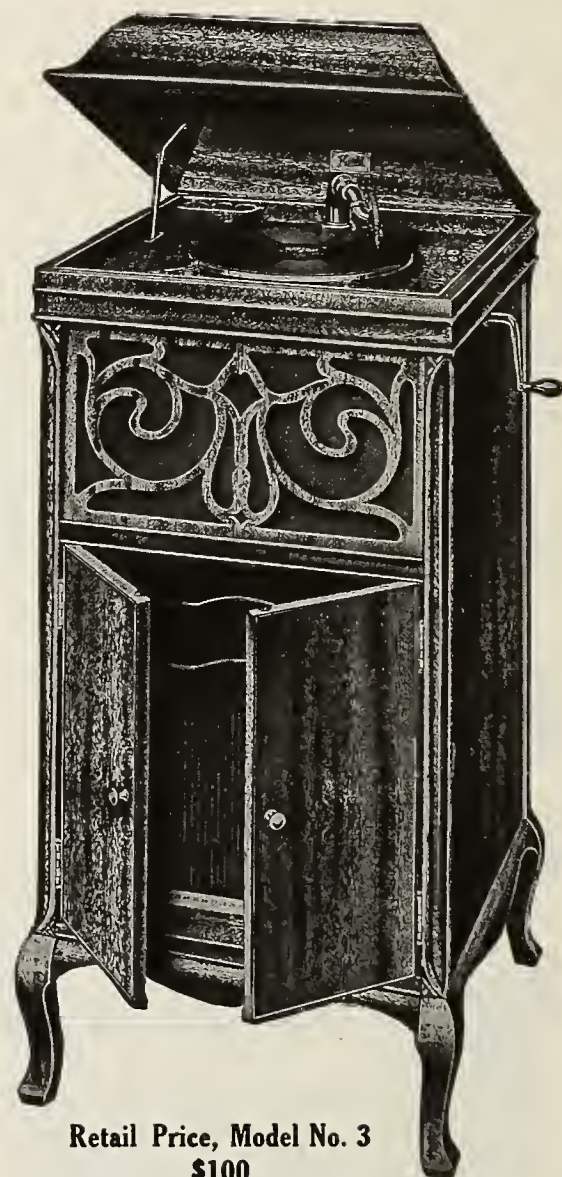

Retail Price, Model No. 3
\$100

No bigger value for the money exists today. This is the machine we will send on FREE TRIAL just to prove that we have confidence in our product

Mandel Manufacturing Co., Inc.

General Offices :
501-511 S. LAFLIN STREET
CHICAGO, ILL.

New York Display Rooms :
41 UNION SQUARE

FROM OUR CHICAGO HEADQUARTERS (Continued from page 85)

and it was in this field that Prof. Cheney, inventor of the instrument, and his corps of expert acousticians concentrated their efforts to bring about scientifically correct results. In this they have succeeded. Their accomplishments are, in a measure, far beyond their anticipation in that the results obtained place the latest Cheney models on a higher plane of standardization than their preceding machines. The various chambers of the orchestral section were given careful scrutinization and if any defects such as improper construction, etc., were found, they were scientifically remedied, thereby adding greatly to the value of the high, medium and low registers.

But inspection such as this does not apply only to the model used for experimental purposes in the Cheney laboratories. It applies to each and every machine turned out of the Cheney work shops. Each part of the machine, no matter how small or insignificant, has a definite service to perform, and this is taught to all employes engaged throughout the plant. The employes receive a thorough schooling along these lines and, for this reason, each individual part of the instrument produced by the Cheney Co. is manufactured with the understanding that the definite purpose to be performed by that particular part necessitates careful consideration if their unification as a whole is to bring about a certain standard of perfection.

Report Increasingly Large Business

The American Phonoparts Co. of this city are having an increasingly large business from manufacturers in two types of tone arm and sound box outfits, which are illustrated in their advertisement elsewhere in this issue. The company was organized in 1914 and has been an important factor in the manufacture of talking machine parts ever since. The No. 7 tone arm and sound box contains several features of particular merit. The sound box can be thrown back so as to insert the needle with one hand. It is the quality of tone produced that is notable.

The sound box is constructed with a rubber gasket in back, the object of which is to eliminate blasting caused by vibrations from the metal frame.

The No. 1W outfit has a reputation among the trade because of the special loudness and clearness of the tone. This also has a number of distinctive features, including spring screws which lock the sound box into either position for playing vertical or lateral cut records. Furthermore, the arm can be adjusted to the required length for centering sound box for playing either type of records.

Leaves for Washington

Frank J. Bowers, formerly general traveler for Pathé Frères Phonograph Co., left Chicago on Monday evening of this week for Washington, D. C., where he went to join the mechanical repair department of Unit 306 of the Quartermaster's Corps at Camp Meigs, which is now being organized for immediate overseas service.

Doing Things at Wilson's

"We are still making things hum around these corners," said W. E. Cotter, manager of the retail phonograph department, Thos. E. Wilson & Co., when called upon by The World this month. "We decided that there was a big bunch of business to be had in Chicago, so we increased our outside force and turned them loose. They sure are getting a nice batch of orders every day, and it certainly is surprising to see the number of prospects they can bring in."

W. C. Fuhri Returns to Chicago

W. C. Fuhri has returned to the Chicago organization of the Columbia Graphophone Co. and has assumed his old duties. Mr. Fuhri and C. F. Baer will operate in close harmony as they have done in past years. Under the plan of re-arrangement Mr. Baer will assume the title of assistant manager and Mr. Fuhri that of manager rather than district manager, as formerly. At the regular monthly dinner and meeting of the sales organization last night the attend-

ance was augmented by other important employes of the Chicago branch and the meeting was turned into a "welcome home" function for Mr. Fuhri, Mr. Baer presiding and joining with the others in saying a lot of graceful things.

Repointer Points

F. D. Hall, president of the B. & H. Fibre Manufacturing Co., makers of the B. & H. Fibre needle, is very enthusiastic over the splendid reception given by the trade to the B. & H. repointer. This handy little device for repointing the fibre needles with a minimum of waste and producing a maximum of tonal efficiency has brought many congratulatory letters from dealers and jobbers the country over. Daily re-orders testify to the sincerity of the tribute.

Patent Cabinet Designs

The Vitanola Talking Machine Co. of this city have recently been granted design patents from the United States patent office on all of their cabinet designs. This, of course, furnishes evidence of the distinctiveness of the Vitanola cabinets and is a step taken in the protection of the manufacturers as well as the jobbers and dealers. J. B. Schiff, company sales manager, vouchsafes the information that they have several new models now in work, samples of which will be on display in about two months.

Thomas Mfg. Co. Open New Offices

The Thomas Manufacturing Co., of Dayton, Ohio, manufacturers of motors, tone arms and sound boxes, have opened extensive sales offices and warerooms at 1026-28 Republic Building in charge of Fred E. Read, the company's Western sales manager. Mr. Read formerly had an office in the Otis building, but the steady growth of their Western business, coupled with the company's appreciation of the importance of Chicago as a talking machine manufacturing center, prompted them in the present move. A very complete stock of the company's product will be carried in Chicago enabling them to make immediate deliveries. Furthermore, Mr. Read

(Continued on page 88)

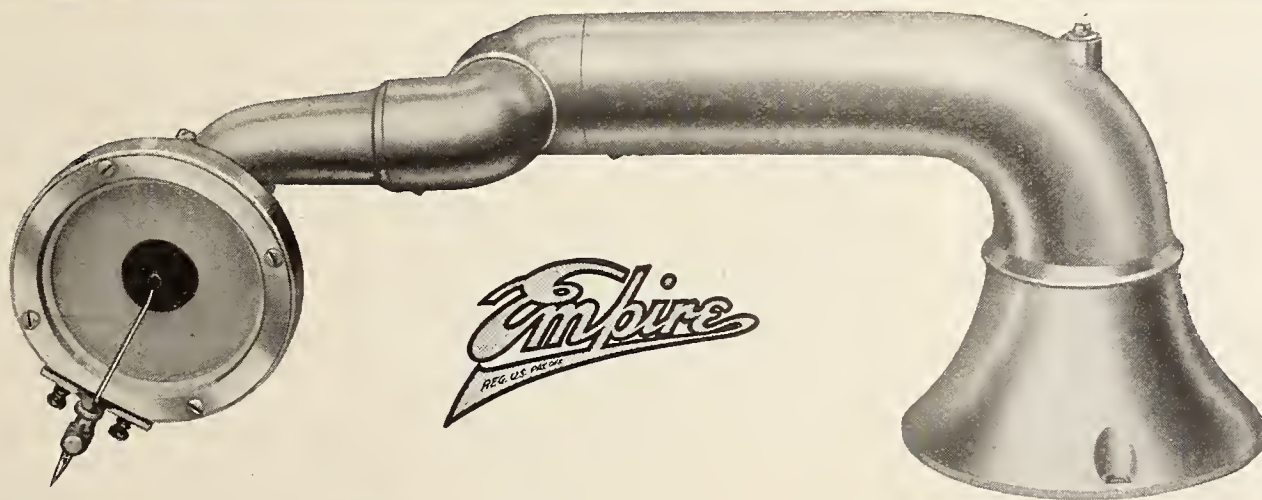

The Empire Tone Arm and Reproducer

MARKS A NEW ERA IN PHONOGRAPH EQUIPMENT

Never before has the Talking Machine manufacturer been offered an opportunity to equip his machines with a Tone Arm and Reproducer possessing so many points of excellence and at a price that will compete with the mediocre equipment with which the market is flooded. Empire equipment adds distinction and selling value to the machines on which it is used.

We solicit inquiries from high grade manufacturers of Talking Machines in position to place orders for a fair sized quantity of Tone Arms and Reproducers in monthly quotas, and for such will make it an object to adopt the Empire equipment.

In ordering samples, kindly state measurement from center of turn table shaft to center of horn hole on motor board.

Address all inquiries to our Chicago office

THE EMPIRE PHONO PARTS CO.
Sales Office, 427 South Wabash Ave., Chicago, Ill.

Factory:
1102 West 9th St.
Cleveland, Ohio

New Lakeside No. 4 JUMBO TONE ARM

Only foolproof arm on the market, as *all* adjustments are *permanent* and *user* has *no* adjustments to make.

Best mica used so fastened to the stylus to prevent same from pulling out. All parts machined to make a perfect mechanical fit. No adjustments when shifting from Victor to Edison. Heavy massive design best for correct reproduction.

Permanent adjustment for all records except Pathé, when a weight is applied (see cut), which makes it just exactly right for playing Pathé. This weight also serves as a retainer for Edison and Pathé needles, which usually are mixed with the steel needles or lost.

Arm fitted with long telescopic neck to make longer or shorter. Punched sound box clamping ring has a curvature preventing rubber gasket from working out.

ALL NEW FEATURE PATENTS APPLIED FOR

We also supply hardware, cabinets, motors and accessories for talking machines. Ask for our Bulletin. We maintain an expert motor repair department.

LAKESIDE SUPPLY CO., Inc.

Tel. Harrison 3840

202 South Clark Street

CHICAGO, ILL.

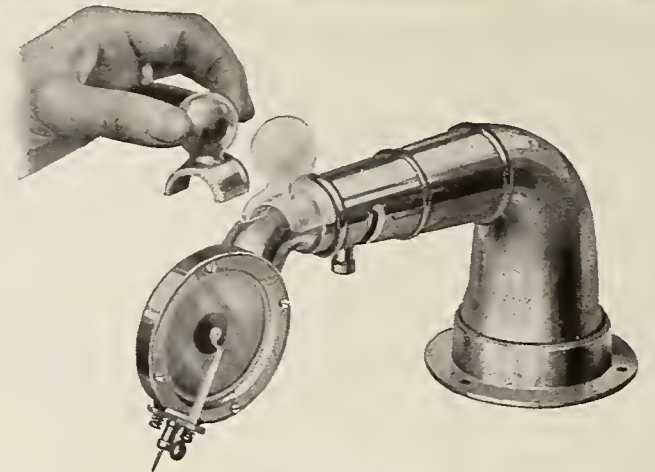

RETAIL PRICE \$7.50 EACH
Prices to Bona Fide Dealers
Sample\$4.00 each
Lots of 6 to 11..... 3.75 each
Lots of 12 to 49..... 3.50 each
Lots of 50 to 100..... 3.25 each
A further slight reduction on yearly contracts
in 100 minimum lot shipments.

FROM OUR CHICAGO HEADQUARTERS—(Continued from page 87)

has established a service branch in Chicago in charge of a competent mechanic. This will enable them to render real motor service. This man will make it his business to go into the factories of talking machine manufacturers using the Thomas product and give instructions and demonstrations regarding the construction and installation of the motors.

"I cannot fully express my satisfaction with the manner in which our product has been received in this territory," said Mr. Read. "We certainly are doing everything in our power to merit this recognition. It is the ideal of W. H. Mathews, president of our company, to turn out the best motors and talking machine parts that can possibly be made. Practically unlimited facilities are offered in our big plant at Dayton and any manufacturer of talking machines who is imbued with the quality idea would be interested in observing the care and precision which characterizes all of our manufacturing processes and also in the laboratory experimental work which is constantly in progress there. We are now making five types of motors and with our five patterns of tone arms and three types of reproducers we are able to offer five complete combinations of exceptional merit."

Mr. Read loosened up on a little item of considerable interest to the trade. In the near future the company will be prepared for the commercial production of an automatic stop which for simplicity and unfailing accuracy of operation he thinks will mark a distinct departure in the trade.

Becomes Manager of Record Department

E. C. Poore has been appointed manager of the record department of the Columbia Graphophone Co., having succeeded F. A. Tatner, who now has charge of the country correspondence for that company. Mr. Poore has been associated with the Columbia Graphophone Co. for the past ten years and was connected with their various branches throughout the middle West.

Lakeside Supply Co. Progress

The Lakeside Supply Co., of this city, has shown a remarkable growth within the past year and a half. In that short space of time they were not only compelled to seek larger quarters on two occasions, but their business has grown to such proportions lately that they are contemplating taking on several additional rooms in the building in which they are at present located.



W. A. Fricke

G. C. Fricke and his brother, W. A. Fricke, president and secretary of the company respectively, are the men at the helm, and it was through their incessant labors and ingenuity that the company has reached its present standard in the trade. The Messrs. Fricke have been associated in various manufacturing enterprises throughout Chicago for the past twenty years, G. C. having been a buyer for a number of years for various manufacturing concerns in Chicago, while W. A. devoted most of his time to working as an electrical engineer.

The Lakeside Supply Co. not only job in phonoparts, but also manufacture a full line of phonograph hardware. They are at present manufacturing a new universal tone arm which is known as the "Lakeside No. 4 Jumbo." This tone arm is made to fit all machines and will play all makes of records. There is supplied with this tone arm a small weight which is easily attached above the sound box whenever a selection of a Pathé record is desired. This tone arm is made in sections that interlock in such a manner that the arm may be easily and instantly lengthened or shortened by the use of a small setscrew as required.

The Lakeside Co. have recently been appointed Chicago representatives of the Stephenson precision motors. They not only will handle these well-known motors, but will also give Stephenson free motor service to their customers. They contemplate carrying a large supply of these motors as well as a large stock of motor parts.

Personals and Visitors

Herman Schefft, of Chas. Schefft & Sons, Milwaukee, Wis.; Ed. Winegar, of the Winegar Furniture Co., Grand Rapids; Don Elble, of Elble Bros., South Bend; C. W. Copp, South Bend; Mr. Hopper, of the Hopper, Kelly Co., Seattle, Wash., were all visitors to the Chicago trade recently.

H. T. Nolan, of the New York Talking Machine Co., was a visitor to Chicago last week. Mr. Nolan is connected with the sales department of the company.

J. S. Mitchell, secretary of the L. S. Donaldson Co. of Memphis, Tenn., called on the trade in Chicago last week.

H. E. Whitman, manager of the Pearson Piano Co., of Indianapolis, was one of the dealers who visited Chicago during the past week.

Train Sales Force

Arthur H. Cushman, director of sales of the Emerson Phonograph Co., of New York, spent the week in assisting F. W. Clement, manager of their Chicago office, in breaking in six new men for sales work. The new travelers were given a good coaching and drilling by both Mr. Cushman and Mr. Clement and were then sent out to take in the new Western and Northern territories, which were just being opened by the Emerson Phonograph Co.

Mr. Clement is in receipt this week of a sample of the first nine-inch Emerson record produced, which the company announced last month. He stated that the many dealers who called at his office each day were enthusiastic regarding the new record and are all anxiously awaiting its release.

PARAMOUNT RECORDS ON MARKET

New York Recording Laboratories Now in Position to Meet Demands of the Trade

CHICAGO, ILL., March 9.—M. A. Supper, sales manager of the New York Recording Laboratories of Pt. Washington, Wis., was in Chicago this week, and during a visit to the Chicago branch of The Talking Machine World told something of the progress that they are making with the Paramount records. "While we have been shipping records to some extent for some little time, we can now say we are ready for the market in the larger sense of the term," said Mr. Supper. "Paramount records, as you know, are recorded in our laboratories at 1140 Broadway, New York, which are in charge of recording experts and musical directors of long and practical experience. While in the introductory stage we lent ourselves mainly to the popular numbers, great stress will be laid in the future on selections both vocal and instrumental of the standard and familiar classical compositions. Plans are at work to this end which when announced will create great interest in the trade. In the meantime we have secured the very best talent for entertainment records of the popular

!!! ATTENTION !!!

Manufacturers of High Class Talking Machines

The new "Orotund" tone-arm and reproducer are now ready.

Universally correct. You can play all records perfectly and safely with this new tone-arm outfit.

Artistic in design. Workmanship perfect. Tone quality exquisite. Acoustically correct.

Two styles—No. 3-A and No. 3-B.

No. 3-A—With mild tone sound-box.

No. 3-B—With loud tone sound-box.

We also make the most perfect universal attachments for the Victor, Edison and Columbia machines.

Send for circular and prices.

COMBINATION ATTACHMENT CO.

324 Republic Bldg.

CHICAGO

STEEL NEEDLES

READY FOR DELIVERY

I also have a quantity of genuine
MAHOGANY CABINETS

43 in., 44 in. and 45 in. Height,

TO BE SOLD AT A VERY LOW PRICE

Ask for Quotations.

W. F. MARTIN

57 E. Jackson Blvd. Chicago

FROM OUR CHICAGO HEADQUARTERS—(Continued from page 88)

type. We have on our list of artists such people as Henry Burr, Peerless Quartet, Shannon Four, University Quartet, Charles Hart, Louis James, Grace Kerns, Arthur Fields, Sam Gardner, Van Epps Trio, Louise and Ferera, Edward Zinco, Allen Turner, George Hamilton Green, zylophonist, Miss Margaret Abbott and many others equally skilled in their respective lines. Our pressing plant at Grafton, Wis., located only a few miles from our general offices at Pt. Washington, is splendidly equipped and of ample capacity. We are rapidly booking up with responsible and enterprising jobbers all over the

country and are preparing for an advertising campaign which will carry the fame of Paramount records to the general public. No pains have been spared in the preparation of catalogs and bulletins of artistic character replete with interesting data regarding our artists together with the stories of the numbers and the show cards and other advertising matter we have prepared for the dealers are the subject of favorable and daily comment."

C. J. Woodward, who has his office at 503 Cable Building, has been made the Chicago representative of Paramount records.

sonal advertising. He pointed out that: "Personal advertising is the face-to-face, eye-to-eye, mouth-to-ear, man-to-man advertising. Summing it up in a few words it is personal contact between the customer and the house. As stated before, printer's ink brings prospective customers to your store and the moment a prospective customer enters through the door, at that moment personal advertising begins.

"The first one to come in contact with a prospective customer is the salesman. Now you have all heard the saying that the first impression is the lasting one. This saying is just as true to-day as when first coined, hence it is the salesman who at the first approach must make a favorable impression. In order to do this he must have a personality—should be of neat appearance, well groomed and pleasant of speech. I say pleasant of speech because personality lies in using words which the customer will understand, high flown speech, however, is seldom used to advantage in salesmanship.

(Continued on page 90)

L. C. WISWELL'S STRONG TALK ON SALESMANSHIP

Gives Some Excellent Advice to Members of Grand Rapids Music Dealers' Association on Subject of Selling Talking Machines to Greater Advantage—Urges Interest Charge

CHICAGO, ILL., March 9.—L. C. Wiswell, manager of the talking machine department of Lyon & Healy, made an address which was eloquent in the best sense of the word and full of practical wisdom, before the Grand Rapids Music Dealers' Association recently. He emphasized the importance of co-operation as illustrated in the good work that can be accomplished by trade associations, pointing out that through co-operation trade evils can be simplified and eliminated, thus enabling the talking machine business to be placed on a clean, substantial and successful basis.

Mr. Wiswell then took up the subject of advertising and emphasized the value of all kinds of publicity, whether in the newspapers, magazines, catalogs or circulars, but especially per-

He pointed out that one of the greatest goods the organization can accomplish is to obtain interest on deferred payment sales, and he remarked: "Gentlemen, do you realize that by your failure to obtain this charge you are losing hundreds and collectively thousands of dollars per year? Could you go to a bank and borrow money to make your purchases of merchandise without being obliged to pay interest? Of course not. Are you not obliged when buying merchandise on long terms from the manufacturers, particularly merchandise that is of staple quality, to pay interest? Surely you are. If this situation is true with you in the purchase of goods, why then should it not be likewise with the consuming public or the party to whom you sell the instrument, granting him a series of deferred payments in settlement of the purchase? Merchandise which you have delivered to your customer surely represents cash, it is money only in a different form. You cannot obtain money from a bank without the payment of interest. Why then should you loan money to your customers without exacting the same stipulation? There is a tremendous leak in your talking machine business if you are not charging interest. It is only a little thing but in time it will reach serious proportions.

"You can easily at this meeting here to-night adopt a resolution that beginning with, say, March 1, each and every one of you will make an interest charge of .6 per cent. on all deferred payment sales. If you do this it will mean more cash business which will give you an argument as to why a man should pay cash instead of buying on the deferred payment plan. As an organization you should get together on the question of uniform allowance for the turning in of used and out-of-date machines towards the purchase of a new machine and regulate the record approval system, and while I do not approve of it you will eliminate the record approval system entirely. Unless you have complete co-operation, complete harmony, proper results cannot be obtained."

Stops the scratch—restores the tone

Takes the noisy scratch out of old, worn records, and restores the tone of your old favorites. Improves the tone and prolongs the life of new records.

The "Little One-der" does it. Instantly attached to any needle machine. Pathe or Victrola. Postpaid for 85c. Order today. Money back if not satisfied. Brown Music Co., Dept. F. 3018 91st Street Chicago

The "LITTLE ONE-DER"

Big Money for Dealers—Sells on Demonstration

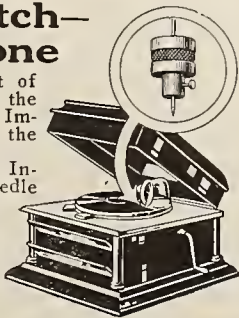

VITANOLA
TALKING MACHINES

We want to put a Vita-nola with every live dealer in the country—we want to show him the merit of our line and that it is a line that stays sold and earns him a good profit. That's why it's to your interest to write for our

FREE TRIAL OFFER

Our beautiful new models have proven very attractive and many of our dealers realize that the Vita-nola line is the one "best bet." With a tone that is "distinctly different" as well as its many other features, it is appealing to the prospective buyer. Seven models to choose from. Prices at retail \$25.00 to \$175.00. Plays all makes of records without extra attachments.



Trade Mark Registered

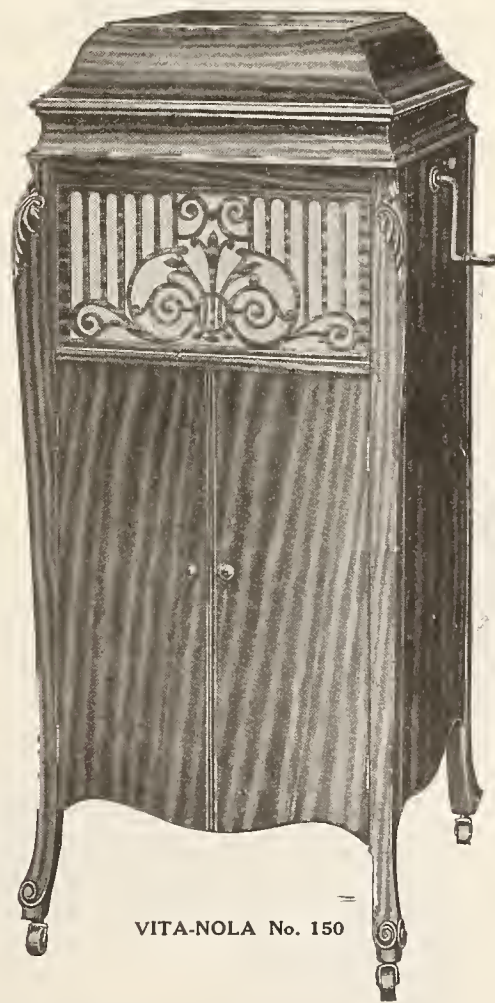

VITA-NOLA No. 150

WRITE FOR CATALOG AND PRICES

Vitanola Talking Machine Company

508 West 35th Street

CHICAGO, ILL.

FROM OUR CHICAGO HEADQUARTERS—(Continued from page 89)

What conditions can be wrought out of these twenty-six little letters of our common alphabet! Words have been called 'terrific engines' since they can either serve or destroy. The salesman's mission is to use his words to serve. A customer, yes, every customer, judges the house with which he trades by the treatment he receives. If the salesman handles him in the proper way and in turn he is handled by the credit department in a businesslike way and lastly if his purchase is delivered in a satisfactory manner, he has only good to speak of your house. The requisites of a successful salesman are many. Successful salesmanship is a condition of the mind more than anything else. A salesman must believe in his goods just as implicitly as he believes that water is wet—this measure of assurance will produce the proper effect on the customer. A heated argument is the worst weapon. No one would argue that water is wet because he knows that it is and the moment a salesman begins to argue, the customer realizes that there is evidently need

of the argument. Moral: Never argue with your customer. If he makes some remarks about the competing line, agree with him as far as you consistently can, but at the same time point out to him in convincing language that your goods are much better.

"Again, a salesman must humanize his talk. Never talk over the shoulder or above the eye. James Whitcomb Riley, the noted Hoosier poet, was asked one day what made his every day, homelike poems, for example, 'The Old Swimming Hole,' 'The Old Man and Jim,' and others, sell so well, while the world's great sonnets written by the most noted poets grew dusty on the booksellers' shelves. He explained that there were only a few thousand people in this great land of ours who knew anything about the classics while everybody did know about the human heart, so in writing his poems he wrote more of the heart—in other words, he understood the masses and how to reach them.

"How many salesmen talk too technically? The personal advertising of your business is

The Perfect Automatic Brake



New Styles To Fit All Makes of Tone-Arms. Now Ready for Shipment.

Patented Aug. 28, '17

Simple construction. Easily attached. No Talking Machine complete without it.

Samples \$1.00 each, cash with order. State make of tone-arm used.

Write for attractive quantity prices.

PERFECT AUTOMATIC BRAKE CO.
Room 400, 425 S. Wabash Ave., Chicago

Hiawatha Phonographs

The extraordinary success of the Hiawatha Phonograph in the past few months is an exact measure of the Ottawa Pianophone Company's success in achieving its purpose.



STYLE 100

The Hiawatha is a machine unusual in refinement of finish, remarkable in tone qualities and embraces a greater number of new and distinctive features than has ever been offered to the trade.

We are demonstrating **QUALITY** to our dealers and not "Talking" it.

We do not take the dealer's orders and then let him shift for himself, but help him in selecting the models that will appeal to his particular clientele.

Models \$40, \$60, \$85 and \$115 Retail

Capacity 300 Machines per Day

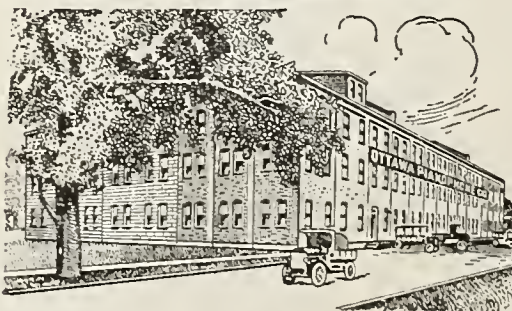

The Home of Hiawatha
OTTAWA ILLINOIS
"All Orders F. O. B. Factory"

Tone chamber made of genuine Spruce. No metal.
Cabinets made of 5-ply stock. Construction guaranteed.
Motors and equipments, using double spring motors, highest standard of Quality.
Electric motor \$25.00 extra.
Tone modifier, built in as part of the machine, not an attachment. Patent applied for.
Plays all records with the same attachment.

OTTAWA PIANOPHONE COMPANY

City Address: 802 Republic Building, Chicago, Ill.

done by your salesman. He must make the talk personal and he cannot do it in the language of the rhetorician, it must be done in every day common sense language. He must get on intimate grounds with his customers.

"Another silent but effective argument in salesmanship is that of integrity. 'Honesty is the best policy' will no longer do as a motto, it should be 'Honesty is the only principle.'

"Nothing drives away customers like an indifferent salesman. When a man or woman calls at your store it is because he or she is interested. They may want to buy. If you show no interest in them you certainly will not get their orders. People will frequently buy a different make of talking machine from the one they really desire rather than buy from a dealer or salesman who does not seem to care. And where is the man who has not gone out of his way to buy a thing he did not want simply for the pleasure of dealing with a certain salesman who was so courteous and considerate and took so much interest in his wants? The real business man goes in a straight path. He finds out the wrong in his business, then he rights the wrong, not haphazardly, but scientifically. There is as much science in the retail talking machine business as there is in the test tube. Business conditions of 1917 are different from those of 1916, and in the coming years they will be different from what they are to-day.

"Service, first, last and all the time is the twentieth century business motto. Should your business not conform to this truth you must pay the penalty in the subtraction from the otherwise possible total of your success. And please do not imagine for one moment that just being honest, loyal and truthful alone will enable you to serve nobly. It is a poor argument to say 'business is business' and proceed to take advantage of your customer. The first of all arguments is service well rendered. Connect personal advertising with service. Give good service to your trade, sell them what they want, make satisfactory delivery, handle their accounts in a businesslike way, be ever ready to look after their needs, no matter how trivial; by doing this you will deliver that character of service that will give you more opportunities to serve. Again, can you see, and do you realize the necessity to make every customer feel that he is getting the best for his money, not only in merchandise but in service. A dissatisfied customer can do you irreparable damage while a satisfied customer can speak more good words and bring you more business than many a good newspaper ad. I have known instances where salesmen by poor tact and poor salesmanship—yes, credit me, through lack of knowledge how to handle a customer—have lost sales that cost money to create.

"There are only two ways of advertising—printers' ink and the personal equation. Personal advertising must be done by a clean-cut representative of the house, therefore it be-

FROM OUR CHICAGO HEADQUARTERS—(Continued from page 90)

hooves every firm to look well to their employes to see that they are of the highest efficiency and that they know their business from A to Z, and that those who come in contact with the people have an understanding of the following terse suggestions:

"There is always room behind the counter for a smiling face."

"Thank you can always be given in change."

"How would you like a salesman to act if you were his customer—that's the way."

"To get the customer's attention, give him yours."

"Talk with the man, not at him."

"A good salesman studies the book of nature."

"The pleasanter you look the pleasanter you will be."

"The man in front of you is entitled to all of your attention."

"Get on the most intimate terms with the goods you sell."

"Keep thinking of what the man in front of you will say when he goes out."

"Show the man with a grouch that you carry good nature in stock."

"A good countenance is the wireless to salesmanship."

"Good salesmanship does not even know failure by sight."

LEASES NEW QUARTERS

The Adams Music Co., Canton, O., leased new quarters in that city and will occupy them after they have been remodeled. The new features will include special soundproof booths for the Victrola department, and elaborate piano and player-piano warerooms.

J. L. Dubreil has joined the sales force of the Cincinnati branch of the Columbia Co., F. F. Dawson, manager in charge. Although a newcomer in the talking machine industry, Mr. Dubreil gives promise of being very successful in his new post.

OFFER NEW PLAN OF DISTRIBUTION

Mandel Mfg. Co. Outlines New System for Increasing Output and Marketing Product

CHICAGO, ILL., March 9.—The Mandel Mfg. Co., of this city, have started out the year with some large plans for Mandel distribution, and they are proving successful in the highest degree, according to M. B. Silverman, sales manager for the company, and who was a prime factor in the introduction and marketing of Mandel phonographs from the first. The company arranged for a much larger output for 1918, and they are already put to it to supply the demand. The plans are progressive, arranging for steadily increasing facilities and prompt deliveries are assured.

"We find that our dealers are very enthusiastic over certain special features of both the product and methods of doing business," said Mr. Silverman. "For instance, I have had a number tell me that they have swung sales simply on the argument that the Mandel phonograph is made completely by us; that we manufacture our own cabinets, our own motors and parts. These facts, of course, carrying with them as they do the assurance of reliability, as we are back of every part of the Mandel machine, coupled with the beautiful appearance and tonal qualities and various distinctive constructional features, give the dealer sales campaign ammunition which is irresistible. We are constantly seeking to improve our product in every possible way, and have a well organized experimental laboratory towards that end, in fact, machines which are being shipped this year, while not showing any marked change yet contain a number of little improvements which, while of no great importance individually, in aggregate spell improvement of product and increased satisfaction. Our trade may be assured that this is a settled policy of this concern, and that Mandel machines will continue to improve.

PRAISE FEATURES OF THE MAGNOLA

Many Dealers Handling That Line of Machines Emphasize the Various Original Points

CHICAGO, ILL., March 11.—Much interest is being maintained among the large line of dealers who handle Magnola talking machines, on account of the many exclusive technical features which tend to make Magnola something as original as it is efficient. Among these, special interest is exhibited in the remarkable system, as simple as it is remarkable, for the impulsion of the sound waves from the sound box to the air. The clearness of Magnola reproduction, which has always been a subject of favorable comment, is largely attributable to what is called the "Tone-Deflecting" system, whereby the sound waves, issuing from the sound box and traversing the gallery of the tone arm, are caused to throw upwards sharply in the course of their entrance into the tone chamber or concealed horn of the machine, so that they reflect against the upper surface of the chamber before issuing into the atmosphere.

The result appears to be that some of the mechanical sounds commonly associated with the tone production of the talking machine are eliminated altogether, and in consequence the whole tone production is clearer, less blurry and cleaner.

This is, of course, an important feature exclusive with Magnola and patents are pending on it. Other features such as the vertical filing system for records, built into the cabinet, and the tone control or graduator, are almost equal factors in Magnola popularity.

Business continues very brisk on all styles of Magnola and President Otto Schulz states to The Talking Machine World that his only difficulty is to get the machines out in sufficient quantities. With the improvement in the freight situation, however, early relief from the present congestion of orders is anticipated.

**Does Your Phonograph Play Rite?
Play-Rite Phonoparts**

*Not merely manufactured—
but created*

We make this claim because we are the originators of this No. 7 Tone Arm illustrated herewith.

Unless this Tone Arm bears our Trade Mark

Play-Rite it is an imitation.

Look for our Trade Mark. It insures quality

Although these Arms are different in appearance and construction, they both represent the very best quality in tonal construction and have the largest number of talking points to choose from.

**REPRODUCERS SOLD IN QUANTITIES
AT VERY LOW PRICES**

Write for descriptive leaflet, samples and prices. WRITE NOW!

AMERICAN PHONOPARTS CO., 512 W. 35th Street, CHICAGO, ILL.

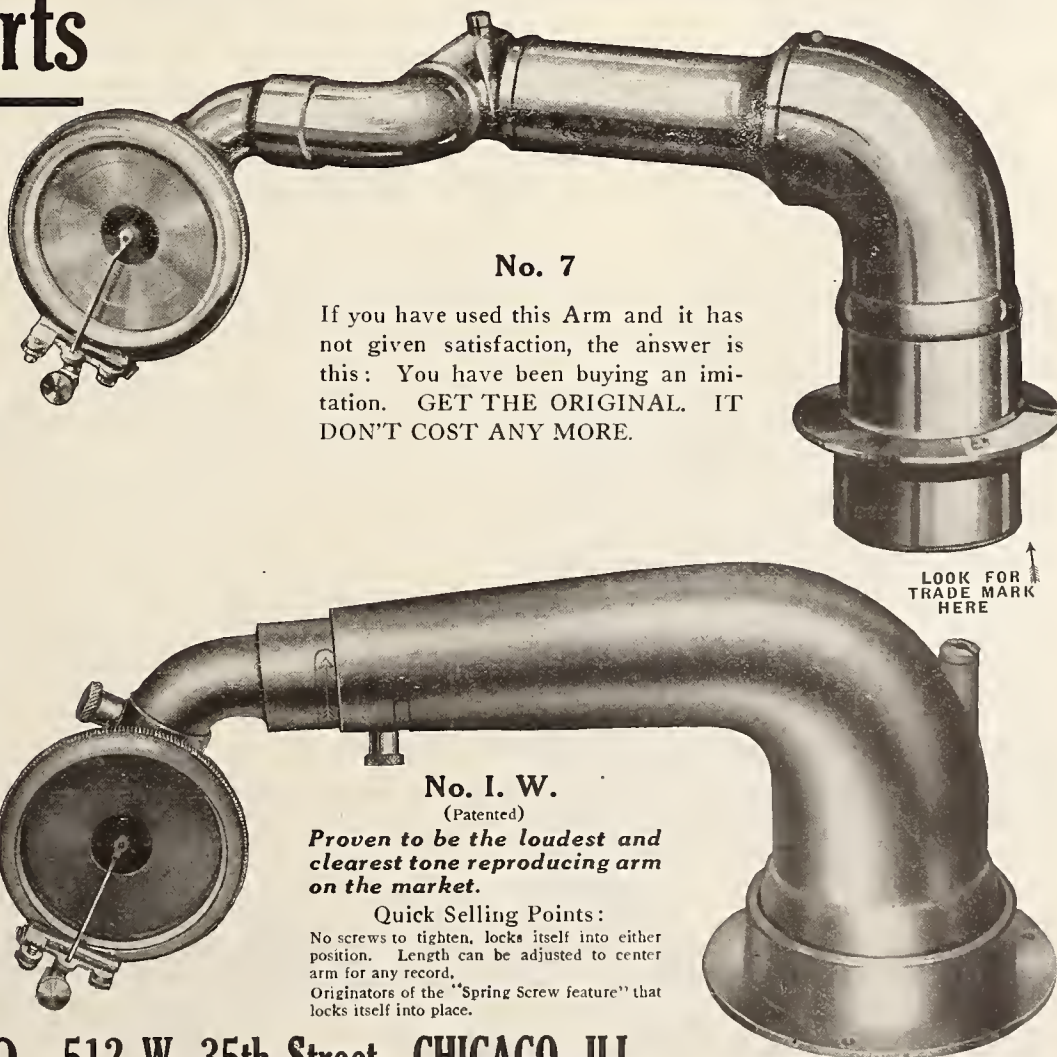

No. 7

If you have used this Arm and it has not given satisfaction, the answer is this: You have been buying an imitation. GET THE ORIGINAL. IT DON'T COST ANY MORE.

LOOK FOR TRADE MARK HERE

**No. I. W.
(Patented)**

Proven to be the loudest and clearest tone reproducing arm on the market.

Quick Selling Points:

No screws to tighten, locks itself into either position. Length can be adjusted to center arm for any record. Originators of the "Spring Screw feature" that locks itself into place.

FROM OUR CHICAGO HEADQUARTERS—(Continued from page 91)

NEW BRUNSWICK REPRODUCER NOW READY FOR THE TRADE

The "Ultona" Sound Box Just Introduced—A New Method for Reproducing Various Types of Records—Distinctly Original in Design and Embraces Some Interesting Features

CHICAGO, ILL., March 9.—The Brunswick-Balke-Collender Co. announce to the trade this month that they have at last perfected their new "Ultona" reproducer and have already equipped two models of the Brunswick phonograph with this new method of reproduction. This sound box includes two distinctly new inventions for which revolutionary importance is claimed by the company.

The reproducer is constructed in form along

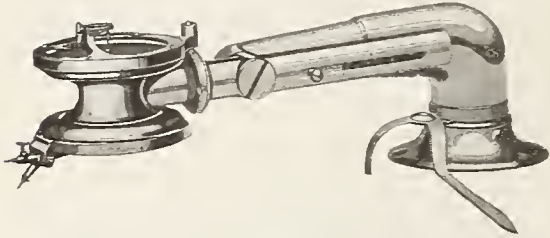

(1) Ultona Reproducer and Tone Arm Ready to Play Pathé and Other Vertical-Cut Records

the same lines as a spool; that is, it contains two diaphragms, and the various makes of records can be played by simply changing its position. It is scientifically designed to adapt itself to the various surface cuttings and tonal requirements of all records, by allowing for the changed weight of reproducer required to play the different makes of records. The pressure of the needle is controlled by a sliding weight placed in one end of the tone arm and is controlled by sliding this weight either forward or backwards. The accompanying "photos" show clearly the various figure number applications of the "Ultona." Figure No. 1 shows the reproducer in the position for playing Pathé and other vertically-cut records. This turns one face of the reproducer towards the records, and the sapphire ball or needle is then in the proper

position to play records of this make. When the other surface of the reproducer is turned

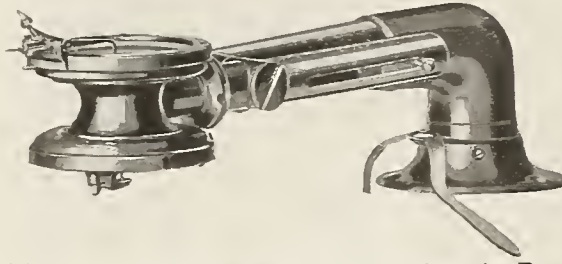

(2) Ultona Reproducer and Tone Arm in Position to Play Records of Edison Type

so as to face the record as shown in illustration No. 2, the reproducer is in position to play all vertically-cut records that necessitate the use of a diaphragm in this position. The lateral-cut records, which are played by means of either the steel or fibre needle, are played by turning the reproducer as is shown by figure three. This is accomplished by simply turning the sound

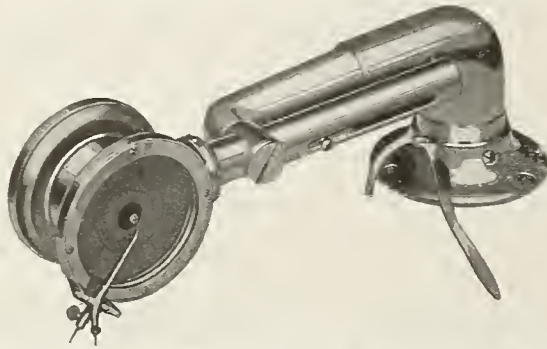

(3) New Brunswick Ultona Reproducer and Tone Arm Ready to Play Lateral-Cut Records

box so that the two diaphragms are parallel to each other. Another feature of the new Brunswick models offered to the trade is their new all-wood tone

amplifier. It is a vast improvement in tone projection in that the sound waves are projected through the all-wood horn, which is built like a violin. This tone amplifier is of all-wood construction and contains no metal whatsoever, thereby breaking away from or avoiding the usual custom of combining wood and metal in the construction of the horn. Not only have

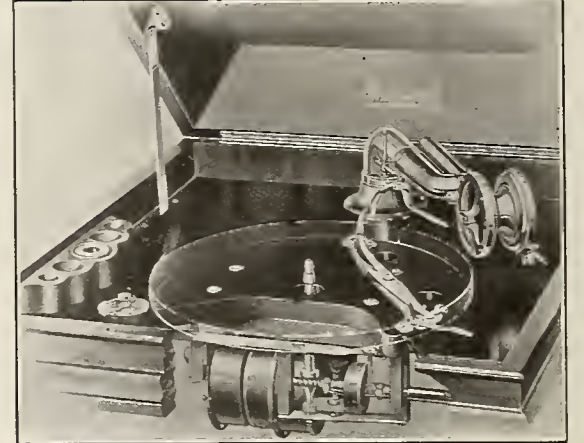

Brunswick Mechanical Equipment Showing Brunswick Motor New "Ultona" Reproducer and Tone Arm, Autostop, Etc.

these two features been added to the latest Brunswick models, but this company has also adapted a new motor with which they are equipping all of their new machines. The following illustration which is a clever "phantom" wash drawing not only shows the new "Ultona" reproducer and tone arm, but also illustrates the automatic stop together with their new motor.

The new Brunswick motor is now used in all Brunswick phonographs. The motor illustrated above is of the three-spring type, but a two-spring motor is also being used for smaller styles of machines.

Beginning with the April 6 issue of the Saturday Evening Post the Brunswick-Balke-Collender Co. will launch their nation-wide advertising campaign. In this issue they will come out with a full-page Brunswick ad.; about the

Different—But Practical

The MORENUS Phonograph is a Distinct Departure from a Tonal Viewpoint.

The horn, which is entirely of wood, is built on the principle of the saxophone and enters the tone chamber at the *bottom*, not the top. The tone is big and full but mellow, and the reproduction of the artist's voice or instrument is faithful to an unusual degree.

Among the other features is a unique tone moderator which actually graduates: an exceptionally high grade and acoustically correct tone arm and reproducer, and a cover support which makes handling the lid a delight.

The case designs are *right* and the cabinet work and finish unexcelled.

The MORENUS is in 3 STYLES

- A. OAK, 48 inches high. Retail price \$110
- B. MAHOGANY, " " " 125
- C. OAK and MAHOGANY, 50 " " 150

Very liberal discounts to the trade Send for our new descriptive catalog

The MORENUS PIANO CO.
 341-371 West Superior Street CHICAGO, ILL.



Style B

same time the daily papers all over the country will begin featuring the Brunswick by means of their advertising columns, but the Brunswick Co. have not confined themselves to the papers for means of advertising. They have been working for several months and have completed their program for advertising by means of the billboards and lithographic color posters. These posters are in various sizes, ranging from a single sheet poster, which is approximately 24" by 36", up to the large size, twenty-four-sheet posters. This method of advertising will be applied mainly to the smaller towns, but the big billboard advertising throughout the larger cities will be handled by means of regular painted color signs.

NOW THE "STEELCRAFT" NEEDLES

That Name Selected by Record Needle & Mfg. Co., Milwaukee, as the Best of the Many Submitted in Recent Contest

The Record Needle & Mfg. Co., Milwaukee, Wis., which has recently been conducting a contest with a view to securing an original and at the same time properly descriptive name for their needles, announce that from the hundreds of names submitted in the contest the one selected for the prize was "Steelcraft," submitted by Harry R. Leithold, of the Fred Leithold Piano Co., Black Cross, Wis. Mr. Leithold, of course, was awarded the 100,000 needles for his effort. The Record Needle & Mfg. Co. plans now to feature the name Steelcraft in a big way in all its advertising, in accordance with its announcement on page 27 of The World this month.

The Unger Furniture Co., Rochelle, Ill., has installed a full line of Victrolas and records, and opened a special department for that purpose.

Nothing can be done successfully without system.

THE READY FILE CO. ANNOUNCES MODELS FOR THE EDISON

Now Prepared to Meet the Demand for an Efficient Filing Device for Edison Models 100-A and 150-C—Wins High Praise From Edison Jobbers at Recent Convention Held in New York

In response to a widespread demand on the part of Edison dealers for a convenient filing device for the lower priced models, the Ready File Co. has just announced the completion of models designed for the New Edison phonograph, Models 100-A and 150-C, as illustrated in the company's advertisement on page 74 of this issue of The World.

The new Ready Files were first shown at the Edison Jobbers' Convention, held at the Knickerbocker Hotel, New York, February 18 and 19. The enthusiasm with which they were received is indicated by the fact that they were endorsed by the convention, an honor which has seldom, if ever before, been accorded an accessory.

President Walter E. Kipp, of the Jobbers' Association, said of the Ready File: "We have long felt the need for such a device. The Ready File will enable the Edison dealer to offer a moderate priced instrument that not only gives a perfect re-creation of music, but also one that is wonderfully convenient. I think that I speak for every jobber here when I say that we extend our heartiest congratulations and good wishes to the Ready File Co."

The new Ready Files are very much like the models that have already become so popular among Victor dealers, except that it has been necessary in designing the Edison models to enclose the trays of the Ready File in a cabinet. In the model for the 150-C Edison this cabinet is composed of an ingeniously arranged wooden front, sides and back, with steel supports for the trays. The file is instantly installed in the instrument without alteration. In the model for the Edison 100-A the cabinet is made to fit on the shelf of the instrument, the design being such that the grace of line of the instrument is in no way marred. The cabinet work is of the very best, and the finish is fully as fine as that of the instrument itself. In both models the

instrument and the Ready File gives a harmonious effect, with none of the makeshift look so often found where articles from two different manufacturers are combined.

The Ready File Co., anticipating a heavy demand, has already started large scale manufacturing of these new models, and in accord with their usual policy, the Ready File Co. will conduct an aggressive campaign on the models for the Edison. Anent the new Edison file, the president of the Ready File Co. said: "The Edison dealer will be shown, as the Victor dealer has been similarly shown, that by placing Ready File in every model 100-A and 150-C on his display floor and in his booths, and by considering the instrument and the Ready File as a single unit, he can sell Ready Files with practically every instrument of these models that he sells, making a nice extra profit on each sale."

FIRE VISITS BUFFALO STORE

Causes Some Damage to Offices of Neal, Clark & Neal Co.—No Delay in Deliveries

BUFFALO, N. Y., March 11.—The wholesale department of the Neal, Clark & Neal Co., the well-known Victor wholesalers of this city, was visited by fire recently. Quick work on the part of the company's employes and the Fire Department resulted in confining the loss to the offices. The company reports that it will be able to take care of dealers' orders as usual.

INCORPORATED IN PUTNAM, CONN.

The Averill-Warner Co., Putnam, Conn., has been incorporated with a capital stock of \$50,000 to deal in talking machines and other musical instruments. The incorporators are Warner W. Averill, John E. Goggin and Edward H. Burt.



Get the Benefit
of the big business doing right now on both talking machines and records by handling

SALTER
Felt Lined Cabinets

These two styles are not only remarkable outfit sellers but are equally attractive to people who have cabinet machines but need more record storage capacity.

SEND FOR CATALOGS

Showing many other attractive styles.

We also make a beautiful line of sheet music and music roll cabinets.

SALTER MFG. CO.
337-49 N. Oakley Boulevard
CHICAGO, ILL.



No. 19. Cabinet
(DOUBLE DOOR FRONT)
Made especially to hold the Victor-Victrola, No. IXA

No. 111. Cabinet (Opened)
For Columbia \$50.00 Machine
33 1/2 inches high. Top, 23 x 19 1/2 inches

HEINEMAN BRANCH MANAGERS HOLD ANNUAL CONFERENCE

Important Social Events Mark Week Spent at Headquarters of Otto Heineman Phonograph Supply Co., Inc.—Enjoy Business Discussions—Adolf Heineman Honored—Visit Factories

The managers of the different branches of the Otto Heineman Phonograph Supply Co., Inc., in this country and Canada convened in New York last week for their first annual conference, and during the course of the week a number of important social events were scheduled which balanced the serious part of the program. This conference was noteworthy for the practical suggestions which were offered by the managers and the executives, and Otto Heineman, president of the company, left nothing undone to provide maximum returns for the time spent by his managers in New York.

The managers arrived in New York on Monday, and during the afternoon attended the first of a series of important business meetings. Plans and policies for the coming year were discussed, and it was the unanimous opinion of everyone present that the conditions in the talking machine industry at the present time evidence a stability and strength which is most gratifying. The remarkable strides made by the company last year influenced the introduction of manufacturing and sales problems which were discussed at length by the company's executives and managers.

On Tuesday morning the business meetings were resumed, and at Tuesday noon the managers were advised that Otto Heineman had arranged for a luncheon at the Hotel Astor to celebrate the sixtieth birthday of his brother, Adolf Heineman, assistant general manager of the company.

Adolf Heineman's Sixtieth Birthday

Adolf Heineman has worked indefatigably during the past few years to place the Otto Heineman Phonograph Supply Co. in the front ranks of the talking machine industry, and the wonderful progress achieved by this company may be attributed in a considerable measure to his unceasing efforts and untiring energy. A capable executive and thoroughly conversant with every phase of the talking machine in-

dustry, he has rendered invaluable service to his brother in the foundation and expansion of the Otto Heineman Phonograph Supply Co. At the present time he is in charge of the company's Dean division, and his keen business acumen is reflected in the fact that this division is growing by leaps and bounds, and under his able direction and management is steadily adding to its prestige.

In addition to the branch managers, there were present at this luncheon the company's executives, a number of prominent members of the talking machine industry, and several invited guests. Everyone present was impressed with the fact that this gathering was an unusual one in many respects, and the congratulations which were showered upon Adolf Heineman made this veteran talking machine man thoroughly happy, although just a trifle ill at ease. A few hours previous he had entered his office to find it transformed into a veritable flower conservatory, and telegrams of felicitation from business and personal friends had been received continuously. The luncheon was a fitting finale to a well-deserved tribute to a man who has worked day and night for the success of the Otto Heineman Phonograph Supply Co.

The Luncheon at the Hotel Astor

At the start of the luncheon A. G. Bean, general manager of the Elyria plant, was introduced as toastmaster, and a better selection could hardly have been made. His introductions of the various speakers were timely and witty, and in his first remarks he paid a tribute to the policies and methods of the Otto Heineman Co. Growing reminiscent, he spoke of the days when the company's floor space consisted solely of a room in a downtown office building, which held two people comfortably, and three with inconvenience. He compared this with the company's present factories in Elyria, O., Newark, N. J., and Putnam, Conn., in addition to the various branch offices maintained in the leading

cities throughout this country and in Canada.

When called upon by Mr. Bean as the first speaker Otto Heineman commented upon the fact that this luncheon was being given in honor of his brother, and was not by any means a "company" gathering. In a stirring address that gave his auditors some idea of the bond of affection that exists between his brother and himself, Mr. Heineman said that any measure of success which his company had achieved must be attributed to the whole-hearted support that he had received from Adolf Heineman many years before the present organization was founded. He emphasized the fact that his brother had investigated and felt the pulse of the talking machine industry long before it had reached its present basis of strength and permanency, and paid a tribute to his brother's foresight and judgment which had been a powerful factor in making possible the establishment of the Otto Heineman Co.

In response to a standing toast to his continued good health and happiness Adolph Heineman was prevailed upon to make a brief address, but with his characteristic modesty, belittled the results of his many years' work, and in turn expressed his appreciation of the spirit of camaraderie and true affection which he and his brother had enjoyed in their personal and business association for many years.

Among the others present who made brief addresses, all of which contributed to the enjoyment of the luncheon were A. F. Meisselbach, S. A. Ribolla, John A. Noble, vice-president Harriman National Bank; H. B. Rosen, director Harriman National Bank; E. A. Widmann, president Pathé Frères Phonograph Co.; Jacob Schector, C. T. Pott, W. G. Pilgrim and Dr. J. J. Klein. It was the unanimous opinion of these speakers that Adolf Heineman had discovered the eternal spring of youth, for his sixty years rest as lightly on his shoulders as though he had just passed the two-score milestone in his busy career.

On Tuesday evening Adolf Heineman entertained the visiting managers, the executives of the company, and a number of invited guests at his home, a delightful dinner bringing this eventful day to a happy close.

A Visit to the Meisselbach Plant

On Wednesday the managers, accompanied by the heads of the Otto Heineman Co., spent the day at the factories of the Meisselbach division in Newark, N. J., and a trip through this up-to-date and thoroughly efficient plant gave the visitors the "reason why" the Meisselbach motor has won world-wide recognition as the leading motor in its field. A. F. Meisselbach, who is vice-president of the Otto Heineman Co., entertained the visitors at luncheon at the Downtown Club, Newark, N. J., where a resumé of the day's trip aroused hearty enthusiasm regarding the Meisselbach products and their unlimited future possibilities.

Thursday at the Dean Factories

On Thursday the party left Putnam, Conn., where the factories of the Dean division are located. The managers learned at first hand some of the intricate processes incidental to steel needle manufacturing, and with Charles E. Dean and John M. Dean, Jr., as guides, explored the large new factory which has just been completed. They marveled at the perfection in manufacturing which is evident in every department at this plant, and returned to New York imbued with a true idea of the important role that this "baby" in the Heineman organization is destined to play in coming years.

Friday was spent in a series of business meetings at the executive offices, and on Saturday the managers departed for their respective territories, tired and travel-worn, but heartily enthusiastic and optimistic regarding 1918 possibilities. The week was a signal success, and Otto Heineman, who arranged every detail of the week's activities, can well be proud of the capable and aggressive corps of managers who are making the Heineman products the standards of the talking machine industry.

On a facing supplement are seen photographs
(Continued on page 95)

L. & H. Khaki Talking Machine Covers

HAVE STOOD THE TEST

Modern Methods Insure Safe Handling

Heavily
Padded
with
substantial
Felt
Quilted
Fleece-lined
Strongly
Sewed



We
specialize
in
making
to order
Covers
to fit any
make
machine

Special Inducements to Jobbers

LYON & HEALY - CHICAGO

Luncheon at Hotel Astor in Honor of A. Heineman



At Speakers' Table—Left to Right: Dr. J. J. Klein, S. A. Ribolla, E. A. Widmann, A. F. Meisselbach, A. Heineman, Otto Heineman, A. G. Bean, John A. Noble, J. Schector

Heineman Managers and Executives Who Attended Conference



Seated—Left to Right: C. W. Neumeister (Cincinnati Manager), W. G. Pilgrim, A. F. Meisselbach, Otto Heineman, S. A. Ribolla (Chicago Manager), Paul L. Baerwald (Eastern Sales Manager)
Standing—Left to Right: C. Martinez, R. C. Ackerman (Export Manager), Chas. Hibbard, Fred W. Hager, C. T. Pott (Canadian Manager), R. Foute, A. Foute, W. Brand

Views in the New Heineman Executive Offices



Otto Heineman, President and General Manager



A. Heineman, Assistant General Manager



W. G. Pilgrim, Assistant General Manager



Treasurer's Office



Export Department



Stenographic Department



Bookkeeping Department

of the Hotel Astor luncheon, the visiting branch managers, and some of the views in the company's new executive offices which have just been completed. In addition to those mentioned previously, there were present at the Hotel Astor luncheon the following: Paul E. Baerwald, R. C. Ackerman, C. W. Neumeister, P. Catucci, W. B. Waltzinger, Johannes Sembach (world-famous tenor), R. Gaertner, E. Rosenthal, S. H. Hirsch, C. M. Estes, R. H. Williams, R. Kanarek, S. Heckler, F. M. Cruciger, M. A. Finke, Charles E. Dean, John M. Dean, Jr., John L. Lotsch, Chas. L. Hibbard, Fred W. Hager, R. Foute, Al. Foute, W. Brand, E. M. Bath, F. Bender, John Meyer, W. Scharuberger, L. Gruen and L. M. Robinson.

FRANK W. CORLEY IN THE SERVICE

Head of Wholesale Victor Department of Corley Co. to Become Member of the Naval Flying Corps—His Good Work in the Trade

Announcement is made that Frank W. Corley, son of John G. Corley, the head of The Corley Co., Richmond, Va., and who is actively in charge of the wholesale Victor department of that company, has been accepted for service in the Naval Flying Corps. Although at the present writing he has not yet been called, the summons to duty is expected at any moment and Mr. Corley is ready.

The Corley Co., one of the leading musical houses of the South, has justly earned its slogan, "The House That Made Richmond Musical." Through the untiring efforts of Frank W. Corley their business as Victor distributors has reached large proportions. The Corley Fibre Victrola Trunk has been one of the products of this firm in which Mr. Corley has been especially interested. The sales of these fibre trunks have reached a very large figure.

Mr. Corley's genial nature has gained for him a host of friends in the trade, not only in the South but throughout the entire country. These friends will learn with interest and admiration Mr. Corley's determination to dedicate his efforts for the duration of the war to his country.

NOW WITH LORD & TAYLOR

R. O. Hunter, formerly manager of the Victrola department of G. Schirmer, Inc., and prior to that Victrola manager for Wm. Knabe & Co., New York, is now manager of the Victor department of Lord & Taylor.



Watching the Music Come Out

Magnola Message No. 1

The Secret of Magnola's marvellously clear reproduction is found in the exclusive

Magnola Tone Deflector
(patents pending)

"Beats 'em all on tone!"

Literature sent on request.

MAGNOLA TALKING MACHINE COMPANY

OTTO SCHULZ, President

711 MILWAUKEE AVENUE CHICAGO 1530 CANDLER BLDG. ATLANTA, GA.

You need this Record System

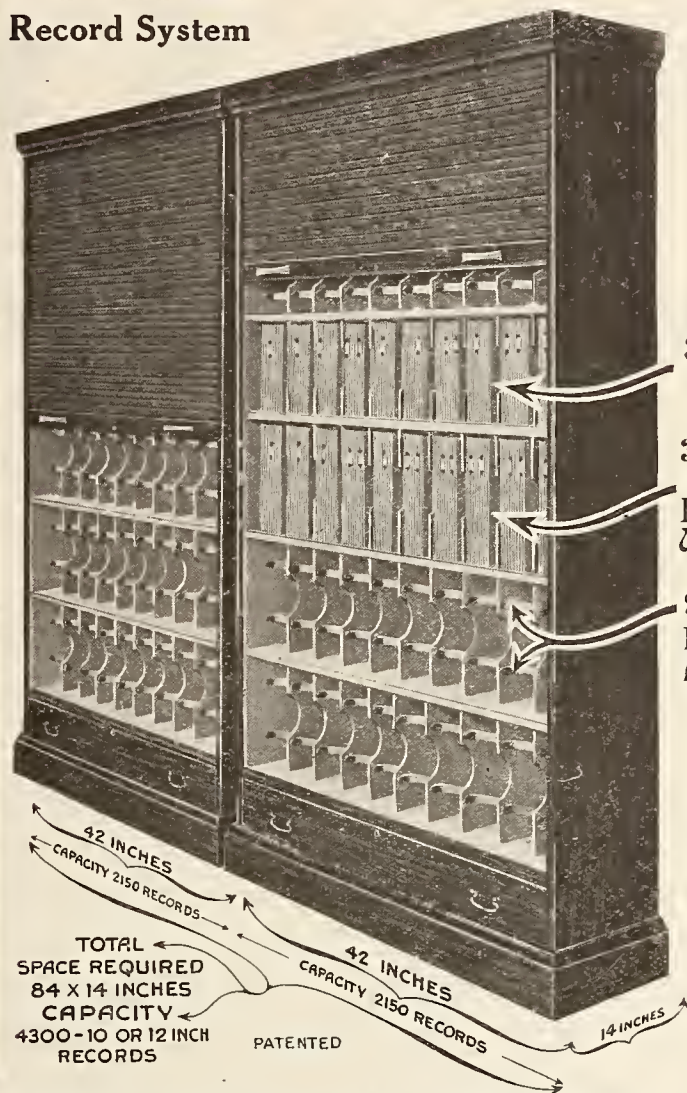

New Model No. 2150 DD

Improved in design and construction. **UNITS** fit flat together on the end. **DOUBLE** drawers in the Base. **SOLID** Oak and Birch in all standard finishes.

Write for Our Manual of Filing Dept. K.

350-10 inch Records

350-12 inch Records Patented Adjuster for Using 10 inch Records

Soft, Flat Springs Hold Records Upright And Prevent Warping.

Capacity 2150 thin records, 1075 Edisons.

Every record at your finger tips as simple as 1-2-3.

Built to fit your needs.

Prices { Oak \$55
 { Birch \$60

UNCONDITIONALLY GUARANTEED

Ogden's Patented Cabinets

Protect against Dust, Warping and Theft. Save Time, Space, Money. :: Prices Subject to Change ::

OGDEN SECTIONAL CABINET CO., Inc., Lynchburg, Va.

CLEANRITE RECORD BRUSH

New Improved No. 10 Model for Victrolas Now Ready for the Trade

The Blackman Talking Machine Co., New York, has announced to the trade this week a new improved No. 10 model of the Cleanrite record brush for Victrolas. This new model

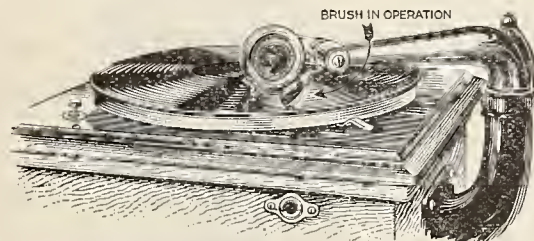

The Cleanrite record brush embodies a number of distinctive improvements over the former models, these improvements constituting patented features that were devised and patented by J. Newcomb Blackman, president of the company.

The Cleanrite record brush has been on the market for several years, and has achieved phenomenal success. It is in use in all parts of the country, and Victor dealers everywhere have expressed their approval of its many distinctive merits. It has been merchandised to the dealers on the principle that it insures long life to disc records and preserves the tone, and there is no doubt but that the proper use of this brush will result in both of these desirable features.

The most important improvement in the new No. 10 Cleanrite brush for Victrolas is a yielding spring, which eliminates the danger of too much pressure on the record, and thereby provides for maximum efficiency in the use of this brush.

The Blackman Talking Machine Co. has prepared attractive literature in behalf of this new model 10, which briefly calls attention to the fact that the Cleanrite brush automatically cleans the record grooves, and gives the needle a clean track in which to run. It preserves a clear reproduction, and by preventing the accumulation of dust and dirt in the record grooves prolongs the life of the records.

The Cleanrite record brush is a model of simplicity in its adjustment and use, and Victor dealers can present this brush as one of the most practical accessories that have been offered to Victrola owners in recent years.

THE BRUNSWICK LINE IN DENVER

Proving Very Popular and Many New Agencies Are Established Among the Dealers—C. J. Carroil Now in Charge of Department

DENVER, COLO., March 9.—The phonograph department of the local branch of the Brunswick-Balke-Collender Co., although established only about a year ago, has met with unusual success and reports that the Brunswick machines are meeting with general favor in this section. A large number of agencies have been established in Colorado and Wyoming, among the most recent being the Chamberlain Furniture & Undertaking Co., Casper, Wyo.; the Howell Drug Co., Ft. Lupton, Colo.; the Davis, Brown, McAllaster Mercantile Co., Berthoud, Colo., and L. E. Frazer, Windsor, Colo.

A recent addition to the staff of the local phonograph department is C. P. Carroll, who has been engaged in the talking machine trade in the Middle West for the past eight years. He will have supervision of the department.

MAIN SPRINGS

1" x 0.25 x 12' long
7/8" x 0.23 x 10' long
3/4" x 0.22 x 8 1/2' long

In stock for immediate delivery. For other repair parts see our ad in Want Section

FAVORITE PHONOGRAPH ACCESSORY CO.

1491 DeKALB AVENUE BROOKLYN, N. Y.

JOSEPH MUSANTE

Electro-plater and Silversmith
Gold, Silver, Nickel and Antique Finishes
Specializing in phonograph parts and musical instruments

168 CENTRE ST. NEW YORK Telephone, Franklin 3053

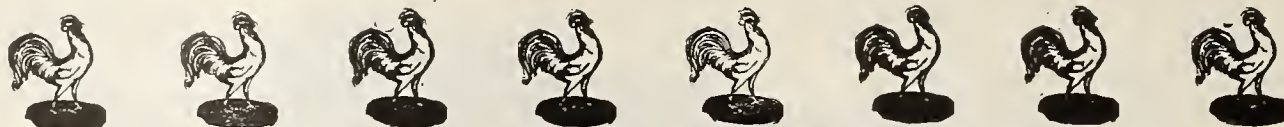

The Fischer Company



Oldest Pathe Jobbers



The Fischer Company were the first to appreciate the wonderful merchandising possibilities of Pathe phonographs and Pathe records.



The growth of our organization has been remarkable. The dealers established by us have all been successful. All have made money. Our service and co-operation have been invaluable to them.



It has been the ONE idea of this house since its inception to give a LITTLE BETTER service than could possibly be expected. The recent establishment of a dealers' service bureau is a concrete example. The object of this department is to originate and perfect merchandising ideas and to give expert advice and assistance to our dealers.



Recent enlargements enable us to adequately serve a few more dealers. We respectfully solicit a trial order. Our ONE DAY SERVICE and SHIPMENTS COMPLETE in these times of crowded carrying conditions mean more sales.



Prospective dealers write for our book just published — "The Other 20%"



THE FISCHER COMPANY

Oldest Pathe Jobbers

940 to 1030 Chestnut Ave.

Cleveland, Ohio



PATHE ART MODELS

Marvelous in Tone Exquisite in Design

Priced—\$190.00

Three periods—William and Mary, Sheraton and Jacobean.



CONCERT AT TEMPLE OF MUSIC

Prominent Victor Dealers in Scranton Arrange Splendid Program and Prove That Concerts Are a Profitable Form of Store Publicity

SCRANTON, PA., March 6.—The Temple of Music of this city, prominent and successful talking machine dealer, recently held a very in-



View of Temple of Music Display Room teresting event in its concert hall, which achieved signal success. Guy Deetz, manager of this



View of Booths and Record Room store, and Mrs. Deetz were the guiding spirits in the presentation of this feature, which was commented upon very favorably in the local newspapers.

Mr. Deetz arranged for the appearance of four charming local girls, pupils of Miss Frederica Deerman, to give a series of interpretative dances, using the Victrolas and Victor records. In addition to these numbers, the new Victor records for March were presented.

Miss Deerman selected for this exhibition four of her prize pupils, the Misses Isabelle Diffin, Alice and Lois Smith and Jean Klonoski, three performances being given from 8 to 11 p. m. These dances were presented to more than 1,000 people and the street was crowded with interested music-lovers who were unable to obtain admittance. The concert hall at the Temple of Music faces the street, and as plate glass is used for the entire front, the dancers were visible to those standing on the other side of the street. The performance was enthusiastically applauded by the audiences, the young dancers finding the Victor records ideal for their interpretative dances.

The most important part of this feature is the fact that the business at the Temple of Music on the day following the dances was the largest the store closed since Christmas. Mr. Deetz is delighted with the success of his new plan, and promises to introduce some other innovations in the near future which will further add to the popularity of his establishment and the sales totals of Victrolas and Victor records.

A patriotic and philanthropic American has purchased thirty-eight Columbia Grafonolas with special carrying trunks for the members of the Twentieth Engineers (Forestry Division) who are now in training, and who expect to leave for France in the very near future.

F. F. DAWSON APPOINTED MANAGER

Takes Charge of the Columbia Graphophone Co.'s Cincinnati Branch

George W. Hopkins, general sales manager of the Columbia Graphophone Co., New York, announced this week the appointment of F. F. Dawson as manager of the company's Cincinnati branch. Mr. Dawson has been acting manager at this branch since the first of the year, and his appointment as manager is a well-deserved tribute to his ability and the success which he has already achieved in Cincinnati.

F. F. Dawson has been associated with the Columbia Co. for a number of years, and during this time has won the esteem of his associates and the Columbia dealers in the different territories where he has been located. He has always been a keen student of merchandising, and has left nothing undone to assist the dealers in the practical solution of their sales problems. He is thoroughly acquainted with every detail of Columbia product and its possibilities, and is generally recognized as a representative of the modern successful talking machine executive.

HELPING THE PUBLIC TO SELECT

The Orchard & Wilhelm Co., of Omaha, Neb., has recently issued a folder which is admirably adapted to helping the public make its record selections. The folder lists twelve individual records which it offers to send out on approval as a set. In explaining the system there is an introductory paragraph which runs as follows: "Sometimes you can afford a few minutes to look through the little book, but a glance over this list will tell you of twelve records that will satisfy, and you can order over the telephone with a confidence begotten of our recommendation."

A system of this sort offers an admirable opportunity to promote the sale of all new records and to specialize on selected numbers. It is also an idea which offers excellent opportunity to put out on approval certain records of unquestionable musical merit often overlooked.

HOME FROM COAST-TO-COAST TRIP

Frank T. Nutze, Vice-President of Stephenson, Inc., Motor Manufacturers, Finds Conditions Excellent Throughout Country

After a trip across the continent Frank T. Nutze, vice-president of Stephenson, Inc., manufacturers of the Stephenson "precision-made" phonograph motor, is again at his desk. While away Mr. Nutze visited several Pacific Coast cities and some of the larger commercial centers of the Middle West.

He reports both the retail and wholesale branches of the talking machine industry in the territory visited to be very prosperous, and the outlook to be healthy. In Chicago he found the talking machine manufacturers very optimistic, the majority of them feeling a constant increase in the demand for their products. One reason he stated for the better business situation in the West has been the absence of a coal problem on anything like the scale which visited the East. Then, too, he found shipping conditions much more favorable. While their shipping facilities are taxed they have avoided the critical conditions which developed in other parts of the country.

Mr. Nutze closed several business deals, some of which involve the shipment of quantities of Stephenson motors throughout the coming year. Arrangements for a Stephenson service station were closed for the city of Chicago and adjacent territory, the Lakeside Co., Inc., of that city, taking over that representation.

Since his return Mr. Nutze has been very busy catching up with his correspondence, and at the same time acting as traffic expert in seeing that the shipments of Stephenson motors are placed on the shortest and fastest routes, which is "some job" in these days of embargoes and freight congestion.

The Phonograph Co., Chicago, Edison jobbers, have increased their capital stock from \$25,000 to \$100,000.



Tone—the vital thing

IF you, as a manufacturer, can talk and prove *tone superiority* in your product, you have a selling argument to overshadow all the "talking points" of cabinets, and designs and accessory features.

And you *can* talk tone superiority. You can put out a product that will be a revelation in tone-purity, tone-quality, tone-volume. When you realize what vivid, lifelike, colorful tone can be produced and sustained by the talking machine equipped with

Parr Magnetic Reproducer

fitted with the **Vibratone Patented Diaphragm**

These two dominating and proven inventions open up wonderful possibilities for manufacturers eager to put their product at the top-notch of class and character.

You want your product to be RIGHT!

If you want your product worthy of your name, you certainly want that product to be right in its most *vital feature*. And it will be right if it is equipped with the Parr Magnetic Reproducer—the reproducer for those who seek *perfection*.

The indestructible, non-crystallizing, always resilient

VIBRATONE PATENTED DIAPHRAGM

Possessing all the good points of mica diaphragms, it overcomes all mica's had features. Guaranteed uniform in quality, free from bubbles, hlisters and waves, the Vibratone Patented Diaphragm is non-porous, non-absorbent.

It has a definite function and it performs it. It improves tone; in fact it creates new tone possibilities for every reproducer of other types.

PARR MANUFACTURING CORPORATION
1 UNION SQUARE At Fourteenth St. NEW YORK

Take the Parr Magnetic Reproducer—

The most sensitive of reproducers. The permanent magnetic device, an integral part of the reproducer, acts on the stylus box. Its possibilities in giving warmth and delicacy in the tonal reproduction of quiet passages make old-style sound boxes seem obsolete. And in fortissimo passages where ordinary reproducers create unpleasant, music destroying blasts, caused by the needle jumping and losing its grip, the Parr Magnetic Reproducer, with its marvelous flexibility, follows every wave and vibration in the record and takes everything the record holds.



Fill your store with laughter—put on the new April “Cohen at the Telephone.” Everybody who hears it will want it. Cohen buys a piece of submerged real estate, and a suit that fits him only here and there—all in one side-splitting record.

Columbia Graphophone Co.
Woolworth Building, New York

SONORA DEALERS ENJOY BANQUETS

Yahr & Lange Drug Co. Entertain Retailers in Their Territory at Elaborate Spread—Minneapolis Drug Co. Follows Suit

The Yahr & Lange Drug Co., Milwaukee, Wis., distributors in Wisconsin for the products of the Sonora Phonograph Sales Co., has been achieving remarkable success with this well-known line, and during the past few months has established many important agencies throughout the State.

Fred Yahr, president of the company, is taking a personal interest in the activities of the Sonora department, and recently invited the



Minneapolis Drug Co. Give Banquet to Sonora Retailers in Their Territory



Sonora Dealers in Milwaukee District Entertained by Yahr & Lange Drug Co.

Sonora dealers in his territory to be his guests at a banquet held at the Plankinton Hotel in this city. This dinner was a signal success, and every dealer present expressed keen enthusiasm

regarding the sales possibilities of the Sonora line, and many practical suggestions were submitted during the course of the evening.

In addition to inviting the Sonora dealers in

Wisconsin to be his guests, Mr. Yahr also extended an invitation to the Sonora jobbers in surrounding territory, and a number of them accepted, including Sewall D. Andrews, Minneapolis Drug Co., Minneapolis, Minn.; O. C. Maurer, Kiefer-Stewart Drug Co., Indianapolis, Ind.; W. J. Hamlin, C. J. Van Houten & Zoon, Chicago, Ill. Frank J. Coupe, director of advertising and sales for the Sonora Phonograph Sales Co., was also present at this dinner, and contributed materially to the success of the banquet.

When Mr. Andrews returned to Minneapolis, he was so favorably impressed with Mr. Yahr's plan that he extended an invitation to the Sonora dealers in his company's territory to be present at a banquet which he gave in Minneapolis. This event was also a decided success, and in addition to the dealers and executives of the Minneapolis Drug Co., there were also present George E. Brightson, president of the Sonora Phonograph Sales Corp., accompanied by Mr. Coupe.

ENTERTAINS CHICAGO FORCE

Arthur D. Geissler, president, and Roy J. Keith, vice-president of the New York Talking Machine Co., Victor distributors, returned last week from a visit to Chicago, where they attended directors' meetings of the New York Talking Machine Co. and the Chicago Talking Machine Co. While in Chicago Mr. Geissler gave a theatre party and dinner to his associates and the members of the board of directors, and Mr. Geissler's well-deserved reputation as a genial host was further emphasized by the success of this party and dinner. The event was marked by a spirit of good-cheer and good-fellowship, and was a fitting finale to a very pleasant Chicago visit.

The Glendale Phonograph & Piano Co., Vincent Salmacia, proprietor, has opened a store in Glendale, Cal.

MR. JONES HAD TOO MANY CABINETS

on hand, and he needed Motors!

MR. SMITH HAD TOO MANY MOTORS

on hand, and he needed Cabinets!

The Phonograph Clearing House, Inc.

is clearing up things like these every day. We can sell you anything you want, from a needle to a complete machine. Whether it's single items or millions, our business is to find it for you.

Direct Representatives of Leading Manufacturers

IF YOU DON'T KNOW WHERE TO GET IT
IF YOU DON'T KNOW WHERE TO SELL IT

Communicate with

THE PHONOGRAPH CLEARING HOUSE, Inc.

51 EAST 42d STREET, NEW YORK CITY

NEEDLES FOR PHONOGRAPHS

STEEL needles, 100 in eleg. envelopes, per 1,000.....\$.65
(In stock, extra loud, full and medium tone)
SAPPHIRE for Pathe or Edison, med. and loud tone, each .25
In lots of 100, each..... .20
DIAMONDS for Pathe or Edison, each..... 1.75
In lots of one doz., each..... 1.50
Made in Switzerland of the finest grade Sapphiro and Diamond
See our ad in Want Section

FAVORITE PHONOGRAPH ACCESSORY CO.
1491 DeKalb Avenue Brooklyn, N. Y.

WHY NOT A TALKING MACHINE MEN'S CLUB IN NEW YORK?

Strong Movement Under Way to Establish a Social and Business Center for the Trade at Large—Plan Would Present Many Genuine Advantages—Piano Men Already Have Club

Why not a talking machine men's club in New York—a social center where members of the trade can meet their friends, and where out-of-town visitors may make their headquarters?

There is a strong sentiment in the trade at the present time for the organization of a talking machine men's club, along the lines of clubs organized in the piano and other trades, and which have proven so successful. It is felt that this industry has reached the point where such an institution would prove most desirable, and that the trade is big enough to assure the support of such a move without any difficulty.

As one well-known talking machine man said to *The World*: "What the trade wants just now is a permanent meeting place where the members of the industry and their friends may gather for luncheon, for dinner, for a social hour or two, to chat, smoke, or otherwise entertain themselves, or to listen to valuable addresses on business topics delivered by men prominent either in or out of the trade. At the present time our industry is one of the few of its size in the city that has not such headquarters, and the fact is to be regarded in the light of a handicap.

"The piano trade some years ago organized the Piano Club of New York, with headquarters in the Bronx, and the club has proven most successful, there being a representative showing for luncheon each day and some big turnouts at special events. One can drop in there most any hour of the day and find somebody, and it proves a most welcome center to which to take piano men from out of town for luncheon or a chat. If the piano men can do it why cannot the talking machine men, who are far more numerous?"

Although the club plan is still in a purely embryonic state, it has already attracted the at-

tention of some active lights in the industry, and one prominent furniture man who conducts a talking machine department in his store has volunteered to provide the furnishings for any quarters that may be selected for a clubhouse, whether simply a floor or an entire building. It is believed that a logical location for a talking machine men's club would be in the forties, somewhere between Fifth avenue and Broadway, convenient to the hotels, theatres and railroad terminals, and within easy reach of trade centers.

It is felt that many speakers could be prevailed upon to address the trade if some place were provided where a fair size audience could be gathered. Then, too, there would be a genuine advantage to the trade in the social intercourse of its members through such a club. Out-of-town visitors, and there are a goodly number of them, would find a talking machine men's club a congenial place in which to spend their leisure moments, and to receive their mail.

Those who have advanced the club plan emphasized the fact that such a movement might well be fathered by the Talking Machine Men, Inc., who with their present organization, representative of the trade at large, could do much to develop interest in the idea. It is pointed out that there are several hundred manufacturers, jobbers and dealers in the metropolitan district who could be depended upon to support a club, a sufficient number in fact to insure the financial success of the venture, if conducted along conservative lines, at a minimum of expense to the individual.

As has already been stated, one advocate of the club idea has volunteered to provide the furnishings for the clubrooms, and this is to be recognized as eliminating one of the big, initial expenses. With the furnishings taken care of, the club members would be called upon to pay

only the rent and the operating expenses, with a return revenue being realized upon any restaurant or refreshment privileges that might be incorporated.

The *World* would be glad to receive any expressions of opinion from the trade in reference to the club idea.

SONORA CO. ELECTIONS FOR 1918

George E. Brightson Again Heads That Concern for Coming Year—The Other Officers

The officers and directors of the Sonora Phonograph Corp. for the ensuing year, as elected at a recent meeting of the stockholders, are as follows:

George E. Brightson, president and treasurer; J. N. Beach, vice president; Joseph Wolff, secretary; W. J. Farquhar, assistant treasurer, secretary American District Telegraph Co.; William Varin, comptroller. Directors: J. N. Beach (president of Lord's Court Realty Co., director Equitable Life Assurance Co., director Atlantic Mutual Marine Insurance Co.); George E. Brightson, H. P. Chilton (member of banking house of Moore & Schley), Waldo G. Morse (vice-president State Bank, Seneca Falls, N. Y.), Joseph Wolff.

The officers and directors of the Sonora Phonograph Sales Co., Inc., for the ensuing year, as elected at a recent meeting of the stockholders, are as follows:

George E. Brightson, president; Lewis Cruiger Hasell, vice-president; J. Schechter, secretary; Joseph Wolff, treasurer; E. H. Jennings, assistant treasurer (formerly manager credit department, Bank of the Manhattan Co.); Frank J. Coupe, manager sales and advertising. Directors: George E. Brightson, John A. Eckert (John A. Eckert & Co., insurance, New York); L. C. Hasell (general manager William Iselin & Co., New York), Waldo G. Morse, Jos. W. Stinson (formerly managing partner, Downing, Clark & Co.), J. Schechter (attorney), Joseph Wolff.

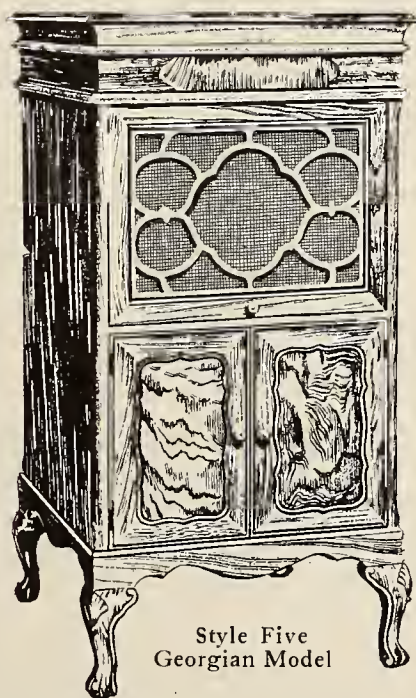

Style Five
Georgian Model

Six
Beautiful
Period Models
\$60 to \$300

The CHENEY PHONOGRAPH

Plays all records—better

The success of the Cheney, from a *selling* standpoint, is a tribute to the public's appreciation of *real musical and artistic worth*.

The serene purity of Cheney tone and its perfect renditions of all makes of records result from entirely new applications of acoustic principles. It puts the *real artist* into the record!

The Cheney is an artistic creation and as such it commands prestige and the subtle, but powerful "word of mouth" advertising that goes with the best.

Each sale becomes a permanent advertisement for your store.

Cheney cabinets cannot be excelled in beauty of design and quality of workmanship.

Cheney sales and advertising co-operation is in keeping with the high quality of the instrument.

Correspondence with dealers invited

CHENEY TALKING MACHINE CO.
24 N. WABASH AVENUE, CHICAGO

— *With exacting care*

The Phonograph manufacturer that I like to sell is the man who buys his materials with exacting care.

Because then it is easy to sell him the Stephenson Precision-Made Motor and easy to keep him sold.

Because he buys with exacting care — which logically means, the Stephenson Precision-Made Motor.

Francis V. Nutze

Vice-President

STEPHENSON, INC., One West 34th Street, New York

MAKING SATISFACTORY PROGRESS

American Graphophone Athletic and Social Club a Social Center for Grafonola Makers

The American Graphophone Athletic and Social Club, which is composed of the employes of the American Graphophone Co.'s factories

ment and amusement which this club affords. The club holds its meetings monthly, and the object of these meetings is to stimulate the interest and activities of the members in athletic and social welfare. The club is meeting with the hearty support of the "Graphites," and has gone a long way in the promotion of good-fellowship among the employes. It is inter-

G. Langham secretary. The officers and their associates have worked with considerable energy during their term to make the club a success, and their efforts have been well rewarded. The members enjoy nearly any sort of diversion, such as cards, checkers, pool, athletic stunts, music, dancing, reading, etc.

The club has a service flag covered with a field of stars, which is rapidly climbing close



Meeting Room of Sport Club



One of the Reading Rooms of the Sport Club

at Bridgeport, Conn. (manufacturer of Columbia products), is making very satisfactory progress, and according to present plans the members will be afforded many opportunities to thoroughly enjoy and appreciate the entertain-

ment and amusements. The club has been ested in pool tournaments, card tournaments, bowling, basket ball, music, dancing and similar entertainments.

In the past year A. C. Whitehead has been president, A. H. Carpenter vice-president, and

to the half hundred mark, and the clubrooms have already won recognition from the enlisted and drafted members as a center where they may congregate, renew old friendships and see familiar faces.

THE NEW VICTOR WIRELESS POSTER

Most Attractive Piece of Publicity for Use of Dealer Just Issued by Victor Co.

The Victor Talking Machine Co. has just sent out a most attractive poster in colors for the use of the dealers in window and store displays, and featuring the special Victor records for wireless operators announced recently. The poster shows an army wireless station, back of an artillery position in France, with the oper-

ator sending messages to headquarters. The coloring is particularly effective, and the whole poster is of the sort to demand immediate attention. The Victor wireless records are produced in accordance with the Marconi system, and are, therefore, to be accepted as the standard.

With the wireless poster there has also been issued a second poster referring to the "Victrola Book of the Opera," showing actual reproductions of the book, with its attractive cover in green and gold.

NEW STORE OPENED

The Jamestown Piano & Phonograph Co. has opened a store in Jamestown, N. Y., featuring the Hallet & Davis pianos, as well as Pathé-phones and records. Special soundproof rooms are being installed.

The man who could earn more through greater effort, but who does not make the attempt, cheats himself—and he cheats the rest of the world.

MUNOLA

Retail Price
\$44.50

By economical manufacturing methods and quantity production we are able to offer what we believe to be by far the greatest Phonograph value to-day on the American market.

Its price places it within the reach of every American home. Its fine appearance makes it fit for a place in the finest home in the land. Its richness of tone and splendid finish and design will delight the most critical buyer.

Mechanically the MUNOLA leaves nothing to be desired. Our especially designed double spring motor plays three ten-inch records with one winding and is absolutely noiseless when running.

The tone arm, sound box and full sized all wood horn are scientifically designed and properly proportioned to produce a full, round, mellow tone. **PLAYS ALL MAKES OF RECORDS AS CLEAR AS A BELL.**

MR. DEALER: The MUNOLA will make you immense profits. It sells to every class of buyer because it is cheap enough for anybody—good enough for everybody. We are rapidly establishing Agencies in cities all over the country. If you are looking for the best and most profitable popular priced Phonograph proposition to be had to-day, write us at once for our dealer proposition and full particulars.

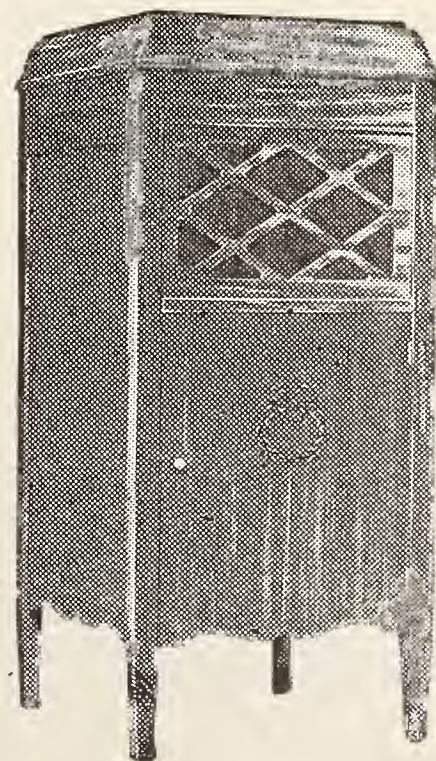

MUNZER MANUFACTURING CORP.
307 Sixth Avenue So. Sole Makers Minneapolis, Minn.



"The Quality Phonograph"

"Strong buying by the public of Pathé Records"



Pathé Phonograph \$225

Sounds like a market report, doesn't it?

It is a *fact*, however.

So great is this insistent buying demand among Pathé purchasers that the monthly release of Pathé Records is hopping along in increasing numbers.

Of course, there's reason for it.

Pathé is establishing a reputation for being first on the spot. Soon as a song, or other musical number, makes a hit, Pathé has it on a Record. That's service.

Then again—in the higher realm of song—such world-famed artists as Muratore, Muzio, Didur, Thibaud, Ganz, Hoffman, Rimini, Ober and a host of others, most of them exclusively Pathé, entrust their finest offerings to Pathé Records because of the *realism* and faithfulness of Pathé Record reproduction.

Get in on this Pathé prosperity.

WRITE TODAY

No Needles to Change

The Pathé Sapphire Ball takes the place of needles. It need not be changed.

Records Don't Wear Out

We guarantee every Pathé Record to play at least one thousand times with the Pathé Sapphire Ball without impairing the unexcelled beauty of tone.

The Pathé Controla

With the Pathé Controla you can increase or decrease the tonal volume of the Pathé Phonograph at will.

Each Pathé Phonograph

Plays not only Pathé Records, but all other makes of records, and plays them perfectly.



The Pathé Sapphire Ball
Enlarged many times

Williams-Davis-Brooks & Hinchman Sons

26 East Congress Street

DETROIT

MICHIGAN

OTTAWA PLANT DESTROYED BY FIRE

Ottawa Pianophone Co. Suffers Total Loss of Factory—Temporary Plant Opened in Chicago to Take Care of Current Orders

CHICAGO, ILL., March 11.—The plant of the Ottawa Pianophone Co., Ottawa, Ill., was totally destroyed by fire on Saturday night. The origin of the fire is unknown, but a high wind storm fanned the flames and firemen were delayed twenty-five minutes waiting for water to be turned on. Had there been a proper water supply the plant could have been saved.

A temporary plant has been secured in this city to take care of the orders on hand, and there is sufficient stock on hand to insure the trade an ample supply of the full Hiawatha line. Manager Fred Moynahan states that a new plant will be ready in sixty days on a location not yet determined upon.

PLANNING FOR JOBBERS' CONVENTION

Louis Buehn Heads Arrangements Committee to Look After Details of Annual Meeting to Be Held at Atlantic City in July

Plans are already under way for the next annual convention of the National Association of Talking Machine Jobbers, which will be held at the Hotel Traymore, Atlantic City, in July. The Traymore headquarters have proven most satisfactory to members of the association during the past two conventions, which accounts for the selection of that hotel for this year.

Of course, as they say in circus land, the coming convention will be bigger and better than ever. The trade is faced with unusual problems this year, and it would seem that every jobber would welcome the opportunity to meet with his fellow jobbers for the discussion of current problems as they affect the talking machine business.

Louis Buehn, head of the Louis Buehn Co., Philadelphia, has been appointed chairman of the arrangements committee for the convention, and is already hard at work lining up the details. Announcements of the various convention plans will appear in *The World* each month up to the time of the meeting.

SUPREME COURT RENDERS DECISION

Price Maintenance Suit of Boston Store of Chicago vs. American Graphophone Co. Decided in Favor of the Chicago Concern

WASHINGTON, D. C., March 5.—The United States Supreme Court handed down yesterday an important decision which in effect limits the rights of a patentee under the patent laws to control the resale price of an article. This decision was rendered in the case of the Boston Store of Chicago versus the American Graphophone Co.

In September, 1915, the United States District Court in Chicago granted an injunction against the Boston Store of Chicago enjoining it from selling Columbia records at cut prices. The case came before the Supreme Court upon a certificate from the United States Circuit Court of Appeals in and for the Seventh Circuit.

The questions certified to the Supreme Court were the following:

1. Does jurisdiction attach under the patent laws of the United States?
2. If so, do the recited facts disclose that some right or privilege granted by the patent laws has been violated?
3. Can a patentee, in connection with the act of delivering his patented article to another for a gross consideration then received, lawfully reserve by contract a part of his monopoly right to sell?
4. If jurisdiction attaches solely by reason of diversity of citizenship, do the recited facts constitute a cause of action?

The Supreme Court in its decision answered the first question in the affirmative, and all the other questions in the negative.

STOCKHOLDERS ASSENT TO PLAN

President Francis S. Whitten, of the American Graphophone Co. and the Columbia Graphophone Co., has sent out a letter to stockholders in which he says that over 90 per cent. of the stockholders have filed their assent to the reorganization plan, 60 per cent. being necessary. Temporary certificates of the Columbia Graphophone Mfg. Co., as the new company to take over American Graphophone will be known, will be issued shortly. The time for stockholders who have not done so to turn in their stock has been extended to March 15.

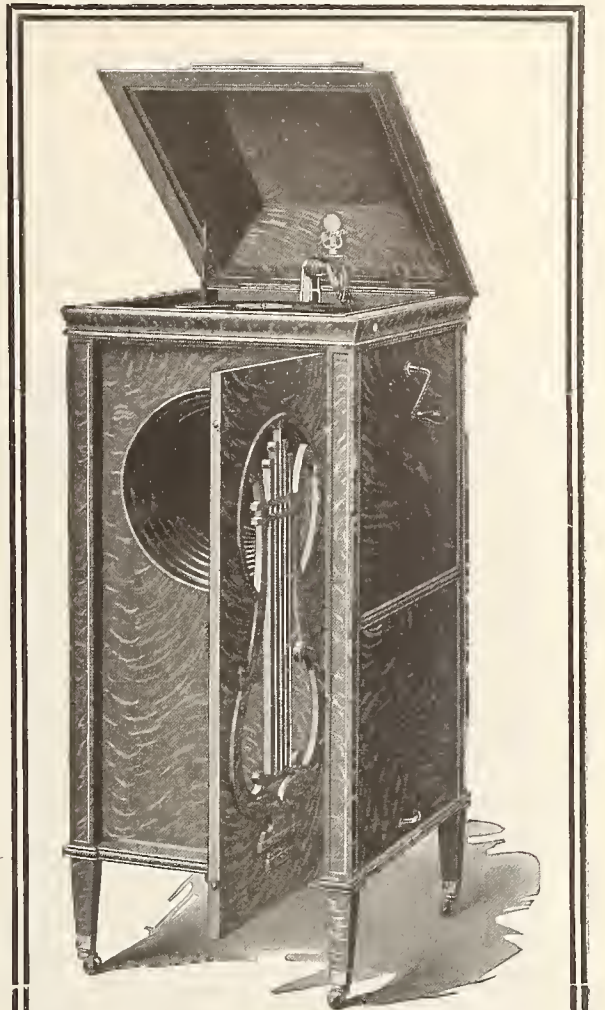

Style A

Price, \$225.00

Size 49 1/2 x 21 x 25

In Fumed Oak or Satin Mahogany

Triple Spring, Spiral Gear, Nickeled Motor, Tone Modifier, Plush-covered Turntable, Automatic Stop, Lock Needle-cups and Rests, Leg Sockets and Casters.

Record compartment opening on side through a rising and falling balanced door, fitted with five ten-inch and four twelve-inch high-grade albums, capacity 108 records.

All exposed metal parts heavily gold-plated.

The patented spun vibratory horn is finished in Roman Gold.

Send for Catalogue

Not Sold Through Jobbers

FULTON-ALDEN CO
INC.

WAUKEGAN, ILLINOIS

An Open Letter

to Every Live

DEALER

in the Trade

We still want 95 dealers of the 200 we started out to get last month—to know about STRADIVARA, and the quickest way we know how to do so is to "deliver the goods," and here's how we intend to do it:

WE WILL SHIP
from our regular stock

95

STRADIVARA
"KNOWN FOR TONE"

Machines

AS DEALERS' SAMPLES

If you consider yourself a "Live Dealer" be one of the remaining 95 to join us in forcing the issue for our big Spring drive for business. Write today for a sample machine while this special allotment lasts.

Join this list of Live Dealers who have sold hundreds of our machines and are making REAL PROFITS:

- | | |
|---|---|
| N. B. Shaw & Sons,
Amsterdam, N. Y. | B. Kantor, Inc.,
Newark, N. J. |
| Wm. Beagle,
Johnstown, Pa. | Geo. L. Schuyler,
Watertown, N. Y. |
| Russell & Rigg,
Altoona, Pa. | Howell Bros.,
Hoboken, N. J. |
| F. P. Weaver,
Meadville, Pa. | Nat'l Furn. Co.,
Newark, N. J. |
| J. Stearns Wyman,
Boston, Mass. | Cannon Furn. Co.,
Newark, N. J. |
| S. Da Boll,
Rochester, N. Y. | Hoffman Furn. Co.,
Newark, N. J. |
| B. E. Pudney,
Owego & Sidney, N. Y. | S. E. Lee Piano Co.,
Bridgeport, Conn. |
| L. B. Van Wagenen Co.,
Kingston, N. Y. | O. W. Merrell,
Winsted, Conn. |
| Larkin Piano Co.,
Yonkers, N. Y. | Walter Andrews,
Jamestown, N. Y. |
| Lindner Piano Co.,
Buffalo, N. Y. | Geo. A. Fellows,
Gloversville, N. Y. |
| Selmore Piano Co.,
Brooklyn, N. Y. | |

Space prohibits us from mentioning several hundred

After all the supreme selling test is quality—by comparison; and STRADIVARA has all the features of other machines, with the REAL Norwegian spruce sound board tone feature added.

7 Models — from \$45 to \$225

SCHILLING PIANO CO., Inc.

Wholesale Distributors

112 WEST 23d ST., NEW YORK

Paragon Mfg. Company, Inc.
HICKORY, N. C.

Manufacturers of

High-Grade Phonographs

\$85.00 to \$265.00. Play all Disc Records

This Ad. is for your Benefit, write us, Hickory, N. C.

RECORDS BY NOTED MEN

To Be Used by the "Nation's Forum" in National Propaganda

St. Louis, Mo., March 8.—As announced recently in The Talking Machine World, Guy Golterman, a prominent attorney of this city, is the director of a new organization to be known as the "Nation's Forum," which has been formed to introduce records made by some of the most prominent men in public life. This



Guy Golterman

forum has already secured an imposing list of names, and several well-known men have already made records which are meeting with considerable favor.

At a recent meeting of the Chamber of Commerce at the Planters Hotel, in this city, a record made by ex-Ambassador Gerard was presented, and proved such a signal success that Edward Buder, chairman of the meeting, wrote the following letter to Mr. Gerard: "Please accept my thanks for yours of the 27th inst. You will be pleased to know that the Gerard talk made a decided hit at the meeting yesterday, and I take this opportunity of thanking you for the use of the machine and the record."

IMPORTANT CHANGE IN EL PASO

EL PASO, TEX., March 9.—The Tri-State Talking Machine Co. has been consolidated with the talking machine department of the El Paso Piano Co. However, the firm name of "Tri-State Talking Machine Co." will be retained, J. M. Spain and W. R. Schutz being the sole owners. The piano department of the El Paso Piano Co. will continue as usual and under its present name. W. R. Schutz is proprietor.

The entire business will be concentrated and conducted in the El Paso Piano Co.'s beautiful new location at 215 Texas street, formerly Everybody's Building, in a few days.

Richard S. Thompson, formerly of the advertising department of the Victor Talking Machine Co., is now a second lieutenant of infantry. He is a graduate of Plattsburg officers' training camp.

MUSIC "SOMEWHERE ON ATLANTIC"

Naval Officer Writes Interesting Description of the Playing of Phonographs on Transport Bound for "Over There"—How Various Kinds of Music Affect the Fighting Man

SAN FRANCISCO, CAL., March 7.—Is the musical instrument a necessity or a luxury? Ask the boys in the cantonments, on the transports or in the trenches. George McConnell, of Fraser & McConnell, piano dealers of this city, is satisfied that at least on the transports music is a very real necessity. In evidence thereof he cites a letter he recently received from a captain, formerly of San Francisco, written while the officer was "somewhere on the Atlantic" headed for "somewhere in France."

In the opening paragraph the officer said: "A phonograph is playing in the distance, sometimes a classic and sometimes a love song." And as he proceeds with his letter he interrupts himself from time to time to tell what the machine is playing. Now it is "A Little Bit of Heaven." And this brings to the soldier's mind visions of dear old San Francisco, as it was there he had a friend who loved to sing the song. Then comes the Largo from Handel and the sadness makes the boys feel that it is very hard to keep a stiff upper lip. But the lighter things of life constantly bob up in youth and the captain refers to one of his comrades who is lying in his bunk, where he "Just Can't Make His Stomach Behave." Towards the end of the letter he says: "Now we are going to have a march and then perhaps a rag," and his friendly communication takes on a sprightlier tone at the prospect. Truly, he says in conclusion, if it were not for the music it would be hard to keep up a fellow's spirits.

Can you not picture the young officer sitting apart from the group about the phonograph, holding commune with his friend by means of the written word, but his every thought dominated by the music that flows from the overworked phonograph? Can you picture such a scene and say that the musical instrument is not a necessity of warfare?

1918 METHODS OF ADVERTISING

BOSTON, MASS., March 5.—George W. Hopkins, general sales manager of the Columbia Graphophone Co., New York, was one of the speakers Saturday at the monthly dinner of the Pilgrim Publicity Association.

Mr. Hopkins chose for his subject "1918 Methods of Advertising," and gave one of his usual effective and inspiring addresses. He told the advertising men present that it is up to them to make business earn more dollars than ever, so that these dollars may be used in supporting the Liberty Loans.

"There never was such a time in history," he said, "for the making or breaking of men in business. I'm not at all pessimistic, but the American business man must get his affairs into such shape that he can take advantage of the \$7,000,000,000 that will be spent by the Government in prosecution of the war. The rich man, too, has less money to spend than he ever had before; and the poor man has more. You must accommodate your business to these changed conditions or you will go down rather than up."

He outlined the various selling appeals in the vending of merchandise. Concerning one change in the psychology of the buyer, he said that the draft has made a Beau Brummel of the private, and this change is reflected in the average man.

NEW HOFFAY CABINET MODEL

A new style of cabinet has been adopted by the Hoffay Talking Machine Co., Inc., and in the future all their models will be produced in this new style, which will make the Hoffay distinctive. A photograph of the new model is reproduced herewith and will give some idea of its attractiveness.

The Hoffay Talking Machine Co. are celebrating this spring their "three years of progress." Announcement of the accomplishments of the firm in that time appears elsewhere in this paper. The recent New Hoffay Style decision of the Hoffay Co. that they would release their two reproducers, the "Resurrectone" and the "Half-fork-tone," for general use to all manufacturers making the necessary arrangements, has brought a flood of requests for these reproducers to the Hoffay offices during the past four weeks.



MAKING IMPORTANT INSTALLATIONS

A. L. Van Veen & Co. Equip a Number of Important Stores With Their Booths

In a chat with The World this week Arthur L. Van Veen, head of A. L. Van Veen & Co., manufacturer of Van Veen bed-set booths, commented upon the fact that the company had been making unusually satisfactory progress in closing important installations in Brooklyn. At the present time, Van Veen booths are being installed in the establishments of several prominent Brooklyn talking machine houses, and in all parts of this territory the company's booths are rendering splendid service. Mr. Van Veen attributes this progress to the satisfaction his booths are giving the dealers, for many of these installations have been repeat orders.

In current literature issued by the company Mr. Van Veen called attention to the fact that in a recent advertisement used by the Columbia Graphophone Co. on the back cover of the Saturday Evening Post an illustration was used that portrayed the Van Veen booths. The illustration in question was the interior of the store of Hardman, Peck & Co., Brooklyn, N. Y., which ordered a Van Veen installation after thoroughly investigating the merits of these booths. As this back cover advertisement costs \$9,000, Mr. Van Veen is naturally gratified to feel that a store with a Van Veen installation was selected for use in this advertising.

Among the recent Van Veen installations in Brooklyn are the following: Ridgewood Grafnola Shop, Frederick Becht, Kirsner Bros., Stultz & Bauer, and a complete installation for the piano and talking machine rooms of Frederick Loeser & Co.



The "INVINCIBLE" A New and Better Sound-Box

- ☐ Plays all makes of records.
- ☐ Pure, clear and sweet tone.
- ☐ Constructed to give service and absolutely guaranteed.
- ☐ No superfluous parts, and production uniform—no seconds
- ☐ Supplied with mica or composition diaphragms.

WRITE TODAY FOR SAMPLES AND PRICES

NEW JERSEY REPRODUCER CO.
847 Broad Street NEWARK, N. J.

SHELTON ELECTRIC PHONOGRAPH MOTOR

We have increased our factory facilities to handle the demand for the Shelton Electric Motor, and are now ready to make prompt deliveries.

Write for our Special Agency Proposition

SHELTON ELECTRIC CO.
30 East 42nd Street, NEW YORK

SERVICE FOR THE DEALER

The Service Department of the New York Talking Machine Co. Has Prepared a Series of Artistic Posters for Use of Dealers

The service department of the New York Talking Machine Co., Victor wholesaler, has prepared for the use of its dealers a series of unusually artistic feature posters that can be displayed to excellent advantage. It is the intention of this department to prepare one of these posters each month, and those issued to date have won the enthusiastic approval of the Victor dealers in metropolitan territory.

One of these recent posters featured the Victor records made by Jascha Heifetz, the phenomenal young violinist, who has taken the country by storm, and who records for the Victor Talking Machine Co. exclusively. This poster presents a cutout of Heifetz in full pose, and was executed by Louis Fancher, one of the leading poster artists in New York.

Another recent poster features the vocal record "Lorraine," which promises to be one of the most popular semi-patriotic songs that have been introduced during the past year. The subject of this poster is in keeping with the text of the song, and is well calculated to attract favorable attention from all Victrola owners. Another recent poster featured the Victor record of the "Missouri Waltz," one of the best selling waltz records that have been introduced in recent years.

The service department of this company has also instituted a special combination service plan, which includes a one-page insert that can be enclosed with the monthly supplements. This insert features ten records which the company has in stock, and this list contains selections that make a definite appeal to all music lovers. The headings of each insert are especially attractive, and usually feature some of the latest hits of the day.

In order to enhance the value of this insert a hanger has been prepared which also lists these ten records, and the progressive Victor dealer can use this hanger in conjunction with this insert, to stimulate the demand for ten records that can be promptly supplied.

NEW SONORA AGENCY OPENED

WEST ALLIS, Wis., March 12.—The exclusive agency for the Sonora phonograph in West Allis, one of the largest and most important suburbs of Milwaukee, has been placed with the Central Drug Co., 6324 Greenfield avenue, by Yahr & Lange, Milwaukee, distributors. The Central Co., owned by Theodore J. Mueller, is remodeling and enlarging its store in order to provide elaborate display and demonstration rooms.

NEEDLE CUPS

HEAVY NICKEL-PLATED

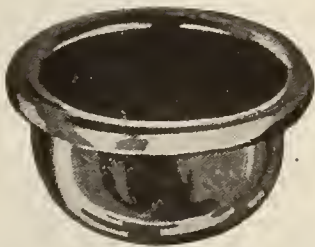

Per 100 . . . \$2.00 OPEN Per 1000 . . . \$17.50



Per 100 . . . \$3.20 CLOSED Per 1000 . . . \$27.50

FAVORITE PHONOGRAPH ACCESSORY CO.
1491 DeKalb Avenue Brooklyn, N. Y.

REMOVE TO LARGER QUARTERS

Ready File Co., Inc., Compelled by Growth of Business to Move Executive Offices to the Fourth Floor of Castle Hall Building

INDIANAPOLIS, IND., March 8.—For the second time within the past year the Ready File Co., Inc., has been forced by the ever-growing volume of business to move to larger executive offices. This time the makers of this fast selling specialty for filing records have gone to the fourth floor of the Castle Hall Building, where they occupy a suite consisting of six departments and an experimental laboratory.

When seen in his new private office, F. O. Wilking expressed great pleasure over the new experimental laboratory. He said in part:

"We are all greatly gratified in having at last the laboratory that has been in our minds for the past several months. Here we can, I am sure, work out the plans for making the new specialties we have in mind. What these are I am not at liberty to disclose, as our patents have not yet been secured, but I may at least say that they are all related to the development of the talking machine. I rather think that before very long we will be in a position to supply many of the wants of the talking machine dealer, and to supply them better than has heretofore been done by any accessory company."

APPOINT NEW BRUNSWICK AGENCIES

Ten Dealers in This Section Take on Line During Month—Changes in Staff at New York Office—Staff Meeting of Sales Force

Both the wholesale and retail departments of the Brunswick phonograph at the New York headquarters of the Brunswick-Balke-Collender Co. report generally good business.

In the period from February 15 to date ten new agencies for the Brunswick phonograph were opened by this office. Seven of this number were opened since the first of the month.

Various changes of territory were made in the sales staff. Chester Abelowitz, formerly in the New Haven district, is now in New York City. F. W. Johnston has been transferred from New Haven to Brooklyn. J. J. Brophy, formerly in New York City, is now in New Haven. A. E. Wengrovius is covering Albany and H. D. Clark, Newark.

The salesmen met in the New York headquarters on Saturday last for a staff meeting at which time the new "Ultona" reproducer and tone arm for playing all records on the Brunswick phonograph was demonstrated.

INCREASES CAPITAL STOCK

Phonograph Co., of Milwaukee, Edison Jobber, Increases Capital From \$30,000 to \$50,000

MILWAUKEE, Wis., March 13.—The capital stock of the Phonograph Co. of Milwaukee, 213-215 Second street, Edison jobber in Wisconsin and Upper Michigan, has been increased from \$30,000 to \$50,000. It is stated that there is no significance in the increase excepting that it is demanded by the constantly growing volume of business. William A. Schmidt is manager of the company, which also controls the Edison Shop, retailers for Milwaukee and vicinity.

SONORA PRICE FOLDER ISSUED

The Sonora Phonograph Sales Co. has just issued an attractive folder which presents photographs of the complete Sonora line, together with list prices. These photographs are clear-cut and well defined, and as usual, carry out the Sonora idea of dignity and quality. The complete line of Sonora phonographs with their prices are as follows: "Supreme," \$1000; "Invincible" No. 1, \$375, No. 2, \$500; "Grand," \$300; "Laureate," \$215; "Elite," \$200; "Baby Grand," \$180; "Intermezzo," \$150; "Imperial," \$115; "Troubadour," \$90; "Rhapsody," \$60; "Mendelssohn," \$55; "Melodie," \$50.



Read the Trade Mark carefully, hear the machine, and you'll agree that it is truly

The World's Musical Instrument

Improves All Records

Send for our Special Proposition

HOFFAY TALKING MACHINE CO., Inc.
3 West 29th Street New York City

WHERE BUYING POWER LIES TO-DAY

Some Interesting Comments on Changed Conditions From Edison Diamond Points

It is no exaggeration to say that the earning capacity of the working man is to-day much higher than it has been in years, says Edison Diamond Points. There are probably five million families in the United States and Canada who to-day are in a position to purchase what they had previously considered far beyond the reach of their purse. The high cost of living notwithstanding, the working man is better situated financially than he has ever been.

The buying power to-day is in the hands of the working man. We believe that in certain localities the large percentage of buyers of New Edisons in 1918 will be working men, men who to-day can afford to have those things that have long been out of their financial reach.

In January, we sent you a questionnaire about your business. The opening question was: "What percentage of your sales in November and December was made to the working class?"

A good many replies have been received, enough, in fact, to shed a good deal of light on your business in the future. There are numerous cities and towns in this country where anywhere from 90 to 100 per cent. of our dealers' business is transacted with men of the working class.

If you are situated in a large manufacturing community, you have an untouched field before you, but bear in mind that you are the one to do the tilling. Indications are that 1918 will be the best year on record for the man who goes after business—it may not be quite so good a year for the dealer who stands behind his counters and waits for business to come to him.

The J. B. Greenhut Co., Inc., the big New York department store, are closing out their business. They held a Victor jobber's license, although selling only at retail, and the Victor stock has been taken over by another local jobber.

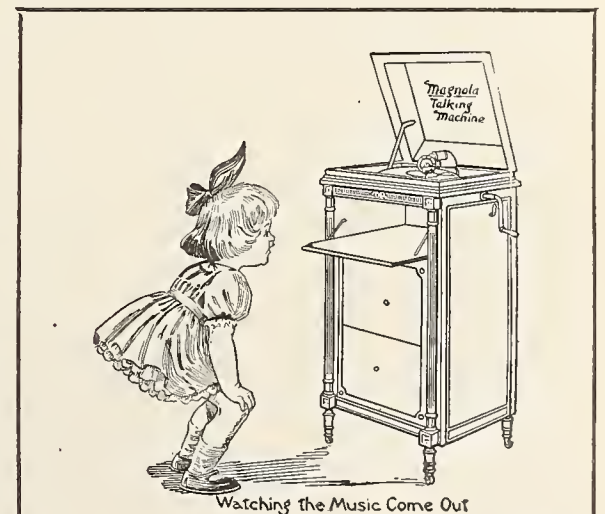

Watching the Music Come Out

Magnola Message No. 2

Control of Loudness is essential to the modern successful Talking Machine, The TONEGRADUATOR carried by every MAGNOLA is simple, efficient and trouble-proof.

Send for handsome illustrated catalog.

And look for other Magnola Messages on other pages of this paper; there are two more to find.

MAGNOLA TALKING MACHINE COMPANY

OTTO SCHULZ, President
711 MILWAUKEE AVENUE CHICAGO 1530 CANDLER BLDG. ATLANTA, GA.



Al Jolson never sang a livelier song than "There's a Lump of Sugar Down In Dixie." It's one of the many sure-fire sellers in the Columbia April program. A2491.

**Columbia Graphophone Co.
Woolworth Building, New York**

THOS. A. EDISON AS A PROPHET

Article Written by Him Forty Years Ago Gave Accurate Forecast Regarding the Wide Sphere of Usefulness of the Phonograph

An article written by Thomas A. Edison for the North American Review May-June, 1878, recently came to light during a search among some old documents in Mr. Edison's laboratory. In this article Mr. Edison presented a number of categorical questions to which he appended answers, covering almost every phase of phonographic development, showing what has been successfully accomplished, as well as certain possibilities which subsequent developments prove that Mr. Edison was a prophet in his own country.

This North American Review article, which by the way, is being reprinted in full in the current issue of the Amberol Monthly for its historical importance, emphasized Mr. Edison's ideas regarding the future of the phonograph, almost forty years ago, in which many of the accomplishments of to-day were then set forth as among the certainties.

In his questions and answers he covered sound production in its various phases, record making and multiplication as well as the preservation of sounds. He said further: "Conceding that the apparatus is practically perfected in so far as the faithful reproduction of sound is concerned, many of the following applications will be made the moment the new form apparatus, which the writer is now about completing, is finished. These, then, might be classed as actualities; but they so closely trench upon other application which will immediately follow that it is impossible to separate them; hence they are all enumerated under the head of probab-

ilities, and each specially considered. Among the more important may be mentioned: Letter-writing, and other forms of dictation, books, education, reader, music, family record; and such electrotype application as books, musical boxes, toys, clocks, advertising and signaling apparatus, speeches, etc., etc."

Mr. Edison treats these subjects in detail and shows how phonographic books may be used in the home; how the phonograph may be used for educational purposes; as a musical entertainer; as a family record; for toys of various kinds, and points out the possibilities of the phonographic clock that will tell the time of day, how phonography may be used for advertising, for transmitting the great speeches of prominent men, posterity and lastly, and in quite another direction, tells how the phonograph will perfect the telephone and revolutionize present systems of telegraphy.

The article, which is very lengthy, certainly demonstrated Mr. Edison's complete grasp of the phonographic field four decades ago.

TELLS OF COMPANY'S PROGRESS

Phonograph Clearing House, Inc., Fills a New Field of Usefulness for Phonograph Manufacturers Generally—Centralizes Supplies

In a recent chat with The World, S. N. Rosenstein, president of The Phonograph Clearing House, Inc., New York, gave some interesting ideas in connection with the foundation of his house, and the success which it is achieving.

Before he established the Phonograph Clearing House, Inc., Mr. Rosenstein was connected with the phonograph industry in various ways for a number of years, and he states that he realized the need of a central depot for the busy manufacturer wherein he might find whatever he wanted without the least waste of energy.

"To this end," said Mr. Rosenstein, "I established connections with the manufacturers in the East and West, and can now supply the manufacturer with anything he wants from a needle to a finished machine. I wish to call the attention of the manufacturers, however, to the fact that, as a rule, when the manufacturer is in the market for a new tone arm, sound box, motor, or other part, he does not know exactly just what he wants, and is desirous of learning just what is on the market that would best suit him.

"He is, of course, hardly willing to enter as yet into direct communication with the 'parts' manufacturer, and that is where our clearing house can help him. We give the manufacturer the benefit of absolute tests on every article, and then sell him whatever he chooses to adopt without any additional cost, and certainly with less worry. In addition, we help many manufacturers dispose of overstock through our study of the sources of supply and demand."

The Texas-Oklahoma Phonograph Co., Edison jobbers, with headquarters in Dallas, Tex., have leased a large storeroom measuring 50 by 200 feet, at 906 Commerce street, that city.

DISTINCTIVE FEATURES HELP

Why the Brown Disc Record Cabinets Grow in Popularity With the Trade

The sales manager of the Globe-Wernicke Co., Cincinnati, O., manufacturer of Brown disc



record cabinets, in a recent chat with The World pointed out that the success of these cabinets may be attributed to the practical utility of its distinctive filing arrangements, and the favorable appeal which its other features make to the talking machine owner. The Brown disc record cabinet is so devised that a record may be found instantly, and the compartment from which it was taken is left open for its return. There is no danger to the record, as it is either on the machine, in the hands of the operator or in its compartment.

From the standpoint of attractiveness the Brown disc record cabinet harmonizes completely with the most expensive furniture in the living room or music room. It is splendidly constructed, and is made in four sizes; two-drawer, four-drawer, six-drawer and twelve-drawer. The Globe-Wernicke Co. has prepared an artistic catalog, designated as No. 317, which is devoted to the Brown disc record cabinet.

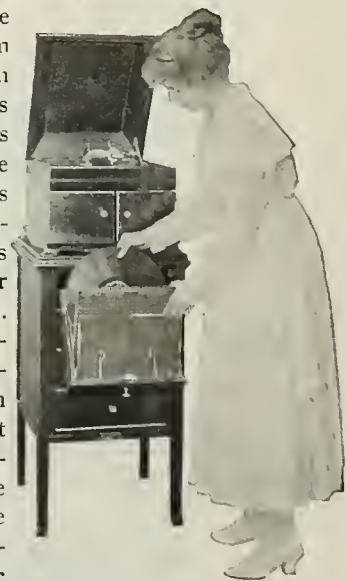

How It Operates

TEST offered to dealers to prove the superiority of Wall-Kane Steel Needles

Take two standard disc records of the same selection, play one ten times with the same WALL-KANE loud needle; play the other record, the same selection, ten times, but with ten, new, full tone steel needles.

You will find that the record played ten times with the same WALL-KANE needle will sound clearer, will have less surface noise, and that under the magnifying glass the grooves of the record played ten times with the ten steel needles will seem to be more disturbed.

Beware of Imitations

Package of 50 WALL-KANE needles. Loud, Extra Loud and Medium, greater value than 500 ordinary steel needles, retails for 10c, costs the dealer 6½c. Jobbing territories open.

Progressive Phonographic Supply Co.
145 West 45th Street, New York





INVISIBLE HINGES

Preserve Beauty
In many beautifully designed, finely finished Talking Machines, Pianos, Music Cabinets, Piano Players, and Benches, the elimination of the unsightly protruding Hinge is essential to preserve the beauty of the design.

Design and Construction
The fine cabinet work which is required in many instances to preserve the disguise of the instrument requires that the hinges be as inconspicuous as possible. SOSS Hinges are *Invisible*.

Write for catalogue "T"

SOSS MANUFACTURING COMPANY

435 ATLANTIC AVENUE BROOKLYN, N. Y.
 LOS ANGELES, 224 Central Bldg. } **Branch Offices** { SAN FRANCISCO...164 Hansford Bldg.
 Canadian Representatives—J. E. Beauchamp & Co., Montreal, Can. } DETROIT—922 David Whitney Bldg.



“COLUMBIA RECORD” REAPPEARS

Popular House Organ of Columbia Graphophone Co. in New Dress and Full of “Live” Copy

The “Columbia Record,” the popular house organ, which was published by the Columbia Graphophone Co. for several years, and which was temporarily discontinued some time ago, made its reappearance this month in new form, and judging from the success of the first number the new “Columbia Record” is destined to become a most popular house organ.

The form of the new “Columbia Record” is decidedly individual and distinctive, the paper being issued as a four-page newspaper, each sheet measuring 18” by 27”. This makeup permits of the introduction of attractive illustrations with plenty of text.

On the first page of this new publication is presented a group of pictures showing how Columbia dealers have utilized the new window display service inaugurated by the Columbia dealer service department. There are also presented several letters received from Columbia dealers throughout the country commenting upon the value of these displays, and the impetus that they have given to record sales.

There is a column story on the first page regarding “Thornton Burgess Week,” and reproducing some of the fantastic characters which have made this author’s Bed-time Stories famous.

Other pages of this new “Columbia Record” reproduce some of the new Columbia car cards, which are multi-colored masterpieces of lithographic art, and which form one of the most effective links in the dealers’ advertising campaigns. There are also reproduced several of the new Columbia advertising cuts, free electrotypes of which are sent dealers on request.

One of the most valuable articles in this new “Columbia Record” is a list of the tentative tours of Columbia artists, giving a detailed account of the different cities at which they are scheduled to appear during the next few months. Among the Columbia artists listed in this section are Barrientos, Casals, Cincinnati Symphony Orchestra, Eddy Brown, Lucy Gates, Leopold Godowsky, Louis Graveure, Josef Hofmann, Margaret Keyes, Morgan Kingston, Florence Macbeth, New York Philharmonic Orchestra, Oscar Seagle, Helen Stanley and Eugen Ysaye. There are other practical suggestions in this first issue of the new “Columbia Record,” which is being ably edited by Paull Hayden. The purpose of the new publication is well summed up in the following editorial comment:

“You are the most important man in the Columbia business—because you sell Columbia product. Without your efforts there would be no Columbia factory, no Columbia Grafonolas, no Columbia records, in fact, no Columbia Co. You are the wheels, the belts, the pulleys, the engine, the coal, the steam, the power which is making Columbia what it is to-day and will make it what it will be to-morrow.

“Our factory knows unless they give you the

right product they will have to shut down. Our executives know that unless they give you what you want and what you can sell there is no excuse for their existence.

“Having proved to you your importance we are glad to announce the reissuing of the ‘Columbia Record.’ It is to help you be more important. It is to be one of the most unique and dealerish dealer house organs in existence.

“We want to tie up the smallest Columbia dealer in America with the biggest Columbia sales ideas.

“In addition to sales plans developed by our sales experts the ‘Columbia Record’ will tell stories of successful plans developed by other

Columbia dealers. Here’s where you come in again. Let us know any time you make a successful sale. Your success is as good as the next fellow’s and we want to give everyone the benefit of your ideas as well as give you the benefit of everyone else’s ideas.”

REPUBLIC CO. CREDITORS TO MEET

CHICAGO, ILL., March 11.—The first meeting of the creditors of the Republic Phonograph Co. of Illinois, which was adjudicated bankrupt on March 5, will be held at the offices of the referee in bankruptcy, Sidney C. Eastman, at 53 West Jackson boulevard, March 19.

STILL MORE PROOF OF HOW WORLD ADS BRING BUSINESS

B. R. FORSTER, PRES. & TREAS. H. ETTINGER, VICE PRES. H. W. ACTON, SECRETARY

BRILLIANTONE STEEL NEEDLE CO.

OF AMERICA, INC.

HIGHEST QUALITY UNIFORM TALKING MACHINE NEEDLE IN THE WORLD

MARBRIDGE BUILDING
BROADWAY & 34TH ST.
ROOMS 657-659 PHONES GREELEY 5978 5979
NEW YORK CITY

MADE IN AMERICA BY AMERICAN LABOR

March 1st, 1918.

The Talking Machine World,
373 Fourth Avenue,
New York City.

Gentlemen;—

We take great pleasure in complimenting your good paper on the splendid results we have obtained from our advertisements in your monthly.

According to records which we have in our office and which are open for inspection, we have received inquiries from prospective buyers of talking machine needles, from all parts of the United States, Canada and foreign countries, who refer to having seen our add in the “Talking Machine World.”

As a constant advertiser in your paper, we believe that you would be pleased to know of these results. We can cheerfully recommend the Talking Machine World to any advertiser in search of an effective advertising medium.

Wishing your paper much success and assuring you of our hearty support, we are,

Yours very truly,

BRILLIANTONE STEEL NEEDLE CO.

BY-  PRESIDENT.

BRF.J.M.

All agreements contingent upon Strikes, Accidents or other causes beyond our control. Prices subject to change without notice.

The Biggest Event in Motordom!

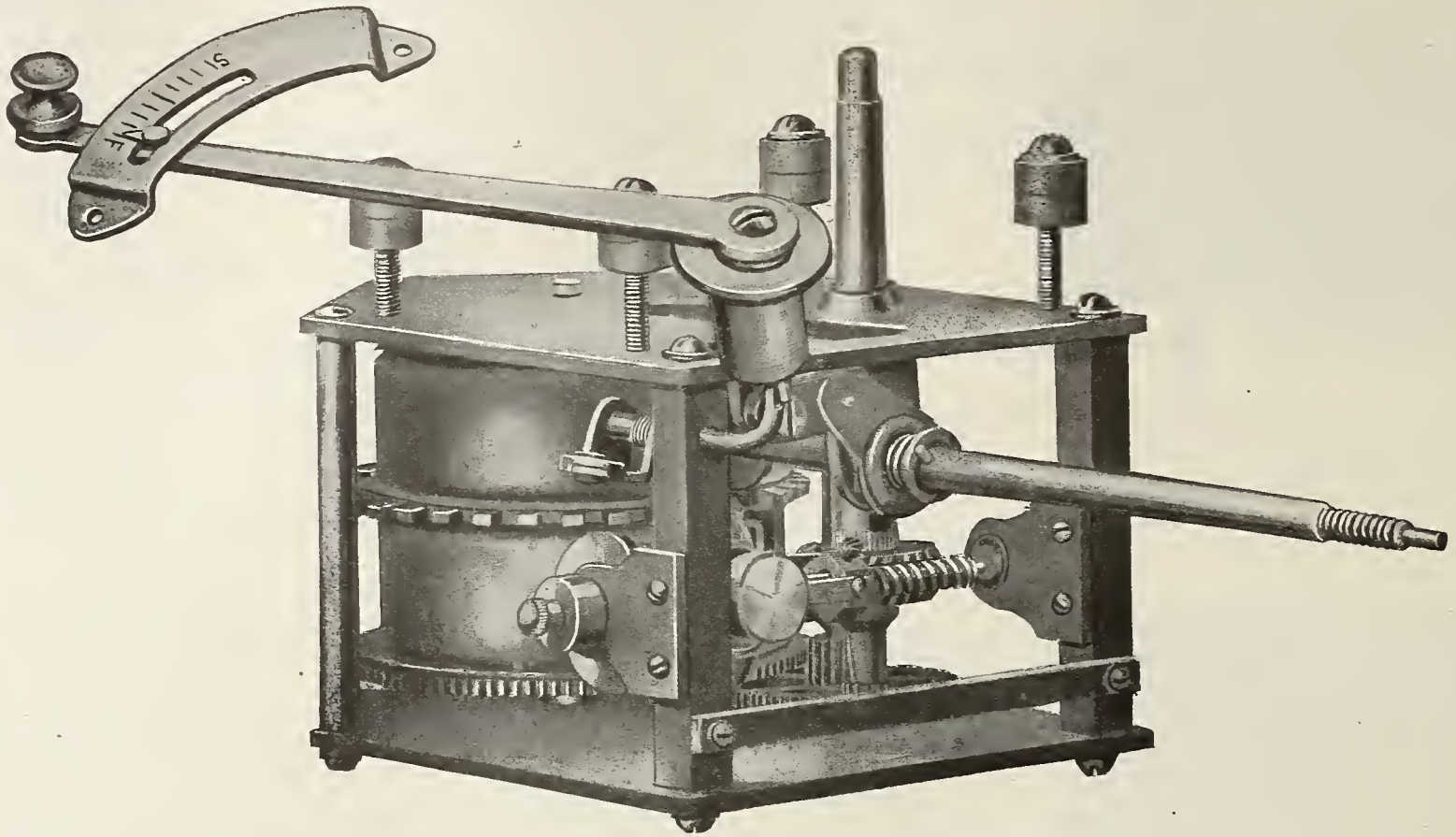

Our Most Popular No. 2 Motor

Over 250,000 are in use.
One of the most prominent manufacturers in the United States alone has used 80,000.

Improved with a combination start and stop and regulating device that works on and with the governor direct instead against the governor.

The Price Will Startle You.

Write at Once and Surprise Yourself

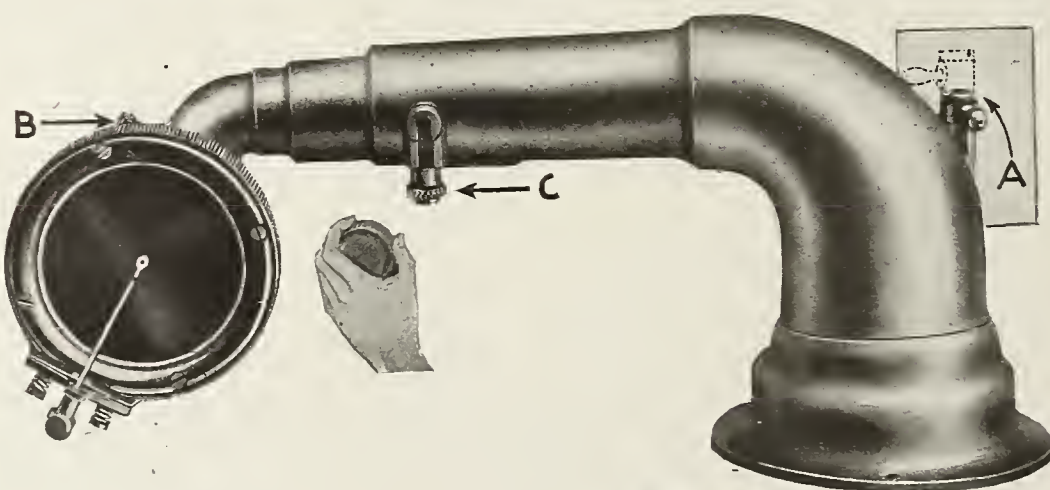

We Have a Tone Arm For Every Purpose

The Two-In-One

Plays any type of record as it should be played. A heavy arm for vertical records; a light arm for lateral records—just a twist of the handle "A"—and the weight is changed from 4 to 8 ounces.

The Improved No. 2 Universal

Known to all manufacturers as a practical and satisfactory arm for all machines ranging in price from \$15.00 to \$75.00.

We can furnish you with every part of a talking machine from a needle up.

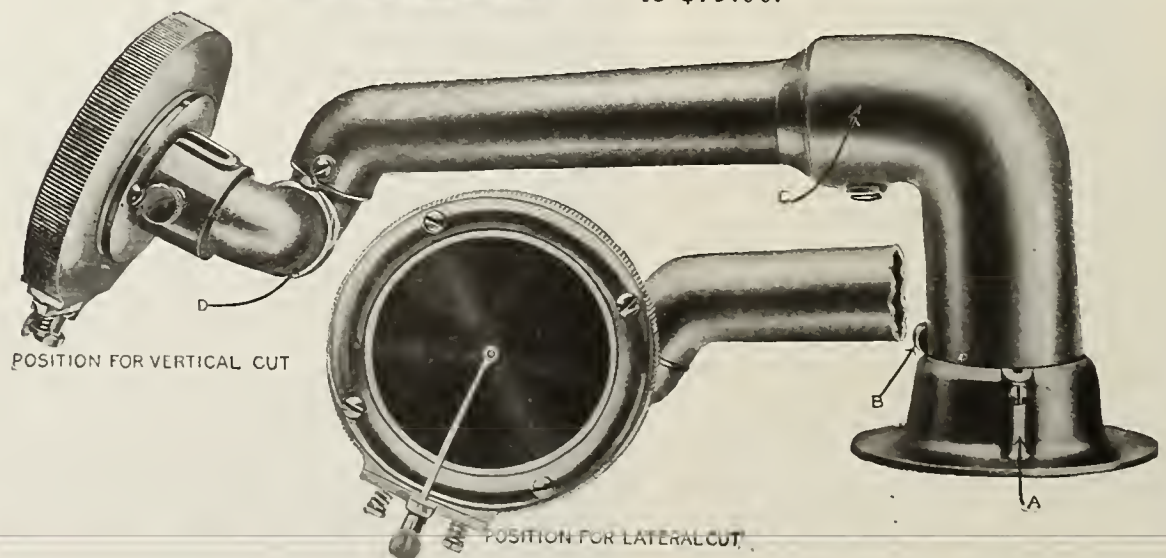

INDEPENDENT TALKING MACHINE CO., Inc.,

54 BLEECKER STREET,
NEW YORK CITY

New Columbia Jazz records supreme—A2421, “Fuzzy Wuzzy Rag” and “The Snaky Blues,” by Handy’s Orchestra: A2482, “Happy Sammies” and “That’s It,” by Jazarimba Orchestra. April winners.

**Columbia Graphophone Co.
Woolworth Building, New York**



JOBBER’S ASSOCIATION APPROVES “REFERENDUM NO. 23”

Cast Affirmative Vote on Proposal to Discriminate Against Enemy in Trade After the War if Necessary for Self-Defense—President Blackman Explains Real Meaning of Proposal

The members of the Chamber of Commerce of the United States were recently requested to vote on a referendum, designated as “Referendum No. 23,” which related “to a proposal to discriminate against Germany in trade after the war, if necessary for self-defense.”

The vote on this referendum was overwhelmingly in the affirmative, and one of the associations that voted “yes” was the National Association of Talking Machine Jobbers, which cast its vote through French Nestor, national councillor, after a meeting of its executive committee.

When the referendum was first received J. Newcomb Blackman, president of the National Association of Talking Machine Jobbers, made a careful study of its different proposals, and about that time the newspapers started a controversy regarding the meaning of certain paragraphs in the referendum. After going into the matter very carefully, Mr. Blackman sent the following interesting letter to Mr. Nestor:

“I have purposely delayed voting on the United States Chamber of Commerce Referendum No. 23, as I wanted the benefit of the controversy, which I have noticed in the newspapers regarding it.

“The referendum itself was not read by me until to-day; and the newspaper articles gave me the impression that it called for a vote to boycott Germany after the war without qualification. I think that represents the prevailing idea.

“A careful analysis satisfies me that this referendum merely attempts to set forth the general belief of American business men, as well as the general public, that we were forced into this war through a military form of government in Germany.

“Furthermore, that, as President Wilson has so clearly pointed out in his various messages, we cannot hope to have a lasting peace if the fulfilment of its terms depends upon the present or some similar government which, in effect, is a military autocracy.

“It is to me a message to the German business man from the American that, to avoid what may possibly be the birth of a commercial war and the introduction of a boycott against Germany, it is absolutely essential that the present form of government give way to one set up by the German people and responsible to them.

“In other words, instead of our agreeing now to boycott Germany, as many seem to think this referendum calls for, we are merely setting forth our convictions, as the present form of German Government having been responsible for the war, and that unless after peace the enemy takes on a different form of government, we will be obliged to discriminate, in order that we will not help a militaristic autocracy regain its strength only to wage another war.

“Inasmuch as this referendum has been issued and must be voted on, I hope our members will have a clear understanding of its object and effect.

“The third paragraph on page 4 of same is a simple explanation and reads as follows:

“This proposal is concerned only in making clear to the business men of Germany that a continuance of the present German military autocracy will compel the rest of the world to unite in a business opposition to Germany as an act of self-preservation.”

“I have endeavored in this detail to discuss the subject, because I so fear a negative vote giving rise to the opinion that, regardless of circumstances, American business would not discriminate against Germany commercially.

“If among our members you have negative votes, and such would sway the balance, so that we should be obliged to cast our vote for the association accordingly, I hope that no time will be lost in bringing this squarely to their attention, so that through no lack of proper interpretation a negative vote will be cast.

“On the other hand, I am frank to say that were this referendum to concern nothing but an unqualified expression of determination to boycott Germany after the war, I would most emphatically vote ‘no.’ To me it means a strong presentation to German business interests of our sincere regret in being possibly forced to take such action and an expression of what would bring this action about, also how it can be avoided.

“If I can be of any further service in this matter, do not hesitate to call on me, for this referendum has been given much publicity, and now that it has come to issue, should be voted on in a most intelligent manner.

“I think we all agree that we are fighting this

war to insure permanent peace and liberty and are prepared to sacrifice everything to accomplish that end, so the least we can do is to leave no misunderstanding among ourselves, or even our enemy that will delay, hamper or defeat such an unselfish motive.”

STRIKING VICTOR ADVERTISING

Feature Value of Talking Machine Record in Preserving Voices of Noted Artists

In their recent advertising in the American Magazine, the Victor Co. has featured most impressibly the fact that the talking machine record renders a genuine service to posterity by permitting them to listen to the actual reproductions of the voices of the famous artists of the present day. The advertisement points out that, although the voice of Patti is lost to those of the younger generation who did not hear that noted songstress in the flesh, the golden tones of Melba will be preserved on talking machine records for all time to come. Both the illustration and the text convey a message to the public that cannot be mistaken, and represent an angle from which to view the importance of the talking machine which, although it may not be new, is nevertheless well worth considering.

The creditors of the Rex Talking Machine Corp., Wilmington, Del., held a meeting recently declaring a final dividend of 3.6 per cent.

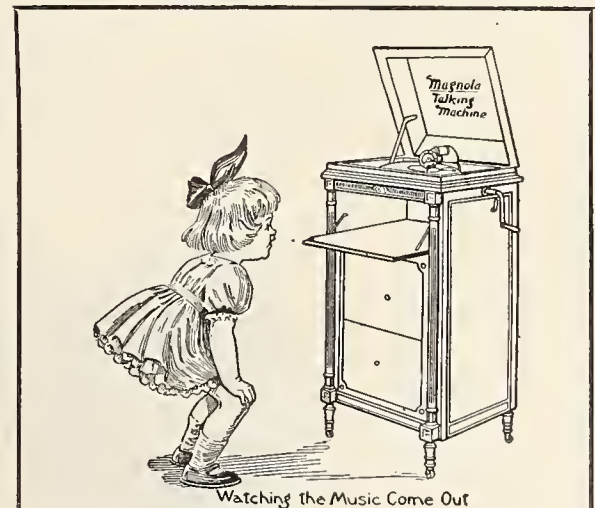

Watching the Music Come Out

Magnola Message No. 3

A Talking Machine of today should play all makes of disc record. Magnola’s Universal Sound-Box does this without extra attachments of any kind.

Look for Magnola Messages Nos. 1 and 2 on other pages and learn more of Magnola.

Handsome illustrated literature sent free on request.

MAGNOLA TALKING MACHINE COMPANY

OTTO SCHULZ, President
711 MILWAUKEE AVENUE CHICAGO 1530 CANDLER BLDG. ATLANTA, GA.

FACTS ABOUT THE KENT ATTACHMENT NO. 1

To Play Lateral Cut Records on the Edison Diamond Disc Phonograph

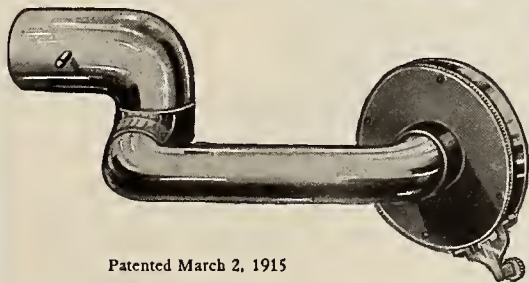

Patented March 2, 1915

It has been recognized by experts the most perfect device of its kind on the market. It has been on the market ever since the Edison Diamond Disc made its appearance. It can be had with or without reproducer and is made in two lengths. It is guaranteed by the Manufacturer in every way.

F. C. KENT & CO.
Manufacturer of Phonograph Accessories
24 Scott Street Newark, N. J.

ANNUAL BANQUET AND DANCE

Of the Talking Machine Men, Inc., Will Be Held at Hotel McAlpin, New York, on April 10—An Interesting Program Has Been Arranged

The entertainment committee of the Talking Machine Men, Inc., has advised the dealers in



J. J. Davin

New York, New Jersey and Connecticut that the association's annual banquet and dance will be held at the Hotel McAlpin, New York, on April 10. Plans for this event are now being formulated, and judging from the indefatigable efforts of the committee, this year's dinner will set a new high-water mark in point of attendance and enjoyment.

Sol Lazarus, chairman of the entertainment committee, and one of the most active workers of the Talking Machine Men, Inc., is being congratulated upon the acquisition of corps of aggressive and wide-awake associates for his committee. J. J. Davin, of the New York Talking Machine Co., is a member of the entertainment committee, and chairman of the reception committee, and in this important post is rendering invaluable service to Mr. Lazarus. Other members of the entertainment committee, who have "put their shoulders to the wheel" in a united effort to make the 1918 dinner a record-breaker are John E. Hunt, A. Galucie and Cass Riddel.

The committee has announced that the speakers of the evening will include Congressman Stephens, sponsor of the Stephens bill; H. C. Brown, assistant general manager of the Victor Talking Machine Co.; George W. Hopkins, general sales manager, and Marion Dorian, chief

auditor of the Columbia Graphophone Co.; J. Newcomb Blackman, president National Association of Talking Machine Jobbers, and J. H. Tregoe, secretary of the Credit Men's Association. James T. Coughlin, president of the association, will preside as toastmaster, and it is safe to say that this important position will be filled with adeptness and skill.

Through Mr. Davin's efforts, the association is enabled to present to the dealers something novel in the way of entertainment, which should insure the certain success of this part of the program. The Hawaiian Troupe, which has made a series of Victor records that have achieved phenomenal success, will render a group of songs and medleys during the course of the dinner, and after the close of the banquet will furnish their inimitable playing for the devotees of dancing. The entertainment committee is making extraordinary efforts to have the fair sex well represented at this year's gathering, and the program, with the Hawaiian Troupe as



Sol Lazarus, Chairman Entertainment Committee an added feature, should make a favorable appeal in this direction.

It is planned to have an exceptionally attractive musical program, and among the well-

known artists who will render a number of selections during the course of the evening are Charles W. Harrison, Arthur Fields, and others. This feature is a decided innovation for the association's banquet, and indicates the activities and progressiveness of the 1918 committee.

In order to make this year's dinner and dance a representative trade gathering, the entertainment committee is urging the dealers to bring as many of their employes as possible, and for those who are unable to be present during the earlier part of the evening, a cordial invitation is extended to enjoy the dancing and entertainment in the latter part of the evening.

The annual banquet of the Talking Machine Men, Inc., has been recognized for several years as one of the most important and enjoyable events in the activities of the talking machine trade, and each year's dinner and dance has outdistanced its predecessor. It is almost a foregone conclusion, however, that the 1918 gathering will leave last year's far behind in every respect, as the dealers intend to bring their families, employes and personal friends.

SUFFER LOSS FROM FIRE

James E. Donnelly, music dealer of Bridgeport, Conn., recently suffered a fire loss of \$2,500 to his stock of talking machines and records. Prompt work by the salvage corps of the Fire Department resulted in the saving of \$4,000 worth of records.

FIRE IN LAWRENCE, MASS.

A fire which caused \$150,000 damage to the furniture and department store of M. J. Sullivan, Lawrence, Mass., last week, destroyed practically the entire stock of talking machines and records on the second floor of the store. Several employes in the department had narrow escapes from the flames.

It's a very unusual trouble that most of us can't stand cheerfully—if it only belongs to the other fellow.

The "Mutual"—the ORIGINAL and PATENTED Universal Ball Bearing Tone-Arm

BEWARE OF INFRINGERS AND IMITATORS

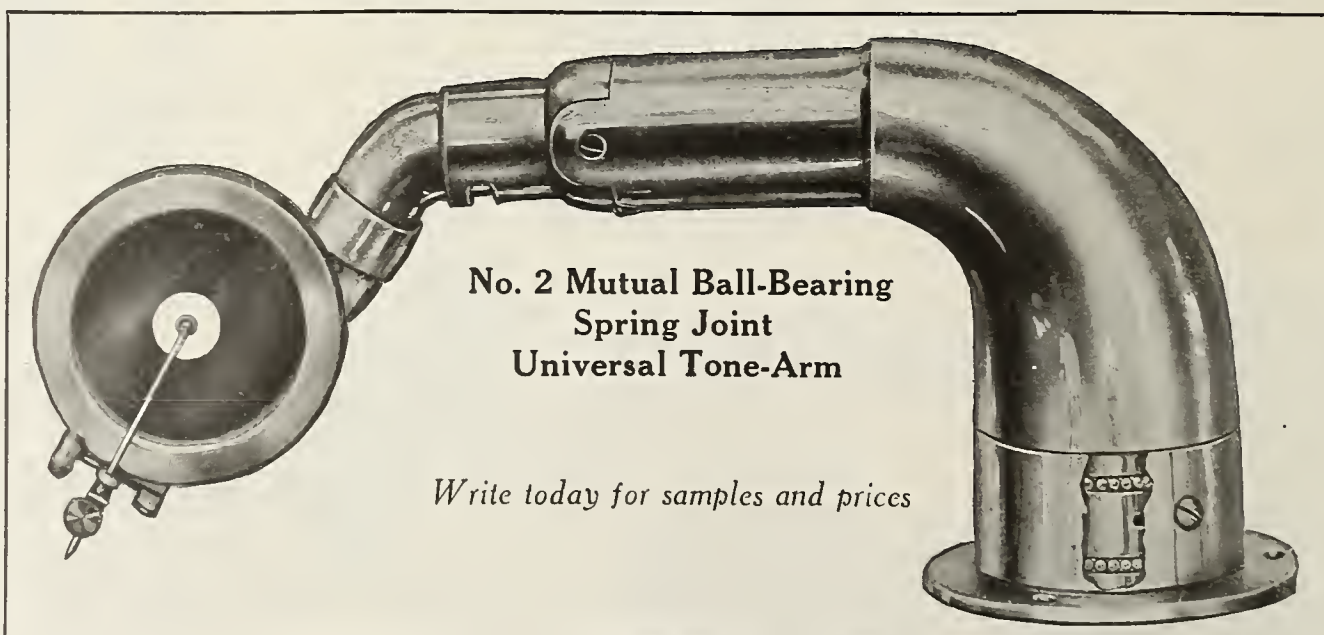

No. 2 Mutual Ball-Bearing
Spring Joint
Universal Tone-Arm

Write today for samples and prices

This Tone-Arm has met with phenomenal success, and is being used exclusively by the leading talking machine manufacturers

WE DO NOT SELL TO MOTOR MANUFACTURERS

Mutual Sound Boxes are accepted as the standard of the phonograph industry

MUTUAL TALKING MACHINE CO., Inc., 145 W. 45th St., New York

FROM OUR EUROPEAN HEADQUARTERS

2 GRESHAM BUILDING, BASINGHALL STREET E. C., LONDON, W. LIONEL STURDY, MANAGER.

British Government Affording Genuine Aid to Industry in Preparing for Post-War Business Development—Gramophone Trade Triumphs Over Serious Obstacles and Still "Carries On"—Greatest Trouble Found in Getting Metal Parts, Particularly Motors—Machines and Records for the Soldiers—Live Publicity the Rule in the Trade—War Takes Its Toll—What is Found in the New Record Lists—Death of Mark Sheridan—Honors for Gypsy Smith—Government Taking More Men for War Work—"Neptune" Records Appear on the Market—General News of Musical Interest

LONDON, ENGLAND, E. C., March 1.—A war-weary determined democracy! Each separate unit in all walks of industrial and social life the world over heartily longing for a termination of Armageddon yet persistently determined to conclude it only on the basis of the triumph of reason over the fanaticism of Teutonic Kultural aberration. That is the spirit of the Allies. The march of civilization will progress the better once this Prussian cancer is removed. We may then look forward to a period of unexcelled prosperity, not merely commercial. But the maintenance of commerce is essential to the achievement of those ideals which the Allies have for their objective. For the moment politics and business must be inseparable companions, as in the future they must not be entirely the subject of that separatist pre-war policy which gave our enemies an enormous advantage, if not indirectly the means to wage war against the world. In this sense, therefore, I make no apology for the presentation of political thought in these columns, as I believe that politics and commerce should be linked to-

gether more strongly than in the past. One helps the other. The British Government has given it official recognition to an extent hitherto considered unnecessary. Additional trade commissioners for all parts of the world are being appointed, consultations arranged with representative business houses, commercial bureaus established, examples of foreign merchandise exhibited, and all necessary information thereto placed at the disposal of exporters and manufacturers. This, and much more that I may refer to another time, is indicative of the machinery set up by the Government with the object of placing British industry on a sure foundation for post-war development. Useful preparatory work is being done in other directions and valuable assistance provided for the cultivation of oversea trade. The remarkable statistics of British export values published each month illustrates the important consideration that every branch of industry, including the musical instruments, is maintaining effort to "carry on" against supreme difficulties. This is as it should be. The theme of my thoughts is to drive home to all traders the absolute necessity of stronger effort to-day; of maintaining a vigorous trade offensive, in order to provide the wherewithal out of income for the prosecution of the war—to achieve the humane ideals for which the world is fighting. No matter the difficulties; the discouragements—they are many; fight on—persistency will win out in the end sure enough. The small trader counts equally with the large; it's unity that stands for concentration of purpose—concentration of strength that moves mountains of difficulty.

As my American readers will appreciate, the British gramophone trade has experienced enor-

mous setbacks and is still in the throes of many elements adverse to good business. What of it? The British trade has fought and won; is still maintaining a remarkable volume of record sales, and means to keep it up! You will do the same—keep at it, that is all!

Let us take a peep at the machine side of our business, and we shall see what has been accomplished towards the maintenance of trade in the face of almost insuperable difficulties. When hostilities commenced, apart from the cabinets and an insignificant quantity of metal parts, the British market relied upon imported motors, etc., the bulk of which came from Germany. In 1915 transport difficulties were met with, and in 1916 onwards became so acute that official restrictions on supplies from Switzerland and America were imposed. To-day the difficulty of importing motors is very severe and less than 50 per cent. of pre-war supplies from these sources is coming through. What happened? The trade, or certain members thereof, got to work on an endeavor to induce suitable firms to start the manufacture of motors, tone arms, sound boxes, trumpets, etc. The need for metal horns failed with the demand for interior-horn cabinet models, but it must be remembered that this demand was purely and simply the outcome of action taken by the trade in developing a call for cabinet instruments as against the ordinary model. Thus was one difficulty successfully overcome. Not without considerable trouble several good firms were at last persuaded to develop on sound box, tone arm, and output of kindred parts, the position at present being very satisfactory as regards these supplies, and in speaking of this, too, as another

(Continued on page 112)



"His Master's Voice"

Copyright

This intensely human picture stands for all that is best in music

—it is the "His Master's Voice" trade-mark, and it brings to you, no matter where you are, the very best music of every kind, sung and played by the world's greatest artists—the greatest singers, pianists, violinists, orchestras and bands—all enshrined in the unequalled "His Master's Voice" records

'His Master's Voice'

—the trade-mark that is recognized throughout the world as the

HALL-MARK OF QUALITY

Branches

DENMARK: Skandinavisk Grammophon-Aktielselskab, Frihavnen, Copenhagen.

FRANCE: Cie. Française du Gramophone, 115 Boulevard Richard Lenoir, Place de la République, Paris.

SPAIN: Compañía del Gramófono, 56-58 Balmes, Barcelona.

SWEDEN: Skandinaviska Grammophon-Aktiebolaget, Drottning Gatan No. 47, Stockholm.

RUSSIA: The Gramophone Co., Ltd., 45, Nevsky Prospect, Petrograd (Petersburg); No. 1 Solyanka, Solyanoi Dvor, Moscow; 9, Golovinsky Prospect, Tiflis; Nowy-Swiat 30, Warsaw; 33, Alexandrowskaya Ulitsa, Riga; 11 Michalovskaya Ulitsa, Baku.

INDIA: The Gramophone Co., Ltd., 139, Balaigbatta Road, Calcutta; 7, Bell Lane, Fort, Bombay.

Great Britain:

Agencies

AUSTRALIA: S. Hoffnung & Co., Ltd., Sole Concessionaries of The Gramophone Company, Limited, 163, Pitt Street, Sydney.

NEW ZEALAND: Gramophonum, Ltd., 118-120 Victoria Street, Wellington.

SOUTH AFRICA: Darter & Sons, Post Box 174, Capetown; Mackay Bros., Post Box 251, Johannesburg; Mackay Bros. & McMabon, Post Box 419, Durban; Ivan H. Haarburger, Post Box 105, Bloemfontein; Franz Moeller, Post Box 108, East London; B. J. Ewins & Co., Post Box 86, Queenstown; Handel House, Kimberley; Laurence & Cope, Post Box 132, Buluwayo; The Argus Co., Salisbury.

EAST AFRICA: Bayley & Co., Lourenso Marques.

HOLLAND: American Import Co., 22a, Amsterd Veerkade, The Hague.

ITALY: A. Bossi & Co., Via Orefici 2, Milan.

EGYPT (Also for the Soudan, Greece and the Ottoman Empire): K. Fr. Vogel, Post Box 414, Alexandria.

The Gramophone Company, Ltd.

HAYES - MIDDLESEX - ENGLAND

FROM OUR LONDON HEADQUARTERS—(Continued from page 111)

triumph, I must emphasize the fact that extreme difficulty was all along experienced in obtaining a sufficient ration of metals for the purpose. Indeed, it may be asserted with truth that the output of these articles is only limited by the small quantity of metal now allowed for their manufacture. We now came to the main attribute of a machine—the mechanism. Here the real trouble commenced. In the first place, few if any firms had experience in this class of work. A gramophone motor is an intricate piece of mechanism requiring high-class precision work. War output occupied all suitable shops, and recourse was had to inferior and less experienced firms. This resulted in great loss of time, owing to the necessity of experimental work and the constant alteration of jigs involved thereby. Just when one or two passable samples were produced, the metal scarcity became more acute, and in other cases the Government stepped in and switched the firms on to war articles. The trade continued its efforts, meeting with discouragements too many to mention. The present position is that several shops are all ready to go ahead as soon as labor and metal troubles can be overcome. One firm, I believe, is putting out a few motors by getting stampings and parts from different shops over the country and assembling them. But this does not make for efficiency. To sum up, we are still mainly dependent upon imports, and these are in quantity inadequate to complete all the machines ready and for which the demand exists.

Free Gramophone Ballot Scheme for Soldiers

In connection with the Daily Express Cheery Fund, which has been established for the provision of games, musical instruments, etc., to the oversea troops, a free gramophone ballot scheme has been started for soldiers and sailors. With the public's free will offerings all sorts of acceptable things are provided. The gramophone scheme has caught on better than anything, and as "Orion" reported in a recent issue—"A staggering number of applications to be included in the ballot arrived from the front over the week-end." The gramophone outfits include a complete trench gramophone, six records, and 1,000 needles, and the ballots will begin as soon as the first delivery is made by the Columbia Graphophone Co. Good luck to the Cheery Fund.

Winning "Winner" Record Publicity

Of the companies who are to any extent supporting their dealers on the publicity side, a meed of praise is due the Winner record people for the very attractive window bills and lists, which are issued monthly. The latest streamer to hand reads: "Winner Records Play on All Gramophones," etc., the lettering, coloring, and general design being so arranged as to reflect the message strikingly, even with a minimum amount of light behind. Each corner is gummed, thus rendering it easy to affix to the window. The company is doing some excel-

lent work on the advertising side, and theirs is an example which one or two other firms might emulate advantageously.

Final Notice in re Carl Lindstrom (London) Ltd.

A recent intimation in the press gave notice to all firms interested that creditors of the above concern who had not already sent in their claims would go by default unless such claims were received by the official controller on or before February 28. This business, by the way, has now been purchased by the Hertford Record Co., Ltd.

"No Dammed German Pianos"

At the Royal Society of Arts, Sir Frederick Bridge said that, in common with other musicians, he was out for the improvement of the musical taste of the country, which would do much to increase the demand for better pianos. He hoped that after the war our musicians would put their heads together and say: "No dammed German pianos shall come near me!" "You would hardly expect such language from an ecclesiastical," said Sir Frederick, amid much laughter; "I did not mean to say 'dammed,' but having said it—well, I'll stick to it. I, for one, will not play on a German piano!"

The Band of H. M. Irish Guards

This fine instrumental organization is generally regarded in musical circles as one of our very best military bands, whose playing is undoubtedly of the highest excellence. It is represented on the "Winner" record current list by six popular items of the quick-selling order. The Band of H. M. Irish Guards is, by the way, exclusive to the Winner Co. On the list under mention, January-February, there is itemized a galaxy of good up-to-date vocal and instrumental selections, including a descriptive record of an air raid, dramatic and realistic in its treatment. An air raid of this type will be welcomed by most gramophonists.

The Johnson Talking Machine Co.

In the wholesale field wartime difficulties are not less acute than in other departments of the gramophone industry, and it is a most encouraging sign that factors are displaying an optimism which influences the dealers to maintain the highest possible efficiency of effort in circumstances that are not always the brightest. The policy of the above concern has never permitted a relaxation of effort, and depressed conditions at times notwithstanding, they have managed to sustain a large trade in machines, records and accessories at both the Liverpool and Birmingham centers. The company is working hard on the forthcoming output of a new home needle resharpening device (particulars of which were published in our January issue), and I have just received news of a new needle called the "Apex," which is soon to make its appearance on this market. In this regard Mr. Johnson writes: "This is a very good line, but unfortunately we are only allowed a very small ration of steel wire and we shall not be able to execute more than about one-

REX GRAMOPHONE CO.

are making a Specialty of

EXPORT

in

Horn, Hornless & Portable Disc Machines**REX GRAMOPHONE CO. 2 Elizabeth Place
Rivington Street, LONDON, E.C. 2**

Cable Address "Lyrecodisc, London"

Enquiries Solicited

quarter of the orders we expect to receive. . . . We are sharing out our stock of goods just the same as the grocers are sharing out their tea, sugar, and butter."

Whatever the position may be, I am of opinion that the trade may rest confident that this enterprising firm of factors will do the very best possible to insure an equitable distribution of those lines which may temporarily run short.

Another Life Laid Down

The trade will learn with extreme regret of the death of Lieutenant Cecil L. Henderson, who was killed in action in November last, when at the head of his men—facing the enemy. As the one-time outer-London representative of "His Master's Voice" Co., Lieutenant Henderson was well known to hundreds of dealers, with whom he used to crack a joke while keeping his eye all the time on the order book. He was a popular "Knight of the Road"—one of the good old sort, ever cheerful; ever businesslike, and successful! He joined up in the early days and was soon singled out for a commission. Although invalided out of the army twelve months ago, he rejoined after several unsuccessful efforts. Such was his spirit!

325,000 Bricks in New Chimney

A new chimney has made its appearance at the Hayes factory of "His Master's Voice." It is 150 feet high, weighs 1,632 tons, and has required for its construction no less than 325,000 bricks. The circumference at the base is 20 feet 8 inches; at the top, 13 feet. It will soon be emitting volumes of smoke in behalf of "His Master's Voice" output.

Blind Pianoforte Tuners

A new field for British soldiers who have suffered the great misfortune of lost or impaired sight, is opened up by the National Institute for the Blind, who are by press advertisements inviting the public to utilize the services of blind tuners. A worthy object which we think will receive the support it deserves.

A Johannesburg Dealer's Irreparable Loss

The story of the casualty lists is one of grief and pain. One day, the name of a friend; another, the name of one connected with the gramophone trade, brings home to us the terrible cost involved in the fight for humanity. This month we have to record the loss of another hero, Captain James Ivan Mackay, R.F.C., killed in action when in charge of his squadron over the German lines. He was regarded as a most promising officer, great things being expected of him, in view of the courage and skill always displayed on every occasion, before his

EDISON BELL**WINNER**
TRADE MARK
GRAMOPHONE RECORDSCABLE
"PHONOKINO,
LONDON"**ARE THE GREATEST VALUE FOR MONEY PRODUCED IN GREAT BRITAIN**

TEN INCH

DOUBLE SIDED

NEEDLE CUT

PLAY ON ALL GRAMOPHONES**Catalogue contains 4000 Titles by the Premier Artistes, Instrumentalists, Orchestras and Bands of the British Empire**

DEALERS PREPARED TO DO BUSINESS ARE INVITED TO COMMUNICATE WITH

Proprietors and Manufacturers, J. E. HOUGH, Ltd., 62 Glengall Road, London, S. E. 15, England

FROM OUR LONDON HEADQUARTERS—(Continued from page 112)

career was so untimely cut short. His spirit and wonderful example will live as an incentive to the young allied airmen who are coming forward in their legions to uphold the mastery of the air. Captain Mackay was the eldest son of James Mackay, the founder of the well-known "His Master's Voice" dealers, Mackay Bros., Ltd., Johannesburg, with whom the trade will deeply sympathize.

The Romance of Recording

In this month's issue of "The Voice" appears the first of a series of articles on the above subject, by Wm. C. Gaisberg, the "His Master's Voice" chief recording angel. His first contribution deals in a most interesting way with the recording tour undertaken in India during 1906. Speaking of the native girl singers and their songs, Mr. Gaisberg tells us that—"one never finds written music for these songs; they are handed down from father to son over hundreds of generations, some of the songs or poems, being 2,000 years old." It is a most instructive article, and one looks forward with interest to the next.

Clara Butt's War Work

As might only have been expected from a leader in her art, Madame Clara Butt, Britain's Queen of Song, has been unostentatiously carrying on a great war work ever since that fateful August, 1914. Those therefore who have remarked that her appearance on Columbia records has, perhaps, been of more frequent occurrence than her appearance on the London concert platforms, will find herein good reason why that is so. Since the outbreak of war Madame Clara Butt has raised between £30,000 and £40,000 for various charities. The British Red Cross Society has received most substantial help, and other charities such as the Scottish Red Cross, Queen Mary's Work for Women Fund, the Arts Fund, War Seals Foundation, Baby Week, Joan of Arc Day and Pageant of Fair Women on behalf of the Three Arts Workrooms. These Three Arts Workrooms were started at the outbreak of war to provide employment for poor musicians, etc., who were not physically strong enough for hard work. They are there taught to make toys, one of which was judged by the Board of Trade to be the finest British toy of its kind on the market. At a trades exhibition £2,700 worth of orders were received, but it was impossible to execute same, owing to lack of capital to purchase the necessary materials. Madame Butt decided to devote the proceeds of Joan of Arc Day and Pageant of Fair Women to place these workrooms on a really sound business basis, and over £2,440 was raised.

Abnormal Zonophone Sales

It means something unusually big to classify Zonophone record sales as abnormal, since ordinarily the demand is remarkable. That, however, is the position with regard to the January issues. Dealers everywhere report a difficulty in maintaining representative stocks,

though the company's output is greater than ever. The situation indicates public appreciation of the quality and variety of the Zonophone monthly programs; a state of things also due to the persistent advertising of these fine records. Some excellent publicity matter accompanies the January samples, and the retail trade will doubtless make the most advantageous use thereof.

Death of Mark Sheridan

The music hall and gramophone world sustained a severe loss in the death under tragic circumstances of Mark Sheridan, the famous rapid-fire comedian. His style was decidedly original and his makeup of tall hat, bell-bottomed trousers, and natty cane will never be forgotten. He gave the world a number of songs that were great successes of their time, among them being "At the Football Match Last Saturday," "One of the B-Hoys," his last big hits being "Here We Are, Here We Are, Here We Are Again" and "When Belgium Put the Kibosh on the Kaiser," both of which he recorded for Columbia and both of them being among the outstanding successes in war songs.

The New "Neptune" Records

A comparatively recent introduction on this market is the ten-inch double "Neptune" disc, which, selling at a popular price, has easily won for itself a "place in the sun." A goodly repertoire already exists and the catalog is being extended by new issues, comprising vocal and instrumental titles of the up-to-date order. The Neptune is marketed by Messrs. Curwen & Sons, Ltd., the well-known sheet music publishers, this city, and when conditions permit they intend to cultivate the patronage of over-sea buyers.

Gipsy Smith Honored

The famous singing evangelist, Gipsy Smith, was honored by the King by inclusion in the new year list of members of the Order of the British Empire. At first the honor passed unnoticed as the celebrated missionary was given as Rodney Smith, a name which few recognized as that of Gipsy Smith. In a day or two, it transpired that the Order had been conferred upon the evangelist for his splendid work in raising some £13,000 for the Y. M. C. A. during his six months' tour of the country. The constant large sales of the records of his Gospel hymns that he made for Columbia a year or two back, will doubtless receive a fresh impetus after this signal evidence of Royal favor.

Men Required From Luxury Trades

Notwithstanding the welcome assistance of the American forces, Great Britain is putting forward every ounce of her strength; is, in fact, speeding up rather than lessening her efforts, to bring this armageddon to a successful conclusion. A further comb-out of men from non-essential trades is proceeding. There are about half a million men of military age engaged in non-essential or luxury trades, a large number of whom are of low medical category and

Soundboxes

If you are after a genuine offer of soundboxes, you'll do well to communicate with us immediately. We have tens of thousands of perfect soundboxes, fitted with the best quality mica. Confidently recommended for cheaper machines, absolutely reliable and give excellent reproduction. Price to clear \$50 per gross, F. O. B. London.

Orders for less than gross lots not accepted

Wire "Knotaslepe, London".

W. H. Reynolds (1915) Ltd.

45, City Road, London, E. C.

Write for new illustrated Complete Catalogue

unfit for general service. The Government expects to secure at least 100,000 of these before the end of this year, and doubtless many others will be switched off their present work on to more important duties connected with war material output. The music industry has already contributed its full quota, and apart from unfits there are few, if any, men of military age exempted from service. But a further call for men for national work is expected, especially now that pianoforte manufacturers are taking on such work. Additional female dilution is therefore the order of the day.

TALKING MACHINE MEN, INC., MEET

Interest and Membership Questions Taken Up at Monthly Session Held on February 20

The regular monthly meeting of the Talking Machine Men, Inc., was held on Wednesday afternoon, February 20, in the rooms of the Merchants' Association in the Woolworth Building, under the direction of the president, J. T. Coughlin.

The committee charged with the work of persuading all dealers to charge 6 per cent. interest on instalment sales reported progress and petitions were distributed to be circulated among the dealers in New York and vicinity for the purpose of securing their endorsement.

Six new members were elected and the membership committee reported excellent results. The question of changing the by-laws to make jobbers non-active members of the association was laid on the table until the next meeting.

A nominating committee was appointed to make its report at the March meeting.

GUARDSMAN RECORDS

REGISTERED

10 inch and 12 inch Lateral Cut

We can ship you immediately, any quantity of Records:

BANDS ORCHESTRAS INSTRUMENTAL SOLOS VOCAL

SELECTION OF AMERICAN AIRS

including, "Marching Through Georgia"—"Dixie"—"Arkansas Traveller"—"Red, White and Blue"—"Star Spangled Banner," etc., etc., Recorded by Full Regimental Band of H. M. SCOTS GUARDS. Get Ready Now for the Big Trade coming and have

THE FINEST RECORDS of THE FINEST TITLES at THE FINEST PRICES

Apply for Lists and Prices to INVICTA RECORD COMPANY, Ltd.

Cables: Duarrab, London

1 New Inn Yard, London, E. C., England



TRADE MARK

MICA Diaphragms

Quotations and samples promptly forwarded upon request
 Send us your requirements No obligation incurred
INTERNATIONAL MICA COMPANY
 Offices and Factory, 37th and Brandywine Streets, WEST PHILADELPHIA, PA.

PHILADELPHIA PA. CHICAGO, ILL. (Insulation Dept.) AMELIA CO. VA. MONTREAL CAN. WEST PHILADELPHIA PA.

SOUTHERN CALIFORNIA NEWS ITEMS

Crop Conditions Mean Good Business—Scarcity of Machines and Records Still Prevails—Value of Association Work—News of Month

LOS ANGELES, CAL., March 6.—The short month has passed and business conditions have not changed very much since the first of the month. There is still the scarcity of both records and machines in all makes with the end not yet in sight.

Southern California was blessed with a six-inch rain in February, and, as up to that time the weather man had only reported one inch for the entire season, it can readily be seen that the country was in desperate need of rain, and it was of inestimable value to this section. Most all of the crops were greatly benefited and everybody feels better regarding business conditions since the downpour. Just what the outcome will be here in the talking machine business is hard to predict, as stocks of records and machines are running perilously low. The railroads seem to be as congested as ever and freight moves very slowly.

The Fitzgerald Music Co., exclusive Edison dealers, report a fine business during the last month, especially in the larger models. Their Edison tone tests netted them some good prospects, and Earl Dible, their manager, says that they have made several sales as a direct result of them.

The Bartlett Music Co., of West Seventh street, exclusive Columbia dealers, are doing a good business in their talking machine department. They have one of the best-equipped departments in the South and carry a complete stock of machines and records.

The Retail Talking Machine Dealers' Association of southern California is already showing results, as at the last meeting the approval system was discussed and in the future a forty-eight-hour limit will be put in effect and the customer must guarantee to keep at least a third of all records taken from the stores. Also all persons wishing to take records on approval are requested to call for same and return them to the store, thus making a great saving in delivery. Machines sold on contract must be paid in full in fifteen months, which will have a tendency to make the terms higher, especially on the more expensive models. Los Angeles has long felt the want of just this kind of an association, and it is to be hoped that it will be the means of eliminating, or at least regulating, some of the evils that have been creeping into this business in the last few years.

Chas. H. Norberg, treasurer of the Daynes-Beebe Music Co., of Salt Lake City, is in the city for a short visit. Mr. Norberg says that business is fine with them. Their only trouble at present is in getting enough goods.

M. X. Dumas, lately on the road for the Brunswick Co., of El Paso, Tex., has joined the sales force of the Southern California Music Co. Mr. Dumas is a talking machine man of a great deal of experience in different parts of the country, and at one time was connected with the Edison Co. at East Orange, N. J.

C. O. Stillings, of Fillmore, Cal., who represents the Brunswick phonograph in his city, is in Los Angeles for the week-end. Mr. Stillings has a small but up-to-date department and says the prospects are good in his district.

C. S. Ruggles, local manager for Sherman, Clay & Co., Victor jobbers, has just returned

from a visit to the Atlantic Coast. While in the East Mr. Ruggles paid a flying visit to the Victor factory and saw Mr. Geissler and the heads of the different departments. Mr. Ruggles says conditions look as bad in the talking machine line in the East as in California, and the other Pacific Coast States. Everyone seems to be out of goods and unable to get any and no one seems to know just the reason. Mr. Ruggles is very much elated over the fact that since his return to the Coast his son, Leslie Ruggles, who is connected with the moving picture department of the United States Army, has been made a lieutenant, and has since sailed for France.

O. A. Lovejoy, manager of the Diamond Disc Distributing Co., is very well pleased with his business since January 1, and is congratulating himself that his stock is in fair condition. He reports the biggest demand for Models 250 and 150, and at present both are out of stock. However, Mr. Lovejoy is expecting a large shipment next week when he will have all models in all finishes. Harold Jackson, road representative for the above house, leaves to-day for an extensive trip through the central part of the State.

Dan Voorhies, who is looking after the Brunswick-Balke-Collender Co., of 845 South Los Angeles street, says business is booming for the "all record" machines, and reports new agencies in the following towns: Bakersfield, Lompoc, Santa Maria, Santa Ana, Pomona, San Bernardino, Pasadena, San Pedro, San Diego, Redlands, Taft and Glendale in California and Yuma, Jerome and Winkelman, Ariz. The Brunswick Co. carry and feature a full line of Pathé records.

The Southern California Music Co. have discontinued their Pasadena branch, and in the future will handle all business in that territory direct from the main store in Los Angeles.

The needle famine seems over for the present, and most all of the local dealers are able to get hold of a few needles, but not the real fine tone ones, which are quite scarce at present.

CO-OPERATION SPELLS SUCCESS

Aggressive Advertising Agency Co-operating With Ready File Co.

According to statements of its officials the Ready File Co., Inc. is particularly fortunate in its recent advertising connection. The McDermott Advertising Service, now in charge of the Ready File account, is one of the younger of Indianapolis agencies, but it is undoubtedly one of the most progressive and the fastest growing of that city.

Specializing, as it does, in musical instrument advertising, McDermott Advertising Service is exceptionally well equipped to work out the advertising problems of Ready File. Ordinarily the advertising agent has to spend a great deal of time and waste considerable effort in getting the readers' viewpoint, especially when these readers are members of a well defined class such as phonograph dealers. In the present case the preliminary work was largely unnecessary, as the heads of the agency were already familiar with the point of view and the problems of the phonograph dealer. In behalf of the Ready File and the numerous other accessories, McDermott Advertising Service is planning a vigorous nation-wide campaign.

Do You Collect Your Accounts?

FOR some time past we have been using a follow up system of collecting both our installment and open accounts that has brought us wonderful results. 90% of the work done right in your office. Saves attorneys' fees and keeps the good will and patronage of your customer.

The complete layout, simply explained, sent for \$5.00. Cash with order. We refer you to any Victor, Edison or Columbia Jobber in our section as to our reliability.

HYATT TALKING MACHINE CO., Portland, Oregon

22 BEE CROFT YEARS



Connected With The Talking Machine Business

Thirty desirable records. You may not have all of these selections We will gladly play any record for you.

INSTRUMENTAL		VOCAL - Continued	
4001	March (Piano)	4051	Swanee
4002	The Blue (Piano)	4052	Swanee
4003	Swanee (Piano)	4053	Swanee
4004	Swanee (Piano)	4054	Swanee
4005	Swanee (Piano)	4055	Swanee
4006	Swanee (Piano)	4056	Swanee
4007	Swanee (Piano)	4057	Swanee
4008	Swanee (Piano)	4058	Swanee
4009	Swanee (Piano)	4059	Swanee
4010	Swanee (Piano)	4060	Swanee
4011	Swanee (Piano)	4061	Swanee
4012	Swanee (Piano)	4062	Swanee
4013	Swanee (Piano)	4063	Swanee
4014	Swanee (Piano)	4064	Swanee
4015	Swanee (Piano)	4065	Swanee
4016	Swanee (Piano)	4066	Swanee
4017	Swanee (Piano)	4067	Swanee
4018	Swanee (Piano)	4068	Swanee
4019	Swanee (Piano)	4069	Swanee
4020	Swanee (Piano)	4070	Swanee

Record Cabinets
 Record Envelopes

Needles

CLEMENT BEECROFT

309 W. Susquehanna Avenue

Philadelphia



WORLD'S CLASSIFIED ADVERTISING

Any member of the trade may forward to this office a "situation" advertisement intended for this Department to occupy a space of four lines,agate measure, and it will be inserted free. Replies will also be forwarded without cost. Additional space will be at the rate of 25c. per line. If bold faced type is desired the cost of same will be 25c. per line.

WANT TO MEET a talking machine man or a business man who would like to enter the talking machine business, one who has large business acquaintance, to help me organize and finance the manufacture of a new and highly meritorious motor for which there is a big demand. Will make the right kind of a proposition to the right man. Address "Box 500," care The Talking Machine World, 373 Fourth Ave., New York.

WANTED—Position as department manager. Either line, Columbia or Victor. Over twelve years' experience. Well posted on both record catalogs. Best references. Wisconsin preferred. Address "Box 501," care The Talking Machine World, 373 Fourth Ave., New York.

HIGH-CLASS salesman wanted; must possess unquestionable ability, also produce selling record. We want an experienced man. Salary and commission proposition. Car furnished. Address The Turner Music Co., 153 North Main St., Wichita, Kan.

ATTENTION, Edison jobbers and dealers. Experienced Edison salesman and manager, with some capital, will consider financial interest in established Edison agency in connection with position. Address "Box 502," care The Talking Machine World, 373 Fourth Ave., New York.

POSITION WANTED—Experienced salesman, wholesale and retail, also expert mechanic, desires position with good house, Chicago and vicinity. Address F. B. 28, care The Talking Machine World, 209 South State St., Chicago, Ill.

TALKING MACHINE REPAIRMEN—Extra money easily earned when repairing machines, demonstrating new phonograph attachment. Every owner a possible customer. Address "Box 504," care The Talking Machine World, 373 Fourth Ave., New York.

POSITION WANTED—A thoroughly experienced Pathé and Victor retail man wishes a situation in or about New York City. Address "Box 506," care The Talking Machine World, 373 Fourth Ave., New York City.

WANTED—Large Gramophone company in London is anxious to procure spring motors, tone arms and sound boxes of the highest grade to assemble their machines. At present using 90 per cent. Swiss and the balance British parts, but would like to get hold of good American parts if they can import them. Manufacturers of these parts are requested to communicate with "Box British," care The Talking Machine World, 373 Fourth Ave., New York.

WANTED—A thoroughly experienced Edison Diamond Disc salesman. In applying state age, experience, and give as references names of former employers. A good opening for a high class man. Address "Box 493," care The Talking Machine World, 373 Fourth Ave., New York.

WHOLESALE SALESMAN desires to make change. Well known and has built up successful record. Can furnish best of references from present connection. Victor line preferred. Address "Box 497," care The Talking Machine World, 373 Fourth Ave., New York.

SITUATION WANTED—Man of 12 years' talking machine experience desires a road position, can produce. Make me a proposition. Address "Lyb," care The Talking Machine World, 373 Fourth Ave., New York.

POSITION WANTED—Cabinet superintendent and designer wishes to connect with live concern March 1. Familiar with up-to-date methods. Good executive and knows how to obtain results. Now employed in New York City. Highest references. Forty years old. Address "Box 494," care The Talking Machine World, 373 Fourth Ave., New York.

POSITION WANTED—Manager or superintendent of phonograph factory will be open for position March 1. Now with a firm manufacturing high grade commercial phonographs. Output 125 a day. Am in a position to show how your production can be increased and your merchandise improved without increasing your cost. Specialize on designing period and modern styles, general construction, cost, elimination of waste. Executive ability in handling labor and labor problems. If it's production you need, address "Box 495," care The Talking Machine World, 373 Fourth Ave., New York.

SITUATION WANTED—Experienced Edison salesman and manager desires to make connection with live Edison dealer. Hold similar position now. Address "Box 496," care The Talking Machine World, 373 Fourth Ave., New York.

WANTED—Capable, experienced, reliable person to take charge of disc manufacturing department. Address "Box 480," care The Talking Machine World, 373 Fourth Ave., New York.

WANTED—A position as manager of talking machine store or department. Young, married man of long, practical experience. All references. Middle West preferred. Address "E. B. 6," care Talking Machine World, 209 S. State Street, Chicago, Ill.

TRAVELERS visiting talking machine trade can make \$50.00 per week easily, selling our sensational novelty for talking machines as a sideline. Pocket samples. Excellent proposition. Only first class men need apply. State particulars, and district you cover. Address Uniset Reproducer Co., Wabash avenue and Jackson boulevard, Chicago, Ill.

POSITION WANTED—Would like to work in phonograph store or anywhere else in phonograph line. Address "Box 489," care The Talking Machine World, 373 Fourth Ave., New York.

SITUATION WANTED—Experienced Edison salesman and manager open to offer. Hold similar position now. Age 33, married. Address "Box 490," care The Talking Machine World, 373 Fourth Ave., New York.

WANTED—By a New York manufacturer, an expert man to develop a phonograph motor. Answer in-detail by letter only, state experience and salary expected. Address M. Weingarten, 286 Fifth Ave., New York.

FOR SALE

Patent and complete manufacturing equipment for new talking machine attachment of real merit. Address "Box 505," care The Talking Machine World, 373 Fourth Ave., New York City.

SITUATION WANTED—Superintendent at present employed, thoroughly familiar with every angle of the phonograph business, desires to make a change. Address "Box 491," care The Talking Machine World, 373 Fourth Ave., New York.

SITUATION WANTED—By high grade finishing foreman. Have had several years' experience on talking machines. Will be open for position February first. Want to connect up with a good, live, growing concern, one that would appreciate first class finishing, production and efficiency in every respect. State amount of men in finishing room, the output whether table or floor cases, the salary you would pay for an A1 man. Address "J. D.," 306 East South Grand Ave., Springfield, Ill.

SITUATION—Mechanical engineer thoroughly understanding the manufacturing of phonograph parts, complete machine assembling or machine work, is open for a position as superintendent or production manager. Highest credentials as to ability. Address "Box 473," care The Talking Machine World, 373 Fourth Ave., New York.

ENERGETIC—Young man with clerical, order and executive experience, familiar with the phonograph record line, desires position in any part of the country. Address Philip Greenberg, 2325 East Sixty-third St., Cleveland, Ohio.

SITUATION WANTED—If it were possible to secure a sales manager who has sold over \$21,000 worth of phonographs, personally, in one year, to manage your department, would you consider him? Have good position now. Will explain reasons for wanting to make a change. Will furnish signed statement of business done. Strictly confidential. Address "Box 472," care The Talking Machine World, 373 Fourth Ave., New York City.

POSITION WANTED by expert mechanic with thorough knowledge of motors, assembling, cabinets and inspection of finished production. Competent to take full charge. Address "Box 487," care The Talking Machine World, 373 Fourth Ave., New York.

SALESMAN—Calling on talking machine and piano dealers, to handle a profitable side-line that may be developed. Territory open. Proposition one that most dealers will not refuse. Steady return on repeat business. Address "Box 488," care The Talking Machine World, 373 Fourth Ave., New York.

WANTED—Experienced salesmen in the talking machine and piano trade (having a slight knowledge of wood finishing will be an asset), to sell a meritorious article as a side line. Write for particulars at once, as territory is going rapidly. Our offer to the trade gets the business for the salesman. Address Master Mfg. Co., Box 96, Camden, N. J.

WANTED—An expert talking machine assembler by a manufacturer in New York City. Permanent position for a man who thoroughly understands the assembling of popular priced machines. Address "Expert," care The Talking Machine World, 373 Fourth Ave., New York.

WANTED—A superintendent for a talking machine plant who is a capable executive and who can organize an efficient working class. We want a progressive and thoroughly efficient man who can take complete charge of the plant, which is one of the most complete in the country. Give full details as to past experience, training, etc. All replies held strictly confidential. Address "Box 476," care The Talking Machine World, 373 Fourth Ave., New York.

WANTED—Experienced talking machine salesmen who are familiar with the wholesale trade, and who are capable of handling a first class line of machines and records. There is an excellent opportunity for the right men, with unlimited earning possibilities. Give full particulars in first letter. This is a proposition that will place the right men with one of the best equipped manufacturers in the trade. Address "Box 477," care The Talking Machine World, 373 Fourth Ave., New York.

WANTED—By a New York distributor an assistant repair man. Salary to start \$14. Address "Repairs," Box 478, care The Talking Machine World, 373 Fourth Ave., New York.

C. E. WARD CO. PLANS TO EXPAND

Will Shortly Open Branch Offices in California and Also in Canada

NEW LONDON, O., March 9.—The C. E. Ward Co., manufacturers of the Ward khaki moving and dust covers for talking machines, as well as other specialties, report that, although held up somewhat recently by the fuel shortage, their plant is now back to normal, and orders are now being turned out in the usual prompt manner. The company plans to open a branch office in California, and another in Canada in the near future for the convenience of the trade in those sections.

Phonograph Supply and Repair Parts

STEEL needles, per 1,000 (100 in envelope)	\$.65
SAPPHIRE needles for Pathe or Edison	.25
DIAMOND for Pathe or Edison	1.75
MAIN-SPRINGS, 1"x0.25x12' long, each	.60
7/8"x0.23x10' long, each	.35
3/4"x0.22x8 1/2' long, each	.24
GOVERNOR springs for Victor motors, per 100	1.50
For Columbia motors, per 100	1.75
THUMB Screws for Victor sound boxes, per 100	1.50
For Columbia sound boxes, per 100	1.50
GREEN Felt for 10" turn-tables, each	.15
GREEN Felt for 12" turn-tables, each	.20
MICA Diaphragms for Victor sound boxes, each	.15
For Columbia sound boxes, each	.25
For Standard sound boxes, each	.25
GOVERNOR pinions for all cheap motors, each	.15
NEEDLE Cups, nickel-plated, per 100	2.00
Nickel-plated, in lots of 1,000, per 100	1.75
NEEDLE Cup Covers for used needles, per 100	1.20
In lots of 1,000, per 100	1.00
SDUND BOXES, fit Columbia tone arm, loud, each	.70
SDUND BOXES, fit Victor, extra loud and clear, each	2.25

FAVORITE PHONOGRAPH ACCESSORY CO.

1491 DeKALB AVENUE BROOKLYN, N. Y.

CASH

Paid for list of names of phonograph owners, any and all makes; all names and addresses must be guaranteed as machine owners, Victor, Columbia, Edison Disc, etc. If you have a mailing list quote us your price.

Address Box 499, c/o The Talking Machine World, 373 Fourth Ave., N. Y. City.

STEEL NEEDLES

Repair parts for all talking machines made; main and governor springs, double and single spring motors, tone arms and sound boxes and complete machines. All at lowest prices.

FULTON TALKING MACHINE CO. 640 Broadway New York City

FOR SALE

Columbia Graphophone store in a city of 150,000 population, near Cleveland, O. Annual business \$35,000. The finest and best store of the kind in the city. Present owner willing to retain some interest in the business if buyer desires. Address "Box 503," care The Talking Machine World, 373 Fourth Ave., New York.

SPOT CASH PAID—WANTED

Any amount of records in all languages, Talking Machines, Horn or Hornless, also parts of all makes. Address Phonograph and Record Exchange, 2104 Third Ave., New York. Telephone 7848 Harlem.

FOR SALE

Thirteen tons Half Hard Cold Rolled Strip Steel in perfect condition and in original boxes as received from mill. Size 3/32" x 3 3/8" x 8'. Will quote an attractive price for quick sale.

THE THOMAS MFG. CO. Dayton Ohio

FOR SALE

Best Quality steel phonograph needles extra loud 49c per thousand, in lots not less than 20 thousand, remittance must accompany order.

M. ELDOT 970 Eastern Parkway Brooklyn, N. Y.

"MAGNET" DECALCOMANIE NAMEPLATES

FROM THE **DORAN CO.** 45 MICHIGAN AVE. DETROIT

FOR TALKING MACHINE CABINETS ETC.

SOLD BY **HURTEAU, WILLIAMS & CO.** MONTREAL — OTTAWA

Kunkel Piano Co. BALTIMORE

Pamphlets with fac-simile illustrations and prices mailed on request.

SMITH-SCHIFFLIN CO. 126 Liberty Street New York City

FROM THE **PHONOGRAPH CO.** 1240 HURON ROAD (ENTIRE THIRD FLOOR) CLEVELAND

PHONES — PROSPECT 2140 — CENT 1406

SOLD BY **WALTER D. MOSES & CO.** Oldest Music House in VA and N.C. 103 E BROAD STREET RICHMOND, VA.

SOLD BY **J. E. STRATFORD** AUGUSTA, GA.

LATEST PATENTS RELATING TO TALKING MACHINES AND RECORDS

WASHINGTON, D. C., March 8.—PHONOGRAPH RECORD CLEANER AND PROTECTOR.—Edward Loomis Christian, Douglas, Ariz. Patent No. 1,249,720.

This invention relates to an improved record cleaner and protector for phonographs and has as its primary object to provide a device of this character which may be attached to the sound box of the phonograph in the rear of the stylus and automatically operable to engage the phonograph record upon the movement of the sound box toward the record for supporting the sound box in position with the needle spaced from the record to thus prevent the marring or scratching of the record by the accidental fall of the sound box.

The invention has as a further object to provide a construction wherein after the sound box has been moved to engage the protector with the record of the phonograph, the protector may then be swung to inactive position for permitting the movement of the sound box to engage the needle with the record.

And the invention has as a still further object to provide a construction wherein the protector when swung to inactive position will provide a cleaner or sweep for the record for removing the dust therefrom as the record is revolved beneath the needle of the phonograph.

Figure 1 is a side elevation showing a portion of a conventional type of phonograph with the sound box thereof equipped with the improved protector, the protector being swung to inactive

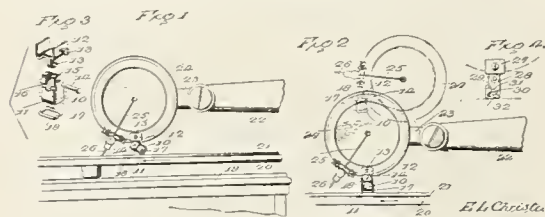

position to provide a cleaner for the phonograph record in the rear of the needle. Fig. 2 is a similar view showing the protector in active position supporting the sound box with the needle of the phonograph spaced from the record, this view also illustrating in dotted lines the manner in which the body of the protector is adapted to gravitate to active position upon the movement of the sound box to seat the phonograph needle upon the record. Fig. 3 is a detail view showing the device detached with the parts thereof disconnected from each other, and Fig. 4 is a detail side elevation showing a slightly modified form of the invention.

RESETTING DEVICE FOR SOUND REPRODUCING MACHINES.—Thomas Ahearn, Ottawa, Ont. Patent No. 1,250,751.

This invention relates to improvements in resetting devices for sound reproducing machines, and the objects of the invention are to provide a simple and effective device adapted to lift the stylus when it reaches near the end of a record and reset it at the beginning thereof. A further object of the invention is to enable the resetting to be effected immediately and continuously, or at given intervals.

In the drawings, Figure 1 is a perspective view of a portion of a talking machine embody-

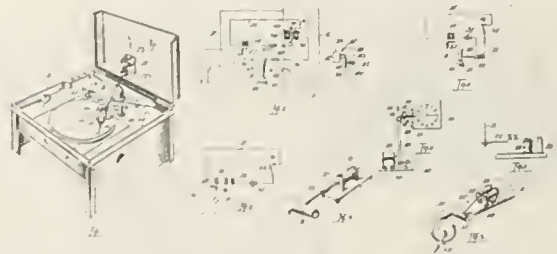

ing the present invention. Fig. 2 is a diagrammatic view of the electric circuit. Fig. 3 is a view partly in plan and partly in horizontal diagrammatic view of an alternative form of one of the circuits. Fig. 4 is a perspective detail of an alternative form of a device for returning the sound tube to normal position. Fig. 5 is a

diagrammatic view of an alternative form of one of the electric circuits. Fig. 6 is a side view of the lifting magnet. Fig. 7 is a perspective view showing an alternative form of the lifting device for the sound box. Fig. 8 is a detail in the elevation of the timing device.

RECORD REMOVING DEVICE FOR TALKING MACHINES.—Stefan Canda, Philadelphia, Pa. Patent No. 1,250,795.

This invention is an improvement in talking machines and has particular reference to a record removing device.

An object of the invention is to facilitate the removal of a record, after the completion of the reproduction thereof, from the turntable of a disc machine by raising the record from engagement therewith and, to this end, use is made of a member pivoted to the machine and having one end extending beneath the turntable and means adapted to engage the bottom of the record when the other end of said member is de-

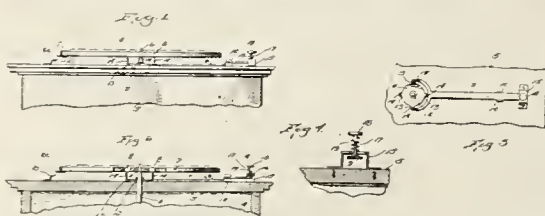

pressed in order that the record may be raised from engagement with said turntable and then removed.

The inventive idea involved is capable of receiving a variety of mechanical expressions, one of which, for the purpose of illustrating the present invention, is shown in the accompanying drawing, wherein figure 1 is a fragmentary side elevation of a talking machine showing the invention applied thereto. Fig. 2 is a vertical sectional view. Fig. 3 is a top plan view of the record raising mechanism. Fig. 4 is a section on the line 4-4 of Fig. 3.

SOUND REPRODUCING MACHINE.—Percival J. Packman, Highbury, London, Eng, assignor to the Aeolian Co., Meriden, Conn. Patent No. 1,250,637.

This invention relates to sound reproducing machines in which "hill and dale" cut records are employed and has for its object to increase the capacity of a record without substantially diminishing the volume of sound.

It has been usual to cut a record of the "hill and dale" type with the groove in the form of a U in cross section which has necessitated the use of a reproducing stylus terminating in a small ball.

Owing to the U form of the groove, it is not possible to obtain a very long record on the usual size of blank, as the convolutions of the spiral cannot be brought very close together and be cut to the required depth to give a good volume of sound owing to the risk of the convolutions overlapping one another to some extent.

According to the invention there has been cut a "hill and dale" groove of substantially a V shape in section and a very fine or needle pointed stylus is employed for the reproduction by contact of its extremity with the bottom of the V shape groove. It will be understood that contrary to what is the case with a record formed by a U-shaped cutting instrument, there is a definite and distinct line of track, that is, the bottom of the groove cut by the point of the instrument, which always coincides with the true convolutions of the spiral or helix, and against which the point of the stylus fundamentally bears, as clearly seen from the drawing.

It will thus be understood that by securing frictional or bearing contact of the stylus with the bottom of the groove only, i.e., the line of track a substantial clearance space will be left on either side, that is to say the angle between the sides of the groove will be greater than the

angle of taper of the fine or needle pointed end of the reproducing stylus itself.

In the drawings, Figure 1 shows diagrammatically on a much enlarged scale by way of example a cutter of sapphire or other suitable substance for cutting the V on the record. The angle between the cutting edges is acute, and the cutting faces or edges are ground so as to leave a sharp point which will actually yield a very narrow space at the bottom of the groove against which the extremity of the fine or needle pointed reproducing stylus may contact.

The stylus used in carrying out this invention has a hard, fine or needle point, and is preferably made of the highest grade hardened tool steel. Figs. 2 to 6 show modified forms of tools adapted

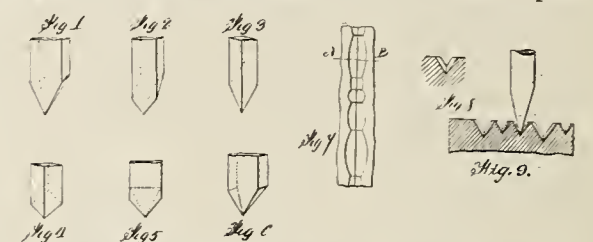

to be employed for cutting the V-shaped groove in a record. The tools are drawn to a large scale for the sake of clearness. Fig. 7 shows a greatly enlarged plan view of a small portion of a track made according to this invention, showing the distinct line of track produced by the cutting of the groove and Fig. 8 shows a cross section of the same on the line A-B of Fig. 7. Fig. 9 shows diagrammatically to an enlarged scale a reproducing stylus in position with its fine or needle point in the bottom of the V-shaped groove of a record.

TONE ARM FOR TALKING MACHINE.—Pliny Cautucci, Newark, N. J., assignor to Otto Heine-man Phonograph Supply Co., New York. Patent No. 1,251,340.

The purpose of the present invention is to provide a tone arm for talking machines with means for adjustably relieving the sound box needle of a portion, or all of the weight of the tone arm, and a portion of the weight of the sound box, so that the pressure upon the surface of the record through the sound box needle may be very materially relieved and the life of the record correspondingly prolonged. The tone arm also embodies a novel form of construction in the swinging or swivel bearing of the tone arm with the stationary sleeve support therefor. It also is provided with detachable sound box tubes of a character to permit the same sound box to be used in connection with either the so-called Berliner record, or the so-called Edison records; that is to say, records wherein the sound groove is a zigzag spiral of uniform depth, or where the record groove is a spiral of varying depth.

Figure 1 is a plan view of a complete tone arm as constructed and ready for attachment to a talking machine case. Fig. 2 is a side elevation of the same. Fig. 3 is a vertical end elevation. Fig. 4 is a full-sized vertical section on line 4-4



of Fig. 1. Fig. 5 is a view of the tone arm detached from the swivel support. Fig. 6 is a corresponding view of the swivel elbow showing the location of the stop-slot. Fig. 7 is a detached view of a sound box tube for use with so-called Edison records.

SOUND PRODUCING DEVICE.—Harry H. Pratley, Kansas City, Mo. Patent No. 1,251,918.

This invention relates to sound producing devices and has for its principal object to provide a simple and inexpensive device whereby the sound recorded on a disc or like record may be reproduced.

Figure 1 is a perspective view of a sound reproducing device constructed according to the

LATEST PATENTS RELATING TO TALKING MACHINES AND RECORDS—(Continued from page 116)

invention. Fig. 2 is an elevation of the same, the record and a part of the handle member being in section to better illustrate the clamping of the record on the handle. Fig. 3 is a detail perspective view of the needle slide. Fig. 4 is a longitudinal section of the same. Fig. V is an eleva-

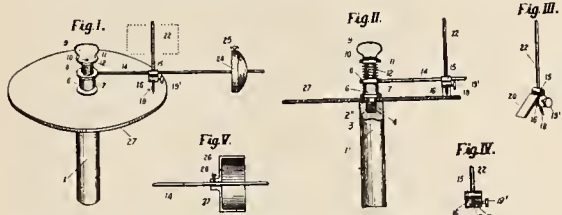

tion of a part of the slide rod, showing a modified form of amplifier.

STYLUS FOR SOUND REPRODUCING MACHINES.—William W. Moyer, Camden, N. J., assignor to the Victor Talking Machine Co., same place. Patent No. 1,251,908.

It has been discovered that tungsten or tungstenic material is peculiarly adapted for styli or needles of sound reproducing machines. A stylus composed of tungsten or tungstenic material exhibits properties differing in a marked degree from those present in styli of other material. Among the characteristics are that a stylus of tungsten or tungstenic material has little injurious effect on the walls of the sound record groove during the reproduction of sound from a record and may be used a large number of times and on different records one after the other without injuriously affecting the walls of the sound record groove. It appears to rapidly wear at first until its sides in engagement with the sound record groove fit and conform to the shape of the groove, after which the wear is negligible or unappreciable throughout the reproduction of sound from the remainder of the groove of the record.

Tungsten is, however, a very difficult material to work, particularly when it is in the form of a wire, the diameter of which is substantially equal to the width of a sound record groove. Tungsten wire is brittle and tends to split. It is also expensive.

Since only a very small portion of a stylus is in actual contact with the walls of the sound record groove in reproducing sound from a record, it is obviously desirable to employ as little of it as possible. If, therefore, a steel shank be provided with a tip of tungsten or tungstenic material to engage and co-operate with the walls of the sound record groove, substantially all of the desirable properties of tungsten or tungstenic materials, as applied to this branch of this art, are utilized, and the present invention in a stylus having a shank of cheaper, more easily wrought material, and a record engaging tip on the point or insert of tungstenic material, firmly and permanently united therewith or attached thereto. The object of the invention is to provide a stylus for sound reproducing machines consisting of a tungsten tip or point of very fine tungsten wire of a diameter substantially equal to the width of a sound record groove, inserted into the end of the shank or stem of malleable metal, such as soft steel, the metal of said shank or stem around said tungsten tip or insert being swaged or forcibly compressed into permanent frictional holding engagement with said tungstenic insert.

The shank or body portion of the stylus may be swaged or compressed tightly around the tungsten tip or insert in any suitable manner, but in order that one way of making or constructing this stylus may be disclosed in this application, the steps of one process of making the same is illustrated in the drawings forming a part of this application in which the same reference characters are used to designate the same parts throughout the various views.

Figure 1 is a side elevational view of a rod or wire of malleable metal, such as soft steel, tapered and slotted at one end, the same being of the size of an ordinary steel sound reproducing stylus. In actual practice, the shank or body portion is less than one-sixteenth of an inch in diameter, and is about three-fourths of an inch

long. For the sake of clearness, the drawings are made on a greatly enlarged scale throughout the various views. Fig. 2 is an end view of the shank or body portion illustrated in Fig. 1. Fig. 3 is a side elevational view of a similar but modified form of shank, the slot in the free end thereof being slightly tapered or V shaped. Fig. 4 is an end elevational view of the shank shown in Fig. 3. Fig. 5 shows the shank or body portion illustrated in Figs. 1 and 2 held in a suitable slidable carrier and positioned in alignment with a die of hard steel. Fig. 6 shows the stylus body or shank together with its carrier, moved to bring the end of the stylus shank into engagement with the die. Fig. 7 is a front view of the die showing the cupped recess therein and the small central aperture at the bottom thereof through which the tungsten wire is adapted to be threaded. Fig. 8 is a cross sectional view on the line 8—8 of Fig. 6 showing the carrier in which the body or shank of the stylus is positioned, held, and moved during the practice of the steps of this process of making the same. Fig. 9 is a view similar to Fig. 6, but in which the tungsten wire has been inserted through the die and into the slot in the free end of the shank or body portion of the stylus. Fig. 10 is an end view showing the shank in the position indicated in Fig. 9 with the tungsten wire in position. Fig. 11 shows the swaging step in which a sharp blow or succession of blows or a high pressure of any kind is imparted to the rear end

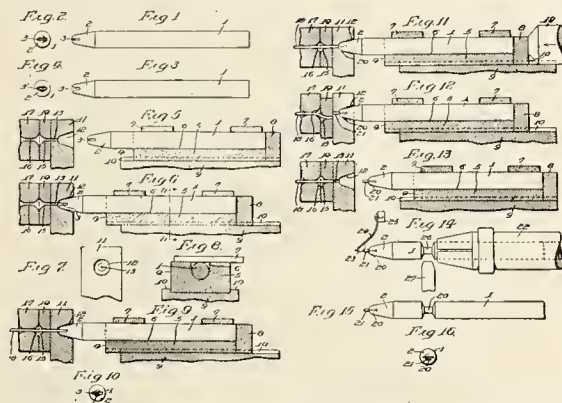

of the carrier to force the tapered end of the malleable steel wire into the bottom of the cup-shaped die, to swage the tapered end of the shank and to make it conform to the shape of the bottom of the die, to close the slots on the sides of the tungsten wire, and to force the metal on the end of the shank into gripping engagement with the tungsten wire insert. Fig. 12 indicates the manner in which the tungsten wire is cut or severed at a short distance from the tapered end of the shank. Fig. 13 shows the carrier moved back to substantially the position shown in Fig. 5 and the tungsten wire tip firmly united with the shank. Fig. 14 indicates diagrammatically the grinding and rounding off, or beveling of the free end of the tungsten insert to remove any burrs or sharp edges which might be thereon and the simultaneous reducing of the diameter of a portion of the steel shank to make it more flexible at that point. Fig. 15 is a side elevational view of the completed stylus. Fig. 16 is an end view of the same.

SOUND BOX ADJUSTMENT FOR TALKING MACHINES.—Louis K. Scotford, Chicago, Ill. Patent No. 1,251,828.

This invention relates to sound reproducing machines and particularly to the adjustment of the sound box of such a machine on the tone arm or sound conveying tube.

The principal object of the present invention is to provide an improved talking machine comprising means for adjusting the sound box and stylus to either of two operative positions, in either of which the point of the stylus is the same distance from the pivotal axis of the tone arm about which the tone arm moves as the stylus moves across the record. Another object is to provide means for adjusting the sound box in different positions on the tone arm so that the diaphragm thereof may be disposed in the proper position for either of the two types of records above mentioned, and to provide means for effecting this adjustment while maintaining the

stylus or needle and the bore of the needle holder coincident with the axis of the end of the tone arm to which the sound box and parts carried thereby are attached. Still another object is to provide a sound box and tone arm having a detachable coupling for connecting the same, whereby the sound box may be adjusted to either of two operative positions, in either of which the stylus will be coincident with the axis of the coupling by which the sound box is connected to the tone arm. A further object is to provide an improved adjustable sound box carrying a stylus which will be located at all times in a plane containing the pivotal axis of the tone arm. A further object is to provide a tone arm having a

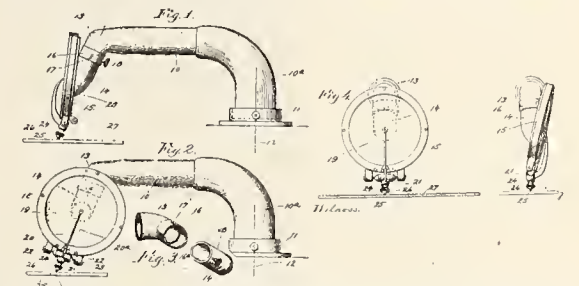

tubular extension telescopically engaging the same and connected to the sound box, whereby the telescoping parts may be disengaged to move the sound box from one to the other of two operative positions of the same with respect to the tone arm, in either of which positions the stylus is located substantially the same distance from and in a plane containing the pivotal axis of the tone arm. A further object is to make provision whereby a single sound reproducing apparatus may be adapted for use with either of the two types of records above mentioned.

In the drawings, Figure 1 shows a side elevation of a tone arm and sound box embodying the features of the invention, the sound box being in the position required for the reproduction of sounds from a record of the vertically undulating type. Fig. 2 is a side elevation of the construction shown in Fig. 1 after the sound box has been removed to a position adapted to a reproduction of sounds from a record having grooves of the laterally undulating type. Fig. 3 is a perspective view of the telescoping parts which form the detachable coupling, by means of which the sound box is adjusted in its relation to the tone arm. Fig. 4 shows an end elevation of the sound box and the tone arm when adjusted as shown in Fig. 1, and Fig. 5 shows an end elevation of the sound box and tone arm when adjusted as shown in Fig. 2.

PHONOGRAPH.—Joseph Hunter Dickinson, Cranford, N. J., assignor to the Aeolian Co., Meriden, Conn. Patent No. 1,252,411.

The present invention relates to improvements in phonographs and particularly to an improved expression device therefor, the features and advantages of which will be apparent from the following description with the drawings:

In the latter, Figure 1 is a partial vertical sectional view through a phonograph tone arm and

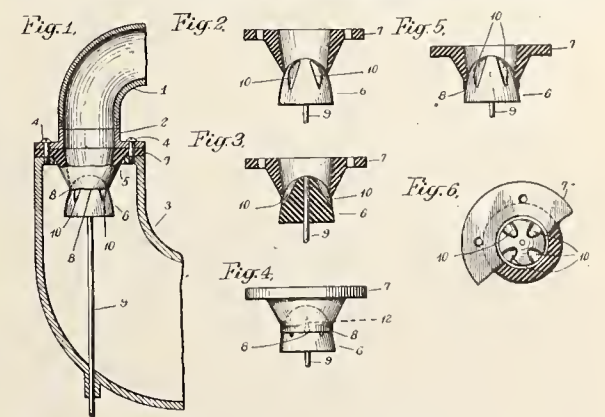

horn equipped with an expression device embodying my present improvement. Figs. 2, 3 and 5 show the value of the expression device telescoped to increasing extents into the throat; Fig. 4 is the same as Fig. 3 except that the parts are shown in elevation instead of vertical section, and Fig. 6 is a top plan view looking down upon the throat and valve, a portion of the throat being shown cut away.

RECORD BULLETINS FOR APRIL, 1918

VICTOR TALKING MACHINE CO.

POPULAR SONGS

- 18435 Are You From Heaven? Henry Burr 10
Give Me the Right to Love You Sterling Trio 10
18436 I'll Take You Back to Italy, Ada Jones and Billy Murray 10
'Round Her Neck She Wears a Yellow Ribbon, American Quartet 10
18438 Tom, Dick and Harry and Jack Shannon Four 10
Au Revoir but Not Good-bye, Soldier Boy, Peerless Quartet 10
18439 Just a Baby's Prayer at Twilight Henry Burr 10
On the Road to Home, Sweet Home, Percy Hemus 10

VOCAL AND INSTRUMENTAL RECORDS

- 45149 I'd Like to Be a Monkey in the Zoo, Francis White 10
Go-Zin-To Francis White 10
18440 Cradle Song (Wiegenlied) (Brahms) (Op. 49, No. 4) Laura Littlefield 10
The Little Dustman (From "20 Song Classics"), Laura Littlefield 10
18437 Tickle Toe—Medley Fox-trot, For dancing, Victor Military Band 10
Going Up—Medley One-step, For dancing, Victor Military Band 10

RED SEAL RECORDS

BOSTON SYMPHONY ORCHESTRA

- 64766 Marche Miniature Tschaikowsky 10
ENRICO CARUSO, Tenor—In Italian
88587 Uocchie Celeste (Eyes of Blue), Armando Gill-Vincenzo de Crescenzo 12
AMELITA GALLI-CURCI, Soprano—In Italian
74558 I Puritani—Qui la voce (In Sweetest Accents), Vincenzo Bellini 12
ALMA GLUCK, Soprano (With Orpheus Quartet)
64729 Darling Nelly Gray B. R. Hanby 10
JOHN McCORMACK, Tenor
64726 The Lord Is My Light Frances Allitsen 10
EVAN WILLIAMS, Tenor
64771 A Little Bit of Honey, W. G. Wilson-Carrie Jacobs-Bond 10
EFREM ZIMBALIST, Violin (Pianoforte by Sam Chotzinoff)
64736 Chant Nègre (An Idyl) (Op. 32, No. 1), A. Walter Kramer 10

COLUMBIA GRAPHOPHONE CO.

POPULAR HITS

- A2496 Tom, Dick and Harry and Jack (Hurry Back), Arthur Fields 10
I'll Come Back to You When It's All Over, Arthur Fields 10
A2492 Bluebird Samuel Ash 10
Forever Is a Long, Long Time George Wilson 10
A2493 Au Revoir But Not Good-bye, Soldier Boy, Henry Burr 10
There's a Service Flag Flying at Our House, Sterling Trio 10
A2476 There'll Be a Hot Time in the Old Town Tonight, Arthur Fields and Peerless Quartet 10
Good-bye Dolly Gray, Hugh Donovan and Broadway Quartet 10
A2480 American Thru and Thru Frederick Wheeler 10
The Dream of a Soldier Boy Charles Harrison 10
A2474 Any Time's Kissing Time (From "Chu Chin Chow"), Robert Lewis 10
At Siesta Time (From "Chu Chin Chow"), Charles Harrison 10

DANCE RECORDS

- A2482 Happy Sammies—One-step, Jazarimba Orchestra 10
That's It—Fox-trot, Jazarimba Orchestra 10
A2421 Fuzzy Wuzzy Rag—One-step, Handy's Orchestra of Memphis 10
The Snaky Blues—Fox-trot, Handy's Orchestra of Memphis 10
A2483 L'il Liza Jane—One-step, Introducing (1) "In Old Japan," (2) "Almost Home," Prince's Band 10
One Look, One Word—One-step, Introducing "Gypsy Song" from "Rambler Rose," Prince's Band 10
A6025 Oh, My Darling!—Medley one-step, Introducing "Off to Spain" from "Land of Joy," Prince's Band 12
Torerito, Torerazo—Medley fox-trot, Introducing "Cucu" from "Land of Joy," Prince's Band 12
A6019 Cecile Waltz Prince's Orchestra 12
Millicent Waltz Prince's Orchestra 12

INSTRUMENTAL SELECTIONS

- A2486 Defend America—March Prince's Band 10
American Eagle March Prince's Band 10
A2489 It's a Long Way to Berlin, Introducing (1) "Good-bye Broadway, Hello France," (2) "I Don't Want to Get Well," Marconi Brothers 10
Over There, Introducing "When the Yanks Come Marching Home," Marconi Brothers 10
A2484 The Dancer of Navarre Prince's Orchestra 10
Whispering Flowers Prince's Orchestra 10
A2485 Pretty Peggy Vincent C. Buono 10
La Golondrina, Vincent C. Buono and Harry Brissett 10
A6020 Spring Song Pablo Casals 12
Apres Un Reve Pablo Casals 12

VOCAL SELECTIONS

- A2487 Beautiful Isle of Somewhere Oscar Seagle 10
Ten Thousand Times Ten Thousand, Oscar Seagle 10
A6021 Sleep, Baby, Sleep Lucy Gates 12
On the Valley of Sunshine and Roses, Lucy Gates 12
A2494 In the Valley of Sunshine and Roses, Henry Burr and Sybil Sanderson Fagan 10
The Boy and the Birds, Prince's Band and Sybil Sanderson Fagan 10
A2495 Meet Mother in the Skies William McEwan 10
My Mother's Bible William McEwan 10
A7525 Peter Rabbit Plays a Joke Thornton W. Burgess 12
Little Joe Otter's Slippery Slide, Thornton W. Burgess 12
A2467 A Legend Paulist Choristers of Chicago 10
Sing Ye to the Lord, Paulist Choristers of Chicago 10
49192 Rigoletto—"Cortigiani vil razza dannata," Riccardo Stracciari 12

THOS. A. EDISON, INC.

Edison Diamond Disc

- 80385 U. S. Army Camp Songs Chorus of Male Voices 80381
Bungalow in Quogue (Kern)—The Riviera Girl, Soprano and Tenor, Rachael Grant and Billy Murray
Just a Voice to Call Me, Dear (Kalman)—The Riviera Girl, Soprano and Male Chorus, Gladys Rice
80382 Leave It to Jane—Fox-trot (Kern), For dancing, Jaudas' Society Orchestra
Siren's Song—Leave It to Jane (Kern), Soprano, Contralto and Chorus, Gladys Rice and Helen Clark

NEW HAWAIIAN RECORDING

- 20290 Wailana Waltz (Drowsy Waters), Louise and Ferera Waikiki Orchestra 10
Sweet lei lehua (Fragrance of the Lehua Wreath) Irene Greenus, with Louise and Ferera Waikiki Orchestra 10
20195 Auld Lang Syne (Burns)—"Old Scotch Air," Unaccomp. University Quartet 10
I Cannot Sing the Old Songs (Claribel), Mezzo-Soprano Isabelle Cannon 10
BAND AND ORCHESTRA RECORDS
40120 Première Valse (Durand) Concert Waltz, Garde Republicaine Band of France 12
Valse Militaire (Maton), Garde Republicaine Band of France 12
40119 Déjanire (Saint-Saëns) "Prelude, Act I," Garde Republicaine Band of France 12
Déjanire (Saint-Saëns) "Marche du Cortege," Garde Republicaine Band of France 12
20305 Love and Life in Holland (Joyce) "Waltz," Imperial Symphony Orchestra 10
Omaha (Wood) "Intermezzo," Imperial Symphony Orchestra
PATHE GOLD LABEL DEMONSTRATION RECORD
29195 Romeo et Juliette (Gounod), Act III, "Romeo, tu choisis Juliette pour femme?" In French, Mlle. Yvonne Gall, Mme. Goulancourt, MM. Affre et Journet
Romeo et Juliette (Gounod), Act III, "Eh bien donc!" In French, MM. Affre, Tirmont, Boyer and Grand Opera Chorus
OPERATIC RECORDS
63021 Aida (Verdi) "Ritorna vincitor." Part I. (Return Victorious!). In Italian, Soprano, Claudia Muzio 12
Aida (Verdi) "Ritorna vincitor." Part II. (Return Victorious!). In Italian, Soprano, Claudia Muzio 12
59052 Zara (Leoncavallo) "Ed ora io mi dormando" (I Now Ask Myself). In Italian, Tenor, Tito Schipa 12
La Tosca (Puccini) "Amaro sol per te m'era il morire" (The Bitterness of Death). In Italian, Tito Schipa and G. Baldassare 12
SACRED RECORDS
59053 Creation (Haydn) "In Native Worth." Tenor, Paul Althouse 12
Stabat Mater (Rossini) "Cujus animam." In Latin, Tenor, Paul Althouse 12
20304 Softly and Tenderly (Thompson), Tenor, organ accomp. William Wheeler 10
Saved by Grace (Stebbins), Tenor, organ accomp. William Wheeler 10
INSTRUMENTAL RECORDS
27010 Serenata (Moszkowski), Piano solo, Rudolph Ganz 10
Poupée Valsante (Podini), Piano solo, Rudolph Ganz 10
29197 The Comet (Brewer), Piccolo solo, Charles Wagner 12
Whistle for Me (Fane) "Serenade," Piccolo solo, Charles Wagner 12
40121 Tesoro Mio (Beccucci), Violin solo, Emile Mendels 12
Thais (Massenet) "Meditation," Violin solo, Emile Mendels 12

PATHE FRERES PHONOGRAPH CO.

POPULAR "HITS" OF THE MONTH

- 20309 Sweet Little Buttercup (Paley) Peerless Quartet 10
In Berry Pickin' Time (Wenrich), Baritone, Louis Winsch 10
20308 Homeward Bound (Meyer), Duet, Royal Dadmun and Arthur Fields 10
When the Boys From Dixie Eat the Melon on the Rhine (Breuer) Big City Four 10
20314 I Don't Want to Get Well (Jentes), Tenor, Arthur Fields 10
An Old Horse That Knows His Way Home (Olman), Baritone, Louis Winsch 10
20311 In the Land of Wedding Bells (Meyer), Duet, Campbell and Burr 10
I'm Going to Follow the Boys (Monaco), Baritone, Louis Winsch 10
20307 A Baby's Prayer at Twilight (Jerome), Tenor, Harry McClaskey 10
Valley Rose (Lloyd), Tenor, Harry McClaskey 10
20310 Are You From Heaven? (Friedland), Tenor, Irving Gillette 10
I'm Writing to You, Sammy (Harriman), Tenor, Arthur Fields 10
20313 Liberty Bell (Mohr) Peerless Quartet 10
There's a Million Heroes in Each Corner of the U. S. A. (Abrahams), Baritone, Royal Dadmun
NEW STANDARD BALLADS SUNG IN ENGLISH
25010 The Blue Bells of Scotland (Hopkirk), Contralto, Alma Beck 10
Ah, Love, But a Day! (Beach), Contralto, Alma Beck 10
25009 Comin' Thro' the Rye (Hopkirk), Soprano, Grace Hoffman 10
The Wind's in the South (Scott), Soprano, Grace Hoffman 10
20193 Sometime You'll Remember (Head), Tenor, Lewis James 10
I'll Sing Thee Songs of Araby (Clay), Mezzo-Soprano, Isabelle Cannon 10
20194 Can't Yo' Heah Me Callin' Caroline? (Roma), Tenor, Noble Sissle 10
Little Alabama (Coon (Starr), Tenor, Noble Sissle 10

"DE LUXE" DANCE RECORDS

- 20316 Long Boy (Herschell-Walker)—One-step, American Republic Band 10
Calicoco (Frey)—Fox-trot, American Republic Band 10
20317 The Tickle Toe, from "Going Up" (Hirsch)—Medley Fox-trot, Introducing "If You Look in Her Eyes," American Republic Band 10
The Moonlight Waltz (Logan), American Republic Band 10
20196 Sing Ling Ting (Cobb)—One-step, Van Eps-Banta Dance Orchestra 10
When the Saxophone Is Playing, from "The Grass Widow" (Hirsch), Medley Fox-trot, Introducing "Dance With Me," Van Eps-Banta Dance Orchestra 10
20306 Goulash (Hyde-Egan)—Fox-trot, Klass' Accordeon Dance Orchestra 10
My Dough Boy (Frey)—One-step, Klass' Accordeon Dance Orchestra 10

- 20290 Wailana Waltz (Drowsy Waters), Louise and Ferera Waikiki Orchestra 10
Sweet lei lehua (Fragrance of the Lehua Wreath) Irene Greenus, with Louise and Ferera Waikiki Orchestra 10
20195 Auld Lang Syne (Burns)—"Old Scotch Air," Unaccomp. University Quartet 10
I Cannot Sing the Old Songs (Claribel), Mezzo-Soprano Isabelle Cannon 10
BAND AND ORCHESTRA RECORDS
40120 Première Valse (Durand) Concert Waltz, Garde Republicaine Band of France 12
Valse Militaire (Maton), Garde Republicaine Band of France 12
40119 Déjanire (Saint-Saëns) "Prelude, Act I," Garde Republicaine Band of France 12
Déjanire (Saint-Saëns) "Marche du Cortege," Garde Republicaine Band of France 12
20305 Love and Life in Holland (Joyce) "Waltz," Imperial Symphony Orchestra 10
Omaha (Wood) "Intermezzo," Imperial Symphony Orchestra
PATHE GOLD LABEL DEMONSTRATION RECORD
29195 Romeo et Juliette (Gounod), Act III, "Romeo, tu choisis Juliette pour femme?" In French, Mlle. Yvonne Gall, Mme. Goulancourt, MM. Affre et Journet
Romeo et Juliette (Gounod), Act III, "Eh bien donc!" In French, MM. Affre, Tirmont, Boyer and Grand Opera Chorus
OPERATIC RECORDS
63021 Aida (Verdi) "Ritorna vincitor." Part I. (Return Victorious!). In Italian, Soprano, Claudia Muzio 12
Aida (Verdi) "Ritorna vincitor." Part II. (Return Victorious!). In Italian, Soprano, Claudia Muzio 12
59052 Zara (Leoncavallo) "Ed ora io mi dormando" (I Now Ask Myself). In Italian, Tenor, Tito Schipa 12
La Tosca (Puccini) "Amaro sol per te m'era il morire" (The Bitterness of Death). In Italian, Tito Schipa and G. Baldassare 12
SACRED RECORDS
59053 Creation (Haydn) "In Native Worth." Tenor, Paul Althouse 12
Stabat Mater (Rossini) "Cujus animam." In Latin, Tenor, Paul Althouse 12
20304 Softly and Tenderly (Thompson), Tenor, organ accomp. William Wheeler 10
Saved by Grace (Stebbins), Tenor, organ accomp. William Wheeler 10
INSTRUMENTAL RECORDS
27010 Serenata (Moszkowski), Piano solo, Rudolph Ganz 10
Poupée Valsante (Podini), Piano solo, Rudolph Ganz 10
29197 The Comet (Brewer), Piccolo solo, Charles Wagner 12
Whistle for Me (Fane) "Serenade," Piccolo solo, Charles Wagner 12
40121 Tesoro Mio (Beccucci), Violin solo, Emile Mendels 12
Thais (Massenet) "Meditation," Violin solo, Emile Mendels 12

EDISON BLUE AMBEROL RECORDS

(APRIL-MAY LIST)

CONCERT LIST

- 28282 O Sole Mio (My Sunshine) (Eduardo di Capua), Tenor, in Italian, orch. accomp. Guido Ciccolini
28283 (a) Vallat (b) Fjorton ar. Soprano, in Swedish, orch. accomp. Marie Sundelius

REGULAR LIST OF HITS

- 3453 Daddy, I Want to Go (Eddie Stembler), Male voices, orch. accomp. Assisted by Ada Jones, Premier Quartet
3456 Further It Is From Tipperary—Odds and Ends of 1917 (Dudley-Godfrey-Byrnes), Orch. accomp., Billy Murray and Chorus
3452 Just as Your Mother Was (Harry Von Tilzer), Male voices, orch. accomp. Harmony Four
3455 Longing for My Dixie Home (J. R. Shannon), Tenor, orch. accomp., Harvey Hindermeyer and Chorus
3445 My Sunshine Jane (Ernest R. Ball), Tenor, orch. accomp. Manuel Romain
3447 When Yankee Doodle Learns to Parlez Vous Francais (Ed. Nelson), Orch. accomp., Arthur Fields and Chorus of Girls
SONGS, HEART-SONGS AND BALLADS
3440 Garden of Allah (Little-Baskette-Flatow), Tenor, orch. accomp. Vernon Dalhart
3454 Hush-a-bye, Ma Baby (Missouri Waltz) (Frederick Knight Logan), Contralto and Tenor, orch. accomp., Marion Evelyn Cox and Vernon Dalhart
3459 Just a Voice to Call Me, Dear—The Riviera Girl (Emmerich Kalman), Soprano, orch. accomp., Gladys Rice and Male Chorus
3457 Laddie in Khaki (The Girl Who Waits at Home) (Ivor Novello), Orch. accomp. Glen Ellison
3441 Life's Railway to Heaven (Charlie D. Tillman), Baritone and Tenor, orch. accomp., Edward Allen, Charles Hart and Chorus
3451 Silver Threads Among the Gold (H. P. Danks), Soprano, orch. accomp., Elizabeth Spencer and Chorus
3443 We Want the Flowers Now (Byron Gay), Tenor and Baritone, orch. accomp., Vernon Dalhart and Lawrence E. Gilbert
A CHRISTIAN SCIENCE HYMN
3438 Shepherd, Show Me How to Go (Brackett), Mezzo-Contralto, orch. accomp., Nevada Van der Veer

DANCES FULL OF PEP

- 3442 Rambler Rose—One-step (Victor Jacobi), For dancing, Jaudas' Society Orchestra
3450 Wasatch Fox-trot (Carlotta Lake), For dancing, Jaudas' Band
3444 When I Hear That Jazz Band Play—Fox-trot (Buck-Stamper), For dancing, Jaudas' Society Orchestra
INSTRUMENTAL GEMS
3460 Battle Song of Liberty March (Bigelow-Hildreth), New York Military Band
3439 Garden of Love—Caprice (Ascher-Mahl), Peerless Orchestra
3449 Glow-worm (Lincke), Imperial Marimba Band
3448 I'll Take You Home Again, Kathleen (Thomas P. Westendorf), Violin, violoncello, flute and harp, Venetian Instrumental Quartet
3446 Kohala March, Instrumental Trio, Ford Hawaiians
3458 Uncle Tom's Cabin—A Dream Picture (J. Bode-walt Lampe), Edison Concert Band

GENNETT RECORDS

- 7642 I'll Come Back to You When It's All Over (Brown-Mills), Baritone, orch. accomp., Arthur Fields
There'll Be a Hot Time for the Old Men (While the Young Men Are Away) (Clarke-Meyer), Baritone, orch. accomp. Arthur Fields

- 10037 Good-bye Barnie (O'Brien-Morse). Vocal quartet with orch.....Peerless Quartet
- Yock-A-Hilo Town (Brice-Donaldson). Vocal quartet with orch.....Peerless Quartet
- 7641 Hello, I've Been Looking for You—From "The Big Show" at New York Hippodrome (Golden-Hubbell). Tenor, orch. accomp.....Arthur Hall
- Liberty Bell (It's Time to Ring Again) (Goodwin-Mohr). Tenor, orch. accomp.....Arthur Hall
- 7637 Says I to Myself, Says I (Moran-Von Tilzer). Soprano, orch. accomp.....Ada Jones
- I'm Old Enough for a Little Lovin' (Walter-Skidmore). Soprano, orch. accomp.....Ada Jones
- NEW DANCE RECORDS**
- 10035 Fox-trot Medley. "Darktown Strutters' Ball," "Barnyard Blues," "Mother, Dixie and You," "Cocoanut Grove Jazz".....Gennett Military Band
- One-step Medley. "Good-bye Broadway, Hello France," "It's a Long Way to Berlin, But We'll Get There," "I Don't Want to Get Well," "Hail, Hail! The Gang's All Here," "Where Do We Go From Here, Boys," "Over There," Gennett Military Band
- 7633 The Spinning Top—Waltz (Knecht), Gennett Dance Orchestra
- Valse Fascination—Waltz (Gray), Gennett Dance Orchestra
- 7628 Paddle-Addle—Fox-trot (Snyder), Vess Ossman's Banjo Orchestra
- He's Just Like You—One-step (Von Tilzer), Vess Ossman's Banjo Orchestra
- INSTRUMENTAL SELECTIONS**
- 10036 Spring Song (Mendelssohn).....Gennett Orchestra
- La Blanche Waltzes (Sheridan).....Gennett Orchestra
- 7644 New Orleans Jazz (My Dixieland) (Richardson), Gennett Orchestra
- Jasmo (One-step Oddity) (Klohr), Harry Junior's Jazz Orchestra
- 10028 La Marseillaise—Marcia Reale (National Airs of France and Italy).....Gennett Military Band
- God Save the King—Rule Britannia (English National Airs).....Gennett Military Band
- STANDARD VOCAL RECORDINGS**
- 10034 Bonnie Sweet Bessie (Root-Gilbert). Tenor, orch. accomp.James Harrod
- I'll Take You Home Again, Kathleen (Westendorf). Tenor, orch. accomp.....James Harrod
- 10033 Danny Deever (Kipling-Damrosch). Baritone, orch. accomp.Royal Dadmun
- The Pauper's Drive (Noel-Homer). Baritone, orch. accomp.Royal Dadmun
- ART TONE RECORDS**
- 12503 Swanee River (Old Folks at Home) (Foster). Violin, with piano accomp. by Francis Moore, Helen Ware
- Gentle Shadows (Ware). Violin, with piano accomp. by Francis Moore.....Helen Ware
- 12502 Humoresque (Dvorak). Violin, with piano accomp. by Francis Moore.....Helen Ware
- Ave Maria (Schubert). Violin, with piano accomp. by Francis Moore.....Helen Ware
- 10030 When the Bell in the Lighthouse Rings (Lamb-Solman). Bass, orch. accomp.....Frederic Martin
- Rocked in the Cradle of the Deep (Knight). Bass, orch. accomp.....Frederic Martin
- 12501 Largo (Handel). Violin, with piano accomp. by Francis Moore.....Helen Ware
- Meditation—"Thais" (Massenet). Violin, with piano accomp. by Francis Moore.....Helen Ware

EMERSON PHONOGRAPH CO.

MARCH LIST

- 7324 A Baby's Prayer at Twilight For Her Daddy Over There (Lewis-Young-Jerome). Patriotic solo, orch. accomp.....Jack Warner
- Give Me the Right to Love You All the While (Bard-Glatt). Baritone solo, orch. accomp., Jack Warner
- 7325 Sweet Little Buttercup (Bryan-Paley). Baritone solo, orch. accomp.....Harry Lawrence
- I Miss the Old Folks Now (Van-Schenck-Porray). Character song, orch. accomp.....Edward Levey
- 7322 The Wild, Wild Women Are Making a Wild Man of Me (Wilson-Piantadosi-Lewis). One-step.....Emerson Military Band
- The Tickle Toe (Hirsch). Fox-trot, Emerson Military Band
- 7321 Give Me the Moonlight, Give Me the Girl And Leave the Rest to Me (Brown-Von Tilzer). Tenor solo, orch. accomp.....Henry Burr
- Are You From Heaven? (Gilbert-Friedland). Tenor solo, orch. accomp.....Frank Woods
- 7318 When Yankee Doodle Marches Through Berlin, There'll Be a Hot Time in the U. S. A. (Sterling-Lange). Patriotic solo, orch. accomp., Eddie Nelson
- When the Boys From Dixie Eat the Mellon on the Rhine (Bryan-Breuer). Comic patriotic solo, orch. accomp.....George L. Thomson
- 7320 Tishomingo Blues (Williams). Character song, orch. accomp.....Eddie Nelson
- Mama's Blues—Papa's Blues (Johnson-Farrell). Character song, orch. accomp.....Eddie Nelson
- 7323 Wait for Your Honey Boy (Pfeiffer). Patriotic solo, orch. accomp.....Edward Levey
- When the Yanks Come Marching Home (Jerome-Furth). Patriotic solo, orch. accomp.....Edward Levey
- 7317 That's the Kind of a Baby for Me (Eagan). One-step.....Emerson Military Band
- March Lorraine (Ganne).....Emerson Military Band
- 7319 Indianola (Henry-Onivas). Instrumental novelty and fox-trot.....Emerson Military Band
- Some Jazz Blues (Lake). Fox-trot, Emerson Military Band
- 7315 American Republic March (Thiele), Emerson Military Band
- Midnight Fire Alarm (Paul). Descriptive-march gallop.....Emerson Military Band

GETTING READY FOR THE NEXT LIBERTY LOAN CAMPAIGN

How Geo. H. O'Connor, a Noted Columbia Artist, Figures in the Motion Picture Reels Being Made for Exploitation Purposes—An Attorney and Character Song Artist

In the forthcoming Liberty Loan publicity campaign, there will be used a series of motion pictures that will be displayed in the moving picture theatres throughout the country. This film will contain many features of interest, and

Mr. O'Connor from the committee on public information, George Creel, chairman, and is presented herewith. In addition to Secretary of War Baker and Mr. O'Connor, there are shown in this scene the members of the Liberty



G. H. O'Connor Buying Bond From Secretary of War

will be almost identical with the pictures used in the last Liberty Loan campaign.

Included in these films is one scene entitled: "The Secretary of War Sells a Bond to the Cheerful Subscriber, George H. O'Connor." The "still" of this film has just been received by

Loan committee—John Poole, president, Federal National Bank; Corcoran Thom, vice-president, American Security & Trust Co.; B. F. Saul, president, Home Savings Bank; Eugene Ailes, National City Co.; E. E. Thompson, of Crane, Parris & Co.

George H. O'Connor is an exclusive Columbia artist, whose records have achieved country-wide success. He is the son of an American army officer, and was born, reared and still resides in Washington, D. C., where in his serious moments he is known as an attorney and counsellor at law. He is one of America's most popular character song artists, and his splendid tenor voice is remarkably well adapted for recording.

INVENTORIES AND THE TAX LAW

New War Revenue Bill Will Serve to Make Many Merchants Take Their First Accurate Inventory—Should Help Business

A member of the National Association of Credit Men makes the excellent point that under the new War Revenue Law numerous unskilled merchants will, for the first time, be called upon to make out an income tax report, and believes that this will prove a very direct advantage to business, because merchants who have not been in the habit of taking regular inventory will now be forced to do so. Revenue collectors emphasize the point that every merchant will be expected to take an exact annual inventory, else his tax report can be based on nothing better than guessing, which will not satisfy the Government.

For the benefit of the small merchant who has seldom been called upon to do anything of the sort, the following formula is offered for determining net profit:

A SIMPLE FORMULA FOR DETERMINING NET PROFIT

1. Inventory of Dec. 31st, 1916, at cost.....\$
2. Add Purchases in 1917.....\$
3. Total.....\$
4. Subtract Inventory of Dec. 31st, 1917, at cost.....\$
5. Cost of goods sold in 1917 (item 3 less item 4).....\$
6. Sales in 1917 (Cash and Credit).....\$
7. Subtract item 5 from item 6 to arrive at GROSS PROFIT.....\$

DEDUCTIONS

8. Expense of doing business (Rent, Wages, a Reasonable Salary to Proprietor, Light, Fuel, Taxes of all kinds, except those not on the business, and all other business expenses).....\$
9. Depreciation on Fixtures.....\$
10. Bad Debt Losses.....\$
11. Total Deductions.....\$
12. NET Profit.....\$

PATHE WINDOW HANGER FOR APRIL

Contains All the Latest Hits and Is Most Attractively Printed

The Pathé Frères Phonograph Co., Brooklyn, N. Y., has just sent out to its dealers an attractive hanger featuring the new Pathé records for April. This hanger presents a splendid portrait of Rudolph Ganz, the famous concert pianist, who records for the Pathé library exclusively. The April list contains a new record played by Mr. Ganz, together with an excellent array of popular song successes, latest dance records, Hawaiian records, operatic and classic vocal numbers, standard and sacred vocal records, and instrumental numbers. The artists featured in this list include Claudia Muzio, Paul Althouse and Grace Hoffman.

One of the interesting features of the Pathé list for April is the presentation of a special Pathé Gold Label demonstration record featuring two selections from "Romeo and Juliet," sung by a group of famous operatic artists.

READY REFERENCE OF GENERAL SUPPLIES

DEALERS

Send for our "Trial Proposition" on the Regina Hexaphone—the latest and best paying popular priced coin-operated instrument for use in public places.



211 Marbridge Bldg., 34th St. and Broadway, New York City
Manufacturers of Regina Music Boxes; Reginaphones; Coin-operated Mandolin Orchestrions; Vacuum Cleaners and other specialties.

NEEDLES

WE MANUFACTURE

Diamond needles for Edison
Sapphire needles for Edison
Sapphire needles for Pathe
in stock ready for delivery
MERMOD & CO., 505 5th Ave., N. Y.

REPAIRS

All Makes of Talking Machines
Repaired Promptly and Efficiently

TALKING MACHINE REPAIR
AND SALES CORPORATION

ANDREW H. DODIN, President
176 Sixth Avenue New York
TELEPHONE, CHELSEA 8437

"TALKING MACHINE WORLD TRADE DIRECTORY"

In order to make this directory as accurate and up-to-date as possible, we have listed alphabetically only those concerns whose advertisements have appeared in the TALKING MACHINE WORLD during the past six months. This is the fourth edition of the TALKING MACHINE WORLD TRADE DIRECTORY, each new appearance canceling the preceding list. It aims to answer in a nutshell the prevailing questions of "Where can I get it?" and "Who makes it?"—which questions we are emphatically interested in answering for our readers. No attempt has been made to differentiate between the merits of the various types of machines, records and miscellaneous supplies listed.

MACHINES

- AMERICAN PHONOGRAPH CO.** Offices, 39 Fountain street, Grand Rapids, Mich. Manufactures line retailing from \$40 to \$175.
- ARTOPHONE CO.** Executive offices and factory, 1113 Olive street, St. Louis, Mo. Est., 1915. Manufactures the "Artophone" line, four models, retail prices \$65 to \$150. Also makes electric machines.
- BELL TALKING MACHINE CORP.** Executive offices, 44 West Thirty-seventh street, New York. Manufactures "Schubert Magnetic" line, retail prices \$60 to \$215.
- BROOKS MANUFACTURING CO.** Executive offices and factory, Saginaw, Mich. Est., 1903. Manufactures the "Brooks" line of phonographs.
- BRUNSWICK - BALKE - COLLENDER CO.** Executive offices, 623 South Wabash avenue, Chicago. Factories, Chicago, New York City, Muskegon, Dubuque and Toronto. Est., 1845. Manufactures the "Brunswick" line, twelve models, retail prices \$40 to \$1,500. Also makes electric machines.
- CELINA FURNITURE CO.** Executive offices and factory, Celina, O. Manufactures "Harponola" line of talking machines.
- CENTURY CABINET CO.** Executive offices, 25 West Forty-fifth street, New York City; factory, Utica, N. Y. Est., 1908. Manufactures "Century" line of phonographs, seven models, retailing from \$30 to \$200. Built to order \$500 up.
- CHENEY TALKING MACHINE CO.** Executive offices, 24 North Wabash avenue, Chicago. Manufactures "Cheney" line period models, retail prices \$60 to \$300.
- CLASSIQUE PHONOGRAPH CORP.** Executive offices and factory, 401 North Lincoln street, Chicago. Manufactures "Cowan Classique" gramophones, twenty models, retailing from \$75 to \$1,000.
- COLUMBIA GRAPHOPHONE CO.** Executive offices, Woolworth building, New York City. Manufacturers of "Columbia Gramophones." Retail prices \$18 to \$2,100. Also makes electric machines.
- COMPACTO PHONO. CORP.** Executive offices, 285 North Sixth street, Brooklyn, N. Y. Markets "Compacto" portable phonograph.
- CONSOLIDATED TALKING MACHINE CO.** Executive offices, 227 West Lake street, Chicago. Manufactures "Consolidated," "Standard," "Harmony" and "United" lines. Retail prices \$19.50 to \$115.
- THE CRYSTOLA CO.** Executive offices, 3134 Elm street, Cincinnati; factory, Cincinnati. Est., 1917. Manufactures "Crystola" line machines, two models, retailing from \$100 to \$200. Also electric machines. To add new models in near future.
- DELPHOON CO.** Executive offices and factory, 810 Boutell place, Bay City, Mich. Est., 1916. Manufactures the "Delphoon" line, seven models, retail prices \$75 to \$400. Also makes electric machines.
- DOMESTIC TALKING MACHINE CORP.** Executive offices and factory, Thirty-third and Arch streets, Philadelphia, Pa. Est., 1916. Manufactures "Domestic" line, six models, retail prices \$15 to \$135.
- THOMAS A. EDISON, Inc.** Executive offices and factories, Orange, N. J. Manufactures "Edison Diamond Disc" line, seven models, retail prices \$106 to \$450; eight period models retailing \$1,000-\$6,000. Also makes "Edison Diamond Amberola" cylinder line, three models, retail prices \$25 to \$82.50.
- ELMBROLA TALKING MACHINE CO.** Executive offices and factory, St. Paul, Minn. Manufacture the "Elmbrola" line, four models.
- EMPIRE TALKING MACHINE CO.** Executive offices, 429 South Wabash avenue, Chicago; factories, Chicago, Cleveland and Indianapolis. Est., 1915. Manufactures "Empire" line, nine models, retail prices \$27.50 to \$215.
- THE FRITZSCH PHONOGRAPH CO.** Executive offices, 228 West Seventh St., Cincinnati, O. Manufacturers of the "Phon d'Amour," eight models, retail prices \$110 to \$450.
- FULTON-ALDEN CO.,** Executive offices, 123 N. Genesee street, Waukegan, Ill. Manufactures "Fulton" line, three models, retail prices \$125 to \$350. Also makes electric machines.
- GABEL'S ENTERTAINER CO.** Executive offices and factory, 210 North Ann street, Chicago, Ill. Manufactures Gabel's Automatic Entertainer and Gabelola (strictly automatic).
- HOFFAY TALKING MACHINE CO.** Executive offices, 3 West Twenty-ninth street, New York City. Est., 1915. Manufactures "Hoffay Airtight" line, five models, retail prices \$75 to \$250.
- IMPERIAL TALKING MACHINE CO.** Main office and factory, 9 Vandever avenue, Wilmington, Del. Showrooms, 35 West Thirty-first street, New York. Manufactures "Imperial" line, six models, retail prices \$25 to \$190.
- ANDS KOCH.** Executive offices, 296 Broadway, New York City. Manufactures the "Koch-O-Phone" line, twenty models, retail prices \$4.50 to \$220.
- LUCKY 13 PHONOGRAPH CO.** Executive offices and factory, 3 East Twelfth street, New York City. Est., 1913. Manufactures the "Cleartone" phonographs, thirty-three models, retail prices \$4 to \$200.
- MAGNOLA TALKING MACHINE CO.** Executive offices, 711 Milwaukee avenue, Chicago; factory, Chicago. Manufactures "Magnola" line of machines, five models, retailing from \$65 to \$210. Also manufactures "Magnola Mobile" line, two models, retailing \$75 and \$95. Also electric machines.
- MANDEL MANUFACTURING CO.** Executive offices, 501 Laffin street, Chicago; factories, Chicago and Benton Harbor, Mich. Est., 1915. Manufactures "Mandel" line, four models, retail prices \$35 to \$250. Also makes electric machines.
- MELOPHONE TALKING MACHINE CO., Inc.** Executive offices, 376 Lafayette street, New York City. Est., 1915. Manufactures "Melophone" line, seven models, retail prices \$5 to \$200.
- MORENUS PIANO CO.** Executive offices and factory, 341 West Superior street, Chicago, Ill. Manufactures "Morenus" line, three models, retail prices \$110 to \$150.
- MOZART TALKING MACHINE CO.** Executive offices, 2608 North Fifteenth street, St. Louis. Est., 1916. Manufactures the "Mozart" line, seven models, retail prices \$15 to \$100.
- MUNZER MANUFACTURING CORP.** Executive offices and factory, 307 Sixth avenue south, Minneapolis, Minn. Est., 1916. Manufacturers of "Munola" phonographs. Retail prices range from \$44.50 to \$75.00.
- OPEROLLO PHONOGRAPH CO.** Executive offices, 420 Lightner Bldg, Detroit, Mich. Manufactures "Operollo" phonographs.
- OTTAWA PIANOPHONE CO.** Executive offices, 802 Republic Building, Chicago; factory, Ottawa, Ill. Manufactures "Hiawatha" line of phonographs; retail prices \$35 to \$100.
- PARAGON MFG. CO.** Executive offices and factory, Hickory, N. C. Manufactures "Paragon" line, three models, retail prices \$85 to \$265.
- PATHE FRERES PHONOGRAPH CO.** Executive offices, 10-32 Grand avenue, Brooklyn, N. Y.; factories, Brooklyn, N. Y.; London, Paris, Berlin, Vienna, Milan. Manufactures the "Pathephone" line, eight models, retail prices \$25 to \$225.
- REED, DAWSON & CO., INC.** Executive offices and factory, 6 West Park street, Newark, N. J. Est., 1897. Manufactures "Dolce-Tone" line of machines, seven models, retailing \$65 to \$325.
- REGINA CO.** Executive offices, Marble Building, New York City; factory, Rahway, N. J. Est., 1892. Manufactures coin operated "Hexaphones." Also "Regina" music box and "Reginaphone" lines.
- SCHILLING PIANO CO.** Executive offices, 112 West Twenty-third street, New York. Wholesale distributors for the "Stradivara" line, seven models, \$45 to \$225. Also electric machines.
- J. P. SEEBURG PIANO CO.** Executive offices, Republic Building, Chicago, Ill.; factories, Chicago and Tonawanda, N. Y. Manufactures "Phonograph," a combination talking machine and player-piano without keys.
- CHARLES W. SHONK CO.** Executive offices, Monroe Building, Chicago, Ill.; factory, Maywood, Ill. Est., 1877. Manufactures "Mag-Ni-Phone" line, six models, retail prices \$15 to \$100.
- SONORA PHONOGRAPH CORPORATION.** Executive offices, 57 Reade street, New York City. Manufactures the "Sonora" line, eleven models, retail prices \$50 to \$1,000.
- STARR PIANO CO.** Executive offices and factory, Richmond, Ind. Est., 1872. Manufactures "Starr" line, eleven models, retail prices \$55 to \$320.
- STERLING PHONOGRAPH CO.** Executive offices, 285 N. Sixth street, Brooklyn, N. Y.
- STEWART PHONOGRAPH CORPORATION.** Executive offices 327 Wells street, Chicago. Factory, 2843 North Lincoln street, Chicago. Est., 1916. Manufactures "Stewart" line, retail prices \$7.75 and upwards.
- SUPERTONE TALKING MACHINE CO.** Executive offices, 18 West Twentieth street, New York. Est., 1916. Manufactures the Supertone line, three models of floor cabinets, retailing at \$65 to \$125.
- TON-O-GRAF CORP.** Executive offices and factory, 112 East South Water street, Chicago. Est., 1916. Manufactures "Ton-O-Graf" line, one model. After January 1 will make four models, retailing \$50 to \$150. Electric machines to order.
- VICTOR TALKING MACHINE CO.** Executive offices and factory, Camden, N. J. Manufactures "Victor" and "Victor-Victrola" lines, thirteen models, retail prices \$17.50 to \$400. Electric machines included. Also manufactures Victor period line, forty models, retail prices from \$300 to \$900.
- VITANOLA TALKING MACHINE CO.** Executive offices, 501-509 West Thirty-fifth street, Chicago. Factories, Chicago, Rockford and Michigan. Manufacture the "Vitanola" line, eight models, retail prices \$25 to \$200.
- WESER BROS., INC.** Executive offices, 520 West Forty-third street, New York City; factory, New York City. Est., 1879. Manufactures "Weser" line, six models, retailing from \$35 to \$200. Also electric machines.
- WIDDICOMB FURNITURE CO.** Executive offices and factory, Grand Rapids, Mich. Est., 1865. Manufactures the "Widdicomb" line of period models.
- THOS. E. WILSON & CO.** Executive offices and warehouses, 701 North Saugamon street, Chicago. Makes "Thos. E. Wilson" phonographs, two models, retailing at \$40 and \$60.
- WONDER TALKING MACHINE CO.** Executive offices and factory, 105 East Twelfth street, New York City. Est., 1915. Manufactures the "Wonder" line, retail prices \$5 to \$75.
- WORLD PHONOGRAPH CO.** Executive offices and factory, 736 Tilden street, Chicago, Ill. Manufactures "World" phonograph line, four models, retail prices \$75 to \$175.

RECORDS

- BRUNSWICK - BALKE - COLLENDER CO.** Executive offices, 623 South Wabash avenue, Chicago. Est., 1845. Markets the "Pathe" records, manufactured by the Pathe Freres Phonograph Co., New York.
- COLUMBIA GRAPHOPHONE CO.** Executive offices, Woolworth building, New York City. Manufactures "Columbia" records, ten and twelve inches.
- CONSOLIDATED TALKING MACHINE CO.** Executive offices, 227 West Lake street, Chicago. Markets "Consolidated," "Standard," "Harmony" and "United" 10-inch double-faced records.
- CORTINA ACADEMY OF LANGUAGES.** Executive offices, 12 East Forty-sixth street, New York City. Est., 1882. Markets Cortina Phone-Method, lateral cut, sold in sets. Language records only.
- DOMESTIC TALKING MACHINE CORP.** Executive offices and factory, Thirty-third and Arch streets, Philadelphia. Est., 1916. Manufactures "Domestic Blue" records, ten and twelve-inch, vertical cut, retail from 70c. to \$1.25.
- THOMAS A. EDISON, Inc.** Executive offices and recording laboratories, Orange, N. J. Manufactures "Edison Disc" line, ten-inch record, vertical cut, retail prices \$1 to \$4. Also manufactures "Edison Blue Amberol" cylinder records, retail prices 60 cents to \$1.25.
- EMERSON PHONOGRAPH CO.** Executive offices and laboratory, 3 West Thirty-fifth street, New York City; factories at various points. Est., 1915. Manufactures "Emerson Universal Cut" double disc records, seven-inch retail at 35 cents and nine-inch retail at 65 cents.
- EMPIRE TALKING MACHINE CO.** Executive offices, 429 South Wabash avenue, Chicago. Est., 1915. Markets "Empire" line, vertical cut, ten and twelve-inch records, retailing at 75c. up.
- GENNETT RECORDS (Division Starr Piano Co.).** Executive offices, 9 East Thirty-seventh street, New York City; factory, Richmond, Ind. Est., 1872. Manufactures "Gennett" records, ten-inch double face, vertical cut records, retailing from 65c. to \$4.
- IMPERIAL TALKING MACHINE CO.** Main office and factory, 9 Vandever avenue, Wilmington, Del. Recording laboratory and showrooms, 35 West Thirty-first street, New York. Manufactures "Rex" and "Imperial" records, ten and twelve-inch; vertical cut, retail prices 75c. to \$2.
- LYRAPHONE CO. OF AMERICA.** Executive offices, 12 West Thirty-seventh street, New York City; factory, Brooklyn. Manufactures "Lyric" line, ten and twelve-inch double face, vertical cut records, retailing from 75c. to \$3. Est., 1916.
- PATHE FRERES PHONOGRAPH CO.** Executive offices, 10-32 Grand Avenue, Brooklyn, N. Y.; factories, and recording laboratories, New York City, N. Y.; Brooklyn, N. Y.; London, Paris, Berlin, Vienna and Milan. Manufactures "Pathe" line, vertical cut, 10½, 11½ and 14-inch records.
- STARR PIANO CO.** Executive offices and factory, Richmond, Ind. Est., 1872. Manufactures "Gennett" line, ten-inch double disc record, vertical cut, retail prices 65c. to \$4.00.
- VICTOR TALKING MACHINE CO.** Executive offices and factory and recording laboratories, Camden, N. J. Manufactures "Victor" line, ten-inch and twelve-inch records, lateral cut, retail prices 75c to \$7.

JOBBER'S

Columbia Jobbers

COLUMBIA GRAPHOPHONE CO. Wholesale distributing branches are located in the following cities under the name of the "Columbia Graphophone Co." unless otherwise noted—Atlanta, Ga.; Baltimore, Md.; Boston, Mass.; Buffalo, N. Y.; Chicago, Ill.; Cincinnati, O.; Cleveland, O.; Dallas, Tex.; Columbia Stores Co., Denver, Colo.; Detroit, Mich.; Indianapolis, Ind.; Kansas City, Mo.; Los Angeles, Cal.; Minneapolis, Minn.; New Haven, Conn.; New Orleans, La.; New York City; Schmoller & Mueller Co., Omaha, Neb.; Philadelphia, Pa.; Pittsburgh, Pa.; Portland, Me.; Portland, Ore.; Grafonola Co., Rochester, N. Y.; Columbia Stores Co., Salt Lake City, Utah; San Francisco, Cal.; Seattle, Wash.; Columbia Stores Co., Spokane, Wash.; St. Louis, Mo.; Tampa Hardware Co., Tampa, Fla.

Victor Jobbers

W. D. & C. N. ANDREWS. Buffalo, N. Y.
BADGER TALKING MACHINE CO. 135 Second street, Milwaukee, Wis.
BLACKMAN TALKING MACHINE CO. 97 Chambers street, New York City.
C. BRUNO & SON, Inc. 351 Fourth avenue, New York City.
LOUIS BUEHN CO., Inc. Philadelphia, Pa.
CHICAGO TALKING MACHINE CO. 12 North Michigan avenue, Chicago.
CORLEY CO., Inc. Richmond, Va.
I. DAVEGA, JR., Inc. 125 West 125th street, New York City.
S. B. DAVEGA CO. 831 Broadway, New York City.
CHARLES H. DITSON & CO. 8 East Thirty-fourth street, New York City.
OLIVER DITSON CO. Boston, Mass.
E. F. DROOP & SONS. Washington, D. C., and Baltimore, Md.
W. J. DYER & BRO. St. Paul, Minn.
EASTERN TALKING MACHINE CO. 117 Tremont street, Boston, Mass.
ECLIPSE MUSICAL CO. Cleveland, O.
GATELY-HAIRE CO., Inc. Albany, N. Y.
GRINNELL BROS. Detroit, Mich.
LYON & HEALY. Chicago, Ill.
MICKEL BROS. CO. of Des Moines, Ia., and Omaha, Neb.
W. D. MOSES & CO. Richmond, Va.
NEW YORK TALKING MACHINE CO. 119 West Fortieth street, New York.
GEO. D. ORNSTEIN CO. 9 North Eleventh street, Philadelphia, Pa.
SILAS E. PEARSALL CO. 18 West Forty-sixth street, New York City.
PENN PHONOGRAPH CO., Inc. 17 South Ninth street, Philadelphia.
SCHMELZER ARMS CO. Kansas City, Mo.
SHERMAN, CLAY & CO. San Francisco, Cal.
STANDARD TALKING MACHINE CO. Pittsburgh, Pa.
M. STEINERT & SONS CO. 35 Arch street, Boston, Mass.
STEWART TALKING MACHINE CO. Indianapolis, Ind.
H. A. WEYMAN & SON, INC. Philadelphia, Pa.
THE WHITNEY & CURRIER CO. Toledo, Ohio.
PERRY B. WHITSIT CO. Columbus, O.
G. T. WILLIAMS CO. 217 Duffield street, Brooklyn, N. Y.
RUDOLPH WURLITZER CO. Cincinnati, O.

Pathe Jobbers

ARMSTRONG FURNITURE CO. Memphis, Tenn.
FISCHER CO., Detroit, Mich.
MOONEY-MUELLER WARD CO. Indianapolis, Ind.
PATHEPHONE DISTRIBUTORS CO. 95 Southern boulevard, New York City.
PHILADELPHIA PATHEPHONE CO. Philadelphia, Pa.
PITTSBURGH PATHEPHONE CO. 936 Liberty avenue, Pittsburgh, Pa.
G. SOMMERS & CO. St. Paul, Minn.
A. VICTOR & CO. Buffalo, N. Y.
WILLIAMS, DAVIS, BROOKS & HINCHMAN SONS. Detroit, Mich.

Sonora Jobbers

ELECTRIC SUPPLY & EQUIPMENT CO. 278 Broadway, Albany, N. Y.
ELECTRIC SUPPLY & EQUIPMENT CO. Little Building, Boston, Mass.

ELECTRIC SUPPLY & EQUIPMENT CO. 105 Allyn street, Hartford, Conn.
PIERSOL CARPET CO. Lancaster, Pa.

SMITH, KLINE & FRENCH. Philadelphia, Pa.
C. W. SNOW & CO. Syracuse, New York.

Delpheon Jobbers

DELPHION CO., INC. 68 Park street, Atlanta, Ga.
DELPHION SALES CO. 25 Church street, New York City.

Manaphone Jobbers

G. GENNERT. 24 East Thirteenth street, New York City.

CASES—COVERS

E. H. LANSING. Executive offices and factory, 611 Washington street, Boston, Mass. Est., 1881. Manufactures the "Lansing" Khaki moving covers, and slip covers.
LYON & HEALY. Executive offices, Chicago, Ill. Manufactures Khaki carrying covers for talking machines.
C. E. WARD CO. Executive offices and factory, New London, O. Est., 1905. Manufactures phonograph wareroom and carrying covers for all purposes.

PARTS

ACME DIE CASTING CORPORATION. Executive offices and factory, Bush Terminal, Brooklyn, N. Y. Sales offices in leading cities. Products manufactured: Tone arms, sound boxes, regulators, tone modifiers, special die castings, stops and miscellaneous parts.
AMERICAN PHONOPARTS CO. Executive offices, 3500 Normal avenue, Chicago; factory, Chicago. Products manufactured: "Play-rite" spring motors, electric motors, tone arms, sound boxes and other parts.
BARNHART BROTHERS & SPINDLER. Executive offices and factory, Monroe and Throop streets, Chicago, Ill. Est., 1868. Products manufactured: "Superior" spring motors, tone arms, reproducers, needle cups, die castings and stampings.
COMBINATION ATTACHMENT CO. Executive offices, 209 South State street, Chicago. Established, 1915. Products manufactured: Reproducers and tone arms.
CONSOLIDATED TALKING MACHINE CO. Executive offices, 227 West Lake street, Chicago. Manufactures accessories.
DOEHLER DIE CASTING CO. Executive offices and factory, Court and Ninth streets, Brooklyn, N. Y.; also factories in Toledo, O., and Newark, N. J. Products manufactured: Tone arms, sound boxes, tone modifiers, special die castings, stops and miscellaneous parts to order only.
EMPIRE PHONO PARTS CO. Executive offices, 427 South Wabash avenue, Chicago, Ill.; factory, 1102 West Ninth street, Cleveland, O. Est., 1912. Products manufactured: tone arms, sound boxes and attachments.
OTTO HEINEMAN PHONOGRAPH SUPPLY CO., INC. (Meisselbach Division). Executive offices, 25 West Forty-fifth street, New York City; factory, Newark, N. J. Est., 1887. Products manufactured: spring motors, tone arms, sound boxes, stops and miscellaneous parts.
OTTO HEINEMAN PHONOGRAPH SUPPLY CO., Inc. Executive offices, 25 West Forty-fifth street, New York City; factories, Elyria, O., Putnam, Conn., and Newark, N. J. Est., 1915. Products manufactured: Spring motors, tone arms, names: "Motor of Quality" and "Meisselbach" motors, tone arms, sound boxes, "Dean" needles, etc.
HOFFAY TALKING MACHINE CO., INC. Executive offices, 3 West Twenty-ninth street, New York City. Est., 1915. Manufacturers of the Hoffay "Resurrectone" and "Half-Fork Tone" sound boxes.
INDEPENDENT TALKING MACHINE CO., Inc. Executive offices and factory, 54 Bleecker street, New York City. Est., 1913. Products manufactured: Spring motors, tone arms, sound boxes, tabulators, tone arm rests, brakes, lid stops, springs, needle cups, etc.
INDIANA DIE CASTING CO. Executive offices and factory, Cornell and Eleventh streets, Indianapolis, Ind. Products manufactured: Tone arms, sound boxes, special die castings, stops and miscellaneous parts to order only.
INTERNATIONAL MICA CO. Executive offices, 1228 Filbert street, Philadelphia, Pa.; mines at Amelia, Va. Est., 1913. Specialize in mica diaphragms.
JACQUITH MACHINERY BUREAU, INC. Executive offices, 100 Purchase street, Boston, Mass. Manufactures spring cups, spring cup separators, motor governors, etc.
KAROLA LABORATORY. Bloomfield, N. J. Products: "Eureka" phonograph fiber diaphragms in all types for all sound boxes.

F. C. KENT & CO. Executive offices and factory, 24 Scott street, Newark, N. J. Est., 1914. Products manufactured: Tone arms, sound boxes and various attachments. Also does gold-plating for the trade.
KIRKMAN ENGINEERING CO. Executive offices and factory, 237 Lafayette street, New York City. Est., 1912. Manufactures: "Kirkman" spring motors and miscellaneous parts.
ANDS KOCH. Executive offices, 296 Broadway, New York City. Products manufactured: Tone arms and sound boxes.
LAKESIDE SUPPLY CO., INC. Executive offices, 202 South Clark street, Chicago. Manufacturers and jobbers of tone arms, phonograph hardware, accessories and motors.
LUCKY 13 PHONOGRAPH CO. Executive offices, 3 East Twelfth street, New York City. Manufacturers and jobbers of: Motors, tone arms, sound boxes, main springs, governor springs and miscellaneous parts.
MANHATTAN PHONO PARTS CO. Executive offices, 32 Union Square, New York. Manufactures sound boxes and wooden tone arms.
LEONARD MARKELS. Executive offices and factory, 165 William street, New York City. Est., 1911. Products manufactured: "Markels" Butterfly jewel-bearing motors; also tone arms, sound boxes and miscellaneous phonograph parts.
MELOPHONE TALKING MACHINE CO., Inc. Executive offices, 376 Lafayette street, New York City. Est., 1915. Products manufactured: Motors and miscellaneous parts.
MERMOD & CO. Executive offices, 505 Fifth avenue, New York City; factory, Ste. Croix, Switzerland. Est., 1816. Products manufactured: Spring motors, tone arms, sound boxes and miscellaneous parts.
MUTUAL TALKING MACHINE CO. Executive offices, 145 West Forty-fifth street, New York City. Products manufactured: Tone arms and sound boxes.
NATIONAL LEAD CO. Executive offices, 111 Broadway, New York; factories, Brooklyn. Products manufactured: tone arms, sound boxes, regulators, tone modifiers, stops and miscellaneous die castings to order.
NEW JERSEY REPRODUCER CO. Executive offices and factory, 10 Oliver street, Newark, N. J. Manufactures "Invincible" sound box.
PARR MFG CORPN. Executive offices, 1 Union Square, New York. Patentees and manufacturers of the Parr "Magnetic" reproducer.
PERFECT AUTOMATIC BRAKE CO. Executive offices and factory, 425 South Wabash avenue, Chicago. Est., 1915. Manufactures automatic brakes.
PHONOGRAPH APPLIANCE CO. Executive offices, New Brighton, S. I., N. Y. Factory, 109-113 West Broadway, New York City. Est., 1915. Products manufactured: "Crystal Edge" mica diaphragms.
PRESTO PHONO PARTS CORP. Executive offices and factory, Sperry Building, Manhattan Bridge plaza, Brooklyn, N. Y. Est., 1916. Products manufactured: Tone arms, sound boxes, motors, turntables, cover supports, cabinet hardware.
RENE MFG. CO. Executive offices and factory, Montvale, N. J. Products manufactured: Springs, sound boxes and repair parts.
SOSS MFG. CO. Executive offices and factory, 435 Atlantic avenue, Brooklyn, N. Y. Est., 1908. Products manufactured: "Soss" hinges, "Soss" die castings, tone arms, sound boxes, tone arm supports and miscellaneous parts.
STARR PIANO CO. Executive offices and factory, Richmond, Ind. Est., 1872. Manufactures "Ku-Allen" spring motors.
STEPHENSON, INC. Offices, 1 West Thirty-fourth street, New York. Factory, DeCamp and Sloan, Newark, N. J. Manufactures "Stephenson" Precision-made spring motor.
STEWART PHONOGRAPH CORPN. Executive offices, 327 Wells street, Chicago. Products manufactured: Motors, tone arms, reproducers and other parts.
THOMAS MFG. CO. Executive offices and factory, Dayton, O. Est., 1916. Products manufactured: "Dayton" motors, tone arms and sound boxes.
TIPHANY MOTOR CO. Executive offices, 32 Union Square, New York City. Manufactures "Typhany" spring motors.
TONOLA PHONOGRAPH CO. Offices, 11 South Seventh street, Minneapolis, Minn. Distributors of motors, tone arms, sound boxes, etc.
THE UNION PHONOGRAPH SUPPLY CO. Executive offices and factory, 1100-1108 West Ninth street, Cleveland, O. Products manufactured: Tone arms, sound boxes and attachments.
UNISSET REPRODUCER CO. Executive offices, Cable Building, Chicago, Ill. Manufacture "Unisset" reproducer for playing both lateral and vertical cut records.

UNITED PHONOGRAPH PARTS CO. Executive offices and factory, 3248 West Sixteenth street, Chicago, Est., 1916. Manufactures "Perfecto" tone arms and "Perfecto" reproducers.
VEECO COMPANY. Executive office, 248 Boylston street, Boston, Mass.; factory, New Hampshire. Est., 1916. Products manufactured: Electric motors and "Vitraid" turntables.
VITALIS HIMMER, JR. Executive offices, 77 Reade street, New York City. Est., 1913. Products include tone arms, sound boxes and "Audion" sound boxes.
WILSON-LAIRD PHONOGRAPH CO., Inc. Executive offices, 136 Liberty street, New York City. Est., 1916. Manufactures "Bliss" reproducers.
WONDER TALKING MACHINE CO. Executive offices and factory, 105 East Twelfth street, New York City. Distributors of motors, sound boxes and tone arms.
MFRS. CABINETS
CELINA FURNITURE CO. Executive offices, Celina, O.
CENTURY CABINET CO. Executive offices, 25 West Forty-fifth street, New York City; factory, Utica, N. Y.
GRAND RAPIDS CABINET FURN. CO. Offices, Empress Building, Grand Rapids, Mich.
GEO. A. LONG CABINET CO. Executive offices and factory, Hanover, Pa. Est., 1911.
C. J. LUNDSTROM MFG. CO. Little Falls, N. Y. Est. 1900.
NORTHWESTERN CABINET CO. Executive offices, Menomonee, Mich. Manufactures cabinets.
UDELL WORKS. Executive offices and factory, Indianapolis, Ind. Est. 1873.
RECORD CABINETS
Manufacturers and Distributors
EMPIRE TALKING MACHINE CO. Executive offices, 429 South Wabash avenue, Chicago. Est., 1915.
GLOBE-WERNICKE CO. Executive offices and factory, Cincinnati, O. Est., 1882. Manufactures "Brown" disc record cabinets. Also manufactures sectional disc record cabinets, sectional book cases, sectional filing cabinets, wood and steel; Globe safes and steel shelving.
HERZOG ART FURNITURE CO. Executive offices and factory, Saginaw, West Side, Mich. Est., 1900. (Manufacturer.)
KANE MANUFACTURING CO. Executive offices and factory, Kane, Pa. Manufactures "Kane" instrument stands for table model machines.
GEO. A. LONG CABINET CO. Executive offices and factory, Hanover, Pa. Est., 1911. (Manufacturer.)
LUCKY 13 PHONOGRAPH CO. Executive offices, 3 East Twelfth street, New York City. Est., 1913. Markets cabinets.
C. J. LUNDSTROM MFG. CO. Executive offices and factory, Little Falls, N. Y. Est., 1900. (Manufacturer.)
K. NICHOLSON FURN. CO. Executive offices and factory, Chase City, Va. Est., 1911. (Manufacturer.)
OGDEN SECTIONAL CABINET CO. Executive offices, Lynchburg, Va.; factories, Lynchburg, Va., and Kankakee, Ill. (Manufacturer.)
FRANK P. READ. Executive offices, 27 South Fifth avenue, Chicago. Manufactures the "Automatic" record container. Est., 1917.
SALTER MFG. CO. Executive offices, 339 North Oakley boulevard, Chicago, Ill; factory, Chicago. Est., 1876. (Manufacturer.)
UDELL WORKS. Executive offices and factory, Indianapolis, Ind. Est., 1873. (Manufacturer.)
WONDER TALKING MACHINE CO. Executive offices, 105 East Twelfth street, New York City. (Manufacturer.)
BOOTHS AND FIXTURES
OGDEN SECTIONAL CABINET CO. Executive offices, Lynchburg, Va.; factories, Lynchburg, Va., and Kankakee, Ill. Manufactures sectional record filing cabinets.
SYRACUSE WIRE WORKS. Executive offices and factory, Syracuse, N. Y. Est., 1887. Manufactures metal filing record racks (disc and cylinder).
UNIT CONSTRUCTION CO. Executive offices and factory, 121 South Thirty-first street, Philadelphia, Pa. Est., 1915. Manufactures "Unico" demonstration booths, record racks, record counters and store interiors.
ARTHUR L. VAN VEEN & CO. Executive offices, Marbridge Bldg., New York City; factory, Eighth street, New York City. Est., 1908. Manufactures "Van Veen" demonstration booths and store fixtures and general interior decorations.

ACCESSORIES, ETC.

- AUTOMATIC CONTAINER CO., INC.** Executive offices, 303 Tacoma Building, Chicago; factories, Chicago and Buffalo. Manufactures "Automatic" filing cabinets for disc records, "Automatic" insert files and "Automatic" filing equipment for talking machine cabinets.
- BLACKMAN TALKING MACHINE CO.** Executive offices, 97 Chambers street, New York. Est., 1902. Manufactures "Cleanrite" record brushes.
- CHICAGO HINGED COVER SUPPORT & BALANCE CO.** Executive offices and factory, 2242-46 West Sixty-ninth street, Chicago. Est., 1915. Manufactures balanced cover supports.
- CORLEY CO., Inc.** Executive offices, 213 East Broad street and 206 East Grace street, Richmond, Va. Est., 1889. Manufactures traveling cases for Victrolas.
- DISK-LITE MFG. CO.** Executive offices, 2611 Adams Mill road, Washington, D. C. Manufactures "Disk-Lite" electric light for all makes of talking machines.
- FAVORITE PHONOGRAPH ACCESSORY CO.** Executive offices, 1491 DeKalb avenue, Brooklyn, N. Y. Markets main springs, mica diaphragms and needle cups.
- LEO FEIST, INC.** Offices, 235 W. Fortieth street, New York. Publishers "Feist" line of sheet music and books.
- OTTO HEINEMAN PHONOGRAPH SUPPLY CO., Inc.** Executive offices, 25 West Forty-fifth street, New York City; factories, Elyria, O., Putnam, Conn., and Newark, N. J. Est., 1915. Manufactures needle cups and tone arm rests.
- B. ILLFELDER & CO.** 29 Union Square, New York. Selling agents for authorized stuffed "Victor" dogs.
- JONES-MOTROLA, Inc.** Executive offices and factory, 29-33 West Thirty-fifth street, New York City. Est., 1915. Manufactures "Jones Motrola" electric winder, attachable to an electric lamp connection.
- KIRKMAN ENGINEERING CORP.** Executive offices and factory, 237 Lafayette street, New York City. Manufactures "Simplex" and "Standard" automatic stops, "Simplex" and "Standard" record cleaners.
- LYON & HEALY.** Executive offices, Chicago, Ill. Manufactures fibre needle cutters.
- NATIONAL TOY CO.** Executive offices and factory, 271 Congress street, Boston, Mass. Manufactures talking machine toys and novelties.
- PEABODY PIANO CO.** Executive offices, 216 West Saratoga street, Baltimore, Md. Markets the "Eject-o-file" record files for installation in any style or make of talking machine.
- RECORD-LITE CO., INC.** Executive offices, 133 Second street, Milwaukee. Manufacturers of fibre needle cutters and record lights for all makes of talking machines.
- WM. I. SCHWAB.** Executive offices, 120 North Main street, Providence, R. I. Manufactures "Dustoff" record cleaners.
- SHELTON ELECTRIC CO.** Executive offices, 30 East Forty-second street, New York City; factory, Ft. Wayne, Ind. Manufactures the "Shelton" electric motor, attachable to an electric lamp connection.
- SHERMAN, CLAY & CO.** Wholesale offices, 741 Mission street, San Francisco, Cal. Market ukuleles and Hawaiian sheet music books.
- SOUTHERN CALIFORNIA MUSIC CO.** Executive offices, 332 South Broadway, Los Angeles, Cal. Market the "Rolando" disc record file to set in talking machines.
- VESTA SALES CO.** Executive offices, 348 Southport avenue, Chicago, Ill. Manufacture the "Vesta" cover support.
- WADE & WADE.** Executive offices, 3807 Lake Park avenue, Chicago; factory, Chicago. Est., 1907. Manufactures fibre needle cutters, various screws and parts for different makes of machines.
- ILSLEY-DOUBLEDAY & CO., Inc.** Executive offices and factory, 229 Front street, New York City. Est., 1853. Manufactures "Ilsley's" graphite phono spring lubricant; "Eureka" noiseless talking machine lubricant, greases, lubricating oils and graphite.
- KEYSTONE MINERALS CO.** Executive offices, 329 Broadway, New York City; factory, Antefort, Pa. Est., 1908. Manufactures rotten stone.
- THE LOUISVILLE VENEER MILLS, INC.** Executive offices and factory, Louisville, Ky. Manufactures "built up" stock and veneers.
- LUCKY 13 PHONOGRAPH CO.** Executive offices, 3 East Twelfth street, New York City. Est., 1913. Markets cover supports, needle cups, continuous hinges and cabinet hardware.
- LYON & HEALY.** Executive offices, Chicago, Ill. Manufactures lubricants.
- MEYERCORD CO.** Executive offices, 133 West Washington street, Chicago; factory, Chicago. Est., 1894. Manufactures decalcomania name plates for manufacturers and dealers.
- WILLIAM F. NYE.** Executive offices and factory, New Bedford, Mass. Est., 1865. Manufactures oil.
- PHANTOM METER CO.** Executive offices and factory, Needham, Mass. Est., 1916. Manufactures instantaneous speed indicators or tuning timers for use with alternating current electric light.
- GEORGE A. SMITH-SCHIFFLIN CO.** Executive offices, 126 Liberty street, New York City. Est., 1912. Manufacturers of decalcomania transfer name plates, price marks, etc.
- WADE & WADE.** Executive offices, 3807 Lake Park avenue, Chicago. Est., 1907. Manufactures "Wadopolish" "Wadolatum," "Wado-oil" and a spring barrel lubricant.
- WEBER-KNAPP CO.** Executive offices and factory, Jamestown, N. Y. Est., 1900. Manufactures hardware, lid supports, needle cups, knobs, etc.

ATTACHMENTS

- COMBINATION ATTACHMENT CO.** Executive offices, 209 South State street, Chicago. Est., 1915. Manufactures "Orotund" sound reproducers, tone arms and attachments for all standard machines.
- DISK-LITE MFG. CO.** Executive offices, 2611 Adams Mill road, Washington, D. C. Manufactures "Disk-Lite" electric light for all makes of talking machines.
- DUO-TONE CO.** Executive offices, Ansonia, Conn. Est., 1917. Manufactures "Duo-Tone" needle attachment and "de Luxe" needles.
- EMPIRE PHONO PARTS CO.** Executive offices, 427 South Wabash avenue, Chicago, Ill.; factory, 1102 West Ninth street, Cleveland, O. Est., 1912. Makes attachments for Edison, Victor and Columbia machines.
- HOFFAY TALKING MACHINE CO., INC.** Executive offices, 3 West Twenty-ninth street, New York City. Est., 1915. Manufacturers of the Hoffay "Resurrectone" and "Half-Fork Tone" sound boxes.
- F. C. KENT & CO.** Executive offices and factory, 24 Scott street, Newark, N. J.
- NEW ENGLAND TALKING MACHINE CO.** Executive offices and factory, 16 Beach street, Boston, Mass. Est., 1913.
- RECORD-LITE CO., INC.** Executive offices, 133 Second street, Milwaukee. Manufacturers of fibre needle cutters and record lights for all makes of talking machines.
- RE-PLA-STOP CO.** Executive offices, Cincinnati, Ohio. Manufactures "Re-Pla-Stop" attachment for repeating records on all machines.
- THE UNION PHONOGRAPH SUPPLY CO.** Executive offices, 1100 West Ninth street, Cleveland, O.
- UNISET REPRODUCER CO.** Executive offices, Cable Building, Chicago, Ill. Manufacture "Uniset" reproducer for playing both lateral and vertical cut records.
- VICSONIA MANUFACTURING CO., Inc.** Executive offices and factory, 313 East 134th street, New York City. Manufactures "Vicsonia" reproducer.
- T. F. WALSH PHONOGRAPH SUPPLY CO.** Executive offices, 631 Euclid avenue, Cleveland, O. Manufacture attachments for playing lateral cut records on Edison and Pathé machines; also attachments for playing vertical cut records on Victor and Columbia machines.

SUPPLIES, ETC.

- CHICAGO HINGED COVER SUPPORT & BALANCE CO.** Executive offices, 144 South Wabash avenue, Chicago; factory, 2242 West Sixty-ninth street, Chicago. Est., 1915. Manufactures balanced cover supports.
- DISPLAY SERVICE CO.** Executive offices, 113 West Seventeenth street, New York City. Manufacturers of art window displays, hangers, etc.
- FAULTLESS CASTER CO.** Executive offices and factory, Evansville, Ind. Manufacturers of the "Faultless" pivot bearing caster for all kinds of talking machines.

NEEDLES, JEWELS, ETC.

- W. H. BAGSHAW.** Executive offices and factory, Lowell, Mass. Est., 1870. Manufactures steel needles.
- BLACKMAN TALKING MACHINE CO.** Executive offices, 97 Chambers street, New York. Manufactures "Playrite" and "Melotone" steel needles.

- B. & H. FIBRE MFG. CO.** Executive offices, 33 West Kinzie street, Chicago; factory, Chicago. Est., 1907. Manufactures fibre needles.
- BRILLIANTONE STEEL NEEDLE CO., INC.** Executive offices, Marbridge Building, New York. Manufactures "Brilliantone" steel needles.
- COMBINATION ATTACHMENT CO.** Executive offices, 209 South State street, Chicago; factory, Chicago, Ill. Est., 1915. Manufactures jewel points, sapphires and diamonds.
- DUO-TONE CO.** Executive offices, Ansonia, Conn. Est., 1917. Manufactures "Duo-Tone" needle attachment and "de Luxe" needles.
- EMPIRE PHONO PARTS CO.** Executive offices, 427 South Wabash avenue, Chicago, Ill.; factory, 1102 West Ninth street, Cleveland, O. Est., 1912. Manufactures Zephyr multi-playing needles.
- FAVORITE PHONOGRAPH ACCESSORY CO.** Executive offices, 1491 DeKalb avenue, Brooklyn, N. Y. Markets steel needles.
- FRED GRETSCHE MFG. CO.** Executive offices and factory, 58 Broadway, Brooklyn, N. Y. Manufactures "Violaphone" steel needles.
- OTTO HEINEMAN PHONOGRAPH SUPPLY CO., INC.** (Meisselbach Division.) Executive offices, 25 West Forty-fifth street, New York City; factory, Newark, N. J. Est., 1887. Manufactures sapphire and diamond point needles.
- OTTO HEINEMAN PHONOGRAPH SUPPLY CO., INC.** (Dean Division.) Executive offices, 25 West Forty-fifth street, New York City; factory Putnam, Conn. Est., 1899. Manufactures "Dean" steel needles.
- INDEPENDENT TALKING MACHINE CO., Inc.** Executive offices and factory, 54 Bleecker street, New York City. Est., 1913. Manufactures sapphire needles.
- LUCKY 13 PHONOGRAPH CO.** Executive offices, 3 East Twelfth street, New York City. Est., 1913. Markets steel and jewel needles.
- MERMOD & CO.** Executive offices, 505 Fifth avenue, New York City. Factory, Ste. Croix, Switzerland. Est., 1816. Manufactures sapphire and diamond needles.
- ONEIDA IMPORTING CO.** Executive offices, 47 East Ninth street. Markets steel needles.
- PROGRESSIVE PHONOGRAPHIC SUPPLY CO.** 145 West Forty-fifth street, New York. Sole distributors of "Wall Kane" needles.
- RECORD NEEDLE & MANUFACTURING CO.** Executive offices, Manhattan Building, Milwaukee, Wis.; factory, Milwaukee. Manufacture "Steelcraft" steel needles.
- RENE MFG. CO.** Montvale, N. J. Manufactures steel needles.
- SONORA PHONOGRAPH CORPORATION.** Executive offices, 57 Reade street, New York City. Manufactures the "Multi-playing" jewel needle.
- SUPERTONE NEEDLE WORKS.** Executive offices, 18 West Twentieth street, New York. Manufactures Supertone steel needles, multi-playing "magnedo" and "electro" needles, also jewel needles.
- VALLORRES JEWEL CO.** Executive offices and factory, Lancaster, Pa. Manufacture sapphire ball jewels, recording jewels and Vallorbes semi-permanent needles for playing lateral cut records.
- VICTOR TALKING MACHINE CO.** Executive offices and factory, Camden, N. J. Manufactures steel needles and Victor "Tungs-Tone Stylus" semi-permanent needles.
- CLIFFORD A. WOLF.** Executive offices, 65 Nassau street, New York City; factory, Brooklyn, N. Y. Est., 1911. Manufactures sapphire and diamond needles for recording and reproducing.

ALBUMS, ENVELOPES,

- AUGUR, SWYERS & MACHOLD.** Executive offices, 461 Eighth avenue, New York City. Manufactures fancy record boxes for Christmas, etc.

- CLEMENT BEECROFT.** Executive offices, 309 West Susquehanna avenue, Philadelphia. Est., 1911. Manufactures record envelopes and record holders.
- BOSTON BOOK CO., Inc.** Executive offices, 43 West Fourth street, New York. Est., 1911. Manufactures record albums.
- LEWIS C. FRANK.** Executive offices, 654 Book Building, Detroit, Mich. Markets record delivery envelopes, monthly supplement envelopes and corrugated sheets.
- J. L. GILLESPIE CO.** Executive offices, Pittsburgh, Pa. Manufactures record envelopes, stock record pockets, paper products.
- INDEXO PHONO RECORD FILE CO.** Executive offices and factory, 16 Wooster street, New York City. Manufactures "Indexo" record holders.
- NATIONAL PUBLISHING CO.** Executive offices, 239 South American street, Philadelphia; factory, Philadelphia. Est., 1863. Manufactures "National" record albums.
- NEW YORK ALBUM & CARD CO.** Executive offices and factory, 23 Lispenard street, New York City. Est., 1910. Manufactures "Nyacco" record albums.
- PLAZA MUSIC CO.** Executive offices, 18 West Twentieth street, New York. Manufactures record albums, stock and delivery envelopes.
- READY-FILE CO., Inc.** Executive offices, Castle Hall Bldg., Indianapolis, Ind. Manufactures record files.

MISCELLANEOUS

- WOODWARD CLINTON.** Mount Vernon, N. Y. Manager of concerts for several artists making talking machine records.
- KOHLER & CAMPBELL, INC.** Executive offices and factory, Eleventh avenue and Fifth street, New York. Manufactures "Kohler & Campbell" line pianos and player-pianos.
- JOS. MUSANTE.** Executive offices, 68 Center street, New York. Electroplating of tone arms, etc.
- PHONOGRAPH CLEARING HOUSE, INC.** Executive offices, 51 East Forty-second street, New York. Markets cabinets, motors, accessories, needles and machines.
- TALKING MACHINE REPAIR & SALES CORPORATION.** Executive offices, 176 Sixth avenue, New York City. Est., 1916.
- H. A. WEYMANN & SON.** Executive offices, Chestnut street, Philadelphia. Manufactures "Keystone State" strings for stringed instruments.

LONDON MARKETS

- GRAMOPHONE CO., Ltd.** Manufactures "Victor" and "Victor Victrola" machines and Victor line of records and have branches and agencies through Denmark, France, Spain, Sweden, Russia, India, Australasia, New Zealand, South Africa, East Africa, Holland, Italy, Egypt and England.
- J. E. HOUGH, Ltd. (EDISON BELL WORKS).** Executive offices, Gleggall Road, Peckham, London. Manufacture "velvet-face" (V. F.) records, ten-twelve-inch, lateral cut, retail price two-six to four shillings.
- LEVETUS & CO.** Executive offices, 6194 Bishops Gate, London, E. C. 2, England. Market needles.
- THE INVICTA RECORD COMPANY, Ltd.** Executive offices, No. 1 New Inn Yard, London, E. C. Manufactures "Invicta" line of records.
- REX GRAMOPHONE CO.** Executive offices, 2 Elizabeth place, Rivington street, London, E. C. 2, England. Manufacture horn, hornless and portable talking machines.
- W. H. REYNOLDS, Ltd.** Executive offices, 45 City Road, London, E. C. Est., 1915. Manufactures "Reyno Carbo" main-springs and talking machine parts. Also markets records.
- SOUND RECORDING CO., LTD.** 18 Swallow street, Piccadilly, London.
- J. STEAD & COMPANY, Ltd.** Executive offices, Sheffield, England. Manufactures talking machine springs.
- LOUIS YOUNG & CO.** Executive offices, 54 City Road, London, E. C., England. Market gramophones all types. Also motors, tone arms, sound boxes, needles, etc.

We would greatly appreciate it if our advertisers and subscribers will advise us promptly regarding any errors which they may notice in this directory.

When writing please say you
saw it in the

TALKING MACHINE WORLD
TRADE DIRECTORY

Some of the Leading Jobbers of Talking Machines in America

1856 **WURLITZER** 1916

VICTOR
DISTRIBUTORS
VICTORS EXCLUSIVELY

*We make a specialty of getting the order
out on time—every time.*

The Rudolph Wurlitzer Co.
CINCINNATI AND CHICAGO

Two points of supply; order from the nearer

TEST IT. 

OUR VICTOR

Record Service

has a reputation for efficiency.
Suppose you try it.

E. F. DROOP & SONS CO.
1300 G. STREET, WASHINGTON, D. C.
231 N. HOWARD STREET, BALTIMORE, MD

Smith, Kline & French Co.
PHILADELPHIA

Wholesale Distributors for

THE INSTRUMENT OF QUALITY

Sonora 

CLEAR AS A BELL

In PENNSYLVANIA, NEW JERSEY
and DELAWARE

W. J. DYER & BRO.
NORTHWESTERN DISTRIBUTORS
OF THE

VICTOR
Machines, Records and Supplies



Shipped Promptly to all
Points in the Northwest

**THIS REFERS TO YOU,
MR. DEALER**

Every talking machine jobber in
this country should be represented
in this department, no matter what
line he handles or where he is lo-
cated. The cost is slight and the
advantage is great. Be sure to have
your card in this department of
The Talking Machine World
each month. It will pay you a big
profit on the investment.



Where Dealers May Secure

COLUMBIA

Product

Ready, Full Stocks, and Prompt Deliveries
from Convenient Shipping Centers
all over the United States.

Distributors

Atlanta, Ga., Columbia Graphophone Co., 63 N.
Pryor St.
Baltimore, Md., Columbia Graphophone Co., 111
West German St.
Boston, Columbia Graphophone Co., 137 Federal
St.
Buffalo, N. Y., Columbia Graphophone Co., 622
Main St.
Chicago, Ill., Columbia Graphophone Co., 14 N.
Michigan Ave.
Cincinnati, O., Columbia Graphophone Co., 117-
119 W. Fourth Ave.
Cleveland, O., Columbia Graphophone Co., 1376
Euclid Ave.
Dallas, Tex., Columbia Graphophone Co., 1011
Elm St.
Denver, Colo., Columbia Stores Co., 1608 Glen-
arm Place.
Detroit, Mich., Columbia Graphophone Co., 401
Woodward Ave.
Indianapolis, Ind., Columbia Graphophone Co.,
44 N. Pennsylvania St.
Kansas City, Mo., Columbia Graphophone Co.,
1027 McGee St.
Los Angeles, Cal., Columbia Graphophone Co.,
745 S. Broadway.
Minneapolis, Minn., Columbia Graphophone Co.,
412-414 Nicollet Ave.
New Haven, Conn., Columbia Graphophone Co.,
206 Meadow St.
New Orleans, La., Columbia Graphophone Co.,
517-525 Canal St.
New York City, Columbia Graphophone Co., 55
Warren St.
Omaha, Neb., Schmoller & Mueller Plauo Co.
Philadelphia, Pa., Columbia Graphophone Co.,
210 N. Broad St.
Pittsburgh, Columbia Graphophone Co., 101
Sixth St.
Portland, Me., Columbia Graphophone Co., 43
Exchange St.
Portland, Ore., Columbia Graphophone Co., 429-
431 Washington St.
Salt Lake City, Utah, Columbia Stores Co.,
221 South West Temple.
San Francisco, Cal., Columbia Graphophone Co.,
334 Sutter St.
Seattle, Wash., Columbia Graphophone Co., 911
Western Ave.
Spokane, Wash., Columbia Stores Co., 818
Sprague Ave.
St. Louis, Mo., Columbia Graphophone Co., 1127
Pine St.
Tampa, Fla., Tampa Hardware Co.

DEALERS WANTED—Exclusive selling rights
given where we are not actively represented.

Write for particulars to the Columbia Graphophone
Co., Wholesale Department, Woolworth Building
New York.

Headquarters for Canada:
Columbia Graphophone Co., 363-5-7 Borauren Ave
Toronto, Ont.

STANDARD SERVICE
EXCLUSIVELY VICTOR WHOLESALE ONLY

STANDARD TALKING MACHINE CO.
PITTSBURGH

Victor Exclusively
EASTERN TALKING MACHINE CO.
177 Tremont Street, Boston
VICTOR DISTRIBUTORS



Sherman, Clay & Co.

San Francisco, Los Angeles, Portland, Seattle, Spokane
PACIFIC COAST DISTRIBUTORS OF
VICTOR PRODUCTS

The Electric Supply & Equipment Co.

Exclusive Wholesale Distributors for
Southern New England

THE INSTRUMENT OF QUALITY

Sonora 

CLEAR AS A BELL

Complete stocks carried in Boston and Hartford

Little Bldg. 103 Allyn St.
BOSTON, MASS. HARTFORD, CONN.

The PERRY B. WHITSIT CO.
Distributors of
Victrolas and Victor Records
COLUMBUS, OHIO

Southern Victor Dealers
Largest Stock VICTROLAS and RECORDS.
Prompt Shipment and Low Freight Rates.
WALTER D. MOSES & CO.
Oldest Music House in Virginia or North Carolina.
RICHMOND, VA.

**OLIVER
DITSON
COMPANY**

Largest VICTOR Talking
Machine Distributors East of
Chicago.

Creators of "The Fastest Victor
Service." Let us tell you more
about our service.

BOSTON



The New Edison

Official Laboratory
Model—William and
Mary Cabinet
Developed in Walnut.

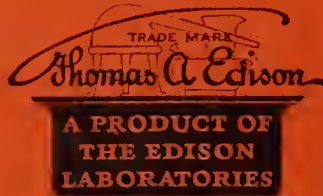

JOBBER'S OF THE NEW EDISON, EDISON RE-CREATIONS,
THE NEW EDISON DIAMOND AMBEROLA AND BLUE AMBEROL RECORDS

CALIFORNIA
Los Angeles—Diamond Disc Distributing Co.
San Francisco—Edison Phonographs, Ltd.
COLORADO
Denver—Denver Dry Goods Co.
CONNECTICUT
New Haven—Pardee-Ellenberger Co., Inc.
GEORGIA
Atlanta—Phonographs Inc.
ILLINOIS
Chicago—The Phonograph Co.
James I. Lyons. (Amberola only.)
INDIANA
Indianapolis—Kipp Phonograph Co.
IOWA
Des Moines—Harger & Blish.
Sioux City—Harger & Blish.

LOUISIANA
New Orleans—Diamond Music Co., Inc.
MASSACHUSETTS
Boston—Pardee-Ellenberger Co.
MICHIGAN
Detroit—Phonograph Co., of Detroit
MINNESOTA
Minneapolis—Laurence H. Lucker.
MISSOURI
Kansas City—The Phonograph Co. of Kansas City.
St. Louis—Silverstone Music Co.
MONTANA
Helena—Montana Phonograph Co.
NEBRASKA
Omaha—Shultz Bros.
NEW JERSEY
Paterson—James K. O'Dea (Amberola only.)
NEW YORK
Albany—American Phonograph Co.

New York—The Phonograph Corp. of Manhattan.
Syracuse—Frank E. Bolway & Son, Inc.
W. D. Andrews Co. (Amberola only.)
Buffalo—W. D. & C. N. Andrews Co. (Amberola only.)
OHIO
Cincinnati—The Phonograph Co.
Cleveland—The Phonograph Co.
OREGON
Portland—Edison Phonographs, Ltd.
PENNSYLVANIA
Philadelphia—Girard Phonograph Co.
Pittsburgh—Buehn Phonograph Co.
Williamsport—W. A. Myers.
RHODE ISLAND
Providence—J. A. Foster Co. (Amberola only.)
TEXAS
Dallas—Texas-Oklahoma Phonograph Co.

El Paso—El Paso Phonograph Co., Inc.
UTAH
Ogden—Proudfit Sporting Goods Co.
VIRGINIA
Richmond—C. B. Haynes & Co.
WISCONSIN
Milwaukee—The Phonograph Co. of Milwaukee.
CANADA
Montreal—R. S. Williams & Sons Co., Ltd.
St. John—W. H. Thorne & Co., Ltd.
Toronto—R. S. Williams & Sons Co., Ltd.
Vancouver—Kent Piano Co., Ltd.
Winnipeg—R. S. Williams & Sons Co., Ltd.
Calgary—R. S. Williams & Sons Co., Ltd.

The TALKING MACHINE WORLD

For the
makers &
sellers of
talking
machines

Published Each Month by Edward Lyman Bill, Inc., at 373 Fourth Ave., New York, April 15, 1918



The best-known trade mark in the world

“The Victor talking machine’s design, ‘His Master’s Voice,’ has become a household word, and the quaint little fox terrier at attention before the horn is familiar to more Americans than any of the world’s great masterpieces”—*Collier’s Weekly*.

The Highest Class Talking
Machine in the World

THE INSTRUMENT OF QUALITY
Sonora
CLEAR AS A BELL



THE PRIDE OF POSSESSION

of the owner of a SONORA is one of the reasons for SONORA'S popularity today. Sonora is and has always been recognized as the *quality* instrument. Its makers have done their utmost in helping place the industry on a higher plane.

TODAY phonographs are handled by the most exclusive dealers and appeal to the critical connoisseurs of music. This applies especially to the Sonora which won the highest score for tone at the Panama Pacific Exposition.



POSSESSING many important, exclusive, valuable features and playing all makes of disc records with unequalled beauty, the Sonora is extremely popular. It is well known, well advertised and easily sold.

A Portable in keeping with Sonora quality

The Sonora Portable weighs 15 lbs. complete! It is the most highly developed of all portable instruments and plays all makes of disc records perfectly.

The Sonora Portable possesses to a marked degree the richness and fullness of tone which have made Sonora famous, and it is just the thing for automobilist, vacationist,

soldier, and all who want a light, high grade phonograph. Size 10 $\frac{3}{4}$ x 10 $\frac{3}{4}$ x 10 $\frac{1}{2}$. Double spring motor, polished cowhide leather-lined case.

Write today for an agency in your territory.

\$50	\$55	\$60	\$90	\$115	\$150	\$180
\$200	\$215	\$300	\$375	\$500	\$1000	

Art models made to special order to suit any taste.

Sonora Phonograph Sales Company, Inc.

GEORGE E. BRIGHTSON, President

Executive Offices: 279 Broadway, NEW YORK

Sonora operates and is licensed under BASIC PATENTS of the phonograph industry

The Talking Machine World

Vol. 14. No. 4

New York, April 15, 1918

Price Twenty Cents

SELLS IDEAS AS WELL AS GOODS

The Real Salesman Finds It Difficult to Sell Successfully Anything in Which He Doesn't Believe—The Influence of Quality Products

Many writers who have made a thorough study of the principles of salesmanship have stated that a salesman sells, not goods, but rather his ideas about goods. This statement contains much of truth, and consequently it is a difficult task for a man to sell successfully anything in which he doesn't believe. For this reason many salesmen often refuse to sell inferior products which look good but which possess no solid merit, not merely because of any ethical issue involved, but rather because they fear the effect upon their own sales ability. Articles which sell upon a quality basis rather than a price appeal are as a rule represented by abler salesmen.

There is a reason for this, a reason which applies to the selling of talking machines as well as to the selling of any other line of merchandise. Able, conscientious workmanship in a talking machine inspires support and admiration. This is reflected in the salesman's canvass. The cheaper instrument almost always lacks this element. As a result, even though a competent salesman is selling the line, he cannot put into his sales the same amount of ginger that would otherwise be at his command. His "ideas about the goods" are not of a sort to awaken his enthusiasm.

The customer himself is also unconsciously affected by a quality product. The salesman may sincerely believe that he is selling talking machines merely for the money there is in it, but at the same time he does take a certain artist's pride in handling a first-class line of goods. Then, too, there is much more to be said in favor of goods of quality than for those manufactured with nothing but the price element in view. Quality products offer the salesman opportunities for a much more interesting, much more convincing selling canvass.

Every salesman should endeavor to sell as good a line, within reasonable limits, as is possible. In the long run it will pay better. The very fact that he is handling instruments and records of reputable standing and real intrinsic worth will tend to develop his selling ability, which in turn is the quality through which, in the final analysis, he must score a permanent success in his chosen field.

FIX NEW TERMS ON VICTROLAS

Famous & Barr Co. Advertise New Instalment Schedule for Benefit of Public

ST. LOUIS, Mo., April 8.—The Famous & Barr Co. have been advertising these terms on Victor machines since March 1. The difference in proportion of the prices is, it is explained, to protect somewhat the numbers that are hard to obtain:

TERMS ON VICTROLAS Beginning March 1, 1918

Style IV or IV-A (\$15 or \$20)	\$5	cash, \$5 per month
Style IV or VI-A (\$25 or \$30)	\$5	cash, \$5 per month
Style VIII..... (\$45)	\$5	cash, \$5 per month
Style IX or IXA (\$50 or \$57.50)	\$6	cash, \$5 per month
Style X or X-A.. (\$75 or \$85)	\$10	cash, \$6 per month
Style XI or XI-A (\$100 or \$110)	\$12.50	cash, \$7 per month
Style XIV..... (\$165)	\$15	cash, \$10 per month
Style XVI..... (\$215)	\$20	cash, \$10 per month
Style XVII..... (\$265)	\$25	cash, \$12 per month

The amount in records never to exceed the first payment of cash.

Just what has become of the former Talking Machine Dealers' Association does not appear to be definitely known, but those who were active say that if terms should drop too low again, a meeting will be called. Under the present scarcity of machines, conditions have been very good. The above terms are generally observed by all Victor dealers. Interest is charged on deferred payments.

NEW MULTIPLE DISC MACHINE

Max Krauss, of Philadelphia, Patents a New Talking Machine Designed to Play a Large Number of Records Automatically—Some Interesting Features of the New Invention

PHILADELPHIA, PA., April 2.—Patents for a new multiple disc talking machine have been granted to Max Krauss, of 233 North Alden street, this city. It is designed to play, automatically, a number of disc records in succession or separately if desired. The record need not be shifted after its termination nor turned over to play the second side.

The entire absence of a turntable is noted in this new machine. Twelve records are attached in a vertical position to a horizontal driving axis. The shifting of a small lever from slot to slot places the desired record in playing position. A semi-permanent needle obviates the necessity of frequent needle changes and an automatic stop, also the invention of Mr. Krauss, insures the proper stopping of the record at its termination. It is planned to furnish additional driving axis on which a large stock of records may be kept in a position that they may be easily placed in the machine.

Mr. Krauss is an experienced talking machine mechanic, and familiar with the trade. The first working model of the multiple disc machine, twenty-two inches wide by twenty-four inches deep by forty-eight inches high has already been produced, and Mr. Krauss is proudly showing the product of his brains to all comers. He intends to sell his patent outright or release it on a royalty basis.

HAD A \$3,000 RECORD LIBRARY

Registrar of Rutgers College, Who Died Recently, Left Unusually Valuable Collection of Records of the Higher Class of Music

NEW BRUNSWICK, N. J., April 3.—It is reported that Irving S. Upson, registrar at Rutgers College here, who died recently, left a collection of Red Seal records estimated to be worth \$3,000. The records had been handled very carefully and many of them were as new as could be found in the stock of the average dealer. A peculiar feature was that, although Prof. Upson had several thousand dollars' worth of the finest records in his library, he used for reproducing them a Victor V machine. It is believed that Prof. Upson held the record for the value of a private collection of talking machine records.

TALKER NEEDLES IN GRENADES

According to an American surgeon who is home on furlough, having spent some time in the French army hospitals on the Western front, the Germans at times use some peculiar materials for filling their grenades and trench bombs. He cites one case where a poilu was badly wounded in the arm by a trench bomb. Investigation at the hospital showed that his arm was full of steel talking machine needles with which the bomb had been filled. Just why the needles had been used was not learned, but as the surgeon expressed it, "The Boches must have thought it took a lot of needles to play a French record, judging from the number we took out of the poor soldier."

War Lecture Concerts Emphasize Patriotism and Business

From time to time the talking machine dealers throughout the country give concerts to specially invited guests. These entertainments are given either in the concert hall, with which so many retail establishments are now equipped, or in the store proper. The idea is herewith advanced to put into these highly commendable affairs a war-time note in the form of a short war talk by a man who has been "over there." The present store concerts, which many talking machine merchants are employing as a means of gaining local business and popularity, are a decided success. This being so it will follow that a program including a war speaker will be doubly attractive from the viewpoint of the public.

The war speakers can deliver "close-up" impressions of the great war along the line which has brought Arthur Guy Empey into national prominence. But good speakers, men whose experiences have been every bit as violent as Empey's, can be secured at a very nominal sum. There are a number of booking agencies which, at the present time, are offering speakers at a very moderate fee. As the influx of war veterans continues to grow no doubt speakers may be obtained at still more economical figures. The talk itself need not include any appeal for money for any of the various war charities but can be a newsy discourse about conditions and events on the battle front that will hold and interest the audience.

Any merchant who puts on a program like this is bound to win attention throughout his city and to earn an easy entrance to the news columns of the local papers. Surely no one can doubt but that the United States Government will be highly pleased to see the talking machine industry making it finally possible for

many heroes of the war to convey their stirring messages to the American people. In fact, the nation can feel justly proud of an industry that is striving to inspire the war spirit that will spell victory for the Allied Cause and worldwide safety for democracy.

But aside from the patriotic standpoint a war lecture feature is calculated to do wonders for any retail institution. From an advertising standpoint it can't be beaten, because it is 100 per cent. timely and 100 per cent. full of gripping human interest. The dealer will have a powerful attention stimulant for his newspaper advertising and some real live news for the newspapers besides. He will have the opportunity to definitely identify his establishment as up-to-the-minute in patriotism, and his house will win the resultant favor that is bound to go with such a reputation. Furthermore, he will have an ideal opportunity to introduce selections on the talking machine, on the player-piano and by human musical artists as a very logical part of the program. In fact, he will be showing his wares to the audience, even while rounding out the program in the way that would be duly fitting no matter where the war talk might be given or no matter under what auspices. And at one and the same time he will be demonstrating the close relationship that exists between war and music.

On the whole the war lecture concert idea seems to be one that will materially increase the talking machine industry's contribution toward winning the war, that will provide an income for many of the brave fellows who have done their "bit" on the firing line, and that will do both of these things at a minimum expense and a maximum benefit to the talking machine dealer.

Making the Instalment Sale a Lengthened Opportunity for Cultivating and Holding Trade

"Instalment business is worth more to me than the actual sales it represents," remarked a wide-awake talking machine dealer to *The World* man recently. "Every instalment contract that I accept is scrutinized for possibilities of record business after the account is paid. There are quite a number of these customers who have very little money to spend on records while they are meeting their instalments, but when the payments are completed they could go on paying at the same rate for records. Of course, there are people who can buy all the records they want while paying for their outfits, but these are not the people I refer to just now. My staff has very definite instructions regarding these instalment customers, and acting towards them in a manner that will retain their good will and keep them coming after their obligations have been completed. The cost of getting people to the store is considerable, and it takes a lot of thinking, then why not make the very most of such an asset as regular weekly or monthly visitors?"

"When a customer comes in here to pay an instalment he is made to feel that we are still interested in him. We ask about his machine, how the children like it, if he has heard such-and-such a record, etc., and we make him feel that he can have a record played without being urged to buy it, or to feel that we are disappointed if he doesn't buy it. So many people become resentful while still on your books if

in any sense the attitude of the store or its staff is one of the non-interest. We aim to keep people from thinking we are only interested in their payments and through with them as soon as they are through. Many of our sales have been made to persons whose names were given us by instalment customers.

There are various kinds of service, but service to my mind should have thought of the future. For example, while I may not be here

*"With Every Sale
Must Go the Spirit
of Service, Even
After the Goods
Are Paid For"*

a year from now, I expect to be doing business here for the next forty years. In that case wouldn't I be foolish to ignore the children, even from a cold, unsentimental business point of view? These boys and girls are men and

women before you know it. They are mighty susceptible to being noticed and treated courteously. They don't forget, and other things being equal, when they commence making purchases on their own account the man who respected their childhood personalities will get the preference.

"Nearly a year ago an elderly gentleman came in here and bought a high-priced outfit. I had not seen him before, and wondered why he came. Since then I have become acquainted with him and learned that he came to reside with a married son, whose youngsters had some reason or other to feel kindly toward my establishment. The old gentleman said the children were responsible for his coming to the store. I could tell you quite a lot about the results from this kind of service."

"One thing to be remembered, however, is that with any kind of sale should go the spirit of service, service that will continue even after the goods are paid for. Every sale means a fresh opportunity to make friends for the store, friends that may develop into customers later. The instalment sale means a lengthened opportunity for making and cultivating new friends for business inasmuch as business relations continue over several months or years as the case may be. These opportunities should not be lost, therefore, through lack of interest or careless neglect. They represent the most valuable assets of business."

ELABORATING THE TALKER CABINET

Some Views of Interest From the Standpoint of the Veneer Specialist

The increasing desire of manufacturers of talking machines to get away from the ordinary, or commonplace, in designing their instruments, is the subject of general commendation among not only the members of the general trade and the purchasing public, but in the woodworking trades they are following these developments with exceeding interest, and it has been the subject of considerable notice. For instance, that bright and always interesting publication, *Veneers*, in a recent issue says:

"The idea of elaborating the talking machine cabinet has been with us for some time. Perhaps it made its appearance upon the scene a little too early and that held it in check a while. Anyway, while some of the first ideas of this kind were elaborate enough to be satisfactory to the artistic instinct they did not at first prove very satisfactory as a business proposition."

"Perhaps it was mainly because the talking machine itself was something of a novelty in

its new role as a dispenser of music and this novelty had to wear off before the public would give thoughtful attention to artistic departures in cabinet design, especially if those departures involved the outlay of materially increased sums of money. There were first the plain box-like cabinets, then a steady enlarging of the artistic idea in connection with these until some have elaborately-faced box cabinets, offered at somewhat increased prices.

"These are still popular, but notwithstanding this, other ideas are making their way now in a manner suggestive of possibilities that may assume magnitude in the near future. Plainly, too, manufacturers are casting about for patterns and ideas which will offer novelty of design as well as elaboration. Some have followed what we might term natural ideas associated with music, that of patterning after pianos; some have turned toward the idea of embodying the designs of familiar articles of furniture into the case of talking machines, and perhaps eventually we will settle down to a series of recognized design aside from those, or rather in addition to those of the regulation cabinet."

"The interesting thing about it to the veneer

manufacturer is to follow the tendency and see what it may mean in the way of new departures or new requirements for veneer and built-up work used in connection with these machines."

PUSHING "FIRST AID" FRENCH

Victor dealers generally, and particularly those located in the vicinity of military encampments, report an unusually strong demand for the Victor "First Aid Course in French," all contained in three records and a text book. The recent booklet issued by the Victor Co. on "How to Demonstrate the First Aid Course in French" has been put to excellent advantage by salesmen generally, enabling them to meet intelligently questions that would ordinarily tax their ingenuity.

NEW QUARTERS IN DAYTON, O.

The Superior Phonograph Co., which handles a complete line of Superior phonographs, as well as the Steger line of pianos and player-pianos, are now settled in attractive quarters in the new Mercantile Building on South Ludlow street, near Fourth, Dayton, O.

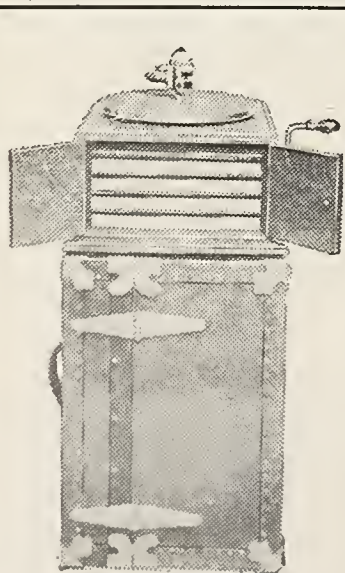

Corley Fibre Victrola Trunks Are Making Dollars for Dealers Everywhere

The ideal gift for the Military Camp here or abroad. Also in much demand for the bungalow or vacation trips. A big sales help for the smaller Victrolas.

STYLE IV NET, \$7.50
STYLE VI NET, \$8.45

*We have applied for patents for Fibre
Victrola Trunks—they are made to last.*

The Corley Company,

ORIGINATORS OF FIBRE VICTROLA TRUNKS

213 EAST BROAD STREET

RICHMOND, VA.



THE PULLING TEST—THE STRENGTH IS THERE

THE STRONGEST ALBUM MADE AT ANYWHERE NEAR ITS LOW PRICE

The Well-Known "National"
Record Albums
Are Always the Leaders

Our Nos. 2110 for
10-inch Records
and 2112 for 12-
inch Records

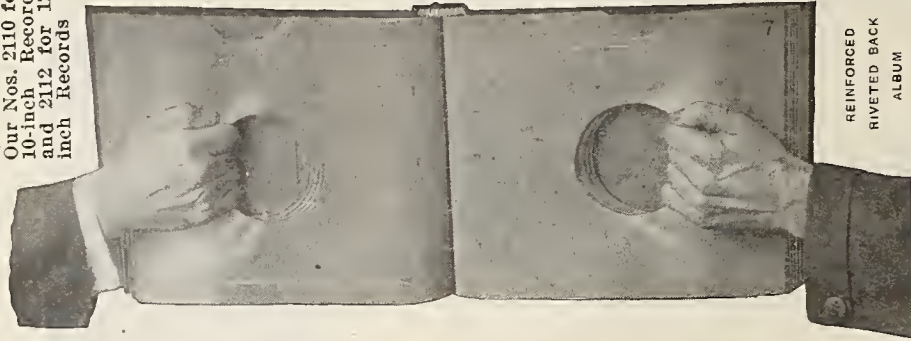

For Durability, Finish and
Artistic Design
Our Albums Have No Equal

The only Safe and Conveni-
ent Way to
Protect Disc Records

They are made in the most
substantial man-
ner by skilled workmen

STRENGTH AT THE STRESS AND STRAIN POINT PRACTICALLY UNBREAKABLE FOR REGULAR USAGE

We manufacture disc Record Albums containing 12 pockets to fit cabinets of all sizes and styles. We also make Albums containing 17 pockets. With the indexes they are a complete system for filing all disc Records.

THESE ALBUMS ARE THE BEST FOR VICTOR, COLUMBIA, EDISON, PATHE AND ALL OTHER DISC RECORDS

CORRESPONDENCE SOLICITED
WRITE FOR PRICES

NATIONAL PUBLISHING CO., 239 S. American St., PHILADELPHIA, PA.

HONOR ST. PATRICK IN CLEVELAND

Collister & Sayle Co. Arrange a Most Attractive Window Display for Erin's Saint

CLEVELAND, O., April 2.—One of the really effective window displays in honor of St. Patrick in this city was that at the store of the Collister & Sayle Co., Victor dealers, 252 Su-



An Attractive St. Patrick Day Window

perior avenue, and which is shown herewith. Shamrocks, green ribbon, Irish flags and records of Irish songs predominated in the display.

The floor of the window was covered with large squares alternately green and white. On each green square was placed an appropriate record, and the white squares were set off with a shamrock in each corner. In the center of the display was a large harp, backed by an Irish flag, kept waving by an electric fan. To carry out the scheme even the Victor dogs in the window were decorated with green ribbons about their necks.

According to the manager of the store a record was kept playing for ten minutes, in which time 574 people passed the store, 185 "rubbered" and forty-two stopped. It was not learned how many of those who stopped were Irish.

ATLANTA CONTINUES TO BE A VERY BUSY TRADE CENTER

Some Dealers Getting Machines in by Express—Pathé Line in Haverty Chain of Stores—Jascha Heifetz a Big Attraction—Out-of-Town Business Unusually Good—Prosperity Prevails

ATLANTA, GA., April 8.—Trade conditions in this city are most satisfactory in every respect, and the prospects could hardly be better. A recent visitor to the wholesale department of the Columbia Graphophone Co. was George W. Hopkins, general sales manager, who expressed himself most appreciatively regarding the progress of the local branch during the past twelve months. Manager Terhune accompanied him on a call on the Columbia local dealers, and this visit was productive of excellent results in the exchange of ideas and new friendships.

A happy incident during Mr. Hopkins' visit was the distribution of bonus checks to Columbia employes.

I. M. and R. D. Bame, Victor and Sonora dealers, say that they have been receiving express shipments from the Sonora Phonograph Corp., so active and insistent has been the demand for Sonora goods, from \$100 up. It speaks well for the enterprise of the Atlanta dealer, and for the Sonora Co., that they are willing to stand the expense and effort to haul their stock by express the nine hundred miles from New York to Atlanta in order that their customers might not be disappointed.

The Haverty Furniture Co., having recently installed the Pathé line in all their furniture stores, from Charleston, S. C., through Georgia, Alabama and Tennessee to Texas, found it necessary to have some one from the Pathé Frères Co. visit them to explain the details of operation of the Pathé, and incidentally to be present at their Pathé opening and "boost" sales. J. F. Collins, sales manager, accordingly made the trip to Atlanta, which city was used as a base point to radiate to the other cities in the Haverty chain of stores.

With his co-operation and assistance the sale of Pathé goods was most successful, the Atlanta store being sold out on the \$50, \$75 and \$100 models in two days after the opening, and additional large orders were placed at once.

Jascha Heifetz, Victor artist, was recently in the city, and entertained a large and cultured audience at the local auditorium.

The Cincinnati Symphony Orchestra, which organization makes records for the Columbia Co., gave a concert on March 26 in the city, and every one who heard them was delighted with their performance.

The Edison line is still selling well locally. The increase in prices, which took place January 1, seems not to have caused any cessation in the demand, nor to form any impediment in closing a sale.

All local Victor dealers are doing a most satisfactory business, and the demand for Victor goods exceeds the supply. The average purchaser who formerly bought a 75-cent record occasionally, now buys \$5 worth, and more frequently than formerly.

It has gotten to be quite usual for a customer from out-of-town to drop in one of the talking machine stores here, and buy a \$160, \$215 or higher-priced instrument, and a substantial selection of records, pay cash in full and have the goods shipped by express to his home town. This kind of business can be traced directly to the high price of cotton, and the large amount of money in circulation. The South, as a section, has more money than in fifty years, and the eyes of the nation are turned this way, both as a land of commercial opportunity, and as a place to buy animal products and foodstuffs.

Let NYACCO Solve Your Record Album Problem



With These Two Dependable Albums

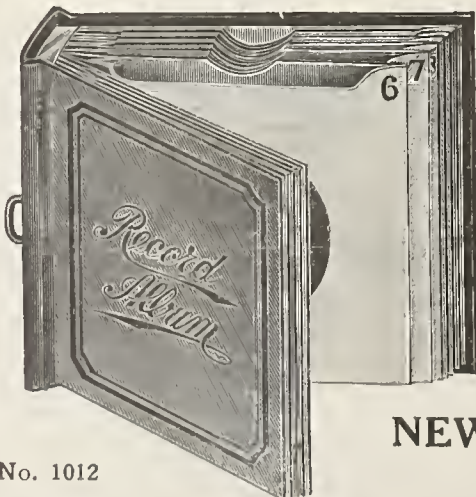

No. 1012

Our No. 1012 (see illustration) is the strongest album obtainable to retail at a moderate price. Has heavy green envelopes, interlocked so that each envelope forms an individual container. Both ends are finished with brass metal tops.

The NYACCO Metal Back Quality Album (the only genuine metal back album being manufactured) has a binding which consists entirely of one piece of metal, and envelopes of heavy fibre green paper, re-enforced with strips of flexible canvas; the result being a practically indestructible album.

Let us quote you prices on these albums

NEW YORK ALBUM & CARD CO., Inc.
23-25 Lispenard Street, New York



NYACCO Metal
Back Album
Absolutely
Guaranteed

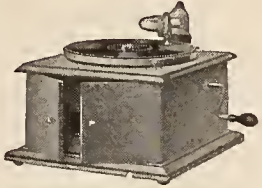

Victrola IV-A, \$20
Oak

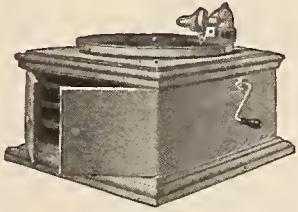

Victrola VI-A, \$30
Oak



Victrola VIII-A, \$45
Oak



Victrola IX-A, \$57.50
Mahogany or oak

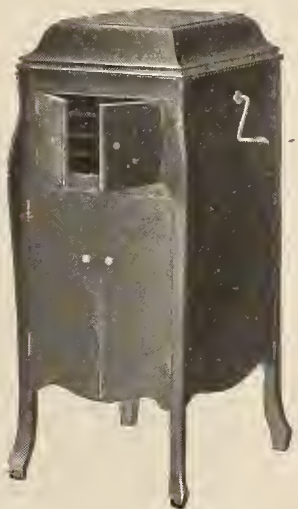

Victrola X-A, \$85
Mahogany or oak



Victrola XI-A, \$110
Mahogany or oak

Victor Supremacy

The universal recognition of Victor supremacy is one of the greatest assets of every Victor retailer.

With genuine Victrolas from \$20 to \$400 Victor retailers can satisfy every demand, and the volume of business is limited only by the individual efforts of each retailer.

Victor Talking Machine Co.
Camden, N. J., U. S. A.

Berliner Gramophone Co., Montreal, Canadian Wholesalers



Victrola XIV, \$165
Mahogany or oak



Victrola XVI, \$215
Victrola XVI, electric, \$270
Mahogany or oak



Victrola XVII, \$265
Victrola XVII, electric, \$325
Mahogany or oak

"Victrola" is the Registered Trade-mark of the Victor Talking Machine Company designating the products of this Company only.

Warning: The use of the word Victrola upon or in the promotion or sale of any other Talking Machine or Phonograph products is misleading and illegal

Important Notice. Victor Records and Victor Machines are scientifically co-ordinated and synchronized in the processes of manufacture, and their use, one with the other, is absolutely essential to a perfect reproduction.



The **TALKING**
For the makers & sellers of talking machines **MACHINE**
WORLD

PUBLISHED BY EDWARD LYMAN BILL, Inc.

President, C. L. Bill, 373 Fourth Ave., New York; Vice-President, J. B. Spillane, 373 Fourth Ave., New York; Second Vice-President, J. Raymond Bill, 373 Fourth Ave., New York; Secretary and Treasurer, August J. Timpe, 373 Fourth Ave., New York.

J. B. SPILLANE, Editor

J. RAYMOND BILL, Associate Editor

AUGUST J. TIMPE, Business Manager

Trade Representatives: B. BRITAIN WILSON, L. M. ROBINSON, WILSON D. BUSH, C. CHACE, E. B. MUNCH, L. E. BOWERS, A. J. NICKLIN, V. D. WALSH

Boston: JOHN H. WILSON, 324 Washington Street

Chicago Office: E. P. VAN HARLINGEN, Republic Building, 209 South State Street. Telephone, Wabash 5774

London, Eng., Office: 2 Gresham Buildings, Basinghall St. W. LIONEL STURDY, Mgr. The Talking Machine World has regular correspondents located in all of the principal cities throughout America.

Published the 15th of every month at 373 Fourth Ave., New York.

SUBSCRIPTION (including postage): United States, Mexico, \$1.00 per Year; Canada, \$1.25; all other countries, \$1.75. Single copies, 20 cents.

ADVERTISEMENTS: \$4.50 per inch, single column, per insertion. On quarterly or yearly contracts a special discount is allowed. Advertising pages, \$125.00.

REMITTANCES should be made payable to Edward Lyman Bill, Inc., by check or Post Office Money Order.

NOTICE TO ADVERTISERS.—Advertising copy should reach this office by the first of each month. By following this rule clients will greatly facilitate work at the publication headquarters.

Long Distance Telephones—Numbers 5982-5983 Madison Sq.
Cable Address: "Elbill," New York.

NEW YORK, APRIL 15, 1918

BUSINESS in the talking machine industry, broadly considered, is in excellent shape despite innumerable annoyances in the way of a shortage of machines and records, due to the unusual conditions prevailing. Meanwhile manufacturers, jobbers and dealers are doing their best to fill all demands with the utmost available despatch. Fundamental conditions are healthy, and there seems evident an increased buying power in certain sections of the country, due to the large distribution of money among the working people who are earning unusually large wages. They are buying talking machines and records of good quality, and the great problem of the day is to produce and distribute sufficient stock to satisfy the demands.

With this month we enter the Spring campaign for business. The bleak, dismal, wintry days have at last been replaced by sunlight and brightness, and this seasonable change is undoubtedly having its influence on the mental viewpoint of everyone.

A few weeks ago there seemed to be an undercurrent of dissatisfaction, or uneasiness—a lack of faith in the future; in contrast to this we find to-day a better feeling prevailing—one of hope, trust and confidence.

This is the right viewpoint. The man who sees disaster ahead, either in business or in war, is not a good American. It is the time for courage, energy and enterprise, and there should be no harboring of doubts as to our success as a Nation. It is the time for the booster, and not the knocker. We must work to help the business progress of the country by being optimistic in our opinions, and not give way to an indulgence in doubts or uncertainties.

There is a disposition at times among business men to run to extremes of either over-enthusiasm or the gloomiest "gloom." When the latter prevails the croaker or pessimist rides his hobby horse to the danger of the community.

To-day we are in the midst of serious times, it is true, but it is the period when strong men—unselfish, broad-visioned, and able men are needed, when reason and sound sense should dominate all our movements rather than whim or caprice. Whether in war or in business great victories can only be won by good generalship, backed by men, money and the support of the American people. The talking machine trade has always been noted for its go-aheadness, for its freedom from harmful mercantile traditions, and it is going to face the future with courage and confidence and win new triumphs.

MEMBERS of the trade who have recently visited leading cities in the South are quite enthusiastic over the prospects for an enlarged volume of business in that section of the country. The Southern people have more money to spend to-day than ever before. They have a tremendous purchasing power, due to the billions of dollars that have reached them through their efforts in the past year in agricultural activities.

The Southern people are turning their eyes northward for all those home furnishings that appeal to those esthetically inclined, and naturally they are buying talking machines, player-pianos, and other essentials to the enjoyment of music in the home.

This prosperity in the South is not confined to the white people, but throughout Louisiana the colored people who have small farms have got prices for their cotton and other products which have enabled them to pay up any indebtedness on their land, and with the surplus they are buying talking machines and records in goodly numbers.

The purchasing power of the people in the South is a factor worthy of consideration, for the laboring people who are working in the factory centers are earning such large wages that they are manifesting a desire to own a musical instrument of some kind.

It would be invidious, however, to make distinctions when speaking of the trade in the South, for the demand exists among all classes and conditions of people, and it is steadily growing. It is a source of satisfaction that the South is coming into its own in an industrial and agricultural way.

THE great campaign for the successful flotation of the Third Liberty Loan is now under way, and every one in the talking machine industry is planning to do his level best to have this Three Billion Loan oversubscribed. We now have an opportunity to express our confidence in the Government and in the boys at the front, who are fighting as truly for human rights, and the tearing down of autocratic rule, as did our forefathers during revolutionary days.

Every talking machine man can "do his bit" not only by subscribing for bonds but by utilizing his windows for poster display, and by sending out informative literature in his letters, in fact, he must consider every available means to exploit and make successful this Third Liberty Bond campaign.

The military situation at the front has now assumed a critical stage, and every man at home must consecrate himself to the service of the Nation in some one way or other. If we cannot fight we must help in a monetary way toward the maintenance of our forces; therefore let us devote our most enthusiastic efforts to making a new record in this great campaign.

IN the making of instalment contracts during the period of the war, piano merchants would do well to be guided by the provisions of the Soldiers' and Sailors' Civil Relief Act passed recently, and thereby avoid the chance of facing a loss that may be guarded against by the exercise of foresight. Although the act is calculated to protect the soldier or sailor while still being fair to the merchant, in deferring but in no sense canceling the obligation, the dealer selling on instalments can, unless he watches things carefully, tie up considerable money in instalment accounts that under the law need not be met until after the war, which at best is rather an indefinite length of time.

It has been suggested by a prominent attorney in the trade that where practical the wife or some person other than the soldier, or likely-to-be-soldier, be called upon to execute the contract. There will no doubt be numbers of unscrupulous people quick to take unfair advantage of the new law with fraudulent intent, and special efforts should be made to guard against this class.

IN co-operation with the Music Industries Better Business Bureau, located in Milwaukee, and whose activities have on previous occasions been mentioned in 'The World', the National Vigilance Committee of the Advertising Clubs of the World has been quite active recently in proceeding against "gyp" dealers in various parts of the country—in other words, dealers who make a practice of advertising talking machines and records

from private homes, and ostensibly at a sacrifice, frequently making misleading statements in their advertising to forward their ends. The Vigilance Committee already sent out one bulletin regarding the operations of a "gyp" dealer in Chicago, who uses the name of a prominent make of machine to promote the sale of another much cheaper machine for which he had the agency.

The Better Business Bureau at the present time is making a special drive against the "gyp" operations and has solicited the assistance of legitimate dealers in all sections in an endeavor to rout out the evil. When members of the trade learn of the operations of irresponsible individuals they will be doing themselves a service by investigating the methods employed by the advertiser, and placing the information thus obtained before C. L. Dennis, secretary of the Bureau. The complaints are handled promptly, and in a surprising number of cases the activities of particular "gyp" dealers are curtailed or stopped entirely by appealing to the newspapers to exclude such advertisements, and by other means, without going to court.

Every machine sold by a "gyp" dealer not only takes a sale away from a legitimate merchant, but by supplying the purchaser with a machine of inferior quality shatters his belief in the talking machine as a whole.

WORKING steadily, energetically and persistently to sell what stock he has on hand or can get, instead of sitting around and waiting for machines and records for which there is an unsolicited demand, is the system that is going to keep the average talking machine dealer in business during these war times. The overhead expenses of his establishment are going on just the same, whether he gets in new stock or not, and he cannot afford to sit back and wait for something to happen. From present prospects, any improvement in the present situation will be gradual. Even when the labor and transportation problems ease up they will not do so with a rush, and the retailer must make up his mind to adjust himself to conditions. The situation looks blue and hopeless only to the man who has plenty of time to sit and think. The fellow who is too busy to stop and worry is going to keep his business in fairly good shape, even if he doesn't make as much money as in any previous years, and it has yet to be proven that 1918 in the long run is not going to be a good, big year for talking machine dealers. It depends largely upon the individual whether his business goes forward, stands still or slides back.

JUST at the present time members of the trade in all sections of the country should keep a close watch on the various State legislative bodies with a view to checking without delay measures that may prove inimical to the interests of the trade.

In normal times there are always a few bills introduced

TO OUR SUBSCRIBERS

If your copy of The Talking Machine World does not reach you on publication date, or a few days thereafter, do not assume that it has gone astray. The existing railway congestion has had a serious effect on the handling of mail, particularly second class matter, and brought about unusual delays. Kindly wait a few days longer than usual before writing to us, as the paper will probably arrive safely.

that are calculated to harass the trade in some way or another, even though such intent is well hidden. Quick action is generally quite effective in disposing of such measures, but under present conditions it must be borne in mind that many legislators are only too quick to hide behind the shield of patriotism, and to defeat their object, without creating the wrong impression, presents a serious problem for the business man. Bills providing for special taxes or license fees are particularly numerous, and likewise particularly dangerous, for anything that looks as though it would bring revenue into the coffers of the State or the Nation finds favor with law-making bodies, regardless of whether the burden it places on one particular line of industry is just.

There was introduced in Congress recently, by Representative Cary, of Wisconsin, a bill which provided that all merchants selling goods on instalments should pay a license fee of \$200 and should give the customer not only a receipt for his payments, but a statement showing the actual cost of the merchandise upon which a profit of not more than 30 per cent. was to be allowed. The bill applied only to the District of Columbia, but instalment interests from all sections of the country were quick to realize that the bill was most pernicious in its provision, and, if passed, was liable to be accepted as a model by various State legislators. The opposition by the various interests, including both talking machine and piano men, was, therefore, very strong and is believed to have killed the measure.

Another bill in the New York Assembly, for instance, provided for an annual license fee of \$2 on all automatic instruments, and was so worded that it could be construed to cover talking machines and player-pianos. It is estimated that the revenue from those instruments alone would amount to practically a million dollars annually, and it was strongly hinted that the whole idea back of the bill was to provide a score of jobs for political claimants who would be charged with carrying out the provisions of the bill. Even the most harmless looking measure should be scrutinized for the "joker," and the simpler the wording of the bill the closer it should be investigated. When questionable measures are discovered the organized forces in various branches of the trade will be quick to take any action necessary either to defeat the bill, or have it amended as may be deemed desirable.

NO STRING TO THIS



Sidestep it, perhaps, on April first only. But on ALL OTHER days of 1918, pick up the full pocketbook of Victor record profits.

These five words mean what they say:

Pearsall Service for Record Profits

A brand new list of the best music in the world is at your service every month for increasing profits. The complete Victor catalog numbers thousands of selections that you CAN put into the homes of Victrola owners.

SILAS E. PEARSALL CO.

VICTOR DISTRIBUTORS

18 West 46th Street

New York, N. Y.

Edison Message No. 20

Forging the Third Link

On April 6th we began forging the third link in the chain that will hold the dogs of war forever in check. And the business end of that chain is going to be in the hands of the people in all countries, and not in the hands of a self-chosen few who can hurl the world into a maelstrom of blood and fire whenever it suits their fancy. Already the metal of resolve has been heated white-hot in the furnace of patriotism and every dollar invested in a Liberty Bond is a hammer-blow that will help weld an indestructible bond of world control among liberty-loving peoples.

Edison dealers, by our contributions to the Third Liberty Loan let us show the world, and especially our enemies, that America is rapidly getting into her full, irresistible stride, and

Let them come from the east,
Let them come from the west,
From Maine to the Philippines.
From the frosty north,
From the balmy south,
And all of the in-betweens.

Let us renew our pledge of allegiance to the flag and reconsecrate our patriotism by doing our utmost to make the Third Liberty Loan a landslide that will crush militarism out of the world forever.

THOMAS A. EDISON, Inc.

Orange, N. J.



THIS TRADE MARK ON EVERY EDISON PHONOGRAPH
Thomas A Edison

The Redistribution of Records, One of the Answers to the Present Shortage Problem

Those members of the trade who have made a close study of the present record situation and means for offsetting in some measure the effect of the shortage declare that considerable relief can be obtained by an intelligent system of redistribution of records among the dealers themselves, as well as by exploiting consistently records known to be in stock, or obtainable from wholesalers.

The plan for exchanging surplus records is not by any means a new one, although it has not been carried out to any great extent in the retail field. The Jobbers' Association has had such a plan in force for a number of years among its members, various local associations of dealers have attempted something of the sort, and here in New York the Talking Machine Men, Inc., have a committee charged with the work of gathering lists of surplus records from dealers and bringing them to the attention of other dealers who have a demand for such records.

Under normal conditions there was not a great deal of interest taken in plans for exchanging record stock, there being a sufficient number of popular records to keep business going, the surplus stock being looked upon as one of the necessary burdens of the trade. Just now a surplus stock is a heavy load to carry, especially in view of the fact that such records may be used to advantage by a dealer in some other locality.

As an instance in point: a New York dealer who found it impossible to get locally certain McCormack and light opera records and other good selling numbers for this section, learned by accident that a Western dealer was overstocked on many of the records for which the New York man had a general demand. It did not take long to negotiate the transfer of those particular records from the West to the East, giving the New Yorker something to do business with, and giving the Western dealer cash instead of surplus stock. It is very probable that many other instances along the same general lines could be cited.

There are very few records that sell equally well in all sections. As a matter of fact the demand is found to vary in various districts even in the confines of one city, depending largely upon the character of the population. If surplus stocks of records can by any means be so

redistributed as to place them in sections where they are most likely to be sold, then many members of the trade will be able to cut down the amount of money they have tied up in slow moving stock while giving their fellow dealer an opportunity to do some business. In other words, all hands will benefit.

One local dealer suggests strongly that effort be made to establish a series of central clearing houses in the various cities to act for the dealers in the various sections, and endeavor to make the most out of present record stock on the shelves.

"A central clearing house," said the dealer,

"Why Not Central Clearing Houses for Surplus Records to Offset Shortage?"

"could be maintained at a small annual expense of, say, \$10 per member, and if properly conducted should bring back to each individual represented profits of many times that amount. There are enough established associations of talking machine dealers in various cities to provide foundations upon which to build such clearing houses. The matter will have to be taken seriously, however, by the majority of the dealers who participate, to make it worth while.

In the first place, arrangements should be made for the filing of weekly reports by every member, showing the records of which he has a surplus, as well as the special records of which he is in the greatest need. Salaried employes going over and comparing the lists could very easily tell the individual dealer where his surplus could be disposed of or where he could obtain certain desired records.

"The time is past when the average dealer

can sit tight and let his surplus stock accumulate in anticipation of being able to take advantage of a record exchange proposition from the manufacturer. Such a course may be excusable when the dealer is doing plenty of business with new records, but when he is not getting the new records every dollar's worth of stock on his shelves represents a real loss in tied up capital and potential profits.

"The clearing house suggestion, although offering quite a number of details to be worked out, nevertheless seems to point the way to providing some way from the present record situation. It will not cure it by any means, but anything that will help is worth considering with all seriousness."

There are already a number of wholesalers who themselves are conducting clearing houses for the benefit of their dealers. The wholesale salesman being in close touch with the dealers, knows just about what records certain retailers are overstocked with, and can, and does, in many cases, arrange for the transfer of such records to some retailer who can use them to advantage. Such instances, however, are few and far between, and it seems the dealers themselves should make some attempt to help themselves.

Wholesalers, too, have endeavored to assist the dealers by supplying each week lists of from a half dozen to twenty records that are in stock with the suggestion that such records be specially featured during the week. It gives the dealer something tangible to work on and he knows that any demands he may create for those records through special efforts can positively be met.

One wholesaler has gone to the extent of taking a page advertisement in *The Talking Machine World* this month to call the attention of dealers to a list of desirable records he has on hand and is able to supply.

This action of the wholesaler is simply in line with the arguments that have been put before the trade for months past. In short, now is the time to concentrate on selling stock on hand or that can be obtained, instead of bemoaning the loss of sales of more popular machines and records. As a matter of fact, summed up, real salesmanship consists of selling the customer what you have to offer, rather than what he is particularly anxious to buy.

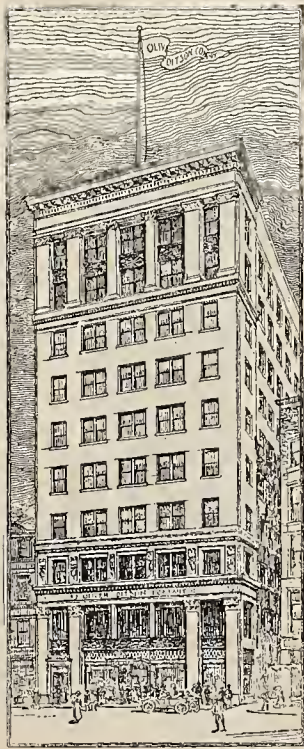

DITSON SERVICE

Makes the Dealer's Road Smoother

It helps to overcome some of the wartime difficulties
Real effort takes the place of wild promises

VICTOR EXCLUSIVELY

OLIVER DITSON CO.
BOSTON

CHAS. H. DITSON & CO.
NEW YORK

The Biggest Event in Motordom!

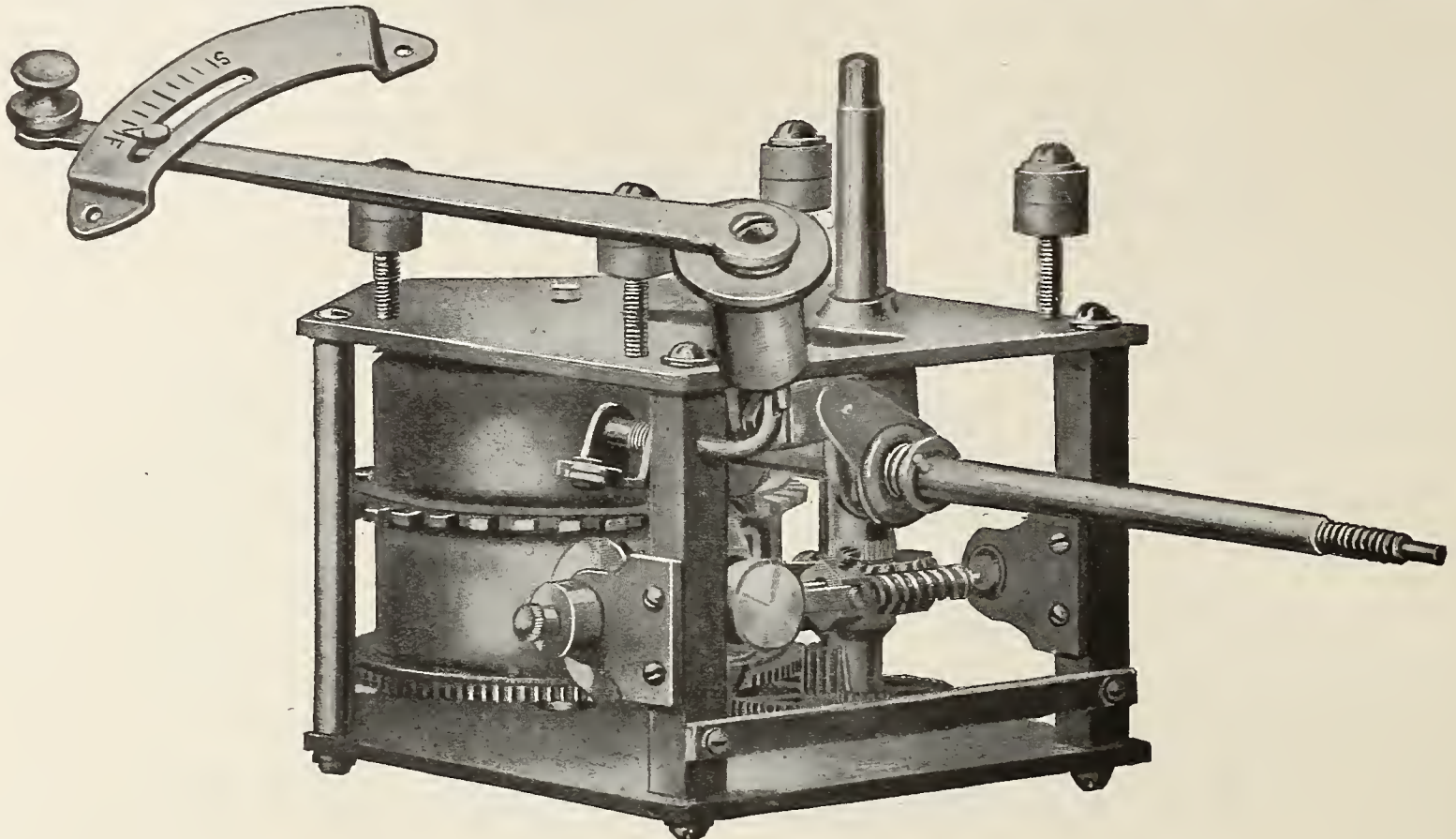

Our Most Popular No. 2 Motor

Over 250,000 are in use.
One of the most prominent manufacturers in the United States alone has used 80,000.

Improved with a combination start and stop and regulating device that works on and with the governor direct instead against the governor.

The Price Will Startle You.

Write at Once and Surprise Yourself

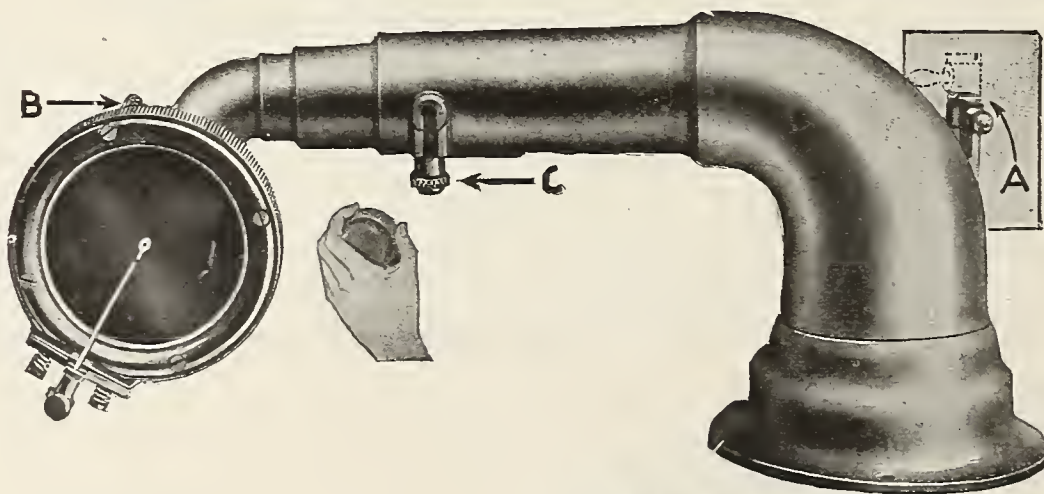

We Have a Tone Arm For Every Purpose

The Two-In-One

Plays any type of record as it should be played. A heavy arm for vertical records; a light arm for lateral records—just a twist of the handle "A"—and the weight is changed from 4 to 8 ounces.

The Improved No. 2 Universal

Known to all manufacturers as a practical and satisfactory arm for all machines ranging in price from \$15.00 to \$75.00.

We can furnish you with every part of a talking machine from a needle up.

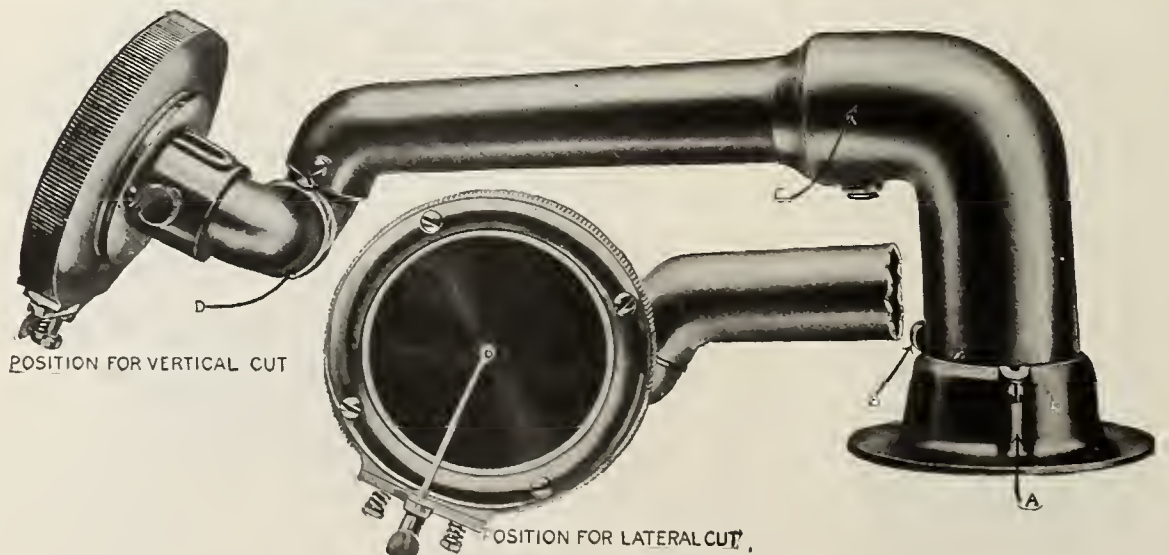

INDEPENDENT TALKING MACHINE CO., Inc.,

54 BLEECKER STREET,
NEW YORK CITY

The sales-experts in the Columbia Dealer Service Department have solved many problems vexing local dealers. Risk a few of your pet problems with these nut-crackers.

**Columbia Graphophone Co.
Woolworth Building, New York**



EFFECTIVE GALLI-CURCI DISPLAY

People's Outfitting Co., Detroit, Takes Full Advantage of Appearance of Noted Soprano in That City—Record Sales Stimulated

DETROIT, MICH., April 8.—The talking machine department of the People's Outfitting Co. took full advantage of the recent visit of Galli-Curci to this city by arranging an elaborate window display featuring the noted soprano and her



A Classic Galli-Curci Window

records, together with four other Victor artists of renown. The figures of the artists, including Farrar, Caruso, Tetrassini and Harry Lauder, were life size and plainly labeled. A special list of records by Galli-Curci were shown on both sides of the window, and it is reported that the display proved most effective in stimulating the sale of records of all types.

IMPORTANCE OF SMALL DETAILS

Little Things Often Determine the Success or Failure in the Marketing of a Product

Seemingly insignificant details are often most essential to the success of a business or a product, and it is the business man who studies these small things who is apt to score a success in his sphere of activity. The fact that little things often determine the success or failure of a product was emphasized recently by George W. Hopkins, general sales manager of the Columbia Graphophone Co. He said that in marketing a high grade of candy it was discovered that the public will not buy candy packed in green colored fancy boxes. Just why this is so he could not say. Possibly the color of the package suggests arsenic, a poison. But whatever the reason, the company found after spending several thousand dollars that green boxes killed all chances for making the candy popular. When pink was substituted sales increased in a most satisfactory manner. Biscuit manufacturers have learned from sad experience that round packages, no matter what the character of the biscuit may be, do not appeal to the public. Square shaped, or oblong boxes, on the other hand, immediately find favor. As fully 75 per cent. of all goods are sold on their appearance, it behooves manufacturers to see to it that products are put up in packages that have an attractive eye appeal.

There are better ways to do everything now accomplished. The simplest device can still be simplified; the speediest engine quickened; the sanest system convicted of waste.

LIVELY BUSINESS IN GRAND RAPIDS

Local Branch of Brunswick-Balke-Collender Co. Reports Strong Demand for Phonographs

GRAND RAPIDS, MICH., April 2.—The local office of the Brunswick-Balke-Collender Co., through C. W. Kalder, reports that the phonograph business of the company in Michigan, Ohio and Indiana is unusually good. Excellent results were obtained at the National Furniture Show held in January, which was attended by a number of Brunswick dealers, and the volume of business booked for that month alone was greater than for any four previous months.

Several new dealers have been signed up recently, among them being the J. E. Anderson Co., Saginaw, Mich.; W. A. Stilwell, Big Rapids, and the F. N. Arbaugh Co., Lansing. The latter concern is one of the largest department stores in the State, and their phonograph department is a new venture.

The local Brunswick headquarters was recently called upon to ship one of their \$1,500 machines to Fort Worth, Tex., by express, the expressage alone being about \$50.

GIVES VICTROLA TO SERVICE CLUB

The Henry F. Miller & Sons Piano Co., in Portland, Me., recently donated a Victrola to the National Service Club, recently opened in that city to provide entertainment and comforts for the soldiers and sailors.

ADA JONES DENIES BEING DEAD

Prominent Talking Machine Artist Sets Latest Rumors of Demise at Rest

Ada Jones, like Mark Twain, objects to being reported dead, and the veteran talking machine artist was quick to deny the latest rumor of her demise in the following letter:

"I have often been reported dead. I even have a double who has been singing throughout the country, using my name, as 'Ada Jones, the phonograph artist.'

"I have just been out with a troupe of phonograph artists giving several entertainments where I was introduced as 'Ada Jones, the mother of the phonograph.' Which made me feel very ancient, I assure you. Cordially yours, Ada Jones, Long Island."

NEW BOOTHS FOR HOMER KLOCK CO.

The Homer Klock Piano Co., which handle the Columbia and Sonora machines and records in Stamford, Conn., have just installed some very attractive booths finished in white enamel, for the purpose of demonstrating their machines and records, which add quite materially to the facilities of this establishment as well as to the appearance of the store. This company are quite enthusiastic over the line which they handle and report an excellent business so far this year.

This is no time for being just half a man—try being a man and a half.



When a dealer gets an intelligent prospective customer to the point where he will listen to a machine play, nine times out of ten he will select a



SCHUBERT PHONOGRAPH

Schubert dealers know this.

We'd like an opportunity to prove it to the satisfaction of every other dealer in the country.

Five Models, \$60 Up

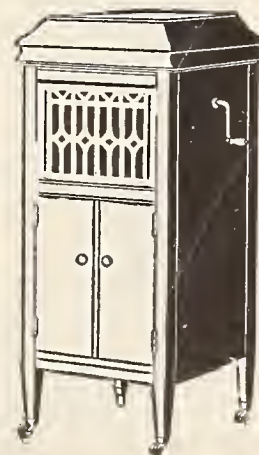

The BELL TALKING MACHINE CORPORATION

Offices and Show Rooms, 44 W. 37th St., New York

Factory, 1 to 7 West 139th St.

Smith-Woodward Piano Co., 1018 Capitol Ave., Houston, Tex., Local Distributor

Give Them What They Want!



The tremendous demand for PATHE PATHEPHONES during the past year is UNQUESTIONABLE PROOF that the people are no longer satisfied with a ONE-RECORD machine.

The people have been educated regarding Records—They know that there are good Pathe Records—They know that there are good Victor Records—that there are good Columbia Records and good Edison Records—

The people want to hear ALL makes of records and they must have a talking machine THAT WILL PLAY all makes of records—

The *Pathe* Pathephone

Is the Only Standard Talking Machine That Gives You This Great Selling Advantage

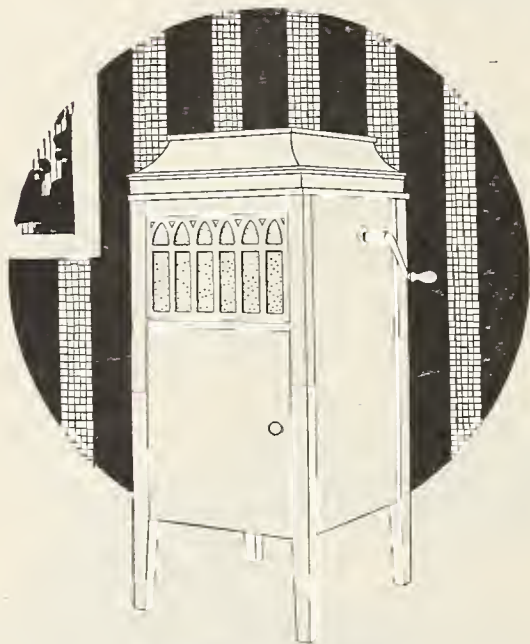

Pathephone \$75 Model

This and other grand features—the **Pathe Sapphire Ball** and **Pathe Everlasting Records**—make Pathe the greatest of all phonograph propositions.

*Hook Up With the
Pittsburgh Pathephone Co.
for Real Pathe Service!*

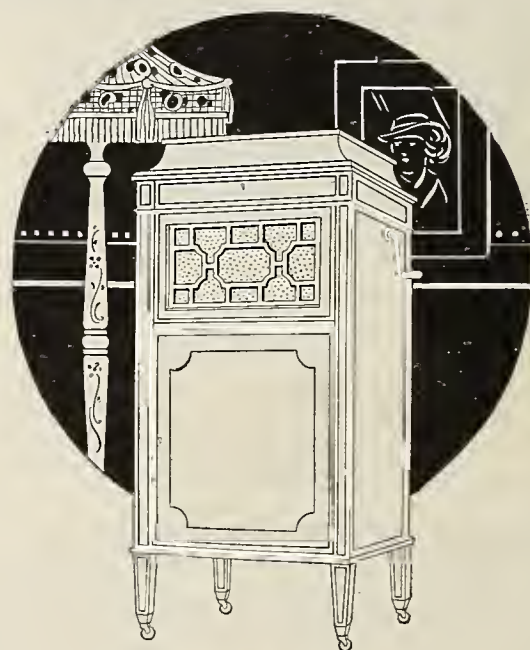

Pathephone \$225 Model



Pathephone \$100 Model

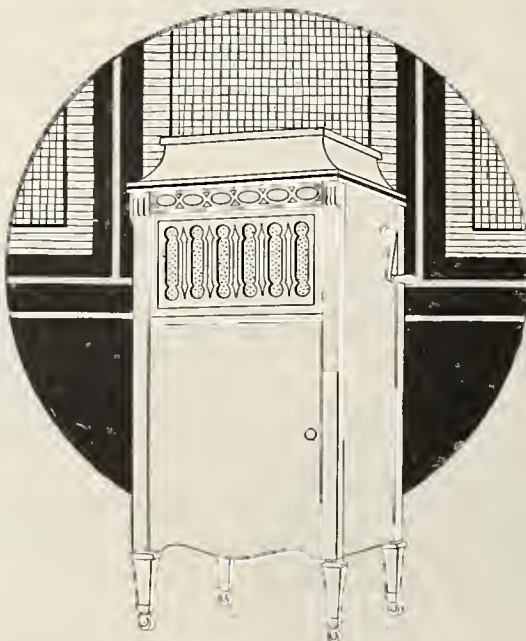

Pathephone \$110 Model

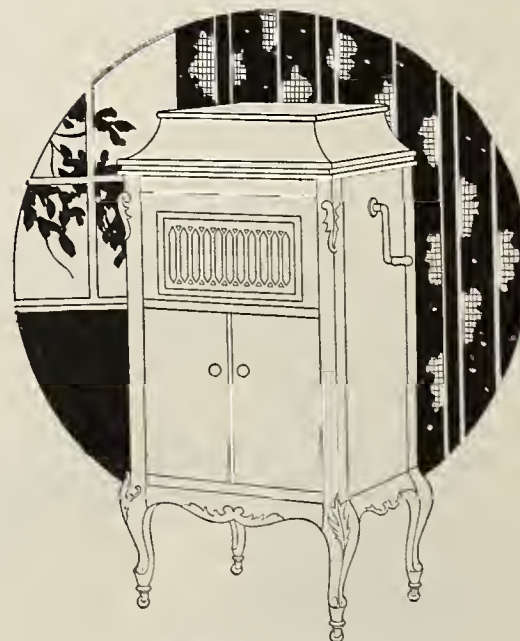

Pathephone \$175 Model

PITTSBURGH PATHEPHONE CO.

963 LIBERTY AVENUE, PITTSBURGH, PENNSYLVANIA

Why Not Make a Vigorous and Successful Drive On the Sale of Foreign Records

The talking machine dealer in the average city in the United States, especially if it happens to be an industrial center, who is not making a consistent and energetic drive on foreign records is neglecting a most important feature of his business. In some instances it would be just as logical for him to forget to call attention to the popular records of the day, or the records of the world's famous artists.

There are enough facts and figures to prove that the ordinary mortal has but a faint conception of the extent of the foreign and semi-foreign population of this country. There are cities in the West where over 65 per cent. of the population is foreign born, or the children of foreign-born parents. No matter how thoroughly Americanized these foreigners or sons of foreigners may be, there is naturally a strong sentimental regard for their native land—a sentiment to which music, and particularly folk songs of that native land, appeal with particular strength.

There are a number of prominent houses, Grinnell Bros., in Detroit, for example, who do pay particular attention to foreign record business with gratifying success. It means work

and consistent effort to do it successfully. Special advertisements should be run in foreign language newspapers in order to reach the thousands, or even millions, who still demand the

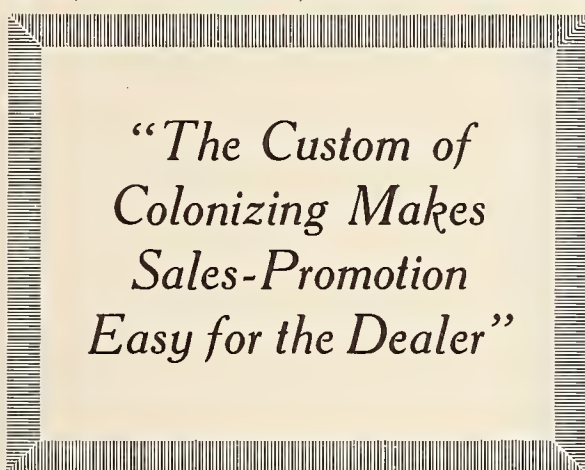

popular things in their native tongue, although newspapers in English can also be used to distinct advantage—those who combine a thorough knowledge of the English language with the sentiments of their native land.

In the great majority of cities there are foreign colonies, the boundaries of which are wonderfully distinct. The emigrant who lands in this country naturally seeks out those who speak his own language, and practically to some extent in this new locality the mode of living to which he is accustomed. Once having found the colony he either remains in it or else keeps in close touch with his people. This habit of colonizing makes it particularly convenient for the talking machine dealer.

Foreign records, even though carefully listed in the catalogs and stocked on the shelves, do not mean anything to the dealer's business unless he brings them to the attention of those most likely to be interested, and there are many owners of talking machines who have supplied their record wants from the regular catalogs without having learned that there may be particular gems in their native tongues simply awaiting their order.

A successful foreign-record business cannot be handled in a haphazard manner any more than the regular record business can be handled in that fashion.

ISSUE LIST OF RECORD CLASSES

Various Types of Victor Records, Placed in Regular Order on Special Card by Thos. Goggan & Bro., Proves Big Sales Aid

Thos. Goggan & Bro., Victor wholesalers of Houston, Tex., recently brought out a welcome help to their dealers and salesmen in the form of a framed card bearing a list of the types of records put out by the Victor Talking Machine Co. The different classes of records are arranged in alphabetical order, from band records, through coon songs, dance records, humorous talking records, minstrel records, solos, trios, instrumental, down to yodling records. The instrumental list proves particularly valuable, because it enables the salesman to call the customer's attention to solos on instruments which he did not know had ever been recorded, such as the ocarina, etc.

The list is in large type, and is to be hung in each demonstrating room. By referring to it both the salesman and the customer can quickly find the sort of records that will make the strongest appeal. It saves going over the

entire catalog and narrows the salesman's work down to pleasing the customer with records of one or two particular classes, which the customer himself can select from the list. This is a sales help of real merit.

F. W. CORLEY IN AVIATION SERVICE

RICHMOND, VA., April 3.—Frank W. Corley, who for some years maintained and developed the successful wholesale Victor business of the Corley Co., Victor distributors here, went into the Naval Aviation Service a couple of weeks ago. During Mr. Corley's absence, Fred R. Kessnich, who has long been connected with the company, will look after the Victor business of the company as wholesale manager.

NEW \$300,000 CORPORATION

The Commercial & Postal Phonograph Co. has been incorporated under the laws of Delaware with capital stock of \$300,000 to engage in the manufacture of sound producing machines. The incorporators are W. I. N. Lofland, George W. Morgan and Frank Jackson, of Dover, Del.

NEW ASSOCIATION IN DALLAS, TEX.

Local Music Trade Organization Elects Officers and Names Committees

DALLAS, TEX., April 3.—The Dallas Music Trades Association recently organized by the piano and talking machine men in this city has selected the following officers and committees: President, Robert N. Watkin, of the Will A. Watkin Co.; vice-president, J. C. Phelps, of the Field-Lippman Piano Co., and secretary and treasurer, B. F. Hollingsworth, of Thos. Goggan & Bro.

B. F. Gupton, of the Goettinger Co., and B. W. Gratigny, of the Bush & Gerts Piano Co., together with the above officers, were made members of the executive board.

D. L. Whittle, of the Western Automatic Music Co., was made chairman of the membership committee.

C. H. Mansfield, of the Edison Shop, was made chairman of the press committee.

Fred Giebel, of Sanger Bros., was made chairman of the always important entertainment committee.



THE BROOKS Automatic Repeating Phonograph

Plays Any Kind of Record—Any Desired Number of Times and Then Stops Automatically—The Phonograph Sensation of the Age

MR. DEALER:—

You cannot duplicate the value we offer for twice the price. In size and appearance the "Brooks" compares favorably with Instruments retailing for \$300.00 and up.

In tone qualities it is unexcelled by any talking machine on earth! In mechanical equipment and automatic features it is years in advance of its nearest competitor. We have been building talking machines for three years—last year our sales doubled every four months. The BROOKS DEALER has no competition. The machine creates interest and discussion—it is self-advertising. Send for particulars, terms, prices. Do it Now.

BROOKS MANUFACTURING COMPANY
Talking Machine Dept. - SAGINAW, MICH., U. S. A.



View of Controlling Dial

This dial sets, starts and stops the machine. Will play any desired number up to nine or continuous.

Simplest Machine to Operate

Instructions

Set the needle at the inner edge of record cutting and then move pointer to the figure designating the number of times you wish record played.

That is all. You can now forget the machine. When the record has been played as many times as set for, the machine will stop automatically with the tone arm suspended in the air above record.

HEIGHT OF CABINET 50 INCHES
FURNISHED IN OAK OR MAHOGANY
SPRING OR ELECTRIC MOTOR

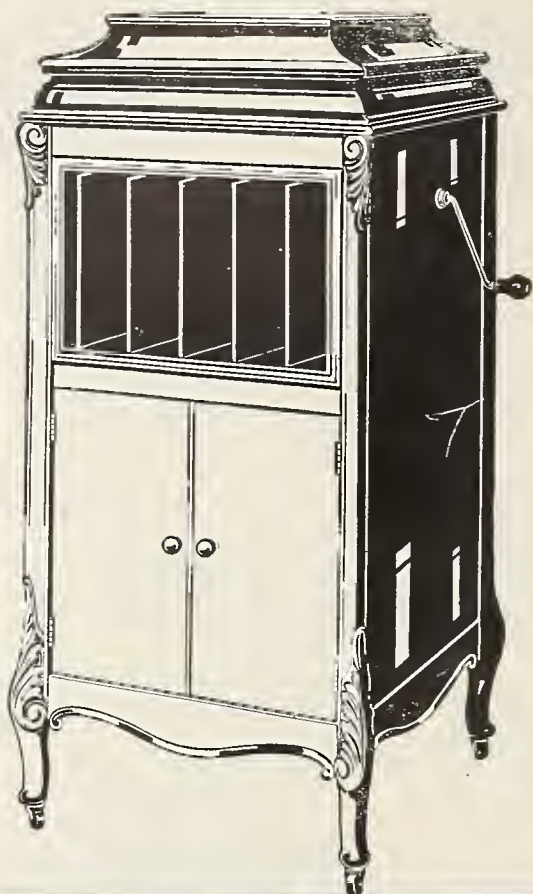

Columbia
Grafonola
Price \$215

Columbia Grafonola and Columbia



Columbia
Grafonola
Price \$30

Giving the People Artists They Want

Educating the people is all right—in school. But grown-ups usually know pretty well what they want in music. And Columbia gives them what they want.

Nora Bayes, for instance. Nora Bayes can get more over to more people in one song than any other American comedienne. What of that? Well, Nora Bayes now sings for Columbia exclusively. Columbia just naturally had to have her. And she just naturally had to come to Columbia.

And Nora Bayes is merely one more in Columbia's Milky Way of Stars. There are the Chicago Symphony Orchestra, Percy Grainger, Al Jolson, Prince's Band, Geo. H. O'Connor, Samuel Ash, Robert Lewis, Arthur Fields, The Peerless Quartette, Campbell and Burr, Oscar Seagle, Henry Burr, Harry C. Browne, Mery Zentay, Nellie Hoone Wetmore, the Columbia Stellar Quartette, Louise, Ferera and Greenus, and the Paulist Choristers of Chicago.

These aren't all the stars in Columbia's Milky Way of Stars. These are merely those shining in its May List of Records.

Nor are these all the world-wide known stars Columbia employed to give the people what they want for just one month. For those eagerly waiting for more, Billy Williams and Harry Champion, of English music hall fame, contributed, and Thornton W. Burgess supplied some more of his Bedtime Stories for children. Some Milky Way for Just May—what?

Giving the People Records They Want

No question about the first two records by Nora Bayes. There'll be a public scramble for "Some Day They're Coming Home Again" and "I May Stay Away a Little Longer." They add something to even the laurels of Nora Bayes.

There's always a scramble for Al Jolson's new records, and he has a song in Columbia's May List that seems made to order for him. "Wedding Bells (Will You Ever Ring for Me?)" is already popular in the big cities where Al Jolson has sung it. Now that it is recorded, it is bound to sweep the country.

Percy Grainger, the "Musical Viking," brings his power into full play in Chopin's Polonaise in A-Flat Major.

Samuel Ash has made many a song popular. In "My Sweetie" he has come upon one so catchy that it is likely to make him more popular.

Oscar Seagle has sung "Keep the Home Fires Burning" and "Pack Up Your Troubles in Your Old Kit Bag and Smile, Smile, Smile," two of the big war songs, so that more may enjoy them.

And there are marches for the martial and dance-records for the dancers and talking records for those who want their vaudeville on tap at home, and a great variety of more music of sorts the public has shown that it wants. Columbia's May List is a whopper!



Columbia Graphophone Co.
Woolworth Building, New York



Columbia Graphophone Co.
Woolworth Building, New York

Columbia Grafonola Columbia Records

Columbia
Grafonola
Price \$45



Giving the People Grafonolas They Want

When customers enter your salesroom, give them prompt, courteous individual attention. If they are left to themselves too long they may wander out.

Attend them promptly. Try to discover tactfully about what priced instrument they can afford to buy. Show different Grafonolas within a reasonable range around that price—but never so many different models that the customers are merely confused and cannot decide on any instrument.

Ascertain as quickly as possible the kind of music a customer likes—and then play that kind on the Grafonola that seems to make the best impression. Of course you will play any record the customer wants on any Grafonola.

Give customers all the time they need to decide, but good salesmanship will help them decide before they leave the store. Good salesmanship means in a word selling the customer the Grafonola he wants at the price he ought to pay.



Columbia Graphophone Co.
Woolworth Building, New York

Columbia
Grafonola
Price \$110



The Result of Giving People What They Want

People who get the records they want by the artists they like and play them on the best Grafonola they can afford to buy are Columbia fans for good and all.

Columbia fans are steady customers for Columbia dealers. It is worth taking time and trouble to see that your first sale makes a permanent Columbia fan of your customer.

By the way, Columbia makes records in 30 different languages, all made by native artists under direction of masters of each tongue. Are you making the most of our many records in foreign languages?

A small investment—you have a full catalogue department in the two or three languages commonest in your territory—and the turnover is quick and highly profitable.

Where not already actively represented, Columbia wants a few more dealers in their International records. Get into this fine field among the early ones and reap a tidy profit. People of foreign birth—well, you know what fans they just naturally are about music.



Columbia Graphophone Co.
Woolworth Building, New York

THE MISSION OF THE VICTROLA IN THE PRESENT WAR

Through the Medium of the Talking Machine Our Fighters Are Receiving the Benefit and Solace Which Music Alone Can Bring—Educational Records Proving of Great Value

Somewhere behind the battle line in Flanders, Walter R. Creighton, son of the late Lord Bishop of London, wrote to Maud Powell: "I have just been listening to you playing and I wanted to write and tell you of our gratitude," in which short sentence he summed up a condition which will be met by every American soldier who goes abroad, as well as by the relatives and friends who stay at home.

Even in war we do not live by bread alone, and that which can bring shaken men back to self-respect, to decency and a determination to "carry on" is a thing the value of which cannot be computed in dollars and cents, says the Victor Co. in its March record supplement.

Apart from their purely military equipment our men will experience three essential needs, if they are to be preserved through the stagnation of trench warfare. Those three essentials are food, shelter and recreation.

Rudyard Kipling knew what music can do to stabilize the morale of slaughter-wearied men when he wrote the "Song of the Banjo." "You couldn't pack a Broadwood half a mile—you mustn't leave a fiddle in the damp." These lines are as true to-day as they were when Kipling wrote them.

Young Creighton heard Maud Powell play out there on the edge of "no man's land," because she has made records for the Victor Talking Machine Co. and because that company has made it possible for human beings everywhere to enjoy the solace and the inspiration of good music.

An instrument which requires somebody to play it is useless except when some such person is at hand. Every one of the warring governments has made special and strenuous efforts to supply music and entertainment for its soldiers, but human needs do not keep regular hours. A musical instrument which can be operated by anyone at any time, and which, like Kipling's banjo, can, if need be, "travel with the cooking pots and pails," performs a service obtainable through no other agency.

The Victor Co. has a picture of a gigantic "Anzac"—a sergeant—six feet six in his stocking feet, peering over the edge of a trench in Gallipoli. The photograph was taken by Lieutenant Throssell, of the Tenth Light Horse, just before the men went "over the top" in a bayonet charge, and in the immediate fore-

ground of the picture is a Victrola—playing.

When Steffanson's ship, the "Karluk," caught and crushed by the Polar ice, finally sank down to the ocean bed, a Victrola played the Chopin Funeral March for requiem.

Those whose efforts enable men to endure the unendurable might safely be classed as among those who are already "doing their bit," but the Victor Co. is doing all this and more.

The most valuable work a man can do is that.

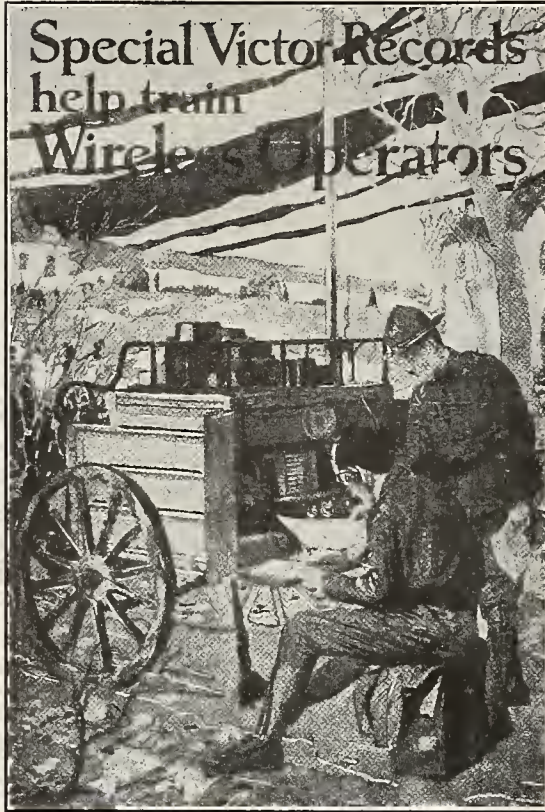

Poster Featuring Wireless Records

which he has best learned to do. As a result of conscription, England sent engineers, machinists, draftsmen into the trenches, and subsequently had to recall them because the work they already knew how to do was more valuable to the nation than anything they could do in the trenches—and in such work as the Victor Co. is already best qualified to serve some noteworthy special efforts have materialized.

One of the critical concerns of the nation at the moment is the educating of thousands and thousands of wireless operators. A system of teaching by means of records has been devised

and recently introduced by the Victor Co. The American soldier in France, with no knowledge of the language, is likely to face some critical embarrassments, if not actual dangers, which might otherwise be avoided. After months of labor, research and expense the Victor Co. developed a system of French lessons which gives the soldier something he can really use the moment he steps ashore or at any time when he may be left to his own resources.

These are specific things—thrown in for good measure—but however much more the Victor Co. may do along such special lines it can do no more valuable work in the mobilization of national energies than that of enabling men to endure the mental and nervous strains of modern warfare, which are always so nearly unendurable. Morale is an essential element of victory—at the front, behind the lines and at home, and moralè is a mental condition. There are many agencies through which the strain on the body may be relieved, but there are few practical avenues of relief for the mind, and certainly none that can be spared.

NEWS BRIEFLETS FROM DENVER

Displaying the Pathé Line in New Quarters—Improvements at Darrow's—Brunswick Line With Swanson—Other News of Interest

DENVER, COLO., April 6.—The Swanson & Nolan Supply Co., which handles the Pathephone at wholesale and retail in this territory, is now at home in its new quarters at 1514 Welton street. The store is most attractively fitted up, and there are ample conveniences to carry an excellent stock of Pathé goods.

The Darrow Music Co., which carries the Columbia line in its talking machine department, is putting in a handsome new store front, with an entrance at the corner which will insure a larger window space.

Albert Giesecke, president of the Denver Music Co., who handles the Victor and Columbia machines, is very enthusiastic regarding trade prospects in his section.

The Knight-Campbell Music Co., which handles the Victor, is advocating larger monthly payments on musical instruments of all kinds purchased at this store.

The Brunswick phonograph is now handled in this live territory by Swanson's Jewelry Store, 39 Broadway, and this fact is being made known to Denverites through some very attractively arranged billboard signs throughout the city.

ANTICIPATE REQUIREMENTS

E. L. Knapp Tells Why Canadian Trade Should Anticipate Needs—Recent Company Change

JAMESTOWN, N. Y., March 25.—Announcement is made that A. F. Weber, who has been identified with the Weber-Knapp Co., of this city, as president and treasurer, has severed his connections with this company.

It is further announced that Edward L. Knapp, formerly vice-president, will now take full charge of the plant, and that business will continue along exactly the same high-class lines without interruption.

Mr. Knapp reports an increased demand for talking machine hardware, and from a larger area than there has ever been before. Shipments to the Canadian markets, he states, have been materially interrupted, due to the necessity of procuring an individual license for each shipment.

Mr. Knapp feels that it would be to the interest of those houses in the Canadian territories that order from the States to take this fact into consideration, and to anticipate their requirements if possible at least six months in advance. It usually takes two weeks to procure the necessary license, and as each individual shipment is required to have this license the same delay is naturally caused each time a shipment is made. Conditions are apt to grow worse rather than better, hence this caution.

Ward's Khaki Moving Covers



Grade "D" Cover with No. 3 Straps.

PROTECT YOUR MACHINES FROM ALL KINDS OF WEATHER

and will enable you to deliver them free from dust, scratches, bruises and all other finish destroyers

Our covers are faced with Standard Khaki, lined with a heavy grade flannel, interlined with an exceptionally good grade of heavy cotton or felt, diagonally and closely quilted, and manufactured according to the usual superior "WARD New London" quality.

Grade "D", medium size, \$5.50
Grade "D", large size, \$6.00
Grade "K", medium size, \$8.00
Grade "K", large size, \$8.50

Carrying Straps: No. 1 \$1.00; No. 2 \$2.00; No. 3 \$3.50

ORDER SAMPLE COVER ON APPROVAL

With Name of Machine silk embroidered on any Cover; extra, 30c.
With Dealer's Name and Address, first Cover; extra, \$1.15
Same on additional Covers, each extra, 60c.

Write for booklet

THE C. E. WARD CO.

(Well-known Lodge Regalia House)

101 William St., New London, Ohio

Also Manufacturers of Rubberized Covers and Dust Covers for the Wareroom

TRANSFER BUREAU NOW ORGANIZED

Tri-State Victor Dealers' Association of St. Louis Arranges a Real Constructive Program That Should Be of Wide Benefit to Members

ST. LOUIS, Mo., April 4.—The Tri-State Victor Dealers' Association has set itself for an earnest program for the rest of the year. The officers believe that the association now is safely established.

The first work undertaken was that of establishing an exchange for records and machines that happen to be dead stock on one dealer's hands, but would be live stock elsewhere. That bureau is now working under direction of John F. Ditzell of the Famous & Barr Co. of this city.

Next comes the associated membership work. The associate members are to be the salesfolk who will be invited to join the Association and special meetings will be arranged for their benefit. The control will remain in the hands of the department managers and store proprietors. The first meeting to which associate members were admitted was held yesterday and a big meeting is planned for May. The April meeting was preliminary. The program for the associate members will be a help in selling goods, a plan whereby sales people can get the training desired as to machine construction, etc. One of the first features provided along this line will be moving pictures of the Victor factory and later will come talks on salesmanship and Victor reasons.

At the last business meeting E. C. Rauth, of the Koerber-Brenner Co., was elected secretary to succeed C. H. Lippman of the Field-Lippman Piano Stores. Mr. Lippman explained that his duties had increased so heavily since former employes of the firm had departed for war work that he was unable to get time to attend to outside duties. It was decided that weekly meetings of the directors of the association would be held in preparation for the May meeting.

Chairman Ditzell of the Transfer Bureau sent out this letter to all members as a memo. of the rules of the bureau:

"It is with pleasure I can advise you that the Transfer Bureau is now organized and ready to serve you in the very best possible way.

"In the operating of this Bureau your chairman respectfully asks for your co-operation in following conditions and rules by which this Bureau will operate.

"The most prominent advantage that members will obtain from this Bureau will be that they will be given the opportunity to dispose of in a wholesale way any overstock they may have of slow selling records.

"Members that avail themselves of the privileges of the Bureau will also be able to obtain a great many records that they were unable to get from the distributor.

"The following is the plan by which we shall operate:

"Each member is privileged to use the enclosed form to list with the Chairman any Victrolas and Victrola records that are in perfect condition and which he wishes to dispose of in a wholesale way.

"Each member in turn will be notified of the Victrolas and Victrola records that are available through the Bureau.

"The Association will in no way be responsible for credits, condition of goods sent through Bureau, etc. As to credits, any dealer can get such information from the Koerber-Brenner Company. Any controversy relative to the condition of Victrolas or Victrola records sent or received through the Bureau will be settled by your Chairman and all must abide by his decision.

"A request for information regarding the Bureau must be made in writing to the Chairman. Time prohibits the consideration of phone calls or personal calls regarding the Bureau.

"All transfers must first have the approval of the Chairman and after approval is granted the dealings will be directly between the members."

"Any suggestions regarding the operating of this Bureau will be appreciated. If we can all work with the one thought, 'An Efficient Transfer Bureau,' every member will find many advantages in the work that will be accomplished."

The membership campaign of the association is meeting with splendid success. Concerning the reasons for an exclusive association, Mr. Ditzell said: "An exclusive association appeals more to the exclusive dealer than to the dealer selling several machines. We assume, however, wherever a dealer sells Victors that his highest interest is there. But a Victor dealer, who is enthusiastic in his line, does not care to make criticisms and suggestions in a meeting of mixed interests. I would freely say things in a Victor association that I would not care to say if an exclusive dealer in another line was there. I believe also that if a man was selling Victors, Columbias, Edisons and Artophone machines, etc., he would offer suggestions and criticisms in meeting where all dealers sold these machines that he would not make in a meeting where

there were dealers who did not sell this machine.

"He would assume that all dealers selling this machine knew its weak points in machine or service, but he would not be willing to hand that statement, on his authority, to a competitor."

In this connection, the following statement has been made officially as to the object of the association:

"Its object shall be to advance, promote and extend the commercial interests of its members; to inculcate just and equitable principles of trade, and to improve business standards; to acquire, preserve and disseminate valuable business information; to promote friendly intercourse and to establish closer business relations between its members, and also between said members and the Victor Talking Machine Co.; to increase the facilities of its members for an interchange of ideas, and for the purpose of co-operating with other organizations upon important matters pertaining to and affecting business; to discuss and disseminate proposed legislation affecting the business welfare of members; and to investigate existing laws and encourage their enforcement."

RECORDS BY AUGUSTA BOUILLIEZ

The Starr Piano Co. announce that they have successfully negotiated with Mr. Augusta Bouilliez, the famous Belgian baritone, to make exclusive recordings, which will be issued about the middle of April and will be listed in the Gennett Art Tone series. The recordings which Mr. Bouilliez has made are as follows: Les deu Grenadiers (the two Grenadiers); Ballo in Maschero "Eri tu"; Hamlet, "Chanson Bashique" (drinking song); Faust, Serenade of Mephisto; Faust, "Aria of Valentine." They are very highly spoken of.

Repeat orders make pretty good testimony to the fidelity of a business institution, and regular customers are of more importance than first sales.

"MICKEL"

A Great Name in the Victor Game

TWO Representative Stocks of Victor Records In TWO Hustling Western Centres of Commerce!

Omaha and Des Moines! Spots of Action on the U. S. Map. If you are nearer Omaha or Des Moines than to some other point, why shouldn't you serve your own interests by putting the "Source of Supply" question up to the Mickels? Better look into this today—You'll gain nothing by staving the matter off!

Mickel Bros. Co.

15th and Harney Streets
411 Court Avenue

OMAHA, NEBRASKA
DES MOINES, IOWA

Those "Lively" Westerners.



THE TRADE IN BOSTON AND NEW ENGLAND

JOHN H. WILSON, MANAGER, 324 WASHINGTON STREET, BOSTON, MASS.

BOSTON, MASS., April 4.—The Third Liberty Loan and the forthcoming great parade, to come off on the sixth of this month, are the uppermost topics of conversation in the trade just now. The various talking machine houses made a handsome showing in the purchase of bonds on the two previous drives and there is every reason that more will be forthcoming from them this time, especially as the right propaganda of education has been spread abroad, and people now better than ever before understand what the nation is really up against. The trade is likely to be well represented in the parade, which will enlist the services of upwards of 80,000 men, women and children.

Business Continues Good

Business with the various dealers continues good, but many of them complain that the call for goods is in excess of what they are able to secure from the factories. Toward the end of April there should be an enormous demand for the records of the various grand opera stars as the Metropolitan Company begins a week's engagement here at the Boston Opera House on April 22. The visits of the big opera companies invariably stimulate business.

Death of Andrew J. Lyons

The Victor and Edison departments of Chickering & Sons were called upon to part with a valued employe a week ago, Andrew J. Lyons, who died at his home in Roxbury, after a short illness. Mr. Lyons had been with the department several years and was married only a year and a half ago. He was devoted to athletics, and was especially interested in baseball and was among the foremost in promoting the game among the various talking machine houses in the city. Manager Currier of the Chickering house and the employes of the Victor and Edison department attended the funeral, and they were represented also by some beautiful floral offerings.

Ciccolini Appears in Concert

Considerable interest centered Sunday afternoon, March 31, in the appearance in this city of the famous Guido Ciccolini, the Italian tenor, who is one of the leading Edison artists. His concert at the Boston Opera House attracted an enormous crowd of people, and the Italians especially were most enthusiastic over the man, his voice and his fine presence. Ciccolini had the assistance of Pierre Henrotte, concert master in the Chicago Opera orchestra as violinist,

and Mr. Fabbrina as pianist. For several days prior to the concert the tickets were on sale at the Edison warerooms of the C. C. Harvey Co. in Boylston street, in the window of which establishment there was a large placard announcing the concert by this talented musician. In the Saturday advertisements which the Harvey company put out announcing the concert were these suggestions: "Hear him there to-morrow. Hear him Monday at our store. Hear him Monday night in your own home." Besides the Harvey company those especially interested in the concert were George Lincoln Parker, the F. H. Thomas Co., Chickering & Sons, all of whom are Edison dealers, and, of course, the leading Edison jobbers, the Pardee, Ellenberger Co., Inc.

An Attractive Easter Display

Among the especially attractive window decorations at Easter, and which was highly significant of the season, was that of the Eastern Talking Machine Co., where Wholesale Manager Fitzgerald arranged a profusion of Easter lilies in both windows as a frame and background for the exhibit of the latest of the month's novelties in Victor records.

Has An Eye for the Artistic

Manager R. S. Hibshman, of the Vocalion Co., is another who has an eye to artistic effect when it comes to adorning his warerooms and show window. There is not a week going by that there are not pots of blossoming plants and cut flowers placed effectively about, and these help a great deal in beautifying what is really one of the most home-like phonograph warerooms in the city. Manager Hibshman is making ready to give his customers quite a surprise very shortly, a foretaste of which some of them already have had in visits to the warerooms.

Interested in Marriage of Chas. Edison

The local Edison dealers were especially interested in the announcement of the marriage at Seminole Lodge, near Fort Myers, Fla., of Charles Edison, son of the inventor, Thomas A. Edison, and Miss Carolyn Hawkins, of Cambridge, by reason of the fact that the young man was at one time a student at the Massachusetts Institute of Technology, and during his years at that school made many friends here.

Fred. H. Silliman a War Expert

Manager and Vice-President Frederick H. Silliman, of the Pardee, Ellenberger Co., Inc., is

one of those men who are not only deeply interested in the war, but who can discuss its various phases most intelligently. Mr. Silliman studies carefully the situation day by day and is always ready to analyze and speculate on the various moves and counter-moves made on the battle front.

Cupid Invades Ditson Department

Two of Manager Henry A. Winkelman's valued women employes at the Victor department of the Oliver Ditson Co. have taken unto themselves husbands. One is Miss Ethel Chools, who lately was married to Joe Carlson, who also has been with Manager Winkelman and is now in service at Camp Devens, Ayer. Their wedding took place at Quincy. The other young lady, Miss Gertrude Lockardt, is now Mrs. Brown. Fortunately for Manager Winkelman the young ladies are now back at work, so he is not without their valued services.

To Do Educational Work for Columbia

James M. McLaughlin, who has been prominently identified with the music department of the Boston public schools for which he has been director for several years, has identified himself with the Columbia, and will have offices at the Grafonola Co. of New England. His position will be director of the educational department, and he will devote his time, especially during the summer, to the development of music in the school and home. Mr. McLaughlin for a long time has been a great believer in the future of the phonograph as an educational medium among the young.

R. H. White Co. Department Busy

The Graphonola department at the R. H. White Co.'s department store is finding many sales these days and Manager Fred L. MacNeil says that the only difficulty that confronts him and his staff of men and women salesmen is the difficulty of getting a sufficient supply of goods. This department handles the Victor, Edison and Columbia lines. Mr. MacNeil has had considerable experience in this line of business, and came to manage this R. H. White department a few months ago.

Gillis Takes Over the Miller Victor Business

Walter J. Gillis, who for some time has been retail manager for the Henry F. Miller Piano Co., has taken over the Victor business of the house and henceforth will manage it as his own business. He has purchased the entire stock and the good-will, and his staff for the present

Foresight Proves Its Value

Some years ago we adopted a policy of conducting our Victor business "with the dealer's viewpoint foremost in mind."

By practicing this policy we have acquired a knowledge which in times like the present makes Eastern Victor Service of triple value to the dealer who wants *practical* co-operation from his jobber.

EASTERN TALKING MACHINE CO.

177 TREMONT STREET

BOSTON, MASS.

will include Herman Mahr, Miss Edythe Austin and Miss A. J. Daly. Mr. Gillis has been in the Miller house for twenty-three years, and is therefore intimately in touch with the piano industry. He has a host of friends who will wish him unlimited success in his new undertaking. A son, Walter J. Gillis, Jr., is with the 101st Engineers in France, and encouraging letters continue to be received by the family.

Sending Letters from the Front

Jerry Spillane and Ed Welch, of the Eastern Talking Machine Co., Victor distributors, are proving themselves good letter writers. They have been in France with a hospital corps now almost a year, and their old associates hear from them quite regularly. Thus far they are quite well and having many exciting experiences.

Plan Tone Test for Fitchburg

The Iver Johnson Sporting Goods Co.'s Edison department is arranging for a tone-test to be given in City Hall, Fitchburg, on the evening of April 11. For this test Miss Marie Morrissey, the well-known contralto singing for the Edison company, is coming on from Chicago. Arthur W. Chamberlain, the Edison manager for this Boston house, will be in immediate charge.

At Local Brunswick Headquarters

One of the additions to the local staff of the Brunswick-Balke-Collender Co. at 94 Washington street is M. J. Graff, who comes here from the company's Chicago quarters as repair man. Mr. Graff is a Brunswick enthusiast and has a persuasive manner in presenting the claims of the Brunswick machine. The "Ultona," which is one of the cleverest devices yet put on the market for reproducing the various makes of discs, is about to be put out by the Brunswick as a component part of its machine. Anyone, therefore, possessing a Brunswick will be able to play any record. As a piece of mechanism this Ultona is worth careful study. F. H. Walter and E. S. Campbell, as the local travelers for the company, are finding a good call for the Brunswicks and March proved a surprisingly productive month for the company.

Sonora Territory is Enlarged.

Through a new arrangement with the Sonora Co., Richard Nelson, New England manager, now has the State of Connecticut added to his territory and this will be operated in conjunction with Massachusetts and Rhode Island. To better facilitate the situation Joseph H. Burke, assistant sales manager, who is doing excellent work, will spend a part of his time at Hartford, making visits meantime to the Boston offices which are so pleasantly located in the Little Building. The People's House Furnishing

Lansing Khaki Moving Covers

PROTECT VARNISH IN THE COLD WEATHER

and enable you to deliver your phonograph free of blemishes of all kinds.

These covers are made of Government Khaki, interlined with heavy felt or cotton, fleece-lined, quilted and properly manufactured. Perfect protection in all weather.



No. 3 Carrying Strap Shown in Cut, \$1.15

GRADE B
\$6.00

GRADE A
\$8.50

Carrying Straps Extra

Use the Lansing Khaki Moving Cover and your delivery troubles will be over.

Write for booklet

E. H. LANSING
611 Washington St., BOSTON

SAN FRANCISCO OFFICE, Room 530 CHRONICLE BLDG.
WALTER S. GRAY, Manager

Co. at Haverhill is one of the latest concerns with which Manager Nelson has signed up. Some of the largest orders for the Sonora line are coming from the large Boston department store of the Jordan Marsh Co.

Fred Peabody on Road to Recovery

The Boston phonograph dealers have been sorry to learn of the serious illness of Fred Peabody, who runs a chain of stores at Haverhill and Gloucester. He was threatened with pneumonia, but thanks to good care he is on the road to recovery. Mr. Peabody comes up to Boston quite often and always gets a warm welcome from his many friends.

Wholesale Columbia Department Busy

The last day of the month found Manager Fred E. Mann's wholesale Columbia department a busy place, for it was quarterly stock taking day. In the city at the present time are C. A. Klebart and Stephen Gilroy, auditors from the New York office who have been spending a week or more at the Federal street headquarters. Another visitor here from the New York

offices has been A. R. Harris, of the general sales department. F. K. Pennington, assistant general sales manager, is expected here in a day or two. Manager Mann is quite enthusiastic over the good showing that the month of March made, which was the best of the three of the current year thus far.

Featuring Nora Bayes' Records

It is of special interest to the trade that just as Nora Bayes is making her appearance in Boston in the "Cohan Revue" the first of this comedienne's records are being put out by the Columbia Co. The engagement began at the Colonial Theatre April 1 and the windows of the Grafonola Co. of New England made a most attractive display of her records.

Make Splendid Victor Display

One of the attractive booths at the big exhibit at Horticultural Hall, which opened to-day under the auspices of the Boston Herald, is that of the M. Steinert & Sons Co., whose display of Victor outfits is attracting many persons. The

(Continued on page 22)

**—Oldest and Largest
Manufacturers of Talking
Machine Needles in the
World—**

W. H. BAGSHAW CO., Lowell, Mass.

TRADE CONDITIONS IN BOSTON

(Continued from page 21)

exhibit is in charge of William A. Burnes, of the Steinert house, and the demonstrations, which occur at regular intervals, are listened to by crowds of people. Robert Steinert, who is in charge of the Arch street Victor headquarters, makes a most encouraging report of the March business both in machines and records, but he, like others, is feeling the shortage of goods.

The New England Vitanola Talking Machine Co., exclusive distributors of the Vitanola talking machine, made in Chicago, for the New England States, are steadily building up a very satisfactory dealer clientele for this excellent product.

NEW ENGLAND T. M. CO. EXPANDS

Add 3,000 Square Feet of Floor Space to Boston Factory to Meet Demands

BOSTON, MASS., April 3.—Announcement is made that the New England Talking Machine Co., of this city, have found the necessity of adding some 3,000 feet of floor space to their factory, due to the strong demand evidenced for their products. The "Perfection" ball bearing tone arm and the new "Perfection" flexitone reproducer need no introduction to the trade. Their increasing popularity has necessitated this change.

NEW QUARTERS FOR H. G. APPLIN

SOMERVILLE, MASS., April 5.—H. G. Applin, talking machine dealer, formerly located at 20 College avenue, has moved to new and larger quarters in the Medina Building, where he has installed several soundproof booths, commodious record racks, and a complete repair department. Mr. Applin handles both the Victor and Edison lines, and has been in business here for over ten years. This is the fourth time that he has been compelled to move, owing to the expansion of his business.

URGES CARE IN RECORD PACKING

Post Office Department Notifies Postmasters Regarding Packages and Their Packing

WASHINGTON, D. C., April 6.—Complaints having reached the Post Office Department that many phonograph records are broken in the mails when sent by parcel post, Otto Prager, Second Assistant Postmaster General, has notified the postmasters and other employees to be careful to see that the articles are properly packed, properly marked and carefully handled. The order reads as follows:

"Numerous complaints of damage to phonograph records shipped in the mail indicate that postal employees are not giving proper attention to these fragile articles. Therefore, it is directed that postmasters and all employees receiving parcel post from the public for transmission in the mail shall be particularly careful to see that such parcels are suitably and sufficiently prepared for safe transmission, and that they are plainly labeled 'Fragile.' All postal employees are also cautioned to use special care in handling such parcels with a view to preventing damage thereto."

CLEVER SWINDLER GETS RECORDS

Young Man Manages to Get Forty-five Records From Two Stores of Shroyer Music House

BETHANY, Mo., April 2.—The Shroyer Music House, of this city and Albany, Mo., was stung twice recently by the same swindler, and both times for a goodly bunch of Edison records. A young man about twenty years old entered the Shroyer store in Albany recently and contracted to purchase an Edison phonograph on instalments without making an initial payment. He ordered nine records and offered to take them with him to save the trouble of delivery. The man left on the next train for Bethany without waiting for the machine to be delivered. He next visited the Shroyer store

ILSLEY'S GRAPHITE PHONO SPRING LUBRICANT

Ilsey's Lubricant makes the Motor make good
Is prepared in the proper consistency, will not run out, dry up, or become sticky or rancid. Remains in its original form indefinitely.

Write for special proposition to Jobbers.

MANUFACTURED BY

ILSLEY-DOUBLEDAY & CO., 229-231 Front St., New York
Established 1853

here, and by some smooth talk managed to get thirty-six Edison records on approval, agreeing to pay for those his folks selected. The music house does not yet know how the records appealed to the young man, for he got out of town without delay. It is stated that the Shroyer Music House will adopt a definite policy of letting no records go out on approval in the future.

SEMI-PERMANENT NEEDLE POPULAR

Vallorbes Jewel Co. Make Enthusiastic Report Regarding Latest Addition to Their Line—Export Demand Steadily on the Increase

LANCASTER, PA., April 4.—The Vallorbes Jewel Co. of this city report that their new semi-permanent needle is growing in popularity by leaps and bounds not only throughout the United States but in Canada and other countries as well. W. F. Meiskey, president of the company, reports that although they are just about finishing taking care of the large number of initial inquiries, recorders are coming in fast for large quantities.

The original card that was announced to the trade has been improved in design and is printed in three different colors so as to differentiate between the three tones in which the needle is made—soft, medium and loud. Mr. Meiskey announces that they might use an adaptation of a familiar phrase and say, "We couldn't improve the needle so we improved the card."

Ault & Miller, who handle the Edison line in Fort Collins, Colo., are making a great drive on bringing the merits of the Edison record to the attention of the purchasing public.

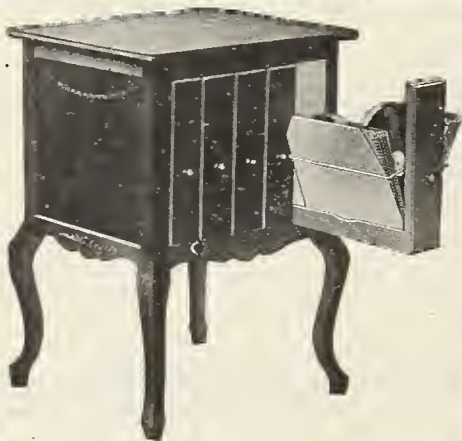

Style 5H—Holds 100 Records

Filing Cabinet for use with Victrola VIII or IX; Columbia Grafnola 15, 25, 35 and 50; Aeolian Vocalion D. & E., and other portable styles of talking machines.

Automatic Insert Files will re-equip any standard Talking Machine with durable up-to-date files—on dealers' sales floor or in customers' homes. Every dealer and jobber should carry them in stock.

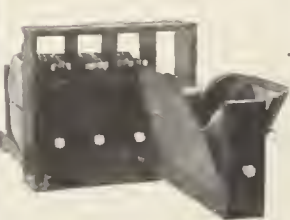

Automatic RECORD CONTAINER

Every Record in Plain Sight

Opens automatically—remains open at the right place—all records accessible—closes easily and quickly—no weight to handle—no more broken or misplaced records. Records properly filed give maximum use and enjoyment.

Mr. Dealer: You ought to add this profitmaker to your line. Many thousands of phonographs and records have been sold and thousands more are being sold every day! There is a real demand and a growing demand for efficient filing cabinets.

Automatic Record Containers meet every requirement. Simple—flexible—durable—nothing to wear out—nothing to get broken or misplaced. A delight to use them.

Manufacturers, get shop rights to equip your line

FULL PARTICULARS AND PRICES ON REQUEST

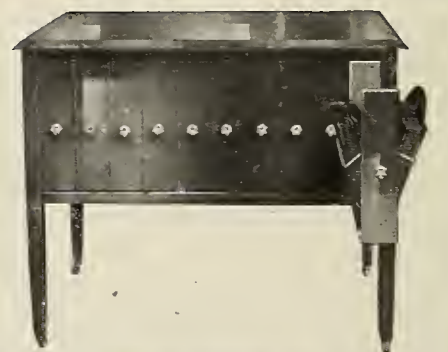

Filing Cabinet—Style L. T.
Holds 200 Records

Attractive in Parlor or Library. Satisfies your customer, sells readily. Ample filing capacity increases sales of records.

Automatic Carrying Cases for Salesmen and Repairmen are ideal—constructed on the same principle as our Record Containers. Every dealer and jobber should equip his salesmen with them to increase their efficiency.



AUTOMATIC CONTAINER COMPANY

5 North La Salle Street CHICAGO, ILL.

The Unequaled Selling Features of the AEOLIAN-VOCALION

ON the three pages following we are showing specimen advertisements from the strong campaign of Vocalion publicity carried on in the national magazines and newspapers of the leading cities.

These advertisements emphasize two of the many impressive features of the Aeolian-Vocalion.

No phonograph made to-day is so easy to sell as the Aeolian-Vocalion, disposes so readily of competition, brings so good a class of patronage to a merchant, or reflects more prestige on his store.

This one point alone; the Vocalion's ability to *play all records*, is already coming to be recognized as of vital importance. Moreover, the Vocalion's method of doing this—the remarkably effective tone-arm, which makes it possible to shift from “lateral” to “hill and dale” records by a *single turn of the reproducer*—gives the Vocalion a notable advantage over other phonographs.

Vocalion representation is the most valuable franchise the phonograph dealer or progressive merchant can secure. This is not alone because this great phonograph is demonstrably the finest instrument made, but because of Aeolian methods of doing business.

The unparalleled character and excellence of Aeolian service, which has recently been still further augmented by the establishment of convenient distributing points in different parts of the country, is proverbial in the music trade. Added to this service is the well-known Aeolian policy of fairness and courtesy in business dealings which make the representation of this house one of the most satisfactory connections offered in the business world.



F. W. J. S. 1864

*The Music of the Entire World Is Yours
If You Own the*
AEOLIAN-VOCALION

THE owner of an Aeolian-Vocalion is not confined to one, or at most two, groups of artists.

Every artist, every instrumentalist, every entertainer, every orchestra and band that has made a record, has made it for him to hear and to enjoy.

No matter what the make of record, no matter by what system it is produced—so-called “hill and dale” or “lateral” cut—the Aeolian-Vocalion will play it and play it *better* than it can be heard from any other phonograph.

DID the Aeolian-Vocalion possess no other advantage; were it only the equal of other phonographs in other respects, this ability to play *all makes* of records would make it the most desirable phonograph to own.

No single manufacturer, nor any two manufacturers, controls the musical talent of the world. The phonograph field is constantly broadening, new artists are appearing, and the phonograph owner who is in a position to enjoy them all commands the situation.

But the Aeolian-Vocalion is not merely the equal of the best phonographs of other makes. It is absolutely supreme and alone among all such instruments.

The *tone* of the Aeolian-Vocalion has been scientifically demonstrated to be far nearer that of any instrument or voice it reproduces, than has hitherto been possible in phonographic reproduction.

The tone-controller of the Aeolian-Vocalion—the celebrated “Graduola”—is the first and only effective and artistic means devised for modulating phonographic tone without muffling it or changing its character.

The *cases* of the Aeolian-Vocalion represent the first serious effort on the part of phonograph manufacturers to fit this instrument to take its place among the other furnishings of the modern home. The simplicity of Vocalion case-designs, the depth and richness of its case woods, are notable in their contrast to what has hitherto been typical of phonographs.

OTH^{ER} features of the Aeolian-Vocalion—mechanical features such as its automatic stop—represent equal progress.

From every standpoint this great phonograph, made by the world's most progressive and largest builders of musical instruments, offers the utmost in musical value, in pleasure and entertainment and in architectural beauty, that the expenditure of any sum of money in such an instrument can procure.

*Vocalion Prices: Conventional Models, \$45 to \$375
Sixteen Beautiful Period Styles, from \$215 to \$650*

THE AEOLIAN COMPANY
AEOLIAN HALL, NEW YORK

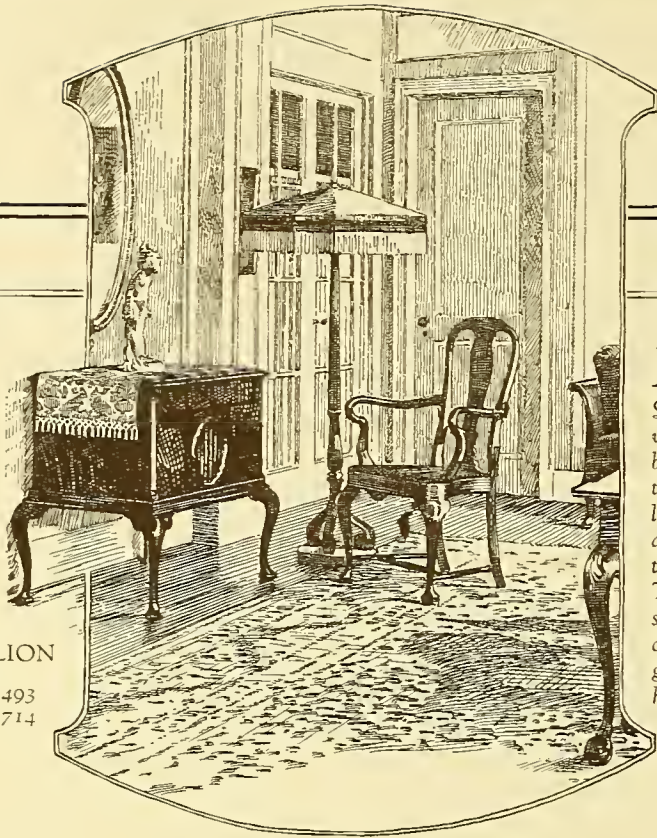

The
AEOLIAN-VOCALION
PERIOD STYLE 1493
Queen Anne, 1702-1714

IN this design the Holland influence, a factor in Queen Anne Furniture, is very marked. The coved base, its curve continued by the characteristic "cabriole" leg, gives this Vocalion a grace very pleasing to those who admire this Period. The finely moulded top, the shaped chamfering of the corners and the decorative grille, all contribute to the harmony of the whole.

PERIOD STYLE VOCALIONS

THE introduction of these superbly cased instruments represents the third great achievement of the Aeolian Company in developing the phonograph.

First—this Company produced the most musical phonograph that has ever been heard.

Second—in the Graduola expression attachment it provided the only satisfactory and artistic means for controlling the phonograph's tone yet devised.

Third—The Aeolian Company, the first to depart from the conventional lines in designing Art Style Phonographs, now presents this superior phonograph in a wide variety of Period Cases that are in line with the finest furniture designing of the present day and that in price are within the reach of almost every phonograph purchaser.

HARMONY IN HOME FURNISHING

In selecting furniture for even the moderate home the purchaser is now enabled to secure a harmony of effect that in the past was available only to the wealthy. The Aeolian Company has recognized this condition and has taken steps to meet it. The superb group of Period Style Vocalions here announced is its response to the growing popular demand for *phonographs* of reasonable price that will harmonize with the finest

modern furniture. Like the best examples of furniture of today, these Period Vocalions have their origin in the rich traditions of the historic past. Furthermore, they are thoroughly adapted to the practical needs of the present, making them a true product of this age as well as beautiful illustrations of the art of the cabinet-maker of ages past.

These Period models introduce motifs ranging from Gothic and Jacobean through Queen Anne, Chippendale and others, to our own American Duncan Phyfe.

SUPERIORITY OF THE AEOLIAN-VOCALION

The Aeolian-Vocalion is now recognized as the leading phonograph upon the market.

Its positive superiority of cases, as manifested both in the new Period Styles and in the many conventional models in which it is made, is but one of its striking advantages.

The Aeolian-Vocalion's supremacy extends to *Tone, Tone-Control, Ability to Play All Records, Appearance, and Auxiliary Features.*

Vocalion Prices are—Conventional Models, \$45 to \$375
With Graduola from \$110. Period Models from \$215 to \$650
Sold on Moderate Down Payments and Most Liberal Terms

THE AEOLIAN COMPANY
AEOLIAN HALL, NEW YORK

HOW CLEVELAND TRADE PLANS TO HELP UNCLE SAM'S BOYS

Entertainment First Week of May for Y. M. C. A. and K. of C. Funds—President Bennett Appoints Association Committees—Helping Liberty Bond Campaign—Attractive Window Displays

CLEVELAND, O., April 9.—The Talking Machine Dealers' Association of Northern Ohio is going to give a big benefit performance and concert in some local theatre or armory during the first week of May, the entire net proceeds to go to the Y. M. C. A. and Knights of Columbus. Singers whose voices are reproduced by talking machine records will be asked to cooperate in making the benefit a success. If Keith's big Hippodrome can be obtained it will be used, as it is the largest theatre in the Middle West.

At the March monthly meeting of the association Charles K. Bennett, president, appointed the following committee to arrange for the benefit: W. G. Bowie, chairman; L. Meier, of L. Meier & Sons; A. W. Roos, manager of the Columbia Graphophone Co.; J. J. Schriener, music department manager; L. W. Bloom, secretary of the Phonograph Co.; Richard Svehla, a West Twenty-fifth street dealer in musical instruments, and A. L. Maresh, of the Maresh Piano Co.

At the April meeting of the association plans will again be discussed and the arrangement committee will report progress.

Mr. Bennett is very enthusiastic over the prospects of a big benefit and thinks that the appearance of several musical stars featured through Victor, Pathé, Edison, Columbia and other records will insure a big attendance and net a goodly sum for the Knights of Columbus and the Y. M. C. A. The proceeds will be split fifty-fifty with these two organizations which are doing so much to make camp life of soldiers a pleasant existence.

During the March meeting, which was held at Schuester's Cafe, trade conditions were variously discussed. There were twenty-four members present and assurances of two more members were received.

Mr. Bennett announced the following standing committees for the association for 1918: Executive—L. W. Bloom, secretary of the Phonograph Co., chairman; L. Meier, of the L. Meier & Sons Co.; Herman Wolfe, president of the Wolfe Music Co.; T. A. Davis, manager of the piano department of the Bailey Co.'s department store, and J. O. Raeder, secretary-treasurer of the Caldwell Piano Co.

Grievance—W. G. Bowie, chairman; Richard Svehla, dealer in musical instruments, and E. A. Friedlander, manager of the Diamond Disc Co.

The presence of several piano dealers who are active members of the association, gave assurances of hearty support to the organization during the year.

Mr. Bennett and others said transportation conditions are still bad. "We are not getting stock," said Mr. Bennett. "A consignment of stock from the Victor factory, Camden, N. J., started for Cleveland February 2, had not been heard from March 21. At that date we had received no machines started during March. It is expensive business getting machines by express and the transportation charges eat up profits. Of course, needles and records can be sent by parcel post, as they are not so bulky as machines."

After the meeting Mr. Bennett left for a vacation trip to New York, Atlantic City and other places, from which he has just returned.

Talking machine dealers of the Cleveland Association are staging some unusual activities for the third Liberty Bond sale campaign, which opened April 6. Cleveland has always "gone over the top" in its war subscriptions, whether for the Red Cross, "Y," or Liberty Bonds and War Savings Stamps, and during the "Liberty Day" celebration, April 6, piano dealers and talking machine men will play an important role. Music will be a big lever in the campaign, and no means will be spared by talking machine men to do their bit in putting over the third Liberty Loan.

Cleveland is the home of the nation's Sec-

retary of War and his assistant, also the National Fuel Administrator, Harry A. Garfield, Christian Girl, head of the motor truck department of the war council, and other "dollar-a-year men" now serving their country in Washington. For this reason Cleveland will have a big wave of patriotism April 6 and launch the third loan with a series of parades and other demonstrations in which music of all kinds will play an important role.

Eastertide found talking machine dealers all set for the event. Many effective window displays attracted attention to stores. The Collier & Sayles Co., Victor dealers, put on a fine show window attraction, as did the Wolfe Music Co. The Eclipse Musical Co., Victor distributors, went the limit with a display in the company's retail store, Euclid avenue, that won high praise.

The B. Dreher's Sons Co. also had a fine display of machines. The Caldwell Piano Co., the "Harmony Music Shoppe" of the Hart Piano Co., and other well-known concerns displayed machines, player-pianos, music rolls, records and other seasonable stock. Easter found Cleveland in an optimistic mood, the weather having moderated, making "glad rags" appropriate for the "joyous season." All the churches had extra musical programs and "music was in the air."

Among the latest hits in talking machine records in Cleveland are:

Columbia—"Au Revoir, But Not Good-bye, Soldier Boy," by Henry Burr; "There's a Service Flag Flying at Our House," by the Sterling Trio; Charles Harrison's "Li'l Liza Jane"; Marconi Brothers' "It's a Long Way to Berlin."

Starr—"When the Bell in the Lighthouse Rings," by Frederick Martin; "Oh, Promise Me," by Chester W. Smith; "Drink to Me Only

With Thine Eyes," by Albert Widerhold; "Vulcan's Song," by Frederick Martin.

Pathé—"In the Land of Wedding Bells," by Campbell and Burr; "Are You From Heaven?" by Irving Gillette; "Liberty Bell," by the Peerless Quartet; "Love and Life in Holland," by the Imperial Symphony Orchestra.

"When the Boys From Dixie Eat the Melon on the Rhine," "I'm Writing to You, Sammy," "American Through and Through" and "There's a Service Flag Flying at Our House"—these are among the newest patriotic hits of the past few days.

ISSUE WEEKLY RECORD BULLETINS

Standard Talking Machine Co. Urges Dealers to Push Selected List of Victor Records, All of Which Are Now Obtainable

PITTSBURGH, PA., April 2.—The Standard Talking Machine Co., in connection with their service department for dealers, have issued a series of new weekly bulletins for the use of retailers, listing from twenty to twenty-five of the most desirable records in regular form, with the names of the selections, the artists who make them, size and price. It is urged that the dealers during the week call the particular attention of the customers to these selected lists of records, all of which the Standard Co. have in stock before the bulletin is issued. Up-to-date the plan has proven most successful, and has stimulated the sale of a number of records that usually would rest on the dealer's shelves, and likewise has compensated in some measure for the dearth of some of the more popular selections.

OCCUPYING NEW QUARTERS

The Glendale Phonograph & Piano Co., Glendale, Cal., is now located in attractive new quarters at 323 Grand Boulevard, that city. The company features the Baldwin pianos in addition to phonographs and musical merchandise. Two soundproof booths have been installed.

To the Talking Machine Man Who Is Not Selling Pianos—Why?

When Piano Dealers started to sell Talking Machines with so much success, did they do so at the expense of their piano business? NO—the combination proved to be an instantaneous success—each has helped the other.

Your business, selling talking machines only, is probably as big as an exclusive business as you can make it. Why not branch out? You can do with Pianos what the piano man did with Talking Machines.

With little additional investment and the same overhead expense, you can sell Pianos and Player Pianos profitably. Your piano business will help your talking machine business, and you will make more money. For particulars address

KOHLER & CAMPBELL, Inc.

11th Avenue and 50th Street
NEW YORK CITY

The most successful
manufacturers of Pianos,
Player Pianos and Grand
Pianos in America.

Kohler &
Campbell,
Inc.

11th AVE. and 50th ST.
NEW YORK

Dear Sirs: Kindly
send us full particu-
lars of your plan to
combine profitable Piano
and Player Piano selling
with our present business.

TEAR OFF THIS COUPON AND MAIL

TRADE ACTIVE IN THE NORTHWEST

Scarcity of Stock a Serious Problem—Hedman Tells of Prosperity With Farmers—L. H. Lucker Tells of Conditions—Other News

ST. PAUL and MINNEAPOLIS, MINN., April 4.—The business situation in St. Paul and Minneapolis is just what it was last month, the month before, six months ago and a year ago. Dealers, whether retailing or jobbing, simply are unable to supply machines as they are desired and no one has any idea as to the proportions the Victrola trade, for instance, could assume in this territory if the machines were obtainable as freely as desired. W. J. Dyer & Bro. are buried in urgent appeals for instruments not only from dealers in their territory, but often from houses at a distance. The Beckwith-O'Neill Co. has discontinued sending its representatives to the dual city trade because there is nothing to offer except apologies and excuses. It is not easy to discourage such confirmed optimists as E. F. O'Neill and George Mairs, but they have to be content in view of conditions.

South Dakota farmers never were so busy as they have been this spring, declares E. W. Hedman, traveler for the Columbia Graphophone Co. There is a greater acreage of grain than the State ever saw before, and if the Lord will aid occasionally they promise to give Uncle Sam the greatest supply of grain that ever came from that State. Other travelers bring the same hopeful reports, and with a March increase of between 60 and 70 per cent. in the volume of business as between 1917 and 1918 Manager Sprague sees a chance to win another silver tank and some laurels. J. W. Hayes, local scout for the Columbia Co., is credited with some record business in Minneapolis and St. Paul. The company plans to restrict the number of dealers in the Twin Cities by centering their efforts with the strong accounts.

F. S. Binger, chief assistant auditor of the parent company, left last week for the East after working here about a month. He was accompanied by Richard Grant, who leaves the Columbia Co. on his arrival in New York to become a rookie at Camp Mills, and get a blue star in the Columbia flag. The appointment of R. C. Tanner as chief clerk at the Minneapolis headquarters office is announced by Manager Sprague.

Officials of the Minnesota Phonograph Co., jobbers of Edison phonographs, feel in a somewhat complacent mood, although the Twin City retail trade hardly is up to expectations. Recent arrivals of carloads and other shipments of instruments and records have placed the company in a position to supply the wants of the large growing circle of dealers. Manager Laurence H. Lucker was in a sorry position some months ago, but the trade skies are much brighter now that he can command the goods.

Minneapolis and St. Paul newspapers are carrying the want ads of the Brunswick-Balke-Collider Co. for rubbers and finishers at the Dubuque, Ia., factory. The Brunswick business is excellent, particularly in Minneapolis, where the Brunswicks are handled by Boutell Bros., big furniture dealers, and the exclusive Brunswick shop of Nye & Nye, who are housed in one of the most artistic talking machine shops in the Northwest. E. L. Kern, one of the directors of the company, is head of the Northwestern organization.

Pathé phonographs and records continue to be distributed on a generous scale by the G. Sommers Co., which has a most wonderful and extensive organization. Jay H. Wheeler, head of the phonograph department, is a veteran in the business, and is understood to be making a distinct mark with the house.

Sewell D. Andrews, who looks after the interests of the Sonora phonograph in the Northwest, is out of town for the time being, but it is stated that the business is on a satisfactory basis with a goodly increase as a result of the Sonora convention in Minneapolis in January.

EDISON WINDOW DISPLAYS DESIGNED

Thos. A. Edison, Inc., Prepares a Number of Suggestions for Window Trims for Retailers—The Basic Principles Illustrated

Realizing that many more Edison dealers would show attractive windows if they fully understood some of the basic principles of window display, the advertising department of Thomas A. Edison, Inc., have devised a num-

ber of appropriate displays which a dealer can place in his window at very slight cost.

In the above sketch originality and good taste have joined forces to present the idea of music's re-creation so convincingly that all who pass must pause and consider.

Characteristic spring colors of green, yellow and light gray are used. The background is made by hanging green denim at the sides and back of the window. The New Edison is well

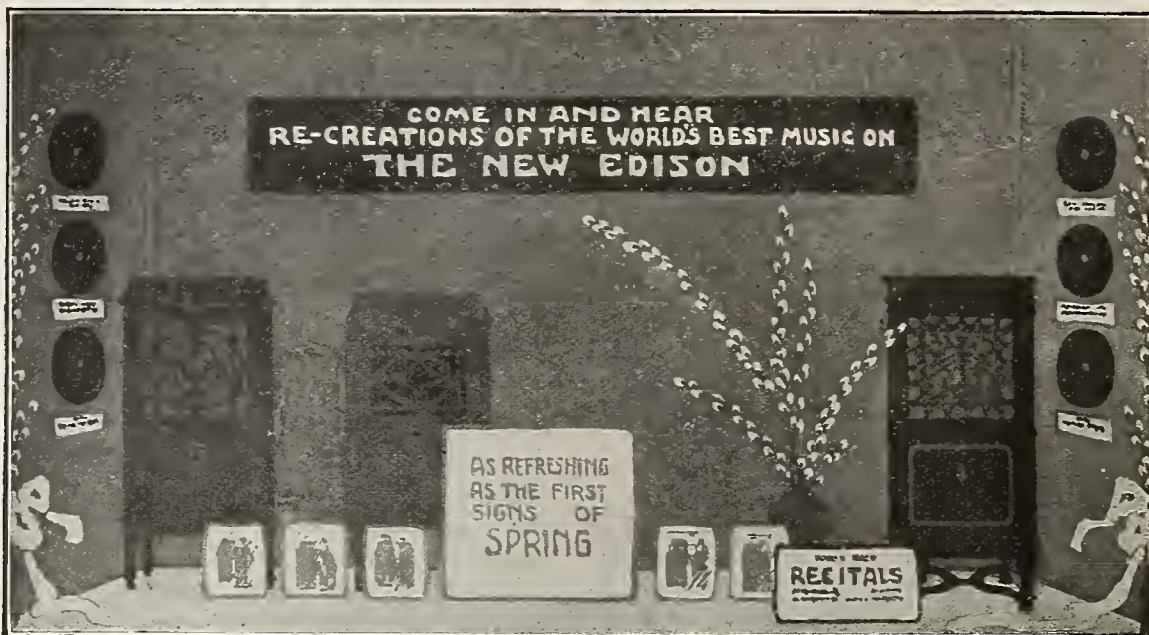

An Attractive Spring Window Featuring the Edison Phonograph

tered in light gray and yellow, says: "Come in and hear re-creations of the world's best music on the New Edison." "As refreshing as the first signs of spring," the poster below tells you. Here the cardboard is of light gray and the lettering of yellow. A third and smaller sign to the right might announce recitals. As a final argument pictures of famous artists singing with their Edison Re-Creations are grouped at either side of the poster.

Chicago Display
Sixth Floor, Republic Building

Delpheon

the
Incomparable

Your nearest distributor will give you prompt service and the fullest co-operation.

DELPHEON plus DELPHEON SERVICE brings SUCCESS

The Delpheon Shop
117-119 Peachtree Arcade
Atlanta, Georgia

Delpheon Sales Company
25 Church Street
New York City

Walter Verhalen
Busch Building
Dallas, Texas

Verbeck Musical Sales Co.
435 William Street
Buffalo, New York

Chicago Display
Sixth Floor, Republic Building

Or write direct to

The DELPHEON COMPANY

BAY CITY

MICHIGAN

THE STANDARD AUTHORITY



OF THE INDUSTRY IT SERVES

A Price Announcement

For over twelve years, the size of The Talking Machine World has steadily increased.

For over twelve years the editorial scope of The Talking Machine World has steadily grown.

For over twelve years the circulation of The Talking Machine World has steadily expanded.

To-day The Talking Machine World is triply dominant—in circulation, in prestige of editorial columns, and in the amount of advertising carried.

For over twelve years there has been no increase in the subscription price, but

With the May, 1918, issue the subscription price of "The World" will become \$2 a year

A Chance to Save Money

Subscriptions will be accepted at the existing rate of \$1 a year for one, two, or three years in advance, providing the remittance is in the mail prior to May 15, 1918. Every dollar spent now means a dollar saved. Act now if you want to economize.

EDWARD LYMAN BILL, Inc.

Publisher of
THE TALKING MACHINE WORLD
THE MUSIC TRADE REVIEW
E. L. B. TECHNICAL LIBRARY

373 FOURTH AVENUE
NEW YORK CITY



Nora Bayes singing exclusively for Columbia Records! Can you see the cash value of this combination?

Columbia Graphophone Co.
Woolworth Building, New York

HAS OBJECTIONABLE FEATURES

Cary Bill, Taxing Dealers Doing Business on Instalments, Excites Countrywide Opposition—J. N. Blackman Gives His Views

The National Association of Talking Machine Jobbers is keenly interested in the Cary bill now before Congress, which provides for a license of \$200 per year for all merchants selling goods on instalments, and which includes a number of decidedly objectionable features. The bill was introduced by Congressman Cary, of Wisconsin, and, although it applies only to the District of Columbia, the measure is exciting countrywide opposition.

Action by the Jobbers' Association on this bill was referred to its legislative committee, and in the meantime J. Newcomb Blackman, president of the association, has taken up the matter by correspondence with Washington, and the legislative committee is planning to take any action that is deemed advisable.

Mr. Blackman thinks that this bill is decidedly inimical to the best interests of the country, and that because of its serious faults it will practically defeat itself. Mr. Blackman points out that the bill will not regulate instalment business, but will tend to annihilate it, as it contains features that will make it practically impossible for an instalment house to do business.

VIGILANCE COMMITTEE IS ACTIVE

Issues Bulletin Regarding Operations of "Gyp" Dealer in Chicago and Is Co-operating With Music Industries Better Business Bureau

The National Vigilance Committee of the Associated Advertising Clubs of the World has entered the fight against "gyp" dealers in musical instruments who use the classified columns of newspapers to dispose of instruments from residences under claims that are generally

THREE ATTRACTIVE HANGERS

Gotten Out by the Advertising Department of the Columbia Graphophone Co. for Use of Their Dealers—Should Stimulate Sales

The advertising department of the Columbia Graphophone Co. recently prepared for the use of Columbia dealers three very attractive

this popular selection having been recorded by the Columbia Co. three different ways—an instrumental arrangement by Prince's Orchestra, a tenor duet by Campbell and Burr, and an Hawaiian guitar combination.

The hanger featuring the big war hits has a definite and timely appeal that is certain to stimulate the demand for the records listed on this hanger. The Al Johnson hanger can not fail

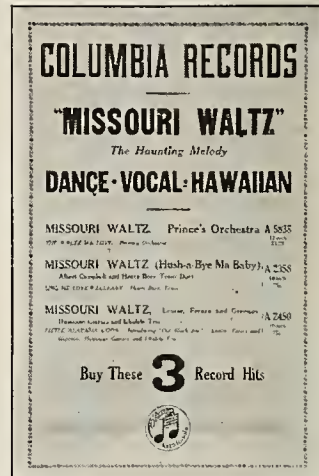

Hangers Featuring Popular Columbia Records

hangers featuring Columbia records that are destined to be successful in all parts of the country. These hangers are presented herewith, and the fact that they are being used by Columbia representatives everywhere indicates their practical value.

One hanger features the "Missouri Waltz,"

to attract attention, as this popular star is now adding to his laurels in a new revue at the Winter Garden. His rendition of the successful song, "I'm All Bound Round With the Mason Dixon Line," has won considerable praise, and this record has met with a ready sale.

questionable. The committee has gone so far as to issue a bulletin regarding the advertising of R. Nordin, appearing in the Chicago papers over that name, and also over the name of A. Nordin, F. Nordin, B. Nordin, etc.

Nordin's specialty was advertising "My beautiful \$150 Victrola size phonograph and records, guaranteed ten years. Will accept \$60. Used only ten weeks. Wonderful bargain, etc." The

Vigilance Committee declares that the name Victrola is misleading, and that Nordin handles another make of phonographs. An advertising agency is also mixed up in the case, having placed the advertising for Nordin.

The National Vigilance Committee is working in co-operation with the Music Industries Better Business Bureau, and bulletins covering other transactions will soon be issued.

Dayton Motors

**Sold all over the world
Used in all high class
Talking Machines**

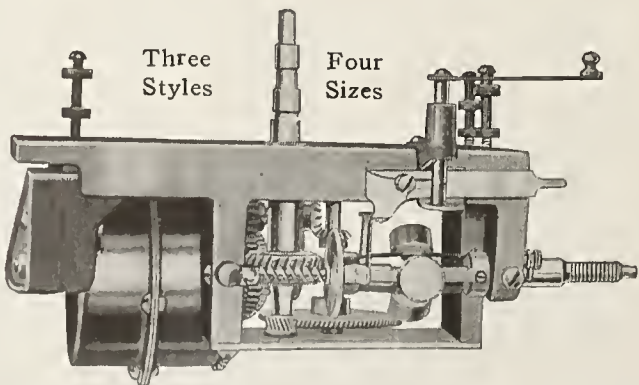

They have won wonderful and enduring popularity and embody the silent running, reliable and durable features that delight the customer and satisfy the builder. The Dayton Motor is considered by manufacturers and users as being

The Best Built Motor in the World

It has made good in Thousands of machines. Give us an opportunity to prove it.

Build satisfaction into your products by using our Quality Line—Dayton Motors, Dayton Tone Arms, Dayton Reproducers. All styles and sizes. They will bring you more business and satisfy your customers. Write for full particulars.

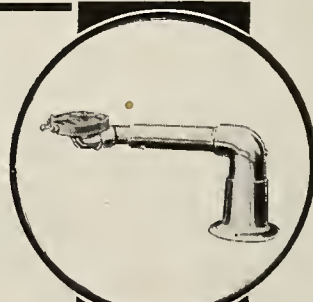

THE THOMAS MFG. CO., 322 Bolt Street, DAYTON, OHIO, U. S. A.

McCORMACK'S SAN FRANCISCO CONCERT REALIZES \$24,700 GETTING AFTER THE "GYP" DEALERS

Famous Irish Tenor Scores Phenomenal Success in Concert for American Red Cross—Sherman, Clay & Co. Co-operate in Generous Way—Entire Affair Splendid Evidence of Patriotism

SAN FRANCISCO, CAL., April 4.—Local talking machine and music circles are still agog over the recent sensational appearance of John McCormack, the famous Irish tenor, in this city. Mr. McCormack's appearance in the interests of the American Red Cross served to enrich the funds to the extent of \$24,700.

The admittance fees—the place was filled—totaled close to \$20,000, and Tom Skeyhill, the

brought \$550 from J. J. Tynan, while Mayor Rolph paid \$250 for "I Hear You Calling Me." Mrs. S. R. Maynard paid an even \$500 for the "Long, Long Trail," and Mrs. E. J. Knight paid a like amount for the Berceuse from "Joselyn." Skeyhill auctioned the records off until his voice failed him and he was led from the platform in a storm of cheers.

McCormack sang unimagined pathos and beauty into "Mother Machree," which came as an encore. "Has Sorrow Thy Young Days Faded" brought tears to the eyes of many, and it is no exaggeration to say that the rafters rang with the applause which greeted the noble "God Be With Our Boys To-night." The program was well-balanced, with tender Irish airs and songs of the more martial type.

San Francisco has established a record for the McCormack

tour. The sale of records exceeded that of any other city. Cleveland is second with a record sale of \$3,500.

The records by McCormack which were auctioned off by Skeyhill were donated by Sherman, Clay & Co., well-known Victor wholesalers, of this city, who did their full share in making the concert a success, and incidentally arranged a most elaborate and attractive McCormack window to their store to mark the event. In the window display was a life-size figure of McCormack, as the centerpiece, which is shown herewith. The entire affair proved how patriotic are San Franciscans.

Assistant District Attorney Goldstein Planning to Prosecute Those Who Offer to "Sacrifice" Talking Machines at Prices in Excess of Real Values—Busy in Harlem District

As was prophesied some time ago, "gyp" dealers in musical instruments, and particularly talking machines, have been quick to take advantage of conditions brought about by the draft, and the sudden calling of young men from their homes and occupations. Dealers have been particularly active in the upper section of New York City, and the newspapers are quite full of announcements of machines and records offered at a "sacrifice, owing to the fact that the owner has been called to the colors and must dispose of his effects." Assistant District Attorney Goldstein has taken cognizance of the activities of "gyp" dealers, and is investigating their operations. He threatens that when sufficient proof is forthcoming he will take immediate action to stop their activities.

Investigators in one instance, lured by the announcement that a "\$200 model machine and library of records, little used, could be purchased for \$60 from a young man Upton-bound," found that not only could the machine on exhibition in the front room of the apartment be purchased at the special price, at least 50 per cent. more than it was really worth, but there were a dozen or more machines in the adjoining room ready to be moved in and "sacrificed" one at a time.

Mr. Goldstein urges that dealers, or individuals, who obtain proof of fraud in the operation of "gyp" dealers, communicate with him that he may take legal action. It may also be said that dealers in other cities who run against "gyp" operations can secure action by reporting the same to the Music Industries Better Business Bureau in Milwaukee, who are co-operating with the National Vigilance Committee of the Advertising Clubs of the World, in an effort to check the evil in all sections of the country.

OCCUPYING NEW QUARTERS

William Gulden, furniture and talking machine dealer of Union Hill, N. J., is now located in a fine new store at 149 Bergenline avenue. Mr. Gulden features the Brunswick phonograph.



Sherman, Clay & Co. Window Advertising of McCormack's Concert

twenty-one-year-old Anzac boy who for three years battled with the English colonial forces, to leave his eyes behind him on the western front, sold records of the golden McCormack voice, adding \$5,250 to the box office receipts. All will be given to the Red Cross.

Skeyhill, his sightless face making mute appeal to the hearts of the audience, was eminently successful as a seller of records. The "Star-Spangled Banner" went to E. J. Carroll, of the St. Francis Hotel, at \$550, and E. Brule, of the Palace Hotel, paid \$1,000 for "The Sunshine of Your Smile," immediately reselling it for \$500. "Keep the Home Fires Burning"

CHANGES IN PORTLAND STAFFS

Various Talking Machine Men Make New Connections in That City and Vicinity

PORTLAND, ORE., April 3.—Many changes have taken place in the employed forces of the talking machine departments of local big music houses in the last month. C. B. Cordner, of Eilers Music House, has taken the position of manager of the talking machine department, succeeding to the place formerly held by H. S. Rayner, who is now in Seattle with the Hopper-Kelly Co. Mr. Cordner is well known and well liked by Portland people. He has long been with the Eilers people. The new manager has started out a drive for cash sales and has been having remarkable success, due, he believes, to the prosperous condition of the people of Portland.

R. C. Coltart, of the Columbia Graphophone Co.'s Portland branch, has gone to San Francisco, where he will take charge of the Columbia branch there.

Henry Schmidke has succeeded Mr. Coltart with the Columbia people. Mr. Schmidke, who has been traveling for the Portland branch through the Oregon territory, is considered one of the most efficient officers of the local house.

W. L. LeVanway, Jr., has been placed in charge of the phonograph department of the Graves Music Store. The position was formerly held by I. W. Lane, who has gone to Tulsa, Okla., and is now connected with the Tulsa Automobile Co.

C. V. Jones, traveling salesman of the Portland branch of the Columbia Graphophone Co., has been meeting with big success in the spruce districts of Southwestern Oregon.

H. A. Yerkes, of New York, traveling man-

ager of the Columbia Graphophone Co., enjoyed a trip up the Columbia Highway while here. Mr. Yerkes and his wife were guests of L. D. Heater, manager of the local Columbia branch.

"GLOBE" TRANSFER NAME PLATES



STYLE 1



STYLE 2



STYLE 3



STYLE 4



STYLE 5



STYLE 6



STYLE 7

Illustrations are Half Size.

WRITE FOR SAMPLES

Are being applied on Talking Machines, Pianos, Furniture, Typewriters, Sewing Machines, Sporting Goods, etc., by progressive dealers everywhere.

ARTISTIC — PERMANENT — EASILY APPLIED

You can order any of the designs illustrated opposite, Style 1 to 7, with your copy, at following prices:

- 250, \$16.00 2000, \$40.00
- 500, 20.00 3000, 50.00
- 1000, 27.50 5000, 65.00

Terms, 30 days net, F. O. B. Jersey City, N. J. Firms not rated should send cash with order. No C. O. D. orders accepted.

Write for folder, "You Need Decalcomanie In Your Business."

GLOBE DECALCOMANIE CO.

Manufacturers and Importers

74 Montgomery St.

JERSEY CITY, N. J.

TRANSFERRING OUTFIT

Consisting of one 1 in. Felt Roller, Bottle of Transfer Size, Brush and complete directions shipped with every order.



STOP! LOOK!

VICTOR DEALERS

If you are unable to obtain the Victor records you want, why not push the sale of those available. We have a good supply of the following, most of which are desirable. Have your sales-people play these for your trade and you will be surprised at the amount of obtainable records you can sell. Let us have your order at once for any of this list and any others you can use. Orders will be shipped same day received.

17525	17789	18006	18179	35009	35579	60136	64637	76030	88510
17592	17790	18007	18180	35333	35581		64641		88511
17606	17801	18008	18187	35349	35587	64442	64645	87121	88512
17629	17812	18009	18188	35362	35588	64450	64652	87138	88513
17630	17831	18013	18191	35372	35589	64482	64660	87161	88514
17631	17836	18021	18197	35396	35590	64491	64661	87166	88515
17636	17844	18022	18200	35402	35593	64492	64664	87172	88518
17637	17850	18024	18201	35404	35595	64493	64665	87174	88519
17644	17851	18025	18203	35405	35596	64496	64675	87177	88520
17649	17857	18027	18213	35406	35597	64497	64677	87178	88524
17658	17866	18041	18216	35414	35599	64498	64705	87183	88533
17659	17875	18044	18217	35417	35600	64500	64713	87189	88534
17667	17879	18050	18218	35421	35604	64505	64732	87190	88536
17671	17883	18053	18227	35422	35607	64512	64741	87193	88542
17674	17889	18058	18229	35431	35609	64513	64747	87194	88545
17676	17896	18061	18232	35436	35612	64516	64761	87195	88547
17678	17903	18067	18234	35438	35616	64518		87201	88548
17679	17905	18072	18235	35439	35617	64520	65715	87209	88550
17680	17908	18078	18236	35445	35618	64530	65717	87220	88555
17683	17912	18080	18244	35478	35619	64532		87228	88556
17684	17915	18088	18253	35480	35626	64533	74163	87235	88557
17691	17916	18108	18262	35487	35627	64537	74392	87239	88562
17692	17923	18109	18270	35488	35634	64539	74406	87244	88564
17693	17933	18123	18285	35495	35636	64541	74420	87246	88568
17698	17938	18125	18293	35496	35640	64542	74421	87248	88569
17699	17949	18128	18294	35501	35649	64545	74429	87253	88571
17707	17961	18129	18300	35502	35654	64550	74434	87254	88574
17708	17963	18134	18312	35505	35656	64552	74443	87256	88577
17711	17967	18136	18314	35514	35661	64553	74450	87260	88582
17713	17970	18137	18315	35521		64554	74452	87261	
17722	17972	18138	18317	35523	45076	64562	74458	87262	89052
17726	17973	18139	18320	35528	45092	64582	74459	87265	89053
17728	17977	18141	18328	35535	45095	64585	74462	87270	89058
17734	17978	18143	18340	35541	45097	64591	74479	87271	89064
17748	17981	18150	18349	35542	45106	64595	74486	87510	89068
17749	17985	18151	18355	35546	45107	64601	74492		89072
17751	17987	18153	18361	35548	45108	64608	74495	88447	89077
17752	17992	18154	18363	35550	45112	64613	74497	88467	89078
17753	17993	18156	18365	35554	45113	64615	74498	88478	89080
17754	17994	18164	18371	35556	45117	64616	74504	88482	89082
17758		18165	18379	35561	45121	64617	74505	88486	
17762	18000	18166	18406	35562	55043	64624	74506	88496	95207
17763	18001	18169	18411	35571	55075	64626	74511	88497	95208
17769	18002	18173	18414	35572	55080	64628	74528	88503	95212
17770	18003	18175	18414	35574		64630		88505	
17778	18004	18176	18428	35576	60093	64635	76020	88506	96200
17783	18005	18178	18429	35578	60133	64636	76027	88508	96201

W. D. & C. N. ANDREWS
BUFFALO, N. Y.

The Importance of Knowing Both Your Own and Your Competitors' Line :: :: By Frank D. Parsons

The ideal talking machine salesman is careful to maintain the reputation of his wares. Every instrument has a certain standing and reputation, and it behooves the retail salesman to guard that reputation as carefully as though he himself were the manufacturer. To accomplish this the salesman must know his line thoroughly—must know its good points, its exclusive features, and also its defects, if any there be. In addition to this he must also have a general knowledge of competing lines and their merits and shortcomings. A knowledge of the peculiarities of competing instruments is invaluable to the salesman.

It is human nature for a prospective customer to walk into a talking machine store, and disparage the line of instruments for sale therein, praising the qualities of some other line. This is done, often as not, not because the prospect really believes the other line is better, but because he, the prospect, wants to settle his mind absolutely in regard to the instrument the salesman is showing him, before the sale is consummated. In other words, the prospect wants to convince himself that he is making the best possible purchase, and if the salesman can point out the difference between his products and those being sold by a competitor, and point out these differences so clearly and convincingly that the prospect remembers and believes the salesman's statements, the sale will not only be made, but it will "stick."

In doing this, however, the salesman must carefully refrain from "knocking." The verbal hammer of the salesman, pounding against a competitor's line, has spoiled more possible sales than any other single factor. If the

prospect praises the tone of a competing line, the salesman should be able to point out the fact that this own line is equal, if not superior, in tone to the instrument being praised by the prospect, and to do this the salesman must know enough about the principles of construction to prove that his line need not take second place when compared with competing instruments. If the prospect is enamored of some special feature of case design in a competing line, the salesman should know enough about case construction to point out the special features embodied in his own instruments, and be able to convince the prospect of the beauty and attractiveness of the wood and the finish,

as well as other points which his line possesses.

These and similar arguments can be used most effectively by the salesman, without in any way knocking his competitor, or his competitor's line. The arguments can only be made effective, however, if the salesman has a thorough knowledge of his own line, and knows enough concerning competing lines to talk about them intelligently. The salesman who attempts to sell talking machines without first fortifying himself with a practical knowledge of the instruments he is selling is no surer of success than would a schoolboy be of solving a problem in algebra without first having committed to memory the multiplication table.

MOULDING THE AMERICAN CITIZEN

Striking Victor Co. Advertisement Calls Attention to What the Victrola Is Doing in the Schools of the Country Just Now

One of the most effective Victor advertisements yet presented was that appearing in the Saturday Evening Post of March 23, which emphasized in a striking manner, through the medium of both text and illustrations, the strong position held by the Victrola in the schools of the country. The advertisement was captioned: "Moulding the American Citizen of To-morrow," and offered an appeal along a new line. The border was made of a series of views showing the Victor machine furnishing music for folk dances, singing and writing exercises, calisthenics, etc., in graded and high schools, and the text called attention to the fact that the Victrola was used in more than 25,000 public schools in 6,000 cities and towns. The Victrola XXV,

manufactured especially for school use, was shown in one corner of the announcement.

RECEIVING CONGRATULATIONS

G. C. Jell, general manager of the recording laboratories of the Columbia Graphophone Co., New York, is receiving the congratulations of his friends and co-workers upon the arrival at his home a fortnight since of a baby girl, who has been christened Mary Caroline. Miss Jell will doubtless have unlimited opportunities to become an operatic artist, under the guidance of the Columbia recording laboratory manager.

HOLD OPENING OF NEW QUARTERS

The Victoria Music Co., Wilmington, N. C., recently held the opening of their new quarters in the new Theatre Building, at the corner of Second and Market streets. The company features Victrolas and records exclusively.

A HERZOG Cabinet for the Victrola IXA

And we have other cabinets for all talking machines and phonographs. HERZOG Art Record Cabinets are correctly designed, substantially constructed and exceedingly well finished. They stimulate the sale of machines and records. Many are being sold daily to those who already own small machines and the dealer who does not carry a representative stock of HERZOG Record Cabinets is overlooking a prolific source of additional and easy profits.

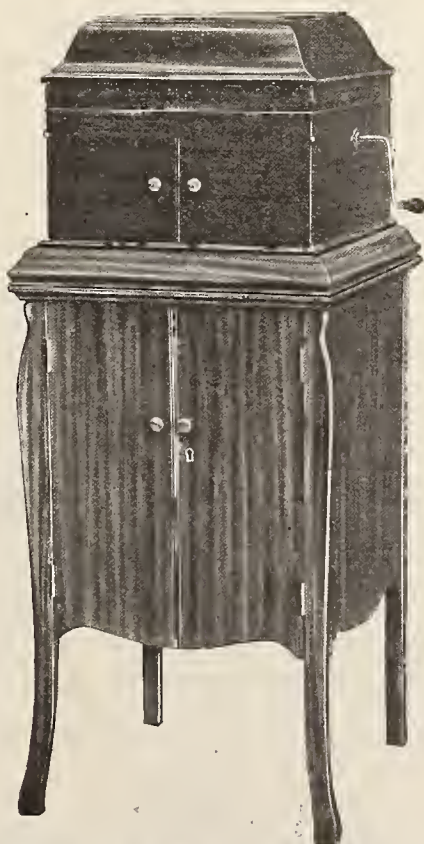

A handsome new Catalog showing the complete line is just off the press. Ask for a copy of Catalog No. 22 and see the biggest and best line of Art Record Cabinets on the market.

Artistic
CABINETS
for
All Machines

HERZOG ART FURNITURE CO.,

SAGINAW, W. S., MICH.



Good intentions! Honestly, now, do they ever get you anywhere? Put your sales problems up to Columbia Dealer Service Department TODAY. We're only waiting to hear from you.

**Columbia Graphophone Co.
Woolworth Building, New York**

COLUMBIA DEALERS HOLD MEETING

Lambert Friedl Prepares Many Interesting Subjects for Discussion at Third Monthly Gathering of Columbia Retail Dealers

The third monthly meeting of Columbia dealers was held last month in the auditorium of the Columbia Shop, and a representative gathering of Columbia retailers was on hand to participate in the various business discussions that constituted the program. Lambert Friedl, manager of the local wholesale branch of the Columbia Graphophone Co., who inaugurated these meetings, prepared for the dealers a number of interesting topics that were the subject of serious discussion, the principal topic being the new Columbia records, which will be issued on April 10.

Ralph W. Knox, advertising manager of the



Lambert Friedl

Columbia Co., delivered an effective and timely address regarding the company's advertising plans for the present and the future, telling the dealers how they can tie up their local advertising with this campaign, and pointing out just what the publicity will represent. Edward N. Burns, vice-president of the Columbia Co., who is taking a keen interest in Columbia recording,

and G. C. Jell, general manager of the recording laboratory, were also present at this meeting for the purpose of deriving all possible benefit from the dealers' suggestions, etc.

A number of Columbia artists rendered pop-

ular selections as a part of the musical program: the artists present including Chas. W. Harrison, Frank Croxton and Reed Miller, with Chas. A. Prince at the piano. A. Oblo, a successful Columbia dealer in Brooklyn, N. Y., also gave a number of musical selections.

At the close of the meeting the dealers expressed their hearty enthusiasm regarding the practical value of these business sessions, and it is quite likely that Mr. Friedl will call these meetings regularly for the next few months.



Columbia Retailers Who Attended Recent Monthly Meeting

ular selections as a part of the musical program: the artists present including Chas. W. Harrison, Frank Croxton and Reed Miller, with Chas. A. Prince at the piano. A. Oblo, a successful Columbia dealer in Brooklyn, N. Y., also gave a number of musical selections.

They give the dealers an opportunity to get together and talk over common business problems, and under Mr. Friedl's direction every possible effort is being made to co-operate with the dealers and carry out their suggestions along practical lines.

BEAUTIFULLY EQUIPPED QUARTERS

Now Occupied by the Outlet Co., Which Celebrates Its Eighteenth Anniversary

PROVIDENCE, R. I., April 3.—The Victrola department of the Outlet Co., of this city, recently celebrated its eighteenth anniversary, and Manager Harold A. Glasser, who for a long time was identified with the Victor trade in New York City, has been receiving congratulations on the success of this enterprise, which is the largest Victor establishment in the State of Rhode Island.

In the new talking machine department, which is located on the third floor of the monster Outlet building, there are eighteen soundproof booths, a complete repair shop, a record library, office, and a room devoted especially to the sale of records by telephone. The entire woodwork is finished in antique oak, and the booths are so

attractively arranged that the entire department is one of the most imposing and most artistic to be found anywhere in the trade. Mr. Glasser is quite enthusiastic about the trend of business this spring, and is preparing for one of the most satisfactory years in the history of this house.

NEW PAMPHLET ON DECALCOMANIE

Containing Samples of New Name Plates for Talking Machines by Smith-Schiffin Co.

The Smith-Schiffin Co., manufacturers of "Magnet" decalcomanie name plates, are finding the demands for their product to be greatly on the increase, so states Geo. A. Smith, of the firm. Since the first of the year the calls for samples and the return orders from dealers have been very heavy, and this, with the addition of a substantial demand from the manufacturing trade, has kept the company working to capacity. A new pamphlet is now being sent out to the trade containing facsimile illustrations of name plates together with price quotations.

Whether a commander of a ship or a stoker in the ranks, "act well your part; there all the honor lies." And if called upon to assume the heavy burdens and great duties—go to them without flinching.

COTTON FLOCKS

.. FOR ..

Record Manufacturing

THE PECKHAM MFG. CO., 238 South Street
NEWARK, N. J.



The "INVINCIBLE"

The Sound-Box that has Gained the World's Confidence

- ☑ Plays all makes of records perfectly.
- ☑ Pure, clean, sweet and with a solid and round tone.
- ☑ Constructed to give service and absolutely guaranteed.
- ☑ No superfluous parts, and production uniform—no seconds
- ☑ Supplied with mica or our special composition diaphragm.

Write today for samples and prices. Ask also to send you our No. 2 "Invincible."

NEW JERSEY REPRODUCER CO.
847 Broad Street
NEWARK, N. J.

NEEDLES

Manufactured by the

DEAN DIVISION

of the

OTTO HEINEMAN PHONOGRAPH SUPPLY CO.

INCORPORATED

25 WEST 45th STREET, NEW YORK

FACTORIES: Elyria, Ohio Newark, N. J. Putnam, Conn.

BRANCH OFFICES: Chicago, Ill. Cincinnati, O. Seattle, Wash. Toronto, Ont.

STEEL NEEDLES

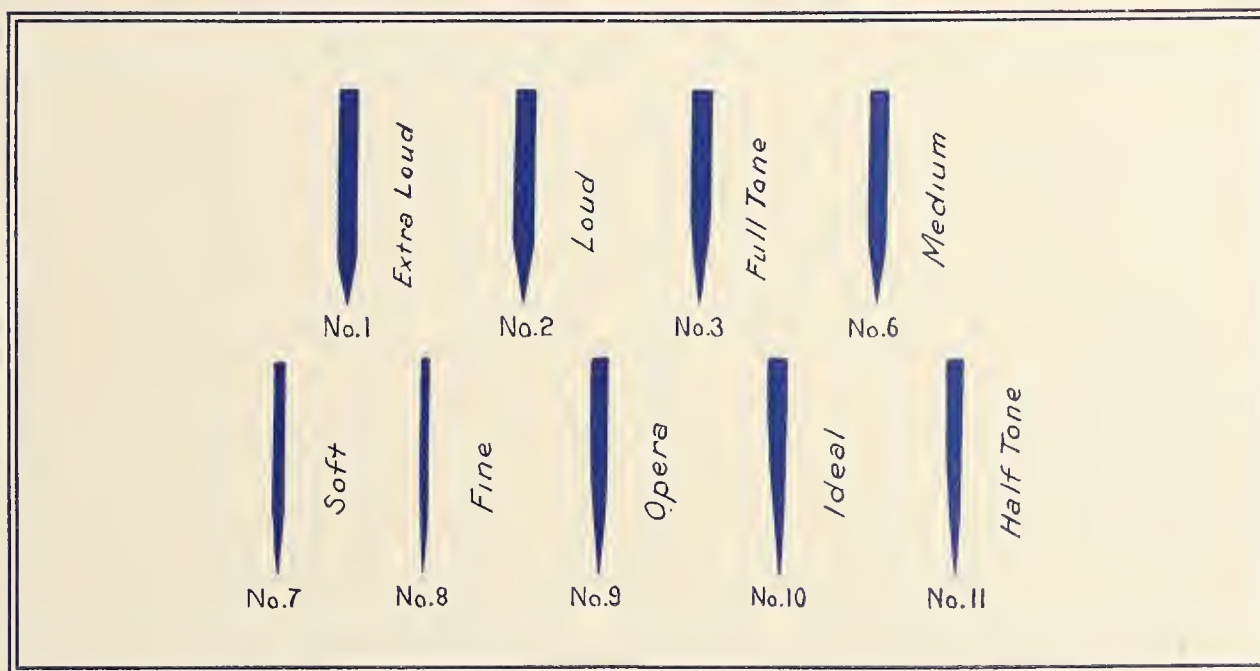

PERMANENT NEEDLES

TO PLAY PATHÉ RECORDS

Half Tone Points

Full Tone Points

TO PLAY EDISON RECORDS

Sapphire Points

Genuine Diamond Points



PORTLAND, ORE., ASSOCIATION MEETS

Many Interesting Business Questions Discussed—Urged That Terms Be Held Up to Good Standard—Condemn Approval Practice

PORTLAND, ORE., April 2.—The monthly meeting and banquet of the recently organized Portland Dealers' Talking Machine Association, held at the Imperial Hotel March 19, did much to cement business relations between the dealers in this city and to wipe out unfair methods of competition. Following a delightful banquet, E. B. Hyatt, president of the association, called the twenty-one members to order and an interesting session was held in which many things of interest to the local trade were discussed.

L. D. Heater, manager of the Columbia Graphophone Co., and James Loder, manager of the talking machine department of the Bush & Lane Co., called particular attention to the necessity of keeping terms up to a dignified and businesslike standard—to put the goods before the public and sell them in a legitimate way. It was decided that the firms should all require payment of 10 per cent. down and require the contract to be paid up within one year.

Taylor C. White, manager of the talking machine department of Sherman, Clay & Co., and L. D. Heater started a discussion in regard to sending out records on approval. The practice was generally condemned, the speakers maintaining that the public abused the confidence of the dealers in this way and injured the records. There were a few present, however, who thought that better business could be obtained by the old method of allowing customers the privilege of taking records home to make their selections in that way.

Attention was called to the fact that there were dealers who were offering records free with higher-priced machines as a means of developing trade. Stress was laid on Portland's present prosperity and the needlessness of this method of getting business, and the dealers all finally agreed to discontinue any such practice. It was decided that the records henceforth should all be sold separately. Almost all the houses have been following this course of separate sales.

The best of feeling was exhibited at the meeting, despite wide variance of opinion on some of the subjects discussed, and there was no doubt that the association has co-ordinated the business, and that the firms are now on the best of terms with each other and are disposed to help one another, whereas before the association was formed each firm was out for itself to the detriment of the talking machine business as a whole.

The representative of The Talking Machine World was elected to honorary membership in its association.

MAURICE LANDAY GETS ACTION

Proves Right Man as Advertising Manager of "The Range Finder," Issued by His Artillery Regiment Now Stationed at Fort Hancock

Maurice Landay, brother of Max and James Landay, of Landay Bros., local Victor wholesalers, is a private in Battery E, Fifty-seventh Artillery, C. A. C., at present stationed at Fort Hancock, N. J., and incidentally fills in his spare time as advertising manager of "The Range Finder," a snappy publication gotten out in the interests of the regiment at various intervals. The magazine is full of clever cartoons, excellent jokes and interesting articles regarding army life and happenings at the Fort.

Mr. Landay has shown convincing proof of his ability as advertising manager by lining up several pages of good business for the publication, a number of local talking machine jobbers having taken liberal space.

The regular quarterly dividend has been declared by the Victor Talking Machine Co. on both common and preferred stocks, payable April 15 to holders of record March 31.

SHOW FILMS OF VICTOR PLANT

Talking Machine Dealers in Pittsburgh See Motion Pictures Showing How Victrolas and Records Are Manufactured—Large Attendance

PITTSBURGH, PA., April 10.—A large number of talking machine dealers in the local territory, as well as a generous sprinkling of the public at large, had the opportunity last night of seeing by means of motion pictures just how talking machine records are made in the factory of the Victor Talking Machine Co. The film, which has been shown in various sections of the country, was made under the direct auspices of the Victor Talking Machine Co., and its showing in this city was arranged for by the Pittsburgh Talking Machine Dealers' Association. The exhibition was held in the auditorium of the Chamber of Commerce, and officers of the association made special efforts to secure a large attendance, particularly of dealers and their employes. The general results were most gratifying.

COMES HOME FROM THE WAR

Louis Older, of Portland, Ore., Honorably Discharged From Canadian Service

PORTLAND, ORE., April 2.—Portland boasts one veteran of the great European war among its talking machine men—Louis Older, recently Private Louis Older, of the First Depot Battalion, Vancouver, B. C. Mr. Older prior to the war was known as the pace-maker and enthusiast of the Columbia Graphophone Co.'s Portland branch. He has now returned to Portland and has resumed his duties with the Columbia people.

Mr. Older obtained an honorable discharge after serving seven months in Canada and Scotland. He enlisted and was assigned to the forestry division and was in Scotland when he was kicked by a horse, the accident incapacitating him from further war duty—a broken ankle and stiff knee being the regrettable result of the accident.

OPEN NEW BRANCH IN ROME, N. Y.

Buckingham & Moak, well-known piano and talking machine dealers of Utica, N. Y., have opened a new store at 170 West Dominick street, Rome, N. Y., where in addition to pianos and other musical goods they will feature the Vocalion phonograph.

PLAN EDISON DEALERS' CONVENTION

Annual Sessions to Be Held at Waldorf-Astoria Hotel During Week Beginning June 3

The annual convention of the Edison phonograph dealers will again be held in New York this year, and is scheduled to occupy the entire week, beginning on June 3, with headquarters at the Waldorf-Astoria Hotel, where last year's convention was held. While, of course, it is too early to judge, it is nevertheless believed by the Edison officials that this year's convention will surpass in attendance that of last year, which in itself broke all previous records for gatherings of that nature.

It will be a dealers' convention in every sense of the word, and they will be in charge of all sections of the convention. Plans are now being laid for the preparation and reading of a number of special papers, both by the dealers themselves and by factory officials who will be invited to attend.

A particularly interesting fact in connection with this year's convention is that it will be held during the week of the National Music Show at the Grand Central Palace, at which Thomas A. Edison, Inc., will have an elaborate exhibit. The various piano trade associations will also hold their conventions the same week, which will tend to make New York City a musical center for the time being at least.

AN ATTRACTIVE ESTABLISHMENT

Odeon Music Co. Handling Brunswick Phonographs in New Brunswick, N. J.

NEW BRUNSWICK, N. J., April 3.—The Odeon Music Co., 28 Liberty street, this city, has a most attractive establishment for the sale of all kinds of musical instruments, including pianos, player-pianos, Brunswick phonographs, as well as music rolls and sheet music. The company, of which D. E. Elmer is president, and J. C. Cramer is manager, have installed three soundproof demonstrating booths in their phonograph department and have equipped them in an elaborate manner with rugs, comfortable furniture, decorative plants, etc., and report an excellent business.

Miller & Kades of Harrisburg, Pa., have recently installed six soundproof booths costing \$6,000. This firm is the sole distributor of the Columbia line in that district and reports an increase of 50 per cent. in business last year.

LIBERTY BONDS—BOSTON ALBUMS SAFEST INVESTMENTS

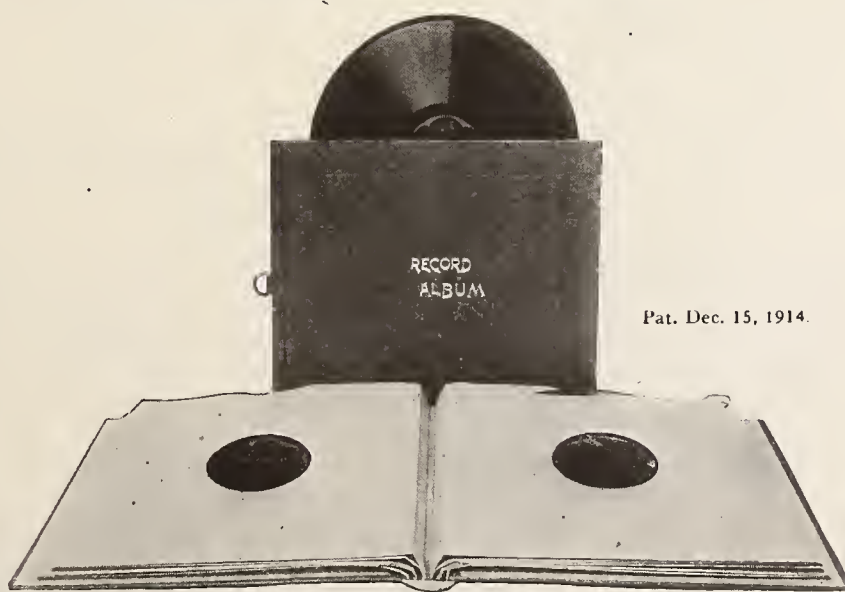

Buy Your Albums Direct From the Manufacturer

43-51 W. Fourth St.
New York, N. Y.

THE BOSTON BOOK CO., Inc.

The only exclusive Record Album Factory in the world.

Chicago Office:
1470 So. Michigan Ave.



DO IT NOW

This is your busy season and ours.

We strongly advise that orders for future delivery of B & H Fibre Needles be placed as early as possible in order to secure prompt delivery.

Your orders will be entered and delivered in such installments as your needs may require.

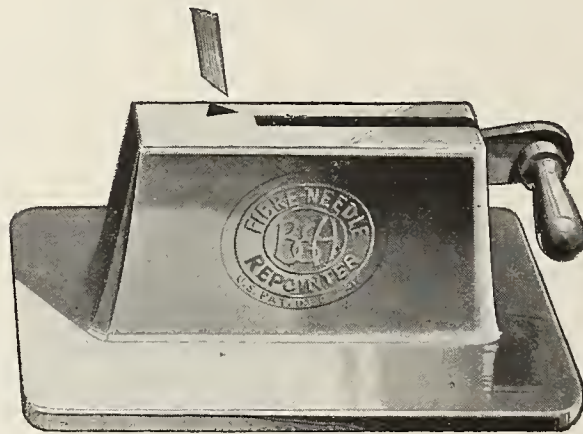

U. S. Patent December 5, 1916

Don't forget to place sample orders for the B & H Fibre Needle Repointer.

It constitutes the most practical and logical method of repointing the fibre needle.

B & H FIBRE MANUFACTURING CO.

33-35 West Kinzie Street

CHICAGO, ILL.

PHENOMENAL MONTH'S BUSINESS IN PORTLAND, ORE.

Leading Houses Make Most Encouraging Reports Regarding Business, But Complain of Shortage of Machines and Records—Fine Spirit of Optimism Prevails Throughout the Trade

PORTLAND, ORE., April 2.—Talking machine dealers in Portland report spring business of such volume as never before experienced in this district. March sales eclipsed all marks, both for machines and records, and the only real complaint heard among the dealers is regarding transportation conditions and shortage of stock.

So heavy has the demand for Victrolas been in Portland that an actual shortage exists and many dealers have lost sales through inability to deliver desired models.

The Wiley B. Allen Co., of Portland, followed its February business, which was 100 per cent. increase over that of February, 1917, by making even a better record for March, the figures for the latter month being even greater than that of the big San Francisco house. Shortage of stock alone prevented Wiley B. Allen from breaking all existing records at the Portland branch. In spite of this Paul B. Norris reports a wonderful sale of Victor and Edison machines and the rapidly diminishing stock testifies to the fact. Hopes are entertained for an early arrival of new machines and Mr. Norris says unless more stock is soon forthcoming there will be a big falling off in business.

Sales continue large at the Hyatt Talking Machine Co. store. E. B. Hyatt, manager of the firm, says trouble has been experienced in getting Victrolas, especially models Nos. 14 and 16. In one week 250 "Joan of Arc" records were disposed of by this house and 150 more have been ordered. A big new consignment of Edison records has just arrived and Miss Emma Reynolds, who has charge of the record department, says they are an unusually fine lot. Mr. Hyatt says the demand for Columbia machines keeps up well and this is especially pleasing inasmuch as the Columbias are much more easily obtained than are the other lines.

February and March were the biggest months

ever experienced by the Portland branch of the Columbia Graphophone Co. L. D. Heater, manager of the house, says that he had thought December, 1917, would for a long time be unparalleled, but that February showed 2,000 more records sold than in December, and March even more than in February. Columbia machines have been finding a greater sale than ever before, too, and this is in part attributed to the fact that a great deal of the competition has been removed because of shortage of stock in the Victor and Edison lines. Mr. Heater, however, says that there is little hope of escaping a real shortage of Columbia machines because of the ever-increasing demand and railroad conditions which prevent the arrival of enough machines to supply this demand. The Columbia Co. has heretofore always been able to supply all retail houses, but Mr. Heater says before long customers will have to wait.

So great has been the increase of business in the Dictaphone department of this company that it has been found necessary to buy an additional truck to speed the delivery. L. C. Callahan, manager of the Columbia Dictaphone department, says that the trade for February and March has never been equaled in Portland.

Sonora machines have been finding a ready sale at the Bush & Lane house. Patrick Murphy has been making some big deals, one \$375 Sonora invincible topping a goodly list of sales for the last month. Mr. Murphy also disposed of a big line of Victrolas in the last month. James Loder, manager of the department, declares that the high-priced Sonoras and Victors are the favorites in Portland and he says if present indications are to be trusted the month of April will be a memorable one for the department.

Excellent results have been obtained in the Victrola department of the G. F. Johnson Music

Co.'s store. The firm is now well established in business and though it has only been in operation five months, a growing list of customers attests to the fine management and the excellent character of the house. A lack of Victrolas and records interferes with some sales, but Mr. Johnson says freight is slowly delivering long-belated orders and a fine spring trade is regarded as certain.

The Meier & Frank Co. received a big shipment of Edison records which have been on the way for some time and a good supply of Edison machines is still in stock at this big house. Large sales of Edisons are reported, the \$100 and \$160 models being the best sellers. The house reports a shortage of Victor records and machines and therefore curtailed sales of these instruments for which the demand continues strong. Miss Madeline Larsen, saleswoman in this department, says there is a good stock of Columbia records and machines and that sales of these goods have been heavy.

The Wakefield Music Co. reports big sales of Brunswick phonographs. Several machines a day has been the record for the last month or so and Miss Hazel Raymond, in charge of the record department, says that never has the demand for records been so great.

The Reed-French Piano Co. has been having a fine trade in Columbia and Edison machines and the spring business is said to eclipse all previous marks at this store.

The Edwards Furniture Co. is congratulating itself on the receipt of a shipment of forty-seven Unolas from Chicago, which were on the road only twenty-one days. A big shipment of Brunswicks was also received by this house, which reports ready sales. J. E. Allen, manager of the talking machine department, says he is finding it increasingly difficult to procure enough sales people to look after the business which has been constantly expanding.

The Copp Music Shop of South Bend, Ind., Victor dealers, are planning to enlarge their establishment.



Get the Benefit
of the big business doing right now on both talking machines and records by handling

SALTER
Felt Lined Cabinets

These two styles are not only remarkable outfit sellers but are equally attractive to people who have cabinet machines but need more record storage capacity.

SEND FOR CATALOGS

Showing many other attractive styles.

We also make a beautiful line of sheet music and music roll cabinets.

SALTER MFG. CO.
337-49 N. Oakley Boulevard
CHICAGO, ILL.



No. 19. Cabinet
(DOUBLE DOOR FRONT)
Made especially to hold the Victor-Victrola, No. IXA

No. 111. Cabinet (Opened)
For Columbia \$50.00 Machine
33 1/2 inches high. Top, 23 x 19 1/2 inches

Talking Machine Men

BUY LIBERTY BONDS



THEN

**PROTECT
YOURSELF**

and buy Brilliantone Steel Needles
at Present Prices

FULL TONE HALF TONE EXTRA LOUD

American Made by American Labor

WRITE
FOR
SAMPLES



WRITE
FOR
PRICES

The Truly Reliable and Honestly Meritorious Steel Needle



the Needle of uniform length
the Needle with uniform points
the Needle that is uniformly hard
---Therefore---THE BEST



BRILLIANTONE STEEL NEEDLE CO., OF AMERICA, INCORPORATED

Suite 657-659 Marbridge Building, Broadway at 34th Street

B. R. FORSTER, President

NEW YORK CITY

HALLET & DAVIS START CAMPAIGN

Famous Boston Institution Arrange for Active Development of Their Pathé Business With R. O. Ainslie as Manager—Affair Started With Dinner and Business Meeting

BOSTON, MASS., April 1.—Toward the middle of March the Hallet & Davis Co. started in on a campaign by way of booming the Pathé line of machines, and the program was opened with a dinner at the Hotel Thorndike which was attended by the officers and managers of the Hallet & Davis Co., and several from New York, including Eugene Widmann, president of the Pathé Co., and James Watters, the secretary of the company. The dinner was followed by a business meeting in the concert room of the Hallet & Davis Co., 146 Boylston street. The purpose of the meeting was to explain the Pathé advertising campaign and to perfect plans for the distribution of the Pathé line throughout New England. This meeting was presided over by O. A. Card, the Hallet & Davis retail manager, and there were speeches by C. C. Conway, vice-president of the company; Secretary Watters, President Widmann and R. O. Ainslie, who has come from the West to take the management of this new Pathé line for the Hallet & Davis house.

The advertising campaign was begun in one of the Boston newspapers on the following Sunday, and the local house began at the same time to establish many new Pathé dealers both in Boston and in New England, and one roadman has been kept busy doing nothing else but visiting those who are anxious to take on this line of talking machine. In the meantime the retail business has been very large this past fortnight, and it has been necessary to increase the floor salesmen to take care of customers who have been flocking to the store both day and night, for the Boylston street warerooms have been open every evening since the campaign was on. In the delivery of goods it is a fact that the vans and trucks have been busy up to midnight. Each day since the campaign was opened it has been gathering momentum and the success of the present Pathé campaign is now an assured success. The Hallet & Davis dealers everywhere have been heartily co-operating with the home offices and this has meant a lot in creating popularity for these machines.

Mr. Ainslie, the new manager, is a Williams college graduate, and has had some valuable experience in the commercial world, and therefore comes to the Hallet & Davis house well fitted for taking up this new work. He says that the whole phonograph business among the Hallet & Davis dealers all over the country is going way ahead of all expectations and the roadmen are putting in a lot of their time on this department of the business and are sending in large-sized orders for Pathéphones and Pathé records every day.

HEAVY LOSS CAUSED BY FIRE

Many Machines and Records Destroyed in Store of W. F. Frederick Co., in Johnstown, Pa.—Planning to Open New Quarters

JOHNSTOWN, PA., March 30.—The building occupied by the local retail warerooms of the W. F. Frederick Piano Co. was completely gutted by fire on March 17. The entire loss to the stock of the Frederick Co. totaled over \$60,000, and in addition to a number of pianos and player-pianos, there were destroyed over seventy-five Victrolas, and over 5,000 records, valued in all at about \$15,000.

Pending the opening of new retail quarters, the company is now doing business direct from its large warehouse, where, fortunately, there was a considerable reserve stock, and the other stores of the company were also called upon to fill gaps in the stock where possible. The business offices are maintained at 221 Franklin street, a few doors from the burned building, for the convenience of the public, until new quarters are ready.

HEARS OWN VOICE ON VICTROLA

Miss Marion Harris, Victor Artist, Visits Sherman, Clay & Co. in Tacoma, Wash.

TACOMA, WASH., April 1.—While Marion Harris, the well-known concert singer and Victor artist, was in this city recently, in the course of a recital tour, she visited the store of Sher-



man, Clay & Co., Victor wholesalers, and took occasion to listen to the reproduction of several of her latest records. The accompanying picture shows Miss Harris enjoying the sound of her own voice coming from the Victrola, with the Victor dog on the other side, showing a very intent, even though inanimate, interest.

LARGER QUARTERS IN FRAMINGHAM

A. A. Vose, who features the Vocalion phonograph in addition to his line of pianos in Framingham, Mass., has moved to larger quarters in the new Crouch Building that city. Mr. Vose has conducted a music store in Framingham for over forty years.

FIRE IN THE POOLEY PLANT

Several completed and partially completed talking machines were destroyed in a fire which broke out in the factory of the Pooley Furniture Co., Seventeenth and Indiana avenues, Philadelphia, recently, causing \$1,000 damage.

SHOWS NEW VIBRATING HORN

Western Inventor Devises Method for Supplementing Vocal and Instrumental Tones on Records by Special Vibrating Tongues Keyed in Sympathy With Different Tones

Several times recently authorities have claimed that the chief difficulty with the present form of talking machine is that one diaphragm is relied upon to record or reproduce, as the case might be, various instrumental and vocal tones each with its distinct series of vibrations, and that confusion results therefrom to a certain extent.

Now comes an inventor from the West, Frederick Lyon, of Fayetteville, Ind., to be exact, with a new talking machine invention designed to separate and emphasize the different vibrations of instruments or voices. Mr. Lyon's invention consists of a specially constructed sound chamber, which in the first place considerably augments the tone and which is equipped with a series of vibrating reeds set in a row and supported by wires, each reed resembling in magnified form the reeds in a harmonica, and keyed to respond in sympathy with certain vibrations. For instance, the rapid vibration of a soprano voice sets one reed in motion and the slower vibration of the basso affects another reed. These supplementary vibrations tend to emphasize the particular tone with which the reed is in sympathy, and the effect is remarkable to say the least.

Mr. Lyon had a machine in New York recently for the purpose of demonstrating it before various talking machine interests, and it was well received. A special horn and amplifying sound chamber can be placed in almost any talking machine instead of the ordinary sound chamber. It is of metal and, according to the inventor, can be manufactured accurately at little expense.

A Western concern is now planning to manufacture a new talking machine embodying Mr. Lyon's device.

NOW SETTLED IN NEW STORE

The Peoria Phonograph Co., of which O. F. Zimmerman is the manager, is now located in attractive new quarters on the second floor of the Hippodrome Building in Peoria, Ill. The company handles both the Edison and Brunswick phonographs, and reports a steadily growing business.

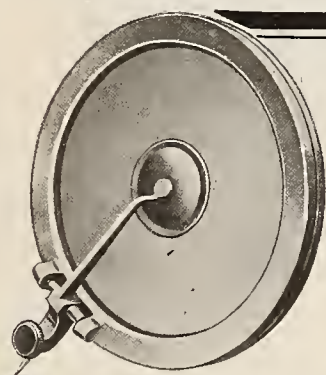

The Bliss Reproducer Will Play All Records

A new superior and scientifically constructed sound box—no mica, rubber or cork used.

Beautiful full, rich tone quality, clear articulation. It individualizes each voice and instrument in the record. Greater volume with lighter needles, thus minimizing wear on records.

A demonstration of the Bliss reproducer means a sale—each sale brings another, for every music lover who hears the Bliss reproducer wants one.

Comparative tests solicited. Write today for dealer proposition.

WILSON LAIRD PHONOGRAPH CO., Inc.
29 West 34th Street, New York City

Canadian Distributors: HAWTHORN MFG. CO., 145 Yonge St., Toronto, Can.

Lucky 13 Phonograph Co., 3 East 12th St. NEW YORK

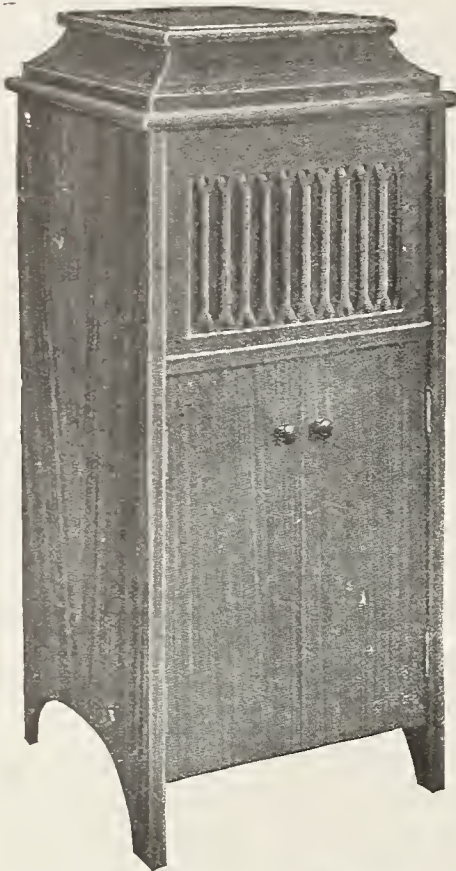

Type B—40 in. high. \$19.50 Wholesale
Mahogany Finish Double Spring Motor Plays all Records

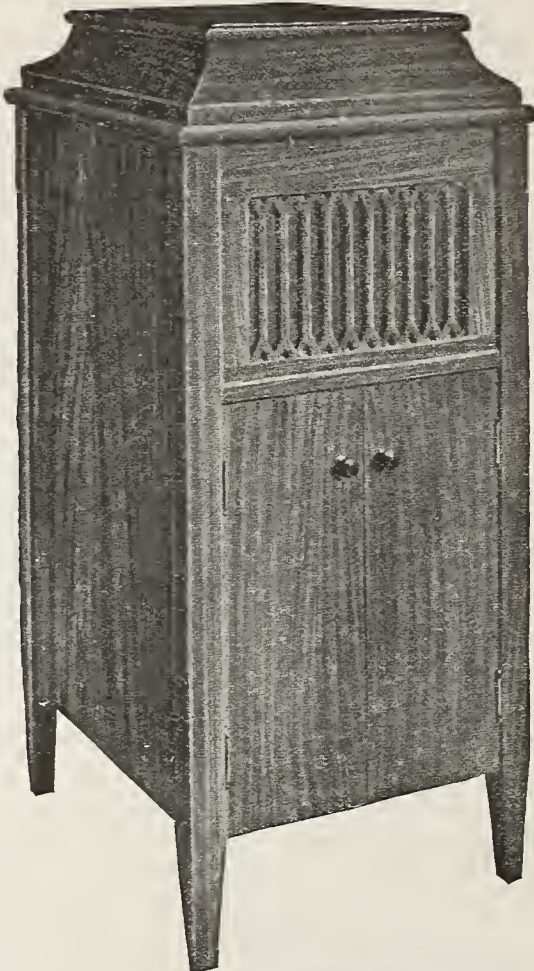

Type C—43 in. high. \$22.50 Wholesale
Mahogany Finish Double Spring Motor Plays all Records

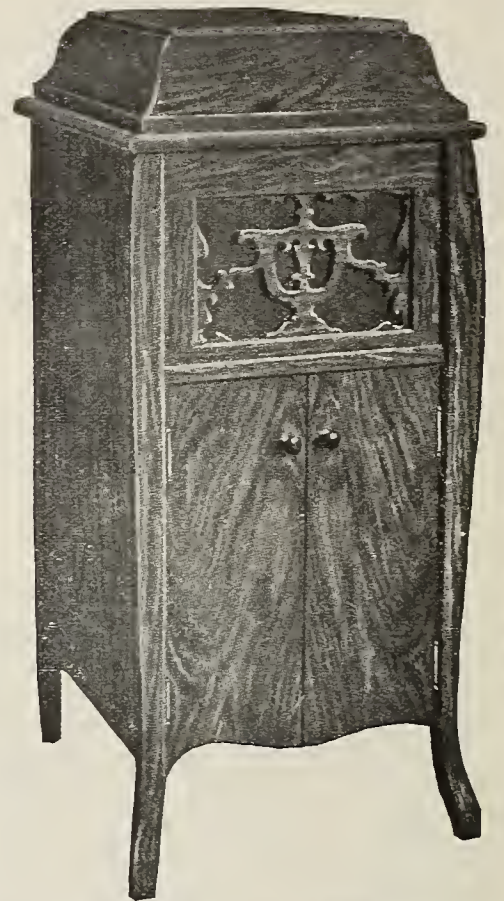

Type D—46 in. high. \$29.50 Wholesale
Mahogany Finish Double Spring Motor Plays all Records

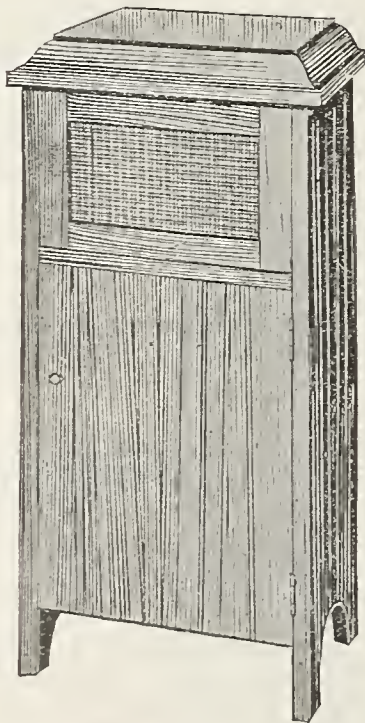

Type A, in Oak—35 in. high. \$13 Wholesale
Double Spring Motor Plays all Records

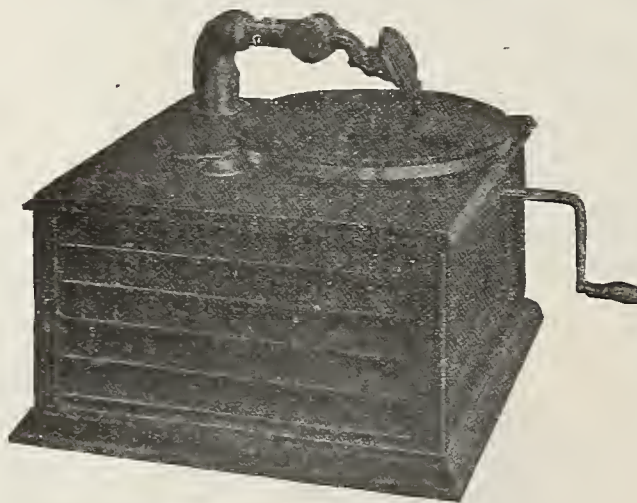

No. 15C \$7.50 Wholesale
Double Spring Motor Plays all Records

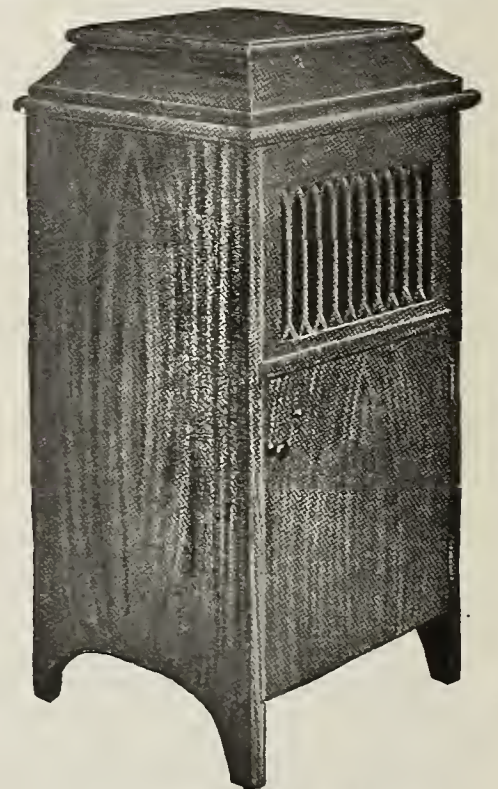

Type A, in Mahogany Finish—35 in. high
\$15 Wholesale
Double Spring Motor Plays all Records

STEEL NEEDLES

65c per thousand. Immediate Delivery.

RECORDS

The "Popular" Brand, 10-in. double face, lateral cut, all instrumental:

32c in lots of 100
30c in lots of 1000
29c in lots of 5000

MOTORS

No. 01—8-in. turntable\$1.25	10-in. turntable\$1.40
No. 5—10-in. turntable, double spring, plays 2 records 2.75		
No. 6—10-in. turntable, double spring, plays 3 records\$3.50	12-in. turntable 3.85
No. 8—12-in. turntable, double spring, plays 3 records 4.75		
No. 9—12-in. turntable, double spring, plays 3 records 5.75		
No. 10—12-in. turntable, double spring, plays 4 records 6.75		
No. 11—12-in. turntable, double spring, plays 7 records 8.50		

MAIN SPRINGS

No. 01—1 in. 22 gauge 7 ft.	20c ea.	100 lots 18c ea.	1000 lots 16c ea.
No. 0—3/4 in. 20 gauge 8 ft. 6 in.	25c ea.	100 lots 20c ea.	1000 lots 19c ea.
No. 1—3/4 in. 25 gauge 10 ft.	39c ea.	100 lots 35c ea.	1000 lots 33c ea.
No. 2—13/16 in. 25 gauge 10 ft.	39c ea.	100 lots 35c ea.	1000 lots 33c ea.
No. 3—7/8 in. 25 gauge 11 ft.	49c ea.	100 lots 44c ea.	1000 lots 42c ea.
No. 4—1 in. 23 gauge 10 ft.	49c ea.	100 lots 44c ea.	1000 lots 42c ea.
No. 5—1 1/4 in. 25 gauge 11 ft.	90c ea.	100 lots 85c ea.	1000 lots 80c ea.

GOVERNOR SPRINGS

\$1.00 per hundred. Special price on large quantities for motor manufacturers.

GENUINE DIAMOND POINTS, \$1.25 EACH

SAPPHIRE POINTS AND BALLS

Sapphire Points13c each in 100 lots	12c each in 1000 lots
Sapphire Balls15c each in 100 lots	14c each in 1000 lots

TONE ARMS AND REPRODUCERS

No. 1—Tone Arm and Reproducer \$.90
No. 2—Tone Arm and Reproducer, for playing all records 1.25
No. 6—Tone Arm and Reproducer, for playing all records 2.25
No. 7—Tone Arm and Reproducer, for playing all records 2.25
No. 8—Tone Arm and Reproducer, for playing all records 2.25
No. 4—Tone Arm and Reproducer, for playing all records 2.65

NEEDLE CUPS

\$20.00 per thousand, \$17.50 per thousand in 5,000 lots. Larger quantities still lower.

NEEDLE CUP COVERS

\$10.00 per thousand, \$9.00 per thousand in 5,000 lots. Larger quantities still lower.

We also manufacture special machine parts such as worm gears, stampings, or any screw machine parts for motor manufacturers. Special quotations given for Canada and all other export points. Merchandise delivered with custom duty, war tax and freight paid by us. Write for our 84 page catalogue, the only one of its kind in America. Illustrating 33 different styles talking machine and over 500 different phonographic parts, also gives description of our efficient repair department.

CINCINNATI TRADE COMPLAIN OF SHIPPING CONDITIONS

Talk of Revival of River Traffic—All Branches of Trade Enthusiastic Over Business Outlook—Demand for Art Styles Grows—Some Big Orders Being Booked—News of the Month

Cincinnati, O., April 6.—Shipping conditions are the one big bone of contention in the Middle West, the trade as a unit finding some outlet for its energy west of Cincinnati, but practically shut off from accommodations in the opposite direction.

Cincinnati just now is giving some attention towards a revival of the river traffic and this will be of benefit to the trade when regular lines are again established. The few steamers which survived the ice floes of the past winter are unable to handle all freight offerings. One boat, which did not turn a paddle in six years, reached the harbor Saturday and will be overhauled at a cost of \$30,000 and placed in the Cincinnati and Louisville trade. In due time the Government is expected to compel an exchange of freight between railroads and river lines which will benefit river communities. Last week talking machine merchants, taking advantage of the new postal regulations, attempted to send small-sized machines through the mails. This resulted in the local facilities being clogged and it also affected first-class mail.

F. F. Dawson, manager of the local branch of the Columbia Graphophone Co., is very enthusiastic over the present outlook, and believes the territory will make a splendid increase over last year. Since he took charge of the local branch nearly one hundred new dealers have been established, and an increase in business of nearly 100 per cent. over last year tells the story of the progress that has been made. The month of March just ended is by far the banner month in point of total sales for the Cincinnati branch since it has been established.

J. L. DuBrueil, who came to Cincinnati more than a month ago from the general sales department, New York office of the Columbia Co., is still here, and giving valuable assistance to Manager Dawson, and it is largely due to his efficient efforts in handling the details of the Cincinnati branch that "the mill keeps grinding."

Chester Luhman, representing the educational department of the Columbia Co.'s executive office, is in this territory visiting the schools in the interest of better music, and for the promotion of this phase of Columbia activity.

J. D. Bright, who joined the sales force of the local Columbia branch, is making splendid progress. Mr. Bright covers Kentucky territory, and in the five weeks he has been on the road he has opened fifty new accounts.

W. S. Givler, Columbia's "old stand-by," recently made a very successful trip, including Dayton, Springfield and Columbus. At Columbus he secured one initial order for \$15,000 from one of the largest music firms in Central Ohio.

Recent visitors among the Columbia dealers receiving their supplies from the Cincinnati branch were Walter Lewis, of the Lewis Furniture Co. of Huntington, W. Va.; W. F. Higgins, furniture dealer, Richmond, Ky.; C. A. Campbell, of the Campbell Furniture Co., Piqua; F. R. Follis, of Rike-Kumler Co., Dayton; Mr. Rothenberg, of May & Co., Dayton; C. C. Baker, of Columbus, and Mr. Kramer, of the Sterling Jewelry Co., Dayton.

A recent visitor to the local Columbia headquarters was Miss Sybil Sanderson Fagin, an exclusive Columbia whistling artist. Miss Fagin has made some recent Columbia records which are very attractive and are having rapid sale throughout the Cincinnati territory. She is a native of Springfield, O.

Manager Byars, of the Vocalion department of the Aeolian Co., reports a substantial increase in Vocalion business for March as compared with the same month last year. There were a number of high-priced instruments sold, and a tendency seems to prevail toward the more expensive instruments.

"There has been a shortage in Vocalions since Christmas," said Mr. Byars, "but shipments are beginning to arrive from the East again, and there is every reason to believe that we will

not be troubled with any further stock shortages.

"The recent advertising of the art styles has stimulated quite an interest in these new period models, and we have every reason to expect that from now on a substantial portion of our Vocalion business will be in the art style models."

The Fritsch Phonograph Co. is in receipt of its second order from Wilkes & Co., Ltd., Sydney, Australia, which firm is about to establish five branches in that country. This dealer is enthusiastic over the possibilities of the market for the Cincinnati machine. W. Musselman, of Cynthiana, Ky., has taken on the company's full line for his immediate territory.

The Crystola Co. is shipping practically all its output to Western points because of the limited railroad facilities eastward.

HOME FROM 5,000-MILE TRIP

W. P. White, of Thos. Goggan & Bro., Very Successful in Work of Disposing of Surplus Record Stock and Filling Up Own Gaps

HOUSTON, TEX., March 30.—W. P. White, manager of the wholesale Victor department of Thomas Goggan & Bro., this city, is now settled at his desk after a 5,000-mile trip throughout the Middle West and Eastern section of the country, calling on Victor wholesalers for the purpose of negotiating the exchange of surplus records.

Mr. White visited jobbers in Washington, Baltimore, Philadelphia, New York, New Haven, Providence, Boston, Pittsburgh, Cleveland, Chicago, St. Louis, and other cities, as well as calling at the factory in Camden, and reports that he was able to dispose of approximately 65 per cent. of his surplus record stock and was likewise able to obtain about 25 per cent. of records from other jobbers. He considers that the trip, unusual in its way, owing to the expense involved in wartime traveling, proved a very profitable venture, and has enabled Thomas Goggan & Bro. to increase by just so much their ability to take care of dealers' demands.

Emil E. Steinmetz, general sales manager for the Barron Victrola Co., Superior, Wis., will open a talking machine store in St. Paul.

Northern Ohio dealers of the Phonograph Co., Cincinnati, are demanding tone-test recitals, and Manager Peterson is now trying to arrange a tour for one or more artists to take place later in the month.

The Victor situation in this district is summed up as follows by Manager Rudolph Dittrich, of the Rudolph Wurlitzer Co.: "The transportation problem is still the greatest and most important question in the talking machine business to-day. The demand for Victrolas is excellent and the record demand is exceptionally good. There has been no improvement in freight and express conditions since the warm weather began and there is no very great improvement in sight. Accordingly, it behooves the talking machine trade to take this fact into consideration when ordering goods. If a dealer can stay ahead of the game far enough, he will suffer comparatively less. It will mean larger stocks and large stocks mean greater efforts on the part of the merchant in bigger sales."

PATRIOTIC DECALCOMANIE EMBLEM

Interesting Novelty Issued by the Globe Decalcomanie Co.—Sending Out New Booklet

The Globe Decalcomanie Co., Jersey City, N. J., have just issued a new novelty patriotic emblem to be placed on store windows, doors or the wind shield of automobiles. It contains the flags of the United States, England and France, with an American shield and the Statue of Liberty placed in the center. The emblems are neat and attractive in appearance and according to a recent statement of the president of the above company are becoming popular. The company is sending the emblems out to the trade at the retail price of twenty-five cents, which are followed by quotations for quantities. Under the caption of "You Need Decalcomanie In Your Business," the above firm is sending out a new folder with illustrations of transfer name plates.

OCCUPY NEW QUARTERS IN DENVER

DENVER, COLO., April 2.—The Swanson & Nolan Supply Co., local distributors and retailers for the Pathéphone and Pathé records, formerly located at Eighteenth and Curtis streets, have moved to new and larger quarters at 1514 Welton street, which have been remodeled to meet the particular requirements of the company's business.

What Does STRADIVARA Mean To You?

To some not acquainted with this wonderful machine it simply means a name but it really means more than the name because it is the symbol of all that is best in tone perfection, containing a sound board of seasoned Norwegian Spruce, a feature not to be found in other machines.

IT ALSO MEANS PROFIT TO HUNDREDS OF DEALERS

The steady ever-increasing demand for this superior talking machine is conclusive evidence of its ability to "stand up" by comparison with other machines as the repeat orders received from hundreds of satisfied dealers throughout the land testify.

Are you among the skeptical? Why not ask for our proposition and at least make comparison?

The Stradivara Plays EVERY Kind of Record

Each Stradivara is equipped with the Stradivara Automatic Stop Device.

7 Models—from \$50 to \$225

SCHILLING PIANO CO., Inc.

Wholesale Distributors

112 WEST 23d STREET, NEW YORK

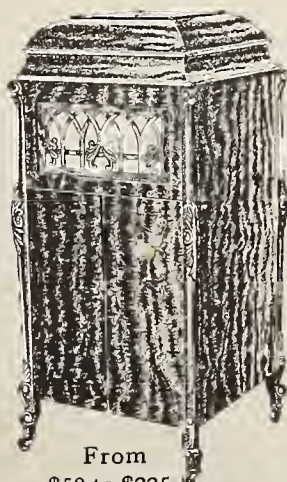

From
\$50 to \$225

TRADE REACHES HIGH WATER MARK IN SAN FRANCISCO

Sales Made in First Quarter of 1918 Break All Records—Interested in Galli-Curci Concert—New Brunswick Agencies—Sonora Shop Expands—General News of the Month

SAN FRANCISCO, CAL., April 2.—Business in talking machines continues to grow in California, despite the war and the consequent cutting down of the factory output. March was one of the best months ever enjoyed by the trade, and this in the face of the fact that during the last week there was a falling off in the rush of business earlier in the month, due without doubt to the concentration of the attention of the people on the critical battle raging on the Western front in Europe. The first quarter of 1918 will go down in history as the high water mark to date in the sales of talking machines. Some good shipments have been received, and the general freight situation seems to be easier, but the arrivals have been absorbed so rapidly by the back orders on the books of the various dealers that it can hardly be said that the available stock is any better on the first of April than it was on the first of March. This is especially true of the higher-priced machines. Of the cheaper machines and medium-priced ones the situation is a little better in the aggregate, but there are still plenty of dealers who are short on this class of goods as well as on the expensive ones. However, with the enormous demand continuing so strong, a spirit of optimism is everywhere evident, and the almost universal good nature of the customers is taking the sting out of the "worry-bee," brought to life by the freight situation and the incompleteness of stocks.

Gray Features Brilliantone Needle

W. S. Gray, a dealer in phonograph accessories, states that he has just received a shipment of 7,000,000 steel needles from Japan. These needles added to his stock and the lot of 3,000,000 Brilliantone steel needles he recently received from New York, makes his stock conspicuous on the Coast at the present time. Mr. Gray thinks he should be congratulated on having accumulated such a stock of such a needful article at such a time.

New Brunswick Agencies

The Brunswick-Balke-Collender Co. has recently signed up two new agencies, one at Woodlands, Cal., and the other at Mill Valley, Cal. James F. Mahoney, salesman for the company, who injured his ankle while taking a train at Fresno a month ago, is very much improved and will soon be able to cover his territory again.

Miss V. E. Wells has bought the Martinez Music Store at Martinez, Cal., and has thus secured the Victrola and Sonora agencies in Mar-

tinéz. As Martinez is a rapidly growing community, located near one of the largest ship-building yards on the Coast, the business under the aggressive new manager should grow rapidly. Miss Wells will also carry a line of pianos as agent for Sherman, Clay & Co., of San Francisco.

Robert M. Bird, of the talking machine department of Sherman, Clay & Co., has resigned the position he held for many years to associate himself with the Victor Co. Mr. Bird has been succeeded by Otto Rathlin.

Frederick Stern, of the Stern Phonograph Co., visited the southern part of the State this month, and from the reception the Rex talking machine received in that section he thinks that the new branches he has in mind will be money makers from the start. He is planning several of these, but is held back until he can accumulate enough stocks of machines, records and accessories to insure ample supplies.

Galli-Curci to Sing

It is confidently expected that another big business is going to be done in the records of Galli-Curci, who is scheduled to sing here in May. Indeed, one of the prominent music dealers predicted that the sales would exceed those of the McCormack records. His reasons for thus believing are that despite the fact that the concert does not occur for over two months two-thirds of the immense auditorium has already been sold out, and secondly the demand for these records is far in excess of the demand for the McCormack records a month before he appeared. One reason for this is curiosity, as Galli-Curci is unknown to most of the music lovers of San Francisco.

Rearranging Sonora Stock

A complete rearrangement of the stock in the Sonora Phonograph Shop, on Stockton street, is being made. When it is completed F. B. Travers, the manager, says that it will afford a considerable increase of floor space. The shop will be entirely newly decorated and refurnished. Mr. Travers says that he intends to concentrate his efforts on the Victor and Sonora machines.

The John Breuner Co., of Oakland, has secured the exclusive agency for the Sonora phonograph for that city.

Children's Records in Strong Demand

The Burgess Bedtime Story records and the Bubble Books are proving excellent sellers in this territory. All the dealers handling these records, especially the talking machine depart-

ments of the department stores, which are visited by women with children more than the regular music stores, say the demand is increasing all the time and that the next holiday season should see an enormous demand for these records.

The Edison Phonograph Shop reports a good demand for its machine, especially for the higher-priced machines in art cabinets.

The W. W. Kimball Co. continues to spread in this State. It recently opened a branch store at Eureka and another at Woodlands. Both will handle the entire Kimball line, including the Pathé phonograph.

The Sonora Shop is displaying a new auxiliary record cabinet which is said to be becoming very popular. The manager says that since he began to show these cabinets he has had to double his order at the factory.

FOR TWO PRICE MARKS ON GOODS

Bill in New York Legislature Provides That Both Cash and Instalment Prices Must Appear on All Articles Sold on Credit

The attention of the trade of New York State has just been called to a new bill introduced in the Legislature by Assemblyman Earl A. Smith, of New York, which provides that all retail merchants in the State selling goods other than for cash shall attach to the article in plain figures both the cash and instalment price for the information of prospective purchasers.

TO MAKE THE TONKOLA

Wm. Tonk & Bro., New York, to Put Talking Machines On the Market

Announcement was made recently by William Tonk & Bro., Thirty-sixth street and Tenth avenue, New York, that they will manufacture a talking machine to be known as the "Tonkola." There will be several styles of cabinet machines which will be equipped to play all makes of disc records.

TO HANDLE VICTORS EXCLUSIVELY

W. J. Killea, who has for some years past conducted a very successful Victrola business in Albany, N. Y., while at the same time acting as telegrapher for the Associated Press, has given up his telegraph work to devote his entire time and attention to the talking machine business.

The North Hudson Maxaphone Service Co., of Union Hill, N. J., has been incorporated with a capitalization of \$100,000 for the purpose of transmitting news and music by wire.



NYOIL is put up in the following sizes:

No. 16 (Cans)	1 Pint
No. 32	1 Quart
No. 128	1 Gallon
No. 540	5 Gallon

NYOIL

is the last word in the refining of high-grade oils, for every impurity is taken from it, leaving nothing but what is required to keep machines in perfect condition, being combined of four oils perfectly blended.

Will not Gum, Chill or become rancid; is free from acid. It is colorless and has no sickening smell, being absolutely odorless.

"The finest and most delicate pieces of mechanism do not prove efficient unless properly lubricated. Skill, Genius, Invention and Workmanship must have the proper Oil. Stop and consider this when you have to buy an Oil for household use."

Hundreds of satisfied customers have written us that they would never use anything else for
TALKING MACHINES, GRAPHOPHONES, PHONOGRAPHS AND SEWING MACHINES

NYOIL will lubricate the machinery and polish all woodwork

and can be obtained of any "Up-to-date" Talking Machine Dealer in the world, and is manufactured by Wm. F. Nye, who for 50 years has made 80% of all the Watch, Clock and Chronometer Oil that is used in America.

WM. F. NYE, NEW BEDFORD, MASS., U. S. A.



NYOIL is put up in the following sizes:

No. 1 Bottle	1 ounce
No. 4	3 ounces
No. 8	8 ounces

GLORIA



ANNOUNCING THE

Gloria Steel Needle

THE FINEST NEEDLE MADE OF
HIGHEST GRADE CARBON STEEL.

Immediate Deliveries
Guaranteed

Orders accepted for any
quantity and prompt deliveries
will be made to all customers
regardless of size of order.

PRICES AND SAMPLES
of all styles on application.

THE GLORIA PHONOGRAPH
SUPPLY CO., Inc.
200 FIFTH AVENUE
NEW YORK CITY



Many a fond, but weary mother will buy Thornton W. Burgess' Bedtime Stories for Children with a sigh of relief, if you only let her hear one.

Columbia Graphophone Co.
Woolworth Building, New York



SECURE PATHE JOBBING RIGHTS

Wm. Volker & Co., of Kansas City, Mo., Have Most Attractive Quarters for Pathé Display

KANSAS CITY, Mo., April 8.—Wm. Volker & Co., of this city, one of the leading wholesale concerns in this part of the country, is meeting with



Wholesale Pathé Demonstrating Room No. 1 very pleasing success in the merchandising of the products of the Pathé Frères Phonograph Co. This company recently secured the jobbing rights for this line in its territory, and its sales-



Demonstrating Room No. 2 men have already established many agencies in the different cities and towns.

The company has installed in its general offices in its building on Main, Second and Third streets two demonstrating rooms, which are shown in the accompanying illustrations. These rooms have been visited by many Pathé dealers in this territory and from far distant points, and these visitors have been unanimous in stating that they constitute one of the most artistic wholesale displays in the talking machine industry. Wm. Volker & Co., who installed these rooms for wholesale purposes only, should be congratulated upon their initiative and progressiveness in furnishing such attractive display rooms for the benefit of their dealers.

The Harlem Phonograph Shop & Typewriter Exchange, Inc., has been incorporated with capital stock of \$10,000, to deal in pianos, organs, phonographs, musical instruments of all kinds, typewriters, etc. The incorporators are: Allys Lennon, Francis B. Wood, and Joseph A. MacKnight.

WEEKLY RELEASE PLEASURES

Dealers Handling the New Nine-Inch Emerson Records—A. H. Cushman Optimistic

Arthur H. Cushman, director of sales of the Emerson Phonograph Co., New York, states that the Emerson dealers who have signed for an exclusive Emerson agency for the new nine-inch records report that the new weekly release arrangement is one of the most important factors in their merchandising success. The purchasing public are taking to the idea of weekly releases rapidly, and this plan gives the dealer an opportunity of putting the latest records on sale one to four weeks earlier than under the system of monthly releases.

The dealers have told Mr. Cushman that their customers now go in the store every week for new records instead of visiting their establishment only once a month. This not only gives the dealers an opportunity to sell the released records for that week, but almost invariably the customer picks out other numbers as well. The individual sales to a record buyer do not always run as high, but the total sales for the month to the individual customers have been greatly increased under this system, according to the records received at the Emerson offices.

The Emerson nine-inch records carry only the latest popular, patriotic, and dance hits, and the company is making it a point to place the big hits in the hands of its dealers in the shortest possible space of time.

UTILIZES AUTOMATIC REPEATER

Owner of Brooks Talking Machines Finds the Automatic Repeater of Convenience for Other Purposes—Uses Talker as Awakener

SAGINAW, MICH., April 6.—C. C. Brooks, president of the Brooks Mfg. Co., recently received a letter from one of the company's dealers describing a unique way in which one of this dealer's customers had utilized the automatic repeater on the Brooks talking machine.

This repeater is equipped with a dial which starts the machine and sets it to repeat a record any number of times, and Mr. Brooks' correspondent states that his customer has conceived the idea of turning the machine into a melodious alarm clock, by taking the dial from an ordinary alarm clock, and touching a spring to the alarm winding key, so that when the alarm goes off the spring will be wound up. At the other end of the spring is a loop which is hooked over the end of the pointer dial which starts the machine; this loop slipping off the end of the pointer after it has pulled it in the starting position.

It is understood, of course, that he has placed on the machine, the night before, the record which will most harmonize with his awakening dreams, and the dealer has been assured that each member of this particular family is enthusiastic over this innovation, for they find that this method of awakening starts the day off far more pleasing than the blare of the ordinary alarm clock.

To Edison Dealers:—

Until you Stock
Ready File

You are Losing \$6
Profit on every 100-A
and 150-C you Sell.

PARTICULARS ON REQUEST

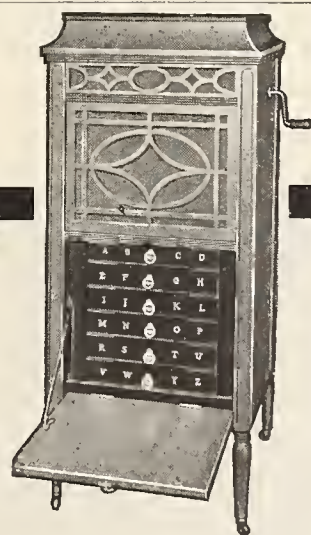

Ready File Co., Inc.

Indianapolis, Ind.

THE TRADE IN PHILADELPHIA AND LOCALITY

PHILADELPHIA, PA., April 8.—March was another most productive month for the talking machine dealers in Philadelphia. The business ran at most of the stores considerably ahead of last year, and where there was a neck-to-neck race, or a slight falling off in business, it was not due to the desire for the instruments, but because the firms were unable to secure the much desired supplies.

Scarcity Still Prevails

The scarcity of machines and records is still striking, and especially for the Victor and Columbia product. The Victor dealers were very much handicapped again in March. They were not able to get nearly the number of machines for which they had orders, nor were they able to supply a full measure of the demands for the most popular of the records by this company. The Columbia dealers are also complaining of a shortage of stock. There seems to be no indication that conditions would be changed during this month, although the manufacturers are promising better results.

Tells of Pathé Expansion

Walter L. Eckhardt, the Philadelphia wholesaler and retailer of the Pathé machine, with headquarters at 1026 Chestnut street, reports that they had a wonderful increase in their business in March over that of February. He has just returned from a two weeks' trip to Atlantic City, where he went with his family for a much-needed rest after the strenuous work he encountered in getting the Pathé Shop into shape. To-day it is one of the business show places of this city.

Mr. Eckhardt says: "With each month my enthusiasm regarding the Pathé product increases, due to the continued increase in our sales, and the enthusiastic manner with which our trade is receiving the Pathé. Considering that we are still in our infancy and the fact that the Pathé products were unknown in Philadelphia prior to December, I feel absolutely confident that we are enjoying our full proportion of the local patronage.

"At the present time there are approximately seventy Pathé dealers in Philadelphia. Each and every one of these merchants contributes substantially to the demand that is being created. Had we been in business several years, a month like we had in March would have been readily

TALKING MACHINE DEALERS

can greatly increase their profits without additional overhead expense, by selling the world-famous

Weymann "KEYSTONE STATE" Musical Instruments

a combination that has proved to be an instantaneous success.

Write for catalogue

H. A. WEYMANN & SON

Manufacturers

Victor
Wholesalers

1108 Chestnut St.
Philadelphia, Pa.

Established 1864

understood, but to have developed a momentum such as we experienced in the March business in so short a time is a decidedly new experience.

"At the outset of the month of March, as is my usual custom, different quotas were established for the various departments, which were accomplished, and frankly they were established at such figures that it required full steam ahead through the month to reach the goal. I would have been fully satisfied with the result, but when I state that the quota established was exceeded by the organization by 40 per cent. it reflects most creditably upon the organization, and discreditably upon my own judgment as a prophet. As an incentive for the month of

April I have placed my figures well in a comparative advance, and even at that I doubt whether my organization will not compel me to again acknowledge my inability as a prophet."

Among the visitors to the Pathé Shop recently were E. A. Widmann, president of the Pathé Co., and George W. Lyle, assistant to the president, as well as Frank Capps, the factory manager.

Weymann Enjoying an Active Business

H. A. Weymann & Son enjoyed a wonderful March business in their talking machine department, considerably ahead of last year in spite of the fact that they experienced a shortage of machines and records. They have again gotten their Victor force fully organized. The draft drew heavily upon this department of their establishment, but they have gotten three new men of much past experience in this line from other talking machine stores in this city, including Mr. Hoegerle, for a long time connected with the Columbia retail store here.

The Weymann firm have been having some unusual windows during the past month, and they find that this effort on their part fully repays them. There is no business window in Philadelphia that attracts more attention. Most all of the Philadelphia dealers are now using the Weymann record holder for their window displays, and they have sold this convenient record display contrivance pretty generally throughout the country.

March Business Was a Record-Breaker

The Columbia Graphophone Co., 210 North Broad street, report that their business in March was a record-breaker and was limited only by the amount of machines they were able to secure from the factory. They have had a phenomenal demand for their March records, and an especially big seller was "Baby's Prayer at Twilight." R. F. Bolton, the sales manager of the international record department of the Columbia Co., was at the Philadelphia offices recently in the interest of the foreign records. Among other trade visitors was Harry C. Grove, of H. C. Grove, Inc., and A. Weil, treasurer of Lansburgh & Brother, both of Washington, D. C. H. C. Kohn & Son, big furniture dealers at Eleventh and Filbert streets, this city, are

SELL RECORDS



Mme. Amelita Galli-Curci, Soprano

Because there may be a general shortage of certain records, there is no reason for "laying down". If you *sell* the higher class records, you won't need to make as *many* sales.

PENN PHONOGRAPH CO.
17 S. NINTH STREET PHILADELPHIA

“Value Received” are two mysterious words that are incorporated into legal documents. These two words mean much in the commerce of the world.

In every Victor record sale VALUE RECEIVED is the dominating force. No mention of this is required because *you* know your customer is getting great musical value and the *customer knows it*. This is true, so sell MORE RECORDS. Educate your customers musically! Feature better music—the higher priced records.

Buehn Service does help you render “value received.” It is exclusively wholesale, with every energy devoted to assisting your growth.

THE LOUIS BUEHN CO., PHILADELPHIA

VALUE RECEIVED applies with like force to Liberty Bonds. Buy them for yourself, and urge your customers to buy them. GIVE THE BOYS A HAND OVER THERE is the slogan. Buy a Bond!

LIBERTY BONDS

about to install a full line of the Columbia product.

The Grafonola Shops, Inc., in this city, at 1109 Chestnut street, are the first handlers here of the Columbia to advertise their records on the club plan, which several department stores have been doing for some time.

P. J. Leonard Addresses Edison Dealers

Blake & Burkart, the leading Edison representatives here, report that they had a most satisfactory month in March, and their business was way ahead of March, 1917. They were able to get machines through almost to the extent of their requirements, and the record situation has eased up considerably. P. J. Leonard, the sales manager of the Edison, was in Philadelphia on Tuesday and addressed the Edison Dealers' Association at their monthly meeting held at the Bingham House. C. J. Gardner, the traveling representative of Edison, was also in attendance at this meeting. The association is making elaborate plans for its annual meeting which will be held the first Tuesday in June, when it will have several prominent Edison talking machine men to make addresses.

Start Sonora Concert Campaign

The Sonora Phonograph Co., 1311 Walnut street, will start on Monday evening, April 8, and continue until the end of the month, one of the most remarkable series of concerts ever given in this city at a talking machine establishment. They will be given in the Sonora Hall, well suited for the purpose. They will be by invitation to the Philadelphia Navy Yard men, the men at Hog Island, Cramps Ship Yard and the Philadelphia Arsenal. Aside from the Sonora programs there will be a number of assisting artists.

The Sonora business in Philadelphia was very fine in March, and Manager F. D. W. Connelly is very optimistic as to the spring business on this remarkable machine. The Sonora visitors the past month included Frank I. Coupe, sales manager, and Mr. Pringle, of the main New

York office. Mr. Connelly spent several days in New York last week.

To Handle the Cheney Phonograph

Strawbridge & Clothier, the department store people, having purchased the Henry F. Miller local store, instruments, leases, prospects, etc., they will also take over the handling of the Cheney phonograph here which has been handled from the Miller store as the Cheney headquarters in this city. G. D. Shewell, who is the Eastern representative of the Cheney machine, will remain as such here, and will either have his headquarters at the old Cheney store, 1105 Chestnut street, or if a piano firm take that building, he will open private offices as the Philadelphia representative of the Cheney phonograph. There is some likelihood of the machine remaining where it is.

Report Fair Month's Business

The Louis Buehn Co. report that their business in March was fair, and was as large as the machine and record supply would warrant. There was a great scarcity of Victor records in March, and all the handlers here in that line have experienced the same handicap. The shortage of records in March was greater than it has ever been before, and conditions are not very encouraging for a betterment in April.

Louis Buehn and his family motored to his cottage to Ocean City last week and spent the Easter holidays there.

W. E. Holland, representing the Robelen Piano & Talking Machine Co., of Wilmington, Del., was a Philadelphia visitor the past week. He reports conditions good in his section.

Joseph Goodman, the Manayunk handler of Victor talking machines, contemplates making extensive alterations in his store, including the addition of several more booths.

The Geo. D. Ornstein Co. are gradually getting their new building in shape. The general offices on the front of the building, second floor, with Mr. Ornstein's private office in the rear of this floor, have been handsomely furnished. The

third floor will be devoted to the record department, and the fourth and fifth floors will be used for reserve stock. George A. Lyons is the assistant to Mr. Ornstein.

Featuring the Ediphone

The Edison Dictating Machine Co. in Philadelphia have had all their stationery and advertising matter changed to the new name, “Ediphone,” and will shortly place this new title on their window. They enjoyed a wonderful business in March. They are preparing an elaborate exhibition for the industrial show which will be held here from April 15 to 20. They will have two booths, Nos. 67 and 68, and as a feature of their exhibition they will demonstrate the Telescribe. N. C. Durand, vice-president of the company, was a recent Philadelphia visitor. The local store has opened a branch office for the Ediphone in Wilkes-Barre, Pa.

Booked Good Business on Trip

The Penn Phonograph Co. report that their business in March was good, very much of an improvement over January and February. They note that machines are coming in very slowly, and as to records they can only depend on the monthly list.

T. R. Clarke, manager of the wholesale department of the Penn Co., and T. W. Barnhill, a member of the firm, recently made a trip to New York, Pittsburgh, Detroit, Chicago, Cleveland and Indianapolis, calling on the various jobbers at these points and looking over their plants with a view of adopting various ideas which they could pick up for use in their business here.

Some Trade Brieflets

Charles K. Bennett, of the Eclipse Talking Machine Co., of Cleveland, O., was in town calling on the various dealers.

Rudolph Wurlitzer was a Philadelphia visitor the past week.

The local Brunswick-Balke-Collender Co. offices tell of expanding business in the Brunswick phonograph in this territory.



Is there any form of local advertising—bill boards, window display or store fixtures—that you suspect you're not getting what you might get out of? The Columbia Dealer Service Department will go into the problem with you willingly.

Columbia Graphophone Co.
Woolworth Building, New York

BIG STRIKE HAS LITTLE EFFECT ON KANSAS CITY TRADE

Talking Machine Dealers Suffer Very Little as Result of Tying Up of Transportation Lines—Offer to Take Pianos in Exchange for Talking Machines—Situation Reviewed

KANSAS CITY, Mo., April 5.—The business of this territory in talking machines has gone steadily forward during year after year despite drought, floods, and all sorts of incidents that might be considered obstacles. The local trade ran up against the worst retailing conditions during the week starting March 27 that it has ever encountered. Although the weather was fair, and there was also a general prosperous condition, a sympathetic strike, starting that morning, so upset the people that very few retail stores did any business the rest of the week. The union men who joined the sympathetic strike, about 4,000 in number, were supporting laundry drivers who, since the middle of February, have been trying to get concessions from their former employers. By the last of the week the number of strikers had increased to more than 10,000, and after a total suspension of street car service for twenty-four hours, from Thursday afternoon, the street cars were running at about 50 per cent. of their usual schedules. It is a remarkable fact, however, that talking machines happen to be one of the few commodities that did not suffer severely from the general depression. Where, for instance, people who had been planning to get a piano might postpone their purchase till the trouble was over, those who were getting talking machines were all the more eager to have them in their homes so that they might have some consolation through being forced to forego their street car rides and their usual outdoor pleasures that involved possible mixing up with the strike trouble. In only a few instances were stores that handled talking machines directly affected by the strike. These were chiefly furniture stores where union workmen quit to join the sympathetic movement.

An advertisement in Kansas City papers offering to take pianos in exchange for talking machines attracted some little attention. Queries of several of the music dealers, however, revealed that most of them were making no special effort to pull in pianos. As a matter of fact, even those who dealt chiefly in talking machines, merely handling pianos in the disposal of their used instruments received in exchange, did not exploit their exchange features prominently. One dealer suggested that as a rule the pianos that people wanted to exchange for talking machines were in such bad condition that they could not economically be put into shape for sale.

Another dealer, however, said that he occasionally did take a piano in exchange for a talking machine; in one instance, of recent date, the piano was a \$350 instrument he had sold to the customer seven years ago—and it had not been tuned since its purchase. The customer wanted to sell this piano for a \$50 credit on a talking machine. The instrument was in good condition despite its apparent neglect.

The dancing classes of the Edison Shop in Kansas City have proved to be an even more important feature of the life of the city than was anticipated when they were begun. Photographs of some of the dances were recently exhibited in the window of the retail shop and attracted even more attention than some of the spectacular stunts that were being pulled in windows nearby, for these photographs showed Kansas City young people in these artistic poses. A group of the dancers who have been learning and practicing at the Edison Shop are arranging for a public performance at a local theatre.

A. A. Trostler, manager of the Victrola department of the Schmelzer Arms Co., said that nothing seemed to make any difference in the big demand for Victrolas and records—neither labor unrest, the price of wheat, nor war prices. People continue to demand machines, in all styles, and they are bought before they arrive. Mr. Trostler says it is same old story, of course, about deliveries, he himself continuing to almost wear a path to the factory with his frequently trips there after the goods.

THE TIMELY EDISON MESSAGES

Unique Editorial-Like Announcements of Thos. A. Edison, Inc., Attract Wide and Favorable Comment—Good Work for Music

The Edison messages appearing under serial numbers in the columns of The Talking Machine World monthly constitute something unique in advertising. These messages have a distinctive editorial flavor, for without exception the Edison "selling talk" one would naturally expect to be included in all Edison advertising copy is omitted, and forceful, well chosen English is utilized to drive home points of overwhelming interest.

The officials of the Edison Co. have evidently recognized that a part of its duty as one of the leading institutions of the industry is to interpret the relation between current national conditions and the Edison retailer. Meanwhile interpreting in the trade press the effect of current and national conditions for the Edison retailer is at one and the same time interpreting conditions for the entire industry. Hence the Edison messages are publicity of an exceedingly influential, broad-minded sort, and the

William C. Chestnut, of the Brunswick Shop, was one of the talking machine men who, in belonging to the Missouri Seventh Regiment, Home Guards, was called out during the recent strike.

Mrs. Nellie Williams, manager of the Victrola department of the Jones Store Co., stated that business continued splendid and that there was not quite as great difficulty in getting machines as was the case around Christmas, and that the department has finally gotten its Christmas substitutions on machines cleared up. Mrs. Williams stated that no unusual advertising was being done—that business was so good it was not necessary.

Miss Patsy Ann Epperson, who had been with the J. W. Jenkins' Sons Music Co. for some time, is now connected with the Wunderlich Piano Co. Miss Ruth Burriss, formerly cashier, has succeeded Miss Epperson in the talking machine department.

Porter Lasseter, formerly head of the talking machine department at the Kansas City Photo Supply Co., has accepted a position with the Paige Motor Car Co. His successor has not yet been named.

The talking machine made by Wilson & Co. is said to be getting a wide distribution, especially in the smaller points.

retail merchants handling all makes of instruments who read these discourses will benefit the industry by propagating such forceful utterances as have appeared in the series of Edison messages under such captions as "The Recent Food Control Legislation Will Do Much to Stabilize Living Conditions," "Woodrow Wilson's Address to the Soldiers of the National Army," "General Optimism in Command," including a quotation from Printer's Ink; "Music's Part in War Times," including a quotation from the New York Evening Mail; "Where Music Stands," "The Need for Music," and "What the World Would Lose If I Lost Music," and that very timely talk which appears on page 10 of this issue of The World, entitled: "Forging the Third Link," a forceful plea for the successful flotation of the third Liberty Loan, which we aim to make a landslide, so that it will crush militarism out of the world forever.

Every day music is proving both in civil and military life that it is the fourth essential of life.

Thos. A. Edison, Inc., are certainly doing their bit in a most emphatic way in spreading the gospel of good music, and inculcating a deeper spirit of patriotism among the people.

Talking Machine Hardware

We manufacture hardware for all styles of cabinets

Lid Supports
Needle Cups
Needle Rests

Door Catches
Sliding Casters
Continuous Hinges

Sockets
Tone Rods
Knobs, etc.

BEST QUALITY

LOWEST PRICES

WEBER-KNAPP COMPANY

Jamestown, N. Y.

The Real Importance of the Talking Machine in the Daily Life of the People

The talking machine dealer who is not taking full advantage of the present demand for both machines and records for various military units in the training camps, and for groups enlisted in the naval service of the country, is overlooking a mighty fine chance to corner some publicity not only for himself, but for the trade in general—publicity that is going to put the talking machine business in an enviable position perhaps in the eyes of the Government under conditions that may develop if the war continues.

One can hardly pick up a daily paper these days in any part of the country without seeing therein either letters direct from soldiers asking for donations of machines, and particularly records, or appeals from various organizations

for records for the fighting men. Then, too, the daily papers themselves in many instances publish requests that the public contribute new and old records and music rolls sent to certain distributing centers for delivery to camps and ships. Never has the public of the United States had brought home to them the real importance of music in the daily life of the people. If the men in training for deadly combat find it necessary to have music to lighten their leisure hours, how necessary must that same music be in the daily life of the people at home.

In the matter of supplying music for the soldiers and sailors, the talking machine shines in a class by itself; no matter how sudden the shifting of military units or how limited

the transport space for extra equipment, there is always found room for a talking machine and records. There is hardly a daily paper or magazine in the United States featuring war photographs that has not at one time or another published pictures of soldiers and sailors grouped about a machine and listening to their favorite records. The dealer who makes proper use of these pictures in his window displays and in his store—who takes full advantage of the publicity that the war is giving the talking machine, who enters into the plan for supplying outfits for the fighting men, is putting himself on the map in his local community. The more generous the spirit in which he participates in the drive the more substantial will be his returns.

COLUMBIA LINE WITH KRAKAUER

Krakauer Bros., 125 West Forty-second street, New York, have secured the agency for the Columbia line of talking machines and records, and this new department will be in charge of Miss D. R. Schwinger, formerly with Bloomingdale Bros. Milton Weil, manager of these warehouses, has devoted generous space for the display of this line, and the various models are displayed amid surroundings that show them off to their best advantage. It is planned to maintain a full stock of records at all times.

ATTRACTIVE HEINEMAN FOLDER

The Otto Heineman Phonograph Supply Co., Inc., has just issued a very attractive four-page folder that is devoted primarily to the products of the company's Dean division. On one page of this folder there are presented some of the most popular styles of Dean steel needles and attention is also called to the fact that the company manufactures permanent needles to play Pathé records and sapphire and genuine diamond points to play Edison records.

There is also shown on another page of this folder two of the most popular motors manufactured by this company; these motors being the Meisselbach Motor No. 18, and the Heineman Motor No. 77. It is suggested that the manufacturers utilize the idea of combination orders for these motors, and it is mentioned that the ideal combination for a \$165 machine is the Meisselbach motor No. 18, tone arm No. 98, and sound box No. 2C. The ideal combination for an \$85 machine is the Heineman motor No. 77, tone arm No. 11, and Ideal sound box No. 2. The company offers to send interested manufacturers and dealers a copy of its complete catalog, which includes sixteen different styles of tone arms and sound boxes.

GETS CARLOAD OF PHONOGRAPHS

HELENA, MONT., April 2.—The Montana Phonograph Co., Edison jobbers in this section, have had the stock problem solved in some measure for them through the receipt of a full carload of new Edison machines. The shipment included 129 machines, and was valued at \$23,000. It represents an additional order and will serve to supplement the stock regularly received by the company.

J. C. ROUSH ENJOYING LIFE

J. C. Roush, president of the Standard Talking Machine Co., Pittsburgh, postcards from Florida that he is enjoying his midwinter vacation with his family to the fullest extent. He has visited Palm Beach, Key West, Miami and other resorts, and states that he is having "the time of his young life." He expects to return about April 15 in fine fettle and ready for a busy campaign.



A Display Card Series of Value

The cards are 14" x 22", each individual card painted by an artist, and present a striking sales appeal for Victor Records.

Designed especially for Bruno Service and are "exclusive." The service consists of two cards monthly.

Send us your order for May Service and give it a month's trial.

C. BRUNO & SON, Inc.

VICTOR WHOLESALE ONLY

351-353 Fourth Avenue

NEW YORK

We Do Not Retail



LUCIEN MURATORE
Exclusive Pathé Artist



The Quality Phonograph

And it started something when Muratore sang the Marseillaise at the Metropolitan Opera House

OF course it's a Pathé Record. Muratore only records for Pathé and it's the one he made for Pathé just after his return from service in the French army.

But what *did* it start? First, it brought the Metropolitan Opera House audience to its feet with one of the greatest ovations ever accorded a singer.

Then it turned loose the greatest activity in the sales of Muratore Records that Pathé has ever known.

And what's more. Something has shot ahead the sales of all Pathé Records.

Do you know that any dealer can get in on it if he wants to—because Pathé Records are playable on any standard make of machine.

Write for particulars.

PATHÉ FRÈRES PHONOGRAPH CO.
20 Grand Avenue Brooklyn, New York
Pathé Frères Phonograph Co., 5 Clifford St., Toronto, Ont.

Ever Realize the Real
Selling Value in the name—



The Quality Phonograph

THE minute you do, you're making a good start—yes, for yourself.

How many times do you suppose "Pathé" is flashed on the motion picture screens? No use computing nor guessing—anyway, it's thousands—hundreds of thousands.

What does that mean to a dealer in selling Pathé Phonographs—when Pathé is only identified with *quality* product—whether phonographs or pictures?

Perhaps you haven't thought of it before, but you should now.

Write for "The Other 20%" booklet. It will tell you something you ought to know.

PATHÉ FRÈRES PHONOGRAPH CO.

20 Grand Avenue

Brooklyn, New York

Pathé Frères Phonograph Co., 5 Clifford St., Toronto, Ont.

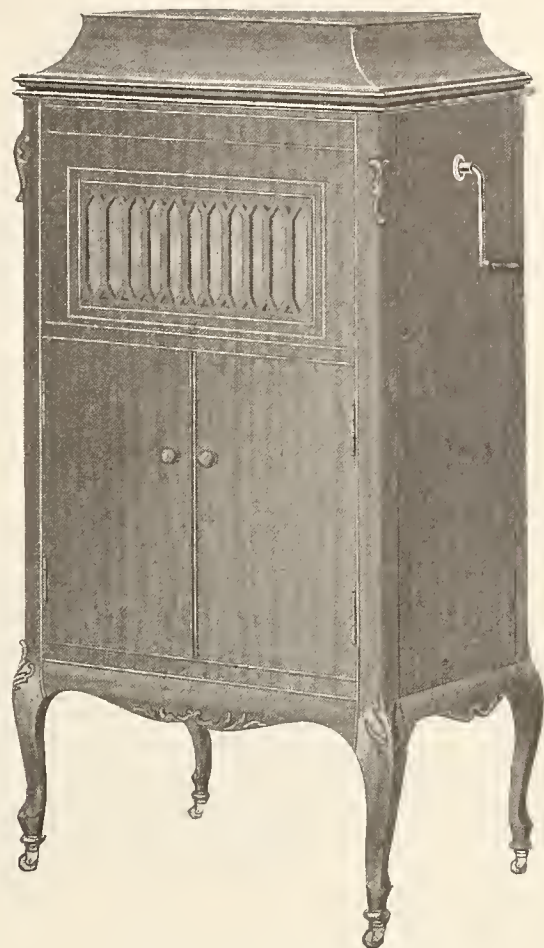

Path Phonograph \$175
Other Models \$25 to \$225

No Needles to Change

The Pathé Sapphire Ball takes the place of needles. It need not be changed.

Long Life to Records

The Pathé Sapphire Ball cannot possibly cut, grind, rip or mar the record's surface.

The Pathé Controla

With the Pathé Controla you may increase or decrease the tonal volume of the Pathé Phonograph at will.

Plays All Records

Each Pathé Phonograph plays not only Pathé records, but all other makes of records, and plays them perfectly.

CONVENTIONS OF DEALERS ARE HELD IN INDIANAPOLIS

Edison and Pathé Retailers Entertained by Jobbers of Their Respective Lines—Volume of Business on the Increase—Planning Co-operative Advertising Campaign—Other News

INDIANAPOLIS, IND., April 4.—The talking machine business both in the wholesale and retail fields during March showed an increase over January and February, local dealers report. Most of the dealers express the opinion that business is getting better and steadier every day and they are not expecting even the strenuous Liberty Loan campaign to have much effect in curtailing the business for April.

A meeting of the dealers of the Kipp Phonograph Co., jobbers of the Edison, was held March 22, when Harrison Durant, manager of the Edison department for financing dealers' instalment paper, told the dealers of the new arrangement the Edison Co. has made to enable dealers to expand their business. The dealers were enthusiastic over the plan, and Walter Kipp, president, and Jewell Cartmill, secretary of the Kipp Co., expressed the belief that the plan would result in a greatly increased Edison business, as it will enable the smaller dealers to handle their business more efficiently.

A meeting of the Pathé dealers of the Mooney-Mueller-Ward Co., jobbers of the Pathé line, was held two weeks ago and Charles T. Reinhart, from the Pathé factory, demonstrated to the dealers the mechanical features of the machines, showing them how to adjust the machines in event any trouble arose.

R. B. Goldsbury, in charge of the company's Pathé department, said that the Pathé "Pop" supplements are making a big hit with the dealers and are getting the results as shown in the increased record sales. Mr. Goldsbury added that there seems to be a phenomenal demand for the 175 model Pathé, and that the general preference of the trade leans to the higher-priced models with the art models becoming daily more popular.

W. E. Pearce, of the phonograph department of the Brunswick-Balke-Collender Co.'s branch

here, reports that the new "Ultona" tone arm and reproducer is proving popular with the trade. Billboard advertising being done in this territory for the Brunswick is also getting results, Mr. Pearce said.

Ben Brown, manager of the Columbia Co.'s branch, said that March business showed an increase of 50 to 60 per cent. over March last year. Mr. Brown pointed to the fact that business is unusually good in the smaller towns in his territory as substantiating his belief that business is getting steadier and better every day.

Louis Sayers is now traveling in Kentucky for the Columbia Co.

The Craycraft Dry Goods Co., of Noblesville, Ind., has put in a talking machine department, handling Columbia machines.

H. A. W. Smith, manager of the Pathé Shop, is in Buffalo, N. Y., at the offices of the H. R. Ness Co., owner of the shop.

O. C. Mauer, manager of the talking machine department of the Kiefer-Stewart Co., jobbers of the Sonora, said that the price increase of Sonoras, which went into effect March 1, had no effect on sales, and that March business was good.

Business continues good at the Stewart Talking Machine Co., wholesalers of the Victor line, the chief difficulty being in getting the machines. Emerson Knight, advertising manager of the company, is expecting to receive a call to the colors soon. He has been accepted for a training school for military balloon observation work.

George Standke, manager of the Brunswick Shop, is proving to be as enthusiastic a plugger for the third Liberty Loan as he is for the Brunswick. He already has more than \$2,000 in subscriptions for the loan, and is making his store the headquarters for the American Club

Liberty Loan campaign. Mr. Standke is also advertising the Liberty Loan in connection with billboard advertising being done for the new "Ultona."

C. P. Herdman, of the Columbia talking machine department of the Baldwin Piano Co. store, reports that March business was good, and that the business that is being done is high class on a sound basis.

One of the daily newspapers is planning a co-operative dealers' advertising campaign in connection with publicity boosting music in the home, and most of the music dealers are getting in on the proposition which is somewhat similar to the campaign that has been conducted in Milwaukee. The local music dealers have recently on several occasions, subscribed to co-operative advertising, and some of the dealers who were boosting for a talking machine dealers' association point out that the reason the attempt to start the association failed was because some of the dealers held back on the proposition of doing any co-operative advertising. These dealers are now doing it with the newspapers.

A. H. Snyder, manager of the Edison Shop, said that March business was good, and the general outlook for spring business is excellent.

Serge L. Halman, manager of the Aeolian Co. branch, said that the Vocalion business is good; in fact, this instrument is steadily increasing its popularity. Mr. Halman is an ardent worker for the Thrift and War Savings Stamps.

He is acting as chairman of the advertising committee of the local retail merchants, having got up the scheme of co-operative advertising on the part of local merchants to boost the sale of the stamps. This campaign will start after the Liberty Loan campaign.

"We merchants don't have to worry about business if we keep a stiff upper lip and keep plugging," said Mr. Halman. "The people have the money and they will buy and we can all afford to do our part, too, in helping in every way to win the war."

LONG CABINETS



No. 83

In all finishes. Specially adapted for use with Columbia 50. Front posts made to follow lines of posts on Columbia 75.

FIRST and FOREMOST

In the cabinet field.

Why? Because we've *specialized* in

**CONSTRUCTION
FINISH and
ADAPTABILITY**

Our supremacy in these essentials warrants your handling *the perfect line*.

That's why you should anticipate your wants NOW.

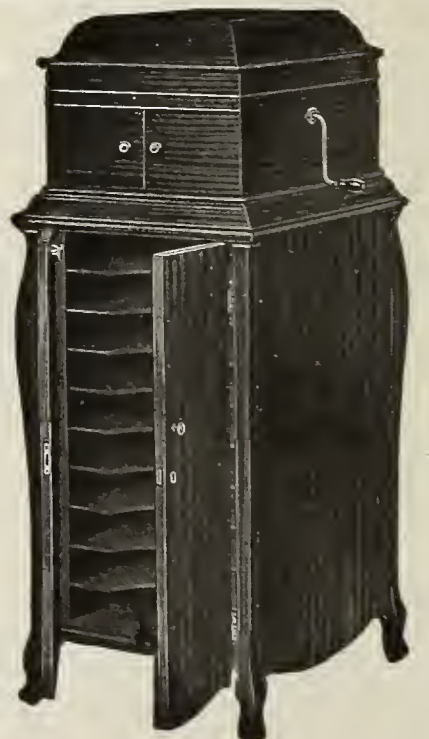

No. 79

In all finishes. Shown with top moulding and shelves. Specially adapted for use with Victrola IX.

Prompt deliveries on all orders. Write for Illustrated Catalogue of complete line

THE GEO. A. LONG CABINET COMPANY
HANOVER, PA.

MEISSSELBACH PHONOGRAPH MOTORS



TRY THESE COMBINATIONS

The Ideal Combination for your **\$165** Talking Machine

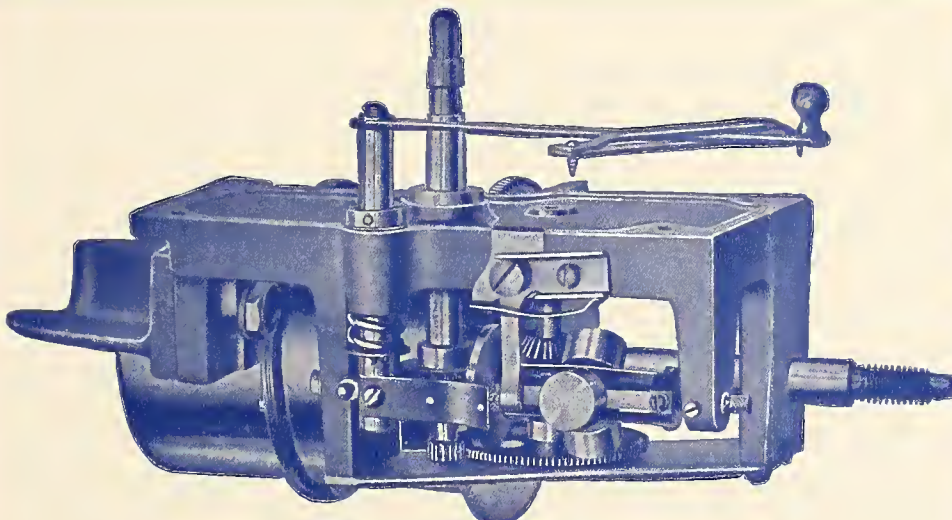

Meisselbach Motor No. 18

Meisselbach Motor No. 18 Meisselbach Tone Arm No. 98 Meisselbach Sound Box No. 2C

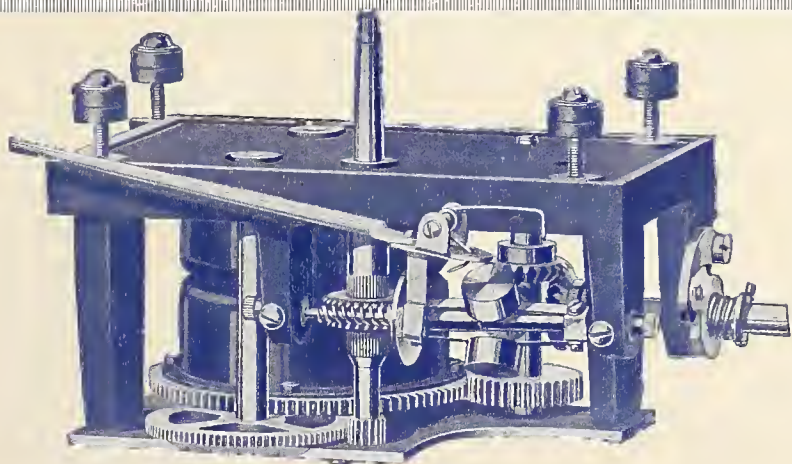

Heineman Motor No. 77

The Ideal Combination for your **\$85** Talking Machine

Heineman Motor No. 77 Heineman Tone Arm No. 11 Heineman Ideal Sound Box No. 2

ASK FOR complete catalog. We can offer 16 different styles of Motors and 12 different styles of Tone Arms and Sound Boxes.

Otto Heineman
President

HEINEMAN PHONOGRAPH MOTORS



BUFFALO TALKING MACHINE MEN AFTER COUNTRY TRADE

Combing the Rural Communities as Roads Become Passable—Give Earnest Support to Liberty Loan—Arrange Special Display—More Trade Members in the Military Service

BUFFALO, N. Y., April 9.—In a whole-souled, patriotic way Buffalo talking machine dealers and their salesmen are contributing their time, enthusiasm and financial aid in helping to make the third Liberty Loan a success. Even if the public purse is almost turned inside out this month and a veritable Niagara of dollars is being diverted to the Government by loyal Buffalonians the dealers are still forging ahead with their "Business Better Than Usual" slogan. Greater efforts than ever have to be put forth to reach the high business mark of last April. Some of the dealers say they are attempting "to go over the top" and even surpass their trade figures of a year ago.

Rural highways are becoming passable for the motor cars of the salesmen whose business it is to reach the farming population. Deliveries of talking machines throughout the country are now made with little difficulty. Easter and patriotic records have been in great demand.

At the store of Victor & Co., Pathéphone jobbers, there was a remarkable display to promote the sale of Thrift Stamps. There were life-size representations of President Wilson, General Pershing, Colonel Roosevelt, Washington, Lincoln and Uncle Sam. In a window displaying cards to advertise the sale was George E. Beckwith dressed as Uncle Sam. At a table just inside the door was Marie M. Ginther, representing Liberty and selling the stamps. The display attracted large crowds and large sales of stamps were made.

In the window of Walbridge & Co., Victor dealers, there also was a Thrift Stamp display. There was a life-size picture of Liberty clinging to a cross. To the right was a life-size representation of an infantryman, and on the other side a U. S. marine, while the window was handsomely decorated in the national colors. Thrift Stamp advertisements were well placed in the window.

E. O. Hock, salesman for Robert L. Loud's Victrola department, is at Camp Upton, as is Harold Kuhn, of Kuhn Bros.

Mme. Galli-Curci had to postpone her April engagement in this city on account of illness. Local dealers, however, boomed the Galli-Curci records during the week.

Bach Utley, who formerly had charge of the New Edison department of his father, C. H. Utley, is attending the U. S. Aviation School at Lake Charles, La.

The Winegar Piano Corp., Columbia dealers, has been organized in Buffalo with a capital of \$30,000, by A. C. Winegar, F. W. Zabel and C. A. Winegar. This concern has taken over the store of Winegar, Lindsay & Seales.

G. H. Poppenberg, Inc., of Buffalo, capitalized at \$500,000, has been incorporated. The concern handles talking machines. "Instead of a partnership this firm now becomes a corporation," said G. H. Poppenberg.

J. N. Adam & Co., Victor dealers, will have special Liberty Loan displays this month. Ralph C. Hudson, president of the company, will represent the Buffalo Retail Merchants' Association in the campaign.

Increased wages for Buffalo mechanics are helping trade at the local talking machine stores. One industrial plant, constantly seeking workmen, is running illustrated street car ads to show that men who work at that factory can have plenty of money to buy all kinds of comforts, talking machines included.

Corporal P. H. Barenthaler, of the 303d Engineers, Camp Dix, has asked Buffalonians to ship some of their used records to the boys in camp.

Charles L. Bricka, son of Charles F. Bricka, of Bricka & Enos, Columbia dealers, has been promoted to captain and assigned to Company 2, train and military police division, National Army. He is a graduate of the first officers' training camp at Madison barracks.

Jascha Heifetz, violinist, whom Buffalo music critics called a "superb artist," recently played in this city. His appearance here helped the sale of the Heifetz Victor records.

A fifty-first anniversary sale was recently conducted by Adam, Meldrum & Anderson Co., Pathéphone dealers. When this store was founded in 1867 Buffalo's population was only 110,000. T. M. Gibson, vice-president and retail manager of the concern, was employed at the store when it was first opened.

Richard Nevils has joined the sale force of John G. Shuler, the Sonora dealer.

Harold Verbeck, of the Verbeck Musical Sales Co., has joined Uncle Sam's aviation section at San Antonio, Tex. On account of his departure the Verbeck Co. has closed its Genesee street branch, which he managed.

Work of remodeling the building at 733-737

Main street, where the Columbia Graphophone Co.'s wholesale department will occupy the second and third floors, is progressing rapidly. The new quarters will be ready for occupancy May 1. O. M. Keiss, manager of the Buffalo branch, has been ill for a few days. George W. Hopkins, general sales manager of the company, was a caller. March business at this store was greater than that of March, 1917. April trade may be somewhat hindered by temporary embargoes on eastbound shipments. For a time the company may have to use trucks to ship machines east of Buffalo.

Wallace Currier has been appointed manager of the William Hengerer Co.'s Victrola department. He succeeds Herbert A. Brennan, now traveling representative of the Victor Talking Machine Co. Mr. Currier was formerly with the Victrola department of the Lion Drygoods Co., Toledo. Before going to Toledo he had an Edison store of his own in Portland, Me. Mr. Currier conducted a Victrola week early in April. Special advertising and window displays contributed to the success of this event.

VALLORBES Economical Semi-Permanent NEEDLES

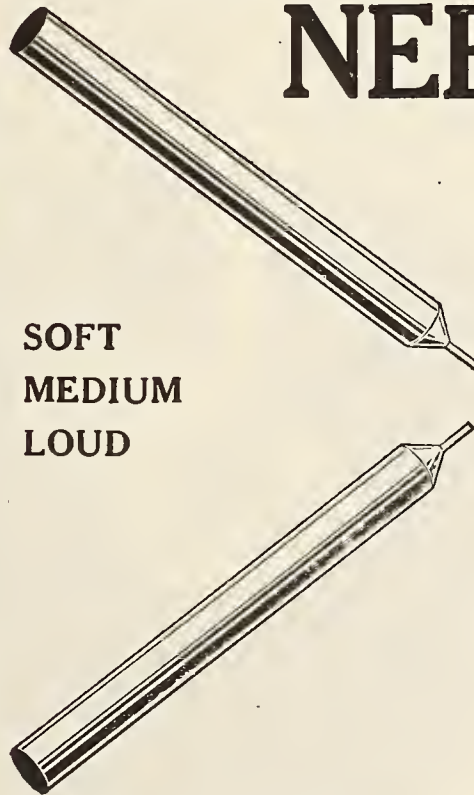

SOFT
MEDIUM
LOUD

Point the Way to

Conservation
Economy
True Reproduction
Re-orders
Profits
Satisfied Customers

Heavy responses met the initial announcement of our needles. Large re-orders have invariably resulted where samples have been sent.

These needles are semi-permanent and may be used many times with true reproduction. They wear themselves rather than the record and being parallel in shape, as they wear down they do not enlarge their diameter as does an ordinary tapered needle, hence prolong the life of record. They are produced in three grades—soft, medium and loud.

BUY LIBERTY BONDS and THRIFT STAMPS

We advertised this last month and again devote part of our space to this cause.

Another patriotic pleasure is to use the Vallorbes needle and thus conserve steel for Uncle Sam.

SEND 30c. IN STAMPS FOR THREE SAMPLE PACKAGES (ONE SOFT, ONE MEDIUM, ONE LOUD), DEALERS' DISCOUNTS, ETC.

Originators and
Largest
Manufacturers of
Diamond Points



Sapphire
Ball Jewels
Loud
and Half-tone

LANCASTER, PA., U. S. A.

FOR DESCRIPTION OF THE HOFFAY AIRTIGHT SOUND MECHANISM SEE MARCH ISSUE OF THE WORLD

"HOFFAY"

The AIRTIGHT Machine.
As the trade-mark reads, is

"The World's Musical Instrument"

Increases the value of records of all makes

No. 100

The Home Music Leader

Unquestionably the best value on the market. Genuine mahogany, quartered or fumed oak. Metal parts nickel-plated. automatic stop, double spring motor, plays from four to five records.

Two hundred needles for Columbia and Victor records and sapphire points for Edison. If diamond point \$5.00 extra.

Height, 41 3/4", width 19", depth 20 1/2". Equipped with Resurrectone \$100.00, with Half-Fork-Tone \$95.00.

No. 140

A Great Instrument

Finest construction throughout, genuine mahogany, quartered or fumed oak. Distinctive design. High class double spring motor, playing from four to five records. Metal parts heavily nickel-plated. Two hundred needles for Victor and Columbia records, one sapphire point for Edison. Diamond point \$5.00 extra. Height 47", width 21", depth 21". Equipped with Resurrectone \$140.00, with Half-Fork-Tone \$135.00.



No. 100—\$100.00

The Wonderful Resurrectone

With its exclusive "tuning fork" has no equal in the world. Its clearness and mellowness have the timbre and warmth of the natural voice, string or wind instruments. Forms the regular equipment for the Hoffay, but is also sold for other machines.

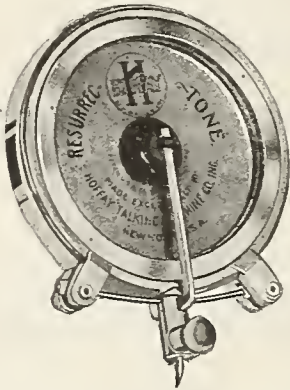

PRICE: Nickel-plated \$10. 22 karat gold-plated \$12.50. To fit Victors, Sonoras, and attachments for Edison machines, etc. Money refunded if reproducer returned within 5 days from receipt.



No. 140—\$140.00

The Half-Fork-Tone

The next best reproducer. Remarkable for its clear and loud sound. It is equipped on the Hoffay wherever specially ordered. It is also sold to fit other machines.

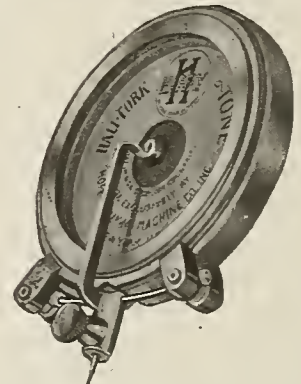

PRICE: Nickel-plated \$6. 22 karat gold-plated \$7.50. To fit standard machines and attachments for Edisons. Money refunded if reproducer returned within five days from receipt.



No. 190

The "Second" Hoffay Choice

Elegance of style enriched by inlaid mahogany of extremely high finish, lends special charm of "finesse" to this superior instrument. Fine treble spring motor will play six or seven records. Speed regulator and automatic stop. 200 needles for Victor and Columbia records, Sapphire needle for Edison. Diamond point \$5.00 extra. Metal parts gold-plated.

Height 46 1/4", width 20", depth 20 1/4". Equipped with Resurrectone \$190.00, with Half-Fork-Tone \$185.00.

No. 250

The Supreme Achievement in Musical Instruments

An extra smart creation, made in genuine mahogany, that symbolizes the acme of perfection. Silent treble spring motor will play six or seven records. Speed regulator and automatic stop. Metal parts are 22 karat gold-plated. 200 needles for Victor and Columbia records and one sapphire point for Edison records; diamond point \$5.00 extra. Height 50 3/4", width 24 1/2", depth 24 1/4", equipped with Resurrectone \$250.00, with Half-Fork-Tone \$245.00.



No. 190—\$190.00



No. 250—\$250.00

Hoffay Talking Machine Co., Inc.

3 West 29th St., New York City, N.Y.

(Hoffay products are protected by patents granted and pending. Infringements will be prosecuted.)

What Y. M. C. A. and Other Agencies Are Doing to Provide Music for the Fighting Men

There are various national organizations at work providing music for the army and navy men both at home and abroad. Perhaps the most important of these is the Y. M. C. A., which recognized at an early date the value of music in maintaining the morale of the fighting men.

During the past month The World has learned much through Y. M. C. A. officials anent what this worthy institution is doing to see that the men in the service have plenty of talking machines and records. The general policy of the

conducting more aggressive local campaigns for talking machines and records, they will find the explanation in that fact.

The reports to date indicate that comparatively few machines have been received by the association through donation, but that a great many records have been given by the public, and several manufacturers, notably the makers of Victor, Columbia and Emerson records. The data available shows, however, that the free donation of records and machines to the Y. M. C. A. represents a small percentage of the total

and for the men in our own expeditionary forces. No exact figures can be given as to the total number of machines and records that have been sent to the other side. Last month, however, in a news bulletin showing what the Y. M. C. A. has shipped abroad, there were included one hundred talking machines and 2,500 records, all sent over in a thirty-day period for the use of our soldiers in France.

There has been much controversy over just what kind of records the soldiers prefer, and the association has gone so far as to conduct



Copyright, Committee on Public Information

In a Y. M. C. A. Hut at a Cantonment

One of the Recreations in the Y. M. C. A. Building at Columbus Barracks, O.

Y. M. C. A. is against the solicitation of either machines or records on a free contribution basis, although good use can be made of all machines and records that may be donated. No direct donations are solicited because it is felt the American people have stood nobly behind the association in the way they oversubscribed to its national campaign for money last fall. There are so many war charities continually approaching the public for outright donations that the Y. M. C. A. prefers to acquire its materials in a regular business way, with the money that has been subscribed for the purpose. Therefore, if talking machine dealers should wonder from time to time why the Y. M. C. A. is not

number of machines and records that have been given to the fighting men, because the majority of the donated instruments and discs have been presented to particular soldiers in the different cantonments or to specific companies, corps, etc., and through the Y. M. C. A.

The Y. M. C. A. has long since established a "hut" in each of the military camps in the United States. In one of the largest camps several huts have been erected, each being equipped with a talking machine and an excellent supply of records.

A considerable number of machines and records have been sent to Europe for the entertainment of men in the armies of our Allies

special investigations to determine what kind will give the "men in khaki" the greatest pleasure. On the evening of March 22 P. F. Jerome, purchasing agent for the National War Work Council of the Y. M. C. A., gathered together six sailors from the Brooklyn Navy Yard and six soldiers loaned for the purpose by Captain Andrew C. Gardner, post-adjutant of Fort J, Governors Island. These men-of-war became musical critics for the time, and sat as a jury to determine which out of a total of 15,000 records would bring the greatest joy to Uncle Sam's fighting forces. The members of the jury were picked at random without regard for

(Continued on page 50)

On Selling Records



There are many excellent ideas the Victor Dealer can use to stimulate the sale of slow moving stocks. Some of these ideas have already been put into practice, others have not yet been discovered. We urge Victor dealers to encourage their salesmen in originating new plans for selling records, and along the same line our travelling representatives will be glad to offer several good suggestions.

ECLIPSE MUSICAL COMPANY
CLEVELAND OHIO



Bringing in more customers and making more sales for every dealer accepting its aid, is the sole aim of the Columbia Dealer Service Department.

**Columbia Graphophone Co.
Woolworth Building, New York**

THE PROVIDING OF MUSIC FOR OUR FIGHTING MEN

(Continued from page 49)

their familiarity with music. Their main mission was to decide what records should be scrapped for the duration of the war, and among those put into the scrap barrel were pieces of musical merit with unfortunate names and all German music, including some operatic selections. Among the records barred because of their names were such as "I Didn't Raise My Boy to Be a Soldier" and "The Prussian Military March."

Popular records without doubt are the ruling favorites. The songs of the operatic stars and the great masters on the violin, etc., are exceedingly well liked by a certain percentage of the soldiers, but in volume of demand run second to the "popular" selections. Patriotic pieces are in the third class.

Miss Kate Pope, an English girl, who has served in an important American Y. M. C. A. "hut" across the sea since last September, makes the following interesting commentary on what kind of music the soldiers want:

"Write a rag—at least a song with some syncopation. That is what the boys always ask for. Don't be too patriotic in your song-writing. The boys don't like that sort of thing. When they do it's an exception like 'Tipperary.' But if you analyze that you will find that it is not the usual type of patriotic song. It is simply considered patriotic because of time and usage.

"A good point to bear in mind is to introduce the humorous side of the war. The soldiers know the other side, and when they are out to sing and to listen to music it is for diversion. For instance, the most popular song with the soldiers here is 'I Don't Want to Get Well.' Other popular songs of the moment with the men are 'Joan of Arc,' 'Huckleberry Finn' and 'Are You From Dixie?' They sometimes like what Americans call 'sob stuff'—such sentimental ballads as 'God Send You Back to Me,' 'A Little Bit of Heaven' and 'Mother Machree.' But rag is the rage."

Very probably talking machine dealers will be asked by the public from time to time regarding what kind of records the soldiers like best. The result of the study given to the matter by the Y. M. C. A., as presented above, will indicate the kind of advice to offer these inquiries. As far as the disposal of donations of either records or machines is concerned, the best plan seems to be to deal with the Y. M. C. A. headquarters in the nearest cantonment in case the donation is for the military forces on this side of the Atlantic, and in case the donation is made for the overseas forces to get in touch with the Division of Music, National War Work Council, 124 East Twenty-eighth street, New York.

In addition to machines and records supplied to camps and ships by the Y. M. C. A., or under its direction, there have been hundreds of outfits supplied through other channels which have made a specialty of collecting machines and

records for distribution among the fighting forces. Special committees, as well as newspapers throughout the country, are constantly making appeals for donations of talking machines and discs, and are getting excellent results.

The Knights of Columbus, who are operating huts in all the leading cantonments and camps here, and also in France, and who, with recently collected funds, plan to broaden their work along this line materially, see to it that each hut is supplied with a machine and a suitable collection of records, and in addition have supplied outfits to various company and regimental units.

CHANGE NAME TO "ELMBRO"

Talking Machine Put Out By the Elmbrola Co. Will Bear Above Name Hereafter

ST. PAUL, MINN., April 5.—J. Neiger, general manager of the Elmbrola Talking Machine Co. of this city, has announced that the company has changed the name of its product from "Elmbrola" to "Elmbro." Mr. Neiger states that the company has achieved very pleasing success with this product, and had already established wholesale agencies in important cities, and made arrangements for dealer representation throughout the country. He recently visited New York and expects to have an announcement ready in the near future regarding the presentation of the Elmbro line in the eastern part of the country.

The Elmbrola Talking Machine Co. manufactures a complete line of machines, and Mr. Neiger, who has been associated with the industry for a number of years, is devoting considerable time to effective dealer co-operation. He states that he is making a drive for the better class of business, and the dealers which he recently established are well known in their respective localities.



SONORA PAINTED SIGNS ATTRACT

The Sonora Phonograph Sales Co. has recently made arrangements whereby they will feature artistic painted signs along the route of each railroad just before reaching New York. The object of these signs is to impress out-of-town visitors with the fact that the company has artistic salons at Fifty-third street and Fifth avenue, which are at the disposal of these visitors for demonstration and display.

The accompanying picture is that of a sign which is located in two places—one on the Long



A Sonora Signboard

Island railroad near Jamaica, and one on the New York Central railroad, just below High-bridge. This sign has attracted very favorable attention, and Frank J. Coupe, director of sales and advertising for the Sonora Phonograph Sales Co., is well pleased with the publicity that this advertising affords.

CLEVELAND MAN WELCOMED IN EAST

C. K. Bennett, the well known executive of the Eclipse Musical Co., Victor jobbers in Cleveland, has recently completed a two weeks' trip through the East. He spent part of his time calling on the trade in New York, and also made quite a visit at Victor headquarters in Camden, N. J. In talking with The World during his visit to New York, Mr. Bennett said that he was going to Cleveland with a better knowledge of general conditions and lots of new ideas for boosting the Victor business.

NEW MULTIPLE DISC TALKING MACHINE

Inventor Will Sell Patent Out-right or on Royalty Basis

Plays 28 selections in one set which can be replaced set for set according to the number of records. Equipped with automatic stop which requires no setting. Fine tonal reproduction.

Send for Descriptive Circular

MAX KRAUSS

233 N. Alden St.

Phila., Pa.

CHAS. J. ORTH HOST AT DINNER

Milwaukee Talking Machine and Piano Man Entertains Officials of United Phonograph Corp. and Members of Own Staff in Milwaukee

MILWAUKEE, Wis., April 2.—A most enjoyable dinner party was given in the Gold Room of the Hotel Wisconsin on Thursday evening,

family gathering, without an unduly serious aspect, in preparation for the real work that is now being undertaken by him in behalf of the Puritan. This thought was carried throughout the dinner. When the guests took their seats they found favors of a humorous character and a menu that was particularly Puritan-esque.

The guests of honor were Fred A. Dennett, president and general manager of the United

horn. Representatives of the press included Alfred B. Cargill, W. A. Dudley, Harry J. Grant, Leonard Meyer and Frank Effinger. Other guests were James Orth, J. B. Thiery and Roy Steffen.

ORGANIZED IN KALAMAZOO, MICH.

Electric Phonograph Co. Incorporated to Manufacture Coin-Operated Machines

KALAMAZOO, MICH., April 4.—The Electric Phonograph Co., of this city, has been incorporated with capital stock of \$30,000, to engage in the manufacture of coin-operated electric phonographs, designed particularly for use in public places. The equipment for a factory has been ordered, and a plant will be established in this city. It is stated that the company owns a number of new patents covering their instruments.

The officers of the new company are: President, John W. Adams; vice-president, E. B. Desenberg, and secretary-treasurer, A. J. Reams.

MAKING NEEDLES FROM CACTUS

PORTLAND, ORE., April 2.—Oregon never considered its scrub cactus growth—which is found in the waste sections of Eastern Oregon—of much value, but even this is now being turned to account by the phonograph people. The scrub cactus needles, tests have shown, are admirably fitted, after proper treatment, for record needles, and these, with a variety also found on the Mexican border, are rapidly being turned to commercial advantage. These needles have been placed on sale in Portland by the Wiley B. Allen Co. and are found to give pleasing sweetness and softness to the tone. There is little danger of the supply of raw material ever being exhausted in Oregon, no matter to what extent the manufacture of the thorns into record needles expands.



Dinner Given by Chas. J. Orth to United Phonograph Corp. Officials and Members of His Staff

March 21, by Charles J. Orth, 504 Grand avenue, the well-known piano and talking machine dealer who recently took over the distribution of the Puritan phonograph in Wisconsin and the Upper Peninsula. The event served to introduce the men responsible for the Puritan to the Orth force and members of the press.

Phonograph Corp., Sheboygan; William H. Thommen, general superintendent of the company and designer of the Puritan, and Lloyd Jenkins, general sales manager. Mr. Orth's staff was represented by W. H. Heise, Adam C. Schroeter, W. H. Hadert, Gustav Kleemann, G. M. May, Paul Wachs, Roy Hettinger, Albert Mueller, Henry Staab and George E. Ball-

Mr. Orth stated the dinner was a little

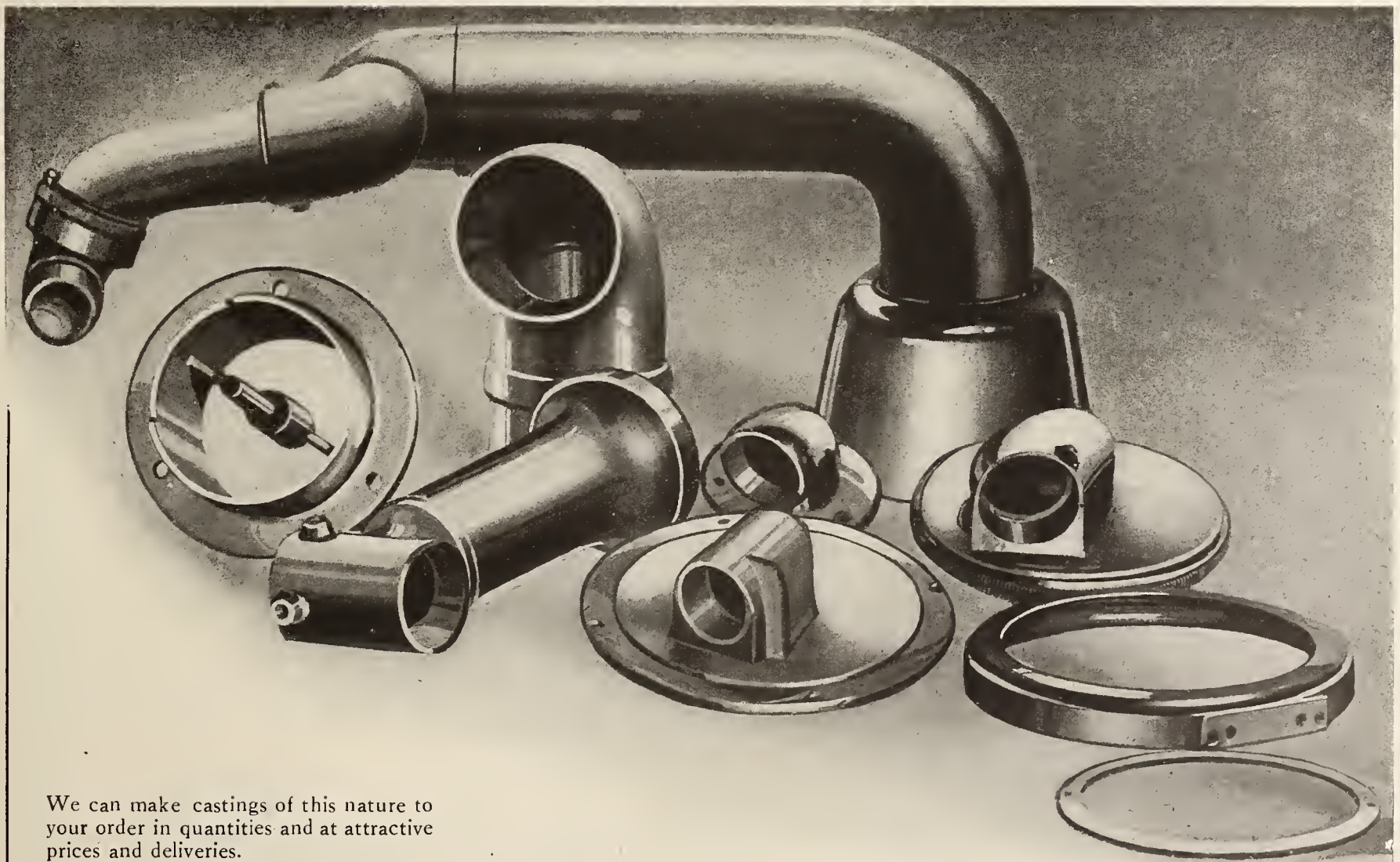

We can make castings of this nature to your order in quantities and at attractive prices and deliveries.

Send samples or blue prints for estimate.

“INDIANA” DIE CASTING CO.

CORNELL and 11th STREETS

INDIANAPOLIS, IND.

INCREASE YOUR SALES

Here is your chance, Mr. Edison Dealer, to close the undecided prospect.

KENT Attachment and Sound Box

FOR THE
EDISON DISC PHONOGRAPH

Patent No. 1,130,298



Patented March 2, 1915

SIMPLE AND ACCURATE

Made by manufacturers who have specialized in Edison attachments for years.

This is not a new product—hundreds of dealers are now selling them, and thousands of them are on the machines of Edison owners.

If you are not already acquainted with the Kent Attachment and Sound Box, don't lose time—send for one to-day.

Most Edison jobbers handle our products. If yours does not write direct.

F. C. KENT & CO.

Manufacturers of Phonograph Accessories

Cor. MULBERRY AND CHESTNUT STS.

Newark

New Jersey

USES INFORMATIVE ADVERTISING

Famous & Barr Co. Using Educative Copy in Their Announcements With Great Success—Featuring Victor Line Strongly

St. Louis, Mo., April 8.—A novelty in the way of advertising of records has been the series of informative advertisements run in the newspapers by Manager Ditzell, of the Famous & Barr Co. The series is running and will continue indefinitely, according to present plans, and Mr. Ditzell hopes to gather a series that can be put into book form after they are run as ads.

The text in the ad below, bearing on the soprano voice, will illustrate what the series is. The introduction reads:

"There are two principal soprano voices—the coloratura and the lyric—each with its fair and measured province in the field of song. The first, or coloratura, corresponds with the flute in the orchestra—it is the sparkling, dazzling voice, abounding in trills, turns and tremolo—the 'showy' voice. Its most striking exponent is Galli-Curci, who sings the famous 'Bell Song' from Lakme with almost uncanny brilliance.

"The lyric, on the other hand, is essentially the sweet voice, the voice of romance, poetic fancy and emotion. Of the lyric voice, one of the best examples is that of Lucy Marsh, who sings 'Birth of Morn' divinely."

Then follows a list of records set out as to the kind of soprano voice each presents. Other ads deal with the various kinds of voices, the quartet male and mixed, and then will come the various instruments. Mr. Ditzell says that in preparation of these ads he uses information gathered by work on the floor in the record department, where he asks customers as to which kind of soprano they wish and other leading questions to develop what will really be information to the average record buyer.

Another novelty from the Famous & Barr Co. is the new form of announcement of the monthly record lists. This idea first was that of photographing the regulation Victor record list and reproducing it. But the list did not lend itself well to photographic reproduction by printing, so a redrawing of the Victor dog that illustrates the hanger was made and the names of the records set in type in exact facsimile of the original. The result is a neat mailing card that will easily catch the eye of the Victor record buyer. Of this Mr. Ditzell says:

"Of course, next to the trade-mark dog, the most familiar advertisement to a Victrola owner is the monthly record bulletin. You will notice that a Victrola owner always is ready to stop and read the hanger. Now we hope to catch the eye in a way that the bulletin ordinarily mailed does not. Also some Victrola owners get the bulletins from the several sources, and we hope our announcement will be distinctive. We believe it is a move in the direction of conservation of paper, mail weight and in other ways meets the demands of the times."

NEW PRICES ON LANSING COVERS

E. H. Lansing Announces New Schedule, Owing to Greatly Increased Cost of Production

BOSTON, MASS., April 1.—E. H. Lansing, who manufactures the Lansing khaki moving cover for talking machines and accepted as the pioneer in that field, announces that he has been compelled to increase the prices of his various covers, and the new prices will be, Style A, \$8.50, and Style B, \$6. Mr. Lansing has been absorbing the increased cost of both materials and labor for some time past, and has found it impossible to do so any longer. The increase of \$1 per cover, however, means the placing of as light a burden as possible on the purchaser. Incidentally, Mr. Lansing reports that the business is keeping up in good shape in all sections.

Both prophets and profits are without honor in every country and just now.



The 1st of May Will Be Thrift Stamp Day In the U. S. A.

The Active Co-operation of
Every Reader of

THE TALKING MACHINE WORLD

Is Urgently Requested to
Make It a Success

May 1st, 1918, will be observed throughout the United States as Thrift Stamp Day! On that day retail stores everywhere in every line of business will ask customers to take PART OF THEIR CHANGE IN THRIFT STAMPS! It will be patriotic for every man, woman and child to accept at least one Thrift Stamp as change on every purchase made that day—and to make as many purchases as possible on May 1st.

Here is a big, practical way of getting millions of Thrift Stamps into the hands of the people of the United States, and of insuring the success of the Government's War Savings Stamps campaign. Thrift Stamp Day will HELP EVERYONE. It will prove a tremendous boost to business. On May 1st, 1918, the nation should do the biggest total retail business of any single day in our history! The beneficial habit of Thrift will be sown broadcast among the citizens of the U.S.A.! Most important of all, Uncle Sam will be furnished with the sinews of War and Victory!

American business must go "over the top" AT ONCE in a quick drive to make Thrift Stamp Day an overwhelming success. You wholesalers, you jobbers, you salesmen, must TALK Thrift Stamp Day among your trade, arouse the ENTHUSIASM of the retailers, the storekeepers, the clerks behind the counters. Uncle Sam NEEDS YOUR HELP. A practical PLAN has been prepared showing how each one of you can "do your bit" to make Thrift Stamp Day a red letter day in American business annals. Write for this plan TO-DAY WITHOUT FAIL. Remember, in helping Uncle Sam you are helping business and helping yourselves. Address Mr. W. Ward Smith, National War Savings Committee, 51 Chambers St., New York City.



National War Savings
Committee

51 Chambers St.

New York City

AS SOON AS IT'S A HIT IT'S AN EMERSON

**IF You Had Been An
Emerson Dealer on March 1st
You Would Have Sold These BIG HITS**

- "A Baby's Prayer At Twilight"
- "Liberty Bell, It's Time To Ring Again"
- "Are You From Heaven"

Emerson dealers nine times out of ten beat the game by bringing out the wanted music—the big hits of the day way in advance of anybody else.

Sometimes Emerson dealers are two months ahead of anybody else. Sometimes a month. This is an advantage plus the many other money making advantages that come to Emerson dealers. Because they sell for 35c—3 for \$1.00, the number of buyers is increased many fold. Because they bring you more profit per record, it is worth more to you to sell them. Because they will play on any machine without an attachment, everybody can play Emerson records.

**IF You Are An
Emerson Dealer NOW
You Will Have For Sale These BIG HITS**

- "My Mind's Made Up to Marry Carolina"
- "On the Road to Home Sweet Home"
- "There'll Be a Hot Time for the Old Men"
- "I'm the Brother of Lily of the Valley"

**IF You Are An
Emerson Dealer On April 20th
You Will Supply the Demand for These BIG HITS**

- "Cleopatra," Al Jolson's Winter Garden Hit
- "What Are You Going To Do To Help the Boys"
- "Good Bye Barney Boy"
- "If You Look In Her Eyes"
- "Lafayette"

Emerson Phonograph Company INC.

3 West 35th Street New York, N. Y.

Boston Office: 80 Boylston St. Chicago Office: 7 East Jackson Blvd.

Dept.
A

Clip this coupon to your letter-head and we will send you full information.

Name

Address

City State.....

INTRODUCE NEW STEEL NEEDLE

The Gloria Phonograph Supply Co. Makes an Important Announcement—To Make Needles in All Standard Styles and Tone Qualities

The Gloria Phonograph Supply Co., 200 Fifth avenue, New York, has just placed on the market a new steel needle which will be known as the "Gloria." The company is marketing this needle in all standard styles and tone qualities, and is instituting an aggressive campaign to present this needle to the jobbers and dealers throughout the country.

Realizing that the talking machine dealers have been badly handicapped the past year by a shortage of steel needles, the Gloria Phonograph Supply Co., before announcing its new needle, completed factory arrangements whereby it could promise the dealers immediate delivery on their orders. The company felt that it was unfair to the trade to announce a new steel needle without being in a position to take care of the dealers' requirements promptly, and delayed their announcement accordingly until the officers were certain they could guarantee immediate shipments of the needles.

In its literature the Gloria Phonograph Supply Co. will emphasize the fact that the Gloria steel needle is constructed of the finest carbon steel, and that it is guaranteed to give absolute satisfaction to every user. The company's manufacturing and sales campaign will feature this important constructional merit, in order to impress the dealers with the fact that they can offer the Gloria steel needle to their customers with perfect confidence in the satisfaction that it will render.

The president of the Gloria Phonograph Supply Co. is Rudolf Gaertner, who for a number of years has been prominent in manufacturing and import circles. Mr. Gaertner will devote

his entire time to the new company, which was recently incorporated with a capital stock of \$25,000, and his lengthy experience in the mercantile world will doubtless enable him to cooperate effectively with the dealers throughout the country.

R. R. Debacher, president of William Schimper & Co., Hoboken, N. J., and a director of the Trust Co. of New Jersey, a well-known manufacturer of metal goods, and prominent in New Jersey financial circles, is first vice-presi-



Rudolf Gaertner

dent of the company, and as such will act in an advisory capacity.

Roswell Francis Easton, who has been associated with Mr. Gaertner for a number of years, is second vice-president of the company, and will be actively interested in its activities.

On another page in this issue of The World is the first announcement of the Gloria steel

needle, and this announcement, which, by the way, is a splendid example of lithographic art, features the copyrighted trade mark of the needle—the lark. It is planned to use this trade-mark on all posters, window cards, etc., and all publicity will probably feature the same poster design as shown in this announcement. The company is now preparing to distribute a series of window cards to the dealers, in order that the public may be acquainted with the qualities of the new needle.

DOUGLAS PICTURES IN NEW YORK

Process for Making and Projecting Motion Pictures in Natural Colors, Invented by Leon F. Douglas, Proves Decidedly Interesting—Wonderful Effects Produced by the Process

Members of the local talking machine trade were much interested recently in the special showing in this city of motion pictures in natural colors produced by a new process invented by Leon F. Douglas, of San Rafael, Cal., who for many years was actively connected with the Victor Talking Machine Co., is still a director in that company, and had much to do with the early development of the Victor product.

The Douglas pictures have been shown in various sections of the country recently and with much success, and when offered at the Eighty-first Street Theatre served to attract much attention not only from the public but from members of the motion picture trade. The pictures shown include really wonderful views of Yellowstone Park, with its geysers, falls, flora and fauna. Then there were magnificent pictures of the Grand Canyon of Colorado, remarkably natural in their reproduction. Likewise views of a forest fire, of Californian flower gardens and of motion picture celebrities. While the films showed the natural colors of the landscape with great faithfulness, depicting the subtleties of the sky, ground, water and plant life very closely, they reached their best when showing closeups of people. Whether a young lady has copper-colored hair or is a typical blonde or brunette, her locks show up with startling faithfulness, and even her complexion is given its full value. The closing feature of the exhibition, and one that greatly impressed the audience, was a sunset scene, with the sun's last rays merging into the purple tinge of twilight.

Mr. Douglas' device consists of an inexpensive attachment that may be affixed to any motion picture camera and which permits of the production of a film containing a series of images so colored as to give, when projected, a moving picture in natural colors, without the use of the rotary colored shutter usually required.

"By this contrivance," declares Oliver Jones, formerly a well-known talking machine man, and now acting as representative for Mr. Douglas, "the brilliancy and intensity of the projected colored picture are increased and a stereoscopic effect is obtained impossible in black and white. There is no more light required than is used in projecting black and white, and a speed of only twenty-four to the second is necessary, and through certain experiments being made this speed will be reduced. The cost of producing pictures by this process is slightly more than that for making black and white, while the advantage in the art of producing motion pictures is considerable."

NEW QUARTERS IN IRVINGTON, N. J.

A. H. Redden, who has been conducting a bicycle and sporting goods store in Irvington, N. J., has moved to new quarters at 1065 Clinton avenue, that town, where he is featuring Brunswick phonographs very successfully. He has handled the Brunswick line since last fall.

MOVING TO NEW LOCATION

H. G. Applin, the Victor dealer of 20 College avenue, Somerville, Mass., has arranged to move to new quarters in the Medina Building on April 1.

KOCH-O-PHONE

\$18.00



No. 18

The KOCH-O-PHONE is the FORD of the Phonograph world. There is no charge for the name or expensive advertising added to the cost. Most people would rather pay \$36 (resale price) than \$75 for the same amount of pleasure. Plays all makes of disc records. No disconnecting needed in exchanging from one make of record to another. Simply turn the sound box and change needle to suit make of record. This machine for tonal quality and volume is not excelled by any \$75 machine on the market.

No. 18—Height 40 in., width 18 in., depth 18 in.; double spring worm driven motor; 12 in. turntable, all metal trimmings are nickel plated; made in mahogany finish. Weight about 100 lbs. \$18.00

Cabinet alone, complete with needle cups . . . \$10.00

Tone Arms and Sound Boxes

(Genuine Mica)

Our new universal tone arm and sound box, No. 3, has proven a big success. Has all the desired requisites in the way of producing a clear, rich and musical tone.

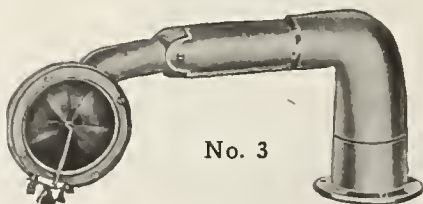

No. 3

Price \$1.50
In Lots of One Thousand

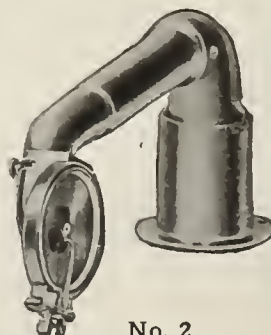

No. 2

Real Mica, \$1.00
in 100 Lots
Imitation Mica, 85c

ANDS KOCH, Manufacturer

296 Broadway

NEW YORK



Lend Him A Hand

Your Hand—My Hand

Every hand in the land stretched out to help him to **VICTORY!**



In defense of **LIBERTY, JUSTICE** and **CIVILIZATION**, we must use every weapon at our command. And not the least of these is money. Never in the history of the world has there been a truer cause.



INVEST IN

LIBERTY BONDS

(This space donated by the OTTO HEINEMAN PHONOGRAPH SUPPLY CO., Inc.)

CONDITIONS IN TALKING MACHINE INDUSTRY IN ENGLAND

Louis S. Sterling, Manager of Columbia Co. in London, Tells Most Interestingly of Business Activity—Labor Problem Serious, But It Is Being Mastered—Record Trade Enormous

"Our sales during 1917 showed a gain of 25 per cent. over 1916, making this year the best in our history," said Louis S. Sterling, managing director of the Columbia Graphophone Co., Ltd., London, who arrived in New York recently for a visit to the executive offices. "Our figures for the year show that our business was double that of 1913, and we therefore have every reason to feel gratified at the prosperous condition of talking machine activities abroad, notwithstanding the war.

"The preponderance of our business last year was in records, and the actual production of records was larger in 1917 than ever before in our history. Although the demand for machines

ballads and the very fine string and orchestra selections. In fact, to the casual observer the demand for this class of music is almost remarkable.

"We are shipping many thousands of records per month to the boys at the front, and the orders for these records almost invariably call for 50 per cent. of popular music, and the remainder good standard selections and operatic numbers. The demand for the so-called patriotic popular number has practically passed into oblivion, the boys at the front calling for the straight popular selections.

"The demand for table machines is by far in the preponderance, but this is attributable to the fact that it is almost impossible to get cabinets to manufacture the floor machines. The demand for cabinet machines is far in excess of the supply, and it is for this reason that the table machine is selling in such large quantities.

"There is a very bright future ahead for the talking machine business in England. We are all optimistic regarding the future, and whether or not the war continues for any extended period, the talking machine industry is certain to enjoy an era of activity and prosperity."

MAKING RICHMOND MUSICAL

Corley Co. Doing Much for City's Musical Advancement—How This Company Serves the Dealer—Widely Known as Victor Distributors

RICHMOND, IND., April 9.—Fred. R. Kessnich, now in charge of the wholesale department of the Corley Co., this city, had in his possession during the past week substantial evidence of the fame of the Corley Co. as Victor distributors. Two large cases addressed to widely separated cities in the Middle West were in some unaccountable way delivered to the Corley Co. in Richmond. The only accountable reason being that these cases bore on them the Victor trade-mark.

Mr. Kessnich reports generally good business in both the wholesale and retail departments and the continuing popularity of their Victrola fibre trunks.

The aim of the Corley Co. has ever been service to the dealer. For a long time the Corley Co. has owned a print shop where they have printed the large volume of literature that they send out and in addition turned out many printing jobs for their dealers at a small cost. Another service department of the Corley Co., which is in the highest state of efficiency, is the repair department, which is in charge of M. F. Burnett, who has been with the Corley Co. for a number of years. In order to keep this department up to this high state Mr. Burnett makes it a point to make a yearly visit to the Victor factory.

The slogan of the Corley Co.—"The house that made Richmond musical"—has been especially proved this year. Through the efforts of the Corley Co. many world-renowned musical artists have come to Richmond during the past season. For these series the large City Auditorium is engaged and is usually filled to capacity. Literature is now being mailed concerning the Spring Festival to be held at the City Auditorium on April 29, 30 and May 1, 1918. Prominent operatic artists, such as Paul Althouse, tenor; Sophie Braslau, contralto; Mabel Garrison, soprano, and Lambert Murphy, tenor, are to appear. Attention is called in the literature describing this festival that these artists are well known to all Victrola owners, and the opportunity is offered to get acquainted and to make comparison between their voices and the perfect reproduction of the Victor records. Other artists that will appear are May Peterson, Nina Margana, Helena Marsh, Thomas Chalmers and Rafaelo Diaz. The Wednesday Club Chorus of Richmond and the Russian Symphony Orchestra will also appear.



Louis S. Sterling

is bigger at the present time than it was before the war, we must consider the fact that the production of machines is only 30 per cent. of the total production before the war started, owing to the necessary restrictions placed upon our product, the scarcity of raw material, and the dearth of labor.

"General conditions in the talking machine industry in England are very satisfactory, although all of the factories have been obliged to face very serious labor problems. When the war broke out in 1914 there were 291 men employed in our record factory in England. At the present time there are only eleven men employed, the rest being women, and in order to produce the same efficiency in our factory, we found it necessary to increase the force of women by 40 per cent. Out of the eleven men at the plant six are over fifty years of age.

"The numerous air raids over England, the lightless nights, and the various curtailments of amusements are influencing the people to stay home more now than ever before. They naturally must have some relaxation from the seriousness of war, and it is in this respect that the talking machine is 'doing its bit,' and affording the public pleasure and entertainment.

"There exists in England to-day a tremendous demand for the straight popular songs, and there is also a notable increase in the call for good music. I refer particularly to high-class

FOR SALE

25 SHARES

**Victor Talking Machine Co.
Common Stock
at \$825**

WILLIS O. HEARD

LAFAYETTE BUILDING PHILADELPHIA, PA.

The
FULTON

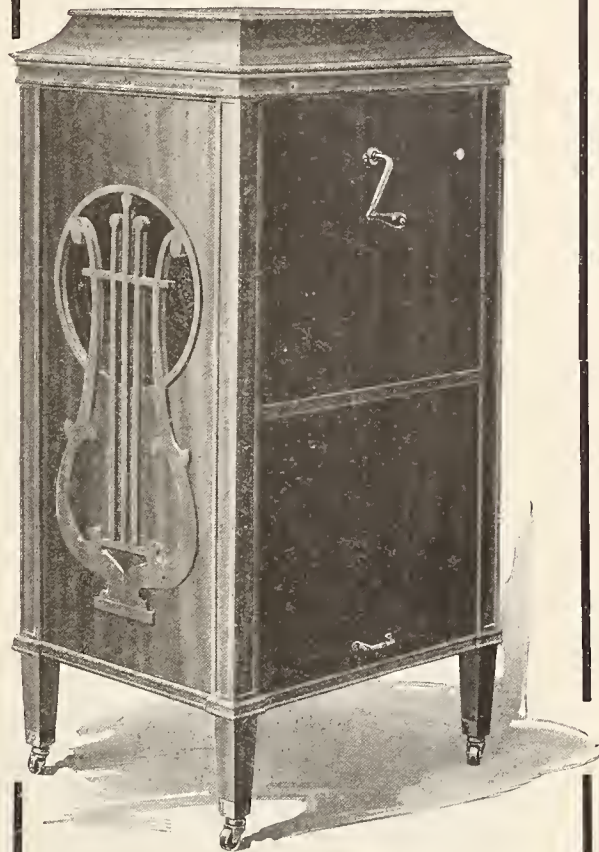

**Style F
Price, \$150.00**

Size 45 x 19 x 23

In Fumed Oak Waxed, and Satin Mahogany, Double Spring Spiral-gear Motor, Tone-Modifier, Automatic Stop, Lock, Needle-Cups and Rest, Leg-Sockets and Casters, Balanced Cover Lift, Universal Tone-Arm. All exposed metal parts heavily nicked.

Record compartment opening on side through a rising and falling balanced door, fitted with five ten-inch and three twelve-inch high grade albums, capacity 98 records.

The patented spun vibratory horn is finished and grained to match the woodwork of cabinet.

Send for Catalogue

Not Sold Through Jobbers

FULTON-ALDEN CO
INC.

WAUKEGAN, ILLINOIS

TALKING MACHINES A WAR NECESSITY IN MILWAUKEE

This Is Proven by the Demand in Camps and in the Homes—Badger Activity—New Brunswick Dealers—Phonograph Co. Increases Capital—Four New Sonora Dealers—Puritan Developments

MILWAUKEE, WIS., April 12.—As the nation enters the second year of active participation in the world war as a combatant, it is becoming more and more evident that of all the instruments ever created to assuage mental and physical pain and suffering the talking machine has outdistanced all others and is secure in the first rank, not only so far as the boys at the front are concerned, but among those who must remain at home. Never since its origin has the talking machine been in such tremendous demand as it is today. At the same time, the output of the country's talking machine factories, while probably the largest that it ever has been, is becoming more and more inadequate to fill requirements. In the case of so popular a line as the Victor, it is conservatively figured that if twice as many machines were available immediately, not all orders could be filled. Even some of the newer and relatively lesser known makes are selling so well that the big problem in the talking machine industry of Wisconsin today is to produce enough instruments. In the case of records, needles and other supplies and accessories, the condition is similar.

Talking machine business predicated upon the Easter holiday this year assumed such volume that it was wholly reminiscent of the pre-Christmas season. Saturday, March 30, the day before Easter, seemed like a Christmas eve in local retail establishments. Stores were crowded until closing time with customers demanding delivery of machines and records for Easter. Regular delivery systems had to be supplemented with extra trucks and wagons. The situation has not before been known here, although the Easter season also has been a distinct feature of spring business.

Retail dealers attribute the remarkable demand, especially at Easter time, to the influence of the war. In fact, the splendid business that has been done during the last six to eight months is believed to be the direct result of the need for solace which all people have come to experience since thousands of homes have given up sons, and even fathers—and some, daughters.

The dealers who a year ago feared that the declaration of war would shortly result in the collapse not only of talking machine business, but business in general, have had ample reason to change their opinions. There was a lull of about thirty days' duration immediately following the opening of hostilities. But after that talking machine business swung into the most active period in its local history, and it has grown day by day until at this moment it has reached the most prosperous point ever known.

"It's the same old story," said Harry A. Goldsmith, secretary of the Badger Talking Machine Co., Victor jobber, when asked "What's new?" by The World representative. "Our customers still are asking for more machines than we can possibly deliver, and our back orders are piling up every day. So far as records are concerned, we are still worse off. We try to do the best we can and take care of all our retailers, but in spite of this effort, not all disappointments can be obviated. The demand for the Victor to-day is by far the greatest we have known since we established this business. The same is true of Victor business in all other parts of the country. Our situation is not unusual among Victor jobbers, for they all are overwhelmed with business."

According to Thomas I. Kidd, manager of the local branch of the Brunswick-Balke-Collender Co., 275-279 West Water street, the Brunswick factory is having an extremely difficult time in filling all of its requirements, due to the rapidly growing demand for the Brunswick phonograph in Wisconsin and elsewhere. The still serious congestion of freight traffic forms another handicap. Express lines are used from time to time to relieve acute shortage among

dealers, but in recent weeks the express companies have been so overwhelmed with business that, considering the extra expense, not a great deal is gained by making shipments by express. The nine Brunswick retailers in Milwaukee have been doing an exceptionally large business since the beginning of the year, and reports which they make to Mr. Kidd indicate that 1918 is destined to be the greatest Brunswick year since the line first was introduced in this city.

The Yahr & Lange Drug Co., 207-217 East Water street, this city, wholesale distributor of the Sonora for Wisconsin and Upper Michigan, has increased its local city selling organization by the appointment of four prominent retail stores in as many widely separated sections of the city. The new retailers include Alfred W. Fuchs, jeweler, 1403 Green Bay avenue; William Klug & Sons, furniture, 543 Twelfth street; Bruno W. Thien, jeweler, 3401 North avenue, and the Noll Piano Co., 1057 Muskego avenue. A successor to Charles J. Orth, 504 Grand avenue, as the main downtown retail representative, will be selected shortly. Pending the closing of a new connection, the Yahr & Lange Co. has inaugurated a complete service department for the benefit of Sonora owners in Milwaukee, in connection with the Sonora jobbing department of its big wholesale house.

The New Edison continues to increase in popularity throughout Wisconsin, and the Phonograph Co. of Milwaukee, 211-213 Second street, wholesale representative in the territory, has never been quite so busy as now in keeping the wants of its retail representatives fully supplied. The Edison Shop, which is the retail department, is doing a splendid business locally. To accommodate the growth of the business in general, the Phonograph Co. has been obliged to increase its capital stock from \$25,000 to \$50,000. William A. Schmidt is general manager of the company and is ably assisted by Herbert W. Gausewitz, retail sales manager.

Since taking over the wholesale distribution of the Puritan phonograph and records in Wisconsin and Upper Michigan on March 1, Charles J. Orth, 504 Grand avenue, this city, has built up a remarkably efficient sales organization and is giving the Wisconsin-made instrument an exceptionally strong representation in its home state and contiguous territory. In all respects Mr. Orth is duplicating the splendid achievement credited to him in putting the Sonora on the map in Milwaukee as exclusive retail distributor in this city for the past two years, a connection which he relinquished to broaden out as one of the principal distributors of the Puritan line. Arthur Roelke, formerly state representative of the Sonora, has joined Mr. Orth and is looking after retail contracts throughout the Wisconsin and upper Michigan territory. Gustave Kleeman also has joined the traveling sales force. W. H. Heise and Adam C. Schroeter are managing local sales. Numerous excellent retail connections already have been established and before long the Puritan will be represented in practically every nook and corner of the territory. The "home agency," as it were, at Sheboygan, Wis., where the Puritan is manufactured, has been placed with M. W. Brand, 1103 North Eighth street.

Milwaukee and Wisconsin people are respond-

ing generously to the appeal to donate records and music rolls to the soldier boys in camps and afield. The National League for Woman's Service, with the assistance of the Milwaukee County Council of Defense, the Milwaukee Association of Music Industries, and numerous other agencies, is daily collecting scores of records and rolls, which are being forwarded to the various camps as rapidly as they can be classified and packed. This part of the work of the Bureau for the Advancement of Music is regarded here as an especially beneficial undertaking and one in which much pride is taken to make it a success. The recent visit to Milwaukee of C. M. Tremaine, manager of the bureau, did much to stimulate interest and place the local campaign on a sound footing. It is interesting to note that practically no worthless records have been tendered so far.

Fay R. Smith, dealer in talking machines, pianos, etc., New London, Wis., recently has been appointed local chairman of the Waupaca County Council of Defense; city chairman of the Waupaca County Liberty Loan Committee, and was elected president of the New London branch of the Wisconsin Loyalty Legion upon its organization. He is taking an active part in numerous other patriotic movements requiring in all a large personal sacrifice.

The Milwaukee board of school directors has indefinitely postponed action on the proposition recently made to provide talking machines to assist in the instruction of high school boys and girls in stenography and typewriting. Although the success of the plan at Indianapolis and other cities was forcibly presented to the finance committee, it felt that under existing conditions the expense hardly would be warranted.

CANADA CONSIDERING EMBARGO

Reported to Be Planning to Bar Importation From the United States of Musical Instruments and Many Other Articles

Reports from Canada are to the effect that the authorities in the Dominion are planning to reduce imports from the United States by \$150,000,000 a year, by means of an embargo on the importation of specified articles, including all musical instruments, as well as jewelry, furniture, clothing, automobiles, etc.

For the manufacture in Canada of the articles on the embargo list, it will be necessary to import large quantities of parts and raw materials from the United States, but it is maintained that two articles can be manufactured in Canada for practically the same cost as one can be imported.

To compensate the Canadian Government for the loss of customs revenue and to cover the extra protection given manufactures by the embargo, it is proposed to levy a special war tax of 10 per cent. on all Canadian articles that will be sheltered thus from competition.

Should the embargo be put into effect, it will prove a blow to many American manufacturers, particularly of pianos, which are in great favor across the border. Talking machines and records manufactured by companies with headquarters in the United States are in most cases produced in Canadian factories to meet the demand in that country, and avoid customs charges.

Sentiment has no place in charity work. Giving just to help the "forever-wanting," both undermines the independence of the individual you seek to help, and tends to make him not only perpetually poor, but a parasite.



PERSONAL SERVICE

The members of our Company are always available and will gladly see you personally or write you at any time we can possibly serve you.

Why not communicate at once with us?

BADGER TALKING MACHINE CO. 135 Second Street
MILWAUKEE, WIS.
VICTOR DISTRIBUTORS

BUTTERFLY MOTOR

Leonard Markels

Jewel-Bearing

SPECIAL QUANTITY
PRICES FOR
APRIL ORDERS

SPECIAL QUANTITY
PRICES FOR
APRIL ORDERS

This is the MOTOR whose phenomenal success made it necessary for us to double our factory capacity.

The "Butterfly Motor" has won the endorsement of leading talking machine manufacturers everywhere. It is giving excellent service under exacting conditions, and is a motor that is *guaranteed* in every detail. Read its specifications and you can readily understand why the Butterfly Motor is accepted as a standard in its field.

**BUY
LIBERTY
BONDS**

Special Quantity Prices if orders are placed *immediately*

**SAVE MONEY BY
ORDERING NOW**

Try a Sample of
The **BUTTERFLY**
Motor. You will
use it exclusively
after a thorough
test.

**SILENT
BUTTERFLY
MOTOR**
Jewel Bearing

Specifications

Beveled gear noiseless winding.
New ratchet device that prevents clicking.
Bakelite intermediate gear—absolutely silent.
Plays seven to eight 10-inch or five and a half 12-inch records at one winding.
Cast iron nickeled frame.
Powerful, durable, compact, accessible.
Built especially for the highest-grade machines.
Guaranteed in every minutest detail.
The perfection of mechanical genius as applied to the phonograph motor.

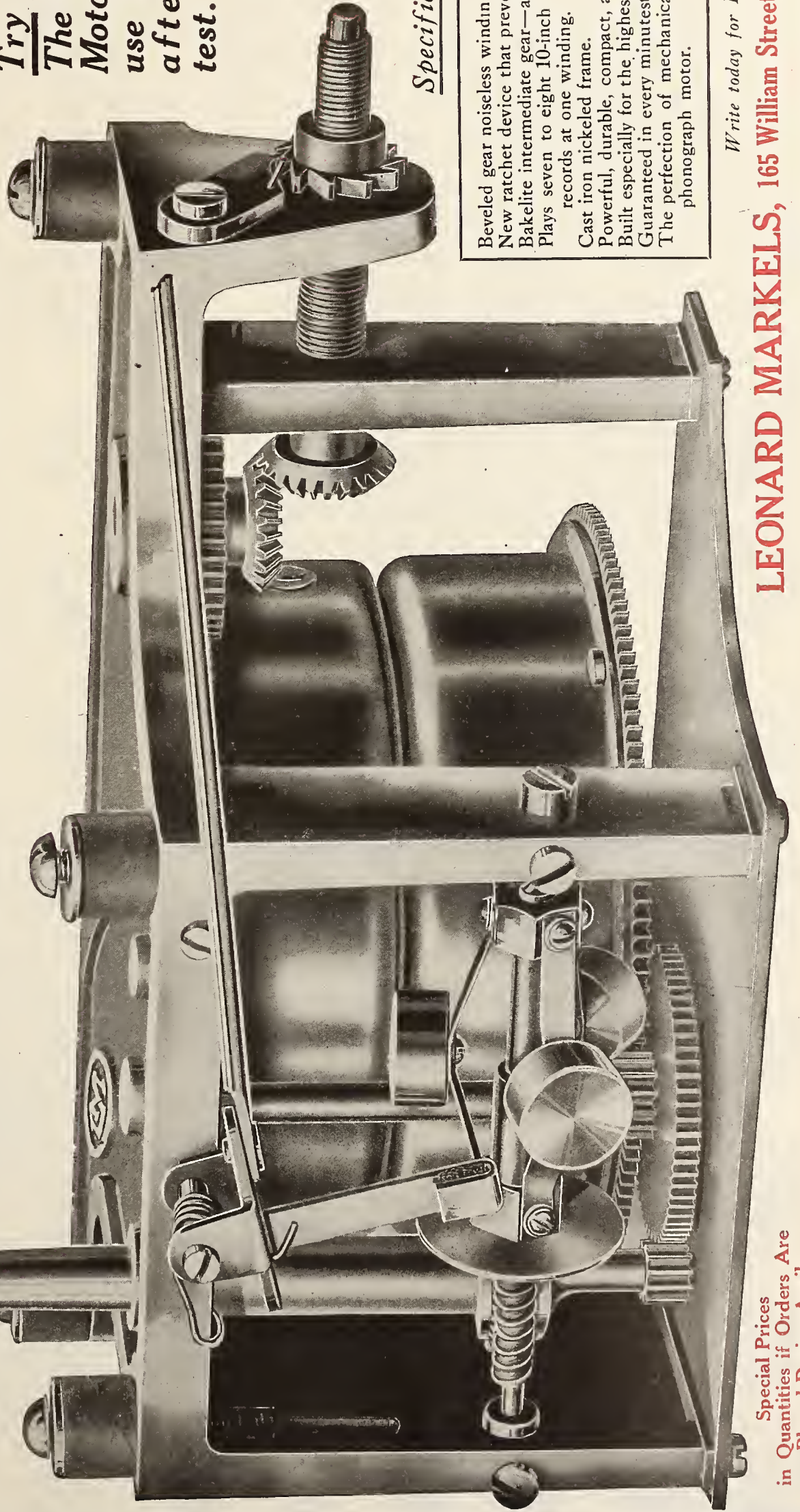

Write today for Butterfly Folder

LEONARD MARKELS, 165 William Street, NEW YORK

Special Prices
in Quantities if Orders Are
Placed During April

PLAN CONCERT UNDER AUSPICES OF DETROIT ASSOCIATION

Prominent Artists to Appear at Public Affair on April 30—Proceeds to Be Given Over to Local Regiment—Hudson Co. Preparing to Move—Trade Keeps Going at Lively Pace

DETROIT, MICH., April 10.—We won't declare that Detroit talking machine dealers have had a record business, but we will say that they have had a very satisfactory business during January, February and March, and that they are anticipating excellent business before the end of the year. Some go so far as to predict that business will stay about as it has been for the past three months, and that there will be big business early in the fall continuing to improve until after holiday time. After all there is every reason to look for good business, as Detroit has been blessed with war orders that run into nearly a billion dollars, while workmen are getting higher wages than ever before. There is no scarcity of money and, despite Liberty Bonds, the Income Tax and Red Cross, people seem to have plenty of cash to buy whatever they make up their mind to.

In talking machine circles locally, the big event of interest and importance is the recital to be given at the Arcadia, April 30, under the auspices of the Detroit Talking Machine Association. For many, many months the association has had in mind something that would be along patriotic lines, but they wanted to do something that had not been done before. The idea of giving a concert and turning the money over to some patriotic fund appealed to the members of the organization, and the decision was reached unanimously that such an event take place. A special committee was appointed and the work began. Sam E. Lind, president of the Detroit Association, and chairman of the concert committee, immediately got busy by long distance, by letters and by telegrams, lining up the different artists with the various companies making records. He received splen-

did support from the companies and the artists themselves—greater than he had even anticipated. The final result of Mr. Lind and his committee is that the concert will surely take place at the Arcadia on April 30, and among the artists who have agreed to appear personally are Henry Burr, Albert Campbell, Arthur Collins, Byron G. Harlan, John H. Meyers, Billy Murray, Theodore Morse, Fred Van Epps, the Peerless Quartet and the Sterling Quartet. The committee has 5,000 as the number of tickets to be disposed of, and each member of the association, aggregating fifty, has individually agreed to take and sell a specified number of tickets. "I believe we will easily dispose of 5,000 tickets—with everybody co-operating and working together on the proposition," said Mr. Lind. "We are getting splendid support all around—everybody is with us heart and soul, knowing the purpose for which it is given. Whatever money we raise will be turned over to the regiment known as Detroit's Own. Something like \$600 is to be spent in the Detroit newspapers for advertising and publicity." Here's wishing the enterprise every success in their patriotic venture.

J. L. Hudson Co. are getting ready to move from 118-120 Woodward avenue to 68-70 Library avenue. The new building is six stories in height, with full basement, and the company is expending nearly \$75,000 in fixing up the new building, which formerly was devoted to the toy departments. The Hudson officials want to make their new music store the finest of its kind in the country and they will get results if money counts. The talking machine departments will occupy the first and third floors. On the first floor will be the various record booths, record stock and a large counter for selling records. The booths will be ventilated in the latest fashion, will be carpeted and right up to the minute. On the third floor will be the retail salesrooms of the Victrola and Sonora machines, which are handled by Hudsons. There will be many new, interesting, original and unique features that will be described after the store is opened.

Max Strasburg, of the Max Strasburg Shops, has returned after spending four weeks in the South. He had a splendid vacation, played a lot of golf, and is now on the job regularly each day. Mr. Strasburg looks for a good year, although he says there are sure to be times during the year when trade is off.

The W. E. Metzger Co., who retail the Victrola, are devoting more time than ever to the line, and are carrying larger stocks than ever.

Quite a number of Columbia dealers are displaying the company's line of period Grafonolas in their store displays.

Frank Bayley, Edison dealer, recently purchased for himself and family a handsome new residence on Chicago boulevard, costing \$40,000.

In talking with jobbers, such as Grinnell Bros., who handle Victrolas, Williams, Davis, Brooks & Hinchman Sons, who handle the Pathé line, the Phonograph Co., who job the Edison, and the Brunswick Co., who job the Brunswick phonograph, we find that they are carrying good-sized stocks of both machines and records, and that shipments are easier than they have been in some time. They don't believe there is going to be any difficulty in taking care of customers, but they believe that customers should order well in advance to offset any unforeseen delays that might occur. All of these jobbers are exceedingly optimistic and can't see anything but good business ahead.

Some splendid displays recently in connection with the Victrola, particularly the cheaper models, have attracted considerable attention to the windows of the People's Outfitting Co. We will say one thing for this concern—every display is carefully planned and thought out and they are usually timely and in keeping with the news and events of the day.

The Strand Talking Machine Co. was incorporated recently at Albany, with a capital stock of \$6,000. Those interested are S. Birnswieg, S. Friedberg and H. Weiner.



The Fischer Co.



Oldest Pathe Jobbers



A little better Pathe service than you could possibly expect. Our very best efforts—Our entire resources and fourteen railroads are at your command.



Give us the opportunity to serve you ONCE.



THE FISCHER CO.



Oldest Pathe Jobbers

940-1030 Chestnut Avenue

CLEVELAND, OHIO





FOR those of us who are not privileged to bear rifles, there is no quicker, no surer and no more powerful way to insure our national safety than to buy Liberty Bonds. We urge every reader of THE TALKING MACHINE WORLD to go the limit.

EDWARD LYMAN BILL, INC.



SPECIAL WINDOW DISPLAY FOR COLUMBIA MAY RECORDS

Dealer Service Department of Columbia Graphophone Co. Prepares Excellent Window Attraction for the Use of Retailers—Service Meeting With Much Popularity

The dealer service department of the Columbia Graphophone Co. has prepared for Columbia representatives a very attractive window display for the May records that can be used to

by the accompanying illustration, the display has all the necessary attributes of a profitable sales stimulant.

This regular Columbia monthly window dis-

ice have been received from dealers in Canada, China, Italy, England and the Philippines.

There is a big selling idea back of the Columbia Co.'s new style advertising in the national magazines and newspapers, and the ac-



Window Display for May Prepared by Dealer Service Department of the Columbia Co.

excellent advantage by the dealers. This display has been designed throughout to tie up the dealers with the vast amount of current Columbia national advertising, and, as may be seen

display service is meeting with great popularity throughout the trade, and not only have Columbia representatives in this country endorsed it unreservedly, but requests for this display serv-



Columbia Advertising in the Magazines

companioning illustration, showing a recent magazine advertisement, will visualize this idea. Brilliant, picturesque and familiar characters of popular musical comedies and the vaudeville stage give a live, wide-awake appearance to this copy from an illustrative standpoint. The text also carries out the idea in back of this advertising, and there is no doubt but that this publicity will prove invaluable to Columbia representatives everywhere. This same message of live, up-to-date music is carried out in all of the Columbia Co.'s advertising campaigns, including newspaper "ads," dealers' "ads," monthly supplements, hangers, etc.

The Criterion Phonograph Co., of New York City, has been incorporated with a capitalization of \$150,000 by W. H. Hoschke, J. N. Harris and J. P. Battles.

PLAYERPHONE POPULARITY PROVED



Playerphone 150
William and Mary Model
Height 50 inches
Width 22½ inches
Depth 22½ inches

Des Moines Drug Co.,
Des Moines, Iowa.
Exclusive Playerphone
Distributors
One Car in February,
1918

GREAT Jobbing Houses Have Found The Playerphone Such a Wonderful Seller That They Now Order Playerphones *By the Carload*

Shortage of materials and shortage of freight cars are the only things that have prevented the Playerphone sales being over twice as great.

Now, that difficulty is being overcome, orders can be filled with reasonable promptness, either in small lots or in car load shipments.

See Where These Shipments Go Note the Firms

In all the world there is no tone like the Playerphone's. The Human Voice is its only rival. Plays any make of disc record perfectly without change of equipment.

Your Profit Enormous in a Car of Playerphones

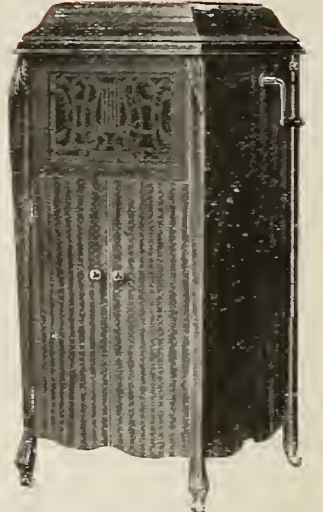

Playerphone 125
Liberty Model
Height 50 inches
Width 22½ inches
Depth 23½ inches

E. E. Bruce Co.,
Omaha, Neb.
Exclusive Playerphone
Distributors
One Car in February,
1918

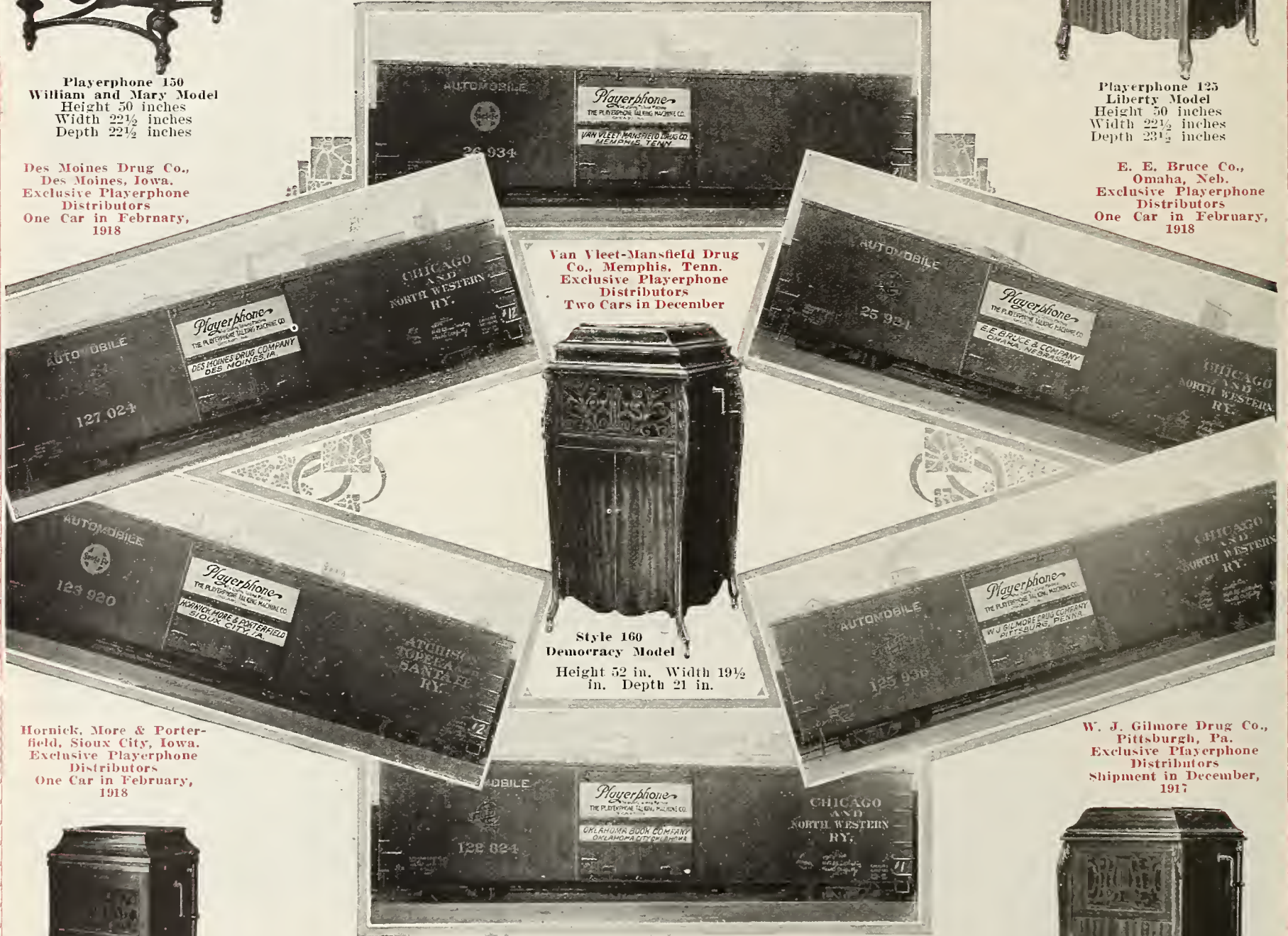

Van Vleet-Mansfield Drug Co., Memphis, Tenn.
Exclusive Playerphone Distributors
Two Cars in December

Style 160
Democracy Model
Height 52 in., Width 19½ in., Depth 21 in.

Hornick, More & Porterfield, Sioux City, Iowa.
Exclusive Playerphone Distributors
One Car in February,
1918

W. J. Gilmore Drug Co.,
Pittsburgh, Pa.
Exclusive Playerphone Distributors
Shipment in December,
1917

Oklahoma Book Co., Exclusive Playerphone Distributors
Oklahoma City, Okla. Two Cars in December, 1917—2 in March, 1918.

In addition to the above jobbers we are shipping to in carloads, we have twelve other very large Playerphone jobbers, who are making direct shipments of Playerphones. Their names are as follows:

- | | |
|---|--|
| BLUMAIER-FRANK DRUG CO., Portland, Ore. | CHAS. M. MONROE STATIONERY CO., 209 N. 3rd St., St. Louis, Mo. |
| CHAPMAN DRUG CO., Knoxville, Tenn. | ORCHARD & WILHELM CO., Omaha, Neb. |
| DAY DRUG CO., Akron, Ohio. | PARKER-BLAKE CO., New Orleans, La. |
| GEO. A. LOWE CO., Ogden, Utah. | TOOTLE-CAMPBELL DRY GOODS CO., St. Joseph, Mo. |
| A. C. McCLURG & CO., 330-352 E. Ohio St., Chicago, Ill. | WACO DRUG CO., Waco, Tex. |
| McKESSON & ROBBINS, 91 Fulton St., New York City, N. Y. | WYMAN-PARTRIDGE & CO., Minneapolis, Minn. |

There is a complete line of Playerphones of sizes and styles to suit every pocket-book and please every taste. All are famous for their high quality and remarkable for their reasonable price, comparing in every way with instruments retailing at from \$25 to \$155 more.

The Playerphone Has the Call—Your Sales Are Assured—Your Profits Are Big—Put in Your Order Today

WE SHOW HERE FIVE CUTS OF OUR LINE OF NINE MODELS



Playerphone 65
Colonial Model
Height 43 inches
Width 18 inches
Depth 18 inches



Playerphone 85
Young America Model
Height 45 inches
Width 19½ inches
Depth 21 inches

PLAYERPHONE TALKING MACHINE CO.

W. D. McKENZIE, Pres. and Gen'l Manager

338 to 352 NO. KEDZIE AVENUE, CHICAGO

THE PLAYERPHONE OFFERS GREAT OPPORTUNITIES TO JOBBERS IN FOREIGN COUNTRIES

Featuring the Musical Possibilities of the Talking Machine

By William Braid White

[Note.—This is the fourteenth in a series of articles on the general subject of the musical possibilities of the talking machine. The aim of the series is to develop these possibilities from all angles, thus opening up fields for sales expansion oftentimes neglected wholly or in part.—Editor.]

OPERA AND THE TALKING MACHINE

I suppose that, in one sense of the word, no other idea is as strongly impressed on the mind of the layman who goes to buy a talking machine as the idea of what he calls "opera." The mere fact that the greatest successes of the talking machine have had to do with the reproduction of great voices, especially of the best advertised among the great voices, has intensely directed public attention to that field of musical enterprise where great voices are mainly developed. That is the field of grand opera. The great artists who, in earlier days, were first and most splendidly exploited by the talking machine makers, were operatic singers; and the progress of the talking machine therefore has peculiarly been mixed up with the progress of grand opera in this country. Indeed, it would not be going too far to say that the talking machine has actually done more than any other agency to teach the public the fascination of operatic music and create a demand for it.

But with all this, I shall venture the remark that the demand for operatic records is a demand just as uneven, just as scattering, as can be said of any other type of musical performance available through the talking machine. One of the most astonishing things about the talking machine business is to be found in the disproportion between the public knowledge of certain artists and public familiarity with their recorded works. Any talking machine dealer, I am sure, will agree with me that of all those thousands who know the names of the dozen best-advertised operatic artists, not one in ten knows familiarly six separate numbers which any one of these artists actually sings. Indeed, when I have gone shopping for records in the guise of a simple-minded member of the great public, I have found that the salesmen themselves are quite often rather narrow-minded in these matters; knowing plenty of names, but precious little about the actual work that is being done through the talking machine by the owners of those names.

Exploring One's Stock

Now, I shall perhaps not be too seriously contradicted if I say that it would be a very good thing for every man who is interested in the sale of talking machines and records to undertake a little series of explorations into the great territory of operatic music as exhibited in the hundreds of operatic records now listed in the catalogs of the great companies. The literature of grand opera is in quantity immense and has a history stretching back more than three hundred years. The art of singing has developed along with that of operatic composition and the greatest singers in the world have always been operatic singers. If one is going to know his record stock, then it is perfectly obvious that he must know something about that which is mainly responsible for filling his record shelves. For a talking machine dealer to carry in stock hundreds of operatic records and then to confine his knowledge of them to two or three each of a very small number of well-advertised singers, is like a bookseller knowing Dickens and Mark Twain, the Encyclopaedia Britannica and the Bible, but hopelessly at sea when a customer asks for Thackeray or Emerson, for Shakespeare or Walt Whitman. Such a bookseller would not last long. Nor would such a dealer in records last any longer if the public were generally as ill-informed as he himself.

The public may indeed be ill-informed, but to

sell one's goods in a half-baked way merely because there is reason to believe that one's customers know no better, is not exactly sound business. I have always contended that if the contents of the great record catalogs were really appreciated, really studied and really known, there would not be the unevenness in sales there now is. The field for the sale of records is scarcely scratched as yet, if we but knew it. Indeed, the field of sales in operatic records alone is scarcely scratched.

Something in General

Therefore, I am hoping, for all these reasons, that you will not take it ill of me if I say something about operas in general, some things quite different from anything you will read in catalogs or even in books professedly designed to teach you how to be musical. Frankly, I don't believe in trying to teach people to be this or to be that. It is time enough when they ask of themselves. But, if I can do something to make you believe in the worth-whileness of studying your wonderful record catalogs from end to end, and studying especially the wonderful reproduction of great operatic music, I shall do as much as I could reasonably expect; and you will, some day I believe, bless me.

I am not setting up to be a teacher or lecturer or uplifter or anything of the sort; but simply a suggester. That is certainly humble enough and I hope you will accept what I say in that spirit.

Two thousand five hundred years ago great assemblies of wonderful people, people more generally intelligent than have ever since trod the globe, people whose efforts at understanding the meaning of life and the glory of beautiful living and thinking have given us literature, art and thought wholly unsurpassed by the product of any later age, gathered together upon the several occasions of their great national festivals under the genial skies of fairest Greece, by the side of the blue waters of the Aegean Sea, to hear and see the supreme intellectual, physical and aesthetic works of their greatest men. To the ancient Greek, life rightly lived included the right cultivation of every function. The mental and the physical must be developed equally. Music, gymnastics (in-

cluding in these terms, as the Greek did, all artistic and all physical culture), poetry, the drama, history and philosophy were the common studies of every child and the common possession of every citizen. At the great "games" held each fourth year, at the foot of Mount Olympus, the ripest products of Greek intellectual genius were publicly recited and the most powerful products of the dramatists publicly performed before the multitudes who gathered within the amphitheatre, in the intervals between the athletic contests. The tragedies of Aeschylus, of Sophocles and of Euripides, the comedies of Cleon and of Aristophanes, the Iliad and Odyssey of Homer, the Histories of Herodotus and Thucydides, were thus acted or recited, as the case might be; and in this way were duly "published" to the intellectual world.

Acting to Music

The great dramas, such as the Oedipus of Aeschylus, the Philoctetes of Sophocles and the Alcestis of Euripides, as well as the merry comedies of Aristophanes, in all the exquisite absurdities of the birds, the frogs and the clouds, were acted by professional performers, who appeared in masks and declaimed their lines to the accompaniment of musical instruments, which provided a rising and falling melody appropriate to the sense of the words. The practice of the Greek dramatists to provide a chorus, which was grouped on either side of the stage and furnished a running commentary on the action, personifying Fate, the Gods, Nemesis or some similar abstraction, not only gave opportunity to paint clearly the moral lesson worked out in the fates and tragedies of the characters, but afforded full sway to the musical science of the Greeks by allowing them to develop the idea of rhythmic singing or, rather, declamation, to a point of very considerable perfection. This wonderful Greek drama we still can read and still appreciate, but we can never thoroughly understand it because we do not know just exactly how the verses were declaimed or how the chorus went through its work.

The intellectual night that settled down over Europe after the barbarian invasion of Italy in the fifth century A. D. was relieved by scarcely

(Continued on page 62)

7th Floor

229 Fulton Street

Clifford A. Wolf

MANUFACTURER OF

Diamond and Sapphire

Phonograph Points

New York City

Phone, 1678 Cortlandt

Note New Address

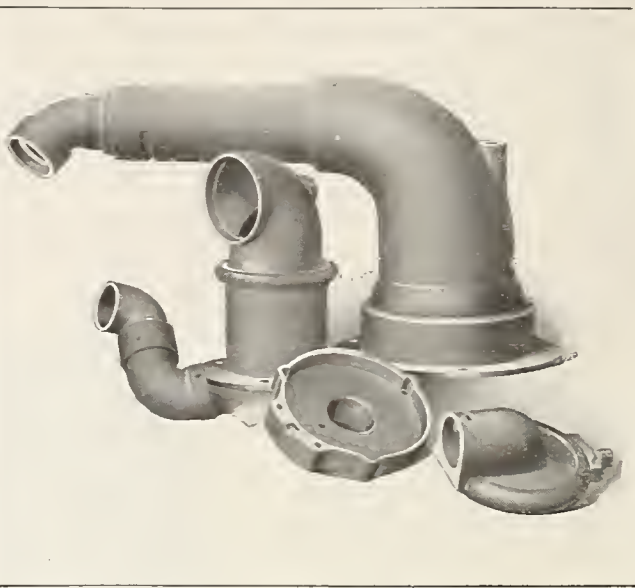

DOEHLER DIE-CASTINGS

for tone arms, sound boxes and talking machine attachments are STANDARD throughout the industry.

Of the many instruments produced to-day from the most prominent makes down, the greater number, by far, are equipped with Doehler die-cast tone arm and sound box.

The enormous output of our three large plants permits of advantages to the users of die-castings, as regards prices and deliveries, not otherwise possible.

DOEHLER DIE-CASTING CO.

MAIN OFFICE AND EASTERN PLANT
BROOKLYN, N. Y. NEW JERSEY PLANT
NEWARK, N. J.
WESTERN PLANT
TOLEDO, OHIO.

THE MUSICAL POSSIBILITIES OF THE TALKING MACHINE

(Continued from page 61)

a glimmer save the light that burned at Constantinople, and the fitful candle gleam that burned, only to be brutally stamped out, in those valleys where dwelt the Waldensian and Albigensian peoples. But the fire of the Renaissance, bursting into full flame at the taking of Constantinople by the Turk in 1453 A. D., together with the discovery of the New World by Columbus forty years later, brought about a liberation of the human intellect and the creation of a spirit of inquiry to an extent scarcely credible even to-day. The study of classical Greek and Roman literature became the passion of every man and woman who would be thought liberal minded. Popes took more interest in Horace than in Thomas Aquinas, cardinals and princes translated Sophocles and forgot the Latin current of the convent and the breviary. The death of the Greek Empire at the hands of the Turk was the signal for the spread of Greek learning throughout Europe. The Dark Ages were dead and modern Europe had begun.

The Gentlemen of Florence

During the sixteenth century, what with the religious reformation and the growth of liberal learning which has sprung into birth at the Renaissance, the musical ideas of the polite world progressed amazingly. No longer confined to the uses of the Church, music became secular. Every lady played the Virginal, every gentle-

man the lute. Persistent efforts were made to discover some connection between music as then known, and the great Greek poetry and drama which were now forming the models for composition to all the world. At last, during the closing years of this century, a society of wealthy musical and artistic amateurs, meeting in the beautiful city of Florence, decided to attempt the reconstruction of the Greek drama, adapting it to contemporary taste, with the music arranged as nearly as possible like the original; and in this way to bring about a revival of dramatic writing and acting in its ancient purity.

Count Bardi and his friends had no notion that they were about to make a musical revolution. But how often it happens that the most important and revolutionary ideas are born unnoticed. These sixteenth century Italian gentlemen thought they were going to make an impossible revival of Greek art; in fact, they were going to create opera.

Messer Peri

Persevering in their task, the musical friends finally brought their labors to a conclusion, with an adaptation of the legend of Orpheus, he of the magic lyre, as told in Greek mythology, the story of the poet and singer who sang so sweetly that the birds and beasts followed him, forgetting ancient animosities. Orpheus and his Eurydice (their stories were most beautifully made into music by that great man Gluck, two hundred years later, and you can hear Louise Homer's lovely record of the great "Che faro" air); this was the theme of the first opera. Commissioned by Count Bardi and his friends as a revival of the Greek drama with music, it turned out, under the hand of Messer Jacopo Peri, to be a real music-drama, with action, chorus and stage business performed to music composed in best Italian style and played by a band of viols, virginals, flutes and shawms.

Jacopo Peri did not succeed in reviving Greek music; but he did something ever so much better and more important. He invented a method of declaiming to music and he invented the operatic "air." He discovered how to write music in such a way that the spoken parts of the story, which carry the plot, could be sung by the voice accompanied by a simple chord here and there struck in just to carry the singer on the pitch. This was the famous "recitative" which all the old Italian operas employ and which can be heard to its perfection in the oratorios of Handel.

Peri went further. He also developed the operatic air; that is to say a song, forming part of the drama but developed so as to show off the vocal capabilities of the singer and to afford the latter an opportunity for display. With these two ideas Peri practically invented the modern opera.

The Greek drama had no notion of the song or air; but Peri found his Italian temperament

dissatisfied with continuous recitative and he could not, at that stage of the game, in musical development, find a way of making it more than dry and formal at the best. Three hundred years later, very nearly, Richard Wagner took the same idea and made continuous recitative the basis of his great works. Yet when you listen to the Ring, to Tristan or to Parsifal, you never think that this is what it all is; for Wagner was able to weld thought and tune, music and word, so perfectly that the two coalesce like two elements in a chemical affinity. But it took three hundred years to bring about the perfect union.

Laid the Foundation for Modern Opera

That little experiment, three centuries and more ago, with the tinkling little band of old-fashioned queer-shaped fiddles and the rippling little spinets, the soft sweet flute and the rest of Peri's "concert," would not have seemed much to a modern observer could he have dropped back in the ages to hear it. But with it, and with his invention of the accompanied song and the half-sung, half-spoken recitative, he laid the foundations for every modern record you can put on your machine to-day, in which the glorious art of great singers is reproduced to you.

"Opera" is a Latin word and means simply "works." Bardi's friends called these pieces of theirs just "works." The larger styles were called "opera majora," meaning "greater works," and so to-day we call them "grand opera." The smaller and less serious pieces were "opera minora" or "smaller works" and later on called by the irrepressible Italians in their own tongue "opera buffa," or "comic opera."

Rightly speaking, then, any and all operas are dramatic pieces, tragic or comic, set to appropriate music, sung instead of spoken. You can study out the differences between Italian and German, English and French opera (for all schools have had their day) just as long as you like, and can hear whole operas from records from overture to finale; yet you can never get away from the fundamental notion of recitative and air; the story and its embellishment.

Close of This Recitative

That is my little recitative on the beginning of opera. Perhaps you will not mind if I return to the subject in a different way a little later on. Meanwhile, you can try a perfect example of the ancient recitative and aria by getting the wonderful *Lascio ch'io piang* from Handel's Rinaldo, written by him in the Italian style as early as 1711. Schumann-Heink and Julia Claussen have recorded it and perhaps others. It is a perfect type of the sweet, stately and wholly beautiful old manner. If you want to know opera rightly, begin by studying that. It is still near enough to the days of Peri to be marked with his original impress and still close enough to our own days to be musically interesting. To study it well and drink in its beauties is not only to take a step in a fascinating pursuit, but to be vastly entertained the while.

A BIG DEMAND

Throughout the Country for

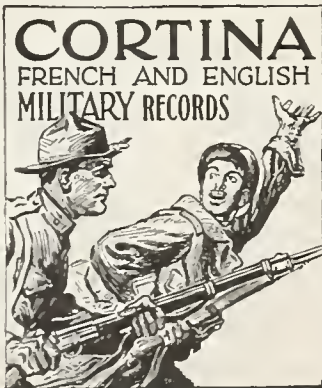

Get your share of this business. An ideal gift for the boys in training or the trenches. It often sells a machine with it.

The course consists of an authoritative Military Manual containing a foreword by Major-Gen. Leonard Wood.

WITH TWENTY PHONOGRAPH RECORDS (10-12" double face discs). Send for full information. Advertising matter, military poster-hangers free.

Also Spanish, Italian, German, and English and French for Spaniards

CORTINA ACADEMY OF LANGUAGE
12 East 46th Street, New York

ST. LOUIS TRADE MOST OPTIMISTIC

Labor Troubles Hurt Retail Trade, But Talking Machine Men Are Not Blue—Artophone Display—News at Aeolian Hall—Silverstone Returns From Vacation Spent at French Lick

St. Louis, Mo., April 9.—The reports of business for March are a bit spotted, but the jobbers say that their business has been above previous records and that they are expecting a big run throughout the spring.

The retail reports in the city possibly vary as the trade has been hit by the several labor troubles. Since the street car strikes of six weeks ago there has been a continuous series of strikes in some line or other, the most disastrous to the talking machine trade being that of a number of department store clerks and cash girls. Not enough people left the employ of the stores to really cause much difference, but those who did go out had the support of organized labor and a boycott was declared on all of the stores. This naturally hurt some of the stores more than others. All are reported to have felt it, some because of loss of trade from labor union members, but a harder proposition was that many women who are not directly interested in organized labor in itself have sympathy with the young worker and these women would not enter the stores while the pickets were outside.

Several Piano Row firms report that their March record sales were the heaviest they ever had. While they do not assert that the increase came from labor or sympathy trade, the amount of business is of record. The boycott was on for five weeks, and was ended only the last Friday in March. During that time one of the department stores—the Lindell—which sold cheap machines and records, was put into the hands of a receiver. This store had a large labor trade and was most seriously affected by the number of clerks going out and also by the boycott.

Samuel Limberg, of the Columbia international record department, came here the first of the month to spend several weeks with C. R. Salmon, of the Columbia Co., in boosting the language records and they report an excellent showing for the first few days.

Robert H. Cone, Jr., of the Artophone Co., is proudly showing a new line of eleven Artophone machines on the floor of the Artophone retail salesroom. The prices range from \$40 to \$300, including one table or low cabinet model. A catalog will be issued very soon setting forth these new styles and prices.

"Our retail trade has been better than we expected," said Mr. Cone, "and the jobbing trade is what we can make it. The demand throughout our entire territory is excellent, and I wish we could care for all of the business in sight. Now that we have co-ordinated our facilities for getting out these eleven styles of machines and will be able to offer more than our previous two models, we expect to be able to handle a much greater proportion of our trade."

THE WIDDICOMB

A FINISHED PRODUCT

The most expensively constructed and intelligently assembled line of Phonographs in the world—yet so reasonably priced that greater value is shown a prospective purchaser—

*Special Introductory Offer—Order from our illustrations in December, January and February issues of this publication any model as a sample at less 40-10, that you may know how well it is possible to make a reproducing instrument—you will receive a combination of—tone excelled by none—a motor less noisy than your watch and guaranteed to stay so—a better constructed and finished case than you have ever seen for the money. More convenient and commodious filing devices—except in numbers 1 and 5, where partitions for albums are used—together with unusual minor improvements—in fact you may secure the agency for *A Better Phonograph than your Competitors.**

REVISED PRICES

Console Tables, \$125 - \$150 - \$175 - \$200
Upright Cases, \$110 - \$150 - \$175 - \$250

Phonograph Division

WIDDICOMB FURNITURE COMPANY

We Are Ready—

Grand Rapids, Michigan

At Aeolian Hall, Manager Guttenberger reports the best month of the history of the talking machine department, not including the wholesale department which is getting under way satisfactorily. Harry B. Levy, once manager of the talking machine department here when a jobbing business was done through this wareroom but now Vocalion wholesale manager at Chicago, was here for several days during March and approved of the plans and assisted in getting the work under way.

Aeolian Hall also has found the record business exceedingly good during the month and reports unusually large sales of the more popular numbers.

C. R. Salmon, wholesale manager of the Columbia Co., is having an "off agin, on agin, gone agin" time with his draft call. Not long ago we reported him in class one. Next month he was in class five on physical examination. Now he has been recalled for further examination and finds himself in class one again, under the revised physical requirements. Mr. Salmon is making no claim for exemption, but would like to get a final decision.

Mark Silverstone has been back from his trip to French Lick, where he went for a much-needed rest. But his health is not entirely restored and he is taking things pretty easy, only visiting the store occasionally and then for only a short time. The organization he built up before he was compelled to rest is carrying forward the business in excellent style.

CONTRACTS ARE CANCELED

Important Letter From President of Columbia Graphophone Co. to Dealers

The following letter has been sent to Columbia dealers by Francis S. Whitten, president of the Columbia Graphophone Co.:

"In view of the recent Supreme Court decision, we consider it our duty to notify you that the dealers' contract existing between you and this company is no longer valid, and is hereby canceled.

"We anticipate that this new condition will not interfere with or disrupt our present business relations. We expect to continue to furnish you with our product and give you the same hearty and helpful co-operation as heretofore, and we expect you to give us the same loyal and interested representation.

"We have in course of preparation a certificate which will formally indicate that you have qualified as a Columbia dealer and are authorized to handle Columbia products, which certificate we hope to send you in the near future."

MAINTAIN YOUR INDIVIDUALITY

Do not surrender your individuality, your identity. Stand for something. The carbon copy is seldom sent out of the office. Better be a ten-penny nail in the plant where you work than try to be a steel girder that won't fit.

NORTHWESTERN CABINET COMPANY
MENOMONIE WISCONSIN

We are exclusive manufacturers of talking machine cabinets. We can furnish them either in white or finished. Special designs created and submitted if desired.

SPECIAL OFFER

We have a quantity of cabinets made for a concern which went out of business before shipment could be made. They are in oak and mahogany, height 50 inches, depth 23 inches and width 22 inches, with fancy carved legs, well top, beautiful massive design throughout. This is a big bargain for a quick purchase. Write for particulars regarding this special offer.

NORTHWESTERN CABINET COMPANY
MENOMONIE WISCONSIN



Pathe Phonograph \$175
Other models \$25 to \$225

Pathe



The Quality Phonograph

**Don't you want to line up—
With a phonograph that—
promises best for the future?
Yes — Pathe —**

It's going strong right now—
And so are the Pathe Records—
But the dealer with business
vision should look way beyond
the present.

And if he does—he can see the fine
desirability of a Pathe connection.

Pathe arrived long ago—is moving ahead
fast—but it's this present momentum of
Pathe publicity that later on will provide
the greater returns for the dealer who
starts now, and builds with Pathe.

Write us about the Pathe proposition.

No Needles to Change

The Pathe Sapphire Ball takes the place
of needles. It need not be changed.

Long Life to Records

The Pathe Sapphire Ball cannot possibly
cut, grind, rip or mar the record's surface.

The Pathe Controla

With the Pathe Controla you may increase
or decrease the tonal volume of the Pathe
Phonograph at will.

Plays all Records

Each Pathe Phonograph plays not only
Pathe Records, but all other makes of
records, and plays them perfectly.

Williams-Davis-Brooks & Hinchman Sons

26 East Congress Street

Detroit, Michigan

Pathé



The Quality Phonograph

Just now—

Some don't know the value in
"daylight saving"

But they will.

Some dealers don't know what
Pathe would mean to them.

But they might.

There's many a value that has
not been given its due appraisal.

As a suggestion—investigate
Pathe.

From the inside point of view,
we can tell you of terms and
conditions that should appeal to
you.

Williams-Davis-Brooks & Hinchman Sons

26 East Congress Street

Detroit, Michigan

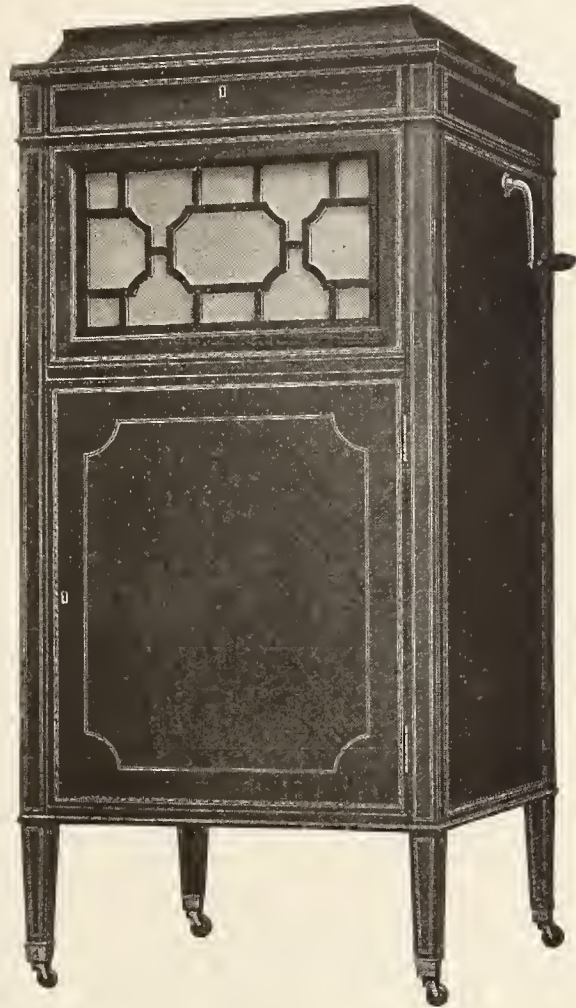

Pathe Phonograph \$225

Other models \$25 to \$225

No Needles to Change

The Pathe Sapphire Ball takes the place of needles. It need not be changed.

Long Life to Records

The Pathe Sapphire Ball cannot possibly cut, grind, rip or mar the record's surface.

The Pathe Controla

With the Pathe Controla you may increase or decrease the tonal volume of the Pathe Phonograph at will.

Plays all Records

Each Pathe Phonograph plays not only Pathe Records, but all other makes of records, and plays them perfectly.

NEW YORK STATE SONORA DEALERS HOLD CONVENTION

Gather in Syracuse and Discuss Business Problems—Hear Interesting Addresses by President Brightson, of Sonora Phonograph Corp., and Others—Enjoy Banquet at Onondaga Hotel

About seventy Sonora dealers and members of the Gibson-Snow Co., Syracuse, N. Y., Sonora distributors, were in attendance at the first annual convention of the Sonora dealers in this jobber's territory, which was held recently under the auspices of the Gibson-Snow Co.

The purpose of this meeting was to enable the various Sonora representatives of New York State to get better acquainted with each other, and to have an opportunity of meeting the directing heads of the Sonora Phonograph Sales Co. The convention was a decided success, and all of the dealers were enthusiastic in their praise of the practical benefit derived from the meetings.

The dealers convened at the Gibson-Snow headquarters at 9 o'clock, and during the morning and the early part of the afternoon a number of informal conferences were held regarding distinctive features of Sonora products, and practical sales suggestions.

At 3 o'clock they adjourned to the Onondaga Hotel, where a short address of welcome was made by Nelson P. Snow, vice-president of the Gibson-Snow Co., Inc. Among the other addresses made at this meeting was a splendid talk on "Sonora Quality," by George E. Brightson, president of the Sonora Phonograph Sales Corp., which is reproduced herewith. Joseph Wolff, treasurer of the Sonora Phonograph Sales Co., spoke on "Trade Possibilities in Connection With the Sonora," and Frank J. Coupe, the company's director of advertising and sales, gave one of his usual effective addresses on "Advertising as a Whole," and as applied particularly to the Sonora line. Mr. Coupe gave the dealers some idea of the tremendous publicity campaign which the Sonora Phonograph Sales Co. has in view for 1918.

A banquet was held in the evening at the

Onondaga Hotel, and during the course of the dinner informal addresses were made by a number of the dealers who told of their experiences in handling the Sonora product, and of the remarkable strides in popularity which have been made by this high-grade phonograph in recent years.

Among those present at the convention in addition to the names already mentioned were the following: C. T. Malcomb, assistant manager of the Gibson-Snow Co.; L. M. Cole and Mr. Trotter, of the Gibson-Snow Co.; E. C. Beshgetoor, Jamestown, N. Y.; F. A. Jenss, Niagara Falls, N. Y.; J. Gordon Jenss, Niagara Falls, N. Y.; P. Moody, Saratoga Springs, N. Y.; F. W. Mead, Middletown, N. Y.; Fred L. Weinheimer, Syracuse, N. Y.; E. N. Weinheimer, Syracuse, N. Y.; Wm. Hile, Syracuse, N. Y.; Messrs. Bentley, Caldwell, Thompson and Schindwein, Syracuse, N. Y.; Chas. J. Ziegler, Palmyra, N. Y.; W. P. Smith, Palmyra, N. Y.; L. H. Wheat, Newark, N. J.; W. C. Ludwig, Rochester, N. Y.; J. E. Bird and J. E. Bird, Jr., Rome, N. Y.; Giles H. Dickinson, Binghamton, N. Y.; W. A. Jones, Oxford, N. Y.; F. E. Barnes, Herkimer, N. Y.; Chas. F. Hoffman, Buffalo, N. Y.; P. Farb, Saginaw, Mich.; C. G. Smythe, Binghamton, N. Y.; Fred Walters, Lancaster, N. Y.; T. Amesbury Goold, Buffalo, N. Y.; W. H. Patterson, Fulton, N. Y.; D. H. Clarke, Watertown, N. Y.; Mr. Hammond, Cortland, N. Y.; R. Guy Coe, Kirkville, N. Y.; E. F. Schepp, Boonville, N. Y.; E. K. Ruhl, Buffalo, N. Y.; C. F. Foster, Earlville, N. Y.; Geo. Kempf, Dolgeville, N. Y.; Miss F. Kempf, Little Falls, N. Y.; W. C. Al-peter, Rochester, N. Y.; J. H. Anderson, Utica, N. Y.; Taylor Chapin, Oneida, N. Y.; R. Gang, Syracuse, N. Y.; Mr. Churchill, Syracuse, N. Y.; Miss Elizabeth Kushnic, Syracuse, N. Y.; John

Gang, Syracuse, N. Y.; R. P. Smith, Marcellus, N. Y.

Geo. E. Brightson's Speech

At this time it might be well to bring to your notice that it has been the policy of Sonora Phonograph Co. to be original and lead, rather than follow what other manufacturers have done. At no time are we influenced by learning what some others are doing—such as offering inducements in the way of discounts or terms. Understand me, I hold in very high respect our greatest rivals for supremacy, and appreciate and give them full credit for whatever they are doing, or have done, in the way of improvements or production.

This applies particularly to the Victor Co. The world has them to thank for the really wonderful results of their efforts. The great industry they have built up is the public's tribute to the value of the work they have done. They have spent tremendous sums of money to record the genius of the foremost vocal and instrumental artists of our time. This will be appreciated by the generations to come, and will form a lasting monument to the remarkable and gigantic Victor organization. Their expensive advertising has helped every one, who has had under consideration the purchase of a phonograph, to determine they should have one.

The Columbia Co. also deserves much credit for many of its productions.

Personally, I have repeatedly said, during the past four years, that I would not want an instrument that could not play all disc records. These thoughts are not new with me, for our 1913 and 1914 advertising substantiates my views in that respect.

At the time of the formation of the Sonora Phonograph Corporation, we formulated a plan of keeping off of all other band-wagons; we refused to hire any person who had ever been in the employ of either of the then existing companies, whether it be a mechanic or a clerk. We would not consider a pattern for a cabinet that looked like one of the others, and we also followed original plans of our own for distribution. It has been our fixed policy to build our own foundation, to give full credit for that which belongs to our rivals, but to hold on to our own with a strong arm. While we are glad to give other manufacturers all they are entitled to, in return we ask only for that which belongs to us.

Here are some facts, which it is worth while to remember—and remember they are facts:

Referring to Sonora's production, I will say, and furnish absolute proof, if it be necessary, that Sonora was the first company to manufacture a cabinet under the \$200 list price.

The first to make a machine for disc records, with feed screw mechanism (as now used by another manufacturer and abandoned by the Sonora Co. about seven years ago).

The first to have an automatic stop—the first to have a tone modifier—the first and only one to have a motor-meter.

The first to play a disc record with a jewel needle—the first to play all makes of disc records in the world, and our earliest advertising told what we had accomplished in this respect.

Sonora was the first to deprecate the growing evil of "easy payments"; the first and only one to receive notice and a recommendation by the Jury at the Panama-Pacific Exposition for the highest award for tone quality.

Our recent advertising, condemning the growing evil of increasing the "easy payment" plan for selling is because we have an interest in the welfare of our dealers' bank balances. "Easy payments" are not easy—they are hard for the buyer, because they mortgage his future earnings. They are hard for the dealer, because they tie up his capital and load him up with extended debts, and often many return second-hand instruments.

Why **MUNOLA** Sales Are Increasing

Co-operation offered the dealer is of such caliber that it creates business, stimulates his confidence, and his sales to the consumer are made with greater assurance that satisfaction is guaranteed.

Owners of MUNOLA Phonographs appreciate what this medium priced instrument has brought to them: Tone qualities, cabinet work, and the distinct advantage of playing all records. Qualities such as these have never before been expected of an instrument selling at so low a price. Dealers make money on MUNOLA Phonographs because:

FIRST—The retail price is low and advertised.

SECOND—The MUNOLA is good.

THIRD—The discounts are legitimate.

You can become a MUNOLA dealer in your town if there is not one there already. Write today for full particulars.

America's Leading Popular Priced Phonograph

MUNZER MANUFACTURING CORP.

307 Sixth Avenue So.

Minneapolis, Minn.

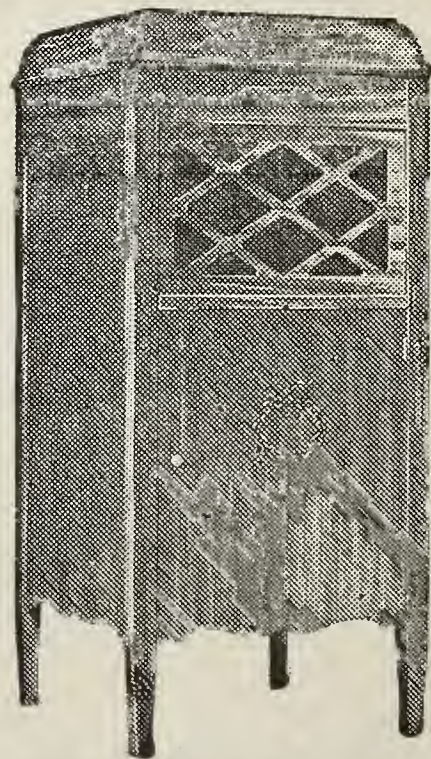

\$44.50

In New York City one of our highest class piano dealers, on Fifth avenue, who sells our instrument, tells us that most of his sales for Sonora are made for cash, and at no time will they ever consider any partial payment, which carries the debt beyond six months. This same dealer has other phonographs for sale in his store, and he is compelled to follow what others are doing with those instruments, because of the publicity occasioned by great advertising.

It is difficult for me to understand just why a phonograph should be offered for sale differently than other necessities, and at this time I recommend to our dealers, when confronted with competition of that nature, and with the claim of some possible purchaser that he can get "easy" terms elsewhere; that you promptly say: "This is a Sonora I am offering you, and the Sonora is sold only with a quality inducement, and has never followed any other method. It is worth in value more than we are asking you for it." You can also say to your possible customers that their friends will recognize, when they see a Sonora in their homes, that they own the phonograph, that they have paid at least more than \$1 or 25 cents per for same. Pride of possession is prob-

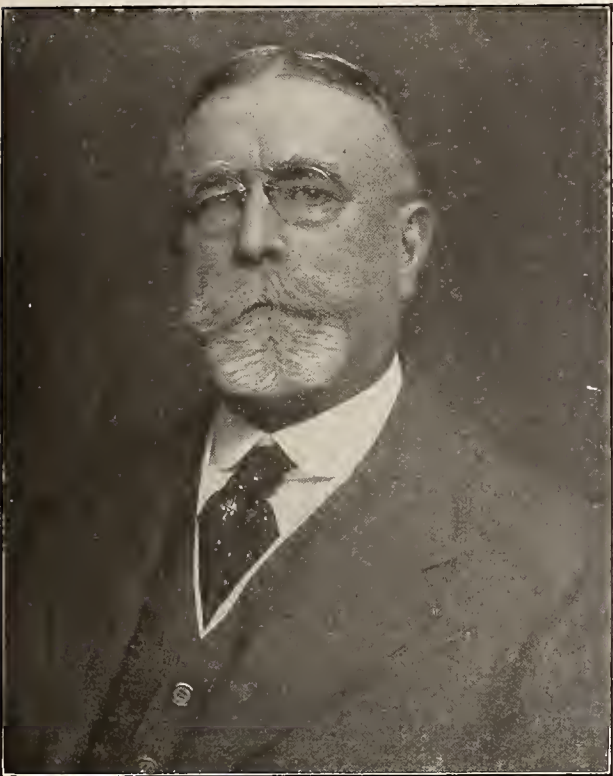

George E. Brightson

ably the strongest selling force that exists, and that degree of pride is largely felt by Sonora owners.

Our advertising has been different from all others, and will continue to be "classy." We believed a phonograph was entitled to an advertising and sales plan, which aims to reach the masses, and not merely the masses. Our steadily increasing sales, and the very high class dealers, who now sell Sonora are a convincing proof that we were right in the course we pursued, and which we steadfastly are pursuing.

We have not stopped making improvements, nor are we resting on our laurels. I do not wish at this time to give away trade secrets—for that reason I cannot tell you at present, but will merely indicate that within a year from now we shall have the results of some of our lengthy and expensive experiments, which, when placed before our dealers, will cause you to add a largely increased value on your contract for selling Sonoras. I wish you would all remember this reference, and in less than six months I can say, "I told you so."

The marked favor Sonora has found, and our great success have caused some unscrupulous ones to attempt to deceive the public—in a few instances by advertising names closely resembling ours—in one case the changing of a letter, such as an "r" for an "n," otherwise it would be Sonora—making statements such as "about as good as Sonora" or "this part like Sonora," and generally making untruthful statements. To protect our industry as far as we can, I wish to ask your co-operation in these efforts of ours, which are now being made, to protect our rights, your business, and prevent the deception of the general public.

Notwithstanding the troubles of the world existing to-

day, present indications of 1918 are that it is going to be a far greater and better business year for phonographs than any that has gone before, which I hope will enable you to comfortably pay much larger excess profit taxes to the Government, in the spring of 1919, than you are paying to-day.

Homes with absent ones will need cheer. Invalids may return—the home will again need cheer. What can fill the void or vacancy equal to and for less money than a good phonograph?

England and France, I am informed today, after having been in this terrible war for such a long period, are manufacturing and selling more phonographs than at any time prior to the war. The demand is greater here to-day with us than before the war. I trust it will continue, for the comfort it brings to all that need it, and while it is our business, it is a pleasant thought to feel that we are all instrumental in making it possible for those requiring same, to have this cheerful proposition in their homes. If you could read the many hundreds of letters which this company has received from those who have gone to fight for our great cause, you would enjoy with me my feelings in this regard. We have them from Plattsburg, Spartanburg and from about all the camps in this country, as well as from the trenches abroad, and from our sailor boys, whom we must feel are our great protection against the invasion of our land.

We are going to keep right on making the "highest class talking machine in the world," and are going to do more to help you sell it than ever before. Expect it, and tell us if you do not get it.

NEW RETAILER IN PHILADELPHIA

Theodore Presser Co. Opens Handsome Victor Salesrooms at 1710 Chestnut Street, That City, With A. D. Proudfit as Manager

PHILADELPHIA, PA., April 2.—The latest addition to the retail Victor showrooms in this city are those opened recently by the Theodore Presser Co., well-known music publishers and dealers, at 1710 Chestnut street, in the building adjoining their old-established quarters. The new showrooms have been fitted up in a most elaborate manner, with Unico equipment throughout and under the management of A. D. Proudfit, formerly manager of the retail warehouses of the Estey Piano Co., in New York City. It is expected that the standing of the Presser Co. in local music and business circles will insure the success of the department from the outset. A satisfactory stock of machines and records has been secured, and Manager Proudfit reports that a satisfactory business has been transacted since the opening day.

NEW COLUMBIA DESIGNATIONS

George W. Hopkins, general sales manager of the Columbia Graphophone Co., New York, has sent out a letter to Columbia dealers informing them that in an endeavor to simplify the ordering of Grafonolas the company has inaugurated new type designations covering the instruments in the Columbia catalog.

In the future, when a dealer for example orders a mahogany Grafonola No. 15, the order will call for type "A" mahogany; when ordering a No. 35 oak, the new designation will be type "C" oak, etc. When ordering electrics, the word "electric" is utilized, as for example the 125 "E" mahogany Grafonola will be ordered as type "G" electric mahogany Grafonola.

The complete list of the old and new designations with the list prices is as follows: Grafonola No. 15 is now type "A," list price \$18; No. 25 is type "B," \$30; No. 35 is type "C," \$45; No. 50 type "D," \$55; No. 75 type "E," \$85; No. 85 is type "F," \$95; No. 100 type "G," \$110; No. 110 type "H," \$120; No. 150 type "K," \$160; No. 200 is type "L," \$215; No. 125 "E" type "G electric," \$135; "E" is type "H electric," \$145; No. 175 "E" is type "K electric," \$185; No. 225 "E" is type "L electric," \$240.

JOIN IMPORTANT ASSOCIATION

The Otto Heineman Phonograph Supply Co., Inc., has been elected a member of the American Manufacturers' Export Association and the National Association of Manufacturers. This company's export activities have increased tremendously during the past year, and Mr. Heineman is making plans to take care of a record-breaking export trade during the coming year.

The best and biggest men of all times have been self-made men—most of them started out with what the world would call a poor chance. Their chances were no worse and no better than those which surround every individual to-day.



No. 498 [vertical interior] For Victrola IX For Columbia 50 For Pathe 50

Height, 32 in. Width, 19 in. Depth, 22 in. Holds 240 records. Mahogany front. Quartered oak front. Average weight, crated, 80 pounds. [If horizontal shelving is desired, order No. 1498.] [When felt interior is wanted, order No. 498F.]

We started advertising Udell record cabinets in the first issue of The Talking Machine World that was ever published.

Every year since then we have consistently advertised Udell cabinets.

As a result of our publicity several thousand Americans are familiar with Udell cabinets and the Udell trade mark.

The industry has been steadily kept on intimate terms with Udell cabinets and the Udell trade mark.

Today the Udell trade mark on a record cabinet is nationally recognized by talking machine dealers as a guarantee of superior quality and of an excellent profit for the dealer.

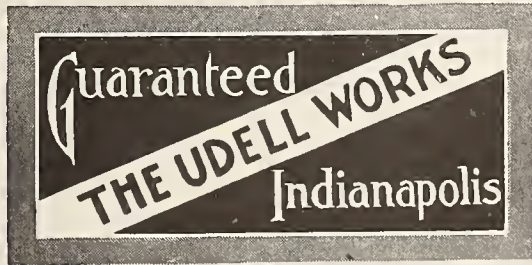

TRADE MARK

Write for Particulars

THE UDELL WORKS
1205 WEST 28th STREET
INDIANAPOLIS, IND.

The BEST TALKING MACHINE NEEDLE

On the Market—Packed in Counter Salesman



50 Needles to a box and they retail at 10c. per Box.

60 Boxes to a package \$6.00.

This package costs you \$3.90 net.

Your profit is \$2.10 and your customer gets a needle that will give satisfaction.

The Fred. Gretsch Mfg. Co. 60 Broadway
Brooklyn, N.Y.
Manufacturers of Musical Instruments



UNICO SYSTEM

THE SALES BUILDER

UNICO RECORD DEPARTMENTS

are the
Standard of Service and
Sales Efficiency

THE PURCHASING Public quickly discriminates. Look for the busiest Record Department in your community and you will usually find The Unico System of Demonstrating Rooms, Record Racks and Record Counters

MAXIMUM CAPACITY
MINIMUM SPACE
MODERATE COST

Record Sales in 1918 will surpass all previous demands. Prepare *now* to secure your share of this business by installing

THE UNICO SYSTEM

Patriotic Records will help
win the War

UNICO DEMONSTRATING ROOMS
RECORD RACKS
RECORD COUNTERS
WALL DECORATIONS
COMPLETE INTERIORS
(Patented as to design and construction)

In six standard styles and in special period design such as Adam, Louis XVI, Colonial, Modern French, etc.

- Offer 1—Individuality and Class
- 2—Highest Sales Efficiency
- 3—Most Economical Investment

Follow the lead of the leaders. Double sales and profits through
THE UNICO SYSTEM

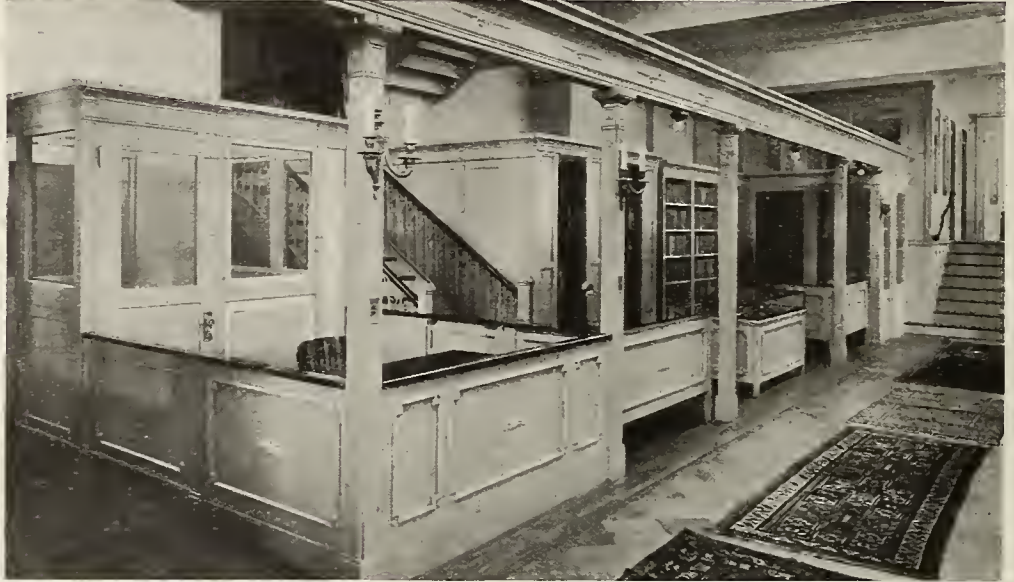

THE UNIT CONSTRUCTION COMPANY

RAYBURN CLARK SMITH, President

Fifty-eighth Street and Grays Avenue, PHILADELPHIA, U. S. A.

Send today dimensions of your available space

Plans for a complete department will reach you promptly

Happenings in Dominion of Canada

NEW MANUFACTURING HOME FOR COLUMBIA IN TORONTO

Occupancy of Large Building at 54-56 Wellington Street Gives Company Double Present Factory Space—New Concerns Enter Field—Some Staff Changes—Other News of Interest

TORONTO, ONT., April 8.—The Columbia Graphophone Co. have just closed a deal whereby they will occupy, within a few days, the large modern building at 54-56 Wellington street, West. This will not only give the company more than double the manufacturing space heretofore necessary, but will bring them into the heart of Toronto's wholesale district, enabling Jas. P. Bradt, the company's general manager for Canada, to keep in close touch with the talking machine trade, and making it easy for Columbia dealers to keep in personal touch with the management.

The company announce that they have extensive plans in view of aiding the dealers even more than before. In this connection the latter will, no doubt, quickly get the habit of dropping in and talking things over, as Mr. Bradt's score of years' experience in talking machine affairs in different parts of the world, which is freely placed at the command of Columbia dealers, should be of inestimable benefit to them.

The primary reason for this move is the increase in Columbia business, which has made it impossible to keep pace with the demand for Columbia products, particularly records, in the quarters being vacated. New record-making equipment is already on hand, and is being rapidly installed. This, Mr. Bradt states, will at once increase the output to take care of the business, which has more than doubled during the past year, and with an eye to the future, facilities are provided to again double the output as soon as necessary.

The cabinet manufacture and the making of completed Grafonolas will continue as at present, a number of large woodworking plants being busy on this work. So the new premises will be reserved to supply ample record manufacturing, stock and distribution facilities. The Dictaphone will also be taken care of in the new location.

Large and handsome offices and ideal showroom facilities are being provided, as the chief consideration in locating on Wellington street was the central location, convenient for the trade. It is primarily this reason, state the management, that influenced the company in going to the expense of establishing in what is chiefly a wholesale, showroom district.

James P. Bradt, Columbia general manager for Canada, was wearing an unusually happy expression when asked about the new Columbia factory. "It is great," he said, "a lot better than we expected to secure, and ideally located. We hunted Toronto from end to end, and at different times found three factories which appeared to be the last word in desirability, but they were all bowled over and forgotten when we found the Wellington street premises. There is no better wholesale block in the whole of Toronto than that on Wellington street, between Bay and York streets.

"My Lyle, who was introduced to the Canadian trade in February, is very ably and strongly on the job as my co-worker. His intimate acquaintance with and knowledge of all our manufacturing problems will be of great value in making our new factory efficient and dependable in every department. Assistant Manager Hoffman, who came here from our Bridgeport factory two years ago, is enthusiastic over the prospect of having a model plant in Toronto. We hope to be 'at home' in Wellington early in April. We extend a very cordial invitation to our friends to come in and look us over."

C. J. Pott, Canadian sales manager of the

Otto Heineman Phonograph Supply Co., Inc., New York, has returned to the Toronto branch after a strenuous week in New York, where he attended a convention of the firm's head office officials, branch managers and factory managers.

Mahood Bros., Kingston, Ont., Victor dealers, C. W. Lindsay, Ltd., Columbia, etc., also of Kingston, in their advertising feature largely a



New Columbia Building in Toronto

selected list of popular selling records of classic, instrumental, patriotic and dance listings and find this a capital way of disposing of a selected list.

During the period of "heatless days" when theatres and movies were closed, the Columbia Graphophone Co. and their dealers throughout the country featured large-sized copy advocating the purchase of Grafonolas and records as a constant reminder of music in the home and never off the job entertainers.

The Talking Machine Supplies Co. has been registered in Toronto.

Arthur Middleton, the well-known Edison artist, recently appeared in a concert recital here in conjunction with the Toronto Symphony Orchestra. The dealers report having sold a large number of records of this artist as the natural sequence.

F. J. Kennedy, formerly of the Mason & Risch staff, Toronto, is again with headquarters, having returned in the capacity of manager of the Victrola department. A couple of years ago Mr. Kennedy went to Winnipeg and was manager of the Victrola department there, which position he resigned to return East.

A recent trade visitor to Toronto was M. H. Matthews, president of the Thomas Mfg. Co., Dayton, O., who was over having a look at his firm's Toronto branch, in charge of P. K. Wood and F. J. Foley. Mr. Matthews reports a

largely increased output of Dayton motors, tone arms and reproducers, as a result of the recent installation of new machinery and enlargement of their manufacturing facilities.

W. B. Puckett, vice-president and general manager, and F. A. Trestrail, advertising manager of the Williams Piano Co., Ltd., Oshawa, recently resigned their respective offices with that firm to devote their entire time and attention to the business of the Musical Merchandise Sales Co., distributors in Canada of Brunswick phonographs. John E. White, sales manager of the Williams Piano Co., announces that he is also joining the Brunswick distributing organization. The plans of the Musical Merchandise Co. include the opening of branches at Winnipeg and Montreal. Their offices and showrooms in Toronto are in the Excelsior Life Building, at the corner of Adelaide and Toronto streets.

J. W. Caswell, formerly Eastern sales manager of White Sewing Machine Co., has resigned that position to join the Starr Co., of Canada. His territory will be all of Ontario, and as he makes a change only after a close observation of the phonograph business in general, and the Starr line in particular, he should make good.

To avoid confusion because of similarity in names, and also to make their name more indicative of their business, the distributors in Canada of Starr phonographs and records have changed their firm name. In the future it will be "The Starr Co. of Canada," instead of "Canadian Phonograph Supply Co." The headquarters of the firm remain at London, Ontario. John A. Croden and W. D. Stevenson, proprietors of the firm, are just approaching the close of their first year's business, which has exceeded their brightest hopes. For some time they have been receiving phonographs from the factory at Richmond, Ind., by express, in order to have goods for delivery.

Rea's Drug Store, Woodstock, Ont., have had the formal opening of their music room, which has just been completed at the rear of the store. Rea's are featuring the Brunswick phonograph.

W. C. Wilson has taken up his new duties with the Pathé Co., and is already deeply engaged in evolving new ways and means of giving service to Pathé dealers.

T. A. Dillon, formerly Ontario traveler for R. S. Williams & Sons Co., Ltd., Edison sales branch, is now located at the Toronto headquarters as manager of the Edison sales department. Mr. Dillon is succeeded on the road by J. A. MacKay.

James Malcolm, president of the Pathé Co., is at present on a Western trip, which will take him out to the Coast.

Thomas Mundy, Toronto, has joined the Canadian Symphonola Co. as sales manager.

Recent additions to the growing list of Pathé dealers are: Claxton & Co., Lindsay; E. V. Warnock, Peterboro; Minifies Music Store, Sarnia; Jury & Leslie, Owen Sound; Wesley Walker, Goderich; A. G. Day, Orillia; Martin Music House, Brampton; Tucker Piano Co., Port Arthur.

Talking Machine Supplies and Repair Parts

SPRINGS, SOUND BOX PARTS, NEEDLES

THE RENÉ MANUFACTURING CO.
MONTVALE, NEW JERSEY

TRADE CONDITIONS IN THE DOMINION OF CANADA—(Continued from page 69)

“MUSIC IN THE HOME” IN MONTREAL

Talking Machine Men Support the Campaign—American Machines in Favor—General Business Outlook Reported Most Satisfactory

MONTREAL, QUE., April 4.—A representative meeting was held recently of piano and talking machine dealers to listen to E. C. Scythes, president of the “Music in the Home” movement in Toronto, and J. A. Fullerton, secretary. A goodly amount was subscribed by those of the trade present, and it was announced that Montreal’s leading English Daily and Weekly and French Daily would feature a “Music in the Home” page very shortly.

W. W. O’Hara, general sales manager for Layton Bros., Edison and Columbia dealers, won the third prize in the recent Canadian Edison window display contest.

C. W. Lindsay, Ltd., lately displayed in their handsome show windows two new art design Pathéphones, the first to arrive in Montreal.

N. G. Valiquette, Ltd., have inaugurated a Pathé Club open to 100 members. As special inducements they offer easy weekly payments, reasonable extension in case of sickness, accident or loss of employment and clear receipt in case of purchaser’s death.

Sales Manager W. W. O’Hara with his usual aggressiveness made capital out of St. Patrick’s Day by dressing Layton Bros. show windows appropriately in honor of Ireland’s patron Saint. Edison and Columbia models were decorated with green ribbons, pots of shamrocks and records of Irish artists prominently displayed. The whole drew most favorable attention from passersby.

The Melodia Co., of Canada, have recently put on the market a new model.

The Berliner Gramophone Co., Ltd., are now distributing the new 584-page Victor catalog listing over 9,000 records.

The following world-known Victor celebrities will shortly appear in Montreal—Alma Gluck, Efrem Zimbalist, Martinelli and Heifetz.

Joseph Brien is now calling on the French trade in the interests of the Pathé Co. He is working from the Montreal office.

J. G. Harrison, of W. H. Thorne & Co., Ltd., St. John, N. B., Edison jobbers in the East, has returned from New York, where he attended the Edison jobbers’ convention. This firm has arranged for Odette Le Fontenay, soprano, assisted by Jan Glockner, cellist, to give a series of Edison tone tests in different Maritime Province towns, including St. John, Fredericton, Pictou, New Glasgow, Sydney and Glace Bay.

Ed Archambault has purchased the old J. A. Hurteau business from C. W. Lindsay, Ltd., and is turning his own store and the Hurteau store, which are next door to each other, into one large store. He will feature the Pathéphone and Pathé records.

Madame A. Didier, who has been in charge of the French section of the Pathé Co., has gone into business on her own account, opening a large Pathé department in the store of Dupuis Frères, the leading French departmental store in Montreal. Madame Didier is well acquainted with the talking machine business, having been in charge of the Pathé department at N. G. Valiquette, Ltd.

H. L. Hewson & Son, Ltd., Amherst, N. S., distributors of the Pathéphone for the Maritime Provinces, are moving into their new warehouse and offices, where ample facilities will be afforded for the development of their growing business.

The Cowan Piano & Music Co. are delighted with results since handling the Brunswick line and are building up a large clientele with this make as their leader.

Charles Culross reports exceptionally good Sonora and Aeolian-Vocalion business the past month with an increased demand over February in the call for the various higher-priced models of machines.

H. C. Wilson & Sons, Ltd., Sherbrooke, Que., are firm believers in the continued popularity of Victrolas and Victor records, to which they are giving aggressive and exclusive representation in Sherbrooke and the surrounding country and in their branch stores. Owing to the increased business a large part of the grand piano floor has been given over to soundproof demonstration rooms.

A. Ramsberger, in charge of the Grafonola department of J. W. Shaw & Co., reports that since removing the department to the ground floor business has increased wonderfully. The new style Columbia, No. 100, is quoted as an exceptionally good seller.

The Canadian Graphophone Co., Columbia distributors in the Province of Quebec in both their wholesale and retail departments, report briskness that augurs well for the future in both machines and records.

OPEN NEW SALESROOMS

The Ideal Phonograph Co., of Rockford, Ill., has opened two salesrooms in that city, one at 819 West State street, under the management of C. R. Poole, and the other at 1324 Seventh street, in charge of John King.

WITH THE TRADE IN WINNIPEG

Collecting Old Records for Soldiers—W. P. Trotzke Re-enters Trade—Hudson Bay Co.’s Payment Chart for Instalment Sales

WINNIPEG, MAN., April 2.—Stanwood’s, Ltd., Columbia dealers, recently appealed through the press for old records which they collect and send overseas without any expense to the donors. This example could easily be emulated by other aggressive dealers.

W. P. Trotzke, of Kinistino, Sask., who some time ago dropped out of the phonograph business, is back in the game again good and strong with the Edison line.

C. E. Locke, Tara; W. A. Bowen, Ridgeway; W. K. Elliott, Brampton, and Niagara Music Store, of Niagara Falls, have added the Brunswick phonograph line.

The Winnipeg Piano Co. secured first prize in the Canadian Edison window display contest, and feel quite elated over their victory by beating out Toronto in second place, and Montreal in third.

The following system of extended payments is announced by the Hudson Bay Co.’s Calgary, Alta., Grafonola department:

Price of Instrument.	Initial Cash Payment.	Monthly Payments.
\$24.00	\$5.00	\$4.00
\$38.00	\$8.00	\$5.00
\$58.00	\$10.00	\$6.00
\$73.00	\$13.00	\$6.00
\$112.00	\$22.00	\$9.00
\$122.00	\$22.00	\$10.00
\$155.00	\$30.00	\$10.00

It is reported that Edison Hall (the Kent Piano Co., Ltd.), are having a \$50 Edison prize essay contest open to the school children of that city and vicinity.

ESTABLISH MANY NEW DEALERS

BOSTON, MASS., April 8.—Oscar W. Ray, New England manager of the Emerson Co., makes a most enthusiastic report of the way dealers are taking hold of the new nine-inch records. Among the houses that are taking large consignments are the Jordan Marsh Co., Magrane Houston Co., Timothy Smith’s, out in Roxbury; J. C. Cauldwell, of East Boston; Harry Schulz, of South Boston; Sage Allen Co., of Hartford, Conn.; John Peitti, of Roxbury; M. J. Elvedt, of Allston; Kittredge’s, in Lowell; James W. Hill, at Manchester, N. H.; Krey’s Music Store, in Boston, and Seaford’s at Portland, Me. Mr. Ray says that March has been the best month in the New England territory since he took hold of it and that prospects are excellent.

AMERICAN



No. 22—\$175.00



No. 13—\$135.00



No. 5—\$50.00



No. 4—\$40.00

AMERICANS embody all the good qualities and special features of phonographs, clear in tone, beautiful in design, finest finish, smooth running motors.

We stand back of every American



No. 8—\$65.00



No. 9—\$80.00



No. 10—\$100.00



No. 11—\$115.00

American Phonograph Co.

39 Fountain Street, N. W. GRAND RAPIDS MICH.

An Artistic Spring Window Suggestion Described for Talking Machine Dealers

By Ellis Hansen

This is the fourteenth of a series of articles on window display written by Ellis Hansen, who is recognized as one of the most practical designers of talking machine window displays in the United States.

Once upon a time when the talking machine industry was very young indeed, hardly older than a baby that could only talk baby talk, and sing little simple songs, the public, nevertheless, was beginning to grasp the wonderful possibilities of the "talker" as a home entertainer. One day a well-known manufacturing concern woke up to the fact that its business was entirely too brisk. Letters and telegrams were pouring in on the concern from every part of the land, and it didn't know what to do to fill the orders. You see this concern had previously started an advertising campaign in the national magazines and the result was that it was hopelessly swamped with orders. Although its factory was working overtime far into the night, new orders were piling up and no relief was in sight. Something desperate had to be done. It was done. The advertising in the wicked magazines that had caused so much trouble was withdrawn for the time being. Soon after the factory caught up with all the orders on hand. The frantic telegrams and unpleasant letters from dealers urging deliveries ceased to trouble the order department. The working forces stopped overtime work and slept quietly at night and everybody was happy. Moral: Whenever you need a good rest stop advertising.

This little story may be true or it may not. It is a fact, however, that many dealers have cut down their advertising appropriations during the war, not only curtailing expenses for newspaper advertising but window display services as well. That sort of economy is bad business. The time to advertise and put in lots of work in your show windows is when business is slow.

Talking machine dealers should keep on hammering the fact into the public that music in war time is as necessary as food and clothes, and the dealer's best means for such a campaign is his show windows. Music helps to keep our boys in France or in the training camps strong and fit. It brings joy and pleasure into their life and helps them to stand the hardships that military life imposes on all new recruits.

But even the ones that are left behind—the



Detail of Dance Group

mothers and children—need music to cheer them up far more than before the war. The horrors of the war—our war—that are brought to our very doors every morning through the newspapers requires the greatest amount of reserve power, not only for our soldier boys but equally so for us, who by circumstances are compelled to stay at home.

The talking machine is the ideal instrument to provide the relaxation, refresh and strengthen the mind and dispel gloom and fear. But to bring these facts home the dealers must advertise and the show window is the best medium through which to demonstrate the entertainments, the diversion and the inspiration that the talking machine is able to bring to the millions

cealed back of the arms and figures to the nearest floor plug which, of course, would heighten the effect considerably. The figures were made separately, the girl standing in front of the boy with about four inches between them, which made the arrangement much more realistic. To make the most out of this display one fine talking machine should be arranged near the center



A Well Arranged Spring Window That Will Appeal to Dealers

of homes that are more or less affected by the war.

In former articles of this series I have called dealers' attention to the great aid "cut out" figures have proved to be in making interesting and inexpensive "talker" displays in connection with records. No other special feature that I can think of stimulates the sales of records more than such displays, probably on account of the human interest.

The "craze" for dance records seems to be as strong now as it was before our country entered the war. Several prominent dealers have urged me to design a dance window on that account and describe it in *The World*. The display shown in the photograph is intended to illustrate what a splendid time and entertainment people can enjoy in their own home by the aid of a talking machine. A simple baluster, finished off at each end with vases, forms a graceful background for the two dancers. Back of this are about a dozen Japanese lanterns in red, green, blue and yellow, which form a most dazzling color combination, and give atmosphere to the display. The two little trellises arranged back of the vases are thirty-six inches high, enameled white and made into a hub or ring at the top to support the two birds of paradise. These trellises also serve to support the rose branches which fit so nicely into an early summer window. The two figures are adapted from a *Vanity Fair* title page which pictured a skating scene. The two lanterns held by the dancers could be used with any lettering the dealer might desire. The dancers could also be provided with real lanterns and electric bulbs placed inside, the wires being con-

group. On the opposite side a program made up for the supposed entertainment should be placed. This program should consist of six musical numbers, the disc of each of which should be placed on stands in the display. The program should be headed with "America" or some other patriotic selection. The other five numbers could be made up from records the dealer is anxious to sell, and of which a good supply is kept on hand. The lanterns held by the dancers could also be used for important announcements of new records, or other advertisements desired by the dealer.

The baluster and vases are made of heavy cardboard cut out and air brushed and reinforced by strips of wood. The figures are almost life-size and painted in the natural colors. The artificial flowers in the vases consist of three branches in each, and can be procured from dealers in artificial flowers for less than \$2. The Japanese lanterns cost 10 cents each retail. Each one should have a little sand in the bottom to hold it in shape.

WORLD RECORD SOUNDS OF BATTLE

Henry G. Rhodes, Whiteville, Tenn., who describes himself as a "Phonograph fan," is shortly to enter the military service, and advises us that his ambition is to carry about 100 blank records to France with him and record the sound of the big guns right back of the firing lines in order to let the folks at home hear what they sound like. A motion picture has shown us the big guns in action, and probably the phonograph will let us hear how they sound in action.

SONA-TONE SHOP OPENED

New Brooklyn House Featuring Sona-Tone Phonographs—Now Able to Make Prompt Deliveries of All Types of Those Machines

A spacious and attractive Brooklyn Sona-Tone Shop was opened in Brooklyn on April 3, with Franklin Riker, a well-known musician, as sales manager. This shop is situated at 322 Livingston street, within a half block of the Montauk Theatre. The Nevins street subway station is just around the corner, and Mr. Riker is enthusiastic over the desirability of the shop's location and the unlimited opportunities for closing an excellent business.

This shop will carry a complete line of Sona-Tone phonographs, and arrangements have been made which will enable the shop to make immediate deliveries of all types. The showrooms are attractively furnished and decorated, and Mr. Riker is leaving nothing undone to make the warerooms a Mecca for music-lovers in that section of the city.

One of the most interesting features of the organization of this Brooklyn Sona-Tone Shop is the fact that Mr. Riker is a thoroughly trained and experienced musician, having studied for the concert stage in Italy, under some of the best-known maestros. Possessing a remarkably fine tenor voice, his concert work has attracted considerable attention from critics and from members of the musical world. At the present time he holds a position as soloist in one of the largest and most influential churches of Brooklyn. Mr. Riker believes that every salesman of musical instruments, especially talking machines, is a 100 per cent. salesman only when he knows the practical side of music, and knows when and how to appeal to his patrons through understanding tone quality. He has a number of important plans to announce in connection with his work at the Sona-Tone Shop, and sales during the first ten days have been very gratifying.

FINISHING FRET WORK PROPERLY

How One Cabinet Manufacturer Solved This Particular Problem in a Logical Way

One of the features of many phonograph cabinets that has called forth criticism has been the unsatisfactory finish of the fret work covering the sound chamber. In a good many cases cabinets, beautiful in every other particular, have been marred by poor work in this connection, due oftentimes to the fact that the cabinet finishers did not understand just how to go about handling the fret work. One cabinet maker managed to overcome the difficulty by having the panels finished before the fret sawing was done, the panels being rubbed down after the three coats of varnish, just the same as the rest of the case.

The panels were then nailed together, four in a bunch, with ordinary drafting paper between them, the top panel being turned face downward, and the marking done on the back, it being sanded if needed. The panels turned out well and they presented a fine, clean-cut appearance that was impossible in the old method.

In order to stain the edges left white by the sawing, an oil stain is used, as water stain is inclined to swell the wood and mar the clean-cut appearance of the work. The top side of the fret sawing that shows when it is placed in the case is shellacked with a small, soft brush from the back side of the panel, and the result is very satisfactory. These panels are of five-ply veneer and are three-sixteenths inch in thickness and go into a small mitered frame that is removable. Any finisher knows how much tedious and fussy work is required to finish a fret sawed panel, the rubbing is never flat and the picking out of pumice stone from the corners of the fret is an almost impossible job, while what is left turns white in time.

The above plan does away with this nuisance. Four panels are fret sawed at one time and the work is done on a McKnight saw. For panels in the fumed finish, no paper is required between

Most Efficient for Record Filing



Here is shown the Edison style C 150, equipped with an Eject-o-File style 150 E.

The instrument equipped with this device offers a wonderfully simple and efficient receptacle for records.

The record is always at your finger tip.

Simply press the index lever and the desired record is gently rolled into your hand.

It completes the instrument.

them while fret sawing. By using a good saw blade with little set, or one of the French pattern blades, having no set and running to a narrow back, the work is very smooth and no further labor is required before sending the panels to the finisher.—Veneers.

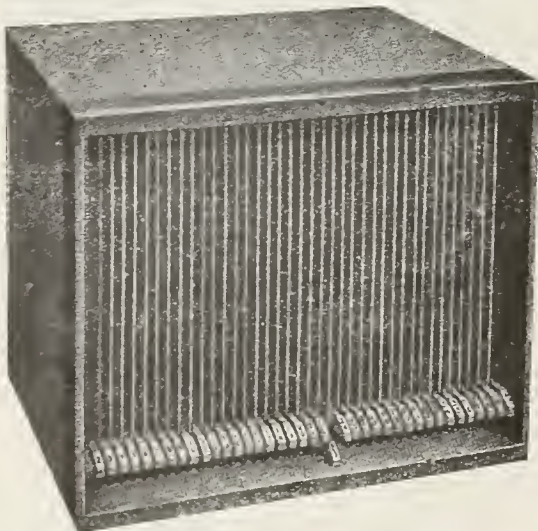

Style 70—Retail \$10.00

7 IN 1

Seven strong points in our feature is a powerful selling argument.

1. Controlled entirely by gravity. Will not get out of order.
2. Non-abrasive individual record compartments.
3. Records cannot warp, scratch or mar and are kept clean.
4. 10" and 12" records can be filed in any compartment indiscriminately.
5. In beautiful oak and mahogany finish. Polished, waxed and dull finish.
6. Automatic out signal shows "when and where" a record is missing.
7. Filing and finding a pleasure. Get the desired record when it is desired.

COLUMBIA DEALERS: Eject-o-files are built to fit the style 75 and others. Slip them in as they are wanted. Why carry that big stock of 85's, etc., when the Eject-o-file does the trick. "The Eject-o-file is Efficient" and you are in business for dollars and cents.

VOCALION DEALERS: A receptacle for records that can be slipped into your style F.-G.-H.-J.-&-K. They are "built to fit." Wonderful convenience and a powerful selling argument. Ask the Salesman.

EDISON DEALERS: Eject-o-files are built to fit the style C-150 and 100. Many dealers are reaping the benefits. Why not you?

"BUILT TO FIT" any machine and a powerful asset for any dealer. Why offer Albums, Envelopes and other antiquated methods of filing to your customer? Eject-o-files are modern and efficient. Prices are phenomenally low.

The "sectional Eject-o-file," an auxiliary cabinet, compact, large capacity. Can be conveniently placed on table, stand, etc., or stands especially adaptable can be had. Beautiful and artistic, mahogany and oak finish, polished, waxed or dull. Each section a complete unit, can be added to, one upon the other, you know, sectional bookcase idea.

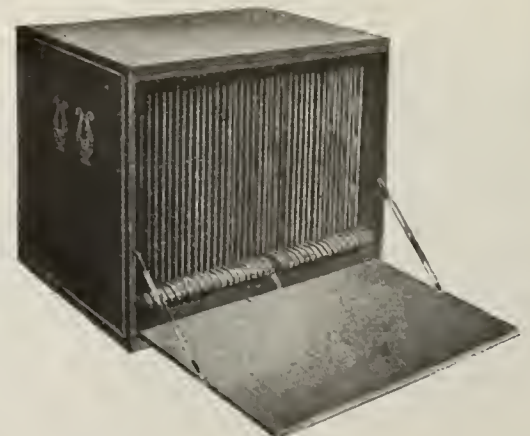

Style 60—Retail \$15.00

EJECT-O-FILE SALES CO.

216 W. Saratoga Street

Baltimore, Md.

THE EXCLUSIVE VS. GENERAL STORE

Some Strong Arguments in Favor of the Former Set Forth by M. E. Taylor, Victor Dealer of Jackson, Miss., and a "Specialist"

Since the talking machine business was young—and that is not so very long ago—one of the points of discussion has been whether or not it was advisable to handle talking machines exclusively, or, whether the better course was to handle several lines of merchandise in conjunction with the talking machine department. The views, of course, are varied, according to the personal experiences of those giving them.

The man with the exclusive store, who has won success, naturally maintains the arguments for his method, while the other merchant who carries side lines can see some merit in his system. There is no doubt, however, that in many particulars the exclusive talking machine



An Inspiration for Other Dealers

store has some advantages in the matter of attractiveness to the customer, and the service that can and must be given, to insure the success of the business. With an exclusive store, the dealer has no other line to rely upon to make up in profits what he may miss by his neglect of the talking machine trade. In support of the exclusive idea, therefore, the following comment by M. E. Taylor, Victor dealer, of Jackson, Miss., is of general interest. He says:

"We are 'specialists.' We started in business here in November, 1913, confining our entire capital and energy into the talking machine business and to prove that this is a business big enough to sustain itself and not a 'side line' issue as so many have thought. We have now gone through four years and for your information and for the information of thousands of others we take great pride in stating that our business has grown to quite large proportions.

"The customer has learned to come to the exclusive dealer because he has learned from actual 'service' rendered him that he gets what he wants and that well trained employes are telling him the history of each particular record, and in every way making things interesting to him.

"The exclusive dealer as stated before places his whole time and energy into this which he considers as big a business and requires as much time as another business in order to give the most critical customer the service he is looking for.

"We believe that more dealers are waking up to the fact that specializing is what is needed. We have time to give close study to every detail to think out what your trade wants, to study each customer, to keep records of each customer's purchases on cards for future reference so as to follow him up closely, to be able to intelligently get to the kind of music he wants without boring him and shortening both his time and yours. This kind of service the customer appreciates. He feels that you are taking that special interest in him and appreciates it.

"We carry the complete line of records because this is 'service.' When the customer asks for a particular record he expects to get it. It is true that some records don't move as quickly as others, but you never know when a certain record will be asked for and to have this rec-

<h1 style="font-size: 2em; margin: 0;">MICA</h1> <h2 style="margin: 0;">Diaphragms</h2>	Quotations and samples promptly forwarded upon request Send us your requirements No obligation incurred			
	<h3 style="margin: 0;">INTERNATIONAL MICA COMPANY</h3> Offices and Factory, 37th and Brandywine Streets, WEST PHILADELPHIA, PA.			
PHILADELPHIA PA.	CHICAGO, ILL. (Insulation Dept.)	AMELIA CO. VA.	MONTREAL CAN.	WEST PHILADELPHIA PA.

ord creates an impression at once on the customer that this store in the future is where he will come. So our advice is to carry the complete catalog and have it so systematized as to order immediately as fast as you sell a record to get it right back in stock, and thereby never be out and never lose a sale and never disappoint a customer.

"Now by specializing you can easily do this, because you are just in the talking machine business and by giving your whole time to it it becomes not only profitable but extremely interesting, and, Oh! my! watch it grow, watch the customers multiply, watch them come in from your side line competitor. Now the writer does not in the least wish to hamper the trade by discouraging side line agencies, but if the dealer who thinks this is a little business and places it in just to pay the rents and other items, he is overlooking the biggest business he has ever had.

"If possible for him to do so, let him rent a store elsewhere and just specialize, if not, then by all means build booths and place in a most prominent place at the front of his store a well equipped talking machine department with nothing short of the complete catalog of records.

"There is nothing to fear, just start it right, and watch it grow to be the most interesting business you have ever entered.

"Don't employ cheap help, look around and get the best. It pays. Remember you have the highest grade talking machine with the world's greatest singers, and don't employ cheap help. At all times keep the high prestige of your line before the public in every possible way.

"The same applies to your advertising department. Get up a nice attractive ad or nothing at all.

"The writer may be an extreme enthusiast, but we have found that the above are facts, and to be more frank about it, I have found time to take but one three-day vacation in four years, working even into the night many and many times until 11 or 12 o'clock.

"Now suppose this was a side line and kept us this busy, what would become of the other business?"

MAKING TALKING MACHINE PARTS

The Popular Talking Machine Co., New York, has just placed on the market a complete line of talking machine parts, including single and double spring motors, tone arms, governor springs, main springs, etc. The company has made arrangements to supply the trade with these parts in large quantities, and has already closed contracts with several manufacturers. According to present plans it will also market a line of talking machines which will be known as the "Popular," and these instruments will include all of the types that are in active demand.

TAKES CHARGE IN SCRANTON

Frederick Delano, of New York, has taken charge of the talking machine department in the store of Stoehr & Fischer, on Washington street, Scranton, Pa.

TO HANDLE THE COLUMBIA

Harry Stevenson, furniture dealer of Circleville, O., has put in a line of Columbia Gramophones and records in a large new department just opened.

The Perfection

Ball Bearing Tone Arm

is the original ball bearing tone arm



WARNING

is hereby given against infringement of our patents, as prosecution will follow. All claims as to origination of ball bearing tone arms by other manufacturers are false. This we can prove.

The ball bearing tone arm was originally announced by us through the columns of *The Talking Machine World* on April 15, 1914.

We also produce the new Perfection Flexitone Reproducers for playing lateral cut records on Victor, Columbia, Sonora, Edison Disc and Pathe Machines. Write to us for prices and full information.

NEW ENGLAND TALKING MACHINE CO.

16-18 Beach Street BOSTON, MASS.

For your customers who want Real
Music and whose limit is below \$100

THE NEW EDISON DIAMOND AMBEROLA

MANY families in your community want a phonograph that will give them real music, but cannot afford to pay \$100 or more for such an instrument. Such families are the best kind of prospects for the New Edison Diamond Amberola because it will give them genuine Edison music at nominal cost.

¶ We have ample and convincing evidence that, musically, the New Edison Diamond Amberola and Edison Blue Amberol Records far outclass any line of phonographs (or talking machines) and records not bearing the Edison hall-mark.

¶ Are you one of those skeptics who like to be "shown"? We hope so, because we like to "show."

THOMAS A. EDISON, Inc.

AMBEROLA DEPARTMENT

Orange, New Jersey



MODEL 75
(Two other models
Model 50 and
Model 30)

NEW DISTRIBUTIVE PLAN SOON

To Be Announced by Wm. H. Alfring, Manager of Wholesale Vocalion Dept. of Aeolian Co.

Wm. H. Alfring, manager of the wholesale Vocalion department of the Aeolian Co., New York, announced this week that the company



W. H. Alfring

will soon be in a position to advise the trade regarding the establishment of several important points of wholesale distribution. Mr. Alfring has been busy the past few weeks working

out this plan of distribution, and, according to present arrangements, Vocalion wholesale headquarters will soon be located in many of the principal cities.

At the present time the Vocalion is being distributed from St. Louis and Chicago, and the dealers in these territories handling this line are enthusiastic regarding the service and co-operation that they are receiving from these two distributing points. The demand for the Vocalion has increased so rapidly that it has been found advisable to divide the country into a number of wholesale distributing centers, so that the dealers in each section of the country may be given maximum service and co-operation.

During the past few months Mr. Alfring has visited Vocalion representatives throughout the country, and, according to reports he has received, this high-grade line will enjoy a banner era of prosperity during the coming year. Vocalion representatives have been concentrating their activities on the development of the better class of business, and the fact that this

instrument is manufactured, marketed, and guaranteed by the Aeolian Co., the world's largest



A Period Style Vocalion

manufacturer of musical instruments, has been an important factor in the success which this instrument has achieved during the past two years. Meanwhile, plans already laid should mean even greater progress for the Vocalion in the future.

MANY AIDS FOR THE DEALER

Kohler & Campbell, Inc., Have a Well-Managed Department Equipped to Help Dealers Secure Business Along the Lines of Least Resistance

The value of a thoroughly perfected organization has been manifested in the success of Kohler & Campbell, Inc., Fiftieth street and Eleventh avenue, New York, who are counted among the world's largest manufacturers of pianos, player-pianos and reproducing pianos. The growth of this concern has not only been rapid but has been particularly healthy, and they have, besides developing phenomenal manufacturing facilities, maintained for many years a sales promotion department, which places at the disposal of the dealers many merchandising aids.

The main object of this department has been to study the requirements of the purchasing public as well as the dealer, and to help the latter secure business along the lines of the least resistance, consequently this department, which is under the supervision of Chas. A. Stein, advertising manager, who has had a wide experience in merchandising, has planned several forms of promotion work which have proved most successful. These include circular letters for the dealer's use, catalogs, pamphlets, envelope stuffers, window displays, window cards which may also be used for trolley car advertising, and electrotyped advertisements for use in various sized newspaper advertising. The department is also able to supply the dealer with lantern slides, which may be used in the various moving picture houses in his locality. All of these sales promotion features have been planned after a thorough study so that they will have a most appealing effect on the minds of the people and prove to be a magnet which will draw prospects to the dealer's store.

Veritone Talking Machine Co., Inc., has been incorporated with capital stock of \$2,000, to deal in phonographs and musical instruments. The incorporators are Walter B. Craighead, Edith Craighead and Isabell Ross

The Unger Furniture Co. have set aside a large section of their store as a talking machine department handling the Victor line exclusively.

COLUMBIA FORCE IN DALLAS, TEX.

DALLAS, TEX., April 4.—H. A. Yerkes, field manager of the Columbia Graphophone Co., was a visitor to this city recently, and spent some time at the company's local branch, which is under the management of F. E. Erisman. While here Mr. Yerkes congratulated Mr. Erisman upon the efficiency of his sales organization, and the accompanying photograph gives the facsimiles of these live wires.

During the past few months the sales totals of the Dallas branch have shown a good-sized gain over 1917, and the figures for last December, which set a new record, were exceeded by February. March sales totals are not yet available, but it is more than likely that this month established a new high-water mark for this very successful organization.



Columbia Force in Dallas, Tex., With H. A. Yerkes in Center

THE DEALER WHO FAILED

Shop front dirty—unclean windows—inadequate stock—rusty stock of machines—records heaped together indiscriminately on the counter,

scratched, and with torn envelopes—untidy shop, etc.; that is the story of the dealer who failed. It is told in an interesting way by M. E. Ricketts in "The Voice," of London, and makes instructive reading, embodying, as it does, helpful hints and much useful advice for all who would be successful in their business.

Record Cleaners

The "Standard" Circular Cleaner grips the surface and clings as if on rails. A cleaner that has "made good."

PRICE, 50 CENTS, LIST

We also manufacture the "Simplex" Record Cleaner, 15 cents list price.

SEND 10 CENTS FOR A SAMPLE CLEANER

Automatic Stops



Automatic

Stops are in use everywhere. They give excellent service, are easily installed and are absolutely guaranteed.

SEND 50c FOR SAMPLE STOP

KIRKMAN ENGINEERING CORPORATION, 237 Lafayette St., New York



Shoot A2505 at a few sad-looking customers. They'll lose their long faces listening to Billy Williams' patter. That London music hall artist has been cracking serious English faces for years.

Columbia Graphophone Co. Woolworth Building, New York

TRADE ACCEPTANCE PROVES POPULAR

Delpheon Co. Finds That Its Dealers Generally Are Pleased With That System of Handling Accounts as Increasing Credit Prestige

Talking machine manufacturers throughout the country are taking a keen interest in the adoption of the trade acceptance as an ideal

authorities, the National Association of Credit Men, and, in fact, all members of the business world are advocating its prompt adoption. The Federal Reserve Banking System has been urging business men to utilize the trade acceptance, and it is quite likely that its use will soon be universal and common.

The average business man is familiar with the principle of trade acceptance, which is an acknowledgment of the debt by the buyer in favor of the seller, for merchandise that the latter has placed in the hands of the former, with which to pay his debt. The buyer agrees to pay at a certain date at his own bank, to the seller, the amount of this invoice, by writing across the face, the word "accepted," with the name of his own bank and his own signature.

duced herewith, and this form is meeting with the unanimous favor of the company's representatives.

NEW INVINCIBLE SOUND BOX MODEL

Hector Pocaroba, sales manager of the New Jersey Reproducer Co., Newark, N. J., manufacturer of the "Invincible" sound box, returned recently from a two months' trip through the north and central West. He states that conditions throughout this territory are very satisfactory, and substantiates this optimism by showing good-sized contracts which he has closed for 1918.

In a chat with The World Mr. Pocaroba said: "It is pleasing to note that a number of well-known manufacturers have adopted the 'Invincible' sound box as the standard equipment for their 1918 product, and as they reached this decision because of the tonal qualities of our product, we are naturally gratified at the success which this sound box is achieving. We have received many letters of commendation from dealers regarding the 'Invincible' sound box, and our facilities in 1918 will enable us to adequately take care of the demands of our trade."

Upon his return to Newark Mr. Pocaroba learned that the company now has ready a new model of the "Invincible" sound box, which was invented and perfected by A. Luciano, superintendent of the company's laboratories. It will be known as the "Invincible" No. 2, and is now being introduced to the trade. Initial orders indicate that it will soon outrival the first model in popularity.

SECURES THE COLUMBIA AGENCY

The Sanitary Bedding & Furniture Co., of Binghamton, N. Y., has secured the agency for the Columbia Grafonolas and records, and has opened a handsome department to handle that line.

THE DELPHEON COMPANY BAY CITY, MICHIGAN. \$ _____ 19 ____ days after date pay to the order of OURSELVES Dollars. Invoices of THE DELPHEON COMPANY

The TRADE ACCEPTANCE—Read Carefully. If you do not care to take the cash discount, sign the above Trade Acceptance and return it. Our obligation to make wholly satisfactory all goods shipped to you does not cease under the above manner of settlement.

Form of Trade Acceptance Used by the Delpheon Co. Many manufacturers regard the trade acceptance as the solution of one of the biggest problems in the business world to-day, and are calling the attention of their dealers to its value and advantages.

an acceptance increases the financial standing and prestige of the giver, because it evidences his desire to pay his invoices promptly. One of the many prominent talking machine manufacturers who have adopted the trade acceptance is the Delpheon Co., of Bay City, Mich., which recognizes in the trade acceptance the ideal method of doing business.

MOTORS—TONE-ARMS—SPRINGS—ETC.

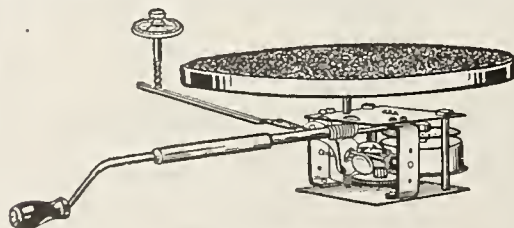

Single Spring Motor (Illustrated)

Complete with 10 inch turntable, regulator, brake, etc.

\$1.25 in quantities of 100 \$1.15 in quantities of 1000

MAIN SPRINGS 3/4 in., 20 gauge, 8 1/2 ft., 15c in lots of 100 3/4 in., 20 gauge, 8 1/2 ft., 13c in lots of 1000 3/4 in., 25 gauge, 10 1/2 ft., 23c in lots of 100 3/4 in., 25 gauge, 10 1/2 ft., 20c in lots of 1000 Governor Springs, 30c per hundred. Special prices on large quantities. Double Spring Motor Complete, \$3. In quantities, \$2.75.

50,000 latest Emerson Records \$30 per thousand



No. 1 Tone-Arm

UNIVERSAL TONE-ARMS PLAY ALL RECORDS

No. 1, 70c in hundred lots No. 2, 85c in hundred lots No. 3, \$1.00 in hundred lots

POPULAR TALKING MACHINE CO., 253 Bowery, New York

Those of us denied the satisfaction of personally

Hunting the Hun

out of his unspeakably dirty and unbelievably horrible atrocities in Belgium and France are providing the mightiest, the most relentless fighting proxies when we

Buy Liberty Bonds

This is America's *great fight*. She has never fought to lose—and by the Grace of God she shall not now. Your dollars and mine—consecrated to the **THIRD LIBERTY LOAN**, along with the dollars of all others we can influence—shall make this our *great victory*.

Buy a Bond to-day!

JOSEPH C. ROUSH

STANDARD TALKING MACHINE CO.
PITTSBURGH





Al Jolson has "Wedding Bells, Will You Ever Ring For Me?" in Columbia's May List. Does Al Jolson pick 'em or make 'em? Another blue ribbon taker!

Columbia Graphophone Co.
Woolworth Building, New York

LOCAL VOCALION DISTRIBUTION

Retail Manager Fletcher Announces New Distribution Plan for Metropolitan Territory—Promotions for Members of Sales Organization

Thomas H. Fletcher, retail manager of the Aeolian Co., New York, in a chat with The World last week announced a new plan of Vocalion distribution for the metropolitan district which went into effect on the first of the month. This plan was evolved in order to give Vocalion dealers in metropolitan territory 100 per cent. efficient service and co-operation in handling this line. The demand for the Vocalion has increased tremendously within the past year, and Mr. Fletcher has perfected a distribution plan which will undoubtedly meet with success throughout this territory.

Aeolian Hall in New York, together with the three Aeolian branches in the Bronx, Brooklyn and Newark, will be the distributing points in this new system, the New York headquarters, of course, being the principal basis for distribution.

E. M. Wheatley, who has been in charge of the retail Vocalion department at Aeolian Hall, New York, for the past two years, has been placed in charge of Vocalion metropolitan distribution with headquarters in New York, and will also continue as head of the retail department at Aeolian Hall. Mr. Wheatley is one of the best-known members of the local retail trade, and during his two years' association with the Aeolian Co. has achieved gratifying success.

Louis E. Vannier, who has been in charge of the Bronx branch, has been appointed assistant to Mr. Wheatley in both retail and wholesale distribution. Mr. Vannier is one of the veterans of the Aeolian sales organization, and his conscientious and loyal work in the past well merits his promotion to his present important post.

M. Stein, who has been connected with the Aeolian organization the past seventeen years, has been appointed manager of the Bronx branch, and will be in charge of the metropolitan distribution north of 125th street. Mr. Stein joined the Aeolian forces when a boy, in charge of one of the stockrooms, but soon developed such marked sales ability that he was appointed a member of the outside sales staff. Within a period of two years he became the

"top" man of the outside force, and year after year maintained this enviable record. During the past few years he has been in charge of Vocalion agencies in the metropolitan district, and as he is a native of the Bronx, his appointment as manager of this branch will undoubtedly mean additional laurels for him.

C. J. Davis, manager of the Brooklyn branch since September, 1916, will be in charge of distribution in Brooklyn and the adjacent metropolitan territory. Mr. Davis joined the Brooklyn sales staff two years ago as an outside salesman, but advanced steadily to the post of manager of this branch. His thorough knowledge of salesmanship and his keen executive ability have been important factors in the success of this branch.

W. O. Black, who is well known in piano circles throughout the country, and who has been manager of the Aeolian Newark branch since it opened, will be in charge of metropolitan distribution for Newark and the adjacent territory, and under his able direction the Vocalion will receive splendid representation in this district.

TALKING MACHINE EXPORTS

The Figures for January Presented—Exports Show Machines and Records Both Increase

WASHINGTON, D. C., April 1.—In the summary of exports and imports of the commerce of the United States for the month of January, 1918 (the latest period for which it has been compiled), which has just been issued, the following figures appear:

Talking machines to the number of 5,731, valued at \$150,649, were exported in January, 1918, as compared with 6,190 talking machines, valued at \$149,569, sent abroad in the same period of 1917. The total exports of records and supplies for January, 1918, were valued at \$164,074, as compared with \$163,632 in January, 1917. For the seven months' total 55,146 talking machines were exported, valued at \$1,520,738 in January, 1918, and 44,943, valued at \$1,111,761 in 1917, while records and supplies, valued at \$1,171,138 were sent abroad during 1918, as against \$877,283 in 1917.

ANDREWS AD WORTH READING

BUFFALO, N. Y., April 3.—On another page will be found a large list of Victor records from the stock of W. D. & C. N. Andrews, of this city. This firm will be able to make immediate shipments on these records.

"Our idea of publishing this list," said C. N. Andrews, "was that perhaps we could furnish to many dealers certain records that they were unable to obtain elsewhere and also to induce them to push the sale of records that can be obtained.

"As we are catering to the wholesale trade exclusively we always stand ready to do anything to assist the dealer. We have a very good stock and would like to have any dealer who is having difficulty in getting what records he wants to give us a trial order."

NEW WINDOW DRESSING SERVICE

First Instalment Issued by the Emerson Phonograph Co. to the Trade—Offered to Dealers at an Insignificant Monthly Charge

The accompanying photograph presents an illustration of the first instalment of the new window dressing service inaugurated by the Emerson Phonograph Co., which has made arrange-



Emerson Window Dressing Service

ments to issue similar window displays each month. The display will be furnished to those Emerson dealers who take advantage of the special plan which the company has prepared, by the terms of which the service will cost the dealer 50 cents a month for a subscription of four months, or a full year.

The company made the first announcement of this new service a few weeks ago, and has already received numerous requests for the service from dealers throughout the country, who appreciate the fact that the use of this display will give them an attractive window without necessitating the employment of skilled window dressers.

SCHUBERT PHONOGRAPH RECORDS

The greatest series of 75c. records ever made.

**10-INCH DOUBLE SIDED
ALL STARS ALL SELLERS**

New list by 15th monthly.
Dealers, write for list and prices

BELL TALKING MACHINE COMPANY
44 WEST 37th STREET, NEW YORK

DEALERS EVERYWHERE ARE SELLING
QUANTITIES OF OUR

HANAIE BANJUKES

(Ukuleles in Banjo Form)

A bigger hit than the Ukulele because much louder and more pleasing in tone, and of more substantial construction. Perfect two octave scales. A thoroughly practical instrument for both solo playing and club work. Send for illustrated catalogue and price list today, as

The Banjuka is One of the Biggest Sellers in the Musical Instrument Line.

SHERMAN, CLAY & CO.
Sole Manufacturers
163 Kearny Street San Francisco

HEINEMAN'S GIFTS APPRECIATED

Vanophones and Records Sent to U. S. Marines at Various Points Bring Forth Letters of Earnest Thanks From the Recipients

As noted recently in the columns of The Talking Machine World, Otto Heineman, president of the Otto Heineman Phonograph Supply Co., New York, has donated a Vanophone and a supply of Emerson records for the various companies of the U. S. Marine Corps located in different stations throughout Cuba, Haiti, etc. These companies have received their machines and records, and they are being used to excellent advantage by the members of the Marine Corps. In fact, they are so enthusiastic over the entertainment that this gift has afforded that Mr. Heineman has already made arrangements to furnish the various companies of the Marine Corps with additional machines and records.

Some of the letters received from the commanding officers of the different companies of the Marine Corps in acknowledging these gifts read as follows:

"Wish to acknowledge receipt of one Vanophone and twenty-five records, for which I want to thank you for your kindness, and can assure you that it will be very much appreciated by the men of this command. I am sure that they will derive much pleasure from these excellent machines, and will encourage them to buy more records from you."

"Many thanks for the Vanophone received. The men derive great pleasure in the daily Vanophone concerts, and are very grateful for your kindness and consideration. It is a joy to hear reproduced the new music and songs of our native land.

"The men contemplate purchasing an additional supply of your Emerson records and would very much appreciate a catalog with price list of Emerson records that they may still further enjoy the kind and thoughtful gift."

"Through the graciousness of the Otto Heine-

man Phonograph Supply Co., the Fifty-seventh Company, U. S. Marines, is in receipt of a Vanophone and one set of Emerson records. I am sure that the men of this company will receive much pleasure and enjoyment from your good gift.

"Through your beneficence you have afforded an abundance of pleasure to the men of the Marine Corps stationed here.

"The Fifty-seventh Company takes this opportunity to offer its thanks."

"I am in receipt of a box containing five Vanophones and records therefor. By direction I have distributed one to the Fifty-third Company and one to the Fifty-seventh Company under my command at this post. The other three have been shipped to Cape Haitien for distribution to the Fifty-fourth, Sixty-second and Sixty-fourth companies.

"Permit me to thank you on behalf of the Fifty-third and Fifty-seventh companies for your kindness in this matter. The Vanophones are extremely unique and they will give an im-

mense amount of pleasure to the men and also to the officers. It is a donation that is highly appreciated."

"Referring to your letter dated New York City, January 14, 1918 (R.C.A.:C.F.) signed by R. C. Ackerman, export manager, we all wish to thank you for your kindness in sending us the three Vanophones with twenty-five records for each, which have just been received in good condition.

"The machines and records have been distributed to the three companies mentioned, and are now in use and being appreciated by all the men; these are excellent little instruments and appear very strong and compact.

"The men are deriving a great deal of pleasure from these machines, and we are truly greatly indebted to you for this generous and welcome contribution to our amusement and entertainment.

"Please accept my personal thanks for having our interests and welfare at heart, and our best wishes for your success."

GRADED LIST OF VICTOR RECORDS

The latest and most important addition to the educational literature sent out by the Victor Talking Machine Co. is a new graded list of records for the home, kindergarten and school, a handsome volume of over 270 pages, illustrated in detail, and with the various types of song and instrumental numbers carefully classified, according to the school grade in which they are intended to fit to the best advantage. In the descriptive matter the list follows closely along the lines of the regular Victor catalog, and that makes for convenience.

The illustrations show the use of the Victrola in the various schools for games, folk dancing and various exercises, and for other special purposes. There are shown portraits of some of the famous Victor concert artists, together with illustrations that show the various instruments of the orchestra, strings, woodwind, brass and percussion. The list also acts as a

guide to the teacher in the selection of appropriate records and their proper use.

NOW WHOLESALE EXCLUSIVELY

PEORIA, ILL., April 8.—The Putnam-Page Co., Victor wholesalers of this city, have discontinued their retail department and now handle Victor machines and records at wholesale exclusively. The rapid growth of the company's wholesale business necessitated the move. The company will remain at its present address and arrangements have been made for securing considerable additional space in the same building.

J. W. MARKS NOW IN CHARGE

J. W. Marks, of Chicago, has taken over the management of the piano and phonograph department of the O. T. Johnson Co., Galesburg, Ill. Mr. Marks was for a number of years connected with the Cable Company, of Chicago.

SONA-TONE

A Phonograph of Distinction with the Tone You Can't Forget

THE American public today—those who purchase phonographs and other domestic conveniences—want above all else—

-- QUALITY -- RELIABILITY -- SERVICE --

SONA-TONE *Quality* means a resonant, full, liquid tone that comes from an especially designed, all-wood sound chamber—and superior workmanship in material, finish and equipment.

SONA-TONE *Reliability* means simplicity of mechanical construction—ease of operation—and convenience and solidity of working parts.

SONA-TONE *Service* means the immediate ability of the purchaser to play all makes of records—without attachment of any sort—and to play a library of from 250 to 1000 assorted records without further expenditure.

We believe that a Sona-Tone eliminates—to a greater extent than any other phonograph—the surface noises of the record.

We believe that it has the same quality of resonance as exists in the Stradivarius violin.

From our sales record—previous to advertising—we believe that a SONA-TONE is a superior phonograph for retail merchandising.

SONA-TONE PHONOGRAPH, INC.
3421 Broadway, New York City

"The music is on the record—the tone is in the phonograph."



MODEL 100

SIX MODELS

\$70 -- \$100 -- \$150

-- \$200 -- \$250 --

A Popular Suit-Case Model

-- \$35 --

Orders taken for Special Finishes
to suit patrons



OUR OPPORTUNITY

VICTORY DEMANDS THE
FULLEST UTILIZATION OF
ALL OUR RESOURCES

OF THESE MAN-POWER IS
UNQUESTIONABLY THE
MOST VITAL

MUSIC STRENGTHENS AND
INCREASES THE EFFECTIVE
NESS OF OUR PEOPLE "OVER
THERE" AND AT HOME

IT INSPIRES · EDUCATES
CHEERS AND COMFORTS
IT MAKES BETTER MAN
POWER · IT HAS NO
SUBSTITUTE

OUR DUTY IS CLEAR
THE WIDEST POSSIBLE DIS
TRIBUTION OF GENUINE
AMERICAN MUSIC

Chicago Talking Machine Co.
Chicago, Ill.

New York Talking Machine Co.
New York City

FROM OUR CHICAGO HEADQUARTERS

E. P. VAN HARLINGEN,
Manager

World Office
Republic Bldg., 209 South State St., Chicago
Telephone: Wabash 5774

CHICAGO, ILL., April 10.—The wholesale trade in general is unanimous in claiming that the past month was fully up to their anticipation and that they have exceeded in some instances the business carried on during the corresponding month last year. There were some doubts, however, at the beginning of the month as to whether or not they would come up to anything like last year's business, owing to the chaos then existing in the railroad center due to storms and other mishaps which generally bring rolling stock to a standstill. As these conditions righted themselves and the shipments of both the completed product and the raw material found their way through in periods of time that were not much greater than those of normal, conditions began to get brighter and the better the shipping facilities became there naturally followed an increased amount of business.

The record situation which was quite keen during the first three months of the year also began to get back to the normal, and as records came rolling in the retail dealers began to get busy and for the first time during the year they were allowed to have the stock for which they were clamoring the most; that is, the popular numbers.

The retail trade suffered a slight set-back during the latter part of March and the first part of April, but this set-back had been anticipated because as is usual during Holy Week there is a general dropping off in business. However, after the public had finished eating its usual quota of Easter eggs and had digested them they began to think of "Music in the Home," which was only natural, and as a result the trade began to pick up again.

L. C. Wiswell to Go East

L. C. Wiswell, manager of the wholesale Victor department of Lyon & Healy, is making preparations for a contemplated visit to the Victor factory next week. Mr. Wiswell also intends to visit various other plants in the East before returning to headquarters in Chicago.

Cheated the Doctor

H. J. Fiddelke, assistant manager of the wholesale Victor department of Lyon & Healy, returned to his desk this week after having been confined to his home for several days with an attack of acute appendicitis. During his illness

Mr. Fiddelke stated that he had lost twenty-five pounds in weight and suffered intense pain. He was fortunate enough to recover, thereby avoiding an operation. Mr. Fiddelke anticipates going to a hospital and having an operation performed just as soon as he regains his strength, as he figures there is no use in having a reoccurrence of the attack.

Singers Give Concert

Oscar Shaw, leading man of the "Leave It to Jane" company, now playing at the La Salle Theatre, accompanied by several other artists of this company, was heard in a special Columbia recital on the afternoon of April 2 at the



Columbia Recital of Adam Schaaf

recital hall of Adam Schaaf. Several of the big "hits" of the show were rendered to the large audience by Mr. Shaw and Columbia records of these "hits" were also played. The Columbia graphophone and a player-piano were used throughout the entire performance in conjunction with the various numbers sung. R. H. Walley, of the Columbia Co., and Charles Hertzman, manager of the "Leave It to Jane" company, were instrumental in making arrangements for the concerts. Among some of the numbers rendered were "I've Got the Blues for Home, Sweet Home," "The Stormy Sea of Love" and "Michael and His Motorcycle," which were sung by Mr. Shaw, accompanied by the graphophone. Other members of the cast, accompanied by the graphophone, rendered various "Leave It to Jane" selections.

A. R. Harris Visits

A. R. Harris, in charge of the record sales department of the Columbia Graphophone Co., with headquarters in New York, made a short

visit to the Chicago offices of the Columbia Co. this week. Mr. Harris held a meeting in the Palmer House on Wednesday evening, April 3, which was attended by the Columbia office force and a number of Columbia dealers. He gave an interesting talk on the selection of records and went into detail explaining just why certain songs were chosen for the purpose of making records.

New Loop Man

C. L. Morey now has charge of the Chicago loop district for the Columbia Graphophone Co. Mr. Morey is one of the best-known talking machine salesmen in the city and was formerly connected with other big companies here.

G. M. Rickoff, formerly with A. Neihause & Co., proprietors of the Band Box Shop, Columbia dealers, is now connected with the advertising department of the Chicago offices of the Columbia Co.

Joins Empire Co. Forces

E. B. Kropp is the latest addition to the large office force of the Empire Talking Machine Co. Mr. Kropp was formerly connected with several of the largest establishments in Chicago, and in his new connections with the Empire Co. has entire charge of the office in addition to being advertising manager.

Increased Business

C. F. Baer, assistant manager of the Chicago office of the Columbia Graphophone Co., remarked this week that their business for the month of March was 50 per cent. greater than for the corresponding period last year. "Our shipments are coming in in fine shape," stated Mr. Baer, "and it certainly keeps us hustling to fill the demand. Records are especially good and the Columbia Co. is sure getting out some very good numbers. The demand is very heavy at present for popular songs, and we have a large supply on hand to take care of this demand. Our stockrooms are well supplied to meet any contingency, such as a freight embargo, and we feel that at present we are very well equipped to overcome any future difficulties.

Brunswick Portfolio

The Brunswick-Balke-Collender Co. have compiled a handsomely illustrated portfolio in colors showing the various cuts, complete advertisements and direct mailing literature concerning

(Continued on page 83)

THE "WADE" FIBRE NEEDLE CUTTER

Service Feature Is of Immense Importance

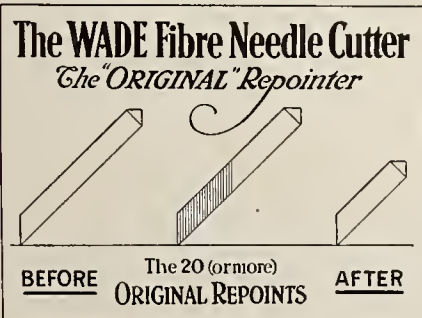

Your greatest revenue, Mr. Dealer, is from record sales.

The average customer seldom buys more than one talking machine in a lifetime, but may be readily educated to systematically accumulate a record library and thereby become a constant source of revenue to you.

The Wade Fibre Needle Cutter Is the Connecting Link

It permits the use of Fibre Needles, with all their acknowledged advantages, at the minimum expense, with its 20 or more original re-points to each fibre needle, and is very cheap insurance on the life of their records.

Instruct your salespersons to use these sales arguments and you will soon have a Wade Cutter and Fibre Needle in every customer's home, which will naturally result in increased record sales.

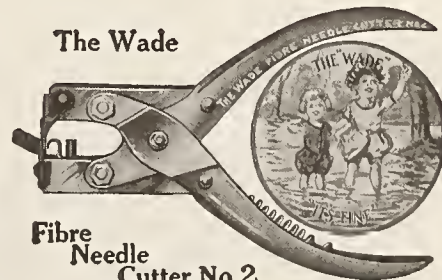

Price \$2.00

WADE & WADE, 3807 Lake Park Ave., Chicago, Ill.

Victrola Newspaper Advertisements That Produce

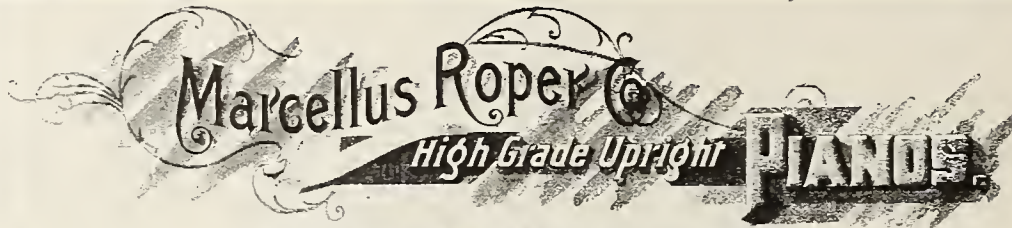

PIANOS, PLAYER PIANOS, VICTROLAS
284 MAIN STREET,

Worcester, Mass. February 27,
1918.

One
Advertise-
ment
Did It

Lyon & Healy,
Wabash Avenue,
Chicago, Ill.

Gentlemen:-

We want to tell you how pleased we are with your advertising co-operation. We have made frequent use of your suggestions, and used your copy and illustrations with gratifying results.

A short time ago we used one of your small ads, which appeared four times. Within the next few days we sold forty-four pianos that were directly traceable to this advertisement.

In our opinion, your advertising service cannot but be a great help to any piano merchant who avails himself of it.

With kindest regards, I am

Your sincere,

Marcellus Roper Company.

President.

MR/K

Sold
44
Pianos

Lyon & Healy Victrola Newspaper Advertisements are equally productive. 52 advertisements per year complete for \$8.33 per month. Half Service at Half Price.

Other Lyon & Healy advertising services are a monthly Container which replaces envelopes for mailing the Victor monthly supplements.

Illustrated Victor Record Window Display Cards.

A Small Instruments Newspaper Advertising Service. 36 advertisements per year for \$4.17 per month.

Piano Newspaper advertising service 48 cuts per year complete. Free to Lyon & Healy Piano Dealers.

WRITE FOR SAMPLES

Lyon & Healy
Victor Distributors
CHICAGO



(Actual Size)
LAKESIDE ROTOMETER. RETAIL PRICE \$2.50
 Calibrated so swinging arm is level with pointer at 78 revolutions per minute.
WRITE FOR PARTICULARS
 Patents Pending

LAKESIDE SUPPLY CO., Inc.
 Tel. Harrison 3840
 202 South Clark Street CHICAGO, ILL.

NOW PLAYS ALL RECORDS IN ONE POSITION
JUMBO
LAKE SIDE TONE ARM 4

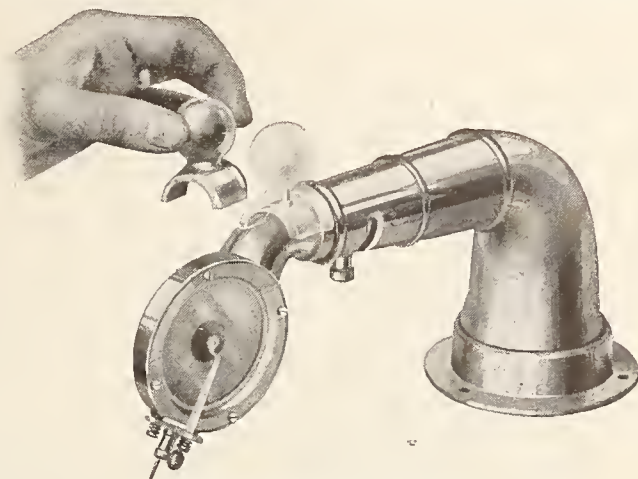

RETAIL PRICE \$7.50 EACH
 Prices to Bona Fide Dealers
 Sample\$4.00 each
 Lots of 6 to 11..... 3.75 each
 Lots of 12 to 49..... 3.50 each
 Lots of 50 to 100..... 3.25 each
 A further slight reduction on yearly contracts in 100 minimum lot shipments.
 PATENTS APPLIED FOR

FROM OUR CHICAGO HEADQUARTERS—(Continued from page 81)

ing Brunswick phonographs which they are supplying to their dealers. The advertisements contained in this portfolio are furnished free to Brunswick dealers and can be used exactly as they are written or can be changed at will by the dealer. Suggestions for a follow-up campaign of advertising by the dealer are printed in the back of the book, where several samples of leaflets pertaining to the new Ultona reproducer are tipped in.

Business Increasing

When called upon by The World this month, R. F. Morenus, president of the Morenus Piano Co., stated that although they had but recently moved to larger quarters at 342 West Huron street, from present indications they will have to make a further enlargement. "We have been growing very fast of late," he declared, "and have been putting on more help and turning out more material than we ever d'd, but we are finding that more space is necessary. The trade thinks very well of the results obtained through the unique and special construction of our horn and tone chamber and the workmanship and finish of our talking machines are given the same care and attention as those of the pianos we turn out, that is, they receive first-class piano finish."

Deserved Promotion

Fred E. Reid, who for five months worked in this territory for the Thomas Mfg. Co., makers of motors and parts, Dayton, Ohio, made such an excellent showing that President Matthews has made him general sales manager of the company with headquarters at the factory at Dayton, O. Mr. Reid left early this month to resume his new duties, but not until he had appointed a successor in the person of N. S. Richmond. Mr. Richmond will have his headquarters in the recently opened offices on the tenth floor of the Republic Building and will have the title of Western sales manager. He will visit the trade in Chicago and contiguous

territory. He has considerable experience in the talking machine industry and has a technical knowledge of motors and everything entering into the construction of talking machines.

Empire Window Trims

The Empire Talking Machine Co. of this city have had prepared for them several very beautiful window trims, which they are prepared to furnish Empire dealers. These trims were prepared in response to numerous requests from Empire dealers all over the country for something individual and distinctly characteristic. John H. Steinmetz, president of the Empire Co., stated that the policy of co-operation existing between his company and his dealers has been meeting with marked success and that these new window displays which he has had prepared are receiving much favorable comment.

The impressive illustration shown herewith is a photograph of the window trims which were prepared especially for the formal opening of the Troup Bros. new store, 34 Market street, Lewistown, Pa. This store was thrown open to the public on April 1, and the display as shown in the illustration attracted much attention, as the art work was beautifully colored and harmonized with the Empire talking machines to the fullest degree. This new store of the Troup Bros. is under the personal supervision of Manager W. S. Lewis, who is enthusiastic over the

tonal qualities and values of the Empire machines.

In addition to the window trim which was used at the opening of the Troup Bros. store a special concert was arranged under the supervision of A. R. Mitchell, of Williamsport, Pa., the Empire representative in Pennsylvania. This concert was held on Tuesday evening, April company with headquarters at the factory at



Empire Window Trim Used by Troup Bros., Lewistown, Pa.

2. in Troup Bros.' recital hall. Miss Emma Keiss, soprano, was accompanied by Empire record selections played on the Empire talking machine. At the conclusion of this concert both Mr. Mitchell and Miss Keiss left for Greenburg, Pa., where Miss Keiss will be heard in another similar concert at the Porch Bros., Inc., establishment on April 5. A series of concerts will be

(Continued on page 85)

TRANSFER NAME-PLATES

We make the Transfer Name-Plates and Trade-Marks for the largest talking machine manufacturers in this country and for dealers in every state.

YOUR NAME, Mr. Dealer, on every machine brings the owner back to you for records and his friends to you for a machine.

Samples, Suggestions and Sketches Furnished Free

THE MEYERCORD COMPANY, CHICAGO

Largest Manufacturers of

DECALCOMANIA

Transfer Name-Plates

The Brunswick

ALL PHONOGRAPHS IN ONE

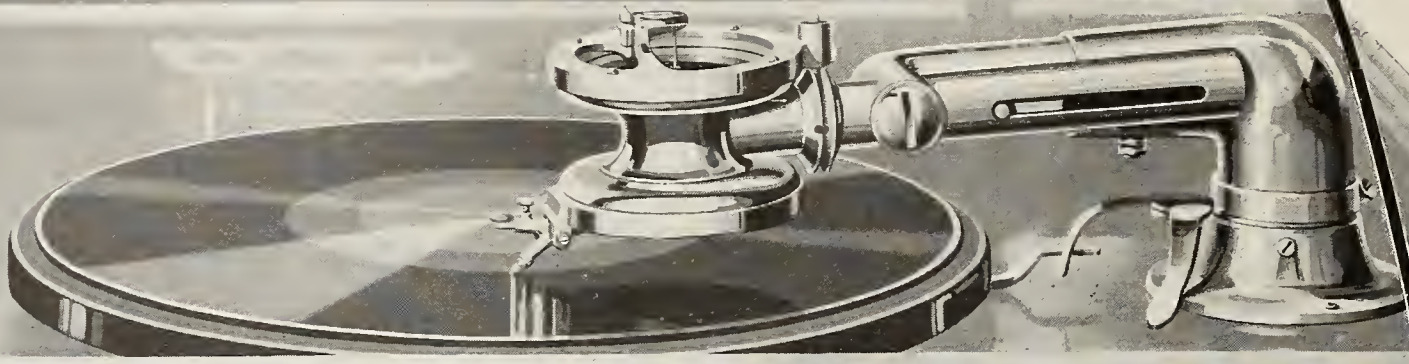

The Ultona

Now! The Final Achievement

Brunswick introduces a new Method of Reproduction, a real sensation

HERE, at last, is the supreme phonograph achievement of recent years . . .

The Brunswick Method of Reproduction.

It includes two distinctly new improvements, two inventions that absolutely revolutionize old standards.

Some maker was bound to build this ultimate phonograph, freed from ancient handicaps.

The honor has come to The House of Brunswick, a pioneer in developing the all-record idea. The first Brunswick met with phenomenal success, showing that we might spend thousands of dollars in perfecting this idea.

Better Than Ever

Now, with the new Brunswick Method of Reproduction, distinctly new, we offer a super-phonograph.

It not only plays *all* records, but plays them at their *best*.

This is accomplished chiefly by The Ultona, our new all-record reproducer, and the new Brunswick Tone Amplifier.

Tone values are now given a naturalness hitherto unattained. Some of the gravest problems in acoustics are solved.

The Ultona is an amazingly simple contrivance. It plays all records according to their exact requirements. The proper diaphragm is presented to each record, whatever make, and the exact needle, the exact weight.

So you see that this is not a makeshift, not an attachment, but a distinctly new creation.

Simplicity Itself

At the turn of a hand you adapt The Ultona to any type of record. A child can do it. It is practically automatic.

Now your library of records can be bought according to your favorites. For instance, each record maker has a famous tenor. On a one-record instrument you are confined to one. Others are barred. And who likes to be restricted? Who wants to be confined to buying from only one catalog, when there are several from which to choose?

The Ultona, we think, is the greatest feature offered any music-lover. And it is obtainable *solely* on the new Brunswick.

Another vast improvement in tone projection comes in our all-wood Tone Amplifier, built like a violin. All metal construction is avoided, thus breaking away from the usual custom.

Wood, and *rare* wood at that, is the only material that gives sound waves their proper vibration. With The Ultona and the new Brunswick Tone Amplifier, phonographic art is brought to higher standards.

See and Hear

You cannot afford now to make a choice until you've heard the latest Brunswick. Until you become acquainted with The Brunswick Method of Reproduction. Until you hear this marvelous instrument.

You are invited particularly to examine The Ultona and note how simply it adapts itself to each type of record.

Once you hear the new Brunswick, you'll be delighted and convinced that this super-phonograph is in a class heretofore the ideal, but unattained.

All you want in any phonograph is found in this composite type. Plus superiorities not found elsewhere.

A Brunswick dealer will be glad to play this super Brunswick for you and explain the new Brunswick Method of Reproduction.

Brunswick Models—Price \$32.50 to \$1,500

THE BRUNSWICK-BALKE-COLLENDER COMPANY

Canadian Distributors:
Musical Merchandise Sales Co.
Excelsior Life Bldg.
Toronto

General Offices: Chicago

Branch Houses in Principal Cities of the United States,
Mexico and Canada

Dealers:
Write for our Profitable Plan
with all the details

(1147)

DEALERS:
This ad appears in the
SATURDAY EVENING POST
April 6

FROM OUR CHICAGO HEADQUARTERS—(Continued from page 83)

given by Miss Keiss under the supervision of Mr. Mitchell at various other Empire establishments throughout that territory in the near future.

Notable B. & H. Fibre Needle Month

March came as a surprise to the B. & H. Fibre Needle Co. It was not only one of the best months they have had for some time in point of orders actually shipped, but they entered April with a gratifying amount of unfilled business on their books. In their viewpoint the trade, as shown by the demands from their jobbers all over the country, is in excellent shape, at least the fibre needle is in steadily increasing demand.

Notwithstanding the conditions produced by the war the company is in excellent shape so far as supplies are concerned and is getting shipments of the finest quality of bamboo it has ever had both from Japan and India. They have recently received samples of some very excellent bamboo grown on the Governmental experimental plantation in Porto Rico. Mr. Hall's test of the quality of this bamboo produced very excellent results and would indicate that a new source of supply is available in this direction.

Talks on Conditions

When called upon by The World this month H. B. Bibb, sales manager of the talking machine division of the Brunswick-Balke-Collender Co., stated: "Our factory is making a tremendous effort to supply us with machines, but the shortage of competent mechanics, finishers, etc., is a serious handicap, and for that reason we are advertising for expert cabinet finishers and mechanics in all parts of the country. In order to meet the demand and relieve the strain put upon both our Muskegon and Dubuque factories, we have made arrangements to equip our large plant in Chicago with the necessary utilities for manufacturing talking machines. This building covers an entire block on Orleans and Huron streets and is located in the heart

of the manufacturing district on the north side of Chicago. It is but a few minutes' ride from the loop, and it will, therefore, be convenient for out-of-town visitors, as well as for shipping goods. This building takes up a hundred thousand square feet of floor space and will be in full running order within the next thirty days. It will be equipped so as to turn out at least ten thousand machines for the balance of this year.

"Our new Ultona reproducer is going over in great shape, and the matter of properly serving our established dealers is occupying practically our entire time, as we have made some very important contracts lately. J. E. Anderson, of Saginaw, Mich., is one of the dealers in his part of the country who is now handling the Brunswick exclusively. Other dealers who have taken on the Brunswick within the past week are the American Furniture Co. and the T. P. Pattison Music Co., both of Denver, the Wilbur Templin Music Co., of Elkhart, Ind., and Herb & Kalmer, of Sandusky, O., the leading department store."

Joliet Visitor

Geo. Wiswell, of the West Music Co., Joliet, Ill., spent several days in Chicago this week. Mr. Wiswell is a brother of L. C. Wiswell, manager of the wholesale Victor department of Lyon & Healy. Mr. Wiswell stated that they are "doing things" down in his town, and that the only trouble they are having at present is the shortage of records.

Empire Phono Parts Co. Literature

The Empire Phono Parts Co., of Chicago and Cleveland, have issued a beautiful little leaflet dealing with the Empire universal tone arm and reproducer. This leaflet contains three illustrations of the Empire products and is arranged in a very attractive manner, the wording being very brief, but to the point. It contains the story of the Empire tone arm and sound box and deals with the attractiveness of design of these phono parts in a manner which appeals to the manufacturers in many ways.

Two of the three illustrations presented show the tone arm in a position for playing lateral cut records and the other position shown is that of the reproducer turned back to permit the insertion of the needle. It is stated that when in this position the cover of the cabinet may be lowered without striking the needle point. This throw-back position appeals particularly to the purchaser, as it eliminates all chances of injury to the record and insures that the sound box is always in a correct position for playing.

Brunswick Man to Army

H. E. Nelson, advertising manager of the Brunswick-Balke-Collender Co., left Chicago April 2, bound for Portland, Me., where he entered the U. S. Aviation Training School for Mechanics. Several other boys from the Brunswick Co. were also called to the colors and left during the week for various training camps throughout the country.

Having Vacations

C. L. Davidson, of the Talking Machine Shop, in an interview with The World this month, stated that the stock was coming in in fine shape and that they were enjoying a very good business. "The first of our girls started their vacation last month, when Evelyn Brackenridge left for Saginaw, Mich., to visit her mother. She will be gone for the whole month. Ruth Hartman, also of our sales forces, took a two weeks' vacation the first of April." Mr. Davidson stated that his brother, G. W., took a little flying trip to the Victor factory about two weeks ago and from there went down to Philadelphia to visit his relatives. He was accompanied on the trip by Mrs. Davidson.

Six Best Sellers

Edison announce the following as the six best sellers for the month: "U. S. Army Camp Songs," "Bungalow in Quogue" and "Just a Voice to Call Me, Dear," "Leave it to Jane" and "Siren's Song," "Jack O'Lantern Fox-trot" and "Knit, Knit, Knit," "That's Why My Heart is Calling"

(Continued on page 87)

Empire
—the Machine
that Plays
any Record

**This Machine Will Bring
You Wonderful Results**

The many features embodied in the Empire machine have made it wonderfully popular and all of our dealers are selling a great many of them at the present time. The Model B as illustrated represents the biggest value ever offered in a talking machine retailing at that price.

The Empire line comprises nine beautiful models. Each one is equipped with universal tone arm which plays all makes of records. Motors are all smooth running and powerful. Prices at retail from \$27.50 to \$215.00.

We also make a complete line of Empire records which retail at popular prices. Dealers interested in putting in a line of machines and records should write for our exclusive agency proposition.



Model B.
\$110

Write us for "Dorothy" Booklet

EMPIRE TALKING MACHINE COMPANY

JOHN H. STEINMETZ, President

429 SOUTH WABASH AVE.

CHICAGO, ILL.

Why MANDEL SERVICE is a guarantee of sales

Dealers have learned the advantage of handling the MANDEL LINE of superior Talking Machines because they are made in their entirety *under one roof*—a guarantee of uniformity throughout.

THE MANDEL LINE of Talking Machines is sold on a written guarantee for *service* backed up by one of the most efficient up-to-date factories in existence. A fitting assurance of its superiority.

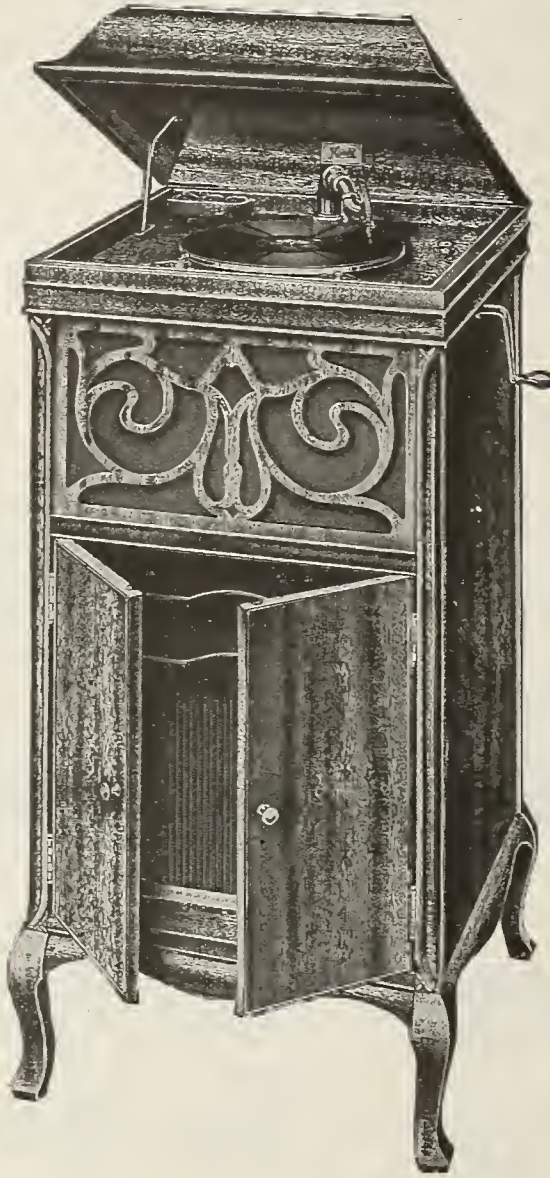

This is our handsome Model No. 3 Machine.

Note our plan of sending it on FREE TRIAL

In quality, workmanship and richness of tone MANDEL TALKING MACHINES measure up to the highest accepted standard, yet in price are within the reach of the most modest purse.

The Mandel Talking Machine is the Machine "Without a come-back." Its standardized make-up assures service even under the stress of severe usage.

Our co-operative plan to dealers is the biggest inducement ever offered by any reliable talking machine line. We not only help *sell* our line but *help dealers buy it*.

Send to-day for details of this unique plan—it is "opportunity pounding on your door"

MANDEL MANUFACTURING CO., Inc.

CHICAGO

501-511 Laflin Street

NEW YORK

41 Union Square

FROM OUR CHICAGO HEADQUARTERS (Continued from page 85)

You" and "Will You Remember," "Naval Reserve March" and "Spirit of America."

Six best Victor sellers for the month are: "Id' Like to be a Monkey in the Zoo" and "Go-Zin-To," "Are You from Heaven" and "Give Me the Right to Love You," "Just a Baby's Prayer at Twilight" and "On the Road to Home Sweet Home," "Tickle-Toe" and "Going Up," "The Lord is My Light," "I Puritani."

The six best Pathé sellers for the month are: "Romeo et Juliette," "Can't Yo' Heah Me Callin'," "Caroline?" and "Little Alabama Coon," "Sweet Little Buttercup" and "In Berry Pickin' Time," "Homeward Bound" and "When the Boys from Dixie Eat the Melon on the Rhine," "A Baby's Prayer at Twilight" and "Valley Rose," "Liberty Bell" and "There's a Million Heroes in Each Corner of the U. S. A."

Columbia Graphophone Co. announce for the past month the following six best sellers: "Long Boy" and "For You a Rose," "Darktown Strutters' Ball" and "I'm All Bound Round With the Mason-Dixon Line," "What 'Til the Cows Come Home" and "Somewhere in France Is the Lily," "Do Something" and "Liberty Bell," "Hello, My Dearie" and "Ching Chong."

Resting Up

C. E. Goodwin, general manager of the Phonograph Co., recently left for Hot Springs, Ark., for a two weeks' resting period. Mr. Goodwin has been very active for the past several months and thought that this time of the year would be beneficial to his well-being. He is expected to return to Chicago on Monday.

Ryde Visits

Joseph Ryde, formerly assistant manager of the Victor department of Lyon & Healy, but now of the Fuller-Ryde Music Co., of Indianapolis, was a visitor to Chicago for several days last week. Mr. Ryde has a partnership in the firm of Fuller-Ryde and stated that he likes the new field. "Business is very favorable in our territory," said Mr. Ryde, "and the trade is keep-

ing us mighty busy. We are having some very good sales. I expect to permanently locate in Indianapolis in the fall, when I will move my family and belongings from Chicago to that progressive city.

Move to New Quarters

The Automatic Container Co., manufacturers of the automatic record filing device for talking machines and who are producing an extensive line of record cabinets and carrying cases incorporating this feature, have moved their general offices and warerooms from the Tacoma Building to more centrally located quarters at 506 Republic Building. The company is constantly adding to the number of talking machine manufacturers who are adopting their device and the sale of cabinets is continually increasing. The company is arranging for exclusive wholesale agencies in various parts of the country. They recently made the Phonograph Clearing House, Inc., at 51 East Forty-second street, New York, their representatives in that city. H. E. Taylor, formerly superintendent of the Jacko Furniture Co., of Buffalo, will represent the Automatic Container Co. in western New York. The company will have an exhibit at the National Music Show to be held at the Grand Central Palace in New York the first week in June.

Will Represent Widdicomb Line

H. P. A. Mossner, a piano and talking machine man of wide experience, has secured handsome warerooms at 532 Republic Building. The warerooms are immediately opposite the elevator and with its handsome crystal front constitutes one of the shops for which the building is noted. Mr. Mossner will have the Chicago wholesale representation for the Widdicomb phonographs, made by the Widdicomb Furniture Co., of Grand Rapids, Mich., and will shortly have a complete line of these beautiful machines in the various period styles on display for the benefit of visiting dealers. He will

also handle a line of pianos made by the Chute & Butler Co., of Peru, Ind., and an extensive line of talking machine accessories.

Chicago Headquarters for Puritan Phonographs

What may be properly termed one of the most important news items of the month is the closing of a deal by which James B. Orth secures the wholesale representation for the Puritan phonographs and records of the United Phonographs Corp., of Sheboygan, Wis., for Illinois, Indiana, Michigan, inclusive of the upper peninsula and Missouri. Offices and demonstration rooms have been secured at suite 422 Republic Building, where a complete line of Puritan phonographs and records will be carried for the inspection of the trade. Mr. Orth is a successful Chicago business man of years of experience and is a brother of C. J. Orth, well-known piano and talking machine dealer of Milwaukee, who, by the way, has recently become distributor for the Puritan line for Wisconsin and the upper peninsula in Michigan. Mr. Orth will have a valuable assistant in Miss Helen Essen, a young woman who has been associated for some years with leading talking machine concerns in Chicago, and who will be the "campaign manager," doing some traveling and giving dealers the benefit of her experience in demonstrating and selling.

New Mandel Model

The Mandel Mfg. Co. are out with a new member of the Mandel talking machine line. It is known as Model No. 5 and is a full cabinet machine, forty inches in height, retailing at the moderate price of \$65. The company state that it has the same high-grade equipment which characterizes the other models and has been produced to meet the demand for a cabinet machine selling at a lower price than the other models. The company has also inaugurated a very extensive dealers' co-operative service, consisting not only of attractive advertisements for inser-

(Continued on page 89)

The Empire Tone Arm and Reproducer



Patent Applied For

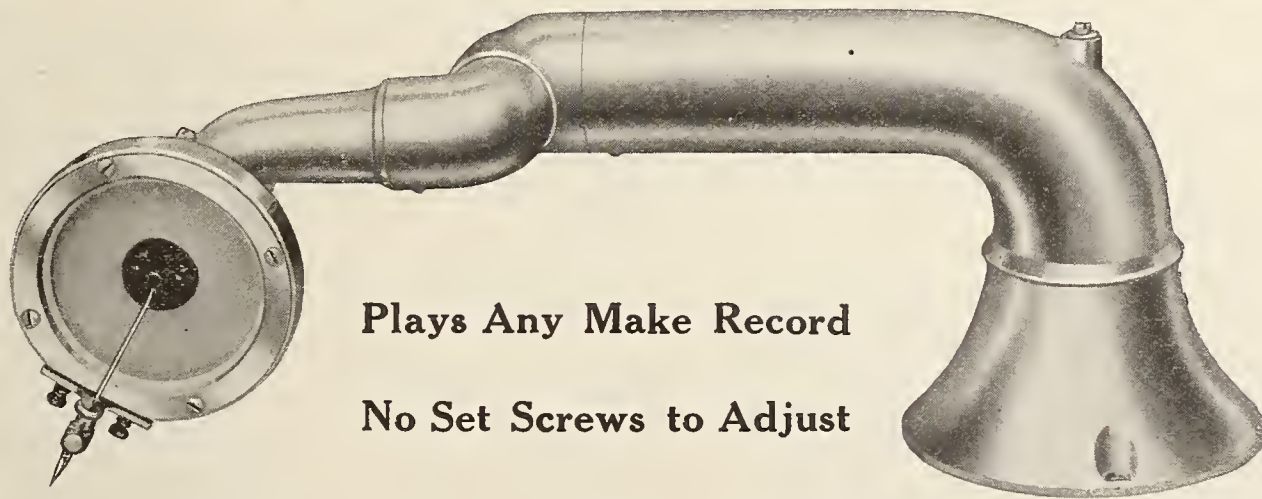

Plays Any Make Record

No Set Screws to Adjust

The Empire Universal Tone Arm will appeal to the talking machine manufacturers because it possesses wonderful tonal qualities and because it will add distinction to their machines.

The Empire Reproducer has been pronounced by competent critics to be the best sound box on the market. It is adjustable to any position without the use of set screws and the throw back position for inserting needle will appeal particularly to the retail purchaser.

The Empire Tone Arm and Reproducer can be furnished in several lengths, and in ordering samples state measurements from center of turntable shaft to center of horn hole on motor board. Made in both nickel and gold plated finish.

Write for Descriptive Circular and Prices

Address all inquiries to our Chicago office

THE EMPIRE PHONO PARTS CO.
Sales Office, 427 South Wabash Ave., Chicago, Ill.

Factory:
1102 West 9th St.
Cleveland, Ohio

The Scotford Tonearm And Superior Universal Reproducer

Perfect in acoustics—affording supreme quality and volume of tone

Handsomest and most distinctive in design and finish

The Reproducer that pivots on its axis, taking the correct angle for all makes of Records—and retains the same center in both positions—which feature, as shown below, is covered by United States Letters Patent, Number 1,251,828

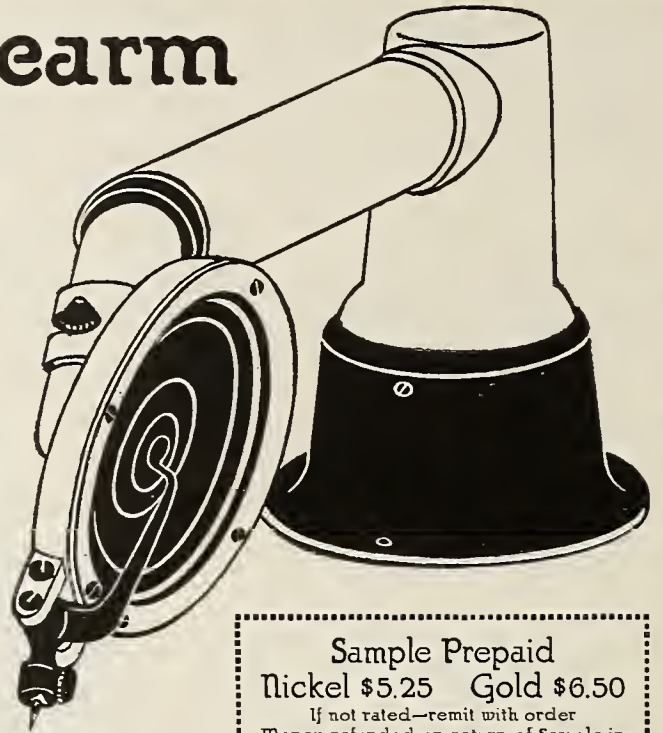

Sample Prepaid
Nickel \$5.25 Gold \$6.50
If not rated—remit with order
Money refunded on return of Sample in good condition within 30 days

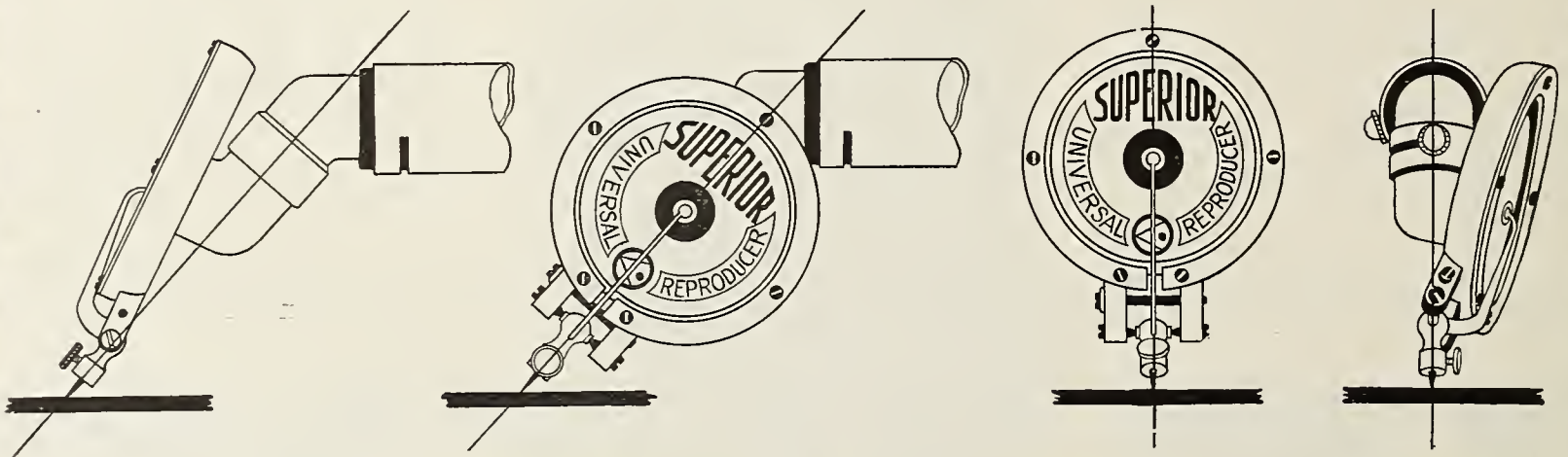

And this is but one of the Patented features which make it the Superior Universal

Mills & Cooper
Manufacturers of Mills Gramophones
2725 Calumet Avenue
Chicago

Barnhart Brothers & Spindler,
Chicago.

Sirs: We should like to have you share with us the enthusiasm that comes from hearing the Superior Reproducer at its best. We have completed our experimental work and have placed the Mills Gramophone on the market. As you know, we are using the Superior Reproducer and we consider it head and shoulders above anything made.

We have been experimenting for more than a year and have tried almost every combination under the sun. We like the Superior better than any other we tested and with it have been able to get probably the best reproduction ever attained.

It is only proper here to mention the intelligently rendered service which goes to users of your product. Your Mr. Louis K. Scotford has helped us immeasurably by his interest and suggestions. We have developed an amplifier which brings out the more subtle tones and gets the expression of the original with a character and musical ring we have never heard in another machine.

The Mills Gramophone is made in small quantity only for the higher class trade. It has made a profound impression among the music lovers who have heard it, and especially among those who do not care for the usual colorless phonographic results. It is absolutely toneless—that is it has no flavor of its own to mar the beauty of the original tones in the records. Our idea is that a phonograph has about as much business with tone as a cup has with flavor. With this idea in mind we have worked until we now have an instrument which will play every make of record better than the machines of the record manufacturers. The improvement is so marked in some cases as to be almost uncanny.

Respectfully, Mills & Cooper.
By G. K. Mills.

March 30, 1918

To Jobbers and Dealers in Edison, Pathe and Other Hill-and-Dale Records

You can greatly increase the demand for your Records by selling these Reproducers and Attachments applying them to various standard machines. Write for quantity prices Liberal Arrangement for Jobbers

The Superior Universal Reproducer

	Sample Prepaid	Retail Price
With Attachment for Victor	Nickel \$4.10 Gold 5.00	\$6.50 8.00
With Attachment for New Victor	Nickel 3.50 Gold 4.25	5.50 6.75
With Attachment for Columbia	Nickel 3.70 Gold 4.55	5.35 7.25
With Attachment for Edison	Nickel 4.10 Gold 5.00	6.50 8.00
With Attachment for Pathe	Nickel 3.70 Gold 4.40	5.35 7.00

The Scotford Model I Reproducer

The original Scotford Reproducer—plays only Hill-and-Dale Records, but plays them at their best

	Sample Prepaid	Retail Price
As is—it fits the Victor	Nickel \$3.50 Gold 4.10	\$5.50 6.50
With Attachment for Columbia	Nickel 3.75 Gold 4.45	5.35 7.00
With Attachment for Pathe	Nickel 4.05 Gold 4.75	6.35 7.50

Can be used on the Edison with the Kent Attachment

*This refers to the latest type having the enlarged Tonearm



Barnhart Brothers & Spindler

Monroe and Throop Streets
Chicago

Makers of Superior Specialties for Phonographs

FROM OUR CHICAGO HEADQUARTERS—(Continued from page 87)

tion by the dealer in his local paper, but an excellent window display and direct mailing material of a forceful nature. The company has also lately put into effect a liberal selling plan which is proving very interesting to the trade and resulted in adding a number of good dealers to the Mandel Co.'s list of important representatives.

W. E. Cotter Now General Manager

W. E. Cotter, who for the past few months has been in charge of the retail talking machine department of Thos. E. Wilson & Co., has been made general manager of the entire talking machine division and will have charge of both the wholesale and retail departments. Mr. Cotter

stated that they are getting out a new line of talking machines, embracing six new models and all models to be in three different woods. Preparations are being made for elaborate wholesale display rooms in connection with the retail department at 42 South Wabash avenue. Mr. Cotter is assisted in the wholesale department by Miss Mabel Winchell, formerly of the Talking Machine Co., of New York. Miss Winchell, who will act in the capacity of secretary, will assist Mr. Cotter in entertaining visiting dealers to the wholesale department. He is assisted in the retail department by Miss Hazel M. Walker, who will have entire charge of the retail end of this business.

defeat of 30,000 Huns and saving the lives of 30,000 American boys.

"The Playerphone dealers who buy direct from the Playerphone Talking Machine Company, and not through our jobbers, should establish the Liberty Bond and Thrift Stamp Fund at the rate of \$2 instead of \$1 for each Playerphone, in order to maintain the \$3 standard and help reach the \$30,000 Playerphone Liberty Bond and Thrift Stamp campaign.

"We sincerely hope and believe that our Playerphone jobbers and dealers will join us in the Playerphone Liberty Bond and Thrift Stamp campaign, as Uncle Sam must win, or the Playerphone business can not continue. This also applies to your other lines of business."

A PIONEER IN THE CHICAGO MARKET

D. W. McKenzie, President of Playerphone Talking Machine Co., Among First to Realize Trade Possibilities in That Section—Plan to Help Liberty Bonds and Thrift Stamps

CHICAGO, ILL., April 8.—D. W. McKenzie, president and general manager of the Playerphone Talking Machine Co., was among the first Western men to perceive the advantage offered by Chicago, the "great central market," for the manufacture of talking machines. Associated with him in this enterprise is D. D. Caldwell, one of Oklahoma's most enterprising citizens, and vice-president of the State National Bank of Oklahoma City. This company, of which Mr. McKenzie is the head, has become a very strong factor in the trade and is marketing its product through many of the largest jobbers and dealers, whose strength and extent of operations in itself is evidence of the recognition of the company's product as one of merit and of stability.

The Playerphone line embraces no less than nine cabinet machines ranging in price from \$65 to the beautiful \$500 White House model. Just as the country has inaugurated the third

Liberty Bond campaign, Mr. McKenzie has made an announcement which is as timely and generous as it is unique. It is to the effect that the Playerphone Talking Machine Co. will establish a Liberty Bond and Thrift Stamp fund on the first of each month, according to the amount of Playerphones shipped the previous month, one dollar being placed to the credit of this fund for each Playerphone shipped from March 1, 1918, until the close of the war. Further details of the plan are contained in a leaflet which is now being sent to the trade and which runs as follows:

"Every Playerphone jobber is cordially invited to participate in this Playerphone Liberty Bond and Thrift Stamp campaign by establishing a fund similar to the Playerphone Talking Machine Company's plan and placing one dollar to said fund for each Playerphone sold, and to invite their dealers to whom they sold Playerphones to do the same.

"Therefore, if this plan is followed out and complied with, by the time the Playerphone reaches the customer there will be \$3 worth of Liberty Bonds or Thrift Stamps bought. If 10,000 Playerphones are sold during the year it will mean \$30,000 worth of Liberty Bonds or Thrift Stamps purchased and possibly mean

ANNOUNCE A NEW TONE ARM

Barnhart Bros. & Spindler Offering Scotford Tone Arm and Superior Universal Reproducer to the Trade—Some Features

CHICAGO, ILL., April 10.—Barnhart Bros. & Spindler announce to the trade this month that they are now in a position and are offering to the trade their Scotford tone arm and Superior universal reproducer. Both the reproducer and the tone arm are the inventions of Louis K. Scotford. In breaking away from the general design of tonearms, Mr. Scotford has confined his experiments to the well-founded fact that tone waves act upon the same principle as light waves, i. e., traveling in a straight line until they meet some obstruction from which they are deflected at right angles. Having in mind the well known laws that a straight line is the shortest distance between given points and that sound waves are deflected at right angles, Mr. Scotford set out to produce a tone arm that would embrace both of these laws and as a result the tonearm which is being manufactured by Barnhart Bros. & Spindler is char-

(Continued on page 90)

Superior in Quality—Prompt in Service!

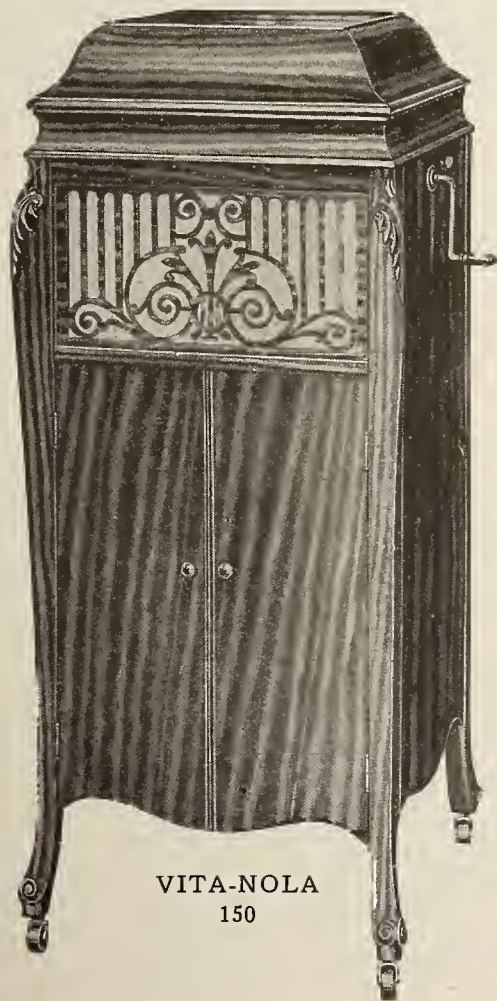

VITA-NOLA
150



MARK OF QUALITY

Write for our dealers proposition

VITANOLA TALKING MACHINE COMPANY
501-509 WEST 35th STREET
CHICAGO, ILL.

NOW that you've taken the trouble to turn this magazine over so that you could see the large cut of

THE CHICAGO COVER

BALANCE No. 1

to better advantage, you have accomplished something. You have enhanced your memory. That's psychology. Equip your machines with our cover support and your customers will be better satisfied. That's business. Think it over.

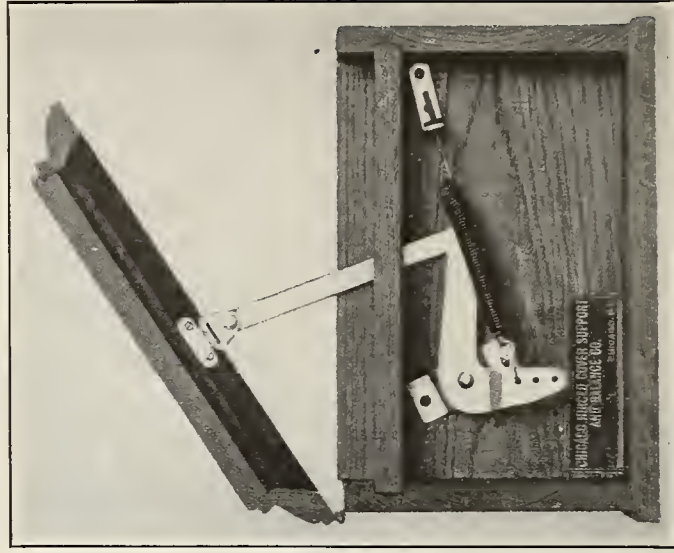

(Pat. Applied For) COVER BALANCE No. 1

Chicago Hinged Cover Support and Balance Co.

2242-44 W. 69th St. CHICAGO, ILLINOIS

FROM OUR CHICAGO HEADQUARTERS—(Continued from page 89)

acterized by being angular instead of curved, the result being that the tones are given the shortest possible route over which to travel from the sound box to the amplifier. This has the effect of giving the sound produced the seeming point of origin directly in front of the machine instead of the muffled unnatural sound within the machine. This, as can be seen, adds volume to the tone owing to the short distance through which the tone must travel. In producing the superior and universal reproducer, Mr. Scotford has gone off the path generally followed and has produced a sound box which is carried above the record at a slight angle instead of a vertical line as is generally the case. To bring the vertical line into play, which is necessary for playing the record, the needle is also placed in the clip which is built at an angle; the result being that the point of the needle is directly centered no matter in what position the sound box is placed. This sound box has many interesting features embodied in it. Mr. Scotford has also produced a tone amplifier which is made of especially prepared composition. This amplifier is also worked out on the law of angles, the throat being very short and set on a right angle with the body of the amplifier. The sound waves coming down into the throat do not vibrate the amplifier in the least, Mr. Scotford's idea being that the sound vibrations be reflected back

into the air column, thereby giving more volume and throwing the tone out of the machine in its entirety.

R. M. McArthur, of Barnhart Bros. & Spindler, stated that they had gone slow in announcing their Scotford tone arm and Superior universal reproducer to the trade because they wanted to have it perfected to the highest degree and be in a position to meet the demands of the trade. The desired result of perfection having been obtained and enough material on hand to produce the goods in order to meet the demand that would be put upon it by the trade the formal announcement was made. "We have been sending out samples for some time and have been receiving many interesting letters from those to whom we have sent the samples," stated Mr. McArthur. The following letter was received from Alfredo L. Demorest, vice-consulado del Paraguay, Wilmington, Delaware:

Gentlemen: I consider the Superior universal reproducer and tonearm the best leader made; they are, in fact, above all competition. Your reproducer gives a depth of sound that is so wonderful that all other sound-hoxes that I have ever heard seem obsolete. Besides this marvelous depth and warm richness of tone, it has the great advantage of a surprising musical volume. In all makes of records overtones and undertones never before heard with other reproducers are brought out with pure, crystal-like clearness. Your reproducer, turning with absolute correctness upon your ideal tonearm, places the needle in exactly the right angle for either the lateral or vertical cut

records. Your Superior universal reproducer and tonearm is the only outfit of its kind that, to my knowledge, will safely play the vertical cut records without skidding across the record which causes a jewel point to dig into the record and ruin it. This is impossible with your reproducers as they, in position for playing hill-and-dale records, take the grooves at the only correct angle. Other makes of reproducers slant too much, therefore there is always the tendency for them to slip from the groove and skid. All that I have said of the Superior is also true of the Scotford Model I, that wonderful reproducer of yours that, with its large diaphragm, plays the vertical-cut records with so great and beautiful a tone. Though I am not in the talking machine business, being a writer and artist, aside from consular duties, I have made a deep study of phonograph parts, also experimented a great deal, from pure love of the thing. I even have made sound-hoxes, or reproducers after my own ideas. I am considered an expert on sound-reproduction. I have sixteen different reproducers fitted to my talking machine, but I know that for perfect articulation, beautiful tone and volume, your sound-hoxes and tonearm have no equal.

Wilmington, Delaware. Vice-Consulado del Paraguay. ALFREDO L. DEMOREST,

A BIG VITANOLA SELLER

Model No. 150 a Great Favorite With the General Trade of the Country.

CHICAGO, ILL., April 6.—The Vitonola Talking Machine Co. report that the No. 150 Vitonola

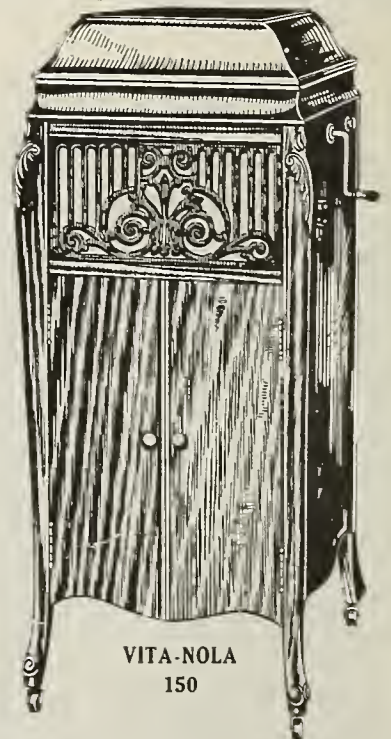

VITA-NOLA 150

which is herewith illustrated is proving one of the biggest sellers on the line of new models which they have recently put on the market, and in fact is the biggest seller they have ever had. It is an extremely attractive instrument in exterior appearance and stands 50½ inches in height. It is very symmetrically designed with massive carvings at the top and bottom of the legs. It contains a double spring motor of unusual strength and accuracy of operation which winds for eight records. The tone arm and sound box are of special design and of the company's own creation. One of the minor

Presenting the Puritan



In our new demonstrating rooms, 422 Republic Building, Chicago, we are now showing the Puritan Phonograph, the instrument of new and exclusive features.

Service is our slogan. And we are equipped to render active and immediate service to all dealers in Michigan, Indiana, Illinois and Missouri territory.

Write, wire or 'phone for full particulars regarding the PURITAN and PURITAN RECORDS — or, better still, come in.

James B. Orth

Special Representative

UNITED PHONOGRAPHS CORPORATION

422 REPUBLIC BUILDING

Phone Wabash 7630

CHICAGO

FROM OUR CHICAGO HEADQUARTERS—(Continued from page 90)

features which yet adds one to the many talking points of the machine is the tilting motor board, which gives easy and instant access to the motor. Another detail which many dealers will appreciate is that the sound chamber is finished in harmony with the exterior of the case. It is equipped with horizontal felt-lined shelving. No. 150 is supplied in either golden or fumed oak or in mahogany.

NEW LINE OF MACHINES AND CASES

Lakeside Supply Co., Inc., Offering Cases Woven of Luxfibre Which Are Distinctly Attractive in Appearance—Company Also to Market a New Jumbo Tone Arm

CHICAGO, ILL., April 10.—The Lakeside Supply Co., Inc., of 202 South Clark street, this city, are just ready to put on the market a brand new line of talking machines and cases. These cases are made up of what is known as Luxfibre, which can be woven into the most artistic patterns, as is shown by the illustration. Unlike reed or rattan it does not crack or break in making short curves or bends, it is claimed.

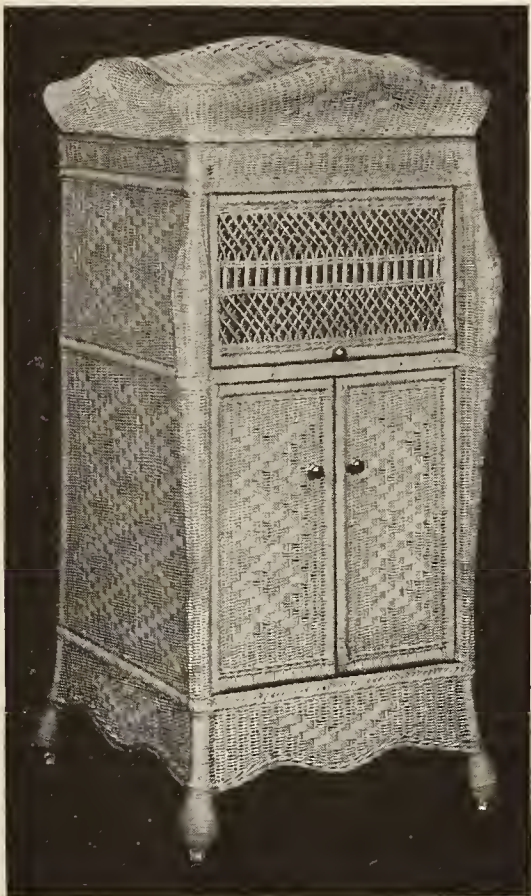

The Luxfibre Case

The cases are finished in old ivory, mission, oak, chocolate brown, frosted ebony and frosted brown. However, they can be produced in almost any shade desired to match the surroundings.

It takes an expert weaver from four to six days to weave the cases. They are then well sized, next given a spray of the finish desired and then two spray coats of spar varnish. The Lakeside Supply Co. does not specialize in making completed phonographs, as it furnishes all parts to manufacturers and assemblers, but in marketing the Luxfibre machines they are not competing with any one, as these cases are distinctive and not being sold by the trade generally.

The Lakeside Supply Co. expect to put on a man to handle the Luxfibre line exclusively and introduce it to the trade.

Another important announcement from the Lakeside Supply Co. is the fact that they have just developed their new No. 4 Jumbo tone arm to play all records in one position without any appreciable loss in quality or volume. This means absolutely no shifting or moving of arm or sound box for playing any disc record. The company have worked very hard for a number of months and now believe they have a thoroughly practical combination. Patents have been applied for.

METAL SPECIALTIES CO. ORGANIZED

Benton Harbor Concern to Have Capital Stock of \$60,000 in Their New Enterprise

BENTON HARBOR, MICH., April 9.—The Metal Specialties Co., of this city, have been organized with a capital stock of \$60,000 and have purchased and fully paid for a substantial two-story factory building and are now preparing to produce talking machine motors, tone arms and other specialties. The officers are Wm. R. Everett, president; A. R. Knight, vice-president, and Milton Hinckley, secretary and treasurer.

President Everett, whose inventions the company will manufacture, is a man of long experience in the talking machine and supply business and was formerly the Western representative in Chicago of the Crescent Talking Machine Co., of New York. Added to his experience in the talking machine business, he has had fifteen years' experience in the manufacturing line. He is a mechanical engineer and a member of the Society of Automobile Engineers. In speaking of the company's product Mr. Everett says:

"You may state that our motor is not a radical departure in any way from accepted engineering practice, but on the other hand it is not a copy, nor yet an 'improved modification' of any existing type of motor. Our use of worm and spiral gears with one jack shaft only, and this set at an original angle, is an invention. Our use of a vertical governor and with solid links instead of the usual spring weight links, while an invention, is nothing more or less than good mechanics.

"I think we are the only people in the United States using the galvanic copper process for the making of tone arms. In the first place, the copper metal itself is resonant and has a real musical tone. In the second place, the use of this process enables us to make tone arms without extravagant tool cost. In other words,

Why Break Records? Just File Them!

That is if you have the wonderful Record filing system which is a feature of

The Marvelous MAGNOLA



Watching the Music Come Out

This is only one feature of many that will command your interest and attention. Let us send you handsome illustrated catalog and information as to our plans for helping you to make money with MAGNOLA.

MAGNOLA TALKING MACHINE COMPANY

OTTO SCHULZ, President

General Offices
711 MILWAUKEE AVENUE
CHICAGO

Southern Wholesale Branch
1530 CANDLER BLDG.
ATLANTA, GA.

each phonograph manufacturer can have his own exclusive design of tone arm and at practically competitive prices with other processes and without tool cost."

G. T. Williams, popular Brooklyn Victor wholesaler, is back at his desk after a well-deserved rest down South.

Different—But Practical

The MORENUS Phonograph is a Distinct Departure from a Tonal Viewpoint

The horn, which is entirely of wood, is built on the principle of the saxophone and enters the tone chamber at the *bottom*, not the top. The tone is big and full but mellow, and the reproduction of the artist's voice or instrument is faithful to an unusual degree.

Among the other features is a unique tone moderator which actually graduates: an exceptionally high grade and acoustically correct tone arm and reproducer, and a cover support which makes handling the lid a delight.

The case designs are *right* and the cabinet work and finish unexcelled.

The MORENUS is in 3 STYLES

- A. OAK, - - 48 inches high. Retail price, \$110
- B. MAHOGANY, 48 " " " " 125
- C. OAK and MAHOGANY, 50 inches high, Retail price, - - - - 150

*Very liberal discounts to the trade
Send for our new descriptive catalog*



Style B

The MORENUS PIANO CO.

342 West Huron St.

CHICAGO, ILL.

FROM OUR CHICAGO HEADQUARTERS—(Continued from page 91)

MAKING CABINETS EXCLUSIVELY

Wm. A. Johnson, Now Owner of the Northwestern Cabinet Co., Is a Progressive

MENOMONIE, Wis., April 6.—Really no one could conceive of a better location for a cabinet factory than this city. It is located right in the heart of the big lumber industry and from the roof of any of the factories one can see the forests whose product is continually going through the mill rooms in Menomonie.

Wm. A. Johnson, who recently acquired the interest of his former associates in the Northwestern Cabinet Co., is now the entire owner of that business and is devoting himself exclusively to the manufacture of cabinets for talking machine manufacturers. He is a man of long experience in the making of pianos and talking machines and has built up an excellent business since he became a part of the industrial activities in Menomonie. He is himself a skilled designer and is prepared to submit special de-

signs for cabinets as well as to make them after the ideas of others. He also has facilities for installing the working parts of machines into the cabinets if the customer so desires. The factory is excellently located, being near the junction of the Chicago, Milwaukee & St. Paul and Chicago & Northwestern railroads, and therefore enjoys unusual shipping facilities. Mr. Johnson is a brother of Henry G. Johnson, vice-president and superintendent of the Holland Piano Mfg. Co., and the two men have become dominating influences in the business life of this thriving city because of their goaheadness.



W. A. Johnson
ident and superintendent of the Holland Piano Mfg. Co., and the two men have become dominating influences in the business life of this thriving city because of their goaheadness.

Equip Your Phonographs With Perfect Automatic Brakes

Samples \$1.00 Each
Cash with order

State make of tone arm used



Easy to Operate

Patented Aug. 28, '17

Simple construction and easily attached. Made in four styles to fit any make of tone arm.

Write for attractive quantity price

PERFECT AUTOMATIC BRAKE CO.
Room 400, 425 S. Wabash Ave., Chicago

WIDDICOMB POPULARITY

Line of Phonograph Made by Grand Rapids House Grows in Trade Favor

GRAND RAPIDS, MICH., April 9.—The Widdicomb Furniture Co. is meeting with excellent success with the Widdicomb line of phonographs, which have attracted great attention in the trade because of the unusual character of the beautiful period designs and of the high-class construction and tone qualities. E. C. Howard, the manager of the phonograph department, says that they are shipping goods just as rapidly as they are completing them, and that they are straining every effort to give their dealers prompt satisfactory service.

SAFELOWERS MAKE A BIG HAUL

Get Much Cash, Liberty Bonds and Notes at Collister & Sayle Store in Cleveland

CLEVELAND, O., April 8.—Safeblowers early this morning broke open the store of the Collister & Sayle Co., 252 Superior avenue, dealers in Victor talking machines and records. The safe was wrecked with nitroglycerine and \$700 in cash and \$500 in Liberty Bonds and \$10,000 in promissory notes stolen. The robbery was discovered by a porter when he opened this store. W. F. Sayle, treasurer of the company, said he thought the above items would cover the loss. The store is in the very heart of the shopping section, directly across the street from the post office. The robbers cut a hole through the rear wall. After blowing the safe they dragged the loot to a vacant room and sorted it. There is no clue.

NEW AGENCIES FOR THE BRUNSWICK

New York Office of Brunswick-Balke-Collender Co. Opens Number of New Accounts

Among the new agencies for Brunswick phonographs recently opened by the New York office of the Brunswick-Balke-Collender Co., is included the firm of Anderson & Duchene, Torrington, Conn. The formal opening of the new department, in charge of J. J. Brophy, of the Brunswick Co., was quite an event, and was heralded by liberal advertising. The company is composed of Victor Anderson and Rene Duchene, both experienced talking machine men.

The Brunswick phonograph was also recently placed with Simon Bersin, a well-known piano dealer at 410 Grand street, New York.

Chester Abelowitz, of the Brunswick Co., is now in Trenton during the recital week held at the warerooms of the Hurley-Tobin Co., of that city, and who carry the Brunswick line.

Very enthusiastic reports have been received during the past week from John Duncan, manager of the Brunswick department of the Gamble-Desmond Co., of New Haven. Mr. Duncan reports that sales have been fine recently.

Hiawatha Phonographs AND Hiawatha Success



STYLE 100

In the past two years HIAWATHA dealers have realized that the HIAWATHA Phonograph has enabled them to sell a Phonograph to their trade, the Quality of which they can guarantee with every assurance that it will reflect credit to the reputation they have established for square dealing and their motto of "Quality First".

HIAWATHA Phonographs mean Success which has been established by their wonderful Quality of *Tone*, *Construction* and *Finish*. The same opportunity is waiting for you. Write today and let us prove that your initial order will not only be satisfactory, but a good investment.

Models \$40, \$60, \$85 and \$115 Retail

Tone chamber made of genuine Spruce. No metal.
Cabinets made of 5-ply stock. Construction guaranteed.
Motors and equipments, using double spring motors, highest standard of Quality.
Electric motor \$25.00 extra.
Tone modifier, built in as part of the machine, not an attachment. Patent applied for.
Plays all records with the same attachment.

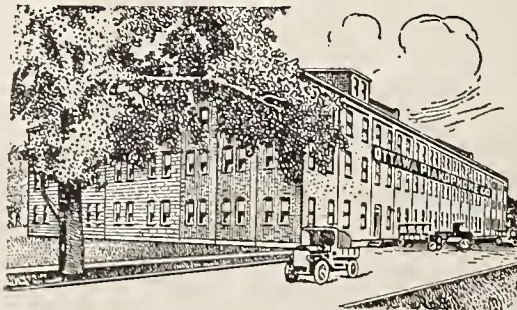

The Home of Hiawatha
"All Orders F. O. B. Factory"

OTTAWA PIANOPHONE COMPANY

City Address: 802 Republic Building, Chicago, Ill.

Wouldn't a fresh, tailored, new Spring dress for your window help your sales? The Columbia Dealer Service Department has one all ready for you. Ask for it. It's to be had for the asking.

**Columbia Graphophone Co.
Woolworth Building, New York**



NEW MODEL OF PURITAN PHONOGRAPH READY FOR MARKET

Handsome Machine, Designed on the French Baroque Order, Embodies the Various Distinctive Puritan Features of Construction, Including the Long Horn—New Distributors

The United Phonograph Corp., makers of the Puritan phonograph and records, Sheboygan, Wis., are just putting on the market a new design of the Puritan phonograph, illustrated elsewhere in this issue, and which is calculated to attract instant attention because of its uniqueness as well as artistic symmetry and gracefulness. It is on the French Baroque order and with its utter distinctiveness, curved surfaces and exquisite veneers, handsome hand carvings, heavy base and carved feet, is bound to be considered an artistic triumph. The design, by the way, has been patented. A notable feature of all Puritan phonographs is the long horn built entirely of wood and extending from the tone arm to the tone chamber at the bottom of the cabinet. It has only one bend and closely resembles an organ pipe in construction. Unusual resonance and beauty of tone are claimed as a result of this construction. The drop door at the base gives egress to the tone and operates as a modifier, being manipulated by a button at the side of the machine near the crank handle and can

be set at any angle desired. While the tonal idea was the desideratum in the horn construction and the location of the tone chamber, the consequent position of the record compartment in the upper part of the cabinet is another advantage, as it gives most convenient access to the records. The United Phonographs Corp. is a subsidiary of the the great Wisconsin Chair Co., of Port Washington, Wis., a million dollar concern, and has the advantage of practically unlimited manufacturing facilities. The line of cabinet machines is extensive, meeting the demand of practically all classes of the trade as to price. The men at the helm have high ideals as to the maintenance of a high quality standard in everything they produce.

The company has recently made Charles J. Orth, of Milwaukee, distributor for Wisconsin and the upper peninsula of Michigan, while J. B. Orth, who has just opened warerooms in the Republic Building in Chicago, has for his territory Illinois, Indiana and Michigan with the exception of the upper peninsula.

NEW HOME FOR PENN PHONO. CO.

Well-Known Victor Wholesalers of Philadelphia Lease Large New Building on Arch Street

PHILADELPHIA, PA., April 8.—The Penn Phonograph Co., the well-known Victor wholesalers at 17 South Ninth street, has signed a lease for the modern fireproof building at 913 Arch street, and will move to that location some time in June. The building is a four-story and basement structure. The exterior is as unusually striking in appearance as the interior is complete and practical. The expanding business of the company has made this change necessary. The company believes the future of the business means much greater things than in the past and is preparing for the expansion when it comes.

GUEST OF PHILADELPHIA DEALERS

T. J. Leonard, General Sales Manager of the Musical Phonograph Division of Thomas A. Edison, Inc., Speaks at Regular Monthly Meeting of Philadelphia Edison Dealers

PHILADELPHIA, PA., April 4.—The guest of honor at the regular monthly meeting of the Philadelphia Edison dealers held at the Hotel Bingham on Tuesday of this week was T. J. Leonard, general sales manager of the musical phonograph division of Thomas A. Edison, Inc. H. E. Blake, of Blake & Burkart, acted as chairman and introduced Mr. Leonard, who spoke on general business conditions. Supervisor Gardiner, of the Edison house, was also present at the meeting.

The big majority of the dealers present reported a large increase for March, 1918, over the same month 1917, and Mr. Somers, of Starr & Moss, reported that their company had an increase of 177 per cent. for the month of March. Many of the dealers present declared that they would be present at the coming Edison dealers' convention which will be held in New York on June 6 and 7.

Milton Isaacs, son of Joseph Isaacs, Victor dealer of 176 Sixth avenue, New York, and who is well known in the local trade, went to Camp Upton on April 4 to join the National Army.

WATCHING CARY BILL CLOSELY

Talking Machine Dealers and Others Selling on Instalments See Genuine Danger of Measure Designed for District of Columbia

WASHINGTON, D. C., April 6.—The thing of interest to local music trade men, as well as members of the trade throughout the country, outside of war troubles, is the progress made by the Cary bill, a measure introduced by Representative Cary of Wisconsin, and designed to put heavy burdens on dealers selling merchandise on instalments.

As the measure now stands, it requires a payment of a license fee of \$200 by every merchant who is engaged in the instalment business, under a plan whereby he retains title to an instrument until the full purchase price has been paid. The bill applies only to the District of Columbia, but it is realized such measures in the National Capital are frequently accepted as models to be followed by legislatures in various States and cities.

If this Cary bill, which provides among other things that no merchant shall make a profit of more than 30 per cent. of the actual cost price of any article sold, should be copied in various States of the Union it is easy to foresee the predicament of the merchants who have testified under oath that their cost of doing business is in excess of 30 per cent. Such irksome restrictions as the requirement of annual reports on all business done would be bad enough, but the particularly perilous feature of this amazing bill is the restriction under which no sale greater in amount than \$200 can be made to any one person under a license for instalment sales.

In its original form the bill provided that a purchaser might sue and recover any profit made by the dealer in excess of 30 per cent. of the original cost of the article. In its amended form, however, the bill provides that the buyer can, in addition to recovering the excess profit, recover a credit on the principal amounting to one-quarter of that principal. On the whole, the Cary bill is regarded as a most pernicious piece of legislation.

A violation of the act would be construed as a misdemeanor punishable by a fine of not less than \$5 nor more than \$500, or, by imprisonment for not less than five, nor more than thirty days, or by both fine and imprisonment. George W. Pound, counsel and general manager of the Music Industries Chamber of Commerce, who has been in Washington several days recently, has opposed the bill very strongly, and the National Association of Talking Machine Jobbers has filed a strong protest, as have other trade organizations, whose members are liable to be affected by the provisions of the act.

"MAGNET" DECALCOMANIE NAMEPLATES
FOR TALKING MACHINE CABINETS ETC.

Pamphlets with fac-simile illustrations and prices mailed on request.

SMITH-SCHIFFLIN CO.
126 Liberty Street New York City

From the **DORAN CO.**
115 MICHIGAN AVE.
DETROIT

SOLD BY **HURTEAU WILLIAMS & CO.**
MONTREAL — OTTAWA

Kunkel Piano Co.
BALTIMORE

FROM **THE PHONOGRAPH CO.**
1240 HURON ROAD (1st floor)
PHONES - PROSPECT 2140 - CENT 1404
CLEVELAND

SOLD BY **WALTER D. MOSES & CO.**
Oldest Music House in VA. and N.C.
103 E. BROAD STREET
RICHMOND, VA.

SOLD BY **J. E. STRATFORD**
AUGUSTA, GA.

PROGRESS OF NATIONAL MUSIC SHOW

Prominent Talking Machine Concerns Arrange to Take Space at Big Exhibition to Be Held at Grand Central Palace, New York, in June

Plans for the National Music Show, to be held at the Grand Central Palace, New York, on June 1 to 8 inclusive, are progressing most satisfactorily, and a large part of the available exhibit space has already been taken by prominent concerns in various branches of the music trade.

In keeping with the times, the patriotic spirit will be much in evidence at the show. It will be opened by Governor Whitman, of New York, and various representatives of the United States Army and Navy have promised to be in attendance, if the opportunity presents itself.

Conducted on Co-operative Basis

With a view to making the National Music Show co-operative it has been decided to hold it under the auspices of the Music Trade Exhibitors' Association. Each manufacturer who engages space automatically becomes a member of this association without expense or liability of any kind beyond the amount of space engaged, and he will participate in any surplus remaining after expenses are paid in proportion to the amount paid for space. This co-operative spirit has been the nucleus for the holding of a number of very successful industrial expositions throughout the country and it is safe to assume that this plan will work out unusually well for the National Music Show.

The show committee includes representatives of all the various branches of the music industry, the talking machine trade being represented by William Maxwell, vice-president of Thomas A. Edison, Inc., and H. L. Willson, general manager of the Columbia Graphophone Co. Charles H. Green is the general manager of the show, and has at his command experience gained through conducting several similar exhibitions in the past. Walter T. Sweatt is manager of the exhibits.

Will Dispel Gloom and Doubt

It is expected that the National Music Show will be the year's greatest dispeller of gloom and doubt. It will start off with a high keynote of optimism, which will sound throughout the music trade and will reach beyond to revivify general business conditions. It is generally realized that it is more important to hold a show during a period of depression than when all lines of business are active and when optimism reigns supreme. Panics and hard times

are psychological—at least they are largely due to doubts and uncertainty. The visible evidence of confidence and activity presented by the music industry will react on the minds of the whole public and will re-establish waning confidence. The vitality and the firm foundation of America's music industry will be proved conclusively by the forthcoming show, which will be a reply to the many false reports that the industry was in the non-essential class. There never has been a year when the need for music was so important as now.

Without a doubt the Music Show will be the most unique of any exhibition ever held in Grand Central Palace so far as the individual displays of the exhibitors are concerned. Each exhibitor will have a distinct display of his own, so constructed as to be soundproof.

The talking machine companies who will exhibit at the show include Columbia Graphophone Co., New York; Thomas A. Edison, Inc.,

Orange, N. J.; Otto Heineman Phonograph Supply Co., New York, and the Pathé Frères Phonograph Co., Brooklyn, and others.

There will be a number of conventions held in New York during the week of the show, including the annual gathering of the Edison dealers at the Waldorf-Astoria. The National Piano Manufacturers' Association, the National Association of Piano Merchants, and the National Piano Travelers' Association, will also hold their conventions in New York during the week.

All the money taken in at the door for admissions, and it is expected to be a large amount, will be devoted entirely to the purchase of musical instruments, records, etc., for the men in the service. Moreover, all those who bring a new or used talking machine record as a contribution for the use of our soldiers and sailors will be admitted to the show without further charge.

INCREASE DELIVERY EQUIPMENT

C. Bruno & Son, Inc., Put New Truck Into Service for Metropolitan District

C. Bruno & Son, Inc., 351 Fourth avenue, New York, Victor wholesalers, have just added to



Latest Addition to Delivery Equipment of C. Bruno & Son, Inc.

their delivery equipment a handsome Ford-Dearborn truck, which is shown in the accompanying illustration. The body of this truck, which is a dark blue with the lettering in gold, presents a very attractive appearance. The truck is utilized for metropolitan deliveries, and has contributed materially to the efficiency of C. Bruno & Son's delivery system.

Germany is listening—make your money talk—buy a Liberty Bond.

SUCCESS OF THE BUTTERFLY MOTOR

Leonard Markels Planning Factory Expansion to Take Care of Increasing Demands

Leonard Markels, 165 William street, New York, motor manufacturer, states that during

the past month or two he has received very large orders for the Butterfly motor which he introduced last year, and which has achieved remarkable success in the comparatively short while it has been in the market. The Markels factory is working to capacity to turn out this motor, and plans are now being formulated

whereby the factory output will be materially augmented during the course of the next month or two.

Mr. Markels states that this motor has been adopted for exclusive use by prominent manufacturers throughout the country, who are pleased with its distinctive merits, and who are equipping their machines with this motor, in order that their dealers may have convincing sales arguments for their product.

It is probable that in the near future Mr. Markels will have some significant announcements to make regarding the perfection of several important new models which will be added to his line as quickly as possible.

PLAN EXHIBIT OF RECORD MAKING

One of the features of the National Music Show to be held at the Grand Central Palace, New York, on June 1 to 8, will be the exhibit of the Pathé Frères Phonograph Co. This company plans to install a complete record-making plant in its booth, to show the public how records are recorded and pressed. The exhibit will be under the direction of H. N. McMennen, managing director of the Pathé Co., and not only will the pressing equipment be installed at heavy expense, but an orchestra and a galaxy of recording artists will be on hand to give demonstrations. The Pathé Co. installed a record-pressing plant in their exhibit at the Music Show in Chicago last year, and it was one of the big attractions of the show.

"NICHOLSON" New Catalog Showing New Styles RECORD CABINETS

strictly high-grade construction at prices
BELOW COMPETITION

Write for a copy of the catalog and our
special free advertising help for dealers.

K. NICHOLSON FURNITURE CO. Chase City,
Virginia
Sectional Bookcases and Record Cabinets



Diaphragm

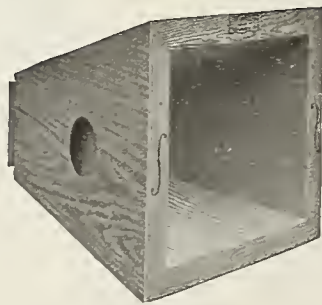

Amplifier

The
Phon d'Amour



Reproducer

Must Be Heard To Be Appreciated

Fritzsches patents have given to music lovers a triumph of artistry and craftsmanship. To be satisfied with a phonograph other than the *Phon d'Amour* is to be content with something less than the final achievement in phonographs. You should see the *Phon d'Amour* and have its wonderful patented features explained to you. Hear it play, then compare it. Plays records of whatever make.

THE FRITZSCH PHONOGRAPH COMPANY

228-230 W. Seventh St.

CINCINNATI, OHIO

First Presentation to the Trade—the PURITAN

THIS great instrument embodies the most striking discoveries that have come into the talking machine industry since tone reproduction was first invented. These discoveries are exclusive features—giving the dealer a series of *new*, powerful and definite selling arguments found in no other phonograph made. And, in addition, you have the Puritan Records, made by us.

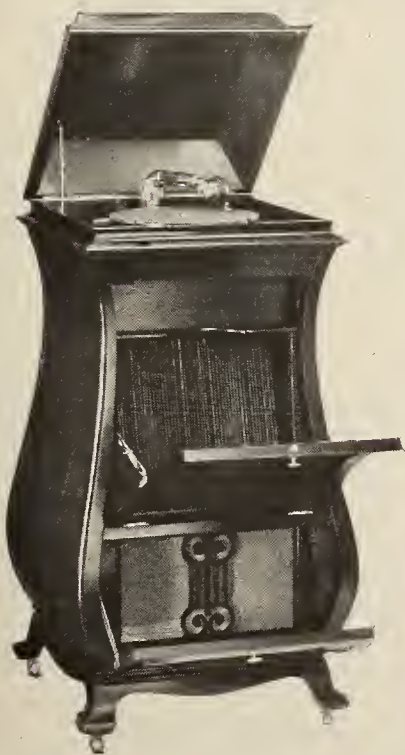

THE LONG HORN, extending the full height of the instrument, from tone arm at the top to the sound chamber at the bottom, gives a fullness, richness and life-like quality of tone absolutely unheard of in reproduced music. The horn is of saxophone design and entirely of wood. With the sound chamber at the bottom, the sound waves *rise* to where you stand or sit. The graceful convex cabinet design is another exclusive and patented Puritan feature.

The long horn extends from top to bottom

The Puritan plays any disc record. Prices range from \$85 to \$350. Write or wire today for full details of our attractive proposition on Puritan Phonographs and Puritan Records.

UNITED PHONOGRAPHS CORPORATION
SHEBOYGAN, WISCONSIN



REPAIRS

TALKING MACHINE TROUBLES AND
HOW TO REMEDY THEM

Conducted by Andrew H. Dodin

[This department of The Talking Machine World is designed for the service of all classes of our readers, including those who make, and those who sell, talking machines. Andrew H. Dodin, who conducts this department, has a wide and enviable reputation as a repairer of talking machines and conducts an exclusive talking machine repair shop at 176 Sixth avenue, New York. Tell him your troubles through The World and he will help you if possible. The service is free.—Editor.]

A SLIDING SAPPHIRE BALL

Repair Department,

Talking Machine World:

I have a talking machine with so-called Universal tone arm, which plays all styles of records. When I place the sapphire ball needle in the sound box and try to play the Pathé records, the sapphire always slides out of the groove of the record. Can you tell me what the trouble is?

S. R. A.

ANSWER.—Your trouble without doubt is in not having the sapphire ball at the proper angle to the surface of the record. Try bending the sapphire holder out at an angle of about 45 degrees and then place it in the sound box with the sapphire pointing up. This will bring the ball at about the proper angle when placed on the record.

Regarding Motor Knocking

The Talking Machine World:

Could you suggest a way to overcome the following troubles which I am having with my Victrola? While playing it often makes a loud knocking noise in the motor, and while it used to play five records with one winding it now has to be wound up after playing one record.

Miss J. K.

ANSWER.—The knocking is caused by lack of graphite mixture on the main spring. If the machine will only play one record no doubt one

of the main springs is broken which prevents the full winding of the motor.

Adjusting the Speed Indicator

Editor Talking Machine World:

Can you tell me through your Repair Column the cause of the following trouble with my talking machine? When playing a record at the proper pitch of voice the pointer on the speed adjuster points to 60 instead of 78, as the instruction book with the machine says it should. How can I fix pointer so that it will point to the 78 mark on the regulator dial when machine is playing 78?

I. C.

ANSWER.—There are several styles of dials and regulators used on talking machines. As a rule, there is an adjusting screw either on the bottom or top of the dial, and by screwing in or out with this screw, the position of the governor lever rod is changed and the speed of the motor is adjusted accordingly.

EDISON BOOK OF INTEREST TABLES

Harrison Durant, financial supervisor for Thomas A. Edison, Inc., has just completed a very valuable book, including the interest tables to be used in connection with Edison phonograph deferred payment sales. In this connection it might be of interest to say that the Edison Co. was the first phonograph company to demand that dealers charge interest on deferred payment sales, and this book of interest tables was prepared as a ready reference and information chart, and it is certain that the demand for the book will be very general.

A NEW LINE OF TALKING MACHINES

C. John A. Woods & Son, 30 Church street, New York, well known in expert circles, have just placed in the market a new line of phonographs, which will be known as the "American Maid" phonograph. This machine is being manufactured in six different models, retailing from \$17.50 to \$150, and each model is equipped

with a universal tone arm, which plays all makes of records without any attachment. The concern is not only planning to develop an export demand for this instrument, but is also making arrangements to take care of an active domestic trade. Mr. Woods has already established important expert connections, and expects to announce in the near future a number of domestic agencies for the "American Maid" phonograph.

SENDING TRUCKS FOR VICTROLAS

I. Davega, Jr., Inc., Haul Machines From Victor Factory to New York in Their Own Motor Trucks to Overcome Transportation Delays

The motto of the firm of I. Davega, Jr., Inc., 125 West 125th street, appears in their various communications and advertisements and is "The House of Service." How well this motto has been lived up to is shown in the steadily increas-



New Delivery Truck of I. Davega, Jr., Inc. ing growth of their wholesale Victor business.

The freight delays arising from the crowded conditions of the railroads during these war times have been a source of much annoyance and loss of profit to the dealers. To overcome this difficulty in some measure, I. Davega, Jr., Inc., are now sending their auto trucks down to Camden at regular intervals to get their Victrolas and supplies. These trucks are spacious and will hold as many as forty Victrolas at one loading. Another truck is now nearing completion for this service.

TEN INCH

OPERAPHONE RECORDS

HILL AND DALE

DOUBLE DISC

RETAIL AT 75 CENTS

ARE NOW READY FOR IMMEDIATE SHIPMENT

Order Now!

A Splendid Catalogue, Standard Selections, Comprising All the Best Sellers

Instrumental Solos, Trios, Symphony Orchestra, Bands, Standard Vocals, Duets, Quartets, Dance Records and all the latest popular songs, including *all the big war-time hits*.

With Operaphone Records on hand to demonstrate with, you can sell your line of machines. Operaphone 10-in. records play on all universal tone arm machines with steel needles, which follow the line of least resistance.

Operaphone Records are known from coast to coast and are on the market to stay. New numbers every month.

Send for samples and special terms to dealers. Monthly booklets and window hangers supplied with orders.

OPERAPHONE CO., Inc.

CREEK AND MEADOW STREETS

LONG ISLAND CITY, N. Y.

"Does It Play All Records?"

Certainly MAGNOLA does; and without any extra attachments, too. This is only one feature, albeit a most important one, in the thoroughly up-to-date equipment of the MARVELOUS MAGNOLA.

MAGNOLA "Built by Tone Specialists"



Watching the Music Come Out

May we send you our handsome illustrated catalog chock full of information concerning the wonderful construction system of Magnola and the beauties of its musical results, its artistic appearance and its moderate price?

Send your name and let us tell you more!

MAGNOLA TALKING MACHINE COMPANY

OTTO SCHULZ, President

General Offices
711 MILWAUKEE AVENUE
CHICAGO

Southern Wholesale Branch
1530 CANDLER BLDG.
ATLANTA, GA.

SUGGESTS NEW RECORDING SYSTEM

Henry G. Rhodes Would Use Film Instead of Circular Record and Record Tones of Each Instrument or Each Voice Separately

Henry G. Rhodes, of Whiteville, Tenn., in a letter to The World suggests that the conventional record be done away with and that a specially prepared paper, a little wider than a movie film, be substituted for recording purposes. Explaining his idea, Mr. Rhodes says:

"If a quartet and orchestra were to make a record, let there be five recorders mounted on a rigid frame so as to be exactly parallel; each diaphragm to vary in thickness. The bass singer would have his horn and separate recorder—as bass vibrates slowly his diaphragm should be thicker than even the baritone. The tenor of course vibrating very fast, should have a thin diaphragm. The orchestra would have a horn and record to themselves—possibly two horns to take in all of it.

"The four singers and the orchestra would sing and play separately each to their appropriate diaphragms—each in a separate room so that their respective recorders would record only their voices or music. Then when this record was to be reproduced, each stylus would track the original groove, using a diaphragm of the exact thickness as the recorder that made that especial groove. This tape would be moved much like a moving picture machine film, from one reel on to another. The five reproducers to be mounted so they would touch the tape about where the conventional phonograph's reproducer is.

"The tape would move under these reproducers at about one hundred feet a minute. Thus one diaphragm would not have to vibrate with so many and varied pitches."

ENLARGING THEIR DEALER CLIENTELE

PITTSBURGH, PA., April 10.—The Pittsburgh Pathéphone Co., of this city are enjoying a most prosperous spring season. They are gradually enlarging their line of dealers, among the most recent being Samuel Levi & Co., Portsmouth, Ohio; the Preston Piano Co., Ashland, Ky., and Anderson & Newcombe, Huntington, W. Va. Manager Brennan announces the opening of a new repair and adjustment factory for the convenience of his trade. It is connected with the Pathé Shop on Liberty avenue.

ANOTHER FEIST MUSIC CAMPAIGN

Prominent Publishers to Carry New Copy in Saturday Evening Post at an Early Date—All Advertisements Planned to Stimulate Record Sales as Well as Music Sales

Leo Feist, Inc., the well-known publishers of popular music who from time to time have used space in The Talking Machine World describing to the dealers in this industry the cooperation they offer them in handling Feist songs of the moment which have been recorded by the leading record manufacturers, have again brought to the trade's attention their advertising co-operation in this issue. Throughout the past two years the house of Leo Feist, Inc., have run advertisements in mediums of national circulation inducing the public to buy their songs and in every case they also stated that the numbers could also be secured for the talking machine and player-piano.

Not only does the firm carry on a national advertising campaign in behalf of their songs, but they also see to it through their various branch offices, located in the larger centers of the country, that their songs are sung in vaudeville and played in the moving picture houses, cabarets, and by the dance orchestras in almost every city. This is done by the traveling representatives of the firm working from the cities.

In an announcement to appear in an early issue of the Saturday Evening Post, which is reproduced on another page of this paper, the House of Feist will feature three of their new songs, all of which have already been given public approval. The numbers are entitled "I'm Sorry I Made You Cry," "Belgian Rose" and "Just Like Washington Crossed the Delaware, General Pershing Will Cross the Rhine." The advertisement will also include mention of all the active numbers in the Feist catalog.

PATENTS REPLAYING DEVICE

Patents covering a replaying and repeating device for talking machines has been granted to the Rev. John Prout, of this city. The device described in this patent allows of the complete control of the replaying of the record or the repeating of parts of the selection from various parts of the room without other exertion than a slight pull on a cord. The action is so simple that various persons who have seen this device have marveled that it was not used before.

EXECUTIVE COMMITTEE TO MEET

Governing Body of National Association of Talking Machine Jobbers to Hold Session in Philadelphia to Discuss Conditions

President J. Newcomb Blackman, of the National Association of Talking Machine Jobbers, has called a meeting of the executive committee of that organization for April 22 and 23, at the Ritz-Carlton Hotel, Philadelphia. The committee will discuss primarily the effect of the latest war conditions on the trade, and endeavor to devise ways and means whereby through cooperation between the wholesalers and the Victor factory the conditions can be met and overcome. The talking machine men realize that they must make sacrifices as a result of the country being in the war, but feel that there are ways of adjusting their businesses so that the burden may be carried as lightly as possible. At the meeting in Philadelphia plans will also be discussed for the annual convention of the association to be held in Atlantic City in July.

The members of the executive committee are: President, J. N. Blackman, Blackman Talking Machine Co., New York; vice-president, I. Son Cohen, Cohen & Hughes, Baltimore; secretary, Jos. C. Roush, Standard Talking Machine Co., Pittsburgh; treasurer, A. A. Trostler, Schmelzer Arms Co., Kansas City; W. D. Andrews, W. D. Andrews Co., Syracuse; J. F. Bowers, Lyon & Healy, Chicago; A. A. Grinnell, Grinnell Brothers, Detroit; George Mickel, Mickel Bros. Co., Omaha; Andrew McCarthy, Sherman, Clay & Co., San Francisco; E. C. Rauth, Koerber-Brenner Co., St. Louis; W. H. Reynolds, Reynolds Music House, Mobile; E. F. Taft, Eastern Talking Machine Co., Boston; C. A. Wagner, Musical Instrument Sales Co., New York; P. B. Whitsit, Perry B. Whitsit Co., Columbus; and Rudolph Wurlitzer, R. Wurlitzer Co., Cincinnati.

NOW IN TALKING MACHINE TRADE

Harry Jasper, formerly sales manager at the factory warerooms of Paul G. Mehlin & Sons, prominent piano manufacturers of West New York, N. J., is now conducting a Victrola store in Englewood, N. J., under the store of the Franklin Parlors. Mr. Jasper also conducts Jasper's Orchestra, a well-known musical organization which last week provided dance music at the dinner of the Talking Machine Men, Inc.



Victor Records

To Victor Retailers:

Here are a few good records which we have in stock for immediate delivery.

35351	64759	74336
35615	74163	74499
55066	74180	74510
64732	74197	74534
	74562	

Try us on a stock order

I. DAVEGA, JR., INC.

Victor Factory Wholesalers

125 WEST 125th STREET

NEW YORK

"The House of Service"

VICTROLAS—SUPPLIES—NEEDLES



For Immediate Delivery

☑ Loud Magic Tone steel needles packed in envelopes of 100. Prices:

In lots of 10,000 and up 65c per thousand
In lots of 100,000 and up 60c per thousand
In lots of 500,000 and up 55c per thousand

Or, if you desire, in tin boxes, packed 300 to the box, at the following prices:

In lots of 10,000 and up 65c per thousand
In lots of 100,000 and up 60c per thousand
In lots of 500,000 and up 55c per thousand

Owing to the scarcity of needles, it would be to your advantage to anticipate your requirements and send us your order by return mail.

BUSINESS PRIDE

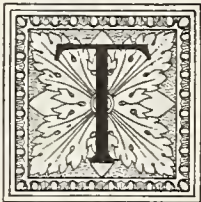

HERE is more in business than just financial gain..... the satisfaction of accomplishment, the making of friends, the establishing of goodwill.

When the Stephenson Precision-Made Motor was perfected we faced the selling problem; faced it with hearts full of faith and confidence, and high ideals.

We have now a pardonable pride in our success. We have profited, but the pride is not on this score, but rather because of the thousands of Stephenson Precision-Made Motors that are giving perfect satisfaction; of the friends we have made through the sincere service given. And for these friends we are grateful.

And always we will be ambitious to render this service and make it even more complete, and to guard jealously the goodwill that the Stephenson Precision-Made Motor has won.

Francis V. Nutze

Vice-President

STEPHENSON, INC., One West 34th Street, New York

EDISON EMPLOYEES ORGANIZE FOR THE THIRD LIBERTY LOAN

Meeting and Dinner Held in Orange, N. J., Attended by Many Prominent Speakers Who Tell of the Work Already Accomplished by Our Government in Prosecuting the War

On April 2 the Edison employees' war committee of 200 members assembled in one of the Edison buildings to dine and discuss the Third Liberty Loan. William Maxwell, vice-president and manager of the musical phonograph division, acted as chairman, and in his opening remarks made humorous reference to three chairs in the background which were labeled: "For the Newlyweds, Mr. and Mrs. Charles Edison." Mr. Maxwell stated that the three chairs meant three cheers for Mr. Edison and his bride, and they were given with a will.

The first man introduced was William Mead-

plished. Aeroplanes were being sent over by every ship, not completed but in parts and assembled on the other side, and that hundreds of American machines were at present in the air over there. It is comparatively easy, asserted Dr. Hutchison, to get a reputation by muck-raking, but it would be a great deal better for everybody concerned if they did something instead of talk. We are not in it for fun but for good, and we will not stop until things are over "over there." Material is going over with every ship and no little seventy-two-mile gun can bluff us because we're in the game to win.

This "down with the trusts" propaganda was



A Section of the Head Table at the Edison Liberty Loan Banquet

owcroft, assistant to Thomas A. Edison, who read the following telegram from the inventor who is at present in the South:

"William Meadowcroft, Edison Laboratory, Orange, N. J.

"Say to the committee I am highly pleased that they have all banded together to help the Government. Our Government suits us because we make it ourselves and we will fight to maintain it and all other governments, of which the people are masters, against any predatory aggression of barbarians.—Edison."

Mr. Meadowcroft then emphasized the tremendous amount of time, effort and money that Mr. Edison is expending for the Government and for which he refuses to accept one cent in payment.

Mr. Maxwell discussed the telegram and remarked that America should not feel oversecure. The Germans were only sixty miles from Paris, but 3,000 from Washington, which acted as a present source of self-defense, but unless everybody got in and did the best that they were capable of, God help us all. In the course of his talk Mr. Maxwell declared that it was his opinion that the war would be decided this year, and from newspaper comment that our boys were evidently in the big fight to-day and were carrying on to the best of their ability. He said that we must all do as the Government bid us without any heroics, that we were to exercise our influence whatever work is to be done and should do whatever work was assigned to us to the best of our ability.

He then introduced W. S. Mallory, vice-president and manager of the Edison Cement Works at New Village, N. J., the division that made such a splendid record at the last Liberty Loan drive. Mr. Mallory said that Mr. Maxwell had started the campaign and said that he looked for big things and that the Cement Works would show up as well in the Third Liberty Loan as in the others that preceded it.

Mr. Maxwell next introduced Dr. Miller Reese Hutchison, who is a member of the Naval Consulting Board, and whose remarks were exceedingly interesting, particularly the reference to ignoring the muck-raker.

Dr. Hutchison claimed that despite all the newspaper talk of the muck-rakers that nothing had been done a great deal had been accom-

plished. Aeroplanes were being sent over by every ship, not completed but in parts and assembled on the other side, and that hundreds of American machines were at present in the air over there. It is comparatively easy, asserted Dr. Hutchison, to get a reputation by muck-raking, but it would be a great deal better for everybody concerned if they did something instead of talk. We are not in it for fun but for good, and we will not stop until things are over "over there." Material is going over with every ship and no little seventy-two-mile gun can bluff us because we're in the game to win.

At the conclusion of his remarks, which were heartily applauded, Dr. Hutchison claimed that many of Mr. Edison's inventions were holding

up his reputation as an inventor on the other side.

In the matter of the loan, Dr. Hutchison subscribed \$10,000 on the spot, and declared that he believed the employees of the Edison Co. would excel their excellent records in connection with the first and second Liberty Loans.

Mr. Maxwell, after the applause had subsided, said that it was not the intention of the meeting to start subscriptions, but Dr. Hutchison had the honor to be the starter. Mr. Maxwell then introduced whom he called the get-the-money-man, Gene Philips, credit manager. Mr. Philips characterized his talk as the bum show after a star act. He congratulated everybody on the War Savings Stamp effort, and said that, although all the details hadn't been received, the rate of the new loan will be 4¼ per cent, which was exceedingly liberal considering that it was backed by the best security in the world and that savings banks only gave 4 per cent. Mr. Philips quoted from figures. He said that up to March 12 there had been invested in War Savings Stamps in the country \$96,298,402, and he also thought that by April 2 at least \$100,000,000 worth of War Savings Stamps had been sold. He also illustrated by figures the vast increase in our armed forces, showing how the men of the country had rallied to the colors. Mr. Philips said that despite the fact of all their bragging, the Germans would never reach Paris, and that it was up to us to make a business of winning the war.

At this point Mr. Maxwell said that it would be the best time to introduce the author of this slogan, "Make a Business of Winning the War," and introduced Nelson C. Durand. Mr. Durand said that it was up to everybody to "make a business of winning the war." He said that it might be necessary, as in the Civil War, for the women to make bandages, etc., and he characterized the mere giving of money as a joke compared to the sacrifices our soldier boys were making. He said that the Edison organization was investing over \$2,100 a week in War Stamps.

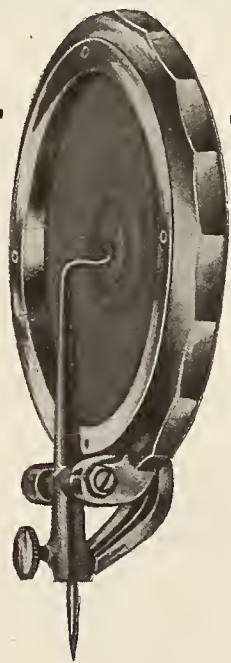

Tone—the vital thing

IF you, as a manufacturer, can talk and prove *tone superiority* in your product, you have a selling argument to overshadow all the "talking points" of cabinets, and designs and accessory features.

And you *can* talk tone superiority. You can put out a product that will be a revelation in tone-purity, tone-quality, tone-volume. When you realize what vivid, lifelike, colorful tone can be produced and sustained by the talking machine equipped with

Parr Magnetic Reproducer

fitted with the

Vibratone Patented Diaphragm

These two dominating and proven inventions open up wonderful possibilities for manufacturers eager to put their product at the top-notch of class and character.

You want your product to be RIGHT!

If you want your product worthy of your name, you certainly want that product to be right in its most *vital feature*. And it will be right if it is equipped with the Parr Magnetic Reproducer—the reproducer for those who seek perfection.

The indestructible, non-crystallizing, always resilient

VIBRATONE PATENTED DIAPHRAGM

Possessing all the good points of mica diaphragms, it overcomes all mica's bad features. Guaranteed uniform in quality, free from bubbles, blisters and waves, the Vibratone Patented Diaphragm is non-porous, non-absorbent.

It has a definite function and it performs it. It improves tone; in fact it creates new tone possibilities for every reproducer of other types.

PARR MANUFACTURING CORPORATION

1 UNION SQUARE

At Fourteenth St.

NEW YORK

Take the Parr Magnetic Reproducer—

The most sensitive of reproducers. The permanent magnetic device, an integral part of the reproducer, acts on the stylus box. Its possibilities in giving warmth and delicacy in the tonal reproduction of quiet passages make old-style sound boxes seem obsolete. And in fortissimo passages where ordinary reproducers create unpleasant, music destroying blasts, caused by the needle jumping and losing its grip, the Parr Magnetic Reproducer, with its marvelous flexibility, follows every wave and vibration in the record and takes everything the record holds.

EVERY TALKING MACHINE DEALER

THREE SONG HITS

- from "SONG HEADQUARTERS" -

FROM the Great White Way—where songs are made—to every home and place where songs are played, these three Feist hits are becoming part of America's daily life. Take this page to your piano and try the wonderful melodies. Get the complete sheet music from your dealer today. They're printed in the Feist easy-to-read style—no leaves to turn.

ON SALE NOW at all music and department stores or at any Woolworth, Kresge, Kress, Kraft, Grant or Metropolitan Store.

OTHER POPULAR "FEIST" SONGS

- | | |
|---|---------------------------------------|
| Bring Back My Daddy to Me | Give Me a Kiss by the Numbers |
| I'll Come Back to You, When It's All Over | Each Stitch is a Thought of You, Dear |
| We'll Knock the Heligo, Out of Heligoland | Good Morning, Mr. Zip-Zip-Zip |
| Over There Homeward Bound | I Don't Want to Get Well |
| In the Land of Wedding Bells | It's a Long Way to Berlin |
| Don't Leave Me Daddy K-K-K-Katy | Hail, Hail, the Gang's all Here |
| Tom, Dick and Harry and Jack | At the Darktown Stutter's Ball |
| Round Her Neck She Wears a Yeller Ribbon | Where Do We Go From Here |

15c a copy, any seven for \$1. Postpaid. Band or Orchestra, 25c each. Male Quartette, 10c each.

Also Get Them For Your Talking Machine

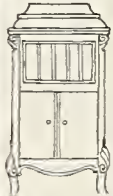

Get Them For Your Player Piano



The Kaiser Will "Strafe" It

NO sir—it won't tickle the Kaiser. But maybe that's why it's sweeping the good old U. S. A. with its wonderful melody and inspiring words. Geo. W. Meyer has put the real spirit of 1918 into his peppery military music—and Howard Johnson has written the words that will linger in the memory of every American when the Rhine is crossed and the guns are stacked. Get it—it will get you.

Just Like Washington Crossed The Delaware

General Pershing Will Cross The Rhine

CHORUS

Just like Wash-ing-ton crossed the Del-a-ware, So will Per-shing cross the Rhine, As they fol-lowed af-ter George, At dear old Val-ley Forge, Our boys will break that line. It's for your land and my land And the sake of Auld Lang Syne, Just like Wash-ing-ton crossed the Del-a-ware, Gen-ral Per-shing will cross the Rhine.

© LEO. FEIST, Inc. N.Y.

It Will Tease You Till It Gets You

A REAL "kiss and let's make up" song—with a teasing melody and tantalizing words. You can't help but hum it, sing it, or whistle it once you've heard it. Full of life and spirit—the kind of song you like to hear once, twice, and a hundred times. True love doesn't run smooth but "I'm Sorry I Made You Cry" is the smoothest love song in years. Words and music by N. J. Clesi.

I'm Sorry I Made You Cry

CHORUS

I'm sor-ry, dear, so sor-ry, dear, I'm sor-ry I made you cry! Won't you for-get, won't you for-give? Don't let us say good bye! One lit-tle word, one lit-tle smile, One lit-tle kiss won't you try? It breaks my heart to hear you sigh, I'm sor-ry I made you cry!

© LEO. FEIST, Inc. N.Y.

A Hit That Hits Home

OUT of Belgium, for four years a land of desolation has grown Benoit's, Levenson's and Garton's "My Belgian Rose"—a beautiful song that reaches the heart. It's a real, undeniable appeal that makes a real impression—you can't get away from its captivating melody and wonderful words. "And tho' they've taken all your sunshine and dew, we'll make an American beauty of you" are two of the lines you'll love in this song. Learn it now.

My Belgian Rose

CHORUS

Bel-eian Rose, my droop-ing Bel-gian Rose, For ev-ry hour of sor-row you've had, You'll have a year in which to be glad; You were not born in vain, for you will bloom a-gain, And tho' they've tak-en all your sun-shine and dew, We'll make an A-mer-i-can beau-ty of you, And you will find re- pose, ov-er here, My Bel-gian Rose.

© LEO. FEIST, Inc. N.Y.

will be benefited by this advertisement which will appear in

THE SATURDAY EVENING POST

On Thursday, MAY 16th

"You can't go wrong" by featuring these 3 Songs in your displays.

You, of course, notice how we "plug home"; get them for your Talking Machine, etc.

Hook Up With the HITS!

BUY W.S.S. WAR SAVINGS STAMPS

Leo Feist, Inc., Feist Building, New York.

ALL PROFITS FOR LIBERTY BONDS

B. R. Forster, President of Brilliantone Steel Needle Co., Pledges All Profits for Current Year to Patriotic Purpose—Splendid Step

On the opening day of the Third Liberty Loan an important announcement was issued from the offices of the Brilliantone Steel Needle Co. in the Marbridge Building, New York, to the effect that B. R. Forster, president of the company, will dedicate every dollar of profit made during the year 1918 to the purchase of Liberty Bonds. The company have already purchased \$25,000 worth of these bonds and will continue so to do as their profits accrue.

It was announced at the formation of this company, months before they actually started in business, that their business slogan would be "Made in America by American Labor." It is needless to state that this slogan has been rigidly lived up to. This latest patriotic endeavor is entirely in accord with the spirit of the firm. According to the achievements of the Brilliantone Steel Needle Co. during the first three months of their existence, it would seem that the amount to be invested in Liberty Bonds during the year will reach a very large figure.

B. R. Forster has just returned from an extensive trip which covered twenty-seven States and totaled about 8,000 miles. He found business conditions good throughout the territory he covered, but particularly in the South. Orders are coming in very strong, he reports, but they are somewhat hampered at the present moment by not being able to turn out the needles fast enough. During the shortage their factories have concentrated in turning out half-tone needles only and for the past few weeks deliveries have been made of this grade exclusively.

Their rapid growth has already necessitated the enlarging of their offices. Adjourning offices have been secured and work will be shortly started in tearing down the partitions.

Eugene Latham, who recently joined the col-

ors from this company, was a recent visitor at the offices. B. R. Forster, with Mrs. Forster,



B. R. Forster

are enjoying the pleasures of Atlantic City, where Mr. Forster is at present taking a much-needed rest.

EDISON INSPECTORS CALLED IN

The staff of Edison mechanical inspectors have been called in for their annual get-together to check up the developments in connection with the New Edison phonograph preparatory to their returning to the road. The mechanical inspectors will remain at Orange to assist in the School of Mechanical Instruction, which will be given for the benefit of the dealers who attend the coming Edison dealers' convention and will return to their territories late in the summer.

Mrs. H. C. Ernst, wife of H. C. Ernst, of the executive offices of the New York Talking Machine Co., Victor wholesalers, left for Dayton this week to attend the funeral of her stepfather, who was killed in an elevator accident.

WILL HAVE 28 STARS IN FLAG

The Service Flag of the New York Talking Machine Co. Is Steadily Becoming Starrier—The Men Are Ready for Service

The service flag in the offices of the New York Talking Machine Co., Victor wholesalers, will have six new stars within a few weeks, for six members of the company's forces have either enlisted or will join the National Army in the very near future. These men are Maurice Stegner, one of the assistants to George A. Kelley; Roy Johnson, receiving clerk; Frank Ferrier, packer; Y. Moore, packer; Henry Roth, stock clerk; Fred Meltzer, stock clerk, and Rocco Renna, porter. All of these boys will be in the National Army with the exception of Mr. Meltzer, who is a member of the U. S. Army, Cavalry Division.

With these new names the New York Talking Machine Co.'s flag will have twenty-eight stars, for twenty-one of the company's staff are now in the service of Uncle Sam. Considering the fact that this organization is a comparatively small one, this record is remarkable, and it is probable that this company's staff has a greater proportion of boys who are "doing their bit" for their country than any other concern in this industry. Quite a number of the New York Talking Machine Co.'s staff are now "somewhere in France," and the letters that are being received by their friends "over here" reflect a spirit of optimism and patriotism which is characteristic of the American boys "over there."

FRED MARASAK JOINS THE ARMY

Fred Marasak, who for the past couple of years has been assistant to A. H. Dodin, president of the Talking Machine Repair & Sales Corp., 176 Sixth avenue, recently enlisted in the United States Army. Mr. Marasak already has two brothers in the army. A third brother, Charles Marasak, is manager of the Victor store of L. A. Smith, Brooklyn, N. Y.



ANSWER



**WILL YOU COME ACROSS
OR WILL THE KAISER?**

**BUY LIBERTY BONDS
AND MAKE THE KAISER WISER**



Blackman
TALKING MACHINE CO.
97 CHAMBERS ST. NEAR CHURCH ST. NEW YORK
VICTOR DISTRIBUTERS





The Century

A Phonograph That
Has Made Good Because
It Is Made Right!



No. 200—Quartered Oak or Genuine Mahogany, 24x24x49½, \$200.00



No. 3—Oak or Imitation Mahogany, 17x18½x13 inches high, \$30.00

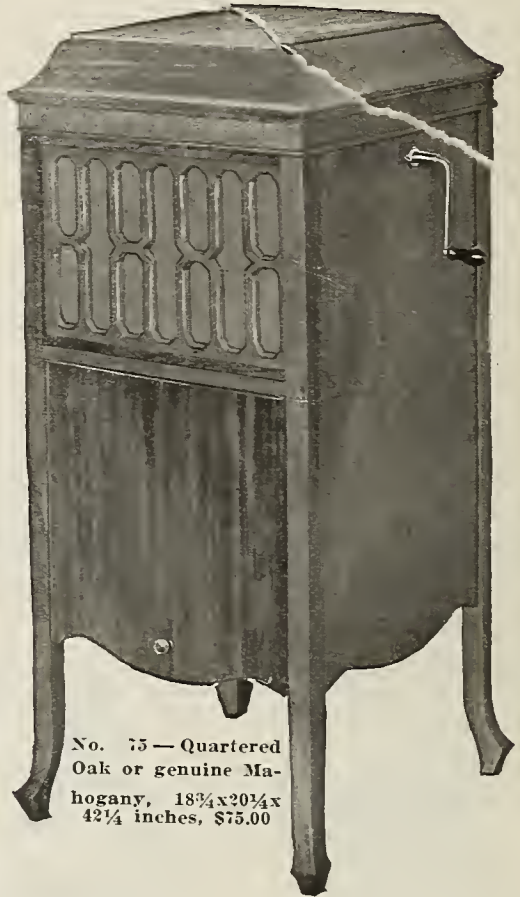

No. 75—Quartered Oak or genuine Mahogany, 18¾x20¼x42¼ inches, \$75.00

Three Popular Century Models

Why Century Dealers Are Successful

The Century Phonograph is manufactured, marketed and absolutely guaranteed by the world's largest talking machine cabinet manufacturers.

There is a Century model to fit every purse, and the Century dealer can depend upon the co-operation and service of a thoroughly responsible and efficient organization.

Century Cabinet Co., 25 West 45th St., New York

Factory, UTICA, N. Y.

The Talking Machine Men, Inc. Hold Their Annual Banquet

The annual dinners of the Talking Machine Men, Inc., have always been notable events in the local trade, but the last dinner, held on April 10 at the Hotel McAlpin, outshone all previous affairs, due largely to the efforts of the entertainment committee, under the direction of J. J. Davin and Sol. Lazarus, who provided an array of talent of a caliber that at various stages made most of the diners forget to eat, temporarily. The dinner itself was a mighty good one at that, as vouched for by over 300 talking machine men, their wives and friends in attendance. The entertainers included the Hawaiian Troupe, which has made so many successful Victor records, Joseph C. Smith and his orchestra, Charles Harrison, Arthur Fields, Henry Burr, Sally Hamlin and Jasper's Trio, all of them well

much for their country as those who are actually under arms, for the music that they supply aids in assuaging the sorrows of those who are called upon to face the loss of loved ones, and likewise helps the boys actually in the trenches by providing them with cheering melodies. In every sense the business is essential.

He also referred to the recent Supreme Court decision in the matter of price fixing, declared that manufacturers must now depend upon legislation to get redress, and referred to steps now being taken by the various Governmental boards in the fixing of prices on basic raw materials.

Mr. Hopkins described the operations of the price cutter and the reason for his actions and told how certain standard articles were offered

Important addresses made by President Coughlin, Geo. W. Hopkins, J. Newcomb Blackman, Marion Dorian, John R. Young and J. H. Tregoe—Fine Program Offered

"Endeavor to learn of the houses in your vicinity which are not supplied with Grafonolas. Then take a kodak snapshot of the house, have it finished and attach it to the head of a letter, send to the owner or occupant of that house with the query: 'Why is there not a Grafonola in this house?' accompanied by a short selling talk. The personal touch is almost sure to make the proper impression."

Mr. Hopkins also made a plea for consistent and liberal advertising by the dealer, and stated that statistics show that 84 per cent. of the business failures are among non-advertisers. He also maintained that organization funds should be used liberally in the cause of music, with the ultimate idea of making America a singing nation. Mr. Hopkins closed his address by tell-



Annual Banquet of the Talking Machine Men, Inc., at Hotel McAlpin on Evening of April 10

known to the talking machine men through records they have made for various companies. Miss Hamlin, in fact, is believed to be the youngest record artist, and proved her ability in person by reciting "Pollyanna."

Must Watch Credits, Says J. H. Tregoe

When the time came for the after-dinner talks President J. T. Coughlin took up his duties as toastmaster and after explaining that Congressman Daniel Stephens, father of the Stephens' Bill for price maintenance, and Henry C. Brown, assistant to the general manager of the Victor Talking Machine Co., who had been scheduled to speak, were unable to be present, introduced J. H. Tregoe, secretary-treasurer of the National Association of Credit Men of New York, who gave a talk that was for the most part along patriotic lines. In the matter of credits, however, Mr. Tregoe declared that this was the time for merchants to co-operate and that loose credit, a mistake in normal times, was little less than criminal right now. He declared that business men must see to it that terms of credit were closely observed for their own protection.

George W. Hopkins' Inspiring Address

The feature of the evening was a talk by George W. Hopkins, general sales manager of the Columbia Graphophone Co., who fully lived up to his reputation as a speaker on the subject of salesmanship. Mr. Hopkins declared that in his opinion the business men of the country should endeavor to do twice as much business as in the past as one factor in doing their part in the war and in developing the nation's financial power.

He maintained likewise that the talking machine manufacturers and dealers were doing as

at reduced prices, with a view to selling the customer other articles upon which a profit could be made. The speaker drew upon his experiences in other lines of industry to prove the necessity of the salesman believing first in his own product and mentioned that only the man who is himself sold on his product can really be successful.

Mr. Hopkins said it is his belief that the average talking machine salesman was too technical and failed to realize that the buyer likes to be flattered by having the features of the machine or records presented to him in a manner that he can understand and appreciate.

For the dealer and manager Mr. Hopkins declared that the head of the house should endeavor particularly to stamp his personality on the people employed by him, and by that means multiply himself among his salesmen. Everyone likes to do business with the head of the house, he said, and proper training will give to assistants the ability to give the same personal sort of service.

"Don't run your store the other fellow's way, but work out your own way," said the speaker. "To follow in the footsteps of a competitor and to adopt his ideas is a sign of weakness and the imitator rarely meets with any success. Think up new ways of getting business and holding it. As an instance in point, don't leave a customer alone in a booth while searching for the record he has asked for. See that there is a selected bunch of records in each booth, and put one on the Grafonola and start it playing, on leaving the room. This idea as one has actually resulted in increasing record sales where it has been adopted. There are also many other plans that will get results if properly applied.

ing what Columbia service represented at this particular time, and offered some convincing facts for the consideration of the dealer.

J. N. Blackman Talks for Liberty Loan

J. Newcomb Blackman, president of the National Association of Talking Machine Jobbers, was the next speaker, and reviewed briefly some of the problems that are facing the trade at this particular time. Mr. Blackman pointed out what business men were expected to do in support of the war program of the nation, and emphasized the fact that we had a big job ahead of us and were handling it in a big way. He declared that in this country business men were asked to buy Liberty Bonds bearing interest, to provide finances for the war, while in Germany business men had all their assets conscripted in exchange for a piece of paper possibly of no value. Mr. Blackman cited some of his experiences at Washington in connection with the war excise tax, the Cary bill and other important legislative matters, and ended his address by making a strong appeal for subscriptions to the Third Liberty Loan through the trade committee. Mr. Blackman is chairman of the talking machine division of the Liberty Loan committee of the Allied Music Trades.

Marion Dorian's Witty Address

Marion Dorian, auditor of the Columbia Graphophone Co., spoke next, and as is his usual custom confined himself principally to some genuinely humorous remarks about nothing in particular. He kept his audience convulsed for several minutes and in closing became serious for the moment and urged liberal support for the Liberty Loan, not only for patriotic reasons, but in appreciation of what Mr.

(Continued on page 104)

BANQUET OF TALKING MACHINE MEN

(Continued from page 103)

Blackman had done in the interests of the industry as a whole at Washington.

Columbia Record by General Pershing

Mr. Dorian sprung the sensation of the evening, however, when he announced that his company had just received a cablegram from England to the effect that General Pershing, of the American Expeditionary Forces in France, had made a Columbia record. General Pershing is probably the leading figure in America's military life to-day, therefore the announcement of his record was accepted at its true value.

Some Other Talks

John R. Young, head of the convention bureau of the Merchants' Association of New York, through whose efforts the talking machine men have been able to use the rooms of the Merchants' Association as a meeting place, next offered some comments on the commercial importance of New York and other matters within his ken, after which J. T. Coughlin, president of the association, spoke at some length on organization and co-operation, urging the necessity of talking machine dealers getting together, particularly in times such as these. He spoke for honesty in business dealings, and pleaded that the dealers forward their own cause by placing their confidence one in another.

Dancing Ends Evening's Entertainment

At the conclusion of the dinner and speech-making the talking machine men indulged in dancing to the strains of Jasper's Celebrated Jazz Orchestra until it was time to go home and change to business suits in order to take up the threads of business the next morning.

The success of the evening as a whole was due to the untiring efforts of J. J. Davin, of the New York Talking Machine Co., and chairman of the arrangements committee, and Sol. Lazarus, secretary of the Talking Machine Men, Inc. Their elaborate plans of entertainment went through without a hitch, for which they deserve congratulations.

The present officers of the Talking Machine Men, Inc., are James T. Coughlin, president; Henry Mielke, vice-president for New York; H. Jaffee, vice-president for New Jersey; A. P. McCoy, vice-president for Connecticut; A. Galuchie, treasurer; Sol. Lazarus, secretary, and William Berdy, financial secretary.

Genuine Period Styles

Authentic adaptations of Adam, Louis XVI, Sheraton and Queen Anne periods, harmonizing perfectly with the styles whose names they bear, are a feature of the case work on the Marvelous

MAGNOLA "Built by Tone Specialists"



Watching the Music Come Out

Give us the Opportunity to tell you more about this and other sales-making features of MAGNOLA construction, by sending us your name and address.

We have a handsome catalog, illustrated in colors, that tells Magnola's story—and is yours for the asking.

MAGNOLA TALKING MACHINE COMPANY

OTTO SCHULZ, President

General Offices 711 MILWAUKEE AVENUE CHICAGO
Southern Wholesale Branch 1530 CANDLER BLDG. ATLANTA, GA.

**WE GUARANTEE
—YOU CAN—
Buy Liberty Bonds**

with profit from increased sales by using the

Ogden Filing and Sales System

of guaranteed value (to satisfy you in every particular).

Guaranteed to buy itself and **A Liberty Bond** the first six months—or is returnable to us for full credit.

Get our proposal and new catalog of a war-time necessity.

**FILES, FINDS
and
SELLS RECORDS
in a modern way**

OGDEN SECTIONAL CABINET CO., Inc.

Prompt Shipments.

LYNCHBURG, VA.



LOCATES IN NEWARK, N. J.

W. C. Strong to Make Headquarters at Meisselbach Division of Otto Heineman Phonograph Supply Co.—An Authority on Motors

Otto Heineman, president of the Otto Heineman Phonograph Supply Co., announced this week that W. C. Strong, who has been one of the company's factory executives at Elyria, O., for the past two years, will in the future make his headquarters at the plant of the company's Meisselbach division in Newark, N. J. Mr. Strong, who is recognized as one of the foremost authorities on motor construction in this country, will act as assistant to A. F. Meisselbach, head of the Meisselbach division and vice-president of the Otto Heineman Phonograph Supply Co. Mr. Strong's many years' experience will doubtless enable him to render invaluable assistance to Mr. Meisselbach.

BUILDING UP A GOOD TRADE

S. N. Rosenstein, president of the Phonograph Clearing House, Inc., states that he has achieved remarkable success with the products of Barnhart Bros. & Spindler, Chicago, the agency for which he secured recently. These products, which include "Superior" tone arm reproducers, etc., are meeting with a ready sale, and Mr. Rosenstein considers himself very fortunate in being able to offer these phonograph parts to the Eastern trade. He states that it requires only a demonstration to sell these products, as the manufacturer and dealer is easily convinced by actual demonstration that this tone arm and reproducer can be merchandised to excellent advantage.

Miss N. L. Moody is now in charge of the Victor retail department of Philip Werlein, Ltd., New Orleans, La.

**DON'T YOU KNOW WHERE
TO GET**

**THAT MOTOR—
OR THAT TONE ARM—OR CABINET?**

Why Not Let Us Find It For You?

**DIRECT REPRESENTATIVES OF ALL
LEADING MANUFACTURERS**

**WE CAN GIVE YOU MERCHANDISE, SERVICE AND ADVICE
NO CHARGE FOR THE LAST TWO**

THE PHONOGRAPH CLEARING HOUSE, Inc.
51 EAST 42d STREET, NEW YORK CITY

TELLS OF REVERSING RECORDS

John B. Taylor Conducts Interesting Experiment in Playing Records Backward—Declares Tonal Effects Are Entirely Changed

John B. Taylor, who is a talking machine enthusiast, has done much experimenting with talking machines and records, and has delivered a number of illustrated lectures on the "Development of the Phonograph and a Microscopic Study of Records," has aroused particular interest through his experiences in playing records backward and reversing tones, tune and speech. In telling of his experiments in reversing records, Mr. Taylor said recently:

"Such reversed sounds, besides being curious, are worthy of study from a physical and psychological basis. Playing backwards was an old device in the early days of hand-driven, tin-foil phonographs, but these were so imperfect as to tone quality that any critical study of the change in quality was not possible. According to the theories of tone quality since Helmholtz, the quality of a tone is not influenced by the phase relations of the several sound wave partials which make up the tone. By this theory the quality of a tone should be unchanged by playing backwards. Experiment shows that this is true provided tone quality is defined in a restricted, physical sense which is more limited than the average musician means by the word 'quality.'

"In these experiments it appears that an even, sustained tone, whether vocal or instrumental, is practically the same for normal or backward rotation of the record, but, since many instruments do not, and others are quite incapable of producing even, sustained tones, there are surprising effects from these reversed records, especially from the percussive instruments such as piano, cembalon, harp, xylophone, bells and celesta. When reversed, these all in some degree resemble wind instruments.

"To show the ability of the phonograph as a single instrument to reproduce the tone qualities of the many musical instruments of diverse shapes, sizes and means of sounding, a pleasing and instructive feature has been the display of a slide picture showing a performer and instrument at the same time that the phonograph plays a characteristic bit by the same instrument. I have had more difficulty in finding suitable records for this series than in finding pictures for the slides."

A NOTABLE VISITOR FROM CHICAGO

George L. Davidson, one of the owners of the Talking Machine Shop, Chicago, Ill., exclusive Victor retailers, accompanied by Mrs. Davidson, was a visitor to New York this week, after spending a few days in Philadelphia visiting some of Mrs. Davidson's friends and relatives. While in New York Mr. Davidson took advantage of the opportunity to call upon several of the local Victor retailers in order to gain an insight into conditions in the local trade.

Mr. Davidson is one of the foremost members of the retail talking machine industry in Chicago, and his rise in this business has been little short of phenomenal. He started several years ago with a small capital, and last year did a business of more than \$250,000. His establishment now occupies a four-story building in the "musical center of America," and this store, which contains more than twenty demonstration booths, is considered one of the finest Victor establishments in America.

SHELTON ELECTRIC PHONOGRAPH MOTOR

We have increased our factory facilities to handle the demand for the Shelton Electric Motor, and are now ready to make prompt deliveries.

Write for our Special Agency Proposition

SHELTON ELECTRIC CO. 30 East 42nd Street, NEW YORK

ADDITION TO BUEHN ORGANIZATION

Louis Buehn Secures Services of William H. Nolan, a Victor Man of Countrywide Reputation—Now Building for the Future Trade

PHILADELPHIA, PA., April 8.—Louis Buehn, head of the Louis Buehn Co., prominent Victor wholesalers of this city, is one of those who have full



William H. Nolan

confidence in the future of the talking machine business, and is making preparations accordingly in building up and strengthening the organization of the company. Mr. Buehn realizes that the present shortage in machines and records is but the natural temporary result of wartime economic readjustment, and that conditions are bound to return to normal.

One of the factors that has meant success for the Buehn Co. in the past, and means further success in the future, is the practice of selecting for the organization young men of broad experience in the Victor game—men like F. B. Reineck and Chas. W. Miller; E. P. Bliss, a former factory man and later with Lyon & Healy; and L. D. Callahan, who came to him with the experience of several years gained in traveling from coast to coast for the Victor Co. And now Mr. Buehn announces the addition to his organization of Wm. H. Nolan.

Wm. H. Nolan is known to the trade from California to Long Island. During Mr. Nolan's connection with the Victor factory he traveled all sections of the country, and during the Panama-Pacific Exposition directed much of the work of the Victor Temple at San Francisco—an exhibit unsurpassed by anything ever before attempted in the annals of the talking machine industry. Mr. Nolan's work won such flattering attention that Lyon & Healy, of Chicago, induced him to take the management of their retail department, probably the largest retail department in the United States.

After two years with Lyon & Healy Mr. Nolan re-entered the wholesale end of the work with the New York Talking Machine Co., where his wide experience was utilized in the development of improved retail methods among the dealers of New York City and vicinity.

IMPORTANT VOCALION SALE

Among the interesting Vocalion sales closed this week at Aeolian Hall was that of a Vocalion, style "K," to Johan Baumann, a delegate representing the Norwegian Commission which has been visiting this country for some time past in the interest of the Norwegian Government.

It is interesting to note that the Brazilian, Danish and Norwegian Commissions have all recently purchased Vocalions to take with them to their home countries. Incidentally they all selected style "K" Vocalions.

Advertisement for CLEMMENT BEECROFT featuring a record cabinet, record envelopes, and needles. Includes a list of 30 records and a bee logo.

22 BEE CROFT YEARS

Connected With The Talking Machine Business

Record Cabinets Record Envelopes

Needles

CLEMMENT BEECROFT

309 W. Susquehanna Avenue

Philadelphia

Thirty desirable records. You may not have all of these selections We will gladly play any record for you.

Table listing 30 records with categories: INSTRUMENTAL, BANTY MUSIC, VOCAL, VOCAL - Continued, and SACRED.



SUBSCRIBING TO LIBERTY LOAN

Local Talking Machine Trade Interests Going "Over the Top" With Flying Colors—J. N. Blackman, Committee Chairman, Anxious to Establish New Trade Record

As The World goes to press the drive for the Third Liberty Loan is in full swing and there is every prospect that the local talking machine trade will go "over the top" with far more than its normal share of subscriptions. The Allied Music Trades of New York have pledged through Julian T. Mayer a minimum of \$1,000,000 for the loan, and J. Newcomb Blackman, president of the Blackman Talking Machine Co., and sub-chairman of the committee with direct responsibility for the talking machine trade, stated that his trade would probably raise at least one-quarter of the total amount.

Late this week Mr. Blackman stated that possibly \$200,000 had already been raised by the talking machine men, with much more in sight, and that trade subscriptions to the third loan would far exceed those recorded for the second. Liberty Loan talks at the annual dinner of the Talking Machine Men, Inc., on Wednesday night are believed to have stimulated subscriptions to a considerable degree. The members of the committee assisting Mr. Blackman include George W. Hopkins, of the Columbia Graphophone Co.; Emanuel Blout, Roy J. Keith, New York Talking Machine Co.; Lipman Kaiser, S. B. Davega Co.; A. P. Plumb, Musical Instrument Sales Co.; E. H. Jennings, Sonora Phonograph Corp.; R. H. Morris, American Talking Machine Co.; Thos. S. Green, Silas E. Pearsall Co.; G. T. Williams; C. L. Price, Ormes, Inc.; Max Landay, Landay Bros.; T. E. W. Carlson, C. H. Ditson & Co., and Joseph Schwetz, I. Davega, Jr., Inc.

It might be mentioned that a substantial subscription to the Liberty Loan from the talking machine trade at this particular time should have a most desirable effect in Governmental circles, as indicating full support of the Government in the war, and that subscriptions, therefore, should be made wherever possible through the trade committee.

COVERING NEW YORK TERRITORY

Thomas McCreedy, who formerly represented the Victor Co. in Ohio, is now in charge of New York territory, succeeding R. N. Lagow. He is a man splendidly equipped for this important post, who believes in co-operating with Victor dealers for the best interests of the industry.

F. W. C. Hayes, formerly manager of the Victor department of Philip Werlein, Ltd., New Orleans, La., has left to take charge of the Brunswick phonograph department in that city. He has recently established new Brunswick dealers in Jackson, Meridian, Columbus, Hattiesburg, Brookhaven and Lexington, Miss., Baton Rouge, Crowley and Jennings, La.

CRYSTAL EDGE MICA DIAPHRAGMS

**M
I
C
A**

Let us send you samples *today* of our diaphragms and you will readily understand why the best talking machines are equipped with *Crystal Edge Mica* diaphragms exclusively.

We use only the very finest selected mica, the best diaphragm material in the world.

PHONOGRAPH APPLIANCE CO., 109 West Broadway, NEW YORK

GLOBE-WERNICKE LITERATURE

Interesting Information About the Sectional Disc Record Cabinet of This Company Issued

CINCINNATI, O., April 6.—In connection with the exploitation of its sectional disc record cabinets, the Globe-Wernicke Co. of this city has prepared attractive literature, which can be used to excellent advantage by the dealer.

The company has emphasized the fact that these sectional disc record cabinets solve an important problem, and a recent piece of literature entitled "How to sell more records" reads in part as follows: "Why is it, Mr. Talking Machine Dealer, that for three or four months after a customer

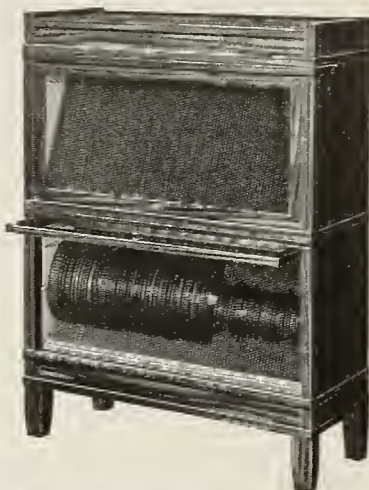

buys a talking Sectional Disc Record Cabinet machine he will also buy records in quantities, and then suddenly refuse to buy more? Why is it that, a few months after selling a machine, you can telephone the buyer and get his permission to send him the latest records from which to make a selection, and that after this period, your experience reaches you that it is useless to send him any more of these records with the hope of his retaining any appreciable number?

"At first hand the reason would seem to be that he is tired of his new 'toy,' but many dealers have told us that the difficulty is the proper and adequate housing of the records he has bought from you. The space at his disposal for filing the records has become crowded, and he has taken the road of least resistance and made up his mind not to buy any more records for the time being.

"We believe that we have solved this problem for you by the introduction of our sectional disc

record cabinet, which is an elaboration of the Globe-Wernicke system of sectional bookcases.

that is, a top, a unit, and a base. The unit has ninety compartments, so that each record, whether 10-inch or 12-inch, has its own compartment. In other words, there is a place for every record and every record is in its place. When the unit is filled, a second unit is placed between the first and the top sections, and so unit after unit is added vertically and horizontally as space permits.



The Unit Idea

"Dealers who place these sections on their salesroom floors, and explain the quick filing and finding facilities of this system, will undoubtedly develop an active demand for records, as the use of this system eliminates the 'bugbear' of 'No room for any more records.' Our new catalog, No. 317, will give you an adequate idea of our unit system."

GOLDSMITH BREAKS INTO PRINT

MILWAUKEE, Wis., April 9.—Harry A. Goldsmith, secretary and sales manager of the Badger Talking Machine Co., Victor wholesalers, broke into the "Who's Who" column of the Milwaukee Journal on last Friday evening. A personal sketch stated in part that "Harry A. Goldsmith acquired a becoming bashfulness while engaged in the newspaper business in Calumet, Mich., from which he has never recovered. Mr. Goldsmith believes a bass drum never sounds so loud as when one pounds it himself, but is more effective if the world is doing the pounding." The sketch also stated that Mr. Goldsmith was born in Chicago thirty-four years ago, and was brought up in Calumet, Mich.; that he is unmarried, but is willing, and is a member of the Press, Elks and Advertisers clubs, the M. A. C., the M. A. of C., and the Masons. A portrait of Mr. Goldsmith accompanied the sketch.



Model No. 90 Mahogany or Oak

"American Maid" Phonograph

We are ready to offer the trade the "American Maid" phonograph, an instrument which has a *tone* quality that is unsurpassed. Hence—the slogan—"Purity and Sweetness of Tone". No matter *what record* you may want to hear, the "American Maid" is at your service. Every model plays any and all records.

We manufacture six models, retailing at **\$17.50, \$45, \$65, \$90, \$125 and \$150**, and each model is finished in mahogany or oak. We guarantee prompt deliveries.

Manufactured by

C. JOHN A. WOODS & SON, 30 Church Street, New York

WRITE FOR DEALER PROPOSITION



Our \$17.50 Model—Mahogany or Oak

EXPORT TRADE A SPECIALTY

NOW THE COLUMBIA GRAPHOPHONE MANUFACTURING CO.

President Whitten Makes Formal Announcement of the Change of Name of the American Graphophone Co.—Will Not Affect the Personnel or the Policies of the Company

Francis S. Whitten, president of the Columbia Graphophone Co. and the American Graphophone Co., sent out a letter this week to Columbia representatives formally announcing the change of the latter company's name to the Columbia Graphophone Mfg. Co. The name of the Columbia Graphophone Co. remains as it is at the present time.

The letter sent out by President Whitten announcing the American Graphophone Co.'s change in name reads as follows:

"As of this date, April 1, the name of the American Graphophone Co. is changed to that of the Columbia Graphophone Mfg. Co. This change is made pursuant to a special meeting of the stockholders of the American Graphophone Co. held on March 25, 1918, at which time the officers and directors of the company were authorized to sell and transfer practically all the assets of the American Graphophone Co. to the Columbia Graphophone Mfg. Co. under

a reorganization plan dated December 14, 1917.

"The names of the American Graphophone Co. and the Columbia Graphophone Co. have always been more or less confusing to our dealers, and for this reason and other advantages in the reorganization we have changed the name 'American Graphophone Co.' to 'Columbia Graphophone Mfg. Co.'

"The Columbia Graphophone Mfg. Co. assumes all the liabilities of the American Graphophone Co. and the officers, directors and department heads of the Columbia Graphophone Mfg. Co. are now occupying the same positions they previously held with the American Graphophone Co.

"The change in question does not in any way affect your relations with the Columbia Graphophone Co., which continues to be the sole sales agent of the Columbia Graphophone Mfg. Co., as it previously was of the American Graphophone Co."

play, so that each Columbia representative can use that part of the service which best suits his particular needs. This department has recently completed its newspaper advertising schedule, which includes a campaign in seventy



Window Display of United Music Stores
papers published in twenty-three languages. This advertising is inserted without using the Columbia Co.'s address, so that the local talking machine dealers may receive the full benefit of this publicity.

ARTISTIC WINDOW DISPLAY

Made by the United Music Stores of Portland, Me.—Features Display Put Out by Columbia International Record Department

The international record department of the Columbia Graphophone Co. recently received the accompanying photograph from the United Music Stores, Portland, Me.; this illustration showing a window display that was recently used by this progressive and successful Columbia dealer. This display incorporates some of the new window service ideas completed by the international record department which are being used to excellent advantage by many dealers throughout the country.

The United Music Stores expressed their hearty commendation of this display and stated

that two days after it was installed the store closed the biggest foreign language record business in its history. As an example of the sales appeal of this display, it is interesting to note that on the very day it was placed in the window two Danish sailors happened to pass the window and were so favorably impressed with the Danish cut-out that they left an order for a \$78 outfit, to be delivered to their ship.

The United Music Stores conducts one of the most attractive talking machine establishments in New England. It has a remarkably fine location, being situated on the most prominent corner of Portland's best business street.

R. F. Bolton, sales manager of the Columbia Co.'s international record department, states that this department has made arrangements whereby it can furnish the dealers with the complete display, or different sections of the dis-

ORGANIZE BEECROFT-BLACKMAN, INC.

Beecroft-Blackman, Inc., has been organized in New York for the purpose of taking over by assignment the Beecroft United States Letter Patent No. 1,244,944, issued October 30, 1917, covering the placing of moulding on top of talking machine cabinets to hold Victrola IX. The new corporation plans to issue licenses on a royalty basis to desirable manufacturers of cabinets for the use of Beecroft patents. Several arrangements to that end have been entered into. The leading figures in the new corporation are Clement Beecroft, long connected with, and widely known in, the talking machine cabinet field, and J. Newcomb Blackman, president of the Blackman Talking Machine Co., New York, who likewise needs no introduction to the members of this trade.

Your Record Order

—Placed with us is handled with that promptness and satisfactory attention to every detail which is only possible to a large, perfectly equipped distributing organization

You want your order promptly filled; you want the records carefully packed; you want your shipping instructions followed; you want conscientious, painstaking attention given your needs; you want service that is real co-operation— These factors applied to each and every order, large and small, is each month increasing the list of retailers whom we serve. TRY US ON YOUR NEXT ORDER! Our service is based on the desire to aid in adding to your business.

Are there those of foreign nationality in your territory? They want records

<p>HAVE YOU THE Marconi-Victor Course in Wireless Telegraphy? Don't be without this important special!</p>	<p>"First Aid Course in French" On Victor Records is an added source of profit for every dealer. How is YOUR stock?</p>
---	--

in their own tongue. The vocal and instrumental music of every country is embraced in our vast stock. Don't neglect this field for greater business.

Grinnell Bros

Distributors of Victrolas and Records

First and State Streets
DETROIT

VAN VEEN BED-SET BOOTHS

BUY LIBERTY BONDS

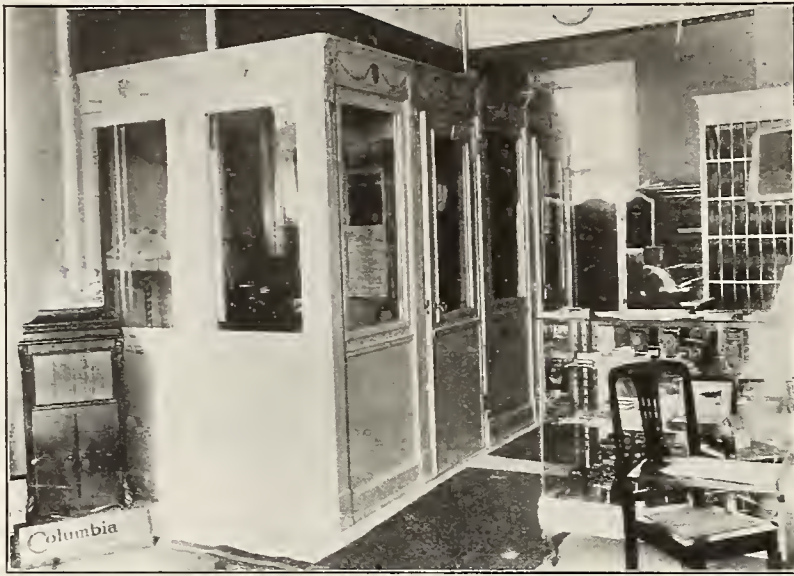

INVEST IN LIBERTY BONDS

MODEL "D-A"—BED-SET—DOUBLE CONSTRUCTION—SOUNDPROOF

CONSTRUCTION

Sectional or knock-down, built in three-foot units, with pilaster columns between, with a patented, simple and efficient interlocking device permitting satisfactory setting-up by local labor. Regular stock booths and knock-down construction most economical and satisfactory to the buyer, allowing the purchase of matched additions at any time, or the rearrangement or removal of the whole installation without damage to equipment or building walls or partitions.

REGULAR SPECIFICATIONS

This equipment is specified as soundproof. It must be understood, however, that the booths are only commercially soundproof. It is impossible to make demonstration booths absolutely soundproof unless masonry walls are built between. The booths specified are as nearly soundproof as it is possible to construct with air chambers between all the wood and glass panels and with invisible felt insulation provided at points in contact with walls or floors.

PARTITIONS—Each three-foot section complete in itself, in a single piece, eight feet over all. Double laminated and veneered panels to prevent warping or splitting, with air chambers between, throughout. Double, extra heavy, "A" quality glass, 24 in. x 46 in., throughout. Inner glass lights set in removable frames for cleaning.

DOORS constructed with double wood panel and glass surfaces, with air chambers between, like sections. With double rabbeted jambs all around. Doors fitted with glass knobs and sanded brass finished hardware.

ROOFS of heavy, ribbed sky-light glass set in framed, interlocking sections.

FINISH in any natural wood color—same inside and outside.

THE INSTALLATION PHOTOGRAPHED

This installation consists of two 6 x 9-foot booths, white enamel finish, with Adam decorative treatment on cornice and pilasters. Decorations finished in old ivory glaze. The record racks were specially designed and may be seen in the rear of the store photographed.

This installation built for R. F. Fitzsimons, 2885 Broadway, New York City.

RECORD RACKS

These record racks are made in 3-foot sections, 8 feet high, to match the booths. Each record rack has three shelves for 10-inch records and three for 12-inch records, with upright dividing partitions, 3½ inches apart on centers. Each section of rack holds about 1,400 records.

Write for a copy of our new catalog.

ARTHUR L. VAN VEEN & CO., Marbridge Building, New York City.

BUSINESS IN BALTIMORE ONLY AWAITS SUFFICIENT STOCK

Some Dealers and Distributors Report Wonderful Trade, Others Slowed Up by Lack of Goods—Good Advertising From Concerts—Why W. S. Parks Is Happy—Activity With Victor Dealers

BALTIMORE, Md., April 9.—Talking machine business in Baltimore is in a peculiar condition at this time. Some of the dealers and distributors are reporting wonderful business with remarkable increases over the same period of previous years, while others report a falling off due to the lack of goods—not to the lack of demand for machines and records, however. The month opened with better receipt of goods than for some time past, but not near enough to meet the pressing demand.

The present condition has caused several of the distributors to adopt a policy of forcing dealers to sell the kind of records they can get or do without additional machines. This in a measure has resulted in creating business of a new kind and records that have been in stock for as long as six and eight years are now moving out of showrooms. Many instances are reported of the buyers accepting what they could get instead of what they want. Dealers are forcing their salesforce to study their stock better so as to meet the present conditions of shortage of goods with as small a loss as possible.

Both the Victor and Columbia concerns were

able to obtain some good advertising for their records last week. The Victor Co. took advantage of the fact that Amelita Galli-Curci was billed to be the special soloist with the Symphony Society of New York at the Lyric on April 4 and advised music lovers to hear her and then hear her on the Victor in the home. Two days before the performance announcement was made of the illness of the artist and Lucy Gates, soprano, was substituted. The Columbia Co. at once let loose display advertising urging the public to hear Miss Gates and then to have Columbia records make her ever present in their home. Thus both companies benefited by the unfortunate event for one and the fortunate event for the other as the demand for Galli-Curci records and the Gates records are the greatest the dealers in the respective lines have ever had for any individual record. It's the old saying that it's an ill wind that blows no good.

W. S. Parks, manager for the Baltimore branch of the Columbia Co., is very happy over the phenomenal business done by his branch during March. It proved to be the greatest month's business that the branch has ever done,

and what it did to the figures of the same month a year ago would be a shame to tell. But Mr. Parks is right on the job; for instance, on Saturday, before the close of the month, he received a carload of machines. He had a lot of orders for Washington and Southern points, so he hired two big motor trucks and at 4 o'clock in the morning had the machines at the station. These machines were loaded as soon as business opened and the machines were rushed to Washington. The facilities for Southern shipping out of Baltimore by boat being a little congested at this time Mr. Parks through this stunts was able to get his goods started for their destination promptly by this move. It was just a trifle more expensive, but proved to be a way to get around the freight situation. Mr. Parks announces the appointment of Daniel De Foldes, as head of the dealers' service department.

F. K. Pennington, assistant general sales manager of the Columbia Co., was in Baltimore during the month and expressed himself as well pleased with the business conditions here. It was his first visit to the new quarters.

From General Manager H. L. Willson, of the Columbia Co., Mr. Parks received the following wire: "Heartiest congratulations to you and Baltimore's sales force on splendid March sales." He also received a wire from A. J. Heath, former Baltimore manager, but now in charge of Philadelphia headquarters for the Columbia, which stated: "Put it over on Philadelphia." Mr. Heath was in Baltimore to spend Easter and met Mr. Parks.

The Hopewell Furniture Co., Hopewell, Va., who have just received their first line of Columbia goods, are overjoyed with the outlook for good business. Thurman & Boone Co., Roanoke, Va., who have been handling the Columbia line for some time, have just rearranged their store, installed new booths and redecorated their talking machine department.

A. B. Creal and W. M. Korhammer, Jr., who are on the road for Columbia, have been sending in fine orders. P. W. Peck, who looks after the Carolinas, made a hurried trip to headquarters during the week looking after stock.

W. C. Roberts, manager of E. F. Droop & Sons Co., Victor distributors, is doing a fine retail business, but his wholesale business is retarded because of his inability to obtain goods. He says it's a regular record famine. With his wholesale trade he is demanding of all dealers that they buy an equal amount of the kind of records obtainable with every order for machine. In this way he says that he has been able to move records that have been on the shelf for at least eight years. Mr. Roberts reports that the demand for Galli-Curci and Heifetz records have been phenomenal. Had he been able to get the goods he says he would have shown very close to a 50 per cent. if not better increase over last year's business.

Henry Eisenbrandt, of H. R. Eisenbrandt & Sons, Inc., Victor distributors, is very short of goods and is making every effort to get more goods, but with little success. He says that business has naturally suffered because of the lack of records. He visited headquarters during the month and will make another trip there the coming week.

I. Son Cohen, of Cohen & Hughes, Victor distributors, says he has been unable to fill the demand for goods, despite the fact that he has been able to obtain some goods by shipment, although not near enough to go around.

Jesse Rosenstein, for the National Piano Co., Pathé distributors, has been able to get some goods, but is still short of machines and records.

The Brunswick-Balke-Collender Co. have changed their Baltimore headquarters and are now located at 107 Hopkins place. They are steadily expanding their business.

Hammann-Levin Co., Victor dealers, report a fine business in both machines and records, and say the business of the past six months is way ahead of the same period of a year previous.

The Mann Piano Co., Leopold Ehrlich, sales manager, Victor dealers, says that March business is simply fine in both records and machines.

Lufranc Quality



THE SAFEST ENVELOPES MADE

RECORD DELIVERY ENVELOPES

START THE NEW YEAR WITH A GOOD SUPPLY by Placing Your Order Now

Samples and Prices Furnished Cheerfully

Write Today Get the Best Always

LEWIS C. FRANK

654 Book Building

DETROIT, MICH.

T.M.W.1217

Columbia advertising is aimed to get more business—through you dealers. Some little time, attention and money are devoted to that one end.



**Columbia Graphophone Co.
Woolworth Building, New York**

WHY MUSIC IS AN ESSENTIAL

During War Times Discussed Most Interestingly by H. N. McMenimen

H. N. McMenimen, of the Pathé Frères Phonograph Co., recently gave a very interesting interview in connection with the importance of music in war times, and the fact that it should be recognized as an absolute essential.

In this talk Mr. McMenimen said in part as follows: "In war times music is an essential. It is a necessity in the ranks of the fighting man, for it instils the firmness of morale neces-



H. N. McMenimen

sary to success in war. It is important in the lives of civilians because it strengthens moral fibre and dissipates depression. Whether it be the stirring strains of a sonorous band, or the sounds of a soothing, sympathetic voice, it is a tonic in war times; it is a mental exhilaration that engenders physical recuperation. England and France found profound solace in melodious sounds. We may sacrifice nonessentials in this period of stress, but we can ill afford to neglect a cherished part of our cultural activities.

"Music is the universal tongue, the democracy of art, it is mental food; the kind that sustains and brings out the finer things of character, and is as necessary to us in war times as the smile of fortitude on the face of our soldiers."

The line of demarcation between luxuries and necessities is hard to see—when the necessities insist on masquerading as luxuries.

JOSEPH MUSANTE

Electro-plater and Silversmith
Gold, Silver, Nickel and Antique Finishes
Specializing in phonograph parts and musical instruments
168 CENTRE ST. NEW YORK
Telephone, Franklin 3053

TO CALCULATE PROFITS

What Additions to Cost Necessary to Determine Them—Some Interesting Data

A letter has been received by the New York Times from John Connors, secretary and treasurer of the Howe & Rogers Co., of Rochester, N. Y., containing a schedule of profit calculations which he thinks will be found very useful by the average business man. It shows, for instance, that 5 per cent. added to the cost of an article is equal to a 4 3/4 per cent. profit on the selling price. The remainder of the table follows:

ADDITION TO COST.	PROFIT ON SELLING PRICE.
8 1/2 per cent.	7 per cent.
10 per cent.	9 per cent.
12 1/2 per cent.	11 1/8 per cent.
15 per cent.	13 per cent.
16 per cent.	14 1/4 per cent.
17 1/2 per cent.	15 per cent.
20 per cent.	16 2/3 per cent.
25 per cent.	20 per cent.
30 per cent.	23 per cent.
33 1/3 per cent.	25 per cent.
35 per cent.	26 per cent.
37 1/2 per cent.	27 1/4 per cent.
40 per cent.	28 1/2 per cent.
45 per cent.	31 per cent.
50 per cent.	33 1/2 per cent.
55 per cent.	35 1/2 per cent.
60 per cent.	37 1/2 per cent.
65 per cent.	39 1/2 per cent.
66 2/3 per cent.	40 per cent.
70 per cent.	41 per cent.
75 per cent.	42 2/3 per cent.
80 per cent.	44 1/2 per cent.
85 per cent.	46 per cent.
90 per cent.	47 1/2 per cent.
100 per cent.	50 per cent.

"This schedule," Mr. Connors says in his letter, "appeared some years ago in a newspaper which I believe was and is still published in Springfield, Mass. I have never seen it published since in any paper."

HOW BOTEFUHR DEVELOPS TRADE

Live Talking Machine Man of Pittsburg, Kan., Has Built Up Big Business Among the Miners as Well as the Wealthy in His Section

PITTSBURG, KAN., April 3.—Frank S. Botefuhr has developed a business in Grafonolas that keeps him hustling. He has been established in the music business in Pittsburg for several years and has a high-class retail store which is patronized by the wealthy classes as well as others. The chief trade in Grafonolas, however, is though the Pittsburg territory, scores of machines having been placed in the last few months even in the homes of the miners, that, judging from their exterior, would have none of the modern conveniences and the essentials of American life. The miners, however, are getting \$4 and \$5 a day and they can work three days a week and have more money to spend than the ordinary city clerk who makes \$100 a month.

One of the plans of distribution Mr. Botefuhr has operated very successfully is as follows: One of his subagents will take two or three machines to his automobile and drop them at houses along the route. He will place maybe five or six along one of the main roads in the territory, in houses as close together as he can. Perhaps the next day and the following day he

will spend in placing more machines in houses along this same road. Then he will start gathering up the machines, a day or so being sufficient for a trial. In nine cases out of ten the people who have tried the Grafonola will keep it. However, if one of them should decline to buy, the agent will load the machine in his car and take it with him on his further work down this road. When he finally comes to a house that has not yet tried a machine, he will leave it at this house. In this manner the agent saves a great deal of time in placing machines and his work is even simpler than that of an agent working in a city, because his delivery expense and time occupied in picking up the Grafonola when it is not sold is reduced to a minimum. Mr. Botefuhr has been distributing considerably over twenty-five Grafonolas a month in the Pittsburg neighborhood, and one can easily imagine the large trade in records which he is building up for himself.

TEST offered to dealers to prove the superiority of Wall-Kane Steel Needles

Take two standard disc records of the same selection, play one ten times with the same WALL-KANE loud needle; play the other record, the same selection, ten times, but with ten, new, full tone steel needles.

You will find that the record played ten times with the same WALL-KANE needle will sound clearer, will have less surface noise, and that under the magnifying glass the grooves of the record played ten times with the ten steel needles will seem to be more disturbed.



Beware of Imitations

Package of 50 WALL-KANE needles. Loud, Extra Loud and Medium, greater value than 500 ordinary steel needles, retails for 10c, costs the dealer 6 1/2c.

Jobbing territories open

Progressive Phonographic Supply Co.
145 West 45th Street, New York

STOCK SITUATION A LITTLE EASIER IN LOS ANGELES

Jobbers and Dealers Getting Some Small Shipments of Machines and Records—Talking Machine Dealers' Association Discusses Trade Problems—General Happenings

LOS ANGELES, CAL., April 6.—The situation here in regard to getting stock has brightened up to a certain extent, and all of the local jobbers have been receiving small shipments of both records and machines during the last month. However, most dealers are a long way from having all the goods they need, as most of the machines received are already spoken for, which leaves none for present trade. The demand keeps up to all expectations and only the lack of goods prevents last year's records from being broken.

The Victor, Edison and Columbia jobbers seem to think that the freight situation will not be as strained as before and that goods will be coming through nearer to schedule time than before. This will be a great relief to the local dealers as the old "freight" excuse is getting rather time-worn even if true.

It really is remarkable that business has kept up as well as it has, considering the number of ways in which our patriotic citizens are coming to the front in defense of our Government by buying bonds, stamps, etc.

A great many persons are still sending machines and records to our nearby cantonments and many soldiers and sailors are themselves purchasers, especially of records, when in our city on leave. The phonograph has become very popular with the soldier boys, who get a great deal of enjoyment and entertainment from playing them. When donated for that purpose, all dealers will be glad to send them to the camps free of charge.

Talking Machine Association Meets

The Retail Talking Machine Dealers' Association of Southern California held its regular monthly meeting at the Platt Music Co. store last Tuesday evening, with practically every member present. It was decided at this meeting to continue the trial plan of refraining from advertising talking machine terms for another thirty-day period, as it seems to have been proving very satisfactory. The proposition was also discussed to further regulate sales, on a more uniform basis, by requiring that the first payment equal 10 per cent. of the contract price, with \$5 as the minimum for such payment; that 7 per cent. interest be exacted in all instances on deferred payments, and that the free records accompanying machine sales shall not exceed one-half the amount received as the first payment. These matters, however, were only discussed with a view to preparing the members for definite action at the next meet-

ing, which will be held on April 30, at Barker Bros.

A. A. Tanner, Victor dealer in Monrovia, Cal., recently gave a benefit concert for the Red Cross with a Victrola XVI electric. The machine alternated with other musical numbers and the concert was a big success with a large attendance. In all more than \$500 was made for the Red Cross.

Dan Voorhies, with the Brunswick Phonograph Co., is very enthusiastic about the way his line of machines is taking in southern California. Mr. Voorhies has placed agencies from Bakersfield in the north to San Diego in the southern part of the State, also several agencies in Arizona. The Brunswick is represented in Los Angeles by the Barnes Music Co., Lyon-McKinney and Smith, large furniture dealers, and Hamburger & Sons, the largest department store in the Southwest. The Brunswick Co. are located at 845 South Los Angeles street.

McCormack's Sensational Drive

One of the most notable musical events that have taken place in our city for some years was the Red Cross concert given by John McCormack and his company on March 18, at the Shrine Auditorium. An immense audience was present. In fact, hundreds were unable to obtain tickets and the concert was a huge success from every standpoint. Mr. McCormack was very enthusiastically received by the large audience and had to respond to numerous encores. About \$11,000 was realized for the Red Cross Society, and besides donating his services to the concert Mr. McCormack autographed forty-five of his favorite records, which were sold by the Red Cross at prices ranging from \$25 to \$100. Twenty-five of the records were donated by Barker Bros. and twenty by the Southern California Music Co.

The T. J. Johnston Music Co., for many years located on Main street, near Fourth, are moving to 406 South Broadway, where they will open an up-to-date music store of pianos, sheet music, small goods and talking machines. They are agents for the Victor and Columbia lines, and will have a very fine department.

The Curtis-Colyear Furniture Co., of 507 South Main street, Pathé dealers, report a fine business for March. Their business has been growing so fast that they are contemplating enlarging the department in the near future.

Sherman, Clay & Co. Expand

Sherman, Clay & Co., Victor wholesale, who have occupied part of the fifth floor in the Par-



Read the Trade Mark carefully, hear the machine, and you'll agree that it is truly

The World's Musical Instrument
Improves All Records
Send for our Special Proposition

HOFFAY TALKING MACHINE CO., Inc.
3 West 29th Street New York City

malee-Dohrmann Building for the last ten years, have just succeeded in leasing the entire floor, and are busy at present moving and remodeling. Chas. Ruggles, their local manager, is delighted with the change as his former space was entirely too small for the volume of business that he now has. When finished they will have nearly 13,000 square feet of space which will give them one of the largest jobbing houses for their line in the West.

The Columbia Phonograph Co., wholesale, report a brisk demand from dealers for their new period designs, several of which have been sold since they were placed on exhibition. Mr. Stidham, their manager, is very much pleased with their business, and has placed many new agencies since January 1—several of whom handle the Columbia line exclusively.

Edison Co. Take Over Local Concern

One of the most important changes in the jobbing line that has taken place in Los Angeles has just been consummated—namely, the taking over by Thomas A. Edison, Inc., of the Diamond Disc Distributing Co. This is in accordance with the policy of the Edison Co. to control the wholesale line on the Pacific Coast, this office being the last link in the chain, which extends now from Seattle to San Diego. A. C. Ireton, with headquarters at San Francisco, will be Coast manager for the new company, which will be known as the Edison Phonograph, Ltd. Mr. Ireton was formerly general sales manager for the Edison Co. at East Orange, N. J. The Los Angeles office will now have the entire State of Arizona as the El Paso wholesale house will be closed. C. A. Lovejoy, who has had charge of the Edison wholesale both for the Southern California Music Co. and afterward the Diamond Disc Distributing Co., will be retained as local manager.

Barker Bros. have enlarged their talking machine department by the addition of several new demonstration booths. C. A. Booth, their manager, says business is fine, and if it keeps up and they are able to get the goods, it will be necessary to enlarge again next fall. April first was the day for the formal opening and each customer was presented with a beautiful rose as a souvenir. Barker Brothers handle the Victor, Edison and Sonora machines.

Madam Melba was the recipient of a most beautiful loving cup given to her by several of

The "Mutual" —the ORIGINAL and PATENTED Universal Ball Bearing Tone-Arm

Beware of
Infringers
and
Imitators

No. 2 Mutual
Ball-Bearing
Spring Joint
Universal
Tone-Arm

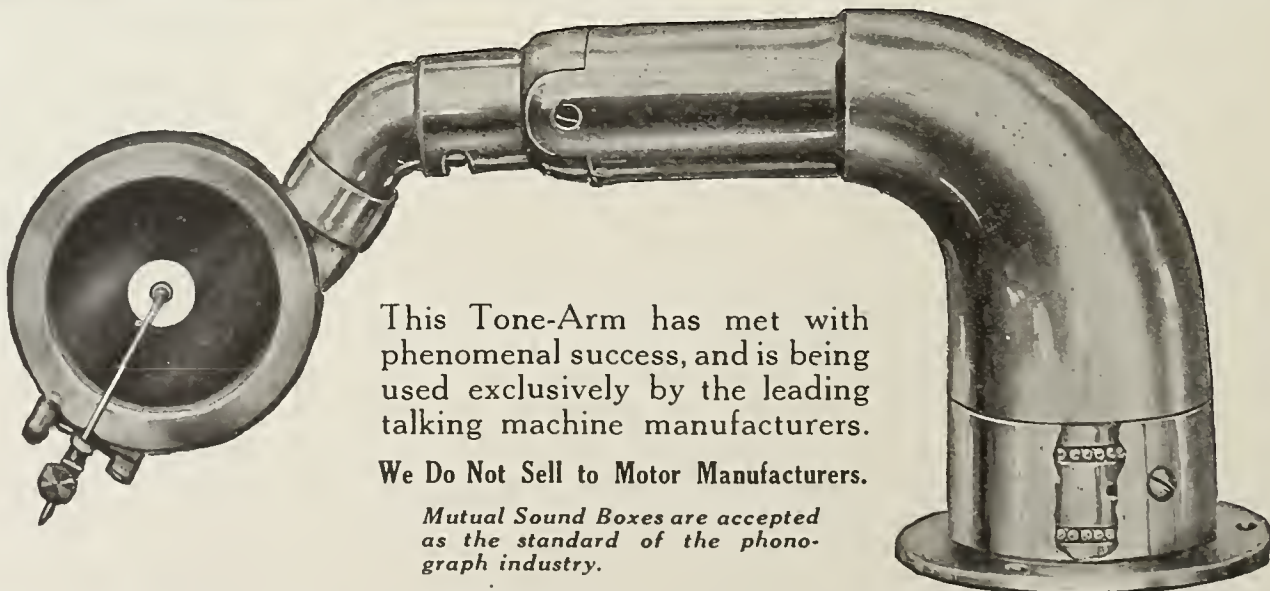

This Tone-Arm has met with phenomenal success, and is being used exclusively by the leading talking machine manufacturers.

We Do Not Sell to Motor Manufacturers.

Mutual Sound Boxes are accepted as the standard of the phonograph industry.

Write To-day
for
Samples
and
Prices

MUTUAL TALKING MACHINE CO., Inc., 145 W. 45th St., New York

Are you selling your share of Columbia Records heartening our boys at the front? There are Grafonolas in every Y. M. C. A. and Knights of Columbus Hut, and new records are like letters from home.

Columbia Graphophone Co.
Woolworth Building, New York



the leading dealers of Los Angeles. The occasion was on the night of her concert, April 8, at Trinity Auditorium. The presentation speech was made by Len Behymer, our local impresario, in his usual faultless style, and the Madam responded with a few well-chosen words of thanks. The following dealers were the donors of this beautiful gift: Andrews Talking Machine Co., Barker Brothers, Geo. J. Birkel Music Co., Southern California Music Co. and the Wiley B. Allen Co.

Hamburger & Sons had the formal opening of their new phonograph department on April 1. It is located on the third floor and is complete in every detail. Every person calling at the department received a beautiful souvenir. This house will carry the Columbia and Brunswick machines.

C. H. Yates, special Coast representative of the phonograph department of the Brunswick-Balke-Collender Co., is now making his headquarters in Los Angeles, dividing his time between this city and San Francisco. He formerly covered Southern territory for the Diamond Disc Distributing Co., Edison jobbers, and later managed the Spokane branch of the Pacific Phonograph Co. until sold to Edison Phonographs, Ltd., in 1917. Mr. Yates expects to build up an excellent trade for the Brunswick in this territory.

STRONG DEMAND FOR SMALL MOTOR

Reported by the Melophone Talking Machine Co.—Materials Purchased Before War

The Melophone Talking Machine Co. are finding the demands for the small single spring motor to be on the increase. Since the first of the year several contracts have been closed whereby deliveries in quantity lots during the balance of the year will be made to several concerns. The Melophone Co. has been unusually successful in meeting the requirements of the trade wishing a small motor for popular-priced machines which will give reasonable service. One of the reasons why this house can still market their small motor at low prices, according to the officers of the company, is the fact that all the materials entering into the motors were purchased before the war. Henry Sobel, president of the Melophone Talking Machine Co., is very active in the third Liberty Loan drive, being a member of one of the committees of the Patriotic Service League.

OTTO B. HEATON'S NEW WAR POST

COLUMBUS, O., April 8.—Otto B. Heaton, one of the proprietors of the Heaton Music Store, at 369 Fifteenth avenue, this city, has been appointed Army Secretary for the Y. M. C. A., and will leave for France very shortly to take up his new duties. Mr. Heaton has long been interested in Y. M. C. A. work and feels that he can best do his bit by assisting that organization in its efforts to increase the comfort of the soldiers on the field. The business will be continued by his brother, C. W. Heaton.

THRIVING SCRANTON STORE

Temple of Music Has Most Artistic Victor Quarters Under Management of G. W. Deetz

SCRANTON, PA., April 8.—One of the most successful talking machine establishments in this section of the State is the Temple of Music in this city, which handles the Victor line, and has developed a profitable Victrola and Victor record business.

This establishment is under the management of Guy W. Deetz, formerly connected with the Emerson Piano Co., Decatur, Ill., and well known in Western talking machine circles. Mr. Deetz came to Scranton with a thorough knowledge of the retail Victor business, and his practical experience in this field has been an important factor in the success of the Temple of Music.

This establishment was opened last fall by Stoehr & Fister, and is considered one of the most attractive Victor establishments in the East. It is a consistent user of advertising space in the newspapers, and Mr. Deetz, who is a firm believer in the value of this publicity, takes advantage of every opportunity to feature the Victor line.



G. W. Deetz

The Temple of Music is becoming more than a retail store, for it has a concert hall, which seats 500 people, and which has been the scene of many important musical events. Mr. Deetz has made this store a community proposition, and its prestige, together with the store's splendid sales totals, reflect the practicability of his ideas in this field.

CLEVER PUBLICITY POINTER

The J. L. Roark Estate, house furnishers and Victor dealers in Greenville, Ky., have adopted a most attractive gummed label for placing on Victrolas sold by the company. The gummed label is attractive in design and, in addition to the well-known Victor trade-mark, carries the name and address of the company. It has a metallic finish, and represents dull brass in appearance. The company states that it will be glad to send a sample of the label to other dealers on request.

CREDITORS TO MEET

A meeting of the creditors of the W. K. Cowan Furniture Co., bankrupt, Chicago, will be held on April 15 in Room 907, Monadnock Block, 53 West Jackson boulevard, when creditors may examine the bankrupt, file their claims and transact other business in like order.

Don't put off till to-morrow the Liberty Bond you can buy to-day.

THE NEW VEECO MOTOR

MAKES

The Electric Way the Ideal Way

All experimenting has been done in advance at the Veeco factory. Any mistakes have been rectified before, and not after, the Motors have been put on the market.

The Improved Veeco Electric Motor is designed primarily and exclusively for talking machines. Runs on either A. C. or D. C., 100-125 volts, without adjustment. Supplied to run on any voltage from 6 to 250. Mounted on 12 or 12½ inch square mahogany boards ready to install.

Combined with the VITRALOID Turntable it makes a complete motor unit for high-class machines.

SEND FOR THAT SAMPLE TODAY

Then rush your order to insure prompt deliveries.

THE VEECO COMPANY

248 Boylston St.

Boston, Mass.

ENJOY VISITS TO THE MEISSELBACH AND DEAN FACTORIES

The Resources of These Establishments and the Methods of Manufacturing the Various Products Enlighten Branch Managers of Otto Heineman Phonograph Supply Co. During Recent Visit

When the branch managers of the Otto Heineman Phonograph Supply Co., Inc., visited New York recently for their annual conference, one of the most enjoyable trips during this conference was a visit to the factories of the company's Meisselbach division at Newark, N. J. One day was spent at this plant, and the visiting managers were greatly impressed with the efficiency which characterizes every department of the Meisselbach factories. They marveled at the new machinery which was recently installed, and, after going through the factory from garret to cellar, stated that they now readily understood how the Meisselbach motor had gained its fame and prestige in the phonograph industry.

A. F. Meisselbach, head of the Meisselbach division of the Otto Heineman Phonograph Supply Co. and vice-president of the company, is a pioneer in the motor manufacturing industry, and his intimate knowledge of every detail of motor production has enabled him to place his motor in the front ranks of the industry's products. Mr. Meisselbach is ably assisted by Pliny Catucci, who is recognized throughout the trade as possessing a technical knowledge of motor construction that is second to none. He has developed and perfected many important improvements that have contributed materially to the success of the Meisselbach motor.

A. F. Meisselbach & Bro. started in business thirty-five years ago as manufacturers of fishing reels, and a few years ago placed the Meisselbach motor on the market. From the moment it was introduced this motor won the approval of the manufacturers, and this factory has been

arms, and sound boxes have won new laurels in the talking machine industry.

how Dean steel needles are manufactured. They quickly recognized the fact that, there are many intricate processes connected with steel needle production that are hardly appreciated by the talking machine industry as a whole, and under the guidance of Chas. E. Dean and John M. Dean, Jr., inspected every department of the

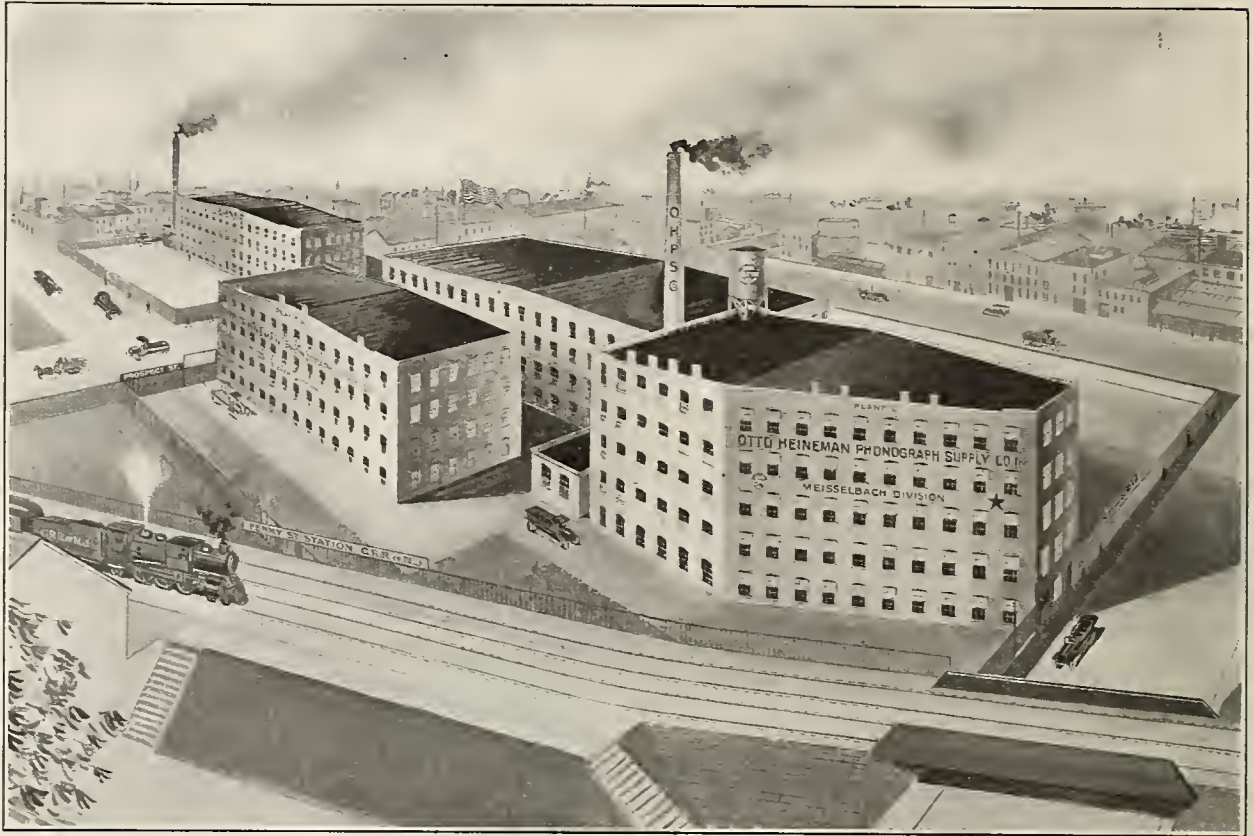

Plant of the Meisselbach Division of the Otto Heineman Phonograph Supply Co., Newark, N. J.

During their stay in New York the branch managers of the Otto Heineman Co. also spent a day at the factories of the company's Dean plant. The Dean division of the Otto Heineman Co., although the "baby" of the organization, is becoming more important day by day,



A Group of the Visiting Branch Managers

far oversold for more than two and a half years. The company was amalgamated with the Otto Heineman Phonograph Supply Co. a year ago, and since that time Meisselbach motors, tone

division at Putnam, Conn., where Dean steel needles are manufactured. They had an opportunity of going through the new building, which was recently completed, and saw at first hand

and Adolf Heineman, assistant general manager of the company, who is in charge of this division, is proud of its equipment and increased output aimed to meet world-wide demands.



Plant of the Dean Division, Putnam, Conn.



Harponola

Mr. Manufacturer

Wonderfully, artistically and well-built Cabinets, produced by a furniture manufacturer of high repute.

Mr. Jobber

Fully equipped Machines under your trade mark or ours, in carload lots at jobbing discounts.

Mr. Dealer

High-class Cabinets, equipped with the best mechanical equipment money can buy.

Prices that are right in each case. Send for particulars.

THE CELINA FURNITURE CO.
CELINA OHIO

A6032 is a dance record in Columbia's May List, certain to set one-steppers prancing. Put it on and watch it sell itself.

**Columbia Graphophone Co.
Woolworth Building, New York**



TALKER MEN HAVE LIVELY TIME

Talking Machine Men, Inc., Cast Tie Vote on Question of Barring Jobbers From Active Membership—Other Questions Taken Up

The feature of the regular monthly meeting of the Talking Machine Men, Inc., held in the rooms of the Merchants' Association in the Woolworth Building on Wednesday, March 20, was the discussion and vote on the amendment to the by-laws recently introduced and designed to confine active membership in the organization to retail dealers exclusively and place jobbers and wholesalers in the class of associate members.

J. Newcomb Blackman, who is president of the National Association of Talking Machine Jobbers, made a strong talk in favor of the amendment and gave some excellent reasons for making the change. Henry Mielke and others also spoke in favor of the measure. Those opposed to making the change in the by-laws included Irwin Kurtz, A. H. Mayers and Max Landay. Several votes were taken on the question, but the final result was a tie, and it was decided to postpone the final decision until the next meeting, when all members will be notified to attend for that special purpose.

Various other committees, including that on membership, and the one entrusted with securing a general agreement to charge 6 per cent. interest on instalment contracts, reported progress.

J. H. Mayers, chairman of the nominating committee, presented the following slate for the coming year, which will be voted on later: J. T. Coughlin, for president; Sol Lazarus, vice-president, New York; A. H. Tusting, vice-president, New Jersey; A. B. Clinton, vice-president, Connecticut; E. Leins, financial secretary, and A. Galuchie, treasurer. Irwin Kurtz was nominated recording secretary but declined and the nomination was left open.

It was felt by the majority of the jobbers, as well as a number of the dealers, that to obtain the best results each branch should have its own association, and that the membership in the Talking Machine Men, Inc., should be confined exclusively to retailers, as planned originally. The wholesalers were of the opinion that they could still give the retailers the benefit of their advice when desired, and of their cooperation through the holding of associate memberships in the association.

The opposition centered largely around the claims of Max Landay, of Landay Bros., who has done excellent work in developing the membership of the association and strengthening its treasury, that to bar him as a jobber from active membership, would be to curtail his usefulness to the organization.

The sacrifices we are exacting of the noble American boys who are going to the bloody fields of France for the lives and liberty of us who stay at home call to us with an irresistible appeal to support them with our most earnest efforts in the work we must do at home.—Secretary McAdoo. Buy Liberty Bonds.

DEVELOPED MAIL ORDER TRADE

J. A. Sandee, of the Victrola Department of L. S. Donaldson Co., Minneapolis, Tells of Plans of Procedure in This Connection

MINNEAPOLIS, MINN., April 3.—J. A. Sandee, manager of the Victrola department in the big department store of L. S. Donaldson Co., this city, has methods of doing business that should interest talking machine dealers generally, inasmuch as they have proven successful. Mr. Sandee came to Minneapolis something like a year ago from Milwaukee, and, although the Donaldson department was supposed to be on a very profitable basis at that time, he made it yield still greater returns.

The big end of the increased sales Mr. Sandee attributes to the mail order department which he has cultivated most assiduously while the approval system for records has been of substantial help in building up the business. The house issues twice each year a big mail order catalog in which Mr. Sandee is allotted two pages; one he devotes to records and the other to machines, and on both he has planted the most compelling advertisements he is able to produce. They are pulling the business, the approval feature for records having proven most successful. The approval plan also is operated in the city, but not to as great dimensions as in the country.

In the city the delivery wagons leave records as indicated by approval customers. These are allowed twenty-four hours in which to make se-

lections and must then deliver the records or the equivalent in cash to the delivery wagon drivers, who cover the entire city and have regular routes. Rural patrons are permitted forty-eight hours within which to make returns.

All approval customers are listed in a card index. On the respective cards are enumerated the catalog numbers of the records requested in black ink and the numbers of the records taken later appear in green ink. A hasty glance at the card discloses at a glance whether the customer is a "live" one, that is to say, an actual buyer, or a "dead" one. The latter soon are eliminated, if they refuse to heed a gentle reminder that the Donaldson Co. is not operating its approval system solely for the amusement of people. From 12,000 to 14,000 records are kept in stock.

Manager Sandee makes excellent use of the appearance of phonograph stars in Minneapolis by striking advertisements and in other ways. Harry Lauder on a recent visit to Minneapolis was the guest of the Donaldson Co. at the store for an entire day and made a big hit. Galli-Curci and Evan Williams records were featured when those distinguished artists visited Minneapolis.

Says an experienced salesman: The great factor in selling is the human factor, and not the things we sell. The things must be right, of course; but it's people who buy and use the things, and therefore it's people whom we must interest and deal with in getting rid of things.

Melophone Single Spring Motor

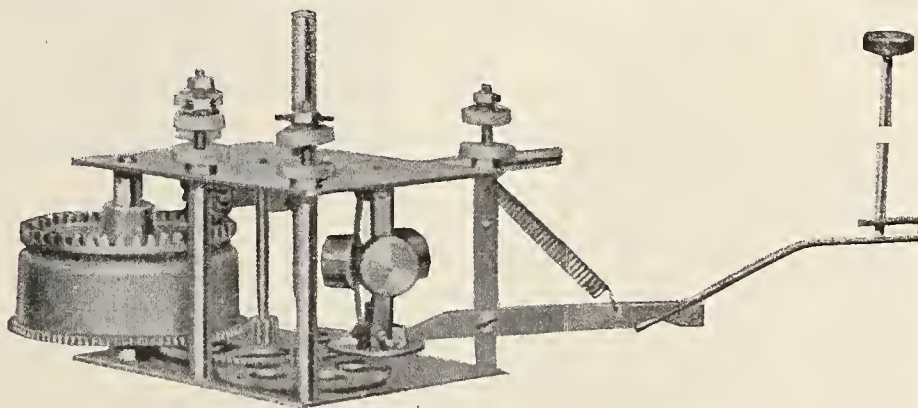

COMPLETE WITH 10-INCH TURNTABLE

Simple in construction, the most satisfactory and durable of all small motors.

Plays 2 ten-inch records with one winding.

Three years' successful record as the best single spring motor manufactured.

PRE-WAR PRICES

IMMEDIATE DELIVERIES

Melophone Talking Machine Co.

380 Lafayette Street, New York

29 E. Madison Street, Chicago

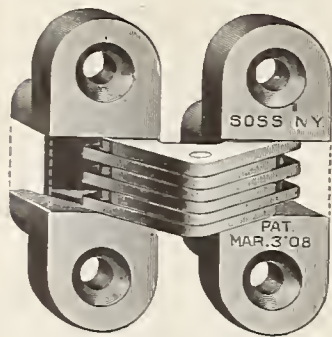

SOSS

INVISIBLE HINGES

Preserve Beauty

In many beautifully designed, finely finished Talking Machines, Pianos, Music Cabinets, Piano Players and Benches, the elimination of the unsightly protruding Hinge is essential to preserve the beauty of the design.

Design and Construction

The fine cabinet work which is required in many instances to preserve the disguise of the instrument requires that the hinges be as inconspicuous as possible. SOSS Hinges are *invisible*.

WRITE FOR CATALOGUE "T"

SOSS MANUFACTURING COMPANY, 435 Atlantic Avenue, BROOKLYN, N. Y.

DETROIT—922 David Whitney Bldg.
SAN FRANCISCO—164 Hansford Bldg.

LOS ANGELES—224 Central Bldg.
CHICAGO—John C. Bold & Co., Clark and Washington Sts., Conway Bldg.

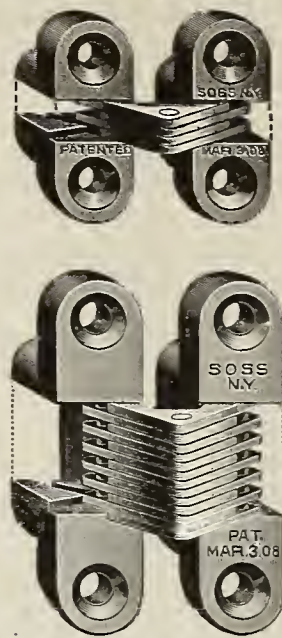

PENNINGTON ON WESTERN TRIP

Assistant General Sales Manager of Columbia Co. to Visit Company's Branches

Frank K. Pennington, assistant general sales manager of the Columbia Graphophone Co., left Wednesday night for a trip to the Columbia branches in Pittsburgh, Cincinnati, Cleveland and Detroit.

Before leaving for the West Mr. Pennington commented upon the fact that the Columbia Co. closed in March the biggest month in the history of its business. This record is remarkable in many respects, and indicates the wonderful strides which the Columbia Co. has made during the past year. April has also started in as a record-breaker, and it is quite possible that this month will outdistance the figures for March.

BRICK BROS. MERGE STORES

Leon & M. B. Brick, proprietors of Brick's Music House, Brooklyn, N. Y., successful dealers in talking machines, music kodaks, etc., have merged their two stores, formerly located at 1808 Pitkin avenue and 1743 St. John's place, and moved the entire stock of both stores to elaborate new quarters at 1803 Pitkin avenue. Formal opening of the new store was held on April 6.

ONE OF DETROIT'S PROGRESSIVE TALKING MACHINE STORES

DETROIT, MICH., April 6.—Under the heading of "The Store Within a Store," there recently appeared in the Michigan Druggist, a magazine for the retail druggist, a very interesting article in connection with the Pathéphone salesrooms in the general offices of Williams, Davis, Brooks

an impression that will please and last. Even the 'stars' hang on the walls.

"Especially interesting is the view of the show windows from the 'street.' They are dressed in the latest approved displays which are made from cut-outs and panels furnished by the pho-



"The Music Without the Blur!"

This ideal of talking machine manufacture is attained more nearly than by any other, in the construction of the

MARVELOUS MAGNOLA
"Built by Tone Specialists"

"Magnola's Tone Deflector eliminates the scratch"



Watching The Music Come Out

We want to show you how to make money with MAGNOLA; and how MAGNOLA is the best buy on the Talking Machine Market to-day.

Send us your name and let us send you some real Talker Tips.

MAGNOLA TALKING MACHINE COMPANY

OTTO SCHULZ, President

General Offices 711 MILWAUKEE AVENUE CHICAGO
Southern Wholesale Branch 1530 CANDLER BLDG. ATLANTA, GA.

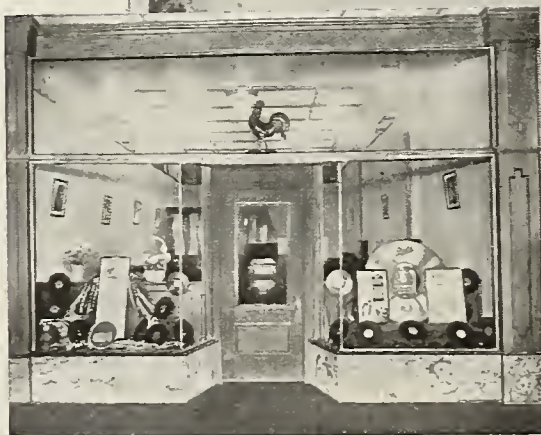

Interior and Facade of Pathéphone Salesroom in the General Offices of Williams, Davis, Brooks & Hinchman Sons, Detroit

nograph manufacturers, some standard fixtures and a few records taken from stock. The illustration, which is greatly reduced, conveys but little of the real 'sales-ability' of the displays which were arranged with much thought and care.

"The 'store within a store,' besides being an admirable model in every detail, makes a convenient salesroom for Williams, Davis, Brooks & Hinchman Sons, as it is pleasantly isolated in their large general offices.

"Williams, Davis, Brooks & Hinchman Sons is perhaps the oldest firm handling phonographs, having been established in 1819. The company, however, has been in the phonograph jobbing business about two years. In this time they have twice enlarged their record stock floors to meet the requirements of a rapidly growing business."

L. N. Bloom, Edison jobber at Cleveland, drove to Orange last week to personally deliver the new Marmon car purchased by C. H. Wilson, vice-president and general manager of Thomas A. Edison, Inc. Mr. Bloom reported bad roads in places and made the trip in remarkably short time considering the period of the year.

& Hinchman Sons, of this city. This well-known concern is the Michigan jobber for the products of the Pathé Frères Phonograph Co., and has succeeded in developing a splendid dealer representation for these products. The firm was established in 1819, and is therefore one of the oldest firms in the country handling talking machines. The article reads:

"The phonograph dealer who visits Williams, Davis, Brooks & Hinchman Sons, Michigan agents for Pathéphones, finds in their office a 'store within a store.' This store within a store, as illustrated by the above photographs, is like hundreds of phonograph shops on the main streets of New York, Chicago, Detroit and other large and small cities.

"In this store, which is of the usual dimensions, is a demonstrating booth with the familiar ventilators; several phonographs in an interesting arrangement—set at various angles, here a lid lifted or doors open—all planned to make

FROM OUR EUROPEAN HEADQUARTERS

2 GRESHAM BUILDING, BASINGHALL STREET E. C., LONDON, W. LIONEL STURDY, MANAGER.

The Economic Position of the Gramophone Industry Interestingly Analyzed—Displaying Enemy Manufactured Goods for Information and Emulation Where Necessary—The Labor Situation—War Needs Dominating Everything—Records Continue to Go Up in Price—Murdoch Trading Co., Ltd., Rehabilitated After the Fire—Winner's Record Exchange Scheme—Talking Machine Society News—Granados Dances Recorded—Records by Clara Butt—J. H. Pease's Enterprise—The Apprenticeship System Being Revived—All the News From England Interestingly Presented

signs already point to a severe British handicap, not on production capacity, as so much on the question of prices, whatever the terms of peace may be. The claims of labor are growing somewhat exorbitant, and the enormous wages now paid reflect the standard which is already on the cards as a post-war demand. There are many other prospective factors, but none the less real, which British commerce must face. Enterprise and new developments are thereby restricted. The German workman will put in longer hours at a less wage than the British workman, and with the additional aid of Government support in the way of subsidies, continental concerns possess a flying start on their competitors. Face the position frankly; look both ways, and we shall be able better to appreciate where our prospects of commercial growth commence and end. One is moved to the expression of such thoughts by the continual reproaches leveled at the heads of British manufacturers for their alleged inability to study local conditions in the different world markets. There may be something in it, but not to the great extent the newspaper scribes would have us believe. Let us have done with the persistent adjurations to prepare for the war after the war; let's get the real war over first, and then act instead of talking. The Government is doing all that need be at the moment, by arranging exhibitions of enemy manufactured goods from all parts of the world. One such display has recently been opened at the Department of Overseas Trade, 73 Basinghall street, London, where some 10,000 samples of German and Austrian goods are on view. Eighty different world markets are represented. It should be of the greatest possible service to

British firms, as showing in which branches of trade the Germans excelled, and the demands of the markets to which they sent their goods. To meet these indicated trade openings every effort will doubtless be made, but we must not run away with the idea of attaining immediate success. There are too many insurmountable difficulties in the way, which cannot be overcome while the war is on. As an instance to manufacture one line of goods in which the Germans previously excelled, one British firm put down plant no less than four times, but on each occasion it has been commandeered by the Government for war output. It is now almost an impossibility to obtain sanction for the installation of plant for other than actual war work, and as all suitable factories are fully utilized, it will be seen that the prospects of capturing enemy trade is not so bright as to justify so much discussion as is gratuitously leveled at British enterprise. In this connection, the talking machine trade is a typical example. Before the war our markets were controlled by enemy and neutral manufacturers, particularly as regards motors. Where are the British motors to-day, after three and one-half years of freedom from enemy imports? Their absence is not due to lack of ability to make them. It is due solely to lack of facilities, and until the war is over these facilities will not be available. By then, however, the British motor will soon make its appearance. Meanwhile, let us have done with so much talk. Let us get on with the humanitarian task ahead and get the war over!

"His Master's Voice" Records of Pamela

The popular musical comedy "Pamela," now

(Continued on page 116)

LONDON, ENGLAND, E. C., March 30.—The future economic position of the British gramophone and record industry, as with other trades, is a matter in which we all are interested. During the last decade statistics have enlightened us regarding the rapid growth of continental exports to all parts of the world, and particularly so in the case of Germany. In the latter instance, the percentage of increased returns in almost every department of commerce, has given our manufacturers, and indeed, the British Government, reason to think. There is much to ponder over. While I need not at any great length enter upon a disquisition as to the reasons why British world trading has proportionately declined in comparison with German attainments, one cannot balk the fact that continental methods and adaptability have proved superior to the British system in the race for commercial eminence. Consideration must also be given to the important difference between the two systems as regards labor conditions and fiscal policies. I am not going to commit myself to any definite prognostication, but the



"His Master's Voice"

Copyright

'His Master's Voice'

—the trade-mark that is recognized throughout the world as the

HALL-MARK OF QUALITY

Branches

DENMARK: Skandinavisk Grammophon-Aktieselskab, Frihavnen, Copenhagen.

FRANCE: Cie. Française du Gramophone, 115 Boulevard Richard Lenoir, Place de la République, Paris.

SPAIN: Compañía del Gramófono, 56-58 Balmes, Barcelona.

SWEDEN: Skandinaviska Grammophon-Aktiebolaget, Drottning Gatan No. 47, Stockholm.

RUSSIA: The Gramophone Co., Ltd., 45, Nevsky Prospect, Petrograd (Petersburg); No. 1 Solyanka, Solyanoi Dvor, Moscow; 9, Golovinsky Prospect, Tiflis; Nowy-Swiat 30, Warsaw; 33, Alexandrowskaya Ulitsa, Riga; 11 Michailovskaya Ulitsa, Baku.

INDIA: The Gramophone Co., Ltd., 139, Balhaghatta Road, Calcutta; 7, Bell Lane, Fort, Bombay.

Great Britain :

The Gramophone Company, Ltd.

HAYES - MIDDLESEX - ENGLAND

Agencies

AUSTRALIA: S. Hoffnung & Co., Ltd., Sole Concessionaries of The Gramophone Company, Limited, 163, Pitt Street, Sydney.

NEW ZEALAND: Gramophonium, Ltd., 118-120 Victoria Street, Wellington.

SOUTH AFRICA: Darter & Sons, Post Box 174, Capetown; Mackay Bros., Post Box 251, Johannesburg; Mackay Bros. & McMahon, Post Box 419, Durban; Ivan H. Haarburger, Post Box 105, Bloemfontein; Franz Moeller, Post Box 108, East London; B. J. Ewins & Co., Post Box 86, Queenstown; Handel House, Kimberley; Lanrence & Cope, Post Box 132, Buluwayo; The Argus Co., Salisbury.

EAST AFRICA: Bayley & Co., Lorenzo Marques.

HOLLAND: American Import Co., 22a, Amsterd Veerkade, The Hague.

ITALY: A. Bossi & Co., Via Orefici 2, Milan.

EGYPT (Also for the Soudan, Greece and the Ottoman Empire): K. Fr. Vogel, Post Box 414, Alexandria.

This intensely human picture stands for all that is best in music

—it is the "His Master's Voice" trade-mark, and it brings to you, no matter where you are, the very best music of every kind, sung and played by the world's greatest artists—the greatest singers, pianists, violinists, orchestras and bands—all enshrined in the unequalled "His Master's Voice" records

FROM OUR LONDON HEADQUARTERS—(Continued from page 115)

being played at the Palace Theatre, is rich in pretty songs and love melodies, a combination of fun and sentiment. The part of fair Pamela is charmingly undertaken by Miss Lily Elsie, whose beautiful voice has been faithfully "caught" by the "His Master's Voice" in a series of solo and duet records (with Owen Nares), comprising the hits of the piece. All the vocal numbers are accompanied by the Palace Theatre Orchestra, conducted by Herman Finck. On a splendid twelve-inch double we have a potpourri of the songs charmingly recorded by the Mayfair Orchestra. The music by Frederic Norton is throughout of that quality, which quickly attains the standard of popularity that greets one here, there, and everywhere. These "Pamela" records bid fair to reach great sales, and the trade is therefore ordering heavily.

Another Record Increases in Price

As I foretold when the comparatively recent increase in the price of eighteen-penny discs was announced, it has come about that other record makers are falling into line on the question of price. Messrs. Pathé Frères have held out as long as possible, as much for political reasons as any, I imagine. Outside a few insignificant makes, records of all grades have been affected by war-time circumstances, necessitating an alteration in price. The enormously increased cost of materials, labor, transit and other charges since the war blazed out in August, 1914, has either meant increased prices for records, or bankruptcy. Manufacturers loyally refrained from making any alteration until compelled by these conditions so to do, and even now I venture to think that the 33 $\frac{1}{3}$ % average price increases agreed upon will have to be revised in alignment with the still expanding cost of manufacture, before the war is over. The manufacturer's profit is cut to a minimum. Record buyers are, generally speaking, earning exceptionally good money, and it would be no hardship to them if they had to pay a little more for the splendid quality records now issued. Output facilities are short of the demand, and increased prices would ease the situation to the advantage of the trade generally.

A Continuous Record Exchange Scheme

It has ever been a thorny question as to the best way of insuring to every dealer an up-to-date stock. Some records get broken, some become second-hand by reason of shop use, while others take up more or less permanent lodgings with the dealer, for somehow or other their sales are too few and far between to warrant house room. These three classes of records represent scrap, which may now be exchanged under a system recently devised by the Winner Record Co. for new records. The scheme is based upon a continuous exchange in force all the year round, except during the busy months of November, December and January. By this system dealers can at any time make a clearance of their scrap records for new "Winners"

at the rate of six to one. All makes of records, except two or three specified, are accepted as scrap, and on a minimum consignment of six dozen, the Winner people pay carriage both ways. Dealers who agree to the terms are offered a guarantee that the company will not vary the exchange terms, notwithstanding the upward tendency of prices, for a period of two years, subject to three months' notice being given in writing. There are various minor qualifications, and all interested are invited to write the Winner Co. for exact particulars.

As between dealer and manufacturer there is a mutual value in this exchange scheme. The company secure a goodly supply of material, of which there is a shortage, in addition to the obvious publicity advantages. On the dealer's side is the important consideration of always having fresh up-to-date stock by the acquisition of new current titles for broken or otherwise unsalable records. It is therefore a business scheme which, as such, benefits equally all parties subscribing thereto. On these grounds there can be no hesitation in recommending the retailer to investigate the merits of this offer, which, I think, can be accepted on its face value as a good proposition for both sides.

Proposed Revival of Apprenticeship System

This subject, which had become a strongly advocated one generally before the war, is again arousing interest in certain trade quarters, though it is realized that no substantial revival can take place until after the declaration of peace. Upon the occasion of a recent address, Lord Leverhulme, who, by the way, himself served an apprenticeship, said:

"We welcome the proposed revival and strengthening of the ancient apprentice system. There is no doubt that the individual training given by the father or master with expert knowledge was far more to them than any other experience they had. What is most valuable in this system is the individual human touch. We were becoming far too mechanical. Businesses in every direction were getting larger, and the shopman might never see the manager."

Some few years ago the writer took an active part in developing the old apprenticeship system. It was found that employers, especially those of the arts and crafts school, were eager to sign indentures of apprenticeship with suitable boys, often without a premium, but were in later years somewhat reluctant to bind themselves, owing to the failure of the courts to strongly uphold the agreement when, as not infrequently happened, the apprentice broke away for a more immediately lucrative blind-alley occupation.

To-day, the system is more or less a dead letter, though, owing to the general scarcity of labor, employers are only too willing to teach their trade to women. And the women have come forward splendidly. They have shown an aptitude which has quickly won an undreamt-of success, in trades previously thought to re-

REX GRAMOPHONE CO.
are making a Specialty of
EXPORT
in
Horn, Hornless & Portable Disc Machines
REX GRAMOPHONE CO. 2 Elizabeth Place
Rivington Street, LONDON, E.C. 2
Cable Address "Lyrecodisc, London" Enquiries Solicited

quire years of tuition to insure proficiency. May the good work go on, as much in the interests of the gramophone, as of other industries, until our warriors are ready to discard the sword in favor of their old-time associations.

Smart Reorganization After Disastrous Fire

Notwithstanding the loss of their Farringdon road premises and the whole of the valuable stock by fire, as reported a few issues ago, the Murdoch Trading Co., Ltd. (now incorporated with J. & G. Murdoch, Ltd.), have already got things in fine working order at their new location, 59 Clerkenwell road, London, E. C., and are replenishing as fast as possible new stocks of gramophones and records and other musical instruments. In certain lines and parts there will naturally be a shortage for some little time, owing to the great difficulty of manufacture, but dealers may continue to rely upon a good service from this enterprising firm.

A Reputation Regained: Old Offense Wiped Out

How a musical instrument trader regained his good name and was restored to his rank is told in a brief announcement in a recent issue of the London Gazette, as follows:

"The permission granted to Lieutenant-Colonel and Hon. Colonel Thomas James Stockall (now known as Thomas James) to retain his rank and to wear the prescribed uniform on retirement, also the award of the Volunteer Officers' Decoration, which were canceled in the London Gazette on November 16, 1909, are hereby restored. Never mind what was his offense; it is a thing of the past and rightly belongs thereto, in view of his Royal pardon, upon which all having knowledge of the past incident, will heartily congratulate the gallant Colonel."

On the outbreak of war Colonel Stockall unsuccessfully offered his services to the war office, and upon attempting to enlist in the ordinary way was rejected on account of age. He eventually took a position as civilian clerk in the army pay corps under an assumed name. The happy sequel was the grant of a free pardon from the King. Good luck, prosperity and long life to Colonel Stockall

The Elman String Quartet

An outstanding record of merit on the "His Master's Voice" March supplementary list is No. 08056 Quartet in G major, Adante (C. Von Dittersdorf) by the Elman String Quartet, comprising Mischa Elman and Messrs. Bak, Rissland and Nagel, of the Boston Symphony Orchestra. This attractive melody is rendered in a manner which bespeaks a true sympathy be-

EDISON BELL**WINNER**
TRADE MARK
GRAMOPHONE RECORDSCABLE
"PHONOKINO,
LONDON"**ARE THE GREATEST VALUE FOR MONEY PRODUCED IN GREAT BRITAIN**

TEN INCH

DOUBLE SIDED

NEEDLE CUT

PLAY ON ALL GRAMOPHONES**Catalogue contains 4000 Titles by the Premier Artistes, Instrumentalists, Orchestras and Bands of the British Empire**

DEALERS PREPARED TO DO BUSINESS ARE INVITED TO COMMUNICATE WITH

Proprietors and Manufacturers, J. E. HOUGH, Ltd., 62 Glengall Road, London, S. E. 15, England

FROM OUR LONDON HEADQUARTERS—(Continued from page 116)

J. Stead & Co., Ltd.
Manor Needle Works
SHEFFIELD, ENGLAND
 MANUFACTURERS OF
Talking Machine
Main Springs
Best Prices—Best Quality
Inquiries Solicited

tween the players, each instrument blending in a rich volume of sound and perfect ensemble, controlled by the great violinist, Mischa Elman. Of the recording itself one need only say that the "H. M. V." musical director is a master.

Memos From "The Voice"

Home on leave, Corporal Stewart Gardner was a recent visitor to "His Master's Voice" factory. He took the opportunity of recording several songs.

Congratulations to Lieutenant Toplis Green on winning the military cross for a brave action at the front!

A Musical Box on Records

A refreshing novelty, with a charm all its own because it brings back memories of former days, will be found in William Murdoch's Columbia record this month of Laidow's "Musical Box."

Historical Notes as Aid to Advertising

Most advertisers commence their advertisements with a mention of the goods they have to sell. For displayed advertisements that is perhaps the best method. But there are other forms of publicity, and particularly effective is the editorial style adopted by Thos. Edens Osborne, the Belfast gramophone factor, who centers the interest of his readers by an initial chat regarding Belfast history. The "Historical Notes" series is running in all the chief local newspapers. Easily coupled up with an introduction along these lines is the advertisement offer, and I should imagine it is a profitable style to adopt; it is certainly commendable.

The Talking Machine Society Movement

Society news is now a regular feature of the various British gramophone journals, which allocate each month a liberal amount of space to the doings of these associations. Notwithstanding that many members are now engaged in more warlike pursuits, the movement is as vigorous as ever. Occasionally we hear that some new society is in process of formation at this or that town, the object being to promote the development of music generally, and of the gramophone or phonograph in particular. As a result of these informal gatherings, where discussions take place anent the relative values of different makes of records, helpful criticism and suggestions for the betterment of mechanical

music often emanate to the advantage of record manufacturers, who are not adverse to trying out any suggestion likely to prove of value.

The societies are composed of enthusiasts, each of whom in turn takes over the responsibility of the weekly-night entertainment. This is usually in the form of a carefully-chosen program, interspersed with studiously critical comments, both instructive and highly interesting. Each member is nothing less than a walking advertisement for the gramophone, and as such deserves every encouragement.

Much Illness Prevalent

The changeable weather conditions recently experienced, combined with the extra strain placed upon all by wartime circumstances, has resulted in much illness, the talking machine community being no exception. The tendency is to carry on at all costs, owing to scarcity of stuff, and early symptoms of illness which in the ordinary way would justify a rest, are neglected. It is perhaps an unwise policy in the long run, for in many cases a serious breakdown sooner or later is in consequence unavoidable. A number of leading gramophone men in this way have been compelled to rest awhile, though in a few cases illness has supervened. Among others, I learn that Mr. Gilberg, of W. H. Reynolds, Ltd., who has been laid up for some time, is now well on the road to convalescence. It is to be hoped he will soon be in harness again.

Employment of Aliens Controlled

By an order in council the provisions of the Aliens Restriction (Consolidation) Order, 1916, is extended to provide that as from March 1 a male alien between the ages of eighteen and sixty-one may not undertake or perform work for an employer in certain scheduled occupations, unless permission in writing has been obtained by him from the Director-General of National Service. Aliens engaged upon such work prior to March 1 may continue without any such permission until notice to the contrary is sent or given to him and to his employer by the Director-General. Employers are required to have regard to the provisions of this order in employing aliens. A list of occupations and trades classified is given, but in the usual official way, so that it is not quite clear whether the gramophone trade is affected. I should be inclined to think it is, as coming under the item of "miscellaneous manufactures," or "miscellaneous occupations." Anyway, to be on the safe side, British firms should obtain a ruling from the Director-General of National Service.

Granados' Spanish Dances

Probably no single orchestral record of the kind has ever attained so immediate a success as has met the Columbia record of the first two of Granados' five Spanish dances, played by Sir Henry J. Wood's Orchestra. Sympathy with the ill-fated composer, who lost his life at the hands of the Germans, probably played some part in this, but, over all, the merit of the enchanting music itself, and the remarkable per-

Soundboxes

If you are after a genuine offer of soundboxes, you'll do well to communicate with us immediately. We have tens of thousands of perfect soundboxes, fitted with the best quality mica. Confidently recommended for cheaper machines, absolutely reliable and give excellent reproduction. Price to clear \$50 per gross, F. O. B. London.

Orders for less than gross lots not accepted

Wire "Knotaslepe, London".

W. H. Reynolds (1915) Ltd.
 45, City Road, London, E. C.

Write for new illustrated Complete Catalogue

formance of Sir Henry J. Wood's musicians, must have met with their reward.

"The Old Folks at Home," by Clara Butt

There are songs of which the world will never weary—songs, that hackneyed though they may be, seem to clutch at the heartstrings and fill the air with memories. And there are singers—but not many—who can infuse those songs with a life that makes them throb in our very ears. Such a song is "The Old Folks at Home"—such a singer, Madame Clara Butt. Once more, a perfect Columbia record by the divinely-gifted contralto who seems to have sung her soul itself into it. Indeed, she declares it to be the finest record of her voice yet made.

A Dealer's Wartime Enterprise

A retailer of the "push and go" order is J. H. Pease, of Southend and Leigh. Nowadays most dealers are on the defensive, which, circumstances considered, is not altogether a matter for criticism. Offensive tactics though usually prove the more successful way of conducting a business, as witness the bold move recently made by Mr. Pease in opening up additional showrooms in Southend. The business has been formed into a private limited liability company under the style of J. H. Pease (Southend), Ltd., and, following this, certain developments have taken place. The whole concern has been reorganized, and, with the addition of the new premises mentioned, Mr. Pease will undoubtedly enhance his already splendid local reputation for prompt and up-to-date service. In addition to most musical instruments, all the chief makes of records are stocked as fully as is possible these days, and it is seldom a customer cannot get the titles he wants.

GUARDSMAN RECORDS

REGISTERED

10 inch and 12 inch Lateral Cut

We can ship you *immediately*, any quantity of Records:

BANDS ORCHESTRAS INSTRUMENTAL SOLOS VOCAL

SELECTION OF AMERICAN AIRS

including, "Marching Through Georgia"—"Dixie"—"Arkansas Traveller"—"Red, White and Blue"—"Star Spangled Banner," etc., etc., Recorded by Full Regimental Band of H. M. SCOTS GUARDS. Get Ready Now for the Big Trade coming and have

THE FINEST RECORDS of THE FINEST TITLES at THE FINEST PRICES

Apply for Lists and Prices to INVICTA RECORD COMPANY, Ltd.

Cables: Duarrab, London

1 New Inn Yard, London, E. C., England



TRADE MARK

WORLD'S CLASSIFIED ADVERTISING

Any member of the trade may forward to this office a "Situation" advertisement intended for this Department to occupy a space of four lines, agate measure, and it will be inserted free. Replies will also be forwarded without cost. Additional space will be at the rate of 25c. per line. If bold faced type is desired the cost of same will be 25c. per line.

WANT to meet a talking machine man or a business man who would like to enter the talking machine business; one who has a large business acquaintance to help finance and assist an established, growing manufacturing business. We have the best patented sound box and tone arm on the market, and have been in business since 1912. We want to branch out, and have a splendid, paying proposition for the right man. All details gladly furnished to responsible parties. Address "Box 516," care The Talking Machine World, 373 Fourth Ave., New York.

SALESMEN WANTED—Salesmen calling on the music and phonograph trade. We are offering a side-line that will double your income by calling on one or two people in each town. No samples to carry. Article very much in demand. In answering please state territory you are now covering. Address Morton J. Ross Music Co., 54 West Lake St., Chicago, Ill.

WANTED—High-class Victrola salesman. We have a permanent position with exceptional opportunities for a young man of ability and ambition. Must be clean cut, of unquestioned habits, capable and willing to work. City and climate the finest in the world to live and work in. Answer with full particulars, references and salary expected. Address Thearle Music Co., 640 Broadway, San Diego, Cal.

WANTED—Young man with ten thousand dollars cash that has had experience in the phonograph business to take half interest and the management of an Edison disc and cylinder business established ten years, in a city of two hundred and fifty thousand in the northwestern part of Ohio. Ten thousand dollars in good accounts and about ten thousand dollars in new stock and fixtures. Excellent opportunity for an active man. Address "Box 508," The Talking Machine World, 373 Fourth Ave., New York.

AN OPPORTUNITY FOR EXPERIENCE AND CAPITAL—The war opens an opportunity to join a firmly established organization for a man with actual and thorough experience in the manufacture, marketing or financing of a high grade phonograph or records. Only a man whose past record shows results accomplished; who is resourceful and aggressive and possesses initiative and who is willing to back these qualities with capital will meet the requirements. Your first letter must contain the proof and complete information. Address "Box 509," care The Talking Machine World, 373 Fourth Ave., New York.

WANTED—A reliable salesman well acquainted with wholesale and retail trade, to introduce an article used in the phonograph line. Gives more value for the money than others. Costs less. Apply stating experience, firms worked for, salary or commission, etc. Address "Box 510," care The Talking Machine World, 373 Fourth Ave., New York.

TO THE TRADE—Dealer has stock of records which he will close out in 100 lots for cost. First answers will be first served. Address Jos. Dumas, 54 West Lake St., Chicago, Ill.

WANTED—Exclusive Victor agency, city or nearby town. Price no object. Address "Box 511," care The Talking Machine World, 373 Fourth Ave., New York.

SALESMEN wanted on a commission basis to sell popular priced talking machines. Only those capable to show results need apply. Address R. L. Kenyon Mfg. Co., Inc., 220 Fifth Ave., New York.

TO COMBINE Retail Phonograph Stores

Business established 15 years, possessing many valuable contracts and exclusive rights, in one of the most desirable locations in Massachusetts. Is rapidly growing and is now doing considerably over \$100,000 business. Owner has many money-making ideas, and would like to combine with individual or individuals, preferably those in same or kindred lines. No triflers or curiosity seekers need apply, and only those possessing either capital or resources of \$10,000 and above should answer this advertisement. Negotiations are to be treated in strictest confidence.

Address Box 507, c/o The
Talking Machine World,
373 Fourth Ave., N. Y. City.

EXPERT FINISHERS WANTED—We can use a number of coarse rubbers, oilers and patchers on phonograph cabinets at once. Our men in this department of our factory are earning \$4 to \$5 per day. Address Brunswick-Balke-Collender Co., 629 South Wabash Ave., Chicago, Ill.

WANTED—By a firm in Canada an expert phonograph mechanic, one who thoroughly understands the assembling, adjustment and repairing of motors and sound boxes. Address "Box 512," care The Talking Machine World, 373 Fourth Ave., New York.

WANTED—An experienced lateral cut recorder for New York record manufacturing plant. Splendid proposition and permanent position for A1 man. Address "Box 513," care The Talking Machine World, 373 Fourth Ave., New York.

JOBBERS and salesmen wanted to handle high-class line of phonograph on commission basis. Exclusive territory can be arranged. These instruments are attractive in design and absolutely trouble proof. Retail from \$50 to \$215 in six models. Applicants must be in position to purchase own samples. We will carry acceptable accounts in any amount. Write, giving full particulars. Address "Box H. P. S. No. 65," care The Talking Machine World, 373 Fourth Ave., New York.

WANTED SPECIAL REPRESENTATIVES—Paramount records are now ready for the trade. An attractive proposition is open for several good salesmen in various parts of the country. Strictly commission basis. If interested send photo of yourself, give your employer, territory you cover and how often. Also any other information that you think fits you to handle the Paramount record. Address The New York Recording Laboratories, Inc., Port Washington, Wis.

SITUATION WANTED—Thoroughly reliable young man wishes to make connections with responsible firm in the capacity of assistant traffic man, or shipping clerk, where there is a chance for advancement. Has had several years of practical experience in this line, much of which was in Chicago talking machine trade, and can furnish the best of reference. Is prepared to go to any point for interview. Address "M. R. 30," care The Talking Machine World, 209 South State St., Chicago, Ill.

POSITION WANTED—Mechanic with 15 years' experience constructing and repairing phonographs of all makes, part of years with Victrola line, with one of the largest music houses in this country desires to make a change. Capable executive, thoroughly efficient with modern methods. Can furnish the very best of references. Address "Box 514," care The Talking Machine World, 373 Fourth Ave., New York.

POSITION WANTED—Talking machine salesman, five years' experience. Inside position large city preferred. Familiar with all well known machines. References. Address "A. P. 2," Talking Machine World, 209 So. State St., Chicago, Ill.

SALESMEN WANTED—Calling on music and furniture trades to sell popular line of records and talking machines. Address "A. P. 7," The Talking Machine World, 209 So. State St., Chicago, Ill.

STEEL NEEDLES

100 Needles in Envelope, per 1,000.....	0.60
Sapphire Needle for Pathé or Edison.....	0.25
MAIN SPRINGS	
For Columbia Motors, size 1"x0.28x11", each...	0.60
" " " size 7/8"x0.23x10", each..	0.35
" " " size 3/4"x0.22x8 1/2", each.	0.24
GOVERNOR SPRINGS	
For Columbia Motors, bent, per 100.....	1.75
For Victor Motors, per 100.....	1.50
For Heineman, Markell, etc., per 100.....	0.60
THUMB SCREWS FOR STYLUS BARS	
For Victor Soundboxes, per 100.....	1.50
For Columbia Soundboxes, per 100.....	1.50
MICA DIAPHRAGMS	
For Victor Soundboxes, each.....	0.15
For Columbia Soundboxes, each.....	0.25
For all standard Soundboxes, each.....	0.22
NEEDLE CUPS	
Needle Cups, nickel plated, per 100.....	2.00
Needle Cups, per 1000.....	17.50
Covers to nickel cups for used needles, per 100..	1.25
Covers, per 1000.....	10.00
Green Felt for 10" turn-tables, each.....	0.15
Green Felt for 12" turn-tables, each.....	0.20

FAVORITE PHONOGRAPH ACCESSORY CO.

1491 DeKalb Avenue

Brooklyn, N. Y.

DEALERS

We pay cash for your stock or overstock of records. We buy all makes in any quantity.

Please give detailed information and the lowest price acceptable.

ILLINOIS RECORD SERVICE,
Commercial Bldg.,
Dearborn and Lake Sts., Chicago, Ill.

FOR SALE

An established talking machine and piano store situated in a live Massachusetts city. Store has two soundproof booths, large display space and is attractively fitted up. Rent low. A big bargain for some one, and can be purchased at a low figure. Reason for selling owner has two other stores and cannot give it his best attention. A live wire can get a nice income out of it. Address "Live Wire," care The Talking Machine World, 373 Fourth Ave., New York.

WILL PAY SPOT CASH for any amount of disc records in any language, and for talking machines of all descriptions; phonograph parts of all makes and steel needles. Address "Box 515," care The Talking Machine World, 373 Fourth Ave., New York.

ATTENTION DEALERS

50 Double Spring latest style mahogany machines with cover \$10; 100 Horn disc machines, \$1.75; new reversible tone arms, 50c up. Bargains in envelopes, albums, reproducers, etc. (References the Chatham Bank). The Woolworth (Est. 1886), 1065 Second Ave. (56th St.), New York.

FIXTURES FOR SALE

Will sacrifice at a loss 158 lineal feet of shelving, 6 feet high and 12 inches deep, in the white, made of good lumber and in good condition. Also 15 upright pieces, 6 feet high and 12 inches deep, that can be used for these same shelves which have already been notched and only need fitting up, also additional record shelving in white enamel and a counter in white enamel. If you desire to secure shelving and a fine counter at a real bargain, write at once. Address "M. R. 21," care The Talking Machine World, Republic Bldg., Chicago, Ill.

STEEL NEEDLES

Repair parts for all talking machines made; main and governor springs, double and single spring motors, tone arms and sound boxes and complete machines. All at lowest prices.

FULTON TALKING MACHINE CO.
640 Broadway
New York City

WANTED—Position as salesman or department manager by A-1 Victor man, 26, married. At present in charge of talking machine department of large Western music house. Six years' experience in Victrola business, doing buying, newspaper advertising, window trimming. Can furnish the references you want. Prefer town west of Chicago of not less than 25,000. Address "W. N.," care The Talking Machine World, 373 Fourth Ave., New York.

POSITION WANTED—Thoroughly experienced Phonograph and Record salesman for either road or managing establishment, can vouch for seventy-five thousand dollars gross business per annum, now with leading company, highest grade credentials. Address G. H. Coryell, Saratoga Hotel, Chicago, Ill.

LATEST PATENTS RELATING TO TALKING MACHINES AND RECORDS

WASHINGTON, D. C., April 8.—TALKING MACHINE.—Emile Pathe, Paris, France, assignor to the Pathé Frères Phonograph Co., New York. Patent No. 1,251,565.

Some of the objects of this invention are to provide in a talking machine improved means for supporting a sound box arm; to provide in a talking machine an improved sound box arm.

In the accompanying drawings, Figure 1 is a fragmentary top plan view of a talking machine constructed in accordance with this invention; Fig. 2 a fragmentary front elevation of the same; Fig. 3 a fragmentary side elevation of the same; Fig. 4 a fragmentary horizontal section on line 4—4 of Fig. 2; Fig. 5 a fragmentary section on line 5—5 of Fig. 1; Fig. 6 a fragmentary top plan view of a modified form of sound box arm constructed in accordance with this invention; and Figs. 7 and 8 are a fragmentary side elevation and a fragmentary rear elevation respectively of a modified form of sound box arm constructed in accordance with this invention.

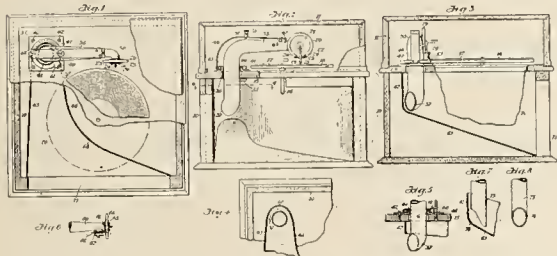

the connection between the sound pipes and the amplifying chamber. Fig. 3 is a horizontal section on line 3—3, Fig. 2, and Fig. 4 is a plan view of a cabinet cylindrical in form.

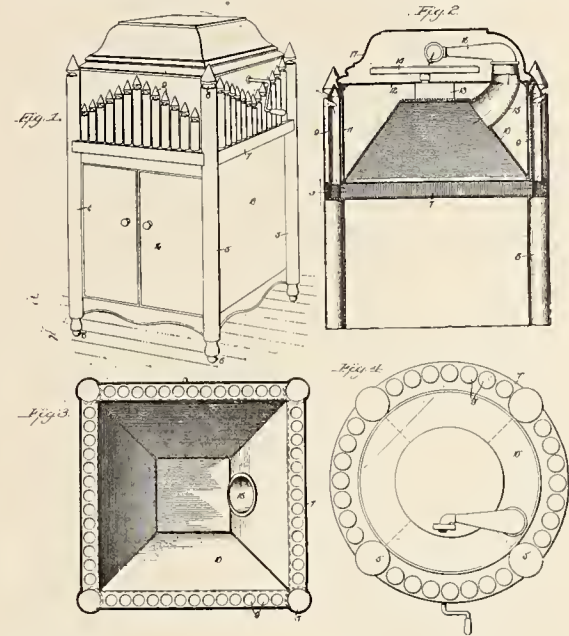

SOUND REPRODUCING MACHINE.—Anton H. Rintelman, Chicago, Ill. Patent No. 1,252,843.

This invention is concerned with the styli and their supporting mechanism used in sound reproducing machines, and is designed to produce such styli and to support them as to produce the very best possible reproduction of the tones recorded, thus enabling the varying of the loudness of said tones at will.

To this end, a novel needle or stylus has been devised, preferably with a plurality of points to adapt it for the different types of this record, such as the zigzag Columbia and Victor records and the hill and dale Edison and Pathé records, together with a holder therefor, which enables one to easily position the needle perfectly relative to the groove in the disc, and also to regulate within a very wide degree the loudness of the tone produced by the single needle, without impairing the quality thereof.

Figure 1 is a side elevation of a sound box and a part of a tone arm having the invention applied thereto. Fig. 2 is a central longitudinal section, on an enlarged scale, through the needle holder in a plane parallel to the face of the

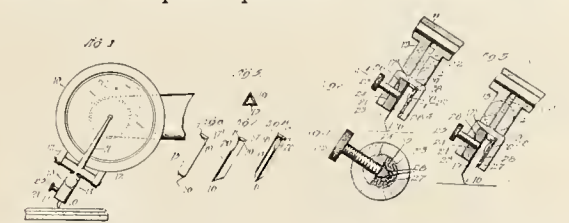

diaphragm. Fig. 3 is a similar view, but with the needle adjusted for a lighter tone. Fig. 4 is a cross section, on a still larger scale, on the line 4—4 of Fig. 2. Fig. 5 is an end view of the needle detached, on the same scale as it appears in Fig. 4, and Figs. 6, 7 and 8 are side elevations of the needle as seen from three different sides.

SOUND MODIFIER FOR PHONOGRAPHS.—Peter McAllister Maccaskie, Hot Springs, Alaska. Patent No. 1,253,407.

This invention relates to phonograph sound boxes and particularly to means for regulating or modifying and thereby improving the tone of a phonograph without the necessity of changing the needles.

The general object of the invention is the provision of a device of this character which is adapted to be detachably mounted upon any ordinary sound box and be therefore applicable to a large number of different phonographs.

A further object of the invention is to provide a device of this character which has a tone modifying element which may be applied to the stylus arm or lever at various points there along so as to dampen, modify or soften the vi-

brations of the diaphragm and thus achieve the same object as is achieved by changing the needles or styli from hard needles to medium and soft needles.

A further object of the invention in this connection is to provide a dampening or modifying member composed of a combination of different substances disposed in such relation to each other that the modifying member may be shifted to bring any one of the different substances into engagement with a stylus arm, to thus variously modify the action of the stylus arm.

A further object of the invention is to provide means whereby the tone modifying element may be pressed with greater or less force against the stylus arm.

Still another object is to provide a shifting tone modifying element, shiftable not only into various positions relative to the stylus arm itself, but also into various positions with relation to the diaphragm.

This invention is illustrated in the accompanying drawings, wherein: Figure 1 is a face view

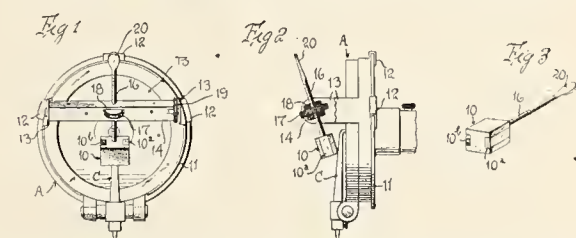

of the sound box provided with attachment; Fig. 2 is a side view of the sound box provided with attachment, the cross bar 14 being in section; and Fig. 3 is a perspective view of the sound modifying member and rod 16.

CENTERING MEANS FOR PHONOGRAPH RECORDS.—Bertram M. Hansen, San Francisco, Cal. Patent No. 1,253,374.

This invention relates to improved center bearings for phonographic records and the like wherein the aperture is brought concentric with the approximately concentric sound convolutions; and the objects of the invention are:

First, to provide an improved central bearing for phonographic records and the like that shall be adapted to resist wear and thereby prevent the enlargement of the record aperture whereby the alinement of the sound convolutions to the axis of rotation may be preserved.

Second, to provide an improved central bearing or centering means whereby the central aperture of the record may be alined or arranged approximately concentric with the sound convolutions of the record.

Third, to provide improved means adapted to reduce the frictional engagement of a reproducing needle with the record and thereby improve the harmony of the selection being rendered.

Fourth, to provide improved means whereby the wear on the sound or impression convolutions or grooves may be eliminated.

Figure 1 is a plan view of a phonographic record disclosing the invention applied thereto.

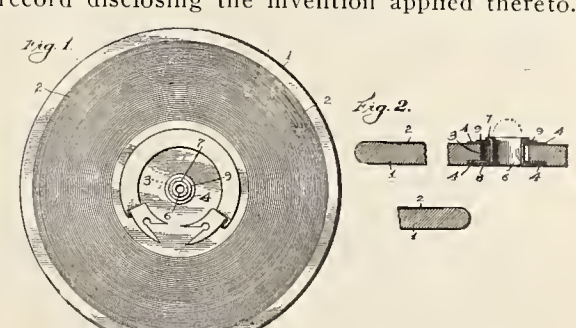

Fig. 2 is an enlarged broken transverse sectional view of a record disclosing more fully in detail the construction and arrangement of the invention.

TALKING MACHINE.—John A. Weser, New York, assignor to Weser Bros., same place. Patent No. 1,253,317.

This invention is concerned primarily with talking machines in which disc records are used to vibrate the reproducing diaphragm through the usual needle. For such machines there are, at present, two popular types of records on the

(Continued on page 120)

subject matter of Fig. 1. Fig. 3 is a central longitudinal sectional view of a form of amplifier embodying the invention. Fig. 4 is a similar view illustrating another form of amplifier. Fig. 5 is a detail view illustrating a means for giving the amplifier bias toward movement in one direction.

CABINET TALKING MACHINE.—Howard D. Darlington, Dayton, O. Patent No. 1,253,010.

This invention relates to cabinets for talking machines. An object thereof is to provide a cabinet of a novel construction in which sound pipes are utilized in connection with the amplifying chamber of the cabinet. Another object is to provide a cabinet which is made of metal.

Figure 1 is a perspective elevation of a cabinet embodying the invention. Fig. 2 is an enlarged longitudinal section thereof illustrating

LATEST PATENTS RELATING TO TALKING MACHINES AND RECORDS—(Continued from page 119)

market, in one of which the groove for causing vibrations of the diaphragm is of a uniform depth with respect to the disc but has its sides of irregular outline to cause lateral movements of the needle therein as the groove is moved with respect thereto, while in the other type of disc the groove is of true spiral form with respect to the disc but is of irregular depth so as to impart vertical movements to the needle with respect to the disc as the record rotates. It has been proposed previously to provide a tone arm and sound box of such construction as to permit the use of the sound box with either of the above described types of records, it being understood, of course, that the direction of vibration of the needle must, at all times, be normal to the plane of the diaphragm. Such known devices, however, usually entail a complete modification of the usual type of tone arm and the construction thereof in several sections interconnected through pivotal joints which permit movement of the sound box through widely divergent planes. Such movement entails a displacement of the needle and the sound box through a very appreciable angle so that such known constructions not only involve the objections of expensiveness of manufacture and multiplicity of parts, but also those of bulkiness and awkwardness in adjustment. The principal object of the present invention is to overcome all of the objections enumerated above and so to construct the tone arm and the sound box and mount the same with respect to each other that the needle may be quickly and easily positioned with respect to the grooves of the particular type of disc to be played without moving the tone arm and without displacing the sound box bodily with respect to said arm. Another object of the invention is to make it possible to secure such adjustment without modifying appreciably the usual form of tone arm and by making the adjusting devices between the latter and the sound box of simple and inexpensive character. Still another object of the invention is to permit an adjustment of the character described without displacing the needle itself through an appreciable distance, the movement of the sound box with respect to the tone arm taking place about an axis which is nearly coincident with the axis of the needle. A further object is to improve the construction of tone arms for graphophones by providing a simple and effective pivotal joint therein whereby the outer end of the arm with the sound box may be readily swung in a vertical plane when the needle is lifted from the record.

In these drawings Figure 1 is a view, partly in vertical section and partly in elevation, of a tone arm and sound box embodying the invention, the range of movement of the tone arm

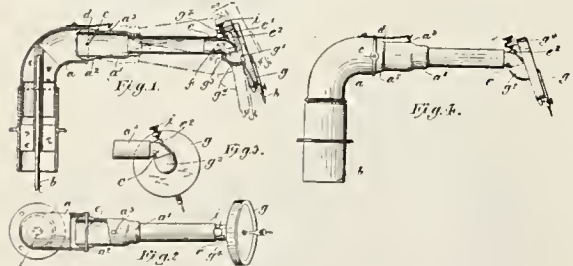

by reason of the improved joint therein being indicated in dotted lines. Fig. 2 is a view in plan of the devices illustrated in Fig. 1, part of the tone arm being broken away to show, in horizontal section, the improved joint. Fig. 3 is a fragmentary view indicating a portion of the tone arm and showing the sound box in a position at 90 degrees to that shown in Figs. 1 and 2 to permit the reproducing of vibrations caused by a laterally undulating groove. Fig. 4 is a view in side elevation showing the sound box illustrated in Figs. 1 and 2.

SOUND RECORDING AND REPRODUCING MACHINE.—David Frederick McGuire and Kenneth Douglas McGuire, Hornchurch, England. Patent No. 1,254,330.

This invention relates to sound recording and sound reproducing machines employing disc rec-

ords and of the type adapted both for the recording of sounds and for the reproduction of sounds thus recorded, the invention being principally adapted for domestic and office use.

The object of the present invention is to provide an improved form of machine of the above character in which the reproduction of the recorded sounds may be effected through the usual tone arm, sound chamber or amplifying horn without damage to the record, due to the fact that by reason of this inventor's construction the recording stylus or like member and the reproducing member both move across the face of the record in the same path instead of as is usual the one member moving in a rectilinear path and the other in a curved path.

The invention consists in a sound recording and sound reproducing machine comprising in combination a record supporting member, a tone arm, a member movable rectilinearly across the face of the record and means connecting the tone arm with this latter member but slidable upon said member.

The invention also comprises a sound recording and sound reproducing machine of the above character, having a carrier for the recorder and reproducer, rotatable about a vertical axis, so that either the recorder or reproducer may be moved into its operative position.

The accompanying drawings illustrate two modes of carrying out the invention: Figure 1 is a front elevation of one form of device in accordance with the invention when applying it

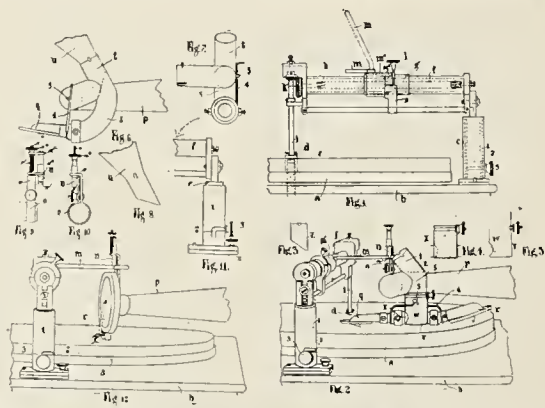

to an ordinary gramophone; Fig. 2 is a perspective view of the arrangement shown in Fig. 1; Figs. 3, 4 and 5 are views illustrating details; Fig. 6 is a view showing a modification in accordance with the invention; Fig. 7 is a side view of the arrangement shown in Fig. 6; and Fig. 8 is a fragmentary view of a portion of the device in Fig. 6; Figs. 9 and 10 are a side view and front view respectively of a detail shown in Fig. 2; Fig. 11 is a view showing a detail; while Fig. 12 is a view illustrating a modified form of reproducer.

SOUND BOX.—Henry C. Miller, Waterford, N. Y. Patent No. 1,254,425.

This invention relates to improvements in means for dispensing with individual needles in connection with sound reproducing machines, particularly where records having grooves provided with lateral undulations are employed.

The principal objects of the invention are to provide means for employing a continuous piece of thin wire to be used as a stylus, and gage the feeding of the latter to insure of the correct projection of the wire; to provide improved means for feeding the wire; and to provide safety means to prevent the sound box falling and destroying a record.

The use of a continuous wire for a stylus for sound reproducing machines is old in the art, numerous attempts having been made to operate the wire automatically, others semi-automatically, and still others being operated purely by guess. However, in all such structures known the details are so arranged that foreign sounds are produced, the same being necessarily conveyed to the amplifier and mingling with the reproduction. Furthermore, these foreign sounds cause a material loss of a number of the finer tones, and according to this invention these defects are materially over-

come by improving the construction.

In the use of a continuous wire employed as a stylus, it is of the utmost importance when feeding the wire that the latter be fed a predetermined distance, and to this end it is the purpose to provide a gage so arranged that when positioned in the path of the end of the wire, the latter will be limited, which always insures a uniform stylus. Then again when

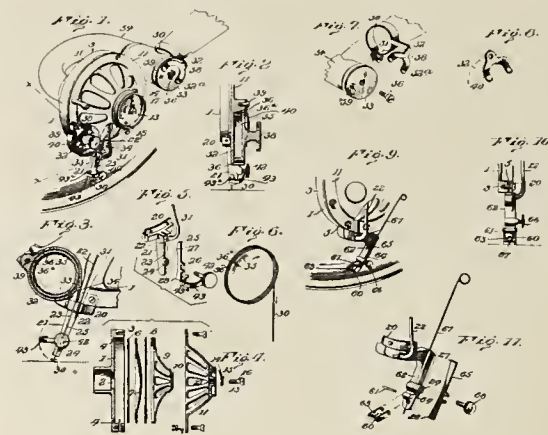

the wire is to be fed the gage is so constructed that when it is in operative position the wire clamp will be simultaneously released to permit the feeding of the wire.

This invention also aims to provide simple and effective means for storing the wire, the same consisting of a magazine having frictional means for holding it in any position when properly set.

A number of records are destroyed by the sound box dropping, and to overcome this difficulty there is provided special means for holding the sound box in any position within a given range. This feature of the invention is so constructed as not to interfere with the free movement of the needle in the record grooves, the binding action between the parts taking place only after the sound box is slightly elevated from the record.

In the drawings: Figure 1 is a perspective view of the improvement. Fig. 2 is an enlarged detail view on the line x—x of Fig. 1. Fig. 3 is an enlarged view of a portion of the sound box and the magazine, the latter being in section. Fig. 4 is a central section taken through the sound box, the parts being separated. Fig. 5 is a perspective view of a part of the stylus lever, and the wire clamp, the parts being separated. Fig. 6 is a detail perspective view of the wire and the manner in which its end is held in the magazine. Fig. 7 is a detail perspective view of the means for preventing the sound box falling on the record. Fig. 8 is a detail view of the magazine friction clamp. Fig. 9 is a detail perspective view of a different form of the invention. Fig. 10 is a detail end view of the same. Fig. 11 is a detail perspective view of the parts shown in Figs. 9 and 10.

SOUND BOX.—Richard James Prettie, Jamaica, N. Y., assigned to the Aeolian Co., New York. Patent No. 1,253,527.

This invention relates to improvements in sound boxes, the features and advantages of which will be apparent to those skilled in the art from an understanding of the following description.

In the latter, Figure 1 is a face view of the sound box with a portion broken away; Fig. 2 is a section partly in elevation on the line 2—2 in Fig. 1 looking in the direction of the arrows;

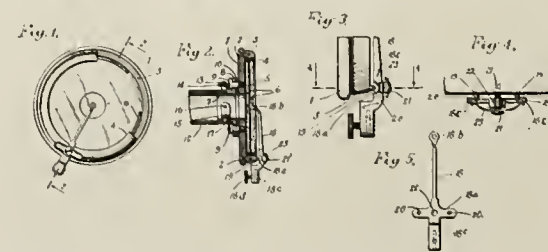

Fig. 3 is an enlarged detail of Fig. 2. Fig. 4 is a section partly in plan through the line 4—4 in Fig. 3, and Fig. 5 is an enlarged view of the back of the stylus arm.

RECORD BULLETINS FOR MAY, 1918

VICTOR TALKING MACHINE CO.

THOS. A. EDISON, INC.

- POPULAR SONGS
18441 Send Me a Curl.....Goeffrey O'Hara 10
All Aboard for Home, Sweet Home,
Louis James and Shannon Four 10
18443 Everybody's Crazy 'Bout the Dog-gone Blues
(But I'm Happy).....Marion Harris 10
In the Land o' Yamo Yamo....Van and Schenck 10
18452 If You Look in Her Eyes,
Elizabeth Spencer-Henry Burr 10
Blue Bird.....Elizabeth Spencer 10
18453 Each Stitch is a Thought of You, Dear,
Henry Burr 10
A Little Bit of Sunshine,
Charles Hart and Shannon Four 10
18455 The Last Long Mile,
Charles Hart and Shannon Four 10
K-K-K-Katy.....Billy Murray 10
VOCAL AND INSTRUMENTAL RECORDS
45150 Roses of Picardy.....Lambert Murphy 10
Love's Garden of Roses.....Lambert Murphy 10
18442 Long Boy—Medley one-step (for dancing),
Victor Military Band 10
Indianola—Fox-trot (for dancing),
Victor Military Band 10
18450 Sweet Emalina, My Gal—One-step (for dancing),
Sergeant Markel's Orchestra 10
While the Incense is Burning—Fox-trot (for dancing).....Earl Fuller's Orchestra 10
RED SEAL RECORDS
GIOVANNI MARTINELLI, Tenor—In Italian
64772 O ben tornato, Amore! (Welcome, Love!),
Cecilia Deni-Emilio A. Roxas 10
MAUD POWELL, Violinist
74547 Four American Folk Songs..... 12
HERBERT WITHERSPOON, Bass

- 83074 Elegie (Jules Massenet). Tenor, in French,
Guido Ciccolini
'O Sole Mio (My Sunshine) (Eduardo di Capua).
Tenor, in Italian.....Guido Ciccolini
82125 Chant Hindou (Hindoo Song) (H. Bemberg).
Soprano, in French.....Odette Le Fontenay
Le Nil (The Nile) (Xavier Leroux). Soprano,
in French.....Odette Le Fontenay
82129 O Dry Those Tears! (Teresa del Riego). Con-
tralto.....Caroline Lazzari
Oft in the Stilly Night. Contralto.....Caroline Lazzari
80365 Douglas Tender and True (Lady John Scott).
Contralto.....Amy Ellerman
Wonderful Thing (Clare Kummer). Soprano,
Betsy Lane Shepherd
80388 Down in Lily Land (F. Wallace Rega). Con-
tralto and Tenor,
Marion Evelyn Cox and John Young
Is it Nothing to You? (Edgar-Trevor). Soprano,
Betsy Lane Shepherd
80389 Hold Thou My Hand—Sacred (Emelyn R. Mof-
fatt).....Metropolitan Quartet
Why I Love Him—Sacred (B. D. Ackley). Bari-
tone.....Robert E. Clark
80390 Zampa Overture—Part 1 (F. Herold),
American Symphony Orchestra
Zampa Overtrue—Part 2 (F. Herold),
American Symphony Orchestra
80391 I'll Take You Home Again, Kathleen (Thomas
P. Westendorf). Violin, Violoncello, Flute
and Harp.....Venetian Instrumental Quartet
Quanto io t'amo (Satta). Violin, Violoncello,
Flute and Harp.....Venetian Instrumental Quartet
50459 Felicia Waltz (Vernon Eville). For Dancing,
Jaudas' Society Orchestra
Sunshine of Your Smile Waltz (Lilian Ray).
For Dancing.....Jaudas' Society Orchestra
50466 Sari Waltz (E. Kalman). Imperial Marimba Band
Stars and Stripes Forever March (Sousa),
Imperial Marimba Band

- SPECIAL RELISTING OF THE CYCLONIC SUCCESS
"THE MISSOURI WALTZ," VOCAL AND
INSTRUMENTAL
20024 Missouri Waltz (Logan). American Republic Band 10
Love Me at Twilight, from "Step this Way"
(Grant). Fox-trot...American Republic Band 10
20293 Hush-abye, Ma Baby (Missouri Waltz) (Knight-
Logan-Eppel).....Campbell and Burr 10
They Needed an Angel in Heaven (Morecaldi).
Tenor.....Henry Burr 10

N. Y. RECORDING LABORATORIES

- SUPPLEMENT 5—RELEASED APRIL 20
INSTRUMENTAL RECORDS
30014 Pasadena Day March (Vessella). March
Paramount Military Band
Lights Out (McCoy). March
Paramount Military Band
30015 Herc They Come (Bergh). March,
Paramount Military Band
Liberty Lads (Lee-Orian-Smith),
Paramount Military Band
30016 Poet and Peasant Overture, Part 1 (Von Suppe),
Paramount Symphony Orchestra
Poet and Peasant Overture, Part 2 (Von Suppe),
Paramount Symphony Orchestra
2046 Sunshine of Your Smile (Cook-Ray). Cornet
solo.....Richard McCann
Oh, Dry Those Tears (Del Riego). Cornet solo,
Richard McCann
VOCAL RECORDS
30017 Good Bye (Tosti). Soprano solo, orch. accom.,
Grace Kerns
Sing Me Love's Lullaby. Contralto solo, orch.
accom.....Margaret Abbott
30018 Where the River Shannon Flows (Russell).
Tenor solo.....McClaskey
When You and I Were Young, Maggie (John-
son). Tenor.....McClaskey
30019 Come Where My Love Lies Dreaming (Foster),
University Quartet
The Rosary (Nevin). Baritone solo...Royal Dadmun
30020 Love's Old Sweet Song (Bingham-Molloy). Con-
tralto solo.....Abbott
I Love You Truly (Jacobs-Bond). Contralto
solo.....Margaret Abbott
30021 Hosanna (Gramer). Baritone solo...Royal Dadmun
The Palms (Faure). Baritone solo...Royal Dadmun
OPERATIC SELECTIONS
50002 Dio Possenti (Even Bravest Heart), (Gounod).
Italian. From Faust.....Edward Zinco
Sei Vendicata Assai (Thou Art Avenged),
(Meyerbeer). Italian. From Dinorah,
Edward Zinco

COLUMBIA GRAPHOPHONE CO.

- A2514 Any Old Place the Gang Goes (I'll be There),
Arthur Fields and Peerless Quartette 10
Fugh-a-Ballah.....Peerless Quartette 10
A2507 Jazzin' the Cotton Town Blues,
George H. O'Connor 10
There's Always Something Doin' Down in
Dixie.....George H. O'Connor 10
A2506 On the Road to Home, Sweet Home,
Campbell and Burr 10
Bring Back My Daddy to Me.....Robert Lewis 10
A2513*Then I'll Find My Paradise.....James Harrod 10
Are You From Heaven?.....Henry Burr 10
A6032*Tom, Dick and Harry and Jack (Hurry Back)
—Medley one-step. Introducing (1) Give Me
a Kiss by the Numbers; (2) I'll Come Back
to You When It's All Over; (3) When I'm
Thru With the Arms of the Army,
Prince's Band 12
The Wild, Wild Women—Medley one-step. In-
troducing (1) The Greatest Thing I Ever
Did; (2) There's a Green Hill Out in Flanders;
(3) For France and Liberty...Prince's Band 12
A2499*Rag-a-Minor—One-step.....Prince's Band 10
Rigoletto Rag—One-step.....Prince's Band 10
A2500*Yankee from "The Land of Joy"—Fox-trot,
Prince's Band 10
Off to Havana—A La Habana Me Voy from
"The Land of Joy"—Fox-trot...Prince's Band 10
VOCAL SELECTIONS
A2505 I've Found Kelly.....Billy Williams 10
Little Bit of Cucumber.....Harry Champion 10
A2502 Polly-Wolly-Doodle.....Harry C. Browne 10
Push Dem Clouds Away.....Harry C. Browne 10
A2504 The Larboard Watch.Columbia Stellar Quartette
Bring Back My Bonnie to Me,
Columbia Stellar Quartette 10
A2468 Old Black Joe...Paulist Choristers of Chicago 10
My Old Kentucky Home,
Paulist Choristers of Chicago 10
HENRY BURR SINGS FAVORITE HYMNS
A2498 Where is My Wandering Boy Tonight?
Henry Burr 10
Jesus Lover of My Soul.....Henry Burr 10
A7526 How Old Mr. Toad Won a Race,
Thornton W. Burgess 12
How Old Mr. Toad Happened to Dine with
Buster Bear.....Thornton W. Burgess 12
INSTRUMENTAL SELECTIONS
A2503 Melodie in F,
Mery Zentay, Philip Hauser at the Piano 10
Tales of Hoffman. Barcarolle (Radiant Night),
Mery Zentay, Philip Hauser at the Piano 10
A2497 Carry Me Back to Old Virginia,
Nellie Hoone Wetmore 10
Old Folks at Home...Nellie Hoone Wetmore 10
A6031 Rigoletto. Quartette.....Prince's Band 12
Lucia Di Lammermoor. Sextette,
Prince's Band 12
TWO THRILLING MARCHES
A2510*Hands Across the Sea—March...Prince's Band 10
Anchor's Aweigh—March.....Prince's Band 10
A2501 The Lizard and the Frog....Prince's Orchestra 10
Arabian Serenade.....Prince's Orchestra 10
A6026 (a) Madrigale (b) Moment Musical,
Chicago Symphony Orchestra 12
Grande Valse from Suite Ruses D'Armour,
Chicago Symphony Orchestra 12
MAY MID-MONTH LIST ON SALE APRIL 10
A6030*Someday They're Coming Home Again,
Nora Bayes 12
I May Stay Away a Little Longer...Nora Bayes 12
A2512*Wedding Bells (Will You Ever Ring for Me),
Al Jolson 10
Just a Little Cottage (I'll Call it Home, Sweet
Home).....Sterling Trio 10
A6028*Keep the Home Fires Burning,
Oscar Seagle and Columbia Stellar Quartette 12
Pack Up Your Troubles in Your Old Kit Bag
(And Smile, Smile, Smile),
Oscar Seagle and Columbia Stellar Quartette 12
A2511*My Sweetie.....Samuel Ash 10
I Don't Care to Live in Any Marble Halls
(With You).....Samuel Ash 10
A2508*I Hate to Lose You.....Robert Lewis 10
For the Two of Us.....Samuel Ash 10
A6029*Just a Baby's Prayer at Twilight—Medley fox-
trot. Introducing (1) Wedding Bells (Will
You Ever Ring for Me); (2) I'll Take You
Back to Italy.....Prince's Band 12
Liberty Bell—Medley fox-trot. Introducing (1)
Never Forget to Write Home; (2) Some
Night; (3) Just a Simple Country Maiden,
Prince's Band 12
A2509*O Sole Mio (My Sun),
Louise, Ferera and Greenus 10
My Hawaii (You're Calling Me),
Louise, Ferera and Greenus 10
A6027 Valse in A Flat, Opus 42.....Percy Grainger 12
Polonaise in A Flat Major, Opus 53,
Percy Grainger 12

PATHE FRERES PHONOGRAPH CO.

- 40122 Vocal Gem Medley, No. 1. "Musical Comedy
Hits" (Bolton-Wodehouse-Kern). Introducing
1. "Siren's Song." 2. "An Old-Fashioned
Wife." 3. "Till the Clouds Roll By,"
Lyric Vocal Quintet 12
40122 Vocal Gem Medley, No. 2. "Camp Fire Songs."
Introducing 1. "Good-bye Dolly Gray." 2.
"Honey Boy." 3. "Comrades." 4. "When
Johnny Comes Marching Home." 5. "There'll
Be a Hot Time in the Old Town To-night,"
Lyric Vocal Quintet 12
20315 The Darktown Strutters' Ball (Brooks). Tenor
—Accordion Accomp.....Arthur Fields 10
In the Land o' Yamo Yamo (McCarthy-Fischer).
Tenor—Accordion Accomp.....Arthur Fields 10
20198 One Day in June (Hanley)...Campbell and Burr 10
"I'm Sorry I Made You Cry" (Clesi). Tenor,
Harry McClaskey 10
20201 The Wild, Wild Women Are Making a Wild
Man of Me (Piantadosi). Tenor,
Eugene Mack 10
Chin, Chin Chinaman (Hanley)...Peerless Quartet 10
20199 Lorraine (My Beautiful Alsace-Lorraine) (Bryan-
Fischer). Baritone.....Warwick Williams 10
Give Me the Right to Love You (Glatt),
Sterling Trio 10
20200 When the "Yanks" Come Marching Home
(Jerome-Furth). Baritone...Warwick Williams 10
Tom, Dick and Harry and Jack (Ager). Tenor,
Eugene Mack 10
20197 Keep Cool, the Country's Saving Fuel (McCar-
ron). Baritone.....Arthur Collins 10
Regretful Blues (Hess). Tenor...Arthur Fields 10
20312 There's Another Angel Now in Old Killarney
(Bernard).....Big City Four 10
Fugh-a-Ballah (Olman). Tenor,
James Doherty 10
NEW STANDARD BALLADS SUNG IN ENGLISH
27011 The Star Spangled Banner (Key). Tenor,
Paul Althouse 10
When Johnny Comes Marching Home (Lam-
bert). Tenor.....Paul Althouse 10
52028 Moonlight, Starlight (Gilberte), (Waltz Song).
Soprano.....Grace Hoffman 12
The Nightingale's Trill (Ganz). Soprano,
Grace Hoffman 12
25011 Who Knows? (Ball). Tenor...Craig Campbell 10
Mary of Argyle (Nelson). Tenor,
Craig Campbell 10
20323 Little Mother of Mine (Burleigh). Tenor,
Lewis James 10
Come Where My Love Lies Dreaming (Fos-
ter). Tenor.....Lewis James 10
20324 Keep the Home Fires Burning (Novello),
University Quartet 10
When the Great Red Dawn Is Shining (Lockton-
Sharpe). Baritone.....Royal Dadmun 10
NEW PATHE "DE LUXE" DANCE RECORDS
20319 When You Come Back (Frey). One-step,
American Republic Band 10
The Story Book Ball (Montgomery-Perry). Fox-
trot.....American Republic Band 10
20320 Going Up, from "Going Up" (Harbach-Hirsch).
Medley one-step. Introducing "Here's to the
Two of You".....American Republic Band 10
Midnight Waltz (Holland),
American Republic Band 10
NEW NOVELTY ACCORDION DANCE RECORDS
20321 My Sweetie (Snyder-Louis-Young). Medley fox-
trot. Introducing "Meet Me at the Station,
Dear." Accordions.....Boudini Brothers 10
A Scotch High-Ball (Arr. by Boudini Brothers),
Medley one-step. Introducing 1. "Bag Pipes,"
2. "Annie Laurie," 3. "Blue Bells of Scotland,"
4. "Auld Lang Syne." Accordions.
Boudini Brothers 10
NEW PIANO AND DRUM RECORDS
20326 Hungarian Rag (Lenzberg). One-step,
Eubie Blake Trio 10
American Jubilee (Claypoole). Fox-trot,
Eubie Blake Trio 10
NEW INSTRUMENTAL RECORDS
59055 Minuet in G (Op. 14. No. 1) (Paderewski).
Piano solo.....Rudolph Ganz 12
Melody in F (Rubinstein). Piano solo,
Rudolph Ganz 12
20322 Hearts and Flowers (Tobani). Violin solo,
Edmund Thiele 10
Will You Remember (Sweetheart), from "May-
time" (Romberg). Violin.....Edmund Thiele 10
29193 White Bird (Hager), "Whistling Nolette,"
Joe Belmont 12
La Matichiche (Borel-Clerc). Ocarina solo,
Albert Carroll 12

BROADWAY HITS

- 2047 Baby's Prayer at Twilight (Jerome). Tenor
solo.....Henry Burr 10
One Day in June (Goodwin-Hanley). Duet,
Campbell and Burr 10
2048 Liberty Bell (Goodwin-Mohr). Quartette, bell
effects.....Peerless Quartette 10
Hail, Hail, the Gang's All Here (Morse). Quar-
tette.....Peerless Quartette 10
2049 I Wasn't Skeered—But I Just Thought I Bet-
ter Go Home, Negro dialect.....Arthur Collins 10
Everybody's Crazy 'Bout the Doggone Blues
(Creamer & Layton). Comic duet.Collins & Harlan 10
DANCE RECORDS
2050 Havanola. Dance number, foxtrot. Banjo,
saxophone, piano.....Van Eps Trio 10
Ragging the Scale. Dance number, fox-trot,
Banjo, saxophone, piano.....Van Eps Trio 10

EMERSON PHONOGRAPH CO.

- PATRIOTIC AND POPULAR SONG HITS
7338 Au Revoir, But Not Good-bye Soldier Boy
(Brown-Al Von Tizer). Patriotic solo, orch.
accomp.....Harry Evans 10
On the Rockin' Rosa Lee (Overstreet). Darkey
comedy duet, orch. accomp....Collins and Harlan 10
7345 Say a Prayer for the Boys Out There (Gross-
man-Marr). Patriotic solo, orch. accomp.,
Harry Evans 10
I'm Going to Follow the Boys (Monaco-Rogers).
Patriotic solo, orch. accomp.....Harry Evans 10
7346 Lorraine, My Beautiful Alsace-Lorraine (Bryan-
Fisher). Tenor solo, orch. accomp...Robert Rice 10
Lafayette We Hear You Calling (Mary Earl),
Patriotic solo, orch. accomp.....Harry Evans 10
7349 Good-bye Barney Boy (Breshem-Morse). Irish
patriotic solo, orch. accomp...Peerless Quartet 10
Off to France (Sullivan-Pollak). Patriotic solo,
orch. accomp.....Harry Evans 10
7344 Cleopatra (Bryan-Tierney). Character song,
orch. accomp.....Arthur Collins 10
Keep Cool the Country's Saving Fuel, I Had
to Come Home in the Dark (C. R. McCarron).
Character song, orch. accomp....Arthur Collins 10
7348 The Missouri Waltz (Hush-a-Bye, Ma Baby)
(Shannon-Logan). Tenor solo, orch. accomp.,
Robert Rice 10
Kathleen Mavourneen (Crawford-Crouch). Tenor
solo, orch. accomp.....Frank Woods 10
7347 Sing Me Love's Lullaby (Terris-Morse). Tenor
solo, orch. accomp.....Frank Woods 10
A Dream (Cory-Bartlett). Tenor solo, orch.
accomp.....James Price 10
FAVORITE DANCE RECORDS
7342 If You Look in Her Eyes (L. A. Hirsch). Fox-
trot.....Emerson Military Band 10
National Emblem (E. E. Bagley). March and
one-step.....Emerson Military Band 10
7341 A Baby's Prayer at Twilight for Her Daddy Over
There (Jerome-Lewis-Young). Fox-trot,
Emerson Military Band 10
Gate City (A. F. Weldon). March and one-step,
Emerson Military Band 10
7343 Li'l Liza Jane (Countess Ada De Lachau). One-
step.....Emerson Military Band 10
'A Frangesa! (P. M. Costa). March and one-
step.....Emerson Military Band 10
7339 Kilima Waltz (Hawaiian Ukulele and guitar duet),
Louise and Ferera 10
Hilo March (Hawaiian ukulele and guitar
duet).....Louise and Ferera 10
7340 Calicoco (Hugo Frey). Fox-trot, banjo, piano
and saxophone.....Van Eps Banta Trio 10
Silver Heels (Neil Moret). One-step, banjo,
piano and saxophone.....Van Eps Banta Trio 10

GENNETT RECORDS

- NEW POPULAR RECORDINGS
7646 Just a Baby's Prayer at Twilight (Lewis &
Young-Jerome). Tenor with orch accomp.,
Chas. Hart 10
The Dream of a Soldier Boy (Dubin-Monaco),
Tenor with orch. accomp.....Chas. Hart 10
7647 Minnehaha (She Gave Them All the Ha! Ha!)
(Hart-Nelson). Tenor with orch. accomp.,
Ad. J. Hall 10
(Continued on page 122)

RECORD BULLETINS FOR MAY

(Continued from page 121)

- There's Something 'Bout a Uniform That Makes the Ladies Fall (Fink-Silver). Tenor with orch. accomp. Arthur Hall
- 7642 I'll Come Back to You When It's All Over (Brown-Mills). Baritone with orch. accomp. Arthur Fields
- Three Wonderful Letters From Home (Goodwin & MacDonald-Hanley). Tenor with orch. accomp. Chas. Hart
- 7641 Hello, I've Been Looking for You—From New York Hippodrome (Golden-Huhhell). Tenor with orch. accomp. Arthur Hall
- Liberty Bell (It's Time to Ring Again) (Goodwin-Mohr). Tenor with orch. accomp. Arthur Hall
- STANDARD VOCAL NUMBERS
- 10039 Où voulez-vous aller? (Tell Me, Beautiful Maiden!) (Gounod). In French—Soprano with Flute Ohhligato by Paul Henneberg, Frida Bennèche
- "Lucia"—Mad Scene (Donizetti). In Italian—Soprano with Flute Ohhligato by Paul Henneberg, Frida Bennèche
- 7648 Silver Threads Among the Gold (Rexford-Danks). Vocal Trio with orch. Sterling Trio
- When You and I Were Young, Maggie (Butterfield). Tenor with orch. accomp. Henry Burr
- INSTRUMENTAL RECORDS
- 10038 Starr March (Rich). Starr Military Band
- French National Defile March (Turlet). Gennett Military Band
- 10040 Serenade (Titl). Violin, Flute and Piano, Gennett Trio
- Sérénade d'amour (Von Blon). Violin, Flute and Piano. Gennett Trio
- 7517 A Love Thought (Migliacca). Accordion Solo, Peppino
- Faust—Waltz (Gounod). Accordion Solo. Peppino
- 7644 New Orleans Jazz (My Dixieland) (Richardson). Gennett Orchestra
- Jasmo (One-step Oddity) (Klohr), Harry Junior's Jazz Orchestra
- SPECIALTY NUMBERS
- 7643 Cohen Telephones the Garage (Comic Monologue). Geo. L. Thompson
- Cohen at the Telephone (Comic Monologue), Geo. L. Thompson
- 7619 A Coon's Trip to Heaven (Golden) (Coon Comic Selections with Traps and Banjo), Golden-Heins
- Jimmy Trigger (Golden) (Coon Comic Selection with Drums and Traps). Golden-Heins
- GENNETT ART TONE RECORDS
- 12503 Swanee River (Old Folks at Home) (Foster). Piano accomp. by Francis Moore. Helen Ware
- Gentle Shadows (Ware). Piano accomp. by Francis Moore. Helen Ware
- 12502 Humoresque (Dvorak). Piano accomp. by Francis Moore. Helen Ware
- Ave Maria (Schubert). Piano accomp. by Francis Moore. Helen Ware
- 10019 Vulcan's Song—"Philemon et Baucis" (Gounod). With orch. accomp. Frederic Martin
- Gipsy John (Clay). With orch. accomp. Frederic Martin
- 10030 When the Bell in the Lighthouse Rings (Lamb-Solman). With orch. accomp. Frederic Martin
- Rocked in the Cradle of the Deep (Knight). With orch. accomp. Frederic Martin

SELLING EDISON PHONOGRAPHS TO MINERS IN NEVADA

Mrs. C. W. Friend, who has been a very successful Edison dealer at Carson City, Nevada, was recently asked to whom she sells New Edisons. In reply Mrs. Friend wrote: "I am sending you a photograph given me by a pleased customer, and shows some of the people to

The owner of this instrument has already purchased seventy records, and there has been a good deal of comment on the class of music he selects for his miner friends back in the mountains. Think of those fellows listening to the Rigoletto Quartet, Chopin's Nocturne in E flat,



The New Edison Furnishing Music in the Wilds of Nevada

whom I am selling New Edisons. It is not only a great advertisement for the New Edison, but shows our beautiful Nevada scenery to advantage. I have found that a miner always buys the best money can buy and this sale was the most satisfactory sale I have ever made.

Meyerbeer's Cavatina and such things. Think of this sort of music floating up from a canvas tent up among the pines while miners in overalls listen attentively. They don't want ragtime. They want the best music the New Edison offers."

DEATH OF PHILIP WOHLSTETTER

Philip Wohlstetter, vice-president and general manager of the Imperial Talking Machine Co., New York, N. Y., and Wilmington, Del., died suddenly April 2 at his home in New York. Mr. Wohlstetter, who was forty-eight years old at the time of his death, was well known in talking machine circles throughout the country, having been identified with the industry for many years. He is survived by a widow and four children. Funeral services were held at his late home on the afternoon of April 4 and were largely attended.

PUBLISHES INTERESTING ARTICLE

Samuel Wein, who is well known in the talking machine industry as a technical expert, has recently published an interesting article entitled "Modern Photographic Developers," which has been issued as a practical hand book. Mr. Wein has contributed many articles to prominent magazines, and his present work in the laboratory of a well-known talking machine manufacturer may result in important technical discoveries.

NURSERY RHYMES WITH RECORDS

Volume of Children's Verse Issued, Containing Columbia Phonograph Records of the Same

If you were suddenly asked for a plan to make nursery rhymes sell phonograph records, or for a scheme to make valentines sell garden seeds, or to devise a method whereby candy and books would sell each other, the chances are you would be stumped, says "Printers' Ink." Yet if those interested in such a plan had a chance to think over the proposition for awhile no doubt they would be able to suggest several ways whereby one product would sell another that may be entirely foreign to it. Such plans are being worked right along. For instance, Harper & Brothers recently issued what they call a "Bubble Book." It contains, in illustrated verse, the stories of "Tom, Tom the Piper's Son," "Jack and Jill" and "Mary Had a Little Lamb." Three of the pages in the book are in the form of envelopes. In each of these is a special Columbia record, giving the singing version of these famous nursery rhymes, and which can be played on a phonograph. It is a unique combination of pictures, verses and

music. By listening to the songs a child can learn to read the book, and sing the verses.

Here we have an idea that induces the music store to handle nursery books—an item which formerly they would consider entirely out of their line. On the other hand, the plan gets phonograph records into book stores.

RECEIVING MANY REPEAT ORDERS

"Our new No. 1012 album is meeting with very pleasing success, and we have received numerous repeat orders from our dealers," said Philip A. Ravis, vice-president of the New York Album and Card Co., New York. "We were fortunate in securing additional factory facilities for the production of our albums, as the demand for the 1012 album has taxed our resources, even though our capacity has been considerably augmented. Our Nyacco metal back album continues to be the leader of our line, and judging from the orders already in hand for this album, this season will be an active one for the Nyacco metal back product. This album has many distinctive features, and the fact that it lies perfectly flat when opened is one of the reasons for its success."

READY REFERENCE OF GENERAL SUPPLIES

DEALERS

Send for our "Trial Proposition" on the Regina Hexaphone—the latest and best paying popular priced coin-operated instrument for use in public places.



211 Marbridge Bldg., 34th St. and Broadway, New York City
Manufacturers of Regina Music Boxes; Reginaphones; Coin-operated Mandolin Orchestrions; Vacuum Cleaners and other specialties.

NEEDLES

WE MANUFACTURE

Diamond needles for Edison
Sapphire needles for Edison
Sapphire needles for Pathe
in stock ready for delivery

MERMOD & CO., 505 5th Ave., N. Y.

REPAIRS

All Makes of Talking Machines
Repaired Promptly and Efficiently

TALKING MACHINE REPAIR
AND SALES CORPORATION

ANDREW H. DODIN, President
176 Sixth Avenue New York

TELEPHONE, CHELSEA 8437.

Some of the Leading Jobbers of Talking Machines in America

1856 **WURLITZER** 1916

VICTOR
DISTRIBUTORS
VICTORS EXCLUSIVELY

*We make a specialty of getting the order
out on time—every time.*

The Rudolph Wurlitzer Co.
CINCINNATI AND CHICAGO
Two points of supply; order from the nearer

TEST IT. 

OUR VICTOR

Record Service

has a reputation for efficiency.
Suppose you try it.

E. F. DROOP & SONS CO.
1300 G. STREET, WASHINGTON, D. C.
231 N. HOWARD STREET, BALTIMORE, MD

Smith, Kline & French Co.
PHILADELPHIA

Wholesale Distributors for

THE INSTRUMENT OF QUALITY
Sonora
CLEAR AS A BELL 

In PENNSYLVANIA, NEW JERSEY
and DELAWARE

W. J. DYER & BRO.
NORTHWESTERN DISTRIBUTORS
OF THE

 **VICTOR**
Machines, Records and Supplies

Shipped Promptly to all
Points in the Northwest

**THIS REFERS TO YOU,
MR. DEALER**

Every talking machine jobber in this country should be represented in this department, no matter what line he handles or where he is located. The cost is slight and the advantage is great. Be sure to have your card in this department of *The Talking Machine World* each month. It will pay you a big profit on the investment.



Where Dealers May Secure

COLUMBIA

Product

Ready, Full Stocks, and Prompt Deliveries
from Convenient Shipping Centers
all over the United States.

Distributors

Atlanta, Ga., Columbia Graphophone Co., 63 N. Pryor St.
Baltimore, Md., Columbia Graphophone Co., 111 West German St.
Boston, Columbia Graphophone Co., 137 Federal St.
Buffalo, N. Y., Columbia Graphophone Co., 622 Main St.
Chicago, Ill., Columbia Graphophone Co., 14 N. Michigan Ave.
Cincinnati, O., Columbia Graphophone Co., 117-119 W. Fourth Ave.
Cleveland, O., Columbia Graphophone Co., 1375 Euclid Ave.
Dallas, Tex., Columbia Graphophone Co., 1011 Elm St.
Denver, Colo., Columbia Stores Co., 1608 Glenarm Place.
Detroit, Mich., Columbia Graphophone Co., 401 Woodward Ave.
Indianapolis, Ind., Columbia Graphophone Co., 44 N. Pennsylvania St.
Kansas City, Mo., Columbia Graphophone Co., 1027 McGee St.
Los Angeles, Cal., Columbia Graphophone Co., 745 S. Broadway.
Minneapolis, Minn., Columbia Graphophone Co., 412-414 Nicollet Ave.
New Haven, Conn., Columbia Graphophone Co., 206 Meadow St.
New Orleans, La., Columbia Graphophone Co., 517-525 Canal St.
New York City, Columbia Graphophone Co., 55 Warren St.
Omaha, Neb., Schmoller & Mueller Piano Co.
Philadelphia, Pa., Columbia Graphophone Co., 210 N. Broad St.
Pittsburgh, Columbia Graphophone Co., 101 Sixth St.
Portland, Me., Columbia Graphophone Co., 43 Exchange St.
Portland, Ore., Columbia Graphophone Co., 429-431 Washington St.
Salt Lake City, Utah, Columbia Stores Co., 221 South West Temple.
San Francisco, Cal., Columbia Graphophone Co., 130-150 Sutter St.
Seattle, Wash., Columbia Graphophone Co., 311 Western Ave.
Spokane, Wash., Columbia Stores Co., 818 Sprague Ave.
St. Louis, Mo., Columbia Graphophone Co., 1127 Pine St.
Tampa, Fla., Tampa Hardware Co.

DEALERS WANTED—Exclusive selling rights given where we are not actively represented.

Write for particulars to the Columbia Graphophone Co., Wholesale Department, Woolworth Building, New York.

Headquarters for Canada:
Columbia Graphophone Co., 363-5-7 Borauren Ave.
Toronto, Ont.

STANDARD SERVICE
EXCLUSIVELY VICTOR WHOLESALE ONLY



STANDARD TALKING MACHINE CO.
PITTSBURGH

Victor Exclusively
EASTERN TALKING MACHINE CO.
177 Tremont Street, Boston
VICTOR DISTRIBUTORS

 **Sherman, Clay & Co.**

San Francisco, Los Angeles, Portland, Seattle, Spokane
PACIFIC COAST DISTRIBUTORS OF
VICTOR PRODUCTS

The Electric Supply & Equipment Co.

Exclusive Wholesale Distributors for
Southern New England

THE INSTRUMENT OF QUALITY
Sonora
CLEAR AS A BELL 

Complete stocks carried in Boston and Hartford

Little Bldg. 103 Allyn St.
BOSTON, MASS. HARTFORD, CONN.

The PERRY B. WHITSIT CO.
Distributors of
Victrolas and Victor Records
COLUMBUS, OHIO

Southern Victor Dealers
Largest Stock VICTROLAS and RECORDS.
Prompt Shipment and Low Freight Rates.
WALTER D. MOSES & CO.
Oldest Music House in Virginia or North Carolina.
RICHMOND, VA.

**OLIVER
DITSON
COMPANY**

Largest VICTOR Talking
Machine Distributors East of
Chicago.

Creators of "The Fastest Victor
Service." Let us tell you more
about our service.

BOSTON



The NEW EDISON

Bears the Stamp of Edison's Genius

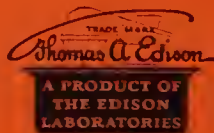

JOBBER'S OF THE NEW EDISON, EDISON RE-CREATIONS, THE NEW EDISON DIAMOND AMBEROLA AND BLUE AMBEROL RECORDS

CALIFORNIA
Los Angeles—Diamond Disc Distributing Co.
San Francisco—Edison Phonographs, Ltd.
COLORADO
Denver—Denver Dry Goods Co.
CONNECTICUT
New Haven—Pardee-Ellenberger Co., Inc.
GEORGIA
Atlanta—Phonographs Inc.
ILLINOIS
Chicago—The Phonograph Co.
James I. Lyons. (Amberola only.)
INDIANA
Indianapolis—Kipp Phonograph Co.
IOWA
Des Moines—Harger & Blish.
Sioux City—Harger & Blish.

LOUISIANA
New Orleans—Diamond Music Co., Inc.
MASSACHUSETTS
Boston—Pardee-Ellenberger Co.
MICHIGAN
Detroit—Phonograph Co., of Detroit
MINNESOTA
Minneapolis—Laurence H. Lucker.
MISSOURI
Kansas City—The Phonograph Co. of Kansas City.
St. Louis—Silverstone Music Co.
MONTANA
Helena—Montana Phonograph Co.
NEBRASKA
Omaha—Shultz Bros.
NEW JERSEY
Paterson—James K. O'Dea (Amberola only.)
NEW YORK
Albany—American Phonograph Co.

New York—The Phonograph Corp. of Manhattan.
Syracuse—Frank E. Bolway & Son, Inc.
W. D. Andrews Co. (Amberola only.)
Buffalo—W. D. & C. N. Andrews Co. (Amberola only.)
OHIO
Cincinnati—The Phonograph Co.
Cleveland—The Phonograph Co.
OREGON
Portland—Edison Phonographs, Ltd.
PENNSYLVANIA
Philadelphia—Girard Phonograph Co.
Pittsburgh—Buehn Phonograph Co.
Williamsport—W. A. Myers.
RHODE ISLAND
Providence—J. A. Foster Co. (Amberola only.)
TEXAS
Dallas—Texas-Oklahoma Phonograph Co.

El Paso—El Paso Phonograph Co., Inc.
UTAH
Ogden—Proudfit Sporting Goods Co.
VIRGINIA
Richmond—C. B. Haynes & Co.
WISCONSIN
Milwaukee—The Phonograph Co. of Milwaukee.
CANADA
Montreal—R. S. Williams & Sons Co., Ltd.
St. John—W. H. Thorne & Co., Ltd.
Toronto—R. S. Williams & Sons Co., Ltd.
Vancouver—Kent Piano Co., Ltd.
Winnipeg—R. S. Williams & Sons Co., Ltd.
Calgary—R. S. Williams & Sons Co., Ltd.

The TALKING MACHINE WORLD

For the
makers &
sellers of
talking
machines

Published Each Month by Edward Lyman Bill, Inc., at 373 Fourth Ave., New York, May 15, 1918



Victrola XVI, \$215
Victrola XVI, electric, \$270
Mahogany or oak

The instrument by which the value of
all musical instruments is measured



The Highest Class Talking Machine in the World

THE INSTRUMENT OF QUALITY

Sonora

CLEAR AS A BELL



THE most valuable asset of any manufacturer is the reputation his product has won.

Sonora is everywhere known as the *quality* phonograph—not the quantity phonograph, not the phonograph offering “terms” as the main sales feature, but the *value* instrument which the buyer is proud to own and which is shown to friends with the remark “I bought this phonograph because of its quality of tone and appearance.”

The owner’s pride of possession in a Sonora is a factor in Sonora’s increasing popularity.

In proportion to the total number of instruments on sale, more Sonoras are sold for cash than any other instrument. This is conducive to a higher bank balance for the Sonora dealer.



The Sonora sells easily, turns every buyer into a Sonora enthusiast, and makes money for the dealer. If you wish to sell Sonoras this year write us NOW for information.

\$50	\$55	\$60	\$90	\$115	\$150	\$180
\$200	\$215	\$300	\$375	\$500	\$1000	

Art models made to special order to suit any taste.

Sonora Phonograph Sales Company, Inc.

GEORGE E. BRIGHTSON, President

Executive Offices: 279 Broadway, NEW YORK

Sonora operates and is licensed under BASIC PATENTS of the phonograph industry

The Talking Machine World

Vol. 14. No. 5

New York, May 15, 1918

Price Twenty-five Cents

LOVING CUP FOR MME. MELBA

Famous Diva, so Widely Known Through Her Records, Surprised at Her Concert by Gift From Leading Victor Dealers in Los Angeles

LOS ANGELES, CAL., May 1.—In recognition of the fact that she was the first great prima donna to give her art to the world through the medium of the Victor, Mme. Melba was presented with a silver loving cup by L. E. Behymer, the local impresario, during her concert at Trinity Auditorium on the evening of April 3.

The presentation was made on behalf of the Andrews Talking Machine Co., Barker Brothers, Wiley B. Allen, Geo. J. Birkel and Southern California Music Co., leading Victor dealers of this goahead city.

"I don't know what to say. I don't think I deserve this. Give them all my love. I shall



Mme. Melba and Cup Presented to Her

always keep this trophy among my most treasured possessions. I thank those who have given me this most heartily," said Mme. Melba.

In presenting the cup Mr. Behymer said that the Victor dealers of southern California recognized in Mme. Melba one of the greatest benefactors the talking machine knows, making possible the development and recognition of the talking machine as a musical instrument of the highest order, by her co-operation with the Victor Co.

The cup was an elaborate silver affair, presented just after she had finished singing Tosti's "Good-bye." The following inscription was engraved on the face: "To Mme. Nellie Melba, Dame Commander of the British Empire, the first great prima donna to give her art to the world through the medium of the 'Victrola.'" Then followed a list of the names of the dealers making the presentation.

TALKERS FOR COOLIES IN FRANCE

Records From America Help to Cheer Chinese Laborers Behind the Lines

Not only is the talking machine with its records a friend of the allied soldiers in the trenches on the Western front, and for that matter of the enemy soldiers, but it appears that even Chinese coolies, who are employed in large numbers back of the French front, are also strong admirers of that instrument. Talking machine records in the Chinese language and recordings of Chinese music have been sent to France from the United States, and proved the source of entertainment for the Chinese worker.

Knowing a dozen languages won't help unless you know how to make a living in one of them.

THE "TALKER" IN THE WAR

Samuel Gompers Pays Tribute to the Influence of the Talking Machine for Good in the Trenches in France as in the American Home

While in Cleveland recently to boost the sale of Liberty Bonds Samuel Gompers, president of the American Federation of Labor, paid a high tribute to music and musical instruments and the part they are playing in the world war. Mr. Gompers declared that the talking machine has made army camps and even the trench dug-outs "seem like home" to tens of thousands of American soldiers.

"The war is developing a love for music and talking machines are doing their part wonderfully well," said Mr. Gompers. "Through the agency of these instruments and records the boys who have given up homes and home environment are permitted to enjoy good music, to listen to the words of the world's great singers, orchestras and bands. The words of that wonderful song, 'Home, Sweet Home,' mean more than they ever did to all true Americans. Talking machines, player-pianos and other musical instruments are making 'home, sweet home' out of many a place that would be dreary if these musical instruments were not available. Like the movies, talking machines are great stimulants to back up our fighting men on sea and land, in training camps or back of the firing line in the war zone."

Douglas Fairbanks also paid a high tribute to the "good that talking machine music is doing during this war" while here. He appeared jointly with Mr. Gompers at the Keith Hippodrome and the Central Armory making appeals for bond buyers.

NEW DEPARTMENT IN ASBURY PARK

ASBURY PARK, N. J., May 4.—The Steinbach Co., this city, has opened an elaborate new Victrola department in its present store. The new department is equipped with four handsome sound-proof demonstration booths, and an excellent equipment for the display of machines and the storing of records. It is declared to be one of the finest departments in this section of the State.

Music for the Camps Provided by the Knights of Columbus

Robert G. Wulf, director of construction on the Committee of War Activities of the Knights of Columbus, recently outlined for The World what the Knights of Columbus are doing toward providing talking machine music for the military forces. Mr. Wulf said in part: "Up to the present time this organization has erected something like ninety buildings in the various cantonments, encampments and marine and naval stations throughout the country. In each building a talking machine has been installed with a collection of at least twenty-five of the latest records.

"It is our information from our secretaries in the different camps that the talking machines and records play an important part in the entertainment of the soldiers, and that the records are being played from early in the morning until late at night.

"We feel confident that the soldiers are interested in all kinds of music; and record donations from any source will be greatly appreciated.

"We cannot say what kind of machines or records are most desired, for the reason that in the majority of instances we ordered this equip-

WHAT CO-OPERATION ACCOMPLISHED

Brooklyn Dealers Saved From Loss Through Exchange of Information Regarding Operations of a Talking Machine Swindler

How co-operation can save money for talking machine dealers was instanced in a most emphatic manner recently in this city. It appears that a man giving a New York City address attempted to purchase a talking machine from Frederick Loeser & Co., of Brooklyn. The deal was just about to be closed when the quick-witted salesman glanced at the name and remembered that he had seen an advertisement in one of the New York papers giving the same name and address as did the customer, and offering a Victrola, slightly used, at a low price. He, of course, refused to conclude the sale, except on a cash basis, and the customer went out.

The salesman immediately called up J. J. Cavanaugh, manager of the talking machine department of A. I. Namm, in Brooklyn, and advised him of the occurrence. Mr. Cavanaugh also recalled the name and address of the New York party, and found that his house had sold a Victrola to the man some time before. He immediately went to the New York address in his automobile and asked the party if he had a Victrola to sell at a bargain. "Sure," said the man, and pulled off the cover of a machine from which the nameplate had been removed. Mr. Cavanaugh flashed a Deputy Sheriff's badge, made known the real purpose of his errand, and ended up by taking the machine back to the store with him. Inasmuch as the second payment was not yet due on the machine there would have been little redress for the store through the courts.

It is lack of co-operation between merchants that encourages many swindlers to operate, and permits them to operate successfully. With the talking machine men getting together, as they are in New York, watching advertisements as did the Loeser salesman, and endeavoring to remember names of those who it is believed are fraudulently inclined, much can be done to prevent losses. The important thing, however, is co-operation and a willingness to advise a competitor of the operations of swindlers and thereby offer protection to one another.

ment long before the soldiers arrived at camp. It was our idea that they would be mostly interested in popular music and not in the classical music or songs.

"In addition to the talking machines, we also have player-pianos in each building with a new assortment of music rolls for the entertainment of the soldiers."

The Knights of Columbus very evidently have a clear conception of the part that music plays in keeping up the morale of the soldiers, and will undoubtedly make good use of any donations of records, machines or music rolls sent to them.

In answering the inquiries of the general public, talking machine dealers can refer prospective givers to the Committee on War Activities, Knights of Columbus, Woodward Building, Washington, D. C. Talking machine merchants who may themselves be collecting records for the use of the Knights of Columbus by getting in touch with the same headquarters will be able to determine what military units have the greatest need of records, etc. This will be a move along the lines of efficiency and concentration.

The Man Who Is Hard to Sell Is a Challenge to Salesmanship and a Stimulus to Effort

There are two mental attitudes regarding the prospect who is a hard nut to crack, a difficult man to sell. One of these attitudes is that of the salesman who gets peevish over such a prospect and gives him up and tries ever after to get even with the fellow for not buying.

The other attitude, and the right one, is that of regarding the hard man to sell as a challenge to salesmanship and a stimulant to effort. The salesman who gets this attitude sets deliberately about finding a way to get behind the defense of the customer—for there is a way to get behind the defense of anyone in a position to buy.

The man who is not easily won over usually sticks better when he is won. He does not

change his mind or back out without reason. If you find out how a man feels about your proposition, and why he feels so, you will be able to handle him. Put yourself in his place and talk from that side. Instead of so much about what "I have to sell," say more about what "you need to buy." Emphasize the "You" instead of the "I."

Dig into that man's problems and discover why he thinks your talking machine or phonograph would not suit him. Don't begin to try to get him to buy before you have even shown the advantages of what you have to offer. Sales are not made so easily. And don't waste preliminary time in talk about the weather, war or politics. You may inadver-

tently get the man into a discouraged frame of mind by reminding him of extraneous business conditions. You know what will interest people who are prospective buyers of musical instruments, even if they are hard nuts to sell. The prospect may not at the outset care two straws about your particular line, but if he is interested in music at all, he will discuss with you many phases of the question and if he listens, you can get him coming your way.

When you get a person asking questions about and showing an interest in something you know more about than he does, then you have made a start. Once you have made a start, if you get no farther, the fault is your own.

PLANNING FOR IOWA CONVENTION

Elaborate Arrangements to Be Made for the Third Annual Meeting of the Iowa Victor Talking Machine Dealers' Association

DES MOINES, IA., May 6.—A meeting of the executive committee of the Iowa Victor Talking Machine Dealers' Association was held in this city recently at the offices of the Mickel Bros. Co., the Victor wholesalers, at 411 Fourth avenue, for the purpose of considering various plans and suggestions for framing a program for the third annual convention of that organization, some time in August.

The executive committee consisting of W. A. Stoaks, president; W. P. Deal, secretary; Joseph Britt, treasurer, and E. E. Hobbs, member at large, was present in a body, as were a number of association members, including representatives from the following houses: McGregor Bros. & Coen, Creston, Ia.; Schlick's Music Store, Charles City, Ia.; Lohr & Donahoe, Ft. Dodge, Ia., and Harmony Hall, Iowa City, Ia. Through their co-operation a tentative program was considered, details of which will be worked out and announced to the association during this month.

George E. Mickel, member of the association and general manager of Mickel Bros. Co., of Des Moines and Omaha, suggested that the association endeavor to have Galli-Curci and Jascha Heifetz appear during the convention in a recital or concert to be held in Des Moines at the Coliseum.

This event, which would have been extraordinary, was found to be impossible after investigation on the part of Mr. Mickel, owing to the fact that neither of the artists was in a position to specify definitely whether his or her appearance would be an assurance, owing to certain engagements, which were contracted for previously. However, the services of these two artists are still in question as to whether the contracts can be filled.

Should it be impossible for the above-mentioned artists to appear, a suitable program (such as has always been successful at these conventions) will certainly be instituted, and it is desired by the executive committee that a two-day session be held instead of the one-day session as of previous conventions. Judging from the responses already noted from members, the third annual convention will be a far greater success than the two previous ones, as the interest on the part of the members is very noticeable. The membership is increasing each year.

Matters of the utmost importance will come up for discussion at the convention, owing to the shortage of Victor products, and it is to be hoped that by the time of the convention (which will be held the latter part of August) the Victor Co. will have had an opportunity to overcome the ever-increasing shortage of its products and that the fear which has been entertained, and which naturally would be entertained on the part of some dealers, will be a matter of past history as to the future outlook of their business.

ENJOY GALLI-CURCI CONCERT

By Means of Victor Records in the Osterhaus Free Library in Wilkes-Barre

A representative of a New York publishing house who recently visited Wilkes-Barre, Pa., made the following observations which are passed along to readers of The World for information and use when available. He said: "I am a plain, ordinary book agent, classed with the dogs and baby carriages and therefore unwelcome in most public buildings. However, my roving disposition carries me all around the country, and I have noticed a few things which would benefit 'us' New Yorkers. For instance, I dropped into the Osterhaus Free Library here, and enjoyed a really fine concert by Galli-Curci and other stars. Of course, it was on the talking machine, but what does that matter? The place was crowded. It was a regular concert with programs, and the 'Star Spangled Banner' was played and honored. The local merchants loan selections to this library."

INCORPORATES BUSINESS

WESTFIELD, MASS., May 4.—The business of George H. Sharp & Son, which was established in this city in 1893 by George H. Sharp, was recently incorporated, and in future will be known as the George H. Sharp Co. The company specializes in talking machines and music, and the business will be enlarged to take in considerably more territory.



DITSON SERVICE

Makes the Dealer's Road Smoother

It helps to overcome some of the wartime difficulties
Real effort takes the place of wild promises

VICTOR EXCLUSIVELY

OLIVER DITSON CO.
BOSTON

CHAS. H. DITSON & CO.
NEW YORK

Victrola VI-A, \$30
Oak



Victrola IX-A, \$57.50
Mahogany or oak



Victrola XI-A, \$110
Mahogany or oak



Victrola XVI, \$215
Victrola XVI, electric, \$270
Mahogany or oak

Victor Supremacy

The enormous public demand for the Victrola, the unparalleled success of Victor retailers everywhere, unmistakably tell of Victor supremacy.

Victor Talking Machine Co.
Camden, N. J., U. S. A.

Berliner Gramophone Co., Montreal, Canadian Wholesalers

"Victrola" is the Registered Trade-mark of the Victor Talking Machine Company designating the products of this Company only.

Warning: The use of the word Victrola upon or in the promotion or sale of any other Talking Machine or Phonograph products is misleading and illegal.

Important Notice. Victor Records and Victor Machines are scientifically co-ordinated and synchronized in the processes of manufacture, and their use, one with the other, is absolutely essential to a perfect reproduction.



Victor Wholesalers

- Albany, N. Y.... Gately-Haire Co., Inc.
- Atlanta, Ga..... Elyea-Austell Co.
Phillips & Crew Co.
- Austin, Tex..... The Talking Machine Co., of
Texas.
- Baltimore, Md.... Cohen & Hughes.
E. F. Droop & Sons Co.
H. R. Eisenbrandt Sons, Inc.
- Bangor, Me..... Andrews Music House Co.
- Birmingham, Ala. Talking Machine Co.
- Boston, Mass..... Oliver Ditson Co.
The Eastern Talking Machine
Co.
The M. Steinert & Sons Co.
- Brooklyn, N. Y... American Talking Mch. Co.
G. T. Williams.
- Buffalo, N. Y..... W. D. & C. N. Andrews.
Neal, Clark & Neal Co.
- Burlington, Vt... American Phonograph Co.
- Butte, Mont..... Orton Bros.
- Chicago, Ill..... Lyon & Healy.
The Rudolph Wurlitzer Co.
Chicago Talking Machine Co.
- Cincinnati, O.... The Rudolph Wurlitzer Co.
- Cleveland, O..... The W. H. Buescher & Sons
Co.
The Collister & Sayle Co.
The Eclipse Musical Co.
- Columbus, O..... The Perry B. Whitsit Co.
- Dallas, Tex..... Sanger Bros.
- Denver, Colo..... The Hext Music Co.
The Knight-Campbell Music
Co.

- Des Moines, Ia.... Mickel Bros. Co.
- Detroit, Mich..... Grinnell Bros.
- Elmira, N. Y..... Elmira Arms Co.
- El Paso, Tex..... W. G. Walz Co.
- Honolulu, T. H.... Bergstrom Music Co., Ltd.
- Houston, Tex..... Thos. Goggan & Bro.
- Indianapolis, Ind.. Stewart Talking Machine Co.
- Jacksonville, Fla.. Florida Talking Machine Co.
- Kansas City, Mo... J. W. Jenkins Sons Music Co.
Schmelzer Arms Co.
- Lincoln, Nebr.... Ross P. Curtice Co.
- Little Rock, Ark... O. K. Houck Piano Co.
- Los Angeles, Cal.. Sherman, Clay & Co.
- Memphis, Tenn.... O. K. Houck Piano Co.
- Milwaukee, Wis... Badger Talking Machine Co.
- Minneapolis, Minn. Beckwith, O'Neill Co.
- Mobile, Ala..... Wm. H. Reynolds.
- Montreal, Can.... Berliner Gramophone Co.,
Ltd.
- Nashville, Tenn... O. K. Houck Piano Co.
- Newark, N. J.... Price Talking Machine Co.
- New Haven, Conn. Henry Horton.
- New Orleans, La... Philip Werlein, Ltd.
- New York, N. Y... Blackman Talking Mach. Co.
Emanuel Blout.
C. Bruno & Son, Inc.
I. Davega, Jr., Inc.
S. B. Davega Co.
Charles H. Ditson & Co.
Landay Bros., Inc.
New York Talking Mach. Co.
Ormes, Inc.
Silas E. Pearsall Co.

- Omaha, Nebr..... A. Hospe Co.
Mickel Bros. Co.
- Peoria, Ill..... Putnam-Page Co., Inc.
- Philadelphia, Pa.. Louis Buehn Co., Inc.
C. J. Heppel.
The George D. Ornstein Co.
Penn Phonograph Co., Inc.
The Talking Machine Co.
H. A. Weymann & Son, Inc.
- Pittsburgh, Pa.... W. F. Frederick Piano Co.
C. C. Mellor Co., Ltd.
Standard Talking Machine Co.
- Portland, Me..... Cressey & Allen, Inc.
- Portland, Ore..... Sherman, Clay & Co.
- Providence, R. I... J. Samuels & Bro., Inc.
- Richmond, Va.... The Corley Co., Inc.
W. D. Moses & Co.
- Rochester, N. Y... E. J. Chapman.
The Talking Machine Co.
- Salt Lake City, U. Consolidated Music Co.
The John Elliott Clark Co.
- San Antonio, Tex.. Thos. Goggan & Bros.
- San Francisco, Cal. Sherman, Clay & Co.
- Seattle, Wash..... Sherman, Clay & Co.
- Sloux Falls, S. D.. Talking Machine Exchange.
- Spokane, Wash.... Sherman, Clay & Co.
- St. Louis, Mo.... Koerber-Brenner Music Co.
- St. Paul, Minn.... W. J. Dyer & Bro.
- Syracuse, N. Y.... W. D. Andrews Co.
- Toledo, O..... The Whitney & Currier Co.
- Washington, D. C. Cohen & Hughes.
E. F. Droop & Sons Co.
Robt. C. Rogers Co.

ALL RECORD CUSTOMERS ARE ALBUM CUSTOMERS



MAKING THEIR SELECTION

A Place for Every Record and Every Record in its Place

Albums are an Indispensable Requisite in the talking machine business and wherever records are sold. Practical and handy. Save time and records. A profitable adjunct to the business.

We manufacture disc Record Albums to fit cabinets of all sizes and styles. With the indexes they are a complete system for filing all disc records.

We have unexcelled manufacturing facilities, and considering quality our prices are the lowest. Write us, giving quantity you may desire, and we will quote prices.

OUR ALBUMS ARE MADE TO CONTAIN VICTOR, COLUMBIA, EDISON, PATHE AND ALL OTHER DISC RECORDS

NATIONAL PUBLISHING CO., 239 S. American St., PHILADELPHIA, PA.

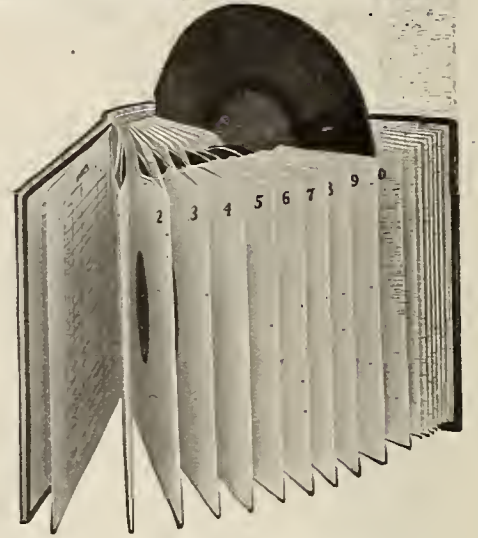

THE PERFECT PLAN

ATLANTA TRADE SOMEWHAT SPOTTY

Shortage of Machines and Records Felt—Meanwhile Business in General Was Never Better

ATLANTA, GA., May 4.—The talking machine business in this city during April was a little "spotted." In addition to the very critical condition in Europe there was and is a shortage of goods, one of the leading manufacturers not having in stock at the present writing a single \$55, \$160 or \$215 model.

Just what effect the conference of the manufacturers recently held in New York City will have on the future of the business is somewhat uncertain, but it certainly appears that there is to be some curtailment in production. Probably this will make the public eager for what is left to be marketed and will in this way make easy sales for the dealer.

After cable news in regard to General Haig's famous "back to the wall" stand was received, there was a noticeable increase in buying and a better feeling all round. This now world-celebrated order will live in history with "Don't give up the ship" and "England expects every man to do his duty."

Talking machine dealers in the South and many of the fraternity in New York, Philadelphia, Bridgeport and elsewhere, will read in this paper with regret of the death recently of Richard Thornton, of Atlanta, Ga., for years identified with the phonograph business in Atlanta, and one of the pioneers of recent years in the growth and development of the industry.

Chamberlin, Johnson, DuBose Co., this city, one of the best-known and foremost dry goods houses in the South, have recently moved into a new six-story fireproof building on Whitehall street, in the shopping center, and have engaged Edgar Brotherton, a former Atlantian, but recently with D. H. Holmes Co., New Orleans, to take charge of their Victrola and Sonora department.

Without detailing reports from each individual firm in the city, we can say that business in general is good, and all are anticipating a continuance of activity throughout the summer.

The Columbia Graphophone Co. has qualified the Kenny Furniture Co., locally, and it is understood that this concern is doing well with this widely known line.

ATTRACTIVE STORE IN MINNEAPOLIS

Nye & Nye, in the Brunswick Shop, Have an Elaborate Establishment

MINNEAPOLIS, MINN., May 8.—One of the outstanding establishments in the talking machine trade in this city is the Brunswick Shop of Nye



Nye & Nye's Attractive Store

& Nye, who are in possession of most attractive quarters, fitted out elaborately for the special requirements of their business.

The Nye & Nye shop is located at 712 Marquette avenue, right in the center of things, and the amount of business already being han-



View of Display Room and Booths

dled more than justifies the handsome equipment. The firm is composed of Walter G. Nye, a former Mayor of Minneapolis, and George M. Nye, a former member of the Minneapolis Legislature. Both men are naturally widely known to the citizens of the city, and this fact has helped them to build up a clientele that is constantly growing.

TRADE MOVES IN WAR TIMES

The Attitude of Dealers Toward Goods Other Than Machines and Records Discussed by F. O. Wilking, of the Ready-File Co.

In a recent letter to The World F. O. Wilking, president of the Ready-File Co., Indianapolis, Ind., points out the tendency which that company has found on the part of the dealers toward making a special effort to push the sale of accessories during war times. He says in part:

"One of the most interesting developments of war times is the changing attitude of talking machine dealers toward goods other than machines and records. This was forcibly brought to my attention during a recent trip through the Central West, when both dealers and jobbers of the most progressive type showed an entirely new disposition to warm up to the extra profit that Ready-File makes for them. Dealers who had previously shown only slight interest in our proposition have become enthusiastic boosters; distributors that have been ordering in 100 lots are now ordering in 400 and 500 lots.

"The explanation lies partly in the fact that our goods are constantly becoming better known, but deeper than that is the inability of either distributor or dealer to get all the machines and records needed to supply the demands of the trade. The fact that his profit on machines and records has been cut by curtailed production has made many dealers to put more effort behind selling other goods. Each dealer is anxious to have his books look at least as good at the end of 1918 as they did a year before, and he is consequently keenly interested in any device such as ours, which permits him to make an extra profit on each sale.

"In this awakening may lie the salvation of many dealers. It is a fact that there are accessories, a number of them, that show the dealer a better profit than either machines or records. Our advice to every dealer is to investigate these devices now, while his machine and record stock is short, pick out those that suit him and get his sales force in the habit of including them in every deal. Thus he will keep his business up to the mark for the present, and be in a position to greatly increase it when the factories get through doing war work."

NEW PATHE NUMERICAL CATALOG

The Pathé Frères Phonograph Co., Brooklyn, N. Y., has just issued a new numerical catalog of Pathé records which lists all records up to and including the May supplement. It is interesting to compare this catalog with the old edition, as the increased size of the publication indicates the remarkable strides made by the Pathé Frères record library during the past few months. At the present time the Pathé library contains a complete library of all classes of records, and the popularity of Pathé recordings is increasing rapidly with Pathé representatives in all sections of the country.

A Really Good Album At a Moderate Price is a Money Maker for the Dealer



METAL BACK ALBUMS

will give the dealer and his patrons true value and the highest quality. A complete line of albums that stand for the best in their respective grades.

Write for samples of our three numbers

NEW YORK ALBUM & CARD CO., 23-25 Lispenard St., NEW YORK

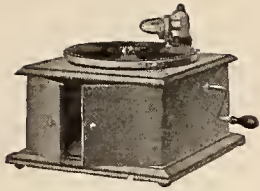

Victrola IV-A, \$20
Oak

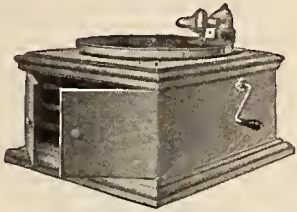

Victrola VI-A, \$30
Oak

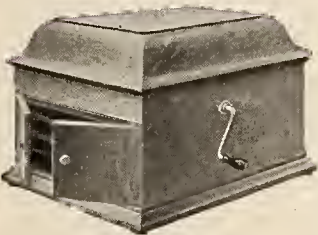

Victrola VIII-A, \$45
Oak



Victrola IX-A, \$57.50
Mahogany or oak



Victrola X-A, \$85
Mahogany or oak



Victrola XI-A, \$110
Mahogany or oak

Victor Supremacy

—all the time
and everywhere

Viewed from the stand-
point of musical art, judged
by the character and pres-
tige of the stores that
handle it, measured in
dollars for its ability as a
profit producer, the Vic-
trola is supreme.



Victrola XIV, \$165
Mahogany or oak



Victrola XVI, \$215
Victrola XVI, electric, \$270
Mahogany or oak



Victrola XVII, \$265
Victrola XVII, electric, \$325
Mahogany or oak

Victor Talking Machine Co.

Camden, N. J., U. S. A.

Berliner Gramophone Co., Montreal, Canadian Wholesalers

“Victrola” is the Registered Trade-mark of the Victor Talking Machine Company designating the products of this Company only.

Warning: The use of the word Victrola upon or in the promotion or sale of any other Talking Machine or Phonograph products is misleading and illegal

Important Notice. Victor Records and Victor Machines are scientifically co-ordinated and synchronized in the processes of manufacture, and their use, one with the other, is absolutely essential to a perfect reproduction.



“HIS MASTER'S VOICE”
REG. U.S. PAT. OFF.

The **TALKING**
MACHINE
WORLD

*For the
 makers &
 sellers of
 talking
 machines*

PUBLISHED BY EDWARD LYMAN BILL, Inc.

President, C. L. Bill, 373 Fourth Ave., New York; Vice-President, J. B. Spillane, 373 Fourth Ave., New York; Second Vice-President, J. Raymond Bill, 373 Fourth Ave., New York; Secretary and Treasurer, August J. Timpe, 373 Fourth Ave., New York.

J. B. SPILLANE, Editor

J. RAYMOND BILL, Associate Editor

AUGUST J. TIMPE, Business Manager

Trade Representatives: B. BRITAIN WILSON, L. M. ROBINSON, WILSON D. BUSH, C. CHACE, E. B. MUNCH, L. E. BOWERS, A. J. NICKLIN, V. D. WALSH

Boston: JOHN H. WILSON, 324 Washington Street

Chicago Office: E. P. VAN HARLINGEN, Republic Building, 209 South State Street. Telephone, Wabash 5774

London, Eng., Office: 2 Gresham Buildings, Basinghall St. W. LIONEL STURDY, Mgr. The Talking Machine World has regular correspondents located in all of the principal cities throughout America.

Published the 15th of every month at 373 Fourth Ave., New York.

SUBSCRIPTION (including postage): United States, Mexico, \$2.00 per Year; Canada, \$2.25; all other countries, \$3.75. Single copies, 25 cents.

ADVERTISEMENTS: \$4.50 per inch, single column, per insertion. On quarterly or yearly contracts a special discount is allowed. Advertising pages, \$125.00.

REMITTANCES should be made payable to Edward Lyman Bill, Inc., by check or Post Office Money Order.

NOTICE TO ADVERTISERS.—Advertising copy should reach this office by the first of each month. By following this rule clients will greatly facilitate work at the publication headquarters.

**Long Distance Telephones—Numbers 5982-5983 Madison Sq.
 Cable Address: "Elbill," New York.**

NEW YORK, MAY 15, 1918

THE need for some definite central organization of talking machine manufacturers was emphasized strongly last month when the industry was called upon to appoint a committee to confer with the United States Fuel Administrator regarding measures for curtailing the output of talking machine factories.

It is true that representatives of the larger companies conferred with the Fuel Administrator, but he preferred to deal with the trade at large and, therefore, a representative committee was suggested. Of course, such a committee was appointed at the meeting in New York on April 30, but it meant a delay of several weeks before definite action could be taken. Had there been an organization in existence representative of the entire trade, an agent of, or committee from that body would have been in a position to have followed up the matter to a conclusion with the Fuel Administrator earlier in the month.

It is probable that there will be other matters which will require the attention of the united trade in the future and before the war is over, and the industry should not be caught napping again. Hence the necessity of a permanent committee of representative men, or an individual, if one can be found to satisfy all parties, being appointed to provide official representation for talking machine manufacturers. Matters with the Government can thereby be discussed and adjusted quickly to avoid suspense. The piano and allied trades have followed this plan through the Music Industries Chamber of Commerce, and it has proven most successful.

The request from the Fuel Administrator that the talking machine trade appoint a committee to confer with him on the question of curtailment came as a surprise to many, as it was believed that the general order curtailing the output of musical instrument factories 30 per cent applied also to talking machine plants. It was learned, however, that an order was issued for a conference with the General Counsel of the Music Industries Chamber of Commerce, who was unable to state at that time that he represented the talking machine division of the trade. The Government does not desire to take up matters affecting the trade at large with any one or two companies in the trade. When a united trade opinion is desired, it must be what it professes to be—the opinion of the members, or a majority of the members, of one particular industry. It is only by getting together in some form of organization, even if only for the period of the war, and the appointment of a committee with the power to speak

for the trade as a whole, that this result can be accomplished. It is not the time for standing aloof or arguing over details. Any orders issued, or any actions taken against the industry, are going to be against the trade as a whole and will hit every individual manufacturer in it. This fact must not be overlooked.

With a committee appointed, an effort should be made to gather together honest statistics regarding trade, capital invested, number of employes engaged, those beyond the draft age, or women, amount, value and character of materials used, value and equipment of plants, and other essential details for presentation in collated form to the Federal officials. It has already been learned by other branches of the industry that the general statement that "music is a war necessity," for its worth in preserving the morale of citizens and soldiers, does not get anywhere in Washington. The fact that there is a large amount of capital invested and that so many thousands of people are dependent upon the industry for their livelihood is listened to with attention.

There are many ways of gathering these statistics without jeopardizing the business secrets of any one manufacturer. The disinterested outsider has been intrusted with similar statistics by more than one big industry, and practically without exception has proven faithful to the trust. These are not times for fancy talks. What Washington wants are facts—cold, hard facts—that can be considered in a businesslike manner, and the trade should see that such facts are available.

RECENT events indicated that conditions demand a more general co-operation between talking machine wholesalers and between dealers in the matter of a redistribution of surplus record stocks in order to preserve a most efficient balance. It is an acknowledged fact that record supplies from the factories are far from being normal, and due largely to labor conditions will possibly drop off even more, regardless of any Federal curtailment order. This shortage does not exist alone in the new and most popular records, but it is felt right through the line of the standard catalog selections. The seriousness of the situation is evidenced by the fact that not alone wholesalers but dealers have felt warranted in sending out representatives throughout the country to gather up what surplus stock they could to fill gaps in regular catalog stocks, but often with indifferent success.

One jobber, in calling upon his fellow jobbers for any record stock they could spare, declared that he was completely out of close to 2,000 records from his regular lists. Under such conditions, the wholesaler or dealer who is burdened with surplus records is simply fooling himself by neglecting to make an effort to get in touch with jobbers or dealers in or out of his territory, who may not only be able to use those particular records, but who would be glad to get them. When wholesalers are willing to pay retail prices for stock records, and perhaps a few popular numbers thrown in, for the sake of keeping their record assortments in half-way presentable shape, then the situation is serious enough to receive earnest consideration.

FROM the earliest ages the value of music as a therapeutic has been recognized and appreciated and it is not surprising to learn that Mrs. Isa Maude Ilsen, of Hamilton, Ont., has made extensive use of music to win the convalescent and diseased soldiers of Canada back to the fulness of health and happiness. Music she believes—and she has been demonstrating in practice the truth of her tenets—possesses a tremendous power considered as a medicine.

She says the part that music may play toward bringing back to normal our soldiers who are sick with minor ailments before they go to the front or are wounded after reaching the battle line is no small one. Mrs. Ilsen knows whereof she speaks. For nearly two years she has been the volunteer superintendent of the Military Infirmary of Hamilton, where a great number of Canadian soldiers suffering from wounds and illnesses caused by the war have been treated. It is in this institution that she has proved the practical value of music in the sickroom.

At present Mrs. Ilsen is drafting a plan for the United States military authorities which will give them an idea of the possibilities to be gained from the application of her principle. She will use her recent experience to illustrate the enormous possibilities of music in therapeutics.

Talking machine music is being used to-day in many hospitals as a curative influence, and has been especially effective particularly where soldiers are suffering from forms of "shock" which disturb the entire nervous system, making them in a measure a wreck for a considerable time. The selection of the records to be used is, of course, an important matter. They have to be gauged in accordance with the actual physical condition of the patient so that the influence exercised is most beneficial. The effect of music on different patients varies, and just like medicine, what cures one may harm another. In this domain the talking machine is destined to fulfil a noble mission.

JUST another reminder about terms: The stock of machines and records on the dealer's floor are, regardless of fixed price agreements or anything else, worth more to him right now than when he bought them, whether it was three weeks or three months ago. This higher value is based on the fact that once off his floor they will leave a gap that may not be filled for some months to come. Meanwhile, he is paying rent and carrying overhead on that gap. Why, therefore, sacrifice these machines and records on long time terms. Demand cash wherever possible, for right now it is the dealer's right to do so, and barring cash, make the terms reasonable—that is, reasonable to the house. Meanwhile many dealers are selling only for cash.

RECENT cases in the West where "gyp" dealers, and even that class of legitimate dealers in talking machines who have been convicted of misleading advertising and punished therefor, indicate that State advertising laws and local ordinances really have some "kick" in them and are not to be trifled with. When a few more cases are successfully pushed in other sections of the country that will serve to force on erring members of the trade generally that they either have to be good and tell the truth or stand punishment, so much the better off will be the industry.

Up to a couple of years ago the talking machine industry was remarkably free from misleading advertising. The leading manufacturers have always set high standards for their publicity. They endeavored to present facts instead of fiction; based their claims on truth and devoted their arguments to selling their own lines rather than in knocking those of competitors and trading upon competitors' reputations.

There is now evident in some quarters, however, definite attempts to cast reflection on the products of competitors, or to market unknown lines on arguments based on instruments of recognized standing. The "Victrola-like" or "Grafonola-style" of instruments offered at bargain prices by "gyp" dealers have become too common to permit of their being ignored any further, and the Music Industries Better Business Bureau, with headquarters in Milwaukee, is taking cognizance of this fact and has

TO OUR SUBSCRIBERS

If your copy of The Talking Machine World does not reach you on publication date, or a few days thereafter, do not assume that it has gone astray. The existing railway congestion has had a serious effect on the handling of mail, particularly second class matter, and brought about unusual delays. Kindly wait a few days longer than usual before writing to us, as the paper will probably arrive safely.

already succeeded in prosecuting several cases successfully, while others are under investigation.

The New York District Attorney's office has also been investigating local advertisers of the "gyp" type, and has promised to prosecute any of this ilk when proof can be furnished that they are uttering misstatements.

It is all up to the legitimate dealer to protect his own interests. If he sits quietly by and considers that the "gyp" dealer is not doing enough to hurt him to make prosecution worth while, he is simply encouraging a malignant growth in the industry. The thing to do is to investigate personally so far as possible every questionable advertisement, whether by "gyp" or legitimate dealers, and to present the facts before local authorities or before the Better Business Bureau, and prompt action can be obtained. Keeping the industry clean means to keep it healthy.

TALKING machine and record manufacturers are taking no undue credit to themselves when they acknowledge that they are doing real good for the fighting men of the nation at this time. Hardly a military unit, ship or hospital but has one or more talking machines, and a suitable supply of records, and the cry is constantly for further supplies of talking machine outfits for new units not yet equipped. The Y. M. C. A., for instance, consider the talking machine sufficiently important to appropriate a substantial portion of their funds for the purchase of such outfits for their various huts in this country and France. And so it is with the Knights of Columbus. Even the enemy enjoys the talking machine, for a story comes from London of an officer who while engaged in a drive against the Germans found several records in No Man's Land, and close to their trenches. It is said that Washington has divided the products of the country into three classes unofficially, they being first, food; second, war materials, and third, everything else. From results already shown it would seem that talking machine records might have a fair chance of edging into the second class.

THE phenomenal success of the Liberty Loan Rally of the Allied Music Trades, at Carnegie Hall, on April 30, was due in great measure to the work of the talking machine men and the generosity of the manufacturing companies and their artists.

"Plant" Records This Spring

Join the corps of successful dealers who are planting seeds of record profits for "picking" during the coming months. And if the seeds are planted in the

**PEARSALL GARDEN
of SERVICE**

you'll find its fertile soil is prolific of early crops and good ones, too, "Big Oaks from Little Acorns Grow"—use Pearsall Service on Victor Records and watch the Acorn bank balance grow into a big oak.

SILAS E. PEARSALL CO.

Victor Distributors

18 West 46th Street

New York, N. Y.



Meet Us at the Music Show

Those of us whose part it is to "keep the Home Fires Burning" while our boys are at the Front will be doing our part if we feed with an inexhaustible supply of fuel the fires of love and sympathy—if we cheerfully perform every service of which we are capable and bear every sacrifice and burden that comes to us, for the sake of those who are bearing still greater burdens on the field of action.

Music will help a lot. It is helping to keep our boys mentally fit and inspire them to the utmost of sacrifice and achievement. With music at the front, music in the camps and music in our homes, we have a bond of spiritual strength that will defy all apprehension, disappointment or discouragement (real or fancied). That will support to the end our resolve to purge the world of the monstrous, perverted doctrine that puts might above right. That will make unbending our determination to be stripped of all our possessions and drown in a sea of blood rather than permit the policy of the cloven-hoof to prevail on earth.

For our boys there is hardly a moment when music will not fit in, from the time they change from "civilians" to khaki until they return to their earthly homes triumphant in victory or, with thousands of brother heroes, are borne aloft where the supreme award for valor awaits them.

The spirit behind the National Music Show, June 1st to June 8th at the Grand Central Palace, New York City, is in harmony with the "Home Fires" sentiment. That spirit is a missionary spirit which has not only taken music into the remotest parts of our own country, but has carried it to the four corners of the world. Its influence in the lifting of humanity to higher levels of conception and accomplishment has been tremendous. May the National Music Show be instrumental in the musicalizing of every home in every land.

We shall keep open house for all visitors to the National Music Show at Sections 19 and 20 where they will find a most cordial welcome awaiting them.

THOMAS A. EDISON, Inc.
Orange, N. J.

How Music Aids in Maintaining the Nation's Faith, Hope and Courage

By M. C. Schiff

There are reasons why it would be unwise, from a broadly patriotic point of view, to curtail talking machine production. No doubt the representatives of every industry designated as non-essential have countless arguments to present against the propriety of such designation. In the case of the modern talking machine, however, the morale of the home itself, the very foundation of the nation's institutions, is affected. It is that, and not any inclination to evade bearing our full share of our country's burden, that actuates talking machine manufacturers in feeling that the proposed curtailment of fuel supply is not wise.

According to my understanding, it is the sense of the administration that the production of talking machines should be curtailed to the end that labor thus released may be employed in Government operations, and the money which would be expended for the instruments may instead be invested in Liberty Bonds, thereby providing the Government with the means of purchasing the product of the labor. The benefit that eventually would accrue to the Government under such program with reference to some industries, such as pleasure automobiles, for instance, is obvious. The difference in the value of the program as applied to the automobile industry, which we have taken for comparison, and the talking machine industry, lies in the fact that the former is not indispensable to the morale of the home, while the latter most certainly is.

Music is the most ennobling of all human agencies. Without it the ideals of the nation, and, hence, the nation itself would suffer. It is essential to the home in which is to be maintained the mental attitude necessary to national hope and courage.

The fact that, notwithstanding the withdrawal of thousands of persons from the usual buying channels, the demand for talking machines has increased proportionately with the stress of war conditions, the sales of the past six months having been the largest of any similar period in the history of the industry, proves that the public looks to this universal music reproducing instrument to renew the tremendous mental energy daily consumed under the strain of our present national crisis.

Through the talking machine the emotions may be thrilled and hearts made happy. The

music of the master, reproduced by the talking machine, can send into the very soul of the lonesome mother or heartsick wife a message of hope and cheer from the brave soldier at the front, and only through the talking machine can there be received in the home the message of

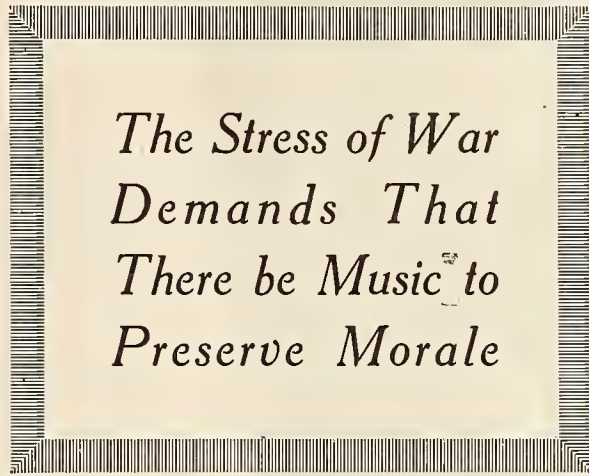

*The Stress of War
Demands That
There be Music to
Preserve Morale*

patriotism that great bands and famous musicians impart in their masterful interpretation of our national songs, expressing in the most po-

tent manner the great ideals for which America stands.

The talking machine brings democracy into the home and at this time, when events transcend the powers of the ablest writer or orator, the amplification of music must be permitted to perform its appropriate work of binding the people throughout the country so they may be held together by common ideals and sympathies.

Music in the home is the most positive preventive of our deterioration to a morose practicability; it will inspire the home folks to in turn inspire the boys "over there," and it will prove the greatest element in preserving the morale of the nation's war workers, both here and at the front, by preserving the morale of the home.

Talking machine manufacturers are not only willing, but in common with every other American industry, are anxious to go to any limit to serve the interests of the country, but they hope a way may be found to do that without risking injury to the spirit of the nation which now, more than ever, needs and depends upon the talking machine for economical mental relaxation and clean home entertainment.

DEATH OF RICHARD THORNTON

Well-Known Talking Machine Man of Atlanta, Ga., Passes Away in New Orleans

Richard Thornton, of Atlanta, Ga., for a number of years identified with the talking machine industry, recently passed away in New Orleans, La., at the Presbyterian Hospital, of acute pneumonia, after an illness of only a few days, in his thirty-fifth year.

He was identified with the Columbia Graphophone Co.'s Southeastern distributing headquarters in Atlanta from 1911 to 1915 as assistant manager, and was regarded as one of the most expert and experienced phonograph men in the United States, his work in the various departments of the Columbia Co. having given him an opportunity to learn the business from the ground up, managerial, selling and financial.

In 1915 the Columbia Co. sold their retail interests in Atlanta, and Mr. Thornton organized the Atlanta Talking Machine Co. at the old stand on Peachtree street, becoming junior partner and manager. His success with this

business was excellent, but when the New Edison entered the Southern field he was selected by the owners of the first modern Edison shop in the Southeast to introduce the line into an undeveloped field. It may be said that the present large sale of Columbia product in Atlanta and vicinity and also the Edison ground work can be attributed very largely to his ability and efforts.

Mr. Thornton was educated at the Atlanta public schools, in preparatory schools in New England and at Emory College, Oxford, Ga. He was a member of the Chi Phi Fraternity, and of the leading clubs of Atlanta, and was universally beloved by all who knew him. His untimely end will be mourned by hundreds of friends all over the country.

HANDLING SONORA PHONOGRAPHS

Charles W. Homeyer, well-known music dealer of 332 Boylston street, Boston, Mass., has just installed a line of Sonora phonographs and is very enthusiastic over the possibilities of the new line.

THE BOSTON BOOK COMPANY ANNOUNCE THEIR NEW

LIBERTY RECORD ALBUM

15,000 SOLD THE FIRST DAY

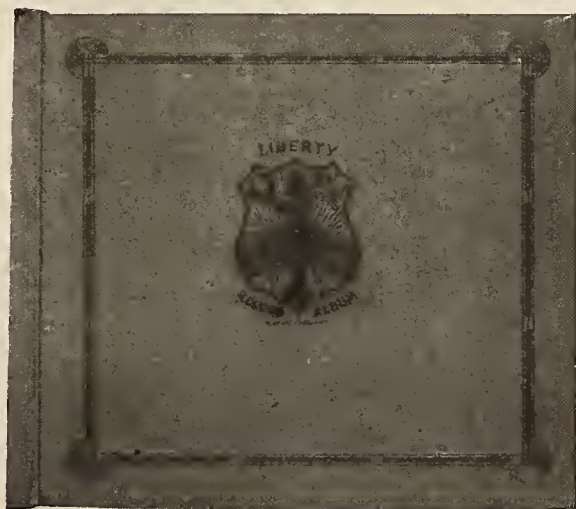

The most timely and appropriate addition to the album field in years.

Beautifully designed, bound in khaki and stamped in gold with a most artistic and patriotic center piece.

Manufactured and patented by the only exclusive record album factory in the world, who for the past ten years have supplied the talking machine trade with quality albums.

BOSTON BOOK COMPANY, 43-51 W. Fourth St., New York, N. Y.

CHICAGO OFFICE: 1470 So. Michigan Avenue

Of what use
 is money
 anyway,
 if we do
 not win
 this War?

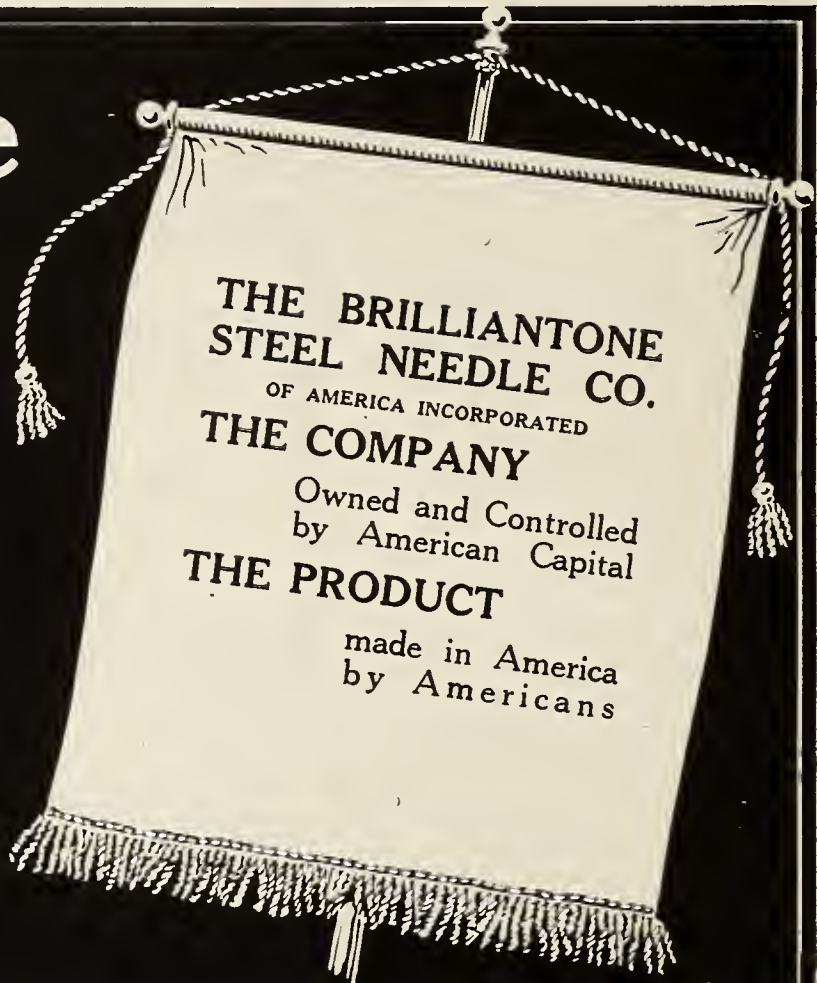

Therefore—every cent of profit made by the Brilliantone Steel Needle Co. of America, Incorporated, during this year of Nineteen Eighteen (1918), will be expended for



Liberty Loan Bonds

When You Sell Brilliantone Steel Needles you help us to subscribe additionally for Liberty Bonds, A-N-D your customers are assured



Needles of Uniform Length
 Needles with Uniform Points
 Needles of Uniform Hardness

Truly Meritorious
 Honestly Reliable

The Best

HALF TONE—FULL TONE
 —MEDIUM—EXTRA LOUD

Write for Samples—Write for Prices

BRILLIANTONE STEEL NEEDLE CO. OF AMERICA INCORPORATED

Suite 657-659 Marbridge Building, Broadway at 34th Street

B. R. FORSTER, President

NEW YORK CITY

“Vacations with Music”—the Big Idea for Summer. Sell every vacationist a Portable Model Grafonola. Columbia National Advertising Will Pull—You Push.

**Columbia Graphophone Co.
Woolworth Building, New York**



IMPORTANT BUSINESS TOPICS DISCUSSED IN ST. LOUIS

Tri-State Victor Dealers' Association Have Interchange of Ideas on the Evils of Free Service, Current Monthly Records and Salesmanship Requisites—Start Repair Shop for the Trade

St. Louis, Mo., May 8.—The last meeting of the Tri-State Victor Dealers' Association, the first to which the associate members—sales people—were admitted, was entirely successful. The experiment was as to whether the sales folk would take an interest. They did. So the experiment was considered successful. More meetings of this kind will be held, and it is believed that the sales folk will become so interested that it will be possible to get out-of-town members to send their sales forces to attend occasional special meetings. The program was especially designed to interest those in the selling end.

Val Reis was to have spoken on “The Evils of Free Service—The Extent to Which Such Service May Profitably Be Extended.” Mr. Reis was unable to be present, but President Magoon introduced the topic and asked those present for ideas. There was a good deal of discussion, the chief idea being that there should be a definite suggestion as to how far the salesman should go in promising service. At present the salesman has to be entirely dependent upon the customer's word as to what other dealers will do, as there appears to be no understanding. Some customers get the idea that they are within their rights when they call to have a service man sent out to wipe out scratches to the cabinet. Others get the free service idea so strong that they do not even try winding up the machine before they call for assistance. On motion, a committee was appointed, of which E. C. Rauth is chairman, to outline suggestions as to what free service is desirable and to report at the next meeting.

J. F. Hunleth talked on “Current Monthly Records.” Mr. Hunleth said that during the present shortage of supplies of new records it behooved each dealer to make his stock go as far as he could. He took a recent monthly list and called attention to the numbers in stock similar to those on the list and suggested that when a customer called for a certain new record—say, a Caruso—that he be reminded of the other and similar Caruso records in older stock, and that these be played for him as well as the new one—with no emphasis on the new one. He said that experiments of this kind carried out in his store have resulted in many sales from the older stock and that in many cases the customer was better pleased with the older records. He said that only the entirely new songs need be sold and sometimes there were good substitutes for these. He also reminded his hearers that some of them had large stocks of excellent musical numbers that could just as well be sold as not, as there was no satisfactory reason for their going out of fashion—mere whim.

J. F. Ditzell, of the Famous & Barr Co., spoke at some length on the “Requisites of a Salesman.” He reminded his hearers that a sales person was made—not born—that there

were certain essentials that it was necessary to teach, and as soon as it was found that the candidate for a sales place could not grasp these requisites, that candidate should be placed in the discard. He reminded the salesmen—and women—present that there were many things that they could do to bring about their own advancement by self-development. These efforts, he reminded them, always brought excellent returns in the way of salary advancement, as there was but one basis on which to fix the salary of the salesman—that of the earning power.

Through the association the St. Louis members have completed an arrangement for a common repair shop. The association has guaranteed a local motor repair man—said to be the best in town—a certain amount of work if he will hold himself at the call of the members. He will make special prices and will guarantee all of the work. This shop is not expected to handle case work—only mechanical—but the repair man will have case work done if desired. This arrangement was made because good repair men are becoming scarce, and it was felt that by consolidating the work better results would be obtained and men could be spared for other work.

J. D. MOORE RESIGNS AS MANAGER

Retires as Head of Successful Talking Machine Department of Lion Drygoods Co.

TOLEDO, O., May 4.—J. D. Moore, who about five years ago opened a talking machine department in the Lion Drygoods Co. store in this city, and has since acted as manager, resigned recently to enter a new field upon leaving the services of the company. Mr. and Mrs. Moore were entertained at dinner by the employes of the talking machine department, on which occasion Mr. Moore was presented with a handsome traveling bag in token of their esteem. The Victrola department of the Lion store is operated on a very successful basis. No records are sent out on approval, and interest is charged on all deferred payments. All accounts are watched carefully through co-operation with the credit department, with the result that there are practically no repossessions.

LEASE LARGER QUARTERS

MINNEAPOLIS, MINN., May 3.—Owing to the increase in their Edison phonograph business, the East Side Phonograph Co., this city, have leased new and larger quarters at 209 East Hennepin avenue, which will be equipped to meet the requirements of the company, and which will be occupied about November 1, when the lease on the present store at 416 Central avenue expires.

Get That \$3

You can sell every Victrola X-A and XI-A you can get—and sell

Ready File

With every one. Or you can sell the Victrolas alone, making \$2.75 or \$3.00 less on each one. Mail us this advertisement, with your name and address on the margin. Full particulars will be mailed at once.

Ready File Co., Inc.

INDIANAPOLIS, U. S. A.

¶ Sentimentally regrettable as it may be, little phonographs, like little nations, live only long enough to demonstrate the *strength* and *permanency* of the big ones.

¶ Pathé stands for a future greatness in proportion to its present magnitude. Pathé is big in every way. Pathé means an immense resource of machines and records. Pathé means good service.

¶ If you are a Michigander, interweave your future with Pathé and grow with a great service in a great state.

Williams·Davis·Brooks·&·Hinchman·Sons.

Established in 1819

Detroit

How the Talking Machine is Disseminating a Knowledge of the World-Famous Musicians

Hector Charlesworth, who has written a series of articles on talking machine and player-piano music for the Canadian Home Journal, in the course of one of them emphasizes a thought that is interesting. He says: "While in a small Ontario town I noticed a large advertisement announcing that records of Jascha Heifetz could be procured from a local dealer. Less than ten months ago the name of Heifetz was unknown, even to the most noted musical critics of New York. He came to America from Petrograd and gave a violin recital in that city about the time of the first snowflakes. At once it was recognized that a great star had risen in the musical world, and his subsequent appearances have created a furor wherever he has gone.

"But a decade ago such an incident would have affected only a few large cities with halls capable of containing the thousands that naturally throng to hear a new and celebrated man of genius. In a small town, such as the one I mention, the idea that Heifetz would become a personage so well known as to be the subject of lengthy advertisements in the local newspapers would have been fantastic. Only a few of the well-to-do, who might go on a journey, could ever hope to hear him play the violin, and his name would have been dismissed from

the mind of the average individual. It is not overshooting the mark to say that ten years ago the ordinary reader of a small town newspaper would have been indifferent as to whether Jascha Heifetz was an anarchist or a new kind of mineral water. Now he is the possession of

*Artists may some day
devote themselves
exclusively to the
making of records*

the whole community. The sure barometer of advertising expenditure shows that he has a public everywhere, a public infinitely larger (who will know him through the records, and probably sees his face) than the throngs who are crowding to hear him in the large cities."

In the course of time, when a greater percentage of homes have talking machines, Mr. Charlesworth thinks that some artists will find it profitable to devote themselves exclusively to the making of records and abandon public appearances altogether; just as certain lecturers and educators have abandoned the rostrum and do their teaching entirely by the correspondence method.

"This is not likely to occur in the case of any artist of first-rate talent," says the writer, in conclusion, "for the very good reason that public appearances in themselves, if successful, form an advertisement for the records of an artist of inestimable value. Yet the situation does hold its possibilities for the singer who happens to meet with misfortune other than the loss of voice.

"Suppose that Caruso, just for instance, had been young enough to have been drafted for the Italian army, and had met with the loss of his legs or with some hideous facial disfigurement which precluded his ever appearing on the stage again. He would, did his voice retain its power, be able to continue to appeal to popular approval by making new records. The same is true of every other noted singer of either sex."

HERZOG ART RECORD CATALOG

New Catalog Portrays and Describes Over Sixty Different Models of Cabinets

A new catalog of "Herzog Art Record Cabinets" has recently been published by the Herzog Art Furniture Co., of Saginaw, Mich. This new catalog, which is a very handsome affair in blue, white and black, portrays over sixty different models of cabinets. It starts in with a comprehensive view of the factory, and a pertinent discourse on why Herzog art record cabinets are a profitable accessory for talking machine dealers. Following this are a series of profusely illustrated sections.

Section 1 is devoted to Victor record cabinets, Section 2 to Columbia record cabinets, Section 3 to Pathé cabinets, Section 4 to Brunswick cabinets, Section 5 to Edison cabinets, Section 6 to Auxiliary cabinets, Section 7 to player roll cabinets, Section 8 to a reproduction of the various newspaper cuts of Herzog cabinets

which are available for use in the dealer's local advertising. The volume is well written, admirably printed and produced, and should prove of interest to all members of the trade.

LEE GILBERT MARRIED

Lee Gilbert, a well-known talking machine man of Omaha, Neb., recently married Miss Weltha Gilbert, of Des Moines. It was a home wedding of a most attractive sort, and the guests included Mr. and Mrs. Geo. E. Mickel, Mr. and Mrs. Fred. Bailey and Hugo Hayne, all of Omaha, and all well known to the talking machine trade of the Middle West.

Mr. Gilbert started his career in the talking machine industry at the Victor factory. From there he went to Chase & West in Des Moines, and later with Mickel Bros. in the same city. He was transferred to the Omaha branch of the Mickel Bros. Co. on February 1 of this year, with which organization he continues to display great energy as a Victor salesman.

TO FEATURE EDISON LINE IN UTICA

New Concern Formed to Take Over the Business of the Utica Music Co., Inc.

UTICA, N. Y., May 6.—A new company has been formed to promote the sale of the new Edison phonograph. This company will handle a probationary zone, having the exclusive sale of the Edison instruments and records. The stock, fixtures and lease of the Utica Music Co., Inc., have been purchased and the Utica business will be conducted at 261 Genesee street, Crown Building, where every model of the New Edison and a complete stock of the Edison Disc and Blue Amberola records will be found. The members of the new company are Clayton L. Wheeler, Arthur R. Knox, E. L. Kuhl and John Schuderer. The Utica headquarters at 261 Genesee street will be under the management of Arthur R. Knox and the Rome branch, 173 West Dominick street, will be managed by John H. Schuderer.



THE BROOKS Automatic Repeating Phonograph

Plays Any Kind of Record—Any Desired Number of Times and Then Stops Automatically—
The Phonograph Sensation of the Age

DEALERS:

You cannot duplicate the value we offer for twice the price. In size and appearance the "Brooks" compares favorably with Instruments retailing for \$300.00 and up.

In tone qualities it is unexcelled by any talking machine on earth! In mechanical equipment and automatic features it is years in advance of its nearest competitor. We have been building talking machines for three years—last year our sales doubled every four months. The BROOKS DEALER has no competition. The machine creates interest and discussion—it is self-advertising. Send for particulars, terms, prices.

BROOKS MANUFACTURING COMPANY

Talking Machine Dept. - SAGINAW, MICH., U. S. A.



View of Controlling Dial

This dial sets, starts and stops the machine. Will play any desired number up to nine or continuous.

Simplest Machine to Operate

Instructions

Set the needle at the inner edge of record cutting and then move pointer to the figure designating the number of times you wish record played.

That is all. You can now forget the machine. When the record has been played as many times as set for, the machine will stop automatically with the tone arm suspended in the air above record.

HEIGHT OF CABINET 50 INCHES

FURNISHED IN OAK OR MAHOGANY

SPRING OR ELECTRIC MOTOR

Columbia

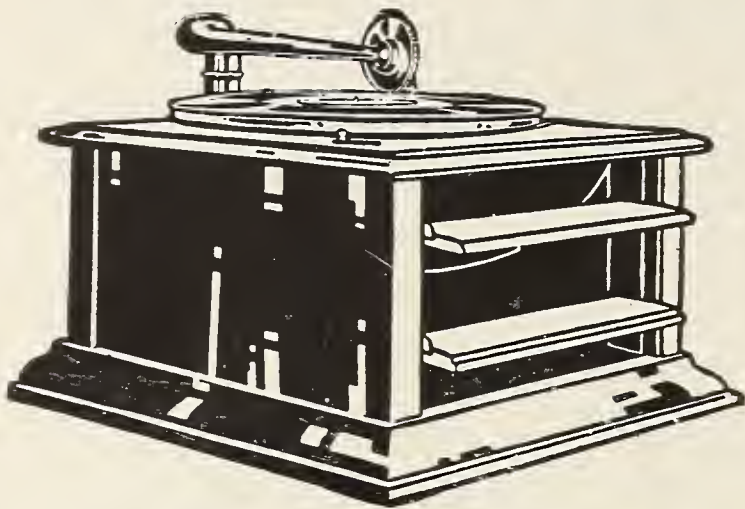

Columbia Grafonola
Price \$18



Columbia Grafonola
Price \$30



Columbia Grafonola
Price \$45

Portable Model Grafonolas for Vacationists

"Vacations with Music"—

That's the Columbia sales slogan for the next ninety days.

Make it yours, and your Summer sales will follow your Thermometer upward. The hotter it gets, the better your business.

Sell Portable Grafonolas to the folks who go to the woods and lakes and shores, and there'll be no Summer Slump for you. Your July will be a big, fat January.

It is sound sales strategy.

Vacation time is joy time. People want to pack all the fun possible into their play days. They jump for anything that makes for mirth and spice-o'-life while they're away.

And how many know what joy there is in a "Vacation with Music?"

Make it your job—and your opportunity—to tell them.

A vacation with all the live, up-to-date music always ready to play. Stirring soldier songs, close harmonies and splendid bands—for the twilight time when the crowd gathers; dear old-time ballads or the haunting strains of violin, floating out over the water in the velvet darkness, when the little waves go slap-slap-slap against the side of the canoe.

Or snappy, catchy, cheery song-hits for rainy days—glorious syncopations for dancing. Who can imagine a vacation without dancing? Think of having all the newest jazz riots, one steps, waltzes, right on tap in a friendly, willing Grafonola.

Here's a big opportunity for the live salesman—go after it.

We've prepared a tremendous barrage of National Advertising on the Portable Grafonolas as vacation companions—to be launched during June, July and August.

People are going to want the Vacation Models.

Tie up, friend dealer, tie up. Write—today—to your Distributor about the Portable Models, prices, Sales Helps, quantities, etc.

Remember the countersign—"Vacations with Music."

Columbia Graphophone Company
Woolworth Building, New York

Grafonola

Columbia Vacation Model Grafonolas

Made for Out-of-door Music

For those jolly, informal parties by seashore, lake, or river the most popular entertainer is always the Columbia Vacation Grafonola. This friendly, companionable Grafonola is a good sport. Take him along with you on your holiday trip this year.

Price \$45.00

Traveling light, strong, and compact, with a voice that is sturdy, sweet, and clear, the Vacation Grafonola will sit up all night to give you music for dancing—and then be ready and cheerful for a bathing or sailing party bright and early in the morning.

Wherever you go in the joyous vacation lands by seashore, lake, or river the Grafonola will give you music.

Price \$18.00

Price \$30.00

To make a good record great, play it on the Columbia Grafonola. COLUMBIA GRAPHOPHONE COMPANY NEW YORK

High-Power National Advertising that will make it Easy for You to Sell Portable Model Grafonolas

During June, July and August—when people are going by the hundred thousand to the Summer resorts—Columbia will make a powerful sales drive on the Portable Model Grafonolas.

The big idea back of the advertising is, "Vacations with Music."

It's a powerful idea—an idea that automatically makes every vacationist a potential customer for a Grafonola.

The advertising schedule comprises full-page space in the Saturday Evening Post, Collier's, American Magazine, Scribner's, Literary Digest and Good Housekeeping.

Over six million combined circulation.
Thirty million readers.

Is it big enough for YOU?
Then you PUSH—our ads will PULL.

COLUMBIA RECORDS IN FOREIGN LANGUAGES

Here's an entirely new field for Columbia Dealers. It is a Department in itself. Foreign Language Records sell fast—people who buy them have plenty of money now.

Nationally Advertised in Foreign Language Papers. Write for Details
INTERNATIONAL RECORD DEPARTMENT, COLUMBIA GRAPHOPHONE COMPANY

Columbia Graphophone Company
Woolworth Building, New York

NEW VICTOR ADVERTISING MANAGER

Ernest John, Widely Known as Editor of "Voice of the Victor," Advanced to This Important Post in the Victor Co. Organization

The following letter sent to the trade by Louis F. Geissler, general manager of the Victor Talking Machine Co., requires no comment beyond the endorsement of Mr. Geissler's views regarding the experience and ability of Ernest



Ernest John

John as qualifying him for his new post as advertising manager of the Victor Co.:

"We take great pleasure in announcing the appointment of Ernest John as manager of the advertising and editorial departments of the Victor Talking Machine Co., which departments will be amalgamated under his direction.

"This highly important position requires not only a broad advertising experience, but certain special qualifications, and, above all, an intimate knowledge of Victor business.

"As editor of the 'Voice of the Victor' and manager of the editorial department, Mr. John, with fourteen years of practical experience as an advertising man, is already well known to the trade. We confidently believe in his ability to maintain in the future as fully as it has

been maintained in the past that high efficiency which has been characteristic of Victor advertising and publicity.

"Associated with Mr. John on the editorial staff, which has already given the trade such excellent service, will be Arthur S. Garbett and F. A. Delano, writers of distinction and high qualifications. On the advertising staff will be W. L. Marshall and H. E. Green, both men of established worth and long experience.

"Ours is a highly specialized business requiring special talents and special training. Our one consistent purpose is to be of greater service to the trade, and so to be of greater service to ourselves. To that end the above appointments have been made; to that end, also, we ask your earnest co-operation, which must assuredly be to the advantage of all concerned."

For Mr. John it can be stated that by experience and training he is particularly well qualified to handle with success the problems connected with his new post. He was born in St. Ives, a summer resort on the Cornish Coast of England, recognized as the mecca for artists, among them some of the greatest painters in England. It was in his native town that he secured a fundamental knowledge of art, that has proved of great advantage to him in the domain of advertising and editing.

Coming to the United States when still a young man, Mr. John became associated with a small town newspaper in Michigan, where he had experience as editor, manager, circulation manager, and more particularly as advertising manager. Mr. John proved particularly successful in the last position, proving to his clients the value of advertising, even selling them advertisements, and finally writing and designing the ads. After five and one-half years as advertising manager, Mr. John resigned in 1910 to go with the Victor Talking Machine Co. to take charge of specialized work. He was engaged to go all over the country giving demonstration lectures before the public on the musical value of the Victrola, and in addition acting as special adviser to the dealers with whom he came in contact. At that time musicians still thought of the talking machine only as a means of supplying "canned" music, and the dealers themselves lacked a full appreciation of the possibilities of the Victrola. It was to overcome this condition that Mr. John was sent on tour.

Mr. John worked so successfully that he was called back to Camden to edit "The Voice of the Victor," the trade organ of the Victor Co. Here his knowledge of practical matters, of

TALKING MACHINE DEALERS
—READ THIS—

"The finest and most delicate pieces of mechanism do not prove efficient unless properly lubricated. Skill, Genius, Invention and Workmanship must have the proper Oil. Stop and consider this when you have to buy an Oil for household use."

NYOIL
IS BEST
FOR ANY TALKING MACHINE



Being made in our Watch Oil Dep't, the same care given in refining as in our "Watch Oil," as all gums and impurities are extracted, leaving it Colorless, Odorless and Stainless.

BEWARE OF SCENTED OILS

Machines will not clog if oiled with NYOIL. NYOIL is used by the U. S. Gov't in Army and Navy. A trial order will make a permanent customer of you.

Ladies use NYOIL for Sewing Machines, for it is stainless.

Sportsmen find NYOIL best for Guns, for it keeps them from rusting.

NYOIL is put up in 1oz., 3¼ oz. and 8 oz. Bottles, and in Pint, Quart and Gallon Cans.

For Sale by all Talking Machine Supplies Dealers
WILLIAM F. NYE, New Bedford, Mass., U. S. A.

typography, design and illustration, combined with a thorough knowledge of the dealers' needs, and of Victor possibilities, enabled him to produce a publication of unquestioned standing and value.

Mr. John's next appointment was that of assistant advertising manager to Henry C. Brown, who was then manager. About eighteen months ago, when the new "Editorial Department" was created, Mr. John was appointed manager, and in addition to editing "The Voice" has been called upon to get out the monthly supplement of new records, as well as catalogs, and take charge of other important tasks. In this new work he made good, and when the time came to choose another advertising manager to replace Mr. Brown, who had become assistant to the general manager, Mr. John was accepted as the logical man for the post.

Mr. John is a man of winning personality and charm of manner. He makes friends quickly, and what is more keeps them, although he is not averse to a "scrap" if he finds that his rights demand it. In other words, he has the necessary qualifications for a man who is advertising manager of the Victor Co. and can be depended upon to do big things in a big way.

VEECO MOTORS ARE IN DEMAND

Improved Model Wins Favor of the Manufacturers—C. F. Simes in France

BOSTON, MASS., May 4.—The Veeco Co., of this city, manufacturers of the Veeco electric motor and the Vitraloid turntables for talking machines, report a strong and growing demand for their motors. The company recently put on the market an improved type of motor, considerably heavier than the old model, and with details added that make for betterment. The motors are coming through in good shape, and shipments are being made with regularity.

Charles F. Simes, formerly sales manager of the Veeco Co., who enlisted in the U. S. Artillery last August, has been in France for some time past, and a letter received at the Veeco headquarters states that his battery has already been in action on the Western front.

A VISITOR FROM CHICAGO

M. C. Schiff, president of the Vitrola Talking Machine Co., Chicago, Ill., was a visitor to The World sanctum in New York the closing days of the month. On his trip East he was accompanied by Mrs. Schiff. While the visit was a business one in a measure, yet it also marked the twenty-fifth anniversary of their marriage. Both Mr. and Mrs. Schiff enjoyed their silver wedding anniversary in a very pleasant sojourn in the nation's metropolis.

Ward's Khaki Moving Covers



Grade "D" Cover with No. 3 Straps.

PROTECT YOUR MACHINES FROM ALL KINDS OF WEATHER

and will enable you to deliver them free from dust, scratches, bruises and all other finish destroyers

Our covers are faced with Standard Khaki, lined with a heavy grade flannel, interlined with an exceptionally good grade of heavy cotton or felt, diagonally and closely quilted, and manufactured according to the usual superior "WARD New London" quality.

- Grade "D", medium size, \$5.50
- Grade "D", large size, \$6.00
- Grade "K", medium size, \$8.00
- Grade "K", large size, \$8.50

Carrying Straps: No. 1 \$1.00; No. 2 \$2.00; No. 3 \$3.50

ORDER SAMPLE COVER ON APPROVAL

With Name of Machine silk embroidered on any Cover; extra...30c.
 With Dealer's Name and Address, first Cover; extra...\$1.15
 Same on additional Covers, each extra...60c.

Write for booklet

THE C. E. WARD CO.
 (Well-known Lodge Regalia House)
 101 William St., New London, Ohio
 Also Manufacturers of Rubberized Covers and Dust Covers for the Wareroom

TIMELY SALES SUGGESTIONS

Prepared by J. I. Carroll on General Phases of Salesmanship Are Right to the Point

J. I. Carroll, assistant manager of sales of the Emerson Phonograph Co., manufacturers of Emerson records, sends out regularly to the members of his sales staff interesting bulletins which contain timely suggestions on important topics, and occasional suggestions on general phases of salesmanship. One of his recent bulletins, entitled "Pep," was enthusiastically received by the members of the staff. This bulletin reads as follows:

"The man who's on the job early in the morning and late at night—he's got it.

"The man who's alive to the opportunities in each town, studies to profit by them, and then goes to it with enthusiasm and determination—that's it.

"The man who works the small towns as eagerly and thoroughly as the big, and gets the business in each—is supplied with it.

"The man who enthuses his dealers, gives them sound advertising and practical merchandising suggestions; who is ever alert to help his customer build up a successful department—has a stock of it.

"The man who wastes no time, makes every minute count, covers ground rapidly though thoroughly; who makes friends for himself and his house—he surely has it.

"The man whose appearance is neat; whose speech is clean cut, straightforward and businesslike; whose manner is tactful, courteous, gentlemanly, and who reflects credit on his house—has a fund of it.

"'Pep' is not noise or buncombe. It is life, enthusiasm, energy, preparation, belief and confidence in yourself, your firm, your goods.

"Every salesman who lacks any of the elements of 'pep' should cultivate them—they bring success."

SURPRISED THE RECORD SALESMAN

Selection by Grand Opera Artist of Ragtime and Popular Records Shocks Salesman

A certain shining light in the operatic world was a visitor recently to one of our talking machine establishments, and needless to say his visit caused quite a stir. The best salesman was called into service, and without much difficulty an expensive talking machine was sold. From there he journeyed to the record department to make a selection of records for his library. Immediately the record salesman prepared what he deemed would be an acceptable list of operatic records to supply to this celebrity, and he was led into the most attractive sound-proof booth the company possessed. List in hand, the record expert suggested a duet from "Boheme," a polonaise from "Mignon," the "Caprice Viennois," and other numbers which he thought would appeal to a man famous in the operatic world.

The celebrity politely waited until the young man had come to the end of the list, and his breath as well, then said: "You are very kind to have taken such trouble for me, but as I hear so much opera and good music all the time" (smiling), "I would now like to purchase all the 'bad' music you have. The most syncopated ragtime, the most popular songs I will have if you please—also some jazz band mixtures. You need not play them, just pick me out about two dozen of your very latest and lightest music."

He arose to go. The record salesman still wore a terribly pained expression. He hovered tremulously around—pencil in hand. "But may I not send any opera records?" he asked rather anxiously.

The celebrity was now at the elevator. "Just a complete set of the kind I have named," he returned, majestically, as he stepped out of the shop.

GETTING AFTER THE CASH

A Suggestion in "System" That Is Worth While Where Cash Is Not Enclosed With Order

The following suggestion of E. R. Marshall, which appears in the current issue of "System," may be of interest to talking machine dealers, some of whose business is by mail on a cash basis:

"Sometimes orders that come into an Eastern house are not accompanied by the necessary remittances. A rule of the house requires cash with each order. How to get the remittance without losing the order, or without offending the customer, puzzled the manager until he drafted this letter:

I note that the envelope which contained your recent order contained no form of remittance. The envelope bore no evidence of having been tampered with in the mails, and it occurred to us that perhaps you inadvertently sealed it without enclosing your remittance.

If this is so, will you be good enough to send it by return mail, sending us back the enclosed order? Or, if you did enclose your remittance, send us particulars regarding it.

We hope to have your reply on the back of this letter by return mail.

"Experiments proved that the letter pulled. Now it is written to every customer who fails to send cash with his order."

MEETING OF COLUMBIA DEALERS

Retailers in Indianapolis District Gather for Business Discussions

INDIANAPOLIS, IND., May 4.—Dealers in this city and vicinity who handle the Columbia line of Grafonolas and records held a meeting recently at the Hotel English, where they listened to excellent business talks by Ben. L. Brown, manager of the local branch of the Columbia Graphophone Co., Samuel Lemberg, special representative of the international record department of that company; William Kobin, special representative of the Dictaphone, and H. C. Barnes, of the advertising department of the local paper.

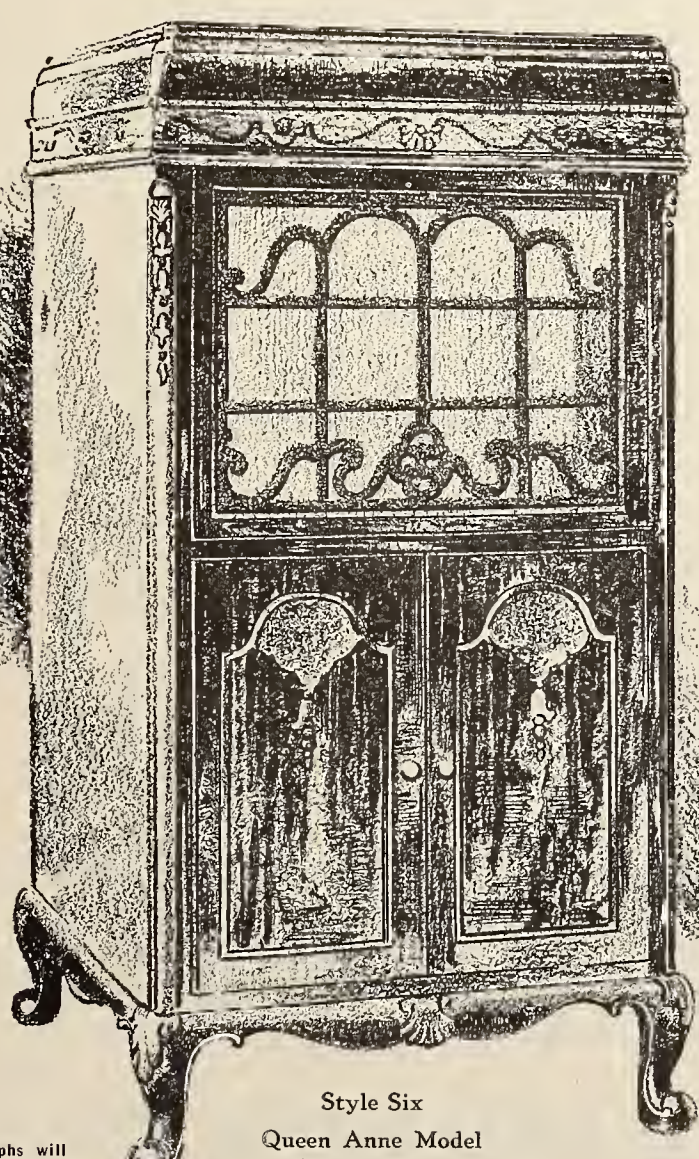

Style Six
Queen Anne Model

Prestige

CONSIDER what it means, from the standpoint of *prestige*, to introduce the Cheney Phonograph in your community.

This is the instrument whose serene purity of tone and superlative cabinet design set a new high standard in phonographs. The Cheney *plays better* and it *pays better*. Each instrument sold *sells others*.

The CHENEY PHONOGRAPH
Plays all records—better

The Cheney acoustic inventions, covered by basic patents, are revolutionary improvements. These commanding advantages bring the Cheney dealer the cream of the phonograph trade.

Six Cheney Models—\$60 to \$300
Art Models—\$200 to \$2000

DEALER CO-OPERATION

Cheney distributors are backed by a very complete and effective Monthly Service, consisting of local newspaper advertising and high-class merchandising helps.

Full information supplied upon request

CHENEY TALKING MACHINE COMPANY
CHICAGO

24 North Wabash Avenue

Cheney Phonographs will be on exhibition at the National Music Show June 1st to 8th. Space 44, Grand Central Palace, New York.

Many phonographs play all records; only the Cheney plays all records *better*

THE TRADE IN BOSTON AND NEW ENGLAND

JOHN H. WILSON, MANAGER, 324 WASHINGTON STREET, BOSTON, MASS.

BOSTON, MASS., May 8.—The Third Liberty Loan campaign has ended and Boston has gone "over the top." The talking machine trade has certainly done its share and both heads of establishments and employes have all been enthusiastic buyers of bonds. Such houses as the Oliver Diston Co., Eastern Talking Machine Co., the wholesale department of the Columbia, M. Steinert & Sons Co., Pardee, Ellenberger Co., Inc., Hallet & Davis Co., and many others having helped considerably to swell the total for this city.

The local business continues to be pretty good, but with the last week of April and the first week of May there was a general improvement all along the line and there is a feeling that the early summer business will be very good. But in the meantime there is a notable shortage of goods which is felt by nearly all the companies.

Great Columbia Meeting

The Columbia people had a great night on Tuesday, April 23. It was the monthly meeting of the dealers and there were some special features to make the occasion something out of the ordinary. Manager Fred E. Mann presided and the 140 or more persons present were entertained by Leon Rothier, of the Metropolitan Opera Co., who graciously consented to take part before going to the opera house where he was to appear later in the evening. Mr. Mann played his accompaniments. Mr. Rothier has seen service in the present war and was in the front trenches at Verdun and has also been at Rheims. Another who entertained was Arthur Fields, who sang quite a number of songs, many of which are familiar to the owners of Columbia records. Mrs. Fields accompanied her husband. A. R. Harris, of the record division of the sales department, came over from New York to give a talk on the June records. A number of the Columbia dealers present came from neighboring and more distant cities.

W. A. Hine and R. F. Ott, of the Columbia forces, visited the factory at Bridgeport, Conn., a short time ago, later going over to New York to visit the executive offices.

Illness of Mrs. F. C. Henderson

F. C. Henderson, of the F. C. Henderson Co., who operates a chain of talking machine departments in a number of the large stores in Boston and other places, has had the sympathy

of his friends in the illness of his wife who recently underwent a serious operation. She is now well on the road to complete recovery.

Joins the Colors

Young Sugarman, a partner of Harry Rosen at his School street talking machine shop, has gone into service and is stationed at the Portsmouth, N. H., Navy Yard.

Victrola on the S.S. "Belfast"

Quite an innovation was tried out on April 29 when the passengers taking the initial trip of the "Belfast" of the Eastern Steamship Lines, Inc., sailing from this city to New York had the pleasure of listening to a high-priced Victrola which had been installed by Herbert L. Royer, who conducts a Victor shop in Chauncey street, this city. Mr. Royer was on the boat, the guest of the management, and he was on hand to give the stewardess instructions from time to time in regard to operating the machine. The selection of records was left entirely to Mr. Royer, and his choice were such as certainly gave pleasure to all on board the boat. It was noticeable that such a machine is admirably adapted for use on a steamer and the music carried well to many parts of the boat. The Victrola is located on the upper saloon deck and Mr. Royer has similarly installed one on the "Camden," which is the sister ship of the line. This route to New York, known as the outside line, has long been popular with talking machine men during the summer months.

Joins Chickering & Sons Forces

F. H. Robie, formerly associated with Steinert & Sons, is one of the latest additions to the Edison and Victor staffs of Chickering & Sons. Business with this house keeps up quite well.

Associated with the Wm. Hengerer Co.

Boston friends of Wallace Currier, who was long identified with the local Victor business, hear occasionally from him in Buffalo, where he is associated with the William Hengerer Co., and in charge of its Victor business. Mr. Currier finds his new association very pleasant.

New Emerson Accounts

Oscar W. Ray, New England manager of the Emerson Phonograph Co., had as a week-end guest the early part of May Arthur H. Cushman, the company's sales manager, who spent several days here going over the New England situation, which is very promising. Some of the new accounts which Manager Ray has just

signed up are Harry Kittridge, of Lowell; the Wentworth Music Co., at Skowhegan, Madison, Brunswick and Waterville, Me.; John J. Forrest, at Lawrence; C. C. Moir, of Cambridge; F. C. Tucker, at Haverhill, and B. L. Couchar, of Springfield. All of these stores are installing the new nine-inch records, which, though out only a short time, have been selling most satisfactorily everywhere.

Steinert Men in the Service

The Arch street Victor headquarters of the M. Steinert & Sons Co., which is in charge of Robert Steinert, is about to fly a service flag to the breeze, for the house has certainly done its share in providing good men for the service of Uncle Sam. There is Emmet Ryan, an outside man for the company, who is now in France attached to General Pershing's staff. Leo McCarthy is another. He was an outside wholesale man, and is now with a unit of heavy artillery. Robert Tiffany is naval aviator and is now in practice at Princeton. Frank Griffin, of the repair department, is in the quartermaster's division at Camp Devens, Ayer. Frank Cunningham, a branch manager, is at the Charlestown Navy Yard attached to the paymaster's department. Charles Von Euw, head of the stockroom, is at Fort Slocum, N. Y.

Represented on Grand Opera Program

The talking machine business was well represented in the program of the Metropolitan Opera Co., which has finished a week's engagement here. Houses included were M. Steinert & Sons Co., Oliver Ditson Co., C. C. Harvey Co., the Victor Co., which had the back page, and the Columbia Co., which was featured by the Gramofola Co. of New England.

Russell Steinert Did Good Work

One of the hardest-working men in the Liberty Loan campaign purchase was Russell Steinert, who makes his headquarters at the Boylston street establishment of the Steinert Co. He was in charge of Precinct 5 of Ward 8 and was an important factor in disposing of a large amount of bonds.

New Sonora Representatives

One of the important deals just closed by Richard Nelson, manager of the New England department of the Sonora, is that of Charles W. Homeyer, a well-known Boylston street sheet music dealer. Mr. Homeyer has arranged a single booth in the center of his warerooms and he already has been able to interest a number

Foresight Proves Its Value

Some years ago we adopted a policy of conducting our Victor business "with the dealer's viewpoint foremost in mind."

By practicing this policy we have acquired a knowledge which in times like the present makes Eastern Victor Service of triple value to the dealer who wants *practical* co-operation from his jobber.

EASTERN TALKING MACHINE CO.

177 TREMONT STREET

BOSTON, MASS.

THE TRADE IN BOSTON AND NEW ENGLAND—(Continued from page 20)

of persons in this new proposition. Another new account signed up by Manager Nelson is the C. B. Moller Co., a large furniture house in Cambridge. Thomas Wardell, of Lowell, is still another who will carry the Sonora. Clinton Royer, formerly with the Steinert house, is one of the latest to join the Sonora local forces.

Joseph H. Burke Married

Joseph H. Burke, who is associated with Richard Nelson in the New England management of the Sonora, and who is now making his headquarters at Hartford, Conn., was married on April 29 to Miss Eleanor H. Keyes, of Auburndale. The ceremony was performed at St. Bernard's church, West Newton, and Mr. Burke and his bride started off on a short trip to Atlantic City.

Visited Edison Factory

George Lincoln Parker, who handles the Edison and Victor outfits, paid a visit to the Orange, N. J., factory and laboratories of the Edison Co. a while ago and he returned to Boston convinced that the company is now turning out some of the best records that have been put out since the Edison proposition has been before the public.

Aeolian-Vocalion Progress in Boston

The Boston office warerooms of the Vocalion Co. have been honored with visits from New York of two of its important men in the business. One was Thomas Pritchett, traveling auditor, who was here for several days; and the other was Douglas Langford, one of the traveling men from the company's New York office. Manager Hibshman makes an enthusiastic report over business which, for the month of April, was considerably in advance of the business of the same month in 1917.

Close Many Good Contracts

Wholesale Manager R. O. Ainslie, of the Pathé line, whose headquarters are at the warerooms of the Hallet & Davis Co., has been closing some very advantageous contracts throughout New England. One of the latest concerns to be signed up is the Tuttle Co., of Rutland, Vt., and it has taken a large initial order. One of the new outside men, R. H. Reid, has gone up to Rutland to help open up the department which promises to be quite an adjunct to the commercial enterprises of that city, for the Tuttle Co. has made special preparations to push the Pathé proposition in that territory.

Joins Brunswick Staff

Austin L. Fordham is the latest addition to the staff of the phonograph department of the Brunswick-Balke-Collender Co., which is featuring the Brunswick machine. Mr. Fordham

Lansing Khaki Moving Covers

PROTECT VARNISH IN ALL WEATHERS

and enable you to deliver your phonograph free of blemishes of all kinds.

These covers are made of Government Khaki, interlined with heavy felt or cotton, fleece-lined, quilted and properly manufactured. Perfect protection in all weather.



No. 3 Carrying Strap Shown in Cut, \$1.15

GRADE B
\$6.00

GRADE A
\$8.50

Carrying Straps Extra

Use the Lansing Khaki Moving Cover and your delivery troubles will be over.

Write for booklet

E. H. LANSING
611 Washington St., BOSTON

SAN FRANCISCO OFFICE, Room 530 CHRONICLE BLDG.
WALTER S. GRAY, Manager

comes here from the company's retail store in Washington, D. C. F. H. Walter, who is meeting with marked success in introducing the Brunswick throughout his New England territory, is especially proud of the new model 350 which has just been received at the Boston warerooms. It is considered an exceedingly handsome machine by all who have examined it.

Big Showing of Artists

The Boston office of the Columbia Co. from Manager Mann down was well represented at the Boston Opera House on the evening of April 24 when three of the Columbia artists sang in "Rigoletto." These were Lazaro, Mardones and Mme. Barrientos, all of whom acquitted themselves splendidly.

Sympathy for the Patriotic Alsen Family

The many friends of the family of John Alsen, formerly head of the Victor and Edison departments of the George Lincoln Parker warerooms, are full of sympathy for them in the death of Henry C. Alsen, a brother, who as a member of the 104th Infantry, was lately killed

in France. John Alsen himself is now in France where he went with the 101st Regiment and it is of special interest that ever since he has been away his sister, Miss Anna Alsen, who is also with the talking machine department of George Lincoln Parker, has sent her brother The World each month, and he writes home that the magazine is eagerly looked for. Thus is The World to be found in the trenches. There is also a third brother in the family who entered the service. He, too, is somewhere in France.

Visits New York Headquarters

W. H. Gould, sales manager of the educational department of the Columbia Co., was over here from New York the latter part of April. Mr. Gould is most enthusiastic over the way the public have been taking hold of the new line of records which are so eminently adapted to the homes where there are young people.

Henry Kahn, who runs a well-equipped talking machine department in the Jefferson build-

(Continued on page 22)

— Oldest and Largest
Manufacturers of Talking
Machine Needles in the
World—There are several reasons

W. H. BAGSHAW CO., Lowell, Mass.

TRADE CONDITIONS IN BOSTON

(Continued from page 21)

ing, Washington street, was a visitor to the New York laboratories of the Columbia a short time ago.

A wedding recently taking place in the ranks of the Columbia forces was that of Miss Marion Davis, of the wholesale order department, and Charles E. Davis, physical instructor at the Springfield Y. M. C. A. The bride's office associates presented her with a magnificent mahogany chest.

BIG VICTOR GATHERING IN BOSTON

Concert and Lecture by Oscar Saenger in Steinert Hall Attended by Many Victor Dealers

Boston, Mass., May 6.—There was a large attendance at a lecture on voice culture given recently by Oscar Saenger, of New York, at Jordan Hall, and they left at the conclusion of a pleasant evening convinced that as an aid to voice culture the Victor plays an important part. In New York Mr. Saenger is widely known as a vocal teacher, and while he has given these demonstrations there at various times it is understood that this was the first time he has given them outside his home city. There was a group of excellent artists to assist and they were heard in compositions from Verdi, Kreisler, Caesar Cui, Tartini, Delibes, Gluck and Paganini. The records which comprise Mr. Saenger's course were brought into use. In the forenoon there was a meeting of Victor dealers held at Steinert Hall when a large group of men was addressed by Mr. Saenger. For this occasion C. V. Egner, one of the assistants of the traveling department of the Victor

Send for Descriptive Circular

Curry DEMONSTRATION BOOTHS
AND RECORD CASES
MADE TO ORDER

"SOUND PROOF"

FRANK B. CURRY
19 Wareham St. Boston, Mass.

Co., came over from New York. This meeting was a valuable heart-to-heart talk and the dealers, who also were responsible for the evening demonstration and concert, felt well repaid for the time and thought put into the arrangements. James A. Frye, of the Victor Co., who happened to be in Boston at the time, played a part in putting the plan through and in working out the details he had the able assistance of Henry Winckelman, of the Oliver Ditson Co., and others. At the evening affair there was a sort of reception committee—Walter Gillis, Harry Parker, Mr. Newman, of Steinert's; Charles Ulass, of the Eastern; Mr. Bond, of the Eastern Co.; Mr. Freemon, F. C. Henderson & Co., taking an active part.

Following is a list of the dealers co-operating to make the concert and lecture a success: M. Steinert & Sons, Eastern, Oliver Ditson Co., Jordan Marsh Co., Walter Gillis, A. M. Hume Piano Co., Kraft, Bates & Spencer, A. J. Jackson Piano Co., George Lincoln Parker, Chickering & Sons, Shepard Norwell Co., Rosen Talking Machine Co., Conclave Phonograph Co., H. W. Savage, Tosi Music Co., A. M. Phinney, Hyde Park; Codman Square Music Co., J. J. Cannell, Everett; McArthur Furniture Co., Royer Talking Machine Shop, C. E. Osgood Co., Iver Johnson Co., M. J. Elvedt, Allston; and C. C. Harvey Co.

A PROGRESSIVE PLYMOUTH STORE

The United Talking Machine Co., which have very attractive quarters on Main street, Plymouth, Mass., report a very excellent demand for Victor Victrolas and the full line of records which they handle. Their establishment is nicely equipped with three mahogany soundproof

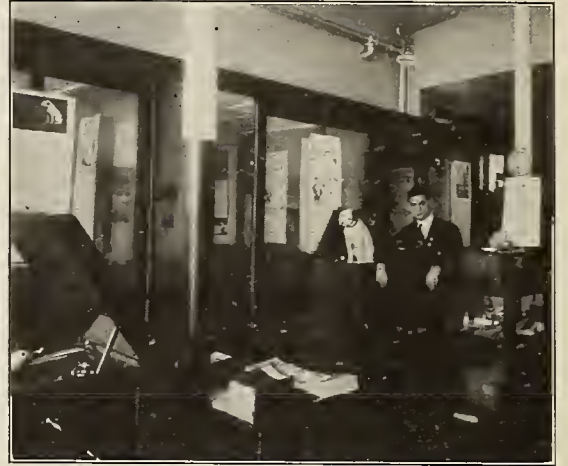

Partial View of Warerooms

booths, and two spacious record racks. Samuel Feldman, manager of the store, is shown in a partial view of the establishment herewith.

EMERSON SELLER SYSTEM A SUCCESS

Boston, Mass., May 6.—By way of proving the efficacy of the self-seller system inaugurated some time ago by Oscar W. Ray, New England manager of the Emerson Co., the following letter is of special interest, and at the same time

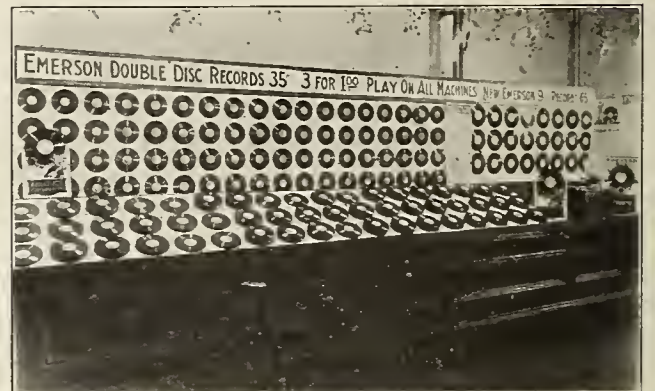

Emerson Display at Smith Co. Store

it refers to the accompanying picture of the display at the Timothy Smith Co. out in Roxbury, which is only a short distance from the downtown section of the city. The letter is addressed to the Boston office of the Emerson Phonograph Co. and reads as follows:

"In reply to your request for information in regard to developing of the sale of Emerson records in our store we are pleased to give you the following data: Since increasing the size of our department and establishing the self-seller display racks with a girl in charge, we have increased our sales so that we are now selling between three and four hundred records a week. Previous to our establishing the self-seller display racks with a girl in charge our sales were only between thirty and forty records a week. We have found the Emerson records a very valuable piece of merchandise, not only paying us a good margin of profit, but also bringing a great many people into our store. Very truly yours, Timothy Smith Co."

F. B. CURRY INSTALLS BOOTHS

In Talking Machine Department of Jordan Marsh Co. Store in Boston

Boston, Mass., May 8.—Jordan Marsh Co. have had recently installed in their talking machine department a number of new "Curry" soundproof demonstration booths and record cases. These booths are of Honduras mahogany and lend to the department a very fine appearance. C. Hewett, manager of the department, enthusiastically expressed his approval of the installation to Frank B. Curry, 19 Wareham street, this city, who has gained quite some prominence through the installation of his booths and record cases in the new Columbia shop which was opened in Boston about a year ago.

Manufacturers—Jobbers—Dealers

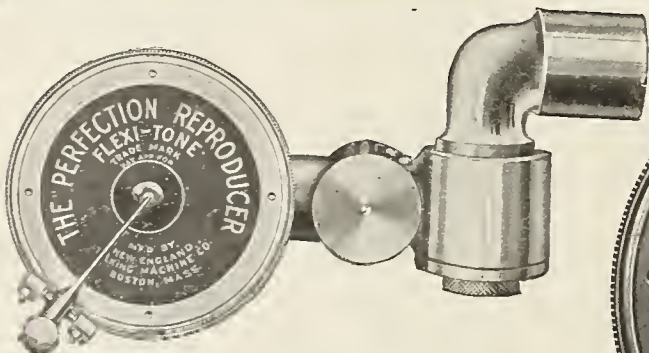

PERFECTION FLEXI-TONE reproducers attached to PERFECTION ball-bearing tone arms No. 3 and No. 4 play all lateral cut records, on all types of Edison machines. Made in nickel and 24 carat gold finish, extra fine quality.

Tone arms fitted to Edison machines only

The PERFECTION Flexi-tone reproducers will also play Victor and Columbia records on all types of Pathe machines, as they can be attached to the joint that is being sold with the machine for playing these records.



PERFECTION FLEXI-TONE reproducers No. 3, No. 6 and No. 7 fit all types of Victor and Columbia machines. Made in nickel and 24 carat gold finish, extra fine quality.

These reproducers and arms are the very finest made mechanically. The PERFECTION FLEXI-TONE reproducers are the most perfect phonograph reproducers built, reproducing all lateral cut records, from highest pitched soprano, to lowest pitched bass, as perfectly as the records were recorded in the recording room. Wonderful clarity of sound, as well as great volume. Extra fine quality of finish guaranteed. Manufacturers, jobbers and dealers will find in this line of reproducers just what they have been looking for, as they are assembled by skilled workmen especially adapted to this kind of work, producing a product built with watchlike precision.

All accessories in stock ready for immediate shipment. Phonograph manufacturers can have PERFECTION FLEXI-TONE reproducers fitted to their machines. Write for prices, information, etc.

PHONOGRAPH MANUFACTURERS

We have 6,000 sets of Universal Tone Arms and Reproducers, Nickel finish, that can be used on any make of phonograph. These Arms and Reproducers are ready for quick delivery. Write us for quantity prices, information, etc.

NEW ENGLAND TALKING MACHINE CO.

16-18 Beach Street

BOSTON, MASS.

THE FOURFOLD SALES APPEAL OF THE

AEOLIAN-VOCALION

IT is more and more coming to be recognized in the music-trade that the Aeolian-Vocalion has the most complete sales appeal of any phonograph on the market. The history of the Aeolian Company is one of extremely active development. It has almost unlimited resources here in the United States and abroad for the creation and development of musical instrument features. The Aeolian-Vocalion, though one of its younger, is one of its greatest and most successful enterprises.

The Aeolian-Vocalion possesses a number of distinctive advantages, among which are four that stand out particularly for their musical value and sales promotion. The primary appeal is that of *tone quality*. Added to this are its up-to-date and efficient mechanical features, such as a new Universal Tone Arm, a superior Automatic Stop, its artistic and fascinating tone control, the famous Graduola, and its uniquely beautiful outward appearance.

These four great points of advantage, coupled with the moderate prices at which the Vocalion is sold, make it by far the most attractive phonograph proposition today.

Among these features will be found an appeal to all classes of people, the highly trained musician, the wealthy connoisseur, the more modestly situated, the young and the old. People

of discriminating taste, musical and artistic, are everywhere finding the Vocalion irresistible.

The volume and quality of the advertising exploiting the special features mentioned above are indicated by the advertisements upon the three following pages, which are part of the aggressive advertising campaign conducted in newspapers and national magazines.

Aeolian service, which is being further strengthened by the establishment of convenient distributing points throughout the country, and the breadth and fairness of Aeolian business dealings, added to the emphatic superiority of the Vocalion itself, make the representation of that instrument one of the most profitable, desirable and satisfactory business connections that can be made.





***B**y virtue of knowledge, experience and equipment, The Aeolian Company was the logical source from which a higher development of the phonograph should spring.*

The privilege of unfettered self-expression in music was first given to mankind more than a quarter of a century ago by The Aeolian Company.

Successively, the reed-organ, the pipe-organ and the pianoforte were taken by this company, carried far beyond existing tonal standards and made available for all to play.

The Aeolian-Vocalion's great point of departure from other phonographs lies in its revolutionary device (the Graduola) for controlling expression.

By using the Graduola one may actually play the records—may shade and color the tone to suit the fancy and thus introduce the delicate variations that every artist himself introduces in his performances.

THE PHONOGRAPH MADE BY THE WORLD'S GREATEST MUSIC HOUSE

The AEOLIAN-VOCALION



WHEN the Aeolian Company decided to build a phonograph, it brought to the problems involved an experience and resources unparalleled in the music industry. This Company, through its genius in developing new musical instruments, and its success in raising the standard of those already established, had assumed a position of unequivocal leadership.

It had become the largest manufacturer of musical instruments in the world, with 14 factories in America and Europe and branches and representatives in all the world's important cities.

It had originated the Pianola, the first and most widely known of the modern instruments called "player-pianos" and the one that has always been recognized as the standard of all instruments of this type.

It had developed the modern residence pipe-organ and had become the largest manufacturer of these costly and magnificent instruments.

It was responsible for the greatest of all pianofortes—the Steinway, the Weber and the Steck Grand Duo-Art Pianos.

And it was credited with having done more towards raising the standard of piano-tone and quality, than had ever before been accomplished by any single manufacturer.

The Tonal Superiority of the Aeolian-Vocalion

It was this imposing and successful music-house from which the new type of phono-

graph—the Aeolian-Vocalion—sprang.

With The Aeolian Company's knowledge of tone-production through various mediums—strings, pipes, sound-chambers and resonant surfaces—this Company experienced little difficulty in improving the phonograph tonally.

Faults, which others with less knowledge and experience in acoustics had been unable to remedy, were wholly or in great part, overcome.

In the Aeolian-Vocalion, stridency or muffling of tone were absent, surface scratch was almost eliminated, depth and free natural tones of correct timbre were secured.

The Graduola Makes the Phonograph a Real Musical Instrument

Important as was the tonal development of the Aeolian-Vocalion, however, this instrument represented in another way a still greater advance in phonograph development.

Tone—or expression control, as offered by its new and exclusive feature—the Graduola—is what essentially makes the Aeolian-Vocalion the phono-

graph of ultimate type toward which progress has been tending.

No music-producing means ever devised, that did not afford opportunity for spontaneous and artistic expression control, has been seriously considered by musicians or taken a permanent place in the music-world.

For the first time in the history of the phonograph this opportunity is offered by the Aeolian-Vocalion.

How vastly it improves the phonograph, how much more interesting it makes both the instrument and its records, and how satisfactorily it meets the desire that practically all human beings feel, for some way to express their music-thought, is written in the wonderful success that has been so quickly achieved by the Aeolian-Vocalion.

Plays All Records

The Aeolian-Vocalion is the ultimate phonograph. Actually it would be difficult for imagination to picture a more completely satisfying instrument.

In addition to its tonal superiority and the new and wonderful privilege it offers for playing and coloring its music with your own feeling, it offers the great advantage of playing *all* records, thus making the performances of not one group, but practically all the world's best musicians available to the owner of an Aeolian-Vocalion, while its cases are far more attractive than any phonographs have hitherto possessed.

Vocalion Prices are—Conventional Models, \$45 to \$375; with Graduola from \$110. Beautiful Models in Prevailing Period Styles

Catalog and complete information sent upon request

THE AEOLIAN COMPANY
AEOLIAN HALL · NEW YORK

AEOLIAN-
VOCALION
P E R I O D
S T Y L E

No. 1514

Price

\$490

The Period Vocalion here shown is thoroughly worthy of the place of honor in this charming setting.



THIS
VOCALION

Although Louis XIV in general design, has characteristics which make it equally suitable for various English or Italian interiors.

The AEOLIAN-VOCALION

during the three years it has been on the market has gained universal recognition not only as a *greater phonograph*, but as a *playable musical instrument*. It is known as the greater phonograph because of its scientifically faithful reproduction of the tones of all instruments and voices. It is recognized by musicians everywhere as the first phonograph to take rank as a *real musical instrument*, because of the *Graduola*—which enables anyone to play the records personally—adding the spontaneity and life to the record which has hitherto been lacking.

Now again taking the lead, the Aeolian Company is introducing sixteen entirely new and original models of Period Vocalions. These Period Vocalions are designed to harmonize with the fine furniture which is being used in the home of today, and which takes its motifs from the famous cabinet designers of the historic past.

These new Period Vocalions are so beauti-

ful in design, material and finish, and yet so moderately priced that they have already caused a sensation wherever they have been exhibited. In price they range from \$215 to \$650.

The attention of dealers is directed to the opportunity that this new line of Period Vocalions presents. Popular demand is turning more and more toward good taste in furniture—and even the most modest of homes are now being furnished in accordance with some historic “period.” Here then, at practically regular phonograph prices, are sixteen handsome models harmonizing with these different furniture periods. This new line of Period Vocalions is being given wide and attractive publicity. It will attract the *best class* of people wherever it is put on sale.

Any progressive merchant will appreciate what an exclusive representation of this new line of Vocalions would mean.

Territory is now being assigned for the representation of the Aeolian-Vocalion. Address the Aeolian-Vocalion Department

THE AEOLIAN COMPANY

AEOLIAN HALL, NEW YORK CITY

Chicago Office: 118 South Michigan Boulevard

A complete display of all models of the Aeolian-Vocalion
may be seen at this office

CLEVELAND TRADE EXPRESSES CONFIDENCE IN THE FUTURE

Business Active But Stock Scarce—Talking Machine Men Do Their Share for Liberty Loan—Talking Machine Dealers' Concert Postponed—Attractive Window Displays—News of Month

CLEVELAND, O., May 7.—Dealers express confidence in the future. All agree that dealers will have to make the best of the situation, now that manufacturers are talking of curtailing their output. There are many handicaps to the business in Cleveland, but distributors and dealers alike are looking at the situation with the hope that conditions will brighten up later.

Cleveland's talking machine men certainly did their share in putting across the Third Liberty Loan. Harland H. Hart, president of the Music Trades Association, was chairman of a committee which directed the loan campaign in the Arcade, where scores of stores and offices are located, and where tens of thousands of people pass daily. At the Euclid avenue entrance Mr. Hart and his committee kept soloists and pianists busy during the noon hour to hold crowds. Mr. Hart devoted the greater part of his time to the bond sale campaign and declared he was glad to do his part.

Charles K. Bennett, president of the talking machine men's organization, as well as the members, have also been doing their bit regularly.

The concert and benefit proposed a few weeks ago by the Talking Machine Dealers' Association of Northern Ohio for the benefit of Y. M. C. A. and Knights of Columbus workers in army camps has been called off indefinitely. The dealers, at their April meeting, decided in view of the fact that the "Y" people will put on a similar stunt, the proposed benefit would interfere with "Y" plans.

In announcing the calling off of the proposed benefit Charles K. Bennett, president of the Talking Machine Men's Association, did not say whether the project will be again taken up later in the spring or summer. It was proposed to give the entire proceeds to "Y" and Knights of Columbus workers. Difficulty was also experienced in obtaining artists who sing for talking machine record manufacturers, as these singers are engaged in Liberty Loan campaigns.

The dealers were addressed by Rex C. Hyre, assistant secretary of the Cleveland Music Trades Association. He is attorney for the association members and discussed long-time payment plans for musical instruments, arguing against these long-drawn-out sales. Mr. Hyre's talk was similar to one he made at the annual meeting of the Music Trades Association, several weeks ago at the Hotel Winton banquet.

Cleveland's music dealers responded faithfully during the third loan campaign and their efforts contributed much in making the sale a success. Music of all kinds played its role in meeting, rallies and special sale stunts in and out of doors.

Talking machine dealers are making some unusually attractive window displays these days which demonstrate their patriotic sentiments. The Eclipse Musical Co.'s Euclid avenue retail store has one of the most attractive displays of Victor machines and records in the city. The window is a decided novelty—a different type from others. The talking machine offerings of the Fischer Co. have never appeared to better advantage, while the Collister & Sayle Co., Victor dealers, also had a novel display window last week. Other concerns utilizing their windows to advantage are the B. Dreher's Sons Co., the Starr Piano Co., the Wolfe Music Co., the Cleveland Piano Co., the Muehlhauser Bros. Piano Co., Sonora dealers, and the "Harmony Music Shoppe," of the Hart Piano Co., whose Boy Scout window introduces a miniature camp in which the talking machine plays a part.

A concert and benefit for Italian war orphans was given at the Hotel Winton the evening of May 2, featuring Signor Ricardo Stracciari, the noted Italian concert singer. Stracciari records by the Columbia Graphophone Co. were sold at auction and the sale realized quite a neat sum in addition to that received for tickets. Stracciari's songs were well advertised through Columbia dealers in the city.

The Brunswick-Balke-Collender Co.'s Huron road store is featuring the new sound reproducer the firm has been extensively advertising. The Ultona promises to make a quick hit with the public. The instrument was exhibited here by a Chicago representative of the firm several weeks ago and was hailed with delight. The Cleveland office of the company reports a good April business in the sale of Brunswick talking machines.

The Ott Piano Mfg. Co. is offering a large line of talking machines. These machines are assembled in the plant, Euclid avenue and East Nineteenth street, this city.

The Kaiser Music Store, in the Arcade, swatted the German Kaiser a few days ago when the word "Kaiser" was dropped. This store has borne this name since 1848. The concern is now known as the R. L. White Music Co. Mr. White, owner of the store, has attested his loyalty to the flag by dropping the widely-advertised name of his place of business.

Cheney talking machines are very popular in Cleveland. In many homes these makes have supplanted other phonographs.

The biggest electric sign flaunted during the night by any talking machine concern is that which advertises the Edison. Few electric signs in Cleveland attract more people at night than this spectacular sign over the distributing offices of Edison machines. No other phonograph distributing agency approaches the Edison illuminations which are close to the Hotel Statler, in one of the most congested districts of the downtown retail sections.

The Phonograph Co. April 29 increased its capital stock as an Ohio corporation from \$150,000 to \$500,000. The increase of capital was for the purpose of expanding the company's business. The company distributes Edison ma-

chines and records for all of Ohio, and D. W. Smith is president, and L. N. Bloom secretary.

"Business is surprising us," said Mr. Bloom in commenting on the increase of capital stock. "We simply are growing and the increase became necessary under our plans for developing. We are getting a fair stock of goods, but it usually takes thirty days to get an order for machines filled."

The Colonial Furniture Co., which handles the Vita-Nola talking machine at retail in this city, report a very excellent business. These instruments, which are made by the Vitanola Talking Machine Co., of Chicago, are certainly appealing to a larger clientele of Clevelandites.

BIG INCREASE IN LOUISVILLE

Talking Machine Department of Kaufman-Straus Co. Reports 300 Per Cent. Increase

LOUISVILLE, KY., May 7.—H. V. Boswell, manager of the talking machine department of the Kaufman-Straus Co., this city, reports that last month they had a fairly good business with a 75 per cent. increase over the same month last year, but April showed a still finer business with an increase of 300 per cent. This house is doing some splendid advertising which is bringing results. Their business extends over the States of Kentucky, Tennessee and Alabama, and even as far East as New Jersey. Recently they sold a C200 Edison in a Tennessee town, and also filled an order the other day from Newark, N. J., for an Edison C150, only five miles from the Edison factory. This concern is "digging" for business all the time and this emphasizes that it pays to be constantly "on the job."

MANAGER OF VICTROLA DEPARTMENT

E. A. Christman, who some time ago left the employ of the G. C. Aschbach Music House, Allentown, Pa., to enter other fields, has returned to the service of that company as manager of the Victrola department.

Talking Machine Men

are becoming more and more interested in selling our pianos, as indicated by inquiries recently received through this advertising.

The slight additional investment means many dollars in increased business. There is practically no extra overhead expense, AND—you receive the active co-operation of what are generally regarded as the most progressive and successful Piano Manufacturers of this country.

Your piano business will help your talking machine business—Your talking machine business will help your piano business.

Write for very interesting particulars to

KOHLER & CAMPBELL, Inc.

**11th Avenue and 50th Street
NEW YORK CITY**

**The most successful
manufacturers of Pianos,
Player Pianos and Grand
Pianos in America.**

**Kohler &
Campbell,
Inc.**

**11th AVE. and 50th ST.
NEW YORK**

Dear Sirs: Kindly send us full particulars of your plan to combine profitable Piano and Player Piano selling with our present business.

TEAR OFF THIS COUPON AND MAIL

THE LATEST CREATION IN MUSIC

The PHONO-GRAND

(Not Coin Operated)

The Most Complete Musical Instrument

Combining in one dainty case the music of the world's most popular instruments

The Piano and The Phonograph

Both electrically operated
Playing all rolls and all records

The Piano plays all Standard 88 note Player Piano rolls. It is especially adapted to the Q R S Expression Rolls with which it reproduces naturally and beautifully the playing of the master pianists.

The Phonograph is of the latest type and plays all phonograph records. Its tone quality is unusually full and clear. It is operated by a separate electric motor independent of the piano.

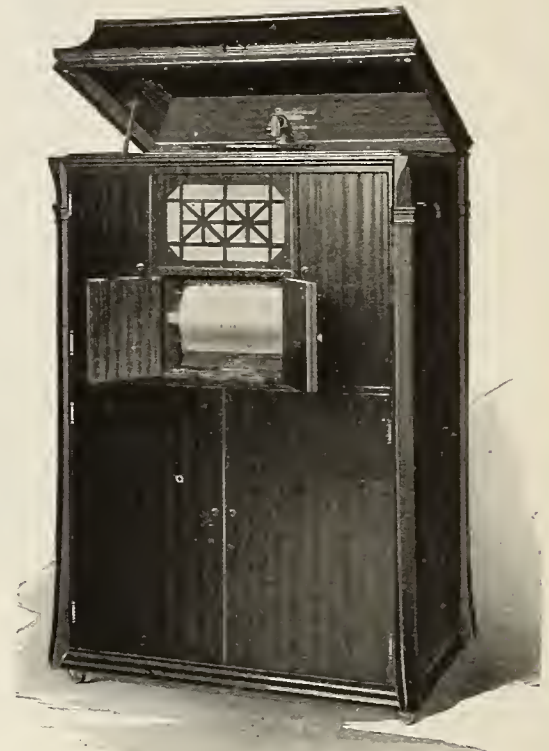

Height 55 inches. Width 34 inches.

The first announcement of this instrument was made last October. Orders came to us immediately in such quantities as to compel us to withdraw further advertising.

A Demonstrated Success

The success of this instrument is assured. Six months' trial before the retail public has proved its utility and wonderful attractiveness.

The representation of the Phono-Grand is

An Invaluable Agency

Will be on display at our Booth, No. 14, at the National Music Show, New York, June 1st to 8th.

Also permanently in New York at our office and salesrooms in the Bush Terminal Sales Building, 130 West 42d Street

A few well-known dealers to whom recent deliveries have been made:

Daynes-Beebe Co., Salt Lake City
Gaston Music House, Hastings, Neb.
Seattle Music Co., Seattle, Wash.
J. D. Mariner, Reno, Nevada
McKannon Piano Co., Denver, Colo.

Kohler & Chase, San Francisco
Bartlett Music Co., Los Angeles
Simon Piano Co., Spokane, Wash.
W. L. Pace Piano Co., Beaumont, Texas
Frederickson-Kroh Co., Oklahoma City

Hollenberg Music Co., Little Rock, Ark.
E. Witzmann Co., Memphis, Tenn.
Seltzer Music Co., Pittsburgh, Pa.
Hoeffler Mfg. Co., Milwaukee, Wis.
Scofield Music Co., Columbia, S. C.

Write to-day for prices and further particulars

J. P. SEEBURG PIANO CO.

REPUBLIC BUILDING

Leader in the Automatic Field

CHICAGO

HOW SOME GERMANS "OPERATE"

Banker of Berlin Poses as Talking Machine Dealer and Develops Big Company Which Brings Him in Contact With U. S. Army

Nine days before the world war started in 1914 Johann Mayer arrived in New York and passed the Immigration Inspectors as an ordinary German. He had money, how much is not stated, and within a week or two he started a little shop where he sold talking machines and records. In Berlin he was a banker, but that fact Mayer carefully kept from those with whom he became acquainted. Four weeks ago agents of the Department of Justice arrested Mayer, and since then he has been in the Essex County (N. J.) jail pending action by the Federal authorities.

The investigation, so far as Mayer is personally concerned, is said to have been completed, and a report on the case was sent to Attorney General Gregory in Washington.

For three years after landing in New York, according to officials, Mayer apparently devoted all of his time to managing the little talking machine store. He was quiet and apparently harmless, paid his bills promptly, and always seemed to have plenty of money, although his business was not large.

For a little more than four months after Congress declared war Mayer continued his talking machine shop; but in August the business went out of existence, and when next heard of Herr Mayer had organized the Emm and Ess Trading Co., soon to be followed by another company, of which he was also a head, known as the Military Sales Corp. Mayer was now selling military equipment to officers and enlisted men.

The draft men were called to the colors and began to mobilize. Mayer decided to establish branches near some of the cantonments, and picked out Camp Jackson at Columbia, S. C.; Camp Sevier at Greenville, S. C.; Campe Greene at Charlotte, N. C., and Camp Wheeler, near Augusta, Ga. On the outskirts of each of these big soldier cities the German opened a store; in each he placed stock valued at about \$12,000.

For more than five months the business flourished, nobody dreaming that the man who directed it was a loyal subject of the Kaiser. Sol. Savery, another man concerned in the business, is said now to be in France and to have organized a branch near one of the big American overseas camps.

Savery says he was born in the East Indies, and that he is a loyal friend of the Allies. But he bears a striking resemblance to Mayer, according to the Federal authorities—a resemblance so close that he might easily be taken for a twin brother of the German head of the Emm and Ess concern. All information concerning Savery is withheld by the Federal authorities. It was not admitted that he was under arrest or surveillance in France.

On March 16 agents of the Department of Justice went to a house in Remsen street, Brooklyn, and arrested Mayer. At the same time agents of the Government entered the various stores near the cantonments and seized all the data found, including information relating to military transportation in the United States, facts concerning the camps, the number of men in them, and the nature of their equipment.

NEW WILSON-LAIRD APPOINTEES

H. F. Thornell Becomes Sales Manager and Henry A. Day Office Manager of the Wilson-Laird Phonograph Co., of New York City

The Wilson-Laird Phonograph Co., New York, manufacturers of the Bliss reproducer, have announced the appointment of Harrison F. Thornell as sales manager of the company, and Henry A. Day as office manager. Both of these appointees have already assumed their new duties, and Mr. Thornell is making plans for an aggressive campaign in behalf of the company's product.

H. F. Thornell is well known in the talking machine industry, having been associated with the mechanical and merchandising divisions of the business for many years. He is generally recognized as one of the best-posted members of the trade on recent developments in the perfection of reproducers, etc., and his thorough knowledge of this field will doubtless be reflected in the activities advanced in behalf of the Bliss reproducer.

Mr. Thornell has been visiting the trade throughout the country, and has instituted a campaign to interest the Edison dealers in the Bliss reproducer. This campaign has produced excellent results, and many Edison dealers have placed good-sized orders for these sound boxes.

The company is making plans to have an attractive exhibit during the convention week of the Edison dealers, June 3-8, and as its headquarters at 29 West Thirty-fourth street are directly opposite the Waldorf-Astoria Hotel, where the meetings will be held, the Edison dealers will have an opportunity of inspecting the Bliss reproducer at their convenience.

GODARD FEATURES THE VOCALION

Bringing This Product to the Attention of the People of Syracuse and Central New York

SYRACUSE, N. Y., May 6.—Godard's Music House, 215-17 James street, this city, is conducting an active campaign in behalf of the Aeolian-Vocalion, emphasizing the special individual qualities of this product to the people of Syracuse and Central New York. The importance of a talking machine that will harmonize with the furnishings of the home are brought to the attention of the public, and it is pointed out that the Vocalion in a wide variety of period case designs covers the whole range of present-day requirements. The motifs of these designs have been taken from historic pieces—the Gothic, Elizabethan, Italian, Renaissance, Jacobean, William and Mary, Queen Anne and other periods.

HOLDS SPECIAL SALE

R. Montalvo, Jr., the well-known talking machine dealer of New Brunswick, N. J., recently held a special sale of certain makes of machines and records at his store, 209 Neilson street, his lease of the premises running out on May 1. Mr. Montalvo still maintains another very successful store in New Brunswick,

Let the
Kent Universal Attachment

for the
Edison Disc Phonograph

(Made under Patent No. 1,130,298)

Increase Your Sales

Mr. Edison Dealer, if you are not already acquainted with this master attachment which plays all makes of records you are losing money.



Playing a Lateral Cut Record



Playing a Hill and Dale Cut Record

This accurate and simple device is the product of the manufacturer who has specialized in Edison attachments for years.

Most any Edison Jobber can supply Kent Attachments—if yours does not order direct.

F. C. KENT & CO.

Manufacturers of Phonograph Accessories

Cor. Mulberry and Chestnut Streets
NEWARK, NEW JERSEY

"Globe" TRANSFER NAME PLATES



STYLE 1



STYLE 2



STYLE 3



STYLE 4



STYLE 5



STYLE 6



STYLE 7
CUTS ARE HALF SIZE

Can be easily and quickly applied on

TALKING MACHINES,
PIANOS,
TYPEWRITERS,
SEWING MACHINES,
FURNITURE, ETC.

You can order any of the designs illustrated, Size 1 to 7, with your copy, as follows:

- 250—\$16.00
- 500—\$20.00
- 1000—\$27.50
- 2000—\$40.00
- 3000—\$50.00
- 5000—\$65.00

Complete transferring outfit included with every order.

Write for folder "You Need Decalcomanie in Your Business."

Globe Decalcomanie Co.

74 MONTGOMERY ST.
JERSEY CITY, N. J.



A vacation without music is peaches without cream—you supply the music—by selling every vacationist in your town a Portable Grafonola.

**Columbia Graphophone Co.
Woolworth Building, New York**

A NEW EDISON SALES PLAY

"The Dotted Line" to Be Presented at Forthcoming Dealers' Convention in June

Two years ago one of the big features of the Edison dealers' convention was the sales play, "Bought and Nearly Paid For," and last year this principle was carried out further with an act that made even a deeper impression, called "Mr. Guy Wise, Esq."

There is being prepared for this year's Edison dealers' convention, which will be held at the Waldorf-Astoria June 6 and 7, another sales playlet called "The Dotted Line," which will illustrate some good methods of getting the customer's signature on the dotted line. As in former years, it is expected that a private view of this playlet will be given for the advertising and sales experts in New York City, and it is understood that "The Dotted Line" will be as enthusiastically received as the two plays that preceded it.

FRIEDA HEMPEL TO BECOME CITIZEN

Miss Frieda Hempel, the newest Edison star, who will shortly become an American citizen, has announced her engagement to a prominent silk manufacturer of New York, where she will make her home.

By this step Miss Hempel will forfeit property of considerable value in Germany, because she is disobeying the dictates of Kaiser Bill.

LANDAY WINDOW WITH A HISTORY

Striking Display of Landay Bros. Based on Victrola Used in Crocker Land Expedition

Landay Bros., New York, prominent Victor wholesalers and retailers, have always made it a policy of utilizing their window display space to excellent advantage, and the windows of their various stores in the high-class shopping districts have won favorable comment from members of the talking machine industry and well-known advertising experts. These displays have usually been prepared by the managers of the various stores, who, in addition to their merchandising ability, have proven themselves efficient and successful window dressing experts.

A recent window display in the Landay store at 563 Fifth avenue, which was prepared by H. D. Berkly, manager of the store, is shown herewith, and this window has a human interest ap-

peal that made it the center of attraction during the week that it was displayed.

The keynote of this display was the fact that Donald B. MacMillan, of the Crocker Land Expedition, and famous Arctic explorer, who recently returned from a lengthy trip in the Arctic regions, carried with him a Victrola No. 9, in



A Landay Window Display of Unusual Interest

order to furnish entertainment for the members of his expedition and the native Eskimos in the lands that he visited.

The original Victrola that Mr. MacMillan carried on his expedition is shown in this display, together with many unique and interesting supplies which formed an important part of this expedition. At the left-hand side of the window are displayed several photographs, including a picture which shows the Eskimos listening to a Victrola, and another illustration featuring the Eskimos busily engaged in repairing a Victrola. Included in the display are many unique products incidental to an Arctic expedition, and the fact that the average layman very seldom has an opportunity of viewing these supplies contributed to the distinctiveness and success of this window display. Above the Victrola was placed the original flag which Mr. MacMillan used at the Crocker Land Expedition headquarters.

PATHE RECORD PUBLICITY

The Pathé Frères Phonograph Co. recently mailed to its dealers a proof of the artistic full-page advertisement that appeared in the Saturday Evening Post, featuring the new Pathé record of the "Marseillaise," sung by Lucien Muratore, the great French tenor, who is a member of the Metropolitan Opera Co., and records exclusively for the Pathé Frères record library. Accompanying the proof of this page was a suggestion for newspaper advertising, and there is no doubt but that the record of the French national anthem, sung by this renowned tenor, who has seen service in the French army in the present war, will meet with a ready sale.

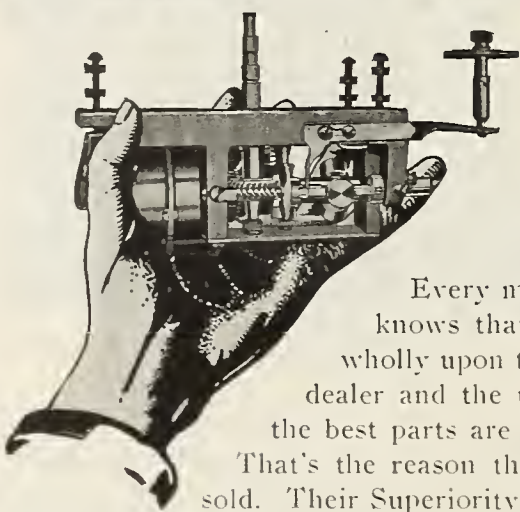

Dayton Motors

Sold all over the world. Used in all high-class talking machines.

Every manufacturer building talking machines knows that the success of his business depends wholly upon the satisfaction his products give to the dealer and the user. Therefore he realizes that only the best parts are good enough to put into his machine. That's the reason thousands of Dayton Motors are being sold. Their Superiority makes them

"The Best Motor in the World"

They embody the highest quality of mechanical perfection. Made in different styles and sizes; noiseless, easy-winding and durable.

Build satisfaction into your products by using our Quality line Dayton Motors, Dayton Tone Arms, Dayton Reproducers. All styles and sizes. They will bring you more business and satisfy your customers. Write for full particulars.

The Thomas Mfg. Co., 322 Bolt St., Dayton, Ohio, U.S.A.

Utilizing St. Paul's Municipal Library For Free Talking Machine Recitals on Sundays

St. Paul has been presented with a musical innovation by Miss Blanche Sorenson, of the educational department of W. J. Dyer & Bro., and St. Paul likes the innovation. The latest enterprise of this versatile and energetic woman is to produce a series of free Sunday recitals by Victrolas in the municipal library—library recitals she calls them. The programs begin at 4 p. m. and are arranged to continue about one and one-half hours, being composed of about fifteen numbers with suitable intermissions for explanatory remarks. The recitals show added attendance with each recurring Sunday until the assembly room of the library is taxed to contain the music lovers bent on hearing the concert. The two pre-Lenten recitals in particular attracted much attention through the careful arrangement and selection of the numbers for the occasions, which ranged from the old classics of ancient church music to the modern sacred songs by John McCormack, Alma Gluck and Schumann-Heink. The recitals are prefaced by instructive talks on the general theme of the day by Miss Sorenson. That she is contributing much to the musical life of St. Paul by this enterprise there can be no question, but the canny dealer will ask if the plan will sell Victrolas. Miss Sorenson says that it will and she is a business woman of marked capacity.

Miss Sorenson, who was connected with the educational department of the Victor Co. for two years before becoming associated with the house of W. J. Dyer & Bro. last fall, has achieved a distinct success in her school work. Her aim is to have the talking machine recognized as one of the indispensable aids to teaching in the public schools. It long has had a place in the music classes and for amusement and entertainment, but also it has a distinct place and duty in the classroom. It can be utilized to advantage in the penmanship classes by stimulating speed and rhythm in writing. By requiring pupils to write certain letters in time to music, suited to the movement in writing, they acquire a swing or rhythm which, by careful manipulation of the talking machine, may be developed into speed.

The study of geography, of history and of English literature is stimulated by the playing to properly chosen music, while folk dances and foreign language study virtually demand the constant use of talking machines to obtain the best results.

Ornithology and kindred subjects also are taught with the aid of talking machines. It's worth while to study Miss Sorenson instructing a class of St. Paul tots with the aid of bird slides and talking machines. The children simply absorb the instruction through every faculty they possess.

It's worth while to tag around after Miss Sorenson for a whole week, if one has the vitality, and observe her manifold duties.

As an instance, she will hear of a school, not necessarily a public school, that is without a Victrola. The first step is to create a demand among the teachers and pupils for such an instrument. She does it in various ways known to herself. The next step is to provide the money. She does this, too. She goes right out among the parents and business men in the district and raises the money. The next step is to dedicate the Victrola with proper ceremony. She does that, too. She arranges the concert, prepares the program, decorates the rooms, and does anything that may be needed. If piano music or a vocal solo is needed here or there for the sake of varying the program she will attend to that herself for she is a skilled performer on the piano and a gifted as well as a thoroughly schooled singer.

And besides she is a fluent and interesting lecturer. The result is that Miss Sorenson is

about the busiest mortal in the entire city of St. Paul.

Reference has been made to the Sunday concerts known as the library recitals, but regularly every Friday afternoon she has charge of the Victrola and Pianola recitals at Dyer's music hall, and regularly every Saturday morning during the school year she is in charge of the children's recitals. These, by the way, were an innovation, by Miss Sorenson. The Friday afternoon recitals have become an established institution. In addition to the Victrola and Pianola numbers some well-known soloist is invited to contribute a few numbers during the recital.

Pianists, violinists and singers of talent appear at the Friday and Sunday recitals and are

pleased to participate on the programs, for they always are assured a large and appreciative body of listeners. Often Miss Sorenson essays the solo roles and invariably receives hearty and generous approbation for her numbers. Good judgment is always displayed in the selections listed—in fact, they are models of program making as far as records are concerned.

Miss Sorenson was induced to come to St. Paul by George A. Mairs, manager of the Victrola department of the big Dyer establishment. It may be revealed that he is more than satisfied with the engagement, and with the extra business accruing therefrom.

The success of every institution is built upon a combination of individual selves.

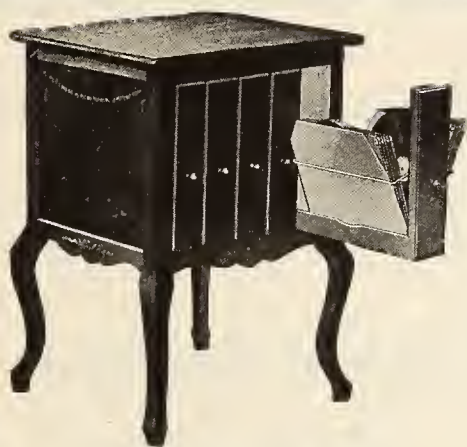

Style 5H—Holds 100 Records

Filing Cabinets for use with Victrola VIII or IX; Columbia Grafonola 15, 25, 35 and 50; Aeolian Vocalion D. & E., and other portable styles of talking machines.

Automatic RECORD CONTAINER

A Durable Album— that opens itself

- No weight of records to handle
- No broken or misplaced records
- 100% increased capacity
- Every record accessible
- Automatic in opening
- Files all records
- Sells on sight

Mr. Dealer:

How will your customers house the thousands of records you have sold them? How can you get them to buy more records today?—

Sell them an ample and efficient filing cabinet.

Automatic Container Cabinets meet these requirements—they are simple and durable too. They satisfy and please your customers—you cannot afford to be without a sample in your salesroom.

Mr. Manufacturer:

Is your competitor "beating you to it" on files? Equip your line with Automatic Containers—they cost no more—hold more records—and sell your machine.

Automatic Insert Files will re-equip any standard Talking Machine with durable up-to-date files—on dealers' sales floor or in customers' homes. Every dealer and jobber should carry them in stock.

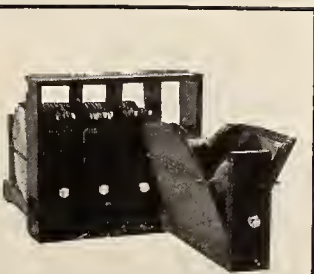

Automatic Carrying Cases for Salesmen and Repairmen are ideal—constructed on the same principle as our Record Containers. Every dealer and jobber should equip his salesmen with them to increase their efficiency.



NATIONAL MUSIC SHOW
Grand Central Palace, New York

JUNE 1st to 8th

BOOTH 116 (Mezzanine)

You are invited to visit us there

Automatic Container Co.
209 South State Street
CHICAGO, ILL.

MAIL THIS COUPON TODAY

AUTOMATIC CONTAINER CO.
209 So. State St., Chicago
Send me your catalog

T.M.W.

The Pittsburgh Pathephone Company says:



HEAR PATHÉ RECORDS NOW!

HEAR THE PATHÉ PATHEPHONE NOW!

Hear Pathé Records NOW! Draw closer to the machine as the record is playing. Lean right up against the machine and listen!

You can hardly believe your own ears! SURFACE NOISE ALL GONE! Pathé Records have eliminated that old aggravation. Nothing but the MUSIC now, from Pathé Records! The full, clear tone of the voice, pure, unmarred! The full, uncontaminated tone of the musical instrument!

If Pathé Records and Pathé Pathephones were good a year or two ago, they are A THOUSAND PER CENT BETTER NOW!

If pleasing your customers is your idea of succeeding in business, sell them PATHÉ PATHEPHONES AND PATHÉ RECORDS!

The Pittsburgh Pathephone Co.

has the largest stock of

**PATHÉ
RECORDS**

in America—and every Pathephone in every finish

Real service—the kind that counts for good business

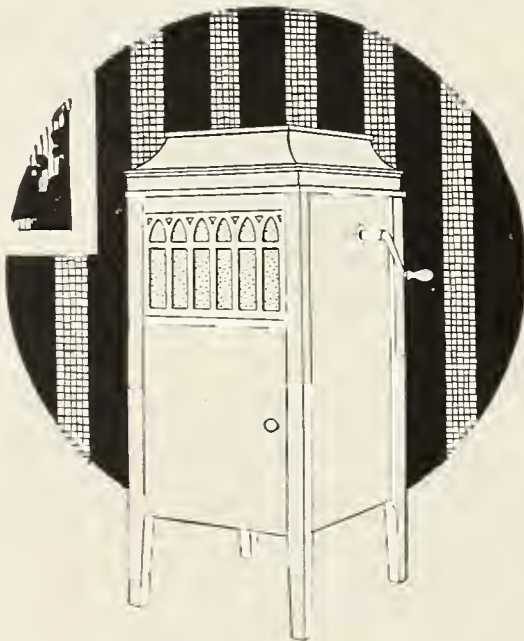

Pathephone \$85 Model

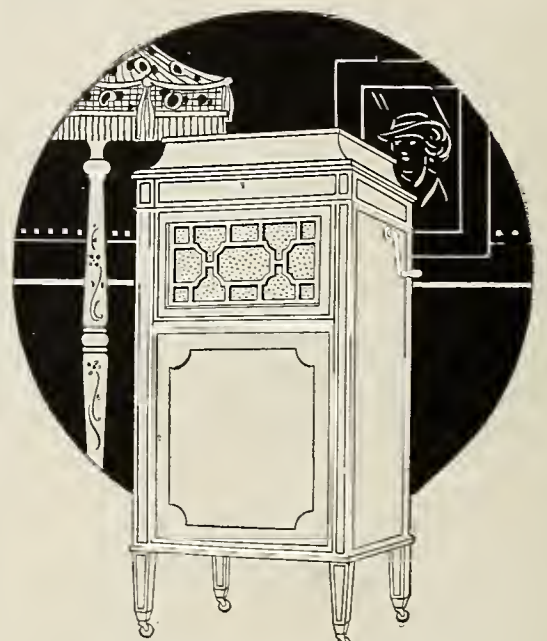

Pathephone \$225 Model



Pathephone \$110 Model

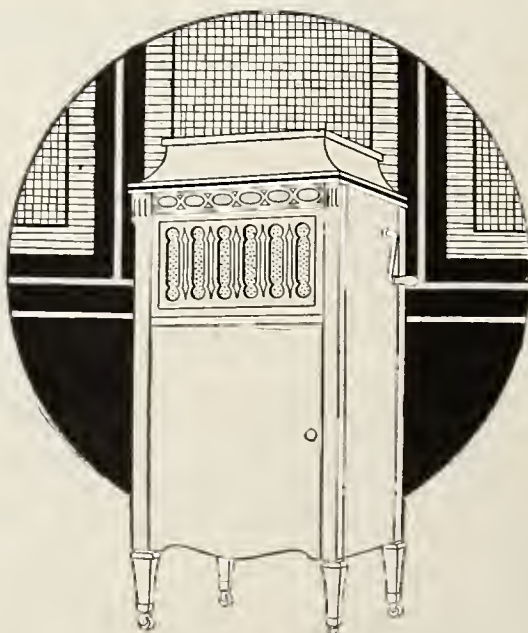

Pathephone \$125 Model

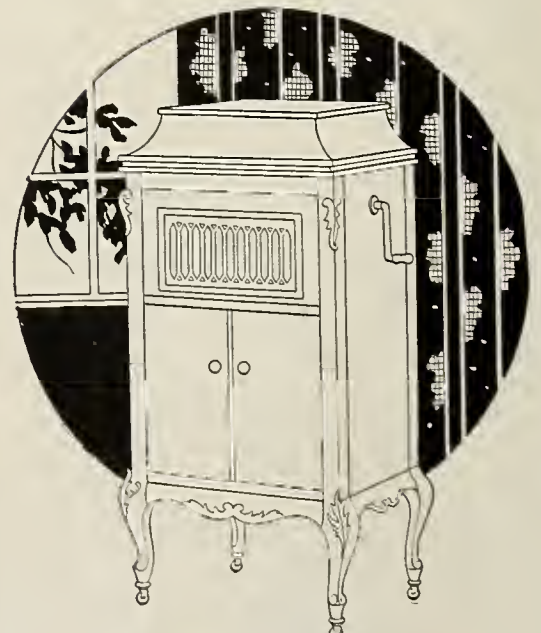

Pathephone \$185 Model

PITTSBURGH PATHEPHONE CO.

963 LIBERTY AVENUE, PITTSBURGH, PENNSYLVANIA

Dealers Should Co-operate with the Manufacturers in Educating the Buying Public

Talking machine dealers should be especially eager at this time to avail themselves of all co-operative service offered to them by the manufacturers whose goods they handle. The leading institutions of the industry have set a pace, as far as window bulletin displays, mailing circulars, electros for use in local advertising, poster cards, etc., are concerned, that is probably the most elaborate and the most brainy offered by any of the great American industries. In fact, four and five colored posters, the handiwork of the finest artists and printers in the country, have been so common that many talking machine dealers have frequently failed to appreciate their real value. The reports compiled by several of the leading manufacturers show that the percentage of dealers who make extensive use of the service provided for their benefit is not much over fifty per cent.

The main reason why dealers have not paid greater attention to this service undoubtedly lies in the fact that their business ran continuously good without special exploitation of the machines and records which they handled. But at the present time, even though orders continue to be far in excess of the dealers' ability to supply, it is important to make use of the service which the manufacturers are offering. In the first place, nobody knows better than the manufacturer what he is going to be able to supply as the war goes on. Therefore, his service to the dealer will be largely built around what he knows he is going to be able to produce in the nearest to satisfying quantities. Therefore, the dealer who utilizes and co-operates with the manufacturers' service in war times will truly be feathering his own nest.

In the second place, the service offered by manufacturers is bound to be increasingly powerful as the war goes on. The prices on printing have advanced not less than twenty per cent., on paper not less than fifty per cent., on postage just fifty per cent., and on all the other materials used in the manufacturer's service to his

vice is going to be "Make everything count." This being so, the talking machine dealer should pay particular attention, as in this way he may keep his promotion overhead low, keep his store in line with the policies expounded by the parent manufacturer and steadily increase the prestige his establishment enjoys in its home community. It is a time to eliminate all waste, and there would be an obvious waste of a very costly service and brain power should the dealer fail to display the proper interest in what the manufacturer is trying to do to help him while our country is at war.

"The Slogan for Dealers' Service should be, 'Make Everything Count.'"

dealers in like proportion. Obviously this means the cost of the free service supplied by the manufacturer has gone up a total of not less than fifty per cent. In the face of this condition, the dealer can rest assured manufacturers are going to condense everywhere and in any way possible. Expensive circulars, posters and bulletins are going to be supplied only when there is a very pertinent message to deliver. Novelties, decalcomanies, etc., for use in interior and window displays are going to be distributed with much care so that they are put only in the hands of those who will make fitting use of them. The slogan for dealers' ser-

NEW VICTOR NUMERICAL CATALOG

Within the course of a few days the latest of the successive editions of the Victor numerical catalog is to be mailed to the Victor trade. This issue of May, 1918, will involve several new features. A new method of binding will be used which makes it possible to open up the catalog flat at any desired position, and which will be of great convenience to every user. Another special feature is the six ruled spaces preceding each record number, which provide an excellent method of taking stock and for keeping track of the demand of each individual record. In addition to this there are extra numbered ruled spaces for the new records announced each month and for use in this space gummed numerical pasters will be supplied as the new records are released.

The American Phonograph Co., Grand Rapids, Mich., has been incorporated with capital stock of \$10,000 to manufacture musical instruments. The incorporators are: Peter Meeuwesen, G. L. Dornbos and Cornelius Essenbager.

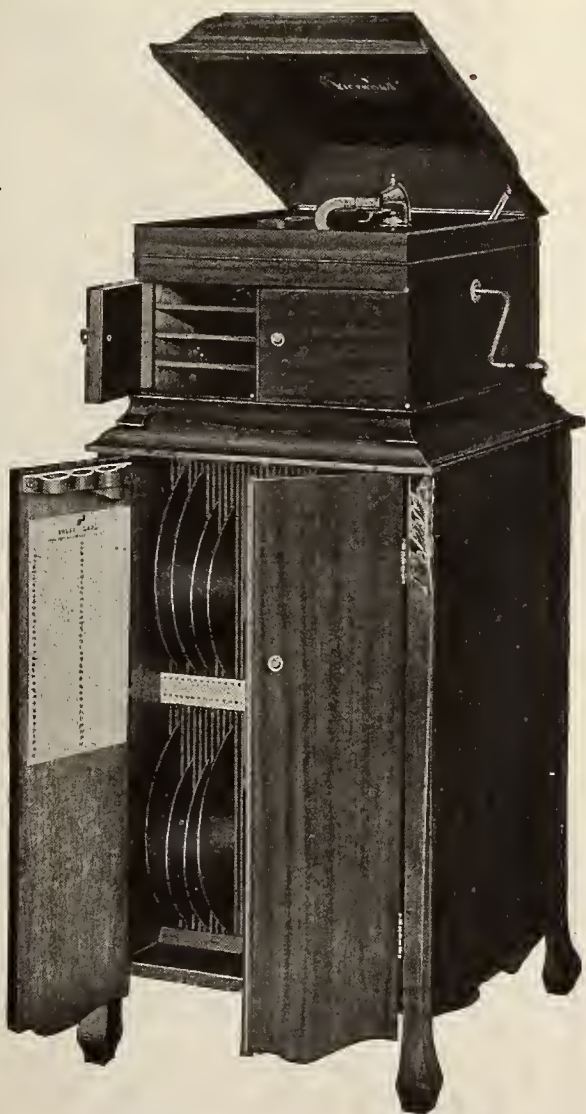

No. 19. Cabinet (DOUBLE DOOR FRONT)

Made especially to hold the Victor-Victrola, No. IXA

Get the Benefit

of the big business doing right now on both talking machines and records by handling

SALTER Felt Lined Cabinets

These two styles are not only remarkable outfit sellers but are equally attractive to people who have cabinet machines but need more record storage capacity.

SEND FOR CATALOGS

Showing many other attractive styles.

We also make a beautiful line of sheet music and music roll cabinets.

SALTER MFG. CO.

337-49 N. Oakley Boulevard

CHICAGO, ILL.



No. 111. Cabinet (Opened)
For Columbia \$50.00 Machine
33 1/2 inches high. Top, 23 x 19 1/2 inches



Push the Portables—Make July better than January. Think of the Great Selling Argument—"Vacation with Music." Don't stop until you sell every vacationist in your town.

**Columbia Graphophone Co.
Woolworth Building, New York**

RECORD WINDOW DISPLAY FOR JUNE

Dealer Service Department of Columbia Co. Has Prepared Very Artistic Display Which Should Make a Strong Appeal to the Trade

The dealer service department of the Columbia Graphophone Co., H. L. Teurs, manager, has prepared for the use of Columbia representatives a very artistic window display for the June records. This display, which is the seventh monthly issue of this service, is reproduced herewith, and, judging from its appearance, it will be one of the most successful that has so far been prepared by this department.



Columbia Record Window Display for June

The principal feature of the June display is the direct tie-up with Columbia national advertising, and it utilizes the same illustrations, the same copy, the same colors, and the same general appearance that is carried by the Columbia Co. in its magazine advertising, supplement covers, and other literature that will be used for the June records. Seventeen pieces, each indicative of "Joyous, sparkling, up-to-the-month music on Columbia records," lithographed in eight brilliant colors, constitute this complete display.

Records in illustrations and copy are the dominating feature of the whole display. Each small and large card has a reproduction of a

Columbia record thereon, and the appearance of all these records, supplemented with the regular Columbia commercial record, make a distinctive record display that should attract the favorable attention of all passers-by.

Another feature of this display is a set of unique price cards for Grafonolas, which depict a large American Eagle swinging on the tone leaves of the Grafonola type "K," with a medal and ribbon effect suspended in the same fashion on the Grafonola type "F," and a miniature trench scene where the boys are "going over the top," for the smaller type instruments. These new price cards, together with the large central figure and the four smaller cut-out records, which mention certain classes of music to be found in the Columbia record catalog, are of a permanent nature, and may be used effectively and indefinitely with almost any window trim or interior decoration.

These displays are sold complete in seventeen pieces, at an extremely nominal price, and many dealers have placed their orders for them, notwithstanding that occasionally their windows are too small to use some parts of the outfit. Quite a number of dealers have advised the dealer service department that they have utilized certain banners and cards with a small Grafonola and similar smaller material as the basis for their display, and have received results which well warranted the expenditure for the whole display.

Every Columbia dealer who has experimented with this display material is enthusiastic in his reports of the results obtained by the use of this service. In fact, subscriptions have been received in such large quantities from the Columbia distributing branches at the present time that more than three times the number of sets are now being turned out than were originally contracted for by the department.

Putting real pep into business is not done with a bass horn. It's the soundless baton that speeds up the band.

EDISON STANDARDS OF PRACTICE

Valuable Booklet for Use of Amberola Dealers Has Just Been Issued

Thomas A. Edison, Inc., have just brought out a booklet for the guidance of their Amberola dealers entitled "Standards of Practice." The data for this book has been gathered from many

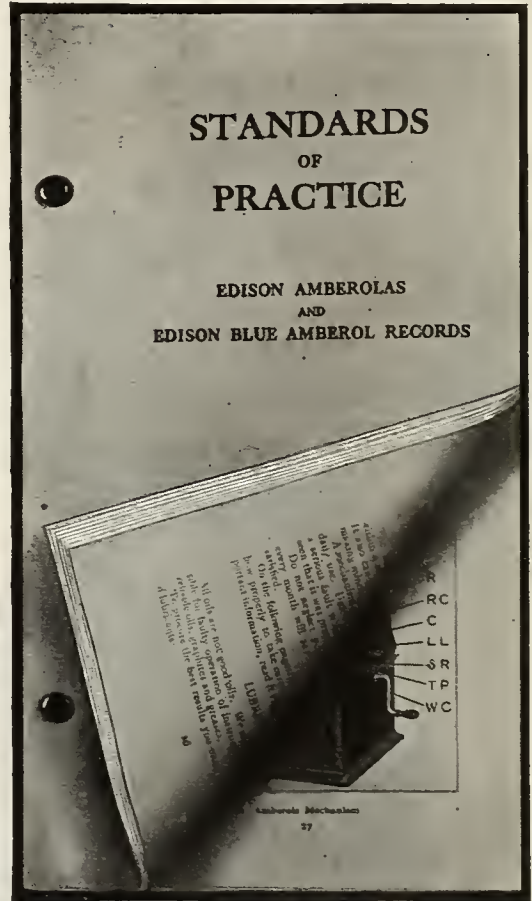

New Booklet for Amberola Dealers

sources and represents years of study, based on experiences and information secured from successful Amberola dealers and other authorities on retail phonograph merchandising. The various paragraphs cover such items of importance as store arrangement, storing of records, window displays, recitals, suggestions for advertising, motion picture slides, circularizing, service to owners, canvassing, advertising, repairs, general adjustments and general instructions, and it is felt that the book will be in great demand, as it answers many questions of interest to Edison Amberola dealers.

Queer how so many would-be salesmen keep themselves on low salaries because they fail to follow the cardinal rule of salesmanship—courtesy.

COTTON FLOCKS
.. FOR ..
Record Manufacturing
THE PECKHAM MFG. CO., 238 South Street
NEWARK, N. J.



The "INVINCIBLE"

The Sound-Box that has Gained the World's Confidence

- ☑ Plays all makes of records perfectly.
- ☑ Pure, clear, sweet and with a solid and round tone.
- ☑ Constructed to give service and absolutely guaranteed.
- ☑ No superfluous parts, and production uniform—no seconds
- ☑ Supplied with mica or our special composition diaphragm.

Write today for samples and prices. Ask also to send you our No. 2 "Invincible."

NEW JERSEY REPRODUCER CO.
847 Broad Street NEWARK, N. J.
New York Office: 1133 Broadway



Otto Heineman Phonograph Supply Co.

INCORPORATED

25 WEST 45th STREET, NEW YORK

FACTORIES, ELYRIA, O.—NEWARK, N. J.—PUTNAM, CONN.

CHICAGO

ATLANTA

SEATTLE

CINCINNATI

TORONTO



Tone Reproduction

Buy only the highest grade HEINEMAN-MEISSELBACH Tone Arm Combinations.
Your machines will then be unexcelled in tone quality.

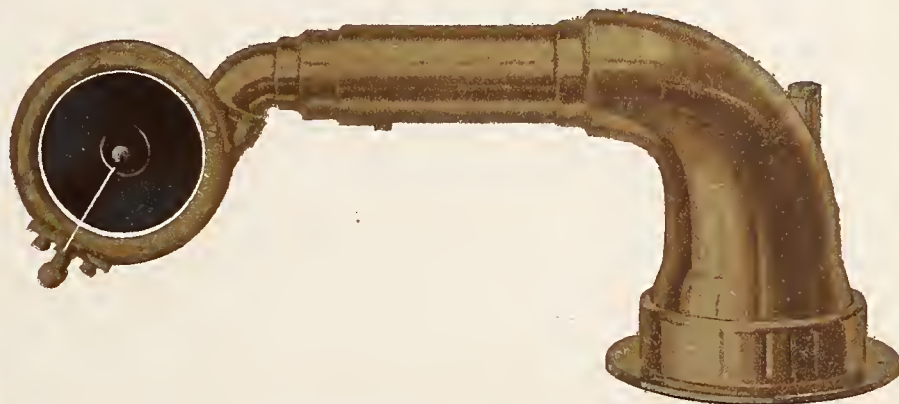

HEINEMAN TONE ARM No. 11
HEINEMAN IDEAL SOUND BOX No. 2

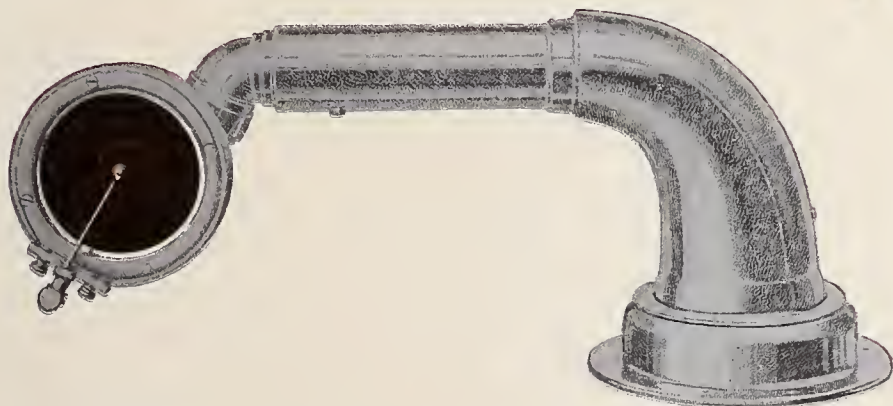

HEINEMAN TONE ARM No. 12
HEINEMAN IDEAL SOUND BOX No. 2



MEISSELBACH TONE ARM No. 97
MEISSELBACH No. 2-C SOUND BOX

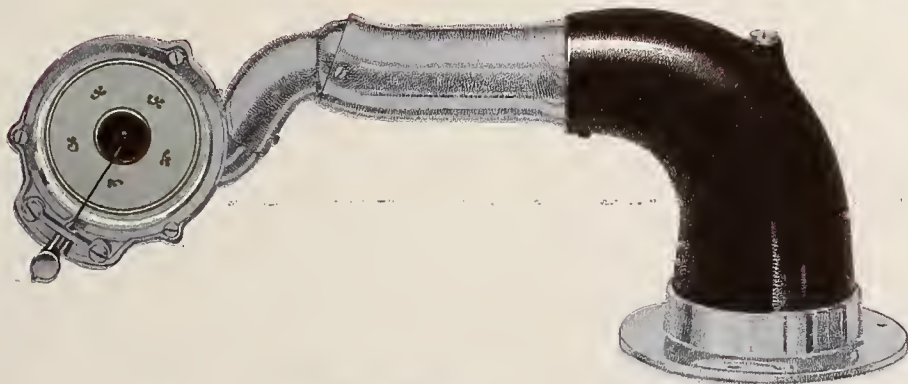

MEISSELBACH TONE ARM No. 97
MEISSELBACH No. 2-C SOUND BOX



MEISSELBACH



TONE ARMS

MOTORS

SOUND BOXES

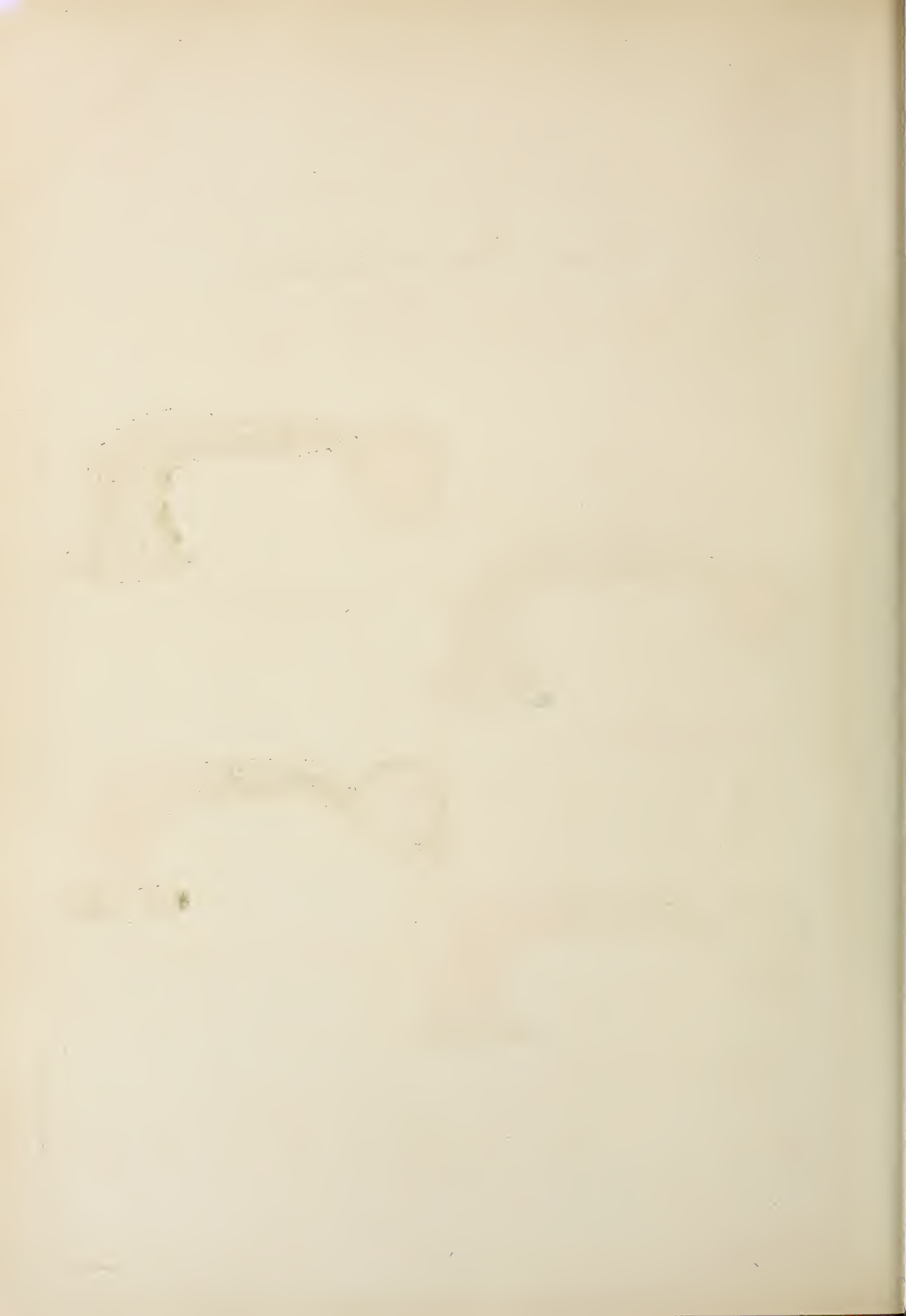

A PROGRESSIVE SONORA MAN

Is L. M. Cole, Traveling Representative of the Gibson-Snow Co., Syracuse—Reports Great Activity in His Territory at the Present Time

L. M. Cole, traveling representative of the Gibson-Snow Co., Syracuse, N. Y., Sonora jobbers, was a visitor to New York this week, and during the course of his stay in the metropolis called at the offices of The Talking Machine World. Mr. Cole, who has been associated with the talking machine industry for many years, thoroughly appreciates the importance of a progressive trade paper, and has frequently suggested to his dealers that they subscribe for, and read, The Talking Machine World from cover to cover.

Mr. Cole leaves nothing undone to co-operate with the dealers in his territory in every possible way, and in order to keep this service before them at all times mails them many unique forms of literature, which emphasize the sales possibilities of the Sonora phonograph, and call attention to some of its many qualities. Mr. Cole recently mailed to his dealers a copy of a very interesting publication, "Sonora Policy," which was compiled by George E. Brightson, president of the Sonora Phonograph Co. Together with this booklet, Mr. Cole sent a brief resumé of the Sonora dealers' convention held in Syracuse last month, together with several personal and individual touches which made this literature well worth reading.

While here Mr. Cole commented upon the fact that the dealers in his territory are closing a splendid business, and that the great majority of them report sales totals for the first four months of this year well ahead of 1917. They are all "cashing in" on the mammoth Sonora advertising campaign, which includes practically every form of profitable publicity.

BIG BUSINESS IN A SMALL TOWN

C. M. Christianson Doing Well With the Columbia Line in Savannah, Mo.

C. M. Christianson, who handles the Columbia line in Savannah, Mo., has sent to The World an interesting picture showing a shipment of fourteen large Grafonolas lined up on the sidewalk in front of his store, with his sales staff standing in front of them. Mr. Christianson states that he does an excellent business in Columbia graphophones and records, both in the store and on trips through the surrounding country. For the latter work he has W. R. Haskins, a veteran salesman, who still clings to the horse and buggy in preference to the automobile, but finds that they get him where he wants to go in all kinds of weather. Mr. Haskins incidentally manages to sell three or four Grafonolas per week from his buggy.

Savannah, Mo., is a town of 1,800 inhabitants, but according to Mr. Christianson shipments of Grafonolas are cleaned out with great regularity. He has a horn projecting over the sidewalk with a tube connected with a Grafonola inside the store in such a way that each time a record is played for a customer the music is also carried into the open air. He states that, although the idea is not new, it has resulted in the sale of a large number of machines and records to people who have stopped to listen to the music.

SUPPLEMENT OF NINE-INCH RECORDS

The Emerson Phonograph Co. has just issued a supplement of its new nine-inch records, which includes recording of patriotic hits, dance numbers, and popular song hits. These records, which are all double-faced, retail at 65 cents each, and Emerson dealers are therefore afforded an opportunity of developing profitable business from the sale of these nine-inch records. Many well-known artists are included in this repertoire, and the Emerson Co. is preparing to handle a country-wide demand for these new records.

A NEW HARPONOLA CATALOG

Just Issued by the Celina Furniture Co. Is Artistic and Full of Interesting Material

A new catalog has recently been issued by the Celina Furniture Co., of Celina, O., covering their talking machine, the Harponola. It is attractively laid out and is well printed on super-calendered paper. The cover is a fine half-tone reproduction of a home scene in which the Harponola plays a prominent part. There is an introductory article on the "Birth of the Harponola," written by Ed. Brandts, vice-president and sales manager of the company. The various models are described in detail and illustrated. The last few pages of the catalog are devoted to advertising helps for the dealer and reproductions of the various electrotypes which are furnished him free for his newspaper advertising, as well as a few pieces of copy suggestions for use in same. At various places throughout the catalog is reproduced the trademark of the Harponola, a girl playing the lute and kneeling on a base marked Harponola.

SILVER SERVICE FOR G. D. ORNSTEIN

Close Friends in the Trade Make Appropriate Presentation to Newest Victor Wholesaler

PHILADELPHIA, PA., May 2.—At the recent meeting of the executive committee of the National Association of Talking Machine Jobbers held in this city was the presentation of a handsome silver service valued at over \$1,000, to George D. Ornstein, who recently became a Victor wholesaler in this city, after serving for twenty years in an executive capacity for the Victor Co. The silver service was the gift of a number of Mr. Ornstein's closest friends in the trade, and with an engraved minute was presented to Mr. Ornstein by Joseph C. Roush, of the Standard Talking Machine Co. The gift was especially appropriate inasmuch as Mr. Ornstein, while with the Victor Co., had acted as guide, teacher and friend to most of the present Victor wholesalers, and many of them he had actually seen through the forming and developing of their organizations.

FAULTLESS CASTERS



Perfect construction and inviting in appearance—**FAULTLESS** Casters are still more pleasing in actual use, in moving phonographs.

Their gentle, easy moving qualities are most essential and agreeable.

Send for Samples

*"Move the **FAULTLESS** Way"*

Full Size
C-65

**FAULTLESS
CASTER COMPANY**
Evansville, Indiana



A TIP TO THE WISE

The question of supply is today a more important one than that of demand.

The dealer should without delay place sufficiently large orders for

B. & H. FIBRE NEEDLES

U. S. Pat. Nov. 12, 1907

with his jobber to meet his future requirements, and should at the same time urge his customers also to lay in a supply.

B. & H. FIBRE NEEDLES are better than ever and in greater demand than ever, but present manufacturing conditions make the anticipation of wants necessary in order to avoid disappointment to the user.

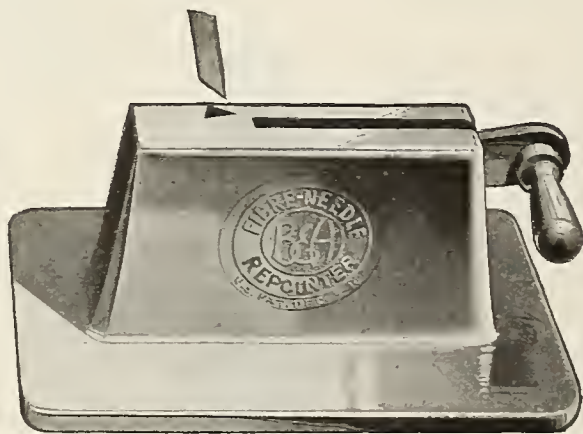

U. S. Patent December 5, 1916

Retail Price \$2.00

The B. & H. Repointer was conceived of necessity and has made good. The principle involved in this device is the only logical and practical one for the purpose intended.

The proof of its efficiency is in the actual test. Play a record with a fibre needle before repointing and then notice the difference in tonal quality after the Repointer has been used.

Write for Descriptive Circular

B. & H. FIBRE MFG. CO.

33-35 West Kinzie Street

CHICAGO, ILL.

The Heavy Increase in Consumer Demand Is Responsible for Current Shortage

Ever since war was first declared, leading members of the music industry, as well as many prominent officials in military and public life, have endeavored to accurately portray the mission of music during times of war. Many of the addresses and writings on this subject have been handled in masterly fashion, in that they are founded on fact and not upon sentiment. Innumerable cases have been cited where music has been an important factor in stirring the elan of the men on the fighting front, in restoring the spirit of the wounded in the hospitals, in providing welcomed entertainment for the soldiers who frequent the Red Cross canteen and the Y. M. C. A. and K. of C. huts, and in maintaining the morale of the great civilian population behind the men in uniform. Indeed, cases of this sort are of such common occurrence that great military leaders and strategists themselves have not hesitated to give due credit to the part that music plays in keeping up the morale of the men in khaki and the civilian army back home.

Further evidence of the great mission of music in wartimes is found in the steadily increasing demand for musical instruments. Naturally, if music is as important as is claimed, then during wartimes there must be a vigorous demand on the part of the army and on the part of the navy and on the part of the general public. This, in fact, is the case. The leading manufacturers of the talking machine report that the demands for talking machines and records are far in excess of any previous years. The American public, notwithstanding certain advice that the present is a time for rigid economy, has apparently, after giving the matter due consideration, decided that talking machine music, considering

the comfort it affords for those left at home, is a necessity and is a good investment during wartime.

No doubt there are members of the talking machine industry who believed that war would mean a falling off in the demand for talking machines and records. But the purchasing public has not so willed, and manufacturers in the talking machine industry find themselves confronted with unfilled orders of a very exceptional proportion. *The fact is, that the shortage of machines and records which one hears so*

much about these days is not really due so much to a decrease in the production of previous years as it is to a tremendous increase in the demand.

Talking machine dealers will do well to bear this in mind before complaining about shortages. It is, of course, understood by all that the production problems of the industry during the period of war have been and are going to continue to be extensive and yet manufacturers who can keep their output up to the figure of 1917 will still be falling far behind the current increase in demand for their product.

W. L. GARBER AGAIN IN SERVICE

Member of New York Talking Machine Co.'s Staff Joins the Tank Service—M. C. Stegner Enlists in U. S. Marine Corps—Given Nice Send-Off by Associates—E. Fontan Writes

W. L. Garber, formerly private secretary to Arthur D. Geissler, president of the New York Talking Machine Co., Victor wholesalers, who enlisted in the U. S. Army some time ago and was discharged because of physical disability, recently appealed to the army authorities for another examination. His appeal was granted, and he passed the second examination with flying colors. According to his present plans he will soon join the tank service, a new branch of the army service that makes a distinctive appeal to those patriots who want immediate action at the front. Since his discharge from the army, Mr. Garber has been visiting the dealers through New York State and Pennsylvania, where he won the friendship of all the company's clientele. He is thoroughly familiar with all methods of Victor merchandising.

M. C. Stegner, formerly assistant to George A. Kelley, of the New York Talking Machine Co., has enlisted in the U. S. Marine Corps, and is now stationed at Charlotte, N. C. Before joining Uncle Sam's service Mr. Stegner was the guest of honor at a luncheon given by Roy J. Keith, general manager of the New York Talking Machine Co., at the New York Athletic Club. There were six members of the company's sales staff present at this luncheon, and Mr. Stegner was surprised to receive from Mr. Geissler a gift of a handsome personal kit, which he can use to excellent advantage "over there."

Ernest Fontan, formerly a member of the company's sales staff, who has been in one of the army camps for several months, has written his former co-workers that all of their supplies have been packed in big wooden cases and nailed up, marked for France. It is safe to say that Mr. Fontan will soon be on the other side of the Atlantic. John Connolly, another member of the company's staff who is "doing his bit" for his country, has sent several cards and letters from "over there," expressing his pleasure at being in the big fight.

LONG CABINETS



No. 83

In all finishes. Specially adapted for use with Columbia 50. Front posts made to follow lines of posts on Columbia 75.

FIRST and FOREMOST

In the cabinet field.

Why? Because we've *specialized* in

**CONSTRUCTION
FINISH and
ADAPTABILITY**

Our supremacy in these essentials warrants your handling *the perfect line.*

That's why you should anticipate your wants NOW.

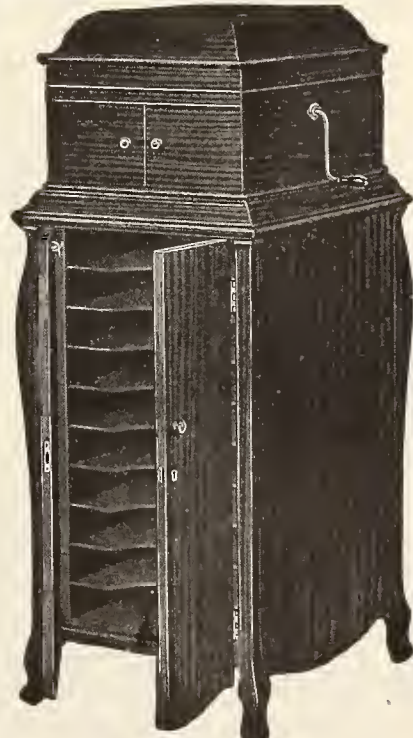

No. 79

In all finishes. Shown with top moulding and shelves. Specially adapted for use with Victrola IX-A.

Prompt deliveries on all orders. Write for Illustrated Catalogue of complete line

THE GEO. A. LONG CABINET COMPANY
HANOVER, PA.

The most wonderful Talking Machine of the present age at the price
An Instrument of Supreme Value, Tone and Quality

CLEARTONE

(Speaks for Itself)



No. 100—\$100



No. 75—\$75



No. 65—\$65

The *Cleartone* has become very popular because of its quality, splendid value and the advertising and sales campaign that now stands in back of it. **Dealers!** Watch us grow—write for our agency and grow with us.

SUNDRY DEPARTMENT

MOTORS—No. 01, 8-in. turntable, single spring, \$1.25; same motor with 10-in. turntable, \$1.40. No. 1, 10-in. turntable, double spring, plays two 10-in. records, \$2.95. No. 6, 10-in. turntable, double spring, plays three 10-in. records, \$3.50; same motor with 12-in. turntable, \$3.85. No. 8, 12-in. turntable, cast-iron frame, double spring, plays three 10-in. records, \$4.85. No. 9, 12-in. turntable, cast-iron frame, bevel gear wind, double spring, plays three 10-in. records, \$5.85. No. 10, 12-in. turntable, cast-iron frame, bevel gear wind, double springs, plays four 10-in. records, \$6.85. No. 11, 12-in. turntable, cast-iron frame, bevel gear wind, double spring, plays seven 10-in. records, \$8.50.

TONE ARMS AND REPRODUCERS—No. 1, \$1.00; No. 2, plays all records, \$1.25; No. 4, \$2.65; No. 6, \$2.25; No. 7, \$2.25; No. 8, \$2.25; No. 9, \$2.25. (Play all records.)

MAIN SPRINGS—No. 00— $\frac{1}{2}$ -in., 23 gauge, 9-0 ft., 29c. each, 100 lots, 25c. each; No. 01, 1-in., 23 gauge, 7 ft., 25c. each, 100 lots, 20c. each; No. 0, $\frac{3}{4}$ -in., 20 gauge, 8-6 ft., 25c. each, 100 lots, 21c. each; No. 1, $\frac{3}{4}$ -in., 25 gauge, 9-6 ft., 39c. each, 100 lots, 35c. each; No. 2, 13-16-in., 25 gauge, 9-6 ft., 43c. each, 100 lots, 39c. each; No. 3, $\frac{7}{8}$ -in., 25 gauge, 11 ft., 49c. each, 100 lots, 45c. each; No. 4, 1-in., 23 gauge, 10 ft., 49c. each, 100 lots, 45c. each; No. 5, 1-in., 27 gauge, 11 ft., 65c. each, 100 lots, 59c. each; No. 6, 1 $\frac{1}{4}$ -in., 27 gauge, 11 ft., 90c. each, 100 lots, 85c. each.

RECORDS—POPULAR and GRAMMAMOVX Brand, 10-

in. double face, lateral cut, all instrumental—32c. in lots of 100; 30c. in lots of 1,000; 29c. in lots of 5,000.

GOVERNOR SPRINGS—\$1.00 per hundred; \$6.00 per thousand. Special price in large quantities for Motor Manufacturers.

Genuine Diamond Points for playing Edison Records, \$1.25 each, 100 lot, \$1.15 each; Sapphire Points for playing Edison Records, 18c. each, 100 lots, 14c. each; Sapphire Balls for playing Pathé Records, 19c. each, 100 lot 16c. each. Needles—Steel in stock at all times at moderate price as per quantity.

NEEDLE CUPS—\$17.50 per M. \$16.00 per M in 5,000 lots. Covers, \$7.50 per M.

COVER STAYS—No. 1, for Table Cabinets, 6 in. long, 9c. each, 100 lot, 7 $\frac{1}{2}$ c. each; No. 2, for Floor Cabinets, 9 in. long, 17c. each, 100 lot, 13c. each; No. 3, heavy for Floor Cabinets, 10 in. long, 20c. each, 100 lot, 16c. each.

Continuous Piano Hinges, 28c. per foot; 100 feet, 21c. per foot.

We also manufacture special machine parts, such as worm gears, stampings, or any screw machine parts for motor; reproducer and part manufacturers.

Special quotations given to quantity buyers in Canada and other export points.

Write for our 84-page catalog, the only one of its kind in America, illustrating 33 different styles of talking machines and over 500 different phonographic parts, also gives description of our efficient Repair Department.



No. 85—\$85

Lucky 13 Phonograph Co., 3 East 12th St., New York

SAN FRANCISCO TRADE ACTIVE DESPITE LOAN CAMPAIGN

Trade Helps to Put Liberty Loan "Over the Top"—Business as Active as Stock Supplies Permit—Columbia Co. Settled in New Quarters—Month's News Tells of Trade Progress

SAN FRANCISCO, CAL., May 3.—The Liberty Loan drive in this city has not had the deterrent effect on the business of the talking machine dealers that was expected. Collections have been a little slower in consequence of the desire of the people to carry the city "over the top," but the new business shows hardly any diminution. The dealers themselves have been busy with the loan and every one has generously subscribed for the bonds. Some makes of talking machines are very scarce on the market, but for nearly all there have been fair receipts this month. The time on the road of these goods seems to average much less than a month ago, and from this the dealers say that the freight situation is practically solved as far as their lines are concerned. The difficulty of getting all the stock wanted lies in the factories, and for this the local dealers say there is no remedy so long as the war lasts. Both wholesalers and retailers say that there is plenty of business to be had in San Francisco, and that the interior of the State is even more prosperous than the city.

Take on the Pathé Line

Fred Stern, president of the Stern Talking Machine Co., has been East for nearly a month. He will return in a few days now, and his associates are looking for him to announce something of importance in the way of increased stock when he gets back. The company have just taken over the Pathé Frères phonograph line and report a good business in their new acquisition.

Featuring Records Successfully

The California Phonograph Co. has been featuring certain records in its windows by means of cards telling of the worth of the record that is being pushed and says that this means of bringing the goods to the attention of the public has been very successful. F. A. Levy, president of the company, says that goods are reaching him in much larger quantities than for some time past. This is especially true with Victor machines. The supply of needles is very much easier, he says.

Miss Frances Gridman, manager of the record department of the California Phonograph Co., will leave for the East in a short time and will visit the various factories making records during her absence.

George Hively, manager of the phonograph department of the Eastern Outfitting Co., says business with him keeps up wonderfully well. April's sales were far ahead of those of last year for the same month.

Big Run on Galli-Curci Records

The singing of Galli-Curci in this city brought about a boom in records made by her. All the Victor dealers featured these records during the entire month and the demand exceeded the supply to such an extent that Byron Mauzy had to have a shipment of records sent him by express. One way of advertising the singer was the display of a grand piano in Mauzy's window with the label that it also was shipped by express for the exclusive use of the singer. This and the other publicity stunts pulled off caused a bigger run on these records than occurred even in the recent case of McCormack.

The Woolworth 5-10-15-cent store recently bought 13,000 Emerson records, which were being closed out at a bargain price by the Emporium. It is expected that the records will go on sale somewhat below regular price.

Pacific Phonograph Co. in New Home

The Pacific Phonograph Co. has moved into new quarters on California street. It formerly occupied a place on Battery street.

Wiley B. Allen Co. Activities

E. P. Corcoran, of the talking machine department of the Wiley B. Allen Co., has been ill for several weeks, and has recently returned to his duties at the store. During the absence of James J. Black, manager of the department, Mr.

Corcoran has been in charge. Mr. Black has been temporarily located in Sacramento, where the company has recently enlarged its store and added a talking machine department. This was the only branch of the company which was without a department for the sale of this popular musical instrument.

New Edison Jobbing House in Los Angeles

The Edison Phonographs, Ltd., the local Edison jobber, with a distributing house at Portland, has purchased the Edison merchandise of the Diamond Disc Distributing Co., at Los Angeles and opened a jobbing house at that place. This gives the company three jobbing houses on the Coast.

Mrs. Howard With Hauschildt Co.

Mrs. Helen B. Howard, who broke into the talking machine business as saleswoman for Sherman, Clay & Co., Oakland, about six months ago, has made such an extraordinary success that she has been called to the management of the talking machine department of the Hauschildt Music Co. in Oakland. Mrs. Howard is a woman of most pleasing appearance and manners and is destined to go high in the music world.

Improvements at Phonograph Shop

The Phonograph Shop on Powell street, which features the Sonora, has about completed the renovation which began a month ago. New racks have been installed and much additional storage space gained thereby. The decorations are in a delicate tint of cream and the shop is one of the most attractive appearing sales places in the city.

The Starr phonographs are making good progress in this State, according to the statement of J. W. Steinkamp, who represents the Starr interests in this season. He is making a drive to place the instrument in the furniture houses and says that he is meeting great success in his activities.

Columbia Co. Settled in New Quarters

The Columbia Grafonola Co., which moved into the new "Daylight" Building on Sutter street last month, is about settled in its new abode. Walter Waters, who was one of the salesmen with the Columbia, has enlisted in the Signal Corps and is now busy learning wireless telegraphy. Eight men have enlisted from the local house.

The Brunswick-Balke-Collender Co. in this city is pushing its machines in all parts of the State. The universal tone arm has proved a great success and more dealers have been signed up since its introduction than in double any like period since the company first began to place agencies.

Ray Solomanson, who has been connected with the sale of talking machines in the Emporium for some time past, was recently drafted in the army, and is now in training to "show goods to the Kaiser."

SUGGESTIONS THAT INSPIRE

George E. Brightson, Author of a Booklet That Is Full of "Meat" for the Man Who Aspires

"Sonora Policy" is the title of an interesting and inspiring article written by George E. Brightson, president of the Sonora Phonograph Corp., New York, and recently issued in booklet form for all Sonora employes.

Mr. Brightson emphasizes the importance of good will, referring to it as follows: "There is one big element of success in this world, of personal success, and of business success, and that is good will." This subject is very interestingly discussed, and is followed by a splendid discourse on "service." The tremendous importance of extending every customer a fair, square and efficient deal is emphasized in one of the paragraphs of this article, and many suggestions embodying sound logic are presented to the employes of the Sonora organization.

Co-operation and team work is the subject of one of the closing paragraphs, and from cover to cover this admirably written article not only reflects Mr. Brightson's many years of experience in the talking machine industry, but forms an inspiration for every Sonora employe.

VICTOR DECALCOMANIE POPULAR

The new trade mark decalcomanie recently offered by the Victor Talking Machine Co. to Victor dealers is proving decidedly popular. This decalcomanie is slightly over twenty inches in width and portrays "His Master's Voice" in the original colors. It can be used on either glass or wood and therefore is well adapted for use on store windows, doors, delivery cars, wagons, etc. These decalcomanies cost 18 cents each.

The Cheney Phonograph Sales Co., of Cleveland, O., has been incorporated with capital stock of \$300,000 by E. M. Buel and others.

A Message to the Edison Dealer

Complete the equipment of your Edison Phonograph by using the "BLISS" REPRODUCER to play lateral cut records better than they are now played on any other Phonograph.

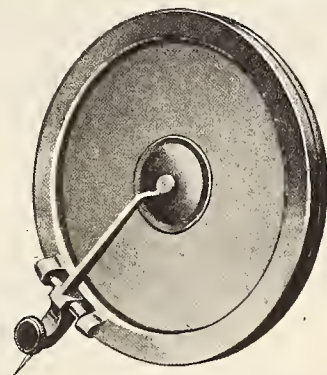

Make the Edison Phonograph as far ahead of other Phonographs on lateral cut records as it now is in interpreting the Re-Created Edison Diamond Disc.

We furnish you with a "BLISS" REPRODUCER to achieve this result.

May we not send you samples and our dealers discount?

WILSON-LAIRD PHONOGRAPH CO., Inc.
29 West 34th Street (Opposite the Waldorf Astoria) New York City
Canadian Distributors: HAWTHORN MFG. CO., 145 Yonge St., Toronto, Can.

Visit us during Convention week and make our office your headquarters while in New York

ECLIPSE MUSICAL CO.'S NEW WHOLESALE HEADQUARTERS

Noted Cleveland Institution Has One of the Most Complete Departments and Executive Offices for the Transaction of a Jobbing Business in the Talking Machine Trade

Ohio has frequently been rated as the liveliest State in the Union as far as the musical industry is concerned. Whether or not Ohio should retain this reputation unchallenged is, of course, a debatable question, but at any event there is no argument about the progressiveness



Office of General Manager

of the Eclipse Musical Co., Victor distributors, located in Cleveland. This institution has steadily moved ahead, as far as its own private business is concerned, and has been decidedly instrumental in the formation and development of the Northern Ohio Dealers' Association, and other activities tending toward the betterment of the retail trade.

The Eclipse Co. recently established new wholesale headquarters in the Cadillac Building, on Euclid avenue. The new headquarters is made up of a very handsome set of executive offices, an extensive department for the many series of record racks in which the wholesale stock is stored, a special division where the surplus stock is kept, a packing department, a shipping department, a department where record orders are filled, checked and double checked, and a repair department.

The executive offices embrace, in addition to



Sales Manager in Conference

the handsome quarters of the officers of the company, a special record statistical department, a record ordering department, a stenographic

department and an accounting and bookkeeping department.

The record racks in the stock department, in their make-up and general arrangement are similar to those used by the leading Victor jobbers in the country. Slightly separated from the main series is a "monthly record rack" accommodating the issues of the two last months. In addition to this there are individual racks for the red seal, blue label and purple label records. This section immediately adjoins the regular record stock section.

The repair department is equipped with a complete repair bench and a sanitary re-graphiting compartment. A complete stock of all Victor parts is kept in a large well-systematized cabinet which may be seen in the background of one of the pictures accompanying this article. There is also a separate apparatus with an adjustable standard for testing motors.

The shipping department is noteworthy for



Well Equipped Repair Department

the efficiency which prevails therein. All scrap paper and scrap cardboard is jammed in a bailing machine and all excelsior is kept in a metal-lined excelsior container. It is as near fire-proof as modern devices can make it. From the packing department Victrolas and Victor records make their exit from the Eclipse headquarters by one of two routes. The first of these is through what is known as the "express bins" which adjoin the packing department and which are immediately in front of the elevators. These express bins are five in number and classified in accordance with the different express companies and other kinds of shippers, so that the representative of each different kind of transportation knows exactly what is meant for him and where to get it.

The other method of shipping goods out is decidedly unique. The Cadillac Building was designed throughout for automobile purposes, and there is a rapid, large-elevator service, and because of this fact the Eclipse Co. is enabled to bring their motor trucks up and right into the floor where the Victor stock is kept as

shown in the illustration. The machines can be loaded right into the car from where the stock is stored and the car run on to the elevator and lowered to the street.



Loading Truck Right on Stock Floor

Among the live-wire officials who are responsible for the efficient way in which the new Eclipse wholesale division has been organized and efficiently conducted are T. H. Towell, president; P. J. Towell, vice-president; C. K. Bennett, general manager; E. B. Lyons, sales manager, and Earl Poling, Jack Kennedy and Norman H. Cook, traveling representatives.

OPENS NEW JEWEL LABORATORY

H. J. Smith Opens Quarters in Newark, N. J., to Manufacture Talking Machine Jewels

H. J. Smith, who for the past twenty-seven years has been connected with the talking machine industry, recently opened a laboratory for the manufacture of jewels at 833 Broad street, Newark, N. J. Mr. Smith has been connected with some of the largest organizations in the field, including Thos. A. Edison, Inc., American



Eclipse Co.'s Room for Packing Records

Graphophone Co. and the Pathé Frères Phonograph Co. He is one of the best-known jewel experts in the country, and his products include phonograph and sapphire reproducing points, recording laboratory jewels, jewel bearings for electrical instruments, rough diamonds and diamond powder. The plant is one of the best equipped in the country, and is fitted for the carrying on of experimental work. One of the policies of the H. J. Smith plant is an open invitation to the trade to visit the laboratory at all times.

THE SCHILLING PIANO CO. of NEW YORK

Announce that **JOSIAH PARTRIDGE & SONS CO.**

NEW YORK FURNITURE EXCHANGE, 46th ST. AND LEXINGTON AVE., NEW YORK

HAVE BEEN APPOINTED SELLING AGENTS

FOR THE WELL-KNOWN

The Quality
Phonograph
with a
Spruce Soundboard

STRADIVARA
"KNOWN FOR TONE"

The Quality
Phonograph
with a
Spruce Soundboard

The house of Josiah Partridge & Sons Co. needs no introduction by us. For 75 years their name has been associated with the furniture trade and they have recently reorganized their expert selling staff throughout United States and foreign countries to cover the piano and music trade.

Stradivara is the only phonograph in the world that contains a spruce sound board, being built on the principle of the piano and violin. This high-grade phonograph truly reflects the genius of the world's greatest violin maker. 7 MODELS FROM \$50 TO \$250. Compare all other makes of present-day phonographs with the *Stradivara* and you will easily learn why it is marvelously superior.

Round up the folks who go to the woods or the shore. Sell every one a Portable Grafonola to take along. We're helping with Big National Advertising Space.

**Columbia Graphophone Co.
Woolworth Building, New York**



SELLING TO THE BUSY MAN

How One Talking Machine Dealer Handled a Difficult Situation Successfully

"I had a little experience with one salesman who knew how to get on with busy people with whom he wanted to do business. It took only about thirty seconds for him to show that he and I would not quarrel because of any tendency to take up my time unnecessarily," said a business man the other day.

"I was busy when he first called and I showed it. 'Pretty busy this morning?' he asked pleasantly. 'Yes,' I said, perhaps a little crustily, 'I am busy. I have a lot of mail I want to get off before noon.' 'All right,' he replied, 'I'm not going to bother you now. I want to talk to you about talking machines and I have something to say that will interest you. Can you give me fifteen minutes some time during the day? I promise to take no more time than that unless you wish me to do so. You needn't worry about my boring you. I don't do business that way.'

"I couldn't refuse a request like that or even be grouchy about granting it. I named a time. At that time he walked in. He did not show up half an hour ahead of time and make me nervous by standing around waiting. He did not act with such deliberation that I would be afraid he would overstay his time. He laid his watch where he could see it and where I could see that he saw it, but where I could not see it. At the end of thirteen minutes he had said his say with the impressiveness and with the brevity of a four-minute speaker. He took up his hat and his watch. 'I appreciate your giving me this hearing,' he said. 'I would like to talk my proposition over with you definitely some day soon, but I won't ask you now to make an appointment.'

"If he knew, or surmised, he had interested me so I would want him to stay longer then and give me his proposition then and there, he did not show it, but he was properly appreciative when I told him I was interested and would hear the rest of his story at once."

TO MAKE DEMONSTRATION BOOTHS

H. Mickelas, 164 McKibben street, Brooklyn, N. Y., who has been in the cabinet business for fifteen years, has inaugurated a department that will devote itself entirely to the construction of demonstration booths, record racks and store interiors for dealers. Some three years ago Mr. Mickelas started to take care of this class of business, and the results were so satisfactory that he determined to enlarge his factory, so that he could cater to the demands of the dealers.

The booths constructed by Mr. Mickelas are soundproof and include all of the features desired by talking machine dealers. A number of installations have been made in local territory, and these customers have expressed their satisfaction with the booths in every respect.

BWARE OF WAR RUMORS

Talking Machine Dealers Should Be on Guard Against Untrue Statements Regarding the Affairs of Manufacturers Put Out by Competitors

In these times talking machine dealers should be particularly upon their guard against insidious rumors. Reports have been circulated in the trade to the effect that the factories of certain manufacturers have been commandeered by the Government, and further that this or that manufacturer will be unable to supply goods as promised, and still further that this or that manufacturer has a financial interest in competitive concerns.

When the talking machine dealer hears rumors of this kind he should make careful note of the sources from which they emanate. It should be easy to detect cases where the representative of a certain line is taking unfair advantage of a contemporary manufacturer. It is reasonable to suppose that each individual company will inform its clientele of dealers regarding any important action it may take affecting the welfare of their dealers, and it is also reasonable to suppose that the circulating reports about competitors which have not been authorized by the company to which they refer is inspired by malicious motives.

Dealers should see that the traveling representatives of every manufacturer in the talking machine industry paddle their own canoe, in that they explain the merit of their own product and

institution and do not resort to unsupported claims about the war weaknesses of other perhaps more successful competitors.

F. C. KENT MOVES TO NEW PLANT

Manufacturer of Talking Machine Attachments in Newark, N. J., Installs New Equipment, Including a Model New Tube Bending Machine

F. C. Kent, the well-known manufacturer of phonograph attachments of Newark, N. J., recently moved from 24 Scott street, to the corner of Mulberry and Chestnut streets. In his new plant he has installed a large number of new machines and among others one of his own design which is used to bend brass tubing. This new machine not only bends the tubing but leaves every angle and dimension at their original size. In speaking of this new machine the officers of the company said "There are only a few such machines in the country and our industry was largely in need of such machines." All the Kent attachments will be produced with the new machine as well as several new products the company has in mind, including a new one-piece brass tone arm. While brass is expensive at the present time the fact that much labor and time is saved by the new method, as well as the fact that there are no joints or rough edges, will, according to F. C. Kent, make his new tone arm very desirable. The announcement of the delivery of the tone arm will be issued later.

The NEW VEECO

THE ELECTRIC MOTOR WITHOUT A FAULT

The improved Veeeco Electric Motor for Talking Machines represents the last word in scientific development with special regard for the purpose for which it is intended.

Runs on either A. C. or D. C., 100-125 volts without adjustment. Can be supplied to run on any voltage from 6 to 250.

Supplied mounted on 12" or 12½" square mahogany boards, all ready to install.

SEND FOR A SAMPLE AT ONCE

Then, after testing it thoroughly, place orders at once to insure delivery.

THE VEEECO motor and the VITRALOID turntable make a complete motor unit for high-class machines.

THE VEEECO COMPANY

248 BOYLSTON STREET

BOSTON, MASS.

The Original Producers of a Complete Electric Drive for Talking Machine Manufacturers' Use

PATHE RECORD-PRESSING EXHIBIT

Bope-Hayes Co. Reports Good Sales Following Recent Exhibit of How Pathé Records Are Made—Fischer Co. Renders Assistance

COLUMBUS, O., May 4.—The Bope-Hayes Co., of this city, which handles the products of the Pathé Frères Phonograph Co., recently installed in its store a very effective record-pressing exhibit, which demonstrated the method employed by the Pathé Frères Co. in pressing Pathé discs. This exhibit attracted wide attention, and crowds of people visited the store daily in order to gain an insight into methods which have usually been considered technical and mysterious to the average layman.

The Bope-Hayes Co. was very well pleased with the success of this exhibit, and after it had closed wrote a letter to the Pathé Frères Co. stating as follows: "We are more than pleased with the success of the exhibit, and moreover believe we will do a wonderful business in Pathé goods this year.

"We placed ten phonographs in country homes yesterday, and notice quite an increase in our record sales. We have continuous inquiries from owners of other phonographs as to how to play Pathé discs on their instruments. We are now arranging quite a campaign of newspaper advertising and soliciting about 5,000 live prospects, which we received during the exhibit. We are going to do our best to lead the Pathé sales in Ohio this year, and thoroughly believe that we can 'go over the top.' We wish to thank you for sending us Mr. Gates, who helped us materially in arranging the exhibit."

The Fischer Co., of Cleveland, O., Pathé distributors, co-operated with the Bope-Hayes Co. in arranging this exhibit, and R. J. Jamieson, of this company's staff, spent the entire week in Columbus in order to co-operate with the company in every possible way.

Mr. Jamieson arranged for a banquet for the Bope-Hayes Co.'s employes, and left nothing undone to assist the company in making the exhibit a success.

BRASS PLAQUE FOR VICTOR DEALERS

Very handsome brass signs are now being offered to Victor dealers by the Goodman Co. of New York. At the left of the brass plaque the Victor trade mark is shown in green, to the right of this in heavy black appears the word "Victrolas," and beneath this in smaller letters and in green "Victor records."

The Government needs the help of every man and woman in the United States. Stand by!

TALKING MACHINE JOBBERS MEET

Executive Committee of the National Association of Talking Machine Jobbers Discuss Important Topics at Meeting in Philadelphia

The executive committee of the National Association of Talking Machine Jobbers held a meeting on April 22 and 23 at the Ritz-Carlton Hotel, Philadelphia, Pa., and at this meeting discussed a number of important topics incidental to present business and national conditions. The members of the committee in behalf of the association determined to utilize all possible means at their command to co-operate with the Government in its war program. They discussed the entire recent situation in the business as it has been affected by the war, and will be affected in the future.

The executive committee discussed at length the means that should be adopted to co-operate with the factory in eliminating all possible waste in the conduct of the business. The members of the committee realized that they must make sacrifices as the result of the country being in war, and discussed ways and means of adjusting their businesses so that the burden may be carried as lightly as possible, and so that they may assist the Government in fulfilling its war plans.

The members of the committee not only pledged their own support to subscribe to the utmost of their ability for Liberty Bonds, but to also help in the general advertising campaign in behalf of the Third Liberty Loan, and to carry out their influence as far as possible among the members of the association in behalf of the loan. The committee also voted to appropriate \$1,000 out of the funds of the association to purchase bonds in the present loan.

Owing to war conditions the committee decided to defer announcing a definite program for the annual convention until a few weeks later. Full details and plans will be ready at that time.

Among the members of the committee in attendance at this meeting were J. N. Blackman, Blackman Talking Machine Co., of New York, president of the association; I. Son Cohen, Cohen & Hughes, Baltimore, Md., vice-president; J. C. Roush, Standard Talking Machine Co., Pittsburgh, secretary; A. A. Trostler, Schmelzer Arms Co., Kansas City, Mo., treasurer; W. D. Andrews, W. D. Andrews Co., Syracuse, N. Y.; A. A. Grinnell, Grinnell Bros., Detroit, Mich.; George Mickel, Mickel Bros. Co., Omaha, Neb.; Andrew McCarthy, Sherman, Clay & Co., San Francisco, Cal.; E. C. Rauth, Koerber-Brenner Co., St. Louis, Mo.; W. H. Reynolds, Reynolds Music Co., Mobile, Ala., and C. Alfred Wagner, Musical Instrument Sales Co., New York.

ILSLEY'S GRAPHITE PHONO SPRING LUBRICANT

Ilseley's Lubricant makes the Motor make good
Is prepared in the proper consistency, will not run out, dry up, or become sticky or rancid. Remains in its original form indefinitely.
Write for special proposition to Jobbers.

MANUFACTURED BY
ILSLEY-DOUBLEDAY & CO., 229-231 Front St., New York
Established 1853

STANDARDIZE THE 'CLEAR TONE' LINE

Lucky 13 Phonograph Co. Make Important Announcement—Will Institute Aggressive Advertising and Sales Campaign

The Lucky 13 Phonograph Co., of New York City, announced this month that it had completed arrangements whereby the Cleartone line of phonographs, which it manufactures, will be standardized, and an aggressive advertising and sales campaign instituted in its behalf. This line has been on the market for several years, but D. Bartelstone, head of the company, decided recently that the success of the line well warranted the inauguration of plans that would make it even more successful than it had been in the past.

With this idea in mind Mr. Bartelstone visited many of the leading cabinet factories throughout the country, and finally succeeded in placing a contract with one of the most prominent manufacturers in the West. This concern has been making high-grade cabinets for several years, and its products have won recognition throughout furniture circles as embodying quality and attractiveness.

Mr. Bartelstone placed a very large order for cabinets, which called for immediate delivery, and also made plans for an advertising and sales campaign to assist Cleartone dealers in developing their business with this line. This campaign is now under way, and judging from the inquiries for agencies already received, this line will receive splendid representation in all sections of the country.

In addition to distinctive cabinet designs, Cleartone phonographs will be equipped with motors, tone arms and sound boxes of recognized standard and prestige. The line is now complete, and dealers are being signed up daily.

C. J. Cassutt, proprietor of the Seattle Music House, 1216 Third avenue, Seattle, Wash., is now having the interior of his store entirely remodeled on an elaborate scale and will in the future devote himself exclusively to featuring the Brunswick phonograph and Pathé records.

The Liberty Talking Machine Co., Chicago, has been incorporated with capital stock of \$5,000 by Robert Bachrach, S. Sidney Stein and Hirsch E. Soble.

AMERICAN



No. 22



No. 13



No. 5



No. 4



No. 8



No. 9



No. 10



No. 11

AMERICANS embody all the good qualities and special features of phonographs, clear in tone, beautiful in design, finest finish, smooth running motors.

We stand back of every American

**American
Phonograph Co.**
39 Fountain Street, N. W.
GRAND RAPIDS MICH.

GLORIA



Gloria Steel Needles

MADE IN U. S. A. OF HIGHEST
GRADE CARBON STEEL

The Gloria Needle has achieved instantaneous success. We have satisfied our Customers by giving them a quality product, and by making

**Immediate
Deliveries**

Dealers:-

Write for samples and prices, and remember that we keep our promises.

THE GLORIA PHONOGRAPH
SUPPLY CO., Inc.
200 FIFTH AVENUE
NEW YORK CITY





THOS. GOGGAN & BROS.' FINE FLOAT

Elaborate Display Attracts Much Attention in Trades' Parade Held During the Recent Annual Spring Carnival in San Antonio

SAN ANTONIO, TEX., May 4.—One of the big features of the recent trades' parade held in this city in connection with the annual Spring Carnival was the elaborate float entered by Thos. Goggan & Bros., and which is shown herewith. The player-piano at one end of the float was kept going almost constantly throughout the parade, and at intervals four young ladies



Goggan & Bros.' Carnival Float

from the Goggan establishment rendered well-known selections in quartet form on violin, mandolin, ukulele and cornet. At one end of the float was a large Victrola electric, with the well-known Victor dog sitting at attention close by and listening to his master's voice. Small signs in red, white and blue were placed about the float bearing such mottos as: "The World Needs Harmony," "Keep the Home Fires Burning," etc. On both sides of the float were placed signs bearing the name "Thos. Goggan & Bros." The fact that the company was established in 1866, and is, therefore, the oldest music house in Texas, was strongly emphasized. The patriotic spirit was carried out in the decorations of the float, which were made up largely of red, white and blue bunting, and large red poppies.

A UNIQUE SYNCHRONIZATION

A. T. Moulton Demonstrates a Perfect Synchronization Between the Pipe Organ, Piano and Victor Auxetophone at the Broztel Hotel

A unique musical novelty has recently been introduced to New York by A. T. Moulton. With the aid of a small pipe organ, a piano and a Victor Auxetophone, he produces a synchronized effect of a decidedly unusual character. The solo effects are carried by the talking machine, and the bass effects by the organ. Mr. Moulton uses his left hand and left foot to play the organ, and his right hand and right foot to play the piano.

For a number of years he made a study of synchronizing these three instruments and first performed for the public in one of Minneapolis' leading hotels. After a number of months' engagement in the Northwest with different hotels he came to New York, and is at present providing musical entertainment for the dining room of the Broztel Hotel, New York.

ATTRACTIVE MUTUAL LITERATURE

The Mutual Talking Machine Co. has just issued an attractive four-page circular featuring Mutual tone arms and sound boxes. One page of this circular illustrates the company's No. 2 and No. 3 sound boxes which have been adopted for general use by manufacturers. Another page is devoted exclusively to the Mutual universal ball bearing tone arm, which, although recently introduced, is now included in the equipment of many well-known makes of talking machines.

Wm. L. Phillips, president of the company, states that the demand for Mutual products is steadily increasing, and that the company is now making arrangements to augment materially its factory facilities. Mr. Phillips has received letters from many manufacturers praising the service given by Mutual tone arms and sound boxes.

OCCUPY ELABORATE NEW QUARTERS

The Neal, Clark & Neal Co., Buffalo, Now Settled in Their New Home

BUFFALO, N. Y., May 6.—The Neal, Clark & Neal Co., the Victor wholesalers, have moved into their new wholesale quarters at 778-780 Washington street, where they occupy two floors running through from street to street. Each floor is 40 x 200 feet, giving the firm a total of 16,000 square feet of floor space. The place was laid out under the supervision of V. W. Moody, who has had considerable experience in the planning and organizing of wholesale talking machine establishments.

Probably the most interesting feature of this new plant is the arrangement of the record stockroom, which might be compared to a gigantic fireproof vault, with ample ventilation. The entire stock, both open packages and reserve stock, will be carried in the new record room, which is 25 x 100 feet. After the record orders have been assembled they are taken into the packing room, off the end of the record

room, and packed and shipped from there. The machine stock is carried in the spacious basement. Incoming machines are run into the basement on a steel chute, specially designed. Outgoing Victrolas are lifted on an electric sidewalk elevator and loaded directly into trucks.

NEW ENGLAND RATES INCREASED

Interstate Commerce Commission Grants Increases in Passenger and Freight Rates

WASHINGTON, D. C., May 3.—Increases in class freight rates ranging between 5 and 15 per cent., and in passenger rates to 2¾ cents a mile on New England railroads were allowed to-day by the Interstate Commerce Commission.

The Commission ordered that mileage rates might be increased to an average of 2¾ cents, and authorized other changes in passenger schedules to bring in many million dollars more to the roads.

The Commission specified a scale of class rates for the leading railroads and somewhat higher rates for minor lines in New England.

**LYRIC RECORDS**

10 and 12 INCH

Standard American Catalog

All the latest popular songs and dance numbers also

Records in the following Foreign Languages

Neapolitan	Russian	Hebrew
Italian	Hungarian	Roumanian
Polish	Jewish	Servian, etc.

The Lyric Record surpasses any record manufactured in tonal quality. The Lyric Record eliminates surface noise—is cut 160 threads to the inch and plays from 3½ to 6 minutes. The catalog embraces all that is best in the world's musical literature and contains the recordings of the most popular artists. The records are made of the very best stock and their wearing qualities are unsurpassed.

Immediate deliveries in any quantity. Send for Catalog.

LYRAPHONE CO. OF AMERICA

12-14 West 37th Street New York, N. Y.

THE TRADE IN PHILADELPHIA AND LOCALITY

PHILADELPHIA, PA., May 8.—The talking machine business in Philadelphia in April was most satisfactory. With most of the dealers it showed a gain over April of last year, and like previous months it was limited to the amount of stock that the Victor Co.—so far as Victor dealers are concerned—were able to secure. The Victor Co. have made promises to their dealers in this district that they will be warranted in looking for more generous treatment this month and in the months to come.

It is generally supposed here that the reason why talker manufacturers have kept retailers so short is that they were bending every effort to get as much stock as possible to the dealers in Canada before the law went into effect in that country prohibiting the importation of musical instruments into the Provinces.

Doing a Maximum of Business

Louis Buehn, of the Louis Buehn Co., states: "We are doing a maximum of business, although the shortage of Victor machines and records is seriously felt. The month's total was slightly less than last year. Business conditions are good, so far as we are concerned, but we are not getting enough goods."

Penn Phonograph Co. Will Remove June 1

The Penn Phonograph Co. report that there was a slight falling off both in their machines and records business over April a year ago, but it was so small as not to leave very much regret. They have the assurance from the Victor Co. that they will be able to give their trade very good service during the remainder of the spring.

The Penn Co. have started the preparations for their moving to their new building at 913 Arch street the first of June. There will be four floors in their new quarters. They will not be able to fix the building to any very great extent before they move in, but they already have their racks under way, as well as all the designs for the new installations.

Reports Large Columbia Business

Manager A. J. Heath, of the Columbia Graphophone Co., reports that their business has been wonderful in April. It is the same old story with them, that the amount of business done was limited only by the amount of product they were able to secure. They have now several

TALKING MACHINE DEALERS

can greatly increase their profits without additional overhead expense, by selling the world-famous

Weymann "KEYSTONE STATE" Musical Instruments

a combination that has proved to be an instantaneous success.

Write for catalogue

H. A. WEYMANN & SON

Manufacturers

Victor
Wholesalers

1108 Chestnut St.
Philadelphia, Pa.

Established 1864

carloads on the road which will place the firm in the position of being able to respond to any reasonable demand.

Mr. Heath says that a number of their dealers have called at their offices during the past month, and they all report that their business has been exceptionally good. One pleasant feature, he says, is that the trend for the taking of the higher-priced instruments is most encouraging, and that in the farm districts they are buying for cash, which indicates a healthy condition prevailing.

Mr. Heath was in New York several days last week, and at the present time F. S. Binger, the traveling auditor of the company, is at the local offices. Mr. Heath says: "The record situa-

tion has improved, and I believe we shall be in a position to give the dealers better service this month than any time in the past. It was a common sight during the past month to have automobile trucks come here from our territory for machines and records. Leading among those who made the trip were J. E. and E. W. Nace, of Hanover, Pa., and Fink & Corbett, the dealers of Pottstown."

Expansion of Dictaphone Business

The Dictaphone Co. report that they had a most satisfactory business in April, and were very much gratified with the attention given the machine at the recent Business Show held in this city from April 15 to 20. They have added a couple of new men to their sales force, and among their visitors were Frank Dorian and N. F. Milnot, general sales manager of the Dictaphone. Both of these men were here for the show.

Closed Good Edison Trade in April

Herbert E. Blake, formerly Blake & Burkart, leading dealer here in the Edison product, reports that his business in April was fair, but not as large as in March. It just about equaled the business of last April. Machines and records, Mr. Blake says, are coming through in very fine shape. The fine surface on the new records is going to be of great help to the Edison dealers.

Mr. Blake, the Edison representative, in his latest publication of "Re-Created Notes," states that he has sold a large number of Edison Army and Navy models to the soldier boys at Camp Dix and Camp Meade. He makes the suggestion that any person wishing to contribute to the pleasure of the boys, either by purchasing new records for these machines or sending them records of which they have become somewhat tired, if they will deliver them to him at Eleventh and Walnut streets, he will see that they reach the boys in the camps in the name of the donor and at no cost to giver or receiver.

Edison Dealers Meet

At the meeting of the Edison Dealers' Association, which was held at the Bingham House yesterday, May 7, there were no set speeches, but all of the dealers participated in a discussion as to the selling proposition. The result was most-satisfactory.

In the campaign for the Liberty Loan in Phila-

SELL RECORDS



Mme. Amelita Galli-Curci, Soprano

Because there may be a general shortage of certain records, there is no reason for "laying down". If you *sell* the higher class records, you won't need to make as *many* sales.

PENN PHONOGRAPH CO.
17 S. NINTH STREET PHILADELPHIA

NO SHORTAGE EXISTS to the man who SELLS the Victor Records obtainable!

To-day requires creative salesmanship.

Make up your mind to get MORE people into your store; to tell them about the thousands of good records in stock, and to SELL *these* Victor Records to *those* customers.

Send for our Special Catalogue of Victor Records we have in stock for immediate delivery.

The Louis Buehn Company Victor Distributors PHILADELPHIA

Philadelphia the piano and talking machine dealers were placed in one class, and a sum set for them to raise. This sum was not entirely reached, and of the money subscribed more than three-fourths came from the leading talking machine dealers.

L. H. Crabtree Somewhere in France

L. H. Crabtree, the son of the president of the International Mica Co., of Philadelphia, is now in the service of his country "somewhere in France." Mr. Crabtree, Jr., is a member of the 109th Infantry, United States Army, and in addition to doing his bit over on the other side is instrumental in turning out large quantities of the International Mica Co.'s product for Government purposes, these products being used for gas masks, etc. This is the kind of service which will win the war, and Mr. Crabtree and the International Mica Co. are to be complimented on their devotion and the patriotic spirit shown in thus serving their country.

Pathé Activity in Quaker City

Walter L. Eckhardt, of the Pathé Shop, has arranged to start a series of unusual concerts in this city beginning this week. They will be given daily at 11.30 in the morning and 3.30 in the afternoon. The Pathé did great work for the Liberty Loan; upon the arrival here of the great Orchestra Pathé it was almost immediately shipped to the Statue of Liberty erected south of the City Hall, where concerts were being given on it constantly for more than a week, and the young ladies in charge of the work there said that the Pathé was the best Liberty Bond salesman they had.

Mr. Eckhardt is delighted with the work accomplished by his men in April. When the month began he set for them the March quota, which had been so gratifying. They protested that with the Liberty Loan and other hindrances they could not accomplish it. They made the quota, and as each man reached his sales quota Mr. Eckhardt took him out and bought him a good dinner.

Among the several visitors to the Pathé Shop

in April were Messrs. Lehming, Emerson and O'Neill, of the Pathé Co.

The Weymann Family in the Nation's Service

Harry W. Weymann, president of H. A. Weymann & Son, widely known as Victor wholesalers, and also as manufacturers of the famous



Herbert W. Weymann



H. Power Weymann



Harry W. Weymann

Weymann and Keystone State instruments and other specialties, which are popular in the talking machine and piano trades, is well represented in the United States Army and Navy, his two sons, H. Power Weymann and Herbert Weymann, being in war service. H. Powers Weymann is with the 315th Infantry, U. S. Army, and is stationed at Camp Meade, Md., while Herbert Weymann is chief yeoman in the United States Navy stationed at League Island, Philadelphia. Both are fine types of manly Americans, who are destined to give a good account of themselves in the service of the United States, and Mr. Weymann has reason to be particularly proud, because he has given his two only children to the nation. Hats off to him!

New Brunswick Distributors

The Brunswick machine, handled in this city

by the Brunswick-Balke-Collender Co., has added a number of new distributors to their list in April, including the Hurley dealers in Camden, Bridgeton, Wilmington, Atlantic City, Wilkes-Barre, etc., and all the stores of the J. B. Gillies Co. They are at present negotiating with one of the largest stores in this city for handling the Brunswick.

The newly developed "Ultona" on the Brunswick—the "all-record reproducer" has been making a very strong impression here. By the use of the "Ultona" the different makes of records can be played by simply changing the position of the attachment. It is a most effective contrivance.

Doing Well With the Vita-Nola

The Vitanola Distributors Co., 1025 Arch street, report a steadily expanding demand for the Vita-Nola made by the Vitanola Talking Machine Co., of Chicago. The diversity of styles displayed combined with the intrinsic merits of these products have enabled them to make a wide appeal.

E. G. EVANS NOW A GARAGE OWNER

Popular Talking Machine Man Embarks in New Venture as a Side Line

E. G. Evans, the popular salesman with C. Bruno & Son, Victor wholesalers, New York, has embarked in the automobile business as a side line, and is one of the owners of the Cos Cob Garage, located on the Boston-New York Post road, near Greenwich, Conn. Mr. Evans says that he is doing a lively business, inasmuch as several hundred cars, including heavy trucks used in cross-country transportation, pass along the Post road every day, and an excellent percentage of them stop for supplies and repairs. Many of Mr. Evans' friends have already found his garage a haven of rest while en route along the Post Road. Meanwhile, Mr. Evans still gives his usual careful attention to the Victor business.



Portable Model Grafonolas for vacationists. Help people have more fun while they're away. Get ready now—No "Summer Slump" this year.

**Columbia Graphophone Co.
Woolworth Building, New York**

BUSINESS CONTINUES VERY ACTIVE IN KANSAS CITY

Stock Somewhat Short and Dealers Are Able to Dictate Their Own Sales Terms—Columbia Expansion—Jones Co. Feature Foreign Records—Liberty Loan Campaign Big Success

KANSAS CITY, Mo., May 4.—Business in the Kansas City territory continues splendid. In fact, it is good in every line, consequently money is plentiful and people are spending it. And more and more the talking machine is being regarded as a necessity in every home, so good prospects are not hard to find. Nowadays every dealer says he has half a dozen prospects to one machine. Dealers are therefore able to dictate their own terms and are almost all cutting out the small payment plan. There is of course in the Kansas City territory, with the big demand for machines, a tremendous shortage of records. The patriotic records continue to be the big sellers. Every dealer reported that, despite the shortage, his record business was excellent for the month of April (and this month was handicapped by the Liberty Loan campaign and the strike).

The Wunderlich Piano Co., which is one of the biggest music firms in the middle West, recently took on the Brunswick line. Martin & Adams, Wichita, Kansas's leading house, also recently added the Brunswick, as did the Darrow Music Co., of Tulsa, Okla. The Brunswick-Balke-Collender Co. Kansas City branch stated that its business was spreading tremendously

and that the Kansas City territory was opening up into a very excellent field.

E. A. McMurtry, manager of the wholesale department of the Columbia Co., reports increasing business not only in Greater Kansas City but in the whole territory. "Particularly in the country, the dealers are waking up to the big field for the Columbia machine," he said. "In fact, so splendid is the demand and the prospects are so good for an even far greater call for machines and records, that we are doubling our floor space in effort to keep pace with the strides of our business." The company has taken over the adjoining storerooms. The remodeling will be done by the middle of the month when a total floor space of approximately 12,500 square feet will be had. This additional room will be used entirely for the wholesale record department. The present quarters of that department are entirely inadequate. Two carloads of records were recently received and as many have been sold in the past few weeks. This department has instituted the new card index system adopted in the record departments of all the Columbia wholesale branches and has added some improvements that will aid in the local distribution. The additional room will give the company two more windows for display purposes; two will be used for the Dictaphone and two for the Grafonola. The Dictaphone department had, during April, the second-best month in its history.

J. J. Wiedeman, formerly Columbia salesman in this territory, has resigned to go back to his home town—Cleveland, O.—where he will enter the automobile supply business. He has been succeeded by William Roy.

The Henly-Waite Music Co. recently took on the Artophone line and is doing splendidly with it in addition to the Columbia.

The Junkins-Riley Co., formerly Pathé jobbers, will soon open a splendid up-to-date retail store, The Pathé Shop, at 202 East Tenth street. They will specialize in the art models.

The Jones Store Co.'s Victrola department has recently fixed a plan concerning the sale of its machines on time. Ten per cent of the purchase price must be paid down at once and the rest must be paid for in twelve months.

A. A. Trostler, manager of the Victrola jobbing branch of the Schmelzer Arms Co., has just returned from a visit to the Victor factory. "Business continues excellent," said Mr. Trost-

ler. "We could dispose of a great many more machines than we are able to get. The demand is great in Kansas City and in local territory."

Miss Jessica Owens has succeeded Robert Laster in the management of the Columbia department in the Kansas City Photo Supply Co.

J. P. Price, Price & McNeal, Maryville, Mo., is going into Government service.

Mrs. Nellie Williams, head of the Victrola department of the Jones Store Co., stated that they have been recently encouraged with the marked success in their foreign record trade, principally Mexican. In the first place, with the present scarcity of labor, the Mexicans all are holding down \$25 a week jobs at the packing houses and, as they live so much more cheaply than Americans, they are better able financially to buy machines than many Americans who are making as much or more. And they are sure pay. They seem to be very timorous and in great awe of the American man's jail, and in fact there is a deep-rooted fear in most of them that if a single payment is missed or delayed they will be thrown immediately into prison. Consequently payments come in as regular as clockwork; in some cases they have even brought their money up before it was due, saying that their wives would not be home on the day the collector came to call.

In the Liberty Loan campaign, in which Kansas City far exceeded its quota, a great deal of credit was accorded to music and talking machine men of the city who were as well represented as subscribers and as volunteer workers the campaign week.

B. F. Woodward, manager of the Edison Shop, was pumping air into a tire on his machine when the rim blew off and struck him, breaking an arm and a leg. He is rapidly improving.

The six weeks of story dancing, under the direction of Miss Baldwin, recently closed at The Edison Shop with a highly successful program in which five hundred Kansas City children took part. The dancing, to the Edison of course, was given in the Auditorium Theatre with a large audience. The newspapers devoted much space to the affair.

C. L. Smith, of the Edison wholesale, in Kansas City, is now at Jefferson Barracks, where he was called May 10.

The Edison Co., in its tone tests with Glen Ellison, Scotch baritone, had the greatest success—both in the city and rural districts. The dealers who held tone tests outside of Kansas City were: Carl Latenser, Horton, Kan., and Atchison, Kan.; D. B. Hickey, Chanute, Kan.; Eshelman, St. Joseph, Mo.; Chas. Sauer, Chillicothe, Mo.; G. W. Sherman, Breckenridge, Mo.

"The Music Without the Blur!"

This ideal of talking machine manufacture is attained more nearly than by any other, in the construction of the

MARVELOUS MAGNOLA "Built by Tone Specialists"

"Magnola's Tone Deflector eliminates the scratch"



Watching The Music Come Out

We want to show you how to make money with MAGNOLA; and how MAGNOLA is the best buy on the Talking Machine Market to-day.

Send us your name and let us send you some real Talker Tips.

MAGNOLA TALKING MACHINE COMPANY

OTTO SCHULZ, President

General Offices 711 MILWAUKEE AVENUE CHICAGO
Southern Wholesale Branch 1530 CANDLER BLDG. ATLANTA, GA.

Talking Machine Hardware

We manufacture hardware for all styles of cabinets

Lid Supports
Needle Cups
Needle Rests

Door Catches
Sliding Casters
Continuous Hinges

Sockets
Tone Rods
Knobs, etc.

BEST QUALITY

LOWEST PRICES

WEBER-KNAPP COMPANY

Jamestown, N. Y.

ISSUE IMPORTANT RULING ON INSTALMENT BUSINESS

Internal Revenue Commissioner Roper Hands Down a New Order Bearing on Sales of Talking Machines and Other Musical Instruments Which Is of Paramount Importance

WASHINGTON, D. C., May 4.—One of several rulings just handed down by Internal Revenue Commissioner Roper affecting income and excess profit taxes is of exceeding interest to this industry, in which he holds that dealers in goods sold on the instalment plan shall return their profits proportionately as the gross profits stand to the gross contract price. Of course this new ruling applies to the business of 1918, on which the income tax returns will be made next year. The decision as to instalment selling follows:

"It has been ascertained that dealers in personal property who sell on the instalment plan adopt one of four ways of protecting themselves in case of default, namely:

"1. A provision that title is to remain in the seller until the buyer has performed his part of the agreement.

"2. A conveyance of title to the purchaser subject to a lien for the unpaid portion of the purchase price.

"3. The conveyance to the purchaser and an immediate reconveyance by way of chattel mortgage to the seller.

"4. Conveyance to a trustee in trust to hold the title, pending performance of the contract and subject to its provisions.

"In view of the fact that in a number of States it is held that the form first mentioned shall not be enforced according to its terms, but will be regarded as a sale with a chattel mortgage back to secure the unpaid purchase price, it is desirable that a uniform rule be established which will be equitable and applicable to all.

"The rule prescribed is that in the sale or contract for sale of personal property on the instalment plan, whether or not title remains in the vendor until the property is fully paid for, the income to be returned by the vendor will be that proportion of each instalment payment,

which the gross profit to be realized when the property is paid for bears to the gross contract price. If, for any reason, the vendee defaults in his instalment payments and the vendor re-

possesses the property, the entire amount received on instalment payments less the profit originally returned will be income to the vendor to be so returned for the year in which the property was repossessed.

"This ruling amends Articles 117 and 120 of Regulations 33, Revised, and revokes all previous decisions and rulings which are in conflict herewith."

TALKING MACHINE EXPORTS

The Figures for February Presented—Exports Show Machines and Records Both Increase

WASHINGTON, D. C., May 4.—In the summary of exports and imports of the commerce of the United States for the month of February, 1918 (the latest period for which it has been compiled), which has just been issued, the following figures appear:

Talking machines to the number of 5,565, valued at \$154,943 were exported in February, 1918, as compared with 3,786 talking machines, valued at \$90,633, sent abroad in the same period of 1917. The total exports of records and supplies for February, 1918, were valued at \$104,376, as compared with \$89,180 in February, 1917. For the eight months' total 60,711 talking machines were exported, valued at \$1,675,681 in February, 1918, and 48,729, valued at \$1,202,394 in 1917, while records and supplies valued at \$1,275,514 were sent abroad during 1918, as against \$966,463 in 1917.

INCORPORATED

The American Recording Laboratories, Pas-saic, N. J., have been incorporated with capital stock of \$25,000, for the purpose of manufacturing phonograph records. The incorporators are: Carlton E. Sanderson, Mabel C. Sanders, and George Thornton.

A reputation built on "front" can never come "back"—after being side-swiped by Time.

COLUMBIA PROGRESS IN THE SOUTH

Conference of Columbia Branch Managers in Atlanta, Dallas and New Orleans Held in the Latter City—Excellent Reports Made

NEW ORLEANS, LA., May 6.—A conference of the Columbia branch managers in New Orleans, Atlanta and Dallas was held in this city at the local offices of the Columbia branch. Many practical subjects were discussed during the course of the meeting, and it was gratifying to learn that every manager in attendance predicted that April and May business would show a substantial gain over last year. The fact that the company had closed in March the biggest single month in its very successful history was the subject of enthusiastic comment among those present. The managers who attended the conference were W. F. Standke, New Orleans manager; Westervelt Terhune, Atlanta manager, and F. R. Erisman, Dallas manager. Several of their assistants were also present, and the executive offices in New York were represented by O. F. Benz, of the general sales department, who gave a very interesting and effective address during the meeting.

APPOINT COAST REPRESENTATIVE

BOSTON, MASS., May 9.—The New England Talking Machine Co., 16 Beach street, manufacturers of tone arms and reproducers, this city, have announced the appointment of W. S. Gray as their representative in San Francisco, whose headquarters are in the Chronicle Building.



DO YOU USE TONE ARMS

"off the shelf"? You spend time and money freely on the design of a cabinet, why compromise on the tone arm? Why don't you put the same thought into the tone arm? Make it at least as distinctive as the cabinet.

We have experts who are specialists in designing tone arms that will blend with your cabinet in quality and appearance—that will continue quality unbroken from sound chamber connection to stylus groove.

These men are ready to serve and prove to you by sketches and figures that "INDIANA" made tone arms will increase the value of your machine and make it a better selling proposition.

Bear in mind that acceptance of this service does not obligate you in any way and anything developed for you is for you exclusively, and is not sold or sampled to your competitors.

WE ESTIMATE FROM SAMPLE OR BLUE PRINT

"INDIANA" DIE CASTING COMPANY

East 11th Street at Cornell Ave.

INDIANAPOLIS, IND.

Pathé



The Quality Phonograph

List of Latest Pathé Hits

POPULAR SONGS

- 10-in. 20360 { ROCK-A-BYE YOUR BABY WITH A DIXIE MELODY (Lewis-Young-Schwartz). Arthur Fields.
WHAT'LL WE DO WITH HIM, BOYS? (Sterling-Lange). Arthur Fields.
- 10-in. 20355 { HOW'D YOU LIKE TO BE MY DADDY? (Lewis-Young-Snyder). The Farber Girls.
THERE'S A LUMP OF SUGAR DOWN IN DIXIE (Bryan-Yellen-Gumble). The Farber Girls.
- 10-in. 20351 { AND EVERYTHING, from "Sinbad," Winter Garden Show (DeSylvia-Kahn-Jolson). Louis Winsch.
K-K-K-KATY (O'Hara). Louis Winsch.
- 10-in. 20354 { THE LAST LONG MILE, from "Toot-Toot" (Breitenfeld). Arthur Fields.
GOOD-BYE, BARNEY BOY (Brennan-Morse). Peeless Quartet.
- 10-in. 20350 { MY LITTLE RAMBLING ROSE (Freeman). Campbell and Burr.
SHE'S THE DAUGHTER OF ROSIE O'GRADY (Brice-Donaldson). Henry Burr.

- 10-in. 20359 { WHAT ARE YOU GOING TO DO TO HELP THE BOYS? (Kahn-Van Alstyne). Arthur Fields.
THE VOLUNTEERS—March (Sousa). American Regimental Band.

HAWAIIAN

- 10-in. 20344 { MISSOURI WALTZ (Hush-a-Bye Ma Baby) (Eppel-Logan). Louise and Ferera Walkiki Orchestra.
LOVE'S OLD SWEET SONG (Molloy). Cora Tracey, Hawaiian Accomp.

DANCE

- 10-in. 20357 { A BABY'S PRAYER AT TWILIGHT—One-step (Jerome). American Republic Band.
FLOWER OF THE ORIENT—Waltz (Savino). American Republic Band.
- 10-in. 20356 { OH! LADY, LADY!—Medley Fox-trot (Kern). Intro. "You Found Me and I Found You." "When the Ship Comes In." American Republic Band.
PACK UP YOUR TROUBLES IN YOUR OLD KIT BAG, from "Her Soldier Boy"—Medley One-step. American Republic Band.

Always,

Just as the Pathé Dealer thinks it must be time for Pathé Sales to slow up a little

Along come

The new Pathé Records.

The latest popular hits, first out on Pathé Records. New and remarkable Records by Pathé exclusive opera artists.

Sending you new customers for Pathé Phonographs. Bringing the old customers straight back again for new Pathé Records.

The Pathé Dealer sells the Pathé Records to every Phonograph Owner because they can be played on all makes of machines.

If you are not a Pathé Dealer, write **at once** for our interesting dealer proposition.

Visit our Booths 10-11-12

Convention Week

NATIONAL MUSIC SHOW

Grand Central Palace

JUNE 1st to 8th

Pathé Frères Phonograph Company

20 Grand Avenue

Brooklyn, New York

THE PATHÉ FRÈRES PHONOGRAPH COMPANY, Ltd.

6 Clifford Street, Toronto, Ontario



Pathe Phonograph \$185

Other models \$30 to \$225

No Needles to Change

The Pathe Sapphire Ball takes the place of needles. It need not be changed.

Long Life to Records

The Pathe Sapphire Ball cannot possibly cut, grind, rip or mar the record's surface.

The Pathe Controla

With the Pathe Controla you may increase or decrease the tonal volume of the Pathe Phonograph at will.

Plays all Records

Each Pathe Phonograph plays not only Pathe Records, but all other makes of records, and plays them perfectly.



The Quality Phonograph

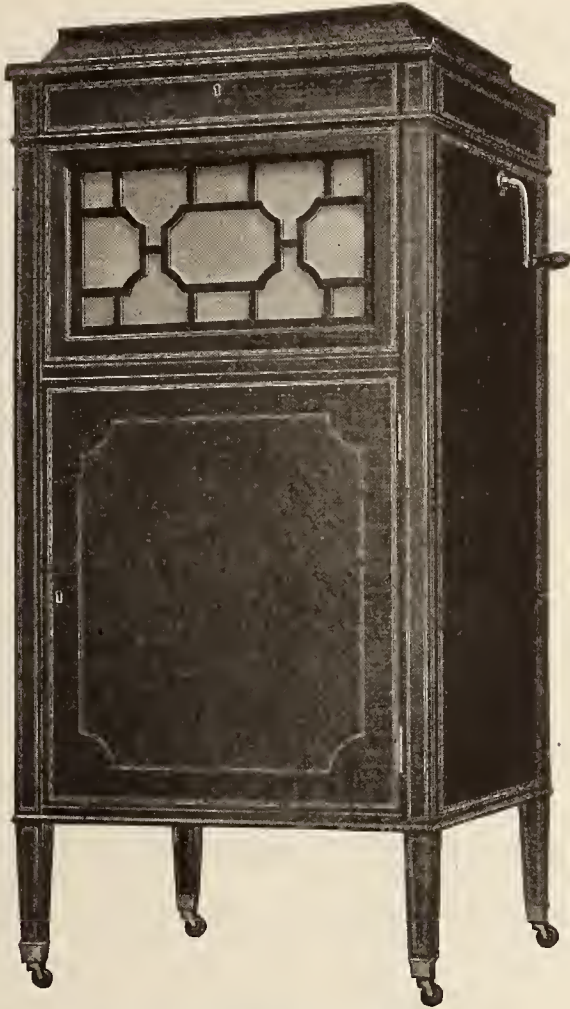

Pathe Phonograph \$225
Other models \$25 to \$225

You see it coming!—

You who are not carrying them,

You're hearing all the time about the fast-spreading popularity of the Pathé Phonographs.

You realize more and more the exceptional selling value of "No needles to change" — "Long life to Records" — "The Pathé Controla" — and "Plays all Records."

You are watching too the new Pathé Records.

Ahead every month with the popular hits. Corraling more and more of the most famous singers and musicians. Offering the only really world-wide repertoire of music and song.

Yes, you see the day coming, and coming soon, when you'll be selling Pathé Phonographs and Pathé Records.

Why put off till tomorrow, the Pathé profits that should be yours today?

Write—now—for book, "The Other 20%"

No Needles to Change

The Pathe Sapphire Ball takes the place of needles. It need not be changed.

Long Life to Records

The Pathe Sapphire Ball cannot possibly cut, grind, rip or mar the record's surface.

The Pathe Controla

With the Pathe Controla you may increase or decrease the tonal volume of the Pathe Phonograph at will.

Plays all Records

Each Pathe Phonograph plays not only Pathe Records, but all other makes of records, and plays them perfectly.

Visit our Booths 10-11-12

Convention Week

NATIONAL MUSIC SHOW

Grand Central Palace

JUNE 1st to 8th

Pathé Frères Phonograph Company

20 Grand Avenue

Brooklyn, New York

THE PATHÉ FRÈRES PHONOGRAPH COMPANY. Ltd.

6 Clifford Street, Toronto, Ontario

MILWAUKEE TALKER TRADE HELPS THE LIBERTY LOAN

Badger Companies on Roll of Honor—Trade Excellent—New Brunswick Dealers—Goldsmith in Public Eye—C. J. Orth Features Puritan

MILWAUKEE, Wis., May 12.—One of the principal duties of the local talking machine trade during the last four weeks or more was to help in effecting a subscription to the Third Liberty Loan that puts most other cities of this class to shame. Uncle Sam asked Milwaukee to subscribe not less than \$14,600,000 to the third issue. As a matter of fact, the total subscription at the close of the campaign was found to be \$21,000,000, or an oversubscription of approximately 50 per cent. On the roll of honor appeared the names of the Badger Talking Machine Co., Victor jobber, and the Badger Talking Machine Shop, Victor retailer, each for \$10,000. So far as can be ascertained, these were the largest subscriptions made by any Milwaukee music industry.

The total subscription made by the music trades division, in charge of Henry M. Steussy, president of the Milwaukee Association of Music Industries, exceeded \$75,000. This fine showing was made without sending a committee to visit the individual factories and dealers to importune them to buy bonds.

Local talking machine dealers, both wholesale and retail, have been kept busy as never before during the early spring season. As April advanced and finally May was entered, it became more and more a question of obtaining machines and records than to sell them. And it appears as if this will continue to be the situation from this time on, at least while the war lasts. It does not apply to all makes of instruments, but is particularly true of the Victor, Edison and other of the older machines.

Thomas I. Kidd, manager of the Milwaukee branch of the Brunswick-Balke-Collender Co., concluded arrangements just prior to May 1 for placing the Brunswick in the new establishment in the Plankinton Arcade of the Milwaukee Piano Mfg. Co. Hundreds of visitors attended the formal opening of the new store on May 1, and much time was spent in inspecting the special exhibit of Brunswick models which Mr. Kidd provided for the occasion. Henry M. Steussy, president of the Milwaukee Association of Music Industries, is general manager of the new store.

Concerning Harry A. Goldsmith, secretary of



PERSONAL SERVICE

The members of our Company are always available and will gladly see you personally or write you at any time we can possibly serve you.

Why not communicate at once with us?

BADGER TALKING MACHINE CO. 135 Second Street
MILWAUKEE, WIS.
VICTOR DISTRIBUTORS

the Badger Talking Machine Co., Victor jobber, Milwaukee, the "Who's Who" column of the Milwaukee Journal in a recent issue had the following interesting things to say:

"Harry A. Goldsmith acquired a becoming bashfulness while engaged in the newspaper business in Calumet, Mich., from which he has never recovered. Mr. Goldsmith believes a bass drum never sounds so loud as when one pounds it himself, but is more effective if the world is doing the pounding.

"Mr. Goldsmith was born in Chicago thirty-four years ago and reduced the city's population by one before he was old enough to begin his education. This, he says, he began in the public schools of Calumet and has not yet finished. Leaving the newspaper business, he returned to Chicago, where he was engaged in the brokerage business until about four years ago, when he became one of the organizers of the Badger Talking Machine Co. and came to Milwaukee. His interests have spread to several other allied industries and Mr. Goldsmith declares he is in Milwaukee to stay.

"Mr. Goldsmith's residence is 585 Stowell avenue; he is unmarried. (But in confidence he said he is willing and named some qualifications.) He is a member of the Press, Elks and Advertisers' clubs, the M. A. C., the M. A. of C. and is a Mason."

Paul F. Seeger, manager of the talking machine department of the Edmund Gram Music House for the past nine years, resigned May 1 in order to accept the position of manager of the North Shore Talking Machine Co., Victor retailer, 603 Davis street, Evanston, Ill. Mr. Seeger will assume his new duties on May 15.

The Ellis Reproducer Co. of Milwaukee has been incorporated with a capital stock of \$15,000 to develop the business created by James H. Ellis, inventor and patentee of a universal reproducer for talking machines that can quickly be substituted for the regular device. Mr. Ellis

has been manufacturing the reproducer at 410 Jefferson street.

Charles J. Orth, since March 1 exclusive distributor of the Puritan in Wisconsin and Upper Michigan, has been obliged to increase both the traveling sales force and the staff at the local store in order to keep pace with the growth of the popularity of the Wisconsin-made product. Mr. Orth has placed a number of excellent agencies throughout the territory and his policy of selecting only the leading merchant in each community to take on the representation of the Puritan has won him a splendid lot of new trade. The sale of Puritan records also is growing beyond all expectations.

Emil O. Schmidt, piano and talking machine dealer, recently paid a fine of \$100 and costs in the police court upon being adjudged guilty of having violated the Wisconsin fraudulent advertising law. Mr. Schmidt advertised that he had purchased the entire bankrupt stock of the Republic Phonograph Co., Inc., Chicago, and was placing it on sale "at considerably less than wholesale price." The advertisement also contained a facsimile telegram purporting to have been received from Arthur S. Nestor, trustee of the Republic Co., reading:

"Your offer accepted for the bankrupt stock of the Republic Phonograph Co. Shipping you fifty machines to-day; balance to go forward upon receipt of packing box. Waiting your instructions."

At the trial it developed that Mr. Schmidt had purchased only a part of the Republic's bankrupt stock and that the prices at which he advertised them for resale were \$30 above the wholesale and \$15 above the regular retail price of the instrument. Furthermore, the telegram was branded as a "fake" and evidence was shown that Mr. Schmidt himself wrote the message, which was taken to Chicago by a friend and dispatched from there. Mr. Schmidt protested his innocence but the court found him guilty and imposed the heaviest fine yet meted out under the act.

Albert E. Smith, proprietor of the Wisconsin Music House, 20 North Carroll street, Madison, Wis., has moved his establishment to beautiful new quarters at 215 State street. The new store is probably the handsomest in the capital of Wisconsin. Due attention has been paid to the Victrola department. A feature is the stock of more than 10,000 Victor records which the house carries at all times. An assortment such as this seldom is seen in a city of less than 100,000 population. Madison has 38,000 inhabitants.

The Madison newspapers recently published illustrations of a huge load of Victrolas being delivered by truck to the Forbes-Meagher Music Co. of that city. The house is a Victor retailer and the shipment, of which a part was illustrated, is considered the largest that has ever been received in the State capital.

Wiley L. Ballinger, retail jeweler, 17 West Main street, Madison, Wis., has installed a talking machine department.

R. Boeing, Hustisford, Wis., is a recent addition to the list of Brunswick retailers.

The George D. Ornstein Co., Victor wholesalers, recently established in Philadelphia, have incorporated with capital stock of \$150,000.

No man can serve Honest Business and Questionable Practices at the same time—and be even moderately happy.

NOW IS THE TIME TO REPLENISH YOUR STOCK

Records prove that the next three months are the best in the year for selling the

VICSONIA

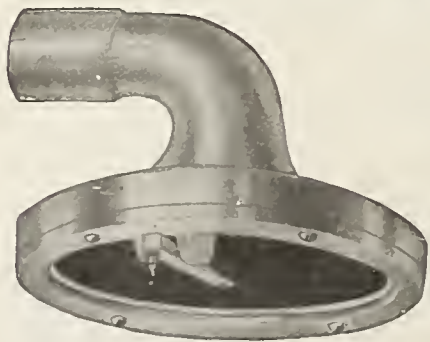

Mr. Dealer:

Don't miss sales by being out of stock. Order NOW.

If you are not familiar with the "best reproducer for playing EDISON RECORDS," send us \$3.50 and we will send you one on 10 days' approval. Money refunded if not satisfactory.

State Make of Machine

Vicsonia Manufacturing Company, Inc.
313 East 134th Street (Bronx) NEW YORK, N. Y.



Otto Heineman Phonograph Supply Co.

INCORPORATED

25 WEST 45th STREET, NEW YORK

FACTORIES, ELYRIA, O.—NEWARK, N. J.
PUTNAM, CONN. SPRINGFIELD, MASS.



CHICAGO

ATLANTA

SEATTLE

CINCINNATI

TORONTO

At the National Music Show

to be held at the Grand Central Palace,
New York, from June 1st to June 8th,
there will be a complete exhibit of

HEINEMAN Motors, Tone Arms, Sound Boxes, etc.
MEISSELBACH Motors, Tone Arms, Sound Boxes, etc.
DEAN Steel Needles, etc.

In Booths Nos. 40 and 41

Make these booths your headquarters
when attending the show, and do not
fail to hear the new

HEINEMAN "OKEH" RECORDS

"We are at Your Service"

Otto Heineman
President

MEISSELBACH

TONE ARMS

MOTORS

SOUND BOXES



VAN VEEN "BED-SET" BOOTHS

Increase Your Record Sales

Write for a copy of our
NEW CATALOG

Van Veen "Bed-Set" Sectional Booths can be erected as easily as a bed (no skilled labor required). Booths shipped on short notice *anywhere*. Room sizes any multiple of 3 feet. High grade finish, will match your sample if desired. Sound-proof construction. We design and build complete interiors. We also build record racks, which are described in our new catalog.

Prepare for a Machine Shortage by Developing Record Sales



Demonstration Booths Mean Additional Record Business

Illustration shows a recent installation for
N. FRIEDBERG
1658 Pitkin Avenue
Brooklyn, N. Y.

Our Style B

Van Veen Booths Will Pay for Themselves by Increasing Your Record Sales

ARTHUR L. VAN VEEN & CO., Telephone Greeley 4749 Marbridge Bldg., 47 West 34th St., New York

HOW THE RECORD SHORTAGE HAS HELPED MANY DEALERS

Has Forced Distributors and Dealers to Analyze the Victor Catalog, Says J. C. Roush, of Pittsburgh—Idle But Meritorious Stock Being Brought to Attention of Public—Interesting Chat

"I am firmly convinced the present record shortage is in one respect at least one of the best things that could happen to the average Victor dealer," said President Joseph C. Roush of the Standard Talking Machine Co. of Pittsburgh to a representative of the Talking Machine World in answer to a question regarding the present record situation. Mr. Roush was in Philadelphia April 22 and 23, attending an executive meeting of the National Association of Talking Machine Jobbers, of which he is secretary.

"And to many of the distributors, too," he continued, "it has forced our noses back into the big general catalog where the best music of all time is waiting for a chance to be sold. All of us have been carrying stocks of hundreds of records on our shelves for years which would have been snatched up by the public only we were too busy selling supplement records to discover them ourselves.

"Distributors and dealers alike are now feverishly thumbing the big catalog, checking old stocks, playing over records which haven't been out of their covers for years—and are getting closer to the heart of the Victor game than ever before in their Victor careers.

"And if the experience of others is anything like my own, they are getting many a surprise—and are having a lot of fun with this research work."

"Can you tell us some of the things you are doing to interest your dealers in these catalog numbers?" he was asked.

"The study of our own record conditions has as an immediate object the supplying of dealers with salable numbers to take the place of those not now available. Such records we list, classify and push through all the agencies at our command.

"In the first place our road men carry lists of numbers and stocks to assist dealers in keeping their shelves filled with good salable records. Orders for the records not being pressed are discouraged—those for available records are encouraged.

"Then twice a month we issue a list of twenty records which we urge the dealer to push through his sales force for two weeks. This serves two important purposes. It boosts a dealer's record sales and it gets his salesman intimately acquainted with twenty good catalog records. After a salesman has played a good record from one of these lists over and over

again for his customers and recognizes how easy it is to sell, that record becomes one of his permanent favorites. He will continue to recommend it long after the two weeks have elapsed—in fact, it has been added to his growing vocabulary of good Victor 'hits.' It goes without saying that only records are so listed which a dealer can get.

"Each month a hanger is furnished dealers listing eight to a dozen numbers of the same nature for a dealer's booths and windows. These hangers are headed 'Victor Records Every One Should Own' and are somewhat similar to those issued by the Victor Co., but list only records in stock in our territory.

"About once in three months a classified list is prepared for the dealer's distribution, listing twenty to twenty-five 'in-stock' records under four different classifications—dances, violin numbers, etc.

"On our record delivery bags, and in fact in every other way we know we list for the dealer and for his record buyers, those General Catalog numbers which are practically unknown, have distinct merit and can be secured in considerable quantities.

"The results have fully justified these special efforts. We have made a feature of these lists since last September, and we would not discontinue them now even though every record in the catalog were available. Despite shortages of all kinds, embargoes, delayed shipments and all the other distributors' troubles during these months, our record business has increased steadily, and we attribute this largely to these special drives on 'records-in-stock.'"

FORDHAM SHOP INCORPORATED

The Fordham Victrola Shop, Inc., New York, has been incorporated with capital stock of \$15,000 to deal in pianos, Victrolas and musical instruments generally. The incorporators are Lillian Stimel, Charles Somberg and James J. Collins.

H. J. SMITH

JEWEL MANUFACTURER

MANUFACTURER OF
Phonograph Diamond and
Sapphire Reproducing
Points
Recording Laboratory
Jewels

Jewel Bearings for
Electrical Instruments
Rough Diamond
Diamond Powder
Experimental Work

TELEPHONE 2896 MARKET

833 BROAD ST. NEWARK, N. J.



No. 100
With "Resurrectone" \$100.00
With "Half-Fork-Tone" \$95.00

The Wonderful Resurrectone

With its exclusive "tuning fork" has no equal in the world. Its clearness and mellowness have the timbre and warmth of the natural voice, string or wind instruments. Forms the regular equipment for the Hoffay, but is also sold for other machines.

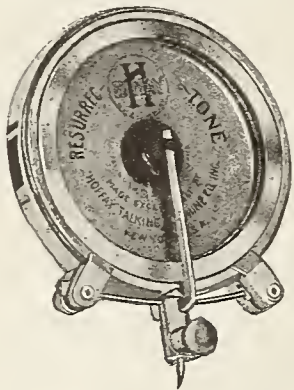

PRICE: Nickel-plated \$10. 22 karat gold-plated \$12.50. To fit Victors, Sonoras, and attachments for Edison machines, etc. Money refunded if reproducer returned within 5 days from receipt.

"HOFFAY"

The AIRTIGHT Machine.
As the trade-mark reads, is

"The World's Musical Instrument"
Increases the value of records of all makes

We Are Closing

DISTRIBUTOR'S TERRITORY

What is your territory and requirements?



No. 140
With "Resurrectone" \$140.00
With "Half-Fork-Tone" \$135.00

The Half-Fork-Tone

The next best reproducer. Remarkable for its clear and loud sound. It is equipped on the Hoffay wherever specially ordered. It is also sold to fit other machines.

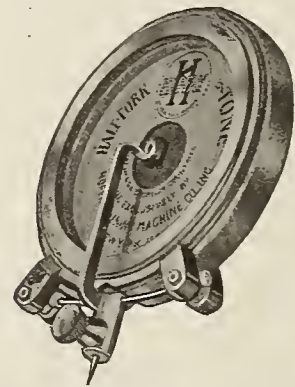

PRICE: Nickel-plated \$6. 22 karat gold-plated \$7.50. To fit standard machines and attachments for Edisons. Money refunded if reproducer returned within five days from receipt.



No. 190
With "Resurrectone" \$190.00
With "Half-Fork-Tone" \$185.00

The "HOFFAY," with its great sound reproducing qualities, and its MANY exclusive features and "Selling Points," is a line worth while handling. Our increasing business and REPEAT orders prove it.

THE "HOFFAY" is THE line to start new dealers; THE line to get a share in the business of dealers handling the most advertised makes, because it truthfully compares favorably with any of them, and THE line that gives maximum value to records of all makes.

The "RESURRECTONE" resurrects music and "resurrects" Dealers. Not only a source of profit to you as a Distributor, but as Sales Agents showing Dealers what to expect from the complete AIRTIGHT instrument.

The "HOFFAY" gives TRIPLE PROFITS.

Write to-day—the Season is nearly on and your territory may be open.

Hoffay Talking Machine Co., Inc.
3 West 29th St., New York City, N.Y.

(Hoffay products are protected by patents granted and pending. Infringements will be prosecuted.)



No. 250
With "Resurrectone" \$250.00
With "Half-Fork-Tone" \$245.00



Reg. U. S.

Pat. Off.

Our Dealer Proposition

We will send you this machine on receipt of \$54.00, or satisfactory references. It comes in either Oak or Mahogany, with space for five albums, and will play five ten-inch records on one winding. Accurate Automatic Stop. Machine mounted on Casters. First grade throughout. Try it out for five days, and if you don't feel that it is the ideal machine and the best you ever handled, return it at our expense, and we will refund the money at once.

Banking references furnished and required

A HOFFAY AGENCY

will bring you profitable business. Profit plus Prestige are two factors that the dealer knows when he handles the Hoffay Air-Tight Talking Machines.

The Hoffay embodies tonal qualities of the highest, superb construction, distinctive design of cabinet and perfected features of modern invention that tend to make the Hoffay the nearest thing to perfection. Each model is a dominant figure in the industry at its price.

TAKE ADVANTAGE

of our trial offer and see what handling the Hoffay will mean to you.

Write for Agency proposition for your territory

For Domestic and Foreign Business Address:

HOFFAY TALKING MACHINE COMPANY, Inc.

3 West 29th St.

New York City

\$100



Height, 44
Width, 20 1/4
Depth, 20 1/4

Other Models
\$140, \$190, \$250

BUSINESS IN INDIANAPOLIS FAR EXCEEDS EXPECTATIONS

Baldwin Co.'s Great Columbia Trade—Aeolian Co.'s Fine Liberty Loan Showing—New Pathé Dealers—Big Call for Victrolas and Records—Some Columbia Changes—The News of the Month

INDIANAPOLIS, IND., May 4.—Business during April exceeded the expectations of most of the local talking machine dealers who had anticipated that the Liberty Loan drive and tax-paying time would be felt.

The Columbia Grafonola department of the Baldwin Piano Co. store rounded out its first year April 1, and C. P. Herdman, manager, said that he was pleased at the record. This April's business was far ahead of April last year, Mr. Herdman said. With each supplement of Columbia records Mr. Herdman is giving a patriotic monthly calendar to his customers, which advertises the Baldwin store's talking machine department.

F. K. Pennington, assistant general sales manager of the Columbia Co., visited the Indianapolis branch several days ago. He informed Ben Brown, Indianapolis Columbia manager, that the business for March was the biggest in the history of the company. C. E. Wilson has been placed in charge of the foreign record department of the local branch which is constantly growing. John Barlow, manager of the Columbia department of the Beasinger Outfitting Co. at Louisville, Ky., is pleased with the Columbia business, Mr. Brown said.

Morris Rosner, manager of the Vocalion department of the Aeolian Co. store, left Wednesday to join the army. Serge L. Halman, manager of the store, said that the Vocalion business has been satisfactory. Mr. Halman was proud to report a 100 per cent. Third Liberty Loan Bond record for the local employees of the Aeolian Co.

H. E. Whitman, manager of the talking machine department of the Pearson Piano Co., said that the Edison business held up well during April, and that a shortage of certain models of Victrolas was all that held down the Victor business. The record business also has been good.

A. H. Snyder, manager of the Edison Shop, reported that April business for this year showed an increase of 42 per cent. over April last year. The average sale was \$207, Mr. Snyder said, showing that his salesmen were putting across the business for the higher-priced Edisons.

George Standke, manager of the Brunswick Shop, said that April proved to be the best

month since the holidays. Mr. Standke attributes many of the Brunswick sales to the new models with Ultona attachment, which is causing much favorable comment and has been well advertised. In featuring the Ultona Mr. Standke had a large model made for the window display electrically lighted to show the idea of the attachment.

At the Pathé Shop business in machines and records is reported good. H. A. W. Smith, manager, is still visiting Buffalo, N. Y.

R. B. Goldsbury, in charge of the Pathé wholesale department of the Mooney-Mueller-Ward Co., has signed a contract with the 'Trustees' Harco Association Store, of Harco, Ill. This is a co-operative store backed by 5,000 miners, and Mr. Goldsbury is expecting to see the store do a big Pathé business. E. J. Groenwoldt has been added to the talking machine department of the Mooney-Mueller-Ward Co., and will be on the road. The W. P. Johnson Drug Co., of Greenfield, Ind., has put in a line of Pathé machines.

W. E. Pearce, of the Brunswick talking machine department of the local branch of the Brunswick-Balke-Collender Co., is urging his dealers to sell the higher-priced models, and not to be content with selling the smaller models. The O'Donnell Hardware Co., of Washington, Ind., has opened a Brunswick department. A. J. Kendrick, of the Brunswick Co., was in Indianapolis recently on a tour of the Brunswick dealers. Charles Veneman, of Muncie, Ind., is doing a nice Brunswick business, Mr. Pearce said.

O. C. Mauer, manager of the talking machine department of the Kiefer-Stewart Co., distributors of the Sonora and Stewart phonographs, said that business was splendid. He has already placed his fall orders.

The demand for Victrolas and Victor records keeps steadily up and both are harder to get, is the report received from the Stewart Talking Machine Co. This concern is striving to keep its stock of machines and records up to the minute in order to give their dealers the best service in spite of all obstacles. Emerson Knight, advertising manager of the company, has enlisted in the U. S. Marine Corps and expects to leave next week for service.

Jewell Cartmill, secretary of the Kipp Phonograph Co., distributors of the Edison, reported a satisfactory April business.

Under the name of the "Music Interests of Indianapolis," local talking machine dealers and piano dealers have started co-operative advertising in the local newspapers featuring the "Music in the Home" idea. A full-page ad appeared last week in one of the evening papers.

SCHOOL OF MECHANICAL INSTRUCTION

There will be a school of mechanical instruction at the Edison laboratory on Monday, Tuesday and Wednesday, June 3, 4 and 5, the three days just preceding the Edison dealers' convention.

This has always been a feature of the week the convention is held and each year the attendance is larger and larger, showing that the dealers are becoming more and more aware of the importance of being fully acquainted with the instruments they are selling. All the new, as well as the old, improvements are going to be discussed during this three-day session and a large attendance is looked for.

DEALERS

Make Big Money

On Our Language Records



FRENCH, SPANISH
ITALIAN, ETC.
ALSO
F.M.C. FRENCH
MILITARY
CONVERSATION

Cash in now on the

Language Phone Method

and Rosenthal's Practical Linguistry

It requires no scientific salesmanship to sell our records. The courses are so simply arranged that the demonstration satisfies the prospect. The French Military Course, 5 Double Discs, and Military Manual, (Retail \$10.00) is ideal for Army, Navy, Red Cross

Excellent Line for Summer Trade

Send for Particulars

THE LANGUAGE PHONE METHOD
992 Putnam · 2 West 45th Street, · New York



Tie up, friend, tie up—

Make our big national advertising campaign on Portable Grafonolas this summer bring business to YOU—

**Columbia Graphophone Co.
Woolworth Building, New York**

TALKING MACHINE MEN MEET

J. T. Coughlin Elected President at Annual Meeting—Reports Show Year's Progress

The annual meeting and election of the Talking Machine Men, Inc., was held on Wednesday afternoon, April 17, in the Assembly Rooms of the Merchants' Association in the Woolworth Building.

Prior to the usual order of business the body was addressed by J. Newcomb Blackman, chairman of the talking machine division of the Al-

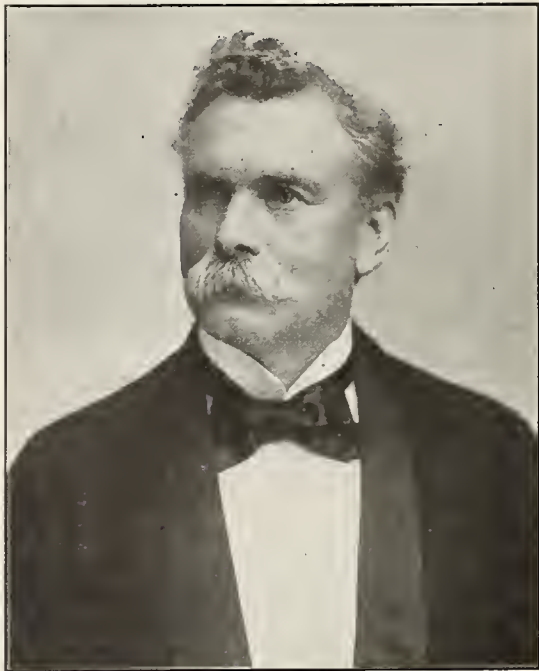

J. T. Coughlin, President

lied Music Trades Liberty Loan committee. Mr. Blackman made a stirring address in the interest of the drive, and the result was that a spontaneous decision by almost every man who attended was made to take some bonds, subscription blanks being on hand for the purpose. The afternoon's total amounted to \$40,000 and, of course, this is only a small part of what the trade is doing, as many had subscribed liberally previously.

The annual reports of the recording and financial secretaries were then read, both of whom in addresses called attention to the growth of the organization and the progress it had made during the past fiscal year.

The new amendment to the by-laws to make jobbers associate members only was next taken

up, and after much discussion this was defeated through the inability of those wishing the change to muster a two-thirds vote. Another amendment was then offered, making it optional with the jobbers whether they became active or associate members. This latter was laid on the table until the next meeting.

The election of officers then followed with the result that J. T. Coughlin was elected president; Sol. Lazarus, vice-president for New York; A. H. Tusting, vice-president for New Jersey; A. B. Clinton, vice-president for Connecticut; E. Leins, financial secretary, and A. Galuchie treasurer. The election of an executive committee and a recording secretary was laid over until the next meeting.

The Talking Machine Men, Inc., have made great strides during the past year, not only in adding to their membership, but in accomplishments, and from the attendance at recent meetings, which has been large, it will not be surprising to see the organization make further gains during the balance of the year; at least the indications point that way.

BROOKS BUSINESS EXPANDING

Manufacturers of the Brooks Phonograph Making Arrangement to Double Their Output

SAGINAW, MICH., May 6.—The business of the Brooks Mfg. Co., of this city, manufacturers of the Brooks phonograph, is increasing to such an extent that the company is planning at the present time an expansion all along the line, with the idea of obtaining facilities which will enable it to more than double its output. The company is adding new dealers to its lists from all parts of the country, and the sales department states that as soon as the dealer receives his sample machine, good-sized orders are forthcoming immediately.

Some of the well-known phonograph dealers who were recently added to the lists of Brooks representatives have informed the company that their requirements for the Brooks automatic repeating phonograph will be covered by carload orders next fall, and that their customers are enthusiastic in their praises of the instrument. The automatic repeater, which is an exclusive Brooks device, has been an important factor in the success of this phonograph, and its simplicity and efficiency has won recognition from the dealers everywhere.

SONORA LIBERTY LOAN PUBLICITY

Two Examples of the Many Striking Ads Used by the Sonora Phonograph Sales Co. to "Put Over" Successfully the Liberty Loan

The Sonora Phonograph Sales Co., Inc., "did its bit" in the recent Liberty Loan campaign by



**Buy
LIBERTY
BONDS**

**or prepare to beg
mercy from drip-
ping German
bayonets!**

This is one of several advertisements contributed by

Sonora
THE INSTRUMENT OF QUALITY
CLEAR AS A BELL

Fifth Avenue at 53rd Street, 50 Broadway (Standard Arcade)
279 Broadway at Reade St. Brooklyn: 1285 Fulton Street.

**The Highest Class Talking Machine
in the World**

One of the Sonora Liberty Bond Ads devoting their entire advertising in a total of fourteen newspapers in New York and Philadelphia to a series of hard-hitting messages which attracted widespread comment and attention.

**Buy as many
LIBERTY BONDS
as you originally
intended to—then
double that amount!**

This is one of several advertisements contributed by
**SONORA PHONOGRAPH SALES CO.
INC.**

GEORGE E. BRIGHTSON, PRESIDENT
1311 WALNUT STREET

Makers of
The Highest Class Talking Machine
in the World

Another Sonora Liberty Bond Ad Two of these advertisements are reproduced herewith, and it can easily be seen that the character and originality of the layouts and text made it difficult for the average newspaper reader to pass them by without giving them due notice and attention.

MOTOR MANUFACTURERS' OPPORTUNITY

WE ARE IN POSSESSION OF THE FOLLOWING PARTS

- 1500 Spring Cups.
- 1000 Spring Cup Separators.
- 335 Ratchets.
- 400 4-weight Spring Governors.

PARTS FOR COLUMBIA MOTORS

We will dispose of these together with the tools complete for making cups and separators.—Write for terms.

JAQUITH MACHINERY BUREAU, Inc.

100 PURCHASE STREET

BOSTON, MASS.

BUFFALO TRADE MAINTAINS ITS CUSTOMARY OPTIMISM

Excellent Volume of Trade Gives Reason for This Attitude—Music Industry Booms Liberty Loan—Columbia Co. in New Wholesale Quarters—Record Orders Should Be Confined to Actual Needs

BUFFALO, N. Y., May 4—Even in face of a shortage of machines and records, embargoes, depleted staffs, etc., Buffalo talking machine dealers and jobbers are maintaining their customary optimism. As hundred percent loyalty will admit of no pessimism, they are not borrowing trouble as to what restrictions the Government may place on their business from now until the time when the tide of Prussian terrorism is stemmed. They are confident that Uncle Sam will place on them no unfair burdens, no business-destroying curtailments.

Buffalo talking machine dealers and jobbers joined with the piano men in putting over the music trades' end of the Third Liberty Loan. Their quota of \$150,000 was oversubscribed. Their committee was composed of William H. Daniels, chairman; C. N. Andrews, George A. Goold, Jacob Hackenheimer, Robert L. Loud, N. R. Luther, Ben Neal and C. H. Wood. They worked at full speed, increasing right up to the last minute. At the close of the campaign Saturday evening, May 4, they attended a jollification dinner at the Iroquois Hotel. At this session Chairman Daniels and his co-workers were warmly congratulated on their success.

The name of the Adams-Koenig Piano Co. has been changed to the A. F. Koenig Piano Co. A. F. Koenig has bought out the interests of L. B. Adams in the concern. Mr. Koenig expects to add an important line of talking machines to his stock.

L. M. Cole, Eastern representative of the Gibson-Snow Co., Inc., Syracuse, was a Buffalo visitor. "Lennon & Clarke, of Watertown, N. Y., have been appointed Sonora agents," said Mr. Cole. "This firm sold its initial delivery before the second shipment arrived."

A. H. Trotter, Western New York representative of the Gibson-Snow Co., has established eleven Sonora agencies in Buffalo.

The business of the former Syracuse branch of the Brunswick-Balke-Collender Co. is now handled by the Buffalo office of that concern. F. G. Eigenbrod is in charge of the phonograph department of the Buffalo branch. L. J. Farrell is resident salesman of the Syracuse territory, with headquarters in Utica.

Lingard Loud, son of Robert L. Loud, will continue his training as a U. S. flyer. He was recently graduated from the ground school of aviation at Princeton. In the Victrola department at Mr. Loud's store two new demonstration booths have been added.

Patriotic rallies were held recently by the employes of the William Hengerer Co. and J. N. Adam & Co., Victrola dealers. Each employe signed a pledge to engage in national service work of some kind and "to constantly support our boys by every means in our power."

Motor truck freight routes from this city to points within a 150-mile radius will be organized by the Buffalo Chamber of Commerce. Talking machines will probably be among the goods shipped over these routes.

Victor & Co., Pathéphone jobbers, had striking window displays for the Third Liberty Loan. This firm and its employes and customers were heavy purchasers of the bonds.

The Jones Piano Co. has closed its Buffalo store.

The store of the Winegar Piano Corporation has been remodeled and attractively redecorated.

A. B. Smith, dealer of Akron, O., was a Buffalo visitor.

R. E. Smith, salesman for the Hoffman Piano Co., Sonora dealers, has originated some attractive merchandising signs at that store.

The Columbia Graphophone Co. has moved into its new wholesale quarters on the second and third floors at 733-737 Main street. The

company has invited its friends to patronize the numerous retail Columbia dealers in this city.

W. D. & C. N. Andrews, Victor wholesalers, are working out a method to reduce the circulation of Victor monthly supplements. The firm has sent out a letter to dealers on this subject. An excerpt from the letter follows: "Owing to war conditions the Victor Talking Machine Co. is experiencing great difficulty in supplying sufficient monthly supplements as well as records. They have asked us to lower our demands to actual needs. In order that we may co-operate with them we are going to ask you to specify the lowest quantity with which you can circularize your customers."

This subject was discussed at the last meeting of the Talking Machine Dealers' Association of Buffalo. A committee was appointed to handle this matter.

IMPRESSIVE SIGN FOR GOETZ STORE

The Goetz Music Store of Philadelphia has recently erected a very handsome Victrola electric sign. It is hung over the sidewalk so as to meet the gaze of people moving both up and down the street. Each letter in the word Victrolas is in white opal glass, which is set into a large dark green square, thus giving a very strong contrast when the interior is lighted up. At the top of the sign is the Victor trade mark, which is worked out in art glass, and which is also illuminated from within. At the bottom is a rectangular glass in which appears the name of the Goetz Music Store. The whole sign measures four and one-half feet in width and twenty feet in height. It is a very impressive affair.

Mr. Talking Machine Merchant: Why not have some advertising cards or postal cards printed; the former you could enclose with a letter. In addition to the article you are featuring on the card, print a little street map showing the vicinity and location of your store. Make it easy for people to find you.

TWO



LEADERS

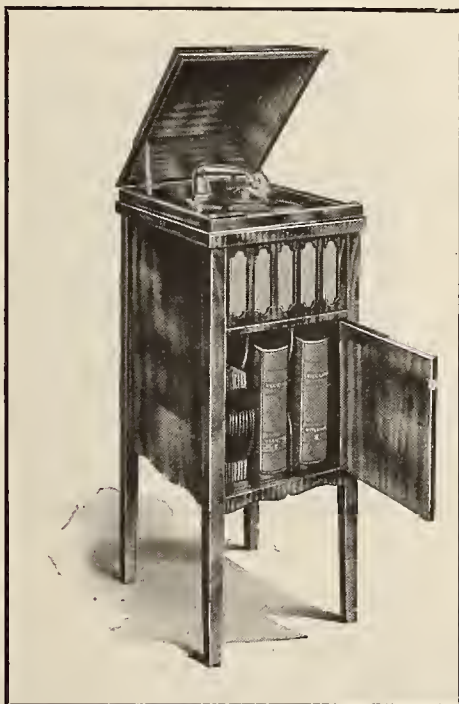

Model "F"
40 in. high, 18 in. deep, 15 in. wide
Retail Price, \$40

By selling low-priced machines you do not tie up your money for a long period

There are Others in Our Line

Some Outstanding Features of Operollos

- Universal Tone-Arm
- Perfect Tone
- First-class Reliable Motor
- Tone Modifier
- High-grade Finished Cabinets
- Wooden Tone Chamber

Distributors
LYRIC and PAR-O-KET RECORDS

Write for Special Discounts
Immediate Shipments of Machines

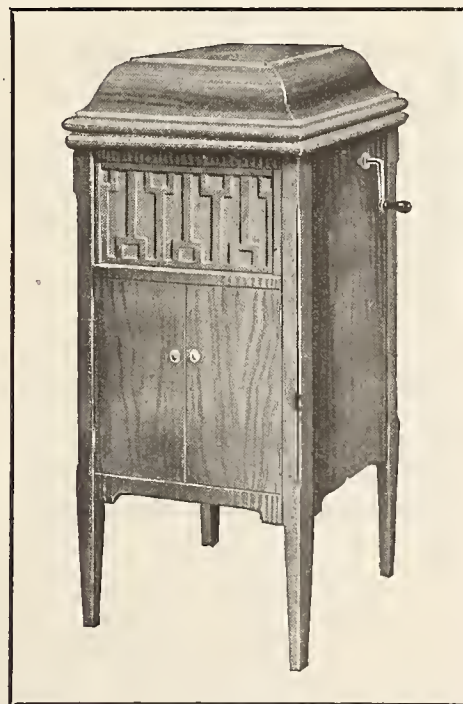

Model "A"
41 in. high, 18 in. wide, 20 in. deep
Retail Price, \$50

Low prices cause quick sales and bring quick returns

OPEROLLO PHONOGRAPH CO.

54 W. LAFAYETTE BLVD.

DETROIT, MICH.

65¢

Emerson Records

The equal of any records at a 75c price—in length of playing, in quality of tonal production, and in value to purchaser.

You can't beat the Emerson dealer who offers these remarkable records at 65 cents each, that play as long as the average standard record.

Hits way in advance of everybody

If you want to know how far Emerson dealers always are in advance, glance over the following hits, already on sale by Emerson dealers.

*If you're an
Emerson
Dealer
you're selling
them NOW*

"They Were All Out of
Step, But Jim"

"What are You Going to do
to Help the Boys"

"I'm Sorry I Made You Cry"

"Cleopatra"

"'N' Everything"

*If you're not,
have you been
able to get
these Hits
Elsewhere?*

It's surely a big advantage to sell Emerson Records. You appeal to a bigger population—every machine owner—with popular song and dance hits way in advance of the others. Emerson Records are now made in 2 sizes—35 cents and 65 cents.

Emerson Phonograph Company INC.

3 West Thirty-Fifth Street Dept. J New York

Happenings in Dominion of Canada

NEW HOME FOR COLUMBIA CO. IN TORONTO SOON READY

When Alterations Are Completed This Will Be One of the Most Complete Plants in the Dominion
—Heineman Co. Branch to Remove—Sonora Distributors Start Service Campaign—Other News

TORONTO, ONT., May 6.—The management of the Columbia Graphophone Co. are literally "camping on the job" in order to rush the completion on their new factory premises which, as announced in the last issue of *The World*, has been secured at 54-56 Wellington street West, this city. The whole interior arrangements of the building are in the hands of the contractors for remodeling. The general offices will be in keeping with what a factory should be. Special thought and planning is being given to the installation of the hydraulic presses for record manufacturing. The workmen will be provided with lockers and a lunchroom. The entire building is to be filled with fireproof partitions and sprinkler system. Every effort is aimed at providing factory conditions that will permit a largely increased output and a closer co-operation with Columbia jobbers and dealers. It is expected that the factory will be ready for occupation by May 1. J. P. Bradt, the general manager for Canada of the Columbia Co., recently paid Montreal a visit.

Multifile Systems, Ltd., are endeavoring to interest the Canadian talking machine trades in their system of filing records which they term "Flexible."

A Victrola XVI was used at the Regent Theatre in Toronto in connection with the run of "Lest We Forget," one of the finest and most thrilling films ever shown in Canada. One of the scenes shows a group of soldiers in the trenches enjoying a talking machine, and for this scene the Victrola supplied the music. At a special invitation showing of the film the Victrola was also used.

Manager C. J. Pott, of the local branch of the Otto Heineman Phonograph Supply Co., Inc., has been obliged, by reason of the firm's increasing business, to arrange for new premises. It is expected by May 1 the company's Canadian headquarters will be moved from the Lumsden Building, where they have been since opening the Canadian branch a year ago, to 172 John street. Here they will have the advantage of having the offices and warehouse together, thereby permitting a closer personal supervision of all incoming and outgoing shipments. Owing to the increased office work at the Heineman Canadian headquarters, Mr. Pott is to have the assistance of L. Green, who has come to Toronto from the New York office. Mr. Green has had a wide experience and is thoroughly posted on the Heineman policy.

One of the most interesting and helpful Musical Hours for Children held since this notable educational feature was commenced by the R. S. Williams & Sons Co., Ltd., some weeks ago, took place at the Williams' Recital Hall, 145 Yonge street, Saturday morning, with an excellent representation of school children and for which the Edison phonograph supplied all the music. The undoubted feature of the occasion was the "Parade of the Allies," a musical promenade in which all school children attending took part, and a flag dance. An extemporaneous talk on the life of Thomas A. Edison by one of the girl scholars and re-creations on the New Edison completed a most enjoyable program.

Ralph Cabanas, formerly manager of the Columbia business in Canada, has just returned to Toronto from a visit to Mexico. Before going South Mr. Cabanas launched the Talking Machine Supplies Co.

The Walker Talker, manufactured by the Walker Bin & Store Fixture Co., Ltd., Kitchener, Ont., is fitted with a Brooks automatic repeating device for which this firm have the Canadian rights.

Columbia dealers all over Canada featuring Bedtime Stories by Thornton W. Burgess are having a phenomenal sale of these records.

I. Montagnes & Co., Canadian Sonora distributors, have inaugurated a retail advertising service for the benefit of their dealers. Messrs. Montagnes are arranging to manufacture all lines of Sonoras in Canada, several of the smaller types having already been produced in Canada. This action was decided upon whether the importation of musical instruments from the United States should be prohibited or not. Mr. Van Gilder has just returned from a visit to the Sonora factory at New York and succeeded in securing a further supply of goods.

The Starr Co. of Canada express their gratification with the success that has followed their introduction of the Starr line to the Canadian trade and they are now starting out on their second year with still greater confidence.

Maud Powell, Victor violinist, and Grace

Kearns, Columbia celebrity, recently appeared in concert recitals in Toronto. The trade benefited from their visit, as a large number of records of both artists were disposed of.

The Robert Simpson Co., Ltd., featured Alma Gluck records prominently on their delivery wagons and in the windows of the store doors just previous to this exclusive Victor artist's appearance in the Queen City.

E. V. Warne, Peterboro, who recently took on the Pathé line, announces that he has had to reorder quickly to keep his range of models and records as complete as possible.

John A. Sabine, of the Music Supply Co., was a recent visitor to New York.

The Music Supply Co., distributors of Columbia lines, announce that they have leased a warehouse for storage purposes. Office and shipping departments remain at the present address, 36 Wellington street East.

Very attractive phonograph salesrooms have been completed by Frank Stanley on the second floor of his building on Yonge street. These rooms are intended for the better class trade, while the cheaper business is to be handled in the rooms on the mezzanine floor.

SOME QUESTIONABLE SALES METHODS IN MONTREAL

Evil of the "Gyp" or Private House Sale Exposed—W. F. Evans Tells of Conditions in British Columbia—Expensive Models in Demand—New Agencies Arranged for—Important News Presented

MONTREAL, CANADA, May 6.—The matter of small manufacturers of phonographs selling machines from private addresses has been brought to the attention of the writer on more than one occasion and it was only recently where one barefaced incident was related to your correspondent which showed how the public are being gulled and the industry as a whole is bound to suffer. Various modes of misrepresentation are being used in their endeavor to sell machines and records, such as "Owner going to the front," "Moving," "Death in the family" and numerous other plausible misleading statements. The trade should call a meeting and stop this practice or evil and should interview the daily newspapers and have them prohibit fraudulent advertising of this nature. It is not fair competition to the manufacturers who have business taxes, war taxes, etc., to have to compete with dealers of this character who have no business tax or overhead charges to meet. The proof is there and all that is wanted is quick action on the part of the trade to suppress for once and all this growing evil and by so doing they will not only be protecting themselves but at the same time confer a favor on the music-loving public by stimulating the interest in music and allowing them to still maintain their belief in the legitimate talking machine dealer, otherwise it is bound to leave a bad taste in the mouths of some people who are always looking for a bargain and in reality are not getting it. Dealers should bring to the mind of every person whom they sell a machine the fact of the one price system which has been the means of building up this industry and putting the phonograph business where it is.

On a recent trip East, Walter F. Evans, head of Walter F. Evans, Ltd., the well-known music house of Vancouver, B. C., visited Toronto and Montreal en route to New York and other Eastern centers. In Montreal Mr. Evans visited the factory of Berliner Gramophone Co., Ltd., his firm being exclusive "His Master's Voice" dealers for many years, in addition to having the Heintzman agency and handling sheet music and small goods. The Evans store is well located, and is one of the brightest and up-to-date in the West, and Mr. Evans is a musician of unusual training and talent.

Regarding conditions and prospects in British Columbia, Mr. Evans had only an optimistic viewpoint. The Vancouver dealers, since deciding to organize some months ago, have had regular meetings, and the resultant acquaintance and greater confidence in each other, he considered an important advantage to the music business of the city.

H. P. Labelle & Co., Ltd., will exhibit a full line of Pathé machines at the forthcoming sportsmen's show to be held in Montreal.

Indications are bright and rosy for a prosperous summer trade, is the way Tom Cowan, of the Cowan Piano & Music Co., puts it, while referring to the Brunswick line, of which he is a great booster.

"Every month sees an increase in our Victrola department," said J. Donat Langelier, "and if indications prove correct we will eclipse all previous records in our talking machine department despite war-time handicaps."

Popular selling Victor records the past month include patriotic songs by Alan Turner and

(Continued on page 54)

Talking Machine Supplies and Repair Parts

SPRINGS, SOUND BOX PARTS, NEEDLES

THE RENÉ MANUFACTURING CO.
MONTVALE, NEW JERSEY

TRADE CONDITIONS IN THE DOMINION OF CANADA—(Continued from page 53)

Gitz Rice, and the recordings of Paul Dufault and Mr. Dufresne and not overlooking Heifetz records, whose appearance in Montreal the past month made an extra heavy demand upon the stocks of Victor dealers.

C. W. Lindsay, Ltd., are well satisfied with present conditions. Recent Pathé sales included a number of art models in Sheraton. Columbia and Sonora lines have showed up equally as good in volume of business closed.

The new Victrola store of Gauvin & Courchesne's in the Auditorium Building, Quebec, has been completely reorganized and a large stock displayed. A number of comfortable parlors for the private hearing of Victrolas and records has been installed.

That a good line of talking machines and records can be sold from a departmental store as well as a music store or anywhere is ably demonstrated by Almy's, Ltd., where Miss Vezina in charge of the Columbia Grafonola department holds sway.

"Our clientele take much more readily to the expensive models of Aeolian-Vocalion and Sonora phonographs than they do to the cheaper types," said Charles Culross, "because," continued the speaker, "merit tells and merit sells."

W. J. Whiteside, who specializes in His Master's Voice lines, is doing so with creditable results and his business is showing rapid strides.

Columbia, Edison Amberolas and other lines continue popular with the rapidly increasing list of customers at Wm. Lee, Ltd., store.

J. J. Freund, of the New York office of the Thomas Motor Co., recently called on the Montreal trade.

Layton Bros. recently pulled off a very successful recital of Edison re-created music and are well satisfied with the results.

The Berlind Phonograph Co., Ltd., are well satisfied with the demand for the Brunswick line.

According to L. J. Bourgette, manager of the Edison department of Goodwin's, his department is exceedingly busy and the call is daily increasing for the Edison Diamond Disc machine and records. Columbia product is likewise showing a good volume of sales.

W. Craig, of the Pathé Co., recently called on the trade in Montreal.

Madame Didier, who has established a Pathéphone business of her own in Dupuis Freres store, is well pleased with the call for period models.

In order to devote their entire efforts to the wholesaling of Columbia products in the Prov-

ince of Quebec, the Canadian Graphophone Co. have disposed of their retail branch store to A. A. Gagnier, who will carry on the business under the name of the Canadian Graphophone & Piano Co.

N. G. Valiquette, Ltd., are consistent believers in printer's ink, the result being that everybody knows that they handle the Pathéphone and Pathé records and can give their clientele A1 service.

C. Lamoureux has recently moved to 661 Mount Royal avenue East, where a store in keeping with the Columbia line is conducted.

Managing-Director J. E. Tourangeau, of H. P. Labelle & Cie., Ltd., is building up a phonograph business second to none in the city with the Pathé as its leader. Manager H. C. Foisy is an energetic hustler. A number of new demonstration parlors have been installed to meet the needs of customers.

J. W. Shaw & Co., since removing their Grafonola department downstairs, have trebled their business both in the number of machines and records sold, says Manager A. Rampsberger. The demand is still confined to the higher priced Columbia models.

An exclusive Brunswick shop will be opened in Montreal very shortly in the premises to be vacated by Gervais & Hutchins at 582 St. Catherine street West on May 1. Peter Sydney Berlind will be in charge.

An exclusive phonograph store has been established at 4864 Sherbrooke street West in Westmount by Fred J. Smith, the first dealer to invade this select territory.

The City House Furnishing Co., 1340 St. Lawrence Boulevard, are now carrying a full and complete line of Victrolas and Victor records.

The Canadian Graphophone & Piano Co. have built up a large business in foreign records and maintain a separate department for the sale of Polish, Russian, Italian, Greek, Hebrew and Rumanian records. This firm are carrying advertising in all the leading foreign papers in the United States and Canada and ship records as far as British Columbia, Sydney, Winnipeg and points in the Far West.

FEATURING PATHE RECORDS

Howard E. Brillhart, who has recently opened a new music store at 531 Thirteenth street, Oakland, Cal., is featuring the Pathé records in addition to the Kimball line of musical instruments.

TRADE NEWS FROM WINNIPEG, MAN.

The Berliner-Gramophone Co. Book Some Big Orders Through Thomas Nash's Visit—Robert Shaw Tells of Columbia Expansion—Edison Sales Reported Good by Babson Bros.

WINNIPEG, CAN., April 29.—Thomas Nash, of the Berliner Gramophone Co., Ltd., who is as well known to the trade here as in his own home town, has returned East after a visit to Winnipeg and Calgary. The Western Gramophone Co., distributor of His Master's Voice products, experienced an avalanche of orders for Harry Lauder records as a result of that idol's recent visit. An interesting development of record business here is the greater ratio of sales of grand opera music and records of the classics. The demands from the most remote places for the best of music is also convincing evidence of the country's musical development and the part that the talking machine has taken in fostering public appreciation of the best in music.

Robert Shaw says that Columbia records are coming in such quantities as to indicate considerable factory improvements, over 25,000 having arrived in the last few days.

The records of Louis Graveure have had a big sale as a result of the two recitals given by this artist. Mr. Shaw also says Columbia needles are now to be had in all four grades. He reports all round vastly increased business.

Babson Bros. report Edison sales up to the average and collections fair, shortage of deliveries from the factory being the chief trouble.

TRADE NEWS FROM REGINA, SASK.

REGINA, SASK., March 11.—In the annual circulation campaign of the Post of this town one Columbia Grafonola valued at \$100 and fifteen Columbia \$24 machines figured in the prize list, all of which were purchased from Child & Gower, Columbia representatives in Regina.

G. W. Johnston, for the past five years manager of the phonograph department of Scythes & Co., of this town, and who has recently joined the 77th Battery, was lately tendered a banquet by the firm and staff. He was also presented by the firm with a shaving kit and by the staff with a wristwatch. Short speeches were made expressing regret at losing Mr. Johnston and wishing him good luck. There was a fine musical program.

CONTAINS PRACTICAL SUGGESTIONS

The May issue of the Emerson "Spotlight," a house organ, published for and by Emerson record dealers, made its appearance this week, and this issue contains many practical suggestions that can be utilized to excellent advantage by Emerson representatives. Under the heading of "What Other Dealers Do," there are presented numerous suggestions in connection with the ideas and plans that have been tried out by Emerson dealers and found successful. There is an excellent article entitled "A Good Phonograph," by Joseph I. Carroll, assistant manager of sales, and the dealers are advised that Emerson record advertising is now appearing in the leading newspapers of New York, Boston and Philadelphia. There are reproductions of various forms of Emerson advertising, and this issue as a whole is the best one that has yet been published.

CLOSE MANY IMPORTANT CONTRACTS

DETROIT, MICH., May 6.—Lewis C. Frank, of this city, who manufactures a complete line of record and delivery envelopes for talking machine dealers, has been closing a number of important contracts during the past few months with well-known dealers throughout the country. Mr. Frank stated recently that paper of all styles and grades has advanced greatly in price within the past six weeks, but that he is leaving nothing undone to co-operate with his clients and is now selling his product at prices considerably lower than the increased costs should warrant.

Melophone Single Spring Motor

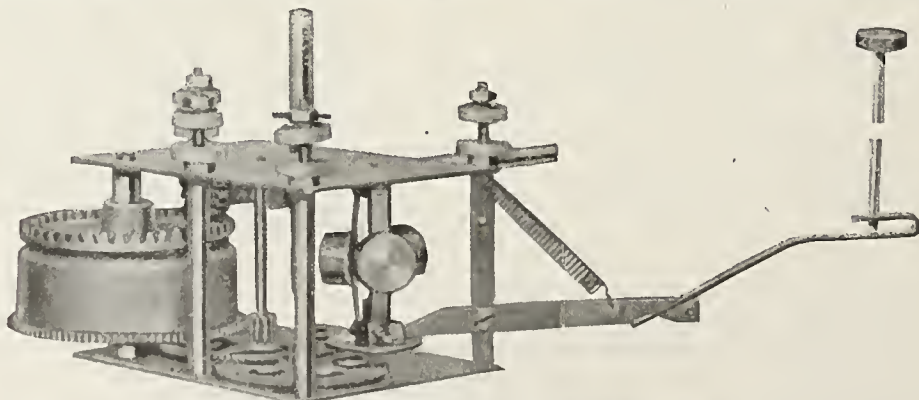

COMPLETE WITH 10-INCH TURNTABLE

Simple in construction, the most satisfactory and durable of all small motors.

Plays 2 ten-inch records with one winding.

Three years' successful record as the best single spring motor manufactured.

PRE-WAR PRICES

IMMEDIATE DELIVERIES

Melophone Talking Machine Co.

380 Lafayette Street, New York

29 E. Madison Street, Chicago



RECORDING LABORATORIES
New York City

PRESSING PLANT
(Occupying Above Buildings Exclusively)
Grafton, Wisconsin

REG. U. S. PAT. OFF.

Paramount Records

The Golden Dawn of Profit For the Independent Dealer

THE continuous profit from come-back record sales is the big end of the talking machine business. Here's the record you can push with your machine without advertising competing lines—an independent record that works with you and for you building up a *constantly increasing* record business—a good record that nets a good profit and brings your customers back to you again and again for more—that's the

Paramount—the new ten-inch hill-and-dale cut double-disc—to be played with steel or fibre needles.

Some of the most popular artists record for **Paramount Records** (see over). We maintain our own recording laboratories in New York City, the home of the best talent, where popular songs are first introduced. The records are pressed in our modern plant at Grafton, Wis., shown above. In clearness of tone, length of selection and appearance, **Paramount Records** are unsurpassed.

A Snappy, Up-to-the-Minute, All-Hit List

The outstanding feature of **Paramount Records** is the **POPULARITY** of the selections offered. There are no weak combinations—*both* selections on *each* record are *winners*. The **Paramount** list comprises only the choicest gems of standard popular sellers in operatic numbers, standard songs, band and orchestra selections, latest dance music, instrumental solos and musical comedy hits especially picked for their *ready selling qualities*.

The regular monthly releases are accompanied by *exceptionally attractive* advertising material in various forms.

Get your full share of the big record profits. Build a **growing trade**. Be one of the first to *cash in* on this live record proposition. Establish *your* store as **Paramount** headquarters in your locality—send the coupon *right now* for particulars. 

JOBBERs: Write for our Special Introductory Proposition.

The New York Recording Laboratories, Inc., Port Washington, Wis.

You Can Get Paramount Records from Any of These Jobbers

Carson, Pirie, Scott & Co., Adams and Franklin Sts., Chicago, Ill.
Automatic Container Co., 301 Tacoma Bldg., Chicago, Ill.
Moore & Evans, 32 So. Wabash Ave., Chicago, Ill.
Jos. Hagn Co., 306 W. Madison St., Chicago, Ill.

J. A. McDonald Piano and Music Co., Halifax, N. S., Canada
Noyes Bros. & Cutler, Inc., Park Square, St. Paul, Minn.
The American News Co., 15 Park Place, New York City
M. D. Swisher, 115 So. 10th St., Philadelphia, Pa.

The New York
Recording
Laboratories, Inc.,
Port Washington,
Wisconsin, U. S. A.

By return mail send prices
dealers' discounts and further
information about Paramount
Records to

T. M. W.
May 15, '18

Date

Name

Address

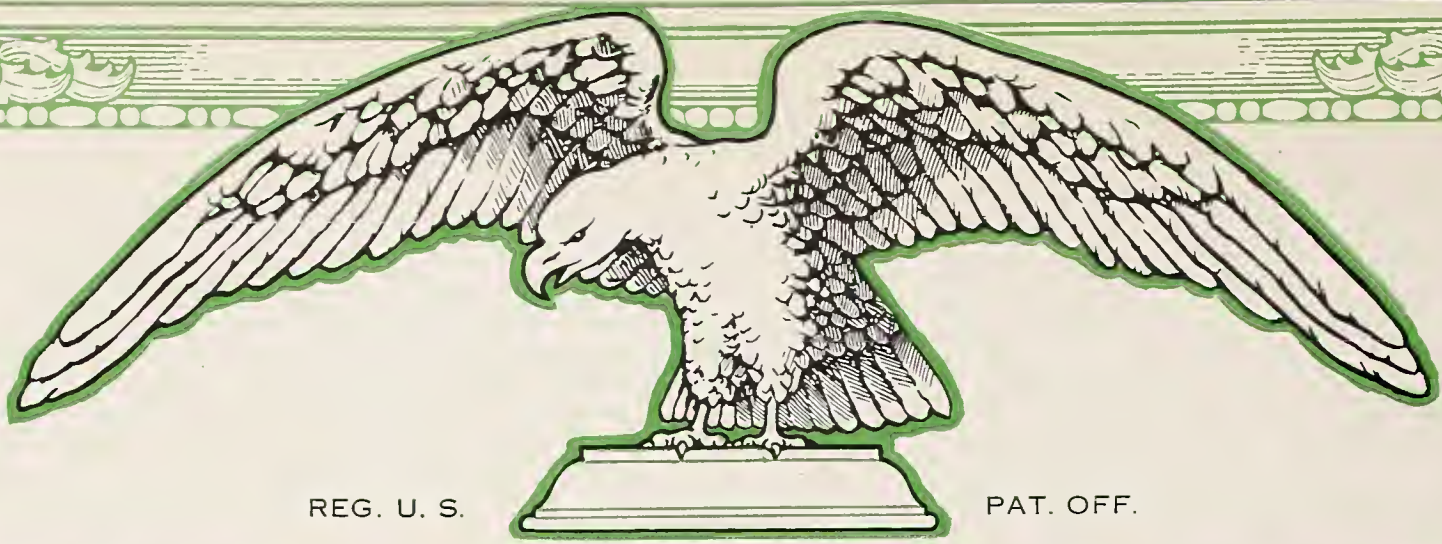

Paramount Records

Supreme in Popularity

Monthly Hanger

Some of Our Artists

Supplement Five
 Released April 20, 1918

Instrumental Records

Parade Day March	Paramount Military Band	3000
Lights Out March	Paramount Military Band	3001
Here They Come March	Paramount Military Band	3002
Liberty Lads	Paramount Military Band	3003
Port and Peasant Overture - Part I	Paramount Symphony Orchestra	3004
Port and Peasant Overture - Part II	Paramount Symphony Orchestra	3005
Staircase of Your Soul	Richard McCann	3006
Oh, Dry Those Tears	Richard McCann	3007

Vocal Records of Standard and Sacred Songs

Good Bye	Criss Kern	3008
Sing My Love's Lullaby	Margaret Abbott	3009
Where the River Shattuck Flows	Harry McClary	3010
When You and I Were Young Maggie	Harry McClary	3011
Come Where My Love Lies Dreaming	Ursula Quast	3012
The Rosary	Royal Dadmun	3013
Love's Old Sweet Song	Margaret Abbott	3014
I Love You Truly	Royal Dadmun	3015
Hosanna	Royal Dadmun	3016
Palm	Royal Dadmun	3017

Operatic Selections

Die Poasens	Edward Zinn	3018
Sei Vendicata Assai	Edward Zinn	3019

Broadway Hits

Baby's Prayer at Twilight	Henry Burr	2047
One Day in June	Conrad and Burr	2048
Liberty Bell	Pauline Quast	2049
Hail, Hail, The Gang's All Here	Pauline Quast	2050
I Want to Skowder	Arthur Collins	2051
Everybody's Crazy 'Bout the Dog Gone Blues	Arthur Collins	2052

Dance Records

Havana	Van Epps	2053
Regging the Nails	Van Epps	2054
Storkard Blues	Van Epps	2055
Unbelievable to Me	Van Epps	2056
Tr-ile Toe	Paramount Military Band	2057
If You Look Into Her Eyes	Paramount Military Band	2058

Some of Last Month's Best Sellers

Battlehip New York March	Paramount Military Band	3008
Under the Double Eagle March	Paramount Military Band	3009
Hawaiian Hula Medley	Louise & Ferera	3010
Kilime Waltz	Louise & Ferera	3011
Honor and Grand	Travis	3012
Fun Going to Follow the Boys	Travis	3013
The Last Rose of Summer	Travis	3014
Honor Sweet Honor	Travis	3015

Ask to Hear These New Paramount Records

Dealer's Advance List

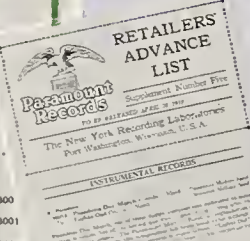

Monthly Supplement



No Doubtful, Dead-Stock Numbers in the Paramount Line

Each Month a Rich, New List of Big-Hit Sellers Like These

Supplement Six (Released May 20, '18)		Records for Dancing	
Livery Stable Blues	Saxojazz Orch.	30033	75c
The Dark Town Strutters Ball	Jazz Orch.	30034	75c
More Candy	Yerkles Jazarimba Band	30034	75c
Wait Till the Cows Come Home	Yerkles Jazarimba Band	30034	75c
Popular Songs of the Day			
Good Morning Mr. Zip, Zip, Zip	Baritone Solo	2052	65c
Aw Sammy	Baritone Solo with Orchestra	2052	65c
Au Revoir, but Not Good Bye	Soldier Boy	2054	65c
Bring Back My Daddy to Me	Henry Burr	2054	65c
Three Wonderful Letters from Home	Massey	2051	65c
A Little Bit of Sunshine	Royden D. Massey	2051	65c
Round Her Neck She Wears a Yellow Ribbon	Byron G. Harlan	2053	65c
Life is a Merry Go Round	Dan Quinn	2053	65c
Instrumental Records			
Pretty Polly	Blondell's Saxophone Quart.	30025	75c
First Love (Waltz)—Accordion Solo	Delroy	30025	75c
Humoresque	George Hamilton Green	30022	75c
Venetian Love Song—Xylophone Solo	Green	30022	75c
Träumerei—Violin Solo	Samuel Gardner	30024	75c
Spring Song—Violin Solo	Samuel Gardner	30024	75c
Aloha Land—Hawaiian Guitars—			
Flute obligato	Louise & Ferera & Rose	2055	65c
O Sole Mio (di Capua)—Hawaiian Guitars	Louise & Ferera	2055	65c
Liberty Loan March	Paramount Mil. Band	30023	75c
Patrol of the Scouts	Paramount Mil. Band	30023	75c
Angels Dream Waltz	Paramount Orchestra	30032	75c
Venetian Love Song	Paramount Orchestra	30032	75c
Standard and Sacred Songs			
My Own United States	Royal Dadmun	30028	75c
Marseillaise	Royal Dadmun	30028	75c
I Hear You Calling Me	C. H. Hart	30029	75c
Ireland Must Be Heaven	Lewis James	30029	75c
For All Eternity	Alan Turner	30031	75c
Oh Promise Me	Alan Turner	30031	75c
Vacant Chair	Shannon Four	30027	75c
Sometime You'll Remember	Lewis James	30027	75c
Face to Face	Royal Dadmun	30026	75c
Brighten the Corner Where You Are	Royal Dadmun	30026	75c
Can't You Hear Me Callin'	Caroline Evans	30030	75c
I Cannot Sing the Old Songs	Lewis James	30030	75c

The New York Recording Laboratories, Inc., Port Washington, Wisconsin

CONDITIONS IN STEEL NEEDLE FIELD

Suggestion Made That Needle Packages Be Increased to Two Hundred at Retail Price of 25 Cents—Timely Chat With Adolf Heineman

Commenting on general conditions in the steel needle field Adolf Heineman, assistant general manager of the Otto Heineman Phonograph Supply Co., New York, who is in charge of the company's Dean division, remarked to *The World*: "The trade doubtless understands that we have been leaving nothing undone to cooperate with our clients in every possible way, even though this has required the expenditure of time and money far beyond expectations. For example, we are using in the manufacture of Dean steel needles only the highest grade carbon steel, and, with the tremendous shortage of raw material the past year, it has been a very serious problem to secure this steel in sufficient quantities to fill the requirements of our trade.

"However, we have surmounted these difficulties until, at the present time, we are producing Dean steel needles in far greater quantities than ever before. Our factories in Putnam, Conn., and Newark, N. J., are working to capacity, and we have every reason to believe that our patrons will be satisfied with our service during the coming year.

"One of the many problems that have confronted us during the past few months is the increased shortage of paper. The use of paper is an important factor in the steel needle industry, as our vast output necessarily calls for the consumption of paper for envelopes in tremendous quantities.

"For many years the standard needle package in this country has been the envelope containing 100 needles, but many of our customers have suggested to us during the past few months that we inaugurate a plan whereby steel needles would be merchandised in packages of 200 instead of 100.

"These jobbers and dealers tell us that this is an opportune time to educate the ultimate consumer to the idea that the standard package for needles is a package of 200 retailing at 25 cents. This plan is timely in view of the fact that many dealers in different parts of the country are now endeavoring to retail the package of 100 needles at 15 cents, but would welcome a standard package of 200 needles at a retail price of 25 cents.

"From a patriotic standpoint this suggestion is an excellent one, for, as the trade probably knows, the Government has already taken steps to readjust the paper situation in view of the alarming shortage of this product. In addition this plan, if generally adopted, will mean a tremendous saving in paper and labor, and will give the dealer a larger profit on every sale.

"As a matter of fact, the unit of needle shipments in the export trade has for some time been a package of 200 needles. We are making shipments to South America, Australia, and all points of the globe on a basis of 200 needles to a package, and we feel sure that this same unit of shipment could be utilized satisfactorily in this country, with a material saving of paper and labor, and increased profits for the dealer."

A form of detectaphone small enough to be worn under a man's shirt front and record conversations on a cylinder attached to his belt has been patented by a resident of Washington.

FOR SALE

20 SHARES VICTOR TALKING MACHINE CO. COMMON STOCK

Their statement as of December 31, 1917, showed undivided profits were more than 4½ times their capitalization. Last year they earned over 130%

WILLIS O. HEARD

Lafayette Building

Philadelphia, Pa.

MEETING OF PORTLAND ASSOCIATION

Oregon Talking Machine Men Discuss Terms and Record Approval System But Fix No Standards of Practice for Members

PORTLAND, ORE., May 4.—The Portland (Ore.) Talking Machine Dealers' Association held a regular monthly meeting at the Imperial Hotel recently with a large attendance and the question of terms was paramount. Frank Case, manager of the Wiley B. Allen Co., made an excellent address in which the province of the association was discussed, Mr. Case taking the stand that while all matters relating to the talking machine business should be fully and freely discussed at these meetings, it was not well for members of the association to criticize terms made by other firms. Each house has its own method of transacting business, Mr. Case said, and as long as the business is done in an honorable manner it is not open to criticism by the association. James Loder, of Bush & Lane, said that members should be broad-minded enough to discuss all subjects and not to take what was said as criticism. There was a lively tilt, free from personalities, and the association seemed to agree that the question of terms should be left to the individual houses, although it was suggested that it was to the interests of all dealers to keep payments up since money has become so easy in Portland.

Strong arguments were made pro and con on the subject of letting records go out on approval. L. D. Heater, of the Columbia; E. B. Hyatt, of the Hyatt Talking Machine Co.; James B. Loder, of Bush & Lane; Paul B. Norris, of Wiley B. Allen; Mrs. Baker, of Sherman, Clay & Co.; C. A. Alphonse, of the Hyatt Co.; W. L. LeVanway, of Graves Music Co.; R. Callahan, of Johnson Piano Co., and Frank Case, of Wiley B. Allen, all took part in a spirited discussion and after a vote of the association it was agreed that it was a good thing to let customers have records on approval. Mr. Heater declared that it would not be long before the association as an association and the members as individuals would find that the practice is not good. Mr. Hyatt took the position that dealers with small demonstration rooms could do nothing else than send out records and said that otherwise much business would be lost. Mr. Case took the position that it all depended on the dealers' using their brains in the approval business and said that if records were sent out to the right people business could be improved in no little degree.

The association went on record as in favor of high terms but declined to make it obligatory on the members to fix any special schedule for the members.

At the May meeting the association will elect officers.

NEW SELECTIONS ON LYRIC RECORDS

Latest List Issued by Lyraphone Co. of America Is Full of Interest

The Lyraphone Co. of America, manufacturers of the Lyric records, have just issued their new catalog of popular songs and dance selections. These latest releases comprise all of the songs of the moment as well as several new additions to the standard catalog of the company. A campaign to popularize the Lyric record is now under way and special emphasis will be made on the firm's long list of foreign records as well as their complete standard catalog.

The foreign records include numbers in Neapolitan, Italian, Polish, Russian, Hungarian, Jewish, Hebrew, Roumanian and Servian. Jacques M. Kohner has been appointed sales manager of the company and promises the trade immediate deliveries in large or small quantities. Mr. Kohner has been connected with several record companies and has an enviable record for creating sales. In a recent statement he said: "Promptness and service is my motto, and that is mostly what the trade wants at this time."

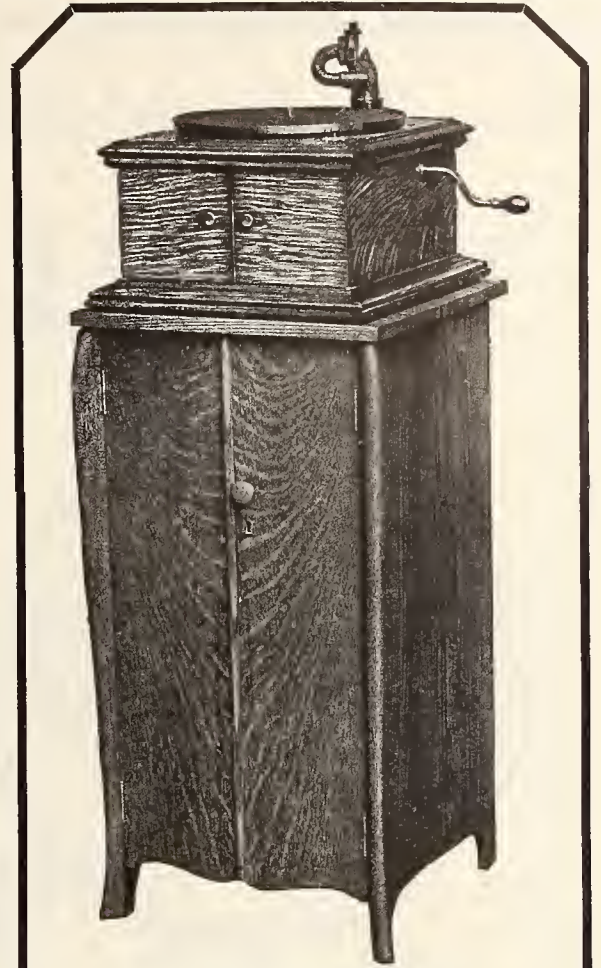

**No. 404 [Vertical Interior]
For Victrolas IV and VI
And Columbia 25 or 35.**

Height, 32 in. Width, 17 in. Depth, 17 in. Holds 208 Victor records. Quartered Oak Front. Mahogany Front. Average weight, crated, 75 pounds. [If horizontal shelving is desired, order No. 1404.] [When felt interior is wanted, order No. 404F.]

Making the Best of Current Shortages

War, among other things, has brought about a national shortage of both talking machines and talking machine records.

Naturally this reduces the normal cash turnover of the talking machine merchant, but many enterprising dealers have been quick to recognize the best way to make up for these shortages is to push the sale of Udell record cabinets.

The Udell line of trademarked cabinets stands supreme in its field. The high quality of workmanship and the unusual beauty of design that characterizes all Udell cabinets, insure a profitable cabinet department for the dealer.

Guaranteed
THE UDELL WORKS
Indianapolis

TRADE MARK

Write for Catalog

THE UDELL WORKS

1205 WEST 28th STREET
INDIANAPOLIS, IND.

The Highest Grade Phonograph Steel Needle in the World

The WALL-KANE STEEL NEEDLE

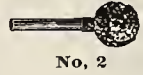
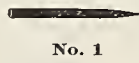
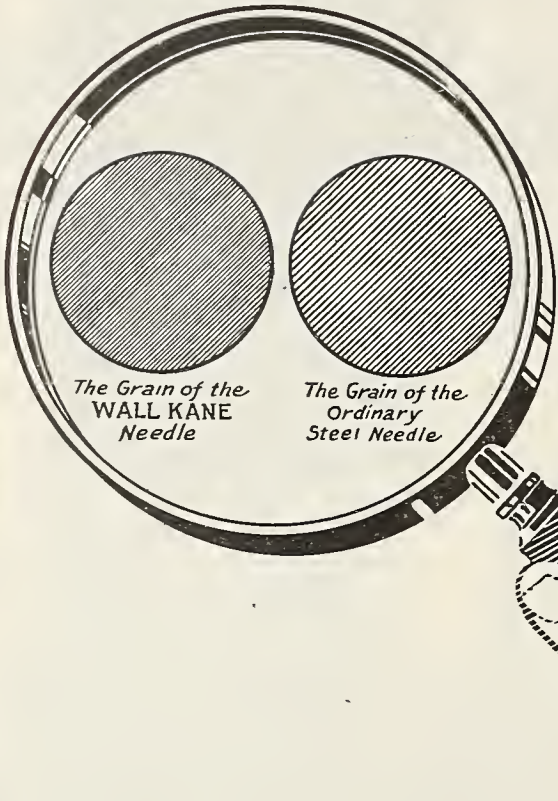

The Wall-Kane Steel Needle is the finest grade of ordinary domestic steel needle, wonderfully improved by chemical processes, which, briefly described, are as follows:

The highest grade of steel needle of domestic manufacture, and playing one record only, is first subjected to chemical processes by which the grain of the needle is made very much finer (see illustration under magnifying glass).

After this process the needle looks all black, like illustration No. 1. Considerable quantity of the charcoal in the original needle is now eliminated, and the needle greatly strengthened by the finer grains and the elimination of the charcoal.

The point of the needle is then subjected to various chemical processes. While in this process the needle looks like illustration No. 2.

Three different coats of certain chemical solutions are placed on the point of the needle, softening the point, so much so that the needle will positively play at least ten records before the friction with the grooves will wear off these coatings and reach the original grain of the point.

Dealers who believe in merchandising an article of the highest quality, and handing out to the public the greatest value should handle the

Wall-Kane Steel Needle

To the Dealers:

Practical test offered to dealers to prove the superiority of

WALL-KANE STEEL NEEDLES

Take two standard disc records of the same selection, play one ten times with the same WALL-KANE loud needle; play the other record, the same selection, ten times, but with ten, new, full tone steel needles.

You will find that the record played ten times with the same WALL-KANE needle will sound clearer, will have less surface noise, and that under the magnifying glass the grooves of the record played ten times with the ten steel needles will seem to be more disturbed.

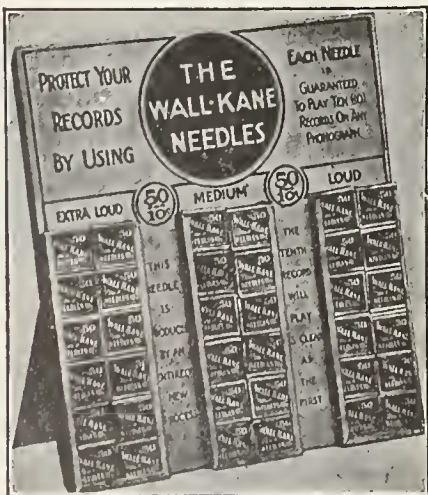

**Jobbing Territory
Open for
ProgressiveHouses**

BEWARE OF IMITATIONS

This handsome metal enamel display stand holds 60 packages, 2 doz. extra loud, 1 doz. medium and 2 doz. loud; each package containing 50 WALL-KANE NEEDLES, retailing for 10c. Price of stand to dealers, \$4.00. Single packages, 6½c.

PROGRESSIVE PHONOGRAPHIC SUPPLY CO.

145 West 45th Street

NEW YORK

Featuring the Musical Possibilities of the Talking Machine

By William Braid White

[Note.—This is the fifteenth in a series of articles on the general subject of the musical possibilities of the talking machine. The aim of the series is to develop these possibilities from all angles, thus opening up fields for sales expansion oftentimes neglected wholly or in part.—Editor.]

THE RECORDS OF STRING QUARTETS

Explain it how you will, mankind has come nearer to producing the harmonies of the blest through the medium of four-stringed instruments than in any other way ingenuity has ever devised or is likely to devise. There may be some to whom the thrilling beauties of a fine quartet are closed, whose mentalities are irresponsive to the loveliness of the most perfect form yet fashioned out of the material of music. But there is no use in worrying about people of that sort. What is worth while is to tell my talking machine friends that when they do not push some of the very fine existing records of concerted string music they fail to do a very wise and a very necessary thing.

Form

Let me go into it a bit deeper. The art of music expresses itself in various ways. Some of these ways have become, as it were, standardized. The opera, the symphony for orchestra, the sonata or ballad or nocturne for piano; these are some of the standardized forms into which musical expression has coalesced. Now, one of these, and one of the most beautiful and appropriate, is the quartet of stringed instruments. More than a hundred years ago Haydn was working out in the peace and security of his position as leader of the private orchestra of a great Magyar prince the problem of putting to the most perfect use the beauties of the violin family of instruments. The violin itself, queen of musical instruments, is unsurpassed—nay, unequalled—in all that makes for musical loveliness. Its tone, at one moment strong and vigorous, at another yielding and melting, at still another joyous and keen, swelling and dying out at the magical touch of the musician's bow, is something that has never been equaled for sheer musical value by any other product of man's ingenuity. It offers an almost literally perfect medium for the production of musical tone. And, to bring the matter up-to-date, it is splendidly fitted to the requirements of the recording disc of the talking machine.

A Melody Instrument

But the violin has one great disadvantage. It is strictly a melody instrument. To a limited extent double-notes can be played on it, and to a still more limited extent chords of three notes; by a process of arpeggiation. Yet both of these extensions of the violin's capacity are technically hard to produce and far from bringing about the needed filling-in which is demanded for a musically self-contained instrument.

Unless, in fact, music can be performed in at least four parts, it is not satisfactory to the ear. The piano and the organ alike, of course, are capable of this and more; hence their tremendous utility, overcoming the obvious defects of their tempered intonation, the shrieking of their minor thirds and the growling of their sixths and sevenths. Their harmonic capacity lifts them above all these defects and makes them musically indispensable.

The Other Strings

Now, in order to produce musical effects as complete and self-contained as the piano or organ alone gives it is necessary to back up the violin with auxiliary instruments. The use of the piano or organ with the violin is not satisfactory, for the tones of piano or organ do not blend well with the smaller instrument. Fortunately, however, the violin family contains other instruments, lower in pitch, which together with the violin enable the composer to

write in at least four separate parts, corresponding to the four-part harmony of soprano, contralto, tenor and bass-baritone, familiar in chorus music. Four-part writing for voices is the oldest form of concerted music and the simplest. Applied to the quartet of stringed instruments, violin (soprano), second violin (alto), viola (tenor) and 'cello (baritone-bass), the musical results are not only satisfactory in width and richness of the chords, but ever so much better in all respects of beauty, sweetness of intonation and capacity for emotional expression.

The String Quartet

The string quartet, so-called, was thus worked out by Josef Haydn and by him developed into the basis of the elaborated form of orchestral writing. Even now, though instead of one instrument for each voice, the modern orchestra may contain sixteen first violins, sixteen second violins, fourteen violas, fourteen violoncellos and ten contrabasses, the basic idea is the same and the composer bases all his writing on the notion of the simple quartet of these stringed instruments, first violin, second violin, viola and bass. Haydn developed this form, as has been said, and wrote many "string quartets"—as the form itself has likewise come to be called. Mozart followed him, and in turn he was followed by the greatest of all quartet writers, as he was the greatest of all musical composers—Beethoven!

Almost every other composer who has ever attempted to express himself in art-forms has tried his hand at the string quartet. Mendelssohn, Schubert, Schumann, Brahms, are a few of them. It is a simple form, merely writing for four instruments, each of which is virtually a duplicate of the next, at a different pitch. Yet no form of music is so hard to write well, none so seldom written well, none so seldom well performed. With all this, nevertheless, no other form of musical expression is half so lovely, half so fascinating to the musical taste, as this.

A really fine quartet, like some of Mozart's, like Beethoven's in B flat, is a breath from Heaven, a glimpse of sweetness and light such as mortal man can scarce experience from any other source. Fortunately, the string quartet

lends itself wonderfully well to recording, and some extremely good records of such music have been made. Of these I shall speak below.

The Four Fiddles

The four instruments which comprise the stringed quartet are two violins, a viola, and a violoncello, or 'cello, as it is usually called. The two violins in no way differ from each other, but to the second violin is allotted the part of the alto voice in a four-part song; that is to say, the range of sound from G below treble staff to C above the staff, or thereabouts. The first violin may range through the entire compass of its tones. It is the solo instrument par excellence, doing the showy work and gaining the hearer's interest more quickly, just as the soprano in the quartet does. But the two violins often interchange. The reason for having two violins is, of course, found in the fact that otherwise there would be a sort of gap between the range of the violin and that of the viola which would be awkward and hard to fill up.

The Viola

The viola itself is a lovely instrument, but one that only too often sinks into obscurity in the light of the violin tone. It is a somewhat larger violin, tuned a fifth below the other. Its strings are C (below middle C), G, D, A, instead of G, D, A and E. It is quieter and somewhat more melancholy in tone quality. But its voice, though gentle, is the voice of all voices the loveliest, the mellow contralto tones of a charming woman.

"Cellos"

The violoncello is the baritone of the quartet. But it is a baritone with a range of voice that runs up to the soprano and down to the bass.

This is a noble instrument and one which has made a wonderful hit with the music-lovers who buy instrumental records. The work of such men as Josef Holmann, Hans Kronold, Anton Hekking, Leo Schultz and Pablo Casals has splendidly brought the beauties of the 'cello before the minds of record buyers. Its tone is noble, manly and capable of considerable nuance; but its prevailing thought is, after all, melancholy.

The string quartet, then, is a powerful instru-

(Continued on page 59)

7th Floor
229 Fulton Street
New York City
Phone, 1678 Cortlandt

Clifford A. Wolf
MANUFACTURER OF
Diamond and Sapphire
Phonograph Points



UNICO

Designs and Construction
Patented

SYSTEM

THE SALES BUILDER

Unico Demonstrating Rooms
Excel from Every
Standpoint

- DESIGN** Six standard styles
Special period styles
- CONSTRUCTION** Patented, Interlocking
Portable Units
Sound Insulated
- FINISH** All standard Oak,
Mahogany and Enamels
- EFFICIENCY** Increased sales at lower
cost per sale
- ECONOMY** Moderate first cost
Always an Asset
Adaptable any location
- DELIVERY** Prompt shipments from
stock ready for imme-
diate use



Unico Racks and Counters
Maximum Capacity
Minimum Space

- DESIGN** Patented to correspond
with Unico Rooms
- CONSTRUCTION** Sectional Units adapta-
ble to any space
- FINISH** All standard Oak, Ma-
hogany and Enamels
- EFFICIENCY** All records always
available instantly
- ECONOMY** Moderate Equipment
Cost
Lower Operating Cost
- DELIVERY** Prompt shipments from
stock in all finishes

Install a
Complete Unico Department

- UNICO** DEMONSTRATING ROOMS
- RECORD RACKS
- RECORD COUNTERS
- CEILING DECORATIONS
- ARCH TREATMENTS

The Unico System has
Increased Sales and Profits
for almost 1000 dealers



Send to-day dimensions of your available space. Plans and estimates for a complete department will reach you promptly

THE UNIT CONSTRUCTION COMPANY

RAYBURN CLARK SMITH, President

Fifty-eighth Street and Grays Avenue, PHILADELPHIA, U. S. A.

THE MUSICAL POSSIBILITIES OF THE TALKING MACHINE

(Continued from page 57)

ment for the production of musical works of the highest order. It is neither noisy nor titillating. Its thought is pure, simple and lovely. It relies on its sweetness and light rather than on adventitious ornament.

Quartets

The various works that have been written in quartet form are very many in quantity. But in form they are the same. The quartet is written just as is a symphony for orchestra or a sonata for piano, but in simpler and less florid form than either of the others. It usually has three movements, or even four, an Allegro, a slow Andante, a gay Scherzo and a brilliant or thrilling Finale. The first movement contains the usual two themes, one bright and vigorous and the other gentle and feminine. These are worked out, developed, repeated and closed, like the regular first movement of a sonata or symphony. The Andante or Adagio is a slow song, in which the full beauty of the singing tone of the instruments can always be brought out. The Scherzo is gay and tripping, testing the technical powers of the performers to the utmost and the Finale is powerful and conclusive, bringing the composer's thought to an appropriate close.

Testing

Much most interesting experience may be had, and much very valuable information, too, by testing out before offering for sale the string quartet records in stock. As a mere beginning, and mainly for the purpose of becoming acquainted with the tones of the four instruments, separately and blended, it is well to try such a piece as the Humoresque on two American airs, as played by the Zoellner String Quartet. This is found in the Columbia catalog. Then the Victor catalog contains records by a string quartet composed of Mischa Elman and Messrs. Bak, Rissman and Nagel, of the Boston Symphony Orchestra. These artists have produced records of the Andante from Haydn's Emperor Quartet, a Minuet (Scherzo) from one of Mozart's quartets and the slow movement from a quartet by von Dittersdorf.

The Victor String Quartet has recorded movements from three of Beethoven's lovely works in this form. These are the very height and depth of the quartet writer's art and every one who wants to appeal to the intelligence of his buyers should soak himself in them. He will then have no trouble in selling them.

Incidentally, the above-named quartets, the Zoellner Quartet and others have recorded also smaller pieces, like Grieg's Spring Song,

Dvorak's Humoresque, and others adapted from piano and orchestra. These are useful indeed for getting the customer acquainted or broken in. The real thing can follow later.

Some day a complete quartet will be recorded on a set of double-faced records. How soon this great step in the musical evolution of the talking machine shall be definitely taken will largely depend upon the intelligent demand of the dealers. The present article has been an attempt to prepare the ground for this demand.

MARVEOLA PLAYS SIX DISC RECORDS

Unique Weser Bros. Model Can Be Controlled by Buttons or Will Operate Automatically—Will Be Feature of Weser Exhibit in Booth Seven National Music Show

Among the unique exhibits at the National Music Show will be that of the Marveola, a talking machine de luxe, manufactured by Weser Bros., Inc., 520-530 West Forty-third street, New York. It will be on display at Booth seven, and will play from one to six standard disc records, of eight, ten or twelve inches. These records may be placed upon the turntable at one time, the operation of the machine being controlled by electric buttons. The mechanism of this machine has been so perfected through the ingenuity of the late John A. Weser, that these buttons may be, if so desired, placed in a different room from the machine. They control the machine in such a way that they start, stop or discharge any particular selection at any time, or will repeat any record, or part of any record, at will, the mechanism shifting to the next record automatically, or at the will of the operator. This machine is particularly adaptable for the purposes of demonstrating records, and for dance music. Besides being controlled by the buttons, it may be set to play at regular intervals, a time arrangement being installed at the side of the turntable in the top of the cabinet.

The operating of the machine is almost human in many respects. As one record is played a metal finger lifts the record off and slips it into a receptacle at the side of the cabinet. The tone arm goes back to its original position and another selection is played automatically. The machine derives its power from ordinary electric light current, a storage battery, a spring motor, or both. This machine will be shown in conjunction with the other styles of Weser phonographs which include various artistic models.

NEW QUARTERS IN PORTLAND, ORE.

Sahlstrom Corporation Acting as Representative for Otto Heineman Phonograph Supply Co., Stradivara Phonographs and Emerson Records

PORTLAND, ORE., May 4.—The Sahlstrom Corp., handling the Stradivara talking machine and Emerson records and distributors of the Western division of the Otto Heineman Phonograph Supply Co., has established itself at 405 Morrison street. L. E. Gilham is the manager of the local branch, the main business here being wholesale. This company has the agency for eleven states for machines, eleven states for the Otto Heineman Co. and six states for the Emerson records. Mr. Gilham says he intends to establish dealers in town for the Stradivara. The company has started off with phenomenal sales for Emerson records, which have not been well-known in Portland until recently. There is a good supply of Stradivara machines yet on hand, but sales have been so large that Mr. Gilham says he is now anxiously awaiting another shipment from the East. A Stradivara grand, just unpacked during the visit of The Talking Machine World correspondent, was sold at once.

The Sahlstrom Corp. is the outgrowth of the Hudson Arms Co., the oldest and for many years the largest sporting goods house in Portland.

JENKINS EMPLOYES FORM CLUB

Men of Kansas City Music House Also Organize a Military Company for Local Guard

KANSAS CITY, Mo., May 6.—Some seventy of the employes of the J. W. Jenkins' Sons Music Co. recently organized a club which is to have for its purpose the social welfare of the employes, and the creation of a military company which will later become a unit of the Seventh Regiment, National Guard of Missouri. Thomas W. Hendricks, who served on the border in 1916, is captain; E. R. Corbett, graduate of a military school, first lieutenant; J. W. Wornock, who has seen service in the navy, second lieutenant; J. Stukenberg, top sergeant, and C. E. Hall, now a member of the National Guard, first sergeant.

Samuel Beatty was elected president of the social club.

Under ordinary conditions, new customers do not appear fast enough to take the place of the old ones, and every progressive merchant realizes the importance of making every customer a permanent one.

On Selling Records

There are many excellent ideas the Victor Dealer can use to stimulate the sale of slow moving stocks. Some of these ideas have already been put into practice, others have not yet been discovered. We urge Victor dealers to encourage their salesmen in originating new plans for selling records, and along the same line our travelling representatives will be glad to offer several good suggestions.

ECLIPSE MUSICAL COMPANY
CLEVELAND OHIO



ECLIPSE

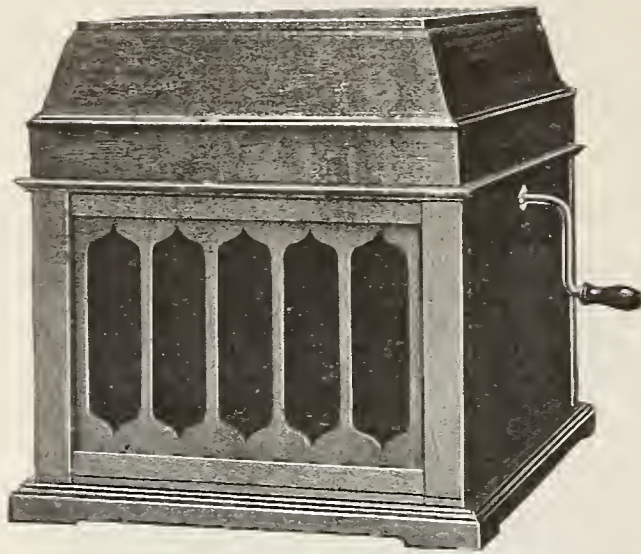

THE NEW EDISON DIAMOND AMBEROLA
MODEL 50

Ten Reasons Why Our Production of the New Edison Diamond Amberola and Blue Amberol Records is Constantly Over-Sold

- 1.—No continual expense for needles, no needles to lose, to be out of just when needed, to become scattered around the house, to prick the fingers, with perhaps serious consequences (especially in the case of children), to be put in their mouths by children, or to wear out expensive records when carelessly used. Instead, a permanent GENUINE DIAMOND stylus.
- 2.—Records almost unwearable and unbreakable, that retail in the United States at 60c, 75c and \$1.00—less than the price of talking machine records of the same individual selections, or selections of the same class.
- 3.—Marvelously sensitive Edison reproducer, the result of more than two thousand separate and complete experiments by the greatest inventor of the age.
- 4.—Simplest and most dependable mechanism ever put into a phonograph.
- 5.—Completely enclosed instrument that retails, in the United States, as low as \$35.
- 6.—Highest class talent in the musical world.
- 7.—Extensive library of records especially suited to the less-than-one-hundred-dollar trade.
- 8.—Musical superiority proven before phonograph experts by comparative tests with talking machines costing from two to five times as much.
- 9.—Manufactured under the personal supervision of Thomas A. Edison.
- 10.—Constant enthusiasm of dealers and sustained interest of owners because of complete satisfaction and extraordinary value for amount invested.

THOMAS A. EDISON, Inc.

Amberola Department

ORANGE, N. J.

BALTIMORE TRADE USING MOTOR TRUCKS TO SUPPLY NEEDS

Business for April Exceeds Expectations—Cohen & Hughes Open Exclusive Wholesale Department—Columbia Expansion—Fifty Per Cent. Increase at Droop's—News of the Month

BALTIMORE, MD., May 4.—There is a much better feeling over business in April among the dealers and jobbers in Baltimore than for several months. The reason is that all of them equaled or bettered the business of the same month of a year ago and went ahead of most of the month's trading for the year. Goods arrived better than those in most instances by express and boat, while the motor truck played a big part in making possible sales. Advertising by individual dealers besides the regular monthly ads of the Columbia and Victor Cos. kept the retail business alive and sound business methods by some of the dealers in going out into new markets for goods helped business.

One of the most interesting events of the month was the opening of the exclusive wholesale department of Cohen & Hughes, Victor distributors, at their Saratoga street building, just east of Howard. This building was erected by the firm less than a year ago, and part of it was leased to the Maryland Piano Co. A few months ago the Maryland Co. needed larger quarters and moved to Howard and Franklin streets, and I. Son Cohen, head of the firm, decided to separate entirely his wholesale and retail businesses.

A feature of this department is that it is headed by a young woman, Miss E. M. Griffin, who for a number of years has been Mr. Cohen's private secretary. Miss Griffin is well acquainted with the wholesale trade and having been a close student under Mr. Cohen has absorbed equally well the Victrola business and knows all of the details. The first floor, that is, half of the first floor, is devoted to general offices with a rest room for visitors, while the other half of the ground floor is devoted to the shipping department, with garage facilities for the company's motor trucks. The building is a three-story affair and the entire second floor and part of the third are devoted exclusively to record department and the balance of the building for the caring for the surplus stock of machines. The two departments of the firm are separated so well now that every record used by the retail department is charged out just the same as an outside customer, and Miss Griffin says she plays no favorites, so that the retail department of the firm is given no preference over any of her outside customers.

The firm has been making good use of its motor trucks to get machines and records. Mr. Cohen has been keeping some of his big trucks busy coming to and from the Victor factories, and a great deal of goods is delivered to customers along the routes without having to be rerouted at the Baltimore office. Mr. Cohen says he has not been able to get nearly enough goods, but business has been coming along very well, and the motor trucks have made possible some business despite the general shortage of goods. Among the customers who visited the firm during the month were James McFaquar, of S. Kann Sons & Co., Washington; J. F. Hargest, Pocomoke City, Va.; Mr. Caulfield, of Burke-Hume & Co., Norfolk, Va.; Mr. Levy, of Ferguson, Lillienfeld Co., Norfolk, Va., and Charles Jacobs, of Jacobs Brothers.

Harry M. Little, in charge of Cohen & Hughes' retail department, reports a fine business for the month. Mr. Little recently had an exceptionally fine window display featuring Victor records and a Victrola. A large American flag from a flag staff with a cardboard soldier on guard and with grass and lanes of gravel made the window most timely. Various Victor records arranged artistically were placed in various places about the display. During the early part of the evening an electric light shaped into a searchlight effect was thrown on the Stars and Stripes. The cardboard soldier was made by Mr. Little, by cutting the figure out of a large Marine poster that is being used to stimulate recruiting.

Showing a substantial increase for April over the same month of a year ago, and making the quota set for the month, W. S. Parks, manager of the Columbia Graphophone Co.'s Baltimore headquarters, is well pleased with business. This was accomplished despite the fact that goods are not coming in as well as he would like to have them. But Mr. Parks just forces goods in when he is able to get the factory to have them started. Motor trucks have been pressed into service. He has his goods shipped to Hagerstown, about a hundred miles from here, and sends trucks there for the goods. Instead of bringing the goods back to Baltimore he has his men reroute them there and a great deal of the shipment is delivered from that point by either freight or motor trucks.

During the month Mr. Parks made a flying trip to Roanoke and Lynchburg, Va., and stimulated the dealers to activity. He says the prospects for business there are bright, and he expects to see some fine results come out of that section. Among the visitors to the Columbia headquarters during the month were Mr. Freeman, of the Hopewell Furniture Co., Hopewell, Va.; Mr. Carey, of the Columbia Co., Norfolk, Va.; Mr. Coteen, of the Phillips, Levy Co., Norfolk, and Mr. Freedberg, of the Virginia Mercantile Co., Norfolk; M. B. Kornman, of 706 H street, N. E., Washington, a new Columbia dealer, and Kelly Moust, now manager for Lansberg, Washington, and formerly of Hecht's Washington store.

Daniel De Foldes, in charge of the dealers' service department and the international record department, made a trip to New York last week and from headquarters obtained some fresh ideas for his place. P. W. Peck and A. B. Creel, two of the Columbia road men, have purchased new motor cars as the result of the fine business done by them in March.

C. Fred Smythe, in charge of the Dictaphone Co., for Columbia, and who took charge of that department in January, has broken all records for sales. He not alone has bettered any previous month's business done here, but he has beaten the fine marks each month that he has been making and Manager Parks is more than pleased with the record of his Dictaphone man, because he was responsible for bringing him to this city. Harry Dise has been placed in

charge of the accounting department of the Baltimore Columbia branch, and he has reorganized the branch and introduced many up-to-date methods.

W. C. Roberts, manager for E. F. Droop & Sons Co., Victor distributors, is very happy this month, for he is able to report an increase of 50 per cent. in his business. This is the first time since the holiday season that Mr. Roberts was enabled to make any kind of showing. Aside from one month's December business April was the best month that the firm ever had. Mr. Roberts was able to get goods through by express and by boat from Philadelphia. Mr. Roberts also was able to run ahead by the fact that he was able to obtain big shipments of records from some Western jobbers. Among the visitors to the Droop Co. during the month were George Lyons, of Ornstein & Co., Philadelphia; J. W. Wheatley, Easton, Md., and Kirk Johnson, Lancaster, Pa. Maurice Kirsch, of the wholesale department, made a tour through Pennsylvania during the month. This is the first time that Mr. Roberts has sent a territory man out for several months. Retail business is more than holding its own, but many sales for records are being lost because of shortage in this department.

Jesse Rosenstein, for the National Piano Co., Pathé distributors, was in New York last week looking over the field and was making a determined effort to get more goods. The Standard Furniture Co., of Murfreesboro, N. C., has become a Pathé distributor. Eddie Rosenstein, who for a time looked after the wholesale department, has enlisted in the Aviation Corps and is now at Kelly Field, Tex. Business with the firm is reported as good.

H. R. Eisenbrandt Co., Victor distributors, report retail business good, but wholesale business not as good as they would like to have it, owing to shortage of goods. They have been able to get in some goods, but not near enough to meet the demand of their trade.

The Victrola department of the Maryland Piano Co., Inc., John Slockbower, manager, is now in shape and the half a dozen booths of white ivory on the first floor make a very attractive place. Indirect light effect is used and the general scheme of the place is of an ornamental and tasteful nature.

Sol. Rosenstein, of the Rosenstein Piano Co., Columbia dealer, has just inaugurated an international department for records in his store and has the place ornamented with the colors of the Allies. He is looking forward to fine business.



Summer time—the play time—
nothing sounds so sweet as a
Schubert out of doors; on the
porch, in the cottage or at the
camp.



Dealers do well to remember that the

SCHUBERT PHONOGRAPH

is being used more and more to furnish after-
noon as well as evening entertainment—out-
doors as well as in the home.

This means a steady source of income for Schu-
bert dealers. Are you one of them?

Five Models, \$60 Up

The BELL TALKING MACHINE CORPORATION

Offices and Show Rooms, 44 W. 37th St., New York

Factory, 1 to 7 West 139th St.

Smith-Woodward Piano Co., 1018 Capitol Ave., Houston, Tex., Local Distributor





Stracciari—

The great baritone who daily grows greater in musical stature.

What do you think of his latest Columbia Records?

Columbia Graphophone Co.
Woolworth Building, New York

LEIBOWITZ OPENS NEW STORE

Talking Machine Man in Bronx Now Has Two Establishments in Fine Residential Center—Handling the Columbia Line With Success

One of the most successful talking machine dealers in the Bronx is Louis I. Leibowitz, who recently opened a new store at 1082 Southern boulevard, which has been meeting with remarkable success. Mr. Leibowitz has another store at 897 East 163d street, and as these two establishments are located in a residential center that is growing steadily, Mr. Leibowitz has been able to build up a very large record trade in addition to a splendid talking machine business.



Louis I. Leibowitz

A few years ago Mr. Leibowitz became interested in the possibilities of the talking machine



The Main Store on 163d Street business, and after making a careful study of the field was successful in securing a license to merchandise the products of the Columbia

Graphophone Co. Mr. Leibowitz then opened the store at 94 East 163d street, handling the Columbia products exclusively, and through the use of aggressive merchandising methods and by carrying a complete stock of machines, with



New Store on Southern Boulevard

a representative library of records, soon succeeded in building up a large and very profitable trade.

Always on the lookout to expand his business Mr. Leibowitz made a survey of the neighborhood and became convinced that Southern boulevard, near Westchester avenue, was a very desirable location for a phonograph store, and last fall leased the store at 1082 Southern boulevard.

This store was fitted up most attractively and an efficient mailing campaign soon produced good results. Mr. Leibowitz is an enthusiastic admirer of Columbia products, and one of the most important branches of his business is the foreign language record division, and the demand for this type of record is increasing rapidly.

Joseph A. Cramer is now the sole owner and proprietor of the Odeon Music Co., which handles the Brunswick phonograph as well as pianos and musical instruments, at 28 Liberty street, New Brunswick, N. J. Dr. F. E. Elmer is no longer connected with the company.

SELLING AGENTS FOR STRADIVARA

Schilling Piano Co. Announces Appointment of Josiah Partridge & Sons Co., Well-Known Furniture House, Who Will Give This Machine Wide Representation

An important deal was consummated the first of the month when the Schilling Piano Co., 112 West Twenty-third street, New York, Eastern distributors of the Stradivara phonograph, consummated an arrangement with Josiah Partridge & Sons Co., with executive offices and showroom at the furniture exchange, Forty-sixth street and Lexington avenue, New York, whereby on May 1 they became the selling agents for the Stradivara.

Josiah Partridge & Sons Co. is one of the oldest furniture houses in the country, having been established over seventy-five years ago, and is selling agent for such well-known concerns as C. B. & J. Warner Co., Inc., Warner Shade & Novelty Co., and the Lewisburg Chair Co., Lewisburg, Pa., and others. They maintain a vast selling organization which will now represent the Stradivara and will cover thoroughly the entire music trade as well as the furniture industry throughout the United States, Canada, Australia, New Zealand, Brazil, Argentina, Chile and various other foreign countries. With the consummation of the new arrangement the promotion of the Stradivara machines has been greatly augmented, and it will undoubtedly acquire an international as well as national reputation.

MCCREERY HELPING "OUR BOYS"

Advertise Plan of Collecting and Buying Records and Machines for Soldiers and Sailors

The Victrola department of James McCreery & Co., Fifth avenue and Thirty-fourth street, carried the following advertisement suitably displayed in the New York papers during the past week:

"To collect records and talking machines for our soldiers and sailors.

"To help this cause James McCreery & Co. have adopted the following plan of buying records and machines for our soldiers and sailors:

"James McCreery & Co. will pay you 10 cents for each old record brought into the store (this excludes all German records, as these have been interned), provided you purchase an equal number of new ones, and

"James McCreery & Co. will pay you from \$5 to \$15 (depending upon condition and value) for every old talking machine, provided you purchase an equal number of new ones.

"Or, if you do not wish to buy any new records or a new machine, and you want to give your old ones to the soldiers and sailors, bring them in, and James McCreery & Co. will deliver them free of charge to the Y. M. C. A., Knights of Columbus or Jewish War Relief, who will forward them to the camps. On request we will call for machines or records."

Record Cleaners

The "Standard" Circular Cleaner grips the surface and clings as if on rails. A cleaner that has "made good."

PRICE, 50 CENTS, LIST

We also manufacture the "Simplex" Record Cleaner, 15 cents list price.

SEND 10 CENTS FOR A SAMPLE CLEANER

Automatic Stops



Automatic

Stops are in use everywhere. They give excellent service, are easily installed and are absolutely guaranteed.

SEND 50c FOR SAMPLE STOP

KIRKMAN ENGINEERING CORPORATION, 237 Lafayette St., New York

ST. LOUIS TRADE "OVER THE TOP"

This Is True Not Only in Sale of Liberty Bonds, But in Business—Active Despite Shortage in Stock—Kieselhorst Takes on Brunswick Line—Vocalion Demand Increases—Other News

St. Louis, Mo., May 8.—Talking machine dealers here expected a quiet month in April because of the Third Liberty Bond campaign, but it appears that St. Louis went "over the top" in talking machines as well as in Liberty Bonds. As a matter of fact, the dealers did not have much to say about April business until after the success of the loan was assured. It may be that they did not want any one to think they had been getting money that should have gone for bonds, but when the success of the loan was announced they talked freely. It may have been that they wanted to wait for the end of the month to be certain of their total, fearing all the time that there would be a slump. Increases as high as 44 per cent. over the previous April are reported.

These increases, of course, were with the fortunate dealers who have sufficient stock to make sales when the opportunity offers. There is no denying that there is a shortage of Victor machines, especially mahogany finish. A good many dealers have waiting lists for these machines and will have a nice run of business when the opportunity offers.

The Columbia, Edison and Brunswick are giving their trade a fair supply, in some cases all demands are being met. The jobbing trade was especially good during April, according to all reports. Small-town merchants are expecting a splendid summer business and are ordering freely. City dealers are piling up orders to fortify themselves against a possible shortage.

The Kieselhorst Piano Co. announce that Brunswick machines, Columbia machines and records and Pathé records would be sold from the Olive street store, which has been heretofore an exclusive Victrola store. Concerning this change, Mr. Kieselhorst remarked: "Of course, the adding of these two lines will mean changes and more business. Our facilities of one floor devoted to talking machine sales booths and another floor for record sales have already proved inadequate, so we are going to enlarge these facilities as rapidly as we can. We expect to put ten additional record sales booths in the basement part of our building at once. At the Market street store (known as the Piano and Talking Machine Exchange) we will show the lower-priced machines. Record sales have not been a great success there, and we will withdraw the records entirely from that store and sell them here." The Columbia line of machines and records have been on sale in the Market street store for some time.

At Aeolian Hall Manager Guttenberger reports excellent increases in Vocalion business, both in jobbing and retail. A number of the new dealers are taking hold well. Vocalion



A Finished Product

THE most expensively constructed and intelligently assembled line of Phonographs in the world—yet priced to show unusual value—

MANUFACTURED AND GUARANTEED BY

Phonograph Division

Upright Cases	Widdicomb Furniture Co.	Art Table Types
\$110 to \$250	Grand Rapids, Mich. Since 1865	\$125 to \$200

Chicago Exhibits

H. P. A. MOSSNER, Sales Agent	WIDDICOMB SALES CO.
532 Republic Building	Wholesale Distributors, 327 S. La Salle St.
SANBORN KINNEY CO.	H. DINWOODEY FURNITURE COMPANY
Sioux City - - - - Iowa	Salt Lake City, Utah
MEYER BROS. DRUG CO. - St. Louis	SHAW SUPPLY CO. - Tacoma, Wash.

Send for literature and information—The Creator of The Widdicomb will call by appointment during May and June on prospective jobbers and large retailers.

records are now being sold at wholesale to the newly-established exclusive Vocalion dealers, but are not yet on sale at Aeolian Hall, the reason being that so far the supply has not been adequate to taking care of the exclusive dealers and the big retail run on a popular number at Aeolian Hall. Mr. Guttenberger hopes to offer Vocalion records at retail after May 15.

Several of the new machines with the Universal tone arm are on exhibit at Aeolian Hall and have been highly praised. Especially has this praise been given to the playing of the various makes of records.

Ben S. Phillips, who was manager of the Columbia retail store here, has joined the Vocalion sales staff.

Manager Irby W. Reid, of the Columbia wholesale department, reports excellent general business in the entire territory. He has been busy keeping in touch with the various promotion plans being put on by his dealers, to all of which he lends especial attention. The continued success of the Columbia window display sets have proven interesting, also to observe how the idea has been adopted by others. A local dealer in a rival line saw the point so well that he is using hand-painted sets of his own design. They are of excellent workmanship, have certain individual touches for this store, which shows how well the idea has taken.

Wholesale Manager Salmon reports excellent country and city trade and that deliveries have been up to the most exacting mark. He says

that record orders have been filled about 95 per cent.

The reports of reductions in the supply of machines is not at all to the liking of dealers; they make no secret of that but they are making no complaint. They believe that the move is toward winning the war and that suffices for them.

The Home Talking Machine Co., a southside Columbia house, on the first of the month announced that it had arranged for a motor delivery service on records and machines for the entire city.

The line of machines made by the Vitrola Talking Machine Co., Chicago, which is distributed in this city by the Witte Hardware Co., is steadily growing in demand, and the Rice-Stix Drygoods Co. and the Phoenix Furniture Co. are doing an excellent retail business with the Vita-Nola. Many new dealers have been entered up during the past month.

THE RIGHT START IN ADVERTISING

A good start in advertising is like a good start in any kind of a race—it gives one courage and confidence. But a bad start does not always foreshadow a failure, rather a reverse. If the experience is used rightly it should switch the advertiser onto the road for success.

The door to the temple of success is never left open. Every one who enters makes his own door, which closes behind him to all others.

"In Tune with the Times"

We offer to the talking machine trade throughout the country a remarkable selling proposition in the

"American Maid" Phonograph

PURITY AND SWEETNESS OF TONE

The "American Maid" is supreme in its "tone" quality and all models are equipped with the "American Maid" universal tone arm playing any make record as it should be played. Each cabinet machine has tone modifier. Our Model A is heavily gold plated on all exposed metal parts.

A COMPLETE LINE OF ALL STYLES, SIZES AND FINISHES. GRACEFUL IN DESIGN, MATCHLESS IN EXECUTION, GENEROUS IN PROPORTION.

We are Specially Equipped and Stocked to Cater to the Export Trade. Inquiries Cordially Solicited.

C. JOHN A. WOODS & SON, -- 25 Church Street, New York, N. Y.

RECITAL UNDER DETROIT ASSOCIATION AUSPICES A HIT

Members Decidedly Well Pleased With Their First Effort, Which Drew a Capacity Audience—Will Benefit Business—J. L. Hudson Co. Occupies Handsome New Home—Other Happenings

DETROIT, MICH., May 9.—In querying Detroit talking machine dealers regarding April business we find that it was just about normal with the same month of 1917, but if we base figures on the gross for the first four months of 1918 as compared with the same period in 1917, we can safely report that this year's business is ahead, regardless of the repossessions this year, which naturally have been greater. It seems to be the same cry as during March—that machine business is fair—record business is very good—and collections improving. And you must remember that the Third Liberty Loan drive was on for three weeks during April.

The future really looks good for Detroit. It is true that we are very short of homes and also we are short about 30,000 mechanics and laborers. Wages are higher than ever before, and the Detroit Board of Commerce is working with the Federal Government doing all it can to bring the required number of workers here. Detroit manufacturers are blessed with big war orders, and it only remains for them to secure sufficient help to increase production.

Michigan went dry on May 1 without any ceremonies or any unusual scenes. A great many of the former saloon places are continuing in business, handling soft drinks and near-beers. However, the ultimate effect of prohibition ought to be beneficial to the music industry inasmuch as many men will be staying home more than formerly, and their wives are bound to have more money with which to equip their homes.

The recital given April 30 at the Arcadia under the auspices of the Detroit Talking Machine Dealers' Association was most successful, and the members feel that they have every reason to feel proud of their initial undertaking in this respect. Something like 3,000 people attended the concert, and had it not been for the hard rain which started right after the supper hour, keeping many people at home who had planned to come, the auditorium would never have held all the people. As it was, the crowd who did come enjoyed every minute of the concert as evidenced by their enthusiastic applause. The function started at 8 o'clock sharp and ran until 11.13. Some of the artists simply could not get through the crowd encoring and insisting upon "more" and "more." The artists who appeared were from the various talking ma-

chine companies and all were very well known in their respective fields. They include Billy Murray, Arthur Campbell, Henry Burr, Sterling Trio, Peerless Quartet, Fred Van Epps, Theodore Morse, Byron G. Harlan, Arthur Collins and John H. Meyers. The artists arrived in the morning and were the guests of members of the Talking Machine Dealers' Association, being entertained at luncheon at the Detroit Athletic Club and taken for motor rides in the afternoon. The concert committee consisted of Sam F. Lind (Columbia), chairman; Wallace Brown (Brunswick); Max Strasbury (Victor and Columbia), and Ed Andrew, of the J. L. Hudson Co. (Victor). But right here we want to give credit to every member of the local association, as all of them did their share in selling tickets and working up interest to make the concert a success. The entire profits of the concert have already been turned over to Detroit's Own Regiment, 339th, at Camp Custer cantonment. Next year, if all is well, the Detroit Association will give another recital or function of some kind for patriotic charity.

The gala event of May was the opening of the new music store of the J. L. Hudson Co. at 68-80 Library avenue, removing from the former location at 188-190 Woodward avenue. The new store is a fireproof building, about 60 by 120 feet in size, six stories high with a full basement. The company spent more than \$75,000 in remodeling it and installing a ventilating system, automatic sprinkler system, pneumatic tube cash carrying system. This is exclusive of the many thousands spent for decorations, rugs, carpets, electric light fixtures, etc. E. P. Andrew, general manager of the store, was given authority by the "powers that be" to spare no expense in making this new store as fine as money would go, and he has brought out an atmosphere of coziness and artisticness that is exemplified in few music stores. There are stores more massive and more impressing in some ways, but not for quietness and coziness. The first floor has two large windows, but they have no background so that from the front you can see clear through to the rear. One of the windows will always be for talking machines and records while the other one will be for pianos, players, etc. The sheet music, small goods departments, and fourteen record demonstrating

booths, occupy the first floor. Also a service counter sales, which is quite an innovation, as all sales are made over this counter, the stock being in racks in the rear of the counter. The second floor has the general accounting offices and the music roll department. The third floor has the private office of Ed Andrew, Jr., an assembly room for his salesmen and about twelve booths for displaying talking machines exclusively. In other words, the third floor is entirely for talking machines, both Victor and Sonora. On the fourth floor is the general office of E. P. Andrew, general manager of the store, the office of the sales manager, an assembly room for the sales staff, and large, roomy parlors for exhibiting straight pianos, both upright and grands. In the rear of this floor is space devoted to used pianos. On the fifth floor is the display of piano players, while on the sixth are finishing, tuning and stock departments. The basement is also for stock. The decorative colors throughout the store are French gray, French blue and French DuBarry rose. All fixtures even to the door hinges are aluminum and silver, and all exposed woodwork is dull finished American walnut, which includes the counters and main entrance doors.

The entire week of April 29 was given over to "openings," and each day was specifically devoted to some particular purpose. For instance, Monday night, April 29, was given over from 7 to 10 p. m. to music dealers, talking machine dealers, anyone affiliated with the allied trades. Nearly every dealer in Detroit, Windsor and nearby towns came to the store and attended the opening. Tuesday was not scheduled, as everybody had their minds on the concert that evening given by the Detroit Talking Machine Dealers' Association, the sale of tickets being at the Hudson music store. Wednesday afternoon, Wednesday evening and Thursday afternoon were for the public. Thursday night was for the music teachers, music instructors and music professors, while Friday evening was for the 3,000 employes of the J. L. Hudson store and the department managers. Saturday was "open" for business in the regular way, and we are glad to say that Saturday business was better than expected. During the first week of the openings there was "something doing" on every floor. On the first floor was a five-piece orchestra; on the second was the Hudson Quartet, one of the finest quartets in the country; on the third floor was a trio; a vocalist was on the fourth floor, Miss Elois Johnson, and Ursula Dietrich demonstrated the Apollo and Art-Apollo on the fifth floor. Among the beautiful floral pieces for the opening were those presented by the Sonora Phonograph Sales Co., Charles Marshall, Detroit manager; Grinnell Bros., Robert Alling, of the Edison Shop, and Sam F. Lind, of the Columbia Graphophone Co. The new Hudson music store is a monument to the music business and the Hudson Co., and it is sure to be very successful, being in the very heart of business activities and convenient to its former Woodward avenue location.

Wallace Brown, Brunswick dealer, has opened a branch store in the Polish district in north-east Detroit, which is in charge of an experienced phonograph man who speaks Polish. In addition to English records, foreign records will be handled. It is the intention of Mr. Brown, inasmuch as he has the exclusive agency for Detroit and Wayne County, to open Brunswick branches in other parts of the city during the next four months, so that by fall he will have branches established in the east, west, north and northeast sections.

The various wholesalers of talking machines and phonographs are of the same opinion in discussing the future. All say they have a good stock on hand, and believe they will have a big fall business if they can only get the goods.

Burton Collver, who formerly was with Grinnell Bros., and now with the Cheney Talking Machine Co., of Chicago, spent several weeks in Detroit and Michigan recently. Mr. Collver has put on quite a number of accounts and is confident of big fall business for the Cheney phonograph.

MAGIC-TONE STEEL NEEDLES



Prices for
IMMEDIATE DELIVERY
LOUD TONE

In lots of 10,000 - - - 65c. per thousand
In lots of 100,000 - - - 60c. per thousand

55c. per thousand in
lots of 500,000
and up

Packed 100 in paper envelopes or
300 in metal boxes

Owing to the uncertain condition of the steel market, we would suggest that you anticipate your requirements for months ahead. Send us your order at once as the price of needles is bound to increase in the near future.

I. DAVEGA, JR., INC.

Victor Factory Wholesalers

125 WEST 125th STREET

NEW YORK

"The House of Service"

VICTROLAS—SUPPLIES—NEEDLES

TWIN CITY TRADE STILL GROWING

Jobbers and Dealers Report Strong Increase in Volume of Business Handled Despite Stock Conditions—Rural Business Coming Well

MINNEAPOLIS and ST. PAUL, MINN., May 6.—Springtime is not the best time for selling talking machines, yet the Twin City dealers, particularly those in the jobbing section, are satisfied and, even more so, with their results in April and the outlook for May. Jobbers figure on a growth of from 25 to 100 per cent. in the volume of sales for the first half of 1918 as compared with the corresponding period of last year. This rather describes the local situation in St. Paul and Minneapolis in a brief way.

W. J. Dyer & Bro., St. Paul, and the Beckwith-O'Neill Co., Minneapolis, Victor jobbers, are making desperate efforts to assemble something that looks like a stock before the big rush begins. They know that it will be difficult to supply their needs, as the demands from the suburban districts even now take everything that comes to their warerooms almost before the goods are unpacked. There is only one satisfaction to the managers, and that is that nothing has any chance of becoming shopworn. Now that is a pleasant thought, as there are some lines of trade in which the fear of goods becoming shopworn is persistent and perennial.

Edison business in this Northwestern territory will show a very substantial increase. The Minneapolis and St. Paul retail houses have sold much more than a year ago while the jobbing trade of the Minnesota Phonograph Co. will show better by from 40 to 50 per cent., according to President Laurence H. Lucker.

A part of this increase is due to a systematic spurring and coaching of the rural dealers. As, for instance, the house had an account in one of the most prosperous towns in Redwood County, Minnesota, but the man was not doing what he should with his operators. So the house sent down one of their live wires—Stinchfield is his name. In an even week he had

MICA
Diaphragms

Quotations and samples promptly forwarded upon request
Don't be caught short
Cover yourselves now
INTERNATIONAL MICA COMPANY
Offices and Factory, 37th and Brandywine Streets, WEST PHILADELPHIA, PA.
PHILADELPHIA PA. CHICAGO, ILL. (Insulation Dept.) AMELIA CO. VA. MONTREAL CAN. WEST PHILADELPHIA PA.

closed sales aggregating more than \$2,700. The dealer got a goodly bundle of money—that he really did not deserve—and also he had his eyes opened. It is believed that his blindness has been cured, at least for a time.

The new Brunswick phonograph is running about 100 per cent. better in sales than it did a year ago, according to E. L. Kern, manager in this territory for the Brunswick-Balke-Coller Co. He predicts that the new tone arm permitting the Brunswick to play any and all disc records will make it the great favorite all over the country, and that the only limit will be the ability of the factories to reproduce instruments. Mr. Kern is devoting considerable time to the task of obtaining men for the company's Dubuque factory, which is losing men continually through the draft. He has met with some success, but finds that other industries are in the field for the same class of men. A shortage of machines is quite within the range of possibilities with the restrictions on material and labor on one side and the continued demand on the other. Mr. Kern has opened an account with the Hagen-Newton Co., Fargo, N. D., which is installing the most modern and complete phonograph headquarters in North Dakota. The plant will include several demonstration booths, a large record rack and proper display facilities, and will take the lead in every way, say its promoters.

Jay H. Wheeler, manager of the Pathé department of the G. Sommers Co., has gone to New York to select the fall stock. While he was away his assistants were superintending the construction of a gigantic record storage plant. It will have a capacity of 100,000 records, and almost any one would concede that such a number of records is quite a lot.

Reports from the Columbia wholesale headquarters in Minneapolis are in every way satisfying. The balance sheets to date show everything in favor of Manager Sprague and a continuance of good business is to be expected.

VERDI'S VIEWS OF THE GERMANS

A letter of exceeding interest appeared in the New York Times the other day from Edwin C. Boykin, who is connected with the editorial department of Edison publicity in Orange, N. J. The communication was based upon an extract from a letter written by Giuseppe Verdi, the great Italian composer, at the time of the Franco-Prussian war in 1870, and which Mr. Boykin deemed most appropriate to bring to light at the present time in view of war developments in the zone in which the Germans are at present operating. It read as follows:

"Our men of letters and politicians well may boast of German knowledge and science and—God forgive them—even of the arts of those conquerors; but a glance backward would let them see that the old blood of the Goth is still running in German veins; hard, intolerant despisers of all that is not German, and inclined to a boundless rapacity. Men of brains, but heartless, strong and uncivilized. And that King [William I., grandfather of the present Kaiser], who, in the name of God and Providence constantly on his lips, destroys the best part of Europe and thinks himself destined to reform the manners and punish the vices of our modern world! What a missionary!

"The composer of 'Trovatore' and 'Aida' was not without insight into the true character of the despoilers of the world," remarked Mr. Boykin in closing.

GIVE YOUR DEALER WHAT HE WANTS

AND HE WILL ALWAYS BE YOUR DEALER

The *Play-Rite* is not merely manufactured—but created.

The very best tone arms you can install in your machines—They have proven to be the loudest and clearest tone reproducing arms on the market—They are beautiful in appearance—and are reliable. Guaranteed to give perfect satisfaction.

Beware of Infringers and Imitators

Unless these tone arms bear our trade mark they are imitations.

Play-Rite

Look for our trade mark. It insures quality.

Although the appearance and construction of these arms are different, they both represent the very best quality in tonal construction and have the largest number of talking points to choose from.

REPRODUCERS SOLD IN QUANTITIES AT VERY LOW PRICES

Write for descriptive leaflet, samples and prices.

Do It Now!

AMERICAN PHONO PARTS CO.

512 WEST 35th STREET
CHICAGO, ILL.



No. 7

If you have used this Arm and it has not given satisfaction, the answer is this: You have been buying an imitation. GET THE ORIGINAL. IT DOESN'T COST ANY MORE.

LOOK FOR TRADE MARK HERE

No. I. W.
(Patented)

Proven to be the loudest and clearest tone reproducing arm on the market.

Quick Selling Points:

No screws to tighten, locks itself into either position. Length can be adjusted to center arm for any record. Originators of the "Spring Screw feature" that locks itself into place.

LOOK FOR TRADE MARK HERE

GENERAL ACTIVITY PREVAILS IN PORTLAND DISTRICT

Oregon Talking Machine Men Keep Things Going and Overcome in Some Measure the Shortage of Machines and Records—New Concerns Enter the Field—General News of Interest

PORTLAND, ORE., May 4.—Scarcity of talking machine records of patriotic and popular airs has been one of the chief barriers to splendid business in the record departments in Portland for several months, but this condition is rapidly being alleviated and some of the lines have so managed that the pinch has scarcely been felt. The Columbia Co.'s local branch has been fortunate in having a splendid supply of records and has been able to supply all dealers with what they have asked for. The Third Liberty Loan has not hurt business at all at this house, according to Manager Heater. Henry Schmidke, a valuable member of the sales force, has been drafted and will leave for camp in a short time.

An arrival of Pathé machines aided materially in assuaging a shortage of stock at Calef Bros., only one machine being on hand when the shipment reached Portland.

Shipments of records from Chicago, Salt Lake

and Denver have done much to relieve the shortage at the Hyatt Talking Machine Co. The situation as regards Victor and Edison records was becoming critical, but now Mr. Hyatt believes he will be able to take care of his trade.

Four months ago the Graves Music Co. received two carloads of talking machines. The day before Easter only ten of them were left. To-day there is not a machine in stock and orders have been taken for so many more that another big shipment, momentarily expected, will last only a short time. In fact, a third big order has been forwarded even before the arrival of the second lot. W. L. Le Vanway, in charge of the phonograph department at the Graves store, says that April business was 50 per cent. greater than in March, with every indication of continued prosperity.

A big shipment of Victor and Columbia records reached the Meier & Frank Co. in mid-

April and a big demonstration was given in the music hall April 16. A large crowd was in attendance. Demand for Brunswick machines has continued at the Wakefield Music House and the supply is now so short that there are not enough left in stock to fill the demonstration booths.

Shortage of Victor and Edison machines is reported by the Reed-French Piano Co.

Dealers report that they have been able to meet the demand for Columbia records and this is ascribed to the fact that the Columbia people are sending virtually all their records by express, although the time required for deliveries is not much less than it was for freight shipments in pre-war days. Small graphophones are also being sent by express. Graves Music Co. has been boosting the sale of small Columbias and has been doing a big business with 15s, 18s and 45s. Special advertising has been given by this house to these instruments. The same house reports sales of Edison and Stradivara machines in such quantities that it is almost impossible to supply the demand.

Classical records as well as popular and patriotic records have been in demand. Since the Frieda Hempel, Louis Graveure, Mischa Elman and Galli-Curci concerts in Portland the records of these artists have been very popular.

The G. F. Johnson Music Co. reports an ever-increasing demand for records of the Victor French courses, both teachers and soldiers making heavy inroads on the stock of these records.

Reports from Baker, in Eastern Oregon, are that Frey's Sporting Goods Store is making a fine display of Brunswick talking machines.

From the Morris Music House at Eugene, Ore., in the Willamette Valley, comes word that the new Edison is having a big sale.

Eilers Music Store has been fortunate in disposing of surplus record stock through the energy of Miss A. Bennett, in charge of the record department. Miss Bennett has realized the shortage of popular and patriotic records and has been showing customers good numbers, of which there is a surplus, and satisfactory sales have resulted.

Sherman, Clay & Co. are feeling the shortage of Victrolas, according to F. D. Addis, of the Victrola department. Business is increasing so rapidly at this house that sales could be tripled over last year's mark if machines could be obtained. Machines shipped more than two months ago have not yet been received here. The public is still calling for the larger machines.

Shortage of the larger-sized Victrolas at the G. F. Johnson piano store has made it necessary to supply customers with smaller machines, says R. F. Callahan, sales manager of the talking machine department of this house. Now a big shipment of big machines has arrived and sales are picking up wonderfully.

One of the new houses in Portland has been doing a large business with the Victor and Brunswick machines. The Seiberling-Lucas Music Store, formerly a small goods and sheet music store, has become one of the big houses of the city since putting in talking machines.

Graves Music Store has one of the liveliest phonograph departments in the city. Manager Le Vanway delivered twenty-three talking machines in one day recently, all makes, and some were large, handsome instruments.

BOOKING GOOD BUSINESS

Illsley, Doubleday & Co., New York, manufacturers of Illsley's graphite phono spring lubricant, are making plans for a prosperous year with this product, as the majority of the manufacturers using this lubricant have already placed large orders for 1918 to cover their requirements. The company states that it is receiving inquiries month after month from dealers and jobbers, through its advertising in The Talking Machine World, and that these inquiries have been turned into profitable sales. This lubricant has been merchandised to the trade with the idea of making it a standard in the field, and the results to date have been very satisfactory.

CABINET

SUPREMACY



A Century Model

¶ In every industry there is a *leader* and this Company has conducted its business with the one thought in mind of being the *leader* in the talking machine cabinet industry.

¶ How well we have succeeded is indicated by the fact that

CENTURY CABINETS

are being used exclusively by the majority of the leading talking machine manufacturers. **Century Cabinets** are giving absolute satisfaction to every user, and every cabinet is guaranteed by the *world's largest manufacturer* of talking machine cabinets.

CENTURY CABINET CO., 25 West 45th St., New York
FACTORY: UTICA, N. Y.

There are more reasons which you can give a man for buying a Vacation Model Grafonola than there are pretty girls on the beach in August—

And that is quite some!

**Columbia Graphophone Co.
Woolworth Building, New York**



U. S. COURT GIVES FINAL DECISION ON VICTOR CONTRACTS

District Court Hands Down Findings Against the Contract System of That Company to Settle Formally Long Discussion—System Already Abandoned—L. F. Geissler Explains Situation

The daily papers on May 4 published some sensational and, in many cases, misleading statements regarding the decision handed down recently by Judge Augustus N. Hand in the United States District Court for the Southern District of New York, against the Victor Talking Machine Co. Some of the papers even went so far as to declare or insinuate that the decision practically ordered the dissolution of the company.

As a matter of fact, the ruling of the Federal District Court above referred to was upon the contract system of the Victor Co., regarding which there was some question following a decision of the Supreme Court against that company a year or so ago. It was decided to get a court ruling on the contract, and the decision of the District Court represents that ruling, which will be accepted by the Victor Co. without appeal.

In discussing the case, Louis F. Geissler, general manager of the Victor Talking Machine Co., said: "The decree issued by Judge Hand against the Victor Talking Machine Co. is the outcome and final and formal action in a long discussion which has been pending with the Government for some time relative to our license or contract system of doing business.

"The decision of the Supreme Court of more than a year ago against us made it patent to us that our contract system, although sustained by practically all court decisions up to that time, would no longer be considered legal by the Government; hence, on May 29, 1917, we notified, by letter, all our trade that our license agreements were voided and no longer effective, for, while we and our counsel thought the contract all right, the Government evidently did not, and it was necessary to get a definite ruling in order to close the discussion. The company agreed to accept the court decree.

"The decree signed by Judge Hand is of importance only in the sense that it definitely concluded the discussion which had been in progress between the Government and the company. The practices complained of having been discontinued long ago, no changes by the Victor Co. as a result of the decree are necessary."

REPEAT ORDERS FOR HOFFAY LINE

Ingenious Features of "Air-Tight" Talking Machines Commend Them to Trade—Sales Manager Kingsberg Planning Trip Throughout Country—Secure Larger Floor Space

"Repeat orders evidence, as nothing else can, what favor the Hoffay air-tight talking machines find with dealers," declared Alexander Kingsberg, sales manager of the Hoffay Talking Machine Co., 3 West Twenty-ninth street, New York.

He is at present calling on the trade in adjacent territory, preparatory to covering the United States and Canada to place agencies, and states that the manifestations for the Hoffay are more marked than ever and will result in a banner year. The steadily increasing demand for the Hoffay talking machines has necessitated the expansion of quarters at the Twenty-ninth street address and negotiations are being made for still larger floor space.

"It is not at all surprising that the Hoffay machines with their ingenious features are being taken up so rapidly by dealers throughout the United States and Canada," Mr. Kingsberg remarked: "The universal tone arm enables the playing of all makes of records and the 'Resurrectone' reproducer to the highest degree acquits itself of the artist's interpretations. Voluntary testimonials have given us more ground than ever upon which to substantiate our claims regarding the standing of the Hoffay air-tight talking machines."

"Don't send out letters simply to keep stenographers busy. Employ a sufficient number to mail the necessary amount—and keep them going all the time. Don't let mail leave your office without an advertising enclosure of some kind.—Publicity.

10 PER CENT. WAR TAX IN CANADA

War Excise Budget Provides Heavy Burden for Talking Machine and Record Manufacturers

OTTAWA, CAN., May 4.—Nothing has created so much talk in commercial circles for some time as the recent budget speech delivered by the Hon. A. K. MacLean, acting Minister of Finance. The piano and phonograph industries came in for their share as was expected, and there will be levied a war excise tax equal to 10 per cent. upon automobiles, gramophones, graphophones, phonographs, talking machines, cylinders and records therefor, mechanical piano and organ players and records therefor, when manufactured or imported after the 30th day of April, 1918, on the duty paid value when imported and on the price when manufactured and sold, provided that such war excise tax shall not be payable when the articles are manufactured for export.

USES FOR RECORDS AND NEEDLES

When Musical Value Is Gone They May Still Prove of Use to the Handy Housewife

All the phonograph records you don't care to hear any more are still of use, the Illustrated World advises housewives. On ironing day take out one record and place on the board and you will be introduced to a new and improved ironing wax when you lightly place the iron on the record.

Take all the old needles and put them into a bottle or small jar on the sink, and whenever you have a dirty bottle, such as a milk bottle, vinegar cruët, etc., just pour them into it and shake well. In half a minute the bottle will be clean.

**Why Break Records?
Just File Them!**

That is if you have the wonderful Record filing system which is a feature of

The Marvelous MAGNOLA



Watching the Music Come Out

This is only one feature of many that will command your interest and attention. Let us send you handsome illustrated catalog and information as to our plans for helping you to make money with MAGNOLA.

MAGNOLA TALKING MACHINE COMPANY

OTTO SCHULZ, President

General Offices Southern Wholesale Branch
711 MILWAUKEE AVENUE 1530 CANOLER BLDG.
CHICAGO ATLANTA, GA.

The BEST TALKING MACHINE NEEDLE

On the Market—Packed in Counter Salesman



50 Needles to a box and they retail at 10c. per Box.
60 Boxes to a package \$6.00.
This package costs you \$3.90 net.

Your profit is \$2.10 and your customer gets a needle that will give satisfaction.

The Fred. Gretsch Mfg. Co. 60 Broadway
Brooklyn, N.Y.
Manufacturers of Musical Instruments

THE AEOLIAN CO. ANNOUNCES THE VOCALION RECORD

Aeolian-Vocalion Record Now Ready for the Market—Embodies New Recording Features—Is Hill and Dale Cut, Ten and Twelve-Inch, Single and Double Faced—Will Be Marketed Through Vocalion Representatives—Recording Studio in New York Splendidly Equipped

The Aeolian Co., New York, is now ready to announce to the talking machine trade the new Aeolian-Vocalion record. The first list of records is now ready for general distribution, and plans are being formulated whereby the merchandising of this record will be conducted in the thoroughly efficient manner which characterizes all Aeolian merchandising plans.

Behind this important announcement in behalf of the Vocalion record lies an interesting history of progress and development. The Aeolian Co. has never been satisfied to place any product on the market bearing its name, without knowing that this product represented something different and distinctive. In fact, it has been this constant aim to give the musical world something new that has made the Aeolian Co. world-famous and a recognized leader in international musical development.

The Aeolian Co. in its very successful history has always endeavored to create rather than to imitate. It has been a pioneer in the player-piano and organ fields, and its player-piano products have won recognition the world over. The Duo-Art reproducing piano, the company's most recent development in the player-piano industry, has won enthusiastic endorsement from the most famous musicians, who acclaim it as one of the greatest achievements in the history of music.

When the Aeolian Co. a few years ago decided to manufacture talking machines it did not make any immediate announcement to this effect, but for several years the company's technical experts thoroughly investigated the scientific features of the talking machine. Every known improvement and scientific achievement was given careful consideration during this period of investigation, and this research was especially significant in view of the fact that the Aeolian Co.'s technical staff comprises not only musicians and artisans of great ability, but several scientists of note. For several years these men labored to develop the phonograph, working for two years in collaboration with Professor Dayton C. Miller, of the Case School of Applied Science, one of the greatest living authorities on tone and tone quality.

Finally in 1914, these technical experts decided that they were ready to introduce the Aeolian-Vocalion phonograph and this instrument was presented to the musical world as an instrument that embodied numerous improvements of great musical value. The subject of musical tone was thoroughly discussed in all literature that the company issued; and when the instrument was placed in the hands of the dealers, it carried with it the absolute

introduction of the "Graduola," which was embodied in the Vocalion in order to permit of tone control. The "Graduola" has won recognition as one of the simplest and most efficient means of phonographic tone control yet devised.



Where the Vocalion Records Are Made

After the perfection of the Aeolian-Vocalion phonograph and its subsequent success with musicians and the general public, the Aeolian Co. continued to experiment in the different realms of phonograph research, but the company's technical experts finally reached the stage where they were in a position to tell the officers of the company that in their opinion "the Aeolian-Vocalion phonograph represented the acme of perfection, musically and scientifically."

In this report there was also submitted a suggestion that the musical prestige of the Aeolian-Vocalion phonograph could be further strength-

lian Co. decided that a talking machine record bearing the Aeolian name was the only practical solution of this problem. It was determined that nothing would be left undone to make the record bearing the Aeolian name a worthy companion to the other famous Aeolian products, and with this determination in mind, the technical staff was instructed to concentrate its efforts upon the production of such a record.

For two years these scientists and tone experts experimented with new and different systems of recording. No time or expense was spared in the hope that one of these new systems might be utilized in the production of a record that would fully satisfy the Aeolian executives and technical staff.

Experimentation was going forward in the Aeolian technical laboratories when a cablegram was received at Aeolian Hall from the company's English branch, saying that an inventor had submitted samples of a phonograph record which was of marked superiority, and that there was a possibility of acquiring the process by which it was made. Following this cablegram a number of specimen records were received and given exhaustive hearings and tests.

In order to insure the acquisition of so valuable a method the president of the Aeolian Co. made a special trip to London in order to investigate the matter personally. He found that the improvements in the new process were so important that its inventor had already been able to secure patents in all of the principal countries.

Further investigation strengthened the first favorable impression the records had made, and after a short period of negotiation, the patented rights to the new method were purchased, and the men responsible for the new record were engaged to continue the development of the system under the auspices and in the laboratories of the Aeolian Co.

Discussing this method of recording from a scientific standpoint one of the Aeolian Co.'s technical experts remarked:

"As is generally understood, all sounds—musical tones included—are conveyed to the ear by what are known as sound, or tone waves. These waves, while intangible and invisible, can, by means of recently devised scientific appliances, be observed, measured and accurately estimated, through certain effects they produce.

"While investigation of musical tones through various apparatus is not new, no such accurate observation has hitherto been possible, and it is of more than passing interest to know that the Aeolian Co., in addition to its own completely equipped acoustical laboratories, has been in a position to profit by these new appliances and researches of their inventor, who is recognized as one of the most noted contemporary authorities on the phenomena of sound.

"It has been established that all musical



Two Views of the Handsome and Splendidly Appointed Artists' Room in Aeolian Recording Studio

endorsement and guarantee of the Aeolian Co. The success instantly achieved by the Aeolian-Vocalion reflected the importance of the new scientific and musical qualities which it embodied.

The distinctive and outstanding feature of the Aeolian-Vocalion was its tone quality and the

ened if a record was perfected that would harmonize completely with the scientific perfection of the Aeolian-Vocalion. In other words, these experts expressed their belief that further progress in the phonograph field was not possible, except in the development of the record.

With its customary progressiveness the Ae-

tones are composite in character—that is, each tone is composed of a greater or less number of individual tones. Every composite tone, such as a note of the human voice, the violin, or other instrument, has a fundamental or basic tone, and a long or short series of overtones as well.

"These overtones or partials are what determine the character of each distinctive tone, their number and relative amplitude being the decid-

the waves entering the large end of the horn, and being brought down and intensified as they approach the smaller end. Here they strike

the process employed makes possible, are reproductions of the sound waves that have been recorded. The fidelity of this correspondence is the exact measure of the similarity between the original instrument and the phonograph's reproduction of it.

The Vocalion Method of Recording

"The problems presented in record-making are exceedingly difficult. Sound waves are usually delicate and complex. To reproduce the natural timbre of the violin, or any other instrument, every minute variation of its wave must not only have its exact counterpart in the line cut in the wax, but the needle, or reproducing point of the phonograph, must be of a nature to 'feel' and respond to these almost imperceptible variations. Herein lies the superiority of the Vocalion method of recording and reproducing. By this method the resistance of the cutting tool to the wax is reduced to a minimum, and the minute vibrations in the sound waves, caused by partials or overtones, are capable of being accurately recorded. The new method catches these delicate tone elements and faithfully records them.

"The Vocalion method of reproduction with the fine-pointed needle in turn seeks out and reproduces what has been recorded, with the result that recorded tones, whether of voice or



One of the Recording Rooms in the Aeolian-Vocalion Laboratories

ing factor. When sounded, a musical note creates a number of distinctive waves, one for each of its partials. These vary in what may be called strength, as the partials themselves vary with the voice or instrument.

"No sooner are these waves formed than they all merge into one wave which carries in the irregularities of its outline all the waves of all its partials. It is essential to a comprehension

upon the diaphragm, which vibrates in response to their impulse.

"Connected with the center of this diaphragm by a delicate lever bar is a fine cutting tool. This tool, moving in response to the motion of the diaphragm, cuts a line in a revolving disc of soft wax, which line corresponds in configuration with the outline of the sound waves entering the horn.

"The wax is then allowed to set or become hard. After receiving a bath in an electro-chemical solution, which cuts it with copper, the disc with the line of sound imprinted upon it is carried through various depths before the phonograph record is finally completed.

"The reproduction of the sounds recorded is practically a reversal of the process of record-



Reception Salon in the Vocalion Studios

instrument, reappear in almost their exact original character, far clearer than has ever been possible before. This gives a sense of satisfaction in listening to Vocalion records not ex-



No. 1. Tuning Fork.—The tone of a scientifically mounted tuning fork is absolutely devoid of partial tones, hence the tone wave it creates is entirely free from the irregularities found in other tone waves, which are caused by their partial waves.

of this subject to understand that in recording and reproducing musical sounds the realism of effect is entirely dependent on maintaining the shape of these waves. (The accompanying illus-

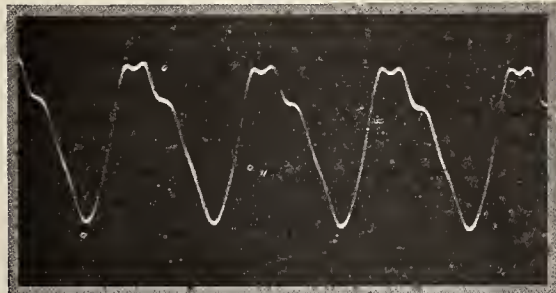

No. 2. The Flute.—The tone of the flute contains but few partial tones. The tone wave it creates is consequently far less regular than those caused by other instruments. This simplicity in the flute's tone, while possessing distinctive beauty, especially by contrast, makes it comparatively uninteresting as a solo instrument.

trations show the differently shaped waves peculiar to various instruments.)

Making a Record

"The process of record making is to-day practically standard with all the older companies, and remarkable results have been achieved in view



No. 3.—French Horn.—Here is another instrument with a smooth, more or less fluent tone, though quite different in quality from that of the violin. From the appearance of its tone waves, one might almost anticipate the rounded mellow beauty of this instrument.

of the difficulties offered by the systems employed.

"Briefly, this method involves a specially devised horn, into which the sound is projected,



No. 4. Oboe.—Here we have a tone wave which shows unmistakably a tone of very distinct individuality. The pronounced irregularities of the oboe's tone wave are caused by the dominance of certain of its partial tones.

ing. A needle or some other point is inserted in the sound groove, and as the record revolves, is moved either back or forth or up and down, in obedience to the variations in the line.

"Through another lever, to which the needle is attached, its movements are transmitted to a reproducing diaphragm contained in the phono-

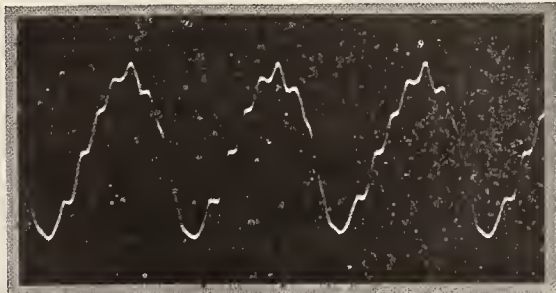

No. 5. Violin.—The tone of the violin has many partial tones. None of these is aggressively dominant, however; hence the fluent smooth quality of the instrument. This is shown in the photograph of its tone wave. There are many irregularities in the wave, but they are all too small to influence its general symmetry.

graph sound box. This diaphragm, vibrating in consonance with the movements of the needle, creates new sound waves. These, as nearly as

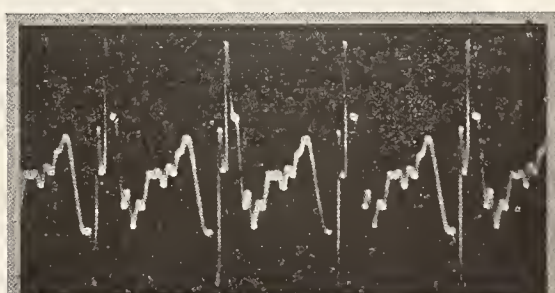

No. 6. Trombone.—The tone wave of this instrument denotes unmistakably the quality of its tone. Rich in partial tones and hence interesting and expressive, it is very characteristic and dominated by full, pealing notes.

perienced in others. They sound richer, fuller, deeper, more beautiful and more natural.

"Moreover, due to the difference in method, Vocalion records contain practically one-third more music than others; ten-inch records playing as long as the ordinary twelve-inch, and

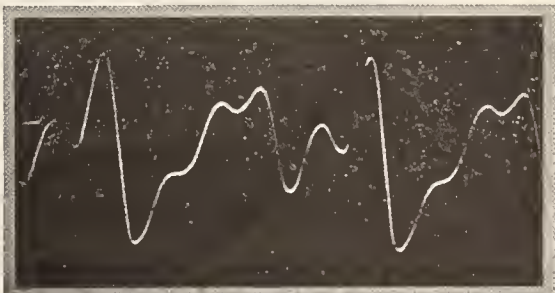

No. 7. Human Voice.—This tone wave was created by pronouncing the vowel sound "ah." The voice is particularly rich in partial tones, some voices indeed containing as many as forty very appreciable.

twelve-inch records playing correspondingly longer."

When the Aeolian Co. had perfected its new (Continued on page 70)

ANNOUNCE THE VOCALION RECORD

(Continued from page 69)

method of recording and was ready to start manufacturing Aeolian-Vocalion records, it decided that it would give this very important branch of its business befitting quarters. The company believed that the actual work of recording should be recognized as the most vital factor in the production of a record, and, although there was plenty of room available in Aeolian Hall on Forty-second street, arrangements were made to occupy an entire building at 35 West Forty-third street for recording purposes exclusively.

After leasing the building the Aeolian Co.'s executives made a careful study of the most intimate details of recording from a general standpoint. Negotiations were completed where by many well-known artists were engaged to make Aeolian-Vocalion records exclusively, and as this list steadily increased, the company realized that the subject of environment was an important item in the making of a successful record.

It is only logical to assume that an artist who enters a cold and dreary room prior to making a record will hardly be imbued with a spirit of warmth and enthusiasm. On the other hand, if the artist is received in a tastefully furnished and artistically decorated saloon, where a piano is at hand for impromptu and informal rehearsal or practice, it is only natural that he should enter the recording room with complete assurance and enthusiasm, and the finished record will doubtless reflect the mood of the artist.

Recording Studios Beautifully Furnished

With this idea in mind, the Aeolian Co. arranged to furnish its recording studios on Forty-third street in a thoroughly artistic and attractive manner. The reception room on the main

floor and the artists' room on an upper floor are all furnished in a way that cannot fail to impress the artist favorably and at the same time arouse in him a keen desire to make the best record that is possible.

This recording studio is splendidly equipped in every department, and under the capable di-

The Vocalion record will be merchandised through Vocalion representatives exclusively, and a complete library of all classes of music will be offered to these dealers. According to present plans the records will be double and single faced, and a ten-inch double-faced record will retail at 75 cents and upward, and a twelve-inch double-faced record at \$1.25 and upwards.

Is a Hill and Dale Cut Record

The Aeolian-Vocalion record is a hill and dale cut record, played with a needle, and the accompanying reproduction of the opening announcement in local newspapers will give some idea of the campaign that the Aeolian Co. will inaugurate in behalf of its new record. These records will be presented through the medium of consistent national magazine advertising, and through every other form of publicity that has been utilized in Aeolian advertising campaigns in the past.

With the Aeolian spirit and organization behind this record, together with its musical and scientific qualities, it is safe to assume that the Aeolian-Vocalion record will soon take its place as an Aeolian product that is entitled to worldwide recognition. Every form of co-operation will be offered the company's dealers in merchandising the Aeolian-Vocalion record, carrying out the company's plans of giving their dealers 100 per cent. service in handling Aeolian products.

H. N. BARRIGER IN NATION'S SERVICE

Head of Traveling Sales Staff of Crafts-Starr Phonograph Co., Richmond, Va., Joins Colors

RICHMOND, VA., May 6.—H. N. Barriger, who has been at the head of the traveling sales staff of the Crafts-Starr Phonograph Co., of this city, factory distributors for the Starr phonograph and Gennett records, has just been called into Uncle Sam's service. Mr. Barriger had been remarkably successful in introducing these products to the dealers in his territory, and among the representatives which he recently established were the following: Darnell & Thomas, Raleigh, N. C.; Winchester Electric Co., Charlotte, N. C.; F. H. Andrews Music House, Charlotte, N. C.; Lancaster Department Stores, Lancaster, S. C., and many other dealers who are well known in their respective localities.

A. J. Crafts, president of the company, states that business has kept up very well this year, and that collections are excellent. The only difficulty experienced by the company is in the accumulation of reserve stocks, but so far this house has been able to take care of its dealers with a reasonable degree of promptness, which, in view of existing transportation difficulties, is a very gratifying record. Owing to the difficulties in obtaining large shipments from the factory, the company has done no retailing, but the fact that it has conducted its wholesale department exclusively has been quite a factor in enabling it to take care of its dealers' requirements.



The AEOLIAN COMPANY ANNOUNCES THE VOCALION RECORD

A new phonograph record produced under a system differing from and superior to any hitherto used and resulting in a record of revolutionary character and quality.

IN this important announcement is chronicled the second great step taken by The Aeolian Company in its development of the higher musical values of the phonograph.

First, the Aeolian-Vocalion—that wonderful phonograph which three years ago startled the musical world and leapt almost overnight into the premier position among all such instruments.

Second, the Vocalion Record—giving the Aeolian-Vocalion, for the first time, a Record fully worthy of its extraordinary powers of reproduction.

Product of the World's Leading Music House

FOR nearly half a century, The Aeolian Company has maintained its position as the foremost creative influence in the music

industry. As a source of invention, progress and improvement, no other house has even remotely approached this Company's notable record of achievement. Today, The Aeolian Company stands without a rival in its comprehensive understanding of music and its broad and scientific knowledge of the various instruments for producing it.

The New Musical Values of the Vocalion Record

THE phonograph record itself is a marvelous invention. To hold in an inert and inarticulate disc the melodious notes of a human voice—the vibrant tones of a violin—almost baffles comprehension.

If these notes and tones have hitherto fallen a little short of nature—if some character, some richness, some of the more delicate qualities have been lost in their recording—it is no wonder. The only wonder is the marvel-

ous nature of the results accomplished.

The new Vocalion Record comes a sympathetic step nearer to reality.

Where with the old system only the broader, stronger elements in any tone could be recorded, the new system records the tone in its entirety. The finer overtones—those subtle partials that give to every instrument and voice its final touch of individuality and beauty—are, for the first time, caught and imprisoned by a far more delicate and scientific method.

Those who hear the new Vocalion Record are conscious of new impressions. To sight the phonograph remains—to hearing it is gone. The tendency to stridency—the lack of richness and of body—the vagueness of individuality—all the effects hitherto typical of even the best phonograph performances are replaced by natural verities of sound.

AN INVITATION—At Aeolian Hall on West 42nd Street and at The Aeolian Company's various Branches in the Metropolitan district, the new Vocalion Record is now on exhibition. The numerous owners of the Aeolian-Vocalion, the owners of phonographs of other make and all persons to whom progress in music is of interest, are cordially invited to the public informal demonstration of these Records, which for the present will be continuous throughout each day.

The AEOLIAN COMPANY

A. MANHATTAN 29 West 42^d Street
 B. THE BRONX 367 East 149th St.
 C. BROOKLYN 11 Flatbush Ave.
 D. NEWARK 895 Broad St.

Opening Announcement of Aeolian-Vocalion Records

rection of experienced musical and recording experts the record is turned out in its entirety in this studio. There are accommodations for every process incidental to the manufacture of the record, and the officials of the company, together with the artists and other interested department heads, are afforded the opportunity of listening to the completed record in the studios with the knowledge that every detailed process has been completed in that building.

Save Money on your next BOOTH Installation

We are in a position to build attractive sound-proof booths from \$100 up. We have been building booths, record racks and store interiors for three years, and can save you money on your installations. We use the best materials available and guarantee our work in every detail.

Let our representative quote you prices

H. MICKELAS - 164 McKibben Street - Brooklyn, N. Y.

PITTSBURGH DEALERS PLACE BAN ON GERMAN RECORDS

Association Formally Advocates the Internment of All Records of German Music, Those Made by Enemy Alien Artists and of Pacifist Tenor, for Period of the War—An Important Move

PITTSBURGH, PA., May 7.—German operas and music have been placed under the ban by the Metropolitan Opera Co. and other operatic and concert organizations. German books and books showing German influence have been removed from public and private libraries, and now the executive committee of the Talking Machine Dealers' Association of Pittsburgh has made plans for interning German vocal and instrumental records and records of a pacifist nature for the period of the war.

The executive committee declares that there is a distinct public sentiment against the sale and use of records of German music or records made by Germans, or German sympathizers, and that in their opinion it is better to remove the German records from shelves voluntarily than to wait for a suggestion to that end from outside sources.

The association has recommended that the German records be interned, but the action is not compulsory on the individual member. Each dealer must determine for himself whether he is to take the step of laying aside such records for the period of the war, or scrapping them entirely.

The resolution as adopted by the executive committee of the local association reads:

"Whereas, Victor, Edison and Columbia record stocks now on hand in the trade generally include vocal selections in the German language and instrumental records of German airs, and

"Whereas, Traffic in these German records, or the playing of them, is not consistent with our conception of true Americanism,

"Be It Resolved, That there be prepared, at once, a list of all Victor, Edison and Columbia records in any essential respect German, including other records of a pacifist nature, or by organizations or artists of known pro-German tendencies; and that such list be supplied to our

membership and the trade, with the recommendation of this committee that the records named therein be immediately withdrawn from stock and interned for the period of the war.

"Talking Machine Dealers' Association of Pittsburgh."

The resolution was sent to all members of the association, accompanied by the following explanatory letter:

May 6, 1918.

To Talking Machine Dealers:

We are face to face with the German record problem.

Talking machine dealers have the alternative of some quick action on their own initiative or of the same action but at the direction of our Government. The day is close at hand when German records and those who distribute them will both stand as menaces before the public.

In our opinion it is far better for us as patriotic citizens to remove from stock and store for the duration of the war every record which, by any possibility, might cause displeasure to a true American or give pleasure to a "Hun."

In conformity with the above the enclosed resolution and list were adopted. This list is the result of a very intimate study of the Victor, Edison and Columbia catalogs. It includes all records, both vocal and instrumental, which, in any particular, show either German origin or sympathy, all patriotic and national airs of other enemy countries, all records by artists or organizations whose whole-hearted loyalty for America has been questioned.

It is recommended that every one of these numbers be packed away until the final shot against Germany and her allies has been fired, and all insidious propaganda, espionage and sabotage have been crushed out of existence for all time.

Give as wide publicity as possible to the en-

closed resolution—it will put you solidly on record as a 100 per cent. American. Your customers will think more of you and will tell others of your patriotic stand.

Let us take this aggressive action without any delay—the situation demands it.

Executive Committee,

Talking Machine Dealers' Association of Pittsburgh.

A list containing close to one thousand records in German or records of German music, and other records deemed objectionable during the war, taken from the Victor, Columbia and Edison catalogs, were sent to members of the association, with a letter and the copy of the resolutions.

After sounding the sentiments of the local trade, it appears that the great majority of the dealers will follow the suggestion of the association officials to the letter, although there are some who will follow their own ideas as to the records to be interned.

EXHIBIT AT FURNITURE EXPOSITION

During the first week in May business was particularly good with both the wholesale and retail phonograph departments of the New York branch of the Brunswick-Balke-Collender Co. In the wholesale department during this week an average of one new dealer a day was added to their already large list.

E. G. Bryson, representing the house in Baltimore, has been transferred to the New York branch and been placed in charge of the Brooklyn territory.

The Brunswick phonograph has been displayed at the Furniture Exposition held at the Grand Central Palace, New York City, from April 29 to May 18. The exhibit was under the immediate supervision of Chester Abelowitz and C. J. Klacke. Results so far have proved very satisfactory, indeed, and the exhibit has been directly responsible for the closing of several new dealers for the Brunswick line who placed large initial orders.

Increase Your Record Business

Through Taking Advantage of the Grinnell Record Service

Increase it through carrying "live" numbers. Through having the stock to meet the demands of your record-buying public—and through their coming to know that their Record wants can always be supplied at your store.

Our service aids you in keeping your stock to a point of highest completeness at all times.

We make it a point to fill every order within a few hours' time, at the most, after it is received. The transportation facilities at our command enable us to make delivery to any part of the country with utmost dispatch.

The same superior service that is so rapidly building our business can have a definite part in increasing your own!

TRY US ON YOUR NEXT RECORD ORDER!

Grinnell Bros

Distributors of Victrolas and Records

First and State Streets

DETROIT

You shouldn't be without—

First Aid Course in French

**Marconi-Victor Course in
Wireless Telegraphy**

**Oscar Saenger Course in
Vocal Instruction**

**Foreign Language Records of
the Nationalities in
Your Locality**

—They're a sure source of added profits!

Let us add your name to our list of those receiving our advance announcement of best selling Records—as selected by our committee of twelve. You'll find it of great assistance in ordering. Mailed free each month.

HOW RICHMOND DID ITS SHARE

Great Concert Arranged for by the Corley Co. Helps to Raise Over \$2,250,000 for the Liberty Loan—An Inspiring Gathering

RICHMOND, VA., May 8.—During the intermission at the annual May Festival of the Wednesday Club, of this city, a patriotic scene was enacted that stirred Richmond deeply and was felt throughout the country. This concert was one of a series arranged for by the Corley Co., of Richmond, in direct keeping with their slogan, "The House That Made Richmond Musical." The affair was held in the Auditorium, the largest meeting place in the city and a capacity attendance was recorded.

The Russian Symphony Orchestra stirringly rendered "Dixie" and spirited Liberty Loan appeals in speech and song were made by Sophie Breslau, Mabel Garrison and others. The scene was thrilling. The audience rose to its feet as one man and the pledges commenced to pour in. And they continued to pour until approximately \$2,250,000 was subscribed. This, together with amounts pledged at other meetings, put Richmond away ahead of her allotted quota to the Liberty Loan.

It is interesting to note that this meeting in Richmond was held on the identical night and hour that the members of the music trade rallied at Carnegie Hall and pledged their contributions to the great loan at an equally enthusiastic meeting.

THE SCARCITY OF NEEDLES

The Otto Heineman Phonograph Supply Co. is using to excellent advantage an article which recently appeared in the newspapers entitled "Phonograph Needles Scarce." The company has made a reprint of this article and is utilizing it as an envelope enclosure in order to impress upon members of the trade that it is to their advantage to place their orders now for phonograph needles.

The article, which appeared in the New York Times, reads as follows: "Due primarily to the difficulties manufacturers are experiencing in obtaining carbon steel, there is said to be developing a scarcity of phonograph needles. And in face of this condition, the demand for needles of this sort in this country is constantly increasing. In export fields also, it is reported phonograph needles from this country are sought in steadily increasing quantities. There have been a few lots of needles imported to this country from Japan, but there also the shortage of carbon steel has militated against any increased production."

COLUMBIA DEALERS MEET

Important Addresses Made at Fourth Regular Meeting—Stracciari Entertains and Addresses Made by Messrs. Friedl, Hopkins and Sterling

The fourth regular meeting of Columbia dealers in metropolitan territory and up-State was held last month in the Green Room of the Hotel McAlpin, under the auspices of the local



Riccardo Stracciari

wholesale branch of the Columbia Graphophone Co. Lambert Friedl, manager of this branch, who was responsible for the inauguration of these meetings, which have been a remarkable success, presided at this meeting, and in his opening address gave a stirring appeal in behalf of the Third Liberty Loan. In fact, his appeal was so effective that during the course of the meeting subscriptions were received from more than fifteen Columbia representatives present.

In the course of his address Mr. Friedl called the dealers' attention to 1917 figures, which indicated that on the basis of a population of 100,000,000 in this country there were sold last year talking machines on a proportion of one to every 120 people. Figuring on a basis of five people to a family, Mr. Friedl stated that only one family out of twenty-four had bought machines in 1917, and expressed the belief that at least one family out of every eight could be sold a phonograph without choking the channels of trade.

The dealers convene for these monthly meetings in order to hear and discuss the midmonth records which are placed on sale the 10th of each month. These meetings really afford the only satisfactory means of demonstration for the dealers, and the interest which is being evidenced in these monthly gatherings is shown by the fact that more than 300 Columbia representatives were present at this meeting.

A. R. Harris, of the general sales department of the Columbia Co., who is directly in charge of record promotion, and who is a recognized authority in his field, commented briefly upon each record, leaving it to the dealers to decide whether or not the record was worth a large or small order. Order blanks were furnished to each dealer, so that after hearing the records they could indicate their initial orders.

During the course of the afternoon Mr. Harris introduced the Farber Sisters, co-stars with Al Jolson in his new production at the Winter Garden. These talented and popular actresses have arranged to make Columbia records exclusively, and their first record will go on sale in the very near future. This record is entitled "How'd You Like to Be My Daddy?" and these artists favored the company with a rendition of this selection, which was reproduced immediately afterward from their Columbia record.

Short addresses were made by Louis S. Sterling, managing director of the Columbia Graphophone Co., Ltd., London, Eng., who is in this country for a month's visit, and by George W. Hopkins, general sales manager of the Columbia Co.

The most important feature of the afternoon was the introduction of Riccardo Stracciari, famous operatic baritone, who records exclusively for the Columbia Co. He recently appeared in New York for the Chicago Opera Co. and won unanimous praise from every musical critic. He favored the dealers with several selections, and the enthusiastic applause which he received from the Columbia representatives reflected the importance of his acquisition to the Columbia recording staff. Mr. Stracciari has made several new Columbia records which will go on sale in the near future. These, like his previous recordings, are destined to win favor.

There were present at the meeting several dealers from Albany, Poughkeepsie, Middletown, Nyack, and other points up State, and in addition to the Columbia executives mentioned previously, there were also in attendance R. W. Knox, advertising manager of the Columbia Co.; N. F. Milnor, sales manager of the Dictaphone division; Theodore Bauer, director of the operatic and concert division; G. C. Jell, general manager of the record laboratory, and L. L. Leverich, assistant advertising manager.

The Difference Between

Phon d'Amour

and other Phonographs is resultant from difference in construction; the patented features of Phon d'Amour being exclusive.

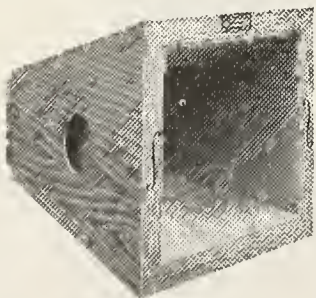

Amplifier

The Amplifier in Phon d'Amour

is of an entirely new type and one never before used. It is constructed in two chambers, being walled about with violin wood and is constructed upon the same principle as that of a violin. Not only is the volume in "Phon d'Amour" materially increased, but this is accomplished without any sacrifice of the characteristic overtones of voice or instrument.



Copyright, 1917, by
The Fritsch Phonograph Co.
Trade Mark

THE FRITZSCH PHONOGRAPH COMPANY

228-230 West 7th Street

CINCINNATI, OHIO

H. T. LEEMING, GENERAL MANAGER

Prominent Member of the Trade Assumes This Important Position With the Emerson Phonograph Co.—Splendidly Equipped for the Post

The Emerson Phonograph Co., New York, manufacturer of Emerson records, announced this week the appointment of H. T. Leeming as general manager of the company with headquarters at the executive offices, 3 West Thirty-fifth street, New York. Mr. Leeming assumed his new duties on Monday, and in this important post will be in complete charge of the production and merchandising of Emerson records.

H. T. Leeming has been associated with the talking machine industry for more than fifteen years, having spent thirteen years with the phonograph division of Thos. A. Edison, Inc., and during the past few years, has occupied important executive posts with the Pathé Frères Phonograph Co. He is thoroughly familiar with every detail of the production and marketing of talking machines and records, and as general manager of the Emerson Phonograph Co. will have unlimited opportunities to develop the tremendous possibilities for the Emerson record.

R. D. Wyckoff, treasurer of the Emerson Phonograph Co., who formerly occupied the post of general manager, remains as treasurer and a director of the company. Mr. Wyckoff has many other important interests in addition to the Emerson Phonograph Co., and the appointment of Mr. Leeming as general manager will give him a chance to devote a part of his time to these varied interests.

HEINEMAN EXHIBIT AT MUSIC SHOW

Otto Heineman Phonograph Supply Co. Extend Invitation to Industry to Visit Their Booth at National Music Show, New York, June 1 to 8

The Otto Heineman Phonograph Supply Co., New York, has extended a cordial invitation to all members of the talking machine industry who are planning to be in New York during the week of the National Music Show, June 1-8, to make the company's booths their headquarters during their visit in the East. This music show will be held at the Grand Central Palace, and judging from all indications will be an emphatic success.

This company has arranged to install a complete exhibit of Heineman products in Booths 40 and 41, and in addition these products will be displayed through the medium of the various exhibits conducted by the talking machine manufacturers who use Heineman and Meisselbach motors, tone arms, sound boxes, etc.

At last year's music show held in Chicago the Heineman exhibit was one of the most popular at the show, but Otto Heineman, president of the company, has made arrangements whereby this year's exhibit in New York will far surpass the 1917 display. There will be many unique and timely ideas introduced during the course of the show, which will doubtless make the Heineman booths a popular Mecca for visitors.

One of the most interesting features of the Heineman exhibit will be the first formal presentation of the new Heineman records. This latest addition to the Heineman family is now ready for the trade, and judging from the inquiries received from manufacturers and dealers throughout the country this part of the exhibit will receive the careful attention of all members of the talking machine industry who visit the National Music Show.

EDISON EMPLOYEES TO AID RED CROSS

The Edison war committee of 200, composed of employes and executives of Thomas A. Edison, Inc., have prepared a popular entertainment and dance for the evening of May 16 for the benefit of the Red Cross. The music for dancing will be furnished by the Edison Band, and the entertainment will be provided by Edison artists.

WORKING FOR RED CROSS FUND

Piano and Talking Machine Dealers Asked to Give 10 Per Cent. of Receipts on May 22 to the Fund—C. Alfred Wagner Is Chairman

May 22 has been set aside as the day on which every piano and talking machine dealer in New York City will give 10 per cent. of their gross sales to the Red Cross. C. Alfred Wagner, vice-president and general manager of Chickering & Sons, is chairman of the piano and talking machine committee of the profit-sharing days for the Red Cross, and under his able direction it is expected that splendid results will be secured.

Berthold Neuer, retail manager of Wm. Knabe & Co., and A. P. Plumb, of the Musieal Instrument Sales Co., are doing intensive work in the piano and talking machine fields respectively under Mr. Wagner's direction, and the responses to date to this patriotic appeal have been very gratifying. Mr. Wagner has been quite active the past year in behalf of Red Cross work, and his efforts have been fraught with success.

TALKING MACHINE MEN JOIN

Two Eastern Concerns Become Members of Music Industries Chamber of Commerce

It was announced last week at the offices of the Music Industries Chamber of Commerce, that the first members of the talking machine trade to apply for membership in that organization had been duly elected to membership. They are the Pathé Frères Phonograph Co., Brooklyn, N. Y., and the Bell Talking Machine Corp., New York.

HAS LEFT FOR ENGLAND

Louis S. Sterling, managing director of the Columbia Graphophone Co., Ltd., London, England, who has been spending the past six weeks at the executive offices in New York, left the city last week for London. While here Mr. Sterling discussed plans and policies for the future, and visited the factory and various branches throughout the country. He enjoyed his visit greatly.

HERE IS A NEW PHONOGRAPH With MANY EXCLUSIVE FEATURES



New Reginaphone Style 900

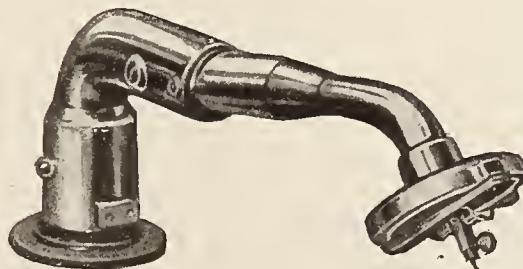

Regina Sound Box

THE NEW REGINAPHONE THE IDEAL TALKING MACHINE

is produced in seven beautiful models (mahogany or oak), each is equipped with the Regina Co.'s new sound box and tone arm. The larger types of Reginaphones have quadruple spring motors which play for thirty minutes and all models have our own make motors, simple, durable, smooth running, with worm driven governors.

The new Regina sound box is unique, always in the same position; to change from lateral cut position to vertical or vice versa a quarter turn is made, the sound box still remaining at the same angle and the needle's position never changing. This feature while revolutionary is the greatest improvement the industry has had in years.

The tone arm and sound box are the simplest in construction and performance of any playing both the lateral and vertical cut records and do away with any objections found in the universal tone arm. The special diaphragm brings out the tone of either type of record with equal facility and in full volume.

The tone amplifying chamber found in most of the larger models sends the sound waves up instead of in the usual forward manner, thus giving the Reginaphone a tone of rare beauty and almost perfect naturalness.

These machines will sell on demonstration. Our proposition will therefore interest every live dealer.

THE REGINA CO.

47 W. 34th Street
New York City

209 So. State Street
Chicago, Ill.

FACTORY: RAHWAY, N. J.

Manufacturers of the Regina Music Box and other musical instruments
for over 25 years

TALKING MACHINE MEN DISCUSS FEDERAL CURTAILMENT

Several Meetings Held in New York Recently and Committee Appointed to Act for Entire Trade to Discuss With the Washington Officials the Proposed Curtailment of Output

In the assembly hall of the Columbia Shop, New York, there was held on Tuesday afternoon, April 30, for the first time in the history of the trade, a convention of talking machine manufacturers and their representatives, for the purpose of discussing a matter of vital interest to the entire trade, i. e., the curtailment of the output of talking machines and records by order of the Government.

The call for the meeting was sent out by R. L. Freeman, secretary of the Victor Talking Machine Co., at the suggestion of P. B. Noyes, director of curtailment, after a conference some time ago between Mr. Noyes and representatives of several talking machine manufacturers, with the idea of reaching some trade agreement regarding a basis of curtailment that would be presented to the Federal officials.

Over thirty talking machine men, representing the leading concerns in various sections of the country, answered the call and the meeting was presided over by H. L. Willson, general manager of the Columbia Graphophone Co., as temporary chairman, with J. Schechter, representing the Sonora Phonograph Corp. and the Otto Heineman Phonograph Supply Co., as secretary.

After a lengthy and frank discussion of the general trade situation, particularly as it is at present affected and may in the future be affected by war conditions and Government requirements, during the course of which various suggestions were offered as to the course to be pursued by the trade, a committee of ten was appointed to act upon the matter of curtailment for the trade as a whole.

In addition to H. L. Willson, the chairman, and J. Schechter, the secretary, the committee of ten consisted of R. L. Freeman, Victor Talking Machine Co.; Chas. Edison, Thomas A. Edison, Inc.; E. A. Widmann, Pathé Frères Phono-

graph Co.; Arthur Cushman, Emerson Phonograph Co.; L. Rommell, Bell Talking Machine Corp.; W. H. Alfring, Aeolian Co.; Julius Balke, Brunswick-Balke-Collender Co., and Louis Mandel, Mandel Mfg. Co., Inc.

It had been generally believed that the recent order of the fuel administrator curtailing the output of pianos and parts 30 per cent. for the months of April and May also applied to talking machines and records, inasmuch as the order referred to "musical instruments." Several representatives of prominent manufacturers, however, were called to Washington to confer with the fuel administrator regarding the plans for curtailing the industry, and it was learned that the talking machine trade was to be considered by itself, in the issues of any curtailment order.

The first general notice to the trade that the fuel administrator contemplated a second curtailment order was found in a letter sent out by P. B. Noyes, director of curtailment, to sixteen well-known concerns in the industry, and which read in part as follows:

"In order that sufficient fuel may be assured industries essential to the conduct of the war, the United States Fuel Administration has under consideration curtailment of fuel to be used by less essential industries.

"Before taking any action regarding talking machines we should be glad to confer with the committee representing your industry.

"If the talking machine industry can organize itself and form a war service committee that will represent the industry as a whole, we will be glad to arrange a conference with them before any action is taken."

The letter of Mr. Noyes was followed almost immediately by the call from R. L. Freeman for the meeting at the Columbia Shop.

In addition to the committee already mentioned, those who attended the meeting at the

Genuine Period Styles

Authentic adaptations of Adam, Louis XVI, Sheraton and Queen Anne periods, harmonizing perfectly with the styles whose names they bear, are a feature of the case work on the Marvelous

MAGNOLA "Built by Tone Specialists"



Watching the Music Come Out

Give us the Opportunity to tell you more about this and other sales-making features of MAGNOLA construction, by sending us your name and address.

We have a handsome catalog, illustrated in colors, that tells Magnola's story—and is yours for the asking.

MAGNOLA TALKING MACHINE COMPANY

OTTO SCHULZ, President

General Offices 711 MILWAUKEE AVENUE CHICAGO
Southern Wholesale Branch 1530 CANDLER BLDG. ATLANTA, GA.

Columbia Shop included: H. B. Schaad, Aeolian Co.; George W. Lisle and H. N. McMenimen, Pathé Frères Phonograph Co.; F. N. Needham, Sears-Roebuck & Co.; George E. Brightson, president Sonora Phonograph Corp.; C. C. Brooks, Brooks Mfg. Co., Saginaw, Mich.; R. D. Wyckoff, Emerson Phonograph Co.; H. D. McNulty, Wonder Talking Machine Co.; J. D. Manton, the Manton Shop, Inc., New York; Harry Gennett, Starr Piano Co., Richmond, Ind.; J. Bartelstone, Lucky 13 Phonograph Co., New York; L. Blumberg, Regina Co., New York; M. C. Schiff, Vitanola Talking Machine Co., Chicago, and others.

The committee of ten appointed on April 30, after a thorough study of the situation, met again at the Columbia Shop on May 9 to report their findings and decide upon a definite course of procedure. At this meeting a subcommittee of five was named to go to Washington and confer with the United States Fuel Administrator.

The committee of five consists of H. L. Willson, W. H. Alfring, R. L. Freeman, E. A. Widmann and Julius Balke.

At the meeting of the committee of ten also a sub-committee of three, consisting of R. L. Freeman, J. Schechter and E. A. Widmann was appointed to compile data regarding the industry, from statistics that have been gathered, and to prepare a brief for presentation before the director of curtailment at Washington.

The committee has arranged to hold another meeting at the Columbia Shop on May 16, when the brief will be submitted for discussion, and an effort will be made to hold a conference with P. B. Noyes, director of curtailment, in Washington, on the following Monday.

WOODS & SON IN NEW QUARTERS

C. John A. Woods & Son, manufacturers of the "American Maid" phonograph, have moved their executive offices from 30 Church street to 25 Church street, New York, in order to have sufficient room at their command to properly display this line of phonographs. At this address the company has ample space for demonstration display rooms for the service of dealers.

The company states that it has made a number of important agency connections during the past few months, and it has also completed its line in all styles and types. Factory facilities have been also increased, and Mr. Woods is making an energetic drive for the better class of trade.



I HAVE severed my connection with the George A. Long Cabinet Co., and have consummated arrangements with the Nanes Art Furniture Co., whereby I will handle record cabinets made by this company. New improved designs to match the various types of talking machines will be introduced to the trade. Correspondence invited.

CLEMENT BEECROFT

309 W. Susquehanna Avenue
Philadelphia

Also

Record Envelopes, Needles, etc.

PURITAN

The Long-Horn Sensation of the Phonograph Industry

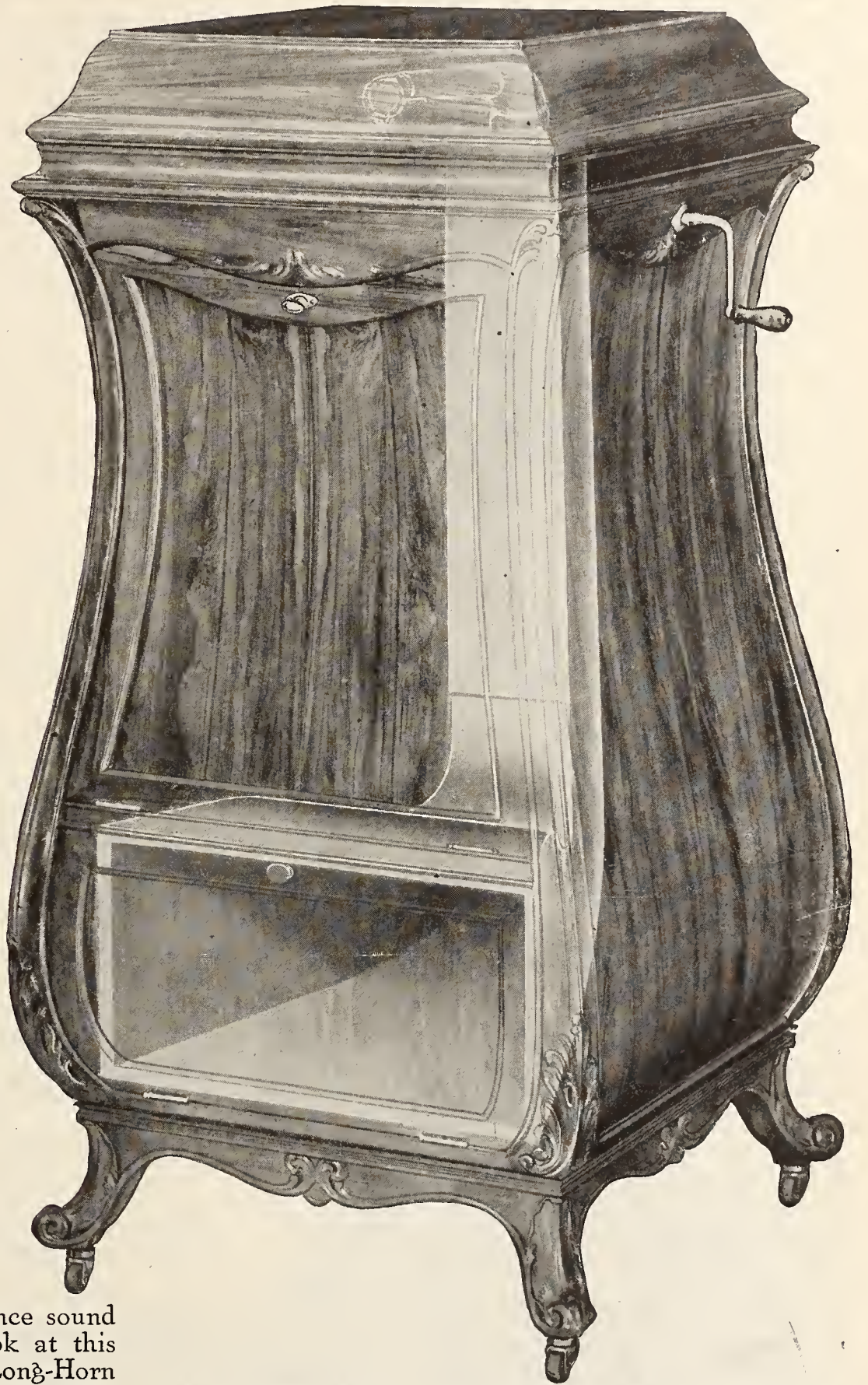

HERE is the most important discovery since sound reproduction was first invented. Look at this phantom illustration. See how the Long-Horn extends from tone arm at the top to the sound chamber at the bottom of the instrument. It means a big fullness, richness and resonance of tone beyond comparison with other sound-reproducing instruments. The Horn is of saxophone design and entirely of wood. It is an exclusive and patented feature of the Puritan.

It is a remarkable selling argument for the dealer and a real, definite, actual advantage to the purchaser.

Note that the sound chamber is at the bottom of the instrument—another exclusive Puritan advantage—and still another is the beautiful convex cabinet. Another tremendous advantage in handling the Puritan line is that you have also our line of Puritan Records made in our own recording laboratory. The Puritan plays any disc record made. Prices range from \$85 to \$350.

Write, wire or phone for our attractive proposition today.

UNITED PHONOGRAPHS CORPORATION
SHEBOYGAN, WISCONSIN



NEW INCREASE IN VICTROLA AND VICTOR RECORD PRICES

New Schedule of List Prices Formally Announced on May 8 and Became Effective on May 10—Increased Manufacturing Costs and Curtailment of Output Given as the Reason

A new increase in the list prices of Victrolas and records was announced by the Victor Talking Machine Co. in a telegram sent to Victor wholesalers throughout the country on the evening of May 7, and received by them on May 8, the increased prices becoming effective on May 10.

The increase in the list price of the various styles of Victrolas, ranging from something less than 5 per cent. to a trifle more than 10 per cent. in certain cases, has become necessary, it is explained, by the fact that manufacturing costs are mounting steadily, while at the same time production has been greatly curtailed through scarcity of labor and other conditions brought about by the war. A revision of the list prices has been expected by the trade for some time past, and therefore caused little excitement, even though the notice carried with it the first increase in record prices.

The new prices on Victrolas are as follows: Victrola IV-A, \$22.50; Victrola VI-A, \$32.50; Victrola VIII-A, \$50; Victrola IX-A, \$60; Victrola X-A, \$90; Victrola XI-A, \$115; Victrola XIV, \$175; Victrola XVI, \$225; Victrola XVI, electric, \$282.50; Victrola XVII, \$275; Victrola XVII, electric, \$332.50; Victor 25, school machine, \$85. Other new machine prices are in proportion.

The list price of the Marconi records, covering the course in wireless telegraphy, have been increased from \$5 to \$6 per set, and the price of the French course from \$2.50 to \$3. The list prices on all other Victor records, except double faced, Black Label, remain unchanged.

The 10-inch double-faced Black Label records will be listed in future at 85c. and the 12-inch double-faced Black Labels at \$1.35. There has in some cases been a readjustment of dealer's discount by jobbers, but this is a matter that rests entirely with the individual wholesaler.

In announcing the increase, together with the discount that will apply to the wholesalers, the Victor Co. stated in part: "It is necessary to advise the trade that the demand for our products is far in excess of our capacity for production. For some years the Victor Co. has found it difficult to meet the requirements even of its old customers, and this deficiency in supply has increased with the labor conditions caused by the present war. So far as possible

the company will endeavor as heretofore to protect its old customers, through whom its business has been so largely developed, by meeting their requirements as fully as possible."

It is a known fact that, although the costs of materials and every other element entering into manufacturing have increased tremendously since the beginning of the World War, the list prices of Victrolas have only advanced about enough to barely cover the War Excise Tax. The company has been absorbing increased manufacturing expenses, and dealers have been meeting heavy selling expenses out of the same margin of profit. According to an official of the Victor Co. a substantial increase in prices would have been warranted over a year ago, and yet the move was delayed.

Up to the present time the company has stood pat on the list prices of records, although the cost of shellac, the principal ingredient, has jumped many hundred per cent., as has the cost of everything else entering into record making. The new increase in record prices does not begin to offset the increased costs, to say nothing of taking care of the 3 per cent. war excise tax on each record produced.

WORKING FOR THE RED CROSS

The Pittsburgh talking machine trade has appointed a committee of six, consisting of J. C. Roush and French Nestor, Standard Talking Machine Co.; C. L. Hamilton, S. Hamilton Co.; W. C. Dierks, C. C. Mellor Co.; A. C. Henk, Columbia Graphophone Co., and George Hards, W. F. Frederick Piano Co., to solicit subscriptions in the Red Cross campaign.

TALKING MACHINE MEN TO MEET

A regular meeting of the Talking Machine Men, Inc., will be held on Wednesday, May 15, in the assembly room of the Merchants' Association in the Woolworth Building, when final action will be taken on various amendments to the constitution and by-laws and committees appointed to act during the year.

Mrs. H. J. Raymond has taken over the talking machine business recently conducted by W. E. Johnson in Corona, L. I.

BRILLIANTONE CO. EXPANSION

Larger Quarters Needed to Meet the Increased Demand for the Brilliantone Steel Needle—Will Have Exhibit at National Music Show

That the additional space added to the headquarters of the Brilliantone Steel Needle Co. in the Marbridge Building, New York City, was an absolute necessity is well proven by the fact that every square foot is utilized and it will not be long before more room will be needed. B. R. Forster, president of the company, reports that their output has reached tremendous proportions and, in keeping with the policy that has been theirs since their incorporation, every order that is received is given their immediate attention and shipped that very day with the possible exception of cases where the stock of the grade requested has run temporarily low. Several additions have been made to the office force of the company, and the addition of a Mr. Kaufman has been announced for the sales staff.

The Brilliantone Steel Needle Co. will be represented at the forthcoming National Music Show to be held at the Grand Central Palace, New York City, from June 1 to 8 by an interesting exhibit occupying two booths on the mezzanine floor, numbers 101 and 102. Mr. Forster will be glad to have the out-of-town talking machine men make that booth their headquarters during the show.

VICTROLA FOR HOSPITAL TRAIN

Machine and Supply of Records Will Entertain Wounded Soldiers on First of New Hospital Trains Turned Out by Pullman Co.—The Donation of a Chicago Club

CHICAGO, ILL., May 11.—A Victrola XI and Victor records will entertain the wounded soldiers on the first hospital train that will be operated in this country.

The H. Reichardt Piano Co., of 6423 South Halsted street, this city, has just sold an outfit to the Englewood Fellowship Club of Chicago, who are donating it to the Government for use on this hospital train.

They are now building at the Pullman shops here twenty-four complete hospital trains which will operate between the Atlantic ports and the permanent Base Hospitals.

Train No. 2 is now nearing completion and will be turned over to the Government within a few days and this will be the first train put in operation. It has been assigned to Fort Sheridan and the Great Lakes Training Station, both located just outside of Chicago.

EDISON MEN MATCH PRESIDENT

When President Wilson made his subscription to the Liberty Loan at a Washington theatre toward the end of the Third Liberty Loan drive, he did not realize that he was starting a popular movement which was called "Match the President" and which eventually added many millions to the Liberty Loan total.

The officials of the Edison Co. enthusiastically set out to get as many of the Edison executives as possible to make a last-minute subscription on this "Match the President" drive, with the result that ninety-one subscriptions were obtained. The subscription sheet that was passed around was headed "Match the President," and Thomas A. Edison headed the list, followed by Charles Edison. A telegram was sent by Charles Edison to President Wilson telling him of the eleventh hour successful drive.

OPENS BRANCH IN RUTLAND

RUTLAND, VT., May 10.—The United Talking Machine Co. opened its branch at 7 Center street, this city, last week with an interesting concert at which the special features of the Columbia and Pathé machines were demonstrated to a large crowd of people.

SERVICE FOR THE JOBBER



Write today

Seven Patterns in stock
**STYLE FOR EVERY
DEMAND**

Cabinets only

**SELL BEFORE YOU
BUY**

Send us Motors; we
install and ship
your

Customer Direct

No freight
No handling
Save you \$4.00 to \$5.00
each Cabinet

Established 40 years
Capacity, 150 per day

JOSEPH KNITTEL SHOW CASE CO. - - - Quincy, Ill.

PLANS FOR JOBBERS' CONVENTION

Sessions to Be Held at Hotel Traymore, Atlantic City, on July 1 and 2—Program Will Carry Out the Present War-Time Spirit

Plans for the forthcoming convention of the National Association of Talking Machine Jobbers are progressing nicely, although, due to the uncertainty of existing conditions, the final arrangements will not be announced until just prior to the convention to avoid possible disappointment.

The business sessions of the convention will be held at the Hotel Traymore, the official headquarters, on Monday and Tuesday, July 1 and 2, with the annual banquet held on July 2. The program of the convention, both in the business sessions and the entertainment features, is strictly in keeping with the war-time spirit, and the main object for the jobbers getting together will be to consider how they may adjust themselves and their businesses to current conditions, and at the same time render the most helpful effort in support of the Government and its work in the matter of backing Liberty Loans, Red Cross and other drives, and in other ways. It is planned to have several prominent speakers make addresses.

The banquet will be a modest affair, devoid of the usual wines, although the diners may gratify their individual desires in the matter of refreshments.

Those planning to attend the convention should make reservations direct to the Hotel Traymore management to insure accommodations when the time comes.

In connection with the convention there will also be held the annual golf tournament, the arrangements for which are in the hands of T. H. Towell, of the Eclipse Musical Co., Cleveland. The tournament will be held at the Atlantic City Country Club, where the talking machine men have shown their skill, or lack of it, on previous occasions.

SOLDIERS WANT GOOD MUSIC

Professional entertainers who have appeared before thousands of soldiers in the training camps in the United States are of the opinion that one result of the innumerable concerts has been the raising of the standard of the programs. Says one singer:

"When the mobilization first began it was supposed by many, including those who gave talking machines and records, that the men wanted only ragtime, jazz band and mooney-looney-wishy-washy stuff, but a few of the good old musical standbys given as encores soon proved by the applause they won that the soldier boys' tastes are above those credited by some producers to the Tired Business Man.

"The troops want the best music we can give them, and since many of the headliners have appeared in the camps the audiences have become critical.

WE GUARANTEE

Our System will pay for itself in 6 months by increasing your sales or it is returnable for FULL CREDIT

FILES, FINDS

and

SELLS RECORDS

in a modern way

It saves your time and keeps track of what you sell and what you need in the simplest way.

Write today for our new proposal on this

War Time Necessity

Prompt Shipments

OGDEN SECTIONAL CABINET CO., Inc.
LYNCHBURG, VA.

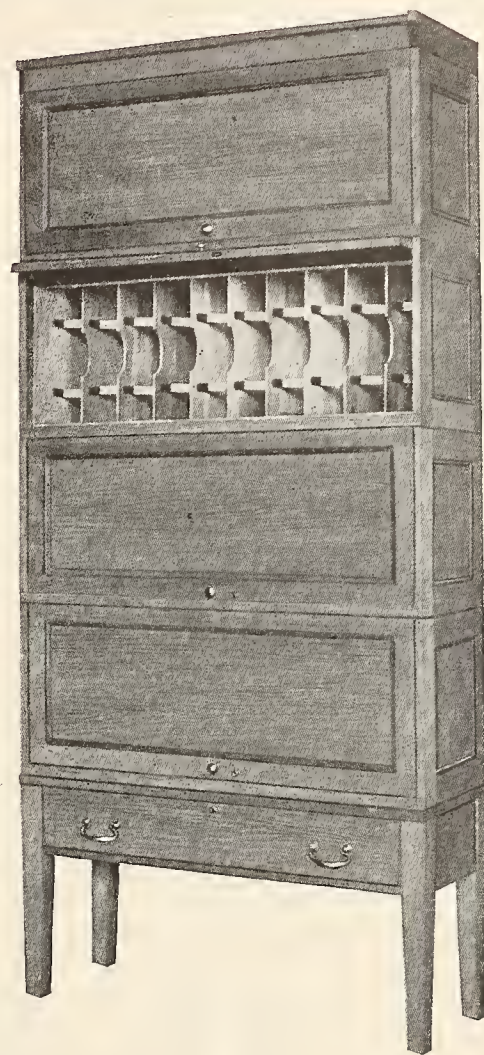

"One thing is sure, they don't want cheap heroics about marching into Berlin. It doesn't ring true, and if there is any place where a man learns true valuations it is in the training camps."

DISCUSSES TRADE CONDITIONS

The editor of the business department of the New York Times keeps in close touch with the talking machine trade evidently, judging from the frequent mentions made of this industry in his columns. For instance, Saturday, he said:

"Considering the time of the year, the phonograph trade is experiencing considerable activity, according to reports from a number of manufacturers with offices in this city. Instalment business in the medium-priced instruments is said to be holding up very well in most sections, and in many cases is increased over the same period in former years. The demand for very high-priced phonographs in elaborate cabinets

seems not to be particularly heavy just now, but the Third Liberty Loan and the season are held to be chiefly accountable for this fact."

ATTRACTIVE WINDOW DISPLAY

PITTSBURGH, PA., May 11.—The Goldenson Furniture Co., of this city, have recently been making some very attractive window displays of the Brunswick phonograph, and the picture herewith, which was taken at night, gives an excel-



The Goldenson Furniture Co.'s Window Display lent idea of the splendid arrangement of this display, which has proven of exceeding public interest.

Although only seventeen he had come to "join up," and was in the recruiting office answering some questions that the sergeant was putting to him.

"Look here, my man," said the sergeant, "are you willing to die for your country?"

The recruit opened his eyes with astonishment.

"No, sir," he replied; "I'm joining up to make a German die for his."

John H. Jensen, manager of the Brunswick Shop in Terre Haute, Ind., has just opened a branch in Clinton, Ind., where he is handling a full line of Brunswick phonographs, pianos and other musical instruments.

WAR SAVINGS STAMPS DELIVERED TO YOUR HOME

Tear Out—Fill In—Hand Letter-Carrier—or Mail to Post Office

TO THE LOCAL POSTMASTER:—Kindly have letter-carrier deliver

to me on _____ for which I will pay on delivery:

(Date) \$5. U. S. WAR-SAVINGS STAMPS at \$_____ each

(State number wanted) (See prices below) 25c. U. S. THRIFT STAMPS at 25c. each.

(State number wanted) Name _____

Address _____



W. S. S. COST DURING 1918			
April	\$4.15	July	\$4.18
May	4.16	Aug.	4.19
June	4.17	Sept.	4.20
		Oct.	\$4.21
		Nov.	4.22
		Dec.	4.23
W. S. S. WORTH \$5.00 JANUARY 1, 1923			

P. A. FUSS JOINS EDISON STAFF

Comes From Toronto to Take Editorship of the Amberola Monthly—Has Had Wide Experience in Newspaper and Phonograph Fields



P. A. Fuss

P. A. Fuss has recently become editor of the Amberola Monthly, published by Thomas A. Edison, Inc. He has had a broad experience and one which fits him well for the new work he has undertaken. He started business with a brokerage house on Wall street, later became traveling auditor for the National Surety Co., and next was traveling salesman with the Thomas J. Plant Co., manufacturers of shoes, becoming subsequently assistant to the advertising manager.

In the talking machine field he has acquired two kinds of experience, the first with the phonograph department of a well-known trade journal, and the second, as the Edison sales manager of the R. S. Williams & Sons Co., Ltd., of Toronto, Canada. In addition to editing the Amberola Monthly Mr. Fuss will serve as general assistant to the advertising manager of Thomas A. Edison, Inc., and will specialize along the line of issuing publicity of general trade interest.

PLEASED WITH BUSINESS PROGRESS

Joseph Hoffay Enthusiastic Regarding Outlook—Improved Cabinet Construction Augments Various Mechanical Attractions

Joseph Hoffay, president of the Hoffay Talking Machine Co., Inc., in a recent statement to a representative of The World said he was very much pleased at the development and prospects of the Hoffay business. In speaking of the new grill work of the Hoffay machines Mr. Hoffay said: "Increasing quantities of Hoffays are being sold throughout this country and abroad and our purpose in giving our new cabinets this distinctive feature was that they might be immediately recognized, so that even when placed on display in the show windows the passer-by would note they were Hoffay instruments. As we believe the Hoffay tone is immediately recognized by those who have heard our machines they also will now be able to recognize the cabinet itself."

INCORPORATED

The American Recording Laboratories, Passaic, were recently incorporated with the authorities of New Jersey, for the purpose of manufacturing and dealing in phonograph records, with a capital of \$25,000. The incorporators are C. E. Sanders, M. E. Sanders and George Thornton, all of Passaic.

BUSINESS ACTIVE IN PITTSBURGH

Conditions Favorable Despite Shortage—Peerless Record Makers Score—J. C. Roush Returns—Edison Tone Tests—German Records Being Interned—Other News of Interest

PITTSBURGH, PA., May 6.—Stock shortage in many lines of machines and records and other wartime conditions to the contrary notwithstanding, the Pittsburgh talking machine trade continues to go ahead in a really satisfactory manner. Jobbers and retailers are working hard, and the results are apparent.

Two big things in the trade during the month have been the appearance of the Peerless Record Makers, under the auspices of the Talking Machine Dealers' Association, and a decision of the executive committee of the association to "intern" records of German music and records by German artists for the period of the war. The relative importance of these two big things naturally depends upon the attitude of the individual.

The Peerless Record Makers, including such well-known artists as Arthur Collins, Byron G. Harlan, Billy Murray, Henry Burr, Albert Campbell, Fred Van Epps and Theodore Morse, appeared at Carnegie Music Hall on April 24 and attracted an overflow audience. Without doubt the majority of the audience were talking machine and record owners who appreciated the opportunity of hearing and seeing their favorite record artists in the flesh. The concert was well handled, and without doubt produced results.

Just how the plan to intern records of German flavor during the war will work out remains to be seen, but a list of nearly a thousand selections in the Victor, Columbia and Edison catalogs has been submitted to the association members.

At the local branch of the Columbia Co. Manager S. H. Nichols declares that March and April have been the best months in the matter of sales that have ever been experienced by the branch. Moreover, May has started off in a big way, and indicates that this month, too, will probably set a new record.

Joseph C. Roush, president of the Standard Talking Machine Co., Victor wholesalers, who returned recently from a vacation spent in Florida, was tendered a special dinner at the William Penn Hotel by the boards of governors of the Mount Lebanon Country Club and the St. Clair Country Club. The dinner was in the nature of a special welcome.

The Dawson Bros. Piano Co. are displaying Emerson records in a big way at their store, 957 Liberty avenue, and have given over considerable show window space to boost that line.

The Pathé Shop, the local headquarters of the Pathé Frères Phonograph Co., has been featuring with great success recently a new twelve-inch demonstration record bearing two scenes from the third act of "Romeo and Juliet," by the principals and chorus of the Paris Opera Co., accompanied by the Opera Orchestra. The demonstration record is offered at \$1, which is said to be just one-quarter of its actual value.

A number of new dealers have been signed up for the Pathé line recently, they including the Salem Music Co., Salem, W. Va.; Butch & Son, Harding, W. Va.; Dowdy Phonograph Co., Clarksburg, W. Va., and C. C. Denham, Fairmount, W. Va.

A number of very successful Edison tone tests have been held in towns embraced in the Pittsburgh territory, under the direction of the Buehn Phonograph Co., Edison jobbers of this city. Other tone tests are also scheduled for the near future.

TAKES ON NEW LINE

Clement Bccroft announces that he has relinquished his connection with the George A. Long Cabinet Co., of Hanover, Pa., and will hereafter represent the line of talking machine cabinets made by the Nanes Art Furniture Co., which he will show in a large number of styles.

IT SELLS

That's why you should have them



THE
IMPROVED
No. 10

Cleanrite
TRADE MARK
RECORD BRUSH

Patented Sept. 26 and Oct. 2, 1906
Sept. 10, 1907 and Nov. 27, 1917
Others Pending

RECORD
BRUSH

**For Victor Victrolas**

NICKEL PLATED PRICE GOLD PLATED
35c. 75c.

Insures Long Life to Disk Records and Preserves Tone

Automatically cleans the **Record Grooves** and gives the needle a clean track to run in. Preserves a clear Reproduction and prevents Records from soon getting scratchy. Makes the Needle wear better. Dust and dirt in the Record grooves wear the Record out quickly and grind the Needle so it cuts the Record. **SAVE THE LIFE OF YOUR RECORDS.**

DIRECTIONS FOR ATTACHING BRUSH

No. 1



No. 2

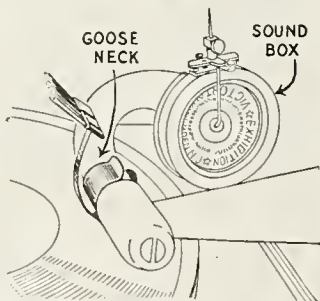

No. 3

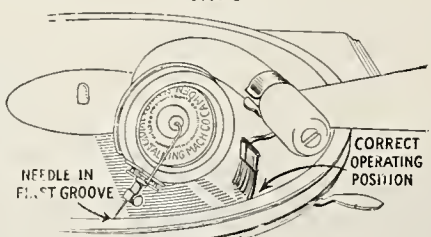

- 1st. Clamp Spring Clips of Brush around Goose Neck. (see 1 and 2). Place Record on Turn Table and Needle in Sound Box. Move Spring Clips along Goose Neck to a position where only outer bristles of brush will sweep the first few threads of record. Test this by resting needle in first groove of record. (See No. 3).
- 2nd. Turn Spring Clips on goose neck to produce necessary pressure on record through yielding spring. Brush top must not touch edge of Sound Box when in operation (see correct position of brush on No. 3). Yielding Spring of Improved Cleanrite Brush eliminates danger of too much pressure on record.

Circulars and Price List mailed on request.
Order from your Distributor or



Blackman
TALKING MACHINE CO.
97 CHAMBERS ST. NEAR CHURCH ST. NEW YORK



NEEDLES

Manufactured by the

DEAN DIVISION

of the

OTTO HEINEMAN PHONOGRAPH SUPPLY CO.

INCORPORATED

25 WEST 45th STREET, NEW YORK

FACTORIES: Elyria, Ohio Newark, N. J. Putnam, Conn.

BRANCH OFFICES: Chicago, Ill. Cincinnati, O. Seattle, Wash. Toronto, Ont.

STEEL NEEDLES

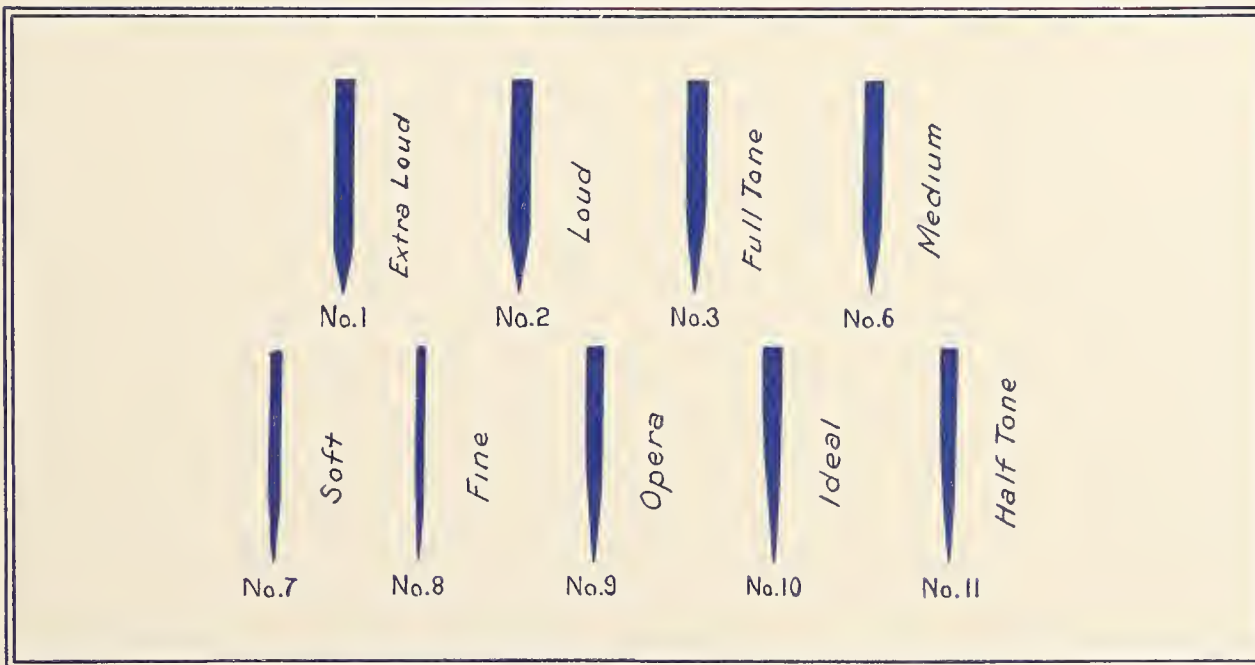

PERMANENT NEEDLES

TO PLAY PATHÉ RECORDS

Half Tone Points

Full Tone Points

TO PLAY EDISON RECORDS

Sapphire Points

Genuine Diamond Points



KOERBER-BRENNER FORMAL OPENING

Great Gathering of Talking Machine Men on May 8 Helped to Celebrate Formal Opening of Their Handsome New Building

St. Louis, Mo., May 8.—The Koerber-Brenner Music Co., Victor jobbers here, held the formal opening of their handsome new quarters, which they occupied more than a year ago without special observance, to-day. An opening was planned when the new quarters were occupied, and then came war delays, transportation delays, a rush of business and other things that happen to business these days; so no auspicious time appeared until now.

The program called for steady entertainment from 11 a. m. until midnight, and nearly 100 dealers of the district who were in attendance enjoyed every minute of the day.

The guests assembled at the Koerber-Brenner warerooms, and, after an inspection of their splendidly equipped and modern merchandising and stock-keeping plant, left in automobiles for a drive about the city, thence to the Sunset Country Club Inn—a beautiful place where many of the best St. Louis folk go to play golf and for dinner dances. A luncheon was served here, and the party returned to the Missouri Athletic Association for the afternoon session, which was along instructive as well as constructive lines. There were two factory men as speakers and a repair expert. Moving pictures of the Victor factory, to give the dealers an idea of what a considerable industry they are a part, was one of the several features of the gathering. The afternoon was all devoted to a discussion of business matters.

In the evening the visiting dealers were the guests of the Koerber-Brenner Co. at dinner—as liberal a dinner as is compatible with war times. Aside from the good things to discuss on the menu, the entertainment included the Temple Quartet—and there are few better in or out of the record studios—the Haenschen Ragtime Orchestra—which is so good that it has had records made and sells them independently—and other features that added to the enjoyment of the evening.

The post-prandial program was in charge of R. E. Lee as toastmaster. Mr. Lee has been a newspaper man, soldier, and is a clever talker. He introduced the various speakers and the hosts. The chief speaker was W. E. Bilhimer, who is regarded as the champion organizer of life insurance salesmen in this section of the country, and for the last year has been the most popular speaker in the community. He was followed by A. W. Magoon, president of the Tri-State Victor Dealers' Association, who told of the good work the association is doing. L. C. Wiswell, manager of the Victor department of Lyon & Healy; A. A. Trostler, Victor manager of the Schmelzer Arms Co., Kansas City, Mo., were also among those who made eloquent addresses and were given an enthusiastic reception. Messrs. Brenner and Rauth, the hosts, were also called upon for remarks.

The Koerber-Brenner warerooms, at 1714 Washington avenue, are on the ground floor of a magnificent white tile building in the wholesale section. They are of massive mahogany furnishings, very much on the plan of a banking office. The plans were made by a business engineer who studied the business for several months, and who gauged his plans for the time when the Victor Co. would be able to supply all of the machines needed for this territory. The feature of the front office is a model show window and demonstration room for the inspection of dealers. This is built in the corridor and not seen from the street. The demonstration rooms are constructed of the latest folding doors and are used for firm and dealer assembly meetings, as twenty-four can be seated. The real pride of the establishment is the record stockroom, which is so ample that it has never been taxed to capacity. It combines all of the features which go to make an up-to-date jobbing stockroom.

ROY J. KEITH'S GREAT SUCCESS

Vice-President and General Manager of New York Talking Machine Co. Sold \$200,000 Worth of Liberty Bonds in Recent Drive

Roy J. Keith, vice-president and general manager of the New York Talking Machine Co., Victor wholesalers, was one of the most energetic workers in behalf of the Third Liberty Loan. As a member of the talking machine committee working for this loan Mr. Keith left nothing undone to increase the figures for this division, and when the final totals were ready for presentation he had the honor of being able to report the receipt of more than \$200,000.

This total included the subscriptions of the members of the New York Talking Machine Co., every one of whom subscribed to one or more bonds. The company itself also subscribed very liberally, and it is interesting to note that at the present time the New York Talking Machine Co. owns Liberty Bonds totaling more than its entire capitalization.

Arthur D. Geissler, president of the company, in addition to a handsome subscription in New York, also subscribed liberally at French Lick Springs, where he spent a fortnight during the loan drive. Incidentally, while at this famous resort, Mr. Geissler bought a golf ball, which was auctioned in behalf of the Red Cross. As he paid \$400 for this golf ball it is safe to assume that he will keep it for tournament play.

The \$200,000 reported by Mr. Keith also includes a subscription of \$33,000 given to Mr. Keith by the Otto Heineman Phonograph Supply Co., well-known motor manufacturers, and \$60,000 of this total was raised at a concert given at the University Glee Club at the Hotel Astor. At this concert Reinald Werrenrath, the famous baritone and exclusive Victor artist, conducted the drive for the Liberty Loan.

Twenty local Victor dealers also subscribed to Mr. Keith's Liberty Loan total, and when it is considered that twenty-nine members of the company's staff are now in the service of Uncle Sam, it can safely be said that this company is "doing its bit" for democracy.

SEMI-PERMANENT NEEDLES

TO FILL AN EVER PERMANENT NEED
IN THESE MOST WONDERFUL



NOT ONLY BECAUSE THEY SELDOM NEED TO BE CHANGED—A PACKAGE OF FIVE NEEDLES PLAYING FAR MORE RECORDS THAN THE SAME NUMBER OF NEEDLES PROCURED FOR THE SAME COST VALUE—BUT ALSO BECAUSE OF A REAL IMPROVEMENT IN QUALITY OF REPRODUCTION AND BY COMPARISON WITH THE ORDINARY STEEL NEEDLE, WHICH IS TAPERED AND ENLARGES ITS DIAMETER AS IT WEARS DOWN, WEARING EACH RECORD NEAR ITS CENTRE MORE THAN AT THE BEGINNING OF THE RECORD, "VALLORBES NEEDLES" REALLY PROLONG THE LIFE OF RECORDS

If your Jobber is one of the large Representative Distributors, write him for prices

SOFT — MEDIUM — LOUD TONE

Send 30c in stamps for a sample package of each

Originators and
Largest
Manufacturers of
Diamond Points



Sapphire
Ball Jewels
Full
and Half-tone

LANCASTER, PA., U. S. A.

REGARDLESS of his product, if a manufacturer is to grow, to prosper, his product must stay sold. A phonograph is made up of many parts, and of these the motor is of major importance.

When the Stephenson Precision-Made Motor was introduced, many compliments were received; on the spring drum construction, the tapered bearing turntable shaft, the silent wind, the running qualities and many initial orders were received. The initial orders were trial orders the subsequent repeat orders were because of the inherent merit of the Stephenson Precision-Made Motor. Because manufacturers appreciate that this motor helps them to keep their product sold helps them to make satisfied customers helps them to prosper, to grow.

Francis V. Nutze

Vice-President

STEPHENSON, INC., One West 34th Street, New York

L. W. McCHESNEY WINS PROMOTION

Is Appointed Assistant General Manager of Thos. A. Edison, Inc.

Leonard W. McChesney, for many years connected with Thomas A. Edison, Inc., has been appointed assistant general manager of Thomas A. Edison, Inc., under C. H. Wilson.

Mr. McChesney started with the Edison organization about fourteen years ago in the ad-



Leonard W. McChesney

vertising department under his father, L. C. McChesney, and gradually progressed to the position of assistant advertising manager. In 1912 he resigned to become advertising manager of the General Film Co., but returned shortly after to the Edison Co. as sales manager of the motion picture division, succeeding H. G. Plimpton as general manager of this division. Until the motion picture business of the Edison Co. is entirely liquidated and closed out, Mr. McChesney will also retain the title of manager of motion picture division.

R. F. BOLTON OFF ON WESTERN TRIP

Columbia Foreign Language Record Business Shows Great Increase—New Literature

R. F. Bolton, sales manager of the international record department of the Columbia Graphophone Co., left this week for a trip through the Middle West, which will include a visit to the Columbia branches and representatives as far west as Kansas City and Minneapolis. Before leaving for the West Mr. Bolton commented upon the fact that the Columbia foreign language record business had shown a splendid increase this year, the sales totals for the first four months of 1918 being far ahead of last year. This record is particularly gratifying in view of the many merchandising problems incidental to the war.

This department has just issued a very attractive set of booth hangers, listing records in the various languages, each accompanied by a descriptive cut. These records are carefully selected from the general catalog, and as the lists are changed monthly, the dealers will have an opportunity of displaying practically the entire catalog in their booths.

The newspaper campaign in behalf of foreign language records which was recently inaugurated under Mr. Bolton's direction is producing splendid results.

STEEL NEEDLES

2,000,000 Steel Needles Medium Tone, immediate delivery, (100 in envelope), Samples upon request. All goods C.O.D. with examination privileges.

H. C. FLEMING
223 W. Jackson Blvd. Chicago, Ill.

SOME IMPORTANT APPOINTMENTS

Ratified at Recent Meeting of Directors of Otto Heineman Phonograph Supply Co.

At a meeting of the board of directors of the Otto Heineman Phonograph Supply Co. held May 8 at the executive offices of the company, 25 West Forty-fifth street, New York, the following appointments were ratified:

A. L. Fritzsche was elected a director of the company. Mr. Fritzsche is general sales manager of the General Fire Extinguisher Co., Cleveland, O., being a member of the executive committee of that company. This is one of the most prominent industrial concerns in the Middle West, and is credited with doing the largest fire extinguisher business in the country.

J. Schechter, a member of the law firm of Schechter & Lotsch, New York, identified for many years with the industry, was elected treasurer of the company, and Miss F. Aufrichtig was appointed cashier.

Thos. E. Griffen was appointed manager of the new Springfield, Mass., factory, and Charles B. Kraemer assistant manager. Both are well known in manufacturing circles, and will be in charge of the new record factory.

PRICE QUOTATION SHEETS

Prepared by the Gloria Phonograph Supply Co. for Convenience of Their Dealers—Plan Intensive Sales Campaign to Start Soon

The Gloria Phonograph Supply Co., New York, which placed on the market last month the Gloria steel needle, has just prepared a complete set of price quotation sheets for their needles, in order to provide its patrons with a standard set of prices that will apply to all orders. The company believes that this is the only way to successfully merchandise any product, and this policy will be one of the important factors in the company's sales and merchandising plans.

Since the introduction of the Gloria steel needle last month requests for the agency for this needle have been received from all parts of the country. The company is living up to its promise of making prompt deliveries of its products, and arrangements have been consummated whereby factory facilities will be materially augmented in order to adequately handle the increasing demand for Gloria steel needles.

Plans have been completed for an intensive sales campaign in behalf of this needle, and

Rudolf Gaertner, president of the company, expects to announce the details of this plan within the next few weeks. The company will endeavor to provide the dealers handling Gloria steel needles with an efficient system of co-operation, and several practical ideas have been developed along these lines, to be soon released.

GOOD WORK FOR LIBERTY LOAN

Talking Machine Trade Subscribes \$1,000,000 of \$3,017,250 Reported by the Allied Music Trades—J. N. Blackman's Able Chairmanship

The local talking machine trade made a wonderful showing in the recent Third Liberty Loan drive, when the committee in charge of the talking machine division of the Allied Music Trades, under the chairmanship of J. Newcomb Blackman, rolled up a total of \$1,000,000 in subscriptions, allowing the piano trade, as a matter of courtesy, to tie them at that figure. The total subscriptions to the loan for the Allied Music Trades was \$3,017,250.

Although the official figures for the talking machine men were given as a round million, that department of the trade is also to be credited with a substantial portion of the \$651,700 subscribed at the great rally at Carnegie Hall on April 30, at which musicians and artists associated with talking machine companies supplied the greater part of the program. The story of the rally appears in another section of The World.

The showing made by the talking machine trade is particularly significant inasmuch as subscriptions to the second Loan amounted to something under \$250,000. In other words, the trade quadrupled its record, and in doing so made a bigger gain than any other branch of the industry.

When the totals of the subscriptions to the Third Loan were reported by the committee of the Allied Music Trades, the following significant telegram was sent to William G. McAdoo, Secretary of the Treasury: "We pledged you \$1,000,000 for Third Liberty Loan and actually raised \$3,017,250, a gain of 276 per cent. over our quota, which we hope will be considered a highly essential response from a so-called non-essential industry. We are always ready to answer the call."

So successful was the work of Chairman Blackman and his associates in the Liberty Loan campaign that the piano men tried to have him take the chairmanship for the trade in the coming Red Cross drive, but for business reasons Mr. Blackman was compelled to decline.



809

Mahogany, Golden Oak, Fumed Oak, Weathered Oak, Nickel-plated trimmings. Lock and key. Height, 33 inches. Top, 22 3/4 x 19 1/4 inches. Holds 192 twelve-inch records. Matches new Victrola IX. Highest type of cabinet, both in construction and finish. Average weight crated, 80 lbs.

Specials

FOR

Victrola IX



702

Mahogany, Golden Oak, Fumed Oak, Weathered Oak, Nickel-plated trimmings. Lock and key. Rubber-tired wheels. Height, 30 inches. Top, 17 x 20 1/2. Matches New Victrola IX. Top has countersunk holes to accommodate rubber bumpers on machine. Moulding on top securely fits base of machine. Average weight, crated, 75 lbs.

We also make many other styles for cabinets and will be glad to send our catalog for the asking.

Schloss Bros.
635-37 West 55th St.
NEW YORK
Phone
Columbus 7947

You Ought to Know

In case you are contemplating expanding the sphere of your business to include departments devoted to Pianos, Player-Pianos, Musical Merchandise or Sheet Music, that you'll find news and comments about them all in



ESTABLISHED 1876

The oldest and leading music trade weekly, which covers every branch of the industry.

It Contains

instructive and educational articles. Hints on salesmanship and advertising. Editorials that are timely and authoritative. Facts about the new things in the trade. Trade happenings in all parts of the United States.

“Review the Music Trade With Us”

Send your \$2 now for a full year's subscription to

THE MUSIC TRADE REVIEW
373 FOURTH AVENUE NEW YORK

Drop us a line—

Our Service Department is full up and running over with live, up-to-date selling helps on Portable Grafonolas—

Dip in—they're yours for the asking.

Columbia Graphophone Co.
Woolworth Building, New York



LOS ANGELES "TALKER" MEN MEET

Large Attendance at Recent Meeting—Some Important Resolutions Passed Regarding Time Sales and Interest—Some Interesting Talks

LOS ANGELES, CAL., May 4.—The Retail Talking Machine Dealers' Association of Southern

California had its regular meeting at Barker Brothers on the evening of April 30. In all sixteen out of the twenty-three firms belonging to the association were represented, and many things of interest to the trade were discussed.

A resolution was passed limiting all contracts to fifteen months, with all contracts to draw 7 per cent. interest. While most of those present seemed to be in favor of not advertising terms, this matter was left to the discretion of the different dealers with the understanding that if they did the advertisement must contain a cut, the model and the price of the machine.



Meeting of the Retail Talking Machine Dealers' Association of Southern California

The following firms, Johnston Music Co., Starr Piano Co., Walter R. Gage Co., Broadway Department Store, Hamburger & Sons and the Musical Record Shop, have not joined the association as yet, but committees have been appointed to call on them, and it is expected they will all be in the fold by the next meeting.

Through the courtesy of Mr. Booth, of Barker Brothers, the association picture was taken in the Barker Brothers photographic department.

Only officers and department managers are eligible to membership in this body, but the association kindly elected as an honorary member The Talking Machine World's local correspondent, H. H. Fish.

Frank Anrys, vice-president and general manager of the Wiley B. Allen Co., was present and spoke at length on several subjects of interest.

Wm. H. Richardson, chairman of the publicity committee, gave an interesting talk on that subject, and among other things spoke of the "Memory Contest for School Children," advocated by C. M. Tremaine, of the National Bureau for the Advancement of Music, and its bearing on the trade.

It was decided to make the next meeting an open one and all employes in the local talking machine departments are invited. A banquet followed by an informal dance will be the features. Following are the names of the persons in the accompanying picture: Reading from left to right, seated, are Harold Jackson, manager talking machine department, Wiley B. Allen Co.;

president, J. W. Booth, manager talking machine department, Barker Brothers; first vice-president, C. W. Colyear, proprietor Colyear's Furniture Co.; second vice-president, E. Holland, proprietor Vernon Music Co. Standing, left to right, J. B. Chamberland, president Hollywood Furniture Co.; Frank Salyer, manager talking machine department, Bartlett Music Co.; Nathan Shiresohn, proprietor Shiresohn Brothers; Howard Brown, manager talking machine department, Lyon-McKinney Smith Co.; H. H. Fish, representative The Talking Machine World; Wm. H. Richardson, manager talking machine department, Southern California Music Co.; Maurice Caulderon, proprietor, Repertorie Musical Mexicano; George S. Marygold, vice-president and general manager, Southern California Music Co.; F. A. Hartment, manager talking machine department, Eastern Outfitting So.; B. Platt, proprietor, Platt Music Co.; Frank Moreno, Barker Brothers; D. A. Costa, manager talking machine department, Repertorie Musical Mexicano.

EXHIBIT AT NATIONAL MUSIC SHOW

CHICAGO, ILL., May 9.—The Cheney Talking Machine Co., of Chicago, will exhibit a full line of their beautiful instruments at the coming music show to be held in New York June 1 to 8. The exhibit will be shown in Booth No. 44 on the main aisle and will be under the personal supervision of Burton Collver, Eastern representative for the Cheney Co.

ASSIGNEE'S SALE

Paroquette Record Mfg. Company's Assets

Supreme Court: Kings County, New York.

In the matter of the General Assignment for the benefit of creditors of the Paroquette Record Mfg. Company, Inc., Notice is hereby given that the undersigned Assignee will sell at public auction, through Joseph Feldstein, Auctioneer, on Wednesday, the 22nd day of May, 1918, at 10:30 A. M. at Model Loft Building No. 1, Bush Terminal Building, between 2nd and 3rd Avenues, 37th St., Borough of Brooklyn, City of Brooklyn, New York, property and assets of the above estate, consisting of a complete plant for the Recording and Manufacture of Phonograph Records, consisting of:

Hydraulic Record Presses, Moulds, Rings, etc.
Steam Tables, etc.
Accumulator, Pump, and Tank complete.
Auto Shellac Grinder, etc.
16" x 42" Mixing Mills, Blanking Rolls, Cooling Tables, etc.
Tumbler and complete mixing outfit.
Recording and Shaving Machine and complete recording equipment.
Plating Tanks, Trimmers, etc.
Complete Machine Shop equipment.
Lathes, Drill Presses, etc.
Complete equipment for making and melting wax.
Complete Etching equipment, camera, chemicals, etc.
Edging Machines.
Generators 600 Amp. and 1000 Amp., Motors, Fans, etc.
Switchboards, Rheostats, etc.
Pipes, Valves, Tanks, etc.
30,000 Par-O-Ket Records, Phonographs, etc.
Master and Mother Matrices.
Office Furniture, Desks, Typewriters, Safes, etc.

BURNSTINE & GEIST
Attorneys for Assignee
35 NASSAU ST., NEW YORK

MAURICE L. SHAINÉ
Assignee

NEEDLES

Immediate Deliveries Guaranteed
of all Styles of

STEEL NEEDLES Wall-Kane STEEL NEEDLES

SAPPHIRE POINTS
DIAMOND POINTS

Prompt Deliveries of All Orders, Large
or Small

REGULAR DEALER DISCOUNTS

STEPHENSON & CO.

ROOM 1625

1133 Broadway, New York

COLUMBIA RECORDS OF FOLK DANCES

Educational Department of Columbia Co. Announces a Special Set of Country Dances

Because of the introduction of physical training in schools throughout the country and the widespread interest in folk dancing, the Columbia Co.'s educational department has prepared a special set of English country dances, Morris dances, and sword dances, recorded under the personal supervision of Cecil J. Sharp, a recognized authority on this work. These records have been accepted for use in the New York City schools. Mr. Sharp is an honorary director of the English Folk Dance Society and of the Stratford-on-Avon School of Dance and Song. For three years he has been teaching these English dances in the leading educational centers of America, and his work has received the highest praise.

There is a growing demand for penmanship records that will give rhythmic count and instruction helpful to the school children in their daily penmanship exercises. The Columbia Co. takes care of this demand by the issuance of the Kirby rhythmic penmanship records, which is a splendid adaptation of the correct rhythmic forms found in music, woven into rhythmic counting patterns, for use in instructions in handwriting. These records were made by J. Albert Kirby, penmanship teacher of the High School of Commerce in New York City, where this rhythmic system is in daily use.

PROMINENT EDISON STAR "ADOPTS" COMPANY OF INFANTRY

Herewith is shown a picture of Christine Miller, noted Edison artist, inspecting Company G of the 320th Infantry, at Camp Lee, Peters-

J. F. WATTERS JOINS NATIONAL ARMY

Secretary of the Pathé Frères Phonograph Co., Brooklyn, Receives Several Handsome Gifts From His Co-workers on His Departure

J. F. Watters, secretary of the Pathé Frères Phonograph Co., Brooklyn, N. Y., is now a member of the National Army, and, after spending a few weeks in camp, will leave for "over there." Before joining the National Army Mr. Watters was presented with several handsome gifts from his co-workers as a mark of their affection and esteem; these gifts including a gold wrist watch and a silver cigarette case striped and lined with gold.

Although Mr. Watters has been connected with the talking machine industry for only the past few years, he has already won the friendship and esteem of Pathé jobbers and dealers throughout the country. A tireless worker and possessed of a pleasing personality, Mr. Watters during his two years' association with the Pathé Frères Co. has rendered the company's clientele invaluable assistance and co-operation.

He joined the Pathé Frères forces as a member of the sales department, but his unusual ability and thorough knowledge of merchandising soon enabled him to win important promotions until he was finally appointed secretary of the company. Every member of the Pathé force is numbered among his personal friends, and they all wish him "God speed" as a member of Uncle Sam's fighting forces.

RETURNS FROM CANADIAN TRIP

George W. Hopkins, general sales manager of the Columbia Co., returned to New York late last week, after a visit to the company's branches in Toronto, Buffalo and Cleveland. Mr. Hopkins was gratified to find conditions in these sections very satisfactory, and Canadian business in particular is increasing by leaps and bounds.

While at Buffalo Mr. Hopkins addressed the members of the Greater Buffalo Club, who were in session at the Hotel Lafayette, on the subject of "Psychology of the Little Things of Business." This address was enthusiastically received by the Buffalo business men, who appreciated the many effective points that Mr. Hopkins emphasized in his talk.

Twenty-five submarine chasers, built at the Bremerton Navy Yards, have been equipped with Victrolas.

because her former accompanist is a member of it, and the picture shows the company going through "inspection arms" for the benefit of its



Miss Christine Miller Inspecting Her Favorite Company at Camp Lee, Va. Miss Miller, who in private life is now Mrs. Clemson, has "adopted" this company distinguished visitor, who appears to be greatly interested in the procedure.

"MANAGING BUSINESS IN WARTIME"

Two Volumes Just Issued by A. W. Shaw Co. Designed to Help the Business Man In This Country to Meet His Present Problems

"Managing a Business In Wartime," a most valuable work in two volumes, has just been issued by the A. W. Shaw Co., of Chicago and New York, and is designed to help the business man in this country to meet the problems he is encountering just now, aided largely by the experience of British business men during their several years of war.

In the very first chapter—Adjusting a Business to Wartime Conditions—T. J. Zimmerman, managing editor of the British System, tells exactly how a British business met the new conditions and sudden problems that the war brought.

Other chapters in the first volume are: What American Business Men Can Learn from British Experience; Hints on Handling Wartime Business; How Working Hours Affect Output; Training the Boy Worker.

The second volume treats particularly of ways for American business to meet wartime conditions, and the list of chapter titles suggests the possibilities. For instance, The Probable Effect of the War Upon Prices; A Short Cut in Financing; How to Sell to the Government; More Production with Fewer Men; Wartime Buying Problems; and many others.

Nor are the business problems that will confront us, when peace is declared, forgotten. Here are one or two of the subjects covered: Where Will European Competition Find Us Weakest? What Chance Has America After the War? Preparing for the Trade Contest.

Some of the men who have made these books valuable for American business men by their contributions are Lord Leverhulme, Sir Charles W. Macara, Rt. Hon. John Hodge, M.P., Minister of Labor; Laurence R. Dicksee, of the University of London; Ralph E. Heilman, of Northwestern University; W. R. Basset, of Miller, Franklin, Basset & Co.; Reginald Trantschold, John Hays Hammond, Theodore E. Burton, Noble F. Hoggson, and other successful business men.

In short, these books show the American business man just what he must do to readjust his business to the demands of war, from securing the necessary help to the character of the product he should handle, from the minor problems which may be more or less obvious to anticipating the modifications that the Government might otherwise suggest, sooner or later.

"Managing a Business in Wartime." A. W. Shaw Co., Chicago and New York. Two volumes, cloth bound, \$3.

SALES STAFFS MADE WELCOME

The general sales department of the Columbia Co. has inaugurated a policy of inviting members of the sales staffs in the different branches throughout the country to visit the executive offices, in order to permit the executives to become better acquainted with the men "on the firing line," and so that the salesmen may acquire first-hand information regarding Columbia products. The salesmen visit the factory at Bridgeport and the recording laboratory and return to their home cities imbued with an adequate appreciation of Columbia efficiency and quality.

Among the salesmen who visited New York this week were H. L. Ireland and H. L. Fields, of Pittsburgh, accompanied by Mrs. Ireland and Mrs. Fields; Wm. Roy, Kansas City branch; Louis B. Sayer and George L. Schuetz, of the Indianapolis branch, and W. M. Korhammer, of the Baltimore branch. Mr. and Mrs. Ireland and Mr. and Mrs. Fields made the trip to New York from Pittsburgh, accompanied by K. Mills, assistant manager of the New York branch, and formerly assistant manager of the Pittsburgh branch, who had returned to the "Smoky City" for a day or two in order to bring his automobile to New York.

OPPOSE ZONE POSTAL RATES

Merchants' Association Declares It Will Harm Publishers

The Merchants' Association recently sent the following telegram, protesting against the application of zone postal rates on second-class mail matter, to Senator John H. Bankhead, chairman of the Senate Committee on Post Offices and Post Roads:

"This association believes that the application of zone postal rates on second-class matter must inevitably greatly reduce the circulation of periodicals by making the cost of distant circulation prohibitory, thereby greatly reducing the revenues of publishers, making the business generally profitless, and forcing many publishers out of business. Such zone rates will be especially destructive to the great publishing interests of the Eastern States, inasmuch as the cost of circulation of their publications to distant points will exceed their revenues from such circulation and will, moreover, create conditions which will heavily discriminate in favor of centrally located publishers.

"The Government, because of enforced decrease in the circulation of periodicals, would fail to realize the increase in postal revenues expected from the application of zone rates to second-class matter, and, further, would be deprived of large revenues from the excess profits and income taxes by reason of the unprosperous condition of the publishing business arising from a prohibitory postal charge. The great decrease in the circulation of periodical literature which must result from a prohibitory postal charge will, to a considerable extent, deprive the American people of educational opportunities of great importance and benefit to them. For these reasons we urge that the proposed application of postal zone rates to second-class mail matter be not approved."

PHONOGRAPH HARDWARE CATALOG

Hammacher, Schlemmer & Co. Issue Booklet Bearing on Talking Machine Cabinets

Hammacher, Schlemmer & Co., Fourth avenue and Thirteenth street, New York, have just issued a catalog in which are illustrated and listed various items of hardware which are used on talking machine and phonograph cabinets. Various kinds of hinges are shown, including hinges of wrought brass with dipped butts, the Soss invisible hinges, which are used by a great many talking machine manufacturers, as well as the top supports and slides, stay joints and desk slides.

The book also contains illustrations of elbow catches, grip neck casters, Philadelphia stem casters, faultless casters and "Steel Gem" roller-bearing casters and the various parts which are installed with it. A complete line of furniture slides and leg tips as well as brass leg sockets and flush pulls are shown. Several pages are devoted to knobs, including brass knobs both wrought and cast, polished and dull finished, glass knobs and wooden knobs. A complete line of mortise locks are also included, as well as a display of fancy keys. Other items are corrugated steel fasteners, used for joints and wood screws, paper covers, packing bolts and felt for washers, discs, lining, etc.

TO SELL PAROQUETTE ASSETS

By order of the Supreme Court, Kings County, there will be sold at auction on Wednesday, May 22, the property and assets of the Paroquette Mfg. Co., which has made a general assignment for the benefit of creditors. The assignee, Maurice L. Shaine, will sell at public auction through Joseph Feldstein, auctioneer, at Building No. 1, Bush Terminal, Brooklyn, N. Y., the entire property and assets consisting of a complete plant for the recording and manufacturing of phonograph records, 30,000 Par-o-Ket records, and a large number of master and mother matrices.

THE BRONX EXPOSITION

To Open May 30 and to Remain Open Five Months Each Year

In order to assist the manufacturers of the United States in capturing their just share of the export business of the world, and to provide them with a market place where they may meet the foreign buyers who are coming to this city from all over the globe, the New York International Exposition of Science, Arts and Industries is now being constructed here. It will be opened to the public, beginning on May 30 and continuing until November 1. The exposition is to be permanent, along the lines of Shepherd's Bush, London, and the annual trade conference at Lyons, France. Each year it will be open during the period indicated.

The exposition grounds cover twenty-seven acres, and are situated at the East 177th street subway station, West Farms. This is one of the most accessible points in Greater New York, and is said to have the best transportation facilities ever possessed by an international exposition in this or any other country. The exhibit buildings now under construction include a Palace of American Achievements, Palace of Fine Arts, Temples of Liberal Arts and Varied Industries, and others housing features found at previous expositions of this character.

That Canada will have a representative exhibit now seems assured. The directors of the exposition have received notice that exhibits are being assembled by the Provinces of Quebec, Manitoba, Nova Scotia, New Brunswick, and Ontario. It is expected that for the second year of the exposition Canada will have an entire building in which to house its products.

Charles F. Lilley, proprietor of the New York Phonograph Co., of Elmira, N. Y., recently celebrated his second anniversary in the business. He has been most successful since opening his store in Elmira, and has built up a large and profitable clientele.

EDISON THEATRE AT MUSIC SHOW

Splendid Program Arranged for the Edison Display to Be Made at the National Music Show in Grand Central Palace Early Next Month

Thomas A. Edison, Inc., have arranged their section of the music show exhibit at the Grand Central Palace as an Edison Theatre. This theatre is to be fully equipped with all the necessities of a regular theatre, will seat about six hundred people and have a splendidly arranged stage.

Verdi E. B. Fuller, who is in charge of the Edison tone test work, is arranging a series of recitals for afternoon and evening to be given by such artists as Marie Tiffany, of the Metropolitan Opera Co.; Marie Morrisey, concert contralto; Vernon Dalhart, Frederick Wheeler, the Fleming Trio and others. Anybody who has never heard a tone test will find this a splendid opportunity to become acquainted with this feature of Edison advertising.

The exhibit will be a view de luxe of the celebrated Period models with some surprises in new styles, and will be in a space adjoining the Edison Theatre. There will also be shown in this space the famous Army and Navy model as well as some of the regular models.

The Edison dealers' convention, which will be held at the Waldorf-Astoria, takes place during the same week as the music show, and it is expected that the Edison Theatre will be headquarters for hundreds of Edison enthusiasts.

L. Lehman, of May, Stern & Co., Pittsburgh, Pa., was a visitor to New York recently calling at the Columbia executive offices and renewing his friendship with Manager Friedl, of the New York branch, who, prior to his arrival in New York, had been manager of the Pittsburgh branch. May, Stern & Co. are one of the largest Columbia dealers in that territory, and Mr. Lehman's satisfaction with Columbia product is reflected in the company's fast-growing sales totals.



Ten Inch

OPERAPHONE RECORDS

(HILL & DALE)

PLAY ON ALL

Universal Tone Arm Machines

With Steel Needle

No Jewel Point Needed

Standard American Catalogue Now Ready

*If your line of Machines will play all Records
prove it by demonstrating Operaphone Records*

ALL THE POPULAR ARTISTS

Send for Complete Catalogue and Special Terms to Dealers

OPERAPHONE CO., Inc.

Creek and Meadow Streets

Long Island City





The GREATEST MOTHER in the WORLD

Stretching forth her hands to all in need; to Jew or Gentile, black or white; knowing no favorite, yet favoring all.

Ready and eager to comfort at a time when comfort is most needed. Helping the little home that's crushed beneath an iron hand by showing mercy in a healthy, human way; rebuilding it, in fact, with stone on stone; replenishing empty bins and empty cupboards; bringing warmth to hearts and hearths too long neglected.



Seeing all things with a mother's sixth sense that's blind to jealousy and meanness; seeing men

in their true light, as naughty children—snatching, biting, bitter—but with a hidden side that's quickest touched by mercy.

Reaching out her hands across the sea to No Man's Land; to cheer with warmer comforts thousands who must stand and wait in stench and crawling holes and water-soaked entrenchments where cold and wet bite deeper, so they write, than Boche steel or lead.

She's warming thousands, feeding thousands, healing thousands from her store; the Greatest Mother in the World—the RED CROSS.



Every Dollar of a Red Cross War Fund goes to War Relief



Contributed through Division of Advertising United States Government Committee on Public Information.

This page contributed to the Winning of the War by the

NEW YORK TALKING MACHINE COMPANY

119 West 40th Street, New York

CHICAGO TALKING MACHINE COMPANY

10 No. Michigan Ave., Chicago, Ill.

FROM OUR CHICAGO HEADQUARTERS

E. P. VAN HARLINGEN,
Manager

World Office
Republic Bldg., 209 South State St., Chicago
Telephone: Wabash 5774

CHICAGO, ILL., May 10.—Both the wholesale and retail trade of Chicago are jubilant over the showing that they made during the recent Liberty Loan campaign. While it is true that the allotment for the music trades of Chicago was handled principally by piano men, the talking machine men proved themselves a potent factor during the big drive by helping push their quota of \$700,000 over the top. When the final returns of the big drive were officially announced it was shown that from the music trade alone there were 3,485 subscribers, and the amount subscribed was actually \$740,150 or approximately 6 per cent. above the original allotment. All the manufacturers, distributors, jobbers and retail men rolled up their sleeves and took part in the fray, devoting every possible moment that they could to make the drive a success.

However, the wholesale trade had a very good month and are trying the best they can to take care of their orders, which kept coming in principally from the outlying districts. The supply, however, was way below the demand, and as a result distributors were very careful in apportioning their goods in order to keep peace in the family, so to speak. The record situation is somewhat improved over last month and shipments are coming through from the plants in better shape.

If the demand for records may be used as an indicator of the nation's pulse, it is an assured fact that the great wave of patriotism which has swept over the country is growing more intense. This is apparent because the demand for patriotic numbers has increased in greater proportion than any other time during the past.

With the retail trade there was a slight falling off in Chicago during the past month. This was expected as, according to the majority of the dealers, it is customary at this time of the year—moving season. The falling off, however, was principally for machines, but the record business made a good showing and the sale of patriotic and dance records had a tendency to balance the deficiency in sales of machines, and as a result kept the trade in a somewhat even status.

He Went to Rockford

H. Elthorn, who for the past five years has been traveling through the Indiana and Illinois

territory for the wholesale Victor department of the Rudolph Wurlitzer Co., was called to Rockford with others of the draft contingent, leaving on Monday of this week.

H. S. Conover Manages Department

H. S. Conover, who was formerly connected with the wholesale Victor department of the Rudolph Wurlitzer Co., has accepted a position with Simon Bros., of Gary, Ind., and is now manager of their talking machine department.

Enlists With Canadians

Ray Cepek, who is in charge of the Victor record order department at the Rudolph Wurlitzer Co., left Chicago last week bound for the Canadian training camp at Toronto, where he enlisted in the British-Canadian overseas forces.

Edison Artist Sings

Hardy Williams, an Edison artist, is entertaining in person during the showing of the Thos. A. Edison war film, "The Unbeliever," now appearing at the Auditorium Theatre. This war drama was produced by Thos. A. Edison, Inc., in conjunction with the United States Marine Corps. Mr. Williams renders patriotic songs during the intermission.

S. A. Ribolla in New York

S. A. Ribolla, manager of the Chicago headquarters of the Otto Heineman Phonograph Supply Co., spent a few days last week in New York in the company's interests.

Move to Larger Quarters

The Emerson Phonograph Co. within a few days will move the headquarters which it now occupies on the fifth floor of the Regal Building, 7 East Jackson boulevard, to its new location on the fourth floor of the same building. Manager F. W. Clement states that the new headquarters will occupy the space of approximately five thousand square feet and the offices are being arranged so as to provide for several large demonstration rooms. The shipping department will be on the same floor as well as the general offices and demonstration rooms, and arrangements have been made for a large space in the basement which will be devoted entirely to stockroom. Mr. Clement states that the new nine-inch Emerson records have impressed the trade very favorably, and from present indications the new field for these records is unlimited in that the independent dealers are now

able to supply their trade with large records, which heretofore they were unable to do. A large stock of these nine-inch records is carried by the Chicago headquarters and the wants of the Central Western territory are supplied from this point.

To Jefferson Barracks

H. W. Higgins, assistant to F. W. Clement, manager of the Chicago branch of the Emerson Phonograph Co., received his official notice this week to report to Jefferson Barracks, St. Louis, Mo., on April 6. Mr. Higgins has been Mr. Clement's assistant for the past two years and will be a great loss to the Chicago branch.

Reduced Price on Certain Styles

The Columbia Graphophone Co. announced through a letter which was sent out to their dealers a few days ago that their small-size talking machine type "E" had been reduced from \$85 to \$75. Columbia has two types of this machine, the large and the small, and this reduction was made in order to differentiate as both were formerly quoted at the same figure.

W. C. Fuhri Visits

W. C. Fuhri, manager of the Chicago headquarters of the Columbia Graphophone Co., made a short visit to the Columbia headquarters in New York this week.

Singing Lullabies

W. H. Wade, of the Wade Talking Machine Co., is receiving congratulations from his many friends in the trade, due to the fact that a young lady by the name of Ruth Hall Wade is now residing at his home. About two weeks ago "along came Ruth" and since the arrival, Daddy Wade has been an exceptionally busy man memorizing various well-known lullabies.

A Busy Man

Frank P. Read, of the Automatic Container Co., is up to his neck in work these days in making preparations for the big show at New York, and formulating plans for the big sales campaign to be launched by his company within the next few weeks. He is establishing a large corps of competent traveling salesmen and fitting them out with sample displays. He is also fitting out a full line of the company's product for exhibition purposes at the New York show and will be in personal charge of the company's booth, number 116 on the mezzanine floor. W.

(Continued on page 85)

THE "WADE" FIBRE NEEDLE CUTTER

Still in the Lead and Running Well

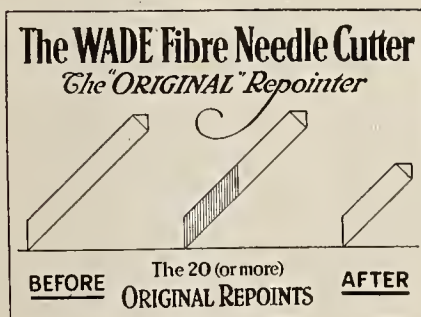

Another milestone in the great talking machine industry is almost reached. The success of the coming year will largely depend upon the wisdom with which the experience of the past is applied.

Ask the man who sells Wade Fibre Needle Cutters—he knows from experience that they are ready sellers.

BECAUSE

- they give "20 or more" new points to *each* fibre needle.
- each* repoint is identical to the *original* point—their use means *increased sales* of fibre needles, the habitual use of which lengthens the life of the records, renders more natural reproduction, increases the enjoyment and
- last but not least, regular jobbers' discounts apply

Write for Samples or Further Information

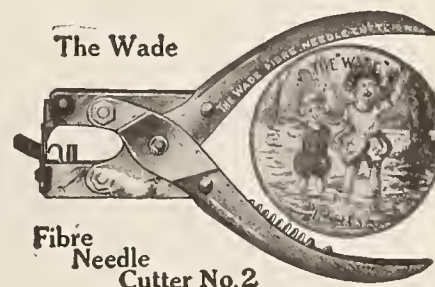

Fibre Needle Cutter No. 2

Price \$2.00

WADE & WADE, 3807 Lake Park Ave., Chicago, Ill.



Dependability!

Service during constantly changing conditions.

The demands of our Army and Navy come first—then come our civilian needs.

This organization is on a strictly up-to-the-minute basis—alert at all times to render our customers the very best possible service that the situation permits.

Good advertising now is more important than ever.

Write for information on our tested Advertising Services—

- Newspaper Advertising.
- Window Card Advertising.
- Container for Monthly Supplement Advertising.

EVERYTHING KNOWN IN MUSIC

LYON & HEALY

Victor Distributors

CHICAGO

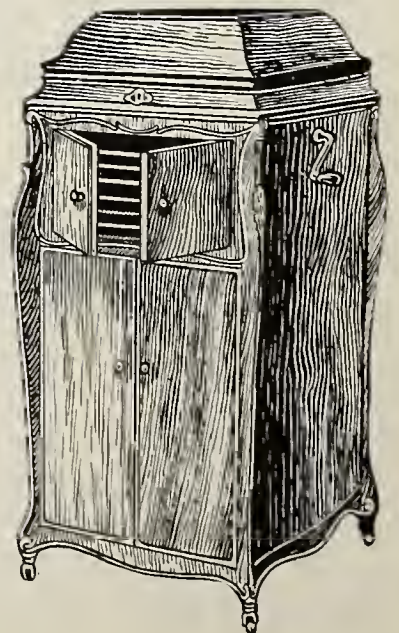

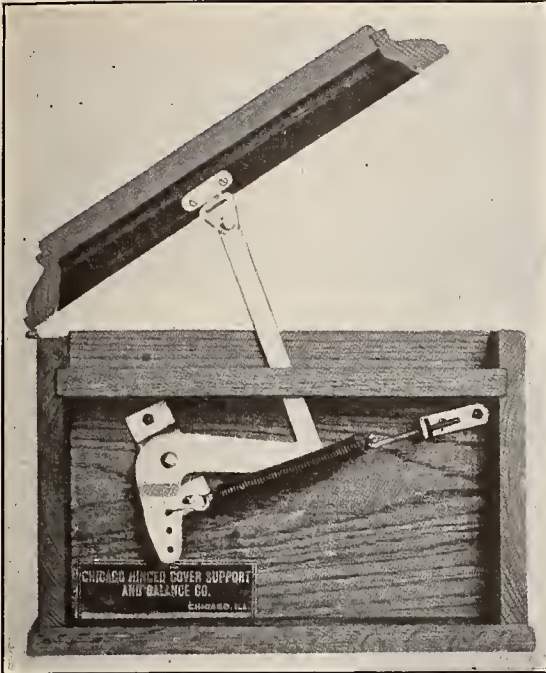

(Pat. Applied For) COVER BALANCE No. 1

The Block Signal is essential in preserving the lives of passengers and preventing accidents. For that reason wise travelers select the railroad with this kind of equipment.

The Chicago Cover Balance No. 1

is essential in preserving the lives of records and preventing smashed fingers. There's no possible way for the cover to fall and break a record or smash a finger when a talking machine is equipped with the

CHICAGO COVER BALANCE No. 1

The cover is "PUT" and "STAYS PUT"

WE ALSO MANUFACTURE CONTINUOUS AND GRAND TOP HINGES

Chicago Hinged Cover Support and Balance Co. 2242-44 W. 69th Street CHICAGO, ILLINOIS

FROM OUR CHICAGO HEADQUARTERS—(Continued from page 83)

A. Fricke, of the Lakeside Supply Co., will accompany Mr. Read to the show and will assist him in taking care of the display. Both Mr. Read and Mr. Fricke will demonstrate for the benefit of the manufacturers attending just how the Automatic Container Co.'s filing devices can be used in all models of talking machines. A very beautiful Artkraft model containing the latest design of the automatic container filing device is being prepared for the show by the Lakeside Supply Co.

A. D. Geissler Visits

A. D. Geissler, president of both the Chicago Talking Machine Co. and the New York Talking Machine Co., was a visitor to Chicago the first part of the week, having come from French Lick Springs, where he was enjoying himself for about two weeks. After spending a few days in Chicago Mr. Geissler left for his headquarters in New York.

Six Best Sellers

The six best Edison sellers for the past month are: "U. S. Army Camp Songs"; "Bungalow in Quogue" and "Just a Voice to Call Me Dear"; "Leave It to Jane" and "Sirens' Song"; "Jack O'Lantern Fox Trot" and "Knit, Knit, Knit"; "That's Why My Heart Is Calling You" and "Will You Remember"; "Naval Reserve March" and "Spirit of America."

Pathé announce for the past month the six best sellers as follows: "Who Knows?" and "Mary of Argyle"; "Keep the Home Fires Burning" and "When the Great Red Dawn Is Shining"; "Vocal Gem Medley, No. 2"; "One Day in June" and "I'm Sorry I Made You Cry"; "Hungarian Rag" and "American Jubilee"; "Hearts and Flowers" and "Will You Remember."

Six best Victor sellers for the months are: "Four American Folk Song"; "Sweet Emalina, My Gal" and "While the Incense Is Burning"; "Each Stitch Is a Thought of You, Dear" and "A Little Bit of Sunshine"; "Everybody's Crazy

'Bout the Dog-Gone Blues" and "In the Land o' Yamo Yamo"; "Roses of Picardy" and "Love's Garden of Roses"; "The Last Long Mile" and "K-K-K-Katy."

The six best Columbia records for the month are: "Quartet From Rigoletto" and "Sextet From Lucia"; "I Hate to Lose You" and "For the Two of Us"; "Any Old Place the Gang Goes (I'll Be There)" and "Faugh-a-Ballah"; "On the Road to Home, Sweet Home" and "Bring Back My Daddy to Me"; "Keep the Home Fires Burning" and "Pack Up Your Troubles in Your Old Kit Bag (and Smile, Smile, Smile)"; "Tales of Hoffman" and "Melodie in F."

Six best Emerson sellers for the month are: "Au Revoir, But Not Good-bye, Soldier Boy" and "On the Rockin' Rosa Lee"; "The Missouri Waltz" and "Kathleen Mavourneen"; "A Baby's Prayer at Twilight" and "Gate City"; "Kilima Waltz" and "Hilo March"; "What Are You Going to Do to Help the Boys?" and "I'm Going to Follow the Boys"; "Cleopatra" and "K-K-K-Katy."

The six best Paramount sellers for the month are: "Pasadena Day March" and "Lights Out"; "Poet and Peasant Overture, Part 1" and "Poet and Peasant Overture, Part 2"; "Where the River Shannon Flows" and "When You and I Were Young, Maggie"; "Come Where My Love Lies Dreaming" and "The Rosary"; "Baby's Prayer at Twilight" and "One Day in June"; "Havanola" and "Ragging the Scale."

Gennett records: "Humoresque" and "Ave Maria" (Helen Ware) (Art Tone record); "Mary of Argyle" and "Eileen Allanna"; "Hilo March," Aloha Oe" and "Ua Like No a Like" (Hawaiian instrumental trio); "Good-bye Barney Boy" and "Yock-a-Hilo Town"; "Fox-Trot Medley" and "One-Step Medley"; "Hello, I've Been Looking for You" and "Liberty Bell."

Donates Victor to U. S. S. "Wilmette"

Mrs. Edwin Allen Mead, a prominent society

woman of Wilmette, has donated a large Victor cabinet talking machine to the crew of the U. S. S. "Wilmette." The "Wilmette" was formerly the old steamer "Eastland," which capsized in the Chicago River, causing a loss of six hundred lives. This boat has been recently remodeled and converted into a scout ship for the U. S. Navy and received its overhauling and complement of men and guns at the shipbuilding yards in South Chicago. Many of the boys of the crew are sons of well-known families of Wilmette, and for this reason Mrs. Mead made her donation. The talking machine was purchased from P. S. Ridgeway, manager of the Victor department of the Cable Company.

New Home for Hiawatha

The Ottawa Pianophone Co., whose plant at Ottawa, Ill., was destroyed by fire a few weeks ago, have purchased a splendidly equipped factory at Geneva, Ill., only an hour's ride from the Chicago market. It is a three-story brick structure, thoroughly equipped for the exclusive manufacture of phonographs and is run entirely by electric power with individual motors for each machine. The plant is now in operation and several hundred cabinets are already in progress through the factory. Within the next few weeks they will be ready to make shipments to their trade. At the general offices and wholesale warerooms in the Republic Building, Sales Manager Fred Moynahan expressed his satisfaction that, although six weeks elapsed between the burning of the plant and the resuming of operations in the new factory no cancellations of orders had been received, this showing conclusively the value placed on the Hiawatha agency by the dealers. It is the intention of the company to change the name to the Hiawatha Phonograph Co., and a meeting of stockholders has been called for June 3 in order to take the necessary steps to that end.

(Continued on page 87)

TRANSFER NAME-PLATES

We make the Transfer Name-Plates and Trade-Marks for the largest talking machine manufacturers in this country and for dealers in every state.

YOUR NAME, Mr. Dealer, on every machine brings the owner back to you for records and his friends to you for a machine:

Samples, Suggestions and Sketches Furnished Free

THE MEYERCORD COMPANY, CHICAGO

Largest Manufacturers of **DECALCOMANIA** Transfer Name-Plates

PLAYS ALL RECORDS

If All Phonographs Were Like The Brunswick

IF ALL were endowed with The Brunswick Method of Reproduction, the opportunity for dealers would be similar and uninteresting.

Brunswick Dealers, however, have infinitely more to offer their customers.

And ideas that are exclusive.

No other instrument has, or can ever have, this new-day way of playing records.

Some may attempt, but our patents are broad.

Only Brunswick Dealers, in pointing out the advantages of The Brunswick Method of Reproduction, can offer The Ultona, the wonderful all-record player.

Only Brunswick Dealers can offer The Brunswick Tone Amplifier, the latest and greatest advancement of all in acoustic arrangements.

Other dealers cannot offer these wanted features.

And we are creating a demand for them among music lovers in our national advertisements.

People want to know about The Brunswick Method

of Reproduction. They want to hear this instrument.

Only Brunswick Dealers can satisfy this demand and make the sales.

A peep in our new sales portfolio will make you read the whole interesting story.

A copy will be sent on request to super-dealers who are interested in handling the super-Brunswick in a super-way.

We already have a great many fine dealers, but there are several locations offering profitable opportunities.

Ask for The Brunswick Dealer Portfolio now — it tells a money-making story.

Brunswick Models
Price \$32.50 to \$1,500

THE
BRUNSWICK-BALKE-COLLENDER
COMPANY

General Offices
CHICAGO

Branch Houses in Principal Cities of the
United States,
Mexico and
Canada

Canadian Distributors:
Musical Merchandise
Sales Co.
Excelsior Life Building
Toronto

(1132)



The
Brunswick
ALL PHONOGRAPHS IN ONE

FROM OUR CHICAGO HEADQUARTERS (Continued from page 85)

Makes Important Widdicomb Deals

E. C. Howard, manager of the phonograph division of the Widdicomb Furniture Co., of Grand Rapids, spent considerable time in Chicago last month and announced that very important arrangements for the distribution of Widdicomb phonographs had been made. A full line of the beautiful instruments is now on exhibition at the warerooms of H. P. A. Mossner, who opened headquarters at 532 Republic Building last month as sales agent. The Widdicomb Sales Co. has been organized to do a jobbing business in the Widdicomb product with headquarters at 327 South LaSalle street. Mr. Ernst and Mr. Stewart, who control the concern, are experienced talking machine men and are very enthusiastic regarding the new line. They will carry a stock in Chicago for the benefit of their trade.

Mr. Howard made a trip to St. Louis a week ago, and on his return announced that the great Meyer Bros. Drug Co., of that city, known as the largest wholesale drug house in the world who have an army of seventy-five traveling salesmen covering Southern and Southeastern territory, had taken on the Widdicomb line and would push it vigorously. Other Western distributors recently reported are Sanborn Kinney Co., Sioux City, Ia., and the H. Dinwoodey Furniture Co., Salt Lake City, Utah. Ben Schweneger, formerly with the Manophone Co., is now on the road for the Widdicomb people. He is making his headquarters in Cleveland and has established some excellent dealers accounts in the Buckeye State.

Youthful Record Maker

Good talking machine records have been made of the voice of Master Howard Dewar, whose mother, Mrs. Mary Allene Dewar, is a saleswoman for H. A. Rintleman, manufacturer of Goldentone needles, with headquarters in the Republic Building. The boy soprano has an unusually fine voice and has appeared at very notable entertainments in Chicago. Mrs. Dewar

is herself handling the records of her son's voice with considerable success.

Attends Koerber-Brenner Opening

L. C. Wiswell, manager of the Victor department of Lyon & Healy, left for St. Louis on Tuesday evening of this week to attend the opening of Koerber-Brenner Co.'s new store at 1712-16 Washington avenue. The formal opening of the new quarters took place on Wednesday, May 8, and an elaborate program was offered. An informal reception and inspection of the new quarters took place in the morning. This was followed by a twenty-five-mile auto trip through the business and residence section in St. Louis up to the Sunset Hill Country Club, where the guests partook of a buffet luncheon. After luncheon the return trip was made to the convention hall of the Missouri Athletic Association Clubhouse, where a Victor factory film was shown. This was followed by practical demonstrations by window trimming experts, and in the evening the guests were given a banquet in the Athletic Club, where many speeches were made. After the banquet Mr. Wiswell gave a strong talk on salesmanship, which was eloquent in the best sense of the word and full of practical wisdom. Mr. Wiswell was accompanied by Mrs. Wiswell.

Andrew McCarthy a Visitor

Andrew McCarthy, treasurer of Sherman, Clay & Co., San Francisco, and in charge of the Victor department of that company, was a visitor to Chicago the early part of the month. Mr. McCarthy was returning to his headquarters from a visit to New York and the Victor factories at Camden.

C. L. Egner Visits

C. L. Egner, assistant traveling manager of the Victor Co. with headquarters in Camden, N. J., was in Chicago during the latter part of April. While here he held a sales conference with W. F. Fries, J. E. Durham and Wm. Yeager, Victor traveling representatives. After the meeting Mr. Egner left for St. Louis to hold

a conference with the Texas, Oklahoma and other Southern Victor travelers. Mr. Fries travels Minnesota, Mr. Durham, Michigan, and Mr. Yeager, Illinois for the Victor.

Ellis Visits Trade

G. P. Ellis, sales manager of the Chicago Talking Machine Co., spent the entire month of April visiting dealers in Illinois, Indiana, Iowa, Michigan, Missouri, Wisconsin, Kentucky and Ohio.

The Lakeside Rotometer

The Lakeside Supply Co. have installed their new punch presses for making the Lakeside Rotometer and are now ready to supply these instruments in any quantities. These little instruments are designed so as to take up the least possible space and are calibrated to indicate when the proper turn table speed has been attained. This company also carries a large stock of the Stephenson precision motors and has established a repair service department especially for this motor to serve the users in Chicago and adjacent territory. The Lakeside Supply Co. is also assembling one of their beautiful Artkraft models of their Luxfibre talking machine for the Automatic Container Co. for the purpose of demonstrating its automatic filing device during the coming New York show. The Artkraft Luxfibre machines are very beautiful and have been most favorably commented on by the trade, although they have been only on the market about six weeks.

Godfrey Isaac, a son of the late Theodore Isaac, who was president of the Klingsor Talking Machine Co., is now connected with the Lakeside Supply Co., and is specializing on the sale of their Artkraft Luxfibre talking machine in both the wholesale and retail lines.

W. A. Fricke, secretary of the company, will accompany Frank P. Read, of the Automatic Container Co., to the New York show and will assist him in demonstrating the Automatic Container Co.'s full line of filing devices.

(Continued on page 89)



Model A 1
\$140

EMPIRE RECORDS RETAIL
AT POPULAR PRICES



Write us for "Dorothy" Booklet

A Distinctive Line for Exclusive Dealers

WE do not aim to manufacture a cheap line of talking machines—our proposition is not a merchandising one but rather one to establish permanent Empire dealers in each city, on an exclusive agency basis. We are proud to state that all our dealers are more than satisfied with the results they are having in handling the Empire line and you are certain to find this machine the one best "bet."

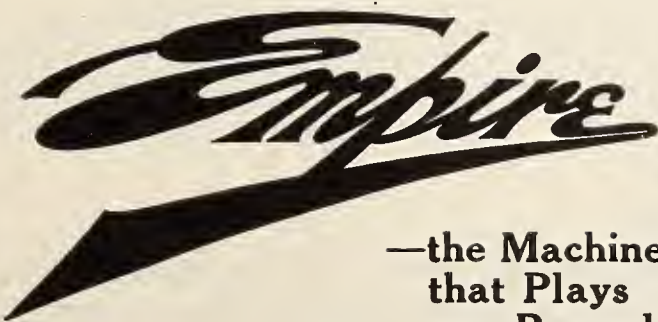

—the Machine
that Plays
any Record

The Empire line comprises nine attractive models. Each one has an automatic stop and our own Empire tone arm and reproducer and an exceptionally high-grade motor. Prices retail are from \$27.50 to \$215. Write today for our dealers proposition and new catalog.

EMPIRE TALKING MACHINE CO.

JOHN H. STEINMETZ, President

429 South Wabash Ave.

Chicago, Ill.



Model B.
\$110

Why MANDEL SERVICE is a guarantee of sales

Dealers have learned the advantage of handling the MANDEL LINE of superior Talking Machines because they are made in their entirety *under one roof*—a guarantee of uniformity throughout.

THE MANDEL LINE of Talking Machines is sold on a written guarantee for *service* backed up by one of the most efficient up-to-date factories in existence. A fitting assurance of its superiority.

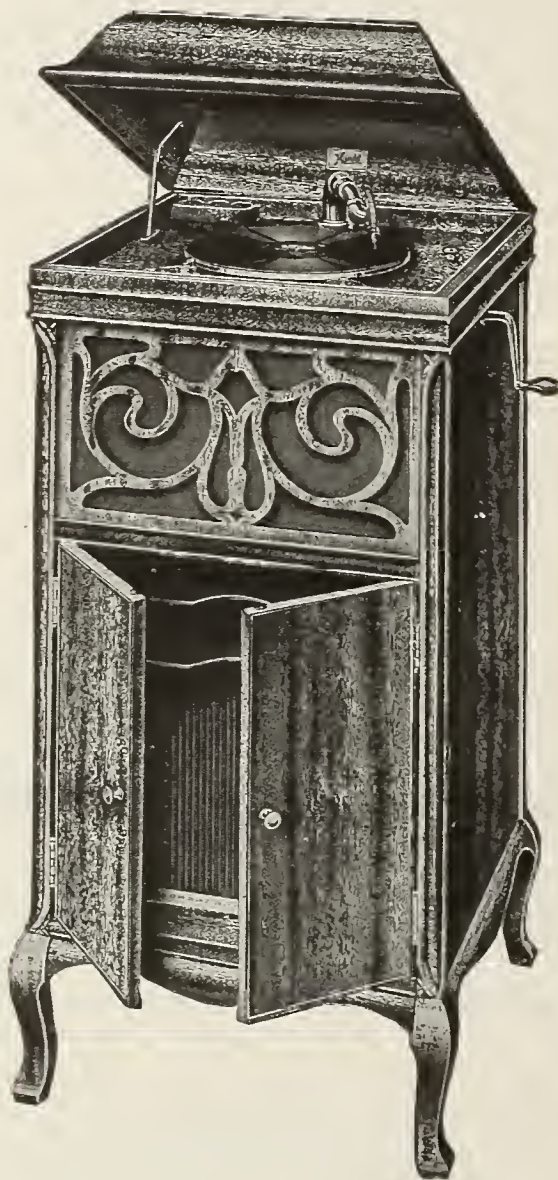

This is our handsome Model No. 3 Machine.

Note our plan of sending it on FREE TRIAL

In quality, workmanship and richness of tone MANDEL TALKING MACHINES measure up to the highest accepted standard, yet in price are within the reach of the most modest purse.

The Mandel Talking Machine is the Machine "Without a come-back." Its standardized make-up assures service even under the stress of severe usage.

Our co-operative plan to dealers is the biggest inducement ever offered by any reliable talking machine line. We not only help *sell* our line but *help dealers buy it*.

Send to-day for details of this unique plan—it is "opportunity pounding on your door"

MANDEL MANUFACTURING CO., Inc.

CHICAGO

501-511 Laflin Street

NEW YORK

41 Union Square

FROM OUR CHICAGO HEADQUARTERS—(Continued from page 87)

Returns From Vacation

G. W. Davidson, of the Talking Machine Shop, who for the past six weeks had been visiting Philadelphia as well as the Victor plant in Camden, returned to headquarters in Chicago this week. Others of the Talking Machine Shop now on vacations are Miss Pauline Tishler and Frank Nall.

Like Morenus Talking Machines

The Morenus Piano Co., of this city, report that business is developing very nicely, and that dealers are particularly well pleased with the special horn construction and acoustic properties of the talking machine. R. F. Morenus has been out on the road a large part of the last month demonstrating the Morenus machine for some of his old friends in the piano trade with the result that he has secured some excellent accounts who are already sending in largely repeat orders.

B. & H. Co. Increase Capacity

The B. & H. Fibre Mfg. Co., makers of the B. & H. fibre needles, have found the demand for their product increasing at such a heavy rate as to necessitate larger facilities; consequently, they have taken an entire additional floor of the building at 35 West Kinzie street, in which their factory is located, and it is now being equipped for their purposes.

Inside of thirty days the company will place a new package of fibre needles on the market. The needles which will be known as the No. A needles are considerably shorter than the standard fibre needles and naturally produce a greater volume of tone. The price, however, will be the same as the regular package, namely, 40 cents per hundred needles.

Puritan Distributor Active

James B. Orth, the new distributor for Puritan phonographs in Chicago, is dispensing luxurious-looking cigars in glass cases in his richly furnished display rooms in the Republic Building. Also he is enthusiastic about the

prospects for the new long horn wonder—as the Puritan is being advertised.

Mr. Orth says he never realized what students dealers are until they began to come to him in ever-increasing numbers to inspect this new long-horn principle and tell him what he didn't know about physics and the principles of sound. Every one who sees it is so enthusiastic that sometimes the cabinet is threatened with destruction to get a real look at the horn, consequently Mr. Orth is having especially built a skeleton model showing this feature, and will have this on exhibition in a few days. G. A. Langheck and E. W. Graham, both salesmen on Mr. Orth's staff, are now calling on the trade in Missouri and southern Illinois, where a lively interest is reported.

Empire Phono Parts Progress

John H. Steinmetz, president of the Empire Talking Machine Co., spent several days at Cleveland last month at the plant of the Empire Phono Parts Co., of which he is secretary and treasurer. President McNamara and he made plans for the increasing of the output of the plant in order to take care of the large volume of business for the company's product. "Our tone arms and reproducers will soon be the standard equipment on a number of well-known talking machines," said Mr. Steinmetz. "Furthermore, we will be ready about the middle of this month with our new attachment for playing lateral cut records. The trade is showing much interest in this device and we are anticipating a large demand for it."

Big April for Vitanola

Jeffrey B. Schiff, sales manager of the Vitanola Co., states that April proved to be one of the largest months they have had since December. Orders are coming from all points.

Use Victor Machine

During the big Liberty Bond drive in Chicago a small Victor table machine was used by those in charge of the Geo. P. Bent Co.'s booth

at Wabash avenue and Adams street. Various well-known patriotic records were rendered on this machine, and by its use large crowds were constantly attracted to the booth. The little machine was donated for the purpose by the Victor department of the Rudolph Wurlitzer Co.

Sings at Empire Concerts

Miss Emma A. Kiess, music teacher and concert singer of Williamsburg, Pa., has made an



Emma Kiess.

arrangement with the Empire Talking Machine Co., of this city, by which she is appearing in recitals given by Empire dealers throughout Pennsylvania, singing in accompaniment with

(Continued on page 90)

The

THE EMPIRE PHONO PARTS CO.

Showing the Empire Reproducer turned back to permit insertion of needle

Showing the Empire Tone Arm set in position for playing vertical cut records

Patent Applied for

Plays Any Make Record Perfectly

This wonderful tone arm and sound box has been adopted by several large talking machine manufacturers and the outlook is that we are going to be kept very busy taking care of our orders.

No Set Screws to Adjust

We are, however, splendidly equipped to handle a large volume of business, and those manufacturers who are looking for a tone arm that will be an improvement over the equipment they are now using should write us at once to submit sample and prices. The Empire Tone Arm and Reproducer are without question superior to any on the market.

Write for Descriptive Circular

Address all inquiries to our Chicago office

THE EMPIRE PHONO PARTS CO.
Sales Office, 427 South Wabash Ave., Chicago, Ill.

Factory:
1102 West 9th St.
Cleveland, Ohio

FROM OUR CHICAGO HEADQUARTERS—(Continued from page 89)

Empire records as played on Empire talking machines. Miss Kiess' reputation as a singer results in attracting large audiences to these concerts, and her superb rendition of numbers has been the subject of much comment in local papers. Her engagement by President Steinmetz was brought about by a letter she wrote the Empire Co. expressing her delight with the Empire machine which she had purchased. Her tribute to its excellence and her appreciation of its value to her both as a singer and a teacher led to a correspondence which resulted in her engagement.

New Aeolian Manager

Fred Aylesworth, who for the past three years has been manager of both the Aeolian-Vocalion and Sonora departments of Julius Bauer & Co., has resigned his position and will take charge of the Vocalion department of the Aeolian Co.'s branch at Indianapolis on May 15. For a youngster he is to be complimented upon the excellent results he produced in building up

the fine talking machine trade for Julius Bauer & Co.

Occupy New Offices

The Combination Attachment Co. have moved from the Republic Building to new and larger quarters in the U. S. Annuity Building, 20 Jackson boulevard, E. They have four large rooms, as suites 401 and 402 on the fourth floor, furnishing them with excellent offices and salesrooms with a comfortable demonstrating parlor for the purpose of showing the visitors the excellence of the Orotund and Superior sound boxes and attachments for playing the various types of records on all classes of machines.

New Perkins Plant

The Perkins Phonograph Co. has developed a very large talking machine business in the last two years and has purchased the plant of John Kimmeth & Co., formerly utilized as a furniture factory on the southeast corner of Wood and Clarinda streets. The purchase included a four-story mill constructed sprinkler building

Equip Your Phonographs With Perfect Automatic Brakes

Samples
\$1.00 Each
Cash with order

State make
of tone arm used



Also made
with long
brake shoe
for 1 inch
offset

Patented Aug. 28, '17

Simple construction and easily attached.
Made in four styles to fit any make of tone arm.

Write for attractive quantity price

PERFECT AUTOMATIC BRAKE CO.
Room 400, 425 S. Wabash Ave., Chicago

Hiawatha Organization

Demonstrates the Caliber of the

Responsibility

behind the

Hiawatha Phonograph

In Six Weeks from the date of the fire that destroyed their Mammoth Factory at Ottawa, Ill., **the New Modern Hiawatha Factory** is now in full operation.

Working day and night to meet with the demand for Hiawatha Phonographs from all parts of the world.



**New Home of the Hiawatha Phonograph
Geneva, Illinois**

Dealers appreciate the wonderful quality of tone, construction and finish.

Write today and embrace the opportunity

Address all correspondence to

209 So. State St., Room 802, Republic Building
CHICAGO, ILL.

with ground dimensions of 70 by 130 feet and a lot of 115 by 30 feet. The purchase price is said to be \$70,000. The company has heretofore manufactured at two plants, one on Wright street and the other at the headquarters of Wilbur Perkins interests, 1925 South Western avenue. Now, however, all case work and assembling will be done at the new plant, although the company will continue manufacturing their own tone arms, motors and sound boxes at the old location.

Manufacture New Cover Support

Barnhart Bros. & Spindler announce that they will soon have ready for the market a new cover support for phonographs. They state that it has been thoroughly covered with patents and will support the cover at any point at which it is placed and will prevent it from warping.

The company is having an excellent demand on the Scotford tone arm and the Superior universal reproducer.

Paramount Records Popular

C. J. Woodard, Chicago representative for the New York Recording Laboratories, Inc., of Port Washington, Wis., has moved his office from 503 Cable Building to Room 204 Athenaeum Building, 59 East Van Buren street. Mr. Woodard has a larger and more modern office than formerly, and the new location enables him to carry a larger sample stock of new Paramount records and to also accommodate visitors. Mr. Woodard has done excellent work on the Paramount, and the numbers of local dealers specializing on these records is constantly increasing. There are now four Chicago Paramount jobbers, namely, Carson, Pirie, Scott & Co., the Automatic Container Co., Moore & Evans and Joseph Hagan Co.

M. C. Schiff Talks on Curtailing Music

The following article on the curtailment of music, written by M. C. Schiff, president of the Vitanola Talking Machine Co., appeared recently in the Chicago Daily News, and it makes good reading:

"Recently there appeared an article indicating the possibility that the Government would take steps to curtail the production of musical instruments, the industry being designated as non-essential.

"Since music in the home is the most positive preventive of deterioration to a morose practically, it is essential to the degree that it affects the morale of the home, the very foundation of the nation's institutions, and therefore the morale of the nation. Music is the most ennobling of all human agencies. Without it the ideals of the nation and hence the nation itself would suffer. It is essential to the home in which is to be maintained the mental attitude necessary to national hope and courage.

"The message of patriotism that great bands and famous musicians impart in their masterful interpretation of our national songs, expressing in most potent manner the great ideals for

FROM OUR CHICAGO HEADQUARTERS—(Continued from page 90)

which America stands, will go a long way at this time, when events transcend the powers of the ablest writer or orator, toward binding together in common ideals and sympathies the people throughout the country.

"Let us find some way for the industry to serve the country without risking injury to the spirit of the people who now, more than ever, need and depend upon music for economical relaxation and clean entertainment."

Personals and Visitors

Among the recent visitors to the Chicago trade the past month were A. Cleveland, Beloit, Wis.; Fred Leithold, of Leithold Piano Co., La Crosse, Wis.; Wm. Hubble, of Wm. Hubble Bro., Monroe, Mich.; W. C. Larrew, Knox, Ind.; H. G. Power, Taylor Carpet Co., Indianapolis, Ind.; H. E. Whitman, Pearson Piano Co., Indianapolis, Ind.; Fred Pearson, Pearson Piano Co., Indianapolis, Ind.; Geo. P. Cheatle, Music Shop, Springfield, Ill.; Ensign Thor Norberg, Norberg Music House, Moline and Rock Island, Ill.; and D. J. Maher, of Maher Bros., Jackson, Mich.

New District Sales Managers

The Jones-Motrola, Inc., announce that W. Afton Carter has been appointed district sales manager for Illinois, Indiana, Michigan and Wisconsin with headquarters in Chicago, and that F. L. Sheppy has been appointed district manager for Missouri, Kansas, Nebraska and Iowa with headquarters in Kansas City.

S. J. Turnes With Brunswick

Sam J. Turnes, who was formerly connected with the Geo. P. Bent Co. in the capacity of advertising manager, is now associated with the phonograph division of the Brunswick-Balke-Collender Co. as advertising manager. After leaving the Geo. P. Bent Co. Mr. Turnes went over with the Burnett & Weinberger Co. as sales service manager and remained with them until he accepted his present position. Mr. Turnes succeeds H. E. Nelson, who is now stationed at the U. S. Government Aviation School

for Mechanics at Portland, Me. To use his own words, "Sam," as he is popularly known throughout the trade, says that he just couldn't keep away from the old stamping ground and is glad to be back among his congratulatory friends on the Row.

Brunswick Activities

The following is a partial list of new agencies that have been established by the talking machine department of the Brunswick-Balke-Collender Co. during the past month: Porch Bros., Altoona, Pa.; Wunderlich Piano Co., Kansas City; Kieselhorst Piano Co., St. Louis; the Knabe Warerooms, Inc., Baltimore, Md., and Washington, D. C.; J. Goldsmith & Sons Co., Memphis; E. Witzmann Piano Co., Memphis; and Hollenberg Music Co., Little Rock and Pine Bluff, Ark.

SEEBURG EXHIBIT AT MUSIC SHOW

Chicago Manufacturers Will Make Fine Display of Phonogrand at National Music Show

CHICAGO, ILL., May 9.—One of the most interesting exhibits at the National Music Show in New York from June 1 to 8 will be that of the J. P. Seeburg Piano Co., of this city. They will occupy Booth No. 14, and will be devoted to the Phonogrand, the company's remarkable combination of electrically-driven player-piano and phonograph. Illustrations of the instrument will be found in the company's advertisement elsewhere in this paper. The Phonogrand was announced to the trade last fall, but the company is now ready to go on the general market with it and have perfected their productive capacity to that end. In the meantime it has been tested in actual use, and a number of the instruments have been sold from the retail warehouses of this city, where it has proven to be a sight seller. In every instance the greatest degree of satisfaction has been expressed by purchasers. Furthermore, some of the best-known

dealers in the country have placed sample orders and are extremely pleased with the instrument and its selling possibilities. Repeat orders are coming in rapidly.

The Phonogrand is but a little larger than a large phonograph. The piano plays all standard eighty-eight-note player rolls and is especially adapted to the Q R S expression rolls with which it reproduces wonderfully the playing of the great piano artists. The phonograph is of the latest type and is equipped for playing all types of records. It is operated by a separate electric motor, independent of that operating the player-piano. The Phonogrand is, it must be understood, not a coin-operated instrument. It is designed particularly for home use, but is also particularly adapted for clubs, hotel parlors and other places where it competently substitutes for both a good talking machine and a full player-piano. Those who have heard the instrument have been surprised at the volume and quality of tone of both the player and the phonograph. The Phonogrand is a strictly unique instrument and will be inspected with keenest interest by the visitors to the show. It will also be shown permanently in New York at the company's new offices and salesrooms in the Bush Terminal Exposition Building, at 130 West Forty-second street.

WHAT'S TIME TO A HOG?

Does not this old story illustrate clearly the wrong viewpoint of the merchant who is habitually slow when meeting his obligations?

The mountaineer's razor-backs were running loose and feeding on such fattening forage as grass and green apples. "Why don't you pen them up and fatten them quick with corn?" asked the summer boarder. "It takes so much time to get them ready for market so long as they run wild." "Hell!" snorted the mountaineer, "What's time to a hog?"—Kansas City Association Bulletin.



Trade Mark Registered

Claims Are All Right— But Only Proofs Count

Any manufacturer may claim for his product all the qualities there are. That is his privilege. He may even think his claims are justified. You read the advertisements, so you know that makers, as a rule, are not over-modest in that regard. If you believe them all, they all make super-phonographs. In your experience, that theory doesn't hold.

THE VITANOLA

must be good, because it sells—and stays sold. Many propositions look good on paper—but when you apply the real test—selling—how many can stand up and sell the way the Vita-nola does? AFTER THE FIRST VITA-NOLA IS SOLD IN YOUR TOWN more buyers will come in and ask for it. The consumer likes the Vita-nola—because it gives a round dollar's worth of value for every dollar put into it. For this reason every owner is a Vita-nola booster—and you know what consumer boosting means to your store. YOU GET A NICE PROFIT FROM EACH SALE. You get advertising of the best kind from each buyer—why shouldn't you handle the Vita-nola in your town?

Write today for our catalogue and prices

VITANOLA TALKING MACHINE COMPANY
501-509 WEST 35th STREET
CHICAGO, ILL.

Lakeside Supply Co., Inc.

See and hear this beautiful talking machine at the New York Music Show. Booth No. 116 (Mezzanine)



The Luxfibre Case

Our ART-KRAFT Luxfibre case machines are now ready for the market and can be supplied in any finish on short notice. Equipped with best materials at prices ranging from \$200 to \$300 retail. Liberal dealers' discount. Write for particulars.

Lakeside Rotometers now ready for delivery. We carry a full line of hardware and motors. We also handle the Stephenson precision motor. Send us your orders for diaphragms—any size—any material.



Jumbo Tone Arm No. 4
Latest model plays all records in ONE position.

RETAIL PRICE \$7.50 EACH
Prices to Bona Fide Dealers

Sample, \$4.00 each; lots of 6 to 11, \$3.75 each; lots of 12 to 49, \$3.50 each; lots of 50 to 100, \$3.25 each. A further slight reduction on yearly contracts in 100 minimum lot shipments. Patents applied for.

LAKESIDE SUPPLY CO., Inc.

Phone, Harrison 3840

202 S. Clark St. Chicago, Ill.

FROM OUR CHICAGO HEADQUARTERS—(Continued from page 91)

OPENING OF ELBEL BROS. STORE

Nearly 12,000 People Attend—All Entertained With Delightful Program—Description of Building—Many Representatives From Prominent Music Houses Present

SOUTH BEND, IND., April 29.—Elbel Bros., Inc., new store was a veritable bower of spring-time blossoms and greenery Saturday on the occasion of the formal opening. Nearly 12,000 people visited the store and were shown throughout the day and evening.

On the basement floor the sheet music is to be found, an endless array of all kinds of music. Three soundproof "tryout" rooms are given over to the player-pianos on this floor. On the first floor in the rear of the building is a beautiful green-tinted room, which is the recital hall. This room has a seating capacity of about sixty persons and was filled during the entire day. On the first floor are to be found twelve soundproof rooms for the trying out of Victrolas. An instant service record counter is on the first floor near the offices.

The front display window was tastefully arranged as a music room. Near the window was placed a wonderful floral creation, the compliments of the Chicago Talking Machine Co., Victor distributors. A beautiful basket of pink roses which stood at the entrance of the music room was the gift of the Whitney-Currier Co., Toledo, Victor distributors.

On the second floor, which extends over the Max Adler store as well as the Ebel Building, the rooms are given over to the exhibition of grand and Duo-Art pianos. The walls of the rooms are beautifully tinted and add much to the general attractiveness of the display rooms. Donahue's Orchestra played in these rooms during the evening. Beautiful roses were given as favors to the guests during the day and evening. Hundreds of pianos and Victrolas were on display in the six rooms on the second floor,

and on the third floor is to be found the stock and repair room. An automatic electric elevator in the rear building gives service to the four floors.

Representatives from several of the leading music houses were guests at the store for the opening day. They were W. W. Michaels, W. C. Griffith and G. P. Ellis, of the Chicago Talking Machine Co.; J. F. Dunham, of Camden, N. J.; Warren K. Kellogg, of Toledo, O.; Henry Gennet, of the Starr Piano Co., of Richmond, Ind., and David F. Cordingley, New York City.

FEATURE PARAMOUNT RECORDS

Active Campaign Inaugurated by the New York Recording Laboratories, Inc., Port Washington, Wis., in Behalf of These Records

An interesting feature of The World this month is a supplement devoted to Paramount records, made by the New York Recording Laboratories, Inc., Port Washington, Wis. The facts set forth therein give an excellent idea of the development of this organization both in the numbers represented as well as the artists connected with the recording department. This company have inaugurated an active sales campaign, and with a well-developed organization will bring the Paramount records to the attention of a large dealer and a purchasing clientele throughout the entire United States.

WINDOW THAT ATTRACTED MANY

During the recent drive for the Third Liberty Loan the Flatbush Music Co., Brunswick dealers of Brooklyn, N. Y., trimmed their windows in a particularly attractive and patriotic manner, which drew quite heavy crowds. The Brunswick-Balke-Collender Co. were so pleased with the window that they had photographs taken of it and sent to all their dealers with a suggestion that they use similar window displays.

Different—But Practical

The MORENUS Phonograph is a Distinct Departure from a Tonal Viewpoint

The horn, which is entirely of wood, is built on the principle of the saxophone and enters the tone chamber at the bottom, not the top. The tone is big and full but mellow, and the reproduction of the artist's voice or instrument is faithful to an unusual degree.

Among the other features is a unique tone moderator which actually graduates: an exceptionally high grade and acoustically correct tone arm and reproducer, and a cover support which makes handling the lid a delight.

The case designs are right and the cabinet work and finish unexcelled.

The MORENUS is in 3 STYLES

- A. OAK, - - 48 inches high. Retail price, \$110
- B. MAHOGANY, 48 " " " " 125
- C. OAK and MAHOGANY, 50 inches high, Retail price, - - - - 150

Very liberal discounts to the trade
Send for our new descriptive catalog



Style B

The MORENUS PIANO CO.

342 West Huron St.

CHICAGO, ILL.

A TRIBUTE TO THE COLUMBIA

Letter of Praise for the Columbia Grafonola From Iowa Dealer Contained in Latest Issue of the "Columbia Record"—Other Items

There is published in the latest issue of the "Columbia Record," a house organ issued by the Columbia Graphophone Co., New York, an interesting letter from L. Ginsberg & Sons, Des Moines, Ia., relative to their satisfaction with the Columbia line, which they handle in their successful retail establishment in that city. This letter, which is a tribute to the sales possibilities of the Columbia product, reads as follows:

"After six months of pushing Columbia Grafonolas we wish to compliment you on the wonderfully dependable machines you people put out. Our troubles have been so small that you can call them practically nothing considering the number of Grafonolas we sell.

"We may here state that our business during the month of November, on Columbia Grafonolas exclusively, was over six times as much as the month of November, 1916, when we handled several different makes, and did not push any particular make.

"We also wish to take this opportunity of expressing our appreciation for the way the Schmoller & Mueller Piano Co. have handled our business, as they have many times gone out of their way to give us service.

"Hoping that the Columbia Grafonolas will continue to progress in the future as they have in the last six months; we remain, yours truly, L. Ginsberg & Sons (Signed), I. D. Ginsberg."

Other interesting articles in this issue of the "Columbia Record" include a letter from the president of Townsend Harris Hall, College of the City of New York, referring to the fact that this society has become deeply interested in the artistic series of window displays produced by the Columbia dealer service department for the use of Columbia representatives. The president

of the society requests the Columbia Co. to supply them with copies of this display material for use by the members of the society.

There are the usual number of articles featuring attractive window displays, with special mention of the signal success achieved by the Columbia international record department with its new display service.

10 PER CENT. WAR TAX IN CANADA

Musical Instrument Manufacturers Much Perturbed Over Proposed War Budget

OTTAWA, CAN., May 6.—The members of the piano and talking machine trade in the Dominion are naturally quite excited over the War Revenue Budget urged by the Hon. A. K. MacLean, acting Minister of Finance, and which, among other things, would levy a war excise tax equal to 10 per cent. upon automobiles, gramophones, phonographs, talking machines, cylinders and records therefor, mechanical piano and organ players and records therefor . . . when manufactured or imported after the 30th day of April, 1918, on the duty paid value when imported and on the price when manufactured and sold, provided that such war excise tax shall not be payable when the articles are manufactured for export.

Musical instrument manufacturers in the United States, who are paying only a 3 per cent. war excise tax on certain of their products, are being regarded with envious eyes by the manufacturers of this country who see little hope of having the proposed tax of 10 per cent. cut to any appreciable degree. An appeal, however, has been sent to George W. Pound, general counsel of the Music Industries Chamber of Commerce of America, in New York, who carried on the fight before Congress in the interests of the trade in that country, for advice and assistance in our own time of trouble.

Attention!

Victor, Edison and Columbia Dealers and Distributors

Don't forget, when a customer questions you as to what attachment will equip his machine to make it universal, in playing all makes of records most perfectly and without destruction, that

The Orotund and Superior

attachments are the only scientifically perfected outfits on the market, playing all makes of records, producing the greatest musical results, positively reducing surface sounds, and in many instances entirely eliminating disagreeable scratching and nasal effects. If you have not as yet had a real demonstration as to the highest type of music and entertainment from the various makes of records, you should visit our office, or ask for a personal demonstration.

If, after hearing our different attachments and reproducers with a few of the most beautiful records ever recorded, you do not believe we have produced some wonderful results which you have never before thought possible on a talking machine, we will then apologize for wasting your time.

You will increase your sales of records by handling these attachments.

We guarantee to improve the tone of your machine. We sell attachments, tone arms and jewel points, Diamond and Sapphire.

Write for circulars and prices.

COMBINATION ATTACHMENT CO.
20 Jackson Boulevard, East, Chicago, Ill.

To Jobbers and Dealers

Especially those selling Hill-and-Dale Records

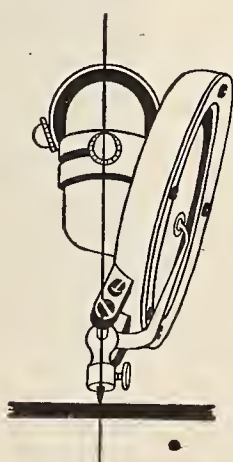
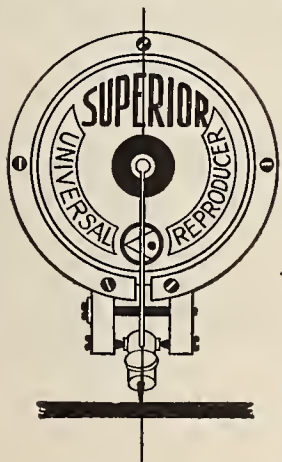

YOU can greatly increase the demand for the best Records by selling these Reproducers and Attachments applying them to standard machines.

Write for Quantity Prices

Liberal Arrangement for Jobbers

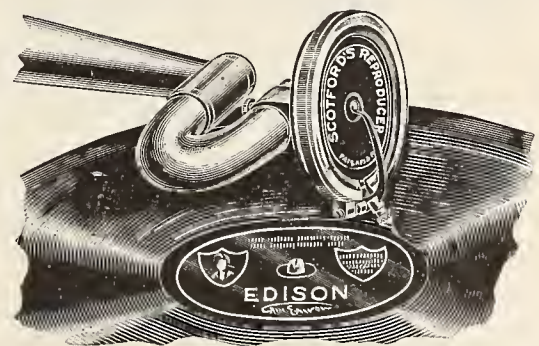

Superior Universal Reproducer

The Reproducer that pivots on its axis—taking the correct angle for all makes of Records—and the needle retains the same center in both positions

	Sample Prepaid	Retail Price
With Attachment for Victor	Nickel \$4.10 Gold 5.00	\$6.50 8.00
With Attachment for New Victor	Nickel 3.50 Gold 4.25	5.50 6.75
With Attachment for Columbia	Nickel 3.70 Gold 4.55	5.85 7.25
With Attachment for Edison	Nickel 4.10 Gold 5.00	6.50 8.00
With Attachment for Pathe old style arm	Nickel 3.70 Gold 4.40	5.85 7.00
As is—it fits the new Pathe universal arm	Nickel 3.15 Gold 3.75	5.00 6.00

*This refers to the latest type having the enlarged Tonearm

"The Superior Universal Reproducer gives a depth of sound that is so wonderful that all other sound-boxes that I have ever heard seem obsolete. Besides this marvelous depth and warm richness of tone, it has the great advantage of a surprising musical volume. In all makes of records overtones and underlines never before heard with other Reproducers are brought out with pure, crystal-like clearness. Your Reproducer places the needle in exactly the right angle for either the Columbia and Victor or the Pathe and Edison Records. It is one of the few which safely play the Edison Diamond Disc Records without skidding across the record, which causes the jewel point to dig into the record and ruin it. Other makes slant too much, therefore there is always the tendency for them to slip from the groove and skid. All that I have said of the Superior is also true of the Scotford Model I, that wonderful Reproducer of yours that, with its large diaphragm, plays the Pathe, Edison, Lyric and other vertical-cut records with so great and beautiful a tone. I have sixteen different Reproducers fitted to my machine, but I know that for perfect articulation, beautiful tone and volume, your sound-boxes have no equal."

Wilmington, Delaware
March 28, 1918

Alfredo L. Demorest
Vice-Consul of Paraguay

Scotford Model I Reproducer

The original Scotford Reproducer—plays only Hill-and-Dale Records, but plays them at their best

	Sample Prepaid	Retail Price
As is—it fits the Victor	Nickel \$3.50 Gold 4.10	\$5.50 6.50
With Attachment for Columbia	Nickel 3.75 Gold 4.45	5.85 7.00
With Attachment for Pathe	Nickel 4.05 Gold 4.75	6.35 7.50

Can be used on the **Edison** with the Kent Attachment

Barnhart Brothers & Spindler
Manufacturers of Superior Specialties for Phonographs
Monroe & Throop Sts.—Chicago

BUSINESS HAS BEEN SOMEWHAT SLOW IN LOS ANGELES

Liberty Loan Campaign, Successfully "Put Over," Engaged the Attention of Public—Machine Stock Situation Improves—War Records in Favor—Harold Jackson With Wiley B. Allen—Other Items

LOS ANGELES, CAL., May 6.—The month of April did not prove to be a very good month for business in the talking machine line. In fact, it was the poorest so far this year. Of course, there were several good reasons for this, and the best excuse, probably, was the great Liberty Loan drive, which has just been brought to a successful finish.

The machine situation has cleared up to a considerable extent, and all of the local dealers have more machines in stock now than at any time since January 1. Records, however, are still hard to obtain and most stocks are sadly depleted with very little hope of any shipments in the near future. This shortage has been a sort of blessing after all, as it has made the merchants push the sale of many good records that were poor sellers before.

The demand for the popular war records keeps up, and it is impossible to get some of the numbers at present. The call for patriotic music is good—the most popular being the "Star Spangled Banner" with "America" second. The French national air seems to be the best liked of the foreign songs.

G. C. Beckwith, of Beckwith-O'Neal Co., Victor wholesalers at Minneapolis, Minn., paid a visit to Los Angeles after a month's sojourn with his family at Coronado, Cal.

R. C. Daynes, who was connected with the talking machine department of Barker Brothers for several years, has left there to go into the farm tractor business.

John Miller has left the Wiley B. Allen Co. to accept a position with Sherman, Clay & Co., local Victor wholesalers.

Howard Brown, manager of the talking machine department for Lyon-McKinley-Smith, is very much pleased with his last month's business, and says that, although he did not do as much as some months before, yet the cash business was larger and his average down payments on instalment sales was 22½ per cent. This company handles the Brunswick line exclusively.

Harold Jackson, for many years connected with the Southern California Music Co., and for the last three years on the road for the Diamond Disc Distributing Co., now the Edison Phonograph, Ltd., has taken the management of the talking machine department for the Wiley B. Allen Co. Mr. Jackson is well known in southern California in the music business, and has handled the Edison line for years. The Wiley B. Allen Co. are also agents for the Victor.

E. Holland, proprietor of the Vernon Music Co., says business has been as good with him

OPPOSE NEW POSTAL LAW

Hear Protests Against Zoning Provisions for Second Class Mail

Further protests against the application of the new postal zoning provisions for second class mail matter in the war revenue law were made public this week. Ex-Attorney General George W. Wickersham said: "There should be no law against limiting intelligence. It is against the public interest. The people are entitled to all the information they can get."

Dr. Charles A. Beard called the principle of the provisions "contrary to the principles on which our Government was founded. Jefferson," he said, "promulgated the theory more than a hundred years ago that newspapers and periodicals were essential to the success of our democracy. It is wrong in spirit and wrong in theory to hamper the national development of the country."

Newcomb Carlton, president of the Western Union Telegraph Co., said that the measure should be repealed and a more equitable method of raising revenue substituted.

NEW INCORPORATION

The Disk Phone Piano Method, New York, has been incorporated with capital of \$100,000, by L. T. Fetzer, J. V. and T. H. Robinson.

as ever. This is certainly a ray of sunshine to the other dealers who have complained of a considerable slow-up during April and are glad to hear of some one whose business did not let up. Mr. Holland's business is located quite a way from the business center of the city, but he has a fine trade and is always hustling for more.

W. G. Bailey, window trimmer for the Southern California Music Co., has had some very interesting displays for the talking machine department lately. One that attracted unusual notice was the "Spirit of '76." In this the figures were all working, the three dummies keeping time and even the flute player's fingers working to the tune of a lively piece. Mr. Bailey displays great ingenuity in his animated signs and has no equal on the Coast in this work.

BROWN RECORD CABINET CATALOG

The Globe-Wernicke Co., Cincinnati, O., has recently published a handsome catalog featuring the Brown disc record cabinets which are made in four sizes, and the Globe-Wernicke sec-



Cover of a Globe-Wernicke Catalog

tional cabinets which are manufactured in standard and art mission styles. This catalog is being generally distributed among talking machine dealers, who are using it to excellent advantage in developing disc record cabinet business.

COLUMBIA DEALERS TO MEET

Lambert Friedl, manager of the local wholesale branch of the Columbia Graphophone Co., has announced that the fifth monthly meeting of Columbia dealers in this territory will be held on May 17 in the Myrtle Room of the Waldorf-Astoria Hotel, at 2 p. m. A very interesting program is now being prepared for this meeting.

Arthur Goyet has taken over the music store of H. J. Provost on Main street, Woodland, Cal. He will handle talking machines.

PURITAN

The Long-Horn Wonder

The Greatest Jobber
and Dealer Proposition
in America Today

Phone, Write or Wire Us for
Territory in Illinois, Indiana,
Michigan and Missouri

YOU want deliveries—you want action—you want service. We are in position to give you all three. We want to demonstrate the advantages of the Puritan to you. We want to show you how we are equipped to serve you and help you make a bigger thing of the talking-machine business than you ever made before. Come in and look over the line. Remember, it means an excellent line of records as well. All backed by a big advertising campaign.



Factory Distributors:

JAS-B-ORTH & CO.
422 Republic Bldg. Chicago Phone Wabash 7630

DEALERS EVERYWHERE ARE SELLING
QUANTITIES OF OUR

HANAIE BANJUKES

(Ukuleles in Banjo Form)

A bigger hit than the Ukulele because much louder and more pleasing in tone, and of more substantial construction. Perfect two octave scales. A thoroughly practical instrument for both solo playing and club work. Send for illustrated catalogue and price list today, as

The Banjoke Is One of the Biggest Sellers
in the Musical Instrument Line.

SHERMAN, CLAY & CO.

Sole Manufacturers
163 Kearny Street San Francisco

HEINEMAN "OKEH" RECORD NOW READY FOR THE TRADE

Otto Heineman Phonograph Supply Co. Announces Heineman Record—Hill and Dale Cut—Will Be Sold Through Authorized Jobbers—Recording Studio in New York—Factory in Springfield, Mass.

Otto Heineman, president of the Otto Heineman Phonograph Supply Co., New York, announced this week that the company is now



Otto Heineman

ready to place on the market the Heineman record, which will be known as the "OkeH" record. This name is derived from the original Indian spelling of the term colloquially known as O. K., standing for "all right." This record has been in course of development the past year, and Mr. Heineman has been devoting a considerable part of his time to the perfection of this record, in order that it might be fully commensurate with the prestige and quality of the other Heineman products.

According to present plans the Heineman record will make its formal trade appearance at the National Music Show to be held at the Grand Central Palace from June 1 to June 8, in conjunction with the annual convention of the National Association of Piano Merchants. The Otto Heineman Co. has made arrangements for an extensive exhibit at this show, and the Heineman record will be one of the features of this exhibit, which will appear in Booths 40 and 41.

The Heineman record is a hill and dale cut record, to be played with either a sapphire point or a steel needle. The company is planning to manufacture only ten-inch records at this time, retailing at the uniform price of 75 cents. All of the records will be double-faced, and the library will include popular and standard se-

lections. The first list, ready for distribution to the trade on June 1, will contain about fifty records, and the artists listed in this first supplement include many of the best-known recording artists now before the public.

It is planned to merchandise the Heineman record to the dealers through duly authorized jobbers, and the prominence of the Otto Heineman Co. in the talking machine industry is reflected in the fact that the company has already received numerous requests from all parts of the country for this valuable jobbing franchise. In fact, several appointments have already been made, and will be announced in the very near future.

The recording laboratories for the Heineman record are located in New York, and are under the supervision of Charles L. Hibbard, technical director, and Fred W. Hager, musical director. Both of these men are generally recognized as two of the best-posted members of the technical and musical divisions of talking machine recording, and Mr. Heineman is very pleased to announce their addition to his staff.

This record is manufactured in a large and up-to-date factory at Springfield, Mass., which is now a member of the Heineman group of factories. This manufacturing is under the supervision of Thos. E. Griffen and Charles Kramer, both well known in their fields. Mr. Kramer has personally supervised the construction of several record manufacturing plants and is thoroughly familiar with every phase of this important work.

During the past few weeks visitors to the company's executive offices have had an opportunity of listening to the Heineman record, now christened the "OkeH," and they have all expressed their hearty approval of this record, stating that it possesses musical qualities which

will undoubtedly win instant recognition from talking machine dealers and the music-loving public.

This announcement of the Heineman record marks another stride in the remarkable progress achieved by the Otto Heineman Phonograph Supply Co. during the past two years. From a modest beginning in a small office in New York this company has marched steadily forward, until to-day it is the recognized leader in talking machine motor production, and, in addition to its executive offices in the leading cities, owns and controls factories in Elyria, O., Newark, N. J., Putnam, Conn., and Springfield, Mass.

The original product, the Heineman motor, is now the head of a family of products which includes Heineman motors, tone arms, sound boxes, etc.; Meisselbach motors, tone arms, sound boxes, etc.; Dean steel needles, etc., and finally the Heineman record.

Each one of these products is a leader in its field, and full credit for this wonderful progress in the short period of two years must be given to Otto Heineman, president of the company. Thoroughly familiar with every phase of the talking machine industry, and internationally prominent as an expert on the technical end of the business, Mr. Heineman has worked indefatigably to place his company in the front ranks of the talking machine field. That he has succeeded even beyond his expectations is indicated in the prestige and position that the company now occupies.

DOEHLER EMPLOYEES BUY BONDS

The patriotism of the employes of the Brooklyn plant of the Doehler Die Casting Co. was splendidly manifested by their subscriptions to the extent of \$56,000 to the Third Liberty Loan so successfully launched recently. These men, like millions of others throughout the country, helped in a most emphatic way to put this loan well "over the top."

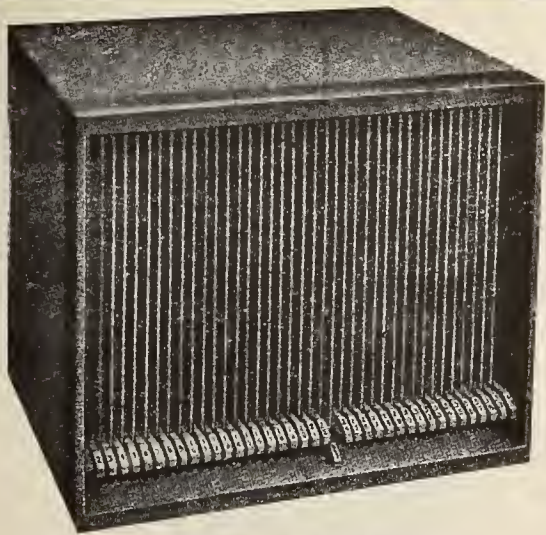

Style 70—Retail \$10.00

7 IN 1

Seven strong points in our feature is a powerful selling argument.

1. Controlled entirely by gravity. Will not get out of order.
2. Non-abrasive individual record compartments.
3. Records cannot warp, scratch or mar and are kept clean.
4. 10" and 12" records can be filed in any compartment indiscriminately.
5. In beautiful oak and mahogany finish. Polished, waxed and dull finish.
6. Automatic out signal shows "when and where" a record is missing.
7. Filing and finding a pleasure. Get the desired record when it is desired.

COLUMBIA DEALERS: Eject-o-files are built to fit the style 75 and others. Slip them in as they are wanted. Why carry that big stock of 85's, etc., when the Eject-o-file does the trick? "The Eject-o-file is Efficient" and you are in business for dollars and cents.

VOCALION DEALERS: A receptacle for records that can be slipped into your style F.-G.-H.-J.-&K. They are "built to fit." Wonderful convenience and a powerful selling argument. Ask the Salesman.

EDISON DEALERS: Eject-o-files are built to fit the style C-150 and 100. Many dealers are reaping the benefits. Why not you?

"BUILT TO FIT" any machine and a powerful asset for any dealer. Why offer Albums, Envelopes and other antiquated methods of filing to your customer? Eject-o-files are modern and efficient. Prices are phenomenally low.

The "sectional Eject-o-file," an auxiliary cabinet, compact, large capacity. Can be conveniently placed on table, stand, etc., or stands especially adaptable can be had. Beautiful and artistic, mahogany and oak finish, polished, waxed or dull. Each section a complete unit, can be added to, one upon the other, you know, sectional bookcase idea.

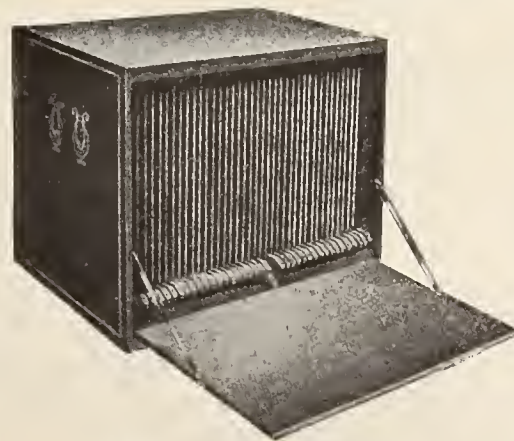

Style 60—Retail \$15.00

EJECT-O-FILE SALES CO.

216 W. Saratoga Street

Baltimore, Md.

REPAIRS

TALKING MACHINE TROUBLES AND
HOW TO REMEDY THEM

Conducted by Andrew H. Dodin

[This department of The Talking Machine World is designed for the service of all classes of our readers, including those who make, and those who sell, talking machines. Andrew H. Dodin, who conducts this department, has a wide and enviable reputation as a repairer of talking machines and conducts an exclusive talking machine repair shop at 176 Sixth Avenue, New York. Tell him your troubles through The World and he will help you if possible. The service is free.—Editor.]

KEEPING TRACK OF THE MOTOR

It seems to be the natural and usual thing that a talking machine owner never looks at the motor of his machine until it won't play properly. Then almost without hesitation he calls on the dealer from whom he purchased the instrument and requests that it be repaired at once. The dealer turns the matter over to his repairman and upon his arrival at the scene of the trouble he often finds a broken governor spring—the leather out of the brake—the motor screws loose so that the turntable hits the brake or regulator—or some other little thing wrong that takes about five minutes' actual working time to remedy. The dealer has spent some valuable time—the repairman possibly has spent an hour or so riding to the house to remedy a little fault that the owner could have prevented if he had been given a few helpful words at the time he purchased his machine.

In this time of war when all things call for the conservation of resources, time in particular, why not make it a point to call the buyer's attention to the following important facts:

1. A machine must be oiled at stated times.
2. If used to any great extent make a point of going over the governor spring screws and tightening them up about once every six months—also the motor board screws and nuts.
3. Make a point of taking out the winding key and oiling the threads on the winding shaft and

also oiling the key where it rubs against the escutcheon.

4. Put vaseline on the spiral cuts of the turntable spindle and governor spindle.

5. See that brake leather is properly held in place, and that turntable does not hit or rub against any parts of the motor board attachments.

These little hints, if given to and followed by the machine owner, will save him trouble and expense and will certainly conserve for other purposes, the time of the dealer and repairman.

Proper Pressure of the Needle Point

New York, May 1, 1918.

Editor, Talking Machine World:

Would you kindly advise me regarding the proper pressure of the talking machine needle on the record to secure the best results? I have had a lot of varied opinions on the subject, but nothing authentic, and believe that the pressure of the needle has much to do with the reproducing and wearing qualities of the record.—S. B. B.

ANSWER.—Too much weight or pressure at the needle point will certainly affect the wearing qualities of the record. The correct weight pressure at the needle point for disc records of the lateral cut type is six ounces, and for the Edison record four ounces.

When the Reproducer Goes Bad

Philadelphia, April 29, 1918.

A. H. Dodin, care Talking Machine World:

Some of my customers have complained that after a year or more their machines have lost certain of their tone qualities. I have investigated and everything seems to be all right even to the adjustment of the reproducer. A friend of mine suggested that perhaps the diaphragm has lost its vibratory qualities. Could this be a possible explanation of the trouble, and how can it be remedied?—J. A. C.

ANSWER.—If the diaphragm is made of any composition or material other than mica, it is possible that the trouble will be found in the diaphragm itself. In boxes where mica diaphragms are used it is always found that the

PROOF

Mr. Fred T. Cunningham, Hattiesburg, Miss., said: "I find your products are all you claim for them and that is considerable." Thousands of Dealers and Repairmen are as well satisfied with **LESLEY'S PATCHING VARNISH**, which dries in 10 seconds and enables them to make perfect patches. Scratches, Holes, Broken Veneer and Molding, or any other damage done to varnish, can be repaired successfully with our No. 275 Finishers' Outfit. Price \$3.00 U. S. A., or \$3.30 Canada. Contains enough material for 100 average patches and is sold on a **MONEY BACK GUARANTEE**. If you have this kind of trouble, order today. **LESLEY'S CHEMICAL CO., 350 Virginia Ave., Indianapolis, Ind.**

gaskets and adjustment of the needle arm are the general cause of all troubles. It is understood that the mica is the correct thickness for the diameter of the box, and it is shellacked to the gasket in such a way that its edges do not touch the cap of the box at any point in its circumference.

When Spring Slips While Winding

Harrisburg, Pa., April 26, 1918.

Editor, Talking Machine World:

I have an old style Columbia disc machine with horn, and notice that every once in a while the spring seems to slip and then catch on again while winding. I may wind the machine constantly for several hours without a slip and then suddenly the spring will slip several times in succession. When wound up the machine seems to run without difficulty. Can you tell me what is likely to be the trouble, so that I may have some guide before taking the machine apart?—T. L. B.

ANSWER.—You will find upon examination of the springs that the trouble lies somewhere in the hooking of the spring ends either on the cage or shaft rivets. I have often had cases like this and have found that in many instances the spring would slip off the rivet head and then on the next winding catch and hold firm, only to slip off again when spring had completely unwound.

KOHLER & CAMPBELL SUCCESSFUL

Great Piano Manufacturing Concern Who Made Intensive Study of Retail Phonograph Trade, Has Found Many Dealers Who Can Successfully Handle Pianos in Their Display Rooms

A few months ago Kohler & Campbell, Inc., Fiftieth street and Eleventh avenue, New York, numbered among the most enterprising organizations in the piano industry, started to devote considerable attention to the piano requirements of talking machine dealers.

In connection with their campaign they have been conducting a consistent effort through the advertising columns of The World with the result that they have discovered that talking machine dealers are finding that the handling of pianos in connection with their line of machines and other musical products is proving very successful.

The Kohler & Campbell organization has been built up in such a way that they are in a position to offer not only pianos of an exceptional value, but also a legitimate dealer's service, which helps greatly in the presenting of the product to the public as well as to the closing of sales. The building up of this aid work to the retail trade has been the result, in the phonograph field as well as in the retail piano field, of intensive study of the requirements of the general public and the various retail merchants. In this way the very best methods have been adopted and are at the disposal of all dealers who handle Kohler & Campbell pianos and player-pianos.

The belief, which Kohler & Campbell had, that the greater the harmony between the piano industry and the talking machine industry the more mutual benefits derived, has proved to be a far-sighted reality, and to-day many talking machine dealers are finding it profitable to handle pianos and player-pianos in connection with their regular business.

If you are short of cash capital try investing a few thousand smiles. Many a man has built a business with nothing much but a capital of smiles.

Delpheon
the
Incomparable

Your nearest distributor will give you prompt service and the fullest co-operation.

DELPHEON plus DELPHEON SERVICE brings SUCCESS

THE DELPHEON SHOP
117-119 Peachtree Arcade
Atlanta, Georgia

DELPHEON SALES COMPANY
25 Church Street
New York City

WALTER VERHALEN
Busch Building
Dallas, Texas

VERBECK MUSICAL SALES CO.
435 William Street
Buffalo, New York

Chicago Display
Sixth Floor, Republic Building

Or write direct to

The DELPHEON COMPANY

BAY CITY

MICHIGAN

MANY NEW JOBBERS APPOINTED

To Handle the Wall-Kane Steel Needles Reported by President Tauber—Good Reports From Talking Machine Trade in the East

In a chat this week with The World D. Tauber, president of the Progressive Phonographic Supply Co., New York, sole distributor for Wall-Kane steel needles, stated that the company's business during the past six weeks had far exceeded expectations. New jobbers have been appointed in all parts of the country, and these jobbers state that their dealers are well satisfied with the sales possibilities of the Wall-Kane needle.

This needle is being merchandised to the dealers with an absolute guarantee that it will play ten records perfectly, and the company's entire campaign has been based on this important sales argument. The Wall-Kane factory has been considerably enlarged since the first of the year, in order to handle the demand for this needle, and judging from present indications additional factory space will be imperative in the near future, as the dealers throughout the country report a constantly increasing call for the Wall-Kane needle.

Mr. Tauber has been visiting the trade in the East during the past six weeks and states that the dealers are enthusiastic in their praises of the Wall-Kane needle. He has encouraged the dealers to interest their customers in the scientific merits of this needle, and has prepared a simple test, which the dealers are using to excellent advantage, in order to illustrate the distinctive features of the Wall-Kane steel needle.

The more customers of the store a man shakes hands with, the more of them are going to get acquainted with him and come back. The politicians haven't made handshaking the first move in every campaign without having first discovered that it is the very best-known method of making folks feel friendly at first sight.

PATHE RECORD BY ADAMO DIDUR

One of the Features of the Diversified Supplement Issued by This Company for June

The new list of Pathé records for June features an interesting record by Adamo Didur, basso, of the Metropolitan Opera Co., who has achieved signal success in many important roles. This list also includes operatic vocal records by Claudia Muzio and Florencio Constantino, both of whom are well known in musical and operatic circles.

The popular records for the month include two songs by the Farber Girls, co-stars with Al Jolson in his new show at the Winter Garden. There are, of course, the usual number of popular selections by the Peerless Quartet, the Sterling Trio and other well-known artists.

There are also represented on the June list the latest dance records, standard and sacred vocal numbers, and instrumental records, including two records made by the Garde Republicaine Band.

ISSUE SUPPLEMENTARY CATALOG

Wm. Volker & Co., Kansas City, Mo., Pathé distributors, have just issued a spring supplementary catalog, which contains several pages devoted exclusively to Pathé phonographs. This catalog is mailed to more than 10,000 "live" dealers throughout the company's territory, and is therefore a valuable link in the company's Pathé campaign. There are reproduced in the pages of the Pathé section several illustrations of the standard Pathéphone models, together with some of the salient features of the Pathé sales plan. There are three pages featuring Pathé art models, together with photographs of the Wm. Volker & Co.'s wholesale demonstration booths. This section is artistically compiled and cannot fail to impress the dealers favorably, and produce results for the Volker Pathé department.

NEW QUARTERS FOR SONA-TONE CO.

Company Discontinues Retail Branch to Concentrate on Wholesale Business—Many New Agencies Will Soon Be Announced

The executive offices of the Sona-Tone Phonograph Co., Inc., have been moved from 3421 Broadway to 3366 Broadway, New York, corner of 136th street. The company has discontinued its retail branch in order to concentrate upon the development of wholesale trade, and in its new quarters will have plenty of room for the expansion of its business.

In a chat this week with The World L. C. Seiler, manager of the company, stated that the only trouble experienced so far has been the inability to secure sufficient merchandise to handle the requirements of the dealers, but this condition is now showing improvement, and shipments are being made to all parts of the country. Mr. Seiler expects to announce in the near future a long list of agencies that have been established the past few months, and judging from all indications this phonograph is meeting with a ready sale.

GETS AGENCY FOR CHICAGO PRODUCT

Phonograph Clearing House to Represent Automatic Record Container Co. in the East

S. N. Rosenstein, president of the Phonograph Clearing House, New York, stated this week that his company had been appointed Eastern representative for the Automatic Record Container Co., Chicago. This device is meeting with great success in all parts of the country, and will be represented at the National Music Show to be held at the Grand Central Palace next month. Mr. Rosenstein states that he has been closing a very satisfactory business the past few months, and that the various lines he now represents in the East are meeting with a ready sale with leading manufacturers who speak highly of their merits.



Pathé Phonograph \$225
Other Models \$30 to \$225

No Needles to Change
The Pathé Sapphire Ball takes the place of needles. It need not be changed.

Long Life to Records
The Pathé Sapphire Ball cannot possibly cut, grind, rip or mar the record's surface.

The Pathé Controla
With the Pathé Controla you may increase or decrease the tonal volume of the Pathé Phonograph at will.

Plays All Records
Each Pathé Phonograph plays not only Pathé Records, but all other makes of records, and plays them perfectly.

Pathé



"The Quality Phonograph"

and

FISCHER SERVICE—

Both Are Important to You!

PATHÉ Phonographs and Records are important to you because they mean more customers and more sales right along month after month.

Fischer Service is important because it means that you won't disappoint any of these customers—that you can supply any Pathé Model or any Pathé Records within 24 hours' time.

No, you won't lose any sales because of the frequent rushes on certain Models or Records—you'll make all the big money coming to you on Pathé Phonographs and Records, if you *use Fischer Service*.

THE FISCHER COMPANY

"Oldest Pathé Jobber"

940 to 1030 Chestnut Street

CLEVELAND, OHIO

CRYSTAL EDGE MICA DIAPHRAGMS

**M
I
C
A**

Let us send you samples *today* of our diaphragms and you will readily understand why the best talking machines are equipped with *Crystal Edge Mica* diaphragms exclusively.

We use only the very finest selected mica, the best diaphragm material in the world.

PHONOGRAPH APPLIANCE CO., 109 West Broadway, NEW YORK

FEDERAL COMMISSION RECOMMENDS FIXED PRICE LAW

Federal Trade Commission Emphasizes the Need of Congressional Action to Deal With the Price-Cutting Evil in View of Recent Decisions—Powers of Commission Curtailed by Present Statutes

WASHINGTON, D. C., May 7.—In a formal public statement published May 4, the Federal Trade Commission announced the policy which must govern the disposition of all cases involving resale price control and the right of refusal to sell. The commission declares itself bound by the recent decision of the United States Supreme Court in the Graphophone Case to forbid producers to indicate prices, to secure agreements from dealers as to prices, or to refuse to sell to or discriminate against price-cutters.

The most important feature of the statement is its final paragraph in which the commission frankly admits its inability under present law, as laid down by the courts, to deal adequately with the price-cutting evil and emphasizes the need of remedial standard price legislation by Congress "in the manner suggested by Mr. Justice Brandeis."

It seems unnecessary, and would obviously be improper at this time, to comment further upon the significance and potentiality of this vital declaration by the governmental agency whose special duty it is to study and pass upon the ethics and public policy of commercial practices.

A complete copy of the commission's statement is as follows:

"For a considerable time there has been a controversy throughout the country over the question of the right of manufacturers, wholesalers, etc., fixing resale prices at which their articles could be sold, and the right to maintain such resale prices has been contended for by them, and the question whether such right exists has been brought before the Federal Trade Commission numerous times.

"Many hearings have been had, many complaints have been made, and much consideration has been given to the subject by that Commission. Many business concerns have been refusing to sell to customers who would not agree to maintain the resale price fixed by the seller.

"The Federal Trade Commission has just disposed of the first of these cases in which com-

plaints have been issued charging violations of law through fixing the resale price of articles, and an order to cease and desist from this practice has just been issued by it in the case of Chester Kent & Co., Inc., of Boston, manufacturers of proprietary medicines.

"Attorneys for the company admitted that in the past the practices complained of had been in use. The order, the first in cases of this character, forbids the company to:

"(a) Indicate to dealers the prices for which its proprietary or patent medicines shall be resold.

"(b) Securing agreements from dealers to adhere to such prices.

"(c) Refusing to sell to dealers who fail to adhere to such prices.

"(d) Refusing to sell to dealers who fail to adhere to such prices upon the same terms as dealers who do so adhere.

"(e) Furnishing any advantage to dealers who adhere to the resale prices, while refusing similar treatment to dealers who do not adhere to the prices.

"This order of the Commission follows the decision of the Supreme Court of the United States in the American Graphophone Co. case lately decided by it.

"Some of the most distinguished lawyers in the United States have appeared before the Commission to argue this question, as well as many of the leading business concerns of the country, some of whom have insisted that the maintenance of resale prices was proper, and others who have contended that it was not. Almost all of the large department stores of the country have been heard in opposition to it.

"After full consideration the Federal Trade Commission has decided to issue complaints against all business concerns who refuse to sell unless the purchaser will agree to maintain a resale price fixed by the seller. The case just decided is the first formal finding by the Commission to that effect.

"When once an article has passed from the

maker to a purchaser, he owns it, and the owner of such article may sell it at any price that he chooses, provided he does not himself sell it at such price as to be below cost, and thus thereby enter into unfair competition with other retailers selling the same article.

"This decision is going to be open to considerable controversy in relation to the subject matter thereof, and the matter will probably have to be settled by an act of Congress in the manner suggested by Mr. Justice Brandeis in his concurring opinion in the Supreme Court of the United States, in the case of the American Graphophone Co. The Stephens Bill which is now in Congress is in relation to that matter, but in the estimation of many business men and others it is thought to be broader than it should be. It may be that resale prices can be so regulated by placing the power somewhere protecting against unfair prices as to make it work equitably, and be a fair method of competition in commerce, but that question will undoubtedly have to be settled by Congressional action."

C. L. STEPHENSON NOW SALES AGENT

The New Jersey Reproducer Co., Newark, N. J., manufacturer of the "Invincible" sound box, has announced the appointment of C. L. Stephenson as general sales agent. Mr. Stephenson has opened New York offices at 1133 Broadway, and is making plans for an aggressive campaign in behalf of the company's products.

C. L. Stephenson has been associated with the talking machine industry for the past two years, and was formerly president of the Wilson-Laird Phonograph Co. He is familiar with the most important details of sound box manufacture and merchandising, and is now making arrangements whereby the users of the "Invincible" products will receive 100 per cent. co-operation and service. Mr. Stephenson is planning to visit the trade in the very near future, in response to many inquiries that have been received from well-known manufacturers regarding the use of the "Invincible" sound box on their machines.

A PROGRESSIVE BELFAST MERCHANT

T. Edens Osborne, the enterprising talking machine merchant of Belfast, Ireland, with his usual keen-sightedness utilized for his publicity in the local papers the article which appeared in *The Talking Machine World* of March 15, referring to a "speaking machine" invented by Mr. Miller, of Lurgan, in 1758. After giving the "meat" of this article Mr. Osborne closes one of his reading announcements as follows:

"One hundred and forty years later, October, 1898, the first type of 'His Master's Voice' gramophone was introduced in Belfast by T. Edens Osborne, of 11 Wellington place, who holds the most extensive stock of gramophones, phonographs and records in Ireland." This is educational publicity of the right kind.

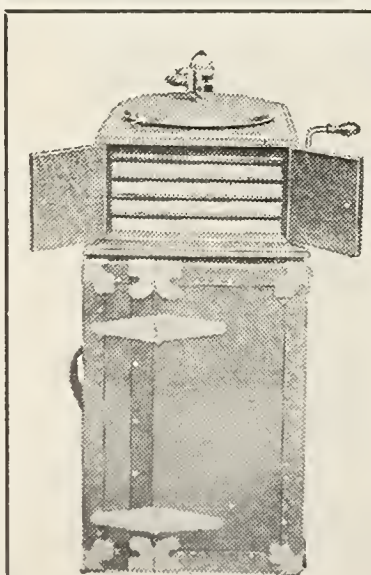

Corley Fibre Victrola Trunks Are Making Dollars for Dealers Everywhere

The ideal gift for the Military Camp here or abroad. Also in much demand for the bungalow or vacation trips. A big sales help for the smaller Victrolas.

STYLE IV NET, \$7.50

STYLE VI NET, \$8.45

We have applied for patents for Fibre Victrola Trunks—they are made to last.

The Corley Company,

ORIGINATORS OF FIBRE VICTROLA TRUNKS

213 EAST BROAD STREET

RICHMOND, VA.



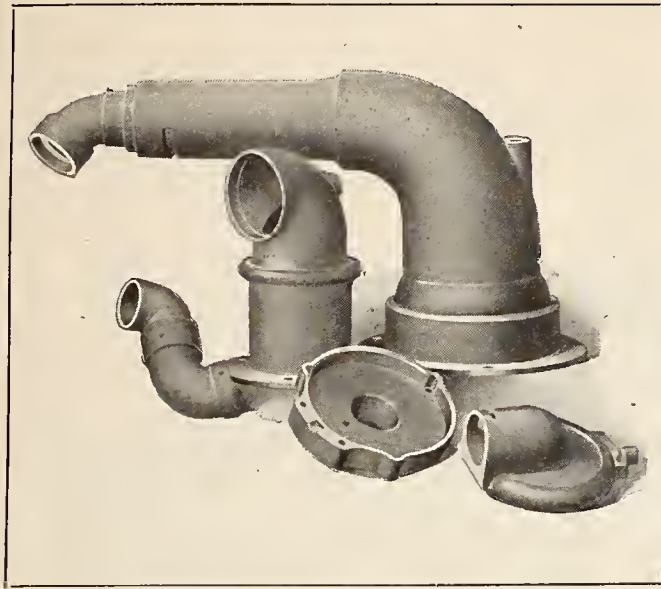

DOEHLER DIE-CASTINGS

for tone arms, sound boxes and talking machine attachments are STANDARD throughout the industry.

Of the many instruments produced to-day from the most prominent makes down, the greater number, by far, are equipped with Doehler die-cast tone arm and sound box.

The enormous output of our three large plants permits of advantages to the users of die-castings, as regards prices and deliveries, not otherwise possible.

DOEHLER DIE-CASTING CO.
MAIN OFFICE AND EASTERN PLANT
BROOKLYN, N.Y. NEW JERSEY PLANT
WESTERN PLANT **NEWARK, N.J.**
TOLEDO, OHIO.

ACTIVE ADVERTISING IN CINCINNATI

Believed That New Campaigns by Dealers Will Bring About Improvement in Conditions—New Machines on the Market—General News

CINCINNATI, O., May 8.—Talking machine merchants are again devoting space towards advertising machines and are giving attention towards pushing records. This let-up in publicity may explain a decline in the retail field of the past month. Jobbers find exceptionally good business in the smaller centers in close reach of rural sections, but not much doing in the big towns.

The John Church Co. last week put its talking machine on the market through the Church-Beinkamp Co., the first lot consisting of two sizes, the smaller one selling for \$85. The feature of the instrument is a tone clarifying chamber, the entire throat of the machine being so shaped as to eliminate any harshness that otherwise might be heard.

W. E. Summers, Washington C. H., Ohio, was a caller at the Phonograph Co. last week, being entertained by Manager Peterson, who reports a slight increase in shipping facilities.

Otto A. Gressing, recently with the Melville Clark Co., has taken charge of the selling department of the Crystola Co., this city. Mr. Gressing is entirely familiar with the machine field, having been connected with the Victor Co. and the Musical Instrument Sales Co. At one time he had charge of the latter's St. Louis branch. He comes here from New York City.

April business with the Cincinnati branch of the Columbia Co. was by far the largest April in the history of this branch. Manager Dawson states that record orders are coming in from the factory more promptly than at any time for several months.

The Cincinnati branch now has three traveling men covering the territory, and shipping requirements have so increased that the local branch finds it necessary to consider the matter of moving to new quarters. They have taken an option on a six-story building on West Fourth street, near Central avenue, and hope in a short time to complete negotiations for leasing the building which will be ample for their requirements. This is a six-story building with more than fifteen thousand square feet of floor space and will be occupied exclusively by the Columbia Co.

Carl Kraner, who recently made his first trip for the Columbia Co., is making a splendid record, and reports that business is showing more than usual activity in the mining sections of West Virginia, surrounding Huntington.

Mr. Spring, of Spring Brothers Co. department store, Eaton, O., was in Cincinnati a few days ago visiting the local branch of the Columbia Co., and while in the city arranged with the company for franchise to handle Columbia goods. Their initial order was considerably above a thousand dollars.

The Walnut Hills Grafonola Shop recently

opened a beautiful Columbia store at 2507 Gilbert avenue, which is one of the best trading points in Cincinnati, as it serves a community of many thousand people. Miss Carrie Althaus, who was for several years assistant manager of the Columbia Co.'s store in Louisville, Ky., is the owner and manager of this enterprise.

H. L. Moorey, one of the traveling auditors from the New York office of the Columbia Co., has been spending the past two or three weeks at the Cincinnati branch going over the accounts.

J. C. Dubriel, who has been spending some time with the Cincinnati branch, has gone to Cleveland as assistant manager of that branch.

C. L. Byars reports a very satisfactory Vocalion business in April at the local Aeolian store. A number of the larger instruments were sold. Mr. Byars says business is not easy to get these strenuous times, but the right kind of salesmanship can get sales over, and it is the hard sales that give the salesman real pleasure after all.

H. L. Lewis, formerly connected with the Edison Shop at Indianapolis, is now enlisted with the Vocalion forces. Mr. Byars has also had the good fortune of acquiring the services of Geo. Kleeman, who was connected for some time with the local Edison Co. These two men have finished their preliminary training and are now taking their regular turns in the trenches.

C. W. Neumeister, local representative of the Otto Heineman Co., is about the happiest man in the talking machine field of the Middle West just now, for he stands to establish a new record in orders this year, thereby bearing out a prediction made earlier in 1918.

"People," he said, "are just mad for needles. This is just one of the big wants that are being supplied in liberal quantities just now. The manufacturers want supplies. Many are turn-

ing out goods to their limit, believing that the field will be unlimited for talking machines before the end of the year. This bears out an assertion that I have made, claiming that 1918 ought to be almost a record-breaker in the retail line. The histories of the allied belligerent countries is identical to what the United States is going through. There was a time when production almost disappeared, which was followed by a demand.

"There are several manufacturers in the Middle West, with good machines, who will be badly disappointed with their results when the books for the year are closed. They do not realize, apparently, that these are abnormal times and have not used methods which should be in use under such conditions. Yes, business is good in the Middle West."

WOMAN MANAGER MAKING GOOD

Miss N. Moody Introduces New Ideas in Retail Department of Philip Werlein, Ltd.

NEW ORLEANS, LA., May 4.—Miss N. Moody, who recently took charge of the Victor retail department of Philip Werlein, Ltd., reports an unusual sale of Victrolas and records for this time of the year. Miss Moody bears the distinction of being the only retail Victor lady manager in a large Southern city, and is fast making a name for herself as being a very successful one. She has installed some very novel selling ideas that are bringing in a large amount of business.

NEW BRUNSWICK DEALERS

The Winegar Piano Corp., Buffalo, the Thomas Piano Co., Inc., Lockport, and O'Reilly & Son, Medina, N. Y., have been appointed agents for the Brunswick talking machine.

**DON'T YOU KNOW WHERE
TO GET**

**THAT MOTOR—
OR THAT TONE ARM—OR CABINET?**

Why Not Let Us Find It For You?

**DIRECT REPRESENTATIVES OF ALL
LEADING MANUFACTURERS**

**WE CAN GIVE YOU MERCHANDISE, SERVICE AND ADVICE
NO CHARGE FOR THE LAST TWO**

THE PHONOGRAPH CLEARING HOUSE, Inc.

51 EAST 42d STREET, NEW YORK CITY

NUMEROUS TALKING MACHINE DISPLAYS AT MUSIC SHOW

Machine, Record and Accessory Manufacturers Planning Elaborate Displays at Big Exposition to Be Held at Grand Central Palace, New York, on June 1 to 8

Within two weeks after this issue of The Talking Machine World is in the hands of its readers, the National Music Show will be in full swing at the Grand Central Palace, New York City, the formal opening taking place on Saturday, June 1, and the show running until the following Saturday, June 8.

The plans for the exhibition are now practically completed, and the exhibit space still available is being contracted for rapidly. There will be approximately fifty exhibitors, representing almost every branch of the music industry, with the talking machine trade particularly well represented, and the exhibits will occupy two floors of the Grand Central Palace.

The show committee, consisting of H. L. Willson, Columbia Graphophone Co.; William Maxwell, Thos. A. Edison, Inc., as well as J. A. LeCato, George W. Gittins and C. C. Conway, the latter three representing the piano and supply trades, have been working hard for several months in co-operation with Charles H. Green, manager of the show, to make the exhibition the largest and most impressive of its kind ever held, and it appears as though their efforts would prove successful.

During the week of the show a number of important trade conventions will be held in New York, several of them right in the Grand Central Palace Building. There will be the annual gathering of the Edison dealers at the Waldorf-Astoria, which it is expected will be attended by over a thousand dealers. There will also be held the annual conventions of the National Piano Manufacturers' Association, the National Association of Piano Merchants, the National Piano Travelers' Association, the National Music Roll Manufacturers' Association, and the Music Industries Chamber of Commerce, bringing hundreds of dealers to the city, and incidentally to the show.

The Grand Central Palace itself is New York's largest exposition building, and the home of the

automobile, flower, motor boat, electric, and other shows of international reputation and importance. The building is located at Forty-sixth street and Lexington avenue, and within easy reach of the various prominent hotels in the city.

Governor Charles S. Whitman, of New York,

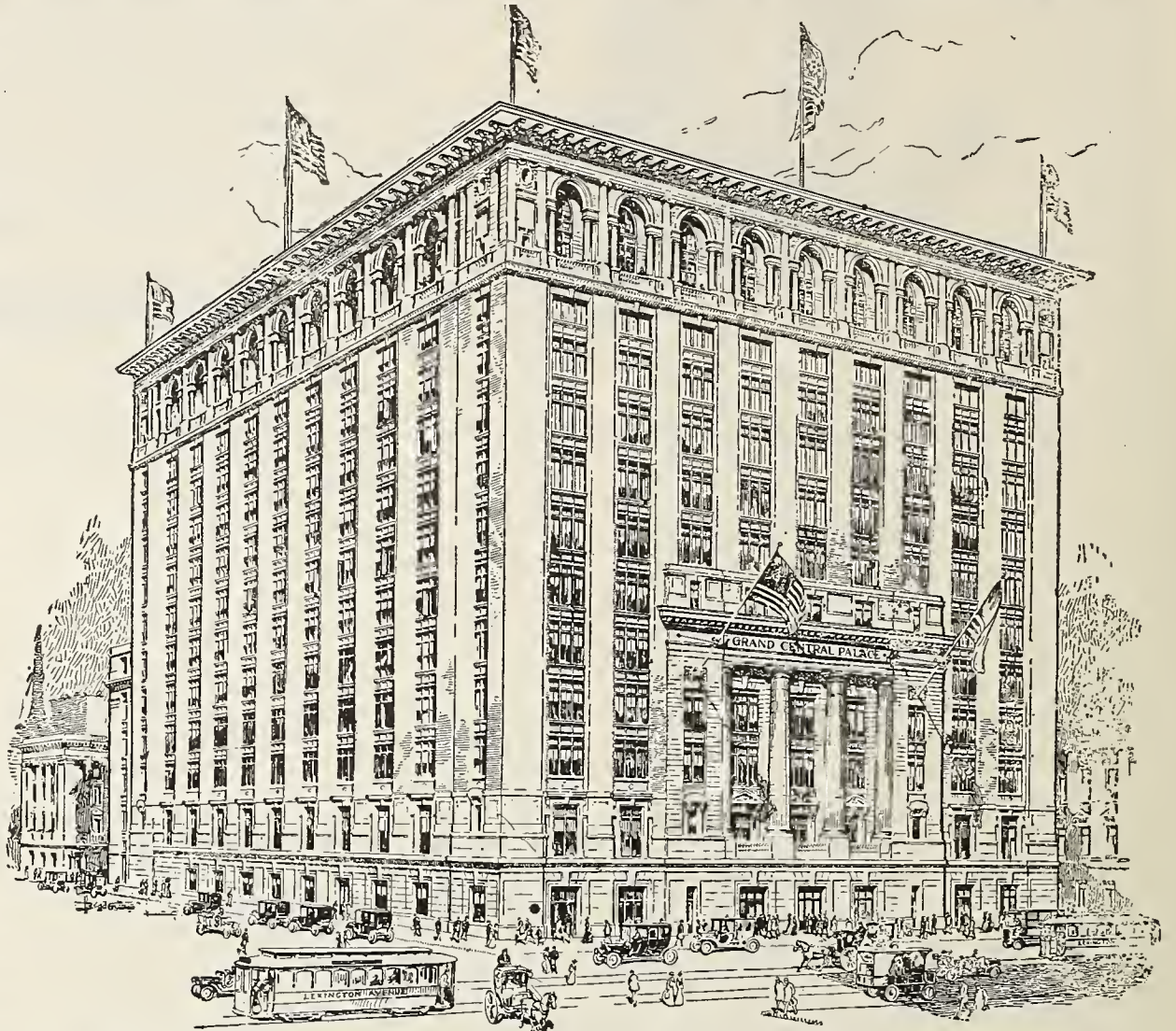

The Grand Central Palace, New York, Where the National Music Show Will Be Held



Tone—the vital thing

IF you, as a manufacturer, can talk and prove *tone superiority* in your product, you have a selling argument to overshadow all the "talking points" of cabinets, and designs and accessory features.

And you *can* talk tone superiority. You can put out a product that will be a revelation in tone-purity, tone-quality, tone-volume. When you realize what vivid, lifelike, colorful tone can be produced and sustained by the talking machine equipped with

Parr Magnetic Reproducer

fitted with the

Vibratone Patented Diaphragm

These two dominating and proven inventions open up wonderful possibilities for manufacturers eager to put their product at the top-notch of class and character.

You want your product to be RIGHT!

If you want your product worthy of your name, you certainly want that product to be right in its most *vital feature*. And it will be right if it is equipped with the Parr Magnetic Reproducer—the reproducer for those who seek perfection.

The indestructible, non-crystallizing, always resilient

VIBRATONE PATENTED DIAPHRAGM

Possessing all the good points of mica diaphragms, it overcomes all mica's bad features. Guaranteed uniform in quality, free from bubbles, blisters and waves, the Vibratone Patented Diaphragm is non-porous, non-absorbent.

It has a definite function and it performs it. It improves tone; in fact it creates new tone possibilities for every reproducer of other types.

PARR MANUFACTURING CORPORATION

1 UNION SQUARE At Fourteenth St. NEW YORK

Take the Parr Magnetic Reproducer—

The most sensitive of reproducers. The permanent magnetic device, an integral part of the reproducer, acts on the stylus box. Its possibilities in giving warmth and delicacy in the tonal reproduction of quiet passages make old-style sound boxes seem obsolete. And in fortissimo passages where ordinary reproducers create unpleasant, music destroying blasts, caused by the needle jumping and losing its grip, the Parr Magnetic Reproducer, with its marvelous flexibility, follows every wave and vibration in the record and takes everything the record holds.

will officiate at the opening of the show, and representatives of the United States Army and Navy will be in attendance. Many prominent men of America's leading industries, recognizing the national scope of the exposition and the work that the music industry is doing in the war, will be present during the week of the show. The exposition will be the most dignified and educational affair of its kind ever housed under one roof.

The increasing importance of the music industry undoubtedly will be felt when the public becomes acquainted with the rapid advances made during the past year in things musical. The various exhibits are bound to create an interest which will work for the benefit of the entire industry as a whole. The show will be a means of cementing co-operation on a broader scale than ever before, and manufacturers, dealers and others will profit through this co-operation. In other words, the show will be a big store window for the industry, in which everything new and novel will be displayed for the public's approval. Those who believed that the music industry was a non-essential one will suddenly realize how important it really is, what it is doing to bring cheer to the boys in our army and navy, what gladness and sunshine has penetrated into saddened homes through the medium of music, and what can be expected of the music industry of the future.

To single out what each exhibitor is to show would prove quite a task, although each one is planning special features of distinct interest to both the trade and the public.

The Pathé Frères Phonograph Co. is to practically transplant its laboratory from Brooklyn

JOSEPH MUSANTE

Electro-plater and Silversmith
Gold, Silver, Nickel and Antique Finishes
Specializing in phonograph parts and musical instruments
168 CENTRE ST. NEW YORK
Telephone, Franklin 3053

Make your Summer Sales follow the thermometer—up!

Sell Portable Model Grafonolas for out-of-door music. It's the Big Idea this year.

Columbia Graphophone Co.
Woolworth Building, New York



to the Palace, but, of course, it will be in miniature. Phonograph records will be made right in the Palace, and in order to do this it will be necessary to install all the equipment used in the regular laboratory. Each night of the show Pathé artists will be in attendance to register their talents.

Thomas A. Edison, Inc., of Orange, N. J., are to have a section of the show set apart for the Edison Theatre. It will be fully equipped, will seat about 600 persons and will be complete in every way. Artists whose voices have been recorded by Mr. Edison will be in attendance daily and a comparison of their tone quality will be made with that of the New Edison instruments.

The Columbia Graphophone Co., while it has not announced the details of its exhibit, will, nevertheless, have numerous surprises to offer visitors to the show when the time comes, as will the Otto Heineman Phonograph Supply Co., the Cheney Talking Machine Co., the Emerson Phonograph Co., the Automatic Record Container Co. and other concerns.

There will likewise be a distinct patriotic touch given to the show by the announcement that every dollar taken in for admission tickets at the door will be devoted to the purchase of musical instruments, records, etc., for the soldiers and sailors. The show, moreover, has the endorsement of many of the leading members of the trade who believe that just at this time it will prove a powerful factor in impressing upon the public generally the importance of our industry.

Among the concerns who have already taken space at the show are: American Piano Co., American Player Action Co., the Autopiano Co., Auto Pneumatic Action Co., Automatic Record Container Co., Bennett & White, Inc., Brambach Piano Co., Bjur Bros., Inc., Chickering & Sons, Cheney Talking Machine Co., Columbia Graphophone Co., Thomas A. Edison, Inc., Estey Piano Co., Estey Organ Co., the Glidden Varnish Co., Hallet & Davis Piano Co., Hazelton Bros., Inc.,

Otto Heineman Phonograph Supply Co., Wm. Knabe & Co., Kranich & Bach, Kohler & Campbell, Inc., Laffargue Co., Murphy Varnish Co., Paul G. Mehlin & Sons, L. J. Mutty Co., Milton Piano Co., National Lead Co. (Atlantic branch), Operators Piano Co., Pathé Frères Phonograph Co., Ricca & Son, Rythmodik Music Roll Co., Standard Pneumatic Action Co., Pease Piano Co., J. P. Seeburg Piano Co., Staib-Abendschein Co., Steinway & Sons, Soloelle Co., Inc., Q R S Music Roll Co., Weser Bros., Inc., Wilcox & White Co., Melville Clark Piano Co., Emerson Phonograph Co. and Armour & Co.

H. A. YERKES' NEW POST

Becomes Assistant to H. L. Willson, General Manager of the Columbia Graphophone Co.

H. A. Yerkes, one of the most popular members of the Columbia Graphophone Co.'s sales staff, who has been occupying the post of field sales manager since the first of the year, has been appointed assistant to H. L. Willson, vice-president and general manager of the company, and will in the future make his headquarters at the executive offices in the Woolworth Building, New York.

Mr. Yerkes is one of the "veterans" of the talking machine industry, and has been associated with the Columbia Co. for many years. He is thoroughly familiar with every angle of talking machine merchandising, and in the executive posts that he has occupied has achieved signal success.

WHEN IT'S TIME TO TRANSFER

If you are on the gloomy line,
Get a transfer;
If you're inclined to fret and pine,
Get a transfer;
Get off the track of doubt and gloom,
Get on the sunshine train—there's room,
Get a transfer.

NOW ANNOUNCE THE REGINAPHONE

Regina Co. Ready to Place Their Latest Talking Machine Product on the Market—New Line Is Produced in Seven Models

The Regina Co. with offices in the Marbridge Building, New York, and a factory in Rahway, N. J., who for the past twenty-five years have been manufacturers of musical instruments and who in more recent years have been actively associated with the talking machine industry, being the manufacturers of the Regina Hexaphone and other talking machine products, now announce the Reginaphone, a talking machine with many exclusive features.

This new line of machines is produced in seven models, five of them of full cabinet size and three table models. All the machines are equipped with a new patent tone arm and sound box, which plays all makes of records with equal facility. Of special note is the fact that the sound box always remains in the same position, the point of needle remaining in the direct center and the vertical and lateral cut changes are made by a quarter revolution of the sound box without changing the angle.

All the larger styles are equipped with a quadruple spring motor, which will play for over thirty minutes, and every model is equipped with a tone modifier. While the larger models are manufactured with an automatic stop there are also start and stop push buttons. They also contain a new style sound chamber which throws the sound upward instead of in the usual forward manner. The cabinets are in both mahogany and oak and are unusually attractive in appearance.

A. J. KENDRICK VISITS SOUTH

A. J. Kendrick, of the phonograph division of the Brunswick-Balke-Collender Co., was recently a visitor in New Orleans, giving his old friends there the pleasure of seeing him once more.



MODEL 100

SONA-TONE

A Phonograph of Distinction with the Tone You Can't Forget

SONA-TONE *Quality* means a resonant, full, liquid tone that comes from an especially designed, all-wood sound chamber—and superior workmanship in material, finish and equipment.

SONA-TONE *Reliability* means simplicity of mechanical construction—ease of operation—and convenience and solidity of working parts.

SONA-TONE *Service* means the immediate ability of the purchaser to play all makes of records—without attachment of any sort—and to play a library of from 250 to 1000 assorted records without further expenditure.

We believe that a Sonatone eliminates—to a greater extent than any other phonograph—the surface noises of the record.

We believe that it has the same quality of resonance as exists in the Stradivarius violin.

From our sales record—previous to advertising—we believe that a SONA-TONE is a superior phonograph for retail merchandising.

SONA-TONE PHONOGRAPH, Inc.

3366 Broadway, New York City

\$35, \$70, \$100, \$150, \$200, \$250

"The music is on the record—the tone is in the phonograph."

ALLIED MUSIC TRADES HOLD GREAT LIBERTY LOAN RALLY

Greatest Demonstration of the Patriotism of the Music Industry Ever Seen Took Place at Liberty Loan Meeting at Carnegie Hall on April 30—Subscriptions Total \$2,200,000—Farrar and Caruso Sing—French and American War Heroes Wildly Applauded—Credit to Committee

Carnegie Hall was filled to capacity, and a little more, and a tremendous crowd estimated at close to 15,000 battled with police reserves to enter the hall after the doors had been closed in order to participate in the Liberty Loan Rally of the Allied Music Trades on Tuesday evening, April 30. It was without question the greatest affair ever held under the auspices of the music industry, and is believed to be the most successful rally held by any industry, or organization, in connection with the Liberty Loan campaign.

It was a wildly enthusiastic crowd that answered the public call of the Allied Music Trades to help Uncle Sam by subscribing for bonds, and there was every reason for the audience to be enthusiastic, for sensation followed sensation. For nearly two hours the audience was almost constantly on its feet as a tribute to the national anthems of one of the allied countries, or in enthusiastic welcome of some unit, military or naval, marching down the center aisle.

Even the most blasé New Yorker might well have fought for the privilege of enjoying a musical treat such as only the industry itself could offer, and it might be said right here that, although men of all divisions of the trade worked hard to make the affair a success, it was the talking machine trade that contributed most to the entertainment by providing the musical features which were a big factor in its success.

Bringing in the Colors

It was just about 8.45 p. m. when the Columbia Band on the stage, under the able directorship of Chas. A. Prince, opened the program with a medley of patriotic American music, bringing the audience to its feet at the end with "The Star Spangled Banner." Hardly had the strains of the national anthem ended when the doors opened and down the center aisle and on to the stage was carried Old Glory under escort of a full company each of sailors and soldiers. After a brief drill, to the accompaniment of much cheering, the fighting men took their places on the stage where they remained for the entire evening.

Geraldine Farrar Sings National Anthems

Geraldine Farrar, the famous opera artist, next created a wave of patriotic emotion in the audience by singing "The Star Spangled Banner" after kissing the emblem. As an encore she sang the "Marseillaise," with a sailor holding over her the Tri-Color of France. Next came a selection from "Madame Butterfly," and as a

finale, "Annie Laurie," all sung to the accompaniment of the Victor Orchestra, under the direction of Joseph A. Pasternack.

Music's Contribution to Patriotism

James M. Beck, the noted publicist, who was scheduled for an address, chose for his subject "Music's Contribution to Patriotism," and in a most interesting way cited many historical instances where music had played a part in matters of world importance. He told how music served to reflect courage, and cited as an example the fact, that as the names of a few survivors of a naval engagement early in the war were flashed on the screen in a small town theatre in England, where the non-appearance of a name meant that some one in the audience had probably lost a loved one, the women arose en-masse to sing "Rule Britannia." He offered as a prophecy that the time will come when the Hymn of France will be sung again in the city of Strassburg. "Let us hope," said he, "that its strains will go down the Unter den Linden in Berlin."

The Edison double male quartet next appeared, and sang several of the most popular of the war songs of the day, including "Long, Long Trail," "Keep the Home Fires Burning," and finally the Liberty Bond song, "What Are You Going to Do to Help the Boys?" with Cesare Sodero as director. For a time the audience refused to let them leave the stage.

French "Blue Devils" Prove Sensation

Next came one of the big sensations of the evening, when the company of French "Blue Devils," the men who at the beginning of the war, nearly four years ago, occupied a section of Alsace-Lorraine, and have not since yielded an inch of the ground thus gained, came swinging down the aisle and on to the stage with their needle-like bayonets gleaming in the light. The men uniformed in dark blue, with tam-o-shanters rakishly perched on one side of their heads, were accorded an uproarious reception, and lined up across the stage, stood at attention while their commander read a message to the American people from General Foch, urging support of the Liberty Loan.

Boys From "Over There" Wildly Received

Although it seemed as though the limit of enthusiasm had been reached in the reception of the "Blue Devils," it was not a marker to the tumult that arose when, unannounced, except by the sudden playing of the band, a dozen of Pershing's own men, three of them members of the old Sixty-ninth Regiment, N. Y. N. G., and now a part of the 165th U. S. Infantry, trooped up to the stage. The United States soldiers, all of whom had seen at least six months of actual fighting, and several of them wearing the Croix de Guerre, had arrived direct from the firing line only a few days before, and were introduced individually to the audience. Sergeant Eugene MacNeff, of the Sixty-ninth, explained modestly how he happened to win the French War Cross, but gave most of the credit to his pal, Corporal Milo Plant, of the Sixty-ninth. The unit to which the men belong made an excursion into the German trenches, but were caught in a barrage, and had to make their way back to their own lines as best they could. It was then learned that eight men were left in No Man's Land wounded or dead, and Sergeant MacNeff and Corporal Plant volunteered to go after them. Seven were brought in success-



Read the Trade Mark carefully, hear the machine, and you'll agree that it is truly

The World's Musical Instrument
Improves All Records
Send for our Special Proposition

HOFFAY TALKING MACHINE CO., Inc.
3 West 29th Street New York City

fully. The eighth man was picked up in a bag next morning and buried. The committee could have started bond subscriptions right then and there wouldn't have been a slacker in the house.

"Fighting Parson" Tells Experiences

Some first-hand information of what the fighting men of the Allies are enduring on the Western Front, of the barbarous fighting methods of the Germans, and their delight in killing deliberately the aged, the women and infants, and the hopes that the world is placing upon America to turn the tide to victory, was furnished in a most graphic manner by the Rev. Dr. Travis, an American of the Canadian forces, and known as the "fighting parson." Dr. Travis made a long address, but every bit of it was interesting. He declared that, although America had done much she had not done enough if victory was to be assured, and recalled the promises that had been made at our entrance into the war regarding the airplanes we were to put over the European lines. "We were under shell fire for four months," he said, "and, by God, we never saw an American airplane, although I had told my comrades to look for the coming of machines bearing the star."

Sergeant Empey Pleads for Support

Sergeant Arthur Guy Empey, the author of "Over the Top," and probably the best known among the fighting men who have returned to relate their experiences, gave one of his characteristic addresses, during the course of which he flayed Americans for their apparent lack of interest in, and support of, the war. He pictured a very dismal future unless America woke up, and incidentally made a strong attack upon pro-Germanism and the activities of German agents in this country, who he said represented a greater menace than the Kaiser's army. He said the man to look out for was not the man who yelled "Hoch the Kaiser" in public, because he was brave but foolish and we knew where he stood. The fellow to guard against was the man with the American flag in his button hole and wearing Liberty Bond and Red Cross buttons, who worked to poison the minds of his neighbors.

The Mutual
TONE ARMS & SOUND BOXES

Place Your Orders
TO-DAY
for

Mutual

TONE ARMS AND
SOUND BOXES

"Mutual Products Have Made Good"

Mutual Talking Machine Co., Inc.
145 West 45th Street, New York

"NICHOLSON"
New Catalog Showing New Styles
RECORD CABINETS
strictly high-grade construction at prices
BELOW COMPETITION
Write for a copy of the catalog and our
special free advertising help for dealers.

K. NICHOLSON FURNITURE CO., Chase City,
Virginia
Sectional Bookcases and Record Cabinets

"Does It Play All Records?"

Certainly MAGNOLA does; and without any extra attachments, too. This is only one feature, albeit a most important one, in the thoroughly up-to-date equipment of the MARVELOUS MAGNOLA.

MAGNOLA "Built by Tone Specialists"



Watching the Music Come Out

May we send you our handsome illustrated catalog chock full of information concerning the wonderful construction system of Magnola and the beauties of its musical results, its artistic appearance and its moderate price?

Send your name and let us tell you more!

MAGNOLA TALKING MACHINE COMPANY
OTTO SCHULZ, President

General Offices 711 MILWAUKEE AVENUE CHICAGO
Southern Wholesale Branch 1530 CANDLER BLDG. ATLANTA, GA.

For joyous, sparkling, up-to-the-minute music that everybody loves—

Columbia Records on the Columbia Grafonola.

Columbia Graphophone Co.
Woolworth Building, New York



At the conclusion of his address Sergeant Empey asked for bids on a poster in oils rep-



"Victory," by Mrs. Julian T. Mayer

resenting "Victory," draped in an American flag and pleading for Liberty Bonds. The poster was the work of Agnes E. Mayer, and was donated by her to the cause. The bidding quickly jumped to \$160,000, the successful bidder being H. L. Willson, of the Columbia Graphophone Co., who immediately returned the picture for further bids.

The oil painting of "Victory," which was auctioned off for bonds, was the work of Agnes E. Mayer, a well-known portrait artist, with studios in New York, and the wife of Julian T. Mayer, chairman of the Liberty Loan Committee of the Allied Music Trades. Mrs. Mayer donated the picture for Liberty Loan work, and at various rallies it was the means of raising several hundred thousand dollars' worth of bonds.

Caruso Sings Own Composition

One million four hundred thousand dollars was subscribed in about fifteen minutes, when bond selling ceased temporarily to permit of the appearance of Enrico Caruso, the famous tenor, who sang several selections and as a finale rendered his own stirring composition in march time, entitled "Liberty Forever," accompanied by the Victor Orchestra.

\$2,200,000 Subscribed for Bonds

Bond selling was then resumed with a vim, with the result that the total subscriptions for the evening were over \$2,200,000. In other words, the trade went "over the top" with a will.

Sergeant Empey proved an excellent stimulator of interest in bonds, and created some amusement by throwing a German helmet on the stage and permitting all who would subscribe \$1,000 to kick it off. Two young ladies

took a kick at the helmet, one of them Sergeant Empey's sister, who managed to knock over a couple of music stands in the orchestra. Even the soldiers on the platform entered into the spirit of the occasion and subscribed \$6,500.

Rally a Huge Success

The rally was the biggest thing that has ever been attempted in the trade, and the fact that it went over without a flaw, and that the details were carried out like clockwork, is a distinct tribute to those who conceived the idea and had the matter in charge. Anyone who has ever had doubt regarding the possibilities of music in arousing enthusiasm to the highest pitch and in preserving the spirit of civilians and soldiers, could not have left Carnegie Hall without being converted to the cause.

Much credit, too, is due to the members of the various committees in the trade and their assistants for their work in soliciting bond subscriptions in the audience.

The committee in charge of the rally consisted of the following: C. H. Child, Victor

Talking Machine Co., Camden, N. J., chairman.

Talking machines and phonographs: J. Newcomb Blackman, Blackman Talking Machine Co.; George W. Hopkins, Columbia Graphophone Co.; George Babson, Phonograph Corp. of Manhattan; Walter Miller and E. H. Jennings, Thos. A. Edison, Inc.

Pianos: Julian T. Mayer, J. & C. Fischer; Frederick Steinway, Steinway & Sons; Mark Campbell, Brambach Piano Co.; William V. Swords, Aeolian Co.; E. P. Hamilton, Frederick Loeser & Co., and George W. Gittins, Estey Piano Co.

Music publishers: George H. Bliss, Q R S Co.; Isidor Witmark, M. Witmark & Sons; J. M. Prialux, Charles H. Ditson & Co.; Lawrence Ellert, B. F. Wood Co.

Musical instruments and supplies: George H. Hilbert, of Carl Fischer, and A. W. Johnson.

Liberty Loan representatives: M. K. Parker and George P. Learned.

Director of publicity: Henry C. Brown, the Victor Talking Machine Co.

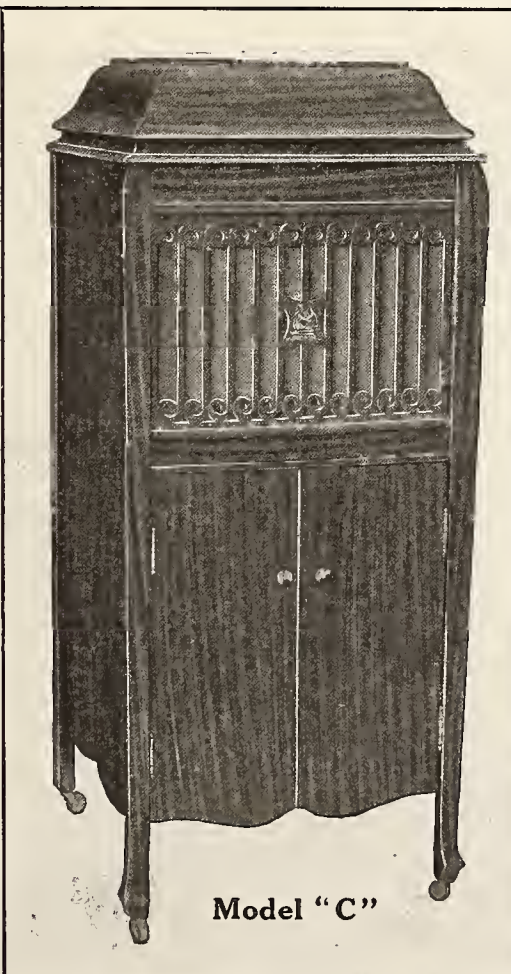

Model "C"

The
HARPONOLA

A Talking Machine of Splendid Performance and within the means of the great American People

A machine that is within the means of the masses means quantity sales and quantity profits for the dealer.

Take on the Harponola line and see for yourself how it sells.

Tone—Marvellously sweet.

Cabinets—Artistic to the highest degree.

Equipment—Most modern and best money can buy. Plays all records.

Send for fully descriptive illustrated catalogue. We will send you cases only or complete out-fitted machines.

Guaranteed and Manufactured by

THE CELINA FURNITURE CO.
CELINA :: :: :: :: :: OHIO

EDISON FORCES PARTICIPATE IN LIBERTY LOAN PARADE

The employes of Thomas A. Edison, Inc., helped in a very material way to celebrate the success of West Orange in going "over the top" in the Third Liberty Loan drive. Robert A. Bachman, vice-president and general manager of the storage battery division, was grand mar-

shal, and one of his principal aides was William Maxwell, vice-president and general of the musical phonograph division.

One of the features of the parade was the attractive floats designed and built by Edison employes, a few of which are shown in the illustrations herewith, demonstrating the patriotism of the entire Edison organization in a very practical and forceful manner. The floats attracted much favorable comment for their artistic appearance.

pany, is the originator of this new product which has been named the "Liberty Album." The binding itself attracts attention by the fact that it has a gold center imprint of Uncle Sam surrounded by ships, guns and other war material which will make the world safe for democracy, and is a fitting addition to the company's products at this time. Over fifteen thousand of the "Liberty Albums" were sold on the first day of their release, thus demonstrating that the trade feels the new product will have a favorable reception from the public.



NEW "LIBERTY" RECORD ALBUM

Important Additions to the Line of the Boston Book Co., Bound in Khaki

The Boston Book Co., manufacturers of record albums, have just placed on the market a timely and appropriate record holder. The album is bound in khaki and is very patriotic in appearance. J. M. Alter, president of the com-



Scenes Taken During Recent Liberty Loan Parade in West Orange, Showing Edison Employes in Line, and Floats Built by Them

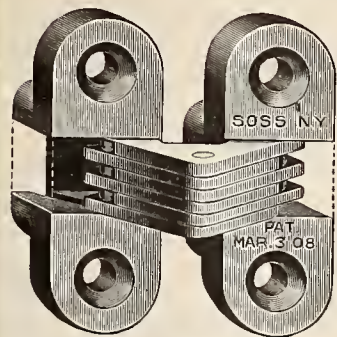

No. 103

SOSS

INVISIBLE HINGES

Preserve Beauty

In many beautifully designed, finely finished Talking Machines, Pianos, Music Cabinets, Piano Players and Benches, the elimination of the unsightly protruding Hinge is essential to preserve the beauty of the design.

Design and Construction

The fine cabinet work which is required in many instances to preserve the disguise of the instrument requires that the hinges be as inconspicuous as possible. **SOSS Hinges are invisible.**

WRITE FOR CATALOGUE "T"

SOSS MANUFACTURING COMPANY, 435 Atlantic Avenue, BROOKLYN, N. Y.

DETROIT—922 David Whitney Bldg.
SAN FRANCISCO—164 Hansford Bldg.

LOS ANGELES—224 Central Bldg.
CHICAGO—John C. Bold & Co., Clark and Washington Sts., Conway Bldg.

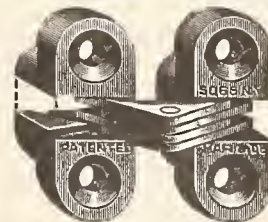

No. 100

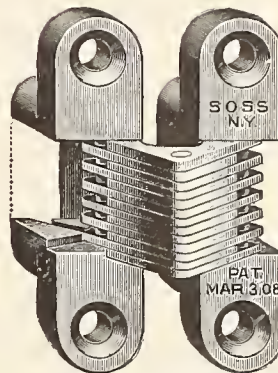

No. 101

WOMEN WORKERS ADORN UDELL FLOAT IN LOAN PARADE

On April 6 a Liberty Loan parade took place in Indianapolis which was unquestionably the biggest and most patriotic parade ever staged in that city. In this parade the Udell Works, well known manufacturers of music roll and talking machine record cabinets, participated with one of their big 3½-ton trucks. This truck was loaded with some of the good looking women that are now so conspicuous around the Udell factory. The sign displayed on the top of the truck was 12 feet long by 3 feet wide. The slogan on the sign brings out the excellent point that the Udell Co. is helping to win the war by employing female labor, thereby releasing men for military service.



The Udell Float in Liberty Loan Parade

SONORA SALES SERVICE

Individual Sales Service for Dealers Introduced by Sonora Phonograph Sales Co., Inc.

The Sonora Phonograph Sales Co., Inc., has introduced a dealer's individual sales service, which is well calculated to produce excellent returns for Sonora dealers. This sales service will be issued each month, and in its present form constitutes one of the most complete and valuable dealer helps that has ever been prepared. A brief summary of this sales service will give some idea of its practicability, although this resumé hardly does justice to the quality and attractiveness of the many helps included in the service.

According to this summary this service will include the following: 1. Answers to questions the dealer wishes to ask about his business. 2. Large window display frame with monthly card change. 3. Small window display frame with card change. 4. Appropriate window display material of a decorative nature. 5. Examples of good form letters. 6. Printed post cards to send to prospects. 7. Leaflets, catalogs and folders to send to prospects. 8. Suggestions on selling. 9. Methods of securing filing and using prospects' names. 10. Ideas as to effective office furniture, files, cabinets, etc. 11. Electrotypes or matrices of several suitable advertisements monthly, and special advertisements made to the dealer's order. 12. A certain amount of stationery free—the rest at cost. 13. Special signs of various kinds. 14. Moving picture slides. 15. Latest advance news of what other dealers are doing throughout the country.

Frank J. Coupe, director of advertising and sales for the Sonora Phonograph Sales Co., is in charge of this very important work, and is being ably assisted by L. C. Lincoln, who is now associated with the Sonora advertising division under Mr. Coupe's direction. Mr. Lincoln is well known in the piano and talking machine fields, having previously been advertising manager of Otto Wissner, Inc., where he was very successful. Sonora dealers throughout the country are enthusiastic regarding the new service, and Mr. Coupe confidently believes that every Sonora representative throughout the country will soon be enrolled for this monthly service.

MANY INTERESTING ARTICLES

To Be Found in the Latest Issue of the Columbia Record—Advertising Plans and Window Displays Used by Local Dealers Featured

Volume 2 of the "Columbia Record" in its new form reached Columbia representatives recently, and this very successful house organ, which is intensely practical in its make-up and arrangements, has won high praise.

There are many interesting articles in this issue, including the result of a tone test down South, where the Columbia Grafonola won first place by a substantial margin, and a timely article featuring the Grafonola military trunk, which was recently introduced. There are several articles on different phases of Columbia advertising, one article emphasizing the big selling idea which is in back of it. A reproduction of a recent window display prepared by the international record department gives representatives who handle foreign language records an opportunity to display these records to excellent advantage.

There are presented various illustrations of the shops of Columbia dealers, each carrying out some special feature worthy of mention. Buffham & Co., of Idaho Falls, Idaho, sent in a very artistic window display that is reproduced, and an artistic window display presented recently by the Rosen Talking Machine Co., of Boston, is also shown. The delivery of a large shipment of Grafonolas to N. E. Everitt, in North Bend, Ore., forms another interesting illustration.

There are reproductions of various newspaper "ads" for Columbia dealers, together with a wealth of incidental items received from all sections of the country that should prove of interest to dealers.

NEW ORLEANS BRANCH DOING WELL

Many New Brunswick Agencies Established in That Section of the Country

NEW ORLEANS, LA., May 4.—The local branch of the Brunswick-Balke-Collender Co. reports a very large sale of Brunswick phonographs and the establishment of many new agencies for that instrument in this territory. Among the new dealers recently recorded are: R. C. Gaddis, Laurel, Miss.; Sharp Furniture Co., Natchez, Miss.; T. M. Bissat, Lafayette, La.; Hyde Drug Co., Poplar, Miss.; Richard Bell Furniture Co., Lake Providence, Miss.; J. McGrath & Sons, Brookhaven, Miss.; J. E. Briggs Jewelry Co., Fayette, Miss.; Picon Drug Co., Eunice, La.; J. J. Hollins Jewelry Co., Jennings, La.; W. Hemingway, Vicksburg, Miss.; Harry Hollins Jewelry Co., Crowley, La., and the Heidelberg Furniture Co., Hattiesburg, Miss.

The fellow who gives as little as he can get by with will generally be forced to get by with very little.

"MAGNET" DECALCOMANIE NAMEPLATES

FOR TALKING MACHINE CABINETS ETC.

Pamphlets with fac-simile illustrations and prices mailed on request.

SMITH-SCHIFFLIN CO.
126 Liberty Street New York City

From the **DORAN CO.**
95 MICHIGAN AVE.
DETROIT

SOLD BY **HURTEAU, WILLIAMS & CO.**
MONTREAL — OTTAWA

Kunkel Piano Co.
BALTIMORE

FROM **THE PHONOGRAPH CO.**
1240 HURON ROAD (First Lane Road)
CLEVELAND

SOLD BY **WALTER D. MOSES & CO.**
Oldest Music House in VA and N.C.
103 E BROAD STREET
RICHMOND, VA.

SOLD BY **J. E. STRATFORD**
AUGUSTA, GA.

Headlines?

Nora Bayes—Al Jolson—Van and Schenck—

Just a few of the Top Notchers who make live, snappy, joyous melody on Columbia Records.

Columbia Graphophone Co.
Woolworth Building, New York



HEINEMAN MOTOR NO. 77 LIKED

Although on the Market But Short Time Has Met With Great Favor

The Otto Heineman Phonograph Supply Co., New York, has been achieving signal success with the Heineman new No. 77 motor, which,

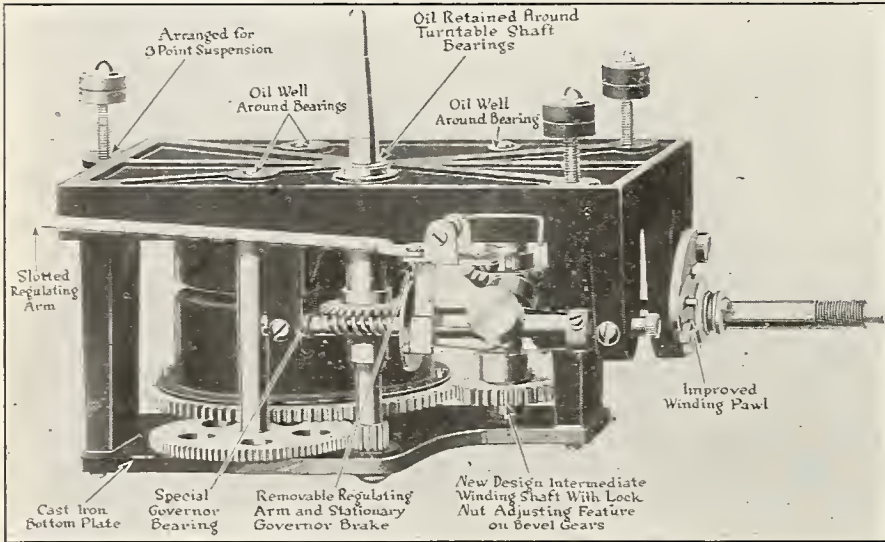

Heineman Motor, New No. 77 Model

although it has been on the market a comparatively short while, has met with the hearty approval and endorsement of talking machine manufacturers throughout the country. This motor embodies many new and exclusive features, some of which are shown in the accompanying illustration. The company's technical engineers spent many months perfecting these new improvements, and the motor is offered to manufacturers with the usual iron-clad Heineman guarantee.

Record Delivery Envelopes
Safe - Swift - Secure

The heavy paper means protection; the button and cord mean speed — you can wait on more customers.

Bring out YOUR OWN NAME. Every time an envelope leaves your store, let the advertisement on it take your name to the homes and bring new trade. The advertising more than pays for the envelope. Write for samples and prices.

Lewis C. Frank, 694 Book Bldg., Detroit

CHANGES IN PORTLAND, ORE., TRADE

Several Managers and Salesmen Make New Connections in That City

PORTLAND, ORE., May 4.—Changes were comparatively few in the various talking machine stores in Portland in April. Dealers are congratulating themselves on the fact that their experienced help has stayed as well as it has in the face of big opportunities opening on every side and the great labor shortage in the Pacific Northwest. There have, however, been changes in virtually every house in Portland.

J. H. Matney has been made manager of the talking machine department in the Meier & Frank Co. store, taking the place of Mrs. M. E. Gibson, who has resigned. Mr. Matney has had a great deal of experience in the talking machine business, having been with the Wiley B. Allen Co. in Portland and with Sherman, Clay & Co. in Spokane, Portland and Seattle. He has recently been at the Graves Music Store here.

Donald Smith, who has been with the Meier & Frank talking machine department, is at present in San Francisco visiting friends.

H. A. Rayner, the well-known and popular manager of the talking machine department of the Eilers Music House, has resigned and accepted a position with the Hopper-Kelly Co. of Tacoma, Wash.

N. Dunphy, for many years a phonograph salesman and recently connected with Bush & Lane Co. here, has resigned on account of ill health and has gone to Los Angeles to recuperate.

Miss Mabel Le Vanway, formerly with the Graves Music store, has been elected treasurer of the Oregon-Eilers Music House.

Portland had a visit late last month from F. B. Travers, manager of the Sonora Co., of San Francisco. Mr. Travers visited the Northwestern cities and is well pleased with the showing made by the Sonora dealers. The Sonora is becoming popular in Portland and the demon-

stration rooms at the Bush & Lane house, which has the exclusive sale of this machine, are always well filled with interested prospects.

Mrs. Thomas Carrick Burke, chairman of the music committee for the Fosdick commission, is asking for Victrola records for the Soldiers' and Sailors' Club of Portland, Ore. A piano and Victrola have been donated by the G. F. Johnson Piano Co., but records are needed.

EDISON HAS SECOND GRANDSON

Thomas A. Edison has a second grandson who was born on April 22. He is John Edison Sloane, son of Mr. and Mrs. John E. Sloane, and was born in the Edison home at Llewellyn Park. When the child was twenty-two hours old Mrs. Edison, his grandmother, purchased a \$100 Liberty Bond for him.

The Fordham Talking Shop of the Bronx was incorporated at Albany recently with a capital stock of \$15,000.

STATEMENT OF THE OWNERSHIP, MANAGEMENT, CIRCULATION, ETC., REQUIRED BY THE ACT OF CONGRESS OF AUGUST 24, 1912, OF THE TALKING MACHINE WORLD, PUBLISHED MONTHLY AT NEW YORK, N. Y., FOR APRIL, 1918.

STATE OF NEW YORK,
COUNTY OF NEW YORK, ss.

Before me, a Notary Public, in and for the State and county aforesaid, personally appeared August J. Timpe, who, having been duly sworn according to law, deposes and says that he is the Business Manager of The Talking Machine World, and that the following is, to the best of his knowledge and belief, a true statement of the ownership, management (and if a daily paper, the circulation), etc., of the aforesaid publication for the date shown in the above caption, required by the Act of August 24, 1912, embodied in section 443, Postal Laws and Regulations, printed on the reverse of this form, to wit:

1. That the names and addresses of the publisher, editor, managing editor, and business managers are:
Publisher—Edward Lyman Bill, Inc., 373 Fourth avenue, New York City.
Editor—J. B. Spillane, 373 Fourth avenue, New York City.
Managing Editor—J. B. Spillane, 373 Fourth avenue, New York City.
Associate Editor—J. Raymond Bill, 373 Fourth avenue, New York City.
Business Manager—August J. Timpe, 373 Fourth avenue, New York City.

2. That the owners are: (Give names and addresses of individual owners, or, if a corporation, give its name and the names and addresses of stockholders owning or holding 1 per cent. or more of the total amount of stock): Edward Lyman Bill, Inc., 373 Fourth avenue, New York City; Caroline L. Bill, New Rochelle, N. Y.; J. B. Spillane, 373 Fourth avenue, New York City; J. Raymond Bill, 373 Fourth avenue, New York City; August J. Timpe, 373 Fourth avenue, New York City; B. B. Wilson, 373 Fourth avenue, New York City; Carleton Chace, 373 Fourth avenue, New York City; L. M. Robinson, 373 Fourth avenue, New York City; E. P. Van Harlingen, 209 South State street, Chicago, Ill.

3. That the known bondholders, mortgagees, and other security holders owning or holding 1 per cent. or more of total amount of bonds, mortgages, or other securities are: (If there are none, so state.) None.

4. That the two paragraphs next above, giving the names of the owners, stockholders, and security holders, if any, contain not only the list of stockholders and security holders as they appear upon the books of the company but also, in cases where the stockholder or security holder appears upon the books of the company as trustee or in any other fiduciary relation, the name of the person or corporation for whom such trustee is acting, is given; also that the said two paragraphs contain statements embracing affiant's full knowledge and belief as to the circumstances and conditions under which stockholders and security holders who do not appear upon the books of the company as trustees, hold stock and securities in a capacity other than that of a bona fide owner; and this affiant has no reason to believe that any other person, association, or corporation has any interest direct or indirect in the said stock, bonds, or other securities than as so stated by him.

5. That the average number of copies of each issue of this publication sold or distributed, through the mails or otherwise, to paid subscribers during the six months preceding the date shown above is..... (This information is required from daily publications only.)

AUGUST J. TIMPE,
Business Manager.
Sworn to and subscribed before me this 20th day of March, 1918.

(Seal) EUGENE R. FALCK,
Notary Public, 8.
(My commission expires March 30, 1920.)

SCHUBERT PHONOGRAPH RECORDS

The greatest series of 75c. records ever made.

10-INCH DOUBLE SIDED ALL STARS ALL SELLERS

New list by 15th monthly. Dealers, write for list and prices

BELL TALKING MACHINE COMPANY
44 WEST 37th STREET, NEW YORK

SHELTON ELECTRIC PHONOGRAPH MOTOR

We have increased our factory facilities to handle the demand for the Shelton Electric Motor, and are now ready to make prompt deliveries.

Write for our Special Agency Proposition

SHELTON ELECTRIC CO.
30 East 42nd Street, NEW YORK

FROM OUR EUROPEAN HEADQUARTERS

2 GRESHAM BUILDING, BASINGHALL STREET E. C., LONDON, W. LIONEL STURDY, MANAGER.

Passing of the New Man Power Bill Causes Much Uneasiness in Talking Machine Trade—Expected That the Trade Will Survive Any Upheaval—Women Will Help Solve Labor Problem—The United States Import Embargo—New Editor for "The Voice"—What the Various New Record Lists Have to Offer—Supplying Machines and Records to the Fighting Men—Experimenting With Substitutes for Steel Needles—Records by the Late Lord Roberts—General Trade News of the Month

LONDON, ENGLAND, E. C., April 26.—During the last few months nothing so seriously untoward has happened, as things go these times, to mar the general belief of a steady future of war-time prosperity for the talking machine trade as the passing of the new man-power bill. In common with other trades, it will materially affect the gramophone industry in more ways than one. But only for a time, I think.

Let us examine the situation calmly, in the light of the nation's need. In the latter sense, however much one may feel inclined to deplore the recent reverse to the British arms and its probable result, the potent fact remains that the Allies are as ever determined to brook no thought of defeat. There is some consolation in the fact, too, that history is only repeating itself—that, however we muddle through, we shall eventually get there all the same. The war has become more than ever a national one for us, and I believe the Government is at last alive to its importance. Officialdom no longer holds the enemy as cheaply as the last three and a half years' policy would seem to suggest. The nation has now to get into harness and work and fight as never before. Let the

necessity for that sink into all minds, and we shall the more easily resign ourselves to the drastic action centered in the new bill which provides for the wholesale cancellation of exemptions and the call up of all citizens between the ages of eighteen and fifty.

Now, as to its effect. That there will be a temporary dislocation and upheaval of commercial life there can be little doubt. Deletion has been brought to such a pitch that one is inclined to think trade will suffer more by withdrawal of men from the administrative side than by the calling up of subordinates and general routine workers.

Among the luxury trades to be "combed" is the musical instrument industry, most sections of which are specifically mentioned in the official schedule. Whether this comb is to operate at once or gradually has not been clearly defined, but this much is certain—a strict cancellation of exemptions held by the eighteen to forty-one men of grades one and two if not of grade three. Men of the first category coming within the new age extension limit will doubtless be called up almost immediately; those of category two, gradually, and of the third class not at all unless, of course, conditions develop which may render it necessary.

With the aid of women it is the forty to sixty men who have kept alive the output of records—only just. Indeed, during the height of the season output has fallen short of demand. We start then with a new demand for men that can ill be spared from an already labor-pressed industry. Yet these men are necessary in the national interests, and they must go, however much one regrets the cause which has made it necessary. How to replace them?—that is the

question. On the one hand suitable female labor is growing more scarce each day; on the other hand, the gramophone trade is determined to somehow survive. That it will triumph I have not the slightest doubt. There may be vacant places at the factory benches or the pressing tables for a time. That cannot be avoided. Salvation must come through two sources, the women and time-expired or discharged soldiers. A further demand must be made in the columns of the daily press and employment agencies for women, and if need be the rate of pay for each "accepted" record must be slightly increased. No effort must be spared to bring in as quickly as possible the largest number of women so that when the men have to go they may be semi if not wholly proficient to carry on the good work of providing the nation with a plentiful supply of music. To fill up the gaps I am of opinion that to a great extent reliance will need to be placed upon women rather than ex-soldiers, since, if medically fit, few of the latter can withstand for long a close atmosphere, particularly the heat of a record-pressing room, after their open-air life. Still, there exists a very large reservoir of discharged men from whom to choose a suitable number, and for some time I believe record manufacturers have been taking advantage of this class of labor.

Given a due recognition of the immediate need for persistent effort, there should be no prolonged shortage of factory labor, and in this regard I am much more hopeful of the situation than of the likely effect of the new bill on the executive and administrative side of our industry. The loss of the men upon whom devolves

(Continued on page 108)



"His Master's Voice"

Copyright

This intensely human picture stands for all that is best in music

—it is the "His Master's Voice" trade-mark, and it brings to you, no matter where you are, the very best music of every kind, sung and played by the world's greatest artists—the greatest singers, pianists, violinists, orchestras and bands—all enshrined in the unequalled "His Master's Voice" records

'His Master's Voice'

—the trade-mark that is recognized throughout the world as the

HALL-MARK OF QUALITY

Branches

DENMARK: Skandinavisk Grammophon-Aktiesselskab, Frihavnen, Copenhagen.

FRANCE: Cie. Française du Gramophone, 115 Boulevard Richard Lenoir, Place de la République, Paris.

SPAIN: Compañía del Gramófono, 56-58 Balmes, Barcelona.

SWEDEN: Skandinaviska Grammophon-Aktiebolaget, Drottning Gatan No. 47, Stockholm.

RUSSIA: The Gramophone Co., Ltd., 45, Nevsky Prospect, Petrograd (Petersburg); No. 1 Solyanka, Solyanoi Dvor, Moscow; 9, Golovinsky Prospect, Tiflis; Nowy-Swiat 30, Warsaw; 33, Alexandrowskaya Ulitsa, Riga; 11 Michallovskaya Ulitsa, Baku.

INDIA: The Gramophone Co., Ltd., 139, Bal-laghatta Road, Calcutta; 7, Bell Lane, Fort, Bombay.

Great Britain:

The Gramophone Company, Ltd.

HAYES - MIDDLESEX - ENGLAND

Agencies

AUSTRALIA: S. Hoffnung & Co., Ltd., Sole Concessionaries of The Gramophone Company, Limited, 163, Pitt Street, Sydney.

NEW ZEALAND: Gramophonum, Ltd., 118-120 Victoria Street, Wellington.

SOUTH AFRICA: Darter & Sons, Post Box 174, Capetown; Mackay Bros., Post Box 251, Johannesburg; Mackay Bros. & McMahon, Post Box 419; Durhan; Ivan H. Haarburger, Post Box 105, Bloemfontein; Franz Moeller, Post Box 108, East London; B. J. Ewins & Co., Post Box 86, Queens-town; Handel House, Kimberley; Laurence & Cope, Post Box 132, Bulawayo; The Argus Co., Salisbury.

EAST AFRICA: Bayley & Co., Lourenso Marques.

HOLLAND: American Import Co., 22a, Amsterd Veerkade, The Hague.

ITALY: A. Bossi & Co., Via Orefici 2, Milan.

EGYPT (Also for the Soudan, Greece and the Ottoman Empire): K. Fr. Vogel, Post Box 414, Alexandria.

FROM OUR LONDON HEADQUARTERS—(Continued from page 107)

all the responsibility for the successful conduct and administration of large businesses is regarded in trade circles with something like consternation, though, forsooth, in no spirit of cavil.

Their chief concern is to reconcile the official call with their very natural anxiety for the carrying on of businesses which have been nursed and built up over a period of long years to a state of prosperity. It is rightly said these times that no man is indispensable. True enough though it may be, how is replacement to be effected when all men of the same class have also to direct their services into State channels? That is the problem which time and circumstance alone can solve. Each firm will, of course, make every effort to adjust itself to the situation, and must succeed to an extent, but the measure of their success is obviously dependent upon the chance needs of the military situation. An important man may be called up at any time, subject to a few days' notice. His removal would very likely throw out of gear the whole commercial machinery, other employes being interdependent upon his particular work. It is not altogether a pleasing prospect and one can only trust that in looking upon the extreme side of things the result may not be so disheartening as at present appears.

Among gramophone firms the present is a time of preparation. An ounce of quick decision now is better than a ton of effort a month hence. Never was the old adage "procrastination is the thief of time" more true than it is to-day. We must all buckle to in the knowledge that if the Germans get through our businesses wouldn't be worth a damn.

In the foregoing I have touched upon but one aspect of the new man-power bill, excluding to the last any reference to its likely effect upon record sales. Owing to the general social and commercial upheaval it will entail, talking machine men are of opinion that sales of luxury articles may be adversely affected, for a time at least. Consideration of the position convinces me that there will be no great falling off in the demand for mechanical music; it is too much of a necessity in the national life, these times, and as for soldiers and sailors—to them record music is absolutely essential. If, therefore, a shortage of sales is registered I firmly believe it will be more the result of an output failure rather than anything else. America is out to do her "big" bit; so is Great Britain. We are, in fact, doing it at terrible cost. In the face of that, who shall say that anyone must over-worry as to the preservation of the gramophone industry?

United States Import Restrictions

The Board of Trade are in receipt, through the Foreign Office, of telegraphic information from His Majesty's representative at Washington to the effect that the War Trade Board have issued a list of commodities, licenses for the import of which into the United States will be

granted only under the following conditions:

If the goods are shipped to the United States as return cargo from ports in Europe, and then only when (a) They are shipped from a convenient port, and (b) They are loaded without delay.

The list of restricted imports from all countries specifies musical instruments and parts thereof, while from Europe only phonographs, gramophones, graphophones and parts thereof included.

It is understood that the United States authorities, subject to the foregoing conditions, will grant licenses freely for the import of United Kingdom goods.

Applicants for import licenses will be required to show that the conditions laid down have been complied with. In the case of shipments from Europe on and after April 15, therefore, it will practically be necessary for the applicant for a license to afford proof that shipping space for the goods has been engaged; and such is understood to be the intention of the regulations.

After April 15 United States Consuls will not certify Consular Invoices for goods included in the list unless they are furnished with the number of the import license granted, or other evidence that a license has been issued. Shipping agencies are advised not to accept for shipment consignments of listed articles without similar evidence.

New Editor for "The Voice"

In the current issue of "His Master's Voice" house organ C. F. Higham announces his relinquishment of "The Voice," which he has so interestingly conducted since its inception. The editorship passes to Miss G. Ivy Sanders.

It is interesting to note, by the way, that Mr. Higham was recently admitted to the freedom of the city of London.

The Wireless Voice at Sea

At the Royal Institution lectures Prof. J. Joly recently described a radio-telephone in use by the United States. In certain lighthouses where there was no human being, a phonograph spoke into a receiver, which converted its sounds into ether waves, which in turn were picked up by the ships and again translated into sounds. Thus, on approaching Point Judas, the sailor hears the words "Point Judas" called out again and again. As he nears the dangerous point the wireless voice will notify in a considerably deeper tone: "Keep off; you are getting into danger."

Sound travels under water with such clearness, said Prof. Joly, that a watertight watch which had been lost in the sea and continued to go was recovered by a diver, who traced it by its tick from a considerable distance.

"His Master's Voice" Issue "The Mikado"

It will come as welcome news to the lovers of the gramophone that the Gramophone Co. has prepared a series of twelve-inch double-sided records bearing the entire opera of Gilbert and Sullivan's great favorite. Many records of "The

REX GRAMOPHONE CO.
are making a Specialty of
EXPORT
in
Horn, Hornless & Portable Disc Machines
REX GRAMOPHONE CO. 2 Elizabeth Place
Rivington Street, LONDON, E.C. 2
Cable Address "Lyrecodisc, London" Enquiries Solicited

Mikado" have, of course, been issued from time to time, but this is the first complete set recorded under the direction of the popular D'Oyly Carte Opera Co. The music and song is produced in conformity with this company's high standard of quality, the chief executants having been chosen from such eminent artists as Ernest Pike, John Harrison, Robert Radford, Edna Thornton, Violet Essex, etc. It is altogether an artistic achievement of which everybody concerned may be justly proud, while from a sales point of view it furnishes the dealer with an excellent opportunity for unlimited trade, having regard to the very wide appeal which this opera makes.

"Winners" for Popular Titles

Shorn of all embroidered language one can only describe the current issues of Winner records as representing the utmost possible value in quality of recording as in the class of fare provided. The current program presents a galaxy of good things, there being a well-chosen variety of vocal and instrumental numbers of the popular order by artists of considerable repute, as, for instance—The Two Bobs, Stanley Kirkby, Band of H. M., First Life Guards, De Busse, the Carlton Vocal Trio, the Bijou and the Royal Court Orchestras, Corner House Rag-time Band, etc. A recent issue comprises a double bearing thereon two of the greatest favorites of the day—"When the Bells of Peace Are Ringing" and "Sergeant Daddy, V. C." (No. 3180), by Stanley Kirkby. It is altogether an excellent record, and one which live overseas dealers would do well to order heavily.

Not Quite Up-to-Date

What must be regarded as a tribute to the value of continuous publicity is found in the publication of the Gramophone Co.'s title as the Gramophone Typewriter Co. The artist who drew the cartoon on the front cover of a recent issue of "The Passing Show" will evidently be surprised at the information that this well-known firm dropped out the word typewriter from its title almost a decade ago. He should take an interest in some of the more current "His Master's Voice" advertisements!

Records by the Late Lord Roberts, V. C.

The great field marshal was not the only wideawake man in this country (though there were precious few) to warn us against, and to prepare for, Armageddon, but his efforts and the weight of his reputation created an impression which cut deep into the minds of all thinking men. His advocacy of conscription was fortunately "canned" by the "His Master's Voice"

EDISON BELL

WINNER

TRADE MARK

GRAMOPHONE RECORDS

CABLE
"PHONOKINO,
LONDON"

ARE THE GREATEST VALUE FOR MONEY PRODUCED IN GREAT BRITAIN

TEN INCH

DOUBLE SIDED

NEEDLE CUT

PLAY ON ALL GRAMOPHONES

Catalogue contains 4000 Titles by the Premier Artistes, Instrumentalists, Orchestras and Bands of the British Empire

DEALERS PREPARED TO DO BUSINESS ARE INVITED TO COMMUNICATE WITH

Proprietors and Manufacturers, J. E. HOUGH, Ltd., 62 Glengall Road, London, S. E. 15, England

FROM OUR LONDON HEADQUARTERS—(Continued from page 108)

company on a series of six records. These records find many buyers these days, though in this regard it is seldom one comes across a public reference to them. One would have thought to the contrary. Curious to relate, the first public announcement of these records I have seen for a long time reaches me from the Emerald Isle, of all places! It is in the form of an advertisement by Thos. Edens Osborne, the great Belfast factor, whose temerity would be surprising were it not that he evidently knows his public. That a demand is anticipated is distinctly pleasing, and I hope the results will prove even more so!

Gramophone Outfits for Jack and Tommy

There is no general conspiracy to provide our soldiers and sailors with free gramophones and records, but it is really surprising the several channels which exist for their distribution and collection from a generous public. One of the most popular organizations for this purpose is the Daily Express Cheery Fund, which under the guidance of one named "Orion" dispenses all sorts of games and amusements to the different services. Free "drawings" have been instituted for outfits consisting of a fine Columbia trench gramophone, six double records and a thousand needles. Any soldier or sailor acting for a group of comrades may participate by making application, countersigned by an O. C., to the Daily Express office, London. The "drawings" take place periodically, the outfits being equally divided between the two services. By this scheme about forty free gramophone outfits, value nearly £10 each, have been distributed in a few weeks. The demand is, of course, greater than the supply, which is dependent upon a generous public. Unless more funds are subscribed within the near future there will be a falling off in the number of outfits available for distribution. Here is a chance therefore to supplement Orion's splendid efforts to provide the right kind of amusement for the rest camps behind the line—the line that keeps the enemy from desecrating our Homeland. Who will help? Any reader wishful of so doing either in goods or in hard cash should communicate with Orion at the above address, and receive his grateful acknowledgment. Do it to-day!

The Shortage of Steel—Substitutes for Needles

Owing to the available supplies of steel for all purposes other than war work having been seriously curtailed, recourse has been had to substitutes for the ordinary steel gramophone needle. A measure of success has been achieved by two or three enterprising firms in the direction of resharpening by a special process old or used needles, but this method does not seem to have altogether met what is to-day a difficult problem.

The bamboo or fibre needle is coming into vogue at a greater rate than formerly, though a certain amount of prejudice remains to be overcome before this substitute can be regarded as likely to materially counterbalance the steel needle shortage, owing in part to its soft tone,

and mainly to the initial expense of the repointing equipment. Where volume is the great desideratum, as it is with a large circle of gramophonists, the fibre point makes little or no appeal, and, except of necessity, is scarcely likely to displace the steel needle.

There are a few sapphire points on the market, and a glass one, too, I believe. But what I have seen and heard of these types does not impress me with any favorable leaning towards them. Their reproducing qualities are harsh and strident, to say nothing of the abnormal damage they cause to the record sound walls.

Experiments, I am told, with the ordinary bush thorn, have given delightful results from the viewpoint of tonal quality. But here again the work of their collection and shaping precludes the general use of such, as it is not a commercial proposition by any means.

A more interesting prospect is furnished by the suggestion to utilize the spines from hedgehogs. This suggestion is reported as a "discovery" by an army officer, who has tried the plan with great success. He gives it as his opinion that there is nothing to equal the purity and detail of tone derived from a hedgehog spine, and recommends all gramophonists to try it. A somewhat dangerous piece of advice, I think, though amusing to picture a band of music lovers indulging in the noble sport of hedgehog hunting. I think, after all, 'twere better not to forsake the steel needle!

A Special Sunday at Home Program

Quite a novelty in record lists is announced by the British Zonophone Co. It comprises a program embodying sacred, classical and semi-religious musical items suitable for Sunday rendition for the family circle. The idea has caught on immensely among the wholesale and retail trade, and many a live dealer reports the inauguration of special period sales, coupled with local advertising and attractive window dressing. It is certainly an unique opportunity for a big local sales campaign.

A Gramophone Firm's "Tank" Contribution

As mobile banks, the Tanks have been doing great things around the country. The story of an individual firm's contribution makes interesting reading, as reflecting the determination of the people to see the war through to the bitter end. One week's contribution from Brown Bros., Ltd., and their staff amounted to no less than £8,500, representing a further investment of £5,000 by the firm, and £3,500 by its members' War Saving Association. If every firm did as well as this in the purchase of certificates and bonds when the Tank calls, there will be little need of worrying about the financial part of the war. Many other music trade concerns have also made substantial contributions.

The Adventures of Four "H. M. V." Records

In a letter to the Gramophone Co., Ltd., a captain in the R. E.'s outlines an interesting story of the adventures of four records. He writes: "After doing their bit in the Cambrai

Soundboxes

If you are after a genuine offer of soundboxes, you'll do well to communicate with us immediately. We have tens of thousands of perfect soundboxes, fitted with the best quality mica. Confidently recommended for cheaper machines, absolutely reliable and give excellent reproduction. Price to clear \$50 per gross, F. O. B. London.

Orders for less than gross lots not accepted

Wire "Knotaslepe, London".

W. H. Reynolds (1915) Ltd.
45, City Road, London, E. C.

Write for new illustrated
Complete Catalogue

show they had the misfortune to become booty for the Boche, who quite possibly made them serve their turn for him. However, he, too, had to abandon them, evidently in a hurry, as we found them lying out in the open in No Man's Land, where they had lain for a month, exposed to rain and frost, not to speak of barrages, and so forth. We think that after such a dose of the horrors of war the records really play quite well, even on our old war-worn machine."

To say the least, it speaks well for the quality of the "His Master's Voice" record material, that it could withstand so well the elements of weather and warfare to the extent mentioned.

"Yes, Uncle," First on Columbia

Two orchestral records on a special issue of Columbia are the first to be announced of the popular musical play at the Prince's Theatre. One is an orchestral selection giving the eight principal numbers. The record is in two parts, played by the London Revue Orchestra. The other "Yes, Uncle," record is by Jacob's Trocaderoians, and provides an unusually sparkling performance of "Widows Are Wonderful" and "Think of Me," the play's outstanding songs.

A Strong "Double"

In response to a very wide demand, there is announced this month a Columbia record of "Smoke Clouds," the delightful song first introduced by Miss Jennie Benson in "Topsy Turvy" and since the rage of the whole country. It is sung by Basil Lloyd, with 'cello obbligato. On the back it carries a fine recording of "Roses of Picardy."

The End of a Perfect Day

All that was left after a fire at the mess of a Provincial military camp was a copy of the song, "The End of a Perfect Day."

GUARDSMAN RECORDS

REGISTERED

10 inch and 12 inch Lateral Cut

We can ship you immediately, any quantity of Records:

BANDS

ORCHESTRAS

INSTRUMENTAL SOLOS

VOCAL

SELECTION OF AMERICAN AIRS

including, "Marching Through Georgia"—"Dixie"—"Arkansas Traveller"—"Red, White and Blue"—"Star Spangled Banner," etc., etc., Recorded by Full Regimental Band of H. M. SCOTS GUARDS. Get Ready Now for the Big Trade coming and have

THE FINEST RECORDS of THE FINEST TITLES at THE FINEST PRICES

Apply for Lists and Prices to INVICTA RECORD COMPANY, Ltd.

Cables: Duarrab, London

1 New Inn Yard, London, E. C., England



TRADE MARK

WORLD'S CLASSIFIED ADVERTISING

Any member of the trade may forward to this office a "Situation" advertisement intended for this Department to occupy a space of four lines, agate measure, and it will be inserted free. Replies will also be forwarded without cost. Additional space will be at the rate of 25c. per line. If bold faced type is desired the cost of same will be 25c. per line.

WANTED—Manager for phonograph department. A man with organizing ability and selling experience (with Edison phonographs) preferred. A good proposition will be offered to the party who can show results. Apply with full particulars, in confidence, to Layton Bros., 550 St. Catherine St., W., Montreal, Canada.

WANTED—A manager for our phonograph department at our Ottawa warerooms. Apply with reference to C. W. Lindsay, Ltd., 512 St. Catherine St., W., Montreal, Canada.

WANTED—A thoroughly experienced man in selling and ordering records; one experienced in Victor and Columbia records preferred; capable to take charge of record department for a leading firm in large Western Coast city. Good permanent proposition to right party. Must be a business producer and know how to handle other record sales people and get results. References required. Address "Box 517," care The Talking Machine World, 373 Fourth Ave., New York.

FOR SALE—Old established Victor agency in Pacific Coast town of 45,000. Reasonable rent and fine location. Also Eastman Kodak agency and only stock of classified sheet music in city. Best of reasons for selling. Address "Box 518," care The Talking Machine World, 373 Fourth Ave., New York.

WANTED—High class salesman in our wholesale department to cover Southern States principally. Excellent position for high class salesman. Must be energetic and enjoy a reputation for getting results. Address Crafts-Starr Phonograph Co., 218 North Second St., Richmond, Va.

SALESMEN wanted to sell phonograph dealers nationally advertised very successful phonograph attachment. Will give exclusive rights in territories of six States each or less contributory to Boston, Philadelphia, Pittsburgh, Atlanta, Dallas, Denver, Los Angeles, Seattle, Minneapolis and San Francisco. Liberal commission. Drawing account possible. State age, experience, present employer and expectations. May arrange as side line some territories. Address Jones-Metrola, Inc., 29 West Thirty-fifth St., New York.

LINES WANTED—Wholesale representative with fine warerooms in Republic Building, Chicago, wants agency for medium grade talking machine and also for accessories and articles that go hand in hand with talking machine and piano trade. Address "A. P. 27," care The Talking Machine World, 209 South State St., Chicago, Ill.

EXPERIENCED SALESWOMAN of personality, driving automobile. Will solicit phonograph sales from farmers. Submit offers to "M. A. 4," care The Talking Machine World, 209 South State St., Chicago, Ill.

WANTED in Chicago, experienced packer and repair man on talking machines. Give experience and references. Address Channing L. Sentz, Marquette Building, Chicago, Ill.

POSITION WANTED—Would like position with talking machine manufacturer as laboratory experimental man or charge of construction. Am thirty-five years old with several years' experience in every phase of the art. I also have complete mechanical equipment for experimental work and several valuable inventions which I would gladly turn over along with my services to the right concern. Address "Box 519," care The Talking Machine World, 373 Fourth Ave., New York.

SITUATION WANTED—Young married man now employed as manager of a wholesale phonograph house wishes to make new connections with some large Chicago manufacturer. Thoroughly capable of assuming management of sales and advertising or handling sales promotion work. Can furnish unquestionable references. Would also consider position as Chicago representative for some outside manufacturer. Address "A. P. 30," care The Talking Machine World, 209 South State St., Chicago, Ill.

WE WANT JOBBERS to represent us and sell our product in Ohio, Wisconsin, Illinois, New York State, Louisiana, Connecticut, Georgia, Minnesota, Montana, New Jersey, Michigan, Texas and Missouri. We manufacture high grade tone arms for Edison disc machines, also high grade reproducers for use on Victor, Columbia, Sonora and Edison disc machines. We have recently enlarged factory space, and can make quick deliveries of large quantities. Write for information, New England Talking Machine Co., 16-18 Beach St., Boston, Mass.

TO THE TRADE—Have just bought 15,000 records. Closing out in hundred lots. Full details will be given upon inquiry. Address Jos. Dumas, 54 West Lake St., Chicago, Ill.

SALESMEN WANTED—Salesmen calling on the music and phonograph trade. We are offering a side-line that will double your income by calling on one or two people in each town. No samples to carry. Article very much in demand. In answering please state territory you are now covering. Address Morton J. Ross Music Co., 54 West Lake St., Chicago, Ill.

POSITION WANTED—Mechanic with fifteen years' experience constructing and repairing phonographs of all makes. With the largest houses in this country; desires to make a change. Capable executive, thoroughly efficient with modern methods. Can furnish best of references. Will go anywhere. Address "Mechanic," care The Talking Machine World, 373 Fourth Ave., New York.

WANTED—Salesmen, sideline to dealers, filing cabinets for phonograph records, patented, advertised, no samples, sell from photographs; liberal commission. Automatic Container Co., 506 Republic Bldg., Chicago, Ill.

POSITION WANTED—Young man, married, would like to get position anywhere in talking machine line where there is a chance for advancement. City or country. Can be used as all-around man, as I can be a shipping clerk, salesman, repair man, assembler, delivery man; willing to work, not afraid of hard work or long hours. Address "Box 520," care The Talking Machine World, 373 Fourth Ave., New York.

POSITION WANTED—Experienced cabinet factory manager and designer wishes to make a change. Thoroughly familiar with up-to-date methods. Forty years old. Highest reference. Now employed. Address "Box 521," care The Talking Machine World, 373 Fourth Ave., New York.

POSITION WANTED—Mechanic with 15 years' experience constructing and repairing phonographs of all makes, part of years with Victrola line, with one of the largest music houses in this country desires to make a change. Capable executive, thoroughly efficient with modern methods. Can furnish the very best of references. Address "Box 514," care The Talking Machine World, 373 Fourth Ave., New York.

POSITION WANTED—Talking machine salesman, five years' experience. Inside position large city preferred. Familiar with all well known machines. References. Address "A. P. 2," Talking Machine World, 209 So. State St., Chicago, Ill.

SALESMEN WANTED—Calling on music and furniture trades to sell popular line of records and talking machines. Address "A. P. 7," The Talking Machine World, 209 So. State St., Chicago, Ill.

WANTED—Position as salesman or department manager by A-1 Victor man, 26, married. At present in charge of talking machine department of large Western music house. Six years' experience in Victrola business, doing buying, newspaper advertising, window trimming. Can furnish the references you want. Prefer town west of Chicago of not less than 25,000. Address "W. N.," care The Talking Machine World, 373 Fourth Ave., New York.

POSITION WANTED—Thoroughly experienced Phonograph and Record salesman for either road or managing establishment, can vouch for seventy-five thousand dollars gross business per annum, now with leading company, highest grade credentials. Address G. H. Coryell, Saratoga Hotel, Chicago, Ill.

CASH

Paid for list of names of phonograph owners, any and all makes; all names and addresses must be guaranteed as machine owners, Victor, Columbia, Edison Disc, etc. If you have a mailing list quote us your price.

Address Box 499, c/o The Talking Machine World 373 Fourth Ave., N. Y. City

STEEL NEEDLES

Table listing prices for various types of steel needles including 100 Needles in Envelope, Sapphires, Main Springs, Governor Springs, Thumb Screws, Mica Diaphragms, and Needle Cups.

FAVORITE PHONOGRAPH ACCESSORY CO.

1491 DeKalb Avenue Brooklyn, N. Y.

DEALERS

Cash in on your surplus and overstock records.

We pay cash. We buy all makes in any quantity.

Please give detailed information and the lowest price acceptable.

ILLINOIS RECORD SERVICE, Commercial Bldg.,

Dearborn and Lake Sts., Chicago, Ill.

WANTED—Victor and Columbia records in any quantity. Instant cash. Describe fully.

JOSEPH GRANGER, 1125 Wilson Ave., Chicago, Ill.

WANTED—Will pay cash for dealers' stock of talking machines and records, all makes. State quantity, quality, whether records have been out on trial or new stock and price in first letter.

THE RECORD EXCHANGE 328 West 2nd St. Daveuport, Iowa

FOR SALE PHONOGRAPH RECORDS

10-inch, 12-inch lateral-cut, standard make, at low prices. A fine lot of different selections.

I. DECKINGER 3064 Albany-Crescent Ave. New York, N. Y.

FOR SALE

An established talking machine and piano store situated in a live Massachusetts city. Store has two soundproof booths, large display space and is attractively fitted up. Rent low. A big bargain for some one, and can be purchased at a low figure. Reason for selling owner has two other stores and cannot give it his best attention. A live wire can get a nice income out of it. Address "Live Wire," care The Talking Machine World, 373 Fourth Ave., New York.

COMPLETE stock of Victor records for sale. Price according to quantity purchased. Also large quantity of steel and jewel needles. Also record racks.

WILSON-BROADWAY MUSIC CO. 1140 Wilson Avenue Chicago, Ill.

STEEL NEEDLES

Repair parts for all talking machines made; main and governor springs, double and single spring motors, tone arms and sound boxes and complete machines. All at lowest prices.

FULTON TALKING MACHINE CO. 640 Broadway New York City

LATEST PATENTS RELATING TO TALKING MACHINES AND RECORDS

WASHINGTON, D. C., May 8.—AUTOMATIC RECORD REPEATING MEANS FOR PHONOGRAPHS AND THE LIKE.—Richard James Prettie, Jamaica, N. Y., assignor to the Aeolian Co., New York. Patent No. 1,255,117.

The present invention relates to automatic record-repeating means for phonographs and the like, the features and advantages of which will be apparent to those skilled in the art from the following description in connection with the drawings.

In the latter, Figure 1 is a plan view of a phonograph comprising one embodiment of the record-repeating means, said figure showing the parts in set position with the record playing; Fig. 2 is a similar view except that the parts are shown in tripped position with the needle and sound box lifted off the record and in the act of being carried back by the conveyer to be replaced on the record at its starting point; this figure further illustrates a change in the adjustment of the device to make it do this for a smaller record, e. g., a ten-inch record, whereas Fig. 1 shows the adjustment for a twelve-inch record. Fig. 3 is a plan view, on an enlarged scale, of the mechanism underlying the turntable; Fig. 4 is a vertical section partly in elevation on the line 4—4 in Fig. 3 looking in the direction of the arrows; Fig. 5 is a similar view on the line 5—5 in said Fig. 3; Fig. 6 is an underneath fragmentary view of the turntable on a larger scale to illustrate the movable dog carried thereby; Fig. 7 is a vertical section partly in elevation on the line 7—7 in Fig. 6 looking in the direction of the arrows; and Fig.

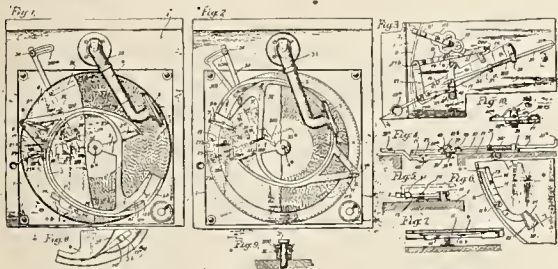

8 is an enlarged detail of Fig. 1, the switch member being shown adjusted as for a ten-inch record, Fig. 9 is an enlarged sectional view on the line 9—9 in Fig. 2, looking in the direction of the arrows, and Fig. 10 is a vertical section on line 10—10 in Fig. 3.

SOUND CONTROL MECHANISM.—Nicolas Kolby, Chicago, Ill. Patent No. 1,256,025.

This invention relates to improvements in volume controlling apparatus for sound reproducing machines. An important object of the invention is to provide apparatus of the above mentioned character, which is attractive in appearance, highly efficient in operation, and convenient to actuate.

Figure 1 is a side elevation of apparatus embodying the invention. Fig. 2 is a detail transverse section through the lower track for the panel curtain. Fig. 3 is an enlarged horizontal

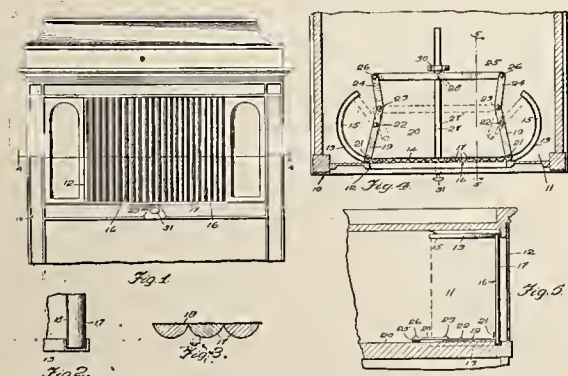

sectional view through a portion of the panel curtain, Fig. 4 is a horizontal sectional view taken on line 4—4 of Fig. 1, and Fig. 5 is a transverse sectional view taken on line 5—5 of Fig. 4.

NEEDLE SHARPENER.—Harry L. Notter, Chicago, Ill. Patent No. 1,256,034.

This invention has for its object to provide a device for sharpening needles, and which is particularly adapted for sharpening needles of metal or other material used on talking machines.

The invention has for its main object to provide a needle-sharpening attachment for sound-reproducing instruments constructed and arranged with relation to the sound box thereof, and the horn carrying such sound box so that when it is desired to sharpen a needle engaged with the sound box the latter may be swung on the pivot of the horn so that the needle enters the sharpening means and is held firmly in position with relation to the sharpening element, and may then be sharpened and returned to normal position for playing further talking machine records.

The invention has for its further object to provide a small, simple and efficient device of the character set forth which may be easily attached to the casing of a sound-reproducing instrument in position for ready operation to re-sharpen needles used thereon.

Figure 1 is a perspective view of a needle-sharpening device constructed in accordance with the invention. Fig. 2 is a top plan view

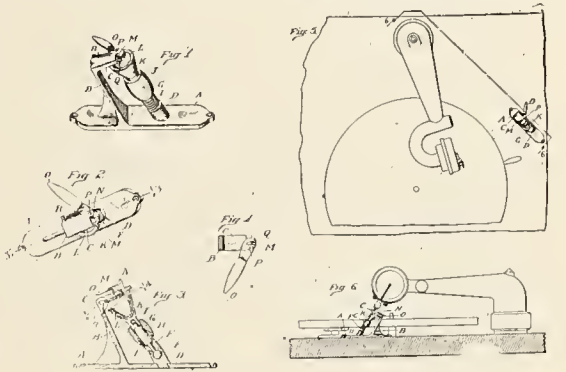

of the same. Fig. 3 is a vertical longitudinal section of the same on the line 3—3 of Fig. 2. Fig. 4 is a fragmentary detail section on the line 4—4 of Fig. 3. Fig. 5 is a fragmentary view in side elevation partly in section showing a portion of the casing of a sound-reproducing instrument equipped with a needle-sharpening device constructed in accordance with the invention. Fig. 6 is a top plan view of the same.

PHONOGRAPH ATTACHMENT.—Robert L. Baker, Aurora, N. Y., assignor of one-half to Henry Morgan, same place. Patent No. 1,256,099.

This invention relates to improvements in phonograph attachments and particularly to devices for cleaning a record in advance of the needle so as to remove particles of dirt and dust therefrom.

Devices have been provided for the same purpose as this invention but by reason of the particular construction of this device and by reason of the specific way in which it is mounted upon the native parts of the talking machine, advantages are secured that are not attained by the previous devices. One disadvantage of such devices already produced is that they are attached to the shell of the sound box and since they include spring elements, they present readily vibrated bodies which are in position to receive their vibrations from the diaphragm of the sound box through the shell of the sound box and when the phonograph is in operation there is a tendency for such devices to vibrate with a singing sound and interfere with the clear tones of the instrument. In the construction the device is mounted upon the stem of the needle post and moves therewith as the needle post is moved with the needle. The needle post, of course, has a positive movement with the needle and not a vibration such as is imparted to the diaphragm and thus the tendency of the

metal portions of this device to vibrate is prevented.

One object of the invention is to provide a device of this character which is resilient in its nature so as to readily accommodate itself to varying conditions, due to the use of longer or shorter needles.

Another and primary object of the present invention is to provide a cleaning brush which may be mounted upon the stem of the needle post of a sound box and which will lie with its brush portion transversely of the line of movement of the record so that with the lateral movement of the needle as it engages the sides of the record groove, the brush will also move laterally and as a result of this movement will

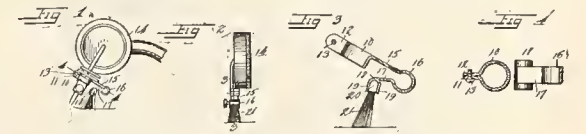

more thoroughly clean the record groove.

Another object is to provide a structure in which, while the brush portion is movable vertically with respect to the needle and is held against the record by spring action, there will be resistance to lateral movement of the brush with respect to the needle so that the brush will move with the needle positively as stated above.

Another object is to provide a device of this character in which the cleaning element or brush can be removed when worn out and a new one placed therein, without the necessity for removing the device from the phonograph.

In the drawing: Figure 1 is an enlarged elevation of the invention applied to the needle clamp of a phonograph sound box; Fig. 2 is a front elevation; Fig. 3 is an enlarged vertical section on the line 3—3 of Fig. 2; Fig. 4 is an enlarged section on the line 3—3 of Fig. 1.

TALKING MACHINE TONE ARM.—Arthur R. Schwarzkopf, Muskegon, Mich., assignor to the Brunswick-Balke-Collender Co., Chicago, Ill. Patent No. 1,257,939.

This invention has for its object to provide a universal talking machine tone arm for use with records of both the bottom cut and side cut types and particularly those familiarly known as the Victor, Edison and Pathé records.

A further object of the invention is to dispense with the necessity for detaching any parts of the tone arm when it is desired to play one or the other make of records, but to enable this to be done by simply moving parts into and out of operative position and which can be done easily and quickly by any user without special skill or instruction.

A further object of the invention is to proportion and dispose the parts so that the stylus for each type of record will be held in place in the groove under the proper pressure, thereby preserving the desired tone volume and quality.

Figure 1 is a side elevation showing the invention arranged for playing an Edison record; Fig. 2 is a top plan view of the invention as shown in Fig. 1; Figs. 3 and 4 are sectional

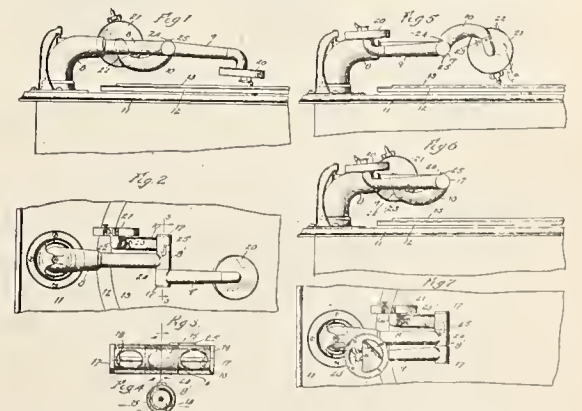

views on the lines 3—3 and 4—4 of Figs. 2 and 3, respectively; Fig. 5 shows the invention arranged to play a Victor record; Fig. 6 shows both sound boxes thrown back in position at rest, and Fig. 7 is a plan view of the invention as shown in Fig. 6.

(Continued on page 112)

LATEST PATENTS RELATING TO TALKING MACHINES AND RECORDS—(Continued from page 111)

TALKING MACHINE SOUND BOX.—Thomas F. Jones, Maywood, Ill. Patent No. 1,258,341.

This invention relates to sound boxes of talking machines, and its object is to provide a novel and improved mounting therefor whereby it is free to rotate about its own axis rather than swing bodily about an axis outside of itself, this arrangement resulting in advantages.

Figure 1 is a side elevation of a fragment of the tone arm of a talking machine and the sound

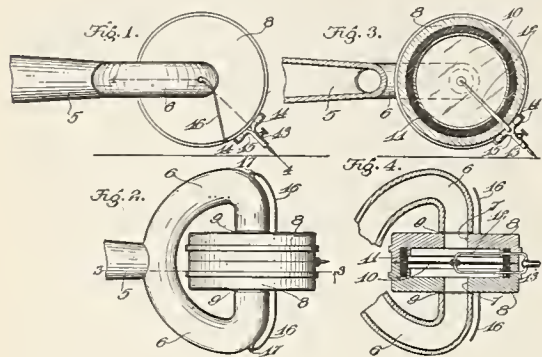

box carried thereby; Fig. 2 is a plan view thereof; Fig. 3 is a section on the line 3—3 of Fig. 2, and Fig. 4 is a section on the line 4—4 of Fig. 1.

SOUND REPRODUCING MACHINE.—Willard E. Cleveland, Rochester, N. Y., assignor to George Clay Cox, same place. Patent No. 1,258,189.

This invention has reference to sound reproducing machines and its purpose is more particularly to provide an apparatus that is readily applicable to and used in conjunction with pianos so that a phonograph mechanism may be used either independently of or in conjunction or harmony with a piano. A more especial purpose of the invention is to afford a novel drive or controlling mechanism that permits ready application of the device to a piano structure. Another object of the improvement resides in the novel construction and relationship of the horn to the record table, so as to create a maximum of sound volume and clearness in a minimum space and with due regard to the simplicity of the construction.

In the drawings: Figure 1 is a front elevation of a piano, with a portion of the case broken away, and showing the application of a preferred form of the invention; Fig. 2 is a horizontal sectional view on the line 2a—2a of Fig. 1; Fig. 3 is a front elevation of the upper part of the piano case, with the record table in playing position; Fig. 4 is a horizontal sectional view showing the position of the record table when out of operation; Fig. 5 is a plan view of the keys and key levers; Fig. 6 is a central vertical sectional view of the record table; Fig. 7 is a plan view of the same partially broken

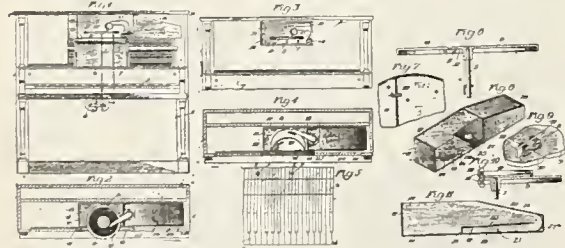

away; Fig. 8 is a perspective view of the housing and horn for the record table; Fig. 9 is an enlarged detail view showing the hinge connection between the two parts of the record table; Fig. 10 is a sectional view taken through the hinge portion of the table and showing the latter in its folded and inoperative position, and Fig. 11 is a sectional view of the housing and horn for the record table.

TALKING MACHINE.—Henry Lobschutz, New York. Patent No. 1,258,128.

The object of this invention is to provide an improved tone arm for talking machines. More particularly it is one of the objects of the invention to provide a tone arm in which the passages for the sound waves are constructed almost entirely of wood. By using a wooden tone arm, the objectionable metallic, harsh or

scratching sounds accompanying tone reproduction in talking machines may be almost entirely eliminated and only the tones sought to be reproduced are heard. This invention further provides a wooden tone arm of a certain novel interior construction whereby a clearer and more soft tone reproduction is obtained.

Figure 1 is a view, partly in section, of a tone arm and sound box embodying the invention; Fig. 2 is a plan view of the supporting bearing for the tone arm.

ATTACHMENT FOR TALKING MACHINE.—André Junod, New York. Patent No. 1,259,242.

This invention relates to that type of talking machine employing a record carried on the face of a disc which is revolved by a suitable motor, and has for its object to produce a device whereby a sound box or reproducer may be employed for the purpose of reproducing sound from a disc having a sinuous record groove in which the reproducing stylus is moved laterally relatively to the face of the disc, and the same reproducer may be employed to reproduce sound from a disc having a vertically cut record groove in which the stylus is moved in the direction perpendicular to the plane of the disc.

A further object is to produce a device whereby the position of the sound box may be reversed to give access to the needle holder without reversing or in any way altering the position of the tone arm or any part thereof.

A further object is to produce a device in which the sound vibrations set up by the diaphragm will be caused to travel into and through the tone arm without encountering obstructions and without making sharp turns.

In the drawings: Figure 1 is a plan view of the device operating in conjunction with a record disc having a sinuous or lateral cut groove; Fig. 2 is a side elevation of the same; Fig. 3 is a view similar to Fig. 1, but showing the de-

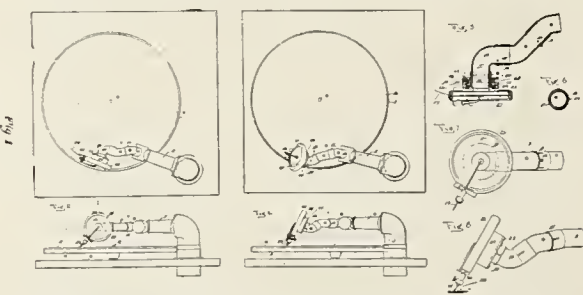

vice engaging a vertical cut record; Fig. 4 is a side elevation of the same; Fig. 5 is an enlarged detail sectional view of a reproducer in position to operate on a sinuous groove record; Fig. 6 is a section on the line 6—6 of Fig. 5; Fig. 7 is a side elevation of the parts shown in Fig. 5; and Fig. 8 is an enlarged side elevation of the device in position to operate on a vertical cut record.

LOCKING DEVICE FOR TALKING MACHINE.—Joseph Wolff, Brooklyn, N. Y., assignor to the Sonora Phonograph Co., New York. Patent No. 1,259,189.

This invention relates to locks and more particularly to a device for securing the repro-

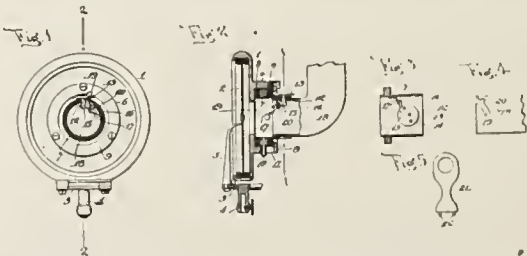

ducer or speaker of a talking machine to the tone arm, and has for its object to produce a device whereby the reproducer will be securely locked to the tone arm, and cannot be removed by an unauthorized person.

In the drawings: Figure 1 is a rear elevation

of a reproducer partly in section, the section being taken on the line 1—1 of Fig. 2; Fig. 2 is a section on the line 2—2 of Fig. 1; Fig. 3 is a plan view of the lock with the thimble in section; Fig. 4 is an elevation of the end of the tone arm; and Fig. 5 is an elevation of the key.

SOUND BOX.—Richard James Prettie, Jamaica, N. Y., assignor to the Aeolian Co., New York. Patent No. 1,263,468.

The present invention relates to improvements in sound boxes and comprises improvements whereby the sound box can be converted to play either lateral or vertical wave records.

In the latter Figure 1 is a face-view of a sound box illustrating one form or embodiment of this improvement shown as if playing a lateral-wave disc record. Fig. 2 is a partial edge view of the sound box in Fig. 1; Fig. 3 is similar

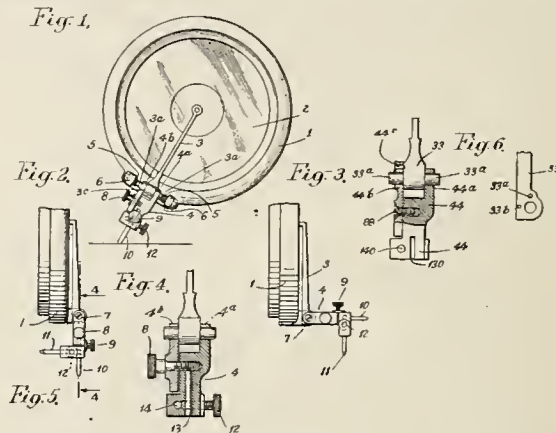

to Fig. 2 except that it shows the device adjusted as if to play a vertical-wave disc record; Fig. 4 is an enlarged vertical section partly in elevation on the line 4—4 in Fig. 2 looking in the direction of the arrows; Fig. 5 is a modification, the view being otherwise similar to Fig. 4; and Fig. 6 is a side view of one of the parts in Fig. 5.

HINGED-COVER SUPPORT.—Charles J. Bousfield, Bay City, Mich., assignor to the Delpheon Co., same place. Patent No. 1,262,167.

This invention relates to hinged cover supports for talking machine cabinets and the like.

One object of the invention is to provide means for holding the cover open through the instrumentality of suitable mechanism controlled by the tension of a spring.

Another object resides in the provision of

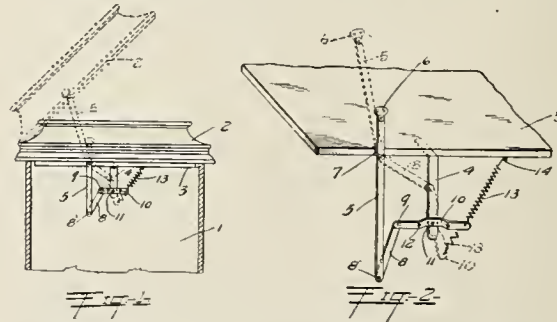

means whereby the tension of the spring is exerted only when the cover is in open position.

Figure 1 is a partial sectional side elevation of a talking machine cabinet equipped with the improved cover supporting means, showing the mechanism in two different positions.

Fig. 2 is an enlarged isometric view of the mechanism comprising the supporting means.

IMPROVEMENT IN FOREIGN TRADE

Department of Commerce Reports Substantial Recovery From Recent Decline

WASHINGTON, D. C., May 10.—March imports and exports show a partial recovery from the decline in recent months, according to a statement issued to-day by the Bureau of Foreign and Domestic Commerce.

Exports for March amounted to \$531,000,000, an increase of \$119,000,000 over February. For the nine months ended with March exports were valued at \$4,394,000,000, a decrease from the \$4,637,000,000 recorded for the nine months' period a year ago.

RECORD BULLETINS FOR JUNE, 1918

VICTOR TALKING MACHINE CO.

- POPULAR SONGS
18458 For the Two of Us...Wright and Dietrich
18460 What'll We Do With Him, Boys?...Peerless Quartet
DANCE RECORDS
18457 At the Jazz Band Ball...One-step, Original Dixieland Jazz Band
VOCAL RECORDS
70117 The Laddies Who Fought and Won (Lauder), Harry Lauder
RED SEAL RECORDS
74572 Rinaldo—Lascia ch'io pianga (My Tears Shall Flow)...

COLUMBIA GRAPHOPHONE CO.

- A6038*Regretful Blues...Nora Bayes
T2528*The Yanks Started Yankin' (The Russians Were Rushin')...Arthur Fields
A2525 I'm in Love...Gus Van
A2530 Good Morning Mr. Zip-Zip-Zip (Camp Song), Eugene Buckley and Peerless Quartet
A2529 Three Wonderful Letters From Home, Henry Burr
A2522*The Makin' of the U. S. A...Peerless Quartet
A2520 If You Look In Her Eyes—From "Going Up," Robert Lewis
A2524*The Tickle Toe—Medley fox-trot, Intro.: (1) If You Look in Her Eyes, (2) Do It for Me—From "Going Up"...

THE MONTH'S INSTRUMENTAL SELECTIONS

- A6039 Martha—Overture, Philharmonic Orchestra of New York
A2531 Wisconsin Forward Forever—March, Prince's Band
A2516 Espana Waltz...Alexander Prince
A2517 Andante Cantabile...Boston String Quartet
A6034 Prince Igor—March of the Opera, Symphony Orchestra
A49215 Traviata—Di Provenza III Mar II Suol, Riccardo Stracciari
A6033 Gunga Din...H. E. Humphrey
A2515 Flee as a Bird...Henry Burr
A7527 Buster Bear Gets a Good Breakfast, Thornton W. Burgess
A2521*In the Land O'Yamo Yamo...Van and Schenck
A2526*Lafayette (We Hear You Calling)...Reed Miller
A2519*N Ev'rything...Arthur Fields
A2366*Levinsky at the Wedding—Part III, Julian Rose
A2523*Sweet Emalina, My Gal—One-step, Earl Fuller's Rector Novelty Orchestra

- JUNE MID-MONTH LIST, ON SALE MAY 10
A6035*Medley of Old Waltz Songs—Part I. Intro.: (1) Sweet Rosie O'Grady, (2) The Bowery, (3) Little Annie Rooney, (4) Daisy Bell, (5) After the Ball, (6) Molly 'O, Prince's Band
A6037*Au Revoir, But Not Good-Bye (Soldier Boy)—Medley one-step, Intro.: (1) That's the Kind of a Baby for Me, (2) Won't You Say a Word for Ireland?...Prince's Band
A6038*Medley of Old Waltz Songs—Part II. Intro.: (1) Just One Girl, (2) My Pearl's a Bowery Girl, (3) The Sidewalks of New York, (4) Just as the Sun Went Down, (5) She is More to be Pitied than Censured, (6) In the Shade of the Old Apple Tree...Prince's Band

- Medley of Old Waltz Songs—Part II. Intro.: (1) Just One Girl, (2) My Pearl's a Bowery Girl, (3) The Sidewalks of New York, (4) Just as the Sun Went Down, (5) She is More to be Pitied than Censured, (6) In the Shade of the Old Apple Tree...Prince's Band
A6037*Au Revoir, But Not Good-Bye (Soldier Boy)—Medley one-step, Intro.: (1) That's the Kind of a Baby for Me, (2) Won't You Say a Word for Ireland?...Prince's Band
A6038*Medley of Old Waltz Songs—Part I. Intro.: (1) Sweet Rosie O'Grady, (2) The Bowery, (3) Little Annie Rooney, (4) Daisy Bell, (5) After the Ball, (6) Molly 'O, Prince's Band

*Records marked with an asterisk will be featured on cards and cut-outs of the June Dealers' Window Display.

EDISON BLUE AMBEROL RECORDS

- BEAUTIFUL CONCERT NUMBERS
28285 Melody in F (Rubinstein-Spalding), Violin, Pianoforte by André Benoist...Albert Spalding
28284 Sunshine Song (Solvejg's Lied) (Grieg), Soprano, orch. accomp...Julia Heinrich
3476 Darktown Strutters' Ball (Shelton Brooks), Male voices, orch. accomp...Premier Quartet
3479 Dixie Volunteers (Leslie-Ruby), Male voices, orch. accomp...Premier Quartet
3478 Everybody's Crazy 'Bout the Doggone Blues, But I'm Happy (Creamer-Layton), Orch. accomp, Arthur Collins and Byron G. Harlan
3483 I'll Take You Back to Italy—Jack O'Lantern (Irving Berlin), Orch. accomp, Ada Jones and Billy Murray
3477 I'm Going to Follow the Boys (James V. Monaco), Conversational duet, orch. accomp, Rachael Grant and Billy Murray
3480 'Round Her Neck She Wears a Yeller Ribbon (For Her Lover Who is Fur, Fur Away) (Geo. A. Norton), Tenor, orch. accomp, Byron G. Harlan and Chorus
3473 Says I to Myself, Says I (Harry Von Tilzer), Orch. accomp...Ada Jones
3474 Tickle Toe—Going Up (Louis A. Hirsch), Tenor...Vernon Dalhart and Chorus
TWO BLOOD-STIRRING MARCHES
3471 American Aviation March (Creator), Creator and His Band
3481 Wisconsin Forward Forever March (John Philip Sousa)...New York Military Band
HEART SONGS AND A NEGRO MELODY
3468 A Little Love, a Little Kiss (Lao Silesu), Tenor, orch. accomp...Ralph Errolle
3469 Magic of Your Eyes (Arthur A. Penn), Tenor, orch. accomp...George Wilton Ballard
3472 Mother's Old Sweet Lullaby (H. C. Weasner), Counter-tenor, orch. accomp...Will Oakland and Chorus
3470 Nobody Knows the Trouble I See (American Negro Melody) (Arranged by J. Rosamond Johnson), Tenor, orch. accomp...Vernon Dalhart
3465 On the Banks of the Brandywine (Anatol Friedland), Tenor, orch. accomp. (vocal obligato by Elizabeth Spencer)...Walter Van Brunt
SACRED SONGS
3475 There's a Wideness in God's Mercy (F. G. Illsley), Contralto, orch. accomp...May E. Wright
3467 Work, for the Night is Coming (Mason); and Jesus, Saviour, Pilot Me (J. E. Gould), Sacred, orch. accomp...Metropolitan Quartet
"SOME" DANCES
3462 Darktown Strutters' Ball—Fox-trot (Shelton Brooks), For dancing...Jaudas' Society Orchestra
3463 Li'l Liza Jane—One-step (Countess Ada De Lachau), For dancing...Jaudas' Society Orchestra
3461 "Old Timers" Waltz, For dancing, Jaudas' Society Orchestra
3482 Watermelon Whispers Fox-trot (George Hamilton Green), Xylophone, orch. accomp, George Hamilton Green
AN INSTRUMENTAL COMEDY
3464 Elephant and the Fly (H. Kling), Piccolo and Bassoon, orch. accomp, Weyert A. Moor and Benjamin Kohon
A WORRY CHASER
3466 Whistling Coon (Sam Devere), Edward Meeker and Empire Vaudeville Co.

PATHE FRERES PHONOGRAPH CO.

- POPULAR "HITS" OF THE MONTH
20355 How'd You Like to Be My Daddy? (Lewis-Young-Snyder)...The Farber Girls
20351 'N Everything—From "Sinbad," Winter Garden Show (DeSylvia-Kahn-Jolson), Louis Winsch, Baritone
K-K-K-Katy (O'Hara)...Louis Winsch, Baritone
20354 The Last Long Mile—From "Toot-Toot"—(Breitenfeld)...Arthur Fields, Baritone
Good-Bye, Barney Boy (Brennan-Morse), Peerless Quartet
20350 My Little Rambling Rose (Freeman), Campbell and Burr
She's the Daughter of Rosie O'Grady (Brice-Donaldson)...Henry Burr, Tenor
20330 The Soldiers of the King (Stuart), Warwick Williams, Baritone
Laddie in Khaki (Novello), Warwick Williams, Baritone
20353 I'll Come Back to You When It's All Over (Brown-Mills)...Peerless Quartet
On the Road to Home Sweet Home (Van Alstyne-Kahn)...Sterling Trio
20352 Where the Morning Glories Grow (Whiting-Kahn-Egan)...Sterling Trio
For the Two of Us (Leslie-Ruby), Campbell and Burr
NEW "LIBERTY LOAN" RECORD
20359 What Are You Going to Do to Help the Boys? (Kahn-Van Alstyne)...Arthur Fields, Baritone
The Volunteers (Sousa), March, American Regimental Band
20360 Rock-a-Bye Your Baby With a Dixie Melody (Lewis-Young-Schwartz), Arthur Fields, Baritone
What'll We Do With Him, Boys? (Sterling-Lange)...Arthur Fields, Baritone
NEW STANDARD BALLADS SUNG IN ENGLISH
27507 Calm as the Night (Bohm), Kathleen Howard, Contralto
Just A-Wearyin' for You (Carrie-Jacobs-Bond), Kathleen Howard, Contralto
25012 The Little Gray Dove (Victor Saar), Violin, flute and piano accomp, Grace Hoffman, Soprano
The Fairy Pipers (Brewer), Piano and flute accomp...Grace Hoffman, Soprano

- 20340 Loch Lomond...Myrtle Moses, Soprano
Irish Love Song (Margaret Ruthven Lang), Myrtle Moses, Soprano
20343 The Kilties March (Murchison), University Quartet
Lafayette, We Hear You Calling (Mary Earl), Warwick Williams, Baritone
NEW SACRED SONGS
20342 The Church in the Wildwood (Dr. W. S. Pitts), Unaccomp...Chautauqua Preachers' Quartet
When the Roll Is Called Up Yonder (Black), Unaccomp...Chautauqua Preachers' Quartet
20341 Whispering Hope (Hawthorne), Lillian Heyward, Soprano and Louise Brentwood, Contralto
Sweet Hour of Prayer (Bradbury), Organ accomp...Louise Brentwood, Contralto
NEW RECORDINGS BY THE HAWAIIANS
20344 Missouri Waltz (Hush-a-Bye Ma Baby) (Eppel-Logan), Louise and Ferera Waikiki Orchestra
Love's Old Sweet Song (Molloy), Hawaiian accomp...Cora Tracey, Contralto
NEW PATHE "DE LUXE" DANCE RECORDS
20357 A Baby's Prayer at Twilight (Jerome), One-step...American Republic Band
Flower of the Orient (Savino), Waltz, American Republic Band
20356 O! Lady, Lady! (Kern), Medley Fox-trot, intro.: "You Found Me and I Found You," "When the Ship Comes In," American Republic Band
Pack Up Your Troubles in Your Old Kit Bag—From "Her Soldier Boy," Medley one-step, American Republic Band
NEW NOVELTY DANCE RECORDS
20358 Sarah From Sahara (Frey), "Oriental Fox-trot," Piano duo with drums, Eubie Blake Trio
Bunch of Blues—Fox-trot, accordion solo, Charles Klass
20328 Stockyard Blues (Pinkard)—Fox-trot, Van Eps-Banta Dance Orchestra
Popularity (Cohan)—One-step, Van Eps-Banta Dance Orchestra
NEW BAND AND ORCHESTRA RECORDS
40124 Hymn of the Nations, Part 1 (Verdi), Garde Republicaine Band of France
Hymn of the Nations, Part 2 (Verdi), Garde Republicaine Band of France
40123 Scènes Bohémiennes (Bizet), Prélude, Garde Republicaine Band of France
Scènes Bohémiennes, No. 2 (Bizet), Sérénade, Garde Republicaine Band of France
29199 A Thousand Kisses (Joyce), Waltz, Royal Court Orchestra
L'Amour Qui Rit (Fragson-Christine), Royal Court Orchestra
20348 Fireflies (Savino), Intermezzo, Pathé Concert Orchestra
Heart's Ease (Macbeth), Intermezzo, Pathé Concert Orchestra
20347 Deauville (Corbin),* Polka for flute, Pathé Freres Orchestra
Nesting Song (Buot), Fantasie for clarinet, Pathé Freres Orchestra
NEW OPERATIC VOCAL RECORDS
63023 Mignon (Thomas), "Non conosco il bel sual?" (Knowest Thou the Land?), in Italian, Claudia Muzio, Soprano
Madame Sans Gêne (Giordano), "Che me ne faccio" (What Will I Do?), in Italian, Claudia Muzio, Soprano
59056 Manon Lescaut (Puccini), "Ange, Sirène ou Femme" (Angel, Siren or Woman), in French...Florence Constantino, Tenor
I Pescatori di Perle (Bizet), "Mi par d'udire ancora" (I Hear As in a Dream), in Italian...Florence Constantino, Tenor
27506 Tales of Hoffman (Offenbach), "Coppellius Song," in French...Adamo Didur, Basso
Sonnambula (Bellini), "Vi ravviso o luoghi ameni" (O, lovely scenes long vanished), in Italian...Adamo Didur, Basso
NEW INSTRUMENTAL RECORDS
20346 Souvenir de Venise (Quinn), Violin solo, piano accomp...Jan Rubini
Firelight Fancies (Loth), Violin solo, piano accomp...Jan Rubini
20345 American Patrol (Meacham), Boudini Brothers, Accordionists
Hiram's Huskin' Bee (Sweetman-Bonnell-Daly)—Characteristic medley, Intro.: 1. "Down Home Rag," 2. "Turkey In the Straw," 3. "Chicken Reel," Boudini Brothers, Accordionists
29198 Carefree and Happy, Zither and mandolin duet, piano accomp...Hofer Brothers
How Well You Dance! Mandolin solo, piano accomp...Antonio Devito

PARAMOUNT RECORDS

- N. Y. Recording Laboratories, Inc., Port Washington, Wis. Supplement Six—All 10-inch. Released May 20, 1918
STANDARD AND SACRED SONGS
30028 My Own United States (Stange-Edwards), Royal Dadmun
Marseillaise (de L'Isle)...Royal Dadmun
30029 I Hear You Calling Me (Harford-Marshall), Charles H. Hart
Ireland Must Be Heaven (McCarty-Johnson-Fisher)...Lewis James
30031 For All Eternity (Mascheroni)...Alan Turner
Oh Promise Me (de Koven)...Alan Turner
30027 Vacant Chair (Root)...Shannon Four
Sometime You'll Remember (Harms)...Lewis James
Face to Face (Herbert Johnson)...Royal Dadmun
Brighten the Corner Where You Are (Gabriel), Royal Dadmun
30030 Can't You Hear Me Callin' Caroline (Caro Roma)...Greek Evans
I Cannot Sing the Old Songs (Claribel)...Lewis James
INSTRUMENTAL RECORDS
30025 Pretty Polly (Arranged by Blondell), Blondell's Saxophone Quartet
First Love (Waltz), Accordion Solo...Delroy
30022 Venetian Love Song (Nevin), Xylophone Solo, George Hamilton Green
Humoresque (Dvorak), Xylophone Solo, George Hamilton Green
30024 Traumerei (Schumann), Violin Solo, Samuel Gardner
Spring Song (Mendelssohn), Violin Solo, Samuel Gardner
2055 Oloha Land (Hawaiian Guitars), Flute Obligato, Louise & Ferera
O Sole Mio (di Capua), Hawaiian Guitars, Louise & Ferera
30023 Liberty Loan March (Sousa)...Puritan Military Band
Patrol of the Scouts (Boccalari), Puritan Military Band
30032 Angels Dream Waltz (Herman)...Puritan Orchestra
Venetian Love Song (Nevin)...Puritan Orchestra
POPULAR SONGS OF THE DAY
2052 Good Morning, Mr. Zip, Zip, Zip (Lloyd), Baritone Solo...Arthur Fields
Aw Sammy (Baritone Solo), With Orchestra, Arthur Fields

(Continued on page 114)

RECORD BULLETINS FOR JUNE
(Continued from page 113)

- 2054 Au Revoir, But Not Good-bye, Soldier Boy (Brown-Von Tilzer).....Henry Burr
Bring Back My Daddy to Me (Tracy-Johnson-Meyer).....Henry Burr
- 2051 Three Wonderful Letters From Home (Goodwin-McDonald-Hanly).....Royden D. Massey
A Little Bit of Sunshine (McDonald-Goodwin-Hanly).....Royden D. Massey
- 2053 Round Her Neck She Wears a Yeller Ribbon (Norton).....Byron G. Harlan
Life Is a Merry Go Round (Golden-Burt).....Dan Quinn
- RECORDS FOR DANCING
- 30033 Livery Stable Blues—Fox-trot,
Saxophone Jazz Orchestra
The Dark Town Strutters' Ball (Shelton-Brooks),
Cordes Jazz Orchestra
- 30034 Wait Till the Cows Come Home (Caldwell-Caryll).....Yerkes Jazarimba Band
More Candy.....Yerkes Jazarimba Band

EMERSON PHONOGRAPH CO.

PATRIOTIC AND POPULAR SONG HITS

- 7350 What Are You Going to Do to Help the Boys? (Kahn-Van Alstyne). Patriotic solo, orch. accomp.Harry Evans
Way Down There a Dixie Boy Is Missing (Tierney-Murphy). Patriotic solo, orch. accomp.Harry Evans
- 7355 They Were All Out of Step But Jim (Irving Berlin). Patriotic character song, orch. accomp.Eddie Nelson
Second Regiment Connecticut March (D. W. Reeves). March and one-step,
Emerson Military Band
- 7353 Tom, Dick and Harry and Jack, Hurry Back (Johnson-Ager). Patriotic solo, orch. accomp., D. (Bud) Bernie
That's All One Mother Can Do (Reid-De Rose). Tenor solo, orch. accomp.Robert Rice
- 7354 All Aboard for Home, Sweet Home (Burkhart-Piantadosi-Glogau). Patriotic solo, orch. accomp.D. (Bud) Bernie
Mothers of America, You Have Done Your Share (Ellis-Porter). Patriotic solo, orch. accomp.Harry Ellis
- 7357 The Last Long Mile (Emil Breitenfeld). Patriotic solo, orch. accomp.Arthur Burdin
The Stars and Stripes Forever (J. P. Sousa). March and one-step.....Emerson Military Band
- 7351 K-K-K-Katy (Geoffrey O'Hara). Stuttering song, orch. accomp.D. (Bud) Bernie
What a Wonderful Dream It Would Be (Charles K. Harris). Tenor solo, orch. accomp.,
Frank Woods
- 7358 'N Everything (De Sylvia, Kahn and Jolson). Character song, orch. accomp.Eddie Nelson
Chu Chin Chinaman (Hanley-MacDonald). Quartet, orch. accomp.Peerless Quartet
- 7356 I'm Sorry I Made You Cry (N. J. Clesi). Tenor solo, orch. accomp.James Matthew Killarney (Michael W. Balfe). Tenor solo, orch. accomp.Frank Woods
- 7359 You're a Better Man Than I Am, Gunga-Din (Ehrlich-Osborne). Character song, orch. accomp.Henry Lewis
I Think You're Absolutely Wonderful, What Do You Think of Me? (McCarthy-Carroll). Baritone solo, orch. accomp.Henry Lewis
- FAVORITE DANCE SELECTIONS
- 7360 There'll Be a Hot Time for the Old Men While the Young Men Are Away (George W. Meyer). One-step.....Emerson Military Band
The Handicap (George Rosey). March and one-step.....Emerson Military Band
- 7361 While the Incense is Burning I Dream of You (Walter Smith). Fox-trot.....Emerson Military Band
The Drums.....Emerson Drum Corps
- 7362 Le Pere De La Victorie (Father of Victory) (L. Ganne). March and one-step,
Emerson Military Band
Garde Du Corps (Paris Chambers). March and one-step.....Emerson Military Band

LYRAPHONE CO. OF AMERICA

CONCERT AND OPERATIC SERIES

- 7109 Rigoletto ("La Donna e Mobile" and "Questa o quella").....George Rasely, Tenor
Trovatore ("Miserere")...Olive Marshall, Mario Rodolfi and Metropolitan Chorus
- 7110 Faust (Selections From),
Lyric Symphony Orchestra
Trovatore (Selections From),
Lyric Symphony Orchestra
- 9106 William Tell Overture (Part One),
Lyric Symphony Orchestra
William Tell Overture (Part Two),
Lyric Symphony Orchestra
- 9107 1812 Overture (Tschaikowsky),
Lyric Symphony Orchestra
Peer Gynt Suite (a) "Morning"; (b) "Asa's Death".....Lyric Symphony Orchestra
- STANDARD SONGS
- 6136 (a) The Star (Rogers); (b) May Morning (Denza).....Olive Marshall, Soprano
She Is Far From the Land (Lambert),
George Rasely, Tenor
- 6137 Lead, Kindly Light (Dykes),
Stanley Male Quartet
Nearer, My God, to Thee (Mason),
Stanley Male Quartet

- 6138 I Once Loved a Boy (Old Irish),
Mary Cavendish, Soprano
'Twas One of Those Dreams (Old Irish),
Mary Cavendish
- 6130 Villanelle (dell' Acqua).Olive Marshall, Soprano
Deep River (Burleigh)..Marion Green, Baritone
- 6131 'Twas Early One Morning (Old Irish),
Mary Cavendish, Soprano
Come Buy My Nice Fresh Ivy (Old Irish),
Mary Cavendish
- 3791 Bird's Song.....Lydia Lindgren, Soprano
Swedish Folk Song.....Lydia Lindgren, Soprano
- 3792 Solveig's Song.....Lydia Lindgren, Soprano
Little Star in the Sky Above....Lydia Lindgren
- 3712 The Lord's Prayer (In Russian),
Russian Choir Double Quartet
O Divine Redeemer (In Russian),
Russian Choir Double Quartet
- POPULARS
- 5126 A Baby's Prayer at Twilight (Lewis-Young-Jerome).....Tenor Solo
Sombre et Meuse (French March),
Lyric Military Band
- 5127 Au Revoir, But Not Good-bye, Soldier Boy (Al Von Tilzer).....Baritone Solo
Red, White and Blue (Shaw),
Lyric Military Band
- 5128 My Belgian Rose (Benoit-Levenson-Garton),
Tenor Solo
- 5129 The Flag of Victory.....Lyric Military Band
Just Like Washington Crossed the Delaware (Johnson-Meyer).....
American Patrol (Meacham).Lyric Military Band
- 5118 That's the Kind of a Baby for Me (Egan),
Samuel Ash, Tenor
Bring Me a Rose (Shisler)...Samuel Ash, Tenor
- 5119 There's Something in the Name of Ireland (Ager).....Henry Burr, Tenor
Hawaiian Butterfly (Santly).....Sterling Trio

- 5120 Cheer Up, Liza (Golden-Hubbell),
Peerless Quartet
- Melody Land (Golden-Hubbell),Peerless Quartet
- 5121 I May Be Gone for a Long, Long Time (Von Tilzer).....Stanley Cochran, Baritone
Hail, Hail, the Gang's All Here (Sullivan-Morse)....Arthur Fields and Peerless Quartet
- INSTRUMENTAL RECORDS
- 3782 Marche Rakoczy.....Lyric Gypsy Band
Gypsy Waltz.....Lyric Gypsy Band
- 3783 Hungarian Potpourri.Lyric Hungarian Orchestra
Chanson Bohemienne.Lyric Hungarian Orchestra
- DANCE RECORDS
- 4139 Tickle Toe (Hirsch)—Fox-trot,
Lyric Dance Orchestra
Mighty Lak' a Rose (Nevin)—Waltz,
Lyric Dance Band
- 4140 Some Jazz Blues (Lake)—Fox-trot,
Lyric Dance Orchestra
- Valse Boston (Drdla)...Lyric Dance Orchestra
- 4141 Oh, Johnny, Oh, Johnny—One-step,
Lyric Dance Orchestra
- Love's Old Sweet Song—Waltz,
Lyric Dance Orchestra
- 4142 Tom, Dick and Harry and Jack—One-step,
Lyric Dance Orchestra
- The Wild, Wild Women...Lyric Dance Orchestra
- 4143 Throw Me a Rose (Kalman)....Marimba Band
Tropical Skies—Waltz.....Marimba Band
- 4136 Spooky Spooks (Claypoole)—One-step,
Lyric Dance Orchestra
- Homeward Bound (Johnson-Meyer)—One-step,
Lyric Dance Orchestra
- 4137 I Don't Want to Get Well—Medley One-step....
Darktown Strutters' Ball (Brooks),
Lyric Dance Orchestra
- 4138 That's It (Creamer-Layton)—Fox-trot,
Lyric Band
Broadway Fox Trot—Medley.....Lyric Band

SOLDIERS ATTEST TO POPULARITY OF THE NEW EDISON

The popularity of music, and especially music of the "canned" variety, is shown by the three accompanying photographs, which depict the New Edison Army and Navy model phonograph doing its bit in some of the army camps in the United States. The boys play the phonograph whenever they find any spare time on their hands, and the soldier who sent these pictures wrote that the hardest worker in the entire camp is the New Edison, as it is going practically all of the time, and the more it is played the more the boys seem to enjoy it. All classes of records, from grand opera to the jazziest ragtime, are played and enjoyed by the soldiers,



The New Edison Is Very Much in Evidence in the Army Training Camps and the commanding officers of the various units are unanimous in their praise of the New Edison as a means of keeping up the morale of the soldiers in the training camps.

READY REFERENCE OF GENERAL SUPPLIES

DEALERS

Send for our "Trial Proposition" on the Regina Hexaphone—the latest and best paying popular priced coin-operated instrument for use in public places.



211 Marbridge Bldg., 34th St. and Broadway, New York City
Manufacturers of Regina Music Boxes; Reginaphones;
Coin-operated Mandolin Orchestrions; Vacuum
Cleaners and other specialties.

NEEDLES

WE MANUFACTURE

Diamond needles for Edison
Sapphire needles for Edison
Sapphire needles for Pathe
in stock ready for delivery

MERMOD & CO., 505 5th Ave., N. Y.

REPAIRS

All Makes of Talking Machines
Repaired Promptly and Efficiently

TALKING MACHINE REPAIR
AND SALES CORPORATION

ANDREW H. DODIN, President
176 Sixth Avenue New York
TELEPHONE, CHELSEA 8437

SOME OF THE LEADING JOBBERS OF TALKING MACHINES IN AMERICA

1856 **WURLITZER** 1916

VICTOR
DISTRIBUTORS
VICTORS EXCLUSIVELY

We make a specialty of getting the order out on time—every time.

The Rudolph Wurlitzer Co.
CINCINNATI AND CHICAGO

Two points of supply; order from the nearer

TEST IT. 

OUR VICTOR

Record Service

has a reputation for efficiency.
Suppose you try it.

E. F. DROOP & SONS CO.
1300 G. STREET, WASHINGTON, D. C.
231 N. HOWARD STREET, BALTIMORE, MD



Chas. L. Marshall & Co.
Wholesale Distributors for Michigan of

THE INSTRUMENT OF QUALITY

Sonora
CLEAR AS A BELL 

also representing Sonora Phonograph Sales Co. of New York in State of Ohio

810 Empire Bldg., Detroit, Mich.



Where Dealers May Secure

COLUMBIA

Product

STARR Phonographs and GENNETT Records

Complete Stock and REAL Service

Crafts-Starr

PHONOGRAPH CO.

Factory Distributors
218-220 NORTH SECOND STREET, RICHMOND, VIRGINIA

Write for Dealers' Proposition

Smith, Kline & French Co.
PHILADELPHIA

Wholesale Distributors for

THE INSTRUMENT OF QUALITY

Sonora
CLEAR AS A BELL 

In PENNSYLVANIA, NEW JERSEY and DELAWARE

Ready, Full Stocks, and Prompt Deliveries from Convenient Shipping Centers all over the United States.

Southern Victor Dealers

Largest Stock VICTROLAS and RECORDS.
Prompt Shipment and Low Freight Rates.

WALTER D. MOSES & CO.
Oldest Music House in Virginia or North Carolina.
RICHMOND, VA.

- Distributors**
- Atlanta, Ga., Columbia Graphophone Co., 63 N. Pryor St.
 - Baltimore, Md., Columbia Graphophone Co., 111 West German St.
 - Boston, Columbia Graphophone Co., 137 Federal St.
 - Buffalo, N. Y., Columbia Graphophone Co., 622 Main St.
 - Chicago, Ill., Columbia Graphophone Co., 14 N. Michigan Ave.
 - Cincinnati, O., Columbia Graphophone Co., 117-119 W. Fourth Ave.
 - Cleveland, O., Columbia Graphophone Co., 1375 Euclid Ave.
 - Dallas, Tex., Columbia Graphophone Co., 1011 Elm St.
 - Denver, Colo., Columbia Stores Co., 1608 Glenarm Place.
 - Detroit, Mich., Columbia Graphophone Co., 401 Woodward Ave.
 - Indianapolis, Ind., Columbia Graphophone Co., 44 N. Pennsylvania St.
 - Kansas City, Mo., Columbia Graphophone Co., 1027 McGee St.
 - Los Angeles, Cal., Columbia Graphophone Co., 745 S. Broadway.
 - Minneapolis, Minn., Columbia Graphophone Co., 412-414 Nicollet Ave.
 - New Haven, Conn., Columbia Graphophone Co., 206 Meadow St.
 - New Orleans, La., Columbia Graphophone Co., 517-525 Canal St.
 - New York City, Columbia Graphophone Co., 55 Warren St.
 - Omaha, Neb., Schmoller & Mueller Piano Co.
 - Philadelphia, Pa., Columbia Graphophone Co., 210 N. Broad St.
 - Pittsburgh, Columbia Graphophone Co., 101 Sixth St.
 - Portland, Me., Columbia Graphophone Co., 43 Exchange St.
 - Portland, Ore., Columbia Graphophone Co., 429-431 Washington St.
 - Salt Lake City, Utah, Columbia Stores Co., 221 South West Temple.
 - San Francisco, Cal., Columbia Graphophone Co., 130-150 Sutter St.
 - Seattle, Wash., Columbia Graphophone Co., 911 Western Ave.
 - Spokane, Wash., Columbia Stores Co., 818 Sprague Ave.
 - St. Louis, Mo., Columbia Graphophone Co., 1127 Plue St.
 - Tampa, Fla., Tampa Hardware Co.
- Headquarters for Canada:
Columbia Graphophone Co., 263-5-7 Sorara Ave.
Toronto, Ont.
- Executive Office
COLUMBIA GRAPHOPHONE CO.
Woolworth Building New York

OLIVER DITSON COMPANY

Largest VICTOR Talking Machine Distributors East of Chicago.

Creators of "The Fastest Victor Service." Let us tell you more about our service.

BOSTON

W. J. DYER & BRO.
NORTHWESTERN DISTRIBUTORS OF THE

VICTOR
Machines, Records and Supplies

 Shipped Promptly to all Points in the Northwest

ROUNTREE-CHERRY
RICHMOND VIRGINIA

Wholesale Distributors for

THE INSTRUMENT OF QUALITY

Sonora
CLEAR AS A BELL 

YOU
above all must be satisfied!

IN NORTH AND SOUTH CAROLINA

The Electric Supply & Equipment Co.

Exclusive Wholesale Distributors for Southern New England

THE INSTRUMENT OF QUALITY

Sonora
CLEAR AS A BELL 

Complete stocks carried in Boston and Hartford

Little Bldg. 103 Allyn St.
BOSTON, MASS. HARTFORD, CONN.

Victor Exclusively

EASTERN TALKING MACHINE CO.
177 Tremont Street, Boston
VICTOR DISTRIBUTORS

Sherman, Clay & Co.

San Francisco, Los Angeles, Portland, Seattle, Spokane
PACIFIC COAST DISTRIBUTORS OF VICTOR PRODUCTS

THIS REFERS TO YOU, MR. DEALER

Every talking machine jobber in this country should be represented in this department, no matter what line he handles or where he is located. The cost is slight and the advantage is great. Be sure to have your card in this department of The Talking Machine World each month. It will pay you a big profit on the investment.

The PERRY B. WHITSIT CO.
Distributors of
Victrolas and Victor Records
COLUMBUS, OHIO



The NEW EDISON

Bears the Stamp of Edison's Genius

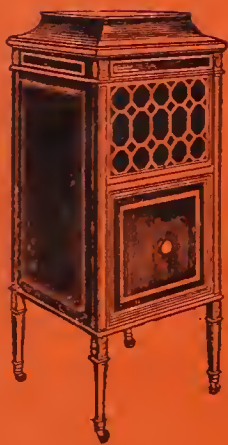

JOBBER'S OF THE NEW EDISON, EDISON RE-CREATIONS, THE NEW EDISON DIAMOND AMBEROLA AND BLUE AMBEROL RECORDS

CALIFORNIA
Los Angeles—Edison Phonographs, Ltd.
San Francisco—Edison Phonographs, Ltd.

COLORADO
Denver—Denver Dry Goods Co.

CONNECTICUT
New Haven—Pardee-Ellenberger Co., Inc.

GEORGIA
Atlanta—Phonographs, Inc.

ILLINOIS
Chicago—The Phonograph Co.
James I. Lyons. (Amberola only.)

INDIANA
Indianapolis—Kipp Phonograph Co.

IOWA
Des Moines—Harger & Blish.
Sioux City—Harger & Blish.

LOUISIANA
New Orleans—Diamond Music Co., Inc.

MASSACHUSETTS
Boston—Pardee-Ellenberger Co.

MICHIGAN
Detroit—Phonograph Co., of Detroit.

MINNESOTA
Minneapolis—Laurence H. Lucker.

MISSOURI
Kansas City—The Phonograph Co. of Kansas City.

MONTANA
Helena—Montana Phonograph Co.

NEBRASKA
Omaha—Shultz Bros.

NEW JERSEY
Paterson—James K. O'Dea (Amberola only).

NEW YORK
Albany—American Phonograph Co.

New York—The Phonograph Corp. of Manhattan.

Syracuse—Frank E. Bolway & Son, Inc.

W. D. Andrews Co. (Amberola only.)

Puffalo—W. D. & C. N. Andrews Co. (Amberola only.)

OHIO
Cincinnati—The Phonograph Co.
Cleveland—The Phonograph Co.

OREGON
Portland—Edison Phonographs, Ltd.

PENNSYLVANIA
Philadelphia—Girard Phonograph Co.
Pittsburgh—Buehn Phonograph Co.

Williamsport—W. A. Myers.

RHODE ISLAND
Providence—J. A. Foster Co. (Amberola only.)

TEXAS
Dallas—Texas-Oklahoma Phonograph Co.

UTAH
Ogden—Proudfit Sporting Goods Co.

VIRGINIA
Richmond—C. B. Haynes & Co.

WISCONSIN
Milwaukee—The Phonograph Co. of Milwaukee.

CANADA
Montreal—R. S. Williams & Sons Co., Ltd.

St. John—W. H. Thorne & Co., Ltd.

Toronto—R. S. Williams & Sons Co., Ltd.

Vancouver—Kent Piano Co., Ltd.

Winnipeg—R. S. Williams & Sons Co., Ltd.

Calgary—R. S. Williams & Sons Co., Ltd.

The TALKING MACHINE WORLD

For the
makers &
sellers of
talking
machines

Published Each Month by Edward Lyman Bill, Inc., at 373 Fourth Ave., New York, June 15, 1918



The best-known trade mark in the world

"The Victor talking machine's design, 'His Master's Voice,' has become a household word, and the quaint little fox terrier at attention before the horn is familiar to more Americans than any of the world's great masterpieces"—*Collier's Weekly*.

The Highest Class Talking Machine in the World

THE INSTRUMENT OF QUALITY

Sonora

CLEAR AS A BELL



BECAUSE of its magnificent tone which won highest score for quality at the Panama Pacific Exposition, Sonora is of especial interest to those who are accustomed to demand the very best and who can afford to, and who do pay cash for what they want.

There is a great advantage in selling a phonograph for cash instead of tying up your capital with long installment payments. Sonora keeps your bank balance strong, and you don't have to worry how to make ends meet as your business grows, because you are not obliged to meet the unbusiness-like "easy payments" offered by your competitor.



Sonora, because of its many exclusive features sells easily and quickly on sheer merit. It is worth all that is asked for it. It delights the purchaser and makes money for the dealer. Sonora plays all makes of disc records perfectly without extra attachments. Write us regarding the Sonora agency in your territory.

\$50	\$55	\$60	\$75	\$120	\$135	\$175
\$190	\$215	\$230	\$300	\$375	\$500	\$1000

Art models made to special order to suit any taste.

Sonora Phonograph Sales Company, Inc.

GEORGE E. BRIGHTSON, President

Executive Offices: 279 Broadway, NEW YORK.

Sonora operates and is licensed under BASIC PATENTS of the phonograph industry

The Talking Machine World

Vol. 14. No. 6

New York, June 15, 1918

Price Twenty-five Cents

TALKING MACHINE MAN IN FRANCE

E. W. Dahlberg, of Montgomery, Ala., Writes in a Graphic Manner Regarding His Experiences as an American Soldier "Over There"

ATLANTA, GA., June 5.—E. N. Upshaw, secretary of the Elyea-Austell Co., Victor wholesalers of this city, recently received a letter from E. W. Dahlberg of the Dahlberg Talking Machine Co., of Montgomery, Ala., who left his business in the hands of his partner some time ago and enlisted in the United States Marine Corps. Mr. Dahlberg, who has been in France for some time, took occasion to remark upon the presence of "His Master's Voice" trade-mark in that country. In fact, it is about as well known in that country as it is in the United States. In this letter, which was delayed in transit, he says:

"It's near 'taps' now, and someone just told me to-day was Easter. How unlike a year ago. But, you know, in a headquarters office in the American forces yesterdays are the same as to-days, and all to-morrows are the same. We seldom know that Sunday has come, unless someone reminds us. That is, unless one is of Catholic religion; if he is, he goes to church. There are some wonderful cathedrals here. I wish I had the nerve to enter during 'session' and see them inside. The two largest down town have quite historic values. I haven't seen a church of 'my kind' since I have been here. Ninety per cent. of the people seem to be Catholics.

"Your friend, Mr. Edmond Clement, is singing in town. He has quite a wonderful voice. Reminds me quite a lot of our own John. Recently I have heard Manon, Cavalleria and Pagliacci—all in French. Can you imagine 'Pagliacci,' a cheap Italian tragedy-comedy, translated into French? Gosh, when the nasal hit it, I could hardly recognize it. Baritone only fair. If Alma Gluck has a twin sister, she sang 'Nedda' deliciously.

"'His Master's Voice' appears in great big letters on the main street, in front of a fine, artistic place—having signs of much former luxury. I asked my companion if the people understood the meaning of 'His Master's Voice' (because it's always in English), and she answered that it was a byword, even among the kiddies, and about as well known as in America. They haven't had a cabinet machine in years, and not a new record in several months. Only have a few old horns left. But they have the usual Victor feeling over prospects, etc.

"Say, this is a great town for you and Foster and Jack to visit while your wives stay home.

You know New Orleans, New York? I never thought that any place could make them look like country villages, but this one does. There's more champagne, wine, booze (of all kinds) on one block downtown than in fifty blocks in New Orleans!

"I am several miles out (in the woods) and have a big time getting into town. Hold up trench trains—get cursed in French, but for all that, I make it in due time. The town is as large or larger in peace time than New Orleans, and it's some burg.

"You should hear me speak this lingo. I can do it better than the natives, or rather I guess I do, because when I pronounce a word absolutely according to Hoyle and they don't get it, why, it's just over their heads (!). But, at that, we get by—mostly with the aid of our hands. The sign language, I find, is universal.

"The Big Uncle is taking care of us 'over here' better than back in God's country—I mean with reference to equipment, shelter, clothes, food, etc.—and we very genuinely appreciate you people's efforts and sacrifices in our behalf."

MUSIC FOR SUBWAY WORKERS

Lively Strains Keep Track Repair Crew Going at Lively Pace Throughout the Night

Both plain and fancy labor is getting so scarce that special inducements are being offered by the big corporations. In the hope of keeping a track repair crew interested in its work and entertained, a large talking machine is kept playing lively reels and jigs in the subway, just south of the Ninety-sixth street station, where the men are working at nights.

"We've had the talking machine playing for the men all night," said the foreman, "and they are doing good work. When they slacken up a bit the record is played faster and they get in the habit of keeping step with the music."

Just at that minute a particularly lively jig was being played, and the subway laborers had to step so lively that they got their feet all tied up in the rails. Straightening them out caused a grievous loss of time and then the talking machine was slowed down to a dog trot.

NEW INCORPORATION

The Farron S. Betts Co., of Brooklyn, N. Y., was incorporated recently for the purpose of manufacturing albums and cabinets for talking machine records. The capitalization of the concern is \$300,000, the incorporators being F. S. Betts, J. W. Murphy and J. S. Keith.

ALMA GLUCK AND THE RED CROSS

Noted Artist Asked Everyone Who Enjoys Her Victor Records to Subscribe \$1 to the Recent Red Cross Drive—Results Are Excellent

Alma Gluck, noted singer and Victor record artist, hit upon an unique plan for aiding the American Red Cross during its recent drive for \$100,000,000. Mme. Gluck, who has given her time and services in many ways for entertaining the soldiers at the camps, and in helping to provide for their comfort, came forth with the suggestion that everyone who had heard her voice through the medium of Victor records should contribute at least \$1 to the Red Cross for the special Alma Gluck "Love Fund," in care of that organization. It is said that close to one million of Mme. Gluck's records are sold each year, which led her to hope for big returns.

In talking of her plan Mme. Gluck said:

"It occurred to me that of all persons likely to be moved into generous assistance of the Red Cross in its humanitarian work in the midst of this terrible war, the people who love music, the men and women and children of tender hearts that thrill with joy or sorrow or sympathy when they listen to simple songs, are those naturally most likely to respond here. I recalled the many notes of sweet and tender sentiment that had come to me from my own big musical family in this connection, and I made up my mind that, if it were possible, I should mobilize all of them—all to whom my voice reached and who might care in some sweet way to repay me for any pleasure it gave them—into forming a sort of Alma Gluck army for the Red Cross. If thereafter the plan is extended by other singers to their circle of song-lovers in turn, I shall be most happy indeed."

The suggestion was certainly a happy one, for no sooner was the plea sent out than money came pouring in from admirers of Alma Gluck in New York, from young girls who live way out in little towns in the West, who love to hear Alma Gluck sing "Little Grey Home in the West," and checks came in from the South, where her "Carry Me Back to Ole Virginny" has won its way into their hearts—in fact, Alma Gluck must have friends galore, for money in abundance came in to the Red Cross as a result of this appeal.

Besides collecting thousands of dollars through the "Love Fund" Mme. Gluck also donated \$25,000 personally to the Red Cross, and auctioned \$10,000 worth of tickets for the Josef Hofmann recital at Carnegie Hall. On the opening day of the Red Cross campaign she collected \$15,000. She said that she would endeavor to send each one of those who contributed to the "Red Cross Love Fund" an autograph photograph as an acknowledgment of their kindness.

DOEHLER CO. EXPANSION

Additional Buildings May Soon Become a Necessity to Meet Business Needs

The department of the Doehler Die-Casting Co.'s Brooklyn plant devoted to the die-casting of phonograph parts reports great activity. The general business executed by this concern has reached such proportions that additional building operations are already rumored. It is less than a year since the great modern concrete building, now used as the main building was added to their group of buildings.

The General Recording Co., Manhattan, was incorporated at Albany recently with capital of \$20,000, for the purpose of manufacturing records. Those interested are: J. C. Jackson, F. W. Weeks, and H. Hemming, 1476 Broadway.

Value of Stick-to-it-iveness to Talking Machine Salesmen

Pretty nearly every good prospect for a talking machine buys one sooner or later. The reason so many of them do not buy from the dealer who first discovers they are prospects is not so much that that dealer's line is not satisfactory as that the dealer does not stick to the prospect long enough.

We find a man who is talking of buying. We present our proposition to him. He is non-committal and we accomplish nothing the first time. We see him again after a few days and he is less encouraging than before. We grow discouraged. Then the third time we see him he says he is not going to do anything at present.

We think that he has put off buying when all that has happened is that we have not got him interested in our proposition and he doesn't want to encourage us to keep coming. At all

events, he does not prove responsive and we have other prospects demanding attention and we become interested in them and forget about this one until the first thing we know we hear he has bought elsewhere.

The only trouble was that we did not stick to him, studying his case and trying to see the proposition from his point of view, seeking to discover just what he wanted and what we had that would fill the bill. It may be that the reason we did not get the order was that we did not keep going until we happened to catch the prospect in the right frame of mind. We may have simply developed him to a point where another dealer found him all ready to sign up for almost anything with a case and a sound box. Let's stick and study in every instance until the prospect absolutely refuses our proposition.

Why the Persistently Dissatisfied Man Is a Real Menace to a Sales Organization

Look out for the disturber in the sales organization, the fellow who is never satisfied, who declares that everything about the store is operated on the wrong basis, who maintains that he never gets a square deal and never loses an opportunity for wailing to his fellow employes. Such a man can do a surprising amount of injury in any organization, unless he is checked without delay.

There are times when a most competent salesman feels that he has considerable kick against the way he has been treated or is being treated by the house he is working for. If the manager is wise he will endeavor to find out if there is any basis for the complaint or dissatisfaction and seek to adjust it. If the salesman has a real grievance, and ponders over it, it interferes materially with his efficiency, and if he airs it, it starts the rest of the staff to wondering whether or not they are getting everything they should. Adjust any warranted grievance without delay. Either give the salesman what is coming to him, if it is right, or explain to him where he is in error, if such should be the case.

The thorn in the side of the average manager who wants to treat his men fairly and keep them happy is the fellow who is continually oppressed by those employing him or associated with him—that is, to hear him tell it. He is just a disturber, without any definite aim other than to appear cynical, and at the same time downtrodden. He gets the ear of the young salesman who is perfectly happy over a recent increase in commission or salary, explains to him that he is getting an unfair proportion of the money he is making for the house, is worth more money for the work he is doing, and generally has not much to be thankful for beyond the fact that he happens to be living.

The younger salesman is more than likely to be impressed and influenced by the talk, to a certain degree at least, and instead of working at full speed for the generous reward he feels will be his, is inclined to lay down and endeavor to give to his house only that amount of effort which his colleague declares he is being paid for.

The chronic disturber is the I. W. W. of the

business organization, and should be pulled up with a jerk. If he has a legitimate complaint, give it attention. If, after adjustment, he is still complaining, or if he cannot prove any genuine reason for dissatisfaction, then the best thing to do is to ask him to retire from the organization.

No business organization, the majority of whose members are dissatisfied, can work in a way to get the greatest results. The handicap is too great. Instead of entering wholeheartedly into the joy of the work at hand, the salesmen go about with the feeling that there is something wrong with conditions in general which they may or may not be able to fathom, and they are inclined to spend too much time consoling one another over what they consider to be their hard lot.

By endeavoring to satisfy those that are willing to be satisfied, and putting the quietus on the chronic growler without hesitation, the manager can do his share at least in endeavoring to preserve an organization that is working hard because it finds pleasure and profit by so doing.

THE HANDLING OF RECORD STOCK

Goodwin's, Ltd., of Montreal, Give Some Pointers on a Very Important Subject That Are of Considerable Interest to the Trade at Large

MONTREAL, QUE., June 3.—A simple, inexpensive and satisfactory method of keeping their stock of Blue Amberol records is thus explained by Goodwin's, Ltd., of Montreal:

"Each compartment is twelve and one-half inches high, four inches deep and two and three-quarter inches wide. This permits the placing of five records in each compartment and each record projects about three-quarters of an inch, so that it can be easily taken out. The most important part of the system is that we do not carry any duplicate numbers in any compartment. Briefly, in one set of racks we carry a complete stock of every record (one of each only), as listed in the numerical catalog. In this way we can tell at a glance the missing records, and the entire stock can be taken in a very short time. Of course, we carry a reserve stock in addition to the above, and each morning a list of records sold the previous day is taken and if in the reserve stock, they are placed in

the regular stock. If not in the reserve stock they are immediately ordered, and in this way our stock is always complete.

"The title and number of each record is kept on separate cards. When records are ordered, the number of records received is placed on each card and those sold during the day are crossed off each morning. When checking up the records sold, if we find a particular record is desired, the card is taken out and the record ordered. The card is kept out until the record is received.

"The importance of our system is that we can tell in five minutes exactly the number of each record out of stock and which it is necessary to order; thus, as previously stated, keeping our stock as complete as possible with practically very little time and effort.

"It would hardly seem necessary for us to add that an orderly and systematically kept record stock helps a lot toward increasing record sales. Many Amberol dealers show this, but for the benefit of those who do not appreciate the fact we might say that the more systematic and complete a dealer keeps his record stock the fewer sales he will lose through being out of stock of certain records. A systematic stock-

keeping method will help the dealer keep his stock complete and a complete stock will help him meet most any requirement of his record customers."

NOW THE C. B. HAYNES CO., INC.

RICHMOND, VA., June 3.—The firm of C. B. Haynes & Co., 200 East Broad street, this city, which has been conducting a wholesale and retail business in Edison products since 1906, have incorporated under the style of the C. B. Haynes Co., Inc., with \$100,000 paid up capital, consisting of the following officials: C. B. Haynes, president; Geo. E. Garnett, vice-president; E. Bowman, secretary and treasurer. Mr. Bowman, a resident of this city, became connected with the firm in September, 1915, and has proved a very valuable asset. Geo. E. Garnett is a traveling representative, and has been connected with the company for the last ten years. C. B. Haynes, who is known as "Pop Haynes," is still at the helm. The firm's business has shown an increase every month this year of from 50 to 75 per cent. over last year—"even if in war times"—and expect it to continue all the year.

SINCERITY

That's the slogan back of every factor in

Ditson Service

It means much just now

Oliver Ditson Co.
B O S T O N

VICTOR
Exclusively

Chas. H. Ditson & Co.
N E W Y O R K

Victrola IV-A, \$22.50
Oak



Victrola VIII-A, \$50
Oak

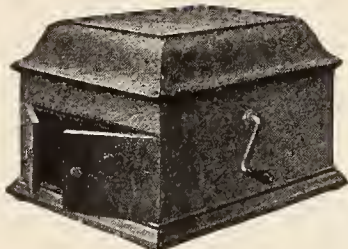

Victrola X-A, \$90
Mahogany or oak



Victrola XVI, \$225
Victrola XVI, electric, \$282.50
Mahogany or oak

Victor Supremacy is real

It is backed by its wonderful musical achievements.

It is the power behind the success of every Victor retailer.

Victor Talking Machine Co.
Camden, N. J., U. S. A.

Berliner Gramophone Co., Montreal, Canadian Wholesalers

"Victrola" is the Registered Trade-mark of the Victor Talking Machine Company designating the products of this Company only.

Warning: The use of the word Victrola upon or in the promotion or sale of any other Talking Machine or Phonograph products is misleading and illegal.

Important Notice. Victor Records and Victor Machines are scientifically co-ordinated and synchronized in the processes of manufacture, and their use, one with the other, is absolutely essential to a perfect reproduction.



Victor Wholesalers

- Alhany, N. Y.... Gately-Haire Co., Inc.
- Atlanta, Ga..... Elyea-Austell Co.
Phillips & Crew Piano Co.
- Austin, Tex..... The Talking Machine Co., of Texas.
- Baltimore, Md.... Cohen & Hughes.
E. F. Droop & Sons Co.
H. R. Eisenbrandt Sons, Inc.
- Bangor, Me..... Andrews Music House Co.
- Birmingham, Ala. Talking Machine Co.
- Boston, Mass..... Oliver Ditson Co.
The Eastern Talking Machine Co.
The M. Steinert & Sons Co.
- Brooklyn, N. Y... American Talking Mch. Co.
G. T. Williams.
- Buffalo, N. Y..... W. D. & C. N. Andrews.
Neal, Clark & Neal Co.
- Burlington, Vt.... American Phonograph Co.
- Butte, Mont..... Orton Bros.
- Chicago, Ill..... Lyon & Healy.
The Rudolph Wurlitzer Co.
Chicago Talking Machine Co.
- Cincinnati, O..... The Rudolph Wurlitzer Co.
- Cleveland, O..... The W. H. Buescher & Sons Co.
The Collister & Sayle Co.
The Eclipse Musical Co.
- Columbus, O..... The Perry B. Whitsit Co.
- Dallas, Tex..... Sanger Bros.
- Denver, Colo..... The Hext Music Co.
The Knight-Campbell Music Co.

- Des Moines, Ia.... Mickel Bros. Co.
- Detroit, Mich..... Grinnell Bros.
- Elmira, N. Y..... Elmira Arms Co.
- El Paso, Tex..... W. G. Walz Co.
- Honolulu, T. H.... Bergstrom Music Co., Ltd.
- Houston, Tex..... Thos. Goggan & Bro.
- Indianapolis, Ind.. Stewart Talking Machine Co.
- Jacksonville, Fla.. Florida Talking Machine Co.
- Kansas City, Mo.. J. W. Jenkins Sons Music Co.
Schmelzer Arms Co.
- Lincoln, Nebr.... Ross P. Curtice Co.
- Little Rock, Ark.. O. K. Houck Piano Co.
- Los Angeles, Cal.. Sherman, Clay & Co.
- Memphis, Tenn.... O. K. Houck Piano Co.
- Milwaukee, Wis... Badger Talking Machine Co.
- Minneapolis, Minn. Beckwith, O'Neill Co.
- Mobile, Ala..... Wm. H. Reynolds.
- Montreal, Can.... Berliner Gramophone Co., Ltd.
- Nashville, Tenn.... O. K. Houck Piano Co.
- Newark, N. J..... Price Talking Machine Co.
- New Haven, Conn. Henry Horton.
- New Orleans, La... Philip Werlein, Ltd.
- New York, N. Y... Blackman Talking Mach. Co.
Emanuel Blout.
C. Bruno & Son, Inc.
I. Davega, Jr., Inc.
S. B. Davega Co.
Charles H. Ditson & Co.
Landay Bros., Inc.
New York Talking Mach. Co.
Ormes, Inc.
Silas E. Pearsall Co.

- Omaha, Nebr..... A. Hospe Co.
Mickel Bros. Co.
- Peoria, Ill..... Putnam-Page Co., Inc.
- Philadelphia, Pa.. Louis Buehn Co., Inc.
C. J. Heppie.
The George D. Ornstein Co.
Penn Phonograph Co., Inc.
The Talking Machine Co.
H. A. Weymann & Son, Inc.
- Pittsburgh, Pa... W. F. Frederick Piano Co.
C. C. Mellor Co., Ltd.
Standard Talking Machine Co.
- Portland, Me..... Cressey & Allen, Inc.
- Portland, Ore.... Sherman, Clay & Co.
- Providence, R. I... J. Samuels & Bro., Inc.
- Richmond, Va.... The Corley Co., Inc.
W. D. Moses & Co.
- Rochester, N. Y... E. J. Chapman.
The Talking Machine Co.
- Salt Lake City, U. Consolidated Music Co.
The John Elliott Clark Co.
- San Antonio, Tex. Thos. Goggan & Bros.
- San Francisco, Cal. Sherman, Clay & Co.
- Seattle, Wash..... Sherman, Clay & Co.
- Sioux Falls, S. D.. Talking Machine Exchange.
- Spokane, Wash.... Sherman, Clay & Co.
- St. Louis, Mo.... Koerber-Brenner Music Co.
- St. Paul, Minn.... W. J. Dyer & Bro.
- Syracuse, N. Y.... W. D. Andrews Co.
- Toledo, O..... The Whitney & Currier Co.
- Washington, D. C. Cohen & Hughes.
E. F. Droop & Sons Co.
Robt. C. Rogers Co.

ALL RECORD CUSTOMERS ARE ALBUM CUSTOMERS



MAKING THEIR SELECTION

A Place for Every Record and Every Record in its Place

Albums are an **Indispensable Requisite** in the talking machine business and wherever records are sold. Practical and handy. Save time and records. A **profitable adjunct** to the business.

We manufacture disc Record Albums to fit cabinets of all sizes and styles. With the indexes they are a complete system for filing all disc records.

We have unexcelled manufacturing facilities, and considering quality our prices are the lowest. Write us, giving quantity you may desire, and we will quote prices.

OUR ALBUMS ARE MADE TO CONTAIN VICTOR, COLUMBIA, EDISON, PATHE AND ALL OTHER DISC RECORDS

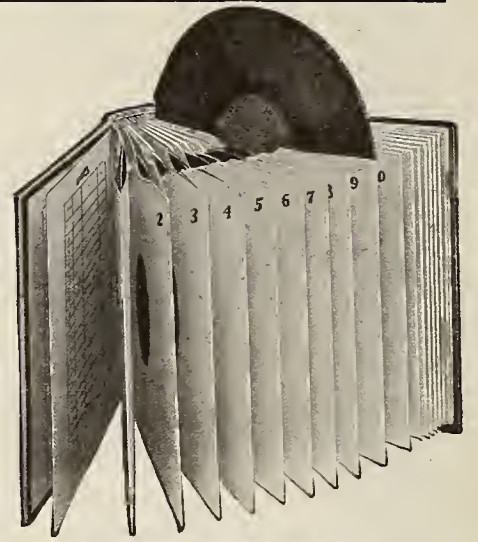

THE PERFECT PLAN

NATIONAL PUBLISHING CO., 239 S. American St., PHILADELPHIA, PA.

DEATH OF EVAN WILLIAMS

Singer Long Popular in the Talking Machine Trade and the Musical World Passes Away—Was Striking Figure in Concert and Oratorio

The announcement of the death of Evan Williams, the popular Victor artist, which occurred in Akron, O., after a short illness on May 24, has brought a sense of personal loss into every home where there is a talking machine, for there are few makers of records in the vocal field who enjoy a wider popularity than did this big-hearted and genial personality, who has passed from us.

Evan Williams was probably the most distinguished oratorio tenor and lyric singer of the old school on the concert stage. His concerts were always a delight because of his programming of many English and American ballads, which he sang with rare charm, and better still with an enunciation that was a delight. He made records exclusively for the Victor Co., and it may safely be stated that every one of his records is a splendid example of good singing and perfect record making. For some years his record of Bartlett's "A Dream" was considered to be one of the finest vocal records made. Every expression, every nuance, every feeling was revealed in this record so masterfully that it never failed to move its hearer as the singer would in person.

Another fine example of his oratorio singing in record form was "Sound the Alarm" from "Judas Maccabeas"; but it is unjust to differentiate, for all of Evan Williams' records, those in oratorio or ballad form, are perfect examples of fine singing, and they will remain the greatest monument to his memory—records that will ever be treasured and admired.

Mr. Williams had well been termed a national figure in the musical world. For twenty-seven years he thought and sang and studied for better music throughout the nation. He was intensely American, and naturally very patriotic. He had been doing magnificent work at the camps entertaining the soldiers, and two of his sons are fighting for Uncle Sam at the front.

Evan Williams was born in Mineral Ridge, O., of Welsh parents, on September 7, 1867, and as a young man was employed in the coal mines near his home. His rise from poor cir-

cumstances to a high place in the musical profession was considered one of the most remarkable achievements in American musical history. Mr. Williams made his first concert appearance with a Welsh choir in Galion, O., in 1891, and five years later he distinguished himself in an appearance with noted soloists at the music festival in Worcester, Mass. He appeared in England in 1894, and sang at many important



Evan Williams

concerts in London, returning to this country in 1897. His fame grew rapidly and he was the soloist with leading choral societies both in England and the United States.

Mr. Williams' death occurred in the City Hospital in Akron, O., and was due to blood poisoning.

ATTRACTIVE VICTROLA PRICE CARDS

I. Davega, Jr., Inc., Victor factory distributors, 125 West 125th street, New York, are issuing an attractive line of Victrola price cards for warerooms and window display. These cards come in sets of nine and are printed in three colors, red, white and blue, on a good quality cardboard five and one-quarter by ten and one-half inches. The card also contains a cut of the style and the famous Victor trade-mark. It is announced that these cards may be obtained from any Victor distributor or direct from I. Davega, Jr., Inc. A large demand has already been felt, it is reported, for these cards.

FRAUDULENT DEALERS PROSECUTED

Music Industries Better Business Bureau Proceeds Against Those Who Advertise Talking Machines in Misleading Manner

MILWAUKEE, WIS., June 4.—The very interesting report of the Music Industries Better Business Bureau for the month of April, issued recently, includes briefs of four cases against concerns advertising and selling talking machines on a misleading basis. The action of the bureau brought about several changes for the better in the advertising of a Chicago mail order concern. Another dealer in Milwaukee likewise changed his selling methods when approached by a representative of the bureau. Still another concern in Grand Rapids is being investigated at the present time, while a Milwaukee dealer was fined \$100 and costs for making false statements in his advertising.

The Better Business Bureau asks for the cooperation of all members of the trade interested in an effort to stamp out misleading advertising and the operations of "gyp" dealers or those who sell from homes.

PUBLISHER AIDS RECORD SALES

Sam Fox Publishing Co. Issues Special Advertising Matter Featuring Various of the Company's Songs Appearing in Record Form

The Sam Fox Publishing Co., Cleveland, O., is making a special feature of elaborate folders and slips calling attention to the various numbers published by the company and recorded on Victor records by Victor artists. Special attention has been given to the recording of "The Prayer Perfect," by Alma Gluck, and of "I'm A-longin' Fo' You," by Sophie Braslau. In addition to the folders produced in elaborate form, the Fox Co. has also issued hangers and posters for window and showroom display.

AN IDEA THAT SHOULD BE USED

Piano Dealer Adopts Clever Stunt That Should Appeal to Talking Machine Men

A progressive piano dealer has introduced an idea into his store that might be copied with profit by some talking machine dealers who have demonstrating booths on an upper floor. The piano dealer in question has an electric reproducing piano in a room on the second floor in connection with a lighting fixture so that when he is ready to take a prospect upstairs he switches on the light, the piano starts to play much to the mystification and genuine pleasure of the visitor. It would be a very simple thing for a live talking machine dealer to work the same plan by connecting an electrically-operated machine either in a room in the rear of the store, or on an upper floor, with a lighting socket so that it could be controlled with the regular lighting switch and caused to start when the light was turned on.

A Really Good Album At a Moderate Price is a Money Maker for the Dealer



METAL BACK ALBUMS

will give the dealer and his patrons true value and the highest quality. A complete line of albums that stand for the best in their respective grades.

Write for samples of our three numbers

NEW YORK ALBUM & CARD CO., 23-25 Lispenard St., NEW YORK

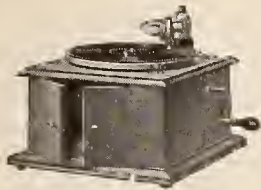

Victrola IV-A, \$22.50
Oak

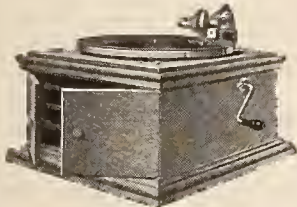

Victrola VI-A, \$32.50
Oak



Victrola VIII-A, \$50
Oak



Victrola IX-A, \$60
Mahogany or oak

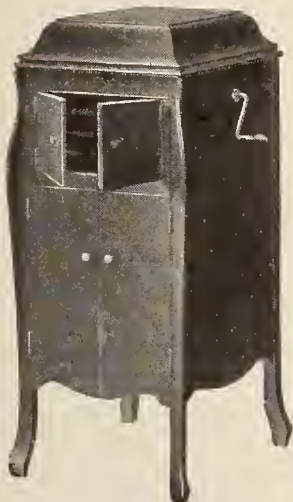

Victrola X-A, \$90
Mahogany or oak

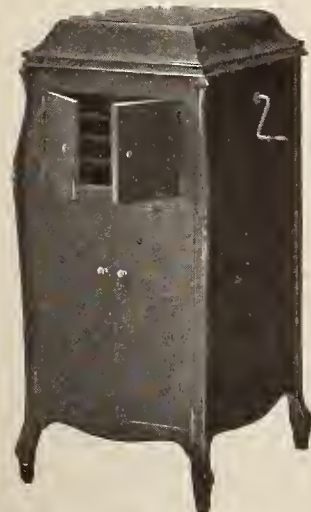

Victrola XI-A, \$115
Mahogany or oak

Victor Supremacy

Victor supremacy
is the surest index
of which way the
trade goes.

It spells success for
every Victor retailer.

Victor Talking Machine Co.

Camden, N. J., U. S. A.

Berliner Gramophone Co., Montreal, Canadian Wholesalers



Victrola XIV, \$175
Mahogany or oak



Victrola XVI, \$225
Victrola XVI, electric, \$282.50
Mahogany or oak



Victrola XVII, \$275
Victrola XVII, electric, \$332.50
Mahogany or oak

"Victrola" is the Registered Trade-mark of the Victor Talking Machine Company designating the products of this Company only.

Warning: The use of the word *Victrola* upon or in the promotion or sale of any other Talking Machine or Phonograph products is misleading and illegal

Important Notice. Victor Records and Victor Machines are scientifically co-ordinated and synchronized in the processes of manufacture, and their use, one with the other, is absolutely essential to a perfect reproduction.



"HIS MASTER'S VOICE"
REG. U.S. PAT. OFF.

The **TALKING**
For the makers & sellers of talking machines
MACHINE
WORLD

PUBLISHED BY EDWARD LYMAN BILL, Inc.

President, C. L. Bill, 373 Fourth Ave., New York; Vice-President, J. B. Spillane, 373 Fourth Ave., New York; Second Vice-President, J. Raymond Bill, 373 Fourth Ave., New York; Secretary and Treasurer, August J. Timpe, 373 Fourth Ave., New York.

J. B. SPILLANE, Editor

J. RAYMOND BILL, Associate Editor

AUGUST J. TIMPE, Business Manager

Trade Representatives: B. BRITAIN WILSON, L. M. ROBINSON, WILSON D. BUSH, C. CHACE, E. B. MUNCH, L. E. BOWERS, A. J. NICKLIN, V. D. WALSH

Boston: JOHN H. WILSON, 324 Washington Street

Chicago Office: E. P. VAN HARLINGEN, Republic Building, 209 South State Street. Telephone, Wahash 5774

London, Eng., Office: 2 Gresham Buildings, Basinghall St. W. LIONEL STURDY, Mgr. The Talking Machine World has regular correspondents located in all of the principal cities throughout America.

Published the 15th of every month at 373 Fourth Ave., New York.

SUBSCRIPTION (including postage): United States, Mexico, \$2.00 per Year; Canada, \$2.25; all other countries, \$3.75. Single copies, 25 cents.

ADVERTISEMENTS: \$4.50 per inch, single column, per insertion. On quarterly or yearly contracts a special discount is allowed. Advertising pages, \$125.00.

REMITTANCES should be made payable to Edward Lyman Bill, Inc., by check or Post Office Money Order.

NOTICE TO ADVERTISERS.—Advertising copy should reach this office by the first of each month. By following this rule clients will greatly facilitate work at the publication headquarters.

Long Distance Telephones—Numbers 5982-5983 Madison Sq.
Cable Address: "Elbill," New York.

NEW YORK, JUNE 15, 1918

THERE is much to disturb one's mental poise these days. The business man is face to face with problems of a most complex and serious nature. There are demands on his purse and on his time that are unprecedented, and it is not at all unnatural that he should be worried. And yet anxiety over business problems is the hardest thing with which a man's physical apparatus can be burdened. It corrodes, wears and wastes the body and the mind. The worrying habit is a mighty harmful one, because things that frighten us most in business rarely ever happen. And this applies just as fully to national affairs in these strenuous war days.

During the month which immediately followed the entrance of the United States into the war the calamity howlers were much in evidence with statements that business was going to smash, and that every industry would be extinct in due time, unless those devoted to the making of munitions.

We are now entering on the second year of the war, and none of these things has happened. The sensational news-monger no longer has an audience; we have oversubscribed to three liberty loans, invested millions in thrift stamps, are building a bridge of ships that will enable our men and supplies to cross the Atlantic, we have hundreds of thousands of men right at the front facing the enemy, and our factories everywhere are running at top speed to furnish needed supplies.

The money borrowed by our Government is wending its way back into the channels of trade, for the working man is getting a large share of it—a larger share than ever he got in history. His pay has been doubled and tripled, and he is enabled to make purchases of essential luxuries, such as talking machines and other musical instruments in keeping with his wish to have that which he has long desired.

The war has demonstrated that music is the great essential, the great consoler, the great up-lifter in the home of the workingman as well as in the home of the rich in these days of stress. It helps to stimulate the optimism of our people as it heartens the youths of the country to don their martial habiliments to fight for right and justice.

There is no room for the pessimist to-day, for the country was never in such a sound condition financially, and never before was there such a wonderful illustration that the heart of the nation has been stirred as never before in history. Men and money are being supplied to meet the nation's requirements

in a manner that typifies that the United States is in the war for keeps, and in the war to win.

Business, of course, will be what we make it. It would not be well to waste our energy and anticipate our strength worrying and arguing over each changing phase which the daily reports from the Western front depict. In fact it is not well to ride the bumps of the war news from day to day. Of course to follow and feel all the glees and glooms that reach us from the front is human and exciting, but it involves much useless wear and tear of the spirit. As James H. Collins recently remarked:

"It is good business, good patriotism and good conservation to forget most of the headlines in the morning paper and concentrate strictly upon the long, hard grind between to-day and the final result. That will save your spirit, buck up your resolution, and enable you to do your utmost in winning the war. Moreover, it will enable you to get out of the war, as a business man and a patriot, the utmost benefit from war adjustments. Those adjustments make for wiser and more economical personal habits, as well as a business grounded in sound economy."

DECISIONS by the Supreme Court, as well as action taken by the Federal Trade Commission, indicate that if retail prices on patented and trade-marked articles are to be maintained at a fixed standard in the future, special legislation to that end will be required. As a matter of fact, it is reported from Washington that even now plans are being made for introducing a new, or amended, Stephens bill into Congress at an early date, the bill to be drafted along lines that will meet the situation as now developed.

In addition to giving the manufacturers of trade-marked goods the right to fix the retail selling price, or the resale price on their goods, it is stated that the revised bill will provide that any method of price fixing must have the approval of the Federal Trade Commission.

Noted jurists with open minds have agreed that the manufacturer of a trade-marked article must have some protection, for he is the special victim of the price cutter. A nameless article advertised at a reduced price may, or may not, be worth anything the advertiser agrees to claim. Trade-marked goods, however, have a fixed value in the public mind, due to advertising, and the trade-marked name used in cut rate advertising naturally proves of distinct advantage to the merchant following such methods.

No less a man than Justice Brandeis of the United States Supreme Court, in a dissenting opinion in a recent price fixing case, gave it as his view that price maintenance should be brought about through legislation, and intimated that the Federal Trade Commission should be given some authority in the matter. Under such auspices there should be no fear of a manufacturer endeavoring to assert his price fixing prerogative in a manner unfair to the retailer, for not only the retailer but the ultimate consumer would have recourse to the Federal Trade Commission in such an event.

The main thing now, however, is for the talking machine trade, and particularly the retail element, to urge and support legislation looking towards price maintenance. The industry has been built on that basis. Standard prices have meant the success of every house in it, particularly the smaller dealers. Future progress will undoubtedly depend upon the fixed price element to a substantial degree. It is a cause worth fighting for.

SUMMER is with us and thousands of families throughout the country are planning for their annual sojourn in the country. The time is not too early for the dealer to decide on ways and means of getting some extra business out of the summer resorts. Every cottager and every vacationist realizes that the summer outing is incomplete without music. Whether for the parlor, or the piazza, for dancing, or other entertainment, the talking machine is always ready to co-operate, and its versatility is such that an orchestra, famous pianist, violinist, or singer, or one of the famous military bands can be provided on demand.

It matters little whether it is war time or not, the fact remains

that the talking machine is indispensable. It is truly an essential to the joy and comfort of those who need consolation, owing to the absence of loved ones, or affording joy and pleasure to those who feel that victory is in the air—that our boys will soon come marching home triumphant.

Where summer cottages are already supplied with talking machines there certainly is a big opportunity for selling records. No matter how you view it there is business to be had, but it must be gone after intelligently and persistently. These are days when it doesn't pay a business man to rest on his laurels; he must be up and doing, bringing his products continually before a new constituency.

In this respect advertising is one of the necessary concomitants to success. The form of this publicity and how it is placed must depend upon the individual dealer, but there is no getting away from the fact that advertising is an insurance against failure. It is true that some succeed without advertising, but it cannot be denied that their successes would have been much larger and more pronounced had they advertised.

THE fact that booze and instalment collections don't mix has been proven by his experience since Detroit went dry, according to Wallace Brown, a well-known talking machine dealer in that city. In other words, the workman who formerly spent several dollars investing in the regular Saturday night "edge," increasing his expenditures as the price of alcoholic refreshment has advanced, now wends his weary way homeward with a full pay envelope and the extra money therein is more than sufficient to meet the payments on a talking machine or piano. Business men in other sections of the country where Prohibition has gone into force report the development of similar conditions. Regardless of personal opinion on the question of Prohibition, from the viewpoint of the man doing an instalment business with the average wage earner, the bone-dry movement is a good thing, even though he is called upon to make good on some of the taxes formerly paid by the liquor interests.

A RECENT ruling by Internal Revenue Commissioner Roper regarding the manner in which returns must be made on instalment transactions during this year, on which an income tax will be due in 1919, is of particular interest to talking machine retailers who do an instalment business.

The Commissioner has ruled that in making out the income tax return next year, on business done during 1918, the dealer who sells on instalments must enter upon his return a percentage of each instalment collection equivalent to the percentage which the gross profit bears to the gross contract price.

To use a purely arbitrary example, the tax will work out in this fashion: A talking machine costing \$100 wholesale is sold on the instalment plan for \$150, the payments running over a

TO OUR SUBSCRIBERS

If your copy of The Talking Machine World does not reach you on publication date, or a few days thereafter, do not assume that it has gone astray. The existing railway congestion has had a serious effect on the handling of mail, particularly second class matter, and brought about unusual delays. Kindly wait a few days longer than usual before writing to us, as the paper will probably arrive safely.

period of fifteen months. The gross profit on this sale is \$50, which is 33⅓% of the gross selling price of \$150. If the talking machine dealer collects twelve payments during 1918 of \$10 each, he must enter 33⅓% of such collections, or \$40 as income, when he makes out his income tax return for 1918. Should the customer suddenly default in his payments after paying twelve instalments, and the talking machine is consequently repossessed in 1919, the dealer must enter \$80 on his return for 1919, payable in 1920, as a result of such repossession. This figure represents the entire amount of money collected on the instrument (\$120) less the \$40 entered in the 1918 report on which the tax will have already been paid.

Dealers should bear in mind that the percentage of profit for the tax returns should be figured on the gross selling price instead of on the cost. In the example quoted above the talking machine dealer really makes a gross profit of 50% (\$50 profit on \$100 cost), but the percentage to be returned on the income tax blank is only 33⅓% (\$50 on \$150 selling price).

The ruling is in no sense complex, but talking machine dealers should keep a careful account of their collections during the year, so that they will have accurate figures on which to base their returns in 1919.

WHAT is to be accepted as a matter for congratulation by the business world generally is the evident tendency at present to place in positions of authority in the various war bodies at Washington business men of recognized standing and ability. In other words, it seems as though the day of the theorist is passing away, and that the practical business man—the man who, while realizing the demands of war, has at the same time a proper conception of means for meeting those demands at a minimum sacrifice on the part of business—is taking his place. It is true that since the outbreak of the war business men have been in the service of the Government, but in a majority of the cases they have been subordinated to Government departments, and their efforts made ineffectual by the yards of peace time red tape. It looks now as though modern efficiency is taking the place of hide-bound precedent in Governmental work, and it is a good sign for the country in general. It means that we will get more action for the money we spend.

IT'S almost impossible to tell today what you will want for Victor Records next week.

There's always a few records constantly needed so why not use P. S. S.—Pearsall Short Service.

Uncle Sam feels that men buy W. S. S. to take care of the odd quarters for big bonds.

Everyone can buy W. S. S. And every dealer can use P. S. S.

So you have a combination—one to make good profits and the best way of investing them. "Shorts" is only a part of

Pearsall Service

Silas E. Pearsall Co.

Victor Distributors

18 WEST 46th STREET

NEW YORK, N. Y.



You Are Cordially Invited

TO MAKE THE
BRILLIANTONE
OFFICES YOUR
NEW YORK
HEADQUARTERS

We recommend the all quality
HALF TONE-MEDIUM-FULL TONE-EXTRA LOUD



UNIFORM POINTS - UNIFORM LENGTH - UNIFORM HARDNESS
Made in America - By Americans

WHEN YOU
BUY



YOU HELP US TO
SUBSCRIBE FOR

Liberty Loan Bonds

BECAUSE—We have
pledged ourselves to
contribute every cent
of profit we make
during the year 1918
to the purchase of
Liberty Bonds

Ask us to send you this
hanger, printed in Red,
White and Blue (size 8x12
inches). Display it in your
store. Help us to buy
Still More Liberty Bonds

**BRILLIANTONE
STEEL NEEDLE CO.**

OF AMERICA, INCORPORATED

Suite 656-657

Marbridge Building
Broadway at 34th St., New York

B. R. FORSTER, President

How to Fill the Ranks of the Sales Force, is the Merchants' War Problem :: :: :: By G. D. Crain, Jr.

(Copyright, 1918)

Help continues to be big war problem of the retail merchant.

The recent order of the Provost-General, declaring that men of draft age must "work or fight," and that employment as a salesman in a store does not come within the conception of useful employment, means that many additional men will have to give up positions in retail establishments and seek employment having a more direct application to war activities.

There are obviously two principal sources from which the merchant must draw his help to fill the places of those who are barred by the new regulations.

One of these consists of men under or over the draft age—boys of from eighteen to twenty-one, and men over thirty-one. Apparently the latter class is the more desirable, from the standpoint of experience and judgment, though in most cases higher remuneration would be necessary.

The other class is composed of girls and women. They are already being used in great number in retail sales work, but principally in department stores, specialty stores in most cases preferring men except for selling women's garments, toilet accessories, etc. But they must be trained to handle all classes of retail sales.

Male help, as a general proposition, is extremely scarce. The inroads already made by the war have limited the available supply, even making use of those included in the draft, but enjoying deferred classification as a result of dependents or for some other reason. With the latter eliminated as a result of the newest order, which will doubtless be obeyed by most draft registrants without hesitation or argument, the merchant must look around harder than ever for desirable employes.

In England and other countries where retail salesforces have been decimated as a result of the war, it is noteworthy that about the only men left on the floors of the shops are those too old to go to the front. It must be admitted that there is something incongruous in the sight of a young and sturdy man devoting his efforts to selling in a store while thousands of others are fighting and dying in the great war. That is something that cannot be explained away, for the contrast is evitably felt by the customer. Perhaps the substitution of those who obviously are not fitted for military

duties will have an excellent effect from the standpoint of showing the public that the merchants of the country are not using up manpower that could be more profitably employed, from the standpoint of winning the war.

Salespeople are necessary; there is no gain-saying that; but the immediate problem is to find those who can be utilized in the store organizations without hampering the work of

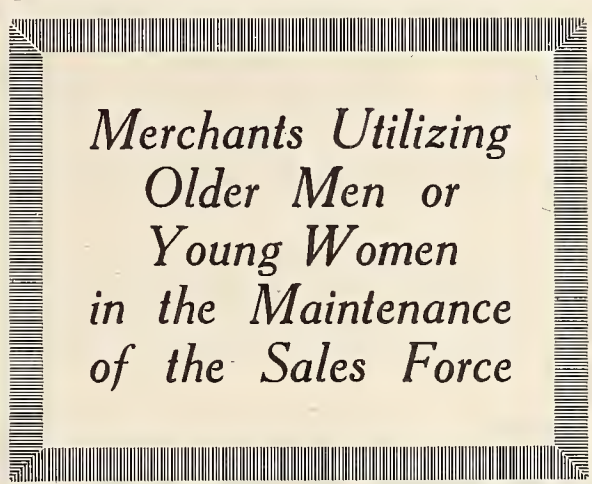

Merchants Utilizing Older Men or Young Women in the Maintenance of the Sales Force

producing war materials, and without taking those who could do more good for the country if they were in uniform.

Older men, say about forty-five, make excellent workers. There are many such who are available, and for whom the demand is less active than for any other class of men. The merchant may insist that these men are "failures," since one of this type, who has reached middle age without making a definite success and winning permanent and profitable employment, evidently lacks the quality which makes for business advancement. Yet this is not always equivalent to saying that they are not suited for work in stores. In many cases they fit into it splendidly, and not only make efficient clerks, but prove to have the knack of making friends. What they have lacked is initiative or something similar to it, but in a store the work of the salesman is usually "cut out for him," as the saying goes.

One advantage of employing older men is that they are more likely to remain on the job and be satisfied. The younger man, even though somewhat more aggressive and productive, is always looking around for a little better

place. The store which employs him is thus unconsciously competing for his services with every other in the community, and he thinks nothing of quitting one job for another. This is part of the general situation and irresponsibility of young men just starting out in the business world.

The older man, on the other hand, has been buffeted in the sea of experience. He has learned that things are not always what they seem, and that a good position is not to be tossed away lightly. Thus he is in earnest and is determined to hold on to what he has. He obeys willingly, he meets the trade courteously, and is satisfied with his situation. He is the sort of dependable, reliable salesman who can be counted on to be on time and to stay until the store closes.

Comparatively few warrooms are at present made up largely of men of this age and type, but one feels justified in saying that the most recent war development will bring many of them into positions in the shops, taking the place of younger men who are leaving for war work, either in industry or in the ranks of the fighters.

Many recruits will doubtless be obtained also from the ranks of women workers. In spite of the large number who have been impressed for industrial work, and who already have filled into positions vacated by men who have gone to war, there seems to be no trouble about getting others. College girls and other students who realize the importance of productive labor, and of releasing as many men as possible, are taking up work of all kinds, and of course many wives and other relatives of soldiers are doing what they can to support themselves by employment in and out of stores.

The main feature of employing girls and women is training. Few of them are inherently capable of taking a position in a wareroom and handling it to advantage without preliminary coaching and instruction, and the store which has a large number of "new beginners" on its floor should make a point of seeing that they are properly supervised, in order that the sales service may not suffer.

By drawing on these two big sources of supply, the labor situation and the help question in the domain of retailing will be effectively dealt with.



THE BROOKS Automatic Repeating Phonograph

Plays Any Kind of Record—Any Desired Number of Times and Then Stops Automatically—The Phonograph Sensation of the Age

DEALERS:

You cannot duplicate the value we offer for twice the price. In size and appearance the "Brooks" compares favorably with Instruments retailing for \$300.00 and up.

In tone qualities it is unexcelled by any talking machine on earth! In mechanical equipment and automatic features it is years in advance of its nearest competitor. We have been building talking machines for three years—last year our sales doubled every four months. The BROOKS DEALER has no competition. The machine creates interest and discussion—it is self-advertising. Send for particulars, terms, prices.

BROOKS MANUFACTURING COMPANY
Talking Machine Dept. - SAGINAW, MICH., U. S. A.



View of Controlling Dial

This dial sets, starts and stops the machine. Will play any desired number up to nine or continuous.

Simplest Machine to Operate

Instructions

Set the needle at the inner edge of record cutting and then move pointer to the figure designating the number of times you wish record played.

That is all. You can now forget the machine. When the record has been played as many times as set for, the machine will stop automatically with the tone arm suspended in the air above record.

HEIGHT OF CABINET 50 INCHES
FURNISHED IN OAK OR MAHOGANY
SPRING OR ELECTRIC MOTOR

YOU OWE YOUR PATRONS A BETTER PHONOGRAPH

The Widdicomb is a Better Phonograph

A Product of 1918, **THE WIDDICOMB** is the very last word
in the Art of Phonograph Construction

Art Table Type
\$125
to
\$250

*The
Widdicomb*

Upright Cases
\$110
to
\$250

A Finished Product

TONE—No phonograph on earth will reproduce any record of any
make more faithfully than **The Widdicomb** without attachments.

MOTOR—No motor on earth winds and runs with so little noise or
vibration as **The Widdicomb** motor.

Spring Breakage is unknown in The Widdicomb

CASES—All you can see in a phonograph is furniture. At the
retail prices no line on earth shows such designs—such high grade
woods—such construction or finish as **The Widdicomb**.

FEATURES—More convenient and commodious record containers
—all wood horn—jewel points—improved cover support—tone control
which can be set at any required volume or operated from a distance.

Manufactured and Guaranteed by

WIDDICOMB FURNITURE COMPANY
Grand Rapids, Michigan Since 1865

Chicago Exhibit

H. P. A. MOSSNER, Sales Agent

532 Republic Bldg.

Distributors

WIDDICOMB SALES CO., 327 South La Salle St.
H. DINWOODY FURNITURE CO.
Salt Lake City, Utah

SHAW SUPPLY CO., Tacoma, Wash.
SANBORN KINNEY COMPANY
Sioux City, Iowa

MEYER BROS. DRUG CO., St. Louis

Every family in your town is a live prospect for a Vacation Grafonola. Are you ready to go after this business? Let Columbia Dealer Service Department help you.

**Columbia Graphophone Co.
NEW YORK**



VALUE OF CO-OPERATIVE PUBLICITY

How the Yahr & Lange Drug Co. Advertised the Eight Dealers Handling the Sonora Line and Themselves in Milwaukee Recently

MILWAUKEE, Wis., June 3.—The Yahr & Lange Drug Co., of this city, distributors in this territory for the products of the Sonora Phonograph Sales Co., recently used in the local newspapers a striking half-page advertisement which won considerable comment in the local trade. This advertisement was the first one in a series of co-operative advertisements, and it served to definitely establish in the minds of the local trade the prestige and importance of the Sonora line.

The center of the space was used by the Yahr & Lange Drug Co., which presented a splendid selling talk relative to the tone qualities of the Sonora phonograph. Surrounding this advertisement were the cards of eight Sonora dealers in this territory, each card presenting a distinctive message, and calling attention to some special merit of the Sonora phonograph. Among the dealers represented in this co-operative advertising were Wm. Klug & Sons, Thien-Pentler Sonora Shop, Alf. W. Fuchs, J. B. Bradford Piano Co., Theo. Mueller, Noll Piano Co., Edward Jensen and the Model Drug Co.

EMERSON CO.'S ANNUAL REPORT

President Emerson Tells of Company's Progress for Year—Substantial Profit Reports

The Emerson Phonograph Co., New York, has just issued its annual report for the year ending April 30, 1918. Considering general manufacturing conditions for the past year, this report is very satisfactory, as it shows a substantial net profit.

In submitting the report to the stockholders, Victor H. Emerson, president of the company, called attention to some of the important factors that entered in the company's manufacturing activities the past year. He commented upon the fact that the retail price of the 7-inch record was advanced from 25 cents to 35 cents, insuring a more satisfactory profit to the company, its jobbers and its dealers. He also stated that the new 65-cent record was meeting with pleasing success, and that plans are now being made for an aggressive campaign during the remainder of the year. Referring to the outlook for 1918, Mr. Emerson said: "The outlook for the coming year is difficult to forecast, as it depends very largely upon the duration of the war, the price of raw material, as well as fuel, labor and transportation conditions."

The Helbig Bros. Piano Co., Washington, D. C., has been incorporated with capital stock of \$40,000 to manufacture and deal in pianos, organs, talking machines and records. The incorporators are Fred W. Helbig, Jr., Harold H. Helbig and Nettie M. Helbig.

TALKING MACHINE EXPORTS

The Figures for March Presented—Exports Show Machines and Records Both Increase

WASHINGTON, D. C., June 4.—In the summary of exports and imports of the commerce of the United States for the month of March, 1918 (the latest period for which it has been compiled), just issued, the following figures appear:

Talking machines to the number of 9,234, valued at \$239,049, were exported in March, 1918, as compared with 7,417 talking machines, valued at \$187,833, sent abroad in the same period of 1917. The total exports of records and supplies for March, 1918, were valued at \$199,903, as compared with \$163,632 in March, 1917. For the nine months' total 69,945 talking machines were exported, valued at \$1,914,730 in March, 1918, and \$1,390,227 in 1917, while records and supplies valued at \$1,475,417 were sent abroad during 1918, as against \$1,130,095 in 1917.

There isn't much hope for the man who gets so peeved that he isn't on speaking terms with his own conscience.

CONCERTS FOR FACTORY WORKERS

Phonograph Co. of Cleveland Adopts Interesting Method for Reaching the Employees of Various Industrial Plants in That City

CLEVELAND, O., June 2.—The Phonograph Co., Edison phonograph wholesaler and dealer in this city, has been conducting a series of factory concerts for the purpose of stimulating business. The concerts are given at the various factories during the noon hour, the first being held at the plant of the Ohio Varnish Co. In almost every case immediate sales of machines and records to employees were noted.

L. N. Bloom, general manager of the Phonograph Co., felt that although the workmen in the various plants, especially those with war contracts, were making more money than they ever made before in their lives, they were kept so busy that they did not have time to investigate the full possibilities of the phonograph as a factor in their homes, and took the opportunity to bring the machines and records to them to simplify the matter of selection. It was also proved that their judgment was right.

Ready-File Company
INDIANAPOLIS

Mr. Edison Dealer,
Anywhere, U. S. A.

Dear Mr. Dealer:-

Lots of Edison dealers are making \$6.00 more on every A100 and C150 sale than you are.

We want to tell you how to do it, but we don't know your name or address.

Drop us a card and find out how to get these extra profits.

Cordially yours,
READY FILE COMPANY.

Our *Forecast* for this Summer



Lucien Muratore
Exclusive Pathé Artist

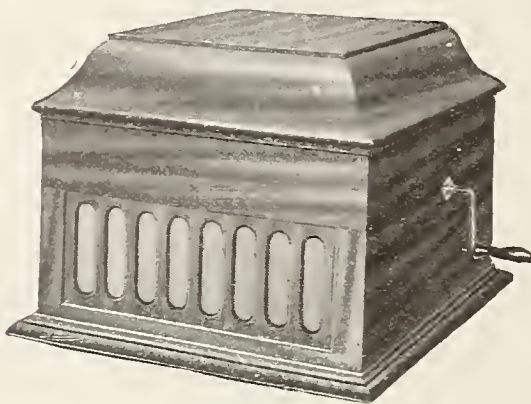

Pathé Phonograph \$30
Other Models to \$225

ECONOMY is now essential as it never was before. But so, too, is amusement.

The Pathé Dealer is able to supply the amusement that is most economical and can be easily carried to Summer home, hotel, bungalow or camp.

These portable Pathe Phonographs

By far the finest both in appearance and performance at the price.

Hence the Pathé Dealer can safely count on a most profitable summer.

That's our forecast.

This is our advice—if you're not a Pathé Dealer, write us at once about the Pathé Proposition.

No Needles to Change

The Pathé Sapphire Ball takes the place of needles. It need not be changed.

Long Life to Records

The Pathé Sapphire Ball cannot possibly cut, grind, rip or mar the record's surface.

The Pathé Controla

With the Pathé Controla you may increase or decrease the tonal volume of the Pathé Phonograph at will.

Plays all Records

Each Pathé Phonograph plays not only Pathé Records, but all other makes of records, and plays them perfectly.

Williams - Davis - Brooks & Hinchman Sons
26 E. Congress Street - - - Detroit, Mich.

Pathé

The Quality Phonograph

Supplying Successfully the Needs of the Buyers of Foreign Records :: :: :: :: By Harry A. Goldsmith

Harry A. Goldsmith, of the Badger Talking Machine Co., Milwaukee, Wis., Victor wholesalers, recently contributed the following interesting article on: "The Buyer of Foreign Records," through the "Voice of the Victor." The article, which is worthy the consideration of every talking machine dealer, reads as follows:

Groping about in darkness seeking musical light the buyer of foreign records offers the average Victor dealer a source of income of considerable proportions. Nor should his business be sought after only for this reason, for the buyer of foreign records knows a goodly number of folks who are very anxious to own talking machines, and he can give you a wealth of prospects who are likely to be very profitable for many years to come.

When you, as a Victor dealer, were asked to interest yourself in educational work—to open an educational department—you looked askance at the proposition. You did not grasp, possibly, just what latent opportunities there were. It is needless to remind you of the tremendous success that has attended this particular feature of the Victor business.

To the live Victor dealer is offered like opportunities in starting a foreign record department. Many dealers, no doubt, have felt they would like to get some of the foreign business, but have been a bit hesitant, fearing the complexities which might arise.

A careful analysis of the subject clarified conditions materially. It is not so hard as it seems. You ask how to proceed? It is really easy if you will but take a little time to work out the details.

Tony Andrianopolis shyly enters your store, hat in hand, and asks if you have some Greek records. Of course you have none, and in the past simply told him so and turned away from him. He slinked out of your store. You soon forgot the incident. Now, had you invited Tony into your office, inquired from him about how many Greeks, for instance, lived in your city, and put it up to him squarely if he thought it would be profitable for you to carry Greek records, you might sit up surprised that you had wasted some wonderful opportunities.

Tony would likely have told you that there were probably a hundred or more Greeks in town, a score or more of whom owned talking machines, and they have been buying records

in large quantities from some dealer in Milwaukee, Chicago or New York. He would add that because of the difficulty in getting records there were at least a dozen or more of his friends who had not bought machines.

You feel satisfied, now, that there is some fine business to be had among the Greeks, but don't know how to stock up with Greek records. Go a bit further. You have discovered that Tony

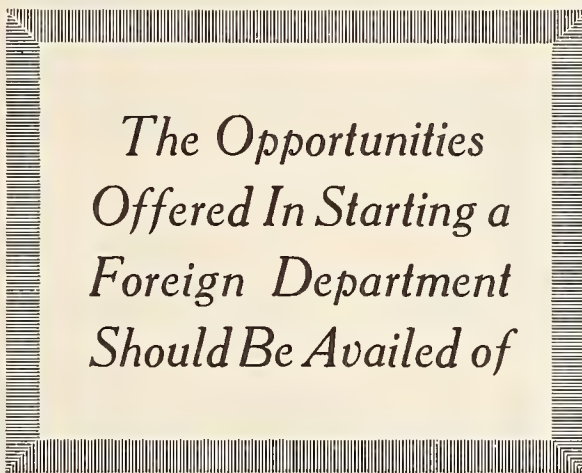

The Opportunities Offered In Starting a Foreign Department Should Be Availed of

gave you some mighty good advice. Don't let him get away. Just hand him a Greek catalog and ask him to mark in this what records he thinks you ought to carry for a starter. Tony is going to be a little shy here. The moral obligation of stocking you up with merchandise is great, and before he gets through with that catalog he will have made a mental note of every Greek talking machine owner and just about what records each will buy.

Have faith in Tony. Order every single record he tells you to and go him one better. When sending in your order to your jobber tell him to include in this order such Greek records as might have been omitted which he knows are good sellers, and every wholesaler can give you this information at a moment's notice. When you get these Greek records in stock let Tony know. Tony will do the rest.

He will come into your store with one or two friends and ask for Greek records. Now don't make the mistake of just taking a pile of them and passing these out to him. Treat him as you would one of your regular customers. Better still, wait upon the group yourself. Watch the face of each listener light up as they

hear some good old folk song. Maybe, after a half hour's visit they will buy only two records, but you can gamble anything you want that within another day the news will have spread throughout the entire Greek community that you have some Greek records. You can make another mental wager, and win, that several Greeks will buy machines from you within a week after you have put in your stock of Greek records.

What is true of the Greeks of your city is equally true of other nationalities. With only slight modifications you can proceed in a like manner with each and every nationality represented in your community.

Just bear in mind one important factor, and that is, every foreigner is just as hungry for music as are your present regular patrons. The B. of F. R. will prove a more loyal and consistent customer of yours than you ever before had. He will be your booster through thick and thin, and more patient.

There are certain characteristics quite common to each group of B. of F. R. To illustrate, Italians respond quite the quickest to purchases of records from the general catalog, and early buy Red Seal records. The Poles will start out demanding loud records, progressing later to a better class of selections. The Greek, with a love of his old traditions, is a bit harder to get interested in the general list. Because they are neighbors, do not think the Swedish and Norwegian folks will buy the same records. If a Turkish customer happens in and you have nothing to offer him in his language he will be interested in instrumental records listed in the Assyrian and Greek catalogs, and vice versa.

The B. of F. R. will be greatly interested in accordion records if his home was in any European country. The same is true of harmonica records. Band numbers are extremely popular among your foreign friends. The old-fashioned waltzes, polkas and schottische are always desired. It is needless to say that folk songs find a ready sale. Modern English songs rarely find favor when sung in a foreign tongue.

One might continue indefinitely pointing the way to develop foreign record sales, but, after all, the few suggestions given above and a willingness on the part of the Victor dealer to go half way with the B. of F. R. should quickly result in profitable business development.

THE BOSTON BOOK COMPANY ANNOUNCE THEIR NEW LIBERTY RECORD ALBUM



15,000 SOLD THE FIRST DAY

The most timely and appropriate addition to the album field in years.

Beautifully designed, bound in khaki and stamped in gold with a most artistic and patriotic center piece.

Manufactured and patented by the only exclusive record album factory in the world, who for the past ten years have supplied the talking machine trade with quality albums.

BOSTON BOOK COMPANY, 43-51 W. Fourth St., New York, N. Y.

CHICAGO OFFICE: 1470 So. Michigan Avenue

Columbia

Make This Advertisement Sell
Your Vacation Grafonolas

Columbia

Vacation Model
Grafonolas



Made for Out-of-Door Music

For those jolly, informal parties, by seashore, lake, or river, the most popular entertainer is always the Columbia Vacation Grafonola. This friendly, companionable Grafonola is a good sort and a good sport. Take him along with you on your holiday trip this year.

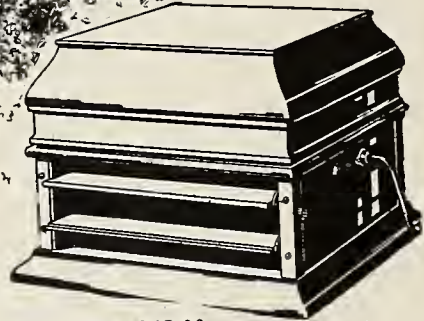

Price \$45.00

Traveling light, strong, and compact, with a voice that is sturdy, sweet, and clear, the Vacation Grafonola will sit up all night to give you music for dancing—and then be ready and cheerful for a bathing or sailing party bright and early in the morning.

Wherever you go in the joyous vacation lands, by seashore, lake, or river, the Grafonola will give you music.

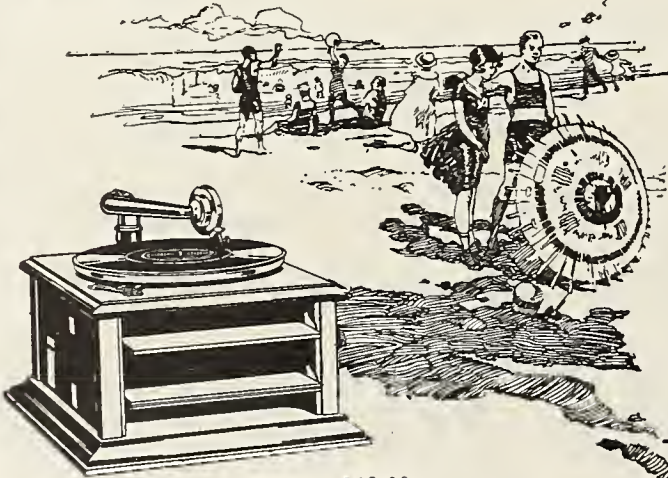

Price \$18.00

We will gladly show you these Vacation Model Grafonolas. They range in price from \$18 to \$55. And for \$7.50 you can buy twenty selections on standard Columbia Records that will give a good variety of vacation music—popular hits, war songs, dance music—anything you like from the great Columbia musical library.

To make a good record great, play it on the Columbia Grafonola

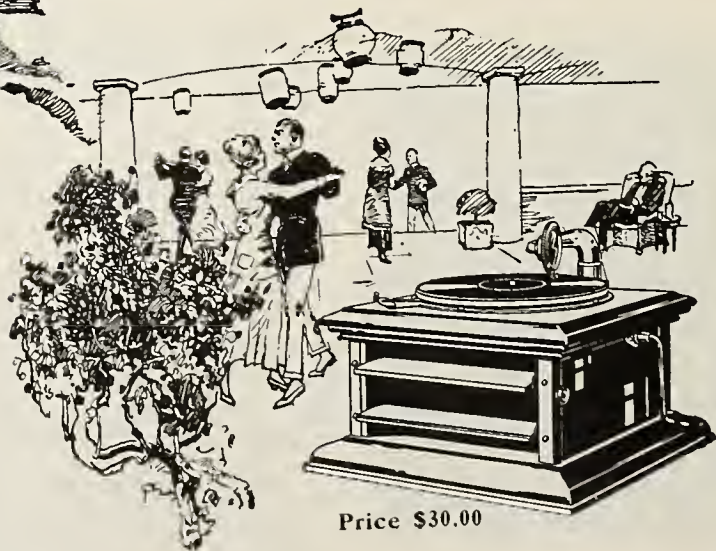

Price \$30.00

Dealer's Name and Address

Grafonola

Here is the Kind of Service Columbia gives to Dealers

The advertisement on the opposite page—9 inches deep by 3 columns wide, and plated on zinc that will print clearly and sharply in the newspapers—is an exact reproduction of the full-page advertisement which Columbia is inserting in the *Saturday Evening Post* and many other national magazines in the vacation season.

The Columbia Dealer can secure this advertisement now from his Distributor.

When the big national magazine advertisements begin to appear, creating a demand in thousands of homes for vacation Grafonolas, he will insert this advertisement in his local newspapers, thus diverting this demand into his store.

And this is only a *part* of Columbia's Service to the retailer. There are window displays, hangers, cards, letters and all manner of sales helps ready to move your vacation Grafonolas.

Write the Columbia Service Department for full particulars.

How About Military Trunk Grafonola Outfits?

They sell on sight—not only to folks who have soldiers in camp, but to vacationists, automobilists, week-end parties, summer cottagers. You can make up very attractive propositions on this model—let us send you details of construction, prices, selling helps.

Columbia Graphophone Co., New York

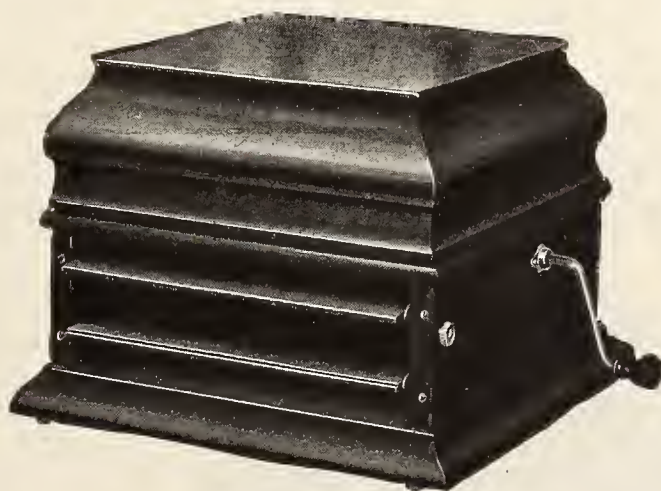

There's Profit in Columbia Foreign Language Records

Here is a department that requires a small investment—yet gives a quick turnover of stock at a good profit. Write for details.

International Record Department
COLUMBIA GRAPHOPHONE CO.
102 West 38th Street New York



CREATING INTEREST IN THE STORE

How the Mason Furniture Co., of Huntsville, Brought Crowds to Their House and Orders for Their Products—Enterprise That Pays

HUNTSVILLE, ALA., June 2.—One of the most progressive of the Columbia dealers in this section of the country is the Mason Furniture Co., of this city, who handles the Columbia line exclusively. The Mason Co. owes much of its success to its unique methods of publicity which attract unusual attention and get excellent results. In connection with the company's annual spring opening held recently, one of the evenings was devoted to the appearance of Mason's Columbia Minstrels. The event was widely advertised, and at the opening hour the store was thronged with people, many standing



Mason Furniture Co.'s Recital Hall

on the street, being unable to get into the store. The balcony at the back of the store had been arranged for the stage, the railing on either side of the stairway had been removed, and curtain, wings, and drop all arranged in place, footlights from an extension cord, all lending to the atmosphere of a real theatre:

The program opened with "America," sung by Louis Graveure, followed by a Columbia minstrel record, a trombone solo, violin solo, quartet numbers, etc. The secret was a Grafonola concealed behind the scenes, but the acting was done by seven of Mr. Mason's employes dressed up as black-face comedians, acting out the records, even to the lip movement. The result was such that some of the audience were extremely hard to convince that a Grafonola entered into the evening's entertainment at all. The audience was very generous with applause, calling several members back again and again, and Mr. Mason found it necessary to give a second performance of his "Famous" minstrel two nights later. The first performance had been

so popular and so much talked about that people came from quite a distance to see it, one party motoring sixteen miles in order to witness the second showing.

Throughout the entire week the store was thronged with the people. The interior had been tastefully decorated for the occasion, and music was furnished by the Grafonola. The Mason Columbia Minstrel has proved so popular that Mr. Mason has received numerous requests to stage this performance in several nearby towns, which he will do, under the auspices of the local schools, charging a small admission, the proceeds of which will go to the school in providing a school Grafonola outfit.

The accompanying photograph gives an idea of the store, and the Grafonola department with its goodly array of soundproof rooms will be seen on the right side.

Mr. Mason carries the complete Columbia record catalog, and does an exceedingly large business, in both Grafonolas and records. This enterprising firm recently received one shipment of over sixty Grafonolas and has met with considerable success in the sale of the higher-priced instruments.

In closing let us state that Huntsville is given a population of 8,000 people, and there is nothing unusual in the surrounding territory to make it more prosperous than other counties.

Unique advertising, an attractive store, courteous and efficient clerks, and last but not least tie ups, and taking advantage of the many helps offered by the Columbia Co., are responsible for their success.

FAIR METHODS IN BUSINESS

Business is more or less selfish. The average man aims to get the most that is possible for his labor without much thought of the other fellow. It is in the line of human nature. But there is a clear line of demarcation between selfishness and reason. Reason demands that selfish interests be at least directed in a manner that will not arouse injurious antagonism. The merchant who employs unfair methods to obtain trade through his unchecked selfishness ignores good reason by inviting dangerous antagonism. Treating competition fairly, treating the public right, is in reality the best method for promoting selfish business interests.

The Linton Co., Philadelphia, Pa., has been incorporated with capital stock of \$25,000 to manufacture musical instruments. The incorporators are William Friehofer and others.

SONORA CO.'S GIFT TO RED CROSS

Contribution of \$1,000 Made to Second War Fund on First Day of Drive Appreciated by Officials of the American Red Cross

As announced in last month's World, May 22 was generally observed by local talking machine dealers as the day on which they donated 10 per cent. of their sales to the Second War Fund of the American Red Cross. Quite a number of the local dealers joined in this plan, but the Sonora Phonograph Sales Co., when advised of this method of donation to the War Fund, decided that instead of contributing 10 per cent. of its retail sales on May 22, it would do its share for the War Fund through its usual channels.

George E. Brightson, president of the company, who has for many years been active in behalf of a number of philanthropic and charitable interests, received recently a letter from Wm. E. Breed, chairman of the American Red Cross War Fund committee of New York, acknowledging the contribution of the Sonora Phonograph Sales Co. This letter reads as follows:

"I cannot let this opportunity go by without officially and personally acknowledging the splendid contribution of \$1,000 made by your corporation to the Second Red Cross War Fund. I trust that you will express to your board of directors the grateful appreciation of the War Fund committee for your generous gift, which is a material help in continuing the work of the Red Cross. Sincerely yours (Signed) Wm. C. Breed, chairman."

Mr. Brightson also received recently a letter of acknowledgment from Vice-President Jones, of the National Park Bank, captain of the bank's Red Cross War Fund team. Mr. Jones acknowledged a contribution of \$1,000 from the Sonora Phonograph Sales Co., expressing his appreciation of the company's liberal donation, which incidentally was given to the bank the first day of the drive.

NEW VICTOR PATRIOTIC RECORD

The Victor Talking Machine Co. have made a special announcement of a new patriotic ten-inch double-faced, Black Label, Victor record, "What Are You Going to Do to Help the Boys?" Chas. Hart and Shannon Four, and "Keep Your Head Down, Fritzie Boy," American Quartet. This record was put out in advance as a special, and will be listed in the regular July supplement.

The Victor Co. further state that there is positively no end to the demand for patriotic music. "What Are You Going to Do to Help the Boys?" was one of the big hits of the Third Liberty Loan drive and is enormously popular.

FOR NATIONAL TRADE-MARK

WASHINGTON, D. C., June 4.—Senator Pomerene, of Ohio, has introduced a bill "to authorize the adoption, registration and protection of a national trade-mark to distinguish merchandise manufactured or produced in the United States of America and used in commerce with foreign nations, or among the several States, or with Indian tribes, and to authorize the Secretary of Commerce to license the use of same, and for other purposes." The bill has been referred to the Senate Committee on Patents. A somewhat similar bill was introduced in the House of Representatives early at the present session of Congress, but up to the present time the committee to which it was referred has not reported it out.

J. B. SILVER IN NEW STORE

J. B. Silver, proprietor of the Progressive Piano Co., formerly located at 3036 Kensington avenue, Philadelphia, is moving to larger quarters at 3051 Kensington avenue, where he will handle the Pease and DeRivas & Harris pianos and players, as well as the Pathé Pathéphone.

Ward's Khaki Moving Covers



Grade "D" Cover with No. 3 Straps.

PROTECT YOUR MACHINES FROM ALL KINDS OF WEATHER

and will enable you to deliver them free from dust, scratches, bruises and all other finish destroyers

Our covers are faced with Standard Khaki, lined with a heavy grade flannel, interlined with an exceptionally good grade of heavy cotton or felt, diagonally and closely quilted, and manufactured according to the usual superior "WARD New London" quality.

Grade "D", medium size, \$5.50
Grade "D", large size, \$6.00
Grade "K", medium size, \$8.00
Grade "K", large size, \$8.50

Carrying Straps: No. 1 \$1.00; No. 2 \$2.00; No. 3 \$3.50

ORDER SAMPLE COVER ON APPROVAL

With Name of Machine silk embroidered on any Cover; extra, 30c.
With Dealer's Name and Address, first Cover; extra, \$1.15
Same on additional Covers, each extra, 60c.

Write for booklet

THE C. E. WARD CO.

(Well-known Lodge Regalia House)

101 William St., New London, Ohio

Also Manufacturers of Rubberized Covers and Dust Covers for the Wareroom



DEALERS



Have **you** written us
asking about the

OKEH RECORDS

If not, send us your name and address and we will put you on our monthly mailing list. Get familiar with the latest product backed by the House of

Otto Heineman Phonograph Supply Co., Inc.

25 West 45th Street
New York City

Heineman
Meisselbach

Motors
Tone Arms
Sound Boxes

Dean
Steel Needles
Quality
Counts

Sign this and mail it to us today

Otto Heineman Phonograph Supply Co., Inc.
25 West 45th Street
New York City

Gentlemen:
Place us on your monthly mailing list

Name _____
Street _____
City _____
State _____

NEW INDIANAPOLIS COLUMBIA CO. WHOLESALE QUARTERS

Located at 209-217 West Washington Street—Increased Business Makes Move Necessary—Geo. Stewart Appointed Fuel Administrator—Cheney Line With Pearson Co.—Interesting News Budget

INDIANAPOLIS, IND., May 31.—The wholesale department of the local branch of the Columbia Co. is moving into large quarters on the second floor of the Kirschbaum Building, 209-217 West Washington street. The retail store in North Pennsylvania street will be conducted as usual, but Ben Brown, manager, will have his office in the wholesale department.

Increased business made it necessary for the Columbia Co. to find suitable quarters for its wholesale department. Up to the present time the company has been handling its machines through a warehouse, but now it will have room enough in its new quarters to handle all incoming and outgoing shipments. Part of the first floor of the building will be used for the shipping department. Mr. Brown is determined to make his new department one of the best distribution places in the Columbia service.

George L. Schuetz, representative of the Columbia Co. in Indiana, says that the country business is keeping ahead of the city business.

H. P. Dahlen, owner of the Talking Machine Shop of Terre Haute, Ind., has sold out to the Robertson Music Co. of that city. The latter company will handle a complete line of Columbia machines and records.

C. P. Herdman, manager of the Columbia department of the Baldwin Piano Co. store, reports that business during May was good and the demand for small machines for summer purposes has been brisk.

At the last monthly meeting of the Columbia dealers, L. B. Sayer, Kentucky representative of the Columbia Co., and George L. Schuetz, Indiana representative, told of their recent visit to the Columbia factory and explained the features of record making. The monthly meetings of the Columbia dealers have been well attended and the dealers appreciate the opportunity they get to come together.

Walter E. Kipp, president of the Kipp Phonograph Co., has gone to the Edison factory and Jewell Cartmill, secretary of the company, joined him in New York, where he attended the Edison dealers' convention.

At the Edison Shop, A. H. Snyder, manager, says that the Edison business is holding up well with last year. Mr. Snyder has rearranged his recital hall for the summer, calling it the rose room and inviting women to use it as a rest room during the summer while downtown shopping.

The Pearson Piano Co. is now selling the Cheney phonograph and has been conducting an advertising campaign on it. H. E. Whitman, manager of the talking machine department, is enthusiastic over the Cheney and says he hopes to see it meet with satisfaction of the public, as he believes his store is offering something that is right.

Business in the Edison and Victor lines continues substantial, Mr. Whitman says. The new velvet Edison records are meeting with approval and Mr. Whitman expects to see them increase the sale of Edison machines.

F. A. Aylesworth, formerly manager of the talking machine department of the Julius Bauer store in Chicago, is now manager of the Vocalion department of the local Aeolian, succeeding Morris Rosner, who is in the army.

The Ultona is still the feature of the Brunswick business, George F. Standke, manager of the Brunswick shop, reports. Mr. Standke says that many owners of other machines come into the shop and ask to buy the Ultona, thinking it is an attachment which can be bought separately from the Brunswick. Mr. Standke continues to arrange clever electric window display featuring the Ultona from the standpoint that it plays all records.

There is one new feature of the Brunswick

Shop worthy of comment. It is a canary bird. This bird is a little singer than accompanies the playing of records so that many people who come into the store are under the impression the bird notes are in the record. The bird likes the Jazz band records and he sways his body to and fro while he warbles an accompaniment. Mr. Standke has had many offers to sell the bird, but there is nothing doing.

George Stewart, vice-president and wholesale manager for the Stewart Talking Machine Co., jobbers of the Victor line, has been named assistant fuel administrator for Marion county. Mr. Stewart served in this capacity for a time last winter.

Emerson Knight, advertising manager of the Stewart Co., is now in the U. S. marine corps at Paris Island.

General Sales Manager Collins of the Pathé Co. visited the Mooney-Mueller-Ward Co., Pathé distributors, recently. R. B. Goldsbury, in charge of the local company's Pathé department, says that the new process records of the Pathé Co. are meeting with approval and with the new tone arm are boosting the sale of Pathé machines.

W. E. Pearce, of the Brunswick talking machine department of the local branch of the Brunswick-Balke-Collender Co., says that the Brunswick business continues nicely. Mr. Pearce is after contracts in some of the larger cities of the State which he expects to close soon.

E. L. Ruffing, of the Ruffing music store, Delphi, Ind., which recently began handling the Brunswick, visited Mr. Pearce this week to place an additional order for machines.

COMPETITION IS AN INCENTIVE

In the fight for business no man or concern has a monopoly of all the best brains and methods. Let competition be an incentive to your energy and ambition. Give the other fellow a fair, square deal and beat him out on your merits.

Get the Benefit

of the big business doing right now on both talking machines and records by handling

SALTER Felt Lined Cabinets

These two styles are not only remarkable outfit sellers but are equally attractive to people who have cabinet machines but need more record storage capacity.

SEND FOR CATALOGS

Showing many other attractive styles.

We also make a beautiful line of sheet music and music roll cabinets.

SALTER MFG. CO.

337-49 N. Oakley Boulevard
CHICAGO, ILL.

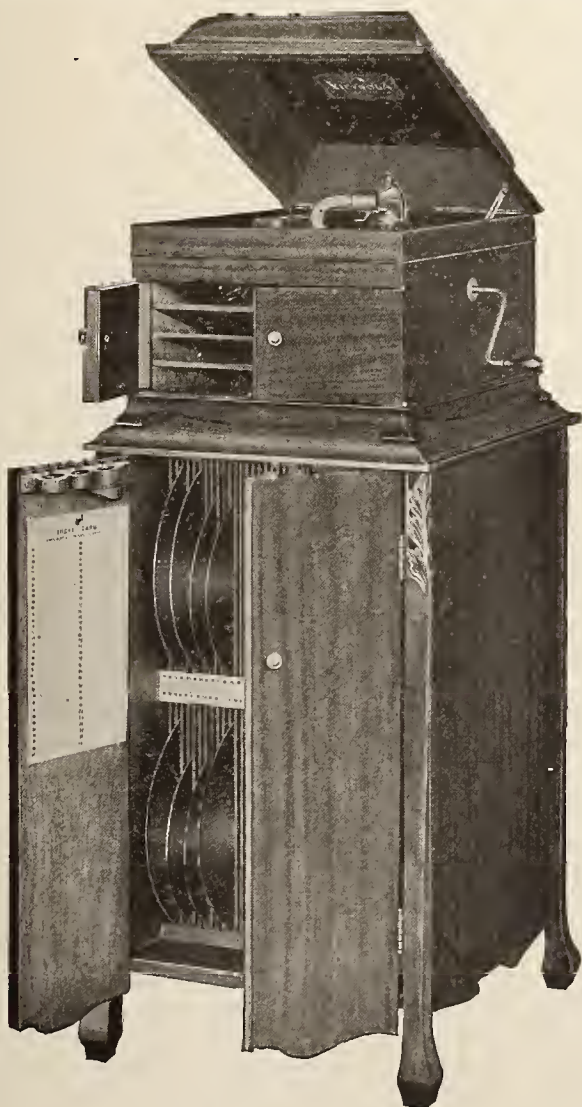

No. 19. Cabinet
(DOUBLE DOOR FRONT)
Made especially to hold the Victor-Victrola, No. IXA



No. 111. Cabinet (Opened)
For Columbia \$50.00 Machine
33 1/2 inches high. Top, 23 x 19 1/2 inches

THE TRADE IN PHILADELPHIA AND LOCALITY

PHILADELPHIA, Pa., June 8.—The talking machine situation in Philadelphia at the beginning of June is practically the same as at the beginning of May. May was a very satisfactory month so far as the amount of business is concerned, and where this business was not satisfied was due entirely to the fact that the Victor dealers were compelled to turn much of it away for want of merchandise.

The condition in May was about the same as April in this respect. The percentage of shortage was about the same in the amount of goods received, and the month showed a loss over the May of a year ago—though not to any very great extent—due entirely to conditions stated.

With the Edison, with the Columbia, with the Pathé, and all other machines, this shortage was not an existing feature, and in consequence all of the companies named supplied their representatives here with the goods that were immediately needed. The transportation conditions by these companies have been overcome during the month and by means of the auto-truck transportation system now so adequately conducted between Philadelphia and New York and intermediate points goods have been rushed through by this means and with great promptness.

Big Columbia Business for May

Manager A. J. Heath, the local Columbia representative, reports that the business of the Columbia has been exceptionally good in May. During the past few months they have given a great deal of attention to the ordering and building up of their stock in Philadelphia, and they are, therefore, fortunate enough, at the present time, to give their dealers exceptionally good service on records from this on, and with the same degree of completeness as they did in May.

Mr. Heath says that records are coming through in exceptionally good shape, but they have experienced some difficulties in getting machines through due to existing embargoes. They brought over a number of shipments by express during the month, which helped them to keep their dealers supplied with merchandise. Mr. Heath notes that business has been generally very good with the Columbia dealers throughout his territory. Among his recent visitors were F. W. Zerker, of the Regal Umbrella Co., York, Pa., and H. Israel, of the Harold-French

TALKING MACHINE DEALERS

can greatly increase their profits without additional overhead expense, by selling the world-famous

Weymann "KEYSTONE STATE" Musical Instruments

a combination that has proved to be an instantaneous success.

Write for catalogue

H. A. WEYMANN & SON

Manufacturers

**Victor
Wholesalers**

**1108 Chestnut St.
Philadelphia, Pa.**

Established 1864

Co., Reading, Pa. F. K. Pennington, the assistant general sales manager of New York, spent several days in Philadelphia during the month.

M. J. Rogers, one of the Columbia boys, was called to the colors in May. He was in charge of their shipping and stock departments, and was well known to all the dealers in Philadelphia.

Blake Doing Well With the Edison

Herbert Blake, the leading Philadelphia dealer in the Edison, reports that things were fine with them in May, and that he had a "dandy" month. He doubled the business of May a year ago, in spite of the fact that at that time they conducted a piano department, since discontinued.

He says they have been having some difficulty in getting a complete supply of both machines and records from the factory, and to put it in his words: "We are selling like the devil, and nothing coming in in comparison." He says that he was over to the factory last week, and that he found them optimistic, but he added "we cannot sell optimism."

They received, however, quite a shipment of both machines and records last Friday, which will help them out materially.

News From Buehn Headquarters

Louis Buehn, of the Louis Buehn Co., reports business somewhat below that of last year, and added that Victor goods are coming over to about the same extent as during April. Miss A. M. Kiefer, who had been the bookkeeper at the Buehn establishment for the past eight years, was married on May 22. The employes of the store presented her with a complete Victor outfit, machine, records, etc., and the firm presented her with a very substantial check. Robert Carpenter, for a number of years connected with the Buehn house, was called to the colors on the 11th of May.

M. M. Hart, of Chester, Pa., has just completed extensive improvements to the talking machine section of his business, and has added several new booths.

Louis Buehn and his family motored to Ocean City on Decoration Day, and Mr. Buehn did not return to this city until Monday. He will shortly open his cottage there for the summer.

Brunswick Activity

The Brunswick-Balke-Collender Co. report that their May business far exceeded their expectations, and went away ahead of anything for which they had hoped.

Last week the Brunswick-Balke people gave a big recital at Atlantic City, which resulted in the sale of a number of high-priced Brunswick machines. The recital was in charge of a representative from the factory. The Ultona attachment has been creating a tremendous sensation in this city. The firm is about to open some big accounts here, and they have a number of dealers up the State who recently signed up, including an especially gratifying account at Bethlehem.

LL Victor Jobbers are now, and have been for some time past, operating on a war-time basis. The Penn organization has been quick to adapt itself to the changed state of affairs and is extending to Victor dealers the utmost in service that is possible under war conditions.

Penn Phonograph Co.
17 S. NINTH STREET PHILADELPHIA

Make June an Educational Month

FEATURE the value of more knowledge and the advantage of using the Summer for improved mental equipment. You can sell "Education," for example, in The Oscar Saenger Course of Vocal Training, the Victor French Course, the Victor Wireless Course, not to forget the benefit of knowing more about the records of good Music.

Buehn Victor Service will co-operate with you to make this month a *good* one.

The Louis Buehn Company Victor Distributors PHILADELPHIA

Pathé Shop Exceeding Quota

The Pathé Shop notes that the sales force not only exceeded the quota that Mr. Eckhardt had set for May, but recorded the best month's sales that they have had since they went into the handling of the Pathé here. They also exceeded their best previous month in the retail end of their business. Strange as it may seem, the minimum they inaugurated in April carried their retail business for May over with flying colors regardless of the war saving stamps and the war chest campaigns.

Mr. Eckhardt closed several very satisfactory wholesale accounts in May, including the Bowby Co., of Shickshinny, Pa., and Fread & Beam, of Lansdale, Pa. Mr. Eckhardt's representative said: "While we can naturally anticipate a falling off in our June business, nevertheless the fact that the majority of our dealers are anticipating fall requirements, they are beginning to place their orders now for large fall stocks, and this will enable us to roll up a splendid business in the month of June."

The Pathé Shop gave an elaborate series of recitals from the 6th to the 11th of June inclusive, on the Orchestra Pathé, which created a great deal of talk, so much so, in fact, that they have been requested to grant the loan of this machine by one of the largest moving picture houses in this city.

Penn Phonograph Co. Prepared to Move

The Penn Phonograph Co. expect to move to their new home at 913 Arch street some time during the month. Mr. Barnhill says they will have "a spasmodic flitting." Just at the present time they are removing the material from their warehouse, and when the new building is equipped to receive their regular stock they will move it into place as rapidly as possible. The entire establishment will be quartered in the new home by July 1. They will have about 8,000 more square feet of space in their new building, and it will be otherwise better adapted to their business.

Business with the Penn Co. in May showed a

slight falling off, due to the inability to get goods, and it is becoming clearly evident that they will have to work with a curtailed stock of machines and records during the remaining summer months.

Doing Well With the Cheney Phonograph

G. Dunbar Shewell states that he has a fair stock of Cheney phonographs on hand. He has been doing a very satisfactory business with these machines. The entire building is being remodeled, and the talking machine end will be adequately cared for. A section of fine booths is being put in place on the first floor, and Mr. Shewell will have a fine office on the third floor front of the building.

H. A. Weymann & Son Report Progress

H. A. Weymann & Son have been most fortunate in being able to supply their dealers in May in a way that has been most satisfactory to them, although not to a full 100 per cent. The system they inaugurated some months ago of getting a big stock on hand has helped them out considerably, and they are in very excellent shape for the rest of the summer. While they have lost several of their best men from this department to enter the Government service, they have been able to replace them with some experienced salesmen and shippers.

Philadelphians at Edison Convention

There was a large representation from this city to the Edison Convention in New York. The first annual meeting of the local Edison dealers was held at the Bingham House on Tuesday evening of this week. There was to be an annual banquet, but due to the fact that it is also convention week in New York, the Philadelphia banquet has been postponed until the meeting in July. There was no election of officers at this annual meeting, as it has been arranged that the officers will be elected hereafter every January to serve for the year.

Miss Katherine Fuicheon, for many years connected with the Estey Piano store, has left that firm and has assumed a position with the Edison section of N. Stetson & Co., where her wide

experience will add much to the effectiveness of that department.

George D. Ornstein, the new Victor distributor at Eleventh and Chestnut streets, did a very good business in May, his second active month. Mr. Ornstein has taken his family to the shore for the summer, and he went down on Decoration Day to remain over the week end. George A. Lyons looks after the business at the store in Mr. Ornstein's absence.

Recent Visitors to Quaker City

Among the out-of-town prominent dealers the past month who were in this city were Rudolph Wurlitzer, of Cincinnati; John W. Jenkins, of J. W. Jenkins' Sons Co., Kansas City, Mo., and O. R. Boone, of the Birmingham Talking Machine Co., Birmingham, Ala.

PHILADELPHIA DEALERS ORGANIZE

Victor Retailers Form New Association in That City at Meeting on May 27

PHILADELPHIA, PA., June 3.—The launching of the Philadelphia Victor Dealers' Association was accomplished with great enthusiasm at a meeting on May 27 at the Adelphia Hotel, when over fifty dealers turned out and enjoyed a pleasant luncheon together. Everyone became better acquainted, and good fellowship seemed to be the spirit of the meeting, while problems of mutual interest were discussed.

The officers of the Philadelphia Association are J. Ralph Wilson, president; Berthold B. Todd, vice-president; Walter G. Linton, secretary, and George W. Huver, treasurer.

Firms in Camden, Wilmington, Norristown and other localities adjacent to Philadelphia have come into the association, thus greatly widening its influence.

These dealers have organized with a desire for a friendly acquaintanceship and a free and frank interchange of ideas for the advancement and development of their respective businesses

(Continued on page 22)

PHILADELPHIA DEALERS ORGANIZE

(Continued from page 21)

so that the interests of each individual member will be promoted.

It is estimated that much good is going to be derived from the discussion of such subjects as "The Rendering of Better Service to the Public," "Store Management," "Proper Stocking and Purchasing of Goods," "Overhead Costs and Expenses," "Credits," "Advertising," and other economic questions. The better solution of such problems is bound to elevate the industry in the eyes of the public, and have a direct bearing upon the success of every member.

COURTLAND SHAW, JR., APPOINTED

Becomes Manager of the Dealer Service Department of the Columbia Co.

The general sales department of the Columbia Graphophone Co., New York, announced this week the appointment of Courtland Shaw, Jr., as manager of the dealer service department. Mr. Shaw succeeds H. L. Tuers, who left for Ithaca recently to go in training at the aviation grounds in that city, preparatory to obtaining an



Courtland Shaw, Jr.

officer's commission in the Aviation Section of the Signal Corps.

Mr. Shaw has been associated with Columbia retail activities for the past eleven years, and is thoroughly familiar with all details of the retail merchandising of Columbia products. From his long and continuous experience in the retail selling field he has acquired an adequate idea of the dealer's requirements, and therefore knows the true meaning of the term "dealer service."

CHENEY PHONOGRAPH SALES CO. ORGANIZED IN CLEVELAND

New Company With Capital of \$50,000 to Take Over the Distribution of This Phonograph—German Records to Be Interned During War—Collister & Sayle Novel Display—News of the Month

CLEVELAND, O., June 2.—The Cheney Phonograph Sales Co., with a capital of \$300,000, has been organized under the Ohio laws to take over the distributing business of the Cheney Sales Co., and will maintain offices at 4400 Euclid avenue, this city. The officers of the company are E. M. Buel, president; T. R. Buel, secretary-treasurer, and G. R. Madson, sales manager. He was formerly with the Columbia Graphophone Co. and is well known to the trade in Ohio, West Virginia and central and western Pennsylvania, the territory the newly organized firm will supply.

The Cheney talking machine has a rapidly increasing sale in this section of the country and the volume of business necessitated the formation of the company just launched.

The distributing agency will put out the product of the Cheney Talking Machine Co., of Chicago, and will have well-equipped offices in this city for looking after business.

The Cheney talking machine has found popular favor in Cleveland because of the construction of the cabinets, which are from the widely-known Grand Rapids, Mich., firm of Berkey & Gay.

Charles K. Bennett, president of the Talking Machine Dealers' Association of Northern Ohio, has furnished the members with a list of the German records to be interned during the war period. The list contains about 1,000 titles and includes all records which reproduce vocal or instrumental selections in the German language as well as selections of pro-Germans. This action will bar all the orchestral selections of Dr. Carl Muck, of Boston, and those of any other musical director who has been interned by the Federal Government.

The barred list has 535 Victor, 271 Columbia, and 53 Edison records. The association members are pledged not to sell any of the records listed and to withdraw them from sale.

In conformity with the association's action the Muehlhauser Brothers Piano Co., dealers in Sonora machines, displayed cartoonist Oppen's cartoon drawn for the National Security League, in their shop window. The cartoon represents a machine called the "American Citizenship Phonograph." Before it stands a German-American who offers a record bearing the words "Deutschland—Uber Alles." The cartoon is labeled, "You Cannot Play That Record on This Machine." These Oppen cartoons have made a big hit in Cleveland.

The Collister & Sayle Co., Victor retailers,

have been attracting attention by a novel display of war weapons, including a gatling gun. The firm's show windows are always attractive and the novel features were shown during the city's campaign to raise a \$6,000,000 "Victory Chest," which was oversubscribed \$5,000,000.

During the drive Charles K. Bennett, manager of the Eclipse Musical Co., Victor distributors, was a member of the Cleveland Athletic Club's team of record-breaking money finders.

The May Co.'s piano department is making an advertising drive on Victrolas, featuring them in extensive displays in the local daily newspapers.

Cleveland police a few days ago had a chase after a lot of talking machine records. Crafty crooks robbed the music store of Charles H. Rudolph, 10010 St. Clair avenue, of \$200 worth of property, mostly talking machine records. Two well-dressed men called at the store and asked to hear the strains of "Nancy Jane" played. The pair selected \$150 worth of records and told a clerk to put them aside until the next morning. During the night the records were stolen.

Henry Dreher, of the B. Dreher's Sons Co., was one of the hardest workers for the "Victory Chest" fund Cleveland raised. He is quite a golfer, and after he had held up the players of the Willowick Club, the caddies "came across" with a substantial sum.

The Starr Piano Co. is making a drive on talking machines and using considerable space in the Cleveland daily newspapers.

Bings' furniture store, one of the biggest in Cleveland, is featuring Sonora talking machines. This enterprising firm is one of the many which is using phonographs to attract trade successfully.

WELCOME TO THE TALKER FIELD

A. H. Taylor, formerly traveling representative for the piano house of F. G. Smith, and well known in piano circles throughout the country, has purchased the Victor establishment formerly conducted by Mrs. Kaplan at Jamaica, L. I. Mr. Taylor has entirely renovated this store, installing new decorations and additional soundproof booths, with the idea of making the establishment one of the most attractive talking machine stores in Long Island.

Probably the best and most profitable kind of ability is amiability.

Efficient Record Service

ECLIPSE

THE accompanying illustration shows one of the numerous efficiency systems we have installed in order to make Eclipse Victor second to none in the matter of giving prompt attention to orders.



Loading Truck Right on Stock Floor

ECLIPSE MUSICAL COMPANY
CLEVELAND OHIO



REGISTERED
TRADEMARK

Here Are the Points

that make the Nightingale the highest quality machine offered to the American public. This wonderful combination of features is the result of several years' successful manufacturing.

It is equipped with the Stephenson Precision-made Motor.

The Scotford Tone Arm and Reproducer are used.

Not only are the finest veneers used, but the solid parts of the cases are of *genuine* mahogany, black walnut and quarter sawed oak.

We make our own cases and in cabinet work and finish they are unsurpassed.

We guarantee it unconditionally against broken or defective parts for a period of two years.

The selection of a phonograph line is a serious matter—on your decision both profits and prestige hang. You must give perfect satisfaction to your customers and assure yourself of an adequate profit. On both these points the Nightingale scores big.

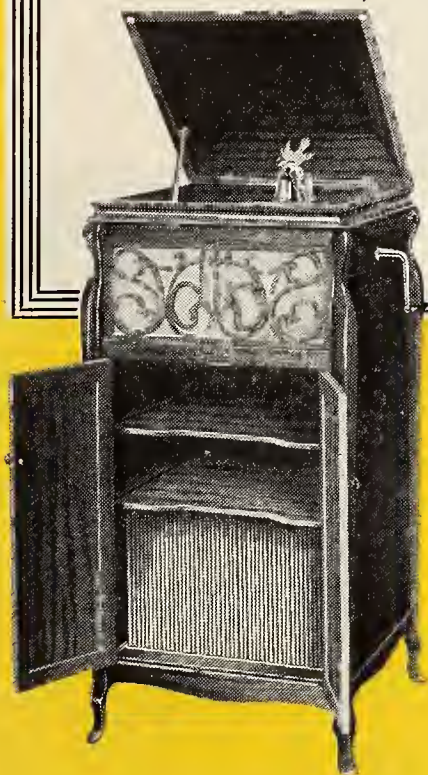

Nightingale Mfg. Co.

422-26 N. Armour Street

CHICAGO

INCREASE YOUR SALES

Here is your chance, Mr. Edison Dealer, to close the undecided prospect.

KENT Attachment and Sound Box

FOR THE
EDISON DISC PHONOGRAPH

Patent No. 1,130,298



Patented March 2, 1915

SIMPLE AND ACCURATE

Made by manufacturers who have specialized in Edison attachments for years.

This is not a new product—hundreds of dealers are now selling them, and thousands of them are on the machines of Edison owners.

If you are not already acquainted with the Kent Attachment and Sound Box, don't lose time—send for one to-day.

Most Edison jobbers handle our products. If yours does not write direct.

F. C. KENT & CO.

Manufacturers of Phonograph Accessories
Cor. MULBERRY AND CHESTNUT STS.

Newark

New Jersey

KANSAS CITY CONTINUES TO BE A LIVELY TRADE CENTER

Business During the Past Month of Large Volume Despite Red Cross and Other Drives—High-Class Machines in Demand—Sales Have Been Limited Only by Supplies—Other News

KANSAS CITY, Mo., June 8.—The talking machine trade in this vicinity for the past month has been more than usually good, taking into consideration the Red Cross drive and various other patriotic activities. Many of the talking machine men gave up an entire week's time to the Red Cross. Burton J. Pierce, manager of the Victrola department of the J. W. Jenkins' Sons Music Co., and A. A. Trostler, who has charge of talking machines for the Schmelzer Arms Co., were both captains in General Jaccard's division in the campaign during War Fund week, and devoted the entire week of May 20-27 to this work. The Kansas City quota of \$800,000 was reached the third day of the campaign and the final figures carried the city over the top with a total of \$1,296,000. Mr. Pierce was the life of his division, leading the cheering and demonstrations with the energy which characterizes his ball playing and recently his golf. Just at this point it may be well to mention that Mr. Pierce would suggest that any members of the trade who visit Kansas City during the summer months had better bring their golf sticks along. He promises them an interesting trip to the Meadow Lake Country Club links. Mr. Trostler was in charge of a district which extended over a large section of territory and was consequently difficult of access. However, the results were very satisfactory, for although not so large in amount as some of the more prosperous districts, it registered practically 100 per cent. in the number of subscriptions, a point more worthy of commendation.

William C. Chestnut, sales manager of the Brunswick Shop, 923 Walnut, has been enjoying an unusually high class of trade, especially in the more expensive machines. The majority of the instruments sold range in price from \$175 to \$225, and a number of \$350 models have been sold. The new Brunswick line, which carries the Ultona reproducer, has been very successful. There will be an exhibition of the special \$1,500 model which was shown at the Music Show in Chicago last year at the Brunswick Shop in the near future. Mr. Chestnut said this week: "In order to protect ourselves from any difficulty in completing a deal with drafted men, we have adopted a ruling that no sales will be made on the instalment plan to unmarried men who are in class A of the first draft."

A. A. Trostler, manager of the Victrola department, Schmelzer Arms Co., said in regard to business conditions: "It is not a question of how business has been but one of getting goods. If we could only secure the merchandise, trade would be phenomenal under the existing circumstances. It has been very good. We have interned all Central Power records or anything pacific in nature, such as 'I Did Not Raise My Boy to Be a Soldier,' for the duration of the war. All records having a semblance of half-hearted support to the Government have been suppressed."

D. M. Guthrie, manager of the retail department of the Columbia Graphophone Co., says that business is going along very nicely with good prospects for an excellent summer season. The Columbia Co. recently sold a beautiful period design to Mrs. Wallace Robinson, wife of the proprietor of the Hotel Baltimore. The instrument, which sold for \$1,750, was specially ordered by Mrs. Robinson as part of the furnishings of her beautiful Country Club home. Mrs. Robinson, who is a fine soprano and prominent in musical circles, has signed an exclusive contract to make Columbia records. Her first two numbers will be "Mighty Lak a Rose" and "When You and I Were Young, Maggie," with orchestra accompaniment. The records will be catalogued in September. The deal was consummated by Mr. Guthrie.

M. M. Blackman, manager of the wholesale department of the Edison Co., is in the East, attending the convention at New York.

Mrs. Nell Williams, manager of the Victrola

department of the Jones Store Co., has been in charge of the department for just one year. During that time the Victrola business has grown remarkably, showing increases not only in the sales but in the class of trade. "Although we have suffered from shortage in goods, we have been very successful in substituting machines and with our wide variety of records satisfying that phase of the demand. It has been a year in which it has been necessary to resort to original plans in salesmanship to overcome the influence of the war. With us, the old plan of selling Victrolas at just the price of the records is now as though it never existed. People seem to have the cash and are willing to pay. We are now carrying a large stock of accessories such as record files and Motrolas to give complete service to our customers," said Mrs. Williams.

O. D. Standke, who has charge of the Victrola department of the Geo. B. Peck Dry Goods Co., is visiting his home near Clinton, Mo., for a week or ten days.

E. S. Hall, of the Hall Music Co., considers the increase in price in all talking machines and records the principal matter of interest to the talking machine dealers at present.

Miss Hazel Godfrey has recently been added to the sales force of the Victrola department of the Jones Stores Co.

Mr. C. L. Schwager has recently resigned his position as office manager of the wholesale department of the Columbia Co., and left May 26 for Atlanta, Ga. He has accepted a position as traveling auditor for the Columbia Co., and his first work will be in Atlanta. For four years Mr. Schwager had been with the Kansas City office.

O. A. Field, of the Field-Lippman Piano Store, St. Louis, was in Kansas City recently as a guest of A. A. Trostler.

The Columbia Co. is receiving a number of very large orders for the General Pershing records.

F. S. Allen, of the Musical Record Co., of Los Angeles, Cal., was in Kansas City recently on his way to the East.

F. S. Horning, Victor representative for the central West, has been in Kansas City en route to the Atlantic coast.

"Globe" TRANSFER NAME PLATES

SOLD BY
PAYETTE MUSIC HOUSE
ABERDEEN, WASHINGTON

STYLE 1

FROM
McDonald's
CONNELLSVILLE, PA.

STYLE 2

FROM
C. E. WALKER & CO.
SPORTING GOODS & VICTOR VICTROLAS
HOLYOKE, MASS.

STYLE 3

Keller's Temple of Music
ELEVEN ENTIRE FLOORS
EASTON, PA.

STYLE 4

SOLD BY
Gaston
MUSIC CO.
HASTINGS, KEARNEY
GRAND ISLAND

STYLE 5

GEORGE A. MULLIN Co.
CEDAR RAPIDS, IOWA

STYLE 6

SOLD BY
WHITE PIANO CO.
FAIRBURY, NEBR.

STYLE 7

CUTS ARE HALF SIZE

Can be easily and quickly applied on

TALKING MACHINES,
PIANOS,
TYPEWRITERS,
SEWING MACHINES,
FURNITURE, ETC.

You can order any of the designs illustrated, Style 1 to 7, with your copy, as follows:

250—\$16.00
500—\$20.00
1000—\$27.50
2000—\$40.00
3000—\$50.00
5000—\$65.00

Complete transferring outfit included with every order.

Write for folder "You Need Decalomanie In Your Business."

**Globe
Decalomanie
Co.**

74 MONTGOMERY ST.
JERSEY CITY, N. J.

Why Not a Record Window That Has Some Real Human Interest Features? :: By Albert B. Parsons

It is often more difficult to fool the public in the matter of making a human interest window display than some of us might believe. The reason why so many displays of this kind are failures is due to this very cause. There is nothing in the window that will excite attention, admiration or comment. The public simply will not become aroused in the commonplace. Further the public will not respond to the show that is a make believe. You can fool the children with fairy stories and kindred tales of fascinating lore, but the grown ups demand a more well-defined reason for showing the same interest in your window.

Now, there is a great deal more truth in this than some dealers might even think possible. You may feel that your imitation, papier-mache figures and your make-believe scenes that give a faint idea of the impression you are trying to make have really been effective, but the truth of the matter is that your object more often has not been attained. The interest in your own windows cannot be had unless there is something of value to attract.

Say that you have a new or a special record that you want to advertise. If you care to arouse the public interest in this, an interest that will make the sale of the record worth while, then you will have to give the public a reason for stopping at your window and of becoming interested. Your display signs and the little effort that you add with a number of reading signs, even though they depict something in connection with your record, will not bring the desired results. The dealer who has a window that simply has a talking machine therein and then hopes that the public will come in to buy a machine, can really count on little in this way. There is lacking the very interest that you have been hoping to arouse.

This is best given a personal test by trying it on yourself. You might be induced to stop and look at a competitor's window display, but this is simply because you want to see what he is showing. It is not from the fact that you have been impelled to stop on account of the novelty of the display. Try it on another kind of display. Does the imitation window that lacks human interest appeal to you like that which has this feature?

If you can put a person in your window and make him portray a given subject, and make the background a part of the setting, will you not arouse a larger share of interest in your display? If you even place a figure in there that can do more than remain a figure you have aroused an interest that will impel the public to stop and ponder. If you place an animal in the window that has a part to play in the role you will have aroused attention. The public does not want to be fooled, however, and you should make your display real. The imitation is a poor means of arousing and holding the public's attention.

To-day there are a number of popular soldier records. There is a wide interest in all that pertains to the life of the soldier. Why not the display that has something of this kind in connection with the record? Why not the real war relics, the real rifles, bugles, flags, Red Cross fixings? Why not the display that has a man dressed up to represent a soldier or a woman as a Red Cross nurse, that will make clear the idea of a real scene? Pick out any number that is now popular. Make it a part of the window display that has a human interest side.

Best get away from the commonplace and make the record a real picture. Place a phonograph in the window and fix up a camp scene. Place therein also some tents and a man or two. If you cannot get live men, why, take figures, but make the display a real one.

You will find an interest in this kind of display that you can never feel in the window that has only a make-believe show. Invite the public to come in and hear these records. Ask them to permit you to play them for the passer-by. Come in and hear this record and all others. Show that you are fully alive to the needs of the hour and that you can arouse a feeling in the public that will find a ready response.

You Cannot Arouse Interest in Your Windows unless there is Something of Value to Attract

You will be surprised to see how eager the public is for a story of this kind. But the imitation will never arouse that same display of interest. The public has been given so much of this ordinary show that it has tired of the sameness. There is a longing for something that will be a real display. If you only have an ordinary record you can make it appeal by the nature of the window show that you make.

If you care to go to a little additional expense or to make an extra effort to arouse the public in this way you can find ample time to

keep the public interested in your display. If you can do so you should make a complete change at least once a week. But keep the public guessing as to the next window show that you make. Pick out the popular records and play them up. You will be surprised how much real profit there is in this idea when it has been given serious study. But it must be real. If it is only a stick, or a hatchet, or a gun, make these items real, and not an imitation. You cannot fool the public. No, there are too few of them now that will fall for your make-believe style.

It is astonishing how much all of us love a reality. It is a part of our human make-up to love that which is real. Can you not be benefited by this idea and by the suggestion that can be made a part of your display? You want to sell machines and records, but the only way to do so with anything like a profit to yourself is to keep the interest of the public alive and the show window is the logical means when it is made to act as a medium for the telling of a human interest story.

NEW QUARTERS FOR PEARSALL CO.

The Silas E. Pearsall Co., Victor distributors, has leased the entire fourth floor of the building at 10 East Thirty-ninth street, New York, a few doors east of Fifth avenue. According to its plans the company will move from its present location at 18 West Forty-sixth street about the 20th of June, and in its new quarters will concentrate exclusively upon the development of wholesale Victor business, discontinuing its retail business entirely.



"Perfection" Universal Tone Arm No. 9 with Pur-i-tone reproducer in position for playing lateral cut records

PHONOGRAPH MANUFACTURERS

Our new PERFECTION Universal tone arms models 7, 8, 9, and 10 are now ready for shipment. Our new PUR-I-TONE reproducers models 6 and 7 that are attachable to these tone arms are ready for shipment in any quantity.

Our new Universal arms will play all makes of lateral and Hill and Dale records by a simple turn of the reproducer. We guarantee that the PUR-I-TONE reproducers will not only reproduce all records with perfect amplification of sound, but we also guarantee a perfect reproduction of high pitched soprano voices on lateral cut records, and with extra fine clarity of sound. We have 50,000 sets of arms in 4 different forms ready for quick shipment, also 4 different models of reproducers that are attachable to these arms. PERFECTION Universal tone arms models Nos. 9 and 10 can be supplied with or without ball-bearing base, models Nos. 7 and 8 without ball-bearing base. These arms and reproducers are guaranteed to be the very finest that are manufactured for use on all kinds of phonographs. Write to us for quantity prices, advertising matter, etc.

NEW ENGLAND TALKING MACHINE CO.

Manufacturers of PERFECTION Phonograph Accessories

16-18 Beach Street

BOSTON, MASS.



Columbia Service "follows through." It will help you sell those Portable Model Grafonolas you have. Write to the Dealer Service Department for information concerning advertising material and window display.

**Columbia Graphophone Co.
NEW YORK**

PROGRESS OF TRI-STATE VICTOR DEALERS' ASSOCIATION

Exchange Bureau of Association Proving of Great Value—Many Conferences on Jobbers' Prices—Membership Now Includes Leading Houses of St. Louis and Adjacent Cities

St. Louis, Mo., June 3.—Victor dealers in this trade territory are showing much interest in the Tri-State Victor Dealers' Association since the formal opening of the Koerber-Brenner Music Co. warerooms on May 8. At the dinner given in connection with the Koerber-Brenner meeting, President Magoon of the Tri-State Association was a speaker and he explained the objects and benefits of the association. As a result, a number of membership applications have been received by the membership committee. These will be submitted to the association at the next meeting, probably the third week in June.

The greatest direct benefit of association has been the Exchange Bureau. While not many machines have changed ownership through this bureau, which is under direction of John F. Ditzell, of the Famous & Barr Co., the record transfer has been very heavy. Some dealers reported unusually heavy stocks of standard records and these were eagerly taken by other dealers, especially by those dealers who have learned the art of suggesting as substitutes for the new numbers, older records by the same singer or player.

Since the notices of the advanced prices by

the Victor Co., local members of the Association have held several conferences to consider the dislocation of jobbers' prices and the lessened profits to retailers on certain items. The dealers decided not to take action at present but authorized John F. Ditzell, who attended the Piano Merchants' Convention in New York City, to take up the point with the Victor factory while he was in the East. He will report to members of the association at the June meeting.

The following list of members does not include the applications received as a result of the Koerber-Brenner house-warming meeting:

A. M. Magoon, Kieselhorst Piano Co.; C. F. Lippman, Field Lippman Piano Stores; Val Reis, Smith Reis Piano Co.; J. F. Ditzell, May Department Stores Co.; F. Schanzle, Home Phonograph Co.; J. F. Hunleth, Hunleth Music Co.; E. C. Rauth, Koerber-Brenner Co.; A. C. Thiebes, Thiebes Piano Co.; W. Gus Haenschen, Scruggs, Vandervoort & Barney; Wm. Bauer, 2619 Gravois, St. Louis, Mo.; J. Raigor, Raigor Art & Music Co., St. Louis, Mo.; J. Glaser,

Tower Talking Machine Co.; J. Mediar, Stix, Baer & Fuller D. G. Co.; A. E. Geitz, Geitz Sewing Machine & Furn. Co., 4706 Easton; Fred Coleman, Wellston Talking Machine Co., all of St. Louis, and E. A. Parks, Parks Music House Co., Hannibal Mo.; T. J. Price, Bracy-North Hdwe. Co., Carterville, Ill.; Jos. Knapp, Knapp Jewelry Co., Belleville, Ill.; W. L. Rhein, Walter L. Rhein Piano Co., Belleville, Ill.; Fred Lehman, Lehman's Music House, East St. Louis, Ill.; Frank Beach, C. L. Beach & Son, Mansfield, Mo.; E. Pat Boverie, Boverie Store Co., Ste. Genevieve, Mo.; T. S. Gravenhorst, Gravenhorst's Store, Effingham, Ill.; W. C. Daumueller, Lebanon, Ill.; Frank H. Feraud, Feraud Bros., Granite City, Ill.; H. E. Arcularius, Neosho, Mo.; J. T. Lochridge, Lochridge & Ridgway, Mayfield, Ky.; J. V. Johnson, Bry Block Merc. Co., Memphis, Tenn.; Herbert Highfill, Highfill Neifind Furn. Co., Caruthersville, Mo.; John Calveard, L'Harmonie Compagnie, Louisville, Ky.; E. T. Ballagh, Nevada, Mo.; Frank C. Cochran, Piggott Music & Nov. Co., Piggott, Ark.; E. E. Baker, Harrisburg, Ill.; J. P. Brown, Jacksonville, Ill.; Walter H. Shackleton, Kranusgill Piano Co., Louisville, Ky.; W. B. Decker & Sons, Fairbury, Ill.; Franklin Meyer, Carlinville, Ill.

IMITATION RECORDS FOR WINDOWS

Dealer Service Department of Columbia Co. Announce Unified Display Feature for Dealers

In response to requests from Columbia dealers throughout the country, the dealer service department of the Columbia Graphophone Co. has just announced that it is ready to supply Columbia representatives with an imitation record lithographed on sheet steel. These records can be utilized to excellent advantage, as the dealers have hitherto been hampered in exhibiting records in their display windows by the deterioration caused by the heat of the sun and the gathering of dust in the record sound grooves, rendering the records thus displayed unfit for use, and a direct loss in money.

Many requests for the solution of this problem actuated the experimentation with substitutes that would withstand the extraordinary requirements of window display and still maintain the appearance of actual records. Trials of cardboard, wooden and fiber substitutes proved unsatisfactory for many reasons, and after lengthy tests of various materials, an imitation record lithographed on sheet steel was perfected.

Imitations of Columbia records have been manufactured in ten and twelve-inch diameters, single-faced, with regular blue and symphony labels. Record edges are round-rolled giving the appearance of actual record thickness. Each imitation is punched with a hole in the center so they may be substituted wherever the others may be displayed.

These records are furnished to the dealers in sets of twelve assorted comprising three of each type of record. There has also been issued for use with these imitations a record display easel

consisting of a sheet steel and wire record holder with easel adjustable to any angle. This easel holds ten-inch or twelve-inch records and a metal pin inserted through the record hole keeps the record in display position.

The Orpheum Record Co. of Manhattan was incorporated in Albany recently with a capital stock of \$10,000, by A. and K. Poulus and M. A. Stadhoupoul, 247 West Twelfth street.

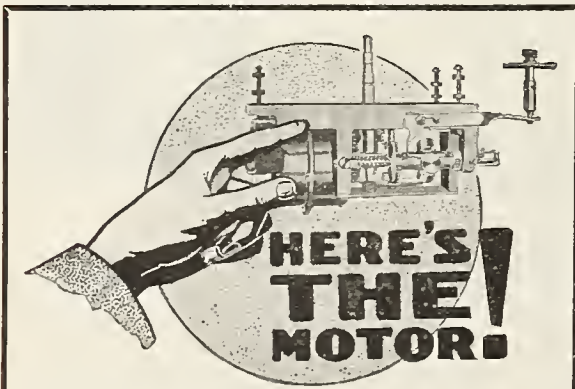

That has made good in thousands of machines. It has won wonderful and enduring popularity and embodies the silent-running, reliable and durable features that delight the customer and satisfy the builder. The Dayton Motor is considered by manufacturers as being

The Best Built Motor In the World

Build satisfaction into your products by using our Quality line. *Dayton Motors, Dayton Tone Arms, Dayton Reproducers.* All styles and sizes. They will bring you more business and satisfy your customers. Write for full particulars.

THE THOMAS MFG. CO.
322 Bolt Street DAYTON, OHIO

DEALERS Make Big Money On Our Language Records



FRENCH, SPANISH
ITALIAN, ETC.
ALSO
F.M.C FRENCH
MILITARY
CONVERSATION

Cash in now on the

Language Phone Method and Rosenthal's Practical Linguistry

It requires no scientific salesmanship to sell our records. The courses are so simply arranged that the demonstration satisfies the prospect. The French Military Course, 5 Double Discs, and Military Manual, (Retail \$10.00) is ideal for Army, Navy, Red Cross

Excellent Line for Summer Trade
Send for Particulars

THE LANGUAGE PHONE METHOD
992 Putnam · 2 West 45th Street, - New York

How Talking Machines Play a Prominent Part In the History of the World War :: By Wm. J. Fitzgerald

One of the real problems of every military organization in active service is that of preserving the morale of the troops at the highest point. Modern war conditions are particularly nerve-racking to the soldier, for he is called upon to spend weeks, or even months, inactive in the trenches, but alert and ready at all times to enter into a death grapple with the enemy. In short, the heroics that have gone with other wars are almost entirely lacking in this. There are few charges across the open, or the excitement of passing from one battlefield to another. It is a war of waiting, of methodical campaigning, the sort of campaigning that wears on the nerves.

Our allies, even before we entered the war, realized the necessity of talking machines at the front. The English Government and private organizations sent thousands of talking machines and records over to France for the use of troops in the field, and found them most effective in distracting the mind of the soldier from the grind of war during his brief periods of rest. There is hardly a military organization in the United States to-day that is not provided with some sort of talking machine and a library of records.

The talking machine has established its place in the military life of the country, and has been accepted as an essential. Hundreds of talking machines are in the camps over there. Thousands are in the cantonments here. I really believe that individuals to-day are endeavoring to see that talking machines are placed aboard every vessel afloat. Music is getting to play an important part in this war. The music of the talking machine soothes the raw nerves of the boys who have just returned from the trenches, lessening the mental lassitude of the reaction that follows, with soothing melody, and helps in every way to make their lives more comfortable. Every one of the warring governments has made special efforts to supply music for its soldiers, but human nature needs to keep regular hours, and talking machines, which can be operated by any one at any time, perform a service obtainable through no other agency. We know, for instance, that it is an established fact that the soldiers will not endure the waiting periods of modern warfare without the relaxation. Commanders of the army have found that the morale deteriorates when the men

are given only the so-called necessities of life. Military men have found that the modern man requires something different. Therefore, to-day, we find in the cantonments of the country, even with the expeditionary forces abroad, that our troops are being well taken care of by the kind of music from the talking machine, and also by the good literature which is so kindly allowed them even in the greatest hours of danger. I do not hesitate to predict that the music in-

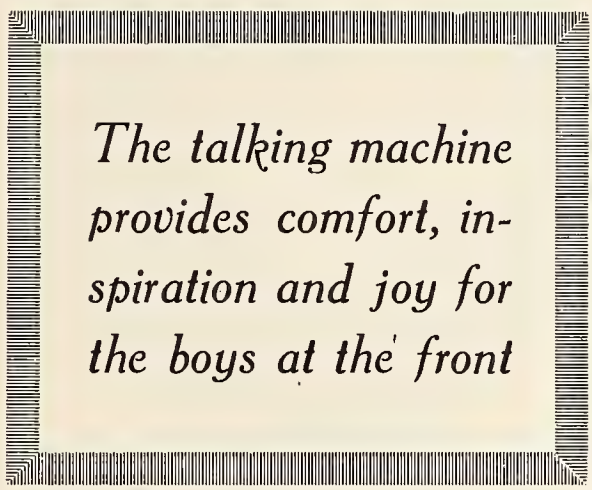

The talking machine provides comfort, inspiration and joy for the boys at the front

dustry will come sooner or later to be recognized as a war industry, and something absolutely necessary for our army and navy and even for our military camps at home. It has been taken as a matter of course, by everybody from the President down, that talking machines must be provided for the boys training and for the boys at the front. The talking machine has never been known to be a traitor; it means good music, and helps to provide comfort and inspiration which usually follows. All good music is patriotic, because in wartime comfort and inspiration are to be regarded as a national state in every home.

* * *

The foregoing article by Mr. Fitzgerald appeared in the Boston Sunday Advertiser and American of May 26 followed by a striking advertisement of the Eastern Talking Machine Co., depicting many of the leading Victor artists, with suitable text matter, emphasizing that the greatest artists of the world make records for the Victor exclusively. This was followed by the individual cards of some fifty-four dealers. In this connection it was pointed out to the

reader that "It is your patriotic duty to-day to trade with the Victor dealer in your own city."

The following had cards attached to the advertisement: Geo. H. Herrick Co., Attleboro; John H. Newell, Beverly; Chickering & Sons, Conclave Phonograph Co., Walter T. Gillis Co., C. C. Harvey Co., Iver Johnson Sporting Goods Co., Kraft, Bates & Spencer, Inc., Osgood, Rosen's Royer Talking Machine Shop, M. Steinert & Sons Co., Henry H. Savage & Sons and the Tosi Music Co., Boston; United Talking Machine Co., Brockton; W. E. Moore & Co. and C. C. Moir, Cambridge; Fred B. Emerson and Chelsea Music Co., Chelsea; Codman Square Music Shop, Dorchester; S. Hirshberg & Son, East Boston; Saul A. Rouffa, East Cambridge; J. F. Chaffin, Fitchburg; Travis & Cunningham, Framingham; Fred W. Peabody, Gloucester; J. G. Heidner, Holyoke; A. M. Phinney, Hyde Park; Kneupfer & Dimmock, N. F. Edmester, John J. Forrest, Lawrence; Bon Marche Dry Goods Store and Wardell's Music Store, Lowell; Harry M. Curtis and G. W. Lord Co., Lynn; Marblehead Song Shop, Marblehead; Caswell's Music Store, Middelboro; Reynolds Music Store, Milford; Harry Barish and M. A. Wood, Roxbury; H. G. Applin, Somerville; E. Caldwell, Stoneham; the Edwards Co., Southbridge; K. M. Cahoon Co. and Clarkson Furniture Co., Waltham; Fred'k J. Caldwell, West Somerville; Geo. Sharp, Westfield; Edw. Caldwell, Woburn; Barnard, Summer & Putnam Co. and the Worcester Phonograph & Supply Co., Worcester; C. F. Maher, Laconia, N. H.; Desautels Music House, Manchester, N. H.; Hasset's Music & Art Shop, Poursmouth, N. H.; Miles, McMahon & Son, Stowe, Vt.; Harris & Mowry, Woonsocket, R. I.

In complimenting Mr. Fitzgerald on the splendid work accomplished in this co-operative advertisement, he very modestly said: "I wish to emphasize that Thomas O'Brien, classified manager of the Boston American, and Arthur Burns, his able assistant, are certainly two men in the advertising field that deserve wonderful credit for their ability to stick and win out on any hard proposition that may arise, and believe me co-operative advertising is one of the hardest propositions known."

Sometimes a better outlook is secured by a critical inlook. Tried that lately?

NYOIL

is the last word in the refining of high-grade oils, for every impurity is taken from it, leaving nothing but what is required to keep machines in perfect condition, being combined of four oils perfectly blended.

Will not Gum, Chill or become rancid; is free from acid. It is colorless and has no sickening smell, being absolutely odorless.

"The finest and most delicate pieces of mechanism do not prove efficient unless properly lubricated. Skill, Genius, Invention and Workmanship must have the proper Oil. Stop and consider this when you have to buy an Oil for household use."

Hundreds of satisfied customers have written us that they would never use anything else for

TALKING MACHINES, GRAPHOPHONES, PHONOGRAPHS AND SEWING MACHINES

NYOIL will lubricate the machinery and polish all woodwork

and can be obtained of any "Up-to-date" Talking Machine Dealer in the world, and is manufactured by Wm. F. Nye, who for 50 years has made 80% of all the Watch, Clock and Chronometer Oil that is used in America.

WM. F. NYE, NEW BEDFORD, MASS., U. S. A.

NYOIL is put up in the following sizes:

No. 16 (Cans)	1 Pint
No. 32	1 Quart
No. 128	1 Gallon
No. 540	5 Gallon

NYOIL is put up in the following sizes:

No. 1 Bottle	1 ounce
No. 4	3 ounces
No. 8	8 ounces

The Pittsburgh Pathephone Company says:



HEAR PATHÉ RECORDS NOW!

HEAR THE PATHÉ PATHEPHONE NOW!

Hear Pathé Records NOW! Draw closer to the machine as the record is playing. Lean right up against the machine and listen!

You can hardly believe your own ears! SURFACE NOISE ALL GONE! Pathé Records have eliminated that old aggravation. Nothing but the MUSIC now, from Pathé Records! The full, clear tone of the voice, pure, unmarred! The full, uncontaminated tone of the musical instrument!

If Pathé Records and Pathé Pathephones were good a year or two ago, they are A THOUSAND PER CENT BETTER NOW!

If pleasing your customers is your idea of succeeding in business, sell them PATHÉ PATHEPHONES AND PATHÉ RECORDS!

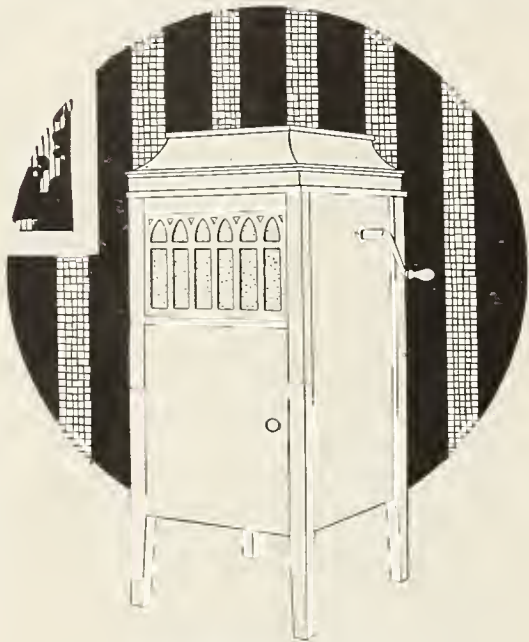

Pathephone \$85 Model

The Pittsburgh Pathephone Co.

has the largest stock of

**PATHÉ
RECORDS**

in America—and every Pathephone in every finish

Real service—the kind that counts for good business

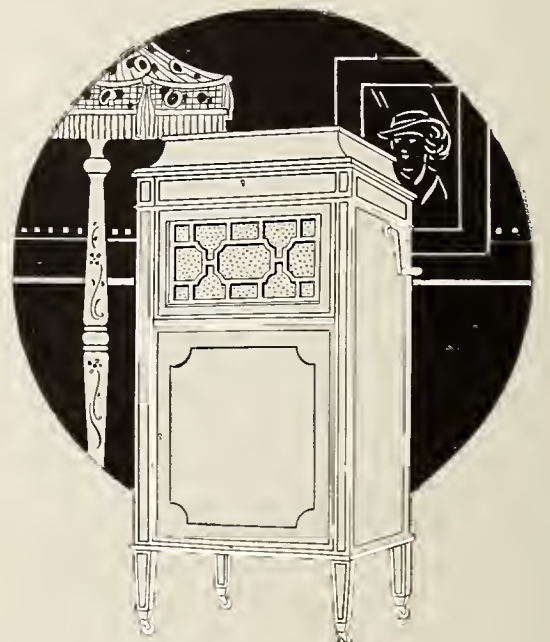

Pathephone \$225 Model

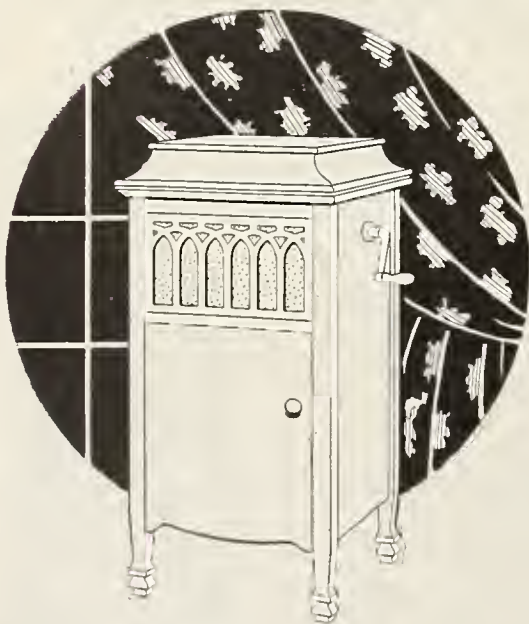

Pathephone \$110 Model

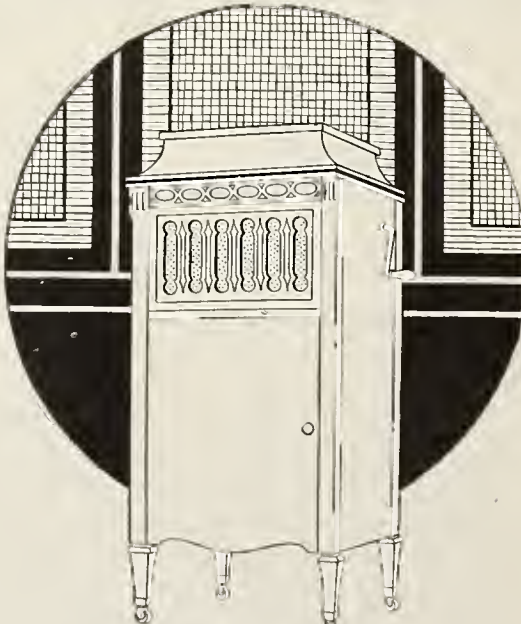

Pathephone \$125 Model

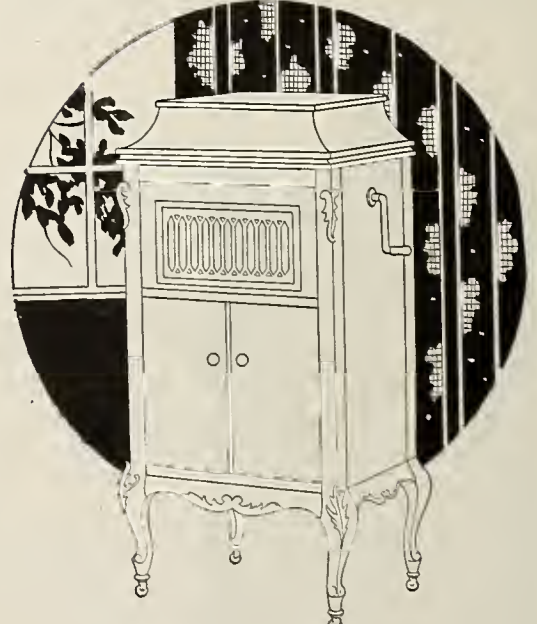

Pathephone \$185 Model

PITTSBURGH PATHEPHONE CO.

963 LIBERTY AVENUE, PITTSBURGH, PENNSYLVANIA

MAY REDRAFT THE STEPHENS BILL

Believe That a Remodeled Measure, or an Entirely New Bill, Providing for Maintenance of Resale Prices Under Auspices of Federal Trade Commission, Will Be Offered

It is now predicted that in view of the various recent decisions against the existing methods of providing for the maintenance of fixed retail prices, and particularly in view of the recent action of the Federal Trade Commission in the matter of price fixing, a new, or amended, Stephens bill will be introduced into Congress at an early date which will be drafted along lines to meet the situation as now developed.

It is believed that in its new form the Stephens bill will still be designed to give manufacturers of trade-marked goods the right to fix the retail selling price, or the resale price, on their goods, but will also provide that the price fixing must have the approval of the Federal Trade Commission. It is believed that legislative and judicial interests at present opposed to the fixing of retail prices by private concerns can be won over to the policy of price maintenance, provided such a policy shall be under Government supervision.

Even Justice Brandeis, of the United States Supreme Court, in a dissenting opinion in a recent price-fixing case, gave it as his view that price maintenance should be brought about through legislation, and intimated that the Federal Trade Commission should be given some authority in the matter.

With the Federal Trade Commission in charge, the retailer, or the final purchaser, will have some recourse in the event that he felt that the price fixed on a certain article was higher than was warranted by the cost of manufacture and distribution, in which event the Commission would probably order an adjustment.

There are four things a business man ought to know—himself, his business, how to use his means and knowledge, and the—other fellow.

WM. A. CONDON NOW SOLE AGENT

For the Gloria Steel Needle—Plans an Aggressive Sales Campaign—Demand Grows

The Gloria Phonograph Supply Co., New York, has announced the appointment of Wm. A. Condon as sole agent for the Gloria steel



Wm. A. Condon

needle. He has already assumed his new duties, and is making plans to establish an aggressive campaign in behalf of these products.

Wm. A. Condon is well known to the talking machine jobbers and dealers throughout the country, as he has been identified with the talking machine industry for many years. As one of the founders of the Condon Auto-Stop Co. he had occasion to visit practically all of the important cities from coast to coast, and while

on these trips met the leading jobbers and dealers in every trade center of importance.

He is now making plans whereby the Gloria steel needle, which was introduced to the trade a few months ago, will be merchandised efficiently and successfully. Arrangements are being completed for the adequate distribution of these needles, and Mr. Condon has perfected sales and publicity plans which will doubtless be of interest to the trade generally.

Since it was placed on the market a few months ago the Gloria steel needle has achieved pleasing success. Shipments have been made to jobbers and dealers in all parts of the country, and the company is working on a strictly uniform price basis, leaving nothing undone to fulfil its promises of prompt deliveries of its product.

GREAT ROSTER OF PATRIOTS

Another star was added this week to the service flag flying from the offices of the New York Talking Machine Co., Victor wholesalers. This star was occasioned by the fact that Henry Roth, one of the company's stock clerks, is now a member of the National Army and is in training at Camp Upton. The patriotism of this company's sales staff constitutes a remarkable record, for there is probably a greater proportion of the New York Talking Machine Co.'s force now in the service of Uncle Sam than any concern in the talking machine or allied music industries. Several of the members of the staff are now engaged in battle at the Western front, while others are getting ready to leave for France at a moment's notice.

NEW AUTOMATIC BRAKE

The Weber-Knapp Co. of Jamestown, N. Y., have made preliminary announcement of a new automatic brake which they have been developing for some time and which is already in the process of manufacturing. It is claimed that the device is very simple and a cordial reception of the new invention is expected.

LONG CABINETS



No. 83

In all finishes. Specially adapted for use with Columbia 50. Front posts made to follow lines of posts on Columbia 75.

FIRST and FOREMOST

In the cabinet field.

Why? Because we've *specialized* in

**CONSTRUCTION
FINISH and
ADAPTABILITY**

Our supremacy in these essentials warrants your handling *the perfect line.*

That's why you should anticipate your wants **NOW.**

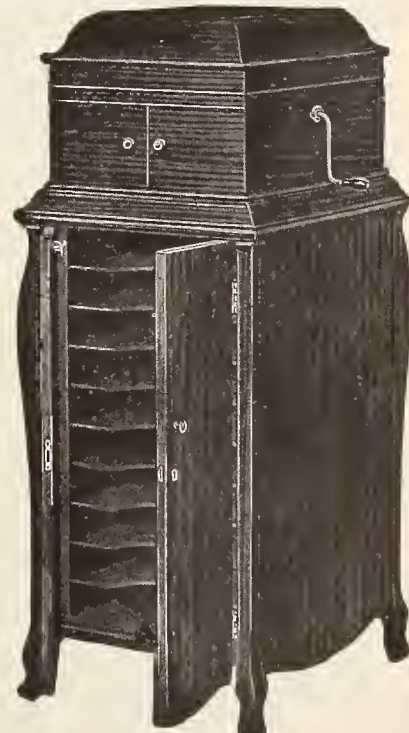

No. 79

In all finishes. Shown with top moulding and shelves. Specially adapted for use with Victrola IX-A.

Prompt deliveries on all orders. Write for Illustrated Catalogue of complete line

**THE GEO. A. LONG CABINET COMPANY
HANOVER, PA.**

The most wonderful Talking Machine of the present age at the price
An Instrument of Supreme Value, Tone and Quality

Clearstone
SPEAKS FOR ITSELF



No. 100—\$100



No. 75—\$75



No. 65—\$65

The *Clearstone* has become very popular because of its quality, splendid value and the advertising and sales campaign that now stands in back of it. **Dealers!** Watch us grow—write for our agency and grow with us.

SUNDRY DEPARTMENT

MOTORS—No. 01, 8-in. turntable, single spring, \$1.25; same motor with 10-in. turntable, \$1.40. No. 1, 10-in. turntable, double spring, plays two 10-in. records, \$2.95. No. 6, 10-in. turntable, double spring, plays three 10-in. records, \$3.50; same motor with 12-in. turntable, \$3.85. No. 8, 12-in. turntable, east-iron frame, double spring, plays three 10-in. records, \$4.85. No. 9, 12-in. turntable, east-iron frame, bevel gear wind, double spring, plays three 10-in. records, \$5.85. No. 10, 12-in. turntable, east-iron frame, bevel gear wind, double springs, plays four 10-in. records, \$6.85. No. 11, 12-in. turntable, east-iron frame, bevel gear wind, double spring, plays seven 10-in. records, \$8.50.

TOPE ARMS AND REPRODUCERS—No. 1, \$1.00; No. 2, plays all records, \$1.25; No. 4, \$2.65; No. 6, \$2.25; No. 7, \$2.25; No. 8, \$2.25; No. 9, \$2.25. (Play all records.)

MAIN SPRINGS—No. 00— $\frac{1}{4}$ -in., 23 gauge, 9-6 ft., 29c. each, 100 lots, 25c. each; No. 01, 1-in., 23 gauge, 7 ft., 25c. each, 100 lots, 20c. each; No. 0, $\frac{3}{4}$ -in., 20 gauge, 8-6 ft., 25c. each, 100 lots, 21c. each; No. 1, $\frac{3}{4}$ -in., 25 gauge, 9-6 ft., 39c. each, 100 lots, 35c. each; No. 2, 13-16-in., 25 gauge, 9-6 ft., 43c. each, 100 lots, 39c. each; No. 3, $\frac{7}{8}$ -in., 25 gauge, 11 ft., 49c. each, 100 lots, 45c. each; No. 4, 1-in., 23 gauge, 10 ft., 49c. each, 100 lots, 45c. each; No. 5, 1-in., 27 gauge, 11 ft., 55c. each, 100 lots, 59c. each; No. 6, $1\frac{1}{4}$ -in., 27 gauge, 11 ft., 90c. each, 100 lots, 85c. each.

RECORDS—POPULAR and GRAMMAYOX Brand, 10-

in. double face, lateral cut, all instrumental—32c. in lots of 100; 30c. in lots of 1,000; 29c. in lots of 5,000.

GOVERNOR SPRINGS—\$1.00 per hundred; \$6.00 per thousand. Special price in large quantities for Motor Manufacturers.

Genuine Diamond Points for playing Edison Records, \$1.25 each, 100 lot, \$1.15 each; Sapphire Points for playing Edison Records, 18c. each, 100 lots, 14c. each; Sapphire Balls for playing Pathé Records, 19c. each, 100 lot 16c. each. Needles—Steel in stock at all times at moderate price as per quantity.

NEEDLE CUPS—\$17.50 per M. \$16.00 per M in 5,000 lots. Covers, \$7.50 per M.

COVER STAYS—No. 1, for Table Cabinets, 6 in. long, 9c. each, 100 lot, 7 $\frac{1}{2}$ c. each; No. 2, for Floor Cabinets, 9 in. long, 17c. each, 100 lot, 13c. each; No. 3, heavy for Floor Cabinets, 10 in. long, 20c. each, 100 lot, 16c. each.

Continuous Plano Hinges, 28c. per foot; 100 feet, 21c. per foot.

We also manufacture special machine parts, such as worm gears, stampings, or any screw machine parts for motor; reproducer and part manufacturers.

Special quotations given to quantity buyers in Canada and other export points.

Write for our 84-page catalog, the only one of its kind in America, illustrating 33 different styles of talking machines and over 500 different phonographic parts, also gives description of our efficient Repair Department.



No. 85—\$85

Lucky 13 Phonograph Co., 3 East 12th St., New York

Make up some attractive combinations of Columbia Portable Grafonolas and Records, feature them in window and local advertising—and watch results.

**Columbia Graphophone Co.
NEW YORK**



TRIBUNE ATTACKS RECORD OFFER

The "Ad-Visor" Alleges That Certain Sections of Landay Bros. Retail Advertising Were Not Lived Up to in Actual Practice—Talking Machine Men., Inc., Congratulate Paper

The "Ad-Visor" column of the New York Tribune, in which the attention of the public is called to advertising statements in the New York papers by various concerns which are believed by the Tribune critic to be misleading, launched an attack recently on Landay Bros., local wholesalers and retailers of Victrolas and records, regarding a certain phrase in the Landay advertising.

The Landay advertising recently carried the line: "A genuine \$85 Victrola with all the records you want for \$5 down and easy monthly payments." The Tribune investigators claim that the Landay salesman informed them that \$5 worth of records were allowed on the \$5 down basis, and that records to a greater value would require a larger initial deposit. The investigators allege that they demanded \$50 worth of records with the \$85 machine and were informed that a \$25 deposit would be required. "In other words," as the published report of the case reads, "they could have 'all the records they wanted' on a \$5 deposit provided they did not want more than \$5 worth of records." The Tribune people claim that they brought the matter to the attention of the Landay house, and that there was a temporary change in the advertising phraseology, but that the old offer again appeared.

At the meeting of the executive committee of the Talking Machine Men, Inc., held in this city on May 23, the following resolution was adopted:

"That the management of the New York Tribune be congratulated on the stand it has taken in the matter of the 'Landay advertising' as discussed and criticized in their issue of even date, and this committee does hereby concur and sustain the action taken in this matter and believes that it will be of great benefit to the talking machine trade of New York and vicinity, and it does furthermore instruct the secretary to send a copy of this resolution to the New York Tribune and trade papers showing the action taken at this meeting."

The Everton Phonograph Co., Chicago, Ill., has been incorporated with capital stock of \$2,500. The incorporators are Thomas Wilkinson, Earl F. Hurd and Raymond B. Cunliffe.

Other than a state of mind, happiness is not in what we have; for a lot of us were happy before we had much.

COTTON FLOCKS

.. FOR ..

Record Manufacturing

THE PECKHAM MFG. CO., 238 South Street NEWARK, N. J.

PATRIOTIC PATHEPHONE WINDOW

Recently Carried by Brushaber in Detroit Has Won Much Favor and Praise

DETROIT, MICH., June 3.—The accompanying illustration presents a patriotic Pathéphone window display installed by Brushaber in their Gratiot

kind, as he was handicapped by unusual angles for a phonograph display, as, owing to Detroit's lay-out, almost every building has all manner of angles but right angles.

The results, however, were very satisfactory, and this display was commented upon very favorably by passersby and members of the local trade. In this display commercialism did not



Patriotic Pathé Display by Brushaber of Detroit

avenue store during the recent Liberty Loan campaign. This window is worthy of more than passing attention in view of the various handicaps that were surmounted before it was installed. The manager of Brushaber's window display department was "up against" a real problem in attempting to install a display of this

kind, as he was handicapped by unusual angles for a phonograph display, as, owing to Detroit's lay-out, almost every building has all manner of angles but right angles. The results, however, were very satisfactory, and this display was commented upon very favorably by passersby and members of the local trade. In this display commercialism did not

You can't learn to live without your income, so learn to live within it.



AUTOMATIC STOPS

The simplest and most efficient Automatic Stop on the market. They give excellent service, are easily installed and are absolutely guaranteed.

Send 50 cents for Sample Stop

KIRKMAN ENGINEERING CORPORATION, 237 Lafayette St., New York



This shows the
Artistic Design
of the
New Liberty
Phonograph
The
Popular Price
Machine

\$75.00



Specifications

High, 43 inches
Depth, 21½ inches
Wide, 19½ inches
Equipped
with Wooden Horn
and Tone Arm.

Model B-75

Write for our attractive Dealers' Proposition for your territory.

The Liberty Phonograph Co.

313 Wilmac Building, Minneapolis, Minn.

EMERSON LOSES BIG JUDGMENT

Appellate Division Reverses Decision of Supreme Court, Which Awarded \$46,485 to Victor Emerson as Against Henry Waterson—"Little Wonder" Records Basis of Suit

In a decision handed down by the Appellate Division on May 31 the judgment for \$46,485.59, obtained by the Emerson Phonograph Co., as assignor for Victor H. Emerson, in the Supreme Court, was reversed. The case grew out of an arrangement made by Mr. Emerson with Henry Waterson, whereby the latter secured exclusive distributing rights for the small "Little Wonder" records made by the American Graphophone Co., by which company Emerson was employed. Mr. Emerson declared that he

demanded that Waterson agree to pay to him one-half the profits he made from the sale of the records, and in fact paid \$1,700 at various times.

Waterson claimed that he had to pay the American Graphophone Co. so much royalty that he did not make the profit he expected out of Little Wonders and he sued Emerson for the money advanced. Emerson, on the other hand, alleged that Waterson had made a profit of \$200,000 out of Little Wonder records and wanted the court to give him a judgment of half that amount against Waterson. The lower court did give Emerson a verdict of \$46,485.59 against Waterson, which is now set aside.

The opinion handed down states that the testimony as to the alleged verbal contract between Emerson and Waterson is not conclusive,

but even if such a contract did exist, it would be null and void in law, because Emerson was at the time it was made a trusted employe of the American Graphophone Co., and was receiving pay to work in their interests, therefore he had no right to make such a contract.

HEAVY DAMAGE BY FIRE

The surplus stock of talking machines and records in the cellar of the store of the Worcester Phonograph Co., 11 Trumbull Square, Worcester, Mass., was badly damaged by fire recently.

George W. Harris, piano dealer of Burlington, Vt., is planning to move to a new location at 200 Main street, where he will feature the Henry P. Miller piano, and the Edison phonograph.

Happenings in Dominion of Canada

CANADIAN MANUFACTURERS ASSESSED TEN PER CENT. TAX

Proposed Bill, Which Will Undoubtedly Become a Law, Provides for a War Tax of 10 Per Cent. on the Manufacturers' Price on Players, Talking Machines, Rolls and Records

TORONTO, ONT., June 5.—When the daily papers on May Day announced that certain musical instruments were included in the list of articles that the Government proposed to tax, uncertainty and much anxiety were felt in music trade circles. The first report made it appear that a 10 per cent. tax was to be imposed upon the retail selling prices of certain lines. This misapprehension was corrected by later reports that made it clear that the proposed tax was to be on the manufacturers' selling price, although even at present writing there is necessarily indefiniteness of detailed confirmation as to the proposed tax measures and the working out of the collection of them. It is clear that the specific lines are player-pianos, player organs and music rolls, talking machines and records.

In Toronto a general trade meeting of piano and talking machine manufacturers and wholesalers was hurriedly summoned and a delegation appointed to visit Ottawa and obtain, if possible, information that would remove some of the uncertainty as to the conduct of business in view of the proposed legislation. Inland Revenue officers at various centers had notified dealers that they must keep a record of all sales made on May 1 and take an inventory of goods on hand. It now appears that this warning was not necessary in the case of retailers.

The delegation to visit Ottawa included Fred. Killer, Henry H. Mason, H. G. Stanton and E. C. Scythes. On their return, meetings of both the piano and phonographic branches of the business were held to receive reports and decide on the next step to be taken. As a result a circular letter has been issued to the trade from the office of the secretary of the Canadian Piano & Organ Manufacturers' Association, reporting that the following points were tentatively established in connection with the excise tax. The regulations here announced are subject to official confirmation:

- (1) Tax applies only through manufacturers and importers.
 - (2) Tax applies on all goods imported or shipped or delivered by manufacturers after April 30 (except in cases mentioned in "exceptions").
 - (3) Tax applies on all imports whether now in bond or transit.
 - (4) Tax is payable on duty paid price for imported goods, and manufacturers' selling price for goods made in Canada. The manufacturers' invoice price to dealers in each individual case to form basis of tax.
 - (5) Tax does not apply to parts or unfinished materials.
 - (6) Exceptions. Where manufacturer or importer has received and accepted orders previous to May 1, which he is legally bound to deliver at former prices and where he cannot collect the tax, will have consideration as to refund by applying to the Department of Inland Revenue.
 - (7) Payable from Canadian Manufacturers. Tax collected by Government for phonographs, records and player rolls; May sales on June 1, 1918. For player-pianos and mechanical organs; May sales on June 1, 1918.
- Note: Efforts are being made to secure extension of collection of records tax for two months, and players tax for six months. No decision yet rendered. In event of postponement of tax, a guarantee year bond will require to be furnished satisfactory to the department.
- (8) Tax is payable when goods are passed through Customs. This does not change present regulations covering bonding.
 - (9) While bill has not been passed, it is understood that when it is put in force it will be made effective as from May 1, 1918.

While up to the time of going to press the excise bill is still before the house, it is not expected there will be any serious objection, and that it will become law and effective as on May 1, 1918.

This special war tax of 10 per cent. on the manufacturers' selling price applies to player-pianos and rolls, mechanical organs, talking machines and records.

Various opinions are, of course, expressed concerning the inclusion of musical instruments among those lines on which a tax might fittingly

be placed, but your correspondent believes the general sentiment is one of cheerful readiness to co-operate with the Government in raising much needed revenue and a feeling that the Government has been careful not to impose an assessment that would seriously restrict the industry. It is felt that the piano trade has reason to feel elated that the contention of the piano being a household and educational necessity has been recognized by the Government. In regard to the 10 per cent. on player sales there is a little uncertainty as to how this will affect the financing of the sales as the tax may be required by the Government in a lump sum when the sale has been made. The optimists in the trade figure that this tax may do good to the industry in forcing better terms of payment.

So far as the talking machine trade is concerned it is not felt that the tax will interfere with business. Because of the impost dating from May 1, manufacturers and wholesalers are uncertain as to what the necessary changes in

prices will be and are protecting themselves by a clause on all invoices of goods going out since May 1.

Exception is taken, however, to the act and the following vigorous protest is registered by a prominent dealer in the East: "The writer, personally, feels that a big protest should have been made against this tax on talking machines by all manufacturers and dealers in phonographs. Talking machines are far more than a luxury. They are just as necessary for the uplift of humanity and civilization as schools and colleges, and the Government might with as much judgment and common-sense, tax school books, newspapers, magazines, etc.

"Thought is a great motive power in this world, and music is a mighty factor in helping people to think aright. Some great writer has said: 'If you wish to grow better then you should look on a beautiful picture every way, read a beautiful poem, and listen to a beautiful musical composition.'

"We feel sure that if the members of our Parliament realized the great blessing that talking machines are in the homes they would not have placed such an excessive tax on these instruments."

OTTO HEINEMAN PHONOGRAPH SUPPLY CO.'S NEW HOME

Now Located in Toronto at 172 John Street—G. W. Hopkins' Visit Enjoyed—Many New Stores and New Agencies Announced—Recent Visitors to Toronto—Other News

TORONTO, ONT., June 6.—The local branch of the Otto Heineman Phonograph Supply Co., Inc., is now at home in the new quarters at 172 John street. The manager, C. J. Pott, has taken a lease of the entire ground floor in the new concrete, fireproof building at the foregoing address and has rearranged the floor space to house both the offices and warehouse. Substantial quarter-cut oak fittings have been put in, private offices for Mr. Pott and his assistant, Mr. Green, and an interdepartment phone service. From Mr. Pott's desk he will be able to overlook both the incoming and outgoing shipping departments. Soundproof rooms are also being installed.

The increased floor space will permit the carrying of a much larger stock of Heineman and Meisselbach motors, tone arms and all parts. The advantage of having all departments under one roof and on one floor are quite obvious.

The Heineman branch had the recent pleasure of a visit from A. F. Meisselbach of the firm's Meisselbach division in Newark, N. J. In company with Mr. Pott, Mr. Meisselbach visited a number of phonograph manufacturing plants in Ontario centers, and Mr. Meisselbach makes no secret of his enjoyment of a visit to Canada.

Mr. Pott is again visiting New York, where he is attending the National Music Show in the Grand Central Palace during the week of June 1 to 8.

H. M. Shaw, until recently in charge of the Home Outfitting Co.'s exclusive Pathé store at St. Catharines, has removed to Windsor, where he is in charge of the Pathé department of Baum & Brody, furniture dealers.

Armand Heintzman, vice-president of Gerfard Heintzman, Ltd., had a display of styles of his firm's phonograph at the National Music Show, which was recently held in New York.

The Musical Merchandise Sales Co., distributors of the Brunswick phonograph, announce the introduction of the new "Ultona" reproducer with which three models of the line have been equipped.

J. L. De Vaney, who was the Musical Merchandise Sales Co.'s representative in Alberta and British Columbia, has enlisted in the Royal Flying Corps. He is succeeded by K. A. Ross, who has already a considerable connection in the West. The firm also announce the opening of a Brunswick Shop in Winnipeg under the management of H. E. Etenberg, in connection with which it is proposed to put on an extensive advertising campaign. The Musical Merchandise Sales Co.'s Western headquarters have been located at 143 Portage avenue.

George W. Hopkins, New York, general sales manager of the Columbia Graphophone Co., addressed the Ad Club at London on May 16. Mr. Hopkins addressed the Toronto Board of Trade recently when his speech made a hit.

W. S. Carr, of Niagara Falls, Ont., who is well known in the Niagara Peninsula, has taken on the Columbia line which he is featuring quite extensively.

Judging from the letters received from John Sabine, while the latter was in New York recently, he was considerably enthused over the Columbia period models, displayed at the Columbia Co.'s Fifth avenue store. Mr. Sabine

(Continued on page 34)

Talking Machine Supplies and Repair Parts

SPRINGS, SOUND BOX PARTS, NEEDLES

THE RENÉ MANUFACTURING CO.
MONTVALE, NEW JERSEY

TRADE CONDITIONS IN THE DOMINION OF CANADA—(Continued from page 33)

visited the company's head office in New York and the factories at Bridgeport.

The Adams Furniture Co., after trying out various makes of machines and records, are now handling the Columbia line exclusively.

In their contribution to a patriotic fund being raised in London, the Starr Co., of Canada, included a Starr phonograph trench outfit. This is one that regularly sells at \$110. With other contributions it was put up at auction at the Tecumseh House and realized \$250, being purchased by Sir George Gibbons, who, with his usual generosity, donated it to the boys who are serving at the front.

O. C. Dorian, general manager of the Pathé Co., will soon leave for an extended trip which will take him right through to the Western Coast. He will call on some of the most important Pathé representatives in the West and will make a thorough study of conditions there.

W. K. Elliott, Brampton, Ont., has added the Brunswick line to his piano business.

At the recent motor show in the armories in

Peterboro there was an exhibit of Pathé records and machines shown by E. V. Warne.

H. S. Berliner, vice-president of the Berliner Gramophone Co., Ltd., Montreal, was a recent trade visitor to Toronto.

G. W. Hopkins, general sales manager of the Columbia Graphophone Co., New York, spent a week-end in Toronto looking over the company's new factory and Canadian head office premises.

At the opening of the Commodore Jarvis branch of the Navy League of Canada held in Toronto's new Masonic Hall, the Sonora in charge of H. R. Braid, of I. Montagnes & Co., Canadian distributors of the Sonora, provided the musical entertainment in the luncheon parlors.

The first firm to pay the new excise tax of 10 per cent. at the port of Toronto was I. Montagnes & Co., who released a shipment of Sonora phonographs on May 2. The 10 per cent. is payable on the importer's price plus the regular tariff charge.

cating in their advertising copy the purchase of machines before the new additional 10 per cent. war tax is applied.

The Berliner Gramophone Co., Ltd., with their usual thoughtfulness for their customers on May 1 (moving day in Montreal) placed their motor trucks at the disposal of their customers moving their Victrolas and records absolutely free of charge.

R. W. Burgess, manager of the Montreal branch of the Pathé Co., has been obliged to take a few weeks' rest in a sanitarium at Three Rivers, owing to a nervous breakdown.

The Musical Merchandise Sales Co. have been using large space in the dailies in the interest of the Brunswick and the new Brunswick Shop in particular which was opened to the public the past week at 582 St. Catherine street West. New dealers in Montreal include J. A. Ethier, 1901 St. Catherine street East, and J. L. Ethier, 734 Notre Dame street, West.

George S. Pequegnat, who has been in charge of Wilder's Music Supply Co. (phonograph department) for some time, is severing his connection with that company on the first of June. His plans as yet are unsettled, although he has had a number of flattering offers.

The death occurred very suddenly the past month of John Ferns, who for some years had been handling "His Master's Voice" products in the north end of the city. The late Mr. Ferns was for some years superintendent of the Berliner Gramophone Co.'s plant leaving there on account of ill health, and was one of the first men to press Victor records in Canada.

TRADE NEWS FROM WINNIPEG, MAN.

G. W. Johnston Joins the Forces—Edison Tone Test Attracts—Robt. Shaw Discusses Record Situation—Big Order for Pathéphones

WINNIPEG, MAN., June 1.—G. W. Johnston, who has been for the past five years manager of the phonograph department of W. G. F. Scythes & Co., Regina, Sask., and has recently joined the Seventy-seventh Battery, was tendered a banquet by the firm and staff, and presented by the firm with a shaving kit and by the staff with a wrist watch.

E. D. Morris, of the Morris Music Store, New Westminster, B. C., who suffered considerable loss by fire in March last, has opened up again with a full line of Victrolas, pianos and players, small goods and sheet music.

The New Edison with Florence Fennell in a tone test recital drew large audiences to the Hotel Vancouver in Vancouver, B. C. Edison Hall (The Kent Piano Co., Ltd.) report some nice sales as a direct result of the recital. This artiste was also heard in recital in the Hotel Empress ballroom in Victoria, B. C.

The Canadian Phonograph & Sapphire Disc Co. report business good and collections ahead of the average. Mr. Poisson recently visited Montreal.

Robert Shaw says that the Columbia trade is increasing every month with no shortage of records, owing to the improved factory facilities. He says the supply of European records is well to the fore. Owing to the publicity methods of the dealer service department many dealers are coming in on the window scheme.

Babson Bros. say Edison business has been normal and records are coming through the factory a little better. On the whole there is little or no complaint. The new Edison records are winning high praise.

The Hudson Bay Co., of Vancouver, B. C., have just placed an order for one carload of Pathéphones. The most gratifying feature in connection with it is that nearly 75 per cent. of the whole order was made up of machines from \$125 up. The Hudson Bay Co.'s Calgary, Alta., house have also become agents for the Pathé line of phonographs.

The Musical Merchandise Sales Co., Brunswick distributors, have located their Western headquarters in Winnipeg at 143 Portage avenue.

MONTREAL TRADE DISCUSSES PROFITABLE ADVERTISING

Does Display or Classified Advertising Bring Best Results—Talking Machines as Wedding Gifts—Artistic Sonora Display—New Brunswick Dealers—Death of John Ferns

MONTREAL, QUE., June 5.—An increasing demand is noticeable in the sale of phonographs as wedding gifts. In sounding out the local dealers it seems that this business is not gone after as aggressively as it might be by some firms, while others are hot foot on the trail of the would-be bride and bridegroom. The information is gained from the engagement column of the daily newspapers and from private sources.

The Montreal Light, Heat & Power Co., Ltd., in their new and well-appointed showrooms in their new building, have a rest room for their lady patrons, et al. Musicales are given every afternoon. The Sonora furnishes the music and is from the warerooms of Charles Culross. One of their handsome show windows for demonstrating some of their electrical lines suitable for a den featured an Aeolian-Vocalion furnished by Charles Culross. It showed up to splendid advantage in the cozy and well-furnished room.

Speaking with a representative phonograph dealer who believes very strongly in printer's ink the question was put to him as to whether he found display advertising or condensed classified advertising the most productive of results. He stated that on second-hand machines

and exchanges the classified columns brought him excellent returns, but when it came to advertising and featuring a new machine he had to resort to display advertising and an illustration of the machine for direct results.

At Layton Bros. warerooms a window full of Grafonolas attracted considerable attention and represented eighty-nine models of Styles 24 and 38. Summer sales were considerably stimulated by this effective window display. Sales Manager W. W. O'Hara was responsible for the unique window trim.

An annual event with Eugene Julien Co., Quebec, who do an extensive piano and phonograph business, is their exhibition which this year was preceded by a dinner tendered to the press and the directors of the firm by Eugene Julien. H. V. Roy, who has charge of the music department, had a full orchestra and his musical features were appreciated by large audiences.

The recent appearance here of Martinelli revived interest in the recordings of this famous Victor artist and the Berliner Gramophone Co., Ltd., and all "His Master's Voice" dealers shared alike in the spirited call for his records.

Nearly all the phonograph dealers are advo-

MELOPHONE MOTOR

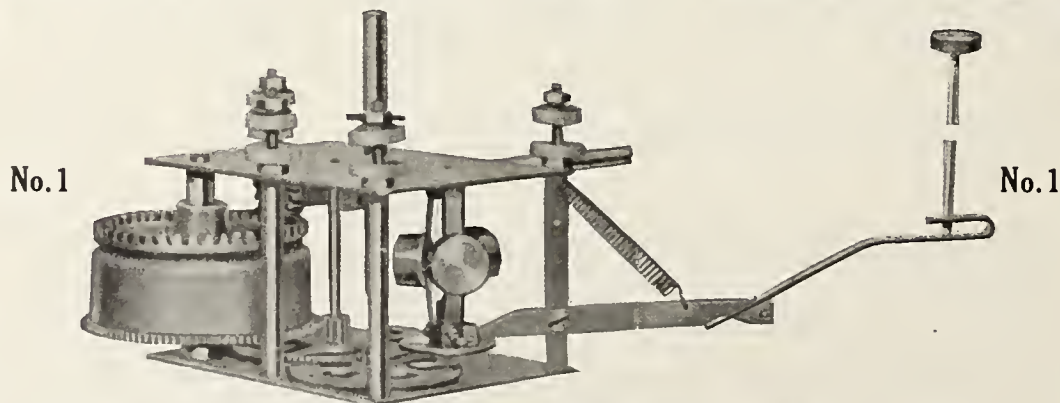

COMPLETE WITH 10-INCH TURN TABLE

Simple in construction, the most satisfactory and durable of all small motors.

Will play two ten-inch records with one winding.

Three years' successful record as the best single spring motor manufactured.

Immediate Deliveries

Sample \$2.00

Write for Quantity Prices

Melophone Talking Machine Co.

380 Lafayette Street, New York

NEEDLES

Manufactured by the

DEAN DIVISION

of the

OTTO HEINEMAN PHONOGRAPH SUPPLY CO.

INCORPORATED

25 WEST 45th STREET, NEW YORK

FACTORIES: Elyria, Ohio Newark, N. J. Putnam, Conn.
BRANCH OFFICES: Chicago, Ill. Cincinnati, O. Seattle, Wash. Toronto, Ont.

STEEL NEEDLES

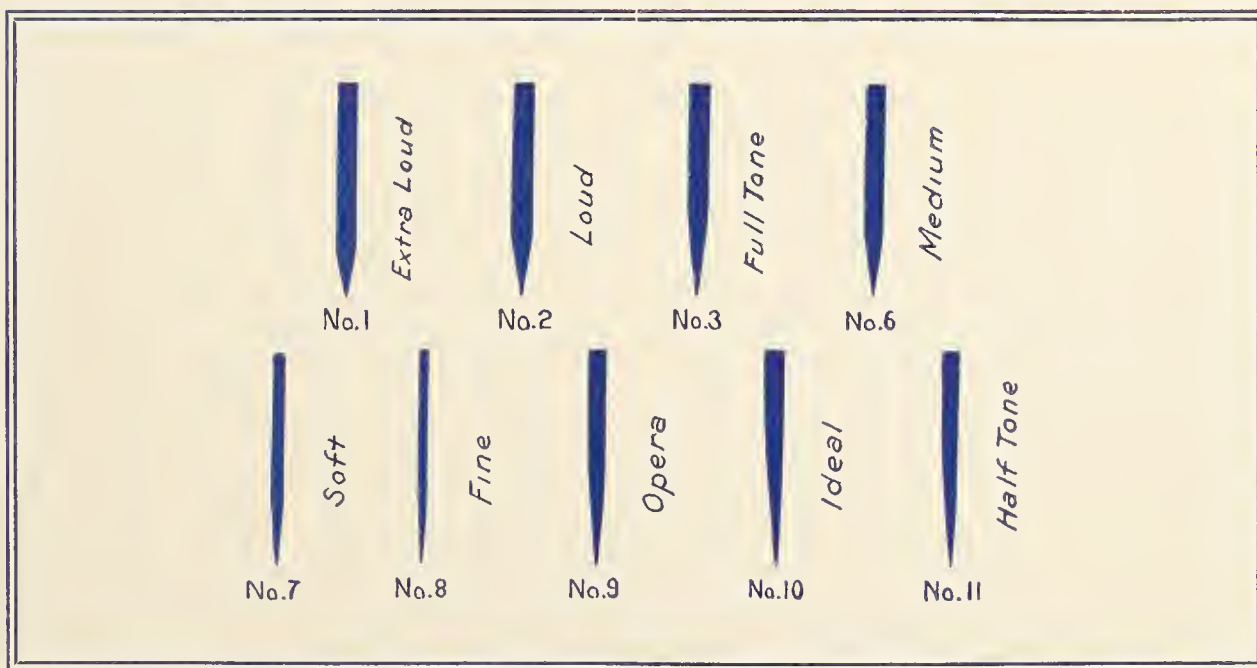

PERMANENT NEEDLES

TO PLAY PATHÉ RECORDS

Half Tone Points

Full Tone Points

TO PLAY EDISON RECORDS

Sapphire Points

Genuine Diamond Points



ACTIVE CALL FOR TALKING MACHINES ON PACIFIC COAST

All Sections Report Increased Demand Despite Campaign for Red Cross and Other Funds—Northwest Especially Prosperous—What Leading Talking Machine Houses Say About the Outlook

SAN FRANCISCO, CAL., June 2.—Taken as a whole the month of May was a thoroughly satisfactory one for the San Francisco talking machine trade, both wholesale and retail, according to reports from various establishments; in fact, better than might have been expected in view of the strenuous campaign for Red Cross funds and other diverting influences. Advices from other Pacific Coast cities indicate that the active demand for talking machines and records was not confined to the Bay district. Local music houses maintaining branch stores or selling dealers in other sections of the Western territory report very good returns from all directions. The Northwest is especially prosperous on account of the rapid growth of its shipbuilding industry, which makes toward activity in practically all lines of business including talking machines; the interior of this State is in splendid condition from an agricultural standpoint, and dealers in southern California, Arizona and New Mexico seem to be getting their full quota of business also. The increased freight rates did not come as joyous news, but the local trade shows little inclination to complain about war-time readjustments over which they have no control.

Acting With Sherman, Clay & Co.

"Business was never better at this time of the year," is the way Andrew G. McCarthy, treasurer of Sherman, Clay & Co., sums up the month's report for the Victor department, which he gives his personal attention. The only difficulty, he says, is to get stock. Shipments have been coming through from the factory in fairly good time and in fairly large quantities, but more goods could be used to excellent advantage on the Pacific Coast. Mr. McCarthy returned from an Eastern trip early in the month, during which he visited the Victor headquarters and looked after other matters for his company. Since he returned he has been interested in the extensive improvements Sherman, Clay & Co. are making at their wholesale Victor branch in Los Angeles, Cal. The work was started some months ago, but it was only this month that tenants occupying part of the additional space vacated, so the plans for expansion could be brought to a close. Now the company's Southern California quarters compare very favorably with any place of the kind in the entire country, it is claimed. The same plan of arrangement has been carried out in the Southern city as was worked out for the new wholesale Victor establishment, fitted up last year by the company on Mission street, San Francisco.

Trade in Southern Points

Jas. J. Black, of the Wiley B. Allen Co., is back at the San Francisco headquarters giving his attention to the talking machine department of the business, after spending some little time at the firm's branch store in Sacramento, Cal., where a talking machine department was being added. R. R. Draper has accepted a position with the company as manager of the new department, and Mr. Black says he is sending in very good reports from the capital city. At the local store, business for May gave no ground for complaint. Frank Anrys, general manager of the Wiley B. Allen Co., has gone East on a combined business and pleasure trip.

Conducting an Active Campaign

Mrs. Helen Plummer Howard, who was placed in charge of the talking machine department of the Hauschild Music Co., in Oakland, Cal., a few weeks ago, has been conducting a very active campaign and is getting splendid results. At her instigation the company is giving away a talking machine each week to some training camp, cantonment or other branch of the army or navy service, and is collecting records for the use of the soldiers and sailors stationed in this part of the country. A call for records is incorporated in the firm's advertising, and a box has been placed at the Liberty War Hut. In this way a great many are received, and

Mrs. Howard says the men in the service are very appreciative. Machines have been placed on three submarine chasers built in this vicinity. Mrs. Howard now has associated with her Miss Fay Otis, formerly music history teacher at the University High School in Oakland. Together they are specializing along educational lines and have succeeded in working up considerable interest. A few days ago Mrs. Howard demonstrated a machine at the shipyards in Alameda, and she has arranged for a public demonstration at the Quericli branch of the Public Libraries in Oakland.

The Hauschild Music Co. has recently added the Brunswick line of phonographs at its Oakland store.

Columbia Warerooms Almost Cleaned Out

The local warerooms of the Columbia Graphophone Co., under the supervision of F. A. Denison, are almost entirely cleaned out of stock, as a result of very active selling during the past month, and it now looks as if June business might be curtailed to a considerable extent by lack of machines to sell. The shortage of stock applies particularly to machines, as records are coming through in better shape than was the case a few months ago, according to Mr. Denison, which is largely due to the fact that he is having most of the shipments come by express instead of depending upon freight service.

Move Mauzy Machine Department

The talking machine department of the Byron Mauzy music business in Stockton street has just been moved from one of the upper floors of the building to prominent space on the main floor. Several soundproof demonstration rooms have been installed and the new quarters are being nicely fitted up. Edw. Humphreys has charge of the department. He reports business exceedingly good for this time of the year. Mr. Mauzy left for New York recently, accompanied by his wife and daughter.

The White Music Co., which was organized several months ago by Arthur White, formerly manager of the talking machine department of the Emporium in this city, to engage in business in Berkeley, Cal., has been granted permission by the State Corporation Commissioner to issue fifty shares of its capital stock to Mr. White and G. H. Leathurby in consideration of money advanced to the corporation.

A nicely fitted up talking machine department

is one of the principal features of the new branch store opened by Byron Mauzy in Oakland.

A new music store was recently opened at 531 Thirteenth street, Oakland, by Howard E. Brillhart, who is handling the Pathé line.

ORDERS TWO CARLOADS OF PATHES

Stern Talking Machine Corp. to Act as Pathé Dealer in San Francisco

SAN FRANCISCO, CAL., June 3.—Fred'k Stern, president of the Stern Talking Machine Corp. of this city, who returned recently from a two weeks' trip to the East, closed arrangements on this trip whereby his company will act as Pathé dealers in this territory. Mr. Stern states that he has already placed an order with the Pathé Frères Co. for two solid carloads of Pathéphones and for approximately 20,000 records for immediate shipment.

It is the intention of the company to carry a complete stock of Pathé records, having on hand every single number in the catalog at all times. The total stock of Pathé records will therefore be approximately 100,000 records. A permanent stock of Pathéphones of about 750 to 1,000 machines will also be on hand, so that the company can adequately handle the requirements of its clientele.

During the past month or so the Stern Talking Machine Co. received about 10,000 Pathé records and about 100 Pathéphones from the local Pathé jobber, and these machines and records met with a ready sale. In fact, the business was almost phenomenal, and Mr. Stern is naturally enthusiastic regarding the prospects for Pathé business in all of the company's stores.

In a chat with The World correspondent he said: "Having been able for the past two years to declare a cash dividend to our stockholders, amounting to about 20 per cent. at the close of each year, we feel that we ought to be able to do much better than that the coming year, as the result of our handling Pathé products, because we consider the Pathé line far superior to anything we have heretofore handled. If the Pathé Frères Phonograph Co. will supply us with merchandise as fast as we order it, and I have every reason to believe that they will, I am sure that our business during the coming year will far exceed our expectations.

"One other item which will materially increase our volume of business is the fact that the Pathé Frères Co. is so prompt in getting out new record selections of the new popular numbers.

A Message to Phonograph Manufacturers

Are you making *Just Another Talking Machine?*

Is it your aim to manufacture a line of Phonographs for the future?

Do you realize that the Reproducer is the vital feature in a Phonograph?

The **BLISS REPRODUCER** meets all comparative tests both as to tone and volume.

The diaphragm of the **BLISS REPRODUCER** is constructed along scientific and mechanically correct lines, and is a laboratory product in every sense.

If you are interested in *Quality First*, write us.

WILSON-LAIRD PHONOGRAPH CO., Inc.

Factors and Distributors of the **BLISS REPRODUCER**

29 West 34th Street

NEW YORK CITY



Edison Message No. 23

Music A Vital Force

"Theoretically, music is a gratuity, a luxury; practically, it has proven itself to be a necessity. The simple truth is that one of the vital forces of a nation is its music, and that in the accomplishment of a huge task wherein all its energizing processes are required, the value of music should be carefully regarded."

— Colonel E. M. Markham,
303d Engineers, National Army

Colonel Markham speaks from experience and with authority. During his many years in the army, he has served in China, the Philippines, Cuba, Mexico and no doubt by now he is serving in France. He says a man away from home requires the refining influence of good music and that it makes him a better man and a more efficient soldier.

If music is so indispensable to our soldiers, whose entire time seems to be actively employed, how much greater is the need for those who must remain behind to hope and pray and wait.

THOMAS A. EDISON, Inc.
Orange, New Jersey



THIS
TRADE
MARK
ON EVERY
EDISON
PHONOGRAPH
Thomas A Edison

TRADE IN BUFFALO ACTIVE DESPITE RED CROSS DRIVE

Last Month's Business Exceeded Expectations—Death of C. H. Utley Regretted—Getting After Vacation Trade—Laxity of Credit Out of Date—Columbia's Biggest Month—Other News of Interest

BUFFALO, N. Y., June 9.—Even if millions of dollars of Buffalo's money were diverted in May to two worthy causes, the Third Liberty Loan and the Red Cross, the local demand for talking machines and records was extra heavy in the past month. May business at some of the wholesale and retail stores showed a gain in May, 1918, over the preceding period a year ago.

The A. F. Koenig Piano Co. has taken on the Pathé agency. President Koenig is enthusiastic over this line. His Pathé window display is enhanced by the use of a valuable oriental rug.

In the Red Cross campaign in May local talking machine dealers figured prominently and contributed generously. Red Cross posters and banners were well displayed by these merchants.

The funeral of Benjamin D. Bing, of Bing & Nathan, Sonora dealers, was held here recently. Mr. Bing was sixty-one years old.

Members of the music trade industry learned with great regret of the death of Chas. H. Utley, the Edison dealer, and veteran piano merchant of this city, who passed away recently after an extended illness. The funeral from Trinity chapel, of which Mr. Utley was vestryman for twenty-five years, was largely attended. Mr. Utley was born in Buffalo September 1, 1847, and is survived by a widow and one son, Lieutenant Chas. Bach Utley.

Will local talking machine dealers follow the lead of some of the piano dealers, who are clearing house on account of a shortage of goods and slow transportation? In many cases the merchants in question are repossessing instruments on bad accounts and selling them over again to good prospects.

The advent of warm weather has various effects on the talking machine trade. When the temperature rises some dealers and salesmen sink into a state of coma, so far as stirring up

active business is concerned. Others cultivate the summer resort and country trade, or strive for success among city prospects. The last-named campaigners have the foresight to realize that the going is easier now than it may be in face of "heatless Mondays" and other wartime handicaps next winter.

C. Kurtzmann & Co. were represented at the conventions in New York by J. H. Hackenheimer, H. C. Rice and Roy S. Dunn.

The wise talking machine salesman these days is impressing on his prospective customer that music and patriotism are inseparable and that, in wartime, music is really essential.

L. L. Hatfield, of this city, formerly sales representative of the Edison Co. in Canada, has joined the Canadian Heavy Artillery.

War gardening is being practiced as an act of patriotism and recreation by Charles Hereth, New Edison dealer. Mr. Hereth has a farm at Bomansville, twelve miles from Buffalo. He is also an amateur florist. So far as business is concerned, he advocates the extension of short-term credit.

Harold J. Verbeck, of the Verbeck Musical Sales Co., Columbia and Delpheon dealers, expects to go overseas shortly. He has been training in aviation at Lake Charles.

Bach Utley has received his commission as second lieutenant in aviation at Lake Charles.

The Kaepfel Piano Co. has taken on the Sonora line. Carl Kaepfel, of this firm, attended the New York trade conventions. This firm is displaying a service flag, Alvin Kaepfel having joined the navy.

Laxity of credit by talking machine jobbers and retailers is going out of date. Figuratively speaking, "Get the Money" is seared into the mind of every salesman. In the employers' estimation, the sales person who can "bring home the bacon" in the form of tangible payments for

goods is the man who doesn't have to worry about his job.

Salesmen of the following firms are selling War Savings Stamps: J. N. Adam & Co., Victor dealers; Adam, Meldrum & Anderson Co., Pathéphone dealers; Bricka & Enos, Columbia dealers; William Hengerer Co., Victor dealers, and Walbridge & Co., Victor dealers.

Ralph C. Hudson, president of J. N. Adam & Co., Victor dealers, is a member of an advisory committee to draft rules to govern talking machine and other mercantile establishments along lines on which factories are controlled.

In times like these railroad men are regarded as good talking machine prospects. As substantial wage increases are headed their way, their purchasing power may be considerably increased within a few weeks.

"We have closed the biggest month in the history of this branch," said O. M. Kiess, local manager of the wholesale department of the Columbia Graphophone Co., in speaking of his May trade. "The largest previous month we ever had was December, 1916. We have gone ahead of that month by several thousand dollars. Our May, 1918, business was 81 per cent. over May, 1917, and 90 per cent. over the trade in April, 1918."

F. K. Pennington, assistant general sales manager of the Columbia Co., stopped off to inspect the company's new quarters which he said have the best facilities of any branch of the Columbia Co. in the United States. New Columbia dealers include Lewin Bros., Ellicott Square, Buffalo, and the Crane Piano Co., Syracuse.

At the Buffalo branch of the Brunswick-Balke-Collender Co. a well-equipped balcony is being built for the exclusive demonstration and display of Brunswick phonographs.

W. R. Gardner, manager of J. N. Adam & Co.'s Victrola department, is pushing the sale of the record "God Be With Our Boys Tonight." This song was featured by John McCormack, who appeared at the Broadway Auditorium for the benefit of the Knights of Columbus War Camp Fund.

The Leonard Markels BUTTERFLY MOTOR

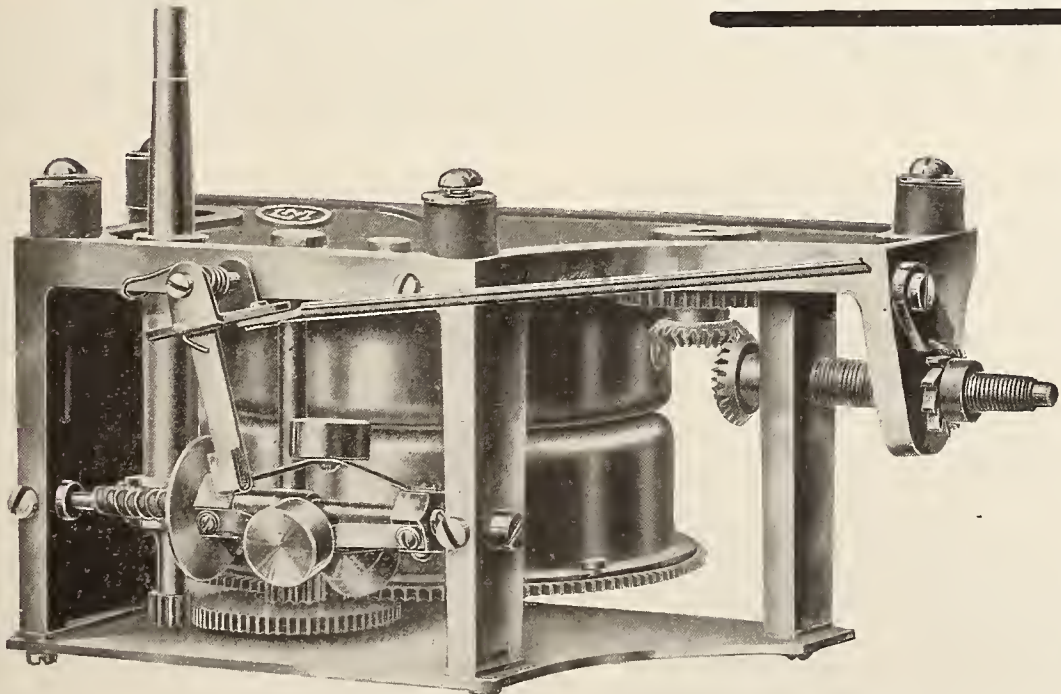

The Leonard Markels Jewel Bearing Butterfly Motor

has revolutionized the motor industry. It is silent running and silent winding and represents the acme of perfection in motor construction.

This motor has achieved phenomenal success, and is being used exclusively by leading phonograph manufacturers in all parts of this country and Canada.

Write today for a copy of our New Butterfly folder

- Specifications*
- Beveled gear noiseless winding.
 - New ratchet device that prevents clicking.
 - Bakelite intermediate gear—absolutely silent.
 - Plays seven 10-inch or five 12-inch records at one winding.
 - Cast iron nickered frame.
 - Powerful, durable, compact, accessible.
 - Built especially for the highest-grade machines.
 - Guaranteed in every minutest detail.

LEONARD MARKELS - 165 William St., New York



Traveling light, strong and compact, the Columbia Portable Grafonola is first-aid to a joyous vacation. Apply it to your customers.

**Columbia Graphophone Co.
NEW YORK**

READY-FILE CO. ENLARGES FACTORY

Experiencing Big Call for Ready-Files for New Edison Models and Needs More Room to Fill the Orders Which Are Pouring in

INDIANAPOLIS, IND., June 6.—The Ready-File Co. announces the enlarging of that part of its factory devoted to Ready-File for the New Edison. It is stated that these models were put out to fill a market that was thought somewhat limited, because the New Edison had been considered in the trade as an instrument that was chiefly sold in the higher-priced models, while Ready-File was to be made only for the 100A and 150C models. However, the Edison dealers have shown unexpected interest towards this filing device, and the demand has been very much stronger than was anticipated. It is especially worth noting that many dealers have been sending in frequent repeat orders for large quantities, which seems to disprove entirely the theory that the New Edison is sold only in the more expensive models.

Ready-File for the New Edison is now considered by the officials of the company to be well over the experimental stage, and to have come to the point where a strong, well-balanced market can be relied upon. Hence the resolve to give the manufacturing of it larger quarters. Edison dealers in Indianapolis are wishing the Ready-File Co. the "best o' luck" in developing this new necessity for New Edison phono-

graphs, for, as one dealer put it, "the greater demand they can create for Ready-File the greater will be our extra profits from the sale of it."

Officials of the Ready-File Co. have expressed themselves as being sure that the enlargement now under way will enable them to give faster and more satisfactory service to their customers.

M. E. SCHECHTER'S NEW POST

Appointed Eastern Sales Manager of the Otto Heineman Phonograph Co.

The Otto Heineman Phonograph Supply Co., New York, has announced the appointment of M. E. Schechter as Eastern sales manager of the company, with headquarters at the executive offices, 25 West Forty-fifth street, New York. Mr. Schechter assumed his new duties the first of the month, and spent considerable time at the music show getting acquainted with the members of the out-of-town trade who visited New York during convention week.

Mr. Schechter is splendidly equipped to occupy his new post, as for several years he was associated with the Sonora Phonograph Sales Co., having been purchasing agent for this company for the past two years. He is therefore familiar with the manufacturing end of the industry, and numbers among his friends and acquaintances talking machine manufacturers from coast to coast. He is enthusiastic regarding the sales possibilities of Heineman products, and is planning to co-operate with the manufacturers in every possible way.

APPOINTED SONORA DISTRIBUTOR

RICHMOND, VA., June 3.—The Rountree Cherry Corp., 111 West Broad street, has been appointed a distributor for the products of the Sonora Phonograph Sales Co. The company is planning an active campaign in behalf of this popular line, and well-known dealers throughout this territory are being signed up regularly. The Rountree Cherry Corp. is well known in local retail circles, and every member of its sales staff is enthusiastic regarding the possibilities for developing Sonora business in this territory.

You never know under what conditions a worth-while idea may come to you. Keep your eyes and ears open to impressions when you are on the street, in any place where people gather and talk. It is this alertness of mind that makes you every day more and more receptive to outside impressions and furnishes you with ideas you can use.

BOLTON ON WESTERN CONDITIONS

Sales Manager of International Record Department, Columbia Co., Tells of Progress Throughout West Based on Recent Trip

R. F. Bolton, sales manager of the international record department of the Columbia Graphophone Co., New York, returned recently from a Western trip which included a visit to the company's branches in the leading Western cities as far as Kansas City and Minneapolis. This was Mr. Bolton's first Western trip in his new capacity, and he was accorded a hearty welcome everywhere.

In a chat with The World Mr. Bolton expressed his appreciation of the splendid sales efforts which the branch managers and their staffs are advancing in behalf of Columbia foreign language records. The demand for these records is steadily increasing, and judging from all indications 1918 will be a banner year for this important branch of Columbia activity.

The dealers throughout the West are utilizing to excellent advantage the series of new hangers recently prepared by the Columbia Co.'s international record department. They are enthusiastic regarding the sales value of these hangers, and are also well pleased with the new advertising campaign inaugurated by this department a few months ago. In fact, many of the dealers are tying up their local advertising with this national newspaper campaign in order to secure maximum results from this publicity.

THE LIBERTY PHONOGRAPH CO.'S LINE

MINNEAPOLIS, MINN., June 4.—The Liberty Phonograph Co., of this city, has just placed on the market a line of phonographs which is meeting with considerable success. The company has established quite a number of dealers and, according to present plans, an active campaign will be advanced in behalf of these products. At the present time the company is concentrating on the production of two models retailing at \$75 and \$95, and these instruments embody numerous distinctive features, including a wooden tone arm, automatic stop, speed regulator, and other desirable features. The company is making it a point to fill the orders of its dealers promptly, and arrangements are being made to take care of an active fall trade.

Do not mistake activity for progress. If Paul Revere had ridden a rocking horse he would not have arrived.

"The Music Without the Blur!"

This ideal of talking machine manufacture is attained more nearly than by any other, in the construction of the

**MARVELOUS MAGNOLA
"Built by Tone Specialists"**

"Magnola's Tone Deflector eliminates the scratch"



Watching the Music Come Out

We want to show you how to make money with MAGNOLA; and how MAGNOLA is the best buy on the Talking Machine Market to-day.

Send us your name and let us send you some real Talker Tips.

MAGNOLA TALKING MACHINE COMPANY

OTTO SCHULZ, President

General Offices 711 MILWAUKEE AVENUE CHICAGO
Southern Wholesale Branch 1530 CANDLER BLDG. ATLANTA, GA.

Talking Machine Hardware

We manufacture hardware for all styles of cabinets

- Lid Supports
- Door Catches
- Sockets
- Needle Cups
- Sliding Casters
- Tone Rods
- Needle Rests
- Continuous Hinges
- Knobs, etc.

BEST QUALITY

LOWEST PRICES

WEBER-KNAPP COMPANY - Jamestown, N. Y.



UNICO

Designs and Construction
Patented

SYSTEM

THE SALES BUILDER

Unico Demonstrating Rooms
Excel from Every
Standpoint

- DESIGN** Six standard styles
Special period styles
- CONSTRUCTION** Patented, Interlocking
Portable Units
Sound Insulated
- FINISH** All standard Oak,
Mahogany and Enamels
- EFFICIENCY** Increased sales at lower
cost per sale
- ECONOMY** Moderate first cost
Always an Asset
Adaptable any location
- DELIVERY** Prompt shipments from
stock ready for im-
mediate use

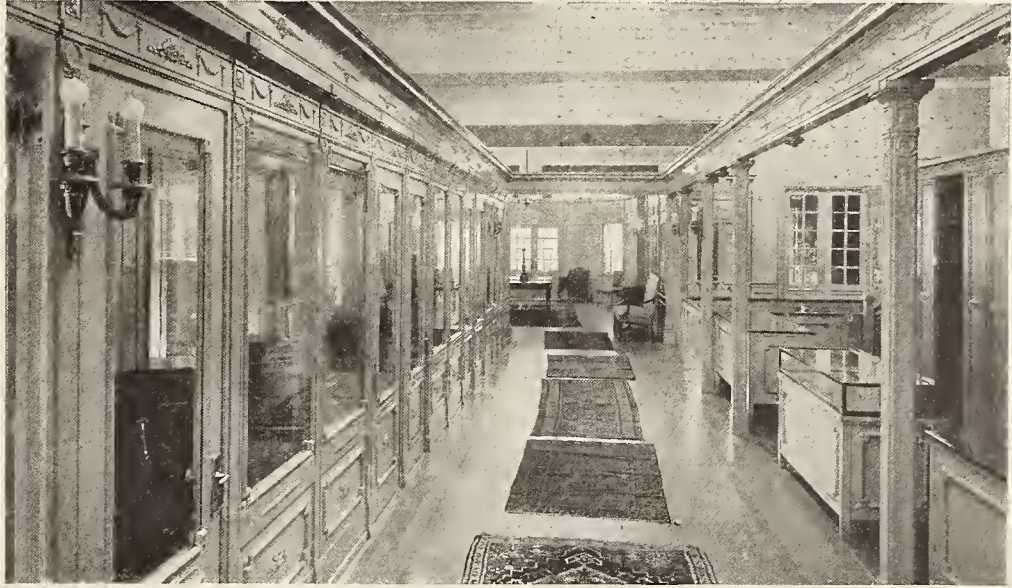

Unico Racks and Counters
Maximum Capacity
Minimum Space

- DESIGN** Patented to correspond
with Unico Rooms
- CONSTRUCTION** Sectional Units adapta-
ble to any space
- FINISH** All standard Oak, Ma-
hogany and Enamels
- EFFICIENCY** All records always
available instantly
- ECONOMY** Moderate Equipment
Cost
Lower Operating Cost
- DELIVERY** Prompt shipments from
stock in all finishes

Install a
Complete Unico Department



- DEMONSTRATING ROOMS
- RECORD RACKS
- RECORD COUNTERS
- CEILING DECORATIONS
- ARCH TREATMENTS

The Unico System has
Increased Sales and Profits
for almost 1000 dealers



Send to-day dimensions of your available space. Plans and
estimates for a complete department will reach you promptly

THE UNIT CONSTRUCTION COMPANY

RAYBURN CLARK SMITH, President

Fifty-eighth Street and Grays Avenue, PHILADELPHIA, U. S. A.

THE TRADE IN BOSTON AND NEW ENGLAND

JOHN H. WILSON, MANAGER, 324 WASHINGTON STREET, BOSTON, MASS.

BOSTON, MASS., June 9.—Business is about what one might expect at this season of the year and with the conditions as they are recognized to be. The times are surely just opportune to test the mettle of a man, and those who hustle seem to be the ones that get the goods. There are times when business often comes to a man; and there are occasions such as the present when one waits a long time if the proper attraction is not offered to induce trade. There are men in Boston who are doing a most creditable business because they go after it, they exercise every honorable means to draw business to their establishments, and it is not to be wondered at that they are optimistic. Even these houses are working against great odds, for as is distinctly known in one or two cases they are badly handicapped through lack of help, due to the draft and other things. There is on the other hand the men who complain that business is not what it should be; and while this is a statement of fact that admits of great truth these same men do not press out, branch forth as they should to invite a better feeling.

Good Showing of Bostonians at Conventions

There is something of a laugh going the rounds of the trade at the expense of some of the boys who got "cold feet" and didn't care to take any chances the first of the month in going to New York for the music trade convention via the outside water line. On the day of the story of the U-boat escapades there was some expectation that the port of Boston would be closed, so this offered a fairly reasonable excuse for quite a group to cancel their passage on the Eastern steamship line to New York; but it happened that the "Belfast" sailed that night all right, and the alternate boat sailed the following night. Incidentally quite a number of talking machine men went over to New York for the conventions, and it is seldom that the trade has been so well represented from Boston as this year. And nearly all of them went by train!

Impressive Educational Exhibits

At the Eastern Music Supervisors' conference held lately in Boston both the Victor and the Columbia Cos. had exhibitions which attracted the attention of all the men and women in attendance. The exhibits were at the Hotel Brunswick, which was the headquarters for the conference, and each of these talking machine companies occupied a large room of its own.

The Victor demonstration was in charge of Mrs. Frances E. Clark, manager of the educational department for the company; and Miss Gladys Barr, supervising instructor of the company's educational department. In charge of the Columbia exhibit, which included several of the leading styles of machines, was Frederick Goodwin, and he had the assistance of Harry B. Goodwin, of the western Massachusetts department, who is located at Holyoke; and Mrs. Grace Drysdale, representing the educational department for the company in eastern Massachusetts and Rhode Island.

McCormack Records in Demand

John McCormack, the Irish tenor, was in town the other evening to sing at Mechanics' Hall for the benefit of the Knights of Columbus War Camp Fund, and a feature of the concert was the selling at auction of some of the McCormack records which had been autographed. One of "The Star Spangled Banner" brought \$120, and one of "God Be With Our Boys To-night" brought \$100, while one of "Mother Machree" sold for \$105. Naturally the day following the concert there was a renewed call for the McCormack records, but there were few of the popular ones that could be had, owing to their scarcity.

W. H. Merrick Joins Emerson Forces

Oscar W. Ray, New England manager of the Emerson Co., has just appointed a new salesman, Wilfred H. Merrick, who has been manager of the Cressey stores at Buffalo, N. Y., and the Metropolitan stores at Pittsfield and Fitchburg. He will take for his territory Maine, New Hampshire, Vermont and Eastern Canada.

Announce Many New Agencies

Manager Ray has lately signed up the F. H. Thomas Co., which conducts a large establishment in the Back Bay and will handle the Emerson records; the Lippet Bros. at New Bedford; Archie MacDonald at New Bedford; the Tuttle Co. at Rutland, Vt.; Adams Music Co. at Burlington, Vt. Manager Ray, who is over in New York, where he attended the music show, said before leaving that the company's new nine-inch record has been meeting with unparalleled success. H. T. Leeming, the new general manager for the Emerson Co., has been a visitor in town, making his headquarters with Manager Ray.

Aeolian-Vocalion Expansion

Manager Hibshman, of the Vocalion Co., was

one of the many attendants from this city to the music trade convention in New York. Lately his staff have been successful in interesting a number of prominent persons in the Aeolian-Vocalion proposition and some large purchases have resulted.

Sonora Activity

Richard Nelson, manager for Southern New England of the Sonora Co., went over to New York the first part of the month, to be away for the week. A few days earlier Mr. Nelson was over at Hartford, Conn., conferring with Joseph H. Burke, who is associate manager of the Sonora Co. Mr. Burke subsequently went over to New York also. Business with Manager Nelson has been good for the month of May.

Signs Up Many Pathé Agents

Wholesale Manager R. O. Ainslie, of the Pathé line, was another who went over to New York the first of the month. Mr. Ainslie since taking hold of the Pathé line has met with marked success. Within the next few weeks he expects to make a trip through New England, visiting the concerns which he has signed up since associating himself with the Pathé.

Ditson's Immense Victor Business

The Victor department of the Oliver Ditson Co. has been able to show a splendid volume of business both in and out of season, and Manager Henry Winkelmann was lately congratulated by the officers at the Ditson Co.'s annual meeting for the good showing his department had made during the preceding year. That's the sort of recognition that makes a man feel good.

Some Recent Distinguished Visitors

H. L. Wilson, the vice-president and general manager of the Columbia, accompanied by Louis Sterling, the London manager of the company, spent a few days in Boston lately, and Mr. Sterling was most interesting in his recital of some of the German bombing atrocities perpetrated on London. While here Mr. Wilson and Mr. Sterling were entertained by Manager Fred E. Mann. Another local visitor from New York, too, was F. K. Pennington, assistant general sales manager of the Columbia.

Geo. Lincoln Parker Honored

Local Edison dealers were quite delighted at the honor that came to George Lincoln Parker, of the Colonial Building, in being invited to preside at the sessions of the Edison dealers. It was known in advance that Mr. Parker would make a good presiding officer because of his

Victor Dealers In New England Territory

can rest assured that EASTERN VICTOR SERVICE has their interests individually at heart, particularly with respect to the securing of Victor stock. Our aim is to help the Victor dealer make the most of the existing conditions.

EASTERN TALKING MACHINE CO.

177 TREMONT STREET

BOSTON, MASS.

many qualities which would serve him in good stead in such a position, one that invariably tests a man's tact and good judgment.

Doing the Best to Please All

Wholesale Manager William Fitzgerald, of the Eastern Talking Machine Co., these days is called upon to exercise all the suavity of manner he can muster because of the letters and phones and wires which he receives complaining or remonstrating at the poor service received by dealers. This is all due to the scarcity of goods, a fact which dealers do not seem to appreciate, for having placed a good sized order they think they should receive, if not the whole consignment, at least a large proportion of it, which is not always possible these days. So Manager Fitzgerald is doing the best he can and trying through amiability and diplomacy to minimize all alleged grievances, which, one may add, he is doing quite satisfactorily.

Interesting Many in the Vitanola

A very good May is reported by the New England Vitanola Talking Machine Co., which has local offices at 52 Chauncy street. Harry Bergson, the treasurer, has been able to interest a great many persons in the Vita-Nola proposition and to-day many furniture houses and periodical stores are carrying this line. All of New England is covered from this headquarters here and the two traveling men, James Birmingham and J. S. Whitney, are finding business good throughout the territory.

Will Soon Join Uncle Sam's Forces

Fred L. MacNeil, the affable young manager of the talking machine department in the R. H. White Co.'s department store, expects to be called into service soon as he is in the present draft call. He is hoping to be able to get in a week's vacation before starting in upon his duties for Uncle Sam. Mr. MacNeil has been able to show some good business lately, and a sale of Edison machines and records recently advertised in the daily papers brought many customers to the department.

Attended Edison Convention

Francis T. White, manager of the Victor and Edison departments of the C. C. Harvey Co., is over in New York for the Edison convention. Ernest A. Cressey, vice-president of the Harvey Co., also went over, he being interested in both the Edison and the piano conventions.

New Brunswick Dealers

F. H. Walter, of the Brunswick-Balke-Collender Co., returned to-day from Pittsfield, whither he went to sign up Rice & Kelly, of that city, who are to carry the Brunswick line. The company has installed handsome quarters for the display and demonstration of the Brunswick

Lansing Khaki Moving Covers

PROTECT VARNISH IN ALL WEATHERS

and enable you to deliver your phonograph free of blemishes of all kinds.

These covers are made of Government Khaki, interlined with heavy felt or cotton, fleece-lined, quilted and properly manufactured. Perfect protection in all weather.



No. 3 Carrying
Strap Shown in
Cut

Made in Two Grades

*Write for Prices and Descriptive
Catalogue*

Use the Lansing Khaki Moving Cover
and your delivery troubles will be over.

E. H. LANSING
611 Washington St., BOSTON

SAN FRANCISCO OFFICE, Room 530 CHRONICLE BLDG.
WALTER S. GRAY, Manager

machines. Mr. Walter also has signed up the Burke-Tarr Co., of Providence, R. I., and this concern, too, has made ready to handle the Brunswick machines under the most attractive conditions. Mr. Walter is leaving to-night for New York for the convention to remain away until the end of the week.

Henning Enters the Navy

Edward Henning, Victor retailer at Egleston square at the south side of the city, has entered the navy. Prior to his enlistment in the service he sold his stock of Victor goods to Harry Barish, at 324 Blue Hill avenue, and the latter is now operating at this location as a Victor retailer.

Reports a Good Business

Walter Gillis, manager of the Victor department, lately handled by the Henry F. Miller Co., reports a very good business for May, and he has been called upon to furnish quite a number of packages of records for families about to start on summer vacations. Mr. Gillis hears frequently from his son, Walter, Jr., who is

with the 101st Engineers at the French front.

Attended Edison Convention

L. H. Ripley, F. S. Boyd, Guy R. Coner and T. E. Dean representing the traveling staff of the Pardee-Ellenberger Co., went over the first of the month to New York for the Edison convention. They had planned to go by the outside line, but at the last moment changed their mind and took the train. Two days later Manager Silliman, of the Boston headquarters, went over to New York to attend the Edison conferences.

Ralph W. Longfellow, manager of the Victor and Edison departments of Chickering & Sons, was numbered among the Boston men who attended the Edison convention. One of Mr. Longfellow's recent appointments as a new attache of his force is William Sundell.

Dealers Hear Evan Davies

A dealers' night held a while ago at the quarters of the Columbia Co. in Federal street brought together a company of about 125 men

(Continued on page 42)

— **Oldest and Largest
Manufacturers of Talking
Machine Needles in the
World—**There are several reasons

W. H. BAGSHAW CO., Lowell, Mass.

TRADE CONDITIONS IN BOSTON

(Continued from page 41)

and women who listened with the greatest delight to Evan Davies, one of the Columbia artists, who entertained with songs and monologues. Manager Fred E. Mann presided at the entertainment and played Mr. Davies' accompaniments with rare artistic finish, for Mr. Mann is a musician of distinction. O. F. Benz, who is connected with the sales department, came over from New York, and gave an informing talk on records, which furnished the dealers with a new insight into this department.

Some Other Columbia Happenings

M. H. Hanson, concert manager for Riccardo Stracciari, the Columbia baritone, who is one of the Chicago Opera Co. members, was in town a few days ago making the preliminary plans for a concert to be given in the fall by this artist. He was a Columbia caller.

The many friends of "Billy" Parks, of the Columbia, who went to Baltimore some time ago, received the joyful information a few days ago that he has become a proud father, the heir to the father's business ability and good nature being named William Scott Parks, Jr. There's still time to enjoy a smoke, Bill.

H. E. Gardiner, who has lately joined the sales department of the Columbia, is spending a week at the Boston offices of the company.

Thornton Burgess, the Columbia artist, came over to Boston a few days ago for the opening of the children's educational department at the Shepard Norwell Co.'s store. In his story telling he was accompanied by a Columbia machine. Mrs. Grace Drysdale, of the Columbia's educational department, was on hand to assist.

Diplomatic J. A. Frye

James A. Frye, the business promoter for the Victor, passed through Boston a few days ago. Mr. Frye is spending much of his time throughout New England territory, and he has many intricate business problems to settle, which the trade says he is doing with rare judgment and satisfaction to all concerned.

Send for Descriptive Circular

Curry DEMONSTRATION BOOTHS
AND RECORD CASES
MADE TO ORDER

"SOUND PROOF"

FRANK B. CURRY
19 Wareham St. Boston, Mass.

SONORA IN NORTHERN NEW ENGLAND

Many Important New Agencies Announced by W. B. Glynn Distributing Co., Who Cover This Important Business Territory

The W. B. Glynn Distributing Co. for the Sonora phonograph in Northern New England have recently placed this well-known instrument with the following concerns in Maine: the Bussell & Weston Co., Augusta; Maine Music Co., Rockland; Larose-Marcotte Co., Lewiston; D. T. Percey & Sons, Bath, and Jas. Fenderson & Son, Biddeford; the following houses in New Hampshire: the J. E. Lothrop Piano Co., Dover; F. P. Meader, Rochester; Carey Furniture Co., Ashland, and these concerns in Vermont: the Remington Furniture Co., Rutland; the Bailey Music Rooms, White River Junction. These are all representative concerns, who are splendidly fitted to display the Sonora to the best advantage.

COLUMBIA LINE WITH BAILEY CO.

ST. JOHNSBURY, VT., June 5.—Alden L. Bailey, president of the Bailey Music Co., leading piano dealers in northern Vermont and New Hampshire, have lately added the Columbia line to their store in this city. This line also has been added to the company's stores at Hardwick and White River Junction, Vt., and Lancaster, Berlin, Littleton and Colebrook, N. H. The Vermont stores are under the management of G. R. Magoon, while the New Hampshire stores are supplied through the Portland, Me., branch. The Columbia line has been taking very well with the patrons of the several establishments.

NEW UNIVERSAL TONE ARMS

Are Now Being Marketed by the New England Talking Machine Co.

BOSTON, MASS., June 1.—The New England Talking Machine Co., 16 Beach street, are now ready to market their new Universal tone arms, models 7 to 10, inclusive, together with the new Puritone reproducers 6 and 7 that are attachable to these tone arms. Many fine points are claimed for the reproduction qualities of the Puritone and its high popularity in the trade is forecasted. A large stock of these tone arms and reproducers is on hand, which assures immediate delivery of orders. Descriptive advertising matter has also been prepared.

TAKES ON THE COLUMBIA LINE

BURLINGTON, VT., June 5.—The McAuliffe-Pope Co., of this city, has taken on the exclusive line of Columbia products which gives the company two good representations in this city, the other being the E. E. Clarkson Co., which is the principal department store of Burlington. Mr. McAuliffe recently went to Boston to inspect the line at the Federal street headquarters, and was delighted at the methodical, shipshape arrangement of everything, and with the easy way business is dispatched, thanks to the careful system insisted on by Manager Mann.

D. A. Ingalls, the Columbia's traveling associate for Vermont, has moved from Springfield to this city. Mr. Ingalls has been with the company two years, and he reports the conditions excellent in the Green Mountain State for the Columbia line.

RUTLAND DEALER EXPANDS

RUTLAND, VT., June 5.—The Tuttle Co., of this city, has taken over the goods of the Columbia Co. and has opened a special shop next door to its printing and stationery establishment. Mr. and Mrs. M. O. Tyrrell are conducting the new place, under the name of the United Talking Machine Co. For jobbing purposes the Tuttle Co. is carrying the Pathé line. The opening of the Columbia store was quite an event in the city, and the Boston headquarters was represented by J. F. Carr, who went up especially for the opening, while D. A. Ingalls, the company's traveling associate for the Vermont territory, also was on hand for the event. In the several weeks that the shop has been in operation the Columbia line has received its share of recognition.

INSTALL FULL VICTOR LINE

WORCESTER, MASS., June 3.—The firm of Barnard, Sumner & Putnam Co., Main street, has lately installed a complete line of Victor Victrolas and records, having bought out the Victor stock held by the Worcester Phonograph Co. at 11 Trumbull street. This is one of Worcester's leading department stores, and judging by the way it has begun to interest the lovers of the Victor machines there is a big success ahead.

MUSIC FOR WORKERS

From a paper by Gordon Gray, a writer on sociological questions, we select the following paragraphs:

"Too much music mixed in might mean work mixed up; but, on the whole, harmony is the antidote for monotony.

"The way to drain off life's drudgery is to drink at the fountain of melody. Take all you want. Musical inebriation has no harmful after effects.

"What the world needs is more lilting music and less alcohol. Turn on the phonograph and turn off the spigots. Give the workers more and better bars of music and fewer of the baser sort.

"Work accompanied by music is never hard.

"Obviously if music can take the sweat out of sweatshops, the principle that harmony makes burdens light and work easy is susceptible of wide application."

Manufacturers—Jobbers—Dealers

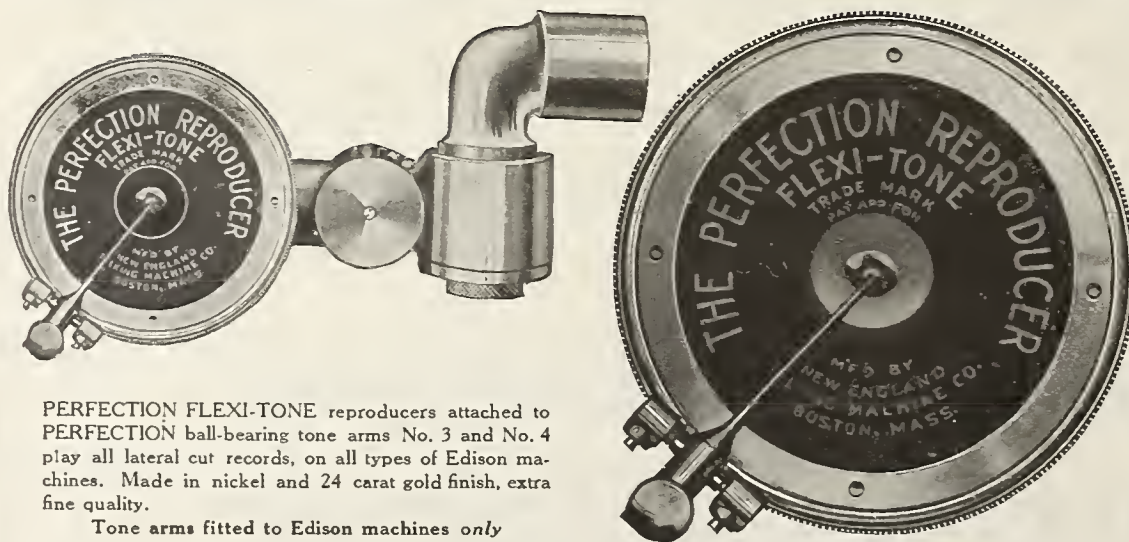

PERFECTION FLEXI-TONE reproducers attached to PERFECTION ball-bearing tone arms No. 3 and No. 4 play all lateral cut records, on all types of Edison machines. Made in nickel and 24 carat gold finish, extra fine quality.

Tone arms fitted to Edison machines only

PERFECTION FLEXI-TONE reproducers No. 3, No. 6 and No. 7 fit all types of Victor and Columbia machines. Made in nickel and 24 carat gold finish.

These reproducers and arms are the very finest made mechanically. The PERFECTION FLEXI-TONE reproducers are the most perfect phonograph reproducers built, reproducing all lateral cut records, from highest pitched soprano to lowest pitched bass, as perfectly as the records were recorded in the recording room. Wonderful clarity of sound, as well as great volume. Extra fine quality of finish guaranteed. Manufacturers, jobbers and dealers will find in this line of reproducers just what they have been looking for, as they are assembled by skilled workmen especially adapted to this kind of work, producing a product built with watchlike precision.

All accessories in stock ready for immediate shipment. Write for prices, information, etc.

NEW ENGLAND TALKING MACHINE CO.

16-18 Beach Street

BOSTON, MASS.

On the matter of the Price of Records

No matter what happens in the phonograph record market, you know that Emerson Records cost the least. With the constant shifting of costs it behooves every dealer to hang tightly to the line which assures him a good profit with the smallest investment.

The good, new and popular size Emerson record at 65c. now means more to you than ever before.

65¢

Emerson

is the name which more and more is coming to mean:—Big hits; Out first; Made right. It is the record of the people. The record which fills the need of the present day. It is the only record made with the universal cut. While other records are useful on one or more machines, Emerson records are right for any machine, without attachments.

Now is the time, if you have not already, to tie up to the Emerson product.

Send off this coupon today.

Emerson Phonograph Company INC.
3 West 35th Street - - - New York

DEPT. A

Send me **Emerson** Sales Plan

Show me how to make the most of this timely opportunity for profits from Emerson Records.

Name.....

Address.....

City.....

DETROIT TRADE STOCKING UP TO MEET FALL DEMANDS

Jobbers and Dealers Admit That Stock Situation Is Serious—Hope for Improvement—C. H. Grinnell's Views on the Subject—Brown Opens Branch Store—New Columbia Models—News in Detail

DETROIT, MICH., June 5.—For the next three months dealers in Detroit are going to give most of their attention to stocking up with merchandise that is going to sell next fall. Dealers here are extremely optimistic about big fall trade and the only question with them is "will we be able to get goods?" That's the big bone of contention—the big problem confronting every dealer regardless of whose line they are handling. Some of the jobbers express little hope of there being any improvement—in fact, some jobbers who have regularly sold local dealers have frankly admitted that the situation is most serious and that so many conditions have to do with making the future look rather gloomy for merchandise. There is the labor shortage which is by no means improving; then again, the Government having taken over so many of the needed materials has hampered the manufacturers' production and no one looks for the manufacturers to increase production under these conditions; as a matter of fact, production is certain to be curtailed and every jobber admits that, they know it to be a fact; then again, shipments are very bad—extremely slow—whether by freight or express. Goods on the way for weeks and weeks have yet failed to put in an appearance, and there is no encouragement that this condition will improve. It's no longer a question of being able to sell talking machines and records but merely a question of getting the goods.

C. H. Grinnell, manager of the Victrola jobbing division of Grinnell Bros., says the situation is most serious and he is more than willing that his views be expressed in *The Talking Machine World*. "Some of the trade papers have said we had a big stock and we want to correct this impression," he declared to the writer. "We have a good stock of old record numbers and certain styles of Victrolas, but they are not the kind that are in popular demand and that are selling and we don't know of any way that they can be pushed out. You can hardly expect a dealer to push records that they have tried to sell and cannot—and the same thing applies to some of the models. The kind of Victrolas that we could sell large quantities of we simply can't get except in such small quantities that they don't stay in the warehouse long enough to be noticed. Unless something

is done and done quick to relieve the tense situation—giving dealers merchandise that they can sell—I am sorry to think what the dealers will be up against in the fall when business really starts to boom. Even right now the demand is very good with Victor dealers both for machines and records but the trick is to get merchandise."

What Mr. Grinnell says is no different than what jobbers all over the country have to say. One leading dealer recently showed *The World* correspondent a letter he had sent out to some thirty jobbers, and every answer was about as follows: "We would be glad to take care of you if we had the merchandise."

Wallace Brown, the Brunswick dealer, now has a branch store on Chene street in the Polish northeast section of Detroit, with a Polish manager in charge. Business there is reported as being very good. Recently several professional dancers were engaged for two days to "step the light fantastic" in the show windows. It resulted in tremendous crowds in front of the store—at times the crowds blocked the street car tracks. It was a good advertising stunt and considerably popularized the branch. Mr. Brown, who has the exclusive Wayne County agency for the Brunswick, is planning to extend his activities to all sections of the city, giving him representation in every part of town. Mr. Brown celebrated his thirteenth month as Brunswick dealer in May—and is quite enthusiastic over the outlook.

A number of dealers told the writer that most of their talking machine sales were among the working people who were earning big money in the munition factories. "They are the real buyers of talking machines these days," said one dealer. "The wealthy people are not buying and neither are the poor people."

There has been quite a big demand for small talking machines for boats and canoes priced not over \$15 or \$25.

F. S. Kratzet, manager of the Brunswick-Balke branch at 247 Jefferson avenue, is not only very optimistic about future business, but says that since the department was established sales have exceeded considerably his anticipations. Of course, in Detroit Mr. Kratzet has just the one dealer—Wallace Brown—but through the State he has put on some splendid

ILSLEY'S GRAPHITE PHONT SPRING LUBRICANO

Ilsey's Lubricant makes the Motor make good
Is prepared in the proper consistency, will not run out, dry up, or become sticky or rancid. Remains in its original form indefinitely.

Write for special proposition to Jobbers.

MANUFACTURED BY

ILSLEY-DOUBLEDAY & CO., 229-231 Front St., New York
Established 1853

accounts of late and is getting many inquiries from every corner of the State.

The Edison Shop of Detroit has had a number of interesting window displays of late of warfare equipment for the soldiers. One display, loaned by a Detroit physician just back from the fighting lines, comprised a number of German souvenirs, and they attracted a lot of attention.

Max Strasburg, of the Max Strasburg Shop, Victor and Columbia dealer, says that while he has a larger stock than ever, he could still stand a lot more, and especially of certain models which he is finding almost impossible to get. Mr. Strasburg is watching every phase of his business closer than ever—both the selling and collecting end. In other words, he is really after quality instead of quantity business. He wants to avoid repossessions and troubles later in locating anybody of doubt.

Sam F. Lind, the local Columbia branch manager, is showing a number of new models which the Columbia have added lately. Sam is very happy these days, as this year will be a record one for the local branch. In the past three months Sam has received a number of offers from leading firms who were willing to spend unlimited money to get a Columbia agency, but he had to turn them down. "We are not trying to take on more accounts in Detroit, but we prefer to protect those already established," he said. "While I have to turn down some wonderful offers, it pleases me to know that these people at least selected the Columbia."

Dealers selling Pathé phonographs and records are getting unusually good service and shipments, in spite of war conditions. The Michigan jobbers—Williams, Davis, Brooks & Hinchman Sons—are carrying enormous stocks in their warehouses, having anticipated some time ago that there would be a time when manufacturers would of necessity slow up on their production on account of labor conditions, etc. They report an excellent business and most satisfactory prospects.

In the recent drive for contributions to the Detroit Patriotic Fund the talking machine stores co-operated most liberally. Not only did 100 per cent. of the Detroit dealers subscribe, but many of them went so far as to underwrite the subscriptions of their employes who pledged themselves to pay on the monthly instalment plan. The Edison Shop employes hit well over the thousand-dollar mark. The employes of Grinnell Bros. went around \$7,000, while the J. L. Hudson Co. employes, including those at the music store, went up to nearly \$50,000.

The Buhl Sons Co. and Geo. C. Wetherbee & Co., who feature the Vita-Nola talking machine, made by the Vitanola Talking Machine Co., of Chicago, report an increasing demand for these products in this section of the country. The attractiveness of the styles and the satisfactory tonal results have won for them a special clientele.

DISTINGUISHED VISITORS TO CITY

D. A. Creed, vice-president of the Chicago Talking Machine Co., Victor wholesalers, and G. P. Ellis, sales manager of this company, were visitors to New York to attend the annual stockholders' meetings of the New York Talking Machine Co. and the Chicago Talking Machine Co., and also the regular directors' meetings of the two concerns. These visitors from the "Windy City" spoke optimistically of the business situation in the West, stating that the outlook is very satisfactory, with Victor dealers closing a business that is limited only by the available merchandise.

W. I. Smith, of Sebree, Ky., has recently secured the agency for the Edison phonograph.



Would you have a steady source
of revenue all Summer?
Then prepare to push the



SCHUBERT PHONOGRAPH

During the next few weeks there will be an increased demand for machines. You know they are being used largely for outdoor entertainment. Get after the people—make summer a play time. We can help you in many ways.

Six Models, \$60 Up

The BELL TALKING MACHINE CORPORATION

Export Department, 498-504 Broadway, New York, N. Y., E. U. A.

Offices and Show Rooms:
44 West 37th Street, New York

Factory:
85 Southern Boulevard, Bronx, New York

Smith-Woodward Piano Co., 1018 Capitol Ave., Houston, Tex., Local Distributor



SHORTAGE OF STOCK RETARDS BUSINESS IN CINCINNATI

Dealers Complain of Lack of Machines and Records—Hope Lack Will Be Remedied This Month—Crystola Co.'s Latest Novelty—Vocalion Expansion—Columbia Co.'s New Wholesale Quarters

CINCINNATI, O., June 4.—A rather serious shortage of records occurred during May, this causing quite a slump in the volume of business for the month. A like condition prevailed in the machine end, which has not improved to any extent with the change in the calendar month. All the dealers report the record situation to have improved with the entrance of June.

Between fighting for sufficient supplies and trying to keep enough help around the shops the man in the talking machine field is kept quite busy these days. There is a general tendency on the part of all to anticipate some kind of a bump these days and to try to overcome the annoyance without the commotion a change might have caused in the old days.

The Crystola Co., this city, is experimenting with something new in the talking machine line. The exact idea of the change, this being an attempt to get away from the conventional phonograph atmosphere, has not been made known as yet. It is intimated that the new machine will be much more musical. The company is figuring on getting out new advertising material, one being a folder of four colors.

D. W. Martin, Washington Court House, O., has become one of the dealers for the John Church Co.'s phonograph, spending part of last week in the city arranging for his supplies.

A 10 per cent. increase in the price of all things that go to make up a phonograph is predicted by C. W. Neumeister, Cincinnati, representative of the Otto Heineman Phonograph Supply Co. He believes the boost will be along very shortly. In his opinion any person building phonographs now will double his money in the next six or eight months.

"A splendid business in May" is the report of C. L. Byars, of the local Vocalion forces. He reports a substantial increase for the month of May over the same month of last year. These results were especially gratifying in view of the fact that owing to the shortage of help the sales force was operating throughout the month considerably crippled by lack of salesmen.

"It is my impression," says Mr. Byars, "that one of the most serious problems facing the retail phonograph business during the coming months is the securing and holding of men of selling ability. There is a probability that women will have to be impressed into the outside selling in the phonograph business if the dealer intends to continue his aggressive policy of following up the prospective buyers on the

outside. Just how well this is going to work out of course can only be learned through experience. As a general rule, girls do not prove very satisfactory for outside selling work, but I am inclined to think that the phonograph dealer is going to have to start a regular training course for women, and gradually train them for this class of work."

The new wholesale headquarters of the local Columbia Graphophone Co. is now a reality. The company has moved to its new quarters and is located at 427-29 West Fourth street, three blocks west of present location. The retail department will continue to operate as formerly at the old address, 117-119 West Fourth street, where the local Dictaphone offices will also be located for the present.

The wholesale department will take up six floors and the basement of the new building and will have every facility for handling all orders with dispatch and accuracy.

During the moving period business was a little retarded and Manager Dawson stated to our representative that he desired to take this opportunity of thanking the trade for the consideration extended the company during that time and to extend the hospitality of the new headquarters to all Columbia dealers.

The increase in business during the past year has made this move imperative and the outlook is greater than at any time in the past. With the enlarged quarters and adequate facilities for handling the orders, etc., Columbia "Service" is assured.

F. K. Pennington, assistant general sales manager of the Columbia Graphophone Co., spent a day at the local Columbia store injecting "pep" and enthusiasm into everyone and his usual good humor permeated the entire store. Mr. Pennington is quite a favorite among Columbia employes and his visit was greatly enjoyed by all.

Miss Stella Green, formerly connected with the local Columbia store, has again cast her lot with the company as assistant to Manager Arrington of the Dictaphone department and was cordially welcomed by all the old employes.

William C. Wornhoff, who for some time has conducted the Phonograph Shop at 7512 Madison street, Oak Park, Ill., has rented the store at 131 Marion street, Oak Park, and has occupied the premises with a big line of Edison phonographs and Columbia Grafonolas. Pianos will also be handled in the new quarters.

HELPS IN PATRIOTIC CAMPAIGN

How the Pathé Phonograph Was Effectively Used in the Recent Third Liberty Loan Campaign in Philadelphia—Scored Big Success

PHILADELPHIA, PA., June 2.—The Pathé phonograph manufactured by the Pathé Frères Phonograph Co. was an active factor in the recent Third Liberty Loan campaign, being used to excellent advantage by the local Liberty Loan committee. The instrument was "on duty" in front of the Liberty Statue during the four weeks of the Liberty Loan drive, and was the center of attraction during this period.

The loan committee was so enthusiastic regarding the success of the Pathé phonograph at this particular location that when the Phila-



Pathé in Front of the Liberty Statue

delphia Pathéphone Co., local distributors for the Pathé product, wanted to send the instrument to some other point, the members of the committee offered to lease the machine for the balance of the campaign. This offer was declined, however, as the company preferred to let the machine remain where it was without any charge, in view of the splendid cause for which it was working.

Handling a good line helps. Handling one that is well known brings reputation to the retailer and more business.

The Difference Between

Phon d'Amour

and other Phonographs is resultant from difference in construction; the patented features of Phon d'Amour being exclusive.

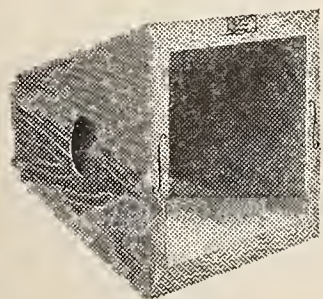

Amplifier

The Amplifier in Phon d'Amour

is of an entirely new type and one never before used. It is constructed in two chambers, being walled about with violin wood and is constructed upon the same principle as that of a violin. Not only is the volume in "Phon d'Amour" materially increased, but this is accomplished without any sacrifice of the characteristic overtones of voice or instrument.



Copyright, 1917, by The Fritsch Phonograph Co. Trade Mark

THE FRITZSCH PHONOGRAPH COMPANY

228-230 West 7th Street

CINCINNATI, OHIO



Pathé Phonograph \$30
Other Models to \$225

You Get Them Going—

Going away for the summer.
You get them with the portable
Pathé Phonographs.

The "expensive look," the beautiful
Pathé Tone and

The fact that the Pathé plays all
makes of Records,

And that Pathé are first with the
latest hits,

Make the Pathé the "preferred"
for summer purposes.

Make it wise for you to
Write—

Pathé Frères Phonograph Company

20 Grand Avenue Brooklyn, New York

THE PATHÉ FRÈRES PHONOGRAPH CO., Ltd.
6 Clifford Street, Toronto, Ontario

No Needles to Change

The Pathe Sapphire Ball takes the place of needles. It need not be changed.

Long Life to Records

The Pathe Sapphire Ball cannot possibly cut, grind, rip or mar the record's surface.

The Pathe Controla

With the Pathe Controla you may increase or decrease the tonal volume of the Pathe Phonograph at will.

Plays all Records

Each Pathe Phonograph plays not only Pathe Records, but all other makes of records, and plays them perfectly.

Latest Records

- 20367 { Just Like Washington Crossed the Delaware . . . Invincible Four } 10" 75c
- 20360 { Hello, Central, Give Me No Man's Land Irving Gillette } 10" 75c
- 20363 { Rock-a-Bye Your Baby With A Dixie Melody . Arthur Fields, Baritone } 10" 75c
- 20363 { What'll We Do With Him, Boys? Arthur Fields, Baritone } 10" 75c
- 20363 { Bring Back My Daddy To Me. Harry McClaskey, Tenor } 10" 75c
- 20362 { When the War Is Over I'll Return To You . . . Peerless Quartet } 10" 75c
- 20362 { Just A Little Cottage . Sterling Trio } 10" 75c
- 20362 { The Little Good for Nothing's Good For Something After All Campbell & Burr } 10" 75c



The Quality Phonograph

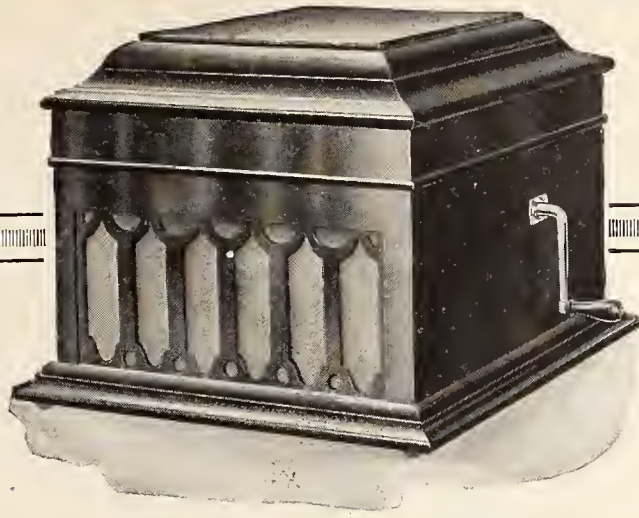

Pathé Phonograph \$60

Other Models \$30 to \$225

—and You Get Them Coming



LUCIEN MURATORE
Exclusive Pathé Artist

Dance Records
by
Hotel Biltmore Orchestra
Hazay Natzy, Director

- 20368 { Why Do They All Take the Night Boat to Albany from "Sinbad" One Step 10'
When I Feel Sad and Lonely, FoxTrot 75c
- 29200 { Toot, Toot, Intro: "When You Wake Up Dancing," "If" 12"
Medley One Step 1.00
The Booster . . . Fox Trot
- 71001 { I'll Think of You, from "The Rainbow Girl" Intro: "My Rainbow Girl", Medley Fox Trot 14"
Songs of the Night . . . Waltz 1.25

Coming back from a vacation brightened by their Pathé Phonograph.

You get them for more of the superior Pathé Records.

And,

Whenever they want a cabinet model,

For another Pathé Phonograph—*only the Pathé Tone can satisfy a Pathé Owner.*

There's something you should get at once, if you're not a Pathé dealer—the Pathé Dealer Proposition.

Pathé Frères Phonograph Company

20 Grand Avenue

Brooklyn, New York

THE PATHÉ FRÈRES PHONOGRAPH CO., Ltd.

6 Clifford Street, Toronto, Ontario



The Quality Phonograph

A POPULAR MEMBER OF THE TRADE

Joseph F. Collins, Sales Manager of the Pathé Frères Phonograph Co., Has a Host of Friends Who Are Glad to Welcome Him

We take pleasure in presenting herewith Joseph F. Collins, sales manager of the Pathé Frères Phonograph Co., and one of the most popular members of the talking machine indus-



Joseph F. Collins

try. Although a young man in point of years, Mr. Collins can well be considered one of the "veterans" of the industry, for he has been associated with the talking machine industry from practically its earliest days of development and possesses an invaluable knowledge of every phase of manufacturing and merchandising.

For the past four years Mr. Collins has been associated with the Pathé Frères Phonograph Co., and in the capacity of sales manager has been an important factor in the success achieved by Pathé products. He has visited the trade in all parts of the country, and his many years'

experience has enabled him to render practical assistance to Pathé jobbers and dealers in developing a market for these popular products.

For the past year Mr. Collins has been devoting a considerable portion of his time to calling upon Pathé jobbers and working in close touch with the members of their sales forces. He has co-operated with the jobbers in the development of their Pathé activities, and has spent quite some time with the various sales staffs while they were perfecting their campaigns for developing Pathé business. He is a Pathé enthusiast, heart and soul, and this enthusiasm is reflected in the fact that Pathé jobbers everywhere are frequently requesting Mr. Collins to visit their cities in order that their travelers may also be instilled with his particular brand of enthusiasm.

LINE OF MOTORS RESTRICTED

The Otto Heineman Phonograph Supply Co., Inc., has just issued the following important notice: "Owing to conditions in the raw material market, due to the necessary Government work going on at present, coupled with the scarcity of experienced labor, it has been deemed advisable to restrict our line of motors to certain types. We will supply motors No. 33, No. 77, and No. 44—this variety will cover a complete line of phonographs from small ones to the very best. By confining our production efforts in this manner, we can assure our customers the very best of service and deliveries."

The Meisselbach division of the Otto Heineman Phonograph Supply Co. has also issued a similar notice, the second paragraph of which reads as follows: "We will supply motors No. 10, No. 12, No. 16 and No. 19 without automatic stops—this variety will cover a complete line of phonographs from small ones to the very best."

A worthy Hindu maxim says: "Work as they work who are ambitious. Respect life as they respect it who desire it. Be happy as they are happy who live for happiness alone."

WIDDICOMB PHONOGRAPHS POPULAR

Manager Howard Extending Agencies for This Instrument Throughout the Country—To Exhibit at National Furniture Show June 25

GRAND RAPIDS, MICH., June 5.—The phonograph division of the great Widdicomb Furniture Co. here is exceedingly busy, having received very large orders from its recently-appointed distributors as well as from representatives throughout the country.

Manager E. C. Howard is highly pleased with the reception so far given his efforts to produce a Widdicomb high-grade phonograph of exceptional merit both as to tone, construction and cabinet design. The beautiful showing of art cases has in itself won many friends to the line. The company now have in preparation several beautiful new higher-priced art models, samples of which they expect to be able to exhibit at the furniture show at Grand Rapids, which commences June 25.

The company now has its phonograph production facilities fully organized and has of late been able to make very prompt shipments to its trade.

ISSUE ATTRACTIVE SUPPLEMENT

The Emerson Phonograph Co. has issued an attractive supplement featuring its new 65-cent records. This supplement has an unusually artistic cover which cannot fail to attract the attention of music-lovers who receive it in the mails from Emerson dealers, or who notice it in the dealers' warerooms. This supplement lists patriotic hits, popular song hits and selected dance records, as the company is issuing only this class of music in its 65-cent records.

These 65-cent Emerson records are meeting with pleasing success throughout the country, and the artists recording for this library include some of the most popular artists now making talking machine records.

TWO



LEADERS

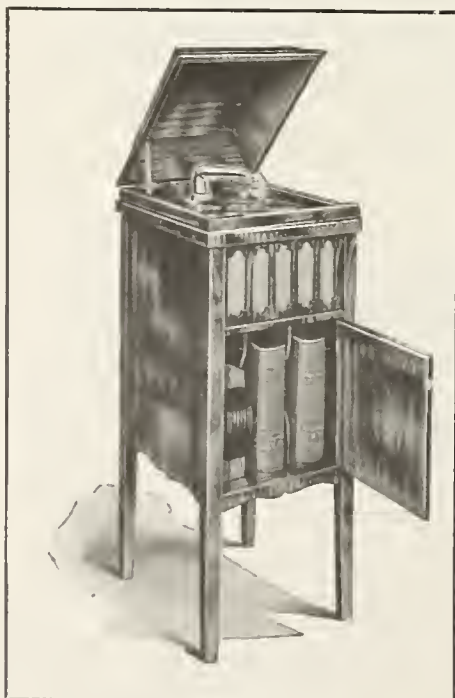

Model "F"
40 in. high, 18 in. deep, 15 in. wide
Retail Price, \$40

By selling low-priced machines you do not tie up your money for a long period

There are Others in Our Line

Some Outstanding Features of Operollos

- Universal Tone-Arm
- Perfect Tone
- First-class Reliable Motor
- Tone Modifier
- High-grade Finished Cabinets
- Wooden Tone Chamber

Distributors
LYRIC and PAR-O-KET RECORDS

Write for Special Discounts
Immediate Shipments of Machines

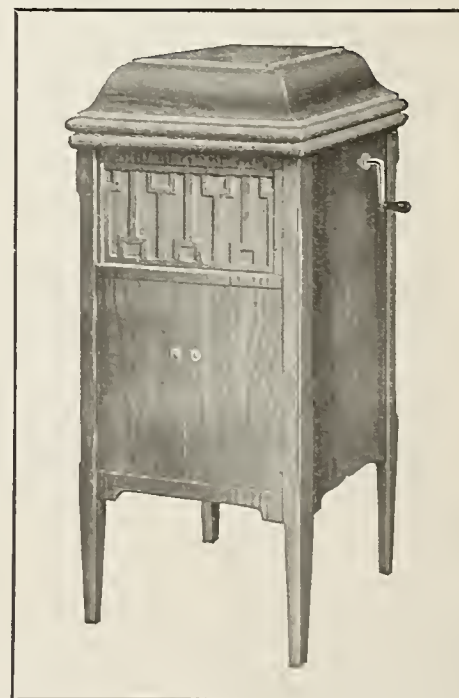

Model "A"
41 in. high, 18 in. wide, 20 in. deep
Retail Price, \$50

Low prices cause quick sales and bring quick returns

OPEROLLO PHONOGRAPH CO.

54 W. LAFAYETTE BLVD.

DETROIT, MICH.

MILWAUKEE NOTES IMPROVEMENT IN STOCK SITUATION

Dealers to Maintain Prices—Death of Geo. H. Eichholz Regretted—Important New Sonora Agents—Badger Business Grows—Kesselman-O'Driscoll Co. Increase Capital—Puritan Phonograph Popular

MILWAUKEE, Wis., June 10.—Although not much improvement can be noted in the promptness of deliveries of machines, the situation in this regard as reported by Milwaukee wholesalers and jobbers is relatively much better than that concerning records. During the last three or four weeks the local trade has encountered unusual difficulties in obtaining adequate stocks of records, due to the enormous demand everywhere and the inability of factories to produce them in sufficient quantities to fill orders. It is said that the number of back orders unfilled at this time is undoubtedly the largest known in the history of the talking machine trade.

The demand for machines in recent weeks has been well maintained and jobbers say that their bookings exceed those of the corresponding period of last year all the way from 20 to 40 per cent., according to make. Certain limitations surrounding both the manufacture and transportation of machines, arising from wartime conditions, make it appear that for the time being the shortage of goods can hardly be relieved. At the same time the public is demanding talking machines and phonographs in an enormous volume, also due directly to the effects of war time, which again is proving to be a great stimulant to music.

An encouraging factor in the local retail situation at this time is the determination of Victor dealers to decline to take advantage of the opening given them to disregard list prices. No Victor dealer in Milwaukee desires to see a price-cutting war and all are agreed that the only way in which they can continue to do business on a scale of reasonable profit is to observe the catalog lists on machines, records and supplies. Giving of discounts now is frowned upon by the Government and, in addition, every modern business principle is against such practices. Victor dealers are "hand-picked" business men of high caliber, for the greater part, and as such they like to observe high-class principles of doing business. Every argument appears to be in favor of adhering to advertised prices, and none against it. Promiscuous discount-giving has started many a price-cutting war that has been the ruination of many a business, and Milwaukee Victor dealers want none of that, especially in times such as these when every resource must be put into play to assist the Government in winning the war in the shortest possible time. It would not be surprising, of course, to find one or two retailers attempting to attract business by discounting lists, but in doing so they undoubtedly are sealing their own doom as business men of standing.

The Milwaukee Association of Music Industries, recognizing the value of the sessions to dealers in talking machines as well as pianos and other musical instruments, was officially represented at the annual convention of the National Association of Piano Merchants in New York, June 4 to 7. The delegates were Paul F. Netzow, with Leslie C. Parker, manager of Gimbel Bros.' Victor department, as alternate. A special meeting of the Milwaukee Association will be held shortly to hear the reports of the New York meetings.

One of the most profound shocks ever experienced by the Milwaukee talking machine trade was the announcement made on Memorial Day of the sudden death of George H. Eichholz, one of the best-known Victor and Edison dealers of Milwaukee and the Northwest, and a pioneer in the trade. Mr. Eichholz was stricken with a neuralgic affection which is believed to have attacked his spine. He complained of feel-

ing ill on Tuesday, May 28, and took to his bed early on Thursday morning, May 30, his condition became acute and he passed away before physicians were able to administer further aid.

Mr. Eichholz was born in Germany in 1870, and when twelve years old came to America with his parents, locating in Milwaukee. When the first talking machine store in the city was opened by Lawrence McGreal in 1898, Mr. Eichholz left the life insurance business to enter his employ as a salesman. This was in the days of the first Edison machine. After five years in the McGreal organization Mr. Eichholz went into business for himself at 542 Twelfth street, where the store is still located. He was appointed retail dealer in both the Edison and Victor, retaining the connections up to the present. In 1912 he admitted as a partner Frank Preuss, a faithful assistant, who, with Mrs. Eichholz, will continue the business.

Mr. Eichholz had intended to be in New York for the national conventions during the first week of June, principally to attend the Edison gathering. He was one of the founders and a commanding figure in the Milwaukee Association of Music Industries. The Middle Western talking machine trade has had few members so widely and favorably known as he.

The Yahr & Lange Co., distributor of the Sonora in Wisconsin and Upper Michigan, recently announced the appointment of the J. B. Bradford Co., 411 Broadway, Mason & Hamlin representative, as a new downtown retail dealer. The Bradford Co. operates a branch store at 429 Mitchell street, Juneau Theatre Building, and has been dealing in the Victor. Fred E. Yahr, president of the Yahr & Lange Co., who is giving his personal attention to its Sonora business, published a half-page advertisement in the Milwaukee papers, giving representation to the eight Sonora retailers who are located in this city and county.

Always one of the busiest places in Milwaukee, the offices and stockrooms of the Badger Talking Machine Co., Victor jobber, 135 Second street, continues to show signs of further rapid growth. The expansion of its trade has required constant enlargement of its working forces, both in the field and at the "base." Harry A. Goldsmith, secretary of the company, says this is going to be its very best year, and when he makes declarations of this kind they invariably are fulfilled. The demand for Victor goods is so large that it cannot be entirely filled, this being true especially of records at this time. However, the situation merely affords the big jobbing house to demonstrate "Badger Service" at its best, and the splendid manner in which Victor retailers have been accommodated has increased the list of patrons to an even greater extent than before in recent weeks.

Miss Julia Wolf, in charge of the Aeolian-Vocalion department of the Edmund Gram Music House, has received word from her brother, who has been in France for more than three months, that he has been promoted from corporal to sergeant of his unit of Wisconsin field artillery.

The Kesselman-O'Driscoll Co., 258 West Water street, better known as the Victor Palace, has been obliged to increase its capital stock from \$75,000 to \$100,000 because of the rapid growth of its business since it moved from the

northwest side to the downtown business district less than a year ago. At its new capitalization, the K.-O. Co. is one of the largest Victor dealers in the Northwest—and still growing. Louis M. Kesselman, president and general manager, is an enthusiast over the Victor's future in Milwaukee, due to the tremendous increase noted especially since the beginning of America's participation in the war.

Brunswick trade throughout Wisconsin and Upper Michigan continues to enjoy a most healthy growth, and Thomas I. Kidd, manager of the local branch of the Brunswick-Balke-Collender Co., has nothing but good words to say concerning business conditions in his territory. The list of Brunswick dealers is constantly undergoing enlargement as dealers see the advantages of handling the line with its splendid backing. Mr. Kidd has a happy faculty of selecting representatives of the highest standing in their respective communities and this has increased prestige mutually for product and dealer.

Kroeger Bros. Co., operating Pathéphone departments in each of its four big department stores, has increased its capital stock from \$350,000 to \$2,500,000. The organization has grown from two stores to four within the last year, requiring the large capital extension. A. Levitt is general manager.

"A prophet is without honor save in his own country" is not applicable to the Puritan phonograph, manufactured by the United Phonographs Corp., Sheboygan, Port Washington and Grafton, Wis., judging from the reports of business made by Charles J. Orth, 504 Grand avenue, Wisconsin and Upper Peninsula distributor of the Badger-made line. Mr. Orth again enlarged his traveling force during the past month and himself spent considerable time in the territory because of the great interest displayed in the Puritan. Mr. Orth is engaged in an interesting friendly competition with his brother, James B. Orth, Chicago, also a large wholesale territorial representative of the Puritan, and the two are working tooth and nail to create targets for the other to shoot at and improve upon.

Schefft's Victrola Shop, 849 Third street, has taken a leading part in the organization of the Upper Third Street Commercial Association, an organization of retail merchants who desire to maintain the prestige of Upper Third street as "Grand Avenue's Only Rival" against the encroachment of leading business thoroughfares in other parts of the city. Ernest Schefft was chosen a member of the executive committee of the association at the first election.

News comes from Eau Claire, Wis., that the Sailstad-Payson Piano Co. is engaging in the manufacture of talking machines, to be marketed under the trade name of Multitone, with a universal reproducer.

"The good old reliable Columbia grows more popular every day," said A. G. Kunde, 516 Grand avenue, this city, distributor of the Columbia line, in reviewing trade in recent weeks. "We are especially hard pressed for stocks of records, although we have none too many machines to spare. If business keeps up this way for six or seven months longer we shall easily outstrip our best previous year and show a splendid surplus. There's nothing the matter with Columbia business."

The Industrial Appliances Corp., New York, has been incorporated with capital stock of \$10,000 to manufacture phonograph devices. The incorporators are N. V. Rothenberg, J. J. Sullivan and M. C. Kahl.

ELECTRO-PLATING of PHONOGRAPH PARTS

AND MUSICAL INSTRUMENTS
Gold, Silver, Nickel and Antique Finishes

JOSEPH MUSANTE

168 CENTRE ST. Tel. Franklin 3053 NEW YORK



PERSONAL SERVICE

The members of our Company are always available and will gladly see you personally or write you at any time we can possibly serve you.

Why not communicate at once with us?

BADGER TALKING-MACHINE CO. 135 Second Street MILWAUKEE, WIS.

VICTOR DISTRIBUTORS



There is a splendid Vacation Grafonola advertisement, with large space for your name, all ready for you. Send for it today—and run it in your local papers when the big national publicity appears.

Columbia Graphophone Co.
NEW YORK

MEISSELBACH MOTOR CATALOG

Most Complete and Interesting Volume Giving
Fullest Details of the Meisselbach Line

The Meisselbach division of the Otto Heine-man Phonograph Supply Co. has just issued a handsome catalog featuring the motors, tone arms and sound boxes that comprise the Meisselbach line. This catalog is complete in every detail and is particularly worthy of praise for the clear-cut illustrations that are featured and the detailed specifications that accompany each illustration.

The Meisselbach motor has for many years been one of the most popular and successful motors in the talking machine industry, and has won recognition as a dependable motor that can be used by the manufacturers of high class machines with every confidence in its ability to render service and satisfaction. Among the Meisselbach motors that are presented in this new catalog are motors Nos. 9, 10, 11, 12, 15, 16, 17, 18 and 19. All of these motors are specially adapted for use in their respective fields, and in addition to featuring illustrations of the motors together with specifications, this catalog also shows the component parts of each motor with their designated numbers so that duplicate parts may be ordered with maximum convenience and ease.

There are also listed in this catalog some of the popular Meisselbach accessories, including speed regulators, turntables, turntable brakes, winding cranks, etc. Two pages are devoted to the Meisselbach Universal tone arms Nos. 97 and 95, which have achieved signal success, and another page shows the Meisselbach sound boxes, jewel needles and attachments.

The foreword of this catalog gives an interesting history of the Meisselbach motor and some of the fundamental qualities that characterize this product. Several paragraphs from this foreword read as follows:

"For thirty years A. F. Meisselbach & Bro. (taken over in May, 1917, by the Otto Heine-man Phonograph Supply Co.) have been manufacturing high-grade mechanical devices. In the production of mechanical devices, it is experience that counts. Clever design, good materials, able workmen are important, but it is long experience which welds all these elements together, and gives the final perfection to the product. It is because of these thirty years manufacturing a large number of items of kindred character, that to-day this same factory is able to turn out a phonograph motor of the highest excellence in every part, and so harmonize and adjust part to part that it satisfactorily fills the phonograph needs and can be counted upon to give perfect performance, even in the most adverse conditions. A. F. Meisselbach & Bro. have reached this position of enviable pre-eminence largely because of the

expert guidance of their activities and the capable and experienced inventors and mechanics that have been associated with them. The best metallurgical and technical experts of the country have continuously worked with the experimenters and designers of the Meisselbach products with the result that no item in any field has been put out which has not been subjected to the very highest scientific and practical tests.

"While the firm has produced items used in many branches of science, art and sport, it has made a special study of the conditions and the requirements of the phonograph trade, and hence the motors, sound boxes, tone arms, needles and other talking machine accessories which are described in the following pages of this catalog, represent really the cream of the factory's efforts. The factory's ideal has been to turn out talking machine motors and accessories that should prove themselves in every way superior in design, workmanship and operation to anything heretofore produced, either in this country or abroad. This reputation has actually been obtained, and is being in every way sustained and improved upon by the present organization.

"No piece of mechanism produced, not even a watch, is called upon to meet so many exacting and practical requirements as a phonograph motor. It has to meet not only the demands of the laws of mechanics, but also the still more rigid demands of the laws of music. It must be miraculously precise and delicate in its operation and yet must be able to endure the handling of the most inexperienced and rough person. For satisfactory musical reproduction the motor must turn the turntable with absolutely perfect rhythm. A shade of hesitation throws the music entirely off key, and the rendition is spoiled. Absolute perfection of speed regulation is therefore imperative. Silence in operation is another imperative essential. Any clicks, or grindings or whirrings in the mechanism will be heard through the music and spoil the rendition. These are only two of the many unrelenting specifications imposed upon the motor maker to the meeting of which this factory has successfully devoted their efforts.

"Meisselbach' motors are super-silent in operation, super-steady in regulation and super-sturdy in construction. They wind easily and silently, are long playing, and in every way eliminate for the phonograph owner all mechanical anxieties.

"The designing and perfecting of a mechanical device is only one operation of the problem. An experimental motor or two, of the highest perfection such as might be turned out by a group of expert mechanics, might not possibly turn out satisfactorily in quantity production. This side of the matter has had special attention, and the wide experience gained in the manufacturing of various kinds of devices has enabled this factory to develop a motor upon the most practical commercial production basis. This has been a matter not only of perfection of design in the motor, but also of inventing and developing production machinery. Rough or approximate work is incompatible with the smooth running and silence absolutely essential in a talking machine motor. All gears must fit, and every dimension must be exact to the fraction of a thousandth of an inch. Therefore, the delicate gauges, carefully tested templates and the accurately adjusted automatic machinery employed in the manufacture of 'Meisselbach' motors, are important factors in their ultimate success.

"Each of these machines is absolutely designed for the purpose as, for example, the hobbing machines for making the spur gears of special design, particularly adapted for the delicate wheels of the phonograph motor. Hobbed gears, after long experimenting, were proved to be the only type that would give the hair-breadth precision required for the true and smooth running of the phonograph motor."

The order of the Australian Controller of Customs, requiring a full statement in the invoice covering goods shipped to Australia of the value of those goods in the country of exportation at the date of the invoice, is to be strictly enforced after June 30 on all shipments subject to ad valorem duties, according to a statement of the official representative of the Australian Department of Trade and Customs in this city.

WALTER S. GRAY

SAN FRANCISCO

NEEDLES

PACIFIC COAST JOBBER FOR THE BEST IN TALKING MACHINE
TRADE ACCESSORIES

CHRONICLE BUILDING, SAN FRANCISCO

JENKINS USING MOTOR TRUCKS

Kansas City Music House Solves Transportation
Problems by Inaugurating Delivery by Motor
Truck to Its Various Branches

KANSAS CITY, Mo., June 1.—The initial step toward utilizing the highways as a means of reducing the burden of railroad transportation of freight was taken by the J. W. Jenkins' Sons Music Co., recently, when a G. M. C. truck made the trip to Tulsa, Okla., carrying a load



One of the Jenkins Delivery Trucks of merchandise. The trip was made in good time, over good roads, and no difficulties were encountered.

A. J. Cripe, manager of the Tulsa branch of the firm, found that in order to give better service and actually cover his rapidly growing field it would be necessary to have a truck for delivery and transfer work. With this in mind, W. H. Cannon was sent to Kansas City and given a two weeks' course in handling pianos. The company, which has a squad of seven G. M. C. trucks to take care of the heavy delivery and transfer work here, then provided a similar one for the Tulsa branch, loading it with two pianos and a full equipment for transfer work, such as derricks, block and tackle, grand boards, etc. On the sides of the truck were large signs bearing the inscription, "Our Own Truck Line, Kansas City to Tulsa."

Mr. Cannon started Monday morning, May 20, at six o'clock, and arrived in Tulsa Tuesday evening without any mishaps.

NEW COMMITTEES ARE APPOINTED

At Meeting of Executive Committee of Talking
Machine Men, Inc.

At a meeting of the executive committee of the Talking Machine Men, Inc., held last month the following committees were appointed by President Coughlin:

Outing committee: Messrs. Leins, Galuchie, Lazarus, Birns and Hunt.

Membership committee: Messrs. Galuchie, Riddle, Davin, Lazarus and Kaiser.

Legal committee: Messrs. Mielke, Kurtz and Leins.

E. G. Brown, of Bayonne, N. J., was elected secretary.

Willingness to learn from others displays intelligence.

Columbia Grafonola

in Period designs



JUST as Columbia Records give you the best music of all ages, so Columbia Grafonolas bring you the most beautiful designs of all artistic periods. More than ever American women are giving careful attention to the harmonious furnishing of their homes. In response to a genuine need, the Columbia Grafonola has led the way in worthily adapting to the uses of good music the best designs of the world's master craftsmen.



Gothic Design
of Columbia Grafonola



THE originals of the twenty-three Period Grafonola designs now available are among the chief treasures of American and European art museums. All artistic periods are represented, from Gothic and Elizabethan to Adam and Chippendale. Thus you may be sure of obtaining a design that will fit in with the decorative treatment of your home.



Italian Renaissance Design
of Columbia Grafonola

These Period Grafonolas have a superb richness of tone—full, smooth, and pure, as the music floats out through the silken inter-spaces of lattice or grille. All are electrically equipped, the motor starting and stopping automatically. As musical instruments, no less than as artistic cabinets, they are worthy of a place in any home. Prices of Period Grafonolas range from \$250 to \$2100; Standard models from \$18 to \$250.

A handsome illustrated catalog of Period Grafonolas sent upon request

COLUMBIA GRAPHOPHONE COMPANY, New York

Adam
Design
of
Columbia
Grafonola



This advertisement will appear in Columbia National Advertising.



RECORD TRADE ASSUMES LARGE DIMENSIONS IN ST. LOUIS

Demand for the Past Month Has Exceeded All Expectations—Salesmanship in Machines Now Counting More Than Ever—Details of Mailing Division—Novel Check on Record Publicity

ST. LOUIS, Mo., June 5.—The talking machine business went through the Red Cross drive in this district, which was the first "over the top," in splendid shape, but according to recent reports there followed a lull after that, lasting until the first of June, when business again began to pick up. But despite the let-up and the handicap of a shortage of machines of particular sizes, a number of the houses report that May of this year will exceed all other Mays.

And this is considerable of a record, too. None would have predicted such a thing two months ago when, with sizes then broken, it was brought home to the dealers that there were to be fewer machines manufactured than for many months previous. Dealers then imagined that their totals would shrink immediately, but they did not foresee the record demand. A number of dealers in this city are now selling more records monthly than the total of their machines and records three years ago, and some are selling more records than machines, in figures.

The record business is a curious proposition. The people have money and they are bound to spend it and they, apparently, want music. They come to the record room dead set on a certain number they have seen advertised recently but which is out of stock. Then enters a bit of salesmanship, if it exists in the demonstrator. J. F. Hunleth read a paper at a Tri-state Victor Dealers' Association meeting in which he outlined, taking several current records as samples, how nearly old records were like new ones, and told of incidents in which older records had proven the first choice when heard in contrast with the new ones. He suggested this because often it is impossible to obtain enough of the new records to meet the demand. A number of dealers recently have been bringing this fact before their help and the result has been astonishing in the selling of what was considered dead stock and selling records of which jobbers had a supply. Dealers who handle several makes of records are having these listed as to common numbers, so that they can meet the demands from the most ample stock and still satisfy the customer. Sometimes a customer insists in having the record asked for or none and goes elsewhere, but the chances are that if he is a few days late in asking for a popular record, some one will get the chance to substitute for him, for the stocks of those records which strike the popular fancy are quickly exhausted, as the distribution is practically equal.

Salesmanship in machines now is counting more than it ever has before, because all local stocks are broken on certain sizes and finishes which are those chiefly in demand, and the task becomes that of turning the customer to something in stock, perhaps to another make, for the exclusive dealers are becoming fewer daily. Practically all of the larger dealers have a second line and some of them are buying on the market lots of machines that appear to be satisfactory, regardless of the name.

Manager Staffelback, of the Hellrung & Grimm House Furnishing Co., Pathé jobbers, has organized a mailing division which he has placed at the disposal of his dealers. The plan is that the dealer supplies the names, the mailing division will prepare the monthly supplements, special releases and other record advertising, all with the dealer's imprint, and address and stamp them and deliver to the dealer by parcel post. All the dealer has to do is to break the wrappings and place them in the postoffice. The idea of sending them to the dealer in package is to give him the advantage of the local postmark and to assure him that the work is being well done. This mailing division has been established to meet the complaints of dealers that they have not the extra help needed to get out the monthly bulletins when they come. As help becomes harder to get, few small establishments have any elasticity in their working

force, most forces being driven to keep up the regular work, consequently the bulletins lay in the corner until too old. The mailing division is scheduled to work at cost and it is believed that after the merchant has paid for the work and stamps, he will not neglect the mailing.

Manager Guttenberger, of the Vocalion department, at Aeolian Hall, says that the newly established jobbing department is meeting with extraordinary success. The recent improvements in the Vocalion and the fact that there is a Vocalion record is making a big hit. He says that already a number of persons have come into the store to hear Vocalion records played on a Vocalion machine, saying that while they do not own a Vocalion, they have heard of this record and are anxious to hear it. The later comment never indicates a disappointment, but many go out of their way to praise the product.

Manager Irby W. Reid and wholesale manager Salmon of the Columbia Co. visited the Columbia factory last month to see what was doing and to get a better understanding of the trend of the trade from a higher up viewpoint. They returned well satisfied with the prospects and were kept busy for a number of days catching up with the business. The Columbia jobbing trade is especially pleasing and deliveries have been of a good average up to date.

Customers are the only trouble at the Mozart factory, according to President Fitzgerald. And the trouble with customers is that there are so many of them and they want so much. Trade has been exceedingly satisfactory and the factory has overcome the handicap of the fire, of some months ago, and is doing wonders toward meeting the demands.

Albert Vogel, for eight years a member of the talking machine staff of the Thiebes Piano Co., joined the Marines and left June 4 for training camp.

General Manager Goldberg and Retail Manager Schlude, of the Silverstone Music Co., attended the Edison convention in New York this month. President Silverstone is going in for golf, motoring and other pastimes that keep him outside much of the time in an effort to get his strength back. He is again feeling in very good health, but has been warned by his doctor not to get too anxious to get back at work.

Manager Ditzell, of the Famous & Barr Victrola department, tried a novel means of checking record advertising. He selected a record not on recent current lists, described it as to music and other features at considerable length, but he took especial pains not to mention the name of the record or give any wide clew to the name. The result was rather satisfactory. There were numerous telephone calls from persons wanting to know what the name of the record was, some informing him that he had spoiled the ad by forgetting to put in the name and other persons frankly came to the department and said their curiosity had been aroused and asked that the record be played for them.

The Kieselhorst Piano Co. is completing the housing arrangements for the two lines of records, Pathé and Columbia, recently added to the Victor as on sale there. The adding of these two lines is going to make the first floor rather crowded for the present, but as soon as men can be spared from more important work, additional record sale space will be provided.

The announcement made the middle of the month that Vocalion records were on sale at Aeolian Hall led to a very satisfactory demand from Vocalion owners. The verdict reported by purchasers was more than satisfactory—"it was extremely pleasing"—according to Manager Guttenberger.

Ben S. Philips, for a long time a salesman and later retail manager for the Columbia Co. here, is on the Vocalion staff at Aeolian Hall.

The Vita-Nola talking machine made by the Vitanola Talking Machine Co., Chicago, which is featured locally by the Rice Stix Drygoods Co., the Witte Hardware Co., and the Phoenix Furniture Co., is in excellent demand.

Delpheon
the
Incomparable

A tone that is ineffably
exquisite—not phonographic



Delpheon \$75 Model

THE DELPHEON COMPANY
BAY CITY :: :: MICHIGAN
OR WRITE TO DISTRIBUTORS



Why—the B & H Fibre Needle?

Because it is:

The needle that *cannot* injure the record.

The needle that is absolutely *silent* on the record.

Because it is:

The *logical* needle.

The *practical* needle and

The *commonsense* needle.

Furthermore it is:

The needle that sells itself—that sells records
and prompts the purchase of Talking Machines.

Finally, it is:

The needle that satisfies the customer and

Thereby Brings Money to the Dealer

B & H FIBRE MFG. CO.

33-35 W. Kinzie Street

Chicago, Ill.

Featuring the Musical Possibilities of the Talking Machine

By William Braid White

[Note.—This is the sixteenth in a series of articles on the general subject of the musical possibilities of the talking machine. The aim of the series is to develop these possibilities from all angles, thus opening up fields for sales expansion oftentimes neglected wholly or in part.—Editor.]

GEORGE FREDERICK HANDEL

The puristical fuss-button might insist on writing it "Georg Friedrich Haendel," but a man who spent only one-third or less of his life in his native Saxony and more than forty years in continuous residence within the limits of the British Isles, who became a naturalized Englishman, spoke, thought and wrote English only, and who composed music in a style peculiarly and characteristically English upon themes which only Englishmen could at the time have relished, can hardly be called aught else than an Englishman. Such George Frederick Handel undoubtedly considered himself and such his whole marvelous career has proclaimed him ever since to be.

It has been well said that no one man has ever had a more extraordinary influence upon the social life of his community. To this day British and the American social life has been astonishingly under Handelian influence in many unsuspected ways. The oratorio of "The Messiah" has formed the most important element in the art-feelings of uncounted thousands of English-speaking people for nearly two hundred years; and its drawing power is as great to-day as ever. The dead are buried to the accompaniment of the "March from Saul," the living sing in Church the hymn-tunes of Handel, the great are welcomed with the strains of "Hail to the Chief" and the musical daughters of uncounted proud parents have struggled through the strains of "Lascia ch'io piangia" and "Angels ever bright and fair."

"The Messiah"

Each Christmas time, in innumerable towns and cities of the United States and Great Britain, great choral societies and humble church choirs alike are to be found giving, wholly or in part, the immortal measures of "The Messiah." The music of Handel is literally the most Anglo-Saxon music that can be imagined and we are perhaps not without justification if we claim Handel for ourselves and decline to be ashamed of our pride in him.

Naturally, the recorded music of Handel available to the owners of talking machines is considerable in quantity and particularly good in quality. Naturally, also, the interest which the dealer should have in becoming acquainted with Handel's music more than superficially, and in promoting its steady sale, ought rightly to be very large. Hence, some few of the very interesting facts about an intensely interesting life and its musical product may rightly claim a place here.

Youth

George Frederick Handel was born at Halle in the year 1685, and was therefore contemporaneous with J. S. Bach, who first saw the light during the same year in the little town of Eisenach. The young George Frederick had for father a worthy but sadly prosaic surgeon, who plied simultaneously the trade of barber. It was not expected that the young boy should be destined for any calling save one of respectability and worth; but genius laughs at bonds.

The lad soon found his own choice and it was music. Forbidden to learn, he discovered in the lumber room of his home, hidden away in an attic, an old broken down spinet. On this he secretly taught himself to play. There is a well-known picture by the British artist Dicksee showing an attic room at midnight and at its door a troop of half-dressed, half-frightened people who have burst in carrying candles and a blunderbuss. The candle light falls on a

slender child seated before a spinet, and the title is "The Child Handel." That was the beginning of one of the most remarkable careers the world has yet witnessed.

The worthy Doctor Handel did not without much reluctance, after much persuasion, agree to permit his son to follow the beggarly profession of music, as he sincerely thought it to be. But a fortunate accident, leading to the child's talent being brought to the attention of the Doctor's princely employer, settled young George's fate and from thenceforth he was devoted to the study and practice of the divine art. His early career was not very exciting and about all that need be said about it is that young Handel made himself the best organist and very nearly also the best harpsichordist of his age, while he likewise became no mean performer on the violin and could even sing quite respectably. He was organist at the university of his native town, when only fourteen years old, and when his father died about this time began to support himself wholly from his musical earnings. In the year 1705 he actually composed and brought out, though without much success, two operas in the then prevalent Italian style, thin and insipid enough in all conscience, but remarkable productions for a boy. But greater work was in store for him.

Italy

In those days the music Mecca was Italy. There the best singers, instrumentalists and composers were to be found, in generous quantity. Young Handel much wanted to get over the Alps but he was twenty-one before he could manage it. Once there, however, Il Sassone (The Saxon) as he soon came to be called, swept all before him. His extraordinary talents astounded the Italian virtuosi and made for him a fame that reached from one end of Europe to the other. His early ventures in Italian opera were further extended during this stay and he for a time became quite Italianized. But this phase of his career was to be only incidental.

"Signor Handello"

In the year 1710 Handel, who had meanwhile become court-musician and composer to the King of Hanover, obtained leave to go to Eng-

land, whither he had been invited on the strength of his now European reputation. He was to compose for his debut an Italian opera and it is a significant commentary on the artificiality and insipidity of public taste that it was thought proper to introduce him as Signor Handello, not as Mr. Handel. In fact, Handel was nicknamed both Mynheer Handel and Signor Handel later on during his British career, but these were rather affectionate pet-names. "Signor Handello," however, meant that a composer had no chance unless he was an Italian or supposed to be one. England has not always been free, in later days, from this affectation. Good honest Dan Foley, one of the finest Irish singers that ever lived, thought it well to call himself Signor Foli, and then there was Signor Sullivan, otherwise Tim Sullivan, bless him!

Anyhow, the "Signor" came to London and found that the enterprising Aaron Hill, who had taken the new Haymarket Theatre and was putting on a season of the fashionable Italian opera, had already let it be known that the Signor would have a new original opera ready for the opening; which was all of fourteen days off! Handel set to work and got it out, and the result was Rinaldo; certainly the finest thing that had ever been done of its kind and one which abounds with still lovely music. Of course, a modern opera audience would find Rinaldo dreadfully tedious, simply because taste has changed and we no longer can sit through an interminable series of recitatives and set airs. Still, you will find recorded in each of the leading catalogs, the gem of the opera "Lascia ch'io piangia," sometimes Englished as "Mid' lures, mid' pleasures," sometimes called "Leave me to languish." Look for it under Rinaldo and you will find it in the Victor, the Columbia and the Edison catalogs.

This record, whether you take Schumann-Heink's, Julia Claussen's or Adelaide Fischer's interpretation, gives a perfect example of the ancient style of Italian operatic music. It consists of a recitative followed by an air. A recitative is a short declamatory passage in which some point vital to the story is brought

(Continued on page 54)

7th Floor

229 Fulton Street

Clifford A. Wolf

MANUFACTURER OF

Diamond and Sapphire
Phonograph Points

New York City

Phone, 1678 Cortlandt

THE MUSICAL POSSIBILITIES OF THE TALKING MACHINE

(Continued from page 53)

out. It is a simple melody intoned by the voice and set to words that explain the stage of the action reached. The voice sings with no accompaniment save that of an occasional chord brought in to give emphasis and support. This is followed by the air or song proper. In the case we are considering, the air "Mid' lures, mid' pleasures" is one of the loveliest melodies ever written by man. Its sweet stately beauties are as fascinating to-day as when they were written more than two hundred years ago. It makes a lovely record and all should know it.

Of the more than forty operas that Handel composed during the next few years, not one survives, but the indefatigable recorders of music have preserved for us the well-known so-called "Handel's Largo" which is in reality an air from his opera "Xerxes." (Classical themes were favorites with opera-makers in those days.) This has been sung, played, orchestraed and banded till everybody knows it. Several good records of it in various forms are available.

"Tweedledum and Tweedledee"

From merely being a composer, Handel became in due course a manager. Now, grand opera management has always been a sure road to bankruptcy except where wealthy guarantors or government subsidies have smoothed the way. So Handel, after his final settlement in England for keeps after 1718, found himself in due course stranded on the shore of the bankruptcy court. His troubles were largely due to the jealousies between his partisans and those of the rival managers who were brought out to ruin him. Troubles with prima donnas and high-priced tenors, the social quarrels with ladies of society that followed, and the consequent formation of a society clique determined to ruin him, led to the importation of Buononcini from Italy as a rival composer at a rival theatre. Thus London enjoyed a first-class operatic war and the town was agog with it. Dean Swift's witty, malicious tongue obtained undue credit for the clever jingle which hit off the tempest in a teapot so cleverly and besides gave two new words to the language. Everybody knows it:

"Some say, compared with Buononcini
That Signor Handel is a ninny;
Others aver that he to Handel,
Is scarcely fit to hold a candle:
Strange that such difference should be
'Twixt Tweedledum and Tweedledee."

The dean was not the author, but what of that.

In the Domain of Oratorio

The solid, honest, bluff character of stout old George Frederick would not stand the petty stupidities of this sort of thing however, and in 1737 he found himself not alone ruined in finances but in health. It was at this time that his naturally religious and quite thoroughly Anglo-Saxon nature found itself drawn towards the contemplation of sacred oratorio, as a form of composition which might give rise to words of real artistic worth and lead to the development of new and splendid musical material. The sacred oratorio is peculiarly a Handelian form of musical work and has remained almost purely English and American. The Anglicized Mendelssohn tried his find hand at it, Papa Haydn too, and such men as Arthur Sullivan, Gaul and Gounod were proud to be associated with it. In effect, the oratorio is an opera, sung without action or costume, its story based on some biblical episode, with words drawn from the scriptures and music of appropriate character. It involves, as developed by Handel, great choruses, quartets and solos for tenor, bass, soprano and contralto. Its subject, as was said, is always biblical.

Judas Maccabaeus, Israel in Egypt, Saul, Judas, Joshua and a number of others flowed in succession from Handel's pen. Beginning with his first experiment in setting the story of Esther, he continued, in face of many disappointments, to persevere in his chosen work, till he burst upon the world with the immortal, forever glorious "Messiah," composed in the extraordinarily short space of twenty-one days, and first sung, not in the London which had irritated and flouted his genius, but in Dublin, where his friend, the Duke of Devonshire, was Lord Lieutenant, for the benefit of the prisoners for debt confined in the city's Marshalsea.

Immortality

Performed with a handful of singers and a small orchestra the success of this extraordinary work was so profound and overpowering that Handel's waning fame was restored in an instant. Since that year, 1742, "The Messiah" has been performed almost annually on the largest scale. Since the great Handel festival of 1784 in London, the choirs have become larger and larger. Crystal Palace performances in London have massed five thousand voices of chorus and five hundred instruments of orchestra, with a great organ to boot, before audiences numbering ten thousand and more. The Handel

and Haydn Society in Boston, for a century last, has faithfully fulfilled its task of keeping green the memory of this marvelous work. Oratorio societies in New York, in Chicago, in Cincinnati and elsewhere have never ceased to carry on the good work; and to-day the man, woman or child within range of a musical center who has not heard "The Messiah" is somehow, one feels, defective.

Push Them!

In the circumstances is it not absurd that every dealer does not push to the limit, especially during the winter months, the sale of Messiah and other Handel records? Between the Victor, Columbia and Edison catalogs one can make up almost the entire Messiah. The immortal airs "He Shall Feed His Flock," "I Know That My Redeemer Liveth" and "The Trumpet Shall Sound," the divinely inspired choruses "The Glory of the Lord" and above all "Hallelujah," have been splendidly recorded. Thus the veriest dweller in the wilderness may become acquainted with the wonders of Handel's genius. It is said of him that, in his later years, he used to tell, in his quaint English, about when he was composing the "Hallelujah," "I did tink the heafen wass opened and the anchels and archanchels ascending and descending!" Who can wonder?

Westminster Abbey!

Handel died in London at his house in Brook street, in the year 1759, at the age of seventy-four. For some years he had been blind, but he continued to direct performances of his oratorios till almost the end. He was given a public funeral, and buried in Britain's Pantheon, Westminster Abbey, near the bodies of Addison and Steele, of Johnson, Goldsmith and Garrick, among such a glory of illustrious dead as perhaps no other so small spot on earth can boast.

In Handel's House

My friends call me a Handel-worshiper. One might have worse titles to consideration. Perchance the fault, which I cheerfully own, is really ineradicable; for my father was married in Handel's house in Brook street, where the grand old man lived for the last twenty years of his life. There in that fine old place still may be seen the very recess where his organ was placed, the very room in which he worked. Most of our family were born in that house. Is it any wonder we love his memory?

AN ARTISTIC WINDOW DISPLAY

The Emerson Phonograph Co. has prepared for the use of its dealers this month an artistic window display service which is the most ar-



Emerson Display for Dealers

tistic display issued in this series to date. The display has found instant favor with Emerson dealers, due to its simplicity of construction, which enables the dealer to install it with the utmost ease and with an extremely small expenditure.

R. H. Coker has opened a music store at 222 East Fourth street, Olympia, Wash., where he will feature the Bush & Lane pianos and players, and the Sonora phonograph.

The only way to beat a time clock is to make it tell of you instead of letting it tell on you.

SERVICE FOR THE JOBBER



Write today

Seven Patterns in stock

STYLE FOR EVERY DEMAND

Cabinets only

SELL BEFORE YOU BUY

Send us Motors; we install and ship your

Customer Direct

No freight

No handling

Save you \$4.00 to \$5.00 each Cabinet

Established 40 years

Capacity, 150 per day

JOSEPH KNITTEL SHOW CASE CO. - - - Quincy, Ill.

Here Is the Greatest Phonograph Proposition In America Today

THE newest discovery in tone reproduction, the long horn, entirely of wood and of saxophone design, with the sound chamber at the bottom, an exclusive, patented feature and a tremendous selling advantage of the

PURITAN

THE FINAL SUCCESS AMONG PHONOGRAPHS

More money is being made in the phonograph industry today than ever before in its history. But to get your full share, you have got to carry an instrument whose *real advantages* stand out among the many lines now being offered.

The Puritan offers you the biggest opportunity in the field today.

Its long horn is the greatest and newest discovery in tone reproduction. It makes true and lifelike the music of the greatest vocalists and instrumentalists on earth. The sound chamber at the bottom is another advantage—based on the scientific fact that sound waves *rise*. That is why the real music lovers at the opera sit in the balcony.

The charming convex cabinet design is another exclusive Puritan feature. And you have in addition a line of superior Puritan Records made in our own recording laboratory. The Puritan plays any disc record made. Retail prices range from \$85.00 to \$350. Write, wire or phone for details of our attractive proposition.

United Phonographs Corporation, Sheboygan, Wis.



Let Columbia help you make your windows work. Plenty of fine display material ready now on the Portable Grafonolas. Write for information.

**Columbia Graphophone Co.
NEW YORK**

BANQUET OF BLACKMAN TALKING MACHINE CO. STAFF

Employees of Victor Wholesalers Enjoy Ninth Annual Get-Together Party at Murray's on June 1 —President Blackman Recites Record of Long Service—Some of the Guests

The ninth annual banquet of the employees of the Blackman Talking Machine Co., New York, Victor wholesalers, was held Saturday, June 1, at Murray's, and was attended by the officers, employes and several invited guests. It had been originally intended to make this annual event similar to the outings of previous years,



J. Newcomb Blackman

and Decoration Day had been chosen as the day on which the 1918 outing would take place. In view of President Wilson's proclamation, however, setting forth the manner in which Memorial Day should be observed this year, the officers of the company decided that it would be more befitting the spirit of the times and the occasion to eliminate the outing and other incidental features, and have instead a dinner at Murray's.

The employes of the company entered enthusiastically into this idea, and when they gathered at the table on June 1 looked forward to an interesting evening which would leave pleasant recollections for the coming year. They were not disappointed in these expectations, for this year's dinner was the most successful that has yet been given by this well-known house.

Some nine years ago J. Newcomb Blackman, president of the company, inaugurated a plan whereby the employes of his company would share in the profits, and based this profit-sharing upon an employe being in the service of the concern for one year. The company's fiscal year closes on April 30, and the distribution of the profits has been marked each year by a gathering of the employes and the officers of the company. These outings and gatherings have undoubtedly been important factors in the splendid success achieved by the Blackman Talking Machine Co., for they have given the employes an opportunity to get acquainted with each other personally, aside from their business interests, and to establish an esprit de corps that has increased steadily year after year.

At Saturday's dinner Mr. Blackman presided

as toastmaster, and in his opening address gave his employes and guests a brief resumé of the history of the Blackman talking machine. He pointed out that the company is now sixteen years old, and that when it inaugurated its profit-sharing plan nine years ago it was one of the very few concerns who recognized the value of such a plan. Since that time the idea of sharing profits with employes has become general throughout the country, and practically all of the leaders in the industrial world have adopted this plan.

When the company started business in 1902 the personnel of the force consisted of Mr. Blackman and one employe, Frank Roberts. Today the staff numbers thirty, and out of this staff of thirty, twenty-one members were entitled to share in the 1918 profits, including Mr. Roberts; a remarkable record that indicates the spirit of loyalty and co-operation which characterizes the activities of the Blackman force.

Delving into statistics Mr. Blackman pointed out that these twenty-one members of his staff had given the company 111 years of service. The veteran of the force, Frank Roberts, secretary of the company, has been with the Blackman Talking Machine Co. for sixteen years; John L. Spillane, assistant secretary, has been a Blackman stalwart for thirteen years; James F. Ashby, assistant treasurer, has been associated with the company for eleven years; H. C. Lansell, traveling representative, and Miss L. D. Peters, of the general sales force, have been members of the Blackman staff for nine years, and George Thau, head of the shipping department, has been a member of the Blackman force for seven years.

Mr. Blackman expressed his appreciation of the loyalty and service of his employes, and in turn assured them that each and every member of his staff could depend upon the heartiest co-operation and assistance from himself and every officer of the company. In the course of his address Mr. Blackman paid tribute to the five members of the company's staff who are now in the service of Uncle Sam, and also furnished those at the dinner with a comprehensive idea of the duty which every true American owes to his Government at this critical time. Mr. Blackman was one of the leading spirits in the remarkable success achieved by the Allied Music Trades division in the recent Liberty Loan, and has always been an active worker in behalf of all patriotic and charitable interests. His talk was enthusiastically received by everyone present, and left a deep impression on the minds of his employes and the other guests.

Two of the guests of honor at the dinner were Seaman Alexander J. Wilckens, who is now a member of the U. S. Naval Reserve Force, and Private A. D. Robbins, who is a member of the 663d Aero Squad. Both of these "boys" were

formerly associated with the company's traveling staff, but are now "doing their bit" for Uncle Sam. Three other members of the Blackman forces are also fighting for democracy, including Lieutenant James H. Giles, 104th Field Artillery, who is now "somewhere in France"; Private C. N. Callanan, Aviation Training Camp, and Private Paul Wordsworth, Ordnance Department. Seaman Wilckens and Private Robbins gave informal addresses which met with hearty applause.

On behalf of the officers and employes Fred P. Oliver, vice-president and general manager of



Fred P. Oliver



Frank Roberts

the company, expressed to Mr. Blackman the sincere appreciation of every member of the staff for the spirit of affection and good will which Mr. Blackman has sponsored in his organization. Mr. Oliver bespoke the continued loyalty of the Blackman staff, with the hope that each year's dinner would mark the closing of a successful year for the company.

Besides sharing the profits, the officers of the company, together with a number of the employes, also received dividend checks as stockholders, including Frank Roberts, Fred P. Oliver, James F. Ashby, John L. Spillane, George Thau and H. C. Lansell. The other stockholders who received dividends were Mrs. J. Newcomb Blackman, Mrs. Fred P. Oliver, Mrs. A. A. Houghton and Mrs. Irene G. Blackman. The other employes of the company who shared in the distribution of profits were A. J. Wilckens, A. D. Robbins, E. S. Palmer, John Hanley, John Mills, Frank Tillinghast, Charles R. Marquis, Miss L. D. Peters, James Toll, Mrs. A. Miller, Miss R. Dunger, Miss M. V. Johnstone, Mrs. E. Reighton and Miss V. Hirshberg.

INCORPORATED

The Prima Talking Machine Co., Wilmington, Del., has been incorporated with capital stock of \$98,000.

H. J. SMITH—Jewel Manufacturer

MANUFACTURER OF—Phonograph Diamond and Sapphire Reproducing Points—Recording Laboratory Jewels—Jewel Bearings for Electrical Instruments—Rough Diamond—Diamond Powder—Experimental Work.

Telephone 2896 Market

833 BROAD STREET NEWARK, N. J.

DEATH OF DANIEL G. WILLIAMS

Veteran of the Cabinet Industry Passes Away in Indianapolis—Was Seventy-eight Years Old and Had Been in the Trade for Forty-five Years

The host of friends in the trade of Daniel G. Williams, "Uncle Dan," veteran traveler for the Udell Works, Indianapolis, Ind., and one of the best-known and most popular men in the cabinet trade, will learn with regret of his death at his home in Indianapolis, on May 21.

A life of remarkable activity came to an end when Daniel G. Williams passed away. This wonderful man had been sick for about thirty

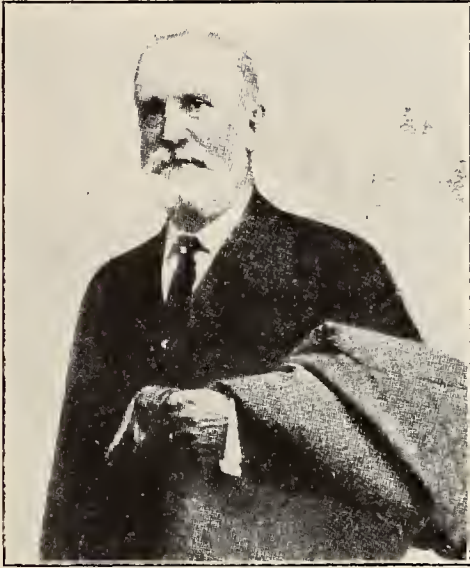

Daniel G. Williams

days, and inasmuch as he was stricken with pneumonia it was impossible at this advanced age to get his strength back and get well.

"Uncle Dan" Williams had traveled continuously for the Udell Works since 1873 or for forty-five years. In fact, he was the first vice-president of the original concern known as the Udell Ladder & Woodenware Works. Before his connection with the Udell Works he was president of the firm of Todd, Carmichael & Williams, who were in the book business many years ago on Washington street. While traveling for this concern he became interested in some original step ladder patents and prevailed on Calvin G. Udell, then of Chicago, to come to Indianapolis and start a factory. It was the year of 1873 when the Udell Ladder & Woodenware Works was launched with Mr. Williams as vice-president.

There are but few men who live to the ripe old age reached by "Uncle Dan," and the remarkable thing about it all is that up until his last sickness he traveled over a big territory, and his last trip when he was gone for six weeks was one of the most successful he ever had. He was of that genial, jovial disposition that makes friends on all sides, but at the same time when he was on the road he was up and coming all the time, and after the exchange of courtesies it was business first with him. It is not an exaggeration to say that Daniel Williams was the best-known and the oldest salesman in the talking machine, piano, woodenware, furniture and music field.

He was born on July 18, 1839, in Cornish, N. H., and would have been seventy-nine years old on the 18th of July of this year. He joined the First Baptist Church of Indianapolis in 1854 and was the oldest member, having belonged to that church for sixty-four years. Besides the widow, he is survived by five children of a former wife, who was Miss Anna Gabbert, of Columbus, Ind. The five children surviving are Frank Williams, of Shreveport, La.; Miss Cora Williams, of Denver, Colo.; Mrs. Grace Heiner, of Waverly, Kan.; Mrs. Maude Koons, of Indianapolis, and Mrs. Charles Greenstreet, of St. Louis.

He was laid to rest in a beautiful lot in Crown Hill Cemetery Friday morning, May 24. "Uncle Dan" Williams was an inspiration to all who came in contact with him, and his acquaintance unquestionably had a wonderful influence upon the younger men he came in contact with. He was a very hard worker—in fact, some of his best friends thought he worked too hard, but

that was the way he was built. We quote from a letter received a few days ago from one of his friends in the trade: "I have had the pleasure of knowing this gentleman for forty years or ever since I was a tiny young fellow. He was an inspiration not only to everyone in this concern, but to all the people he called on throughout the United States. In all my experience I have never known of a man who was so well thought of and highly respected as 'Uncle Dan.' Everybody that he has come in contact with will miss him."

His was indeed a life that was worth while, and, although he is gone, the memory of him will always be fresh in the hearts of those who were privileged to know him.

SENDING "SMOKES" TO THE BOYS

Talking machine men are good sports, and are seeing to it that the boys in the trenches are getting smokes. Contributors to the New York Sun Tobacco Fund contain the names of many talking machine men, and the employes of the Victor Talking Machine Co., of Camden, N. J., are well represented. The "Smokeless Monday Club," of which J. W. Jagers is president, consisting of employes of the Victor Co., send a weekly gift to The Sun, all representing sacrifices made by the members in order to add to the comforts of the boys at the front. Their usual Monday donation runs about \$20.

LOS ANGELES DEALERS MEET

First Open Meeting of Retail Talking Machine Dealers' Association Brought Together About One Hundred and Twenty-five People

LOS ANGELES, CAL., June 1.—The Retail Talking Machine Dealers' Association of Southern California gave their first open meeting on the evening of May 21. A fine banquet followed by a dance was the attraction and nearly everyone connected with the talking machine industry, both retail and wholesale, here was present.

This delightful affair was given by the dealers as a sort of get-together and get-acquainted occasion, and was held at the Sierra Madre Club on the thirteenth floor of the Los Angeles Investment Building.

Everyone had a good time and dancing and other entertainment was in order during dinner and much credit is due to the committee, composed of E. S. Dible, Frank Salyer and Harold Jackson, for the fine time enjoyed by everyone. Never before has there been such a gathering together of the "trade" in Los Angeles, and the festivities did not end until near midnight.

It is to be hoped that the association will give another of these happy parties in the near future, as they will bring the talking machine people closer together and have a tendency to help business in general by establishing a better understanding between the different dealers.

IT SELLS

That's why you should have them



THE IMPROVED No. 10



Patented Sept. 26 and Oct. 2, 1906
Sept. 10, 1907 and Nov. 27, 1917
Others Pending



RECORD BRUSH

For Victor Victrolas

PRICE

NICKEL PLATED 35c.	GOLD PLATED 75c.
------------------------------	----------------------------

Insures Long Life to Disk Records and Preserves Tone

Automatically cleans the **Record Grooves** and gives the needle a clean track to run in. Preserves a clear Reproduction and prevents Records from soon getting scratchy. Makes the Needle wear better. Dust and dirt in the Record grooves wear the Record out quickly and grind the Needle so it cuts the Record. **SAVE THE LIFE OF YOUR RECORDS.**

DIRECTIONS FOR ATTACHING BRUSH

No. 1



No. 2



No. 3



1st. Clamp Spring Clips of Brush around Goose Neck (see 1 and 2). Place Record on Turn Table and Needle in Sound Box. Move Spring Clips along Goose Neck to a position where only outer bristles of brush will sweep the first few threads of record. Test this by resting needle in first groove of record (see No. 3).

2nd. Turn Spring Clips on goose neck to produce necessary pressure on record through yielding spring. Brush top must not touch edge of Sound Box when in operation (see correct position of brush on No. 3). Yielding Spring of Improved Cleanrite Brush eliminates danger of too much pressure on record.

Circulars and Price List mailed on request.
Order from your Distributor or



Blackman

TALKING MACHINE CO.
97 CHAMBERS ST. NEAR CHURCH ST. NEW YORK



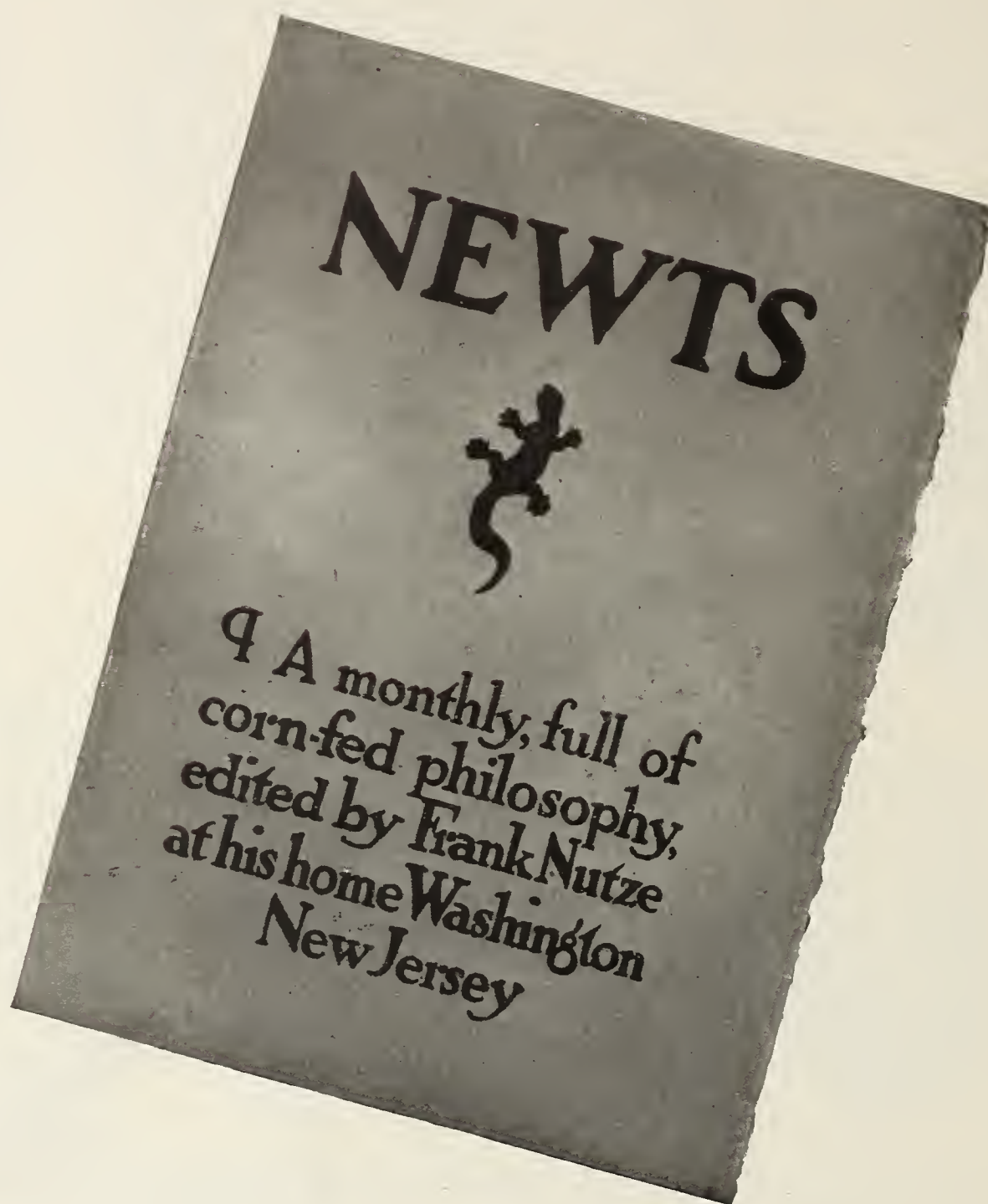

— a house organ that
plays an entirely different
tune: have you received a
copy ?

Frank V. Nutze

Vice-President

STEPHENSON, INC., One West 34th Street, New York

CRYSTAL EDGE MICA DIAPHRAGMS

M
I
C
A

Let us send you samples *today* of our diaphragms and you will readily understand why the best talking machines are equipped with *Crystal Edge Mica* diaphragms exclusively.

We use only the very finest selected mica, the best diaphragm material in the world.

PHONOGRAPH APPLIANCE CO., 109 West Broadway, NEW YORK

TWIN CITY TRADE COMPLAIN OF BIG MACHINE SHORTAGE

Conditions Are Such That Dealers Are Worried—Hope for Better Luck This Month—Enormous Crops in Northwest Insure Big Volume of Trade This Coming Fall—L. H. Lucker Goes East

MINNEAPOLIS and ST. PAUL, MINN., June 6.—Any one having a stock of talking machines, whether it be of Victors, Edisons, Columbias, Pathés, Brunswicks or any other standard make, will be able to dispose of the entire stock in a day or two if he will only bring the lot to the Twin Cities. Jobbers declare that the factories do not begin to supply their needs and what the retail dealers say of the jobbers because of the latter's failure to supply machines is hardly printable in a fastidious periodical such as *The Talking Machine World*.

Take it in the Victor trade. W. J. Dyer & Bro., in St. Paul, and Beckwith-O'Neill Co., Minneapolis, declare that they are able and willing to double their business, but the old mother company won't let them; that is to say, will not supply the wherewithal in the shape of instruments. Then call on the Minnesota Phonograph Co., jobbers in the Edison products, G. Sommers Co., jobbers of the Pathé products, and the Northwest offices of the Columbia, and the Brunswick-Balke-Collender Co., and you hear a repetition of an ancient song, "Can't get goods."

It is known, almost to the point of a fact, that the Northwest can absorb thousands of machines more than are being allotted to it. Every dealer, whether selling in lots or by the instrument, says so, and one is fain to believe the universal story. The policy out this way is to prepare for a big fall trade. It is realized that the Government may curtail the factory output 30 or more per cent., that freight regulation may prevent the shipment of talking machines and that other grievous things may happen, but the Twin City people are going ahead regardless of all and are not borrowing trouble. The blows will be heavy enough, if they come, without anticipating them at this time.

Jay H. Wheeler, manager of the Pathé department of the G. Sommers Co., returned last week from New York and the East after placing a big order for the fall stock. He came home to find the new 100,000-record stacks in place and ready for the arrival of a carload or more

of records. The spring business of the house, he states, was far in excess of the volume for the spring of 1917.

Laurence H. Lucker, president of the Minnesota Phonograph Co., left Saturday evening in the company of Milton Lowy, of the staff, and various Northwestern Edison dealers for the big Edison convention. His reports indicate that trade is not quite as active as it was, but the demand still exceeds the supply. Trial balances show that the gross business for the first four months of 1918 was 18 per cent. above the gross for the corresponding period of 1917.

Road men for all the houses are advising their principals to prepare for a heavy rural demand after the crops begin to move. It looks now as though the yield will be immense and in that event the Northwestern farmers, in spite of the calamity howlers, like the Non-Partisan League, and other professional crepe hangers, will be rolling in money. Some portions of North Dakota are entitled to some returns at that, after two successive bad years.

BUDGET OF OPEROLLO DOINGS

Messrs. Kaufman and Gast Make Strong Team in Patriotic Work as Well as in Booking Orders—Lyric Records Well Distributed

DETROIT, MICH., June 7.—Walter Kaufman, assistant sales manager, and Charles Gast, a couple of live wire boosters for the Operollo Phonograph Co., came back to this city just in time to expend their surplus energies in the Patriotic Fund drive. Walter and Charlie teamed together their last trip and by the extraordinary splendid results produced this combination has proven to be very successful. After Detroit had raised its proper quota for the Red Cross and other patriotic funds these "road wizards" again started out to stock up Operollo dealers throughout the South and Southwest.

Jacques Kohrner, of the Lyrphone Co., stopped in on his way West and was surely

gratified to see the splendid manner in which Lyric records were being distributed. Arrangements were made to triple the stock carried so that better shipments could be made to the various dealers.

Arthur Siewiersky, sales manager, has lately completed plans for an aggressive sales and advertising campaign which will undoubtedly startle the trade. He is well pleased with the way Operollos are being distributed and looks forward for an exceedingly large increase in sales this fall.

It is expected to have the new Operollo models ready for market in a very short time, after certain minor improvements have been perfected.

GRAFONOLAS FOR HOSPITAL UNIT

Two of These Instruments and Records Selected for Albany Base Hospital

The Columbia Graphophone Co., New York, recently sold two Grafonolas and a library of Columbia records to Base Hospital Unit No. 33, known as the Albany Base Hospital. This



Nurses Surrounding Grafonola for Base Hospital unit is now awaiting transportation orders for France, and the nurses are mobilized at Ellis Island, with Miss Mattie M. Washburn, of Albany, chief nurse in charge.

Quite a number of nurses recently visited the Fifth Avenue Shop of the Columbia Co., where they spent some time viewing the beautiful Columbia period models, and listening to some of the latest Columbia records. The Columbia Grafonolas and the records are providing pleasing entertainment for the nurses during their training period at Ellis Island, and will doubtless be in constant demand when the base unit reaches "over there."

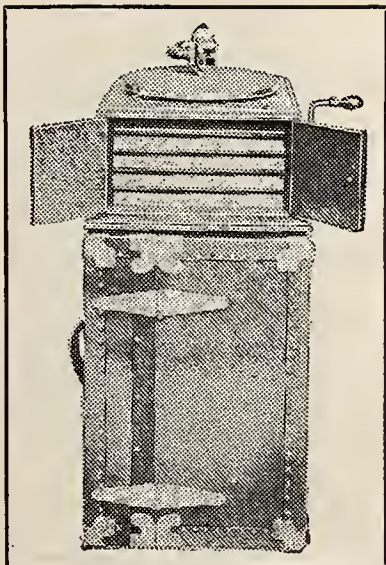

For the Summer Trade

Victor 4-A's and 6-A's in conjunction with Corley Fibre Trunks are an ideal combination for the bungalow. Sell these trunks not only to new prospects, but to every owner of a Victor IV or VI. Also ideal for the military camp.

Retail Prices, Style IV - \$10.00

Retail Prices, Style VI - \$12.00

WRITE FOR WHOLESALE PRICES
PATENTS APPLIED FOR—THEY ARE MADE TO LAST

The Corley Company

ORIGINATORS OF FIBRE VICTROLA TRUNKS

213 EAST BROAD STREET

:: :: :: ::

RICHMOND, VA.

GARBER WRITES OF HIS NEW DUTIES

Interesting Letter From W. L. Garber, Now Training at Gettysburg, Received by World

There was received this week at the office of The Talking Machine World an interesting letter from W. L. Garber, who is now a member of the Tank Corps in training at Gettysburg, Pa. Mr. Garber was formerly private secretary to Arthur D. Geissler, president of the New York Talking Machine Co., Victor wholesalers, and more recently was a member of the company's traveling staff. He selected the Tank Corps because of the unusual opportunities that it affords for vigorous action at the front, and his letter reads as follows:

"I had a letter day before yesterday from Mr. Keith advising me he would see to it that I received each month's issue of The Talking Machine World and 'Voice of the Victor.' This news made his letter doubly welcome. I arrived here on the night of May 23, and the next day two other 'previous service' men and myself out of our new detachment from Fort Slocum were selected as sergeants for the Casual Company—a detention or quarantine camp, through which all recruits are recorded, examined and finally transferred to their respective battalions, either the Light or Heavy Tank service. We keep an average of 1,200 men here and transfer them as needed. Sometimes we receive two hundred or more recruits after midnight, which means 3 a. m. or later before we turn in.

"Most of all officers attached here have now been assigned to new battalions formed and the casual camp has been turned over to the non-coms, and it is some job keeping track of a thousand or more strange faces. Yesterday afternoon we (four of us) drove over to Chambersburg and picked up five men who had been confined to camp and had slipped out.

"I understand my old artillery regiment, in which is Morris Owens, another N. Y. Talking Machine Co. boy, has arrived 'over there.' As anxious as I am to get over, I would rather be here in the 'Tanks,' because when we do get over we'll raise —

"We are camped on the field where Pickett made his famous charge, and have plenty of local atmosphere to make us work hard to get in the big fight. The esprit de corps here is marvelous, and the caliber of men above the average. Lots of good luck. Sincerely, W. L. Garber."

RECENT WILSON-LAIRD PUBLICITY

The Wilson-Laird Phonograph Co., New York, factors and distributors of the Bliss reproducer, have just issued an effective four-page folder that gives eight reasons why the Bliss reproducer should be used. These reasons are presented in handy form, so that the folder may be utilized by manufacturers and dealers as an envelope enclosure, and is directed particularly to Edison dealers. It is noteworthy for the absence of technical details and for the abundance of practical sales arguments.

The company has also issued a new price list that shows a reduction in the retail price of the gold-plated Bliss reproducer and also a reduction in the prices of dozen lots. This reduction in price was made possible because of the company's fast-growing business and the fact that it has been able to place its factory on a basis of maximum efficiency. There will be no further changes made from the new price list for the balance of 1918, and the company has advised its trade that it hopes to maintain these prices without any advance during the period of the war.

Plans are now being made to handle a large fall and winter business, and the company is creating through its advertising an active demand for the Bliss reproducer. This campaign has been particularly successful with Edison dealers, although many well-known manufacturers have expressed their intention of using this reproducer exclusively on their machines during the coming year.

PRIZE WINNER IN EMERSON PHONO CO.'S WINDOW CONTEST

The Emerson Phonograph Co. announced this week the prize winners in the store and window displays that were presented for the consideration of the judges embodied many unusual and praiseworthy features.



display contest, which closed on May 15. The contest was a decided success, and some of the

originality in conceiving artistically arranged window displays.

The first prize, consisting of \$75 worth of records, was awarded to the S. S. Kresge Co., 532 Congress street, Portland, Me. This window display is reproduced herewith, and is undoubtedly worthy of the honors bestowed upon it. The second prize, consisting of \$50 worth of records, was awarded to S. A. Wolpert, 1935 South street, Philadelphia, Pa. The third prize of \$25 worth of records was won by the Black S. Hansen Co., 611 Commercial street, Waterloo, Ia.

The following five Emerson dealers were awarded prizes of \$10 worth of records each: Timothy Smith, 2267 Washington street, Boston, Mass.; Jordan & Marsh, Washington street, Boston, Mass.; the Record Exchange, 2017 South street, Philadelphia, Pa.; Feiler Furniture Co., 819 Central avenue, Cincinnati, O.; S. S. Kresge Co., Indianapolis, Ind.

All the displays presented were most excellent, and reflected credit on the participants. It certainly emphasized their



Harponola

CABINETS

Equipped or Unequipped

Our experience and facilities enable us to offer the trade a line of cabinets of exceptional merit.

These cabinets are supplied either equipped or unequipped.

Manufacturers
Jobbers - Dealers

It will pay you to investigate our proposition.

Send for particulars

Guaranteed and Manufactured by

THE CELINA FURNITURE CO.
CELINA :: :: :: :: :: OHIO

TRADE SITUATION IN ATLANTA

Business Held Up Well for May—New Columbia Dealers—Advance in Price of Machines Interests Trade—Record Sales Are Expanding

ATLANTA, GA., June 6.—Business in Atlanta during May was well up to the standard of previous months, and without exception dealers report that they are doing well.

There have been some changes in connection with lines already established, as well as new stores to open.

The Atlanta Phonograph Co., the president of which is Mr. Riley, was the original Columbia man in Atlanta, way back in 1901 or 1902, but who became later the first Edison dealer in this city, has qualified recently as a Columbia dealer, and is reported as doing finely with that old and popular line.

Zaban Furniture Co., 119 Whitehall street, has also taken on the Columbia line, being new dealers in the talking machine field. They have begun an intensive advertising campaign, and are selling a large quantity of phonographs and records.

The feature of the month was the advance in the price of Victor goods, on May 10, and among those in closest touch with the situation it is considered not improbable that the Columbia and Edison lines will both advance in price within a few weeks.

Notable artists to visit Atlanta in May were Miss Anna Case, of the Edison, who passed through for points further South, stopping here about two days, and visiting the Edison stores. Charles W. Harrison, who sings for nearly all the leading companies, and Miss Geraldine Farrar, the Victor artist, who rendered a delightful concert at the Auditorium Armory, entertaining a large audience of music-lovers and prominent citizens. Miss Farrar is a close friend of a number of the most prominent people in the city, and, owing to her frequent visits here with the Metropolitan Opera Co., has had the opportunity of cultivating these friendships from time to time.

The local distributors for the Columbia, Victor and Edison lines say that their business is far ahead of the same period in 1917.

The small towns throughout the South are heavy buyers of talking machines, most of them having from one to three talking machine stores fully supplied with all types of machines and a complete stock of records. It is estimated that the smaller towns and rural centers are taking from five to seven times as large a volume of goods as they were two years to thirty months ago.

Both the Ediphone and the Dictaphone continue to book an increasing volume of sales. The use of these great time-savers is becoming almost universal.

Edison is announcing the new records by Miss Frieda Hempel. They are excellent re-creations and will find a ready sale among those who really like high grade music.

<h1 style="margin: 0;">MICA</h1> <h2 style="margin: 0;">Diaphragms</h2>	Quotations and samples promptly forwarded upon request Don't be caught short Cover yourselves now			
	<h3 style="margin: 0;">INTERNATIONAL MICA COMPANY</h3> Offices and Factory, 37th and Brandywine Streets, WEST PHILADELPHIA, PA.			
PHILADELPHIA PA.	CHICAGO, ILL. (Insulation Dept.)	AMELIA CO. VA.	MONTREAL CAN.	WEST PHILADELPHIA PA.

Some anxiety is felt as to the ability of dealers to get sufficient stock in future to operate on, as Government requirements are constantly growing, but no acute shortage is anticipated during the rest of this year at least.

A SUCCESSFUL CANADIAN HOUSE

G. W. Lindsay, Ltd., of Montreal, Are Winning a Big Following for the Pathé

MONTREAL, CAN., June 3.—G. W. Lindsay, Ltd., of this city, one of the most successful piano houses in Canada, has been achieving pleasing success with the Pathé line, and has developed an extensive clientele for Pathéphones and Pathé records. This concern is carrying the Pathé line in its branches in Quebec, Ottawa, Three Rivers, Brockville, Bellville, Kingston,



An Artistic Lindsay Window

Cornwall, and the manager of each branch is enthusiastic in the possibilities for future Pathé business.

The window display shown in the accompanying photograph was presented recently in the Montreal branch of G. W. Lindsay, Ltd., and was created by Leopold A. Poulin, one of the most successful members of the Lindsay sales staff. Mr. Poulin is in charge of the various window displays featured at the Montreal headquarters, and these displays have contributed materially to the success of the Pathé line in this city.

VICTROLA FIBER TRUNKS IN FAVOR

John G. Corley, president of the Corley Co., Victor distributors, of Richmond, Va., attended the conventions and music show during the past week in New York. Mr. Corley reported generally good business in his section of the country, and particularly commented on the great popularity of the Victor fiber trunk that they produce. He said that orders for the trunk are now being received from coast to coast, and that at least one of these trunks was in every cantonment in the country. The demand for them is steadily expanding.

KANSAS CITY TRADE HAPPENINGS

Talking Machine Men Throughout Missouri Most Optimistic—Willard Pierce Joins the Victrola Department of the Jenkins House—Other News From a Lively Trade Center

KANSAS CITY, Mo., June 4.—B. T. Woodward, manager of the retail shop of the Edison Phonograph Co. on Eleventh and Grand, is now back at his desk after being confined for seven weeks to his home, from a broken left arm and leg. "Business is far ahead of last year and we considered 1917 very satisfactory from a commercial standpoint. It is interesting to note the demand for our new Art model. Our patrons are calling for a high class machine. Just yesterday our sales included three laboratory models at \$285."

Miss Jessica Owens has been head of the phonograph department of the Kansas City Photo Supply Co. for nine weeks, and since her advent the record sales have increased wonderfully. Miss Owens reports that the demand for the Grafonola is stronger than ever. "We are making 'the most convenient Columbia shop' our slogan," said Miss Owens.

M. M. Blackman, manager of the Edison wholesale, W. Hinde, Northern Missouri representative, and C. T. Cunningham, Kansas traveler, are attending the Edison dealers' convention at New York, June 5, 6 and 7. They are expecting to remain about two weeks longer.

Herman Woolsey, of the Victrola department of the J. W. Jenkins' Sons Music Co., is spending his vacation at the home of his mother at Fort Scott, Kan.

Willard Pierce, son of Burton J. Pierce, manager of the Victrola department of the J. W. Jenkins' Sons Music Co., has completed his year's work at Kansas University and is now assisting his father in the department. Young Mr. Pierce is a member of the Phi Gamma Delta fraternity.

NEW POST FOR O. F. BENZ

George W. Hopkins, general sales manager of the Columbia Graphophone Co., announced this week the appointment of O. F. Benz as a member of the sales department. Mr. Benz succeeds, and will do the work of A. R. Harris, who has enlisted in the U. S. Navy. He will act as a member of the general sales department in connection with record activities, representing the department at the record laboratories at the factory, etc., and will co-operate with the Columbia clientele in the promotion of record sales. Mr. Benz has been associated with the Columbia Co. for the past year, and is well equipped to occupy his new position.

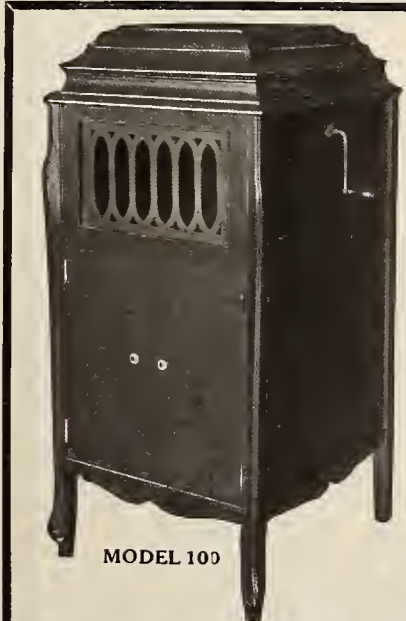

SONA-TONE

A Phonograph of Distinction with the Tone You Can't Forget

SONA-TONE *Quality* means a resonant, full, liquid tone that comes from an especially designed, all-wood sound chamber—and superior workmanship in material, finish and equipment.

SONA-TONE *Reliability* means simplicity of mechanical construction—ease of operation—and convenience and solidity of working parts.

SONA-TONE *Service* means the immediate ability of the purchaser to play all makes of records—without attachment of any sort—and to play a library of from 250 to 1000 assorted records without further expenditure.

We believe that a Sona-Tone eliminates—to a greater extent than any other phonograph—the surface noises of the record.

We believe that it has the same quality of resonance as exists in the Stradivarius violin.

From our sales record—previous to advertising—we believe that a SONA-TONE is a superior phonograph for retail merchandising.

SONA-TONE PHONOGRAPH, Inc.

3421 Broadway, New York City

\$35, \$70, \$100, \$150, \$200, \$250

"The music is on the record—the tone is in the phonograph."

FOUR NEW MODELS OF COLUMBIA GRAFONOLAS INTRODUCED

Arouse the Enthusiasm of Dealers and Visitors to the National Music Show, Where They Were Exhibited the Past Week—Their Individual Features Described

One of the most important features of the exhibit of the Columbia Graphophone Co. at the National Music Show last week was the first public presentation of four new models of Columbia Grafonolas which aroused the enthusiasm of dealers and others who visited the booths by



Type G-2

reason of their distinctive features, everyone predicting that these new artistic Grafonolas would meet with phenomenal success. While the four models are reproduced herewith, the illustrations hardly do justice to the attractiveness and beauty of the cabinet designs.

Type "E-2" measures 42 $\frac{7}{8}$ " in height, 19 $\frac{1}{8}$ " in width, and 21 $\frac{3}{8}$ " in depth, with a record capacity of seventy-five records. This cabinet is made in red mahogany, English brown mahogany, American walnut satin finish, golden oak, fumed oak and early English oak. This design is very pleasing to the eye, and will harmonize in a room with almost any design of furniture.

Type "G-2" has a height of 46 $\frac{1}{2}$ " with casters; a width of 19 $\frac{5}{8}$ " and a depth of 21". It has a record capacity for eighty-five records. This cabinet is made in red mahogany, English brown mahogany, American walnut satin finish, golden oak, fumed oak and early English oak. One of the distinctive features of this cabinet is a drawer in the bottom which may be used for either catalogs or for spare records.

Type "K-2" measures 46 $\frac{5}{16}$ " in height with casters; 21 $\frac{1}{2}$ " in width, 19 $\frac{3}{8}$ " in depth. It is equipped with seven record albums, with a capacity of twelve 12" records for each album.

This cabinet is made in red mahogany, English brown mahogany, American walnut satin finish, golden oak, fumed oak and early English oak.

Type "L-2" measures 47 $\frac{1}{2}$ " in height with casters; 21 $\frac{7}{8}$ " in width, 19 $\frac{3}{8}$ " in depth. It is equipped with ten record albums with a capacity of twelve 12" records for each album. This cabinet is made in red mahogany, English brown mahogany, American walnut satin finish, golden oak, fumed oak and early English oak. It is beautifully inlaid in satin wood, and presents a very artistic appearance.

All of these Grafonolas can be equipped with either spring or electric motors, as the cabinets are designed to accommodate either type of motor.

One of the noteworthy features of these new



Type L-2

Grafonolas is the tone quality, which has won hearty praise from tone experts and well-known musicians. Tone quality was, of course, a prime consideration in the production of these new Grafonolas, but in addition to the tonal merits of these instruments, there are many distinctive mechanical features which will doubtless contribute materially to their success.

The most important feature of this mecha-

nism is the new Columbia motor unit. This unit embodies a new motor plate, which is fitted



Type E-2

with a hinge so that it can be disconnected from the cabinet quickly. This ingenious construction permits of changing motors immediately. A



Type K-2

spring motor can be disconnected and an electric motor installed by loosening two thumb screws, swinging back the motor plate to a ver-

Save Money on your next BOOTH Installation

We are in a position to build attractive sound-proof booths from \$100 up. We have been building booths, record racks and store interiors for three years, and can save you money on your installations. We use the best materials available and guarantee our work in every detail.

Let our representative quote you prices

H. MICKELAS - 164 McKibben Street - Brooklyn, N. Y.

tical position, and by drawing the plate forward. The hinge remains fastened to the cabinet. There is also included in this new motor unit an improved motor frame, made for each of the following spring barrels; one, two, three and four. Three and four spring motors are fastened to the hinge motor plate, the one and two spring motors are attached to the cabinet motor board. There is also a new spring barrel that is fitted with a bayonet lock instead of screws for fastening the cups and separators. These can be easily disconnected by holding the cup and turning the separator slightly, then pulling it endwise.

All of these new models of Grafonolas are equipped with the Columbia non-set automatic stop, which requires no setting or any attention whatever when playing a record. The motor is started in the regular way by moving the start lever and the automatic device will stop the motor when the record is through playing regardless of the size of the record. This does not in any way interfere with moving the start and stop lever by hand. No adjustment is necessary when playing different sized records, because the lever that stops the motor is connected with the tone arm. While a record is playing it holds back the automatic stop until the entire record is played. At this point the tone arm loses its power and the stop works perfectly.

The new Columbia automatic stop is composed of simple durable parts which connect with the tone arm and with the motor. It is concealed beside the other mechanism under the motor plate. Every part is in view and easily accessible when the motor plate is raised.

This automatic stop was perfected after lengthy experimenting at the Columbia laboratories, and was approved by all of the company's mechanical experts before it was pronounced satisfactory. It was in constant use on the models at the music show last week, and won the approval of Columbia dealers who predicted that its use would add considerably to the sales possibilities of the new Columbia Grafonolas.

NEWS FROM SOUTHERN CALIFORNIA

Business in May of Excellent Volume—Dealers Carrying Fair Amount of Stock But Find It Difficult to Get Renewals—Exhibit of Victor Wireless Course—Barnes Co.'s New Quarters

LOS ANGELES, CAL., June 4.—Business during the month of May was very gratifying to all the talking machine dealers in Los Angeles, and showed them that the slump during April was only temporary. The trouble now is the lack of goods which seem harder to obtain all the time. As shipments are coming through much faster under the new management than in previous months it looks as though the shortage is at the factories, and, if so, there appears to be no remedy, at least not at the present.

Most of the Los Angeles dealers have pretty fair stocks on hand at present, but these will not last very long, and it now looks as though there will be a scarcity in most of the popular models of all the standard makes. From September each year business has always increased each month up to the holidays, and the wise man is the one who will look ahead and get his machine and records now and call it a Christmas present.

The Red Cross have interested themselves in supplying the soldiers with machines and records and are handling most of the old records and machines left by persons for the different camps.

The new draft regulations are liable to hit a pretty hard blow to the dealers by taking from them some of their best record and machine salesmen, as many in the trade are eligible for first call. The ladies, acting in this capacity, are liable to be at a premium if many more of our boys are called to the colors.

The Southern California Music Co., 332 South Broadway, Victor and Edison dealers, had a very interesting exhibit last week demonstrating the wireless course gotten out by the Victor Co. An aerial was strung from the second to the third floor and a wireless operator was

placed on a platform in front of the large middle window where he could be plainly seen from across the street. The sounder was placed on the ledge outside the window and the sparking, of course, attracted a great deal of attention. The operators were obtained from the Y. M. C. A., which has included the wireless in its course.

The Barnes Music Co., for many years located at 131 South Broadway, have moved to the old location of the Bartlett Music Co., 231 South Broadway, opposite the City Hall. Mr. Barnes has remodeled his store and now has an up-to-date and attractive store. The Barnes music store are exclusive Columbia dealers.

The Birkel Music Co. report business as good during May and on the increase. Mr. Beck, manager of the talking machine department, says he is pretty well supplied with machines except Victrola XIV, which are hard to get.

T. A. CLARKE WITH CHAMBERLAIN CO.

Theodore A. Clarke, for the past eight years associated with the Victor line in New Haven, Conn., has taken up new duties as manager of the Aeolian-Vocalion department at the Chamberlain Co.—Connecticut's most progressive and finest furniture house.

The Chamberlain Co. have a complete line of Aeolian-Vocalions and records and report Vocalion business in New Haven good at the present time.

SMITH OPENS NEW STORE

Albert E. Smith recently opened a store at 215 State street, Madison, Wis., where he will carry a full line of pianos, Victor talking machines, records and sheet music.

INCORPORATED IN GRAND RAPIDS

The Michigan Phonograph Co., of Grand Rapids, Mich., has been incorporated with a capitalization of \$3,000.

Try the Grinnell Service on Your Next Record Order

- Records new and old of regular stock.
- Foreign Vocal and Instrumental Records.
- Records of the Oscar Saenger Vocal Course.
- Records of "First Aid Course in French."
- Records of Marconi-Victor course in Wireless Telegraphy.

What wonderful profit-making possibilities are presented in the incomparable assortment of Records issued by the Victor Company.

Try the Grinnell Service on Your Next Record Order

- And learn what our great stock, complete equipment, determination to serve you best and unsurpassed facilities mean in your greater satisfaction and as a definite aid in caring for the demands of your Record-buying public.

Let us send you regularly, each month, advance lists of those numbers which our record-selecting committee decide will lead in popularity. It's free. Glad to send it whether you purchase from us or not. You'll find it a great help in ordering.

Complete Stock of Victrola Accessories and Parts

Grinnell Bros

Distributors of Victrolas and Records

First and State Streets DETROIT

Inspections and Tests of the Heineman Motor



DEPARTMENTAL INSPECTION

The parts as taken from the machines are inspected as shown above, before next operation. This prevents any additional operations being performed on any part that may be defective in the preceding operation.

An inspection after each operation has proven to be the logical system of inspection.

Special test fixtures and gauges have been devised and arranged for each of these inspection operations.

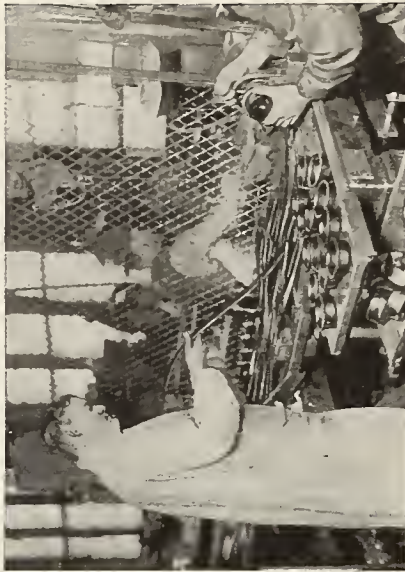

MOTOR SPRINGS

Owing to the difficulty experienced in the past, of securing the proper springs, it was found necessary to manufacture under our own expert supervision by experienced spring maker, all springs used in the Heineman Motor.

Our springs must pass through many rigorous tests for temper, pulling power, and breaking strain before being wound in spring barrels. Even to the last turn of the winding machine which coils the spring in the barrel, the spring has been under the eye of an expert spring inspector, as shown in the illustration.

Additional tests are given the spring after being coiled in the barrel before it is assembled in the motor.

The lubrication of main springs has been brought to a state of perfection by this organization and a lubricating compound prepared to our own formula which gives positive results and lasting satisfaction.

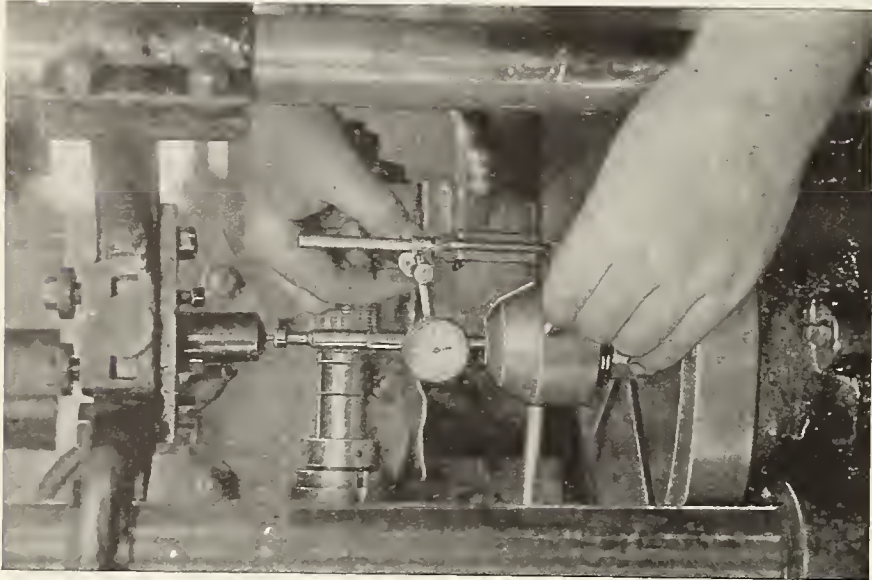

MACHINE INSPECTION

All parts are designed to fit standard holes—thus, we have the care taken with jigs by which castings are drilled and tapped.

The inspection of jigs and tools would be of no value if the machines making parts to fit these castings were not true. Hence this inspection of machines for alignment.

The illustration shows the inspection of master-parts which are used to check the alignment of the machine so when piece-parts are placed in this machine for further operations the result of the machine work will be uniform parts.

Of course only one part is shown, though all parts and machines are similarly checked by an experienced and thoroughly trained inspector before machines are started on the production run.



EXTRA INSPECTION

The governor shaft or worm is one of the most essential parts of a phonograph motor.

Extraordinary care is taken in inspecting and testing this part.

The illustration shows an inspection by a trained expert with glass, scale, micrometer and specially designed fixtures with dial indicators.

Governor shafts are put through numerous similar inspections while passing through different manufacturing operations.

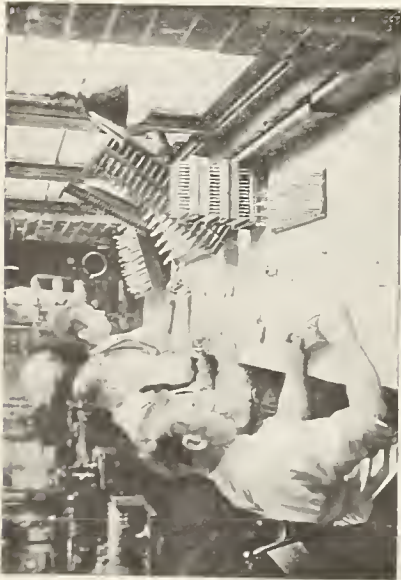

TURNTABLE AND GOVERNOR SHAFT INSPECTION

The cut illustrates the inspection of turntable shafts and governor shafts.

A specially designed fibre worm-wheel and governor shaft are used in Heineman Motors. This fibre wheel must be perfect in shape and cut.

This inspection is extra critical on these parts. Special fixtures and tools of intricate design are used in this operation to insure perfect running of these parts in Heineman Motors.



PROCESS INSPECTION

After machines are checked and set up with master part as previously described, and production proceeds, the process inspector shown in this picture takes up his work, checking the parts under the glass and with micrometer and scale at intervals as these parts come from the machine. This inspection at the machine gives a check on the state of the cutting tools.

These cutting tools are made in duplicates, each set being run a stated length of time. Experience has shown that tools will work to full accuracy for a determined period after which same should be replaced with re-sharpened tools.

In case of mishap causing a deflection of the cutting tool before the allotted lapse of time, this tool is removed and a new one, which has been properly sharpened and inspected, placed.



CHECKING DRILL JIGS AND GAUGES

All parts are jig drilled and, to avoid any deviation in alignment of holes, these jigs and tools are checked regularly to ascertain any wear that may have occurred in use.

This inspection on tools, to some, may seem unnecessary, but if one bushing on any of these jigs should show perceptible wear, and use be continued, each part machined thereafter would be off centers and the inter-changeability of parts would be impaired. We, of course, are advocates of piece part inter-changeability.

This feature of inter-changeability is one of the dominant factors in the successful operation of some of the largest manufacturers of high grade equipment in the country to-day; among many are the Cadillac Motor Car Co. and others too numerous to mention.



GOVERNOR BALANCING

Even though all parts of the governor, consisting of worm shaft, governor disc, sleeve and springs, have passed through the various process and other inspections, it is essential that the assembled governor be inspected for the proper alignment of the springs and correct balance.

Each spring in a set on every governor is of the same tension and each ball identical in weight, giving accurate balance to the governor when in motion, and unvarying reproduction through steady running motors. Special fixtures and trained operators are used in this work, as illustrated above.

Nothing like this *timely* merchandise. That means **Military Trunk Grafonola Outfits and Vacation Grafonolas.** Are you pushing them?

Columbia Graphophone Co.
NEW YORK



"INSPECTIONS AND TESTS"

Details of a Most Informative Booklet Issued by Otto Heineman Phonograph Supply Co.

"Inspections and Tests" is the title of a valuable booklet just issued by the Otto Heineman Phonograph Supply Co. This booklet, which is profusely illustrated, gives manufacturers and dealers some idea of the care that is taken in the manufacturing of the "Motor of Quality." This company has originated and improved many different methods for carrying out in the most exact manner possible the full definition of the words "inspections and tests." From the raw material, throughout every operation in the manufacture, inspections and tests are interposed so that any deviations from the standard that may occur can be corrected immediately. Hundreds of these inspections take place during the processes of manufacturing the various parts.

In the booklet just issued by the company there are listed a few of the most important of these inspections, and in addition there are presented illustrations of some of the most popular Heineman products. There are reproduced herewith on the facing page eight of the illustrations shown in this booklet, together with a brief resumé of each inspection or test. These illustrations will give some idea of the efficiency of the Heineman factories, which has resulted in the international success of the Heineman motor of quality.

SPECIAL FILING CABINET

Made by Salter Mfg. Co. to Fit Into Edison A100 Disc Phonograph in Great Demand

CHICAGO, ILL., June 9.—The Salter Mfg. Co., well-known manufacturers of talking machine record cabinets, of this city, have been having an excellent demand for their special filing cabinet which is made to fit into the shelf of the

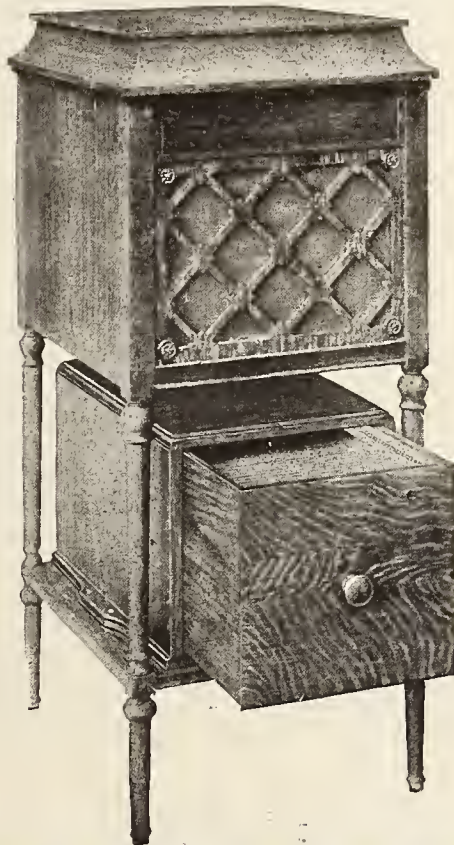

Edison A100 Disc, Equipped With Cabinet Edison A100 Disc machine as shown in the accompanying illustration. This cabinet was produced as a result of numerous demands from Edison dealers for a good filing device for this instrument. It is made, of course, to harmonize with the machine and is finished in the same wood or finish. It is made with the care which characterizes all of the Salter products, and is equipped with the famous Salter felt-lined shelves, holding thirty-two records in individual compartments. The compartments are all numbered and an index card is also furnished. The Salter Co. also furnish a felt-lined filing rack for installation in the interior of the Edison C150 phonograph. The rack fits perfectly and is instantly installed. The company manufactures an extensive line of cabinets for other machines and also a fine line of record cabinets for surplus record use.

R. E. RAE WITH COLUMBIA CO.

Robert E. Rae, formerly sales manager of the Jones-Motrola, New York, is now a member of the general sales department of the Columbia Graphophone Co., with headquarters at the executive offices in the Woolworth Building, New York. Mr. Rae, prior to joining the Jones-Motrola, was associated with the Western Electric Co., and is well qualified for his new post.

LONDON PLANT DESTROYED BY FIRE

Columbia Co. Factory in England a Total Loss —L. S. Sterling on His Way to London

Louis S. Sterling, managing director of the Columbia Graphophone Co., Ltd., London, Eng., who has been spending the past six weeks in New York, received a cablegram last week advising him that the London plant of the Columbia Co. had been totally destroyed by fire. The original matrices, which were stored in a fireproof building some distance from the factory, were saved, but the loss is estimated at from \$500,000 to \$750,000.

The cablegram stated that every building in the London plant was a total wreck, and in view of the restrictions placed by the Government on the construction of new buildings, Mr. Sterling has not yet made any definite plans for the future. He left for London on Monday, June 3, and will immediately assume charge of all reconstruction activities. The disastrous fire started in a building on an adjoining street, and quickly spread to the buildings occupied by the Columbia Co.

SONA-TONE SHOWROOMS IN N. Y.

The Sona-Tone Phonograph, Inc., manufacturer of the Sona-Tone phonograph, has reopened its showrooms at 3421 Broadway, New York, corner of 139th street, where a complete line of these instruments are on display for the convenience of visiting dealers. The executive offices are now located at this address, and L. C. Seiler, general manager of the company, is leaving nothing undone to co-operate with the Sona-Tone clientele. The company's Brooklyn store is closing a very satisfactory business.

Why Break Records? Just File Them!

That is if you have the wonderful Record filing system which is a feature of

The Marvelous MAGNOLA



Watching the Music Come Out

This is only one feature of many that will command your interest and attention. Let us send you handsome illustrated catalog and information as to our plans for helping you to make money with MAGNOLA.

MAGNOLA TALKING MACHINE COMPANY
OTTO SCHULZ, President
General Offices 711 MILWAUKEE AVENUE CHICAGO
Southern Wholesale Branch 1530 CANDLER BLDG. ATLANTA, GA.

The BEST TALKING MACHINE NEEDLE

On the Market—Packed in Counter Salesman



50 Needles to a box and they retail at 10c. per Box.
60 Boxes to a package \$6.00.
This package costs you \$3.90 net.
Your profit is \$2.10 and your customer gets a needle that will give satisfaction.

The Fred. Gretsch Mfg. Co. 60 Broadway Brooklyn, N.Y.
Manufacturers of Musical Instruments
Canadian Wholesale Agent, H. A. BEMISTER
10 Victoria St., Montreal, Can.

BALTIMORE TRADE SHOWING PLENTY OF REAL ACTIVITY

Dealers Are Awakened to Real Opportunities Despite Many Disturbing Factors—Maryland as a Whole Reports Large Volume of Business—Important Changes and Developments of the Month

BALTIMORE, MD., June 7.—Optimism for the future and good business for the past month is the keynote of the Baltimore situation among the talking machine men. Business showed up very well during the past month, many of the dealers reporting increases, while others considered their business good. Shipments of both records and machines were received during the month. The demand for both machines and records continues to be in excess of the supply.

Retailers everywhere are showing good results. Those dealers who were panic stricken a few months ago because of the war have awakened to the present opportunities and are showing plenty of real activity. This is evident from various quarters. Their show windows are more attractive and up to the minute with the appeal to buyers. Newspaper advertising is also showing up very well.

Baltimore has looked after many visitors from the Southern territory during the past month and all of the jobbers entertained their customers. Many of the callers visited all of the establishments in the hunt for goods.

The Brunswick-Balke-Collender Co. added a new account to their list during the month, Knabe Warerooms, Inc., both in Baltimore and Washington putting in a line of machines. Other new accounts are expected to be announced very shortly.

W. S. Parks, manager of the Columbia Graphophone Co. here, is doubly overjoyed this month, the great month's business done during May being one reason and the other being the arrival on Sunday of William Scott Parks, Jr. Mrs. Parks as well as the heir are both reported doing nicely.

S. C. Cook, assistant manager for Columbia, made a trip through North Carolina and part of Virginia and found the dealers in an optimistic frame of mind. The tobacco crop promises to be a record one and this means that the farmers through the section will have plenty of money, which, dealers say, forecasts good business.

During the month the Columbia Co. gave a reception to Evan Davies, of the Columbia vocal staff, and there were present more than fifty dealers of the city and nearby territory. More than sixty persons attended the affair, and it is hoped to hold gatherings of the kind monthly. These gatherings are for the purpose of bringing the dealers and the workers of the company closer together. Mr. Davies impersonated Harry Lauder and many old-time Southern characters.

Miss Katherine Carey, of the local Columbia office, accompanied Mr. Davies as well as other persons on the piano.

Miss E. M. Griffith, in charge of the wholesale department for Cohen & Hughes, Victor distributors, reports good business, but not quite up to a year ago, because of lack of goods. The firm has just added another two-ton motor truck to its equipment, which will be used exclusively in handling the Washington business so as to get goods to customers in that territory and in the South, shipments for the Southern territory being made in some instances better from Washington. Among the visitors to the distributors during the month were Mr. Levy, of Ferguson, Lillienfeld & Lightfoot Corp., Norfolk; Mr. Ripple, of Martinsburg; Mr. Clemens, of Clemens Bros., Chattanooga, Tenn.; Joseph Isaac, of Goldsborough, N. C.

Hipolito Lazaro, the famous tenor of the Columbia, took a prominent part in the Second War Fund drive of the Red Cross. He appeared a number of times at the Liberty Hut, near Union Station and helped to bring money from the pockets of the interested ones to help "Greatest Mother on Earth" to support the nation's Army of Defense.

George C. Maust, manager of the Grafonola department of Lansburg & Bro., Washington, spent several days at Columbia headquarters during the month. He is reorganizing the Grafonola department of which he recently assumed charge. Among the other visitors to Columbia headquarters were Mr. Whipple of O. J. DeMoll & Co., Washington, D. C.; B. H. Sommers, Ellicott City, Md.; Mr. Friedberg, of the Virginia Mercantile Co.; J. J. Carey, of the Columbia Co., Norfolk, Va., and Mr. Phillips, Washington, W. C.

Mr. Foster has been placed in charge of the music department of Hecht Bros. & Co.

Word comes from the Columbia dealers in Richmond, Norfolk and Washington that all of them are making a liberal display of the Period Grafonolas. April and May, according to J. J. Carey, of the Columbia Co., Norfolk, was the largest in the history of the company.

B. A. Koteen, formerly secretary and manager of the Virginia Mercantile Co., Norfolk, Va., has withdrawn from the company and is now manager of the Grafonola department of the Phillips, Levy Furniture Co., of that city.

P. W. Peck, who travels through North Carolina for the Baltimore office of the Columbia Co., delights in figures and says that the per

capita sale of Columbia products in Edgecomb County is \$1 per every inhabitant of the county. He has also figured that the first three months of this year show 124 per cent. increase in Columbia products for North Carolina over the same period of 1917.

W. C. Roberts, manager of E. F. Droop & Sons Co., Victor distributors, reports good business during May, which showed an increase over the same month of 1917. The increase was 25 per cent. Retail business with the firm is showing fine increases, and Mr. Roberts is hoping he will be able to get goods to meet his ever-increasing demand. For several months past Mr. Roberts says the monthly shipments of records from the Victor factory are sold before they arrive, and he is having a hard time keeping his dealers satisfied. E. H. and C. A. Droop, of the firm, were present at the convention in New York during the week.

George White, of the Southern Furniture Co., Richmond, Va., states that the Grafonola business for this year constitutes a very substantial part of their present business, and because of this fact arrangements are now being made to greatly enlarge the department.

H. S. Jones, of Clark & Jones Piano Co., with headquarters in Birmingham, Ala., and with a chain of stores in the South, visited all of the dealers.

Jesse Rosenstein, of the National Piano Co., Pathé distributors, says he has been getting a liberal shipment of machines and records during the month and that business is fine.

W. T. Davis, of the Victor Co., was in Baltimore a great deal of time during the month looking over the trade.

The Vita-Nola talking machine, made by the Vitanola Talking Machine Co., of Chicago, is handled in this city by the Baltimore Bargain House, Robt. Lipnick, 654 West Baltimore street; the Peabody Piano Co., the Hub Piano Co., 122 North Liberty street, and A. W. Steere & Bro., 830 North Gay street, and all of these concerns report a steadily growing demand for this product.

A VISITOR FROM NEWPORT

A visitor this week at the executive offices of the Pathé Frères Phonograph Co., Brooklyn, N. Y., was Mrs. I. Richstaedt, who conducts two successful Pathé shops in Newport, R. I. She is a firm believer in the musical qualities and sales possibilities of Pathéphones and Pathé discs. In a chat with The World she stated that her Pathé sales were steadily increasing, and that, according to her present plans, she would open a third store in the very near future, handling the Pathé line exclusively.

AMERICAN



No. 22



No. 13



No. 5



No. 4

AMERICANS embody all the good qualities and special features of phonographs, clear in tone, beautiful in design, finest finish, smooth running motors.

We stand back of every American



No. 8



No. 9



No. 10



No. 11

**American
Phonograph Co.**
39 Fountain Street, N. W.
GRAND RAPIDS MICH.

Edison Dealers Hold Their Fourth Annual Convention

George Lincoln Parker Presides Over Annual Gathering of Edison Dealers Held Last Week at Waldorf-Astoria —Mr. Edison's Great Message—Mr. Maxwell's Playlet Well Received—New Edison Velvet Surface Record

On Thursday and Friday, June 6 and 7, the fourth annual convention of Edison dealers took place at the Waldorf-Astoria, New York, with Geo. Lincoln Parker, of Boston, as chairman. The program for Thursday morning started with an address of welcome from Thos. A. Edison, Inc., delivered by T. J. Leonard, general sales manager of the phonograph division. Following this Geo. L. Parker delivered his convention address. Wm. Maxwell, vice-president, and manager of the phonograph division, spoke next and his subject was "Yesterday, To-Day and To-Morrow." During his talk he intimated that there would be an increase in price on the Edison instruments about September 1, but that

volving salesmanship psychology of a very high order. It elucidated in an interesting manner the way in which the so-called "High Brow" talk, if used with discretion, becomes a matter of great interest to the prospective purchaser of an instrument. The sketch also brought out various points about the New Edison and the Edison Re-Creation, which the dealer should em-

phasize in case of competition with other instruments.

The session was then adjourned in order that the conventionites might visit the Grand Central Palace in the afternoon, and each one was given tickets for the National Music Show as he passed out of the door. It is needless to say that they enjoyed their visit.

THOS. A. EDISON'S INSPIRING ADDRESS ON FRIDAY

On Friday morning the Edison convention was again resumed and started off with a message from Thos. A. Edison delivered by Wm. Maxwell, which read as follows:

Thos. A. Edison's Message

To my friends, the Merchants of the United States and Canada who handle Edison Phonographs and Records:

These are strenuous days, with the fate of civilization hanging in the balance. However, the world is safer to-day than it was in July last year, when you gentlemen were assembled in this same room. Germany prepared and

the most important thing in the world to-day. We must not put our own selfish interests above the interests of the nation. We must give and



Edison Crowd From Syracuse, N. Y.

there would be a thirty-day notice given out in advance of the change in order that the Edison dealers might, by announcing the coming change in price to the public, have an opportunity to bring some pending sales to the closing point.

E. C. Boykin followed and answered questions 1 to 8, inclusive, which were of great interest to the dealers. Following this there was an open discussion in which matters of general interest were brought up and debated. The next speaker was T. J. Leonard, who answered questions 9 to 14, after which an open discussion again ensued. A speech was then delivered by Robt. J. Bolan, of East Orange, N. J., whose subject was "Too Much Money." A. P. Burns, assistant to Mr. Leonard, then answered question 15. Col. F. B. T. Hollenberg, of Little Rock, Ark., and Gust. Holmquist, of Erie, Pa., in turn discoursed on the subject of "Won't Pay Interest." Phillip Haberman, vice-president of the Commercial Investment Trust, New York City, then treated in a very clear way on the matter of "Borrowing Money." W. D. Wilmot,



George Lincoln Parker, Chairman

trained for this war as a pugilist trains for a championship prize fight. She expected to deliver the knockout punch in the fall of 1914. Her boasted far-sightedness proved to be gravely at fault. To-day, after nearly four years of warfare, Germany is still trying vainly to land a knockout. Like a desperate pugilist, who feels his strength ebbing rapidly and knows he can last but a few more rounds, the Hun is staking everything on the chance of landing a lucky punch. General Foch, like a clever boxer, now parries and gives ground, but the time will come when he will strike, and there will be behind his blow the greatest moral and military force that has ever been invoked on the field of battle—the gallant veterans of France, the dauntless British; the daring Italians, and hundreds of thousands of our own brave boys, who will write during this war the proudest page in this nation's history.

We are in this war and we must see it through to a conclusion that justifies the sacrifices we have made. I do not say that Germany must be crushed. It may be that her deluded people will strike the scales from their eyes and overthrow the powers that have plunged the world into war. But however the result is accomplished, there is but one result with which we can be satisfied. Germany must be cured forever of the desire to wage war.

I have spoken about the war, because it is



The Delegation From Cleveland

we must do to the full limit of our respective abilities, in order that the war may be won in the shortest possible time. On the other hand, we should oppose in all proper ways the hysterical and immature ideas that from time to time are advanced by men, who, either through inexperience in business or indifference to the business prosperity of the country, propose measures of incalculable harm and of relatively small advantage.

No legitimate industry is non-essential except as it interferes with the conduct of the war, and then only to the extent to which it interferes. No statistician can prepare figures that can be accepted safely as a guide to the curtailment that should occur in the manufacture of the so-called non-essentials. What we need to do is to speed up. It is not a question of what



Richmond's Delegation (C. B. Haynes to Left)

We must not do, but a question of what we must do. We must win the war. We must provide all the arms, ammunition, ordnance, aeroplanes and equipment that can be transported to Europe, and we must build ships as rapidly as possible. We must make all the other goods that we can possibly make. We must keep on creating new wealth. We must keep our manufacturing organization in good running order. We must continue to go after foreign

(Continued on page 68)



Delegation From the Boston Zone

of Fall River, Mass, spoke next and took as his theme "Want a Discount." V. E. B. Fuller, general supervisor of the Edison Co., closed the speakers' session with a brief talk about the National Music Show, which he urged the dealers to attend while they were in New York and incidentally to visit the Edison exhibit there.

The morning session closed with a one-act comedy entitled "The Dotted Line," written by Wm. Maxwell and produced by E. C. Boykin. It was a very cleverly written sketch in-

FOURTH ANNUAL CONVENTION OF EDISON DEALERS IN NEW YORK—(Continued from page 67)

trade, and we must prepare ourselves for the intense competition for foreign markets that will occur after the war.

We hear a good deal of talk about luxuries. Luxury is a relative term. What is luxury for one man is almost a necessity to another. No matter what is said or done, the increased earning power of the American people is going to result in the increased purchase of luxuries and the urge to possess luxuries will do more to speed up production than all the prize contests, bonus plans and proclamations that can be devised. The laziest and most non-productive man in the world is the man whose wants are the simplest. The fellow who has a family that



William Maxwell

wants luxuries and is endeavoring to gratify them is the man who is usually working the hardest and procuring the most.

Some of you may have been told that music is a non-essential. My views on that subject are probably well known to you. The time is not far distant when music will be recognized as a greater essential than books. Don't let anybody make you believe that music is a non-essential. Merchants who sell good musical instruments are performing a useful service to the nation.

Many Interesting Talks

The next dealer on the program was M. L. Eshelman, of St. Joseph, Mo., who spoke on "Conditions Too Uncertain." J. Craig Youmans, of Newton, N. J., came next and dwelt on "Paying for Bonds," and he was followed by A. Petrone, of Newark, N. J., and C. J. Lionhart, of Norman, Neb., both of whom spoke on "Living Costs So Much." W. W. O'Hara, of Montreal, Canada, and A. P. McCoy, of Waterbury, Conn., made interesting talks on the subject of "Don't Want to Buy Luxuries."



Knock-Out Kid

J. W. Scott, the Amberola supervisor, followed with a discussion on "The Diamond Amberola," and in his talk he was assisted by the "Knock-Out Kid," whom he introduced in part as follows: "Ladies and gentlemen, before making a few remarks about the Diamond Amberola, I want to introduce the world's champion lightweight. He has never been defeated. He is known from the Atlantic to the Pacific and from Hudson Bay to the Rio Grande as the 'Knock-Out Kid.' Ladies and gentlemen, I take great pleasure in introducing Amberola 50, the

Knock-Out Kid, who has never lost a decision." Gust. Holmquist, of Erie, Pa., came next and treated on "Records on Approval." E. Trautwein, mechanical supervisor of the Edison company, explained the method for "Keeping Instruments Properly Timed." M. A. Alfred, of Hartford, Conn., and W. E. Jones, of Cape Charles, Va., both spoke on "Will Wait for More Records." R. Montalvo, Jr., of New Brunswick, N. J., treated on the subject "Am Not Quite Ready Yet." Lesley I. King, of Columbus, O., discussed the solution to "Want to Talk It Over With My Husband," and D. H. Marchant, of Wadsworth, S. C., held the other side of this subject and took as his theme "Want to Talk It Over With My Wife."

Tone Tests Discussed

V. E. B. Fuller, general supervisor of the Edison Co., followed this series of short talks with a discussion on "Tone Tests" and "Lectures on Music." W. McPhillips, of London, Canada, then talked on the matter of "Record Service." An open forum was then declared and discussions followed bearing on numerous topics of interest. Mr. Maxwell closed the session with a little speech entitled "Until We Meet Again."

The New Edison Velvet Surface Record

The outstanding feature of the Edison dealers' convention was the announcement of the new velvet surface record. This latest re-creation of the Edison laboratories is considered a great step forward in the manufacture of disc records, in that it practically eliminates the surface noise hitherto found on records. It was also stated that this record is of a nature which simplifies production. A novel method of announcing this new velvet surface record to the conventionites was used. It was introduced by a most beautiful and charming young lady, who made her debut in the early part of the convention and offered to auction off the first velvet surface record. The offer was promptly accepted and after considerable cross-bidding W. O. Pardee, of the Pardee-Ellenberger Co., of New Haven, Conn., finally bid in the prize at the very liberal figure of \$550. "The Velvet Surface Girl," as she became familiarly known by all the conventionites, spent the balance of the two days during which the convention lasted selling autographed velvet surface records, the proceeds of the sales going to supply Army and Navy Models of the New Edison and Edison re-creations for use on the transports plying between the United States and France. Needless to say, a great many autographed records were purchased and the transport fund rose to considerable proportions.

Comprehensive Advertising Display

In Suite 122 in the Waldorf-Astoria during the Edison dealers' fourth annual convention at New York a comprehensive and exhaustive display was made of the many ways in which Thos. A. Edison, Inc., employs publicity for the benefit of Edison dealers. Samples of all of the different kinds of advertising were on exhibition, as were the different advertising novelties that are available through the Edison company for the dealer to display in his own establishment. The novelties included the rotogravure portraits of the best-known and most popular ar-



The Velvet Surface Girl

tists, the special signs, placards and busts of the great masters of music, etc., etc. At one end of this hall was shown a model window prepared by Ellis Hansen, the famous window display man. This window display was most attractive and was designed in such a way that the panels could be replaced from time to time so as to give an entirely new effect at a very moderate cost.

L. C. McChesney, advertising manager, Arthur J. Palmer, assistant advertising manager, and P. A. Fuss, editor of the Amberola Monthly, took a very justifiable pride in the exhibit shown in Room 122.

BANQUET OF THE EDISON JOBBERS AND DEALERS

On Friday evening, June 7, the Edison jobbers and dealers, many of whom brought their wives, sat down to a most excellent repast in the banquet hall of the Waldorf-Astoria, as the guests of the officials of Thos. A. Edison, Inc. There were in all nearly eight hundred guests, the greater part of whom were old-time friends with each other.

The banquet hall had been decorated most tastily along patriotic lines for the occasion and the entire assemblage rose to sing the "Star Spangled Banner" as the prelude to partaking of a most excellent dinner, about which the attractive menu card contained the following words: "Mr. Oscar Tschirky has sought to demonstrate by our dinner this evening that the strictest observance of the Food Administration's rules imposes no hardship on the epicure"—and it didn't. During the meal an all-star vaudeville was presented on the stage at one end of the hall through the courtesy of Joseph M. Schenck and under the direction of J. H. Lubin.

The "Dinner Show," as it was called, contained several acts from "Keith's First Circuit," and needless to say proved very entertaining. At one point during the show program an interruption was made for the rendering of

a "Gag Song" which contained many clever quips about various celebrities in the Edison trade. The verses ran as follows:

GAG SONG

Now listen, friends, just for a bit, just keep your seats right where you sit
And lend an ear to what I have to say.
Now, with your attention, I'll thank you not to mention
Any indiscreet remarks that come your way.

Of course you all have heard of that tiny little bird
That comes and twitters gossip in your ear.
Well, he met me at the door, and I hope no one gets sore,
For what he said was all in fun—so never fear.

He said, "Now Walter Kipp is known as quite a clip,
He's the Bourbon Kid and likes his little toot,
He loves the merry clatter of the chips—but can the chatter
When he's playing 'Home, Sweet Home' upon his flute.

There's our old friend, H. E. Blaks. He can hardly keep
awake.
You know, he comes from Etherburg, Pa.,
Sh, what's that I hear? Wake up, papa, dear,
For you'll have to walk the floor till break of day.

Hello, L. J., how's friend Bourgette? Now don't get in a
pet,
Just sit calmly there and keep a level head.
There's nothing to get riled about. All your friends will
sure run out
If you start to cuss and shout to raise the dead.

FOURTH ANNUAL CONVENTION OF EDISON DEALERS IN NEW YORK—(Continued from page 68)

Well, well, if there ain't Ollie Rouse. Live anywhere near Bryan's house?

Whose Bryan? Dogged if I remember now. How's things out in Nebraska? Hooverizing? Nitsky, Did I hear you say? You tip 300! Wow!

Have you heard the story told of how Montalvo, Junior, bold

And daring as the bravest pioneer,
Made a talker of his own. He *must* be 'shown.'
Now he'd swap one for a stein of 'almost' beer.

K. M. Kahoon, of Waltham, Mass., he dreams of diaphragms and gas-

Kets. If he had a million still he'd pine
For another million more. O, please don't slam the door.
Where you going? Out for more Priscilla wine?

Charlie Sauer, it's awful sweet for you with us to-night to meet,

How could you leave your prospects for a day?
Won't they be lonesome, Chas.? Won't they miss your
knockout gas?
What's the latest rag out Chillicothe way?

Here, waiter, bring a microscope. I thank you. That will help. I hope

To find a man I'm trying hard to see.
"Does anybody know muh? I'm from Enid, Oklahoma."
Why, sure we do. You're great, big, little Mr. Lee.

I've another search to make for a lanky, human rake,
He's long and lean, but his heart's as big as that.
Say, how d'ye leave St. Jo? Did the hull town see yuh go?
What you drinkin', Estrelman? A split of anti-fat?

There's a Coca-Cola souse and he's somewhere in this house,
He's E. G. Bassett--hails from Bristol, Conn.

"Have a piece of gum? No? Why?" "No, thank you, sir,
for I
Still has the piece I learned to chew upon."

Mr. Thomas, you all know Dan. Why, he's the only man
Who gave a thousand tone tests, so they say,
He'd rather fish than eat. As he walks along the street
The barbers swear they'll get him yet some day.

Out Erie way there lives a man. Why, long ago he tied
the can

To anything related to a smile,
Saloon's his middle name. Not the kind *you're* thinking—
shame!
Mr. Holmquist's eating ice cream all the while.

In the good old sunny South, where they water at the
mouth

When you mention chicken broiled or stewed or fried,
Lives Pittman, suh, whose mind is always on "the other
kind,"
Of Greenville. North Ca'lina, he's the pride.

Billie Maxwell, here's a tip. The favorite has got the pip.
I heard it from a stableboy who knows.

Here's your chance to make a kill that will make the
bookies ill
Play all your cash and then go hock your clothes.

As sure as I'm a sinner, it was at the jobbers' dinner
That they carried out Tom Leonard by his feet.

Says Tom, "I can't recall what happened there at all."
No pink stuff, waiter. Lemonade, and make it sweet.

In an old Rhode Island town lives a man of great renown,
They call him Daddy Wilmot with affection,

They must have shut the place up tight, bein's he's down
here to-night,
At least he started off in this direction.

If in Chicago you should be and you went around to see
Mr. Goodwin at his office, home or club,

And you asked "Say, where's the bach'?" They'd simply
say, "You'll catch
Him playing porpoise in the A. A. Swimming tub."

From "Our Lady of the Snows" he came down to see the
shows.

That *isn't* what he told the folks at home.
With golf Dick Williams piddles and he dotes on ancient
fiddles,
While the little flies do fox-trots on his dome.

When the dinner was nearly over, William Maxwell jumped up on the rostrum and in his characteristically vigorous style announced that there were a few left of the new Velvet Surface Recreations, autographed by Mr. Edison, that would be sold at five dollars each, the proceeds going to the Transport Fund. These were quickly grabbed up by the crowd until just one remained and this Mr. Maxwell would not part with except by auction to the highest bidder. The first offer was for \$50 and from that figure the bidding steadily climbed until it reached the high mark of \$480. By this time Mr. Maxwell had warmed up to his role as auctioneer in great style and it was quite evident that the last of the Velvet Surface Recreations was going to go

(Continued on page 70)

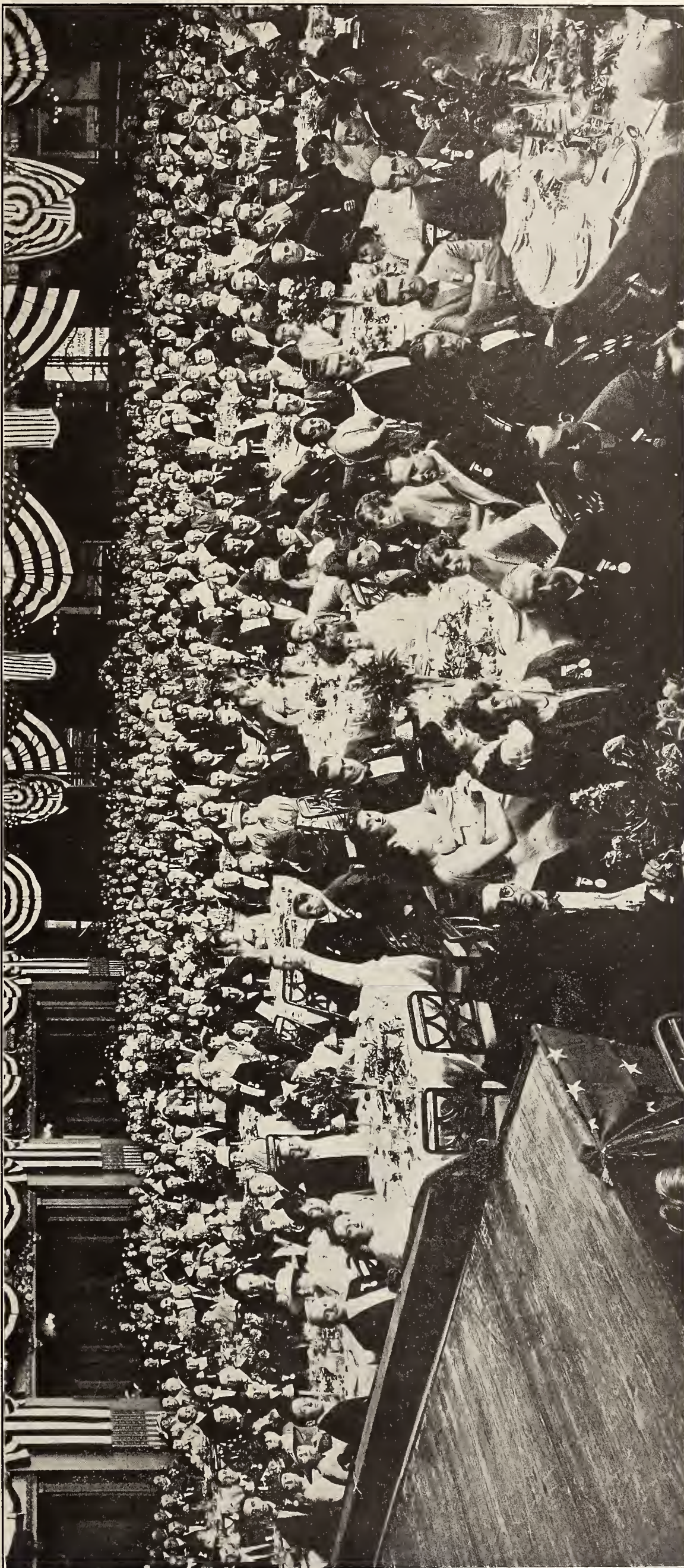

Banquet of Edison Jobbers and Dealers Held at the Waldorf-Astoria, New York, June 7, 1918

FOURTH ANNUAL CONVENTION OF EDISON DEALERS IN NEW YORK—(Continued from page 69)

for more than the first, which Mr. Pardee secured for \$550. But at this point Walter Kipp suggested that after all the money for the Transport Fund was more important than the winning of the particular record. He announced that Charles Edison would start a pot with \$400 and that he as a jobber would add \$200 to that amount. The idea quickly spread and as each new jobber pledged \$200 he was called up on the stage. Before the wave of enthusiasm became exhausted for lack of additional material, the very large amount of \$6,000 was raised by the Edison Jobbers. Mr. Maxwell announced then that each of the subscribing jobbers would be sent an autographed Velvet Surface Recreation together with a personal letter from Mr. Edison. Following this a great number of dealers contributed \$25 each until the total for the evening reached \$8,000.

The "Transport Fund" having been successfully oversubscribed, a most delightful concert was given by a number of the most popular

Edison artists. The caption of this concert was "The Songs Our Soldiers Sing," and in line with this each of the artists sang two or three of the best of the war compositions, such as "Keep the Home Fires Burning" and a few of the national anthems, notably the "Marseillaise" and the "Battle Hymn of the Republic." Among the popular Edison artists who were present for the banquet and who favored the banquetees with songs were Frieda Hempel, now Mrs. William Kahn, Marie Morrissey, Ida Gardner, Edette le Fonteney, Merle Alcock, Caroline Lazzari, Amy Ellerman, Betsy Lane Shepherd, Ralph Errole, Arthur Middleton, Marie Tiffany, Arthur Fields, Billy Murray and Ed Meeker.

The attendance at the dealers' convention and banquet was unquestionably the largest in the history of Edison reunions. The register showed over 660 names covering Edison dealers, jobbers and travelers from all parts of the country. The list is so extensive that lack of space prevents us from printing it.

guests of Thos. A. Edison, Inc., a social event which was greatly enjoyed.

The important feature of the travelers' convention was the manner in which all those present got together, and discussed in the open forums, which followed every talk, problems of particular interest to the man who is handling Edison goods. Many of the informal talks made by those present were deemed so important that each man who participated has been requested to write a brief resumé of his talk and send the same in to the Edison headquarters in order that every one of the many good ideas introduced at the convention may be put into practical operation.

Despite the fact that this was the first gathering of Edison travelers which has been held, the attendance was so large, and the interest so evident, that the success of the future conventions of the Edison travelers is unquestionable.

Those present at the Travelers' convention and their location were: Albany, N. D. Griffin, P. R. Hawley; Atlanta, W. L. F. Rosenblatt, B. K. Troutman, A. C. Witherington; Boston, F. H. Silliman, L. H. Ripley, G. R. Coner, F. S. Boyd, T. E. Dean; Chicago, C. E. Goodwin, H. D. Buchanan; Cincinnati, A. O. Peterson, P. H. Oelman; Cleveland, B. W. Smith, L. N. Bloom, M. G. Kreuzsch; Dallas, A. H. Curry, O. P. Curry, N. B. Johnson, C. L. Rankin; Denver, W. C. Wyatt; Des Moines, G. C. Silzer; Detroit, R. B. Alling; Indianapolis, W. E. Kipp, L. P. Brock, J. Cartmill; Kansas City, M. M. Blackman, C. P. Cunningham, W. M. Hinde; Milwaukee, W. A. Schmidt, G. J. Campbell; Minneapolis, L. H. Lucker, H. E. Stinchfield; New Haven, W. O. Pardee, F. T. Keeney, F. L. Stoddard; New Orleans, F. S. Hemenway, L. T. Donnelly; New York, G. L. Dabson, F. O. Faul, C. R. Lee, A. W. Toennies, R. Montalvo, Jr.; Ogden, R. Proudft, T. S. Hutchison; Omaha, D. W. Shultz, C. Hough; Philadelphia, R. B. Cope, W. Babcock, J. Robinson; Pittsburgh, A. A. Buehn, J. B. Gowdey, W. S. Rippey, Jr.; Richmond, C. B. Haynes, G. R. Garnett, Edgar Hill; St. John, N. B., J. G. Harrison, J. D. McCarthy; St. Louis, M. Goldberg, A. O. Reynolds, J. A. Schlichter; Sioux City, G. U. Silzer; Syracuse, F. E. Bolway, Jr., J. G. Brown, J. Essig, Jr., C. I. Eddy; Toronto, R. S. Williams, T. A. Dillon; Vancouver, B. C., D. H. Kent; Williamsport, W. A. Myers; Winnipeg, O. Wagner.

FIRST ANNUAL CONVENTION OF EDISON TRAVELERS

Wm. Maxwell Presides at Important Gathering of Edison Traveling Men at the Waldorf-Astoria on June 4—Many Valuable Suggestions Brought Out in the Important Subjects Discussed

The first annual convention of the travelers of Thos. A. Edison, Inc., which was held at the Waldorf-Astoria, New York, on Wednesday, June 4, was attended by approximately one hundred Edison travelers from all over the country, and so successful was the affair that it will become an annual event in connection with the regular yearly Edison conventions.

The morning session opened at 9.30, with T. J. Leonard, sales manager of the phonograph division, as temporary chairman. Mr. Leonard greeted the travelers with a happy speech, in which he introduced the permanent chairman of the convention, William Maxwell, vice-president of Thos. A. Edison, Inc., and manager of the musical phonograph division, who opened the program with an interesting talk on the "Velvet Surface—the New Edison Re-Creation," which was followed by five-minute talks on the record shortage situation and how best to meet it, the talks being in the nature of an open forum. E. C. Boykin, director of sales promotion and editor of "Along Broadway," next told of the aims and purposes of that interesting Edison house organ, and was followed by L. C. McChesney, who gave a most important talk on advertising. Following another general discussion by those

present, Verdi E. B. Fuller talked on the Edison tone tests and their value as a means of creating interest and sales, following which the convention adjourned for luncheon at the Waldorf, at which Mr. Maxwell acted as toastmaster, and during which the travelers vied with each other in saying "Here's one you haven't heard yet."

The afternoon session convened at 2.30, the first talk of the afternoon being given by W. Taylor, the new Edison supervisor, who took as his subject "Factory Circularizing," which was followed by an open forum concerning the best methods to be pursued by the travelers in aiding the dealers in their territory to build up sales. A. P. Burns, assistant sales manager, next talked on travelers' reports, followed by a general discussion concerning suggested improvements which could be made in the method of making reports, during which many valuable ideas were brought out.

E. C. Trautwein next gave a terse talk on "Mechanical Service," and the convention was closed by H. P. Durant, who talked on banking accommodation.

Following the adjournment, the travelers went for dinner, and in the evening attended a performance of "Sinbad" at the Winter Garden as

IDENTIFYING AIR RAIDERS BY SOUND

Interesting Experience Which Shows That Anyone With a Sense of Absolute Pitch Should Be Able to Identify Hostile Air Raiders

The writer of an article in an English musical paper who points out that Gotha aeroplanes "drone" on the note A flat, while English machines prefer E and F, has surely overlooked an important point, says the London Daily Chronicle, when he suggests that anyone with the sense of absolute pitch should have no difficulty in identifying hostile raiders by their sound. The pitch of a sound depends on the number of vibrations reaching the ear in a given time, and the number varies according as to whether the source of the sound is moving towards or away from the listener. Given a Gotha hustling at 100 miles an hour, its A flat could vary as much as a perfect fourth, which is more than the difference between it and the British machines' E or F. If an express train sounds its whistle while approaching and passing through a station, the pitch of the whistle—though actually the same all the time—will appear to rise as the train comes into the station and fall as it passes out. In the first case, the sound waves reach the ear more frequently, as the source is approaching, and in the second less frequently as the source is retreating. It would be the same with the Gotha's A flat—if it is always that note, whatever the speed of the machine, which is highly improbable. Some rather interesting deductions.

THE NEW VEECO MOTOR

MAKES

The Electric Way the Ideal Way

All experimenting has been done in advance at the Veeco factory. Any mistakes have been rectified **before**, and not **after**, the Motors have been put on the market.

The Improved Veeco Electric Motor is designed primarily and exclusively for talking machines. Runs on either A. C. or D. C., 100-125 volts without adjustment. Supplied to run on any voltage from 6 to 250. Mounted on 12 or 12½ inch square mahogany boards ready to install.

Combined with the VITRALOID Turntable it makes a complete motor unit for high-class machines.

SEND FOR THAT SAMPLE TODAY

Then rush your order to insure prompt deliveries.

THE VEECO COMPANY

248 Boylston St.

Boston, Mass.

Happy, cheerful music means happy, cheerful vacations—that means a Grafonola Traveling Trunk Outfit. How fast are you selling them?

**Columbia Graphophone Co.
NEW YORK**



STEPHENS TO PRESENT NEW BILL

Father of Present Stephens Bill States to The World That He Plans to Present a New Measure to Congress Embodying New Ideas in the Matter of Controlling Resale Prices Under Supervision of Federal Trade Commission

WASHINGTON, D. C., June 6.—Since the recent decisions in the United States Supreme Court and the District Court against price fixing under certain conditions, and against systems to that end which were formerly in vogue, and in view of the attitude taken by the Federal Trade Commission in the matter of retail price maintenance, there has been considerable speculation as to what attempts will be made to legalize retail price fixing on trade-marked articles, and especially what will be the fate of the Stephens bill. No less a person than Justice Brandeis of the United States Supreme Court has stated that there is an opportunity for establishing price maintenance through legislation and under Governmental supervision, and it has been hinted that an amended Stephens bill, or perhaps an entirely new measure along the suggested line, will be offered in Congress.

Congressman Dan V. Stephens, of Nebraska, father of the present Stephens bill, is of the opinion that it is possible to legalize the fixing of retail prices by producers, if the Federal Trade Commission is given some jurisdiction, and plans a new bill embodying that idea. In an interview with The Talking Machine World to-day Congressman Stephens set forth his ideas as follows:

"In my opinion legislation will be possible, after the pressure of this war legislation is past,

along the lines that I have heretofore indicated in a statement given to the press, namely, that in my judgment it will be possible to legalize the fixing of resale prices by producers, providing a complainant who feels that a price is unfair can have recourse by filing his protest against the price fixed with the Federal Trade Commission for review, the Federal Trade Commission being empowered to go into the question of the fairness of the price fixed and coming to a final decision. The penalty that would follow an adverse decision of the Trade Commission would be the withdrawal of the right to fix the resale price. Each case would be decided upon its own merits. The advantage of this legislation appears to me to lie in the fact that the rights of the people would be absolutely preserved when anyone felt justified in making a complaint. The probabilities are that there would be practically no complaints made as there will be ample and vigorous competition between all brands. In the second instance the producer would be no worse off under such legislation than he is now, as under the court's decision he is unable to control his resale price at all. Under the proposed legislation he would be able to control the resale price, providing his price was fair. If it wasn't fair he would be no better off under the new legislation than he is now.

"It appears to me that legislation along this line is feasible and will meet the approval of many members of Congress who have heretofore had doubts of the wisdom of the legislation that has been proposed in the Stephens bill. As soon as the war work clears away sufficiently to justify it my intention is to present a bill to Congress embodying this idea."

NEW SCHUBERT RECORDS

Dealers Will Receive New Numbers Each Month—First Records Bring Praise

The Bell Talking Machine Co., of 44 West Thirty-seventh street, New York, is now producing a number of new Schubert records, which are being heartily received by representative dealers throughout the country. The announcement of the records, which came a few months ago in The World, brought many inquiries, and the company has been making every effort to get matters into such shape that the dealers should receive a steady supply. From now on this supply will be available, and a considerable number of new records will be produced each month. The first records include a number of standard and most popular selections of the day, and many enthusiastic letters regarding the success which the dealers are having with them have been recently received at the office of the company.

NEW DEPARTMENT IN ST. PAUL

Howard Farwell & Co. Install New Series of Demonstrating Booths in Their Store

ST. PAUL, MINN., June 3.—The new talking machine department of Howard Farwell & Co., piano and music dealers of 25-27 East Sixth street this city, are now considered among the most attractive in the Northwest. The elaborate sound-proof booths are grouped on the main floor, and occupy about half the space there. The booths are built of lathe and plaster, and have a very permanent appearance. Both the Victor and Columbia lines are handled.

The B & H Fibre Needle Repointer
SPEAKS FOR ITSELF

It repoints a needle *perfectly*.

It perfects a bad needle.

It secures a sharp, clear reproduction—in fact—



U. S. PAT. DECEMBER 5, 1916

It does everything to a Fibre needle that should be done in order to obtain best results.

ORDER ONE—TRY IT—TEST IT—THEN—

Notice the difference in tone produced by the needle before and after repointing!

RETAIL PRICE \$2.00

The B & H Fibre Mfg. Co.

33-35 W. Kinzie Street

Chicago, Ill.

"A WONDERFUL INSTRUMENT"

THE HIT OF THE SHOW THE

"GOING TO BE A BIG SELLER"

PHONO - GRAND

"IT'S WORTH FEATURING BIG"

"I ORDERED SIX"

"THERE'S SURE MONEY IN THAT AGENCY"



"SOME COMBINATION IT TOOK SEEBURG TO DO IT"

THE LATEST CREATION IN MUSIC

AND THE PRICE IS RIGHT

"WHERE DO THEY GET THAT BIG TONE"

"A MIGHTY SENSIBLE INSTRUMENT"

J. P. SEEBURG PIANO Co. CHICAGO.

FROM OUR CHICAGO HEADQUARTERS

E. P. VAN HARLINGEN,
Manager

World Office
Republic Bldg., 209 South State St., Chicago
Telephone: Wabash 5774

CHICAGO, ILL., June 10.—The wholesale trade of Chicago is working harder than ever before in an effort to take care of the vast amount of business on hand. There is, seemingly, no let-up in the steady stream of orders coming in, especially from the country districts. Wholesale dealers in general agree that the major factor governing their activities depends entirely upon the amount of goods being turned out by the manufacturers. The manufacturers in turn are working overtime in trying to take care of the demands made upon them. Nevertheless, in spite of the overtime their output is way below normal owing to a scarcity of skilled labor. Some of the larger manufacturers in trying to meet the situation have instructed their traveling representatives not to spend so much time in booking orders, but to scout around and be constantly on the lookout for labor—especially experienced woodfinishers, coarse rubbers and trimmers are needed.

This is the situation that the wholesale trade of Chicago is facing. It is practically true of the entire country. For this reason the wholesale dealers of this section are using the utmost care in taking orders and are delivering only to those who are able to buy on short time and pay the most cash with their orders. As one jobber so aptly stated, there exists in the trade to-day an ideal condition, one that every jobber and manufacturer in the country should take advantage of, and that is, pick your trade, cull out the weeds and in a short while the "Gyp" dealer will be a part of history only.

The record situation remains in about the same condition that it has been for the past few months, that is, the demand is greater than the supply. A few large shipments of records brought a slight relief to the situation the latter part of the month, but this stock quickly disappeared in filling back orders.

The retail trade is not so active locally as compared with country business. The demand for machines in Chicago is not very strong, as a whole and, if we may be permitted to use the expression, the record situation is a "goat getter." The buying public continues to make strong demand for popular patriotic selection, especially war songs and dance music with a touch of the military, but these are not forthcoming in adequate quantities and as a result

a great deal of business that could be carried on by the retailer is lost, for a time at least, so many of them declare.

New Empire Art Model

The Empire Talking Machine Co. has just announced the completion of their new period design art model talking machine which will be offered to the trade in the near future. This machine is of Queen Anne design and is one of the most beautiful ever offered to the trade. The workmanship is of the same fine quality so characteristic of all Empire instruments. The artistic beauty of the machine is enhanced by an elaborately designed grill covering the opening of the tone chamber and a delicate festoon is arranged around the borders of the paneling.

W. B. Fulghum Visits

Walter B. Fulghum, formerly manager of the order department of the Victor Co. and who now operates the Victrola Shop at Richmond, Indiana, spent Sunday of this week in Chicago. After a brief visit here he left for the East, where he intends to visit Philadelphia and New York and renew acquaintance with his old friends at the Victor factory and others in the trade. In addition to the Victor store Mr. Fulghum owns and operates four prosperous farms near Richmond. He reports that he has increased his business 200 per cent. and that the country trade is very good.

C. T. M. Co. Men With Colors

W. C. Griffith, assistant sales manager and junior member of the Chicago Talking Machine Co., is now one of Uncle Sam's boys, having entered the army service on May 27 with other selects. He has been assigned to the Fourth Co., First Provisional Regiment, which is stationed at Camp Wheeler, Macon, Ga. Mr. Griffith tried to enlist with the regulars four times but was declined on account of defective vision. Mr. Griffith was one of the most popular men in the Chicago trade and began his career with the Chicago Talking Machine Co. about four years ago, and in January, 1917, was made junior member in the company by President Geissler. His work brought him rapid promotion. He started as a floor salesman with the company and was then given a traveling representative's position, which was followed very quickly by his promotion to assistant sales manager.

Another popular man of the Chicago Talking Machine Co. who recently entered the service was Richard G. Johnson, who had charge of the shipping department. He started with the company about six years ago and was very well liked for his happy and genial disposition. Mr. Johnson enlisted in the regular army on May 21 and is now attached to the Fourth Recruiting Co. at Fort MacIntosh, Laredo, Texas.

Private Emmett A. Creed, brother of D. A. Creed, vice-president of the Chicago Talking Machine Co., is now with the regular army and is stationed with Co. I, Thirteenth Infantry, at Camp Fremont, Cal.

Wins Promotion

James A. Coudret, former assistant to J. H. Steinmetz, president of the Empire Talking Machine Co., has won his chevrons as sergeant and has been appointed as instructor of calisthenics, gas defense and pistol practice. Sergeant Coudret is connected with Co. 5, Quartermaster's Division, Camp Johnston, Fla., and gives instructions to two classes each day.

Praises Paramount Records

The Michigan Phonograph Co., of Grand Rapids, Mich., were recently appointed jobbers for the Paramount records. In a letter to the manufacturers the New York Recording Laboratories, of Port Washington, Wis., Geo. M. Cook, the president of the company, speaks very enthusiastically regarding the records, and in conclusion says: "The future of the 'Paramount' is assured, as it fills a long-felt want in the talking machine industry. Paramount recordings are clear and distinct, surface noise is reduced to a minimum, and the catalog is well balanced, both musically and commercially."

Returns From Eastern Visit

D. A. Creed, vice-president of the Chicago Talking Machine Co., and G. P. Ellis, sales manager, returned the first part of the month from a visit to New York, where they had been attending a directors' meeting both of the New York and Chicago Talking Machine Companies.

Fibre Needle Popularity

F. D. Hall, president of the B. & H. Fibre Mfg. Co., is heartily satisfied with the current demand for both the B. & H. fibre needles and for the B. & H. pointer, which met with such favorable reception from the trade since it was

(Continued on page 75)

THE "WADE" FIBRE NEEDLE CUTTER

Still in the Lead and Running Well

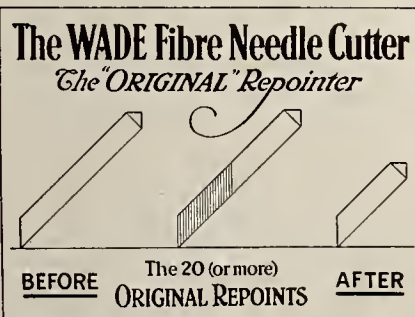

Another milestone in the great talking machine industry is almost reached. The success of the coming year will largely depend upon the wisdom with which the experience of the past is applied.

Ask the man who sells Wade Fibre Needle Cutters—he knows from experience that they are ready sellers.

BECAUSE

- they give "20 or more" new points to *each* fibre needle.
- each* repoint is identical to the *original* point—their use means *increased sales* of fibre needles, the habitual use of which lengthens the life of the records, renders more natural reproduction, increases the enjoyment and
- last but not least, regular jobbers' discounts apply

Write for Samples or Further Information

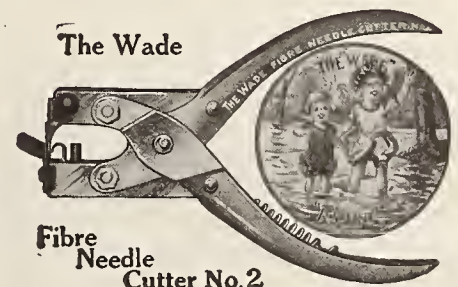

The Wade
Fibre
Needle
Cutter No. 2

Price \$2.00

WADE & WADE, 3807 Lake Park Ave., Chicago, Ill.



Music Will Win!

This is the logical time for you to build firmly the foundations of your future business.

Shortages caused by war curtailment may cease anytime. The dealer whose name is then most strongly impressed on the public is the one who will then be favored by the rush of business.

Here are four Victrola Advertising Services, which, at a minimum cost, will enable you to strikingly keep your name before the people of your community:

52 Newspaper Illustrations per year, \$8.33 per month.

26 Newspaper Illustrations per year, \$4.17 per month.

Containers for Mailing Monthly Victor Supplements.

Colored Window Cards, 36 per year, \$1.25 per month.

Reserve the rights for your town today.

Everything Known In Music

Lyon & Healy

Victor Distributors

CHICAGO

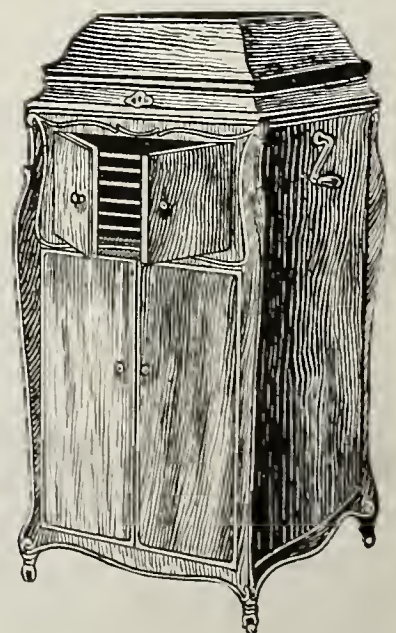

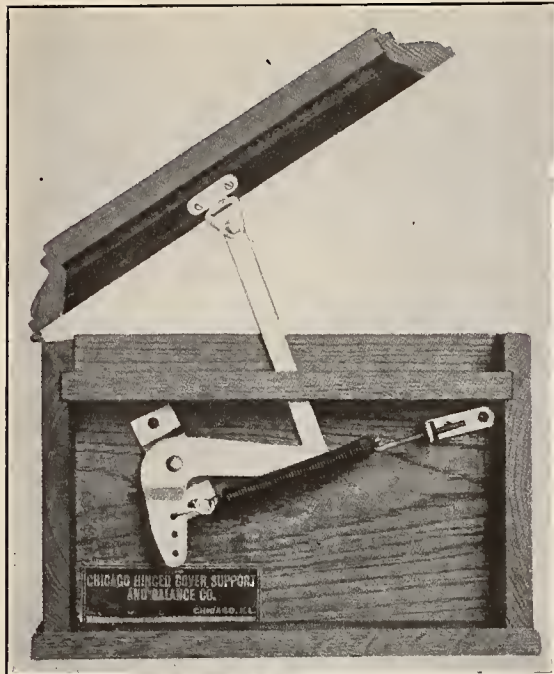

(Pat. Applied For) COVER BALANCE No. 1

The Block Signal is essential in preserving the lives of passengers and preventing accidents. For that reason wise travelers select the railroad with this kind of equipment.

The Chicago Cover Balance No. 1

is essential in preserving the lives of records and preventing smashed fingers. There's no possible way for the cover to fall and break a record or smash a finger when a talking machine is equipped with the

CHICAGO COVER BALANCE No. 1

The cover is "PUT" and "STAYS PUT"

WE ALSO MANUFACTURE CONTINUOUS AND GRAND TOP HINGES

Chicago Hinged Cover Support and Balance Co. 2242-44 W. 69th Street CHICAGO, ILLINOIS

FROM OUR CHICAGO HEADQUARTERS—(Continued from page 73)

placed on the market a few months ago. The necessity of increasing the capacity of the plant because of the increasing demand for the fiber needle and the consequent enlargement of the working forces revealed a peculiar condition. Mr. Hall found that, although the wages paid by the B. & H. Co. are very liberal the scarcity of younger women on account of the demands made by munition and war supply manufacturers was so great that it was necessary to train in women ranging between fifty-five and sixty-two years of age. Somewhat to his surprise he finds these women all proving themselves most decidedly efficient, and show an interest and enthusiasm in the work that is highly commendable.

Brunswick Shop Activities

A. B. Stowall, retail manager of the Brunswick Shop, is enthusiastic over the business conditions now prevailing. "We have a very good demand for higher grade instruments," stated Manager Stowall, "but with the lower price machines we are not doing so well. Collections have been exceptionally good with us, and we look forward to a very good business during the summer months."

Six Best Sellers

The six best Victor sellers for the month are: "Just Like Washington Crossed the Delaware, General Pershing Will Cross the Rhine" and "I May Stay Away a Little Longer"; "War Ballad Medley" and "Eclipse Medley"; "There's a Little Blue Star in the Window" and "Some Day They're Coming Home Again"; "From the North, South, East and West"; "Little Mother of Mine"; "The Volunteers" and "Liberty Forever!"

The Columbia announce the following six best sellers for the month: "Levinsky at the Wedding" (part III) and "Levinsky at the Wedding" (part IV); "Regretful Blues" and "A Little Bit of Sunshine"; 'N Everything" and

"When You Play With the Heart of a Girl"; "In the Land O' Yamo Yamo" and "My Mind's Made Up to Marry Carolina"; "If You Look in Her Eyes" and "Fancy You Fancying Me"; "Medley of Old Waltz Songs."

The six best Edison sellers for the month are: "Explanatory Talk for 'Ve lo Dissi'" (did I not tell you?) and "Ve lo Dissi" (did I not tell you?); "Bendemeer's Stream" and "My Love She's But a Lassie Yet"; "Forever is a Long, Long Time" and "My Hawaii, You're Calling Me"; "Light as a Feather" and "Valse 'Erica'"; "Band Festival at Plum Center" and "Bill's Dog Towser"; "Buzzin' the Bee" and "Pozzo One-Step."

Pathé dealers announce the following six best sellers for the month: "The Yanks Started Yanking" and "Round Her Neck She Wears a Yeller Ribbon"; "What'll We Do With Him Boys" and "Rock-a-Bye Your Baby With a Dixie Melody"; "Tishomingo Blues" and "Somebody's Done Me Wrong"; "American Patrol" and "Hiram's Huskin' Bee"; "Fireflies" and "Heart's Ease"; "Deauville" and "Nesting Song."

The Aeolian Co. announce the six best selling new Vocalion records as follows: "Annie Laurie"; "Review of the U. S. Fleet" and "Liberty March"; "Pussy Willow" and "Sally Trombone"; "Un Bel Di" (Some Day He'll Come); "Hungarian Rhapsody (parts I and II); "Just a Baby's Prayer at Twilight" and "Wondrous Eyes of Araby."

The six best Gennett records for the past month are: "Swanee River" and "Gentle Shadows" (violin) (art tone) Helen Ware; "Fox Trot Medley" and "One-Step Medley"; "Spring Song" and "La Blanche Waltzes"; "Hail! Hail! the Gang's All Here" and "I Don't Want to Get Well"; "'N Everything" and "Somebody's Done Me Wrong"; "Good-Bye, Barney Boy" and "Yock-A-Hilo Town."

Paramount six best sellers for the month are: "Aloha Land" and "O Sole Mio"; "Three Wonderful Letters from Home" and "A Little Bit of Sunshine"; "Good Morning Mr. Zip, Zip, Zip" and "Aw Sammy"; "Can't You Hear Me Callin', Caroline?" and "I Cannot Sing the Old Songs"; "Wait Till the Cows Come Home" and "More Candy"; "Livery Stable Blues" and "The Darktown Strutters' Ball."

The six best Emerson sellers are: "What Are You Going to Do to Help the Boys?" and "Way Down There a Dixie Boy is Missing"; "They Were All Out of Step But Jim" and "Second Regiment Connecticut March"; "The Last Long Mile" and "The Stars and Stripes Forever"; "'N Everything" and "Chu Chin Chinaman"; "K-K-K-Katy" and "What a Wonderful Dream It Would Be"; "The Missouri Waltz" and "Kathleen Mavourneen."

Miss Stein in Charge

Miss Esa Stein is now in charge of the recital hall at Lyon & Healy, having succeeded Bob Taylor, who was recently called to the colors. Miss Stein was formerly connected with the record department of Lyon & Healy.

Enthusiastic Over Conditions

W. E. Cotter, wholesale and retail manager of the phonograph division of Thos. E. Wilson & Co., returned on Wednesday of this week from a very successful ten-day trip through Dallas, Houston, Ft. Worth, Kansas City and St. Louis. Mr. Cotter is very enthusiastic regarding conditions throughout the district which he visited, and states that prospects are increasing more and more. While in Houston he visited the Rick Furniture Co., who were holding a ten-day sale, and on the first day they sold eighty-five phonographs.

"Considering the conditions brought about by the war," stated Mr. Cotter, "business is very good. The harvesting crop throughout (Continued on page 77)

TRANSFER NAME-PLATES

We make the Transfer Name-Plates and Trade-Marks for the largest talking machine manufacturers in this country and for dealers in every state.

YOUR NAME, Mr. Dealer, on every machine brings the owner back to you for records and his friends to you for a machine.

Samples, Suggestions and Sketches Furnished Free

THE MEYERCORD COMPANY, CHICAGO

Largest Manufacturers of

DECALCOMANIA

Transfer Name-Plates

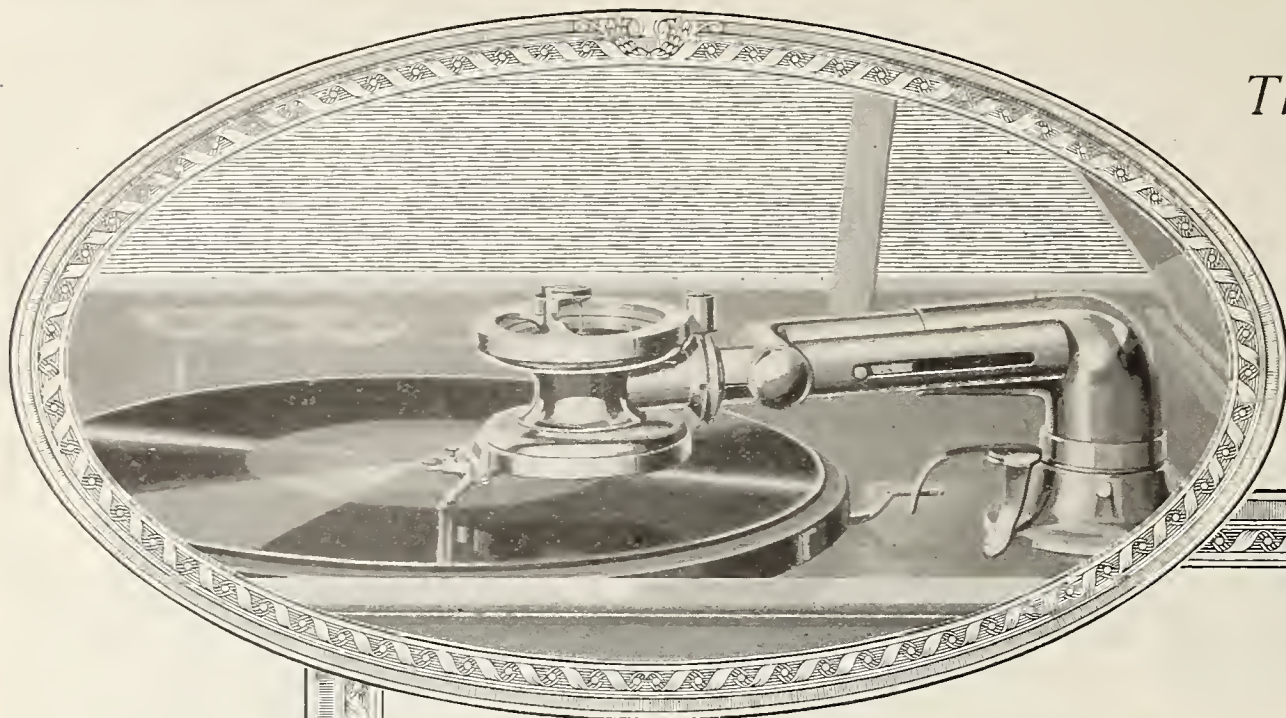

The Ultona—a distinctive feature of the New Brunswick Method of Reproduction. Here the *Ultona* is in position for playing a *Pathé Record*. The *Ultona* is adapted, very simply, to play all records, whatever make, and play them at their best. Only The Brunswick has this wonderful feature.

Old vs. New

Which Type of Phonograph For Your Customers?

The Story of The New Brunswick

THE choice is now distinct. Your offering is one or the other—old type or new. Of the old, there are many. So far the *one* instrument that has attained the coveted new standards is The Brunswick.

And this is due to The Brunswick Method of Reproduction.

Until all phonographs abandon the one-record idea, until all discard metal in tone amplification, until all forsake old crudities, the new Brunswick will have few rivals. It stands magnificently alone—the supreme phonograph achievement of recent years.

Only The Brunswick

Until the coming of The Brunswick, each phonograph had its own chief attractions. None had them all.

And mostly, the fame depended on the make of records with which the instrument was co-named.

Some folks said all phonographs were alike—all good. And that the records depended upon luck for their tone.

But The Brunswick has gained its nationwide fame by combining all the better features and discarding the troublesome. And so it is called "All Phonographs in One."

The new Brunswick Method of Reproduction sets higher standards. Never before have records been played so faithfully.

"Phenomenal"—The Verdict

The new Brunswick came out in April. Now thousands know them. All over the country. And these thousands agree that there is no phonograph like The Brunswick.

They praise The *Ultona*, and The Brun-

wick Tone Amplifier, two features of The Brunswick Method of Reproduction.

The *Ultona* is adapted, at the turn of a hand, to any type of record. It is practically automatic. Each type of record is reproduced according to its exact requirements—the proper diaphragm, the exact needle, the precise weight.

The *Ultona* is a distinctly new creation, not an attachment nor a makeshift. *Every* record is played at its best, whatever make.

The Brunswick Tone Amplifier is equally far in advance. Old acoustic problems have been solved. This brings the utmost in fine tone.

Only Brunswick Dealers have all the advantages and opportunities that come with the new Brunswick. From every Brunswick Dealer we are receiving substantial and increasing orders, and generous expressions of increased success due to this bettered instrument.

In a number of cities there are openings for Brunswick Dealers, and in such places we offer complete co-operation. Maybe such an opportunity exists for *you*. Upon your inquiring, we shall be glad to explain our proposition.

THE BRUNSWICK-BALKE-COLLENDER CO.

Branch Houses in Principal
Cities of United States,
Mexico and Canada

General Offices: CHICAGO

Canadian Distributors
Musical Merchandise Sales Co.
Excelsior Life Building
Toronto

(1202)

The
Brunswick
ALL PHONOGRAPHS IN ONE



The Brunswick
Retails from
\$32.50 to \$1500

FROM OUR CHICAGO HEADQUARTERS (Continued from page 75)

Texas, especially around Dallas, was a bumper. In some parts of this section the corn is shoulder high. Wheat was fine all the way through Oklahoma, Kansas, Missouri and Illinois. This is the finest crop we have had in years, and if the present satisfactory condition continues it augurs well for our trade."

Business Is Flourishing

"Judging from the orders we are receiving from talking machine manufacturers for die cast parts, the trade is maintaining a healthy condition at present and counting on a substantial demand this fall," says L. D. Allen, manager of the die casting department of Barnhart Bros. & Spindler, this city. Mr. Allen also remarked that many manufacturers located in the Central States were finding it advisable to establish supply connections nearer home so as to avoid delays caused by embargoes. Chicago labor for normal pursuits is more plentiful than in the East, where so many factories have been placed on munitions and war supplies exclusively.

Good Business in Pennsy.

A. R. Mitchell, of Williamsport, Pa., was a visitor to the Chicago trade this week. Mr. Mitchell, who is the Pennsylvania wholesale representative for the Empire Talking Machine Co., spoke very enthusiastically concerning the business conditions throughout his territory. "There seems to be no end to the business in sight for the talking machine men in our part of the country," stated Mr. Mitchell, due to the big wages of the munitions workers as well as large crop prospects.

Booze Versus Music

Hundreds of Detroiters are now buying music instead of booze, according to an article which appeared in a Detroit newspaper quoting Wallace Brown, the well-known Brunswick dealer of that city, as saying that during the brief time prohibition has been in force in Michigan many citizens who once used their dollars each week for drink are now buying machines and records instead. The people who purchase on the

weekly payment plan are less often in arrears now since Detroit went dry. Mr. Brown stated further that he is selling more machines this year than last and traces the increase in his business directly to the abolition of intoxicating liquors. His portrait accompanied the article.

New Manophone Offices

The Chicago offices and warerooms of the Manophone Co. have moved from their former quarters in the North American Building to Room 604 in the same building where they have more space and better opportunity for display. Manager A. C. Einstein has been on a trip through the South and Southwest.

New Factory Facilities for Wilson & Co.

W. E. Cotter, manager of the phonograph department of Thomas E. Wilson & Co., states that they have made arrangements by which they will have a large plant in Wisconsin devoted to the manufacture of Wilson machines. They will have a complete new line of seven machines and will be in a position to care for their trade as they have not been hitherto.

New Phonograph Co.

The Everton Phonograph Co., of Chicago, has been incorporated with a capital stock of \$2,500. The incorporators are Thomas Wilkinson, E. F. Hurd and Raymond B. Cunliffe.

Opens Repair Shop

Oscar J. Kloer, well known in the talking machine and piano trades of Chicago, has opened a talking machine repair shop in the Athenaeum Building, 59 East Van Buren street, and is already doing an excellent business. Mr. Kloer is making a specialty of dealers' work and has the facilities and expert assistance to take care of it promptly.

Vitanola Busy

The Vitanola Co. have been having an unusually fine business the past month, they report, and the demand from their distributors has been greater than they have been able to cope with. The Standard Phonograph & Ac-

cessory Co., of Dallas, Texas, Vitanola distributors for the Lone Star State, have been running practically without stock, awaiting carload shipments which are on the way.

New Incorporation

The Stetson Phonograph Manufacturing Co. has been incorporated with a capital stock of \$3,000 by A. V. Carney, Francis V. Healey and B. B. Collins.

R. R. Souders for Service Abroad

Robert R. Souders, at one time with the Columbia Co. in Berlin, Germany, later manager of their branch at Dallas, Tex., for ten years and recently featuring the Sonora record for the Minneapolis Drug Co., passed through Chicago a few days ago en route for overseas duty for the Y. M. C. A. Mr. Souders is an active church man and is well fitted in every way for the work he is undertaking. He leaves behind him his family consisting of Mrs. Souders and four children in Minneapolis where he owns a beautiful home.

C. J. Woodard Marries

C. J. Woodard, the Chicago representative for the New York Recording Laboratories, Port Washington, Wis., manufacturers of Paramount records, will be married on June 12 to Miss Elizabeth Roach, a charming young Milwaukee woman at the Jesu Church in that city. After a honeymoon spent in Michigan the couple will take up their residence in Chicago. Mr. Woodard is a man long connected with the talking machine and piano trades and since he took the Chicago representation for the Paramount people has not only widened his acquaintance in the trade, but has established some excellent accounts. He has a host of friends in Chicago and elsewhere who extend him their very best wishes.

Mandel Progress

M. B. Silverman, sales manager of the Mandel Mfg. Co., returned this week from a business trip East made especially for the purpose of

(Continued on page 79)



Showing Miss Emma Kiess singing to the accompaniment of an Empire Talking Machine illustrating Model A-1, \$140

Don't take a chance—

Don't take the chance of losing a good customer by selling him a phonograph of inferior quality and have him dissatisfied with it later on.

Give your customers the best value their money can buy—put in the EMPIRE line and build up a real and permanent phonograph business.

The Empire machines are of excellent construction and the equipment is all of the highest quality. Each model has an automatic stop.

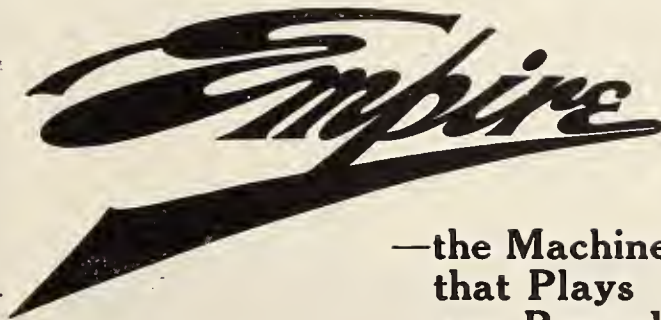

—the Machine that Plays any Record

Made in nine models, ranging from \$27.50 to \$215 list.

Tonal quality is beyond comparison.

EMPIRE RECORDS
RETAIL AT
POPULAR PRICES



Write today for our complete catalogs of Empire Machines and Empire Records, and full information regarding our Splendid Dealer Helps

Empire Talking Machine Co.

JOHN H. STEINMETZ, President

429 South Wabash Avenue

Chicago, Ill.

We Offer An Unusual Proposition To Dealers

It doesn't matter what make of phonograph you are now handling, you owe it to yourself to investigate what we have to offer you.

We have developed a great talking machine co-operative plan—one that enables the aggressive dealer to make big money on quality talking machines.

We are staking our money and our reputation on this proposition to establish successful talking machine dealers in every community.

In this advertisement we illustrate Model No. 3—our big seller. It is stately in design, wonderful in tone, and is sold under our guaranteed service. It sells for \$125.00, and unquestionably represents greater value than was ever offered at this price.

This machine is one of the big factors in our co-operative selling plan.

Two additional models—Model No. 6 at \$90.00, and Model No. 5 at \$65.00, give the MANDEL dealer three popular priced machines, all of which embody high quality coupled with big value to the consumer.

What we offer you, Mr. Dealer, is liberal terms, liberal discounts, big profits, and our guarantee of absolute satisfaction to every ultimate purchaser of a MANDEL Phonograph.

Act quickly. Write for our complete proposition. We are closing up territory at record speed.

Mandel Manufacturing Company

General Offices:
501-511 So. Laflin Street
CHICAGO, ILLINOIS

New York Display Rooms:
41 Union Square
NEW YORK CITY, N. Y.



Model 3
\$125.00

FROM OUR CHICAGO HEADQUARTERS—(Continued from page 77)

perfecting their selling organization in that section. While in New York Mr. Silverman engaged Lawson V. Moore, who has had long experience in the talking machine and piano lines, to represent the company in Georgia and Florida with headquarters at Jacksonville, Fla. Colonel Moore is thoroughly acquainted with the Southern trade and will, no doubt, receive excellent results with the Mandel in his territory.

Herman Levy, formerly with the Bell Talking Machine Corp., will travel in the interests of the Mandel Co. in the eastern portion of New York State under the direction of S. Auerbach, manager of the company's Eastern offices at 41 Union square. George W. Howe will cover the western part of New York.

The company has recently developed a most liberal co-operative plan for the dealers which has met with the decided approval of those to whom it has been presented and are operating under it. "It enables the dealers to extend their talking machine business in a most satisfactory manner," said Mr. Silverman, "and our trade is showing its appreciation of our liberal policy. Details are naturally of a confidential nature, but we would be glad to take the matter up in detail with those who are interested." In view of the comparative shortage of machines, owing to war conditions, the company had decided to concentrate on the manufacture of three models only, and selected those selling at retail at \$60, \$90 and \$125, as these had proven to be those for which the demand was the greatest.

Now Hiawatha Phonograph Co.

At a meeting of the stockholders of the Ottawa Pianophone Co. on Monday of this week it was formally voted to change the name of the company to the Hiawatha Phonograph Co. The new name incorporates the name of the company's product and avoiding reference to the former location of the plant. The new factory at Geneva is now in full operation and shipments are going forward in a most satisfactory manner. The company is to be congratulated on the very speedy recovery from the fire which destroyed the Ottawa plant only a few weeks ago and the loyalty of their dealers, none of whom canceled their orders, but expressed evidence of their appreciation of the merits of the Hiawatha line. The new plant is splendidly equipped for the production of quality goods, and the Hiawatha phonographs are coming through in more perfect condition than ever. The general offices and wholesale warerooms of the company are, as from the inception of the business, on the tenth floor of the Republic Building, Chicago.

Brunswick News Items

"Business with us has really never been better," said H. B. Bibb, sales manager of the phonograph division of the Brunswick-Balke-Collender Co., "and our entire attention at this time is being given to the matter of increased production. Both our Chicago and Dubuque factories are working overtime and we are scouring the country for experienced woodfinishers, coarse rubbers and trimmers. This class of labor is scarce, but we have been able to hold our old employes and secure a number of new ones. We have found it necessary to discontinue many of our small contracts and are not accepting the larger ones except in a few cases where representation is particularly desired."

W. T. Houston, formerly assistant manager of the Brunswick Shop, Chicago, has now been appointed manager of the Brunswick Shop at Toledo, O.

Morris Summerfield, who has been in charge of the record stockroom at Brunswick headquarters here, left this week for the Great Lakes naval training station.

The Field-Lippman Piano stores at Dallas, Texas, and Flat River, Mo., have taken on the Brunswick line.

Emerson Activities

F. W. Clement, manager of the Chicago branch of the Emerson Phonograph Co., reports a very big demand for their new nine-inch records. This record is proving to be a

very attractive seller with the trade, due to its keeping up with the popular music of the day. "Our shipping department is kept busy all the time in supplying the entire Central West from this office. We have established quite a number of big accounts during the last month and are carrying on an extensive advertising campaign throughout the local newspapers of Chicago as well as the papers in the States adjacent to Illinois. The demand for seven-inch records has grown and we are keeping up to date with these records as well as with the new large ones. We have put on two new traveling representatives for Michigan and Indiana. Harry Zimmerman is covering the former State for us and H. T. Steiner is our new man for Indiana."

Uncle Sam Kicks the Kaiser

The Aeolian Vocalion is attracting passersby to its window by means of a little automatic contrivance which sets upon the record impersonating by means of two miniature dolls Uncle Sam kicking the Kaiser. This is

placarded by an attractive sign bearing editorial comment from the New York Sun relative to this little contrivance. It is identical with the one that attracted so much attention throughout the trade several summers ago wherein Uncle Sam was booting Villa, but in this instance Uncle Sam is being kept busy using his foot on Wilhelm.

More Stars on Service Flag

The large service flag in the retail Vocalion warerooms on Michigan avenue which bore 803 stars has had three more added to it this week, A. C. Mason and Fay Fulton, both of the sales force, having entered the service. H. W. Fredericks, cashier, has also been called to the colors. Messrs. Fredericks and Mason went into the army, but Mr. Fulton joined the navy.

Over the Top

Ed Blimke, Columbia's wholesale representative, who covers the west side territory of Chicago, went over the top during the month of May for the sale of records and is credited

(Continued on page 81)



UNIVERSAL TONE ARM and REPRODUCER





Patent Applied For

**Plays
Any Make Record**

No Springs Nor Weights To Adjust—Plays All Makes of Records Perfectly

Dealers who have once seen the EMPIRE Tone Arm and Reproducer will never be satisfied with any other style of equipment on the machines they handle. Manufacturers who have not yet ordered samples should do so at once, as we are now still in position to accept a limited number of contracts for 1918 delivery.

The EMPIRE Tone Arm can be furnished in 4 standard lengths, or in special lengths to fit any requirement of the manufacturer, thus insuring that it will fit borings of motor boards properly, and without alteration.

Made in either nickel or gold-plated finish.

Write our Chicago Office for Descriptive Circular and Quotations



Showing the Empire Tone Arm set in position for playing vertical cut records



Showing the Empire Reproducer turned back to permit insertion of needle

The Empire Phono Parts Company

427 So. Wabash Ave. - - Chicago, Ill.
Factory - 1102 W. 9th St., Cleveland, Ohio

The VITA-NOLA.

Backed by the unlimited facilities, and strong financial resources of a big organization, our talking machine experts have developed the most remarkable phonograph on the market today—the Vita-Nola.

Step by step, with past failures and successes to guide them—with new and hitherto unknown scientific facts to aid their work—these men have produced a veritable triumph in phonograph construction.



Vita-Nola 100—\$100



Vita-Nola 125—\$125

Vita-Nola

is the ultimate and final product in the evolution of the phonograph. In the Vita-Nola is found every worth while improvement known to phonograph manufacture. To these are added the refinements and discoveries exclusively developed in this instrument.



Trade Mark Registered

Every live merchant with an eye for increased business and larger profits should write for our catalog and our unusual sales co-operative assistance.



Vita-Nola 150—\$150

7 Vita-Nola Models Ranging from \$25-\$175

DO IT NOW!



Vita-Nola 175—\$175

Vitanola Talking Machine Company
501-509 West 35th Street CHICAGO, ILL.

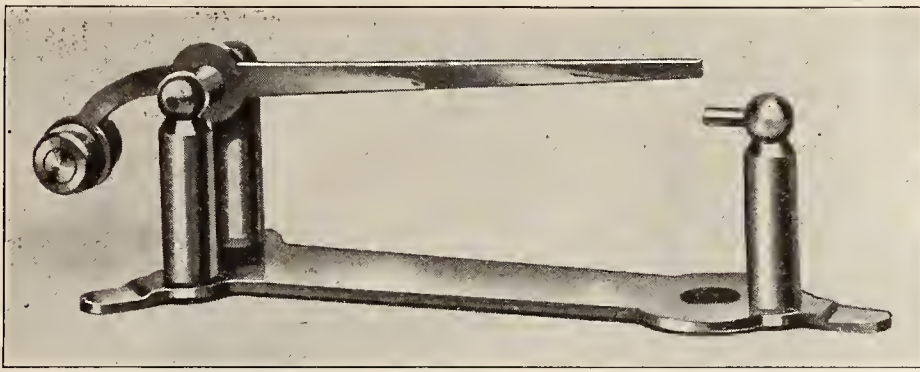

(Actual Size)

LAKESIDE ROTOMETER. RETAIL PRICE \$2.50

Calibrated so swinging arm is level with pointer at 78 revolutions per minute.

WRITE FOR PARTICULARS

Patents Pending

We have a large quantity of both Edison and Pathé Sapphire needles.

Write for prices.

LAKESIDE SUPPLY CO., Inc.
 202 South Clark Street Tel. Harrison 3840 CHICAGO, Ill.

NOW PLAYS ALL RECORDS IN ONE POSITION
JUMBO
LAKESIDE TONE ARM 4

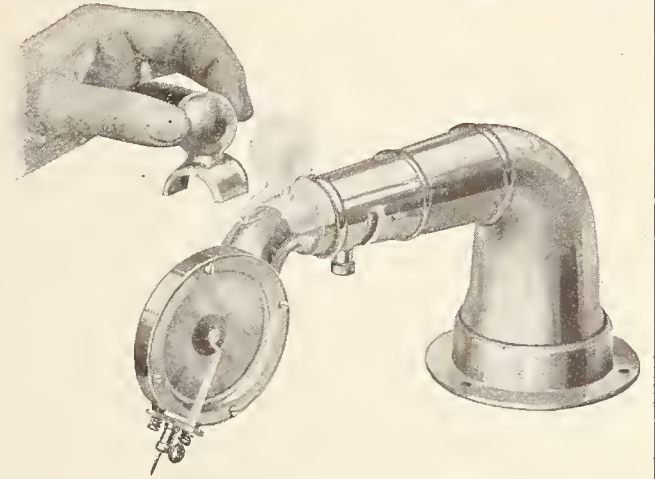

RETAIL PRICE \$7.50 EACH
 Prices to Bona Fide Dealers

Sample	\$4.00 each
Lots of 6 to 11	3.75 each
Lots of 12 to 49	3.50 each
Lots of 50 to 100	3.25 each

A further slight reduction on yearly contracts in 100 minimum lot shipments
 PATENTS APPLIED FOR

FROM OUR CHICAGO HEADQUARTERS—(Continued from page 79)

with disposing over 30 per cent. of the total sales of Columbia records from the Chicago office.

Record Container Demand Grows

The Automatic Container Co. announce that they are rapidly completing their plans for an extensive selling campaign to cover the entire country. Many new agencies have been taken on and these, together with the traveling representatives, cover practically the entire



Style 5-I Automatic Container

United States from Texas to the Canadian border and from the Atlantic to the Pacific. Their new style 5-I cabinet has met with much favor throughout the trade, and as a result numerous large orders are coming in. This cabinet is very artistically designed and it comes either in mahogany or oak. Each cabinet holds a maximum of one hundred records, being built in one tier of five units each, as may be seen by the accompanying illustration. Each unit will hold twenty of either the ten or twelve inch records. This cabinet comes with a complete filing system, index book and numbered guides and comes in handy for those dealers who make a specialty of handling the small table machines. W. L. Ceperly is now associated with the Automatic Container Co. and has been appointed secretary. Mr. Ceperly will have charge of the retail cabinet sales of the company and has made his headquarters with that of the Automatic Container Co. in Room 506, 209 South State street, this city.

Victrola or U. S. S. "Leviathan"

A well-known resident of Chicago recently purchased a No. 17 Victrola from the Talking Machine Shop and has presented it to the officers' lounge of the U. S. S. "Leviathan." This ship was formerly the "Waterland."

Edison Men to Convention

Among those making up the large party of Edison dealers who left on the evening of June 4 for the Edison dealers' convention at New York were E. A. Vaughn, of Princeton, Ill.; Zar Hagley, of South Bend, Ind.; Frank Hoover, of Sterling, Ill.; H. E. Wigell, of Towle & Hypes, Clinton, Ill. The party which was in charge of A. D. Wayne, retail manager of the Phonograph Shop, Chicago, stopped off for a day's visit to Niagara Falls before going on to New York, where they arrived Thursday morning. C. E. Goodwin, general manager of the Phonograph Co., had intended to be among those going down, but business matters necessitated his leaving for New York on last Friday.

New Diaphragm Perfected by Scotford

L. K. Scotford, the inventor of the Superior reproducer, Scotford tone arm, and other phonograph specialties, has perfected a new dia-

phragm for their new Superior universal reproducer now being manufactured by Barnhart Bros. & Spindler, of this city. Tests of the new diaphragm were recently conducted by Mr. Scotford in the presence of a number of prominent talking machine men and music lovers, and the verdict was universal that Mr. Scotford has scored another triumph and produced a diaphragm that for mellowness and natural quality of tone, without losing any of the brilliance or volume afforded by the best mica, is unique. The diaphragm is of a very handsome appearance, contrasting nicely with the nickel or gold finish of the reproducer frame. Patents have been applied for, and Barnhart Bros. & Spindler are already producing the diaphragms in considerable quantity.

Columbia Business Big

W. C. Fuhri, manager of the Chicago branch of the Columbia Graphophone Co., reports a
 (Continued on page 82)

A Tonal Wonder

The Morenus Phonograph has won widespread recognition because of its unusual tonal quality. The novel all-wood horn which enters at the bottom (not the top) of the scientifically constructed tone chamber has proven itself astonishingly efficient in securing a most pleasing tone and a remarkably faithful reproduction of the record.

The Equipment is high grade in every respect, plays both types of records, has cover support setting top at any desired angle, original tone moderator, etc.

The Morenus cases are superb productions in every respect.

The MORENUS is in 3 STYLES

- A. OAK, - - 48 inches high. Retail price, \$110
- B. MAHOGANY, 48 " " " " 125
- C. OAK and MAHOGANY, 50 inches high, Retail price, - - - - 150

*Very liberal discounts to the trade
 Send for our new descriptive catalog*



Style B

The MORENUS PIANO CO.
 342 West Huron St. CHICAGO, ILL.

FROM OUR CHICAGO HEADQUARTERS—(Continued from page 81)

very large increase in business for the month of May over that of the corresponding month of last year. "In comparison with May of this year and May of last year," stated Mr. Fuhri, "we have more than doubled our business. The month of June is starting out very good and from present indications will undoubtedly overshadow June of last year. Shipments of records are coming through in fine order, but machine shipments are not coming through the way we would like to have them."

C. F. Baer, assistant manager of the Columbia Graphophone Co., has been a very busy man these days holding two jobs. One is his regular position with the Columbia Co. and the other is as a juror in the Civil Courts.

Visitors and Personals

James Meagher, of the Forbes-Meagher Music Co., Madison, Wis., spent a few days in Chicago the early part of the month.

H. L. O'Brian of the retail sales force of the Aeolian Vocalion has been called to New York owing to the death of his father. Mr.

O'Brian, Sr., it is said, was one of the most prominent dental surgeons in the city of New York.

H. H. Michael, V. K. Tremblett, and H. L. Woodward, all traveling representatives for the Chicago Talking Machine Co., are enjoying a month's vacation.

Mr. Henschen, manager of the phonograph department of Scruggs, Vandervoort & Barney, St. Louis, was a Chicago visitor this week. He reported business with his house as good and came to Chicago to see what the prospects were of securing goods.

Earl C. May's New Post

Earl C. May, who for the past year has held important positions, including that of advertising manager, with Bunte Bros., of Chicago, has resigned this important post, and on June 17 will assume charge of the advertising and sales for the Cheney Talking Machine Co., whose products are steadily gaining in popularity throughout the country. Mr. May's headquarters will be at 725 Marshall Field Annex.

Phonographs and Equipment

Phonograph Value is based on the
Standard of Equipment used

Realizing the truth of this statement and what it means to the dealer and his future success,

Hiawatha Phonographs

are equipped with the highest standard of construction, of *Motor, Tone Arm and Reproducer*, which conform with the *beautiful cabinet and artistic lines* of the **Hiawatha**.

Hiawatha Phonographs enables the dealer to put his stamp of approval on each sale and be assured of only the normal percentage of mechanical trouble, which will result in a satisfied customer and increased business.



Style 100

Hiawatha Phonograph Company

209 South State Street
CHICAGO, ILL.

Equip Your Phonographs With Perfect Automatic Brakes

Samples
\$1.00 Each
Cash with order

State make
of tone arm used



Also made
with long
brake shoe
for 1 inch
offset

Patented Aug. 28, '17

Simple construction and easily attached.
Made in four styles to fit any make of tone arm.

Write for attractive quantity price

PERFECT AUTOMATIC BRAKE CO.
Room 400, 425 S. Wabash Ave., Chicago

INTRODUCING THE NIGHTINGALE

Details of the Progress of the Nightingale Mfg. Co., Who Make the Nightingale Phonograph, Under the Presidency of H. B. Wolper

CHICAGO, ILL., June 1.—The Nightingale Mfg. Co., whose well-appointed factory is at 426 North Armour street, is a concern that has grown rapidly since the inception of the business several years ago. Harry B. Wolper, the president, is a thoroughly practical man and has entire active charge of the business, the other officers and stockholders being prominent men associated in other lines of trade. From the beginning Mr. Wolper worked along extremely conservative lines until they knew that they had passed through the experimental stage and had a machine which they could successfully offer to the trade at large. The machine proved a success at first and successive increases in output have been necessary. Only four months ago they added an entire additional floor in the large building in which their factory is located. Unlike many of the newer manufacturers, the company makes all its own cases and takes a great deal of pride in their perfection. There is no skimping anywhere. Not only are the finest veneers used in the panels, but all the solid parts of the case are made of genuine mahogany, oak or walnut as the case may be. The company have sought to use the very best possible equipment in their machines and are proud of the fact that the Nightingale is equipped with the Stephenson precision-made motor, a fact which Mr. Wolper says has enabled him to eliminate motor complications entirely. They are using the Scotford tone arm and reproducer and the best possible equipment throughout. The choice of the name, Nightingale, for the talking machine was a happy one and the attractive trade-mark is becoming increasingly well known in the trade. An artistic announcement from this company appears on page 23, this issue.

TAX ON SALESMEN IN ARGENTINA

The matter of replacing the various separate provincial taxes on commercial travelers in Argentina by a single tax for the entire country has again come up for discussion, according to Commercial Attaché Robert S. Barret in Buenos Aires. The proposal is indorsed by the leading newspapers of Buenos Aires, which point out that the overcentralization of Argentina's business, making Buenos Aires the center of commerce, is largely due to the old system which has tended to keep commercial travelers out of the interior of the country. It is thought that a law requiring these "commercial missionaries" to pay one tax to the Federal Government which would permit them to take their samples anywhere in the country would do a great deal toward developing the business of the entire country more evenly.

MISS ESSEN IN UNIQUE POSITION

Is the Only Woman Demonstrator in the Wholesale End of the Talking Machine Trade—Now With James B. Orth & Co., of Chicago

CHICAGO, ILL., June 6.—No, Helene Essen is not a movie actress, but a much rarer specimen of femininity. She is said to be the only traveling woman demonstrator of phonographs in the wholesale end of the talking machine business.



Helene Essen

When the Edison Diamond Disc phonograph was first introduced to musical Chicagoans, Miss Essen occupied the platform in the concert hall of the Edison Shop, and gave "Talks With Records," showing the merits of the instrument, and gave facts and anecdotes concerning the artists and composers. Later, she helped to introduce the Sonora, and now she is connected with James B. Orth & Co., of 422 Re-

public Building, this city, where she is demonstrating to dealers the merits of the new Puritan phonograph.

In discussing the Puritan she said: "If you love a jazz band or the beautiful organ tones of a saxophone alone, you will quickly understand the point the Puritan scores in the 'Saxophone Construction' of its tone chamber. It is just this long horn construction that makes the music, whether it is Galli-Curci's singing, or Sousa's Band playing brass instruments, as mellow as an organ note." After she explains a few more points to you, you will find yourself an enthusiast before you know it.

Miss Essen is tackling a regular man's size job, but says that is always what she wanted, and now feels she can take it without cheating some poor man out of a job, because he is needed "over there."

TO MAKE BUYING PLEASANT

S. E. Lambert Tells of the Good Work of the Columbia Co. in Printers' Ink

Under the heading of "Campaign to Make Buying a Pleasant Transaction," S. E. Lambert presented in last week's "Printers' Ink" a very interesting article in which he called attention to the campaign that is being inaugurated by the Columbia Graphophone Co. to make it easy to shop for talking machines.

Included in this article were reproductions of some of the recent advertisements used by this company in its national advertising, and the text of the article emphasized their distinctive features, pointing out that the advertisements that have been appearing the last few months are designed to make it easy for people to buy a Grafonola. The article further reads:

"George W. Hopkins, general sales manager of the company, points out another reason why it is advisable to employ such copy at present. Thousands of workmen are now earning more money than they ever dreamed of making before. For the first time in their lives a musical instrument is possible and naturally many of them will wish to gratify their desire to own one. However, these men are not accustomed to going into elegant stores, such as phonographs are sold in. They are apt to be a bit shy about visiting such places. The advertising overcomes their hesitancy and makes it much easier for them to take the step.

"The make-it-easy-to-shop appeal is not monopolizing the campaign. Another object of the effort is to give class and distinction to the product. An interesting phase of this end of the advertising is the publicity that is brought to bear on the company's Fifth avenue shop in New York. This is regarded as one of the handsomest specialty stores in America. Something over \$80,000 was put into its furnishings. Each demonstration parlor in it is furnished to correspond with the period designs of the cabinets shown in it. As dealers from all over the country come to New York, they are, of course, anxious to see this store. It shows them the ideal way to sell Columbias, and it inspires them with the possibilities of the business. In a sense it might be called a manufacturer's laboratory store, as it gives the company first-hand knowledge of the buyer in action. Dealers are encouraged to send their prospects to the Fifth avenue store. There they meet the Columbia under ideal conditions. Any sales that are made in this manner are credited to the out-of-town retailer sending the customer to the store on the avenue.

"Many advertisers labor under the delusion that it is not necessary for advertising men to have an intimate knowledge of retailing. If it were necessary to explode this delusion, the present Columbia campaign, which is accounted highly successful, would do so. It is a typical example of how a study of the problems that the dealer is up against can be turned into ammunition for national advertising. In the last analysis the influences that get people to buy goods at retail are the same influences that sell goods nationally or through advertising."

The
Scotford Tonearm
 and
Superior Universal Reproducer
The Ideal Combination
Plays All Makes of Records as they should be played
 Price of Sample Prepaid
Nickel, \$5.25 Gold, \$6.50
Adjusted for Cabinet measuring 8 1/2 inches from center of Tonearm base to center of Turntable shaft

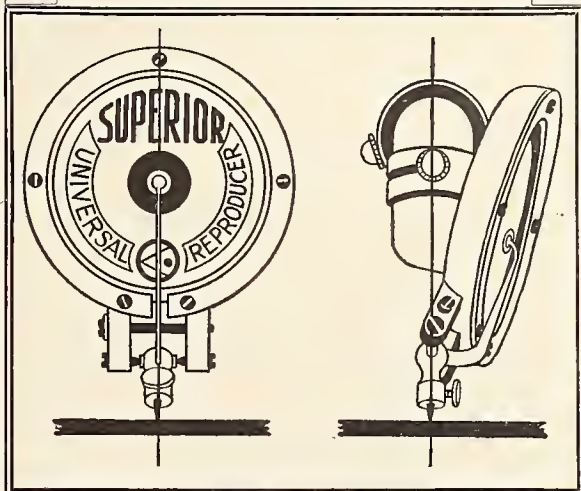

Distinctive Features

- Ⓒ The Reproducer pivots on its axis (as illustrated above), taking the correct angle for all makes of records, and the needle retains same center in both positions.
- Ⓒ Surface noise is less than with any other reproducer—surface scratchings being reduced to a minimum through perfect proportioning of the stylus construction, and placing the needle in the center of the groove at the correct angle.
- Ⓒ The split construction of the frame and face ring of the Reproducer, together with the method of pivoting the stylus bar, and perfect insulation—effect a sensitive and free vibration—and prevent a pinched tone resulting at any time from natural contraction or expansion of the metal parts.
- Ⓒ The reproduction is the mellow, natural quality of tone—absolutely getting away from the usual sharpness and metallic effect so noticeable in most reproducers.
- Ⓒ Sound waves act upon the same principle as light waves—they travel in a straight line until they meet some obstruction, from which they are deflected at right angles. The right angle turn at the back of the Scotford Tonearm causes less breaking up and confusion of the sound waves than occurs in the curved arm.
- Ⓒ The connection between the Reproducer and Tonearm is perfectly insulated with a hard rubber bushing. Inside diameter of the Tonearm is correct to accommodate the volume obtained from the latest records.
- Ⓒ The right-side turn for changing needle is handier than the old style turn-back, and when in position for the Hill-and-Dale records there is no interference with lowering the cabinet cover.
- Ⓒ The lateral movement at the base is simple, free and permanently satisfactory. Inside there is no obstruction to interfere with passage of the sound waves. There are no loose balls in the bearings, therefore no buzzing noise can occur from the great vibration on high notes.



Barnhart Brothers
& Spindler
 Monroe and Throop Streets—Chicago

Attention!

Victor, Edison and Columbia Dealers and Distributors

Don't forget, when a customer questions you as to what attachment will equip his machine to make it universal, in playing all makes of records most perfectly and without destruction, that

The Orotund and Superior

attachments are the only scientifically perfected outfits on the market, playing all makes of records, producing the greatest musical results, positively reducing surface sounds, and in many instances entirely eliminating disagreeable scratching and nasal effects. If you have not as yet had a real demonstration as to the highest type of music and entertainment from the various makes of records, you should visit our office, or ask for a personal demonstration.

If, after hearing our different attachments and reproducers with a few of the most beautiful records ever recorded, you do not believe we have produced some wonderful results which you have never before thought possible on a talking machine, we will then apologize for wasting your time.

You will increase your sales of records by handling these attachments.

We guarantee to improve the tone of your machine. We sell attachments, tone arms and jewel points, Diamond and Sapphire.

Write for circulars and prices.

COMBINATION ATTACHMENT CO.
 20 Jackson Boulevard, East, Chicago, Ill.

CONDEMNS HOARDING OF MONEY

Rotary Club Editorial Urges Normal Spending for Luxuries, Especially in View of the Fact That War Has Brought Profit to Many

In the page conducted in the New York Tribune by the local Rotary Club each week, there appeared recently a most convincing editorial on the fallacy of hoarding and saving to an unusual degree during these war times. It is all well enough, the editorial declared, to save for a rainy day, as the average individual is taught in childhood. The editorial continues, however, to say:

"But there is a difference between saving for a rainy day and hoarding up money for a peaceful one.

"The war has profited many. Men whose manual labor brought them little more than the proverbial crust of bread in years gone by, today, by that same labor, are able to afford a talking machine, a suburban lot, or even a flivver. Men whose particular business has been an atrophied branch on the tree of commerce have had an influx of orders which have simply swamped them.

"To save this country from a financial panic and subsequent business depression which would prove fatal under the existing conditions, it is necessary to put that money in circulation. It must not be hoarded!

"It is legitimate to make unexpected money. It is legitimate to save some of it to guard against future discomfort. But it is decidedly illegitimate to corner currency or merchandise at this critical period.

"Get busy and circulate your money. This is no time to have a 'one way pocket.' If your profits warrant it, be as profligate as your nerve permits. Paint your house. The painter needs the money and will sing your praises.

"Buy a talking machine and send your old one to one of the camps. Ride in taxis. Even though you suspect the chauffeur of being a thug he may have a wife and eight very hungry children to support.

"Buy generously of things not needed on the other side—the shopkeeper's rent is the same, if not increased. Spruce up your wardrobe.

AIDS RED CROSS IN NEW HAVEN

Loomis Temple of Music Arranges a Most Effective Window Display While Manager Leichter Assists in Collecting Funds

New Haven, Conn., June 3.—One of the most effective window displays in this city in the interests of the Red Cross drive, which ended



Red Cross Window at the Loomis Temple of Music

recently, was that arranged by the Loomis Temple of Music at 837 Chapel street. The

Perhaps the designer, the buttonhole maker and the tailor are too old to enlist or learn a new trade. Circulate your money. Help people to smile. Don't compel them to weep. And if you can, forget about that rainy day. Because if there ever comes a day rainier than this one, God help us all. It is the world's Rainy Day!

"Keep moving yourself. And keep your money moving. That's what is going to make the Kaiser move from Berlin to Bondage!"

The Friedberg Talking Machine Co., Brooklyn, N. Y., has been incorporated with capital stock of \$10,000 by T. W. Guttenberg, H. Schnapp, and N. Friedberg.

chief feature of the display was a life-sized figure of a wounded soldier with a Red Cross nurse bending over him, and the appeal was unmistakable. A reproduction of the window is shown herewith.

Max B. Leichter, manager of the Loomis Temple of Music, in addition to giving the window, also gave much of his time to working on one of the teams in collecting money. The al-

lotment for the city was \$350,000, and New Haven went over the top with over \$625,000, or nearly double its quota.

The Loomis Temple of Music has adopted a very attractive poster label, resembling in form an automobile wheel with the company name running around the rim, while between the spokes appear the names of the various pianos, including the Knabe, Emerson, Fischer, Mehlin and other makes, Victrolas, music rolls, various small musical instruments, sheet music, etc., handled by the company.

R. A. IZOR BECOMES SALES MANAGER

Well-Known Talking Machine Man Appointed Sales Manager of the Brunswick Shop in Indianapolis—Has Had Wide Experience

INDIANAPOLIS, IND., June 8.—R. A. Izor, who has been identified with the phonograph business in Indianapolis for a number of years, has



R. A. Izor

recently been appointed sales manager of the Brunswick Shop. George F. Standke, manager of the shop, is pleased with the acquisition of Mr. Izor to his sales force.

ENLARGE VICTOR DEPARTMENT

TERRE HAUTE, IND., June 8.—Four new and attractive soundproof demonstration rooms have just been completed for the enlargement of the Victrola department of the Herz store. The rearrangement of the department also provides for more attractive display parlors and more convenient record stock files. The enlarged department was formally opened on Wednesday, Thursday and Friday, June 5, 6 and 7, with special musical programs which pleased the large audiences in attendance.



- 1. The Long Horn.
- 2. Sound Chamber at Base.
- 3. The Convex Cabinet.

These are exclusive, patented features. Write, wire or phone us for territory in Illinois, Indiana, Michigan and Missouri.

PURITAN

THE dealer or the jobber who handles the Puritan line can dominate the phonograph business in his territory—by offering real and exclusive advantages to prospective customers.

In addition to these advantages you have also the Puritan line of Records, making this a doubly profitable proposition. And back of all this you have our active service, deliveries and a big, live advertising campaign.

There is some excellent open territory. Get in touch with us now.

Factory Distributors:

JAS-B-ORTH & CO.
422 Republic Bldg. Chicago Phone Wabash 7630

National War Savings Day June 28th

That's the day we sign up.

That's the day we tell Uncle Sam just how hard we want to win this war. That's the day our government has officially set for us to purchase War Savings Stamps.

On June 28th every man, woman and child in the United States will be called upon to pledge his or her full quota of War Savings Stamp purchases for 1918.

You will be expected to pledge the **full** amount that you can afford—no more—but by the same token, no less.

In every state, county, city, town and village the War Savings Committees are preparing for this big patriotic rally of June 28th. Unless you have already bought War Savings Stamps to the \$1,000 limit, get busy with paper and pencil and figure out the **utmost** you can do.

Remember this. You take no chances when you go the limit on War Savings Stamps. They are the best and safest investment in the world.

They pay you 4% interest compounded quarterly. They **can't** go below par. You can get back every dollar you put into War Savings Stamps **any time you need it**. You can turn them in at the Post Office **any time** for their full value plus interest.

Uncle Sam is asking hundreds of thousands of men to **give** their lives to their country. He is asking you only to **lend** your money.

What are you lending?

National War Savings Committee, Washington



This page contributed to the Winning of the War by the
NEW YORK TALKING MACHINE COMPANY

119 West 40th Street, New York

CHICAGO TALKING MACHINE COMPANY

10 No. Michigan Ave., Chicago, Ill.

ANNUAL MEETING OF PORTLAND, ORE., ASSOCIATION

Many Subjects of Interest to Talking Machine Trade Considered at Gathering of Portland Men—
E. B. Hyatt Unanimously Elected President—Other Officers—Shortage of Records Discussed

PORTLAND, ORE., June 4.—Early closing of the talking machine houses in Portland on Saturday evenings during the summer months was decided upon at the regular monthly meeting of the Portland Talking Machine Dealers' Association which was held at the Imperial Hotel Wednesday evening, May 29, at which twenty-seven dealers were present and at which the Victor, Columbia, Edison, Brunswick and Sonora machines were represented.

As to early closing it was decided that in June all talking machine dealers would close their stores at 7 p. m. and during July, August and September at 6 p. m.

Paul B. Norris, manager of the Wiley B. Allen Co. talking machine department, called the attention of the dealers to the fact that it could only be suggested to dealers not belonging to the association to observe this rule, and that they would have to decide for themselves relative to early closing, although he maintained that the propriety of a suggestion could not be denied. Taylor C. White and C. A. Alphonse were appointed a committee to get signatures of those agreeing to the early closing plan irrespective of what non-members of the association might do.

Interest on deferred payments was one of the principal topics of the session. With the exception of the furniture stores and department stores—all of which handle talking machines—all dealers in talking machines have adopted the interest plan. H. E. Burr, who has charge of the talking machine department of Gadsby's Furniture Store, thought it very probable that the firm would adopt the plan of the talking machine houses. W. Matney of the Meier & Frank Co., thought the management of that big department store would also fall in line. James Loder, manager of the phonograph department of the Bush & Lane Co., sug-

gested that the furniture and department stores might co-operate if they were asked to do so and were invited to join the association.

E. B. Hyatt was unanimously elected president of the association at the annual election, which was one of the features of the meeting. Taylor C. White was elected vice-president and C. A. Alphonse secretary. W. L. LeVanway, who has been acting secretary for two months, has joined the signal corps and will leave Portland in a few weeks. He will be much missed by the association, as he has been one of its most valued members. On announcement of his enlistment, the entire membership rose silently and stood at salute in tribute to the young patriot.

Shortage of records came in for interesting discussion and revealed a rather serious condition in the trade. It was brought out that word from the factories of the Columbia, Victor and Edison people was that the labor shortage was acute and that many women are filling places formerly held by men. L. D. Heater, manager of the Columbia branch in Portland, said that in the London factory of his firm there are only two or three men left and they are old men unfit for war. He pointed out that it is impossible to supply goods in England, despite England's reduced purchasing power, so said it could be seen readily how hard it must be to meet an ever-increasing demand in this country. Dealers on the Coast are inclined to look for a serious shortage in the fall, especially as the Government will use more cars for wheat and troop movements.

The question of sending out records on approval was again brought up and it developed among the dealers that almost all had discontinued the practice, save in the cases of well-known customers who really wanted to buy after hearing the records at home. It was

brought out that the custom had been abused, but E. B. Hyatt showed a card which he pastes on all records taken out on approval which he thinks has solved the difficulty. This card reads:

EXTRA SPECIAL

When records are taken on approval and none retained, a minimum charge of 50 cents will be made to cover cost of bookkeeping and clerical expenses.

Mr. Hyatt said this relieved them from a great deal of trouble from people who would get records for use at parties and return them the next day without purchasing any.

C. Guy Wakefield, of the Wakefield Piano Co.; H. E. Burr, of Gadsby's Furniture Co., and W. A. Matney, of the Meier & Frank Co., were elected members of the association.

TELLS OF BUSINESS GROWTH

Chas. Staffelbach, Who Visited New York Last Week, Reports Big Pathé Business Being Done by the Hellrung & Grimm Co., St. Louis

Chas. Staffelbach, manager of the Pathé division of the Hellrung & Grimm House Furnishing Co. of St. Louis, Mo., Pathé jobbers, was a visitor to New York this week, spending some time at the executive offices of the Pathé Frères Phonograph Co., and also visiting the Pathé booth at the music show. In a chat with The World Mr. Staffelbach commented upon the fact that his company is closing a remarkable Pathé business, the sales of Pathéphones and Pathé records so far this year showing a substantial increase over the entire year of 1917. He states that Pathé products are gaining rapidly in popularity throughout his territory, and that his house is planning to institute an aggressive Pathé campaign in behalf of this line, which will include active and intensive cooperation with the Pathé dealers. He placed a good-sized order while in New York, and judging from all indications his optimism will be reflected in a banner Pathé business this coming fall.

PERFORMANCE

alone interests the purchaser.

GLORIA NEEDLES

stand on performance and expectations are realized upon receipt of the merchandise.

—and **PROFITS** are doubly insured in immediate fulfillment of orders.

Will you test *our* performance?

- SOFT TONE
No. 1
- MEDIUM TONE
No. 3
- HALF TONE
No. 5
- FULL TONE
No. 7
- LOUD TONE
No. 9
- EXTRA
LOUD TONE
No. 11

Gloria Phonograph
Supply Co., Inc.

200 FIFTH AVE. NEW YORK

WM. A. CONDON, Sole Agent



Military Trunk Grafonola Outfits for vacationists, summer cottagers, automobile parties—to say nothing of the cantonments.

Columbia Graphophone Co.
NEW YORK



CONVENTION OF JOBBERS' ASSOCIATION IS POSTPONED

Membership Votes Almost Unanimously to Call Off Annual Gathering Scheduled for July at Atlantic City, Owing to War Conditions—Follow Recommendation of Executives

It has been officially announced that the annual convention of the National Association of Talking Machine Jobbers, scheduled to be held at Atlantic City, July 1 and 2, has been postponed indefinitely, as a result of the practically unanimous vote of the membership of the organization. It was felt by the officers that in view of war conditions, and the general situation existing in the trade, no real benefit could be gained by holding a general convention, although it is probable that a meeting of the executive committee will be held in the near future.

The abandonment of the convention brings up the question of taking care of the annual election of officers at the expiration of the present terms, but some move will likely be made to re-elect the present board.

Secretary J. C. Roush, secretary of the association, sent out a general letter to the members under date of May 31, the letter reading in part as follows:

"At the executive committee meeting of our association held in Philadelphia, April 22 and 23, the advisability of holding our convention this July was thoroughly discussed and it was the consensus of opinion of your committee that this year's convention be called off for patriotic and other reasons. Final action was to be postponed, however, until May 20 to await further developments.

"Nothing having arisen, however, to justify a reversal of this opinion, I have been instructed by President Blackman to notify you that your executive committee recommends that no convention or meeting be held this year, unless conditions change enough to make said meeting necessary, at which time you will be asked to vote on the advisability of holding

a meeting in the fall. Every member is aware of the constant changing war and other situations affecting our business, and it is believed that we will show a more patriotic spirit by not meeting as usual in Atlantic City this year."

In voting against the holding of the convention as scheduled, the members of the organization agreed thoroughly with the officers on the fact that their interests could best be served by postponing the proposed convention indefinitely. Should the situation warrant it, a general convention of the body may be held some time in the fall.

BECOMES GENERAL SALES MANAGER

John A. Cromelin, of International Fame in the Talking Machine Trade, Assumes This Important Post With the Otto Heineman Phonograph Supply Co., New York

Otto Heineman, president of the Otto Heineman Phonograph Supply Co., New York, announced this week the appointment of John A. Cromelin as general sales manager of the company. Mr. Cromelin will assume his new duties next week, and make his headquarters at the executive offices of the company, 25 West Forty-fifth street.

John A. Cromelin is one of the best known members of the talking machine trade, having been associated with the industry for many years. Until recently he was vice-president and general manager of the Columbia Graphophone Co., and for a number of years held the important post of general manager of the Columbia Co.'s European interests with headquarters at London. He possesses a thorough knowledge of every phase of

talking machine manufacturing and merchandising, and is generally recognized as one of the ablest executives in this field. Mr. Cromelin has for some time been a keen admirer of the plans and policies of the Otto Heineman Phonograph Supply Co., and the rapid strides that this company has made the past two years will



John A. Cromelin

doubtless enable Mr. Cromelin to develop the sales of Heineman, Meisselbach and Dean products to excellent advantage.

Mr. Cromelin will, of course, devote a considerable portion of his time to the new Heineman "OkeH" record, which was placed on the market last month. This record is achieving signal success, and Mr. Cromelin's intimate familiarity with record production and merchandising will undoubtedly contribute to the international success of the "OkeH" record.



CABINETS

We have cabinets to match all Victor Victrolas ready for immediate delivery.

Write us for Quotation

MAGIC-TONE STEEL NEEDLES



Prices Immediate Delivery Loud Tone

55c per thousand and in lots of 500,000 and up.

In lots of 100,000—60c per thousand
In lots of 10,000—65c per thousand

In paper envelopes or metal boxes

Anticipate your requirements and take advantage of present low prices.

I. DAVEGA, Jr., Inc.

125 West 125th Street

Victor Factory Wholesalers

NEW YORK

VICTROLAS—SUPPLIES—NEEDLES



ENLARGED FAC-SIMILE OF PACKAGE

“MOBILIZED in the SERVICE of OUR COUNTRY”

Vallorbes Economical Semi-Permanent Needles perform more than double duty—their use not only conserves steel for vitally essential war weapons and materials, but serve their users in equally as serviceable and effective manner.

If you are inclined to these needles simply because of patriotic motives or perhaps on account of the shortage of steel needles, you have a surprise awaiting you, for, unlike most enforced economies, they really do you a favor—either as a dealer or user. In the first instance, they attach to the sale of a single package, the highly required and desired profit, and, in the second case, their reproducing qualities are really wonderful—no needles yet have quite equalled them. This is especially true of the soft and medium tone grades. Finally, they also do the records they play a real favor, for it is quite obvious that with their parallel shape of needle points that do not enlarge their diameter as a result of wear, they cannot exert unequal wearing influences on walls of record grooves, as do the old style changeable steel needles, all of which are tapered in shape and dimension, and which from the start of playing a record to the finish is undergoing a change in dimension from which arises the necessity of discarding the needle once used.

Vallorbes Semi-Permanent Needles are made of a special alloy metal, which results in combining to an appreciable degree the hardness of carbon and the toughness of chrome. Moreover, being made of one piece throughout, there are no separate points to work loose and a better sympathetic relationship arises with stylus bar of sound box than would be the case with a separate needle point inserted into a different kind of metal holder. Furthermore, this one-piece construction also permits of three separate and distinct tone grades, i. e., soft, medium and loud.

Neat, handy and attractive cards are especially made to accommodate these needles. Each card of five needles is placed in a separate transparent moisture-proof envelope and readily retail for 15 cents for the card of five needles and play far more records than 15 cents' worth of old-style changeable steel needles.

They are packed for shipment in cartons containing 100 packages of a tone grade, and, as orders invariably follow samples, better save time and order a carton of each tone grade at once, otherwise,

Send 30 Cents in Stamps for a Sample Card of Each Tone Grade



LANCASTER, PA.



GETTING AFTER THE VACATIONIST

Talking Machine Retailers Now Have Opportunity for Realizing on Stocks of Smaller Machines for Use of Campers, Etc.

From practically every section of the country comes the report that the heaviest demand is for the higher, or rather medium-priced machines, those selling from \$75 up to \$165 or so, and that therefore the most serious machine shortage is found in the styles retailing at those prices. At the same time, both wholesalers and retailers have on hand for the most part substantial supplies of the smaller types of machines, those without tops, retailing for \$35 or



Wiley B. Allen Co. Vacation Window less, and for which the normal demand is not at all heavy at this time.

Quite a number of retailers have already realized that this year, as has been the case in other years, the small machines in substantial numbers can be sold to campers and vacationists generally, who do not care to subject their high-priced machines to the rough handling and exposure incident to the summer vacation. It would seem that this year particularly an especially strong drive should be made to place the small machine, and thus make up in some measure for the loss of business, due to the shortage of the more elaborate models.

There has already been received at The World office numerous photographs of special window displays designed to attract the attention of vacationists, and the accompanying view of the show window of the Wiley B. Allen Co., Portland, Ore., offers a fair example of elaborate window treatment.

The campaign should not stop at the window, however, but machines for vacation use should be advertised strongly and matter sent out through the regular mailing list and advertisements in the resort sections of the local newspapers. Publicity in summer resort booklets and advertising sections of newspapers hits the vacationist just at the time he is making his plans for the summer and therefore at a time when he is most interested.

Why not make every "talker" store a center of neighborhood war activity?

WE GUARANTEE

Our System will pay for itself in 6 months by increasing your sales or it is returnable for FULL CREDIT

FILES, FINDS

and

SELLS RECORDS

in a modern way

It saves your time and keeps track of what you sell and what you need in the simplest way.

Write today for our new proposal on this

War Time Necessity

Prompt Shipments

OGDEN SECTIONAL CABINET CO., Inc.
LYNCHBURG, VA.



TO HELP IN THE WAR

Must Back the Government With All Our Strength—How Best to Do It

President Wilson, in his statement calling upon every man, woman and child to pledge themselves on or before June 28 to save constantly and to buy regularly the securities of the Government, says: "May there be none unenlisted on that day!"

As the President points out, "This war is one of nations—not of armies—and all of our 100,000,000 people must be economically and industrially adjusted to war conditions if this nation is to play its full part in the conflict."

Our nation, not our army and navy only, is at war. And that means that all of us not actually fighting must do our part.

That part consists in giving the army and the navy all the support of which we are capable. To do that each one of us must first of all be a producer to our maximum ability and a consumer of necessities only, for every bit of man power and every particle of material is necessary for the use of the army and navy and for the making of the things essential to our citizens.

As a maximum producer and as a consumer of necessities only, each one of us will be an accumulator of savings. And these savings can be invested in War Savings Stamps with benefit both to the Government and ourselves.

CHANCE TO MAKE FIFTY DOLLARS

One of the surprises at the National Music Show held in New York last week was the offer of a prize of \$50 in Thrift Stamps by The Music Trade Review, New York, for the best article treating on "The Value and Importance of Music in War Time." The judges to pass upon the merits of the essays submitted are Lieutenant John Philip Sousa, C. M. Tremaine and the Editor of The Review. The contest closes on June 20.

LAW TO END TRADE BRIBERY

WASHINGTON, D. C., June 6.—The Federal Trade Commission last month sent to both branches of Congress a communication urging "the enactment in the public interest as an aid to the preservation of fair and free competition, a sufficient law striking at the unjustifiable and vicious practices of commercial bribery; and that such law be so comprehensive as to strike at each person participating in any such transactions."

The Federal Trade Commission has found commercial bribery to be general throughout many branches of industry, and scores of complaints have been issued by it on that account. Fourteen States at present have laws prohibiting such practices.

Jobbing Rights

Several large distributing contracts with exclusive territorial rights have been closed by us as a result of a

HOFFAY AIRTIGHT

trial machine, model 100, sent for examination.

Let us ship you this wonderful instrument, which you may return at our expense within two weeks from receipt. No obligation to buy it.

Write to-day. Your territory may be open and you may secure valuable rights.

HOFFAY TALKING MACHINE CO., Inc.
3 West 29th St. New York City



NEW YORK TIMES ON "MISTREATMENT OF 'BIG BUSINESS'"

Prominent Metropolitan Newspaper Treats Most Illuminatingly in Its Editorial Columns of Recent Supreme Court Decision in the Shoe Machinery Combination Litigation

Under the caption, "Mistreatment of 'Big Business,'" the New York Times in a recent editorial made some illuminating comments on the decision of the Supreme Court in the shoe machinery combination litigation which will be read with interest by business men in every line of trade in view of recent developments in this and other industries. It is a comprehensive handling of a question which is of vital moment to business men who desire to build up a business along honorable lines of expansion that will be of benefit to the nation and to humanity and still enjoy protection for their rights. The editorial read:

"For seven years the Shoe Trust has been bitterly pursued upon what the Supreme Court calls the 'innuendo' of the Government that it restrained interstate trade. By four to three the court decides that the Government was wrong in its aspersion as matter of law. As the court was so evenly divided, the defendant trust can hardly be blamed for a course which had never been condemned by authority and which was approved by business practice. The acquittal of the trust is condemnation of its prosecutors because they have so persistently refused to take their law from the courts. One Attorney General has even gone so far as to complain that he alone cannot enforce the law against restraint of trade. He formally expressed his regret that 'a number of Federal judges have been and still are apparently reluctant to enforce the Sherman act.' Now the highest court asserts that the Department of

Justice prosecutes by insinuation on a mistaken view of the law.

"If the case stood alone, it would be an undesirable state of affairs, but it is only one of many cases. Only a short time ago Government representatives sat around the same table with many distinguished defendants, at the suit of the Government on complaints which the Government could not proceed with. Public interest would not allow that seven suits against the biggest of the trusts should be pressed to a conclusion, although the trusts were eager for finality regarding their legal status. Such a condition of affairs indicates nothing less than a reign of terror which should be ended. Is it extreme to take the position that the Attorney General and the trusts alike should take their law from the courts?"

"Another suggestion—the trust cases are mostly prosecuted and decided on the law rather than the facts. There have been not a few cases where trusts were attacked on the ground that they restrained trade under the law, although they promoted trade in fact. In the Shoe case there is no question that the manufacture of shoes was enlarged, whatever may have been the fact about the machinery trade. The interest of the public is that the law should be enforced, and restraint of the machinery trade is not to be condoned, if proved. But the public interest is rather in shoes than in shoe machinery, and the effect of the trust's plan is affirmed by the court to be helpful to the small shoemakers, who were able to operate with



Read the Trade Mark carefully,
hear the machine, and you'll agree
that it is truly

The World's Musical Instrument
Improves All Records

Send for our Special Proposition

HOFFAY TALKING MACHINE CO., Inc.
3 West 29th Street New York City

leased machinery which they could not buy. To prosecute big business which helps the little men in trade cannot be in the public interest. If there were complaint from the public that the making of shoes was obstructed, or made costly, or that other shoemakers were estopped in their trade by the trust, the Department of Justice might have an excuse for its persistence. But the public is not in court, except through the Attorney General. The court explicitly remarks that the victims of the lease system were not in court.

"All unobserved, there has grown up a practice oppressive to business which has not been convicted of anything. Within a few days a plea of guilty has been accepted by the Attorney General in what might be called his personal court. He arraigned the trust before him, and the trust accepted his view of the law rather than contend in such an unequal contest. It is natural enough, and yet those trusts which resist such practice are more to be commended. The Department of Justice is empowered to prosecute the guilty, but it is an innovation that the Attorney General should arrange the terms on which business men may engage in interstate commerce without the assistance of the courts. If such trade licenses are to be issued, it should be by authority of law, by some official who has been given the authority which the Attorney General seems to usurp. Between the abdication of the Interstate Commerce Commission and the quasi-usurpation of the Department of Justice, the men of large affairs who wish to obey the law are put in an undeserved quandary. The railways and the trusts have deserved discipline and have been scourged until they have repented. Is it not also time that the Government should recognize that conditions have altered, and that the law has teeth enough of its own, without a false set condemned by the courts and common sense?"

BRUNSWICK NEWS IN NEW YORK

Occupying Larger Quarters—New Dealers Appointed—Many Visitors During Month

The Brunswick-Balke-Collender Co. have moved the New York branch of their phonograph department to the second floor in the same building at 29 West Thirty-second street. This change has provided larger and more attractive quarters for the proper display of their exceptional line of talking machines.

The space formerly occupied by the department is now being used by the Railroad Administration of the Government for an immense midtown ticket office for all roads.

Two models of the Brunswick phonograph were sent to the music show held at the Grand Central Palace, New York, during the past week and were to be seen at the attractive exhibit of the Brilliantone Steel Needle Co., where they were used in demonstrating these needles.

P. L. Deutsch, assistant secretary of the company, came East from headquarters in Chicago to attend the music show, also F. H. Walters, of the Boston branch sales staff. Mr. Walters reported excellent business in his territory.

Among the many Brunswick dealers in town for the occasion were O. A. Field, of Field-Lippman Co., St. Louis, and John Duncan, manager of the Brunswick department in the Gamble-Desmond Co. store in New Haven, Conn. Mr. Duncan placed his fall order while in town.

Among the list of new Brunswick dealers for the month is James Quinn, of Brooklyn. Mr. Quinn is a well-known dealer and the prestige of the Brunswick line in that borough is greatly enhanced by his taking over the line.

S. Bersin, 410 Grand street, New York, has also installed the Brunswick line in his new store on Second avenue.

Operaphone Records

Ten Inch Retail 75 cents

The popular standard American catalog dealers have been waiting for.

We know you must have records.

Operaphone Records follow the line of least resistance, they play with steel needle on all universal tone arm machines with sound box facing front.

Order direct from Long Island City or from your machine jobber.

Send for our trial package assortment including window display and regulation catalog book.

Operaphone Co., Inc.
LONG ISLAND CITY, NEW YORK

ANNUAL OUTING OF THE TALKING MACHINE MEN, INC.

Annual Red Letter Event Takes Place on Wednesday, August 7—Bear Mountain Will Be the Rendezvous and Every Talking Machine Man Should Keep the Date in Mind

Mark the date on your calendar now with a big red circle, Wednesday, August 7, the date of the annual outing of the Talking Machine Men, Inc.

According to information already obtainable regarding the plans for the affair it will be a genuine trade event, and the member of the local trade who is unfortunate enough to miss it will be cheating himself out of some real enjoyment.

The outing will be held at the Bear Mountain Inn, the popular up-the-Hudson resort, and arrangements have been made for the party to sail up the river on the Albany Day Line, leaving the foot of West Forty-second street at 9 a. m.

In order to prevent the trip from becoming monotonous in any sense J. J. Davin, of the New York Talking Machine Co., has arranged for the original Dixie Land Jazz Band from Reisenweber's to accompany the party and fill the air with sweet melodies on frequent occasions during the sail and at the park. The band has donated its services for the occasion, in appreciation of efforts put forth by Mr.

Davin in its behalf. There will also be other surprises in the way of entertainment during the day.

At Bear Mountain there will be a baseball game between Columbia and Victor interests in the association as the chief event. There will also be races of various sorts and other games in sufficient variety to suit all tastes.

An elaborate dinner will be served at the Bear Mountain Inn at 1 o'clock.

Those in charge of the arrangements urge that jobbers and dealers not only attend themselves, but arrange to let as many of their employes off for the day, in order to make the affair successful in every way. It is felt that with employes called upon to do much extra work through shortage of help, a little recreation is really due them.

The committee in charge of the outing consists of Sol. Lazarus, E. Leins, J. E. Hunt, J. T. Coughlin, Saul Birns and J. J. Davin. Information regarding the outing, as well as tickets, may be obtained from A. Galuchi, treasurer of the Talking Machine Men, Inc., 724 Bergen avenue, Jersey City, N. J.

SOME HINTS ON CLEAN BUSINESS

Misdirected Effort and Pep Back of the Wrong Product Often Gets Surprising Results—The Proper Idea Is to Put Energy Behind the Right Kind of Business and Right Product

J. E. Gerlick, a well-known figure in the Western music trade, contributes some words of value to every talking machine salesman who believes in doing business on an energetic, straightforward basis, in the following remarks:

The truth will win if we make serious ef-

forts to disseminate it. Enthusiasm and energy carry with them a convincing power.

Unfortunately this convincing power results from enthusiasm and energy put forth in a wrong cause, just as truly as when expended in the interests of right.

Wait a minute! Perhaps "unfortunately" is not the right term to use in relation to the undoubted fact just stated. Maybe it's fortunate that this is so. Perhaps it is calculated to make the fellow with a bag full of truth work and energize and enthuse harder to sell his commodity than the fellow who is spending his young life in a frenzied effort to peddle a bunch of wrong.

It doesn't put cast iron deers on your front lawn or gold-plated lightning rods on your house if you make a blanded good rat trap and then sit down and think about it. The chances are that you won't have the lawn for the cast iron deer or a house that could sport a gold-plated lightning rod. You'll just keep on washing your own dishes in the shack in the wilderness, and the fellow with the cheap trap and lots of sand and advertising ability and sales push will be working towards a monopoly on deers and dears and lightning rods.

Of course, he would go a good deal farther if he had both your rat trap and his own pep and persistence. But that's an additional narrative, as R. K. would enunciate.

Take it in the talking machine trade. There are two classes of intrinsically good talking machines, those which sell (in a large way) and those which don't. Just think this over and after you have thought a while ponder somewhat and then contemplate.

On the other hand, Mohammed had a rotten sort of religion, but he managed to get a lot of disciples, didn't he?

There has never been a suspicion on the fact of the white-robed ones that the Devil and his imps were easy competition. It's difficult to get the same punch in a clean advertisement as in one of the bunko-steering type.

Business is a game. It would never be a con game if everyone played in accordance with the rules.

If the clean athletes all exercised their powers every minute of the time, the boys with the stiletto would never get a look in in this or any other industry.

MAKING DRIVE ON SUMMER TRADE

The Shepard Co., of Providence, R. I., are making a special drive these days after summer trade, and in this connection are boosting the Victrola VI-A.

Automatic RECORD CONTAINER

PATENTS ALLOWED



Style 5H—Holds 100 Records

Filing Cabinets for use with Victrola VIII or IX; Columbia Grafonola 15, 25, 35 and 50; Aeolian Vocalion D. & E., and other portable styles of talking machines.

A Flexible File

—Expands Outside the Cabinet

- No weight of records to handle
- No broken or misplaced records
- 100% increased capacity
- Every record accessible
- Opens Automatically
- Files all records
- Sells on sight

These cabinets combine business sense with parlor style. A complete modern filing system adapted to home use. An efficient ornament to parlor or library.

Automatic Carrying Cases for Salesmen and Repairmen are ideal—constructed on the same principle as our Record Containers. Every dealer and jobber should equip his salesmen with them to increase their efficiency and multiply record sales.



Automatic Insert Files will re-equip any standard Talking Machine with durable up-to-date files—on dealers' sales floor or in customers' homes. Every dealer and jobber should carry them in stock. Special for Edison 100A and 150C machines.

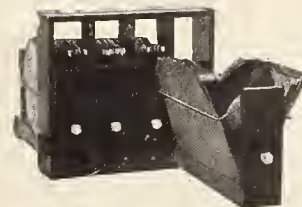

MAIL THIS COUPON TODAY
Manufacturers: Write for shop-rights under our patents

AUTOMATIC CONTAINER COMPANY

209 So. State St. Chicago

AUTOMATIC CONTAINER CO.
209 So. State St., Chicago
Send me your catalog:

T.M.W.

TEST offered to dealers to prove the superiority of Wall-Kane Steel Needles

Take two standard disc records of the same selection, play one ten times with the same WALL-KANE loud needle; play the other record, the same selection, ten times, but with ten, new, full tone steel needles.

You will find that the record played ten times with the same WALL-KANE needle will sound clearer, will have less surface noise, and that under the magnifying glass the grooves of the record played ten times with the ten steel needles will seem to be more disturbed.

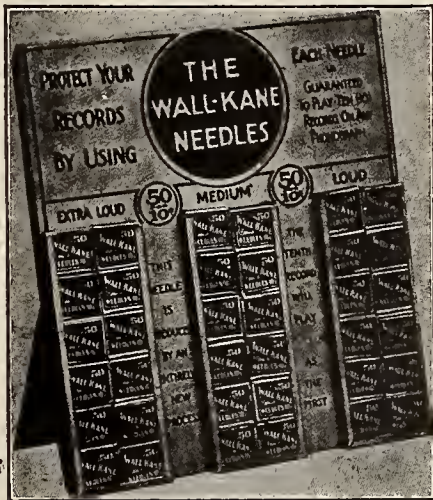

Beware of Imitations

Package of 50 WALL-KANE needles. Loud, Extra Loud and Medium, greater value than 500 ordinary steel needles, retails for 10c, costs the dealer 6 1/2c.

Jobbing territories open

Progressive Phonographic Supply Co.
145 West 45th Street, New York

Music One of the Greatest Weapons America Has for Winning the War, Says A. W. Mason

A. W. Mason, retail manager of the Gately-Haire Co., Victor wholesalers, in the capital city of New York State, is not letting the public in Albany forget that music is proving a decidedly important factor in the war. In a recent interview published in the Knickerbocker Press Mr. Mason declared that music was one of the greatest weapons America has for winning the war, and said:

"In music, as in our lives, there are many kinds of food, and there is a field which is far greater and almost limitless in its scope. That is the lieder and concert songs of a great number of composers of the older classical schools and of the present day such as Debussy, Chadwick and many others.

"If one would take time to study the programs of the concert artists they would find this kind of music represented in a far greater degree and used much more frequently than they realized. It appeals to all classes. It is musically instructive and the increased demand for this music shows conclusively that the public is rapidly acquiring a taste for such instructive material.

"Some of the greatest things musically have been done for the music loving public within the last few years, through the talking machine. My experience has taught me that the public is ever willing, receptive and ambitious to grasp the better class of music, although I will add that many still prefer the so-called popular music, but this is to be expected, notwithstanding the aim of the minority toward expecting better things.

"A short time ago Caruso made the statement that he did not understand why two records from a noted opera which he had made for

one of the large talking machine manufacturers a few years previous, were among the poorest selling records in his repertoire. Artistically he considered them of great credit to himself, and he spoke with much disappointment at the lack of appreciation of these and other numbers of the same character.

"I do not claim to be original in this, but some years ago I realized that the music loving public was constantly looking for the 'gems.' I started to gather these 'Pearls of Great Price' at that time, and believe at present that I have the greatest collection of the 'prizes' of any individual in the Victor talking machine business. I study the catalog to-day as a boy at school studies his grammar. Thus each day new ones are unfolded to me.

"Another department of which the public has but little knowledge is the educational. Few realize that at present there are 5,250 talking machines in the schools of the country, and many thousands of records. These records are by no means confined to marches and dances, but in many instances are used in the English literature classes, in the study of music forms and compositions. Even the little folks are taken care of in this department, as all the widely known fairy tales are reproduced.

"It is indeed gratifying to the retail salesman to see the constant demand for this class of records.

"We have recently installed an extensive Red Seal department in our store and here every day we meet the music lovers of our city.

"Never, in the history of the nation, has the value of music been so clearly demonstrated as at the present time.

"Simply because we are at war, and simply

because the average individual has become reconciled to the fact that we must sing while we fight, we now have a condition that has never presented itself before.

"We have community singing, army singing at cantonments, and many other forms of vocal work, all of which tend to promote the music atmosphere and aid the spirit of the nation. Food, shelter, clothing and music are the four essentials of life, but too little attention is paid to the real merit and the great value of music.

"A disgruntled nation lacks the spirit essential to success. We must have a happy, willing, aggressive nation. Every man's son of us must be there and there with the happy punch. We, as Americans, have the punch, but let it be the happy, willing punch, backed with a song, and we have accomplished more than weeks and weeks of dry military routine can accomplish, toward making our boys feel that we are there to win.

"Sending our boys to the front without music is akin to sending them without our well wishes. We will win, and the quicker we realize, both combatants and noncombatants, that their spirit is their success, the quicker the great conflict will be over. Just let our boys, our red-blooded boys, feel that they can whistle and sing, and swear, when and where they please while in the conflict, and just so quick will we see the merit of our American blood: the initiative produced from such liberties. Discipline is essential, to be sure, but freedom of mental activities is also essential. Let them sing. Encourage it. It makes them fight like hell in fact.

"They have their own little pet parodies that we little realize in civil life and every one of them has a kick to it that might make us hesi-



Style 70—Retail \$10.00

7 IN 1

Seven strong points in our feature is a powerful selling argument.

1. Controlled entirely by gravity. Will not get out of order.
2. Non-abrasive individual record compartments.
3. Records cannot warp, scratch or mar and are kept clean.
4. 10" and 12" records can be filed in any compartment indiscriminately.
5. In beautiful oak and mahogany finish. Polished, waxed and dull finish.
6. Automatic out signal shows "when and where" a record is missing.
7. Filing and finding a pleasure. Get the desired record when it is desired.

COLUMBIA DEALERS: Eject-o-files are built to fit the style 75 and others. Slip them in as they are wanted. Why carry that big stock of 85's, etc., when the Eject-o-file does the trick? "The Eject-o-file is Efficient" and you are in business for dollars and cents.

VOCALION DEALERS: A receptacle for records that can be slipped into your style F.-G.-H.-J.-&-K. They are "built to fit." Wonderful convenience and a powerful selling argument. Ask the Salesman.

EDISON DEALERS: Eject-o-files are built to fit the style C-150 and 100. Many dealers are reaping the benefits. Why not you?

"BUILT TO FIT" any machine and a powerful asset for any dealer. Why offer Albums, Envelopes and other antiquated methods of filing to your customer? Eject-o-files are modern and efficient. Prices are phenomenally low.

The "sectional Eject-o-file," an auxiliary cabinet, compact, large capacity. Can be conveniently placed on table, stand, etc., or stands especially adaptable can be had. Beautiful and artistic, mahogany and oak finish, polished, waxed or dull. Each section a complete unit, can be added to, one upon the other, you know, sectional bookcase idea.



Style 60—Retail \$15.00

EJECT-O-FILE SALES CO.

216 W. Saratoga Street

Baltimore, Md.

Columbia Dealer Service Department will help you make money on Vacation Grafonolas. Have you written for it?

**Columbia Graphophone Co.
NEW YORK**



tate in private life were we to hear it, but it is the good old American spirit that prompts it. You have heard the proverbial 'Don't swear, or you won't catch fish' which is simply another sample of the spirit of Americans who will not accept defeat easily, and are bound to win in a mild fishing contest—a contest between the angler and the fish.

"John McCormack says 'Send Me Away With a Smile' is the ideal soldier song. John knows, for he is just in the very youthful fervor of life—only thirty-two years old, and were it not for the fact that he is of greater value individually as a singer, for he has got together some \$100,000 for the Red Cross, he would undoubtedly be a soldier this very minute. He is one of the type of which we proudly say 'That's Our American Boy.'

"While I heartily agree with John in everything he says, for he has pleased millions in his career, there is still another side to vocal work amongst the soldiers and civilians of this nation, namely, that of creating an appreciation among all for better music. Music that will last just as 'Silver Threads Amongst the Gold' has lasted with our parents and forebears.

"We should introduce to the public, favor, encourage and insist upon, recognition of such artists as Gluck and Galli-Curci and the lovely melodies emanating from the instruments of such artists as Heifetz and Powell. What a wonderful treat to think of our boys singing some of Gluck's sweet little simple airs—our own homely selections that are peculiarly ours. These selections last with our boys. They do not tire of them quickly, and furthermore they speak of our musical America in far away France."

AVIATORS SEND PLEA FOR RECORDS

Fliers at West Point, Miss., Have a Talking Machine, But Lack Records

The aviators who are in training at West Point, Miss., have written the New York Evening Journal stating that they have a talking machine which they bought from their none too generous salaries, but they are shy on discs, particularly of patriotic songs, and that cheering jazz music stuff which set so many Broadway feet to tripping last winter. One of these aviators suggested that perhaps through publicity these much-needed records may come their way, so the suggestion is passed along.

CLOSE BIG DEAL IN SOUTH AMERICA

Byron R. Forster, president of the Brilliantone Steel Needle Co., New York, in a chat with The World this week predicted an increasing shortage in needles and a general raise in prices in the needle market in the not far distant future. Mr. Forster also reports that they have very recently closed one of the largest details in the history of the firm with a large South American firm. Mr. and Mrs. Forster expect to make their summer home in Atlantic City, Mr. Forster commuting each week-end.

EXPECTS STEPHENS BILL TO PASS

Secretary of American Fair Trade League Believes That It Will Become a Law With Very Few Changes—Many Misleading Statements

Concerning the question of Federal legislation to provide for the maintenance of resale prices by the producers of trade-marked articles, Edmond A. Whittier, secretary of the American Fair Trade League, declares that there have been many inaccurate and misleading statements made by individuals and published in newspapers and magazines regarding the standard price situation.

"The situation has been so delicate that I have felt it unwise to let any statement concerning the situation or the league's attitude go out," stated Mr. Whittier to The World. "I think I am justified, however, in saying that I have no doubt of the eventual passage of the Stephens bill without modification or change except the wholly inconsequential one which will reserve to the Federal Trade Commission, upon complaint or on its own initiative, the right to investigate the economic effect of any specific contract and to prevent its use or require such modification as the commission may decide the public interest requires. All rumors or suggestions of the probable passage of a different form of bill have nothing to justify them in fact."

You can at least be in the second line of defense—be a war saver.

DISCUSS CURTAILMENT QUESTION

Following Receipt of Letter From Director of Curtailment, Local Talking Machine Manufacturers Meet and Discuss Situation

Upon receipt of a letter from P. B. Noyes, director of curtailment, a few days ago, regarding the question of curtailing in some measure the production of talking machines and records, a number of local talking machine manufacturers held a meeting at the Columbia Shop on Wednesday afternoon, and went over the situation thoroughly in an effort to arrive at some definite basis upon which to approach the director of curtailment should any reduction in output become necessary.

Despite reports to the contrary, it was stated that no curtailment order directed against the talking machine industry had been issued from Washington to date, nor has any announcement been made that such an order will be issued at any definite date, or at all.

The talking machine manufacturers plan to hold another meeting of the committee appointed to act in the interests of the trade on Wednesday of next week, when the question of possible curtailment will be further threshed out and an effort made to secure an audience with Dr. Noyes and go over the situation with him in person.

Curran Bros., of Portland, Ore., have secured the Brunswick agency.



I HAVE consummated arrangements with the Nanes Art Furniture Co., whereby I am handling record cabinets made by this company. I shall present to the trade new improved designs to match the various types of talking machines that should invite consideration. Correspondence solicited.

CLEMENT BEECROFT
309 W. Susquehanna Avenue
Philadelphia

*Also
Record Envelopes, Needles, etc.*

VAN VEEN "BED-SET" BOOTHS

Increase Your Record Sales

Write for a copy of our
NEW CATALOG

Van Veen "Bed-Set" Sectional Booths can be erected as easily as a bed (no skilled labor required). Booths shipped on short notice *anywhere*. Room sizes any multiple of 3 feet. High grade finish, will match your sample if desired. Sound-proof construction. We design and build complete interiors. We also build record racks, which are described in our new catalog.

Prepare for a Machine Shortage by Developing Record Sales



Illustration shows a recent installation for

N. FRIEDBERG

1658 Pitkin Ave., Brooklyn, N. Y.

Our Style B

ARTHUR L. VAN VEEN & CO.

Marbridge Building

47 W. 34th St., N. Y.

Telephone - - Greeley 4749

FIXTURES FOR DISPLAY PURPOSES

Series of Five Attractive Fixtures for Columbia Dealers Just Prepared by the Dealer Service Department of This Company

The dealer service department of the Columbia Graphophone Co., New York, has just advised Columbia distributors throughout the country that there is now ready for the use of Columbia dealers a series of five attractive fix-



Columbia Catalog Rack

tures for the display of the various Columbia hangers and catalogs in the dealers' warerooms.

This department experimented with various models, and after receiving sets of these fixtures from many manufacturers finally adopted the designs that are shown herewith as best suited for the requirements of Columbia representatives. These fixtures are being sold to the dealers at cost price, giving them not only the benefit of the additional business that this method of publicity cannot fail to produce, but also providing them with store equipment carefully worked out and delivered to them at a price considerably lower than that for which they could be secured from the manufacturers through ordinary channels.

This series includes three metal fixtures for

DEALERS EVERYWHERE ARE SELLING QUANTITIES OF OUR

HANAIE BANJUKES

(Ukuleles in Banjo Form)

A bigger hit than the Ukulele because much louder and more pleasing in tone, and of more substantial construction. Perfect two octave scales. A thoroughly practical instrument for both solo playing and club work. Send for illustrated catalogue and price list today, as

The Banjoke Is One of the Biggest Sellers in the Musical Instrument Line.

SHERMAN, CLAY & CO.

Sole Manufacturers

163 Kearny Street San Francisco

the display of the "Columbia Midmonth Specials" hangers; two large monthly hanger display fixtures, and a Columbia catalog rack. The midmonth hanger fixtures comprise a wall, window and a counter fixture, all calculated to



Hanger for Monthly Lists

attract the attention of passers-by and visitors to the warerooms. The monthly hanger display fixtures include wall and window fixtures of



"Midmonth Specials" Hanger

artistic design, and the catalog rack provides plenty of room for the adequate display of all the catalogs incidental to Columbia products.

VISITORS TO THE CITY

Several of the salesmen connected with the Columbia out-of-town branches were visitors at the executive offices recently, including S. W. Lukas and J. P. J. Kelly, of the Pittsburgh branch, and Lyman Bryan, of the Baltimore branch.

TO SHOW COUNTRY OF ORIGIN

Bill Now Before Congress to Enforce Labeling of Articles Made in This Country With Distinctive Mark to Indicate Their Origin

A bill is now before Congress to enforce the labeling of articles made in this country with a distinctive mark so as to show their place of origin. It is hoped that, despite the present pressure on the time of our Congressmen, this measure will receive consideration. The proposition is not a novel one, having been broached from time to time for several years. There is much to be said in its favor, and from more than one standpoint. The first impression of the merits of the proposal would be that its enactment would prevent the use of the sign "imported" on many things which are really made here, but which is employed as a pretext to get higher prices for them. This has resulted in a belittling or undervaluing of many meritorious goods of domestic make. But this is only one aspect of the matter. There is no questioning the advertising value in export trade of a distinctive American stamp on articles produced here. This implies, of course, that the articles themselves have merit, and it is part of the plan to see to it that they are kept up to standard. Such a control would also be of much value to domestic purchasers, assuring them of quality. The Germans, in their foreign trade, set great store on the value of the "Made in Germany" label. So much so was this the case that they did not hesitate to apply it to articles made elsewhere but which their exporters handled. In this way they managed to get a lot of business which other countries, the United States included, might have obtained direct.

TRANSFER ENTIRE VICTOR STOCK

GRAND RAPIDS, MICH., June 9.—M. Marin has transferred his entire Victor stock and good will to the Lyric Music Co., who will carry on this business in the Boston Store, this city.

MAESTROLA MAHOGANY CABINET MACHINES, SIZE 15 x 15 x 7 1/2

Motor worm gear plays 2 1/2 to 3 minute records, one winding. Price in dozen lots \$5.00 each, sample machine \$5.50.

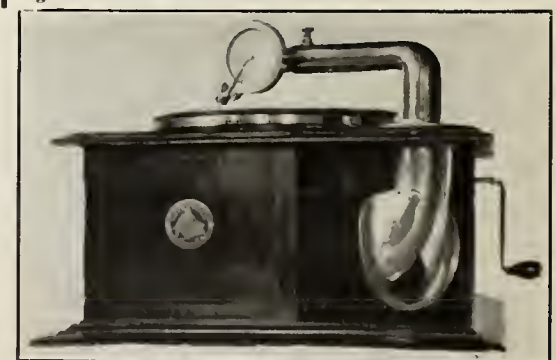

Steel needles and phonograph parts selling at the old prices during June and July regardless of the scarcity of these supplies. Now is the time to place your order. Be wise and save money.

FULTON TALKING MACHINE COMPANY
640 Broadway New York City, N. Y.

PERSHING RECORD READY SOON

Matrix Made by General Pershing for the Columbia Graphophone Co.—Original Brings Big Price at Auction—Will Be One of a Series of Records to Be Made by Famous Americans

As announced some time ago in *The World*, the Columbia Graphophone Co. has made arrangements whereby it will soon release a record made by General Pershing, commander of the American Expeditionary Forces in France. A golden matrix of this record was auctioned at the Metropolitan Opera House during the recent Red Cross drive, and was purchased by George M. Cohan, the actor, for \$2,700. Mr. Cohan re-donated the matrix to the Red Cross committee, who will in turn present it to President Wilson to be filed in the archives at Washington.

In connection with this Pershing record the following article appeared this week in one of the local newspapers:

"One of the most valuable historic records of the present war is a phonograph record. It is a matrix of General Pershing's voice amid the din of battle—a wax cylinder contained in an ordinary leather sack now in the mail compartment of a convoyed vessel which was headed yesterday for an Atlantic port on the American continent.

"Duplicates of this priceless vocal record have been hidden away in France and England to insure them against loss from submarine attack. It is an exhortation to the American people and will be produced at patriotic meetings, rallies, school, club and social gatherings and in homes throughout the length and breadth of the land.

"Unlike the text of Lincoln's Gettysburg address and similar priceless national historic papers, this record will not be merely a Pershing relic to look reverently upon, but a new Liberty Bell, to be rung when desired—an ever-living voice, transmitting through the sense of sound the message of its author.

"Immediately upon the arrival of the matrix it will be rushed to Bridgeport, Conn., home of phonograph record and munition making, where everything is in readiness to strike off copies of the record. Then, with all the speed that the mails afford, the message will start on its nation-wide circle of inspiration—to every city, village and hamlet, to cantonments and scattered, isolated camps.

"The germ of the idea out of which this movement grew had its inception in the brain of Guy Golterman, a prominent attorney of St. Louis."

WAR PLANS FOR CREDIT MEN

Association Will Discuss How Best to Aid the Government

Plans outlining how the business men of America may give the most efficient support to the Government in time of war will be discussed at the war convention of the National Association of Credit Men to be held in Chicago June 18, 19, 20 and 21. There will be 1,800 delegates present, representing the 24,000 members of the association. Among those who will address the convention are John Burke, treasurer of the United States; and Paul Warburg, vice-governor of the Federal Reserve Board.

J. H. Tregoe, secretary of the association, said yesterday that one of the principal topics of discussion at the convention would be the great burden placed upon business men by war taxes. Another topic will be the matter of preparing for after-the-war business problems. Prizes will be awarded for the best papers on trade acceptances. It is estimated that \$50,000,000,000 is carried annually by the credit men, with \$4,000,000,000 always on the books.

BUILDING UP LARGE TRADE

Forbes & Wallace, of Springfield, Mass., are featuring the Victrola and Victor records to good advantage these days and building up a very large volume of business.

MEIKLEJOHN CO. IN LINE

Open Talking Machine Department in Providence Store Under Management of Allen T. Waite, an Experienced Talking Machine Man

The Meiklejohn Co., the well-known piano dealers of Providence, Pawtucket and Woonsocket, R. I., have recently opened a talking machine department on the second floor of their handsome building in the first named city. The business is under the management of Allen T. Waite, and Edison and Starr phonographs and records are being handled. The new department is admirably arranged, and under the capable management of Mr. Waite should score a great success.

VICTROLA FOR TORPEDO STATION

The Y. M. C. A. hut at the Naval Torpedo Station at Newport, R. I., is now proud of a magnificent new Victrola which has been donated by a prominent New York woman. The sailor boys are quite tickled with this gift.

\$50,000 RAISED TO SUPPLY MUSIC

For the Sailors of the American Navy—To Buy Talking Machines and Other Musical Instruments—Noted Artists Assist at Concert

About \$50,000 was raised to buy talking machines and other musical instruments for the sailors of the American Navy at a remarkable concert given at the Metropolitan Opera House on the evening of June 10, which was participated in by every operatic artist of international fame. Not only the entire staff of the Metropolitan, but others such as Lucien Muratore, John McCormack and Harold Bauer, pianist, contributed their services. The money will be distributed by the Women's Naval Service.

REMOVE TO LARGER QUARTERS

The Columbia Stores Co., Spokane, Wash., have removed from W818 Sprague avenue to N161 Post street, a splendidly equipped three-story building. This company has stores also in Denver and Salt Lake City.

The Ellis Melodious Reproducer

(illustration is exact size)

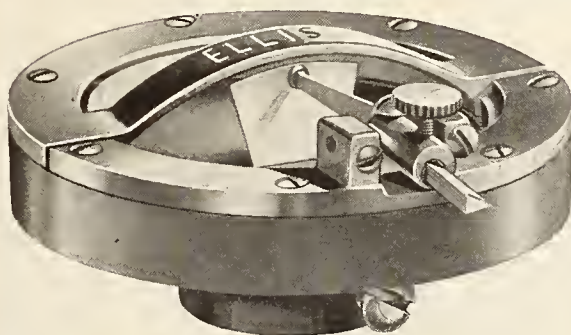

Weight is less than four ounces. It brings to life the individual voices and instruments in REAL-TONE: No soprano note too high. No bass tone too low. ALL reproduced as natural as life—as perfect as contained in the record.

Retails for Nickel \$10.00—Heavy Gold Plated \$12.50

That the ELLIS "melodious" REPRODUCER "Talks for itself 'most convincingly'" is the evidence of all users. It makes a special appeal to lovers of the better class of music, although at the same time it brings out detail of individual instruments of Jazz Bands and "rag-time."

"Phonograph Cranks," enthusiasts, some having had six years' continuous usage of the Ellis Melodious Reproducer to back up their judgment, tell the many wonderful stories that visiting friends say "I thought that voice human and you surprise me by telling me 'it's a talking machine playing.'"

The following is a testimonial from Mr. J. F. Poche, a "musical critic and well known to the Piano Trade and Talking Machine Industry." He writes over his signature.

"Mr. Ellis: It affords me great pleasure indeed to add my testimonial to the great number of those that you already have in qualifying your wonderful reproducer, as the only one in the country. It is so far superior to any that comparison is unnecessary. The following incident is conclusive proof of above statement. The early part of December took me to the Providence Building to see Mr. LaVelle, who has his Operatic Studio in said building. As I was waiting for the elevator I heard a gorgeous voice, in a most delightful selection, and I was so much impressed with the voice that I inquired of the Elevator man 'who is the singer?' 'This is not a lady singing,' said the elevator man, 'it is a Victrola.' I replied, 'it is

impossible, I am familiar with all of the different styles and makes of talking machines, having sold them for a number of years, and it is impossible to reproduce a voice in that way. To my great surprise I was ushered into Mr. Ellis' Studio, where I was entertained by Mr. Ellis with his marvelous Melodious Reproducer with selections from Caruso, Galli-Curci, Mabel Garrison, Journet, Martinelli, Melba, Gluck, Homer and others. I must in conclusion state unqualifiedly that your Reproducer is the only one giving an absolute reproduction of the Human voice, Violin, Piano, thereby deceiving the most exacting experts.

"(Signed) Very truly yours, J. F. POCHE."

There is a gentleman who wrote "would be willing to walk from Chicago to Milwaukee to get an Ellis Reproducer were there no other way to obtain one."

A dealer in a far-off country wrote, "Mr. Ellis, my customers wonder why your wonderful reproducer isn't known all over the World . . . please find draft to pay for forty more."

MR. DEALER: I am now able to take good care of a few more dealers who wish to give their patrons "the finest of music" with "all the harmonics" which are "hidden" in the wonderful Victor and Columbia Records.

The Ellis Melodious Reproducer is intended for exclusive trade—your customers will "appreciate your kindness for introducing the Ellis Melodious Reproducer."

J. H. ELLIS

P. O. Box 882 - - - - - Milwaukee

You Ought to Know

In case you are contemplating expanding the sphere of your business to include departments devoted to Pianos, Player-Pianos, Musical Merchandise or Sheet Music, that you'll find news and comments about them all in



ESTABLISHED 1876

The oldest and leading music trade weekly, which covers every branch of the industry.

It Contains

instructive and educational articles. Hints on salesmanship and advertising. Editorials that are timely and authoritative. Facts about the new things in the trade. Trade happenings in all parts of the United States.

“Review the Music Trade With Us”

Send your \$2 now for a full year's subscription to

THE MUSIC TRADE REVIEW
373 FOURTH AVENUE
NEW YORK

SEXTON'S NEW DELIVERY TRUCK

Washington Dealer Perfects His Victor Service by Installing Automobile Service

WASHINGTON, D. C., June 8.—K. C. Sexton, 629 Pennsylvania avenue, S. E., Victor dealer, recently added to his delivery equipment a handsome Ford delivery truck, which is one of the most attractive trucks used by any member of the local talking machine trade. This truck is being used to excellent advantage, and Mr. Sex-



Sexton's New Delivery Auto

ton states that it is enabling him to render his patrons maximum service and efficiency in delivering Victrolas and Victor records.

The truck, which is shown herewith, was manufactured by the Hoover Wagon Co., York, Pa., and represents the last word in the development of the small motor truck. The famous Victor trade-mark is reproduced on the side panels, and the general appearance of the truck has won many favorable comments.

ORGANIZE COMPANY IN COLORADO

LOVELAND, COLO., June 6.—A company is being reorganized in this city by C. I. Jackson, to be known as the Jackson Phonograph Co., for the purpose of manufacturing talking machines. The capital will be \$250,000, and the majority of the preferred stock will be taken up by local people. Those interested outside of Mr. Jackson are J. M. Cunningham, George Walker, E. McNeal and Thomas McKee. It is planned to build a factory in Loveland as soon as capital is secured to commence manufacturing this machine, which is the invention of Mr. Jackson. An acoustic feature of the instrument is a wooden tone arm and tone chamber.

FILE PETITION IN BANKRUPTCY

The Cathedral Chime Co., Inc., chimes and phonographs, at 106 Reade street, has filed a petition in bankruptcy, with liabilities of \$35,800, of which \$35,669 are unsecured claims, and assets of \$9,462, consisting of stock, \$6,130; machinery and tools, \$2,250; debts due on open account, \$421, and cash in bank, \$30. Judge Mayer has appointed Maurice Meyer receiver in \$2,000 bond.

PROSPERITY IN THE SOUTH

C. B. Haynes, of the C. B. Haynes Co., Inc., the veteran phonograph jobber of Richmond, Va., who was in the city recently attending the Edison convention, expressed himself enthusiastically regarding business conditions in the South. In the course of a chat with The World he stated that the purchasing power of the people had materially increased within recent years, and that there was a good demand for phonographs of the more expensive types, with the popular demand running from \$150 to \$200.

The Denver Drygoods Co., which handles the Edison in Denver, has started a vigorous billboard advertising campaign in which the Edison is strongly featured.

The Victor department of the Anthony Furniture Co., of Providence, R. I., reports a very excellent volume of business which is only limited by the scarcity of stock.

J. R. Leach, of Arleta, Ore., has secured the agency for the Brunswick phonograph.

NEW WAR REVENUE BILL COMING

Trade Would Do Well to Watch Progress of Proposed New Measure and Be Prepared to Protect Their Interests if Threatened

Members of the talking machine trade, and particularly the organizations within the trade, would do well to watch closely the actions of Congress in connection with the proposed new War Revenue bill, which it is planned to rush through with little delay. President Wilson has already signified his determination to have a tax bill, the burden of which shall rest chiefly upon incomes and war profits, with a good share placed on luxuries. Although no particular products are classed as luxuries in the first announcement, it will not be improbable that some Congressman may insist at the outset in putting musical instruments in that class, despite all that has been done to prove to the contrary.

It is declared that the Government has secured the services of financial experts in drafting the proposed new law, and it is declared that the evidence now in possession of the Government

is of the sort to permit the officials to draft what they believe will be the best measure to meet the situation. Incidentally, the President has taken the stand that lobbying on the proposed measure should be prohibited. It is stated in Washington that, should the Ways and Means Committee follow the recommendations of the Treasury Department in drafting the bill, there will be little opportunity for protest from individuals, but should the House Committee draw a bill along its own lines, it will simply invite protests in the sending of multitudes of attorneys and witnesses to Washington to petition to the Senate Committee for relief, as was the case with the last bill.

Members of the trade will do well to keep informed regarding the progress of the bill and the conditions under which it is drafted, in order to be prepared to put forward their claims for relief in the event that such action is desirable. The trade is perfectly willing to carry its full share of the burdens of war, but it may be that the proposed bill might intentionally, or unintentionally, contain something that would place an excess burden on the industry.

LYRIC RECORDS

HILL AND DALE—STEEL NEEDLE—10 AND 12 INCH



A Three-Fold Opportunity for Dealers

**A Record That Will Sell on Its Merits
Prompt Deliveries—Liberal Discounts**

Lyric Records are unequalled in tone quality and musical value. The old surface noise is gone—Lyric Records are *all music*. The

Standard American Catalogue

includes all that is best in the world's literature of standard songs, operatic arias, instrumental solos, band and orchestra records, etc., etc., by the world's best artists. New Bulletin issued monthly, listing the best of the song hits and dances when they are new.

Write To-day for Catalogue and Complete Information

LYRAPHONE CO. OF AMERICA

12-14 West 37th Street New York, N. Y.

REMARKABLE VICTOR POSTERS

Lyon & Healy Have Now Ready for Dealers Twenty-four-Sheet Poster Nine Feet High, Twenty Feet Long, in Four Colors, Which Should Command Public Attention—Also Issuing an Exclusive Victrola Calendar

CHICAGO, ILL., June 12.—Lyon & Healy have ready for dealers another of the remarkable Victor posters for which they have achieved such a reputation. It is a twenty-four sheet poster, nine feet high by twenty feet long, lithographed in four colors on high quality sunproof poster paper. It is extremely timely, the legend being "Get your home a Victrola. Music is a necessity." The illustration shows a charming little maiden and a Victor record emerging from an envelope on which is the legend, "Here comes the record fairy." Ample space is left for the name of the dealer. The supply of the posters is limited and dealers are urged to place their orders now. The exclusive use of this poster will be given to one dealer in each town. They are furnished the trade practically at cost.

Lyon & Healy have also just published for the benefit of the dealers a very beautiful exclusive Victrola calendar. The essential feature is a reproduction in colors from a painting by Arthur J. Wells of a home group of mother and children around a Victrola, and it is one of the most artistic productions of the kind that have reached this office in many a day. There is no other printing on the calendar except a flap at the top on which the name of the dealer is printed. The company is taking orders now for delivery November 1.

OUR ENORMOUS EXPORT TRADE

From a position of third place among the nations of the world as an exporter of manufactures, which it occupied previous to the war, the United States has suddenly become the leader, having outstripped Great Britain and Germany, according to a compilation by the National City Bank. In 1917 our exports were over \$4,000,000,000.

SECOY CO. INCORPORATED

The Secoy Co., of Piqua, O., recently incorporated with a capital stock of \$10,000, and will manufacture automatic stops for talking machines. The company formerly operated a plant at Sidney, O.

An Investment That Will Give You Exclusive Control of the BEST SOUND BOX on the Market

We offer for immediate sale a plant in the east that has been manufacturing a well-known and successful sound box for the past year.

Purchaser will secure absolute rights to VALUABLE BASIC PATENTS that cover exclusive features which make this sound box the best on the market. We can prove this assertion.

We have an established trade; over 5,000 sound boxes have been sold, and purchaser will get a paying business in addition to stock on hand, fixtures, lathes, etc. Owner leaving for the coast necessitates sale.

Have you a Real Offer?

Address BOX Z, Talking Machine World 373 Fourth Avenue NEW YORK

A SUMMER ADVERTISING NOVELTY

At the request of Columbia dealers to provide them with a summertime advertising novelty, the dealer service department of the Columbia Graphophone Co. has worked out a plan whereby Columbia dealers can secure at a comparatively little cost a supply of unusually attractive fans bearing effective and specific selling suggestions.

The department has suggested to the dealers that the distribution of these fans inside of the store covers only a small part of its possibilities. Its biggest opportunity to produce sales comes in the many ways that will readily occur to the live dealer. A fan may be included with every package leaving the store. It may be sent to the mailing list, and be used also in adding to the mailing list by its distribution at opportune affairs. Picnics, athletic meets and parties provide many opportunities for effective distribu-

tion. This also applies to garden parties, hotel dances, indoor affairs, etc.

The face of the fan conveys forcibly the gen-



eral selling idea of using Grafonolas during the summer. This general message is made specific on the reverse side, where the popular-priced models are featured, together with a suit-

NOW IS THE TIME TO REPLENISH YOUR STOCK

Records prove that the next three months are the best in the year for selling the

VICSONIA



Mr. Dealer:

Don't miss sales by being out of stock. Order NOW.

If you are not familiar with the "best reproducer for playing EDISON RECORDS," send us \$3.50 and we will send you one on 10 days' approval. Money refunded if not satisfactory.

State Make of Machine

Vicsonia Manufacturing Company, Inc. 313 East 134th Street (Bronx) NEW YORK, N. Y.



able list of summertime records. Special lists of international records may also be inserted. All details are given, and sufficient room is left for the dealer's name and address.

Exhibitors of Talking Machines and Supplies at National Music Show, New York

Largest Music Show in the History of the Trade Formally Opened by Gov. Whitman on June 1st

At the National Music Show which was held at the Grand Central Palace, New York, during the week of June 1 to 8 inclusive, and which was formally opened with appropriate ceremonies by Governor Charles S. Whitman, of New York, the talking machine trade vied with the other branches of the music industry in the prominence of its various displays. In fact, a large part of the informal entertainment provided in connection with the various exhibits was offered by the various talking machine concerns, who brought prominent artists to the show to sing in tone tests and in demonstrating recitals in their special booths or theatres.

Thos. A. Edison, Inc., for instance, gave two fine test recitals each afternoon and evening in the Edison Theatre at the east end of the mezzanine floor, where 300 people could be accommodated at one time. The prominent artists appearing at the tone tests seldom failed to attract a capacity audience.

Then the Columbia Graphophone Co. with a large space on the main floor entertained the crowd at intervals with the songs by prominent artists on the Columbia list, while the Pathé Frères Phonograph Co. made one of the hits of the show with its complete record pressing plant at which records were actually made before the eyes of the visitors and then distributed to the holders of lucky numbers.

The manner in which the piano trade has taken cognizance of the value of the talking machine was evidenced not alone by the displays of machines made by the different piano houses, by at least three types of player-pianos in which were incorporated talking machines, making combination instruments.

The list of talking machine exhibitors at the show and what they had on display was as follows:

Automatic Record Container Co.

The Automatic Record Container Co., Chicago, manufacturers of the clever automatic filing cabinet for talking machine records, had a comprehensive display in charge of Frank P. Read. The automatic record container was shown installed in several types of cabinets, and also in a handsome wicker case machine, the products of the Lakeside Supply Co., Chicago,



DEALERS

Tell your customers how their phonographs may teach them a language by the

CORTINA Phone-Method

Increase your record sales by selling them Cortina language record sets. A timely set for which there has been a great demand is the Cortina Military French-English course.

Send for full information. Advertising matter and poster-hangers free.

Cortina Academy of Languages
12 East 46th Street :: New York

and which in itself represented the exhibit of the latter company. The Automatic Record Container Co. also showed and demonstrated the Paramount records for which they have the Western jobbing agency. The display greatly interested the visitors.

The Autopiano Co.

The Autopiano Co., New York, player-piano manufacturers, showed a new type of Pianista, a player-piano in which was incorporated a talking machine with a horn running to the spool box in the center of the instrument. It aroused the attention of visitors.

Brilliantone Steel Needle Co.

The Brilliantone Steel Needle Co. had a large exhibit at the music show held at the Grand



Exhibit of Brilliantone Steel Needle Co.

Central Palace, New York, from June 1 to 8. Besides Booths 101-102 on the mezzanine floor they also had a table at one of the important entrances where their needles were on display. Their booth was attractively furnished and their shield trade-mark, which has become so well known in the trade, was much in evidence. Steel needles, probably 10,000 times larger than actual size, were also featured in the display and attracted much attention. Not only were samples of the Brilliantone needle freely distributed but attractive souvenirs were issued as well in the form of leather-covered memorandum books. Byron R. Forster and H. W. Acton were personally in attendance at the booth and welcomed many of their out-of-town friends.

Two of the most attractive styles of Brunswick phonographs were installed in the exhibit. These machines not only added to the general effect of the exhibit but served to demonstrate the reproducing qualities of the Brilliantone steel needles. These machines also furnished many impromptu concerts during the day and evening.

Cheney Talking Machine Co.

The Cheney Talking Machine Co. exhibited a new line of console models ranging in price from \$225 to \$1,100. A feature of the exhibit was a Japanese model known as a Fuji design, which was created by one of the most noted Japanese artists in the world.

A complete line of the regular Cheney models was also displayed and a new machine in a Berkey & Gay cabinet, for the retail price of \$60, created much attention on the part of the dealers and other manufacturers. The booth was in charge of Burton Collver.

Cortina Academy of Languages

The Cortina Academy of Languages had a very interesting exhibit at the music show at the Grand Central Palace, New York. Their various language courses were demonstrated to all callers at their booth on the mezzanine floor.

Of timely interest was the Cortina Military French-English course with manual. The exhibit was in charge of A. Sage Swanson, of the Cortina sales staff.

Melville Clark Piano Co.

One of the features of the exhibit of the Melville Clark Piano Co. was the Apollophone, a combination of the Apollo player and a talking machine introduced some time ago, and which has proven very popular. This instrument is the work of Melville Clark, the noted inventor of the Apollo player-piano.

Columbia Graphophone Co.

The Columbia Graphophone Co. presented a remarkably handsome display occupying four booths on the center aisle. This display was divided into several sections, each one of which attracted the attention of visitors to the show. This exhibit was noteworthy for the many new products which made their initial bow to the trade, and which are described in detail in another section of this issue of *The World*. Several popular Columbia art models were also featured to excellent advantage in one of the booths.

The international record department of the Columbia Co. displayed a large map of Europe, which was accompanied by detailed figures showing the population in the United States of the various



Columbia Art Model Room

European nationalities. Group figures, which form a part of the new Columbia international record window display, were also used with this map, and the exhibit as a whole combined



Columbia International Record Room

practicability and attractiveness. The display was conceived by Anton Heindl, manager of the Columbia international record department, (Continued on page 101)

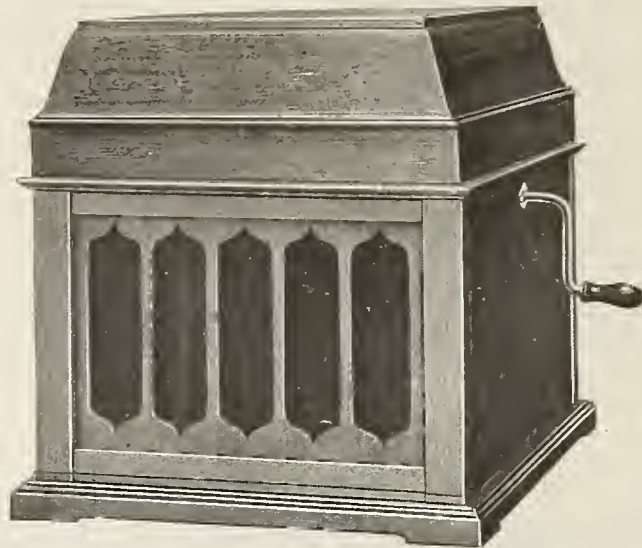

THE NEW EDISON DIAMOND AMBEROLA
MODEL 50

Ten Reasons Why Our Production of the New Edison Diamond Amberola and Blue Amberol Records is Constantly Over-Sold

- 1.—No continual expense for needles, no needles to lose, to be out of just when needed, to become scattered around the house, to prick the fingers, with perhaps serious consequences (especially in the case of children), to be put in their mouths by children, or to wear out expensive records when carelessly used. Instead, a permanent GENUINE DIAMOND stylus.
- 2.—Records almost unwearable and unbreakable, that retail in the United States at 60c, 75c and \$1.00—less than the price of talking machine records of the same individual selections, or selections of the same class.
- 3.—Marvelously sensitive Edison reproducer, the result of more than two thousand separate and complete experiments by the greatest inventor of the age.
- 4.—Simplest and most dependable mechanism ever put into a phonograph.
- 5.—Completely enclosed instrument that retails, in the United States, as low as \$35.
- 6.—Highest class talent in the musical world.
- 7.—Extensive library of records especially suited to the less-than-one-hundred-dollar trade.
- 8.—Musical superiority proven before phonograph experts by comparative tests with talking machines costing from two to five times as much.
- 9.—Manufactured under the personal supervision of Thomas A. Edison.
- 10.—Constant enthusiasm of dealers and sustained interest of owners because of complete satisfaction and extraordinary value for amount invested.

THOMAS A. EDISON, Inc.

Amberola Department

ORANGE, N. J.

EXHIBITORS OF TALKING MACHINES AND SUPPLIES AT MUSIC SHOW—(Continued from page 99)

and the exhibit was in charge of R. F. Bolton, sales manager of the department.

During the course of the week a number of Columbia artists appeared at the booth and gave informal concerts; these artists, including the Farber Sisters, Arthur Fields, Lewis James, Evans Davies and others. Under the auspices of the International Record department there were also presented the Serbian Tambouritza Sextet and the Russian Balalaika Orchestra, who gave several concerts during the week. The Sextet's offerings were decidedly unique, and their records will also be presented in the general Columbia lists, in addition to the regular "E" series of international records.

One corner of the Columbia booth was devoted to the educational department, which conducted a "Children's Hour." This very interesting display was in charge of W. A. Willson, business manager of the department, and W. H. Gould, sales manager.

The complete Columbia display was in charge of R. W. Knox, advertising manager of the Columbia Co., assisted by H. E. Speare, manager of the Columbia Fifth Avenue Shop. Lambert Friedl, manager of the New York branch, was on hand daily, with members of his staff to welcome the dealers. Visitors from the executive offices included H. L. Willson, general manager; George W. Hopkins, general sales manager, and Frank K. Pennington, assistant general sales manager of the company.

Eclipse Talking Machine Co.

The Eclipse Talking Machine Co., of Paterson, N. J., had an exhibit of their Eclipse electric self-starting phonograph. The Eclipse is novel inasmuch as it can be operated by dry batteries or by direct or alternating current. Among the exclusive features of the Eclipse is the Sibley sound box, and the push button that repeats the record at any time during the rendition, a point which is advertised as especially helpful to singers. The booth was in charge of James T. Sibley, president of the company and inventor of the instrument; Albert R. Winans, vice-president of the company; Thomas E. Platt, treasurer, and Walter O. Bacon, secretary.

Thos. A. Edison, Inc.

One of the chief centers of interest during the entire period of the show was the Edison Theatre, occupying a large section at the Western end of the mezzanine floor, and with a capacity of 300. Throughout the week special recitals were given twice each afternoon and evening, at which prominent artists appeared and sang and played in comparison with their recreations on the new Edison. Among the artists were Miss Marie Morrissey, contralto; Vernon Dalhart, tenor; Harold Lyman, flutist;



Part of Edison Exhibit Showing Period Models

Marie Tiffany, of the Metropolitan Opera Co.; the Fleming Trio, and others. The concerts never failed to attract a large audience. In the exhibition space outside the theatre were shown several of the leading period models of the new Edison, as well as the new Edison Am-

berola phonograph, and the Edison army and navy disc phonograph, which has proven so popular with the fighting forces. Verdi E. B.



Edison Concert Hall at Music Show

Fuller, general supervisor of Thos. A. Edison, Inc., with a staff of assistants was in charge of this magnificent display.

Emerson Phonograph Co.

The Emerson Phonograph Co. showed a complete line of Emerson products, including the new 65-cent records and the popular Emerson 7-inch records. Artistic displays of these records together with effective window-hangers and showcards gave visitors to the show an adequate idea of the splendid publicity and co-operative helps that are being issued by this company for the benefit of Emerson dealers. Arthur H. Cushman, manager of sales, was in charge of this exhibit, assisted by J. I. Carroll, assistant sales manager, and several members of the sales staff.

Otto Heineman Phonograph Supply Co., Inc.

One of the most attractive exhibits at the show was that of the Otto Heineman Phono-



Partial View of Extensive Heineman Exhibit

graph Supply Co., Inc., which occupied two booths on the center aisle. The company had many new and important products to call to the attention of visiting members of the trade, including the new Heineman "OkeH" record,

which was presented to the public and to the trade formally for the first time. This new record was heartily praised by visiting dealers and manufacturers, who were surprised to learn that the Otto Heineman Co. had already completed an extensive repertoire which included records made by some of the most popular artists now before the public. The records were demonstrated throughout the week in a soundproof booth. A complete line of Heineman and Meisselbach motors,

tone arms, sound boxes, etc., were also on display, together with Dean steel needles. These products were also featured through the medium of various well-known phonographs which used these motors, tone arms, etc.

During the week many well-known artists

recording for the Heineman record library appeared at the booth and gave informal concerts; among these artists being Joseph Phillips, Miss Inez Barbour, Miss Rosa Torregrosa, comic opera prima donna, Chas. Hart, John Myers, Lewis James and Byron G. Harlan.

The Heineman exhibit was in charge of W. C. Strong, who was ably assisted by M. E. Schechter, A. A. Foute, and other members of the staff. Otto Heineman, president of the company, W. G. Pilgrim, assistant general manager, A. Heineman, assistant general manager, C. J. Pott, Toronto manager, and G. R. Kunkle, chief engineer of the Elyria factory, were also on hand to receive visitors.

Innovation Electric Co., Inc.

The Innovation Electric Co., Inc., New York, displayed the "Innovation" electric motor, a self-winding motor that can be attached to any phonograph without change in construction or interfering with the regular crank wind. The booth which attracted attention was in charge of W. W. Rosenfield, president of the above company, and F. N. Davison, sales manager of the company.

Lakeside Supply Co.

The Lakeside Supply Co., of Chicago, exhibited several of their new tone arms and sound boxes which were very original in design and one of which latter played either lateral or vertical cut records without any shifting of the position of the sound box. The Lakeside Co. also had on display one of its luxifibre Art-Kraft talking machines which embraces several novel features. The new Lakeside rotometer,

which is a great "shortcut" in the testing and regulating of motors, was also on exhibit. Mr. Fricke came on from Chicago to take charge.

National Lead Co.

The booth of the National Lead Co., in charge of W. P. Brown, contained an exhibit of die castings of talking machine and player-piano parts. Of particular interest to the player or talking machine man were sound boxes, tone arms, el-

bows, player valves and transmission frames as well as parts for mechanical players.

Operaphone Mfg. Co.

The Operaphone Mfg. Co., Long Island City, N. Y., displayed and demonstrated a complete selection of the new Operaphone ten-inch hill and dale records, under the direction of E. A. Carter, of the company. The new records mark a distinct improvement over the former Operaphone products, and interested the visitors.

Pathé Frères Phonograph Co.

The Pathé Frères Phonograph Co. occupied three large booths at the show, this exhibit being one of the most interesting displays from a trade and general viewpoint. The feature of this exhibit was the presentation of a record press in actual operation, and this press turned out hundreds of records which were distributed to the visitors free of charge on the basis of the drawing of winning numbers. The exhibit was crowded every afternoon and evening, and the New York public evinced the keenest interest in the complicated equipment which is incidental to the pressing of records.

In another section of this display there were featured several new Pathé art models which will be ready for formal announcement in the very near future. These designs include several models after the antique periods, and their distinctive beauty won considerable praise from the visitors to the show. A new Pathéphone trench model was also displayed for the first time, and its practicability was thoroughly ap-

(Continued on page 102)



All the newest dance tunes—played on a Military Trunk Grafonola that can be packed up and strapped on the back of the car. Isn't that an idea for you?

Columbia Graphophone Co.
NEW YORK

EXHIBITORS OF TALKING MACHINES AND SUPPLIES AT MUSIC SHOW—(Continued from page 101)

preciated by the many dealers who visited the Pathé booths.

During the course of the week many Pathé artists appeared at the exhibit and gave informal concerts, among these artists being the following: Jan Rubini, famous violinist; Grace Hoffman, concert soprano; Fred Van Eps, Frank Banta, Arthur Fields, Lewis James, the Farber Sisters, Dominico Savino, Wm. Simmons, Louis Winch, Royal Dadmun and the very popular team, Collins and Harlan.

The display was in charge of H. N. McMenimen, managing director of the company, together with J. F. Collins, general sales manager, Marshall Brugman and O. J. Valliere. E. A. Widmann, president of the company, was also a frequent visitor at the booth.

Plaza Music Co.

The Plaza Music Co. and the Supertone Talking Machine Co. occupied a joint exhibit, and displayed a complete line of Supertone talking machines, Magnedo and steel needles, B. & H. fibre nedeles, Wade & Wade fibre needle cutters, etc., together with standard music rolls, Thomas Mfg. Co. talking machine motors, sheet music and accessories. J. H. Roos and A. Germain were in charge of this exhibit.

J. P. Seeburg Piano Co.

The J. P. Seeburg Piano Co., of Chicago, devoted the spacious and richly furnished quarters of Booth 14 to an exceedingly attractive exhibit of the Phono-grand, which is a new combination instrument of individual exterior appearance, including a player-piano and phonograph as separate units. The Phono-grand was shown in many different finishes, including mahogany, Circassian walnut, golden oak and mission.

In addition to the large display of Phonographs the consoles of two of the very famous Seeburg-Smith unified organs were shown. One of the consoles was of a \$15,000 organ and the other was of a \$5,500 organ, and both gave an excellent idea of the musical possibilities in the great unified organs built by this company.

J. P. Seeburg, president of the company, came on from Chicago for the purpose of acquainting the many dealers visiting New York with the great sales possibilities of the new type instrument, the Phono-grand, through retail piano and talking machine establishments. Chas. Seltzer came on from Pittsburgh to co-operate with Mr. Seeburg at the National Music Show.

Starr Piano Co.

The Starr Piano Co., Richmond, Ind., devoted their space at the show to an elaborate display of a half dozen of the more popular models of the Starr phonograph which has come strongly to the fore during the past year. In connection with the phonographs there were displayed and demonstrated the new Gennett records, also made by the Starr Co. The exhibit, which attracted much attention during the week, was under the supervision of Wm. C. Klumpp.

STEPHENSON, INC., ENTERTAIN

Stephenson, Inc., manufacturers of the "Stephenson Precision Made" talking machine motor, had a special display of their motors during the past week at their New York offices at 1 West Thirty-fourth street, where Frank T. Nutze, vice-president and general manager, was in charge. Mr. Nutze is well known to both talking machine manufacturers and to piano dealers, having been for many years interested in the trade as a piano manufacturer, and during convention week he was enabled to meet many of his friends. A very novel invitation to visit the Stephenson offices was sent out by the company to the trade in the form of a little magazine edited by Frank T. Nutze, very friendly in tone and carrying information in regard to entertainment to be found by the visitors while in New York.

VISITORS TO HOFFAY SHOWROOMS

The Hoffay Talking Machine Co., 3 West Twenty-ninth street, had a number of visitors at their showrooms during the past week. These included both manufacturers and dealers, the manufacturers being chiefly interested in the Hoffay "Resurrectone," the patented sound box which the company produces. According to Jo-

Compton-Price Co.

Among the talking machines which were displayed in the booth of the Otto Heineman Phonograph Supply Co. at the National Music Show, June 1 to 8, was the Stradivara manufactured by the Compton-Price Co., of Coshocton, O., the selling agents for which are the Schilling Piano Co., 112 West Twenty-third street, New York.

Thomas Mfg. Co.

Thomas Mfg. Co., of Dayton, O., made a comprehensive exhibit of the different models of the "Dayton" motor and the "Dayton" tone arms in its booth. The parts of the motors were shown before assembling and gave an excellent chance to see the high quality products and principles of construction incorporated in them.

Weser Bros.

Weser Bros. had as their particular feature, besides a great variety of pianos and player-pianos, the Marveola, the talking machine which plays six disc records, and can be controlled at will by three electric buttons. This machine attracted considerable attention. The booth was in charge of W. S. Weser, vice-president and general manager of the company, and sales manager M. Levian.

seph Hoffay, president of the above company, he was successful in forming connections with a number of live piano dealers who in the future intend to feature the Hoffay products.

The Mutual
TONE ARMS & SOUND BOXES

Place Your Orders
TO-DAY

for

Mutual

TONE ARMS AND
SOUND BOXES

"Mutual Products Have Made Good"

Mutual Talking Machine Co., Inc.
145 West 45th Street, New York

"NICHOLSON"
New Catalog Showing New Styles
RECORD CABINETS

strictly high-grade construction at prices
BELOW COMPETITION

Write for a copy of the catalog and our
special free advertising help for dealers.

K. NICHOLSON FURNITURE CO., Chase City,
Virginia
Sectional Bookcases and Record Cabinets

"Does It Play All Records?"

Certainly MAGNOLA does; and without any extra attachments, too. This is only one feature, albeit a most important one, in the thoroughly up-to-date equipment of the MARVELOUS MAGNOLA.

MAGNOLA "Built by Tone Specialists"



Watching the Music Come Out

May we send you our handsome illustrated catalog chock full of information concerning the wonderful construction system of Magnola and the beauties of its musical results, its artistic appearance and its moderate price?

Send your name and let us tell you more!

MAGNOLA TALKING MACHINE COMPANY

OTTO SCHULZ, President

General Offices
711 MILWAUKEE AVENUE
CHICAGO

Southern Wholesale Branch
1530 CANDLER BLDG.
ATLANTA, GA.

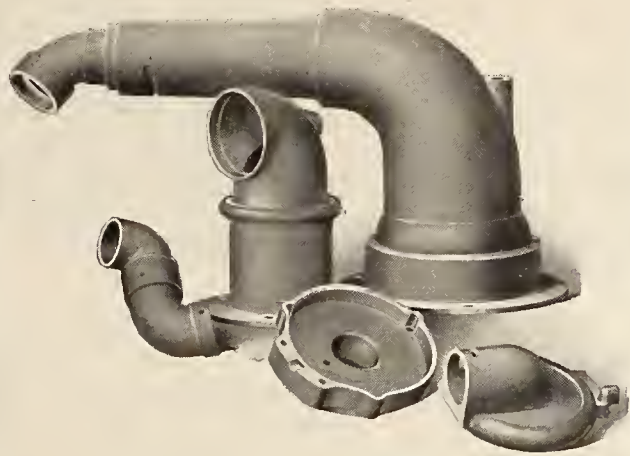

DOEHLER DIE-CASTINGS

for tone arms, sound boxes and talking machine attachments are STANDARD throughout the industry.

Of the many instruments produced to-day from the most prominent makes down, the greater number, by far, are equipped with Doehler die-cast tone arm and sound box.

The enormous output of our three large plants permits of advantages to the users of die-castings, as regards prices and deliveries, not otherwise possible.

DOEHLER DIE-CASTING CO.
 MAIN OFFICE AND EASTERN PLANT
BROOKLYN, N.Y. NEW JERSEY PLANT
 WESTERN PLANT
TOLEDO, OHIO. NEWARK, N.J.

STEADILY IMPROVING CONDITIONS PREVAIL IN PORTLAND

Dealers Make Excellent Reports Regarding Business Prospects—Labor Conditions Are More Settled in Various Lines—Stock Shortage Is the Only Serious Worry Prevailing in the Trade

PORTLAND, ORE., June 4.—That labor conditions are growing more stable in Portland is apparent from a visit to the various talking machine houses in the city where there have been almost no important changes in the sales staffs in the last month. Dealers attribute this largely to the tone of the business, which is such as to make the salesmen want to stay with their positions. The approach of summer, however, has found a start of the vacation period and this has somewhat disrupted some of the staffs.

May business in the talking machine field was more than satisfactory and dealers all have excellent comparative reports showing a big increase in sales and a remarkably better condition in collections than at this time last year. Collections are reported to be even better now than they were a month ago and this end of the business is declared to have been never healthier. Sales were not quite as large in May as in the earlier months of the spring, when Portland experienced a real boom in the talking machine field, but they were large enough to cause satisfaction to the dealers.

Dealers are a unit in declaring that shortage of stocks is the one and only cause for falling off in sales in machines, many customers refusing to await deliveries which cannot be made on the spot and finally not buying at all.

Taylor C. White, manager of the Victrola department of Sherman, Clay & Co., says that his firm could not ask for any better business than that of the past month. Three electric Victrolas were sold in one day by F. D. Addis, of the department, and this was only a sample of the business being done by the firm. The visit of Galli-Curci to Portland did much to stimulate the sale of her records.

The Victrola department of the G. F. Johnson Piano Co. reports even better business in May than in April. R. F. Callahan, manager of the department, says they cannot get enough Victor machines and he attributes the growing business of his department as much to the popularity of the line as to the methods which he has put forth to get business.

Paul B. Norris, manager of the talking machine department of the Wiley B. Allen Co., handling a large line of Victrolas and Edisons, said: "We didn't get business in big bunches in May as we did in April, but compared with last year at this time business is away up." Mr. Norris' business has been so good that he has just bought a new automobile truck to deliver machines. The show windows of the Wiley B. Allen Co. have recently presented some unusual and attractive scenes arranged by Mr. Norris and his assistants. The excellent location of the store on a corner of two principal streets makes these windows well known and admired by Portlanders.

L. D. Heater, manager of the Portland branch of the Columbia Graphophone Co., says that the freight congestion is very much lessened and that his firm is now receiving shipments in from thirty to forty days after they leave the factory. Part of a carload of Columbias is now on the way from Seattle and several carloads are due any day from the factory.

One unusual demand which Mr. Heater notes is for military trunks for holding Grafonolas. These come from soldiers at Camp Lewis, Wash., and Vancouver Barracks, Wash. Mr. Heater says the soldier trade is a big one. He recently sold 235 Columbias to Camp Lewis in one order. Soldiers at Vancouver are also buying a great number of Columbia records at the local Columbia stores.

The Wakefield Music House reports excellent sales of Brunswick machines. C. Guy Wakefield, manager, says that many new handsome styles have recently been received and that these have added materially to sales.

When \$9,000 worth of Sonora machines arrived at the Bush & Lane house recently the firm congratulated itself on the fact that at last it had a complete line of Sonoras—all lines and finishes—on hand. Under the excellent management of James Loder, manager of the talking machine department, many sales have been made of all machines handled.

L. E. Gilham, manager of the Stradivara Talking Machine Co., says that business is very good and that the out-of-town trade has been very brisk. New record rooms have been added. The Johnson Phonograph Co., of Astoria,

Ore., has sold out its entire business, carrying the Columbia and Victor lines, to the Owl Drug Store, of Astoria, of which John L. Ray, formerly of Lewiston, Idaho, is proprietor.

J. H. Dundore, general manager of the Portland branch of Sherman, Clay & Co., has gone to Washington, D. C., on governmental business. Mr. Dundore is connected with the food conservation movement.

Absolute confidence in the Edison phonograph was displayed by E. B. Hyatt, of the Hyatt Talking Machine Co., where he presented Madame Florence Ferrell, who sings for the Edison Co., in a most successful concert before a large and fashionable audience last month at the White Temple here.

"I was greatly surprised," says C. R. Corder, manager of the phonograph department of Eilers Music House, "to find how little effect the recent Liberty Loan and Red Cross drives had on the talking machine business. For a week it was rather dull, but the interval between the two drives was so lively and we have been so busy that it has more than offset the lack of business throughout the drives.

A new method for finishing checked talking machine and piano cases has been invented by Joe Baker, of the Harold S. Gilbert Piano Co. It is of such value that since its inception Mr. Baker's time has been fully occupied in finishing checked machines for the various talking machine houses of Portland.

The Victrola department at the Lipman, Wolfe & Co. store is well supplied with both machines and records. While some popular records have been entirely sold out, Miss Florence Isaacs, in charge of the record department, shows her good salesmanship by persuading customers to listen to other records and always with good results.

**DON'T YOU KNOW WHERE
TO GET**

**THAT MOTOR—
OR THAT TONE ARM—OR CABINET?**

Why Not Let Us Find It For You?

**DIRECT REPRESENTATIVES OF ALL
LEADING MANUFACTURERS**

**WE CAN GIVE YOU MERCHANDISE, SERVICE AND ADVICE
NO CHARGE FOR THE LAST TWO**

**THE PHONOGRAPH CLEARING HOUSE, Inc.
51 EAST 42d STREET, NEW YORK CITY**



Snappy, catchy music out-of-doors—on a Vacation Grafonola! That's a selling talisman to turn the gold into your cash drawer.

**Columbia Graphophone Co.
NEW YORK**

HIPOLITO LAZARO SINGS AT COLUMBIA DEALERS' MEETING

Large Attendance at Fifth Monthly Gathering of Columbia Metropolitan Dealers, Held Recently at the Waldorf-Astoria—Midmonth Records Introduced by Lambert Friedl

The fifth monthly meeting of the Columbia dealers in metropolitan territory was held late last month in the Myrtle Room of the Waldorf-Astoria Hotel, and this meeting was the most successful that has yet been held in this



Hipolito Lazaro

important series of gatherings. Lambert Friedl, manager of the local wholesale branch of the Columbia Co., under whose auspices these meetings are held, presided at this gathering, and, as usual, his informal address and general comments contributed materially to the enjoyment of the meeting.

These meetings are called monthly in order to permit Columbia dealers to listen to the mid-month records, and Mr. Friedl has been providing programs that have won the hearty appreciation of the Columbia representatives.

More than 300 Columbia dealers and their friends were present at this meeting, and Mr. Friedl took advantage of the opportunity to thank the dealers for their loyalty and co-operation the past year, and mentioned that he is now entering upon his second year at the local Columbia wholesale branch. He ascribed any measure of success that he may have achieved

the past year to the assistance received from the Columbia dealers, and bespoke their continued co-operation during the coming year.

During the course of the afternoon Mr. Friedl reminded the dealers that a Columbia record made by General Pershing would be placed on sale very shortly, and incidentally introduced a record made by Ambassador James W. Gerard, for the Nation's Forum. This record, which is remarkably clear and distinct, carries an important message to the American people.

The most important feature of the meeting was the introduction of Hipolito Lazaro, the famous Spanish tenor, who is a member of the Metropolitan Opera Co., and an exclusive Columbia artist. Mr. Lazaro has won international renown, and is generally recognized as one of the foremost tenors of the present generation.

Responding to the hearty reception which he received from the Columbia dealers, Mr. Lazaro sang selections from "Rigoletto," "L'Africana" and "La Favorita."

The closing address of the meeting was made by W. J. Johns, president of the George Batten Co., New York, one of the country's foremost advertising agencies, which is in complete charge of Columbia publicity. Mr. Johns emphasized the fact that the main idea back of recent Columbia advertising is to link up every item of this publicity in such a way that the dealers will receive maximum benefits from this advertising. To visualize this thought he used enlarged sketches of recent Columbia advertisements, and pointed out to the dealers how the color pages used by the Columbia Co. in all of the leading national magazines are also made the basis of the monthly supplements, the monthly hangers, window displays, and, in fact, every form of publicity used during that particular month.

HOME FURNISHERS MEET

The semi-annual convention of the National Home Furnishers' Association, Inc., will be held at the Auditorium Hotel, Chicago, on Thursday, July 11, at 10.30 a. m. An important program of discussion has been arranged for the dealers who attend.

NEW DEPARTMENT IN SACRAMENTO

Kimball-Upson Co. Enters the Phonograph Field on Large Scale With Brunswick Line

SACRAMENTO, CAL., June 3.—The Kimball-Upson Co., the prominent sporting goods house of this city, has opened a phonograph department, and will handle Brunswick phonographs and Pathé records exclusively. The company has purchased the building adjoining their present quarters, and have installed a number of handsome demonstrating booths. The new department will be in charge of R. R. Bent, while Mrs. Baker will have supervision of the record end. New Brunswick dealers are also reported in Oroville, Red Bluff, Willows, and Corning, Cal.

TIMELY COLUMBIA LITERATURE

Attractive Folder on Patriotic and Wartime Records Just Issued Is Up to Date

"Columbia Patriotic and Wartime Records" is the title of a timely and attractive folder just issued by the Columbia Graphophone Co. for use by its dealers during the Fourth of July period. This folder is designed in the national red, white and blue colors, and the front cover is especially worthy of note, as it depicts five thumb nail sketches in colors incidental to the music of "Yankee Doodle," "Oh, Say, Can You," "Tramp, Tramp," "There'll Be a Hot Time" and "Over There." In fact, this cover, because of its distinctive beauty, could well be adopted for use on expensive posters and window hangers.

Under the heading of "Patriotic and Wartime Records" there are listed in this folder practically every type of record that the Columbia dealer can feature to his clientele for Independence Day. In addition to the standard patriotic records that are always prime favorites in the home of every music-lover, there are listed popular hits of the day, which form an important part of the present monthly supplements issued by the Columbia Co. Medleys of patriotic airs and the leading semi-patriotic, vocal and instrumental selections of the day make this list an excellent one for Columbia dealers.

Leo. E. D. Schatney, formerly manager of the Providence store of the Aeolian-Vocalion Co., has been awarded a commission as second lieutenant in the National Army.

SCHUBERT PHONOGRAPH RECORDS

The greatest series of 75c. records ever made.

**10-INCH DOUBLE SIDED
ALL STARS ALL SELLERS**

New list by 15th monthly
Dealers, write for list and prices

**BELL TALKING MACHINE COMPANY
44 WEST 37th STREET, NEW YORK**

SHELTON ELECTRIC PHONOGRAPH MOTOR

We have increased our factory facilities to handle the demand for the Shelton Electric Motor, and are now ready to make prompt deliveries.

Write for our Special Agency Proposition

**SHELTON ELECTRIC CO.
30 East 42nd Street, NEW YORK**

Record Delivery Envelopes

Safe - Swift - Secure

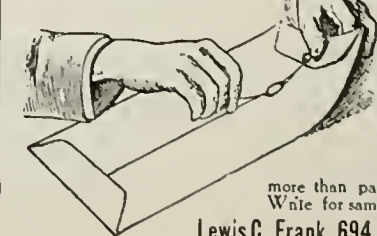

The heavy paper means protection; the button and cord mean speed — you can wait on more customers.

Bring out YOUR OWN NAME. Every time an envelope leaves your store, let the advertisement on it take your name to the homes and bring new trade. The advertising more than pays for the envelope. Write for samples and prices.

Lewis C. Frank, 694 Book Bldg., Detroit

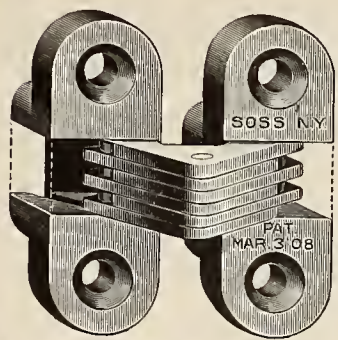

No. 103

SOSS

INVISIBLE HINGES

Preserve Beauty

In many beautifully designed, finely finished Talking Machines, Pianos, Music Cabinets, Piano Players and Benches, the elimination of the unsightly protruding Hinge is essential to preserve the beauty of the design.

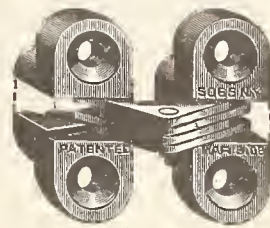

No. 100

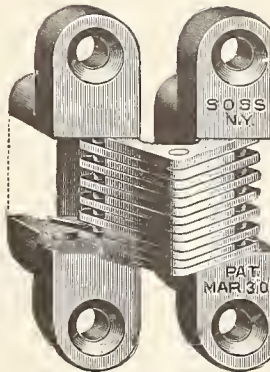

No. 101

Design and Construction

The fine cabinet work which is required in many instances to preserve the disguise of the instrument requires that the hinges be as inconspicuous as possible. SOSS Hinges are *invisible*.

WRITE FOR CATALOGUE "T"

SOSS MANUFACTURING COMPANY, 435 Atlantic Avenue, BROOKLYN, N. Y.

DETROIT—922 David Whitney Bldg.
SAN FRANCISCO—164 Hansford Bldg.

LOS ANGELES—224 Central Bldg.
CHICAGO—John C. Bold & Co., Clark and Washington Sts., Conway Bldg.

THE ELLIS-MELODIOUS REPRODUCER

Receives High Praise From Prominent People Who Have Used It—Fits Any Machine

The Ellis-Melodious reproducer has been recently introduced to the trade by J. H. Ellis, P. O. Box 882, Milwaukee. This new repro-

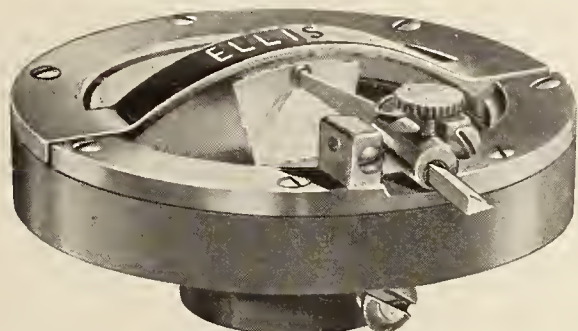

Ellis-Melodious Reproducer

ducer, invented more than five years ago, has since that time been put through all kinds of tests through which it has emerged victoriously and with a long line of recommendations and tributes regarding the artistic quality of its reproduction. Many very complimentary letters have been received from lawyers, doctors, musicians, newspaper critics and others who have tried it out and are still using the Ellis-Melodious reproducer. It is made to fit practically any make of machine, and is furnished nickel-plated, heavy gold-plated and finest gold-painted.

DOEHLER TOLEDO PLANT EXPANDS

The Toledo plant of the Doehler Die-Casting Co., which is housed in a model factory building completed a little over a year ago, has in this short space outgrown its quarters.

In order to provide for this expansion this company has found it necessary to take over the adjoining plant of the Ohio Electric Co., doubling the present capacity of the plant.

While the greater part of the plant's activities are devoted to Government war work, the needs of the regular trade are getting close attention.

WALTER L. ESHELMAN HONORED

St. JOSEPH, Mo., June 6.—Walter L. Eshelman, an Edison dealer, was recently elected president of the Rotary Club, of this city. This honor was conferred upon him in recognition of his high standing in the community and his untiring efforts in the advancement of music in St. Joseph and vicinity.

Louis S. Sterling, managing director of the Columbia Graphophone Co., Ltd., London, Eng., sailed for London Monday, after spending two months in this country visiting the executive offices. Mr. Sterling is not quite ready to announce his plans for the rebuilding of the Columbia plant in London, which was totally destroyed by fire recently.

WINDOW DISPLAY MAKES BIG SALE

Portland, Ore., Woman Buys Fifteen Victrola Outfits for Use of Soldiers in Camps

PORTLAND, ORE., June 4.—Fifteen handsome Victrola machines and \$10 worth of Victrola records for each machine were bought at the Portland store of Sherman, Clay & Co. this month by Miss Constance Brown, a patriotic woman from New York City who is visiting Portland. Miss Brown sent the machines and records as a donation to the soldiers of the spruce division in camp near Newport, Ore. She was passing the Sherman, Clay & Co. store, was attracted by a patriotic window display and entered the Victrola department and made the purchase. She told Taylor C. White, manager of the Victrola department, that had it not been for the window display the thought of buying the Victrolas would possibly never have entered her mind.

R. S. SOUDERS IN Y. M. C. A. WORK

Robert S. Souders, who has long been prominent in the talking machine industry, through his early connection with the Columbia Co., and who has helped to introduce the Sonora in Northwestern territory since his association with the Minneapolis Drug Co., was in New York last week on his way to Europe, where he will be associated with Y. M. C. A. work for the United States soldiers abroad. Mr. Souders will act as field or hut secretary, and it goes without saying that, owing to his experience as a talking machine man, he will look after the needs of our boys abroad and provide them with the best of entertainment. Mr. Souders is not unacquainted in Europe, having served the Columbia Co. in an important capacity in Germany and other European points.

Don't tell all you know. Conversation is better than conversation.

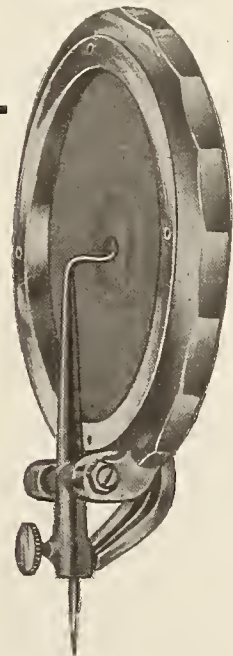

Tone—the vital thing

If you, as a manufacturer, can talk and prove *tone superiority* in your product, you have a selling argument to overshadow all the "talking points" of cabinets, and designs and accessory features.

And you *can* talk tone superiority. You can put out a product that will be a revelation in tone-purity, tone-quality, tone-volume. When you realize what vivid, lifelike, colorful tone can be produced and sustained by the talking machine equipped with

Parr Magnetic Reproducer fitted with the Vibratone Patented Diaphragm

These two dominating and proven inventions open up wonderful possibilities for manufacturers eager to put their product at the top-notch of class and character.

You want your product to be RIGHT!

If you want your product worthy of your name, you certainly want that product to be right in its most *vital feature*. And it will be right if it is equipped with the Parr Magnetic Reproducer—the reproducer for those who seek *perfection*.

The indestructible, non-crystallizing, always resilient

VIBRATONE PATENTED DIAPHRAGM

Possessing all the good points of mica diaphragms, it overcomes all mica's bad features. Guaranteed uniform in quality, free from bubbles, blisters and waves, the Vibratone Patented Diaphragm is non-porous, non-absorbent.

It has a definite function and it performs it. It improves tone; in fact it creates new tone possibilities for every reproducer of other types.

PARR MANUFACTURING CORPORATION
1 UNION SQUARE At Fourteenth St. NEW YORK

Take the Parr Magnetic Reproducer—

The most sensitive of reproducers. The permanent magnetic device, an integral part of the reproducer, acts on the stylus box. Its possibilities in giving warmth and delicacy in the tonal reproduction of quiet passages make old-style sound boxes seem obsolete. And in fortissimo passages where ordinary reproducers create unpleasant, music destroying blasts, caused by the needle jumping and losing its grip, the Parr Magnetic Reproducer, with its marvelous flexibility, follows every wave and vibration in the record and takes everything the record holds.

WORLD'S CLASSIFIED ADVERTISING

Any member of the trade may forward to this office a "Situation" advertisement intended for this Department to occupy a space of four lines, agate measure, and it will be inserted free. Replies will also be forwarded without cost. Additional space will be at the rate of 25c. per line. If bold faced type is desired the cost of same will be 25c. per line.

SALESMEN WANTED—If you cover the phonograph trade in any section of the United States and are interested in a live proposition, either as a side line or as your main line, we have an interesting offer. In answering state territory now covered. Address "Box 522," care The Talking Machine World, 373 Fourth Ave., New York.

TRAVELING SALESMEN WANTED—Salesmen having a record for producing clean high-class business will do well to communicate with the Widdicomb Furniture Co., Grand Rapids, Mich.

EXPERT FINISHERS WANTED—For our Chicago factory. Course rubbers, oilers and patchers on phonograph cabinets at once. Wages \$4 to \$5 per day. Apply Brunswick-Balke-Collender Co., 340 West Huron St., Chicago, Ill.

PARTNER wanted by an established wood-working and cabinet manufacturer who has also been specializing on the construction of sound-proof talking machine booths. A responsible business man with small capital will find this proposition an excellent one. A growing business and a fine opportunity for the right man. Address with full particulars, "Box 523," care The Talking Machine World, 373 Fourth Ave., New York.

SALESMEN WANTED—Salesmen calling on the talking machine trade. We are offering a side line that will add materially to your income. In answering please state territory you are now covering. Address "Box 524," care The Talking Machine World, 373 Fourth Ave., New York.

WANTED TOP NOTCH SALESMEN—We desire to secure a few top notch salesmen who can represent the Cheney phonograph in Southern and Middle Western territory. Men of the very highest type, who possess the qualities of initiative, tact, enthusiasm and genuine sales ability will find this a most unusual opportunity. If you feel that you are the man we are looking for write giving a brief resumé of your experience and qualifications, references required. Address Cheney Talking Machine Co., 24 North Wabash Ave., Chicago, Ill.

MANAGER wanted for the only exclusive phonograph store in Ottawa, Ontario, having excellent location, established organization and handling Edison and Columbia lines. Exceptionally good opportunity for man of ability. Write, giving experience, age, qualifications and salary expected, to "Box 525," care The Talking Machine World, 373 Fourth Ave., New York.

TO THE TRADE—Dealer has stock of 1,950 Columbia records, all new, not let out on trial, will sell for cost. First answers will be served first. Address "Box 530," care The Talking Machine World, 373 Fourth Ave., New York.

POSITION desired by manager of Victrola department. Have had ten years' experience as manager of one of New York's largest stores doing \$500,000; salary \$3,000. Further particulars by letter. Address "Box 531," care The Talking Machine World, 373 Fourth Ave., New York.

POSITION WANTED—Would like position with talking machine manufacturer as laboratory experimental man or charge of construction. Am thirty-five years old with several years' experience in every phase of the art. I also have complete mechanical equipment for experimental work and several valuable inventions which I would gladly turn over along with my services to the right concern. Address "Box 519," care The Talking Machine World, 373 Fourth Ave., New York.

FOR SALE—Victor Victrola business in New York City, centrally located, doing a large and prosperous business, with unlimited possibilities. Must sell on account of being drafted for National Army. Have also Columbia contract, and do an excellent kodak business. Big opportunity for live man. Address "Box 533," care The Talking Machine World, 373 Fourth Ave., New York.

FOR SALE—Old established Victor agency in Pacific Coast town of 45,000. Reasonable rent and fine location. Also Eastman Kodak agency and only stock of classical sheet music in city. Best of reasons for selling. Address "Box 518," care The Talking Machine World, 373 Fourth Ave., New York.

TO THE TRADE—Have just bought 15,000 records. Closing out in hundred lots. Full details will be given upon inquiry. Address Jos. Dumas, 54 West Lake St., Chicago, Ill.

SALESMAN, experienced, wants position with phonograph house, who knows the music, piano, furniture and department store trade in the entire South and Middle West; fine reference. Address "Box G. R.," care The Talking Machine World, 373 Fourth Ave., New York.

POSITION WANTED—Talking machine salesman or manager, nine years' experience, inside position. New York or Brooklyn preferred. Can furnish best references. Address "Box 526," care The Talking Machine World, 373 Fourth Ave., New York.

POSITION WANTED—Manager of phonograph department open for place. Now employed. Can bring two good salesmen with him. Address "Box 527," care The Talking Machine World, 373 Fourth Ave., New York.

POSITION WANTED—Expert in hill and dale and lateral recording. Have sample of work that shows superior quality, also knowledge of latest methods of plating and familiar with every detail of record making. Address "Box 528," care The Talking Machine World, 373 Fourth Ave., New York.

POSITION WANTED—Sales or advertising manager with Chicago talking machine manufacturer or local representative for outside concern. Experienced. References. Address "J. N. 6," care The Talking Machine World, 209 South State St., Chicago, Ill.

POSITION WANTED—An exceptionally good talking machine repairman seeks new position. Will go anywhere. Address "Box 529," care The Talking Machine World, 373 Fourth Ave., New York.

SALESMEN wanted who are desirous of making big money selling standard records. Address "J. N. 8," care The Talking Machine World, 209 South State St., Chicago, Ill.

POSITION WANTED—Mechanic with fifteen years' experience constructing and repairing phonographs of all makes. With the largest houses in this country; desires to make a change. Capable executive, thoroughly efficient with modern methods. Can furnish best of references. Will go anywhere. Address "Mechanic," care The Talking Machine World, 373 Fourth Ave., New York.

WANTED—Salesmen, sideline to dealers, filing cabinets for phonograph records, patented, advertised, no samples, sell from photographs; liberal commission. Automatic Container Co., 506 Republic Bldg., Chicago, Ill.

POSITION WANTED—Young man, married, would like to get position anywhere in talking machine line where there is a chance for advancement. City or country. Can be used as all-around man, as I can be a shipping clerk, salesman, repair man, assembler, delivery man; willing to work, not afraid of hard work or long hours. Address "Box 520," care The Talking Machine World, 373 Fourth Ave., New York.

POSITION WANTED—Experienced cabinet factory manager and designer wishes to make a change. Thoroughly familiar with up-to-date methods. Forty years old. Highest reference. Now employed. Address "Box 521," care The Talking Machine World, 373 Fourth Ave., New York.

POSITION WANTED—Mechanic with 15 years' experience constructing and repairing phonographs of all makes, part of years with Victrola line, with one of the largest music houses in this country desires to make a change. Capable executive, thoroughly efficient with modern methods. Can furnish the very best of references. Address "Box 514," care The Talking Machine World, 373 Fourth Ave., New York.

POSITION WANTED—Talking machine salesman, five years' experience. Inside position large city preferred. Familiar with all well known machines. References. Address "A. P. 2," Talking Machine World, 209 So. State St., Chicago, Ill.

SALESMEN WANTED—Calling on music and furniture trades to sell popular line of records and talking machines. Address "A. P. 7," The Talking Machine World, 209 So. State St., Chicago, Ill.

WANTED—Position as salesman or department manager by A. I. Victor man, 26, married. At present in charge of talking machine department of large Western music house. Six years' experience in Victrola business, doing buying, newspaper advertising, window trimming. Can furnish the references you want. Prefer town west of Chicago of not less than 25,000. Address "W. N.," care The Talking Machine World, 373 Fourth Ave., New York.

POSITION WANTED—Thoroughly experienced Phonograph and Record salesman for either road or managing establishment, can vouch for seventy-five thousand dollars gross business per annum, now with leading company, highest grade credentials. Address G. H. Coryell, Saratoga Hotel, Chicago, Ill.

STEEL NEEDLES

100 Needles in Envelope, per 1,000 needles.....	0.60
Sapphire Needle for Pathe or Edison, each.....	0.25
MAIN SPRINGS	
For Columbia Motors, size 1"x0.28x11', each...	0.60
" " " size 7/8"x0.23x10', each...	0.38
" " " size 3/4"x0.22x8 1/2', each.....	0.24
GOVERNOR SPRINGS	
For Columbia Motors, bent, per 100.....	1.50
For Victor Motors, per 100.....	1.50
For Heineman, Markell, etc., per 100.....	0.60
THUMB SCREWS FOR STYLUS BARS	
For Victor Soundboxes, per 100.....	1.50
For Columbia Soundboxes, per 100.....	1.50
MICA DIAPHRAGMS	
For Victor Soundboxes, each.....	0.15
For Columbia Soundboxes, each.....	0.25
For all standard Soundboxes, each.....	0.22
NEEDLE CUPS	
Needle Cups, nickel plated, per 100.....	2.00
Needle Cups, per 1000.....	17.50
Covers to nickel cups for used needles, per 100..	1.25
Covers, per 1000.....	10.00
Green Felt for 10" turn-tables, each.....	0.10
Green Felt for 12" turn-tables, each.....	0.15

FAVORITE PHONOGRAPH ACCESSORY CO.

1491 DeKalb Avenue

Brooklyn, N. Y.

The Robert Simpson Co., Ltd. Toronto, Canada

Require a first class experienced manager for

Victrola and Gramophone Department

Repairs for the Trade at Reasonable Prices

Out-of-town work solicited. We have a full supply of Springs for all makes of Phonographs, also a line of phonographs at remarkably low prices. See our wonderful double Spring Motor that works with the Governor instead of against it.

Tone arms, sound boxes and needles, automatic stops. Send postal for prices to

AGLOW BROS. 325 Suediker Avenue BROOKLYN, N. Y.

RECORDING MACHINE

Will purchase a new, or used, if in perfect condition, with necessary accessories. Also experienced recording man is wanted. "Box 532," care The Talking Machine World, 373 Fourth Ave., New York.

DEALERS

We give record service to any dealer on all makes of disc records.

Illinois Record Service

Commercial Building

Chicago, Illinois

RETURNS FROM WESTERN TRIP

Frank K. Pennington, assistant general sales manager of the Columbia Graphophone Co., returned Monday from a week's Western trip, which included a visit to Columbia branches in Cincinnati, Cleveland, Indianapolis and Buffalo. Mr. Pennington states that conditions in this territory are splendid, every Columbia branch manager reporting sales totals far in advance of last year. The Buffalo branch closed in May the largest business in its history, and Mr. Pennington was advised this week by Fred E. Mann, manager of the Boston branch, that the month of May was the largest month so far this year. Another encouraging report was also received this week from W. C. Fuhri, manager of the Chicago branch, who states that the sales totals for May showed an increase of 100 per cent. over last year. In fact, in all sections of the country the business situation is most satisfactory.

FROM OUR EUROPEAN HEADQUARTERS

2 GRESHAM BUILDING, BASINGHALL STREET E. C., LONDON, W. LIONEL STURDY, MANAGER.

Great Deal of Nonsensical Talk About Luxuries, in Which Talking Machines Are Featured, Appearing in the Daily Press—The Subject Reviewed—The Manufacturing Outlook—Death of Eric Dunlop—Vallorbes Jewel Needle in London—Important Association Formed—Review of New Records—Gramophone Co., Ltd., Announce Adjustment in Prices—French Tax on Luxuries—The News

LONDON, ENGLAND, E. C., June 3.—A good deal of unnecessary alarm has been engendered in trade circles by the repeated ravings of a certain section of the press anent the plans of the Government for the alleged suppression of luxury trades, among which most of the scribes alluded to are pleased to include all musical instruments. Arising from the official decision to levy a tax on so-called luxuries the subject is one which may or may not apply to the musical instrument trade. Until the committee appointed to enquire into this matter has issued its report clearly defining the class of goods that may reasonably be considered pure luxuries in contradistinction to actual necessities, any discussion along definite lines is not only futile but is likely to create an impression which, perhaps unwittingly, would lead to official conclusions unfavorable to the best interests of the trade. There can be no doubt that the feeling in official circles regarding the defining of luxury goods mainly applies at present to such commerce as expensive articles of feminine attire. The only shadow of justification for inclusion under this category of musical instruments is the fact that pianos are taxed as luxuries by the French Government, the amount being 10 cents. Beyond this no official ruling

has yet been indicated, and the supposition that gramophones and records, for instance, are a luxury is entirely premature. The claim might not have stood the test of too close an investigation in pre-war days, but in war time there is a decided argument against it.

Evidence of the necessity for an unlimited supply of mechanical music is felt on all hands, anywhere and at all appropriate times. More especially is this so with regard to military and naval establishments, where music is officially encouraged. To hospital patients music is medicine. Without it their recovery would be prolonged considerably. That is recognized by the medical profession as an actual fact. At the rest camps, too, the gramophone occupies an honored position. The daily demand is for more, and yet more, and the pity is that the call from our gallant lads cannot be wholly satisfied. The situation at home is much the same; music being an absolute necessity for many weary munition workers whose main relaxation it is after their overlong daily strenuous labor. These facts challenge completely those scribes whose pens might be used to better advantage than in writing ignorantly of the relative value of mechanical music, and in this connection a good case is furnished for immediate counter-action on the part of the recently established Gramophone Association. Steps should at once be taken for the formation of a propaganda section. Its value would prove inestimable during the period of crisis through which the talking machine trade is now passing.

Another aspect of the present situation, here, and which I have previously mentioned in these columns, refers to the threatened Government action that luxury or non-essential trades must

furnish a larger quota of men for the forces and for work of urgent national importance. This has been interpreted by many as in the nature of a serious proposal to suppress the musical instrument trade altogether. Serious though the position may be, it is quite unthinkable that the Government has any such intention. A vital factor in the prosecution of the war from a financial viewpoint is the maintenance of general commerce and the upkeep of money values abroad by the encouragement of export trade. In these circumstances, to suggest that the Government is out to destroy or seriously impair our industry, is, to say the least, scarcely founded upon a good perspective. That the sifting of men from the factories will temporarily dislocate output is quite possible. But the transfer of such labor will most certainly be sufficiently gradual to enable manufacturers to find and, it is hoped, train suitable substitutes. In this regard, the chief difficulty is to find the right class of labor. It must be borne in mind that the country is pretty well drained, the prior claims of the services and munitions factories having left but a residue from which to choose. The mainstay will, of course, be women, but the sources of labor supply provided by discharged soldiers is not being neglected. No great success has so far attended the manufacturers' efforts to secure the services of discharged men owing to their inability or unwillingness after an open-air life to stand the humid atmosphere, for instance, of the record-pressing departments. But such as are available for this and other perhaps more suitable work in talking machine factories should be impressed into the service of this in-

(Continued on page 108)



"His Master's Voice"

Copyright

'His Master's Voice'

—the trade-mark that is recognized throughout the world as the

HALL-MARK OF QUALITY

Branches

DENMARK: Skandinavisk Grammophon-Akti eselskab, Frihavnens, Copenhagen.

FRANCE: Cie. Française du Gramophone, 115 Boulevard Richard Lenoir, Place de la République, Paris.

SPAIN: Compañía del Gramófono, 56-58 Balmes, Barcelona.

SWEDEN: Skandinaviska Grammophon-Aktiebolaget, Drottning Gatan No. 47, Stockholm.

RUSSIA: The Gramophone Co., Ltd., 45, Nevsky Prospect, Petrograd (Petersburg); No. 1 Solyanka, Solyanoi Dvor, Moscow; 9, Golovinsky Prospect, Tiflis; Nowy-Swiat 30, Warsaw; 33, Alexandrowskaya Uitsa, Riga; 11 Michailovskaya Uitsa, Baku.

INDIA: The Gramophone Co., Ltd., 139, Balaiahhatta Road, Calcutta; 7, Bell Lane, Fort, Bombay.

Great Britain:

The Gramophone Company, Ltd.

HAYES - MIDDLESEX - ENGLAND

Agencies

AUSTRALIA: S. Hoffnung & Co., Ltd., Sole Concessionaries of The Gramophone Company, Limited, 163, Pitt Street, Sydney.

NEW ZEALAND: Gramophonum, Ltd., 118-120 Victoria Street, Wellington.

SOUTH AFRICA: Darter & Sons, Post Box 174, Capetown; Mackay Bros., Post Box 251, Johannesburg; Mackay Bros. & McMahon, Post Box 419, Durban; Ivan H. Haarbuerger, Post Box 105, Bloemfontein; Franz Moeller, Post Box 108, East London; B. J. Ewins & Co., Post Box 86, Queens-town; Handel House, Kimberley; Laurence & Cope, Post Box 132, Bulawayo; The Argus Co., Salisbury.

EAST AFRICA: Bayley & Co., Lourenso Marques.

HOLLAND: American Import Co., 22a, Amsterd Veerkade, The Hague.

ITALY: -A. Bossi & Co., Via Orefici 2, Milan.

EGYPT (Also for the Soudan, Greece and the Ottoman Empire): K. Fr. Vogel, Post Box 414, Alexandria.

This intensely human picture stands for all that is best in music

—it is the "His Master's Voice" trade-mark, and it brings to you, no matter where you are, the very best music of every kind, sung and played by the world's greatest artists—the greatest singers, pianists, violinists, orchestras and bands—all enshrined in the unequalled "His Master's Voice" records

FROM OUR LONDON HEADQUARTERS—(Continued from page 107)

dustry with the least possible delay. Time is the essence of all things, and not more so than in this matter. We may rest assured, therefore, that every effort will be made to suitably replace those men in the factories and offices who in the national interests are required for work rightly considered of greater importance.

The call-up of men of the new age classes—forty-one to fifty-one—has already commenced, notices have been issued to those up to the age of forty-five. This does not necessarily mean that men of these groups occupying executive and administrative positions in the commercial world, if medically passed, will be drafted to military or naval units right away. A great deal, of course, depends upon their medical classification and the needs of the services. But in any case official consideration will be shown, and possibly time allowed for the firms concerned to find substitutes, as in the case of factory employes. Given a sufficiently reasonable period of time, business should not be so seriously dislocated as many at first were inclined to think, but for all that the prospect is not regarded with indifference, as it will be exceedingly difficult to replace the class of men in question.

With it all, the possibility of gramophones and records being placed under the category of a luxury must not be overlooked. By many it is regarded as certain. If the tax is levied on the sale of talking machine goods, I am able to say the rate will be in the neighborhood of 17 per cent. of the retail purchase price. The duty is recoverable from the seller and it is to be denoted, and collected, by stamps.

Details of New French Tax

According to reports from France the new French Finance Law promulgated on March 22, and one section of which applies particularly to articles classed as de luxe, places a tax of 10 per cent. on the retail selling price on all the various articles listed, including all pianos other than upright (cottage) pianos. Among the articles subject to the tax when their retail price exceeds a certain sum are included: musical instruments, other than the piano (phonographs, gramophones and mechanical pianos) and all their accessories, when the selling price is over 150 francs, and upright pianos and harmoniums, when the retail selling price is more than 1,200 francs.

The Toll of War—Eric Dunlop

It is with something akin to a sense of personal loss that we have to record the death of Eric Arthur Dunlop, only son of Arthur S. Dunlop, the editor of *The Sound Wave*. As may be surmised it is yet another case among the many young lives sacrificed to the god of war. Mr. Dunlop was but twenty-three years of age. A few years ago he emigrated to the Golden West where he was making splendid headway when this Armageddon suddenly descended upon an unprepared world. With the spirit of his race he joined up as soon as was possible, and after a period of training both in

Canada and England was drafted abroad as a not unimportant unit of the Canadian Camerons.

It all happened at the time of the great retreat; a terrible head wound which, though borne with patience and cheery fortitude right to the last, ended fatally on April 20 at the King George Hospital, London. The funeral took place with full military honors at St. Andrew's, Hornchurch. In the general condolence and sympathy extended by the trade to Mr. and Mrs. Arthur S. Dunlop, the writer begs sincerely to participate.

Increased Prices of "His Master's Voice" Models

The gramophone trade is not unaffected by the generally increased cost of commodities and materials, and it is not therefore surprising that new prices are from time to time necessitated. In this regard the Gramophone Co., Ltd., recently advised the trade of an adjustment in the price of their various models, the new rates to go into effect May 15. Dealers were warned that after this date any sale below the new prices would be construed as a breach of the price-maintenance agreement.

Vallorbes Jewel Needle for British Market

A British sales depot for the Vallorbes Jewel Co.'s 50-record needle has been established here by the Murdoch Trading Co. On the face of it, this new needle may be regarded as a veritable godsend, for the supplies of steel for needles do not improve, and are not likely to. The scarcity still exists, and as I have reported in these columns at different times we are reduced to meeting the shortage by collections of used needles and placing them on the market again after resharpening. This is, of course, not general, the percentage of repointed needles being but small in comparison with the sales of new needles. Nevertheless, any efficient substitute, such as that now under mention, is welcome. The claim, however, that the Vallorbes needle is good for fifty records should be accepted liberally, especially so anent its likely effect on the wear of the records. On the other hand, if the claim is justified by results, it must be accepted as meaning that fifty is the safety margin beyond which it would be undesirable in the interest of the record to go. This is an academic question. The number of records played by one needle depends on the operator. We have heard of a steel needle being used twenty or more times, and still considered good. It should be used only once, but there are people who fail to detect any difference in quality after several times' playing, and therefore to them it is all right. Anyway, the Vallorbes is very welcome, and we have no doubt will find a ready market.

The Clarion Record Exchange Plan

I am advised that the Clarion Record Co. is prepared to exchange unsalable, worn, or otherwise tired-out records (cylinder wax only) for new ones, on the basis of three to one. Each returned record must be complete in its own cylinder box with lid complete. Broken records

REX GRAMOPHONE CO.*are making a Specialty of***EXPORT***in***Horn, Hornless & Portable Disc Machines****REX GRAMOPHONE CO. 2 Elizabeth Place
Rivington Street, LONDON, E.C. 2**

Cable Address "Lyrecodisc, London"

Enquiries Solicited

which cannot be so returned the company will purchase as old wax at the rate of nine pence per pound. All parcels must be carriage paid. Other details in connection with this exchange may be obtained direct from the company.

The Sense of Winner Records

Whoever is responsible for the Winner repertoire knows a thing or two. That is evidenced by the presentation each month of just those titles which seem to be most in demand. Obviously, it is not merely coincidence, for the lists, as we know, have to be prepared often many weeks in advance of publication. It is just the outcome of knowing one's public—the exercise of a discrimination which is at times almost second-sight. The latest Winner program to hand bespeaks this sense in a wonderful degree. It comprises a real galaxy of up-to-date selling titles by such talent as for instance the Two Bobs, the Elliotts, Stanley Kirkby, the Carlton Vocal Trio, De Busse (organ accordion solos), the Band of H. M. First Life Guards, Royal Court Orchestra, the Corner House Ragtime Band, and other artists equally good.

A special issue is "On the Good Ship Yacki-Hicki-Doo-La," by the one and only Billy Merson, the popular character comedian. With the aid of a sort of buccannering crew, Billy boldly lays siege to the fair damsels, and we may be sure he doesn't get the worst of his temerity. "When First We Met," on the reverse of this disc, is a capital sentimental ditty in which Billy Merson is at his best. Overseas traders could not do better than carry a goodly stock of these quick-selling records.

Gramophones and Records Wanted at the Front

These days when we hear so much regarding the non-essentiality of the talking machine trade, it is a severe commentary upon ignorant scribes who never lose a chance to run down the trade in that sense, that the Y. M. C. A. are appealing for a large number of gramophones and records on the strength of their being urgently necessary at the Front, to make good the losses incurred during the recent great retreat, when 130 fully equipped Y. M. C. A. huts were destroyed. Who will help?

An All-British Gramophone at Last!

The story of an enterprising trader's fight in behalf of an industry that was previously monopolized by enemy manufacturers was recently told to the Shoreditch Military Tribunal by Francis Nottingham, of the Rex Gramophone Co. Since war broke out his machines had been made from parts mainly imported from Switzer-

EDISON BELL**WINNER**
TRADE MARK
GRAMOPHONE RECORDSCABLE
"PHONOKINO,
LONDON"**ARE THE GREATEST VALUE FOR MONEY PRODUCED IN GREAT BRITAIN**

TEN INCH

DOUBLE SIDED

NEEDLE CUT

PLAY ON ALL GRAMOPHONES**Catalogue contains 4000 Titles by the Premier Artistes, Instrumentalists, Orchestras and Bands
of the British Empire**

DEALERS PREPARED TO DO BUSINESS ARE INVITED TO COMMUNICATE WITH

Proprietors and Manufacturers, J. E. HOUGH, Ltd., 62 Glengall Road, London, S. E. 15, England

FROM OUR LONDON HEADQUARTERS—(Continued from page 108)

J. Stead & Co., Ltd.
Manor Needle Works
SHEFFIELD, ENGLAND
 MANUFACTURERS OF
Talking Machine
Main Springs
Best Prices—Best Quality
Inquiries Solicited

land, and during the last twelve months £1,000 was paid as import duty. Mr. Nottingham explained how, after three years' continuous effort, he at last succeeded in getting a British firm to make motors and other parts. An all British Rex Gramophone is now being supplied to the trade, and before long it is anticipated that the main output may honestly be described and guaranteed as British throughout. This accomplishment necessitated the placing of orders for thousands of different parts. Notwithstanding the almost hopelessness of the prospect during this period, Mr. Nottingham has won out. His persistency of effort has reached the success it deserves, and what I have seen of the British Rex Gramophone leads me to conclude that complete success is in store.

Incidentally it might be mentioned that Mr. Nottingham established his claim for exemption, the Tribunal agreeing that he was doing much better work than he could do in the army!

Organize Important Association

It will be good news to many that a serious attempt is in being to grapple with the many problems which beset the trade. With this object a meeting of musical instrument manufacturers and others was held last month, the result being the formation of a society under the somewhat long-winded title of The Association of Gramophone and Musical Instrument Manufacturers and Wholesale Dealers. Of the important firms represented, the following may be mentioned: Barnett Samuel & Sons, Ltd, Barnes & Mullins, Beare & Sons, Besson & Co., Ltd., J. E. Hough, Ltd., J. G. Murdoch & Co., Ltd., the Gramophone Supply Co., Ltd., Columbia Graphophone Co., Ltd., British Polyphone Co., Ltd., etc.

The general objects are: To promote, protect and secure the varied interests of manufacturers of and wholesale dealers in gramophones and musical instruments and their accessories. The specific objects will cover a variety of matters of vital trade interest, as for instance post-war conditions, etc., prospects, tariffs, import and export difficulties, supplies of raw material, transit facilities, wages, to supply information anent foreign trade, etc. Membership is open to any firm or person engaged in the musical instrument trade as a manufacturer or wholesale dealer. The minimum annual subscription

has been fixed at the sum of three guineas, pre-paid.

The present endeavor, it will be observed, excludes retail dealers from membership. Previous trade associations, long since defunct, were confined solely to the retail section. We now branch out in an entirely opposite direction, in which we hope success may be achieved. At no time perhaps was an association more necessary than to-day, when a strong lead is required for the direction generally of the whole trade. We should have welcomed an open invitation for membership of the retail trade, for undoubtedly the inclusion of the leading retailers would tend to strengthen the work of the association and carry influence in official quarters. However, while the position is one of great interest, we refrain from further comment at the moment, as undue criticism at this stage would perhaps not be of great advantage until the association is fairly "on its feet," so to say.

"Popular" Records to the Fore!

Some of the many difficulties which beset British record manufacturers during war time were referred to in the course of an interview with the manager of the Sound Recording Co., Ltd., makers of the "Popular" series of records. One of the chief sources of concern is the constant upward tendency in the price of all materials, the effect being to render quotations for parcels of records almost impossible. The cost of paper bags has increased from a few shillings per thousand to anything up to 35/—; insurance and freightage rates generally are to-day a serious item, not to mention the extra import dues levied on goods into the United States, and a hundred-and-one other war-time expenses too numerous to mention. The price of records must go up proportionately, and another general rise is likely within the near future. Notwithstanding, a big export trade is still maintained.

Up-to-date issues of "Popular" records are a regular feature, and traders may always rely upon being able to obtain the latest London hits, vocal and instrumental. Details of the company's offer will be found elsewhere in this section.

What They Say of Zonophones

What they say of Zonophones is "Play that again!" The sentiment reflects nothing but universal appreciation of Zonophone quality. Glance at supplement No. 2 for 1918 and the reason is immediately obvious. Its fare is particularly rich in talent and the variety of selections must be acceptable to all dealers.

There are no less than twenty double-sided discs! G. O. 29 carries Harry Lauder's stirring appeal for £1,000,000 to complete the fund he is raising on behalf of maimed Scottish soldiers and sailors, and on the reverse side he sings that patriotic song, "Shoulder to Shoulder." The great violinist, Miss Mary Law, gives a fine example of her technique, the selections being accompanied with string quartet and piano. Vic-

Soundboxes

IF you are after a genuine offer of soundboxes, you'll do well to communicate with us immediately. We have tens of thousands of perfect soundboxes, fitted with the best quality mica. Confidently recommended for cheaper machines, absolutely reliable and give excellent reproduction. Price to clear \$50 per gross, F. O. B. London.

Orders for less than gross lots not accepted

Wire "Knotaslepe, London".

W. H. Reynolds (1915) Ltd.
45, City Road, London, E. C.

Write for new illustrated Complete Catalogue

tory Overture, Part I and II, the Bing Boys on Broadway, Victoryland selections, all by that splendid instrumental organization, the Black Diamond Band—represents typical examples of good recording. Other artists contributing to the list may be mentioned, Sydney Coltham, Herbert Payne, Foster Richardson, Peter Dawson, Florrie Forde, George Formby, Juan Okoni (ukulele with piano), Elsie and Dorothy Southgate (violin and Mustel organ), Royal Cremona Orchestra, etc., a list that of a truth represents the essence of all good things musically.

Gertie Millar for Columbia

Another great musical comedy "star," in the person of dainty Gertie Millar, joins the ranks of those recording only for Columbia, the medium through which her talents are conveyed being the charming musical comedy "Flora," which graces the stage at the Prince of Wales' Theatre, London.

"The Lilac Domino" on "His Master's Voice"

This attractive musical play is the rage of London just now, and judging by the favorable attitude of the public, it is likely to run an unusual period. It teems with music of an exquisite and light character—the mind-staying kind that attains the height of popularity by being hummed here, there, and everywhere. A series of six double records has been issued by "His Master's Voice" Co. consisting of instrumental and vocal numbers, played and sung by eminent artists.

Pathé Frères Appoint New Recorder

Congratulations to G. C. Hallett upon his recent appointment as Messrs. Pathé's superintendent of recording. Of wide experience in

(Continued on page 110)

GUARDSMAN RECORDS

REGISTERED



TRADE MARK

10 inch and 12 inch Lateral Cut

We can ship you *immediately*, any quantity of Records:

BANDS ORCHESTRAS INSTRUMENTAL SOLOS VOCAL

SELECTION OF AMERICAN AIRS

including, "Marching Through Georgia"—"Dixie"—"Arkansas Traveller"—"Red, White and Blue"—"Star Spangled Banner," etc., etc., Recorded by Full Regimental Band of H. M. SCOTS GUARDS. Get Ready Now for the Big Trade coming and have

THE FINEST RECORDS of THE FINEST TITLES at THE FINEST PRICES

Apply for Lists and Prices to INVICTA RECORD COMPANY, Ltd.

Cables: Duarrab, London

1 New Inn Yard, London, E. C., England



YE "POPULAR" RECORDS

Double-Sided
Superb Needle Cut
"Lateral"



LONDON'S LEADING VALUE!!!

"OUR POINTS"
SET OUT BELOW

Have Attracted Keen Overseas Houses

from SCANDINAVIA to PATAGONIA
AND THE PRINCIPAL
EAST and WEST MARKETS of the WORLD

REMEMBER  You Can Have CLOSE QUOTATIONS

For 5,000 Lots and up Your Selection or a Sample
1,000, 75% "Bands and Orchestrals."

Address: SOUND RECORDING CO., Ltd.
EXPORT DEPT., 18-19 Swallow Street
Piccadilly, London, England

CABLES "Grammavox"
London
QUOTATIONS CABLED FREE

POINTS

- ➔ Repertoire Approx 2,000 Titles
- ➔ Superb Selection, Bands and Orchestrals
- ➔ Lightning Shipments under Government Export License
- ➔ Packing by Experts
- ➔ Rock Quotations "Always"
- ➔ F. O. B. London
- ➔ We attend to all Insurances "if Requested" to Buyers A/c
- ➔ Our Shipping Services, this Side FREE

FROM OUR LONDON HEADQUARTERS—(Continued from page 109)

all branches of the talking machine trade, Mr. Hallett is, we should surmise, eminently fitted for the job. His talents are exceptional and up-to-date—fresh from Wadsworth, where he lately held the onerous position of manager of the Clarion Record Co., Ltd.

"The Lilac Domino" for Columbia

In "The Lilac Domino," J. L. Sacks' magnificent production at the Empire Theatre, London, has a feast of music the like of which has not been enjoyed in light opera for many years. At the Empire it promises to repeat the success achieved in New York, and certainly has the advantage of a fine cast, with Miss Clara Butterworth, the well-known prima donna, Mr. Jamieson Dodds, the popular baritone, and Mr. Frank Lalor as comedian, as principals. And the Columbia Co., with an enterprise that is thoroughly typical, has secured the exclusive rights to the Empire production with the original artists, the present being a series of six fine double records.

Link Between Manufacturer and Dealer

The new editress of The Voice, the chatty "His Master's Voice" organ, inaugurates in her first issue an excellent plan whereby the local difficulties of dealers may be solved by mutual ventilation and discussion in The Voice. To this end a page will be reserved each month, and it is hoped an exchange of views or advice from the company, which is freely offered, will result in the elimination of many of the small difficulties which beset the retail trade under present conditions.

Norwegian Exports Prohibited

It is announced that the exportation of commodities of all kinds from Norway is now prohibited except under official authorization.

Women Substitutes at the Victor Co.

Much interest has been aroused in British trade circles by the announcement in The Voice that the Victor Talking Machine Co. has replaced 2,000 of its cabinet factory male staff by women workers! The same scheme is operating in most of the gramophone factories here.

Tax on Luxuries—French Report

French Parliamentary papers contain the text of a report on the French Luxury Tax addressed by M. de Villeneuve, president of the Commission to the Minister of Finance. In view of the introduction of a similar impost in this country the President's explanation of the principles which guided his colleagues and himself in preparing the schedules of articles to be taxed is of interest, and the salient passages of the report are reproduced below. The actual schedules have already appeared in The Daily Telegraph, and other journals.

It would have been vain (says the report) to attempt a rigorously exact definition of objects called luxury objects. We judge that the quality of luxury articles depends on three elements; the nature of the article, its price, and its destination. In the first category are included articles which are essentially de luxe, such as dia-

monds, pearls, jewelry in gold or platinum. In the second, objects which in a general way are in every-day use, such as clothing, but which are of a sumptuous character, when they fetch high prices. Finally, certain articles which are de luxe by nature, such as motor-cars, lose this character when they are employed in the exercise of a profession; for example, the furs of a chauffeur or the carriage of a doctor. The law, indeed, is intended to hit only the display of wealth and not the instruments of labor; it taxes luxury but does not wish to paralyze effort.

The first difficulty that the commission had to grapple with in drawing up the schedules consisted in making a classification as complete as possible, with designation sufficiently clear as to avoid all difficulties in application. In this matter we thought we could not do better than to follow the customs of the trade; it is the traders who will be, in the application of the law, the principal collectors of the tax; it was necessary, therefore, to make our schedules con-

form to their traditions and their customs.

Since the tax is to be collected at once, the figures given represent current prices. The result has been that in a large number of cases we have allowed exceptional figures, clearly higher than those ruling for purchases before the war. It will evidently be necessary to proceed with a revision of these basic prices when the market resumes its normal state.

A very important question, and one which may have a serious reaction on the yield of the tax, has been settled by the heading of Schedule B, which stipulates that the tax is due, not by reason of the sale price, but only by reason of the excess of this price over the basic price appearing in the schedule. This solution appears to satisfy the demands of equity and to accord with the conception of luxury which we have indicated above. Up to a certain price the purchase of a piece of furniture, of an article of clothing, corresponds to a real need: luxury and consequently the tax, only ought to begin above that price.

FAREWELL DINNER TO H. L. TUERS NOW IN THE SERVICE

H. L. Tuers, formerly manager of the dealer service department of the Columbia Graphophone Co., New York, left Saturday for Ithaca, N. Y., where he will take a course in training preparatory to becoming an officer in the Aviation Branch of the Signal Corps. Mr. Tuers was the guest of honor at a farewell dinner, given last Wednesday by his former associates, who presented him with an aviator's coat and helmet. This dinner, which was informal, served to emphasize the affection and esteem in which Mr. Tuers is held by every member of the Columbia organization.

Mr. Tuers is succeeded as manager of the



Former Associates of H. L. Tuers Entertain Him at Dinner

dealer service department by Courtland Shaw, Jr., who has had several years' experience as a member of the Columbia sales staff, and who has a thorough knowledge of the dealers' requirements.

SELLING FACTS TO CONSIDER

Pertinent Pointers That Are Worthy of Consideration by Young Salesmen in the Talking Machine and Every Other Trade

When you start to sell, bear in mind one fact—the prospective customer has a mind, and on this mind depends much whether we do or whether we don't sell. The mind of every customer runs through the same process before the sale: first, attention; second, interest; third,

desire. Almost any one can attract attention. Plenty of people can create interest. Lots of folks can bring about desire. But the essential thing is to have the customer satisfied after the goods are bought. It is expensive to sell customers goods they do not want. You cannot treat all customers alike. To some customers you must smile, to others you may speak freely. A firm, fixed rule cannot be laid down for selling. One thing is certain: All customers are attracted by a face that does not frown. It is well to keep this in mind.

LATEST PATENTS RELATING TO TALKING MACHINES AND RECORDS

WASHINGTON, D. C., June 8.—PHONOGRAPH.—Marshall B. Peal, Brooklyn, N. Y. Patent No. 1,265,502.

This invention relates to a phonograph, and particularly to means for automatically causing the phonograph to cease all mechanical motion after the stylus or needle has completed its course of travel relatively to the sound producing surface of the record.

A further object is to provide a record having means adapted to co-operate with features embodied in the phonograph structure for causing the rotation of the record to cease after the sound producing surface of the record has been traversed by the stylus or needle.

A further object is to provide a device which may be either incorporated into the record at the time of manufacture of the record, or which may be attached to the record at a subsequent time adapted to co-operate with features of the phonograph machine for causing the operation of the machine to cease at a pre-determined time.

Figure 1 is a top plan view of a phonograph machine having a record in position thereon, provided with this invention, certain mechanism of the machine being illustrated diagrammatically. Fig 2 is an enlarged vertical detail sectional view taken upon the plane of line II—II of Fig. 1. Fig. 3 is a fragmentary sectional view taken upon the plane of line III—III of Figs. 1 and 2. Fig. 4 is a similar view taken upon the

without stopping the machine to change the disks, and to provide controlling means whereby a second disk is brought into operation successively with a former disk when the latter has reached the end of the subject matter recorded thereon, thereby causing a continuity of the sound or speech.

Figure 1 is a view in perspective of a machine embodying this invention. Fig. 2 is an elevation showing the mechanism employed to operate the turn-tables and the mechanism connected with the reproducer. Fig. 3 is an elevation, partly in section, of a fastening-nut to center the disk on the false-turntable, and spindle for the latter. Fig. 4 is a vertical sectional view of a hollow shaft, turn-table and attaching means for the latter. Fig. 5 is a detail showing the

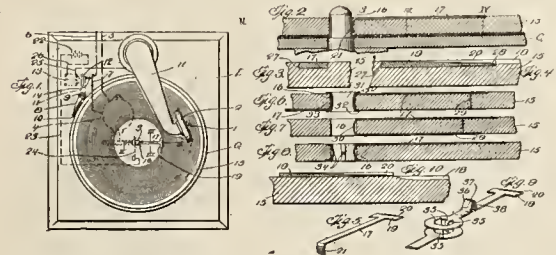

plane of line IV—IV of Fig. 2. Fig. 5 is a perspective view of one of the parts included in this invention. Figs. 6, 7 and 8 illustrate modifications. Fig. 9 is a perspective view illustrating a further modification; and Fig. 10 is an enlarged sectional view illustrating still a further modification.

TALKING MACHINE MECHANISM.—Archie E. Parnall, Chicago, Ill., assignor to Frank W. Williams, same place. Patent No. 1,265,498.

This invention relates to talking machine mechanism. One of the objects of the invention is to provide improved means whereby the tone arm may be connected with machines having different types of amplifiers.

Figure 1 is a vertical section of a talking machine in which the amplifier is inclosed in a

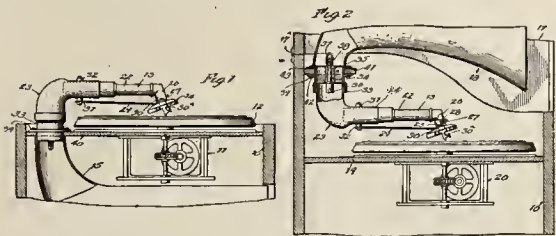

casing below the record support. Fig. 2 is a vertical section of a talking machine in which the amplifier is mounted above the record support.

MACHINE FOR CONTINUOUS REPRODUCTION OF PHONOGRAPHIC COMPOSITIONS.—Charles S. Andres and Wm. T. Jones, Philadelphia, Pa., assignors to the Sound-O-Photoplay Co., same place. Patent No. 1,265,286.

This invention relates to a machine in which means are provided whereby the continuous reproduction of speech or music recorded on phonographic disks may be obtained.

The object of this invention is to provide means whereby a number of phonographic disks may be played or operated one after the other

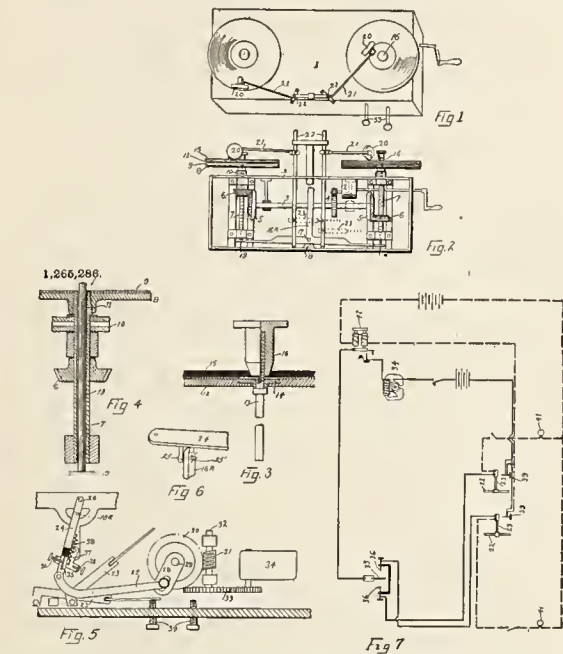

mechanism for operating the bell-crank lever. Fig. 6 is a detail showing the means for connecting the bell crank and the lever for operating the same. Fig. 7 is a diagrammatic view of a motor operating circuit, shown in full lines, and a test lamp circuit, the latter being shown in dotted lines, as contemplated in this invention.

PHONOGRAPH OR TALKING MACHINE.—John P. Constable, West Orange, N. J., assignor to the New Jersey Patent Co., same place. Patent No. 1,265,179.

This invention relates to phonographs or talking machines. The principal object of the invention is to provide an improved mounting for the horn or sound conveyor which forms a part of the phonograph or talking machine. In the preferred form of the invention, the phonograph reproducer is caused to move across the record by mechanical feeding means, and another object of the invention is to provide improved means for rendering the mechanical feeding means inoperative and for disengaging the reproducer stylus from the record surface.

Figure 1 represents a view partly in elevation and partly in section showing the preferred em-

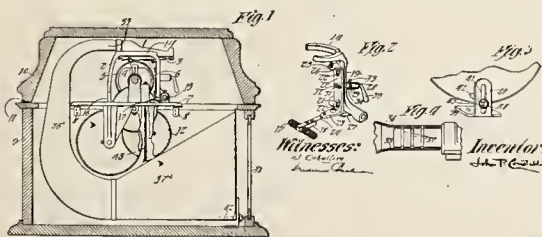

bodiment of the invention. Figs. 2 and 3 represent views in perspective of parts of the device shown in Fig. 1; and Fig. 4 represents a view partly in section and partly in elevation of a detail of construction.

TALKING MACHINE.—William G. Beard, New York, assignor to Henry C. Burnstine, same place. Patent No. 1,264,883.

The present invention relates to certain im-

provements in means for reproducing sound, and more particularly in such as employ a rotating disk record.

The object of the invention is to provide an improved mounting for the tone arm whereby the necessary movements thereof are facilitated, and assembling of the various parts is simplified.

Figure 1 is a plan view of the top of a machine employing the invention, Fig. 2 is a sec-

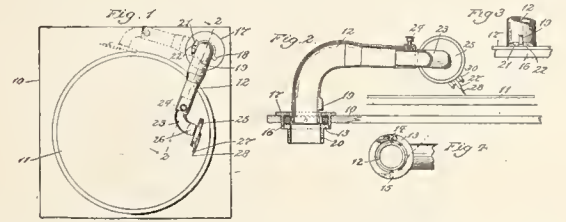

tional view on the line 2—2 in Fig. 1, Fig. 3 shows a detail in elevation, and Fig. 4 is a bottom plan view of the tone arm gimbal removed.

SOUND BOX.—Louis Menge, East Orange, N. J. Patent No. 1,264,201.

This invention relates in general to sound transmitting mechanisms and specifically relates to improvements in recording and reproducing sound boxes for gramophones, phonographs, and like machines which employ a vibratory diaphragm in connection with a stylus arm or lever operatively associated with the diaphragm to transmit motion to and from the same.

It is well known in the phonographic trade at present that different types of sound boxes now on the market respond differently to the different characters of records used. For instance, a machine using one form of sound box gives the most pleasing effect when used with a record having high vibratory notes, such as a violin record; while another form of sound box responds best to some other character of record, such as a vocal record. It is generally true that each sound box works best with only one or possibly two similar types of records. Under these conditions an obvious objection to the known types of sound boxes now in general use is that they are not susceptible of giving uniformly good results with the different forms of records and accordingly one of the objects of the invention is to provide a sound box capable of being quickly adjusted to best suit the particular character of playing record in use.

Most of the sound boxes now in general use appear to reproduce, superimpose, and rather emphasize the overtones on the record and perceptibly reproduce the high pitch foreign noises

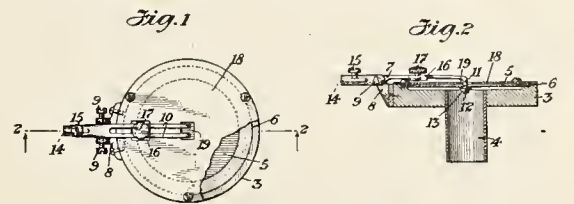

resulting in the squeaking so objectionable in phonographic devices. Another object of the invention is to minimize this sharp note effect and to provide a sound box which while accurately reproducing the basic sounds originally produced on the record, at the same time will mellow the reproduced tones so as to give a rich, full timbre without depriving the tones of their full musical note values.

This latter object is attained broadly by providing a very thin and sensitive vibratory diaphragm formed from a specially adapted wood and by securing to the diaphragm one end of a relatively light and delicately pivoted stylus arm, the other end of which arm is designed to have a playing stylus operatively mounted therein. As a further refinement in the stylus arm feature of the invention, the same is constructed from a relatively small tuning fork, the free ends of the prongs of which are fixed to the diaphragm transversely of the line of grain therein.

In the drawings: Figure 1 is a face view shown in plan of a sound box illustrating a preferred form of the invention; and Fig. 2 is a central sectional view taken approximately on the line 2—2 of Fig. 1.

(Continued on page 112)

LATEST PATENTS RELATING TO TALKING MACHINES AND RECORDS—(Continued from page 111)

PHONOGRAPH.—Charles S. Burton, Oak Park, Ill., assignor to the Melville Clark Piano Co., Chicago, Ill. Patent No. 1,264,268.

The purpose of this invention is to provide an improved construction of a phonograph adapted to be combined with a piano and contained within the casing thereof.

Figure 1 is a perspective view of a piano embodying this invention. Fig. 2 is a front elevation of the phonograph mechanism contained in the piano case, showing certain parts of the

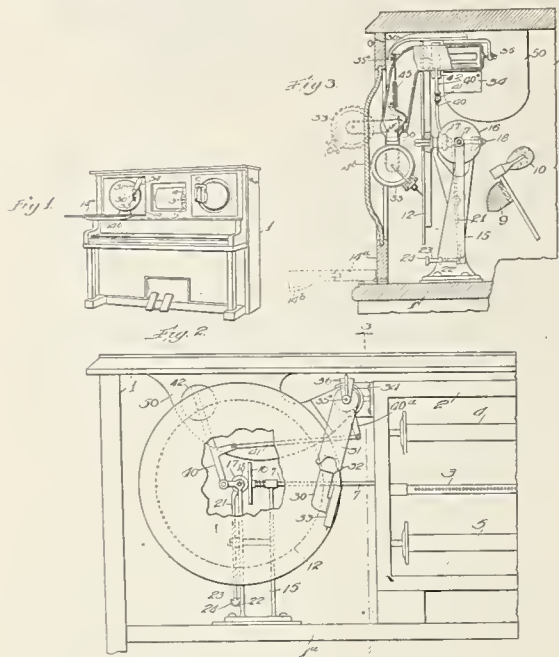

piano case and mechanism for the purpose of indicating the relative location of the phonograph in the case. Fig. 3 is a vertical section at the line 3—3 on Fig. 2.

TALKING MACHINE.—Francesco Cirelli, Philadelphia, Pa. Patent No. 1,264,273.

One object of this invention is to provide improved sound transmitting apparatus for talking machines which renders it unnecessary to employ a horn or cabinet construction such as has been the custom to employ prior to this invention.

Another object is to so construct the improved sound transmitting apparatus that it can be used in various positions and places, such for example as on an ordinary table or board and can be moved bodily independently of the record support.

Figure 1 is a side elevation of the invention shown in operative engagement with but mounted independently of a motor driven record. Fig. 2 is a view of similar nature to Fig. 1 but showing the invention out of engagement

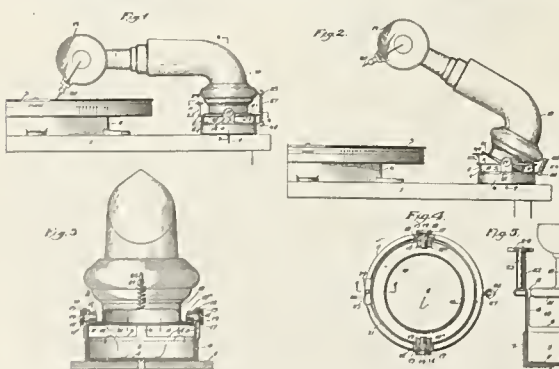

with the record. Fig. 3 is an enlarged section on the line 3—3 of Fig. 1 showing the upper portion of the horn in outside view. Fig. 4 is an enlarged sectional plan taken on the line 4—4 of Fig. 1. Fig. 5 is an enlarged fragmentary section taken on the line 5—5 of Fig. 4 showing a portion of the tone arm in outside view.

GUIDING DEVICE FOR PHONOGRAPH TONE ARMS.—John A. Shoemaker, Ada, Minn. Patent No. 1,264,691.

The object of this invention is to provide means for automatically locating the position of the tone arm and the diamond point or needle with respect to the starting point of the groove or path in the record, the device having particular application to the Edison phonograph where the tone arm is raised and lowered to separate the diamond point from the record or position

it thereon preparatory to the operation of the machine.

Figure 1 is a plan view of the top of an Edison phonograph with the invention applied thereto. Fig. 2 is a plan sectional view of the horn arm, with the invention connected therewith. Fig. 3 is a detail sectional view, taken on the line 3—3 of Fig. 4, showing a portion of the

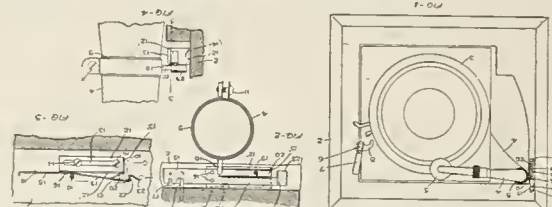

device mounted on the wall of the cabinet. Fig. 4 is an elevation of the horn arm and a section of the cabinet, showing the relative arrangement of the path-finding device thereon.

TONE ARM FOR PHONOGRAPHS.—Robert H. Cone, Jr., St. Louis, Mo. Patent No. 1,264,017.

This invention relates to phonographs of the disk type, and its object is to enable both records having vertical undulations and those having transverse undulations to be played by the same instrument.

The invention consists in an arrangement of sound box and tone arm, and a joint connection between the sound box and the tone arm for enabling the sound box to be set in either of two positions at right angles to each other. The invention further consists in a joint connection between the sound box and tone arm permitting the sound box to be turned up off of the record and out of the way. The invention also consists in a joint connection for holding securely the sound box in either of two

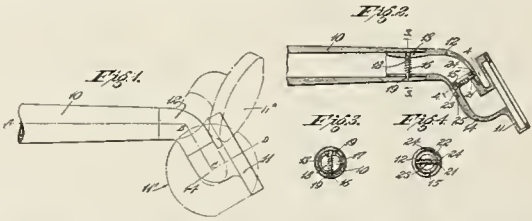

positions of adjustment, and which permits changing from one position to the other by merely twisting the sound box with the hand.

Figure 1 is a side elevation of a tone arm and sound box embodying the invention, showing the sound box in position for playing records having vertical undulations. Fig. 2 is a longitudinal section of the same in a vertical plane through the axis of the tone arm; Fig. 3 is a cross-section of the tone arm on the line 3—3 in Fig. 2; and Fig. 4 is a cross-section of the elbow portion of the tone arm, on the line 4—4 in Fig. 2.

SOUND REPRODUCING MACHINE.—David L. Suiter, Philadelphia, Pa. Patent No. 1,263,816.

This invention relates to improvements in sound reproducing machines, an object of the invention being to provide improved means for modifying or restraining the sound waves during the operation of the device so as to bring out the desired expression, and to control the volume of sound by manually operated means without interfering with the ordinary functions of the device.

Heretofore, various attempts have been made to control the volume of sound, but it is understood that such devices have been defective, largely, because of the fact that the controlling device or damper is located too far away from the diaphragm so that the sound waves are thrown backwardly, causing a confusion of sound and therefore interfering rather than aiding in the proper reproduction.

With these improvements the damper is located as close to the diaphragm as possible so that the control of the sound waves is had before any appreciable volume of air is in motion toward the outlet.

Figure 1 is a top plan view illustrating a preferred form of the invention. Fig. 2 is a view in longitudinal section, partly in elevation showing the improved damper located in a coupling

connecting the sound box with the sound tube. Fig. 3 is a view in longitudinal section taken at right angles to Fig. 2. Fig. 4 is a view similar to Fig. 3 illustrating a modification in which the damper is in the sound tube and the coupling is dispensed with. Fig. 5 is a view in longitudinal section illustrating a modification in which the damper is located entirely in the

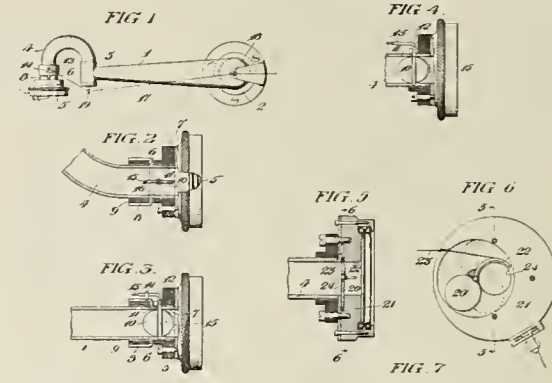

sound box. Fig. 6 is a view in section on the line 6—6 of Fig. 5; and Fig. 7 is an enlarged view in section illustrating the butterfly valve or damper shown in Fig. 2.

SOUND AMPLIFIER FOR PHONOGRAPHS.—Herman Thimgan, Denver, Col., assignor to the Colorado Phonograph Co., same place. Patent No. 1,263,625.

This invention relates to improvements in means which, when used in conjunction with the horn of a phonograph, will amplify the sound of the instrument, obviate the harsh, metallic sound so apparent in such instruments, and eliminate all unnatural conditions in the reproduction of the voice or sound.

In the drawings, Figure 1 is an elevation view of the invention, partially in section; Fig. 2 is

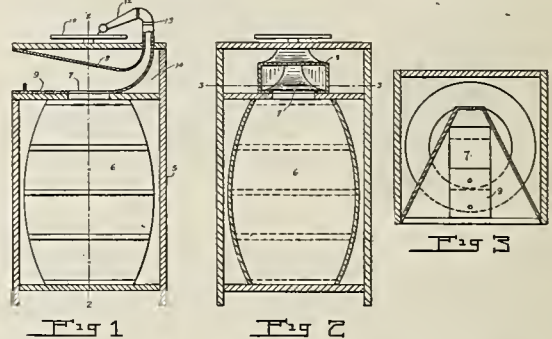

a longitudinal sectional view taken on the line 2—2, Fig. 1; and Fig. 3 is a cross-sectional view taken on the line 3—3, Fig. 2.

TALKING MACHINE.—Thomas Kraemer, Philadelphia, Pa., assignor to the Domestic Talking Machine Corp., same place. Patent No. 1,262,810.

This invention relates more particularly to means for modifying the sounds produced by a talking machine, and its primary object is to provide an improved expression device adapted for convenient manual operation to effect individual interpretations of musical or spoken compositions.

In the drawings, Figure 1 is a side elevation of a talking machine embodying the improvements; Fig. 2 is a broken sectional view taken vertically through the mouth of the amplifier illustrating improvements of the invention in side elevation; Fig. 3 is an enlarged broken sectional view taken on a vertical plane through

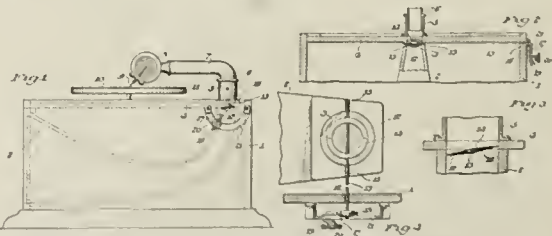

the mouth of the amplifier and the valve therein, transversely to the view shown in Fig. 2; and Fig. 4 is a broken sectional plan view taken on a horizontal plane coinciding with the bottom of the deck of the talking machine.

Galli-Curci scored a great success in Los Angeles at her recent appearance there.

RECORD BULLETINS FOR JULY, 1918

COLUMBIA GRAPHOPHONE CO

- POPULAR HITS OF THE MONTH
A2539 "Pay Day" (That Was His Favorite Call), Arthur Fields 10
What'll We Do with Him, Boys? Peerless Quartet 10
A2540*We Stopped Them at the Marne, Arthur Fields and Peerless Quartet 10
Hike! Hike! Hike! (Along the Old Turn Pike), Peerless Quartet 10
A2541 When Alexander Takes His Band to France, Bob White 10
When it Comes to a Lovingless Day, Arthur Fields 10
A2543 There's a Little Blue Star in the Window (And it means all the world to me)....Henry Burr 10
Mammy's Little Pansy.....Chas. Harrison 10
A2533 The Story Book Ball.....Campbell and Burr 10
Musical Sam from Alabam'...Peerless Quartet 10
A2544*Won't You Be a Dear, Dear Daddy (To a Itta Bitta Doll Like Me).....Farber Sisters 10
I Want a Daddy Like You.....Farber Sisters 10
DANCE RECORDS
A2547*Down Home Rag—Fox-trot, Earl Fuller's Rector Novelty Orchestra 10
I Ain't Got Nobody Much—Fox-trot, Earl Fuller's Rector Novelty Orchestra 10
A2537*Turkey in the Straw—Medley fox-trot. Intro.: (1) Arkansas Traveler, (2) The Preacher and the BearJazarimba Orchestra 10
Hello, America, Hello!—Medley one-step. Intro.: (1) In the Land of O'Yamo Yamo, (2) I'm Always Thinking of Georgia, Jazarimba Orchestra 10
A6044*There's a Service Flag Flying at Our House—Medley one-step. Intro.: (1) Who Said Dixie, (2) Say a Prayer for the Boys Out There, Jockers Brothers 12
I'll Think of You—Medley fox-trot. Intro.: (1) Alimony Blues, (2) My Rainbow Girl from "The Rainbow Girl"...Jockers Brothers 12
A6043*My Mind's Made Up to Marry Carolina—Medley fox-trot. Intro.: (1) Ev'rybody's Crazy 'Bout the Doggone Blues, But I'm Happy, (2) I Want a Daddy Like You...Prince's Band 12
Keep the Trench Fires Going for the Boys Out There—Medley one-step. Intro.: (1) The Little Good-for-Nothing's Good for Something After All, (2) You're a Better Man Than I Am, Gunga-Din.....Prince's Band 12
METROPOLITAN OPERA HOUSE ORCHESTRA
A6041*Ballet Music from "Faust." Part I. (a) Valse, (b) Allegretto, Metropolitan Opera House Orchestra 12
Ballet Music from "Faust." Part II. Adagio, Metropolitan Opera House Orchestra 12
AMERICAN FANTASY PLAYED BY PHILHARMONIC
A6040*American Fantasie. Under the direction of Josef Stransky. Philharmonic Orchestra of New York 12
L'Estudiantina—Waltz. Under the direction of Josef Stransky, Philharmonic Orchestra of New York 12
NEW PIANO RECORD BY JOSEF HOFMANN
A6045*Valse Brillante Opus 34 No. 1. Josef Hofmann 12
(1) The Hunting Song, (2) La Jouglesse, Josef Hofmann 12
A2536 The Regiment's Return (March)...Prince's Band 10
On Review (March).....Prince's Band 10
A2534 The Torpedo and the Whale from "Olivette," Columbia Stellar Quartet 10
Noah's ArkColumbia Stellar Quartet 10
A2532 Come Join in Our Laughter, Irene Young and Al H. Weston 10
He Laughs and So Do I.....Al H. Weston 10
A2469 Nobody Knows de Trouble I've Seen—Negro SpiritualOscar Seagle 10
I Don't Feel No Ways Tired—Negro Spiritual, Oscar Seagle 10
JUNE MID-MONTH LIST ON SALE JUNE 10
A2542*Hello, Central, Give Me No-Man's Land, Al Jolson 10
We'll Do Our Share (While You're Over There)Robert Lewis 10
A2545*Just Like Washington Crossed the Delaware (General Pershing Will Cross the Rhine), Arthur Fields and Peerless Quartet 10
What Are You Going to Do to Help the Boys, Peerless Quartet 10
A2538*Just a Baby's Prayer at Twilight (For Her Daddy Over There), Edna White Trumpet Quartet 10
Fancy You Fancying Me, Edna White Trumpet Quartet 10
A2546*I'm Sorry I Made You Cry.....Robert Lewis 10
I Want Him Back Again.....Sterling Trio 10
A2535*Sweet and Low, Amparito Farrar and Columbia Stellar Quartet 10
Mighty Lak' a Rose.....Amparito Farrar 10
49333*Elegie. Ricardo Stracciari, Violin Obligato by Sascha Jacobsen 12
A2548*Regretful Blues—Fox-trot, Wilber C. Sweatman's Original Jazz Band 10
Ev'rybody's Crazy 'Bout the Doggone Blues But I'm Happy—Fox-trot, Wilber C. Sweatman's Original Jazz Band 10
A6042*Are You from Heaven—Medley Waltz. Intro.: "Chimes of Normandy"...Prince's Orchestra 12
Blue Bird—Medley Waltz. Intro.: "Mammy's Little Pansy"Prince's Orchestra 12

*Records marked with an asterisk will be featured on the cut-outs and cards of July Monthly Window Display.

VICTOR TALKING MACHINE CO.

- POPULAR SONGS
18451 A Soldier's Day.....Geoffrey O'Hara 10
Parodies of the Camp.....Geoffrey O'Hara 10
18468 There's a Little Blue Star in the Window, Henry Burr 10
Some Day They're Coming Home Again, Macdonough and Orpheus Quartet 10
18469 Just Like Washington Crossed the Delaware, General Pershing Will Cross the Rhine, Peerless Quartet 10
I May Stay Away a Little Longer, Peerless Quartet 10
18470 Your Lips Are No Man's Land But Mine, Campbell and Burr 10
Our Country's in it Now.....Orpheus Quartet 10
DANCE RECORDS
18466 War Ballad Medley—Fox-trot.....Pietro 10
Eclipse Medley—One-stepPietro 10
35675 The Rainbow Girl—Medley fox-trot, Victor Military Band 12
Oh Lady! Lady!—Medley fox-trot, Victor Military Band 12
VOCAL AND INSTRUMENTAL RECORDS
70120 From the North, South, East and West, Harry Lauder 12
45152 Bring Back My Soldier Boy to Me...Olive Kline 10

- God Bring You Safely to Our Arms Again, Elsie Baker 10
18471 The Volunteers—March...Victor Military Band 10
Liberty Forever!—March...Victor Military Band 10
RED SEAL RECORDS
ENRICO CARUSO, Tenor
EMILIO DE GOGORZA, Baritone—In Spanish
89083 A la luz de la luna (In the Moonlight), Anton-Michclena 12
GERALDINE FARRAR, Soprano
87290 The War Baby's Lullaby.....Adele Farrington 10
ALMA GLUCK, Soprano
74559 Angels Ever Bright and Fair (from "Theodora"),Handel 12
JOHN McCORMACK, Tenor
64778 Little Mother of Mine, Walter H. Brown-H. T. Burleigh 10
PHILADELPHIA ORCHESTRA—Leopold Stokowski, Conductor
74567 Orpheus—Ballet (Dance of the Spirits), Christoph Willihald Gluck 12
The following record appears in the July, 1918, supplement. Do not duplicate order on this number:
18467 What Are You Going to Do to Help the Boys? (Gus Kahn-Egbert Van Alstyne), Charles Hart and Shannon Four 10
Keep Your Head Down, Fritzie Boy (Lieut. Gitz Rice)American Quartet 10

EDISON BLUE AMBEROL RECORDS

- FRIEDA HEMPEL ON THE FIRST ROYAL PURPLE AMBEROL RECORD
29007 Aloha Oe (Farewell to Thee), (Queen Liliuokalani). Soprano and Male Voices, Orch. accomp.....Frieda Hempel and Criterion Quartet 10
29008 My Old Kentucky Home (Stephen C. Foster). Soprano and Male Voices, Orch. accomp., Frieda Hempel and Criterion Quartet 10
CONCERT RECORD
28286 Gypsy Trail (Tod B. Galloway). Orch accomp., Arthur Middleton 10
REGULAR LIST
3494 Bing! Bang! Bing 'Em on the Rhine (Mahoney-Flynn). Male Voices, Orch. accomp., Premier Quartet 10
3500 Daughter of Rosie O'Grady (Walter Donaldson). Orch. accomp.....Ada Jones 10
3496 Each Stitch Is a Thought of You, Dear (Billy Baskette). Contralto and Quartet, Orch. accomp.....Helen Clark and Criterion Quartet 10
3488 Farmyard Medley, Descriptive Sketch. Unaccomp.....Premier Quartet 10
3489 Frivolity One-step (George Hamilton Green). Xylophone, Orch. accomp., George Hamilton Green 10
3499 Tickle Toe—Fox-trot—Going Up! (Louis A. Hirsch).....Jazarimba Orchestra 10
3485 Umbrellas to Mend One-step (Mel B. Kaufman). For Dancing.....Frisco Jazz Band 10
3503 When the Ships Come Home—Oh, Lady! Lady! (Jerome Kern). Contralto, Orch. accomp., Helen Clark and Chorus of Girls 10
3081 Garden Dance (Vargas)....Imperial Marimba Band 10
3025 In Honeysuckle Time (Marshall). Collins and Harlan 10
3080 Just One Day (Lange). Tenor, George Wilton Ballard 10
3146 Poor Butterfly (Hubbell). Fox-trot...Jaudas' Band 10
3077 Wondrous Rose (Burnham). Contralto.Helen Clark

THOS. A. EDISON, INC.

- 83074 Elegie (Jules Massenet). Tenor in French, Guido Ciccolini
'O Sole Mio (My Sunshine), (Eduardo di Capua). Tenor in Italian.....Guido Ciccolini 10
82125 Chant Hindou (Hindoo Song), (H. Bemberg). Soprano, in French.....Odette Le Fontenay 10
Le Nil (The Nile), (Xavier Leroux). Soprano, in French.....Odette Le Fontenay 10
82129 O Dry Those Tears! (Teresa del Riego). Contralto.....Caroline Lazzari 10
Off in the Stilly Night, Contralto...Caroline Lazzari 10
80365 Douglas! Tender and True (Lady John Scott). Contralto.....Amy Ellerman 10
Wonderful Thing (Clare Kummer). Soprano, Betsy Lane Shepherd 10
80388 Down in Lily Land (F. Wallace Rega). Contralto and Tenor. Marion Evelyn Cox, John Young 10
Is it Nothing to You? (Edgar-Trevor). Soprano.....Betsy Lane Shepherd 10
80390 Zampa Overture—Part 1 (F. Hérold). Sacred.....Metropolitan Quartet 10
Why I Love Him (B. D. Ackley). Sacred. Baritone.....Robert E. Clark 10
80390 Zampa Overture—Part 1 (F. Hérold). American Symphony Orchestra 10
Zampa Overture—Part 2 (F. Hérold). American Symphony Orchestra 10
80391 I'll Take You Home Again, Kathleen (Thomas F. Westendorf). Violin, Violoncello, Flute and Harp.....Venetian Instrumental Quartet 10
Quanto io t'amo Violin, Violoncello, Flute and Harp.....Venetian Instrumental Quartet 10
50459 Felicia Waltz (Vernon Eville). For Dancing, Jaudas' Society Orchestra 10
Sunshine of Your Smile Waltz (Lilian Ray). For Dancing.....Jaudas' Society Orchestra 10
50466 Sari Waltz (E. Kalman)...Imperial Marimba Band 10
Stars and Stripes Forever (Sousa). March, Imperial Marimba Band 10

PATHE FRERES PHONOGRAPH CO.

- POPULAR "HITS" OF THE MONTH
20367 Just Like Washington Crossed the Delaware (Johnson-Meyer).....Invincible Four 10
Hello, Central, Give Me No Man's Land (Lewis-Young-Schwartz). Irving Gillette, Tenor 10
20360 Rock-A-Bye Your Baby With a Dixie Melody (Lewis-Young-Schwartz), Arthur Fields, Baritone 10
What'll We Do With Him, Boys? (Sterling-Lange).....Arthur Fields, Baritone 10
20361 Round Her Neck She Wears a Yeller Ribbon (Norton).....Collins and Harlan 10
The Yanks Started Yankin' (McCarron-Morgan), Louis Winsch, Baritone 10
20362 Just a Little Cottage (Harriman-Egan), Sterling Trio 10
The Little Good For Nothing's Good For Something After All (Klein-Von Tilzer), Campbell and Burr 10
20363 Bring Back My Daddy to Me (Tracey-Johnson-Meyer).....Harry McClaskey, Tenor 10
When the War Is Over I'll Return to You (Dudley-Watson).....Peerless Quartet 10
20364 I Hate to Los You (Gottler)...Peerless Quartet 10
A Little Bit o' Sunshine (Hanley), Louis Winsch, Baritone 10
20365 Tishomingo Blues (Williams), Arthur Mack, Baritone 10
Somebody's Done Me Wrong (Walker-Skidmore), Arthur Collins, Baritone 10

- 20366 Three Wonderful Letters From Home (Goodwin-MacDonald-Hanley), Harry McClaskey, Tenor 10
When You Sang Hush-A-Bye Baby to Me (Olman-Logan-Glick).....Sterling Trio 10
25014 Au Revoir, But Not Good-Bye Soldier Boy (Brown-Von Tilzer), Percy Hemus and his Buddy Boys 10
Break the News to Mother (Harris), Percy Hemus and his Buddy Boys 10
NEW STANDARD BALLADS SUNG IN ENGLISH
27012 The Melody of Home (Stephenson), Paul Althouse, Tenor 10
Jean (Burleigh).....Paul Althouse, Tenor 10
25013 Lullaby, from "Erminie" (Jakobowski), Alma Beck, Contralto 10
Oh, Hush Thee, My Baby (Wittaker), Alma Beck, Contralto 10
20377 Sorter Miss You (Smith), William Simmons, Baritone 10
Gypsy Love Song (Herbert), Gordon MacHughes, Baritone 10
29201 De Ole Banjo (Gatty), American Harmony Quartet 12
Good-Night (Gatty). American Harmony Quartet 12
NEW SACRED RECORDINGS
40126 Jerusalem (Parker-Nella)...B. Stonehill, Baritone 12
Zion (Huhn).....B. Stonehill, Baritone 12
NEW BAND RECORDS
20369 Lights Out (McCoy)—"March," American Regimental Band 10
Liberty Lads (Smith)—"March," American Regimental Band 10
20370 O, Canada, Medley, Intro.: "The Maple Leaf Forever," "Vive La Canadienne," American Regimental Band 10
God Save the King—Rule Britannia (British Anthems)American Regimental Band 10
40127 Espana, Part 1 (Chabrier), Garde Republicaine Band of France 12
Espana, Part 2 (Chabrier), Garde Republicaine Band of France 12
NEW "CASEY" LAUGHALOGUES
20327 Casey at the Circus.....Russell Hunting 10
Casey Serenades His Girl.....Russell Hunting 10
NEW DANCE RECORDS PLAYED BY THE HOTEL BILTMORE DANCE ORCHESTRA
20368 Why Do They All Take the Night Boat to Albany? from "Sinbad" (Schwartz)—One-step Hotel Biltmore Dance Orchestra 10
When I Feel Sad and Lonely (Fuller)—Fox-trot, Hotel Biltmore Dance Orchestra 10
29200 Toot Toot (Kern)—Medley one-step. Intro.: "When You Wake Up Dancing," "If," Hotel Biltmore Dance Orchestra 10
The Booster (Lake)—Fox-trot, Hotel Biltmore Dance Orchestra 10
71001 I'll Think of You, from "The Rainbow Girl" (Hirsch)—Medley fox-trot, "My Rainbow Girl"...Hotel Biltmore Dance Orchestra, (Hazay Natzy, Director) 14
Songs of the Night (James)—"Waltz," Hotel Biltmore Dance Orchestra 14
NINE PATRIOTIC PATHE RECORDS RETESTED FOR JULY
40033 America (My Country 'Tis of Thee), Peerless Quartet 12
Massa's in de Cold, Cold Ground, Peerless Quartet 12
40094 Joffre March, "dedicated to Marshal Joffre," American Regimental Band 12
Army Bugle Calls—Star Spangled Banner, American Regimental Band 12
20125 Departure of the First U. S. Troops for France, Russell Hunting with Chorus and Band 10
My Own United States...David Irwin, Tenor 10
27002 Dixie.....David Bispham, Baritone, and Male Chorus, Band accomp. 10
Our Country Forever. Band Accomp., David Bispham, Baritone 10
27003 Tommy Lad.....David Bispham, Baritone 10
Marching Through Georgia, David Bispham Baritone, with Male Chorus and Band accomp. 10
70119 Columbia, the Gem of the Ocean, James Stevens, Baritone 14
Maryland, My Maryland, James Stevens, Baritone 14
20126 The Star Spangled Banner, George Stewart, Tenor, and Male Chorus 10
Good-Bye, Little Girl, Good-Bye, David Irwin, Tenor 10
70140 The Stars and Stripes Forever, Pathé Military Band 14
Light Cavalry Overture.....Pathé Orchestra 14
30373 American Overture, Part 1, including "Hail Columbia," "Home Sweet Home," and "Red, White and Blue"...Pathé Concert Orchestra 12
American Overture, Part 2, including "Yankee Doodle," "America," "Dixie Land," and "Star Spangled Banner".....Pathé Concert Orchestra 12
NEW OPERATIC AND CLASSIC VOCAL RECORDS
63024 Mefistofeles (Boito) "L'altra notte" (Last Night In the Deep Sea)—In Italian, Claudia Muzio, Soprano 12
La Wally (Catalani) "Ehene andro sola e lontano" (Then I Will Go Alone, and Far)—In Italian.....Claudia Muzio, Soprano 12
52029 Theme and Variations (Proch), Grace Hoffman, Soprano, Piano, Flute and Violin accomp. 12
Nymphs and Fauns (Bemberg), Grace Hoffman, Soprano, Piano, Flute and Violin accomp. 12
NEW INSTRUMENTAL RECORDS
40128 Caprice de Paganini, No. 13 (Paganini-Herman), Violin solo.....Charles Herman 12
Danse Hongroise, No. 5 (Brahms), Violin solo, Charles Herman 12
20371 Washington Post (Sousa)—"March," Boudini Brothers, Accordionists 10
Dolores Waltz (Miglia)—Old Italian Waltz, Boudini Brothers, Accordionists 10
20375 Martin et Martine (Chaulier)—"Fantaisie with Bells"Pathé Freres Orchestra 10
The Bells of Saint-Quentin (Cantelon), "Fantaisie with Bells"...Pathé Freres Orchestra 10
20376 The Deep Blue Sea (Brewer)—Piccolo solo, George Ackroyd 10
Romping Bessie (Rossiter)—Banjo solo, Thomas Malin 10
20378 The Memphis Blues—Fox-trot (Saxophone and Piano).....Wadsworth and Arden 10
My Lonesome Girl—Fox-trot (Saxophone and Piano).....Wadsworth and Arden 10

EMERSON PHONOGRAPH CO.

- Seven-Inch Records
PATRIOTIC AND POPULAR SONG HITS
7372 God Be With Our Boys To-night (Bowles-Sanderson)—Tenor Solo, orch. accomp..Frank Woods 10
(Continued on page 114)

RECORD BULLETINS FOR JULY

(Continued from page 113)

- Just Before the Battle, Mother (George F. Root)—Tenor Solo, orch. accomp... Frank Woods
7370 Just Like Washington Crossed the Delaware, General Pershing Will Cross the Rhine (Johnson-Meyer)—Patriotic Solo, orch. accomp., D. (Bud) Bernie
Bring Back My Soldier Boy to Me (Hirsch-Magine)—Tenor solo, orch. accomp. Frank Woods
7373 When Johnny Comes Marching Home (Louis Lambert)—Patriotic Novelty Song, orch. accomp., Harry Evans and Excelsior Trio
The Russians Were Rushin', the Yanks Started Yankin' (McCarron-Morgan)—Patriotic Solo, orch. accomp., D. (Bud) Bernie
7366 We'll Keep Things Goin' Till the Boys Come Home. Won't We Girls? (Sterling-Solman)—Character Song, orch. accomp., Edith King
What'll We Do With Him, Boys? The Yanks Made a Monkey Out of You (Sterling-Lange)—Patriotic Character Song, orch. accomp., George L. Thompson
7371 After the War Is Over Will There Be Any "Home Sweet Home?" (Pourmon-Woodruff-Andriou)—Tenor Solo, orch. accomp., Frank Woods
A Little Bit of Sunshine From Home (Macdonald-Goodwin-Hanley)—Patriotic Solo, orch. accomp., Harry Evans
7365 I'm Hitting the Trail to Normandy, So Kiss Me Good-Bye (Charles Snyder)—Tenor Duet, orch. accomp., Rice & Rhodes
Oh! Min! (Olsen-Jones)—Novelty Comedy Song, orch. accomp., Eddie Nelson
7364 Those Draftin' Blues (Maceo Pinkard)—Character Song, orch. accomp., Arthur Collins
When It Comes to a Lovingless Day (Jack Frost)—Character Song, orch. accomp., Eddie Nelson
7363 Just a Little Cottage, I'll Call It "Home Sweet Home" (Harriman-Egan)—Vocal Trio, orch. accomp., Excelsior Trio
Turn Those Wonderful Eyes Away (Spero-Peck)—Sentimental Ballad, orch. accomp., Henry Lewis
7352 The Sunshine of Your Smile (Lilian Ray)—Tenor Solo, orch. accomp., Robert Rice
Somewhere a Voice Is Calling (Arthur F. Tate)—Tenor Solo, orch. accomp., Robert Rice
BIG DANCE HITS
7368 I Hate to Lose You (Archie Gottler)—Fox-trot, Emerson Military Band
Jack Tar (John Philip Sousa)—March and one-step, Emerson Military Band
7369 Some Shape (George L. Cobb)—One-step, Emerson Military Band
Valse Marie (Harry Israel), Emerson Military Band

HEINEMAN PHONOGRAPH SUPPLY CO.

- 1001 Star Spangled Banner... Band 10
American Patriotic Medley... Band 10
1002 Dance of the Hours... Band 10
Ballet Music from Coppelia... Band 10
1003 Poet and Peasant... Band 10
Carmen Selection... Band 10
1004 OkeH Military March... Band 10
American Patrol... Band 10
1005 National Emblem... Band 10
Naval Reserve... Band 10
1006 Boston Commandery March... Band 10
Land of the Maple... Band 10
1007 Over There... Sterling Trio
Just Before the Battle, Mother... Campbell-Burr
1008 They Were All Out of Step But Jim... Ada Jones
The Little Good for Nothing, etc., Campbell-Burr
1009 Keep the Home Fires Burning... Joseph Phillips
There's a Long, Long Trail... Harry McClaskey
1010 When the Boys Come Home... Henry Burr
The Trumpeter... Charles Hart
1011 Because... Harry McClaskey
I'm Only Dreaming of You... Reed Miller
1012 Good-night, Little Girl, Good-night, Harry McClaskey
Because I Love You, Dear... Lewis James
1013 Maid of the Mill... Reed Miller
Clang of the Forge... Greek Evans
1015 Just a Wearyin' for You... Marie Morrissey
Violets... Grace Kerns
1016 Silver Threads Among the Gold... Sterling Trio
Way Down Yonder in de Cornfield, Peerless Quartet
1017 When You and I Were Young, Maggie, Sterling Trio
Kentucky Babe... Peerless Quartet
1018 Beautiful Isle Somewhere... Meyer and Gillette
Sweet and Low... Croxton Quartet
1019 Holy City... Joseph Phillips
Praise Ye-Attila... Croxton Quartet
1020 O Morning Land... Meyer and Gillette
Crucifix... Hart and Phillips
1021 Down, Down, Down on the Ohio, Collins and Harlan
Cleopatra... Collins
1022 Alimony Blues... Collins
Three Pickaninnies... Collins and Harlan
1023 Derby Day in Dixie... Jones and Thompson
'N' Everything... Thompson
1024 Coken Phones the Garage... George Thompson
Colored Recruit, The... Golden and Heins
1025 Oh, Lady, Lady... Van Eps Quartet
Sing, Ling Ting... Van Eps Quartet
1026 Rainbow Girl... Jazarimba Orchestra
Castle Valse... Jazarimba Orchestra
1027 Camouflage... Orchestra
Leave It to Jane... Van Eps and Orchestra
1028 Jazzie Addie... Jazarimba Orchestra
Tinkle Toc... Band
1029 Drowsy Water... Hawaiian Duet
Hawaiian Hula Medley... Hawaiian Duet
1030 Traumerci... V. Dubinsky

- The Swan... V. Dubinsky 10
1031 Cavalleria Rusticana Intermezzo—Violin solo, Fred Landau 10
Titl's Serenade—Cello and Flute Duet, Schubert and Wagner 10

LYRAPHONE CO. OF AMERICA

- CONCERT AND OPERATIC SERIES
7111 Good-night—Quartet (from "Martha"), Lyric Opera Quartet 10
Potpourri (from "Lohengrin"), Lyric Symphony Orchestra 10
9108 Tannhauser Overture—Part I (Wagner), Lyric Symphony Orchestra 12
Tannhauser Overture—Part II (Wagner), Lyric Symphony Orchestra 12
STANDARD SONGS
6139 Just a Wearyin' for You (Jacobs-Bond), Miss Esther May, Contralto 10
Kentucky Babe (Geibel), Miss Esther May, Contralto 10
6140 The Americans Come (Fay Foster), John Vernon, Tenor 1
Freedom, For All, Forever (Lieut. Hillian), John Vernon, Tenor 10
6141 Will You Remember (from "Maytime"), James Tree, Tenor 1
Because... James Tree, Tenor 10
6142 Any Time's Kissing Time (Chu Chin Chow), Henry Burr, Tenor 10
At Siesta Time (Chu Chin Chow), Esther May, Contralto, and Henry Burr, Tenor 10
POPULAR SONG HITS
5130 What'll We Do With Him, Boys (Sterling-Lange), Arthur Fields, Baritone 10
5131 We Stopped Them at the Marne (Lieut. Gitz Rice), Arthur Fields and Male Quartet 10
Canadian Patrol (Dewellyn)—March, Lyric Band 10
5132 If He Can Fight Like He Can Love, James Tree, Tenor 10
The Volunteers (Sousa)—March... Lyric Band 10
5133 Your Lips Are No Man's Land But Mine (Empey-Morgan), John Lawrence, Tenor 10
United Empire March (Hughes)... Lyric Band 10
DANCE AND INSTRUMENTAL RECORDS
4143 Sweet Little Buttercup. Intro. "Cleopatra," from "Sinhad"—Medley One-step, Lyric Dance Band 10
4144 Oh, Lady, Lady (Kern)—Medley Fox-trot, Lyric Dance Band 10
Stock Yard Blues (Pinkard)—Fox-trot, Van Eps Trio 10
4145 When the Saxophone Is Playing—Medley Fox-trot, Van Eps Trio 10
While the Incense is Burning—Medley Fox-trot, Lyric Dance Band 10
4146 Somewhere in Hawaii (MacMeekin), Louise and Ferera 10
Hawaiian Nights (Roberts)... Louise and Ferera 10

EMERSON PHONOGRAPH CO.

- Sixty-five Cent Records
Patriotic and Popular Song Hits
932 They Were All Out of Step But Jim (Irving Berlin)—Patriotic Character Song, orch. accomp., Eddie Nelson
'N' Everything (DeSylvia-Kahn-Jolson)—Character Song, orch. accomp., Eddie Nelson
937 The Russians Were Rushin'. The Yanks Started Yankin' (McCarron-Morgan)—Patriotic Song, orch. accomp., Arthur Fields
We Stopped Them at the Marne. It's To With Germany (Lieut. Gitz Rice)—Patriotic Solo, orch. accomp., Arthur Fields
928 The Last Long Mile (Emil Breitenfeld)—Comic Patriotic Solo, orch. accomp., Harry Evans
A Little Bit of Sunshine From Home (Macdonald-Goodwin-Hanley)—Patriotic Solo, orch. accomp., Harry Evans
934 Take Me Back to Dear Old Blighty (Mills-Godfrey-Scott)—Patriotic Solo, orch. accomp., Arthur Fields
Keep the Home Fires Burning Till the Boys Come Home (Ford-Novelle)—Patriotic Solo, orch. accomp., Harry Evans
931 You're a Better Man Than I Am, Gunga Din (Ehrlich-Osborne)—Character Song, orch. accomp., Henry Lewis
I Think You're Absolutely Wonderful. What Do You Think of Me? (McCarthy-Carroll)—Baritone Solo, orch. accomp., Henry Lewis
930 I'm Sorry I Made You Cry (N. J. Clesi)—Tenor Solo, orch. accomp., James Matthew
I'm Always Chasing Rainbows (Carroll-McCarthy)—Tenor Solo, orch. accomp., Samuel Ash
935 Just a Little Cottage, I'll Call It "Home Sweet Home" (Harriman-Egan)—Vocal Trio, orch. accomp., Sterling Trio
"Forever" Is a Long, Long Time (MacBoyle-Al Von Tilzer)—Tenor Solo, orch. accomp., Frank Woods
936 Chimes of Normandy (Wells-Bryan)—Vocal Trio, orch. accomp., Sterling Trio
Bring Back My Soldier Boy to Me (Hirsch-Magine)—Tenor Solo, orch. accomp., Frank Woods
929 There's a Long, Long Trail (King-Elliott)—Tenor Solo, orch. accomp., Henry Burr
The Missouri Waltz, Hush-A-Bye Ma Bahy (Shannon-Logan)—Tenor Solo, orch. accomp., Henry Burr
FAVORITE DANCE AND BAND HITS
938 There'll Be a Hot Time for the Old Men While the Young Men Are Away (Clarke-Meyer)—One-step, Emerson Military Band
I Hate to Lose You (Archie Gottler)—Fox-trot, Emerson Military Band
933 National Emblem (E. E. Bagley)—March and one-step, Emerson Military Band
Gate City (A. F. Weldon)—March and one-step, Emerson Military Band

N. Y. RECORDING LABORATORIES

- RECORDS FOR DANCING
30036 Athene Waltz... Paramount Dance Orchestra
Missouri Waltz (Knight-Logan-Eppel), Paramount Dance Orchestra
30042 Moonlight Waltz, Red, White and Blue Marimbo Band
Captain Betty—One-step, Red, White and Blue Marimbo Band
30033 Livery Stable Blues—Fox-trot, Original Saxo-Jazz Orchestra
The Darktown Strutters' Ball (Shelton-Brooks), Cordes Jazz Orchestra
POPULAR, STANDARD AND SACRED SONGS
2057 They Were All Out of Step But Jim... Ada Jones
Lovingless Day... Ada Jones
30043 Onward, Christian Soldiers (Sullivan), Shannon Four
Believe Me If All Those Endearing Young Charms (Moore)... Harry McClaskey
30037 Danny Deever (Kipling-Damrosch)... Royal Dadnum
Evening Star (Tannhauser)... Royal Dadnum
30044 The Dear Little Shamrock (Cherry)... Charles H. Hart
The Kerry Dance (Molloy)... Charles H. Hart
30038 Sing Me to Sleep (Greene)... Lewis James
Killarney (Balfe)... Lewis James
INSTRUMENTAL RECORDS
30040 Morning, Noon and Night Overture, Part I (Von Suppe)... Rogers Symphony Orchestra
Morning, Noon and Night Overture, Part II (Von Suppe)... Rogers Symphony Orchestra
30031 Minuet in "G" (Beethoven)—Violin Solo, Samuel Gardner
Serenade (Shubert)—Violin Solo... Samuel Gardner
30041 Annie Laurie (Scott)—Violin Solo... Arthur Gramm
Silver Threads Among the Gold (Danks)—Violin Solo... Arthur Gramm
30035 Blaze Away March (Holzmann), Paramount Military Band
Jolly Coppersmith (Peters), Paramount Military Band

PROSPERITY IN THE SOUTH

W. Terhune, of Atlanta, Tells of Improved Conditions in That Section—Visitors to Columbia Headquarters During the Past Week

There were quite a number of visitors recently at the executive offices of the Columbia Graphophone Co. in the Woolworth Building, New York, including several of the branch managers from different parts of the country. Among these visitors were James P. Bradt, general manager of the Columbia Co.'s Canadian business; Irby W. Reid, manager of the St. Louis branch, accompanied by C. R. Salmon, one of the members of his sales force; Westervelt Terhune, manager of the Atlanta branch, and A. J. Heath, manager of the Philadelphia branch.

All of these callers spoke enthusiastically of the Columbia business being closed in their respective territories, and as every Columbia branch is showing a substantial gain over 1917 this enthusiasm was substantiated by sales totals for the past four months.

In a chat with The World Mr. Terhune commented upon the very satisfactory industrial and financial status of the South at the present time. The Columbia branch in Atlanta has averaged more than 100 per cent. gain for every month of 1918 as compared with 1917, and Columbia dealers in the Atlanta district are closing a banner year. Mr. Terhune commented upon the fact that a large proportion of Columbia representatives in his territory are discounting their bills, and retail merchants in the South are in splendid financial shape. This gratifying condition cannot fail to benefit the Eastern manufacturers in all lines, who will find in the South a permanent and profitable market for their merchandise.

SOME SALES POINTERS

Before you make an approach, put yourself in your prospect's place. Try to imagine how he feels, what he is thinking, what he needs. Talk your goods over with him beforehand. Don't say one word that will bump him off the order-track. And when you've sold him in your mind, march in and sell the man himself.

Many a sale is lost because the salesman did not get at the real object in his prospect's mind. Don't use up your energy, therefore, overcoming a "straw" objection set up for you to shoot at. Use strategy to find the real obstacle—then demolish it. Don't understudy the machine that turns out form letters by the hours.—System.

DISPLAY CORTINA METHOD

The show windows of C. H. Ditson & Co. were devoted last week to a novel display of the Cortina method of studying military French by means of talking machine records and accompanying text books.

NEEDLES WE MANUFACTURE Diamond needles for Edison Sapphire needles for Edison Sapphire needles for Pathe in stock ready for delivery MERMOD & CO., 505 5th Ave., N. Y.

REPAIRS All Makes of Talking Machines Repaired Promptly and Efficiently TALKING MACHINE REPAIR AND SALES CORPORATION ANDREW H. DODIN, President 176 Sixth Avenue New York TELEPHONE, CHELSEA 8437

SOME OF THE LEADING JOBBERS OF TALKING MACHINES IN AMERICA

1856 **WURLITZER** 1916

VICTOR
DISTRIBUTORS
VICTORS EXCLUSIVELY

We make a specialty of getting the order out on time—every time.

The Rudolph Wurlitzer Co.
CINCINNATI AND CHICAGO
Two points of supply; order from the nearer

TEST IT. 

OUR VICTOR

Record Service

has a reputation for efficiency.
Suppose you try it.

E. F. DROOP & SONS CO.
1300 G. STREET, WASHINGTON, D. C.
231 N. HOWARD STREET, BALTIMORE, MD



Chas. L. Marshall & Co.
Wholesale Distributors for Michigan of

Sonora
THE INSTRUMENT OF QUALITY
CLEAR AS A BELL 

also representing Sonora Phonograph Sales Co. of New York in State of Ohio

810 Empire Bldg., Detroit, Mich.



Where Dealers May Secure

COLUMBIA

Product

STARR Phonographs and GENNETT Records
Complete Stock and REAL Service

Crafts-Starr

PHONOGRAPH CO.
Factory Distributors
218-220 NORTH SECOND STREET, RICHMOND, VIRGINIA
Write for Dealers' Proposition

Smith, Kline & French Co.
PHILADELPHIA

Wholesale Distributors for

Sonora
THE INSTRUMENT OF QUALITY
CLEAR AS A BELL 

In PENNSYLVANIA, NEW JERSEY and DELAWARE

Ready, Full Stocks, and Prompt Deliveries from Convenient Shipping Centers all over the United States.

Southern Victor Dealers
Largest Stock VICTROLAS and RECORDS. Prompt Shipment and Low Freight Rates.

WALTER D. MOSES & CO.
Oldest Music House in Virginia or North Carolina.
RICHMOND, VA.

Distributors

- Atlanta, Ga., Columbia Graphophone Co., 63 N. Pryor St.
- Baltimore, Md., Columbia Graphophone Co., 16 South Howard St.
- Boston, Columbia Graphophone Co., 137 Federal St.
- Buffalo, N. Y., Columbia Graphophone Co., 737 Main St.
- Chicago, Ill., Columbia Graphophone Co., 14 N. Michigan Ave.
- Cincinnati, O., Columbia Graphophone Co., 117-119 W. Fourth St.
- Cleveland, O., Columbia Graphophone Co., 1375 Euclid Ave.
- Dallas, Tex., Columbia Graphophone Co., 1011 Elm St.
- Denver, Colo., Columbia Stores Co., 1608 Glenarm Place.
- Detroit, Mich., Columbia Graphophone Co., 401 Woodward Ave.
- Indianapolis, Ind., Columbia Graphophone Co., 44 N. Pennsylvania St.
- Kansas City, Mo., Columbia Graphophone Co., 1027 McGee St.
- Los Angeles, Cal., Columbia Graphophone Co., 745 S. Broadway.
- Minneapolis, Minn., Columbia Graphophone Co., 412-414 Nicollet Ave.
- New Haven, Conn., Columbia Graphophone Co., 206 Meadow St.
- New Orleans, La., Columbia Graphophone Co., 517-525 Canal St.
- New York City, Columbia Graphophone Co., 55 Warren St.
- Omaha, Neb., Schmoller & Mueller Piano Co.
- Philadelphia, Pa., Columbia Graphophone Co., 210 N. Broad St.
- Pittsburgh, Columbia Graphophone Co., 632-640 Duquesne Way.
- Portland, Me., Columbia Graphophone Co., 43 Exchange St.
- Portland, Ore., Columbia Graphophone Co., 429-431 Washington St.
- Salt Lake City, Utah, Columbia Stores Co., 221 South West Temple.
- San Francisco, Cal., Columbia Graphophone Co., 130-150 Sutter St.
- Seattle, Wash., Columbia Graphophone Co., 911 Western Ave.
- Spokane, Wash., Columbia Stores Co., 818 Sprague Ave.
- St. Louis, Mo., Columbia Graphophone Co., 1127 Pine St.
- Tampa, Fla., Tampa Hardware Co.

OLIVER DITSON COMPANY
BOSTON

Largest VICTOR Talking Machine Distributors East of Chicago.

Creators of "The Fastest Victor Service." Let us tell you more about our service.

W. J. DYER & BRO.
NORTHWESTERN DISTRIBUTORS OF THE

VICTOR
Machines, Records and Supplies

 *Shipped Promptly to all Points in the Northwest*

ROUNTREE-CHERRY
RICHMOND VIRGINIA

Wholesale Distributors for

Sonora
THE INSTRUMENT OF QUALITY
CLEAR AS A BELL 

You
above all must be satisfied!

IN NORTH AND SOUTH CAROLINA

The Electric Supply & Equipment Co.
Exclusive Wholesale Distributors for Southern New England

Sonora
THE INSTRUMENT OF QUALITY
CLEAR AS A BELL 

Complete stocks carried in Boston and Hartford

Little Bldg. 103 Allyn St.
BOSTON, MASS. HARTFORD, CONN.

Victor Exclusively
EASTERN TALKING MACHINE CO.
177 Tremont Street, Boston
VICTOR DISTRIBUTORS

Sherman, Clay & Co.

San Francisco, Los Angeles, Portland, Seattle, Spokane
PACIFIC COAST DISTRIBUTORS OF
VICTOR PRODUCTS

THIS REFERS TO YOU, MR. DEALER

Every talking machine jobber in this country should be represented in this department, no matter what line he handles or where he is located. The cost is slight and the advantage is great. Be sure to have your card in this department of The Talking Machine World each month. It will pay you a big profit on the investment.

Headquarters for Canada:
Columbia Graphophone Co., 54-56 Wellington St., West, Toronto, Ont.

Executive Office
COLUMBIA GRAPHOPHONE CO.
Woolworth Building New York

The PERRY B. WHITSIT CO.
Distributors of
Victrolas and Victor Records
COLUMBUS, OHIO



The NEW EDISON

Bears the Stamp of Edison's Genius

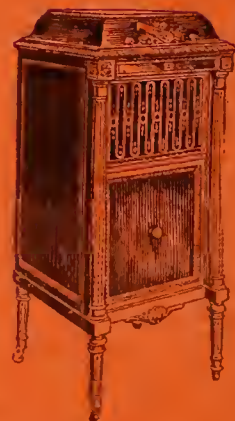
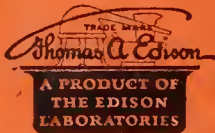

JOBBER'S OF THE NEW EDISON, EDISON RE-CREATIONS, THE NEW EDISON DIAMOND AMBEROLA AND BLUE AMBEROL RECORDS

CALIFORNIA
Los Angeles—Edison Phonographs, Ltd.
San Francisco—Edison Phonographs, Ltd.

COLORADO
Denver—Denver Dry Goods Co.

CONNECTICUT
New Haven—Pardee-Ellenberger Co., Inc.

GEORGIA
Atlanta—Phonographs, Inc.

ILLINOIS
Chicago—The Phonograph Co.
James I. Lyons. (Amberola only.)

INDIANA
Indianapolis—Kipp Phonograph Co.

IOWA
Des Moines—Harger & Blish.
Sioux City—Harger & Blish.

LOUISIANA
New Orleans—Diamond Music Co., Inc.

MASSACHUSETTS
Boston—Pardee-Ellenberger Co.

MICHIGAN
Detroit—Phonograph Co., of Detroit.

MINNESOTA
Minneapolis—Laurence H. Lucker.

MISSOURI
Kansas City—The Phonograph Co. of Kansas City.
St. Louis—Silverstone Music Co.

MONTANA
Helena—Montana Phonograph Co.

NEBRASKA
Omaha—Shultz Bros.
NEW JERSEY
Paterson—James K. O'Dea (Amberola only.)
NEW YORK
Albany—American Phonograph Co.

New York—The Phonograph Corp. of Manhattan.
Syracuse—Frank E. Bolway & Son, Inc.

W. D. Andrews Co. (Amberola only.)

Buffalo—W. D. & C. N. Andrews Co. (Amberola only.)

OHIO
Cincinnati—The Phonograph Co.
Cleveland—The Phonograph Co.

OREGON
Portland—Edison Phonographs, Ltd.

PENNSYLVANIA
Philadelphia—Girard Phonograph Co.

Pittsburgh—Buehn Phonograph Co.
Williamsport—W. A. Myers.

RHODE ISLAND
Providence—J. A. Foster Co. (Amberola only.)

TEXAS
Dallas—Texas-Oklahoma Phonograph Co.

UTAH
Ogden—Proudfit Sporting Goods Co.

VIRGINIA
Richmond—C. B. Haynes & Co.

WISCONSIN
Milwaukee—The Phonograph Co. of Milwaukee.

CANADA
Montreal—R. S. Williams & Sons Co., Ltd.

St. John—W. H. Thorne & Co., Ltd.

Toronto—R. S. Williams & Sons Co., Ltd.

Vancouver—Kent Piano Co., Ltd.

Winnipeg—R. S. Williams & Sons Co., Ltd.
Calgary—R. S. Williams & Sons Co., Ltd.



LIBRARY OF CONGRESS



0 021 248 783 1