

GETTING ACELA BACK ON TRACK

(109-17)

HEARING
BEFORE THE
SUBCOMMITTEE ON
RAILROADS
OF THE
COMMITTEE ON
TRANSPORTATION AND
INFRASTRUCTURE
HOUSE OF REPRESENTATIVES
ONE HUNDRED NINTH CONGRESS
FIRST SESSION

MAY 11, 2005

Printed for the use of the
Committee on Transportation and Infrastructure



U.S. GOVERNMENT PRINTING OFFICE

22-496 PDF

WASHINGTON : 2005

For sale by the Superintendent of Documents, U.S. Government Printing Office
Internet: bookstore.gpo.gov Phone: toll free (866) 512-1800; DC area (202) 512-1800
Fax: (202) 512-2250 Mail: Stop SSOP, Washington, DC 20402-0001

COMMITTEE ON TRANSPORTATION AND INFRASTRUCTURE

DON YOUNG, Alaska, *Chairman*

THOMAS E. PETRI, Wisconsin, *Vice-Chair*
SHERWOOD L. BOEHLERT, New York
HOWARD COBLE, North Carolina
JOHN J. DUNCAN, Jr., Tennessee
WAYNE T. GILCHREST, Maryland
JOHN L. MICA, Florida
PETER HOEKSTRA, Michigan
VERNON J. EHLERS, Michigan
SPENCER BACHUS, Alabama
STEVEN C. LATOURETTE, Ohio
SUE W. KELLY, New York
RICHARD H. BAKER, Louisiana
ROBERT W. NEY, Ohio
FRANK A. LoBIONDO, New Jersey
JERRY MORAN, Kansas
GARY G. MILLER, California
ROBIN HAYES, North Carolina
ROB SIMMONS, Connecticut
HENRY E. BROWN, Jr., South Carolina
TIMOTHY V. JOHNSON, Illinois
TODD RUSSELL PLATTS, Pennsylvania
SAM GRAVES, Missouri
MARK R. KENNEDY, Minnesota
BILL SHUSTER, Pennsylvania
JOHN BOOZMAN, Arkansas
JIM GERLACH, Pennsylvania
MARIO DIAZ-BALART, Florida
JON C. PORTER, Nevada
TOM OSBORNE, Nebraska
KENNY MARCHANT, Texas
MICHAEL E. SODREL, Indiana
CHARLES W. DENT, Pennsylvania
TED POE, Texas
DAVID G. REICHERT, Washington
CONNIE MACK, Florida
JOHN R. 'RANDY' KUHL, Jr., New York
LUIS G. FORTUÑO, Puerto Rico
LYNN A. WESTMORELAND, Georgia
CHARLES W. BOUSTANY, Jr., Louisiana
VACANCY

JAMES L. OBERSTAR, Minnesota
NICK J. RAHALL, II, West Virginia
PETER A. DeFAZIO, Oregon
JERRY F. COSTELLO, Illinois
ELEANOR HOLMES NORTON, District of
Columbia
JERROLD NADLER, New York
ROBERT MENENDEZ, New Jersey
CORRINE BROWN, Florida
BOB FILNER, California
EDDIE BERNICE JOHNSON, Texas
GENE TAYLOR, Mississippi
JUANITA MILLENDER-McDONALD,
California
ELIJAH E. CUMMINGS, Maryland
EARL BLUMENAUER, Oregon
ELLEN O. TAUSCHER, California
BILL PASCRELL, Jr., New Jersey
LEONARD L. BOSWELL, Iowa
TIM HOLDEN, Pennsylvania
BRIAN BAIRD, Washington
SHELLEY BERKLEY, Nevada
JIM MATHESON, Utah
MICHAEL M. HONDA, California
RICK LARSEN, Washington
MICHAEL E. CAPUANO, Massachusetts
ANTHONY D. WEINER, New York
JULIA CARSON, Indiana
TIMOTHY H. BISHOP, New York
MICHAEL H. MICHAUD, Maine
LINCOLN DAVIS, Tennessee
BEN CHANDLER, Kentucky
BRIAN HIGGINS, New York
RUSS CARNAHAN, Missouri
ALLYSON Y. SCHWARTZ, Pennsylvania
JOHN T. SALAZAR, Colorado

SUBCOMMITTEE ON RAILROADS

STEVEN C. LATOURETTE, Ohio *Chairman*

THOMAS E. PETRI, Wisconsin	CORRINE BROWN, Florida
SHERWOOD L. BOEHLERT, New York	NICK J. RAHALL II, West Virginia
JOHN L. MICA, Florida	JERROLD NADLER, New York
SPENCER BACHUS, Alabama	ROBERT MENENDEZ, New Jersey
JERRY MORAN, Kansas	BOB FILNER, California
GARY G. MILLER, California	ELIJAH E. CUMMINGS, Maryland
ROB SIMMONS, Connecticut	EARL BLUMENAUER, Oregon
TODD RUSSELL PLATTS, Pennsylvania	LEONARD L. BOSWELL, Iowa
SAM GRAVES, Missouri	JULIA CARSON, Indiana
JON PORTER, Nevada, <i>Vice-Chair</i>	PETER A. DeFAZIO, Oregon
TOM OSBORNE, Nebraska	JERRY F. COSTELLO, Illinois
MICHAEL E. SODREL, Indiana	EDDIE BERNICE JOHNSON, Texas
LYNN A. WESTMORELAND, Georgia, <i>Vice-Chair</i>	JAMES L. OBERSTAR, Minnesota <i>(ex officio)</i>
DON YOUNG, Alaska <i>(ex officio)</i>	

CONTENTS

TESTIMONY

	Page
Crosbie, William, Senior Vice President of Operations, Amtrak	46
Hecker, JayEtta Z., Director, Physical Infrastructure Issues, Government Accountability Office	13
Jamison, Robert D., Acting Administrator, Federal Railroad Administration ...	13
Jelensperger, Francis, President, Alstom Transportation Inc. of America	46
Spurr, William A., President, Bombardier Transport of North America	46
Weiderhold, Fred E., Jr., Inspector General, Amtrak	13

PREPARED STATEMENTS SUBMITTED BY MEMBERS OF CONGRESS

Brown, Hon. Corrine, of Florida	61
Costello, Hon. Jerry F., of Illinois	63
Oberstar, James L. of Minnesota	96

PREPARED STATEMENTS SUBMITTED BY WITNESSES

Crosbie, William	65
Hecker, JayEtta Z	71
Jamison, Robert D	89
Jelensperger, Francis	93
Spurr, William A	103
Weiderhold, Fred E., Jr.	111

SUBMISSIONS FOR THE RECORD

Jelensperger, Francis, President, Alstom Transportation Inc. of America, responses to questions	94
Mica, Hon. John L., a Representative in Congress from Florida:	
Letter to the Inspector Generals for the U.S. Department of Transportation and Amtrak, May 11, 2005	6
California Rail News, "Amtrak's Gunn Displays a Disarming Honesty", August 2002	30
Spurr, William A., President, Bombardier Transport of North America, responses to questions, and chart	108

ADDITION TO THE RECORD

Federal Transit Administration, Transit Threat Level Response Recommendation, report	117
--	-----

GETTING ACELA BACK ON TRACK

Wednesday, May 11, 2005

HOUSE OF REPRESENTATIVES, COMMITTEE ON TRANSPORTATION AND INFRASTRUCTURE, SUBCOMMITTEE ON RAILROADS, WASHINGTON, D.C.

The committee met, pursuant to call, at 10:00 a.m. in room 2167, Rayburn House Office Building, Hon. Steve LaTourette [chairman of the committee] presiding.

Mr. LATOURETTE. Good morning. The Subcommittee on Railroads will come to order.

I want to welcome all of our members and witnesses here today for the hearing entitled Getting Acela Back on Track. This will be one in a series that this Subcommittee will hold relative to Amtrak. Today's hearing will focus on the Acela train sets and the great difficulty. There will be additional hearings, we believe, in the months of May and June focusing on other aspects of Amtrak's operations. Then hopefully with the bipartisan work of all members of this Subcommittee, we hope to look at a number of reform proposals that are being circulated relative to the operation of Amtrak.

As all of you are probably aware, Amtrak's Acela train, which runs in the northeast corridor, was removed from service last month due to cracked brakes. As of today, all 20 Acelas remain parked while Amtrak, Bombardier and Alstom and various subcontractors work out the necessary repairs. Back in the 1990s, the Acela train was billed as America's answer to the French TGV and the Japanese bullet train. But the Acela has been faced with challenges from the beginning, even before the train went into service in the year 2000.

In 1999, the manufacturers had to deal with design issues which reduced the train's speed on curves and increased trip times. Then problems arose with excessive wheel wear, undercarriage vibration and broken bolts. The introduction of the Acela was delayed for many months while engineers developed a fix.

In 2002, after about 18 months of service, cracks began to develop in the brackets for the Acela's yaw dampers, a suspension component that look like a giant shock absorber. Engineers eventually worked out a solution to that problem as well.

Last month, Amtrak and the FRA were running an Acela speed test in the northeast corridor with the intention of raising the train's operating speed over a certain stretch of track. After the test, an FRA official asked to have a look at the train's undercarriage. That official was Rich Thomas, the FRA's motive, power and equipment specialist for region II. I think I would like to express on behalf of the Subcommittee a debt of gratitude to Rich.

His sharp eyes caught an important defect that everyone else to that moment in time had missed, serious cracks in the Acela's disc brakes. I don't know if the FRA gives out commendations and medals, but I think Rich certainly deserves one for his eagle eyes.

After further inspection, inspectors found cracked brakes on virtually every axle of every Acela train and the entire fleet was grounded. The decision to remove Acela train sets from service, though dramatic, was the right thing to do. In my opinion, Amtrak put the safety of its passengers and commuter operators in the northeast corridor and the traveling public at large ahead of revenue. They put safety first, and for that I think they should be commended.

I would also like to bring attention to another fact that seems to have been lost in all of this. Amtrak, due in large part to the size of its fleet and flexibility of its dedicated work force, was able to recall equipment from around the country to build complete Metroliner sets and place them in the Acela express time slots between New York and Washington with very little disruption to its customer base. This was a herculean task that was planned with little notice and executed with discipline and precision. If this had been almost any other operator, I question whether the results would have been the same.

We need to get to the root cause of the current difficulties with Acela, but more than that, we need to know how the lessons learned can help us improve rail safety in the future. For example, there is a serious question of information flow. I understand that the Acela technicians on the shop floor had not been fully informed as to what type of cracks to look for and where to look on the discs for cracks. There were no testing procedures in place to find these cracks, and the shop technicians apparently did not have access to the appropriate manufacturer's service bulletins.

In closing, I want to say that today's hearing is not about assessing blame, but rather about finding the best way to ensure the safety and efficiency of high speed rail service on the northeast corridor.

Before I yield to our distinguished Ranking Member, Ms. Brown, I want to issue an apology to the witnesses and members of the Subcommittee today. Even though the Chair believes that testimony to appear at this and any other hearing is embargoed until the time of the hearing, for some reason I woke up this morning and was able to read the testimony in the newspaper. I hope in the future the staff and members or whoever who has access to the testimony that helps us prepare for these hearings in the future will respect that embargo.

One reason that that is important is at least one of the witnesses today has brought additional testimony and an addendum that may in fact alter the nature and character and substance of the testimony that he or she intends to give. It is very important to the integrity of the hearing process that that information remains with us.

Also, I would like to ask unanimous consent for 30 days for members to revise and extend their remarks and permit the submission of additional statements and materials by the witnesses. Without objection, so ordered.

Now it is my pleasure to yield to our distinguished Ranking Member, Ms. Brown of Florida.

Ms. BROWN. Thank you, Mr. Chairman. Good morning, and I am glad you got a chance to read the paper.

I want to first of all thank you for holding this hearing. I think this is a very important hearing.

On April 15th, during a routine inspection of the Acela express train, the Federal Railroad Administration discovered cracks in the train's brake discs. This led to an investigation of brake discs on the entire system. Among the 1,400 brake discs, about half of the rotors had failed. As a result, Amtrak has been forced to suspend express service.

Let me first of all congratulate Amtrak for being cautious and erring on the safety side. I understand while the FRA recommended that Amtrak ground the fleet, it was Amtrak's decision to do so. Too often, this Subcommittee has investigated mechanical failures after the accident has occurred.

A few weeks ago, I attended a press conference on the crisis, and I just want to once again state how much I appreciate Amtrak and Amtrak workers for stepping up to the plate, working hard to minimize service disruptions and addressing the needs of Amtrak passengers. Amtrak has a lot to deal with. Since its inception in 2000, Amtrak has been plagued with a host of problems. First, there were problems with construction. There were delays, and of course the overruns in cost in delivering this train.

But let me say that I do not think the entire problem was Amtrak's. The Northeast Corridor Maintenance Company, under the auspices of the consortium, is responsible for maintaining these trains, not Amtrak. The consortium, however, never discovered the cracks. I understand that there is evidence that the consortium should have been inspecting and replacing brake discs with cracked spokes and hubs, but this never happened. In fact, a technical manual and a separate service bulletin that was sent to the consortium both recommended routine inspections and replacement of cracks, but these recommendations were ignored.

I feel that if FRA inspections had not found the cracks in these spokes, the consortium would not have identified these problems until it was too late, until a major accident had occurred. I believe, however, that this tragedy was a blessing in disguise. But I wish that the Administration, who has proposed separate operations from infrastructure in a so-called Amtrak Reform plan, this crisis is the perfect example of why this is a bad idea.

About a month ago, this Committee visited Europe, the British system. We found out that the separation of maintenance and operations was a major reason why they had several disastrous accidents, and now the whole system is going forward with trying to pull it back together. We do not have to make that mistake here in the United States. We need to work together to ensure that we have quality transportation rail service in the United States.

I yield back the balance of my time.

Mr. LATOURETTE. I thank the gentlelady very much.

Mr. Mica?

Mr. MICA. Thank you, Mr. Chairman and Ranking Member. Both of you I think quoted the story that is in the Washington Post

today. Let me just correct the story. It starts out: "The brake problem that sidelined Acela high speed trains last month appears to be the result of fatigue in the metal components." First of all, that is a gross misstatement, because what has happened here is not the failure of a brake system, it is the failure of Amtrak to be able to properly run a high speed system or high speed corridor. It is difficult when you have a dysfunctional organization trying to operate.

Then it says—let me read the next part. "Amtrak is losing a million dollars every week that the Acela express train is out of service and faces a serious cash crunch to continue operations to the end of the fiscal year." Even if Acela were running, it would still face similar losses.

Then let me read, "Meantime, the April 15th shutdown of the high speed service continues to inconvenience thousands of commuters on Amtrak's northeast corridor, which runs from Washington to New York." Now listen to this, this is the best part. "Amtrak has substituted more regular speed Metroliner service between the three cities." Acela only ran between one and two miles an hour difference than the Metroliner.

So there are a number of errors and misconceptions that the press is reporting today. In fact, ladies and gentlemen of the Subcommittee, this is probably the most costly and mismanaged rail project in the history of passenger rail service, not only in the country but probably the world. Three point two billion dollars spent to date. In fact, if you look at the costs over the period of time, it is subsidized to the tune of about \$14,000 per passenger that we are running on this. We probably could have bought limousines and brought them back and forth from Washington to New York and Boston cheaper.

This is frightening, because it was not Amtrak that discovered the flaw in this braking system. It was not the vendor, who has been paid millions of dollars and is also responsible. But what it was in fact was FRA that accidentally, as I understand it, found this flaw. What you have here, ladies and gentlemen, is again, a problem from the very start in the structure and Amtrak trying to run a high speed corridor.

Even if we fix this, they won't get it right. First of all, the bungled the acquisition, they bought the wrong equipment. They changed the specs. Read the history of it. They have bungled management. I could go on and detail that, but it is almost farcical. They have bungled oversight. Again, FRA found this, neither the vendor nor Amtrak found this error that could have resulted in a great tragedy.

I am a strong supporter of high speed rail system and service, not only for the northeast corridor but across the United States. It will take billions and billions of dollars to build these. I have no problem with supporting that corridor, the northeast corridor or additional corridors which we desperately need in at least a dozen approved corridors across the United States. But I'll be darned if I will give it to people with a record like this. We need to take Amtrak out of the high speed service, turn it over to a consortium of the States and the private sector. We can run a service that will relieve our congested airports and highways.

Finally, Mr. Chairman, I am going to ask, I have looked at this whole problem, the whole bungled acquisition. One thing that frightens me is the hosing that the taxpayers have taken in this entire matter of again, a bungled management oversight and acquisition program. I have found that tens of millions of dollars have been spent in legal fees, some for in-house and some for contracted consulting service. I have a letter today, and I will ask for that to be part of the record, I am going to ask the Inspector General of the Department of Transportation to investigate and review all the expenses, not just on this braking system, but on this entire failed enterprise, report back to me and also to the Subcommittee.

So with that, Mr. Chairman, again, I am a strong supporter of high speed service alternatives for passengers on rail, and look forward to working with you and hopefully changing this whole structure, not just the brakes. Thank you.

Mr. LATOURETTE. I thank the gentleman for his observations. Without objection, your letter will be made part of the record.

[The information follows:]



U.S. House of Representatives
Committee on Transportation and Infrastructure
Washington, DC 20515

Don Young
Chairman

James L. Oberstar
Ranking Democratic Member

May 11, 2005

Lloyd A. Jones, Chief of Staff
Elizabeth Megginson, Chief Counsel

David Heymsfeld, Democratic Chief of Staff

Mr. Kenneth M. Mead
Inspector General
U.S. Department of Transportation
400 Seventh St, SW
Washington, DC 20590

Mr. Fred E. Weiderhold, Jr.
Inspector General
National Railroad Passenger Corporation
10 G Street NE
Washington, DC 20002

Dear Mr. Mead and Mr. Weiderhold:

I respectfully request that the Department of Transportation Inspector General, contemporaneous with the Inspector General of the National Railroad Passenger Corporation, audit and investigate all of Amtrak's legal expenditures and costs, including counsel or other project professional services retained under private or other auspices, relating to the Northeast High Speed Rail Improvement Project since its inception.

Please include detail on Amtrak's legal procurement process and expenditures relating to the acquisition and maintenance of the Acela equipment, the electrification of the Northeast Corridor (NEC) and other improvements required for the project.

It would be most appreciated if you could provide both me and the House Subcommittee on Railroads with your findings as soon as possible.

Sincerely,

John L. Mica
Member of Congress

JLM:grb

Mr. LATOURETTE. Mr. Blumenauer.

Mr. BLUMENAUER. Thank you, Mr. Chairman. I deeply appreciate the Committee having the hearing today to focus on these issues. I hear my good friend from Florida talk about turning something over to Amtrak and talking about their record. Well, the people, in my judgment, with the record that is not something that I am proud of is the record that Congress has of unrealistic expectations and failure to fund an adequate capital program.

The people that I am concerned about and one of the questions I would like to explore in the course of this hearing deals with, what is it that forces Amtrak to have to, as Ms. Hecker has in the first page of her testimony, talk about the fact that they can't buy something off the shelf. There are products that work all over the world with proven records of safety. Why is it that Amtrak is forced to have to assemble something that has serial number 0000001 in the backdrop of Congress and others' steady drumbeat to force Amtrak to move quickly over tracks where there is not adequate capital investment and where Congress refuses to give them the opportunity to be flexible in terms of the management. And they are still liable, in some cases, for costs that date back far before Amtrak was even formed.

So Mr. Chairman, I appreciate the hearing. I appreciate the fact that we are going to be getting at some short term concerns about these safety issues. I too am pleased that we got ahead of the curve and I am looking forward to answers about maintenance and expectation.

But I am hopeful that before this Subcommittee finishes its job that it stops having Amtrak service as some sort of punching bag and that we look at the forces that require us to have these train sets established in the first place and the unrealistic expectations and the pressures that are brought to bear with the regulatory agencies. I have had experience in my hometown when we are trying to get rail initiatives that we can't buy off the shelf equipment from Europe for smaller scale projects that add cost and complexity, and as near as I can tell, don't add safety.

So I think we ought to get at the regulatory regime and the context in which this goes. I will submit a more extensive statement, even though it is hard to believe. But I want to at least put this on the record as we move forward.

Mr. LATOURETTE. I thank the gentleman very much.

It is the Chair's intention to permit every member to make an opening statement, particularly those in the northeast corridor who have great concerns with Acela. But staff has advised me that Mr. Jamison and his wife are expecting a child any minute. So if we could sort of move through it expeditiously, I would appreciate it.

Mr. Westmoreland? No statement. Mr. Nadler.

Mr. NADLER. Thank you, Mr. Chairman.

Mr. Chairman, I thank you for holding this hearing today regarding Amtrak's Acela. This is an issue of particular concern to me, given that my district contains Penn Station in New York City, by far the largest Amtrak station in the country. I am personally a frequent rider of Amtrak from New York to Washington, practically every week that Congress is in session. So I have a great person

interest in seeing Amtrak's Acela back in operation and running in reliable service.

We know that Amtrak has problems. While I am interested to hear from the witnesses today as to the particular causes of this particular problem, we know the larger answer to the larger problem is quite clear. I hope that the Acela issue is not used as an excuse to further dismantle the railroad.

The Administration has long seen problems with Amtrak and decided to chuck the whole thing. The Administration wants to derail the system by breaking Amtrak up into small pieces, gutting protections for railroad workers and trying to split the northeast corridor, the jewel of the Amtrak system, in a way that has failed spectacularly elsewhere, most notably in Great Britain.

And in a spectacular display of contempt for the northeast part of the country, the Administration has proposed spending no money on Amtrak this year in order deliberately, intentionally to drive it into bankruptcy. This Administration looks at Amtrak and says, if only we had better management, or if only we busted the unions. Or if only we let private companies come in and run the trains. If only we had competition, then we would have a profitable passenger rail network and everything would work itself out.

Apparently the Administration forgets, as do some members of this panel, that the reason Amtrak was created in the first place was because the private railroads begged the Government to stop making them carry passengers. We took these money-losing routes off the hands of the private railroads with their inadequate infrastructure and attempted to create a new railroad. Not surprisingly, things have not gone entirely smoothly.

I believe the answer is actually quite simple. First, people need to stop making the false assumption, the absurd assumption that transportation systems are profitable. The airlines and the highways are both heavily subsidized by taxpayers, and they should be. Because they provide a vital public service and they are critical to our economy. But neither of them is profitable, at least not without significant public investment. At the very least, they are not self-sufficient. We should not try to require Amtrak to be self-sufficient, either. It is impossible, it is illusory. It does not make good sense as transportation public policy and the requirements that this Congress has imposed on Amtrak, to promise to be self-sufficient, are requirements to be hypocritical and self-defeating.

Second, we need to finally start investing adequate resources in Amtrak to allow the railroad to provide stable, reliable service. One of the reasons, I believe, perhaps the chief reason for the problems we are having with the Acela now is that the prototype testing was rushed and skimmed on to a large extent to save money, because they did not have the funds. We spend approximately \$50 billion a year on highways and aviation, but only about \$1 billion on Amtrak, even though rail is a more energy efficient mode of transportation.

Mr. Menendez and I are working on legislation called TRAIN-21 that would provide Amtrak the funding it needs to improve service in its current system, as well as provide a funding mechanism to upgrade high speed corridors around the country. I believe that positive measures that invest in rail, such as TRAIN-21, are what

is needed to keep Amtrak stable, or rather to restore it to stability, and to give it the resources it needs to get the Acela back on track and to get better systems in place.

I hope this hearing can be useful in determining exactly what steps need to be taken to fix this problem in the most efficient manner possible. I look forward to working with my colleagues to make sure that Amtrak has the resources it needs to do the job and does not fall prey to the kind of delusions that the Administration and some members of this panel that we heard a few minutes ago are subject to.

Thank you, Mr. Chairman.

Mr. LATOURETTE. I thank the gentleman.

Ms. Brown tells me that Mr. Cummings, you are next in seniority. Mr. Cummings.

Mr. CUMMINGS. Thank you very much, Mr. Chairman.

I want to associate myself with everything that has been said by my Democratic colleagues. I want to thank you, Mr. Chairman, for calling this hearing today to enable us to assess what must be done to ensure that Acela does not continue to be plagued by service interruptions.

Acela is critical to Amtrak's revitalization and to transportation on the northeast corridor. We must ensure that Acela is a reliable service. Unfortunately, the history of Acela has been one of disappointment almost from its inception. The scheduled start date of Acela service was delayed by more than one year, and when the service finally did begin, the first Acela train arrived at its destination more than 10 minutes late. The current problems with Acela's brake system are just one in a series of equipment failures that have resulted in service interruptions since 2001.

A brief review of the history of the creation of Acela reveals essential lessons that must be considered by the Subcommittee as we examine what should be done now to improve Acela. After committing to develop high speed service, Amtrak examined high speed trains already in use in Europe. However, according to statements by Amtrak board members reported in the papers at the time, Amtrak ultimately chose a new and completely untried system because it came with an attractive financing package provided by the Canadian government. Amtrak ordered the first Acela trains even before the Federal Railroad Administration had promulgated safety regulations for such Tier II trains.

When these regulations were announced, they required Acela's engines to be heavier than any other high speed train in the world. Compliance with these regulations also required Amtrak to make extensive design changes. Despite the fact that Acela design was new, Amtrak apparently felt pressure to put it into service quickly, and therefore decided not to build and test a prototype. As a result, design flaws, such as the impact of its weight that might have been resolved before Acela was in revenue service, are now being addressed through these repeated service suspensions.

What happened between the time the promise of groundbreaking high speed rail service was made and the delay a year later than planned that this troubled train was put into revenue service? To begin with, Amtrak was pressured to develop its high speed service as quickly as possible, but the effort was underfunded. Unfortu-

nately, these pressures shaped Amtrak's choices, starting with the choice of the Acela design itself, which could be described as a choice of funding over function.

Further, the Administration and Congress committed to develop high speed rail service without committing to spend the full amount necessary to create the track infrastructure needed to support truly high speed service. As a result, Acela is designed to travel at 150 miles per hour but it is able to achieve that speed on less than 35 miles of track along the entire northeast corridor. Consequently, the introduction of Acela has not reduced the trip time between New York and Boston to less than three hours, as required by the 1992 Amtrak Reauthorization and Development Act.

Finally, unfortunately it seems that Amtrak failed to manage properly the limited funding it was given to upgrade track along the northeast corridor. A report issued by the well-respected GAO in February 2004 found that "Neither Amtrak nor the FRA exercised effective management or oversight of the northeast high speed rail improvement project." The GAO report also found that Amtrak failed to develop a comprehensive management plan for its infrastructure project.

In other words, the story of Acela train is the story of Amtrak itself. Amtrak has been given competing goals over the years, sometimes being told to focus on providing the broadest possible service and at other times being told to obtain financial self-sufficiency. Throughout its existence, however, it has been underfunded and the capital infrastructure on which it operates is still in need of extensive upgrades and repairs.

So, Mr. Chairman, we must set clear goals for Acela. We must fund it adequately and we must be vigilant in demanding that Amtrak respond to our investment by improving its own management and service efficiency. We cannot continue to repeat our past mistakes regarding our Nation's inter-city passenger rail service.

With that, I yield back.

Mr. LATOURETTE. I thank the gentleman.

Mr. Oberstar?

Mr. OBERSTAR. Thank you, Mr. Chairman.

I think it is important to have this hearing. I hope it does not evolve into a hearing on whether Acela or whether Amtrak, but stay focused on the issue of what went wrong here in this very important aspect of the Acela technology. I am for Amtrak, said it many times, I don't need to repeat all that. I think the Acela was a great innovation in American rail technology. It still leaves us a third world country in terms of high speed passenger rail transportation.

But this technology of Acela, Mr. Chairman, has had repeated problems. What we are confronted with today as the subject of our hearing is the disc brakes, or brake discs. This is not a new issue of technology. Fifteen years ago, a DC-10 crashed in Iowa, crash landed in Sioux City after losing a disc in the tail engine. Titanium, not just any piece of metal, highest quality metal cast anywhere in the industrialized world. It failed.

We can take lessons from the DC-10 experience and apply them to Acela as we do throughout aviation. Redundancy in the manu-

facturing process and redundancy in the oversight and conduct and oversight of maintenance.

There are two issues here. One is the casting of the brake discs themselves, and the maintenance conducted on those brakes. Let me deal with the first issue. The bible of steel, which I keep in my office, Making, Shaping and Treating of Steel, the U.S. Steel Company, has an entire chapter on castings of steel and iron. What is critically important are, or factors that are critically important are the temperature at which the steel is cast, the rate at which the cast is cooled, the gating through which the steel is poured from the ingot into the mold, and the purity of the product itself.

As far as I can tell from the testing done so far, neither Bombardier-Alstom nor Amtrak has gone far enough into the technology of the casting of this steel. That is why I have asked for further inquiry into this matter of the original equipment manufacturer's technical manual. I have asked the Amtrak inspector general to deliver the technical manual on brake disc rotors. I think we will, I will probe, of course, in this hearing, the extent to which oversight has been conducted by the Federal Railroad Administration, Amtrak itself and its contractor, Bombardier.

The failure in the DC-10 was a failure both of casting and of oversight. There have been no accidents yet on Acela, been no injuries or fatalities, thank God. But there were 110 lives lost in that failure of the United Airlines DC-10 in Sioux City, Iowa. Fine, fine submicroscopic hairline crack, propagated over a period of time to cause catastrophic failure. The discs separated, the engine went through the hydraulic lines, landed in a cornfield, was recovered by NTSB. And the metallurgical analysis done in meticulous detail, notably absent in the inquiries so far, and in that respect this hearing may be somewhat premature, but nonetheless, it is important for us to stay on top of this matter.

The same principle applies here. You have a fine crack, and it propagates. Then you are in the presence of a real or potential catastrophic failure. The design life of the brake disc rotors, from all the documents I have read, and I have read a good many of them, 1 million miles. But the cracks appeared much earlier, 300,000, 400,000, 650,000 miles. Now, if this vehicle had been traveling at true high speeds of 175, 185 miles an hour, it very likely could have had catastrophic failure.

So we have to review in considerable detail not only the casting, the manufacture and the specifications for this part, but also the conduct of maintenance. That is critical to safety. That is where I think there has been a lapse.

Back to the casting, you have to look at the shape, the metal specifications, chemical composition of the molten metal, whether there is a possibility that sulfur wax from the molds could have propagated into the molten metal, creating gating, risering and whether in fact the metal was heated to its required specification, 3,000 degrees Fahrenheit. Until we understand all of those issues, we are not going to fully understand what has gone wrong here. Those are the issues, should be the primary factors.

Then I think we have to look very carefully at the qualifications of the maintenance personnel, their skill in detecting submicroscopic cracks in the hubs, the connections of the spokes. And I

think we need to oversee Amtrak's and Bombardier's inquiry into this process. I think we need some outside metallurgical consultants to take a close look at this issue, Mr. Chairman.

I thank you very much for the time.

Mr. LATOURETTE. I thank the gentleman very much for his observations. One of the reasons that members on both sides of the aisle benefit so greatly from the distinguished Ranking Member's institutional knowledge and other knowledge, I would venture to say you are probably one of the few members that has the steel bible here on his bookshelf in Washington, D.C.

[Laughter.]

Mr. LATOURETTE. Mr. Menendez.

Mr. MENENDEZ. Thank you, Mr. Chairman, for holding this hearing and for this opportunity.

Mr. Chairman, if we can accomplish one thing at today's hearing, I hope that we can correct the misperception, at least my belief a misperception, that this whole problem was Amtrak's fault. Let's be clear. Amtrak did not design the brake discs, they did not produce them, and everything that I have seen at least to date indicates that they had no knowledge of any of the potential problems until the cracks were discovered. Amtrak has in fact, in my view, performed admirably by moving quickly in taking the Acela out of service, even though they knew it would cost millions of dollars in lost revenue.

I believe the real problem is the combination of unrealistic expectations and insufficient support that Amtrak has struggled with since its creation. Thirty-four years of funding Amtrak does not even equal one year of highway funding. We should not be surprised that Acela has suffered a number of embarrassing setbacks since they were encouraged to rush a high speed train into service in the name of becoming profitable. Instead of being able to select a train purely on its merits, they were forced to take a largely untested design because it had the most attractive financing deal.

To solve Amtrak's problems, we do not need to sell off the northeast corridor, force the States to pay the whole cost so that their State transit systems that largely run, as in my State of New Jersey, on Amtrak's lines and would leave tens of thousands of travelers either stranded or with increasingly high fares, or break it into a number of smaller companies, I don't think those are our solutions. Those solutions, in a similar set of circumstances, were utter failures in Great Britain.

What we need to do is make the serious financial commitment that should have been there from the beginning. We need to provide Amtrak with a stable and robust funding source so that it can fix its backlog of deferred maintenance, run more trains, run them faster and run them on time. To that end, I will soon be introducing my TRAIN-21 legislation, along with Congressman Nadler and others, that provides Amtrak the money it needs, establishes a new State matching program designed to improve the quality of train service in rail corridors throughout the country.

Amtrak is a national transportation asset that provides a vital service for the 25 million people who ride it each year. It is time we treated it as such.

As someone who sits right across from New York City in the context of my congressional district, and who lost many citizens on September 11th, it is astounding to me that we do not view Amtrak as a vital component of national security in the need for multiple modes of transportation in the eventuality of a terrorist attack. On that fateful day, when September 11th took place, the only way out of downtown Manhattan was ultimately through a ferry system into New Jersey. Days later, when the airlines were still grounded, it was rail that connected cities one to each other. Multiple modes of transportation are critical in the post-September 11th world. Amtrak is part of that.

We started the process, I hope, of understanding the value of Amtrak two weeks ago when the Committee reported out the Amtrak Reauthorization and RIDE-21, and we continue today by trying to figure out how Amtrak can get its most lucrative train back on track. I hope we can get some answers about what caused these brake problems, and I look forward to figuring out exactly who knew what and when.

Thank you, Mr. Chairman, for holding this hearing.

Mr. LATOURETTE. I thank the gentleman very much.

It is now time for our first panel. I want to thank all of the witnesses and remind you all that we have received your testimony, so has the Washington Post, apparently. But we have received your testimony and reviewed it. Because of the importance of this, we are not going to be real sticklers on the five minute clock. But if you could confine your comments to as close to that as possible, we would appreciate it.

On the first panel is Robert Jamison, the Acting Administrator and expectant father from the Federal Railroad Administration; Fred Weiderhold, Jr., who is the Inspector General for Amtrak; and JayEtta Hecker, who is the Director of the Physical Infrastructure Issues section of the GAO. Welcome to you all, thank you for coming today, and thank you for providing us with your testimony ahead of time.

Mr. Jamison, when you are ready.

TESTIMONY OF ROBERT D. JAMISON, ACTING ADMINISTRATOR, FEDERAL RAILROAD ADMINISTRATION; FRED E. WEIDERHOLD, JR., INSPECTOR GENERAL, AMTRAK; JAYETTA Z. HECKER, DIRECTOR, PHYSICAL INFRASTRUCTURE ISSUES, GOVERNMENT ACCOUNTABILITY OFFICE

Mr. JAMISON. Thank you, Mr. Chairman and members of the Subcommittee. I appreciate the opportunity to appear before you today, on behalf of Secretary Mineta, to discuss the recent developments concerning Amtrak's Acela service. As you have already mentioned, Mr. Chairman, an FRA Safety Specialist, Mr. Rich Thomas, first detected cracks on the spokes of an Acela train disc brake rotor on the evening of April 14th. The detection occurred while FRA personnel were closely inspecting a trainset that had been involved in test runs. The test runs, unrelated to the brake issue, were being conducted to ensure safe operating performance of the Acela at higher speeds in curves than are currently permitted.

While conducting a very thorough post-test inspection of the brakes on the trainset, Mr. Thomas noticed what appeared to be rust from a small mark on one of the rotor's spokes. On closer examination, the mark proved to be a crack. After the initial discovery of the cracks, the FRA inspectors, along with personnel from Amtrak and the Acela maintenance contractor, then inspected the other trainsets. As the inspections concluded that evening, it became clear that a significant percentage of the disc brakes had similar cracks. After discussions with FRA personnel that night, Amtrak suspended Acela service immediately on April 15th and ordered a detailed inspection of the entire Acela fleet for the presence of such brake rotor cracks.

The good news is, as has already pointed out by members of this Subcommittee, these cracks were detected before they led to a catastrophic failure of the rotor with potentially very serious consequences. My staff and I met with Amtrak President David Gunn and his staff on April 15th, and again on April 20th to discuss the problem and potential solutions. Amtrak formed a working group consisting of its staff, its contractors who are responsible for Acela maintenance, the suppliers of the equipment and several technical experts to determine the cause of the problem and to explore solutions to the problem. FRA experts are fully cooperating with that effort. Amtrak has no intention of running the Acela equipment with cracks in the disc brakes, and all concerned understand that FRA will not permit that to happen.

FRA has a broad safety program. Our efforts to ensure the safety of the Acela service are but one component of a comprehensive railroad safety program. Although the railroad industry's overall safety record is very positive and most safety trends are moving in the right direction, very serious train accidents still occur, and the train accident rate has remained stubborn. To meet these challenges, FRA is targeting its regulatory program on the most frequent causes of train accidents. We are focusing our inspection resources on the areas of highest risk, and we are accelerating our R&D efforts that have the largest potential to mitigate those risks.

More than 70 percent of all train accidents are caused by either human factors or track defects. FRA is taking aggressive action to address these leading causes of accidents.

One component of our program is a focused national inspection plan. FRA recently began phasing in this national inspection plan to improve the agency's allocation of inspection resources. The NIP will use sophisticated trend analysis of inspection and accident data to produce an optimal distribution of resources to minimize fatality, injury and accident rates. We began implementing the NIP last month in the first two disciplines of operating practices and track, which correspond to the leading causes of accidents.

FRA closely monitors all aspects of Amtrak safety, as it does for all freight and passenger railroads. Amtrak's safety record is comparably quite good. In 2004, Amtrak's rate of accidents, 2.8 per million train-miles, was well below the industry average of 4 accidents per million train-miles. Contrary to the industry trend over the last two years, Amtrak's human-factor-caused accidents have fallen substantially, comprising 20 percent of Amtrak's accidents in 2004.

Employee injury rates, particularly in the transportation department, also improved in 2004.

FRA will continue to monitor Amtrak very closely and assure that its generally positive safety record is maintained and does not deteriorate.

As mentioned previously, we are working very closely with Amtrak as the railroad tries to determine a long-term solution to Acela's disc brake problem. Public safety is of utmost importance, and we will continue to ensure that the solution that Amtrak adopts fully protects Acela's passengers and crews. We will also ensure that Amtrak's implementation of its equipment inspection program for the Acela trainsets is improved so as to ensure that any such safety-critical problems are found and corrected well before they reach the dimension that this problem had reached by the time that we detected it.

I believe that the extra effort that has already been pointed out, that was displayed by FRA Safety Specialist Thomas and the other FRA personnel involved in the Acela brake issue, quite possibly averted a very serious accident. Those efforts are emblematic of the dedication of the FRA employees to their safety mission. We will continue to exercise that level of effort in working with Amtrak to ensure that the resumption of Acela service is safely done.

I look forward to answering any of your questions.

Mr. LATOURETTE. Thank you very much, Mr. Jamison.

Mr. Weiderhold, thank you for coming, and we are ready to listen to you.

Mr. WEIDERHOLD. Good morning, Mr. Chairman and members of the Committee.

Mr. Chairman, with your permission, I have two requests. One request, I have a written statement that I would like to be submitted for the record.

Mr. LATOURETTE. Without objection, so ordered.

Mr. WEIDERHOLD. The second request is to allow Mr. Oberstar to be hired on my staff, given his knowledge of steel. I think he is exactly on point when it comes to some of the issues that my office is very concerned with. I have an engineering degree, but it is about 30 years old. I know enough to be dangerous on that, sir, but I would be pleased to work with you on that issue.

I want to kind of echo the comments of some of the members in recognizing the FRA. I have worked with Mr. Thomas for a couple of years. I think that when we interviewed him, I asked him, I called him the following morning and I said, Rich, how did you find the crack. He said, Fred, we ended the run, I go under the train, and it was just out of the corner of my eye I saw a rust spot, and it didn't look like a surface crack. I think he pushed at it a little bit, and it had some indentation, there was rust, indications of rust. So he quickly called down Steve Play, who joined him under the train and they proceeded to check out and through visual inspections they found a number of cracks in spokes.

Really what we want to do is to figure out kind of why it took so long for the FRA or anyone to notice those cracks before some type of corrective action was taken.

I also want to commend the FRA, because as soon as this occurred, they ordered, and Amtrak fully cooperated with, a fleet-

wide inspection of all the brake discs across the system on the non-Acela fleet. There are many, many more cars out there that needed to be inspected. The FRA executed that within a couple of days over the fleet. I have reviewed their reports and their reports make clear that there is no systemic problem with Amtrak cars, the non-Acela Amtrak cars. But I think the FRA should be recognized for that quick effort.

I do want to commend Amtrak. Within hours after being alerted with the FRA and speaking with the consortium, Mr. Crosbie, who is their senior VP of operations, I think about 12:30 in the morning made the decision to ground the fleet. That was certainly the right decision in hindsight. I think Amtrak did a very commendable job and acted in the best interests of everyone in making that timely decision.

Also, Amtrak did institute very quickly a recovery stage with respect to bringing the Metroliners back. I think that is good news, because what has happened is, there has not been any serious degradation of riders in the northeast corridor. I think regardless, in listening to the members, regardless of the positions on Acela as to how we got here, I think Amtrak is a common carrier, it does have common carrier obligations, it does need to keep its trains running, and it was able to accomplish that.

You will hear later on a lot of discussion about the fix. I think everybody is very interested in getting to the fix. We are concerned about that. We watched the various vendors in the supply chain, the Knorr Corporation, Fadely Transport, SAB WABCO and others working very hard daily, seven days a week, trying to figure out what went wrong. Likewise, the manufacturers' consortium of Bombardier and Alstom have been working very hard and have dedicated staff and a lot of time to getting to the fix.

But I want to elaborate a little bit more, and I think the members have all touched on this, about what more you need to do. And this gets to the OIG's role.

While the fix is a priority, I think it is our responsibility to examine the entirety of the root causes of the failure. The root cause does not stop at just finding the reason for the failure. There are, as this Committee is very familiar with, what I would call human factor issues that the NTSB is very familiar with, and that is, why did certain people make some decisions and why did some people make other decisions with respect to the brake discs.

Like you, we want to know why it took so long for the cracks to be discovered. There were many people involved in the inspection and servicing of the wheel sets onto which the brake discs are affixed. Why did so many brake discs with cracks passed unnoticed?

We also want to know who was aware of the cracking problem. Did the responsible person or persons act differently because an action or non-action would result in financial harm? Are there organizational impediments to information sharing?

Sometimes people make bad decisions with good intentions. We need to know if that happened here.

Very briefly, because I know we do not have a lot of time in the opening statements, I would like with your permission, Chairman LaTourette, at least talk about what we have found so far to kind of get the ball rolling. First, with respect to why the cracks went

unnoticed by the maintainers and the inspectors. We have two possible explanations for that, if you will bear with me.

First, the cracks are very hard to see. We had some of the Committee staff out at Ivy City looking at the Acela trains. I took them under the trains, they viewed the wheel sets off from under the cars. I think even with their, in some cases, younger eyes they would have had a hard time finding those cracks.

We do not have an actual disc for you today. They are fairly large, and as Mr. Oberstar points out, this is poured cast steel, they are pretty heavy. What I do have is a diagram over here, and there is a diagram attached to the back of the testimony that kind of gives you an orientation of the disc. Essentially you've got, if I can reach it over here, you've got the disc itself, you have the hub in the center, you've got six spokes that kind of radiate from the hub and you have this space here which is the friction ring for the brake pad to reply. That's how the wheels are stopped.

You should also understand, I think Mr. Oberstar will appreciate this, that there are a number of forces acting on the disc. There are lateral forces due to shocks and due to centrifugal force. This is normally measured in g-forces, as g-forces is the pull of gravity. I think people who serve on the Aviation Subcommittee are intimately familiar with what a g-force is. There are vertical forces that act on that disc as a result of the train moving up and down on the tracks, different amplitudes of forces that are applied. There are radial forces that are applied onto the disc. This disc is designed to heat up.

As you can well imagine, you have a lot of weight, going at speed, and the brakes are applied, this is carbon on steel, there is a heat buildup. So the discs have a design, essentially, to expand when they are hot and contract, go back into compression, when they are cold.

There are also brake torque forces around this in a circumferential direction of the brake disc. The possible reasons for the spoke cracking, the loads are higher than expected, or the discs simply don't meet the specification.

I think Mr. Jamison touched on how Rich found the crack in the disc. I won't expand on that too much.

I do have, and I think I put it up on the dais, Mr. Chairman, I do have some pictures of the cracks in the disc. Some of those were passed around, some of those are in color. You can see from some of these, I think it should be up there that some of these cracks are hairline and some of these cracks are a lot more visible to visual inspection.

The second reason the cracks passed unnoticed is a little bit more disconcerting. If I can refer you to another exhibit, another chart, I want to walk you through the brake disc supply chain and the organizational relationships involved in the acquisition, installation and maintenance and servicing of the disc. You can refer to, there should be a handout for you on the chart that looks like an organization chart over there. I am sorry, Mr. Chairman, next time I'll have this in Power Point so we can get it up on the screen.

But what you see in that chart is essentially the supply chain going from SAB WABCO, who is the OEM Of the original manufacturer of the brake disc part, as a sub to Knorr Corporation, that

is the owner of the brake disc assembly. They have a contractual relationship with the consortium that is made up of Bombardier and Alstom. They in turn create a wholly-owned subsidiary, that's the NEC-MS, the Northeast Corridor Maintenance Service Corporation, who in turn issues a preventive management work order, which we would call a checklist, which is used, which goes to the shop floor.

The only other box on that chart, which is a very important box, is a company called ORX, very reputable company just outside of Altoona, Pennsylvania. ORX was the original assembler of the wheel sets. They have what we call a horizontal press. This is where the wheels are pressed onto the axle, the brake discs themselves are pressed onto the axle. So they were there when the wheel sets were originally assembled and when there is wear on the wheels or on the brake discs, the wheel sets are removed, they are sent to ORX. ORX inspects them, refurbishes them and then returns them back to NEC-MS.

Within one day of the brake disc spoke cracks being reported, Amtrak management and the OIG were also provided with an excerpt from an inspection procedure manual prepared by the disc manufacturer, SAB WABCO, in November 2004. This procedure included steps for crack inspection in the hub and spoke areas of the disc at least every 20,000 kilometers.

There is another chart, if I could get it up, this chart becomes very important very quickly. This is an excerpt from the manual that Mr. Oberstar requested. These are instructions that are developed by the manufacturer at the get-go when the part is made. What they include in their detailed inspection, in the first step, is to look for cracks in the hubs, cracks in the connection spokes hubs and the friction ring. So there is a contemplation on the part of the OEM that there will be periodic inspections. Accompanying this procedure, there is also an inspection schedule requirement for this 20,000 kilometers, or about 12,400 miles cycle for the brake discs to be inspected, and specifically to be inspected for cracks.

What happens, when you go back to the organization chart, what happens is you have this large technical manual that is out there, 66-page technical manual, that has this step to inspect for cracks. The technical manual goes up and it is boiled down into something a little bit smaller. It is a service bulletin. In the service bulletin, the procedures shift. That detailed information, to inspect for the cracks, basically is kind of lost in translation. What happens when you get to the service bulletin, which is a shorter document, is there is only a one-line reference to go to the specific procedures for looking at the cracks.

That service bulletin in turns makes its way back over to the maintainers at the NEC-MS. It makes its way into the training documents, into the training curricula for the maintainers. But in this case, it does not make it to the shop floor. So there was an expectation on the part of the OEM that there would be periodic inspections. But because of a breakdown in the way the procedures were promulgated and worked their way through the system, they never make it to the person that is actually doing the inspection. That is a major finding, that is a lesson learned, that is something that has to be corrected, especially for a safety-critical part.

Mr. OBERSTAR. Mr. Chairman, could I ask Mr. Weiderhold just to repeat that comment about only one line in the manual that deals with that?

Mr. WEIDERHOLD. Yes, sir. What we found was, when we started looking at these detailed procedures, you want to start at the beginning. We had found these procedures in the SAB WABCO manual. When we traced that specific recommendation to look for cracks and spokes up the supply chain and over to the maintainer, what we found was it was only referenced in the service bulletin. So when you get to, this is not 66 pages, but this is probably 30 pages worth of instructions that are issued by Knorr, when you get to a very critical stage on the axle-mounted disc, the part that I have highlighted here, which is just one line, refers you to this procedure.

Now, what happens as you get further into the service bulletin, which is what the maintainers use, within the service bulletin there are pictures of the disc and they tell you what to check for. They tell you what to check for what are called the normal wear and tear on the friction surfaces, which is what peoples' eyes are drawn to. When you get under the train and you look at all the gear down there, you kind of look for the shiny surface, because that gets the most wear and tear.

If you don't know to look at the hub or to look at the spokes, and if you're not trained to look at that, then you are not going to look at it. There is carbon dust flying around, there is a lot of things on the running gear, and that is one of the reasons why those cracks went unnoticed for as long as they did. So we have a breakdown in a critical inspection process, and we have a breakdown in the safety critical part.

Next, I think one of the big questions, and the questions that you asked me, Mr. Chairman, was who is responsible or who knew what when. Let me kind of tell you where we are to date. From all of our interviews and document reviews thus far, we have no evidence that Amtrak was ever made aware of the brake disc spoke and hub cracks prior to April 14th, or was even aware of the manufacturer's detailed procedures for brake disc inspections. We have spoken with Amtrak employees from the shop floor through first line management to senior managers, and thus far no one has stated that they had any knowledge of brake spokes cracking prior to April 14th.

As is our practice, we basically took this chart, we looked at this organizational layout, we looked at the relationship among the supply chain and our maintainer, and then we began our interviews. Our first interview was a visit to ORX, that organization on the bottom right hand, who basically seize the wheel sets off the train and should have, should have the best eyes to put onto the brake disc.

When we visited ORX, we were very impressed with their facility and the forthcomingness of the ORX employee. We were informed by ORX on at least two occasions they recalled finding and reporting cracks in the Acela brake disc spokes. However, at the time of our interviews, ORX staff could not recall the exact dates of finding and reporting the problem. They believed this occurred some 12 to 24 months ago.

We asked ORX to research their records, and they have supplied us with additional information that we are now reviewing. We are zeroing in on the time line, ORX is cooperating and we are seeking out current and former employees to pinpoint better when and to whom these reports would have been made. I cannot overemphasize that we have a number of open questions that need to be resolved, and we are only midstream in our investigation. I would not normally release information such as this at this stage of the investigation, but I think it is important to share it with the Committee, because we are investigating failures of a safety critical part.

We got, all of us collectively, got very lucky that this was found when it was. When the examination of the brake discs was made, the first slight through the train was a visual inspection. I think that's where the Committee was informed that there were failures on a rate of 20 to 30 percent. When you do a more definitive test, when you do a magnetic particle inspection test, you find that you miss half of the cracks. So a visual inspection alone is not going to do it. You are going to have to adopt some procedures, probably taken from airline experiences, to look for those cracks, to understand when they began, how long they stayed before they propagate.

Because the danger is, here is what we think we know so far, the danger is the crack propagates very early, and it starts out small, maybe invisible. Over time, that crack will reside and stay there for a while and then it will slowly makes it round around the first spoke. Once it goes through the entire first spoke, the disc itself, it is hard to see because the spoke pulls both in tension and compression. So when the disc is hot, you can't observe it, but it's pulled farther apart. When it cools, it closes the crack back down. That's the mechanism. So that's why those little cracks were kind of hard to see, because there was compression to return the crack to its normal position.

But once you get through that first spoke, it will start propagating to the adjacent spokes. Eventually it will make its way through all six spokes. If that happens, we could have a catastrophe on our hands. When the inspections were made, the first report that came out found 317 spoke cracks over 300 discs. That means that there were some discs that had more than one crack in the disc. Some discs had two cracks, cracks in two spokes, some had cracks in three spokes. We are finding after the mag particle inspection there were probably discs out there with cracks in as many as four or five spokes. There were only a handful of these, but it shows you that you were getting dangerously close to a very, very serious problem.

We have, I have issued subpoenas to everybody on that chart. I have done that both in a friendly way and I have also done that to make sure that we get all of the information that relates to this problem to try to answer the questions of who knew what when. As soon as we have that information, we will certainly provide it to the Committee.

Thank you for the extra time, Mr. Chairman.

Mr. LATOURETTE. I thank you very much, Mr. Weiderhold.

Ms. Hecker, thank you for coming, and we look forward to hearing from you.

Ms. HECKER. Thank you, Mr. Chairman.

I am very pleased to be here today to provide some contributions based on completed GAO work. We don't have anything on the brakes and none of the details that you have heard. But we have a comprehensive report that we completed on the overall Northeast Corridor Improvement Project, of which the Acela was a portion. Then another report on the settlement and the dispute between the consortium and Amtrak and a special issue about maintenance as a key part of that settlement.

The issues that I will cover today will be, four issues that I will cover. First, quickly, some of the issues that have affected the Acela development since its inception. I think some of the members already alluded to that, the issues that led to the suits and counter-suits and then the settlement. Then how our report basically identified that while the settlement was probably a good thing in many ways, certainly it kept the parties working together, it really wasn't self-executing. There were lots of risks and challenges that remained, and they remain today and I think provide a very relevant context for the discussion today about the Acela performance.

Then a second product that we did on the overall management of the project and how the issues here relate to challenges in managing large scale projects. On the first issue, basically as has been alluded, there have been significant issues affecting the Acela program since its inception. The first four points really were all about the production of the train sets. As several of you alluded, there was new technology, it was not over the shelf, which presented considerable risks. It was finalized, the procurement, before the new safety standards were promulgated. Those safety standards had a very substantial impact on the weight and cost of the train set.

Third, there were obviously many production and manufacturing delays. And finally, because of those delays and the pressures that all of you have alluded to, there was extremely abbreviated testing on this train set. FRA told us that there was an electric locomotive that they told us was an appropriate model. The testing on that was 165,000 miles. The testing on the Amtrak Acela model was 35,000 miles. So you basically had an extremely abbreviated testing, which was an environment where you really would have been able to identify and presumably resolve some of the issues that have continued to plague the program.

The second issue is basically setting up that one of the unique things about this contractual relationship is that the consortium that built the train set actually agreed to build the facilities, maintain the train sets and supervise Amtrak employees until 2013. Amtrak would just provide the employees to conduct the maintenance.

The next page basically gets to the issues that led to the suit. There were major performance issues that led Amtrak to withhold payments. Bombardier then first sued. The allegations they had are very important to the discussion today, because they allege that they had been provided inaccurate information on the infrastructure conditions, as well as concerns about changed designed specifications.

The infrastructure conditions, I think several of you alluded, are important because the curves that affect the speed and the curves and the poor condition potentially have some relationship to the whole fatigue on the brake issue being discussed today.

Finally, then, Amtrak counter-sued. They maintain that the consortium had not met the performance requirements, had deficient engineering and poor management. The terms of the settlement, though, in March 2004, basically had the consortium agreeing to complete many outstanding modifications. Some are still outstanding, and that remains.

The most critical one perhaps is to achieve the performance requirements of the original contract. The main performance requirement is 17,500 miles of the mean distance between failures. So that's basically a core measure. The train set still hasn't reached it. And it needs a six month rolling average before that requirement will have been deemed to have been met. So the consortium is still liable for that.

Under the new terms of the relationship, they would provide training to Amtrak staff, provide technical information and honor the existing warranties and actually extended a bumper to bumper warranty. Amtrak then was responsible for assuming the facility management and the maintenance as of October 2006. This could be in jeopardy. This whole issue of these evolving roles could be affected by what we are talking about today.

The other major responsibility actually written in the agreement, that Amtrak was responsible for creating a transition plan to hire, designate particular staff, maintain the train sets and the facilities and make a choice about a procurement plan and how they would proceed.

As I said in my opening, we believe that the Acela program still faces considerable risk under the terms of the settlement and the terms of the original contract. As I mentioned, the first one is getting these modifications and performance requirements met. As I said, many are still open and the performance requirements for reliability, speed and comfort have yet to be achieved. Obtaining technical expertise for the maintenance and training, I think this relates to some of the details of the communication about the actual technical issues of maintenance. These are not unimportant issues, and they certainly pervade way beyond the brake issue.

Finally, there was the issue of sufficiently funding the maintenance and integrating the responsibility. All of these three concerns, we felt, ought to be dealt with in a comprehensive implementation plan. Our report recommended that Amtrak deal with these risks and have a comprehensive plan. To our knowledge, it is still not done. There are critical elements that are missing. We think it exacerbates the risks which now are so complicated by the brake problem.

Finally, I would say that not only would I put these issues in the context of the Acela, but in the context of the management of the Northeast Corridor Improvement Program. The challenge is clearly larger than the brakes, and reaches issues of broader challenges that Amtrak has had in managing large scale projects.

Our report on the Northeast Rail Improvement Project, and again, this has three elements. There was an electrification, there

was the train set to achieve the three hour time limit and then there were infrastructure improvements. Our review of how Amtrak managed this program is that it was very short-term and it was very segmented. It was focused on the electrification and of course there were suits and problems with that.

Then there was a focus on acquisition of the train sets, which I have just described, had many problems. There wasn't really adequate focus on the major infrastructure improvements and we actually have a number of the critical components identified that we couldn't even identify the status of. The project was not managed like a project and there was no financial plan. While it is probably true that they never got all the money they needed, they never presented it in the comprehensive form of a plan to identify, this is the plan we need. Rather, they worked the plan around the annual budget and what they received each year.

So an overall observation we have there, and it is one that actually required some action by both Amtrak and FRA, the oversight of this major modernization, I think Mr. Mica referred to it, it was the most costly Federal investment in inter-city passenger rail in the last century, and this one too. The oversight of it was grossly incomplete by both Amtrak and FRA. FRA told us they didn't even think they had the authority. We were surprised, we scoped it out and looked and agreed that they actually hadn't been given the authority.

So you had a \$3.2 billion acquisition including the costs of other parties, who are very important: the State of New Jersey and the transit agencies that were party to this. It was not a comprehensively managed project.

As you alluded, we have some ongoing work on other aspects of Amtrak management. We hope when we are ready to report that those will provide further light on the systemic challenges and moving toward comprehensive solutions. Thank you, Mr. Chairman. I would be glad to take any questions.

Mr. LATOURETTE. Thank you very much. Again, I want to thank you all. I tell the members of the Subcommittee, it looks like our first series of votes is going to be about 11:30. It will be my hope, because of Mr. Jamison's situation and others, we could vote as quickly as possible and get back.

Mr. JAMISON. I understand from talking to Amtrak that they have made a request to operate an instrumented Acela train on the northeast corridor in an attempt to begin the process of getting the train back into service. Has the FRA reviewed and approved that request?

Mr. JAMISON. We have. We expect that test to take place sometime later this week.

Mr. LATOURETTE. Has the FRA made a determination as to what additionally is necessary on the part of Amtrak to put the Acela back into operation, aside from this test?

Mr. JAMISON. In a nutshell, it really depends on the solution. As Mr. Weiderhold referred to, there are still several alternatives on the table. There is still a lot of analysis yet to be done. So depending on whether or not there is a move to try to put the existing design rotor back into place or if there is a move to go to a new, redesigned rotor, there will be a lot of analysis required.

But, in a nutshell, we are going to require qualification of the new components or the existing replacement component; a new inspection, testing and maintenance plan that addresses some of the inspection issues that have been pointed out, to make sure that, if these cracks are so hard to detect through visual inspection, to state what other types of inspection techniques are necessary to return it to service, and finally, a review of the training program to make sure that items, such as were pointed out by Mr. Weiderhold, when manufacturers' specifications update current inspection techniques and correspondence which routinely happens, to make sure that that information is actually getting to the people doing the inspections.

Mr. LATOURETTE. During her testimony, Ms. Hecker mentioned, I think it's GAO's opinion that the settlement agreement between Amtrak and the consortium has risks and challenges yet remaining. The Secretary of Transportation sits on the Amtrak board of directors. Are you aware of what role the DOT played in approving the settlement agreement and also ensuring its successful implementation to this point in time?

Mr. JAMISON. Actually, I am not 100-percent sure of the vote at that time, since it preceded me. I believe that our member voted "yes" to the settlement agreement.

Mr. LATOURETTE. Aside from voting on the settlement agreement, maybe you could get back to us, if you would, someone at FRA or DOT, specifically what role DOT or the representative of DOT had in not just passing on the settlement but participating in the discussions on the settlement. When other witnesses come, I have some questions on the settlement as well.

And lastly, I am going to ask Amtrak this, it does not have anything to do with this hearing, but there was a report on one of the local television stations last night relative to the tunnel under the Cannon Building. It is my understanding that the tunnel is patrolled by the Amtrak police, and as a matter of fact, the camera crew was met by the police when they arrived. That only passenger trains travel through that tunnel, and that rail access is controlled by a switch operated by CSX, and that both CSX, in cooperation with FRA and also DHS, has developed extensive security plans for that tunnel, which obviously we are not going to discuss in public. Am I incorrect in any of those observations?

Mr. JAMISON. That is my belief as well. I would also add that in my other duties, I am currently also Deputy Administrator of the Federal Transit Administration. FTA provided technical assistance, including a vulnerability assessment, to Virginia Railway Express (VRE) that addressed some concerns about that tunnel. I would be happy to discuss some of the findings and some of the actions that have taken place. But I agree with your statement.

[The information received follows:]

The settlement was negotiated between Amtrak and the Consortium, and the related discussions were undertaken without the involvement of the U.S. Department of Transportation, including FRA. Amtrak's Board, including the Secretary's representative on the Board, were briefed on the progress of negotiations and participated in general discussions about strategy and the acceptability of alternative outcomes.

Mr. LATOURETTE. Thank you.

Mr. Weiderhold, I am going to ask unanimous consent, because I did not see it attached to your testimony or the 8 1/2 by 11 sheets of your charts, so without objection, those will be made part of the record.

I just wanted to be clear on two of them, one, the schematic flow chart and then also the SAB WABCO scheduled maintenance observation. As I understood your testimony, the WABCO service notification indicates that aside from inspecting the brake surface that also it was their recommendation that the spokes be inspected for cracks as well.

Mr. WEIDERHOLD. That is correct, sir.

Mr. LATOURETTE. But somehow, as you look at this flow chart that you provided from WABCO to Knorr to the consortium back down to where it eventually winds up, either at ORX or on the shop floor, it is your understanding that that information, other than a slight reference to please refer to a larger, another document, is it your finding to this point in time that that information did not make it to the men and women, I suppose, that were actually performing the inspection services?

Mr. WEIDERHOLD. Yes, sir. We spoke to the NEC-MSD senior managers, we talked to supervision, we talked to the guys with the lights that go under the train, and they were unaware of that requirement.

Mr. LATOURETTE. I mentioned in my opening remarks the newspaper article this morning. The last box, well, it's not even a box, I don't know what kind of shape that is that you put down here at the bottom, it has ORX, which is the company that I think you mentioned is located in Altoona, Pennsylvania.

Mr. WEIDERHOLD. That's correct, sir.

Mr. LATOURETTE. According to the newspaper this morning, and I think also from your observations, you have collected information that 12 to 24 months ago, someone at ORX recalls seeing the cracks in the spokes that are the subjects of our concerns today?

Mr. WEIDERHOLD. Yes, sir. We have conducted two site visits, several interviews, both in person and in telephone interviews with current and former ORX employees. They do recall finding cracks in the spokes. We asked them to pull their quality assurance, quality control, QA/QC records. We do have some documentation that validates their recollection. We are in the process of kind of tracking that down. The time line is very important. And the time line may be, I learned last night the time line may be 12 to 36 months.

Mr. LATOURETTE. Okay. And specifically, I think I heard you say, but I would just ask you to repeat it, and if you didn't, I apologize, but was it your finding to this moment in time that that information, if that in fact is what ORX was discovering 12 to 36 months ago, to your investigation to this moment in time, was never communicated to Amtrak?

Mr. WEIDERHOLD. No, sir, we have no information at all that Amtrak ever received that information.

Mr. LATOURETTE. Do you have information that that finding of 12 to 36 months ago was reported to anyone on your flow chart?

Mr. WEIDERHOLD. Yes, we do. We had been given information that the cracks were reported to Knorr.

Mr. LATOURETTE. Anybody else besides Knorr?

Mr. WEIDERHOLD. We have an allegation that we need to run down, I am not comfortable yet until we do some more interviews.

Mr. LATOURETTE. Okay. But that, I assume, as you continue your investigation, if in fact the ORX information proves to be reliable based upon not only memory but documentation, is it your intention to work through this maze to determine where that information went and where it stopped?

Mr. WEIDERHOLD. Yes, sir, and I think the use of the term maze is a good, descriptive adjective.

Mr. LATOURETTE. Is it also your intention or have you completed the discussion as to why the WABCO service bulletin that indicated that we should, not we, but inspectors should not only look at the surface of the brake but also the spokes, why that did not make it from WABCO to the shop floor?

Mr. WEIDERHOLD. We have not conducted interviews of the WABCO and Knorr individuals yet. We would hope to do that soon in order to answer that question. All we can do is track the document flow. And based upon the document flow, it seems strange that a critical inspection step was truncated with a one-sentence reference. I think that's really what I would call a lost in translation problem.

Mr. LATOURETTE. And my last question is, you mentioned you have issued some friendly subpoenas. Has everyone on this flow chart been cooperative as you proceed with your investigation?

Mr. WEIDERHOLD. You have to understand, Mr. Chairman, I want to correct one thing, just like Mr. Mica was correcting some of the mistakes in the Post, there was in the Post, I believe, reports that we have had some recalcitrance. That recalcitrance was not with Bombardier and Alstom or NEC-MS. They have been cooperating fully. We sometimes have to issue what we call friendly subpoenas because the contractual relationships and confidentiality agreements that exist between and among these parties require that they keep that information close. The only way that information would be released is through the subpoena process. We often-times have to issue what are called friendly subpoenas.

The answer to the rest of your question is, no, we have not had, we have had some people either get lawyered up or basically tell us that they don't have time to meet with us. We ask not just once but twice and three times, because we thought it was in their better interest to kind of come and talk to us, just an hour of their time to come and let us know kind of what happened here.

Mr. LATOURETTE. And just so I'm clear, you have subpoena duces tecum authority, but if you were lobbying on behalf of the IGs of the world, you would like to have a little more authority to get at people that may not want to discuss things with you?

Mr. WEIDERHOLD. That's correct, Mr. Chairman. In the IG world, with the exception of maybe Justice and I think DOD, all of the cabinet level IGs, as well as the smaller IG office, were referred to as the designated Federal entity IGs. There are about 30 of us. We only have duces tecum subpoena authority, we do not have testimonial subpoena authority. I think that the Committee, Congress ought to consider granting the IG community that in all matters relating to safety and security. That would be extremely beneficial in moving these types of investigations along.

Mr. LATOURETTE. Thank you.

Mr. MICA. Mr. Chairman, if you would yield just a second, would it be possible to request that FRA report to the Committee on those who have not been cooperative or any who in their estimation are not cooperating with their investigation?

Mr. LATOURETTE. Sure. I would make that request of both you, Mr. Weiderhold, and also the FRA. I think that's an excellent suggestion.

Obviously not only your suggestion on subpoena power, but we're dealing with a safety issue. I think Mr. Oberstar was right in indicating this could have been catastrophic had it not been for the good work of the FRA inspector. So I would ask you to get back to the Committee staff if you find somebody being recalcitrant.

I appreciate your correcting the record, and again, not to harp on it, but that's why we don't really like to read about the hearing before the hearing has occurred, because sometimes there can be misstatements.

Ms. Brown.

Ms. BROWN. Thank you.

I guess what I am most concerned about was that a disaster could have occurred, but we were very lucky. That dog just doesn't hunt. We need to know who was responsible for the inspections, whose responsibility it was, and is it not a part of the procedures to check for maintenance, and whose responsibility was it to check over a period of time? That's the part that I'm kind of confused about.

Mr. WEIDERHOLD. I have an adage that safety is everybody's responsibility. Safety trumps everything. I think everybody on that organization chart has a responsibility for safety. Where liability lies, I will leave that to the lawyers. But safety is everybody's concern.

One of the things we had worked with NEC-MSD on a few years ago was to actually get to that checklist on the floor so we could kind of cull out and highlight any inspection on a safety-critical part. Because normally you have more detail, different tools, you have a higher certified supervisor, all those things take place on other safety critical parts. But for some reason, and it is a why, both of those are the right questions to ask, for some reason that did not work in that case.

The why, I think we have a pretty good indicator, based upon the documents. The who is tougher. Because if someone knew about this and for whatever reason put their head in the sand, that is a bad decision. We want to make sure that it was not an unintentional kind of oversight. We need to get that information.

Ms. BROWN. Ms. Hecker, you have done at least eight investigations of Amtrak since 2000 and you are working on one now. You have interviewed Amtrak employees and requested materials, we have this report. You have done an extensive investigation. I am wondering, how much has it cost Amtrak, and is this just another report that we are going to put on the shelf?

Ms. HECKER. How much do our studies cost in Amtrak employees' time?

Ms. BROWN. And money.

Ms. HECKER. Well, we only do work that's requested by Congress. We are set up to provide investigative support for issues that are of interest to the Congress. One of the few areas of Government accountability that Amtrak is covered by is that they both have an IG and that they are subject to GAO audits. I suppose the Congress could undo that, if you didn't think that we add value.

Ms. BROWN. No, I guess my question is, so Congress has requested these nine investigations?

Ms. HECKER. That's correct.

Ms. BROWN. Okay. How much has it cost Amtrak?

Ms. HECKER. We don't do studies of the amount of time that it takes people to respond to our requests. I don't have that information. I could say that on both of these investigations, we experienced substantial delays in getting the information required from Amtrak. In the case of one report, when we sent the report to them for comments, they disagreed vehemently with the report and said the problem was that they hadn't given us all the information that we should have had, and that delayed the report three months.

So yes, it takes time, but if you are comprehensive in the response the first time, it will take a lot less time.

Ms. BROWN. Well, I guess it's something that Congress needs to take a look at. Because like I said, we have had nine reports since 2000.

Ms. HECKER. I think some of those are testimonies that are based on the reports.

Ms. BROWN. Thank you. I yield back the balance of my time.

Mr. LATOURETTE. Mr. Mica.

Mr. MICA. Thank you, Mr. Chairman.

First of all, I appreciate the data flow chart on Acela brakes. I am more interested in a flow chart of who is responsible. Obviously if Amtrak signed a contract, and I understand with this consortium, to provide maintenance, someone was responsible. Who was responsible for overseeing that contract? Mr. Jamison?

Mr. JAMISON. I would refer the contractual questions to Mr. Weiderhold about exactly how the contract works inside Amtrak's guidelines. My overall concern is the requirement that Class I brake inspections be done daily and that the other overriding regulation, which is—

Mr. MICA. Well, I want to get into that in a minute. But who was responsible? I mean, here is a multi-million dollar contract, billion dollar contract probably, \$700 million just for the equipment. Now, who is responsible for the contract management? Is it Amtrak or maybe this panel?

Mr. WEIDERHOLD. I think you could—

Mr. MICA. Do we have a flawed system in Amtrak in managing the contract?

Mr. WEIDERHOLD. I think what you've got is you've got less than an optimal model here. If—

Mr. MICA. I asked the staff for, can you get me a flow chart for Amtrak and who oversees what. We don't have one. That's scary.

Mr. WEIDERHOLD. I think there are a couple of ways to use this chart, if I could explain a little bit.

Mr. MICA. This again, I am going beyond the chart in who's responsible. Now, we also have the original equipment manufacturer

bulletin that has recommended inspections be done every 20,000 kilometers, approximately 10,000 miles. That wasn't done. Was that done, Mr. Jamison?

Mr. JAMISON. It was done, in our opinion. The issue is whether or not the—

Mr. MICA. It was done, in your opinion?

Mr. JAMISON. Yes. There is a requirement—

Mr. MICA. So we have a service record where the consortium, those that were responsible for the maintenance did perform this. I just want to know, is that true?

Mr. JAMISON. There is a daily requirement to do an in-the-pit, undercarriage inspection of all major components. I don't have the document in front of me that you are referring to.

Mr. MICA. Again, the original equipment manufacturer bulletin recommended an inspection of the spokes be done every 20,000 kilometers.

Mr. JAMISON. I'm not aware of that inspection, no.

Mr. MICA. The information I have, it was, the inspection was surface only, not the brake rotor spokes as required under the service manual. So someone was not doing the maintenance.

Now, Amtrak didn't discover the flaw and the consortium that was charged with maintenance didn't discover the flaw. FRA, how did you discover this, or was this?

Mr. WEIDERHOLD. How did I get notice of it?

Mr. MICA. I'm sorry?

Mr. WEIDERHOLD. How did I personally get notice of it?

Mr. MICA. No, how did FRA—

Mr. WEIDERHOLD. FRA discovered it during a post-test inspection of a speed test to improve curve speeds. They detected rust and actually—

Mr. MICA. We are very fortunate that someone did find it. Thank God this thing, you know, the Post talked about the high speed service. The average speed, I am told, of the Acela is between 83 and 84 miles per hour in the northeast corridor, in that range, which is one to two miles faster than the Metroliner, I'm also told, at least from New York to Washington, D.C. Thank God this thing was not going 150 miles per hour as it was designed continuously. Because we would have an incredible disaster, by any technical evaluation.

Part of the problem stems back, though, to a flawed acquisition, first, buying the most expensive equipment. I just want to put in the record, so we have this, because I like these records to go back and refer to. This is Mr. Gunn's statement saying, and this is back in 2002 when he was questioned about the system, we could have bought off the shelf technology at \$2.5 million for the locomotive, about \$2 million each for the deck and he says it himself here, instead we bought a \$700 million, \$34 million for the Acela locomotive and very expensive equipment, and probably could have made money. But I'd like this to be made part of the record if we could, Mr. Chairman, showing that from the beginning, the acquisition was flawed.

[The information follows:]

Amtrak's Gum Displays ADsaming Hbresty

In two recent excerpts from public appearances, President David Gunn cleared the air by being candid about Amtrak finances and Acela's impact:

I've always been a bit of a critic of the industry. . . . My criticism is that too much of our activities are not focussed on the basic economics of the business. We spend an awful lot of time. . . [on] appropriations and legislative strategies and the like and there's precious little time we spend talking about improving revenue-cost ratio of our properties. That's an absolutely critical measure, because we're always running around. . . talking about expansion.

For years, we've been dreaming of the day when rail passenger service and transit will expand—double, triple, quadruple, the amount of transit and the amount of investment that's out there. And when you have an industry, and I don't know the current cost recovery figure but for say for the sake of argument that it's fifty percent, doubling tripling the size of these properties, because when you double or triple the size of these properties you go into lower cost recovery areas. I can tell you that the trouble with Amtrak and a lot of transit properties have with the politicians is they view us as a bottomless pit. And that's one thing that I don't think we do a good job at.

If you look at our cost recovery, a whole lot of different things drive it. It's the type of equipment we buy, it's our ability to control our labor cost, our absenteeism and the like, and our ability to generate and to utilize fuel efficient vehicles, and to make good use of capital. And we don't do a very good job on this score. We have big problems in all of these areas, but we tend to focus on trying to find somebody who will fund us.

And I remember at SEPTA, where I was General Manager, they went on this endless hunt for predictable funding. They figured that was the answer to their problem. They eventually got some funding but it immediately got chewed up and the cost recovery dropped from where it used to be, like Toronto in the high sixties, and it dropped. I think it got down to forty percent.

So what I'm trying to say is we're not focussing on the right. . . issue. Let's just look at for a minute—equipment. You all know that we have a new set of electric trains running between Boston and New York. Acela. I never understood why they did that change. It would be like Coca-Cola taking a good brand name, Metroliner, and changing it to "brown liquid in a bottle"

But anyway, what we now have is Acela. And actually what a cela is is the room before the first floor. (Laughter) I don't know why they did that. And anyway we have these new trains and they're really nice and they go like hell, up to 150 miles per hour. I rode one, I rode the head end in the 150 mile an hour territory up to Boston, and all of a sudden we see a headlight.

You know I didn't want to say anything, but I was thinking this could be a real problem and a short career. . . cause trains close really fast at 150 miles per hour, but in this case the train was stopped and we slowed down, and we went through a high speed turnout, and I pretended that I wasn't nervous at all.

Let me ask you a question. Between New York and Washington we can run Acelas or we can run the AEM-7, the Mighty Mite locomotive, which is an off-the-shelf locomotive from Europe. It's just a garden variety locomotive that we bought, and Amfleet cars, and we can run the same schedule as we can with Acela. Now I want

to ask you something. If I have a train of passengers in an AEM-7 and Amfleet coaches in good condition, I realize there aren't very many of them left but if they were fixed up, and if you got an Acela, which train has the better profit margin? This is a trick question.

It's the Amfleet! I mean we went and spent a bundle of capital, we sold debt, we put the debt on our balance sheet. We're up to 3.7 billion dollars of indebtedness. Last year alone we added \$700 million dollars of debt to our balance sheet. How do you pay for that? I don't know. And we put a train into service, which is good, it's a very nice train from a passenger's point of view, [but it] made our economic situation worse.

The only thing you can say is north of New York, we cut the running time from four and a half hours to about three hours and forty five minutes. That was the benefit. Now, we needed new equipment I guess, but what did we do? We went out and specified equipment that is one of a kind. There'll never be another one bought. I think. At least there'll never be another bought anytime soon. I can tell you. They're one of a kind, they're very expensive to run.

I mean, you look at that train, it is five revenue cars, one cafe car, and two locomotives. There's enough power on that train to run a ten car train and make the schedule. But I mean it is overpowered. There's absolutely no sense to the amount of power we are consuming to the benefit we are getting on that train. So, what we have done to ourselves is that we have made our economic situation worse. Now, the only thing you can say is that now that we own them, we've gotta run them—it's better than not running them.

What I'm saying is in this industry, you always want to look at the net income impact on the bottom line. Why did this happen with the Acela? It wasn't just because Amtrak didn't push the numbers. But what happened is it got totally screwed up when the politicians got into it and the Buy America and the FRA rulemakers got into it, and we ended up with a train that had to be custom built and is much more expensive than a train that we bought off the shelf.

The point in all of this is I'm not sure we did ourselves any favors with what we've done because if Amtrak was viewed as a bottomless pit before and we just did something that cost us a lot of money, we've got the debt on our balance sheet, and we didn't improve our bottom line.

On the MacNeil/Lehrer report, he managed to set things straight about long haul subsidies versus the Northeast corridor.

JIM LEHRER: When you look at the long range. . . I mean what you call intercity passenger service, particularly the transcontinental, I read something today that they only haul 18 percent of your passengers, but account for 75 percent of your loss?

DAVID GUNN: No. You've got to be very careful. There's a lot of mythology about Amtrak's economics. Everything loses money. In other words, people will say it's the long-distance trains, and if you got rid of them, the corridor would be a profitable company. Not so. The passenger movement or transportation market in the United States is thoroughly subsidized, whether it's highway airlines or rail. And what's happened, like the basic structure of Amtrak is the Northeast Corridor covers most of its operating costs, the costs of the train crews and maintenance of the cars and so forth, but it does not cover its capital expenses. And we have an enormous deficit in that area.

Coast Observations

THE SIGNS ON THE WINDOWS OF San Joaquin and Capitols promoting cafe service may just be window dressing. Anyone who thinks new San Joaquin menus featuring Salisbury Steak and Macaroni and Cheese will save dining service, order up pronto. Informed sources say the decision already was made to drop the second cafe job and adopt a simplified menu. Given the \$1 million annual cost of that job, change is long overdue. A chronic absence of clear thinking has hobbled the food service for years. A recent furinstitute saw a Caltrans badge-wearer placing the signs, and asked what the purpose was. "To get people to visit the Cafe Car." Rider: "But this IS the Cafe Car." Caltrans: "Well, we don't know what order the cars are going to be in, any given day." Rider: "So you're telling me that when you change the cars around, you change the windows around?"

Caltrans badge stomps off to resounding laughter. . . THE CHANGE THAT MAKES SENSE is to make some rational use of the non-revenue space in the Capitols and San Joaquins, which is upwards of 25 percent of the train, an even higher ratio than Acela. Caltrans has always claimed that there is no room for first class seats on the San Joaquin and Capitols. That room can be found in the 2/3 of the Cafe Car that is not needed for the food line or the server. . . AS THE GERMANS HAVE DISCOVERED, first class seating with free beverages, laptop hookups and meal service at the seat is a big seller and commands a great price. It's time to replace irrational non-revenue furniture in the Cafe Cars and start producing fares in the vast empty space. . .

BART IS SHARPENING ITS PENCILS to penalize Caltrain riders to SFO with a pair of surcharges. First, a \$1.50 SFO premium, then a surcharge on top of regular prices for all new San Mateo stations. Nobody is saying how much the total is for Millbrae-SFO, but insider say it's the highest California transit fare per mile. The current SFO shuttle is FREE, guys. . . CAPITOL CORRIDOR PLANS to redesign its timetables.

Current complaints include: "Difficulty using the schedule to plan trips from one point to another; Confusion identifying train vs. motorcoach segments. . .

Distraction by the number of colors, shapes, lines and type treatments;

Difficulty in understanding connecting motorcoach schedules; Difficulty [with] symbols throughout, including use of vertical lines to indicate "skipped" stations;

Connections to other transit systems are confusing; Footnoted items are not noticed by users." It looks like passengers aren't buying the Caltrans marketing dogma that the current format is the best ever. . . UNION PACIFIC

NEGATIVITY toward Amtrak has erupted again in a go-to-hell letter in response to a state offer of funding for a track capacity study of extension of one San Joaquin to L.A. Perhaps it's time for California to adopt a policy of only investing public funds in railroads that aren't involved in lobbying to kill Amtrak. . . CHECK OUT OUR REBUILT

WEB SITE AT www.calrailnews.com and while you're there tell Congress to

retain funding for Amtrak, especially long haul trains serving California. E-mail Congress directly with a single

click at: www.calrailnews.com

Mr. MICA. Then we had numerous, we have 15 different models of 20 train sets, is that right, Mr. Jamison, do you know?

Mr. JAMISON. There are 20 trainsets.

Mr. MICA. But there are 15 different models.

Mr. JAMISON. They all have unique characteristics, from my understanding.

Mr. MICA. And yes, in all the change orders, we changed the weight, the size, all of these things. So we have a train that really doesn't run on the tracks or the catenary that it was to be accommodated by. Are we going to have more lawsuits as a result of this, Mr. Jamison? Do you know? Is there a potential for lawsuits?

Mr. JAMISON. Well, since the contractual agreement that will be the basis of the lawsuits is between Amtrak and the Consortium, probably Mr. Weiderhold is better prepared to answer that.

Mr. MICA. One of the reasons I asked for the legal costs for Amtrak, we spend about \$60 million a year on legal costs for Amtrak. We spend \$4 million a month on maintenance for this system. If this had not been so entangled, we probably could have spent some of this money on maintenance or at least oversight instead of the mangled acquisition and lawsuits that have resulted.

Finally, again, we have to fix the problem with management, we have to fix the problem with oversight. Maybe each of you can tell us what you would recommend and how we proceed from here to fix this so that this does not happen again. Mr. Jamison, we will start with you.

Mr. JAMISON. As I testified earlier, I mean, before the Acela is brought back to service, our utmost concern is the safety of the crew and the passengers. There are basically going to be three requirements for returning Acela to service: doing qualification testing on the replacement component to make sure that it is designed to meet the loads and that we have tested to determine what the loads are in the corridor; to make sure that they do a revised inspection, testing, and maintenance plan that will get at the inspection procedures that are necessary and the different inspection techniques that are necessary—

Mr. MICA. Can you provide us with a recommended flow chart for Amtrak and how to follow and pursue, again, adequate contract management, so this will not happen again and your recommendation, just for the record?

Mr. JAMISON. We can provide some recommendations.

[The information follows:]

As discussed in the hearing by the witness from the Government Accountability Office, the Acela trainsets did not go through a rigorous testing regimen at the prototype phase. Thus, it is unclear how the equipment will age and whether additional defects and design shortcomings will be identified during the aging process. It makes the most sense from FRA's perspective that Amtrak select one or two Acela trainsets as cohort leaders. A conscious effort should be made (1) to maximize the mileage and service time accumulated by these trainsets and (2) that on a periodic basis they be subjected to a rigorous examination to identify these components of the equipment that are most subject to deterioration due to age and use. In the way, an ongoing, updated preventive maintenance program, including assuring the availability of adequate inventories of critical replacement components, can be developed and implemented for the other 18 trainsets. This could help assure that a total loss of Acela service due to mechanical failure is avoided in the future.

Mr. WEIDERHOLD. Sir, two thoughts. First, with respect to the brake discs very narrowly, there are some things that can be done on these processes that can be improved. There are a number of parts on the train. There are some that are more safety-critical than others. What you are talking about with respect to cleaner, more robust project management, definitely that is one of the biggest lessons learned thus far in our investigation.

I happen to agree with you to some extent on the project management issues facing Amtrak. I think there have been examples of large projects that could have been better managed over the years. I think David Gunn inherited some of those, he is having to manage through those. He is a railroader's railroader. He reminds me a lot of Graham Claytor, for whom I used to work. But he's got something that he needs to manage, and he and I work very closely, work very closely with senior managers.

There are some signs of hope. There is a fire-life safety project up in New York that is being used as a pilot program to put in world class project management techniques. That is a close to a billion dollar program for fire-life safety mitigation, security concerns in New York Penn Station. We are about 18 months into that. I think there are some organizational lessons learned and some process lessons learned that I hope to cede to other parts of the corporation, because that has been a problem in the past. So there is some hope, Mr. Mica, that the corner has been turned in a few areas.

Mr. MICA. Ms. Hecker?

Ms. HECKER. We have outstanding recommendations that Amtrak ought to adopt and follow best practices for managing large scale projects in the railroad industry. Our review found that they clearly had not done that.

We also have an outstanding recommendation that they ought to have a comprehensive transition plan to deal with implementation of the settlement and assumption and integration of the maintenance responsibilities. We have not had a positive response to that recommendation in terms of the comprehensiveness of the plan we are looking for. And we have recommendations in both of those reports for improved FRA oversight of both of those matters.

Mr. MICA. Thank you, Mr. Chairman.

Mr. LATOURETTE. I thank you very much. It would be the Chair's predisposition to recess. There are 8 minutes and 30 seconds left in this vote. When we come back, we will go to Mr. Oberstar, so he has plenty of time to proceed.

I would advise everybody that the Highway Subcommittee has a hearing set here at 2:00 o'clock, so if we could hustle back here and move expeditiously so we could get to the next panel, I would appreciate it. We stand in recess.

[Recess.]

Mr. LATOURETTE. The Subcommittee will come to order. Other members will join us as they are able to, then we will go to Mr. Oberstar, as promised, when he gets back. But at this time, since our witnesses are back, it is my pleasure to yield to Mr. Menendez of New Jersey.

Mr. MENENDEZ. Thank you, Mr. Chairman.

I want to thank the witnesses for their testimony, and I want to go over a few things here that have been said as part of your testimony.

Mr. Weiderhold, you are not at the point at which obviously you have concluded your review, you are somewhat away from that, right?

Mr. WEIDERHOLD. No, sir, I would say I am probably midstream through the process.

Mr. MENENDEZ. Midstream, all right. But to the extent that you have reviewed up to this point and based upon your testimony here today, there is a statement in, there is a paragraph in your statement on page four that says, "From all of our interviews and documents reviewed thus far, we have no evidence that Amtrak was ever made aware of brake disc spoke web cracks prior to April 14th, 2005, the date on which this was found, or was even aware of the manufacturer's detailed procedures for brake disc inspections."

Mr. WEIDERHOLD. That is entirely correct.

Mr. MENENDEZ. So that is the reality up to this point.

Mr. WEIDERHOLD. Yes, sir.

Mr. MENENDEZ. We might find something different tomorrow, but right now, that is the reality.

Mr. WEIDERHOLD. Yes, sir.

Mr. MENENDEZ. And in that respect, is it fair to say Amtrak didn't design these brakes?

Mr. WEIDERHOLD. Amtrak did not design the brakes.

Mr. MENENDEZ. They didn't manufacture it?

Mr. WEIDERHOLD. They did not manufacture it.

Mr. MENENDEZ. So to suggest that this is Amtrak's fault seems to me to be an enormous leap of responsibility from an entity that did not design it, didn't manufacture it, didn't produce it, and didn't know, at least up to this point from your testimony, that they had any prior evidence that they were ever aware of any of these cracks prior to the date on which the inspector found it is just a huge leap.

Mr. WEIDERHOLD. I think I can every clarify that one step more.

Mr. MENENDEZ. Sure.

Mr. WEIDERHOLD. If you look at the diagram that we have, this organization chart, one way to view this is if you took everything below Amtrak, it's almost like kind of a black box. What Amtrak contracted for is essentially a variation of consists at the block. In other words, bring the trains to me, put it in my terminus, let me run the trains, bring it back down the railroad, send it back to you and you maintain it.

What has changed a little bit since the settlement is Amtrak has certain responsibilities that it has to assume in taking over that maintenance operation. That is going to take place over a period of many months. It is scheduled to complete in October of 2006. I do not know if that time line is going to be affected by this problem.

But probably one way to look at this is Amtrak as a customer of receiving a product.

Mr. MENENDEZ. I appreciate that. So to the extent that based on this diagram you have given the Committee, it seems to me, and

tell me if this is a fair statement, that to the extent there is a problem of who knows what and what they did, it starts from here downwards, or from somewhere here upwards. Up to the consortium.

Mr. WEIDERHOLD. I think that's true, but at the same time, the experience we have with the train sets and several members have commented on the train's too heavy, the train's too wide and all the things that we kind of read in the press, I think that's a lot of history. The product is the product, at the end of the day.

I think as I mentioned, I think Amtrak has a responsibility here, but it has not and could not assume that responsibility to date.

Mr. MENENDEZ. Thank you. Let me ask you this. You also stated on page five of your testimony, we requested interviews with the supplier-manufacturer, but so far we have been told that they are too busy to meet with us. Who are those suppliers and manufacturers?

Mr. WEIDERHOLD. Well, the supply chain here is WABCO is the OEM and Knorr is the owner of the brake assembly. We had approached both companies. We had some preliminary conversations with WABCO. They have since been shut down. And Knorr is taking the lead on working on the fix, and they said they are too busy to meet with us right now.

Mr. MENENDEZ. So WABCO, when you say they shut down, they shut down in terms of communications with you?

Mr. WEIDERHOLD. They got lawyered up.

Mr. MENENDEZ. They got lawyered up, i.e., their lawyers told them, don't talk to you.

Mr. WEIDERHOLD. I would imagine that was the case.

Mr. MENENDEZ. And Knorr is basically saying, well, we're in the midst of trying to fix this, so we don't have time now to talk to you?

Mr. WEIDERHOLD. They are working very hard on the fix.

Mr. MENENDEZ. I hope they understand, though, that at the crux of this will be the necessity for them to talk to you or Mr. Chairman, if necessary, at some point, to this Committee. And I would be one who would be willing to be supportive of the Chair's use of whatever subpoena powers may be necessary to get them to come. We have to get at the root of what it is that caused this and what people knew and when they knew it and the consequences here.

Can I ask you one other question before I turn to Ms. Hecker? That is, your review really starts, to some degree, with the whole, or is focused with the issue of the brakes and whatever defects may have been found in those brakes and the process under which they were found to be, the cracks were found and maybe as to who knew what in the context of getting to that point.

But it doesn't go back to what I consider a foundation question, unless I am wrong, and I'd be happy for you to correct me, it doesn't go back to the foundation question as to how did we get Amtrak to make these decisions in the first place about choosing this particular set of transportation options in the Acela?

Mr. WEIDERHOLD. That in a way is probably a subject of a whole separate hearing, because there are a lot of opinions on that. We have been focused strictly on the brake disc problem.

But I can say, I was around when these decisions were made. I was around when Amtrak brought over the X-2000 train from Swe-

den and the German ICE train to test in 1992. There were two great trains that we had, we ran I believe for about six months each up and down the northeast. They performed pretty well.

The Acela train was a train on paper. But the Acela train brought with it at the time a financing package, because Amtrak did not have the money to devote to purchasing the train sets. In hindsight, if you ask the consortium or if you ask Amtrak right now would you have done it this way knowing what you know today, you would probably get a very different answer.

Mr. MENENDEZ. That point that you just said, Amtrak did not have the money, to me is so telling about the genesis of where we are today. I appreciate your answers up to this point.

Ms. Hecker, you said in your testimony, and I have read through some of the report, that Amtrak worked their plan around their annual budget and what they received each year.

Ms. HECKER. Yes, sir.

Mr. MENENDEZ. Now, that isn't a good business model, is it?

Ms. HECKER. No, it's not.

Mr. MENENDEZ. But then again, if you can't count on having a multiple year of revenue streams that are guaranteed to you, or that you can fairly project because you hobble along by Congressional appropriations that leave you far less off than you should be to operate successfully, how do you achieve success under that set of circumstances? Is it a fair criticism to say, well, they worked this year by year, and of course, any business plan you would like to work five, maybe ten years, but ultimately if you can't depend upon the resources, how do you plan ahead?

Ms. HECKER. Well, many Federal agencies, of course, face the problem of the dependency on Federal resources. For a number of years, I did work on the Coast Guard with their Deepwater acquisition. That clearly was dependent on annual funding. But there was a comprehensive plan, a financial management plan, and a scenario structured in their whole project that really made it, I think, clearer to the Congress what the consequences of a certain level of funding not being met in any year would be.

So it was the absence of a financial plan. It's true, they were dependent on the resources. And it's very hard to plan when you don't know how much you are going to get. But I don't think it undermines the value of having a comprehensive financial plan of what ideally the project would be.

In fact, I think it was you who said in response to a 1992 Act, the FRA prepared a whole blueprint that did have milestones, that did have cost estimates for the Northeast Corridor Improvement Project, including the new train set. But Amtrak didn't adopt that, they didn't use the set of milestones and didn't adopt the financial plan that—

Mr. MENENDEZ. But let me ask you a question. Even if they had adopted that financial plan, just answer this maybe for me yes or no, haven't we wholly underfunded Amtrak from what that financial plan would have been had they adopted it?

Ms. HECKER. Yes.

Mr. MENENDEZ. Okay. And lastly, your study also, from what I gather, and correct me if I'm wrong, does not start off as well with the foundation issues as to why these choices were made in the

first place, in terms of the Acela, what I just discussed with the Inspector General. You don't go that far back, you move forward from a different point in time, is that correct?

Ms. HECKER. I don't think we explicitly mention the financing package, but we are aware that that was in fact a significant factor.

Mr. MENENDEZ. Mr. Chairman, just as a final note, I would note that as in anything in life, when I was a trial attorney, we could take a picture in time. And if we take a picture in time, it will depict a certain set of circumstances. The question is, having the totality of the circumstances to understand in part where we are today. Thank you, Mr. Chairman.

Mr. LATOURETTE. I thank you very much.

Mr. Simmons, we will get to you in a second. I think I went out of order when we broke for our emergency or whatever it was, I promised Mr. Oberstar we would get to him. So I will go to Mr. Oberstar then you.

Mr. OBERSTAR. Thank you very much, Mr. Chairman. I appreciate your courtesy. I would like to ask unanimous consent that the record remain open for written questions to be submitted to the panel, in light of our truncated hearing, due to this evacuation of the building.

Mr. LATOURETTE. Without objection.

Mr. OBERSTAR. Thank you.

I am concerned about two systemic issues here. One is the specifications for the casting of the steel brake disc unit. And the inspection and maintenance process. What we have learned in aviation is first of all, to have redundancy. Because in contrast to surface transportation, there is no curb at seven miles in the air to pull over and look under the hood or look at structures or engines. The backbone of aviation safety is redundancy.

A second principle is excruciatingly painstaking inspection and replacement of parts that are time-sensitive. There are several levels of maintenance required for air frames and power plant. And there are time limits which certain things have to be done, even if there was a check a week ago, if this is your time limit that the part has to be taken out and replaced with new.

There is a paper trail for everything. Every maintenance over the lifetime of that aircraft. There is also coordination among manufacturer, airlines with same type and model aircraft, within the records of the NTSB and the FAA.

I do not see this same level of attention to detail and maintenance and specificity for safety in the rail sector, which is why seven, eight years ago, I introduced very comprehensive legislation to substantially elevate the level of quality of maintenance and oversight of maintenance in the rail sector.

Now, I reviewed some of the work orders and nowhere on the forms do I see a requirement to inspect hubs or spokes. There is a requirement for inspection of friction rings for cracks, but not the spokes. There was a service bulletin issued in 2003, it says failure of the brake discs could "result in considerable damage to equipment and extensive and possible fatal injury to passengers and onboard personnel." The service bulletin referenced the technical manual requiring inspection and replacement of the cracked

spokes. But when you go to the next step along the line, there was not the same requirement to inspect hubs and spokes. Now, in aviation, that would be a colossal failure, a problem.

A second collateral issue is the personnel doing the inspection work themselves and certified maintenance. In aviation, airline mechanics are certified by the FAA. They get an A&P license, air frame and power plant. Then they go through the training, they get their qualification status so that when this mechanic says this part is the wrong part, this part is defective or this aircraft will not go back into service, it doesn't go back into service. The same standard does not apply in railroad maintenance. That elevates the quality and the integrity of personnel performing maintenance to have this status.

Now, what we find here is lack of training, lack of communication and lack of clarity and instructions on maintenance. So where was the disconnect? Why did the workers not know they were supposed to be inspecting spokes for cracks?

Mr. WEIDERHOLD. I probably could not have phrased it any better than you just did in outlining exactly what the problems are, Mr. Oberstar. I think the analogies with the aviation industry are right on point. Because part of what we are going to be looking for is that redundancy.

Right now, all I have is paper. That's all I can compel right now. So I start with those procedures. And having a little bit of engineering background, you look for certain things. The other things I would look for in the chain you just described is I would expect the OEM would have done some type of testing beyond just a finite and limited analysis or the like. So I would like to see what those tests are.

One of the very interesting things right now is, working on the fix, is that all of, there is a new Knorr brake disc design and a manufactured product that goes to German, to Munich for testing, to Knorr Brimms, Knorr Brimms has a hydraulic pulsator to actuate and imitate the amplitude and the forces that are applied on the disc. The Knorr disc, the new disc is performing very well. It took lateral forces up to 150 gs, at one point 4 million cycles.

The WABCO product, the current product that was out there started exhibiting cracks somewhere between 0 and 50,000 cycles at 46 gs. That does not say it's failing, but it says that there is a problem. That's why we need to get those results back.

What I am really interested in is, was there a failure analysis done at any point prior to the time that the crack was discovered? Were there tests that were done by the OEM at the time of manufacturing? I have asked for the mil certs, I have asked for a casting analysis. This is a poured cast, it's not force fed. You know what happens in casting, when you put it in the sand, the way that it is cured. All those things kind of come into play.

The Amtrak metallurgist has informed me that he does not believe this is a casting problem. However, I would like to see the test results. I would like to see the metallurgy, I would like to see the yield and strength tests, all those things that go into steel. Steel is a great product. It is elastic. You generally design a safety factor of about 1.5 over the specification in anticipation of load, be-

cause it does have elasticity. There are certain things that you look at.

The new Knorr products, when you look at that diagram of the spokes, the biggest difference between that existing brake part and the new Knorr disc is you take the spoke and you turn it 90 degrees, so you have increased the section modulus and you have by definition strengthened it against the bending moment. That's what we would expect on a bench test that it would perform superiorly.

I would like to know when that was designed, why it was designed, get answers to all those questions. Because this time line is very important.

With respect to the procedures, I think there are some very good lessons to be brought over from aviation into the rail industry, and especially, especially with safety critical parts. If you don't have it anywhere else, at least have redundancy when you know you have a safety critical part.

Mr. OBERSTAR. I appreciate your answer and the depth to which you went in responding. All the issues about metallurgy are matters that I think we have to await the outcome of further investigation. The fact that, what I consider to be a fact, from reading the documents, the FRA inspector cut the spoke out of the rotor and then it fell apart in his hand.

Mr. WEIDERHOLD. At first, there was some concern about how deep the crack was, did the crack go through the entirety of the width of the spoke. The first one that looked like the worst one, there was a plasma cut that was done above and below the identified crack. When that piece was taken out, the two pieces fell apart, which confirmed that the crack was clean through the spoke.

Mr. OBERSTAR. Which raises questions about the standards, Mr. Chairman, set for the metallurgy itself. What are the standards and who crafted them? Those are questions that we should not pursue here, because I think we have to await the outcome of metallurgical testing. I hope there will also be some independent metallurgical lab testing of these parts, so we get a balanced kind of a consensus view and not just one viewpoint of this matter, which is, it is extremely important.

Again, in aviation, there are standards that are set, have to be followed. The parts that are cast, parts that are machined and parts that are composites have to be subjected to extraordinary testing and assure the continuity of quality.

Mr. WEIDERHOLD. If I could, you also made a point about the AMT and the certification that is required. There is, in this model, a certification that is required for a sign-off by a supervisor that includes slightly greater training than that of the person actually performing the work. But I think that it does not have the same panache that an AMT card has in the aviation industry.

The other thing I believe in the aviation industry is that if you miss things, there are penalties if you miss them. I am unsure as to what rules could be applied, barring a catastrophic event, which we I think we were lucky here. There can be incentives for people to do the right thing.

Mr. OBERSTAR. Mr. Chairman, you have been very generous with the time. I just have one more. At the end of all this process, we

may be making the case for hearings on safety procedures generally in railroading and the qualifications and status of rail maintenance providers. But Mr. Jamison, the IG's office staff seems to feel these cracked spokes and webs would not have been found on a typical FRA routine maintenance check. What is a routine maintenance check? How does that differ from the inspection that led to finding the cracks in the disc rotors? What is the difference there?

And again, I know in this specification sheet there are certain comments, at this level, such and such is inadmissible. Well, we know the catastrophic failure on the Aloha Airlines 737 when 18 feet of the roof of that aircraft bound for Honolulu ripped off, it was because of the propagation of a hairline crack that could be discovered only by eddy current technology inspection. That's the level of inspection that we need in aviation and on a safety critical part, it seems to me that that's also the level of attention to detail that is necessary.

Mr. JAMISON. Congressman, first let me respond to the "routine inspection" question. It is my belief that the inspection requirements that are in place now would have picked this up if the proper training was done and the proper inspection techniques were conducted. So, for instance, we require a daily inspection of the undercarriage of the Amtrak trains for Tier I Class or Tier II Class I brake inspections.

But to your point, I by no means have your expertise on the aviation industry. But I also believe that they have learned greatly from where they have had equipment failures. That is what we are focused on, to try to make sure that we learn from this. The failure in the spoke has not been a common problem from FRA's experience in the railroad industry, even though there have been isolated instances. Now that there is a common problem specifically with this high-speed equipment, we need to go back, reevaluate the inspection, testing and maintenance plan that we approved, make sure it is appropriate, given the design, the loading and the possible cracks that may occur in this equipment.

Mr. OBERSTAR. Thank you.

Mr. Chairman, in conclusion, may I ask unanimous consent for Ms. Norton to ask questions at the appropriate time in the proceedings?

Mr. LATOURETTE. Absolutely.

Mr. SIMMONS.

Mr. SIMMONS. Thank you, Mr. Chairman, for having this hearing, and I have listened with great interest to my colleagues, Mr. Oberstar, Mr. Menendez in their discussions of this problem.

Mr. Chairman, we have more than a broken brake system here. We have a broken train system here. I think the whole system is broken and I think perhaps this problem with Acela is fortuitous, because it focuses our attention and the attention of everybody like me who is interested in providing good train service, passenger rail service in America on the fact that we need some major surgery and major overhauls here.

Let me just back up to some of the things Mr. Menendez was saying. The history of this project and decisions that have been made over the last 10 years, Amtrak has known about the prob-

lems of putting a high speed train on low speed tracks for years and years. I served on the Connecticut transportation committee, was ranking member back in the days when these decisions were being made. I remember when the ICE was running these lines and when the X-2000 was running these lines.

I also remember that Amtrak made a decision following a study, I believe, in 1988, that they could never run high speed along the shoreline of Connecticut. There were nine full turns of circles between Westerly and New Haven. It was impossible. So this study recommended an inland route where they could design a high speed track that would be straight. The decision was made not to pursue that because condemning land was considered to be so difficult.

So from the very, very inception of this project, it has been known that the shoreline between Westerly, Rhode Island, and New Haven, with nine full circles, was not congenial to true high speed.

Secondly, the train set that was decided upon was unanimously rejected by the Connecticut General Assembly Transportation Committee. They recommended test trials for a number of years using the turbo jets which would have avoided the tremendous cost of the catenaries and could have demonstrated whether there was a market for high speed. That recommendation, that unanimous recommendation of the State of Connecticut was rejected outright by Amtrak. They went ahead to develop their own tilt train.

Again, the fact that they were going with a tilt train shows that they knew there was a problem with winding tracks. They knew that winding tracks or more than three degrees of turn on a high speed track stresses the system. The systems are generally not designed for that. They designed the train to be crash-proof with freight trains, because freight trains run along the line, but that made it twice as heavy. So you are putting a substantial amount of more weight on these train sets.

Then if you look at the deployment schedule, where the wheels, since September of 1999, the wheels were wearing out too fast, they were hunting or oscillating, in 2000, bolts were broken and in December of 2000 the trains ran for a day then broke down, then there were cracked yaw dampers, etc., etc. My wife rode the Acela a month ago. When she got off in Boston and asked the train master what was the smell, and he said, it's the brakes, nothing wrong with that, they do that all the time.

Mr. Chairman, this project has been fraught with difficulties for a long period of time. And the problems of this project go way beyond the problems of a single piece of equipment failing. I think that we have systemic failures here that in fact led Mr. Gunn to say in 2002, or to question in 2002 whether Acela was worth its cost for Amtrak to operate, or whether they should go back to conventional trains and the Metroliner in fact can operate within 10 or 15, maybe 20 minutes of the time of the Acela.

We have a serious, serious set of problems here. And I am very concerned about it. I am concerned about the fact that the summer season for train passengers in Connecticut and New England generally is the season of tourism, you have high ridership and we're

not going to have these trains on the tracks. I am concerned that workers are transferred from one train set to another.

I just can't express to you my distress over what I have heard here this morning, over what I have observed over the last 10 years. I would hope, Mr. Chairman, that we could use this hearing and this situation as a springboard for a substantial and comprehensive review of every aspect of this system with some serious reorganizational recommendations to follow.

I don't know whether any of the panelists want to respond to my comments. I do have questions for the record, but I know we are short of time. But that is where this Amtrak supporter seems himself at this point in time, and it's not a happy situation that I see for myself.

I yield back.

[The information received follows:]

The Department agrees that part of the problem is organizational. Amtrak does not recognize its limitations and tries to do too many things and thus does not have the focus or resources to do many things well. The Acela procurement is an excellent example of how these shortcomings now hamstringing the corporation's ability to meet its transportation mission in a cost effective and reliable manner. The Administration proposes to turn Amtrak into a pure operating company and thus remove from management the obligation to oversee maintenance of the most complex rail infrastructure in the Western Hemisphere. This in turn will permit the company to focus on serving customers and maintaining the necessary equipment for its service. Just meeting the complex challenges associated with that truncated mission would stretch the capabilities of most well run transportation companies.

Mr. LATOURETTE. I thank the gentleman very much.

I have been advised that when the House goes back into session, they are going to reopen the vote on the previous question. But if you have already cast your vote on the previous question, there is no need to return. So it is my intention, unless someone has a big problem with it, to just plow ahead.

Ms. Norton.

Ms. NORTON. Thank you very much, Mr. Chairman. I appreciate the opportunity to ask a question or two.

First, on this hearing, I know that the witnesses feel as I do that the loss of the Acela could not have occurred at a worse time, when many of us are here on both sides of the aisle trying to save Amtrak, and have you only real money-maker go out on you this way. We will go a little further into how to keep that from happening in the future. I don't understand how the folks who built it, and I do understand, I do understand that we've got a custom built Acela here. Nevertheless, particularly sitting here where I am, where the Acela is not only good for you, it is good for the entire east coast, I can only say, what next.

I sat in on, because of the good graces of the Committee, I sat in on a hearing on rail safety that was held last year. At that time, I was very, very concerned, post-Madrid, sitting here with Union Station in our face, the Senate very close to Union Station, trains running under Union Station, my own Amtrak safety people had come to see me months before about their concerns, just to alert me.

I asked, I believe it was Chairman Quinn who was chairman at the time, that you have a plan, a cohesive plan by the end of the year. The chairman was adamant he wanted that plan by the end

of the year. So far as I have been able to tell, no plan was forthcoming for securing passenger rail. That's very concerning, considering that where the people are is really not in aviation, it's really on rail and subways and light rail. Huge numbers of people every day get on.

In my own questioning to the Administrator at the time, it was clear that a lot of work had been done with operators all across the country, a lot of work. Of course, there was nothing coherent for any of us to look at. And it looked like it was each man for himself, although people sat around and talked to each other and apparently something close to best practices was being developed, so it didn't seem like a big thing to get to Congress what it asked for, which was a plan for securing rail travel.

The Homeland Security Committee, on which I also serve, I am on this full committee as well, had a reauthorization markup just last week, ten days ago. I got an amendment in that bill, and I got some report language in the bill. The amendment should help you do what I think you can easily do, you haven't been just sitting there not talking to operators all around the country. It simply would have, it says the Department of Homeland Security, actually, the Homeland Security Committee is already talking with the staff of this Committee, because obviously the two are intertwined here.

But essentially it would have the Administration develop passenger security best practices to be used by operators on rail, light rail, etc., and a national plan for public outreach, an awareness, so that employees and the public alike can have a sense of what they ought to do on rail travel the way many of us understand what to do on air travel. That wouldn't cost anything, probably already going on, but again, there is nothing coherent that a member of Congress could look at and do oversight on. That's the first thing.

The second thing is the embarrassment of the CSX litigation. Here we have a local jurisdiction trying to reroute trains that are in your jurisdiction, sir. The reason is, nobody could get your agency or the Department of Homeland Security to come up with a plan of any kind that they are willing to talk with the District about for making sure that trains which travel carrying toxic materials within four blocks of the Capitol were in fact properly secured.

There was un rebutted testimony at the hearing that if one of these trains, one car on this train was successfully attacked, you could have an explosion with gases emitted for as many as 14 miles in either direction, and if it was the right car at the right time with the wind blowing at the right time, as many as 100,000 people could die within a half hour. After South Carolina, I don't think anybody can doubt what a well-planned attack of that kind would do.

I was able to get report language in that really begins at the basics on the CSX type matter. All of the concern has gone off on re-routing. Everybody knows that you are not going to be able to re-route trains in the United States very much. Perhaps some rerouting can be done around the Capitol, I don't know. The National Capital Planning Commission is looking at whether or not the Federal Government could do something with some tracks in that regard.

But clearly, rerouting is probably an impractical way to deal with the situation nationwide. So what you need is a Federal agency to step up to the plate, so that we don't have what cities are now beginning to do all over the country. They are all saying, okay, let us do something like the District of Columbia did. And to show you just how compelling what the District of Columbia did was, it won at the trial court level on commerce grounds, it was overturned, at least at the preliminary injunction stage, at the court of appeals level.

But the court looked at what your agency said it had done. It must have said the equivalent of, is this it? Because it said, a local jurisdiction has the right to protect itself from such a deadly risk.

I give you that predicate to say first, do you have any objection to this language that I hope will remain in the bill. It was passed by the Committee concerning the development of a coherent set of written best practices to be used by operators of appropriate facilities and a plan for public outreach and awareness for employees on the one hand and passengers on the other. Is that something you think could be appropriately done by the agency so that for example, I was pressed to make it an amendment because no plan, so far as I could tell, had been received.

I would like first to have an answer on that, and then I would like to ask you a question on what to do about the CSX type problem.

Mr. JAMISON. Ms. Norton, I am not familiar with your amendment. But I can tell you this. I feel like what you are asking for, in the way you described it, has already been done.

Ms. NORTON. So where is it, sir?

Mr. JAMISON. Well, you can go to the—

Ms. NORTON. Why wasn't it submitted to this Committee as the Chairman asked last year?

Mr. JAMISON. I wasn't at the Committee hearing, first of all, and quite honestly, I don't even know if the agency that prepared it, which I am getting ready to tell you about, was at that hearing.

Ms. NORTON. The agency was at that hearing. The Railway Administration was at the hearing.

Mr. JAMISON. The Federal Transit Administration, of which I happen to be the Deputy Administrator, shortly after 9/11, established a comprehensive action plan for passenger rail security. As you mentioned, public awareness is a key issue. It is an issue that was brought up in Madrid, and one of the fundamental, basic things that you have to do to make sure that you protect passenger rail. The comprehensive national public awareness campaign was rolled out by the Federal Transit Administration, approved materials were disseminated to every public transit agency in the country. Technical assistance was provided to all those transit agencies to not only conduct vulnerability assessments, but to make sure that they had proper training in place to educate their employees on how to spot suspicious behavior and that they have public awareness messages across the country.

So a lot of that stuff has been done. I will reiterate, though, that DHS has the lead in security. Those "best practices", as you call it, were developed and comprehensively laid out in a top 20 action item list that is still posted on the Federal Transit Administration

Web site. I contend that every transit agency in the country is aware of that list.

Ms. NORTON. Could you submit to this Committee a copy of all the documents you have just described?

Mr. JAMISON. Absolutely.

Ms. NORTON. Thank you very much.

Ms. HECKER. Ms. Norton, I just wanted to add to actually after that hearing, Mr. Quinn, as well as several members of the Senate, asked GAO to do a global analysis of best practices in rail and transit security. That work is ongoing. As a successor, we briefed Mr. LaTourette's staff. That study is due out that summer. We basically covered eight European capitals and all of the rail manufacturers and operators and three Asian countries. We visited every transit organization in this country, as well as Amtrak. We will likely have comprehensive recommendations at that time. I know it is not speaking to your legislation that would direct that kind of leadership, but we will have some conclusions, and with the clearance of the other members, we would be happy to brief you on that.

Ms. NORTON. That does speak directly to it, and I am glad that you are looking at it, as other countries have also engaged in it. Finally, on the report language, the first responders, the fire chief, for example, in D.C. said he had no idea when these substances were coming through. At the very least, apparently the League of Cities the mayors said they wanted that kind of notification. So this language goes to prenotification of shipments to local law enforcement agencies, protocols on effective communication between shippers and local authorities, training of employees in handling hazardous materials. Really the basics.

Do you have any problem with that, or are you going to tell me that's already been done? Because the litigation came precisely because the District of Columbia did not have any information on what to do. And here you have a local jurisdiction that moved out on its own and now has a whole bunch of local jurisdictions moving out on its own, showing that there is a void, a gap in leadership here.

Mr. JAMISON. I just want to clarify. The comments I was making before were strictly related to passenger rail, and a lot of the work that I headed personally at the Federal Transit Administration. So I'm intimately aware of that, would be happy to share that with the Committee.

As far as prenotification goes, Graniteville taught us a lesson about not only security but also safety around hazardous materials and the impact that TIH can have, particularly chlorine can have, in a situation. However, I have concerns about prenotification. As a result, we are accelerating the use of our research resources, with those of the Department of Homeland Security, the Office of Domestic Preparedness, to come up with a Railinc demonstration project that actually would allow us to have consist information available in a push-pull type of system. So, for instance, if there is an accident in the vicinity of five emergency responders, automatically they would be in a database, and the information of what's on that train would be pushed out to them, as well as giving them the opportunity via Internet or other opportunity to go in and pull that information to them.

However, I do have a lot of concerns about prenotification. There were 1.7 million hazardous material shipments by rail in the United States in a year, and I don't want to overburden or take away the importance of key data with a constant stream of information that would keep coming to emergency responders who have a lot of other critical work to do. More importantly, I think it's critical that we give them the access to information when they need it most.

Ms. NORTON. If there are appropriate guidelines or regulations, do you know what you would get? You would get responses back from agencies and you would be able to work that out. In the absence of that, you have a local jurisdiction out on its own. I must tell you that their notion of rerouting was not my idea of the only available option. But when people who are sitting where they are sitting, without any leadership, think about what to do, they can only think about move the train away from where it is.

So I would simply ask you, I am very pleased that you responded as you did on prenotification. What it does is to show the importance of publishing something, so that local jurisdictions can speak back to you and we can iron out this problem before you get this proliferation of concerns already developing, surely you must know that, already developing in cities and towns around the United States. I am confident this language will remain, because it is report language, and I want to assure you that I am personally going to make it my business to follow up on both of these issues I have raised at this hearing.

Thank you very much, and thank you, Mr. Chairman.

Mr. LATOURETTE. I thank the gentlelady. We are going to bring this panel to a close. I want to thank each of you, and Ms. Hecker, we look forward to your continued work and appreciate the work you have done already. Mr. Weiderhold, I speak for members on both sides of the aisle, that your investigation to this point has been very impressive and we look forward to your further work.

And Mr. Jamison, I know that your role as Acting Administrator is about to come to an end with the confirmation of the Administrator. You go with our thanks and my thanks for your service to the country to this moment in time in filling that role on an acting basis, and good luck with the addition to your family. Thank you for being so patient. Thank you all.

While we wait for the second panel, the House has notified those who do not have access to the outside communications, it indicates an apparent air space violation by an unidentified aircraft over Washington today prompted the evacuations that we just encountered. F-16 fighter jets scrambled to intercept the aircraft, it was a small, single-engine plane forced to land in Frederick, Maryland. There are two subjects now in custody and being interviewed by the Secret Service. That's what happened to us a little bit ago.

It is now my pleasure to welcome the second panel today. The second panel will be comprised of William Crosbie, who is the Director of Operations at Amtrak; William A. Spurr, who is the President of Bombardier Transport of North America; and Francis Jelensperger, who is the President of Alstom Transportation, Inc., of America. I want to thank all of you for coming here today. I apologize for the deadline.

I just notified the members of the Subcommittee, there was a Highway Subcommittee meeting that was supposed to start at 2:00 o'clock. They are now going to wait for us. If we can sort of shoot for a 3:00 o'clock out time from this, I don't want to short anybody the opportunity to ask any questions, but if we can sort of aim towards 3:00 o'clock, I think we can facilitate our brethren on the Committee.

I would say to the panel, this is a pretty funny place, Washington, as most of you know. While we were outside in the parking lot, some of the wags were suggesting after the second panel was sitting in the audience and saw Mr. Mica's questions of the first panel, perhaps we should check your fingerprints on the smoke detectors and fire alarms in the building.

[Laughter.]

Mr. LATOURETTE. I'm sure that that was not right. But I again thank you very much for coming. I want to say, as an editorial comment, that when the Inspector General was here, I am personally impressed that all three of your organizations are cooperating fully with the IG and what he is attempting to do. I think you are to be commended for it. He made the observation that one entity not represented here today may be lawyering up, and while I understand business concerns, I think it is commendable that all three of your organizations have stepped up to the plate and are helping us try to find a solution.

So with that, welcome, and Mr. Crosbie, we look forward to hearing from you.

TESTIMONY OF WILLIAM CROSBIE, SENIOR VICE PRESIDENT OF OPERATIONS, AMTRAK; WILLIAM A. SPURR, PRESIDENT, BOMBARDIER TRANSPORT OF NORTH AMERICA; AND FRANCIS JELENSPERGER, PRESIDENT, ALSTOM TRANSPORTATION, INC. OF AMERICA

Mr. CROSBIE. I am just going to walk through a series of slides for the record, we would like to submit them for the record, which has some photographs that you might be interested in. I will do that quickly and then I would like to move on to my testimony if that's okay.

The first slide there, photograph, gives you a sense of the shop environment. It is a modern facility and the train set over a pit. This area here is the undercarriage of the train, the wheel axle set, there are three rotors or discs on an axle. That is something you may not have heard until now.

When we talk about the friction surface, Mr. Weiderhold mentioned that, there is a good photograph of it there. This is what is referred to as the web, and you can see the spokes in here.

This is a good example of the type of crack that you would see. You can see that one we have submitted, it is barely visible to the naked eye. Now we know where to look, so your mind and eye can play some tricks on you as to is it there or isn't it there. That is the same spoke a little bit closer in.

Then this is a different spoke. You can see that that crack is clearly visible. So what I wanted to give you today is a sense of the degree of variation in visibility.

Mr. Chairman and members of the Committee, I appreciate the opportunity to come before you for an update on the status of Amtrak's Acela service. This afternoon, I am going to address what happened last month regarding our decision to pull the Acelas, what is being done to return the trains to service and what the financial impact has been to date. I am Williams Crosbie, Senior Vice President of Operations for Amtrak. I joined Amtrak in January 2003.

I am a professional electrical engineer with over 20 years' experience in railroad operations, maintenance and engineering. Let me begin by saying that this incident has not affected our resolve to return Acela to service. Acela was introduced nearly five years ago. The train is popular among our passengers and ridership has grown from just under a half million in its first year of operation, 2001, to more than two and a half million in fiscal year 2004.

Last year, it accounted for nearly \$295 million in ticket revenue, or approximately 25 percent of all Amtrak ticket revenue. Its popularity among passengers was continuing this year until the trains were sidelined in April, with revenue up 10 million and ridership up 7 percent through March against the same period last year.

In the early morning hours of Friday, April 15th, I was contacted by Amtrak's high speed rail master mechanic and told that cracks in the spokes of the brake rotor had been found. The first crack was found following a post-run inspection of one train set. The initial Amtrak high speed rail mechanical engineering assessment was that the defect existed on every train set inspected to that point, and that it likely existed across the fleet.

Amtrak's high speed rail maintenance and engineering staff recommended to me that the train sets be taken out of service because based on their assessment, it could be unsafe to operate the train sets. After reviewing their findings in detail, I concurred with their recommendation and ordered the entire fleet of Acela train sets out of service.

Simultaneously, I also ordered an immediate fleet-wide inspection of all train sets to detail and document the cracked spokes by train set, by car number, axle number and rotor number. Each of the 6 coaches of the 20 train sets has 12 broken brake rotors. That means the full fleet has 1,440 rotors. Of those 1,440 rotors, approximately 300 cracks were found on 250 of the rotors. These cracked spokes, many of which were not visible to the naked eye, were found on every train set. At a meeting on Friday, April 15th, all parties agreed that taking the Acelas out of service was the right decision.

These train sets were assembled in the United States for Amtrak by a consortium of Bombardier Transportation of Canada and Alstom of France. In addition to the 20 train sets, the consortium provided 15 other high horsepower locomotives, 3 new maintenance facilities, and through its subsidiary, the Northeast Corridor Maintenance Service Company, better known as NEC-MS, a service contract to maintain the equipment. Under this service contract, NEC-MS is obligated to inspect, service and maintain the equipment with NEC-MS management supervising Amtrak employees.

The brake systems used on the Acela were supplied by Knorr, a subcontractor of the consortium, and the discs or rotors at issue

were supplied by Knorr and SAB WABCO. Under our management services agreement, NEC-MSO is responsible for inspecting and maintaining the train sets and managing the inventory of spare parts. When this incident occurred, we discovered that there were only 64 spare rotors on hand and none on order.

Consequently, this required Amtrak to deliver the news on April 20th that the train sets would in all likelihood not return to service until some time this summer, and then only gradually. We then moved on parallel paths to determine the cause of the problem and the solution, and to quickly begin a service recovery plan. The absence of Acela initially left a substantial hole in our northeast corridor service. On weekdays we had been running 15 round trips between Washington and New York, 11 between New York and Boston. These trips accounted for average weekday revenue of \$1 million a day.

Moving quickly with replacement Metroliner service, we reduced the daily revenue loss by more than 50 percent. Starting the week of April 25th, we were able to offer nearly hourly service from 6:00 a.m. to 6:00 p.m. in both directions between New York and Washington with Metroliners. Starting last week, we expanded that to 7:00 p.m. in both directions, and added two Metroliner round trips between New York and Boston. So we now have 14 Metroliner round trips south of New York and 2 round trips north of New York. We did all this by a combination of actions, including the re-deployment of equipment from throughout the country, reducing the shop count of our other service cars and borrowing equipment from third parties.

The Metroliners have performed well. Since starting their full schedule on April 25th, on-time performance as of May 9th was 83 percent. A good day for us is typically between 85 and 90 percent with the Metroliners. This is equivalent to the Acela's on-time performance in March, which was 83 percent. The trip time also compares favorably with the run time that is within 10 minutes of the Acela express.

However, despite quick action to redeploy equipment and construct a Metroliner schedule that meets our passengers expectations, the loss of revenue has been and will continue to be substantial until the train sets are returned to service. Our estimate is that net of expenses, we will lose somewhat more than a \$1 million a week that the Acela express trains are out of service.

This has the potential to seriously jeopardize our end of fiscal year 2005 cash balance. Right now the projection stands at \$32 million before considering the impact of Acela service disruption. This incident may well exhaust our cash by the end of the fiscal year. We are taking every opportunity to mitigate the financial consequences of this incident. Also the FRA and U.S. DOT, who are on our board of directors, are up to date with daily cash on hand reports as well as monthly cash flow projections.

The Subcommittee may also be interested in knowing that under the maintenance agreement, NEC-MSO may be assessed liquidated damages of \$10,000 per missed trip, although typically liquidated damages are subtracted from the regular monthly payments that we make to NEC-MSO for its services. As of April 15th, Amtrak has not made any payments to NEC-MSO.

We do want to know what caused this. And on April 15th, I asked Fred Weiderhold, Amtrak's Inspector General, to investigate this matter for us. I believe he is asking all the right questions. The IG is independent, experienced and professional. And you have the benefit of his testimony today.

As I said earlier, Amtrak's focus is on seeing that the new parts are procured, satisfactorily tested and installed, the appropriate spares are in inventory, and that the trains are returned to service. Acela express is both popular with our passengers and is a very important part of our bottom line.

This concludes my testimony and I look forward to your questions.

Mr. LATOURETTE. Thank you very much, Mr. Crosbie.

Mr. Spurr, thank you for coming and we would like to hear from you.

Mr. SPURR. Mr. Chairman and members of the Subcommittee, good afternoon. My name is William Spurr. I am the President of Bombardier Transportation for North America.

Bombardier appreciates the opportunity to appear before the Subcommittee today and discuss issues related to the recent grounding of the Acela train sets. You have my written statement, it is part of the record.

The consortium of Bombardier and Alstom fully understands the importance of the issue and the impact it is having on rail transport along the northeast corridor. I am here today to reaffirm our commitment to finding a solution that brings the Acela equipment back into service as quickly as possible while at the same time ensuring public safety.

As is clear from the statements of the preceding panelists, the comprehensive analysis of the situation is underway. We expect to know more as analysis and testing winds down toward the end of May. We are pressing Knorr and their sub-suppliers to identify and correct the root cause of this issue. Knorr is currently subjecting the disc to a strenuous battery of testing at their labs in Munich, in Germany. There are some preliminary results but it would not be appropriate to discuss them until the conclusions are finalized.

We are also working with the parties to conduct field testing of the component using one Acela train set in operation on the NEC soon. Rather than speculate on what the test may show when completed, I will confine my oral comments to what we know to be facts and to the process now underway to return these cars safely to service.

With regard to the facts, I want to address certain misconceptions that have arisen in recent days. First, this is a fundamental component performance issue, not a maintenance issue. The brake disc spokes do not have hairline fissures because of the lack of maintenance. The problem arose due to design, manufacture or environmental factors. The root cause analysis will tell us whether the problem is design, manufacturing or the operating environment or a combination of these factors. But it is not a lack of maintenance. No maintenance as such is required for the disc spokes.

Second, the grounding of the Acela fleet is not due to a lack of spare parts. Amtrak and the consortium have on hand ample spares for all regular maintenance requirements. No railroad or

manufacturer can be expected to carry spares to cover a fundamental problem like this, in which virtually every component in the fleet has to be replaced all at once. That would be like requiring an auto manufacturer to equip every car with four spare tires. The level of inventory available to Amtrak was based on historical usage and is in line with standard industry practices.

This was indeed a completely unexpected development. Bombardier contracted with Knorr Brake Corporation to deliver a brake system and components in line with Amtrak's specifications. Knorr was well-known as a reputable supplier in the industry, used by many rail equipment manufacturers. Bombardier has worked with Knorr successfully on numerous projects. We had every reason to believe that the system would perform properly.

Now that I have spoken to what the issue is and is not, let me spend a few moments on our approach to resolving it. We are pursuing three options in parallel. The three options are each contingent, of course, on Amtrak and FRA approval. First, we are developing an approach to recertify the discs we have on hand for continued use. This would be an interim solution to get as many trains back in service as soon as possible. Trains, of course, would be closely inspected on a daily basis until a permanent solution was achieved.

Second, we are pressing Knorr and its sub-suppliers to secure new discs of the same design as quickly as possible. And again, this would be also a temporary solution. Finally, we are looking at the potential for using completely a different brake disc design produced by Knorr itself. The design has already been pre-qualified as a replacement part by Amtrak and would serve as an interim solution. Knorr has committed that it can produce brake discs of the new design and start delivering them in June 2005.

The objective behind these parallel approaches is to secure a solution that ensures public safety, gets as many train sets into service as soon as possible and ultimately arrives at a viable permanent solution to the issue.

In closing, let me once again stress Bombardier's commitment to resolving this issue quickly and safely. Since the fissures were discovered, Bombardier has been cooperating fully with the FRA, Amtrak and the Inspector General of Amtrak. Last week, for example, NEC-MSA, the Northeast Corridor Maintenance Services Company, held jointly by Bombardier and Alstom, met with the Inspector General of Amtrak. We supplied documents and the Inspector General's staff interviewed privately maintenance employees.

We will continue to cooperate fully with all parties, including the Inspector General of Amtrak. It is also in our interest to go to the bottom of this and understand exactly what happened.

Thank you to the members of this panel for inviting us to participate today. I will respond to any questions you may have.

Mr. LATOURETTE. Mr. Spurr, we thank you very much.

Mr. JELENSPERGER, thank you for coming and we look forward to hearing from you.

Mr. JELENSPERGER. Mr. Chairman, members of the Subcommittee, thank you for the opportunity to appear before the Subcommittee to discuss issues related to the Acela train sets. We are pleased to be here this afternoon with our colleagues from Amtrak and

Bombardier, and together we are fully committed to ensuring a long-term, expeditious and most of all safe solution to the issue at hand.

Bombardier-Alstom, acting in a consortium, contracted with Amtrak in 1996 to provide 20 train sets and 15 high horsepower locomotives and for providing maintenance services for the Acela train sets in joint venture. Alstom was approximately 28 percent of the value of the consortium contract. Our scope of work was focused primarily on supplying the propulsion system.

Alstom, working together with Bombardier, is fully confident that our team will resolve the current situation by working with Amtrak, the Federal Railroad Administration and the consortium suppliers to get the equipment back into service as quickly as possible. As we do so, passenger safety continues to be our utmost priority for us all.

Alstom is committed to working closely with Bombardier and its subcontractor, Knorr Brake, to resolve the issue as Bombardier presented in its prepared statement. I have had an opportunity to review the statement of my colleague from Bombardier and can say that Alstom is in agreement with the substance of Bombardier's statement.

We understand and appreciate Congress' concern in this issue. Alstom will continue to work closely with Amtrak and Bombardier to rectify the situation quickly, effectively and most importantly, safely.

Attached to our prepared testimony are the responses to the questions raised by the Committee. I would be pleased to answer any additional questions the Committee may have.

Mr. LATOURETTE. I thank you very much, and I thank all of you for your testimony.

Mr. Crosbie, I think I want to start with you. When the FRA was here, we were talking about the instrumented tests, I guess we will call them. They are scheduled to start next week?

Mr. CROSBIE. We are working through the inspection, the test procedures. Once we get the final procedures finalized, and it is the responsibility of all parties, Amtrak included, and the FRA, if that goes through as planned, we hope to have a test through the weekend.

Mr. LATOURETTE. Okay. And Mr. Spurr was talking about perhaps, and I think the Inspector General also talked about, a redesigned or another disc that is being manufactured by Knorr. Is that currently being tested somewhere in the world as well?

Mr. CROSBIE. That is being tested. We are reviewing the design. There are items such as finite element analysis of the disc and Amtrak will be certainly engaged in testing it. We have done some laboratory tests in Munich, Germany, along with the existing disc.

The tests, I want to be clear, though, in terms of the tests in the corridor, we are really testing to see what the lateral forces underneath the train set. It is not a specific disc that we're testing.

Mr. LATOURETTE. Right. I asked you this the other day when you came to visit me, and while the Inspector General will complete his work and we will have some answers about how we got from here to there, I think what everybody, at least that we represent, want to know, aside from the money that it's costing, which you have al-

ready testified to, and not holding you to any certain date, but if things go swimmingly, when do you think the Acela trains are going to be back in operation?

Mr. CROSBIE. That is a very tough question to answer. I think the next two weeks are really going to tell us when they will come back. We need to complete the tests on the northeast corridor to understand those lateral forces underneath the train set. That will really tell us which disc we should be using.

A concern I have is that the existing disc, once we understand what's going on underneath the train set, may not be appropriately designed and we may need to move to the alternative disc that's been suggested. Each one has its own production rate. From that you would be able to determine when the train sets will be back in service.

I am sorry I can't give you a specific date. It will be summer, June, July, with the information I have right now.

Mr. LATOURETTE. Would you concur, I thought there was some good news today, and that is that the people that are supposed to be working together at least seem to be working together at this moment in time to solve the problem?

Mr. CROSBIE. Absolutely. For all the corporations involved, there has been one focus and that is getting the train sets back in service.

Mr. LATOURETTE. I was interested in this data flow schematic. I have to be honest with you, this does not look like something that I expected to see, as to how this will work. Why, if you can tell me, was this set up so that NEC-MSA is responsible for the maintenance, I understand originally until 2013? And I will want to talk to you about that in a minute. But it's Amtrak employees who are on the shop floor. Who designed this?

Mr. CROSBIE. I was not with Amtrak at the time when they made those decisions. But the people that were in place told me that they felt that at the time, they did not necessarily have the work force in place to take on the high speed train set. There were a number of other reasons, in terms of using the agreement employees, the unionized employees. That's around some labor agreements as well.

So it was a combination of things, from what I understand. Again, I was not there at the time, but it is not the way I would have put it together.

Mr. LATOURETTE. Right. That gets to my next question, and that is, you and Mr. Gunn are considered by many to be railroad experts. You have earned that, given your experience. Given that experience, how many times have you been in a position to contract with outside firms, such as NEC-MSA, to perform critical maintenance functions on various properties on which you have been involved?

Mr. CROSBIE. I have been in this situation many times. The one that I have seen that works the best is the operator needs to be the one that is responsible for the overall system. That includes the train set and all its subsystems as well as the infrastructure, everything from track, signals, catenary and the like. They need to be the one responsible for that. We like to call that a vertically integrated organization.

What seems to work is picking pieces that you, for various reason that you wish to outsource and contract out, but you need to retain the knowledge base and the understanding of those systems. You may do that because of costs, schedules and the like.

Mr. LATOURETTE. And the follow-up to that is, given the events surrounding the Acela express train sets, do you believe that Amtrak is not capable of managing such large and technically complex infrastructure projects, or are they?

Mr. CROSBIE. I believe they are capable of managing this. And Mr. Weiderhold had mentioned, in terms of new projects, fire-life safety is a good example of one that is being managed properly. In terms of the Acela train set and taking over the maintenance, the reason, we are very comfortable taking over the maintenance of those train sets.

Mr. LATOURETTE. I think Mr. Spurr indicated that the alternative disc, the Knorr disc, I guess I can call it, it's my understanding from you and other testimony that the big difference is the spokes seem to be turned 90 degrees, which may give it better strength.

There was a June 2005 potential delivery date. Just for the purposes of the record, am I correct that the WABCO disc has a slower production rate than potentially the Knorr?

Mr. CROSBIE. That's right.

Mr. LATOURETTE. Can you just for the record tell us, how many WABCO discs do you think you could get in a month if you would ask them to send some stuff over, and how many discs do you think Knorr can supply? Have they at least informed you of that?

Mr. CROSBIE. They have informed me of that, and they can certainly correct me if I get this incorrect, and if there is new information. The WABCO disc, as I understand it, can have a production rate of between 18 and 25 per week. You have to remember there is three per axle. And you can do the math on that.

Mr. LATOURETTE. Well, I can't, maybe you can.

[Laughter.]

Mr. CROSBIE. The Knorr disc, I think the initial commitment we had was mid-June of 50, then it ramps up to 100 per week at mid-July, I believe it is, and then on to 150 discs per week in early August. So the production rates are substantially better with the Knorr alternative.

Mr. LATOURETTE. I think the last question for each of you, again when the Inspector General was here, he may be developing information that ORX in Altoona, Pennsylvania has either documents or witnesses that indicate that the spokes were developing cracks between 12 and 36 months ago was the observation. I heard him say that that information was communicated to perhaps some on this schematic, but it certainly didn't get to the shop floor. So first to you, Mr. Crosbie, are you, until you heard that or were advised of that by the Inspector General, are you aware of Amtrak having any information about those findings prior to April 14th or 15th?

Mr. CROSBIE. No.

Mr. LATOURETTE. Mr. Spurr and Mr. Jelensperger, the same for you on behalf of the consortium?

Mr. JELENSPERGER. We had no idea of the litigation before last night, in my case.

Mr. LATOURETTE. And Mr. Spurr?

Mr. SPURR. Well, most of the information we got from the Wall Street Journal.

Mr. LATOURETTE. Right. Welcome to Washington.

[Laughter.]

Mr. LATOURETTE. One thing is bothering me, Mr. Crosbie, however, and then I will yield to the distinguished Ranking Member. The settlement agreement, I understand why there was litigation, I understand why parties would want to settle the case. But it has been described to me that the maintenance end of this thing, because of the difficulties, is not a money-maker. So I would understand while the consortium may want to get out of the maintenance end of things, my understanding is that in a settlement reached between the consortium and Amtrak that you moved up, we will see what happens based upon what's going on right now, but if everything had gone along fine, that you moved up the assumption by Amtrak of the maintenance of this fleet from 2013 to 2000, instead of fall of 2006.

First of all, am I correct that the maintenance does not appear to be a money-maker?

Mr. CROSBIE. I would let my esteemed colleagues answer that question. But in terms of, for Amtrak, it is part of our budget. It's built into the 2005 budget. Maintenance, I would let them answer.

Mr. LATOURETTE. I'll ask them in a second. But my question to you is, I assume they are going to tell me it's not. But if I'm wrong, we'll double back.

Mr. CROSBIE. If you are asking in the industry, there are other examples where they have made money doing this. It is not a lot, though. It is not something that one would invest heavily in.

Mr. LATOURETTE. Mr. Spurr, I have a follow-up question that I want to ask you, but just to confirm, Mr. Spurr, is it a money-maker? Have you made money on this contract? My understanding is NEC-MSA is a subsidiary of the consortium, is that right?

Mr. SPURR. That's correct.

Mr. LATOURETTE. Is this a money-maker for you?

Mr. SPURR. This particular contract, no, but we have other contracts that make money in a similar kind of service environment.

Mr. LATOURETTE. But not on this one?

Mr. SPURR. I would say it's just about break-even. You must realize that following the agreement, the settlement agreement that we had with Amtrak, that the relationship improved greatly, so better work could be done. We had a lot of modifications to be done, as the GAO explained earlier on. And these modifications were basically 80 percent complete right now on these modifications. Unfortunately, this new incident happened.

But that will be completed also, once we are done it will be a better brake system. But also the reliability of the trains was increasing. We are already months where we were hitting above the requirement. So things were getting better on the operational side.

Mr. LATOURETTE. But my question goes to the settlement, and my last question to Mr. Crosbie is, if it was part of the settlement that Amtrak is going to assume or subsume the maintenance responsibilities seven years earlier, what did you get for that? That sounds like that isn't what you were bargaining for. What did you

get for taking over, slicing seven years off of a losing maintenance contract?

Mr. CROSBIE. One of the big things that Mr. Spurr had mentioned is, first we had extended the warranties with the train sets. That was part of the things that we got for it. There is a list of items. Obviously we settled the lawsuit. I think we did well, all parties did well, I think it was fair.

We also under the parts area, we reserved our rights on the number of options. We have at least two options we can exercise under the contract which are very important to us as well. And a commitment resolving a lot of down in the details, a lot of technical things that were under discussion or debate as to who is responsible for them. That is probably the most important thing for me as the operations person that got resolved, was a commitment to fix those items. We cleared the decks. I am very happy to hear that they are going to continue in that spirit.

Mr. LATOURETTE. Sure. And not to cast blame on somebody that was there before you got there, but again, the settlement cleaned up what maybe wasn't the best contract to begin with, is that fair?

Mr. CROSBIE. That is a fair assessment of it. What is not written in that settlement is, it rebuilt the relationship between the parties. I think evidence of that is the recent events and the cooperation. I couldn't imagine doing this in the middle of a lawsuit.

Mr. LATOURETTE. I agree with you, and I said at the outset I am impressed that all three of you are not only at the same table today but also seem to be working together to solve it. I thank you, and yield to the distinguished Ranking Member, Ms. Brown.

Ms. BROWN. Thank you. I want to start with Mr. Crosbie, too. As you know, I came to the press conference where you announced that you were replacing the Acela service with Metroliner and regional service to offset revenue losses. How has the brake problem impacted Amtrak's ridership level on the northeast corridor and what is the financial impact? Are all the costs recoverable?

Mr. CROSBIE. In terms of the ridership, it is down, slightly down. It is down by 5 to 10 percent. We are very early in this, and just for the systems we use internally, we like to do what's called a ticket lift and understand that better.

We are also seeing, though, that it is improving as people get used to a regular Metroliner schedule. So we think that at the end of this, as we move through the month of May and June that it will stay flat to where it was. The financial impact, as I mentioned, is roughly a net of expenses. We have taken action to lower the expenses where we could in the order of, in terms of positions, because we are not running as many trains. Total is just over 85 positions have been reduced within the organization.

We have also taken action on food and beverage in terms of what we are serving on the trains. That has resulted in 30 positions that are external to Amtrak, but is a savings to us.

So net of expenses, it is \$1 million a week in terms of the net loss.

Ms. BROWN. What is the time frame? For example, on the other trains it took how long to come from Washington to New York and vice versa. What is the time frame now?

Mr. CROSBIE. On paper it is 12 minutes between Washington and New York, the difference. The Metroliner is off the Acela schedule by 12 minutes. In all reality, it is typically only eight minutes.

Ms. BROWN. Another question. Would you tell me how Amtrak and the other organizations involved with the maintenance of the train set communicate with one another as problems arise? I am most interested in how this work operationally. I understand that the maintenance function is the responsibility of the consortium, but why didn't someone tell Amtrak about the problems if they knew months ago?

Mr. CROSBIE. The last part I obviously can't answer.

Ms. BROWN. We are going to ask the other parties there on the last part. Answer what you can please.

Mr. CROSBIE. Obviously we wait, I await the Inspector General's final report on this. That is the question I am asking as well, how did this happen, how did we not know, who knew and why did we get this end result. On an operating basis, we have under my direction, we have a regular meeting once a month with all the parties. It is referred to as the Acela oversight committee meeting. We go through in great detail, these meetings last typically a half a day or more. We go through all the open technical items, operational items, we go through on-time performance.

So we cover both, to put it in some buckets, if you will, the contractual part of this as well as the operational part. We have all parties at the table for that meeting. I chair the meeting. We have minutes. I have what is typically a month's worth of work that we go through.

It also covers the transition plan. We have submitted this this week to the GAO for their review in answer to the request for a comprehensive transition plan. They now have that document. It details with Gant charts, organization charts, and in great detail as to how we are going to get from where we are today to taking over the maintenance of these train sets.

So the communication, what is really frustrating me at this point is the communication was certainly there since the settlement agreement. It is very unfortunate that this one piece did not find its way into the right hands. I was very happy to see, though, that my people, my master mechanic, my engineers that night, the night of April 14th into the 15th, once they got it, they knew what to do with it.

I want to be clear on that point. I authorized the train sets being taken out of service. It was the engineers, my engineers and our maintenance personnel that made a clear recommendation. They knew what to do.

Ms. BROWN. Mr. Spurr, can you answer that question? Let me just say that just recently, you all run the set from London to Paris, don't you?

Mr. SPURR. Yes, we do.

Ms. BROWN. We just completed it, less than a month ago. It was very interesting, because I think it usually takes about four hours, and it took us about six. But it was a demonstration on the French side, human error, that kept, that delayed the train. So there are many factors that trains to not run on time.

But would you tell us a little bit about the consortium, your responsibility? I understand it is like subcontracted out to you, your company?

Mr. SPURR. Yes. We maintain the 20 train sets for Amtrak under contract with Alstom. We have a joint company to do that. We share in that company 50-50. The work in that, under the contract, is just in simple terms, we have what we call preventive maintenance and regular maintenance, inspections that we do on a daily basis for every train set that goes out into service. We have 92 day inspections which are regulatory and that take a week, actually, it is a very thorough checking of the train, every 92 days, all the safety elements. And we have annual inspections that take actually around two weeks to perform.

In response to the other part of your question, if anything, what's happened is actually extraordinary. So when problems like that arise, it is our duty to inform our client immediately of the situation. We would, if we knew exactly what was happening.

Ms. BROWN. Mr. Spurr, I know that you would not intentionally not inform them. But why do you think the system broke down? Because from everything that I've heard this morning, it was lucky, our luck that we found out about it. So it wasn't, even though you are inspecting the train, evidently the brakes were not being inspected?

Mr. SPURR. If you look at the report of the Inspector General, the person who actually found what he thought was a little rust spot on the disc, on the spoke, actually mentioned himself in the report that he has been under those trains hundreds of times to do his routine inspections, and he is never able to detect anything. Actually, I think these hairlines fissures were so hard to see that it's, I think we're very happy that they were detected, like everybody else. Because it could have been a calamity if we hadn't, that it hadn't been checked.

Nonetheless, these discs have been operating for four years actually without one single failure. There are 1,440 of them in the system. So statistically, it is a good number to work on. But it doesn't mean, I think we were lucky to have found it and we are grateful to the inspector for finding the crack.

Ms. BROWN. Yes, Mr. Spurr, but I'm not a mechanic, so believe me, I don't know anything about cars or trains as far as how they operate. But I have this car. And when something goes wrong, it just stops. That's a part of the system. It just will not go over five miles an hour if something is wrong with the brakes.

So I guess I'm trying to find out, is that safety mechanism, can it be built into the system? Because even though you were doing the inspections as you are telling us, it was just luck that we found the flaw.

Mr. SPURR. No, I think the reason we found it was that there was an inspector under the car looking at it. So—

Ms. BROWN. But you have already told me that he looked several times.

Mr. SPURR. No, it's just that—

Ms. BROWN. It's something that you couldn't find with the naked eye. But I'm just telling you, the computer in my car, it just shuts my car down if something is wrong with the brakes.

Mr. SPURR. The inspections that we do are standard practice. It is the same inspections, not in detail, but in terms of checking the brakes, the spokes and so on, that we do in Europe. We are the largest maintainer of railway equipment in Europe ourselves. And it is the same, we checked it, it is the same kind of visual inspection that we do for the spokes. This component should not be failing. It is a problem of component failure.

It's like if the rims, when you go out and check your tires for winter driving, you don't check the rims of the tire, you assume that the rim is solid and is built properly. Every now and then you send it in, and yes, there is an inspection. There is an overhaul coming up on all the trucks, for instance, the wheel sets. And at that time, there is an opportunity to do a more detailed inspection of the discs.

Ms. BROWN. Right. My understanding is that you are supposed to have been operating, doing a certain level three maintenance requirement that you do a check so often. You had only completed 70 or so of the brakes. That percentage should have been much higher.

Mr. SPURR. Are you talking about spare parts? I didn't understand.

Ms. BROWN. Yes, it says, why did the consortium only have 70 or so brakes, discs in reserve, spare parts, yes.

Mr. SPURR. No, we had around 40 in reserve, plus we had around 14 wheel sets also in reserve. But the wheel sets, unfortunately, unbeknownst to us, had the same disc on them as the ones that were found to be faulty. So unbeknownst to us, the wheel sets that were in reserve were not necessarily all adequate directly for usage. And we had also under order an additional 40 discs with WABCO.

So that in actual fact we believe was sufficient to do what we call normal maintenance on wear and tear of the discs.

Ms. BROWN. Would you like to add something to that, sir?

Mr. JELENSPERGER. Well, I would have answered exactly the same way, maybe just a little piece of additional information. In the life of these trains, I think we changed 15 discs altogether. They were damaged by ice, damaged by other things, but only 15 were changed. We had basically enough wheel sets to change two train sets. And we had new discs that would have been used also. I think we had an adequate supply to respond to normal wear and tear.

Ms. BROWN. Well, are you saying that the problems that existed were not normal problems, is that correct?

Mr. JELENSPERGER. That's exactly right, that's what we think. It had nothing to do with maintenance, it had to do the quality of the component. And we discovered, thank God early enough, that that component was flawed. I guess all we are doing together with FRA is trying to find out what has happened, what was the cause, and once we knew, once we made the tests, we can basically reinstall the discs on these brakes, the brakes on the trucks and finally have the train in service.

Ms. BROWN. I am just hoping that we can come up with a system that just doesn't operate on luck. I yield back the balance of my time.

Mr. LATOURETTE. I thank the gentlelady. I just have a couple more questions, and I will be happy to yield to the gentlelady if she has additional questions as well, and I thank you for your patience.

But two things that I wanted to clear up. One I asked the FRA, and I just want to get back to you, Mr. Crosbie, as my last one. On this disc we're talking about, my understanding is that when the contracts were let out, Knorr was the winning bidder on the brake assembly but not on the disc? The disc comes from WABCO to Knorr and Knorr does the rest of the brake, Mr. Spurr, is that right or not?

Mr. SPURR. No, let me explain it a little bit. We gave a contract to Knorr for the total braking system. It was their responsibility to select the appropriate disc for the system. Of course, they had to go through a qualification process and they have to go through a design review process for all the components for the whole system. But that's the way it works.

Mr. LATOURETTE. I had thought Amtrak did not find the—so it's Knorr that didn't even take its own disc, they decided to take the WABCO disc? Amtrak, FRA had nothing to do with that, Mr. Crosbie?

Mr. CROSBIE. No, they did not.

Mr. LATOURETTE. They did not. Okay. The last question on the disc is, this new disc that is being tested in Germany with the spoke turned 90 degrees, do you know if that was in existence at the time of this original contract? Did Knorr have such a product or is it a new product?

Mr. CROSBIE. My understanding is it existed some time in 2002 and 2003, in that time frame. At least there was a design and possibly at least two discs on hand.

Mr. LATOURETTE. Which is after the construction of Acela?

Mr. CROSBIE. Yes.

Mr. LATOURETTE. And the last question I have, and I asked the FRA this, but there was a local news report here last night about the tunnel that goes near the Cannon Building. I made a series of declarative statements and I will ask you to either agree with them or tell me that I'm wrong. It's my understanding that that tunnel that was pictured on the news is patrolled by the Amtrak police, that only trains that carry passengers go through and there is no freight, no tank cars, no hazardous materials, only passenger trains, that the rail access is controlled at the CSX dispatch control center, and that both CSX and Amtrak, in cooperation with the FRA and the Department of Homeland Security, have developed an extensive security plan relative to that tunnel, that for obviously security reasons we don't discuss in open session.

And lastly, I understand that the camera crew was met by a police officer when they attempted to begin their filming. Are those things all right or are some of them right and some of them wrong?

Mr. CROSBIE. That is a correct assessment. Amtrak is responsible for that tunnel. We are working with the local and Federal authorities, Homeland Security, DHS, and we have a program in place for security for the tunnel which we are not going to discuss here.

Mr. LATOURETTE. I really appreciate all three of you coming. I appreciate the first panel as well. If there are follow-up questions—

Mr. CROSBIE. Sir, if you wouldn't mind. I just want for the record to note that we have submitted a comprehensive transition plan to the GAO for their comments. We gave it to them this week. They have that, and we look forward to their comments.

Mr. LATOURETTE. Maybe you and Ms. Hecker can make friends after the hearing and get everything all squared away. Thank you, Mr. Crosbie.

Ms. BROWN. Maybe they can answer my time about how much time does it take the GAO studies. You have done nine since 2000. I'm just wondering how much—we mandated it, so I just wanted to know how much time it takes, what's the cost. You don't have to tell me at this point.

Mr. CROSBIE. I couldn't tell you at this point, but it is a lot of work. Amtrak has a number of oversight agencies and GAO is one of them. It is a lot of work to put it together, a lot of time, especially given that Amtrak has gone to great extents to try and reduce its work force in the last few years, so that the people that might have been there that were able to just be at the beck and call of these oversight agencies are no longer there. The people that answer these reports are individuals like myself, my staff, people that are running the railroad. It is an enormous task for us at times with the requests.

Ms. BROWN. Thank you.

Mr. LATOURETTE. Thank you very much for coming. Mr. Oberstar had asked earlier to potentially submit additional questions that may come up. We would appreciate your continued courtesy in answering those if we send them to you.

Thank you all again, and we are adjourned.

[Whereupon, at 2:42 p.m., the Subcommittee was adjourned.]

STATEMENT OF THE HONORABLE CORRINE BROWN, SUBCOMMITTEE ON RAILROADS
 HEARING ON—"GETTING ACELA BACK ON TRACK"—MAY 11, 2005—10:00 AM

I want to begin by thanking Chairman LaTourette for holding this hearing to Get Acela Back on Track.

On April 15, during a routine inspection of an Acela Express train, the Federal Railroad Administration (FRA) discovered cracks in the spokes of the train's brake discs. This led to an investigation of brake discs on the entire Acela fleet. Among the 1,440 brake discs, about half of the rotors have failed. As a result, Amtrak has been forced to suspend Acela Express service.

Let me first congratulate Amtrak for being cautious and erring on the safe side. I understand that while the FRA recommended that Amtrak ground the fleet, it was Amtrak's discretion to do so. Too often, this Subcommittee has investigated mechanical failures after an accident has occurred and lives are taken. In this case, Amtrak did the right thing and grounded the fleet before a catastrophe struck.

A few weeks ago, I attended a press conference on the Acela crisis, and I just want to once again state how much I appreciate Amtrak and Amtrak workers for stepping-up to the plate, I working hard to minimize service disruptions, and address the needs of Amtrak passengers.

Amtrak has a lot to deal with. Since its inception in 2000, Amtrak's Acela has been I plagued with a host of problems. First there were problems with construction of the trainsets. Then the trainsets were delivered late. In 2002, Amtrak was forced to ground the entire Acela fleet because of cracks in the yaw damper brackets, which act as a shock absorber to frames of power cars and locomotives maintained and manufactured by the Consortium. According to Amtrak, the service disruption cost the corporation a net \$17 million in lost revenue.

Now the FRA has discovered cracks in half of the Acela brake discs, and Amtrak is bound to lose even more revenue. The Acela is Amtrak's most successful service. It generates about \$300 million a year, enough to cover its operating costs. In the end, Amtrak stands to lose millions of dollars.

But Amtrak isn't at fault here. The Northeast Corridor Maintenance Co., under the auspices of the Consortium, is responsible for maintaining these trains—not Amtrak. The Consortium, however, never discovered these cracks. I understand that there is evidence that the Consortium should have been inspecting and replacing brake discs with cracked spokes and hubs, but that never happened. In fact, a technical manual and a separate service bulletin that were sent to the Consortium both recommended routine inspection and replacement of cracked spokes and hubs, but those recommendations were ignored and the Consortium never updated its inspection, testing, and maintenance plan to reflect the new inspection procedures. I fear that if the FRA inspector had not found the cracks in those spokes, the Consortium would not have identified the problem until it was too late—until a major accident had occurred.

I believe—however devastating—the Acela crisis was a blessing in disguise, and it should serve as a wake-up call for this Administration. The Administration has proposed separating operations from infrastructure in its so-called Amtrak reform plan. This crisis is the perfect example of why that is a bad idea.

Here we have a private corporation, the Northeast Corridor Maintenance Co., which is under the direction of the Bombardier-Alstom Consortium, and separate from Amtrak, the train operator, that failed to fulfill meaningful maintenance and inspection responsibilities. Just look at the British experience with privatization and separation of operations from infrastructure and maintenance to understand the devastation such failures can cause.

In March, Chairman LaTourette and I traveled to Europe to look at their rail network. We learned that Railtrack, Britain's former rail infrastructure manager, had like Amtrak outsourced all of its maintenance and engineering work. As a result, the condition of the track deteriorated rapidly. Two fatal accidents in 1999 and 2000 revealed the extent of the deterioration and the company's poor understanding of asset conditions, prompting what one observer described as "a collective nervous breakdown of the entire British rail industry." Thankfully, the British Government learned from their mistakes. The Government took back control of their rail network, and is now investing billions of dollars in infrastructure, maintenance, and other improvements to get their trains back on track. Let's hope it doesn't take a few fatal accidents to teach this Congress and this Administration a lesson.

Going back to Amtrak's finances, I am concerned about Amtrak's outlook for the 2005. I heard estimates of what this will cost Amtrak—from \$10 million net per month to hundreds of millions of dollars in total damages. I would appreciate it Mr. Crosbie told me whether Amtrak has assessed liquidated damages, and to what ex-

tent Amtrak and the Consortium have discussed legal liability associated with the brake disk crisis.

Thank you, Mr. Chairman. I look forward to hearing from our witnesses.

**Statement by Congressman Jerry F. Costello
Committee on Transportation and Infrastructure
Subcommittee on Railroads
Hearing on Getting Acela Back on Track
Wednesday, May 11, 2005**

Thank you, Mr. Chairman. I am pleased to be here today as we examine the widespread brake failure of Amtrak's Acela and determine the steps needed to restore the train to full service. I would like to welcome today's witnesses.

Since coming to Congress, I have been a strong supporter of Amtrak. I believe it is important that our nation has a viable nation-wide railroad system.

However, Amtrak has gone through periods of great difficulty due to a variety of reasons, and is dependent on the federal government for funding to keep it operating. I believe that the federal government has a role in providing funding for Amtrak be it through operating and/or capital expense assistance. We subsidize our nation's road, transit and aviation system and it makes sense to provide funds for rail service as well.

With the White House seeking to radically reshape Amtrak through privatization, which I oppose, the service cancellation of Acela could not come at a worse time.

The cancellations put the most strain on service between New York to Boston, where Acela accounts for a greater percentage of passenger trains.

Acela normally makes up about one-fifth of Amtrak's service along the Northeast corridor, carrying an average of 9,000 riders on weekdays and 10,000 per day on the weekend. Further, the train generates approximately \$1 million per day in ticket revenue.

While the railroad hopes to get the first of the 20 high-speed trains back in service in about two months, the lack of revenue from Acela service could deplete its cash balance by the end of the fiscal year. I am interested in getting more of a definitive timeline on when that is expected.

Further, each Acela train has 72 brakes which mean 1440 are needed. Bombardier, Inc., the Montreal-based company that builds the Acela trains, has only 80 disc brakes in stock. Bombardier and Alstom SA of France were working on a delivery schedule. However, I am troubled by the fact that the expected life of the brake discs is about 1 million miles, and the current Acela fleet has traveled about half that far. This adds to other defects and technical issues which required legal action in 2004. I remain concerned that such problems will continue to affect passenger safety, financial insecurity, and declining service quality.

I look forward to today's hearing as we discuss the current status of Acela as well as its future.

65

TESTIMONY

OF

**WILLIAM L. CROSBIE
SENIOR VICE PRESIDENT - OPERATIONS
AMTRAK**

BEFORE THE

SUBCOMMITTEE ON RAILROADS

OF THE

**HOUSE TRANSPORTATION AND
INFRASTRUCTURE COMMITTEE**

**WEDNESDAY, MAY 11, 2005
10:00 A.M.
2167 RAYBURN HOUSE OFFICE BUILDING**

Mr. Chairman, and members of the committee, I appreciate the opportunity to come before you for an update on the status of Amtrak's Acela Express service. This morning, I'm going to address what happened last month regarding our decision to pull the Acelas; what is being done to return the trains to service and what the financial impact has been to date. I am William Crosbie, Senior Vice President of Operations for Amtrak. I joined Amtrak in January 2003. I am a Professional Electrical Engineer with over 20 years experience in railroad operations, maintenance and engineering.

Let me begin by saying that this incident has not affected our resolve to return Acela to service. Acela was introduced nearly five years ago. The train is popular among our passengers and ridership has grown from just under half-a-million in its first year of operation, 2001, to more than two-and-a-half million in FY04. Last year, it accounted for \$295 million in ticket revenue, or approximately 25 percent of all Amtrak ticket revenue. Its popularity among passengers was continuing this year until the trains were sidelined in April with revenue up \$10 million and ridership up 7 percent through March, against the same period last year.

In the early morning hours of Friday, April 15th, I was contacted by Amtrak's High Speed Rail Master Mechanic and told that cracks in the spokes of the brake rotor had been found. The first crack was found following a post-run inspection of one train-set. The initial Amtrak High Speed Rail Mechanical Engineering assessment was that the defect existed on every trainset inspected to that point and that it likely existed across the

fleet. Amtrak's High Speed Rail maintenance and engineering staff recommended to me that the trainsets be taken out of service because, based on their assessment, it could be unsafe to operate the trainsets. After reviewing their findings in detail, I concurred with their recommendation and ordered the entire fleet of Acela trainsets out of service. Simultaneously, I also ordered an immediate fleet-wide inspection of all trainsets to detail and document the cracked spokes by trainset, by car number, axle number and rotor number. Each of the 6 coach cars of the 20 trainsets has 12 brake rotors. That means the full fleet has 1,440 rotors. Of those 1,440 rotors, approximately 300 cracks were found on 250 of the rotors. These cracked spokes, many of which were not visible to the naked eye, were found on every trainset. At a meeting on Friday, April 15th all parties agreed that taking the Acela's out-of-service was the right decision.

These trainsets were assembled in the United States for Amtrak by a consortium of Bombardier Transportation of Canada and Alstom of France. In addition to the 20 trainsets, the consortium provided 15 other High-Horsepower Locomotives, three new maintenance facilities and, through its subsidiary – the Northeast Corridor Maintenance Service Company (NECMSC) – a service contract to maintain the equipment. Under this service contract, NECMSC is obligated to inspect, service and maintain the equipment, with NECMSC management supervising Amtrak employees.

The brake systems used on the Acelas were supplied by Knorr, a subcontractor of the Consortium and the discs or rotors at issue were supplied by Knorr and SAB WABCO. Under our management services agreement, NECMSC is responsible for inspecting and

maintaining the trainsets and managing the inventory of spare parts. When this incident occurred, we discovered that there were only 64 spare rotors on hand and none on order.

Consequently, this required Amtrak to deliver the news on April 20th that the trainsets would in all likelihood not return to service until sometime this summer, and then only gradually. We then moved on parallel paths to determine the cause of the problem and the solution and to quickly begin a service recovery plan.

The absence of Acela initially left a substantial hole in our Northeast Corridor service. On weekdays, we had been running 15 roundtrips between Washington and New York and 11 between New York and Boston. These trips accounted for average weekday revenue of \$1 million a day.

Moving quickly with replacement Metroliner service, we reduced the daily revenue loss by more than 50 percent. Starting the week of April 25th, we were able to offer nearly hourly service from 6:00 am to 6:00 pm in both directions between New York and Washington with Metroliners. Starting last week, we expanded that to 7:00 pm in both directions and added two Metroliner roundtrips between New York and Boston. So, we now have 14 Metroliner roundtrips south of New York and 2 roundtrips north of New York. We did all this by a combination of actions including the redeployment of equipment from throughout the country, reducing the shop count of out-of-service cars, and borrowing equipment from third parties.

The Metroliners have performed well. Since starting their full schedule on April 25th, on-time performance as of May 9 was 83 percent. This is equivalent to the Acela's on-time performance in March, which was 83 percent. The trip time also compares favorably with a run time that is 10 minutes within that of Acela Express.

However, despite the quick action to redeploy equipment and construct a Metroliner schedule that meets our passengers' expectations, the loss of revenue has been and will continue to be substantial until the trainsets are returned to service. Our estimate is that, net of expenses, we will lose somewhat more than \$1 million every week that the Acela Express trains are out of service.

This has the potential to seriously jeopardize our end of fiscal year 2005 cash balance. Right now, that projection stands at \$32 million before considering the impact of the Acela service disruption. This incident may well exhaust our cash by the end of the fiscal year. We are taking every opportunity to mitigate the financial consequences of this incident. Also, the FRA and USDOT, who are on our Board of Directors, are kept up-to-date with daily cash on hand reports as well as monthly cash flow projections.

This Subcommittee may also be interested in knowing that under the maintenance agreement, NECMSC may be assessed liquidated damages of \$10,000 per missed trip. Although typically, liquidated damages are subtracted from the regular monthly payments we make to NECMSC for its services. As of April 15th, Amtrak has not made any payments to NECMSC.

We do want to know what caused this, and on April 15th, I asked Fred Weiderhold, Amtrak's Inspector General, to investigate this matter for us. I believe he is asking all the right questions. The IG is independent, experienced and professional, and you have the benefit of his testimony today.

As I said earlier, Amtrak's focus is on seeing that new parts are produced, satisfactorily tested and installed, that appropriate spares are in inventory and that the trains are returned to service. Acela Express is both popular with passengers and a very important part of our bottom line. This concludes my testimony and I would be glad to answer your questions.

United States Government Accountability Office

GAO

Testimony
Before the Subcommittee on Railroads,
Committee on Transportation and
Infrastructure, House of Representatives

For Release on Delivery
Expected at 10:00 a.m. EDT
Wednesday, May 11, 2005

AMTRAK

**Acela's Continued Problems
Underscore the Importance
of Meeting Broader
Challenges in Managing
Large-Scale Projects**

Statement of JayEtta Hecker, Director
Physical Infrastructure Issues



May 11, 2005

AMTRAK

Acela's Continued Problems Underscore Importance of Meeting Broader Challenges in Managing Large-Scale Projects



Highlights of GAO-05-998T, a report to Subcommittees on Railroads, Committee on Transportation and Infrastructure, House of Representatives

Why GAO Did This Study

In 1996, the National Railroad Passenger Corporation (Amtrak) executed contracts to build high-speed trainsets (a combination of locomotives and passenger cars) as part of the Northeast High Speed Rail Improvement Project. Since that time, Amtrak has experienced multiple challenges related to this program, including recently removing all trains from service due to brake problems. Amtrak has struggled since its inception to earn sufficient revenues and depends heavily on federal subsidies to remain solvent. The April 2005 action to remove the Acela trainsets—Amtrak's largest revenue source—from service has only exacerbated problems by further reducing Amtrak's revenues to levels...

This testimony is based on GAO's past work on Amtrak and focuses on (1) background on problems related to the development of the Acela program; (2) summary of issues related to the suits between Amtrak and the train manufacturers and the related settlement; (3) key challenges associated with the settlement; and (4) initial observations on possible challenges in Amtrak managing large-scale projects.

www.gao.gov/cgi-bin/gettr?GAO-05-998T

To view the full product, including the scope and methodology, click on the link above. For more information, contact Jay Eita Z. Hecker, (202) 512-2834, heckerj@gao.gov.

What GAO Found

Significant issues and controversy have impacted the Acela program since its inception. According to Amtrak, what started out as a simple procurement of train equipment evolved into a complex high-speed rail program. Acela has encountered numerous difficulties due to such things as new technology and production delays. Even after Acela service began, unexpected problems were encountered, which required Amtrak to remove the trainsets from service, resulting in lost revenue.

Concerns about the quality of the Consortium of train manufacturers' (Bombardier and Alstom) work and Amtrak's withholding of payments for the Acela trainsets resulted in the parties suing each other, each seeking \$200 million in damages. Amtrak and the Consortium reached a negotiated settlement in March 2004. Although the settlement agreement protects Amtrak through certain warranties, loss of revenue resulting from removal of trains from service is not directly recoverable. Under the settlement, Amtrak is conditionally scheduled to assume maintenance functions from the Consortium in October 2006.

Aside from the current problems, Amtrak faces other risks and challenges to the recent settlement, including obtaining technical expertise and providing sufficient funding for maintenance. Achieving a successful transition is critical to Amtrak given the importance of the Acela program. The recent brake problems may impact the transition through such things as delayed management training.

As GAO reported in February 2004, Amtrak had difficulties managing the Northeast High Speed Rail Improvement Project and many critical elements of the project were not completed and the project goal of a 3-hour trip time between Boston and New York City was not attained. GAO has ongoing work addressing Amtrak management and performance issues that GAO plans to report on later this year.

Timeline of key events

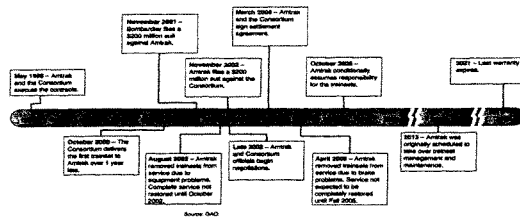

Source: GAO

Mr. Chairman and Members of the Subcommittee:

I appreciate the opportunity to testify on the National Railroad Passenger Corporation's (Amtrak) Acela program and the overall management of the corporation. Intercity passenger rail is at a critical crossroads regarding its future in the United States. Amtrak has struggled since its inception to earn sufficient revenues and depends heavily on federal subsidies to remain solvent. The April 2005 action to remove the Acela trainsets—the combination of locomotives and passenger cars—from service has only exacerbated problems by putting increased stress on Amtrak's ability to maintain ridership and revenue levels and could make Amtrak's financial condition even more precarious. Amtrak's Acela program accounted for not quite one-fourth of the ridership and about 44 percent of revenue on the Northeast Corridor—Amtrak's busiest rail route—in fiscal year 2004.

My statement today addresses numerous issues of interest to the Congress as it delves into Amtrak's handling of this most recent incident involving Acela, and more generally, the future of intercity passenger rail in this country. I will cover four areas: (1) background on the problems Amtrak experienced during the development of the Acela program, (2) a summary of issues related to the lawsuits between Amtrak and the consortium of train manufacturers (the Consortium), Bombardier and Alstom, and the subsequent settlement, (3) key challenges associated with implementing the settlement, and (4) possible broader challenges at Amtrak in managing other large-scale projects. The information I will present is primarily based on reports that we have issued over the last several years.¹

Significant issues and controversy have impacted the Acela program since its inception. Among the issues that have impacted the Acela program are the following: (1) potential difficulties due to new technology, (2) impacts from new safety standards to accommodate high-speed rail, (3) manufacturing and production delays, and (4) abbreviated testing of the trains prior to placement in revenue service. The Acela trainsets are not an "off-the-shelf" piece of equipment but rather a combination of both new and existing technology. According to the Federal Railroad Administration (FRA), this was the first time this particular combination of new and existing technology had been designed as one unit. As such, the equipment required considerable time to develop and test, and the probability of expected and unexpected problems was high. Furthermore, the trainset

¹See the enclosure for a list of related GAO products.

grew in weight and cost due to new safety regulations. The Consortium also encountered production delays. With Amtrak under considerable financial and time pressures to place the trainsets into service; therefore, trainset testing was abbreviated. In addition to building the Acela trainsets, the Consortium entered into a contractual arrangement with Amtrak to manage the Acela facilities and maintain the trainsets, including training and supervising Amtrak employees. Since the trainsets were placed into revenue service in 2000, unexpected problems have been encountered that have resulted in lost revenue and damaged the image of the Acela program. For example, an equipment failure forced Amtrak to withdraw the Acela trainsets from service for 2 months in 2002. As problems and difficulties mounted, increased tension between Amtrak and the trainset manufacturer led to legal action against each other.

- Concerns about the quality of the Consortium's work and Amtrak's withholding of payments for the Acela trainsets resulted in the parties suing each other, each seeking \$200 million in damages. Amtrak and the Consortium reached a negotiated settlement in March 2004. In general, under the settlement, the Consortium must complete modifications to the trainsets and locomotives, achieve established performance requirements, provide training to Amtrak staff, and provide and extend warranties. In addition, Amtrak agreed to release a portion of previously withheld funds and will conditionally assume facility management and trainset maintenance responsibilities as soon as 2006, rather than in 2013, as originally planned; if the Consortium satisfactorily completes its commitments under the settlement agreement.
- Our work evaluating the terms of the settlement led us to conclude that Amtrak faces other risks and challenges to sustain the trainsets and keep them operating.² Achieving a successful transition is critical to the financial well-being of Amtrak, given that the Acela program is such a significant source of its revenue. The challenges include (1) completing modifications and meeting performance requirements, (2) obtaining technical expertise for maintenance and completing training, (3) sufficiently funding maintenance and integrating responsibilities, and (4) preparing a comprehensive implementation plan. Addressing and resolving these challenges will not be easy. Although the settlement agreement

²GAO, *Intercity Passenger Rail: Issues Associated with the Recent Settlement between Amtrak and the Consortium of Bombardier and Alstom*, GAO-05-152 (Washington, D.C.: Dec. 1, 2004).

ensures that Amtrak will be protected by the extended trainset warranties and Amtrak has several methods of financial recourse if the Consortium does not honor warranties, loss of revenue resulting from removal of trainsets from service is not directly recoverable. However, the full extent of the legal liability has yet to be addressed by the parties. Amtrak officials told us that their first priority is getting the trainsets back in service. In addition, the recent brake problems may impact the transition of the maintenance function to Amtrak through such actions as delaying management training. Amtrak officials continue to believe the transition will occur in October 2006, however.

- Amtrak also faces challenges in managing other large-scale projects. As we reported in February 2004, Amtrak had difficulties managing the Northeast High Speed Rail Improvement Project (NHRIP), a multi-year, multi-billion dollar project to electrify the tracks between Boston, Massachusetts, and New Haven, Connecticut, acquire high-speed trains, and make capital improvements. Among the problems we found were that (1) Amtrak's management of this project was not comprehensive but was focused on the short term; (2) project management focused on separate components of the project, such as electrification and acquisition of the high-speed trains, and not on the project as a whole; and (3) Amtrak did not sufficiently address major infrastructure improvements needed to attain project goals. The overall results were that many critical elements of the project were not completed, project costs and schedules increased considerably, and the project goal of a 3-hour trip time between Boston and New York City was not attained.

Background

The Rail Passenger Service Act of 1970 created Amtrak to provide intercity passenger rail service because existing railroads found such service to be unprofitable. Amtrak operates a 22,000-mile network, primarily over freight railroad tracks, providing service to 46 states and the District of Columbia. Amtrak owns about 650 miles of track, primarily on the Northeast Corridor between Boston, Massachusetts, and Washington, D.C. In fiscal year 2004, Amtrak served about 25 million passengers, or about 68,640 passengers per day. According to Amtrak, about two-thirds of its ridership is wholly or partially on the Northeast Corridor. The Northeast Corridor is the busiest passenger rail line in the country, and some 200 million Amtrak and commuter rail travelers use the Corridor, or some part of it, each year. On some portions of the Northeast Corridor, Amtrak provides high-speed rail service (up to 150 miles per hour). The high-speed Acela program is the centerpiece of Amtrak's intercity passenger rail system, with its financial contributions to the company exceeding that of all other routes combined.

Acquisition of the Acela trainsets occurred as part of NHRIP. NHRIP, and its predecessor the Northeast Corridor Improvement Project, date back to the late 1970's and represented a multiyear, multibillion collection of capital improvements to the Northeast Corridor that included electrifying the line between New Haven, Connecticut, and Boston, Massachusetts, improving tracks, signals, and other infrastructure, and acquiring high-speed trains.³ These efforts were designed to achieve a 3-hour trip time between New York City and Boston. As of March 2003, Amtrak, commuter railroads, and others had spent about \$3.2 billion on the project.

In 1996, Amtrak executed contracts with train manufacturers Bombardier and Alstom to build 20 high-speed trainsets and 15 electric high-horsepower locomotives; construct three maintenance facilities; and provide maintenance services for the Acela trainsets. The trainsets, locomotives, and facilities contracts totaled \$730 million.⁴ Bombardier and Alstom, referred to as the Consortium, created the Northeast Corridor Management Service Corporation (NecMSC) to manage the facilities and maintain the trainsets, including supervising Amtrak maintenance employees. Amtrak pays NecMSC a per-mile rate—that is, a fixed rate for each mile the Acela trains travel—on a monthly basis to provide management and maintenance services at three maintenance facilities.⁵

Amtrak's Acela program has undergone a number of events since its inception, which has included the execution of the original contracts in 1996, delivery of the first trainset in October 2000, and the filing of lawsuits by both Bombardier and Amtrak in November 2001 and 2002, respectively (see fig. 1). The trainsets were also withdrawn from service for several weeks in August 2002. In March 2004, Amtrak and Bombardier signed an agreement to settle the lawsuits, which calls for Amtrak to conditionally assume trainset maintenance in October 2006, assuming conditions of the settlement have been met. The last warranties for the trainsets expire in 2021.

³For a more detailed description and discussion of NHRIP and the Northeast Corridor Improvement Project, see GAO, *Intercity Passenger Rail: Amtrak's Management of Northeast Corridor Improvements Demonstrates Need for Applying Best Practices*, GAO-04-94 (Washington, D.C.: Feb. 27, 2004).

⁴The cost of the Management Service Contract is not included in the total contract cost.

⁵As of April 2004, Amtrak had paid NecMSC a total of \$31 million for its maintenance and management services. This amount is adjusted for liquidated damages Amtrak has assessed to NecMSC.

Figure 1: Timeline of key events

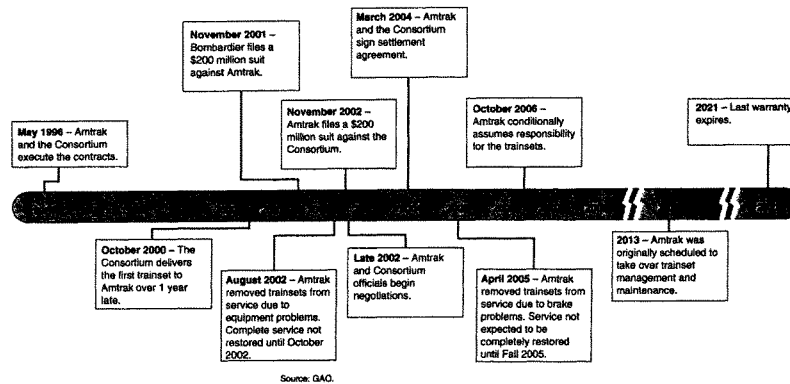

Significant Issues Have Impacted Acela Program Since Its Inception

Significant issues and controversy have impacted the Acela program since its inception. What started out as a relatively simple procurement of train equipment evolved into a complex high-speed rail program, according to an Amtrak official. The Acela trainset is a complex piece of equipment with state-of-the-art electronics and was considered new technology for the United States. As such, it required additional time to develop and test, and the probability of expected and unexpected problems was high.

Among the issues that the Acela program has encountered since its creation are the following:

- **Potential difficulties due to new technology.** Instead of purchasing "off-the-shelf" technology—that is, train equipment that was already designed, engineered, and in use—Amtrak decided to acquire "new" technology. An FRA official told us some components on the Acela trainset (such as

power components and the tilt mechanism⁶) were similar to that used on train equipment in other parts of the world but much of the technology on Acela trainsets was new. In addition, many of the components, whether new or existing technology, had never been used together. Further, this official said that because the components in the Acela trainsets had never before been designed as one unit, Acela was not an off-the-shelf technology train.⁷ Although Acela trainsets were essentially new technology and could be expected to require additional time to develop and test, Amtrak developed an ambitious schedule that called for shipment of the first trainset 32 months—just over 2½ years—after the notice to proceed was issued. According to an Amtrak official, the calendar and electrification delivery date drove the planning for the trainsets. Amtrak worked backwards from these due dates to try and fit project work into the timeline.

- Impacts from new safety standards to accommodate high-speed rail. During the 1996 to 2000 time frame, the same time period when the Acela trainsets were being acquired and manufactured, FRA, in consultation with Amtrak, was developing safety regulations related to high-speed rail operations. These included new rules covering track safety (to accommodate speeds of up to 200 miles per hour), passenger car safety, and train control. According to FRA officials, Amtrak was intimately involved in developing these standards to accomplish its vision of high-speed rail operations on the Northeast Corridor. FRA officials also noted that passenger car safety regulations did not exist prior to the mid-1990's. Developed for safety purposes, these standards had a significant impact on the Acela trainsets. For example, the passenger car safety regulations required a crash energy management system in passenger cars that was designed to increase the strength of both car ends and side posts. FRA also prohibited the operation of high-speed trains (up to 150 miles per hour) in a push-pull manner.⁸ FRA officials acknowledged that the crash energy system increased the weight of the Acela trainsets but said such a system resulted in safer trains. Amtrak told us that prohibiting push-pull operation

⁶This is a mechanism that allows trains to take curves at a higher speed.

⁷It should be noted that during 1993, existing high-speed trains such as the X-2000 and InterCity Express were tested on the Northeast Corridor. One of the bidders for the high-speed train contract proposed a slightly modified version of the X-2000 train but was not selected.

⁸Push-pull operation is when a locomotive "pulls" the train in one direction and then the locomotive "pushes" the train in the opposite direction. According to FRA, this is common in commuter rail operations.

caused them to obtain 20 additional power cars for Acela at a cost of about \$100 million.

- **Manufacturing and production delays.** The Acela program experienced a significant share of manufacturing and production delays. Under FRA's 1994 master plan for NHRIP, developed in response to the Amtrak Authorization and Development Act, delivery of enough high-speed trains to initiate limited 3-hour service between Boston and New York City was expected by 1999.⁹ However, due to design and manufacturing delays, the first Acela trainsets were delivered about a year late, and revenue service using the trainsets did not begin until December 2000. Manufacturing and production delays began early in the procurement process. For example, our review of Consortium progress reports indicated that as early as October 1996, only months after the original contract was signed, change orders and design changes (mainly related to car interiors) were being made that were causing delays in production. In addition, train weight was increasing, a condition that continued to plague the trainsets throughout production. Amtrak attempted to require the Consortium to prepare recovery plans to keep the program on schedule, but we found little evidence of such plans in documents we reviewed. Regardless, these plans did not prevent the trainsets from being delivered about a year late.
- **Abbreviated testing prior to placement in revenue service.** Amtrak's Acela trainsets also appeared to have had abbreviated testing prior to being deployed into revenue service.¹⁰ A fuller testing of the trainsets may have better identified the range of potential problems and defects that could be experienced prior to placing the trainsets in service. The maximum testing any one Acela trainset received was about 35,000 miles of testing—20,000 miles at the Transportation Test Center (Center) in Pueblo, Colorado, and 15,000 miles on the Northeast Corridor between 1999 and 2000. However, an FRA official believed testing of the trainsets was rushed and that

⁹As we reported in February 2004, Amtrak had not yet met the requirement for achieving the 3-hour trip time contained in the Amtrak Authorization and Development Act. See GAO-04-94. It should be noted that Amtrak did not agree with our use of FRA's 1994 master plan to measure the effectiveness of its management of NHRIP, even though Amtrak officials had agreed that this plan was a "blueprint" for the project.

¹⁰This discussion of Acela testing is not meant to imply that the trainsets are unsafe or do not meet federal safety standards. Rather, it focuses on the degree of testing to discover problems and defects that could potentially be fixed prior to deployment into revenue service.

additional testing at the Center should have been conducted.¹¹ This official cited testing of Amtrak's AEM-7 electric locomotive as an example of the testing that is normally done on new equipment. This locomotive, which was a new locomotive that entered service in the early 1980's, was tested for 165,000 miles at the Center prior to placement in service. An FRA official also acknowledged that there were no minimum federal testing requirements for new high-speed trainsets, like Acela, only that such equipment comply with existing safety regulations.¹² However, this official believed Amtrak was under both financial and time pressures to place the trainsets in service, in part because of delays in trainset production.

Since placement into revenue service in 2000, the Acela has experienced a number of unexpected problems. One occurrence was in August 2002 when Amtrak was forced to withdraw the trains from service to address unexpected equipment problems (yaw damper brackets). The trainsets were not returned to complete service until October 2002. According to Amtrak, this withdrawal cost the corporation a net \$17 million in lost revenue. In April 2005, Amtrak once again experienced unexpected problems with the trainsets due to equipment problems (cracks in brake assemblies). Again, the trainsets have been withdrawn from service and Amtrak has stated that it may be months before the trains are returned to service. Although Amtrak is placing substitute equipment into service, it can be expected that there will be revenue loss as well as damage to Amtrak's image.

Legal Suits between Amtrak and the Acela Manufacturer Led to Settlement Agreement in March 2004

As the procurement proceeded, tensions grew between Amtrak and the Consortium. Concerns about the quality of the Consortium's work and Amtrak's withholding of payments for the Acela trainsets resulted in the parties suing each other, each seeking \$200 million in damages. In November 2001, Bombardier filed a suit alleging that Amtrak improperly withheld payments, failed to provide accurate information on infrastructure conditions, and changed design specifications during contract performance. In November 2002, Amtrak filed a suit alleging that the Consortium failed to meet trainset performance requirements. In

¹¹An FRA official acknowledged that the Center was not conducive to testing Acela's tilt mechanism. However, he said that other problems that developed during testing at the Center should have been a clear signal that additional testing was warranted.

¹²According to FRA, in lieu of high-speed testing standards, Amtrak developed its own minimum testing requirements.

addition, Amtrak alleged that the engineering was deficient, workmanship was poor, program management and quality control were inadequate, and the Consortium did not meet contract delivery schedules.

Amtrak and the Consortium reached a negotiated settlement in March 2004, ending their legal dispute surrounding the Acela trainsets.¹⁹ As part of the settlement, Amtrak agreed to release a portion of the previously withheld funds to the Consortium and conditionally assume facility management and trainset maintenance responsibilities as soon as October 1, 2006, rather than in 2013, as originally planned. In general, under the settlement, the Consortium must complete modifications to the trainsets and locomotives; achieve established performance requirements for reliability, speed, and comfort; provide training to Amtrak staff; and provide and extend warranties (see fig. 2). The Consortium is also responsible for the transfer of technical information, rights to third-party contracts, parts information, permits, and licenses to Amtrak. In addition, the settlement requires that the Consortium provide technical services and information technology updates even after the transition date. Amtrak is required to create a transition plan, hire staff to manage the facilities and maintain the trainsets, and determine a parts procurement plan for the trainsets.

¹⁹For a more detailed information on the lawsuits and settlement, see GAO-05-152.

Figure 2: Settlement responsibilities

	Before October 1, 2006	After October 1, 2006
	<ul style="list-style-type: none"> • Create transition plan • Hire staff to manage facilities and maintain trainsets • Decide how to procure trainset parts 	<ul style="list-style-type: none"> • Manage maintenance facilities • Maintain trainsets
Consortium	<ul style="list-style-type: none"> • Complete trainset and locomotive modifications • Meet performance requirements for speed, reliability, and comfort • Train Amtrak staff • Transfer technical information • Renegotiate rights to third-party contracts • Provide parts information, permits, and licenses 	<ul style="list-style-type: none"> • Provide technical services and information technology updates • Honor trainset warranties

Source: GAO analysis of Amtrak data.

Acela Program Still Faces Considerable Challenges

Independent of the Acela brake problem being discussed today, Amtrak faces other risks and challenges to sustain the trainset and keep it operating efficiently. Achieving a successful transition is critical to the financial well-being of Amtrak given that the Acela program is such a significant source of its revenue. A successful transition of maintenance and management responsibilities for the Acela trainsets depends on whether Amtrak and the Consortium can address the numerous challenges. Key challenges include:

- **Achieving trainset modifications and performance requirements.** The Consortium must complete an extensive list of modifications to the trainsets, some of which are complex, before Amtrak will assume

maintenance responsibilities. Although the Consortium has closed three-fourths of the items, they are behind schedule on completing the work on some remaining items. Amtrak has identified certain modifications that potentially may not be completed by October 1, 2006, and has concerns that other modifications may affect service reliability. The Consortium is also responsible for ensuring that the trainsets continue to meet reliability, speed, and comfort performance requirements. The trainsets have not yet met the minimum reliability performance requirement of traveling an average 17,500 miles between service failures.¹⁴ According to Amtrak, the period of time when the trainsets are out of service to resolve the brake problems will not likely be included in the measurement of this standard.

- **Obtaining technical expertise for maintenance and completing training.** Amtrak must secure a workforce with the technical expertise needed to maintain the trainsets. To achieve this, Amtrak is developing a new High Speed Rail Division to assume management and maintenance responsibilities, and it plans to hire at least 50 percent of NecMSC's current staff to benefit from their knowledge and expertise. The Consortium and Amtrak must also develop and implement training programs needed to maintain the complex trainsets after the transition. The trainsets are technically complex and require considerable expertise to identify and make needed repairs and to troubleshoot difficult maintenance problems. According to Amtrak officials, ensuring that technicians are properly trained is one of the most critical points of the transition. As a result of the current brake problem, Amtrak is reevaluating its training materials. Based on the latest progress report (March 2005), troubleshooting training is slightly behind schedule, and Amtrak officials told us that management training has been temporarily delayed due to the brake problem. Under the transition plan, training is scheduled to be completed by October 1, 2005.
- **Sufficiently funding maintenance and integrating responsibilities.** Once the transition occurs, Amtrak will be responsible for maintenance costs to ensure continued trainset performance, including procuring parts and performing overhaul maintenance. Amtrak has experienced problems in the past with delays in completing the maintenance necessary to provide its conventional service; and if these problems continue, they could affect trainset performance and availability for revenue service. At the time of

¹⁴According to Amtrak, this measure is calculated as a 6-month rolling average. The settlement agreement requires the Consortium to meet this reliability standard before the transition will occur and Amtrak may draw down on letters of credit issued by the Consortium should it default and not meet the requirement.

our review, Amtrak had not determined the level of funding necessary to provide regular maintenance and overhauls to the trainsets. Amtrak officials stated that despite the uncertainty of maintenance costs once the transition occurs, they estimate that the costs of managing the maintenance in-house will be no greater than the costs of paying NecMSC to perform the work. We believe the uncertain amount of future maintenance costs and possible lack of adequate funds may have a greater impact than anticipated. Amtrak must also successfully integrate the new maintenance responsibilities into its current organization. Development of a new division requires strategic planning, communication, and performance management. This may prove difficult for Amtrak as our past and ongoing work has shown its shortcomings in managing large-scale projects.

- **Preparing a comprehensive implementation plan.** Creating a comprehensive implementation plan that provides a blueprint of important steps; milestones; contingency plans if milestones are not met; measures for achieving results; and funding strategies will be important for a successful transition. Amtrak has created a critical path schedule for monitoring the status and completion of open items related to the settlement and holds regular meetings, both internally and with the Consortium, to discuss progress and issues that arise. Although Amtrak has taken actions to address the key challenges related to the settlement, these actions did not represent a comprehensive implementation plan, and we recommended in our December 2004 report that Amtrak develop such a plan that encompasses all aspects of the transition in order to ensure a successful transition. We also said that such a plan should include contingency plans, if milestones are not met. In light of recent events, we believe a comprehensive plan that identifies contingency actions could provide the steps necessary to help prevent postponement of the transition. Amtrak officials do not believe the current brake problems will impact the October 2006 transition date, however.

Although the settlement agreement ensures that Amtrak will be protected by the extended trainset warranties and Amtrak has several methods of financial recourse, if the Consortium does not honor warranties, loss of revenue resulting from removal of trainsets from revenue service is not directly recoverable. For example, the settlement agreement included the extension of "bumper to bumper" trainset warranties on all trainsets for the next 5 months, until October 1, 2005. In addition, modifications to the trainsets that are currently under way or planned will be under warranty for 2 years after they are completed to Amtrak's satisfaction. Amtrak also has several methods of financial recourse, if the Consortium does not honor warranties, including letters of credit that Amtrak may draw down.

However, the full extent of the legal liability associated with the April 2005 brake problem has yet to be addressed by the parties. Amtrak officials told us that their first priority is getting the trainsets back in service. Amtrak is considering a number of possible actions regarding the brake problem, including assessing liquidated damages.¹⁵

Challenges In Managing Other Large-Scale Projects

As we reported in February 2004, Amtrak did not effectively manage the entire NHRIP project, of which Acela was a part.¹⁶ Among the problems we found were that (1) Amtrak's management of this project was not comprehensive but was focused on the short term; (2) project management focused on separate components of the project, such as electrification and acquisition of the high-speed trains, and not the project as a whole; and (3) did not sufficiently address major infrastructure improvements needed to attain project trip-time goals. We also found that Amtrak lacked a comprehensive financial plan for the project and that Amtrak did not fully integrate stakeholder interests (commuter rail authorities and state governments), even though work that involved stakeholders was critical to achieving project goals. The overall results of this poor management was that many critical elements of the project were not completed, project costs and schedules increased considerably, and the project goal (3-hour trip time from Boston to New York City) was not attained. While there have been many benefits from the NHRIP, including faster trip times between Boston and New York City, Amtrak's management of this project clearly demonstrates that Amtrak had difficulty keeping such a large-scale project focused, on-time, and on-budget.

We also have ongoing work for this committee on Amtrak's management and performance issues that we plan to report on later this year.

Mr. Chairman, that concludes my statement. I would be happy to answer any questions you or the Members of the Subcommittee might have.

¹⁵Amtrak officials said that, because the Acela trains have been removed from service, they are not currently paying NecMSC the fixed mileage rate for its services.

¹⁶See GAO-04-94.

**Contacts and
Acknowledgements**

For further information, please contact JayEtta Z. Hecker at heckerj@gao.gov or at (202) 512-2834. Individuals making key contributions to this statement include Kara Finnegan Irving, Bert Japikse, Richard Jorgenson, and Randall Williamson.

Related GAO Products

Intercity Passenger Rail: Issues Associated with the Recent Settlement between Amtrak and the Consortium of Bombardier and Alstom, GAO-05-152 (Washington, D.C.: Dec. 1, 2004).

Intercity Passenger Rail: Amtrak's Management of Northeast Corridor Improvements Demonstrates Need for Applying Best Practices, GAO-04-94 (Washington, D.C.: Feb. 27, 2004).

Intercity Passenger Rail: Amtrak Needs to Improve Its Decisionmaking Process for Its Route and Service Proposals, GAO-02-398 (Washington, D.C.: Apr. 12, 2002)

Intercity Passenger Rail: Potential Financial Issues in the Event That Amtrak Undergoes Liquidation. GAO-02-871 (Washington, D.C.: Sept. 20, 2002).

Financial Management: Amtrak's Route Profitability Schedules Need Improvement, GAO-02-912R (Washington, D.C.: July 15, 2002).

Intercity Passenger Rail: Congress Faces Critical Decisions in Developing a National Policy, GAO-02-522T (Washington, D.C.: Apr. 11, 2002).

Intercity Passenger Rail: The Congress Faces Critical Decisions About the Role of and Funding for Intercity Passenger Rail Systems, GAO-01-820T (Washington, D.C.: July 25, 2001).

Intercity Passenger Rail: Amtrak Will Continue to Have Difficulty Controlling Its Costs and Meeting Capital Needs, GAO/RCED-00-138 (Washington, D.C.: May 31, 2000).

Intercity Passenger Rail: Issues Associated With a Possible Amtrak Liquidation, GAO/RCED-98-60 (Washington, D.C.: Mar. 2, 1998).

GAO's Mission	The Government Accountability Office, the audit, evaluation and investigative arm of Congress, exists to support Congress in meeting its constitutional responsibilities and to help improve the performance and accountability of the federal government for the American people. GAO examines the use of public funds; evaluates federal programs and policies; and provides analyses, recommendations, and other assistance to help Congress make informed oversight, policy, and funding decisions. GAO's commitment to good government is reflected in its core values of accountability, integrity, and reliability.
Obtaining Copies of GAO Reports and Testimony	The fastest and easiest way to obtain copies of GAO documents at no cost is through GAO's Web site (www.gao.gov). Each weekday, GAO posts newly released reports, testimony, and correspondence on its Web site. To have GAO e-mail you a list of newly posted products every afternoon, go to www.gao.gov and select "Subscribe to Updates."
Order by Mail or Phone	<p>The first copy of each printed report is free. Additional copies are \$2 each. A check or money order should be made out to the Superintendent of Documents. GAO also accepts VISA and Mastercard. Orders for 100 or more copies mailed to a single address are discounted 25 percent. Orders should be sent to:</p> <p>U.S. Government Accountability Office 441 G Street NW, Room LM Washington, D.C. 20548</p> <p>To order by Phone: Voice: (202) 512-6000 TDD: (202) 512-2537 Fax: (202) 512-6061</p>
To Report Fraud, Waste, and Abuse in Federal Programs	<p>Contact:</p> <p>Web site: www.gao.gov/fraudnet/fraudnet.htm E-mail: fraudnet@gao.gov Automated answering system: (800) 424-5454 or (202) 512-7470</p>
Congressional Relations	Gloria Jarmon, Managing Director, JarmonG@gao.gov (202) 512-4400 U.S. Government Accountability Office, 441 G Street NW, Room 7125 Washington, D.C. 20548
Public Affairs	Paul Anderson, Managing Director, AndersonP1@gao.gov (202) 512-4800 U.S. Government Accountability Office, 441 G Street NW, Room 7149 Washington, D.C. 20548

Statement of Robert D. Jamison
Acting Administrator, Federal Railroad Administration
before
the Subcommittee on Railroads of the
Committee on Transportation and Infrastructure
U.S. House of Representatives
May 11, 2005

Mr. Chairman and members of the Subcommittee, I appreciate the opportunity to appear before you today, on behalf of Secretary Mineta, to discuss recent developments concerning Amtrak's Acela high-speed trains. I will explain what the Federal Railroad Administration (FRA) knows regarding the problems with the rotors on the Acela's disc brakes and how we are working with Amtrak to develop a solution to those problems. I will also touch briefly on FRA's overall safety priorities and Amtrak's general safety record.

Acela Brake Issues

FRA Safety Specialist Rich Thomas first detected cracks on the spokes of an Acela train's disc brake rotors on the evening of April 14. The detection occurred while FRA personnel were closely inspecting a trainset that had been involved in test runs. The test runs, unrelated to the brake issue, were being conducted to ensure safe operating performance of the Acela at higher speeds in curves than are currently permitted. While conducting a very thorough inspection of the brakes on the trainset, Specialist Thomas noticed what appeared to be rust near a very small mark on one of the rotor's spokes. On closer examination, the mark proved to be a crack. Cracks on the spokes of disc brake rotors have not been a common problem. Such an anomaly is very difficult to observe due to the location of the spokes in relation to other components of the undercarriage. Undercarriage components can obstruct a clear view of the spokes, especially on the two discs on the outside of the axle. (Acela trainsets have three discs per axle, which adds up to 72 discs per trainset.) After the initial discovery of the cracks, the FRA inspectors, along with personnel from Amtrak and its Acela maintenance contractor, then inspected other trainsets. As the inspections concluded that evening, it became clear that a significant percentage of the disc brakes had similar cracks. After discussions with FRA personnel that night, Amtrak decided to suspend Acela service immediately on April 15 and ordered a detailed inspection of the entire Acela fleet for the presence of such cracks.

The good news is that these cracks were detected before they led to a catastrophic failure of the rotor with potentially very serious consequences. Having been alerted to the problem, Amtrak then acted quickly to ensure that Acela service would not continue until the potentially hazardous condition was corrected. My staff and I met with Amtrak President David Gunn and his staff on April 15, and again on April 20, to discuss the problem and potential solutions. Amtrak formed a working group, consisting of its staff, its contractors who are responsible for Acela maintenance, the suppliers of the Acela equipment, and several technical experts, to determine the cause of the problem and to

explore solutions to the problem. FRA experts from our Office of Safety and our Office of Railroad Development are cooperating fully in that effort. Amtrak has no intention of running the Acela equipment with cracks in the disc brakes, and all concerned understand that FRA will not permit that to occur.

As to the cause of the cracks, there is much speculation. Some have speculated that one possible reason for the cracks in the discs is FRA's influence over the initial design of the Acela trainsets. In preparing to order high-speed trainsets in 1994, Amtrak sought FRA's comments on its proposed specifications. FRA's comments contributed to Amtrak's including certain design features, including crash energy management features similar to those being built into advanced European equipment during the period and strengthening the crew compartment. Amtrak specified that the trainset be built to comply with the North American standards for buff (anti-crush) strength because the trainset was intended to operate in a North American environment where all other passenger trains (both intercity and commuter) have been built to those standards and where rail freight equipment is much larger and heavier than that encountered in most other parts of the world. Amtrak did not seek permission from FRA to use the European buff-strength standard. Beyond such basic safety requirements, Amtrak and its vendor were free to choose technologies and to design the train as they thought best.

FRA's Safety Program

Our efforts to ensure the safety of the Acela service are but one component of a comprehensive railroad safety program. Although the railroad industry's overall safety record is very positive and most safety trends are moving in the right direction, very serious train accidents continue to occur, and the train accident rate has not declined at an acceptable pace in recent years. To meet these challenges, FRA is targeting its regulatory program on the most frequent causes of train accidents, focusing FRA's oversight and inspection resources on the areas of highest risk, and accelerating research and development (R&D) efforts that have the potential to mitigate the largest risks.

A. Targeting the Leading Causes of Train Accidents

More than 70 percent of all train accidents arise from either human error or defective track. Accordingly, FRA's highest priority must be to reduce these types of accidents.

1. Human Factors

Human factor accidents are now the largest category of train accidents, accounting for 40 percent of the total in 2004. FRA's ongoing analysis of accident trend data has revealed that a small number of particular kinds of human errors (e.g., not properly lining switches, failure to lock and latch switches, not properly conducting shoving movements) account for an inordinate number of human factor accidents. Although these matters are addressed by each railroad's own operating rules, FRA's regulations do not presently address them directly. FRA intends to take action, preferably based on consensus recommendations from its Railroad Safety Advisory Committee, to address these leading

causes of train accidents. We are acting in order to heighten awareness and understanding of the problem and ensure timely application of best practices across the board to achieve substantial reductions in these types of easily preventable accidents. We took a first step in this direction on April 14, by holding an industry symposium to exchange views on the causes and possible remedies for these human-factor accidents.

Important research projects are under way in support of, and to supplement, our regulatory efforts on human factors. We have signed a memorandum of agreement to launch a new FRA-sponsored R&D pilot project with rail management and labor that will gather and analyze data on "close calls" to identify the reasons for the human failures that cause near-accidents and to develop corrective actions to remedy those human-factor causes. Another FRA R&D project will try to develop cost-effective technological counter-measures to misaligned switches and will conduct in-depth behavioral research on why employees make such errors.

2. Defective Track

The second-leading cause of train accidents is defective track. Over the last three years, FRA embarked on an aggressive program to focus its track-related enforcement efforts on the most likely accident causes. We are continuing these efforts, which have generally helped move the track-caused accident trend lines in the right direction. Here, too, our R&D efforts provide a critical complement to our regulatory efforts. Broken joint bars and broken rails account for a large number of track-caused accidents, but the precursor conditions (cracks in joint bars and internal rail flaws) that lead to these causes are not readily detected. FRA is developing a high-speed photo inspection system that will detect joint bar defects much more efficiently than current methods allow. FRA is also working closely with the railroad industry to improve the speed and reliability of rail flaw detection vehicles.

B. National Inspection Plan

While our regulatory and research efforts are focused on the leading causes of train accidents, we are also focusing our inspection resources on the areas of highest risk. FRA has recently begun phasing in a new National Inspection Plan (NIP) to improve the agency's allocation and assignment of inspection resources. The NIP will use sophisticated trend analyses of inspection and accident data to produce an optimal distribution of resources within each of the agency's eight regions to minimize fatality, injury, and accident rates. We began implementing the NIP at the end of last month in the operating practices and track disciplines, which correspond to the two leading categories of train accidents.

C. Research and Development

Our third area of emphasis is accelerating our R&D efforts that have the greatest potential to reduce serious safety risks. For example, FRA is speeding up R&D efforts on the structural integrity of tank cars. FRA also continues use its R&D program to pursue new

approaches to passenger safety. These efforts are focused on strategies to better protect the occupied volume of passenger cars and to mitigate occupant injuries, as carried out through advanced computer modeling by The Volpe National Transportation Systems Center (Volpe Center) and through full-scale passenger car crash tests at the Technology Transportation Center near Pueblo, Colorado. Our research is focusing on applying the principles of Crash Energy Management (CEM) to the next generation of passenger cars. CEM seeks to protect occupants by dissipating collision forces through the use of crush-zones in the non-occupied volume of the vehicles.

Amtrak's Safety Record and FRA's Oversight

FRA closely monitors all aspects of Amtrak safety, as it does for all freight and passenger railroads. We inspect not just Amtrak's rolling equipment but also its track, signals, and operations. As with any other railroad, we use civil penalties and other enforcement tools when necessary to encourage compliance with our safety regulations.

Amtrak's safety record is generally quite good. Based on preliminary data for the year 2004, Amtrak's rate of accidents (2.8 per million train-miles) was well below the industry average of just over four accidents per million train-miles. Contrary to the industry trend, Amtrak's human-factor-caused accidents have fallen substantially in the last two years, comprising 20 percent of its accidents in 2004. One major reason for this improvement was a program that Amtrak adopted two years ago, with FRA's encouragement, to determine the root cause of major operating rule violations. In addition, employee injury rates, particularly in Amtrak's transportation department, improved in 2004. FRA will continue to monitor Amtrak very closely to ensure that its generally positive safety record does not deteriorate and that any safety problems FRA discovers are promptly addressed.

FRA's Continued Efforts to Ensure the Safety of Acela Operations

FRA, as mentioned previously, is working very closely with Amtrak as the railroad tries to develop a long-term solution to the Acela disc brake problem. We intend to make sure that the solution Amtrak adopts is one that fully cures the problem before Acela service resumes. Thus far, Amtrak has been in complete agreement with us on that issue. We will also ensure that Amtrak's equipment inspection program for the Acela trainsets is improved so as to ensure that any such safety-critical problems are found and corrected well before they reach the dimensions that this problem had reached by the time that FRA detected it. When the Acela service does start up again, FRA will resume its quarterly reviews of Acela mechanical issues with Amtrak. We have used this process in the past to resolve other problems detected in the Acela trainsets.

I believe that the extra effort displayed by FRA Safety Specialist Thomas and other FRA personnel involved in the current Acela brake issue may quite possibly have averted a serious accident. Those efforts are emblematic of the dedication that FRA employees generally bring to their safety mission. We will continue to exercise that level of effort in working with Amtrak to ensure that the resumption of Acela service is safely done. Thank you, and I would be pleased to answer any questions.

**House Transportation and Infrastructure Committee
Railroad Subcommittee**

Wednesday, May 11, 2005

Statement of
Alstom Transportation Inc.
Francis Jelensperger
Senior Vice President NAFTA Region

Mr. Chairman and Members of the Subcommittee, thank you for the opportunity to appear before the subcommittee to discuss issues related to the Acela trainsets. We are pleased to be here this morning with our colleagues from Amtrak and Bombardier, and together we are fully committed to ensuring a long-term, expeditious and – most of all – safe solution to the issue at hand.

Bombardier and Alstom, acting in the consortium, contracted with Amtrak in 1996 to build 20 trainsets and 15 electric high-horsepower locomotives, and for providing maintenance services for the Acela trainsets in joint venture.

Alstom, working together with Bombardier, is committed to abiding to the contract with Amtrak to honor the warranty on these trainsets. I am fully confident that our team will resolve the current situation by working with Amtrak, the Federal Railroad Administration and the consortium's suppliers to get equipment back into service as quickly as possible. As we do so, passenger safety will continue to be of utmost priority for us all.

Alstom is committed to continuing to work closely with Bombardier and its subcontractor Knorr Brake to resolve the issues that Bombardier outlined in its prepared statement. I have had an opportunity to review the statement of my colleague from Bombardier and can say that Alstom is in agreement with the substance of Bombardier's statement.

We understand and appreciate Congress' concern in this issue and Alstom will continue to work closely with Amtrak and Bombardier to rectify the situation – quickly, effectively and most importantly...safely. Attached to our prepared testimony are the responses to the questions raised by the committee, and we would be pleased to answer any additional questions the committee may have.

Addendum to Statement

Response to specific questions asked by the Railroads Subcommittee of the Committee of Transportation and Infrastructure, US House of Representatives in its May 4, 2005 letter addressed to Francis Jelensperger.

What is the Northeast Corridor Maintenance Services Co. (NeCMSC) role in maintaining the Acela fleet?

The Northeast Corridor Maintenance Service Company (NeCMSC) is jointly owned and operated by Bombardier and ALSTOM (50-50 Joint Venture Company) and is in charge of the maintenance of Acela trains until October 1, 2006 (started in 2000). NeCMSC manages, oversees and directs the maintenance operations of the Acela trains that are carried out by Amtrak's unionized labor force.

What is ALSTOM's relationship to NeCMSC?

The Northeast Corridor Maintenance Service Company (NeCMSC) is jointly owned and operated by ALSTOM and Bombardier (50-50 JV)

As part of the settlement between Bombardier-Alstom and Amtrak in March 2004, it was agreed that maintenance services be transitioned to Amtrak's own in-house resources by October 1, 2006. The Bombardier-Alstom Consortium is in the process of transitioning maintenance operations back to Amtrak. For example, the Consortium will offer training to employees to secure a seamless transition. The Consortium will also continue to support Amtrak after October 1, 2006 as a supplier of parts and of technical services, if needed.

When did NeCMSC first become aware that 20-30% of the brakes on the Acela fleet had cracks?

This issue surfaced when a visual inspection discovered hairline fissures in brake disc spokes on Acela Express coaches during a FRA routine inspection on the evening of April 14. Following this discovery, the entire fleet underwent a visual inspection during the next day, a process that identified approximately 300 discs having the issue from a total of 1,440 discs in the fleet. Based on additional sample inspections using specialised equipment and processes we estimate that a large percentage of the disc exhibit some degree of hairline fissures.

What procedures did NeCMSC have in place that could have detected the problem before such a large percentage of the Acela fleet was affected?

It is important to understand that the Acela trainsets undergo daily inspections by NeCMSC as part of a routine maintenance program that is in line with standard industry practices and the disc brakes are included in this daily regimen. The 20 trainsets also undergo in-depth inspections and maintenance at 92-day and one-year intervals. To give you an idea of the rigor, the inspection at the 92-day interval is carried out over a week. The inspection at the one-year interval lasts two weeks. As a

result, the brake discs had been inspected by teams from our maintenance operation, the FRA and Amtrak multiple times prior to the first discovery of the fissures in April.

It is unfortunate that the inspections did not detect the hairline fissures earlier. These defects are small and difficult to detect with the naked eye, particularly when the discs are cool and the metal is in a contracted state.

Most of the hairline fissures are not visible at all to the naked eye. Following the visual inspection process, our teams implemented a Magnetic Particle Inspection. The MPI process uses electro-magnetic equipment to detect surface and near-surface flaws in ferromagnetic material. In a nutshell, it helps us see anomalies not visible with the human eye. This is a detailed process, so we used it on a sample of the Acela brake discs in question. Based on the MPI results, we estimate that a large percentage of the discs have some level of hairline fissures, indicating that the issue may be more prevalent than was originally believed.

NeCMSC was following industry maintenance practices with visual inspection performed on the brake discs on a daily basis. Standard industry practice is not to perform MPI as part of the normal daily inspections.

Having said this, the trainsets were grounded as a precautionary measure. The discs have operated for nearly five years without a failure and it is not clear how quickly the hairline fissures were propagating.

The discs were built to a specification provided by Amtrak that called for a minimum operating life equal to the lesser of five years or one million miles. Based on the average mileage travelled by the trainsets, the discs are at about the half-way point in that expected life cycle.

Hairline fissures on the spokes are actually in an area of the disc assembly away from where you would expect to see normal wear. In fact, wear on the disc face (or friction ring) – where the brake pads contact the disc when the brakes are applied – is as it should be at this point in the life cycle. The issue is in the spokes – an area where this sort of issue should not be occurring. It needs to be emphasized that the fissures on the spokes are in an area unrelated to the disc face that really determines the life cycle of the disc.

That points to a fundamental fault in the component, not excessive wear or lack of maintenance. In terms of normal wear on the brake disc face, these discs are performing exactly as they should. The point is that there was no way for the maintenance operation, the consortium or Amtrak to anticipate the type or magnitude of this fault.

STATEMENT OF
THE HONORABLE JAMES L. OBERSTAR
SUBCOMMITTEE ON RAILROADS
HEARING ON
"GETTING ACELA BACK ON TRACK"
MAY 11, 2005

Mr. Chairman, I want to thank you and Ranking Member Brown for holding this hearing to investigate the Acela trainsets, the current interruption of Acela service, and the roles of the Federal Railroad Administration (FRA), Amtrak, and the Bombardier-Alstom Consortium in getting Acela back on track.

It is important to note at the outset that, in its five years of operation, Amtrak's Acela trainsets have not been involved in one serious accident. Nevertheless, today's discussion of the cracks in the spokes of the brake disc rotors only echoes the prior mechanical problems that have plagued the Acela.

It's been almost a month since Amtrak grounded the Acela Express fleet after a FRA inspection of some Acela trainsets uncovered fatigue cracks initiating at the ribs of the spokes of the trains' brake disc rotors. Further investigations have revealed that at least 50 percent of the Acela fleet's 1,440 brake disc rotors may be prematurely defective.

To get Acela back on track, we must ensure that the Acela trainsets' brake discs are able to meet the intense demands of the Northeast Corridor. We must begin by figuring out what caused the cracks in the spokes. The design life of these brake disc rotors is one million miles, but reports indicate that these cracks have appeared much earlier – at 300,000 miles, 400,000 miles, and 650,000 miles on different trainsets.

I understand that Amtrak and the Bombardier-Alstom Consortium's brake manufacturer are conducting tests on the brake discs. It's unfortunate that we didn't get the result of these tests before having this hearing. These tests are crucial to ensure that the chemical composition, metallurgical processing during manufacture, and final internal structure of the brakes met the original design specifications. You must look at the shape of the casting, the metal specifications for the casting, and the chemical composition of the molten metal. You must investigate how the molten metal was poured into the molds in terms of gating and risering, and whether the metal was heated to a temperature of 3,000 degrees Fahrenheit. You have to look at the cooling rate. You have to ensure there were no shrinkage defects or imperfections. Sharp angle bends, notches, or dents in the surface of parts can initiate fatigue cracking. All of this must be examined to explore the possible causes of the fatigue cracks.

In addition, we must consider the design characteristics of this particular brake disc rotor and whether a replacement rotor of a different design is more suitable to the Acela trainsets and the Northeast Corridor. I know that Amtrak and the other parties are also exploring this option.

In the interim, I have asked Bombardier and the Amtrak Inspector General for the Original Equipment Manufacturer's technical manual on the brake disc rotors, and I'm looking forward to receiving that soon. I look forward to hearing more from the witnesses about the tests that are being conducted and the new designs that are being considered.

While the cause of the cracks is important, I am concerned that the Bombardier-Alstom Consortium, which was responsible for maintaining the Acela trainsets, did not find these cracks in earlier inspections.

One of the Consortium's subcontractors distributed a technical manual in March 1998 entitled "Axle-mounted brake disk W 700 S-N". The manual sets forth new inspection procedures for brake disc rotors. It states that maintenance personnel must check for cracks in the hubs, cracks in the connection spokes of the hubs and friction rings, penetrating cracks, and incipient cracks every 12,422 miles. If cracks are found, the manual requires replacement of the axle-mounted brake disc. This

manual was sent to the Consortium and the Consortium's brake manufacturer two years before the Acela came into service.

However, the Consortium's Inspection, Testing, and Maintenance plan, which was submitted and approved by the FRA sometime in 1999, never mentioned the new inspection requirements. The Consortium's maintenance procedures weren't even updated after Knorr (pronounced KUH-NOR), the Consortium's brake manufacturer, issued a service bulletin in 2003, which stated that failure of the brake discs could "result in considerable damage to equipment and extensive and possible fatal injury to both passengers and onboard personnel." In addition, the service bulletin referenced the subcontractor's technical manual requiring inspection and replacement of cracked spokes.

It is clear that the Consortium never updated their preventive maintenance work orders, the checklists that maintenance workers use to conduct train inspections, to reflect the new inspection requirements. In fact, I have reviewed some of the work orders and nowhere on the forms do I see a requirement to inspect the hubs or spokes. They require inspection of the friction rings for cracks, but not the spokes.

This lack of communication and lack of training was evident on April 15 when the FRA inspector found the cracks in the spokes. Amtrak was conducting test runs

from Washington to Boston with FRA assistance. As part of that test, the Consortium's maintenance personnel were required to conduct eight Level I inspections of the train. It wasn't until the end, after the eighth inspection, that the FRA, in conducting its own inspection, had found the cracks in the spokes of the brake discs. As I understand it, the FRA inspector cut the spoke out of the rotor and it actually fell apart in his hand.

So I'm trying to figure out where the disconnect was, and why these workers didn't know they were supposed to be inspecting the spokes for cracks.

I believe that this requires a complete examination of the role of all the parties involved – the FRA, Amtrak, the Consortium, and the Consortium's contractors and subcontractors – to ensure that each of them is doing everything possible to continue the Acela's exemplary safety record.

We need to make sure that the FRA is appropriately monitoring Amtrak and the Consortium to ensure that the trains are safe. I understand that the FRA is recommending the Consortium update their inspection requirements to include inspections for cracks in spokes and hubs. I hope the FRA intends to follow its own advice and update its own Class I, Class IA, and Class 2 inspection requirements for both passenger and freight railroads accordingly.

Separately, I have asked the Department of Transportation's Inspector General to look into FRA's inspections of the Acela trainsets. I understand that FRA inspectors conduct routine maintenance checks on all Amtrak equipment, including the Acela. However, the Inspector General's office has informed me that these cracks would not have been found on a typical, routine maintenance check. The inspector who found the cracks in April was conducting a special inspection, which I am told is only done about two or three times a year. When I asked the Inspector General why these spot checks aren't conducted more often and why more stringent maintenance checks aren't required, the answer given was that the existing regulations predated the Acela and are not geared to call for these types of inspections. I have asked the Inspector General to look into this issue further. In the interim, I'd like the Acting Administrator, Robert Jamison, to tell me whether the FRA has enough inspectors, whether they are knowledgeable about high-speed rail and can do this type of work, and what additional resources, if any, are needed to ensure the continued safety of the Acela trains.

We also need to make sure that Amtrak is taking a leadership role in ensuring that the Consortium is adequately maintaining the Acela trainsets and following through with their commitments under the settlement agreement. A lot of work

needs to be done before the Consortium's contract is turned over to Amtrak in October 2006, and it's up to Amtrak to ensure that work is getting done.

Finally, we need to make sure that the Consortium and its contractors are abiding by industry standards and FRA safety regulations, and that the Consortium's maintenance records and inspection requirements are accurate.

I intend to explore these issues further with each of the witnesses. Thank you, Mr. Chairman.

**Statement to the
Railroads Subcommittee of the
House Transportation and Infrastructure Committee
Wednesday, May 11, 2005**

**William Spurr, President
Bombardier Transportation – North America**

Bombardier appreciates the opportunity to appear before the Subcommittee today and discuss issues related to the recent grounding of the Acela trainsets.

Let me open by stating that the Consortium of Bombardier and Alstom fully understands the importance of this issue and the impact it is having on rail transport along the Northeast Corridor. We have stated repeatedly our commitment to finding a solution that brings the Acela equipment back into service as quickly as possible while at the same time ensuring public safety. I am here today to reaffirm this commitment and to tell you that we continue to work closely with Amtrak, the FRA and our suppliers to resolve the issue to the satisfaction of everyone concerned.

In fact, I can say that we are appreciative of the constructive approach Amtrak is taking in this situation. From our perspective, we are working as a team, and we firmly believe that this co-operation will greatly facilitate movement toward a viable solution.

In that context, I will take a moment to discuss the challenge and the approach we are taking toward resolution. As discussed with staff prior to this hearing, a comprehensive analysis is underway, and we do not yet have definitive information on the reasons behind this issue. We expect to know more as analysis and testing winds down toward the end of May. In the meantime, I will provide an overview of the issue in my statement and be happy to respond to any questions you may have.

As many of you are aware, this issue surfaced when a visual inspection discovered hairline fissures in brake disc spokes on Acela Express coaches. Following this discovery, the entire fleet underwent a visual inspection, a process that identified approximately 300 discs having the issue from a total of 1,440 discs in the fleet. Locomotives, which utilize a different braking system, were not affected.

It is important to understand that the Acela trainsets undergo daily inspections by NeCMSC. This is part of a routine maintenance program in line with standard industry practices. Brake discs are included in this daily regimen. The 20 trainsets also undergo in-depth inspections and maintenance at 92-day and one-year intervals. To give you an idea of the rigor, the inspection at the 92-day interval is carried out over a week. The inspection at the one-year interval lasts two weeks. As a result, the brake discs had been

inspected by teams from our maintenance operation, the FRA and Amtrak multiple times prior to the first discovery of the hairline fissures in April.

It is unfortunate that the inspections did not detect the hairline fissures earlier. These defects are small and difficult to detect with the naked eye, particularly when the discs are cool and the metal is in a contracted state. Some of your committee staff actually visited the Acela maintenance facilities here in Washington last week to see the brake discs first hand. I think they can attest to what I am saying.

Most of the hairline fissures are not visible at all to the naked eye. Following the visual inspection process, our teams implemented a Magnetic Particle Inspection. The MPI process uses electro-magnetic equipment to detect surface and near-surface flaws in ferromagnetic material. In a nutshell, it helps us see anomalies not visible with the human eye. This is a detailed process, so we used it on a sample of the Acela brake discs in question. Based on the MPI results, we estimate that a large percentage of discs have some level of hairline fissures, indicating that the issue may be more prevalent than originally believed.

Having said this, let me be very clear on a few important points. First, the trainsets were grounded as a precautionary measure. These discs have operated for nearly five years without a failure and it is not yet clear how quickly the hairline fissures were propagating.

Second, contrary to assertions in some recent media reports, this is a component performance issue, not a maintenance issue. These discs were built to a specification provided by Amtrak that called for a minimum operating life equal to the lesser of five years or one million miles. Based on the average mileage traveled by the trainsets, the discs are at about the half-way point in that expected life cycle.

Hairline fissures on the spokes are actually in an area of the disc assembly away from where you would expect to see normal wear. In fact, wear on the disc face (or friction ring) – where brake pads contact the disc when the brakes are applied – is as it should be at this point in the life cycle. The issue is in the spokes – an area where this sort of fissures should not be occurring. Let me underscore that these hairline fissures on the spokes are in an area unrelated to the disc face, and the disc face is really what determines the life-cycle of the disc.

This points to a fundamental fault in component performance, not excessive wear or lack of maintenance. In terms of normal wear on the brake disc face, these discs are performing exactly as they should. Let me repeat, the issue lies in component performance and the focus of our investigation is centering on the reason for that.

This is an important point because there has been some confusion about the five-year aspect of the specification for this part. The original specification assumed that five years would be the approximate timeframe for each trainset to travel one-million-miles. During their life, the discs would undergo routine inspections and be machined at their half-life point – about 500,000 miles. Machining is a process where the brake discs faces, which typically become misshapen as a result of normal wear, are returned to a flat state. The

discs are then expected to continue in operation until they are discarded at about one million miles in operation.

The five-year point on the most-used trainset will actually be reached this June, but even that trainset will have traveled only about half as far as originally anticipated by the negotiators of the original contract. As you can understand, wear on the trainsets and components is dictated by miles in use, not by time. For example, a steel disc sitting on a shelf for five years will incur virtually no wear unless it is put into operation. So, the real factor we need to be looking at here is mileage. In terms of mileage and based on the specification, none of the discs, even those on the most-used trainset, are near their expected life capacity, and that is the issue. In fact, at the time of the discovery, the maintenance operation was preparing to begin an overhaul process that included machining and potential replacement of the discs at their half life point. It is our understanding that one hundred and forty four new discs, two trainsets, were ordered or about to be ordered by Knorr in case replacements were needed during that overhaul process. NeCMSC has a life-cycle cost contract with Knorr by which Knorr must provide all the required material for the duration of the maintenance contract. So, the maintenance organization was doing exactly what it was supposed to be doing during this process. Assertions to the contrary are simply inaccurate.

Similarly, we have heard suggestions in the press that the Consortium overestimated the realistic wear on the brake discs and thus was caught with an inadequate parts inventory when the issue arose. That is not the case. As I have noted, disc surface wear, as such, has nothing to do with this problem. In any event, no rail operation in the world would carry enough spare parts in inventory to address a component performance issue of this magnitude.

Amtrak provided a minimum life requirement for the brake discs in their original specification for the Acela trainsets. Bombardier, in turn, contracted with Knorr Brake Corp. to deliver a brake system and components in line with those specifications. Knorr worked with sub-suppliers – Wabco, a division of Wabtec, and SAB Wabco, now owned by Faiveley Transport, a European supplier – to secure the brake discs for that system.

Knorr is a reputable supplier in the industry used by many rail equipment manufacturers. Bombardier has worked with Knorr successfully on numerous projects. Bombardier contracted with Knorr on the Acela coach braking system, and we had every reason to believe that the system would perform properly. For some reason, the brake discs are not doing so, and we need to find out why.

We are working closely with Knorr and their sub-suppliers to understand the root cause of this issue. Analysis is focusing on four general areas – component design, manufacturing process, casting process and environmental factors. Knorr is currently subjecting the discs to a strenuous battery of testing at their labs in Munich, Germany as we speak. Specifically, they are conducting metallurgical and stress testing on a new disc with no fissures and a used disc with hairline fissures to understand how and when the issue evolves. We are also working with the parties to conduct dynamic testing of the

component using one Acela trainset in operation on the NEC in coming days. This will use sensors on the trainset to monitor disc behavior in real-life operation. The dynamic testing process is subject to approval by the FRA.

The maintenance operation and the Consortium had no reason to anticipate the type or magnitude of this fault. There has been criticism of the maintenance operation in the media about the level of spare parts inventory on hand at the time the issue arose. I must underscore that the inventory level was determined based on four plus years of historical usage and was totally appropriate for carrying out normal maintenance on the Acela fleet. Again, no rail operation in the world would carry enough spare parts in inventory to address a component performance issue of this magnitude.

It has also been suggested that the discs should be changed sooner in the life cycle to alleviate the problem. That may be a possible interim solution, but it does not address the underlying problem. The issue at hand is that the hairline fissures in the spokes are not acceptable, and the problem that caused them must be identified and corrected. That is the bottom line.

As the supplier of record for the Acela trainsets and a customer of Knorr, the Consortium wants nothing less than a permanent solution and we want it as soon as possible because we understand the situation that Amtrak is facing. Let's be clear. The Consortium is committed to working with Amtrak, the FRA and with our suppliers to find a solution to this problem. We expect the same commitment from Knorr and assume Knorr expects the same from its own sub-suppliers. The last point, however, is a line of inquiry best addressed by Knorr.

Now that I've spoken to what the issue is and isn't, let me spend a few moments on our approach to resolving it. At this point, we are pursuing three potential avenues of action in parallel. First, we are developing an approach to "recertify" the discs we have on hand for continued use. This would be an interim solution using the existing brake disc design supplied by Sabwabco (now owned by Faiveley Transport) and Wabco to get as many trains back in service as soon as possible. Trains would be closely inspected on a daily basis until a permanent solution was achieved.

Recertification of each disc under this plan would involve close inspection using the MPI process, followed by a qualifying process that would identify which discs are in appropriate condition for use in operation. The qualifying process would be based on criteria approved by Amtrak and the FRA with public safety as the primary objective. The Consortium and Knorr are currently working with these organizations to finalize that criteria, so we can move forward with the assessment of discs.

Second, we are working with Knorr and its sub-suppliers to secure new discs of the same design as quickly as possible. These discs would also be subject to the certification process. To date, Knorr's sub-suppliers have tentatively committed to deliver brake discs of the same design starting in June 2005. We have expressed to Knorr that we are not

satisfied with the timeline on this proposal and have asked them to push their sub-suppliers for faster production and delivery.

Finally, we are looking at the potential for using a completely different brake disc design. This is a design produced by Knorr itself. The design has already been prequalified as a replacement part by Amtrak and would serve as an interim solution, so some of the work has been completed already. It is of course contingent upon FRA approval. Preliminary review indicates that the new design may have some advantages over the SAB Wabco (now Faiveley Transport) and Wabco version. Knorr has committed that it can produce brake discs of a new design and start delivering them also in June 2005.

The objective behind these parallel approaches is to secure a solution that ensures public safety, gets as many trainsets into service as soon as possible, and ultimately arrives at a viable permanent solution to the issue. As we move down these parallel paths, we will compare the merits and drawbacks of each of these approaches. In the end, we will select the proposal that best meets the target for getting some trains back in service in June and the rest of the fleet in following months.

I should note again that each of these plans is subject to review and approval by Amtrak and the FRA, and we will rely on them to provide the go ahead before moving forward.

In closing, let me once again stress Bombardier's commitment to resolving this issue quickly and safely. Thank you to the members of this panel for inviting us to participate today. I will respond to any questions you may have.

Addendum to Statement

*Response to specific questions asked by the Railroads Subcommittee of the
Committee of Transportation and Infrastructure,
US House of Representatives
in its May 4, 2005 letter*

What is the Northeast Corridor Maintenance Services Co. (NeCMSC) role in maintaining the Acela fleet?**What is Bombardier's relationship to NeCMSC?**

The Northeast Corridor Maintenance Service Company (NeCMSC), jointly owned and operated by Bombardier and Alstom (50-50), is in charge of maintenance for the Acela trains until October 1, 2006 (started in 2000). A NeCMSC management team oversees maintenance operations carried out by Amtrak's labour force.

As part of the settlement between Bombardier-Alstom and Amtrak in March 2004, it was agreed that maintenance services be transitioned to Amtrak's own in-house resources by October 1, 2006. The Bombardier-Alstom Consortium is in the process of transitioning maintenance operations back to Amtrak. For example, the Consortium will offer training to employees to secure a seamless transition. The Consortium will also continue to support Amtrak after October 1, 2006 as a supplier of parts and of technical services, if needed.

When did NeCMSC first become aware that 20-30% of the brakes on the Acela fleet had cracks?**What procedures did NeCMSC have in place that could have detected the problem before such a large percentage of the Acela fleet was affected?**

This issue surfaced when a visual inspection discovered hairline fissures in brake disc spokes on Acela Express coaches during a FRA inspection on the evening of April 14. Following this discovery, the entire fleet underwent a visual inspection during the next day, a process that identified approximately 300 discs having the issue from a total of 1,440 discs in the fleet.

It is important to understand that the Acela trainsets undergo daily inspections by NeCMSC as part of a routine maintenance program that is in line with standard industry practices. Disc brakes are included in this daily regimen. The 20 trainsets also undergo in-depth inspections and maintenance at 92-day and one-year intervals. To give you an idea of the rigor, the inspection at the 92-day interval is carried out over a week. The inspection at the one-year interval lasts two weeks. As a result, the brake discs had been inspected by teams from our maintenance operation, the FRA and Amtrak multiple times prior to the first discovery of the hairline fissures in April.

It is unfortunate that the inspections did not detect the hairline fissures earlier. These defects are small and difficult to detect with the naked eye, particularly when the discs are cool and the metal is in a contracted state.

Most of the hairline fissures are not visible at all to the naked eye. Following the visual inspection process, our teams implemented a Magnetic Particle Inspection. The

MPI process uses electro-magnetic equipment to detect surface and near-surface flaws in ferromagnetic material. In a nutshell, it helps us see anomalies not visible with the human eye. This is a detailed process, so we used it on a sample of the Acela brake discs in question. Based on the MPI results, we estimate that a large percentage of the discs have some level of hairline fissures, indicating that the issue may be more prevalent than was originally believed.

NeCMSC was following industry's maintenance practices with visual inspection performed on the brake discs on a daily basis. Standard industry practice does not include performing MPI as part of the normal daily inspection procedure.

Having said this, the trainsets were grounded as a precautionary measure. These discs have operated for nearly five years without a failure and it is not yet clear how quickly the hairline fissures were propagating.

Contrary to assertions in some recent media reports, this is a component performance issue, not a maintenance issue. These discs were built to a specification provided by Amtrak that called for a minimum operating life equal to the lesser of five years or one million miles. Based on the average mileage travelled by the trainsets, the discs are at about the half-way point in that expected life cycle.

Hairline fissures on the spokes are actually in an area of the disc assembly away from where you would expect to see normal wear. In fact, wear on the disc face (or friction ring) – where the brake pads contact the disc when the brakes are applied – is as it should be at this point in the life cycle. The issue is in the spokes – an area where this should not be occurring. It needs to be emphasized that fissures on the spokes are in an area unrelated to the disc face, and the disc face is really what determines the life-cycle of the disc.

That points to a fundamental fault in the component performance, not excessive wear or lack of maintenance. In terms of normal wear on the brake disc face, these discs are performing exactly as they should.

The point is that the maintenance operation and the Consortium had no reason to anticipate the type or magnitude of this fault. There has been criticism of the maintenance operation in the media about the level of spare parts inventory on hand at the time the issue arose. The inventory level was determined based on four plus years of historical usage and was totally appropriate for carrying out normal maintenance on the Acela fleet. No rail operation in the world would carry enough spare parts in inventory to address a component performance issue of this magnitude.

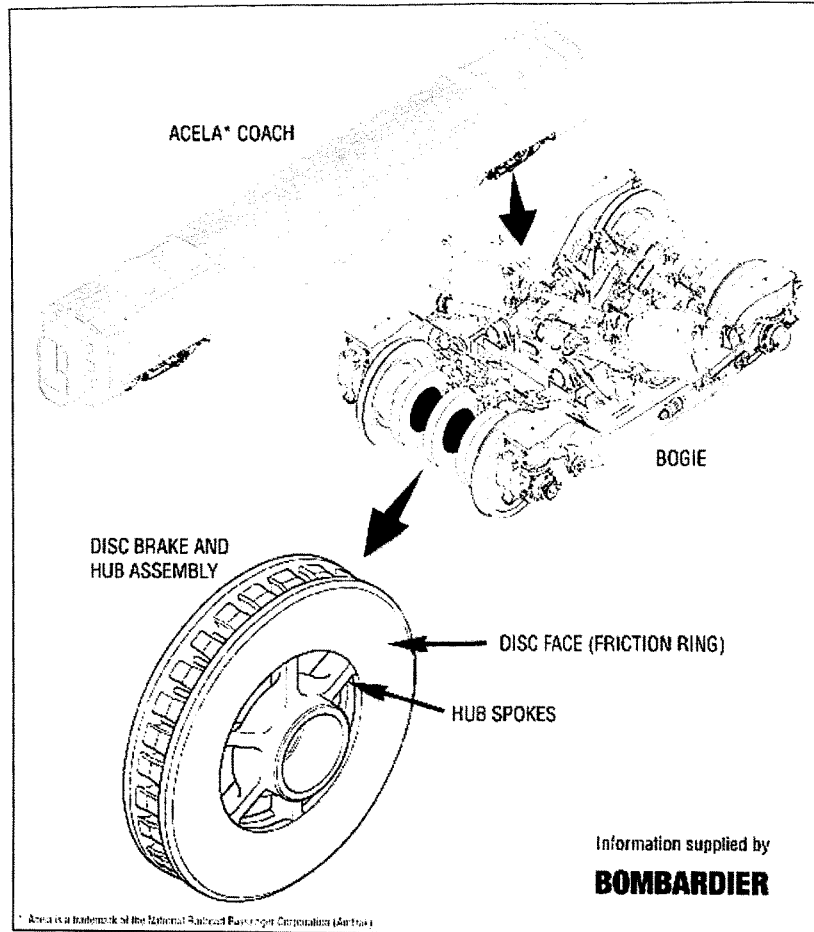

**Statement of
Fred E. Weiderhold, Jr.
Inspector General, Amtrak
Before the
Subcommittee on Railroads
Committee on Transportation & Infrastructure
U. S. House of Representatives
May 11, 2005**

Chairman LaTourette:

Good morning, Mr. Chairman. Thank you for the opportunity to appear today to discuss the circumstances and issues surrounding the recent termination of Amtrak's high-speed Acela service.

This morning I would like to provide you with answers to the three questions included in your May 4 letter to me, as well as to explain the Amtrak Office of Inspector General (OIG) ongoing investigation of the brake disc failures.

At the onset, I would like to make several key points:

First, following discovery of the cracked spokes in the Acela brake discs, the FRA and Amtrak Mechanical forces conducted a fleet-wide inspection of all non-Acela cars. These inspections revealed no systemic problem with the other brake discs. There were, however, a very small number of brake discs that were found to be out of tolerance and exhibiting cracks, probably thermal cracks not cracks in spokes, and those discs were immediately removed from service. My Office has received and reviewed the FRA inspection reports from this effort, and we will follow-up on the problems reported.

Second, there is considerable effort being expended by all affected parties to find a fix to the Acela brake disc problem. It is in everyone's best interest to get the trainsets back into service quickly, but more importantly, safely. The existing brake disc unit is being extensively tested by the brake disc supplier/manufacturer (Knorr, Faively Transport, SAB WABCO). There is concurrent testing of a "new" brake disc design and manufactured product. There will soon be live testing of an Acela trainset, outfitted with instrumentation to measure the actual loads and forces being applied to the brake discs. There is ongoing analysis of finite element models of both the "new" and existing discs. Early indications are that the brake disc is failing as a result of fatigue loading, but not all the results are in. Amtrak, the FRA, and the Amtrak OIG are monitoring all of this testing, inspection, and related work.

Third, while it is necessary and appropriate to focus on the "fix," the OIG is concentrating on the entirety of the root causes for the failures. In our review, we are going beyond simply wanting to know the mode of failure, or physical causation. For

example, did the disc fail because it is defective and could not meet the required performance specification? Are the loads and forces acting on the disc greater than specified? These are important questions that can help lead to the proper disc being used on Acela, but these answers are only part of the story.

In our analysis, we want to know whether the specifications for the brake discs are appropriate. Were the assumptions valid? Were the specifications reviewed and approved by the right persons? Were all specifications shared in their entirety throughout the contracting processes?

We want to know why the cracks were not identified sooner, and what inspection processes failed or were not in place. Toward that end, we have interviewed FRA inspectors, Northeast Corridor Maintenance Service Corporation (NeCMSC) personnel, Amtrak maintenance staff, and staff from ORX (the wheelset maintainer/refurbisher). We have thus far uncovered information from one of the vendors that some cracks in the spokes may have been found and reported as long as 12-24 months ago. We are trying to confirm and determine the existence of these reports, who may have received those reports, and what action was taken.

We are examining the processes and procedures in place for inspecting the brake discs and the training that accompanied the procedures. Has the manufacturer supplied appropriate criteria for inspecting and qualifying the brake discs? Were these inspection procedures and training made available to the appropriate individuals on the shop floor and to all parties responsible for oversight and inspection?

Finally, we want to know WHY the decisions were made and by WHOM. Did the responsible person(s) act differently because an action, or non-action, would result in financial harm? Are there organizational impediments to information sharing? Sometimes people make bad decisions with good intentions, did that happen here? This approach is very similar to the "human factor" analyses conducted by the NTSB.

I hope to eventually provide the Committee with answers to all of these questions. I am providing some detailed responses to the specific questions you raised in last week's letter. It appears that your concerns run parallel to mine, and I hope my responses prove helpful. I am prepared to expand upon these responses whenever called upon by the Committee.

With respect to the specific questions raised in your May 4 letter, my responses follow.

"What review of Amtrak's mechanical inspection procedures, oversight of mechanical service providers, and quality assurance/quality control programs have you done?"

The Amtrak Office of Inspector General (OIG) has conducted several reviews of Amtrak's mechanical inspection procedures and those of its contractors over the past few years. With respect to Acela, my Office is very familiar with Acela operations and with the history of the trainsets. We have conducted several reviews relating directly to

mechanical inspections, detailed below, and we have also conducted audits of change orders, Buy America compliance, and parts ordering. Further, we have also examined other problems with the Acela trainsets, including the “yaw damper bracket” problem that grounded the fleet in August 2002.

As background, you should be aware of the agreement between Amtrak and the Bombardier-Alstom Consortium for maintenance of the Acela trainsets. Amtrak contracted with the Consortium to provide all maintenance services for a ten-year period. The maintenance operation for Acela is managed by a Consortium subsidiary, NeCMSC.¹

The OIG previously reviewed the maintenance operations of NeCMSC in early 2003, and we issued a formal report to Amtrak and NeCMSC in June 2003. In this report, we made a number of recommendations to Amtrak and NeCMSC, including the need to: improve the quality and accuracy of federally mandated inspection reports, improve the inspection and documentation of maintenance work on safety critical maintenance actions, improve Amtrak’s system safety presence, and update and keep current the Inspection, Testing, and Maintenance (ITM) Plan. The ITM is federally mandated and details the procedures, equipment, and maintenance practices used to ensure safe operation of the trainsets. The ITM is the primary document by which standards are set and from which the FRA can make compliance inspections.

Following our June 2003 review, we conducted a subsequent follow-up review in August 2004. To NeCMSC’s credit, we found considerable improvement in record keeping, reporting, and documentation of improved maintenance practices. We also found some improvement in NeCMSC’s inventory control and a significant improvement and reduction in open work orders for the trainsets. However, we continued to observe weaknesses in quality assurance services, most notably in product traceability. Traceability is important to demonstrate compliance with federal regulations and predictive maintenance. For example, replacing components at specific intervals, such as air brake valves (which are required to be replaced at five year intervals), cannot be documented as being compliant, and it was not clear how this component, and others, were being monitored. We also recommended to Amtrak that they confirm that accurate as-built drawings and all technical documentation (including technical manuals, bills of material, updated blueprints, and maintenance instructions) are provided to each of the NeCMSC facilities and are available for maintenance personnel. At the time of our review, only about 85 percent of the drawings had been provided to NeCMSC by the Consortium. Amtrak agreed with our recommendations, and we continue to believe Amtrak should place a priority on quality assurance during the transition of maintenance responsibilities from the Consortium to Amtrak.

¹ As a result of a series of claims and counter-claims between Amtrak and the consortium, and a subsequent settlement agreement, the maintenance responsibility for Acela is to transition from the Consortium to Amtrak by October 2006.

Since August 2004, my Office has been an active member of the Acela Executive Oversight Committee. These monthly meetings are intended to allow senior Amtrak managers to discuss topical Acela performance issues and contract transition issues.

We continue to monitor Acela performance closely, and we make recommendations to Amtrak senior management as appropriate.

“What review have you conducted to determine why Amtrak did not address the brake defects prior to 20% to 30% of them developing cracks?”

From all of our interviews and document reviews thus far, we have no evidence that Amtrak was ever made aware of brake disc spoke/web cracks prior to April 14, 2005, or was even aware of the manufacturer’s detailed procedures for brake disc inspections.

On the evening of April 14, 2005, the FRA notified Amtrak that one of their Inspectors had found brake disc spoke cracks during an inspection of an Acela trainset. The trainset had been undergoing track-related performance testing, and the observation of cracks in that part of the brake disc was totally unexpected. As a result of the FRA’s report, within hours, senior Amtrak management grounded the entire Acela fleet until a better assessment of the problem could be conducted.

Within one day of the brake disc spoke cracks being reported, Amtrak was provided with an excerpt from an inspection procedure manual prepared by the disc manufacturer, SAB WABCO in November 2004. This procedure included steps for crack inspection in the hub and spoke areas of the disc at least every 20,000 kilometers (12,422 miles). To the best of my Office’s knowledge, the maintenance personnel on the shop floor did not know this requirement.

The OIG requested the entire SAB WABCO technical manual, and we obtained the prior version of the manual (1998). We also obtained applicable Service Bulletins that relate to brake disc inspections, and we have requested all training materials associated with such inspections.

It is our intent to document fully the processes used to develop inspection criteria and training curricula. There were many eyes that saw the wheelset assemblies daily, and other eyes that saw the wheelset assemblies (and mounted brake discs) off the train during periodic inspections and re-furbishing. We need to determine what processes broke down to allow these defects on a safety critical part to pass unnoticed.

“What review have you conducted since the Acela trains were taken offline to determine who within Amtrak or the mechanical service providers was aware of brake cracking problem?”

On April 15, my Office immediately contacted the FRA Office of Safety, and we conducted a telephone interview with the FRA Inspector who found the cracks to determine how the cracks had come to his attention. We have worked previously with

this Inspector, and my Office has a high regard for his years of experience and for his integrity. We were told that he had observed what appeared to be a "rust spot" on one of the spokes of a brake disc that simply "caught his eye." He told us that he has been under the train hundreds of times to make his inspections, but that he had never observed cracks in this area of the brake disc.

During the week of April 18, my staff visited ORX, the off-site facility where the Acela wheelsets are serviced. We were informed by ORX that on at least two occasions they recall finding and reporting cracks in Acela brake disc spokes. However, ORX staff could not recall the exact dates of finding and reporting the problem; they believe this occurred 12-24 months ago. We asked ORX to research their records, and we have sought out other current and former employees to pinpoint better when and to whom these reports may have been made. I cannot over-emphasize that we have a number of open questions that need to be resolved, but I want to share this information with the Committee as we are investigating failures of a safety critical part.

We requested interviews with the supplier/manufacturer, but so far we have been told they are too busy to meet with us. We have had better luck with NeCMSC staff, and they have cooperated with our investigation up to this point. Given the seriousness of the issues at hand, I have issued subpoenas to all of the companies involved requesting all documents and records related to the brake discs. We will not allow the lack of cooperation by some entities to deter conducting a complete and full investigation.

Mr. Chairman, we will continue to monitor the technical resolution of this issue. In addition, I want to ensure the Committee that we will continue our investigation into whether appropriate procedures and processes were correctly followed and, if not, what changes need to be made to prevent similar problems from occurring in the future. We plan on issuing a full report at the conclusion of our investigation.

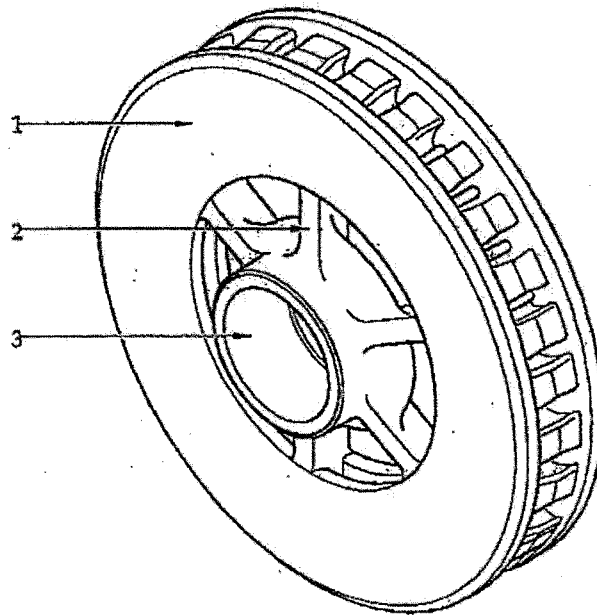

- 1 - Friction ring
- 2 - Connection Spokes
- 3 - Hub

Fig. 3.3

Federal Transit Administration Transit Threat Level Response Recommendation

FTA Policy Statement

The Federal Transit Administration (FTA) has developed a National Transit Response Model that supports the initiatives of the Office of Homeland Security (OHS). The plan is a guide for the FTA's response to the OHS Homeland Security Advisory System (HSAS). The Transit Threat Level Response Recommendation, in turn, provides guidance to the U.S. transit industry in responding to the various OHS threat level designations.

Introduction and Background

The Federal Transit Administration (FTA), in response to the Office of Homeland Security (OHS), has defined the following plan to guide transit response to the HSAS as defined in Homeland Security Presidential Directive #3. The plan establishes a consistent and coordinated transit response to potential threats in order to protect transit passengers, employees, and infrastructure, and to support community emergency response efforts. Further, the plan is compatible with the way transit operates:

- Transit relies on an inherently open architecture, allowing free movement of passengers in public facilities and vehicles. This freedom of movement must be maintained to permit transit to perform its basic functions.
- Transit is geographically widespread, often operating on public infrastructure and requiring important interagency cooperation to ensure protection.
- There is great diversity in how police and security forces are provided and deployed at different transit systems. There is no national mandate to standardize this facet of transit operations and security force policies will remain a local agency decision.
- Transit functions include substantial differences in equipment, infrastructure, operations and security practices from agency to agency. While this plan provides general guidance for response to individual threat conditions, the details of specific implementation vary substantially throughout these agencies.
- Transit systems are routinely under surveillance by their operating staff (e.g., drivers, supervisors, station attendants, and controllers), security employees, and, with increasing frequency, transit passengers. This normal level of vigilance, supplemented by

appropriate awareness training and the protective measures identified under threat condition green/blue, may be sufficient vigilance for some systems.

Threat Level/Attack/Recovery Systems Approach

The FTA National Transit Response Model supplements the existing HSAS Threat Condition model with Black and Purple designations to further define appropriate transit industry activities when an attack is in progress and during the post-event recovery of transit services and facilities.

Color	Condition
Green	Low threat level
Blue	General threat level
Yellow	Elevated threat level
Orange	High threat level
Red	Severe threat level
Black	Actual Attack
Purple	Recovery

The Black and Purple designations are interpreted as follows.

- Black indicates that an attack is underway against a specific transit agency or within the agency's immediate geographic area. The Black state is entered only when an attack has occurred. Black includes the immediate post-attack time period when the transit agency may be responding to casualties, assisting in evacuations, inspecting and securing transit facilities, or helping with other tasks directed by the local emergency management authority.
- Purple indicates the recovery of transit service after an attack has occurred. Purple includes restoration of levels of service, routes, and schedules, repairing or reopening facilities, adjustment of staff work schedules and duty assignments, responding to customer inquiries about services, and other activities necessary to restore transit service. The Purple state follows the Black state and may also exist for short time periods when the agency is transitioning from a higher threat condition to a lower threat condition (e.g., from Red to Orange). The Purple state will coexist with the prevailing threat condition. In other words, business recovery (Purple) will be accomplished while maintaining the prevailing readiness status (e.g., Orange protective measures).

Threat Level Information

The Attorney General makes the decision to change the OHS threat level. Changes in threat levels typically will be in sequential stepwise order. As conditions warrant, elevated threat levels will typically progress in order from lowest (green) to highest (red). Likewise, as conditions warrant, returning from higher to lower threat levels will typically progress sequentially.

Transit response posture may vary depending on the nature of the threat level. For example, threat guidance focused on the northeastern region may dictate that transit agencies in that region maintain a higher response posture than other regions of the country. If the guidance is modal-based, for example a threat to subways and transit agencies with subway modes may maintain a higher response posture than agencies without subways. In fact, large multi-modal transit agencies may operate their different modes with different response postures.

However, based on information and conditions, transit agencies should be prepared for the distinct possibility of a non-sequential threat level advisory. For example, if information and conditions warrant, a current threat advisory level of “Yellow” could be directly elevated to “Red.”

Transit agencies must work collaboratively with their local and regional emergency management organizations, joint terrorism task force, police agencies, and other organizations. Each transit agency is responsible for determining its own appropriate response posture, based on an assessment of the guidance received from all sources and the response posture of the communities where the agency provides service.

FTA Recommended Protective Measures/Activities for Transit Agencies

The FTA recommends the threat level protective measures and activities for transit agencies as suggested or recommended actions, not required actions. While each transit agency should implement measures/activities appropriate to its own operating environment, the following general guidelines apply:

- The threat/risk goes up with each successive level.
- Responses are additive; each level incorporates all activities from the previous levels.
- Threat information may be general or indicated for different geographical regions of the country, metro areas, cities, transit agencies, industries, facility types (e.g., subway, tunnel, bus, control center, etc.), or for a specific facility.
- Specific implementation must be determined by the transit agency in light of actual events; protective measures for a higher level than officially designated may be implemented by the transit agency. For example, if the threat advisory level is elevated from “Yellow” to “Orange” a transit agency may elect to implement not only “Orange” level suggested protective measures, but also some “Red” level protective measures.

The following table presents specific transit industry protective measures in response to the HSAS threat level conditions, as well as for the actual attack and post-attack/recovery phases.

FTA Recommended Transit Protective Measures: GREEN

Low Condition (Green). This condition is declared when there is a low risk of terrorist attacks.

- Measure 1.** Refining and exercising as appropriate preplanned Protective Measures.
- Measure 2.** Ensuring personnel receive proper training on the Homeland Security Advisory System and specific preplanned department or agency Protective Measures.
- Measure 3.** Institutionalizing a process to assure that all facilities and regulated sectors are regularly assessed for vulnerabilities to terrorist attacks, and all reasonable measures are taken to mitigate these vulnerabilities.
- Measure 4.** All contractors and visitors must check or sign in and out of designated facilities or areas within the facility that are considered key command, control or communications centers or areas.
- Measure 5.** Ensure existing security measures are in place and functioning such as fencing, locks, camera surveillance, intruder alarms, and lighting. Identify those additional security measures and resources that can enhance the security at the higher Threat Condition levels, e.g., increased surveillance.
- Measure 6.** Establish local, regional and system-wide threat and warning dissemination process, emergency communications capability, and contact information with law enforcement and security officials, including local FBI Field Offices, first responders, regional and district US DOT and FTA representatives. Emergency communications should have redundancy in both hardware and means to contact security officials, law enforcement agencies, and mobile field command centers.
- Measure 7.** Develop terrorist and security awareness and provide information and educate employees on security standards and procedures. Caution employees not to talk with outsiders concerning their facility or related issues.
- Measure 8.** Advise all personnel at each facility to report the presence of unknown personnel, unidentified vehicles, vehicles operated out of the ordinary, abandoned parcels or packages, and other suspicious activities.
- Measure 9.** Develop procedures for shutting down and evacuation of the facility. Facilities located near critical community assets should be especially vigilant of security measures.

- Measure 10.** Incorporate security awareness and information into public education programs and notifications to emergency response organizations.
- Measure 11.** Survey surrounding areas to determine those activities that might increase the security risks that could affect the facility, e.g., airports, government buildings, industrial facilities, pipelines, etc.
- Measure 12.** Ensure contingency and business continuity plans are current and include a response to terrorist threats.
- Measure 13.** Develop and implement hardware, software, and communications security for computer based operational systems.

FTA Recommended Transit Protective Measures: BLUE

Guarded Condition (Blue). This condition is declared when there is a general risk of terrorist attacks.

- Measure 14.** Establish liaison with each station or facility served to coordinate measures that may be necessary if the Threat Condition increases.
- Measure 15.** Ensure that a response can be mobilized and review facility security plans and procedures including bomb threat, chemical, biological or radiological threat and evacuation procedures. Ensure plans incorporate EOD and tactical teams as necessary, including accessibility to explosive detection capabilities such as K-9 teams or electronic sniffers.
- Measure 16.** Inspect perimeter fencing and repair all fence breakdowns. In addition, review all outstanding maintenance and capital project work that could affect the security of facilities.
- Measure 17.** Review all operations plans, personnel details, and logistics requirements that pertain to implementing higher Threat Condition levels.
- Measure 18.** Inspect all CCTV/Video Camera/VCR equipment and intercom systems where applicable to ensure equipment is operational.
- Measure 19.** Review and ensure adequacy of personnel and ID issuance and control procedures.
- Measure 20.** Require each visitor to check in at designated facilities or areas within the facility that are consider key command, control or communications centers or areas and verify their identification – be especially alert to repeat visitors or outsiders who have no apparent business at the facility and are asking questions about the facility or related issues including the facility’s personnel. Be familiar with vendors who service the facility and investigate changes in vendor personnel.
- Measure 21.** Inspect emergency supplies to ensure equipment is in good working order.
- Measure 22.** Provide the public with any information that would strengthen its ability to act appropriately.
- Measure 23.** At regular intervals, remind all personnel to be suspicious and inquisitive about strangers, particularly those carrying suitcases or other containers. Watch for unidentified vehicles on or in the vicinity of facilities. Watch for abandoned parcels or suitcases and any unusual activity.

FTA Recommended Transit Protective Measures: YELLOW

Elevated Condition (Yellow). An Elevated Condition is declared when there is a significant risk of terrorist attacks.

- Measure 24.** Inform all law enforcement and security officials with an operational need to know of the increased threat. Communicate this information to agency employees who have an operational need to know. Reinforce awareness of responsibilities with employees.
- Measure 25.** Test security and emergency communications procedures and protocols. Post Security Alert if appropriate. Check communications with designated emergency response or command locations.
- Measure 26.** Secure all buildings and storage areas not in regular use. Increase frequency of inspection and patrols within the facility including the interior of buildings and along the facility perimeter. Increase surveillance in areas considered key command, control or communications centers and areas such as truck docks, taxi lanes, parking lots, bridges, tunnels, and interlockings, as applicable.
- Measure 27.** Check designated unmanned and remote sites at more frequent intervals for signs of unauthorized entry, suspicious packages, or unusual activities.
- Measure 28.** Reduce the number of access points for vehicles and personnel to minimum levels and periodically spot check the contents of vehicles at the access points. Be alert to vehicles parked for an unusual length of time in or near a facility.
- Measure 29.** Inspect all mail and packages coming into a facility. Do not open suspicious packages. Review the USPS "Suspicious Mail Alert" and the "Bombs by Mail" publications with all personnel involved in receiving mail and packages.
- Measure 30.** Network with local law enforcement intelligence units, i.e. FBI field offices, and liaison, as appropriate, with other departments.
- Measure 31.** Ensure that personnel with access to building plans and area evacuation plans be available at all times. Personnel should be able to seal off an area immediately. The Director of Safety and Security and staff required to implement security plans should be on call and readily available.
- Measure 32.** Increase security spot checks of vehicles and persons entering facilities.

- Measure 33.** Review and implement security measures for high-risk personnel, as appropriate.
- Measure 34.** Increase the frequency of warnings by Low Condition (Green) and Guarded Condition (Blue) and inform personnel of additional threat information as available. Implement procedures to provide periodic updates on security measures being implemented.
- Measure 35.** Ensure that a company or facility response can be mobilized appropriate for the increased security level. Review communications procedures and back-up plans with all concerned.
- Measure 36.** Review with all facility employees the operations plans, personnel safety, security details, and logistics requirements that pertain to implementing increased security levels. Review notification/recall lists.
- Measure 37.** Confirm availability of security resources that can assist with 24/7 coverage as applicable.
- Measure 38.** Step up routine checks of unattended vehicles, scrutiny of packages and vehicles, and monitor critical facilities and key infrastructure (e.g., directed patrol checks of hatches, traction power substations, signal equipment, tracks, switches, rail yards and shops, rights-of-way, parking lots, etc.) are properly secured.
- Measure 39.** Limit visitor access to key security areas and confirm that the visitor has a need to be and is expected. All unknown visitors should be escorted while in these areas.
- Measure 40.** Advise local police agencies that the facility is at Elevated Condition (Yellow) and advise the measures being employed. Coordinate emergency plans as appropriate with nearby jurisdictions.
- Measure 41.** Resurvey the surrounding area to determine if activities near the facility could create emergencies and other incidents that could affect the facility, e.g., airports, government buildings, industrial facilities, railroads, other pipelines, etc.
- Measure 42.** Instruct employees working alone at remote locations or on the ROW to check-in on a periodic basis.
- Measure 43.** Check to ensure all emergency telephone, radio, intercom, and satellite communication devices are in place and they are operational.

- Measure 44.** Direct all personal, company, and contractor vehicles at the facility are secured by locking the vehicles. Remind Bus drivers to lock vehicles and check vehicles before entering or driving.
- Measure 45.** Interface with vendors and contractors to heighten awareness and report suspicious activity. Post signs or make routine public announcements that emphasize the need for all passengers to closely control baggage and packages to avoid transporting items without their knowledge.
- Measure 46.** Assign canines to visible patrols in stations where applicable.
- Measure 47.** Alert bus and helicopter units, if applicable.
- Measure 48.** Increase special foot patrols, bicycle patrol, and bus and train boardings as appropriate. Use canine patrols if available.
- Measure 49.** Develop and implement a schedule for increasing the frequency of inspection including specific areas and item such as: telephone booths, garbage containers, and all public areas.
- Measure 50.** Assessing whether the precise characteristics of the threat require that further refinement of preplanned Protective Measures.
- Measure 51.** Implementing, as appropriate, contingency and emergency response plans.
- Measure 52.** Keep all personnel involved in implementing antiterrorist contingency plans on call.
- Measure 53.** Secure and regularly inspect all buildings, rooms, and storage areas not in regular use.
- Measure 54.** At the beginning and end of each workday and at other regular and frequent intervals, inspect the interior and exterior of buildings in regular use for suspicious packages.
- Measure 55.** Examine mail (above the regular examination process) for letter or parcel bombs.
- Measure 56.** Check all deliveries to facility and loading docks.
- Measure 57.** Make staff and dependents aware of the general situation in order to stop rumors and prevent unnecessary alarm.
- Measure 58.** At an early stage, inform members of local security committees of actions being taken. Explain reasons for actions.

Measure 59. Operate random patrols to check vehicles, people, and buildings.

Measure 60. Implement additional security measures for high-risk personnel as appropriate.

FTA Recommended Transit Protective Measures: ORANGE

High Condition (Orange) A High condition is declared when there is a high risk of terrorist attacks.

- Measure 61.** Move cars and objects (e.g., crates, trash containers) at least 25 meters from buildings (Where possible) particularly highly populated, mission related, or high profile buildings. Consider centralized parking. Move automobiles and other non-stationary items from station and terminal perimeters and other sensitive buildings or areas. Identify areas where explosive devices could be hidden.
- Measure 62.** Close and lock gates and barriers except those needed for immediate entry and egress. Inspect perimeter fences on a regular basis. Ensure that other security systems are functioning and are available.
- Measure 63.** Increase security manpower for additional surveillance, to act as a deterrent and prevent unauthorized access to secure areas, deploy specialty/technical resources, and enact local tactical plans, if applicable. The areas recommended for additional patrols should include railroad terminals, on trains and busses, at bus stops, parking areas, loading docks, ticket counters, secure areas, bridges, tunnels and interlockings. Increasing surveillance of critical locations.
- Measure 64.** Arrange for and deploy plainclothes law enforcement or security officials for surveillance in terminals, stations and other location as appropriate.
- Measure 65.** Physically inspect visitors and randomly inspect their suitcases, parcels, and other containers.
- Measure 66.** Continue Low, Guarded and Elevated measures or introduce those that have not already been implemented.
- Measure 67.** Activate emergency response plans.
- Measure 68.** Reduce facility access points to the absolute minimum necessary for continued operation. Restrict threatened facility access to essential personnel only.
- Measure 69.** Advise local police agencies that the facility is at a High Condition (Orange) and advise the measures being employed.

- Measure 70.** Consult with local authorities about control of public roads and accesses that might make the facility more vulnerable to terrorist attack if they were to remain open. Take additional precautions at public events and possibly consider alternative venues or even cancellation.
- Measure 71.** Erect barriers and obstacles to control direction of traffic flow and protect that terminal, station or other key area/facility from an attack by a parked or moving vehicle – company vehicles may be used for this purpose. Implement centralized parking and shuttle bus service where feasible.
- Measure 72.** Schedule more frequent visits to remote sites and other locations that are potentially impacted.
- Measure 73.** Increase the frequency of call-ins from remote locations. Employees should not work alone in remote areas.
- Measure 74.** Check all security systems such as lighting and intruder alarms to ensure they are functioning. Install additional, temporary lighting if necessary to adequately light all suspect areas or decrease lighting to detract from the area.
- Measure 75.** Identify the owner of all vehicles parked at key command, control, or communications areas or other critical areas/facilities/ and have all vehicles removed which are not identified.
- Measure 76.** Strictly enforce control of entry. Inspect all vehicles entering key areas/facilities including the vehicle's cargo areas, undercarriage, glove boxes, and other areas where dangerous items could be concealed.
- Measure 77.** Limit access to designated facilities to those personnel who have a legitimate and verifiable need to enter the facility. Implement positive identification of all personnel – no exceptions. Evacuate all non-essential personnel.
- Measure 78.** Implement frequent inspection of key areas or facilities including the exterior and roof of all buildings and parking areas. Increase patrolling at night and ensure all vulnerable critical points are fully illuminated and secure.
- Measure 79.** If threat is region specific, alert connecting region(s) of potential need for additional manpower and/or equipment; commanding officers of connecting region(s).
- Measure 80.** Review procedures and make necessary preparations to establish Command Center(s) where applicable; make necessary preparations to

dispatch Mobile Command Centers and/or Air Wings in the event of an actual emergency; prepare to initiate an incident command system or similar incident management structure for organizing the response to emergencies. Prepare to execute contingency procedures, such as moving to an alternate site or dispersing the workforce.

- Measure 81.** Disable all baggage lockers where applicable.
- Measure 82.** Restrict access to boarding areas to ticketed passengers only.
- Measure 83.** Coordinate necessary security efforts with Federal, State, and local law enforcement agencies or any National Guard or other appropriate armed forces organizations.
- Measure 84.** Keep all personnel responsible for implementing antiterrorist plans on call.
- Measure 85.** Enforce centralized parking of vehicles away from buildings.
- Measure 86.** Increase patrolling of the facilities.
- Measure 87.** Protect all designated vulnerable points.

FTA Recommended Transit Protective Measures: RED

Severe Condition (Red). A Severe Condition reflects a severe risk of terrorist attacks.

- Measure 88.** Increase security patrol activity to the maximum level sustainable. Increase perimeter patrols and inspections of facility.
- Measure 89.** Cancel or delay all non-vital facility work conducted by contractors, or continuously monitor their work with company personnel as applicable.
- Measure 90.** Continue all Low, Guarded, Elevated and High Condition measures or introduce those that have not already been implemented.
- Measure 91.** Implement emergency and continuity plans as appropriate. Reduce restricted area access points to an operational minimum.
- Measure 92.** Augment security forces to ensure absolute control of key command, control or communications centers or areas and other potential target areas. Establish surveillance points and reporting criteria and procedures.
- Measure 93.** Limit schedule or routing.
- Measure 94.** Remove unattended, unauthorized vehicles parked within 300 feet of a terminal building or station where passengers load or unload.
- Measure 95.** Increase or redirect personnel to address critical emergency needs.
- Measure 96.** Assign emergency response personnel and pre-position and mobilize specially trained teams or resources.
- Measure 97.** Monitor, redirect, or constrain transportation systems.
- Measure 98.** Close public and government facilities.
- Measure 99.** Identify all vehicles within operational or mission support areas.
- Measure 100.** Search all vehicles and their contents before allowing entrance to facilities.
- Measure 101.** Control access and implement positive identification of all personnel.
- Measure 102.** Search all suitcases, briefcases, packages, etc., brought into the facility.

Measure 103. Frequent checks of building exteriors and parking areas.

Measure 104. Minimize all administrative journeys and visits.

Measure 105. Coordinate the possible closing of public roads and facilities with local authorities.

FTA Recommended Transit Activities: BLACK

A Black (Attack) condition means that a terrorist attack has occurred.

Measure 106. Activate Immediate Action Drills (IAD) and Emergency Responses to a Terrorist Attack (there are 10 essential IAD's)

Measure 107. Report the attack immediately to all emergency response organizations

Measure 108. Provide for security of the site and other transit system assets during the emergency and be alert to possible secondary attacks.

Measure 109. Assist response to any Casualties

Measure 110. Activate measures to Mitigate the effects of the Attack

Measure 111. Assess immediately impact of the attack on transit service and facilities and adjust or terminate services as required.

Measure 112. Advise FTA and FBI immediately of all know information regarding the nature of the attack so that FTA, FBI and others may immediately disseminate that information to other transit properties nationwide.

Measure 113. Provide Internal and Public Information asap

Measure 114. Designate the Incident Commander and Activate Transit Emergency Response (or Operations) Center and/or dispatch representatives to appropriate Emergency Operations Centers

Measure 115. Mobilize and provide transit assets (communications links, equipment, facilities and personnel) in support of the overall incident response effort.

Measure 116. Identify Attackers for Responders if witnesses and/or surveillance can provide timely and relevant information

Measure 117. Activate "on-call" external contractors or other special support as required

FTA Recommended Transit Activities: PURPLE

A Purple condition designates business recovery activities after an attack.

Measure 118. Activate (or hastily develop) Business Recovery Plan

Measure 119. Restore Transit System capabilities

Measure 120. Restore the Scene of Attack to functionality

Measure 121. Guard against secondary Attacks

Measure 122. Evaluate why Attack succeeded and update Threat and Vulnerability Analysis

Measure 123. Identify and implement corrective measures

Measure 124. Restore Public confidence by announcing new measures

Measure 125. Return to an appropriate preventative level of GREEN thru RED

Measure 126. Coordinate funding and other needs for transit system restoration with FTA

Measure 127. Identify Short and Long Term Capital replacement needs, develop plans and detailed designs

Measure 128. Complete an After Action report