

ELEMENTARY
ELECTRICAL
CALCULATIONS

UC-NRLF



QB 270 800



BY

W. H. N. JAMES

AND

D. L. SANDS

LIBRARY
OF THE
UNIVERSITY OF CALIFORNIA.

Class

$$\frac{300}{4} = 75$$

$$\frac{300}{1} = 300$$

$$\frac{10}{4} = \frac{3000}{4} = 750$$

$$\frac{10}{4} = 2.5$$

$$\frac{1}{10300} = \frac{1}{30000}$$

$$\frac{1}{10} = \frac{300}{1}$$

ELEMENTARY
ELECTRICAL CALCULATIONS

Works on Electricity and Magnetism

- ELECTRICAL ENGINEERING FOR ELECTRIC LIGHT ARTISANS AND STUDENTS.** By W. SLINGO and A. BROOKER. With 383 Illustrations. Crown 8vo, 12s.
- PROBLEMS AND SOLUTIONS IN ELEMENTARY ELECTRICITY AND MAGNETISM.** By W. SLINGO and A. BROOKER. With 98 Illustrations. Crown 8vo, 2s.
- A TEXT-BOOK OF ELECTROCHEMISTRY.** By SVANTE ARRHENIUS. With 58 Illustrations. 8vo, 9s. 6d. net.
- ELECTRO-DYNAMICS: the Direct-Current Motor.** By CHARLES ASHLEY CARUS-WILSON, M.A. Cantab. With 71 Diagrams, and a Series of Problems, with Answers. Crown 8vo, 7s. 6d.
- PRACTICAL ELECTRICITY AND MAGNETISM.** By JOHN HENDERSON, D.Sc., F.R.S.E. With 157 Illustrations and Diagrams. Crown 8vo, 7s. 6d.
- PRELIMINARY PRACTICAL MAGNETISM AND ELECTRICITY.** By JOHN HENDERSON, D.Sc., F.R.S.E. Crown 8vo, 1s.
- MAGNETISM AND ITS ELEMENTARY MEASUREMENT.** By W. HIBBERT, F.I.C., A.M.I.E.E. With 55 Diagrams. Crown 8vo, 2s.
- ELEMENTARY TREATISE ON ELECTRICITY AND MAGNETISM.** By G. CAREY FOSTER, F.R.S.; and ALFRED W. PORTER, B.Sc. Founded on JOUBERT'S 'Traité Élémentaire d'Electricité.' With 374 Illustrations and Diagrams. 8vo, 10s. 6d. net.
- EXAMPLES IN ELECTRICAL ENGINEERING.** By SAMUEL JOYCE, A.I.E.E. Crown 8vo, 5s.
- ELECTRICITY FOR PUBLIC SCHOOLS AND COLLEGES.** By W. LARDEN, M.A. With 215 Illustrations, and a Series of Examination Questions; with Answers. Crown 8vo, 6s.
- PRACTICAL ELECTRICAL TESTING IN PHYSICS AND ELECTRICAL ENGINEERING.** By G. D. ASPINALL PARR, Assoc. M.I.E.E. With 231 Illustrations. 8vo, 8s. 6d.
- MAGNETISM AND ELECTRICITY.** By A. W. POYSER, M.A. With 235 Illustrations. Crown 8vo, 2s. 6d.
- ADVANCED ELECTRICITY AND MAGNETISM.** By A. W. POYSER, M.A. With 317 Illustrations. Crown 8vo, 4s. 6d.
- AN ELEMENTARY TREATISE ON ALTERNATING CURRENTS.** By W. G. RHODES, M.Sc. (Vict.), Consulting Engineer. With 80 Diagrams. 8vo, 7s. 6d. net.

LONGMANS, GREEN, AND CO.

LONDON, NEW YORK, AND BOMBAY

ELEMENTARY ELECTRICAL CALCULATIONS

*A BOOK SUITABLE FOR THE USE OF FIRST
AND SECOND YEAR STUDENTS OF
ELECTRICAL ENGINEERING*

BY

W. H. N. JAMES, A.R.C.Sc. (Lond.), A.I.E.E.,

LECTURER AND DEMONSTRATOR IN THE ELECTRICAL ENGINEERING DEPARTMENT
OF THE MUNICIPAL SCHOOL OF TECHNOLOGY, MANCHESTER,

AND

D. L. SANDS,

DEMONSTRATOR AND ASSISTANT LECTURER IN THE ELECTRICAL ENGINEERING
DEPARTMENT OF THE MUNICIPAL SCHOOL OF TECHNOLOGY, MANCHESTER.



LONGMANS, GREEN, AND CO.
39 PATERNOSTER ROW, LONDON
NEW YORK AND BOMBAY

1905

All rights reserved

QC532
53

UNIVERSITY OF CALIFORNIA

PREFACE

THIS book is the outcome of a number of lectures on electrical calculations, given by the authors to students of electrical engineering, the lectures being supplemented by a large amount of class work.

The authors wish to impress upon students the necessity of actually working numerous examples, and not being content with merely "thinking they can work them;" further, teachers are advised to inspect the books of individual students while class work is in progress.

W. H. N. JAMES.

D. L. SANDS.

MANCHESTER, *July*, 1905.

CONTENTS

CHAPTER	PAGE
I. UNITS	1
II. OHM'S LAW (<i>A</i>).	14
III. RESISTANCE	32
IV. OHM'S LAW (<i>B</i>).	61
V. POWER AND WORK	100
VI. CONVERSION OF ENERGY	121
VII. TRANSMISSION AND DISTRIBUTION	139
VIII. ELECTRO-CHEMISTRY	176
IX. PHOTOMETRY	191
ANSWERS TO EXAMPLES	213

ELEMENTARY ELECTRICAL CALCULATIONS

CHAPTER I

UNITS

WHEN we wish to convey an idea of the magnitude of any quantity, we do so by stating how many times a previously defined unit of that quantity is contained in it; thus to completely specify the magnitude of a quantity two things must be stated, namely, the unit employed and the number of such units; thus we say 12 amperes, 8 volts, or 6 ohms. Units may be divided into two classes, fundamental units and derived units.

A **fundamental unit** is one whose magnitude does not depend upon the magnitude of any other unit; the units which are invariably taken as being fundamental are those of length, mass, and time,

A **derived unit** is one whose magnitude depends upon the magnitude of one or more other units; for instance, the unit of velocity is dependent upon the units of length and time,

Students of electrical engineering will find it necessary to have an acquaintance with two systems of units, one based on the centimetre, gramme, and

second, and hence known as the C.G.S. system; the other based on the foot, pound, and second, and known as the English system.

It has not been thought necessary in this work to give a detailed account of the simpler mechanical units (such as mass, velocity, etc.), a mere enumeration being sufficient.

Length.—The most important units are the centimetre (C.G.S. system), and the foot (English system). The millimetre (0·1 centimetre) is a useful submultiple, and the metre (100 centimetres), a useful multiple of the former; while the inch, yard, and mile can be used in preference to the foot.

Very small distances, such as the diameters of wires, are sometimes measured in terms of the mil, which is equal to 0·001 inch.

$$1000 \text{ mils} = 1 \text{ in.} = 2\cdot54 \text{ cms.}$$

$$1 \text{ metre} = 39\cdot37 \text{ ins.} = 3\cdot28 \text{ ft.}$$

Example 1.—

$$26 \text{ mms.} = \frac{26}{10} \times \frac{1}{2\cdot54} \text{ ins.} = 1\cdot02 \text{ ins.}$$

$$186 \text{ mils} = \frac{186}{1000} \times \frac{2\cdot54}{1} \text{ cm.} = 0\cdot47 \text{ cm.}$$

$$6 \text{ metres} = 6 \times 3\cdot28 \text{ ft.} = 19\cdot68 \text{ ft.}$$

Mass.—The principal units of mass are the gramme (C.G.S. system), and the pound (English system). An important multiple of the former is the kilogramme, which is 1000 grms.

$$1 \text{ lb.} = 454 \text{ grms.}$$

$$1 \text{ kilog.} = 2\cdot20 \text{ lbs.}$$

Example 2.—

$$26 \text{ lbs.} = 26 \times 454 \text{ grms.} = 11800 \text{ grms.}$$

$$38 \text{ kilogs.} = 38 \times 2.2 \text{ lbs.} = 83.6 \text{ lbs.}$$

The student should carefully distinguish between mass and weight. By the mass of a body is meant the quantity of matter contained in the body, while by weight is meant the force of the Earth's attraction on the body; the former is invariable, but the latter depends upon the position of the body upon the earth's surface, being, for instance, greater at the poles than at the equator.

Time.—The most important unit of time is the second, though multiples of this unit, which it is sometimes convenient to use, are the minute and hour.

Having dealt with the fundamental units, we will now consider those units which are derived from them.

Area.—This is defined to be the area of a square, each edge of which is of unit length; thus in the C.G.S. system we have as our unit the square centimetre, which can be defined as the area of a square each edge of which is one centimetre long; for larger areas we can use the square metre.

$$1 \text{ sq. metre} = 10,000 \text{ or } 10^4 \text{ sq. cms.}$$

In the English system we have the square foot, the definition of which is exactly analogous to that of the square centimetre. For small areas we can, of course, use the square inch, or the square mil.

$$1 \text{ sq. metre} = 10.8 \text{ sq. ft.}$$

$$1 \text{ sq. ft.} = 144 \text{ sq. ins.} = 929 \text{ sq. cms.}$$

$$1,000,000 \text{ (or } 10^6) \text{ sq. mils} = 1 \text{ sq. in.} = 6.45 \text{ sq. cms.}$$

Example 3.—

$$4.63 \text{ sq. metres} = 4.63 \times 10.8 \text{ sq. ft.} = 50.0 \text{ sq. ft.}$$

$$3.8 \text{ sq. ft.} = 3.8 \times 929 \text{ sq. cms.} = 3530 \text{ sq. cms.}$$

Areas of cross-section of wires are often measured in terms of the circular mil, which is defined to be the area of a circle whose diameter is 1 mil.

$$1 \text{ sq. in.} = 1,273,000 \text{ circular mils.}$$

$$1 \text{ sq. mil.} = 1.273 \text{ circular mils.}$$

Example 4.—

$$384 \text{ circular mils} = \frac{384}{1.273} \text{ sq. mils}$$

$$= 302 \text{ sq. mils}$$

$$= 0.000302 \text{ sq. in.}$$

It is obvious, from the definition given above, that we can calculate the area of cross-section of a round wire in circular mils, by simply squaring the diameter expressed in mils.

Example 5.—Express in square and circular mils the area of cross-section of a wire whose diameter is 0.035 in.

$$\text{Now, } 0.035 \text{ in.} = 35 \text{ mils}$$

$$\therefore \text{ area of cross-section} = 35^2 \text{ circular mils}$$

$$= 1225 \text{ circular mils ;}$$

$$\text{and area of cross-section} = 35^2 \times 0.785 \text{ sq. mils}$$

$$= 962 \text{ sq. mils.}$$

Volume.—The unit volume is the volume of a cube, each edge of which is of unit length; it will evidently be 1 cub. cm. or 1 cub. ft., according to which system of units we are using.

The litre (1000 cub. cms.) and the cubic metre

(10^6 cub. cms.) may be used when dealing with large volumes.

It is worthy of note that 1 cub. cm. of water weighs 1 grm. at 4° C.

1 cub. ft. = 28.3 litres.

1 cub. m. = 35.3 cub. ft. 3

Velocity.—A body is said to have unit velocity when it passes over unit space in unit time. If we take the centimetre as the unit of length, and the second as the unit of time, the unit of velocity will be 1 cm. per second.

A velocity of 1 ft. per second (1 foot-second) can, of course, be defined in a similar manner.

Force.—The definition of unit force depends upon the fact that when force is exerted on a body which is free to move without friction, the body has a certain velocity generated in it, which is directly proportional to the magnitude of the force, and to the time during which that force is acting, and inversely proportional to the mass of the body.

Hence we may define our unit force as the force which, acting on unit mass for unit time, causes it to have unit velocity.

Applied to the C.G.S. system, our definition tells us that unit force is that force which, acting on one gramme for one second, generates in it a velocity of one centimetre per second; this force is known as the dyne.

The weight of one gramme might be taken as a unit of force, and it would be called a gravitational unit because its value depends upon the value of

the force of gravity; the dyne, it may be noted, is independent of the force of gravity, and hence may be called an absolute unit.

One gram weight is nearly equal to 981 dynes; its actual value will vary slightly at different parts of the earth's surface.

Using the English system, our absolute unit force is that force which, acting on one pound of matter for one second, gives it a velocity of one foot per second. This unit is called the poundal; it is nearly equal to the weight of half an ounce.

The gravitational unit in the English system is defined to be the weight of 1 lb. of matter; it is roughly equal to 32.2 poundals.

Example 6.—How many dynes are there in a force of 1 lb. weight?

$$\text{Number of dynes} = 981 \times 454 = 445,000.$$

As stated above, the force necessary to generate a velocity (V) in a body of mass (M) in the time (T) is directly proportional to the mass and velocity, and inversely proportional to the time, or symbolically—

$$\text{Force } (F) = \frac{MV}{T} \quad . \quad . \quad . \quad (1)$$

This formula can, of course, be applied to either system of units. If the mass, velocity, and time are in grammes, centimetres per second, and seconds, respectively, the force will be in dynes; if the former are expressed in the English system of units, the latter will be in poundals. In the above equation

any of the four quantities concerned can be calculated if the other three are known.

Example 7.—What force is necessary to generate a velocity of 8 cms. per second in 0·5 sec. when applied to a mass of 148 grms. ?

$$\text{Now, } F = \frac{MV}{T} \text{ dynes} = \frac{148 \times 8}{0\cdot5} \text{ dynes} = 2368 \text{ dynes.}$$

Example 8.—What velocity will a force of 72 poundals generate in a mass of 5 lbs. if applied for 8 secs. ?

$$F = \frac{MV}{T}$$

$$\therefore V = \frac{FT}{M} \text{ ft.-secs.} = \frac{72 \times 8}{5} \text{ ft.-secs.} = 115 \text{ ft.-secs.}$$

Work.—Work is performed by a force when it overcomes the resistance opposed to it, and moves its point of application through space. Hence we may define the unit quantity of work as the amount performed when unit force acts through unit distance.

Applied to the C.G.S. system, the definition becomes—unit quantity of work is performed when a force of one dyne acts through a distance of one centimetre; this quantity is known as the erg.

In the English system we have—unit quantity of work is performed when a force of one poundal acts through a distance of one foot; this unit is known as the foot-poundal.

A more common unit is the foot-pound, the definition of which is similar to the above if pound-weight is substituted for poundal; this will, of course, be a gravitational unit, and is nearly equal to 32·2 foot-poundals.

Energy.—When we speak of the energy of a body, we mean its capacity for performing work. Thus we may say that a body has 12 ft.-lbs. of energy, meaning, of course, that it is capable of performing 12 ft.-lbs. of work.

The term “energy” must not be confounded with the term “power;” the latter expression is used to denote the rate at which an agent can perform work.

Having defined the mechanical units which are necessary at this stage, we may now pass on to the electrical and magnetic units. It is important that the student should notice the way in which a logical system of units is built up, and how they are connected one with another.

There are two distinct systems of electrical units—the electrostatic, and the electro-magnetic; for the purpose of this work it is only necessary to deal with the latter.

Magnetic Pole.—Unit magnetic pole is defined to be of such a strength that when placed at unit distance from a similar pole, both being in air, the mutual force of repulsion is one dyne.

Magnetic Field.—In the region round a magnetic pole, and also, of course, round a conductor carrying a current, there exists a certain condition such that a force is exerted on a magnetic pole placed within the region; this is known as a magnetic force, and under given circumstances becomes weaker as the distance from the pole or current increases. This region is known as a field of magnetic force.

It is said to have unit strength when it exerts unit force on unit magnetic pole.

It is obvious, from what has been stated above, that unit magnetic field exists at unit distance from unit magnetic pole in air.

Current.—If a wire is bent to form an arc of a circle and a current passed along it, a force is exerted on a magnetic pole placed at the centre of the circle. We make use of this fact in defining our unit current, which is stated to be a current such that, if passed through a wire one centimetre long, bent so as to form part of a circle of one centimetre radius, exerts a force of one dyne upon unit magnetic pole placed at the centre of the circle.

The above unit is known as the absolute unit, the practical unit, the ampere, being 0·1 of this.

From a practical point of view, it is useful to note that the ampere is that steady current which, passing through a solution of silver nitrate in pure water (the exact strength of the solution being specified), deposits 0·001118 gm. of silver on the cathode per second.

In order to quickly obtain a current of one ampere, pieces of apparatus have been constructed, using the principle of the balance, such that on reversing the current through certain of the coils, the alteration in the forces between the coils is exactly balanced by a given weight.

Quantity.—The absolute unit of quantity is the amount which passes any point in a circuit, along which the absolute unit of current is flowing in one second; the practical unit is 0·1 of this quantity, and is known as the coulomb.

Potential Difference.—When a charge of electricity is moved from a place at a certain potential

to a place at a different potential, work is done by or on the charge, depending on whether the second potential is higher or lower than the first.

Unit potential difference is said to exist between two points when one erg of work is performed in moving one absolute unit of quantity of electricity from the lower to the higher potential.

This absolute unit is much too small for practical purposes, so a practical unit called the volt has been adopted, which is equal to 10^8 absolute units. For practical purposes it may be noted that a volt is $\frac{1000}{1434}$ of the E.M.F. of a Clarke's standard cell at a temperature of 15° C.

Resistance.—The absolute unit of resistance is such that when one absolute unit of potential difference is maintained between its ends, one absolute unit of current will flow through it. This is also far too small for practical purposes, and so a practical unit called the ohm, and equal to 10^9 absolute units, has been adopted.

As will be shown in the next chapter, it follows, from what has been stated, that if a P.D. of one volt is maintained across a resistance of one ohm, the current flowing will be one ampere.

From a practical point of view, the ohm may be taken as being equal to the resistance of a column of mercury at 0° C., 106.3 cms. long, and weighing 14.45 grms.

The area of cross-section of this column, it may be noted, is 1 sq. mm. A convenient multiple of the ohm used in dealing with large resistances is the meg-ohm (10^6 ohms), and a submultiple for use when

dealing with small resistances is the microhm (10^{-6} ohm).

Some resistance coils which were constructed a number of years ago are standardized in terms of what is called the British Association or B.A. unit.

This unit was the standard ohm adopted by a committee of the British Association in 1865; more recent determinations have shown that it was too small.

$$1 \text{ B.A. ohm} = 0.9866 \text{ true ohm.}$$

Example 9.—How many true ohms are equivalent to 63 B.A. ohms?

$$\text{Number of true ohms} = 63 \times 0.9866 = 62.2.$$

EXAMPLES.

1. Convert 12.6 cms. to inches.
2. How many feet are equivalent to 14.82 metres?
3. How many millimetres are there in 386 mils?
4. Convert 3.6 yds. into centimetres.
5. How many grammes are there in 0.58 lb.?
6. Convert 26 lbs. to kilogrammes.
7. How many pounds are equivalent to 4824 grms.?
8. How many square feet are there in 36.8 sq. metres?
9. Convert 1836 sq. cms. to square feet.
10. A wire has a diameter of 0.015 in. What will be its area of cross-section in square inches, square mils, and circular mils?
11. How many circular mils are equivalent to 876 sq. mils?
12. Convert 284 circular mils to square mils.
13. What will be the diameter of wires whose areas are respectively 100 sq. mils and 100 circular mils?
14. Calculate the radius of a circle whose area is 1865 circular mils.
15. How many litres are there in 2.84 cub. ft.?
16. How many cubic centimetres are there in 0.08 cub. ft.?

17. What will be the weight of 1 mil-foot (a wire 1 mil in diameter and 1 ft. long) of copper?

18. A wire is required to have twice the cross-section of another wire of 23 mils diameter. What must be its diameter?

19. What will be the weight in grammes of 1 cub. ft. of water at 4° C.?

20. How many dynes are equivalent to a force of 1 grm.-weight?

21. Which will be the greater force, 0.043 poundal or 700 dynes?

22. Calculate the volume and weight of a copper wire 6 yds. long and 50 mils in diameter.

23. How many dynes are equivalent to 13 poundals?

24. What force must be exerted on a mass of 18 grms., in order that it may be given an acceleration of 2 cms. per second (that is, its velocity increases 2 cms. per second each second)?

25. What force in dynes will be exerted on a mass of 32 lbs. by the action of gravity?

26. For how long must a force of 82 poundals be exerted on 184 lbs. in order that it may attain a velocity of 12 feet per second?

27. What speed will be generated in a mass of 1 kilog. by a force of 12,000 dynes in 6 secs.?

28. What force in dynes would be necessary to give a mass of 2 lbs. an acceleration of 1.2 ft. per second?

29. How many ergs are equivalent to 1 ft.-lb., and also to 1 ft.-poundal?

30. If a circular wire of unit radius, consisting of one complete turn, carries a current of 1 amp., what will be the strength of the magnetic field produced at its centre?

31. How many B.A. ohms are equal to 76 true ohms?

32. Convert 87 true ohms to B.A. ohms.

33. What is the value of the true ohm expressed in B.A. ohms?

34. Which will have the greater resistance, 32 true ohms, or 33 B.A. ohms?

35. What strength of field would be produced by a magnetic pole of 13 units strength at a distance of 1 cm. in air?

36. How much silver per second would 1 absolute unit of current deposit, if passed through a suitable bath?

37. A wire is said to have a resistance of 15 microhms: what will be its resistance expressed in ohms?

Express 1.348 megohms in ohms.

38. What will be the force of repulsion between two north magnetic poles, each of intensity 5 units, when placed at unit distance in air?

39. If a P.D. of 1 volt is applied to a mercury standard ohm as defined above, what would be the voltage drop per centimetre?

40. How many absolute units of E.M.F. will represent the E.M.F. of a standard Clarke's cell?

CHAPTER II

OHM'S LAW (A)

HAVING defined the more common units employed in the measurement of electrical quantities, we are now in a position to deal with the fundamental laws connecting these quantities, upon which all electrical engineering problems are based.

The Electrical Circuit.—The first case considered will be that of a wire through which a current of

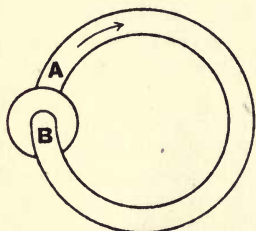

FIG. 1.

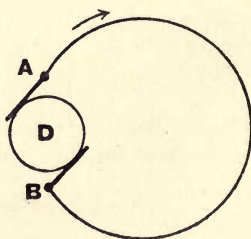

FIG. 2.

electricity flows from a battery or dynamo. This "electrical circuit," as it is termed, is analogous to the case of a hydraulic pump sending a current of water through a pipe, as shown in Fig. 1.

When the pump is at rest, and at all parts of the system the water is at the same pressure, no flow of

water takes place; but once the pump is started, the pressure of water produced at the outlet A is much higher than the pressure of the water at the inlet B, and a current of water flows in the pipe, the direction of flow being as indicated by the arrows—that is, from the point at the higher pressure to the point at the lower pressure, the tendency being to equalize the pressure throughout the system.

Now, these statements respecting the hydraulic circuit apply equally well in the case of the electrical circuit.

The dynamo D, Fig. 2, on being set in motion, produces a difference of electrical pressure, or P.D. (potential difference), between the points A and B, the result being that a current of electricity flows from the point at the higher pressure to the point at the lower pressure, completing its path through the armature of the dynamo.

The magnitude of this current is directly proportional to the P.D. producing it, but it is also dependent upon another factor, namely, the resistance or opposition offered by the circuit to the flow of the current.

The property of resistance will be fully dealt with in the next chapter, but in order to illustrate simply its influence upon the current of electricity, let us refer to the hydraulic circuit in Fig. 1.

Obviously, if the bore of the pipe or circuit be diminished, the flow of water will also be diminished, assuming the P.D. produced by the pump to be kept constant; that is to say, the current of water which will flow is dependent upon the opposition offered by the pipe.

Similarly, in the case of the electrical circuit, the greater the resistance or opposition offered by the wire, the less will be the magnitude of the current produced by a given P.D.

A comparison of Figs. 3 and 4 will illustrate more clearly the relationship which exists between the P.D., current, and resistance.

Referring to Fig. 3, the hydraulic pump P is supposed to send a current of water through the pipes

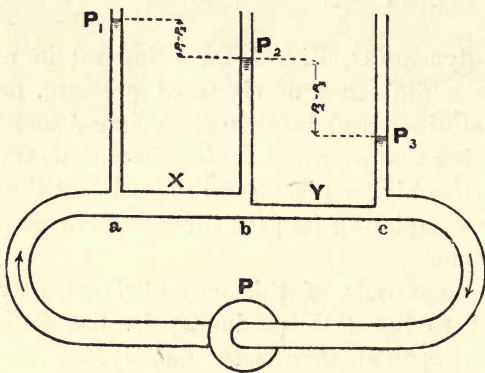

FIG. 3.

X and Y, which are of equal length, the direction of flow being as indicated by the arrows; the vertical tubes simply act as gauges which indicate the difference between the pressure of the water, at the point at which the gauge is inserted, and the pressure of the air.

It will be observed from the diagram that the pressure of water at the point (a) is much higher than at point (b); that is to say, a certain loss of pressure

has taken place in forcing the current of water through the pipe X, the amount of this lost pressure being $P_1 - P_2$ (see figure); similarly, the pressure of water at the point (b) is much higher than that at point (c), from which we again conclude that a certain amount of pressure ($P_2 - P_3$) has been employed in forcing the water through the pipe Y.

It will be noticed that the fall of pressure between (b) and (c) is about double the fall of pressure between (a) and (b), this being due to the fact that the pipe Y has only half the cross-sectional area of the pipe X; and since the current of water is the same in both pipes, twice the amount of pressure is employed in pipe Y as compared with that employed in pipe X.

The sum of the two pressures employed, namely $(P_1 - P_2) + (P_2 - P_3)$, is the total pressure required to force the water through the pipes X and Y; stated more simply, this equals $P_1 - P_3$; that is, the drop of pressure between the points (a) and (c).

Referring to the electrical circuit, Fig. 4, we now employ pressure or potential gauges, termed voltmeters, which indicate the difference in pressure between any two points to which they are connected.

V_1 and V_2 , Fig. 4, represent two voltmeters as described, which measure the difference of electrical pressure or potential between the points (a) and (b) and (b) and (c) respectively; X and Y represent two wires of the same material and length, Y having only half the cross-sectional area, and consequently, as will be explained in the next chapter, twice the resistance of X.

If such a circuit as the above were formed in

practice, it would be found that the indication of V_1 was only half the indication of V_2 ; that is to say, the electrical pressure required to send the current through Y would be double that required to send the same

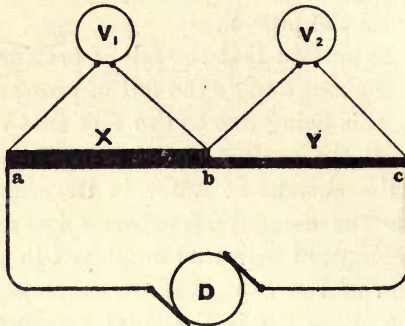

FIG. 4.

current through X. The total pressure required to send the same current through X and Y would be the sum of V_1 and V_2 ; that is, the drop in pressure between the points (a) and (c).

Ohm's Law.—The above statements are more usually expressed by a law, generally known as Ohm's law. This law may be stated as follows:—

“The current which flows in a circuit is directly proportional to the P.D. between the ends of the circuit, and inversely proportional to the resistance of the circuit across which the P.D. is measured.”

Symbolically—

$$C = \frac{E}{R} \dots \dots \dots (1)$$

where C = current in amperes ;

E = potential difference, or "drop" in volts ;

R = resistance in ohms.

This formula holds equally well if the values of C, E, and R are taken in absolute units.

Obviously, if two of the above terms be known, the third may be easily obtained, as the expression may be written—

$$R = \frac{E}{C} \dots \dots \dots (2)$$

$$E = CR \dots \dots \dots (3)$$

Example 1.—Determine the current which flows when a P.D. of 12 volts is maintained between the ends of a wire having 3 ohms resistance.

From (1)—

$$C = \frac{E}{R} = \frac{12}{3} = 4 \text{ amps.}$$

Example 2.—A copper bus-bar carries a current of 200 amps., and it is found that a drop of 0.2 volt is produced between its ends. Determine the resistance of the bus-bar.

From (2)—

$$R = \frac{E}{C} = \frac{0.2}{200} = 0.001 \text{ ohm.}$$

Example 3.—It is required to send a current of 0.3 amp. through the coil of an electro-magnet whose resistance is 150 ohms. What pressure will be required ?

From (3)—

$$E = CR = 0.3 \times 150 = 45 \text{ volts.}$$

Example 4.—Determine, with the aid of Ohm's law, the

relation between the "absolute" and "practical" units of resistance.

From (2)—

$$1 \text{ practical unit of resistance} = \frac{1 \text{ practical unit of P.D.}}{1 \text{ practical unit of current}}$$

But from Chapter I.—

$$1 \text{ practical unit of P.D.} = 10^8 \text{ absolute units of P.D.}$$

$$1 \text{ ,, ,, current} = 10^{-1} \text{ ,, ,, current}$$

$$\therefore 1 \text{ practical unit of } \left. \begin{array}{l} \text{resistance} \end{array} \right\} = \frac{10^8 \text{ absolute units of P.D.}}{10^{-1} \text{ absolute units of current}} \\ = 10^9 \text{ absolute units of resistance.}$$

Ohm's law may be demonstrated very well by actual experiment, and, the results being expressed graphically, the relation between the quantities involved may be seen at a glance.

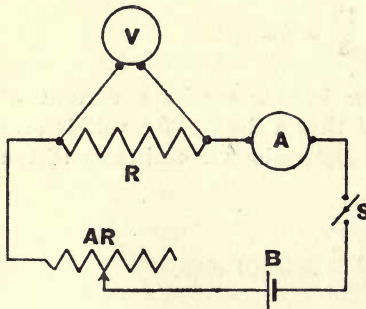

FIG. 5.

- R, constant resistance.
- AR, adjustable "
- A, ammeter.
- V, voltmeter having high resistance.
- B, battery.
- S, switch.

The following records, obtained experimentally, will illustrate these points.

Experiment A.—To show that if the resistance is constant, the current which passes through a circuit is directly proportional to the potential drop across it.

The apparatus employed was connected as shown in Fig. 5.

The switch S was closed, and simultaneous readings of

A and V were taken with various values of the current flowing, as obtained by adjusting the resistance AR.

Fig. 6 represents graphically the result obtained, and since this is a straight line it shows conclusively that the current which flows through a resistance of constant value is directly proportional to the potential difference or fall of pressure across the resistance.

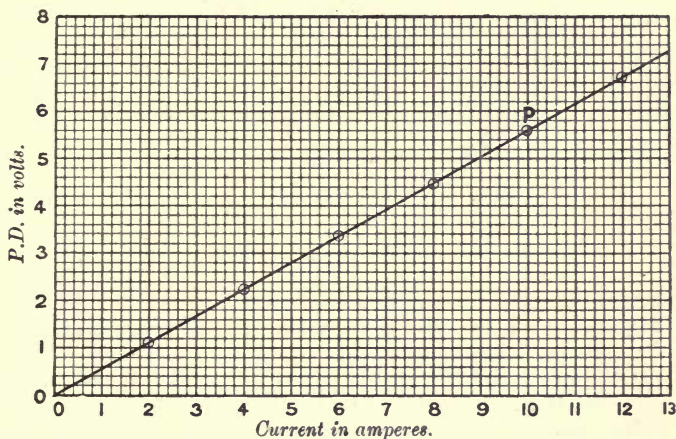

FIG. 6.

Example 5.—Determine from the graph (Fig. 6) the value of constant resistance R.

$$\text{Since } R = \frac{E}{C}$$

then by taking a point, say P, on the curve, and noting the corresponding values of voltage drop and current as shown, we have—

$$R = \frac{5.6}{10} = 0.56 \text{ ohm.}$$

Experiment B.—To show that if the P.D. between the ends of a circuit be kept constant, the current which flows will be inversely proportional to the resistance of the circuit.

Fig. 7 represents the apparatus and connections employed.

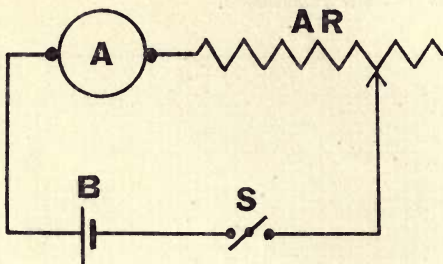

FIG. 7.

A, ammeter.

AR, adjustable resistance of known value. (In this particular case, a P.O. resistance box was used.)

B, large secondary cell whose terminal P.D. remained practically constant throughout the experiment.

S, switch.

The switch S being closed, various values of the current flowing in the circuit, together with the corresponding values of the resistance AR, were noted.¹

Fig. 8 represents a graph of the result obtained, showing that with a constant P.D. the current is *directly proportional* to the *reciprocal* of the resistance (i.e. $\frac{1}{R}$), or as stated

¹ Strictly speaking, the resistance of the circuit should include the resistance of the ammeter, switch, and wire connections, but these are so small in comparison with the values of AR that they may be neglected.

above, the current is *inversely proportional* to the *resistance*.

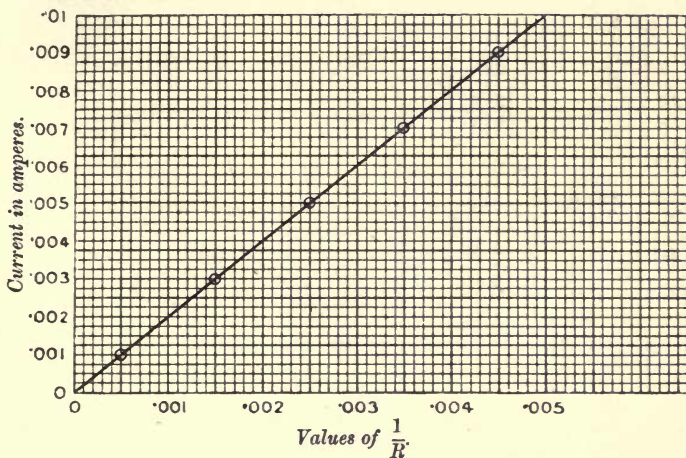

FIG. 8.

Example 6.—Determine from the graph (Fig. 8) the value of the resistance AR when the current flowing was 0.0075 amp.; also determine the P.D. across the terminals of the secondary cell.

From curve—

$$\text{when } C = 0.0075 \text{ amp., } \frac{1}{R} = 0.00375 \text{ mho. ;}$$

$$\therefore \text{ when } C = 0.0075 \text{ amp., } R = 267 \text{ ohms approx.}$$

$$\begin{aligned} \text{also P.D. across terminals of } & \left. \begin{array}{l} \text{secondary cell} \end{array} \right\} = CR = 0.0075 \times 267 \\ & = 2 \text{ volts nearly.} \end{aligned}$$

Experiment C.—To show that if the current in a circuit is constant, the P.D. across any part of that circuit is directly proportional to the resistance of that part.

Connections having been made to the apparatus as

shown in Fig. 9, the current passing through the wire WW was kept constant, and readings were noted on the voltmeter when its contacts were placed across different lengths

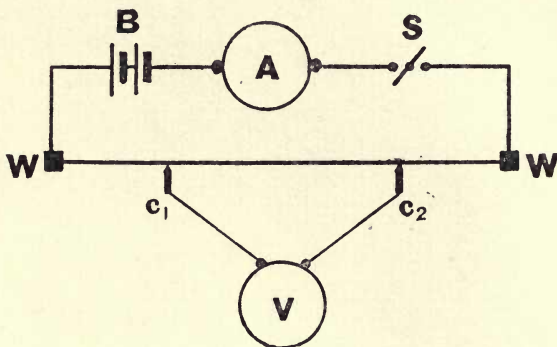

FIG. 9.

WW, a manganin wire of uniform cross-section stretched along a boxwood scale one metre long and graduated in centimetres. The resistance of any portion of a wire, such as the above, is directly proportional to the length of that portion.

C₁, C₂, contact makers attached to voltmeter.

A, ammeter

V, voltmeter.

B, battery.

S, switch.

of the wire. The length of the wire between the contact makers was also noted in each case, a series of results being obtained and plotted, as shown in Fig. 10.

The straight line so produced verifies the statement that, with a constant current flowing, the P.D. or drop in pressure is directly proportional to the resistance across which the drop is measured.

Example 7.—The resistance of a 64-cm. length of the uniform wire being 2.56 ohms, determine by the aid of the

graph (Fig. 10) the value of the constant current which flowed in the wire.

From curve—

when length of wire = 64 cms., voltage drop = 2.3

∴ when resistance of wire = 2.56 ohms, voltage drop = 2.0

$$\therefore C = \frac{E}{R} = \frac{2.3}{2.56} = 0.9 \text{ amp.}$$

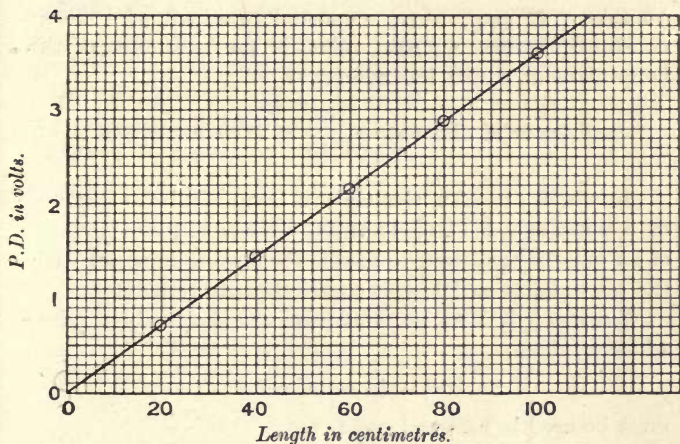

FIG. 10.

Example 8.—A moving coil voltmeter has a resistance of 12,000 ohms. What current will it take when indicating 90 volts?

$$C = \frac{E}{R} = \frac{90}{12,000} = 0.00075 \text{ amp.}$$

Example 9.—What current will flow through the coils of an electro-magnet of 76 ohms resistance, if the voltage applied to its terminals be 220?

$$C = \frac{E}{R} = \frac{220}{76} = 2.9 \text{ amps. nearly.}$$

Example 10.—What must be the maximum resistance of a length of cable such that when a current of 19·5 amps. flows through it the drop of pressure shall not exceed 7·8 volts?

$$R = \frac{\text{drop in volts}}{\text{current}} = \frac{7.8}{19.5} = 0.4 \text{ ohm.}$$

Example 11.—An electric incandescent lamp is found to take 0·45 amp. when connected to a pair of 100-volt constant-pressure mains. What is the resistance of the lamp filament whilst incandescent?

$$\text{Resistance of filament} = \frac{100}{0.45} = 222 \text{ ohms approx.}$$

Example 12.—An electric arc lamp requires a current of 8 amps. at a P.D. of 44 volts. What will be the value of an external resistance suitable for placing in series with the above lamp on 100-volt constant-pressure mains?

Since supply is at 100 volts, and arc lamp only requires 44 volts, then—

$$100 - 44 = 56 \text{ volts}$$

must be used in external resistance.

$$\text{But current} = 8 \text{ amps.}$$

$$\therefore \text{external resistance} = \frac{56}{8} = 7 \text{ ohms.}$$

Example 13.—An electric stove is connected by means of a length of cable to bus-bars at a constant pressure. It is found that when 4 amps. are flowing in the circuit, the P.D. across the stove terminals is 98 volts, but when 6·5 amps. flow this P.D. is reduced to 93 volts. Determine the resistance of the connecting cable.

$$\begin{array}{l} \text{When } C = 4.0 \text{ amps. P.D., across stove} = 98 \text{ volts} \\ \text{,, } C = 6.5 \text{ ,, P.D. ,, } = 93 \text{ ,,} \end{array}$$

and since supply is at constant pressure, drop of pressure at stove terminals is due to loss in connecting cable when current is increased.

Increase of $6.5 - 4 = 2.5$ amps. causes decrease of $98 - 93 = 5$ volts.

$$\therefore \text{resistance of connecting cable} = \frac{5}{2.5} = 2 \text{ ohms.}$$

Example 14.—A number of 100-volt lamps are connected together at the end of a pair of cables which convey current from a dynamo some distance away.

Assuming the current required by the lamps to be 14.6 amps., and the resistance of each cable to be 0.37 ohm, what P.D. must the dynamo produce at its terminals in order that the lamps shall have their full voltage?

$$\text{Dynamo P.D.} = \text{P.D. at lamps} + \text{drop in cables,}$$

$$\text{total resistance of cables} = 2 \times 0.37 = 0.74 \text{ ohm,}$$

$$\therefore \text{drop in cables} = 14.6 \times 0.74 = 10.8 \text{ volts,}$$

$$\therefore \text{terminal P.D. of dynamo } \left. \begin{array}{l} \text{must equal } 100 + 10.8 \end{array} \right\} = 110.8 \text{ volts.}$$

EXAMPLES.

1. If a cable has a resistance of 0.002 ohm, and a current of 5 amps. is passed through it, what will be the fall in volts along the cable?

2. What current would flow if a pair of 110-volt constant-pressure mains were connected across a voltmeter having a resistance of 12,000 ohms.?

3. Determine the resistance of an electric incandescent lamp, which, when connected to 100-volt mains, takes a current of 0.6 amp.

4. Determine the absolute value of the current which will flow in a circuit of 6 ohms resistance when an E.M.F. of 24 volts is applied.

5. What E.M.F. in volts will be required to cause a flow of 22.4 absolute units of current through a resistance of 16 ohms?

6. A current of 123 amps. flows through a cable having a resistance of 0.004 ohm. What will be the loss of pressure in the cable?

7. It is found that a certain voltmeter, when indicating a P.D. of 85 volts across its terminals, is taking 0.3 amp. What is the resistance of the instrument?

8. The field coil of a shunt dynamo has a resistance of 250 ohms. What is the value of the exciting current when the dynamo is producing a terminal P.D. of 110 volts?

9. A milli-ammeter reading 0.001 amp. per division has a resistance of 1.2 ohms, and it is required to read as a voltmeter. What will be the voltage per division of the scale?

10. A dynamo armature has a resistance of 0.015 ohm, as measured across the two brushes. What will be the loss of pressure in the armature and brushes when a current of 50 amps. is flowing?

11. A small electric lamp having a resistance of 5 ohms requires a current of 0.8 amp. in order to light satisfactorily. What voltage must be applied to its terminals?

12. What will be the pressure loss in an ammeter of 0.000075 ohm resistance when indicating 200 amps?

13. A length of cable is required to convey a current of 120 amps. to a motor. What must be the resistance of the cable such that the voltage drop may not exceed 2.5 volts?

14. A certain arc lamp requires a current of 10 amps. at a terminal P.D. of 38 volts. What will be the value of the resistance required to be placed in series with the arc lamp, if used on 100-volt constant-pressure mains?

15. A milli-voltmeter connected across a tramway rail bond indicates a voltage drop of 0.008 volt when a current of 320 amps. is flowing. Determine the resistance of the bonded portion of the rail.

16. An ammeter, when connected in series with a standard resistance of 0.1 ohm, indicates a current of 23 amps., and at the same time the P.D. across the standard resistance is found to be 2.28 volts. Determine the error in the ammeter reading.

17. When a current of 11.8 amps. is flowing through a certain carbon rod, the P.D. between two points 12 cms. apart is 0.324 volt. Calculate the resistance of the rod per centimetre length.

18. If a P.D. of 10 volts is applied to resistances varying from 10 to 200 ohms, plot a curve connecting C and R.

19. The resistance of the filament of a glow lamp when cold is 220 ohms. If this value decreases by 35 per cent. when hot, what current will a pressure of 110 volts send through the filament when in the latter condition?

20. A P.D. of 4 volts was applied to a resistance of 6 ohms, and the current noted; a second resistance was then placed in series with the first, and the current was found to be 0.4 amp. less than before. What was the value of the second resistance?

21. Which will be the greater resistance, one which requires a P.D. of 8 volts to send a current of 4.34 amps. through it, or one which requires a P.D. of 110 volts to send a current of 53 amps. through it?

22. An instrument requires a current of 0.05 amp. to give a full scale deflection. If it is used as a direct-reading ohmmeter on a 110-volt circuit, what is the least resistance it can indicate?

23. In the above example, by how much must the resistance be increased before the deflection is reduced to a quarter of the full scale deflection? (Assume that the deflection is proportional to voltage.)

24. What will be the relative values of the currents through two lamps, having resistances of 180 ohms and 104 ohms respectively, when placed on a 220-volt circuit?

25. Plot a curve showing the relationship between the P.D. applied and the current through a resistance of 8 ohms.

26. An unknown resistance and a standard resistance of 0.002 ohm are placed in series and a current passed through them; the fall of potential across the standard resistance is 0.04 volt, and across the unknown resistance 0.09 volt. What are the values of the current and unknown resistance?

27. A resistance of 20 ohms, on being added to a certain circuit, caused the current flowing to be reduced from 13 to 9 amps. What was the resistance of the circuit originally?

28. If a current of 20 amps. flows through a wire having a resistance of 3 ohms per mile, state what the drop of volts will be per 100 yards of the wire.

29. The P.D. at the terminals of a dynamo is 100 volts when a current of 20 amps. is flowing round the circuit. What is the resistance of the external circuit?

30. A dynamo is situated 100 yds. from a switchboard, and is connected to it by means of a pair of cables having a resistance of 0.04 ohm per 100 yds. What P.D. must be maintained at the dynamo terminals in order that the available P.D. at the switchboard may be 100 volts when a current of 50 amps. is flowing along the cable?

31. A standard Daniell's cell of 1.1 volts, when connected in series with a galvanometer and a resistance of 7000 ohms, produces a certain deflection; but when a Leclanche cell is substituted in place of the Daniell's cell, a series resistance of 8910 ohms is required to produce the same deflection as before. Determine the E.M.F. of the Leclanche cell.

32. It is required to force a current of 16 amps. through various resistances. Plot a curve showing the relationship existing between the P.D. and the resistance.

33. The insulation resistance between the + and the - mains of a two-wire system at 220 volts is found to be 4 megohms. Calculate the current which flows when no load is on the circuit.

34. A telegraph line, when well insulated, has a resistance to earth (the far end of the line being earthed, and the resistance of the earth being considered negligible) of 15 ohms. A bad fault (the resistance of which is very small) takes place, and the resistance to earth becomes 3.4 ohms. Locate the position of the fault.

35. A dynamo supplies current to a set of lamps through a pair of cables. When thirty-four additional lamps, each taking 0.6 amp., are switched on, the P.D. at the lamps decreases 2 volts. Calculate the resistance of the cable.

36. A 32-c.p. lamp for a 220-volt circuit has a resistance of 328 ohms, and a 16-c.p. lamp for a 110-volt circuit has a resistance of 187 ohms. In which case will the current be the greater?

37. Calculate the resistance of a cable in order that the "voltage drop" may not exceed 2 volts when the current is increased from 20 to 50 amps.

38. A voltmeter and an ammeter are placed in series on a circuit, and it is noted that the voltmeter indicates 109 volts and the ammeter 0.028 amp. Calculate the resistance of the voltmeter.

39. A cable has a resistance of 0.156 ohm. Normally, a current of 18 amps. flows through the cable. What is the drop in pressure

in it? To what value must the current be increased if the drop is to become 5 volts?

40. In the case of a current return through "earth," the difference of pressure between the point of earthing and the station is 6.4 volts when the current is 30.6 amps. Calculate the resistance of the "earth" return.

CHAPTER III

RESISTANCE

IN the last chapter it was stated that the resistance of a conductor is the property it possesses, in virtue of which it tends to resist the passage of an electric current through it.

Consider the case of a conductor in the form of a long rod or wire: its resistance will depend upon its length, its area of cross-section, the material of which it is composed, and upon its temperature. For the present we shall consider only the first three of these, assuming the temperature to remain constant.

Relation between Resistance and Length.—If the other quantities involved (area of cross-section, material, and temperature) are constant, the resistance of a wire is directly proportional to its length.

If one conductor has double the length of, but is otherwise similar to, another, it will have double the resistance.

Example 1.—It is required to construct a coil of 100 ohms resistance; a length of 150 cms. of the wire to be used is found to have a resistance of 4.32 ohms. What length will be required?

$$\text{Length} = \frac{100}{4.32} \times 150 = 3472 \text{ cms.} = 34.72 \text{ metres.}$$

Relation between Area of Cross-section and Resistance.—Other conditions remaining constant, the resistance of a wire is inversely proportional to its area of cross-section; thus, if the area of cross-section is doubled the resistance will be halved, assuming the length, material, and temperature remain constant.

Example 2.—A wire 32 mils in diameter has a resistance of 3 ohms. What will be the resistance of a wire of equal length, and composed of the same material, whose diameter is 45 mils?

$$\begin{aligned} \text{Area of cross-section of first wire} & \left. \vphantom{\text{Area of cross-section of first wire}} \right\} = 32^2 = 1024 \text{ circular mils.} \\ \text{Area of cross-section of second wire} & \left. \vphantom{\text{Area of cross-section of second wire}} \right\} = 45^2 = 2025 \quad \text{,,} \quad \text{,,} \end{aligned}$$

Now—

$$\begin{aligned} \frac{\text{resistance of first wire}}{\text{resistance of second wire}} &= \frac{\text{area of section of second wire}}{\text{area of section of first wire}} \\ \therefore \text{resistance of second wire} &= \text{resistance of first wire} \times \frac{\text{area of section of first}}{\text{area of section of second}} \\ &= 3 \times \frac{1024}{2025} = 1.49 \text{ ohms.} \end{aligned}$$

Example 3.—A wire 0.016 cm. in diameter has a resistance of 1.25 ohms. What will be the diameter of a wire of the same material and length, but having three times the resistance?

Reasoning as in the last example, we find that—

$$\text{Area of second wire} = \text{area of first} \times \frac{\text{resistance of first}}{\text{resistance of second}}$$

It may be noted that the area of cross-section of the wire is proportional to the square of the diameter, and hence instead of the above we can say—

$$\begin{aligned}
 & (\text{Diameter of second wire})^2 \\
 &= (\text{diameter of first wire})^2 \times \frac{\text{resistance of first}}{\text{resistance of second}} \\
 &= 0.016^2 \times \frac{1}{3} = 0.0000853
 \end{aligned}$$

or diameter of second wire = $\sqrt{0.0000853} = 0.0092$ cm.

Resistance and Material.—If we have wires constructed of different materials, but all having equal lengths and areas of cross-section, they will vary considerably in resistance; for example, the resistance of an iron wire will be about six times the resistance of a copper wire. We express this fact by stating that different materials have different *specific resistances*.

The specific resistance of a substance is the resistance of a prism of the substance having unit length and unit area of cross-section.

Using the C.G.S. system, we should, of course, use the centimetre and square centimetre as our units of length and area, and the definition therefore becomes—The specific resistance of a substance is the resistance from end to end of a prism 1 cm. long, and having a cross-section of 1 sq. cm.

Using the English system, we should, of course, substitute inch and square inch for centimetre and square centimetre. Since the specific resistance of most substances is a small fraction of an ohm, it is usually expressed in microhms.

It is obvious, from what has been stated, that if the length and area of cross-section of a wire are fixed, the resistance will be proportional to the specific resistance.

We are now in a position to sum up the above facts briefly by employing a formula.

We have seen that the resistance of a conductor is directly proportional to its length and specific resistance, and inversely proportional to its area of cross-section; hence, if we denote the resistance in ohms, length, specific resistance in ohms, and area of cross-section by the letters R , L , S , and A respectively, we have—

$$R = \frac{LS}{A} \dots \dots \dots (1)$$

In using the above formula the student must exercise care in the choice of units. If the specific resistance is taken per cubic centimetre,¹ L must be in centimetres, and A in square centimetres; if the specific resistance is expressed as the resistance per cubic inch, L must be in inches, and A in square inches.

TABLE OF SPECIFIC RESISTANCE.

Material.	Resistance per cubic inch.	Resistance per cubic centimetre	Resistance per mil-foot.
	Microhms.	Microhms.	Ohms.
Copper (hard drawn) ...	0.681	1.73	10.4
„ (annealed) ...	0.668	1.70	10.2
Iron	3.86	9.80	58.9
Platinum	4.29	10.90	65.6

Example 4.—Calculate the resistance of an annealed copper wire 0.1 cm. in diameter and 87 metres long.

¹ The term “per cubic centimetre” is used here and in the following pages for convenience; we should, of course, say “specific resistance per centimetre per square centimetre.”

$$L = 8700 \text{ cms.}$$

$$S = 1.7 \text{ microhms or } 0.0000017 \text{ ohm.}$$

$$A = 0.785 \times 0.1^2 \text{ sq. cm.}$$

$$\text{Now, } R = \frac{LS}{A} = \frac{8700 \times 0.0000017}{0.785 \times 0.1^2} = 1.88 \text{ ohm.}$$

Example 5.—What will be the resistance from end to end of an annealed copper bus-bar 10 ft. long, and whose cross-section is $\frac{1}{2}$ in. \times $\frac{1}{2}$ in.? What will be the voltage drop per foot if the bar is carrying 450 amps.?

$$L = 120 \text{ ins.}$$

$$S = 0.000000668 \text{ ohm.}$$

$$A = 0.75 \text{ sq. in.}$$

$$\text{Now } R = \frac{LS}{A} = \frac{120 \times 0.000000668}{0.75} = 0.000107 \text{ ohm;}$$

$$\text{Resistance per foot} = \frac{0.000107}{10} = 0.0000107 \text{ ohm,}$$

$$\begin{aligned} \text{Voltage drop per foot} &= 0.0000107 \times 450 \text{ volt} \\ &= 0.0048 \text{ volt.} \end{aligned}$$

In the formula given above, four quantities are concerned, and if any three of these are known, the other may be determined.

Students who have a slight knowledge of algebra will have no difficulty in adapting the formula to their needs in any particular case; but for the sake of those who are unable to do so, the formula is given below in each of its three remaining forms:—

$$L = \frac{RA}{S} \dots \dots \dots (2)$$

$$S = \frac{RA}{L} \dots \dots \dots (3)$$

$$A = \frac{LS}{R} \dots \dots \dots (4)$$

Example 6.—An annealed copper conductor 110 yds. long is required to have a resistance of not more than 0.3 ohm. What will be the least area of cross-section? What will be the diameter if it is a single wire?

From (4)—

$$A = \frac{LS}{R} = \frac{110 \times 36 \times 0.000000668}{0.3} = 0.00882 \text{ sq. in.}$$

But area of cross-section = $0.785 (\text{diameter})^2$

$$\therefore \text{diameter} = \sqrt{\frac{\text{cross-section}}{0.785}} = \sqrt{\frac{0.00882}{0.785}} = 0.106 \text{ in.}$$

Example 7.—What is the maximum distance which a current of 30 amps. can be transmitted through an annealed copper cable, the area of cross-section of the copper being 0.05 sq. in., if the “drop” is not to exceed 2 volts?

$$\text{Maximum resistance of conductor} = \frac{2 \text{ volts}}{30 \text{ amps.}} = 0.0667 \text{ ohm.}$$

From (2)—

$$\begin{aligned} L &= \frac{RA}{S} = \frac{0.0667 \times 0.05}{0.000000668} = 4990 \text{ ins. (nearly)} \\ &= 416 \text{ ft. (nearly).} \end{aligned}$$

That is, we can transmit the current a distance of 208 ft. (since the current has to be carried there and back).

Example 8.—An iron wire 3.46 metres long, and 0.026 cm. in diameter, has a resistance of 6.4 ohms. Calculate the specific resistance of the material.

From (3)—

$$\begin{aligned} S &= \frac{RA}{L} = \frac{6.4 \times 0.026^2 \times 0.785}{346} \\ &= 0.0000098 \text{ ohm per cubic centimetre} \\ &= 9.8 \text{ microhms} \quad \text{,,} \quad \text{,,} \quad \text{.} \end{aligned}$$

Sometimes, instead of taking as the basis of our calculations the resistance per cubic inch or per cubic centimetre, it is more convenient to take the resistance per *mil-foot*; that is, the resistance of a wire of the material 1 ft. long and 1 mil in diameter.

The area of cross-section of this wire is, of course, 1 circular mil.

If D is the diameter of a wire expressed in mils, L its length in feet, and S the resistance per mil-foot, then the area of section of the wire will be D^2 circular mils, and we shall have—

$$R = \frac{LS}{D^2} \dots \dots \dots (5)$$

The student must carefully note that this formula can never be used if the specific resistance is measured per cubic inch or per cubic centimetre, for then the area must be in square centimetres or square inches, and this, of course, is not determined by simply squaring the diameter.

Example 9.—What will be the resistance of 1 mile of hard-drawn copper wire whose diameter is 0.25 in.?

$$\begin{aligned} \text{Diameter} &= 0.25 \text{ in.} = 250 \text{ mils,} \\ \text{hence area of cross-section} &= (250)^2 \text{ circular mils;} \\ S &= 10.4 \text{ ohms (from table).} \end{aligned}$$

From (5)—

$$R = \frac{LS}{D^2} = \frac{5280 \times 10.4}{(250)^2} = 0.88 \text{ ohm.}$$

This formula can, of course, be transposed in a similar manner to the previous one, its other forms being—

$$D = \sqrt{\frac{LS}{R}} \dots \dots \dots (6)$$

$$L = \frac{RD^2}{S} \dots \dots \dots (7)$$

$$S = \frac{RD^2}{L} \dots \dots \dots (8)$$

Example 10.—What will be the diameter of an annealed copper wire if 36 yds. have a resistance of 8 ohms?

From (6)—

$$D = \sqrt{\frac{SL}{R}} = \sqrt{\frac{10.2 \times 36 \times 3}{8}} = 11.7 \text{ mils.}$$

Example 11.—What is the greatest length of annealed copper wire 23 mils in diameter, which will carry a current of 4 amps. with a voltage drop not exceeding 1.6 volts.

$$\text{Resistance} = \frac{E}{C} = \frac{1.6}{4} = 0.4 \text{ ohm.}$$

From (7)—

$$L = \frac{RD^2}{S} = \frac{0.4 \times 23^2}{10.2} = 20.7 \text{ ft. (total length).}$$

By filling in appropriate values of specific resistance and length, modifications of the above formulæ can be found which are often very useful from a practical point of view.

Thus, if in formula (1) we fill in for S the resistance per cubic inch, and for L the number of inches per mile (63,630), we find that—

$$\left. \begin{array}{l} \text{Resistance per mile} \\ \text{of hard-drawn} \\ \text{copper wire} \end{array} \right\} = \frac{0.043}{\text{area of section in sq. ins.}} \quad (9)$$

and if, instead of inches per mile, we fill in inches per yard, we obtain—

$$\left. \begin{array}{l} \text{Resistance per yard} \\ \text{of hard-drawn} \\ \text{copper wire} \end{array} \right\} = \frac{0.0000245}{\text{area of section in sq. ins.}} \quad (10)$$

In the case of iron the constants are 0.244 and 0.000139 respectively. The student can readily calculate the constants for other materials if he has need of them.

Example 12.—Calculate the resistance in ohms of $\frac{1}{4}$ mile of hard-drawn copper wire 0.4 in. in diameter.

From (9)—

$$\begin{aligned} \text{Resistance per mile} &= \frac{0.043}{\text{area of section in square inches}} \\ &= \frac{0.043}{0.4^2 \times 0.785} = 0.342 \text{ ohm} \end{aligned}$$

Hence resistance per $\frac{1}{4}$ mile = 0.085 ohm.

Example 13.—How many yards of No. 14 hard-drawn copper wire will have a resistance of 0.25 ohm?

Diameter of No. 14 = 0.08 in.

From (10)—

$$\begin{aligned} \text{Resistance per yard} &= \frac{0.0000245}{(0.08)^2 \times 0.785} \\ &= 0.00488 \text{ ohm}; \\ \text{hence number of yards} &= \frac{0.25}{0.00488} = 51.2. \end{aligned}$$

Resistance and Temperature.—The resistance of all pure metals and the majority of alloys increases with rise of temperature, the increase in resistance being so nearly proportional to the rise in temperature

that it may be assumed to be quite so for moderate rises.

Imagine a wire whose resistance at a temperature t_1 is R_1 , at a temperature t_2 is R_2 , and at 0° C is R_0 , and let its temperature coefficient of increase of resistance be α —that is, the amount by which a wire whose resistance at 0° C. is one ohm increases in resistance when its temperature is increased to 1° C.

Now, when the wire specified above has its temperature raised from 0° C. to t_1° C., the increase in resistance will evidently be $R_0\alpha t_1$. Hence—

$$\begin{aligned} R_1 &= R_0 + R_0\alpha t_1 \\ &= R_0(1 + \alpha t_1). \end{aligned}$$

$$\text{Similarly, } R_2 = R_0(1 + \alpha t_2).$$

$$\text{hence } \frac{R_1}{R_2} = \frac{1 + \alpha t_1}{1 + \alpha t_2}$$

$$\therefore R_1 + R_1\alpha t_2 = R_2 + R_2\alpha t_1$$

$$\text{or } R_1\alpha t_2 - R_2\alpha t_1 = R_2 - R_1$$

$$\alpha(R_1t_2 - R_2t_1) = R_2 - R_1$$

$$\therefore \alpha = \frac{R_2 - R_1}{R_1t_2 - R_2t_1}.$$

Example 14.—The resistance of a coil of copper wire at 16° C. is found to be 8.4 ohms, and at 72° C. it is found to be 10.18 ohms. Calculate the temperature coefficient of increase of resistance of copper.

$$\begin{aligned} \alpha &= \frac{R_2 - R_1}{R_1t_2 - R_2t_1} = \frac{10.18 - 8.4}{8.4 \times 72 - 10.18 \times 16} = \frac{1.78}{442} \\ &= 0.00403. \end{aligned}$$

The above reasoning applies, of course, equally to Centigrade or Fahrenheit degrees. If we use

Fahrenheit degrees, we of course take 32° Fahr. as our standard temperature. The value of α for any given material is less for the Fahrenheit degree than for the Centigrade degree.

Name of material.	Values of α .	
	Fahrenheit.	Centigrade.
Aluminium	0·00203	0·00365
Copper	0·00238	0·00428
Iron	0·0035	0·0063
Platinum	0·00203	0·00365

Practically, we require to use the above for two purposes: firstly, when we know the rise in temperature and desire to calculate the increase in resistance; and secondly, when we know the increase in resistance, and need to calculate the rise in temperature.

It will be found desirable to use a different modification of the general formula given above in each case. Let us first consider the case when we know the rise in temperature and desire to calculate the increase in resistance.

We have already seen that $R_1 = R_0(1 + \alpha t_1)$ and $R_2 = R_0(1 + \alpha t_2)$; but these formulæ both contain R_0 , which is usually not known and would have to be calculated, hence it is desirable to use a formula not containing it.

$$\text{Now, } \frac{R_2}{R_1} = \frac{R_0(1 + \alpha t_2)}{R_0(1 + \alpha t_1)} = \frac{1 + \alpha t_2}{1 + \alpha t_1}$$

$$\therefore R_2 = \frac{R_1(1 + \alpha t_2)}{1 + \alpha t_1}$$

If t_1 and t_2 are not very different, as usually occurs

in practice, it will be quite accurate enough if we say—

$$R_2 = R_1 \left(\frac{1 + \alpha t_2}{1 + \alpha t_1} \right) = R_1 \{1 + \alpha(t_2 - t_1)\} . \quad (11)$$

Example 15.—A platinum wire has a resistance of 6.4 ohms at 16° C. What will be its resistance at 42° C.?

Calculate the result by each of the formula given above, and note what error is introduced by using the simpler form.

$$\begin{aligned} (1) \quad R_2 &= R_1 \cdot \frac{1 + \alpha t_2}{1 + \alpha t_1} \\ &= 6.4 \cdot \frac{1 + 0.00365 \times 42}{1 + 0.00365 \times 16} = 6.4 \times \frac{1.1533}{1.0584} \\ &= 6.97 \text{ ohms (correct value).} \end{aligned}$$

$$\begin{aligned} (2) \quad R_2 &= R_1(1 + \overline{t_2 - t_1} \cdot \alpha) \\ &= 6.4(1 + 26 \times 0.00365) = 6.4 \times 1.095 \\ &= 7.01 \text{ ohms.} \end{aligned}$$

Thus it will be seen that the difference between the true and the approximate value is only four parts in 700, or just over half per cent.

Example 16.—The voltage drop along a certain copper cable at 14° C. is 0.26 volt. What will be the voltage drop for the same current at 25° C.?

Since the voltage drop is proportional to the resistance, then, if the current is constant, we may modify the standard formula—

$$\begin{aligned} R_2 &= R_1 \{1 + \alpha(t_2 - t_1)\} \\ \text{into } V_2 &= V_1 \{1 + \alpha(t_2 - t_1)\} \\ &= 0.26(1 + 0.00428 \times 11) \\ &= 0.272 \text{ volt.} \end{aligned}$$

We must now deal with the second case mentioned

above, that is, to calculate the rise in temperature, knowing the increase in resistance.

We have already seen that—

$$R_1 = R_0(1 + \alpha t_1)$$

$$\text{and } R_2 = R_0(1 + \alpha t_2)$$

$$\therefore R_1 = R_0 + R_0 \alpha t_1$$

$$\text{or } t_1 = \frac{R_1 - R_0}{R_0 \alpha}$$

$$\text{Similarly, } t_2 = \frac{R_2 - R_0}{R_0 \alpha}.$$

Calling the rise in temperature T , we have—

$$\begin{aligned} T = t_2 - t_1 &= \frac{R_2 - R_0}{R_0 \alpha} - \frac{R_1 - R_0}{R_0 \alpha} \\ &= \frac{R_2 - R_1}{R_0 \alpha} \dots \dots \dots (12) \end{aligned}$$

Usually the initial resistance of the coil (R_1) will not be far removed from R_0 , and hence it is conveniently substituted for R_0 in the above equation, since R_0 is usually not known, and would have to be calculated. The error introduced by doing this will usually be not more than one or two degrees; if greater accuracy is required, however, R_0 must be used.

Example 17.—The resistance of the field winding of a certain motor was found to be 74 ohms when at the temperature of the room (16°C). After the machine had been running for some hours, the resistance had increased to 82.8 ohms. Calculate the final temperature of the coils, using each formula, and note the error introduced by using the approximation.

$$\begin{aligned}
 (1) \quad T &= \frac{R_2 - R_1}{R_0 \alpha} = \frac{R_2 - R_1}{\frac{R_1}{1 + \alpha t_1} \cdot \alpha} \\
 &= \frac{R_2 - R_1}{R_1 \alpha} \times (1 + \alpha t_1) \\
 &= \frac{82.8 - 74}{74 \times 0.00428} \times (1 + 0.00428 \times 16) \\
 &= 27.7 \times 1.068 = 29.6^\circ \text{C.}
 \end{aligned}$$

hence final temperature } = 16 + 29.6 = 45.6^\circ \text{C.}

$$(2) \quad T = \frac{R_2 - R_1}{R_1 \alpha} = \frac{82.8 - 74}{74 \times 0.00428} = 27.7^\circ \text{C.}$$

hence final temperature = 16 + 27.7 = 43.7^\circ \text{C.}

Example 18.—The current through the field coil of a dynamo was found to be 8.3 amps., and the voltage actually applied to the field 172 volts immediately after the machine was started up, the temperature of the air being 68^\circ \text{Fahr. After some time, in order to maintain the same current through the field coils, the voltage which had to be actually applied to the field was 212. Determine the average rise in temperature of the coils.

$$T = \frac{R_2 - R_1}{R_1 \alpha}$$

and since the voltage is proportional to the resistance, if the current is constant we can write—

$$\begin{aligned}
 T &= \frac{V_2 - V_1}{V_1 \alpha} = \frac{212 - 172}{172 \times 0.00238} \\
 &= \frac{40}{172 \times 0.00238} = 97^\circ \text{Fahr.}
 \end{aligned}$$

Relation between Resistance and Weight.—Considering only wires of the same material, if the wires are uniform and have equal areas of cross-section, the

resistance will be directly proportional to the weight, because if we increase the length we shall increase the resistance and weight in the same ratio.

Again, if the length is constant, the resistance will be inversely proportional to the weight, for if a wire A has say three times the weight of a wire B, it will have three times the cross-section, and consequently one-third of the resistance.

Example 19.—A certain wire of known length, area of cross-section, and resistance has a weight of W lbs. What will be the weight of another wire having the same resistance and half the length?

Since the length is halved and the resistance is the same, the area of cross-section is also halved, hence the weight will be $\frac{1}{4}$ of that of the first wire, that is $\frac{W}{4}$ lbs.

Example 20.—Determine the ratio between the resistances of equal weights of Nos. 33 and 26 copper wire.

Referring to wire-gauge tables, we find that diameter of No. 33 wire is 0.01 in., and that of No. 26 wire is 0.018 in.; hence the ratio of the diameters is as 1 is to 1.8. The ratio of the areas will then be as 1^2 is to $1.8^2 = 1 : 3.24$.

Since the wires have equal weights, the ratio of their lengths will be $3.24 : 1$ (since weight is proportional to length \times area). We have then two wires, No. 33 and No. 26, the former having 3.24 times the length and $\frac{1}{3.24}$ times the area of cross-section of the latter; hence the resistance of the No. 33 wire will be $(3.24)^2 = 10.5$ times the resistance of the No. 26 wire.

Conductance.—By the conductance of a wire we mean the property it has, in virtue of which a current can flow through it. It is evidently the inverse property to resistance. A wire which has a great resistance will have a small conductance, and *vice versá*. It has been proposed to measure it in terms of a unit called the mho, this being the conductance of a wire having 1 ohm resistance.

A wire having 4 ohms resistance will have a conductance of $\frac{1}{4}$ or 0.25 mho.

It may be noticed that if we multiply the voltage impressed on a certain circuit by the conductance (in mhos), we shall at once determine the current permitted to flow (expressed in amperes), or—

$$C = EK = \frac{E}{R}$$

K being the conductance expressed in mhos.

The idea of conductance, though not often used, is occasionally very useful.

Combination of Resistances.—Hitherto we have considered a single resistance; we must now pass on to resistances in combination. They may be combined in two distinct ways, in series and in parallel, and of course in a number of combinations of these.

Resistances in Series.—In this case the resistances are joined end to end, so that the entire current flows through each.

The total resistance of a number of wires in series is equal to the sum of the separate resistances. This can be demonstrated as follows:—

Suppose we have three resistances R_1 , R_2 , and R_3

ohms respectively, placed in series, as shown in Fig. 11, with a current of C amperes flowing through them.

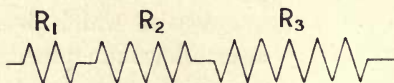

FIG. 11.

Let the voltage drop across the three resistances be E_1 , E_2 , and E_3 volts respectively. Denote the total resistance by R , and the total voltage drop by E .

$$\text{Then } E_1 = CR_1; E_2 = CR_2; E_3 = CR_3$$

$$\text{But } E = CR = E_1 + E_2 + E_3 = CR_1 + CR_2 + CR_3 \\ = C(R_1 + R_2 + R_3)$$

$$\therefore R = R_1 + R_2 + R_3 \dots \dots \dots (13)$$

Example 21.—What resistance must be placed in series with one of 23 ohms, so that when 110 volts are applied the current will be 3.5 amps. ?

$$\text{Total resistance} = \frac{110}{3.5} = 31.5 \text{ ohms,}$$

hence resistance to be placed in series = $32.5 - 23 = 8.5$ ohms.

Resistances in Parallel.—When resistances are placed in parallel, one terminal of the combination is formed by joining together one end of each resistance, the other terminal being formed by joining the remaining ends together, the current dividing itself into as many branches as there are resistances, the least resistance taking the largest current. The current, in fact, divides itself inversely as the resistance or directly as the conductance of the respective circuits. The net conductance is equal to the sum of the separate conductances—that is, if R_1 , R_2 , and

R_3 be the separate resistances (see Fig. 12), and R the resistance of the combination—

$$\text{total conductance } \frac{1}{R} = \frac{1}{R_1} + \frac{1}{R_2} + \frac{1}{R_3}$$

This can be readily demonstrated as follows: Let the currents through R_1 , R_2 , and R_3 be C_1 , C_2 , and C_3 respectively. Call the total current C , and the applied voltage E .

$$\text{Then } C_1 = \frac{E}{R_1}$$

$$C_2 = \frac{E}{R_2}$$

$$C_3 = \frac{E}{R_3}$$

$$\therefore C = \frac{E}{R} = C_1 + C_2 + C_3$$

$$= \frac{E}{R_1} + \frac{E}{R_2} + \frac{E}{R_3}$$

$$\therefore \frac{E}{R} = \frac{E}{R_1} + \frac{E}{R_2} + \frac{E}{R_3}$$

$$\text{or } \frac{1}{R} = \frac{1}{R_1} + \frac{1}{R_2} + \frac{1}{R_3} \dots \dots \dots (14)$$

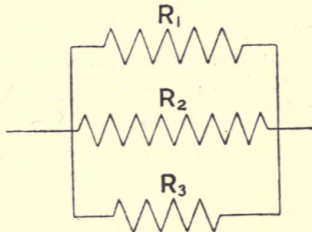

FIG. 12.

The same method of proof will, of course, hold good for any number of resistances.

Example 22.—The P.D. across the terminals of a shunt dynamo is 115 volts. The resistance of the external circuit is 5 ohms, and of the shunt 80 ohms. What is the net resistance connected across the terminals of the dynamo, and what will be the total current flowing?

From (14)—

$$\frac{1}{R} = \frac{1}{R_1} + \frac{1}{R_2} = \frac{1}{5} + \frac{1}{80} = \frac{17}{80}$$

$$\therefore R = \frac{80}{17} = 4.71 \text{ ohms,}$$

$$\therefore \text{total current} = \frac{115 \text{ volts}}{4.71 \text{ ohms}} = 24.4 \text{ amps.}$$

Example 23.—Two resistances, of 8 and 5 ohms respectively, are placed in parallel. What will be the value of another resistance, also to be placed in parallel with these, in order to make the resultant resistance 2 ohms?

From (14)—

$$\frac{1}{R} = \frac{1}{R_1} + \frac{1}{R_2} + \frac{1}{R_3}$$

$$\therefore \frac{1}{R_1} = \frac{1}{R} - \frac{1}{R_2} - \frac{1}{R_3}$$

$$= \frac{1}{2} - \frac{1}{8} - \frac{1}{5}$$

$$= 0.5 - 0.125 - 0.2$$

$$= 0.175 \text{ mho}$$

$$= \frac{1}{0.175} = 5.7 \text{ ohms.}$$

Very often a number of resistances of equal value are combined in parallel, in which case, if there are n resistances each of R ohms, the resultant resistance will evidently be $\frac{R}{n}$ ohms.

Example 24.—Across a pair of 110-volt mains are connected the following lamps:—

Ten	32 c.p.	each having a resistance of	96 ohms
Thirty	16	„ „ „	192 „
Fifty	8	„ „ „	384 „

Determine the net resistance and the total current flowing.

$$\begin{aligned} \text{Net resistance of 32 c.p. lamps} &= \frac{96}{10} = 9.6 \text{ ohms} \\ \text{,, ,, 16 ,,} &= \frac{192}{30} = 6.4 \text{ ,,} \\ \text{,, ,, 8 ,,} &= \frac{384}{50} = 7.68 \text{ ,,} \end{aligned}$$

Hence from (14)—

$$\begin{aligned} \frac{1}{R} &= \frac{1}{9.6} + \frac{1}{6.4} + \frac{1}{7.68} \\ &= 0.104 + 0.156 + 0.130 = 0.39 \text{ mho,} \end{aligned}$$

$$\text{or } R = \frac{1}{0.39} = 2.56 \text{ ohms ;}$$

$$\text{total current} = \frac{E}{R} = \frac{110}{2.56} = 43 \text{ amps. (nearly).}$$

Graphical Methods.—The determination of the effect of combining resistances in parallel may also be performed very simply by using a graphical method.

Draw a line, PT (see Fig. 13), of any convenient length, and from its extremities set off at right angles to it two lines, PN and TM. On each of these mark off any convenient scale of resistance, the zeros of the scales being at P and T respectively. Suppose we wish to determine the effect of combining two resistances of R_1 and R_2 ohms in parallel, then on PN set off PR_1 , representing in length R_1 , and on TM set off TR_2 , representing R_2 to the same scale. Join R_1T and R_2P , and let the lines intersect at R; through R draw RA parallel to PN, and meeting PT at A. Then RA, to the same scale as before, represents the combined resistance.

If more than two resistances have to be combined, take any two of them and combine them as before, then

take the third, R_3 say, and on TM mark off TR_3 , representing it to the same scale that has been used for the others, then TR_3 and AR can be combined in exactly the same way as the first two resistances.

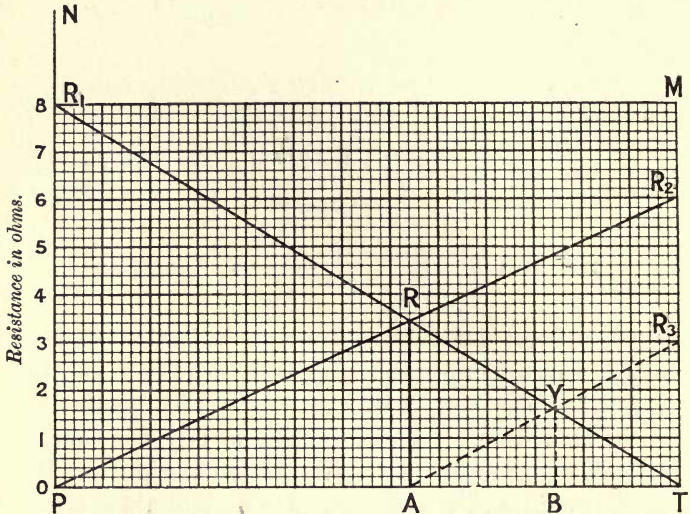

FIG. 13.—GRAPHICAL DETERMINATION OF THE RESULT OF COMBINING THREE RESISTANCES IN PARALLEL.

In the figure the second part of the construction is shown in broken lines, the result of combining the three resistances being given by the line BY.

This method can, of course, be applied to any number of resistances.

Example 25.—Determine graphically the result of combining resistances of 3, 6, and 8 ohms in parallel.

This example is worked out in Fig. 13, the answer is seen to be 1.6 ohms.

The graphical method can also be applied when one resistance (R_2) is known, and it is required to determine what resistance must be inserted in parallel with it in order that the resultant resistance may have a certain value (R).

Draw any line, TP (see Fig. 14), and set off at right angles to it at T a line TR_2 , representing R_2 to any convenient scale. At A in the line TP (the distance

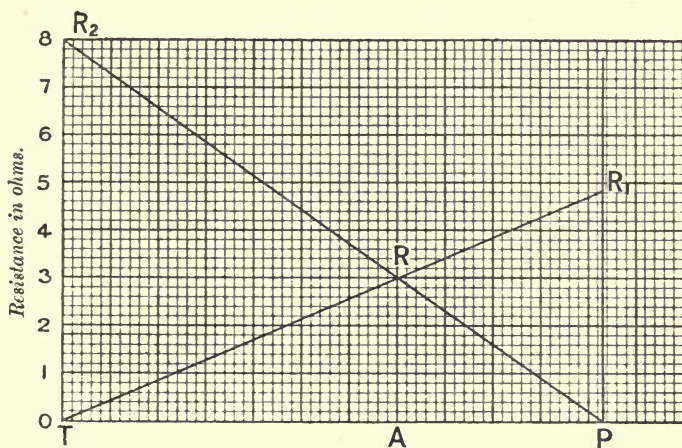

FIG. 14.—GRAPHICAL DETERMINATION OF THE RESISTANCE NECESSARY TO COMBINE WITH A KNOWN RESISTANCE, IN ORDER THAT THE RESULT MAY HAVE A KNOWN VALUE.

TA is immaterial, but should not be too small, for in that case the accuracy of the method will suffer) set off AR at right angles to TA , and representing R to the scale already chosen; join R_2R and produce it to meet TP produced at P . Join TR and produce it to meet the perpendicular to TP , erected at P , at

the point R_1 . Then PR_1 represents to scale the resistance required.

Example 26.—What resistance must be inserted in parallel with 8 ohms in order to bring the resultant resistance to 3 ohms?

See Fig. 14. The answer is found to be 4.8 ohms.

An important example of resistances in parallel is furnished by a cable. A cable, of course, consists of a number of strands which are twisted round one another. The "lay" is usually about twenty times the diameter of the cable, or the wires make one complete twist in a distance equal to twenty times the diameter of the cable.

The result of this is twofold; in the first place, all the wires except the central one will be slightly longer than the cable; and, in the second place, the area of cross-section of the cable will be slightly increased.

We may assume that, owing to the resistance of the contact between adjacent strands, all the current which enters a particular strand at one end of the cable will keep to that strand all the way along the cable, hence it will (except in the case of the centre wire) travel over a longer path than if the wire was straight; that is to say, the resistance of the cable will be slightly greater than the resistance of an equal number of wires, each having the same length as the cable, arranged in parallel. The actual increase in resistance is about 1.2 per cent., but depends to some slight extent upon the number of strands in the cable.

Hence, to determine the resistance of a cable, first calculate the resistance of a single strand equal in length to the cable, divide this number by the number of strands, and increase the result by 1.2 per cent.

Example 27.—Calculate the resistance of $\frac{1}{4}$ mile of 19/18 cable.

Diameter of No. 18 }
copper wire } = 0.048 in.

$$\text{resistance of 1 strand} = \frac{L \times S}{A} = \frac{440 \times 36 \times 0.000000668}{0.048^2 \times 0.785}$$

$$= 5.85 \text{ ohms,}$$

$$\therefore \text{resistance of 19 strands in parallel} \left. \vphantom{\begin{matrix} \text{resistance of 1 strand} \\ \text{resistance of 19 strands in parallel} \end{matrix}} \right\} = \frac{5.85}{19} = 0.308 \text{ ohm,}$$

$$\therefore \text{resistance of cable} = 0.308 \times 1.012 = 0.312 \text{ ohm.}$$

For practical purposes the above correction is so small that it may be neglected.

Case of only Two Resistances in Parallel.—The most common case of resistances in parallel is when only two are involved. The general formula then reduces to—

$$\frac{1}{R} = \frac{1}{R_1} + \frac{1}{R_2}$$

$$\text{or } \frac{1}{R} = \frac{R_1 + R_2}{R_1 R_2}$$

$$\therefore R = \frac{R_1 \times R_2}{R_1 + R_2} \dots \dots \dots (15)$$

This form is much more convenient than the previous one when only two resistances are being dealt with.

Example 28.—A galvanometer of 40 ohms resistance is shunted with a resistance of 6 ohms. What will be the resulting resistance?

$$R = \frac{R_1 R_2}{R_1 + R_2} = \frac{40 \times 6}{46} = 5.2 \text{ ohms.}$$

Example 29.—The resistance of a galvanometer is 2 ohms. What resistance must it be shunted with in order that the resulting resistance = 0·015 ohm?

$$\frac{1}{R} = \frac{1}{R_1} + \frac{1}{R_2}$$

hence $\frac{1}{R_1} = \frac{1}{R} - \frac{1}{R_2} = \frac{R_2 - R}{R_2 R}$

or $R_1 = \frac{R_2 R}{R_2 - R} \dots \dots \dots (16)$

$$= \frac{2 \times 0\cdot015}{2 - 0\cdot015} = 0\cdot0151 \text{ ohm.}$$

No. of conductor, S.W.G.	Diameter in inches.	Cross-section in square inches	Diameter in centimetres.	Cross-section in square centimetres.
1	0·3000	0·0707	0·762	0·456
3	0·2520	0·0499	0·640	0·322
5	0·2120	0·0353	0·583	0·228
7	0·1760	0·0243	0·447	0·157
9	0·1440	0·0163	0·366	0·105
11	0·1160	0·0106	0·295	0·0682
12	0·1040	0·00849	0·264	0·0547
13	0·0920	0·00665	0·234	0·0429
14	0·0800	0·00503	0·203	0·0324
15	0·0720	0·00407	0·183	0·0263
16	0·0640	0·00322	0·163	0·0208
17	0·0560	0·00246	0·142	0·0159
18	0·0480	0·00181	0·122	0·0117
19	0·0400	0·00126	0·102	0·00811
20	0·0360	0·00102	0·0914	0·00657
21	0·0320	0·000804	0·0813	0·00519
21½	0·0300	0·000707	0·0762	0·00456
22	0·0280	0·000616	0·0711	0·00397
23	0·0240	0·000452	0·061	0·00292
24	0·0220	0·000380	0·0559	0·00245
25	0·0200	0·000314	0·0508	0·00203
28	0·0148	0·000172	0·0376	0·00111
33	0·0100	0·0000785	0·0254	0·000507
38	0·0060	0·0000283	0·0152	0·000182
40	0·0048	0·0000181	0·0122	0·000117
45	0·0028	0·00000616	0·00711	0·0000397
50	0·0010	0·000000785	0·00254	0·00000507

EXAMPLES.

1. What will be the resistance of an annealed copper bus-bar 12 ft. long, whose cross-section is 2 ins. \times $\frac{1}{2}$ in.? What will be the voltage drop per foot if the bar is carrying 450 amps.?

2. A coil for an electro-magnet has 550 turns of No. 22 insulated copper wire, the mean length per turn being 10 ins. Calculate the resistance of the coil.

3. A field magnet coil is to be constructed of No. 18 insulated copper wire, and is to have a resistance of 56 ohms. What length will be required?

4. A circular rod of carbon 10 ins. long and 0.5 in. in diameter has a resistance of 0.14 ohm. Calculate its specific resistance.

5. If 70 yds. of No. 26 copper wire have a resistance of 6.4 ohms, what will be the resistance per mil-foot?

6. If 80 yds. of iron wire are required to have a resistance of 1.4 ohms, what diameter must be used?

7. What must be the diameter of a glow lamp filament 7 ins. long if it has a resistance of 120 ohms? (Assume that the specific resistance of carbon when hot is 4000 microhms per cubic centimetre when hot.)

8. A copper cable is required to carry a current of 600 amps. with a potential drop of 10 volts per mile. What must be its area of cross-section?

9. What will be the voltage drop per kilometre in a copper cable whose cross-section is 1.56 sq. cms., and which carries a current of 100 amps.?

10. What will be the resistance per yard of a copper wire 0.023 in. in diameter?

11. What will be the resistance per mile of No. 18 copper wire?

12. What must be the diameter of a column of mercury 1 metre long, to have a resistance of 1 ohm. (Specific resistance of mercury = 94.0 microhms per c.c.)

13. What will be the resistance of a strip of iron 35 cms. long, 5 cms. broad, and 0.3 cm. thick?

14. Calculate the constant in formula (9) when the wire is of platinum.

15. Calculate the constant in formula (10) when the wire is of platinum

16. What rise in temperature will be necessary in order that a field coil (consisting of copper) may increase in resistance 5 per cent.

17. When the temperature of a copper cable is 17° C., the voltage drop along it is 0.21 volt; at another time it is observed to be 0.22 volt when the same current was flowing. What was the temperature in the second case?

18. A platinum wire has a resistance of 8 ohms at 16° C. What will be its resistance at 34° C.?

19. The resistance of the field coil of a certain machine before use was 140 ohms; at the end of a 4-hour run it was 151 ohms. Calculate the final temperature of the coils, assuming the temperature of the air to be 15° C.

20. A voltmeter coil consists of a copper coil of 52 ohms resistance, in series with a manganin resistance of 2448 ohms (assume this has no temperature coefficient). What will be the percentage alteration in resistance of the whole when the temperature is raised 14° C.? What would be the percentage change in resistance of the coil if it was wholly composed of copper?

21. A voltmeter consists of a copper coil of 20 ohms resistance in series with a resistance of 1880 ohms of a wire whose temperature coefficient is negligible. If the instrument is correct at 15° C., what will be the error per cent. at 22° C.

22. The current through the shunt coil of a dynamo at 18° C. is 0.65 amp. What will the current be when the average temperature of the coil is 36° C.? (Assume the applied voltage to be constant.)

23. What current will flow through a system composed of three wires having resistances of 3, 6, and 8 ohms respectively, placed in parallel, when a P.D. of 8 volts is applied?

24. Lamps having resistances of 60, 120, and 240 ohms respectively are connected in parallel, and current is led to them by two mains having a total resistance of 2 ohms. If a P.D. of 110 volts is applied at the station end of the mains, what current will flow through the circuit?

25. Determine graphically the result of combining resistances of 3 and 5 ohms in parallel.

26. Determine graphically the resistance which must be placed in parallel with 18 ohms in order that the resultant resistance may be 8.5 ohms.

27. A resistance of 6 ohms is placed in series with two of 4 and 3 ohms, the last two being placed in parallel. What current will flow through the system if 3 volts be applied?

28. The resistance of 1 mile of No. 10 B.W.G. wire being 3.128 ohms, calculate the united resistances of nineteen pieces of such wire, each $\frac{1}{4}$ mile long, placed in parallel (not stranded). Calculate also the fall in volts along it when a current of 100 amps. flows through it.

29. The diameters of two copper wires are as 1 : 3. What will be the relative resistances of equal lengths? If two carbon rods are taken, one 1 metre long and 1 mm. in diameter, the other 1 in. long and 1 mil in diameter, what will be their relative resistances?

30. Two telegraph wires, each of the same length and of the same material, have resistances of 2000 and 3000 ohms respectively. What are their relative diameters?

31. Three wires have resistances of 1, 2, and 3 ohms respectively. What will be their joint resistances when they are coupled together in multiple arc?

32. A piece of wire 20 ft. long and 10 mils in diameter is found to have double the resistance of another wire of the same metal 15 ft. long and of unknown diameter. Calculate the diameter of the second wire.

33. The resistance of the ohm is approximately that of a column of mercury 106 cms. long, 1 sq. mm. in cross-section, at 0° C. What would be the resistance of a column of mercury 0.1 metre long and 0.5 of a sq. mm. in cross-section at the same temperature?

34. The conductor resistance of a well-insulated telegraph line when the further end is earthed is 2000 ohms. If there were a fault at its centre of 1000 ohms resistance, what would the resistance of the line be reduced to?

35. The total insulation resistance of a telegraph line 100 miles long is found to be 5000 ohms, and the total insulation resistance up to a point 60 miles from where the measurement is made is found to be 8000 ohms. What is the average insulation resistance per mile of the remaining 40 miles of line?

36. The resistance of a bar of iron 1 yd. long, weighing 1 lb., is 0.00174 ohm. Calculate the resistance per mile of wire having the following weights:—400 lbs. per mile, 150 lbs. per mile.

37. If three resistances, r_1 , r_2 , and r_3 , are combined in parallel,

what will be the resultant resistance? If 75 yds. of $7/16$ cable are joined in parallel with 50 yds. of $19/20$ cable, what is the joint resistance? (A single No. 16 has a resistance of 0.8 ohm per 100 yds.; a single No. 20 a resistance of 2.75 ohms per 100 yds.)

38. Calculate the resistance of a gramme armature wound with 144 turns of rectangular wire 0.2 in. \times 2 ins. cross-section; length of armature core = 12 ins., radial depth = 2.5 ins. (The resistance of 100 yds. of copper rod 1 sq. in. in section is 0.0025 ohm.)

39. A rectangle is composed of wire having a resistance of 1 ohm per foot. The sides of the rectangle are 6 ft. and 4 ft. respectively. One diagonal of the rectangle is also composed of the same wire, the other diagonal being absent. Calculate the resistance between the two corners joined by the diagonal.

40. The breadth of a coil is 6 ins., its internal diameter is 4 ins., and external 8 ins., giving a winding depth of 2 ins. It is wound with 1700 turns of No. 18 copper wire. Calculate the total resistance.

CHAPTER IV

OHM'S LAW (B)

HITHERTO we have dealt only with the loss of pressure in a portion of a circuit consequent upon a certain current flowing through that portion; but now let us account for the loss of the total pressure exerted by a battery or dynamo.

Referring to Fig. 15, assume a current C to flow through the external resistance R , completing its path through the cell; the product $C \times R$ denotes the pressure lost in the external resistance between the points (a) and (b).

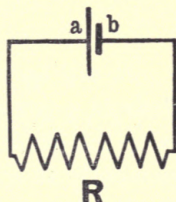

FIG. 15.

Now, this is not the only source of pressure loss in the circuit, for since the current completes its path through the cell, which has a certain internal resistance, there is a consequent loss of pressure in the cell. The amount of this loss of pressure internally is obtained, as before, by multiplying the current flowing by the internal resistance of the cell.

It will be obvious from the above statements that the total loss of pressure in a circuit is made up of two separate losses, namely, the loss in the external circuit and the loss in the internal circuit.

Example 1.—The terminals of a primary cell are connected to a resistance of 10 ohms, and the current flowing is found to be 0.12 amp. Assuming the cell to have an internal resistance of 0.8 ohm, determine the total electrical pressure expended in the circuit.

$$\begin{array}{l}
 \text{Loss of pressure in } \left. \begin{array}{l} \text{external circuit} \\ \text{loss of pressure in} \\ \text{internal circuit} \end{array} \right\} = \text{current flowing} \times \text{external resist-} \\
 \hspace{10em} \text{ance} = 0.12 \times 10 = 1.2 \text{ volts ;} \\
 \hspace{10em} \text{ance} = 0.12 \times 0.8 = 0.096 \text{ volt.} \\
 \therefore \text{total electrical} \left. \right\} = 1.2 + 0.096 = 1.296 \text{ volts.} \\
 \text{pressure expended} \left. \right\}
 \end{array}$$

Since in the above example the current is the same in both resistances, the result may be obtained from the expression—

$$\begin{aligned}
 \text{Total E.M.F.} &= \text{current flowing} \times \text{total resistance} \\
 &= 0.12 (10 + 0.8) \\
 &= 1.296 \text{ volts.}
 \end{aligned}$$

It will be well to note here that the current which flows in a series circuit, such as illustrated in Fig. 15, is of the same value at every part of the circuit, consequently an ammeter would indicate the same current flowing irrespective of its position in the circuit.

Referring again to the above figure, it is usual to denote the pressure drop between the points (a) and (b) (*i.e.* the battery terminals) as the terminal P.D. of the battery; whilst the sum of the pressures lost (internal + external) is termed the E.M.F. (electromotive force) of the cell.

The E.M.F. or total available pressure is that indicated across the terminals of the cell when no external circuit is connected, *i.e.* no current flows;

it will be obvious that since no current flows in the cell there can be no loss of pressure internally.

The following hydraulic analogy will help to impress the foregoing statements:—

Consider a water-tap, as illustrated in Fig. 16, to be fitted with a simple pressure gauge as shown. The gauge will indicate a maximum pressure when the tap is closed; but when the tap is opened and a current of water flows, the pressure indicated will be less than

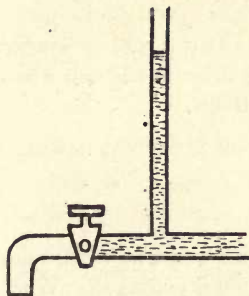

FIG. 16.

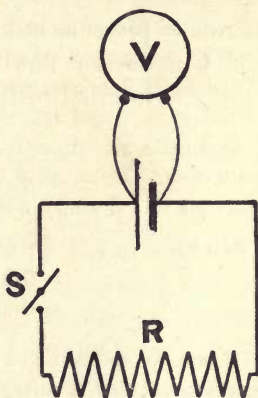

FIG. 17.

before, this drop in pressure being due to a certain loss taking place in forcing the water through the pipe on its way to the outlet.

Now compare the above case with that of the electrical circuit in Fig. 17. V is a voltmeter which indicates the P.D. between the terminals of the cell. When the switch S is open no current flows through the circuit, and consequently the pressure or E.M.F. indicated by the voltmeter is a maximum; but when

the switch is closed and a current of electricity flows through the circuit, the P.D. across the cell terminals falls, as indicated by the voltmeter, this drop of pressure being due to a certain loss taking place in forcing the current through the interior of the cell.

As stated previously, the pressure lost in the cell is equal to the internal resistance of the cell multiplied by the current flowing through it, or symbolically—

$$e = Cr$$

where e = pressure lost in cell,

C = current flowing,

r = internal resistance of cell.

Example 2.—A secondary cell has an internal resistance of 0.2 ohm. Determine the voltage drop in the cell when a current of 1.6 amps. flows in the circuit.

$$\begin{aligned} \text{Volts lost in cell} &= \text{resistance of cell} \times \text{current flowing} \\ &= 0.2 \times 1.6 \\ &= 0.32 \text{ volt.} \end{aligned}$$

Example 3.—When a current of 2.3 amps. flows through a certain battery, a voltage drop of 1.86 is produced. What is the internal resistance of the battery?

$$\text{Since } e = Cr$$

$$\text{then } r = \frac{e}{C}$$

$$\begin{aligned} \text{or internal resistance of battery} &= \frac{\text{lost volts}}{\text{current}} = \frac{1.86}{2.3} \\ &= 0.81 \text{ ohm.} \end{aligned}$$

Example 4.—It is found that the open circuit¹ E.M.F. of a separately excited dynamo is 102.5 volts, but when a

¹ By the term "open circuit" is meant the condition when no external circuit is connected to the generator.

current of 20 amps. flows round the circuit the P.D. indicated across the terminals is only 101.3 volts. Determine the resistance of the dynamo armature.¹

$$\text{Resistance of armature} = \frac{\text{volts lost in armature}}{\text{current flowing}}$$

$$\text{But loss in armature} = 102.5 - 101.3 = 1.2 \text{ volts,}$$

$$\therefore \text{resistance of armature} = \frac{1.2}{20} = 0.06 \text{ ohm.}$$

Example 5.—A thermopile having an internal resistance of 0.52 ohm produces an open circuit E.M.F. of 4.2 volts. Determine the value of the current which will flow through a small incandescent lamp of resistance 2.28 ohms, when connected across the terminals of the thermopile.

$$\begin{aligned} \text{Current} &= \frac{\text{total E.M.F.}}{\text{total resistance}} \\ &= \frac{4.2}{0.52 + 2.28} = 1.5 \text{ amps.} \end{aligned}$$

Example 6.—A separately excited dynamo, having an armature resistance of 0.02 ohm, produces an open circuit E.M.F. of 102 volts, but when a certain number of lamps are connected across the dynamo terminals by means of a pair of cables, the P.D. indicated across the lamps is only 100 volts. Determine the current taken by the lamps, and also their total resistance, assuming the resistance of the cables to be 0.005 ohm.

$$\begin{aligned} \text{Current} &= \frac{\text{drop in armature} + \text{drop in cables}}{\text{resistance of armature} + \text{resistance of cables}} \\ &= \frac{102 - 100}{0.02 + 0.005} = 80 \text{ amps. ;} \end{aligned}$$

¹ It will be assumed in this and the following examples that the E.M.F. or total pressure developed by a dynamo is constant, whatever the value of the current flowing. In practice this is not strictly correct.

$$\begin{aligned} \text{Resistance of lamps} &= \frac{\text{P.D. across lamps}}{\text{current flowing}} \\ &= \frac{100}{80} = 1.25 \text{ ohms.} \end{aligned}$$

Example 7.—Given a circuit as shown in Fig. 18, determine the value of the current flowing and the voltage drop in each resistance, if the open circuit E.M.F. of the dynamo be 120 volts.

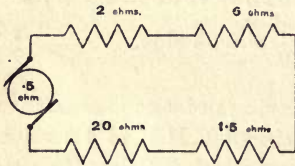

FIG. 18.

$$\begin{aligned} \text{Current} &= \frac{\text{total E.M.F.}}{\text{total resistance}} \\ &= \frac{120}{0.5 + 2 + 6 + 1.5 + 20} \\ &= 4 \text{ amps.} \end{aligned}$$

voltage drop in any }
portion of circuit } = \text{current flowing} \times \text{resistance of portion,}

$$\therefore \text{voltage drop in A} = 4 \times 2 = 8 \text{ volts,}$$

$$\text{,, ,, B} = 4 \times 6 = 24 \text{ ,,}$$

$$\text{,, ,, C} = 4 \times 1.5 = 6 \text{ ,,}$$

$$\text{,, ,, D} = 4 \times 20 = 80 \text{ ,,}$$

$$\text{voltage drop in armature} = 4 \times 0.5 = 2 \text{ ,,}$$

The sum of the various losses calculated is equal to the open circuit E.M.F. of the dynamo. This proves our solution to be correct.

Example 8.—A battery produces a terminal P.D. of 1.8 volts when sending a current of 2.2 amps. through an external resistance. Assuming the internal resistance of the battery to be 0.74 ohm, determine what E.M.F. the battery would give on open circuit.

Open circuit E.M.F. = terminal P.D. + pressure loss in battery.

$$\begin{aligned} \left. \begin{array}{l} \text{But pressure loss in} \\ \text{battery} \end{array} \right\} &= \text{current} \times \text{internal resistance} \\ &= 2.2 \times 0.74 = 1.63 \text{ volts,} \\ \therefore \text{open circuit E.M.F.} &= 1.8 + 1.63 = 3.43 \text{ volts.} \end{aligned}$$

The following example will serve to illustrate the error introduced by using a voltmeter of low resistance for the measurement of internal resistance of cells.

Example 9.—A voltmeter of 14 ohms resistance indicates an E.M.F. of 1.8 volts when connected across the terminals of a certain primary cell, but when a current of 2 amps. flows through an external resistance connected to the cell, the terminal P.D. falls to 0.6 volt. Determine the internal resistance of the cell, (a) neglecting the voltmeter resistance, (b) taking into account the voltmeter resistance.

$$\begin{aligned} (a) \text{ Internal resistance of cell} &= \frac{\text{lost volts in cell}}{\text{current flowing}} \\ &= \frac{1.8 - 0.6}{2} = 0.6 \text{ ohm.} \end{aligned}$$

(b) When voltmeter alone is connected to cell—

$$\text{Current through cell} = \frac{1.8}{14} = 0.13 \text{ amp.}$$

When external circuit is completed, terminal P.D. falls to 0.6 volt ; consequently—

$$\text{Current through cell due to voltmeter} = \frac{0.6}{14} = 0.043 \text{ amp.,}$$

and since current in external circuit = 2 amps.,

$$\text{total current passing through cell} = 2.043 \text{ amps.}$$

Therefore, on increasing current through cell from 0.13 amp. to 2.043 amps., a voltage drop of $1.8 - 0.6 = 1.2$ volts is produced ;

$$\begin{aligned} \therefore \text{internal resistance of cell} &= \frac{\text{voltage drop in cell}}{\text{current producing this drop}} \\ &= \frac{1.2}{2.043 - 0.13} \\ &= 0.627 \text{ ohm.} \end{aligned}$$

It will be evident from the above, that neglecting the voltmeter resistance caused the calculated value of the internal resistance of the cell to be 0.027 ohm too low. This is equivalent to an error of over 4 per cent.

GRAPHICAL METHODS.

Example 10.—A bichromate cell on open circuit produces an E.M.F. of 1.8 volts, but when connected up so as to send a current through an external resistance of 4 ohms the terminal P.D. falls to 1.2 volts. Determine the internal resistance of the cell, (a) analytically, (b) graphically.

(a) Drop in cell when current flows = $1.8 - 1.2 = 0.6$ volt.

$$\text{But current} = \frac{1.2}{4} = 0.3 \text{ amp.,}$$

$$\therefore \text{internal resistance of cell} = \frac{0.6}{0.3} = 2 \text{ ohms.}$$

(b) Fig. 19 represents the graphical solution of this problem. Plotting volts as ordinates and ohms as abscissæ, a point A is obtained corresponding to a terminal P.D. of 1.2 volts and an external resistance of 4 ohms. Now, a straight line drawn from the origin O through the point A cuts the P.D. line 1.8 at the point B, and a perpendicular dropped from B to the axis of abscissæ at C indicates that the length OC is representative of the total resistance of the circuit; but

since the external resistance alone equals 4 ohms, then internal resistance of cell = distance between 4 and point C = 6 - 4 = 2 ohms.

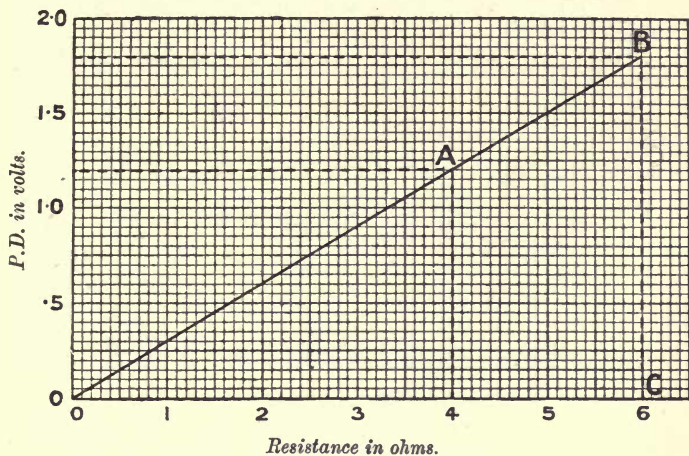

FIG. 19.

Example 11.—A secondary cell, having an internal resistance of 1.25 ohms, produces a terminal P.D. of 1.6 volts when sending a certain current through an external resistance of 5 ohms. Determine the open circuit E.M.F. of the cell, (a) analytically, (b) graphically.

$$(a) \text{ Current flowing} = \frac{1.6}{5} = 0.32 \text{ amp.},$$

$$\therefore \text{ drop of pressure in cell} = 0.32 \times 1.25 = 0.4 \text{ volt,}$$

$$\therefore \text{ open circuit E.M.F. of cell} = 1.6 + 0.4 = 2 \text{ volts.}$$

(b) The graphical solution of this problem is somewhat similar to the previous one, and is as follows:—

Referring to Fig. 20, determine a point A corresponding to 5 ohms and 1.6 volts. Join OA by a straight line, and produce it beyond A. Erect a perpendicular from

point $(5 + 1.25) = 6.25$ ohms cutting OA at B. Trace horizontal P.D. line which cuts point B; the value of this

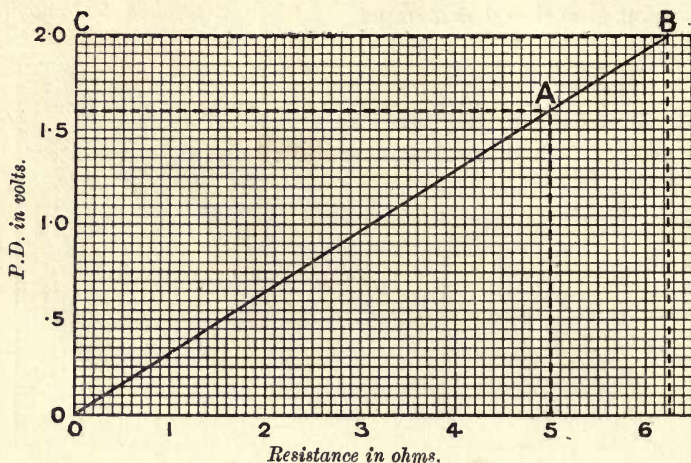

FIG. 20.

line, noted at C, is the open circuit E.M.F. of the secondary cell, which from graph = 2 volts.

Connection of Cells in Series.—When a number of cells are joined in series, so that they all tend to send a current in the same direction, then, since the current has to pass through each of the cells in succession, the total resistance offered by the cells will be the sum of the individual resistances.

Example 12.—Determine the total internal resistance of a battery of 120 secondary cells joined in series, each cell having a resistance of 0.015 ohm.

Total internal resistance = $120 \times 0.015 = 1.8$ ohms.

Fig. 21 represents the arrangement of cells referred to above; and it will be obvious that since the cells all

tend to send current in the same direction, that is, all the E.M.F.'s are acting in the same direction, the total E.M.F. exerted by the battery will be the sum of the individual E.M.F.'s.

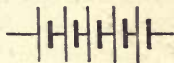

FIG. 21.

Example 13.—Determine the total E.M.F. available when 54 cells, each having an E.M.F. of 1.9 volts, are connected in series.

$$\text{Total available E.M.F.} = 54 \times 1.9 = 102.6 \text{ volts.}$$

Example 14.—A battery of 20 similar secondary cells sends a current of 6 amps. through the coils of an electro-magnet having a resistance of 4 ohms. Determine the internal resistance of each cell, assuming each to have an E.M.F. of 2 volts.

$$\text{Total E.M.F.} = 20 \times 2 = 40 \text{ volts,}$$

$$\text{,, resistance} = 4 + \text{internal resistance of battery,}$$

$$\therefore \text{current} = \frac{40}{4 + \text{int. resist. of battery}} = 6 \text{ amps.}$$

From which—

$$\text{Internal resistance of battery} = \frac{40}{6} - 4 = 2.7 \text{ ohms,}$$

$$\therefore \text{internal resistance of one cell} = \frac{2.7}{20} = 0.135 \text{ ohm.}$$

Example 15.—

Let n = number of cells in a battery with series connection ;

E = E.M.F., and r = internal resistance of each cell ;

R = external resistance.

Determine a formula by means of which the current C in any such circuit as the above may be determined.

$$\begin{aligned} C &= \frac{\text{total E.M.F.}}{\text{total resistance}} \\ &= \frac{nE}{nr + R} \dots \dots \dots (1) \end{aligned}$$

Example 16.—A battery of 12 accumulators, each having an E.M.F. of 2 volts and internal resistance of 1·1 ohms, is connected in series with and employed to excite an electro-magnet having a resistance of 2·8 ohms. What current will flow through the coils of the electro-magnet when in use?

From (1)—

$$C = \frac{nE}{nr + R} = \frac{12 \times 2}{(12 \times 1.1) + 2.8} = 1.5 \text{ amps.}$$

Connection of Cells in Parallel.—The connection of a number of cells in parallel is practically equivalent to using one large cell whose plates have an active area equivalent to the sum of the active areas of the smaller cells; that is to say, the connection of four small cells in parallel is equivalent to using one large cell having plates of four times the area of those of a small cell.

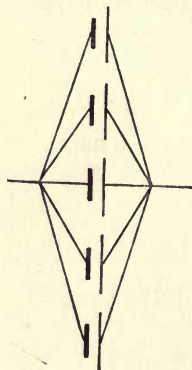

FIG. 22.

Referring to Fig. 22, which represents the connection of five cells in parallel, it will be evident that, since the current has five paths instead of one, as in the case of series connection, the resistance offered by the battery will be one-fifth of that offered by any individual cell.

Example 17.—What will be the internal resistance of a battery of 24 cells connected in parallel, each cell having a resistance of 3·2 ohms?

$$\begin{aligned} \text{Internal resist. of battery} &= \frac{\text{internal resistance of one cell}}{\text{number of cells}} \\ &= \frac{3.2}{24} = 0.133 \text{ ohm.} \end{aligned}$$

Example 18.—The total internal resistance of a battery of 52 similar secondary cells connected in parallel is found to be 0.025 ohm. What is the value of the internal resistance of each cell?

Internal resistance of each cell = $52 \times 0.025 = 1.3$ ohms.

A well-known law in elementary electricity states that the E.M.F. of a cell is independent of the size of the plates employed; and since, as we have stated, the four cells in parallel are equivalent to one large cell with plates of four times the area of a small one, the law mentioned above still holds good, and shows that the E.M.F. of this combination is the same as the E.M.F. of a single cell.

Example 19.—Determine a formula by means of which the current C , which will flow through an external resistance R , from n cells in parallel, may be obtained. Assume each cell to have an E.M.F. E and internal resistance r .

$$\begin{aligned} \text{Current} &= \frac{\text{total E.M.F.}}{\text{total resistance}} \\ &= \frac{E}{\frac{r}{n} + R} \dots \dots \dots (2) \end{aligned}$$

Example 20.—Determine the value of the current which will flow when a battery of 16 cells in parallel is connected to an external resistance of 8 ohms. Assume each cell to have an E.M.F. of 1.63 volts, and an internal resistance of 2.4 ohms.

From (2)—

$$C = \frac{E}{\frac{r}{n} + R} = \frac{1.63}{\frac{2.4}{16} + 8} = 0.2 \text{ amp.}$$

Example 21.—From formula (2), determine an equation from which the value of r may be obtained directly.

From (2)—

$$C = \frac{E}{\frac{r}{n} + R}$$

Multiplying numerator and denominator by n —

$$C = \frac{nE}{r + nR}$$

$$\therefore Cr + CnR = nE$$

$$\text{or } Cr = nE - CnR$$

from which —

$$r = \frac{nE - CnR}{C} = \frac{nE}{C} - nR \dots (3)$$

Example 22.—Six “Carsak” cells, each having an E.M.F. of 1.4 volts, are connected in parallel and employed to ring an electric bell of 0.9 ohm resistance. Assuming the bell takes a current of 1.5 amps., calculate the internal resistance of each cell.

From (3)—

$$\begin{aligned} \text{Internal resistance of } \left. \begin{array}{l} \text{each cell} \end{array} \right\} &= \frac{nE}{C} - nR \\ &= \frac{6 \times 1.4}{1.5} - 6 \times 0.9 = 0.2 \text{ ohm.} \end{aligned}$$

Determination of Best Arrangement of Cells.—

The arrangement of a number of cells so that the maximum possible current is produced through an external resistance, is obtained by making the internal resistance of the battery as nearly as possible equal to the external resistance of the circuit.

Example 23.—A battery of 54 cells, each having an internal resistance of 2 ohms, is required to send the

strongest possible current through an electro-magnet coil having a resistance of 12 ohms. What is the best arrangement of cells to accomplish this?

Let s = number of cells in series;

„ p = „ series groups placed in parallel.

$$\text{Then } sp = 54$$

$$\text{Also internal resistance of battery} = \frac{2s}{p}$$

and in order to obtain maximum current—

Internal resistance = external resistance

$$\frac{2s}{p} = 12$$

$$\therefore s = 6p$$

But from above—

$$sp = 54$$

therefore, substituting $6p$ instead of s —

$$6p \times p = 54$$

$$\text{or } p^2 = \frac{54}{6} = 9$$

$$\therefore p = 3,$$

$$\text{and } s = \frac{54}{3} = 18.$$

therefore the best arrangement consists of three rows of 18 cells, in parallel.¹

Effect of Counter E.M.F. in a Circuit.—One of the best examples of the “counter” or opposing E.M.F. in a circuit, is that of a battery of secondary cells being charged from a dynamo or other source of supply.

¹ It will be found that in some cases a greater current is obtained when, instead of connecting a number of series groups in parallel (each group having an equal number of cells), the cells are connected up irregularly.

In this case, the E.M.F. of the battery acts in opposition to the E.M.F. of the dynamo, so that, before a current will flow from the dynamo through the cells, the dynamo E.M.F. must overcome the back E.M.F. of the battery.

For example, if a battery has an E.M.F. of 98 volts, then, when charging, the dynamo must develop an E.M.F. of over 98 volts.

Having calculated in a particular case the E.M.F. required to exactly counterbalance the back E.M.F. of a battery, then the additional E.M.F. required to send a certain charging current through the battery can be determined by multiplying the total resistance of the battery by the current required.

Example 24.—A series battery consisting of 52 secondary cells, each having an E.M.F. of 2·1 volts and internal resistance of 0·06 ohm, is required to be re-charged at a current of 10 amps. What P.D. must the dynamo develop at the terminals of the battery?

$$\begin{aligned} \text{Counter E.M.F. of battery} &= 52 \times 2\cdot1 = 109\cdot2 \text{ volts.} \\ \text{Total internal resistance of battery} &= 52 \times 0\cdot06 = 3\cdot12 \text{ ohms,} \\ \therefore \text{additional E.M.F. required to} & \left. \vphantom{\begin{aligned} \text{Counter E.M.F. of battery} \\ \text{Total internal resistance of battery} \end{aligned}} \right\} = 3\cdot12 \times 10 = 31\cdot2 \text{ volts,} \\ \text{force 10 amps. through battery} & \\ \therefore \text{total P.D. which dynamo must} & \left. \vphantom{\begin{aligned} \text{Counter E.M.F. of battery} \\ \text{Total internal resistance of battery} \\ \text{additional E.M.F. required to force 10 amps. through battery} \end{aligned}} \right\} = 109\cdot2 + 31\cdot2 = 140\cdot4 \\ \text{develop at battery terminals} & \text{ volts.} \end{aligned}$$

Example 25.—If, in Example 24, the battery was connected to the dynamo by means of a pair of leads, each having a resistance of 0·08 ohm, what terminal P.D. would the dynamo have to develop?

From Example 24—

$$\begin{aligned} \text{P.D. required at battery} & \left. \vphantom{\begin{aligned} \text{P.D. required at battery} \\ \text{terminals} \end{aligned}} \right\} = 140\cdot4 \text{ volts.} \\ \text{terminals} & \end{aligned}$$

But P.D. at dynamo terminals = P.D. at battery terminals
 + "drop" in leads,
 drop in leads = current \times resistance of
 leads
 = $10 \times 2 \times 0.08 = 1.6$ volt,
 \therefore P.D. at dynamo terminals }
 must be $140.4 + 1.6$ } = 142 volts.

Example 26.—A series battery of 55 accumulators is required to be charged from a pair of 150-volt constant-pressure mains, the current not to exceed 16 amps. Assuming each cell to have an E.M.F. of 1.9 volts and an internal resistance of 0.003 ohm, what must be the value of an external series resistance which will limit the current to the specified value?

Counter E.M.F. of battery = $55 \times 1.9 = 104.5$ volts.
 Total internal resistance of }
 battery } = $55 \times 0.003 = 0.165$ ohm,
 \therefore additional E.M.F. to force }
 16 amps. through battery } = $16 \times 0.165 = 2.64$ volts,
 \therefore total E.M.F. required = $104.5 + 2.64 = 107.14$
 volts,
 \therefore E.M.F. to be absorbed by }
 external resistance } = $150 - 107.14 = 42.86$ volts,
 and since current = 16 amps.,
 external resistance = $\frac{42.86}{16} = 2.7$ ohms.

Example 27.—A battery of 60 accumulators is installed to light a country house, but by some mishap, five of the accumulators are connected so as to oppose the remaining 55. Assuming the E.M.F. and internal resistance of each cell to be respectively 2.1 volts and 0.0116 ohm, determine what voltage the lamps would obtain—(a) with faulty connection, (b) with correct connection. Assume resistance of lamps and connecting leads to be respectively 3.5 ohms and 0.21 ohm.

(a) Available E.M.F. = $(55 \times 2.1) - (5 \times 2.1) = 105$ volts.

Total resistance of circuit } = resistance of battery + lamps
+ leads
= $(60 \times 0.0116) + 3.5 + 0.21 = 4.406$
ohms,

$$\therefore \text{current} = \frac{\text{total E.M.F.}}{\text{total resistance}} = \frac{105}{4.406} = 23.8 \text{ amps.},$$

\therefore voltage across lamps = $23.8 \times 3.5 = 83.3$ volts.

(b) Available E.M.F. = $60 \times 2.1 = 126$ volts,

and from (a)—

total resistance of circuit = 4.406 ohms,

$$\therefore \text{current} = \frac{126}{4.406} = 28.6 \text{ amps.},$$

\therefore voltage across lamps = $28.6 \times 3.5 = 100$ volts.

Shunts and External Resistances.—It is usual, in the construction of modern continuous-current ammeters, to make use of delicate D'Arsonval galvanometers in conjunction with shunt resistances.

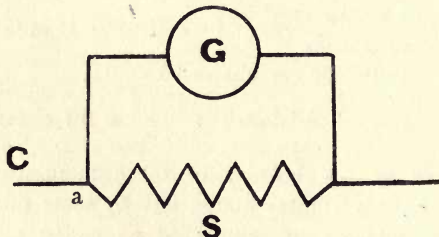

FIG. 23.

This arrangement permits of large currents being measured whilst only a very small portion of the total current passes through the galvanometer.

Let G and S (Fig. 23) represent a galvanometer

and shunt as described above, and let their respective resistances be R_g and R_s ; also let the currents flowing through the galvanometer and shunt be denoted by C_g and C_s respectively. Then the main current C will be divided into two parts at the point a , namely C_g and C_s ; therefore—

$$C = C_g + C_s$$

It will be obvious that if the conducting power of S was three times that of G , then—

$$C_s = 3C_g$$

or, since three parts of the main current would go through S , and only one through G —

$$C_s = \frac{3}{4}C$$

$$\text{and } C_g = \frac{1}{4}C$$

therefore we conclude that the main current will divide itself directly as the conductance, or inversely as the resistance, of the respective paths; therefore, if R_s was $\frac{1}{n}$ part of R_g , the conductivity of S would be n times that of G , and consequently C_s would be n times C_g , from which the main current C would be $(n + 1)$ times C_g , and since $n = \frac{R_g}{R_s}$ —

$$C = \left(\frac{R_g}{R_s} + 1 \right) C_g \dots \dots (4)$$

This value $\left(\frac{R_g}{R_s} + 1 \right)$ is usually termed the multiplying power of the shunt; it is the factor by which the current through the galvanometer must be

multiplied in order to obtain the value of the main current, or—

$$C = C_g \left(\frac{R_g}{R_s} + 1 \right) = C_g \left(\frac{R_g + R_s}{R_s} \right)$$

and transposing—

$$C_g = \frac{R_s}{R_g + R_s} \times C \dots \dots (5)$$

Similarly, it can be shown that—

$$C = C_s \left(\frac{R_s + R_g}{R_g} \right)$$

from which—

$$C_s = \frac{R_g}{R_g + R_s} \times C \dots \dots (6)$$

Example 28.—A galvanometer of 200 ohms resistance is shunted by means of a resistance of 8 ohms. Determine the multiplying power of the shunt.

$$\text{Multiplying power of shunt} = \frac{R_g}{R_s} + 1 = \frac{200}{8} + 1 = 26,$$

that is to say, if at any time the galvanometer indicated a current of say 0.02 amp., the main current in the circuit would be $0.02 \times 26 = 0.52$ amp.

Example 29.—The resistances of a delicate galvanometer and its shunt are respectively 250 ohms and 7.5 ohms. What will be the respective currents in the galvanometer and shunt if the main current = 0.29 amp.?

From (5)—

$$C_g = \frac{R_s}{R_g + R_s} \times C = \frac{7.5}{250 + 7.5} \times 0.29 = 0.00845 \text{ amp.}$$

From (6)—

$$C_s = \frac{R_g}{R_g + R_s} \times C = \frac{250}{250 + 7.5} \times 0.29 = 0.28155 \text{ amp.}$$

Example 30.—A galvanometer of 120 ohms resistance is connected in series with a standard Daniell's cell (E.M.F. 1.1 volts) and a resistance of 10,000 ohms. It is found that when the galvanometer is shunted with a resistance of 2 ohms, the deflection indicated is 30 divisions on the scale. Determine the "figure of merit" of the galvanometer (*i.e.* the current required to produce 1 division deflection). The resistance of the Daniell's cell may be neglected.

Since the combined resistance of the galvanometer and shunt is less than 2 ohms, it may be neglected when calculating the total current.

$$\therefore \text{total current} = \frac{1.1}{10000} = 0.00011 \text{ amp.}$$

But from (5)—

$$C_g = \frac{R_s}{R_g + R_s} \times C = \frac{2}{120 + 2} \times 0.00011 = 0.00001804 \text{ amp.}$$

$$\begin{aligned} \therefore \text{current required to produce 1} \left. \begin{array}{l} \text{division deflection} \end{array} \right\} &= \frac{0.00001804}{30} \\ &= 0.000000601 \text{ amp.} \\ &= 0.0601 \text{ micro-amp.} \end{aligned}$$

Example 31.—A galvanometer of 9 ohms resistance has a "figure of merit" of 0.00000244 amp. per division, and it is found that when a shunt resistance of 2.25 ohms is connected to its terminals, a deflection of 106 scale divisions is produced by a certain battery. What is the value of the current passing through the battery?

$$\left. \begin{array}{l} \text{Current through} \\ \text{galvanometer} \end{array} \right\} = 106 \times 0.00000244 = 0.00025864 \text{ amp.}$$

But from (4)—

$$\begin{aligned} \text{Main current} &= C_g \left(\frac{R_g}{R_s} + 1 \right) = 0.00025864 \left(\frac{9}{2.25} + 1 \right) \\ &= 0.0012932 \text{ amp.} \end{aligned}$$

It is sometimes necessary to provide a galvanometer with three shunts which will allow either $\frac{1}{10}$, $\frac{1}{100}$, or $\frac{1}{1000}$ of the total current to pass through the galvanometer; that is to say, the indication of the galvanometer must be multiplied by 10, 100, or 1000, according to the particular shunt in use, in order to obtain the value of the main current.

Obviously, if only $\frac{1}{10}$ of the total current has to flow through the galvanometer, the remaining $\frac{9}{10}$ must flow through the shunt, therefore the conductivity of the shunt will be 9 times that of the galvanometer, or, in other words, the resistance of the shunt will be $\frac{1}{9}$ of the resistance of the galvanometer. The same reasoning applies to the other shunts whose resistances would be respectively $\frac{1}{99}$ and $\frac{1}{999}$ of the galvanometer resistance.

Example 32.—It is required to provide a galvanometer of 380 ohms resistance with three shunts, which shall allow either $\frac{1}{5}$, $\frac{1}{20}$, or $\frac{1}{100}$ of the total current to flow through the galvanometer. Calculate the resistances of suitable shunts.

From above reasoning—

$$\text{Resistance of } \frac{1}{5} \text{ shunt} = \frac{1}{4} \text{ of } 380 = 95 \text{ ohms.}$$

$$\text{,, ,, } \frac{1}{20} \text{ ,,} = \frac{1}{19} \text{ ,,} = 20 \text{ ,,}$$

$$\text{,, ,, } \frac{1}{100} \text{ ,,} = \frac{1}{99} \text{ ,,} = 3.84 \text{ ,,}$$

Example 33.—A pivoted moving coil instrument has a resistance of 1.2 ohms, and a current of 0.065 amp. is required to produce a full scale deflection. What must be the resistance of a shunt such that when connected to the instrument, a full scale deflection is obtained when the current in the main circuit is 10 amps.?

Since instrument requires 0.065 amp. for full scale deflection—

Current through shunt = $10 - 0.065 = 9.935$ amps.

that is to say, the shunt must have $\frac{9.935}{0.065}$ times the conductivity of instrument; that is, $\frac{0.065}{9.935}$ times the resistance of the instrument.

$$\therefore \text{resistance of shunt} = \frac{0.065 \times 1.2}{9.935} = 0.00785 \text{ ohm.}$$

Example 34.—What resistance would have to be placed in series with the instrument in the previous example, in order that a full scale deflection would be produced when a P.D. of 3 volts was applied?

$$\left. \begin{array}{l} \text{Current required to produce full} \\ \text{scale deflection} \end{array} \right\} = 0.065 \text{ amp.}$$

$$\therefore \left. \begin{array}{l} \text{total resistance required to obtain} \\ 0.065 \text{ amp. at P.D. of 3 volts} \end{array} \right\} = \frac{3}{0.065} = 46 \text{ ohms.}$$

$$\text{But instrument resistance} = 1.2 \text{ ohms,}$$

$$\therefore \left. \begin{array}{l} \text{additional series resistance} \\ = 46 - 1.2 \\ = 44.8 \text{ ohms.} \end{array} \right\}$$

Example 35.—The scale of a moving coil voltmeter is divided into 150 divisions, each of which represents 1 millivolt. The resistance of the moving coil is 2 ohms. Calculate (a) the exact resistance to be put in series so that the whole scale represents 15 volts; (b) the exact resistance of a shunt such that the instrument will read 15 amps. for a full scale deflection.

$$\left. \begin{array}{l} \text{(a) Volts required to produce} \\ \text{full scale deflection} \end{array} \right\} = 150 \times 0.001 = 0.15 \text{ volt,}$$

$$\therefore \left. \begin{array}{l} \text{current required to produce} \\ \text{full scale deflection} \end{array} \right\} = \frac{0.15}{2} = 0.075 \text{ amp.}$$

$$\left. \begin{array}{l} \text{Total resistance to obtain full} \\ \text{scale deflection on 15 volts} \end{array} \right\} = \frac{15}{0.075} = 200 \text{ ohms,}$$

$$\therefore \left. \begin{array}{l} \text{additional series resistance} \\ \text{to be added to instrument} \end{array} \right\} = 200 - 2 = 198 \text{ ohms.}$$

(b) Current required for full } = 0.075 amp.
 scale deflection

∴ current taken by shunt = 15 - 0.075 = 14.925
 amps.

But it has been shown that—

$$\frac{\text{current in instrument}}{\text{current in shunt}} = \frac{\text{resistance of shunt}}{\text{resistance of instrument}}$$

$$\begin{aligned} \therefore \text{resist. of shunt} &= \frac{\text{current in instrument} \times \text{resist. of instrument}}{\text{current in shunt}} \\ &= \frac{0.075 \times 2}{14.925} = 0.01005 \text{ ohm.} \end{aligned}$$

Universal Shunt.—It has been shown that the multiplying power of a shunt, which we shall denote by M , = $\frac{R_g + R_s}{R_s}$.

If by any means the numerator of this fraction (viz. the resistance of the galvanometer + the resistance of the shunt) could be kept constant, then the multiplying power of the shunt will vary inversely as its resistance, or, in any given case, if R_g and R_s be known, and a particular value of M be selected, then—

$$R_s = \frac{R_g + R_s}{M}$$

This principle has been employed in the so-called “Universal shunt” devised by Professor Ayrton and Mr. Mather, a diagram of which is shown in Fig. 24.

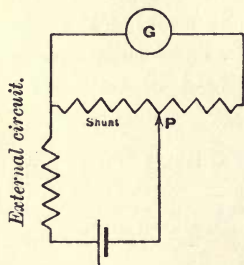

FIG. 24.

It will be observed that the galvanometer is

permanently connected across a high resistance (usually 10,000 ohms), and by varying the position of the contact arm P, any value of shunt resistance can be obtained without altering the value of the combined resistance $R_g + R_s$. Fig. 25 shows the actual connections of a universal shunt box, the fractional number on the contact studs corresponding to the fraction of the total current which will pass through the galvanometer when P is in contact with that particular stud.¹

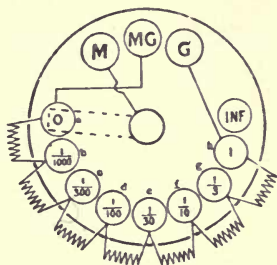

FIG. 25.

Obviously, when P is placed on stud (a), no current will pass through the galvanometer, and when on stud INF, the circuit will be entirely disconnected. The total resistance between (a) and (h) is usually made so high that the galvanometer resistance may be neglected.

Example 36.—Calculate the values of the resistances which must be placed between adjacent contact studs in order that the main current may apportion itself through the galvanometer and shunt as indicated by the respective fractional numbers in Fig. 25; total resistance of shunt between (a) and (h) to be 10,000 ohms.

Since, when P is on contact stud (b), only $\frac{1}{1000}$ of the total current passes through the galvanometer, the multiplying power of the shunt must be 1000. Therefore from formula given—

¹ This statement is made on the assumption that the galvanometer resistance is low.

$$R_s = \frac{R_g + R_x}{1000}$$

$$= \frac{10,000}{1000} = 10 \text{ ohms.}$$

Similarly, the other values of R_s may be calculated as follows—

Resistance between	(a) and (b)	=	$\frac{10000}{1000}$	=	10	ohms.
”	”	(a) ,, (c)	=	$\frac{10000}{300}$	=	33·3 ”
”	”	(a) ,, (d)	=	$\frac{10000}{100}$	=	100 ”
”	”	(a) ,, (e)	=	$\frac{10000}{30}$	=	333·3 ”
”	”	(a) ,, (f)	=	$\frac{10000}{10}$	=	1000 ”
”	”	(a) ,, (g)	=	$\frac{10000}{3}$	=	3333·3 ”
”	”	(a) ,, (h)	=	$\frac{10000}{1}$	=	10,000 ”

From the above values, the resistance between adjacent contact studs may be calculated as follows :—

Resist. between	(a) and (b)	=	10 ohms.
”	”	(b) ,, (c)	= 33·3 - 10 = 23·3 ohms.
”	”	(c) ,, (d)	= 100 - 33·3 = 66·6 ohms.
”	”	(d) ,, (e)	= 333·3 - 100 = 233·3 ohms.
”	”	(e) ,, (f)	= 1000 - 333·3 = 666·6 ohms.
”	”	(f) ,, (g)	= 3333·3 - 1000 = 2333·3 ohms.
”	”	(g) ,, (h)	= 10,000 - 3333·3 = 6666·6 ohms.

Compensating Resistances. — It is sometimes necessary, when shunts are employed, to arrange series or compensating resistances which shall keep the total resistance of the circuit constant, irrespective of the value of the shunt used; for example, when a galvanometer is shunted, the resistance of the galvanometer and shunt in parallel is much less than that of the galvanometer alone, and consequently the introduction of the shunt alters the value of the current flowing in the circuit. If, however, a resistance

is put in series with the combination (see Fig. 26) of such a value as to just compensate for the diminution in resistance when the galvanometer is shunted, then the current flowing in the circuit will remain constant.

Compensating resistances are usually fitted so that when a particular shunt is switched into circuit, the corresponding series or compensating resistance is introduced, as shown in Fig. 26.

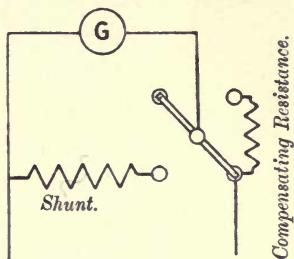

FIG. 26.

Example 37.—A sensitive galvanometer having a resistance of 3600 ohms is fitted with a $\frac{1}{10}$ shunt. What must be the value of a compensating resistance such that the current in the circuit may remain constant whether the galvanometer is shunted or not?

Since $\frac{1}{10}$ of total current flows through galvanometer—

$$\text{Resistance of shunt} = \frac{1}{9} \times 3600 = 400 \text{ ohms.}$$

When shunt is in use—

$$\text{resistance of combination} = \frac{3600 \times 400}{3600 + 400} = 360 \text{ ohms,}$$

$$\therefore \left. \begin{array}{l} \text{additional resistance to} \\ \text{be added} \end{array} \right\} = 3600 - 360 = 3240 \text{ ohms.}$$

One of the best examples of the use of compensating resistances is that of the Kelvin insulation testing set. This testing set, as shown diagrammatically in Fig. 27, consists of a delicate galvanometer having a resistance of 50,000 ohms, and the indications of which are proportional to the current passing through the coil.

The galvanometer is provided with three shunts and corresponding compensating resistances as shown,

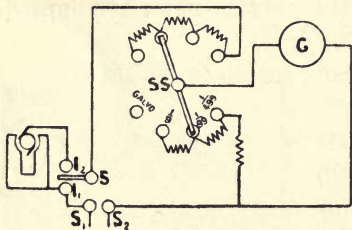

FIG. 27.

so that the resistance of the galvanometer, whether shunted or not, is maintained constant at 50,000 ohms. In using this set, the insulation resistance to be tested (represented as a dynamo in Fig. 27) is connected between the terminals I_1 , I_2 , the remaining terminals S_1 , S_2 being connected to a source of constant E.M.F. supply, say 100 volts, which, as will be shown later, need not be definitely known.

In order to make a test, the galvanometer pointer is adjusted to zero, by means of a controlling magnet, and the switch S is then placed on the contact stud attached to I_1 . The galvanometer is then connected to the main supply, and by adjusting the shunt switch SS , a suitable deflection may be obtained.

Let d_1 = deflection produced in this case ;

s_1 = shunt employed in this case.

Then, since the indication of the galvanometer is proportional to the current passing, total C is proportional to $d_1 s_1$; also E.M.F. of supply = CR , which is proportional to $d_1 s_1 \times 50,000$.

If now the switch S be placed on the contact stud attached to I_2 , the insulation resistance is put in series with the galvanometer, and a suitable deflection may again be obtained by adjusting the shunt switch.

Now, if d_2 and s_2 represent the deflection and shunt respectively in the second case, we have as before, E.M.F. of supply $\propto d_2 s_2 \times (50,000 + x)$, where x represents the insulation resistance to be determined; and since E.M.F. of supply is constant—

$$d_1 s_1 \times 50,000 = d_2 s_2 \times (50,000 + x)$$

from which—

$$x = \frac{d_1 s_1 \times 50,000}{d_2 s_2} - 50,000 \text{ ohms.}$$

It should be particularly noticed that the multiplying powers of the shunts are respectively 10, 100, and 500, and not 9, 99, and 499.

Example 38.—It was required to determine the insulation resistance of (a) the armature, and (b) the field coils of a certain electric motor from the frame. A Kelvin insulation testing set was used for the determination, and the following table of results obtained:—

	Galvanometer alone.		Galvanometer + insulation resistance.	
	Deflection d_1 .	Shunt s_1 .	Deflection d_2 .	Shunt s_2 .
Armature ...	10	100	40	10
Field ...	10	100	7.5	1

Calculate the insulation resistance of the armature and field coils respectively.

From previous formula—

$$\text{Insulation resistance} = \frac{d_1 s_1 \times 50,000}{d_2 s_2} - 50,000 \text{ ohms}$$

$$\begin{aligned} \therefore \text{insul. resist. of armature} &= \frac{10 \times 100 \times 50,000}{4 \times 10} - 50,000 \\ &= 1,200,000 \text{ ohms} \\ &= 1.2 \text{ megohms.} \end{aligned}$$

$$\begin{aligned} \text{Insul. resist. of field coils} &= \frac{10 \times 100 \times 50,000}{7.5 \times 1} - 50,000 \\ &= 6,620,000 \text{ ohms} \\ &= 6.62 \text{ megohms.} \end{aligned}$$

Wheatstone's Bridge.—It will be convenient, at this stage of the work, to introduce calculations involved in the measurement of electrical resistance by the Wheatstone's bridge method. This method is very generally employed by laboratory students, but the actual basis on which their results are obtained is often misunderstood.

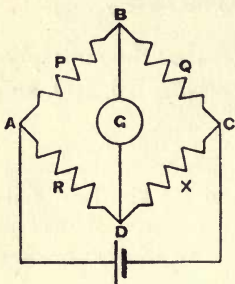

FIG. 28.

Fig. 28 represents diagrammatically the usual form of Wheatstone's bridge arrangement. P, Q, and R are resistances of known value, whilst X is the resistance to be determined.

X is the resistance to be determined.

The usual method of procedure in performing the experiment is to vary the values of the resistances P, Q, and R, until the galvanometer G indicates that no current is passing between the points B and D; then the resistance of X may be determined from the following simple relation:—

$$\begin{aligned} P : Q &:: R : X \\ \text{or } X &= \frac{RQ}{P} \end{aligned}$$

The proof of this formula is a simple application of Ohm's law, and is as follows:—

Referring to Fig. 28, the current from the cell,

on arrival at A, divides into two portions, one portion going by way of P and Q, and the other portion by way of R and X, uniting again at C.

It will be obvious that the fall of potential, or pressure drop along P and Q, will be equal to that along R and X.

Now, if the resistances P, Q, and R have been so arranged that no current passes between the points B and D, then no potential difference can exist between B and D.

It follows, therefore, that there will be the same fall of pressure between A and B as between A and D; similarly, the fall of pressure between B and C will be equal to that between D and C.

Now, let C_1 = current flowing along P and Q;
 C_2 = " " R " X.

Then, from above reasoning—

$$PC_1 = RC_2 \quad . \quad . \quad . \quad . \quad . \quad (i.)$$

$$\text{and } QC_1 = XC_2 \quad . \quad . \quad . \quad . \quad . \quad (ii.)$$

Dividing (i.) by (ii.)—

$$\frac{PC_1}{QC_1} = \frac{RC_2}{XC_2}$$

and cancelling like quantities, we have—

$$\frac{P}{Q} = \frac{R}{X}$$

from which we derive our previous formula, namely—

$$X = \frac{RQ}{P}$$

Fig. 29 represents an elementary form of Wheatstone's bridge arrangement as used in many schools. In this case the value of R is constant, whilst P and Q (usually termed the ratio arms) consist of a length of uniform wire, usually manganin, stretched over a scale.

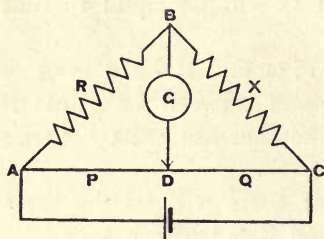

FIG. 29.

When making an observation, the contact wire D is moved along the uniform bridge wire until a point is found at which no deflection of the galvanometer pointer is produced;

then, since the resistance of any portion of the uniform wire is proportional to the length of that portion, our previous formula still holds good, and the value of X may be calculated by noting the lengths P and Q respectively, and also the value of the standard resistance R .

Example 39.—When using a standard resistance of 2 ohms, as indicated by R in Fig. 29, a “balance” was obtained when $P = 24$ cms. and $Q = 76$ cms. Determine the value of X in ohms.

$$X = \frac{QR}{P} = \frac{76 \times 2}{24} = 6.33 \text{ ohms.}$$

The best results are obtained in the above case when the point of balance is near the centre of the bridge wire; this can be effected by selecting a standard resistance, R , whose value is as nearly as possible equal to that of the resistance to be determined.

Post Office Resistance Box.—One of the best known arrangements for resistance measurement is the Post Office resistance box, which is nothing more than an elaborated Wheatstone's bridge.

Fig. 30 is a diagram of the general arrangement of the various coils. The letters correspond exactly with those of Fig. 29, and it will be noticed that P and Q consist respectively of three coils of 10, 100, and 1000 ohms, whilst R consists of a large number of coils varying in value from 1 to 4000 ohms.

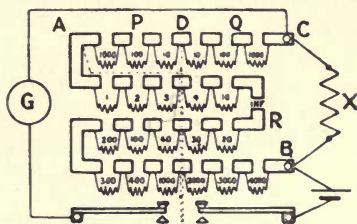

FIG. 30.

The adjustment of the resistance R is made by using metal plugs, which, when inserted between two adjacent brass blocks, short-circuit the resistance coil attached thereto.

The resistances P and Q admit of five different ratios being obtained, namely—

P	Q
10 to	10
10 „	100
10 „	1000
100 „	10
1000 „	10

the particular ratio being selected which, in conjunction with the resistance R, will give the most accurate value of X in ohms.

The following example will illustrate more clearly

the best arrangement of the various resistances for particular values of X.

Example 40.—A 50-c.p. electric incandescent lamp was connected to a P.O. resistance box, in order that its resistance might be determined when cold.

It was found that when $P = 10$ and $Q = 10$, the nearest balance was obtained when $R = 48$ ohms ; therefore—

$$X = \frac{QR}{P} = \frac{10 \times 48}{10} = 48 \text{ ohms.}$$

This result was, however, not sufficiently accurate, and a ratio of $100 : 10$ was taken.

The nearest balance was then obtained when $R = 484$ ohms ; therefore, as before—

$$\text{Resistance of lamp} = \frac{10 \times 484}{100} = 48.4 \text{ ohms.}$$

This second experiment gave the value of the resistance to the first decimal place, but still the accuracy was insufficient. A ratio of $1000 : 10$ was then taken, and the nearest balance was obtained when $R = 4847$ ohms ; therefore—

$$\text{Resistance of lamp} = \frac{10 \times 4847}{1000} = 48.47 \text{ ohms.}$$

which is accurate to the second decimal place.

Example 41.—The resistance of a 200-volt moving coil voltmeter was required to be determined, and after the necessary connections had been made to a P.O. box, a ratio of $10 : 10$ was taken and the nearest approach to a balance obtained when all the plugs in R were removed (*i.e.* all the resistance inserted). It was concluded from this that the resistance of the voltmeter was much above

11,000 ohms (the limit of R), and consequently a ratio of $\frac{P}{Q}$ 10 : 100 was taken, which gave the nearest balance when $R = 1400$ ohms; therefore—

$$\text{Resistance of voltmeter} \frac{100 \times 1400}{10} = 14,000 \text{ ohms.}$$

EXAMPLES.

1. A cell on open circuit gives an E.M.F. of 1.86 volts, but when sending a current of 0.45 amp. through a circuit, the terminal P.D. is only 1.42 volts. Calculate the internal resistance of the cell.

2. A cell has an E.M.F. of 1.43 volts and an internal resistance 0.26 ohm. What will be the P.D. at the terminals of the cell when sending a current of 1.5 amps.?

3. The resistance of the armature of a separately excited dynamo is 0.4 ohm, and of the external circuit 23 ohms. Assuming the P.D. at the terminals of the machine to be 110 volts, determine the open circuit E.M.F. of the machine.

4. Assuming a certain battery to have an internal resistance of 4 ohms, and an E.M.F. of 10 volts, plot a graph connecting current and external resistance.

5. When a certain battery is sending a current of 6 amps. its terminal P.D. is 4 volts, but when sending a current of 4 amps. the terminal P.D. is 4.5 volts. Determine the internal resistance and E.M.F. of the battery.

6. A separately excited dynamo has an open circuit E.M.F. of 110 volts. Assuming the armature resistance to be 1.2 ohms, plot a graph connecting current and P.D. at terminals.

7. When thirty-five lamps, each taking 0.6 amp., are connected to a separately excited dynamo, the P.D. at its terminals is 108.5 volts; but when sixty-four lamps are connected, the P.D. at terminals falls to 107.6 volts. Deduce the open circuit E.M.F. of the machine.

8. The internal resistance of a battery is four times the external resistance. Assuming the E.M.F. to be 12 volts, determine the terminal P.D.

9. A shunt dynamo has an armature resistance of 0.06 ohm, and a field resistance of 82 ohms. The external circuit consists of

eighty-four 16-c.p. lamps, each having a resistance of 180 ohms. If the P.D. at the dynamo terminals is 110 volts, calculate the "drop" in the armature, the shunt current, and the external current.

10. A battery of very small dry cells has an internal resistance of 64 ohms, and when a voltmeter of 2000 ohms resistance was used to measure the E.M.F. of the battery, the reading was 84 volts. Determine the true E.M.F. of the battery.

11. A battery is composed of fifty-six accumulators, each having an E.M.F. of 2.1 volts and an internal resistance of 0.002 ohm. What resistance must be inserted in series with the battery in order to charge it with a current of 30 amps. when a pressure of 150 volts is applied?

12. When measuring the value of a certain resistance, the voltmeter was connected up so as to measure the voltage, not only across the resistance, but also across the ammeter. The resistance of the voltmeter was 200 ohms, and of the ammeter 0.005 ohm. The ammeter reading was 25 amps., and the voltmeter reading was 4.8 volts. Calculate the true value of the resistance.

13. Repeat the last example on the supposition that the voltmeter is connected across the resistance only.

14. Assuming that you were supplied with twenty cells, each having an internal resistance of 0.2 ohm and an E.M.F. of 1.4 volts, what regular arrangement would give you a maximum current through 1 ohm?

15. A battery of 120 accumulators, each having an internal resistance of 0.01 ohm, is being charged by a current of 30 amps., the pressure of supply being 260 volts. Assuming the resistance placed in series with the battery to be 0.3 ohm, calculate the average E.M.F. of each accumulator.

16. The armature resistance of a certain motor is 0.15 ohm. When a resistance of 6 ohms is inserted in series with the armature, and the combination placed across 110-volt mains, the armature current is found to be 6.2 amps. Calculate the back E.M.F. of the armature.

17. A galvanometer having a resistance of 64 ohms is shunted by a resistance of 4 ohms. What is the multiplying power of the shunt?

18. In the case mentioned above, calculate the resistance of a shunt which would have a multiplying power of 100.

19. A galvanometer having a resistance of 18 ohms is shunted by a resistance of 2 ohms. Calculate the value of the multiplying power of the shunt; also calculate the value of the resistance which must be introduced in order to keep the total resistance of the circuit constant when the galvanometer is shunted.

20. It is required to construct a shunt and compensating resistance for a galvanometer having a resistance of 200 ohms. Assuming the multiplying power required to be 3, determine the value of each of the resistances required.

21. A battery having an E.M.F. of 10 volts and an internal resistance of 2 ohms is connected in series with a resistance of 40 ohms and a galvanometer, the latter being provided with a shunt of 0.5 ohm resistance. The galvanometer resistance being 80 ohms, calculate the value of the galvanometer current.

22. A certain galvanometer of 4 ohms resistance requires a current of 0.01 amp. to produce a full-scale deflection. Calculate the resistance of a shunt which, when used in conjunction with the galvanometer, will give a full-scale deflection for 100 amps. What resistance must be inserted in series with the galvanometer in order that a full-scale deflection may be obtained for 100 volts?

23. When a P.D. of 220 volts was applied to a resistance of 1 megohm, a deflection of 23 scale divisions was obtained on a galvanometer inserted in the circuit, the multiplying power of the galvanometer shunt being 100. When an unknown resistance was substituted in place of the megohm, a deflection of 4.5 divisions was obtained with the galvanometer unshunted. Calculate the value of the unknown resistance.

24. A galvanometer, with various shunts, is connected in series with a high resistance and a constant source of P.D. When the high resistance is 2 megohms, a deflection of 24 divisions is obtained with a $\frac{1}{200}$ shunt. What deflection will be obtained if the high resistance is 26 megohms, using the $\frac{1}{25}$ shunt?

25. A battery of twenty-four cells is arranged in four rows, six cells being in series in each row. If the E.M.F. and internal resistance of each cell are respectively 1.4 volts and 0.6 ohm, determine what current would flow through an external resistance of 7 ohms.

26. Which would give the strongest current through a telegraph line of 30 ohms resistance—(a) twelve cells of a battery, the cells

being all in series, or (b) eight cells, arranged four in series and two rows in parallel? The resistance of each cell is 10 ohms.

27. It is required to employ a number of primary cells to send a current of 2.5 amps. through an electro-magnet of 7.5 ohms resistance. If each cell has an E.M.F. of 1.5 volts and an internal resistance of 0.3 ohm, how many will be required?

28. A galvanometer of 200 ohms resistance is connected in series with a Daniell's cell (1.1 volts) and a resistance of 14,000 ohms. When a 2-ohm shunt is employed with the galvanometer, a deflection of 46 scale divisions is obtained. Determine the "figure of merit" of the galvanometer.

29. A milli-voltmeter with 100 scale divisions has a resistance of 1.5 ohms. Calculate the resistance to be put in series with the instrument in order that the full scale deflection shall represent 100 volts; also calculate the resistance of a shunt in order that the full scale deflection shall represent 10 amps.

30. When using a P.O. resistance box to determine the resistance of a voltmeter, a ratio of 10 : 1000 was taken, and a balance was obtained when 120 ohms were unplugged in the rheostat arm. What was the resistance of the voltmeter?

31. What current will 15 cells, each having an E.M.F. of 1.07 volts and an internal resistance of 0.7 ohm, send through an electro-magnet, having 28 ohms resistance, when the electro-magnet is shunted with a wire having 7 ohms resistance?

32. A glow lamp taking 0.5 amp. when supplied with 100 volts at its terminals, is connected with 100-volt constant-pressure mains by means of two leads having together a resistance of two-thirds of an ohm. What will be the current passing through this lamp when connected alone, and also when one, two, three, four, five, and six precisely similar glow lamps are turned on in parallel with the first, assuming that the resistance of the carbon filament is regarded as unchanged through the variation of the current?

33. The P.D. at the terminals of a battery falls from 10 to 6 volts when a resistance of 10 ohms is connected between the terminals. What is the internal resistance of the battery?

34. You are given 16 cells, each having an internal resistance of 1 ohm. How would you connect them up so as to get as large a current as possible through a wire of 4 ohms resistance? If each cell had an E.M.F. of 1 volt, what current would you get through the wire?

35. Calculate the value of the resistances required for the $\frac{1}{10}$ and $\frac{1}{30}$ shunts for a galvanometer of 5000 ohms resistance.

36. A shunt-wound dynamo producing a terminal P.D. of 150 volts is used to charge 60 storage cells, each having an E.M.F. of 2.2 volts and an internal resistance of 0.001 ohm. If the leads joining the dynamo and cells have a resistance of 0.2 ohm, what will be the current generated?

37. The poles of a battery of E.M.F. E are connected by a resistance R ; it is found that the current flowing in the circuit is C , and the P.D. between the poles of the battery is e . What is the resistance of the battery—(a) in terms of E , R , and C ; (b) in terms of E , R , and e ?

38. Two cells, A and B, each of 1 volt E.M.F. and of 5 and 10 ohms resistance respectively, have the positive pole of A joined to the negative pole of B, and the negative pole of A joined to the positive pole of B. What is the P.D. between the respective junctions?

39. Two resistances of 6 and 8 ohms respectively are connected in parallel, and the combination placed in series with a resistance of 4 ohms. What voltage must be applied in order that a current of 4 amps. may flow?

40. What resistance must be inserted in series with two other resistances of 120 and 180 ohms respectively, the latter being connected in parallel, in order that when 110 volts are applied a current of 1.2 amps. will flow?

CHAPTER V

POWER AND WORK

WHEN any force overcomes the resistance opposed to it and moves its point of application, work is performed. Thus, if the pressure of the steam behind the piston of a steam-engine overcomes the resistance opposed to it and moves the piston along the cylinder, work is done by the steam; if, however, the resistance opposed to the force of the steam is sufficient to prevent the piston moving, then no work will be performed.

In a similar manner, if we have an E.M.F. overcoming the resistance opposed to it and sending a current, work is performed in the circuit; if the resistance in the circuit is so high that we may assume no current is sent, then no work will be performed.

The resistance opposed to the impressed E.M.F. may be of the nature of a back E.M.F., as when the current is used to drive a motor or charge an accumulator; or it may take the form of ohmic resistance, as in the case in the glow lamp.

Referring again to the mechanical analogy above mentioned, the amount of work performed is evidently proportional to the impressed force, and also to the displacement produced.

Power and Work. 101

In a similar manner, in the electrical circuit, the amount of work done is proportional to the force exerted (that is, the potential difference applied), and to the electrical displacement produced, this latter quantity meaning the amount of electricity transferred from the higher to the lower pressure, which is equal to the product of the current strength and the time during which it is flowing.

We can briefly express the above by saying that—

$$W \propto ECt.$$

If E is expressed in volts, C in amperes, and t in seconds, and if the sign of equality be substituted for the sign of proportionality, W will be given in terms of a unit known as the joule. This unit is defined to be the amount of work performed in a circuit in one second, in which one ampere is flowing with a pressure drop of one volt.

If the current is half an ampere, and the P.D. between the ends of the circuit is still one volt, we shall evidently have one joule of work performed in two seconds.

The formula which we arrived at above—

$$\text{Work (in joules)} = ECt \quad . \quad . \quad . \quad (1)$$

may be expressed in two other forms, if we remember the relationship existing between E , C , and R expressed in Ohm's law.

In the first place, if we substitute for E the value CR , we obtain—

$$W = C^2Rt \quad . \quad . \quad . \quad . \quad (2)$$

Again, if we substitute $\frac{E}{R}$ for C , we have—

$$W = \frac{E^2}{R}t \quad . \quad . \quad . \quad . \quad . \quad (3)$$

Of the three forms given above, the one made use of in any particular case will obviously depend upon the data available; thus, if we were given the resistance of a circuit, and the current flowing through it, we should naturally use (2), in order to determine the quantity of work performed in a given time.

Example 1.—Calculate the electrical energy absorbed in five minutes by a 220-volt glow lamp taking 0.34 amp.

$$W = ECt = 220 \times 0.34 \times 60 \times 5 \text{ joules} = 22,440 \text{ joules.}$$

Example 2.—What quantity of energy will be absorbed in one minute in the shunt field coil of a motor, if the coil has a resistance of 80 ohms, and carries a current of 1.29 amps. ?

$$W = C^2Rt = 1.29^2 \times 80 \times 60 \text{ joules} = 7988 \text{ joules.}$$

Example 3.—What current must pass through a coil of 45 ohms resistance, in order that 5000 joules may be absorbed in 2 mins. 15 secs. ?

$$\text{Now, } W = C^2Rt,$$

$$\text{hence } C^2 = \frac{W}{Rt}$$

$$\begin{aligned} \text{or } C &= \sqrt{\frac{W}{Rt}} = \sqrt{\frac{5000}{45 \times 135}} \text{ amp.} \\ &= 0.91 \text{ amp.} \end{aligned}$$

Example 4.—What voltage must be applied to a coil of 10 ohms resistance, in order that 3500 joules are dissipated in 3.6 mins. ?

$$\text{Now, } W = \frac{E^2}{R}t,$$

$$\therefore E^2 = \frac{WR}{t} \text{ or } E = \sqrt{\frac{WR}{t}},$$

$$\therefore E = \sqrt{\frac{3500 \times 10}{216}} = 12.7 \text{ volts.}$$

As the joule is rather a small unit, it is not much used in practice; but before we consider the practical units of quantity of energy or work, it will be advisable to discuss the units of power.

When we speak of the power of a machine, we mean the *rate* at which the machine can perform work. In electrical work we use as our unit of power the watt, which is the rate of working in a circuit in which energy is being transformed at the rate of one joule per second. Thus the power used in a circuit in which 60 joules are expended in 1 min. is 1 watt; the power used in a circuit in which 50 joules are expended in $\frac{1}{5}$ sec. is 250 watts.

It will be evident, from what has been stated, that we can define the power developed in a circuit as the quantity of work performed per second (assuming that the current and voltage keep constant during that time).

That being so, we can modify the formulæ given above for the work expended in a circuit, so that they will give the power of a circuit, all that is necessary being to make t equal to unity; thus we obtain—

$$P \text{ (in watts)} = CE \dots \dots (4)$$

$$P \quad \text{,,} \quad = C^2R \dots \dots (5)$$

$$P \quad \text{,,} \quad = \frac{E^2}{R} \dots \dots (6)$$

The student should note that the power expended in a circuit is quite independent of the time during which the current is flowing; if the current only flows say for $\frac{1}{1000}$ sec., the power developed in the circuit is given (during the time the current is flowing) by the above formulæ.

Example 5.—What must be the resistance of the filament of a glow lamp, if it is to absorb 105 watts, when placed across the 110-volt mains?

$$\begin{aligned} \text{Now, } P &= \frac{E^2}{R} & \therefore R &= \frac{E^2}{P}, \\ \therefore R &= \frac{110^2}{105} = 115 \text{ ohms (nearly).} \end{aligned}$$

Example 6.—How many watts will be absorbed in driving the current through the armature of a dynamo if its resistance is 0.046 ohm, and the current passing through it is 25 amps.?

$$P = C^2R = 25^2 \times 0.046 = 28.7 \text{ watts.}$$

Example 7.—The output of a generator is 2000 watts. What will be the maximum current it can produce if its voltage is 250 volts?

$$\begin{aligned} \text{Now, } P &= C \times E & \therefore C &= \frac{P}{E} \\ \therefore C &= \frac{2000}{250} = 8 \text{ amps.} \end{aligned}$$

The watt, as a unit of power, is far too small for most practical purposes, hence the power of large machines is usually expressed in terms of the kilowatt, which, as its name implies, is equivalent to 1000 watts.

Example 8.—When a certain machine was supplying 273 amps., its total output was 150 kilowatts (K.W.). At what pressure was the machine generating?

$$\begin{aligned} \text{Now, } P &= CE \\ \therefore E &= \frac{P}{C} = \frac{150 \times 1000}{273} \\ &= 550 \text{ volts (nearly).} \end{aligned}$$

Example 9.—The output of a machine is 25 K.W. at a pressure of 220 volts. What resistance will be necessary to absorb this?

$$\begin{aligned} \text{Now, K.W.} &= \frac{E^2}{1000R} \\ \therefore R &= \frac{E^2}{1000 \times \text{K.W.}} = \frac{220^2}{1000 \times 25} \\ &= 1.94 \text{ ohms.} \end{aligned}$$

Referring back to the units of work or energy, the joule, it may be remembered, is the quantity of work performed in one second in a circuit in which energy is being expended at the rate of one watt; the joule, therefore, might be termed a watt-second.

In a similar manner, the practical unit of quantity of work is defined as the quantity performed in one hour in a circuit in which energy is being expended at the rate of 1 K.W.; this quantity is termed the kilowatt-hour, and is evidently equal to 1000×3600 joules. The number of kilowatt-hours (K.W.H.) expended in a circuit can be determined by employing either of the following three formulæ:—

$$\text{K.W.H.} = \frac{CEt}{3600 \times 1000} \quad (7)$$

$$\text{K.W.H.} = \frac{C^2Rt}{3600 \times 1000} \quad (8)$$

$$\text{K.W.H.} = \frac{E^2 t}{R \times 3600 \times 1000} \dots (9)$$

t in each case being in seconds.

Example 10.—Calculate the power expended in a circuit in 40 mins. when a current of 20 amps. is passed through a resistance of 25 ohms.

$$\begin{aligned} \text{K.W.H.} &= \frac{C^2 R t}{3600 \times 1000} = \frac{20^2 \times 25 \times 40 \times 60}{3600 \times 1000} \text{ kilowatt-hrs.} \\ &= 6.67 \text{ K.W.H.} \end{aligned}$$

Another name very commonly used for this practical unit of quantity of energy is "Board of Trade unit" (B.O.T. unit).

Example 11.—In the case of a partial short circuit on a pair of 220-volt mains, it was estimated that a current of 1200 amps. flowed for 0.1 sec. How much energy was wasted?

$$\begin{aligned} \text{K.W.H.} &= \frac{CEt}{3600 \times 1000} = \frac{220 \times 1200 \times 0.1}{3600 \times 1000} \\ &= 0.0073 \text{ kilowatt-hr.} \end{aligned}$$

The above formulæ are rather cumbersome, and it will often be found convenient to calculate the B.O.T. units consumed by multiplying the power, expressed in K.W., by the time, expressed in hours T.

$$\text{K.W.H.} = \text{K.W.} \times \text{time in hours} \quad . \quad (10)$$

Example 12.—Determine the number of B.O.T. units developed in six hours by a generator giving 250 amps. at 220 volts.

$$\begin{aligned} \text{Output in K.W.H.} &= \text{K.W.} \times T \\ &= \frac{250 \times 220}{1000} \times 6 \\ &= 330 \text{ kilowatt-hrs.} \end{aligned}$$

Example 13.—To perform a certain amount of work 22 B.O.T. units are required. The output of the machine used is 125 amps. at 220 volts. For how long must it be used?

$$\begin{aligned} \text{Now, K.W.H.} &= \text{K.W.} \times \text{T}, \\ \text{hence T} &= \frac{\text{K.W.H.}}{\text{K.W.}} \\ &= \frac{22}{\frac{220 \times 125}{1000}} = 0.8 \text{ hr.} \end{aligned}$$

Example 14.—The pressure coil of a supply meter for a 110-volt circuit has a resistance of 5000 ohms. If this coil is across the mains for 16 hours each day, how much energy will be consumed in one year?

$$\begin{aligned} \text{K.W.H.} &= \left(\frac{E^2}{R \times 1000} \right) \times \text{T} \\ &= \frac{110^2}{5000 \times 1000} \times 16 \times 365 = 14.1 \text{ kilowatt-hrs.} \end{aligned}$$

Kilowatt Curves.—If a series of curves, which may be called kilowatt curves, be plotted as described below, they will be of great service in rapidly determining the power in circuits in which the current and voltage are known.

On a sheet of squared paper arrange to plot current as abscissæ and voltage as ordinates. Now, suppose we wish to plot the curve corresponding to 1 K.W.; assume any voltage, say 500, then the current necessary to produce 1 K.W. at this voltage is $\frac{1000}{500} = 2$ amps.; mark the point whose abscissa is 2 amps., and whose ordinate is 500 volts on the sheet. Determine other points on the 1 K.W. curve in a similar way, assuming a different voltage for each point.

If a smooth curve is now drawn through the points marked, the product of the current and voltage for any point on this curve represents a power of 1 K.W. Curves for 2, 3, 4, etc., kilowatts should now be plotted on the same sheet.

Suppose, now, we require to determine the power corresponding to a current of 16.6 amps. at a pressure of 183 volts. First draw the line AC, any point on which represents a current of 16.6 amps., and then see where it is cut by the line BC, any point on which represents a pressure of 183 volts. The lines intersect at C, which is seen to represent a power of 3.05 K.W. (nearly).

Efficiency.—When a machine is supplied with power, part of this power is actually utilized and part wasted. We express this by saying that the efficiency of the machine is less than unity, or, if we express the efficiency as a percentage, by saying that the efficiency is less than 100 per cent.

In this book it will be necessary to deal with two efficiencies—the electrical efficiency, and the total efficiency. We can best study the difference between these two efficiencies by considering the case of the dynamo.

In order to drive the generator, suppose that it is necessary to supply it with a power, which, measured in electrical units, is denoted by A. Part of this will be utilized in overcoming the friction, core losses, etc., and a part, which we will call B, appears as electrical power. This will not all be available for external use, as some of it will be wasted in driving the current through the armature, and some in driving the exciting

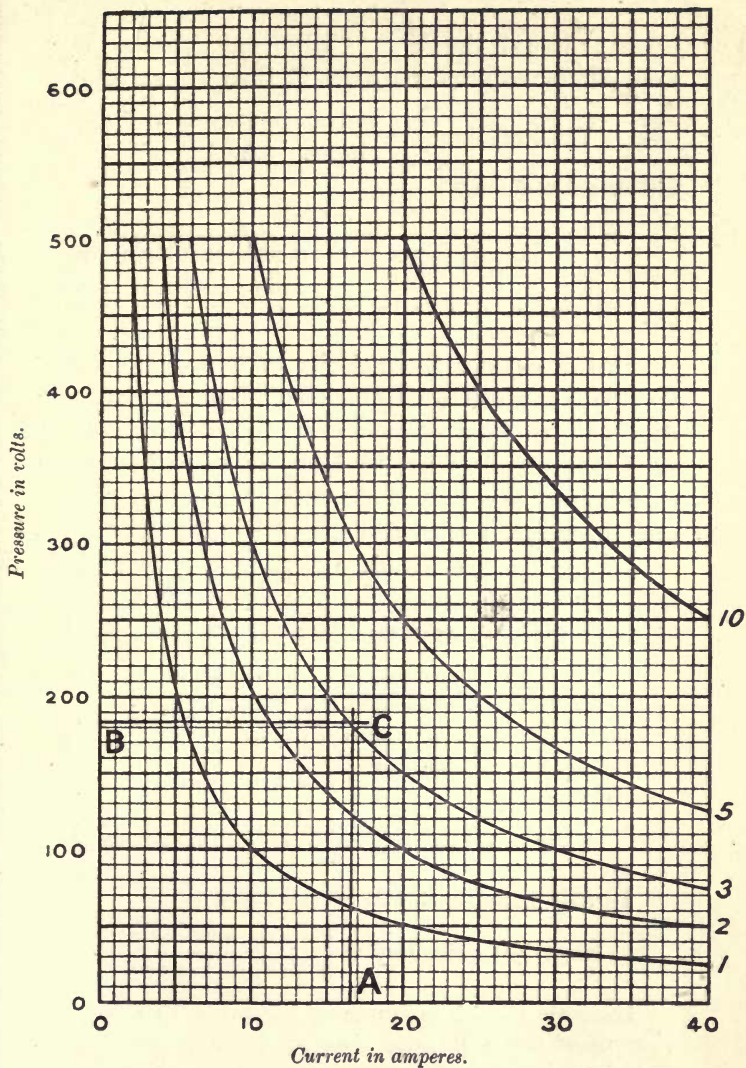

FIG. 31.—KILOWATT CURVES.

current through the field. Calling the power actually available for external purposes C, then we can say—

$$\text{Total efficiency} = \frac{\text{output}}{\text{input}} = \frac{C}{A} \dots (11)$$

Electrical efficiency

$$\begin{aligned} &= \frac{\text{output}}{\text{mechanical power converted to electrical power}} \\ &= \frac{C}{B} \dots (12) \end{aligned}$$

In this chapter the majority of the examples will deal with the electrical efficiency of apparatus, those dealing with total efficiency being left over for the next chapter. It must be borne in mind that when calculating the efficiency of a machine, both numerator and denominator must be expressed in the same units.

Example 15.—A battery has an E.M.F. of 10 volts and an internal resistance of 2 ohms. What will be its electrical efficiency when sending a current of 2 amps.?

Total power expended = $2 \times 10 = 20$ watts,

voltage drop inside the cell = $2 \times 2 = 4$ volts,

hence P.D. at terminals = 6 volts,

and power available for }
external use } = $6 \times 2 = 12$ watts,

\therefore electrical efficiency = $\frac{12}{20} = 0.6$ or 60 per cent.

In this example it will be seen that—

$$\text{Electrical efficiency} = \frac{\text{P.D. at terminals}}{\text{E.M.F. of battery}}$$

Example 16.—A motor-generator takes 15 amps. at a pressure of 220 volts, and gives up 90 amps. at 16 volts. Calculate the total efficiency.

$$\text{Input} = 220 \times 15 = 3300 \text{ watts};$$

$$\text{output} = 16 \times 90 = 1440 \text{ watts.}$$

$$\text{Total efficiency} = \frac{\text{output}}{\text{input}} = \frac{1440}{3300} = 0.436 \text{ or } 43.6 \text{ per cent.}$$

Example 17.—A motor-generator has an efficiency of 40 per cent. ; the motor portion takes current at a pressure of 220 volts, and the generator supplies current at a pressure of 19 volts. Calculate the current taken by the motor when the generator is supplying 110 amps.

$$\text{Output} = 110 \times 19 = 2090 \text{ watts,}$$

$$\therefore \text{input} = 2090 \div 0.4 = 5225 \text{ ,,}$$

$$\begin{aligned} \text{Now, current on motor side} &= \frac{\text{input}}{\text{pressure}} \\ &= \frac{5225 \text{ watts}}{220 \text{ volts}} = 23.7 \text{ amps.} \end{aligned}$$

Example 18.—A shunt dynamo has a P.D. at its terminals of 112 volts ; its shunt resistance is 140 ohms, and its armature resistance is 0.1 ohm.

Calculate its electrical efficiency if it is sending an external current of 20 amps.

$$\text{Output} = 20 \times 112 = 2240 \text{ watts.}$$

$$\text{Shunt current} = \frac{112}{140} = 0.8 \text{ amp.}$$

$$\therefore \text{loss in shunt} = 0.8 \times 112 = 89.6 \text{ watts.}$$

$$\text{Current through armature} = (20 + 0.8) \text{ amps.}$$

$$\text{hence loss in armature} = 20.8^2 \times 0.1 = 43.3 \text{ watts.}$$

$$\begin{aligned} \text{Now, electrical efficiency} &= \frac{\text{output}}{\text{output} + \text{electrical loss}} \\ &= \frac{2240}{2240 + 89.6 + 43.3} = \frac{2240}{2372.9} \\ &= 0.94. \end{aligned}$$

Cost of Energy.—The price charged for energy by supply companies varies considerably, according

to the circumstances under which the supply is desired.

It will be obvious that energy can be supplied at a lower rate in a large than in a small town; again, if the consumer requires a large quantity of energy, he can obtain it at a cheaper rate than if only a small supply is desired.

Some companies also supply energy cheaper if it is required during the daytime than if it is required during the evening, the latter period being one during which there is a heavy demand. The actual price per Board of Trade unit may vary from *1d.* to *9d.*

As stated above, the actual price per B.O.T. unit often varies according to the quantity supplied; but for the present we shall consider the price per unit to be constant whether the quantity required be large or small. On this understanding, therefore, we can say at once that—

$$\text{Cost of energy} = \text{number of units used} \times \text{price per unit} \quad . \quad . \quad . \quad (13)$$

Example 19.—What will be the cost per hour of running a motor taking 50 amps. at a pressure of 220 volts? Energy is charged for at the rate of $2\frac{1}{2}d.$ per B.O.T. unit.

$$\begin{aligned} \text{No. of K.W.H. consumed per hour} &= \frac{220 \times 50}{1000} \\ &= 11 \text{ K.W.H.} \end{aligned}$$

$$\text{Therefore cost} = 11 \times 2\frac{1}{2}d. \text{ per hour} = 2s. 3\frac{1}{2}d. \text{ per hour.}$$

Example 20.—A motor taking 10 amps. at a pressure of 220 volts is used for an average length of time of 6 hours per day, on 6 days each week. If energy costs

$1\frac{1}{2}d.$ per B.O.T. unit, calculate the cost of energy consumed per year.

$$\begin{aligned} \text{Cost} &= \text{K.W.H.} \times \text{price per unit} \\ &= \frac{10 \times 220 \times 6 \times 6 \times 52 \times 1\frac{1}{2}d.}{1000} \\ &= 6177d. = \text{£}25 \text{ } 14s. \text{ } 9d. \end{aligned}$$

As stated before, supply companies do not always charge a uniform price per unit, but charge at a less rate per unit the greater the quantity consumed, this result being brought about by the method of charging described below.

The consumer is supplied not only with a meter to indicate the B.O.T. units consumed, but also with what is termed a maximum demand indicator, this being an instrument which indicates the maximum current (and also the maximum power, since the pressure is constant) taken by the consumer at any time; this instrument is constructed so as to be very sluggish in action, so that a current above the normal, but which only lasts for a short period (as, for instance, occurs when starting up a motor), has no effect on the reading of the instrument. The reading can be taken and the instrument reset several times during the year, and the average maximum demand obtained. The cost of energy supplied is then determined by charging a fixed sum per annum for each kilowatt of average maximum demand, and also an additional charge for each unit consumed.

It will be seen that by using this method the total price per unit (for a fixed maximum demand) becomes less the greater the number of units consumed.

This point will be impressed by examining the

curve given in Fig. 32. In this figure the total price per unit is plotted against the quantity of energy used per quarter, on the assumption that the average maximum demand is one kilowatt at a fixed charge of £7 per annum, and the running charge is $2\frac{1}{2}d.$ per B.O.T. unit.

It may be mentioned that some companies, instead

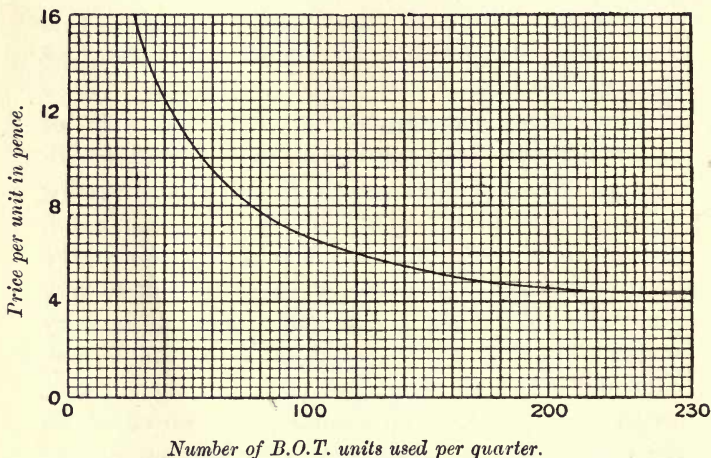

FIG. 32.—CURVE SHOWING RELATIONSHIP BETWEEN PRICE PER UNIT AND NUMBER OF UNITS USED PER QUARTER.

of making a fixed charge per kilowatt on the average maximum demand, make the fixed charge according to the total power installed.

In either of the above cases, instead of making the fixed charge as so much per kilowatt, it may be charged as so much per 8-c.p. lamp. In this case, if the fixed charge is being made on the power

installed, one 32-c.p. lamp would be reckoned as equivalent to four 8-c.p. lamps.

Example 21.—A certain supply company makes an annual charge of £8 per K.W. installed, and, in addition, charges $1\frac{1}{4}d.$ per B.O.T. unit consumed. If a consumer has lamps installed, the maximum capacity of which is $\frac{3}{4}$ K.W., what will be the net price per unit if he uses 200 B.O.T. units per annum? What will be the cost per unit if he uses 400 B.O.T. units per annum?

Case 1.—Fixed cost per annum = $£8 \times \frac{3}{4} = £6.$

Running „ „ = $\frac{1\frac{1}{4} \times 200}{240} = £1\ 0s.\ 10d.$

∴ cost per unit = $£7\ 0s.\ 10d. \div 200$
= $8.45d.$

Case 2.—In this case the total cost comes out to be £8 1s. 8d.; hence the cost per unit is 4.85d.

Example 22.—A supply company charges 4s. per annum for each 8-c.p. lamp of average maximum demand, and in addition a charge of 5d. per B.O.T. unit consumed.

If the average maximum demand of a consumer is equivalent to forty of the above-mentioned lamps, and he consumes in one quarter 110 B.O.T. units, what will his bill for the quarter amount to?

Fixed charge per quarter = $\frac{4 \times 40}{4}$ shillings = 40s.

running charge = $\frac{110 \times 5}{12}$ shillings = 45s. 10d.

Hence the bill will amount to £4 5s. 10d.

Example 23.—Assuming the method of charging is as described in the above example, how many B.O.T. units must a consumer use per quarter per lamp of average maximum demand, in order that the net price per unit be 8d.?

Let x = number of units necessary.

$$\text{Then price per unit (in pence)} = \frac{12 + 5x}{x}$$

$$\therefore \frac{12 + 5x}{x} = 8, \text{ or } 12 + 5x = 8x$$

$$\therefore x = 4 \text{ B.O.T. units per lamp per quarter.}$$

There are, of course, many modifications of the rebate system of charging, but the above examples serve to illustrate the fundamental principles.

EXAMPLES.

1. In order to excite the field coils of an alternator, it is found necessary to supply it with a current of 25 amps. at a pressure of 110 volts. How much energy will be absorbed per hour?

2. The series coil of an arc lamp has a resistance of 0.12 ohm, and carries a current of 8 amps.; the shunt coil has a resistance of 240 ohms, and carries a current of 0.23 amp. How much energy will be wasted per hour?

3. In which of the following cases will the loss be the greater: (a) In a wire of 6 ohms resistance, having 110 volts applied to it or (b) in a wire of 12 ohms resistance, having 220 volts applied?

4. The resistance of No. 9 iron wire is 0.011 ohm per yard when raised to a certain temperature. How many yards will be required to absorb 2.4 K.W. if the wire can carry a current of 60 amps.?

5. A battery having an internal resistance of 0.35 ohm has an E.M.F. of 10 volts, and is connected in series with a resistance of 1.48 ohms. Calculate the power used inside and outside the cell.

6. A battery has an E.M.F. of 4 volts and an I.R. of 1 ohm. Plot a curve showing how the output ($C \times E_x$) varies with the current as the external resistance varies from 0 to 9 ohms.

7. A battery of accumulators is charged with a current of 32 amps. for 10 hours at an average pressure of 134 volts; they are then discharged for 3 hours at the rate of 64 amps., and for a further 4 hours at 12 amps., the pressure in the first case being

108 volts, and in the second 112 volts. Calculate the total quantity of energy put in and taken out of the accumulator.

8. What is the cost per c.p. hour if a 700-c.p. arc lamp is placed in series with a resistance across the 110-volt mains, and takes a current of 8 amps.? Price of energy is 3*d.* per B.O.T. unit.

9. The armature of a shunt motor has a resistance of 0.3 ohm, and the shunt a resistance of 124 ohms. When running at full speed on a 110-volt circuit, the machine takes a total current of 8 amps. Calculate the power lost in exciting the field and in driving the current through the armature. What power is left to be converted into mechanical energy?

10. The resistance of the armature of a motor is 0.15 ohm, and of the shunt 48 ohms. If when running on a certain load it takes 10 amps. at a pressure of 110 volts, calculate the power lost in the armature and field, and the electrical efficiency.

11. A motor generator whose efficiency is 68 per cent. takes 48 amps. at 440 volts. If it supplies current at 24 volts pressure, how many amperes will it supply?

12. A battery of accumulators is charged for 6 hours with a current of 15 amps. at 130 volts. It is then discharged, and after 4 hours is estimated to be in the same state as at first. If the average discharge current was 20.5 amps. at 110 volts, calculate the efficiency of the battery.

13. A glow lamp takes 0.68 amp. at a pressure of 110 volts; its candle-power was measured and found to be 15.4. Calculate the cost per candle-power hour if energy is 6*d.* per unit.

14. An electrical heater for a 220-volt circuit takes 6 amps. If energy costs 3*d.* per B.O.T. unit, what will be the cost per week if it is used for 6 hours per day?

15. The power required to drive certain machinery is 10 K.W.; the resistance of the mains used to convey the current to the motor is 0.14 ohm. Calculate the loss in the leads, (a) if the supply is at 220 volts; (b) if the supply is at 110 volts.

16. An electric car running at 12 miles per hour takes 50 amps. at a pressure of 540 volts. If energy is charged at the rate of 2*d.* per unit, calculate the cost per car mile.

17. A cable has a resistance of 0.018 ohm. What is the least voltage at which 15 K.W. must be transmitted in order that the loss shall not exceed 600 watts?

18. What resistance will be required to absorb 6 K.W. if the voltage is 220?

19. What resistance will be required to absorb 5 K.W. if the current is 120 amps.?

20. If the price of energy is sixpence per B.O.T. unit, how much will it cost to keep ten 15 c.p. lamps glowing for 5 hours? Assume that 3.5 watts are required per candle-power.

21. The resistance of an ammeter shunt, which usually carries 180 amps., is 0.00034 ohm. What will be the cost of the energy lost per week? Price per B.O.T. unit is 6d., and meter is used 140 hours per week.

22. At what voltage will a 550-K.W. machine supply 250 amps.?

23. In an arc lamp the resistance of the series coil is 0.2 ohm, and of the shunt coil 100 ohms. The current through the arc is 12 amps. If the P.D. across the terminals is 60 volts, calculate the electrical efficiency.

24. Calculate the power of a dynamo, in kilowatts, necessary to light 400 lamps, each taking 0.6 amp. at a pressure of 110 volts.

25. The internal resistance of a dynamo armature is 0.12 ohm, and of the shunt 42 ohms. If the output of the machine is 25 K.W. and the P.D. at the terminals 220 volts, calculate the electrical efficiency.

26. In a shunt dynamo the friction, eddy current, and hysteresis losses at a certain speed may be taken to be 350 watts; the armature resistance is 0.08 ohm, and the field resistance 73 ohms. If the output of the machine is 2.3 K.W. at 112 volts, calculate the electrical and total efficiency of the machine.

27. Observations of the input and output of a motor generator were taken, with the following results:—

Input	{ volts	225	225	229	227.5	228	227.5
	{ amperes	5.8	7.6	9.5	11.6	13.6	15.6
Output	{ volts	21	20.6	20.75	20.4	20.1	19.8
	{ amperes	0	20	40	60	80	100

Draw a curve connecting efficiency and output.

28. On testing a thermopile, the following results were obtained:—

P.D. at terminals (volts)	3.8	3.25	2.8	2.3	1.8	1.3	0.9	0.4
Current (amperes)	0	0.5	1	1.5	2	2.5	3	3.5

Plot curves—

- (1) Connecting output watts and output current.
- (2) Efficiency and output current.

29. A series dynamo has an armature resistance of 0.4 ohm and a field resistance of 0.6 ohm, and gives 120 terminal volts at a given speed when 10 amps. are flowing. Work out its electrical efficiency as a dynamo and as a motor at that speed and current.

30. What is the law according to which the amount of heat generated by an electrical current varies with the current and the resistance? If a lead has a resistance of 1 ohm and is traversed by a current of 10 amps, calculate the power wasted in kilowatts.

31. A current of 10 amps. flows through a resistance of 5 ohms for 6 secs., and another current of 6 amps. flows through a resistance of 7 ohms. During what time must the latter current flow in order that the amount of heat generated in the two cases may be the same?

32. Two lamps, of 100 and 150 ohms resistance respectively, are placed in parallel, and the combination is put in series with a lamp of 100 ohms resistance. What E.M.F. must be applied to the system in order that it may consume 250 watts?

33. What must be the output, in kilowatts, of a machine supplying 120 16-c.p. lamps, each taking 0.5 amp. at a pressure of 120 volts?

34. Determine graphically for what value of the external resistance the output of a cell of given E.M.F. and internal resistance will be a maximum.

35. A shunt-wound generator maintains a P.D. at its terminals of 115 volts; the total armature current is 32 amps. If the armature and field resistances are 0.04 ohm and 84 ohms respectively, calculate the electrical efficiency. Would this be the same if the machine was used as a motor under the same conditions?

36. A consumer has his house wired under the following conditions: (a) That he pays £6 per annum per kilowatt of average maximum demand; and (b) a charge of 4d. per B.O.T. unit consumed. In a certain quarter his average maximum demand is $\frac{3}{4}$ K.W., and he consumes 150 B.O.T. units. Calculate his quarter's bill.

37. A consumer is wired for 0.5 K.W., and he is charged £6 per annum per kilowatt installed, and in addition a running charge

of $2\frac{1}{2}d.$ per B.O.T. unit. What will be the total price paid per unit if he uses 40 units per quarter?

38. If a consumer is charged in the manner indicated in the above example, how many units must be used per kilowatt installed per quarter in order that the total cost is $6d.$ per unit?

39. Assuming that a 16-c.p. lamp always consumes 60 watts, no matter what voltage it is constructed for, calculate the resistance, when hot, of such a lamp suitable for a 110-volt, and also for a 220-volt circuit.

40. Assuming that both lamps require the same number of watts per candle-power, calculate the relative resistances of a 32 c.p. lamp for a 220-volt circuit, and an 8 c.p. for a 110-volt circuit.

CHAPTER VI

CONVERSION OF ENERGY

ENERGY, or power to do work, may manifest itself in various forms. Thus it may exist as electrical energy, as, for example, a current flowing in a circuit; as mechanical energy, as in a rotating flywheel; as chemical energy, as in an accumulator; or as heat energy in a hot body.

It is possible to convert energy from any form into any other form: thus heat energy may be converted into electrical energy (with the aid of a thermopile), or electrical energy into heat energy (as when a current flows through a conductor).

Mechanical energy can be transformed into electrical energy (in the dynamo); or electrical energy into mechanical energy (in the motor).

It has been demonstrated by the experiments of Rumford, Joule, and others, that whenever energy is transformed, the energy produced in one form is the exact equivalent of the energy dissipated in the other form. Expressing this in other words, we may say, energy can neither be created nor destroyed; it can only be transformed from one state to another. It is important, therefore, to know the exact relationship

of the units of quantity of energy in the different systems.

Let us first consider the relationship between the mechanical and electrical units. We have already stated in Chapter I. that the unit used in dealing with mechanical energy is called the foot-pound, and is the amount of work performed when a force of 1 lb. weight is exerted through a distance of 1 ft.; it was also seen that we could determine the amount of work performed by a force by multiplying the magnitude of the force by the distance through which it acted.

Work (in foot-lbs.) = force (in pounds-wt.) \times distance (in feet). Now, since the foot-pound is a unit of work, and not a unit of rate of working, it corresponds to the joule, and not to the watt; the latter would correspond to a unit such as 1 foot-lb. per second, both being rates of working.

Careful experiments have demonstrated that the joule is smaller than the foot-pound; in fact—

$$\begin{aligned} 1 \text{ foot-lb.} &= 1.356 \text{ joules,} \\ \therefore \text{ joules} &= \text{foot-pounds} \times 1.356, \\ \text{and foot-pounds} &= \text{joules} \div 1.356. \end{aligned}$$

We can deduce from the above that—

$$\begin{aligned} 1 \text{ foot-lb. per second} &= 1.356 \text{ watt,} \\ \text{and } 1 \text{ watt} &= \frac{1 \text{ ft.-lb. per sec.}}{1.356} = 0.737 \text{ ft.-lb. per sec.} \end{aligned}$$

Example 1.—A motor is required to raise a load of 120 lbs. through a distance of 80 feet in 1 min. How many joules will be expended in the time, assuming the

efficiency of the motor to be 75 per cent.? What must be the power of the motor?

$$\begin{aligned} \text{Number of ft.-lbs. performed} &= 80 \times 120 \\ &= 80 \times 120 \times 1.356 \text{ joules;} \\ \text{hence input of motor} &= 80 \times 120 \times 1.356 \div 0.75 \text{ joules} \\ &= 17,360 \text{ joules.} \\ \text{Power} = \text{joules per second} &= \frac{17,360}{60} \text{ watts} = 289 \text{ watts.} \end{aligned}$$

Example 2.—How much water will a motor absorbing 500 watts pump up through a height of 44 ft. in 10 mins.? Assume the over-all efficiency to be 60 per cent.

$$\left. \begin{array}{l} \text{The motor will absorb in 10 mins.} \\ 500 \times 10 \times 60 \text{ joules} \end{array} \right\} = 300,000 \text{ joules.}$$

Since efficiency is 60 per cent., $300,000 \times \frac{60}{100} = 180,000$ joules will be utilized in raising the water.

$$\begin{aligned} \text{Hence number of foot-lbs. utilized} &= \frac{180,000}{1.356} \\ &= 132,700. \end{aligned}$$

Now, foot-lbs. = force \times distance

$$\begin{aligned} \text{hence force (in pounds-wt.)} &= \frac{\text{foot-lbs.}}{\text{distance}} \\ &= \frac{132,700}{44} = 3016 \text{ lbs. wt.} \end{aligned}$$

hence 3016 lbs. or 301.6 gallons will be raised.

The method described above for converting energy from electrical to mechanical units, and *vice versa*, becomes very laborious when large quantities of energy are concerned, owing to the number of joules involved being very great; in such cases it is far better to convert directly from kilowatts, or kilowatt-hours to the corresponding mechanical unit of power and energy.

The Horse-power.—As stated earlier in the chapter, we might take as our unit of quantity of work when dealing with mechanical energy, a foot-pound per second, or what would be exactly equivalent to it, a rate of working of 60 foot-lbs. per minute; this unit, however, is of little use practically, owing to its small magnitude, the horse-power, which is defined as a rate of working of 33,000 foot-lbs. per minute, or 550 foot-lbs. per second, being used instead.

Now, 1 foot-lb. per sec. = 1.356 watts,

$$\begin{aligned}\therefore 1 \text{ H.P.} &= 550 \text{ foot-lbs. per second} \\ &= 550 \times 1.356 = 746 \text{ watts};\end{aligned}$$

$$\text{hence } 1 \text{ H.P.} = \frac{746}{1000} = 0.746 \text{ K.W.}$$

$$\text{and } 1 \text{ K.W.} = 1 \div 0.746 = 1.34 \text{ H.P.}$$

We must note particularly that the H.P. is a unit of power, and corresponds to the K.W. and not to the K.W.-hour; corresponding to this latter unit we have, in the mechanical system, the horse-power-hour, which is the quantity of work performed if 1 H.P. is exerted for 1 hour.

Evidently—

$$1 \text{ H.P.-hour} = 0.746 \text{ K.W.-hour},$$

$$\text{and } 1 \text{ K.W.-hour} = 1.34 \text{ H.P.-hours}.$$

Example 3.—It is required to raise 2000 gallons of water up a well 200 feet deep, using as a source of power an electric motor. If the over-all efficiency of the motor and gearing is 60 per cent., what will be the cost of the electrical energy used if it is charged for at $1\frac{1}{4}d.$ per B.O.T. unit?

$$\begin{aligned}\text{Energy required} &= \frac{200 \times 2000 \times 10 \times 100}{60} \text{ foot-lbs.} \\ &= \frac{200 \times 2000 \times 10 \times 100}{60 \times 33,000 \times 60} \text{ H.P.-hrs.}\end{aligned}$$

Since 1 H.P.-hour = 33,000 × 60 foot-lbs.

$$\begin{aligned} \therefore \text{energy required} &= 3.37 \text{ H.P.-hours} \\ &= 3.37 \times 0.746 \text{ K.W.-hrs.} \end{aligned}$$

$$\begin{aligned} \therefore \text{Cost} &= 3.37 \times 0.746 \times 1.25d. \\ &= 3.14d. \end{aligned}$$

Example 4.—What current, at a pressure of 480 volts, will a motor need in order to propel a car at a rate of 12 miles per hour, the force needed to propel the car at this speed being 320 lbs.-wt. ? Assume the efficiency of motor and gearing to be 58 per cent.

$$\begin{aligned} \text{Power required} &= \frac{\text{force} \times \text{distance per minute}}{33,000} \text{ H.P.} \\ &= \frac{320 \times 1056}{33,000} = 10.2 \text{ H.P.} \end{aligned}$$

$$\text{Input of motor} = \frac{10.2 \times 0.746}{0.58} = 13.1 \text{ K.W.}$$

$$\begin{aligned} \text{Now, current} &= \frac{1000 \times \text{K.W.}}{\text{voltage}} = \frac{13,100}{480} \text{ amps.} \\ &= 27.3 \text{ amps.} \end{aligned}$$

Example 5.—A generator is driven by a water-wheel, which is supplied with 40,000 cub. ft. of water per hour, the available fall being 20 ft. If the over-all efficiency of the machinery is 64 per cent., what will be the output of the machine expressed in K.W. ? What current will it give at a pressure of 220 volts ?

Neglecting any loss of “head” due to friction—

$$\begin{aligned} \text{The H.P. given to machinery} &= \frac{40,000 \times 62.35 \times 20}{33,000 \times 60} \quad \checkmark \\ &= 25.2 \text{ H.P.} \end{aligned}$$

$$\begin{aligned} \text{Output of machine} &= 25.2 \times 0.64 \times 0.746 \text{ K.W.} \\ &= 12.03 \text{ K.W.} \end{aligned}$$

$$\begin{aligned} \therefore \text{current} &= \frac{12.03 \times 1000}{220} \text{ amps.} \\ &= 54.7 \text{ amps.} \end{aligned}$$

Example 6.—The force required to pull a car along is 400 lbs., and this may be assumed to be constant at all speeds. If the motors are supplied with a total current of 64 amps. at 460 volts, and the over-all efficiency of the motors and gearing is 50 per cent., at what speed will the car travel?

$$\text{Power supplied to motor} = \frac{64 \times 460}{1000} = 29.44 \text{ K.W.}$$

$$\begin{aligned} \text{Power available for} \left. \begin{array}{l} \text{hauling car} \end{array} \right\} &= 29.44 \times 1.34 \times 0.5 \text{ H.P.} \\ &= 19.72 \text{ H.P.} \end{aligned}$$

Work performed per second by motors = 19.72×550 foot-lbs., and this must be equal to "force \times distance ;"

$$\begin{aligned} \therefore 19.72 \times 550 &= 400 \times \text{distance moved per second,} \\ \text{or distance moved per} \left. \begin{array}{l} \text{second} \end{array} \right\} &= \frac{19.72 \times 550}{400} \text{ ft.} \\ &= 27.1 \text{ ft.} \end{aligned}$$

\therefore speed = 27.1 ft. per second, or 18.5 miles per hour.

Another very interesting example, illustrating the connection between electrical and mechanical units, is furnished when we test the output of an electrical motor by using a friction brake.

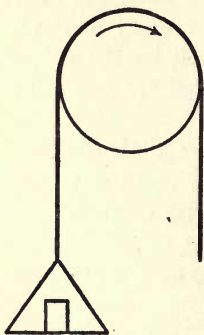

FIG. 33.

If we have a flexible leather belt on the pulley of a motor which is in motion (see Fig. 33), owing to the friction between the belt and the pulley, the former will tend to be carried round in the direction of rotation of the pulley. This force can be balanced by putting weights in a scale pan attached to one end of the belt, as

shown in the diagram. The force of friction between the belt and the force due to the weights will then be equal in magnitude, but opposite in direction, and the belt will exhibit no tendency to move.

Now, the general principle enunciated above, that—

$$\text{Work} = \text{force} \times \text{distance},$$

is also true in this case, and the work performed by the motor in one minute will be equal to the force of friction between the pulley and the belt, multiplied by the distance through which the surface of the pulley moves relatively to the belt in one minute.

At present, it may be noted, we are assuming the belt is of negligible thickness; if this is not so, a small correction must be applied, which we will consider later.

Suppose the speed of the motor is n revolutions per minute. Let the diameter of the pulley be D ft., and let F be the force in pounds needed on one end of the belt so as to just keep the belt from slipping.

Then the circumference of the pulley is πD ft., and this is also the distance moved through by the surface of the pulley, relatively to the belt, in one revolution.

Hence, work performed by motor in one revolution is πDF foot-lbs., and the work performed per minute will be $\pi n DF$ foot-lbs., or the output of the motor in H.P. will be given by the formula—

$$\text{H.P.} = \frac{\pi n DF}{33,000} \dots \dots (1)$$

Sometimes a spring balance is substituted for a weight, but the calculations are, of course, unaltered.

In practice it is found better to use a weight (or spring balance) on either side, the force on one side being greater than on the other. If this is the case, the force F in the formula is the difference between the pulls on the two sides.

Example 7.—A certain motor, when undergoing a brake test, was found to exert a force of 8 lbs. on the tight side of the belt when the force on the slack side was 1.5 lbs. The diameter of the pulley was 8 ins., and the speed 960 R.P.M. Calculate the output of the machine in H.P. and K.W.

$$\text{Now, H.P.} = \frac{\pi D n F}{33,000}$$

$$\text{and } F = (8 - 1.5) = 6.5 \text{ lbs.-wt.}$$

$$\text{hence H.P.} = \frac{3.141 \times 8 \times 960 \times 6.5}{12 \times 33,000} = 0.396,$$

$$\therefore \text{ power in kilowatts} = 0.396 \div 1.34 = 0.295.$$

If the belt has a thickness which is not negligible compared with the thickness of the shaft, then it is obvious that the force F is not exerted at a distance $\frac{D}{2}$ from the axis of the shaft, but at a distance $\frac{D}{2} + \frac{t}{2}$, where t is the thickness of the belt.

It follows at once, from the principle of moments, that the pull actually exerted at the surface of the pulley is—

$$F \times \frac{\frac{D}{2} + \frac{t}{2}}{\frac{D}{2}} = F \times \frac{D + t}{D},$$

hence we see that if we wish to take into account the

thickness of the belt, instead of letting D represent simply the diameter of the pulley, we must let it represent the diameter of the pulley + the thickness of the belt.

If the input of the motor is measured electrically, the brake test can be used to determine the efficiency of the motor, care being taken to express both output and input in the same units. This method is extensively used for small motors.

Example 8.—The input of a motor running at 1400 R.P.M. is found to be 25 amps. at 111 volts. The diameter of the pulley is 12 ins., and the power of the machine is absorbed by a belt whose tension is 15 lbs.-wt. on the tight side, and 2 lbs.-wt. on the slack side. Calculate the output and efficiency of the motor. Neglect the thickness of the belt.

$$\text{Input} = \frac{111 \times 25}{746} = 3.72 \text{ H.P.}$$

$$\begin{aligned} \text{Output} &= \frac{\pi nFD}{33,000} = \frac{3.14 \times 1400 \times 1 \times 13}{33,000} \\ &= 1.73 \text{ H.P.} \end{aligned}$$

$$\text{hence efficiency} = \frac{\text{output}}{\text{input}} = \frac{1.73}{3.72} = 0.465 \text{ or } 46.5 \text{ per cent.}$$

Although we have not mentioned it above, the student will often meet with the term “torque” or “turning moment;” by this is meant the product of the peripheral force, and the perpendicular distance from the centre at which it acts.

For example, if the pulley has a diameter of 8 ins., and the difference between the tight and slack sides of the belt is 18 lbs., the torque will be $18 \times \frac{4}{2} = 6$ lbs.-ft.

If we denote the torque in pounds-feet by the letter T, then from formula (1) we have—

$$\text{H.P.} = \frac{2\pi nT}{33,000} \dots \dots (1a)$$

Example 9.—A motor runs at 800 R.P.M., when taking 24 amps. at 110 volts. If the efficiency is 75 per cent., what will be the torque?

$$\text{Now, H.P.} = \frac{2\pi nT}{33,000}$$

$$\begin{aligned} \text{But H.P.} &= \frac{CE}{746} \times \text{efficiency} = \frac{24 \times 110}{746} \times 0.75 \\ &= 2.66 \text{ H.P.} \end{aligned}$$

$$\begin{aligned} \text{and } T &= \frac{\text{H.P.} \times 33,000}{2\pi n} = \frac{2.66 \times 33,000}{2 \times 3.14 \times 800} \text{ lbs.-ft.} \\ &= 17.4 \text{ lbs.-ft.} \end{aligned}$$

Leaving the mechanical units, we will now consider the connection between the electrical and thermal units of energy.

The quantity of heat necessary to raise a quantity of water through a certain range of temperature is directly proportional to the quantity of water, and also to the rise in temperature. Starting from this point, two unit quantities of heat energy have been defined, one the British Thermal Unit (B.T.U.), and the other the Calorie.

The **British Thermal Unit** is defined to be the quantity of heat necessary to raise the temperature of 1 lb. of water from 60° F. to 61° F.

Since the specific heat of water alters but little with varying temperature, it is sufficiently accurate for most purposes to substitute the words, “to raise its temperature 1° F.,” in the above definition.

In a similar manner, the *calorie* is defined to be the quantity of heat necessary to raise the temperature of 1 grm. of water from 0° C. to 1° C. The latter unit is, of course, rather small, and the major calorie is sometimes used in its place; this is equal to 1000 calories.

Since 1 lb. = 454 grms., and 1° C. = $\frac{9}{5} \times 1^\circ \text{F.}$, it follows that—

$$\begin{aligned} 1 \text{ B.T.U.} &= 454 \times \frac{5}{9} = 252 \text{ cal.} \\ &= 0.252 \text{ major cal.} \end{aligned}$$

Hence we can convert British thermal units to calories by multiplying by 252, and *vice versa*.

Since the above named are units of quantity of heat energy, they must, of course, be compared with the joule. Careful experiments have demonstrated that one calorie is equivalent to 4.2 joules;

$$\therefore 1 \text{ B.T.U.} = 252 \times 4.2 = 1058 \text{ joules.}$$

In the last chapter we found that the quantity of energy dissipated by an electric current was given by the formulæ—

$$W = ECt = C^2Rt = \frac{E^2}{R}t$$

the result in each case being in joules. If the energy is transformed into heat, as, for example, if a current flows through a wire, then we can obtain our answer in B.T.U. or calories, by a slight modification of the formulæ—

$$W \text{ (in British thermal units)} = \frac{C^2Rt}{1058} \cdot \cdot \cdot \quad (2)$$

$$\text{'' '' ''} = \frac{CEt}{1058} \cdot \cdot \cdot \quad (3)$$

$$\text{'' '' ''} = \frac{E^2t}{1058R} \cdot \cdot \cdot \quad (4)$$

$$W \text{ (in calories)} = \frac{C^2 R t}{4.2} \quad (5)$$

$$\text{'' ''} = \frac{C E t}{4.2} \quad (6)$$

$$\text{'' ''} = \frac{E^2 t}{4.2 R} \quad (7)$$

Example 10.—How many calories will be liberated if a current of 10 amps. flows through a wire of 11.2 ohms resistance for 5 mins. ?

Now, from (5)—

$$W = \frac{C^2 R}{4.2} t = \frac{10^2 \times 11.2 \times 5 \times 60}{4.2} \text{ calories}$$

$$= 80,000 \text{ calories.}$$

Since the energy necessary to raise the temperature of a quantity of water is proportional to the quantity of water, and also to the range of temperature, we can calculate the amount of heat absorbed (or liberated) in any case by multiplying the quantity of water by the range of temperature, or, calling the quantity of water W , and the range of temperature θ —

$$\text{Quantity of heat energy} = W \times \theta.$$

If W is in grammes, and θ in degrees Centigrade, then the quantity of heat-energy will be in calories; if W is in pounds, and θ in degrees Fahrenheit, then the answer will be in British thermal units.

If we are dealing with a substance other than water, we can calculate the quantity of heat required by multiplying the weight by the rise in temperature, and then by the specific heat of the substance.

Example 11.—An electrically heated kettle holds 2 lbs. of water. How many B.T.U. will be required to

raise the water from 58° F. to the boiling-point, assuming the efficiency to be 85 per cent.? What current will be necessary to boil the water in 16 mins. if the supply is at 110 volts?

$$\begin{aligned} \text{Energy required by water} &= 2 \times (212 - 58) \text{ B.T.U.} \\ &= 308 \text{ B.T.U.} \end{aligned}$$

$$\begin{aligned} \text{hence total energy supplied} &= 308 \div 0.85 \text{ B.T.U.} \\ &= 362 \text{ B.T.U.} \end{aligned}$$

Now, from (3)—

$$\begin{aligned} \text{B.T.U.} &= \frac{CEt}{1058} \\ \therefore C &= \frac{\text{B.T.U.} \times 1058}{E \times t} \text{ amps.} \\ &= \frac{362 \times 1058}{110 \times 16 \times 60} = 3.63 \text{ amps.} \end{aligned}$$

Example 12.—A strip of metal is desired to emit 4000 calories per minute when placed on a 220-volt circuit. What must be its resistance?

Now, from (7)—

$$\begin{aligned} W. \text{ (in calories)} &= \frac{E^2}{4.2R} t \\ \therefore R &= \frac{E^2 t}{4.2W} = \frac{220^2 \times 60}{4.2 \times 4000} \text{ ohms} \\ &= 173 \text{ ohms.} \end{aligned}$$

Example 13.—A magnet core contains 60 lbs. of wrought iron, having a relative specific heat of 0.114. It is wound with turns having a total resistance of 140 ohms, and placed on a 110-volt circuit. If 30 per cent. of the heat generated goes towards heating the core, what will be the rise in temperature in 30 mins.?

Now, from (4)—

$$\begin{aligned} W \text{ (in B.T.U.)} &= \frac{E^2 t}{1058R} = \frac{110 \times 110 \times 60 \times 20}{1058 \times 140} \\ &= 98. \end{aligned}$$

$$\begin{aligned} \therefore \text{heat energy which} \} &= 98 \times 0.3 \text{ B.T.U.} \\ \text{heats core} & \\ &= 29.4 \text{ B.T.U.} \end{aligned}$$

Now, heat energy = mass \times specific heat \times θ ,

$$\begin{aligned} \therefore \theta &= \frac{\text{heat energy}}{\text{mass} \times \text{specific heat}} \text{ degrees F.} \\ &= \frac{29.4}{60 \times 0.114} = 4.3^\circ \text{ F.} \end{aligned}$$

Example 14.—A resistance is placed across the 110-volt mains, and is immersed in flowing water, 10 gallons of which flow past the wire in 5 mins., the average rise in temperature being 10° F. Calculate the value of the resistance.

In 5 mins. $10 \times 10 \times 10$ B.T.U. are dissipated.

Now, from (4)—

$$\begin{aligned} W \text{ (in B.T.U.)} &= \frac{E^2 t}{1058R} \\ \therefore R &= \frac{E^2 t}{1058 \times W} = \frac{110 \times 110 \times 5 \times 60}{1058 \times 1000} \text{ ohms} \\ &= 3.43 \text{ ohms.} \end{aligned}$$

EXAMPLES.

1. How many British thermal units of heat are equivalent to 1 K.W.H.?

2. A motor undergoing a brake test is observed to take a current of 10 amps. at 115 volts. The speed is 800 R.P.M., and the difference between the pulls on the tight and slack sides of the belt is 12 lbs. Calculate the output of the motor, assuming that the diameter of the pulley together with the thickness of the belt is 6 ins. Calculate also the efficiency.

3. The input of a motor is 12.5 amps. at a pressure of 220 volts. If its efficiency is 81 per cent., calculate its output in H.P.

4. What would be the H.P. of a motor necessary to pump

1000 galls. of water per minute through a height of 24 ft.? Allow 50 per cent. for the over-all efficiency.

5. What would be the power required to drive a car weighing 2 tons at a speed of 10 miles per hour? Tractive force per ton is 35 lbs. weight; over-all efficiency, 63 per cent.

6. How many gallons of water per hour can a 35-H.P. motor (output) pump through a height of 30 ft.? Efficiency of gearing and pump is 65 per cent.

7. A spiral of iron wire, whose resistance is 1.2 ohms, is immersed in a vessel containing water. The total heat capacity of the vessel and its contents is equivalent to 2 kilogs. of water, and its temperature is raised 8° C. in 26 mins., when a current of 6 amps. is passed through it. From the above results deduce the number of joules equivalent to 1 calorie.

8. A motor taking 10 amps. at 440 volts drives a car weighing 6000 lbs. along at the rate of 10 miles per hour. If the tractive effort required to drive the car is 30 lbs. per ton weight, calculate the over-all efficiency.

9. A motor suitable for a 110-volt circuit is used to work a lift. It is required to raise a total load of 300 lbs. at the rate of 2 ft. per second. If the over-all efficiency is 76 per cent., calculate the current and horse-power of the smallest motor which will suffice.

10. The force required to move a car is observed to be 170 lbs.-wt. (assume this to be constant at all speeds), and it is supplied with 8 H.P. from the line. If the efficiency is 42 per cent., calculate at what speed the car will run.

11. Calculate the cost of energy required to raise 1000 tons of soil through a distance of 120 ft. Over-all efficiency, 58 per cent.; cost of energy is $2\frac{1}{2}$ d. per unit.

12. How many horse-power will be needed to drive a dynamo supplying 120 16-c.p. lamps, each taking half an amp. at a pressure of 110 volts? Efficiency, 85 per cent.

13. A dynamo having an output of 20 H.P. is generating at 550 volts. What will be the current produced, and how many 16-c.p. lamps could such a machine be used for?

14. If 600 gallons of water pass over a waterfall 130 ft. deep in 40 secs., how many H.P. will be available?

15. Calculate the power of a dynamo required to light 120 lamps, each taking 1.1 amps., and to drive a motor absorbing 6 H.P. The pressure of the supply is 220 volts.

16. What voltage must be applied to a resistance of 1 ohm in order that sufficient heat may be developed to raise the temperature of 2.5 kilogs. of water from 10° to 100° C. in 5 mins. ?

17. It is required to heat water electrically by slowly passing it through a heating device. If the efficiency of the apparatus is 64 per cent., and 40 kilogs. of water are passed through per minute, what power will be required to raise its temperature 30° C. ? If the pressure of the supply is 440 volts, what must be the value of the resistance used ?

18. In a test made on an electrically heated kettle, it was found that 4 lbs. of water were raised from 62° F. to the boiling-point in 10 mins. If the current used was 6.85 amps., at a pressure of 220 volts, what was the efficiency of the apparatus ?

19. A dynamo is absorbing 5 H.P.; it is supplying 45 16-c.p. 110-volt lamps, each taking 0.59 amp. Calculate the efficiency.

20. Find the number of gallons of water per hour necessary to keep cool a resistance of 10 ohms placed across the 220-volt mains, if the temperature of the water is not to increase above 100° F. Assume that 20 per cent. of the heat generated is lost by radiation.

21. An electric heat radiator takes 10.5 amps. at a pressure of 220 volts. Calculate the number of calories liberated per second, and the number of B.T.U. liberated per hour.

22. How many 16-c.p. lamps, taking 4 watts per candle-power, can be run off a dynamo giving out 7 H.P. ?

23. Define 1 watt, 1 kilowatt, 1 horse-power. If 1 ft. = 30.48 cms., and 1 lb. = 453.6 grms., calculate the number of ergs equal to 1 foot-lb., at a place where the force of gravity on 1 grm. is 981 dynes.

24. A 20-H.P. dynamo is generating at 150 volts. What is the current in amperes produced, and how many 16-c.p. glow lamps could it light, assuming that they require 3.5 watts per candle-power ?

25. What is the numerical relationship existing between the calorie and the foot-pound ?

26. What will be the relative values of two resistances, which must be placed across 100 and 180 volts respectively, in order that equal quantities of heat energy may be produced in equal times in each case ?

27. A kettle holding 4 pints of water is heated electrically, and

the water is raised from 58° F. to the boiling-point in 12 mins. If the heat takes 5.4 amps. at 220 volts, calculate the efficiency.

28. If the efficiency of a motor driving a pump is 85 per cent., and the efficiency of the pump is 40 per cent., calculate the over-all efficiency.

29. The over-all efficiency of a motor-driven generator is 65 per cent. If the efficiency of the motor is 85 per cent., what is the efficiency of the generator?

30. The armature of a motor is taking a current of 10 amps. at 110 volts, and is driving a fan by means of a belt. If the pulley on the motor is 8 ins. in diameter, and it is running at a speed of 900 R.P.M., what will be the difference in tension between the light and slack sides of the belt? Neglect the thickness of the belt, and assume the efficiency of the motor is 80 per cent.

31. A car weighing 4 tons requires a total force of 162 lbs.-wt. to move it at a speed of 11 miles per hour. If the efficiency of the motor and gearing is 54 per cent., and the pressure of the supply is 520 volts, calculate the current taken from the line.

32. If two equal lengths of wire of the same material, having circular cross-sections, are required to absorb the same power when placed on a 110-volt and a 220-volt circuit respectively, what must be their relative diameters?

33. A current of 8.5 amps. makes a wire (copper) of 0.026 cm. diameter red hot. How many calories are radiated from the surface of the wire per square centimetre per minute? Assume the specific resistance of copper to be, when hot, 3.24 microhms per cubic centimetre.

34. In the above question, if the diameter of the wire had been doubled (supposing the current to remain the same), how would the heat energy radiated per square centimetre be affected?

35. If a copper wire of circular cross-section can radiate 1.5 cal. per minute per square inch of surface without getting warm, what is the minimum diameter of wire which will carry 48 amps.?

36. What will be the torque exerted by a motor in pound-feet when it is taking 87 amps. at 220 volts and running at 800 R.P.M.? Assume the efficiency to be 84 per cent.

37. If the efficiency of a motor is 75 per cent., what current will be needed through the armature to cause a torque of 250 lb.-ft. if the pressure of the supply is 440 volts and the speed 750 R.P.M.?

38. On a sheet of squared paper, using current as abscissæ and

volts as ordinates, plot a series of curves representing 1, 2, 3, etc., H.P.

39. The input of a motor while undergoing a brake test is 25 amps. at 110 volts. The difference in tension between the tight and slack sides of the belt is 36 lbs. If the efficiency of the machine is 76 per cent., at what speed is it running? Diameter of pulley, 8 ins.; thickness of belt = $\frac{1}{4}$ in.

40. A motor undergoing a brake test takes 42 amps. at 220 volts, and requires a difference in tension between the tight and slack sides of the belt of 18 lbs. If the diameter of the pulley + thickness of belt is 6 ft., and the speed is 800 R.P.M., calculate the efficiency.

41. How many major calories are equivalent to 1 kilowatt-hour?

42. How many B.T.U. are equivalent to 1 kilowatt-hour?

CHAPTER VII

TRANSMISSION AND DISTRIBUTION

AT the present time, when a large power has to be transmitted through a considerable distance alternating currents are employed; this is on account of the greater facilities they offer for generation and transformation at high voltages. For moderate powers over short distances continuous currents may be used, and in this book transmission by continuous current only will be considered.

Efficiency of Transmission.—When we transmit power through cables, we naturally have to submit to a certain loss owing to the resistance of the cables; that is to say, the output at the far end of the cable is less than the input at the station end.

We may define the efficiency of a transmission as being equal to—

$$\frac{\text{output}}{\text{input}} \times 100 \text{ per cent. . . . (1)}$$

It is also useful to note that the input is the sum of the output and the power lost in the cable.

Example 1.—50 K.W. is to be transmitted over a distance of $2\frac{1}{2}$ miles, the pressure at the far end of the cable being 500 volts. If the cable has a resistance of

0.145 ohm per mile, what must be the voltage at the station end of the cables, and what will be efficiency of transmission?

$$\begin{aligned}\text{Now, } C &= \frac{\text{K.W.} \times 1000}{E} \\ &= \frac{50 \times 1000}{500} = 100 \text{ amps.}\end{aligned}$$

$$\begin{aligned}\text{Total resistance of cable} &= 2.5 \times 2 \times 0.145 \text{ ohm} \\ &= 0.725 \text{ ohm};\end{aligned}$$

$$\text{hence total pressure drop} = 100 \times 0.725 = 72.5 \text{ volts,}$$

$$\therefore \text{pressure at station end} = 572.5 \text{ volts.}$$

$$\begin{aligned}\text{Now, efficiency of transmission} &= \frac{C \times E}{C \times E_1} \times 100 \text{ per cent.} \\ &= \frac{E}{E_1} \times 100 \text{ per cent.} \\ &= \frac{500}{572.5} \times 100 \text{ per cent.} \\ &= 87.3 \text{ per cent.}\end{aligned}$$

Example 2.—In the above example, what must be the resistance per mile of the cable, if the loss is to be 10 per cent. of the power transmitted?

$$C = 100 \text{ amps.}$$

and permissible voltage drop is—

$$10 \text{ per cent.} \times 500 = 50 \text{ volts};$$

$$\therefore \text{total resistance of cable} = \frac{50}{100} = 0.5 \text{ ohm};$$

therefore the resistance per mile is 0.1 ohm.

For a given cable the losses will evidently be less the smaller the current, and consequently, if we transmit our power at an increased voltage, we shall get less current and a higher efficiency, if the same cable is used in the two cases.

This can well be illustrated by taking a definite

power and a cable of fixed resistance, and calculating out the efficiency at various voltages, as shown in Example 1; a curve can then be plotted showing the relationship existing between voltage of transmission and efficiency.

The result of doing this is given in Fig. 34, which is the result of making calculations concerning the cable used above. The abscissæ represent voltages at the far end of the cable, and the ordinates the corresponding efficiencies.

In practice we should use a cable of smaller cross-section for the higher voltage; this, of course, would interfere with the diminution of the watts lost, but we should economize owing to the smaller amount of copper required.

Calculation of Size of Conductor.—In general, the area of cross-section of a conductor must be such as to satisfy two conditions—

- (1) There shall be no undue heating.
- (2) The total voltage drop must not be excessive.

Usually we shall find that for short cables it is the first condition which determines the minimum area of cross-section, while for long cables it is the second condition.

The question as to whether there will be undue heating really resolves itself into the choice of a suitable current density.

Since small conductors have a greater surface in proportion to their cross-section than large conductors, it is evident that it is permissible to use a larger current density for the former than for the latter.

A rule much in vogue for a long time states

that a suitable current density for conductors whose carrying capacity is up to 100 amps., is 1000 amps. per square inch; for larger cables an appropriate diminution of the current density must take place.

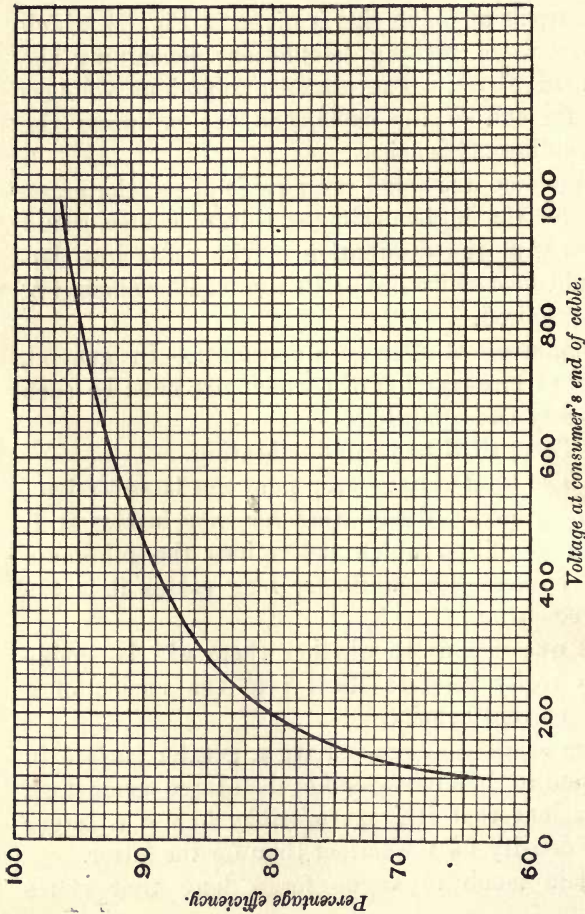

FIG. 34.—CURVE SHOWING RELATIONSHIP BETWEEN VOLTAGE OF TRANSMISSION AND EFFICIENCY OF TRANSMISSION.

Total resistance of cable = 0.5 ohm.
Power transmitted = 50 K.W.

More recently the Institution of Electrical Engineers has given a definite rule for calculating the carrying capacity of any conductor, in terms of its area of cross-section. It is of the form—

$$C = MA^n \dots \dots (2)$$

where C and A are the current-carrying capacity and area of cross-section of conductor (in thousandths of a square inch) respectively, and M and n are constants depending upon the environment of the conductor. Their values for two important cases are given in the table below:—

Nature of environment.	M.	n.
Wires insulated with vulcanized india-rubber, and laid within the mechanical protection stated in the I.E.E. rules, the external temperature exceeding 100° F.	2.0	0.775
Wires insulated and laid as above, but with an external temperature less than 100° F.	2.6	0.82

Example 3.—Assuming the formula given by the I.E.E. for conductors having low external temperatures, calculate the carrying capacity of a 3/22 cable. Also calculate the carrying capacity on the “1000 amp. per square inch” rule.

Diameter of No. 22 wire = 0.028 in.
 \therefore area of cross-section of a } = 0.7854×0.028^2 sq. in.
 single wire } = 0.000616 sq. in.
 \therefore area of cross-section of } = 0.00185 sq. in.
 three strands }

Now, the nominal cross-section of a stranded conductor is taken as being that of a solid conductor which has an

equal resistance, and, since the resistance of a stranded conductor is greater than the resistance of the wires in parallel (each having a length equal to that of the conductor) by about 1.2 per cent., it follows that we can obtain the nominal cross-section of the cable by decreasing the sum of the cross-sections of the separate strands by 1.2 per cent.

$$\begin{aligned} \therefore \text{nominal cross-section} &= 0.00185 \times \frac{100}{101.2} \text{ sq. in.} \\ &= 0.00182 \text{ sq. in.} \\ &= 1.82 \text{ thousandths of a sq. in.} \\ \text{Now, } C &= 2.6A^{0.82} = 2.6 \times 1.82^{0.82} \\ \therefore \log C &= \log 2.6 + 0.82 \times \log 1.82 \\ &= 0.4150 + 0.82 \times 0.2601 \\ &= 0.4150 + 0.2133 \\ &= 0.6283, \\ \therefore C &= 4.2 \text{ amps.} \end{aligned}$$

On the 1000 amps. per square inch rule the carrying capacity is evidently 0.00182×1000 , or 1.82 amps.

Example 4.—What will be the nominal area of cross-section of a conductor to carry 87 amps. and laid in accordance with the I.E.E. rules, the external temperature being above 100° F.?

$$\begin{aligned} \text{Now, } C &= 2A^{0.775} \\ \therefore A &= \left(\frac{C}{2}\right)^{\frac{1}{0.775}} = \left(\frac{C}{2}\right)^{1.29} \\ &= 43.5^{1.29} \text{ thousandths of a square inch} \\ &= 130 \text{ thousandths of a square inch} \\ &= 0.13 \text{ sq. in.} \end{aligned}$$

On the 1000 amps. per square inch rule, the area of cross-section of the cable would evidently be 0.087 sq. in.

Students who are not well acquainted with the use of logarithms may find the I.E.E. formula rather

It will be noticed that Fig. 35 gives the results for small conductors, and Fig. 36 those for conductors of a larger size.

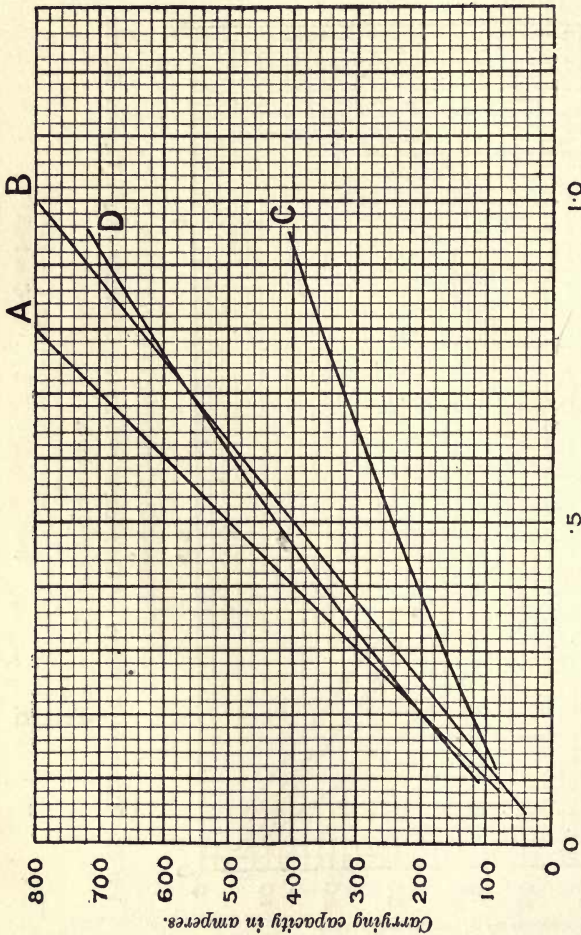

Nominal cross-section of conductor in square inches.

FIG. 36.—CARRYING CAPACITIES OF CONDUCTORS FOR LARGE CURRENTS UNDER VARIOUS RULES.

A, 1000 amperes per square inch.
 B, 800 " " "
 C, I.E.E. rule for high external temperatures, $C = 2A^{0.775}$.
 D, " " " low " " "
 G, " " " " $C = 2.6A^{0.82}$.

Example 5.—From the curves, determine the nominal area of cross-section of a conductor to carry 200 amps.—

- (1) On the I.E.E. rule for low external temperature.
- (2) „ I.E.E. „ high „ „
- (3) „ 1000 amps. per square inch rule.
- (4) „ 800 „ „ „

The results are seen to be—

- | | |
|-----------------|-------------------|
| (1) 0.2 sq. in. | (2) 0.382 sq. in. |
| (3) 0.2 sq. in. | (4) 0.25 sq. in. |

The second condition which must be satisfied is that the voltage drop must not exceed a certain pre-determined value; that is to say, the total resistance must not exceed a certain value, which can be calculated from the known current and permissible drop.

Example 6.—100 K.W. have to be transmitted 2 miles, the pressure at the far end of the line being 550 volts. If the permissible loss is 12 per cent., calculate the minimum area of cross-section of the cable.

$$\begin{aligned} \text{Current} &= \frac{1000 \times \text{K.W.}}{E} \\ &= \frac{1000 \times 100}{550} = 182 \text{ amps.} \end{aligned}$$

$$\left. \begin{array}{l} \text{Voltage drop is 12 per cent.} \\ \text{of 550 volts} \end{array} \right\} = 66 \text{ volts.}$$

The student should note here that the permissible loss is 12 per cent. of the power given up by the cable, and not 12 per cent. of the power delivered to the cable.

$$\text{Total resistance of cable} = \frac{66}{182} = 0.362 \text{ ohm,}$$

$$\therefore \text{resistance per mile} = \frac{0.362}{4} = 0.0905 \text{ ohm.}$$

From formula (9), in Chapter III., we have (putting in the constant for annealed copper)—

$$\begin{aligned} \text{Resistance per mile} &= \frac{0.0423}{\text{area of cross-section in square inches}} \\ \therefore \text{area of section} &= \frac{0.0423}{\text{resistance per mile}} \text{ sq. in.} \\ &= \frac{0.0423}{0.0905} \text{ sq. in.} \\ &= 0.465 \text{ sq. in.} \end{aligned}$$

It was mentioned earlier in the chapter that usually the heating effect settled the minimum size of conductor for a short transmission, whilst the voltage drop settled the minimum size in the case of a longer transmission. These facts will be clearly brought out in the following example:—

Example 7.—50 K.W. have to be transmitted with a pressure, at the consumer's end, of 550 volts, the following conditions being satisfied:—

- (1) The current density is not to exceed that permitted by the I.E.E. rules for low external temperatures.
- (2) The total "drop" is not to exceed 10 per cent. of the pressure at the far end of the line.

Calculate the minimum size of conductor for a short transmission, say 200 yds., and also for a long transmission, say 3 miles.

Let us first calculate the area of cross-section which gives a suitable current density.

$$\text{Now, } C = \frac{50 \times 1000}{550} = 91 \text{ amps.}$$

$$\begin{aligned} \text{also } A &= \left(\frac{C}{2.6} \right)^{\frac{1}{0.82}} = \left(\frac{91}{2.6} \right)^{1.22} \\ &= 76.5 \text{ thousandths of a square inch} \\ &= 0.0765 \text{ sq. in.} \end{aligned}$$

This area will, of course, be the same whatever the distance of the transmission. Next calculate the minimum area of section which will satisfy the second condition.

$$\begin{aligned} \text{Permissible drop} &= 10 \text{ per cent. of } 550 \\ &= 55 \text{ volts,} \end{aligned}$$

$$\text{hence total resistance} = \frac{55}{91} = 0.604 \text{ ohm ;}$$

$$\begin{aligned} \text{hence, considering the first } \left. \begin{array}{l} \text{case, the resistance per yard} \end{array} \right\} &= \frac{0.604}{400} \text{ ohm} \\ &= 0.00151 \text{ ohm.} \end{aligned}$$

$$\begin{aligned} \text{Now, cross-section of annealed } \left. \begin{array}{l} \text{copper} \end{array} \right\} &= \frac{0.000024}{\text{resistance per yard}} \text{ sq. in.} \\ &= \frac{0.000024}{0.00151} \text{ sq. in.} \\ &= 0.0159 \text{ sq. in.} \end{aligned}$$

In this case, therefore, the minimum section is settled by the first condition, and is 0.0765 sq. in.

Let us next consider the case when the transmission is 3 miles. The total resistance must be, as before, 0.604 ohm.

$$\therefore \text{ resistance per mile} = 0.101 \text{ ohm.}$$

$$\begin{aligned} \text{Now, area of section} &= \frac{0.0423}{\text{resistance per mile}} \text{ sq. in.} \\ &= \frac{0.0423}{0.101} = 0.419 \text{ sq. in.} \end{aligned}$$

Hence in this case the minimum area of section is settled by the second condition, and is 0.426 sq. in.

This example will be still more impressed on the student if he considers the graphs given in Fig. 37. The line marked A shows the minimum cross-section which satisfies the first condition, and the line marked B gives the minimum cross-section which will satisfy the second condition. The thick line shows the minimum cross-section which will satisfy both conditions.

In the above examples we have considered that the total current traverses the whole length of the line; it sometimes happens, however, that the current may be considered as being taken off uniformly

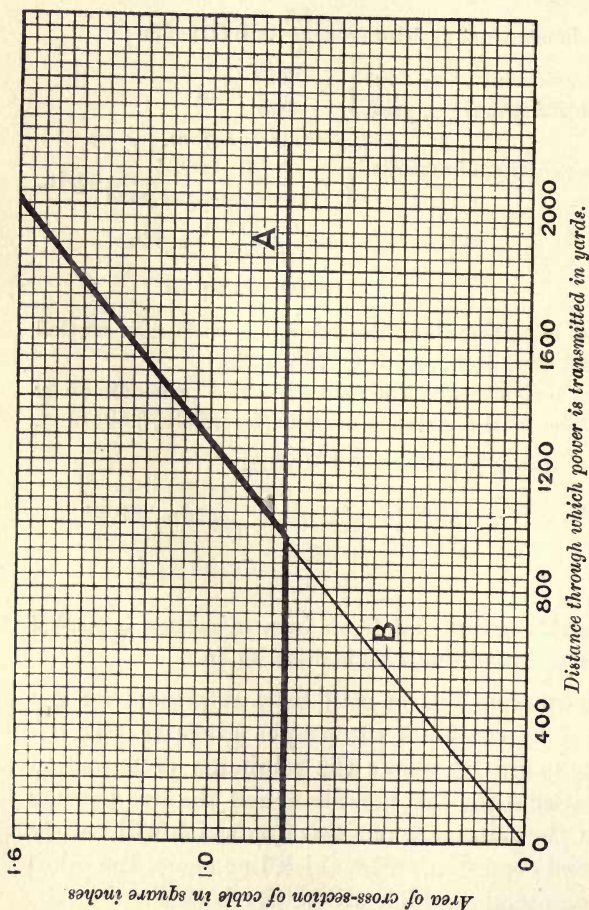

FIG. 37.

Graph A represents the cross-section necessary to ensure a proper current density. Graph B represents the cross-section necessary in order that the "drop" may not be excessive. The thick lines show the minimum cross-section which will satisfy both conditions.

over the whole length of the line. If this is so, the total "drop" will only be one-half of what it would be if the maximum current traversed the whole line.

In most practical cases, the real object aimed at in deciding on the best cross-section is that the total annual charges shall be a minimum. A full consideration of the matter is, of course, far beyond the scope of this work, but a simple example will illustrate the principles involved.

We may divide the yearly charges into two parts—

(1) The interest and depreciation on the initial cost of the mains ;

(2) The cost of the energy wasted.

The interest and depreciation can be again divided into two parts: the part due to the cable itself, and the part due to the conduit, or other means of containing and supporting the cable.

It is not easy to deal with these at the same time, because the cost of the cable (except for small sizes) may be taken as proportional to the area of cross-section ; while, though the cost of the conduit increases with an increased cross-section of cable, it does not increase proportionately.

For the sake of simplicity let us consider a definite problem, in which we need not consider the cost of the conduit.

Example 8.—40 K.W. are to be transmitted a distance of 3 miles at a pressure of 550 volts. The cost of copper made into the form of cable may be taken as being £250 per ton. Interest and depreciation may be taken as 7 per cent., and the cost of energy wasted in transmission may be assumed to be $1\frac{1}{2}d.$ per B.O.T. unit. Determine the most

economical size of cables if they are used to convey the maximum current for 12 hours per day.

First choose any area of cross-section, say 0·2 sq. in., and determine the cost of 6 miles of cable of this section. This, taking the weight of copper to be 0·32 lb. per cubic foot, is found to be £2715, the interest and depreciation on this amount at 7 per cent. being £190.

Remembering that the initial cost will be directly proportional to the area of cross-section, we can now draw graph B in Fig. 38.

Now, for the same area of cross-section (0·2 sq. in.) let us calculate the annual cost of energy wasted.

The total resistance of the cable is found to be 1·269 ohms, and the current is 72·75 amps.; on working out the annual cost of energy wasted, it is found to be £184.

Now, the cost of energy wasted will be directly proportional to the resistance of the cable, and therefore inversely proportional to the area of cross-section. Remembering this fact, we can, from the numbers given above, plot curve A in Fig. 38.

A third curve can now be plotted, such that its ordinate at every point is the sum of the ordinates of the other two. This is shown by curve C in the figure, and its ordinate at each point evidently represents the total annual cost of the cable for that particular cross-section.

From the figure it will be seen that this third curve has a minimum ordinate when the cross-section is 0·198 sq. in., and this will be the most economical cross-section to use.

Now let us consider the effect of taking into account the interest and depreciation due to the conduit or other means of supporting or carrying the cables.

Assume that the cost of the conduit is given by the expression—

$$\text{Cost per mile (in pounds)} = 1200 + 1200A,$$

A being the cross-section of the cable in square inches.

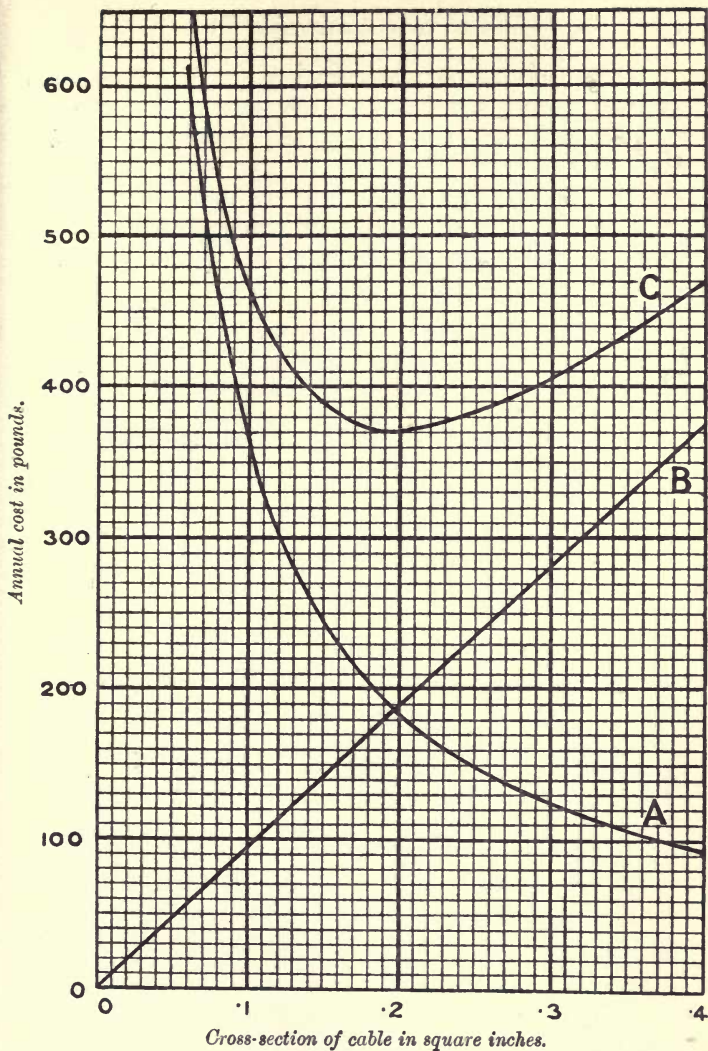

FIG. 38.

Curve **A** shows annual cost of energy wasted.
 Curve **B** " " " interest and depreciation.
 Curve **C** shows total annual cost.

We can, as before, plot curves A and B. We must now plot a third curve, showing the relationship between cross-section of cable and interest and depreciation on the conduit.

It is obvious, from the form of the equation, that the graph will be a straight line, and, assuming interest and depreciation at 7 per cent., can be plotted from the following two points :—

Cross-section of cable in square inches	...	0·2	0·4
Interest and depreciation on conduit (per annum)	} ...	£302	£353

This curve is labelled C in Fig. 39, and the total annual cost, obtained in the same way as before, but of course taking into account the new curve, is labelled D. This curve has its minimum ordinate when the cross-section is 0·175 sq. in., which accordingly would be the most economical cross-section to employ.

If this example is carefully studied, the student may obtain many interesting results; he should try the effect of altering the cost of waste energy, of altering the number of hours per day during which the cable is used, etc., in each case noting the effect on the best cross-section.

The Three-wire System.—An interesting example of the economy in copper produced by using a higher voltage is afforded by the three-wire system of distribution, examples of which are to be found in many towns.

If we have mains, between which a P.D. of 220 volts is maintained, it is not advisable to place two 110-volt lamps in series across them, because, in the first place, if one is destroyed by any means, the other

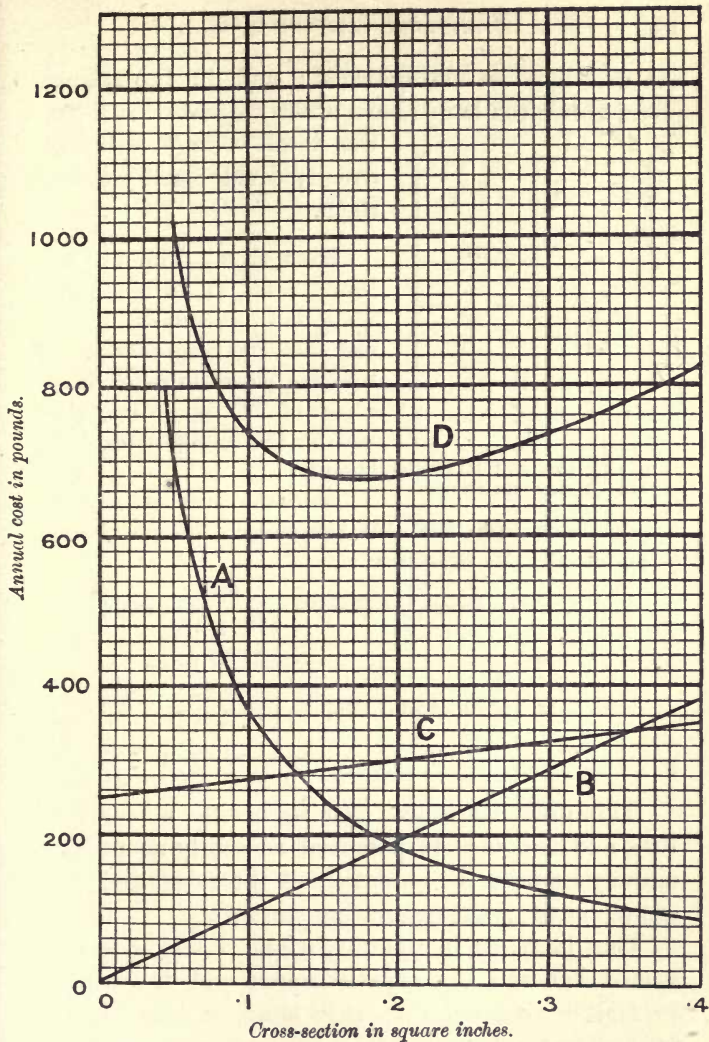

FIG. 39.

Curve **A** shows annual cost of energy wasted.
 " **B** " " interest and depreciation on cable.
 " **C** " " " " " " " " conduit.
 " **D** shows total annual cost.

one will also be extinguished; and, in the second place, unless the lamps have exactly equal resistances, the total voltage will not equally divide itself between them.

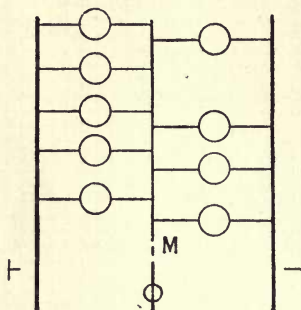

FIG. 40.—DIAGRAM ILLUSTRATING THREE-WIRE SYSTEM.

Example 9.—Two 110-volt lamps, rated at 16 c.p., have, when hot, resistances of 170 and 184 ohms respectively. If they are placed in series across a pair of 220-volt mains, what will be the voltage across each

lamp?

Since the same current flows through each lamp, the P.D. across each will be directly proportional to its resistance.

$$\begin{aligned} \therefore \text{P.D. across first lamp} &= \frac{170}{170 + 184} \times 220 \\ &= 105.65 \text{ volts,} \end{aligned}$$

$$\begin{aligned} \text{and P.D. across second lamp} &= \frac{184}{170 + 184} \times 220 \\ &= 114.35 \text{ volts.} \end{aligned}$$

This difficulty is got over by having a “middle” wire, and keeping its potential as nearly as possible midway between the potentials of the outers (by some arrangement at the generating station).

One lamp, or in practice a set of lamps, is connected between the negative outer and the neutral or middle wire, and the other lamp, or set of lamps, is connected between the positive outer and the neutral wire.

When this is done, the current flowing through

the set of lamps on the positive side is not necessarily equal to that flowing on the negative side, the current flowing through the middle wire being the difference between the currents in the two outers. Since this is so, it is obvious that in a well-balanced system it is unnecessary to have the neutral cable as large as the two outers.

Example 10.—In a three-wire system, with 440 volts between the outers, the lamps on the positive side have a net resistance of 4.8 ohms, and on the negative side a net resistance of 3.9 ohms. Neglecting the resistance of the cables, calculate the magnitude and direction of the current through the middle wire.

$$\text{Current taken by + side} = \frac{220}{4.8} = 45.8 \text{ amps.}$$

$$\text{current taken by - side} = \frac{220}{3.9} = 56.4 \text{ amps.}$$

$$\therefore \text{current in neutral} = 56.4 - 45.8 = 10.6 \text{ amps.}$$

and it will be flowing away from the station.

If the middle wire becomes disconnected through any cause, then if the two sets of lamps have unequal resistances they will have unequal voltages across them, since the two sets will then be simply in series across the outer mains.

Example 11.—In a three-wire system, with 220 volts between the outers, the load on the positive side consists of 44 8-c.p. lamps, 120 16-c.p. lamps, and 38 32-c.p. lamps; on the negative side the load is 36 8-c.p. lamps, 80 16-c.p. lamps, and 52 32-c.p. lamps. What is the magnitude and direction of the current in the middle wire?

If the middle wire is disconnected between the lamps

and the generator, what will be the current taken by, and the voltage across, each set of lamps?

Assume that the lamps require 4 watts per candle-power—

+ side.	- side.
$44 \times 8 = 352 \text{ c.p.}$	$36 \times 8 = 288 \text{ c.p.}$
$120 \times 16 = 1920 \text{ c.p.}$	$80 \times 16 = 1280 \text{ c.p.}$
$38 \times 32 = 1216 \text{ c.p.}$	$52 \times 32 = 1664 \text{ c.p.}$
<hr style="width: 100%;"/>	<hr style="width: 100%;"/>
Total = 3488 c.p.	Total = 3232 c.p.
Watts = 13,952	Watts = 12,928
Current = $\frac{13,952}{110}$	Current = $\frac{12,928}{110}$
= 127 amps.	= 117.5 amps.

Therefore the current through the middle wire is 9.5 amps., and will be towards the station.

When the middle wire is interrupted, the two sets of lamps will be in series across the 220 volts, and, assuming the resistances of the lamps to be unaltered, the current will be—

$$\frac{220}{\frac{110}{127} + \frac{110}{117.5}} = 122.1 \text{ amps.}$$

$$\therefore \text{voltage across + set of lamps} = 122.1 \times \frac{110}{127} = 105.8 \text{ volts,}$$

$$\text{and voltage across - set of lamps} = 122.1 \times \frac{110}{117.5} = 114.2 \text{ volts.}$$

Calculations referring to Distribution in Buildings.—For these calculations no general formula can be given; a few important rules can be laid down, and the student must settle minor points for himself in each case which arises.

In calculating the drop of potential in any system

of wiring, two methods are of use. The first consists in calculating the resistance from the known dimensions of the wire, and then, of course, calculating the drop in the ordinary way; this is a useful method to apply to mains or to large cables. The second consists of calculating the resistance by making use of a table giving the resistance of the cable per 100 ft., or some equivalent constant, and, having determined the resistance, calculating the voltage "drop" as before. This method is especially suitable for the small cables used to carry the current from the distribution board to the lamps.

Before proceeding to attack any problem, the student should carefully study the wiring rules of the Institution of Electrical Engineers, a copy of which he is advised to obtain, and in addition the following points should be noted:—

1. The sectional area of the conductor must be such that the current density is not excessive, and also the "drop" is not excessive.

2. The wires in rooms must run vertically or horizontally, and, if the latter, should be parallel to one of the walls.

3. In some cases the drop of potential across fuses (especially if copper is used) may be a considerable proportion of the total drop.

This is shown in the following table, which is the result of a number of experiments; only average values are given, the actual drop depending to some extent upon the size of the fuse:—

Current.	Volts drop along a single fuse 2 in. long.				
Full load	0·04
Half load	0·02

In this table the material is supposed to be copper, and the fuses are rated to blow at 100 per cent. over load.

Example 12.—A submain carries current to 50 32-c.p. lamps situated 130 ft. from the point of supply, to 8 16-c.p. lamps, and 4 50-c.p. lamps situated 250 ft. away, and also to a small motor taking 3 amps. at a distance of 380 ft. If the mains are of 19/16 cable throughout, calculate the voltage drop—

(a) When all the lamps and the motor are on ;

(b) When all the lamps are on and the motor is off.

Repeat the calculation if the first section consists of 19/16 cable, the second of 7/20 cable, and the third of 3/22 cable.

You may assume that the lamps require 3·5 watts per candle-power. Neglect the voltage drop which may occur in any fuses in the circuit.

Current taken by motor = 3 amps.

$$\left. \begin{array}{l} \text{Current taken by set of lamps} \\ \text{farthest from station} \end{array} \right\} = \frac{(8 \times 16 + 4 \times 50)3\cdot5}{110}$$

$$= 10\cdot4 \text{ amps.}$$

$$\left. \begin{array}{l} \text{Current taken by set of lamps} \\ \text{nearest to station} \end{array} \right\} = \frac{50 \times 32 \times 3\cdot5}{110}$$

$$= 50\cdot9 \text{ amps.}$$

It will be noted that we have assumed, for the purpose of calculating the current, that the pressure on each set of lamps is 110 volts ; in practice, of course, this cannot be exactly true.

Case 1.—When lamps and motor are all on.

Resistance of 19/16 cable = 0·133 ohm per 1000 ft.

$$\therefore \left. \begin{array}{l} \text{resistance of single length of} \\ \text{cable between feeding-point} \\ \text{and first set of lamps} \end{array} \right\} = 0\cdot133 \times \frac{130}{1000}$$

$$= 0\cdot0173 \text{ ohm,}$$

$$\begin{aligned} \therefore \text{“drop” in this length} &= 0.0173 \times (3 + 10.4 + 50.9) \\ &= 1.11 \text{ volts.} \end{aligned}$$

$$\begin{aligned} \text{Resistance of cable between first} & \\ \text{and second sets of lamps} & \left. \vphantom{\begin{array}{l} \text{Resistance of cable between first} \\ \text{and second sets of lamps} \end{array}} \right\} = \frac{120}{1000} \times 0.133 \\ & = 0.01596 \text{ ohm,} \end{aligned}$$

$$\begin{aligned} \therefore \text{“drop” in this length} &= 0.01596 \times (10.4 + 3) \\ &= 0.21 \text{ volt.} \end{aligned}$$

$$\begin{aligned} \text{Resistance of third section of} & \\ \text{cable} & \left. \vphantom{\begin{array}{l} \text{Resistance of third section of} \\ \text{cable} \end{array}} \right\} = 0.0173 \text{ ohm,} \end{aligned}$$

$$\therefore \text{“drop” in this part} = 0.0173 \times 3 = 0.052 \text{ volt,}$$

$$\begin{aligned} \therefore \text{total drop in each lead} &= 1.11 + 0.21 + 0.05 \\ &= 1.37 \text{ volts.} \end{aligned}$$

Since there must be two cables, the total drop will be twice this, or 2.74 volts.

N.B.—The fact that current has not only to be led to, but away from, lamps or other apparatus, is easily lost sight of unless care is taken.

Case 2.—Mains as before, but all lamps on and motor off.

$$\begin{aligned} \text{Resistance of single main in first section} &= 0.0173 \text{ ohm,} \\ \therefore \text{“drop” in this section} &= 0.0173 \times 61.3 \\ &= 1.06 \text{ volts.} \end{aligned}$$

$$\begin{aligned} \text{Resistance of single main in second section} &= 0.01596 \text{ ohm,} \\ \therefore \text{“drop” in this section} &= 0.01596 \times 10.4 \\ &= 0.166 \text{ volt,} \\ \therefore \text{total “drop”} &= 2(1.06 + 0.166) \\ &= 2.45 \text{ volts.} \end{aligned}$$

Case 3.—Cables arranged in second method given above, all lamps and motor on.

$$\begin{aligned} \text{“Drop” between feeding-point} & \\ \text{and first set of lamps} & \left. \vphantom{\begin{array}{l} \text{“Drop” between feeding-point} \\ \text{and first set of lamps} \end{array}} \right\} = 1.11 \text{ volts (as before),} \\ \text{resistance of } 7/20 \text{ cable} &= 1.14 \text{ ohms per 1000 ft.} \\ \therefore \text{resistance between first and} & \\ \text{second set of lamps} & \left. \vphantom{\begin{array}{l} \text{resistance between first and} \\ \text{second set of lamps} \end{array}} \right\} = \frac{1.14 \times 120}{1000} = 0.137 \text{ ohm,} \end{aligned}$$

$$\begin{aligned}\therefore \text{“drop” in this section} &= 0.137 \times 13.4 \\ &= 1.84 \text{ volts.}\end{aligned}$$

Resistance of 3/22 cable = 4.4 ohms per 1000 ft.

$$\therefore \text{resistance between second set of lamps and motor} \left. \vphantom{\begin{matrix} \text{resistance between second} \\ \text{set of lamps and motor} \end{matrix}} \right\} = 4.4 \times \frac{130}{1000} = 0.572 \text{ ohm.}$$

$$\therefore \text{“drop” in this section} = 0.572 \times 3 = 1.72 \text{ volts,}$$

$$\begin{aligned}\therefore \text{total drop in lead and return} &= 2(1.72 + 1.84 + 1.11) \\ &= 9.34 \text{ volts.}\end{aligned}$$

Case 4.—Cables as in case 3, all lamps on and motor off.

$$\text{“Drop” in first section} = 1.06 \text{ volts,}$$

$$\text{“Drop” in second section} = 0.137 \times 10.4 = 1.42 \text{ volts,}$$

$$\therefore \text{total “drop”} = 2(1.06 + 1.42) = 4.96 \text{ volts.}$$

Example 13.—Assuming that power is required as in the previous example, calculate the sizes of mains in order that the total drop is not to exceed 3 volts, evenly divided between the sections, when all lamps and motor are on.

$$\text{“Drop” between motor and second set of lamps} \left. \vphantom{\begin{matrix} \text{“Drop” between motor and} \\ \text{second set of lamps} \end{matrix}} \right\} = 1 \text{ volt,}$$

$$\therefore \text{resistance of this section} = \frac{1}{3} = 0.33 \text{ ohm,}$$

$$\therefore \text{resistance per 1000 ft.} = \frac{0.33 \times 1000}{130 \times 2} = 1.27 \text{ ohms.}$$

Referring to our tables, we see that the nearest size is 7/20.

$$\text{Permissible drop between first and second set of lamps} \left. \vphantom{\begin{matrix} \text{Permissible drop between first} \\ \text{and second set of lamps} \end{matrix}} \right\} = 1 \text{ volt,}$$

$$\therefore \text{resistance of this section} = \frac{1}{13.4} \text{ ohm,}$$

$$\begin{aligned}\therefore \text{resistance per 1000 ft. of cable} \left. \vphantom{\begin{matrix} \text{resistance per 1000 ft. of} \\ \text{cable} \end{matrix}} \right\} &= \frac{1}{13.4} \times \frac{1000}{120 \times 2} \\ &= 0.311 \text{ ohm.}\end{aligned}$$

From the table, it is seen that the cable lies between 37/14 and 37/12; the actual size will be about 61/15.

Drop in section between feeding-
point and first set of lamps } = 1 volt,

$$\therefore \text{resistance of this section} = \frac{1}{64.3} \text{ ohm,}$$

$$\begin{aligned} \therefore \text{resistance per 1000 ft.} &= \frac{1}{64.3} \times \frac{1000}{130 \times 2} \\ &= 0.060 \text{ ohm.} \end{aligned}$$

The nearest-sized cable given in the table is 37/16.

Example 14.—A building consists of two floors, each measuring 60 ft. \times 40 ft., each floor being illuminated by 24 25-c.p. lamps evenly distributed about the room. The height of the first floor is 16 ft., and of the second 15 ft., the lamps in each case being suspended at a height of 10 ft. from the floor. The mains run vertically up the centre of a long side, and a 6-way D.P. distribution board (with fuses) is fixed 1 ft. from the ceiling on each floor. The lamp circuits consist of 3/22 conductor, and each group of four lamps is controlled by a switch, situated vertically underneath the distribution board, at a height of 4 ft. from the floor. The mains to the first distribution board are composed of 19/20 cable, and from thence to the second of 7/18 cable.

If the lamps require 4 watts per candle-power, and the pressure of the supply is 220 volts, calculate the "drop" from the meter (situated 1 ft. below the ground-level) to the farthest lamp—

(a) When all the lamps are in use.

(b) If the lamps on the top floor only are in use.

(a) Length of cable from
meter to first board } = 32 ft.

$$\therefore \text{resistance} = 0.420 \times \frac{32}{1000} = 0.0134 \text{ ohm ;}$$

$$\text{current through this cable} = \frac{24 \times 2 \times 25 \times 4}{220} = 21.8 \text{ amps,}$$

∴ "drop" in this portion = $0.0134 \times 21.8 = 0.292$ volt,
 length of cable from first }
 board to second board } = 30 ft.

∴ "drop" in this section = $0.64 \times \frac{30}{1000} \times 10.9 = 0.210$ volt.

The lamp which will have the least voltage applied to it will evidently be the farthest lamp on the top floor—that is, the one marked A in Fig. 41.

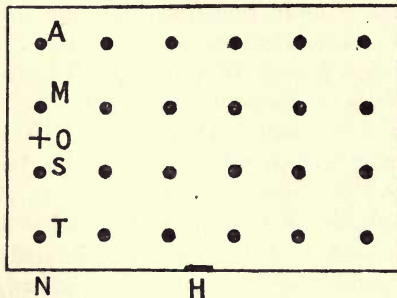

FIG. 41.

Now, the circuit which supplies current to this lamp also supplies current to M, S, and T.

Now, the length of 3/22 conductor traversed by the current in this lamp circuit will be—

From board to switch, $2 \times 10 = 20$ ft.
 From board to roof, $2 \times 1 = 2$,,
 From H to N (see figure), $2 \times 25 = 50$,,
 From N to O (average distance which }
 current has to travel beyond N) } $2 \times 20 = 40$,,
 ∴ total length = 112 ,,
 Resistance of this portion = $\frac{4.4 \times 112}{1000} = 0.493$ ohm,

$$\begin{aligned} \text{Current in this lead} &= \frac{4 \times 25 \times 4}{220} \\ &= 1.82 \text{ amps. (nearly),} \end{aligned}$$

∴ “drop” in this portion = $1.82 \times 0.493 = 0.897$ volt.

The length of “flexible” to each lamp on the top floor will be 10 ft., and since the resistance of 23/36 flexible is about 0.008 ohm per foot, the drop in this part of the circuit will be $0.08 \times 0.45 = 0.036$ volt.

The current to this lamp will have to traverse 2 D.P. fuses, and the drop in these will be about $4 \times 0.04 = 0.16$ volt.

$$\begin{aligned} \therefore \text{total drop} &= 0.897 + 0.292 + 0.21 + 0.036 + 0.160 \\ &= 1.6 \text{ volts nearly.} \end{aligned}$$

(b) In this case the “drop” between the meter and the first board will be half of that in the previous case, that is, 0.146 volt; the other results will be the same as before, hence the total drop will be 1.45 volts.

In practice it is only necessary to make exact calculations in the case of large buildings, but the principles on which the calculations are based are illustrated by the above example.

Example 15.—A rectangular building consists of five stories of 12, 12, 11, 11, and 10 ft. in height respectively; each floor measures 50 by 100 ft., and is to be illuminated by eighty 16-c.p. lamps evenly distributed on the two-wire system, and regarded as taking 60 watts each. The main conductors pass up the wall at the centre of one of the long sides of the building, and distributing fuse boxes are to be provided 1 ft. from the ceiling on each floor; the lamp circuits are to be of 3/22 conductors, and the leads must run parallel to one of the walls.

Calculate the sizes of mains and number of branch circuits in order that the total drop will not exceed $1\frac{1}{2}$ per

cent. when all lamps are on, and the pressure is 200 volts. The drop will occur in—

- (a) Fuses.
- (b) Mains.
- (c) Lamp circuits.

(a) *Fuses*.—Let us decide to diminish the section of the mains after feeding the first three floors ; this will necessitate a D.P. fuse at this point.

We may assume, therefore, that the current to the most remote lamp (*i.e.* on the top floor) will need to pass through three D.P. fuses after passing through the supply company's main fuses. This will involve a "drop" of $6 \times 0.04 = 0.24$ volt at full load.

(b) *Mains*.—

$$\text{Current required per floor} = \frac{80 \times 60}{200} = 24 \text{ amps.}$$

First section, between ground and first box.

Total current carried = 120 amps. ; this will necessitate a 37/16 cable, whose resistance per 1000 ft. is 0.0681 ohm.

$$\begin{aligned} \therefore \text{"drop" in this section} &= \frac{0.0681 \times 22 \times 120}{1000} \\ &= 0.180 \text{ volt.} \end{aligned}$$

Second section, between first and second fuse boxes.

$$\text{As before, "drop"} = \frac{0.0681 \times 24 \times 96}{1000} = 0.157 \text{ volt.}$$

Third section, between second and third boxes.

$$\text{"Drop"} = 0.0681 \times \frac{22}{1000} \times 72 = 0.108 \text{ volt.}$$

Fourth section, between third and fourth boxes.

Current carried in this section = 48 amps., and this will necessitate a 19/18 cable, having a resistance of 0.236 ohm per 1000 ft. ;

$$\therefore \text{"drop" in this section} = \frac{0.236 \times 22 \times 48}{1000} = 0.249 \text{ volt.}$$

Fifth section, between fourth and fifth box

$$\text{“ Drop ”} = \frac{0.236 \times 20 \times 24}{1000} = 0.113 \text{ volt ;}$$

\therefore total drop in fuses and mains = 1.05 volts (nearly).

This leaves 1.95 volts available for the drop in the lamp circuits.

(c) *Lamp Circuits.*—On drawing a plan of one floor, it will be seen that the longest lamp circuit will need about 160 ft. of cable; the resistance of this will be about

$$\frac{4.4 \times 160}{1000} = 0.704 \text{ ohm.}$$

$$\therefore \text{ current which can flow through } \left. \begin{array}{l} \text{this will be} \end{array} \right\} = \frac{E}{R} = \frac{1.95}{0.704} \\ = 2.77 \text{ amps.}$$

Since each lamp takes 0.3 amp., we shall evidently be able to have 10 lamp circuits in each room, each feeding 8 lamps.

Example 16.—A pair of mains 200 yds. long have current taken off them uniformly at the rate of half an ampere per yard. If the current is fed in at one end, calculate the cross-section (on the assumption that it is uniform) in order that the drop may not exceed 3 volts.

Assume the specific resistance of copper to be 0.668 microhm per cubic inch.

Now, total current needed = 100 amps., therefore the average current traversing the cable will be 50 amps., and since the voltage drop is proportional to the current, it will be legitimate to use this in our calculation.

$$\text{Resistance of cables} = \frac{\text{volts}}{\text{amperes}} = \frac{3}{50} = 0.06 \text{ ohm.}$$

$$\text{Now, } R = \frac{LS}{A}$$

$$\therefore A = \frac{L \times S}{R} = \frac{400 \times 36 \times 0.000000668}{0.06} \\ = 0.16 \text{ sq. in.}$$

Calculation of Sizes of Fuse-wires and Strips.—Experiments have shown that if d represents the diameter of the wire, and C the fusing current, then—

$$C = Ad^n \quad . \quad . \quad . \quad . \quad (3)$$

A and n being numbers which depend upon the material and environment of the wire. For a few common cases they are given in the table below.

Material, etc.	Range (amperes).	n .	A (cm. measure).
Tinned copper, 2 in. and upwards } in length; vertical in air ... }	1-10	1.195	775
Tinned copper, 4 in. and upwards } in length; vertical in air ... }	10-100	1.403	1680
Tin, 2 in. and upwards in length; } horizontal in air ... }	1-10	1.131	146.6
Tin, 5 in. and upwards in length; } horizontal in air ... }	10-80	1.32	239.3

Fuses (more especially those composed of copper) are best set to blow at 100 per cent. over load; that is, if the normal full-load current of a certain circuit is 5 amps., the fuse will be of such dimensions as to blow at 10 amps.

For some circuits (as, for instance, arc lamp circuits) the fuses may be set to blow at 50 or 75 per cent. over load instead of 100 per cent.

Example 17.—Calculate the diameter of a copper fuse wire to carry a normal full-load current of 25 amps., and to blow at 75 per cent. over load.

$$\text{Fusing current} = \frac{25 \times 175}{100} = 43.75 \text{ amps.}$$

$$\text{Now, } C = Ad^n$$

$$\therefore d^n = \frac{C}{A} \text{ or } d = \left(\frac{C}{A}\right)^{\frac{1}{n}}$$

$$\therefore d = \left(\frac{43.75}{1680}\right)^{\frac{1}{1.403}} = \left(\frac{43.75}{1680}\right)^{0.713} = 0.0742 \text{ cm.}$$

Example 18.—What will be the fusing current of a tin wire 0.12 cm. in diameter?

$$\begin{aligned} \text{Now, } C &= Ad^n = 239.3 \times d^{1.32} \\ &= 239.3 \times 0.12^{1.32} = 14.6 \text{ amps.} \end{aligned}$$

For fuses of large carrying capacity, strips are often used; in the case of copper strips, a number of experiments have demonstrated that the law

$$C = 6280b(t + 0.009)$$

connects the fusing current C with the breadth and thickness (b and t) of the strip expressed in centimetres, when the latter is in a vertical position in air.

Example 19.—Calculate the fusing current of a strip whose breadth is 1.0 cm., and whose thickness is 0.029 cm.

$$\begin{aligned} \text{Now, } C &= 6280b(t + 0.009) \\ &= 6280 \times 1 \times 0.038 = 239 \text{ amps. (nearly).} \end{aligned}$$

Table of Data referring to Cables.—At the end of the chapter the student will find appended a table giving important data referring to cables in common use. The following points concerning the table are worthy of notice:—

1. The area of cross-section in the second column is not the area of cross-section of one wire multiplied by the number of wires, but is rather less than this; it is, in fact, the area of cross-section of a solid conductor having the same resistance for a fixed length, as the cable in question.

2. Though not used in the table, it is becoming customary in many cases to designate a cable as, for example, 19/0.92, this indicating a cable of 19 strands each 0.092 in. in diameter.

3. In the last three columns the voltage drop is calculated for a *total* length of conductor of 1000 ft., and *not* for a 1000-ft. lead and 1000-ft. return.

TABLE OF CABLE DATA.

Designation of conductor.	Area of cross-section in square inches.	Resistance per 1000 ft.	Carrying capacity (amperes).			Volts drop per 1000 ft.		
			1000 amperes per square inch.	I.E.E. rule.		1000 amps. per square inch.	I.E.E. rule.	
				Normal external temperatures.	High external temperatures.		Normal external temperatures.	High external temperatures.
		Ohms.						
1/20	0.00102	7.86	1.02	2.6	2.03	8.015	20.4	15.95
3/25	0.000931	8.61	0.93	2.45	1.89	8.015	21.1	16.3
1/18	0.00181	4.43	1.81	4.23	3.17	8.015	18.7	14.05
3/22	0.00182	4.40	1.82	4.25	3.18	8.015	18.7	14.0
3/21.5	0.00210	3.82	2.10	4.78	3.55	8.015	18.2	13.6
3/20	0.00302	2.66	3.02	6.4	4.7	8.015	17.0	12.5
7/22	0.00427	1.88	4.27	8.5	6.2	8.015	16.0	11.7
7/20	0.00705	1.14	7.05	12.9	9.1	8.015	14.7	10.4
7/18	0.0125	0.64	12.5	20.6	14.2	8.015	13.2	9.09
19/20	0.0191	0.42	19.1	29.2	19.6	8.015	12.3	8.23
7/16	0.0223	0.36	22.3	33.2	22.2	8.015	11.9	7.99
19/18	0.0340	0.236	34.0	46.9	30.7	8.015	11.1	7.24
19/16	0.0604	0.133	60.4	75.1	48.0	8.015	10.0	6.38
19/14	0.0944	0.0849	94.4	108.0	68.0	8.015	9.17	5.77
37/16	0.118	0.0681	118.0	130.0	81.0	8.015	8.85	5.52
37/14	0.184	0.0436	184.0	187.0	114.0	8.015	8.15	4.97
37/12	0.310	0.0258	310.0	287.0	170.0	8.015	7.40	4.38
61/13	0.401	0.0200	401.0	354.0	208.0	8.015	7.08	4.16
61/12	0.512	0.0157	512.0	433.0	252.0	8.015	6.80	3.96
61/11	0.637	0.0126	637.0	518.0	298.0	8.015	6.53	3.75
91/12	0.763	0.0105	763.0	601.0	343.0	8.015	6.31	3.60
91/11	0.950	0.00843	950.0	719.0	406.0	8.015	6.06	3.42

EXAMPLES.

1. It is required to deliver 115 H.P. by means of continuous current to a motor $1\frac{1}{2}$ miles away from the generator. The terminal pressure of the motor is 550 volts, and the losses due to line resistance are not to exceed 15 per cent. of the power transmitted. Calculate the area of cross-section of the feeder, and the total weight of copper required.

2. In a small water-power plant, the dynamo, which produces a P.D. between its terminals of 120 volts, is 300 yds. away from the place at which the energy is used. The usual load consists of 200 105-volt 35-watt lamps. What size of lead should be employed if the resistance of a cubic inch of copper is 0.68 microhm?

3. A group of 25 16-c.p. lamps, each taking 0.55 amp. at 90 volts, are to be supplied with current by a dynamo situated 50 yds. away. What must be the cross-section of the cable, if the "drop" in it is not to exceed 1 per cent.?

4. A dynamo maintains a pressure of 220 volts between its terminals, and supplies a power of 18,000 watts to a house 200 yds. away. What must be the cross-section of the cable in order that the cable losses may not exceed 4 per cent. of the power delivered?

5. A dynamo supplies current to a set of 100 lamps, grouped in parallel at a distance of $\frac{1}{2}$ mile from the dynamo. The leads have each a cross-section of 0.04 sq. in. If each lamp requires a current of 0.2 amp. at a pressure of 220 volts, what must be the P.D. at the terminals of the dynamo?

6. A point in a distributing network is fed by a pair of feeders from a generating station 600 yds. distant. On turning on a motor which takes 25 amps., the pressure at the ends of the feeders falls 5 volts. What is the resistance and cross-section of each feeder?

7. In a three-wire system of distribution the pressure between the outers is 440 volts; on the + side there are 46 lamps, each of 120 ohms resistance, and on the - side there are 55 similar lamps. Determine the direction and magnitude of the current in the neutral conductor. If the latter becomes disconnected, what will then be the current flowing, and the pressure across each set of lamps?

8. Assuming the data given in the last question, what will be the P.D. across the break in the middle wire?

9. Power has to be transmitted a distance of 3 miles; the resistance of the cable is 0.1 ohm per mile, and the voltage is to be 440 at the consumer's end. Calculate the efficiency when 1, 5, and 10 K.W. are transmitted.

10. A cable having a total resistance of 0.1 ohm is to be used to transmit 11 K.W. Calculate the efficiency of the transmission when the supply at the consumer's end is at pressures of 100, 200, and 500 volts respectively.

11. It is required to transmit a certain power a fixed distance with a given efficiency. What will be the ratio of the amounts of copper used—(a) if the supply is at 220 volts; (b) if the supply is at 550 volts?

12. It is required to transmit power to 1000 16-c.p. lamps over a distance of $\frac{1}{2}$ mile. The current density in the cable is not to exceed 850 amps. per square inch, and the maximum permissible "drop" is 4 per cent. If each lamp requires 60 watts at a pressure of 110 volts, calculate the minimum cross-section of the cable if not more than two-thirds of the lamps are switched on at once.

13. In the previous example what would be the minimum cross-section if the power had to be transmitted 50 yds. only?

14. What is the maximum distance which a cable, having a resistance of 0.03 ohm per mile, can transmit 150 K.W. at a pressure of 220 volts, with a loss not exceeding 10 per cent. of the output?

15. Under the circumstances mentioned in the last question, what would be the maximum distance if the loss was not to exceed 10 per cent. of the input?

16. It is proposed to transmit 300 K.W. a distance of 40 yds. through a cable having a resistance of 0.06 ohm per mile, at a pressure of 220 volts. Would it be wise to do so? If not, why not?

17. Calculate the nominal cross-section of a conductor in square inches to carry a current of 85 amps., using the I.E.E. rule for low external temperature.

18. Calculate the area of cross-section given by the I.E.E. rule to carry a current of 150 amps. Assume that the external temperature is high.

19. What current will a conductor having a nominal cross-section of 0.0764 sq. in. carry under the I.E.E. rule—

(a) For low external temperatures?

(b) For high external temperatures?

20. For what cross-section of conductor will the carrying

capacity as determined by the 1000 amps. per square inch rule and the I.E.E. rule for low external temperatures be equal?

21. Repeat the above example, using the I.E.E. rule for high instead of for low external temperatures.

22. In a three-wire system, on the + side there are 32 16-c.p. lamps each taking 0.64 amp., and 48 32-c.p. lamps, each taking 1.24 amps. (when supplied with their normal pressure); on the - side there are 164 16-c.p. lamps, taking the same current as those on the + side. Calculate the current through the neutral wire (neglecting the resistance of the cable). If a break occurred in the middle wire between the lamps and the station, what would be the P.D. across it? Assume the voltage between the outers to be 220 volts, and that the resistance of the lamps remains constant, though the voltage applied to them varies.

23. In a three-wire system with 220 volts between the outers, it is observed that the current on the + side is 148 amps., and on the - side is 113 amps. If the resistance of the outers is 0.015 ohm, and of the neutral 0.03 ohm, calculate the voltage actually applied to each set of lamps.

24. Assuming that it is only necessary to provide the middle wire with half the cross-section of the outers, what percentage of copper will be saved by transmitting a certain power on the three-wire system with 220 between the outers, instead of on the two-wire system at 110 volts?

25. In the three-wire system described in Example 23, if the load on the - side remains constant at 113 amps., but the load on the + side is liable to fluctuate between 148 and 86 amps., what will be the maximum alteration in pressure to which the lamps on the + side are liable?

26. If the cost of copper in the form of cable is £220 per ton, and the cost of laying is £600 per mile (assume this to be independent of the size of cable), determine the most economical size of conductor to carry a current of 122 amps. over a total length of 3.45 miles. Interest and depreciation on capital is 10 per cent., and cost of energy is $\frac{3}{4}d.$ per B.O.T. unit. Assume the cables are used 120 hours per week.

27. Repeat the previous example on the assumption that the cost of laying is given by the expression—

$$\text{Cost per mile} = \pounds(500 + 400d),$$

d being the area of cross-section in square inches.

28. Repeat the last example on the assumption that the cost of energy is $1\frac{1}{2}d.$ per B.O.T. unit.

29. The P.D. at the station end of a pair of feeders is 215 volts, and at the consumers' end the P.D. is 211 volts, when the load is 120 amps. When a motor is switched on at the extremity of the feeder, the P.D. at this end drops to 209 volts, and then rises, as the motor gets up speed, to 210.1 volts. Calculate the current taken by the motor when first started, and also when it has attained full speed.

30. A pair of feeders, each 200 yds. in length, are to be of such a cross-section that when the normal load, which is 150 amps., is increased 50 per cent. the drop at the far end is not to exceed 3 volts. What is the minimum cross-section?

31. A pair of distributing mains consist of 19/14 cable, and are 250 yds. in length; at a point 86 yds. from the feeding end 28 amps. are taken off, and at the end a further 43 amps. are required. From this point also a pair of 19/20 cables are taken off, which supply a current of 26 amps. to a point 140 yds. away. If the P.D. at feeding point is 110 volts, calculate the P.D. between each pair of points at which the current is taken off.

32. If current is required as in the previous example, what is the smallest size of conductor which can be used throughout, in order that the voltage drop is not to exceed 3 volts?

33. In the previous example what cables would you use (diminishing the cross-section at each point where current is taken off) in order that the total "drop" may not exceed 3 volts, evenly distributed in the three sections?

34. A pair of distributing mains are composed of 19/18 cable, and are 340 yds. in length, the P.D. between them at the feeder end being 226 volts. If current is taken from them uniformly at the rate of 1 amp. every 3 yds., what will be the P.D. at the far end of the mains?

35. A building consists of two floors, each measuring 35 ft. by 75 ft.; each floor is 12 ft. in height, and is illuminated by 40 16-c.p. lamps. There is a five-way distribution board near the ceiling on each floor. The mains (which go up near the centre of one long side of the building) are composed of 19/18 cable. The lamp circuits are composed of 3/22 conductor. If the supply is at 110 volts, and the lamps need 3.5 watts per candle, calculate the "drop" from where the mains enter the building to the farthest lamp.

36. A building of four floors has 100 8-c.p. lamps on each floor ; the height of each floor is 13 ft., and the mains run straight up the middle of the building. On each floor there is a passage extending 100 ft. each way, and in the passage on each side of the middle there are 10 lamps. Opening out of the passage on each floor there are twenty rooms to the front and twenty rooms to the back, each room containing 2 lamps. Calculate the sizes of mains going from the bottom to the top of the building, and of the submains in the passages, on the supposition that when all the lamps are turned on, the drop in pressure from the basement to the farthest lamp does not exceed 2 volts. The pressure of the supply is 220 volts, and the lamps require 3.5 watts per candle-power.

37. A building consists of four floors, each measuring 36 ft. by 80 ft. The rooms into which these floors are to be divided are to be used as offices (for illumination required, see Chap. IX.); each floor is to have a distribution box near the ceiling. If the pressure of the supply is 220 volts, give a scheme of wiring so that the "drop" between the point where the mains enter the basement and the farthest lamp does not exceed 3 volts.

38. At what current will a circular wire of copper, with a free length of 5 ins. between its terminals and 0.026 in. in diameter, fuse ?

39. What diameter of copper wire will be suitable for a fuse rated to carry 75 amps. and to blow at 50 per cent. over load ?

40. What will be the fusing current of a copper strip 1.2 cms. broad and 0.026 cm. thick ?

CHAPTER VIII

ELECTRO-CHEMISTRY

It will be convenient, at this stage of the work, to distinguish clearly between the expressions "current of electricity" and "quantity of electricity."

Suppose it was stated that a certain quantity of water, say 20 gals., had passed through a certain pipe, we should be unable to state the rate of flow of the water. If, however, we were given the time during which this flow of water took place, say 10 mins., we could determine the rate of flow by dividing the total quantity of water passed by the time required for that quantity to pass, or—

$$\begin{aligned}\text{Rate of flow of water} &= \frac{20 \text{ gals.}}{10 \text{ mins.}} \\ &= 2 \text{ gals. per minute.}\end{aligned}$$

The term "rate of flow" corresponds exactly with the more familiar term "current;" therefore, re-writing the above expression, we have—

$$\text{Current of water} = \frac{\text{quantity of water}}{\text{time}}$$

We may, therefore, in any case, express the current

of water in a pipe as the quantity of water which passes in unit time.

It will be seen, from the above expression, that if we know the current of water flowing in a pipe, and also the time during which the current flows, the total quantity of water which passes may be determined.

$$\text{Quantity} = \text{current} \times \text{time.}$$

The term "current" is used electrically in exactly the same sense as in the hydraulic example discussed above.

As explained in Chapter I., the practical unit of quantity of electricity is the coulomb, also the practical unit of current is the ampere; therefore we have—

$$\begin{aligned} \text{current} &= \frac{\text{quantity}}{\text{time}} \\ \text{or amperes} &= \frac{\text{coulombs}}{\text{seconds}} \end{aligned}$$

the second being the corresponding unit of time.

If we denote quantity by Q , current by C , and time by t , we have—

$$Q = Ct \dots \dots \dots (1)$$

$$C = \frac{Q}{t} \dots \dots \dots (2)$$

$$t = \frac{Q}{C} \dots \dots \dots (3)$$

Example 1.—Determine the total quantity of electricity which passes round a circuit when a current of 18 amps. flows for a quarter of an hour.

From (1)—

$$Q = Ct = 18 \times 15 \times 60 = 16,200 \text{ coulombs.}$$

Example 2.—For what length of time must a current of 3 amps. flow through an electroplating vat in order that the total quantity of electricity which passes through the vat may be 2160 coulombs?

From (3)—

$$t = \frac{Q}{C} = \frac{2160}{3} = 720 \text{ secs.} = 12 \text{ mins.}$$

Suppose in our last example that the electroplating vat had consisted of a vessel containing a solution of copper sulphate in which two copper plates were immersed, the plates being connected to a battery and switch as shown in Fig. 42.

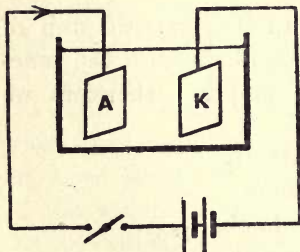

FIG. 42.

If we had weighed the plates before and after the passage of the quantity of electricity, we should have found that the plate A had decreased in weight, while

the plate K had increased by a corresponding amount. This would seem to show that the passage of the quantity of electricity through the solution had transferred a certain mass of copper from the “anode” A to the “kathode” K.

If, after performing the first experiment, we had made another observation with double the quantity of electricity, we should have found that the mass of copper transferred was also doubled.

We may now deduce our first law of electrolysis, namely, “The mass of metal transferred from anode to kathode will be directly proportional to the quantity of electricity passed.”

Since quantity = current \times time, we may say that the mass of metal transferred will be directly proportional to the current flowing and also to the time during which the current flows.

If, instead of one vessel, we had connected up three vessels in series containing respectively, copper plates in copper sulphate solution, silver plates in silver nitrate solution, and zinc plates in zinc sulphate solution, as shown in Fig. 43, we should have found that although the same quantity of electricity passed

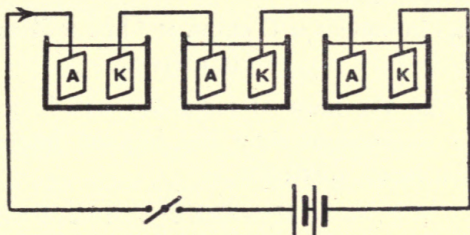

FIG. 43.

through each vessel, the mass of metal transferred between the respective anodes and cathodes would not be the same.

We can express the above result by stating that the mass of metal deposited by unit quantity of electricity is dependent upon the particular metal employed.

The mass of a metal deposited by unit quantity of electricity is termed the "electro-chemical equivalent" of the metal. The table at the end of the chapter gives the value of the electro-chemical equivalent for various pure metals.

If in any particular case the quantity of electricity passed through a depositing cell, and also the electro-chemical equivalent (Z) of the metal deposited be known, then—

$$\begin{aligned} \text{Mass of metal deposited} &= \text{quantity} \times \text{electro-} \\ &\quad \text{chemical equivalent} \\ &= C \times t \times Z. \end{aligned}$$

In C.G.S. units—

$$\begin{aligned} \text{mass in grams} &= C \text{ amps.} \times t \text{ secs.} \times Z \text{ grms.} \\ &\quad \text{per amp.-sec.} \end{aligned}$$

In British units—

$$\begin{aligned} \text{mass in ounces} &= C \text{ amps.} \times t \text{ hrs.} \times Z \text{ ozs.} \\ &\quad \text{per amp.-hr.} \end{aligned}$$

Denoting the mass of metal deposited by M , the following expressions show the relation between the above-mentioned quantities :—

$$M = CtZ (4)$$

$$C = \frac{M}{tZ} (5)$$

$$t = \frac{M}{CZ} (6)$$

$$Z = \frac{M}{Ct} (7)$$

Example 3.—Determine the number of grams of copper which would be deposited from a solution of copper sulphate by a current of 16 amps. in ten minutes.

From (4)—

$$\begin{aligned} M = CtZ &= 16 \times 10 \times 60 \times 0.0003293 \text{ grms.} \\ &= 3.16 \text{ grms.} \end{aligned}$$

Example 4.—A certain bronze medal is to be silver-plated. For what length of time must a current of 0.24

amp. flow in order that 0.05 oz. of silver might be deposited?

From (6)—

$$t = \frac{M}{CZ} = \frac{0.05}{0.24 \times 0.142} = 1.467 \text{ hrs.} \\ = 1 \text{ hr. } 28 \text{ mins.}$$

Example 5.—Determine the time required to evolve 1 litre of hydrogen, employing a current of 1.2 amps.

1 litre of hydrogen weighs—

$$1000 \times 0.0000896 = 0.0896 \text{ gm.}$$

Therefore, from (6)—

$$t = \frac{M}{CZ} = \frac{0.0896}{1.2 \times 0.000010437} = 7154 \text{ secs.} \\ = 2 \text{ hrs. (nearly).}$$

Example 6.—It was found by experiment that 1.788 grms. of zinc were deposited from a solution of zinc sulphate by a current of 2.2 amps. in 40 mins. Calculate the value of the electro-chemical equivalent of zinc.

From (7)—

$$Z = \frac{M}{Ct} = \frac{1.788}{2.2 \times 40 \times 60} = 0.0003386 \text{ grms. per coulomb.}$$

Example 7.—A silver voltameter, when connected in series with a single secondary cell, is found to have deposited 4.025 grms. of silver on the cathode in two hours. What must have been the average value of the current flowing?

From (5)—

$$\text{Average } C = \frac{M}{tZ} = \frac{4.025}{2 \times 60 \times 60 \times 0.001118} = 0.5 \text{ amp.}$$

The standardization of ammeters is very often effected by means of a copper or silver voltameter.

The ammeter to be tested is connected in series with the voltameter, and a steady current is passed through the circuit. The indication of the ammeter is noted, and in addition the correct value of the current is calculated from the mass of metal deposited in a certain time. The error in the indication of the ammeter can then be determined, the process being repeated for various points on the ammeter scale.

Example 8.—An ammeter, whose accuracy is doubted at the 3-ampere mark on the scale, is connected in series with a copper voltameter and a battery, and a constant current, indicated as 3 amps. by the ammeter, is passed through the circuit. It is found that after the current has been flowing for 50 mins., 2.667 grms. of copper have been deposited on the voltameter kathode. Calculate the error in the indication of the ammeter.

From (5)—

$$C = \frac{M}{iZ} = \frac{2.667}{50 \times 60 \times 0.0003293} = 2.7 \text{ amps.}$$

therefore the ammeter reads 0.3 amp. too high at the 3-ampere mark on the scale.

The laws previously stated apply equally well when considering the electro-chemical action which takes place inside a voltaic cell.

Example 9.—A Daniell's cell, having an open circuit E.M.F. of 1.1 volts and an internal resistance of 0.6 ohm, is employed to send a current through a resistance of 1.8 ohms for 20 mins. Determine the amount of zinc dissolved in the cell.

From (4)—

$$M = CtZ$$

But $C = \frac{1.1}{0.6 + 1.8} = \frac{1.1}{2.4}$ amps.

$$\therefore M = \frac{1.1 \times 20 \times 60 \times 0.0003387}{2.4} = 0.1863 \text{ gm.}$$

Example 10.—Determine the mass of copper which will be deposited on the copper plate of a Daniell's cell by sending a current of 0.7 amp. round a circuit for half an hour.

From (4)—

$$M = CtZ = 0.7 \times 30 \times 60 \times 0.0003293 = 0.415 \text{ gm.}$$

Example 11.—A battery of Bunsen's cells, consisting of two rows of 8 cells, in parallel, is employed to excite an electro-magnet having a resistance of 16.6 ohms.

Assuming each cell to have an E.M.F. of 1.9 volts and an internal resistance of 0.6 ohm, determine the total amount of zinc which will be dissolved in the battery after exciting the electro-magnet for 40 mins.

$$\text{Total E.M.F.} = 8 \times 1.9 = 15.2 \text{ volts,}$$

$$\text{total resistance} = 16.6 + \frac{8 \times 0.6}{2}$$

$$= 19 \text{ ohms,}$$

$$\therefore \text{current through electro-magnet} = \frac{15.2}{19} = 0.8 \text{ amp.}$$

But current through each cell = 0.4 amp.,

therefore, from (4)—

$$\left. \begin{array}{l} \text{Mass of zinc dissolved} \\ \text{in each cell} \end{array} \right\} = CtZ = 0.4 \times 40 \times 60 \times 0.0003387 = 0.3252 \text{ gm. ;}$$

$$\therefore \text{total amount of} \left. \begin{array}{l} \text{zinc dissolved} \end{array} \right\} = 0.3252 \times 16 = 5.2 \text{ grms. (approx.)}$$

A certain type of electricity meter consists of a

copper voltameter and compensating coil¹ connected across a metallic shunt as shown in Fig. 44, a balance arrangement being provided for determining the decrease in weight of the anode of the voltameter.

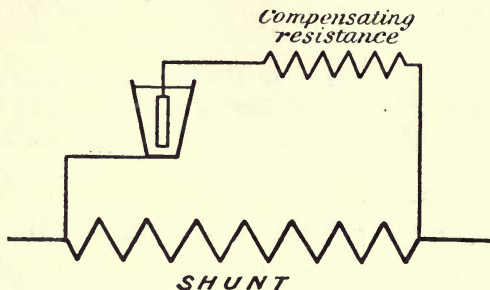

FIG. 44.

A little consideration will show that such a meter measures quantity of electricity and not electrical energy; that is to say, it measures the product, current \times time, and not pressure \times current \times time.

It is necessary, therefore, that such a meter should only be employed on a constant pressure circuit; in which case, having determined from the meter the product $C \times t$, the electrical energy (in joules) consumed can easily be obtained by multiplying by the value of the constant pressure. It is usual, in such meters, to calibrate the scale to read directly in Board of Trade units.

¹ The compensating resistance is so adjusted that its increase in resistance exactly compensates for the diminution in resistance of the voltameter electrolyte when the temperature is increased, and similarly when the temperature is reduced. Such an arrangement maintains a constant ratio between the resistance of the two circuits, the temperature coefficient of the shunt being negligible.

Example 12.—In a particular meter of the type described above, the combined resistance of the voltmeter and compensating resistance is 1.67 ohms, and of the shunt 0.16 ohm. Determine the amount of copper required to be deposited upon the kathode in order that the meter should indicate that 1 B.O.T. unit had been consumed.

Constant pressure of supply = 100 volts.

$$\begin{aligned} 1 \text{ B.O.T. unit} &= 1000 \text{ watt-hrs.}, \\ \text{and at 100 volts} &= 10 \text{ amp-hrs.}, \\ &= 10 \times 60 \times 60 \\ &= 36000 \text{ coulombs;} \end{aligned}$$

that is to say, 36,000 coulombs must pass through the main circuit in order to make the meter indicate 1 B.O.T. unit; but since the voltmeter is shunted, only a portion of this quantity will pass through the voltmeter, which, from Chapter IV., will be equal to—

$$\begin{aligned} &\frac{\text{Resistance of shunt}}{\text{Resist. of shunt} + \text{resist. of voltmeter}} \times \text{total quantity} \\ &= \frac{0.16}{0.16 + 1.67} \times 36000 = 3147.5 \text{ coulombs,} \end{aligned}$$

and since 1 coulomb deposits 0.0003293 gm. of copper from copper sulphate solution, we have—

$$\left. \begin{array}{l} \text{Mass of copper to be deposited in} \\ \text{order that the meter should} \\ \text{indicate 1 B.O.T. unit} \end{array} \right\} \begin{array}{l} = 0.0003293 \times 3147.5 \\ = 1.0363 \text{ grms.} \end{array}$$

It is necessary, when depositing metals electrolytically, to exercise care in the selection of a suitable current density on the kathode surface, this value being dependent upon the particular metal to be deposited. A number of values of suitable current densities for various metals are given in the table at the end of the chapter.

Example 13.—A brass teapot, having an available surface for deposition of 120 sq. ins., is required to be plated with a coating of silver 0.005 in. in thickness. What current would be suitable, and, using this current, how long would it take to silver-plate the teapot?

From table at the end of chapter—

$$\begin{aligned} \text{Suitable current} &= 120 \times 0.03 \\ &= 3.6 \text{ amps.} \\ \text{Volume of metal to be deposited} &= 120 \times 0.005 \\ &= 0.6 \text{ cub. in.} \\ \therefore \text{mass} \quad \text{,,} \quad \text{,,} \quad \text{,,} &= 0.6 \times 6.069 \\ &= 3.6414 \text{ ozs.} \end{aligned}$$

Therefore, from (6)—

$$\begin{aligned} t &= \frac{M}{CZ} = \frac{3.6414}{3.6 \times 0.14197} = 7.125 \text{ hrs. (nearly)} \\ &= 7 \text{ hrs. } 7.5 \text{ mins.} \end{aligned}$$

EXAMPLES.

- Determine the quantity of electricity which would flow round a circuit in 15 minutes, if the value of the current was 1.3 amps.
- A certain electricity meter indicates that 3.2 B.O.T. units have been consumed, the pressure of supply being 110 volts. What quantity of electricity must have passed through the meter?
- Determine the relation between the absolute and practical units of quantity of electricity.
- What weight of copper would be deposited from a solution of copper sulphate by a current of 0.9 amp. flowing for 3 hours?
- It was found that after a certain current had passed through a silver voltameter for $2\frac{1}{2}$ hours, the kathode had increased in weight by 2.518 grms. What was the average strength of the current flowing?
- Determine the increase in weight of the copper plate of a Daniell's cell after sending a current of 0.83 amp. round a circuit for half an hour.
- What length of time would be required to evolve half a litre of hydrogen, employing a current of 4 amps.?

8. Calculate the electro-chemical equivalent of zinc, given that a current of 0.7 amp. will deposit 0.2845 gm. of zinc from a solution of zinc sulphate in 20 minutes.

9. A certain ammeter, connected in series with a copper voltameter and a battery, indicates a current of 1.3 amps., but it is found that after the current has been flowing for 25 minutes the voltameter kathode has increased in weight by 0.6916 gm. Determine the error in the ammeter reading.

10. Two brass ash-trays are required to be silver-plated. Determine the length of time required to deposit 0.04 oz. of silver on each tray if a current of 0.5 amp. is employed.

11. If in the above example three similar Daniell's cells were employed in parallel to form the deposit, how much zinc would be dissolved in each cell during the process?

12. A mercury voltameter is employed as an electricity meter in a certain small installation, and is so constructed that the mercury deposited on the kathode falls into a small measuring cylinder graduated in cubic centimetres. The constant pressure of supply being 110 volts, determine the number of B.O.T. units which will be represented when the volume of mercury in the cylinder is 2 cub. cms.

13. Repeat the previous example, assuming the voltameter to be shunted by a resistance of 0.15 ohm. Assume voltameter resistance to be 2 ohms.

14. The handle-bar of a bicycle, having an available area for deposition of 72 sq. ins., is required to be nickel-plated. What current would be suitable, and, using this current, how long would it take to produce a coating of nickel 0.003 in. thick?

15. A battery of twelve Daniell's cells is required to deliver 44 amp.-hrs. Determine the relative amounts of zinc used—

(a) If the cells are all in series.

(b) If the cells are arranged four in series, and three rows placed in parallel.

16. It is required to electro-gild a bracelet having an available area for deposition of 30 sq. cms., the weight of gold deposited not to exceed 0.04 gm. What current will be suitable, and how long must it flow in order to produce the required deposit?

17. Determine the volumes of hydrogen and oxygen respectively liberated per ampere hour from a water-voltameter.

18. What thickness of silver will be deposited on an ash-tray

having an area of 26 sq. ins., by a current of 0.78 amp. in 3 hours?

19. A presentation cup, having a hemispherical bowl 8 ins. in diameter, is required to be gilded inside with a coating not exceeding 0.001 in. in thickness. How long would it take to gild the bowl, employing a suitable current?

20. What volume of water will be decomposed by a current of 14 amps. in 40 mins.?

21. A copper voltameter, having a resistance of 2.2 ohms, is shunted by means of a resistance of 0.06 ohm, and it is found that after a certain current has been flowing for 50 mins., the kathode of the voltameter has increased in weight by 1.4 grms. Calculate the average value of the main current.

22. A silver voltameter and a zinc voltameter are arranged in series, and it is found that while 10 grms. of silver have been deposited, the zinc kathode has increased in weight by 3.0295 grms. Given the electro-chemical equivalent of silver as 0.001118 gm. per coulomb, determine from the above data the electro-chemical equivalent of zinc.

23. Determine the volume of mixed gas (hydrogen and oxygen) which will be evolved on passing a current of 7 amps. through a water-voltameter for a quarter of an hour.

24. How many B.O.T. units would be required to deposit 1 kilog. of copper at a pressure of 10 volts?

25. Two Daniell's cells of 0.8 ohm and 1.3 ohms resistance respectively, and each having an E.M.F. of 1.1 volts, are connected in parallel and employed to operate a medical coil. Determine the relative amount of zinc dissolved in the two cells.

26. Calculate the cost of depositing 10 lbs. of copper, assuming that a pressure of 14 volts is obtained by converting from 100 volts by means of a machine having an efficiency of 70 per cent. Price of energy is 1*d.* per B.O.T. unit.

27. Using the same current, what are the relative times required to deposit equal weights of copper and zinc?

28. Express the electro-chemical equivalent of copper in pounds per kilo-ampere-hour.

29. Calculate the time required to electrolytically produce a plate of copper $\frac{1}{8}$ in. in thickness, and measuring 2 ft. by 18 ins.

30. If the currents are to flow for the same length of time, calculate the relative values of the currents necessary to deposit equal weights of copper and mercury (ic).

31. Determine the cost of the energy required to deposit 1 kilog. of copper at a pressure of 8 volts. Assume 1 B.O.T. unit costs 6*d.*

32. A standard resistance of 4 ohms is connected in series with a copper voltameter and a battery, and it is found that 4.11 grms. of copper are deposited in 40 mins. A voltmeter connected across the standard resistance indicates a P.D. of 20 volts. Determine the error in its reading.

33. A battery of two rows of six Bunsen cells, connected in parallel, is employed to deposit nickel. State the relation between the weight of nickel deposited and the weight of zinc dissolved in the battery.

34. At what rate (in grammes per minute) would you consider it advisable to deposit silver on a kathode having an area of 140 sq. ins.?

35. A certain coulomb-meter, intended to be used on a 100-volt constant-pressure supply circuit, and having a scale calibrated directly in B.O.T. units, is connected in series with a copper voltameter and a battery in order that its accuracy should be tested. It is found that when the meter indicates 1 B.O.T. unit, 11.6 grms. of copper have been deposited in the voltameter. Determine the error in the indication of the coulomb-meter.

36. A copper voltameter consists of three plates, the central one being the cathode and the two outer ones, which are in electrical connection, forming the anode. If it is to be used for currents up to 40 amps., what must be the size of the plates? If the initial thickness of the plates is 0.05 in., for how many hours can the anode carry the full load before losing 75 per cent. of its weight?

37. What weight of copper would 0.5 B.O.T. unit deposit at a P.D. of 8 volts?

38. A small copper voltameter, having a resistance of 8 ohms at 10° C., is intended for use in an electrolytic meter. Assuming the electrolyte to have a negative temperature coefficient of 0.0156 ohm per ohm per degree C., calculate the value of a copper compensating resistance which will keep the total resistance of the circuit at a constant value.

39. A certain type of electrolytic coulomb-meter consists of a long glass cylinder 2 ins. internal diameter, which is open at the top and terminates at the bottom in a spherical glass bulb. Two platinum electrodes are sealed into the glass bulb, and the whole is

filled up with very slightly acidulated water. Determine how far the surface of the liquid will drop after 10 B.O.T. units have been consumed. Assume constant pressure of supply 200 volts.

40. Given the values of a current after various intervals of time as indicated below, determine the total amount of silver which would be deposited in a voltameter during the whole period.

Time (mins.) 1 3 5 8 10 12 15 18 20.
Current (amps.) 0·85 0·7 0·68 0·76 0·8 0·75 0·65 0·7 0·72.

Metal.	Density.		Current Density.		Electro-chemical Equivalent.		
	Grms. per cubic cm.	Ounces per cubic inch.	Amperes per square cm.	Amperes per square inch.	Grms. per coulomb.	Grms. per ampere-hour.	Ounces per ampere-hour.
Copper (Cupric)	8·9	5·1442	·0155	·1	·0003293	1·1855	·04182
" (Cu- prous) }	8·9	5·1442	·0046	·03	·0006586	2·371	·08363
Gold ...	19·3	11·1554	·001	·006	·0006808	2·4509	·08645
Iron ...	7·8	4·5084	·0046	·03	·0002896	1·0426	·03677
Mercury (Mer- curic) }	13·6	7·8608	·0031	·02	·001036	3·7296	·13155
Mercury (Mer- curous) }	13·6	7·8608	·0031	·02	·002072	7·4592	·26311
Nickel ...	8·8	5·0864	·0031	·02	·0003042	1·0951	·03863
Silver ...	10·5	6·069	·0046	·03	·001118	4·0248	·14197
Zinc ...	6·9	3·9882	·0062	·04	·0003387	1·2193	·04301
<i>Gases.</i>							
Hydrogen ...	·0000896	·00005179	—	—	·000010437	·03757	·00132
Oxygen ...	·001423	·00082654	—	—	·00008287	·29833	·01052

CHAPTER IX

PHOTOMETRY

THE branch of science known as Photometry deals with the measurement of two distinct quantities, viz.—

(a) The “intensity” of various sources of light.

(b) The “intensity of illumination” produced by various sources of light.

The intensity of a source of light may be defined as the light-giving power of the source, and in order to avoid confusion of the terms “intensity” and “intensity of illumination,” it will be well to note that, assuming the supply of fuel is constant, the intensity of a source of light is also constant.

The intensity of illumination produced by the source is, however, a variable quantity, being dependent upon the distance between the surface illuminated and the source.

Suppose, for example, that a candle is employed to illuminate a photographic “dark” room; you could read an ordinary book comfortably at a distance of 1 foot from the candle, but if you took the book 20 feet away from the candle, you would be quite unable to read.

It will now be realized that the intensity of

illumination produced at any point is dependent upon the distance from the candle, but at the same time the intensity of the candle-flame remains unaltered.

The unit of intensity is termed the "candle-power," generally denoted by "c.p.," the candle-power of any source of light being its intensity as compared with that of a specified type of candle.

Although candles have been universally abandoned as standards, the recognized standards of intensity at the present time are generally defined as of so many candle-power.

The "lamp-power" has been suggested as a more practicable unit of intensity, its value being 10 times that of the candle-power;

$$1 \text{ lamp-power} = 10 \text{ candle-power.}$$

The question now arises as to the unit in terms of which intensity of illumination is measured.

The total illumination produced by a source of light really corresponds to the intensity or light-giving power of the source.

The intensity of illumination at any point is defined as the light-energy falling on unit surface at that point.

The unit of intensity of illumination is called the "candle-foot," and is the intensity of illumination produced on a surface held normally at 1 ft. distance from a standard candle.

Now let us examine what this unit really indicates.

Suppose a standard candle to be placed at the centre of a sphere of 1 ft. radius, then from the above definition, since each point of the interior surface of the sphere is normal to and at a distance of

1 ft. from the candle-flame, the intensity of illumination will be unity at all parts of the interior surface.

Now, the total light-energy is represented by 1 c.p., and since the whole interior surface illuminated is $4\pi r^2$ sq. ft., then—

$$\left. \begin{array}{l} \text{Light energy falling on} \\ \text{unit area of surface} \end{array} \right\} = \frac{\text{total light energy}}{\text{area}} = \frac{1}{4\pi r^2}$$

and, since $r = 1$ ft.—

$$\left. \begin{array}{l} \text{Light energy falling on} \\ \text{unit area of surface} \end{array} \right\} = \frac{1}{4\pi} \text{ of total light energy} \\ \text{due to 1 c.p.}$$

and this is unit intensity of illumination.

Now consider a general case in which a source of light of c.p. candle-power is encircled by a sphere of radius D ft.

The intensity of illumination at any point of the uniformly illuminated sphere

$$= \frac{\text{total light energy}}{\text{area illuminated}} = \frac{\text{c.p.}}{4\pi D^2}$$

and in terms of the above unit, the candle-foot, this will equal—

$$\frac{\frac{\text{c.p.}}{4\pi D^2}}{\frac{1}{4\pi}} = \frac{\text{c.p.}}{D^2}$$

We may now deduce our first law, namely, that the intensity of illumination produced on a surface normal to a source of light, is directly proportional to the intensity of the source and inversely proportional to

the square of the distance between the source and surface.

If intensity is measured in candle-power (c.p.), and distance (D) in feet—

$$\text{Intensity of illumination in candle-feet} = \frac{\text{c.p.}}{D^2} \quad (1)$$

Example 1.—Determine the intensity of illumination produced on a wall which is normal to and 6 ft. distant from a candle-flame of unit intensity.

From (1)—

$$\text{Int. of illum.} = \frac{\text{c.p.}}{D^2} = \frac{1}{6^2} = 0.028 \text{ candle-ft. (nearly).}$$

Example 2.—An intensity of illumination of 3 candle-ft. is required at the centre of a small dining table, and the lamp must be suspended at least 4 ft. above the centre of the table. Determine the candle-power required of the lamp.

Since from (1)—

$$\text{Int. of illum.} = \frac{\text{c.p.}}{D^2}$$

$$\begin{aligned} \text{then c.p.} &= \text{int. of illum.} \times D^2 \\ &= 3 \times 4^2 = 48 \text{ candle-power.} \end{aligned}$$

Example 3.—A gasolier of 120 c.p. hung 5 ft. above a table is to be replaced by an electrolier at a distance of 6 ft. above the table. Determine the number of 16 c.p. lamps required.

$$\text{Int. of illum. by gasolier} = \frac{120}{5^2} = \frac{120}{25} \text{ candle-ft.}$$

$$\text{,, ,, ,, electrolier} = \frac{\text{c.p.}}{6^2} = \frac{\text{c.p.}}{36} \quad \text{,,}$$

and since these must be equal—

$$\frac{120}{25} = \frac{\text{c.p.}}{36}$$

$$\therefore \text{c.p.} = \frac{120 \times 36}{25}$$

and number of 16-c.p. lamps required = $\frac{120 \times 36}{25 \times 16} = 11$.

It is very desirable that the student should have some notion of the methods usually employed in the determination of the candle-power of various sources of light.

The most essential portion of the apparatus required for such a test is termed a "photometer disc," a simple form of which consists of two small slabs of clean paraffin wax, each about 0.5 cm. in thickness, which are cemented together as shown in Fig. 45, a piece of tinfoil being placed between them in order that they may be independently illuminated.

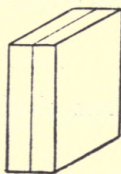

Tinfoil.
FIG. 45.

In order to make a test, the photometer disc is placed between the two light sources to be compared,

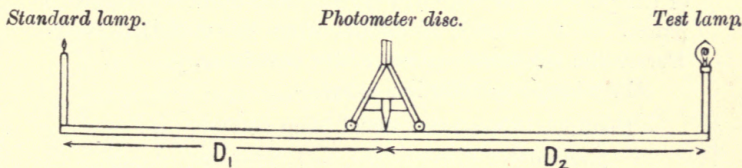

FIG. 46.

as shown in Fig. 46, and its position is adjusted (always keeping the main surfaces of the disc normal to the respective beams of light) until a point is

obtained at which the two sides of the paraffin block, as viewed from the vertical edge, seem to be equally illuminated; then, if S denotes the candle-power of the standard lamp, we know that the intensity of illumination produced at the position occupied by the photometer disc $= \frac{S}{D_1^2}$.

Similarly, if X denotes the candle-power of the test lamp, then intensity of illumination produced at photometer disc by test lamp $= \frac{X}{D_2^2}$; but when a "balance" is obtained, these intensities of illumination are equal, or—

$$\frac{S}{D_1^2} = \frac{X}{D_2^2}$$

from which—

$$X = \frac{S \times D_2^2}{D_1^2} \dots \dots \dots (2)$$

Example 4.—An electric glow lamp, whose candle-power is required, is placed at one end of a photometer bench which is 100 ins. long, the other end being occupied by a standard 10-c.p. lamp. It is found that the two sides of the photometer disc are equally illuminated when it is placed at a distance of 40 ins. from the standard lamp. Determine the candle-power of the test lamp.

Since lamps are 100 ins. apart—

$$\left. \begin{array}{l} \text{Distance between standard lamp and} \\ \text{photometer disc} \end{array} \right\} = 40 \text{ ins.}$$

$$\left. \begin{array}{l} \text{Distance between test lamp and} \\ \text{photometer disc} \end{array} \right\} = 60 \text{ ,,}$$

therefore, from (2)—

$$\text{c.p. of test lamp} = \frac{10 \times 60^2}{40^2} = 22.5 \text{ candle-power.}$$

Example 5.—A 10-c.p. electric glow lamp is placed at a distance of 20 cms. from a photometer disc. At what distance must a 16-c.p. lamp be placed from the opposite side of the disc in order to produce a “balance”?

$$\begin{aligned} \text{Int. of illum. produced by 10-c.p. lamp} &= \frac{10}{20^2} \\ \text{“ “ “ “ 16 “ “} &= \frac{16}{D^2} \end{aligned}$$

where D = distance between 16-c.p. lamp and photometer disc, and since these must be equal—

$$\begin{aligned} \frac{10}{20^2} &= \frac{16}{D^2} \\ \text{or } D^2 &= \frac{16 \times 20^2}{10} \\ \therefore D &= \sqrt{\frac{16 \times 20^2}{10}} = 25.3 \text{ cms.} \end{aligned}$$

A method commonly employed in photometric practice is as follows:—

The photometer disc is fixed in a definite position, and one side of it is constantly illuminated by means of a lamp termed a sub-standard, the candle-power of which need not be known; the standard lamp is then placed on the opposite side of the disc to the sub-standard, and its position on the photometer bench is adjusted until a balance is obtained, the distance between it and the photometer disc being noted.

This process is repeated with the test lamp, the distance between the photometer disc and the test lamp being noted. Then—

$$\left. \begin{array}{l} \text{Intensity of illum. due} \\ \text{to standard lamp} \end{array} \right\} = \text{intensity of illum. due to} \\ \text{test lamp};$$

and using the same letters as in formula (2)—

$$\frac{S}{D_1^2} = \frac{X}{D_2^2}$$

$$\text{or } X = \frac{SD_2^2}{D_1^2}$$

which is the same equation as given in (2).

Example 6.—A photometer bench having been arranged as described above, it is found that a standard 16-c.p. lamp balances at a distance of 90 cms. from the disc, while the test lamp balances at a distance of 66 cms. from the disc. Calculate the candle-power of the test lamp.

From above—

$$X = \frac{SD_2^2}{D_1^2} = \frac{16 \times 66^2}{90^2} = 8.6 \text{ c.p. (approx.).}$$

We have dealt hitherto with light striking surfaces normally, but this is not always the case, and, as will now be shown, account must be taken of the angle at which the beam of light strikes the surface.

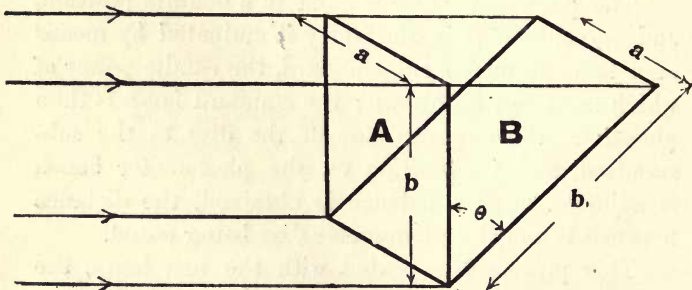

FIG. 47.

Suppose that in Fig. 47 a parallel beam of light passes through an aperture A, and falls upon a surface, B, which is inclined to A at an angle θ .

where c.p. = candle-power of distant source of light ;
 D = distance in feet between source of light
 and surface at B.¹

Now, it can easily be shown that the angle θ is equal to the angle of incidence, *i.e.* the angle between the beam of light and a normal to the illuminated surface.

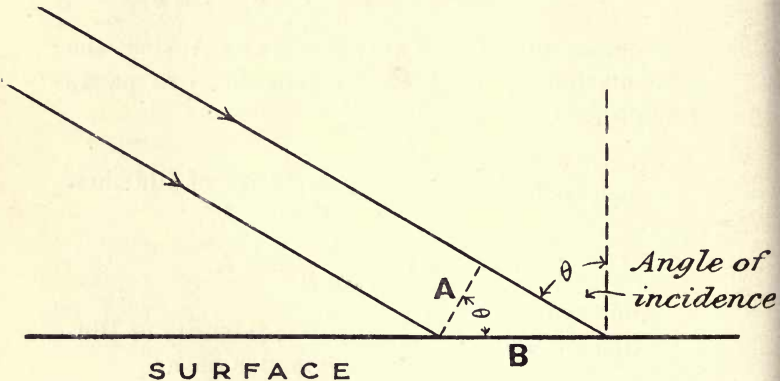

FIG. 48.

We may state our law finally as follows:—

The intensity of illumination produced on a surface is directly proportional to the intensity of the source of light, and also to the cosine of the angle of incidence; and inversely proportional to the square

¹ Fig. 48 is much exaggerated, since we are representing a point by a surface B; so that, in reality, the surfaces A and B are practically equidistant from the light source. And again, since the source is distant, and we are considering an extremely narrow beam of light, the rays may be considered as parallel between the surfaces A and B.

of the distance between the source and the surface illuminated. Stated algebraically—

$$\left. \begin{array}{l} \text{Intensity of illumina-} \\ \text{tion in candle-feet} \end{array} \right\} = \frac{\text{c.p.}}{D^2} \cos \theta \quad \dots (3)$$

D being in feet as before.

If the surface illuminated is normal to the beam of light, the angle of incidence = 0° , and $\cos 0^\circ = 1$, in which case—

$$\text{Intensity of illumination} = \frac{\text{c.p.}}{D^2}$$

which corresponds with our first law for normal surfaces.

Example 7.—Determine the intensity of illumination produced at a position A on a horizontal surface as represented in Fig. 49.

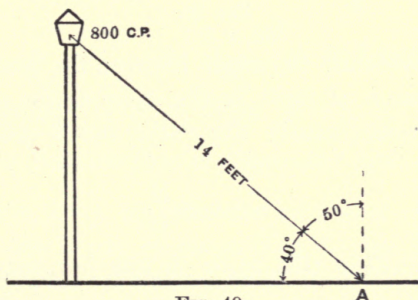

FIG. 49.

From (3)—

$$\begin{aligned} \text{Intensity of illumination} &= \frac{\text{c.p.}}{D^2} \cos \theta \\ &= \frac{800}{14^2} \cos 50^\circ \\ &= \frac{800}{14^2} \times 0.6428 \text{ candle-ft.} \\ &= 2.62 \text{ candle-ft.} \end{aligned}$$

In the majority of cases dealt with in practice, the angle of incidence is not easily obtainable; in fact, the only measurements which are at all practicable are the height of the lamp H , and the distance along the surface L (see Fig. 50).

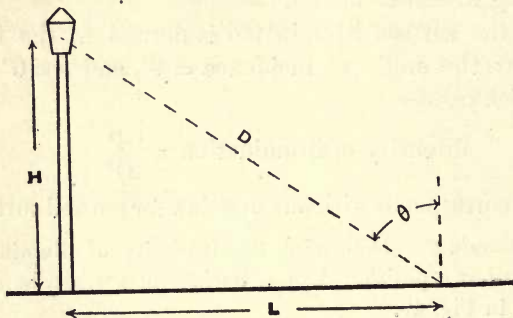

FIG. 50.

Now, evidently the angle between the lamp support and the beam of light is the same as the angle θ in Fig. 50, consequently the value $\cos \theta$ may be expressed—

$$\cos \theta = \frac{H}{D}$$

and substituting this value in our previous formula, we have—

$$\begin{aligned} \text{Intensity of illumination} &= \frac{\text{c.p.}}{D^2} \cos \theta = \frac{\text{c.p.}}{D^2} \times \frac{H}{D} \\ &= \frac{\text{c.p.} \times H}{D^3} \quad \dots \quad (4) \end{aligned}$$

Example 8.—An electric arc lamp of 600 mean hemispherical candle-power is fixed 18 ft. above a roadway. Determine the intensity of illumination produced on the

surface of the roadway at a point 22 ft. from the centre of the arc lamp.

From (4)—

$$\begin{aligned} \text{Intensity of illumination} &= \frac{\text{c.p.} \times H}{D^3} = \frac{600 \times 18}{22^3} \\ &= 1.01 \text{ candle-ft.} \end{aligned}$$

Example 9.—A photometer, when placed horizontally on a footpath at a distance of 28 ft. from the centre of an arc lamp, indicates the intensity of illumination to be 1.8 candle-ft. Assuming the height of the arc lamp to be 20 ft. above the footpath, determine its candle-power.

Since from (4)—

$$\begin{aligned} \text{Intensity of illumination} &= \frac{\text{c.p.} \times H}{D^3} \\ \text{then c.p.} &= \frac{\text{intensity of illumination} \times D^3}{H} \\ &= \frac{1.8 \times 28^3}{20} = 1976 \text{ candle-power.} \end{aligned}$$

A convenient method, which avoids the measurement of the distance D , is to obtain the ratio $\frac{L}{H}$, which equals $\tan \theta$; then, by reference to a table of angular functions, the angle corresponding to $\tan \theta$ can be obtained, and also the value $\cos \theta$.

Example 10.—An electric arc lamp of 800 mean hemispherical candle-power is fixed 20 feet above a certain roadway. Determine the intensity of illumination produced on the surface of the roadway at a point 16 ft. distant from the base of the lamp standard.

From (3)—

$$\text{Intensity of illumination} = \frac{\text{c.p.}}{D^2} \cos \theta.$$

Now, in any right-angled triangle such as in Fig. 50—

$$D^2 = H^2 + L^2$$

$$\therefore \text{intensity of illumination} = \frac{\text{c.p.}}{H^2 + L^2} \cos \theta \quad (5)$$

$$\text{Now, } \tan \theta = \frac{L}{H} = \frac{16}{20} = 0.8$$

and from table—

$$\cos \theta = 0.7808$$

$$\begin{aligned} \therefore \text{intensity of illumination} &= \frac{800 \times 0.7808}{20^2 + 16^2} \\ &= 0.95 \text{ candle-ft.} \end{aligned}$$

Graphical Methods.

Example 11.—To determine by a graphical method the intensity of illumination required in Example 10.

From (5)—

$$\begin{aligned} \text{Intensity of illumination} &= \frac{\text{c.p.}}{H^2 + L^2} \cos \theta \\ &= \frac{800}{20^2 + 16^2} \cos \theta \\ &= 1.22 \cos \theta \quad . . \quad (a) \end{aligned}$$

Now construct a triangle as shown in Fig. 51, letting the height of the lamp and the distance along the surface be represented respectively to scale by AB and BC. The angle θ will then be accurately represented.

Now mark off along AC any distance AD corresponding to 1.22 units; then, on completing the new triangle ADE, the length AE, to the same scale as AD, equals $AD \cos \theta$ —that is, $1.22 \cos \theta$.

But in (a) we showed that—

$$\text{Intensity of illumination} = 1.22 \cos \theta,$$

therefore intensity of illumination required is given by the length AE to the same scale as AD, which from diagram equals 0.95;

\therefore intensity of illumination = 0.95 candle-ft.

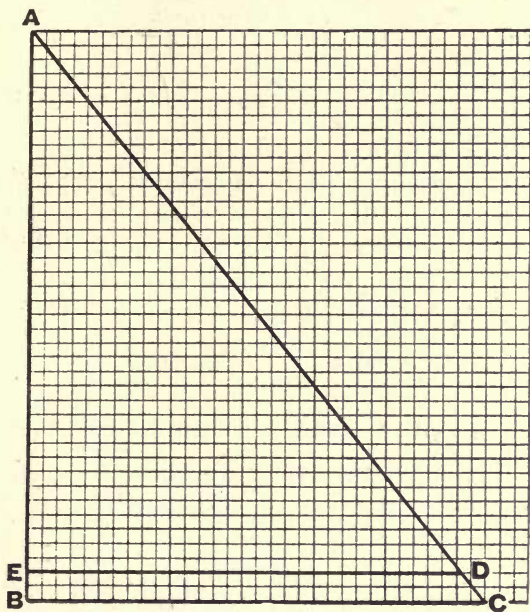

FIG. 51.

Graphical methods can also be applied in cases where candle-power is the quantity to be determined.

Example 12.—An incandescent gas lamp is fixed 9 ft. above the surface of a roadway, and a photometer, placed 3 ft. above the surface and 12 ft. from the lamp standard, indicates an intensity of illumination of 0.85 candle-ft. Determine the candle-power of the lamp.

From (5)—

$$\begin{aligned} \text{Intensity of illumination} &= \frac{\text{c.p.}}{H^2 + L^2} \cos \theta \\ \therefore \text{c.p.} &= \frac{\text{inten. of illum.} \times (H^2 + L^2)}{\cos \theta} \\ &= \frac{0.85 \times (6^2 + 12^2)}{\cos \theta} \\ &= \frac{153}{\cos \theta} \quad \dots \dots \dots (a) \end{aligned}$$

Now, if a triangle be drawn to scale, as in Example 11, the angle θ will be accurately represented, as shown in Fig. 52.

Now, if we mark off along AB a length AD, corresponding to 153 units, we know that on completing the triangle ADE, the length AE, to the same scale as AD, will be equal to $\frac{AD}{\cos \theta}$, that is, $\frac{153}{\cos \theta}$.

But in (a) we showed that $\text{c.p.} = \frac{153}{\cos \theta}$, therefore candle-power required is given by the length AE to the same scale as AD, which from diagram = 342; therefore candle-power = 342.

Interior Illumination.—The candle-power necessary to successfully illuminate the interior of buildings is, to a very great extent, dependent upon the nature of the wall surface, and also upon the interior furnishing.

In consequence of this, no accurate rules can be laid down to enable us to predetermine the candle-power required to suitably illuminate any particular room. A fair approximation may be made, however, by reference to the following table, which applies to the illuminating effect produced by lamps fixed from

7½ to 8 ft. above the floor, the walls of the room being of a moderately light colour:—

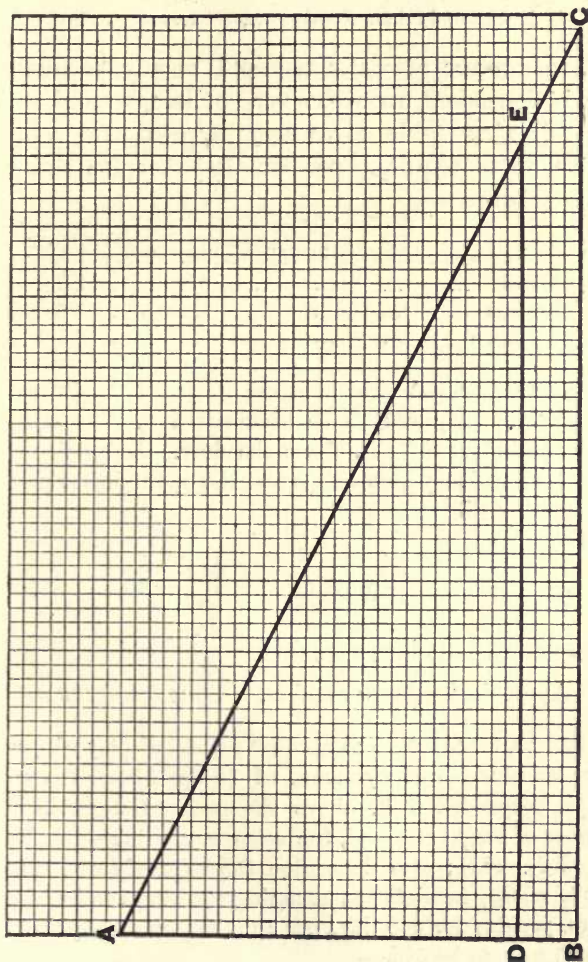

FIG. 52.

	Sq. ft. per c.p.
Lecture, entertainment, and show rooms	... 2
Drawing and dining rooms 3
Shops, warehouses, and churches 5
Bedrooms and minor rooms 10

The number of watts required in any particular case is dependent upon the type of lamps employed. The following table gives some approximate values of the watts required per candle-power for various types of lamps:—

	Watts per c.p.
Ordinary glow lamp (carbon filament)...	... 3·5
Nernst 1·6
Osmium 1·6
Tantalum 2·1

Example 13.—A drawing-room having a floor area of 240 sq. ft. is required to be illuminated by 8-c.p. lamps fixed at a height of $7\frac{1}{2}$ ft. above the floor. Determine the number of ordinary glow lamps and the approximate power required.

From table—

$$\text{c.p. required} = \frac{240}{3} = 80$$

$$\therefore \text{number of 8-c.p. lamps required} = \frac{80}{8} = 10.$$

$$\text{Approximate power required} = 80 \times 3\cdot5 = 280 \text{ watts.}$$

Example 14.—A room allotted for the display of goods is to be illuminated by means of 75-c.p. 110-volt Nernst lamps, suspended 8 ft. above the floor. Determine the number of lamps required, the room measuring 70 ft. long by 42 ft. wide; also determine the approximate annual cost of energy for lighting, assuming the lamps to be in use 4 hrs. per day for 300 days per annum. Assume price per B.O.T. unit to be $5\frac{1}{2}d.$ —

Area to be illuminated = $70 \times 42 = 2940$ sq. ft.

therefore from table—

$$\text{c.p. required} = \frac{2940}{2} = 1470.$$

$$\text{Number of 75-c.p. lamps required} = \frac{1470}{75} = 20 \text{ (approx.)}.$$

$$\text{Energy consumed per annum} = \frac{20 \times 75 \times 1.6 \times 4 \times 300}{1000}$$

$$= 2880 \text{ B.O.T. units ;}$$

$$\therefore \text{cost of energy per annum} = 2880 \times 5.5 = 15,840d. \\ = \text{£}66.$$

EXAMPLES.

1. Determine the intensity of illumination produced on a surface held normally at a distance of 8 ft. from a gas-lamp of 14 c.p.

2. An electric glow lamp of 50 c.p. is placed vertically above an office desk. At what height must it be placed in order to give an illumination of 1.2 candle-ft.?

3. What must be the candle-power of a gas-lamp in order that an illumination of 2.4 candle-ft. shall be produced on a wall situated normally to the rays and 10 ft. from the lamp?

4. It is required to fit an electrolier at a height of 4 ft. above a certain table, to replace a gaslight of 40 c.p. situated 3.6 ft. above the table. What number of 8-c.p. lamps will be required?

5 It is proposed to replace a gasolier giving 270 c.p., placed at a distance of 24 ft. from a certain point, by an electrolier placed 30 ft. from the same point. Calculate the candle-power of the electrolier in order that the illumination at the point shall be the same in both cases.

6. If in the last question the power available for the electrolier is 7 amps. at 110 volts, at what distance must it be placed in order to produce the same illumination as the gasolier?

7. In a certain type of photometer bench the screen is placed between the lights to be compared, the distance between the latter being 120 cms. In making a test a 10-c.p. lamp was used as a standard, and a balance was obtained when the screen was 42 cms. from this lamp. Calculate the candle-power of the lamp under test.

8. Determine the candle-power of an electric lamp such that, when placed at a distance of 36 ins. from a photometric disc, it produces an illumination equal to that produced by a 16-c.p. standard lamp placed at 28 ins.

9. A certain electric incandescent lamp is placed at about 2 ft. from a photometric disc, and it is found that a "balance" exists when a standard 16-c.p. lamp is placed at a distance of 38 ins. on the other side of the screen. When a lamp to be tested is substituted for the standard lamp, a "balance" is obtained when it is 31 ins. from the screen. What is the candle-power of the lamp under test?

10. At what distance from a photometric screen must a lamp of 16 c.p. be placed in order to produce a "balance" with a lamp of 10 c.p. placed at 15 ins.?

11. Calculate the illumination produced upon a surface by a 32-c.p. lamp placed at a distance of 14 ft. Assume the rays of light are incident normally.

12. A surface is illuminated by an electric incandescent lamp of 32-c.p. Calculate the illumination produced on a surface placed 6 ft. from the lamp, and with which the rays make an angle of incidence of 30° .

13. An incandescent gas-lamp of 32 c.p. is fixed 4 ft. above a table. Calculate the intensity of illumination produced at a point on the surface of the table which is 4 ft. distant from a point vertically under the centre of the lamp.

14. An electric incandescent lamp is required to illuminate a circular table 6 ft. in diameter, and is placed 5 ft. above its centre. Calculate the candle-power of the lamp if the minimum illumination on the table is to be 1.3 candle-ft.

15. A certain street is illuminated by arc lamps placed on standards 15 ft. above the ground and 80 ft. apart. If the candle-power of each lamp is 800, what will be the intensity of illumination produced at a point on the surface midway between two lamps? (Neglect the effect of any lamps except the nearest two.)

16. What must be the candle-power of an arc lamp which, when placed on a standard 14 ft. high, produces an illumination on a horizontal surface at a point on the ground 30 ft. away from the base of the standard, of 0.25 candle-ft.?

17. Repeat the above question if an illumination of 0.25 candle-ft. has to be produced at a point 20 ft. away from the standard and 4 ft. from the ground.

18. Determine the best height for an arc lamp to be placed above the pavement in order to secure a maximum illumination at a point on a horizontal plane on the roadway 20 ft. from the base of the lamp. (This is best done by plotting the curve connecting height of lamp with illumination produced.)

19. Plot a curve connecting the illumination produced on a horizontal surface placed on the ground-level, with the distance from the base of an arc lamp standard which supports an arc lamp of 800 c.p. at a height of 15 ft. from the ground.

20. The length of a photometer bench is 150 cms., and it is

graduated from one end. The screen is fixed exactly at the centre, and one lamp is placed towards either end. When the standard 10-c.p. lamp is placed on the 25-cms. mark, and the test lamp on the 140-cms. mark, a state of "balance" is obtained. Calculate the candle-power of the test lamp.

21. If the same photometer bench and lamps are used as in the last question, but the two lamps (standard and test lamps) are placed at the 0 and 150 cms. marks respectively, at what point must the screen be placed in order to secure a balance?

22. Assuming the lamps to be in the same position as in the last example (the standard lamp still being of 10 c.p.), plot a curve connecting the position of the screen when balance is obtained, with the candle-power of the lamp under test.

23. If the standard lamp is of 10 c.p., and it is placed at a constant distance from the screen of 20 cms., plot a curve showing the relationship between the distance of test lamp from screen, when balance is obtained, and the candle-power of the test lamp.

24. Arc lamps of 800 c.p. are placed on standards 15 ft. above the road-level. What is the maximum permissible distance between two lamps in order that the illumination on the road does not fall below 0.2 candle-ft.? (Only consider effect of two nearest lamps.)

25. Calculate the illumination produced by a 1200-c.p. arc lamp placed 15 ft. above the ground, on a horizontal surface placed 4 ft. above the road and 15 ft. from the lamp standard.

26. Repeat the above example, using graphical methods as far as possible.

27. Taking the data given in the last example, plot a curve connecting angle of inclination of surface to the ground with the intensity of illumination produced upon it.

28. Draw a curve connecting the height of an 800-c.p. arc lamp above the road and the illumination produced by it on a horizontal surface on the ground-level 15 ft. from the base of the lamp-standard.

29. An 800 c.p. lamp is placed 18 ft. above the road. At what distance from the base of the lamp will the illumination produced on a horizontal surface be 0.2 candle-ft.?

30. If a lamp is placed on a standard 16 ft. above the road, what candle-power must it have in order to produce an illumination of 0.15 candle-ft. on a horizontal surface at the level of the ground, placed 20 ft. from the base of the lamp?

31. Repeat the above example, using graphical methods as far as possible.

32. Two incandescent gas-lamps, each of 16 c.p., are placed 8 ft. apart, at a height of 4 ft. above a counter. Determine (as far as possible graphically) the intensity of illumination produced on the counter, at a point vertically under the line joining the lamps, and 3 feet from the vertical projection of one of them.

33. The distance of a standard lamp of 10 c.p. from a photometric screen is 30 cms., and the distance of a lamp under test, which takes 0.61 amp. at 110 volts, is 40 cms. when balance is obtained. Calculate the number of watts absorbed per candle-power.

34. A dining-room is 30 ft. long by 20 ft. broad. How many candle-power would be required to illuminate it? If the lamps used are of the carbon filament type, what power will be required?

35. A building consists of four floors, each 40 ft. by 60 ft., the whole of the premises being used as offices. If artificial illumination is required for an average period of 4 hrs. per day for 300 days in the year, calculate the approximate amount of energy consumed in this period, assuming that electric incandescent carbon filament lamps are used.

36. An art gallery measures 100 ft. by 30 ft. Assuming it to be illuminated by Nernst lamps, calculate the approximate cost of energy per annum if the lamps are in use for 800 hrs. during that period, and energy costs $3\frac{1}{2}$ d. per B.O.T. unit.

37. Calculate the approximate number of 8-c.p. lamps needed to illuminate a factory consisting of four floors, each measuring 30 ft. by 40 ft.

38. Rays of light from a certain lamp make an angle of incidence of 60° with the ground. It is found that when a screen is inclined at 20° from the ground (and facing towards the source of light), the illumination is 0.46 candle-ft. Calculate the illumination produced upon a horizontal surface situated in the same position.

39. A piece of apparatus, consisting of two similar white screens connected at right angles and arranged so that each screen is only illuminated by one source of light, is placed midway between two lights whose intensities have to be compared. (The student should note that if the angle of incidence on one screen is θ° , the angle of incidence on the other screen is $90 - \theta^\circ$.) A balance is obtained when the angle of the weaker light is 25° . Calculate the relative intensities of the two sources.

40. If the photoped in the last example is provided with a scale of degrees which reads 0° when the surface illuminated by the standard lamp of 10 c.p. illuminates its screen normally, plot a curve connecting angular deflection (when balance is obtained) with candle-power of the lamp under test.

ANSWERS TO EXAMPLES

CHAPTER I.

- | | | |
|---|---|--------------------------------|
| 1. 4.96 ins. | 2. 48.6 ft. | 3. 9.8 mms. |
| 4. 329 cms. | 5. 263 grs. | 6. 11.8 K.G. |
| 7. 10.6 lbs. | 8. 397 sq. ft. | 9. 1.98 sq. ft. |
| 10. (a) 0.000177 sq. in.; (b) 177 sq. mils.; (c) 225 circular mils. | | |
| 11. 1115 circular mils. | | 12. 223 sq. mils. |
| 13. 0.0113 in.; 0.01 in. | | 14. 43 circular mils. |
| 15. 80.4 litres. | 16. 2264 c.cs. | 17. 3.02×10^{-6} lbs. |
| 18. 32.5 mils. | 19. 28,300 grs. | 20. 981. |
| 21. 700 dynes. | 22. 0.424 cub. in.; 0.136 lb. | |
| 23. 0.18×10^6 dynes. | 24. 36 dynes. | 25. 14.25×10^6 dynes. |
| 26. 27 secs. | 27. 72 cms. per second. | |
| 28. 33,200 dynes. | 29. 13.58×10^6 ergs; 0.422×10^6 ergs. | |
| 30. 0.628 dyne. | 31. 77.4 ohms. | 32. 88.2 ohms. |
| 33. 1.0136. | 34. 33 B.A. ohms. | 35. 13 units. |
| 36. 0.01118 grs. per second. | 37. 0.000015 ohm; 1,348,000 ohms. | |
| 38. 25 dynes. | 39. 0.0094 volt. | |
| 40. 1.434×10^8 abs. units of E.M.F. | | |

CHAPTER II.

- | | | |
|--------------------------------|-------------------|--------------------|
| 1. 0.01 volt. | 2. 0.00917 amp. | 3. 166.7 ohms. |
| 4. 0.4 absolute unit. | 5. 3584 volts. | 6. 0.492 volt. |
| 7. 283 ohms. | 8. 0.44 amp. | |
| 9. 0.0012 volt per division. | 10. 0.75 volt. | |
| 11. 4 volts. | 12. 0.015 volt. | 13. 0.0208 ohm. |
| 14. 6.2 ohms. | 15. 0.000025 ohm. | 16. 0.2 amp. high. |
| 17. 0.00229 ohm. | 18. — | 19. 0.77 amp. |
| 20. 9 ohms. | 21. Second case. | 22. 2200 ohms. |
| 23. 6600 ohms. | 24. 0.577 : 1. | 25. — |
| 26. 20 amps.; 0.0045 ohm. | | 27. 45 ohms. |
| 28. 3.4 volts. | 29. 5 ohms. | 30. 104 volts. |
| 31. 1.4 volts. | 32. — | 33. 0.000055 amp. |
| 34. 0.227 of the total length. | | 35. 0.098 ohm. |
| 36. First case. | 37. 0.0667 ohm. | 38. 3893 ohms. |
| 39. 2.81 volts; 32 amps. | | 40. 0.209 ohm. |

CHAPTER III.

- | | |
|---------------------------------|------------------|
| 1. 0.0000962 ohm; 0.00361 volt. | 2. 5.97 ohms. |
| 3. 4215 yds. | 4. 0.00275 ohm. |
| 6. 0.1 in. | 7. 0.0275 cm. |
| | 8. 2.54 sq. ins. |

- | | | |
|----------------------------------|-------------------------|-------------------------|
| 9. 10.9 volts. | 10. 0.059 ohm per yard. | |
| 11. 23.7 ohms. | 12. 0.109 cm. | 13. 0.000229 ohm. |
| 14. 0.272. | 15. 0.000154. | 16. 11.7° C. |
| 17. 28.1° C. | 18. 8.52 ohms. | 19. 33.3° C. |
| 20. 0.125 per cent.; 6 per cent. | | 21. 0.03 per cent. low. |
| 22. 0.607 amp. | 23. 5 amps. | 24. 3.03 amps. |
| 25. 1.88 ohms. | 26. 16.1 ohms. | 27. 0.39 amp. |
| 28. 0.0412 ohm; 4.12 volts. | | 29. 9 : 1; 0.0254 : 1. |
| 30. 1 : 0.814. | 31. 0.545 ohm. | 32. 12.26 mils. |
| 33. 0.189 ohm. | 34. 1500 ohms. | |
| 35. 0.53 megohm per mile. | 36. 13.5 ohms; 36 ohms. | |
| 37. 0.039 ohm. | 38. 0.0023 ohm. | |
| 39. 3 ohms. | 40. 11.8 ohms. | |

CHAPTER IV.

- | | | |
|---|----------------------------------|-----------------|
| 1. 0.98 ohm. | 2. 1.04 volts. | 3. 111.5 volts. |
| 4. — | 5. 0.25 ohm; 5.5 volts. | |
| 6. — | 7. 109.6 volts. | 8. 2.4 volts. |
| 9. 3.16 volts; 1.34 amps.; 51.3 amps. | | 10. 86.7 volts. |
| 11. 0.968 ohm. | 12. 0.187 ohm. | 13. 0.1922 ohm. |
| 14. Two rows of ten in series. | | 15. 1.79 volts. |
| 16. 71.9 volts. | 17. 17. | 18. 0.6465 ohm. |
| 19. 10; 16.2 ohms. | 20. 100 ohms; 133.3 ohms. | |
| 21. 0.00146. | 22. 0.0004 ohm; 9996 ohms. | |
| 23. 511 megohms. | 24. 14.8 divisions. | 25. 1.06 amps. |
| 26. The same. | 27. 25 cells. | |
| 28. 0.0169 micro-amp. | 29. 1498.5 ohms; 0.01007 ohm. | |
| 30. 12,000 ohms. | 31. 1 amp. (nearly). | |
| 32. 0.498 amp.; 0.497 amp.; 0.495 amp.; 0.493 amp.; 0.492 amp.; 0.49 amp.; 0.488 amp. | | |
| 33. 6.67 ohms. | 34. Two rows of eight in series. | |
| 35. 555 ohms; 263 ohms. | 36. 69.2 amps. | |
| 37. $\frac{E}{C} - R$; $\frac{RE}{e} - R$. | 38. 0.33 volt. | |
| 39. 29.7 volts. | 40. 19.7 ohms. | |

CHAPTER V.

- | | | |
|---|---|-------------------------|
| 1. 9.9×10^6 joules. | 2. 73,350 joules. | 3. Second case. |
| 4. 60.6 yds. | 5. 10.45 watts; 44.2 watts. | |
| 6. — | 7. 42.88 B.O.T. units; 26.11. | |
| 8. 0.00377 <i>d</i> . | 9. 97.5 watts; 15.2 watts; 767.3 watts. | |
| 10. 252 watts; 8.92 watts; 76.3 per cent. | 11. 598.4 amps. | |
| 12. 77 per cent. | 13. 0.029 <i>d</i> . | 14. 13s. 10½ <i>d</i> . |
| 15. 289.2 watts; 1156.8 watts. | | 16. 4½ <i>d</i> . |
| 17. 82 volts. | 18. 8.07 ohms. | 19. 0.347 ohm. |
| 20. 1s. 3¼ <i>d</i> . | 21. 9¼ <i>d</i> . | 22. 2200 volts. |
| 23. 91 per cent. | 24. 26.4 K.W. | 25. 95 per cent. |

- | | |
|------------------------------------|------------------------------------|
| 26. 91·6 per cent.; 80·3 per cent. | 27. — |
| 28. — | 29. 92·3 per cent.; 91·7 per cent. |
| 30. 0·1 K.W. | 31. 11·9 secs. |
| 33. 7·2 K.W. | 34. — |
| 36. £3 12s. 6d. | 37. 7d. |
| 39. 201·7 ohms; 806·8 ohms. | 38. 103 units. |
| | 40. 1 : 1. |

CHAPTER VI.

- | | |
|---|-------------------------------|
| 1. 3402 B.T.U. | 2. 0·457 H.P.; 29·6 per cent. |
| 3. 2·99 H.P. | 4. 14·5 H.P. |
| 6. 150,000 gals. | 5. 2·96 H.P. |
| 9. 1·44 H.P.; 9·73 amps. | 7. 4·21 joules. |
| 11. £1 16s. 4½d. | 8. 36·3 per cent. |
| 13. 27·1 amps.; 250 lamps (approx.). | 10. 7·4 miles per hour. |
| 15. 44·9 H.P. | 12. 10·4 H.P. |
| 17. 176 H.P.; 1·475 ohms. | 14. 35·5 H.P. |
| 19. 78·3 per cent. | 16. 56 volts. |
| 21. 550 calories per second; 786 B.T.U. per hour. | 18. 70 per cent. |
| 23. $13·56 \times 10^6$ ergs. | 20. 13·17 gals. |
| 25. 1 calorie = 3·1 foot-lbs. | 22. 82 lamps. |
| 27. 95·2 per cent. | 24. 99·5 amps.; 266 lamps. |
| 30. 20·6 lbs. | 26. 1; 3·24. |
| 33. 1·285 calories per sq. cm. | 28. 34 per cent. |
| 35. 0·046 in. | 29. 76·5 per cent. |
| 38. — | 31. 12·6 amps. |
| 41. 857·2 major calories. | 32. 2 : 1. |
| | 34. $\frac{1}{8}$. |
| | 37. 80·7 amps. |
| | 40. 66·4 per cent. |
| | 42. 3402 B.T.U. |

CHAPTER VII.

- | | |
|---|--|
| 1. 0·24 sq. in.; 6·52 tons. | 2. 0·0653 sq. in. |
| 3. 0·0367 sq. in. | 4. 0·096 sq. in. |
| 5. 241·2 volts. | 6. 0·1 ohm; 0·144 sq. in. |
| 7. 16·5 amps.; 239·5 volts and 200·5 volts. | 8. 19·5 volts. |
| 9. 99·7 per cent.; 98·5 per cent.; 97 per cent. | |
| 10. 90·1 per cent.; 97·3 per cent.; 99·56 per cent. | |
| 11. 6·25 : 1. | 12. 3·5 sq. ins. |
| 13. 0·428 sq. in. | 14. 0·54 mile. |
| 15. 0·6 mile (nearly). | 16. No; current density too high. |
| 17. 0·0704 sq. in. | 18. 0·262 sq. in. |
| 19. 91·4 amps.; 57·6 amps. | 20. 0·202 sq. in. |
| 21. 0·0218 sq. in. | 22. 25 amps. from station; 15·6 volts. |
| 23. 106·8 volts and 109·3 volts. | |
| 24. 37·5 per cent. of copper used in two-wire system. | |
| 25. 2·7 volts. | 26. 0·248 sq. in. |
| 28. 0·335 sq. in. | 27. 0·237 sq. in. |
| 31. 105·75 volts; 100 volts; 90·8 volts. | 29. 60 amps.; 27 amps. |
| 33. 61/13 cable; 61/12 or 61/11 cable; 61/13 cable. | 30. 0·24 sq. in. |
| 34. 201·1 volts. | 32. 61/13 cable. |
| | 35. 2·1 volts (nearly). |

36. 19/16 to board on second floor; 19/20 from there to top board; 7/22 in corridors.
 37. 60 60-watt lamps per floor; six-way distribution box on each floor; lamp circuits of 3/22 conductor; mains of 19/16 to board on second floor; 7/16 from there to top.
 38. 10 amps. 39. 0·145 cm. 40. 264 amps.

CHAPTER VIII.

1. 1170 coulombs. 2. 104,700 coulombs.
 3. 1 absolute unit = 10 practical units. 4. 3·2 grms.
 5. 0·25 amp. 6. 0·492 grm. 7. 17 mins. 53 secs.
 8. 0·0003387 grm. per coulomb. 9. 0·1 amp. low.
 10. 1·127 hrs. 11. 0·00807 oz. 12. 0·401 B.O.T. unit.
 13. 5·73 B.O.T. units. 14. 1·44 amps.; 19·75 hrs.
 15. 1 : 0·11. 16. 0·03 amp.; 0·54 hr.
 17. 419·3 c.cs. of H; 209·6 c.cs. of O. 18. 0·0021 in.
 19. 21·5 hrs. 20. 3·135 c.cs. 21. 53·4 amps.
 22. 0·0003386 grm. per coulomb. 23. 1100 c.cs.
 24. 8·43 B.O.T. units. 25. 1·625 : 1.
 26. 6s. $4\frac{1}{2}$ d. 27. 1·03 : 1. 28. 2·614.
 29. 153·8 hrs. 30. 3·15 : 1. 31. 3s. $4\frac{1}{2}$ d.
 32. 0·8 volt low. 33. 1 : 6·68.
 34. 0·282 grm. per minute. 35. 2·2 per cent. (approx.).
 36. 20'' × 10''; 46 hrs. 37. 2·614 ozs.
 38. 31·5 ohms. 39. 0·326 in. 40. 0·0344 oz.

CHAPTER IX.

1. 0·219 candle-ft. 2. 6·45 ft. 3. 240 c.p.
 4. 6 lamps. 5. 422 c.p. 6. 21·7 ft.
 7. 34·5 c.p. 8. 26·4 c.p. 9. 10·65 c.p.
 10. 19 ins. 11. 0·163 candle-ft. 12. 0·77 candle-ft.
 13. 0·707 candle-ft. 14. 51·5 c.p. 15. 0·308 candle-ft.
 16. 648 c.p. 17. 280 c.p. 18. 14·1 ft.
 19. — 20. 16·9 c.p. 21. 65·2 cms.
 22. — 23. — 24. 94 ft.
 25. 2·05 candle-ft. 26. 2·05 candle-ft. 27. —
 28. — 29. 37·5 ft. 30. 158 c.p.
 31. 158 c.p. 32. 0·756 candle-ft. 33. 3·78 watts.
 34. 200 c.p.; 700 watts.
 35. 13440 B.O.T. units. 36. £28. 37. 120 lamps.
 38. 0·3 candle-ft. 39. 1 : 2·14. 40. —

THE END

THIS BOOK IS DUE ON THE LAST DATE
STAMPED BELOW

AN INITIAL FINE OF 25 CENTS

WILL BE ASSESSED FOR FAILURE TO RETURN
THIS BOOK ON THE DATE DUE. THE PENALTY
WILL INCREASE TO 50 CENTS ON THE FOURTH
DAY AND TO \$1.00 ON THE SEVENTH DAY
OVERDUE.

JAN 30 1935

Feb 13

Feb 27

Mar 13

Mar 27

Apr 10

Apr 24

May 8

AUG 2 1946

19 Mar 52 HT
15 Mar 52 LU

29 Feb '60 GC

REC'D LD

FEB 15 1960

20 Oct '60 BM

REC'D LD

OCT 7 1960

94
pre m

227928

QC 632
J3

James

1942 21 30

