



Calhoun: The NPS Institutional Archive
DSpace Repository

Theses and Dissertations

1. Thesis and Dissertation Collection, all items

1990-03

The functional integration of communications
and ADP serial technology at NAVCOMMSTA
Stockton and NARDAC San Francisco

Gutierrez, Patricia Ann.; Vasquez, David Reginald.

Monterey, California: Naval Postgraduate School

<http://hdl.handle.net/10945/34849>

Downloaded from NPS Archive: Calhoun



Calhoun is a project of the Dudley Knox Library at NPS, furthering the precepts and goals of open government and government transparency. All information contained herein has been approved for release by the NPS Public Affairs Officer.

Dudley Knox Library / Naval Postgraduate School
411 Dyer Road / 1 University Circle
Monterey, California USA 93943

<http://www.nps.edu/library>

NAVAL POSTGRADUATE SCHOOL Monterey, California

AD-A228 984



DTIC
ELECTE
NOV 29 1990
S B D

THESIS

THE FUNCTIONAL INTEGRATION OF
COMMUNICATIONS AND ADP SERIAL TECHNOLOGY
AT NAVCOMMSTA STOCKTON AND
NARDAC SAN FRANCISCO

by

Patricia A. Gutierrez
David R. Vasquez

March 1990

Co-Advisor:
Co-Advisor:

Carl R. Jones
Nancy C. Roberts

Approved for public release; distribution is unlimited

UNCLASSIFIED

SECURITY CLASSIFICATION OF THIS PAGE

REPORT DOCUMENTATION PAGE

Form Approved OMB No. 0704 0188

1a REPORT SECURITY CLASSIFICATION UNCLASSIFIED		1b RESTRICTIVE MARKINGS	
2a SECURITY CLASSIFICATION AUTHORITY		3 DISTRIBUTION AVAILABILITY OF REPORT Approved for public release; distribution is unlimited	
2b DECLASSIFICATION/DOWNGRADING SCHEDULE		5 MONITORING ORGANIZATION REPORT NUMBER(S)	
4 PERFORMING ORGANIZATION REPORT NUMBER(S)		7a NAME OF MONITORING ORGANIZATION Naval Postgraduate School	
6a NAME OF PERFORMING ORGANIZATION Naval Postgraduate School	6b OFFICE SYMBOL (If applicable) AS	7b ADDRESS (City, State, and ZIP Code) Monterey, CA 93943-5000	
6c ADDRESS (City, State, and ZIP Code) Monterey, CA 93943-5000		9 PROCUREMENT INSTRUMENT IDENTIFICATION NUMBER	
8a NAME OF FUNDING SPONSORING ORGANIZATION	8b OFFICE SYMBOL (If applicable)	10 SOURCE OF FUNDING NUMBERS	
8c ADDRESS (City, State, and ZIP Code)		PROGRAM ELEMENT NO	PROJECT NO
		TASK NO	REPORT OR ACCESSION NO
11 TITLE (Include Security Classification) THE FUNCTIONAL INTEGRATION OF COMMUNICATIONS AND ADP SERIAL TECHNOLOGY AT NAVCOMMSTA STOCKTON AND NARDAC SAN FRANCISCO			
12 PERSONAL AUTHOR(S) GUTIERREZ, Patricia A. and VASQUEZ, David R.			
13a TYPE OF REPORT Master's thesis	13b TIME COVERED FROM _____ TO _____	14 DATE OF REPORT (Year, Month, Day) 1990 March	15 PAGE COUNT 126
16 SUPPLEMENTARY NOTES The views expressed in this thesis are those of the authors and do not reflect the official policy or position of the Department of Defense or the US Government.			
17 COSAT CODES		18 SUBJECT TERMS (Continue on reverse if necessary and identify by block number)	
FIELD	GROUP	telecommunications; ADP; Serial Technology; merger; integration; echelon II, III, IV mergers; NAVCOMMSTA; NARDAC, NAVTELCOM; NAVDAC; functional, Thesis, (S)	
19 ABSTRACT (Continue on reverse if necessary and identify by block number) The thesis examines the functional integration of serial technologies at NAVCOMMSTA Stockton and NARDAC San Francisco, two echelon II Naval Commands affected by the 1989 decision to merge Navy Communications and Automated Data Processing disciplines. Decomposing the transformation process, input to output, is accomplished by viewing the organizations in terms of structural and contextual dimensions and serial technologies. Functional tasks for each organization are derived from interviews, observations, document reviews, telephone calls, and literature. Representative similarities and differences are provided along with recommendations concerning functional integration. Comparison of functional similarities provides a means for approaching a partial functional integration of serial technologies. The organizations are not aligned nor mapped for			
20 DISTRIBUTION AVAILABILITY OF ABSTRACT <input checked="" type="checkbox"/> UNCLASSIFIED, LIMITED <input type="checkbox"/> SAME AS REPORT <input type="checkbox"/> DTIC USERS		21 ABSTRACT SECURITY CLASSIFICATION UNCLASSIFIED	
22a NAME OF RESPONSIBLE INDIVIDUAL JONES, Carl R./ROBERTS, Nancy C.		22b TELEPHONE (Include Area Code) 408-646-2535/2742	22c MAILING CODE CC AS/Rc

19. cont.

comparison of resource and technological interdependencies which would achieve greater efficiency through economies of scope, or both. A strategic design which capitalizes on the strengths of each organization is recommended.

Accession For	
NTIS GRA&I	<input checked="" type="checkbox"/>
DTIC TAB	<input type="checkbox"/>
Unannounced	<input type="checkbox"/>
Justification	
By	
Distribution/	
Availability Codes	
Dist	Avail and/or Special
A-1	



Approved for public release; distribution is unlimited.

The Functional Integration of Communications and ADP Serial Technology
at NAVCOMMSTA Stockton and NARDAC San Francisco.

by

Patricia Ann Gutierrez
Lieutenant, United States Navy
B.U.S., University of New Mexico, 1985

and

David Reginald Vasquez
Lieutenant, United States Navy
B.A., University of New Mexico, 1982

Submitted in partial fulfillment of the requirements
for the degree of

**MASTER OF SCIENCE IN TELECOMMUNICATIONS
SYSTEMS MANAGEMENT**

from the

**NAVAL POSTGRADUATE SCHOOL
March 1990**

Authors:

[Redacted]

Patricia Ann Gutierrez

[Redacted]

David Reginald Vasquez

[Redacted]

Carl R. Jones
Co-Advisor

[Redacted]

Nancy C. Roberts
Co-Advisor

[Redacted]

Robert L. Knight, LCDR, USN
Second Reader

[Redacted]

Allan W. Tulloch, CDR, USN
Second Reader

David R. Whipple, Chairman,
Department of Administrative Sciences

ABSTRACT

The thesis examines the functional integration of serial technologies at NAVCOMMSTA Stockton and NARDAC San Francisco, two echelon II Naval Commands affected by the 1989 decision to merge Navy Communications and Automated Data Processing disciplines. Decomposing the transformation process, input to output, is accomplished by viewing the organizations in terms of structural and contextual dimensions and serial technologies. Functional tasks for each organization are derived from interviews, observations, document reviews, telephone calls, and literature. Representative similarities and differences are provided along with recommendations concerning functional integration. Comparison of functional similarities provides a means for approaching a partial functional integration of serial technologies. The organizations are not aligned nor mapped for comparison of resource and technological interdependencies which would achieve greater efficiency through economies of scale, economies of scope, or both. A strategic design which capitalizes on the strengths of each organization is recommended.

TABLE OF CONTENTS

I. INTRODUCTION.....	1
A. THE MERGING OF COMMUNICATIONS AND AUTOMATED DATA PROCESSING IN THE NAVY	1
B. THESIS CONCENTRATION.....	2
C. ORGANIZATION OF THESIS.....	3
II. METHODOLOGY	5
A. THE DECOMPOSITION OF TECHNOLOGY INTO ORGANIZATIONAL TASKS.....	5
B. METHODS.....	6
1. Develop Basis of Thesis Study.....	6
2. Select Organizational Units of Study.....	7
3. Design Data Collection Scheme.....	8
4. Conduct Study of Organizational Technology.....	8
5. Describe Organizational Technology.....	8
6. Compare Functional Tasks.....	9
III. DESCRIPTION OF NAVCOMMSTA STOCKTON.....	10
A. MISSION STATEMENT FOR NAVCOMMSTA STOCKTON.....	10
1. Uniqueness of the NAVCOMMSTA STOCKTON Mission.....	11
B. STRUCTURAL DIMENSIONS.....	12
1. Formalization.....	13
2. Specialization or Division of Labor.....	16
3. Standardization.....	17
4. Hierarchy.....	18
5. Complexity.....	18
6. Centralization.....	21
7. Professionalism.....	22

8. Personnel Configuration	22
C. CONTEXTUAL DIMENSIONS	23
1. Size	23
2. Organizational Technology.....	23
3. Environment.....	24
D. TECHNOLOGICAL PROCESS.....	25
1. Technology in Use	26
2. NAVCOMMSTA Stockton Serial Technology.....	34
IV. DESCRIPTION OF NARDAC SAN FRANCISCO.....	39
A. MISSION STATEMENT FOR NARDAC SAN FRANCISCO.....	39
B. STRUCTURAL DIMENSIONS.....	40
1. Formalization	41
2. Specialization or Division of Labor.....	43
3. Standardization.....	44
4. Hierarchy	45
5. Complexity.....	46
6. Centralization	47
7. Professionalism.....	47
8. Personnel Configuration.....	48
C. CONTEXTUAL DIMENSIONS	48
1. Size	48
2. Organizational Technology.....	49
3. Environment.....	49
D. TECHNOLOGICAL PROCESS.....	50
1. Technology in Use	51
2. NARDAC San Francisco Serial Technologies	55

V. DISCUSSION AND COMPARISON OF THE NAVCOMMSTA AND NARDAC ORGANIZATIONAL DESCRIPTIONS.....	7 0
A. COMPARISON OF NAVCOMMSTA AND NARDAC STRUCTURAL AND CONTEXTUAL DIMENSIONS.....	7 0
1. Mission.....	7 0
2. Structural Dimensions.....	7 1
3. Contextual Dimensions.....	7 6
B. COMPARISON OF NAVCOMMSTA AND NARDAC SERIAL TECHNOLOGIES	7 8
1. Technological Process.....	7 8
2. Integrating Functional Tasks of Serial Technologies.....	8 1
C. MAJOR THEMES AND ISSUES OF NAVCOMMSTA AND NARDAC SERIAL TECHNOLOGIES	9 1
1. Requirements Drive the Technology.....	9 2
2. Level of Technology	9 2
3. Organizational Spatial Complexity Dimensions.....	9 3
4. Externalities.....	9 4
VI. CONCLUSIONS AND RECOMMENDATIONS.....	9 5
A. THE IDEAL SERIAL TECHNOLOGY	9 5
B. STRATEGY FOR INTEGRATION OF SERIAL TECHNOLOGIES.....	9 6
1. Architecture Defining Communications Tasks.....	9 8
C. RECOMMENDATIONS.....	1 0 0
APPENDIX A.....	1 0 2
APPENDIX B.....	1 0 6
INTERVIEW QUESTIONS.....	1 0 6
APPENDIX C.....	1 0 8
NARDAC NETWORKS.....	1 0 8
A. DACNET NETWORK CONFIGURATION.....	1 0 8

B. BURROUGHS T-CON NETWORK.....	109
C. BURROUGHS NETWORK.....	109
D. SPLICE NETWORK.....	110
E. UNISYS NETWORK.....	110
F. PASS / SDS NETWORK.....	111
REFERENCES.....	112
INITIAL DISTRIBUTION LIST.....	115

I. INTRODUCTION

With the merging of the fields of data communications and computer science, there is no fundamental difference between data processing (computers) and data communications (transmission and switching equipment), and no fundamental differences among data, voice, and video communications. Similarly, the lines between single processor computers, multi-processor computers, local networks, and long-haul networks have blurred. The result is a growing overlap of computer and communications industries, and development of integrated systems which transmit and process all types of data and information. [Ref. 1:p. 1]

A. THE MERGING OF COMMUNICATIONS AND AUTOMATED DATA PROCESSING IN THE NAVY

On 7 August 1989, the Director, Space, Command and Control, VADM Jerry O. Tuttle, sent a memorandum to the Vice Chief of Naval Operations (OP-09) regarding the integration of communications and automated data processing (ADP) disciplines within the Navy. The memo provided rationale for integrating communications and computing, and time lines to accomplish integration. [Ref. 2:p. 1]

By late November of 1989, in a newsletter to flag officers, VADM Tuttle was announcing approval for the plans to integrate the Naval Telecommunications Command (NAVTELCOM) and the Naval Data Automation Command (NAVDAC) to form a new echelon II command

reporting to OP-09. He also announced intentions to integrate, where it made sense, echelon 'II and IV activities (i.e., Navy Regional Data Automation Centers (NARDACs), Naval Data Automation Facilities (NAVDAFs), Naval Communication Stations (NAVCOMMSTAs), and Naval Telecommunications Centers (NTCCs)). [Ref. 3:p. 2]

Throughout the NAVTELCOM claimancy, the Commander, Naval Telecommunications Command (COMNAVTELCOM), RADM (select) T. E. Stone, disseminated the news of integration via letter emphasizing the necessity in being receptive and supportive of the mergers and capturing the benefits of technology. [Ref. 4:pp. 2-3]

B. THESIS CONCENTRATION

The merging of computer science and data communications in industry and the merging of telecommunications and ADP in the Navy raises questions of "technology" and what exactly can be integrated. Technology is the knowledge, tools, techniques, and actions used to transform organizational inputs into outputs [Ref. 5:p. 133]. The thesis examines the serial technologies of two different echelon III Naval commands affected by the decision to merge the Navy's communications and ADP disciplines.

There are two affected echelon III commands within close proximity of the Naval Postgraduate School, Monterey, which became the targets for study: the Naval Communication Station (NAVCOMMSTA), Stockton, CA, and the Navy Regional Data Automation Center (NARDAC), San Francisco, CA.

In researching and following the transformation process from input to output, in either of the two organizations, it became apparent that the technological transformation process was of a serial nature. A serial technology combines products of preceding stages of production as inputs to successive stages. [Ref. 6:p. 40]

From ten baseline interview questions keying on functions performed, main inputs and outputs, and technologies involved at each organization, coupled with initial interviews and approval for follow-on study, emerged two well-defined thesis questions. The intent of the thesis is to focus on answering the two questions:

- Can communications and ADP serial technologies at NAVCOMMSTA Stockton and NARDAC San Francisco functionally integrate?
- If so, how can they be functionally integrated?

C. ORGANIZATION OF THESIS

The thesis is composed of six chapters and three appendixes. The first chapter provides a brief introduction to the setting, the players, and the focus of study for the thesis. The second chapter explains the methodology of how the thesis data was derived. The third chapter is a description of the NAVCOMMSTA Stockton organization and its serial technology. The fourth chapter is a description of the NARDAC San Francisco organization and its serial technology. The fifth chapter is a comparison of the respective serial technologies, and the areas of functional similarity and differentiation. Major issues are discussed for both organizations as well. The sixth chapter offers conclusions and recommendations.

Appendix A provides a listing of acronyms which are used throughout the thesis. Appendix B is the list of interview questions used in gathering data for the thesis. Appendix C provides representative networks of the NARDAC.

II. METHODOLOGY

The focus of the thesis is on the functional integration of serial technologies at NAVCOMMSTA Stockton and NARDAC San Francisco. In order to address functional integration of technologies, a determination and description of the technologies was essential. A technology is the knowledge, tools, techniques, and actions used to transform organizational inputs into outputs. [Ref. 5:p. 133] When a technology is linked to another technology in a sequential fashion, and the output of one stage of technology becomes the input of the next stage, a serial technology exists. This chapter discusses the process utilized to derive the serial technologies and their functional elements at NAVCOMMSTA Stockton and NARDAC San Francisco.

A. THE DECOMPOSITION OF TECHNOLOGY INTO ORGANIZATIONAL TASKS

The approach used to decompose the transformation process (input to output) at the NAVCOMMSTA and the NARDAC was to view the organizations in terms of their structural and contextual dimensions (i.e., internal and total organizational characteristics) and their technologies. The challenge was to determine what each organization produced and the process used to output products and services. Descriptions of the structural and contextual dimensions of each command precede the descriptions of the organizational

technologies in order to provide a setting from which functional tasks were derived. The functional tasks are the basic and inherent work to be performed by the organization and its units or activities. [Ref. 7:p. 26]

B. METHODS

To determine what each organization produced and the process utilized to output products and services, the thesis study followed an adapted model of Case Study Method by Yin, Bateman, and Moore [Ref. 8:p. 51]. The modified methodology model utilized throughout the study is depicted in Figure 1.

Each block of the model is briefly described.

1. Develop Basis of Thesis Study

The basis of the thesis study was viewing communications and ADP organizations as open systems. In an open system model, the organization is viewed as a system of interrelated elements which acquires inputs from the external environment, transforms them, and exports outputs to the external environment. [Ref. 5:p. 10] The interrelated system elements consist of inputs (or resources), outputs, technology, environment, purposes, behavior and processes, culture, and structure. [Ref. 9:pp. 23-25]

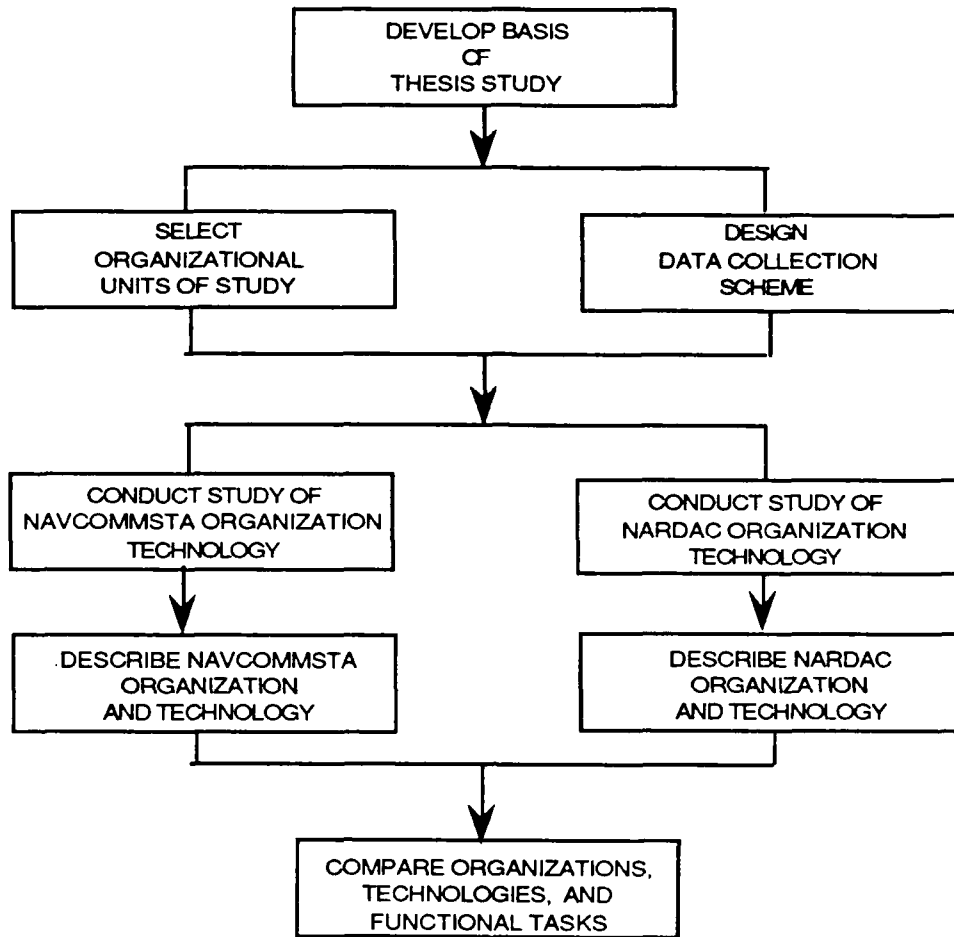

Figure 1. Thesis Study Model

Based on the open system model for organizations and considering only the element of technology, the thesis aims at determining whether functional integration of technologies for communications and ADP can occur.

2. Select Organizational Units of Study

Since the closest comparable communications and ADP organizations were NAVCOMMSTA Stockton and NARDAC San Francisco, they were selected as the organizational units of study.

3. Design Data Collection Scheme

With advisor assistance, a data collection scheme consisting of interviews, observations, organizational document review, telephone calls, and literature search and review was developed.

Ten baseline interview questions were designed to assess the functional tasks, main inputs and outputs, work flows, technologies, and professional level of both organizations. Determination of persons to be interviewed centered around control and knowledge of the organizational technology. The interview questions are found in Appendix B.

All interview responses have remained confidential by random codification of the respondents. Code assignments bear no relationship to respondent names, initials, billet description, job title or position, rank or paygrade. Respondents are referenced only to the organization to which they belong.

4. Conduct Study of Organizational Technology

All site visits and interviews occurred between October 24, 1989 and January 4, 1990. An enormous amount of time was spent designing the data collection scheme and conducting literature reviews prior to the first site visit.

5. Describe Organizational Technology

To provide an adequate representation of each organization's technology, the structural and contextual dimensions of the organization precedes the description of the technology, the serial linkages, and the functional tasking. Each organization is ultimately

described in terms of functional tasking. The tasking elements listed are by no means comprehensive, rather a representative display of the complexity involved.

6. Compare Functional Tasks

The comparison of each organization's functional tasks is presented in terms of similarities and dissimilarities. Major issues affecting the functional tasks and consequent technologies are also discussed.

III. DESCRIPTION OF NAVCOMMSTA STOCKTON

The focus of this chapter is the description of Naval Communication Station Stockton and its utilization of serial technology. The command (organization) is delineated by the mission statement, the structural (internal characteristics) and contextual (total organizational characteristics) dimensions, and the technology processes. Serial technology combines successive stages of a production process and uses products of the preceding stage as inputs in each successive stage [Ref. 6:p. 40]. Telecommunications system elements and capabilities of the NAVCOMMSTA are related to a telecommunications system concept model in order to describe the NAVCOMMSTA in terms of its serial technology and processes. A representation of specific functions directly relating to the NAVCOMMSTA's serial technology is then derived from interview data.

A. MISSION STATEMENT FOR NAVCOMMSTA STOCKTON

The mission of Naval Communication Station Stockton (NAVCOMMSTA Stockton) is to manage, operate, and maintain the facilities, systems, equipment, and devices necessary to provide requisite telecommunications for command, operational control, and administration of the Department of the Navy. [Ref. 10:p. D-13] Primarily, NAVCOMMSTA Stockton is to provide communication

support in the Eastern Pacific Naval Communications Area¹ and act as an interface/relay point among Commanders ashore and the ships operating in the Pacific as an activity of the Naval Telecommunications System (NTS).

In addition, NAVCOMMSTA Stockton is to manage, operate, and maintain the facilities of the Defense Communications System (DCS), and provide communications connectivity for both DCS and non-DCS users.

1. Uniqueness of the NAVCOMMSTA STOCKTON Mission

Unique to NAVCOMMSTA Stockton's mission is the added task to function as an alternate Naval Communications Area Master Station (NAVCAMS) for either the Pacific or Atlantic Naval Communications areas. Stockton was the original NAVCAMS of the NTS; and unlike any other NAVCAMS or NAVCOMMSTA in the system, it is uniquely configured to operate as a "swing CAMS." [Ref. 11:p. 25] By virtue of its geographic location and connectivity, it is able to support the Fleet Broadcast function for three of the four Naval communications areas; Eastern Pacific, Western Pacific, and Atlantic.

¹ There are four Naval Communications Areas (NAVCOMMAREAS) worldwide which correspond to the geographic areas of responsibility of the numbered fleet commanders. [Ref. 2:pp. 22-25]

B. STRUCTURAL DIMENSIONS

To gain an understanding of the NAVCOMMSTA Stockton organization, the communications station will be viewed as an open system of interrelated elements. Composed of several interrelated subsystems or departments, the system acquires various inputs (raw materials and resources), transforms them, then discharges its outputs (products and services). The departments at NAVCOMMSTA Stockton perform essential subsystem functions such as production, boundary spanning, maintenance, adaptation, and management [Ref. 5:p. 12]. In production, the principal products and services output are messages, circuit paths, and over-the-counter service. In boundary spanning, transactions which occur at NAVCOMMSTA Stockton's organizational boundaries are acquiring system inputs and delivering system outputs. For example, an input may be an operational requirement from the Fleet Commander-in-Chief to establish a specific communications circuit, the output is the establishment of the circuit. In maintenance, the operation and upkeep of the base facilities are maintained. In adaptation, environmental and technological developments are used to plan and modify the NAVCOMMSTA structure or operation while making necessary adjustments to new developments. The management subsystem is responsible for directing strategies, goals, and policies for the entire organization, coordinating the other subsystems, and resolving conflict between departments.

Technology is another set of interrelated elements which impact an organization's structural dimensions. Knowledge, tools, techniques, and actions are the elements of technology used to transform organizational inputs into outputs. Transformation processes, which cover an enormous range of activities, are also included as technology [Ref. 5:p. 133].

Serial technology, which combines products of preceding stages of production as inputs to successive stages [Ref. 6:p. 40], is employed at NAVCOMMSTA Stockton to produce products and services. Serial technology also influences the organizational structure, coordination mechanisms, decision-making levels, and size of the organizational units. [Ref. 12:p. 244]

The structural dimensions which characterize the NAVCOMMSTA pertain to the internal characteristics of the organization [Ref. 5:pp. 16-18]. The following structural dimensions are important because they provide static labels to describe NAVCOMMSTA Stockton's organization, and are a basis for measurement and comparison with NARDAC San Francisco.

1. Formalization

Formalization pertains to the amount of written documentation in an organization. Included are all directives, instructions, notices, procedures, publications, regulations, and technical manuals which describe, direct, and influence the behavior and activity at NAVCOMMSTA Stockton [Ref. 5:p. 16].

a. Written Documentation

There is a plethora of instructions, directives, operational orders and plans; technical, operational, and administrative publications; correspondence, records, messages, magnetic tapes and disks, and diagrams that represent NAVCOMMSTA Stockton's written documentation.

A wide variety of sources provides additional documentation: the Joint Chiefs of Staff (JCS), Commander in Chief, Pacific (CINCPAC), Commander in Chief, U. S. Pacific Fleet (CINCPACFLT), the Chief of Naval Operations (CNO), Commander, Naval Telecommunications Command (COMNAVTELCOM), Commander, Naval Base San Francisco (COMNAVBASE San Francisco), Commanding Officer, Naval Communications Area Master Station Eastern Pacific, Western Pacific, and Atlantic (NAVCOMS EASTPAC, NAVCOMS WESTPAC, NAVCOMS LANT), Commander, Naval Security Group (COMNAVSECGRU), and Director, Defense Communications Agency (DCA).

With regard to organizational direction and composition, the Commanding Officer of the NAVCOMMSTA also issues written documentation. Of particular interest are the Standard Organization and Regulations Manual (SORM), and NAVCOMMSTA Stockton instructions, notices, and directives. All of this documentation provides both operational and administrative functional statements that penetrate to the divisional level.

b. Procedures

Following standardized operational procedures to the greatest extent possible is required for continuity of operations. Personnel qualification standard (PQS) requirements are intended to ensure that standardized operational procedures are being followed at all levels. The PQS requirements are a set of formal operation proficiency standards which require an individual to demonstrate a standard level of proficiency before being qualified in a functional task assignment. Each requirement is entered into the individual and command training records. However, written qualification standards may not exist for a number of watch stations or the configurations of technology utilized. Configurations of technology refer to the various constructs utilized to set up a circuit path, such as different combinations of input and output devices, media, transmitters, receivers, and pathways. In such instances, it is incumbent upon the NAVCOMMSTA to establish necessary standards or maintain an oral qualification certification board which ensures operational procedures are standardized by testing the proficiency levels of the individuals.

c. Manning Documents and Job Descriptions

There are two primary sources of information regarding the NAVCOMMSTA's human resources and billets (job positions)--the Shore Required Operational Capabilities (SHOROC) and the Manpower Authorization. Each required billet or position title is specified and listed by pay grade and the number of resources authorized.

2. Specialization or Division of Labor

Specialization pertains to the degree to which tasks are subdivided into separate jobs. A close relationship exists between the division of labor or specialization and the actual manpower assigned. While the Manpower Authorization document specifies the billet position titles, the rates and paygrades assigned, and the number of authorized and actual billets for each command, the organization and distribution of manpower are not specified. The organizational and functional tasks directly influence the command's structure. Ultimately, the overall responsibility for task accomplishment resides with the Commanding Officer.

a. Division of Tasks and Range of Specialization

Division of task responsibilities is accomplished along departmental lines. Departments are subdivided into divisions, and each division is assigned a specific functional task to perform. Various task responsibilities are specified throughout the formalized documentation and standardized operational procedures at the NAVCOMMSTA.

- The Administration department is responsible for performing functional services such as personnel, photography, reprographics, correspondence and records, mailroom, word processing, public affairs, and legal.
- The Plans department provides local coordination with COMNAVTELCOM and Space and Naval Warfare Systems Command (SPAWAR) for implementation of communication electronics projects; operates a base wide test equipment calibration program and laboratory; provides administrative management of contract operations; submits Telecommunications Operating Requirements (TELCOR)

documents; manages manpower planning, management studies and commercial activities programs.

- The Security department is responsible for physical security of the base.
- The Supply department provides auditing, fiscal and supply services for the NAVCOMMSTA and component activities. Services include procurement, receipt, storage, issue, transfer, inventory, and accountability of material.
- The Recreational Services department administers and manages the consolidated mess and enlisted mess (clubs) and recreational facilities.
- The Public Works department repairs and maintains buildings, roads, and auxiliary power systems. It manages the real property on Rough and Ready Island; performs all pest control and sanitary engineering services; and ensures that NAVCOMSTA is in compliance with environmental protection and pollution abatement regulations.
- The Communications department and component activities provide telecommunication services using landline, radio, microwave, and satellite circuits. [Ref. 13]

3. Standardization

Standardization pertains to the extent which similar tasks are performed in a uniform manner. Work content is described in detail so that similar work is performed the same way. There is a high degree of standardization within each department at NAVCOMMSTA Stockton. Deviations from the set standards and procedures may only occur on a case by case basis with both department head and Commanding Officer approval. While the uniformity of task performance is standardized, uniform task assignments are carried out by military and civilian employees alike, even though the level of individual proficiency may differ.

4. Hierarchy

The organization chart in Figure 2 depicts the hierarchy of authority from the Commanding Officer to the departmental level for NAVCOMMSTA Stockton.

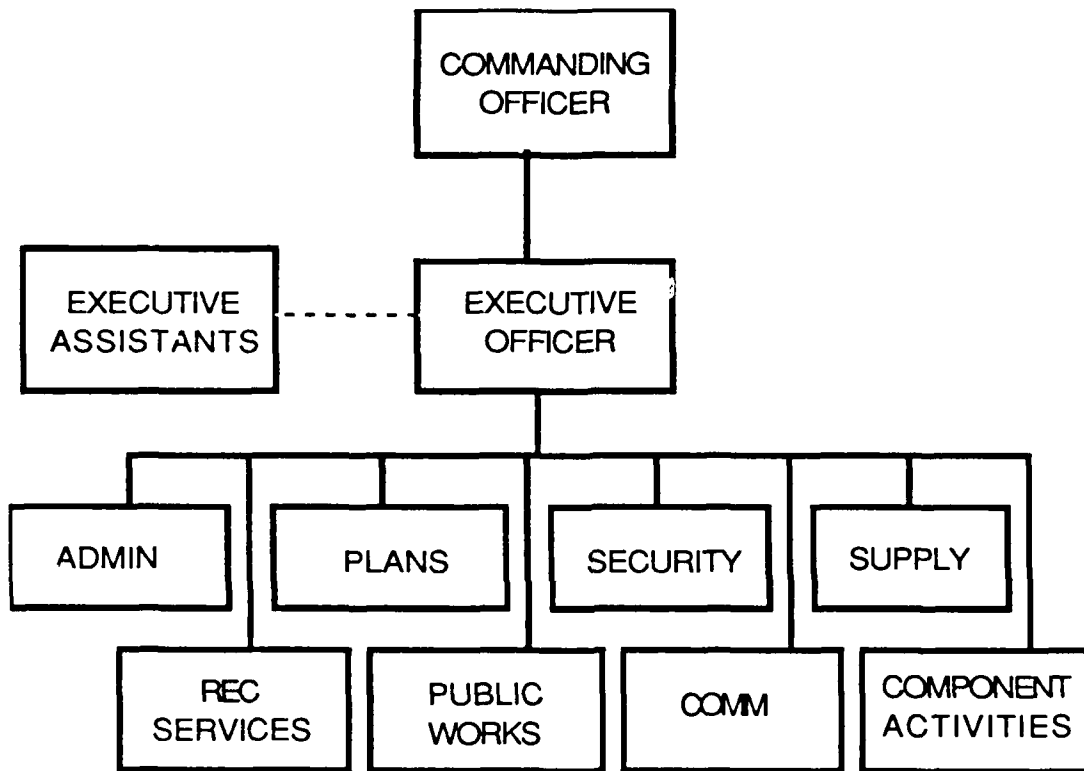

Figure 2. NAVCOMMSTA Stockton Organizational Chart

5. Complexity

Complexity refers to the number of subsystems or activities. The NAVCOMMSTA Stockton command has seven departments, eight executive assistants, nine component activities, and two microwave relay sites. Complexity is described by three dimensions--vertical, horizontal, and spatial.

a. Vertical

Vertical complexity refers to the number of levels of hierarchy in an organization. For example, NAVCOMMSTA Stockton has three levels of hierarchy: Command/Executive, departmental, and divisional.

b. Horizontal

Horizontal complexity refers to the number of departments or subunits existing horizontally across the NAVCOMMSTA. There are seven departments: Administration, Plans, Security, Supply, Recreational Services, Public Works, and Communications.

There are also eight executive assistants: the Chaplain, Career Counselor, Command Master Chief, Internal Review Officer, Training Officer, 3M (Maintenance, Material, Management) Coordinator, Automatic Data Processing (ADP) Security Officer, and Safety Manager. The full range of vertical and horizontal dimensions of the NAVCOMMSTA are supported by the executive assistants.

c. Spatial

Spatial complexity refers to the number of geographic locations associated with an organization. The NAVCOMMSTA departments and executive assistants are physically located on Rough and Ready Island, Stockton, CA. Half of the executive assistants along with the Administration and Plans departments share a common building with the Executive Officer (XO) and the Commanding Officer (CO); the remainder are located in functionally

related centers throughout the island. Within the NAVCOMMSTA organization, located off-site from Rough and Ready Island, there are thirteen mission related component activities which include:

- Naval Radio Transmitter Facility (NRTF), Dixon, CA
- Naval Radio Receiver Facility (NRRF), Skaggs Island, CA
- Naval Telecommunications Center (NTCC) Mare Island, CA
- Naval Telecommunications Center (NTCC) Alameda, CA
- Naval Telecommunications Center (NTCC) Moffett Field, CA
- Naval Telecommunications Center (NTCC) Concord, CA
- Naval Telecommunications Center (NTCC) Monterey, CA
- Naval Telecommunications Center (NTCC) Oakland, CA
- Naval Telecommunications Center (NTCC) Treasure Island, CA
- Naval Telecommunications Center (NTCC) Lemoore, CA
- Naval Telecommunications Center (NTCC) Fallon, NV
- Microwave Relay, Mt. Vaca, CA
- Microwave Relay, Mt. Diablo, CA.

Figure 3 provides a view of the NAVCOMMSTA spatial complexity. The area of coverage spans two states and 15 counties in California alone. The NAVCOMMSTA serves as a "host" command to ten tenant commands, whose missions are different from those of the NAVCOMMSTA. As the host command, the NAVCOMMSTA provides landlord services to the tenant commands as negotiated in a host-tenant agreement. The tenant commands only contract for services which the host is capable of providing. Examples of services provided are public works, security, and supply.

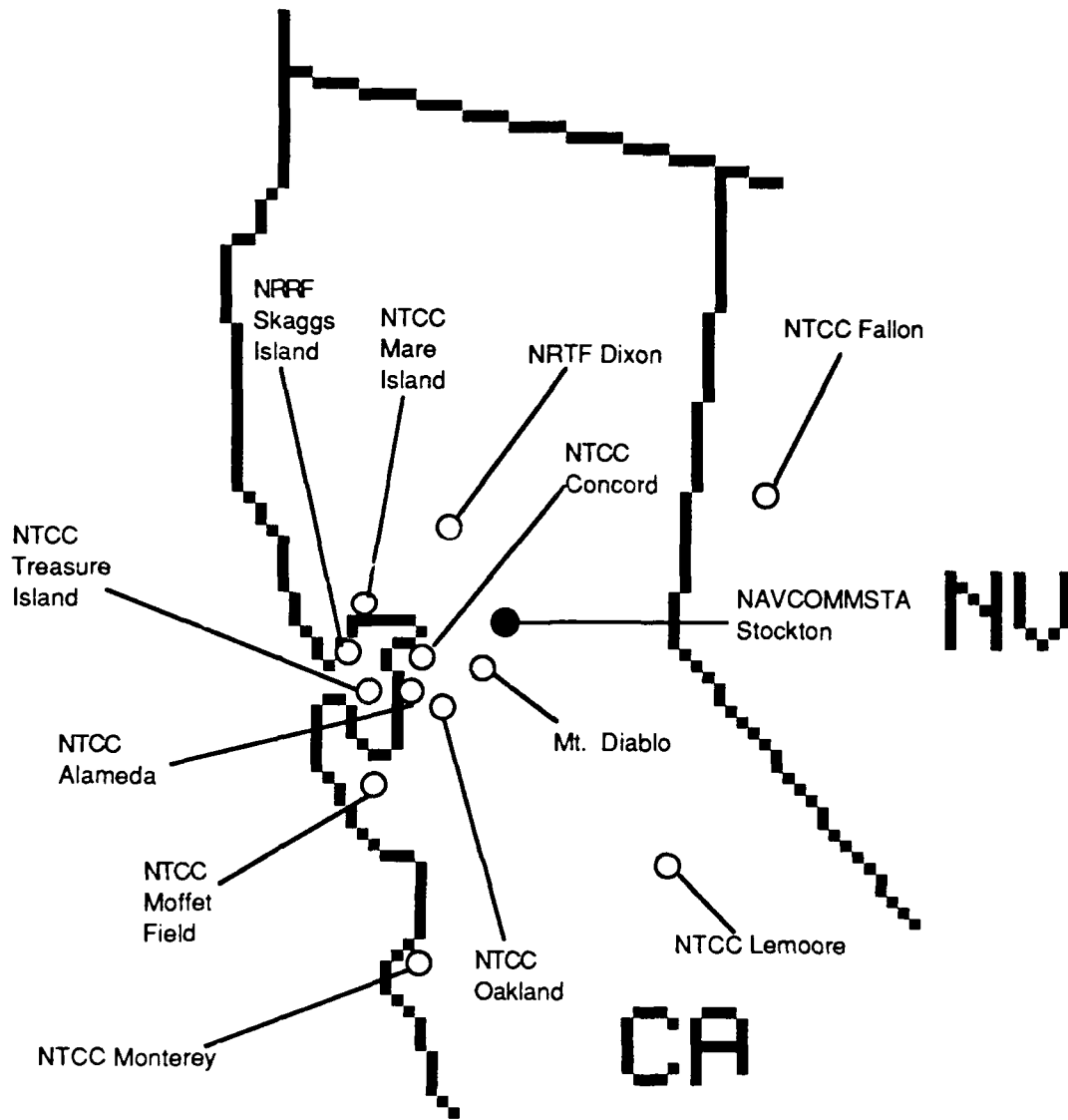

Figure 3. NAVCOMMSTA Stockton Spatial Complexity

6. Centralization

Centralization pertains to the hierarchical level at which decisions are made. Based on the technology and spatial dimension complexity, the Commanding Officer at NAVCOMMSTA Stockton

maintains a centralized decision-making posture in carrying out the command's mission.

7. Professionalism

Professionalism refers to the level of formal education and training held by employees. [Ref. 5:p. 18] The level of training that most typifies that held by NAVCOMMSTA personnel, from entry level to the most senior experienced, would be on-the-job training (OJT). Though formal education in engineering sciences, telecommunications and computer sciences, or administrative sciences is encouraged and invited, it is not a formal requirement for employment.

Formal, government sponsored training courses are available which prepare or reinforce individual proficiency at various levels. Successful completion of courses along with appropriate OJT are sufficient to merit the individual with codification or qualification for certain billets or positions. Certain billets and positions can be filled only by such designated personnel; an example is a technical control operator.

Outside of OJT, formal training courses, and formal education in the sciences, individual interest in trade journals, periodicals, and industry-related literature are frequently utilized to increase the professionalism of employees at all levels.

8. Personnel Configuration

Personnel configuration refers to the deployment of people to various functions and departments. Configuration ratios are

measured by dividing the number of people assigned in a department by the total number of employees. While there are over 1200 people employed in various capacities at NAVCOMMSTA Stockton, only staff and members of the executive (CO and XO), executive assistants, the seven departments, and the component activities are used in computing the total number of employees for the configuration ratios. The remaining employees that work for tenant organizations on the NAVCOMMSTA Stockton base are not included in computing the configuration ratios.

The following configuration ratios apply: the Executive and Executive Assistants accounted for 1.4% of personnel assigned; Administration department 1.8%; Plans department 2.3%; Security department 5.3%; Supply department 5.4%; Recreational Services department 2.4%; Public Works department 16.8%; Communications department 34.9%; and Component activities 29.6% [Ref. 6].

C. CONTEXTUAL DIMENSIONS

1. Size

Size refers to magnitude as reflected in the number of people at the NAVCOMMSTA. There are approximately 735 personnel assigned to NAVCOMMSTA Stockton and approximately 500 additional personnel employed at tenant commands.

2. Organizational Technology

The organizational technology pertains to the nature of the task in a production subsystem, and includes the actions, knowledge, and techniques used to change inputs into outputs. For NAVCOMMSTA

Stockton, a serial technology is employed to provide requisite telecommunications products and services to subscribers. The serial actions and processes that are performed to transform inputs to outputs will be viewed in terms of functionality.

3. Environment

The environment encompasses all requirements and forces outside of the NAVCOMMSTA organizational boundaries.

a. Requirements Outside of the Organizational Boundaries

The command is under the administration and major claimancy of COMNAVTELCOM. It is operationally responsible to CINCPACFLT through NAVCAMS EASTPAC in Wahiawa, Hawaii, and falls under the area coordination of COMNAVBASE San Francisco. Each of the authorities exerts operational requirements on NAVCOMMSTA Stockton such as specific circuit requirements for operational units. Requirements are carefully planned and subject to various contingencies. With changes in the operational environment (i.e., an increase or decrease in readiness posture), planned contingency requirements are evoked and carried out.

Uncontrollable and less stable variables emanate from rule changes and enforcement practices regarding containment of stored industrial waste and pollution abatement from the Environmental Protection Agency (EPA), outages and rate increases or decreases from the utility companies, and requests for military involvement in the local community. Covering a variety of

socioeconomic and sociopolitical reasons, the frequency of requirements or demand changes on NAVCOMMSTA Stockton is not easily predicted.

Other requirements come from the subscribers of the products and services provided by the NAVCOMMSTA. Their demands are met according to the priority given them by the Fleet CINCs. Examples of other requirements would be extended circuit time or an increase in circuits allowed.

Of all of the forces, the most unstable and uncontrollable is weather. From high winds and earthquakes to atmospheric interference, the demands and requirements levied by weather represent the most hostile factor the NAVCOMMSTA must deal with.

For operational matters, the environmental forces change with the perceived threat and thereby influence the readiness posture. For the less stable, non-operational variables, change may occur unexpectedly or not at all, as in the case of a severe storm causing an extended power outage.

D. TECHNOLOGICAL PROCESS

At the organizational level, the technological process from input to output takes place in the production subsystem. Functional tasks are combined with the flow of raw materials through NAVCOMMSTA Stockton's production process in a logical sequence. Work activities are performed using a variety of tools, techniques, and equipment to produce requisite telecommunications outputs. Though each department may utilize the same or dissimilar technologies to

accomplish their functional tasks, the focus of activity is the principal products and services: messages, circuits, and over-the-counter service.

1. Technology in Use

The technology in use at NAVCOMMSTA Stockton is a serial technology. In describing types of interdependencies that influence organizational structure, James Thompson describes serial technology as long-linked technology which "refers to the combination of successive stages of production in an organization; each stage of production uses as its inputs the products of the preceding stage and produces inputs for the following stage." [Ref. 6:p. 40]

a. Systems Concept

In order to arrive at the principal products and services provided by the NAVCOMMSTA's serial technology, a basic understanding of telecommunications system composition is presented. The fundamental concept and purpose of a telecommunications system is to exchange information between two or more agents. The information to be exchanged is a message which conveys meaning or has value. The value of information depends on analysis, interpretation, explanation, and understanding. Human beings and organizations develop the context within which information is valuable. [Ref. 14:pp. 19-20] The message is formatted into a voice or data scheme which is a representation of facts, concepts, or instructions in a formalized manner suitable for

communication, interpretation, or processing by human beings or automated means. The voice or data scheme is transformed at an input device and then presented to a transmitter as a signal that is matched to the characteristics of the transmission medium. The signal is transmitted across the medium and at the other end is received. The signal is then converted into a form suitable for output, approximately matching the original message. A diagram of the Telecommunications System Concept Model appears in Figure 4.

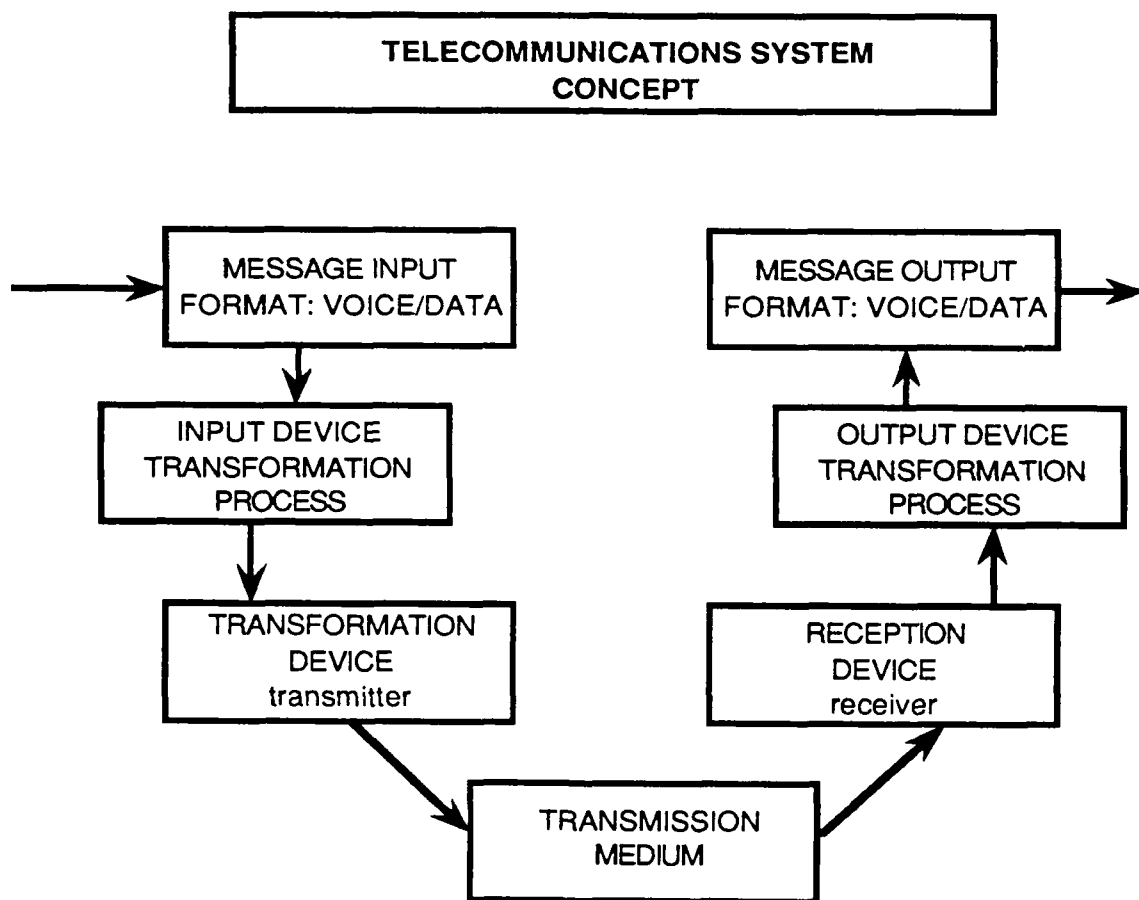

Figure 4. Telecommunications System Concept

There is a wealth of concealed complexity in the above diagram. Each telecommunication system is constructed according to its desired function; it can be decomposed into many variables and be associated with various circuit configurations. For example, a number of circuits may differ in equipment utilization or connection paths yet, perform the same function. From various circuit configurations, the NAVCOMMSTA Stockton provides or produces its products and services.

There are key elements which must be established for any configured telecommunication system. A representation of basic key elements are considered below.

Transmission medium refers to the transmission of a signal through a medium on a path which is guided or unguided. In guided media, electromagnetic signals traverse a physical path contained to twisted pair wires, coaxial cable, or optical fiber. In the case of unguided media, electromagnetic signals are propagated through the media such as the atmosphere or free space, a vacuum, or seawater.

Transmission paths may be established between multiple devices sharing the same transmission medium. Multiplexing techniques are used to economize efficient use of transmission media. If the capacity of transmission medium exceeds the requirements for the transfer of data between two devices, that additional capacity can be shared among multiple transmitters by multiplexing a number of signals onto the same medium. The actual

transmission path is referred to as a circuit or link. The portion of capacity dedicated to each transmitter-receiver pair is referred to as a channel.

The transmission medium may be simplex (signals are transmitted in one direction only, one station transmitting, one receiving), half-duplex (both stations may transmit or receive but only one at a time), or full-duplex (both stations transmitting and receiving simultaneously).

In order to communicate, terminal equipment must interface with the transmission medium through the mediation of circuit-terminating equipment; an example being a modem. In general, both data and control signals must be exchanged and the same encoding schemes must be used at either end. Each interface has mechanical, electrical, functional, and procedural characteristics. Standards known as layer protocols are utilized in order for complementary interfaces to interact effectively.

Once an interface is established, signal generation is required for communication. Signaling is the act of propagating a signal along a suitable medium. Signals are electric or electromagnetic encoding of data; voice is considered to be acoustic data. Data is propagated from one point to another by means of electronic signals. Analog and digital signals must be capable of being propagated through transmission media and interpreted as data at the receiver. An analog signal is a continuously varying electromagnetic wave that may be disseminated over a variety of

spectrum dependent media. A digital signal is a sequence of voltage pulses that may be transmitted over a variety of media. Considerations for transmission or propagation are signal frequency, spectrum, bandwidth, and strength. [Ref. 1:p.29]

Synchronization must occur between the transmitter and receiver. The receiver must be able to determine when a signal begins (initialization), the duration of each signal element (checkpointing), and when it ends (termination).

Beyond the nature and timing of signals are a variety of conventions or requirements for communication. In exchange management, conventions for establishing connections, simultaneous transmissions, the amount of data to be sent at one time, the format of the data, contingencies for errors, error detection and correction, and flow control must be decided.

With transmission facilities utilizing and sharing more than two devices, an addressing and routing scheme provides the source system a means to identify intended destinations through various paths. The initial transmission system must assure that the intended destination system, and only that system, receives the data that has been transmitted.

Recovery techniques allow resumption of activity at points of interrupt which result from faults somewhere in the system, or allow restoration to the state which existed in the system prior to the beginning of an exchange.

Message formatting is the form of the data to be exchanged or transmitted, which is agreed upon by the users of the system. Precedence and preemption are prioritizing schemes which can be included in the formatting.

Protection or cryptography is a measure used for security in telecommunication systems to ensure that only the intended recipients actually receive the data.

Each telecommunications system is a complex system that cannot create or operate by itself. A system management function is necessary for system configuration, status monitoring, failure and overload compensation, and future development. At the heart of the system management function is a qualified technical controller who operates and maintains the system from day to day.

Within a telecommunications system, a collection of devices that are capable of communicating with each other are generically referred to as stations. Stations may be computers, terminals, telephones, or any other telecommunication device. Each station can be attached to a telecommunications network node (a switching center). A set of nodes is the boundary for a telecommunications network that is capable of transferring data between pairs of stations. Telecommunications networks can be categorized by architecture and data transfer technique.

In a switched telecommunication network, data is transferred from source to destination through a series of intermediate nodes. The nodes are not concerned with the content of

the data, rather their purpose is to provide a switching facility that will move data from node to node until the data has reached its final destination. In a broadcast telecommunication network, there are no intermediate switching nodes. A transmission from any one station is broadcast to all other stations. The transmitter-receiver pair between each station communicates through the same medium which is shared by all stations on the network.

b. Capabilities

Approximately 500 circuits traverse NAVCOMMSTA Stockton's technical control facility. Technical control coordinates and provides management control to the many guided and unguided media capabilities in order to provide continuity of communications for all subscribers. A pictorial summary of some of the primary capabilities will facilitate the description of NAVCOMMSTA Stockton's serial technology. The capabilities represented in Figure 4 are specified by the most common form (data or voice), the network category (switched or broadcast), and the media utilized (guided: landline or unguided: radio). The listing of capabilities depicts a mixture of telecommunications systems or circuits which carry both operational and administrative message traffic.

CAPABILITY	DATA			VOICE			NETWORK CATEGORY	
	Guided	Unguided	Sat	Guided	Unguided	Sat	Switched	Broadcast
VERDIN/ISABPS (Integrated Submarine Automatic Broadcast Process System)	X	X						X
Ship-to-Shore Full Period Terminations		X	X				X	
SPERRY-UNIVAC U1100 Computer System NAVCOMPARS	X	X	X				X	X
Common User Digital Information Exchange System (CUDIXS) and Demand Assigned Multiple Access (DAMA)		X	X				X	X
Leased Satellite System (LEASAT)	X	X	X				X	X
International Maritime Satellite (INMARSAT)		X	X				X	X
FSC - 79 SHF Fleet Satellite Communications Terminal		X	X					X
SSR-1 Satellite Fleet Broadcast Receiving System and WSC-5 UHF Fleet Satellite Terminals		X	X					X
AUTODIN	X						X	X
Defense Data Network (DDN)	X	X	X				X	
Microwave Relays	X	X		X	X		X	
Fleet Secure Voice FLTSEVOCOM UHF Satellite				X	X	X	X	
Tactical Data Exchange System (TADIXS)	X	X	X	X	X	X	X	
High Command Voice Network (HICOM)					X		X	

Figure 5. NAVCOMMSTA Stockton Primary Capabilities

The capabilities are circuit outputs resulting from NAVCOMMSTA Stockton's serial technology. The circuits and their various configurations utilize hardware and software that are

common throughout the Naval Telecommunications System (NTS) which ensure network connectivity within a specific NAVCOMMAREA and throughout the NTS. Any circuit configuration or capability results from performing necessary functional tasks associated with each technology in NAVCOMMSTA Stockton's serial or linked technology.

2. NAVCOMMSTA Stockton Serial Technology

A representative transformation process of NAVCOMMSTA Stockton's serial technology is depicted in Figure 6. Accomplishment of a number of functional tasks at each technology link results in a requisite system configuration and desired system outputs.

Distinct technologies exist for each link in the transformation process which are composed of specific technological functional tasks or elements. A representation of required functional tasks in each link of the serial technology follows:

Subscriber Determined Technology Functions

- Defines subscriber geographic limits in terms of NAVCOMMAREA, and equipment capabilities.
- Determines number of subscribers.
- Defines subscriber types (Department of the Navy (DON), Department of Defense (DOD), etc.).
- Determines subscriber priority as directed by the Fleet CINC.
- Identifies subscriber requirements and specific outputs desired. [Ref. 15:interview 1]

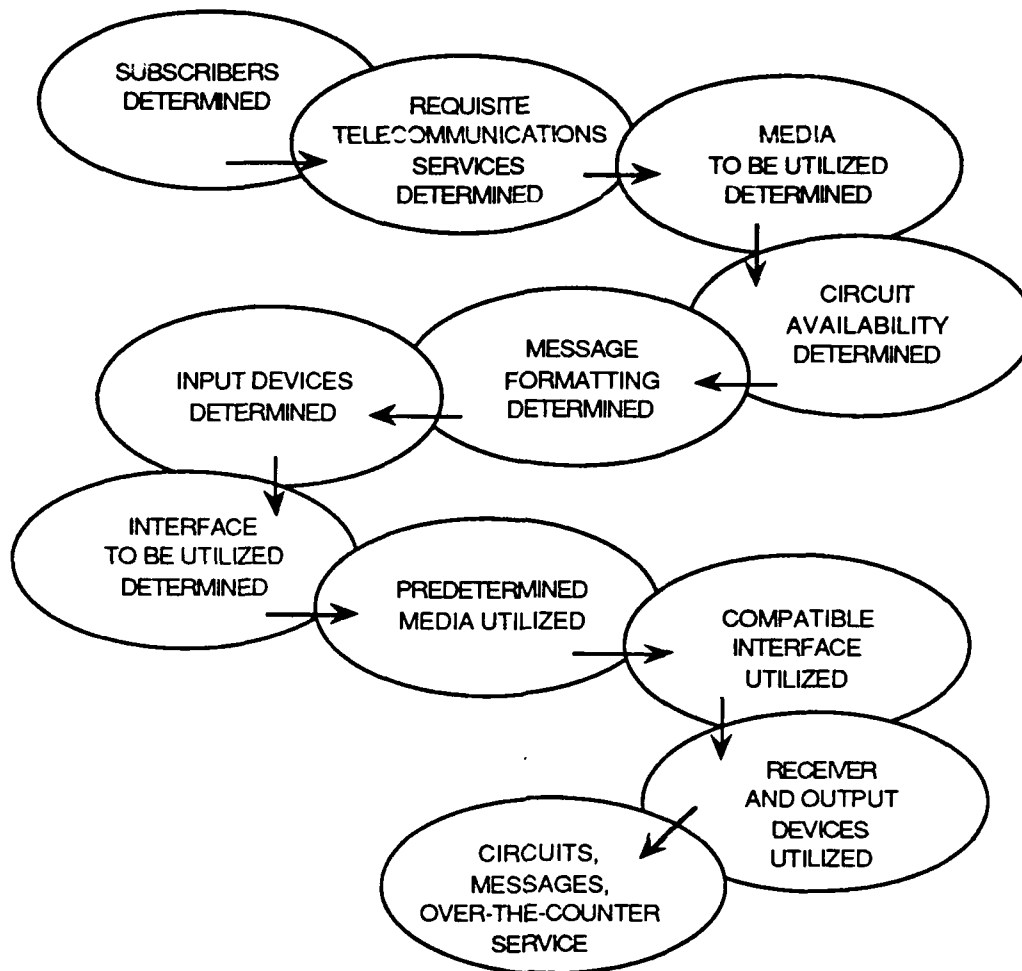

Figure 6. NAVCOMMSTA Stockton Serial Technology

Requisite Telecommunications Services Determined

- Analyzes requirements in terms of source, priority, circuit type, equipment constraints, operator and technician constraints, and security measures.
- Selects service and facility to satisfy requirements.
- Coordinates circuit management with subscriber.
- Validates requirements and changes to services and facilities.
- Submits new or revised telecommunications requirements for recognized deficiencies.

- Plans, programs, and budgets for requisite services.
- Determines network type (switched or broadcast) and size (limits).
- Determines if automatic data processing (ADP) support is necessary, especially for message formatting considerations.
- Determines resources necessary to manage, operate, and maintain the requisite services. [Ref. 15:interview A]

Media To Be Utilized Determined

- Determines use of guided or unguided media as principal path.
- Determines feasibility of using both guided and unguided media.
- Determines the need and utility of multiplexing.
- Determines the multiplexing technique.
- Determines circuit and channel capacity.
- Determines medium as simplex, half-duplex, or full-duplex.
- Determines congestion control techniques.
- Determines signaling scheme (analog or digital) and modulation scheme.
- Determines signal frequency, spectrum, bandwidth strengths and impairments. [Ref. 15:interview P]

Circuit Availability Determined

- Determines if a circuit exists or can be configured using available resources to meet subscriber requirements.
- Determines impact of circuit availability on other circuits.
- Provides telecommunications services (exchange or pass traffic) with circuit availability.
- Establishes and maintains technical control to provide required system management. [Ref. 15:interview G]

Message Formatting Determined

- Determines all necessary protocols for the circuit.

- Determines message formulation information (i.e., determine type of message).
- Determines addressing and routing scheme.
- Determines precedence information.
- Determines coding information.
- Determines access and control information (length of message format or fields).
- Determines security information scheme.
- Determines reliability, availability, and maintainability variables (error checking).
- Determines message header and trailer. [Ref. 15:interview P]

Input Devices Determined

- Determines the terminal equipment to be utilized (phone, teletype (TTY), personal computer (PC)).
- Determines if repeaters or amplifiers are necessary.
- Determines required ancillary equipment such as quality control monitors, converters, and remote keying devices necessary for circuit configuration.
- Determines type of transmitter or network front end processor to be utilized.
- Ensures that keyed (transmitted) data meets necessary interface requirements. [Ref. 15:interview A]

Interface To Be Utilized Determined

- Determines necessary interfaces (such as Naval Communication Processing and Routing System (NAVCOMPARS), Local Digital Message Exchange (LDMX), Remote Information Exchange Terminal (RIXT), Naval Modular Automated Communications Subsystem (NAVMACS)) to manage media.
- Determines appropriate data terminal equipment (DTE) and data circuit-terminating equipment (DCE).
- Ensures compatible encoding schemes are utilized between receivers.

- Ensures physical connections of interface are aligned.
- Ensures electrical characteristics are matched (voltage, time, load).
- Checks functional connections for assigned meanings.
- Checks procedural characteristics for transmitting data. [Ref. 15:interview L]

Predetermined Media Utilized

- Chooses use of guided or unguided media.
- Assigns an alternate route for back-up.
- Determines if system is to be dual homed or simulcast. [Ref. 15:interview H]

Compatible Interface Utilized

- Determines that interface protocols are matched.
- Matches DCE interfaces with receiver or output device. [Ref. 15:interview J]

Receive And Output Devices Utilized

- Captures message traffic as transmitted.
- Ensures message arrives in predetermined format.
- Ensures addressing and routing schemes are effective.
- Ensures devices can handle volume of traffic being sent.
- Plans for redundancy or contingency for missed traffic.
- Plans for internal and external distribution of traffic.
- Plans for the expected form (paper, disk, tape, speakers, etc.) of traffic distribution.
- Plans for shifts in guarding requirements. [Ref. 15:interview K]

Output: Circuits, Messages, Over-the-Counter Service

- Message conveying meaning is received by destination addressee in the form required. [Ref. 15:interview K]

IV. DESCRIPTION OF NARDAC SAN FRANCISCO

The focus of this chapter is the description of Navy Regional Data Automation Center (NARDAC) San Francisco and its utilization of serial technology. The command (organization) is delineated by the mission statement, the structural (internal characteristics) and contextual (total organizational characteristics) dimensions, and technology processes. Serial technology combines successive stages of a production process and uses products of the preceding stage as inputs in each successive stage [Ref. 6:p. 40]. Capabilities are described in order to present the NARDAC in terms of its serial technologies and processes. A representation of specific functions directly relating to the NARDAC's three major serial technologies is then derived from interview data.

A. MISSION STATEMENT FOR NARDAC SAN FRANCISCO

The NARDAC San Francisco is one of nine regional activities established to provide information processing services to Navy, DOD, and other federal government agencies on a reimbursable cost basis. The mission of NARDAC San Francisco is:

to provide automatic data processing (ADP) services to Navy activities in the San Francisco region including: Naval Aviation Depot, Alameda; Naval Air Station (NAS), Alameda; Naval Air Station, Moffett Field; Naval Air Station, Lemoore; Naval Support Activity, Treasure Island; Naval Supply Center, Oakland; Commander in Chief, Pacific Fleet; and other activities as directed by COMNAVDAC. Manage and direct remote facilities as required, to provide local data processing support in

coordination with the regional center; design, develop, and maintain standard Navy automated data systems; and perform other work as directed by COMNAVDAC [Ref. 16:p. 1-1].

B. STRUCTURAL DIMENSIONS

To gain an understanding of NARDAC San Francisco, the organization will be viewed as an open system composed of interrelated elements, subsystems, or departments. The system acquires various inputs, transforms them, and discharges its outputs (products and services). The departments and staffs at NARDAC San Francisco perform essential subsystem functions such as production, boundary spanning, maintenance, adaptation, and management [Ref. 5:p. 11-12]. In the production process, the principal products and services output are ADP security, system software, automated data processing equipment (ADPE), operational support and maintenance of automated data and information systems, and data processing services. In boundary spanning, transactions which occur at NARDAC San Francisco's organizational boundaries are acquiring system inputs and delivering system outputs. For example, an input may consist of a client request for processing data on one of the NARDAC computers; the output would be the processed data service. In maintenance, the upkeep and operation of equipment and systems are accomplished. In adaptation, the environment and technological developments are managed. For example, a technological development may be used to modify a current operation to increase efficiency, as in the use of a new telecommunications line. In the management subsystem,

directing strategies, goals, and policies of the entire organization, coordinating the other subsystems, and resolving conflict between departments is administered.

Another set of interrelated elements which impacts on an organization's structural dimensions is technology. Knowledge, tools, techniques, and actions are the elements of technology which are used to transform organizational inputs into outputs in the production subsystem. The transformation process, which may cover an enormous range of activities, may be viewed as a technology. [Ref. 5:p. 133]

Serial technology, which combines products of preceding stages of production as inputs to successive stages [Ref. 6:p. 40], is employed at the NARDAC to produce its products and services. Serial technology influences the organizational structure, the coordination mechanisms, the decision-making levels, and the size of the organizational units. [Ref. 12:p. 244]

The structural dimensions which characterize NARDAC San Francisco pertain to the internal characteristics of the organization. [Ref. 5:pp.16-18] The following structural dimensions are important because they provide static labels to describe NARDAC San Francisco's organization, and are a basis for measurement and comparison with NAVCOMMSTA Stockton.

1. Formalization

Formalization pertains to the amount of written documentation in an organization. Included are all directives,

instructions, notices, procedures, publications, regulations, advisories, and technical manuals which describe, direct, or influence the behavior and activity at NARDAC San Francisco [Ref. 5:p. 16].

a. Written Documentation

Written documentation at the NARDAC consists of instructions, directives, advisories; technical, operational, and administrative publications; correspondence, records, messages, memos, magnetic tapes and disks, diagrams, and on-line applications. A wide variety of sources such as CNO, COMNAVDAC, CINCPACFLT, COMNAVTELCOM, other NARDACs, and COMNAVBASE San Francisco, all contribute to the wide base of documentation.

Regarding specific organizational direction and composition, the Commanding Officer (CO) of NARDAC San Francisco issues written documentation such as the Organizational Manual and other instructions, notices, and directives which provide operational and administrative functional statements that penetrate to the divisional level.

b. Procedures

Following standardized operational procedures at the NARDAC is desired for continuity of operations. On a large scale, data automation technical standards are set in specific publications such as NAVDAC PUB 17 series [Ref. 17:p. F14]. These standards are recommended for application to the maximum extent possible within the ADP environment. However, in some areas of operation, such as

application development, it is possible to reach a point wherein standardized operations have a substantial neutralizing effect.

2. Specialization or Division of Labor

Specialization pertains to the degree to which tasks are subdivided into separate jobs. The Manpower Authorization documents for both military and civilian personnel specify billet position titles, the rates and paygrades assigned, and the number of authorized and actual billets for the command. While the billets and number of resources per billet are specified, the organization and the distribution of the manpower are not specified. For the NARDAC, the organizational and functional tasks directly influence the command's structure. Ultimately, the overall responsibility for task accomplishment resides with the Commanding Officer.

a Division of Tasks and Range of Specialization

Division of task responsibility is accomplished along departmental lines. Departments are subdivided into divisions or staffs, and each division is assigned specific functional tasks to perform. Various task responsibilities are specified in the formalized documentation and the standard operational procedures of each department at the NARDAC.

- The Liaison-Planning Staff (code OOTL) provides liaison between NARDAC management and customer management, acts as the NARDAC representative and point of contact for potential customers, and markets the NARDAC's ADP services outside of the command. [Ref. 16:p. 3-1]
- The Management Services department (code 20) advises the Commanding Officer on matters dealing with: management procedures and analysis; budgetary and financial planning and

execution; command management information systems; manpower management; training coordination; personnel and physical security; supplies; common services and facilities management. [Ref. 16:p. 4-1]

- The Data Processing Installation Department (DPID (code 50)) administers, operates, and controls all ADPE including peripherals and telecommunications devices, transmission lines and modems within NARDAC San Francisco. The DPID provides batch processing, teleprocessing, and remote job entry data processing services, and manages the command's data library for magnetic storage media. [Ref. 16:p. 7-1]
- The Information Services department (code 60) plans, manages, and coordinates technical activities for the acquisition, implementation, distribution, maintenance and control of systems software for a wide variety of ADPE. It conducts advanced requirements studies within the technical support area and provides technical advice, consultation and assistance in area such as teleprocessing planning and management, software or systems performance measurement, technical standards and procedures, software utilities, hardware and software acquisition, and advanced technical planning support. It provides specialized ADP security technical support. It plans, designs, develops, implements, and provides operational support and maintenance of automated data and information systems. [Ref. 16:pp 5-1, 6-1]

3. Standardization

Standardization pertains to the extent which similar tasks are performed in a uniform manner. Because ADP technology changes rapidly and resources are scarce, each of the nine NARDACs is given responsibility in discrete aspects of the technology. The distribution allows the different sites to keep abreast of the state of the art while avoiding costly duplication of effort, yet fostering standard implementation of enhancements at all NARDAC sites. On a similar but smaller scale, the work content process at NARDAC San

Francisco is standardized within each department, and uniformity of task performance is the main goal. However, the NARDAC goals can be best described as having the ability to provide a full spectrum of ADP services to each individual client. The ADP services can range from a one time technical consultation to full time responsibility for processing applications on a scheduled production basis. Given all of the possibilities, there is much difficulty in determining uniform performance of specific tasks with such a broad range of work content and possible clients.

4 Hierarchy

The organization chart in Figure 7 depicts the hierarchy of authority from the Commanding Officer to the departmental level for NARDAC San Francisco.

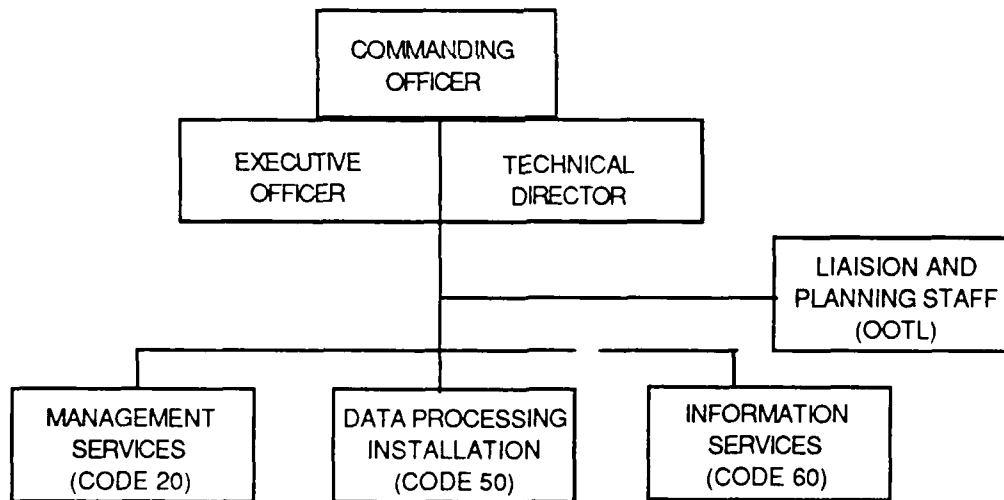

Figure 7. NARDAC San Francisco Organizational Chart

5. Complexity

Complexity refers to the number of subsystems or activities. The NARDAC currently has a technical director, three departments, a liaison planning staff, and two associated subsidiaries (Navy Data Automation Facilities (NAVDAFs)). Complexity is described in three dimensions--vertical, horizontal, and spatial.

a. Vertical

Vertical complexity refers to the number of levels of hierarchy in an organization. For example, NARDAC San Francisco has three levels of vertical hierarchy--command/executive, departmental, and divisional.

b. Horizontal

Horizontal complexity refers to the number of departments existing horizontally across the NARDAC. There are three departments: the Management Services department, the Information Services department², and the Data Processing Installation department.

On the executive level, paralleled with the Executive Officer, the Technical Director is the senior civilian executive of the NARDAC who is accountable to the Commanding Officer for the direction and supervision of the NARDAC departments. The Liaison-

² The Information Services department is a combination of two formerly separate departments; the Technical Support department (code 30) and the Data Processing Programming Support department (code 40).

Planning Staff operates over the full range of vertical and horizontal dimensions.

c. Spatial

Spatial complexity refers to the number of geographic locations associated with an organization. Located on the Naval Air Station, Alameda, CA, NARDAC San Francisco is a tenant command occupying two buildings which physically share space with other tenant commands. The command office spaces in both buildings are interconnected by a local area network (LAN). The hidden spatial complexity for the NARDAC lies in its various network connections which are extensive and in some cases, quite remote as depicted in Appendix B. The NAVDAFs at NAS Lemoore and NAS Moffett Field report to the CO NARDAC San Francisco.

6. Centralization

Centralization pertains to the hierarchical level at which decisions are made. The Commanding Officer of the NARDAC maintains a centralized decision-making posture for carrying out the command's mission.

7. Professionalism

Professionalism refers to the level of formal education and training held by employees. Most of the NARDAC employees are hired based on their ability to meet job code requirements and field experience requirements which are products of a substantial amount of formal education or training at the university or specialized trade school level, in the areas of computer sciences, computer

engineering, telecommunications, or data systems management. [Ref. 6] Coupled with on-the-job experience, in-house formal training such as computer language or software application classes, and trade conferences, the formal education is expanded to fit the ongoing needs of the NARDAC corporate knowledge. In general, the need to keep abreast of current technology motivates the NARDAC employees to attend trade conferences, share new applications, and read and exchange trade journals, periodicals, and industry related literature. Since all NAVDAC commands are intra--networked, each NARDAC also receives periodic advisory bulletins via the network indicating areas that require added or renewed attention.

8. Personnel Configuration

Personnel configuration refers to the deployment of people to various functions and departments. Configuration ratios are measured by dividing the number of people assigned in a department by the total number of employees. The following configuration ratios apply: the executive account for 1.2% of personnel assigned, Liaison-Planning 1.0%, Management Services department 5.5%, Data Processing Installation department 48.5%, and Information Services department 43.8%.

C. CONTEXTUAL DIMENSIONS

1. Size

Size refers to the magnitude as reflected in the number of people employed at the NARDAC. There are approximately 270 personnel assigned to NARDAC San Francisco.

2. Organizational Technology

The organizational technology pertains to the nature of the task in the production subsystem of the organization, and includes the actions, knowledge, tools, and techniques used to change inputs into outputs. For NARDAC San Francisco, three distinct serial technologies are employed to provide the principal ADP products and services to the clients. The serial actions and processes which are performed to transform inputs into outputs will be viewed in terms of functionality.

3. Environment

The environment encompasses all requirements and forces outside of the NARDAC organizational boundaries.

a. Requirements Outside of the Organizational Boundaries

The NARDAC is under the administration and claimancy of COMNAVDAC in Washington, D.C., and falls under the area coordination of COMNAVBASE San Francisco, CA. The NAVDAC charters the NARDAC with its mission, major clients, and non-tactical ADP requirements specific to the geographic region. Other requirements come from the clients of the ADP products and services. Since a contractual relationship exists between the NARDAC and clients, all work to be performed is obligated and accomplished as agreed upon in a reimbursable order for service.

There are also uncontrollable and unstable forces exacting requirements on the NARDAC. For example, an earthquake in

October 1989 temporarily disrupted business and caused minor structural damage to the buildings. As a tenant command, the NARDAC's mission is subordinate to that of the Naval Air Station's mission, thereby lowering its order of priority and affecting the expediency of corrective services.

Another force affecting all obligated work to be performed is the budgetary constraint of the client. The NARDAC is a Navy Industrial Fund (NIF) activity which essentially receives an order for the work to be performed, bills for the service, receives reimbursement from the client, and then performs the required service. If the client is unable to obligate funds for services, the services are not performed.

D. TECHNOLOGICAL PROCESS

At the organizational level, the technological process from input to output takes place in the production subsystem. Functional tasks are combined with the flow of raw materials through NARDAC San Francisco's production process in a logical sequence. Work activities are performed using a variety of tools, techniques, and equipment to produce ADP and ADPE outputs. For each client and Project Request submitted, the technological process is a unique utilization of the serial technology. Each functional task is tailored to the client and project requirements. Though each department may utilize the same or dissimilar technologies to accomplish their functional tasks, the focus of activity is the principal products and services: ADP security, system software, automated data

processing equipment, operational support and maintenance of automated data and information systems, and data processing services.

1. Technology in Use

The technology in use at NARDAC San Francisco is a serial technology wherein the technology of successive stages of a production process uses the products of the preceding stage as inputs in each of the successive stages. [Ref. 6:p. 40] There are three distinct serial technologies in force at NARDAC San Francisco: ADP/ADPE technical services, operational support and maintenance of automated data systems, and data processing services.

a. Data and Information Systems

The NARDAC San Francisco is a data center for non-tactical automatic data processing and data processing services. For the NARDAC, many approaches and technical tools are available to implement various automatic data processing or data information systems.

In order to describe NARDAC ADP capabilities and technologies, some background information on data information systems is presented.

In early versions of computer information systems, computer facilities were centralized. Capabilities for input, processing, output, and storage were typically contained within a small group of special-purpose rooms. Operation usually required transaction documents be brought to the facility. Data were

transferred to computer input media, such as punch cards, by data entry specialists. The submitting, transforming, and processing transactions were generally handled in batches or groups of transactions. Processing occurred in discrete steps or runs. Outputs, such as printouts, were produced as final computer runs for a given system and delivered to the client as the final product.

Later, telecommunications technology was applied to transmitting data between computer devices, such as terminals, over relatively long distances. The transmission of data over communications channels came to be known as data communications. In point-to-point data communications, the computer devices exchange data electronically.

The separation of devices linked by data communication channels results in the decentralization or physical dispersion of computing resources known as distributed processing. Sets of programs or system software including operating systems, make it possible for one computer to be shared among many users. The distribution of processing service among different clients is made possible by timesharing (assignment of processing and memory facilities to users), and memory partitioning (allows two or more programs to share memory). A second computer, called a front end processor (FEP), directs different telecommunications, input, and output functions while the main computer, the mainframe, concentrates on the processing functions. [Ref.18:p. 9]

Telecommunications systems are used to exchange information between two or more agents which include the interface between devices, the actual transmission facility, routing of messages along the medium, processing of information in the system, editing of information, and conversion of information from one format to another.

Four types of data and information telecommunication systems are: short-range computer telecommunications, local area networks (LAN), wide area networks (WAN), and long-haul networks. Systems may use many different media and equipments to accomplish their purpose. For example, short-range computer telecommunications networks use modems, multiplexers, concentrators, and message switches to optimize the flow of messages from remote terminals to central mainframe computers. [Ref. 14:p. 295]

b. Capabilities

The main form of capabilities utilized at the NARDAC is found in the transmission of both digital and analog data. Networks are arranged as switched systems which employ guided and unguided media. Voice is a form of data, but is not the desired form for transmission nor is it intended to be. However, the NARDAC capabilities could be modified to include digital voice configurations if necessary.

Utilization of the three serial technologies at NARDAC San Francisco offers numerous capabilities throughout the spectrum

of ADP services including demand processing, remote batch processing, and central site data processing.

Demand or interactive processing provides clients with a responsive medium for the initiation and interactive execution of programs in a real time mode. The output can then be routed to either the client's output device or to a NARDAC high-speed output device. A data communications network connected to a mainframe accommodates most remote terminals. Remote batch processing enables clients to initiate jobs from terminals located in or near their work station. A full range of software and services (compilers, standard application programs, processors, utilities, and subroutines) are available for remote batch use. The output is routed back to local printers or printed at the NARDAC awaiting mail delivery or customer pick up. Local batch processing or over-the-counter batch provides the capability of remote batch processing without the expense of terminal and telecommunication equipments. [Ref. 19]

Additionally, the NARDAC offers technical support for terminal networking, configuration planning, ADP security, procedure development, consultation services for application development, program debugging, analysis of existing program code, and answering any other ADP technical questions. Micro computer training courses are another form of technical support offered by the NARDAC.

In support of the networking and processing capabilities, NARDAC San Francisco utilizes the following types of computers and equipment: UNISYS Sperry 1100/74, UNISYS Burroughs 4900, Tandem 16, Hewlett-Packard 3000, DEC VAX (11/780 & 8530), Honeywell DPS-6, KOMSTAR 300, DUPLIFICHE, and FOUR PHASE.

2. NARDAC San Francisco Serial Technologies

For each of the three serial technologies at NARDAC San Francisco, ADP Technical Services, Operational Support and Maintenance of Automated Data Systems, and Data Processing Services, a number of functional tasks are associated with each technology link. Cumulative accomplishment of the functional tasks results in the requisite ADP/ADPE service output desired by the client.

a. ADP Technical Services Serial Technology

A graphical representation of the NARDAC's ADP Technical Services serial technology is depicted by the technological links in Figure 8.

Specific technological functional tasks or elements exist for each of the technology links depicted. Representative functional tasks are described for each of the technology links as follows:

Clients Identified

- Establishes, maintains, and provides information and assistance to customers/client managers through a Liaison-Planning staff at NARDAC San Francisco.
- Represents incoming clients at NARDAC San Francisco's departments involving client service or problems.

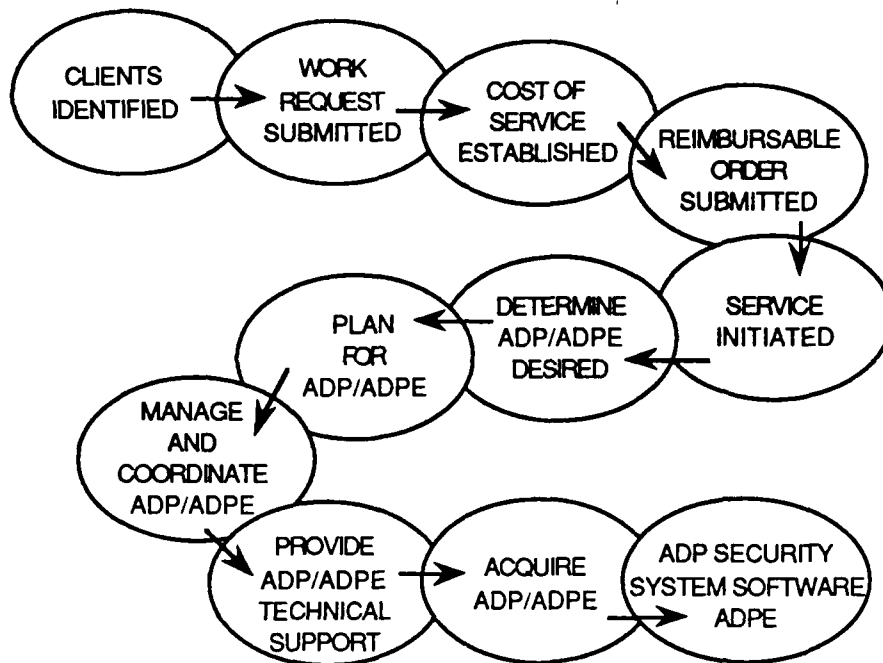

Figure 8. ADP Technical Services

- For other than those who contact the NARDAC, develops and implements marketing strategies for identifying, attracting, and servicing potential clients.
- Assists new or potential clients with submission of Project Requests for development or technical services.
- Instructs and familiarizes clients with the NAVDACINST 5230.1 series [Ref. 20:p. 1] for requesting required services. [Ref. 21:interview F]

Work Request Submitted

- Client prepares and submits Project Request with a letter of transmittal via the appropriate chain of command.
- Client allows sufficient lead time for acquisition of necessary resources. [Ref. 21:interview F]

Cost of Service Established

- With receipt of client Project Request, the NARDAC ensures that the Project Request is complete and sufficiently comprehensive for processing.

- Assigns a project number to the Project Request for controlling and reporting purposes.
- Develops a Planning Estimate for the time and resources necessary to complete a Project Request.
- Coordinates with NAVDAC for possible duplication of projects or conflicts with other information development efforts.
- Submits the Planning Estimate to the client and NAVDAC. [Ref. 21:interview B]

Reimbursable Order Submitted

- In response to the NARDAC Planning Estimate, the client rejects, accepts, or accepts in part the Planning Estimate.
- Client forwards a reimbursable order (i.e., Order for Work and Services (NAVCOMPT Form 2275) or a DOD form such as a Military Interdepartmental Purchase Request) to complete agreement (contract). [Ref. 21:interview B]

Service Initiated

- With receipt of the funding document or reimbursable order, the NARDAC commences work requested by client. [Ref. 21:interview E]

Determine ADP/ADPE Desired

- Referring to client Project Request, the Planning Estimate, and the reimbursable order, the NARDAC specifies the support to be provided across functional areas such as configuration planning, telecommunications network design, ADP technical standards, general purpose systems software or utilities, and ADP security.
- Provides analytical studies, feasibility studies, cost benefit analysis, or developmental testing for acquisition or implementation of new or improved software.
- Develops tasking statements, justifications and attendant documentation to acquire contractor support.
- Reviews and evaluates data base management and file management systems software within the NARDAC departments, other NARDAC activities, and commercial

applications development activities. Documents and recommends acquisition of new software or enhancements to the existing data base or file management software by coordinating with the other sites. [Ref. 21:interview E]

Plan For ADP/ADPE

- Plans for the acquisition or development and maintenance of client systems software, software utilities, and software related products in support of client ADPE.
- Manages and coordinates plans for the NARDAC acquisition of ADPE, teleprocessing equipment and software to ensure availability of computer resources in support of the planned workload.
- Develops and plans adequate consideration of ADP security in all facets of ADP technical work.
- Develops long-range software acquisition plans and provides technical support for pilot testing, evaluation, and certification of software acceptability with planned/approved standards.
- Provides planning inputs to data base for work accomplishment and schedule coordination.
- Develops long range configuration plans for hardware and software.
- Plans and coordinates actions necessary for clients to acquire ADPE and associated telecommunications equipment, network system interfaces, and systems software. [Ref. 21:interview C]

Manage and Coordinate ADP/ADPE

- Serves as focal point for inquiries into new technologies, vendor contacts, and technical services or consultation.
- Coordinates with other NARDACs, private industry, and other governmental agencies to ensure assigned software or related products are generated with the appropriate options to fully support the data base, data communication, and time-sharing system requirements.
- Designs, develops, and maintains a library of general purpose program modules and utilities.

- Coordinates, establishes, and maintains appropriate documentation and guidelines relative to procedures, standards, and techniques in use.
- Manages all phases of acquisition and implementation of technical support, services, and software for all clients. [Ref. 21:interview C]

Provide ADP/ADPE Technical Support

- Provides technical support, advice, consultation, and services including systems software design, development, enhancements or maintenance, and plans or performs advanced studies for determining future support requirements.
- Provides technical support to review and evaluate security functions (assignment and management of passwords, user IDs and other security mechanisms).
- Monitors performance of system software and products to ensure integrity. Provides specialized technical service to maintain and enhance software capability.
- Develops and conducts software tests to ensure software performance, compatibility, and integrity prior to distribution for production processing.
- Develops and conducts training courses and supporting documentation related to the software environment.
- Tests and evaluates various terminal types for hardware/software compatibility and reliability.
- Develops and publishes written technical guidance for development and documentation of teleprocessing network configurations.
- Evaluates methods and procedures related to the performance of ADP and teleprocessing systems and coordinates actions necessary to maintain or improve performance.
- Reviews, evaluates, updates, maintains, and disseminates technical standards for computer languages, compilers, utility libraries, system and program design and development techniques, and hardware/software interface specifications. [Ref. 21:interview E]

Acquire ADP/ADPE

- Acquires or develops software, software tools, and software related products and technical support.
- Maintains technical liaison with software vendors and development activities to ensure supported software is current.
- Participates in client acquisition of ADPE, associated telecommunications equipment, and system software. [Ref. 21:interview C]

ADP Security, System Software, ADPE

- Outputs ADP technical services in the form of ADP security, system software, or ADPE as requested by client.

b. Operational Support and Maintenance of Automated Data Systems Serial Technology

A graphical representation of the Operational Support and Maintenance of Data Systems serial technology is depicted by the technological links in Figure 9.

Specific technological functional tasks or elements exist for each of the technology links depicted. Representative functional tasks are described for each of the technology links as follows:

Clients Identified.

- Establishes, maintains, and provides information and assistance to customers/client managers through a Liaison-Planning staff at NARDAC San Francisco.
- Represents incoming clients at NARDAC San Francisco's departments involving client service or problems.
- For other than those who contact the NARDAC, develops and implements marketing strategies for identifying, attracting, and servicing potential clients.
- Assists new or potential clients with submission of a Project Request for development or technical services.

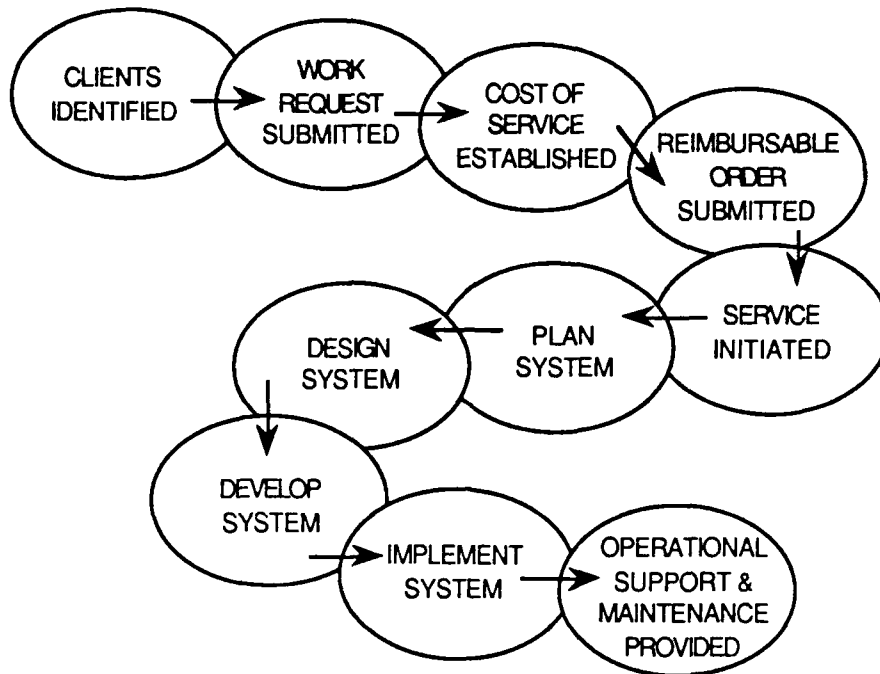

Figure 9. Operational Support and Maintenance of Automated Data Systems

- Instructs and familiarizes clients with the NAVDACINST 5230.1 series [Ref. 20:p. 1] for requesting the required services. [Ref. 21:interview F]

Work Request Submitted

- Client prepares and submits a Project Request with a letter of transmittal via the appropriate chain of command.
- Client provides for sufficient lead time to allow for acquisition of needed resources. [Ref.21:interview F]

Cost of Service Established

- With receipt of client Project Request, the NARDAC ensures that the Project Request is complete and sufficiently comprehensive for processing.
- Assigns a project number to the Project Request for controlling and reporting purposes.
- Develops a Planning Estimate for the time and resources necessary to complete a Project Request.

- Coordinates with NAVDAC for possible duplication of projects or conflicts with other information development efforts.
- Submits the Planning Estimate to the client and NAVDAC. [Ref. 21:interview B]

Reimbursable Order Submitted

- In response to NARDAC's Planning Estimate, the client rejects, accepts, or accepts in part the Planning Estimate.
- Client forwards a reimbursable order (i.e., Order for Work and Services (NAVCOMPT Form 2275) or a DOD form such as a Military Interdepartmental Purchase Request) to complete agreement (contract). [Ref. 21:interview B]

Service Initiated

- With receipt of the funding document or the reimbursable order, the NARDAC commences work requested by client. [Ref. 21:interview E]

Plan System

- Analyzes Project Request and translates functional requirements into ADP concepts to determine feasibility of the project.
- Provides technical assistance in the area of project definition (e.g., analysis and documentation of user requirements, definition of data needs, or determination of interfaces with existing and proposed systems).
- Analyzes ADP system design concepts, determines system scope and complexity, defines development tasks and prepares development milestones and manpower estimates to support and implement the ADP system. [Ref. 21:interview E]

Design System

- Specifies hardware and system software required to support data and information system.
- Designs, codes, tests, debugs, and documents programs which constitute an application system.

- Designs automated data and information system using structured design techniques and structured design tools. [Ref. 21:interview C]

Develop System

- Conducts detailed functional requirement analysis, develops and evaluates system design alternatives, selects the best technical approach and produces system specifications.
- Communicates developments to clients, conducts system tests, and obtains client acceptance of system.
- Develops documentation that reflects the designed system in terms of its technical specifications, procedures for use or application of the system, and procedures for operation of the ADPE.
- Determines need for programing, debugging aids, and other support software.
- Trains client users and turns the system over for operational use. [Ref. 21:interview C]

Implement System

- Reviews and evaluates proposed performance standards, procedures, techniques, and conventions.
- Prepares study reports or technical notes summarizing system analysis and evaluation (conclusions and recommendations).
- Monitors cost and status of assigned projects and ensures that projects are on schedule and conform to established standards and conventions. [Ref. 21:interview J]

Operational Support and Maintenance of Automated Data

Systems

- Provides an output of operational support and maintenance of the required automated data system. [Ref. 21:interview E]

c. Data Processing Services Serial Technology

A graphical representation of the Data Processing Services serial technology is depicted by the technological links in Figure 10.

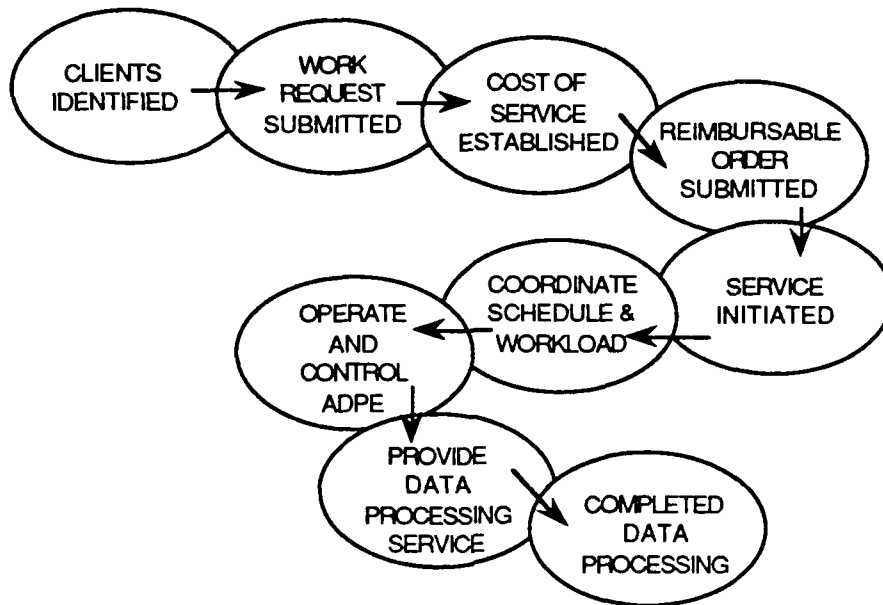

Figure 10. Data Processing Services

Specific technological functional tasks or elements exist for each of the technology links depicted. Representative functional tasks are described for each of the technology links as follows:

Clients Identified.

- Establishes, maintains, and provides information and assistance to customers/client managers through a Liaison-Planning staff at NARDAC San Francisco.
- Represents incoming clients at NARDAC San Francisco's departments involving client service or problems.
- For other than those who contact the NARDAC, develops and implements marketing strategies for identifying, attracting, and servicing potential clients.

- Assists new or potential clients with submission of a Project Request for development or technical services.
- Instructs and familiarizes clients with the NAVDACINST 5230.1 series [Ref. 20:p. 1] for requesting the required services. [Ref. 21:interview F]

Work Request Submitted

- Client prepares and submits a Project Request with a letter of transmittal via the appropriate chain of command.
- Client provides for sufficient lead time to allow for acquisition of needed resources. [Ref. 21:interview F]

Cost of Service Established

- With receipt of client Project Request, the NARDAC ensures that the Project Request is complete and sufficiently comprehensive for processing.
- Assigns a project number to the Project Request for controlling and reporting purposes.
- Develops a Planning Estimate for the time and resources necessary to complete a Project Request.
- Coordinates with NAVDAC for possible duplication of projects or conflicts with other information development efforts.
- Submits the Planning Estimate to the client and NAVDAC. [Ref. 21:interview B]

Reimbursable Order Submitted

- In response to NARDAC's Planning Estimate, the client rejects, accepts, or accepts in part the Planning Estimate.
- Client forwards a reimbursable order (i.e. Order for Work and Services (NAVCOMPT Form 2275) or a DOD form such as a Military Interdepartmental Purchase Request) to complete agreement (contract). [Ref. 21:interview B]

Service Initiated

- With receipt of the funding document or the reimbursable order, the NARDAC commences work requested by client. [Ref. 21:interview K]

Coordinate Schedule and Workload

- Identifies requirements and directs implementation of advanced information storage and retrieval techniques, computer operations techniques, remote terminal or timesharing techniques.
- Analyzes new systems and based on processing requirements such as response, teleprocessing, data base, access and storage time, determines the equipment in which systems should run. Determines if and when commercial ADP and telecommunications services can and should be used.
- Schedules and controls all in-house and contract ADPE preventive maintenance.
- Analyzes all user production requests to determine runs to be scheduled and processed. Evaluates user due dates, equipment availability, system priorities and workload volumes prior to assigning processing priorities.
- Resolves complex scheduling problems caused by resource conflicts, abnormal termination, incorrect operating procedures, and delays in production. Notifies clients of scheduling problems and provides recommended corrective action.
- Operates an automated scheduling system and maintains a related data base. [Ref. 21:interview I]

Operate and Control ADPE

- Operates NARDAC ADPE in a multi-site, multi-shift environment providing production services in support of client requests.
- Loads all accepted application programs and operating system software into the data processing installation department (DPID) software production library.
- Diagnoses hardware, system software, application program or telecommunications malfunctions and identifies sources of problems. Initiates appropriate actions to resolve problems and implements procedures to restore normal operations.

- Recommends and implements changes to methods and procedures to optimize utilization of present ADPE.
- Develops site plans for ADPE installation including space, air conditioning, electrical, and environmental requirements.
- Enforces proper physical control of classified material and classified computer processing.
- Maintains operational logs and statistical records.
- Conducts independent testing of new and modified systems or application software to ensure operability and compliance with existing standards.
- Implements a comprehensive contingency and file back-up plan to include off-site storage and processing facilities.
- Operates communication interface equipment and failure detection equipment utilized on teleprocessing lines including modems and encryption devices. [Ref. 21:interview L]

Provide Data Processing Service

- Conducts studies concerning stability and reliability of DPID computer hardware, software and other resources. Monitors system performance and processing efficiency.
- Performs risk analysis studies to determine level of risk and resources required to provide continuous service and ADP operations support.
- Provides computer operations in support of NARDAC San Francisco clients and internal departments in a multi-shift, multi-vendor, and multi-processing environment using advanced computer systems to provide batch, remote job entry, telecommunications, and over-the-counter services.
- Maintains liaison with vendors of installed equipment to augment technical information as well as to resolve administrative and operational problems related to equipment.
- Provides clients with written procedures concerning all facets of telecommunications services provided. [Ref. 21:interview L]

Completed data processing

- Prepares ADPE output and distribution.

- Coordinates xerographic and micrographic off-line processing.
- Processes data on-line and distributes output either via telecommunications networks or over-the-counter at the NARDAC site. [Ref. 21:interview L]

d. Resource and Technological Interdependency

Utilization of three serial technologies at the NARDAC results in three distinct outputs. The first five links in each of the serial technologies are the same. The outputs are achieved by sequential accomplishment of the serial technologies. Up to the technology link of "Service Initiated", resources and technologies could possibly be shared for all three outputs. However, an interdependence of resources and technologies does not occur simultaneously between the three serial technologies. Currently initiated by the respective department, priorities and plans of each serial technology utilize resources which are independent vice interdependent between the departments. The equipment, personnel, process, or resource being utilized are not the same, and each serial technology process and output is regarded as being independent of the others. [Ref. 21:interview F]

At the "Service Initiated" link and beyond, the possible resources and technological interdependencies are distended. Divisional supervisors and the department head are the managers of the resources and technology used in the production process which are determined by the explicit Project Requests of each client. At the functional level, the extent to which information, knowledge, tools (including hardware and software), techniques, and procedures

can be shared by departments is accomplished via LAN, telephone, and face-to-face exchanges. For example, in-house utilization of resources for planning and scheduling occurs by accessing project requirement data bases. [Ref. 21:interview J]

V. DISCUSSION AND COMPARISON OF THE NAVCOMMSTA AND NARDAC ORGANIZATIONAL DESCRIPTIONS

The focus of this chapter is to discuss the feasibility of functionally integrating elements of NAVCOMMSTA Stockton and NARDAC San Francisco serial technologies; to do so, a comparison of the organizational descriptions is presented. Comparison of the structural and contextual dimensions of both organizations amplifies the subsequent comparison of their technological processes. The motivation for comparing the serial technologies is to determine if similar and integrable functional tasks exist between the two organizations. The feasibility of functionally integrable tasks then triggers a representation of major themes and issues inherent in the NAVCOMMSTA and NARDAC serial technologies.

A. COMPARISON OF NAVCOMMSTA AND NARDAC STRUCTURAL AND CONTEXTUAL DIMENSIONS

The comparison in this chapter will parallel the structural and contextual dimensions described in Chapters III and IV for the NAVCOMMSTA and NARDAC, respectively.

1. Mission

The mission of NAVCOMMSTA Stockton is to provide requisite Naval telecommunications in tactical and operational environments. The mission of NARDAC San Francisco is to provide Navy activities with non-tactical, automatic data processing service. In

comparison, the NAVCOMMSTA mission is orientated toward the movement of messages, and the NARDAC mission is orientated toward the movement of data [Ref. 22:p. 4].

2. Structural Dimensions

The structural dimensions were previously described by the internal characteristics of each organization [Ref. 5:pp. 16-18].

a. Formalization

There is a plethora of written documentation for each of the two organizations. Recent restructuring of COMNAVTELCOM and COMNAVDAC echelon II commands will impact on the volume of administrative and operational documentation at the echelon III and IV levels of command (i.e., the NAVCOMMSTA and the NARDAC). But ultimately, the Commanding Officer of each organization directs, in the command Organization Manual, the procedures to follow in carrying out instructions, directives, and notices.

Changing the form of documentation to a computerized, on-line capability enhances organizational operations. The NARDAC is equipped with a LAN which is highly utilized in performing technology functions. A LAN for the NAVCOMMSTA is currently being implemented [Ref. 15:interview F].

While procedures followed at the NAVCOMMSTA are standardized to the greatest extent possible, to ensure continuity of operations in a multi-shift environment, the NARDAC requires and utilizes greater flexibility in meeting standards (criteria) for client project requests. In particular, the NAVCOMMSTA offers established

circuit types of telecommunications services; the NARDAC may establish any type of network or telecommunication service contingent upon project request approval and reimbursable order submission.

Both the NAVCOMMSTA and the NARDAC utilize the SHOROC and Manpower Authorization documents regarding human resources.

b. Specialization or Division of Labor

The division of task responsibilities for the NAVCOMMSTA and the NARDAC were described as being accomplished along departmental lines with divisions being assigned specific functional tasks to be performed. Both organizations share a departmental and divisional organization scheme for task assignment, and distribute manpower accordingly.

However, the tasks for each organization are quite different. For the NAVCOMMSTA, at least three departments, Security, Public Works, and Recreational Services, have functional tasking directly related to Station site operations. Together with the remaining departments, Administration, Plans, Supply, and Communications, the overall effect of specified tasking results in the established principal products and services of messages, circuit paths, and over-the-counter service.

The NARDAC departments on the other hand, are much more independent in providing Management Services, Data Processing Installation, and Information Services which are noticeably

different products and services. Overall, the effect to the client is production of ADP/ADPE service requested. Yet, each client Project Request determines the departmental and subsequent divisional tasking necessary to produce the required outputs.

c. Standardization

Performance of similar tasks in a uniform manner for NAVCOMMSTA Stockton is necessary for the maintenance of its established circuits and continuity of operations. In that regard, the NAVCOMMSTA maintains a high degree of standardization in its production process. The NARDAC utilizes standards in production and standardizes work flow processes within its departments. But, because of client and job request variabilities, it cannot guarantee uniformity in performance of similar tasks. Production of ADP services aims at standardization but varies with client resources and purposes as well as the state of the technology to be employed.

d. Hierarchy

Organizational structure is reflected in the organizational charts (see Figures 2 and 7) of NAVCOMMSTA Stockton and NARDAC San Francisco down to the departmental level. While both commands maintain the traditional military chain of command with overall organizational responsibility residing with the Commanding Officer, the two organizational structures are different.

The NAVCOMMSTA maintains a functional structure, wherein each functional department provides resources to the

overall production process. [Ref. 5:p. 231] The NARDAC maintains a functional and product structure mix, where for each product or service, the necessary resources for production are grouped within the department structure and the department may utilize the services of the command's other departments as well. [Ref. 5:p. 234]

e. Complexity

Complexity was described as the number of subsystems or activities of the organization. The NAVCOMMSTA has seven departments, the NARDAC has three. The NAVCOMMSTA has an executive assistance staff, the NARDAC has a Liaison-Planning staff and a Technical Director. The NAVCOMMSTA has nine component activities and two microwave sites, the NARDAC has two subsidiaries.

Both the NAVCOMMSTA and the NARDAC have three levels of hierarchy--command/executive, departmental, and divisional.

Spatial complexity for the commands is substantially different. The NAVCOMMSTA Stockton essentially controls Rough and Ready Island (approximately 1425 acres, the site of the NAVCOMMSTA) and is physically dispersed throughout several buildings on the station. Component activities are physically dispersed throughout the central region of California. The NARDAC is geographically confined to two buildings on NAS Alameda except for the NAVDAFs which are located at NAS Lemoore and NAS Moffett Field.

Both commands have further hidden spatial complexity by means of their various clients, networks, and circuit configurations. For example, end-user terminations with access to the world-wide Defense Data Network (DDN) may extend the commands' capabilities to distant locations.

f. Centralization

Since organizations are rarely either fully centralized or decentralized in regard to decision-making [Ref. 7:p. 113], the relevant factor in determining centralization for the commands is the degree of control required. Both commands have technological considerations to keep under control, such as initiating or terminating networks or circuit configurations which cannot be delegated (i.e., circuits or networks may have been established by higher authority). Based on the degree of control required for the technology, both Commanding Officers maintain a centralized decision-making posture.

g. Professionalism

The professionalism, referring to the level of education and training of employees at the NAVCOMMSTA and the NARDAC, differs in two aspects. First, the levels of education and training in data communications, telecommunications, and computer sciences at the NARDAC far exceeds those at the NAVCOMMSTA.

Second, the approaches to professionalism are different. For the NAVCOMMSTA, there are different operators and technicians of circuits and equipment. Operators maintain circuit operations,

technicians maintain and service specific equipment of the circuits. [Ref. 15:interview L] For the NARDAC, the operator and technician are one and the same for the entire system [Ref. 21:interview I]. An operator or technician at the NAVCOMMSTA can function without full knowledge of the entire system. At the NARDAC, full knowledge of the system is essential. The approach to professionalism at the NAVCOMMSTA is on-the-job training. The approach to professionalism at the NARDAC is formal, higher education and training as part of job code requirements and field experience requirements prior to employment.

h. Personnel Configuration

Referring to the deployment of people to the various departments, the only difference between the NAVCOMMSTA and the NARDAC is that the NAVCOMMSTA utilizes almost 17% of its personnel in the Public Works department--a necessity of managing and maintaining its real property. Both the NAVCOMMSTA and the NARDAC have the bulk of their personnel employed in the main production departments, approximately 65% of personnel for the NAVCOMMSTA and approximately 92% for the NARDAC.

3. Contextual Dimensions

The contextual dimensions have been described as the total organizational characteristics [Ref. 5:p. 16].

a. Size

The number of people employed by NAVCOMMSTA Stockton is approximately 735, by NARDAC San Francisco approximately 270.

Of those employed at the NAVCOMMSTA, approximately 48% are civilian, 52% are military; at the NARDAC, approximately 82% are civilian, 18% are military.

b. Organizational Technology

The organizational technology pertains to the nature of the task in the production subsystem. In their production subsystems, both the NAVCOMMSTA and the NARDAC employ serial technology. The serial technology combines successive stages of a production process and uses products of the preceding stage as inputs in each successive stage [Ref. 6:p. 40]. The NAVCOMMSTA uses a single serial technology, the NARDAC utilizes three distinct serial technologies.

c. Environment

The environment encompasses requirements and forces outside of organizational boundaries. For both the NAVCOMMSTA and the NARDAC, higher echelon command authorities may exert operational requirements on their respective commands. Both commands service the requirements of clients and are affected by environmental factors.

The NARDAC however, works in a non-tactical environment and is Navy Industrial Funded (NIF). The NAVCOMMSTA environment is tactical and operational (works with deployed operating forces), and is mission funded. The activity and production levels change for the NAVCOMMSTA as changes occur in the perceived threat and readiness posture. Additional requirements

result for the NAVCOMMSTA caused by the responsibility for real estate, tenants, and spatially diverse components.

B. COMPARISON OF NAVCOMMSTA AND NARDAC SERIAL TECHNOLOGIES

A comparison of the serial technologies for NAVCOMMSTA Stockton and NARDAC San Francisco sets the stage for comparing the functional tasks inherent in each technology link of the serial technologies. Comparing similar functional tasks will answer the question, "Can ADP and Communications serial technologies at NAVCOMMSTA Stockton and NARDAC San Francisco functionally integrate?"

1. Technological Process

In the technological process, functional tasks are combined with the flow of raw materials through the organization's production process in a logical sequence. Work activities of the technological process are performed using a variety of tools, techniques, and equipment to produce requisite outputs previously described as principal products and services. For NAVCOMMSTA Stockton, the principal products and services are: messages, circuits, and over-the-counter service. For NARDAC San Francisco, the principal products and services are: ADP security, system software, automated data processing equipment (ADPE), operational support and maintenance of automated data and information systems, and data processing services.

a. Technology in Use

The technology in use for both organizations is serial technology. Background information on telecommunications systems composition, and data and information systems was presented in Chapters III and IV under Technology in Use to arrive at the fundamental technology links of each serial technology. Both the NAVCOMMSTA and NARDAC utilize telecommunications systems and networks in the exchange of information. The capabilities of each organization are products resulting from utilization of the serial technologies.

b. Serial Technology for NAVCOMMSTA Stockton and NARDAC San Francisco

The production process and technological process at the organizational level refer directly to the NAVCOMMSTA and the NARDAC serial technologies. The serial technologies at each command consist of distinct technologies (knowledge, tools, techniques, and actions) which are linked together in a serial fashion to produce the requisite outputs. In order to compare the serial technologies, they are displayed in Figure 11 in juxtaposition.

From first observation, it would appear that there are few technological similarities between the NAVCOMMSTA and the NARDAC. The first five technologies of the three NARDAC serial technologies parallel each other since all jobs are initiated in a similar manner.

NAVCOMMSTA STOCKTON	NARDAC SAN FRANCISCO	NARDAC SAN FRANCISCO	NARDAC SAN FRANCISCO
COMMSTA SERIAL TECHNOLOGY	ADP TECHNICAL SERVICES TECHNOLOGY	OPERATIONAL SUPPORT & MAINTENANCE OF AUTOMATED DATA SYSTEM	DATA PROCESSING SERVICES
SUBSCRIBERS DETERMINED ↓	CLIENTS IDENTIFIED ↓	CLIENTS IDENTIFIED ↓	CLIENTS IDENTIFIED ↓
REQUISITE TELECOMMUNICATIONS SERVICES DETERMINED ↓	WORK REQUEST SUBMITTED ↓	WORK REQUEST SUBMITTED ↓	WORK REQUEST SUBMITTED ↓
MEDIA TO BE UTILIZED DETERMINED ↓	COST OF SERVICE ESTABLISHED	COST OF SERVICE ESTABLISHED	COST OF SERVICE ESTABLISHED
CIRCUIT AVAILABILITY DETERMINED ↓	REIMBURSABLE ORDER SUBMITTED	REIMBURSABLE ORDER SUBMITTED	REIMBURSABLE ORDER SUBMITTED
MESSAGE FORMATTING DETERMINED ↓	SERVICE INITIATED	SERVICE INITIATED	SERVICE INITIATED
INPUT DEVICES DETERMINED ↓	DETERMINE ADP/ADPE DESIRED	PLAN SYSTEM	COORDINATE SCHEDULE & WORKLOAD
INTERFACE TO BE UTILIZED DETERMINED ↓	PLAN FOR ADP/ADPE	DESIGN SYSTEM	OPERATE & CONTROL ADPE
PREDETERMINED MEDIA UTILIZED ↓	MANAGE & COORDINATE ADP/ADPE	DEVELOP SYSTEM	PROVIDE DATA PROCESSING SERVICE
COMPATIBLE INTERFACE UTILIZED ↓	PROVIDE ADP/ADPE TECHNICAL SUPPORT	IMPLEMENT SYSTEM	COMPLETED DATA PROCESSING
RECEIVER & OUTPUT DEVICES UTILIZED ↓	ACQUIRE ADP/ADPE	OPERATIONAL SUPPORT & MAINTENANCE PROVIDED	
CIRCUITS, MESSAGES, OVER-THE-COUNTER SERVICE	ADP SECURITY, SYSTEM SOFTWARE, ADPE		

Figure 11. Serial Technologies

The first two technologies of the NAVCOMMSTA (subscribers determined and requisite telecommunications service determined) resemble the first two technologies of the NARDAC's three serial technologies (clients identified and work request

submitted). There is a block of linked technologies for the NAVCOMMSTA (from "media to be utilized determined" to "receiver and output devices utilized"), which corresponds to a block of linked technologies for the NARDAC Operational Support and Maintenance of Automated Data Systems serial technology (from "plan system" to "implement system") in that both technologies deal with system configuration or design.

2. Integrating Functional Tasks of Serial Technologies

The technological process which takes place from input to output is decomposed into functional tasks at each technology link in the serial technologies. Work activity centers on accomplishing functional tasks in a logical sequence until the desired output is achieved.

Differentiation of functional tasks is determined by the output product's complexity. The more differentiated the functional tasks are, the more difficult it is to achieve integration among them [Ref. 23:p. 484].

To determine if the serial technologies of the NAVCOMMSTA and the NARDAC can functionally integrate, functional tasks of the NAVCOMMSTA are matched with similar functional tasks of the NARDAC.

a. Similarities of Serial Technology Functions

Listed in TABLE 1 are the technology links of NAVCOMMSTA Stockton serial technology and NARDAC San Francisco ADP Technical Services serial technology which have similar

functional tasks. The numbered combinations for the NAVCOMMSTA to NARDAC functions will be matched for functional task comparison.

TABLE 1. TECHNOLOGY FUNCTIONS

FUNCTION	NAVCOMMSTA	NARDAC
1	SUBSCRIBERS DETERMINED	CLIENTS IDENTIFIED
2	REQUISITE TELECOMMUNICATIONS SERVICES DETERMINED	COST OF SERVICE ESTABLISHED
3	INTERFACE TO BE UTILIZED DETERMINED	DETERMINE ADP/ADPE DESIRED
4		PLAN ADP/ADPE

For the NAVCOMMSTA {1-subscriber Determined, 2- Requisite Telecommunications Services Determined, and 3-Interface to be Utilized Determined} and for the NARDAC {1-Client's Identified, 2-Cost of Service Established, 3-Determine ADP/ADPE Desired, and 4-Plan ADP/ADPE}, similar functional tasks compared are:

- 1/1 Identify subscriber requirements and specific outputs desired. / Assist new or potential clients with submission of a Project Request for development or technical services.
- 2/2 Determine resources necessary to manage, operate, and maintain the requisite services. / Begin development of Planning Estimate of the time and resources needed to accomplish a Project Request.
- 2/3 Analyze requirements in terms of source, priority, circuit type, equipment constraints, operator and technician constraints, and security measures. / Referring to Project Request, the Planning Estimate, and the reimbursable order, specify the support to be provided across NARDAC functional

areas such as configuration planning, telecommunications network design, ADP technical standards, general purpose software or utilities, or ADP security.

- 2/4 Determine if ADP support is necessary, especially for message formatting considerations. / Plan for the acquisition or development and maintenance of client systems software, software utilities, and software related products in support of client ADPE.
- 3/4 Determine necessary interfaces such as NAVCOMPARS, LDMX, RIXT, NAVMACS, to manage media. / Plan and coordinate actions necessary for a client to acquire ADPE and associated telecommunications equipment, network systems interfaces, and systems software.

The technology links of the NAVCOMMSTA serial technology and the NARDAC Operational Support and Maintenance of Automated Data Systems serial technology listed in TABLE 2, have similar functional tasks. The numbered combinations for the NAVCOMMSTA to NARDAC functions will be matched for functional task comparison.

Similar functional tasks compared are:

- 1/1 Identify subscriber requirements and specific outputs desired. / Assist new or potential clients with submission of a Project Request for development or technical services, and provide technical assistance in the area of project definition (e.g., analysis and documentation of user requirements, definition of data needs, or determination of interfaces with existing and proposed systems).
- 2/2 Determine resources necessary to manage, operate, and maintain the requisite services. / Begin development of a Planning Estimate of the time and resources needed to accomplish a Project Request.
- 2/3 Analyze requirements in terms of source, priority, circuit type, equipment constraints, operator and technician constraints, and security measures. / Analyze Project Request

and translate functional requirements into ADP concepts to determine feasibility of the project.

TABLE 2. TECHNOLOGY FUNCTIONS

FUNCTION	NAVCOMMSTA	NARDAC
1	SUBSCRIBERS DETERMINED	CLIENTS IDENTIFIED
2	REQUISITE TELECOMMUNICATIONS SERVICES DETERMINED	COST OF SERVICE ESTABLISHED
3	MEDIA TO BE UTILIZED DETERMINED	PLAN SYSTEM
4	MESSAGE FORMATTING DETERMINED	DESIGN SYSTEM
5	INPUT DEVICES DETERMINED	
6	INTERFACE TO BE UTILIZED DETERMINED	

- 2/3 Determine resources necessary to manage, operate, and maintain the requisite services. / Analyze ADP system design concepts, determine system scope and complexity, define development tasks and prepare development milestones and manpower estimates to support and implement the ADP system.
- 3/3 Determine use of guided or unguided media as principal path. / Analyze ADP system design concepts, determine system scope and complexity, define development tasks and prepare development milestones and manpower estimates to support and implement the ADP system.
- 4/3 Determine all necessary protocols for the circuit. / Analyze ADP system design concepts, determine system scope and complexity, define development tasks and prepare development milestones and manpower estimates to support and implement the ADP system.
- 5/3 Determine the terminal equipment to be utilized. / Analyze ADP system design concepts, determine system scope

and complexity, define development tasks and prepare development milestones and manpower estimates to support and implement the ADP system.

- 5/3 Determine if repeaters or amplifiers are necessary. / Analyze ADP system design concepts, determine system scope and complexity, define development tasks and prepare development milestones and manpower estimates to support and implement the ADP system.
- 5/3 Determine required ancillary equipment such as quality control monitors, converters, and remote keying devices necessary for circuit configuration. / Analyze ADP system design concepts, determine system scope and complexity, define development tasks and prepare development milestones and manpower estimates to support and implement the ADP system.
- 5/3 Determine type of transmitters or network front end processor to be utilized. / Analyze ADP system design concepts, determine system scope and complexity, define development tasks and prepare development milestones and manpower estimates to support and implement the ADP system.
- 6/4 Determine necessary interfaces to manage media. / Specify hardware and system software required to support data and information system.

The technology links of the NAVCOMMSTA serial technology and the NARDAC Data Processing Services serial technology listed in TABLE 3 have similar functional tasks. The numbered combinations for the NAVCOMMSTA and NARDAC functions will be matched for functional task comparison.

Similar functional tasks compared are:

- 1/1 Identify subscriber requirements and specify outputs desired. / Assist new or potential clients with submission of a Project Request for development or technical services.

- 2/2 Determine resources necessary to manage, operate, and maintain the requisite services. / Begin development of a Planning Estimate of the time and resources needed to accomplish a Project Request.

TABLE 3. TECHNOLOGY COMPARISON

FUNCTION	NAVCOMMSTA	NARDAC
1	SUBSCRIBERS DETERMINED	CLIENTS IDENTIFIED
2	REQUISITE TELECOMMUNICATIONS SERVICES DETERMINED	COST OF SERVICE ESTABLISHED
3	CIRCUIT AVAILABILITY DETERMINED	OPERATE AND CONTROL ADPE
4	RECEIVE AND OUTPUT DEVICES UTILIZED	

- 3/3 Provide telecommunications services (exchange or pass traffic) with circuit availability. / Operate NARDAC ADPE in a multi-site and multi-shift environment providing production services in support of clients.
- 3/3 Provide telecommunications services (exchange or pass traffic) with circuit availability. / Operate communications interface equipment and failure detection equipment utilized on teleprocessing lines including modems and cryptographic devices.
- 3/3 Establish and maintain technical control to provide required system management. / Diagnose hardware, system software, application programs or telecommunications malfunctions and identify sources of problems, and initiate appropriate actions to resolve problems and implement procedures to restore normal operations.
- 4/3 Plan for redundancy or contingency for missed traffic. / Implement a comprehensive contingency and file back-up plan to include off-site storage and processing facilities.

b. Differences of Serial Technology Functions

While the functional similarities cited above provide a means for approaching a partial functional integration of serial technologies at the NAVCOMMSTA and the NARDAC, the differences in the technologies and functional tasks overwhelm the similarities.

The differences in technologies can eventually be attributed to the telecommunications requirements for message traffic and circuit paths for the NAVCOMMSTA and to the ADP/ADPE technical, support, and processing service requirements for the NARDAC. The requirements have shaped the functional tasks that need to be accomplished in order to provide the products and services.

There are numerous differences in elements of the serial technology functions which have been associated with the technology links. The differences are illustrated as relationships from the NARDAC to the NAVCOMMSTA serial technology functions.

For ADP Technical Services Technology, the functional tasks associated with {Cost of Service Established, Reimbursable Order Submitted, Determine ADP/ADPE Desired, Plan for ADP/ADPE, Manage and Coordinate ADP/ADPE, Provide ADP/ADPE Technical Support, Acquire ADP/ADPE, and ADP Security, Systems Software, ADPE} do not functionally match the NAVCOMMSTA's serial technology functional tasks.

For Operational Support and Maintenance of Automated Data Systems, the functional tasks associated with {Cost of Service

Established, Reimbursable Order Submitted, Design System, Develop System, Implement System, and Operational Support and Maintenance Provided} do not functionally match the NAVCOMMSTA serial technology functional tasks.

For the Data Processing Services, the functional tasks associated with {Cost of Service Established, Reimbursable Order Submitted, Coordinate Schedule and Workload, Provide Data Processing Service, and Complete Data Processing} do not functionally match the NAVCOMMSTA serial technology functional tasks.

Though the differences in the functional tasks from the NARDAC to the NAVCOMMSTA serial technologies are substantial, functional task similarities remain which provide some means for the functional integration of tasks and eventually, technologies. As new requirements for the NAVCOMMSTA and NARDAC telecommunications and data systems and services change, convergence of the technologies will further shape functional tasks and eliminate some of the differences.

c. Resource and Technological Interdependencies

Because many of the functional task outputs of the four serial technologies did not match, the topic of circuit compatibility between NAVCOMMSTA Stockton and NARDAC San Francisco was not discussed. Both organizations share the similar telecommunications principles of moving data over transmission media and interfacing with input and output devices. However, the circuits currently

utilized are neither aligned nor mapped for comparison; yet, functional task similarities exist between both commands. For example, similar site to site terminations exist from Alameda to Treasure Island for both commands in support of the same type of data being transferred.

Where similar terminations exist, there appears to be a duplication of linkage instead of combined linkage. Currently, there are no resources nor technological interdependencies between the organizations.

With resource and technology interdependence, similar or same resources are utilized in a similar or same technological process to achieve a greater efficiency through either economies of scale or economies of scope or both. For both organizations, resource and technology interdependence would come in the form of similar knowledge (telecommunications, data communications, or data processing), tools (hardware, software, and interfaces), techniques (line management, programming, shift work), and actions (on-line switching, processing, and message delivery).

Within the NARDAC, interdependencies between technologies are minimal. Each job request is independent and similar functional tasks are performed within the boundaries of the specific serial technology. Sharing of the technology functional tasks among the three serial technologies is not done on a repetitive basis. Upon completion of initial coordination efforts inherent with

job/work request submission and initiation of services to be performed, an even wider divergence of interdependencies occurs.

Currently for the NAVCOMMSTA and the NARDAC, there are no resources or technological interdependencies. The prospect of establishing identification of resource and technology interdependence suggests that there would be certain executive tasks which would account for coordination and integration of the serial technologies. Specific executive tasks may be:

- Developing strategies for resource acquisition and cross-utilization.
- Determining end-to-end circuit and network configurations.
- Consolidating and managing circuit lines.
- Acquiring and managing multiprocessing equipment (Integrated Design).
- Coordination and control of combined or grouped technologies.
- Establishing compatible funding controls.
- Establishing and maintaining the number of employees necessary to produce required output.

The current situation allows only for separate organizational strategies. Unmindful and independent of other organizations, network and circuit configurations are devised only within each organization. The line management function of each organization occurs through the technical control center. However, a consolidation of lines between the two organizations is not guaranteed because the acquisition of lines result from external requests and approvals. Multiprocessing equipments currently serve requirements which have been previously established in each of the

four separate serial technologies. To date, a requirement for consolidated multi-serial technology output has not been identified.

The funding controls for both organizations are wholly different and independent; the NARDAC utilizes a NIF scheme while the NAVCOMMSTA utilizes the mission funded Planning, Programming and Budgeting System (PPBS) process scheme. The two schemes are neither determined to be compatible nor incompatible. Finally, the task of establishing and maintaining the number of employees necessary to produce required outputs for both organizations zeroes in on the prospect of unsubstantiated personnel losses or cuts justified by integrating technologies (reduction in the duplication of effort) without improving task accomplishment (increase in completion of effort).

C. MAJOR THEMES AND ISSUES OF NAVCOMMSTA AND NARDAC SERIAL TECHNOLOGIES

Building new or rebuilding old telecommunications systems, data communications systems, or systems related services involves much more than technical rearrangement of equipment, functional tasks, and workflows. Change is involved with who owns and controls the systems, who has a right to access, and who can change and make decisions about the systems. As with the serial technologies at the NAVCOMMSTA and the NARDAC, the controls, accesses, and decisions regarding the telecommunications, data communications, and systems related services bring up major themes and issues.

1. Requirements Drive the Technology

The choice involved with a particular technology is driven by requirements [Ref. 24]. At the most basic level, requirements identify who needs what, where, when, and how. Requirements consider economic, technical, and time constraints, as well as goals, procedures, and actions of the organization. The organization transforms requirements and produces an output. The organization forms itself by grouping internally by activity, output, or client. The grouping decision focuses the organization and shapes the technology. The organizational internal grouping is a strategic decision which can be analyzed for strengths and weaknesses. [Ref. 7:p. 74]

In the case of the NAVCOMMSTA and the NARDAC, there are four sets of outcomes driven by very different requirements. Until a decision is made that there is a requirement for all four sets of outcomes to be gathered into a single, multi-outcome package, the organizations will remain grouped by activity or client and produce their particular serial technology outcome.

The requirements of the NAVCOMMSTA are externally, strategically standardized for extensive multi-user services. The requirements of the NARDAC are externally and internally, strategically flexible for client purchased services.

2. Level of Technology

In the past, emphasis has centered on managing computers and technology. With current system advancements, there is now a

need to manage the information in many systems as strategic resources. Most organizations automate in increments which tends to develop systems in isolation from other functional areas. There may not be an overall plan to manage different systems or the information residing within the different systems.

The level of technology, driven by the requirements of the organization, is determined by design. Major problem areas causing a particular technology to fail are design, costs, operations, and data. With design, if all requirements are not determined, the system may not operate or be user-friendly and may go unused. If all data is not loaded into the system or loaded incorrectly, the system will fail. The system may operate smoothly, but cost may prohibit use. And finally, system operations may simply break down or not function at all. [Ref. 14:p. 605]

For the NAVCOMMSTA, designing to a level of technology is a support function to the principal outcome. For the NARDAC, designing to a level of technology is one of the principal outcomes. The NAVCOMMSTA receives elements of systems already designed to a particular level of technology and fits its organization to support the system and its outcomes. The NARDAC designs to the level of technology required.

3. Organizational Spatial Complexity Dimensions

Although compared as an organizational, structural, spatial complexity dimension earlier, a major theme and issue of functional integration is spatial complexity. Strategic organizational grouping

decisions are greatly affected by the spatial complexity. The wider the dispersion, the greater the need for coordination to obtain the same or increased level of output, and the greater the effect on shaping the technology.

The NARDAC is situated in an optimal location for its client base. The NAVCOMMSTA is located central to its components, but they are widely dispersed to serve the client base. The wide area spatial complexity complicates functional integration of the two commands to a level of technology which may be cost prohibitive.

4. Externalities

There are a number of external agents who may specify, change, alter, influence, or direct the requirements which drive the technology of NAVCOMMSTA Stockton and NARDAC San Francisco. A spattering of these agents include: COMNAVTELCOM, NAVDAC, CINCPAC, CINCPACFLT, COMTHIRDFLT, COMSEVENTHFLT, CINCLANT, COMNAVBASE San Francisco, DCA, Navy Commercial Communications Center (NAVCOMCOCEN), Defense Commercial Communications Office (DECCO), JCS, SPAWAR, Chief of Naval Material (CHNAVMAT), and Naval Facility (NAVFAC) San Bruno.

VI. CONCLUSIONS AND RECOMMENDATIONS

The thesis opens with a statement regarding the industry-wide movement toward merging telecommunications and data processing technologies followed by information in regard to the merging of telecommunications and data processing disciplines in the Navy. Concentrating on one specific, interrelated, open system element-technology, the thesis examines if functional integration between the serial technologies of NAVCOMMSTA Stockton and NARDAC San Francisco can occur. The conclusion is that there exists a number of similar functional tasks which provide a means for approaching integration.

A. THE IDEAL SERIAL TECHNOLOGY

Although reasons for merging technologies are not explored nor essential in determining if and where merging can occur, it is useful to provide one of the primary reasons to explain what is meant by the ideal serial technology. A related telecommunications/ADP technology, office automation systems (OAS), was not addressed in the thesis because of its use as a support function as opposed to a main function which contributes to the overall command missions. A primary reason for integration occurs because of the enormous number of physical interconnections which take place between systems using the telecommunications, data communications, and office automation technologies. Interfaces between the various

facilities are blurred. Difficulties arise in isolating one area from another. Common use of telecommunications lines to support voice, data, video, and office information systems implies that separate technologies cannot be addressed independently of the others. [Ref 26:pp. 3-4]

The ideal serial technology would support integrated telecommunications, data processing, and office automation systems. For example, an Integrated Services Digital Network (ISDN) type of architecture (i.e., all processing and transmission elements of a system) offers an integrated telecommunications network that provides complete digital connectivity from end user to end user. Total digital connectivity allows transparent transmission of voice or non-voice data over one network architecture with performance which would make the system more cost effective and efficient than current dedicated network architectures. [Ref. 26:p. 2]

Ideal serial technologies do not yet exist for most organizations. There is not yet a common, single architecture which ties telecommunications, data processing, and office automation systems together for different organizations. A combined, ideal, serial technology does not yet exist for NAVCOMMSTA Stockton and NARDAC San Francisco.

B. STRATEGY FOR INTEGRATION OF SERIAL TECHNOLOGIES

In the open system concept of each communication or automated data processing organization, there are a number of interrelated,

open systems elements such as inputs, outputs, technology, environment, purpose, behavior and process, culture, and structure. The open system elements influence one another. The focal element of the thesis is technology, which is only one element of the two specific organizations.

An organizational strategy is a statement of the environment and business relevant to the organization, the purpose of the organization within that context, and the distinctive means by which goals can be achieved. [Ref. 23:p. 479] Alignment of the different open system elements reduces the differentiation which complicates integration. A strategy calling for the integration of technologies must also address all other open system elements as well as the technology to be effective in its integration plans.

Alignment refers to the congruence between open system elements of each organization. The congruence of the open system elements is defined by the degree to which the needs, demands, goals, objectives, and structures are consistent between the organizations. [Ref. 7:p. 29] The greater the total degree of congruence, fit, or alignment among the various system elements, the greater the organizational effectiveness. The measure of effectiveness is the degree to which actual integrated organizational output is similar to expected output specified in the organizational strategy.

For the NAVCOMMSTA and the NARDAC, there exist functional tasks which are similar. However, there are also a great number of

tasks which are dissimilar. The thesis study questioned if the serial technologies at the NAVCOMMSTA and the NARDAC could functionally integrate. The simple answer is no; the serial technologies are too complex and differentiated to be integrated at this time. However, the serial technologies could be integrated if all of the open system elements in both organizations are aligned. Then, answering the more complicated question of how to functionally integrate begins with the development of a joint policy statement from the two organizations. A joint policy statement would provide the consolidated direction necessary to set strategic goals for integration.

The strategy for functional integration of the NAVCOMMSTA and the NARDAC technologies would have to be based on one architecture. An architecture is a world view or picture commonly accepted by all parties [Ref. 27:p. 1-1]. The architecture defining communications tasks provides a common denominator for functionally integrating technologies.

1. Architecture Defining Communications Tasks

Communications hardware is reasonably standard, but when communication among heterogeneous systems (i.e., different vendors, or different models from the same vendor) is desired, software development is quickly complicated. Different vendors use different data forms and different data exchange conventions even within a single vendor product line. The desirability for a common set of conventions or standards led to the International Organization

for Standardization (ISO) to decompose and define communications tasks into an architecture. The result was the Open System Interconnection (OSI) reference model, which is a framework for defining standards for linking heterogeneous systems. [Ref. 1:p. 390]

The communications functions are partitioned into a set of seven vertical layers. Each layer performs a related subset of the functions required to communicate with another system. The layers are defined in such a manner that changes in one layer do not affect nor require changes in other layers. Each layer provides independent service to adjacent layers. For example, the lower layers perform basic functions which appear to be transparent but actually contain precise details of the particular functional interaction between layers.

The seven layers of the model, from bottom to top, are: physical, data link, network, transport, session, presentation, and application. At each layer, mutually acceptable sets of conventions referred to as protocols exist. A protocol is a set of rules governing the exchange of data between two systems and determines what is communicated, how it is communicated, and when it is communicated.

The OSI reference model and architecture is well understood throughout the NARDAC San Francisco organization. Architecture is a crucial element of system design for the NARDAC. For the NAVCOMMSTA, configuring systems using assigned architectures is the most crucial element of technology.

C. RECOMMENDATIONS

Based on interview data ([Ref. 15] and [Ref. 21]) and observations, the following recommendations are presented.

The bottom line to functionally integrating communications and ADP serial technologies at NAVCOMMSTA Stockton and NARDAC San Francisco is to first integrate the technology functions of both organizations which support the Navy mission afloat. The functions need to be identified, an architecture needs to be chosen, the systems need to be modified to fit the architecture, and the organizations need to be adapted to the architecture. Continued movement toward the OSI reference model architecture is recommended.

Regarding both the NAVCOMMSTA and the NARDAC, a joint strategy which capitalizes on the strengths of each organization is recommended. For example, a particular strength of the NAVCOMMSTA is the knowledge of tactical and operational communications; a particular strength of the NARDAC is system and circuit design requirements. With respect to resource and technological interdependency, establishment of common executive tasks cited in Chapter V, a single line/circuit manager is recommended within the joint strategy where strategic grouping of current and future circuit, network, and system requirements for both organizations are delineated. Additionally, investigation into a single computer, or several linked computers centrally located to

carry out multiple functional task processes is also recommended.
[Ref. 21:interview I]

There are a number of organizational issues in relation to integration of serial technologies at NAVCOMMSTA Stockton and NARDAC San Francisco which are recommend for further study. They are:

- The effect of the Navy Data Communications Control Architecture (NDCCA).
- The effects of NIF funding on integrated organizations.
- The effect of manning and possible reductions in force (RIF).
- The effect on line and circuit control.
- The effect of spatial complexity on system management.
- The effect of mapping NAVCOMMSTA and NARDAC circuits for comparison (e.g., media, bit rate, termination, equipment, etc.)
- The effect on training and education levels.
- The effect on cross-cultural, cross-organizational knowledge levels of integrated systems on employees.
- The effect of delaying integration.
- The effect on all open system elements.

APPENDIX A

ACRONYMS

ADP	Automated Data Processing
ADPE	Automated Data Processing Equipment
AUTODIN	Automated Digital Network
BCST	Broadcast
CHNAVMAT	Chief of Naval Material
CINC	Commander in Chief
CINCPAC	Commander in Chief, Pacific
CINCPACFLT	Commander in Chief, U.S. Pacific Fleet
CNO	Chief of Naval Operations
CO	Commanding Officer
COMNAVBASE	Commander, Naval Base
COMNAVDAC	Commander, Naval Data Automation Command
COMNAVSECGRU	Commander, Naval Security Group
COMNAVTELCOM	Commander, Naval Telecommunications Command
COMSUBPAC	Commander, Submarine Forces Pacific
CUDIXS	Common User Digital Information Exchange System
DAMA	Demand Assigned Multiple Access
DBMS	Data Based Management System
DCA	Director, Defense Communications Agency
DOE	Data Circuit-Terminating Equipment

DCS	Defense Communications System
DDN	Defense Data Network
DECCO	Defense Commercial Communications Office
DOD	Department of Defense
DON	Department of the Navy
DPID	Data Processing Installation Department
DTE	Data Terminal Equipment
EASTPAC	Eastern Pacific
EPA	Environmental Protection Agency
FEP	Front End Processor
FLTSEVOCOM	Fleet Secure Voice Communications System
HICOM	High Command Voice Communications System
INMARSAT	International Maritime Satellite
ISABPS	Integrated Submarine Automatic Broadcast Process System
ISDN	Integrated Services Digital Network
ISO	International Organization for Standardization
JCS	Joint Chiefs of Staff
LAN	Local Area Network
LANT	Atlantic
LDMX	Local Digital Message Exchange
LEASAT	Leased Satellite System
LF	Low Frequency
MPDS	Message Processing and Distribution System
NARDAC	Navy Regional Data Automation Center

NAS	Naval Air Station
NAVCAMS	Naval Communications Area Master Station
NAVCOMCOGEN	Navy Commercial Communications Center
NAVCOMMAREA	Naval Communications Area
NAVCOMMSTA	Naval Communication Station
NAVCOMPARS	Naval Communications Processing and Routing System
NAVDAC	Naval Data Automation Command
NAVDAF	Naval Data Automation Facility
NAVFAC	Naval Facilities Command
NAVMACS	Naval Modular Automated Communications Subsystem
NAVTELCOM	Naval Telecommunications Command
NDCCA	Navy Data Communications Control Architecture
NIF	Navy Industrial Fund
NRRF	Naval Radio Receiver Facility
NRTF	Naval Radio Transmitter Facility
NTCC	Naval Telecommunications Center
NTS	Naval Telecommunications System
OAS	Office Automation System
OJT	On-the-Job Training
OSI	Open Systems Interconnection
PC	Personal Computer
PQS	Personnel Qualification Standard
RIF	Reduction In Force

RIXT	Remote Information Exchange Terminal
SHOROC	Shore Required Operational Capabilities
SORM	Standard Organization and Regulations Manual
TADIXS	Tactical Digital Exchange System
TELCOR	Telecommunications Operating Requirements
TTY	Teletype
VERDIN	VLF/LF Submarine Broadcast equipment
VLF	Very Low Frequency
WAN	Wide Area Network
WESTPAC	Western Pacific
XO	Executive Officer

APPENDIX B

INTERVIEW QUESTIONS

The following are proposed interview questions to be asked by Lieutenants P.A. Gutierrez and D.R. Vasquez in connection with their joint, Naval Postgraduate School thesis. The thesis is a comparative study on the impact of integrating the Communications and Automated Data Processing disciplines in the U.S. Navy. In particular they are interested in the integration of Naval Communication Station (NAVCOMMSTA) Stockton and Navy Regional Data Automation Center (NARDAC) San Francisco. This interest is based on the communications and automated data processing technologies being utilized by two nearby organizations close to each other and the Naval Postgraduate School. The interview questions are intended to explore the nature of the two serial technologies (i.e., the methods and processes for transforming resources into outputs) for each. Considering the technology factors, they intend to examine how similar, serial technologies like communications and automated data processing can be linked, merged, or managed in an integrated manner. The technological and managerial aspects regarding communications and data processing are being solicited to examine current functions and controls.

1. What task does your unit or division perform?
2. What are the main inputs and outputs of this unit or division?

3. What are the main techniques and means used to perform those tasks? What technologies are involved?
4. What do you use in your work to keep up technologically?
5. With whom (both internal and external) do you have to work to get things done?
6. Are the procedures for coordinating work and information flows appropriate to the tasks and technology?
7. Are there tasks and functions where coordination can be improved?
8. What is your current job position and what is your past experience?
9. What training and skills that you and your subordinates have fit assigned job requirements?
10. How do you plan for short-range and long-range goals and objectives?

APPENDIX C

NARDAC NETWORKS

Chapter IV mentioned the hidden spacial complexity for the NARDAC within its various network connections. Each graphic represents a network of NARDAC San Francisco.

A. DACNET NETWORK CONFIGURATION

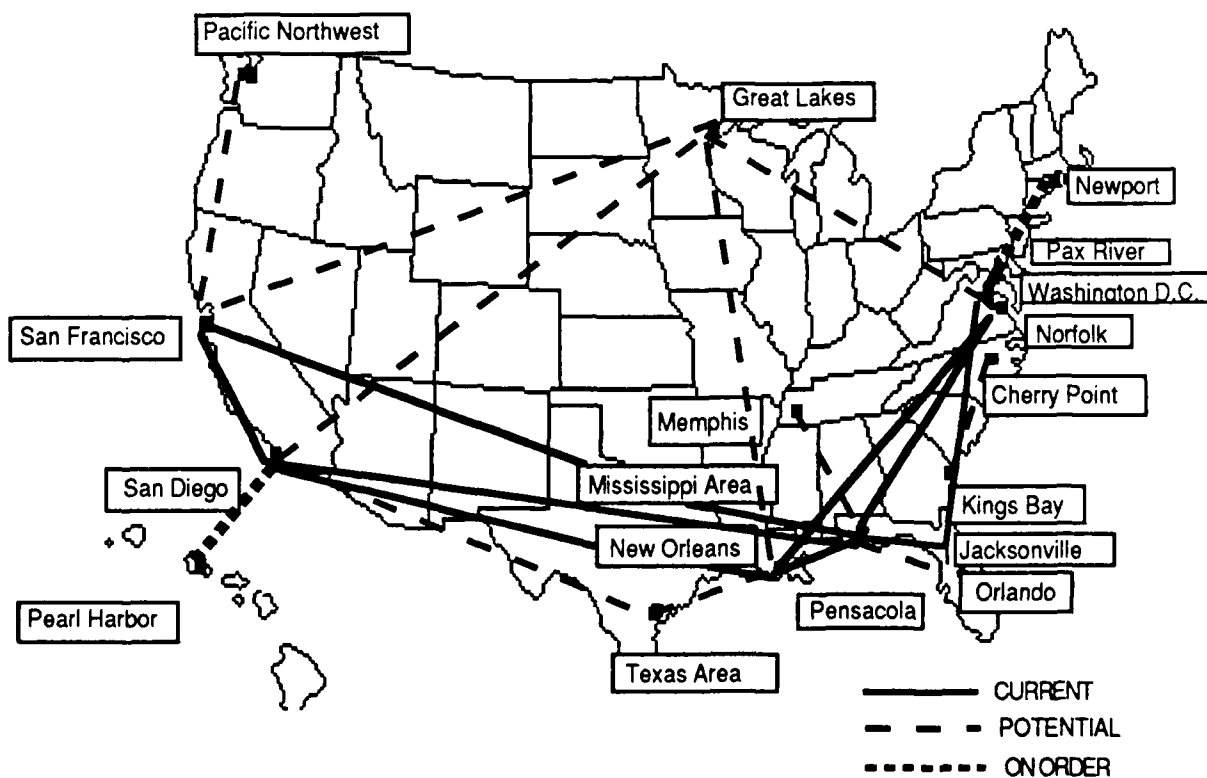

DACNET NETWORK CONFIGURATION
56KB SERVICE As of 9/29/89

B. BURROUGHS T--CON NETWORK

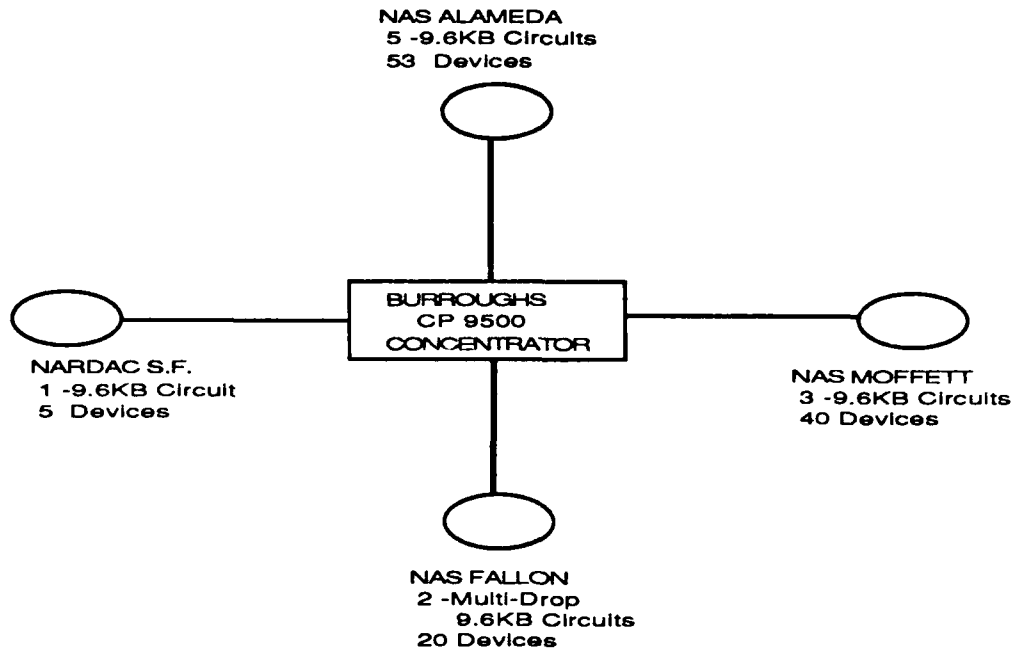

C. BURROUGHS NETWORK

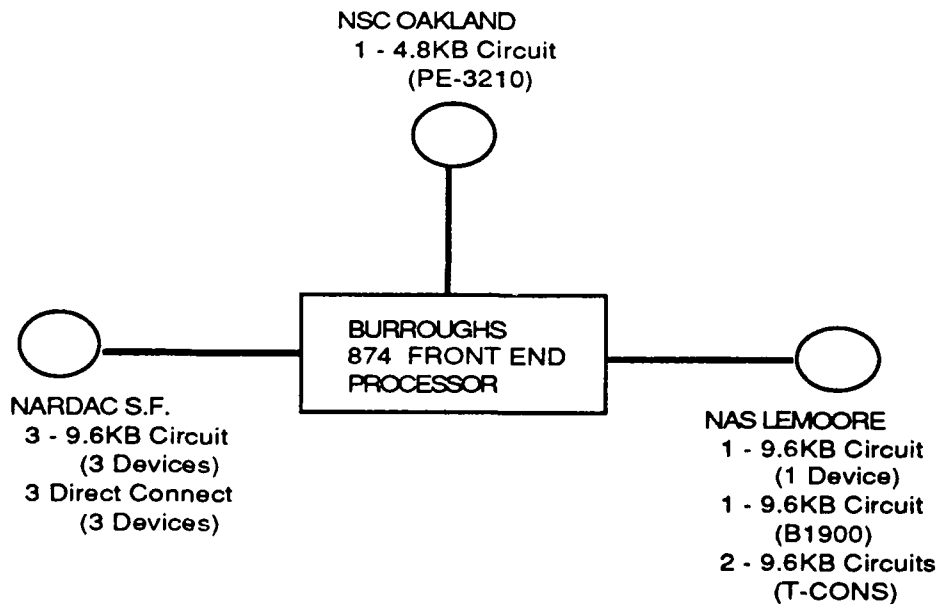

D. SPLICE NETWORK

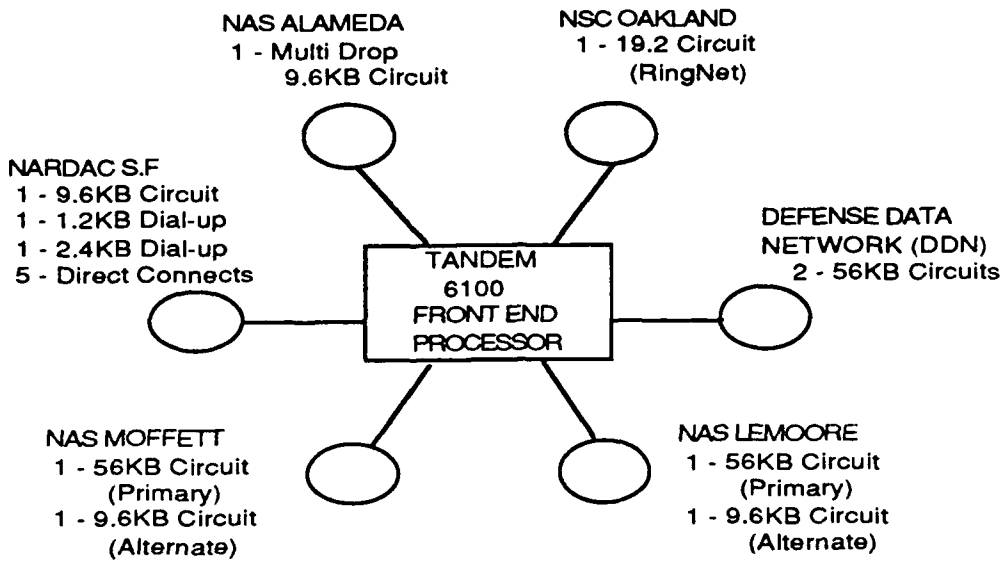

E. UNISYS NETWORK

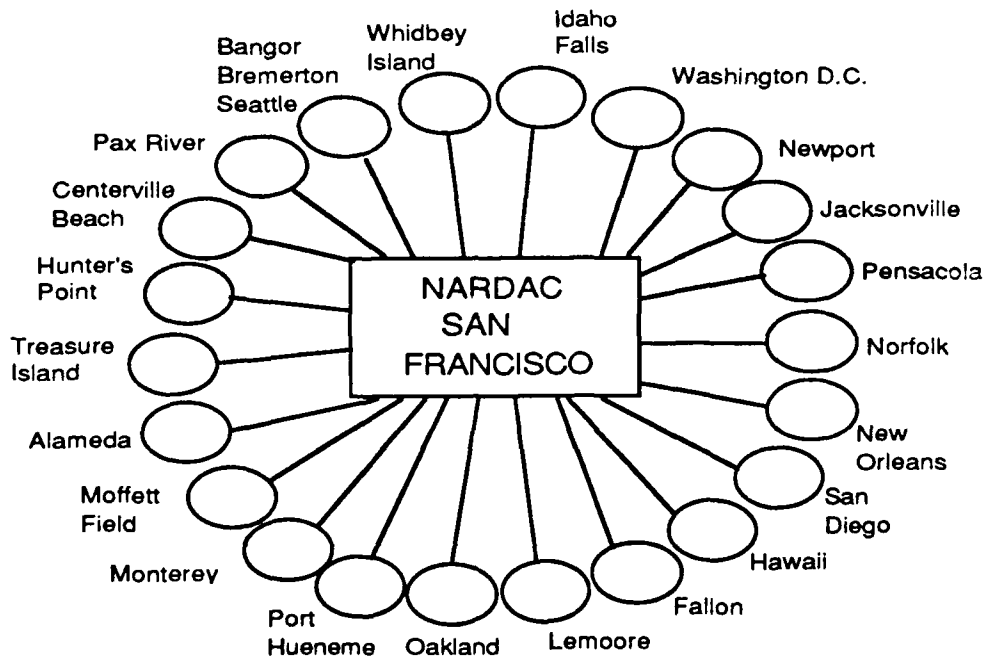

2 UNISYS 1100 Computers 2 UNISYS DCP-40 Front End Processors
150 Circuits 959 Devices

F. PASS / SDS NETWORK

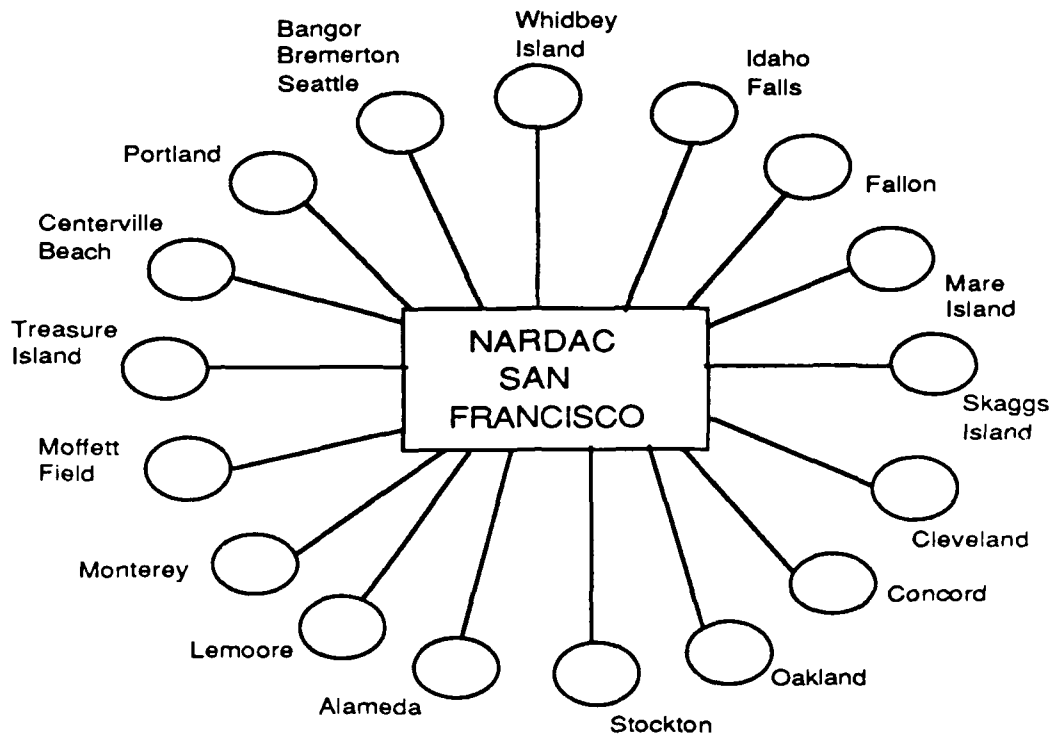

2 HEWLETT PACKARD 3000 Computers 40 Circuits 225 Devices

REFERENCES

1. Stallings, William, *Data and Computer Communications*, Second Edition, Macmillan Publishing Company, 1988.
2. Tuttle, J. O., VADM, USN, *Memorandum for the Vice Chief of Naval Operations (OP-09)*, Ser 094/94535865, 7 August 1989.
3. Jones, Carl R., (Extracts) *Flag Officers Space, Command, Control and Communications Update*, 13 December 1989, VADM J. O. Tuttle's First Newsletter to Flag Officers.
4. Stone, T. E., Commander, Naval Telecommunications Command, *The Merging of Data and Telecommunications*, Ser 00/099, 2 October 1989.
5. Daft, Richard L., *Organization Theory and Design*, Second Edition, West Publishing Company, 1986.
6. Thompson, James, *Organizations in Action*, New York, McGraw-Hill, 1967.
7. Nadler, David, and Tushman, Michael, *Strategic Organizational Design--Concepts, Tools, & Processes*, Scott, Foresman and Company, Copyright 1988.
8. Yin, Robert K., *Case Study Research--Design and Methods*, *Applied Social Research Methods Series*, Volume 5, SAGE Publications, Inc., 1984.
9. Harrison, Michael I., *Diagnosing Organizations--Methods, Models, and Processes*, *Applied Social Research Methods Series*, Volume 8, SAGE Publications, Inc., 1987.
10. NAVTELCOM INSTRUCTION 5450.32D, Naval Communication Station Stockton; mission and function of, 14 April 1983.
11. Babb, Robin M., *The Naval Telecommunications System: A Command and Staff Manual*, M. S. Thesis, Naval Post Graduate School, Monterey, Ca, March 1987.

12. Stoner, James A. F., and Wankel, Charles, *Management*, Third Edition, Prentice-Hall, Inc., 1986.
13. Naval Communication Station, Stockton, *Command Brief*, undated.
14. Laudon, Kenneth C., and Laudon, Jane Price, *Management Information Systems: A Contemporary Perspective*, Macmillan Publishing Company, 1988.
15. Personal Interviews of NAVCOMMSTA Stockton Personnel, Interviewees coded A through P, 24 October 1989 to 4 January 1990 (inclusive dates).
16. Navy Regional Data Automation Center, San Francisco, *Organizational Manual*, 1981.
17. NARDAC ADVISORY BULLETIN No. 28, 23 April 1982.
18. Leigh, William E., and Burgess, Clifford, *Disributed Intelligence: Trade-offs and Decisions for Computer Information Systems*, South-Western Publishing Co., 1987.
19. *A Client Guide to NAVDAC Regional Data Automation Services*. General Overview, undated.
20. NAVDAC Instruction 5230.1B, September 1983.
21. Personal Interviews of NARDAC San Francisco Personnel, Interviewees coded A through N, 24 October 1989 to 4 January 1990 (inclusive dates).
22. Technical Director, NARDAC San Francisco, E--mail correspondence with Technical Director NARDAC Norfolk, *Subj: NAVDAC IRM Support Plan for U. S. Navy*, Thompson, M. A., undated.
23. Tushman, Michael L., and Moore, William L., *Readings in the Management of Innovation*, Ballinger Publishing Company, 1982.
24. Consultation with Advisors, 26 September 1989 to 20 March 1990.

25. Dimas, Treci, and others, *A Proposed Strategy for Merging Navy Computer and Telecommunications Systems*, CM4925 Paper, 6 March 1989.
26. Harrington, J., and Rice, T., *Integrated Services Digital Network (ISDN)*, IS3502 Paper/Presentation, 5 December 1989.
27. OPNAV INSTRUCTION 2800.3, *Navy Data Communications Program*, 6 October 1988.

INITIAL DISTRIBUTION LIST

	No. Copies
1. Defense Technical Information Center Cameron Station Alexandria, Virginia 22304-6145	2
2. Library, Code 0142 Naval Postgraduate School Monterey, California 93943-5100	2
3. Department Chairman Administrative Sciences Department Naval Postgraduate School Monterey, California 93943-5000	1
4. Professor Carl R. Jones, Code CC/ Naval Postgraduate School Monterey, California 93943-5000	1
5. Professor Nancy C. Roberts, Code AS/Rc Naval Postgraduate School Monterey, California 93943-5000	1
6. CDR Allan W. Tulloch Naval Postgraduate School Monterey, California 93943-5000	1
7. LCDR Robert L. Knight Naval Postgraduate School Monterey, California 93943-5000	1
8. Commanding Officer Naval Communication Station Stockton Stockton, California 95203-5000	2

- | | | |
|-----|---|---|
| 9. | Commanding Officer
NARDAC San Francisco
NAS Alameda, California 94501-5007 | 2 |
| 10. | Commanding Officer
Naval Communication Station
Box 30
Jacksonville, Florida 32212-0030 | 1 |
| 11. | Commanding Officer
NARDAC
Jacksonville, Florida 32212-0030 | 1 |
| 12. | Commanding Officer
NAVCAMS EASTPAC
Wahiawa, Hawaii 96786-3050 | 1 |
| 13. | Capt (Ret) M. C. Roth
5289 Camino Alta Mira
Castro Valley, California 94546 | 1 |
| 14. | Commander, Naval Telecommunications Command
Naval Telecommunications Command Headquarters
4401 Massachusetts Avenue, N. W.
Washington, D. C. 20390 | 3 |
| 15. | Commanding Officer
Naval Communication Unit Washington
LT Nancy R. Dillard Code 30
Washington, D. C. 20390 | 1 |
| 16. | Commanding Officer
NAVCAMS EASTPAC
LT Patricia A. Gutierrez Code W30
Wahiawa, Hawaii 96786-3050 | 2 |
| 17. | Shin, In-Sub
Kayagok-Myun, Sannori #518
Nonsan-Gun, Chung-Nam
320-840 Republic of Korea (South) | 1 |

- 18. Pueblo Library District 1
C/O R. G. Pacheco
100 W. Abriendo
Pueblo, Colorado 81003

- 19. Professor Dan C. Boger, Code AS/Bo 1
Naval Postgraduate School
Monterey, California 93943-5000