

West Virginia University Libraries



3 0802 102296254 7

DENTAL AND ORAL RADIOGRAPHY

—
McCOY



The Library
Dental School
West Virginia University

A GIFT FROM

Dr. Claude H. Layman

Fairmont, West Virginia

DATE 1957

DO NOT CIRCULATE

3 1900

OCT 3 1900





Digitized by the Internet Archive
in 2012 with funding from
LYRASIS Members and Sloan Foundation

<http://archive.org/details/dentaloral00mcco>

DENTAL AND ORAL RADIOGRAPHY

DENTAL AND ORAL RADIOGRAPHY

A TEXT BOOK FOR STUDENTS AND
PRACTITIONERS OF DENTISTRY

BY

JAMES DAVID McCOY, D.D.S.

PROFESSOR OF ORTHODONTIA AND RADIOGRAPHY, COLLEGE OF
DENTISTRY, UNIVERSITY OF SOUTHERN CALIFORNIA,
LOS ANGELES, CALIFORNIA.

SEVENTY-ONE ILLUSTRATIONS

ST. LOUIS
C. V. MOSBY COMPANY

1916

LIBRARY
ENTAL SCHOOL
W.V.U.

add ER

RK

309

. m 33

1916

COPYRIGHT, 1916, BY THE C. V. MOSBY COMPANY

Press of
The C. V. Mosby Company
St. Louis

PREFACE

This book has been written primarily as a text book for students of dentistry. It is essentially a book for beginners, and as the majority of the dental profession are at present to be regarded as beginners in this comparatively new branch of dentistry, the author entertains the hope that it will prove of interest to practicing dentists who appreciate the value of the x-ray, and are desirous of adding radiography to their accomplishments.

A few years ago the x-ray was considered in the light of a cultural asset to dentistry, but today the far-seeing members of our profession have awakened to the fact that it is a real necessity.

The x-ray will give the maximum amount of service in dental practice only to such of our profession who master the technic of radiography, and in addition are possessed of an accurate knowledge of the anatomy and pathology of the dental and oral structures.

The author is indebted to the pioneers in dental radiography who have so generously contributed to its literature. Of these, much of value has been derived from the writings of such men as A. H. Ketcham, Weston Price, Sidney Lange, Howard R. Raper, F. L. R. Satterlee and Edw. H. Skinner.

During the preparation of this work, the author has been aided by various manufacturers of x-ray equipment

PREFACE

who have generously furnished cuts whenever requested. Grateful acknowledgment is also made to Dr. J. R. McCoy and to Laura Spruill who have made the drawings used as illustrations, and last and by no means least, to the publishers who have through their forbearance and many courtesies, lessened the burdens of the writer.

JAMES D. MCCOY.

Los Angeles, Calif.

CONTENTS

	PAGE
CHAPTER I	
THE NATURE OF THE X-RAY AND ITS DISCOVERY	17
CHAPTER II	
HIGH TENSION ELECTRIC CURRENTS—MAGNETISM—ELECTRO- MAGNETIC INDUCTION	29
CHAPTER III	
X-RAY MACHINES. RHUMKORFF OR INDUCTION COIL—TESLA OR HIGH FREQUENCY COIL—INTERRUPTERLESS TRANS- FORMER	43
CHAPTER IV	
REQUISITES OF THE DENTAL X-RAY LABORATORY	64
CHAPTER V	
TECHNIC OF DENTAL AND ORAL RADIOGRAPHY	79
CHAPTER VI	
TECHNIC OF DENTAL AND ORAL RADIOGRAPHY (CONTINUED)	109
CHAPTER VII	
DEVELOPMENT OF PLATES AND FILMS	122
CHAPTER VIII	
THE INTERPRETATION OF DENTAL AND ORAL RADIOGRAPHS .	127
CHAPTER IX	
DANGERS OF THE X-RAY AND METHODS OF PROTECTION . .	145

ILLUSTRATIONS

FIG.	PAGE
1. William Conrad Röntgen	20
2. Michael Faraday	22
3. Sir William Crookes	24
4. Henrich Hertz	26
5. The action of iron filings in forming definite curved lines about an ordinary bar magnet	34
6. Diagrammatic illustration of the magnetic lines of force	35
7. Diagrammatic illustration of the magnetic field surround- ing a coil of wire through which an electric current is passing	36
8. An iron bar placed within the windings of a solenoid is subject to its magnetic field and becomes a magnet	37
9. Magnet with diagrammatic illustration of magnetic lines of force surrounding it	39
10. Battery from which an electric current is passing through the solenoid	40
11. Diagrammatic illustration of the essential parts of an induction coil	44
12. Diagram of the electrolytic interrupter	47
13. Diagram of the induction coil	48
14. Induction coil adapted for use in the dental x-ray lab- oratory	51
15. Same as Fig. 14	52
16. Same as Fig. 14	53
17. Diagram of the high frequency coil	55
18. Small type high frequency coil	56
19. Medium-sized high frequency coil	56
20. Large type high frequency coil	57
21. Working principles of the interrupterless transformer .	59
22. Interrupterless transformer adapted for use in the dental x-ray laboratory	60
23. Same as Fig. 22	61
24. Same as Fig. 22	62
25. Diagram of an x-ray tube	65

FIG.	PAGE
26. The coil or transformer tube	67
27. The high frequency tube	68
28. Connecting tube to x-ray machine	69
29. The tube stand	71
30. Illustration of how the tube may be placed at any desired angle	74
31. Illustrating the reasons for using the tube shield, compression diaphragm, and compression cylinder	75
32. Lead glass tube shield	76
33. A convenient manner of arranging the necessary apparatus when not in use	77
34. The patient holding the film in position against the upper teeth	85
35. Correct and incorrect technic	87
36. Technic for the upper molar teeth	89
37. The patient holding the film in position against the lower teeth	90
38. Procedure for making complete radiographic examination of dental arches	92
39. Arrangement of dental chair allowing patient's head to rest easily and firmly upon it	94
40. The arrangement of the apparatus preparatory to seating the patient	96
41. The patient seated and the apparatus arranged for making a radiograph of the left side	97
42. Technic for left side	99
43. Technic for right side	100
44. The result of correct technic	101
45. Incorrect technic	102
46. The result of incorrect technic	103
47. Technic for radiographing areas in the upper and lower jaws extending from the median line to the first premolar	104
48. Technic for radiographing structures at the median line including the incisors, both above and below	105
49. Supporting the patient's head by a bandage of gauze to insure perfect immobility	106
50. Connecting the tube to the x-ray machine	111
51. Diagram of an x-ray tube	115
52. Radiograph showing an impacted upper third molar	130

ILLUSTRATIONS

FIG.	PAGE
53. Radiograph showing a cuspid tooth lying against the anterior wall of the antrum	131
54. Radiograph showing a supernumerary second bicuspid	132
55. A radiograph to determine the state of dentition of the right side in the mouth of a child eleven years old	133
56. A radiograph in which the successors to the deciduous teeth, as well as the developing second and third molars, are shown	134
57. A radiograph in which a very large alveolar abscess is visible below the mesial root of a lower molar . .	135
58. Radiograph showing an alveolar abscess involving the roots of an upper central incisor and lateral incisor	135
59. Radiograph in which an abscess is visible between the central and lateral incisors	136
60. Radiograph showing alveolar abscesses about the roots of the first and second bicuspids	136
61. Radiograph showing alveolar abscesses above two bicuspid teeth	137
62. Radiograph showing large alveolar abscess about the apex of the upper first bicuspid	137
63. Radiograph showing large alveolar abscesses emanating from the upper lateral incisor and extending to the adjacent central incisor and cuspid	138
64. Radiograph showing chronic alveolar abscess cystic in character above an upper lateral incisor	138
65. Radiographs showing an upper bicuspid tooth with alveolar abscess before and after treatment . . .	139
66. Radiograph showing a necrotic area lying below a lower cuspid	140
67. Radiograph showing an area of necrosis about the roots of a lower first molar	141
68. Radiograph showing differentiation of small wires introduced into the tooth and root canal fillings or tooth structures	142
69. Radiograph showing root canal filling material forced beyond the root apex of an upper second bicuspid .	142
70. Radiograph showing an abscess involving the pericemental and alveolar tissues about an upper first bicuspid	143
71. Radiograph showing an osteo-sarcoma of the mandible	143

DENTAL AND ORAL RADIOGRAPHY

CHAPTER I.

THE NATURE OF THE X-RAY AND ITS DISCOVERY.

In order to gain an intelligent conception of the x-ray it is quite necessary that the student start with a consideration of certain phases of electro-physics, and radiant energy, or in fact the very foundation of matter itself.

According to the most plausible theories and beliefs, all matter is suspended or contained in the medium known as ether, which is an elastic medium filling all space, interatomic and interelectronic, as well as all other space of which we have any knowledge.

Furthermore, many facts brought out by the close study of chemistry and physics seem to justify the belief that all substances of matter are composed of minute particles called molecules, and that each molecule is made up of two or more elements called atoms, while these atoms are also further divided in particles known as electrons.

These electrons or units of matter are never

still, but are in a constant state of motion or vibration, each substance having its own specific atom and the electrons of such atoms having their own rate of vibration.

The vibration of these electrons produce disturbances in the ether known as "ether waves" which vary in length according to the rate at which electrons are vibrating. If the rate of vibration of the electrons be changed or disturbed there is a change in the ether waves, resulting in a corresponding change in the phenomenon produced.

If this theory of matter is correct, as the evidence of modern science would lead us to believe, all matter then is made up of the same constituents, and its various forms are determined not by any essential difference of composition, but by the number, arrangement and amount of motion of the ultimate particles making up the atom.

All this has a practical significance to us in understanding the phenomenon which we call the x-ray. As stated before, it is known that a certain rate of vibration of electrons will produce other waves resulting in a definite phenomenon, while a change in this rate will produce an entirely different phenomenon. For instance, a slow rate of vibration (75,000,000 per second) produces what are known as electro-magnetic waves. A little higher up the scale where the electrons are made to vibrate faster, heat waves appear. Another increase and light waves appear. If we

continue to accelerate the rate of vibrations of the electrons, there will be produced successively ultra-violet or Finsen rays; then cathode or radium rays, and finally the x-ray.

It will then be seen that the x-rays are produced as the result of the most rapid rate of vibration of which we have any knowledge. In the laboratory this phenomenon is produced by the sudden stopping of a stream of rapidly moving free electrons in a vacuum tube which has been exhausted to one millionth of an atmosphere.

The x-ray therefore may be defined as that form of radiation which emanates from a highly exhausted tube when an electric current of high tension is passed through the tube. The object of the vacuum tube is to establish a medium in which all source of resistance is removed, so that the electric current may excite the exquisitely rapid vibrations necessary to produce the phenomenon desired, the electric current being the source of excitation.

The radiation thus produced gives neither heat nor light, nor can it be deflected, reflected, or polarized. In fact, it can only be recognized by its effect upon the photographic plate and upon such chemicals as Willemite, Calcium, and Tungstate, which floresce or glow under its influence.

The Discovery of the X-Ray

The x-ray was discovered in 1895 by William Conrad Röntgen, Professor of Physics, at the

Royal University of Würzburg, in Germany. This discovery marking as it did a distinct epoch in the Science of Medicine, was received by the



Fig. 1.

William Conrad Röntgen.

world with incredulity and amazement, for its reported possibilities savored almost of the occult. "A new ray had been discovered by means of

which it was possible to look through opaque substances.”

While it fell to the lot of Prof. Röntgen to make this discovery, there is no doubt but what other experimenters in the field of physics, unconsciously produced this same ray. In fact, its discovery was made possible by the work of other scientists who preceded Röntgen and laid the foundation for its advent.

Of these Michael Faraday was the pioneer. In 1831 he discovered electric magnetic induction, which made possible the induction coil and the other electrical machines utilized to generate currents of great potential. As early as 1838 he conducted a series of experiments to determine the effect of electrical discharges upon rarified gases, and invented the terms “anode” and “cathode” for positive and negative electrodes.

In 1857 Geissler constructed the first vacuum tubes and it was noted at this time that an electrical discharge passed through these tubes would produce a peculiar glow or phosphorescence, the coloring of which depended upon the character of the rarified gas contained in the tube. This phenomenon became known as “florescence.”

A few years later (1860) Prof. Hittoff, a celebrated physicist of Munster, conceived the idea of exhausting the Geissler tube to a higher degree of vacuum and found as a result an increased resistance to the passing of the electrical discharge, and that the color of the rarified gases

under fluorescence, varied with the degree of rarification. He also discovered another fact which was to have an important bearing upon the work

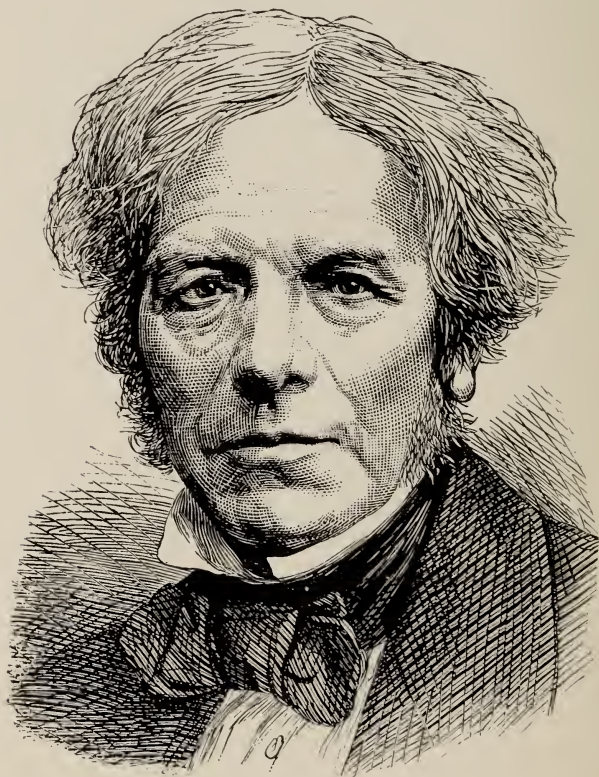

Fig. 2.

Michael Faraday.

of later experimenters, and that was that the luminous discharge in a Geissler tube, *could be deflected by a magnet.*

The important work of these early experimenters was followed later (1878) by Sir William Crookes, who succeeded in constructing a more perfect vacuum tube, that is, one which could be exhausted to a much higher degree of vacuum. With these improved tubes, Crookes discovered that with a sufficiently high vacuum the luminous glow within the tube disappeared, and demonstrated that within it there was a rectilinear radiation from the cathode, which he conceived as being a projection of particles of highly attenuated gas at exceedingly high velocity. To this radiation he gave the name "Cathode Rays," and because of the peculiar behavior of gas in this exceedingly rarified state, he concluded that it was as different from gas in its properties as ordinary air or gas is different from a liquid. He found that the impact of the cathode rays against the wall of the tube would produce within it a greenish "phosphorescence" or "florescence" and an increase in temperature; also that these rays could be intercepted by metallic plates within the tube. By concentrating the rays at the focus of a concave cathode, he was able to produce a brilliant florescence and a very high temperature, both at the walls of the tube and in various substances within it. Without doubt, Sir William Crookes unconsciously produced the x-ray in the course of these experiments.

In 1892 Prof. Heinrich Hertz discovered that cathode rays would penetrate gold leaf and other

thin sheets of metal placed within the tube. Soon after this discovery, Hertz died, and his experiments were continued by his assistant, Lenard, who was able to demonstrate that many of the phenomena of the cathode rays could be observed

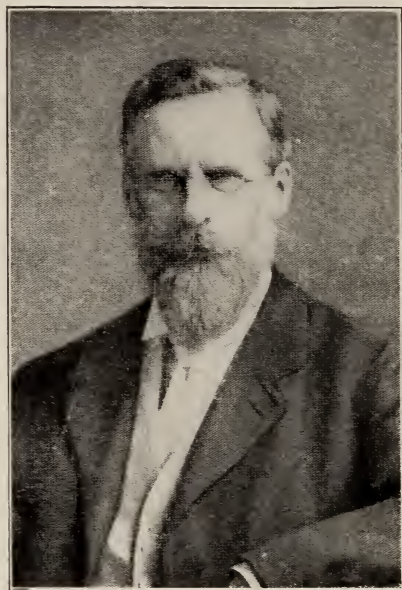

Fig. 3.

Sir William Crookes.

outside of the Crookes tube. By closing a vacuum tube at the end opposite the cathode with a thin sheet of aluminum, he demonstrated that a radiation proceeded through or from the aluminum walls of the tube which would pass through many substances opaque to ordinary light, and after

passing through such substances, it would excite florescence in crystals of barium platino-cyanide, and would effect sensitive photographic plates in much the same manner as ordinary light. Lenard considered that all these phenomena were due to the cathode rays alone although in the light of our present knowledge, there is no doubt that not only in his experiments but in those of Crookes, Hertz, and other investigators, x-rays were produced. However, they were not recognized as such until 1895 when Prof. Röntgen startled the world by the announcement of his discovery.

Upon the memorable day of his discovery, Prof. Röntgen was duplicating one of Lenard's experiments in the laboratory of the Würzberg University. The experiment consisted of passing an electric current through a Crookes tube covered with black cardboard, to test its florescence upon a piece of cardboard coated with barium platino-cyanide. A fresh specimen of this chemical had been prepared and spread upon the cardboard which was placed against the wall on the opposite side of the room to dry. The room was darkened and the current was passing through the tube, when to his amazement, Prof. Röntgen noticed that the chemically covered cardboard on the other side of the room was glowing with a wierd florescence. He approached the cardboard and in doing so passed between it and the Crookes tube, and beheld his shadow upon the cardboard. Pick-

ing up a book, he held it in front of the screen and noticed that it also cast a shadow. He then discovered that the luminous glow or florescence on the cardboard appeared and disappeared with the turning on and off of the current. With the

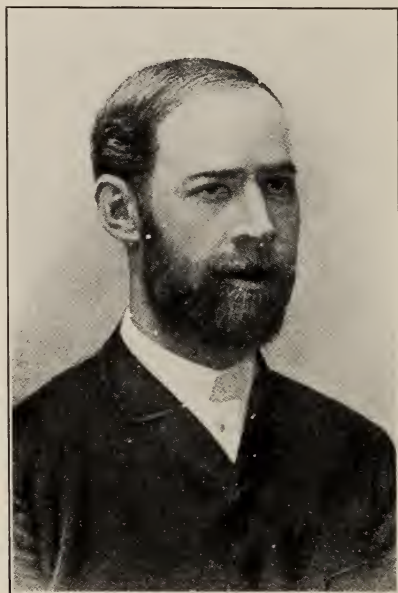

Fig. 4.
Heinrich Hertz.

tube operating, he picked up the cardboard and while examining it, noticed the shadow of his hand on its surface, the bones appearing much darker than the soft parts of the hand. He also found that the florescence was produced in the cardboard regardless of whether the chemically coated

side was turned toward or away from the Crookes tube, showing that the rays had the power to penetrate substances at a distance from the tube.

Further investigation proved that the radiation producing these phenomena emanated from *the point of impact of the cathode rays* against the glass wall of the Crookes tube, that nearly all substances were transparent to it, although in widely different degrees, varying roughly with their density; that the radiation was rectilinear, that it could not be refracted, reflected, or deflected by a magnet. Hence it was plain to Röntgen that these rays were quite different from the cathode rays of Crookes, Hertz or Lenard.

Using photographic plates wrapped in black paper to protect them from ordinary light, he obtained with these new rays shadow pictures of metallic objects in a wooden box, and of the bones of the hand.

He continued his experiments both with the fluorescent screen and the photographic plate, and in December, 1895, communicated his discovery to the Physico-Medical Society of Würzburg. Being unable to determine the exact nature of this new ray other than classing the phenomenon as longitudinal vibrations of ether, Röntgen called it the x-ray, the letter x representing the unknown in the mathematical formula. Even today the exact nature of the rays has not been determined, although the concensus of opinion seems to be that they are violent ether pulses set up by

the sudden stoppage of the cathode rays as they strike upon the walls of the tube or upon any intervening obstruction. If this theory be correct, x-rays are of the same general nature as light waves, but of such short wave length that they lie outside the visible spectrum.

CHAPTER II.

HIGH TENSION ELECTRIC CURRENTS— MAGNETISM—ELECTROMAGNETIC INDUCTION.

High Tension Electric Currents

As stated previously, the x-ray is produced when an electric current of high tension is passed through a vacuum tube. Therefore, let us consider the character of this current and the means employed to produce it.

There are several kinds of electric currents, but of these we need concern ourselves only with two—the direct current, commonly designated by the abbreviation D.C.; and the alternating current, designated as A.C.

The *direct current* is one in which the electricity flows along a conductor *in one direction* at a uniform rate of pressure, while the *alternating current* flows along a conductor first in one direction, then reverses and flows in the opposite direction, these changes taking place with great rapidity (50 to 120 per second). Such a current in making these changes is said to have completed a cycle, and its frequency is designated by the number of alternations which occur each second.

A high tension current is one which has high

voltage or as it is expressed in electrical terms, has great electromotive force, or pressure.

The *Volt* is defined as the unit of electromotive force, and is analogous to the pressure caused by a difference in level of two bodies of water connected by a pipe—the pressure tends to force the water through the pipe and the electromotive force or voltage tends to cause the electric current to flow along a conductor.

The *Ampere* is the unit of current strength, or in other words, the amount of current passing a given point on a conductor in a given time. If we again use the analogy of the two bodies of water at different levels connected by a pipe, it would be the amount of water which could pass through the pipe in a given time.

The *Ohm* is the unit of resistance. Just as the water in flowing through a pipe is resisted somewhat in its passage by the friction offered by the surface of the pipe, or by the limited capacity of the pipe, so likewise the electric current is resisted in varying degrees in its passage along a conductor, the degree of resistance depending upon the degree of conductivity of the material used as the conductor, its length, cross section, etc.

The *Watt* is the unit of electromotive power or the ability of a current to do work. The wattage of a current is determined by the voltage, or pressure, and the amperage or quantity, the wattage of a given current being determined by multiplying the voltage by the amperage.

From the foregoing then we see that the character of an electric current is determined by several factors all of which must be taken into consideration.

If we wish to know the strength of a given current, we have but to remember this strength will depend upon the pressure or electromotive force, and the resistance offered by the conductor through which the current is passing, just as the strength of a stream of water flowing from a tank would depend upon the pressure and the size of the pipe carrying the water. In other words, the strength of the electric current equals the pressure divided by the resistance. Reducing this to an equation we have—

$$\text{Amperes equals } \frac{\text{volts}}{\text{ohms}} \text{ or } C \text{ equals } \frac{\text{E.M.F.}}{R}$$

This is known as “Ohms Law” and is one of the fundamental laws upon which electrical science is based. This important law has two other forms which make it possible to learn the relationship and amount of any of these three units, providing two are known. For instance, by transposing the formula of Ohms law, we have—

Volts equals Amperes X Ohms, or E.M.F. equals CXR.

If we wish to determine the resistance offered by a given conductor, we apply the formula as follows:

$$\text{Resistance equals } \frac{\text{E.M.F.}}{\text{Amperage}} \text{ or } R \text{ equals } \frac{\text{E.M.F.}}{C}$$

As stated before, the current which is passed through the vacuum tube to generate the x-rays must be a current of high tension, or great pressure, or expressed in the terms of the units just described, it must have very high voltage. The ordinary lighting current of 110 volts is inadequate, as this current is of far too low potential to pass through the tube, as the vacuum offers great resistance, a resistance which to the ordinary current amounts to an absolute nonconductor. We are obliged, therefore, to make use of some means which will produce a current of great voltage, a current we will say of at least 75,000 to 150,000 volts.

To do this, we must make use of one of the electrical machines which can generate such a current by utilizing the principle of *electromagnetic induction*. Lest the student become confused, we will first review very briefly some of the elementary principles of electromagnetism and its relation to the production of the high tension current necessary in x-ray production.

Magnetism

Magnetism is the term applied to substances which have the property of attracting small pieces of iron. A material possessing this property was first found by the ancients at Magnesia, in Asia Minor, from which fact arose the name magnet.

The *natural magnet* is an oxide of iron and is also called the lodestone. *Artificial magnets* can

be made by rubbing a bar of hard steel with a lodestone, or with another artificial magnet, or by means of an electric current. Artificial magnets acquire the same magnetic properties which the lodestone or natural magnet possesses except that they acquire them to a much greater extent, and are therefore always used in preference to natural magnets.

In addition to the property of attracting small pieces of iron, magnets have other characteristics worthy of mention such as *polarity*, or the property of assuming, when suspended and perfectly free to move, a north and south position. The compass is quoted as a familiar example.

At the ends of a magnet, or in other words at its *poles*, the greatest power of attraction exists. This is easily illustrated by placing one end of an ordinary magnet in some iron filings and withdrawing it. The filings will cling to it in great numbers, as they will likewise do to the other end of the same magnet if it too be placed in the filings. The middle of the magnet (or that portion midway between the two poles) however, does not possess this property, but as the ends are approached the attraction increases, until the poles are reached where the attraction reaches the maximum.

In observing the action of the two poles of a magnet in attracting the iron filings, no particular difference is observed. *They both attract the iron filings.* There is a difference, however, which

may be shown by experimenting with two magnets, one of which should be suspended at its center like an ordinary compass, while the other is held in the hand. If the north pole of the magnet held in the hand is moved near the north pole of the suspended magnet *they will repel each other*. Likewise if their south poles are approached *they will repel each other*. But if the

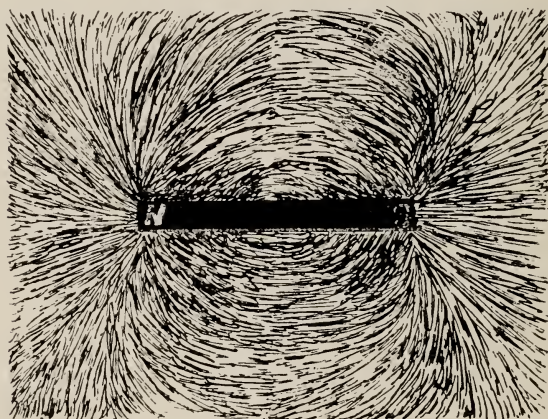

Fig. 5.

The action of iron filings in forming definite curved lines about an ordinary bar magnet indicates that the magnetic field exerts its influence in certain definite directions which are called "the magnetic lines of force."

north pole of one be placed near the south pole of the other they will *attract each other*. This shows that *like poles repel each other, while unlike poles attract each other*.

The space surrounding a magnet which is subject to its influence is known as its *magnetic field*. The presence of this magnetic field is easily dem-

onstrated by placing a magnet under a sheet of paper upon which iron filings have been evenly spread. By tapping the paper lightly, the filings will form into a series of curved lines extending from one pole of the magnet to the other pole, as illustrated in Fig. 5. The formation of these definite curves indicates that the magnetic field exerts its influence in certain definite directions which are called *the lines of magnetic force*.

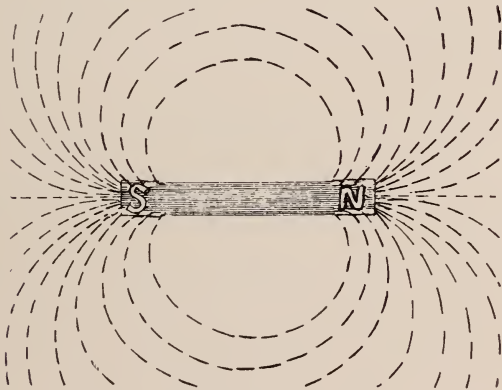

Fig. 6.

Diagrammatic illustration of the magnetic lines of force.

These lines of force start at one pole of the magnet, pass in curved lines around to the opposite pole, where they re-enter and pass on through the magnet again, so that if any line is followed through its entire length, one will eventually come back to the starting point, as shown in Fig. 6.

It is by virtue of its *magnetic field*, that a magnet has the power of attracting pieces of iron.

When a piece of iron is brought under its influence, *it becomes a temporary magnet*, and for the time being has its two poles. If the north pole of a magnet is brought close to a piece of iron, a south pole will be induced in the iron next to this north pole, and a north pole in the portion farthest from it. The attraction is then exactly similar to the attraction between two permanent mag-

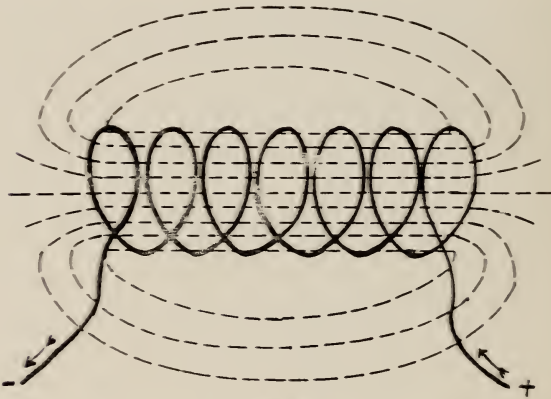

Fig. 7.

Diagrammatic illustration of the magnetic field surrounding a coil of wire through which an electric current is passing.

nets when two unlike *poles* are brought together. This action of a magnet in developing magnetism in iron placed in its magnetic field is called *magnetic induction*.

When a piece of iron is in contact with a magnet the attraction is greatest, but actual contact is unnecessary to magnetize the iron as it need only be placed within the magnetic field, or in

other words, within the magnetic lines of force of the magnet.

Magnetism may be induced in iron in another way not yet described, and to us this is of great importance. If an ordinary electric current is passed through a coil of wire, *the coil becomes equivalent to a magnet and is surrounded by a magnetic field similar to that of a bar magnet.* Such a coil of wire is called a *helix*, and if its

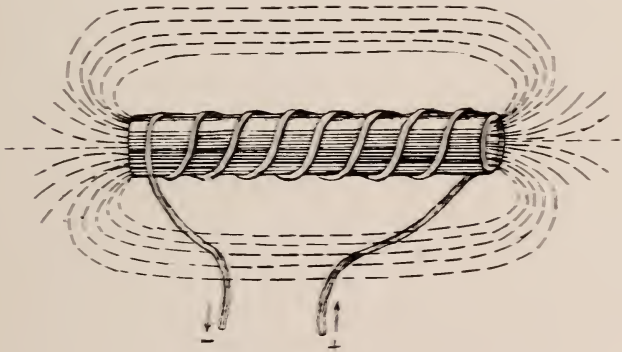

Fig. 8.

An iron bar placed within the windings of a solenoid is subject to its magnetic field and becomes a magnet.

length is many times its diameter, it is called a *solenoid*. Since a *solenoid* is surrounded by a magnetic field similar to that of a magnet (see Fig. 7) it follows that a solenoid is capable of magnetizing pieces of soft iron and attracting them in the same way as does an ordinary steel magnet. The magnetic field of a solenoid is strongest within its windings and therefore if a

bar of soft iron is placed within the coil, the bar will be much more strongly magnetized than if placed in any other position about the coil. Such a coil adapted to carry a current and provided with a soft iron bar or core is called an *electromagnet* (Fig. 8).

In order to permit the wire to be closely wound and at the same time to allow the current to pass through each turn, the wire must be covered with insulation throughout its length. It should also be remembered that the *iron core within the solenoid* remains a magnet *only while the current is passing* through the coil, as "*only electric charges in motion produce magnetic effects.*"

Electromagnets are much more powerful than ordinary magnets, that is, their fields have much greater strength, for *the field of the electromagnet is equal to the sum of the field due to the core, plus the field due to the current passing through the coil.*

Thus far we have discussed the fact that a magnetic substance in the field of an ordinary magnet, or a conductor carrying an electric current, is magnetized. This phenomenon, we know, is due to *magnetic induction*. It is also a fact that an *electric current may be induced in a conductor by causing the latter to move through a magnetic field*. It makes no difference whether this field comes from an ordinary magnet or from an electric charge passing through a conductor. *This action of a magnet or of a current on a conductor*

moved in its field is called electromagnetic induction.

Principles of Electromagnetic Induction

If the ends of a coil of wire are connected with a galvanometer (Fig. 9) and the coil is moved down over an ordinary magnet, the galvanometer

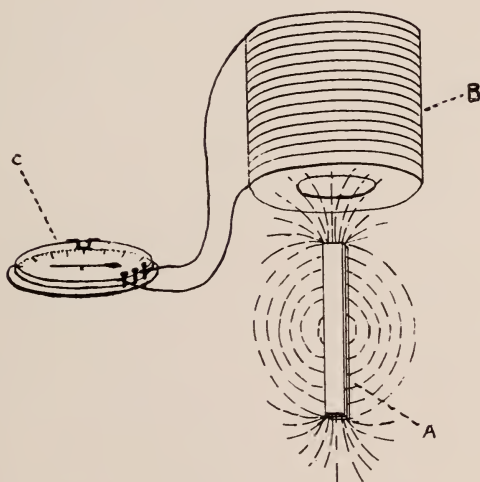

Fig. 9.

A, magnet with diagrammatic illustration of "magnetic lines of force" surrounding it. *B* shows a coil of wire connected to a galvanometer, *C*.

will show that a momentary electric current has passed through the coil. The current continues as long as the coil is in motion and ceases as soon as the coil is brought to rest. If the coil is withdrawn from the magnet, a current is also induced which flows in an opposite direction to

the current which was induced when the coil was carried down over the magnet.

These induced currents are produced by the field surrounding the magnet moving or cutting across the wires composing the coil. If a current is passed through the coil it creates a magnetic field, and on the other hand the movement

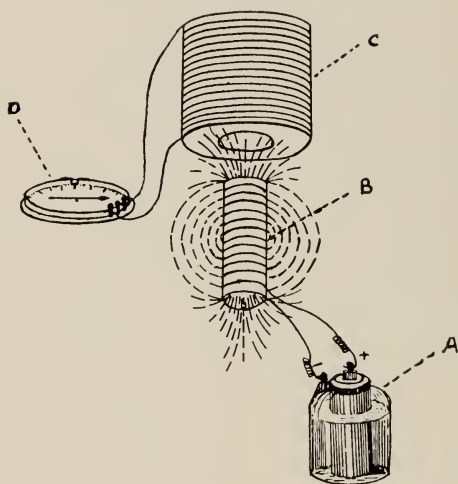

Fig. 10.

A, battery from which an electric current is passing through the solenoid, B; C, large coil into which the smaller coil B is passed; D, galvanometer.

of a magnetic field within the coil produces a current.

As a solenoid is surrounded by a magnetic field similar to an ordinary bar magnet, it follows that if a solenoid carrying a current were thrust within (Fig. 10) another coil, induced currents will be produced in the latter. These induced cur-

rents, as in the case where the magnet is used, only flow while there is a relative movement between the magnetic field and the conductor. When the solenoid is passed into the other coil, the induced current will flow *in an opposite direction to the current flowing in the solenoid*, and upon *withdrawing the solenoid, the induced current will flow in the same direction as the current in the solenoid*.

Suppose the two coils just described are placed one within the other (there being no current passing) and while in this position a current is started in the inner coil. Upon the passage of the current in the inner coil, a momentary current is induced in the outer coil, just the same as if a magnet had been moved within it, as shown in Fig. 9. This induced current remains only while the current in the inner coil is increasing in value from zero to its normal strength. As soon as this normal strength is reached, the induced current ceases to flow. Now if the circuit of the inner coil is broken and its current ceases to flow, at this instant another momentary current is induced in the outer coil, which flows in a direction *opposite* to the current which was induced by starting the current. These two induced currents created by starting and stopping the primary current, or in other words, by "making" and "breaking" the current, are not of equal strength, the one produced by the "break" of the current being much the stronger.

Such an instrument arranged with one coil within the other, but without any connection between the two coils, is known as an "*induction coil.*" The inner coil which is usually supplied with an iron core is known as the "*primary coil*" and the outer coil in which the current is induced is known as the "*secondary coil.*"

Induced currents are greatly intensified when soft iron cores are placed within the primary coils, as the cores become magnets and increase the strength of the field by adding largely to the lines of force therein.

If an induction coil is constructed with the same number of turns of wire in the "*secondary*" as are present in the "*primary,*" the current induced in the secondary will be exactly equal to the current passed through the primary. *The voltage will not be increased.* On the other hand, if the secondary contains twice as many turns as the primary, the induced current will be double the voltage of the primary, *as each turn of the secondary induces a current in the turns directly adjacent to it,* which must be added to the current induced in the first layer by the action of the primary current. Therefore, it should be apparent that as we increase the number of turns in the secondary, we increase the E.M.F. or voltage. This increase of E.M.F. or voltage is due to the phenomena of "*self-induction*" which is the principle utilized in all x-ray machines or other electrical apparatus used to "*step up*" the E.M.F. or voltage.

CHAPTER III.

X-RAY MACHINES.

RHUMKORFF OR INDUCTION COIL—TESLA OR HIGH FREQUENCY COIL—INTERRUPTERLESS TRANSFORMER.

The Rhumkorff or Induction Coil

The Rhumkorff or "induction coil" which is the most common type of x-ray machine in use today, consists of two principal parts, each of which is a coil of wire, one being contained within the other, although they have no electrical connection (see Fig. 11).

The inner coil or "primary" as it is called, consists of a few turns of very coarse insulated wire wrapped about a bundle of soft iron which is known as "the magnetic core."

The outer coil or "secondary" is made up of a great many turns of fine insulated wire. It has been estimated that in a 12-inch induction coil the secondary coil is wound with between twenty and thirty miles of wire. This, of course, makes possible an enormous number of "turns of wire" so that when we consider that each turn of the secondary induces a current in the turn directly adjacent to it, which must be added to the current

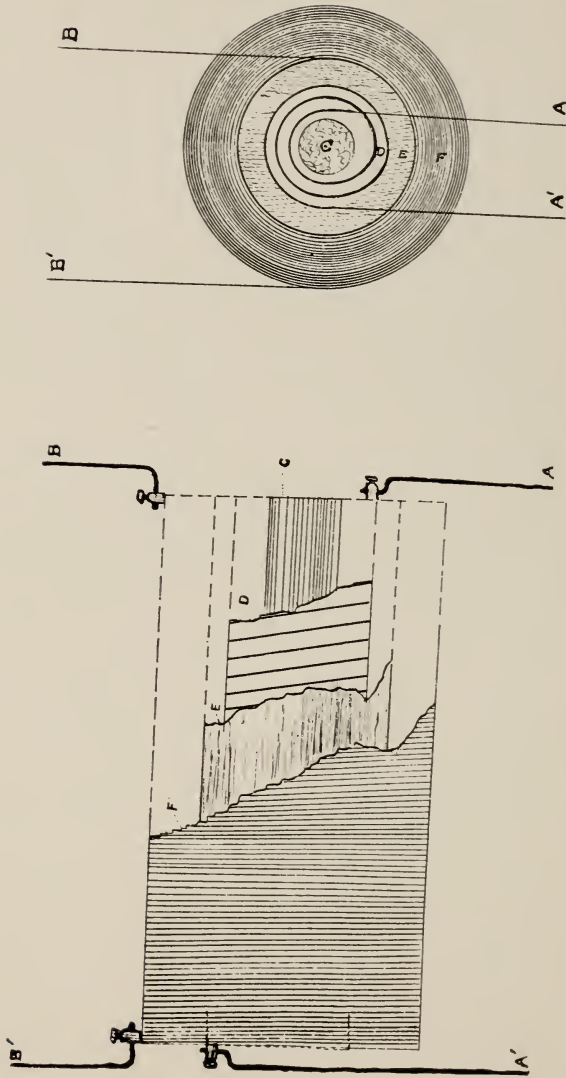

Fig. 11.

Diagrammatic illustration of the essential parts of an induction coil. *A'* and *A* are the terminals of the "primary" coil, *D* represents the windings of the "primary" about the magnetic core *C*. The insulating medium between the "secondary" windings of the "secondary" coil are designated by *F*, and the

induced in the first layer by the action of the primary current, the sum totum of the current coming from the secondary amounts to something tremendous.

To compute the E.M.F. of the induced current (or that coming from the secondary) we have but to remember that "the E.M.F. of the induced current is to that of the primary current, as the number of turns in the secondary coil is to the number of turns in the primary." For instance, suppose we have an induction coil with 10 turns of wire in the primary, and 100 turns of wire in the secondary. If we pass a current of 110 volts through the "primary," the voltage of the "secondary" current will be—

$$\frac{110}{10} \times 100 = 1100 \text{ volts.}$$

Notwithstanding the great change in voltage the wattage of the secondary current is the same as it was in the primary, (except for a small loss due to internal resistance). This is not true, however, of the amperage. For example, if the primary current of 110 volts carries 5 amperes, its wattage would be 550. The wattage of the secondary current would also be 550, and since wattage equals amperes multiplied by volts, the amperage of the secondary current would be—

$$\frac{550}{1100} = \frac{1}{2} \text{ Ampere.}$$

Thus it will be seen that as the voltage or

E.M.F. is increased in the before described manner, the amperage or current strength is decreased in equal ratio. It should be plain, therefore, that the original current running to the primary is not changed in actual value, but is simply transformed to a state or condition where it will do the special work required of it.

In our consideration thus far we have considered the manner in which an electric current may be transformed from a low to the high voltage necessary to energize an x-ray tube. We have not, however, named one important requisite of a current to be used for this purpose, namely that the current must flow *continuously and in the same direction*.

In considering the manner of obtaining a current in the secondary, we learned that such a current is produced by "making" and "breaking" the primary current. If a continuous current is to be kept flowing, we must utilize some instrument which will rapidly "make" and "break" the current in the primary circuit. Such an instrument is known as an "interrupter" and is essential to any induction coil.

There are two classes of these instruments, both of which utilize some automatic principle, and are known as "mechanical" and "electrolytic."

Mechanical interrupters, a simple illustration of which is the ordinary vibrator used on small coils, electric bells, etc., will rapidly make or break

the primary current and thereby induce a fairly constant current in the secondary; but this form of interrupter has not been found to be as satisfactory for x-ray work as the electrolytic type.

Of the various forms of *electrolytic interrupters*, the Wehnelt type is the one most universally

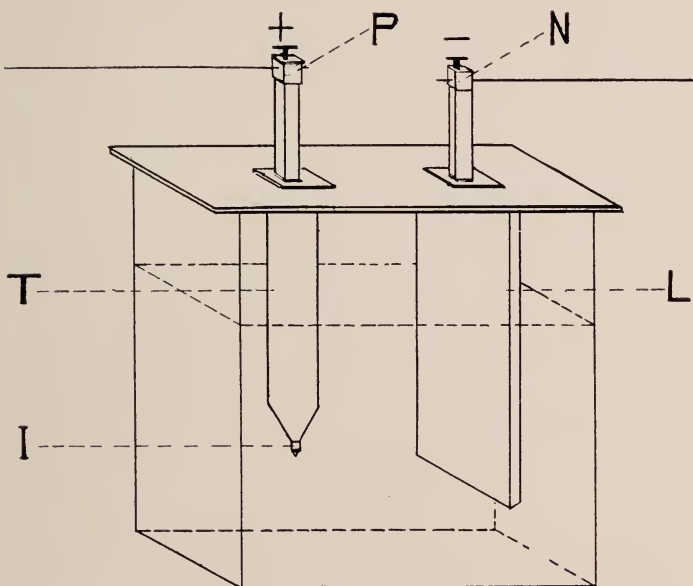

Fig. 12.

Diagram of the electrolytic interrupter. *P*, terminal of the positive electrode; *N*, terminal of the negative electrode; *T*, porcelain sheath or tube covering the positive electrode; *I*, platinum point of the positive electrode; *L*, negative electrode constructed of lead.

used. It consists of a large battery jar which is nearly filled with a solution composed of sulphuric acid one part and water six parts. Into this solution are introduced two electrodes. The

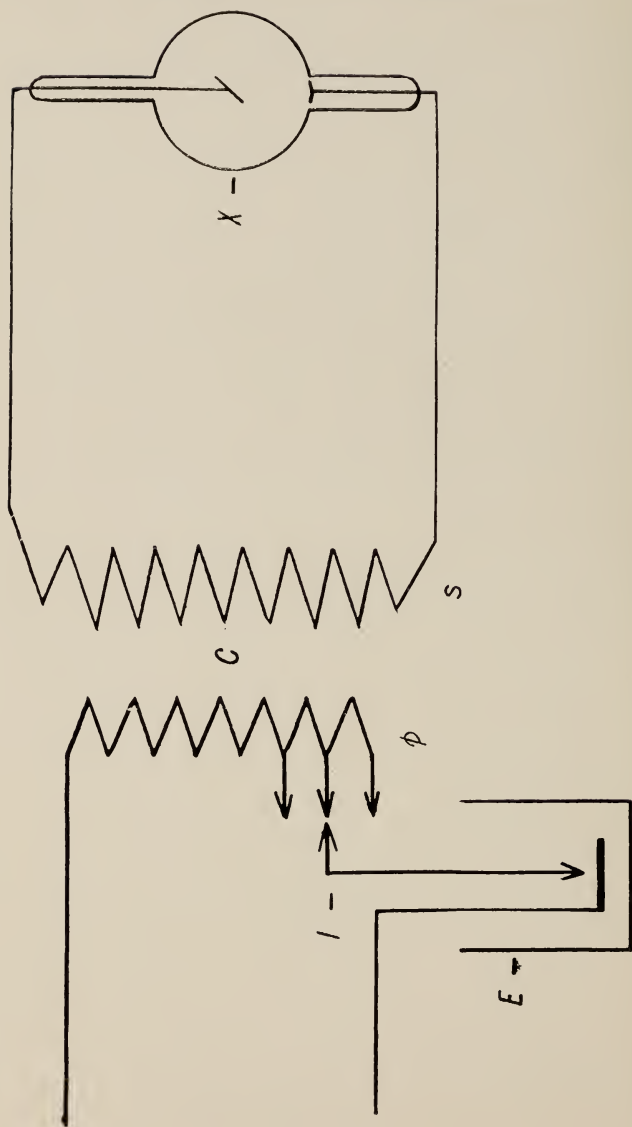

Fig. 13.

Diagram of the induction coil. C , induction coil; P , "the primary;" S , "the secondary;" E , electrolytic in-
 terruiter in circuit with the primary coil; I , rheostat and inductance control; X , x-ray tube connected to the ter-
 minals of the secondary coil.

negative electrode is constructed of lead and has a large surface exposed, while the positive electrode is contained within a porcelain or hard rubber tube extending down into the solution with only the tip or end of the electrode exposed. The tip of this electrode is usually made of platinum. (See Figs. 12 and 13.)

The electrolytic interrupter is connected in the primary circuit and operates briefly as follows: As the current passes from the platinum point (the positive electrode) through the solution to the negative electrode, by virtue of its chemical action upon the solution bubbles of gas are formed around the exposed platinum point. These bubbles act as a source of insulation and the current ceases to flow—"It is interrupted." At the instant it is interrupted, the bubbles are dispersed, the solution again comes in contact with the electrode, and the current is reestablished only to be broken again and so on, these changes taking place with tremendous frequency. With such an instrument the primary current may be interrupted from 60 to 30,000 times per minute. These interrupters are sometimes constructed with several platinum points which makes possible a greater amperage in the current without decreasing the rate of interruptions. For dental radiography, however, a single point interrupter will usually suffice, and at most, not more than a two point interrupter need be used.

The interrupter, then, serves the purpose of

creating the magnetic impulses which keep a constant current flowing from the secondary. We should bear in mind, however, that the current produced by the "make" and "break" are not currents of equal strength, the current produced at the "break" having much the highest value. The fact that this current is the strongest, and that the magnetic impulses come from the same direction (as the induction coil is used on the direct current) it prevails over the weaker. Therefore the induced or secondary current which we use to energize the x-ray tube is the current which is created at the instant of the break.

The other wave, or that created by the "make," is current in the wrong direction, and is called "inverse current." In some induction coils this inverse current is the source of much trouble and where it is present to any appreciable extent, will result in blurred radiographs. It can be controlled, however, by the use of "valve tubes," or a "spark gap," arranged in series with the x-ray tube, the valve tube or spark gap serving the function of cutting out the weaker or inverse current, without interfering to any appreciable extent with the stronger current which is delivered to the terminals of the x-ray tube.

The induction coil is used on the direct current of 110 or 220 volts. Where only the alternating current is available, some means must be used to change the current from alternating to direct before it enters the primary circuit of the coil.



Fig. 14.

Induction coil adapted for use in the dental x-ray laboratory.

This change in the current can be accomplished by the use of "a rotary converter" of which several makes are available, or by a "chemical recti-

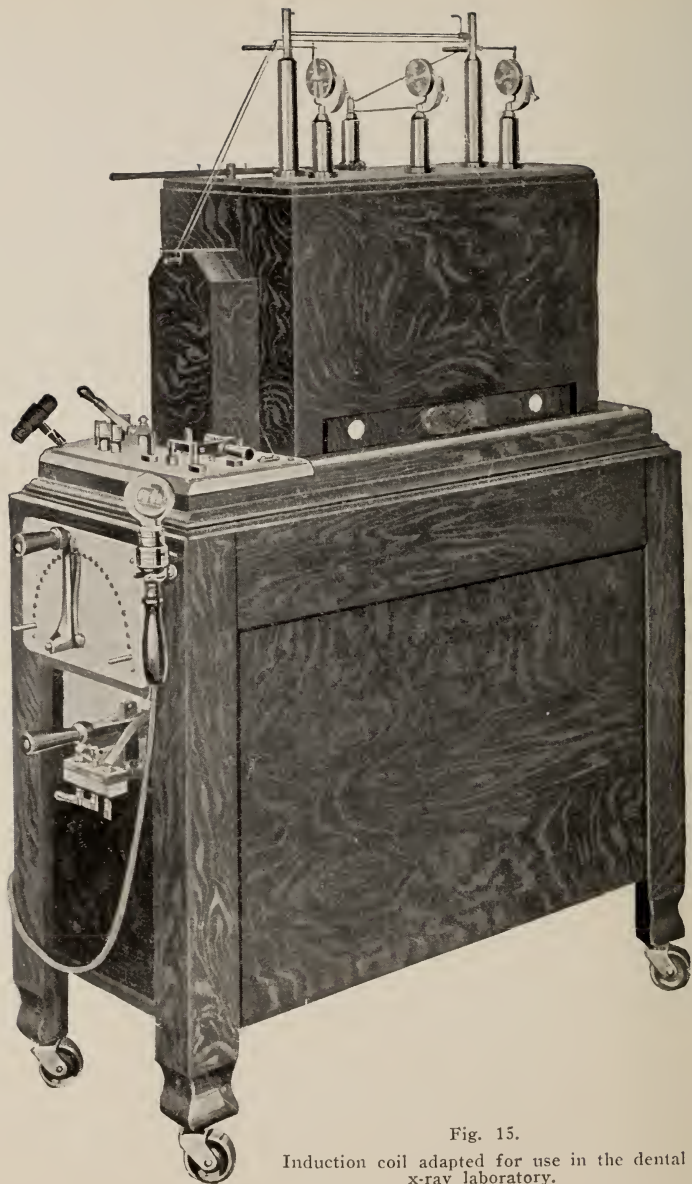

Fig. 15.
Induction coil adapted for use in the dental
x-ray laboratory.



Fig. 16.
Induction coil adapted for use in the dental x-ray
laboratory.

fier." These rectifiers generally consist of two electrodes immersed in a solution of the phosphate salts of potassium, sodium, or ammonium, one electrode being made of aluminum, and the other of lead, iron or carbon. When working properly, the current will flow to the aluminum through the solution, but not away from it, thus cutting out one wave of the alternating current, or it is possible, by properly connecting up three or four jars containing the electrodes, to utilize both waves of the current.

Induction coils are usually rated as to power by the maximum width of the secondary spark gap. That is, the amount of distance the spark will jump between the secondary terminals. For example, a 12-inch induction coil is capable of producing a spark which will jump twelve inches of atmosphere. While these coils are made in various sizes, capable of producing a spark from six inches to forty inches in length, there is no particular advantage in using more than a 12-inch coil for dental radiography. (See Figs. 14, 15 and 16.)

Tesla or High Frequency Coil

The Tesla or high frequency coil differs considerably in construction from the induction coil, although many of its principles are the same (Fig. 17). In a way it is a double induction coil with the secondary of one coil acting as the primary of the other coil. An alternating current is util-

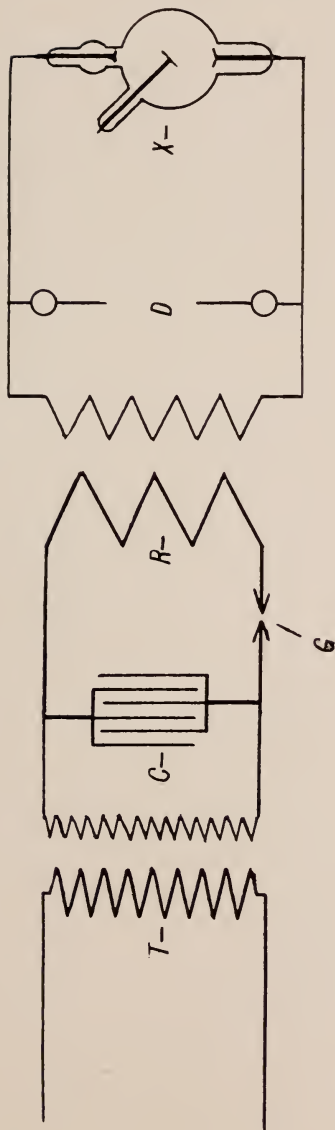

Fig. 17.

Diagram of the high frequency coil. *T*, alternating current transformer; *C*, condenser; *G*, spark gap; *R*, oscillation transformer; *D*, high tension discharge gap; *X*, high frequency x-ray tube.

ized in the primary of the first coil and by means of the secondary of this same coil is stepped up to a high voltage. This stepped up current is

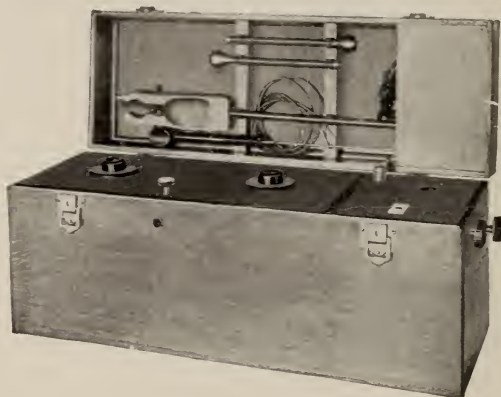

Fig. 18.

Small type high frequency coil.



Fig. 19.

Medium-sized high frequency coil.

then carried to a condenser. As the current leaves the condenser it is oscillating at a great rate of frequency and passes into the primary of



Fig. 20.
Large type high frequency coil.

the Tesla or second coil where it induces a current in the secondary of this coil. From the terminals of the last secondary, it is carried to the x-ray tube. The principles involved in this type of apparatus are shown in Fig. 17.

Like the current of the induction coil, the current from the Tesla coil is high in voltage and low in amperage, but unlike the current from the induction coil it is not uni-directional, but is alternating in character. For this reason, it is considered by some as being less desirable for radiographic purposes. However this apparently objectionable feature is overcome by using an x-ray tube constructed in such a way as to cut out one wave of the current and thereby produce practically the same result as where an uni-directional current is used.

These coils have the advantage of being less cumbersome, require less space and are less expensive than the other form of apparatus, but they cannot be depended upon to do the character of work which the powerful "induction coil" or "interrupterless transformer" will do. Notwithstanding this fact, this type of apparatus undoubtedly has a place in the x-ray laboratory of the dentist, and if constructed along proper lines, can render splendid service. Three sizes of these coils are shown in Figs. 18, 19 and 20.

Interrupterless Transformer

The interrupterless transformer is the newest and by all means the most powerful x-ray machine

made. Aside from controlling and measuring apparatus, it consists of three principal parts, a rotary converter, if direct current is the source of supply, or a synchronous motor if the alternating current is the source of supply, a step-up transformer, and a rectifying switch.

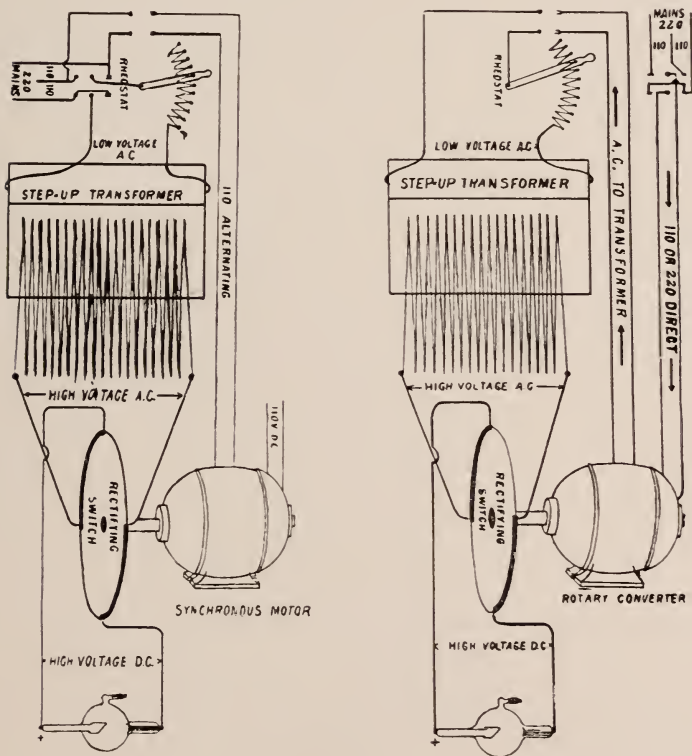

Fig. 21.

The working principles of the interrupterless transformer are here shown. The synchronous motor used to operate the rectifying switch of the alternating current machine may also be used as a rotary converter where the direct current is desired for other purposes in the laboratory.

Two types of these machines are made, viz.: a direct current machine and an altering current

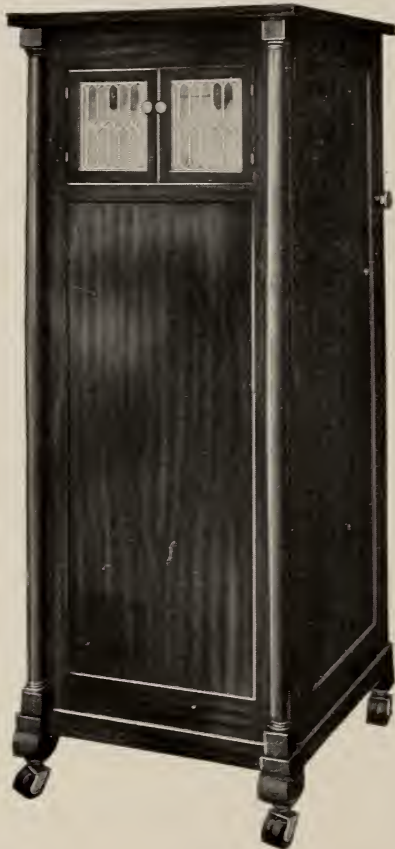

Fig. 22.

Interrupterless transformer adapted for use in the dental x-ray laboratory.

machine, the underlying principles of which are shown in Fig. 21.

When used on the direct current, the rotary



Fig. 23.

Interrupterless transformer adapted for use in the dental x-ray laboratory.



Fig. 24.
Interrupterless transformer adapted for use in the dental x-ray laboratory.

converter is set in motion and generates an alternating current which is sent through the primary of the step-up transformer. This induces a current in the secondary of the proper voltage, but alternating in character. The rectifying switch then changes this current from an alternating to a direct current and as such it is delivered to the terminals of the tube.

The alternating current machine differs only from the direct current machine in that the alternating current is run directly into the primary of the step-up transformer. This induces a current in the secondary of proper voltage but alternating in character. The rectifying switch then changes this high voltage alternating current to a direct current, and as such it is carried to the terminals of the tube.

The interrupterless transformer is, as stated before, the most powerful and efficient type of apparatus available for x-ray work. It is likewise the most expensive,—too expensive in fact to be considered for the x-ray laboratory of the average practitioner of dentistry, in view of the fact that with the induction coil and other less expensive apparatus such excellent results can be obtained.

In Figs. 22, 23 and 24 several interrupterless transformers adapted for use in the dental x-ray laboratory are shown.

CHAPTER IV.

REQUISITES OF THE DENTAL X-RAY LABORATORY.

The requisites of a dental x-ray laboratory are not numerous but consist of—

1st—A so-called x-ray machine.

2nd—An x-ray tube.

3rd—An adjustable “tube stand” for holding the tube, which should include a “tube shield” made of leaded glass, serving as a means of confining the rays and as a source of protection to the operator, and a lead “compression diaphragm” and lead lined “compression cylinder.”

4th—A photographic darkroom.

As x-ray machines have already been discussed, let us now take up the others, in the order in which they have been given.

X-Ray Tube

The x-ray tube is a thin glass bulb six or eight inches in diameter, having two elongations or stems projecting from the bulb opposite and in line with each other (see Fig. 25). One of these elongations has within it a sheet iron tube at one end of which is a block of copper, faced with platinum or tungsten, and set at an angle of 45 degrees. The other end of this sheet iron tube

carries a platinum wire which is sealed into the glass at the end of the elongation and connected to a cap on the outside which serves as an electrical connection.

The other elongation carries a rod at one end of which is a concave aluminum reflector, the other end being connected by means of a platinum wire sealed in the glass to a cap on the out-

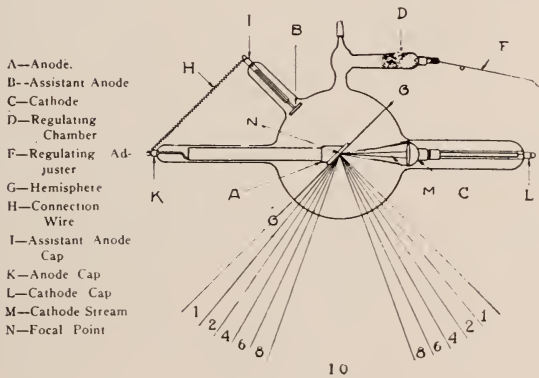

Fig. 25.

Diagram of an x-ray tube.

side of the elongation, and also serves as an electrical connection.

The concave reflector is known as “the cathode” and the metallic block opposite it and located upon the end of the sheet iron tube is known as the “target” or “anode.” Above the anode and at an angle there is another stem projecting which carries a metallic terminal known as the “assistant anode.”

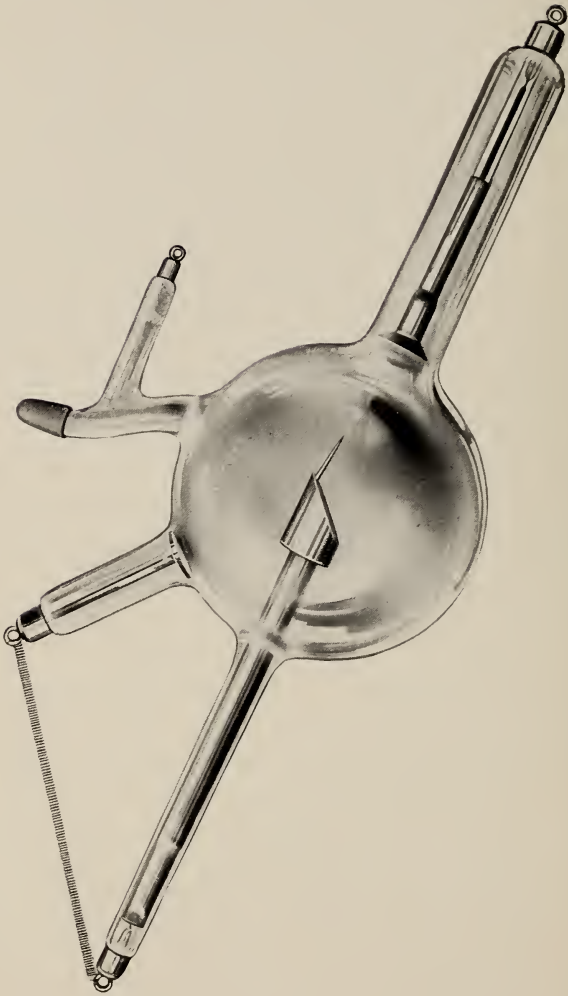

Fig. 26.
The coil or transformer tube.

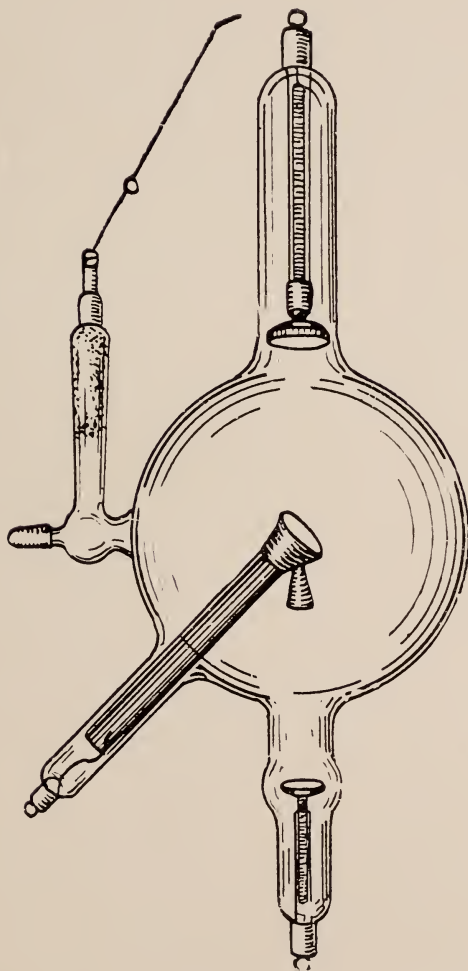

Fig. 27.
The high frequency tube.

This assistant anode has a platinum wire extending from it which is sealed into the glass and connected to a metallic cap on the outside of the tube. The outer terminals of the assistant anode and the anode are connected by means of a spiral spring.

Directly above the anode on the top of the tube there is a small chamber with an arm extending from it at right angles. This is known as "the regulating chamber." The arm extension of this chamber is filled with asbestos impregnated with chemicals, and arranged about or within a metal from which a platinum wire extends, is sealed into the glass and connected to a metallic cap on the outside end of the chamber arm.

Before being finally sealed, the tube is pumped to a high degree of vacuum (about 1/100,000 part of an atmosphere), only enough air being left in it to afford a path for the passage of the electric current.

Three general types of tubes are made for radiographic work, all of which embody the same general principles but vary according to the type of the machine upon which they are to be used.

They are designated as follows:

1. The coil tube.
2. The transformer tube.
3. The high frequency tube.

Coil tubes and transformer tubes are similar in construction but not in vacuum (see Fig. 26). Coil tubes are exhausted to a much higher degree

of vacuum in order to lessen the tendency for inverse current, and give a high degree of penetration. The transformer tube is made comparatively low in vacuum as the current from the transformer is entirely free from inverse, and of such high voltage that the high vacuum is neither necessary nor advisable.

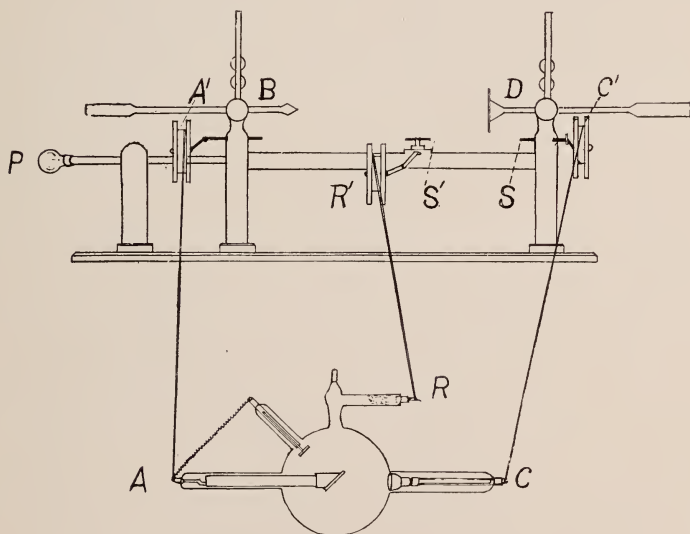

Fig. 28.

The high frequency tube differs slightly in construction from the coil and transformer tubes owing to the fact that the high frequency current is not uni-directional. Therefore, a means must be resorted to for cutting away or disposing of one wave of the alternating current. This is accomplished as shown in Fig. 27 by placing the anode

or target in the position occupied in the coil tube by the assistant anode except that it extends down to the center of the tube. Then by having what really amounts to two cathode terminals, only one of which is focused against the face of the anode, and the other into a funnel in the back of the target, almost the same effect is produced as results from an uni-directional current.

Connecting the Tube to the X-Ray Machine

In connecting up the tube to a coil or transformer (Fig. 28), the anode terminal (*A*) is connected by means of a wire cord coming from a reel attached to the positive terminal of the machine (*A'*), and the cathode terminal (*C*) is connected in a similar manner to the negative terminal of the machine (*C'*).

A third wire cord is usually run from a reel (*R'*) situated on the coil near the negative terminal to the cap on the regulating chamber (*R*). This third terminal on the coil has a spark gap between it and the negative terminal the length of which is adjustable (designated by *S'* and *S*).

Operating the X-Ray Tube

When the current is started in the machine it enters the tube at the anode and passes across the gap to the cathode, from which it is reflected back as the invisible cathode stream to strike a focal point on the target where the x-rays are formed and pass out through the walls of the tube (see Fig. 25).

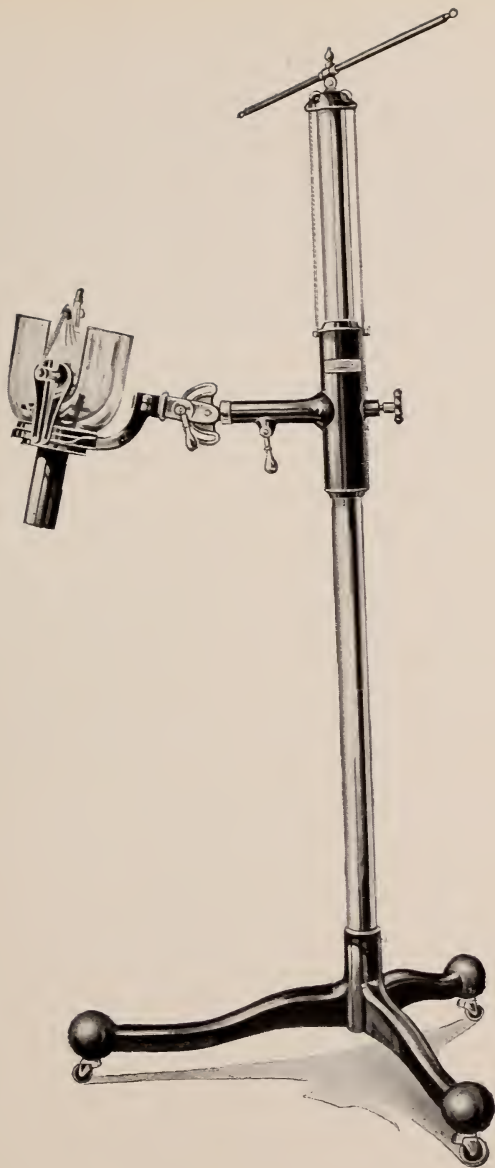

Fig. 29.
The tube stand.

With the passing of the current through the tube, it should light up in a characteristic manner, forming two hemispheres which have a definite line of demarcation. The hemisphere in front of the target which is the active hemisphere, is evidenced by a green florescence, the shade of coloring depending upon the degree of vacuum of the tube. The florescence of a highly exhausted tube will be a light yellowish green, a tube low in vacuum will show a bluish green, while a medium tube will be an intermediate green.

For dental radiography, a fairly high tube is indicated and its vacuum should be kept as nearly uniform as possible. This is made possible by utilizing the third terminal from the x-ray machine. By placing the spark gap of this terminal about three or four inches from the negative terminal of the machine, the current will, when the vacuum of the tube gets high enough to resist its passage, pass over the gap, down the third terminal wire into the regulating chamber where by heating the asbestos it will liberate gas and thereby reduce the vacuum of the tube.

Tube Stand

The tube stand which serves the purpose of holding the tube, should be sufficiently heavy to support it against motion and vibration, and should be sufficiently adjustable so that the tube can be raised or lowered, or placed at any desired angle. Its base should be mounted upon castors

so that it may be moved with ease. Such a tube stand is shown in Figs. 29 and 30.

Tube Shield, Compression Diaphragm, and Compression Cylinder

The tube, tube stand, tube shield, compression diaphragm and compression cylinder when adjusted for work, as shown in Figs. 29 and 30, really comprise a single piece of apparatus. Bearing in mind the fact that the x-rays pass out in every direction from the face of the anode or target, (see Fig. 31-*A*) which is situated in the center of the tube, it is necessary, if the clearest possible shadows are to be produced, to use only those rays which have the same general direction and which have an equal amount of penetration. Now it is known that the most rapid and effective rays are those which pass out at right angles from the cathode stream designated by *PR*. Inasmuch as we desire to use *these rays, and these rays only*, in casting our shadows, we must establish some means of preventing the other rays (*S,S,S,S*) from escaping from the immediate area surrounding the tube, and this is accomplished by means of the tube shield, compression diaphragm and compression cylinder.

The tube shield (Fig. 32) a sectional diagram of which is shown in Fig. 31-*B* by T. S. is made of leaded glass, there being a sufficient amount of lead in the glass to prevent ordinary rays from passing through it. The compression diaphragm

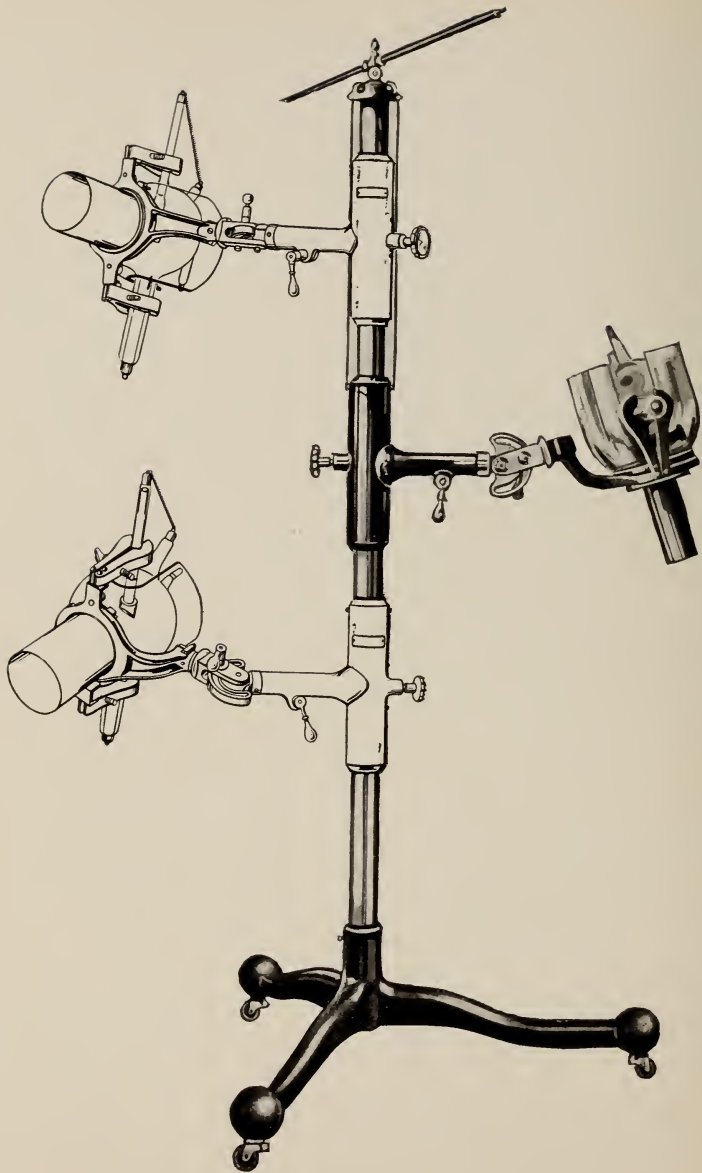

Fig. 30.

Illustrating how the tube may be placed at any desired angle.

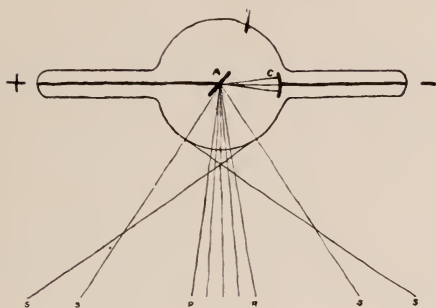

Fig. 31-A.

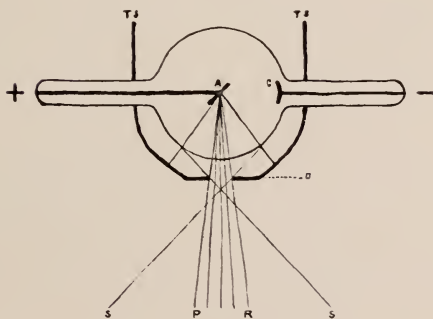

Fig. 31-B.

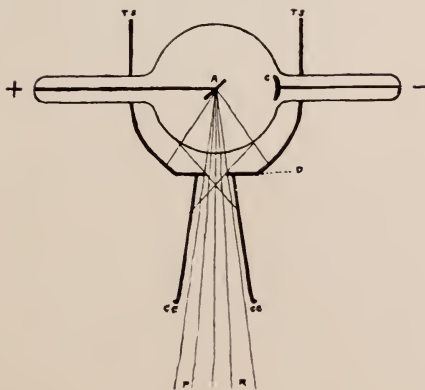

Fig. 31-C.

makes up the floor of the tube shield (*D*), and is constructed of sheet lead with an opening of the proper size to allow the desired rays to pass through. The compression cylinder (*CC*) (Fig. 31-*C*) is made of aluminum with a lead lining which absorbs any secondary rays which have succeeded in passing through the diaphragm. It should be apparent to any one that with this ap-



Fig. 32.

Lead glass tube shield.

paratus, the only x-rays which succeed in leaving the immediate area of the tube are those which are used to cast the shadows of the parts desired, which is of great importance not only in obtaining radiographs which are sharp and clear and uniform, but also to the health of the operator and others associated with him in the office.

Arrangement of the Apparatus in the Office

If dental x-ray equipment is desired, the question naturally arises, where can the necessary apparatus be placed? While a separate room is desirable, it is by no means necessary as the ordi-



Fig. 33.

A convenient manner of arranging the necessary apparatus when not in use.

nary operating room of "healthy size" can be made to accommodate it.

The coil or transformer, and the tube stand can be placed against the wall at the left of the room, while the tubes can be hung in a suitable rack upon the wall where they will be out of harm's way (Fig. 33). Arranged in this manner,

x-ray apparatus is not in the way, and is accessible for use at any time.

The dental chair with its multitude of adjustments serves an important purpose in the dental x-ray laboratory, for the patient must be supported in such a manner as to be able to hold perfectly quiet during the time the exposures are made. Owing to the stability of the chair and its many adjustments, it will not only serve this purpose, but is preferable to having the patient lie upon a table which has been the method employed by many radiographers in the past.

Photographic Darkroom

Thus far we have discussed all but one of the requisites of the dental x-ray laboratory, viz.: the photographic darkroom. This is a very important requisite, and any one attempting to do radiography without it is greatly handicapped. It need not be large or elaborate, and running water is not absolutely essential, although it is an advantage. A closet $3\frac{1}{2} \times 5$ ft. will suffice if nothing better is available. A broad shelf should be placed at one end to hold the developing trays and other photographic accessories.

With a darkroom always available, the dental radiographer is able to develop his plates or films immediately, profit by their findings, or in case they do not come out satisfactorily, make others without subjecting the patient to the inconvenience of another appointment.

CHAPTER V.

TECHNIC OF DENTAL AND ORAL RADIOGRAPHY.

Having discussed the requisites of the dental x-ray laboratory, let us now proceed to a consideration of their application in the actual work of radiography.

The very nature of the structures with which we concern ourselves, their gross as well as minute anatomy, renders them somewhat difficult to radiograph, and necessitates a refinement of technic greater than that demanded with most of the other portions of the human anatomy. It would therefore seem obvious that an accurate knowledge and anatomic appreciation of the structures of the oral cavity and associated organs and structures is the first requisite for successful dental and oral radiography.

We should keep in mind the fact that radiographs are shadow pictures, and that the effect produced by the x-ray upon the photographic plate is but a shadowgraphic representation of the tissues through which the rays have passed. We know that this ray penetrates all matter in inverse ratio to its mass or density, and therefore the shadow picture which is left upon the photographic plate is simply a record of the varying

density of the tissues through which the rays have penetrated.

The x-rays are particularly applicable to the dental and oral structures, owing to the fact that these structures differ enough individually in degree of density to permit of their appearing in a characteristic manner upon the photographic plate. For instance, it will be noted upon the examination of a dental radiograph, that metallic fillings appear as white masses, and root fillings as somewhat less dense lines. The enamel and dentin are next in density, and root canals show plainly as dark channels in the dentin, while the alveolar process and maxillæ show their fine uniform cancellous structure in various degrees of density depending upon their thickness.

As a tooth is much more dense than the bony structures of the jaw, any anomaly of form, size or position in the jaws is easily discernible even though it occupy a position far from what might be expected; as for instance, impacted molars, teeth in the antrum, etc.

The fact that the structures within the field of our specialty have a characteristic appearance under normal conditions, any alterations or change in these structures is at once evident upon the plate. We thus are afforded a means of studying "intravital" the gross pathology of the structures of the oral cavity.

I would again emphasize a point previously made, viz.: that a radiograph is not a photograph,

but a shadow picture which is produced by using the x-ray as the source of illumination and the photographic plate as a screen for recording permanently the shadows cast.

Therefore, in making radiographs, we must adhere to the same rules which apply in making correct shadows with ordinary light. If correct shadows are cast, a certain definite relationship must exist between the source of illumination, the object and the screen. Any change or variance in this relationship will result in a changed image. A simple experiment will suffice to illustrate to a beginner the truth of this statement.

Use a piece of ordinary white writing paper as a screen and hold it about two feet away from a lamp, and place your hand or any other small object, midway between the lamp and the improvised screen, and observe the shadow cast. You will note first, that it is very much enlarged; and second, that it is very faint and indistinct. Now, slowly move the object toward the screen. As it approaches, the shadow becomes more distinct and smaller until at length when the object is almost touching the screen, the shadow will be good, black and distinct, and of practically the exact size of the actual object. It will also be found that the shadow can be altered by changing the position of the light, that is, moving it toward the object or away from it, by lowering it below the level of the object or raising it higher than the object; or by moving it to the right or

to the left. Eventually, however, a point can be found which will cause the shadow to assume its most correct proportions as well as its sharpest outline. When this point is established, the light rays will be traveling in a perpendicular direction to a plane which lies midway between the plane of the object and the plane of the screen, and the light will be placed at what we call the proper focal distance.

Applying the laws deduced from this simple illustration of shadow making to radiography, we learn first, that the closer we can approach the photographic plate to the tissues we wish to show, the clearer and sharper will be the resulting radiograph; second, that the x-rays in passing through the tissues must travel perpendicularly to a line which lies midway between the plane of the tissues desired and the plane occupied by the photographic plate; and third, that the source of the x-ray production (the target of the tube) must be placed at a proper focal distance.

In order to obtain a radiograph of any portion of the body, it is necessary to have a photographic or x-ray plate, or film (properly prepared so as to exclude all light and moisture), placed in such a position that the rays passing through the structures desired, will register their shadows with the least amount of distortion possible upon the plate.

In securing shadowgraphic representations of the dental and oral structures, two general meth-

ods of procedure are open to us, each of which has its values and special indications. These are known as the "intra-oral" and "extra-oral" methods.

With the first, only small films are used which are placed within the mouth opposite the area to be radiographed, and held in position either by means of a tray or film holder, or by the assistant, or better still, by the patient exerting slight pressure with the finger. This method is indicated where radiographs of *small areas only* are desired, as, for instance, two or three of the teeth, with the adjacent alveolar process.

With the other method of procedure mentioned, viz.: the "extra-oral" method, large plates or films are used and the areas desired are brought in as close contact as possible with the plate by pressing or resting the face against it. The x-rays are then passed through the structures from the other side of the skull, and oftentimes must pass through the entire face or skull, in transit.

When using this method, large areas may be radiographed, which in some instances will embrace the lateral halves of both the upper and lower jaws from the cuspid region anteriorly to the angle of the jaw posteriorly, and from the floor of the orbit above to the inferior margin of the mandible below. In fact, it is possible by making several exposures to obtain in detail a shadowgraphic representation of the dental apparatus "in toto" as well as its associated or-

gans and structures, the nasal cavity and pneumatic sinuses, the maxilla and the mandible.

It should be apparent to any one that the first method greatly reduces the possibilities of the x-ray. Both methods have their advantages and neither should be discarded in favor of the other.

Intra-oral Method

We shall first discuss the intra-oral method by which small areas are radiographed. First of all, the patient should be placed in a comfortable position, *and the head supported so that it may be held perfectly still.* After the tube has been tested out and the proper degree of vacuum established, the tube stand (complete with the other apparatus before described) is moved to a position where the rays coming from the tube, through the compression diaphragm and cylinder can be made to pass through the desired areas and cast their shadows upon the small film within the mouth (Fig. 34).

In using this method upon the upper teeth, the greatest care must be exercised if the shadows produced are free from distortion, for the film must be held within the upper arch against the lingual side of the teeth and the palate, and must occupy a position which is in a different plane from that occupied by the roots of the teeth. Whenever it is necessary to direct the rays upon structures which lie at an angle with the plate or film, correct shadows may be obtained by ad-

hering to the following rule: "*Bisect the angle made by the plane of the object, and the plane of the film, and direct the rays so that they will fall perpendicular to this bisected plane.*"

Failure to adhere strictly to this rule is one of the most common causes of partial or complete failure in producing true shadowgraphic repre-



Fig. 34.

The patient can hold the film in position against the upper teeth by exerting slight pressure with the thumb.

sentations of the dental structures. For instance, if the rays are directed from too low a source, the shadows will be lengthened, or if they be directed from too high a source, the shadows will be fore-shortened, the amount of elongation or

fore-shortening being in direct proportion to the amount of deviation from the proper focal point.

The importance of adhering strictly to this rule is graphically shown in Fig. 35,* where an upper central incisor and the adjacent teeth are radiographed. In the upper picture (*A*) the rays are passing in from too low a source with the result that the image imposed upon the film is lengthened to the extent that the resulting radiograph is useless. In the center picture (*B*) the rays are coming from too high a source, the result being a shortened image. Such a radiograph has but little value and in many instances would prove very misleading. In the lower picture (*C*) the rays are passing in at the correct angle, viz.: they are directed perpendicularly to a plane which lies midway between the plane of the teeth desired and the plane of the film. The result is a radiograph in which the images of the teeth desired are imposed upon the film in their correct proportions.

It will be noted upon a close examination of this last radiograph (*C*) that an abscess is present upon the root of the right central incisor. By examining the other radiographs (*A* and *B*) it will be seen that this condition is not apparent in them, which lends emphasis to the importance of an exact technic.

The technic illustrated (by *C* of Fig. 35) is in-

*Technic of Dr. Weston Price.

icated for all of the upper teeth. Occasions may arise, however, where it will not suffice entirely

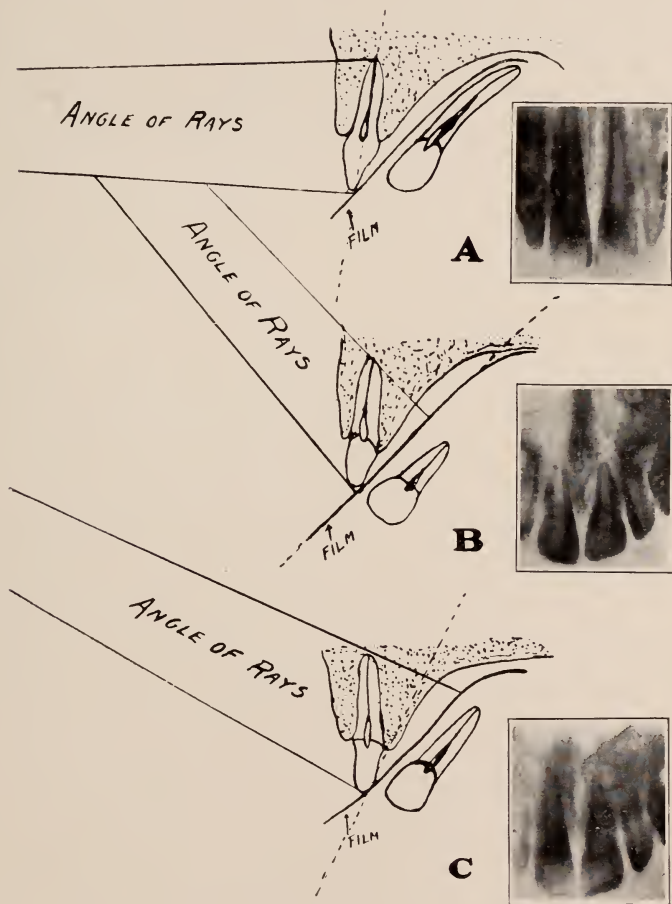

Fig. 35.

Correct and incorrect technic.

for the upper molar teeth owing to the fact that the buccal roots and the lingual roots may diverge to the extent of assuming different planes. In this event, it may be necessary to make more than one radiograph, if information of an exacting character is desired concerning an upper molar. The plan of procedure is shown in Fig. 36, *A*, *B*, and *C*.

If a general picture of the molar is desired (shown by *A*) the plane of the tooth is assumed as lying midway between buccal roots and lingual root, and the rays are passed in perpendicularly to the plane lying midway between this assumed plane and the film. In the resulting radiograph none of the roots will appear in their exact proportions, but the buccal roots will be slightly shortened, while the lingual root will be *slightly lengthened*.

When it is desirable to obtain a radiograph of the buccal roots in their *exact length*, they must be assumed as being the plane of the tooth (*B*) and the rays must pass in perpendicularly to a plane lying midway between them and the film. In this event, the image of the lingual root is elongated.

If the lingual roots are under scrutiny (*C*) they must be considered the plane of the teeth, and the rays passed in perpendicularly to a plane lying midway between the lingual root and the film. In this event, the image of *the lingual root will have its correct proportions*, but the image of the buccal roots will be slightly shortened.

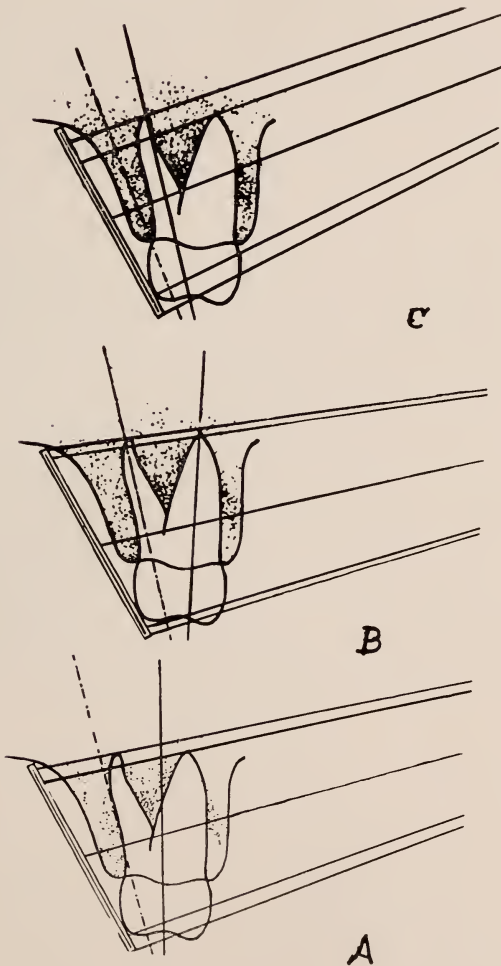

Fig. 36.

Technic for the upper molar teeth.

The upper molars are by all means the most difficult teeth to radiograph. That is, to obtain radiographs which are as comprehensive as those made of the other teeth. However, by going to the extra work entailed by the foregoing procedure, valuable radiographic information can oftentimes be gained.



Fig. 37.

The patient can hold the film in position against the lower teeth by exerting slight pressure with the finger.

With the lower teeth (Fig. 37) we do not have this difficulty to contend with to so great a degree, as the films can be placed for the most part in such a position that they lie parallel to the long axis of the teeth, and the rays can be directed in a perpendicular direction both to the plane of the teeth and the plane of the film.

In placing the films in the mouth preparatory to making radiographs of the lower teeth, difficulty is sometimes encountered, owing to the fact that the tissues are usually quite sensitive. Inasmuch as the film must be *pressed well down between the tongue and the teeth*, it is advisable to first see that no sharp corners exist on the film covering, or better still, provide a rubber envelope or film holder *which has no sharp corners*. Such an envelope is easily improvised by the use of ordinary black vulcanite rubber. A piece of this rubber which should be a little more than double the size of the film, is wrapped about it and the free edges pressed together. These edges are then trimmed with a pair of scissors so that the corners are rounded. Such an envelope containing the film can be introduced into the mouth and placed well down on the lingual side of the teeth with a minimum amount of discomfort to the patient.

Where it is necessary to make a complete radiographic examination of the dental arches, it can be accomplished in the average case, by making six exposures of each arch. The procedure to be followed is diagrammatically shown in Fig. 33. The numbers 1, 2, 3, 4, 5, 6 indicate the position of the x-ray tube in its relation to the dental arch, and the ends of the lines coming from the numbers show the position of the mesial and distal edges of the film used for each exposure. It will be noted that each adjacent film position over-

laps its neighbor which is advisable so that no area is left out.

In making radiographs of the anterior part of the arch, it is a mistake to attempt to radiograph more than two or three teeth at a time, as the curvature of the arch usually renders it impossible to get more than that number free from distortion.

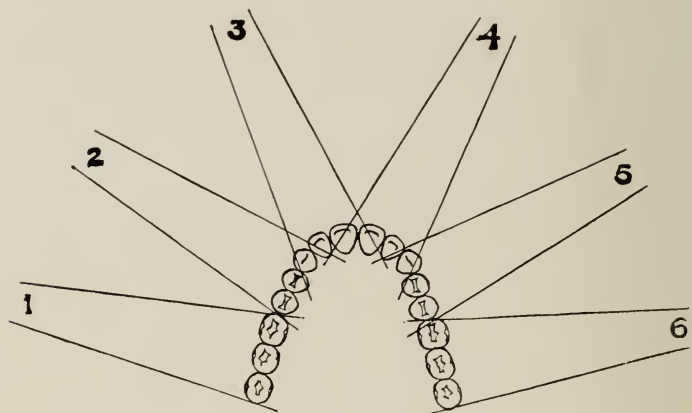

Fig. 38.

Another point in technic which should not be overlooked if sharp outlines are to be obtained, is the one in regard to having the tube placed at the proper distance from the structures to be radiographed. To establish the best focal distance for work about the teeth or jaws, the target of the tube should be about twenty inches from the plate or film.

With a good x-ray machine, and a properly regulated tube, good radiographs can be obtained by

very short exposures, particularly by using the intra-oral method, as the rays need only penetrate a comparatively short distance before reaching the plate. With the apparatus now available good radiographs can often be obtained by instantaneous exposures. However, instantaneous exposures are not necessary for good dental radiography. X-ray apparatus which is capable of producing sharp, clear "intra-oral" radiographs in from two to five seconds, is efficient enough for use in the x-ray laboratory of the dentist.

Extra-Oral Method

The extra-oral method is in the author's opinion, the one offering the widest range of usefulness in our work. As stated previously, this is the method used to obtain radiographs of large areas. Not only can larger areas be obtained by this method, but locations and structures inaccessible to the small films are reached and their images accurately and clearly recorded upon the larger plates. Therefore, the advantage of this method is well founded.

The technic is simple when once mastered, but must be adhered to accurately if the results are to be depended upon for diagnosis. In using the extra-oral method, large plates or films are used and the areas desired are brought in as close a contact as possible with the plate, *by pressing or resting the side or portion of the face upon which*

the structures desired are located, against the plate.

First of all, the patient must be placed in a position so that *the head can be held perfectly still*. The dental chair with a few adjustments offers an excellent means for accomplishing this.



Fig. 39.

The head rest of the dental chair with its many adjustments can easily be arranged so that the patient's head may rest easily and firmly upon it.

One of the chair arms is lowered down against the side of the chair or removed, and the patient placed sideways in the chair. The chair back is adjusted so that the patient lies against it in an easy position, and the headrest wings are adjusted so as to lie flat and thereby form an excel-

lent resting place for the plate. The head rest with its many possible adjustments can easily be placed so that the patient's head rests easily and firmly upon the plate, rendering it an easy matter to remain perfectly quiet. This position is shown in Fig. 39.

Author's Method of Seating the Patient

In the author's opinion, there is another method of seating the patient for this character of work which necessitates less confusion in the office than the method just described. It is accomplished by using an ordinary chair with a straight back and small arms, placed against the back of the dental chair. The head rest of the chair is turned over and adjusted to the proper height, position and angle, so that the patient's head can rest against it in any desired position. In this way the patient is afforded the firm support of the heavy dental chair, and therefore has little difficulty in remaining perfectly quiet, and the operator can by making a few changes in the position of the small chair, by moving and readjusting the tube stand and the head rest, have radiographic access to any part of the oral cavity or associated structures. The arrangement of the apparatus preparatory to seating the patient is shown in Fig. 40.

The fact that this requires but a few moments, does not disarrange the office, or put the patient to discomfort, justifies the author in feeling that

it is by all means the preferable method for use in the dental office.

With the head thus supported, as shown in Fig. 41, the rays are directed from the opposite side of the head, and therefore must pass through the entire face or skull in transit. The question nat-



Fig. 40.

The arrangement of the apparatus preparatory to seating the patient.

urally arises, how is this to be accomplished without superimposing the shadows of one side upon the shadows of the other side, and thereby producing a chaotic result.

For instance, let us suppose that we wish to obtain a radiograph of the left side of the upper

and lower jaws extending from the cuspid region in front to the angle of the jaw behind, and from the floor of the orbit above to the inferior margin of the mandible below. If we are to get a correct shadowgraphic representation of this area, it should be free from the shadows of the oppo-



Fig. 41.

The patient seated and the apparatus arranged for making a radiograph of the left side. The comfortable position of the patient renders it an easy matter to remain perfectly quiet.

site side, and this can only be accomplished by directing the rays in such a manner that they will miss the areas not desired and will pass through those we wish to record.

In accomplishing this, we must take into con-

sideration two structures, viz.: the spine and the ascending ramus of the mandible (on the right side in this instance as the left side is to be radiographed) and cause the rays to pass in through this opening and thereby reach the desired area. The way in which this is accomplished is shown in Fig. 42, *A* and *B*, and Fig. 43, *A* and *B*.

An important factor in accomplishing this is the position in which the patient's head is held as it is pressed against the plate. Held in the manner shown, the rays can be made to pass in between the ascending ramus of the mandible and the spine, and can pass in at approximately a perpendicular direction to the long axis of the teeth and the plate, giving correct shadow lengths upon the plate. Fig. 44 shows a radiograph made by using this technic.

If this rule is disregarded and the rays passed through the structures, as shown in Fig. 45, *A* and *B*, the shadows of the opposite side will be superimposed upon the shadows of the structures desired, and a chaotic result produced. The result of such technic is shown in Fig. 46.

In a similar manner as shown in Figs. 42 and 43, with slight adjustments in the position of the plate, the head and the tube, the areas in the upper and lower jaws extending from the median line to the first premolars, and from the nose above to the inferior margin of the mandible below, can be radiographed (Fig. 47, *A* and *B*). Likewise the structures at the median line includ-

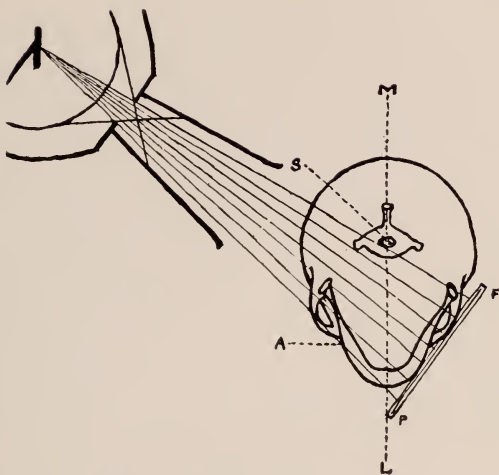

Fig. 42-A.



Fig. 42-B.

Technic for left side. *M-L*, median line; *S*, the spine; *A*, ascending ramus and angle of lower jaw; *P-F*, plate or film.

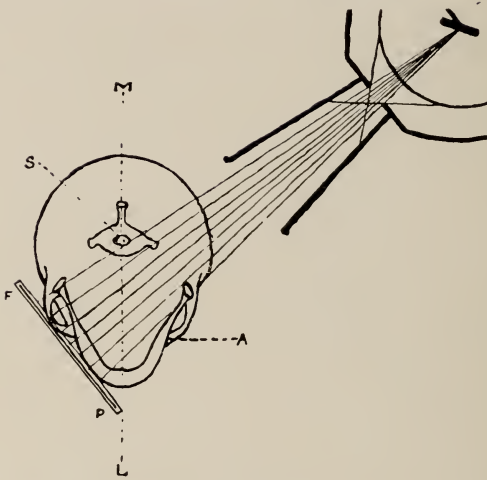

Fig. 43-A.



Fig. 43-B.

Technic for right side. *M-L*, median line; *S*, the spine; *A*, ascending ramus and angle of lower jaw; *P-F*, plate or film.



Fig. 44.

ing the incisors, both above and below, the anterior portions of the mandible and maxilla, the nasal cavity and its accessory sinuses, may be radiographed by passing the rays directly through the skull, as shown in Figs. 48 and 49. In this in-

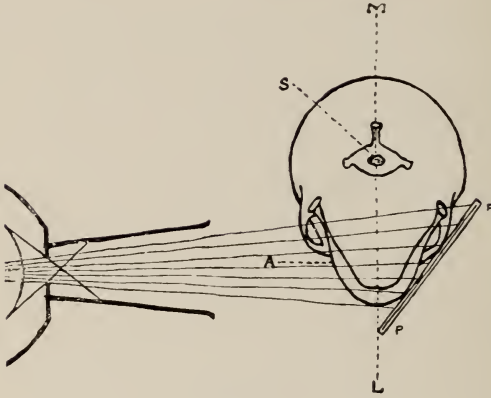

Fig. 45-A.



Fig. 45-B.

Incorrect technic. The shadows of both sides will be imposed upon the plate.



Fig. 46.

The result of incorrect technic. This is a radiograph of the same subject as shown in Fig. 44.

stance, the shadow of the spine will be superimposed upon the dental structures, but owing to the fact that it is so far removed from the plate, its shadow does not interfere seriously. It is im-

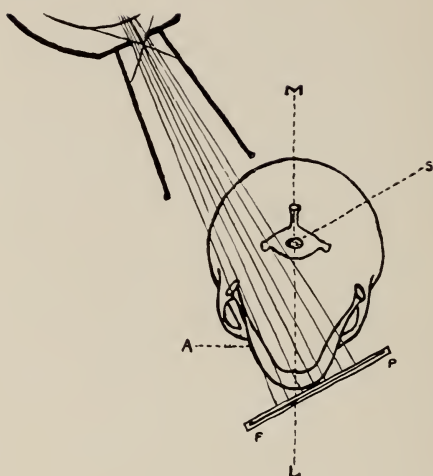

Fig. 47-A.

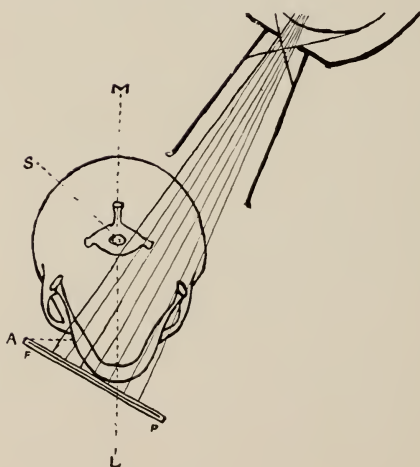

Fig. 47-B.

The areas in the upper and lower jaws extending from the median line to the first premolar can be radiographed by utilizing this technic. *A*, Technic for left side; *B*, Technic for right side.

portant, in making these pictures, to have the patient's head supported in such a manner that it can be held still for a longer period than is required in making the exposures of the other areas mentioned.

When ready to make the exposure for extra-oral radiographs, the apparatus is arranged with the anode of the tube about twenty inches from

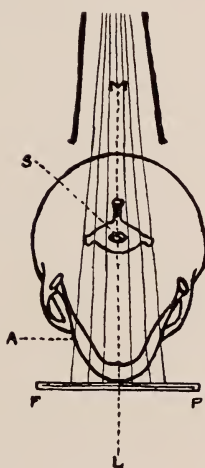

Fig. 48.

The structures at the median line including the incisors, both above and below, may be secured in this way.

the plate. The patient is instructed to *keep the mouth closed with the teeth together in their natural occlusion*. They should also be warned as to the approximate length of time the exposure will require, and that *they must remain perfectly quiet*.

With the more powerful types of apparatus,

extra-oral radiographs require but short exposures, but if an operator does not possess high power apparatus, he should not hesitate to use this method, as a patient properly seated and supported, as shown in Fig. 41, can easily remain



Fig. 49.

In following the technic illustrated in Fig. 48 the patient's head should be supported by a bandage of gauze to insure perfect immobility.

quiet for five or ten seconds, or perhaps even longer, should it be necessary.

In making a complete radiographic examination of the teeth, the maxilla and mandible, the author suggests the following procedure. Extra-oral radiographs should be made of each side, using the technic illustrated in Figs. 42, 43 and

47. This would mean two plates for each side. Then by the use of the intra-oral films, the region lying between the cuspids both above and below, should be radiographed. These plates and films should then be developed and examined. If the procedure has been carried out with due regard for all the elements involved, the result should constitute a general radiographic survey of the teeth, the maxilla and the mandible. Should any of the plates or films exposed fail to result in good radiographs, additional exposures should be made as nothing but good radiographs should be depended upon for diagnosis.

It is sometimes advisable after making a complete radiographic examination by the method just advocated, "to check up" the findings of extra-oral radiographs by the use of the intra-oral films. For instance, suppose a large plate shows what appears to be an abscess upon the root of an upper bicuspid or molar tooth. An intra-oral radiograph of this particular area will often settle any doubts, as a higher degree of detail can often be obtained by concentrating upon the small area in question.

The author would not wish to imply by the preceding remarks upon technic, that the few rules enumerated constitute a safe and never failing means of producing good radiographs. There are many points to be considered which cannot be included in so limited a text, but which must be learned in the school of experience, such as the

necessary variations from the given rules of technic because of anatomic variations in the dental and oral structures of patients. Therefore the rules of technic which have been presented must be accepted only in the light of principles.

CHAPTER VI.

TECHNIC OF DENTAL AND ORAL RADIOGRAPHY.

(Continued.)

Successful radiography depends upon a sequence of operations, each of which must be carried out with scientific accuracy. These steps, upon which the finished product depends, may be enumerated as follows:

1st—Correct technic of position.

2nd—Proper tube and current conditions.

3rd—Correct exposure and development of plates and films.

It would be difficult to determine which of these steps is the most important; in fact, they are all so important that a radiograph is a success or failure in accordance with the degree of accuracy with which each is carried out. In the preceding chapter, the actual technic of radiography, so far as the arrangement of apparatus is concerned and its relative position to the patient and the plate (or film), has been discussed. We will therefore proceed to the next factor for consideration.

Proper Tube and Current Conditions

The character of the x-rays produced in a tube depends upon the degree of its vacuum and the

current which passes through it. We know that the x-rays are produced by the cathode stream striking the anode or target, and that this cathode stream (Fig. 25 M) is generated by the flow of the current in the tube. *The velocity of the cathode stream depends upon the voltage of the current entering the tube, therefore the higher the voltage, the faster the cathode stream travels, and the more intense or penetrating are the x-rays produced. The quantity of x-rays produced depends upon the milliamperage of the current.*

In considering the role enacted by the voltage and milliamperage in the x-ray production, we have assumed that the tube is exhausted to a high degree of vacuum, for the degree of vacuum determines to a large extent, the value of the other two factors. The degree of vacuum of a tube is designated as high, medium or low, a "high tube" being one in which the vacuum is well nigh complete; in a "medium tube" the vacuum is less complete, while a "low tube" is one in which the vacuum is far from complete.

For dental radiography *a fairly high tube* is indicated, as with such a tube x-rays may be produced having a degree of penetration sufficient to pass through the oral structures and produce the desired effect upon the emulsion of the plate or film.

When a current of high voltage is passed through such a tube, it should light up in a characteristic manner forming two hemispheres which

have a definite line of demarcation. The hemisphere in front of the target which is the active hemisphere, is evident by a florescence deep apple green in color, while the other hemisphere should be evident by a lack of greenish light.

To Determine the Vacuum of a Tube

The comparative degree of vacuum of a tube can be determined in the following manner: Con-

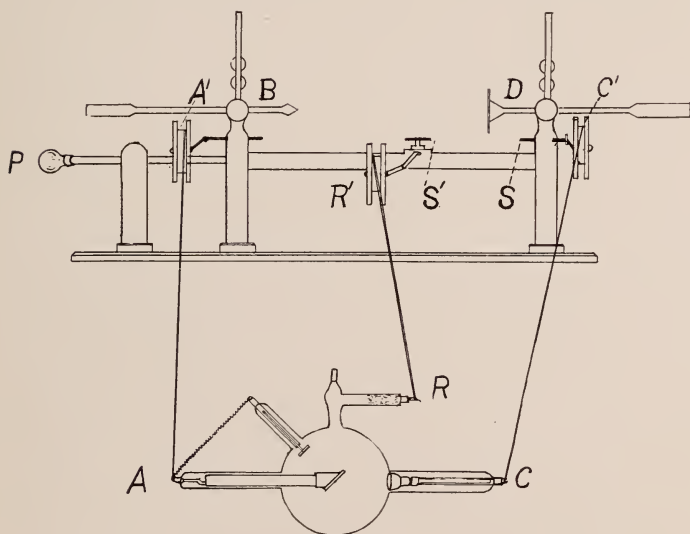

Fig. 50.

nect the tube to the x-ray machine as shown in Fig. 50. See that the third terminal (S') is moved well away from the negative terminal (S), or better still, disconnect the wire running to the regulating chamber (R). Now, move the sliding rods (B and D) of the secondary spark gap, to-

ward each other until they are about three inches apart, and start the current. Unless the tube is *low*, the current will jump the spark gap instead of passing through the tube. If the tube resists the current and causes it to jump the spark gap, it is said to have "backed up" three inches of spark. Thus a "low tube" will back up two or three inches of spark, a "medium tube" five or six inches, while a high tube will back up six or eight inches. In fact, the vacuum of a tube may be so great that only the most powerful x-ray machines will operate it. Such a tube, however, is not useful for dental radiography.

The vacuum of a tube may also be determined by the use of an instrument known as a *milliamperemeter*. This instrument which is usually an accessory of either the induction coil or transformer, is connected in circuit with the tube, and measures the current passing through the tube. With a "low tube" the milliamperemeter will show a reading of 15 to 18, while with a "medium tube" the reading will be from 10 to 12, and with a "high tube" the milliamperemeter will register 5 or less.

Relative Merits of Low, Medium and High Tubes

A "low tube" in operation under average current conditions gives a clear sharp hemisphere of pale greenish light in front of the target, with usually a trace of bluish light in the region of

the assistant anode. If the tube is very low, the cathode stream shows blue, and there is a bluish light back of the active hemisphere. Such a tube will not do good radiographic work as the x-rays produced by it are lacking in penetration.

A "medium tube" gives a clear, sharp hemisphere of light greenish color, and there is an absence of bluish light back of the target. The rays emanating from such a tube are more penetrating than those from the "low tube," but are not as well suited for "bone radiography" as those which come from a tube fairly high in vacuum. When such a tube is operating, it gives a clear sharp hemisphere deep apple green in color, with a lack of greenish light back of the target. The x-rays emanating from such a tube *are of a degree of penetration which is best suited for bone radiography*, for they penetrate and pass through the soft tissues and to a sufficient degree through the bone structure to give good contrast.

It is very important that the vacuum of such a tube be kept uniform, for if it gets low the power of penetration of the rays is decreased, and on the other hand if the vacuum gets too high, the penetrating power of the rays will be increased, with the result that they will penetrate through the bone structure as easily as the soft tissues. Consequently, unless very short exposures are given, there will be little if any contrast, and the plate will be dark and hazy.

Regulating the Tube

Prior to seating and arranging the patient, the tube should be tested out and any needed change in its vacuum effected. This is easily accomplished by utilizing the third terminal of the x-ray machine. The tube should be connected to the machine as shown in Fig. 50. The terminals of the regulating spark gap (S' , S) should be placed about four inches apart, and the current (of correct working strength) turned on for an instant. If a line of sparks jump between S' and S , it shows the vacuum of the tube is too high. In this event the regulating spark gap (S , S) should be reduced to about two inches, and *a small amount of current turned on*. This weaker current will pass across the spark gap S' , S , travel down the wire connected to the regulating chamber and by heating the asbestos (impregnated with chemicals) will liberate enough gas to reduce the vacuum. Unless the tube is very high, a few seconds will suffice to reduce it to the vacuum desired. To be sure the vacuum is right, the regulating spark gap (S' , S) should be widened to about four inches, and the desired working current again passed through the tube for an instant. If the tube lights up with a clear sharp active hemisphere deep apple green in color with a lack of greenish light back of the target, you then know it is ready for work.

If an x-ray machine is not equipped with a third terminal, the same results in regulating the

tube may be effected by using the regulating adjuster (Fig. 51), the end of which can be placed at the desired distances from negative wire near its point of attachment to the tube. The tube may also be lowered by attaching the negative wire directly to the regulating chamber and passing a *small amount* of current through the circuit.

These manipulations should be carried out

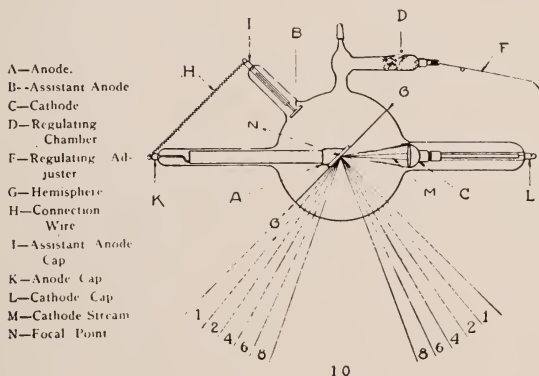

Fig. 51.

with the greatest caution, for a tube is an extremely delicate and sensitive piece of apparatus and will not stand abuse.

A careless operator can quite easily reduce the vacuum to such a degree that the tube is useless. Such a tube has a purple appearance when the current is passed through it. If such a tube has not been too greatly abused, it will often regain its vacuum if given a rest. If this does not bring the vacuum up, it can often be brought back in

the following way: The spiral spring (Fig. 51) connecting the anode and assistant anode, should be removed and the positive wire from the machine attached to the assistant anode (*I*). The negative wire is attached as usual (at *L*) and *a light current is run through the tube* for a minute or two at a time. If this is done once or twice a day for several days, the vacuum will usually come up. Any increase in vacuum will be indicated by the milliamperere readings dropping off, or by the increased length of spark gap the tube will "back up."

If a tube does not respond to this treatment, but continues to be purple while operating, it indicates that it is practically non-vacuous or "punctured." It is then useless and should be sent back to the manufacturer for repairs. In the event a tube is "completely punctured," the current in passing through it simply jumps the gap between the anode and cathode, and is evident as a line of white sparks.

One tube complication not yet mentioned is sometimes encountered in the use of induction coils. This is known as "inverse in the tube," and is the result of the presence of inverse current (current in the wrong direction) in the secondary circuit of the coil. "Inverse" is evident in the tube by the appearance of rings of light back of, and usually running at an angle to the active hemisphere, or by a fullness of greenish

light back of the active hemisphere, with rings about the assistant anode.

Inverse current in a tube will generate secondary rays which have the tendency to make the outline of the image on the plate hazy or "less sharp," as these rays are produced in the tube elsewhere than at a focal point on the target. It also produces heat in the tube which lowers the vacuum and hence lessens the penetration of the rays coming from it.

"Inverse" in the tube can usually be controlled or prevented by the use of "a multiple spark gap" or "a valve tube" arranged in series with the x-ray tube, and by using a tube which *is fairly high in vacuum*. If it still persists after these precautions are taken, it indicates an imperfect adjustment of the induction coil or some of its accessories.

All manufacturers of x-ray tubes furnish full instructions as to the care of and manner of using x-ray tubes. These instructions should be carefully read and *explicitly followed*.

In order that uniform results may be obtained, it is advisable to always use the tube at the same vacuum, with the same amount of current. The proper "working current" may be determined in the following way: With the tube disconnected, set the sliding rods (*B* and *D* of Fig. 50) of the machine about six inches apart. Then start the current in the machine, and beginning with a low current increase it until a fat fuzzy "cater-

pillar spark" is produced across the spark gap. As soon as this spark or discharge appears, the switch should be pulled out, but the rheostat or other controlling apparatus left as it was when the spark appeared, so that when the tube is connected, the proper working current will come from the machine.

The tube should then be connected up and given a trial. If it is not too high in vacuum, it should take the current, or in the event it is too high, it will "back up" the spark, and the discharge instead of passing through the tube will jump the gap. If the tube requires regulating it can be done by the methods before described.

With the working current and vacuum established, it is a good idea to separate the sliding rods on the machine to at least eight inches, to insure against the tube backing up the current, for in the event the tube should start going up during the time the exposure is being made, the startling noise made by the discharge jumping the gap, may cause the patient to move and thereby blur the radiograph. If several exposures of five or ten seconds each are made, the tube should be given sufficient rest between exposures so that it will not heat up. This is important.

With proper tube and current conditions, the length of time required for the exposure will depend upon the type of x-ray machine used, and the thickness and density of the parts to be radiographed, varying with different patients according to age and structural make up.

Correct Exposure and Development of X-Ray Plates and Films

X-ray plates and films differ from those used in ordinary photography in that their emulsion is more sensitive and better adapted to record the shadows produced by the x-ray. Therefore they should always be used in preference to ordinary plates and films.

The same general photographic rules apply to x-ray plates and films as apply to the ordinary kind, except perhaps that they demand a greater degree of accuracy and care throughout the process of exposure and development, if the very best results are to be obtained.

X-Ray Plates

X-ray plates are supplied by the manufacturers, packed in light-proof boxes containing one dozen plates. They are obtainable in any desired size, but for dental and oral radiography, a 5x7 plate is large enough. If stored in the laboratory, they should be kept in a lead-lined box prior to their preparation for exposure, or they will become "fogged," as light-proof boxes offer no protection whatever from the x-ray.

In their preparation for exposure, each plate is placed in two light-proof envelopes, one of which is black and the other red or orange in color. Such envelopes are furnished by plate manufacturers and are obtainable in the desired

size. *The transference of the plate from its original box to the envelopes must, of course, only be done in the photographic dark room.* The plate is first slipped into the smaller envelope which is usually the black one, with the emulsion side of the plate facing the smooth side of the envelope (the side free from seams or overlapping edges). The envelope containing the plate is then placed in the larger or yellow envelope, flap-end first, with the smooth side of the inner envelope facing the smooth side of the outer one. Plates prepared in this way are then ready for exposure and can be placed back in the lead-lined box until needed.

In "loading these envelopes," care should be taken lest the emulsion of the plate become scratched, as scratches even though they be very slight will often curtail the value of the finished radiograph.

It is not advisable to keep large quantities of plates loaded in envelopes, unless they are to be used within a few days, as the contact of the paper with the emulsion will in time affect it adversely.

All "brands" of x-ray plates are not the same, therefore if the best results are obtained in using any particular kind, they must be handled in strict accordance with the manufacturers' instructions. For dental and oral radiography, a plate should be fairly rapid (that is, it should not require a long exposure), give a high degree

of detail and good contrast, and should be uniform in its reaction to the x-ray.

X-Ray Films

In making intra-oral radiographs, a film is preferable to a plate as it is flexible and therefore can be more easily adapted to the inside of the mouth. These films are obtainable in several convenient sizes, wrapped in light-proof and damp-proof coverings ready for exposure. Like plates they should be kept in a lead-lined box for protection.

With these "dental films" as they are called, you have the choice of two different emulsions, one of which is much more "rapid" than the other.

The "rapid" or "fast film" requires only about one-fourth or one-third as long an exposure as the "regular" or "slow film," and therefore is an advantage to the radiographer who uses one of the less powerful types of x-ray machines. However, such a film does not have as much latitude as the slow film, and is therefore more apt to be over-exposed. If properly exposed, either one will give satisfactory results.

When arranging a plate or film for exposure, *the emulsion side should lie next to the structures being radiographed.* If this rule is systematically followed, it is an easy matter to identify radiographs, i.e., whether they represent structures on the right or left side of the median line.

CHAPTER VII.

DEVELOPMENT OF PLATES AND FILMS.

The process of "development" of either plates or films may be briefly described as follows: At a convenient time following the "exposure," the plate or plates (or films) are taken into the "darkroom." Such a room has all white light excluded from it, and is illuminated only by a so-called "ruby light" or darkroom lantern. The darkroom should be supplied with a shelf or table about two and a half feet wide and three feet long placed at ordinary table height from the floor, so that the operator may sit upon a stool while at work. Upon this shelf there should be four trays, one for "the developing solution," one for the "fixing bath," and the other two for water. Where a darkroom is supplied with running water and a sink, only three trays are necessary.

With all light excluded from the room except the ruby light coming from the darkroom lantern, the plate (or film) is taken out of its envelope and immersed *emulsion side up* in the developing solution. In order to insure a uniform action by the developer, the tray should be frequently rocked with a gentle motion. If the plate

(or film) has been properly exposed, development should be complete in about five minutes (although the time varies with different formulæ).

The plate or film is then removed from the developer and placed in a tray of water to thoroughly wash the developing solution from it. This, of course, requires but a moment, and it is then immersed in the "fixing bath," keeping the emulsion side up. As soon as the plate has been in the fixing bath a few seconds, the dark-room door may be opened and light admitted without injurious effects. However, the plate (or film) must still remain in the "fixing bath" until it has "cleared" (until all milkyness is gone from the back of the plate), which will usually require from five to ten minutes. In fact, it is better to let it "fix" for at least five minutes longer than is required for it to become clear.

When the fixing process is complete, the plate must be placed in water and thoroughly washed to remove all the fixing solution from it. This can be accomplished by washing it in several changes of water, or better still, place it in a basin or tray of cold "running water" for ten or fifteen minutes.

When the washing process is complete, the emulsion side of the plate or film should be gently rubbed with a clean piece of wet cotton, holding the plate (or film) under a cold water faucet during the act. The developed radiograph is then

ready to dry. Plates should be stood on edge or placed in a suitable rack so that nothing will come in contact with the emulsion side, and left until perfectly dry. Films may be pinned to the edge of a shelf, or secured to a line with suitable clips. The drying process should take place in a room free from dust or soot, for these will prove injurious to the drying emulsion.

The size of the trays used in the darkroom will depend upon the number of plates or films which are to be carried through the developing process at a time. For plates, the author uses trays 8x10 inches in size. With such trays two 5x7 plates can be carried through at a time. Where a large number of plates are being developed, additional trays can be used and if necessary "tanks" capable of holding a dozen plates, utilized in the fixing or washing process. In developing "dental films," small trays will be found convenient, and unless a large number are to be developed at a time, a 4x5 or 5x7 tray will be large enough.

Trays should be labeled according to the purpose for which they are to be used, *and used for that purpose only*. That is, developing trays should be used for developer only, and "fixing trays" only for the fixing bath, if troublesome chemical reactions are to be avoided.

Any one of several good formulæ may be used in the "developing" and "fixing" process. The

following has given satisfactory results in the hands of the author, and is easily prepared:

Developer.

Water (distilled)	20 oz.
Metol	20 grs.
Hydroquinone	80 grs.
Sodium sulphite (dry)	1 oz.
Sodium carbonate (dry)	1 oz.
Potassium bromide	10 grs.

Fixing Bath

Solution A:

Water (distilled)	30 oz.
Hyposulphite of soda	1 lb.

Solution B:

Water (distilled)	15 oz.
Chrome alum	1 oz.
Sodium sulphite (dry)	2 oz.

Solution C:

Water (distilled)	5 oz.
Sulphuric acid (C.P.)	$\frac{1}{8}$ oz.

Add C to B (when cold) and the mixed solutions to A.

If the best results are to be obtained in developing, the temperature of the solution should be kept between 65° and 75° F. If the temperature gets much over 75°, the plate will develop too fast, while if the temperature goes much below 65°, development will be retarded.

It is a mistake to try to develop a large number of plates with the same mixture of developer, for

after it has developed a half dozen plates, it will become weak and not give the best results. Therefore, do not hesitate to use *plenty of fresh developer* if you expect to get satisfactory results.

The same rule applies to the "fixing solution." It must be *fresh and clean* to give good results.

Under proper tube and current conditions, and with correct length of exposure, a plate should require about five minutes for its development. An over exposed plate will not require so long, while an underexposed plate will require a longer time.

To get the most out of a plate, it should be developed until fairly dense, that is, until it is about the same color on each side. If after it has cleared in the fixing bath, it appears *too dark or dense*, you know that it has been "*overexposed.*" Therefore in making subsequent exposures *decrease the length of exposure*. If, upon clearing, the image on the plate is faint and indistinct, you have reason to think it has been underexposed. Therefore, *increase the length of exposure*.

By keeping the tube and current conditions right, the approximate length of exposure for any given case is easily determined by the operator, after a little experience. As stated before, this will depend upon the type of x-ray machine used, the thickness and density of the parts to be radiographed, and the age and structural make up of the patient.

CHAPTER VIII.

THE INTERPRETATION OF DENTAL AND ORAL RADIOGRAPHS.

The ability to correctly interpret dental and oral radiographs is an accomplishment which every dentist should possess. In fact, it should be viewed not only in the light of an accomplishment, but as a requisite of modern dentistry. It is to be acquired by practical experience which must have for its foundation, *first, a thorough knowledge of the anatomy of the parts involved; second, a familiarity with the appearance in the radiograph of the dental and oral structures under normal conditions; and, third, a knowledge of the pathological conditions which may develop in these structures, and the character of the anatomical changes which they bring about.*

We should keep in mind the fact that radiographs are shadow pictures, and that the effect produced by the x-ray upon the photographic plate is but a shadowgraphic representation of the tissues through which the rays have passed. As this ray penetrates all matter in inverse ratio to its mass or density, the shadow picture which is left upon the photographic plate is simply a record of the varying density of the tissues through which the rays have penetrated.

The x-ray is particularly applicable to the den-

tal and oral structures, owing to the fact that *these structures differ sufficiently in degree of density to permit of their appearing in a characteristic manner upon the photographic plate.* For instance, it will be noted upon the examination of a dental radiograph, that metallic fillings, if they are present, appear as white masses, and root fillings as somewhat less white lines. The enamel and dentin are next in density, while root canals show plainly as dark channels in the dentin, and the alveolar process and maxillæ show their fine uniform cancellous structure in various degrees of density depending upon their thickness.

Because the structures within the field of our specialty have a *characteristic appearance under normal conditions, any alterations or change in these structures is at once evident upon the plate,* thus affording us a means of studying *intravital* the gross pathology of the structures of the oral cavity.

Examination of Radiographs

Dentists often underestimate the value of radiographs because their opinion is based upon their appearance either in halftone engravings or after their transference upon lantern slides. As such they should never be judged, as much of their diagnostic value is lost when reduced to this state.

The original negative itself should be examined carefully and in a proper light. This is best

accomplished by the use of an "illuminating" box or cabinet. Such a cabinet should contain several electric lamps, and the current entering these lamps should be controlled by a rheostat, or some other means, by which the intensity of the light may be changed at the will of the operator, causing it to start with a very dim light and gradually increase until a brilliant illumination is produced and vice versa. The face of this cabinet should be covered with ground glass so that the light will be free from shadows and equally distributed. An opaque mat with an opening the exact size of the plate under examination, should be placed over the ground glass so that the vision is not distributed by the light escaping from around the edge of the plate or film. Only by using such a cabinet can radiographs be examined and interpreted to the very greatest advantage.

To one who has never seen a negative illuminated in this manner, the effect is almost startling in its beauty. As the x-ray negative is a transparency, a dim light behind it will bring out one set of shadows to their greatest clearness; an increase in the light will show forth still other effects, while a still greater illumination will bring out the more dense portions of the negative, and in this way by varying the light in the illuminating box, each portion of the negative may be studied under a degree of light to bring out the maximum amount of detail.

Now with a print or lantern slide one can ex-

amine the field from only *a one light aspect*, and oftentimes in order to secure any degree of detail in the lighter or less dense areas, it will be found that the dense areas must be printed almost to an inky blackness. It should be obvious,



Fig. 52.

This radiograph shows an impacted upper third molar. The outline of the antrum is also plainly visible above the molars and bicuspids.

therefore, that a single-phase print, or a negative, examined under ordinary conditions, cannot approach the various and comprehensive effects which are brought out by means of an illuminating cabinet.

In examining intra-oral radiographs, it is an advantage to place them in a film mount which will hold them securely and render it unnecessary to view them while being held between the fingers.



Fig. 53.

A cuspid tooth lying against the anterior wall of the antrum. It will be noted that the cuspid is inverted in its position.

Such a "mount" should preferably be made of celluloid with one side clear and the other side dull, which allows the light transmitted to be of

the same character as that coming through ground glass.

In examining negatives, we should bear in mind the fact *that very dense tissues are characterized by white areas, while less dense tissues appear darker, and the absence of tissue is indicated by blackness.* To avoid confusion, we should remember that *in prints and lantern slides this color spectacle is reversed.*

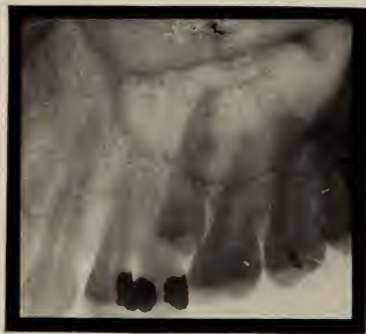

Fig. 54.

A supernumerary second bicuspid. Upon the extraction of the second bicuspid in place at the time the radiograph was made, the "supernumerary" erupted, and was found to be typical in size and form.

Assuming now that we are familiar with the normal appearance of the dental structures under the x-ray, let us now consider some of the variations from their normal appearance which are found in the presence of pathological conditions.

As a tooth is much more dense than the bony structures of the jaw, any anomaly of form, size

or position in the jaws is easily discernible even though it occupy a position far from what might be expected, as for instance, in the case of im-



Fig. 55.

A radiograph to determine the state of dentition of the right side in the mouth of a child eleven years old. The developing second molars are shown, likewise the upper second bicuspid, and the lower first bicuspid about to erupt. It will be noted that the lower second deciduous molar has no successor, nor is there an upper first bicuspid present in the jaw.

pacted molars, teeth in the antrum, etc. (See Figs. 52, 53 and 54.)

Likewise and for the same reason the presence in or absence from the jaws of successors of the



Fig. 56.

The successors to the deciduous teeth are shown, as well as developing second and third molars.



Fig. 57.

A very large alveolar abscess is visible below the mesial root of a lower molar.



Fig. 58.

An alveolar abscess involving the roots of an upper central incisor and lateral incisor. No root canal fillings are present in either tooth.

deciduous teeth can easily be determined, as shown in Figs. 55 and 56.

Fractured roots or fractures of the bone even



Fig. 59.

An abscess is visible between the central and lateral incisors. Its origin could be due to either tooth or perhaps to both.



Fig. 60.

There is evidence of a small alveolar abscess about the apex of the root of the first bicuspid, while a larger one is shown to exist about the root of the second bicuspid.

without displacement are often discernible at the line of fracture, owing to the fact that the line of

fracture offers less resistance to the penetration of the rays and therefore is apparent upon the plate as a dark line.

Where an abscess takes place in the alveolar



Fig. 61.

Alveolar abscesses above two bicuspid teeth. The relationship of the abscess areas to the antrum is also shown.



Fig. 62.

Large alveolar abscess, chronic in character, about the apex of upper first bicuspid.

process, there is always an accompanying destruction of the cancellous bone tissue. Knowing that the absence of tissue is indicated upon the plate by a very dark or black area, such an area would

indicate an alveolar abscess. "In fact, where these dark areas are found in the alveolar process, *and are not natural cavities*, such as the antrum, or the nasal cavities, or such well defined



Fig. 63.

Large alveolar abscesses emanating from the upper lateral incisor and extending to the adjacent central incisor and cuspid.



Fig. 64.

Chronic alveolar abscess cystic in character, above an upper lateral incisor. Root filling material forced through the end of the root is plainly visible.

nerve openings as the mental foramina, and where they are *markedly circumscribed*, that is, having a distinct and abrupt line of demarcation between the dark area and its surrounding tissues, we can

in nearly every case, even if a clinical history be lacking, make the positive diagnosis of alveolar abscess." (See Figs. 57, 58, 59, 60, 61, 62, 63, 64 and 65.)

Necrosis likewise appears upon the plate as a dark area, but differs in a characteristic way from the ordinary alveolar abscess in that it is



Fig. 65.

A shows an upper bicuspid tooth with an alveolar abscess at its root apex. It will be noted that the root canal is improperly filled. *B* shows the same tooth about two months after it was treated and the root canal properly filled. The rarified area about the apex has greatly decreased in size. *C* shows the same tooth about six weeks later. The abscess area has entirely disappeared and the bone structure about the apex appears to be normal.

not circumscribed, *namely, that there is not a distinct and abrupt line of demarcation between the*

dark area and its surrounding tissue, as is the case with the circumscribed infections, but the area gradually shades off from dark into light,



Fig. 66.

A necrotic area lying below a lower cuspid. It will be noted that there is not a distinct and abrupt line of demarcation between the light area and its surrounding tissue as is the case with alveolar abscesses, but the area gradually shades off from light into dark.

portraying the progressive characteristics of this disease. (See Figs. 66 and 67.)

The different filling materials vary but little

in the relative graduation of their shadows. Oxychloride, gutta-percha, and cement have about the same density, and when used as root filling materials, are plainly visible as light lines. Because they differ in density from cementum and dentin, the extent to which they have been introduced into the root canals is easily discernible.



Fig. 67.

An area of necrosis about the roots of a lower first molar.

Broken-off broaches and other instruments, or small wires introduced into root canals to determine their length or the extent to which they have been opened, because of their great density, appear very white and are easily differentiated from root-canal fillings or tooth structure. (Figs. 68 and 69.)

Where a destructive process has ensued in the

peridental membrane, or in the bony wall of the alveolus (pyorrhea pockets) and is present on the mesial or distal side of a tooth, these condi-



Fig. 68.

Small wires introduced into root canals to determine their length or the extent to which they have been opened, are easily differentiated from root canal fillings or tooth structure.

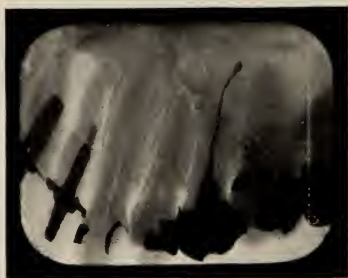

Fig. 69.

Root canal filling material forced beyond the root apex of an upper second bicuspid.

tions appear upon the plate as dark areas owing to the fact that the rays pass through them more easily, and effect the emulsion of the plate to a



Fig. 70.

An abscess involving the pericemental and alveolar tissues about an upper first bicuspid.



Fig. 71.

An osteo-sarcoma of the mandible.

greater degree than if normal bone structure is present. The approximate extent of the destructive process is therefore easily determined. (Fig. 70.)

Cysts and tumors of the maxilla or mandible, owing to the fact that the character of the changes they bring about renders the areas involved less dense, their extent is visible upon the plate as a dark area. (Fig. 71.)

In seeking out the various anomalies and pathological conditions to which the teeth and oral structures are subject, *we should not be misled by indefinite shadows upon x-ray plates.* The very nature of these structures, their gross as well as minute anatomy, renders them somewhat difficult to radiograph, and necessitates a refinement of technic greater than that demanded with most of the other portions of the human anatomy. *Therefore, only radiographs made in accordance with a definite and exacting technic should be relied upon for diagnosis. If a doubt exists in any given instance, an additional or even several more exposures should be made, so that any conclusion reached will be founded upon definite evidence.*

CHAPTER IX.

DANGERS OF THE X-RAY AND METHODS OF PROTECTION.

Almost invariably when any phase of x-ray work is discussed someone raises the query as to the dangers connected with it and the injuries resulting from its use. In fact, the impression is quite broadcast among the laity, and to a degree among the profession, that the x-ray is a dangerous agent and as such should only be employed in cases of dire emergency.

This impression, erroneous as we know it to be for the most part, gained credence as a result of the first few years' use of the x-ray, during which period its dangers were not suspected nor the laws governing its use well understood. During this period a sufficient number of patients and operators were injured so that, notwithstanding the fact that with our present knowledge of the subject and with the marked improvement in x-ray apparatus these accidents are no longer necessary, the early impression still prevails to a certain extent.

In order that we may not underestimate the dangers of this valuable agent and consider lightly our responsibility in using it, we will now consider the character of injuries possible through its misuse.

We should bear in mind the fact that the x-ray in medicine serves a double purpose. It is used as a diagnostic agent, that is in making radiographs and florescopic examinations, and as a therapeutic agent. In the latter capacity patients are subjected to repeated exposures, the length of which are very far in excess of that required in making radiographs. In fact the length of exposure in one average x-ray therapy treatment will more than out-total the necessary exposures to radiograph a half dozen patients for diagnostic purposes. Therefore, the responsibility of the x-ray therapist, and the danger connected with his work are far in excess of the man who limits his activities with the x-ray to radiography alone.

Of the various ill effects attributed to the x-ray the so-called "x-ray burn" or dermatitis is the most common. This injury occurs in various degrees of severity, depending upon the amount of overexposure to which the one afflicted has been subjected, and is designated as "acute" and "chronic."

Acute X-Ray Dermatitis

Acute x-ray dermatitis in its simplest form manifests itself in somewhat the same way as ordinary sunburn. There is a slight pinkish erythema, dry in character, accompanied oftentimes by the sensation of tingling or burning. If x-ray exposures are continued this condition is augmented by the appearance of vesicles and the af-

ected surface becomes moist or “weeping,” and the patient has similar sensations as those produced by any blistering burn. If exposures to the ray be discontinued at this stage, the affected area will slowly clear up with no permanent ill effect except perhaps a slight pigmentation.

If the exposures be continued the next degree of dermatitis will ensue. The affected area becomes an angry red in appearance, congestion is intense, and the surface is covered with a yellowish white necrotic membrane, which is epithelial in character. In fact, up to this point the connective tissue is not affected except for more or less swelling. This degree of dermatitis is exceedingly slow in healing, months being required for the necrotic membrane to disappear, and when this has occurred it is followed by a horny epidermis which appears in spots over the area affected, eventually covering it. This new skin while quite smooth and natural looking is usually characterized by the absence of all hairs and follicles.

The most severe form of acute x-ray dermatitis is characterized by somewhat the same symptoms as those just described except that they are greatly exaggerated. The degree of congestion is very great, the necrotic membrane extends deeper into the tissue, necessitating the surgical removal of masses of dead tissue to prevent gangrene. This sloughing or necrotic area shows a strong tendency to spread and according to some authors is

apt to become malignant. With such a dermatitis patients often suffer very intense pain. Injuries of this degree of intensity are exceedingly slow in healing, a number of years sometimes being necessary for the process of reconstruction. Even after it occurs the skin is not natural in appearance but hard and horny and covered in places with scar tissue.

Chronic X-Ray Dermatitis

After a person has been exposed to the x-ray a great many times covering a period of perhaps months or years, and has had one or more "burns" which were not allowed to heal before new effects were added by additional exposures, the dermatitis which results becomes "chronic." This chronic x-ray dermatitis is confined almost entirely to x-ray operators and others constantly associated with the x-ray. The hands because of their exposed position are most often the seat of this affection. The skin becomes thin and atrophic with red patches of a vascular nature, and there is usually an entire absence of all follicles and hair. Codman describes this condition as follows: "In the less pronounced forms the skin appears chapped and roughened, and the normal markings are destroyed; at the knuckles the folds of skin are swollen and stiff, while between there is a peculiar dotting resembling small capillary hemorrhages. The nutrition of the nails is affected so that the longitudinal striations become marked and the substance becomes

brittle. If the process is more severe there is a formation of blebs, exfoliation of epidermis, and loss of nails. In the worst form the skin is entirely destroyed in places, the nails do not reappear and the tendons and joints are damaged."

Another author states that "while the condition in chronic forms of x-ray irritation is as a whole atrophic, there is usually a peculiar tendency to hyperkeratosis, which shows itself in increased horniness of the epidermis about the knuckles and in the formation of keratotic patches. In some cases this is very marked, so that the affected parts, usually the backs of the hands, have scattered over them many keratoses with or without inflamed bases. The appearance is very similar to that seen in senile keratosis where the patches are inflamed and have a tendency to epitheliomatous degeneration. The development of epitheliomas in these patches of x-ray keratosis has within the last few years been well established." Carcinoma may also have its origin from the same source, in fact many x-ray operators who have failed to take the proper precautions have been subject to this dreaded malady, the hands being the parts most often affected.

Other Ill Effects

In addition to the before described injuries there are still other ill effects attributed to the x-ray, such as loss of hair, sterility, and certain systemic effects. The loss of hair due to x-ray ex-

posure is not to be regarded seriously, unless it is associated with a dermatitis of sufficient severity to destroy the hair follicles, for unless this complication is present the hair comes back within five or six weeks.

The x-ray has a deleterious effect upon developing embryonic cells and can therefore be the cause of sterility in the male by destroying the spermatozoa, and in the female by the destruction of the primordial ovules. This condition is brought about by continued exposures, and x-ray operators are the ones usually affected. It is not accompanied by impotence, is temporary in duration, and can be avoided entirely by adopting protective measures.

Regarding the so-called injurious systemic effects produced by the x-ray, too little evidence of a convincing character has yet been presented to really fasten the blame upon the x-ray for conditions other than those before enumerated. Therefore, until its guilt is scientifically substantiated we must not indict it for conditions which may be but a coincident with its use.

Methods of Protection

The evil effects of the x-ray can be entirely avoided by utilizing the protective measures afforded in modern x-ray apparatus. Inasmuch as lead is impervious to the rays it can be used in different forms and in various pieces of apparatus

in such a way as to control or confine the rays according to the will of the operator.

Tube Shield

The most essential piece of protective apparatus is the tube shield. This is constructed of leaded glass, there being a sufficient amount of lead salts incorporated in the glass to prevent ordinary rays from passing through it. The sides extend up over the highest part of the tube and the opening at the top is often covered with a rubber cap, in which lead is also incorporated. At the bottom directly opposite the target of the tube an opening of the proper size is left to allow the desired rays to pass out. The size of this opening may be controlled by interchangeable diaphragms of various sizes, which are constructed of sheet lead about one-sixteenth of an inch in thickness.

This apparatus is usually augmented by a compression cylinder, which is attached to the base of the tube shield, against or in contact with the lead diaphragm. Such a cylinder is usually constructed of aluminum with a lead lining, is made in various lengths and diameters according to the character of the work it is to be used for, and serves the purpose of confining the rays coming through the diaphragm from the target of the tube.

These pieces of apparatus are usually integral parts of the modern tube stand, sold by all reli-

able manufacturers of x-ray apparatus. It should be apparent to any one that with such apparatus, the only rays which leave the area of the tube are those which pass through the diaphragm and cylinder and are used upon the patient. In radiographic work these do not injure the patient, as the exposures are too short to produce ill effects, even if numerous exposures are necessary.

On the other hand the radiographer who fails to use these protective measures, or who carelessly places himself in the direct path of the rays will in time through the accumulative effect of the x-ray be very apt to reap as a result of his folly some of the dread injuries before described.

Other Means of Protection

In addition to the protective measures thus far described, there are other means which afford additional protection, and if a person is working constantly with the x-ray these should be used. Among these is the leaded screen behind which the operator stands during the time exposures are made. Such a screen is usually placed in front of the controlling apparatus and has a leaded glass window, so that the operator can watch the patient during the exposure. Lead impregnated gloves and aprons are also used by some as a precaution, but such extreme measures are not necessary for the dentist doing his own radiography.

With a properly constructed leaded glass tube

shield, lead diaphragm and lead lined cylinder the operator is safe, providing he takes the precaution of avoiding the direct rays.

We all realize that many very useful agents in medicine and surgery are dangerous when used carelessly, indiscriminately, or may we say ignorantly. The old saying that "fools rush in where angels fear to tread," perhaps applies with greater significance in many branches of medicine than we would care to admit. But the fact that through the misuse of dangerous agents, many patients have met death, or have been subjected to needless suffering, is no argument against their use when placed in competent hands. In such hands the x-ray stands today as one of the greatest adjuncts to the modern art of healing, a blessing to humanity, even if in its early history it left its martyrs here and there; its benefits and triumphs far out-balance any evils connected with its use.

INDEX

A

Anode, 21
Arrangement of apparatus, 77
Alveolar abscesses, 137
Alternating current, 29
Ampere, 30

B

Broken-off broaches, 141

C

Cathode, 21
Cathode rays, 23
Crookes, Sir William, 23
Crookes tubes, 23-24
Compression diaphragm, 73
Compression cylinder, 73
Current conditions for radio-
graphy, 109-117
Cysts and tumors, 144
Coil, 37
Coil, primary, 42-43
Coil, secondary, 42-43

D

Development of plates and films,
122-126
Developer for plates and films,
125
Drying plates and films, 123

E

Electrons, 17
Electric currents, 29
 direct, 29
 alternating, 29

Electric currents—Cont'd
 high tension, 29
 voltage, 30
 amperage, 30
 wattage, 30
Electromotive force, 30
Electromagnetic induction, 32,
 38, 39
Electromagnets, 38
Electrolytic interrupter, 47, 49
Extra-oral radiographs, 83, 93

F

Faraday, Michael, 21
Florescence, 21
Films, x-ray, 119, 121
 preparation for exposure, 121
Fractures, 136
Filling materials, appearance
 of, 140

G

Geissler, 21

H

Hittoff, 21
Hertz, Heinrich, 23
High frequency coils, 54, 56, 57
 diagrams of, 55

I

Induced currents, 39, 40
Induction coil, 42, 43
 essential parts of, 44
 diagram of, 48

Induction coil—Cont'd
 illustrations of, 51, 52, 53
 Interrupters, 46
 mechanical, 46
 electrolytic, 47, 49
 Interrupterless transformer, 58,
 59
 illustrated, 60, 61, 62
 Interpretation of radiographs,
 127
 Illuminating cabinets, 129
 Impacted teeth, 133
 Intra-oral radiographs, 84

L

Leaded glass tube shield, 73,
 151
 Lead compression diaphragm,
 74
 Lead lined compression cylinder,
 75, 151
 Lines of force, magnetic, 35
 Low vacuum tubes, 112

M

Magnetism, 32, 33
 Magnetic field, 34, 35
 Magnetic force, lines of, 35
 Magnetic induction, 36, 37
 Magnetic effect of electric cur-
 rent, 37
 Magnet, electro, 38
 poles of, 33
 Missing teeth, 133
 Milliamperemeter, 112

N

Nature of the x-ray, 18, 27
 Necrosis, 139

O

Ohm, defined, 30
 Ohms law, 31

P

Primary coil, 43
 Power rating of coils, 54
 Photographic darkroom, 78
 Plates, x-ray, 119
 preparation of, 119
 care of, 120
 development of, 122, 125
 drying, 124
 Pyorrhea pockets, 142
 Protection from x-rays, 150, 152
 Penetration of x-rays, 27, 113

R

Rhumkorff coil, 43
 Röntgen, William Conrad, 19, 20
 Rotary converter, 51
 Rectifier, chemical, 51, 54
 Radiographs, 79, 83
 rules for making, 81, 85, 87
 intra-oral, 83, 84
 extra-oral, 83, 93
 Radiographic examination, com-
 plete, 91, 106
 Radiographs:
 examination of, 128
 interpretation of, 127
 proper tube and current con-
 ditions for, 109

S

Solenoid, 37
 Secondary coil, 42, 43
 Self induction, 42

Spark gap, 70, 54
 Tesla coils, 54, 56, 57
 Transformers, interrupterless,
 60, 62

T

Tube stand, 71, 72
 Tube shield, 73, 151
 Tube conditions for radio-
 graphs, 109, 110
 Tubes, low, medium and high,
 110
 Tube, regulation of, 114
 connecting to x-ray machine,
 70
 inverse in, 116
 Technic of radiography, 79, 109
 correct and incorrect, diagram
 of, 87

U

Unit of electromotive force, 30
 current strength, 30
 resistance, 30
 electromotive power, 30

V

Vacuum tubes, 19, 21, 64, 65,
 66, 69
 Vacuum of tubes, how to deter-
 mine, 111, 112

Vacuum of tube, relative merits
 of low, medium and high,
 112

Volt, 30

Voltage, 32

W

Watt, 30

Wattage, 30, 45

X

X-ray, defined, 19
 discovery of, 19, 20, 25
 nature of, 18, 27
 penetration of, 27
 effect upon photographic
 plates, 27
 production of, 27, 28
 machines, 43
 tube, 64
 essential parts, 65
 types of, 66
 vacuum of, 66, 69
 connected to the coil of trans-
 former, 69, 70
 dangers of, 145
 dermatitis, acute, 146
 dermatitis, chronic, 148
 protection from, 150, 152

Dental Materia Medica and Therapeutics

By HERMANN PRINZ, D.D.S., M.D., *Professor of Materia Medica and Therapeutics, The Thomas W. Evans Museum and Dental Institute School of Dentistry, University of Pennsylvania, Philadelphia; formerly Professor of Materia Medica and Therapeutics and Director of the Research Laboratory of the Dental Department of Washington University, St. Louis.*

With special reference to the rational application of remedial measures to dental diseases. 600 pages, with more than 100 engravings. *Fourth edition*, completely revised and rewritten. Price, silk cloth binding, \$4.00.

Dental Anatomy

By MARTIN DEWEY, D.D.S., M.D., *Professor of Dental Anatomy and Orthodontia, Kansas City Dental College; President of the Dewey School of Orthodontia, Kansas City, Mo.*

275 pages, with 133 illustrations, mostly original and drawn especially for this work. Price, silk cloth binding, \$2.75.

Comparative Dental Anatomy

By ALTON HOWARD THOMPSON, D.D.S., *Late Professor of Anatomy, Human and Comparative, Kansas City Dental College; and MARTIN DEWEY, D.D.S., M.D., Professor of Dental Anatomy and Orthodontia, Kansas City Dental College; President of the Dewey School of Orthodontia, Kansas City, Mo.*

225 pages—85 original illustrations. *Second revised edition*, completely rewritten. Price, silk cloth binding, \$2.00.

Fundamentals of Pathology for Dentists

By PAUL G. WOOLLEY, B.S., M.D., *Professor of Pathology, The University of Cincinnati; Director of the Pathologic Institute of the Cincinnati General Hospital, Cincinnati, Ohio.*

200 pages—75 illustrations. Price, silk cloth binding, \$2.50.

Practical Orthodontia

By MARTIN DEWEY, D.D.S., M.D., *Professor of Dental Anatomy and Orthodontia, Kansas City Dental College; President of the Dewey School of Orthodontia, Kansas City, Mo.*

325 pages, with more than 300 original illustrations. *Second edition*, revised and rewritten. Price, silk cloth binding, \$4.00.

Essentials of Operative Dentistry

By W. CLYDE DAVIS, B.S., M.D., D.D.S., *Dean and Professor of Operative Dentistry and Technic, Lincoln Dental College, Associated with the University of Nebraska, Lincoln, Nebraska.*

350 pages—190 illustrations, mostly original. Second edition, completely rewritten, revised, and enlarged. Price, silk cloth binding, \$4.00.

Human Physiology

By R. G. PEARCE, B.A., M.D., *Assistant Professor of Physiology, University of Illinois, Chicago*; and J. J. R. MACLEOD, M.B., D.P.H., *Professor of Physiology, Western Reserve University, Cleveland, Ohio.*

320 pages—59 engravings and ten full-page color plates. *Second edition*, completely revised and rewritten. Price, silk cloth binding, \$3.00.

Surgery and Diseases of the Mouth and Jaws

By VILRAY PAPIN BLAIR, A.M., M.D., *Professor of Oral Surgery in the Washington University Dental School, and Associate in Surgery in the Washington University Medical School, St. Louis, Mo.*

A practical treatise on the surgery and diseases of the mouth and allied structures. 640 pages, with 384 engravings. *Second edition*, completely revised and rewritten. Price, silk cloth binding, \$5.50.

Practical Dental Metallurgy

By JOSEPH DUPUY HODGEN, D.D.S., *Professor of Operative Dentistry, formerly Professor of Dental Chemistry and Metallurgy, Dental Department of the University of California*; Assisted by GUY S. MILLBERRY, D.D.S., *Professor of Chemistry and Metallurgy, College of Dentistry, University of California, San Francisco.*

A text and reference book for students and practitioners of dentistry, embodying the principles of metallurgy and their application to dentistry, including experiments. 374 pages, with 44 special engravings. *Fourth revised edition.* Price, silk cloth binding, \$2.50.

