

E06281

SIXTY HORSES POWER *stationary* CONDENSING ENGINE

as constructed for working Cotton Mills,

by W^r FAIRBAIRN, Engineer, MANCHESTER.

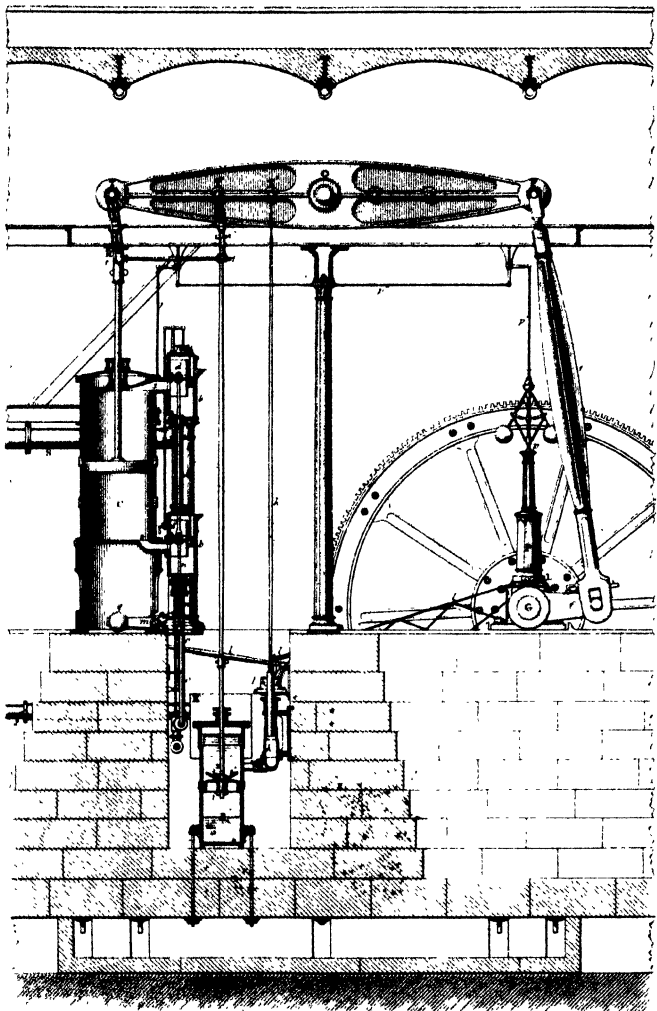

Longitudinal Section

A

RUDIMENTARY TREATISE

OR

THE STEAM ENGINE:

FOR THE USE OF BEGINNERS.



BY DR. LARDNER,

Editor of "The Cabinet Cyclopaedia."



JOHN WEALE, 59, HIGH HOLBORN.

1854.

**T. C. Johns, Printer,
Wine Office Court, Fleet Street.**



CONTENTS.

CHAP.	PAGE
I.—How Steam produces Mechanical Action	3
II.—What Steam is, and what are its Properties	5
III.—How Water is converted into Steam, and how Steam is reconverted into Water	7
IV.—How much Mechanical Effect is produced by the conversion of Water into Steam	12
V.—How much Mechanical Effect is produced by the conversion of Steam into Water	14
VI.—How much Heat is necessary to convert Water into Steam .	15
VII.—How Steam produces Mechanical Force by its Expansion .	19
VIII.—How a Vacuum is produced without cooling the Vessel containing the Steam	24
IX.—How the Mechanical Action of Steam may be augmented by Heat imparted to it directly	27
X.—How a Piston is made to move alternately from end to end of a Cylinder with a definite Mechanical Force	28
XI.—How the Alternate Motion of the Piston-rod is conveyed to the Working Beam	35
XII.—How the Alternate Motion of the Working Beam produces a Motion of continued Rotation	39
XIII.—How the Steam Engine is rendered a Self-acting Machine .	46
XIV.—How the Mechanical Effect exerted by the Piston is ascer- tained	48
XV.—How the Heat is produced by which Steam is made	51

CHAP.	PAGE
XVI —How the Draft through the Furnace of a Steam Engine is maintained	64
XVII —How the Mechanical Virtue of Fuel is estimated and expressed	66
XVIII —How the Power of an Engine is estimated and expressed, as distinguished from its Duty	69
XIX —What Dimensions of the Boiler and Furnace are necessary for an Engine of given Power	70
XX —What Dimensions of the Cylinder and other Machinery are requisite for a given Power of Engine	74
XXI —How the Internal Condition of the Boiler and Engine is rendered externally manifest	76
XXII —How the Wants of the Boiler and Engine are supplied, and how their Operation is regulated	83
XXIII —How the Steam Engine is adapted to the Working of Pumps	91
XXIV —How the Atmospheric Pressure combined with the Properties of Steam is rendered efficient in an Engine	93
XXV —How the Steam Engine is constructed in cases where a Condensing Apparatus is inadmissible	94
XXVI —How the Mechanical Pressure of the Steam on the Piston is limited, and how the Speed of the Piston is affected by this.	97
XXVII —Illustrations :	
Mercurial Steam Gauge for Low-pressure Boilers	114
" " " for High-pressure Boilers	116
Barometer Gauge—Siphon do.	117
Glass Water Gauge.	118
Spring Safety Valve for High-pressure Boilers	<i>ib.</i>
Watt's Indicator	120
Boilers and their Appendages	125
Waggon Boiler and its Appendages	129
The Slide Valves	130
General Arrangement of the Double-acting Steam Engine— <i>frontispiece</i>	131

PREFACE.



IN this little book an attempt has been made to supply, in generally intelligible language, an explanation of the facts and mechanical principles on which the structure and operation of Steam Engines depend. Within the proposed limits of bulk and cost it would be impossible to give much practical detail. The object is, therefore, to supply those who desire to learn how it is that the Steam Engine has accomplished the miracles of power for which it has been so celebrated with the means of doing so, without the technicalities of art and science, and in a form and manner which will not require a greater amount of time and labour than they can readily bestow upon it.

It is hoped that the simplicity of style and language and the comprehensive plan which have been adopted will attain this end, and that almost all who have

learned to read may in these pages learn how it is that steam power plays the important part ascribed to it in the arts and manufactures.

In the Text, the explanations are given with but little reference to diagrams; but a selection of illustrations is added in Chapter **xxvii.**, by reference to which the Text will be still more clearly elucidated.

RUDIMENTARY TREATISE
ON
THE STEAM ENGINE.

CHAP. I.—HOW STEAM PRODUCES MECHANICAL ACTION.

1. THE instrument by which steam accomplishes this is almost invariably a piston, moveable in a cylinder.

A *cylinder* is a tube or pipe, but much larger in its diameter, in proportion to its length, than tubes or pipes usually are. Thus a common proportion for a cylinder is 3 feet in diameter, inside measure, and 4 feet or $4\frac{1}{2}$ feet in length; but this proportion is very variable according to circumstances.

2. The *piston* is a solid plug, fitting the interior of the cylinder with sufficient precision to prevent steam from passing from the one side to the other, but with sufficient freedom of motion to enable it to move along the cylinder without any considerable loss of force to keep it in motion.

3. The ends of the cylinder are understood to be closely stopped by lids. One of these lids is cast with the cylinder, and forms, in fact, part of it; the other is attached to it by screws and nuts, and fitted so exactly that steam cannot escape at the joints.

4. Small apertures are provided at each end of the cylinder, furnished with stoppers or valves, by which steam may be admitted or allowed to escape at pleasure.

5. Now it will be easily understood, that if a blast of steam be admitted at one end of the cylinder it will blow

the piston to the other end : if a blast of steam be admitted at the other end, that which had previously been admitted being allowed to escape, the piston will be blown back again.

If we have the means, then, of taking in a blast of steam alternately at the one end and at the other end of the cylinder, the piston will be blown constantly backwards and forwards from end to end.

The force with which this will be effected will depend on the force of the steam.

6. This alternate motion of the piston from end to end of the cylinder, made with a certain degree of force, could accomplish nothing useful if it were confined within the cylinder ; it must be communicated to something outside which is required to be set in motion.

7. This is accomplished by an appendage to one side of the piston, called the *piston-rod*. This is a round rod, firmly fixed into the centre of the piston, and passing through a hole made in the centre of the cover or lid of the cylinder, which I have already described, to be attached by screws and nuts. It must move in this hole as the piston does in the cylinder, so tightly as not to let any steam escape, and yet so freely as not to require any considerable power to urge it.

8. It will be easily understood, that to attain this object very great precision of form is necessary in the internal surface of the cylinder and in the piston-rod. The cylinder is made of cast iron, but the inner surface of it, after being cast, is reduced to a precise cylindrical form by a boring machine. This machine scrapes off all roughness, and reduces every part of the inner surface to an exact circular form, of precisely the same diameter throughout the entire length of the cylinder.

9. The piston, which is flat on either side and circular at its edge, to correspond with the cylinder, is made to fit the cylinder in steam-tight contact, and at the same time to move freely in it by a variety of contrivances which will be

noticed hereafter. For the present it will be sufficient to assume that mechanical art, in its present state, enables us to construct pistons and cylinders with so great a degree of precision that no steam whatever shall pass between them, and yet that the motion shall be almost perfectly free.

10. The piston-rod, also of iron, is turned in a lathe so as to be truly round, and uniformly of the same diameter throughout its length. The hole through which it plays in the top of the cylinder is surrounded by a packing of hemp, soaked in oil and tallow, which is pressed against the sides of the piston-rod; and in this way, whilst the motion is free, no steam escapes.

11. The piston-rod thus partakes of the alternate motion which the piston itself receives, and conveys this motion to any object outside with which it may be connected.

12. Thus the primary motion produced by steam power is an alternate motion backwards and forwards in a straight line; but by an infinite variety of well-known mechanical contrivances, this alternate motion may be made to produce any other kind of motion that may be desired: thus we may make it keep a wheel in constant rotation, or move a weight continually in the same straight line and in the same direction.

13. These points will be hereafter explained: for the present we establish the fact that steam can by the means indicated produce an alternate force backwards and forwards along a cylinder with a degree of energy proportionate to the force of the steam, and with a degree of speed proportionate to the rate at which the steam can be supplied.

CHAP. II.—WHAT STEAM IS, AND WHAT ARE ITS PROPERTIES.

1. I have spoken of the piston in the cylinder being driven from one end to the other by a *blast* of steam. This will at once suggest the resemblance of steam to air. Steam possesses, in fact, a set of properties precisely the same as air:

if air were heated to the same temperature as steam, it would, to all intents and purposes, possess the same mechanical properties; and if it were as manageable in other respects as steam is, we should have no occasion to resort to steam engines, but should have nothing but air engines. Air could blow the piston from end to end of the cylinder as well and in exactly the same manner as steam does. It will therefore greatly facilitate the comprehension of the qualities of steam to attend, in the first instance, to the corresponding qualities of air.

2. Air is an elastic fluid,—so is steam.

The meaning of an elastic fluid is one which may be squeezed or compressed into a less bulk; or, on the other hand, which will expand itself into a greater bulk spontaneously if room be given to it.

3. All fluids, however, do not enjoy this property: water does not partake of it at all; it cannot be squeezed by any practical force into less dimensions than it naturally occupies, and whatever room you may give to it, it will not expand into greater volume. If air be enclosed in any vessel, it will spontaneously press on every part of the inner surface of such vessel with a certain force, tending, as it were, to burst the vessel. This is what is called its *elasticity*. If it be squeezed into a vessel of half the size, it will press on the inner surface of this vessel with just double the force; and if, on the other hand, it be allowed a vessel of twice the size, it will spontaneously expand and fill every part of such vessel, but will press on it with a diminished force, amounting to one-half its original pressure.

4. In short, you may by compression reduce its bulk in any required proportion, and its bursting or elastic force will be augmented in exactly the same proportion; and you may, on the other hand, permit it to expand to any augmented volume, and its pressure will be diminished in precisely the proportion in which its volume will be increased.

5. All these are equally qualities of steam.

Air is an invisible fluid,—so is steam. It is a great mistake to imagine that the cloudy vapour that is seen issuing like white smoke from steam vessels or boilers is steam: the moment it becomes thus white and cloudy it ceases to be steam.

These misty particles are particles of water, and not steam. If a glass vessel were filled with pure steam, it would be as invisible as when filled with air.

6. Steam is air made from water.

Air may exist in different states of density,—so may steam. In either case the pressure or elasticity (other circumstances being the same) is in proportion to the density.

7. But as air is everywhere accessible and disposable, it may be asked why we may not use it for those mechanical purposes for which steam has proved so omnipotent, especially seeing that the production of one is attended with great cost and trouble, while the other exists in unbounded quantity, and can be had everywhere and for nothing. To answer this we must consider those qualities in which steam differs from air.

CHAP. II.—HOW WATER IS CONVERTED INTO STEAM, AND HOW STEAM IS RECONVERTED INTO WATER.

1. If any source of heat be applied to water, the first and obvious effect will be to render the water hotter.

2. But to this there will speedily be a limit. It will be found that when the water has attained a certain heat, no further application of heat will augment its temperature, but it will then begin to diminish in quantity, and, as it were, to disappear; and if the application of heat be continued, the water will at length altogether vanish. It has in this case been gradually converted into steam, which has ascended into the surrounding atmosphere and mingled with it.

3. But this escape of the steam may be prevented. Let a second vessel be provided and put in connection with that in which the water is heated, and let the communication with the external air be cut off.

4. The steam produced from the water may be collected in this vessel, and when so collected, and submitted to examination, it will be found, as I have stated, to possess all the mechanical properties of air.

It thus appears that the liquid water is converted into the elastic fluid steam by imparting to it a certain quantity of heat.

5. One of the most remarkable changes which the water undergoes when it passes into the form of steam is its change of bulk, which is quite enormous.

6. It is found that a quart of water evaporated under ordinary circumstances will produce about 1700 quarts of steam, but this proportion varies with circumstances, as we shall now see.

7. Let us suppose that a piston is inserted in a tube, and that under the piston a small quantity of water is placed. For simplicity, let us suppose that quantity of water to be a cubic inch. Let the piston be arranged to press upon the water with a force of 15 lb., the magnitude of the surface of the piston in contact with the water being a square inch; and let us in this case put out of consideration any effect of the pressure of the external atmosphere, this pressure being represented by the 15 lb. imputed to the piston. Let a lamp be supposed to be applied under the tube, so as to heat the water within. The effect of the lamp for some time will be merely that of elevating the temperature of the water, but when the temperature shall have attained to 212° of Fahrenheit's thermometer, then the piston will be observed to begin to ascend in the cylinder, leaving an apparently unoccupied space between it and the water. The quantity of water will at the same time apparently diminish. The lamp continuing to act, the piston will continue slowly to

ascend, and the water slowly to diminish, until at length all the water shall have disappeared.

8. The piston will then be found to have ascended to such a height that the space below it in the cylinder will be 1700 times greater than that which the water originally occupied. This space, which, if seen as it might be through glass, would appear empty, would in fact be filled with the steam produced from the water, which, like air, would be invisible.

9. In this case we have supposed the steam to be produced under a pressure of 15 lb. on the square inch. Let us now, however, suppose things restored to their original state, and the piston to be loaded with 30 lb., or with 15 lb. in addition to the atmospheric pressure, which makes a total of 30 lb. If the same process as before be repeated, it will now be found that before the piston begins to ascend, the temperature of the water will rise, not to 212°, as before, but to 252°; the piston will then begin, as before, to ascend, and will continue to ascend until all the water shall have disappeared. It will not, however, rise now so as to leave 1700 times the original bulk of the water below it, but only the half of that amount, leaving a space for the steam, thus produced, about 850 times greater than the bulk of the water.

In short, the piston may be loaded with any pressure greater or less than that which we have supposed. If loaded with a less pressure, the water will expand into steam of greater volume; and if loaded with a greater pressure, it will expand into steam of less volume. The temperature also at which the water will begin to be converted into steam will vary, being higher for greater pressure and lower for less pressure.

10. When the pressure is doubled, the steam produced will not be of precisely double the density, but will not vary much from that proportion. The reason of the variation—small as it is—is, that when the pressure is doubled, the

temperature of the steam is augmented, and an increase of volume due to such increase of temperature causes the density of the steam which results to be a little less than double the original density. This variation, however, is so small that we may disregard it in practice, and assume as a simple and intelligible rule, that the density of steam is in the direct proportion of its pressure.

11. As it is of great advantage to retain in the memory the extent to which the volume of water is expanded when it is converted into steam, the following accidental proportion will be found useful: a cubic foot contains 1728 cubic inches. Now we shall be sufficiently near the truth, for all practical purposes, if we state that a cubic inch of water evaporated under a pressure of 15 lb. per square inch will produce a cubic foot of steam. This statement is at once so simple and so striking, that it cannot be forgotten.

12. Knowing the volume of steam produced by a given quantity of water under this pressure, the volumes which will be produced under other pressures, greater or less, may be inferred with sufficient practical accuracy by the proportion already given. Under double the pressure, the volume would be one-half; and under half the pressure, the volume would be double. Thus, if water be boiled under a pressure of 30 lb. per square inch, a cubic inch of water will produce half a cubic foot of steam; if it be boiled under 45 lb. per square inch, it will produce one-third of a cubic foot of steam; and in like manner, if it be boiled under $7\frac{1}{2}$ lb. per square inch, it will produce two cubic feet of steam; and under 5 lb. per square inch, three cubic feet of steam, and so on.

13. This proportion would be strictly accurate but for the fact that the temperatures at which the water boils in these cases are different; but the difference due to this need not be now attended to.

14. It may also be observed, that in general, when the

water boiled is exposed to the atmosphere, the atmosphere itself produces an average pressure of 15 lb. per square inch, which is understood to be included in the above pressures.

15. Having thus described the manner in which water is converted into steam, let us now see how steam is converted into water.

The steam which is produced from the water in the manner we have described has the same temperature as the water from whence it proceeds. This temperature is indispensable to it. The moment you deprive it of any heat, that moment a portion of it returns to the state of water, and by the continued abstraction of heat from it, it will all return to the liquid state.

16. Let us suppose, in the tube which we have already used for our illustration, that after the piston has ascended, and the water has been all converted into steam, the tube be surrounded by any cold medium, such as a cold atmosphere, the lamp being in the meanwhile withdrawn; immediately a dew will be formed on the inner surface of the tube, and the piston will begin to descend. The dew thus formed is the water reproduced from the steam, which has been restored to its liquid state, in small particles; these are swept down before the piston, and at length, when the piston shall have arrived at its original position, all the water will have re-appeared at the bottom of the tube.

The steam will, in fact, have been reconverted into water.

17. Thus, as heat is the agent by which water is converted into steam, the abstraction of heat is the means by which steam is reconverted into water.

This is one of the most important qualities in which steam differs from air. No known degree of cold is capable of converting air into a liquid, although analogy justifies the inference that some degree of cold, though unattainable by any means yet known, would effect this. There are some

airs, in fact, on which art has produced this effect, but it has never been accomplished on the atmosphere.

18. It is precisely this quality, giving us the power of reconverting steam into water at pleasure, which enables us to use steam so extensively for mechanical purposes, and deprives air of the same mechanical utility.

CHAP. IV.—HOW MUCH MECHANICAL EFFECT IS PRODUCED BY
THE CONVERSION OF WATER INTO STEAM.

1. The most common and general method of estimating the mechanical effect of any agent is by stating what weight it would raise a certain height, or to what height it would elevate a given weight. Thus, if we are told that such or such a mechanical agent is capable of raising 10 tons a foot high, we have a distinct notion of its efficiency as a moving power. In this view of mechanical effect, it will be seen that we omit the consideration of time altogether; whether it be produced in a minute or in an hour, the mechanical effect accomplished is the same. We shall consider it in reference to *time* hereafter.

. Now the questions I propose to examine are these;—

2. What amount of mechanical effect is produced when a given quantity of water, as a cubic inch, is converted into steam?

3. To what extent, if at all, is such mechanical effect influenced by the pressure under which the water is evaporated or boiled?

4. Let it be remembered that in all cases the water is supposed to be boiled in a close vessel, furnished with a valve loaded with a given pressure, so that the steam produced from the water shall have a pressure equivalent to that of the valve; in fact, according to our supposition, it must open the valve to escape, and consequently its force must be '*in equilibrio*' with it. But for our present purpose we shall recur to a mode of illustration which will be more easily

apprehended. Let us, as before, imagine a cubic inch of water placed in the bottom of a tube of indefinite length; a piston being placed in such tube, resting on the water, and so fitting the tube as not to permit the steam to escape. Let us suppose this piston, in the first instance, to press on the water with a force of 15 lb., the surface of the piston in contact with the water having the magnitude of one square inch.

5. According to what has been already explained, it will be understood that when heat is applied to the water to convert it into steam, the piston will be forced upwards, to give room to the steam thus formed. Now it has been shown that the room which the steam will thus require will be 1700 times more than its original volume in the liquid state. If then the section of the tube be a square inch, the piston will be raised 1700 inches high, in order to make room for the steam which will be produced. Thus a weight of 15 lb. will be raised 1700 inches, or about 142 feet. The mechanical effect evolved in the evaporation of a cubic inch of water under these circumstances is therefore equivalent to 15 lb. raised 142 feet high. But 15 lb. raised 142 feet high is equivalent to 142 times 15 lb. raised one foot high, or to 2130 lb. raised a foot high. Now this weight is very nearly a ton, and as we are not here concerned with minute fractional accuracy, the following remarkable fact will follow, and may easily be retained in the memory.

6. *A cubic inch of water converted into steam will produce a mechanical force sufficient to raise a ton weight a foot high.*

7. But it may be objected here, that we have supposed the water evaporated under a particular pressure, and therefore at a particular temperature: may it not happen therefore, that if evaporated under a different pressure and at a different temperature, a different mechanical effect will ensue?

To ascertain this, let us suppose the piston to be loaded with 30 lb. instead of 15 lb. We have already seen that in such case it would be raised to only half the height, for

the steam produced would have double the density. Now 80 lb. raised 71 feet is exactly equal to 15 lb. raised 142 feet, and the same consequences would follow at any other supposable pressure.

8. The above maxim then is general, and it may be assumed that in the evaporation of water the mechanical effect evolved is independent of the pressure under which the evaporation takes place, and is always at the rate of a ton raised one foot for a cubic inch evaporated.

9. It may be well here to observe that this is the *entire mechanical force* evolved, and that it must not be supposed that this effect is practically produced by every cubic inch of water evaporated in the boiler of a steam-engine; a considerable proportion of this force being absorbed by friction and other causes of the waste of power before the *useful effect* can be produced.

CHAP. V.—HOW MUCH MECHANICAL EFFECT IS PRODUCED BY
THE CONVERSION OF STEAM INTO WATER.

1. We have seen that a cubic inch of water makes a cubic foot of steam at the common pressure. If then a close vessel be filled with steam at this pressure, and be so exposed to cold that the steam it contains shall be converted into water, it will only occupy a cubic inch for every cubic foot of steam which the vessel previously contained. In fact, the vessel which was previously filled with steam will now have only a small quantity of water in it, the remainder of the space being a vacuum.

2. It is this property by which steam becomes instrumental in doing, by the mere agency of temperature, what is done by the expenditure of so much labour in air pumps and common water pumps.

3. By whatever agency a vacuum can be produced, by the same agency a given mechanical effect will follow; for if a piston be placed in the tube in which the vacuum be created

beneath it, the pressure of the atmosphere will drive the piston down with a force of 15lb. for every square inch in the section of the piston. In air pumps and common water pumps, where the vacuum is created by pumping out the air, the amount of mechanical force expended in producing the vacuum is equivalent to the amount of mechanical force which the vacuum itself produces when made; but when a vacuum is made by converting steam into water, no mechanical force is expended in producing the effect; and consequently steam thus produces a mechanical agent in its reversion into water, as well as in its production from water.

4. A cubic foot of steam having a pressure of 15 lb. will therefore, by being converted into water, produce a mechanical force equivalent to that which a cubic inch of water produces when converted into a cubic foot of steam.

CHAP. VI.—HOW MUCH HEAT IS NECESSARY TO CONVERT WATER INTO STEAM.

1. Recurring again to the same mode of illustration, let us suppose the tube and piston as before, a cubic inch of water being below the piston; and let us imagine a lamp burning in a perfectly uniform manner under the tube, so that it shall impart heat to the water at an uniform rate. Let us suppose, at the commencement of the process, the water to be at the temperature of melting ice, but without having any ice in it. Let the time be then observed which shall elapse from the first moment of the application of the lamp to the moment at which the water begins to be converted into steam, and let us suppose this interval to be an hour. The application of the lamp being continued, as before, let the process of evaporation go on until all the water shall have been converted into steam. It will then be found that the time necessary to complete the evaporation will be $5\frac{1}{2}$ hours.

2. From this then it follows, since we suppose the action of the lamp to have been uniform, that to convert a given quantity of water into steam requires $5\frac{1}{2}$ times as much heat as would be necessary to raise the same water from the freezing to the boiling point.

3. This is a fact of such capital practical importance that it ought to be engraven on the memory.

It follows from it, that if a given weight of fuel is consumed in raising a quantity of water from the freezing to the boiling point, $5\frac{1}{2}$ times such weight of fuel will be consumed in converting the same water into steam.

4. There is another point of view in which it is both interesting and important to regard this fact.

If a thermometer be immersed in the steam which shall have been produced from the water, it will show that the steam has the same temperature as the water: thus, if the water were boiled under the usual pressure of 15 lb. per square inch, its temperature would be 212° ; the same would be the temperature of the steam into which it would be converted.

5. But it will be naturally asked in this case, what has become of the enormous quantity of heat which has been supplied by the lamp? If in an hour, while the lamp was raising the water from 32° to 212° , it imparted to such water a quantity of heat sufficient to raise it 180° higher in its temperature, it must have imparted an equal quantity of heat in each succeeding hour, and in $5\frac{1}{2}$ hours it would of course have imparted as much heat as would have added $5\frac{1}{2}$ times 180° , or 990° , to 212° , the temperature of the water, supposing the latter not to have been converted into steam: the water would thus, had it not been converted into steam, have been raised to the temperature of 1202° , or about 400° hotter than red-hot iron. But in the present case, in which the water passes from the liquid to the aeriform state, no augmentation of temperature has taken place at all; the steam which has received, and which

actually contains, all this enormous amount of heat, being no hotter than the water which contained nothing of it. Where is the heat then? And why is it not felt or indicated by the thermometer?

6. The answer to the first question is easy. It can be practically proved, as we shall presently show, that the heat is in the steam. But the second question reaches one of the final points of science, and cannot be answered. The heat which is in the steam, and yet neither sensible to the touch nor indicated by a thermometer, is said to be *latent*.

7. But we must not be deceived by the use of this word; it is merely a name given to the fact that the heat is not sensible, but it discloses to us no reason for that fact.

8. It is assumed that the heat has been employed in converting the water from the liquid to the aeriform state, and being employed in maintaining the water in such a state, is not sensible to the thermometer. This, however, is after all but another mode of stating the fact, and is no explanation of it.

9. I observed, that the 990° of heat is in the steam, though not sensible to the thermometer. We might perhaps be justified in considering this as proved, inasmuch as the lamp must be supposed to impart heat uniformly during its action, but we can give a very decisive practical demonstration of it.

10. Let a cubic foot of steam of the temperature of 212°, which has been produced from a cubic inch of water, be supposed to be contained in a close vessel. Let 5½ cubic inches of water, at the temperature of 32°, be injected into this vessel. This cold water, mixing with the steam, will reduce the steam to water, or, to use a technical term, will *condense* it, and we shall find in the vessel 6½ cubic inches of water; namely, the 5½ cubic inches which were injected, and the cubic inch which was contained in the vessel in the form of steam, occupying a cubic foot, but which has now become water, and occupies only a cubic inch. These 6½

cubic inches of water will have the temperature of 212° ; that is to say, the same temperature as that of the steam which was condensed.

Now it is evident that in returning to the state of water, the steam has given out as much heat as has been sufficient to raise the $5\frac{1}{2}$ cubic inches of water which were injected into the vessel from 32° to 212° ; and yet the cubic inch of water into which such steam has been converted has itself the temperature of 212° , being the same as that which it had when in the form of steam. It is clear, then, that the 990° of heat which were in the steam are now in the $5\frac{1}{2}$ cubic inches of water which were injected, and have raised this, as must have necessarily have been the case, from 32° to 212° .

11. It is therefore demonstrated that steam has in it as much heat insensible to the thermometer and to the touch as would be sufficient to raise $5\frac{1}{2}$ times its own weight of water from the freezing to the boiling point.

12. This result has an important relation to the economy of steam power. The heat supplied by any fuel of uniform quality, and used in an uniform manner, will be proportionate to the quantity of such fuel consumed. It follows, therefore, that it requires $6\frac{1}{2}$ times as much fuel to convert water into steam, supposing the process to commence with the water at 32° , as would be sufficient to boil the same quantity of water. If the process be supposed to commence at the more ordinary temperature of 60° , then a still greater proportion of fuel will be necessary for evaporation.

13. I have supposed throughout this exposition that the water has been evaporated under the common pressure of 15 lb. per square inch, and at the temperature of 212° ; but it may be asked, what would be the result if the process were conducted under a different pressure and at a different temperature? Might it not happen that the evaporation would be effected with a greater economy of heat, which would be an important fact in the application of steam power?

14. Such, however, is not the case. It is found that no matter what the pressure may be under which the process is conducted, the same lamp, or other uniform source of heat, acting on the same water, will take exactly the same time to convert it into steam. It is true that the quantity of what is called *latent heat* will be different, and will be diminished as the pressure is increased. Thus each degree which is added to the temperature at which the water boils by increase of pressure, will be subtracted from the latent heat of the steam. The manner in which this remarkable fact is usually expressed is, that the sum of the latent and sensible heats of steam is always the same, namely about 1200° .

15. Thus if water be evaporated under such a pressure that its boiling point shall be 400° , then the latent heat of the steam produced from it will be 800° ; if it be evaporated at 300° , the latent heat will be 900° , and so on.

16. This is curious; but the important fact is, that the consumption of fuel in the conversion of water into steam is the same, whatever be the pressure of steam produced.

CHAP. VII.—HOW STEAM PRODUCES MECHANICAL FORCE BY ITS EXPANSION.

1. We have seen how a piston is urged from one end to another of a cylinder with a definite force by allowing steam to flow in upon it, and that increased efficacy is given to this by creating a vacuum on the side towards which the piston moves. The steam in this case is supposed to flow from the boiler, and to press the piston forward with a certain uniform force. The piston advances because a fresh portion of steam which enters the cylinder requires more room, to give it which the motion of the piston is necessary.

When as much steam has entered in this manner as is sufficient to fill the cylinder, then the piston will be driven to the extreme end of it. Now it is well to observe that in the production of this effect no quality proper to steam,

or which distinguishes steam from any other fluid, is concerned.

If a liquid (water for example) were made to flow into the cylinder with the same pressure and in the same quantity, it would produce precisely the same effect; in fact, the steam acts thus not because it is an *elastic* fluid, but because it is a *fluid*, and is urged from the boiler with a certain force.

2. I now come to notice, however, a mode of action in which steam performs what an inelastic fluid could not perform; one, in short, in which it produces a mechanical effect in virtue of that property which steam enjoys in common with air and other gaseous fluids, and in which inelastic fluids, such as water, do not participate.

3. Let us suppose that the steam flowing into the cylinder acts upon the piston with a certain definite force, as one ton, and continues so to act as long as it enters the cylinder.

4. Now let us imagine that when the piston has been thus pushed to the middle of the cylinder, the aperture at which the steam enters is suddenly closed, so as to prevent any fresh supply. The piston will then be no longer pushed forward by any increased quantity of steam coming from the boiler. It will, nevertheless, be pressed by the elastic force of the steam, just as it would be by the elastic force of air under the same circumstances; it will still be pressed on by a force of one ton, supposing that no adequate resistance obstructs its motion. It will not, therefore, come to rest, but will continue to advance. As it advances, the steam, expanding into a larger space, will acquire a proportionally diminishing elastic force, and will press on the piston with a force less than a ton, in exactly the same proportion as the space occupied by the steam is greater than half the cylinder. Ultimately, when the piston arrives at the end of the cylinder, the steam, which originally filled half the cylinder, will fill the whole cylinder; and the pressure upon the piston, which was originally a ton, will then be half a ton.

5. It appears evident, then, that while the piston is thus moved through the latter half of the cylinder, it is urged by a continually decreasing force, which begins with a ton, and which ends with half a ton.

6. If we could calculate the average amount of this moving force, we could at once declare the mechanical effect which is produced through the latter half of the cylinder in virtue of the expansive power of the steam.

7. At first view it might appear that the average pressure must be a mean between the original pressure of a ton and the final pressure of half a ton, and that such mean would therefore be three-quarters of a ton. But such a conclusion would be erroneous.

8. The method of calculating the exact average of a force decreasing in the manner we have described, requires principles of the higher mathematics which could not be introduced properly here. By the application of these principles it appears that the exact average of the varying pressures, in the case we have described, would be 1545 lb.

9. The mechanical effect, therefore, obtained in this way from the expansive action of the steam would be equal to 1545 lb. driven through a space equal to half the length of the cylinder. It appears, then, that nearly 75 per cent. has been added to the original mechanical efficacy of the steam by this expedient.

10. It may be asked whether there be any limit to the application of this principle. It is known that other fluids, having the same natural properties as steam, are capable of expansion indefinitely, and it might at first be imagined that there is no limit to the augmentation of the mechanical force which might thus be obtained from steam; but practical considerations show that there are not only limits, but comparatively narrow ones, to its application.

11. It will be observed that the piston, which is urged by the force of expansive steam, is acted upon by a continually diminishing power of impulsion. When the pressure of the

steam becomes by expansion less than the load which such piston drives through the intervention of machinery, including the natural resistance of the machinery itself, then it is clear that the moving power will cease to be efficacious, and that the piston must come to rest.

12. The inertia of the machinery may continue the motion somewhat longer than the moment at which an equilibrium takes place between the resistance of the load and the pressure on the piston, but this effect must soon expire.

13. The expedient by which the expansive principle may be most conveniently extended is to use, in the commencement, steam of high pressure and great density; such steam may allow of considerable expansion before it loses so much of its force as to be reduced to an equilibrium with the resistance to the piston.

14. In all cases the expansive principle evidently involves a continual variation in the impelling power of the piston.

Now it seldom happens that there is any similar variation in the resistance which the piston is required to overcome; and in that case an irregularity of action would ensue. In the commencement, the energy of the impelling force being greater than the resistance, an accelerated motion would be produced, and towards the end, the impelling force becoming less than the resistance, a retarded motion would be the effect. A great variety of contrivances have been suggested by mechanical inventors to equalise this varying action,—

15. The most common and the most beautiful of which is the *fly-wheel*. This is a heavy wheel of metal, well centered, and turning upon its axle with but little friction, so that the force necessary to keep it in uniform motion is inconsiderable. The varying action of the piston is transmitted to this wheel. When the impulsive force is greater than the resistance of the load, the surplus is imparted to the wheel,

to which it gives a slight increase of speed. Owing to the great mass of matter in the wheel, an increase of speed which is scarcely sensible absorbs an immense amount of moving force. When the impulsion of the piston by the expansion of the steam becomes less than the resistance, then the momentum of the wheel acts upon the load, and that portion of surplus force which was previously imparted to it is given back, and the wheel assists, as it were, the piston in moving the load when the latter becomes enfeebled by the extreme expansion of the steam.

16. The fly-wheel is thus, as it were, a magazine of force which gives and takes according to the exigencies of the machinery. When the moving force is in excess, the fly-wheel absorbs the surplus; when the moving force is deficient, the fly-wheel gives back what it absorbed.

17. Cases occur, however, in the arts in which the resistance to be overcome by the piston is of a gradually decreasing nature. In such cases, the expansive action of the steam, being also gradually decreasing, may be kept in equilibrio with the work without the intervention of the equalising action of the fly. Thus if the piston work a pump by which a column of water is raised, which column flows off at the top, the length of the column, and therefore its weight, is greatest when the buckets of the pump begin to ascend, and least when they arrive at the summit of their play. The weight in the buckets is in this case of continually decreasing amount, like the decreasing force of expanding steam.

18. But in most cases some equalising contrivance is necessary where the expansive principle is extensively used, and where any thing approaching to uniform action is necessary.

19. The expansive action of steam is applied in steam engines in various ways, but by far the most usual is that which we have described in the above illustration, by cutting off the supply of steam at some point before the completion

of the stroke. In some cases it is cut off at half-stroke, in some at one-third, and in some at much smaller fractions of the entire stroke.

CHAP. VIII.—HOW A VACUUM IS PRODUCED WITHOUT COOLING THE VESSEL CONTAINING THE STEAM.

1. With whatever force the piston be impelled, the effects of that force will be evidently augmented by an ability to produce a vacuum, or even a partial vacuum, in that part of the cylinder towards which the piston moves.

2. It has been already shown that this may be accomplished, if the cylinder be previously filled with steam, by exposing the steam which has filled it to the contact of cold. As heat produces steam, cold kills it. Now if a cubic foot of steam be reconverted into water by cold, it will be reduced to a cubic inch of that liquid, and we shall have the entire cubic foot minus one inch, a vacuum; and, therefore, for every cubic foot of steam in the cylinder, we shall have a cubic foot of vacuum minus one cubic inch.

3. But here we encounter a practical difficulty which long remained without solution. If we produce the vacuum by cooling the cylinder, and thus condensing the steam it contains, we shall be obliged, on the next stroke of the piston, when the cylinder must be refilled with steam, to raise its temperature again to that of the steam it is intended to contain; for otherwise the cylinder itself would condense the steam intended to fill it. Now the heat necessary thus to warm the cylinder at every stroke of the piston would entail upon us an enormous waste of fuel; yet to this waste was every steam engine exposed from the date of the invention of that form of the engine called the atmospheric engine, in the first years of the last century, until the year 1763, when Watt solved the problem *to condense the steam without cooling the cylinder*.

4. Like almost all discoveries of the first order in the

arts, this seems astonishingly obvious now that we know it: and one only wonders how it could remain for more than half a century undiscovered, human invention moreover being stimulated by the prospect of a reward which in the case of Watt proved to be a princely fortune.

5. The first expedient suggested in the progress of discovery for the production of a vacuum in the cylinder, by the condensation of the steam within it, was to cool the cylinder itself by the application of cold water on its external surface.

This process was slow, and consequently retarded injuriously the rate of action of the machine. Accident suggested a much more prompt and effectual method.

It happened that a leak took place in the bottom of a cylinder, at a point where a supply of cold water was placed; the water, pressed by the atmosphere through the hole, spirted up in a jet within the cylinder, and in an instant, by its contact with the steam, condensed it, and produced a sudden vacuum. The unusually rapid descent of the piston attracted the attention of the Engineer, the cause was investigated, and the method of cooling the cylinder on its exterior surface was thenceforward abandoned. A cock or valve was placed at the bottom of the cylinder, by which cold water was injected when it was required to condense the steam, and another was provided by which the water and condensed steam were allowed to escape. In this manner the engine continued to be worked until the application of the invention which, with so many others, has conferred immortality on the name of Watt.

6. Although the condensation by jet has the advantage, as we have stated, of being prompt, yet the cylinder was still cooled, and the waste of fuel attendant upon reheating it still took place. It is true that a jet of water would in the first instance condense the steam within the cylinder without materially lowering the temperature of the cylinder itself; but the effect would be that the heat of the cylinder,

acting on the water contained within it, would immediately reconvert a portion of such water into steam, and destroy the vacuum before it could take effect upon the piston. It was therefore necessary to throw in by the jet as much cold water as was sufficient not merely to condense the steam, but also to cool the cylinder down to the temperature of, at most, 100° ; and even at this temperature a portion of the vapour was still uncondensed, which impeded injuriously the action of the machine.

7. The invention of Watt not only had the effect of producing an almost perfect vacuum, but it did so without in the slightest degree lowering the temperature of the cylinder. The idea occurred to Watt of placing near the cylinder another vessel, submerged in cold water, and having a jet of cold water constantly playing within it. Whenever it was desired to condense the steam in the cylinder, he opened a communication by a cock or a valve between this vessel and the cylinder, and immediately the steam, by its elastic force, rushed into this vessel and was instantly condensed, leaving in the cylinder an almost perfect vacuum, and at the same time exposing the cylinder to no cold which could in the slightest degree lower its temperature.

8. The vessel here described, immersed in a cistern of cold water, and having a jet playing in it, was called a *condenser*. By the continuance of the process just described, such vessel would, after a time, not only be filled with water supplied from the jet and the condensed steam proceeding from the cylinder, but it would also contain more or less air which would enter in a fixed form in the water, and which would be liberated by the warmth of the steam condensed by the water. This air would vitiate to some extent the vacuum in the condenser, into which it would pass in virtue of its elasticity. These impediments were surmounted by the adjunction of a pump to the condenser, by which the water supplied by the jet and the condensed steam, as well as the air just adverted to, were constantly pumped out.

9. This is called the *air pump*.

10. The water surrounding the condenser, unless it were changed, would in time become warm, and fail to effect the condensation. This is remedied by the application of a pump and waste pipe to the cold cistern in which the condenser is submerged. The pump continually supplied cold water, which, by its comparative weight, had a tendency to sink to the bottom; and the waste pipe, placed near the surface, let escape the warm water, which, by its comparative lightness, ascended: thus, with these arrangements, the method of separate condensation became complete.

11. The effect of this invention, with a few others which will be described hereafter, was to save about 75 per cent. of the fuel consumed by the steam engines as previously worked. Watt and his partner Boulton were content to receive, as their reward for this gift to the arts, one-third of the saving which they effected; and this one-third proved to be sufficient to enable each of these illustrious men to leave to their descendants magnificent fortunes.

CHAP. IX.—HOW THE MECHANICAL ACTION OF STEAM MAY BE AUGMENTED BY HEAT IMPARTED TO IT DIRECTLY.

1. In all the ordinary applications of steam, the heat imparted is applied to water from which the steam used for mechanical purposes is raised. Heat, however may be imparted directly to the steam itself after it has been separated from the water, and when so applied it will augment in a certain proportion the mechanical efficacy of the steam.

It has been thought by some projectors that heat applied in this way might be rendered more efficacious than when applied in the evaporation of steam from water. It may, therefore, be worth while to explain here to what extent the mechanical power of steam can be augmented in this way.

2. It is a remarkable fact, that the effect of heat applied to air and all species of gases in augmenting their volume is precisely the same. It is found that if air or any species of gas be confined within a certain volume, and that heat be applied to it until its temperature be raised one degree, its elastic force will be augmented by one 480th part of its whole amount. Thus if a certain surface of the vessel which contains it suffer a pressure from its elastic force of 480 lb., the same surface will suffer a pressure of 481 lb. from the temperature of the air or gas being raised one degree.

3. Now it is still more remarkable, that the very same law applies to every species of vapour, that of water included. If then a cylinder containing steam excluded from contact with water be exposed to any source of heat, it will receive the above augmentation of pressure for every degree by which its temperature is elevated. This increase amounts, in round numbers, to one-fifth per cent. of the whole mechanical effect.

4. It is scarcely necessary to say, without going into details for which our limits would not afford us space, that the same quantity of fuel which would produce this increase of mechanical effect, applied directly to a vessel containing steam, would produce a greater mechanical effect, applied to a boiler to produce steam from water.

It is therefore not necessary to dwell further on this principle, as invention has not yet profitably employed it in the case of steam.

CHAP. X.—HOW A PISTON IS MADE TO MOVE ALTERNATELY FROM END TO END OF A CYLINDER WITH A DEFINITE MECHANICAL FORCE.

1. It is evident that if steam can be admitted on one side of the piston, and withdrawn on the other, the piston will move in obedience to the pressure on the side at which it is admitted.

2. If, when the piston arrives in this manner at the end of the cylinder, the steam which has impelled it be withdrawn, and at the same time steam be admitted on the other side, the piston will move back again from exactly the same cause.

Thus to produce the alternate motion of the piston it is only necessary to provide means for the alternate admission and escape of the steam at each end of the cylinder.

3. This supposes two apertures of some kind at each end, one for the admission and the other for the escape of the steam: it supposes also one of these apertures to communicate with the boiler, where the steam is generated, and the other to communicate with the condenser, where the steam is destroyed.

4. It supposes, moreover, some means of alternately stopping and opening each of these apertures.

The means whereby this is effected are very numerous.

5. It may be done by stoppers which fit steam-tight into holes, from which they are lifted or drawn, and to which they are returned alternately, just as the stopper of a decanter would be, only that they are made more conical, in order that they may be more suddenly opened and closed. These are usually made of brass or gun-metal, and may be ground so as to fit with great precision.

These contrivances are called *puppet valves*. Those which open a communication with the boiler are called *steam valves*, and those which open a communication with the condenser are called *exhausting valves*.

6. Now supposing that we are provided with such contrivances, and are supplied with the proper mechanism for opening and closing them, nothing can be more simple than to work the engine.

7. Although it is not necessary that the cylinder be placed in a vertical position, and very often it is not so, yet, for the convenience of explanation, we shall here suppose it in that position, and we shall distinguish the two steam valves as the *upper* and *lower*, and the same with the two exhausting

be simultaneously opened. Steam will flow through the upper steam valve above the piston, and the steam below the piston will flow through the lower exhausting valve into the condenser, where it will be destroyed. We shall have a vacuum under the piston, and the pressure of steam above it. The piston will therefore descend to the bottom of the cylinder.

8. When it arrives there, let the two valves, which have just been supposed to be opened, be closed. The top of the cylinder will now be shut off from the boiler, and the bottom from the condenser. At the same time let the lower steam valve and the upper exhausting valve be opened. The steam which filled the cylinder above the piston will immediately rush to the condenser through the open exhausting valve, where it will be destroyed, and steam from the boiler will pass below the piston through the lower steam valve. Steam pressure will therefore act below the piston while there is a vacuum above it, and the piston will ascend until it reaches the top of the cylinder. The constant repetition of the same process of opening and closing the valves in pairs would obviously in this manner continue the alternate action of the piston from end to end of the cylinder.

9. In the earlier steam engines this process of opening and closing the valves was executed by the hand of an attendant, and, like all constant mechanical action which depends on the human will, was done irregularly. It soon became apparent that the piston itself could be made to execute this with the most perfect certainty, regularity, and precision. Tradition says that an uneducated child, named Humphrey Potter, was the inventor of this improvement, by which the steam engine first became a self-acting and self-regulating machine.

10. From what has been above explained, it will be evident, that although there are four independent valves, there is in reality only a single motion, and that all the four may be easily managed to be connected so that the motion to be imparted to them may be effected by a single impulse proceeding from any convenient part of the machinery.

11. When the piston arrives at the top of the cylinder, two valves,—the upper steam valve and lower exhausting valve,—are required to be opened; and at the same moment the two other valves,—the lower steam valve and upper exhausting valve,—must be closed. Now, as all these movements are simultaneous, it may be easily imagined that the four valves may be so connected that a single movement imparted to them should open one pair and close the other pair.

12. When the piston arrives at the bottom of the cylinder, a single motion in the contrary direction will evidently effect the object to be attained, that is to say, to open the lower steam valve and upper exhausting valve, and close the upper steam valve and lower exhausting valve.

13. These communications between the ends of the cylinder and the boiler on the one hand, and the condenser on the other, are often governed by means even more simple than the puppet valves we have just described.

14. The two openings at each end of the cylinder are sometimes made in flat surfaces, over which two sliding shutters are moved, these two sliding shutters being connected by a rod or other solid connexion, extending from end to end of the cylinder. By moving this rod upwards or downwards, the position of the shutters being properly adjusted, the openings for the admission or escape of the steam are covered and uncovered by pairs in the manner necessary to produce the effect we have described.

15. These contrivances are called *slides*.

16. If the steam be used expansively, by shutting it off before the completion of the stroke, the times of opening and shutting the several apertures will not be the same.

17. The opening by which the steam is admitted will in that case be closed at the moment when the piston has completed a certain part of the stroke and the valve for the admission of steam at the other end must not be opened till the end of the stroke.

18. When a cylinder is so worked, there will then be three epochs in each stroke at which the valves must be acted upon,—at the commencement when the steam is first admitted to impel the piston, at some intermediate point when its influx is stopped, and at the extremity when it is let in on the other side. If puppet valves be used, such as we have first described, each moving independently of the other, it is easy to conceive how these effects may be produced: but even with slides they are also managed by so adjusting the slide to the opening, that by two successive motions, made at different points of the stroke, the effect is produced. At the commencement, the slide being advanced through a certain space, the steam is admitted on the one side of the piston and withdrawn from the other; at an intermediate point, the slide being further advanced, the influx of steam is shut off, but the efflux on the other side still permitted; at the termination of the stroke, another movement of the slide admits the influx on the other side, and the efflux on the opposite side.

19. There is another class of contrivances for governing the admission and the emission of steam, which are called *cocks*. These are similar in their mechanical construction to the common water-cock. A solid metallic cone with the point cut off, is capable of revolving in a hollow cone which it fits steam-tight. This solid cone is pierced with two or more passages, the openings of which, by turning the cock, may be brought to coincide with corresponding openings in the hollow cone in which it revolves. In this way steam may be admitted to or allowed to escape from the cylinder, in a manner exactly similar to that by which a liquid is enabled to flow from a vessel by means of a common cock.

20. The application of this expedient evidently supposes the practicability of bringing the openings for the influx and efflux of steam communicating with the top and the bottom of the cylinder to the same point ; but there is no difficulty in this. It is only necessary to provide tubes or passages, leading from the point where the cock is placed to the top and the bottom of the cylinder, through which the steam may pass to or fro.

21. A practical objection to this expedient is, that at each stroke as much steam is lost as fills such passages, inasmuch as such steam has no effect in working the piston. A source of waste is therefore produced, expressed by the proportion which the contents of these passages bear to the magnitude of the cylinder.

22. For this reason, among others, cocks or valves placed in this manner, at distances more or less considerable from the ends of the cylinder, are in general used only in small engines of short stroke. In the larger class of engines, with very long stroke, valves are placed at each end, close to the piston, and worked by independent mechanism.

23. The action of the puppet valve, or spindle valve, as it is sometimes called, has in practice some advantages over that of slides or cocks ; it is more prompt in opening and closing, and it is much less likely to leak in consequence of wear ; it is also obviously subject to less friction.

24. As I have already stated, these valves are conical, and rest in a conical seat, being ground so truly as to be steam-tight. The angle of the cone is usually 45° . If it be less conical, the valve is apt to get tightened in its seat ; if more so, it is apt to leak.

25. When slides are used, some expedient is adopted to enable them to move against the surface with which they are in contact so as to be steam-tight. This is either effected by a packing of hemp soaked in tallow, or by the operation of some metallic surface urged by springs, technically called *metallic packing*.

26. The efficiency of the operation of the piston greatly depends on its being steam-tight in the cylinder. The least leakage from the one side to the other would cause the steam to escape to the vacuum side. It is true that, arriving there, it would immediately rush to the condenser so that it might not sensibly impede the action of the piston, but it would still be a source of waste of power.

27. Pistons are rendered steam-tight either by vegetable or metallic packing.

28. A common hemp-packed piston consists of two circular metallic plates, placed one above the other, and connected together by screws: in the space between these two plates, round the edge, is left a cavity which is filled with unspun hemp or soft rope, called *gasket*, which, being wound round the piston, is compressed into an uniform and compact mass by screwing the top and bottom of the piston together.

29. This packing is pressed afterwards so as to be forced against the surface of the cylinder; it is lubricated with melted tallow, let down on the piston from a funnel inserted in the top of the cylinder, and governed by a stop-cock, so as to prevent the escape of the steam.

30. In the most improved modern engines, however, metallic packing is generally used. Between the two plates forming the top and bottom of the piston are placed a number of metallic rings, one above the other, so as to fill the space between the two plates, and having their diameters a little less than that of the cylinder: these rings are usually cut into three or four segments, the points at which each ring is cut not corresponding with those at which the rings above and below are cut. Within these segments are placed springs, which, acting from the centre of the piston, urge the segments against the surface of the cylinder. The construction of these and the form of the cylinder itself have been brought to such a degree of precision, that these pistons act with complete efficacy; and use, instead ofinjuring, improves them.

31. In all the preceding explanations it has been supposed that the steam is admitted at either end of the cylinder at the moment that the piston has arrived there, and is about to commence its action in the opposite direction. In practice, however, it is convenient to admit the steam a little before the moment when the piston reaches the extremity of the cylinder: this is attended with the advantage of its assisting to break the shock which would attend the sudden change in the direction of the motion of the mass of matter composing the piston and rod, and the other parts of the machinery which partake of their alternate motion. The steam admitted just before the motion of the piston is reversed acts as a sort of cushion to receive the piston.

32. These and other matters of practical detail in the operation of the engine render the time of opening the valves a very important matter, and machinery is accordingly provided for regulating the moment of their opening with the greatest certainty and precision.

CHAP. XI.—HOW THE ALTERNATE MOTION OF THE PISTON-ROD IS CONVEYED TO THE WORKING BEAM.

1. With few exceptions, the power exercised by the piston in a steam engine is in the first instance imparted to a beam called the *working beam*, which is supported on a fixed axis, and which vibrates alternately upwards and downwards.

Now it may at first view appear that we might at once impart the motion of the piston to the beam by attaching its extremity to that of the beam by a common joint and pin, but the slightest reflection will show that such an arrangement would be incompatible with what has been already stated.

2. It will be remembered that the piston-rod is a thick rod of iron, accurately formed and polished, that it is firmly attached to the centre of the piston, and that the construction and operation of the cylinder and piston require that the rod should accurately move in a straight line upwards

and downwards. Now the end of the beam, which vibrates alternately on a horizontal axis, will move alternately upwards and downwards, but not in a straight line. It will move alternately in the arc of a circle, the centre of which will be that of the axis on which the beam vibrates. If then we attempt to connect immediately the end of the piston with the end of the beam, the consequence will be that the end of the piston, following the motion of the end of the beam, will be moved alternately upwards and downwards in a circular arc, and consequently would be strained or bent and its action in the cylinder disturbed.

3. There are several ways of surmounting this difficulty, all of which consist in interposing between the end of the piston-rod and the end of the beam some piece of mechanism which will allow the rectilinear motion of one and the alternate circular motion of the other.

4. The most simple expedient of this kind consists of a rod of metal, working at one end by a pivot on the beam, and at the other by a pivot on the end of the piston-rod. In this case, however, there would still be a liability to straining the piston-rod from its rectilinear motion, were it not regulated by some species of guide. A common method of effecting this is to attach to the top of the piston-rod a cross-piece, so as to make with it a form like the letter T. The ends of this cross-piece are made to move on fixed upright rods, so that these last may resist any tendency to strain the piston. The joint or joints connecting the piston with the end of the beam may be attached to the ends of the cross-piece.

5. It is not indispensably necessary that a beam should be employed at all, and in some engines of small magnitude and compact form it is omitted. A rod is brought from the cross head of the piston directly to the object which the engine is intended to drive.

6. In many cases, and especially in the large class of steam engines used in England in manufactories, the piston-rod is connected with the beam by a contrivance called a *parallel*

motion. This is a combination of rods, so arranged and joined together, that while one of their pivots is moved alternately in a circular arc, like the end of the beam, some point upon them will be moved alternately upwards and downwards in a straight line.

7. A great variety of combinations and proportions are capable of effecting this with sufficient precision for all mechanical purposes, but that which is best known as the parallel motion, and which is due to the invention of the celebrated Watt, is in principle as follows :

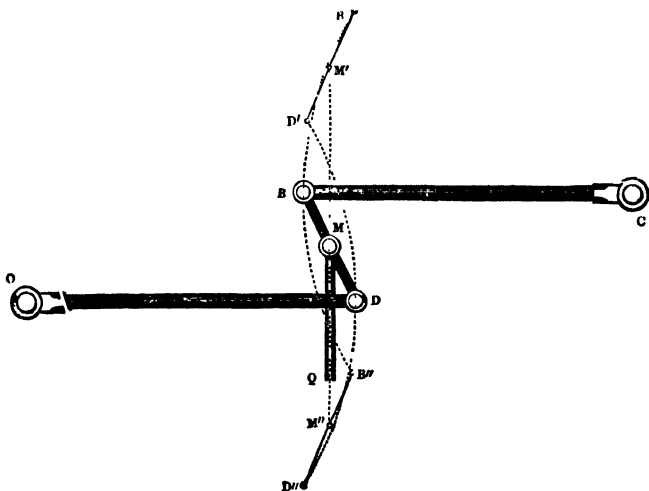

8. Let two equal rods CB and OD be attached by pivots to two fixed points at C and O , on which they shall be at liberty to play alternately upwards and downwards in the circular arcs $B'B''$ and $D'D''$: but let their play be limited to small arcs. Now let a third rod BD be connected by pivots with the ends of the two former.

Let a point M be marked at the middle of the rod BD . Now if CB be made to vibrate on its centre, C alternately in

the arc $B' B''$, which will cause at the same time $O D$ to vibrate alternately in the arc $D' D''$, it will be found that the point M will ascend and descend in a line $M' M''$, which will not deviate sensibly from a straight line, in a vertical direction; in fact, if a pencil were attached to the point M , and a surface held behind it, such pencil, by the motion of the rods, would trace a vertical line upon the surface.

Now if we imagine CB to represent the beam of the engine, and OD and BD rods connected with it in the manner already described, O being attached to a fixed pivot, then the point M , being attached to the top of the piston-rod, will move with it freely upwards and downwards in a true vertical line, and will, through the combination of rods just described, impart motion to the end of the beam B .

9. To demonstrate strictly this would require the application of mathematical principles not compatible with our present object; nor indeed is it strictly true, in a geometrical sense, that the motion of the point M takes place in a straight line: its deviation, however, from a vertical line, within the limits of the play given to the beam and piston, is so extremely small as to have no practical effect whatever.

The general effect of the combination here described may be understood thus. When the point B is moved upwards to B' , the upper extremity of the rod BD is drawn a little to the right, and at the same time the lower extremity D , being moved to D' , is drawn a little to the left. When the extremity B descends to B'' , the extremity D descends to D'' , and the ends are again drawn, the one a little to the right, and the other a little to the left. It will be easily understood that in this case, while the ends of the rod BD are thus alternately made to move right and left, there will be an intermediate point of it which will neither deviate on the one side nor on the other. The upper half of the rod, in fact, is continually inclined towards the right, and the lower half towards the left, the middle point being affected by neither motion, and therefore being moved vertically up-

wards and downwards in a direct straight line. This is the principle of the parallel motion.

10. In its practical application it appears somewhat more complicated, for in order to accommodate the arrangements of the beam and piston-rod, a great number of rods and joints are necessary to be used ; but these are mere matters of mechanical convenience, and have no effect upon the principle of the arrangement.

It is therefore now apparent that the alternate motion of the piston-rod upwards and downwards in a straight line imparts a corresponding alternate motion to the end of the working-beam in a circular arch.

11. Although we have, as usual, here described the arrangements as if the cylinder were vertical and the beam placed over the piston-rod, this position is neither necessary nor is it invariably adopted. Sometimes the beam is placed below the cylinder, and the rods of the parallel motion or connexions, with the cross head and guides, are made of sufficient length to extend down to the beam. Sometimes the cylinder is horizontal and the beam vertical, and cases even occur in which it is found convenient to place the cylinder in an inclined position ; but all these are matters of arrangement to be determined by the circumstances in which the engine is applied, and have nothing whatever to do with its mechanical principle.

CHAP. XII.—HOW THE ALTERNATE MOTION OF THE WORKING BEAM PRODUCES A MOTION OF CONTINUED ROTATION.

1. Of all sorts of motion, that which is most frequently required in the arts, is one of continued rotation. Mills in factories of every kind are impelled by machinery which receives its motion from a wheel kept in constant rotation.

Ships impelled by steam engines over the deep are driven by paddle-wheels or screws, to which constant rotation must be imparted. Carriages on railways are propelled by com-

pulling one or more of their wheels to revolve continually by the application of adequate power to it. This is so evident, that one of the first and most important problems the steam engineer has to solve, is how to make the alternate motion of the piston-rod produce the continued rotation of a wheel.

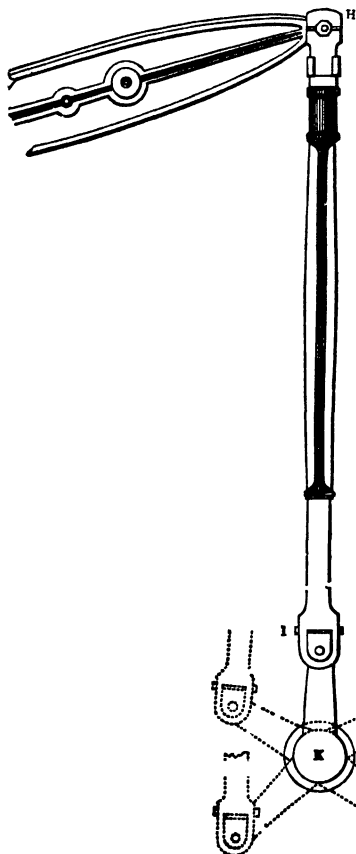

2. The contrivance by which this is effected almost universally is called a *connecting-rod* and *crank*.

The crank is an arm sometimes attached to the centre of the wheel to which revolution is desired to be imparted, and the wheel is made to revolve by it by the same mode of action as that by which a winch turns a windlass.

Thus, if κ be the centre to which motion is to be imparted, κI is an arm or lever fixed upon such centre. A pin, called the *crank-pin*, is attached to this at I , which forms the

joint by which the connecting-rod is united with the crank. $I H$ is a strong iron rod, extending from the crank-pin to the

end of the working beam, with which it is connected by a similar pin. The weight of this connecting-rod is so adjusted that it exactly balances the weight of the piston and its rod attached to the other end of the beam. In the figure the crank is represented by dotted lines in the different positions which it assumes as it revolves. As the end of the beam is moved upwards and downwards, the crank will be turned round the centre κ , and a motion of continued rotation will be produced, which will be communicated to any wheel fastened upon the axle κ .

3. To make the action of the piston upon the crank perfectly clear, let it be supposed that the piston is in its descending stroke. The force of the steam upon it is imparted by the rod and the intermediate mechanism to the end of the beam which is drawn down. At the same time the other end of the beam, with the connecting-rod, is drawn up. The crank is thus made to ascend from its lowest to its highest position, to which it arrives when the piston has reached the bottom of the cylinder. When the piston ascends, the force of the steam is in like manner transmitted to the beam by the piston-rod, which is made to ascend, and the opposite extremity, with the connecting-rod, descends, by which the crank is driven down to its lowest position on the side opposite to that on which it ascended, and thus a motion of continued rotation is produced.

4. But in this action there are particulars necessary to be noticed. There are two positions which the crank assumes, in each revolution, at which the force of the piston can have no effect in continuing its motion: these positions are those which the crank assumes when the piston is at the top and at the bottom of the cylinder, the points at which it changes the direction of its motion. When the piston is at the bottom of the cylinder, the crank-pin is immediately above the axis to which the crank is attached: in this position the force of the piston would have no other effect than to press the crank perpendicularly upon the axle, and evidently would

have no effect whatever in making it revolve. If we were to suppose, then, the entire machinery at rest in this position, the steam acting on it could not put it into motion.

5. Again, if we suppose the piston to be at the top of the cylinder, the crank-pin will then be at its lowest point, and will be directly under the axle: the effect of the steam acting above the piston would then be to press the crank-pin upwards against the axle, but it could have no influence in turning it. If, therefore, the machinery were at rest in this position, it could not be put in motion by the steam.

In any intermediate position, however, the connecting-rod would act on the crank with a leverage more or less effective, and would move it.

6. The two points which we have here described, at which the crank-pin assumes its highest and lowest position, are usually called the *dead points*.

Now it may be asked why the engine does not cease to move every time the crank-pin arrives at these dead points, seeing that there the moving power, however energetic, can have no effect on it.

7. The answer is, that the machinery is extricated from this mechanical dilemma in virtue of the common property of matter called *inertia*, by reason of which, when it has acquired any definite motion in any certain direction, it will not suddenly stop, even though it be impelled by no external force, but will continue to move until the momentum it had acquired be exhausted by friction and other resistance.

8. Since, then, the motive power continues to exercise more or less force up to the dead points, the machinery, arriving at them, has some definite motion, and the momentum consequent upon that motion carries the crank out of the critical position we have referred to.

9. But, independently of the dead points, there are other circumstances attending the action of the connecting-rod on the crank which are necessary to be explained. By the

intervention of the beam, the force of the piston is transmitted to the crank-pin in the direction of the connecting-rod. Now by observing the diagram above given, showing the successive positions of the connecting-rod and crank, it will be seen that twice in each revolution the connecting-rod is at right-angles with the crank, but that in other positions it is more or less oblique to it; the extremes of the obliquity terminating alternately in the dead points, in one of which the connecting-rod and crank are brought into a continued straight line, and in the other the crank is as it were doubled on the connecting-rod.

10. Without resorting to the language of technical geometry, it will be apparent that the action of the connecting-rod on the crank is most energetic when they are at right angles; and that according as they become more and more oblique, and approach the dead points, the action becomes less and less effective. It diminishes rapidly in approaching these points, and is altogether extinguished on arriving at them. It appears then that the action of the connecting-rod on the crank is subject to a regular variation in each semi-revolution: a maximum when they are at right angles, it diminishes, and at length vanishes when it arrives at the highest point; then, in descending, it re-appears, augments, and is a maximum at the point where they are at right angles; then it again diminishes gradually, and ultimately vanishes at the lowest point, having passed which, it again re-appears, augments, and is a maximum when it assumes its rectangular attitude.

11. Now although the inertia of that portion of the machinery which is once put in revolution be sufficient to prevent the motion from ceasing, and the engine coming to a dead lock when the crank-pin comes to the dead points, yet it is not generally sufficient to prevent a very great inequality of motion from arising from the cause which we have here explained. An expedient accordingly has been resorted to, which perfectly counteracts this inconvenience,

and equalises the motion. This expedient is the fly-wheel, which we have already described.

12. The fly-wheel is placed on the same axle κ as the crank, and it is made to revolve simultaneously with the crank. This wheel is so nicely balanced on its centre, and moves with so little friction, that it absorbs a very inconsiderable portion of the moving power. It is usually made of very large diameter, and its ring or circumference is composed of a very ponderous mass of metal. All this metal is put in motion by the moving power, and, from its great mass, has a considerable momentum even when the velocity is moderate. When the crank is at the dead points, this mass, by its momentum, continues the revolution, and carries the crank into a new attitude, where the moving power exercises an influence on it. When the crank and connecting-rod are in such position in which their action is most energetic, the fly-wheel absorbs a part of the moving power. As the crank approaches the position in which the action of the moving power upon it becomes enfeebled, the fly-wheel gives back to the machinery such surplus power as it received when the action of the crank was most energetic.

13. Between the fly-wheel and the engine there is, therefore, a continual reciprocity of action and interchange of power, which in practice completely equalises the velocity; and there is in fact no perceptible difference between the speed of the movement at the dead points, where the moving power loses its influence, and at the middle of the stroke, where its action is most effective.

14. To minds not very familiar with mechanical considerations, it may seem extraordinary that the intense action of the moving power upon the fly-wheel at the middle of the stroke should not at these points produce a perceptible acceleration in its motion, and a corresponding irregularity, therefore, in the motion of the machinery which it drives; but it must be considered that the excessive mechanical

force exerted at the middle of the stroke is imparted to a great mass of metal collected in the rim of a very large wheel. Now the velocity which a given force produces is diminished in the direct proportion of the mass of matter to which it is imparted: thus a force which would give a certain speed to a ton of metal would give only a tenth part of such speed to 10 tons. The weight collected in the rim of the fly-wheel is so great that the excess of power of the engine at the middle of the stroke, when imparted to it, produces an inconsiderable increase of speed. But this increase of speed, inconsiderable as it is, is produced on the circumference of a very large circle, and the mass of matter thus moved must be carried through a very considerable space in making even a single revolution. Thus, what between the great mass of metal collected in the rim of the fly-wheel and the great diameter of the fly-wheel itself, the unequal action of the crank is rendered absolutely imperceptible.

15. In elementary works on the steam engine, sometimes proceeding from persons who, however respectable their practical attainments, are deficient in mathematical knowledge, the crank is often represented as an imperfect contrivance, and an extensive source of waste of power, owing to unequal action.

Nothing can be more fallacious than the reasoning of such writers. It can be demonstrated by the most strict geometrical reasoning, and the result is verified by experience, that in the action of the crank and fly-wheel there is no other loss of power than such as is incidental to the common and well understood causes of friction and atmospheric resistance.

16. Owing to such fallacious notions, much valuable inventive power has been wasted in attempts after the contrivance of what are called *rotatory steam engines*.

A rotatory steam engine is one by means of which a movement of continued rotation may be immediately given to a piston, or in other words, by which the power of the

steam can be immediately applied to a revolving wheel without the interposition of a piston, cylinder, beam, and crank. If such an application could be contrived without the various countervailing losses of power which have hitherto invariably attended such projects, it would certainly have some advantages; but it is not easy to see how such an object can be attained, and at all events, notwithstanding the expenditure of a vast amount of ingenuity and capital, it has never yet been effected.

17. Cases occur in the arts, in which a fly-wheel cannot conveniently be attached to the steam engine, and yet where uniformity of action is necessary. In such cases the object is usually attained by using two cylinders, which drive two cranks constructed on the same axle, but having such positions that when either is at its dead point, the other is at its point of maximum efficiency. Thus, while the efficiency of one crank increases, the other diminishes, and *vice versa*, and the sum of their actions at all times is nearly the same.

CHAP. XIII.—HOW THE STEAM ENGINE IS RENDERED A SELF-ACTING MACHINE.

1. We have already stated that this is accomplished by making the engine open and close, at the proper times, the valves by which steam is admitted to and discharged from the cylinder. In the earlier engines this was accomplished by a *bar* or *rod* attached to the end of the working beam, and carried down parallel to the cylinder. On this bar were attached pins, so placed that as it ascended and descended they struck the handles or levers of the respective valves, and opened or closed them, as the case might be. This method is still used in some of the larger class of engines applied to the pumping of water. Where slides or cocks are used (as indeed is almost invariably the case), they are generally moved by an apparatus attached to the crank shaft, called an *eccentric*.

2. This consists of a circular plate of metal *B D*, which is

fixed upon a point g at some distance from the geometrical centre. Round this eccentric point it is made to revolve, and in revolving it is evident that its geometrical centre, revolving round its centre of motion, will be thrown alternately to the right and to the left of such centre.

3. Now let us suppose this circular plate to be surrounded by a ring, within which it is capable of turning, but so that the ring shall not turn with it.

Then such ring will be thrown alternately to the left and to the right of the centre on which the eccentric plate is made to turn, and the length of its play, right and left, will be equal to twice the distance of the geometrical centre of such circular plate from the centre on which it turns. In the figure annexed, g is the centre on which the circular plate revolves; c is its geometrical centre; $F I$ is the ring which embraces it, and within which it can turn. To this ring is attached a grated bar $L M H$. As the centre c is

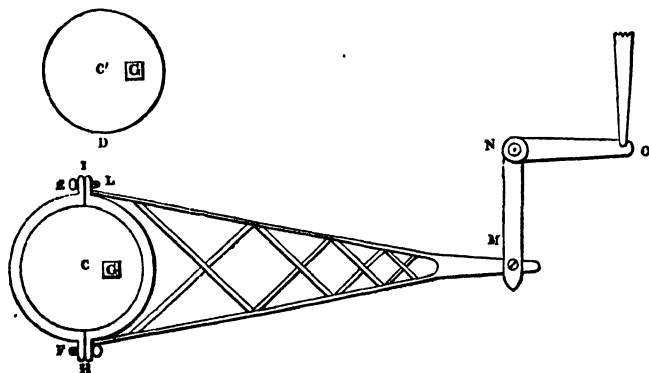

thrown alternately right and left of g by the revolution of the plate, the point M receives a horizontal motion, right and left, to a like extent. This motion is transmitted by means of levers to the slides or cocks of the engine by obvious and well-known mechanical contrivances.

CHAP. XIV.—HOW THE MECHANICAL EFFECT EXERTED BY
THE PISTON IS ASCERTAINED.

1. Whatever be the circumstances under which the engine is worked, it will never happen that throughout the entire length of the stroke the pressure of steam on the piston will be exactly the same. Still less will it happen that the vacuum towards which the piston moves will be uniformly perfect.

The moment the exhausting valve is opened, the steam begins to rush from the cylinder to the condenser, but its condensation is not instantaneous. The first portion which mingles with the jet produces warm water, from whence steam is reproduced, and it is not until so much cold water has been mixed with the steam as will reduce its temperature considerably below 100° , that the vacuum in the cylinder will become practically perfect.

2. The more speedily this effect is produced, the more efficient will be the operation of the machine, but it never is produced until the piston has already made some portion of the stroke. The piston therefore begins to move against a vapour which offers some resistance more or less considerable, and the impelling power of the steam at the other side is to such extent neutralised. This resistance gradually diminishes, and when the piston has made a certain portion of the stroke, it will have been reduced to its minimum amount.

It is evident then that this resistance must be ascertained and calculated before we can determine the mechanical efficiency of the piston.

3. But this is not all; the steam which impels the piston never acts throughout the stroke with uniform effect. When it acts expansively, being cut off at some determinate point of the stroke, we have already seen that it acts with an uniformly diminished pressure; but even where the expansive principle is not used, the steam is still cut off a little before the completion of the stroke.

4. There is still another point to be attended to. We are able by easy means to ascertain the pressure of steam in the boiler, but it would be a great mistake to assume that this must be the pressure of the steam in the cylinder. In passing from the boiler to the cylinder, the steam has to force its way through various passages, some of which are very contracted, and in so doing it suffers an effect which engineers express technically by the term *wire-drawn*. In fact, the steam loses somewhat of its density before it reaches the cylinder. If then we would know the real mechanical pressure on the piston, we must measure directly the pressure of the steam in the cylinder, and not derive our knowledge from its pressure in the boiler.

5. If we can at each successive point of the stroke ascertain the exact pressure of the steam which impels the piston, and also the pressure of the uncondensed vapour which resists it, we have only to subtract the one from the other to obtain the efficient pressure on the piston at the moment; and if we can do this successively throughout the entire stroke, we shall obtain the total mechanical efficiency of the engine.

6. A beautiful little instrument was, among the numerous results of his fertile genius, invented by Watt for this purpose, called an *indicator*. (See Chapter XXVII., title '*Watt's Indicator*.' It consists of a brass cylinder, something less than 2 inches in its internal diameter, and from 8 to 12 inches in length. It is bored with extreme accuracy, and a solid piston moves steam-tight in it with very little friction.

7. This cylinder is open at the top, and the piston-rod is kept precisely in its axis by passing through a ring placed near the top. A spiral spring surrounds the rod of the cylinder, and is attached at one end to the ring through which the rod plays, and at the other end to the piston. When no force acts on the piston, and this spring is therefore neither extended nor compressed, the piston stands at

the centre of the length of the cylinder; when any force presses the piston upwards, the spring is compressed, and the piston rises; and when any force presses the piston downwards, the spring is extended, and the piston descends.

From the known mechanical qualities of a spring of this species, it follows that the space through which the piston rises or falls always indicates the force by which it is urged.

At the top of the piston-rod, and at a right angle with it, is attached a pencil, which plays upon a card properly placed, and traces upon it a line according to the ascent or descent of the piston.

While the piston of the engine descends, the card is moved horizontally against the pencil through a certain space; and while it ascends, it is moved back again through the same space: by this combination of movements a geometrical figure is traced upon the card, the breadth of which, measured vertically, represents for each point of the stroke the effective pressure, and the entire area of such figure represents the total effect.

When the steam acts against the piston of the indicator, the space through which that piston ascends represents the excess of the pressure of the steam above that of the atmosphere; and when it descends by reason of the vacuum, the space through which it descends represents the excess of the pressure of the atmosphere above the pressure of the uncondensed vapour: consequently the sum of these two spaces will represent the excess of the pressure of the steam which impels the piston of the engine above the pressure of the uncondensed vapour which resists it; and this being taken for each successive point of the stroke, it follows that the entire area of the figure will represent the effective action of the piston of the engine. This will be more clearly understood by referring to the figures, with their explanations, in Chap. XXVII.

8. The chief value, however, of this contrivance consisted more in its indication of the action of the condenser than as

affording a direct measure of the effective action of the machine. It showed at once, and in a manner quite unequivocal, whether the condenser was doing its duty, and whether the condensation was sufficiently prompt. The moment the exhausting valve is opened, the piston of the indicator ought suddenly to drop; and although it will sink lower while the stroke proceeds, the chief motion should be instantaneous. When the condensation is not prompt, then the piston falls more slowly, and shows either that there is not enough water injected, or that some other impediment interferes with the due performance of the condenser.

9. The best and perhaps the only practical method of ascertaining the real efficient force with which a steam engine acts, is to attach it to a water-pump, and measure the quantity of water which it is capable of raising through a given height: every other test but this is fallacious.

CHAP. XV.—HOW THE HEAT IS PRODUCED BY WHICH STEAM IS MADE.

1. The cylinder, piston, beam, connecting-rod, crank, and fly-wheel, are, like all other pieces of mechanism, a mere contrivance by which mechanical force is transmitted and modified. There is nothing in them by which mechanical force can be produced. Once at rest, at rest they would for ever remain, unless some motive power were applied to them.

2. This moving power, as we have already described, is derived from the physical phenomena which are exhibited when water is converted into steam; but even the water, in this case, cannot properly be regarded as any more than an instrument by which the mechanical agency of the heat is developed. Heat then is the prolific parent of the vast powers of the steam engine, and it is of the utmost practical importance to comprehend fully how this heat can be produced and applied with the greatest economy and efficiency

3. This will lead us to the consideration of those properties of combustibles on which the production of heat depends,

and the construction of the furnaces and boilers by means of which its application and transmission are effected.

4. The combustibles universally used in the furnaces of steam engines are either pit-coal or wood. The former is used almost invariably in Europe, the latter is used in America, except in particular districts where coal is advantageously attainable.

5. The constituents of coal are chiefly carbon and a gas called hydrogen, combined occasionally with a small proportion of sulphur and incombustible matter.

6. In the process of combustion, the carbon, the hydrogen, and the sulphur combine with the oxygen gas, which is a constituent of the atmosphere, and other products are formed. In this combination a quantity of heat is developed. The incombustible constituents drop from the grate, and are left in the ash-pit. The goodness of coal depends in some degree on the small proportion of incombustible matter which it contains.

7. The proportion of carbon contained in coal varies; in good coal it is seldom less than 75 per cent. of the whole, sometimes considerably more.

8. Hydrogen cannot be said to enter as a constituent of coal in its pure and simple form. It is always combined with a portion of carbon, and is the gas called *carburetted hydrogen*, being that which is commonly used for the purposes of illumination. This gas may be expelled from coal by exposing the latter to heat, by which means the gas, expanding, is forced from the interstices of the coal, and may, if required, be collected in proper reservoirs. This process, applied to the coal, is called coking; and it is in this manner that the gas is collected in gas-works for the purpose of illumination.

9. The proportion of carburetted hydrogen, the element which produces flame, varies in different sorts of coal. The more bituminous sorts, such as those of Northumberland and Durham, generally have a considerable proportion; the

heavy coal called stone-coal, obtained in some of the coal-fields of Wales, Pennsylvania, and elsewhere, have very little. In all cases the proportion of this element by weight is insignificant.

Carbon burns without flame, the product of the combustion being the gas called *carbonic acid*, which escapes from the fuel in a very heated state.

10. These are the general effects of combustion; but for the practical purposes of art, something more must be learned. We must ascertain with some degree of precision the quantitative proportions in which the various elements concerned in the phenomena are present.

11. To begin, then, with the chief ingredient of all combustibles, carbon,—

This substance, when heated to a temperature of 700° or 800° , equal to that of red-hot iron, will enter into chemical combination with the gas called oxygen; the result of this combination will be another gas, called carbonic acid. In forming this combination a large quantity of heat, previously latent in the carbon and the oxygen, is rendered sensible, and is developed in two ways: 1st, in rendering the remainder of the carbon incandescent, or white-hot; and 2ndly, in raising the temperature of the carbonic acid which has been produced to a very high point.

12. From the luminous or incandescent carbon the heat escapes by radiation, according to the same principles and laws that govern the radiation of light. That portion of it which is carried off by the carbonic acid may be taken from such gas by placing in contact with it any surface which is a good conductor of heat, such as metal: the heat of the gas will be imparted to the metal until the temperatures of the metal and the gas be equalised.

13. But it is necessary to know the *quantity* of oxygen gas which is requisite to combine with the carbon.

It is found that a pound of pure carbon will enter into combination with 12 cubic feet of oxygen at the ordinary

temperature and pressure of the air, the result of the combination being 12 cubic feet of carbonic acid, this being supposed to be reduced to the same temperature and pressure. But as the temperature of the carbonic acid, at the moment of combination, is very much elevated, it will then have an enlarged volume.

14. Common combustion, however, is maintained not by an atmosphere of pure oxygen, but by that of the common air.

15. Common air is a mixture of oxygen and azote, in the proportion by measure of 1 to 4,—five cubic feet of common atmospheric air containing but one cubic foot of oxygen. To obtain 12 cubic feet of oxygen, therefore, we must necessarily have 5 times 12, or 60 cubic feet of common air.

16. Supposing then (which is however in practice not the case) all the oxygen contained in the atmospheric air supplied to the fuel in combustion to enter into combination with such fuel, it would be necessary to supply 60 cubic feet of atmospheric air for every pound of carbon consumed.

17. The result of this combination would be the production of 12 cubic feet of carbonic acid, formed by the combination of the oxygen of the atmosphere with the carbon, and 48 cubic feet of azote, which would be mixed with the carbonic acid so produced. This volume of mixed gases would escape from the fuel at a very high temperature, and would in this state pass into the chimney.

18. Hydrogen gas combines with 8 times its own weight of oxygen, and the result of the combination is water, or, more properly speaking, steam; for it is rendered into the vapor form by the great heat developed in the combustion.

19. We have stated that a small proportion of sulphur is present in most sorts of coal. In burning, this produces sulphurous gas. It is inefficient as to its heating power, and insignificant in its quantity, but most injurious in its effects on boilers. Coal, therefore, having much of this element, should be avoided in steam boilers.

20. To maintain the fuel in combustion, it is then evident that it must be continually supplied with atmospheric air. The rate of this supply will depend on the rapidity of the combustion which is required, and the quantity and quality of the fuel. The fuel is spread on a grate, between the bars of which the air which sustains the combustion is admitted. In passing through the fuel, the air enters into combination with it, and the gases resulting from the combustion, including uncombined oxygen and the azote of the atmospheric air, which last plays no part whatever in the combustion, issue together into the upper part of the furnace, all having a very high temperature: these proceed to the chimney, which they soon fill with a column of heated air, the buoyancy of which makes it ascend into the atmosphere, and the vacuum it leaves behind it draws a fresh portion of air through the grate bars, and so the combustion is continued.

21. The azote which forms so large a constituent of atmospheric air has qualities in relation to combustion merely of a negative kind; it does not either check or stimulate it. Thus, as a supporter of combustion, the atmosphere may be considered as diluted oxygen, the azote having the same effect on the particles of the oxygen as water would have upon a strong spirit mixed with it.

22. In what has been just explained, the calculations are based upon the supposition that every particle of oxygen contained in the atmospheric air, urged through the burning fuel, enters into combination with it. Now this is not and cannot be the case, even in the most approximative sense; and therefore, to complete the combustion of the fuel, a much greater quantity than 60 cubic feet of atmospheric air for a pound of carbon consumed must be drawn through the fire. The exact quantity which is necessary is not capable of calculation, for it depends on circumstances which vary with the form and structure of the grate and the mode of working the furnace: but it may be safely assumed that not less than 150 cubic feet of atmospheric air are

necessary in ordinary furnaces for the combustion of each pound of carbon contained in the fuel.

23. It will be understood that when the fuel is laid in a stratum more or less thick upon the grate, and when rapid currents of air are ascending through its interstices, a quantity of the fuel, always existing in a state of powder or small dust, will be carried upwards by the current, unburned.

24. Besides this, as the heat expels the hydrogen gas from the interior of the coal, minute particles of the coal itself escape with the current, and rise above the fuel. Much of this is also unburned, or, to speak scientifically, uncombined with oxygen. It is this minute powder or dust, uncombined with oxygen, that forms what is called smoke. The gaseous products of combustion, properly so called, have not the cloudy and opaque appearance which characterises smoke. The smoke then is unconsumed fuel, and to whatever extent it is produced, it escapes into the chimney, and is a source of waste. It is clear, then, on the grounds of economy, independently of sanitary considerations relating to the neighbourhood of the engine, that the quantity of fuel, more or less, thus escaping should be arrested, and burned before it reaches the chimney.

25. Various methods have been adopted in furnaces for accomplishing this object. Such arrangements are denominated smoke-consuming furnaces; but very simple and obvious arrangements may be adopted in the mode of feeding common furnaces, which will have the effect of consuming the smoke.

26. The following arrangement was adopted with complete success at the establishment of the late Mr. Watt, at Soho, Birmingham, and it has been found equally efficacious wherever the fire-men have been kept under sufficient discipline to enforce its observance.

27. The grate must be constructed with a slight descent backwards, to give facility to the removal of the fuel from the front towards the back of the grate. Let us suppose a layer

of coal of the proper depth spread over the entire surface of the grate, and brought into vivid combustion, so that every part of it shall be incandescent. There will then be no smoke.

The gases of combustion, mixed with the azote and uncombined oxygen, of the atmospheric air, will alone issue from the burning fuel. The doors of the furnace being now opened, the fire-man, with a proper instrument, pushes back a portion of the fuel from the front towards the back of the grate, so as to make a clear space across the front of the furnace. He then introduces a quantity of fresh fuel, which he spreads in a layer of a proper thickness over the portion of the grate which he has thus cleared, and closes the doors. The heat immediately begins to expel the hydrogen from the fuel thus introduced, and, technically speaking, cokes the fuel. With the hydrogen escapes a quantity of dust and minute portions of coal, forming smoke. This smoke and gas are carried by the draft to the back of the grate, where the entrance of the flues is placed, and in passing through it is carried over the remainder of the fuel, which is in vivid combustion.

28. The gas and smoke are thus burned, and this continues until the portion of fuel in front of the grate has been completely coked and reddened. The fire-man then opens the doors, and repeats the process as before, shoving this portion back, and introducing a fresh feed.

29. After this manner, without any special smoke-consuming apparatus, the fuel is completely burned, and no smoke is ever seen issuing from the chimney.

30. To perform this, however, effectually, requires much attention and activity on the part of the fire-man, frequent feeding, and a careful distribution of fuel on the grate.

31. In general it is difficult to enforce from such agents the necessary attention. The fuel in the grate is allowed to burn down, and then the doors are opened and a large quantity thrown in, heaped on every part of the grate from

the back to the front : when this takes place, a prodigious volume of black smoke is suddenly evolved, which is seen issuing from the chimney, and continues to issue from it until the mass of fuel has been coked ; it then ceases, and the combustion is free from smoke until a fresh feed is introduced.

32. It must be admitted, however, that the process above described, for the complete combustion of the fuel and the prevention of smoke, is not without countervailing disadvantages.

33. Instead of large feeds of fuel at distant intervals of time, it supposes smaller and more frequent feeds ; instead of the fuel being quickly and carelessly thrown in, it is carefully distributed upon the grate bars.

34. This supposes the frequent opening of the furnace doors, and the keeping them open for greater or less intervals.

35. Cold air thus rushes in over the fuel, where it ought never to be admitted, and has the tendency of robbing the boiler of a portion of the heat which it ought to receive.

To remedy this, smoke-consuming furnaces have frequently attached to them self-acting feeders. The fuel, being broken by proper machinery, is sprinkled on the grate by means of a hopper, and the grate itself, after it has received its charge, moves from under the hopper by contrivances provided for that purpose. Revolving grates have been sometimes adopted with this view. Such contrivances, however, not only introduce complexity into the machinery, necessitate expense of construction, are liable to become deranged by wear, but also require a portion of the moving power to work them. These disadvantages are to be weighed against those attending the operation of the simple furnace, properly tended. I have, however, known these self-acting furnaces, in places where fuel was expensive, in operation for years with much advantage.

36. If the heated gases proceeding from the fuel passed

directly to the chimney, they would carry with them a much greater quantity of heat than would be necessary to maintain the draft, and thus a portion of the heat developed by the fuel would be lost. To prevent this, the heated air and flames which escape from the fuel, instead of passing directly to the chimney, are conducted through passages of greater or less length in contact with the boiler, and made to impart a portion of their heat to the water before they enter the chimney. These passages are called *flues*, and are very variously constructed, according to the form, magnitude, and application of the boiler.

37. In some boilers the flues are made to wind round them, the external part of the flues being made of brick-work, which, being a bad conductor of heat, takes but little from the heated air and flame.

38. The shape and proportions of *boilers* are so adapted as to accommodate them to such systems of flues. The great object is to adopt such arrangements as shall secure the transmission to the water of all the heat developed in the combustion of the fuel, except such portion of it as may be necessary to maintain a sufficient draft in the chimney.

39. The boilers most commonly used are either cylindrical or waggon-shaped. The cylindrical boilers are generally long in proportion to their diameter, and their ends are often spherical. This shape is highly conducive to strength, but in some cases their ends are made flat.

40. The waggon-shaped boilers resemble, as their name imports, an oblong waggon: the roof is semi-cylindrical; the sides either flat or slightly concave, the convexity being inwards; the bottom is also slightly concave; the furnace is placed at one end of the boiler, having a portion of the concave bottom for its roof. The flame and heated air passing from the grate are carried backwards through a flue which extends the entire length of the boiler. Thus the radiant heat of the fire, issuing directly from the grate, strikes on the concave bottom of the boiler, which is immediately above

the grate, and enters the water. The flame and heated air pass through the flue under the boiler to the remote end, and act upon the remainder of the bottom: having arrived at the remote end, they rise to a point a little above the bottom, and then are conducted through a flue which winds completely round the boiler; and after circulating round it, the heated air is conducted to the chimney. In this way it will be seen that the flame and heated air traverse the length of the boiler three times, once at the bottom, and once at each side.

41. In cylindrical boilers the furnace is generally placed within the boiler, in a large tube which extends from end to end of it. In one end of this tube is placed the grate, and the remainder of it forms a flue. By this arrangement all the heat which radiates from the fire, and even from the ash-pit, acting upon this internal tube, is communicated to the water. The heated air, traversing the tube to the remote end, imparts its heat to the water by this means. Flues circulate round the outside in the same manner as in the wagon boiler.

42. In some cases more than one internal flue is made in the boiler, and the heated air passes alternately through the interior of the boiler, in contrary directions, and is at length discharged into the chimney.

43. Internal flues have the advantage of imparting all the heat to the water, saving that portion which in external flues is imparted to the brick-work.

44. In some forms of boilers, the grate being constructed at one end, the flame and heated air, instead of passing through a single internal flue, traversing the length of the boiler, are distributed among three or more similar tubular flues.

45. This subdivision of flues by the multiplication of the number of tubes, and the diminution of their magnitude, is carried to an extreme in locomotive boilers, in which from 100 to 200 tubes, not more than 2 inches diameter, traverse

the length of the boiler, and divide the flame and heated air into a multiplicity of small threads, so as to enable the water to deprive them of their heat.

46. With these a system of returning flues becomes unnecessary, the reduction of the temperature being completely effected in traversing the boiler once.

47. In some arrangements the flame and heated air passing from the furnace enter a number of narrow upright cells, placed parallel to each other, and traversing the length of the boiler; arriving at the remote end, another tier of cells, at a superior elevation, is provided, by which they return. This is most commonly the expedient adopted in marine boilers.

48. The multiplicity and complexity of flues, whatever be their form, have the double disadvantage of increasing the cost of the boiler and diminishing its strength. They are therefore only resorted to in cases in which circumstances exclude a great magnitude and weight of boiler, such as in locomotive and marine engines. In the boilers used in land engines, the requisite evaporating power can be obtained with more simple expedients, by merely augmenting the bulk of the boiler.

49. The two great objects which are to be attained are—rapidity of evaporation and economy of fuel.

50. The evaporating power of the boiler will depend (other things being the same) upon the extent of surface which it exposes to the action of the fire, the flame, and the heated air. This surface is technically divided into *fire surface* and *flue surface*.

51. By fire surface is meant all that surface of the boiler upon which the radiant heat of the furnace acts.

52. In the case of a waggon boiler, this is that portion of the bottom of the boiler which forms the roof of the furnace; but in well-constructed boilers, the sides and even the bottom of the furnace form part of the boiler, and contain water within them. In such cases they are to be reckoned as part of the fire surface.

53. The flue surface, as the words import, is that portion of the surface of the boiler in contact with which the flame and heated air, proceeding from the fire, pass before they issue into the chimney. This surface is usually of considerable length, in order that the flame and heated air may be detained in contact with the boiler until they have been reduced to a temperature not greater than is necessary for the draft.

54. Whatever be the length and arrangement of the flues, it is indispensably necessary that they should always be below the level of the water in the boiler, for otherwise the heat would be imparted to the metal of the boiler without being transmitted to the water. Steam is a sluggish recipient of heat, and metal in contact with it might become red-hot while the steam itself will remain at a comparatively low temperature.

This would accordingly be the case if the fire or flame acted upon any part of the metal of the boiler which has not water within it.

55. In the economy of steam power, an object of capital importance is to protect the machinery from every cause by which heat can be consumed in any other way than in converting water into steam. A great variety of expedients have accordingly been adopted for this purpose, differing from each other in their effects according to the circumstances in which the machinery is worked.

56. A boiler being a mass of metal of extensive magnitude, raised to a very elevated temperature, and this naturally being a good radiator of heat, a considerable quantity of heat would be lost by the mere radiation from its surface. The obvious remedy for this is to surround it by some material which is a bad conductor of heat.

57. One of the most effectual substances for this purpose is common saw-dust; this is accordingly applied with great effect in cases which do not exclude its use.

58. The boiler and its appendages are surrounded by a

thick casing, stuffed with saw-dust, and so completely does this expedient answer the purpose, that the boiler-room of a Cornish engine, where this arrangement is applied, is often the coolest place that can be found.

59. In marine and other engines, a coating of patent felt is often used with advantage: hemp, and other fibrous and woollen substances, may be resorted to.

60. Locomotive boilers are cased in wood, which is a tolerable non-conductor. The cylinders of large stationary engines are also frequently cased in wood. The steam pipes and other parts of the machinery containing steam are wrapped with tow or other similar substances.

61. By these means the loss of heat by radiation may be reduced almost to nothing.

62. Where fuel is used which burns with little or no flame, such as stone-coal or coke, the chief effect is produced by the radiant heat, and a comparatively small effect by the heated air. In such cases the fire surface should bear a large proportion to the flue surface. In all cases the fire surface, being more active in proportion to its extent than the flue surface, is more liable to wear by intense heating. It may be said, that as the surface of the metal cannot rise to a higher temperature than that of the water within, and as the entire mass of the water within must be maintained at an uniform temperature, the fire surface cannot rise above the general temperature of the mass. This would be true if the boilers and furnaces were worked by a moderate system of combustion, the fuel being consumed very gradually and the heat developed slowly, so that a fierce action should not take place on any part of the boiler. Such is the case, for example, in the boilers and furnaces of the Cornish engines, where space is a matter of little importance, and the economy of fuel pushed to its extreme limit; but in other cases these advantages must be sacrificed, and a combustion so intense maintained in the furnaces that the fire surface becomes heated to a higher temperature than the water in contact

with it, and to a much higher temperature than the flue surface. The formation of steam in contact with the fire surface is so rapid that its bubbles do not escape to the surface quick enough to keep the metal in continual contact with water.

63. The metal, therefore, is momentarily out of contact with water, and has a tendency to become overheated.

64. It is true that upon the escape of the steam bubbles just formed the liquid will again wash the metal and lower its temperature, but still this effect is such (in the case, for example, of locomotive engines and sometimes of marine engines) that the fire surface is exposed to much more rapid wear by temperature than the flue surface.

CHAP. XVI.—HOW THE DRAFT THROUGH THE FURNACE OF
A STEAM ENGINE IS MAINTAINED.

1. The most common method of effecting this is by the ordinary expedient of a chimney.

2. When the products of combustion are allowed to flow through a chimney of sufficient height, the vertical column of heated air thus formed has a certain buoyancy or tendency to ascend into the atmosphere, proportional to the difference between its weight and the weight of an equal column of common air. This difference will be so much the greater as the column has greater magnitude and height, provided only that every part of it shall be, bulk for bulk, lighter than air. Hence obviously follows the necessity of a chimney in creating a draft, whether through the furnace of a steam engine or in any ordinary manner.

3. In stationary engines, as used in the arts and manufactures, chimneys of any desired magnitude can generally be attached to the engine. It is not necessary that the chimney should be immediately over or contiguous to the furnace; it may be placed at a considerable distance from it, provided only it be connected with it by the proper air passages. This is often a matter of convenience in factories, and we

accordingly see the chimney frequently erected at a considerable distance from the boilers and furnaces.

4. But in numerous applications of the steam engine it is not practicable to use chimneys of such elevation, or so placed, and in some cases the tube provided for the escape of the products of combustion must necessarily be so short as to afford no draft of appropriate amount.

5. Such is the case, for example, in locomotive engines: in marine engines this is to some extent also true,—the chimney must be comparatively short.

6. When sufficient length of chimney is not admissible, we are compelled either to throw in the gases of combustion at a very high temperature, so as to make up for want of height in the column, or to adopt some other expedient for creating a draft.

7. A wheel is sometimes placed in the flues where they enter the chimney, by the revolution of which the gases are driven up the chimney with a force proportional to the velocity with which the wheel revolves. This expedient is similar to a sort of bellows commonly used for domestic purposes, and is called a *fanner*, and sometimes a *blower*. A portion of the power of the engine is borrowed to keep this wheel in motion. In this way an upward current is maintained in the chimney of any required power, and the necessary draft sustained through the furnace.

8. Another expedient is used in locomotive engines, and may always be resorted to where steam of high pressure is used. This consists of a *jet*, or, as it is technically called, a *blast pipe*, which is placed at the base of the chimney, and presented upwards. A portion of the steam received from the engine is allowed to escape by puffs, or even in a continued stream, through this pipe, and, being directed up the chimney, creates the necessary draft.

CHAP. XVII.—HOW THE MECHANICAL VIRTUE OF FUEL IS ESTIMATED AND EXPRESSED.

1. In explaining the mechanical effects of steam, it has been already shown that whatever be the purpose to which the force of a steam engine be applied, its effect may always be represented by a certain weight raised a certain height.

2. Whether an engine be employed to drive a mill-wheel, to propel a ship, or to draw a carriage, the tension or resistance to be encountered at the working point may be universally represented by an equivalent weight.

3. Thus it is easily understood, if a locomotive engine draws a train of carriages, that the tension of the chain which connects the engine with the train will be the same as if the same chain, in a vertical position, had a certain weight suspended to it; and the same will be true, whatever be the nature of the resistance to the moving power, or the manner in which this moving power may be applied.

4. It has been usual also to express the mechanical efficacy by the number of pounds raised one foot; for whatever be the resistance, and whatever be the space through which the moving power acts upon it, the effect can always be reduced, as has been already explained, to an equivalent number of pounds raised one foot.

5. The mechanical virtue of coals, thus explained and applied to a steam engine, has been technically called the *duty of the fuel*. Thus a bushel of coals consumed in the furnace of an engine will enable such engine to exert at the working point a mechanical effect equivalent to a certain number of pounds raised one foot high: this effect is the duty of the fuel, or as is sometimes said, the duty of the engine.

6. The duty of the engine is therefore not the entire mechanical effect developed by the fuel in producing evaporation; for a portion of the mechanical power of the steam evolved in the boiler, and in some cases a very large portion of it, is expended in moving the machinery of the engine

itself: all such portion is intercepted therefore between the furnace and the working point. The duty, properly speaking, is the net mechanical force developed by the steam, or such portion only which is available for the work to which the engine is applied.

7. The duty of engines varies within very wide limits, according to the purpose to which they are applied. In this respect engines may be reduced to three classes:—1st, Such as are used in the mining districts of Cornwall, where the economy of fuel is pushed to its extreme limit;—2ndly, The stationary engines used in the manufactories generally, in which class may also be included marine engines;—3rdly, Locomotive engines on railways.

8. In the Cornish engines, where alone very accurate observations are made on the mechanical effect produced, and on the economy of fuel, it has been found, in some cases, that by the combustion of a bushel of coals an effect has been produced by the engine equivalent to 125 millions of pounds, or what is the same, 62,000 tons, raised a foot high. This, however, is not to be understood as an average result. In producing it, the utmost care was taken to guard against every source of waste of power.

9. The more common duty obtained from a well-managed engine used in the mining districts has been from 80 to 90 millions of pounds, or at the rate of one million of pounds raised one foot for every pound of coal consumed,—a result remarkable enough in itself, and easily remembered.

10. In the ordinary stationary engines belonging to the second class, where the same scrupulous attention to economy cannot be or is not paid, the duty, according to the commonly received estimate, is in round numbers about 20 millions of pounds for a bushel of coal, being four times less than that of the good Cornish engines, and six times less than the duty which has in certain cases been obtained.

11. In the locomotive engines worked on railways the economy of fuel is of course still less; but in this application

of the engine the economy of fuel becomes a consideration so subordinate, that it need not be enlarged on here.

12. The great economy obtained in the engines used in Cornwall is the result of a variety of contrivances, some of which, such as the protection of the machinery from radiation, have been already mentioned. The boilers are constructed of extraordinary magnitude, in proportion to the power expected from them; the furnace is of proportionate size; the combustion is slow; the heating surface is very extensive, and the intensity of heat upon it very slight; the flues are of great length, and the heated air is not permitted to escape until the last available portion of heat has been extracted from it; the fuel is managed in the furnaces with the most extreme care, the combustion being perfect. Added to all this, the steam is used at a pressure of from 35 to 50 lb. per square inch above the pressure of the atmosphere, and the expansive principle extensively applied.

13. In giving these last estimates of the duty of fuel in the engines used in the manufactures generally, it is right to observe, that owing partly to the difficulty of ascertaining the actual mechanical effect produced, and partly to the negligence of proprietors of engines, the estimates of duty are of the most loose and inaccurate description. When an engine is applied, as is generally the case in Cornwall, directly to the elevation of water or other heavy matter, it is easy to observe the mechanical effect it produces; but when an engine is applied to give motion to the works of a factory, to drive spinning-frames, power-looms, or printing-presses, it is not so easy a matter to reduce the effect it produces to an equivalent weight raised a given height. In the case of locomotive engines the same difficulty ought not to exist; yet it is surprising that until a very recent period, errors the most monstrous prevailed respecting the real mechanical effect produced by these machines. It was, for example, long assumed as a maxim, that the resistance offered by a given train of carriages to a locomotive engine was independent of the speed, or in other

words, the same at all speeds. This error was not brought to light until the year 1838, when it was demonstrated, by a series of experiments conducted by me, that the resistance was augmented in a very high ratio with the speed.

CHAP. XVIII.—HOW THE POWER OF AN ENGINE IS ESTIMATED AND EXPRESSED, AS DISTINGUISHED FROM ITS DUTY.

1. The duty, as we have seen, is the practical effect produced by the given weight of coal without reference to time. Thus, whether a bushel of coal raises 20 millions of pounds a foot in one hour or in ten hours, the duty of the engine is exactly the same. But the *power* of the engine is quite different.

2. The *power* of the engine is estimated by the mechanical effect it is capable of producing *in a given time*.

When steam engines were first brought into use, the work to which they were applied had been previously done by horses who worked the mills. It was convenient, therefore, and indeed indispensable, to express the mechanical capabilities of these machines by declaring the number of horses which one of them would supersede; and hence the term now so general, *horse-power*, came into use. At first this expression had but a vague signification, and was understood by the manufacturers and capitalists who intended to employ the steam engine in the literal sense of the actual number of horses whose expense would be saved to them by it. But after the engine had completely superseded horses in the arts and manufactures, and it became necessary to express its effects with greater precision, instead of abandoning the term horse-power, an arbitrary signification was given to it by Watt, which it has since retained. The word horse-power, then, as applied to the steam engine, means the capability of the engine to produce a mechanical effect per minute equivalent to 33,000lb. raised one foot.

3. Thus an engine of 10 horse-power means one which in

working is capable of producing a mechanical effect per minute of 330,000 lb. raised one foot, or an effect per hour equivalent to 20 millions of pounds, very nearly, raised one foot.

4. When a steam engine is declared to be of such or such a horse-power, the expression must be understood in a qualified sense. Thus it is assumed that the furnace is worked in a certain average manner, and that a proportional evaporation takes place in the boiler. An engine whose nominal power is that of 100 horses may, by urging the furnace in an extraordinary manner, be made to produce an effect much greater than that of its nominal power; or, on the other hand, by keeping the furnace low, it may be, and frequently is, worked considerably under its nominal power.

CHAP. XIX.—WHAT DIMENSIONS OF THE BOILER AND FURNACE ARE NECESSARY FOR AN ENGINE OR GIVEN POWER.

1. The technical rules adopted by engineers for the proportion of engines corresponding to any required power, are generally understood as applicable only to the second class of engines enumerated already, namely, those generally used in the manufactories and in steam navigation.

2. The Cornish engines, on the one hand, and locomotive engines on the other, are exceptional extremes, each being worked in a manner peculiar to itself. In the one, much larger dimensions are allowed for the production of a given power, the action of the furnaces being of low intensity; while in the other, the dimensions producing a given power are much smaller, and the consequent action of the furnaces much more intense.

What we shall therefore state here will be understood to have reference to the second class of engines above mentioned.

3. In calculating the mechanical force developed in the evaporation of water, we have seen that one cubic inch of water, converted into steam, produces a mechanical force sufficient to raise a ton weight a foot high. It would therefore follow that to raise 20 millions of pounds a foot high,

would require the evaporation of 1000 cubic inches of water. But this calculation refers to the entire mechanical force developed in the evaporation. A portion of this force is, however, expended in moving the engine itself, and is wasted in various ways before it reaches the working point; and it is customary for engine-makers to allow for this from 35 to 45 per cent. of the entire mechanical force developed in the evaporation. Now since there are 1728 cubic inches in a cubic foot, it follows that by such an allowance for waste of power, the net effect of a cubic foot of water evaporated per hour would be one nominal horse-power.

4. Such is the general usage of boiler-makers, but it would be most erroneous to assume that this usage is based upon even a loose calculation: there can be no doubt that the power expended in waste and uncondensed steam, and in moving the engine in any tolerably managed machine, must be considerably less than this. The error, however, lies on the safe side; it is better to have superfluous boiler power than a stint of steam. A boiler having more evaporating power than is needed, can always be worked as much under its power as may be desired; but when an engineer is obliged to push a boiler above its legitimate power, both waste and danger ensue. It must not therefore be assumed, as has been done by some writers, that engine-makers adopt these rules from ignorance. Although they do not in general seek for an accurate knowledge of the amount of power expended in moving the engine and in waste steam, they are nevertheless fully aware that the allowance they make is greater than its amount; and in the absence of such exact knowledge, it is clear they are right in adopting an excessive estimate.

5. From what has been stated, therefore, it follows that for every horse-power which the engine is expected to exert, a power of evaporating a cubic foot of water per hour is provided in the boiler.

6. When the term horse-power is applied, therefore, to

boilers, in reference to their capability of evaporation, it is to be understood as indicating the evaporation at the rate of a cubic foot of water per hour: thus, by a boiler of 50 horse-power, is to be understood a boiler capable of evaporating 50 cubic feet of water per hour, the furnaces being worked in the ordinary way.

7. The magnitude of the grate and the extent of heating surface necessary to produce a given rate of evaporation, vary more or less in different engines, and according to the practice of different engineers; but still, in common engines used in the arts and manufactures, there are average standards which it is useful to know.

8. Thus it is generally agreed, that the dimensions of the grate necessary for a boiler of a certain power should be regulated by allowing a square foot of grate surface for every horse-power in the boiler. Thus it follows, that as much fuel is consumed per hour upon a square foot of the surface of the grate, as is necessary and sufficient to evaporate a cubic foot of water.

9. The dimensions of the surface of the boiler exposed to the action of heat, whether by radiation or by the contact of heated air in the flues, is generally estimated at the rate of 15 square feet for a horse-power. Thus a boiler of 50 horse-power would require a heating surface of 750 square feet.

10. These are not only average standards from which individual boilers and furnaces of the class we more particularly refer to, vary more or less considerably, but they are altogether inapplicable to the two extreme classes of boilers, —the Cornish on the one hand, and the locomotive on the other.

11. In the Cornish boilers a slow combustion is maintained on the grates, and although the fuel is placed upon them in a thicker layer, the intensity of the heat from a given surface is considerably less than in the ordinary boilers. Accordingly, for a given rate of evaporation, at least double the extent of grate surface is allowed. We find, therefore,

that two square feet are given for every cubic foot of water per hour to be evaporated.

12. In like manner, as in these boilers the heat acts with less intensity on a given surface of the boiler, a proportionally greater heating surface is necessary to produce a given rate of evaporation. In these cases a still greater departure from the common boiler is necessary; and instead of 15 square feet being allowed for a cubic foot of water per hour evaporated, we find 4 and 5 times this surface given.

13. The flame and heated air are also made to traverse a much greater length of flues before they enter the chimney.

14. Thus, while 60 feet length of flues are allowed in a common wagon boiler, 150 or upwards are frequently given in the Cornish boilers.

15. These circumstances will at once indicate the different mode of operation, and the different quality of these two classes of boilers.

16. The locomotive boiler is in the other extreme. Instead of one square foot of grate surface evaporating one cubic foot of water per hour, it usually evaporates 8 cubic feet. As the heat developed in a given time may be taken as nearly proportional to the water evaporated, it follows that the calorific action of a square foot of the grate of a locomotive is 8 times that of a square foot of the grate of a common stationary engine, and 16 times that of a Cornish engine.

17. The intensity of the combustion maintained in the furnaces of locomotive engines may be thus in some measure conceived.

I have myself witnessed a set of new grate bars partially fused and rendered useless in a trip of 30 miles. The splendour of the burning fuel in these furnaces is sometimes so intense, that it impresses the eye with the same pain as is sustained in looking at the sun.

18. The Cornish boilers, which differ so extremely in their mode of operation and effects from the locomotives, resemble

them nevertheless very closely in their form. Both are cylindrical, and the flues in both consist of metal tubes, traversing the length of the boiler. In the Cornish boilers the tubes are of iron, and of considerable diameter. In the locomotive boilers they are of brass, and very small in diameter.

19. The diameter of the Cornish boilers is usually about $\frac{1}{8}$ th of their length. Where great power is required, it is found more convenient to use two or more boilers than one of larger dimensions. A common proportion for these boilers is from 36 to 40 feet of length, and from 6 to 7 feet in diameter. The locomotive boilers are usually from 8 to 10 feet long, and from $3\frac{1}{2}$ to $4\frac{1}{2}$ in diameter.

20. The common published reports of the consumption of fuel are usually given by expressing the weight of coal consumed per hour per horse-power; but unless it be ascertained that the real working power of the engine and the consumption of fuel are equal to, and do not exceed its nominal power, such reports lead to erroneous conclusions. The common allowance of fuel for stationary engines and marine engines, when working to their full power, is 10 lb. per horse-power per hour. The consumption, however, is undoubtedly less than this when the engines are properly constructed and carefully worked: 7 and 8 lb. per horse-power is a very common consumption for well-managed engines. In the Cornish engines the common consumption is little more than 5 lb. per horse-power per hour.

CHAP. XX.—WHAT DIMENSIONS OF THE CYLINDER AND OTHER MACHINERY ARE REQUISITE FOR A GIVEN POWER OF ENGINE.

1. Nothing can be more vague, uncertain, and arbitrary, than the rules adopted by engineers in reference to this problem. It may be truly stated that every engine-maker has his own standards, to which he attaches invariably as much infallibility as if this mechanical problem were capable

of as certain and demonstrative solution as a problem in common geometry.

2. It will be obvious, on the slightest consideration, that the magnitude of the cylinder and piston necessary to produce a given working power, must depend on the pressure of the steam after it enters the cylinder, and the velocity with which the piston is driven, the degree of perfection of the vacuum on the other side of the piston, and the extent to which the expansive principle is introduced. In general, however, it has been the practice to apply the calculation to low-pressure engines, that is to say, to those in which the steam, after it enters the cylinder, has not a pressure exceeding the atmosphere by more than 4 or 5 lb. per square inch, and in which the piston is supposed to move at the average rate of 200 feet per minute. These conditions being assumed, and a good vacuum being sustained in the condenser, 22 square inches of the piston are allowed for every nominal horse-power of the engine.

3. Where these rules are observed, the nominal power of an engine may always be obtained by dividing the number of square inches in the surface of the piston by 22; or, which is the same, by dividing the square of the diameter of the piston, expressed in inches, by 28.

4. Again, if it be required to find the magnitude of the piston necessary for an engine of a given power, it is only necessary to multiply the number expressing the power by 28, and the square root of the product will be the diameter of the piston.

5. It must be carefully observed, however, that such rules are only applicable so long as the piston moves with the above velocity, and is urged by low-pressure steam at the above rate.

6. Indeed, it may be observed generally that the mode of expressing the mechanical capabilities of engines by horse-power, frequently leads to most erroneous conclusions, and it has lately been accordingly much discontinued

among engineers and scientific men. In locomotive engines it is not applied at all; nor, indeed, in the Cornish engines.

7. The proportion of the diameter to the stroke of the cylinder, as its length is called, varies very much according to the purposes to which the engine is applied. In marine engines, for example, where the cylinder has a vertical position, and the engine is stinted in height, the stroke very little exceeds the diameter. In stationary land engines the proportion of the diameter to the stroke is frequently that of 1 to 2.

8. The dimensions of the air-pump, condenser, and other parts of the engine, bear a certain proportion to those of the cylinder, which are but little departed from by engine-makers.

9. Thus the air-pump has usually half the stroke and half the area of the piston, and consequently its capacity is a quarter of that of the cylinder: nevertheless some engineers maintain that a larger proportion of air-pump augments the efficiency of the machine.

CHAP. XXI.—HOW THE INTERNAL CONDITION OF THE BOILER AND ENGINE IS RENDERED EXTERNALLY MANIFEST.

1. To enable the engine-man to maintain the boiler and machinery in a state of efficient operation, it is necessary that he should be at all times informed of their internal condition. A class of contrivances for indicating this has therefore exercised the invention of those to whom we are indebted for the improvement of this department of mechanical art.

2. One of the most obvious circumstances attending the internal condition of the boiler, which it is necessary that the engine-man should at all times know, is the quantity of water in it. If the level of the water get below the flues, the boiler incurs the danger of becoming red-hot, and bursting: if the level of the water be too high, the steam room in

the boiler becomes insufficient, and the spray of the boiling water, mingled with the steam, passes through the steam pipes into the cylinder, producing a waste of heat and other inconveniences. This effect is called *priming*. The level of the water in the boiler should therefore always be known.

3. The earliest and most simple contrivance for indicating this is the *gauge-cocks*. These cocks are two common stop-cocks, screwed or cemented into the boiler, one above the point at which the level of the water ought to stand, and the other below it. When the water is at the proper level, steam should issue on opening the one, and water on opening the other. If water issue from the upper cock, the boiler is too full; and if steam issue from the lower cock, the boiler is too empty. So long as steam issues from the upper and water from the lower, the level of the water is at its right point.

4. In boilers maintained in a very violent ebullition, where a highly intense furnace is used, the agitation near the surface renders the indication of the gauge-cocks sometimes uncertain, and another contrivance is either substituted for them, or used in connexion with them.

5. If it were possible to have a glass boiler, the level of the water would always be visible; but instead of a boiler all glass, we may have a strong glass plate inserted into the side or end of the boiler, at the level at which the water ought to stand, and through this plate the surface of the water might be seen; but the great agitation of the water in ebullition would render this observation uncertain: the object is therefore accomplished by the glass *water gauge*, (see Chapter XXVII., title "*Glass Water Gauge*,") which is a strong glass tube placed in a vertical position outside the boiler, communicating at the top and bottom by metal tubes with the interior. The water in the boiler enters the lower end of this tube, and the steam enters the upper end; and by the common principles of hydrostatics, the pressure of the steam in the tube and in the boiler being the same, the water in the tube will stand at the same level as the water in the boiler.

6. To guard against the effects of the accidental fracture of this tube, stop-cocks are usually placed between the ends of it and the boiler, by which the communication between it and the boiler is cut off at pleasure. When the engine-man desires to ascertain the level of the water in the boiler, he opens both the stop-cocks, but at other times it is more prudent to keep them closed.

7. This expedient has the advantage over the gauge-cocks, inasmuch as it indicates the exact level of the water.

8. Another contrivance used for the same purpose consists in a *float*, formed of a hollow casing of metal; to this is attached a rod which passes through the top of the boiler.

As the level of the water rises or falls in the boiler, this float rises or falls with it, and the rod is pushed upwards or drawn downwards, as the case may be. An index of any kind may be attached to this rod, which should play upon a divided scale, indicating the position of the float and the level of the water.

9. Another expedient is sometimes used, which consists of a tube let in through the top of the boiler, and descending to a point below which the water ought not to fall: at the top of this tube is fixed a *steam whistle*.

10. So long as the level of the water is above the lower end of the tube, a column of water will be sustained in the tube by the pressure of the steam within the boiler; but when the level subsides below the mouth of the tube, then steam, rushing through the tube, will issue from the whistle, and produce an alarm which will give notice of the want of water in the boiler.

11. This last contrivance can only be used in low-pressure boilers, where the column of water which will balance the steam is not too high.

12. It is most necessary at all times that the pressure of the steam within the boiler should be known, and provision should be made to prevent its exceeding a certain limit. This is accomplished by the common *safety valve*.

This valve is an ordinary conical valve, placed in the top of the boiler, and fitting into its seat, so as to be steam-tight. It is loaded with a weight which determines the maximum pressure to which the steam is allowed to attain. Thus, if it be intended, as in low-pressure boilers generally, that the steam should not exceed 6 lb. per square inch, then the safety valve is loaded with a weight, regulated in such proportion to the magnitude of its surface exposed to the steam, that whenever the pressure of the steam exceeds this limit, it forces the valve open, and escapes until the pressure is reduced to the proper limit.

13. The safety valve, however, affords an indication that the pressure of the steam does not exceed a certain amount, rather than an indication of what that pressure actually is.

14. The *steam gauge* exhibits the exact amount of this pressure.

15. The mercurial steam gauge generally used in low-pressure boilers (see Chap. XXVII., title "*Mercurial Steam Gauge for Low-pressure Boilers*") consists of a siphon tube with equal legs, half-filled with mercury; one end is cemented into a pipe which enters that part of the boiler which contains the steam; the other end is open to the atmosphere. A stop-cock is usually provided between this gauge and the boiler, so that it may be put in communication with the boiler at pleasure. When the stop-cock is open, the steam acting on the mercury in one leg of the gauge presses it down, and the mercury in the other leg rises. The difference between the two columns is the height of mercury which corresponds to the excess of the pressure of the steam in the boiler above the pressure of the atmosphere; or, in other words, to the effective pressure on the safety valve. If half a pound per inch be allowed for the length of this column, we shall obtain, in pounds per square inch, the effective pressure of the steam.

16. If the siphon steam gauge were made of glass, the height of the mercurial column representing the pressure of

the steam could be obtained by inspection, a scale being annexed; but to avoid accidental fractures, this tube is usually made of iron, and the level of the mercury is indicated by a float, having a rod attached, similar to the gauge-float already described for indicating the level of the water. To this rod may be attached any convenient index and scale.

17. Owing to the obstruction which the steam encounters in passing through the steam pipes and valves, its pressure undergoes a greater or less diminution on its way to the cylinder. To ascertain the effective pressure, therefore, in the cylinder, a steam gauge is sometimes placed upon the steam pipe, as close as possible to the cylinder.

18. A custom has been adopted too generally of estimating the pressure of the steam in the cylinder by its pressure in the boiler, assuming that between the two there is but a slight difference. Nothing can be more erroneous than this. Between the pressure of the steam in the boiler and in the cylinder there may be almost any amount of difference. If the throttle valve be nearly closed while the pressure of the steam in the boiler is very high, the pressure of steam which works the piston may be very low; and, on the other hand, if the throttle valve be nearly open, there may not be a considerable difference between the two.

19. To calculate, therefore, in general the effective power of the engine, by taking, as is commonly done, the pressure of the steam in the boiler, and multiplying that by the area of the piston and its velocity, is a most fallacious method. The indicator already described may be used to determine the average pressure of steam on the piston, and thus the effective action of the piston may be calculated; or, if the actual quantity of water transmitted in the state of steam to the cylinder be known, the mechanical effect of this can be calculated independently of any consideration of the pressure of the steam, or even of the magnitude of the piston. It will, however, be necessary even in this case to determine the resistance of the uncondensed steam.

20. In high-pressure boilers, where steam is worked at 40 and 50 lb. above the atmosphere, or at even higher pressures, the mercurial steam gauge is inconvenient, owing to the height of the column of mercury which the pressure would sustain, and from other causes. This inconvenience is especially felt in locomotive engines. In stationary engines it is always possible to provide a permanent mercurial steam gauge of sufficient height, whatever be the pressure of the steam; and indeed it is desirable so to do, for there is no measure of the force of the steam so certain and exact. In locomotive engines, however, and in other cases where a tall column of mercury is inadmissible, the pressure of the steam is indicated by a spring steelyard, which is made to act upon the safety valve. (See Chap. XXVII., title "*Spring Safety Valve.*") This instrument is in principle precisely the same as the common spring steelyards used in domestic economy. A scale is attached to it, upon which an index plays, by which the pressure on the valve is expressed in lbs. per square inch. The instrument is usually screwed down, so that the valve will only be opened when the steelyard indicates a certain pressure.

21. It is customary, more especially in high-pressure engines, to provide two safety valves, one of which shall be removed from the interference of the engine-man. This precaution prevents the danger which would arise from the engine-man overloading the valve, or from the valve becoming fixed in its seat from accidental causes, which sometimes happens.

22. When a boiler ceases to be worked, and the fire has been extinguished, the steam which filled its interior will be speedily condensed, and the interior would become a vacuum. In this case a prodigious amount of atmospheric pressure, acting on the external surface of the boilers inwards, would have a tendency to crush it. This contingency is sometimes provided against by a safety valve which opens inwards. So long as the boiler is in operation, this valve is kept closed by

the pressure of the steam; when it ceases to be worked, it is opened by the pressure of the atmosphere.

23. It is most necessary for the efficient operation of the engine that the state of the vacuum in the condenser should be at all times known. For this purpose an indicator is adopted, called the *barometer gauge*, forming one of the most important appendages of the condensing steam engine. (See Chap. xxvii., title "*Barometer Gauge.*")

24. This instrument, as its name imports, is a common barometer, but the top of the tube, instead of being closed, is made to communicate with the condenser. The atmospheric pressure, acting as usual in barometers, on the mercury in the cistern, presses a column of mercury up the tube. If the vacuum in the condenser were as perfect as that which is at the top of the barometric tube, then the column of mercury in this instrument would stand at exactly the same height as in the common barometer; but as this is never the case, there is a difference of height which is due to the pressure of uncondensed steam and air, which, notwithstanding the action of the air-pump, will always remain in more or less quantity in the condenser. The difference, therefore, between the height of the column of mercury in the barometer gauge communicating with the condenser, and in a true barometer placed near it, will give, in inches of mercury, the pressure which re-acts upon the piston against the steam.

25. In well-managed engines the barometer gauge is seldom more than an inch below the true barometer, which would give half-a-pound per square inch for the pressure re-acting on the piston.

26. If the barometer gauge stand too low, it indicates the presence either of uncondensed vapour or of air in the condenser. This may arise either from too little or too much water being thrown in by the condensing jet. If too little be thrown in, the condensation will be imperfect, and uncondensed vapour will lower the gauge: if too much be thrown in, an accumulation of air will be produced faster

than the pump can remove it, and the gauge will be similarly affected. The adjustment of the jet is a matter, therefore, that should be carefully attended to. The cock which governs the jet has a handle to which an index is attached, playing upon a divided scale; and according to the position of that index, the cock is more or less opened or closed.

CHAP. XXII.—HOW THE WANTS OF THE BOILER AND ENGINE ARE SUPPLIED, AND HOW THEIR OPERATION IS REGULATED.

1. If the work executed by a steam engine were subject to no variation whatever, the rate at which the steam should be supplied to the cylinder and generated in the boiler would be uniform also; and as the production of such steam necessarily bears an uniform ratio to the development of heat in the furnace, this last would be also uniform. The development of heat in the furnace being in direct ratio to the supply of air, or what is the same, the draft in the chimney, it would follow that an engine perfectly uniform in its action would require an invariable adjustment of the flues, an invariable rate of evaporation in the boiler, and an invariable magnitude of communication between the boiler and cylinder for the supply of steam.

2. But in practice it is found that the work to be executed by machinery of this kind is subject to more or less variation, requiring a greater or less intensity from time to time in the moving power.

3. This necessitates a corresponding variation in the action of the steam in the cylinder. This variation is produced by the *throttle valve*, placed in the pipe by which steam is conducted to the cylinder. (See *fig. art. 17.*) This valve is a circular plate, corresponding nearly with the magnitude of the pipe in which it is placed. It is so constructed as to turn on an axis which coincides with one of its diameters, and its movement is governed by a lever or handle on the outside of the steam pipe. When this circular plate is

turned so as to present its edge to the current of steam, that current is allowed to pass without obstruction to the cylinder; but when it is turned so that its face is presented to the steam, the current is altogether stopped. Between these two extreme positions it may have any intermediate inclination by which the flow of steam to the cylinder shall be regulated in any desired manner.

4. Supposing this valve to be adjusted from time to time, so as to proportion the quantity of steam admitted to the cylinder to the quantity of work to be done, the production of the steam in the boiler will have to be considered. If this production be uniform, it must be adequate in quantity to the greatest amount of steam at any time required by the cylinder.

5. When less than this is admitted to the cylinder by the action of the throttle valve, an accumulation would necessarily take place in the boiler, and the pressure on the safety valve becoming excessive, the surplus steam would blow off. This would occasion, of course, a corresponding waste of fuel. The remedy for this would be a contrivance by which the rate of evaporation in the boiler can be augmented or diminished at pleasure, according to the wants of the cylinder. This will obviously be accomplished by any contrivance which will stimulate or slacken the furnace at pleasure. Now since the action of the furnace is regulated by the intensity of the draft, exactly as the action of the piston is regulated by the intensity of the steam admitted to it, the same kind of regulator may be applied to the one as has been applied to the other. A plate called a *dampner* is therefore introduced at some convenient point in the flue near the chimney. This plate is generally made like a sliding shutter. When it is let down it stops the flue altogether, and the fire would be extinguished; when it is drawn up to the limit of its play, the flue is altogether open, and the draft is at its extreme power; between these limits the dampner may have an indefinite variety of positions, leaving more or less of the flue open, so as to give to the draft any required intensity.

6. It is easy to imagine an attendant working these two instruments so as to regulate the action of the machinery. When the resistance on the working point is lightened, the throttle valve is partially closed, so as to diminish the supply of steam; and at the same time the damper is partially closed, so as to diminish the draft: on the other hand, when the load on the machinery is increased, the throttle valve is opened, so as to augment the supply of steam and increase the action on the piston: and the damper is raised, so as to increase the intensity of the combustion and augment the rate of evaporation in the boiler.

7. It would be obviously desirable that these contrivances, which we have here supposed to be regulated at the discretion of the attendant on the engine, should be regulated by the wants of the engine itself, so as to be made *self-acting*, like the valves which regulate the supply of steam to the cylinder.

8. This is accordingly accomplished by very simple and effectual means in low-pressure boilers, to which we more particularly advert at present. A tube is inserted, which descends in the boiler below the level of the water; the pressure of the steam supports in this tube a column of water of a certain height, and as the pressure of the steam varies, this column varies in height. A float is introduced in the tube, and supported by this column of water. A chain attached to this float is conducted over one or more pulleys, and carried to the damper, which is suspended to it. Now let us suppose the throttle valve either opened or closed, as the case may be. If it be opened, the supply of steam passing from the boiler to the cylinder is augmented; the pressure of steam in the boiler is for the moment diminished by this exhaustion: the column of water in the tube falls by reason of the diminished pressure; the float supported by it falls with it, and, drawing down the chain, draws up the damper; the draft through the furnace is augmented, the combustion is stimulated, the heat which acts on the boiler increased, and the evaporation accelerated

until the production of steam becomes adequate to the demands of the cylinder.

9. In this way the varying demands of the cylinder on the boiler are made to vary in a proportional manner the action of the furnace, on which the generation of steam depends: when the cylinder consumes much steam, the damper is kept open; when little, it is partially closed.

10. The superintendence of the damper by the engine-man is therefore superseded. The engine itself works it more regularly and perfectly than could be done by any manual superintendence.

11. This arrangement is called the *self-acting damper*.

12. In steam-engines in general, and especially in those used in the manufactories, the rate at which steam is supplied to the cylinder ought to be proportionate to the work which the engine has to perform; if not, whenever the resistance on the engine should be diminished, the speed of the piston would be augmented; and whenever the resistance should be augmented, the speed of the piston would be diminished, and a continually varying and irregular motion would necessarily take place in the engine, and would be transmitted to the machinery which it works. This is in general incompatible with the exigencies of the arts and manufactures, in which there is a certain rate of motion or speed which ought to be imparted to the machinery, and which ought neither to be permitted to decline or augment.

13. Now, since occasional variations in the resistance are inevitable, the only way to maintain an uniform velocity in the engine and in the machinery it drives, is to provide means of regulating the supply of steam, so that the rate at which it shall flow into the cylinder shall be varied in the exact proportion of the resistance. This might, as I have already stated, be accomplished by the manual superintendence of the throttle valve, but a much more certain and efficacious expedient was supplied in the *governor*, by the fertile invention of Watt.

14. To make the principle of the governor comprehended, we must refer to a well-known property of the common pendulum used as the regulator of time-pieces. It is the property of this instrument, that when it oscillates in obedience to gravity from side to side in a circular arch, the time of its vibration will be the same whether the arches in which it vibrates are long or short, provided only the angle of its vibration be not considerable: if the arches be short, its motion will be slow; if long, its velocity will be proportionally great; and thus, whether long or short, the time of accomplishing a complete vibration will be the same. This well-known property of the pendulum is called *isochronism*.

15. Now if the pendulous knob, instead of vibrating in a circular arch, be made to whirl with a circular motion round an axis, the knob, in virtue of the centrifugal force produced by the rotation, will have a tendency to recede from the axis round which the motion takes place; and when it assumes such a position that the tendency to recede is equal to its tendency to descend, in virtue of its weight, it will remain at a fixed distance from the axis round which it revolves, neither receding from, nor approaching to it.

16. It is a property of this arrangement, quite analogous to the isochronism of the pendulum, and indeed depending on the same physical principles, that the time of revolution necessary to produce this equilibrium, and to keep the knob at a fixed distance from the axis, without receding from or approaching to it, is the same whatever be the distance of the knob from the axis, provided only that the angle of obliquity of the rod be not considerable; and even though such angle have some considerable magnitude, the times of revolution corresponding to the state of equilibrium will not be considerably different.

17. This expedient, known by the name of the *conical pendulum*, was applied by Watt, with his usual felicity and success, to the regulation of the throttle valve. The arrangement, as usually adopted, is represented in the following

figure. Two balls *i* are attached to the ends of equal rods of metal *h g*. The arrangement is composed of a series of

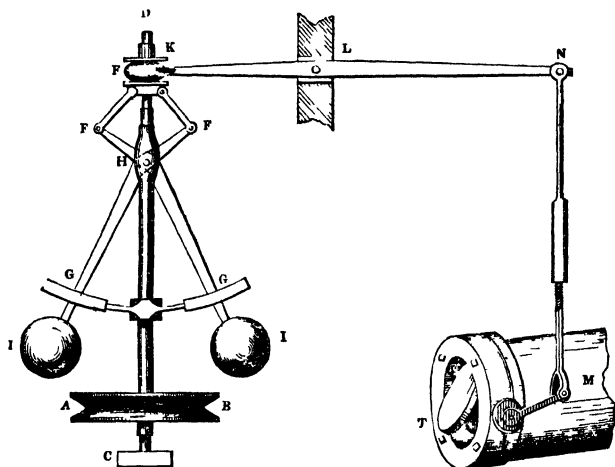

jointed rods *h f e*, which play upon a vertical spindle *c d*, being fixed at *h*, but capable of sliding upon it at *e*. When the balls are separated so that the rods *h g* become more divergent, the arms *h f* open, and the pivots *f*, separating, draw down the collar *e*, which, as I have stated, slides upon the spindle; and on the contrary, when the balls approach each other, the arms *h f* also approach each other, and the collar *e* is forced up. Thus, according to the distances of the balls from the vertical spindle, the collar *e* ascends or descends. In the collar *e* is inserted the forked end *k* of the lever *n l k*. The end *n* of this lever is connected, as represented in the figure, with the throttle valve *t*, and the proportion and position of the rods are so adjusted that when the balls descend towards their lowest position, the throttle valve becomes open; and when they separate, it becomes gradually closed.

A grooved wheel *a b*, or oftener a toothed pinion, is fixed

upon the axle of the spindle, which receives its motion from any convenient part of the machinery.

Now let us suppose that the load on the engine is suddenly diminished. A momentary augmentation of speed will take place in the piston, and an increased velocity be imparted to the wheel *A B* and the balls of the governor; these balls will consequently fly further from the vertical spindle, the fork *K* will be drawn down, the throttle valve *T* partially closed, and the supply of steam to the cylinder diminished.

If, on the other hand, the load on the engine be increased, the speed of the piston will be momentarily slackened, the velocity of the wheel *A B* will be diminished, the balls will descend and approach the vertical spindle, the fork *K* will be raised, and the throttle valve *T* partially opened. In this manner the governor has the effect of admitting at all times to the cylinder just that portion of steam which is necessary to give to the piston the proper velocity, the quantity being always proportioned to the load on the engine.

It is to be understood that this beautiful little instrument exercises powers circumscribed within narrow limits; but these limits are sufficiently extended to accommodate themselves to the variations incidental to the work which the engine performs. If the average amount of work varies from time to time, the governor can be adjusted accordingly.

18. I have already explained in how great a degree the regular supply of water to the boiler is necessary to the efficiency of the machine. Since the water in the boiler will be in the direct proportion of the work executed by the engine and the combustion in the furnace, it seems natural to seek for some self-regulating mode of feeding the boiler, analogous to that which we have described as governing the combustion in the furnace and the supply of steam to the cylinder. It has been already explained that a float within the boiler causes a rod bearing an index to ascend and descend, indicating always the quantity of water in the boiler.

Now if this rod can be made to act upon a reservoir of

water communicating with the interior of the boiler, so as to open the valve and admit water when it descends, and close the valve so as to stop the supply when it ascends, the desired object will be attained. Such an arrangement has accordingly been adopted with complete success, and forms what is called the *self-acting feeder*. To the rod of the float is attached a cord or chain by which it is connected with the end of a lever, which opens and closes a valve placed in the bottom of a small cistern which stands at a sufficient height above the boiler. A tube is inserted in the bottom of this cistern under the valve, which tube descends into the boiler, and in it a column of water is sustained by the pressure of the steam, as already described.

When the level of the water subsides and the boiler requires feeding, the float falls, draws down the rod, opens the valve in the small cistern above, and lets water flow in through the tube: this continues until the level of the water is restored to its proper height, when the valve is closed.

19. But to speak more precisely, this valve is not alternately opened and closed. The float and valve will be so adjusted that the latter is kept just so much open as to allow a stream of water to descend in the tube which is exactly equal to the rate of evaporation in the boiler, so that the level of the water is kept constantly at the same point.

20. This arrangement, however, is only applicable to low-pressure boilers, for in high-pressure boilers the column of water which would be sustained in the tube would be too high.

21. It is customary to supply the feed cistern just mentioned with the water pumped from the condenser by the air-pump: this water, having a temperature more elevated than that of the atmosphere, carries back to the boiler a portion of heat which would otherwise be wasted.

22. In high-pressure boilers, where this feeding apparatus would be inapplicable, the necessary quantity of water is driven into the boiler by forcing pumps, called *feed pumps*,

which are worked by the engine. The dimensions of these pumps are regulated according to the average evaporating power of the boiler, so that the quantity of water which they throw in shall be exactly equal to the quantity which passes in the state of steam to the cylinder.

23. As this proportion, however, cannot be always precisely maintained, it is necessary to provide means for cutting off the feed pumps, or throwing them into operation at pleasure. Arrangements of this kind are accordingly provided, and placed at the disposal of the engineer.

24. An easy and obvious expedient suggests itself for cutting off the feed, and supplying it according to the wants of the boiler, which, however, I do not recollect seeing adopted in practice.

25. The float which rises and falls with the level of the water in the boiler might be made to act by its rod upon the gearing of the feed pumps, exactly as it acts upon the valve in the feed cistern in low-pressure boilers; so that whenever the level of the water should become too high, the pump should be thrown out of gear; and whenever it was too low, it should be thrown into action.

CHAP. XXIII.—HOW THE STEAM ENGINE IS ADAPTED TO THE WORKING OF PUMPS.

1. Hitherto we have considered the piston as driven in both directions, upwards and downwards, by steam, a vacuum being produced alternately on the side towards which it moves.

2. When the engine is applied to work a common pump, the force being only required to be exerted when the pump buckets are raised, but not in their descent, an arrangement would be required in the cylinder by which the piston should be only driven by steam in its descent, the pump buckets being then raised at the other end of the beam; but in its ascent the piston would be drawn up by the weight of the descending buckets, without any aid from the steam. Engines

adapted to work pumps are therefore so arranged that the valve shall only admit steam above the piston, a vacuum being made below it in the descent. Engines constructed in this manner are called *single-acting engines*, while those in which the steam acts both above and below the piston are called *double-acting engines*.

3. The single-acting engine in its principle differs in no respect from those we have described. A valve is provided at the top of the cylinder, by which steam is admitted above the piston when it begins to descend; another valve is provided at the bottom, by which the steam under the piston passes to the condenser; and the piston descends exactly in the same manner as in the double-acting engine. But when the piston has reached the bottom of the cylinder, a valve is opened which gives a communication between the top and the bottom of the cylinder, so that the steam which has just pressed the piston down now passes equally above and below it. The piston being then drawn up by the weight of the descending buckets, the steam which was above it passes below it, through a tube attached, in which the valve just mentioned, communicating between the top and bottom of the cylinder, is placed. When the piston has reached the top of the cylinder, the steam which previously filled the cylinder above the piston will now fill it below the piston; and when the piston is about to descend by the pressure of fresh steam admitted above it, the steam below it is discharged to the condenser by another valve, already mentioned, and so the operation proceeds.

4. These single-acting engines are only applicable to pumping or to some other operation in which an intermitting force, acting in one direction only, is required.

5. The double-acting engine may, however, be also applied to pumping by the use of a double-acting pump, a variety of forms of which are familiar to engineers.

6. The most remarkable examples of the application of the steam engine to pumping are presented in the mining districts

of Cornwall, where engines constructed on an enormous scale are applied to the drainage of the mines. The largest steam engines in the world are used for this purpose. Cylinders 8 and 9 feet in diameter are not unprecedented. The expansive principle may here be applied without limit, inasmuch as regularity of motion is not necessary. Steam having a pressure of 50 lb. per square inch above the atmosphere is admitted to act on the piston, and cut off after performing from $\frac{1}{2}$ to $\frac{1}{4}$ of the stroke, the remainder of the stroke being effected by the expansion alone of the steam.

CHAP. XXIV.—HOW THE ATMOSPHERIC PRESSURE COMBINED WITH THE PROPERTIES OF STEAM IS RENDERED EFFICIENT IN AN ENGINE.

1. The machine called the *atmospheric engine*, which was displaced by the improved steam engine of the celebrated Watt, consisted of a cylinder and piston, working beam and pump-rods, similar in their general arrangement to those of the single-acting steam engine already described. The difference consisted in this, that a vacuum being made under the piston by the condensation of steam, the piston was urged downwards, not by the pressure of the steam, but by that of the atmosphere which was admitted above it, the top of the cylinder being open. In this case the steam was used not directly as a mechanical agent, but indirectly to produce a vacuum under the piston, and so give effect to the atmospheric pressure above it.

2. This system, compared with the single-acting engine, has many defects, the removal of which was so successfully accomplished by the invention of Watt. When the piston was pressed downwards by the atmosphere, the atmosphere had a tendency to cool the cylinder; and when the piston was made to ascend by admitting steam under it, and thus giving effect to the weight of the pump-rods at the other end of the beam, the steam as it entered was more or less condensed by the cold cylinder; and to whatever extent this

condensation took place, there was a proportional waste of fuel. When the piston was at the top of the cylinder, and the cylinder under it filled with steam, a jet was introduced within it, as we have already described, and the steam was condensed; but this method, which produced an unnecessary waste of fuel, is not essential to the principle of the atmospheric engine.

3. The separate condenser of Watt being attached to it, the condensation is made under the piston without cooling the cylinder, in the same manner as in the improved engine of Watt. There still would remain, however, the evil of cooling the cylinder by the admission of the atmosphere above the piston.

4. Nothing, on the other hand, is gained by using the atmosphere in this way. The same steam which is used to make a vacuum under the piston may be previously used to press the piston downwards, and we therefore consume as much mechanical force, in the form of steam, when we use the atmosphere as when we exclude it.

5. In favour of the atmospheric engine, however, as compared with the steam engine, there is a circumstance of sufficient importance to keep this engine still in use in districts where fuel is extremely cheap. In its construction there is much greater simplicity and cheapness, and less liability to get out of order. The arrangements for passing the top of the piston-rod through the top of the cylinder, so as to be steam-tight, are unnecessary, as are also those for parallel motion, and the valves for the admission and emission of steam at the top of the cylinder. These advantages, however, are but small, and will disappear every day as the cost of the construction of engines is diminished.

CHAP. XXV.—HOW THE STEAM-ENGINE IS CONSTRUCTED IN CASES WHERE A CONDENSING APPARATUS IS INADMISSIBLE.

1. It will be perceived that the advantages obtained by the vacuum produced by the condensation of steam are

not without draw-backs. The machinery for condensation is costly, bulky, and heavy, and moreover consumes a considerable portion of the moving power in working it. The condenser requires a cistern of cold water, in which it is submerged. This cistern must be kept constantly supplied with cold water, for which purpose a pump, called the *cold water pump*, must be worked by the engine. The water and air admitted by the condensing jet must be continually pumped out by the air-pump. In many cases the steam engine is worked in situations in which a sufficient supply of cold water cannot be procured, and where the weight and bulk of the condenser, air-pump, and cold water pump, would be inadmissible. In these cases, the power of the steam must be worked without the advantage of the vacuum on the other side of the piston. Engines thus constructed are called *non-condensing engines*, and sometimes, though not with strict propriety, *high-pressure engines*. Steam having a greater pressure than that of the atmosphere, being admitted on one side of the piston, and the other side being left in open communication with the atmosphere, the piston will be urged forwards by a force proportional to the excess of the steam pressure above the pressure of the atmosphere, the friction, and other resistances. When the piston is thus drawn to the other end of the cylinder, the steam being admitted on the opposite side of the piston, and the contrary side being open to the atmosphere, the piston will in like manner be urged back again.

2. Between the *mechanism* by which the admission and emission of the steam is effected in this machinery, and that which we have described in the condensing engine, there is no real difference. Whether the steam be allowed to escape to the condenser, or into the open atmosphere, the mechanism which governs its admission and escape will be the same.

3. As the pressure of the steam in such machines must necessarily exceed that of the atmosphere, in a sufficient

proportion to supply a force necessary for the purpose to which the machine is applied, the pressure is always much greater than is necessary where condensation is used; and hence the application of the term *high-pressure engines* to such machines; but the use of the term is objectionable, inasmuch as steam of an equally high pressure is often used in engines in which the steam is condensed and a vacuum produced. An example of this is presented in the engines used in Cornwall, where steam having a pressure of 50 lb. or upwards on the square inch is used.

4. Properly speaking, therefore, *high-pressure engines* consist of two classes; those in which the steam is not condensed, and those in which it is condensed.

5. The most proper classification of engines, therefore, is into *condensing* and *non-condensing engines*; the latter being always high-pressure engines, and the former sometimes high-pressure and sometimes low-pressure.

6. By low-pressure engines is to be understood those in which the safety valve on the boiler is loaded at the rate of 4 to 6 lb. per square inch.

7. High-pressure engines is a term rather indefinite; but where the valve is loaded with 20 lb. or upwards per square inch, the machine is generally so called.

8. In the United States, the use of high-pressure steam is much more universal than in England, and 20 lb. upon a square inch of the safety valve would hardly be denominated high-pressure. This will be understood when it is stated that from 120 to 150 lb. per square inch is not a very uncommon pressure to use.

9. In locomotive engines, the condensing apparatus is excluded for obvious reasons. The pressure in these is usually from 50 to 60 lb. per square inch. The steam which escapes from the cylinder, after working the engine, is ejected up the chimney, where it plays the part of a blower, and supplies that want of elevation of the chimney which circumstances here exclude.

CHAP. XXVI.—HOW THE MECHANICAL PRESSURE OF THE STEAM ON THE PISTON IS LIMITED, AND HOW THE SPEED OF THE PISTON IS AFFECTED BY THIS.

It is commonly but erroneously supposed that the pressure which the steam exerts on the piston of an engine can be augmented or diminished at pleasure by augmenting or diminishing the pressure of the steam in the boiler. A moment's attention to some universal principles of mechanical science will be sufficient to rectify this error.

It is an established principle, that when a body which offers a definite resistance to motion is impelled by a force whose pressure is precisely equal to that resistance, the body so acted upon must be in one of two states, viz., either at rest, or moving with an uniform velocity.

This principle is convertible. A state of rest or of uniform motion presumes that the body in such state must be acted upon by forces *in equilibrio*,—that is to say, if it be in motion, the energy of the forces which impel it must be precisely equivalent to the resistance which it offers to them.

To illustrate this by a practical example, let us suppose that a carriage placed on an uniform and level road is drawn by a horse at a perfectly uniform speed. The resistance in this case which the carriage offers to the draft is precisely equivalent to the force impressed by the horse on the collar.

If an experimental proof of this be required, it may be easily given. Let a carriage be placed on any level surface, and drawn by a weight carried over a pulley. When its motion is uniform, it will be found that the amount of the weight which gives it such motion is precisely equal to the resistance of the carriage.

But it will be asked, how can the energy of the impelling forces be greater or less than the resistance, if the object to which it is applied be in motion? If it be greater than the

resistance it cannot do more than move it; if it be less than the resistance, why does not the object stop altogether? Admitting that a moving force greater in amount than the resistance of the body moved can be applied, it may be further asked, what becomes of the surplus of such moving force? It is clear that the resistance cannot absorb more than its own amount of the moving force: on what, then, is the surplus expended?

Let the simple and familiar example of a carriage moved on a level road be taken. Let us suppose that the force exercised on the carriage is 150 lbs., while the resistance of the carriage to the moving power is only 100 lbs. On what object, then, are the other 50 lbs. expended?

The answer to this is extremely simple, and easily understood. When the moving force is thus greater in intensity than the resistance, the motion imparted to the body to which it is applied is not, as above, an uniform speed, but a speed constantly accelerated: in every succeeding second of time, the moving force imparts to the body an increased velocity, and consequently an increased momentum. It is by this augmentation of momentum, then, that the surplus moving force is absorbed. It is, therefore, a living force. It is not, properly speaking, extinguished, as is that portion of the moving force which is *in equilibrio* with the resistance. The momentum which it produces in the moving body will be retained and expended upon something before the moving body can come to a state of rest.

Accelerated motion is, then, the consequence of the moving force exceeding in amount the resistance of the body moved.

Analogy will at once raise the presumption, that a gradually retarded motion will be the consequence of the moving force being less in intensity than the resistance of the body moved.

The moving force in this case balances, or as it were extinguishes, so much of the resistance as is equal to its

intensity; the excess of the resistance, however, remains to be accounted for. What is its effect, and what becomes of it? We suppose the body to be already in motion; its weight or mass has therefore a certain momentum, which, by the common properties of matter, gives it a tendency to continue in motion. This tendency is opposed by that portion of the resistance which is not balanced by the moving force. This portion of the resistance, then, gradually robs the moving body of its momentum, makes it move more and more slowly, and at length, extinguishing all the momentum, brings the body to a state of rest.

Thus it will be clearly understood that any inequality between the intensity of the pressure, or traction, or impulsion, by whichever term the moving force be designated, and the intensity of the resistance, will be attended with an accelerated or retarded motion in the body moved, according as the excess lies on the side of the moving power or on the side of the resistance.

There is nothing new in these principles. They are, in fact, the established principles of general mechanics, perfectly familiar to all who have cultivated the higher departments of science.

It would, however, certainly appear from the common language and modes of calculation and reasoning which have prevailed among engineers and practical men, that they have either lost sight of these principles, or never known them.

Let us apply them to the case of a steam engine.

The piston is in this case the body moved. The boiler is the source of the moving power. To simplify the case, we shall imagine the motion of the piston to take place constantly in one direction, instead of being reciprocated from end to end of the cylinder.

Now it follows, from what has just been explained, that if the motion of the piston in the cylinder be uniform, the pressure of the steam which impels it cannot by any mechanical possibility be different from the amount of the resistance

which the piston offers: you may load the safety valve as you please; you may vary the condition of the boiler in any imaginable manner, and the pressure of the steam in that vessel may have any intensity whatever; but it is demonstrably certain that the pressure of the steam in the cylinder cannot be either greater or less than such as would be necessary on the entire surface of the piston to produce an action equal to its resistance. This is as certain as the conclusion of any problem in common Geometry.

But then, it may be objected, we can have no power to vary the pressure of the steam in the boiler, inasmuch as the resistance of the piston has no connection with the source of the moving power.

I have explained in a former chapter that the pressure of steam in the boiler, though it can never be *less* than the pressure of steam in the cylinder, may be to any desired extent greater;—the action of the throttle-valve explains this: the more the throttle-valve is contracted, and the smaller the orifice through which the steam has to pass into the cylinder, the greater will be the ratio of its pressure in the boiler to its pressure in the cylinder. There is, then, a minor limit to the pressure of steam in the boiler. It cannot be less than such a pressure as would produce on the piston an action equal to its resistance.

What is, on the other hand, the major limit of the pressure of steam in the boiler? This limit is obviously determined by the load on the safety valve: when the steam exceeds this limit, the safety valve will be opened, and the surplus pressure reduced by escape.

It thus appears that the piston and the safety valve supply the two limits of the possible pressure of steam in the boiler. The pressure per square inch of the steam in the boiler cannot be less than the resistance per square inch of the piston, nor greater than the pressure per square inch on the safety valve.

In the ordinary action of an engine, the motion must in

the main be uniform. Acceleration or retardation are conditions exceptional and occasional. When the piston is first put in motion from a state of rest, its motion is accelerated until it has attained its normal and regular speed: when the engine is about to be stopped, its motion is gradually retarded until the resistance extinguishes the momentum of the machinery.

When the piston and other reciprocating parts of the machinery change the direction of their motion at each extremity of the stroke, they will be for a short interval, before and after the moment the direction changes, retarded and accelerated; and this retardation and acceleration would be very perceptible, were it not for the fly-wheel: but the momentum of the fly-wheel, as well in consequence of its weight as of the velocity of the matter forming its rim, so prodigiously exceeds the momentum of the reciprocating parts of the machinery, that the effect of acceleration and retardation in the latter is altogether effaced by the great momentum of the revolving mass of the former.

It is for this reason that the fly-wheel justifies us practically in our reasoning in assuming the piston as moving uniformly and constantly in one direction, instead of reciprocating.

When the steam is used expansively, being cut off at one-half, or any other fraction of the stroke, the impelling power necessarily varies in intensity; and as the resistance does not vary in intensity, or at least does not vary in the same manner and proportion, there will consequently not be an equilibrium between the moving power and the resistance, and the motion therefore cannot be uniform.

When steam is thus applied, the pressure, when first admitted on the piston, is greater than the resistance; and so long as the steam valve is open, the motion of the piston will be accelerated. When it is closed, and the steam begins to expand, it gradually diminishes in intensity. The accelerated motion of the piston will, however, continue until

the pressure of the steam becomes equal to the resistance. Further expansion rendering it less powerful than the resistance, the motion of the piston will be retarded to the end of the stroke.

This series of effects is repeated at each stroke of the piston.

Now although in this case the motion of the piston during any one stroke is variable, yet the average motion of the machine will be uniform: although throughout a single stroke the piston be alternately accelerated and retarded, yet the number of strokes performed by the machine per minute will be the same. The average velocity will be uniform, although the velocity within the limit of a single stroke be not so.

But even this variation within the limits of each stroke is almost effaced by the action of the fly-wheel, which absorbs the acceleration and repairs the retardation by giving and taking momentum, as already described.

I have spoken of the uniform velocity of the piston, which, whether it be maintained in the literal sense of the term, or only on the average, as estimated by the number of strokes per minute, must in every case be the result of an equilibrium between the average moving force of the steam and the resistance of the machinery. But what, it may be asked, determines the rate of this uniform speed? What conditions are they which can determine whether the piston shall move 200 feet or 500 feet per minute?

This is obviously determined by the rate at which the boiler is capable of supplying steam of the requisite pressure to the cylinder. Let the resistance on the piston be estimated; say that it is 20 lbs. per square inch of its surface; then the boiler must be capable of supplying steam of 20 lbs. pressure per square inch, in such measure as to enable the piston to move at the required speed.

Let us assume, for example, that the required speed is 200 feet per minute, or 12,000 feet per hour, and that the

area of the piston is 5 square feet; then, to enable the piston to advance through 12,000 feet, a column of steam must follow it, 12,000 feet in length and 5 square feet in its section, which gives 60,000 cubic feet of steam. But steam having the pressure of 20 lbs. per square inch bears to the bulk of water which produces it the proportion of 1281 to 1; therefore, if we divide 60,000 by 1281, we shall find the number of cubic feet of water which must be supplied in the state of steam by the boiler to the cylinder in an hour.

This division gives 47, very nearly. The boiler, therefore, must in this case evaporate 47 cubic feet of water per hour, or, according to the conventional standard of boiler-makers, be a boiler of 47 horse-power.

In general this calculation may be made by the aid of the following Tables.

ON THE SQUARE MEASURE.

TABLE I.—Continued.

Dia.	Area.	Dia.	Area.	Dia.	Area.	Dia.	Area.	Dia.	Area.
Inch.	Inches.	Inch.	Inches.	Inch.	Inches.	Inch.	Inches.	Inch.	Inches.
31	754.76	37	1075.2	43	1452.2	49	1855.7	55	2375.8
	760.86		1082.4		1460.6		1895.3		2386.8
	766.99		1089.7		1469.1		1905.0		2397.4
	773.14		1097.1		1477.6		1914.7		2408.3
	779.31		1104.4		1486.1		1924.4		2419.2
	785.51		1111.8		1494.7		1934.1		2430.1
	791.73		1119.2		1503.3		1943.9		2441.0
	797.97		1126.6		1511.9		1953.6		2452.0
32	804.24	38	1134.1	44	1520.5	50	1963.5	56	2463.0
	810.54		1141.5		1529.1		1973.3		2474.0
	816.86		1149.0		1537.8		1983.1		2485.0
	823.21		1156.6		1546.5		1993.0		2496.1
	829.57		1164.1		1555.2		2002.9		2507.1
	835.97		1171.7		1564.0		2012.8		2518.2
	842.39		1179.3		1572.8		2022.8		2529.4
	848.83		1186.9		1581.6		2032.8		2540.5
33	855.30	39	1194.5	45	1590.4	51	2042.8	57	2551.7
	861.79		1202.2		1599.2		2052.8		2562.9
	868.30		1209.9		1608.1		2062.9		2574.1
	874.84		1217.6		1617.0		2072.9		2585.4
	881.41		1225.4		1625.9		2083.0		2596.7
	888.00		1233.1		1634.9		2093.2		2608.0
	894.61		1240.9		1643.8		2103.3		2619.3
	901.25		1248.7		1652.8		2113.5		2630.7
34	907.92	40	1256.5	46	1661.9	52	2123.7	58	2642.0
	914.61		1264.5		1670.9		2133.9		2653.4
	921.32		1272.3		1680.0		2144.1		2664.9
	928.06		1280.3		1689.1		2154.4		2676.3
	934.82		1288.2		1698.2		2164.7		2687.8
	941.60		1296.2		1707.3		2175.0		2699.3
	948.41		1304.2		1716.5		2185.4		2710.8
	955.25		1312.2		1725.7		2195.7		2722.4
35	962.11	41	1320.2	47	1734.9	53	2206.1	59	2733.9
	968.99		1328.3		1744.1		2216.6		2745.5
	975.90		1336.4		1753.4		2227.0		2757.1
	982.84		1344.5		1762.7		2237.5		2768.8
	989.80		1352.6		1772.0		2248.0		2780.5
	996.78		1360.8		1781.3		2258.5		2792.2
	1003.7		1369.0		1790.7		2269.0		2803.9
	1010.8		1377.2		1800.1		2279.6		2815.6
36	1017.8	42	1385.4	48	1809.5	54	2290.2	60	2827.4
	1024.9		1393.7		1818.9		2300.8		2839.2
	1032.0		1401.9		1828.4		2311.4		2851.0
	1039.1		1410.2		1837.9		2322.1		2862.8
	1046.3		1418.6		1847.4		2332.8		2874.7
	1053.5		1426.9		1856.9		2343.5		2886.6
	1060.7		1435.3		1866.5		2354.2		2898.5
	1067.9		1443.7		1876.1		2365.0		2910.5

Table I.—Continued.

Dia.	Area.	Dia.	Area.	Dia.	Area.	Dia.	Area.	Dia.	Area.
Inch.	Inches.	Inch.	Inches.	Inch.	Inches.	Inch.	Inches.	Inch.	Inches.
61	2922.4	67	3525.6	73	4185.3	79	4901.6	85	5674.5
	2934.4		3538.8		4199.7		4917.2		5691.2
	2946.4		3552.0		4214.1		4932.7		5707.9
	2958.5		3565.2		4228.5		4948.3		5724.6
	2970.5		3578.4		4242.9		4963.9		5741.4
	2982.6		3591.7		4257.3		4979.5		5758.2
	2994.7		3605.0		4271.8		4995.1		5775.0
	3006.9		3618.3		4286.3		5010.8		5791.9
62	3019.0	68	3631.6	74	4300.8	80	5026.5	86	5808.8
	3031.2		3645.0		4315.3		5042.2		5825.7
	3043.4		3658.4		4329.9		5058.0		5842.6
	3055.7		3671.8		4344.5		5073.7		5859.5
	3067.9		3685.2		4359.1		5089.5		5876.5
	3080.2		3698.7		4373.8		5105.4		5893.5
	3092.5		3712.2		4388.4		5121.2		5910.5
	3104.8		3725.7		4403.1		5137.1		5927.6
63	3117.2	69	3739.2	75	4417.8	81	5153.0	87	5944.6
	3129.6		3752.8		4432.6		5168.9		5961.7
	3142.0		3766.4		4447.3		5184.8		5978.9
	3154.4		3780.0		4462.1		5200.8		5996.0
	3166.9		3793.6		4476.9		5216.8		6013.2
	3179.4		3807.3		4491.8		5232.8		6030.4
	3191.9		3821.0		4506.6		5248.8		6047.6
	3204.4		3834.7		4521.5		5264.9		6064.8
64	3216.9	70	3848.4	76	4536.4	82	5281.0	88	6082.1
	3229.5		3862.2		4551.4		5297.1		6099.4
	3242.1		3875.9		4566.3		5313.2		6116.7
	3254.8		3889.8		4581.3		5329.4		6134.0
	3267.4		3903.6		4596.3		5345.6		6151.4
	3280.1		3917.4		4611.3		5361.8		6168.8
	3292.8		3931.3		4626.4		5378.0		6186.2
	3305.5		3945.2		4641.5		5394.3		6203.6
65	3318.3	71	3959.2	77	4656.6	83	5410.6	89	6221.1
	3331.0		3973.1		4671.7		5426.9		6238.6
	3343.8		3987.1		4686.9		5443.2		6256.1
	3356.7		4001.1		4702.1		5459.6		6273.6
	3369.5		4015.1		4717.3		5476.0		6291.2
	3382.4		4029.2		4732.5		5492.4		6308.8
	3395.3		4043.2		4747.7		5508.8		6326.4
	3408.2		4067.3		4763.0		5525.3		6344.0
66	3421.2	72	4071.5	78	4778.3	84	5541.7	90	6361.7
	3434.1		4085.6		4793.7		5558.2		6379.4
	3447.1		4099.8		4809.0		5574.8		6397.1
	3460.1		4114.0		4824.4		5591.3		6414.8
	3473.2		4128.2		4839.8		5607.9		6432.6
	3486.3		4142.5		4855.2		5624.5		6450.4
	3499.3		4156.7		4870.7		5641.1		6468.2
	3512.5		4171.0		4886.1		5657.8		6486.0

Table I.—Continued.

Dia.	Area.	Dia.	Area.	Dia.	Area.	Dia.	Area.	Dia.	Area.
Inch.	Inches.	Inch.	Inches.	Inch.	Inches.	Inch.	Inches.	Inch.	Inches.
91	6503·8	93	6792·9	95	7088·2	97	7389·8	99	7697·7
	6521·7		6811·1		7106·9		7408·8		7717·1
	6539·6		6829·4		7125·5		7427·9		7736·6
	6557·6		6847·8		7144·3		7447·0		7756·1
	6575·5		6866·1		7163·0		7466·2		7775·6
	6593·5		6884·5		7181·8		7485·3		7795·2
	6611·5		6902·9		7200·5		7504·5		7814·7
	6629·5		6921·3		7219·4		7523·7		7834·3
92	6647·6	94	6939·7	96	7238·2	98	7542·9	100	7854·0
	6665·7		6958·2		7257·1		7562·2		
	6683·8		6976·7		7275·9		7581·5		
	6701·9		6995·2		7294·9		7600·8		
	6720·0		7013·8		7313·8		7620·1		
	6738·2		7032·3		7332·8		7639·4		
	6756·4		7050·9		7351·7		7658·8		
	6776·4		7069·5		7370·7		7678·2		

By this Table, when the number of inches in the diameter of the piston is known, the number of square inches in its area can be found on inspection.

QUESTION I.—Given the diameter of the piston in inches, to find its

RULE 1.—Find in Table I. the number of square inches in the area. Divide the number thus found by 144. The quotient will be the area of the piston in square feet.

EXAMPLE.—To find the area of a piston in square feet whose diameter is $86\frac{1}{2}$ inches.

By Table I. we find that the area in square inches is 5910·5. Dividing this by 144 we obtain

$$\begin{array}{r} 144 \overline{)5910\cdot5} \\ \underline{41\cdot04} \end{array}$$

which is the area in square feet.

QUESTION II.—Given the diameter of the piston in inches, and its speed in feet per minute, to find the number of cubic feet of steam per hour which passes through the cylinder.

RULE 2.—By Rule 1, find the area of the piston in square feet. Multiply this by the speed of the piston in feet per minute, and the product will be the number of cubic feet of steam which passes through the cylinder per minute. Multiply this last by 60, and the product is the number of cubic feet per hour.

EXAMPLE.—A 50-inch piston moves at the rate of 180 feet per minute. What number of cubic feet of steam per hour passes through the cylinder?

By Rule 1, we find the area of the piston to be 17·86 square feet.

Multiply this by 180 :

$$\begin{array}{r} 17\cdot86 \\ 180 \\ \hline 3124\cdot80 \\ 60 \\ \hline 187488\cdot00 \end{array}$$

which is the number of cubic feet of steam per hour which passes through the cylinder.

In the following table is given, in the 1st column, the total pressure of steam in pounds per square inch ; in the 2nd column, the corresponding temperature ; in the 3rd column, the number of cubic inches of steam, which would be produced by one cubic inch of water ; and in the 4th column, the total mechanical effect produced by the evaporation of a cubic inch of water under the pressure expressed in the first column.

TABLE II.

Total Pressure in Pounds per Square Inch.	Corresponding Temperature.	Cubic Inches of Steam produced by a Cubic Inch of Water.	Mechanical Effect of a Cubic Inch of Water evaporated in Pounds raised One Foot.
1	102·9	20868	1739
2	126·1	10874	1812
3	141·0	7437	1859
4	152·3	5685	1895
5	161·4	4617	1924
6	169·2	3897	1948
7	175·9	3376	1969
8	182·0	2983	1989
9	187·4	2674	2006
10	192·4	2426	2022
11	197·0	2221	2036
12	201·3	2050	2050
13	205·3	1904	2063
14	209·1	1778	2074
15	212·8	1669	2086
16	216·3	1573	2097
17	219·6	1488	2107
18	222·7	1411	2117
19	225·6	1348	2126
20	228·5	1281	2135
21	231·2	1225	2144
22	233·8	1174	2152

Table II.—Continued.

Total Pressure in Pounds per Square Inch.	Corresponding Temperature.	Cubic Inches of Steam produced by a Cubic Inch of Water.	Mechanical Effect of a Cubic Inch of Water evaporated in Pounds raised One Foot.
23	236·8	1127	2160
24	238·7	1084	2168
25	241·0	1044	2175
26	243·3	1007	2182
27	245·5	973	2189
28	247·6	941	2196
29	249·6	911	2202
30	251·6	883	2209
31	253·6	857	2215
32	255·5	833	2221
33	257·3	810	2226
34	259·1	788	2232
35	260·9	767	2238
36	262·6	748	2243
37	264·3	729	2248
38	265·9	712	2253
39	267·5	695	2259
40	269·1	679	2264
41	270·6	664	2268
42	272·1	649	2273
43	273·6	635	2278
44	275·0	622	2282
45	276·4	610	2287
46	277·8	598	2291
47	279·2	586	2296
48	280·5	575	2300
49	281·9	564	2304
50	283·2	554	2308
51	284·4	544	2312
52	285·7	534	2316
53	286·9	525	2320
54	288·1	516	2324
55	289·3	508	2327
56	290·5	500	2331
57	291·7	492	2335
58	292·9	484	2339
59	294·2	477	2343
60	295·6	470	2347
61	296·9	463	2351
62	298·1	456	2355
63	299·2	449	2359
64	300·3	443	2362
65	301·3	437	2365
66	302·4	431	2369
67	303·4	425	2372
68	304·4	419	2375
69	305·4	414	2378

Table II.—Continued.

Total Pressure in Pounds per Square Inch.	Corresponding Temperature.	Cubic Inches of Steam produced by a Cubic Inch of Water.	Mechanical Effect of a Cubic Inch of Water evaporated in Pounds raised One Foot.
70	306.4	408	2382
71	307.4	403	2385
72	308.4	398	2388
73	309.3	393	2391
74	310.3	388	2394
75	311.2	383	2397
76	312.2	379	2400
77	313.1	374	2403
78	314.0	370	2405
79	314.9	366	2408
80	315.8	362	2411
81	316.7	358	2414
82	317.6	354	2417
83	318.4	350	2419
84	319.3	346	2422
85	320.1	342	2425
86	321.0	339	2427
87	321.8	335	2430
88	322.6	332	2432
89	323.5	328	2435
90	324.3	325	2438
91	325.1	322	2440
92	325.9	319	2443
93	326.7	316	2445
94	327.5	313	2448
95	328.2	310	2450
96	329.0	307	2453
97	329.8	304	2455
98	330.5	301	2457
99	331.3	298	2460
100	332.0	295	2462
110	339.2	271	2486
120	345.8	251	2507
130	352.1	233	2527
140	357.9	218	2545
150	363.4	205	2561
160	368.7	193	2577
170	373.6	183	2593
180	378.4	174	2608
190	382.9	166	2622
200	387.3	158	2636
210	391.5	151	2650
220	395.5	145	2663
230	399.4	140	2675
240	403.1	134	2687

Having these tables before us, we shall be enabled to solve, by the common principles of arithmetic, a multitude of practical problems of considerable utility, the investigation of which will further illustrate and familiarise the principles which have been delivered in general terms throughout this volume.

By the power of a boiler, I would be understood to mean, in what follows, the number of cubic feet of water which the boiler would evaporate per hour in regular operation.

By the speed of the piston, I mean to express the average number of feet per minute through which the piston is moved.

The engine being understood to be in regular and uniform operation, the total resistance of the piston will be equal to the total pressure of the steam upon it; and the resistance of the piston per square inch of surface will therefore be equal to the pressure of the steam in the cylinder per square inch of surface. These terms, therefore, may be taken as synonymous. In general, the term *pressure of steam* is understood to mean pressure per square inch.

The 3rd column in Table II., which is given as expressing the number of cubic inches of steam of a given pressure produced by the evaporation of a cubic inch of water, will equally express the number of cubic feet of steam produced by a cubic foot of water, or, in general, the ratio of the volume of steam to the volume of water from which it is produced.

QUESTION III.—*Given the power of the boiler, the pressure of the steam in the cylinder, and the speed of the piston, to find the diameter.*

RULE 3.—In the first column of Table II. find the given pressure; the corresponding number in the third column is the ratio of the volume of such steam to the volume of water which produced it. Multiply the power of the boiler by such number, and the product will be the number of cubic feet of steam per hour which passes through the cylinder, which, divided by 60, gives the number of cubic feet per minute which passes through the cylinder. Divide this by the speed of the piston expressed in feet per minute, and the quotient will be the area of the piston expressed in square feet. Multiply this by 144,

and the product will be the area of the piston expressed in square inches. Find this number, or the nearest to it, in the second column of Table I, and the corresponding number in the first column will be the diameter of the piston in inches.

EXAMPLE.—A boiler evaporates 55 cubic feet of water per hour. The pressure of steam in the cylinder is 20 lbs. per square inch. What must be the diameter of the cylinder, so as to give the piston a speed of 200 feet per minute?

By reference to the first column of Table II, we find, opposite the pressure of 20 lbs. in the first column, 1281 in the third column.

Multiply 1281 by 55 :

$$\begin{array}{r} 1281 \\ 55 \\ \hline 70455 \end{array}$$

Divide this by 60 :

$$\begin{array}{r} 60 \overline{)70455} \\ 1174 \cdot 25 \end{array}$$

Divide this by 200 :

$$\begin{array}{r} 200 \overline{)1174 \cdot 25} \\ 5 \cdot 8712 \end{array}$$

Multiply this by 144 :

$$\begin{array}{r} 5 \cdot 8712 \\ 144 \\ \hline 845 \cdot 4528 \end{array}$$

In the second column of Table I. we find 845.39 opposite $32\frac{3}{4}$ in. or $32\frac{1}{2}$ in., and 848.83 opposite $32\frac{1}{2}$ or $32\frac{1}{4}$.

If, then, we take a mean between these, we may assume the diameter of the cylinder required to be $32\frac{1}{8}$ inches.

QUESTION IV.—*Given the diameter of the piston in inches, the total resistance it opposes to the moving power, and its speed, to find the power of the boiler.*

RULE 4.—Find in the first column of Table I. the given diameter. The corresponding number in the second column will be the area in square inches. Divide the total resistance of the piston by this number, and the quotient will be the resistance per square inch, or the pressure of the steam. Find this pressure in the first column of Table II., and the corresponding number in the third column will be the ratio of the volume of steam to the volume of water which produces it. The volume of steam will be found by Rule 2. Let this column be divided by the number obtained as above from Table II., and the quotient will be the power of the boiler.

EXAMPLE.—It is required to find how many cubic feet of water per

hour the boiler must evaporate to drive a piston of 34 inches diameter, at the rate of 200 feet per minute, against a gross resistance of 18,000 lbs.

Opposite 34 in the first column of Table I. we find in the second column 907·92.

Divide 18,000 by 907·92 :

$$\begin{array}{r} 907\cdot92 \overline{)18000} \\ \underline{19\cdot8} \end{array}$$

Looking in the first column of Table II., the nearest number to 19·8 is 20, opposite to which, in the third column, we find 1281 :

By Rule 1, we find the area of the piston to be in square feet.

$$\begin{array}{r} 144 \overline{)907\cdot92} \\ \underline{6\cdot305} \end{array}$$

By Rule 2, multiply this by 200 :

$$\begin{array}{r} 6\cdot305 \\ \underline{200} \\ 1261\cdot \end{array}$$

Multiply this by 60 :

$$\begin{array}{r} 1261 \\ \underline{60} \\ 75660 \end{array}$$

Divide this by 1281 :

$$\begin{array}{r} 1281 \overline{)75660} \\ \underline{59\cdot06} \end{array}$$

The boiler must therefore evaporate 59 cubic feet of water per hour.

QUESTION V.—*Given the power of the boiler, the diameter of the piston and its speed, to find the pressure of steam upon the piston, or, what is the same, its resistance per square inch.*

RULE 5.—By Rules 1 and 2, find the number of cubic feet of steam per hour which passes through the cylinder. Divide this by the power of the boiler, and the quotient will be the number of cubic inches of steam which would be produced by a cubic inch of water. Find this number, or the nearest to it, in the third column of Table II., and the corresponding number in the first column will be the pressure of steam in the cylinder, or the resistance of the piston per square inch.

EXAMPLE.—What total resistance per square inch will a 35-inch piston, supplied by a boiler evaporating 55 cubic feet an hour, drive at the rate of 200 feet per minute?

In Rules 1 and 2, we find the number of cubic feet which pass through the cylinder as follows: the diameter of the piston being 35 inches, we find by Table I. that its area is 962·11 square inches; and by Rule 1, that this is equal to 6·68 square feet. Multiplying this by 200, by Rule 2, it gives the product 1336, which, multiplied by 60, gives 80·160 as the number of cubic feet of steam which passes through the cylinder per hour. Divide this by 55, and we find the quotient 1457½. Looking

in the third column of Table II., we find the number 1488 opposite 17, and 1411 opposite 18. Taking a mean between which, we may assume the required pressure to be $17\frac{1}{2}$ lbs. per square inch.

QUESTION VI.—*Given the power of the boiler, the pressure of steam in the cylinder, and the diameter of the piston, to find its speed.*

RULE 6.—In the first column of Table II. find the given resistance or pressure: the corresponding number in the third column, multiplied by the power of the boiler, will give the number of cubic feet of steam per hour which passes through the cylinder. Divide this by the area of the piston in square feet, found by Rule 1, and the quotient will be the speed of the piston in feet per hour, which, divided by 60, will be the speed of the piston.

EXAMPLE.—With what speed will a 35-inch piston be driven against a resistance of 20 lbs. per square inch by a boiler which evaporates 56 cubic feet of water per hour?

Opposite to 20 in the first column of Table II. we find, in the third column, 1281. Multiply this by 56:

$$\begin{array}{r} 1281 \\ 56 \\ \hline 71736 \end{array}$$

By Rule I, we find that the area of the piston in square feet is 6.68. Divide 71736 by 6.68:

$$\begin{array}{r} 6.68 \overline{)71736} \\ \underline{10739} \end{array}$$

Divide this by 60, and the quotient, 179, very nearly, will be the speed of the piston.

CHAP. XXVII.—ILLUSTRATIONS.

The following diagrams and descriptions of the principal parts of steam engines, which have been explained in general terms in the preceding chapters, will render the principles which govern the operation and structure of these machines still more clearly and easily understood.

MERCURIAL STEAM GAUGE FOR LOW-PRESSURE BOILERS.

In the following figure this instrument is represented: *c* is a tube leading from that part of the boiler within which steam is contained; *d* a stop-cock to open or close the communication at pleasure; *m b m* is a siphon tube of iron, which extends to a height sufficiently great for a column of mercury representing the pressure of steam in the boiler.

At $m m$ are two small apertures, stopped by screws, which can be opened or closed at pleasure. The tube is filled through an opening at R until the mercury shall flow from the holes $m m$. The opening R is then closed as well as the apertures $m m$, a small quantity of water having been previously let in through the opening R , on the surface of the mercury at M . A float is placed upon the mercury in the longer leg of the siphon, from which a string is carried over the pulley p , to which a small index (s) is attached, which plays upon a divided scale.

Let us now suppose the stop-cock d opened, steam will flow from the boiler and press upon the fluid in G . The column of mercury in the leg $m b$ will be pressed down to some point, such as x , and the column in the longer leg of the siphon will be raised to a point x , as much above m as x in the short leg is below m .

As the mercury in the long leg rises, it will raise the float, the counterpoise of which (s) will of course descend, and the scale is so adjusted that it indicates the height of the column of mercury from x in the short leg to x in the long leg, which column balances the pressure of steam in the boiler, or more correctly speaking, it balances the excess of the pressure of the steam in the

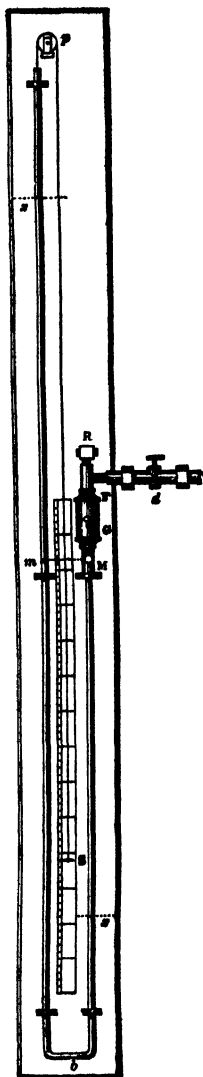

boiler above the atmosphere; in fact, the atmosphere, pressing through the open mouth of the tube upon the mercury in the longer leg, combines with the column of mercury xx in balancing the pressure of steam in the boiler. If, then, 2 inches of mercury be taken to express a pound per square inch, to which it is very nearly equal, such gauge will at once indicate the number of pounds per square inch by which the pressure of the steam in the boiler exceeds that of the atmosphere.

MERCURIAL STEAM GAUGE FOR HIGH-PRESSURE BOILERS.

In high-pressure boilers, a mercurial gauge of the form shown in the preceding figure would be inconvenient, owing to the great height of the column of mercury which would be necessary. In this case a gauge of another form is made use of, an example of which is shown in the annexed figure. Let AB be a cistern of mercury; let t be a glass tube, open at the lower end and closed at the upper end, immersed in the mercury, and containing air in its ordinary state.

When the stop-cock d is open, the steam from the boiler rushes through the passage c , and pressing on the mercury in the cistern, will raise a column of mercury in the tube, by which the air in the tube will be compressed. When the air is compressed into half its original bulk, its pressure will be doubled; when it is compressed into one-third, its pressure will be increased in a three-fold proportion, and so on. The pressure of the steam, therefore will be measured by the space into which it is able to compress the air in the tube. When great accuracy is required, a slight correction will have to be made for the column of mercury sustained in the tube, $\frac{1}{2}$ a lb. per square inch being added to the pressure indicated by the compres-

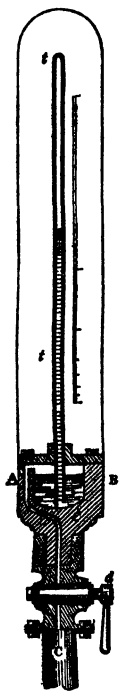

inch being added to the pressure indicated by the compres-

sion of the air for every inch of mercury sustained in the tube.

BAROMETER GAUGE.

This gauge is constructed in various forms. In the annexed figure the cistern A contains mercury; the barometer tube is immersed in it, and the top of the tube, formed into a siphon, communicates with the condenser; a stop-cock P being placed between them, so as to open or close the communication at pleasure.



SIPHON BAROMETER GAUGE.

The following figure is another form, in which the barometer is a siphon, like the steam gauge. The tube and stop-cock P communicate with the condenser, and the other leg of the siphon is open to the atmosphere. A hole, stopped by the screw Q, is placed in one of the legs: mercury being poured in at the other leg, the siphon is filled until the mercury begins to flow from the hole Q. The fluid then will stand at the same level in both legs. The hole Q being then stopped, and the stop-cock P opened, the upper part P Q of the tube will be filled with the uncondensed vapour of the condenser, which will of course press upon the column of mercury in the siphon.

The other leg of the siphon x , being open to the atmosphere, will be subject to the atmospheric pressure; and the column of mercury in the leg P Q, which is above the level x , will represent the excess of the pressure of the atmosphere above the pressure of the uncondensed steam, which is the indication the barometer gauge is required to give.

This siphon being made of iron, a float is placed on the mercury at x , having a rod,

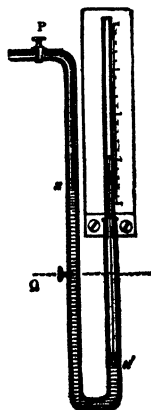

at the top of which is an index, which plays upon a scale so graduated as to express the difference of level of the mercury in the two legs of the siphon.

GLASS WATER GAUGE.

In the annexed figure is represented the glass water gauge described in the text. Its communications with the boiler are opened and closed at pleasure by the cocks *r*. When the cocks *r* are both open, the upper end of the tube *a* is in free communication with the upper part of the boiler where steam is contained, and the lower end of the tube *a* is in communication with the lower part of the boiler where water is contained.

Water enters below and steam above, and as the pressure in the gauge tube is the same as the pressure in the boiler, the level of the water in the tube will be the same as the level of the water in the boiler. At the bottom of the tube is placed a stop-cock *s*, for the occasional discharge of water from the tube.

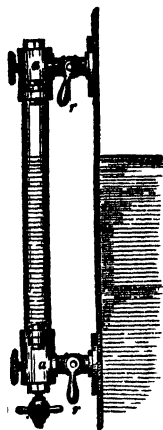

THE SPRING SAFETY VALVE FOR HIGH-PRESSURE BOILERS.

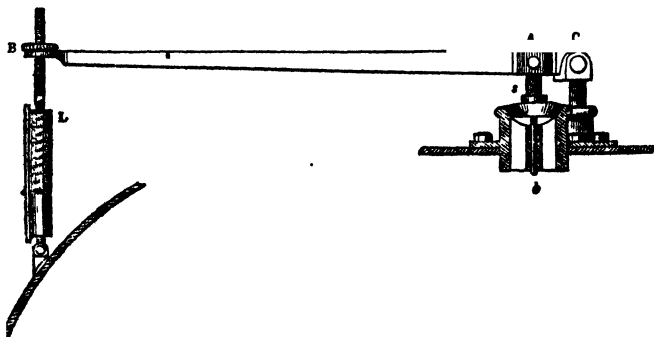

In the preceding figure is represented the safety valve, as used in high pressure engines. The conical valve is represented in its seat, its spindle s being pressed down at A by the lever $B A C$. C is a fixed pivot, on which the lever plays. The pressure on the spindle of the valve at A is produced by a nut at B , which presses that end of the lever downwards. This nut works upon a screw, which screw is attached to a spring balance L , the lower end of which is firmly attached to a fixed point F . The nut at B , may be turned so as to submit the valve to any pressure within the limit of the action of the spring balance. As the nut is turned, the spring becomes more and more compressed. An index and scale are attached to the balance, the scale being so divided as to express the number of pounds per square inch by which the valve is pressed upon its seat. Thus, if the nut B be turned until the index shows the pressure of 50 lbs., then the force on the valve will be at the rate of 50 lbs. per square inch, and the steam will be confined in the boiler until it has attained such pressure: when the pressure exceeds that limit, the lever at B will, by the action of the steam on the valve, press the nut upwards with a force greater than the energy of the spring, and the spring will consequently be further compressed, the valve at the same time opening and allowing the escape of the steam.

There is nothing in the principle of this valve essentially different from the common safety valve, directly loaded with a weight; but in boilers where high-pressures are used, the quantity of weight which it would be necessary to place on the valve, would be inconvenient. A comparatively small force, holding B downwards, will produce a multiplied effect at A , in the proportion of the length of the lever $B C$ to $A C$. Thus, if $B C$ be 20 times $A C$, a force of 5 lbs. at B will produce 100 lbs. at A .

WATT'S INDICATOR.

This little instrument, already described in the text, will be rendered more intelligible by the annexed dia-

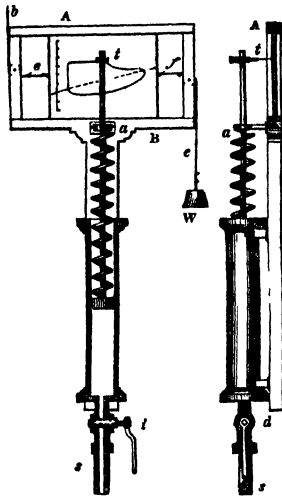

Fig. 1.

Fig. 2.

gram; fig. 1 representing a front view in section, and fig. 2 a side elevation. The rod attached to the piston plays through a collar at *a*. At *t* is a pencil holder. At *s* is a screw by which the instrument is inserted in a hole provided for it in the top of the cylinder. At *d* is a stop-cock, by which a communication may be open or shut at pleasure between the indicator and the cylinder. The piston-rod of the indicator is surrounded by a spiral spring, the lower extremity of which is attached to the piston, and the upper extremity to

a fixed piece *a*, containing the hole through which the piston-rod plays. When the piston rises, the spring is compressed; and when it falls, the spring is extended. The spring is *in equilibrio* when the piston is at the middle of the cylinder, and the space through which it rises and falls is, from the known properties of this species of spring, proportional to the force which presses the piston upwards or downwards. When both extremities of the cylinder are open to the atmosphere, the spring is at rest, and the piston in the middle of the cylinder; but when steam is allowed to pass from the cylinder to the indicator, by opening the stop-cock *d* such steam will press the piston upwards, and compress the spring with a force equal to the excess of the pressure of the steam above that of the

atmosphere. When, on the other hand, a vacuum is produced in the cylinder by the condensation of the steam, the same vacuum will be produced under the piston in the indicator, and the piston will be forced downwards by the excess of the pressure of the atmosphere above that of the uncondensed vapour in the cylinder.

If an index were placed near the extremity of the piston-rod t , the pencil, ascending and descending on this index, would indicate by the space through which it would ascend the excess of the pressure of the steam over that of the atmosphere, and by the space through which it would descend, the excess of the pressure of the atmosphere over that of the uncondensed vapour. Both spaces added together, or the entire play of the piston, would therefore indicate the excess of the pressure of the steam above the pressure of the uncondensed vapour which resists it, and would therefore indicate the effective force of the piston, exclusive of friction.

But as the piston of the indicator would be in rapid and continued motion, it would not be easy to observe and record the limits of its play, and still more difficult to note the rapidity of its motion. An ingenious expedient was therefore contrived to enable the engine itself to record these effects, which converted the indicator into a self-registering instrument. A small square frame $A B$ was constructed, the breadth of which was somewhat greater than the extreme play of the piston of the indicator. In it was placed a card, capable of sliding in a horizontal direction in grooves: a string e was fastened to the side of the card, and, passing under a pulley, was carried upwards towards b , and attached to some part of the machinery which rises and falls with the piston of the engine. Another string f was attached to the other side of the card, and carried over a pulley and fixed to a small weight w . When the piston rises, the string e is drawn to the left, the card drawn in the same direction, and the weight w rises. When the piston falls, the weight w , acting on the string f , draws the card to the right.

Thus, as the piston rises and falls, the card is drawn alternately through a certain space left and right.

Let us now suppose steam admitted above the piston of the engine, pressing the piston down; this steam presses the piston of the indicator up, and the pencil t , passing on the card, would, if the card were at rest, mark upon it a straight line, the length of which would indicate the pressure of the steam; but as the card is drawn from left to right while the piston falls, the pencil will describe upon it a curve by the combined effects of the vertical motion of the pencil and the horizontal motion of the card. The suddenness of the curvature thus described will indicate the rapidity of the action of the steam on the piston.

When the piston has reached the bottom of the cylinder, and the upper exhausting valve is opened, a vacuum is produced in the cylinder, which the vacuum extends to the indicator, the piston of which therefore descends, the pencil t descending at the same time and at the same rate. While this takes place, the card is moved from right to left, and a corresponding curve described upon it by the pencil, the curvature of which will indicate the suddenness with which the vacuum is produced, as well as its degree of perfection.

From what has been stated, it will appear that in a single ascent and descent of the piston, or in one stroke, as it is technically called, a diagram will be formed upon the card, which will exhibit not only the entire mechanical effect of the steam acting on one side against the uncondensed vapour on the other, but will show the entire character of its progressive action at every point of the stroke. Such a diagram is exhibited in the following figure. Let $o x$ be a horizontal line. Let $o y$ be the vertical scale which measures the pressure of the steam according to the movement of the indicator. Let o be the level to which the pencil would be depressed, if there were a perfect vacuum in the cylinder; then the height of the pencil at any moment above the level of the horizontal line $o x$ will indicate the absolute pressure of the steam in the cylinder, independently

of any consideration of the pressure of the atmosphere. Let *A* be the position of the pencil at the moment steam is admitted above the piston. By the action of the steam the pencil will suddenly start up to *B*, and after the piston has

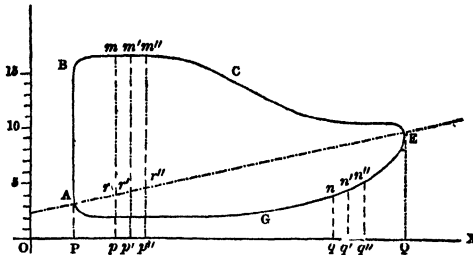

commenced its action, it will rise a little higher, the card meanwhile being drawn to the left. The line will be traced on the card by these means, as represented at *B m m'* and *m''*. As the piston approaches the bottom of the cylinder, if the steam be cut off before the completion of the stroke, the pressure will diminish, and from *c* to *E* the pencil will fall. Let *E* be its position at the end of the stroke, the card being understood to be moved from right to left through the space *P Q* during the stroke. We may consider this motion of the card as representing the motion of the piston, with which it is simultaneous and proportionate. At the commencement of the stroke, the height *A P* of the pencil above *O X* represents the pressure of the uncondensed vapour which was then above the piston; the height *B P* represents the pressure of the steam immediately on its admission; the height *m p* represents its nearly uniform pressure throughout the former half of the stroke; and the decreasing height of the curve from *c* to *E*, above the line *O X*, represents the decreasing pressure of the steam throughout the remainder of the stroke. *E Q* represents the pressure of the steam at the termination of the stroke.

The piston now commences its ascent. The upper exhausting valve being opened, and the steam allowed to flow

to the condenser, according as it is condensed a vacuum is formed while the piston is rising, and while the card is moved back from left to right under the pencil. Starting from *B*, the pencil begins to fall, and falls more and more as the vacuum becomes more perfect. At *G* the vacuum attains its most perfect state, and the line from *G* towards *A* continues nearly horizontal, its height above *O X* representing the nearly uniform pressure of the uncondensed steam; but just before the termination of the stroke the steam is admitted from the boiler, and the pencil rises to *A*. The height of the curve *B G A* at every point represents the varying pressure of the uncondensed vapour which resists the ascent of the piston.

Now although that portion of the curve below the line *A B* represents the state of the vacuum above the piston during its ascent, it may be taken to represent the state of the vacuum below the piston in its descent, for the same circumstances which affect one equally affect the other; and we may consider the diagram generally as representing not only the pressure of the steam which urges the piston downwards, but also that of the uncondensed vapour which resists its descent.

It appears then that the varying heights of the points of the upper curve *B C B* represent the varying pressures on the piston during its descent; and the average pressure upon the piston may be obtained by taking the average of these heights.

In like manner, the heights of the lower curve *A G B* may be taken to represent the varying pressures or resistances of the uncondensed vapour under the piston during its descent: and the average of all these heights will give the average of such resistances. If then we subtract the average of these resistances, represented by the lower curve, from the average of the pressures represented by the upper curve, we shall obtain the effective pressure of the steam in urging the piston.

However accurately such an instrument as this may be constructed, it must be admitted that it cannot be depended on as affording any exact measure of the power of the piston. Its chief value, as stated in the text, is the indication it

affords of the degree of perfection of the vacuum and of the suddenness of its formation. The curve $E G$ should fall to its least height speedily. It is not until it attains its least height that the vacuum has attained its greatest perfection. For the rest, the use of the instrument is sufficiently explained in the text.

BOILERS AND THEIR APPENDAGES.

In fig. 1 is represented a waggon boiler in cross section, and in fig. 2 the same in longitudinal section. The same letters indicate the corresponding parts in the two drawings.

a is the grate supporting the burning fuel; b and b represent the flue which surrounds the boiler; $e e$ are the gauge-cocks described in the

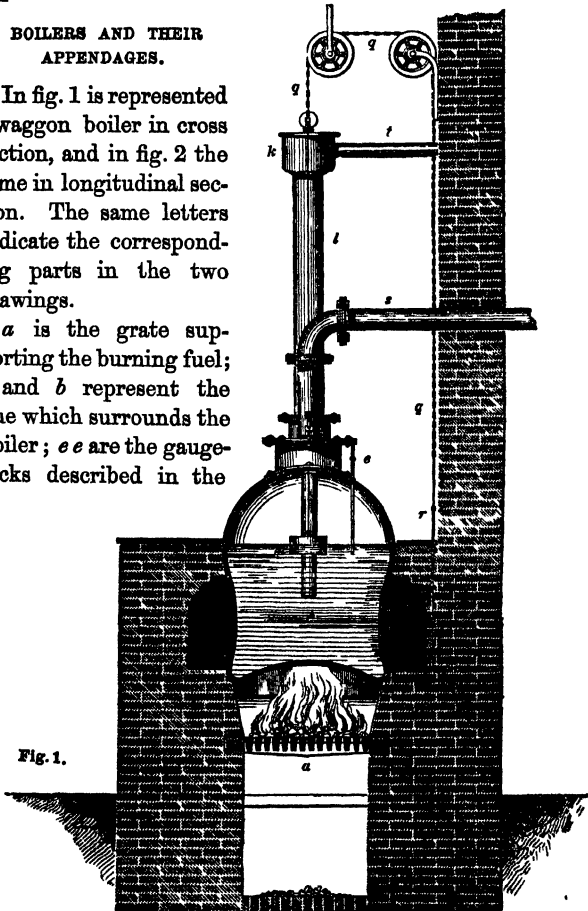
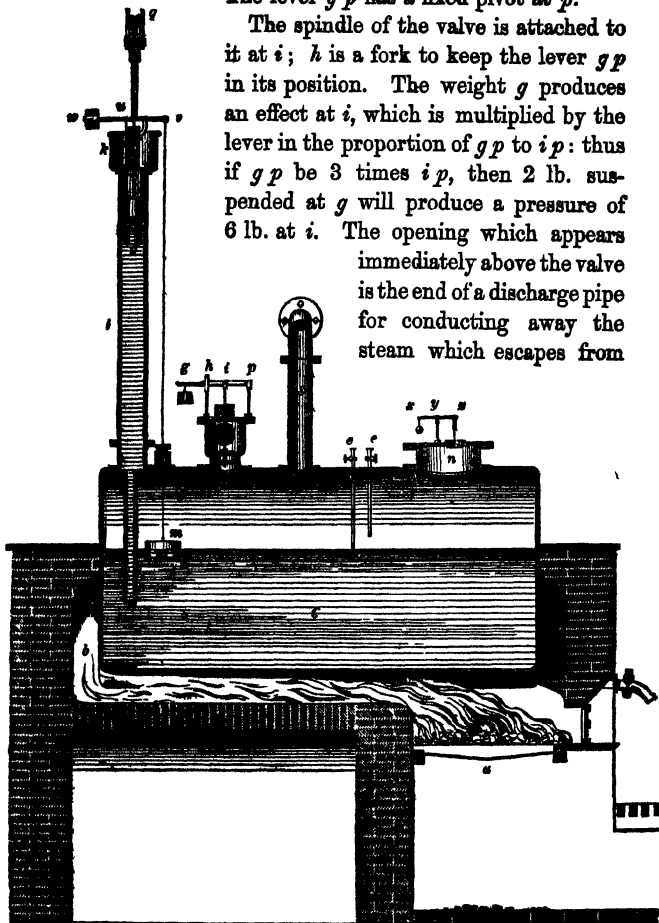

Fig. 1.

text; s is the steam pipe which leads from the boiler to the cylinder; $g p$ is the safety-valve, the pressure upon which may be regulated by the sliding weight g . The lever $g p$ has a fixed pivot at p .

Fig. 2.



The spindle of the valve is attached to it at i ; h is a fork to keep the lever $g p$ in its position. The weight g produces an effect at i , which is multiplied by the lever in the proportion of $g p$ to $i p$: thus if $g p$ be 3 times $i p$, then 2 lb. suspended at g will produce a pressure of 6 lb. at i . The opening which appears

immediately above the valve is the end of a discharge pipe for conducting away the steam which escapes from

the safety valve. When the pressure of the steam in the boiler

exceeds the pressure produced by the weight upon the safety valve, the latter will be raised, steam will escape around it, and issue through the waste pipe. Sometimes this steam is allowed to escape into the atmosphere, and sometimes it is conducted into the cistern of water by which the boiler is fed, where it is condensed, and has the effect of raising the temperature of the water. By this means a portion of heat which would have been otherwise wasted is carried back to the boiler. The internal safety valve is represented at $x y z$. This valve presses at x within the boiler, and is drawn up into its seat by the end of the lever z . y is the pivot which supports the lever, and a weight suspended from x draws x upwards. When a vacuum is produced within the boiler by the condensation of the steam, the pressure of the external atmosphere forces the valve u open, and the air enters and fills the boiler.

The self-acting feeding apparatus is represented at $w u k$, &c.—A tube l is attached to the top of the boiler, and descends within it to a point below the level at which the water should stand. The pressure of the steam within the boiler, acting upon the water, supports a column of water in this tube l : on the surface of this water at o rests a float, sustained by a chain g , which passes over two pulleys represented in figure 1, and which, descending from the second, is attached to a rod r , which supports the damper. This chain, as it rises and falls, raises and lowers the damper, and opens or closes, more or less, the flue across which the damper passes.

When the pressure of steam in the boiler is unduly augmented, the column of water it supports in l rises; with it rises the float o , and consequently the damper r falls, contracts the flue, diminishes the draft, mitigates the intensity of the furnace, and renders the evaporation less rapid in the boiler. When, on the other hand, the evaporation in the boiler does not proceed fast enough, the pressure of the steam in it is unduly diminished, and the column of water it

supports in the tube l is lowered: the float o falls, and the damper r rises; the opening of the flue is enlarged, the draft increased, the furnace stimulated, and the evaporation augmented.

In this manner the varying demands of the engine on the boiler are supplied by the varying power of the furnace, the wants of the engine producing the requisite effect on the boiler.

The float m rests on the surface of the water within the boiler; a wire sustaining it passes steam-tight through a collar in the top of the boiler, and is attached to the extremity v of a lever which is balanced by a weight w at the opposite end; a rod is attached at u to this lever, which descends to the bottom of the small hole in the hot water cistern k , and is attached to a valve at the bottom of this cistern which opens upwards. When u rises, this valve is opened; when it is pressed down, this valve is closed. The cistern k is supplied by a small pump called the *hot water pump*, which draws water from a reservoir which receives the discharge of the condenser of the engine, as thrown out by means of the air pump.

This water is thus pumped by the engine itself into the cistern k , and a waste pipe is provided for the discharge of so much of it as is not consumed by the boiler.

When the water in the boiler begins to be exhausted, the level falls, and with it the float m ; this draws down the extremity v of the lever, and raises u , by which the valve o is opened, and the water from the cistern k allowed to descend by the tube l ; and this continues until the level of the water in the boiler is raised to the proper point: the float m is raised with it, and the end v of the lever also raised, and the valve o closed.

In fact, however, the effect produced is not that of opening and closing the feeding valve o ; the latter becomes adjusted in such a manner as to let a continuous stream from the

cistern *k* into the tube *l*, by which the level of the water in the boiler is maintained at its proper height.

All these arrangements will be still more clearly understood by means of the annexed drawing, which represents the waggon boiler, with all its appendages, in perspective.

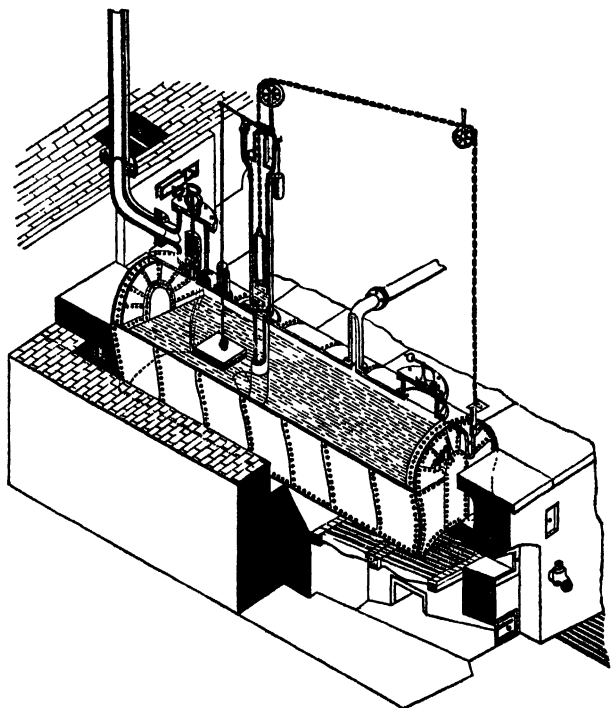

The grate and a part of the flues are rendered visible by the removal of a portion of the masonry in which the boiler is set. The interior of the boiler is also shown by cutting off one-half of the semi-cylindrical roof.

THE SLIDE VALVES

In the annexed figures are represented the most usual forms of slide valves.

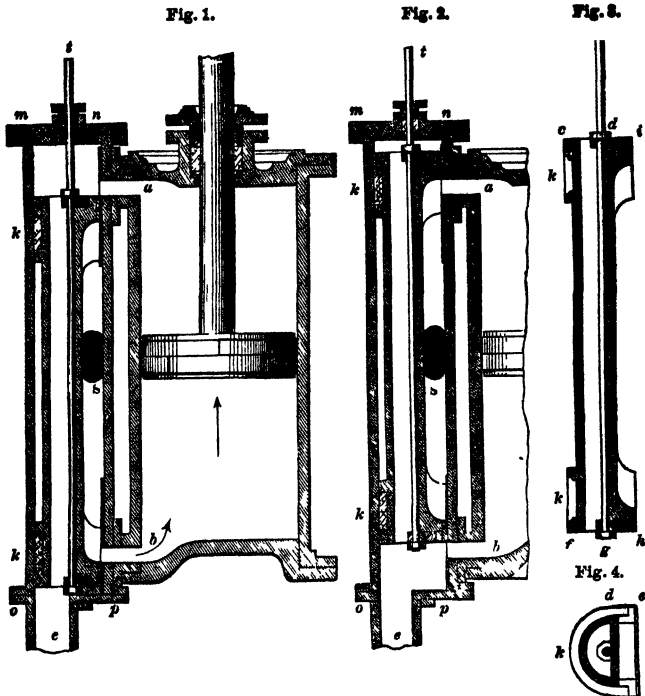

Fig. 1 represents in section the cylinder, piston, and slide: *a* is the mouth of the steam pipe coming from the boiler; *e* is the pipe leading to the condenser; *t* is the rod which is attached to the slide, moving through a stuffing-box *m n*. This slide is represented in longitudinal section, separately, in fig. 3, and in transverse section in fig. 4. In the position of the slide represented in fig. 1, the steam passing from the

boiler enters at *s*, and passes to the bottom of the cylinder through the opening *b*, and acts below the piston causing it to ascend. The steam which was above the piston escapes through the opening at *a*, and descending through a longitudinal opening in the slide behind the mouth of the steam-pipe, finds its way to the pipe *e*, and through that to the condenser.

When the piston has reached the top of the cylinder, the slide will have been moved to the position represented in fig. 2. The steam now entering at *s* passes through the opening *a* into the cylinder above the piston, while the steam which was below it escapes through the opening *b* and the pipe *e* to the condenser.

The form of the valve from which it derives its name of D-valve, is represented in fig. 4. The longitudinal opening through which the steam descends, then appears in section of a semicircular form. The packing at the back of the slide is represented at *k*; this is pressed against the surface of the valve box.

GENERAL ARRANGEMENT OF THE DOUBLE-ACTING STEAM ENGINE.

In the figure facing the title of this volume is represented the 'ensemble' in section of a double-acting steam engine, on the principle of Watt, as constructed by Mr. Fairbairn, of Manchester.

s is the steam pipe leading from the boiler; *o* is the cylinder; *B T T' t'* is the parallel motion; *i''* is the end of the air pump rod attached to the parallel motion; *d* is the upper steam valve; *d'* is the lower steam valve; *b b'* are the upper and lower valve boxes; *i* is the air pump, the piston being represented while descending, and the valves being open; *k* is the feed pump, the plunger of which is driven by a rod *k''* attached to the beam at *T''*. *o* is the centre of the beam, *F* the point at which the connecting-rod is attached

to it; g is the crank pin; f is the crank; l is the jointed arm, one end of which forms the eccentric, and the other end works the valves. The fly-wheel is represented as toothed, and is supposed to drive a pinion. P is a pillar which supports the governor p , which is connected by a series of levers $p' p'' p'''$ with the throttle valve; $q m m'$ is a part of the machinery which transmits the action of the eccentric to the valves.



THE END.

