

BLM LIBRARY



88057371

1978 C-b ANNUAL REPORT

VOLUME 2A

VOLUME 2 SUPPORTING DATA

C-B SHALE OIL PROJECT
OCCIDENTAL OIL SHALE, INC., LESSEE

751 HORIZON COURT
GRAND JUNCTION, COLORADO 81501

APRIL 20, 1979

1D88057371

BLM Library
D-553A, Building 50
Denver Federal Center
P. O. Box 25047
Denver, CO 80225-0047

TN
859
.C64
C3743
1978
v.2a
C.3

1978 C-b ANNUAL REPORT

APPENDIX 2A

VOLUME 2 SUPPORTING DATA

April 20, 1979

Submitted by:

C-b SHALE OIL PROJECT
OCCIDENTAL OIL SHALE, INC., LESSEE
751 Horizon Court
Grand Junction, Colorado 81501

to:

Mr. Peter A. Rutledge
Area Oil Shale Supervisor
Conservation Division
U.S. Geological Survey
Grand Junction, Colorado 81501

FOREWORD

The 1978 C-b ANNUAL REPORT is submitted to fulfill the requirements of the Oil Shale Lease as stated in Section 16(b) of the Lease, Section 1.(C)(4) of the Lease Environmental Stipulations, and Conditions of Approval (No. 3) of the Detailed Development Plan. This report consists of the following volumes:

- Volume 1 - Summary of Development Activities, Costs and Environmental Monitoring
- Volume 2 - Environmental Analysis
- Appendix 2A - Volume 2 Supporting Data
- Appendix 2B - Volume 2 Time Series Plots

LIST OF APPENDIX 2A FIGURES REFERENCED IN TEXT

<u>FIGURE NO.</u>		<u>PAGE</u>
A6.2.1-1	Channel Uptime Time-Lines, Site AB23	166
A6.2.1-2	Channel Uptime Time-Lines, Site AB20	167
A6.2.1-3	Channel Uptime Time-Lines, Site AD56 and Site AD42	168
A6.2.1-4	Channel Uptime Time-Lines, Minisonde and Acoustic Sounder	169
A6.2.1-5	Quarterly SO ₂ Concentration Roses, Station AB23 1976-1978	181
A6.2.1-6	Quarterly H ₂ S Concentration Roses, Station AB23 1976-1978	182
A6.2.1-7	Quarterly NO _x Concentration Roses, Station AB23 1976-1978	183
A6.2.1-8	Quarterly NO ₂ Concentration Roses, Station AB23 1976-1978	184
A6.2.1-9	Quarterly CO Concentration Roses, Station AB23 1976-1978	185
A6.3.2A-1	Meteorological Tower 10M Elevation, Quarterly Wind Roses 1976-1977	225
A6.3.2A-2	Meteorological Tower 10M Elevation, Quarterly Wind Roses 1977-1978	226
A6.3.2A-3	Meteorological Tower 30M Elevation, Quarterly Wind Roses 1976-1977	227
A6.3.2A-4	Meteorological Tower 30M Elevation, Quarterly Wind Roses 1977-1978	228
A6.3.2A-5	Station AB20 Quarterly Wind Rose at 10M, 1976	229
A6.3.2A-6	Station AB20 Quarterly Wind Rose at 10M, 1978	230
A6.3.2A-7	Station AD42 Quarterly MRI Wind Roses at 10M, 1978	231
A6.3.2A-8	Station AD56 Quarterly MRI Wind Roses at 10M, 1978	232
A6.3.2A-9	C-b Average Hourly Inversion Height by Quarter for 1978, Station AB20	233
A6.3.2A-10	June 1976 Inversion Heights Plotted with Constant Potential Temperature Surfaces through Stations AB20 and AB23 on 24 June 1976, 0400-0600 MST	234
A6.3.2A-11	October 1976 Inversion Heights Plotted with Constant Potential Temperature Surfaces the Morning of 14 September 1978	235
A6.3.2A-12	Pibal Altitude - Temperature Profiles for Single and Double Theodolite Observations, (Early Morning)	236
A6.3.2A-13	Pibal Altitude - Temperature Profiles for Single and Double Theodolite Observations, (Afternoon)	237
A12.1-1	Effects Matrix	351
A12.3.2-1	Plot of Deer Kill and Deer Count	353
A12.3.2-2	Plot of Deer Kill and Incoming Cars at Guard Shack	354
A12.3.2-3	Plot of Deer Kill and Snow Depth	355
A12.3.2-4	Plot of Deer Kill and Precipitation	356

LIST OF APPENDIX 2A TABLES REFERENCED IN TEXT

<u>TABLE NO.</u>		<u>PAGE</u>
A5.2.1A-1	Univariate Time Series Analyses Mean Monthly Flow (cfs) Major USGS Stations	13
A5.2.1A-2	Univariate Time Series Analyses SO ₄ Concentration (mg/l) Major USGS Stations	14
A5.2.1A-3	Univariate Time Series Analyses NA Concentration (mg/l) Major USGS Stations	15
A5.2.2A-1	Linear Regression of Water Quality Parameters vs. Time Location WS01	65
A5.2.2A-2	Linear Regression of Water Quality Parameters vs. Time Location WS02	66
A5.2.2A-3	Linear Regression of Water Quality Parameters vs. Time Location WS03	67
A5.2.2A-4	Linear Regression of Water Quality Parameters vs. Time Location WS06	68
A5.2.2A-5	Linear Regression of Water Quality Parameters vs. Time Location WS07	69
A5.2.2A-6	Linear Regression of Water Quality Parameters vs. Time Location WS09	70
A5.2.2A-7	Linear Regression of Water Quality Parameters vs. Time Location WS10	71
A5.3.1A-1	Linear Regression of Water Quality Parameters vs. Time Alluvial Well WA01	100
A5.3.1A-2	Linear Regression of Water Quality Parameters vs. Time Alluvial Well WA02	101
A5.3.1A-3	Linear Regression of Water Quality Parameters vs. Time Alluvial Well WA03	102
A5.3.1A-4	Linear Regression of Water Quality Parameters vs. Time Alluvial Well WA05	103
A5.3.1A-5	Linear Regression of Water Quality Parameters vs. Time Alluvial Well WA06	104
A5.3.1A-6	Linear Regression of Water Quality Parameters vs. Time Alluvial Well WA07	105
A5.3.1A-7	Linear Regression of Water Quality Parameters vs. Time Alluvial Well WA08	106
A5.3.1A-8	Linear Regression of Water Quality Parameters vs. Time Alluvial Well WA09	107
A5.3.1A-9	Linear Regression of Water Quality Parameters vs. Time Alluvial Well WA10	108
A5.3.1A-10	Linear Regression of Water Quality Parameters vs. Time Alluvial Well WA11	109
A5.3.1A-11	Linear Regression of Water Quality Parameters vs. Time Alluvial Well WA12	110
A5.3.1A-12	T-Test Procedure Summary for Between-Station Comparisons of Alluvial Wells	111

LIST OF APPENDIX 2A TABLES REFERENCED IN TEXT

<u>TABLE NO.</u>		<u>PAGE</u>
A5.3.2A-1	Ground Water Quality Analysis of Variance - Specific Conductance	140
A5.3.2A-2	Ground Water Quality Analysis of Variance - Boron (B)	141
A5.3.2A-3	Ground Water Quality Analysis of Variance - Aluminum (Al)	142
A5.3.2A-4	Ground Water Quality Analysis of Variance - Potassium (K)	143
A5.3.2A-5	Ground Water Quality Analysis of Variance - Total Dissolved Solids (TDS)	144
A5.3.2A-6	Ground Water Quality Analysis of Variance - Calcium (Ca)	145
A5.3.2A-7	Ground Water Quality Analysis of Variance - Sodium (Na)	146
A5.3.2A-8	Ground Water Quality Analysis of Variance - Ammonia (NH ₃)	147
A5.3.2A-9	Ground Water Quality Analysis of Variance - Magnesium (Mg)	148
A6.2.1-1	Instrument Specifications	170
A6.2.1-2	Error Analysis Derivation	173
A6.2.1-3a	Diurnal Variation of SO ₂ Difference of Unit 2 - Unit 1 (µg/m ³) Station AB23 April 1977	177
A6.2.1-3b	Diurnal Variation of SO ₂ Difference of Unit 2 - Unit 1 (µg/m ³) Station AB23 May 1977	178
A6.2.1-3c	Diurnal Variation of SO ₂ Difference of Unit 2 - Unit 1 (µg/m ³) Station AB23 June 1977	179
A6.2.1-3d	Diurnal Variation of SO ₂ Difference of Unit 2 - Unit 1 (µg/m ³) Station AB23 July 1977	180
A6.2.1-4	Univariate Time Series Analysis for Ozone AB20 August 1975	186
A6.2.1-5	Univariate Time Series Analysis for Ozone AB23 August 1977	187
A6.2.1-6	Univariate Time Series Analysis for Ozone AB23 August 1975	188
A6.2.1-7	Univariate Time Series Analysis for Particulates AB23	189
A6.2.1-8	Univariate Time Series Analysis for Carbon Monoxide AB23	190
A6.3.1-1	Univariate Time Series Analysis for Temperature AB23	212
A6.3.1-2	Air Temperature, 10M (°C)	213
A6.3.1-3	Growing Season and Degree-Days by Year	214
A6.3.1-4	Direct Solar Radiation	215
A6.3.1-5	Relative Humidity (%)	216
A6.3.1-6a	Monthly Precipitation for 1975	217
A6.3.1-6b	Monthly Precipitation for 1976	218
A6.3.1-6c	Monthly Precipitation for 1977	219
A6.3.1-6d	Monthly Precipitation for 1978	220
A6.3.1-7	Evaporation (cm) @ Station AB23	221
A6.3.1-8	Barometric Pressure, Millibars (Daily Extrema)	222
A8.2.1-1a	Deer Pellet - Group Densities in the Chained Rangeland Habitat, 1977-78	247
A8.2.1-1b	Deer Pellet - Group Densities in the Pinyon-Juniper Habitat, 1977-78	248
A8.2.1-1c	Deer Pellet - Group Densities in the Chained Rangeland Habitat on Big Jimmy Ridge, 1977-78	249
A8.2.1-1d	Deer Pellet - Group Densities in the Pinyon-Juniper Habitat North of Piceance Creek, 1977-78	250

LIST OF APPENDIX 2A TABLES REFERENCED IN TEXT

<u>TABLE NO.</u>		<u>PAGE</u>
A8.2.2-1	Mule Deer Road Counts Conducted From Fall 1977 to Spring 1978	251
A8.5.1-1	Bird Species Observed on Tract C-b During Spring 1977 Census	254
A8.5.1-2a	Avifauna Estimates at Tract C-b for Spring Sample Period 1978. Transect 1, Chained Pinyon-Juniper Rangeland (Control)	257
A8.5.1-2b	Avifauna Estimates at Tract C-b for Spring Sample Period 1978. Transect 2, Pinyon-Juniper Woodland (Disturbed)	258
A8.5.1-2c	Avifauna Estimates at Tract C-b for Spring Sample Period 1978. Transect 3, Chained Pinyon-Juniper Rangeland (Disturbed)	259
A8.5.1-2d	Avifauna Estimates at Tract C-b for Spring Sample Period 1978. Transect 4, Pinyon-Juniper Woodland (Control)	260
A8.6.2-1	Abundance, Percent Relative Abundance and Species Diversity of Periphyton from Artificial Substrates on Piceance Creek, Colorado at Stewart and Hunter Stations, May 18, 1978 . .	261
A8.6.2-2	Abundance, Percent Relative Abundance and Species Diversity of Periphyton from Artificial Substrates on Piceance Creek, Colorado at Stewart and Hunter Stations, June 20, 1978 . .	264
A8.6.2-3	Abundance, Percent Relative Abundance and Species Diversity of Periphyton from Artificial Substrates on Piceance Creek, Colorado at Stewart and Hunter Stations, July 19, 1978 . .	267
A8.6.2-4	Abundance, Percent Relative Abundance and Species Diversity of Periphyton from Artificial Substrates on Piceance Creek, Colorado at Stewart and Hunter Stations, August 18, 1978 .	270
A8.6.2-5	Abundance, Percent Relative Abundance and Species Diversity of Periphyton from Artificial Substrates on Piceance Creek, Colorado at Stewart and Hunter Stations, September 20, 1978	273
A8.6.2-6	Abundance, Percent Relative Abundance and Species Diversity of Periphyton from Artificial Substrates on Piceance Creek, Colorado at Stewart and Hunter Stations, October 18, 1978.	275
A8.6.2-7	Summary Species List of Periphyton Collected at Stewart and Hunter Stations, Piceance Creek, Colorado, 1978	278
A8.6.2-8	Summary of Species Diversity of the Mean for Periphyton Collected at Stewart and Hunter Stations, Piceance Creek, Colorado, 1978	280
A8.6.2-9	Summary of Mean Biomass Expressed as Ash-Free Dry Weight for Periphyton Collected at Stewart and Hunter Stations, Piceance Creek, Colorado, 1978	281
A8.6.2-10	Station P-3 Taxa	282
A8.6.2-11	Station P-6 Taxa	284
A8.6.2-12	Periphyton Productivity Estimates for Piceance Basin Stations, May 1975 - July 1976	286

LIST OF APPENDIX 2A TABLES REFERENCED IN TEXT

<u>TABLE NO.</u>		<u>PAGE</u>
A8.7.1-1	Herb Quadrat Summaries for Plot 1-0, June 1978	287
A8.7.1-2	Herb Quadrat Summaries for Plot 1-F, June 1978	288
A8.7.1-3	Herb Quadrat Summaries for Plot 2-0, June 1978	290
A8.7.1-4	Herb Quadrat Summaries for Plot 2-F, June 1978	292
A8.7.1-5	Frequency, Mean Cover, and Relative Cover Values for Shrub Species in Plot 1-0, 1974-1978	293
A8.7.1-6	Frequency, Mean Cover, and Relative Cover Values for Shrub Species in Plot 1-F, 1974-1978	294
A8.7.1-7	Frequency, Mean Cover, and Relative Cover Values for Shrub Species in Plot 2-0, 1974-1978	295
A8.7.1-8	Frequency, Mean Cover, and Relative Cover Values for Shrub Species in Plot 2-F, 1974-1978	296
A8.7.1-9	Density Values for Shrub Species at Plots 1-0, 1-F, 2-0, 2-F; Chained Pinyon-Juniper Rangeland	297
A8.7.2-1	Oven Dry Weights for Range Cages and Adjacent Open Areas in the Pinyon-Juniper Woodland Community Type, 1978 . . .	299
A8.7.2-2	Mean Production \pm the Standard Error of the Mean (S.E.), Frequency, and Range of Observed Values for Clipped Plots in the Pinyon-Juniper Woodland Community, 1978 . . .	300
A8.7.2-3	Oven Dry Weights for Range Cages and Adjacent Open Areas in the Chained Pinyon-Juniper Rangeland Community Type, 1978	301
A8.7.2-4	Mean Production \pm the Standard Error of the Mean (S.E.), Frequency, and Range of Observed Values for Clipped Plots in the Chained Pinyon-Juniper Rangeland, 1978 . . .	302
A8.7.2-5	Oven Dry Weights for Range Cages and Adjacent Open Areas in the Upland Sagebrush Community Types, 1978	303
A8.7.2-6	Mean Production \pm the Standard Error of the Mean (S.E.), Frequency, and Range of Observed Values for Clipped Plots in the Upland Sagebrush Community, 1978	304
A8.7.2-7	Oven Dry Weights for Range Cages and Adjacent Open Areas in the Bottomland Sagebrush Community Type, 1978	305
A8.7.2-8	Mean Production \pm the Standard Error of the Mean (S.E.), Frequency, and Range of Observed Values for Clipped Plots in the Bottomland Sagebrush Community, 1978	306
A8.7.2-9	Regression Equations Used for Converting Fresh Weight Estimates to Oven Dry Weights for the Intensive Study Plots, May 1977	307
A8.7.2-10	Regression Equations Used for Converting Fresh Weight Estimates to Oven Dry Weights for the Intensive Study Plots, June 1977	308
A8.7.2-11	Regression Equations Used for Converting Fresh Weight Estimates to Oven Dry Weights for the Intensive Study Plots, July 1977	309

LIST OF APPENDIX 2A TABLES REFERENCED IN TEXT

<u>TABLE NO.</u>		<u>PAGE</u>
A8.7.2-12	Mean Production \pm the Standard Error of the Mean (S.E.), Frequency, and Range of Observed Values for Quadrats in Plots 1-0 and 1-F, May 1977	310
A8.7.2-13	Mean Production \pm the Standard Error of the Mean (S.E.), Frequency, and Range of Observed Values for Quadrats in Plots 1-0 and 1-F, June 1977	311
A8.7.2-14	Mean Production \pm the Standard Error of the Mean (S.E.), Frequency, and Range of Observed Values for Quadrats in Plots 1-0 and 1-F, July 1977	312
A8.7.2-15	Mean Production \pm the Standard Error of the Mean (S.E.), Frequency, and Range of Observed Values for Quadrats in Plots 2-0 and 2-F, May 1977	313
A8.7.2-16	Mean Production \pm the Standard Error of the Mean (S.E.), Frequency, and Range of Observed Values for Quadrats in Plots 2-0 and 2-F, June 1977	314
A8.7.2-17	Mean Production \pm the Standard Error of the Mean (S.E.), Frequency, and Range of Observed Values for Quadrats in Plots 2-0 and 2-F, July 1977	315
A8.7.2-18	Mean Production \pm the Standard Error of the Mean (S.E.), Frequency, and Range of Observed Values for Quadrats in Plots 3-0 and 3-F, May 1977	316
A8.7.2-19	Mean Production \pm the Standard Error of the Mean (S.E.), Frequency, and Range of Observed Values for Quadrats in Plots 3-0 and 3-F, June 1977	317
A8.7.2-20	Mean Production \pm the Standard Error of the Mean (S.E.), Frequency, and Range of Observed Values for Quadrats in Plots 3-0 and 3-F, July 1977	318
A8.7.2-21	Mean Production \pm the Standard Error of the Mean (S.E.), Frequency, and Range of Observed Values for Quadrats in Plots 4-0 and 4-F, May 1977	319
A8.7.2-22	Mean Production \pm the Standard Error of the Mean (S.E.), Frequency, and Range of Observed Values for Quadrats in Plots 4-0 and 4-F, June 1977	320
A8.7.2-23	Mean Production \pm the Standard Error of the Mean (S.E.), Frequency, and Range of Observed Values for Quadrats in Plots 4-0 and 4-F, July 1977	321
A8.7.2-24	Mean Production \pm the Standard Error of the Mean (S.E.), Frequency, and Range of Observed Values for Quadrats in Plots 5-0 and 5-F, May 1977	322
A8.7.2-25	Mean Production \pm the Standard Error of the Mean (S.E.), Frequency, and Range of Observed Values for Quadrats in Plots 5-0 and 5-F, June 1977	323
A8.7.2-26	Mean Production \pm the Standard Error of the Mean (S.E.), Frequency, and Range of Observed Values for Quadrats in Plots 5-0 and 5-F, July 1977	324

LIST OF APPENDIX 2A TABLES REFERENCED IN TEXT

<u>TABLE NO.</u>		<u>PAGE</u>
A8.7.2-27	Mean Production \pm the Standard Error of the Mean (S.E.), Frequency, and Range of Observed Values for Quadrats in Plots 6-0 and 6-F, May 1977	325
A8.7.2-28	Mean Production \pm the Standard Error of the Mean (S.E.), Frequency, and Range of Observed Values for Quadrats in Plots 6-0 and 6-F, June 1977	326
A8.7.2-29	Mean Production \pm the Standard Error of the Mean (S.E.), Frequency, and Range of Observed Values for Quadrats in Plots 6-0 and 6-F, July 1977	327
A8.7.2-30	Fresh Weight Estimates for Intensive Study, Plot 1-F, Chained Pinyon-Juniper Rangeland, July 1978	328
A8.7.2-31	Fresh Weight Estimates for Intensive Study, Plot 2-F, Chained Pinyon-Juniper Rangeland, July 1978	329
A8.7.2-32	Fresh Weight Estimates for Intensive Study, Plot 5-F, Pinyon-Juniper Woodland, July 1978	330
A8.7.2-33	Fresh Weight Estimates for Intensive Study, Plot 6-F, Pinyon-Juniper Woodland, July 1978	331
A8.7.2-34	Oven Dry Weights for Chained Pinyon-Juniper Rangeland Plots 1-F and 2-F, 1978	332
A8.7.2-35	Oven Dry Weights for Pinyon-Juniper Woodland Plots 5-F and 6-F, 1978	333
A8.7.2-36	Regression Equations Used for Converting Fresh Weight Estimates to Oven Dry Weights in Plots 1-F, 2-F, 5-F, and 6-F, 1978	334
A8.7.2-37	Mean Production \pm the Standard Error of the Mean (S.E.), Frequency, and Range of Observed Values for Quadrats at Chained Pinyon-Juniper Rangeland Plots 1-F and 2-F, 1978	335
A8.7.2-38	Mean Production \pm the Standard Error of the Mean (S.E.), Frequency, and Range of Observed Values for Quadrats at Pinyon-Juniper Woodland Plots 5-F and 6-F, 1978	336
A8.7.2-39	Oven Dry Weights for Range Cages and Adjacent Open Areas in the Pinyon-Juniper Woodland Treatment Site North of Piceance Creek, 1978	337
A8.7.2-40	Oven Dry Weights for Range Cages and Adjacent Open Areas in the Pinyon-Juniper Woodland Control Site North of Piceance Creek, 1978	338
A8.7.2-41	Mean Production \pm the Standard Error of the Mean (S.E.), Frequency, and Range of Observed Values for Clipped Plots in the Pinyon-Juniper Woodland Development Site North of Piceance Creek, 1978	339
A8.7.2-42	Mean Production \pm the Standard Error of the Mean (S.E.), Frequency, and Range of Observed Values for Clipped Plots in the Pinyon-Juniper Woodland Control Site North of Piceance Creek, 1978	340

LIST OF APPENDIX 2A TABLES REFERENCED IN TEXT

<u>TABLE NO.</u>		<u>PAGE</u>
A8.7.3-1	Production and Utilization of Bitterbrush in the Chained Rangeland Habitat, 1977-78	341
A8.7.3-2	Production and Utilization of Bitterbrush in the Pinyon-Juniper Habitat, 1977-78	342
A8.7.3-3	Production and Utilization of Mountain Mahogany in the Chained Rangeland Habitat, 1977-78	343
A8.7.3-4	Production and Utilization of Mountain Mahogany in the Pinyon-Juniper Habitat, 1977-78	344
A8.7.3-5	Production of Bitterbrush, 1978	345
A8.7.3-6	Baseline Evaluation of Bitterbrush on the Big Jimmy Ridge .	346
A8.7.3-7	Baseline Evaluation of Mountain Mahogany on the Big Jimmy Ridge	347
A8.7.3-8	Sagebrush Ocular Estimates - Fall 1978	348
A8.7.3-9	Production of Bitterbrush and Mountain Mahogany Treated with Fertilizer, 1978	349
A12.3.2-1	Stepwise Regression Analysis Statistics - Step 1	357
A12.3.2-2	Stepwise Regression Analysis Statistics - Step 2	357
A12.3.2-3	Stepwise Regression Analysis Statistics - Step 3	357

LIST OF SUPPORTING APPENDICES

<u>APPENDIX NO.</u>		<u>PAGE</u>
A2.2	Computer Station Codes and Cross Reference	2
A5.2.1A	Summary Tables for Univariate Time Series Analyses	12
A5.2.1B	Data for USGS Major Gauging Stations	16
A5.2.1C	T-Test Procedure Results for USGS Gauging Stations	24
A5.2.1D	Univariate Time Series Analysis, UCS FORTELL Box-Jenkins Package	43
A5.2.2A	Summary Tables for Linear Regression Analyses	64
A5.2.2B	Linear Regression Data for Springs and Seeps	72
A5.2.2C	T-Test Procedure Results for Springs and Seeps	79
A5.3.1A	Summary Tables for Regression and Comparative Analyses	99
A5.3.1B	Linear Regression Data for Alluvial Wells	112
A5.3.1C	T-Test Procedure Results for Alluvial Wells	119
A5.3.2A	Summary Tables for Ground Water Quality Analyses of Variance	139
A5.3.2B	Potentiometric Surface Maps - Upper Aquifer, (1976-1978)	149
A6.2.3	Site Log Sheets for 1978 Visibility Study	191
A6.3.2A	Wind Fields Summaries	224
A6.3.2B	Tracer Test Results	238

USERS GUIDE TO APPENDIX 2A

Appendix 2A contains supporting data for the 1978 C-b Annual Report, Volume 2, Environmental Analysis. These data appear in the forms of figures and tables and within the context of documentation for special analyses performed during the period of this report.

Both a list of figures and a list of tables, which are referenced in Volume 2 as belonging in Appendix 2A, appear immediately following the cover page of this appendix. A list of smaller, supporting appendices can be found following the list of tables; figures and tables not specifically referenced in Volume 2, but found in Appendix 2A, are listed on the title page of each supporting appendix.

Numbers assigned to supporting appendices, figures, and tables serve as a cross reference to section designations of Volume 2. The second- and third-level numbers correspond to the same second- and third-level section numbers in Volume 2 (e.g., Table A5.2.1A contains supporting data for section 5.2.1 of Volume 2, while Appendix A6.3.2B contains supporting data for section 6.3.2 of Volume 2). The header and trailer letter designations on all supporting appendices, figures, and tables refer to the physical location of the document in Appendix 2A and to a special study type (within the third-level designation), respectively. All supporting appendices, figures, and tables appear in numerical order by section number.

APPENDIX A2.2

COMPUTER STATION CODES AND CROSS-REFERENCE

A four-digit computer station code has been designed for identifying stations in the computer data base management system. It consists of two letters followed by two numbers:

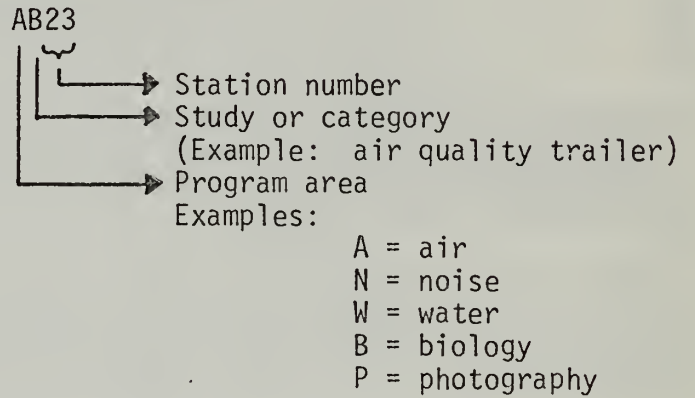

This code is presented on Table A2.2-1 for the environmental program. Associated station maps appearing in this report are:

	<u>Figure</u>	<u>Page</u>
WATER	5.2.1-1	26
	5.2.2-1	39
	5.3.1-1	43
	5.3.2-1	48
AIR	6.2.1-1	53
	6.3.1-1	91
NOISE	7.1.1-1	116
BIOLOGY	Jacket	Back Cover

TABLE A2.2-1
COMPUTER STATION CODES

I Air Quality & Meteorology

	<u>Sta. Designation</u>	<u>Computer Code</u>
Met. Tower:	@ Sta 023	AA23
Trailers:	Sta 020	AB20
	021	AB21
	022	AB22
	023	AB23
	024	AB24
Acoustic Radar	Sta 020	AC20
	021	AC21
	023	AC23
MRI and Particulates	Sta 031	AD31
	032	AD32
	033	AD33
	041	AD41
	042	AD42
	043	AD43
	044	AD44
	056	AD56

II Noise

Traffic Noise	Sta II	NA02
	IX	NA09
	XV	NB15

III Water

USGS Stream Gauging Sta.	09306007	WU07	
	36	WU36	
	39	WU39	
	42	WU42	
	61	WU61	
	50	WU50	
	52	WU52	
	58	WU58	
	33	WU33	
	25	WU25	
	15	WU15	
	08	WU08	
	22	WU22	
	Springs & Seeps	S-1	WS01
		2	WS02
3		WS03	
4		WS04	
6		WS06	
7		WS07	
8		WS08	
9		WS09	
10		WS10	
S-A		WS11	
Alluvial Wells		A-1	WA01
	A-2	WA02	
	-2A	WA14	
	3	WA03	
	3A	WA15	
4	WA04		

TABLE A2.2-1

Computer CodeWater Cont'dAlluvial Wells
Cont'd

5	WA05
5A	WA16
6	WA06
6A	WA17
7	WA07
7A	WA18
8	WA08
9	WA09
10	WA10
11	WA11
12	WA12
13	WA13

TABLE A2.2-1

Deep WellsUPPER AQUIFER

Baseline and Before Recompletions		U1 Level (String 1) After Recompletions		UPC1 Level (String 2) After Recompletions		UPC2 Level (String 3) After Recompletions	
STA.	CODE	STA.	CODE	STA.	CODE	STA.	CODE
CB-2	WX02	CB-2	WC02	CB-2	WD02		
		CB-3	WC03			CB-3	WE03
CB-4	WX04	CB-4	WC04			CB-4	WE04
		AT-1B	WC41	AT-1B-3	WD43		
AT-1C-3	WX44						
SG-1-2	WX12	SG-1	WC12	SG-1	WD12		
		SG-1A	WC13	SG-1A-2	WD13		
SG-6-3	WX63	SG-6	WC60	SG-6-3	WD63	SG-6-1	WE61
SG-8-2	WX82						
SG-9-2	WX92	SG-9	WC90			SG-9-2	WE92
SG-10A	WX10	SG-10A	WC10	SG-10A-2	WD10	SG-10A-1	WE10
SG-11-3	WX55	SG-11	WC50	SG-11-3	WD55	SG-11-2	WE54
SG-17-2	WX17	SG-17	WC17	SG-17-3	WD17	SG-17-2	WE17
SG-18A	WX18	SG-18A	WC18	SG-18A-3	WD18	SG-18A-2	WE18
SG-19	WX19	SG-19	WC19				
SG-20	WX20	SG-20	WC20	SG-20-3	WD20	SG-20-2	WE20
SG-21	WX21	SG-21	WC21	SG-21-4	WD21	SG-21-3	WE21
		33X-1	WC33	33X-1-4	WD33	33X-1-3	WE33
		32X-12	WC32	32X12-4	WD32	32X12-3	WE32

TABLE A2.2-1

Deep Wells (cont'd)LOWER AQUIFER

Baseline and Before Recompletions		LPC3 Level (String 4) After Recompletions		LPC4 Level (String 5) After Recompletions	
STA.	CODE	STA.	CODE	STA.	CODE
CB-1	WY01				
AT-1	WY44	AT-1A	WG40		
		AT-1B-1	WG42		
AT-1C-1	WY45				
AT-1C-2	WY46				
SG-1-1	WY12	SG-1-1	WG12		
SG-6-1	WY61				
SG-6-2	WY62	SG-6-2	WG62		
SG-8	WY80	SG-8-1	WG81	SG-8-2	WH82
SG-8R	WY81				
SG-9-1	WY91	SG-9-1	WG91		
SG-10	WY09	SG-10	WG10		
SG-10R	WY10				
SG-11-1	WY51	SG-11-1	WG52		
SG-11-2	WY54				
SG-11-1R	WY52				
SG-17-1	WY18	SG-17-1	WG17		
SG-17-1R	WY17				
		SG-18A-1	WG18		
		SG-20-1	WG20		
		SG-21-2	WG21	SG-21-1	WH21
		33X-1-2	WG33	ddX-1-1	WH33
		32X-12-2	WG32	32X-12-1	WH32

TABLE A2.2-1

IV Biology

<u>Program</u>	<u>General Location</u>	<u>Computer Code</u>	<u>*Analysis Code</u>	
Deer Days Use	Between Hunter Cr. & Jimmy Gulch	BA01	- PJ-CH-C	
		BA02	- PJ-CH-C	
		BA03	- PJ-CH-C	
		BA04	- PJ-CH-C	
		BA05	- PJ-CH-C	
		BA06	- PJ-CH-C	
		BA07	- PJ-CH-C	
		BA08	- PJ-CH-C	
		BA09	- PJ-CH-C	
	North Side, Piceance Creek	BA10	- PJ	-D
		BA11	- PJ	-D
		BA12	- PJ	-D
		BA13	- PJ	-C
		BA14	- PJ	-C
		BA15	- PJ	-C
	South Side, Piceance Creek On Tract Bet. Willow & Scandard	BA16	- PJ	-D
		BA17	- PJ-CH-C	
		BA18	- PJ-CH-C	
	On Tract bet. Cottonwood & Sorghum	BA19	- PJ	-C
		BA20	- PJ-CH-D	
	On Tract bet. Sorghum & W. Fork Stewart	BA21	- PJ-CH-D	
		BA22	- PJ	-D
		BA23	- PJ-CH-D	
	On Tract bet. W. & M. Fork Stewart	BA24	- PJ	-D
		BA25	- PJ-CH-C	
	On Tract bet. Willow & Scandard North End	BA26	- PJ	-C
		BA27	- PJ	-C
	On Tract bet. Willow & Scandard S.E.	BA28	- PJ-CH-C	
	On Tract bet. Cottonwood & Sorghum North	BA29	- PJ-CH-C	
	On Tract bet. Cottonwood & Sorghum South	BA30	- PJ-CH-C	
		BA31	- PJ-CH-C	

*ANALYSIS CODES:

PJ-CH-C	- Pinon Juniper, Chained, Control Station	(12)
PJ -C	- Pinon Juniper, Control Station	(6)
PJ-CH-D	- Pinon Juniper, Chained, Development Station	(3)
PJ -D	- Pinon Juniper, Development Station	(6)

TABLE A2.2-1

Biology Cont'd

<u>Program</u>	<u>General Location</u>	<u>Computer Code</u>
Deer Mortality	North Side of Piceance Creek	BD01
		BD02
		BD03
		BD04
		BD05
	South Side of Piceance Creek	BD06
		BD07
		BD08
		BD09
		BD10
Deer Age Class	General Area of Tract	BE01
Coyotte Abundance	8 Transects for Total of 30 miles	BF01
	15 mi seg. near Hunter (control) 15 mi seg. on & South of Tract (development)	BF02 thru BF08
Lagomorph Abundance	Identical Locations to deer use days	BA01 to BA27
Small Mammals	Piceance Creek (Development)	BG01
	On-Tract-west (Development)	BG02
	Piceance Creek (Control)	BG03
	On Tract-east (Control)	BG04
Avifauna Songbirds and Gamebirds	N.W. of Tract-near Jimmy PJ-CH-C	BH01
	On Tract-Scandard PJ -D	BH02
	On Tract-Cottonwood PJ-CH-D	BH03
	S. of Tract-bet. W&N Fork Stewart PJ -C	BH04
Raptors	The entire tract and surrounding study areas.	BI01
Aquatic Ecology Benthos	USGS 90306007 (Control)	WU07
	USGS 58 (Development)	WU58
	USGS 61 (Development)	WU61
Periphyton	Piceance Creek Upstream (Control)	WP01
		WP02
	Piceance Creek Downstream (Development)	WP03
Water Quality	USGS 09306061 (Development)	WU61
Vegetation Community Structure	Chained pinyon juniper (1978)(Dev)	BJ01
	Chained pinyon juniper (1978)(Cont)	BJ02
	Upland sagebrush (1980)(Cont)	BJ03
	Bottomland sagebrush (1980)(Cont)	BJ04
	Pinyon juniper woodland (1979)(Dev)	BJ05
	Pinyon juniper woodland (1979)(Cont)	BJ06
Herb Productivity and Utilization	Identical locations to community structure	BJ01 thru BJ06
	<u>Plus</u>	
	60 range cages in random locations	BK01 thru BK60
	20 cages on south facing PJ for baseline 5 cages for fertilization assessment	BK61 thru BK80 BK81 thru BK85
Shrub Productivity and Utilization	Same stations as Deer Use Days Study	BA01 thru BA27
General Condition	By aircraft over entire Tract area	Not in computer

TABLE A2.2-1

Biology (Cont'd)

Programs: Deer Distribution & Migration and Road Kills

Mile Marker	Location	Computer Code	
		North of Piceance Creek	South (Meadows) of Piceance Creek
41	White River City	BN41	BM41
40	Piceance Bridge	BN40	BM40
39	Lower Canyon	BN39	BM39
38	Piceance Canyon	BN38	BM38
37	Yellow Creek	BN37	BM37
36	Stinking Springs	BN36	BM36
35	Old Bridge	BN35	BM35
34	Little Hills Turnoff	BN34	BM34
33	Old Corrals & Buildings	BN33	BM33
32	Burk Ranch	BN32	BM32
31	<u>2</u> Ranch	BN31	BM31
30		BN30	BM30
29		BN29	BM29
28	Bureau of Mines	BN28	BM28
27	Ryan Gulch	BN27	BM27
26	Pump Station	BN26	BM26
25		BN25	BM25
24	Rock School	BN24	BM24
23	AQ 021	BN23	BM23
22	Pat Johnson's Ranch	BN22	BM22
21	Hunter Creek	BN21	BM21
20	PL Gate	BN20	BM20
19	AQ 020	BN19	BM19
18	Sorghum, Cottonwood	BN18	BM18
17	Stewart Gulch Rd.	BN17	BM17
16	A Q Trailer 022	BN16	BM16
15	Oldland's Ranch	BN15	BM15
14	Oldland's Ranch	BN14	BM14
13	Pond and Cabin	BN13	BM13
12	Sprague Gulch	BN12	BM12
11	Cascade Gulch	BN11	BM11
10	13 Mile Gulch	BN10	BM10
9	14 Mile Gulch	BN09	BM09
8	Schutte Gulch	BN08	BM08
7	Robinson's Ranch	BN07	BM07
6		BN06	BM06
5	2 Old Cabins (35 MPH Curve)	BN05	BM05
4	McCarthy Gulch	BN04	BM04
3	Cow Creek	BN03	BM03
2	Mahogany Outcropping	BN02	BM02
1	Woodward Ranch	BN01	BM01
0	Rio Blanco Store	BN00	BM00

TABLE A2.2-1

Biology (Cont'd)

<u>Program</u>	<u>General Location</u>	<u>Computer Code</u>
Micro Climate	MC Sta. 1	BC01
	2	BC02
	3	BC03
	4	BC04
	5	BC05
	6	BC06
	7	BC07
	8	BC08
	9	BC09
	13	BC13

APPENDIX A5.2.1

This Appendix consists of four parts:

- A5.2.1A - Summary Tables for Univariate Time Series Analyses
- A5.2.1B - Data for USGS Major Gauging Stations
- A5.2.1C - T-TEST Procedure Results for USGS Gauging Stations
- A5.2.1D - Univariate Time Series Analysis UCS FORTELL Box-Jenkins Package

APPENDIX A5.2.1A

Summary Tables for Univariate Time Series Analyses

List of Tables Appearing in Appendix A5.2.1A

<u>TABLE NO.</u>		<u>PAGE</u>
A5.2.1A-1	Univariate Time Series Analyses Mean Monthly Flow (cfs) Major USGS Stations	13
A5.2.1A-2	Univariate Time Series Analyses SO ₄ Concentration (mg/l) Major USGS Stations	14
A5.2.1A-3	Univariate Time Series Analyses NA Concentration (mg/l) Major USGS Stations	15

Table A5.2.1A-1

UNIVARIATE TIME SERIES ANALYSES

MEAN MONTHLY FLOW (cfs)

MAJOR USGS STATIONS

USGS Sta #	MODEL PARAMETERS	SERIES MEAN	SERIES S. D.	MEAN OF RESIDUALS	S. D. OF RESIDUALS	CHI SQUARE TEST (95%)	TREND
007	$\mu = 10.176$ $\phi_1 = 0.53076$	9.9997	8.0671	0.36053E-03	0.68633E+01	NOISE	N
022	$\mu = 1.632$ $\phi_1 = 0.62038$	1.6733	0.62628	-0.32148E-05	0.49960	NOISE	N
058	$\mu = 1.7194$ $\phi_1 = 0.65157$	1.7002	0.97969	-0.10046E-02	0.74408	NOISE	N
061	$\mu = 14.239$ $\phi_1 = 0.59035$	14.069	7.3146	-0.20778E-02	0.58856E+01	NOISE	N

General Form of Time Series Model for Mean Monthly Flow

$$(1 - \phi_1 B^1) (Z_t - \mu) = a_t$$

ϕ_a = Autoregressive parameter of order a
 θ_b = Moving average parameter of order b

Table A5.2.1A-2

UNIVARIATE TIME SERIES ANALYSES

S₀₄ CONCENTRATION (mg/l)

MAJOR USGS STATIONS

USGS Sta #	MODEL PARAMETERS	SERIES MEAN	SERIES S. D.	MEAN OF RESIDUALS	S. D. OF RESIDUALS	CHI SQUARE TEST (95%)	TREND
007	M = 165.85 $\phi_4 = 0.25727$	165.40	16.436	0.19576E-03	0.16648E+02	NOISE	N
022	M = 367.99 $\phi_1 = 0.30307$	367.53	17.924	-0.17136E+00	0.17138E+02	NOISE	N
058	M = 337.09 $\phi_1 = 0.41802$	337.00	20.067	0.19789E-03	0.18447E+02	-	N
061	M = 296.93 $\phi_1 = 0.49512$	297.22	47.005	-0.89333E-03	0.41248E+02	NOISE	N

General Form of Time Series Model for S₀₄ Concentration

Stations 022, 058, 061 $(1-\phi_1 B^1) (Z_t-\mu) = a_t$

Station 007 $(1-\phi_4 B^4) (Z_t-\mu) = a_t$

ϕ_a = Autoregressive parameter of order a

θ_b = Moving average parameter of order b

Table A 5.2.1A-3

UNIVARIATE TIME SERIES ANALYSES

NA CONCENTRATION (mg/l)

MAJOR USGS STATIONS

USGS Sta #	MODEL PARAMETERS	SERIES MEAN	SERIES S. D.	MEAN OF RESIDUALS	S. D. OF RESIDUALS	CHI SQUARE TEST (95%)	TREND
007	M = 122.95 $\phi_1 = 0.163$	123.22	19.633	-.17912E-01	0.19441E+02	NOISE	N
022	M = 123.42 $\phi_7 = .47099$ $\phi_8 = 0.012231$	124.64	11.017	-.38878E-04	0.47358E+01	NOISE	N
058	M = 118.93 $\phi_1 = 0.58705$	119.44	8.4474	-.19285E-03	0.65648E+01	-	N
061	M = 146.92 $\phi_1 = 0.46995$	147.33	22.937	-.14461E-03	0.20202E+02	NOISE	N

General Form of Time Series Model for Na Concentration

Stations 007, 058, 061 $(1-\phi_1 B^1) (Z_t - \mu) = a_t$

Station 022 $(1-\phi_7 B^7) (1-\phi_8 B^8) (Z_t - \mu) = a_t$

ϕ_a = Autoregressive parameter of order a
 θ_b = Moving average parameter of order b

APPENDIX A5.2.1B

Data for USGS Major Gauging Stations

PH DATA 10/74 - 5/78

8.5	8.0	8.1	8.7	7.9	8.4	8.5	8.5	8.4	8.3	8.2	8.3	8.2	8.3	8.3	8.2	8.2	8.2	8.2	180	190	210	215	215	210	200	180	240	210		
8.3	8.3	8.0	8.3	8.3	8.3	8.2	MD	8.3	MD	8.3	8.3	8.3	8.3	MD	8.3	8.2	8.2	MD	MD	MD	MD	MD	MD	MD	MD	MD	MD	MD	MD	
8.1	8.2	8.4	8.1	7.9	8.3	8.2	8.2	8.3	8.3	8.3	8.2	8.3	8.3	8.3	8.3	8.2	8.2	8.2	8.2	8.2	8.2	8.3	8.3	8.3	8.3	8.2	8.2	8.2	8.2	8.2

B DATA 10/74 - 5/78

244	240	187	205	175	215	150	265	200	210	215	210	215	215	210	210	200	190	200	190	240	240	210	215	200	200	190	240	210	210	215	215	210	200	180	190	240	210
130	140	220	MD	MD	220	210	MD	190	MD	200	MD	200	MD	MD	MD	MD	MD	MD	MD	MD	MD	MD	MD	MD	MD	MD	MD	MD	MD	MD	MD	MD	MD	MD	MD	MD	MD
250	240	240	190	200	130	150	150	130	130	130	150	150	150	130	130	130	130	130	130	130	130	130	130	130	130	130	130	130	130	130	130	130	130	130	130	130	130

FLUORIDE DATA 10/74 - 5/78

1.1	1.0	1.1	1.2	1.2	1.0	0.5	0.7	0.8	0.9	0.9	0.9	0.9	0.8	1.0	1.1	1.1	1.0	1.1	1.1	1.1	1.1	1.1	1.1	1.1	1.1	1.1	1.1	1.1	1.1	1.1	1.1	1.1	1.1	1.1	1.1	1.1	1.1
0.6	0.9	0.1	1.1	MD	1.1	1.1	MD	1.2	MD	1.3	1.3	1.3	MD	1.1	MD	1.3	1.2	1.2	1.2	1.2	1.2	1.2	1.2	1.2	1.2	1.2	1.2	1.2	1.2	1.2	1.2	1.2	1.2	1.2	1.2	1.2	1.2
1.0	1.2	1.2	1.2	1.3	0.7	0.6	0.6	0.6	0.6	0.6	0.6	0.6	0.6	0.6	0.6	0.6	0.6	0.6	0.6	0.6	0.6	0.6	0.6	0.6	0.6	0.6	0.6	0.6	0.6	0.6	0.6	0.6	0.6	0.6	0.6	0.6	0.6

AS DATA 10/74 - 5/78

USGS Station WU07 Data Prior to Interpolation

PH DATA 10/74 - 5/78

8.2 8.5 8.5 8.4 8.6 8.5 8.5 8.2 8.1 8.5 8.1 8.3 8.0 8.3 8.3 8.3 8.3 8.3 8.3
 8.3 8.3 8.3 8.0 7.1 8.3 8.4 8.2 8.2 8.2 8.2 8.3 8.2 8.2 8.2 8.2 8.2 8.2 8.2
 8.2 8.3 8.2 8.2 8.1 7.9 8.0 8.3 8.3 8.2 8.1 8.3 8.3 8.3 8.3 8.3 8.3 8.3 8.3

B DATA 10/74 - 5/78

100 325 140 120 75 77 85 80 80 70 75 85 145 80 90 80 80 80 180
 80 110 310 MD MD MD MD MD MD MD MD MD MD MD MD MD MD MD MD MD MD
 80 100 90 80 90 80 80 80 80 70 70 80 80 80 80 80 80 80 80

FLUORIDE DATA 10/74 - 5/78

.2 2.0 .8 .2 .3 .2 .2 .2 .2 .2 .2 .2 .2 .2 .2 .2 .2 .2 .2
 .2 .3 .2 MD MD MD MD MD MD MD MD MD MD MD MD MD MD MD MD MD
 .3 .3 .3 .3 .3 .3 .3 .3 .3 .3 .3 .3 .3 .3 .3 .3 .3 .3

AS DATA 10/74 - 5/78

1 2 1 1 2 1 0 1 0 .5 0 0 1 1 1 1 1 1 1
 1 1 MD 2 2 MD 1 1 MD 1 1 MD MD MD MD MD MD MD MD MD MD MD
 1 1 MD 2 2 MD 1 1 MD 1 1 MD 1 1 MD 1 1 MD 1 1 MD MD MD MD MD

USGS Station WU22 Data Prior to Interpolation

PH DATA 10/74 - 5/78

8.4 7.4 8.47 8.71 8.34 8.3 8.56 8.5 8.4 8.5 8.5 8.5 8.5 8.7
 8.9 8.4 8.4 8.4 8.1 8.4 8.3 8.3 8.4 8.1 8.4 MD MD MD
 8.3 MD 8.4 8.3 8.4 MD 8.4 8.4 8.4 8.3 8.4 8.1 8.1 8.3

B DATA 10/74 - 5/78

105 MD MD MD MD MD 120 110 130 100 120 125 120 100
 110 90 100 140 830 130 120 MD MD 100 MD MD MD MD
 100 MD 110 MD MD 120 MD 110 110 100 100 100 130 110

FLUORIDE DATA 10/74 - 5/78

.4 MD MD MD MD MD .3 .4 .4 .4 .4 .4 .4 .4 .4 .4
 .3 .4 MD MD MD MD .5 MD .5 MD .4 .4 .4 .4 .4 .4 .4 .4

AS DATA 10/74 - 5/78

1 MD MD MD MD MD 3 1 1 1 1 1 0 MD 0 0 1 1 MD
 1 13 MD MD MD MD 1 MD 0 MD 3 MD 2 3 2 1 2 1 1 1

USGS Station WU58 Data Prior to Interpolation

PH DATA 10/74 - 5/78

8.3 8.3 8.3 8.2 7.7 8.4 8.0 9.2 7.8 8.4 8.3 8.5 7.8 8.2 8.3 8.3 8.4
 8.3 8.3 8.3 8.2 8.1 8.3 8.1 8.3 8.1 8.2 8.3 8.2 8.0 8.1 8.4 8.2 8.3 8.1
 8.3 8.1 8.3 8.1 8.1 8.2 7.8 8.5

B DATA 10/74 - 5/78

220 210 190 175 155 145 155 160 205 215 185 190 190 200 160 140 200
 390 770 230 240 MD MD 180 190 180 160 150 150 180 200 190 220 200
 190 190 190 170 180 140 120 170

FLUORIDE DATA 10/74 - 5/78

.6 .6 .6 .7 .6 .8 .6 .5 .7 .7 .7 5 .8 .7 .6 .6 .6 .6 .7 .7 .8 MD MD
 .6 .7 .6 .7 .7 .8 .8 .9 .8 .7 .7 .7 .7 .7 .7 .6 .6 .6 .5 .7

AS DATA 10/74 - 5/78

2 3 2 1 3 1 2 2 1 3 3 3 1 2 2 1 1 MD 1 1 4 4 MD MD
 2 3 3 2 0 2 2 2 2 3 3 1 2 3 2 4 2 2 3 2

USGS Station WU61 Data Prior to Interpolation

TIME SERIES ANALYSIS OF MEAN MONTHLY FLOW (STA. 007)

LISTING OF OBSERVED SERIES

1-	8	0.430000E+01	0.654000E+01	0.679000E+01	0.785000E+01	0.772000E+01	0.768000E+01	0.176100E+02	0.463900E+02
9-	16	0.220400E+02	0.107300E+02	0.147600E+02	0.148000E+02	0.807000E+01	0.101200E+01	0.706000E+01	0.723000E+01
17-	24	0.101000E+02	0.105600E+02	0.180000E+02	0.103500E+02	0.104100E+02	0.165000E+02	0.127900E+02	0.893000E+01
25-	32	0.522000E+01	0.786000E+01	0.735000E+01	0.589000E+01	0.572000E+01	0.686000E+01	0.207000E+01	0.413000E+01
33-	40	0.431000E+01	0.595000E+01	0.270000E+01	0.231000E+01	0.196000E+01	0.361000E+01	0.476000E+01	0.340000E+01
41-	48	0.308000E+01	0.117200E+02	0.334300E+02	0.255000E+02	0.833000E+01	0.716000E+01	0.894000E+01	0.660000E+01

TIME SERIES ANALYSIS OF MEAN MONTHLY FLOW (STA. 022)

LISTING OF OBSERVED SERIES

1-	8	0.184000E+01	0.205000E+01	0.196000E+01	0.209000E+01	0.175000E+01	0.206000E+01	0.232000E+01	0.234000E+01
9-	16	0.275000E+01	0.246000E+01	0.202000E+01	0.191000E+01	0.182000E+01	0.170000E+01	0.239000E+01	0.168000E+01
17-	24	0.183000E+01	0.420000E+01	0.248000E+01	0.228000E+01	0.203000E+01	0.152000E+01	0.155000E+01	0.470000E+00
25-	32	0.147000E+01	0.150000E+01	0.147000E+01	0.158000E+01	0.174000E+01	0.161000E+01	0.157000E+01	0.121000E+01
33-	40	0.102000E+01	0.140000E+01	0.660000E+00	0.108000E+01	0.120000E+01	0.110000E+01	0.155000E+01	0.163000E+01
41-	48	0.157000E+01	0.143000E+01	0.142000E+01	0.130000E+01	0.107000E+01	0.490000E+00	0.630000E+00	0.780000E+00

TIME SERIES ANALYSIS OF MEAN MONTHLY FLOW (STA. 050)

LISTING OF OBSERVED SERIES

1-	8	0.670000E+00	0.180000E+01	0.235000E+01	0.241000E+01	0.206000E+01	0.336000E+01	0.294000E+01	0.730000E+00
9-	16	0.136000E+01	0.217000E+01	0.209000E+01	0.101000E+01	0.324000E+01	0.311000E+01	0.317000E+01	0.272000E+01
17-	24	0.435000E+01	0.326000E+01	0.314000E+01	0.139000E+01	0.800000E+00	0.530000E+00	0.110000E+01	0.243000E+01
25-	32	0.257000E+01	0.189000E+01	0.273000E+01	0.167000E+01	0.114000E+01	0.156000E+01	0.710000E+00	0.500000E+00
33-	40	0.800000E+00	0.109000E+01	0.102000E+01	0.950000E+00	0.124000E+01	0.133000E+01	0.145000E+01	0.117000E+01
41-	48	0.158000E+01	0.151000E+01	0.136000E+01	0.420000E+00	0.670000E+00	0.650000E+00	0.380000E+00	0.530000E+00

TIME SERIES ANALYSIS OF MEAN MONTHLY FLOW (STA. 061)

LISTING OF OBSERVED SERIES

1-	8	0.553000E+01	0.165000E+02	0.176000E+02	0.165000E+02	0.164000E+02	0.205000E+02	0.236000E+02	0.367000E+02
9-	16	0.250000E+02	0.134000E+02	0.168000E+02	0.180000E+02	0.112300E+02	0.250000E+02	0.224800E+02	0.172900E+02
17-	24	0.210300E+02	0.218100E+02	0.280900E+02	0.793000E+01	0.506000E+01	0.717000E+01	0.435700E+01	0.197000E+02
25-	32	0.334000E+01	0.102300E+02	0.164200E+02	0.139700E+02	0.129300E+02	0.126900E+02	0.467000E+01	0.614000E+01
33-	40	0.584000E+01	0.710000E+01	0.862000E+01	0.107700E+02	0.335000E+01	0.520000E+01	0.401000E+02	0.109100E+02
41-	48	0.106700E+02	0.146300E+02	0.257700E+02	0.208100E+02	0.931000E+01	0.800000E+01	0.645000E+01	0.497000E+01

TIME SERIES ANALYSIS OF NA CONCENTRATION (STA. 007)

00000160

LISTING OF OBSERVED SERIES

1-	8	0.140000E+03	0.135000E+03	0.125000E+03	0.130000E+03	0.130000E+03	0.115000E+03	0.120000E+03	0.120000E+03	0.950000E+02
9-	16	0.110000E+03	0.135000E+03	0.125000E+03	0.120000E+03	0.130000E+03	0.120000E+03	0.120000E+03	0.120000E+03	0.110000E+03
17-	24	0.110000E+03	0.110000E+03	0.850000E+02	0.110000E+03	0.120000E+03	0.120000E+03	0.120000E+03	0.120000E+03	0.470000E+02
25-	32	0.150000E+03	0.140000E+03	0.130000E+03	0.120000E+03	0.120000E+03	0.120000E+03	0.120000E+03	0.120000E+03	0.130000E+03
33-	40	0.130000E+03	0.130000E+03	0.140000E+03	0.140000E+03	0.140000E+03	0.140000E+03	0.140000E+03	0.140000E+03	0.130000E+03
41-	45	0.140000E+03	0.120000E+03	0.800000E+02	0.980000E+02	0.150000E+03	0.150000E+03	0.150000E+03	0.150000E+03	0.130000E+03

TIME SERIES ANALYSIS OF NA CONCENTRATION (STA. 022)

00000160

LISTING OF OBSERVED SERIES

1-	8	0.122000E+03	0.190000E+03	0.122000E+03	0.120000E+03	0.120000E+03	0.120000E+03	0.120000E+03	0.120000E+03	0.125000E+03
9-	16	0.120000E+03	0.135000E+03	0.130000E+03	0.125000E+03	0.125000E+03	0.120000E+03	0.120000E+03	0.120000E+03	0.120000E+03
17-	24	0.120000E+03	0.120000E+03	0.120000E+03	0.130000E+03	0.130000E+03	0.130000E+03	0.120000E+03	0.120000E+03	0.120000E+03
25-	32	0.130000E+03	0.130000E+03	0.120000E+03	0.120000E+03	0.120000E+03	0.120000E+03	0.120000E+03	0.120000E+03	0.120000E+03
33-	40	0.130000E+03	0.130000E+03	0.130000E+03	0.130000E+03	0.130000E+03	0.130000E+03	0.120000E+03	0.120000E+03	0.120000E+03
41-	45	0.110000E+03	0.120000E+03	0.120000E+03	0.120000E+03	0.130000E+03	0.130000E+03	0.120000E+03	0.120000E+03	0.130000E+03

TIME SERIES ANALYSIS OF NA CONCENTRATION (STA. 058)

00000160

LISTING OF OBSERVED SERIES

1-	8	0.135000E+03	0.125000E+03	0.125000E+03	0.125000E+03	0.125000E+03	0.125000E+03	0.110000E+03	0.110000E+03	0.120000E+03
9-	16	0.130000E+03	0.125000E+03	0.130000E+03	0.130000E+03	0.130000E+03	0.120000E+03	0.120000E+03	0.120000E+03	0.120000E+03
17-	24	0.110000E+03	0.110000E+03	0.110000E+03	0.110000E+03	0.110000E+03	0.130000E+03	0.130000E+03	0.130000E+03	0.110000E+03
25-	32	0.110000E+03	0.110000E+03	0.110000E+03	0.110000E+03	0.110000E+03	0.110000E+03	0.110000E+03	0.110000E+03	0.110000E+03
33-	40	0.125000E+03	0.125000E+03	0.125000E+03	0.125000E+03	0.125000E+03	0.125000E+03	0.120000E+03	0.120000E+03	0.130000E+03
41-	45	0.110000E+03	0.120000E+03	0.120000E+03	0.125000E+03	0.130000E+03	0.110000E+03	0.110000E+03	0.110000E+03	0.130000E+03

TIME SERIES ANALYSIS OF NA CONCENTRATION (STA. 001)

00000160

LISTING OF OBSERVED SERIES

1-	8	0.177000E+03	0.160000E+03	0.140000E+03	0.140000E+03	0.140000E+03	0.130000E+03	0.130000E+03	0.130000E+03	0.150000E+03
9-	16	0.145000E+03	0.170000E+03	0.145000E+03	0.140000E+03	0.140000E+03	0.160000E+03	0.160000E+03	0.160000E+03	0.120000E+03
17-	24	0.120000E+03	0.120000E+03	0.970000E+02	0.170000E+03	0.170000E+03	0.190000E+03	0.150000E+03	0.150000E+03	0.140000E+03
25-	32	0.150000E+03	0.160000E+03	0.140000E+03	0.140000E+03	0.140000E+03	0.140000E+03	0.140000E+03	0.140000E+03	0.160000E+03
33-	40	0.170000E+03	0.170000E+03	0.170000E+03	0.170000E+03	0.170000E+03	0.170000E+03	0.170000E+03	0.180000E+03	0.160000E+03
41-	45	0.140000E+03	0.150000E+03	0.910000E+02	0.130000E+03	0.130000E+03	0.150000E+03	0.150000E+03	0.150000E+03	0.130000E+03

APPENDIX A5.2.1C

T-TEST Procedure Results
for
USGS Stations 6007, 6022, 6058, 6061

TTEST PROCEDURE

VARIABLE: PH

LUC	N	MEAN	STD. DEV	STD ERROR	MINIMUM	MAXIMUM	VARIANCES	T	DF	PROB > T
6058	27	8.35185185	0.18886375	0.03634685	8.00000000	8.90000000	UNEQUAL	2.0054	55.9	0.0498 *
6061	31	8.24677419	0.21013309	0.03774102	7.70000000	8.70000000	EQUAL	1.9905	56.0	0.0514 *

FOR H0: VARIANCES ARE EQUAL, F' = 1.24 WITH 30 AND 26 DF
PROB > F' = 0.5842

VARIABLE: B

LUC	N	MEAN	STD DEV	STD ERROR	MINIMUM	MAXIMUM	VARIANCES	T	DF	PROB > T
6058	24	136.66666667	148.31419841	30.27450898	80.00000000	830.00000000	UNEQUAL	-1.7964	43.3	0.0794 *
6061	30	203.33333333	117.57120611	21.46546723	120.00000000	770.00000000	EQUAL	-1.8434	57.0	0.0710 *

FOR H0: VARIANCES ARE EQUAL, F' = 1.59 WITH 23 AND 29 DF
PROB > F' = 0.2357

VARIABLE: F

LUC	N	MEAN	STD DEV	STD ERROR	MINIMUM	MAXIMUM	VARIANCES	T	DF	PROB > T
6058	26	0.42307692	0.07103629	0.01393136	0.30000000	0.60000000	UNEQUAL	-12.4183	55.7	0.0001 *
6061	32	0.49375000	0.09482582	0.01676299	0.50000000	0.90000000	EQUAL	-12.0562	56.0	0.0001 *

FOR H0: VARIANCES ARE EQUAL, F' = 1.78 WITH 31 AND 25 DF
PROB > F' = 0.1423

VARIABLE: AS

LUC	N	MEAN	STD DEV	STD ERROR	MINIMUM	MAXIMUM	VARIANCES	T	DF	PROB > T
6058	25	1.64000000	2.49799920	0.49959984	0	13.00000000	UNEQUAL	-1.4315	32.9	0.1617
6061	31	2.41935484	1.20482899	0.21639368	0	6.00000000	EQUAL	-1.5324	54.0	0.1313

FOR H0: VARIANCES ARE EQUAL, F' = 4.30 WITH 24 AND 30 DF
PROB > F' = 0.0002

S T A T I S T I C A L A N A L Y S I S S Y S T E M

TTEST PROCEDURE

VARIABLE: MOLY

LOC	N	MEAN	STD DEV	STD ERROR	MINIMUM	MAXIMUM	VARIANCES	T	DF	PROB > ITI
6058	9	6.7777778	6.45712354	2.15237451	2.00000000	20.00000000	UNEQUAL	-0.7044	17.6	0.4904
6061	13	8.76923077	6.61001571	1.83328851	2.00000000	20.00000000	EQUAL	-0.7012	20.0	0.4912

FOR H0: VARIANCES ARE EQUAL, F= 1.05 WITH 12 AND 8 DF PROB > F= 0.9785

VARIABLE: S04

LOC	N	MEAN	STD DEV	STD ERROR	MINIMUM	MAXIMUM	VARIANCES	T	DF	PROB > ITI
6058	27	334.81481481	23.59438825	4.54074214	290.00000000	390.00000000	UNEQUAL	3.1772	48.1	0.0026
6061	33	304.24242424	48.73591483	8.48383381	190.00000000	390.00000000	EQUAL	2.9828	58.0	0.0042

FOR H0: VARIANCES ARE EQUAL, F= 4.27 WITH 32 AND 26 DF PROB > F= 0.0003

VARIABLE: NA

LOC	N	MEAN	STD DEV	STD ERROR	MINIMUM	MAXIMUM	VARIANCES	T	DF	PROB > ITI
6058	27	116.66666667	8.32050294	1.60128154	110.00000000	130.00000000	UNEQUAL	-6.7879	40.5	0.0001
6061	33	147.81818182	24.70634350	4.30082236	91.00000000	190.00000000	EQUAL	-6.2594	58.0	0.0001

FOR H0: VARIANCES ARE EQUAL, F= 8.82 WITH 32 AND 26 DF PROB > F= 0.0001

VARIABLE: NH3

LOC	N	MEAN	STD DEV	STD ERROR	MINIMUM	MAXIMUM	VARIANCES	T	DF	PROB > ITI
6058	25	0.03160000	0.02882129	0.00576426	0	0.09000000	UNEQUAL	-1.7123	51.3	0.0929
6061	33	0.05030303	0.05329663	0.00927775	0	0.22000000	EQUAL	-1.5856	56.0	0.1185

FOR H0: VARIANCES ARE EQUAL, F= 3.42 WITH 32 AND 24 DF PROB > F= 0.0027

VARIABLE: SPECCOND

LOC	N	MEAN	STD DEV	STD ERROR	MINIMUM	MAXIMUM	VARIANCES	T	DF	PROB > ITI
6058	27	1251.66666667	78.36050627	15.08050571	1050.00000000	1400.00000000	UNEQUAL	-1.6806	48.3	0.0993
6061	33	1305.00000000	160.39989090	27.92203702	875.00000000	1550.00000000	EQUAL	-1.5787	58.0	0.1198

FOR H0: VARIANCES ARE EQUAL, F= 4.19 WITH 32 AND 26 DF PROB > F= 0.0004

TTEST PROCEDURE

VARIABLE: TDS

LOC	N	MEAN	STD DEV	STD ERROR	MINIMUM	MAXIMUM	VARIANCES	T	DF	PROB > ITI
8058	32	883.88000000	39.18579675	7.83715935	792.00000000	945.00000000	UNEQUAL	-1.0259	40.2	0.3111
8061	32	905.68750000	111.78159509	19.76038097	584.00000000	1080.00000000	EQUAL	-0.9303	55.0	0.3563

FOR H0: VARIANCES ARE EQUAL, F' = 8.14 WITH 31 AND 24 DF PROR > F' = 0.0001

TTEST PROCEDURE

VARIABLE: PH

LOC	N	MEAN	STD DEV	STD ERROR	MINIMUM	MAXIMUM	VARIANCES	T	DF	PROB > ITI
6022	27	8.20925926	0.18607124	0.03580943	7.80000000	8.60000000	UNEQUAL	-0.7211	56.0	0.4739
6061	31	8.24677419	0.21013309	0.03774102	7.70000000	8.70000000	EQUAL	-0.7150	56.0	0.4776

FOR H0: VARIANCES ARE EQUAL, F* = 1.28 WITH 30 AND 26 DF PROR > F* = 0.5323

VARIABLE: B

LOC	N	MEAN	STD DEV	STD ERROR	MINIMUM	MAXIMUM	VARIANCES	T	DF	PROB > ITI
6022	22	89.54545455	26.09091663	5.56260212	70.00000000	200.00000000	UNEQUAL	-5.1315	32.8	0.0001*
6061	30	203.33333333	117.57120611	21.46546723	120.00000000	770.00000000	EQUAL	-4.4488	50.0	0.0001

FOR H0: VARIANCES ARE EQUAL, F* = 20.31 WITH 29 AND 21 DF PROR > F* = 0.0001

VARIABLE: F

LOC	N	MEAN	STD DEV	STD ERROR	MINIMUM	MAXIMUM	VARIANCES	T	DF	PROB > ITI
6022	27	0.27407407	0.07121253	0.01370486	0.20000000	0.50000000	UNEQUAL	-18.3906	55.4	0.0001*
6061	32	0.68750000	0.10080323	0.01781966	0.50000000	0.90000000	EQUAL	-17.8683	57.0	0.0001

FOR H0: VARIANCES ARE EQUAL, F* = 2.00 WITH 31 AND 26 DF PROR > F* = 0.0742

VARIABLE: AS

LOC	N	MEAN	STD DEV	STD ERROR	MINIMUM	MAXIMUM	VARIANCES	T	DF	PROB > ITI
6022	22	1.13636364	0.46756253	0.09958467	0	2.00000000	UNEQUAL	-5.5137	41.4	0.0001*
6061	31	2.45161290	1.20661260	0.21671402	0	6.00000000	EQUAL	-4.8497	51.0	0.0001

FOR H0: VARIANCES ARE EQUAL, F* = 6.66 WITH 30 AND 21 DF PROR > F* = 0.0001

TTEST PROCEDURE

VARIABLE: MOLY

LUC	N	MEAN	STD DEV	STD ERROR	MINIMUM	MAXIMUM	VARIANCES	T	DF	PROR > ITI
6022	15	4.80000000	5.80517011	2.59615100	1.00000000	15.00000000	UNEQUAL	-1.2489	8.3	0.2459
6061	13	8.76923077	6.61001571	1.83328851	2.00000000	20.00000000	EQUAL	-1.1752	16.0	0.2571

FOR H0: VARIANCEFS ARE EQUAL, F' = 1.30 WITH 12 AND 4 DF PROR > F' = 0.8714

VARIABLE: S04

LUC	N	MEAN	STD DEV	STD ERROR	MINIMUM	MAXIMUM	VARIANCES	T	DF	PROR > ITI
6022	28	363.21428571	19.25531604	3.63891269	320.00000000	400.00000000	UNEQUAL	6.3882	43.1	0.0001
6061	33	304.24242424	48.73591483	8.48383381	190.00000000	390.00000000	EQUAL	6.0110	58.0	0.0001

FOR H0: VARIANCEFS ARE EQUAL, F' = 6.41 WITH 32 AND 27 DF PROR > F' = 0.0001

VARIABLE: NA

LUC	N	MEAN	STD DEV	STD ERROR	MINIMUM	MAXIMUM	VARIANCES	T	DF	PROR > ITI
6022	28	119.42857143	19.44303850	3.67438890	24.00000000	130.00000000	UNEQUAL	-5.0188	58.7	0.0001
6061	33	147.81818182	24.70634350	4.30082236	91.00000000	190.00000000	EQUAL	-4.9214	59.0	0.0001

FOR H0: VARIANCEFS ARE EQUAL, F' = 1.61 WITH 32 AND 27 DF PROR > F' = 0.2074

VARIABLE: NH3

LUC	N	MEAN	STD DEV	STD ERROR	MINIMUM	MAXIMUM	VARIANCES	T	DF	PROR > ITI
6022	24	0.02708333	0.02710353	0.00553249	0	0.10000000	UNEQUAL	-2.1496	50.0	0.0365
6061	33	0.05030303	0.05329663	0.00927775	0	0.22000000	EQUAL	-1.9551	55.0	0.0557

FOR H0: VARIANCEFS ARE EQUAL, F' = 3.87 WITH 32 AND 23 DF PROR > F' = 0.0013

VARIABLE: SPECCOND

LUC	N	MEAN	STD DEV	STD ERROR	MINIMUM	MAXIMUM	VARIANCES	T	DF	PROR > ITI
6022	28	1313.21428571	44.89110870	8.48362212	1200.00000000	1380.00000000	UNEQUAL	0.2815	37.8	0.7799
6061	33	1305.00000000	160.39989090	27.92203702	875.00000000	1550.00000000	EQUAL	0.2621	59.0	0.7941

FOR H0: VARIANCEFS ARE EQUAL, F' = 12.77 WITH 32 AND 27 DF PROR > F' = 0.0001

TTEST PROCEDURE

VARIABLE: TDS

LUC	N	MEAN	STD DEV	STD ERROR	MINIMUM	MAXIMUM	VARIANCES	T	DF	PROR > ITI
6022	28	918.60714286	48.10290526	9.09042453	703.00000000	968.00000000	UNEQUAL	0.5940	43.3	0.5556
6061	32	905.68750000	111.78159509	19.76038097	584.00000000	1080.00000000	EQUAL	0.5669	58.0	0.5730

FOR H0: VARIANCES ARE EQUAL, F= 5.40 WITH 31 AND 27 DF PROB > F= 0.0001

TTEST PROCEDURE

VARIABLE: PH

LOC	N	MEAN	STD. DEV	STD. ERROR	MINIMUM	MAXIMUM	VARIANCES	T	DF	PROB > T
6007	20	8.26964286	0.16851161	0.03184570	7.90000000	8.70000000	UNEQUAL	0.4631	56.2	0.6451
6061	31	8.24677419	0.21013309	0.03774102	7.70000000	8.70000000	EQUAL	0.4579	57.0	0.6487

FOR H0: VARIANCES ARE EQUAL, F' = 1.55 WITH 30 AND 27 DF PROR > F' = 0.2498

VARIABLE: B

LOC	N	MEAN	STD. DEV	STD. ERROR	MINIMUM	MAXIMUM	VARIANCES	T	DF	PROB > T
6007	23	199.56521739	35.86315669	7.47788510	130.00000000	250.00000000	UNEQUAL	-0.1658	35.8	0.8693
6061	30	203.33333333	117.57120611	21.46546723	120.00000000	770.00000000	EQUAL	-0.1482	51.0	0.8828

FOR H0: VARIANCES ARE EQUAL, F' = 10.75 WITH 29 AND 22 DF PROR > F' = 0.0001

VARIABLE: F

LOC	N	MEAN	STD. DEV	STD. ERROR	MINIMUM	MAXIMUM	VARIANCES	T	DF	PROB > T
6007	28	1.02142857	0.20249763	0.03826846	0.60000000	1.30000000	UNEQUAL	7.9104	38.4	0.0001 *
6061	32	0.68750000	0.10680323	0.01781966	0.50000000	0.90000000	EQUAL	8.2409	58.0	0.0001

FOR H0: VARIANCES ARE EQUAL, F' = 4.04 WITH 27 AND 31 DF PROR > F' = 0.0003

VARIABLE: AS

LOC	N	MEAN	STD. DEV	STD. ERROR	MINIMUM	MAXIMUM	VARIANCES	T	DF	PROB > T
6007	24	2.62500000	0.76966961	0.15710815	1.00000000	4.00000000	UNEQUAL	0.6478	51.3	0.5200
6061	31	2.45161290	1.20661260	0.21671402	0.00000000	6.00000000	EQUAL	0.6133	53.0	0.5423

FOR H0: VARIANCES ARE EQUAL, F' = 2.46 WITH 30 AND 23 DF PROR > F' = 0.0294

TTEST PROCEDURE

VARIABLE: M0LY

LOC	N	MEAN	STD. DEV	STD ERROR	MINIMUM	MAXIMUM	VARIANCES	T	DF	PROB > ITI
6007	9	7.222222222	5.01940678	1.67313559	4.00000000	20.00000000	UNEQUAL	-0.6233	19.8	0.5402
6061	13	8.76923077	6.61001571	1.83328851	2.00000000	20.00000000	EQUAL	-0.5922	20.0	0.5604

FOR H0: VARIANCES ARE EQUAL, F' = 1.73 WITH 12 AND 8 DF PROB > F' = 0.4421

VARIABLE: S04

LOC	N	MEAN	STD DEV	STD ERROR	MINIMUM	MAXIMUM	VARIANCES	T	DF	PROB > ITI
6007	28	166.07142857	19.50105139	3.68535231	140.00000000	210.00000000	UNEQUAL	-14.9379	43.4	0.0001
6061	33	304.24242424	48.73591483	8.48363361	190.00000000	390.00000000	EQUAL	-14.0629	59.0	0.0001

FOR H0: VARIANCES ARE EQUAL, F' = 6.25 WITH 32 AND 27 DF PROB > F' = 0.0001

VARIABLE: NA

LOC	N	MEAN	STD DEV	STD ERROR	MINIMUM	MAXIMUM	VARIANCES	T	DF	PROB > ITI
6007	28	121.78571429	23.52989768	4.44673269	47.00000000	160.00000000	UNEQUAL	-4.2081	58.2	0.0001
6061	33	147.81818182	24.70634350	4.30082236	91.00000000	190.00000000	EQUAL	-4.1910	59.0	0.0001

FOR H0: VARIANCES ARE EQUAL, F' = 1.10 WITH 32 AND 27 DF PROB > F' = 0.8019

VARIABLE: NH3

LOC	N	MEAN	STD DEV	STD ERROR	MINIMUM	MAXIMUM	VARIANCES	T	DF	PROB > ITI
6007	26	0.04461538	0.04393001	0.00861538	0	0.17000000	UNEQUAL	-0.4492	56.9	0.6550
6061	33	0.05030303	0.05329663	0.00927775	0	0.22000000	EQUAL	-0.4390	57.0	0.6623

FOR H0: VARIANCES ARE EQUAL, F' = 1.47 WITH 32 AND 25 DF PROB > F' = 0.3229

VARIABLE: SPECCOND

LOC	N	MEAN	STD DEV	STD ERROR	MINIMUM	MAXIMUM	VARIANCES	T	DF	PROB > ITI
6007	28	1047.32142857	102.11179551	19.29731549	825.00000000	1250.00000000	UNEQUAL	-7.5918	55.0	0.0001
6061	33	1305.00000000	160.39989090	27.92203702	875.00000000	1550.00000000	EQUAL	-7.3247	59.0	0.0001

FOR H0: VARIANCES ARE EQUAL, F' = 2.47 WITH 32 AND 27 DF PROB > F' = 0.0190

TTEST PROCEDURE

VARIABLE: TDS

LOC	N	MEAN	STD DEV	STD ERROR	MINIMUM	MAXIMUM	VARIANCES	T	DF	PROR > ITI
6007	28	680.60714286	19960032	14.02240642	528.00000000	827.00000000	UNEQUAL	-9.2893	54.3	0.0001
6061	32	905.68750000	111.78159509	19.76038097	584.00000000	1080.00000000	EQUAL	-9.0479	58.0	0.0001

FOR H0: VARIANCES ARE EQUAL. F' = 2.27 WITH 31 AND 27 DF PROR > F' = 0.0335

S T A T I S T I C A L A N A L Y S I S S Y S T E M

TTEST PROCEDURE

VARIABLE: PH

LOC	N	MEAN	STD DEV	STD ERROR	MINIMUM	MAXIMUM	VARIANCES	T	DF	PROR > ITI
6007	28	8.26964286	0.16851161	0.03184570	7.90000000	8.70000000	UNEQUAL	-1.7012	51.8	0.0949 *
6058	27	8.35185185	0.18886375	0.03634685	8.00000000	8.90000000	EQUAL	-1.7048	53.0	0.0941

FOR H0: VARIANCES ARE EQUAL, F' = 1.26 WITH 26 AND 27 DF PROB > F' = 0.5595

VARIABLE: B

LOC	N	MEAN	STD DEV	STD ERROR	MINIMUM	MAXIMUM	VARIANCES	T	DF	PROR > ITI
6007	23	199.56521739	35.86315669	7.47798510	130.00000000	250.00000000	UNEQUAL	2.0170	25.8	0.0542 *
6058	24	136.66666667	148.31419841	30.27450898	80.00000000	830.00000000	EQUAL	1.9784	45.0	0.0540

FOR H0: VARIANCES ARE EQUAL, F' = 17.10 WITH 23 AND 22 DF PROB > F' = 0.0001

VARIABLE: F

LOC	N	MEAN	STD DEV	STD ERROR	MINIMUM	MAXIMUM	VARIANCES	T	DF	PROR > ITI
6007	28	1.02142857	0.20249763	0.03826846	0.60000000	1.30000000	UNEQUAL	14.6923	34.0	0.0001 *
6058	26	0.42307692	0.07103629	0.01393136	0.30000000	0.60000000	EQUAL	14.2657	52.0	0.0001

FOR H0: VARIANCES ARE EQUAL, F' = 8.13 WITH 27 AND 25 DF PROB > F' = 0.0001

VARIABLE: AS

LOC	N	MEAN	STD DEV	STD ERROR	MINIMUM	MAXIMUM	VARIANCES	T	DF	PROR > ITI
6007	24	2.62500000	0.76966961	0.15710815	1.00000000	4.00000000	UNEQUAL	1.8808	28.7	0.0702 *
6058	25	1.64000000	2.49799920	0.49959984	0.00000000	13.00000000	EQUAL	1.8487	47.0	0.0708

FOR H0: VARIANCES ARE EQUAL, F' = 10.53 WITH 24 AND 23 DF PROB > F' = 0.0001

VARIABLE: MOLY

LOC	N	MEAN	STD. DEV	STD ERROR	MINIMUM	MAXIMUM	VARIANCES	T	DF	PROB > ITI
6007	9	7.22222222	5.01940678	1.67313559	4.00000000	20.00000000	UNEQUAL	0.1630	15.1	0.8727
6058	9	6.77777778	6.45712354	2.15237451	2.00000000	20.00000000	EQUAL	0.1630	14.0	0.8725

FOR H0: VARIANCES ARE EQUAL, F' = 1.65 WITH 8 AND 8 DF PROR > F' = 0.4920

VARIABLE: SO4

LOC	N	MEAN	STD DEV	STD ERROR	MINIMUM	MAXIMUM	VARIANCES	T	DF	PROB > ITI
6007	28	166.07142857	19.50105139	3.68535231	140.00000000	210.00000000	UNEQUAL	-28.8544	50.5	0.0001
6058	27	334.81481481	23.59438825	4.54074214	290.00000000	390.00000000	EQUAL	-28.9553	53.0	0.0001

FOR H0: VARIANCES ARE EQUAL, F' = 1.46 WITH 26 AND 27 DF PROR > F' = 0.3309

VARIABLE: NA

LOC	N	MEAN	STD DEV	STD ERROR	MINIMUM	MAXIMUM	VARIANCES	T	DF	PROB > ITI
6007	28	121.78571429	23.52989768	4.44673269	47.00000000	160.00000000	UNEQUAL	1.0831	33.9	0.2864
6058	27	116.66666667	8.32050294	1.60128154	110.00000000	130.00000000	EQUAL	1.0676	53.0	0.2905

FOR H0: VARIANCES ARE EQUAL, F' = 8.00 WITH 27 AND 26 DF PROR > F' = 0.0001

VARIABLE: NH3

LOC	N	MEAN	STD DEV	STD ERROR	MINIMUM	MAXIMUM	VARIANCES	T	DF	PROB > ITI
6007	26	0.04461538	0.04393001	0.00861538	0	0.17000000	UNEQUAL	1.2556	43.3	0.2160
6058	25	0.03160000	0.02882129	0.00576426	0	0.09000000	EQUAL	1.2456	49.0	0.2188

FOR H0: VARIANCES ARE EQUAL, F' = 2.32 WITH 25 AND 24 DF PROR > F' = 0.0426

VARIABLE: SPECCOND

LOC	N	MEAN	STD DEV	STD ERROR	MINIMUM	MAXIMUM	VARIANCES	T	DF	PROB > ITI
6007	28	1047.32142857	102.11179551	19.29731549	825.00000000	1250.00000000	UNEQUAL	-8.3437	50.5	0.0001
6058	27	1251.66666667	78.36060627	15.08050571	1050.00000000	1400.00000000	EQUAL	-8.3038	53.0	0.0001

FOR H0: VARIANCES ARE EQUAL, F' = 1.70 WITH 27 AND 26 DF PROR > F' = 0.1811

VARIABLE: FH

LOC	N	MEAN	STD DEV	STD ERROR	MINIMUM	MAXIMUM	VARIANCES	T	DF	PROB > T
6007	28	8.26964286	0.16851161	0.03184570	7.90000000	8.70000000	UNEQUAL	1.2601	52.0	0.2133
6022	27	8.20925926	0.18607124	0.03580943	7.80000000	8.60000000	EQUAL	1.2624	53.0	0.2123

FOR H0: VARIANCES ARE EQUAL, F' = 1.22 WITH 26 AND 27 DF PROB > F' = 0.6116

VARIABLE: B

LOC	N	MEAN	STD DEV	STD ERROR	MINIMUM	MAXIMUM	VARIANCES	T	DF	PROB > T
6007	23	199.56521739	35.86315669	7.47798510	130.00000000	250.00000000	UNEQUAL	11.8047	40.2	0.0001*
6022	22	89.54545455	26.09091663	5.56260212	70.00000000	200.00000000	EQUAL	11.7223	43.0	0.0001

FOR H0: VARIANCES ARE EQUAL, F' = 1.89 WITH 22 AND 21 DF PROB > F' = 0.1502

VARIABLE: F

LOC	N	MEAN	STD DEV	STD ERROR	MINIMUM	MAXIMUM	VARIANCES	T	DF	PROB > T
6007	28	1.02142857	0.20249763	0.03826846	0.60000000	1.30000000	UNEQUAL	18.3858	33.8	0.0001*
6022	27	0.27407407	0.07121253	0.01370486	0.20000000	0.50000000	EQUAL	18.1221	53.0	0.0001

FOR H0: VARIANCES ARE EQUAL, F' = 8.09 WITH 27 AND 26 DF PROB > F' = 0.0001

VARIABLE: AS

LOC	N	MEAN	STD DEV	STD ERROR	MINIMUM	MAXIMUM	VARIANCES	T	DF	PROB > T
6007	24	2.62500000	0.76966961	0.15710815	1.00000000	4.00000000	UNEQUAL	8.0006	38.4	0.0001*
6022	22	1.13636364	0.46756253	0.09968467	0.00000000	2.00000000	EQUAL	7.8384	44.0	0.0001

FOR H0: VARIANCES ARE EQUAL, F' = 2.71 WITH 23 AND 21 DF PROB > F' = 0.0250

TTEST PROCEDURE

VARIABLE: TDS

LOC	N	MEAN	STD DEV	STD ERROR	MINIMUM	MAXIMUM	VARIANCES	T	DF	PROR > ITI
6007	28	680.60714286	74.19960032	14.02240642	528.00000000	827.00000000	UNEQUAL	-12.6540	41.9	0.0001
6058	25	883.88000000	39.18579675	7.83715935	792.00000000	945.00000000	EQUAL	-12.2490	51.0	0.0001

FOR H0: VARIANCES ARE EQUAL. F= 3.59 WITH 27 AND 24 DF PROB > F= 0.0023

TTEST PROCEDURE

VARIABLE: MOLY

LOC	N	MEAN	STD DEV	STD ERROR	MINIMUM	MAXIMUM	VARIANCES	T	DF	PROR > ITI
6007	9	7.22222222	5.01940678	1.67313559	4.00000000	20.00000000	UNEQUAL	0.7842	7.4	0.4574
6022	5	4.80000000	5.80517011	2.59615100	1.00000000	15.00000000	EQUAL	0.8203	17.0	0.4281

FOR H0: VARIANCES ARE EQUAL, F' = 1.34 WITH 4 AND 8 DF PROR > F' = 0.6713

VARIABLE: SO4

LOC	N	MEAN	STD DEV	STD ERROR	MINIMUM	MAXIMUM	VARIANCES	T	DF	PROR > ITI
6007	28	166.07142857	19.50105139	3.68535231	140.00000000	210.00000000	UNEQUAL	-38.0648	54.0	0.0001
6022	28	363.21428571	19.25531604	3.63891269	320.00000000	400.00000000	EQUAL	-38.0648	54.0	0.0001

FOR H0: VARIANCES ARE EQUAL, F' = 1.03 WITH 27 AND 27 DF PROR > F' = 0.9479

VARIABLE: NA

LOC	N	MEAN	STD DEV	STD ERROR	MINIMUM	MAXIMUM	VARIANCES	T	DF	PROR > ITI
6007	28	121.78571429	23.52989768	4.44673269	47.00000000	160.00000000	UNEQUAL	0.4086	52.1	0.6845
6022	28	119.42857143	19.443303850	3.67438890	24.00000000	130.00000000	EQUAL	0.4086	54.0	0.6844

FOR H0: VARIANCES ARE EQUAL, F' = 1.46 WITH 27 AND 27 DF PROR > F' = 0.3274

VARIABLE: NH3

LOC	N	MEAN	STD DEV	STD ERROR	MINIMUM	MAXIMUM	VARIANCES	T	DF	PROR > ITI
6007	26	0.04461538	0.04393001	0.00861538	0	0.17000000	UNEQUAL	1.7123	42.1	0.0942
6022	24	0.02708333	0.02710353	0.00553249	0	0.10000000	EQUAL	1.6812	48.0	0.0992

FOR H0: VARIANCES ARE EQUAL, F' = 2.63 WITH 25 AND 23 DF PROR > F' = 0.0228

VARIABLE: SPECCOND

LOC	N	MEAN	STD DEV	STD ERROR	MINIMUM	MAXIMUM	VARIANCES	T	DF	PROR > ITI
6007	28	1047.32142857	102.11179551	19.28731549	825.00000000	1250.00000000	UNEQUAL	-12.6136	37.1	0.0001
6022	28	1313.21428571	44.89110870	8.48362212	1200.00000000	1380.00000000	EQUAL	-12.6136	54.0	0.0001

FOR H0: VARIANCES ARE EQUAL, F' = 5.17 WITH 27 AND 27 DF PROR > F' = 0.0001

VARIABLE: TDS

LUC	N	MEAN	STD DEV	STD ERROR	MINIMUM	MAXIMUM	VARIANCES	T	DF	PROR > ITI
6007	28	680.60714286	74.19960032	14.02240642	528.00000000	827.00000000	UNEQUAL	-14.2420	46.3	0.0001
6022	28	918.60714286	48.10200526	9.09042453	703.00000000	968.00000000	EQUAL	-14.2420	54.0	0.0001

FOR H0: VARIANCES ARE EQUAL, F = 2.38 WITH 27 AND 27 DF PROB > F = 0.0279

TTEST PROCEDURE

VARIABLE: PH

LOC	N	MEAN	STD DEV	STD ERROR	MINIMUM	MAXIMUM	VARIANCES	T	DF	PROB > T
6022	27	8.20925926	0.18607124	0.03580943	7.80000000	8.60000000	UNEQUAL	-2.7946	52.0	0.0073*
6058	27	8.35185185	0.18886375	0.03634685	8.00000000	8.90000000	EQUAL	-2.7946	52.0	0.0073*

FOR H0: VARIANCES ARE EQUAL, F' = 1.03 WITH 26 AND 26 DF PROB > F' = 0.9400

VARIABLE: B

LOC	N	MEAN	STD DEV	STD ERROR	MINIMUM	MAXIMUM	VARIANCES	T	DF	PROB > T
6022	22	89.54545455	26.09091663	5.56260212	70.00000000	200.00000000	UNEQUAL	-1.5308	24.5	0.1386
6058	24	136.66666667	148.31419841	30.27450898	80.00000000	830.00000000	EQUAL	-1.4682	44.0	0.1492

FOR H0: VARIANCES ARE EQUAL, F' = 32.31 WITH 23 AND 21 DF PROB > F' = 0.0001

VARIABLE: F

LOC	N	MEAN	STD DEV	STD ERROR	MINIMUM	MAXIMUM	VARIANCES	T	DF	PROB > T
6022	27	0.27407407	0.07121253	0.01370486	0.20000000	0.50000000	UNEQUAL	-7.6242	50.9	0.0001*
6058	26	0.42307692	0.07103629	0.01393136	0.30000000	0.60000000	EQUAL	-7.6242	51.0	0.0001

FOR H0: VARIANCES ARE EQUAL, F' = 1.00 WITH 26 AND 25 DF PROB > F' = 0.9922

VARIABLE: AS

LOC	N	MEAN	STD DEV	STD ERROR	MINIMUM	MAXIMUM	VARIANCES	T	DF	PROB > T
6022	22	1.13636364	0.46756253	0.09968467	0	2.00000000	UNEQUAL	-0.9886	25.9	0.3320
6058	25	1.64000000	2.49799920	0.49959984	0	13.00000000	EQUAL	-0.9303	45.0	0.3572

FOR H0: VARIANCES ARE EQUAL, F' = 28.54 WITH 24 AND 21 DF PROB > F' = 0.0001

TTEST PROCEDURE

VARIABLE: MOLY

LOC	N	MEAN	STD DEV	STD ERROR	MINIMUM	MAXIMUM	VARIANCES	T	DF	PROB > ITI
6022	5	4.80000000	5.80517011	2.59615100	1.00000000	15.00000000	UNEQUAL	-0.5805	9.2	0.5717
6058	9	6.77777778	6.45712354	2.15237451	2.00000000	20.00000000	EQUAL	-0.5676	17.0	0.5808

FOR H0: VARIANCES ARE EQUAL, F = 1.24 WITH 8 AND 4 DF PROB > F = 0.8931

VARIABLE: SO4

LOC	N	MEAN	STD DEV	STD ERROR	MINIMUM	MAXIMUM	VARIANCES	T	DF	PROB > ITI
6022	29	363.21428571	19.25531604	3.63891269	320.00000000	400.00000000	UNEQUAL	4.8805	50.2	0.0001
6058	27	334.81481481	23.59438825	4.54074214	290.00000000	390.00000000	EQUAL	4.8987	53.0	0.0001

FOR H0: VARIANCES ARE EQUAL, F = 1.50 WITH 26 AND 27 DF PROB > F = 0.3000

VARIABLE: NA

LOC	N	MEAN	STD DEV	STD ERROR	MINIMUM	MAXIMUM	VARIANCES	T	DF	PROB > ITI
6022	29	112.42857143	19.443303850	3.67438890	24.00000000	130.00000000	UNEQUAL	0.6891	36.8	0.4951
6058	27	116.66666667	18.32050294	3.60128154	110.00000000	130.00000000	EQUAL	0.6803	53.0	0.4993

FOR H0: VARIANCES ARE EQUAL, F = 5.46 WITH 27 AND 26 DF PROB > F = 0.0001

VARIABLE: NH3

LOC	N	MEAN	STD DEV	STD ERROR	MINIMUM	MAXIMUM	VARIANCES	T	DF	PROB > ITI
6022	24	0.02708333	0.02710353	0.00553249	0	0.10000000	UNEQUAL	-0.5653	47.0	0.5746
6058	25	0.03160000	0.02882129	0.00576426	0	0.09000000	EQUAL	-0.5646	47.0	0.5750

FOR H0: VARIANCES ARE EQUAL, F = 1.13 WITH 24 AND 23 DF PROB > F = 0.7707

VARIABLE: SPECCOND

LOC	N	MEAN	STD DEV	STD ERROR	MINIMUM	MAXIMUM	VARIANCES	T	DF	PROB > ITI
6022	28	1313.21428571	44.89110870	8.48362212	1200.00000000	1380.00000000	UNEQUAL	3.5571	41.1	0.0019
6058	27	1251.66666667	78.36060627	15.08050571	1050.00000000	1400.00000000	EQUAL	3.5905	53.0	0.0007

FOR H0: VARIANCES ARE EQUAL, F = 3.05 WITH 26 AND 27 DF PROB > F = 0.0054

STATISTICAL ANALYSIS SYSTEM

TTEST PROCEDURE

VARIABLE: TDS

LOC	N	MEAN	STD DEV	STD ERROR	MINIMUM	MAXIMUM	VARIANCES	T	DF	PROB > T
6022	28	918.60714286	48.10200526	9.09042453	703.00000000	968.00000000	UNEQUAL	2.8934	50.6	0.0056
6058	25	883.88000000	39.18579675	7.83715935	792.00000000	945.00000000	EQUAL	2.8598	51.0	0.0061

FOR H0: VARIANCES ARE EQUAL, F= 1.51 WITH 27 AND 24 DF PROB > F= 0.3135

APPENDIX A5.2.1D

Time Series Analysis UCS FORTELL Box-Jenkins Package

APPENDIX A5.2.1D

Univariate Time Series Analysis

a.) Background

Time series analysis based on the Box Jenkins Technique [Box and Jenkins (1976) and Nelson (1973)] is used to capture all the statistically significant information contained in a series for the purpose of forecasting future trends and values for the series. Techniques are developed and programmed in computer models for both single (univariate) and multiple time series (transfer function). The analyses in this report present only the univariate time series case.

The "Box-Jenkins Philosophy" is captured in their iterative model building process. A model is built up from the data and tested for "fit" in four stages. The model determination stage is called identification. It is followed by parameter estimation. The next step is diagnostic checking (residual analysis) to determine if the model provides an adequate description of the data and that the residuals have been reduced to "white noise." If the checking stage shows that the model is deficient in some way, one returns to the identification stage and repeats the process. When one is satisfied with a model resulting from this iterative process of model building, he may wish to continue to the forecasting of future observations.

The identification stage in time series analysis provides the user with a quantitative measure of the amount of statistical information contained within the data series. This is accomplished through the use of the autocorrelation and partial autocorrelation functions. These functions, as well as some other statistically relevant information, allow the user to choose the initial form of the time series model.

A time series must exhibit stationarity (i.e., the series can be represented by a constant mean) before any modeling can be attempted. A stationary time series can be obtained from the original time series by differencing. Once a stationary series has been obtained, the pattern of the lagged autocorrelations and partial autocorrelations of the stationary series will appear as either a decaying exponential or a series of isolated spikes. This model estimation process can be summarized in terms of the ACF (autocorrelation function) pattern.

<u>ACF</u>	<u>Specify</u>
a. decaying exponential	Autoregressive (AR) model
b. isolated spikes	Moving Average (MA) model
c. lumpy exponential	AR model first, then check <u>residual</u> ACF for MA terms (mixed model)

If the ACF pattern indicates an AR model, "significant" spikes from the plotted Partial Autocorrelation Function (PACF) will define the model. If the ACF pattern indicates an MA model, significant spikes from the ACF will define the model.

The most general form of the Box-Jenkins model has the "autoregressive-integrated moving average" form (ARIMA)

$$(1-\phi_1B-\phi_2B^2-\dots-\phi_pB^p)(1-B)^d z_t = (1-\theta_1B-\theta_2B^2-\theta_3B^3-\dots-\theta_qB^q)a_t$$

where $z_t = z_t$ if $d, \text{ the number of differencing terms, } >0$, and $z_t = z_{t-\mu}$ if $d = 0$, with μ representing the series mean. z_t is the value of series z at time t . The $\phi_m, m = 1,2,3,\dots,p$ are autoregressive parameters and appear in the autoregressive factor in the model, while the $\theta_m, m = 1,2,3,\dots,q$ are moving average parameters and appear in the moving average factor in the model. This model is generally shortened to the form ARIMA (p,d,q), where p and q refer to the order of the autoregressive and moving average processes, respectively, and the d refers to the order of differencing necessary to achieve stationarity. Order refers to the highest time lag for backshift operator B used with p and q and to the highest time lag for differencing with d .

If an optimal model has been specified, the residuals in the estimated model should have been reduced to "white noise" as recognized by two tests:

1. The mean of the residuals should be within reasonable confidence limits of zero. Failure of this test indicates the need for the inclusion of a trend term in the model.
2. There should be no significant terms in the ACF of the lagged residuals. Failure of this test indicates that an insufficient number of parameters have been specified.

b.) Computer Programs

Two different time series computer programs have been used by the C-b Shale Oil Project in its environmental analysis. The United Computing Systems, Inc. FORTELL model was developed by Standard Oil of Ohio; the 00727 models were developed by Ohio State University personnel and are stored on the Occidental Computer System. Both methods are based on the Box-Jenkins technique of time series analysis with user enhancements and provide identical models and modeling results. The following explanation of forecasting is based on the FORTELL model.

FORTELL provides three kinds of forecasting: Variable Lead Time, Fixed Lead Time, and Backward. For each of these types of forecasts, three pieces of information are required:

1. Backward Origin - The backward origin refers to the number of points backward from the last point in the series to be used

as the forecast origin. A backward origin of 0 specifies that the forecast begins with the last point in the series.

2. **Lead Time** - The lead time of the forecast specifies the number of forecasted points to be calculated out from the origin.
3. **Confidence Limits** - The confidence limit on the forecast determines a range bounding the forecasted values. This bound indicates to the user that the probability of the actual value, when it occurs, of falling within this bound is equal to the percentage confidence limit chosen.

Variable Lead Time Forecast - a recursive calculation of the projected forecast values from the forecast origin to the end of the forecast. The forecast origin is the last point in the series, minus the background origin chosen, plus one. The end of the forecast is the forecast origin, plus the lead time, minus one.

Fixed Lead Time Forecast - primarily of use as a validation tool which can be used to check for bias in the simulation properties of the model. For this purpose, the lead time should be 1. A lead time greater than 1 results in a series of variable lead time forecasts separated by the lead time chosen, along the length of the portion of the series chosen. The point forecasts are uncorrelated and may be used to check for bias in the model. If the model is unbiased, then the cumulative sum should not steadily increase in either a positive or negative direction.

Backward Forecast - a variable lead time forecast which projects forecast points into the past rather than the future.

A summary page of each of the time series analyses completed for Air Quality and Particulates data from Tract C-b is presented in Tables A6.2.1-4 through A6.2.1-8. These summaries contain basic statistical data for each series as well as a description of the forecasting model used and a summary of forecasting results.

UNIVARIATE TIME SERIES ANALYSIS

USGS STATION WU07

Parameter:	PH
Series Mean:	8.26364
Series Variance:	.022833
Trend:	0.0 at 95% confidence level
Series Minimum:	7.90000
Series Maximum:	8.70000
Chi-Sq. for Data:	19.6666 with 42 d.f.
<u>Chi-Sq. at 95% level:</u>	<u>58.09 with 42 d.f.</u>
Model:	$(Z_t - 8.26364) = (1 + .25176B^2 - .32184B^3 + .56853B^4)(1 - .10349B^{12})a_t$
Coef. of Det:	.225888
Residual Mean:	-.00117546
Residual Variance:	.0173289
Residual Minimum:	-.328833
Residual Maximum:	.374516
Residual Chi-Sq.:	11.2529 with 39 d.f.
<u>Chi-Sq. at 95% level:</u>	<u>54.56 with 39 d.f.</u>

Discussion:

The PH model is of the moving average form of order four with a one year seasonal component. The seasonal component in this model was forced in order to achieve a more realistic forecast. This model is stationary and no trend is indicated. The original chi-square value of the data alone is relatively low compared to the 95% confidence level, so there is little evidence to believe that for any long term forecasting that there is a better predictor than the series mean.

UNIVARIATE TIME SERIES ANALYSIS

USGS STATION WU07

Parameter:	Boron (mg/l)
Series Mean:	205.250
Series Variance:	994.129
Trend:	0.0 at 95% confidence level
Series Minimum:	130.000
Series Maximum:	265.000
Chi-Sq. for Data:	47.1872 with 42 d.f.
<u>Chi-Sq. at 95% level:</u>	<u>58.09 with 42 d.f.</u>
Model:	$(1-.60792B)(1-.19592B^{12})(Z_t-205.250)=a_t$
Coef. of Det:	.365103
Residual Mean:	1.95220
Residual Variance:	595.544
Residual Minimum:	-83.6508
Residual Maximum:	36.1297
Residual Chi-Sq.:	9.58047 with 28 d.f.
<u>Chi-Sq. at 95% level:</u>	<u>41.32 with 28 d.f.</u>

Discussion:

The Boron series is an autoregressive model of order one, the seasonal component is at increments of one year and although in this series the seasonality had to be forced it is never the less considered to be a valid model parameter. There is little doubt that when more data is collected this seasonality will become more pronounced.

The present model is stationary and contains no indication of a deterministic trend, thus for long term forecasting the mean of the series is the best predictor.

UNIVARIATE TIME SERIES ANALYSIS

USGS STATION WU07

Parameter:	Fluoride (mg/l)
Series Mean:	1.02614
Series Variance:	.0390103
Trend:	0.0 at 95% confidence level
Series Minimum:	.500000
Series Maximum:	1.30000
Chi-Sq. for Data:	52.1032 with 42 d.f.
<u>Chi-Sq. at 95% level:</u>	<u>58.09 with 42 d.f.</u>
Model:	$(Z_t - 1.02614) = (1 + .60940B^1 + .62767B^2 + .27527B^3)(1 + .50633B^{11})a_t$
Coef. of Det:	.453538
Residual Mean:	-.00580097
Residual Variance:	.0194271
Residual Minimum:	-.468227
Residual Maximum:	.227841
Residual Chi-Sq.:	13.5053 with 39 d.f.
<u>Chi-Sq. at 95% level:</u>	<u>54.56 with 39 d.f.</u>

Discussion:

The Fluoride series yields a model of the moving average form of order three and with a seasonal component of eleven. This model when expanded will contain a parameter at month twelve, so the season may be considered to be of one year as would be expected.

The present model is stationary and contains no deterministic trend parameter. Due to the stationarity of the series the best predictor for long term forecasting will be the series mean.

UNIVARIATE TIME SERIES ANALYSIS

USGS STATION WU07

Parameter:	AS (mg/l)
Series Mean:	2.40909
Series Variance:	.433403
Trend:	0.0 at 95% confidence level
Series Minimum:	1.00000
Series Maximum:	4.00000
Chi-Sq. for Data:	43.4855 with 42 d.f.
<u>Chi-Sq. at 95% level:</u>	<u>58.09 with 42 d.f.</u>
Model:	$(Z_t - 2.40909) = (1 + .51295B^1 - .27269B^6)(1 - .51076B^{12})a_t$
Coef. of Det:	370791
Residual Mean:	-.00749787
Residual Variance:	.257510
Residual Minimum:	-.988554
Residual Maximum:	1.09799
Residual Chi-Sq.:	13.3345 with 40 d.f.
<u>Chi-Sq. at 95% level:</u>	<u>55.76 with 40 d.f.</u>

Discussion:

The AS series produces a moving average model with two basic parameters at lags one and six, in addition, there is a seasonal parameter at lag twelve. This gives a season of one year as desired. The model is stationary and has no trend present.

UNIVARIATE TIME SERIES ANALYSIS

USGS STATION WU22

Parameter:	PH
Series Mean:	8.23295
Series Variance:	.0518539
Trend:	0.0 at 95% confidence level
Series Minimum:	7.1
Series Maximum:	8.6
Chi-Sq. for Data:	11.2228 with 42 d.f.
<u>Chi-Sq. at 95% level:</u>	<u>58.09 with 42 d.f.</u>
Model:	$(Z_t - 8.23295) = (1 + .28261B^1)a_t$
Coef. of Det:	.0498784
Residual Mean:	.000546660
Residual Variance:	.0481467
Residual Minimum:	-1.06294
Residual Maximum:	.367443
Residual Chi-Sq.:	9.00518 with 42 d.f.
<u>Chi-Sq. at 95% level:</u>	<u>58.09 with 42 d.f.</u>

Discussion:

The model is of the moving average order one form, no seasonal parameter could be forced into this model. Due to the low spike in the autocorrelation function for the one parameter and the low initial chi-square statistic, this series will be best characterized by its mean, i.e. the series appears as a random series about its mean.

The model is stationary and contains no trend parameter.

UNIVARIATE TIME SERIES ANALYSIS

USGS STATION WU22

Parameter:	Boron (mg/l)
Series Mean:	106.205
Series Variance:	3511.93
Trend:	0.0 at 95% confidence level
Series Minimum:	70.00
Series Maximum:	325.00
Chi-Sq. for Data:	25.8120 with 42 d.f.
<u>Chi-Sq. at 95% level:</u>	<u>58.09 with 42 d.f.</u>
Model:	$(1-.54672B^1)(1+.15794B^{12})(Z_t-106.205)=a_t$
Coef. of Det:	.310868
Residual Mean:	737312
Residual Variance:	1982.18
Residual Minimum:	-69.8989
Residual Maximum:	197.582
Residual Chi-Sq.:	6.14870 with 29 d.f.
<u>Chi-Sq. at 95% level:</u>	<u>42.55 with 29 d.f.</u>

Discussion:

The series model is an autoregressive form with parameters at one and twelve. The latter parameter is a forced seasonal parameter included to improve the forecast.

The model is stationary and trendless, and would be best represented in the long run using the mean.

UNIVARIATE TIME SERIES ANALYSIS

USGS STATION WU22

Parameter:	FLuoride (mg/l)
Series Mean:	.315909
Series Variance:	.0783747
Trend:	0.0 at 95% confidence level
Series Minimum:	.20
Series Maximum:	2.0
Chi-Sq. for Data:	5.19742 with 42 d.f.
<u>Chi-Sq. at 95% level:</u>	<u>58.09 with 42 d.f.</u>
Model:	$(Z_t - .315909) = (1 + .26045B^1)a_t$
Coef. of Det:	.0394505
Residual Mean:	.0000311821
Residual Variance:	.0738445
Residual Minimum:	-.125703
Residual Maximum:	1.71428
Residual Chi-Sq.:	2.10518 with 41 d.f.
<u>Chi-Sq. at 95% level:</u>	<u>56.93 with 41 d.f.</u>

Discussion:

The developed model is a moving average of order one. The parameter of lag one was not indicated by the identification module but was forced to produce a forecastable model. A seasonal parameter could not be forced. The series is best represented as random noise about its mean value. This is indicated by the lack of information in the autocorrelation function as well as the small chi-squared statistic for the original data series.

No deterministic trend exists in the series.

UNIVARIATE TIME SERIES ANALYSIS

USGS STATION WU22

Parameter:	AS (mg/l)
Series Mean:	1.05682
Series Variance:	.283269
Trend:	0.0 at 95% confidence level
Series Minimum:	0.0000
Series Maximum:	2.0000
Chi-Sq. for Data:	49.0349 with 42 d.f.
<u>Chi-Sq. at 95% level:</u>	<u>58.09 with 42 d.f.</u>
Model:	$(1 - .53992B^1)(Z_t - 1.05682) = (1 + .19146B^{11})a_t$
Coef. of Det:	.275071
Residual Mean:	.00457330
Residual Variance:	.200152
Residual Minimum:	-1.02614
Residual Maximum:	9.76543
Residual Chi-Sq.:	9.76543 with 21 d.f.
<u>Chi-Sq. at 95% level:</u>	<u>32.66 with 21 d.f.</u>

Discussion:

The AS series yields a mixed model with an autoregressive parameter at one and a moving average parameter at eleven. The seasonal type parameter at lag eleven was forced, i.e. it was not directly indicated by the model identification model.

The series is found to be both stationary and trendless, thus for long term consideration the series mean is the best estimator.

UNIVARIATE TIME SERIES ANALYSIS

USGS STATION WU58

Parameter:	PH
Series Mean:	8.37659
Series Variance:	.0428044
Trend:	0.0 at 95% confidence level
Series Minimum:	7.41000
Series Maximum:	8.9000
Chi-Sq. for Data:	11.3708 with 42 d.f.
<u>Chi-Sq. at 95% level:</u>	<u>58.09 with 42 d.f.</u>
Model:	$(Z_t - 8.37659) = (1 - .35235B^{13})a_t$
Coef. of Det:	.0692568
Residual Mean:	.00562777
Residual Variance:	.0388937
Residual Minimum:	-.966591
Residual Maximum:	.333409
Residual Chi-Sq.:	10.4119 with 22 d.f.
<u>Chi-Sq. at 95% level:</u>	<u>33.92 with 22 d.f.</u>

Discussion:

The developed model is of the moving average form with a seasonal type parameter at lag thirteen, i.e. approximately one year. The initial chi-square statistic indicated that there was very little modelable information in the series, thus it was to be expected that the above model would not yield significantly variable forecasts. The seasonal parameter was forced. Therefore, due to the series stationarity & the low initial chi-square value the series is best characterized using the mean. The series is also without a significant deterministic mean.

UNIVARIATE TIME SERIES ANALYSIS

USGS STATION WU58

Parameter:	Boron (mg/l)
Series Mean:	188.295
Series Variance:	174173
Trend:	0.0 at 95% confidence level
Series Minimum:	90.00
Series Maximum:	2800.00
Chi-Sq. for Data:	3.96482 with 23 d.f.
<u>Chi-Sq. at 95% level:</u>	<u>35.17 with 23 d.f.</u>
Model:	$(Z_t - 188.295) = (1 + .25261B^1)a_t$
Coef. of Det:	.0374869
Residual Mean:	-.325914
Residual Variance:	163907
Residual Minimum:	-.676.577
Residual Maximum:	2447.61
Residual Chi-Sq.:	.756545 with 2.2 d.f.
<u>Chi-Sq. at 95% level:</u>	<u>33.92 with 22 d.f.</u>

Discussion:

The model produced is a moving average of order one; this parameter was not indicated by the identification module, it was forced simply to produce a model to forecast from. The series is stationary and trendless. It is best estimated using the series mean and behaves as a random series with mean equal to data series mean. This is seen by examining the forced model and the chi-square statistic which is extremely small.

UNIVARIATE TIME SERIES ANALYSIS

USGS STATION WU58

Parameter:	Fluoride (mg/l)
Series Mean:	.397727
Series Variance:	.0039482
Trend:	0.0 at 95% confidence level
Series Minimum:	.3
Series Maximum:	.6
Chi-Sq. for Data:	25.4411 with 23 d.f.
<u>Chi-Sq. at 95% level:</u>	<u>35.17 with 23 d.f.</u>
Model:	$(1-.46986B^1)(Z_t-.397727)=a_t$
Coef. of Det:	.201765
Residual Mean:	-.0000280199
Residual Variance:	.00314971
Residual Minimum:	-.0987951
Residual Maximum:	.201205
Residual Chi-Sq.:	4.85830 with 14 d.f.
<u>Chi-Sq. at 95% level:</u>	<u>23.08 with 14 d.f.</u>

Discussion:

The above model is an autoregressive of order one with no trend term. Additionally, the series is stationary and the best estimator for long term forecasting will be the mean of the series.

The series contains little modelable data as is indicated by the initial chi-square statistic and lack of seasonal terms.

UNIVARIATE TIME SERIES ANALYSIS

USGS STATION WU58

Parameter:	AS (mg/l)
Series Mean:	1.93183
Series Variance:	6.11152
Trend:	0.0 at 95% confidence level
Series Minimum:	0.0
Series Maximum:	13.0
Chi-Sq. for Data:	31.7755 with 35 d.f.
<u>Chi-Sq. at 95% level:</u>	<u>43.77 with 35 d.f.</u>
Model:	$(Z_t - 1.93183) = (1 + .5704B^1 - .14753B^6) a_t$
Coef. of Det:	.324379
Residual Mean:	.000485539
Residual Variance:	3.95721
Residual Minimum:	-1.56266
Residual Maximum:	11.2899
Residual Chi-Sq.:	8.98607 with 21 d.f.
<u>Chi-Sq. at 95% level:</u>	<u>32.66 with 21 d.f.</u>

Discussion:

The model is a stationary moving average with parameters at one and six. The parameter at lag six was forced in order to give the series forecasts a seasonal type appearance.

The series has no deterministic trend at the 95% confidence level and would in any long term forecasting be best represented by using the mean.

UNIVARIATE TIME SERIES ANALYSIS

USGS STATION WU61

Parameter:	PH
Series Mean:	8.22500
Series Variance:	.0549419
Trend:	0.0 at 95% confidence level
Series Minimum:	7.70000
Series Maximum:	9.20000
Chi-Sq. for Data:	30.3508 with 42 d.f.
<u>Chi-Sq. at 95% level:</u>	<u>58.09 with 42 d.f.</u>
Model:	$(1+.41062B^1+.27494B^3)(Z_t-8.225)=(1-.18502B^6)a_t$
Coef. of Det:	.219029
Residual Mean:	-.00626798
Residual Variance:	.0422993
Residual Minimum:	-.514645
Residual Maximum:	.738267
Residual Chi-Sq.:	11.2263 with 37 d.f.
<u>Chi-Sq. at 95% level:</u>	<u>52.16 with 37 d.f.</u>

Discussion:

The PH series is modeled by a mixed model with autoregressive parameters at lags of one and three and a seasonal type moving average parameter at lag six. This seasonal parameter may be interpreted as representing the negative of the actual seasonal parameter at lag twelve, i.e. one year. The model is stationary and without a deterministic trend.

The seasonal parameter was forced in order to develop a forecast which follows the data more closely.

UNIVARIATE TIME SERIES ANALYSIS

USGS STATION WU61

Parameter:	Boron (mg/l)
Series Mean:	200.795
Series Variance:	9398.77
Trend:	0.0 at 95% confidence level
Series Minimum:	120.000
Series Maximum:	770.000
Chi-Sq. for Data:	10.8657 with 42 d.f.
<u>Chi-Sq. at 95% level:</u>	<u>58.09 with 42 d.f.</u>
Model:	$(Z_t - 200.795) = (1 + .36876B^1)a_t$
Coef. of Det:	.124810
Residual Mean:	-.0535268
Residual Variance:	8042.99
Residual Minimum:	-155.740
Residual Maximum:	501.525
Residual Chi-Sq.:	2.81552 with 41 d.f.
<u>Chi-Sq. at 95% level:</u>	<u>56.93 with 41 d.f.</u>

Discussion:

The Boron series model is a moving average of order one. An attempt was made to force a seasonal parameter into the model, but all such parameters were estimated to be extremely close to zero, thus the non-seasonal model was accepted. The model developed was stationary with no trend parameter.

Considering the initial and final chi-square statistics, the developed model is probably the best obtainable. Any forecasting beyond one time period is best done using the series mean.

UNIVARIATE TIME SERIES ANALYSIS

USGS STATION WU61

Parameter:	Fluoride (mg/l)
Series Mean:	.677500
Series Variance:	.00744709
Trend:	0.0 at 95% confidence level
Series Minimum:	.50000
Series Maximum:	.90000
Chi-Sq. for Data:	18.806.3 with 42 d.f.
<u>Chi-Sq. at 95% level:</u>	<u>58.07 with 42 d.f.</u>
Model:	$(Z_t - .6775) = (1 + .28493B^1 + .29495B^8 - .22299B^{13})a_t$
Coef. of Det:	.144357
Residual Mean:	.00106531
Residual Variance:	.0060601
Residual Minimum:	-.153992
Residual Maximum:	.192223
Residual Chi-Sq.:	10.4305 with 39 d.f.
<u>Chi-Sq. at 95% level:</u>	<u>54.56 with 39 d.f.</u>

Discussion:

The developed model is of the moving average form with parameters at lags of one, eight and thirteen. The last parameter may be considered to be a seasonal type parameter, and the season may be taken to be on the order of one year. This seasonal parameter was forced and differs little from zero. The above model is stationary and trendless. Due to the chi-square statistic and the stationarity of the series, any long term forecasting would best be accomplished via the series mean.

UNIVARIATE TIME SERIES ANALYSIS

USGS STATION WU61

Parameter:	AS (mg/l)
Series Mean:	2.29773
Series Variance:	1.19883
Trend:	0.0 at 95% confidence level
Series Minimum:	0.0000
Series Maximum:	6.0000
Chi-Sq. for Data:	22.4487 with 42 d.f.
<u>Chi-Sq. at 95% level:</u>	<u>58.07 with 42 d.f.</u>
Model:	$(Z_t - 2.29773) = (1 - .30541B^7 + 61491B^{11})a_t$
Coef. of Det:	.164915
Residual Mean:	.0190615
Residual Variance:	.956252
Residual Minimum:	-1.47668
Residual Maximum:	3.06607
Residual Chi-Sq.:	17.7652 with 40 d.f.
<u>Chi-Sq. at 95% level:</u>	<u>55.76 with 40 d.f.</u>

Discussion:

The above model is a moving average with parameters at lags of seven and eleven, these may be considered as seasonal type parameters. When additional data is collected this seasonal aspect should become more distinct.

The series is trendless and stationary, and the mean should be taken as a good indicator for any long term prediction.

APPENDIX A5.2.2

This Appendix is in three parts:

- A5.2.2A - Summary Tables for Linear Regression Analyses
- A5.2.2B - Linear Regression Data for Springs and Seeps
- A5.2.2C - T-TEST Procedure Results for Springs and Seeps

APPENDIX A5.2.2A

Summary Tables for Linear Regression Analyses

List of Tables Appearing in Appendix A5.2.2A

<u>TABLE NO.</u>		<u>PAGE</u>
A5.2.2A-1	Linear Regression of Water Quality Parameters vs. Time Location WS01	65
A5.2.2A-2	Linear Regression of Water Quality Parameters vs. Time Location WS02	66
A5.2.2A-3	Linear Regression of Water Quality Parameters vs. Time Location WS03	67
A5.2.2A-4	Linear Regression of Water Quality Parameters vs. Time Location WS06	68
A5.2.2A-5	Linear Regression of Water Quality Parameters vs. Time Location WS07	69
A5.2.2A-6	Linear Regression of Water Quality Parameters vs. Time Location WS09	70
A5.2.2A-7	Linear Regression of Water Quality Parameters vs. Time Location WS10	71

Table A5.2.2A-1

LINEAR REGRESSION OF WATER QUALITY PARAMETERS VS TIME

PARAMETERS	NO. OF OBS.	ESTIMATE OF SLOPE	Location WS01		U L* (95% Conf)	T FOR H ₀ : SLOPE = 0	IS SLOPE SIGNIFICANTLY DIFFERENT FROM ZERO? (95% Conf)
			L L* (95% Conf)	U L* (95% Conf)			
pH	5	0.390	0.158	0.622	4.33	Y	
B	4	-0.447	-1.058	0.164	-2.33	N	
F	5	-0.200	-0.489	0.089	-1.93	N	
As	5	0.00538	-0.00227	0.0130	1.95	N	
SO ₄	5	-47.1	-85.5	-8.7	-3.40	Y	
Na	5	-22.4	-54.1	9.26	-1.96	N	
NH ₃	3	0.0271	-0.276	0.330	0.38	N	
Mo	3	0.00124	-0.0788	0.0812	0.07	N	

* Lower and Upper Limits of slope based on standard error of the estimate and the t-statistic for the no. of degrees of freedom.

Table A5.2.2A-2

LINEAR REGRESSION OF WATER QUALITY PARAMETERS VS TIME

Location WS02

PARAMETERS	NO. OF OBS.	ESTIMATE OF SLOPE	L L* (95% Conf)	U L* (95% Conf)	T FOR H ₀ : SLOPE = 0	IS SLOPE SIGNIFICANTLY DIFFERENT FROM ZERO? (95% Conf)
pH	5	0.00783	-0.211	0.227	0.10	N
B	5	-0.261	-0.703	0.181	-1.64	N
F	5	-0.0780	-0.27	0.114	-1.13	N
As	5	0.00190	-0.00087	0.00467	1.90	N
SO ₄	5	-4.86	-19.27	9.55	-0.94	N
Na	5	5.49	0.56	10.4	3.09	Y
NH ₃	4	0.0987	-0.0553	0.253	2.04	N
Mo	4	-0.00941	-0.021	0.00219	-2.57	N

* Lower and Upper Limits of slope based on standard error of the estimate and the t-statistic for the no. of degrees of freedom.

Table A5.2.2A-3

LINEAR REGRESSION OF WATER QUALITY PARAMETERS VS TIME

Location WS03

PARAMETERS	% OF OBS.	ESTIMATE OF SLOPE	L L* (95% Conf)	U L* (95% Conf)	T FOR H ₀ : SLOPE = 0	IS SLOPE SIGNIFICANTLY DIFFERENT FROM ZERO? (95% Conf)
pH	13	0.0280	-0.131	0.187	0.38	N
B	9	-0.191	-0.35	-0.032	-2.78	Y
F	13	-0.0316	-0.116	0.0525	-0.82	N
As	13	0.00146	-0.00612	0.00904	0.42	N
SO ₄	13	-14.9	-47.4	17.65	-1.00	N
Na	13	-9.48	-18.7	-0.22	-2.23	Y
NH ₃	12	0.0383	-0.0437	0.120	1.03	N
MO	8	-0.0123	-0.0186	-0.00604	-4.64	Y

* Lower and Upper Limits of slope based on standard error of the estimate and the t-statistic for the no. of degrees of freedom.

Table A5.2.2A-4

LINEAR REGRESSION OF WATER QUALITY PARAMETERS VS TIME

Location WS06

PARAMETERS	NO. OF OBS.	ESTIMATE OF SLOPE	L L* (95% Conf)	U L* (95% Conf)	T FOR H ₀ : SLOPE = 0	IS SLOPE SIGNIFICANTLY DIFFERENT FROM ZERO? (95% Conf)
pH	7	-0.0633	-0.379	0.253	-0.49	N
B	7	-0.316	-0.705	0.073	-2.00	N
F	7	-0.257	-0.671	0.157	-1.52	N
As	6	-0.00162	-0.0124	0.00918	-0.39	N
SO ₄	7	-2.33	-19.5	14.9	-0.33	N
Na	7	-1.17	-9.69	7.35	-0.34	N
NH ₃	4	-0.0484	-0.257	0.161	-0.74	N
Mo	7	-0.000460	-0.0138	0.0128	-0.08	N

* Lower and Upper Limits of slope based on standard error of the estimate and the t-statistic for the no. of degrees of freedom.

Table A5.2.2A-5

LINEAR REGRESSION OF WATER QUALITY PARAMETERS VS TIME

Location WS07

PARAMETERS	NO. OF OBS.	ESTIMATE OF SLOPE	L L* (95% Conf)	U L* (95% Conf)	T FOR H ₀ : SLOPE = 0	IS SLOPE SIGNIFICANTLY DIFFERENT FROM ZERO? (95% Conf)
pH	7	-0.0852	-0.278	0.108	-1.08	N
B	7	-0.299	-0.61	0.012	-2.36	N
F	7	-0.169	-0.443	0.105	-1.51	N
As	7	-0.00316	-0.00078	0.0071	1.97	N
SO ₄	7	-32.2	-83.8	19.4	-1.53	N
Na	7	-2.83	-8.27	2.61	-1.27	N
NH ₃	5	.195	-0.167	0.537	1.59	N
Mo	5	-0.000296	-0.00769	0.00709	-0.11	N

* Lower and Upper Limits of slope based on standard error of the estimate and the t-statistic for the no. of degrees of freedom.

Table A5.2.2A-6

LINEAR REGRESSION OF WATER QUALITY PARAMETERS VS TIME

Location WS09

PARAMETERS	NO. OF OBS.	ESTIMATE OF SLOPE	L L* (95% Conf)	U L* (95% Conf)	T FOR H ₀ : SLOPE = 0	IS SLOPE SIGNIFICANTLY DIFFERENT FROM ZERO? (95% Conf)
pH	12	-0.0244	-0.172	0.124	-0.36	N
B	7	-0.0928	-0.176	-0.0096	-2.73	Y
F	12	-0.136	-0.396	0.124	-1.15	N
As	11	0.00245	-0.00915	0.0141	0.47	N
SO ₄	12	-30.6	-71.9	10.7	-1.63	N
Na	12	-2.04	-16.3	12.3	-0.31	N
NH ₃	10	-0.0187	-0.0952	0.0578	-0.55	N
Mo	6	-0.0425	-0.0903	0.0053	-2.28	N

* Lower and Upper Limits of slope based on standard error of the estimate and the t-statistic for the no. of degrees of freedom.

Table A5.2.2A-7

LINEAR REGRESSION OF WATER QUALITY PARAMETERS VS TIME

Location WS10

PARAMETERS	NO. OF OBS.	ESTIMATE OF SLOPE	L L* (95% Conf)	U L* (95% Conf)	T FOR H ₀ : SLOPE = 0	IS SLOPE SIGNIFICANTLY DIFFERENT FROM ZERO? (95% Conf)
pH	9	0.0747	-0.106	0.256	0.95	N
B	7	-0.0832	-0.213	0.0468	-1.56	N
F	9	-0.148	-0.386	0.09	-1.44	N
As	9	0.00405	0.00057	0.00753	2.68	Y
SO ₄	9	17.3	9.29	25.4	4.97	Y
Na	9	1.55	-1.85	4.95	1.05	N
NH ₃	7	-0.0320	-0.133	0.069	-0.78	N
Mo	4	-0.00262	-0.0258	0.0206	-0.36	N

* Lower and Upper Limits of slope based on standard error of the estimate and the t-statistic for the no. of degrees of freedom.

APPENDIX A5.2.2B

Linear Regression Data for Springs and Seeps

REGRESSION OF WATER QUALITY PARAMETERS VS TIME

LOC=WS01

OBS	YR	MO	LIST	TOC	PHENOLS	PH	B	F	AS	YRMO	PRED1	PRED2	PRED3	PRED4	RESID1	RESID2	RESID3	RESID4
98	74	10	1	6	7.9	1.40	0.9	0.303	74.7500	7.76339	1.12707	0.697030	-0.0020529	0.13661	0.27293	0.20297	0.0050529	
99	76	5	2	.	8.3	0.03	0.2	0.001	76.3333	8.38099	0.41908	0.380022	0.0064622	-0.08099	-0.38908	-0.18002	-0.0054622	
100	76	16	3	.	8.4	0.16	0.2	0.001	76.4167	8.41350	0.38182	0.363337	0.0069104	-0.01350	-0.01350	-0.16334	-0.0059104	
101	76	10	3	.	8.4	0.02	0.2	0.010	76.7500	8.54352	0.23276	0.296598	0.0087030	-0.024352	-0.21276	-0.00660	0.0019970	
102	77	12	5	.	9.2	0.04	0.3	0.020	77.9167	8.99860	-0.22892	0.063013	0.0149773	0.20140	0.52892	0.23699	0.0050227	

LOC=WS02

OBS	YR	MO	LIST	TOC	PHENOLS	PH	B	F	AS	YRMO	PRED1	PRED2	PRED3	PRED4	RESID1	RESID2	RESID3	RESID4
103	74	10	1	3	8.0	1.20	0.6	0.004	74.7500	8.18722	0.70085	0.387477	0.00129892	-0.18722	0.49915	0.21252	0.0027011	
104	75	9	2	1	8.4	0.10	0.1	0.002	75.6667	8.19439	0.46129	0.315934	0.00303932	0.20561	-0.36129	-0.21593	-0.0010343	
105	76	5	2	.	8.1	0.02	0.2	0.001	76.3333	8.19961	0.28707	0.263902	0.00430507	-0.09961	-0.36129	-0.06390	-0.0033051	
106	76	10	3	.	8.4	0.01	0.2	0.005	76.4167	8.29282	0.17818	0.211383	0.00505619	-0.19713	-0.16818	-0.03138	0.0019988	
107	78	10	5	.	8.1	0.04	0.2	0.010	78.4167	8.29282	-0.225738	0.211383	0.00505619	-0.19713	-0.225738	-0.06870	0.0019988	

LOC=WS03

ORS	YR	MO	LIST	TOC	PHENOLS	PH	B	F	AS	YRMO	PRED1	PRED2	PRED3	PRED4	RESID1	RESID2	RESID3	RESID4
108	74	10	1	4	7.6	1.10	0.7	0.003	74.7500	8.17342	0.620172	0.318584	0.00678081	-0.57342	0.47983	0.38142	-0.00378081	
109	75	2	3	.	8.5	0.05	0.1	0.010	75.6667	8.21070	0.365675	0.276504	0.00872330	0.28930	-0.04421	-0.17650	0.0012770	
110	76	4	4	.	8.3	0.03	0.2	0.050	76.0000	8.21536	0.333863	0.271244	0.00896559	0.08464	-0.31568	-0.07124	0.0419341	
111	76	5	5	.	8.3	0.07	0.2	0.001	76.3333	8.21769	0.317927	0.268614	0.00908873	0.08231	-0.24796	-0.06881	0.0080373	
112	76	6	6	.	8.5	.	0.2	0.001	76.5000	8.22235	0.302051	0.265984	0.0092098	0.27998	.	-0.06535	-0.0082088	
113	76	7	7	.	8.5	.	0.2	0.001	76.5833	8.22468	0.286145	0.263354	0.0093302	-0.42235	.	-0.06072	-0.0084516	
114	76	8	8	.	8.5	.	0.2	0.006	76.7000	8.22434	0.270239	0.255463	0.0096945	0.27532	-0.23843	-0.05546	0.0036954	
115	76	10	9	.	8.4	0.00	0.3	0.006	76.9167	8.26193	0.231842	0.238643	0.0113946	-0.06188	0.02276	-0.01863	0.0086034	
116	77	12	10	.	8.2	0.04	0.4	0.020	77.9167	8.26193	-0.015742	0.218043	0.0113946	0.02873	0.08288	0.19187	0.0019303	
117	78	4	11	.	8.3	0.04	0.4	0.010	78.2500	8.27127	-0.047883	0.208123	0.011800	0.02873	0.11969	-0.00287	0.0021232	
118	78	6	12	.	8.0	0.04	0.2	0.010	78.4167	8.27593	-0.079695	0.202865	0.0121232	-0.27593	0.11969	-0.00287	0.0021232	
119	78	9	13	.	8.2	0.04	0.3	0.010	78.5000	8.27826	-0.095601	0.200235	0.0121232	-0.07826	0.11360	-0.00976	0.0022446	

LOC=WS04

OBS	YR	MO	LIST	TOC	PHENOLS	PH	B	F	AS	YRMO	PRED1	PRED2	PRED3	PRED4	RESID1	RESID2	RESID3	RESID4
121	74	10	1	3	7.8	1.20	0.6	0.003	74.7500	8.07007	0.704271	0.392278	0.0008391	-0.27007	0.49573	0.20772	-0.00014061	
122	75	9	2	1	8.4	0.10	0.1	0.003	75.6667	8.13246	0.597407	0.322543	0.0031406	0.36254	-0.41713	-0.23355	0.00018560	
123	76	5	3	.	8.3	0.06	0.2	0.005	76.3333	8.17784	0.381506	0.271830	0.0048144	-0.12216	-0.52151	-0.03783	-0.00018560	
124	78	6	4	.	8.2	0.20	0.2	0.010	78.4167	8.31964	-0.0043184	0.113346	0.0100450	-0.11964	0.24318	-0.08665	-0.00004499	

LOC=PS06

OBS	YR	MO	DISSOXY	MOLY	SO4	NA	NH3	YRMO	PRED1	PRED2	PRED3	PRED4	RESID1	RESID2	RESID3	RESID4
125	74	10	.	0.01	360	160	0.10	74.7500	0.0207828	363.683	143.996	0.237080	-0.010783	-0.683	16.004	-0.13708
126	75	5	.	0.00	350	140	0.40	75.3333	0.0205146	359.323	143.312	0.208874	-0.027515	0.677	-3.312	0.13708
127	75	6	.	0.05	350	140	0.40	75.5667	0.0203613	358.546	142.621	0.142757	0.029639	-8.546	-2.470	0.20724
128	76	5	.	0.03	346	133	0.30	76.3333	0.0200547	356.492	142.140	0.160522	0.009045	-10.542	-9.140	
129	76	10	.	0.02	374	128	0.10	76.7500	0.0198631	359.071	141.631	0.140275	0.000137	17.770	-13.651	-0.06038
130	77	12	7.5	0.02	387	143	0.03	77.9167	0.0193266	353.201	140.283	0.083564	0.000677	33.640	2.717	-0.02979
131	78	6	4.2	0.01	320	150	0.03	78.4167	0.0190967	352.135	139.697	0.059789	-0.0005097	-32.155	10.303	

LOC=PS07

OBS	YR	MO	DISSOXY	MOLY	SO4	NA	NH3	YRMO	PRED1	PRED2	PRED3	PRED4	RESID1	RESID2	RESID3	RESID4
132	74	10	.	0.01	380	150	0.10	74.7500	0.0147901	397.657	140.316	-0.0109410	-0.0045185	-17.66	5.6836	0.11941
134	76	5	.	0.00	357	133	0.20	76.3333	0.0143210	348.750	135.635	0.288381	0.0000000	10.92	-2.8354	0.04143
135	76	10	.	0.02	381	150	0.10	76.7500	0.0141973	353.353	136.620	0.369510	0.0050025	6.65	-6.0563	-0.26951
136	77	12	9.0	0.01	356	127	0.28	77.9167	0.0138514	293.843	131.355	0.596671	0.0001481	-139.86	-4.3547	
137	78	4	8.3	0.01	320	140	0.28	78.2500	0.0137531	283.126	130.411	0.661574	-0.0003753	34.87	4.3896	-0.33157
138	78	7	5.5	0.01	330	130	1.20	78.5000	0.0136790	277.089	129.704	0.710252	-0.00036790	52.91	0.2961	0.48975

LOC=PS08

OBS	YR	MO	DISSOXY	MOLY	SO4	NA	NH3	YRMO	PRED1	PRED2	PRED3	PRED4	RESID1	RESID2	RESID3	RESID4
139	74	10	.	0.06	350	140	0.10	74.7500	0.0444296	352.288	122.505	0.035401	0.015570	-2.289	17.495	0.06460
140	75	9	.	0.02	330	110	0.20	75.6667	0.0337433	341.455	124.015	0.158430	-0.013743	-11.955	-14.015	0.46107
141	75	10	.	0.01	354	111	0.10	76.7500	0.0211141	328.743	125.799	0.303920	-0.011114	26.238	-14.799	-0.20692
142	78	7	6.2	0.01	300	140	0.64	78.5000	0.0007130	310.015	128.681	0.540749	0.000267	-10.015	11.319	0.05925

LOC=PS09

OBS	YR	MO	DISSOXY	MOLY	SO4	NA	NH3	YRMO	PRED1	PRED2	PRED3	PRED4	RESID1	RESID2	RESID3	RESID4
143	74	10	.	0.200	350	150	0.10	74.7500	0.131392	376.530	125.453	0.111262	0.060008	-26.539	26.547	-0.011262
144	75	9	.	0.030	358	120	0.02	75.6667	0.0924335	348.527	124.588	0.094118	-0.044728	3.55	6.414	-0.06325
145	76	2	.	0.030	358	120	0.02	76.0533	0.074728	335.772	122.738	0.066325	-0.044728	22.21	-2.733	-0.033208
146	76	4	.	0.009	370	124	0.05	76.2500	0.067645	330.670	122.229	0.083208	0.0000000	3.53	1.601	
147	76	5	.	0.009	318	120	0.30	76.3333	0.066103	329.119	122.229	0.091630	-0.055103	-10.172	-7.229	0.219350
148	76	6	.	.	362	122	0.03	76.4167	0.060562	325.568	122.060	0.080091	.	36.43	-0.050041	
149	76	6	.	.	356	120	0.02	76.5000	0.057020	323.017	121.890	0.073332	.	32.48	-1.690	-0.059532
150	78	8	.	.	196	68	0.12	76.5833	0.053479	320.466	121.720	0.076474	.	-12.47	-53.720	0.043026
151	76	9	.	0.020	366	120	0.02	76.6667	0.049937	317.975	121.351	0.075473	-0.026396	4.000	-1.531	-0.053173
153	77	12	6.1	0.020	190	140	0.10	76.7500	0.046396	315.364	121.381	0.073857	-0.023185	34.64	20.394	0.026143
154	78	6	7.0	0.010	310	130	0.03	78.4167	-0.003185	279.648	117.988	0.052037	0.034634	-86.65	12.012	-0.012686

REGRESSION OF WATER QUALITY PARAMETERS VS TIME 10:31 TUESDAY, DECEMBER 12, 1979 105

LOC=WS10

OBS	YR	MO	DISSOXY	MOLY	SO4	NA	NH3	YRMO	PRED1	PRED2	PRED3	PRED4	RESID1	RESID2	RESID3	RESID4
155	74	10	.	0.02	310	120	0.10	74.7500	0.0307759	304.460	110.904	0.160032	-0.010776	5.540	9.0414	-0.060032
156	75	5	.	.	320	110	0.20	75.3333	0.0254502	314.574	111.893	0.141369	.	5.426	-1.8149	.
157	75	9	.	.	320	110	0.20	75.0667	0.0203784	320.354	112.333	0.130734	.	-0.354	-2.3328	.
158	76	5	.	.	310	112	0.30	76.3333	0.0266347	331.573	113.365	0.109424	.	-21.913	-1.3685	0.069266
159	76	6	.	.	342	111	0.01	76.4167	0.0264167	333.358	113.458	0.106762	.	8.642	-2.0490	0.190574
160	76	7	.	.	341	109	0.01	76.5000	0.0261988	334.803	113.627	0.104098	.	6.197	-2.4675	-0.096763
161	76	10	.	0.05	329	110	0.10	76.7500	0.0255449	339.137	114.016	0.096108	0.024455	-10.137	-4.0159	-0.094059
162	77	12	5.2	0.01	354	120	0.03	77.9167	0.0224935	355.366	115.826	0.052820	-0.002493	-5.366	4.1715	0.003892
163	78	6	11.2	0.01	380	120	0.03	78.3167	0.0211857	368.035	116.605	0.042839	-0.011186	11.965	3.3447	-0.012839

LOC=VSU1

OPS	YR	MO	DISSOXY	MOLY	SO4	NA	NH3	YRMO	PRED1	PRED2	PRED3	PRED4	RESI01	RESI02	RESI03	RESI04
98	74	10	.	0.01	440	200	0.10	74.7500	0.0205499	457.673	177.657	0.113528	0.012509	17.673	22.593	0.015563
99	76	5	.	.	373	123	0.24	76.3333	0.0225086	392.509	142.237	0.156452	-0.156452	18.509	-19.237	0.081290
100	74	6	.	0.04	397	122	0.10	76.4167	0.0226117	379.585	140.373	0.158710	0.014976	18.015	-10.416	-0.067742
101	75	10	.	0.02	401	122	0.10	76.7500	0.0230241	363.287	132.916	0.167742	0.004667	20.363	-10.416	.
102	77	12	6	0.02	230	133	.	77.9167	0.0244674	308.340	106.817	0.193555	0.004667	-20.363	26.185	.

LOC=VS02

OBS	YR	MO	DISSOXY	MOLY	SO4	NA	NH3	YRMO	PRED1	PRED2	PRED3	PRED4	RESI01	RESI02	RESI03	RESI04
103	74	10	.	0.04	340	110	0.1	74.7500	0.0417116	349.541	105.840	0.062526	0.0069150	-9.541	4.1599	0.03747
104	75	9	.	0.02	340	110	0.2	75.6667	0.0330860	345.084	110.869	0.133018	0.0069150	2.085	0.8029	0.04693
105	76	5	.	0.02	354	113	0.1	76.3333	0.0268128	341.843	114.529	0.218830	-0.0068128	12.133	-1.8114	-0.15946
106	76	10	.	0.01	354	113	0.1	76.7500	0.0228921	339.817	110.811	0.259963	0.0027909	16.133	-3.5217	0.07551
107	78	6	6.1	0.01	320	130	0.5	78.4167	0.0072041	331.714	125.954	0.424455	0.0027909	-11.714	4.0458	0.07551

LOC=VSU3

OBS	YR	MO	DISSOXY	MOLY	SO4	NA	NH3	YRMO	PRED1	PRED2	PRED3	PRED4	RESI01	RESI02	RESI03	RESI04
108	74	10	.	0.05	370	200	0.10	74.7500	0.055897	417.407	157.982	0.081640	0.005673	-47.41	42.019	0.01836
109	75	9	.	0.02	400	140	0.40	75.6667	0.043265	403.750	149.293	0.116759	0.000793	-3.75	-9.293	0.28374
110	74	2	.	0.02	337	131	0.02	76.0833	0.0392069	397.543	145.344	0.127222	0.000793	17.54	16.344	0.11272
111	76	4	.	0.02	435	135	0.30	76.2500	0.0371591	395.054	143.764	0.134107	-0.000793	37.44	-8.764	-0.03911
112	76	5	.	0.02	398	129	0.30	76.3333	0.0361352	393.818	142.974	0.142300	-0.016135	4.18	-13.974	0.15770
113	74	6	.	.	415	129	0.01	76.4167	0.0351112	392.576	142.184	0.145452	.	22.42	-13.184	-0.13549
114	76	7	.	.	417	132	0.01	76.5000	0.0340873	391.335	141.394	0.148685	.	25.07	-9.394	0.13809
115	76	8	.	0.04	415	138	0.10	76.5833	0.0330634	390.093	140.604	0.151678	0.009984	56.51	-2.605	-0.03188
116	76	10	7.2	0.02	424	135	0.10	76.7500	0.0310155	387.610	139.025	0.158263	0.003319	56.39	14.034	0.09573
117	77	12	7.5	0.01	320	140	0.12	77.9167	0.0166806	370.229	127.968	0.202460	0.003319	-152.23	15.194	0.07469
118	78	6	7.5	0.01	300	130	0.35	78.2500	0.0125849	365.262	124.800	0.215730	0.002585	43.42	-3.564	0.12469
119	78	7	7.5	0.01	300	130	0.35	78.5000	0.0095132	361.538	124.436	0.225308	0.000487	38.45	-3.226	0.07768
120	78	6	8.6	0.01	430	120	0.30	78.4167	0.0103371	362.778	125.226	0.222115	-0.000537	61.62	-3.226	0.07768

LOC=VS04

OBS	YR	MO	DISSOXY	MOLY	SO4	NA	NH3	YRMO	PRED1	PRED2	PRED3	PRED4	RESI01	RESI02	RESI03	RESI04
121	75	10	.	0.010	390	190	0.10	74.7500	0.0164395	309.623	97.237	0.118154	-0.0064395	-10.623	-7.2375	-0.016154
122	75	5	.	0.005	401	129	0.20	75.6667	0.0148403	327.133	104.677	0.178462	0.0151397	-27.133	4.6775	0.021533
123	76	5	.	0.005	401	129	0.20	76.3333	0.0136773	346.456	110.088	0.223776	-0.0066773	54.544	19.7110	0.021533
124	78	6	7.5	0.010	390	120	0.30	78.4167	0.0100429	206.704	120.997	0.365365	-0.0000429	-18.706	-0.3971	-0.003333

REGRESSION OF WATER QUALITY PARAMETERS VS TIME

LOC=VS06

OBS	YR	MO	LIST	TOC	PHENOLS	PH	B	F	AS	YRMO	PRED1	PRED2	PRED3	PRED4	RESID1	RESID2	RESID3	RESID4
125	74	10	1	3	.	8.2	1.60	2.10	0.030	74.7500	8.09345	0.97711	1.15141	0.0140605	0.10655	0.62289	0.94859	0.015939
126	75	5	2	3	.	7.3	0.10	0.60	0.007	75.3333	8.05653	0.79258	1.00163	0.0131153	-0.72653	-0.69258	-0.40163	-0.010575
127	75	9	3	3	.	8.4	1.10	0.40	0.001	75.6667	8.03544	0.68713	0.74604	0.0125753	0.36456	-0.41267	-0.51685	-0.010485
128	76	5	4	3	0.009	8.3	0.10	0.60	0.003	76.7500	7.96688	0.34442	0.63786	0.0106200	0.33312	-0.24442	-0.23766	-0.0007820
129	76	10	5	3	.	7.8	0.04	0.51	0.020	77.9167	7.89305	-0.22465	0.33830	0.0084297	0.09305	0.64465	0.17179	0.011970
130	77	12	6	3	0.003	7.7	0.09	0.49	0.010	78.4167	7.86141	-0.18282	0.20991	0.0081195	-0.016141	0.02762	0.20009	0.011880
131	78	6	7	3	.													

LOC=VS07

OBS	YR	MO	LIST	TOC	PHENOLS	PH	B	F	AS	YRMO	PRED1	PRED2	PRED3	PRED4	RESID1	RESID2	RESID3	RESID4
132	74	10	1	6	.	8.1	1.60	1.50	0.004	74.7500	8.32447	0.92790	0.909441	0.0004068	-0.22447	0.67210	0.59056	0.0035932
133	75	9	2	6	.	8.4	0.20	0.30	0.003	75.6667	8.24635	0.65350	0.754206	0.0033044	-0.15365	-0.45350	-0.45421	-0.0003044
134	76	5	3	6	0.007	8.4	0.10	0.40	0.001	76.3333	8.18993	0.45303	0.641309	0.0054118	-0.08953	-0.35393	-0.24131	-0.0004118
135	76	10	4	6	.	8.4	0.02	0.30	0.002	76.7500	8.15402	0.32920	0.570748	0.0067289	0.24598	-0.30920	-0.27075	-0.0047289
136	77	12	5	6	0.004	8.4	0.04	0.40	0.020	77.9167	8.05458	-0.02004	0.373177	0.0104168	0.34542	0.06004	0.02682	0.0052832
137	78	4	6	6	0.010	7.9	0.03	0.53	0.010	78.2500	8.02618	0.11982	0.311728	0.0114708	0.32618	0.14932	0.17827	-0.0034703
138	78	7	7	6	.	7.7	0.07	0.41	0.010	78.5000	8.00487	-0.19466	0.274391	0.0122608	-0.30487	0.23466	0.13361	-0.0002608

LOC=VS08

OBS	YR	MO	LIST	TOC	PHENOLS	PH	B	F	AS	YRMO	FRED1	FRED2	FRED3	FRED4	RESID1	RESID2	RESID3	RESID4
139	74	10	1	3	.	7.9	0.20	1.20	0.010	74.7500	8.25134	0.202709	1.07872	0.00636693	-0.35134	-0.002709	0.62128	0.0032344
140	75	9	2	3	0.037	8.3	0.20	0.30	0.002	75.6667	8.11310	0.157319	0.84980	0.0071719	0.18690	-0.042781	-0.64930	-0.0052367
141	76	10	3	3	0.002	8.4	0.04	0.30	0.002	76.7500	7.94973	0.103458	0.57926	0.00723669	0.45027	-0.063458	-0.27426	0.0020023
142	78	7	4	3	.	7.4	0.04	0.45	0.010	78.5000	7.68583	0.016613	0.14222	0.00799773	-0.28583	0.023367	0.30778	0.0020023

LOC=VS09

OBS	YR	MO	LIST	TOC	PHENOLS	PH	B	F	AS	YRMO	FRED1	FRED2	FRED3	FRED4	RESID1	RESID2	RESID3	RESID4
143	74	10	1	3	.	8.1	0.40	1.5	0.002	74.7500	8.23502	0.300757	0.716966	0.0039002	-0.13502	0.09924	0.78303	-0.0019002
144	75	9	2	3	.	7.8	0.30	0.5	0.002	75.6667	8.21267	0.21702	0.592202	0.0061495	-0.41267	0.08430	-0.09220	-0.0019002
145	76	2	4	3	.	8.3	0.02	0.3	0.050	76.0833	8.20250	0.177041	0.532807	0.0071719	0.09750	0.08430	-0.23549	-0.0051719
146	76	5	4	3	0.010	8.2	0.08	0.4	0.001	76.2500	8.19844	0.16577	0.512807	0.0075809	0.10156	-0.15704	-0.11281	0.0424191
147	76	5	5	3	.	8.2	0.08	0.4	0.001	76.3333	8.19641	0.153945	0.501465	0.0077853	0.00359	-0.07384	-0.10147	-0.0067853
148	76	6	6	3	.	8.2	0.08	0.4	0.001	76.4167	8.19433	0.146112	0.490123	0.0074898	0.00359	.	-0.29012	-0.0069898
149	76	6	7	3	.	8.2	0.08	0.4	0.001	76.5000	8.19234	0.130668	0.478783	0.0081948	0.10562	.	-0.17918	-0.0081948
150	76	6	8	3	.	8.2	0.08	0.4	0.001	76.5833	8.19031	0.12916	0.4656096	0.0086033	0.21172	.	-0.05610	-0.0076033
151	76	9	10	3	0.031	8.4	0.06	0.2	0.005	76.6667	8.18828	0.115184	0.446754	0.0086077	0.23320	-0.05518	-0.24464	-0.0038077
152	76	10	10	3	0.005	8.4	0.04	0.2	0.005	76.7500	8.18625	0.115184	0.282994	0.0086077	0.23320	0.05307	0.14604	-0.0038077
153	78	12	12	3	.	8.8	0.03	0.2	0.010	77.9167	8.14580	-0.009461	0.271791	0.0128974	-0.34580	0.006946	0.18209	-0.0028974

LOC=WS10

OBS	YR	MO	LIST	TOC	PHENOLS	PH	B	F	AS	YRMO	PRED1	PRED2	PRED3	PRED4	RESID1	RESID2	RESID3	RESID4
155	74	10	1	6	0.60	1.60	0.002	74.7500	8.06169	0.313049	0.710760	-0.0026714	-0.16169	0.28693	0.68924	0.0046714		
156	75	5	2	1	0.40	0.40	0.001	75.3333	8.10524	0.264522	0.624522	-0.0003111	-0.20524	-0.16452	-0.22452	0.0013111		
157	75	9	3	1	0.30	0.30	0.001	75.6667	8.13013	0.236792	0.575243	0.0010377	0.16987	-0.13679	-0.2724	-0.000377		
158	76	5	4	1	0.40	0.40	0.001	76.3333	8.17990	0.181332	0.476684	0.0037352	0.02010	-0.12133	-0.07668	-0.0027352		
159	76	6	5	1	0.20	0.20	0.001	76.4167	8.18612	0.174400	0.464364	0.0040724	0.21388	0.05333	-0.26436	-0.0030724		
160	76	7	6	1	0.30	0.30	0.000	76.5000	8.19235	0.167467	0.452045	0.0044095	-0.09235	0.05333	-0.15204	-0.0044095		
161	77	12	7	1	0.20	0.20	0.002	76.7500	8.21101	0.146670	0.415085	0.0054211	0.16899	0.05333	-0.11509	-0.0044211		
162	77	12	8	1	0.40	0.40	0.020	77.9167	8.50811	0.049615	0.242608	0.0101417	0.30189	-0.00961	-0.18167	-0.009615		
163	78	6	9	1	0.40	0.40	0.010	78.4167	8.53544	0.008020	0.168689	0.00121649	-0.43544	0.09198	0.23131	-0.0021649		

LOC=WS11

OBS	YR	MO	LIST	TOC	PHENOLS	PH	B	F	AS	YRMO	PRED1	PRED2	PRED3	PRED4	RESID1	RESID2	RESID3	RESID4
164	75	5	1	1	0.20	0.20	0.002	75.3333	7.4	0.2	0.2	0.0	0.0	0.0	0.0	0.0	0.0	0.0

APPENDIX A5.2.2C

T-TEST Procedure Results
for
Spring and Seeps WS01, WS03, WS06, WS07

VARIABLE: PH

LOC	N	MEAN	STD DEV	STD ERROR	MINIMUM	MAXIMUM	VARIANCES	T	DF	PROB > T
WS03	13	8.23076923	0.27894261	0.07711514	7.60000000	8.50000000	UNEQUAL	1.4508	9.3	0.1799
WS06	6	7.98571429	0.39761192	0.15028318	7.30000000	8.40000000	EQUAL	1.6190	18.0	0.1228

FOR H0: VARIANCES ARE EQUAL, F' = 2.05 WITH 6 AND 12 DF PROB > F' = 0.2747

VARIABLE: B

LOC	N	MEAN	STD DEV	STD ERROR	MINIMUM	MAXIMUM	VARIANCES	T	DF	PROB > T
WS03	9	0.19777778	0.35912316	0.11970772	0.00000000	1.10000000	UNEQUAL	-0.8926	8.9	0.3956
WS06	7	0.43857143	0.63964648	0.24176364	0.04000000	1.60000000	EQUAL	-0.9574	14.0	0.3546

FOR H0: VARIANCES ARE EQUAL, F' = 3.17 WITH 6 AND 8 DF PROB > F' = 0.1346

VARIABLE: F

LOC	N	MEAN	STD DEV	STD ERROR	MINIMUM	MAXIMUM	VARIANCES	T	DF	PROB > T
WS03	13	0.25384615	0.15063966	0.04177992	0.10000000	0.70000000	UNEQUAL	-2.9498	6.4	0.0964*
WS06	6	0.71428571	0.61492160	0.23241652	0.40000000	2.10000000	EQUAL	-2.6140	18.0	0.0176

FOR H0: VARIANCES ARE EQUAL, F' = 16.66 WITH 6 AND 12 DF PROB > F' = 0.0001

VARIABLE: AS

LOC	N	MEAN	STD DEV	STD ERROR	MINIMUM	MAXIMUM	VARIANCES	T	DF	PROB > T
WS03	13	0.00976923	0.01330510	0.00369017	0.00100000	0.05000000	UNEQUAL	-0.2036	11.1	0.8424
WS06	6	0.01100000	0.01117303	0.00478888	0.00100000	0.03000000	EQUAL	-0.1939	17.0	0.8486

FOR H0: VARIANCES ARE EQUAL, F' = 1.29 WITH 12 AND 5 DF PROB > F' = 0.8309

TTEST PROCEDURE

VARIABLE: M0LY

LOC	N	MEAN	STD DEV	STD ERROR	MINIMUM	MAXIMUM	VARIANCES	T	DF	PROR > ITI
WS03	8	0.02500000	0.01603567	0.00566947	0.01000000	0.05000000	UNEQUAL	0.5966	12.7	0.5613
WS06	7	0.02000000	0.01632993	0.00617213	0.00000000	0.05000000	EQUAL	0.5974	13.0	0.5605

FOR H0: VARIANCFS ARE EQUAL, F' = 1.04 WITH 6 AND 7 DF PROB > F' = 0.9481

VARIABLE: S04

LOC	N	MEAN	STD DEV	STD ERROR	MINIMUM	MAXIMUM	VARIANCES	T	DF	PROR > ITI
WS03	13	386.84615385	59.01108110	16.36672913	218.00000000	435.00000000	UNEQUAL	1.6506	16.6	0.1176
WS06	7	156.71428571	21.39091930	8.08500754	320.00000000	387.00000000	EQUAL	1.2922	18.0	0.2126

FOR H0: VARIANCFS ARE EQUAL, F' = 7.61 WITH 12 AND 6 DF PROB > F' = 0.0207

VARIABLE: NA

LOC	N	MEAN	STD DEV	STD ERROR	MINIMUM	MAXIMUM	VARIANCES	T	DF	PROR > ITI
WS03	13	138.53846154	19.40195602	5.38113441	120.00000000	200.00000000	UNEQUAL	-0.5160	18.0	0.6122
WS06	7	142.00000000	10.59874206	4.00594796	128.00000000	160.00000000	EQUAL	-0.4348	18.0	0.6489

FOR H0: VARIANCFS ARE EQUAL, F' = 3.35 WITH 12 AND 6 DF PROB > F' = 0.1480

VARIABLE: NH3

LOC	N	MEAN	STD DEV	STD ERROR	MINIMUM	MAXIMUM	VARIANCES	T	DF	PROR > ITI
WS03	12	0.15666667	0.14137849	0.04081246	0.01000000	0.40000000	UNEQUAL	-0.0091	4.6	0.9932
WS06	4	0.15750000	0.16500000	0.08250000	0.03000000	0.40000000	EQUAL	-0.0098	14.0	0.9923

FOR H0: VARIANCFS ARE EQUAL, F' = 1.36 WITH 3 AND 11 DF PROB > F' = 0.6104

TTEST PROCEDURE

VARIABLE: SPECCOND

LOC	N	MEAN	STD DEV	STD ERROR	MINIMUM	MAXIMUM	VARIANCES	T	DF	PROR > ITI
WS03	12	1355.33333333	109.48834171	31.60656178	1200.00000000	1559.00000000	UNEQUAL	-0.1467	12.3	0.8858
WS06	7	1363.14285714	113.38346230	42.85492058	1200.00000000	1562.00000000	EQUAL	-0.1481	17.0	0.8840

FOR H0: VARIANCES ARE EQUAL, F' = 1.07 WITH 6 AND 11 DF PROR > F' = 0.8680

VARIABLE: TDS

LOC	N	MEAN	STD DEV	STD ERROR	MINIMUM	MAXIMUM	VARIANCES	T	DF	PROR > ITI
WS03	9	984.66666667	76.40680598	25.46893533	846.00000000	1130.00000000	UNEQUAL	1.8433	10.6	0.0934 *
WS06	4	932.50000000	24.67792536	12.33896268	900.00000000	960.00000000	EQUAL	1.3070	11.0	0.2179

FOR H0: VARIANCES ARE EQUAL, F' = 9.59 WITH 8 AND 3 DF PROR > F' = 0.0895

VARIABLE: PH

LOC	N	MEAN	STD DEV	STD ERROR	MINIMUM	MAXIMUM	VARIANCES	T	DF	PROR > ITI
WS03	13	8.23076923	0.27804261	0.07711514	7.60000000	8.50000000	UNEQUAL	0.6776	12.5	0.5104
WS07	7	8.14285714	0.27602622	0.10432811	7.70000000	8.40000000	EQUAL	0.6761	18.0	0.5076

FOR H0: VARIANCES ARE EQUAL, F' = 1.01 WITH 12 AND 6 DF PROR > F' = 1.0000

VARIABLE: B

LOC	N	MEAN	STD DEV	STD ERROR	MINIMUM	MAXIMUM	VARIANCES	T	DF	PROR > ITI
WS03	9	0.19777778	0.35912316	0.11970772	0.00000000	1.10000000	UNEQUAL	-0.3687	9.5	0.7205
WS07	7	0.29000000	0.58106225	0.21962089	0.02000000	1.60000000	EQUAL	-0.3916	14.0	0.7013

FOR H0: VARIANCES ARE EQUAL, F' = 2.62 WITH 6 AND 8 DF PROR > F' = 0.2085

VARIABLE: F

LOC	N	MEAN	STD DEV	STD ERROR	MINIMUM	MAXIMUM	VARIANCES	T	DF	PROR > ITI
WS03	13	0.25384615	0.15063966	0.04177992	0.10000000	0.70000000	UNEQUAL	-1.7690	6.8	0.1215
WS07	7	0.54857143	0.42670945	0.16128101	0.30000000	1.50000000	EQUAL	-2.2831	18.0	0.0348

FOR H0: VARIANCES ARE EQUAL, F' = 8.02 WITH 6 AND 12 DF PROR > F' = 0.0024

VARIABLE: AS

LOC	N	MEAN	STD DEV	STD ERROR	MINIMUM	MAXIMUM	VARIANCES	T	DF	PROR > ITI
WS03	13	0.00976923	0.01330510	0.00369017	0.00100000	0.05000000	UNEQUAL	0.5856	18.0	0.5654
WS07	7	0.00714286	0.00674360	0.00254884	0.00100000	0.02000000	EQUAL	0.4855	18.0	0.6332

FOR H0: VARIANCES ARE EQUAL, F' = 3.89 WITH 12 AND 6 DF PROR > F' = 0.1063

TTEST PROCEDURE

VARIABLE: MOLY

LOC	N	MEAN	STD DEV	STD ERROR	MINIMUM	MAXIMUM	VARIANCES	T	DF	PROR > ITI
WS03	8	0.02500000	0.01603567	0.00566947	0.01000000	0.05000000	UNEQUAL	1.7811	9.3	0.1076
WS07	5	0.01400000	0.00547723	0.00244949	0.01000000	0.02000000	EQUAL	1.4605	11.0	0.1721

FOR H0: VARIANCES ARE EQUAL, F' = 8.57 WITH 7 AND 4 DF PROB > F' = 0.0553

VARIABLE: SO4

LOC	N	MEAN	STD DEV	STD ERROR	MINIMUM	MAXIMUM	VARIANCES	T	DF	PROR > ITI
WS03	13	386.84615385	59.01108110	16.36672913	218.00000000	435.00000000	UNEQUAL	1.6732	9.6	0.1266
WS07	7	329.14285714	80.31278141	30.35537810	156.00000000	381.00000000	EQUAL	1.8407	18.0	0.0822

FOR H0: VARIANCES ARE EQUAL, F' = 1.85 WITH 6 AND 12 DF PROB > F' = 0.3423

VARIABLE: NA

LOC	N	MEAN	STD DEV	STD ERROR	MINIMUM	MAXIMUM	VARIANCES	T	DF	PROR > ITI
WS03	13	138.53846154	19.40195602	5.38113441	120.00000000	200.00000000	UNEQUAL	0.6878	17.4	0.5007
WS07	7	134.28571429	8.056634917	3.04501377	127.00000000	150.00000000	EQUAL	0.5494	18.0	0.5895

FOR H0: VARIANCES ARE EQUAL, F' = 5.80 WITH 12 AND 6 DF PROB > F' = 0.0413

VARIABLE: NH3

LOC	N	MEAN	STD DEV	STD ERROR	MINIMUM	MAXIMUM	VARIANCES	T	DF	PROR > ITI
WS03	12	0.15666667	0.14137849	0.04081246	0.01000000	0.40000000	UNEQUAL	-1.0312	4.3	0.3573
WS07	5	0.37600000	0.46677618	0.20874865	0.10000000	1.20000000	EQUAL	-1.5276	15.0	0.1474

FOR H0: VARIANCES ARE EQUAL, F' = 10.90 WITH 4 AND 11 DF PROB > F' = 0.0016

S T A T I S T I C A L A N A L Y S I S S Y S T E M

13:38 WEDNESDAY, FEBRUARY 28, 1979

TTEST PROCEDURE

VARIABLE: SPECCOND

LOC	N	MEAN	STD DEV	STD ERROR	MINIMUM	MAXIMUM	VARIANCES	T	DF	PROB > T
WS03	12	1355.33333333	105.48834171	31.50656178	1200.00000000	1559.00000000	UNEQUAL	0.1980	11.1	0.8466
WS07	6	1345.16666667	99.09675407	40.45608044	1250.00000000	1521.00000000	EQUAL	0.1912	16.0	0.8508

FOR H0: VARIANCES ARE EQUAL, F' = 1.22 WITH 11 AND 5 DF PROB > F' = 0.8786

VARIABLE: TDS

LOC	N	MEAN	STD DEV	STD ERROR	MINIMUM	MAXIMUM	VARIANCES	T	DF	PROB > T
WS03	9	984.66666667	76.40680598	25.46893533	846.00000000	1130.00000000	UNEQUAL	0.0810	5.4	0.9384
WS07	4	980.75000000	82.22479350	41.11239675	921.00000000	1100.00000000	EQUAL	0.0835	11.0	0.9349

FOR H0: VARIANCES ARE EQUAL, F' = 1.16 WITH 3 AND 8 DF PROB > F' = 0.7675

VARIABLE: PH

LOC	N	MEAN	STD DEV	STD ERROR	MINIMUM	MAXIMUM	VARIANCES	T	DF	PROB > T
MS06	7	7.98571429	0.39761192	0.15028318	7.30000000	8.40000000	UNEQUAL	-0.8590	10.7	0.4092
MS07	7	8.14285714	0.27602622	0.10432811	7.70000000	8.40000000	EQUAL	-0.8590	12.0	0.4072

FOR H0: VARIANCES ARE EQUAL, F' = 2.07 WITH 6 AND 6 DF PROB > F' = 0.3960

VARIABLE: B

LOC	N	MEAN	STD DEV	STD ERROR	MINIMUM	MAXIMUM	VARIANCES	T	DF	PROB > T
MS06	7	0.43857143	0.63964648	0.24176364	0.04000000	1.60000000	UNEQUAL	0.4549	11.9	0.6574
MS07	7	0.29000000	0.58106225	0.21962089	0.02000000	1.50000000	EQUAL	0.4549	12.0	0.6573

FOR H0: VARIANCES ARE EQUAL, F' = 1.21 WITH 6 AND 6 DF PROB > F' = 0.8215

VARIABLE: F

LOC	N	MEAN	STD DEV	STD ERROR	MINIMUM	MAXIMUM	VARIANCES	T	DF	PROB > T
MS06	7	0.71428571	0.61492160	0.23241852	0.40000000	2.10000000	UNEQUAL	0.5858	10.7	0.5702
MS07	7	0.54857143	0.42670945	0.16128101	0.30000000	1.50000000	EQUAL	0.5858	12.0	0.5689

FOR H0: VARIANCES ARE EQUAL, F' = 2.08 WITH 6 AND 6 DF PROB > F' = 0.3954

VARIABLE: AS

LOC	N	MEAN	STD DEV	STD ERROR	MINIMUM	MAXIMUM	VARIANCES	T	DF	PROB > T
MS06	6	0.01100000	0.01173030	0.00478888	0.00100000	0.03000000	UNEQUAL	0.7110	7.7	0.4981
MS07	7	0.00714286	0.00674360	0.00254884	0.00100000	0.02000000	EQUAL	0.7418	11.0	0.4738

FOR H0: VARIANCES ARE EQUAL, F' = 3.03 WITH 5 AND 6 DF PROB > F' = 0.2102

TTEST PROCEDURE

VARIABLE: MOLY

LOC	N	MEAN	STD DEV	STD ERROR	MINIMUM	MAXIMUM	VARIANCES	T	DF	PROR > ITI
MS06	7	0.02000000	0.01632993	0.00617213	0.00000000	0.05000000	UNEQUAL	0.9036	7.8	0.3935
MS07	5	0.01400000	0.00547723	0.00244949	0.01000000	0.02000000	EQUAL	0.7813	10.0	0.4527

FOR H0: VARIANCES ARE EQUAL, F' = 8.89 WITH 6 AND 4 DF PROR > F' = 0.0531

VARIABLE: S04

LOC	N	MEAN	STD DEV	STD ERROR	MINIMUM	MAXIMUM	VARIANCES	T	DF	PROR > ITI
MS06	7	356.71428571	21.39091930	8.08500754	320.00000000	387.00000000	UNEQUAL	0.8777	6.8	0.4099
MS07	7	329.14285714	80.31278141	30.35537910	156.00000000	381.00000000	EQUAL	0.8777	12.0	0.3073

FOR H0: VARIANCES ARE EQUAL, F' = 14.10 WITH 6 AND 6 DF PROR > F' = 0.0053

VARIABLE: NA

LOC	N	MEAN	STD DEV	STD ERROR	MINIMUM	MAXIMUM	VARIANCES	T	DF	PROR > ITI
MS06	7	142.00000000	10.59874206	4.00594796	128.00000000	160.00000000	UNEQUAL	1.5331	11.2	0.1530
MS07	7	134.28571429	8.05634917	3.04501377	127.00000000	150.00000000	EQUAL	1.5331	12.0	0.1512

FOR H0: VARIANCES ARE EQUAL, F' = 1.73 WITH 6 AND 6 DF PROR > F' = 0.5217

VARIABLE: NH3

LOC	N	MEAN	STD DEV	STD ERROR	MINIMUM	MAXIMUM	VARIANCES	T	DF	PROR > ITI
MS06	4	0.15750000	0.16500000	0.08250000	0.03000000	0.40000000	UNEQUAL	-0.9734	5.2	0.3738
MS07	5	0.37600000	0.46677618	0.20874865	0.10000000	1.20000000	EQUAL	-0.8827	7.0	0.4067

FOR H0: VARIANCES ARE EQUAL, F' = 8.00 WITH 4 AND 3 DF PROR > F' = 0.1190

TTEST PROCEDURE

VARIABLE: SPECCOND

LOC	N	MEAN	STD DEV	STD ERROR	MINIMUM	MAXIMUM	VARIANCES	T	DF	PROR > ITI
MS06	7	14285714	113.38346230	42.85492058	1200.00000000	1562.00000000	UNEQUAL	0.3050	11.0	0.7661
MS07	6	1345.16666667	99.09675407	40.45608044	1250.00000000	1521.00000000	EQUAL	0.3016	11.0	0.7686

FOR H0: VARIANCES ARE EQUAL, F' = 1.31 WITH 6 AND 5 DF PROR > F' = 0.7852

VARIABLE: TDS

LOC	N	MEAN	STD DEV	STD ERROR	MINIMUM	MAXIMUM	VARIANCES	T	DF	PROR > ITI
MS06	4	932.50000000	24.67792536	12.33886268	900.00000000	960.00000000	UNEQUAL	-1.1241	2.5	0.3327
MS07	4	980.75000000	82.22479350	41.11239675	921.00000000	1100.00000000	EQUAL	-1.1241	6.0	0.3039

FOR H0: VARIANCES ARE EQUAL, F' = 11.10 WITH 3 AND 3 DF PROR > F' = 0.0786

TTEST PROCEDURE

VARIABLE: PH

LOC	N	MEAN	STD DEV	STD ERROR	MINIMUM	MAXIMUM	VARIANCES	T	DF	PROR > ITI
WS01	5	8.42000000	0.47644517	0.21307276	7.90000000	9.20000000	UNEQUAL	1.1682	5.9	0.2877
WS07	7	8.14285714	0.27602622	0.10432811	7.70000000	8.40000000	EQUAL	1.2810	10.0	0.2297

FOR H0: VARIANCES ARE EQUAL, F' = 2.98 WITH 4 AND 6 DF PROR > F' = 0.2250

VARIABLE: B

LOC	N	MEAN	STD DEV	STD ERROR	MINIMUM	MAXIMUM	VARIANCES	T	DF	PROR > ITI
WS01	4	0.37250000	0.68504866	0.34252433	0.02000000	1.40000000	UNEQUAL	0.2028	5.5	0.8467
WS07	7	0.29000000	0.58106225	0.21962089	0.02000000	1.60000000	EQUAL	0.2131	9.0	0.8360

FOR H0: VARIANCES ARE EQUAL, F' = 1.39 WITH 3 AND 6 DF PROR > F' = 0.6675

VARIABLE: F

LOC	N	MEAN	STD DEV	STD ERROR	MINIMUM	MAXIMUM	VARIANCES	T	DF	PROR > ITI
WS01	5	0.36000000	0.30495901	0.13638182	0.20000000	0.90000000	UNEQUAL	-0.8928	10.0	0.3930
WS07	7	0.54857143	0.42670445	0.16128101	0.30000000	1.50000000	EQUAL	-0.8415	10.0	0.4187

FOR H0: VARIANCES ARE EQUAL, F' = 1.96 WITH 6 AND 4 DF PROR > F' = 0.5370

VARIABLE: AS

LOC	N	MEAN	STD DEV	STD ERROR	MINIMUM	MAXIMUM	VARIANCES	T	DF	PROR > ITI
WS01	5	0.00700000	0.00815475	0.00364692	0.00100000	0.02000000	UNEQUAL	-0.0321	7.6	0.9752
WS07	7	0.00714286	0.00674360	0.00254884	0.00100000	0.02000000	EQUAL	-0.0332	10.0	0.9741

FOR H0: VARIANCES ARE EQUAL, F' = 1.46 WITH 4 AND 6 DF PROR > F' = 0.6442

S T A T I S T I C A L A N A L Y S I S S Y S T E M

10:25 WEDNESDAY, FEBRUARY 28, 1976

TTEST PROCEDURE

VARIABLE: M0LY

LOC	N	MEAN	STD DEV	STD ERROR	MINIMUM	MAXIMUM	VARIANCES	T	DF	PROR > ITI
WS01	3	0.02333333	0.01527525	0.00881917	0.01000000	0.04000000	UNEQUAL	1.0197	2.3	0.4050
WS07	3	0.01400000	0.00547723	0.00244949	0.01000000	0.02000000	EQUAL	1.2925	6.0	0.2437
FOR H0: VARIANCES ARE EQUAL, F* = 7.78 WITH 2 AND 4 DF PROR > F* = 0.0837										

VARIABLE: S04

LOC	N	MEAN	STD DEV	STD ERROR	MINIMUM	MAXIMUM	VARIANCES	T	DF	PROR > ITI
WS01	5	378.20000000	59.92244988	26.79813426	280.00000000	440.00000000	UNEQUAL	1.2115	9.9	0.2537
WS07	7	329.14285714	80.31278141	30.35537810	156.00000000	381.00000000	EQUAL	1.1501	10.0	0.2769
FOR H0: VARIANCES ARE EQUAL, F* = 1.80 WITH 6 AND 4 DF PROR > F* = 0.5941										

VARIABLE: NA

LOC	N	MEAN	STD DEV	STD ERROR	MINIMUM	MAXIMUM	VARIANCES	T	DF	PROR > ITI
WS01	5	140.00000000	33.86000591	15.14265499	122.00000000	200.00000000	UNEQUAL	0.3700	4.3	0.7290
WS07	7	134.28571429	8.05634917	3.04501377	127.00000000	150.00000000	EQUAL	0.4375	10.0	0.6710
FOR H0: VARIANCES ARE EQUAL, F* = 17.66 WITH 4 AND 6 DF PROR > F* = 0.0036										

VARIABLE: NH3

LOC	N	MEAN	STD DEV	STD ERROR	MINIMUM	MAXIMUM	VARIANCES	T	DF	PROR > ITI
WS01	3	0.14666667	0.04082904	0.04666667	0.10000000	0.24000000	UNEQUAL	-1.0721	4.4	0.3396
WS07	5	0.37600000	0.46677618	0.20874865	0.10000000	1.20000000	EQUAL	-0.6178	6.0	0.4447
FOR H0: VARIANCES ARE EQUAL, F* = 33.35 WITH 4 AND 2 DF PROR > F* = 0.0586										

TTEST PROCEDURE

VARIABLE: SPECCOND

LDC	N	MEAN	STD DEV	STD ERROR	MINIMUM	MAXIMUM	VARIANCES	T	DF	PROB > T
WS01	5	124.20000000	118.22943796	52.87381204	1200.00000000	1521.00000000	UNEQUAL	-0.3149	7.9	0.7610
WS07	6	1345.16666667	99.09675407	40.45608044	1250.00000000	1521.00000000	EQUAL	-0.3205	9.0	0.7559

FOR H0: VARIANCES ARE EQUAL, F = 1.42 WITH 4 AND 5 DF PROB > F = 0.6969

VARIABLE: TOS

LDC	N	MEAN	STD DEV	STD ERROR	MINIMUM	MAXIMUM	VARIANCES	T	DF	PROB > T
WS01	4	946.25000000	111.76276959	55.88138480	839.00000000	1100.00000000	UNEQUAL	-0.4973	5.5	0.6383
WS07	4	980.75000000	82.22479350	41.11239675	921.00000000	1100.00000000	EQUAL	-0.4973	6.0	0.6367

FOR H0: VARIANCES ARE EQUAL, F = 1.85 WITH 3 AND 3 DF PROB > F = 0.6267

TTEST PROCEDURE

VARIABLE: PH

LOC	N	MEAN	STD DEV	STD ERROR	MINIMUM	MAXIMUM	VARIANCES	T	DF	PROR > ITI
WS01	5	8.42000000	0.47644517	0.21307276	7.90000000	9.20000000	UNEQUAL	0.8351	5.1	0.4412
WS03	13	8.23076923	0.27804261	0.077711514	7.60000000	8.50000000	EQUAL	1.0616	16.0	0.3042

FOR H0: VARIANCES ARE EQUAL, F' = 2.94 WITH 4 AND 12 DF PROR > F' = 0.1322

VARIABLE: B

LOC	N	MEAN	STD DEV	STD ERROR	MINIMUM	MAXIMUM	VARIANCES	T	DF	PROR > ITI
WS01	4	0.37250000	0.68504866	0.34252433	0.02000000	1.40000000	UNEQUAL	0.4815	3.8	0.6572
WS03	9	0.19777778	0.35912316	0.11970772	0.00000000	1.10000000	EQUAL	0.6174	11.0	0.5495

FOR H0: VARIANCES ARE EQUAL, F' = 3.64 WITH 3 AND 8 DF PROR > F' = 0.1279

VARIABLE: F

LOC	N	MEAN	STD DEV	STD ERROR	MINIMUM	MAXIMUM	VARIANCES	T	DF	PROR > ITI
WS01	5	0.36000000	0.30495901	0.1368182	0.20000000	0.90000000	UNEQUAL	0.7442	4.8	0.4920
WS03	13	0.25384615	0.15063966	0.04177992	0.10000000	0.70000000	EQUAL	1.0052	16.0	0.3297

FOR H0: VARIANCES ARE EQUAL, F' = 4.10 WITH 4 AND 12 DF PROR > F' = 0.0509

VARIABLE: AS

LOC	N	MEAN	STD DEV	STD ERROR	MINIMUM	MAXIMUM	VARIANCES	T	DF	PROR > ITI
WS01	5	0.00700000	0.00815475	0.00364692	0.00100000	0.02000000	UNEQUAL	-0.5338	12.1	0.6032
WS03	13	0.00976923	0.01330510	0.00369017	0.00100000	0.05000000	EQUAL	-0.4305	16.0	0.6725

FOR H0: VARIANCES ARE EQUAL, F' = 2.66 WITH 12 AND 4 DF PROR > F' = 0.3567

S T A T I S T I C A L A N A L Y S I S S Y S T E M

10:28 WEDNESDAY, FEBRUARY 28, 1978

TTEST PROCEDURE

VARIABLE: M0LY

LOC	N	MEAN	STD DEV	STD ERROR	MINIMUM	MAXIMUM	VARIANCES	T	DF	PROR > ITI
WS01	3	0.023333333	0.01527525	0.00881917	0.01000000	0.04000000	UNEQUAL	-0.1590	3.8	0.8819
WS03	8	0.02500000	0.01603567	0.00566947	0.01000000	0.05000000	EQUAL	-0.1551	9.0	0.8801

FOR H0: VARIANCES ARE EQUAL, F' = 1.10 WITH 7 AND 2 DF PROR > F' = 1.0000

VARIABLE: S04

LOC	N	MEAN	STD DEV	STD ERROR	MINIMUM	MAXIMUM	VARIANCES	T	DF	PROR > ITI
WS01	5	378.20000000	59.92244988	26.79813426	280.00000000	440.00000000	UNEQUAL	-0.2753	7.2	0.7908
WS03	13	386.84615385	59.01108110	16.36672913	218.00000000	435.00000000	EQUAL	-0.2773	14.0	0.7851

FOR H0: VARIANCES ARE EQUAL, F' = 1.03 WITH 4 AND 12 DF PROR > F' = 0.8613

VARIABLE: NA

LOC	N	MEAN	STD DEV	STD ERROR	MINIMUM	MAXIMUM	VARIANCES	T	DF	PROR > ITI
WS01	5	140.00000000	33.86000591	15.14265499	122.00000000	200.00000000	UNEQUAL	0.0909	5.0	0.9310
WS03	13	138.53846154	19.40195602	5.38113441	120.00000000	200.00000000	EQUAL	0.1164	14.0	0.9088

FOR H0: VARIANCES ARE EQUAL, F' = 3.05 WITH 4 AND 12 DF PROR > F' = 0.1201

VARIABLE: NH3

LOC	N	MEAN	STD DEV	STD ERROR	MINIMUM	MAXIMUM	VARIANCES	T	DF	PROR > ITI
WS01	3	0.14666667	0.08082904	0.04666667	0.10000000	0.24000000	UNEQUAL	-0.1613	5.6	0.8775
WS03	12	0.15666667	0.14137849	0.04081246	0.01000000	0.40000000	EQUAL	-0.1157	11.0	0.9096

FOR H0: VARIANCES ARE EQUAL, F' = 3.06 WITH 11 AND 2 DF PROR > F' = 0.5441

TTEST PROCEDURE

VARIABLE: SPECCOND

LOC	N	MEAN	STD DEV	STD ERROR	MINIMUM	MAXIMUM	VARIANCES	T	DF	PROR > ITI
WS01	5	1324.20000000	118.22943796	52.87381204	1200.00000000	1521.00000000	UNEQUAL	-0.5054	7.0	0.6287
WS03	12	1355.33333333	109.48834171	31.60656178	1200.00000000	1559.00000000	EQUAL	-0.5228	15.0	0.6088

FOR H0: VARIANCES ARE EQUAL, F' = 1.17 WITH 4 AND 11 DF PROR > F' = 0.7550

VARIABLE: TDS

LOC	N	MEAN	STD DEV	STD ERROR	MINIMUM	MAXIMUM	VARIANCES	T	DF	PROR > ITI
WS01	4	946.25000000	111.76276959	55.88138480	839.00000000	1100.00000000	UNEQUAL	-0.6256	4.3	0.5635
WS03	9	984.66666667	76.40680598	25.46893533	846.00000000	1130.00000000	EQUAL	-0.7308	11.0	0.4802

FOR H0: VARIANCES ARE EQUAL, F' = 2.14 WITH 3 AND 8 DF PROR > F' = 0.3467

TTEST PROCEDURE

VARIABLE: PH
 LOC N MEAN STD DEV STD ERROR MINIMUM MAXIMUM VARIANCES T DF PROR > ITI
 WS01 5 0.42000000 0.47644517 0.21307276 7.90000000 9.20000000 UNEQUAL 1.6656 7.7 0.1360
 WS06 7 7.98571429 0.39761192 0.15028318 7.30000000 8.40000000 EQUAL 1.7213 10.0 0.1159
 FOR H0: VARIANCES ARE EQUAL, F:= 1.44 WITH 4 AND 6 DF PROR > F:= 0.6581

VARIABLE: B
 LOC N MEAN STD DEV STD ERROR MINIMUM MAXIMUM VARIANCES T DF PROR > ITI
 WS01 4 0.37250000 0.68504866 0.34252433 0.02000000 1.40000000 UNEQUAL -0.1576 6.0 0.8800
 WS06 7 0.43857143 0.63964648 0.24176364 0.04000000 1.60000000 EQUAL -0.1609 9.0 0.8757
 FOR H0: VARIANCES ARE EQUAL, F:= 1.15 WITH 3 AND 6 DF PROR > F:= 0.8071

VARIABLE: F
 LOC N MEAN STD DEV STD ERROR MINIMUM MAXIMUM VARIANCES T DF PROR > ITI
 WS01 5 0.36000000 0.30495901 0.13638182 0.20000000 0.90000000 UNEQUAL -1.3147 9.2 0.2205
 WS06 7 0.71428571 0.61492160 0.23241852 0.40000000 2.10000000 EQUAL -1.1774 10.0 0.2663
 FOR H0: VARIANCES ARE EQUAL, F:= 4.07 WITH 6 AND 4 DF PROR > F:= 0.1958

VARIABLE: AS
 LOC N MEAN STD DEV STD ERROR MINIMUM MAXIMUM VARIANCES T DF PROR > ITI
 WS01 5 0.00700000 0.00815475 0.00364692 0.00100000 0.02000000 UNEQUAL -0.6645 8.8 0.5235
 WS06 6 0.01100000 0.01173030 0.00478888 0.00100000 0.03000000 EQUAL -0.6416 9.0 0.5371
 FOR H0: VARIANCES ARE EQUAL, F:= 2.07 WITH 5 AND 4 DF PROR > F:= 0.5009

S T A T I S T I C A L A N A L Y S I S S Y S T E M

10:23 WEDNESDAY, FEBRUARY 28, 1979

TTEST PROCEDURE

VARIABLE: M04

LOC	N	MEAN	STD DEV	STD ERROR	MINIMUM	MAXIMUM	VARIANCES	T	DF	PROR > ITI
WS01	3	0.02333333	0.01527525	0.00881917	0.01000000	0.04000000	UNEQUAL	0.3097	4.0	0.7720
WS06	7	0.02000000	0.01632993	0.00617213	0.00000000	0.05000000	EQUAL	0.3005	8.0	0.7714

FOR H0: VARIANCES ARE EQUAL, F' = 1.14 WITH 6 AND 2 DF PROR > F' = 1.0000

VARIABLE: S04

LOC	N	MEAN	STD DEV	STD ERROR	MINIMUM	MAXIMUM	VARIANCES	T	DF	PROR > ITI
WS01	5	179.20000000	59.92244988	26.79813426	280.00000000	440.00000000	UNEQUAL	0.7676	4.7	0.4796
WS06	7	156.71428571	21.39091930	8.08500754	320.00000000	387.00000000	EQUAL	0.8871	10.0	0.3958

FOR H0: VARIANCES ARE EQUAL, F' = 7.65 WITH 4 AND 6 DF PROR > F' = 0.0291

VARIABLE: NA

LOC	N	MEAN	STD DEV	STD ERROR	MINIMUM	MAXIMUM	VARIANCES	T	DF	PROR > ITI
WS01	5	140.00000000	33.86000591	15.14265499	122.00000000	200.00000000	UNEQUAL	-0.1277	4.6	0.9039
WS06	7	142.00000000	10.59874206	4.00594796	128.00000000	160.00000000	EQUAL	-0.1489	10.0	0.8846

FOR H0: VARIANCES ARE EQUAL, F' = 10.21 WITH 4 AND 6 DF PROR > F' = 0.0152

VARIABLE: NH3

LOC	N	MEAN	STD DEV	STD ERROR	MINIMUM	MAXIMUM	VARIANCES	T	DF	PROR > ITI
WS01	3	0.14666667	0.08082904	0.04666667	0.10000000	0.24000000	UNEQUAL	-0.1143	4.5	0.9139
WS06	4	0.15750000	0.16500000	0.08250000	0.03000000	0.40000000	EQUAL	-0.1030	5.0	0.9219

FOR H0: VARIANCES ARE EQUAL, F' = 4.17 WITH 3 AND 2 DF PROR > F' = 0.3991

TTEST PROCEDURE

VARIABLE: SPECCOND

LOC	N	MEAN	STD DEV	STD ERROR	MINIMUM	MAXIMUM	VARIANCES	T	DF	PROR > ITI
MS01	5	1324.20000000	118.22943796	52.87381204	1200.00000000	1521.00000000	UNEQUAL	-0.5722	4.5	0.5820
MS06	7	1763.14285714	113.38346230	42.85492058	1200.00000000	1562.00000000	EQUAL	-0.5766	10.0	0.5770

FOR H01 VARIANCES ARE EQUAL, F*= 1.09 WITH 4 AND 6 DF PROR > F*= 0.8831

VARIABLE: TDS

LOC	N	MEAN	STD DEV	STD ERROR	MINIMUM	MAXIMUM	VARIANCES	T	DF	PROR > ITI
MS01	4	946.25000000	111.76276959	55.88138480	839.00000000	1100.00000000	UNEQUAL	0.2403	3.3	0.8745
MS06	4	932.50000000	24.67792536	12.33896268	900.00000000	960.00000000	EQUAL	0.2403	6.0	0.8181

FOR H01 VARIANCES ARE EQUAL, F*= 20.51 WITH 3 AND 3 DF PROR > F*= 0.0336

APPENDIX A5.3.1

This Appendix is in three parts:

A5.3.1A - Summary Tables for Regression and
Comparative Analyses

A5.3.1B - Linear Regression Data for Alluvial Wells

A5.3.1C - T-TEST Procedure Results for Alluvial
Wells

APPENDIX A5.3.1A

Summary Tables for Regression and Comparative Analyses

List of Tables Appearing in Appendix A5.3.1A

<u>TABLE NO.</u>		<u>PAGE</u>
A5.3.1A-1	Linear Regression of Water Quality Parameters vs. Time Alluvial Well WA01	100
A5.3.1A-2	Linear Regression of Water Quality Parameters vs. Time Alluvial Well WA02	101
A5.3.1A-3	Linear Regression of Water Quality Parameters vs. Time Alluvial Well WA03	102
A5.3.1A-4	Linear Regression of Water Quality Parameters vs. Time Alluvial Well WA05	103
A5.3.1A-5	Linear Regression of Water Quality Parameters vs. Time Alluvial Well WA06	104
A5.3.1A-6	Linear Regression of Water Quality Parameters vs. Time Alluvial Well WA07	105
A5.3.1A-7	Linear Regression of Water Quality Parameters vs. Time Alluvial Well WA08	106
A5.3.1A-8	Linear Regression of Water Quality Parameters vs. Time Alluvial Well WA09	107
A5.3.1A-9	Linear Regression of Water Quality Parameters vs. Time Alluvial Well WA10	108
A5.3.1A-10	Linear Regression of Water Quality Parameters vs. Time Alluvial Well WA11	109
A5.3.1A-11	Linear Regression of Water Quality Parameters vs. Time Alluvial Well WA12	110
A5.3.1A-12	T-Test Procedure Summary for Between-Station Comparisons of Alluvial Wells	111

Table A5.3.1A-1

LINEAR REGRESSION OF WATER QUALITY PARAMETERS VS TIME

Alluvial Well WA01

PARAMETERS	NO. OF OBS.	ESTIMATE OF SLOPE	L L* (95% Conf)	U L* (95% Conf)	T FOR H ₀ : SLOPE = 0	IS SLOPE SIGNIFICANTLY DIFFERENT FROM ZERO? (95% Conf)
pH	13	-0.1819	-0.428	0.066	-1.60	N
B	8	-0.111	-0.223	0.001	-2.36	N
F	13	-0.417	-0.877	0.043	-1.98	N
As	11	0.00313	-0.00057	0.00683	1.88	N
SO ₄	12	-92.8	-154.6	-31.0	-3.31	Y
Na	13	-8.73	-28.8	11.4	-0.95	N
NH ₃	12	0.0596	-3.62	3.74	0.04	N
Mo	8	0.0116	-0.0072	0.0304	1.46	N

* Lower and Upper Limits of slope based on standard error of the estimate and the t-statistic for the no. of degrees of freedom.

Table A5.3.1A-2

LINEAR REGRESSION OF WATER QUALITY PARAMETERS VS TIME

Alluvia1 we11 WA02

PARAMETERS	NO. OF OBS.	ESTIMATE OF SLOPE	L L* (95% Conf)	U L* (95% Conf)	T FOR H ₀ : SLOPE = 0	IS SLOPE SIGNIFICANTLY DIFFERENT FROM ZERO? (95% Conf)
pH	5	0.105	-0.947	1.157	0.28	N
B	4	-0.712	-2.151	0.727	-1.58	N
F	5	-1.351	-3.40	06.78	-1.85	N
As	4	-0.00392	-0.010	0.00219	-2.05	N
SO ₄	5	-69.9	-208.0	68.0	-1.41	N
Na	5	-53.1	-117.0	10.8	-2.31	N
NH ₃	5	-0.0917	-0.756	0.572	-0.38	N
Mo	3	0.00672	-0.0630	0.0764	0.41	N

* Lower and Upper Limits of slope based on standard error of the estimate and the t-statistic for the no. of degrees of freedom.

Table A5.3.1A-3

LINEAR REGRESSION OF WATER QUALITY PARAMETERS VS TIME

Alluvial Well WA03

PARAMETERS	NO. OF OBS.	ESTIMATE OF SLOPE	L L* (95% Conf)	U L* (95% Conf)	T FOR H ₀ : SLOPE = 0	IS SLOPE SIGNIFICANTLY DIFFERENT FROM ZERO? (95% Conf)
pH	11	-0.00688	-0.321	0.321	-0.05	N
B	6	-0.171	-0.392	0.05	-1.99	N
F	11	-0.381	-0.717	-0.045	-2.53	Y
As	9	0.00248	-0.0147	0.0197	0.33	N
SO ₄	11	-0.889	-18.8	17.0	-0.11	N
Na	11	-29.9	-58.0	-1.78	-2.37	Y
NH ₃	10	-0.0114	-0.102	0.0789	-0.29	N
Mo	5	0.00146	-0.00582	0.00874	0.56	N
Level	33	-0.2033	-0.5709	0.1643	--	Y

* Lower and Upper Limits of slope based on standard error of the estimate and the t-statistic for the no. of degrees of freedom.

Table A5.3.1A-4

LINEAR REGRESSION OF WATER QUALITY PARAMETERS VS TIME

Alluvial Well WA05

PARAMETERS	NO. OF OBS.	ESTIMATE OF SLOPE	L L* (95% Conf)	U L* (95% Conf)	T FOR H ₀ : SLOPE = 0	IS SLOPE SIGNIFICANTLY DIFFERENT FROM ZERO? (95% Conf)
pH	6	-0.0716	-0.370	0.226	-0.62	N
B	5	-0.273	-0.651	0.105	-2.01	N
F	6	-0.770	-2.59	1.05	-1.09	N
As	6	-0.00496	-0.0250	0.0150	-0.64	N
SO ₄	6	-57.4	-136.6	21.8	1.86	N
Na	6	-25.9	-79.1	27.3	1.25	N
NH ₃	5	-0.107	-0.604	0.390	-0.60	N
Mo	5	-0.000478	-0.0244	0.0234	-0.06	N
Level	33	-0.000409	-0.8580	0.8572	--	N

* Lower and Upper Limits of slope based on standard error of the estimate and the t-statistic for the no. of degrees of freedom.

Table A5.3.1A-5

LINEAR REGRESSION OF WATER QUALITY PARAMETERS VS TIME

Alluvial Well WA06

PARAMETERS	NO. OF OBS.	ESTIMATE OF SLOPE	L L* (95% Conf)	U L* (95% Conf)	T FOR H ₀ : SLOPE = 0	IS SLOPE SIGNIFICANTLY DIFFERENT FROM ZERO? (95% Conf)
pH	11	0.0609	-0.260	0.382	0.42	N
B	6	-0.390	-0.773	-0.007	-2.62	Y
F	11	-0.357	-0.698	-0.016	-2.34	Y
As	10	0.00320	-0.0117	0.0181	-0.49	N
SO ₄	11	-41.9	-64.4	-19.4	-4.15	Y
Na	11	-32.1	-58.5	-5.70	-2.71	Y
NH ₃	10	-0.0828	-0.268	0.102	-1.01	N
Mo	5	-0.0103	-0.0228	0.0022	-2.29	N
Level	33	-0.05	-5.4430	5.5430	--	N

* Lower and Upper Limits of slope based on standard error of the estimate and the t-statistic for the no. of degrees of freedom.

Table A5.3.1A-6

LINEAR REGRESSION OF WATER QUALITY PARAMETERS VS TIME

Alluvial well WA07

PARAMETERS	NO. OF OBS.	ESTIMATE OF SLOPE	L L* (95% Conf)	U L* (95% Conf)	T FOR H ₀ : SLOPE = 0	IS SLOPE SIGNIFICANTLY DIFFERENT FROM ZERO? (95% Conf)
pH	12	-0.103	-0.210	0.0035	-2.12	N
B	7	-0.337	-0.661	-0.013	-2.55	Y
F	12	-0.361	-0.771	-0.011	-2.27	Y
As	11	0.00216	-0.0109	0.0153	0.37	N
SO ₄	12	-31.6	-80.3	17.1	-1.43	N
Na	12	-52.7	-100.6	-4.8	-2.42	Y
NH ₃	11	-1.05	-2.71	0.61	-1.41	N
Mo	6	0.00188	-0.0354	0.0392	0.13	N

* Lower and Upper Limits of slope based on standard error of the estimate and the t-statistic for the no. of degrees of freedom.

Table A5.3.1A-7

LINEAR REGRESSION OF WATER QUALITY PARAMETERS VS TIME

Alluvial Well WA08

PARAMETERS	NO. OF OBS.	ESTIMATE OF SLOPE	L L* (95% Conf)	U L* (95% Conf)	T FOR H ₀ : SLOPE = 0	IS SLOPE SIGNIFICANTLY DIFFERENT FROM ZERO? (95% Conf)
pH	8	-0.0923	-0.352	0.168	-0.84	N
B	7	-0.108	-0.229	0.013	-2.20	N
F	8	-0.0851	-0.206	0.0359	-1.66	N
As	8	0.00301	-0.00011	0.00613	-2.28	N
SO ₄	8	4.27	-26.0	34.6	0.33	N
Na	8	-21.4	-58.5	15.7	-1.36	N
NH ₃	7	0.369	-0.721	1.46	0.83	N
Mo	6	0.00699	-0.0133	0.0273	0.88	N
Level	33	-0.08	-3.7352	3.5752	--	N

* Lower and Upper Limits of slope based on standard error of the estimate and the t-statistic for the no. of degrees of freedom.

Table A5.3.1A-8

LINEAR REGRESSION OF WATER QUALITY PARAMETERS VS TIME

Alluvia1 Well WA09

PARAMETERS	NO. OF OBS.	ESTIMATE OF SLOPE	L L* (95% Conf)	U L* (95% Conf)	T FOR H ₀ : SLOPE = 0	IS SLOPE SIGNIFICANTLY DIFFERENT FROM ZERO? (95% Conf)
pH	8	-0.072	-0.323	0.179	-0.68	N
B	7	-0.0171	-0.318	0.284	-0.14	N
F	8	-0.0877	-0.1991	0.0243	-1.85	N
As	8	0.00284	-0.0004	0.00608	2.08	N
SO ₄	8	-7.54	-69.5	54.4	-0.29	N
Na	8	-7.00	-18.3	4.34	-1.46	N
NH ₃	7	-0.252	-0.918	0.414	-0.93	N
Mo	7	-0.00761	-0.0256	0.0104	-1.03	N

* Lower and Upper Limits of slope based on standard error of the estimate and the t-statistic for the no. of degrees of freedom.

Table A5.3.1A-9

LINEAR REGRESSION OF WATER QUALITY PARAMETERS VS TIME

Alluvial Well WA10

PARAMETERS	NO. OF OBS.	ESTIMATE OF SLOPE	L L* (95% Conf)	U L* (95% Conf)	T FOR H ₀ : SLOPE = 0	IS SLOPE SIGNIFICANTLY DIFFERENT FROM ZERO? (95% Conf)
pH	7	-0.154	-0.312	0.004	-2.38	N
B	6	-0.183	-0.407	0.041	-2.10	N
F	7	-0.0747	-0.228	0.0783	-1.19	N
As	7	0.00375	-0.00039	0.00789	2.22	N
SO ₄	7	-19.6	-37.6	-1.6	-2.66	Y
Na	7	-7.92	-31.4	15.58	-0.82	N
NH ₃	6	-0.0487	-0.268	0.170	-0.57	N
Mo	5	0.00533	0.00166	0.009	4.04	Y

* Lower and Upper Limits of slope based on standard error of the estimate and the t-statistic for the no. of degrees of freedom.

Table A5.3.1A-10

LINEAR REGRESSION OF WATER QUALITY PARAMETERS VS TIME

Alluvia1 Well Wall

PARAMETERS	NO. OF OBS.	ESTIMATE OF SLOPE	L L* (95% Conf)	U L* (95% Conf)	T FOR H ₀ : SLOPE = 0	IS SLOPE SIGNIFICANTLY DIFFERENT FROM ZERO? (95% Conf)
pH	8	-0.0811	-0.344	0.182	-0.73	N
B	7	-0.080	-0.237	0.077	-1.25	N
F	8	-0.0403	-0.0996	0.019	-1.61	N
As	8	0.00247	-0.00098	0.00592	1.69	N
SO ₄	8	-10.7	-50.7	29.25	-0.63	N
Na	8	-3.91	-13.2	5.33	-1.00	N
NH ₃	7	0.704	-0.205	1.61	1.90	N
Mo	5	-0.00651	-0.0530	0.0399	-0.39	N

* Lower and Upper Limits of slope based on standard error of the estimate and the t-statistic for the no. of degrees of freedom.

Table A5.3.1A-11

LINEAR REGRESSION OF WATER QUALITY PARAMETERS VS TIME

Alluvial Well WA12

PARAMETERS	NO. OF OBS.	ESTIMATE OF SLOPE	L L* (95% Conf)	U L* (95% Conf)	T FOR H ₀ : SLOPE = 0	IS SLOPE SIGNIFICANTLY DIFFERENT FROM ZERO? (95% Conf)
pH	8	-0.0654	-0.327	0.197	-0.59	N
B	7	-0.680	-1.81	0.45	-1.48	N
F	8	-0.209	-0.505	0.0865	-1.67	N
As	8	0.00219	-0.00131	0.00569	1.48	N
SO ₄	8	-9.75	-29.4	9.85	-1.18	N
Na	8	-79.6	-195.0	36.0	-1.63	N
NH ₃	7	-0.123	-0.382	0.136	-1.16	N
Mo	6	-0.00140	-0.0175	0.0147	-0.22	N

* Lower and Upper Limits of slope based on standard error of the estimate and the t-statistic for the no. of degrees of freedom.

Table A5.3.1A-12

T-TEST PROCEDURE SUMMARY FOR BETWEEN STATION COMPARISONS OF ALLUVIAL WELLS

<u>Variables</u>	<u>Locations WA03-WA05</u>	<u>Locations WA03-WA06</u>	<u>Locations WA03-WA08</u>	<u>Locations WA06-WA05</u>	<u>Locations WA06-WA08</u>	<u>Locations WA05-WA08</u>
pH	R	R	R	R	R	R
B	R	R	R	R	R	R
F	R	R	R	R	R	R
As	R	R	R	R	R	R
Mb	R	A	R	R	R	R
SO ₄	R	A	A	R	A	R
Na	R	A	R	R	A	R
NH ₃	R	R	R	R	R	R
Spec Cond	R	A	A	A	A	R
TDS	R	A	R	R	R	R
Level	R	R	R	A	R	R

Note: Table entries indicate acceptance (A) or rejection (R) of null hypothesis
H₀: The paired station means are not equal (90% confidence limit).

APPENDIX A5.3.1B

Linear Regression Data for Alluvial Wells

REGRESSION OF WATER QUALITY PARAMETERS VS TIME

LOC=VA01

OBS	YR	MO	LIST	TOC	PHENOLS	PH	B	F	AS	YRMO	PRED1	PRED2	PRED3	PRED4	RESID1	RESID2	RESID3	RESID4
1	74	10	1	7	.	7.8	0.60	3.60	0.005	74.7500	8.53227	0.363242	1.69292	0.0060517	-0.73227	0.23676	1.70708	0.0053052
2	75	5	3	8	.	8.4	0.30	1.30	0.002	75.3333	8.72674	0.296293	1.54629	0.0101783	-0.02674	-0.10830	-0.24959	0.0009823
3	75	6	2	8	.	8.4	0.01	0.70	0.006	75.6667	8.36644	0.261183	1.51024	0.00205935	0.03356	0.33882	-0.61051	0.0039265
4	76	2	4	.	.	8.3	.	0.90	.	76.0833	8.29107	0.214793	1.13674	0.00336169	0.10893	-0.043674	-0.43674	.
5	76	2	4	.	.	8.3	.	0.60	0.001	76.2500	8.26092	0.196959	1.06721	0.00388255	0.03908	.	-0.16721	-0.0031439
6	76	5	9	.	.	8.3	0.10	0.60	0.001	76.4167	8.23077	0.177680	0.95769	0.00414297	0.04623	-0.39769	-0.39769	0.0034038
7	76	6	7	.	.	8.3	.	0.80	0.001	76.5000	8.21569	0.168402	0.96293	0.00466383	0.08431	-0.06840	-0.16293	-0.0031924
8	76	7	8	.	.	8.4	.	0.80	0.001	76.5833	8.20062	0.159124	0.92817	0.00592426	0.19938	.	0.12817	-0.0031924
9	76	8	9	.	.	8.4	.	0.40	0.001	76.6667	8.18554	0.149846	0.89341	0.00518469	0.21440	-0.06057	-0.0041841	0.0004451
10	76	9	10	.	.	8.5	0.09	1.00	0.020	76.7500	8.17047	0.140568	0.85865	0.00544512	-0.42952	0.10932	0.53135	-0.0036451
11	77	1	12	.	.	7.5	0.12	0.91	0.020	77.9167	7.05942	0.010675	0.37199	0.00909112	-0.45942	0.05382	0.53135	-0.0109089
12	77	1	12	.	.	7.5	0.04	0.96	0.010	78.1667	7.91419	-0.017159	0.26771	0.00087240	-0.41419	0.05716	0.69229	0.0001276

LOC=VA02

OBS	YR	MO	LIST	TOC	PHENOLS	PH	B	F	AS	YRMO	PRED1	PRED2	PRED3	PRED4	RESID1	RESID2	RESID3	RESID4
14	74	10	1	7	.	7.4	1.7	5.0	0.010	74.7500	8.03374	1.12311	3.76141	0.00758587	-0.63374	0.57659	1.2386	0.0024141
15	75	5	2	2	.	8.6	0.2	1.0	0.002	75.3333	8.09471	0.70770	2.96880	0.00529778	0.50529	-0.60780	-0.9688	-0.0032978
16	75	6	2	2	.	8.3	.	1.6	0.001	75.6667	8.12955	0.47033	2.51588	0.00399030	0.47045	-1.0159	-1.0159	-0.0003753
17	76	5	7	.	.	7.8	0.0	1.8	0.001	76.3333	8.18923	-0.00443	1.61003	0.00137535	0.10077	0.030115	0.0100	0.0003753
18	76	10	5	.	.	7.8	0.0	1.8	0.001	76.7500	8.24278	-0.30115	1.04388	-0.00025900	-0.44278	0.30115	0.7561	0.0012590

LOC=VA03

OBS	YR	MO	LIST	TOC	PHENOLS	PH	B	F	AS	YRMO	PRED1	PRED2	PRED3	PRED4	RESID1	RESID2	RESID3	RESID4
19	74	10	1	7	.	7.5	0.70	1.90	0.004	74.7500	8.13837	0.42704	1.12202	0.0049515	-0.63837	0.27296	0.77798	-0.0009515
20	75	9	3	3	.	8.4	0.10	0.36	.	75.6667	8.13206	0.27024	0.77280	0.00722460	0.26794	-0.17024	-0.41280	.
21	76	2	4	3	.	8.3	0.01	0.30	0.050	76.0833	8.12920	0.19897	0.61406	0.00825790	0.17080	-0.18897	0.31406	.
22	76	4	5	5	.	8.1	.	0.40	0.001	76.2500	8.12805	0.17046	0.55059	0.00867132	-0.02905	.	-0.15059	0.04133788
23	76	5	6	7	.	8.4	.	0.30	0.001	76.4167	8.12748	0.15621	0.48702	0.00908778	-0.02748	.	-0.1862	-0.0073778
24	76	6	7	.	.	8.1	0.03	0.30	0.001	76.5000	8.12691	0.14195	0.48702	0.0090845	-0.02309	-0.09770	-0.1870	-0.0080945
25	76	6	7	.	.	8.3	.	0.40	0.001	76.5833	8.12574	0.13366	0.45532	0.0094978	0.02634	.	-0.15532	-0.0082911
26	76	6	8	.	.	8.3	.	0.40	0.001	76.5833	8.12574	0.13366	0.45532	0.0094978	0.17481	.	0.00411	-0.0074978
27	76	6	9	.	.	8.4	0.10	0.40	0.001	76.6667	8.12519	0.09019	0.36783	0.0097064	0.17481	0.01506	0.00411	-0.0087044
28	76	10	10	.	.	8.4	0.10	0.40	0.003	76.7500	8.12462	-0.08494	0.36008	0.0099111	-0.27538	0.01506	0.03992	-0.0069111
29	78	1	11	.	.	7.5	0.04	0.42	0.020	78.0000	8.11602	-0.12888	-0.11613	0.0130108	-0.61602	0.16888	0.55613	0.0069892

LOC=VA05

OBS	YR	MO	LIST	TOC	PHENOLS	PH	B	F	AS	YRMO	PRED1	PRED2	PRED3	PRED4	RESID1	RESID2	RESID3	RESID4
30	74	10	1	7	.	7.8	1.20	1.5	0.050	74.7500	8.23273	0.794793	2.38578	0.0208828	-0.43273	0.40521	-0.8858	0.029117
31	75	5	2	3	.	8.5	0.25	5.0	0.003	75.3333	8.19098	0.635438	1.92675	0.0179920	0.30927	-0.38544	3.0632	-0.014992
32	75	6	2	2	.	8.3	0.5	0.2	0.004	75.6667	8.16712	0.562378	1.60017	0.0163402	0.33260	-0.04438	-1.4802	-0.013640
33	76	5	4	5	.	8.2	0.10	0.4	0.002	76.3333	8.11942	0.362238	1.60996	0.0130366	0.08058	-0.7676	-0.017636	0.0005972
34	76	10	5	.	.	8.2	0.10	0.4	0.005	76.7500	8.08960	0.248433	0.84628	0.0109716	0.11040	-0.14843	-0.4463	-0.005972
35	78	1	6	.	.	7.8	0.08	0.4	0.020	78.0000	8.00014	-0.093041	-0.11595	0.0047770	-0.20014	0.17394	0.5160	0.0015223

LOC=VA06

OBS	YR	MO	LIST	TOC	PHENOLS	PH	B	F	AS	YRMO	PRED1	PRED2	PRED3	PRED4	RESID1	RESID2	RESID3	RESID4
36	74	10	1	7	.	7.6	1.40	1.90	0.004	74.7500	8.07446	0.99063	1.11619	0.0035518	-0.67446	0.60037	0.78381	0.0004482
37	75	9	2	6	.	8.5	0.60	0.36	0.002	75.6467	8.13028	0.63350	0.78887	0.0064823	0.36972	-0.03350	-0.42887	-0.0004482
38	76	2	4	.	.	8.2	0.08	0.30	0.050	76.0833	8.15566	0.47117	0.64009	0.0078143	0.24334	-0.39117	-0.34009	0.0004482
39	76	4	5	.	.	8.2	.	0.50	0.001	76.2500	8.16581	0.40623	0.58058	0.0083471	0.03419	.	0.18058	0.0004482
40	76	5	4	.	.	8.2	.	0.30	0.002	76.3333	8.17088	0.37377	0.55082	0.0086135	0.02912	.	0.05032	0.0004482
41	76	9	9	.	.	8.6	0.10	0.40	0.002	76.4167	8.17599	0.34139	0.52106	0.0091709	0.42404	0.20883	0.0091709	0.0004482
42	76	9	8	.	.	8.4	.	0.40	0.001	76.5833	8.18611	0.30883	0.49131	0.0094127	-0.08103	.	-0.06155	0.0004482
43	76	8	9	.	.	8.3	.	0.40	0.002	76.6667	8.19118	0.24390	0.46155	0.0096791	0.01082	.	0.03179	0.0004482
44	76	8	10	.	.	8.3	0.06	0.20	0.004	76.7500	8.19638	0.21147	0.43179	0.0099456	0.19822	0.15157	0.0099456	0.0004482
45	78	1	10	.	.	7.9	0.06	0.48	0.020	78.0000	8.27238	-0.02757	0.40204	0.0139477	-0.47238	0.37557	0.002796	0.0004482
46	78	1	11	.	.	7.9	0.06	0.48	0.020	78.0000	8.27238	-0.02757	0.40204	0.0139477	-0.47238	0.37557	0.002796	0.0004482

LOC=VA07

OBS	YR	MO	LIST	TOC	PHENOLS	PH	B	F	AS	YRMO	PRED1	PRED2	PRED3	PRED4	RESID1	RESID2	RESID3	RESID4
47	74	10	1	8	.	8.4	1.40	1.90	0.010	74.7500	8.43184	0.65486	0.87142	0.0052139	-0.03184	0.54514	1.02858	0.0047861
48	75	9	2	3	.	8.3	0.25	0.20	0.002	75.3333	8.37195	0.65826	0.66056	0.0064714	-0.17195	-0.40826	-0.46056	-0.0047861
49	75	9	3	3	.	8.3	0.50	0.13	0.003	75.6667	8.33773	0.54592	0.54007	0.0071900	-0.03773	-0.04592	-0.41007	-0.0047861
50	76	2	4	.	.	8.3	0.30	0.10	0.050	76.0833	8.29606	0.40550	0.38945	0.0080842	0.00504	-0.10550	-0.28945	0.0004482
51	76	4	5	.	.	8.3	.	0.20	0.001	76.2500	8.27795	0.34935	0.38921	0.0084775	0.02615	.	0.12721	0.0004482
52	76	5	4	.	.	8.5	0.10	0.20	0.001	76.3333	8.29316	0.32125	0.32908	0.0086271	-0.06330	.	0.09408	0.0004482
53	76	6	7	.	.	8.3	.	0.20	0.001	76.4167	8.26074	0.29318	0.26896	0.0088068	0.04791	-0.16508	-0.06896	0.0004482
54	76	7	8	.	.	8.3	.	0.20	0.001	76.5000	8.25219	0.26308	0.23884	0.0089864	0.05632	.	0.03894	0.0004482
55	76	8	9	.	.	8.3	.	0.20	0.001	76.5833	8.24368	0.23089	0.20872	0.0091660	0.12632	.	0.00477	0.0004482
56	76	8	10	.	.	8.2	0.08	0.20	0.002	76.6667	8.23508	0.21089	0.17856	0.0093457	0.12632	.	0.00477	0.0004482
57	76	10	11	.	.	8.2	0.08	0.20	0.003	76.7500	8.22652	0.18082	0.14847	0.0095253	-0.02652	-0.10062	-0.04647	0.0004482
58	78	1	12	.	.	7.9	0.04	0.20	0.020	78.0000	8.09820	-0.02404	0.30338	0.0122209	-0.19820	0.28045	0.50338	0.0004482

LOC=VA08

OBS	YR	MO	LIST	TOC	PHENOLS	PH	B	F	AS	YRMO	PRED1	PRED2	PRED3	PRED4	RESID1	RESID2	RESID3	RESID4
59	74	10	1	8	.	7.6	0.70	0.8	0.004	74.7500	8.29323	0.38519	0.441738	0.0008526	-0.69323	0.31481	0.35826	0.0031474
60	75	9	2	9	.	8.5	0.17	0.2	0.002	75.3333	8.23939	0.321969	0.392071	0.0026093	0.26061	-0.15197	-0.19207	-0.0006093
61	75	9	3	3	.	8.3	0.10	0.2	0.005	75.6667	8.20863	0.285843	0.306929	0.0036131	0.49137	-0.18584	-0.15197	0.0013889
62	76	2	4	.	.	8.3	.	0.2	0.001	76.0833	8.14711	0.213501	0.306929	0.0056207	0.15289	-0.10693	-0.10693	0.0004620
63	76	10	5	.	.	8.1	0.06	0.2	0.002	76.7500	8.10865	0.168433	0.271452	0.0066755	-0.00865	-0.10843	-0.07145	0.0004620
64	78	1	6	.	.	7.8	0.08	0.2	0.020	78.0000	7.99330	0.032961	0.165024	0.0106398	0.19330	0.04704	0.15498	0.0093692
65	78	1	7	.	.	8.3	0.03	0.2	0.010	78.1667	7.97792	0.014898	0.150833	0.0111417	-0.33209	0.01510	0.04917	0.0004620
66	78	1	8	.	.	7.6	0.03	0.1	0.010	78.6667	7.93177	-0.039292	0.108262	0.0126474	-0.33177	0.06929	-0.00626	0.0004620

REGRESSION OF WATER QUALITY PARAMETERS VS TIME

LOC=VA09

OBS	YR	MO	LIST	TOC	PHENOLS	PH	B	F	AS	YRMO	PRED1	PRED2	PRED3	PRED4	RESID1	RESID2	RESID3	RESID4
67	74	10	1	6	7.4	0.70	0.8	0.003	74.7500	8.141	0.435738	0.459274	0.001589	-0.741	0.26426	0.34073	0.0014311	
68	75	5	3	7	8.5	0.18	0.3	0.003	75.3333	8.092	0.425790	0.458107	0.002590	0.401	-0.26579	-0.30611	-0.0002239	
69	75	9	3	7	8.2	0.70	0.2	0.008	75.6667	8.073	0.420106	0.457886	0.001696	0.125	0.27887	-0.07287	-0.0038301	
70	76	6	4	7	8.4	0.2	0.2	0.001	76.3333	8.027	0.408737	0.420393	0.0060611	0.373	0.12039	-0.0050611	-0.0050611	
71	76	10	5	7	8.2	0.06	0.2	0.002	76.7500	7.997	0.401632	0.428384	0.0072432	0.203	-0.24163	-0.08385	-0.0052432	
72	78	1	7	7	7.9	0.04	0.2	0.010	78.0000	7.907	0.380315	0.417896	0.0107859	0.105	-0.34747	0.02580	-0.0092104	
73	78	3	7	7	7.9	0.03	0.2	0.010	78.1667	7.895	0.377473	0.415958	0.0112605	0.105	-0.34747	0.02580	-0.0092104	
74	78	9	8	7	7.6	1.10	0.2	0.010	78.6667	7.859	0.368946	0.411572	0.0126811	-0.259	0.73105	0.08427	-0.0026811	

LOC=VA10

OBS	YR	MO	LIST	TOC	PHENOLS	PH	B	F	AS	YRMO	PRED1	PRED2	PRED3	PRED4	RESID1	RESID2	RESID3	RESID4
75	74	10	1	3	8.0	0.70	0.8	0.001	74.7500	8.2967	0.601979	0.468236	0.0003263	-0.28477	0.09802	0.33176	0.0008737	
76	75	5	3	7	8.2	0.17	0.2	0.003	75.3333	8.1970	0.445150	0.424664	0.0025165	0.00296	-0.32515	-0.22499	0.0009335	
77	75	9	3	3	8.3	0.80	0.3	0.008	75.6667	8.1457	0.434105	0.399767	0.0035680	0.15423	0.36590	-0.09977	0.0044320	
78	76	5	4	7	8.2	0.00	0.3	0.001	76.3333	8.0432	0.421015	0.399767	0.0060710	0.15423	0.36590	-0.09977	-0.0050710	
79	76	10	5	7	8.2	0.00	0.3	0.002	76.7500	7.973	0.4235706	0.318848	0.0076354	0.22087	-0.23571	-0.01783	-0.0056354	
80	78	1	6	7	7.7	0.04	0.3	0.020	78.0000	7.7868	0.406790	0.222548	0.0123285	-0.08685	0.23321	0.07452	0.0026715	
81	78	3	7	7	7.6	0.04	0.3	0.010	78.1667	7.7612	0.4023732	0.213032	0.0129543	-0.16121	0.06373	0.08037	-0.0029543	

LOC=VA11

OBS	YR	MO	LIST	TOC	PHENOLS	PH	B	F	AS	YRMO	PRED1	PRED2	PRED3	PRED4	RESID1	RESID2	RESID3	RESID4
82	74	10	1	3	7.4	0.60	0.5	0.009	74.7500	8.1569	0.478228	0.316393	0.0025463	-0.75899	0.12177	0.18360	0.0064537	
83	75	5	3	1	8.4	0.40	0.2	0.003	75.3333	8.1157	0.431523	0.292893	0.0039846	0.28843	-0.03152	-0.09289	-0.0009846	
84	75	9	3	2	8.4	0.50	0.2	0.002	75.6667	8.0852	0.404834	0.279464	0.0048065	0.31548	-0.09517	-0.07946	-0.0028065	
85	76	5	4	7	8.4	0.08	0.2	0.001	76.3333	8.0303	0.351457	0.252607	0.0064504	0.31957	-0.05260	-0.03352	-0.0054504	
86	76	10	5	7	8.2	0.08	0.2	0.004	76.7500	7.9959	0.318006	0.235821	0.0074777	0.20338	-0.23810	-0.03352	-0.0034777	
87	78	1	6	7	7.9	0.04	0.2	0.020	78.0000	7.8959	0.218013	0.183464	0.0105599	0.00481	-0.17901	0.011536	0.0004601	
88	78	3	7	7	7.5	0.04	0.2	0.010	78.1667	7.8819	0.204669	0.178750	0.0106708	-0.00481	-0.16467	0.011536	-0.0009708	
89	78	9	8	7	7.8	0.56	0.2	0.010	78.6667	7.8411	0.164636	0.158607	0.0122037	-0.04110	0.39536	0.024159	-0.00022037	

LOC=VA12

OBS	YR	MO	LIST	TOC	PHENOLS	PH	B	F	AS	YRMO	PRED1	PRED2	PRED3	PRED4	RESID1	RESID2	RESID3	RESID4
90	74	10	1	3	7.3	1.30	0.7	0.008	74.7500	8.0156	0.33702	0.858452	0.0033938	-0.71563	1.1370	-0.15845	0.0044165	
91	75	5	3	7	8.5	0.20	0.2	0.009	75.3333	7.9746	0.34023	0.67262	0.0038621	0.54355	-1.3368	-0.46726	-0.0034077	
92	75	9	3	2	8.5	0.20	0.2	0.009	75.6667	7.9565	1.21352	0.667262	0.0059232	0.28706	-1.5135	-0.32821	-0.0040532	
93	76	5	4	7	8.0	0.01	0.2	0.003	76.3333	7.9120	1.26007	0.528214	0.0079532	0.28706	-1.5135	-0.32821	-0.0040532	
94	76	10	5	7	8.0	0.01	0.2	0.003	76.7500	7.8847	0.97667	0.441310	0.0073663	0.11523	-0.9667	-0.24151	-0.0049663	
95	78	1	6	7	7.9	0.04	0.2	0.020	78.0000	7.8029	0.12645	0.180595	0.0107056	0.09701	-0.0965	0.01940	0.0092924	
96	78	3	7	7	7.4	0.09	0.2	0.010	78.1667	7.7928	0.01309	0.145833	0.0110708	-0.35208	0.0769	0.05417	-0.0010708	
97	78	9	8	7	7.7	0.04	0.2	0.010	78.6667	7.7593	-0.32700	0.041548	0.0121665	-0.05937	0.3670	0.15845	-0.0021665	

REGRESSION OF WATER QUALITY PARAMETERS VS TIME

LOC=VA01

OBS	YR	MO	DISSOXY	MOLY	SO4	NA	NH3	YRMO	PRED1	PRED2	FRED3	PRED4	RESID1	RESID2	RESID3	RESID4
1	74	10	.	0.02	550	270	0.10	74.7500	0.0184665	565.330	252.680	1.30500	0.001534	-5.133	17.520	-1.2090
2	75	5	.	0.04	420	240	0.30	75.3333	0.0252124	511.263	547.333	1.34375	0.016738	-91.222	-5.395	-1.0437
3	75	6	.	0.02	420	250	0.30	75.6667	0.0240674	480.270	547.333	1.34375	-0.009067	-20.628	5.326	-1.0536
4	76	2	.	0.04	463	246	0.02	76.0833	0.0332860	441.592	240.834	1.38842	0.006115	21.471	5.126	-1.3684
5	76	3	.	.	480	256	15.50	76.2500	0.0358135	426.118	239.379	1.39835	.	33.852	16.021	-1.3685
6	76	4	.	.	447	240	0.01	76.3333	0.0397772	414.362	238.651	1.40332	.	46.62	17.744	-1.3983
7	76	5	.	.	460	240	0.01	76.4167	0.0377409	410.645	237.923	1.40332	.	47.326	2.405	-1.3983
8	76	6	.	0.04	474	240	0.01	76.5000	0.0387047	402.908	237.195	1.41524	0.001245	71.304	7.405	-1.4032
9	76	7	.	.	470	246	0.15	76.5833	0.0396684	395.171	236.467	1.41524	.	73.733	7.333	-1.4282
10	76	8	.	.	274	249	0.12	76.6667	0.0406321	374.435	235.740	1.42316	-0.021596	-113.83	-96.740	-1.3031
11	76	9	.	.	274	240	0.10	76.7500	0.0415959	374.698	235.012	1.42316	-0.035088	34.830	4.038	-1.3281
12	77	12	4.8	0.02	449	240	.	77.0167	0.0550891	271.393	224.822	1.45763	0.0042021	-103.17	32.178	-1.3425
13	78	3	4.0	0.10	140	220	0.17	78.1667	0.0579793	248.173	222.639	1.51253	0.0042021	-103.17	-2.639	-1.3425

LOC=VA02

OBS	YR	MO	DISSOXY	MOLY	SO4	NA	NH3	YRMO	FRED1	PRED2	PRED3	PRED4	RESID1	RESID2	RESID3	RESID4
14	74	10	.	0.005	410	260	0.60	74.7500	0.0151328	325.086	221.179	0.565215	-0.010133	84.932	38.821	-0.08521
15	75	5	.	0.040	210	160	1.10	75.3333	0.0190531	284.300	190.267	0.631731	0.014707	-78.300	-30.207	0.48827
16	75	9	.	.	218	138	0.20	75.6667	0.0212933	260.992	172.509	0.601164	0.014707	-60.932	-32.599	-0.40117
17	76	5	.	.	346	123	0.20	76.3333	0.0174700	214.377	137.114	0.540044	0.014707	3.635	0.336	-0.14004
18	76	10	.	0.020	332	138	0.66	76.7500	0.0285739	195.263	114.991	0.501241	-0.0008574	46.757	25.009	0.15316

LOC=VA03

OBS	YR	MO	DISSOXY	MOLY	SO4	NA	NH3	YRMO	PRED1	PRED2	PRED3	PRED4	RESID1	RESID2	RESID3	RESID4
19	74	10	.	0.020	400	250	0.10	74.7500	0.0150862	361.839	184.632	0.0945607	0.0049138	38.111	62.368	0.025439
20	75	9	.	0.007	330	120	0.10	75.6667	0.0164258	361.074	157.160	0.060913	-0.0094258	-31.074	-31.160	0.015509
21	76	2	.	.	340	127	0.02	76.0833	0.0170347	360.708	144.073	0.0793325	.	14.704	-17.073	0.059332
22	76	4	.	.	370	123	0.05	76.2500	0.0172792	360.556	139.078	0.074265	.	5.444	-12.678	-0.027429
23	76	5	.	.	346	123	0.20	76.3333	0.0174700	360.431	137.181	0.074265	.	-14.681	-14.181	0.123525
24	76	6	.	.	360	124	0.01	76.4167	0.0175218	360.407	134.603	0.075256	.	-0.407	-10.63	-0.065525
25	76	7	.	0.020	361	124	0.01	76.5000	0.0176436	360.333	122.136	0.075738	0.0023584	0.587	-8.186	0.064374
26	76	8	.	.	352	124	0.17	76.5833	0.017653	360.239	124.581	0.0736719	.	6.259	-2.959	0.059378
27	76	9	.	.	359	120	0.02	76.6667	0.0174871	360.185	127.191	0.0726701	.	-1.185	-2.191	-0.052570
28	76	10	.	0.020	358	120	0.10	76.7500	0.0180039	360.111	124.674	0.0717183	0.0019111	-2.111	-4.694	0.0021282
29	78	1	0.8	0.020	383	135	.	78.0000	0.0193350	359.000	97.232	0.0574619	0.0004664	248.000	21.766	.

LOC=VA05

OBS	YR	MO	DISSOXY	MOLY	SO4	NA	NH3	YRMO	PRED1	PRED2	PRED3	PRED4	RESID1	RESID2	RESID3	RESID4
30	74	10	.	0.02	500	250	0.1	74.7500	0.0286647	402.037	216.026	0.348953	-0.003665	97.96	75.974	-0.24395
31	75	5	.	0.01	260	170	0.7	75.3333	0.0283001	365.562	108.895	0.250439	-0.001300	-108.20	-28.895	0.61370
32	75	9	.	0.06	370	130	0.2	75.6667	0.0282070	345.433	100.249	0.203717	0.001793	20.57	-60.249	-0.05072
33	76	10	.	.	263	157	0.1	76.3333	0.0278886	311.175	172.956	0.179272	.	-48.17	-15.956	-0.07527
34	76	10	.	0.03	290	160	0.1	76.7500	0.0276896	287.264	162.148	0.134620	0.002310	2.74	-2.148	-0.03462
35	78	1	0.8	0.02	251	161	.	78.0000	0.0270920	215.530	129.725	0.000062	-0.007093	35.47	31.275	.

LOC=WA06

OBS	YR	MO	DISOXY	HOLY	SO4	NA	NH3	YRMO	PRED1	PRED2	PRED3	PRED4	RESID1	RESID2	RESID3	RESID4	RLS104
36	75	10	.	0.04	300	300	0.10	75.7500	0.0550089	603.373	240.109	0.236057	-0.0055501	-35.673	39.391	-0.13603	
37	75	9	.	0.05	350	180	0.50	75.6667	0.0455901	365.472	210.714	0.160155	-0.0086912	-36.982	-30.714	0.33984	
38	76	2	.	.	385	177	0.02	76.3333	0.0413088	343.016	197.352	0.125650	.	14.467	-20.352	-0.10566	
39	76	4	.	.	360	183	0.05	76.2500	0.0355963	341.033	197.008	0.111867	.	37.438	-9.103	0.06186	
40	76	5	.	.	370	183	0.20	76.3333	0.0387400	337.542	189.333	0.104561	.	10.949	-1.333	0.09304	
41	76	6	.	0.03	353	177	0.06	76.4167	0.0373833	334.051	186.663	0.094002	-0.0070275	-9.560	-9.663	-0.09306	
42	76	7	.	.	321	177	0.01	76.5000	0.0370275	330.560	183.991	0.091163	.	-2.061	-6.991	-0.09116	
43	76	8	.	.	305	170	0.11	76.5833	0.0361713	322.069	181.318	0.084664	.	-16.577	-11.318	-0.02574	
44	76	9	.	0.04	307	168	0.01	76.6667	0.0353150	323.577	177.026	0.077364	0.00555413	-17.086	-10.526	-0.06733	
45	76	10	6.8	0.02	300	168	0.10	76.7500	0.0344587	320.988	175.924	0.070465	-0.0016144	-0.0086	-7.924	0.02953	
46	76	1			263	182	.	76.0000	0.0216149	267.718	135.890	-0.033023	.	0.292	42.110	.	

LOC=WA07

OBS	YR	MO	DISOXY	HOLY	SO4	NA	NH3	YRMO	PRED1	PRED2	PRED3	PRED4	RESID1	RESID2	RESID3	RESID4	RESID4
47	75	10	.	0.04	430	380	0.10	74.7500	0.0387677	348.763	238.959	0.9027	-0.028768	131.237	141.050	-1.9037	
48	75	9	.	0.04	300	140	0.20	75.6667	0.0398646	330.303	150.630	0.7509	-0.000451	-79.353	-68.233	3.9037	
49	76	2	.	0.09	282	137	0.02	76.3333	0.0412749	310.570	168.339	0.6063	0.063725	-21.570	-50.060	-0.0413	
50	76	4	.	.	300	142	0.05	76.2500	0.0415625	301.296	159.993	0.4293	.	-1.266	-17.924	-0.5793	
51	76	5	.	.	230	141	0.30	76.3333	0.0417450	298.659	155.573	0.3421	.	-68.659	-14.573	-0.3793	
52	76	6	.	.	281	137	0.10	76.4167	0.0419017	296.022	151.886	0.2547	.	-15.022	-14.136	-0.1547	
53	76	7	.	0.02	281	133	0.01	76.5000	0.0420594	295.384	146.798	0.1673	-0.022058	-12.326	-11.778	-0.1973	
54	76	8	.	.	258	134	0.12	76.5833	0.0422151	290.747	142.410	0.0999	.	-32.647	-9.419	0.0431	
55	76	9	.	.	307	138	0.01	76.6667	0.0423714	288.110	139.022	0.0075	.	18.640	-0.022	0.0175	
56	76	10	.	0.07	313	142	0.10	76.7500	0.0425285	285.473	135.634	-0.0049	0.027471	27.527	8.566	0.0175	
57	76	1	6	0.02	313	156	.	76.0000	0.0448791	265.917	07.810	-0.0409	-0.026379	67.033	09.190	0.1949	

LOC=WA08

OBS	YR	MO	DISOXY	HOLY	SO4	NA	NH3	YRMO	PRED1	PRED2	PRED3	PRED4	RESID1	RESID2	RESID3	RESID4	RESID4
59	76	10	.	0.01	450	290	0.10	74.7500	0.0142734	303.510	181.136	0.39560	-0.004273	86.493	103.664	-0.02850	
60	76	9	.	.	350	93	0.20	75.6667	0.0183530	300.002	168.659	0.610061	0.00992	-50.002	-35.059	2.0992	
61	76	5	.	0.04	370	130	0.20	75.9967	0.0204803	397.629	161.530	0.72334	0.019319	-27.629	-31.529	-0.5239	
62	76	6	.	.	346	122	0.30	76.3333	0.0253403	400.273	147.671	0.56973	.	-54.279	-25.271	-0.6239	
63	76	10	.	0.02	403	124	0.10	76.7500	0.0282526	402.053	136.359	1.12345	-0.008253	0.947	-14.359	-1.0234	
64	76	1	6.3	0.02	416	137	0.05	75.0000	0.0369890	407.392	111.623	1.58600	-0.010990	3.008	23.377	0.008	
65	76	3	5.9	0.01	440	138	0.08	78.1667	0.0391546	408.104	106.058	1.64605	-0.028155	31.896	-20.058	-1.5661	
66	76	8	6.7	0.06	410	138	0.30	73.0667	0.0416491	410.240	177.366	1.83035	0.038351	-0.020	32.636	-1.4695	

LOC=VA10

OBS	YR	MO	DISSOXY	HOLY	SO4	NA	NH3	YRMO	PRED1	PRED2	PRED3	PRED4	RESID1	RESID2	RESID3	RESID4
67	74	10	.	0.02	760	150	0.20	74.7500	0.022653	327.570	125.458	0.986370	-0.022654	32.69	25.562	-0.73637
68	75	5	.	0.02	260	130	2.70	75.3333	0.0320140	323.114	120.372	0.839577	-0.0318015	-0.11	-27.375	1.66042
69	75	5	.	0.16	360	130	0.20	75.6667	0.0554781	320.601	118.942	0.752076	0.054522	37.60	31.959	-0.55570
70	76	5	.	.	255	98	0.30	76.3333	0.0504045	315.576	115.375	0.779332	0.007932	-60.56	-15.375	-0.26793
71	76	10	6.8	0.02	200	102	0.10	76.7500	0.0272335	312.436	116.458	0.483020	-0.007733	12.44	-8.458	-0.38308
72	77	1	8.8	0.01	210	114	0.03	78.0000	0.0172205	313.035	109.708	0.169524	-0.006452	113.99	12.292	-0.09658
73	78	3	8.8	0.01	410	99	0.03	78.1667	0.0164521	301.753	109.542	0.126563	-0.002647	109.44	-1.542	0.09658
74	79	9	11.2	0.01	140	100	0.25	78.6667	0.0124409	297.990	97.042	0.007091	-0.002647	-157.99	2.559	0.24924

LOC=VA10

OBS	YR	MO	DISSOXY	HOLY	SO4	NA	NH3	YRMO	PRED1	PRED2	PRED3	PRED4	RESULT	RESID2	RESID3	RESID4
75	74	10	.	0.001	450	160	0.10	74.7500	0.0039839	440.650	150.723	0.274032	-0.0027839	9.350	9.277	-0.17403
76	75	5	.	0.010	430	110	0.10	75.3333	0.0070931	429.274	146.803	0.245207	0.0011301	0.766	-36.103	-0.14561
77	75	5	.	.	420	150	0.50	75.6667	0.0034699	422.664	143.463	0.220366	0.0011301	-2.056	42.537	0.37064
78	76	5	.	0.020	370	134	0.30	76.3333	0.0124233	404.583	138.193	0.106879	0.006879	-30.593	-4.193	0.10312
79	76	10	.	0.020	419	106	0.10	76.7500	0.0146442	401.408	136.883	0.176575	0.0033553	16.542	-26.243	-0.07657
80	78	1	6.7	0.020	407	142	0.03	78.0000	0.0213069	376.881	125.993	0.115204	-0.0013069	39.119	-17.017	0.07657
81	78	3	8.3	0.020	350	120	0.03	78.1667	0.0221952	373.611	123.663	0.1107543	-0.0021952	-23.611	-3.663	-0.07754

LOC=VA11

OBS	YR	MO	DISSOXY	HOLY	SO4	NA	NH3	YRMO	PRED1	PRED2	PRED3	PRED4	RESID1	RESID2	RESID3	RESID4
82	74	10	.	.	480	180	0.10	74.7500	0.0555726	467.773	155.289	-0.43243	0.0000000	12.23	24.715	0.5325
83	75	5	.	0.02	470	140	0.20	75.3333	0.0517761	461.548	153.003	-0.02133	0.0000000	-21.55	-13.093	0.4215
84	75	5	.	.	450	140	0.20	75.6667	0.0496066	457.991	151.694	0.21330	-0.029607	-7.99	-11.699	-0.3130
85	76	5	.	0.10	470	142	0.30	76.3333	0.0422677	450.977	147.042	0.66296	0.0000000	6.88	-4.092	-0.3830
86	76	10	.	0.10	472	142	0.10	76.7500	0.0425559	446.430	146.462	0.97444	0.057444	25.57	-5.442	-0.8765
87	78	1	6.3	0.02	539	154	0.03	78.0000	0.0344202	433.091	146.573	1.85710	-0.014420	103.91	11.631	-1.7545
88	78	3	7.9	0.01	320	150	0.22	78.1667	0.0333357	431.314	141.921	1.97451	-0.023336	-111.31	-10.921	-2.0732
89	78	9	8.5	0.04	430	150	0.40	78.6667	0.0300815	425.977	139.965	2.32676	0.0099919	4.00	-10.035	0.00000

LOC=VA12

OBS	YR	MO	DISSOXY	HOLY	SO4	NA	NH3	YRMO	PRED1	PRED2	PRED3	PRED4	RESID1	RESID2	RESID3	RESID4
90	74	10	.	0.02	460	730	0.10	74.7500	0.0366269	486.222	372.955	0.465131	-0.015809	-6.222	357.45	-0.36513
91	75	5	.	0.06	490	150	1.10	75.3333	0.0358084	480.533	376.165	0.393443	0.0024659	9.467	-176.14	0.70656
92	75	9	.	0.06	490	140	0.10	75.6667	0.033407	477.283	299.625	0.352479	0.0024659	12.717	-159.62	-0.25248
93	76	10	.	0.03	455	145	0.30	76.3333	0.0344052	470.782	248.589	0.270331	0.0000000	17.792	-103.58	0.02943
94	76	10	6.6	0.03	446	142	0.10	76.7500	0.0338205	466.719	213.435	0.219346	-0.003821	-20.719	-71.44	-0.11935
95	78	1	6.2	0.02	518	159	0.03	78.0000	0.0320666	454.529	113.985	0.065730	-0.012067	63.471	45.01	-0.01525
96	78	3	6.2	0.02	440	130	0.03	78.1667	0.0318327	452.904	100.725	0.045243	-0.011833	-12.904	29.27	-0.01525
97	78	9	7.5	0.05	420	140	0.00	78.6667	0.0311311	448.023	60.945	0.010193	0.018007	-28.028	79.003	0.01020

APPENDIX A5.3.1C

T-TEST Procedure Results
for
Alluvial Wells WA03, WA05, WA06, WA08

TTEST PROCEDURE

VARIABLE: M0LY

LOC	N	MEAN	STD DEV	STD ERROR	MINIMUM	MAXIMUM	VARIANCES	T	DF	PROR > ITI
WA03	5	0.01740000	0.00581378	0.00260000	0.00700000	0.02000000	UNEQUAL	-1.1795	4.7	0.2946
WA05	5	0.02800000	0.01923538	0.00860233	0.01000000	0.06000000	EQUAL	-1.1795	8.0	0.2721

FOR H0: VARIANCES ARE EQUAL, F' = 10.95 WITH 4 AND 4 DF PROR > F' = 0.0397

VARIABLE: S04

LOC	N	MEAN	STD DEV	STD ERROR	MINIMUM	MAXIMUM	VARIANCES	T	DF	PROR > ITI
WA03	11	360.45454545	18.94393642	5.71181174	330.00000000	400.00000000	UNEQUAL	0.9495	5.2	0.3845
WA05	6	322.33333333	97.34200875	39.73970866	251.00000000	500.00000000	EQUAL	1.2886	15.0	0.2171

FOR H0: VARIANCES ARE EQUAL, F' = 26.40 WITH 5 AND 10 DF PROR > F' = 0.0001

VARIABLE: NA

LOC	N	MEAN	STD DEV	STD ERROR	MINIMUM	MAXIMUM	VARIANCES	T	DF	PROR > ITI
WA03	11	136.27272727	37.93702916	11.43844467	120.00000000	250.00000000	UNEQUAL	-1.6205	7.5	0.1463
WA05	6	178.00000000	56.50840645	23.06946033	130.00000000	290.00000000	EQUAL	-1.8276	15.0	0.0876

FOR H0: VARIANCES ARE EQUAL, F' = 2.22 WITH 5 AND 10 DF PROR > F' = 0.2655

VARIABLE: NH3

LOC	N	MEAN	STD DEV	STD ERROR	MINIMUM	MAXIMUM	VARIANCES	T	DF	PROR > ITI
WA03	10	0.07800000	0.06795423	0.02148902	0.01000000	0.20000000	UNEQUAL	-1.3661	4.3	0.2400
WA05	5	0.24000000	0.26076810	0.11661904	0.10000000	0.70000000	EQUAL	-1.9044	13.0	0.0792

FOR H0: VARIANCES ARE EQUAL, F' = 14.73 WITH 4 AND 9 DF PROR > F' = 0.0011

S T A T I S T I C A L A N A L Y S I S S Y S T E M

11144 WEDNESDAY, FEBRUARY 28, 1978

TTEST PROCEDURE

VARIABLE: PH

LOC	N	MEAN	STD DEV	STD ERROR	MINIMUM	MAXIMUM	VARIANCES	T	DF	PROB > T
WA03	11	8.12727273	0.33193647	0.10008261	7.50000000	8.40000000	UNEQUAL	-0.0399	12.0	0.9689
WA05	6	8.13333333	0.28047579	0.11450376	7.80000000	8.50000000	EQUAL	-0.0378	15.0	0.9703

FOR H0: VARIANCES ARE EQUAL, F' = 1.40 WITH 10 AND 5 DF PROB > F' = 0.7458

VARIABLE: B

LOC	N	MEAN	STD DEV	STD ERROR	MINIMUM	MAXIMUM	VARIANCES	T	DF	PROB > T
WA03	6	0.16333333	0.26553091	0.10840254	0.01000000	0.70000000	UNEQUAL	-1.1218	6.1	0.3042
WA05	5	0.42600000	0.46409051	0.20754758	0.08000000	1.20000000	EQUAL	-1.1811	6.0	0.2678

FOR H0: VARIANCES ARE EQUAL, F' = 3.05 WITH 4 AND 5 DF PROB > F' = 0.2521

VARIABLE: F

LOC	N	MEAN	STD DEV	STD ERROR	MINIMUM	MAXIMUM	VARIANCES	T	DF	PROB > T
WA03	11	0.50727273	0.46426481	0.13998111	0.30000000	1.90000000	UNEQUAL	-1.0462	5.3	0.3408
WA05	6	1.31666667	1.86377753	0.76088399	0.20000000	5.00000000	EQUAL	-1.3979	15.0	0.1825

FOR H0: VARIANCES ARE EQUAL, F' = 16.12 WITH 5 AND 10 DF PROB > F' = 0.0003

VARIABLE: AS

LOC	N	MEAN	STD DEV	STD ERROR	MINIMUM	MAXIMUM	VARIANCES	T	DF	PROB > T
WA03	9	0.00922222	0.01646039	0.00548680	0.00100000	0.05000000	UNEQUAL	-0.5054	9.8	0.6245
WA05	6	0.01400000	0.01885736	0.00769848	0.00200000	0.05000000	EQUAL	-0.5203	11.0	0.6116

FOR H0: VARIANCES ARE EQUAL, F' = 1.31 WITH 5 AND 8 DF PROB > F' = 0.6963

S T A T I S T I C A L A N A L Y S I S S Y S T E M

14116 WEDNESDAY, FEBRUARY 24, 1976

TTEST PROCEDURE

VARIABLE: SPECCOND

LOC	N	MEAN	STD DEV	STD ERROR	MINIMUM	MAXIMUM	VARIANCES	T	DF	PROR > ITI
WA03	11	1378.09090909	121.07886235	36.50665059	1200.00000000	1559.00000000	UNEQUAL	0.5019	9.5	0.6271
WA05	6	1345.16666667	133.49219703	54.49796123	1200.00000000	1521.00000000	EQUAL	0.5175	15.0	0.6123

FOR H0: VARIANCES ARE EQUAL, F' = 1.22 WITH 5 AND 10 DF PROB > F' = 0.7389

VARIABLE: TDS

LOC	N	MEAN	STD DEV	STD ERROR	MINIMUM	MAXIMUM	VARIANCES	T	DF	PROR > ITI
WA03	10	952.30000000	66.08252416	20.89712899	807.00000000	1022.00000000	UNEQUAL	-0.1546	4.9	0.8833
WA05	5	962.40000000	138.39544790	61.89232586	851.00000000	1200.00000000	EQUAL	-0.1953	13.0	0.8482

FOR H0: VARIANCES ARE EQUAL, F' = 4.39 WITH 4 AND 9 DF PROB > F' = 0.0612

TTEST PROCEDURE

VARIABLE: PR

LOC	N	MEAN	STD DEV	STD ERROR	MINIMUM	MAXIMUM	VARIANCES	T	DF	PROB > T
WA05	6	8.13333333	0.28047579	0.11450376	7.80000000	8.50000000	UNEQUAL	-0.2551	12.4	0.8029
WA06	11	8.17272727	0.34377583	0.10365231	7.40000000	8.60000000	EQUAL	-0.2395	15.0	0.8139

FOR H0: VARIANCES ARE EQUAL, F= 1.50 WITH 10 AND 5 DF PROR > F= 0.6836

VARIABLE: B

LOC	N	MEAN	STD DEV	STD ERROR	MINIMUM	MAXIMUM	VARIANCES	T	DF	PROB > T
WA05	5	0.42600000	0.46409051	0.20754758	0.08000000	1.20000000	UNEQUAL	0.1193	9.0	0.9076
WA06	6	0.39000000	0.53617161	0.21889114	0.06000000	1.40000000	EQUAL	0.1176	9.0	0.9089

FOR H0: VARIANCES ARE EQUAL, F= 1.33 WITH 5 AND 4 DF PROR > F= 0.8025

VARIABLE: F

LOC	N	MEAN	STD DEV	STD ERROR	MINIMUM	MAXIMUM	VARIANCES	T	DF	PROB > T
WA05	6	1.31666667	1.86377753	0.76088399	0.20000000	5.00000000	UNEQUAL	1.0045	5.3	0.3589
WA06	11	0.54000000	0.45633321	0.13758964	0.30000000	1.90000000	EQUAL	1.3439	15.0	0.1490

FOR H0: VARIANCES ARE EQUAL, F= 16.68 WITH 5 AND 10 DF PROR > F= 0.0003

VARIABLE: AS

LOC	N	MEAN	STD DEV	STD ERROR	MINIMUM	MAXIMUM	VARIANCES	T	DF	PROB > T
WA05	6	0.01400000	0.01885736	0.00769848	0.00200000	0.05000000	UNEQUAL	0.5693	9.1	0.5830
WA06	10	0.00880000	0.01554778	0.00491664	0.00100000	0.05000000	EQUAL	0.5992	14.0	0.5586

FOR H0: VARIANCES ARE EQUAL, F= 1.47 WITH 5 AND 9 DF PROR > F= 0.5786

STATISTICAL ANALYSIS SYSTEM

TTEST PROCEDURE

VARIABLE: MOLY

LOC	N	MEAN	STD DEV	STD ERROR	MINIMUM	MAXIMUM	VARIANCES	T	DF	PROR > ITI
WA05	5	0.02800000	0.01923538	0.00860233	0.01000000	0.06000000	UNEQUAL	-0.8000	4.5	0.4521
WA06	5	0.03600000	0.01140175	0.00509902	0.02000000	0.05000000	EQUAL	-0.8000	4.0	0.4468

FOR H0: VARIANCES ARE EQUAL, F' = 2.85 WITH 4 AND 4 DF PROR > F' = 0.3353

VARIABLE: SO4

LOC	N	MEAN	STD DEV	STD ERROR	MINIMUM	MAXIMUM	VARIANCES	T	DF	PROR > ITI
WA05	6	322.33333333	97.34200875	39.73970866	251.00000000	500.00000000	UNEQUAL	-0.3352	6.0	0.7489
WA06	11	336.27272727	40.62041583	12.24751619	268.00000000	400.00000000	EQUAL	-0.4209	15.0	0.6798

FOR H0: VARIANCES ARE EQUAL, F' = 5.74 WITH 5 AND 10 DF PROR > F' = 0.0188

VARIABLE: NA

LOC	N	MEAN	STD DEV	STD ERROR	MINIMUM	MAXIMUM	VARIANCES	T	DF	PROR > ITI
WA05	6	178.00000000	56.50840645	23.06946033	130.00000000	290.00000000	UNEQUAL	-0.4032	7.5	0.6981
WA06	11	188.36363636	37.59593789	11.33560178	168.00000000	300.00000000	EQUAL	-0.4558	15.0	0.6550

FOR H0: VARIANCES ARE EQUAL, F' = 2.26 WITH 5 AND 10 DF PROR > F' = 0.2555

VARIABLE: NH3

LOC	N	MEAN	STD DEV	STD ERROR	MINIMUM	MAXIMUM	VARIANCES	T	DF	PROR > ITI
WA05	5	0.24000000	0.26076810	0.11661904	0.10000000	0.70000000	UNEQUAL	0.9878	5.0	0.3664
WA06	10	0.11600000	0.14690889	0.04645667	0.01000000	0.50000000	EQUAL	1.1954	13.0	0.2533

FOR H0: VARIANCES ARE EQUAL, F' = 3.15 WITH 4 AND 9 DF PROR > F' = 0.1410

S T A T I S T I C A L A N A L Y S I S S Y S T E M

14102 WEDNESDAY, FEBRUARY 28, 1979

TTEST PROCEDURE

VARIABLE: SPECCOND

LOC	N	MEAN	STD DEV	STD ERROR	MINIMUM	MAXIMUM	VARIANCES	T	DF	PROR > ITI
WA05	6	1345.16666667	133.49219703	54.49796123	1200.00000000	1521.00000000	UNEQUAL	-2.2303	7.6	0.0581
WA06	11	1481.18181818	90.78195656	27.37178978	1350.00000000	1650.00000000	EQUAL	-2.5063	15.0	0.0242

FOR H0: VARIANCES ARE EQUAL, F' = 2.16 WITH 5 AND 10 DF PROR > F' = 0.2803

VARIABLE: TDS

LOC	N	MEAN	STD DEV	STD ERROR	MINIMUM	MAXIMUM	VARIANCES	T	DF	PROR > ITI
WA05	5	962.40000000	138.39544790	61.89232586	851.00000000	1200.00000000	UNEQUAL	-1.3911	4.0	0.2134
WA06	10	1058.40000000	96.52426293	30.52365203	912.00000000	1200.00000000	EQUAL	-1.5776	13.0	0.1387

FOR H0: VARIANCES ARE EQUAL, F' = 2.06 WITH 4 AND 9 DF PROR > F' = 0.3394

STATISTICAL ANALYSIS SYSTEM

11:39 WEDNESDAY, FEBRUARY 28, 1978

TTEST PROCEDURE

VARIABLE: PH

LOC	N	MEAN	STD DEV	STD ERROR	MINIMUM	MAXIMUM	VARIANCES	T	DF	PROR > ITI
WA05	6	8.1333333	0.28047579	0.11450376	7.80000000	8.50000000	UNEQUAL	0.1124	11.9	0.9124
WA08	8	8.1125000	0.41209396	0.14569722	7.60000000	8.70000000	EQUAL	0.1062	12.0	0.9171

FOR H0: VARIANCES ARE EQUAL, F= 2.16 WITH 7 AND 5 DF
PROR > F= 0.4140

VARIABLE: B

LOC	N	MEAN	STD DEV	STD ERROR	MINIMUM	MAXIMUM	VARIANCES	T	DF	PROR > ITI
WA05	5	0.42600000	0.46409051	0.20754758	0.08000000	1.20000000	UNEQUAL	1.1430	5.5	0.3004
WA08	7	0.16714286	0.23984122	0.09065146	0.03000000	0.70000000	EQUAL	1.2727	10.0	0.2319

FOR H0: VARIANCES ARE EQUAL, F= 3.74 WITH 4 AND 6 DF
PROR > F= 0.1470

VARIABLE: F

LOC	N	MEAN	STD DEV	STD ERROR	MINIMUM	MAXIMUM	VARIANCES	T	DF	PROR > ITI
WA05	6	1.31666667	1.86377753	0.76088399	0.20000000	5.00000000	UNEQUAL	1.3620	4.1	0.2304
WA08	8	0.27500000	0.21876275	0.07734431	0.10000000	0.80000000	EQUAL	1.5880	12.0	0.1383

FOR H0: VARIANCES ARE EQUAL, F= 72.58 WITH 5 AND 7 DF
PROR > F= 0.0001

VARIABLE: AS

LOC	N	MEAN	STD DEV	STD ERROR	MINIMUM	MAXIMUM	VARIANCES	T	DF	PROR > ITI
WA05	6	0.01400000	0.01885736	0.00769848	0.00200000	0.05000000	UNEQUAL	0.9037	5.9	0.4019
WA08	8	0.00675000	0.00638637	0.00225792	0.00100000	0.02000000	EQUAL	1.0237	12.0	0.3262

FOR H0: VARIANCES ARE EQUAL, F= 8.72 WITH 5 AND 7 DF
PROR > F= 0.0129

S T A T I S T I C A L A N A L Y S I S S Y S T E M

15:28 WEDNESDAY, FEBRUARY 28, 1976

TTEST PROCEDURE

VARIABLE: M0LY

LOC	N	MEAN	STD DEV	STD ERROR	MINIMUM	MAXIMUM	VARIANCES	T	DF	PROR > ITI
WA05	5	0.02800000	0.019233538	0.00860233	0.01000000	0.06000000	UNEQUAL	-0.1436	4.9	0.8890
WA08	6	0.03000000	0.02683282	0.01095445	0.01000000	0.08000000	EQUAL	-0.1390	9.0	0.8925

FOR H0: VARIANCES ARE EQUAL, F' = 1.95 WITH 5 AND 4 DF PROR > F' = 0.5386

VARIABLE: S04

LOC	N	MEAN	STD DEV	STD ERROR	MINIMUM	MAXIMUM	VARIANCES	T	DF	PROR > ITI
WA05	8	322.33333333	97.34200875	39.73970866	251.00000000	500.00000000	UNEQUAL	-1.8539	6.7	0.1085
WA08	8	401.87500000	45.75224429	16.17586109	346.00000000	480.00000000	EQUAL	-2.0485	12.0	0.0630

FOR H0: VARIANCES ARE EQUAL, F' = 4.53 WITH 5 AND 7 DF PROR > F' = 0.0734

VARIABLE: NA

LOC	N	MEAN	STD DEV	STD ERROR	MINIMUM	MAXIMUM	VARIANCES	T	DF	PROR > ITI
WA05	6	178.00000000	56.50840645	23.06946033	130.00000000	290.00000000	UNEQUAL	1.2041	11.6	0.2527
WA08	8	139.25000000	63.46821477	22.43940253	88.00000000	290.00000000	EQUAL	1.1827	12.0	0.2598

FOR H0: VARIANCES ARE EQUAL, F' = 1.26 WITH 7 AND 5 DF PROR > F' = 0.8258

VARIABLE: NH3

LOC	N	MEAN	STD DEV	STD ERROR	MINIMUM	MAXIMUM	VARIANCES	T	DF	PROR > ITI
WA05	5	0.24000000	0.26076810	0.11661904	0.10000000	0.70000000	UNEQUAL	-1.3438	6.5	0.2245
WA08	7	1.04000000	1.54462509	0.58381341	0.08000000	3.80000000	EQUAL	-1.1312	10.0	0.2844

FOR H0: VARIANCES ARE EQUAL, F' = 35.09 WITH 6 AND 4 DF PROR > F' = 0.0041

TTEST PROCEDURE

VARIABLE: SPECCOND

LOC	N	MEAN	STD DEV	STD ERROR	MINIMUM	MAXIMUM	VARIANCES	T	DF	PROR > ITI
WA05	6	133.49219703	54.49796123	1200.00000000	1521.00000000	1.00000000	UNEQUAL	1.1098	9.7	0.2939
WA08	7	1269.42857143	108.66900377	41.07302274	1100.00000000	1400.00000000	EQUAL	1.1289	11.0	0.2829

FOR H0: VARIANCES ARE EQUAL, F' = 1.51 WITH 5 AND 6 DF PROR > F' = 0.6263

VARIABLE: TDS

LOC	N	MEAN	STD DEV	STD ERROR	MINIMUM	MAXIMUM	VARIANCES	T	DF	PROR > ITI
WA05	5	962.40000000	138.39544790	61.89232586	851.00000000	1200.00000000	UNEQUAL	-0.7115	7.8	0.4974
WA08	5	1029.60000000	159.50956084	71.33484422	880.00000000	1200.00000000	EQUAL	-0.7115	8.0	0.4970

FOR H0: VARIANCES ARE EQUAL, F' = 1.33 WITH 4 AND 4 DF PROR > F' = 0.7898

S T A T I S T I C A L A N A L Y S I S S Y S T E M

11:35 WEDNESDAY, FEBRUARY 28, 1978

TTEST PROCEDURE

VARIABLE: PH

LOC	N	MEAN	STD DEV	STD ERROR	MINIMUM	MAXIMUM	VARIANCES	T	DF	PROB > ITI
WA03	11	8.12727273	0.33193647	0.10008261	7.50000000	8.40000000	UNEQUAL	-0.3155	20.0	0.7557
WA06	11	8.17272727	0.34377583	0.10365231	7.40000000	8.60000000	EQUAL	-0.3155	20.0	0.7557

FOR H0: VARIANCES ARE EQUAL, F' = 1.07 WITH 10 AND 10 DF PROB > F' = 0.9139

VARIABLE: B

LOC	N	MEAN	STD DEV	STD ERROR	MINIMUM	MAXIMUM	VARIANCES	T	DF	PROB > ITI
WA03	6	0.16333333	0.26553091	0.10840254	0.01000000	0.70000000	UNEQUAL	-0.9280	7.3	0.3831
WA06	6	0.39000000	0.53617161	0.21889114	0.06000000	1.40000000	EQUAL	-0.9280	10.0	0.3753

FOR H0: VARIANCES ARE EQUAL, F' = 4.08 WITH 5 AND 5 DF PROB > F' = 0.1491

VARIABLE: F

LOC	N	MEAN	STD DEV	STD ERROR	MINIMUM	MAXIMUM	VARIANCES	T	DF	PROB > ITI
WA03	11	0.50727273	0.46426481	0.13998111	0.30000000	1.90000000	UNEQUAL	-0.1667	20.0	0.8693
WA06	11	0.54000000	0.45633321	0.13758964	0.30000000	1.90000000	EQUAL	-0.1667	20.0	0.8693

FOR H0: VARIANCES ARE EQUAL, F' = 1.04 WITH 10 AND 10 DF PROB > F' = 0.9576

VARIABLE: AS

LOC	N	MEAN	STD DEV	STD ERROR	MINIMUM	MAXIMUM	VARIANCES	T	DF	PROB > ITI
WA03	9	0.00922222	0.01646039	0.00548680	0.00100000	0.05000000	UNEQUAL	0.0573	14.5	0.9550
WA06	10	0.00880000	0.01554778	0.00491664	0.00100000	0.05000000	EQUAL	0.0575	17.0	0.9548

FOR H0: VARIANCES ARE EQUAL, F' = 1.12 WITH 8 AND 9 DF PROB > F' = 0.8611

S T A T I S T I C A L A N A L Y S I S S Y S T E M

15:37 WEDNESDAY, FEBRUARY 28, 1978

TTEST PROCEDURE

VARIABLE: MOLY

LOC	N	MEAN	STD DEV	STD ERROR	MINIMUM	MAXIMUM	VARIANCES	T	DF	PROR > ITI
WA03	5	0.01740000	0.00581378	0.00260000	0.00700000	0.02000000	UNEQUAL	-3.2497	5.9	0.0177
WA06	5	0.03600000	0.01140175	0.00509902	0.02000000	0.05000000	EQUAL	-3.2497	5.9	0.0117

FOR H0: VARIANCES ARE EQUAL, F' = 3.85 WITH 4 AND 4 DF PROR > F' = 0.2203

VARIABLE: SO4

LOC	N	MEAN	STD DEV	STD ERROR	MINIMUM	MAXIMUM	VARIANCES	T	DF	PROR > ITI
WA03	11	360.45454545	18.94393642	5.71181174	330.00000000	400.00000000	UNEQUAL	1.7894	14.2	0.0950
WA06	11	336.27272727	40.62041583	12.24751619	268.00000000	400.00000000	EQUAL	1.7894	20.0	0.0887

FOR H0: VARIANCES ARE EQUAL, F' = 4.60 WITH 10 AND 10 DF PROR > F' = 0.0242

VARIABLE: NA

LOC	N	MEAN	STD DEV	STD ERROR	MINIMUM	MAXIMUM	VARIANCES	T	DF	PROR > ITI
WA03	11	136.27272727	37.93702916	11.43844467	120.00000000	250.00000000	UNEQUAL	-3.2347	20.0	0.0042
WA06	11	188.36363636	37.59593789	11.33560178	168.00000000	300.00000000	EQUAL	-3.2347	20.0	0.0042

FOR H0: VARIANCES ARE EQUAL, F' = 1.02 WITH 10 AND 10 DF PROR > F' = 0.9778

VARIABLE: NH3

LOC	N	MEAN	STD DEV	STD ERROR	MINIMUM	MAXIMUM	VARIANCES	T	DF	PROR > ITI
WA03	10	0.07800000	0.06795423	0.02148902	0.01000000	0.20000000	UNEQUAL	-0.7424	12.7	0.4714
WA06	10	0.11600000	0.14690889	0.04645667	0.01000000	0.50000000	EQUAL	-0.7424	12.7	0.4674

FOR H0: VARIANCES ARE EQUAL, F' = 4.67 WITH 9 AND 9 DF PROR > F' = 0.0312

TTEST PROCEDURE

VARIABLE: SPECCOND

LOC	N	MEAN	STD DEV	STD ERROR	MINIMUM	MAXIMUM	VARIANCES	T	DF	PROR > ITI
WA03	11	1378.09090909	121.07886235	36.50665059	1200.00000000	1559.00000000	UNEQUAL	1.9774	14.0	0.0480
WA08	7	1269.42857143	108.66900377	41.07302274	1100.00000000	1400.00000000	EQUAL	1.9278	14.0	0.0718

FOR H0: VARIANCES ARE EQUAL, F' = 1.24 WITH 10 AND 6 DF PROR > F' = 0.8241

VARIABLE: TDS

LOC	N	MEAN	STD DEV	STD ERROR	MINIMUM	MAXIMUM	VARIANCES	T	DF	PROR > ITI
WA03	10	952.30000000	66.08252416	20.89712899	807.00000000	1022.00000000	UNEQUAL	-1.0399	4.7	0.3493
WA08	5	1029.60000000	159.50956084	71.33484422	880.00000000	1200.00000000	EQUAL	-1.3548	13.0	0.1986

FOR H0: VARIANCES ARE EQUAL, F' = 5.83 WITH 4 AND 9 DF PROR > F' = 0.0270

TTEST PROCEDURE

VARIABLE: PH

LOC	N	MEAN	STD DEV	STD ERROR	MINIMUM	MAXIMUM	VARIANCES	T	DF	PROR > ITI
WA06	11	8.17272727	0.34377583	0.10365231	7.40000000	8.60000000	UNEQUAL	0.3368	11.5	0.7414
WA08	8	8.11250000	0.41209396	0.14569722	7.60000000	8.70000000	EQUAL	0.3471	17.0	0.7328

FOR H0: VARIANCES ARE EQUAL, F' = 1.44 WITH 7 AND 10 DF PROB > F' = 0.5819

VARIABLE: B

LOC	N	MEAN	STD DEV	STD ERROR	MINIMUM	MAXIMUM	VARIANCES	T	DF	PROR > ITI
WA06	6	0.39000000	0.53617161	0.21889114	0.06000000	1.40000000	UNEQUAL	0.9406	6.7	0.3797
WA08	7	0.16714286	0.23984122	0.09065146	0.03000000	0.70000000	EQUAL	0.9951	11.0	0.3411

FOR H0: VARIANCES ARE EQUAL, F' = 5.00 WITH 5 AND 6 DF PROB > F' = 0.0753

VARIABLE: F

LOC	N	MEAN	STD DEV	STD ERROR	MINIMUM	MAXIMUM	VARIANCES	T	DF	PROR > ITI
WA06	11	0.54000000	0.45633321	0.13758964	0.30000000	1.90000000	UNEQUAL	1.6789	15.2	0.1137
WA08	8	0.27500000	0.21876275	0.07734431	0.10000000	0.80000000	EQUAL	1.5124	17.0	0.1484

FOR H0: VARIANCES ARE EQUAL, F' = 4.35 WITH 10 AND 7 DF PROB > F' = 0.0634

VARIABLE: AS

LOC	N	MEAN	STD DEV	STD ERROR	MINIMUM	MAXIMUM	VARIANCES	T	DF	PROR > ITI
WA06	10	0.00880000	0.01554778	0.00491664	0.00100000	0.05000000	UNEQUAL	0.3789	12.5	0.7111
WA08	8	0.00675000	0.00638637	0.00225792	0.00100000	0.02000000	EQUAL	0.3485	16.0	0.7320

FOR H0: VARIANCES ARE EQUAL, F' = 5.93 WITH 9 AND 7 DF PROB > F' = 0.0285

TTEST PROCEDURE

VARIABLE: M01

LOC	N	MEAN	STD DEV	STD ERROR	MINIMUM	MAXIMUM	VARIANCES	T	DF	PROR > ITI
WA06	5	0.03600000	0.01140175	0.00509902	0.02000000	0.05000000	UNEQUAL	0.4966	7.0	0.6147
WA08	6	0.03000000	0.02683282	0.01095445	0.01000000	0.08000000	EQUAL	0.4631	9.0	0.6543

FOR H0: VARIANCES ARE EQUAL, F' = 5.54 WITH 5 AND 4 DF PROR > F' = 0.1222

VARIABLE: S04

LOC	N	MEAN	STD DEV	STD ERROR	MINIMUM	MAXIMUM	VARIANCES	T	DF	PROR > ITI
WA06	11	336.27272727	40.62041583	12.24751619	268.00000000	400.00000000	UNEQUAL	-3.2333	14.1	0.0069
WA08	8	401.87500000	45.75224429	16.17586109	346.00000000	480.00000000	EQUAL	-3.2981	17.0	0.0042

FOR H0: VARIANCES ARE EQUAL, F' = 1.27 WITH 7 AND 10 DF PROR > F' = 0.7077

VARIABLE: NA

LOC	N	MEAN	STD DEV	STD ERROR	MINIMUM	MAXIMUM	VARIANCES	T	DF	PROR > ITI
WA06	11	188.36363636	37.59593789	11.33560178	168.00000000	300.00000000	UNEQUAL	1.9536	10.5	0.0778
WA08	8	139.25000000	63.46821477	22.43940253	88.00000000	290.00000000	EQUAL	2.1181	17.0	0.0492

FOR H0: VARIANCES ARE EQUAL, F' = 2.85 WITH 7 AND 10 DF PROR > F' = 0.1303

VARIABLE: NH3

LOC	N	MEAN	STD DEV	STD ERROR	MINIMUM	MAXIMUM	VARIANCES	T	DF	PROR > ITI
WA06	10	0.11600000	0.14690889	0.04645667	0.01000000	0.50000000	UNEQUAL	-1.5777	6.1	0.1652
WA08	7	1.04000000	1.54462509	0.58381341	0.08000000	3.80000000	EQUAL	-1.9064	15.0	0.0759

FOR H0: VARIANCES ARE EQUAL, F' = 110.55 WITH 6 AND 9 DF PROR > F' = 0.0001

S T A T I S T I C A L A N A L Y S I S S Y S T E M

14:14 WEDNESDAY, FEBRUARY 28, 1978

TTEST PROCEDURE

VARIABLE: SPECCOND

LOC	N	MEAN	STD DEV	STD ERROR	MINIMUM	MAXIMUM	VARIANCES	T	DF	PROR > ITI
WA06	11	1481.18181818	90.78195556	27.37178978	1350.00000000	1650.00000000	UNEQUAL	4.2902	11.2	0.0012
WA08	7	1269.42857143	108.66900377	41.07302274	1100.00000000	1400.00000000	EQUAL	4.4748	16.0	0.0004

FOR H0: VARIANCES ARE EQUAL, F: 1.43 WITH 6 AND 10 DF PROR > F: 0.5859

VARIABLE: TDS

LOC	N	MEAN	STD DEV	STD ERROR	MINIMUM	MAXIMUM	VARIANCES	T	DF	PROR > ITI
WA06	10	1058.60000000	96.52426293	30.52365203	912.00000000	1200.00000000	UNEQUAL	0.3712	5.5	0.7244
WA08	5	1029.60000000	159.50956084	71.33484422	880.00000000	1200.00000000	EQUAL	0.4400	13.0	0.6671

FOR H0: VARIANCES ARE EQUAL, F: 2.73 WITH 4 AND 9 DF PROR > F: 0.1941

STATISTICAL ANALYSIS SYSTEM

11:42 WEDNESDAY, FEBRUARY 28, 1978

TTEST PROCEDURE

VARIABLE: PH

LOC	N	MEAN	STD DEV	STD ERROR	MINIMUM	MAXIMUM	VARIANCES	T	DF	PROR > ITI
WA03	11	8.12727273	0.33193647	0.10006261	7.50000000	8.40000000	UNEQUAL	0.0836	13.1	0.9347
WA08	8	8.11250000	0.41209396	0.14569722	7.60000000	8.70000000	EQUAL	0.0866	17.0	0.9320

FOR H0: VARIANCES ARE EQUAL, F' = 1.54 WITH 7 AND 10 DF
PROB > F' = 0.5160

VARIABLE: B

LOC	N	MEAN	STD DEV	STD ERROR	MINIMUM	MAXIMUM	VARIANCES	T	DF	PROR > ITI
WA03	6	0.16333333	0.26553091	0.10840254	0.01000000	0.70000000	UNEQUAL	-0.0270	10.3	0.9790
WA08	7	0.16714286	0.23984122	0.09065146	0.03000000	0.70000000	EQUAL	-0.0272	11.0	0.9788

FOR H0: VARIANCES ARE EQUAL, F' = 1.23 WITH 5 AND 6 DF
PROB > F' = 0.7994

VARIABLE: F

LOC	N	MEAN	STD DEV	STD ERROR	MINIMUM	MAXIMUM	VARIANCES	T	DF	PROR > ITI
WA03	11	0.50727273	0.46426481	0.13998111	0.30000000	1.90000000	UNEQUAL	1.4524	15.0	0.1670
WA08	8	0.27500000	0.21876275	0.07734431	0.10000000	0.80000000	EQUAL	1.3060	17.0	0.2089

FOR H0: VARIANCES ARE EQUAL, F' = 4.50 WITH 10 AND 7 DF
PROB > F' = 0.0579

VARIABLE: AS

LOC	N	MEAN	STD DEV	STD ERROR	MINIMUM	MAXIMUM	VARIANCES	T	DF	PROR > ITI
WA03	9	0.00922222	0.01646039	0.00548680	0.00100000	0.05000000	UNEQUAL	0.4167	10.6	0.6853
WA08	8	0.00675000	0.00638637	0.00225792	0.00100000	0.02000000	EQUAL	0.3979	15.0	0.6963

FOR H0: VARIANCES ARE EQUAL, F' = 6.64 WITH 8 AND 7 DF
PROB > F' = 0.0217

S T A T I S T I C A L A N A L Y S I S S Y S T E M

15:28 WEDNESDAY, FEBRUARY 28, 1976

TTEST PROCEDURE

VARIABLE: M0LY

LOC	N	MEAN	STD DEV	STD ERROR	MINIMUM	MAXIMUM	VARIANCES	T	DF	PROR > ITI
WA03	5	0.01740000	0.00581378	0.00260000	0.00700000	0.02000000	UNEQUAL	-1.1191	5.6	0.3095
WA08	6	0.03000000	0.02683282	0.01095445	0.01000000	0.08000000	EQUAL	-1.0214	9.0	0.3337

FOR H0: VARIANCES ARE EQUAL, F* = 21.30 WITH 5 AND 4 DF PROR > F* = 0.0111

VARIABLE: S04

LOC	N	MEAN	STD DEV	STD ERROR	MINIMUM	MAXIMUM	VARIANCES	T	DF	PROR > ITI
WA03	11	160.45454545	18.94393642	5.71181174	330.00000000	400.00000000	UNEQUAL	-2.4145	9.8	0.0397
WA08	8	401.87500000	45.75224429	16.17586109	346.00000000	480.00000000	EQUAL	-2.7213	17.0	0.0145

FOR H0: VARIANCES ARE EQUAL, F* = 5.83 WITH 7 AND 10 DF PROR > F* = 0.0133

VARIABLE: NA

LOC	N	MEAN	STD DEV	STD ERROR	MINIMUM	MAXIMUM	VARIANCES	T	DF	PROR > ITI
WA03	11	136.27272727	37.97702916	11.43844467	120.00000000	250.00000000	UNEQUAL	-0.1182	10.6	0.9081
WA08	8	139.25000000	63.46821477	22.43840253	88.00000000	290.00000000	EQUAL	-0.1280	17.0	0.8996

FOR H0: VARIANCES ARE EQUAL, F* = 2.80 WITH 7 AND 10 DF PROR > F* = 0.1368

VARIABLE: NH3

LOC	N	MEAN	STD DEV	STD ERROR	MINIMUM	MAXIMUM	VARIANCES	T	DF	PROR > ITI
WA03	10	0.07800000	0.06795423	0.02148902	0.01000000	0.20000000	UNEQUAL	-1.6467	6.0	0.1506
WA08	7	1.04000000	1.54462509	0.58381341	0.08000000	3.80000000	EQUAL	-1.9953	15.0	0.0645

FOR H0: VARIANCES ARE EQUAL, F* = 516.67 WITH 6 AND 9 DF PROR > F* = 0.0001

TTEST PROCEDURE

VARIABLE: SPECCOND

LOC	N	MEAN	STD DEV	STD ERROR	MINIMUM	MAXIMUM	VARIANCES	T	DF	PROR > ITI
WA03	11	1378.09090909	121.07886235	36.50655059	1200.00000000	1559.00000000	UNEQUAL	-2.2594	18.5	0.0161
WA06	11	1481.18181818	90.78195656	27.37178978	1350.00000000	1650.00000000	EQUAL	-2.2594	20.0	0.0152

FOR H0: VARIANCES ARE EQUAL, F* = 1.78 WITH 10 AND 10 DF PROB > F* = 0.3776

VARIABLE: TDS

LOC	N	MEAN	STD DEV	STD ERROR	MINIMUM	MAXIMUM	VARIANCES	T	DF	PROR > ITI
WA03	10	952.30000000	66.08252416	20.89712899	807.00000000	1022.00000000	UNEQUAL	-2.8682	15.9	0.0112
WA06	10	1058.40000000	96.52426293	30.52365203	912.00000000	1200.00000000	EQUAL	-2.8682	18.0	0.0102

FOR H0: VARIANCES ARE EQUAL, F* = 2.13 WITH 9 AND 9 DF PROB > F* = 0.2743

APPENDIX A5.3.2

This Appendix consists of two parts:

- A5.3.2A - Summary Tables for Ground Water Quality Analyses of Variance.
- A5.3.2B - Potentiometric Surface Maps - Upper Aquifer (1976-1978)

APPENDIX A5.3.2A

Summary Tables for Ground Water Quality Analyses of Variance

List of Tables Appearing in Appendix A5.3.2A

<u>TABLE NO.</u>		<u>PAGE</u>
A5.3.2A-1	Ground Water Quality Analysis of Variance - Specific Conductance	140
A5.3.2A-2	Ground Water Quality Analysis of Variance - Boron (B)	141
A5.3.2A-3	Ground Water Quality Analysis of Variance - Aluminum (Al)	142
A5.3.2A-4	Ground Water Quality Analysis of Variance - Potassium (K)	143
A5.3.2A-5	Ground Water Quality Analysis of Variance - Total Dissolved Solids (TDS)	144
A5.3.2A-6	Ground Water Quality Analysis of Variance - Calcium (Ca)	145
A5.3.2A-7	Ground Water Quality Analysis of Variance - Sodium (Na)	146
A5.3.2A-8	Ground Water Quality Analysis of Variance - Ammonia (NH ₃)	147
A5.3.2A-9	Ground Water Quality Analysis of Variance - Magnesium (Mg)	148

TABLE A5.3.2A-1 GROUND WATER QUALITY ANALYSIS OF VARIANCE

SPECIFIC CONDUCTANCE

	UPC ₂				LPC ₃				N		
	SG9#2	CB-2	SG11#3	AT-1C#3	CB-4	AT-1C#2	SG6#2	SG10R		SG11#2	AT-1C#1
1974	1600	1600	NM	1200	800	1400	NM	NM	NM	1400	8000
1975	1900	1600	1800	1300	800	1200	1250	NM	1200	1250	8050
1976	1661	1583	1890	1497.5	890	1289.5	1420.5	4795	1287	1357.5	8278.5
1977	2000	1550	1100	NM	700	NM	NM	NM	NM	1250	
N:	5161	4783	3997.5	2490	3889.5	4007.5	24328.5				

ANOVA

Source	SS	DF	MS	F
Years	7348.59	2	3674.3	0.29
Wells (Depth)	1411799.14	5	282359.83	22.34**
Error	126389.89	10	12638.99	
TOTAL	1545537.62	17		

** Significant at 95% level of confidence
 NM Not Monitored

TABLE A5.3.2A-2 GROUND WATER QUALITY ANALYSIS OF VARIANCE

BORON (B)

	UPC ₂				LPC ₃				N	
	CB-2	SG11#3	AT-1C#3	CB-4	AT-1C#2	SG6#2	SG10R	SG11#2		AT-1C#1
1974	2.90	NM	1.30	2.80	1.40	NM	NM	NM	1.10	11.0
1975	.85	1.70	.23	.25	.72	.55	NM	1.90	.51	3.26
1976	.10	.60	.20	.07	.10	.20	.60	.30	.05	0.57
1977	.09	.65	NM	.22	NM	NM	NM	NM	.70	
N:	2.25	3.85	1.73	3.12	2.22				1.66	14.83

ANOVA

Source	SS	DF	MS	F
Years	9.77	2	4.89	20.97**
Wells (Depth)	1.21	5	0.24	
Error	2.33	10	0.23	1.04
TOTAL	13.32	17		

** Significant at 95% level of confidence

NM Not Monitored

TABLE A5.3.2A-3 GROUND WATER QUALITY ANALYSIS OF VARIANCE

Aluminum (Al)

	UPC ₂				LPC ₃				N		
	SG9#2	CB-2	SG11#3	AT-1C#3	CB-4	AT-1C#2	SG6#2	SG10R		SG11=2	AT-1C#1
1974	.700	NM	NM	.900	NM	.500	NM	NM	NM	.900	3.0
1975	.175	.500	.220	.075	.400	.250	.100	NM	.240	.065	0.565
1976	.018	.030	.030	.020	.040	.040	.025	.030	.070	1.000	1.078
1977	.300	.400	.500	NM	.200	NM	NM	NM	NM	.300	

N: 0.893 0.995 0.790 1.965 4.643

ANOVA

Source	SS	DF	MS	F
Years	0.824	2	0.412	4.49
Wells (Depth)	0.295	3	0.098	1.07
Error	0.551	6	0.092	
TOTAL	1.669	11		

NM Not Monitored

TABLE A5.3.2A-4 GROUND WATER QUALITY ANALYSIS OF VARIANCE

Potassium (K)

	UPC ₂				LPC ₃				N		
	SG9#2	CB-2	SG11#3	AT-1C#3	CB-4	AT-1C#2	SG6#2	SG10R		SG11#2	AT-1C#1
1974	5.0	3.0	NM	4.0	1.0	6.0	NM	NM	NM	NM	19
1975	5.0	4.5	8.0	2.5	1.0	3.0	8.0	NM	3.5	7.5	16
1976	2.4	2.0	5.0	2.3	0.7	3.1	2.3	10.6	3.0	8.3	10.5
1977	2.1	4.5	2.9	NM	0.8	NM	NM	NM	NM	15.0	
N:	12.4	9.5	8.8	2.7	12.1						45.5

ANOVA

Source	SS	DF	MS	F
Years	7.43	2	3.72	3.80
Wells (Depth)	20.37	4	5.09	5.20**
Error	7.83	8	0.98	
TOTAL	35.63	14		

** Significant at 95% level of confidence
 NM Not Monitored

TABLE A5.3.2A-5 GROUND WATER QUALITY ANALYSIS OF VARIANCE

Total Dissolved Solids (TDS)

	UPC ₂				LPC ₃				N	
	CB-2	SG11#3	AT-1C#3	CB-4	AT-1C#2	SG6#2	SG10R	SG11=2		AT-1C#1
1974	1300	1000	NM	750	520	890	NM	NM	1200	5660
1975	1350	990	1250	900	545	740	820	790	790	5315
1976	1354.5	1025	1164	945	557	746	566	2651.5	804.5	5432
1977	*	*	*	*	*	*	*	*	*	*

N: 4004.5 3015 2595 1622 * 2794.5

ANOVA

Source	SS	DF	MS	F
Years	10261.0	2	5130.5	0.38
Wells (Depth)	1026939.67	5	205387.93	15.05**
Error	136449.33	10	13644.93	
TOTAL	1173650.00	17		

* Monitoring of parameter discontinued in 1977.

** Significant at 95% level of confidence

NM Not Monitored

TABLE A5.3.2A-6 GROUND WATER QUALITY ANALYSIS OF VARIANCE

Calcium (Ca)

	UPC ₂				LPC ₃				N		
	SG9#2	CB-2	SG11#3	AT-1C#3	CB-4	AT-1C#2	SG6#2	SG10R		SG11#2	AT-1C#1
1974	117.0	6.0	NM	15.0	22.0	28.0	NM	NM	NM	4.0	192.0
1975	80.5	4.0	19.5	47.5	21.5	6.5	8.0	NM	10.0	4.5	164.5
1976	96.0	6.0	43.0	41.0	24.0	6.1	4.8	171.5	7.0	4.9	178.0
1977	52.0	8.7	6.3	NM	23.0	NM	NM	NM	NM	5.0	
N:	293.5	16.0	103.5	67.5	40.6	13.4	534.5				

ANOVA

Source	SS	DF	MS	F
Years	63.03	2	31.52	.21
Wells (Depth)	18626.54	5	3725.31	24.51**
Error	1520.22	10	152.0	
TOTAL	20209.79	17		

** Significant at 95% level of confidence
 NM Not Monitored

TABLE A5.3.2A-7 GROUND WATER QUALITY ANALYSIS OF VARIANCE

Sodium (Na)

	UPC ₂				LPC ₃				N		
	SG9#2	CB-2	SG11#3	AT-1C#3	CB-4	AT-1C#2	SG6#2	SG10R		SG11#2	AT-1C#1
1974	270	380	NM	220	130	230	NM	NM	NM	520	1750
1975	215	360	380	220	145	300	310	NM	305	325	1565
1976	197	367	384	214	140	307	231	645	295	333	1558
1977	180	340	280	NM	135	NM	NM	NM	NM	330	
N:	682	1107	654	837	415	837	1178	4873			

ANOVA

Source	SS	DF	MS	F
Years	3952.11	2	1976.06	0.72
Wells (Depth)	140359.61	5	28071.92	10.30**
Error	27265.89	10	2726.59	
TOTAL	171577.61	17		

** Significant at 95% level of confidence
 NM Not Monitored

TABLE A5.3.2A-8 GROUND WATER QUALITY ANALYSIS OF VARIANCE

Ammonia (NH_3)

	UPC ₂				LPC ₃				N		
	SG9#2	CB-2	SG11#3	AT-1C#3	CB-4	AT-1C#2	SG6#2	SG10R		SG11#2	AT-1C#1
1974	.20	.50	NM	.20	.40	.40	NM	NM	NM	.10	1.8
1975	.65	.55	1.35	.95	.50	.50	2.15	NM	.85	.80	3.95
1976	.71	.19	2.48	1.01	.14	1.58	1.88	2.20	1.15	1.85	5.48
1977	*	*	*	*	*	*	*	*	*	*	
N:	1.56	1.24	2.16	1.04	2.48	2.75	11.23				

ANOVA

Source	SS	DF	MS	F
Years	1.14	2	0.57	2.88
Wells (Depth)	0.80	5	0.16	0.81
Error	1.98	10	0.20	
TOTAL	3.92	17		

* Monitoring of parameter discontinued in 1977
 NM Not Monitored

TABLE A5.3.2A-9 GROUND WATER QUALITY ANALYSIS OF VARIANCE

Magnesium (Mg)

	UPC ₂				LPC ₃				N		
	SG9#2	CB-2	SG11#3	AT-1C#3	CB-4	AT-1C#2	SG6#2	SG10R		SG11#2	AT-1C#1
1974	100.0	4.0	NM	23.0	23.0	29.0	NM	NM	NM	4.0	183
1975	145.0	3.5	60.5	49.5	26.0	7.0	11.5	NM	11.5	3.5	234.5
1976	131.0	4.0	57.0	47.5	26.0	4.5	2.9	110.5	6.0	3.3	216.3
1977	127.0	4.1	4.8	NM	22.0	NM	NM	NM	NM	3.0	

N: 376 11.5 120 75 40.5 10.8 623.8

ANOVA

Source	SS	DF	MS	F
Years	227.35	2	13.68	0.69
Wells (Depth)	32113.24	5	6422.65	39.19**
Error	1638.74	10	163.87	
TOTAL	33979.34	17		

** Significant at 95% confidence level
 NM Not Monitored

APPENDIX A5.3.2B

Potentiometric Surface Maps - Upper Aquifer
(1976-1978)

List of Figures Appearing in Appendix A5.3.2B

<u>FIGURE NO.</u>		<u>PAGE</u>
A5.3.2B-1	Potentiometric Surface Map - Upper Aquifer, December 1976	150
A5.3.2B-2	Potentiometric Surface Map - Upper Aquifer, January 1977	151
A5.3.2B-3	Potentiometric Surface Map - Upper Aquifer, February 1977	152
A5.3.2B-4	Potentiometric Surface Map - Upper Aquifer, March 1977	153
A5.3.2B-5	Potentiometric Surface Map - Upper Aquifer, April 1977	154
A5.3.2B-6	Potentiometric Surface Map - Upper Aquifer, May 1977	155
A5.3.2B-7	Potentiometric Surface Map - Upper Aquifer, August 1977	156
A5.3.2B-8	Potentiometric Surface Map - Upper Aquifer, September 1977	157
A5.3.2B-9	Potentiometric Surface Map - Upper Aquifer, October 1977	158
A5.3.2B-10	Potentiometric Surface Map - Upper Aquifer, December 1977	159
A5.3.2B-11	Potentiometric Surface Map - Upper Aquifer, April 1978	160
A5.3.2B-12	Potentiometric Surface Map - Upper Aquifer, May 1978	161
A5.3.2B-13	Potentiometric Surface Map - Upper Aquifer, July 1978	162
A5.3.2B-14	Potentiometric Surface Map - Upper Aquifer, September 1978	163
A5.3.2B-15	Potentiometric Surface Map - Upper Aquifer, October 1978	164
A5.3.2B-16	Potentiometric Surface Map - Upper Aquifer, November 1978	165

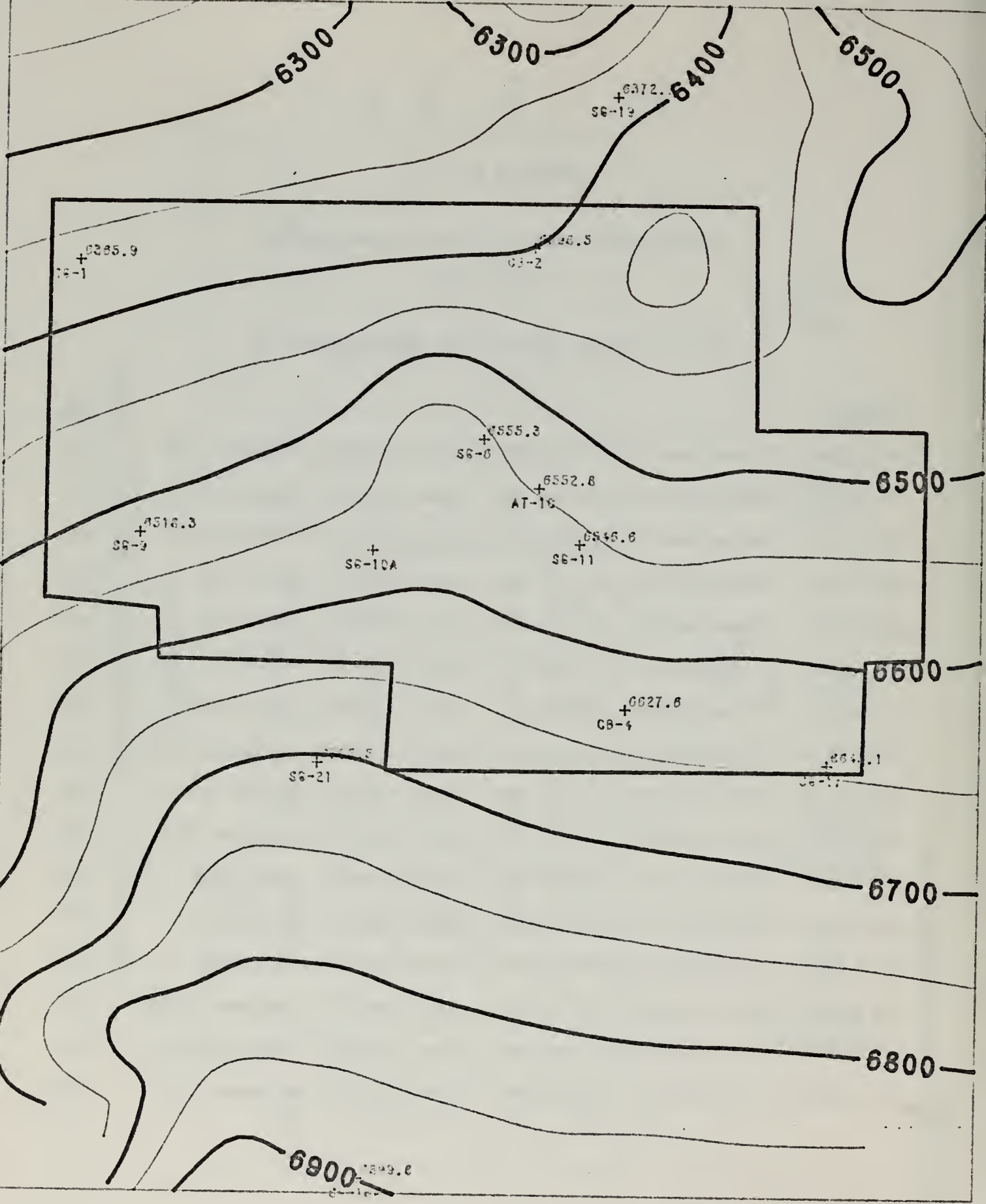

FIGURE A5.3.2B-1 Potentiometric Surface Map - Upper Aquifer, December 1976

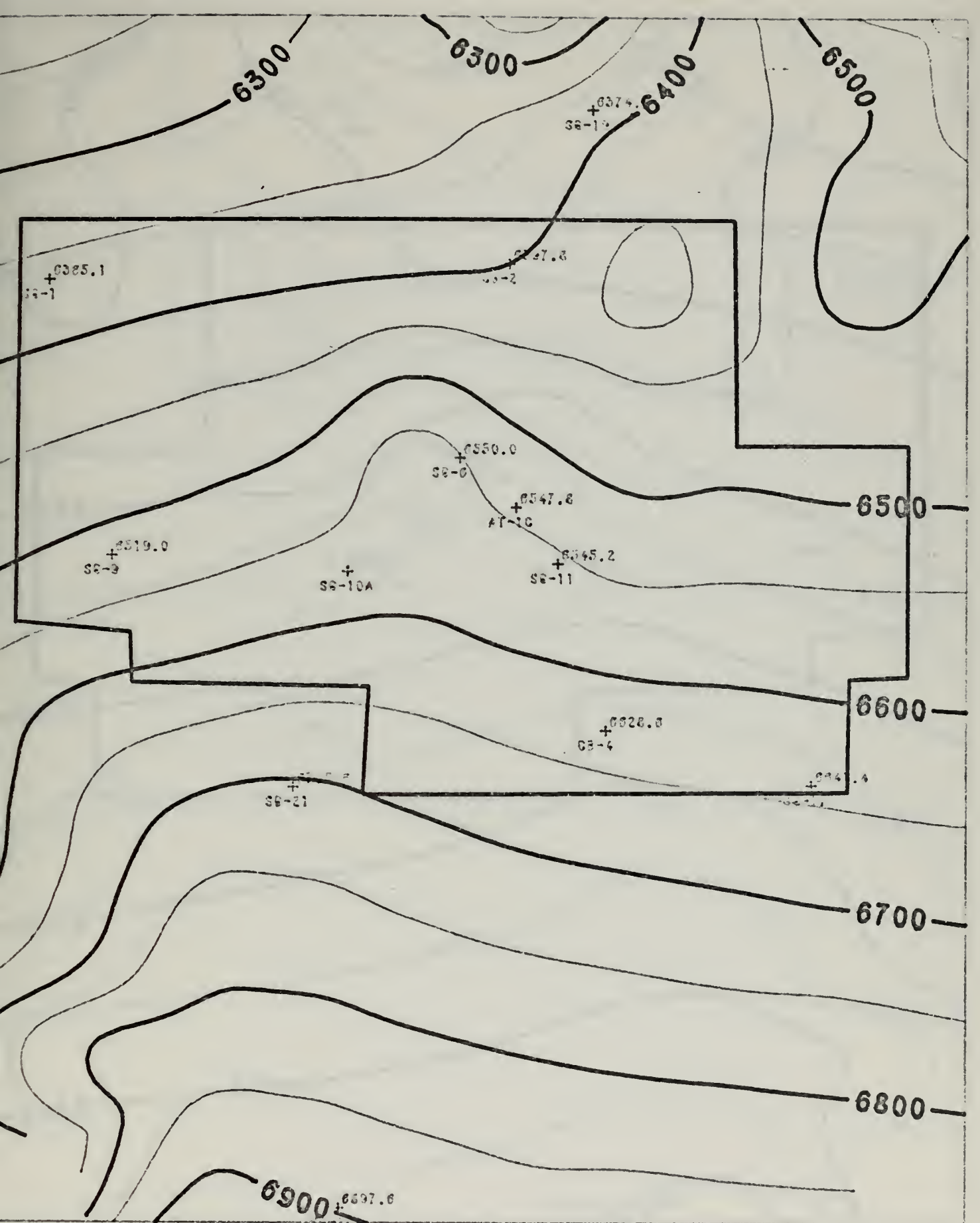

FIGURE A5.3.2B-2 Potentiometric Surface Map - Upper Aquifer, January 1977

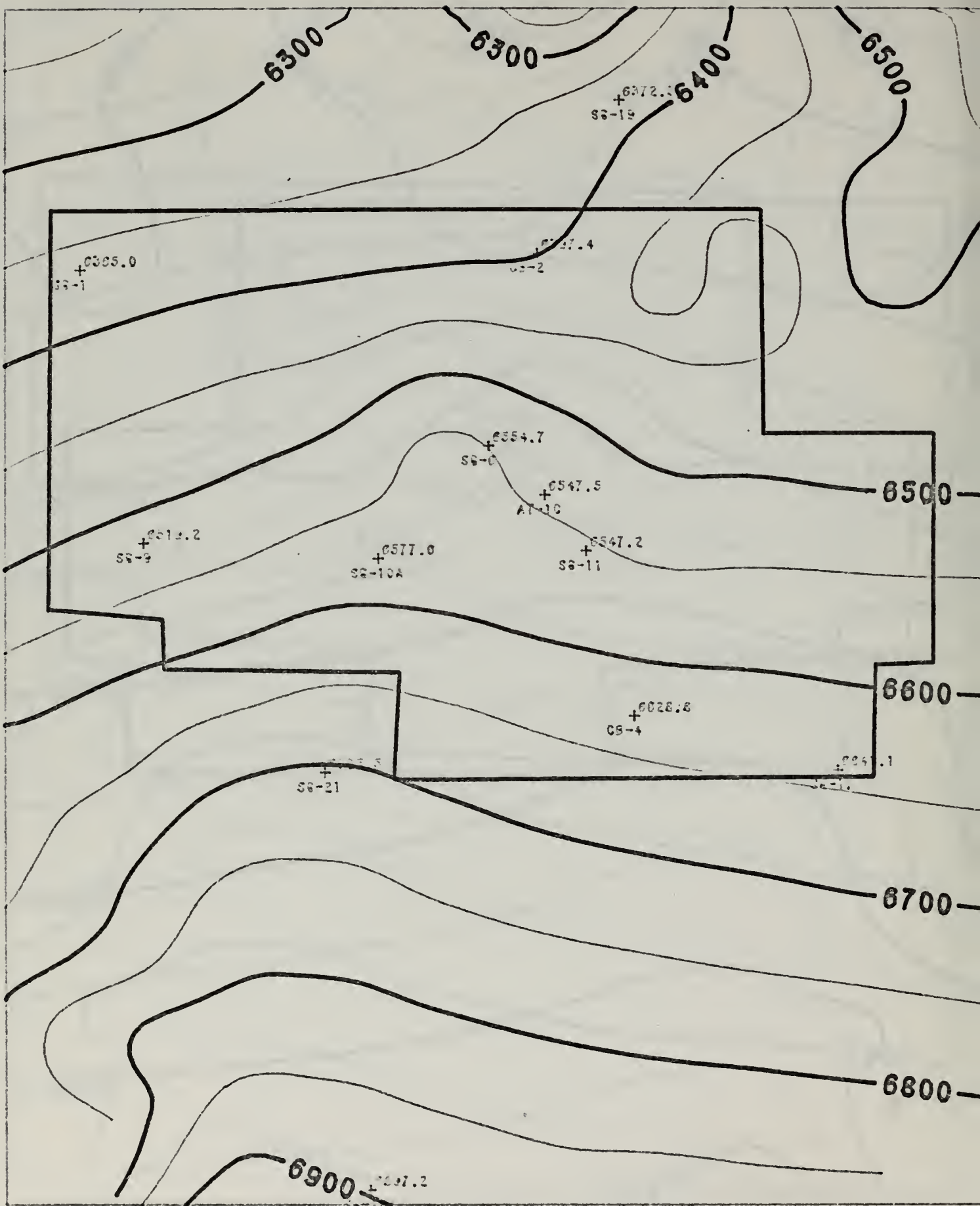

FIGURE A5.3.2B-3 Potentiometric Surface Map - Upper Aquifer, February 1977

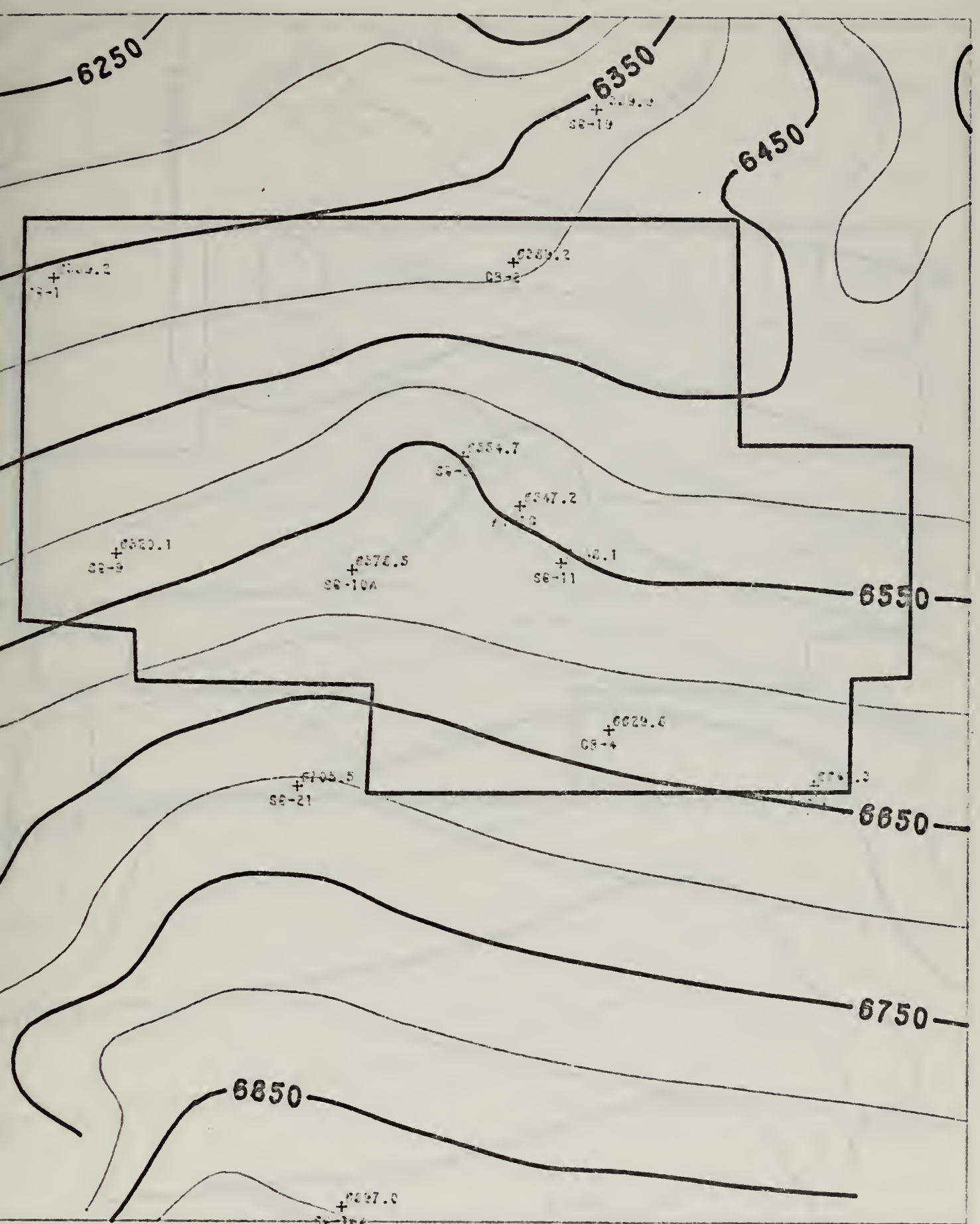

FIGURE A5.3.2B-4 Potentiometric Surface Map - Upper Aquifer, March 1977

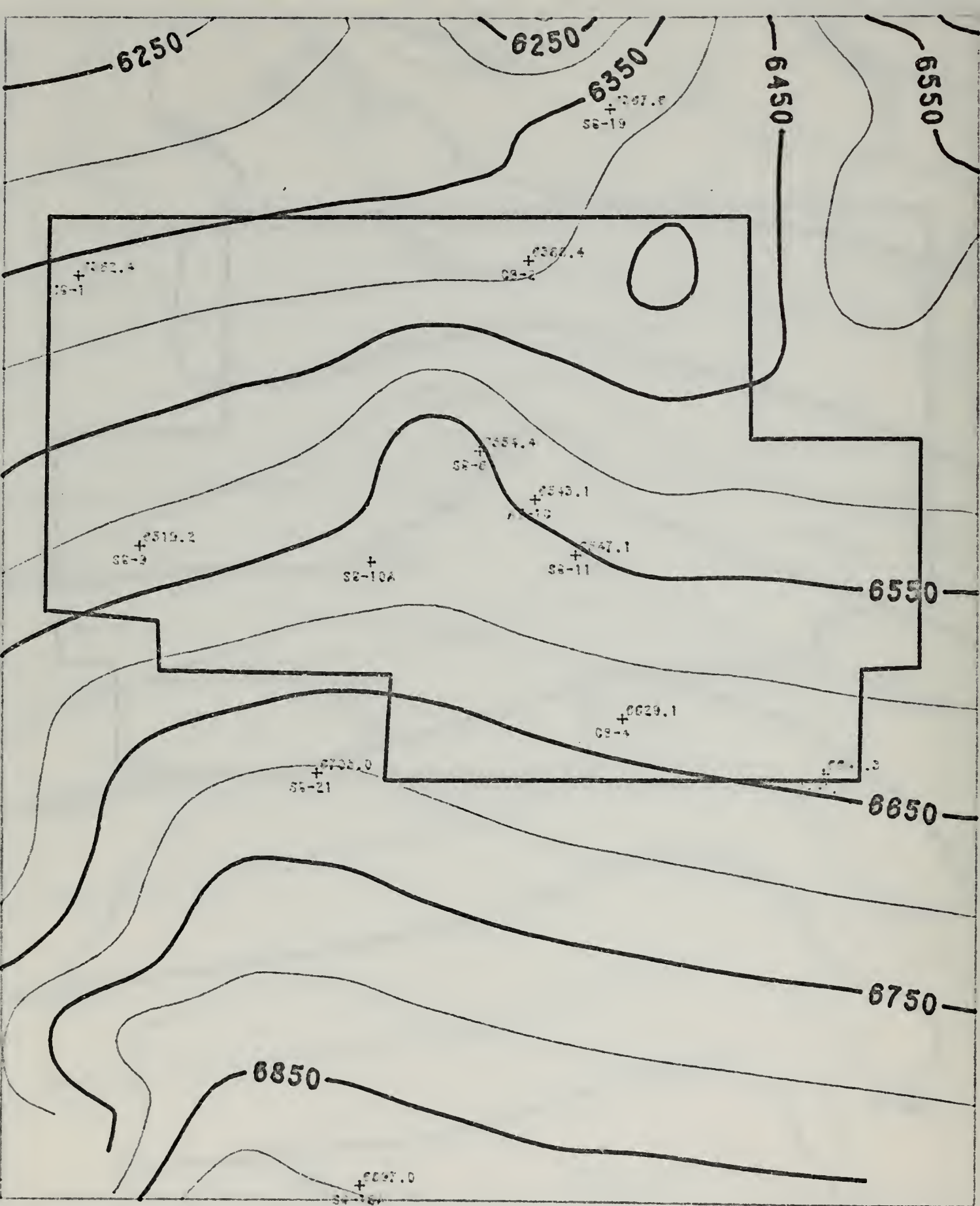

FIGURE A5.3.2B-5 Potentiometric Surface Map - Upper Aquifer, April 1977

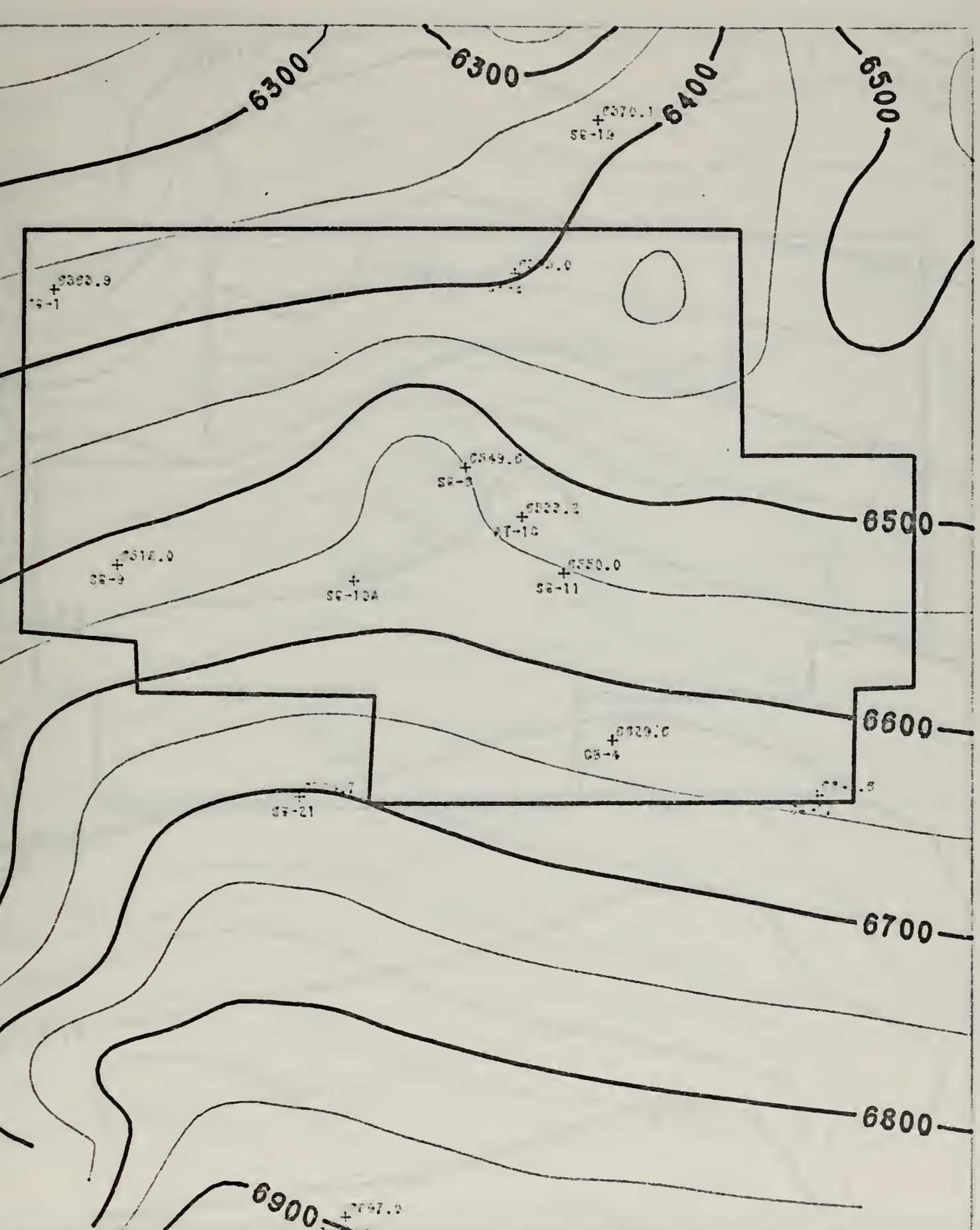

FIGURE A5.3.2B-6 Potentiometric Surface Map - Upper Aquifer, May 1977

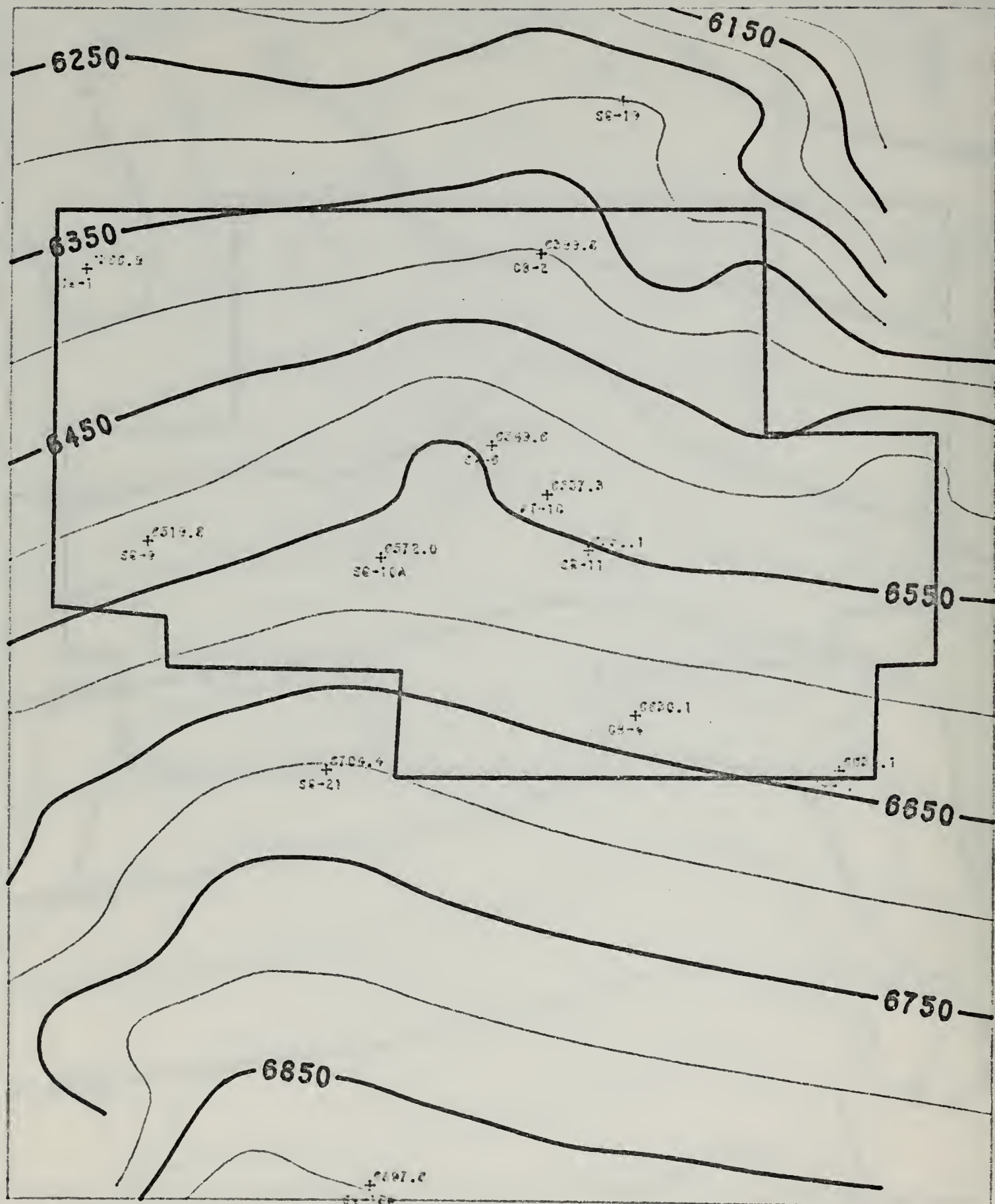

FIGURE A5.3.2B-7 Potentiometric Surface Map - Upper Aquifer, August 1977

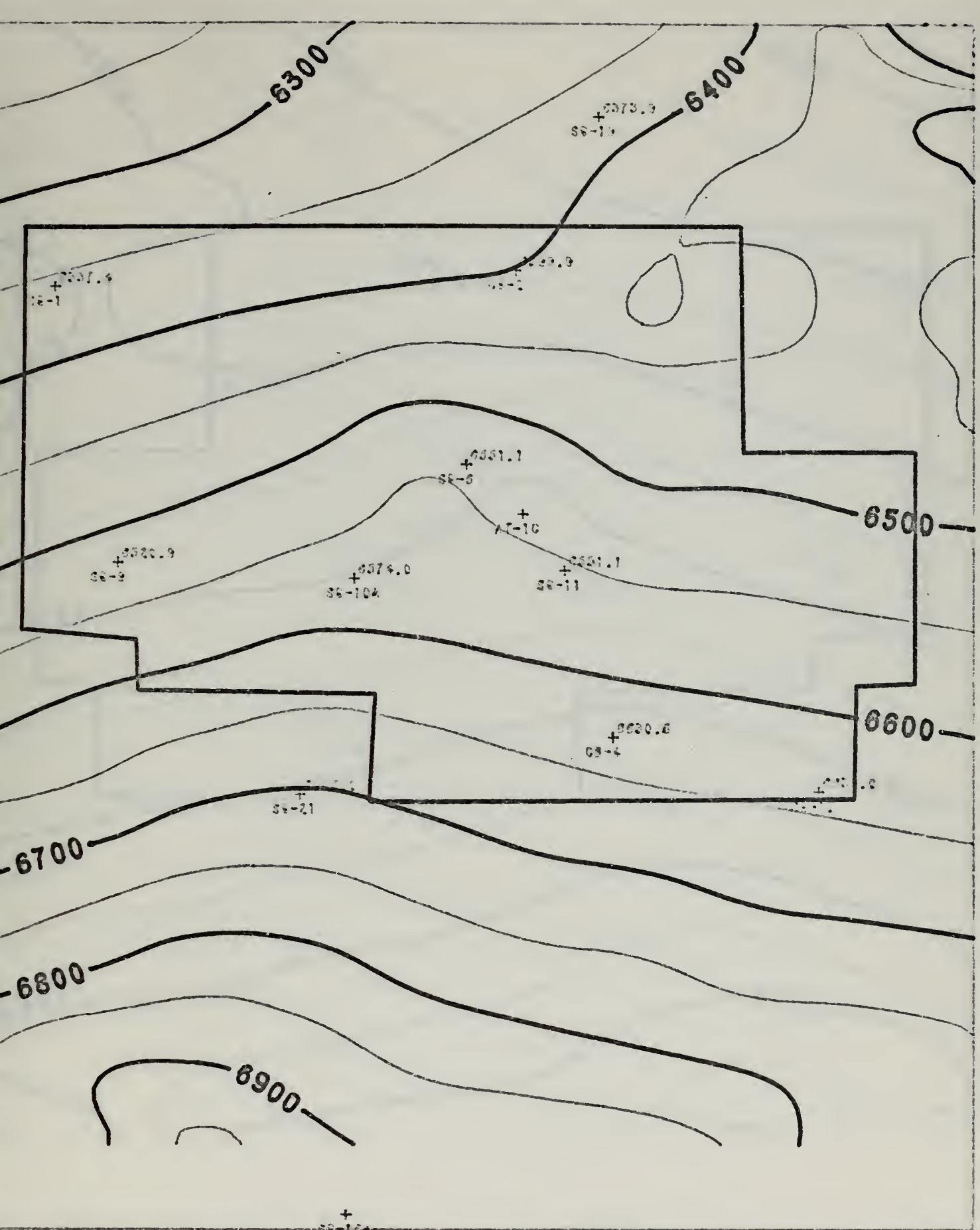

FIGURE A5.3.2B-8 Potentiometric Surface Map - Upper Aquifer, September 1977

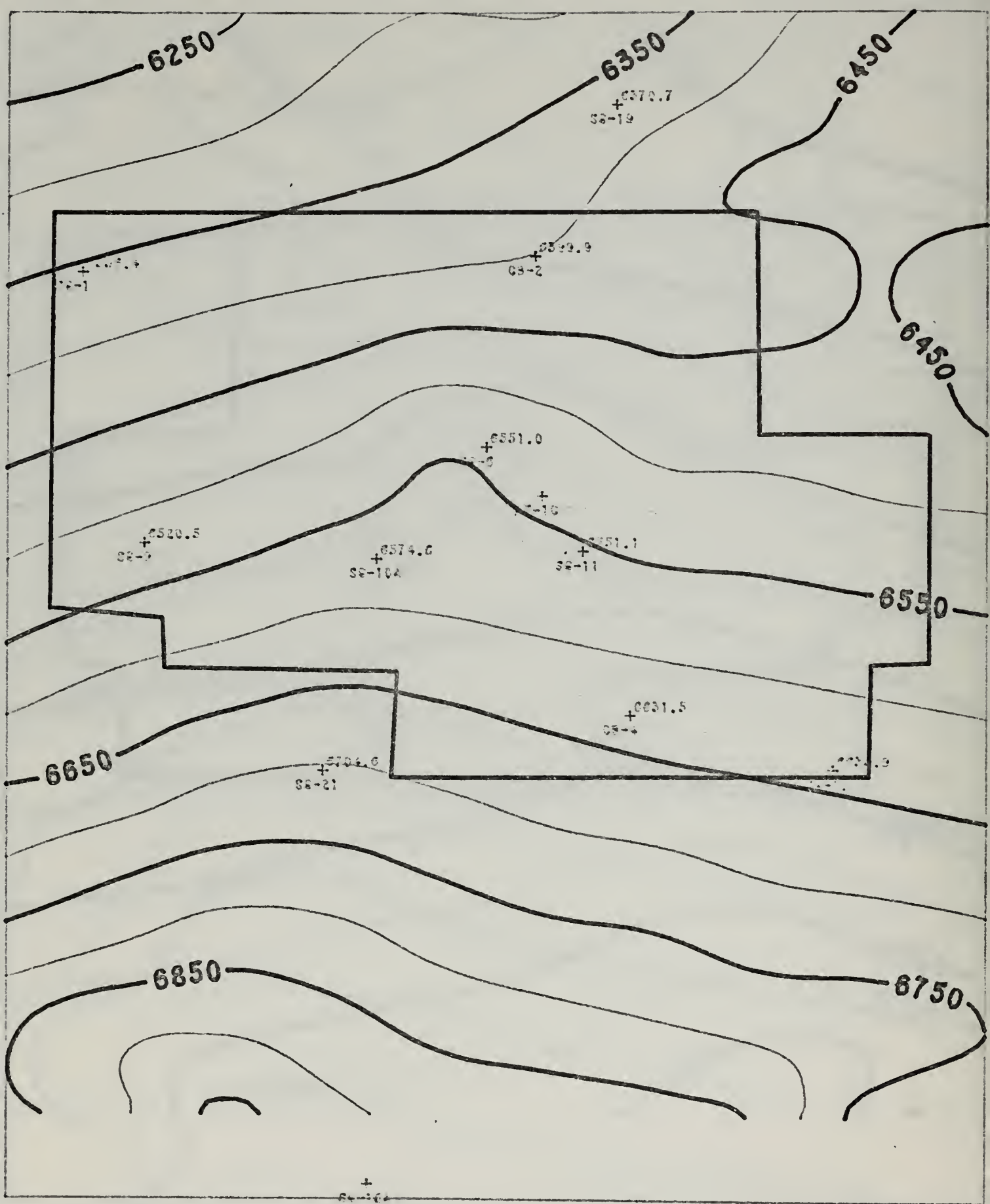

FIGURE A5.3.2B-9 Potentiometric Surface Map - Upper Aquifer, October 1977

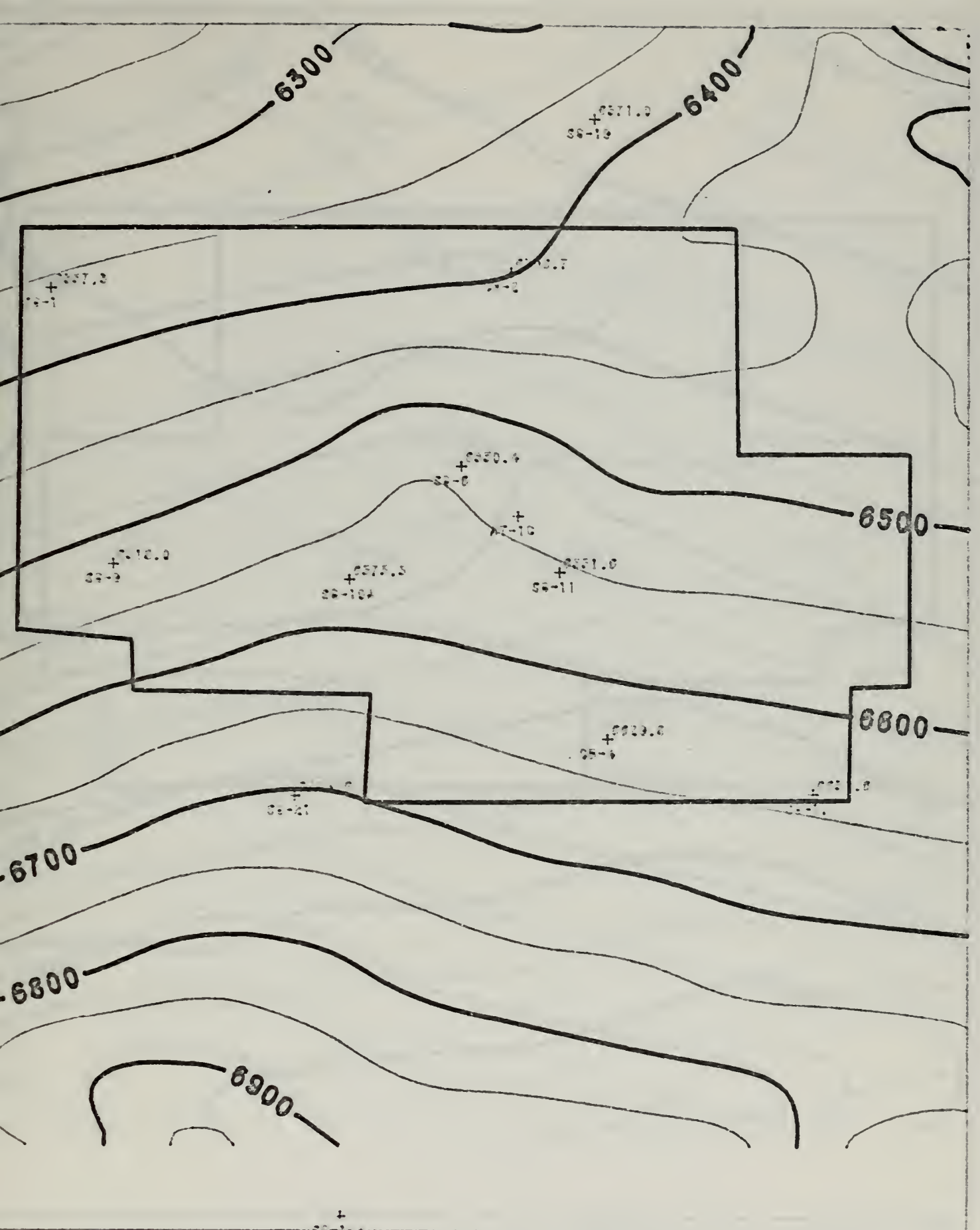

FIGURE A5.3.2B-10 Potentiometric Surface Map - Upper Aquifer, December 1977

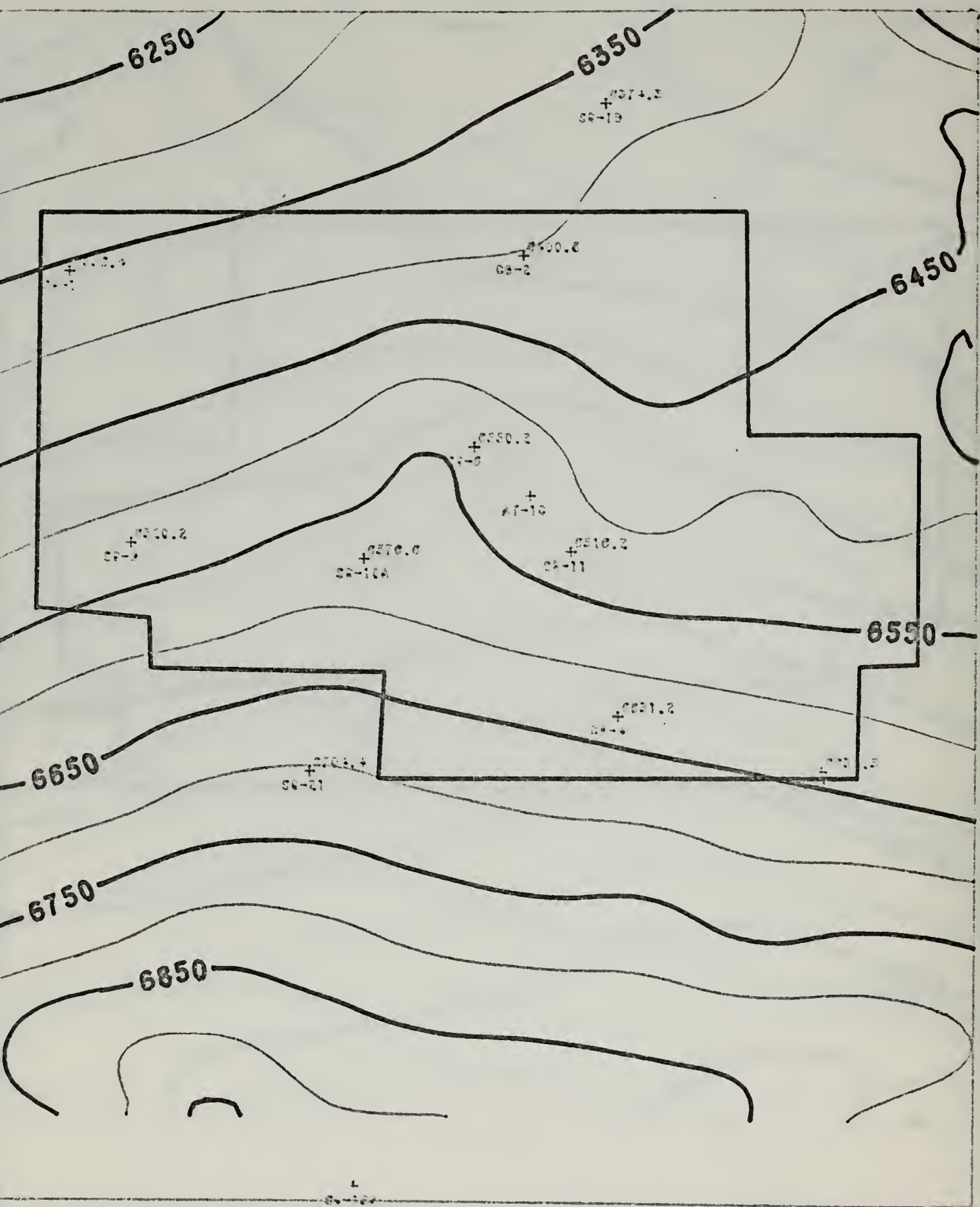

FIGURE A5.3.2B-11 Potentiometric Surface Map - Upper Aquifer, April 1978

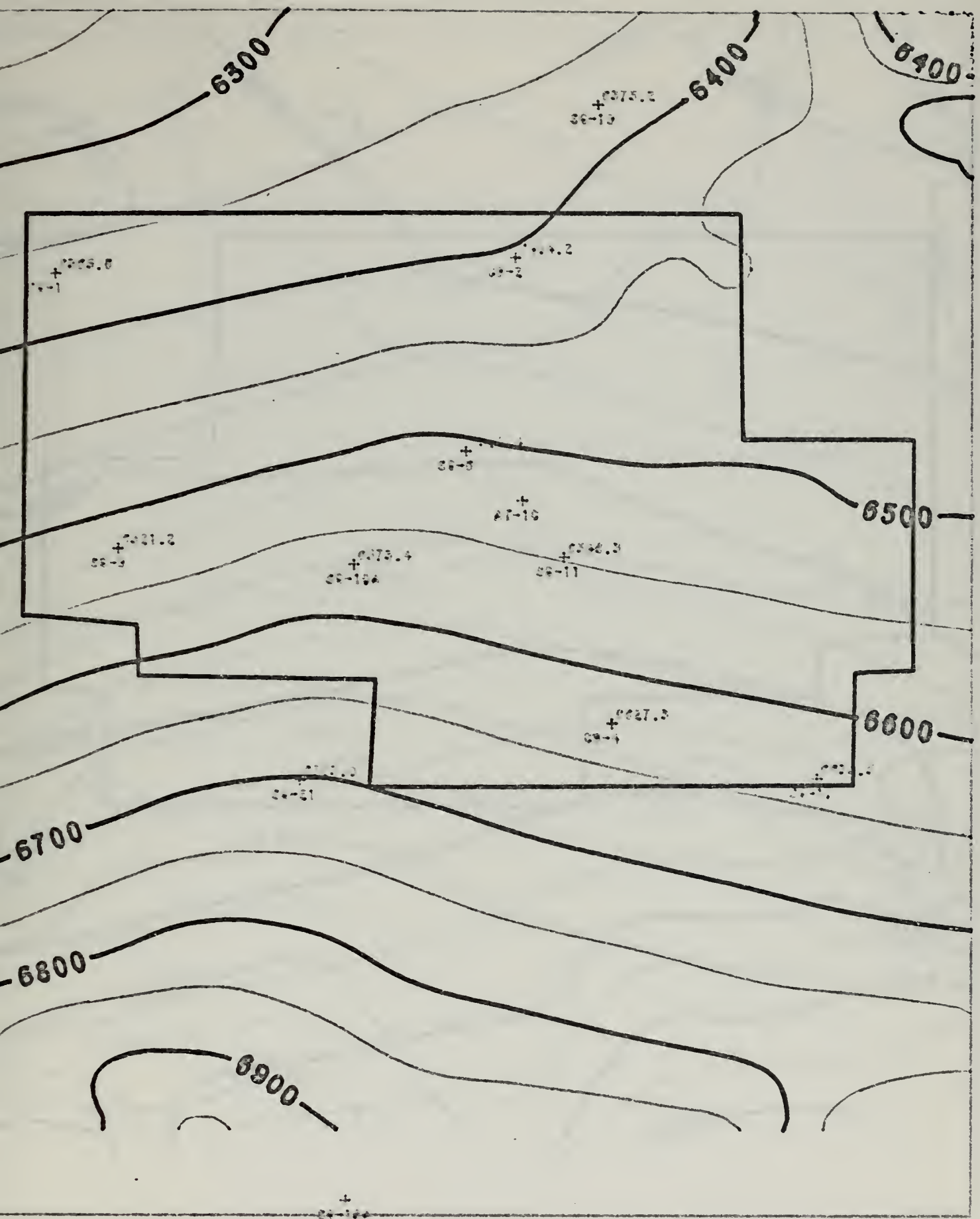

FIGURE A5.3.2B-12 Potentiometric Surface Map - Upper Aquifer, May 1978

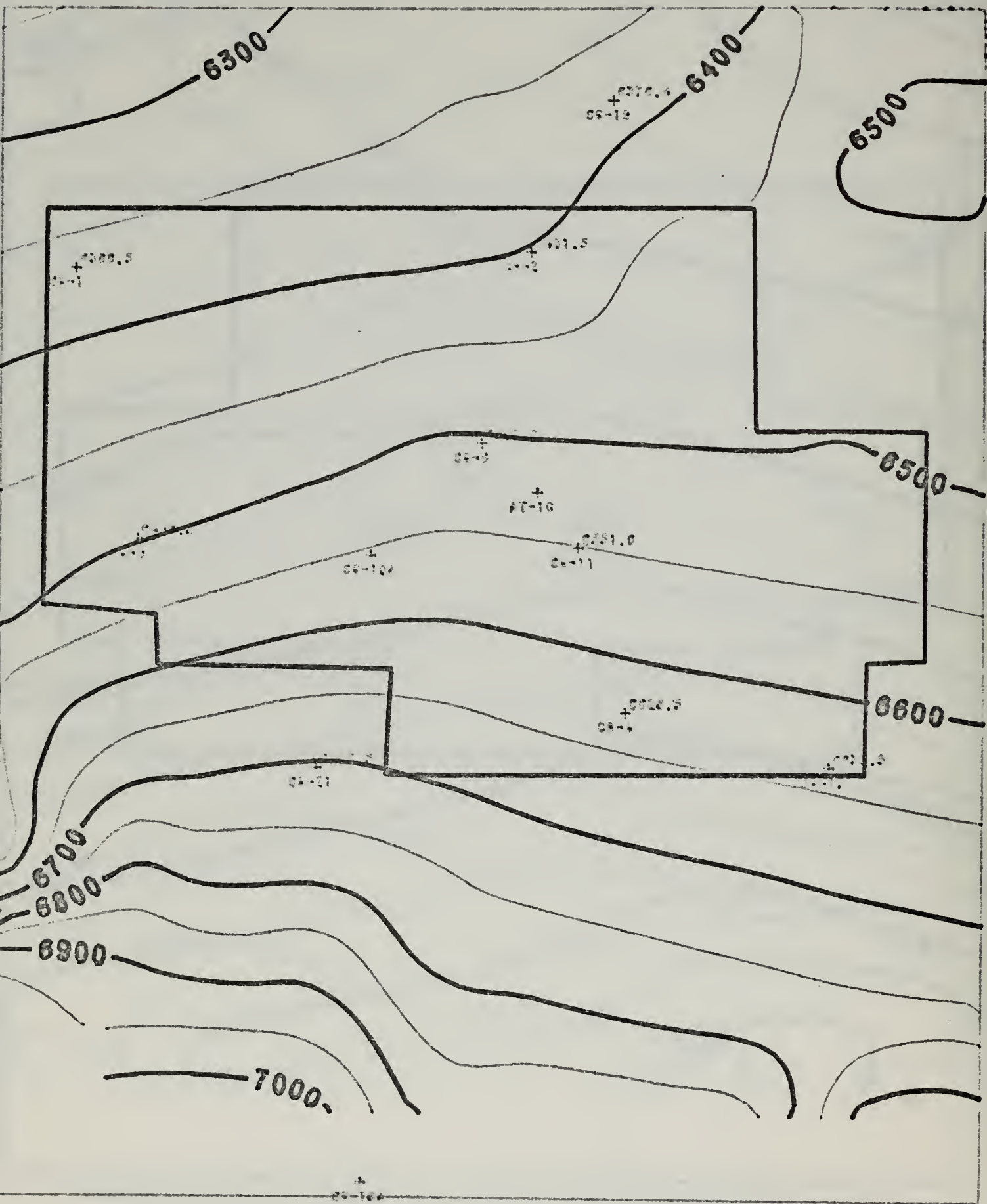

FIGURE A5.3.2B-13 Potentiometric Surface Map - Upper Aquifer, July 1978

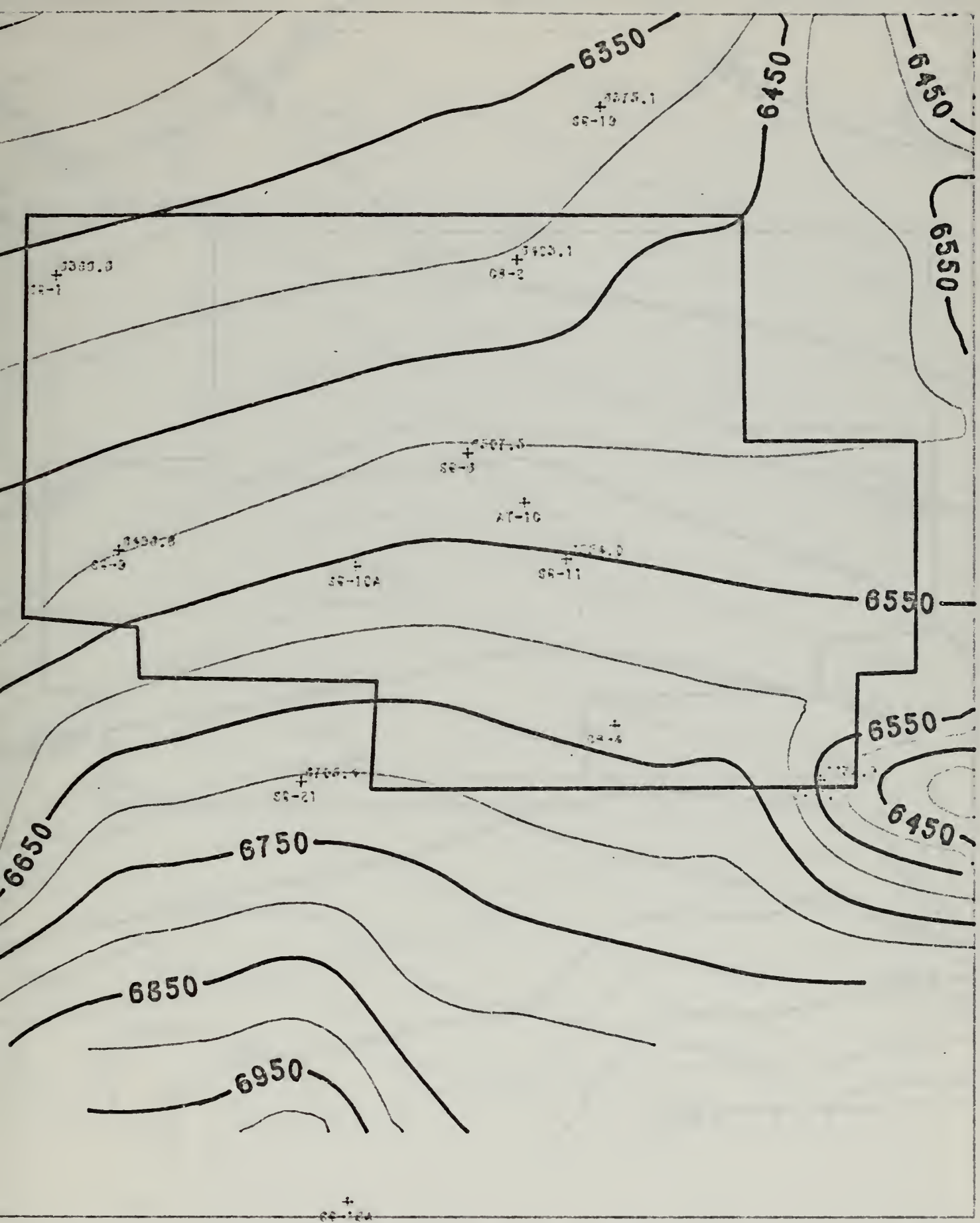

FIGURE A5.3.2B-14 Potentiometric Surface Map - Upper Aquifer, September 1978

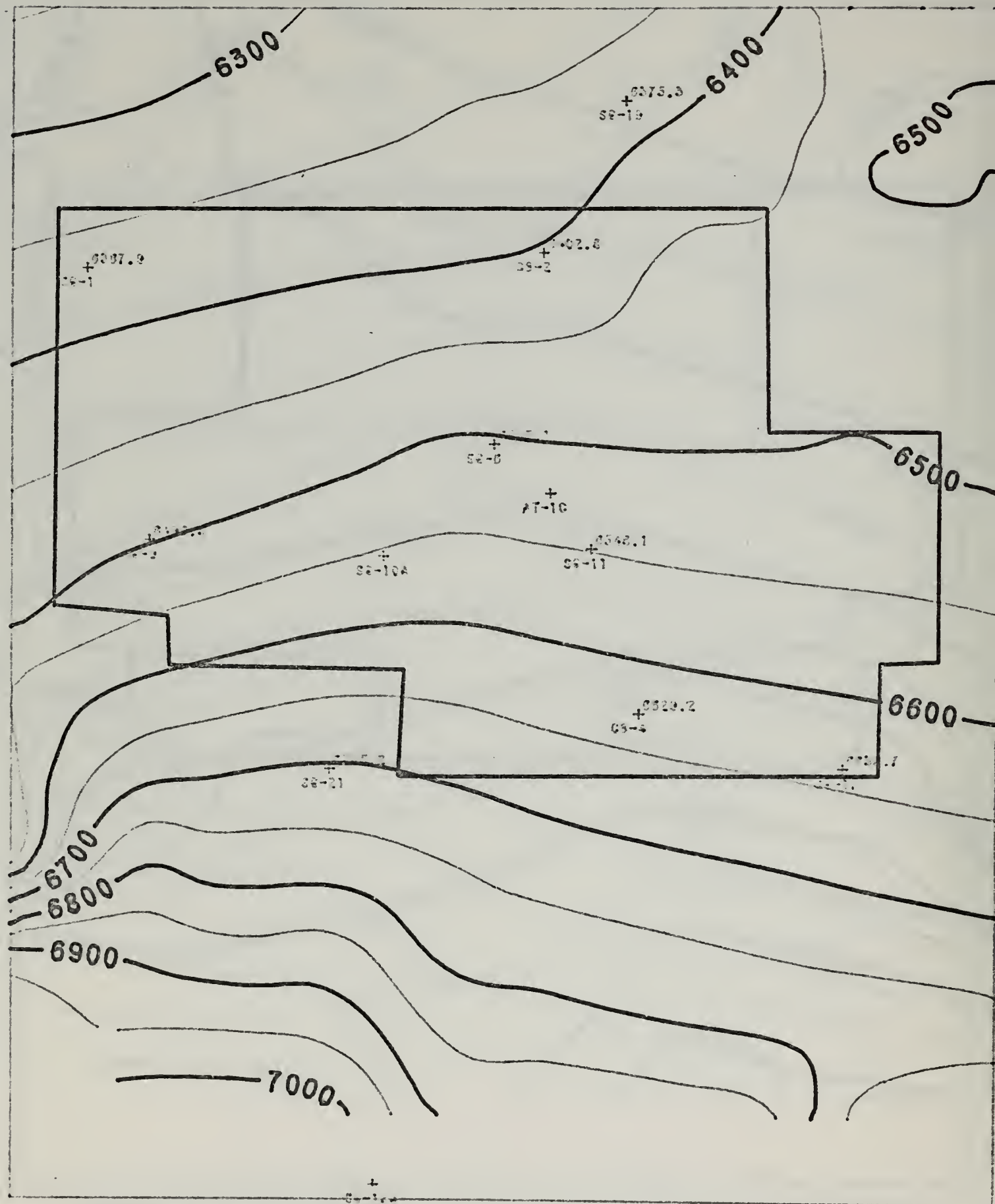

FIGURE A5.3.2B-15 Potentiometric Surface Map - Upper Aquifer, October 1978

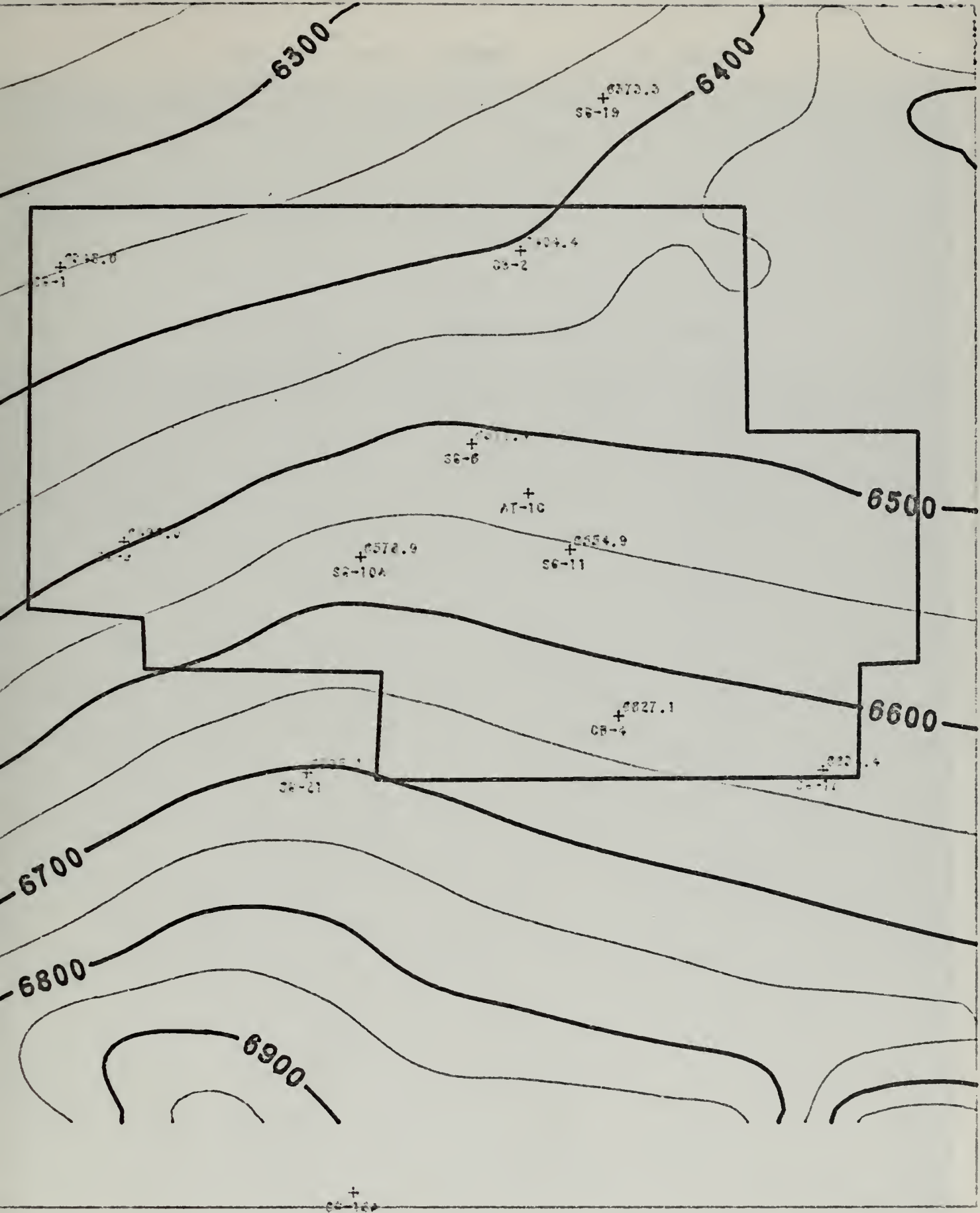

FIGURE A5.3.2B-16 Potentiometric Surface Map - Upper Aquifer, November 1978

SITE AB23

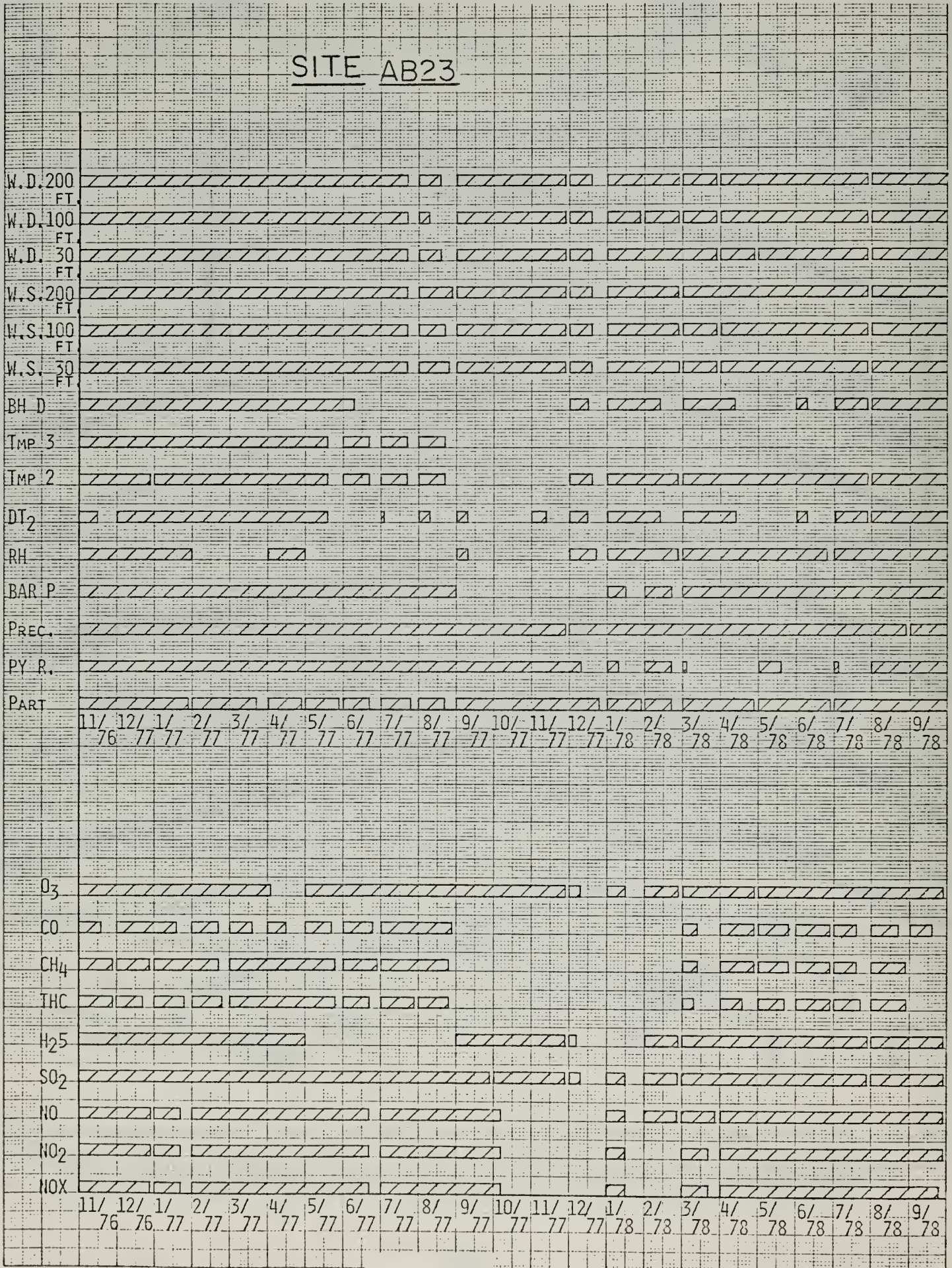

Figure A6.2.1-2 CHANNEL "UPTIME" TIME-LINES

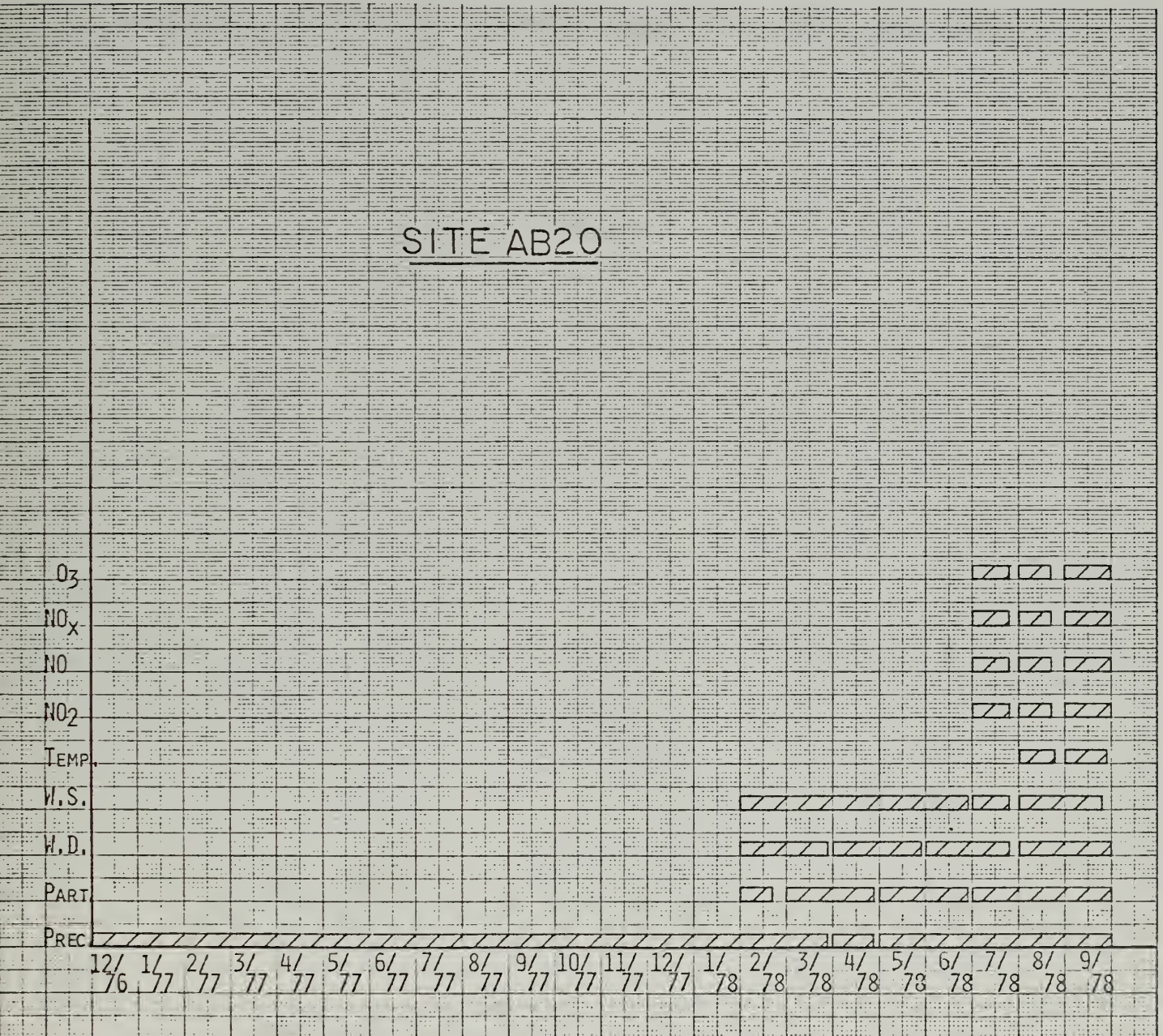
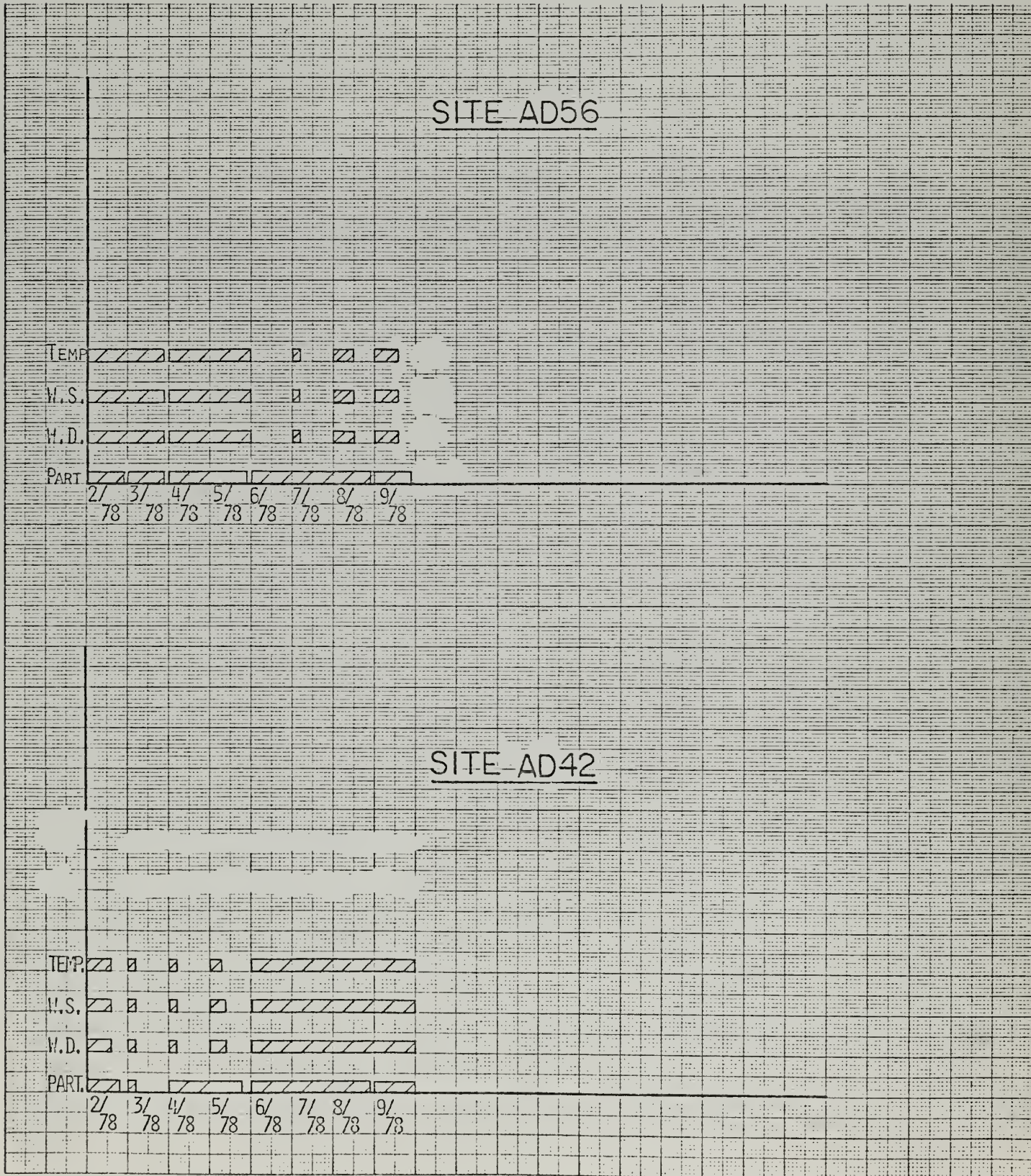
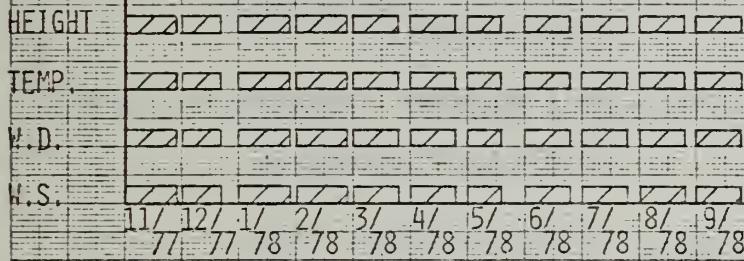

Figure A6.2.1-3

CHANNEL "UPTIME" TIME-LINES



MINISONDE



ACOUSTIC SOUNDER

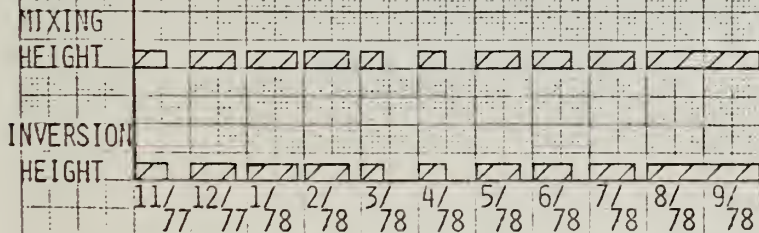

TABLE A6.2.1-1
INSTRUMENT SPECIFICATIONS

These specifications apply to the analyzer types and time periods indicated. In some cases, current instruments will have different specifications, generally reflecting enhanced accuracy and sensitivity.

Sulfur dioxide/hydrogen sulfide November 1974 - March 1977 - Meloy SA-185-2

Range:	0 - 1 ppm (1000 ppb)
Lower Detection Limit:	.005 ppm
Noise:	\pm 0.5% (full scale)
Zero Drift:	\pm 1% per day
Span Drift:	\pm 1% per day
Precision:	\pm 1% (full scale)

March 1977 - September 1978 - Meloy SA-185-2A

Range:	0 - .5 ppm
Lower Detection Limit:	.002 ppm
Noise:	.005 ppm
Zero Drift:	.001 ppm (24 hours)
Span Drift:	3.2% (80% URL)
Precision:	.001 ppm S.D. (20% URL) .002 ppm S.D. (80% URL)

Carbon Monoxide November 1974 - August 1978 - Bendix 8200 Environmental Chromatograph

Range:	0 - 1 ppm to 0 - 100 ppm, stepped
Noise:	0.5% of full scale
Zero Drift:	< 1% per day
Span Drift:	< 1% per day
Precision:	\pm 1% of full scale

TABLE A6.2.1-1 (cont.)

September 1978 - Beckman Model 866 - Ambient CO Monitoring System

Range:	0 - 50 ppm
Lower Detection Limit:	0.4 ppm
Noise:	0.2 ppm S.D.
Zero Drift:	\pm 0.5 ppm (24 hours)
Span Drift:	\pm 1% full scale
Precision:	\pm 0.2 ppm S.D. full scale

Oxides of Nitrogen November 1974 - December 1977 - Meloy NA-520-2 Chemicuminizer

Range:	0 - .5 ppm
Lower Detection Limit:	.005 ppm
Noise:	.005 ppm
Zero Drift:	.005 ppm (24 hours)
Span Drift:	.010 ppm (24 hours)
Precision:	\pm 1% full scale

January 1978 - September 1978 - Monitor Labs Model 8440E Nitrogen Oxides Analyzer

Range:	0 - .5 ppm
Lower Detection Limit:	.002 ppm
Noise:	.001 ppm S.D.
Zero Drift:	<. .003 ppm / 7 days
Span Drift:	< 4% / 7 days
Precision:	.004 ppm S.D. at 0.1 ppm

TABLE A6.2.1-1 (cont.)

Ozone November 1974 - September 1978 - Meloy OA-350-2 - Ozone Analyzer

Range:	0 - .5 ppm
Lower Detection Limit:	.0005 ppm
Noise:	\pm .3%
Zero Drift:	\pm 1% full scale/24 hours
Span Drift:	$< \pm$ full scale/24 hours
Precision:	\pm 2% full scale

ERROR ANALYSIS DERIVATION

Random error distribution about a mean is best described by the standard deviation

$$\delta_x = \left(\frac{\sum_i (X_i - \bar{X})^2}{n-1} \right)^{1/2} \quad \text{EQUATION 1}$$

It should be noted that the term $(X_i - \bar{X})^2$ causes large errors to impact δ_x to a higher degree than smaller errors.

Hagen postulates:

1. Errors are unavoidable
2. observed errors are a composite of smaller errors of equal magnitude.
3. elementary error has an equal probability of having a positive as well as a negative effect. The number of elementary errors become infinite as the magnitude of error diminishes.

The postulate may be expressed as:

$$y = h e^{-h^2 x^2} \pi^{-1/2} \quad \text{EQUATION 2}$$

h = constant, x = precision modulus, x = error magnitude, y = frequency of error occurrence

h may be expressed as:

$$h = \{\delta(2^{1/2})\}^{-1} \quad \text{EQUATION 3}$$

The following curve depicts Equation 2:

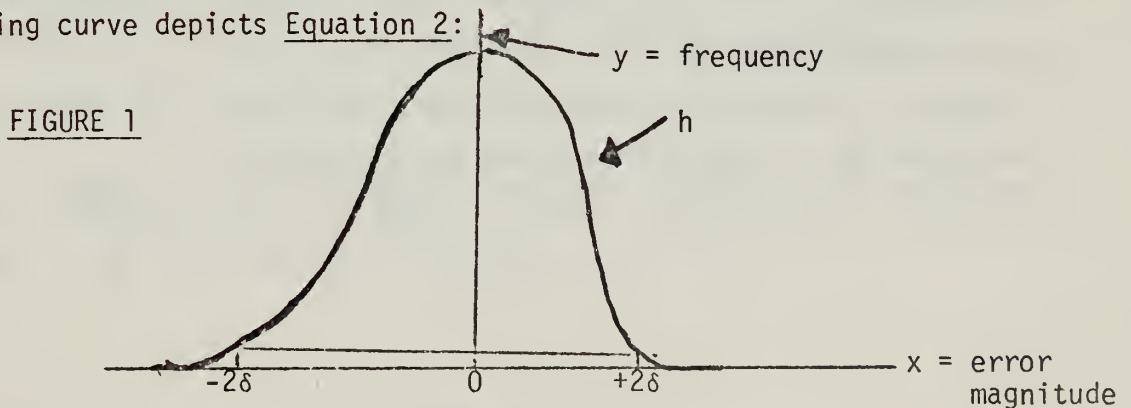

TABLE A6.2.1-2 (Continued)

The following features are evident from the curve in Figure 1:

1. Curve is symmetrical about the y - axis
2. The largest errors occur at minimum frequency and fall off according to e^{-X^2} .
3. For large h values (very precise measurements) small errors occur at higher frequency than cases for small values of h.

The variable y may also be viewed in terms of probability law such that:

$$y = \frac{dP}{dX} \quad \text{EQUATION 4}$$

where, P is the probability of an analyzer's response to a known input. Therefore,

$$P = \int_{-\infty}^{+\infty} y dX = 1 \quad \text{EQUATION 5}$$

From equation 2, h is a constant of integration and upon evaluation is determined to be $\frac{h}{\pi}$. By substitution Equation 4 becomes:

$$P = \frac{h}{\pi} \int_{-\infty}^{+\infty} e^{-h^2 X^2} dX \quad \text{EQUATION 6}$$

The limits of integration can be expressed as mean deviation:

$$a_x = \frac{\sum_i |X_i - \bar{X}|}{n} \quad \text{EQUATION 7}$$

or the standard deviation (Equation 1).

From Equation 1, X = error magnitude, then δ_x would represent the magnitude of error for a data set.

From Equation 3, Equation 6 may now be expressed as:

$$P = \{\delta(2\pi)^{\frac{1}{2}}\}^{-1} \int_{-\delta}^{+\delta} e^{-X^2 / 2\delta^2} dX \quad \text{EQUATION 8}$$

TABLE A6.2.1-2 (Continued)

The area under the curve defined by the limits of this integration represents a 68% confidence level. 2δ would provide a 95% confidence level.

Error Propagation:

Error propagation results from instrument component contribution and operational error. Accepting the validity of the Hagens postulates for random error the following equation is presented:

$$dR = \left. \frac{\partial R}{\partial X} \right|_{y,Z} dX + \left. \frac{\partial R}{\partial Y} \right|_{X,Z} dy + \left. \frac{\partial R}{\partial Z} \right|_{X,y} dZ \quad \text{EQUATION 9}$$

where R = component for which error evaluation is desired and x,y,z, are analyzer components contributing to error in R such that $R = f(X,y,Z)$.

Since dX, dy, and dZ represent deviation from some X, y, Z then δX , δy and δZ could be substituted.

The general case for δ_x^2 where n is large may be expressed as:

$$\delta_x^2 = \Sigma \frac{(dX)^2}{N} \quad \text{EQUATION 10}$$

To substitute the δ_x^2 definition into Equation 9, it must first be squared:

$$(dR)^2 = \left(\frac{\partial R}{\partial X} dX + \frac{\partial R}{\partial y} dy + \frac{\partial R}{\partial Z} dZ \right)^2 \quad \text{EQUATION 11}$$

Upon the summation of the terms from the squaring and considering that dX and dy are independent of each other and recalling from Hagens postulates that there is equal probability of positive and negative values for dX and dy, the positive terms will cancel the negative ones and Equation 11 becomes:

$$\Sigma (dR_i)^2 = \left(\frac{\partial R}{\partial X} \right)^2 \Sigma (dX_i)^2 + \left(\frac{\partial R}{\partial y} \right)^2 \Sigma (dy_i)^2 + \left(\frac{\partial R}{\partial Z} \right)^2 \Sigma (dZ_i)^2 \quad \text{EQUATION 12}$$

The form of Equation 10 may be obtained by dividing by N:

$$\frac{\sum_i (dR_i)^2}{N} = \left(\frac{\partial R}{\partial y} \right)^2 \frac{\sum_i (dX_i)^2}{N} + \dots \quad \text{EQUATION 13}$$

substituting $\delta^2 = \frac{\sum (dX)^2}{N}$

Equation 13 becomes:

$$\delta_R^2 = \left(\frac{\partial R}{\partial X} \right)^2 \delta_X^2 + \left(\frac{\partial R}{\partial y} \right)^2 \delta_y^2 \dots \dots \quad \text{EQUATION 14}$$

Equation 14 is the final form from which error propagation may be calculated.

Table A6.2.1-3a

DIURNAL VARIATION OF SO2 DIFFERENCE OF UNIT2 - UNIT1 (UG/M3)
 STATION AB23
 April 1977
 HOUR

DAY	1	2	3	4	5	6	7	8	9	10	11	12	13	14	15	16	17	18	19	20	21	22	23	24
1	1	2	2	2	1	0	0	0	1	0	0	0	0	0	0	0	0	0	0	0	0	0	0	0
2	0	0	0	0	0	0	0	0	0	0	0	0	0	0	0	0	0	0	0	0	0	0	0	0
3	1	0	0	0	0	0	0	0	1	0	0	0	0	0	0	0	0	0	0	0	0	0	0	2
4	1	1	2	2	1	0	2	2	1	1	0	0	0	0	1	0	0	0	0	0	0	1	1	1
5	2	1	2	2	1	0	1	2	3	2	0	0	0	0	0	0	0	0	0	0	0	0	0	2
6	0	0	0	0	0	0	0	0	0	0	0	0	0	0	0	0	0	0	0	0	0	0	0	0
7	0	0	0	0	0	0	0	0	0	0	0	0	0	0	0	0	0	0	0	0	0	0	0	0
8	0	0	0	0	0	0	0	0	0	0	0	0	0	0	0	0	0	0	0	0	0	0	0	0
9	0	0	0	0	0	0	0	0	0	0	0	0	0	0	0	0	0	0	0	0	0	0	0	0
10	0	0	0	0	0	0	0	0	0	0	0	0	0	0	0	0	0	0	0	0	0	0	0	0
11	0	0	0	0	0	0	0	0	0	0	0	0	0	0	0	0	0	0	0	0	0	0	0	0
12	0	0	0	0	0	0	0	0	0	0	0	0	0	0	0	0	0	0	0	0	0	0	0	0
13	0	0	4	0	0	0	0	0	0	0	2	1	2	2	2	3	2	3	3	3	4	5	5	6
14	5	6	4	6	6	5	7	6	7	5	3	2	1	1	0	3	0	0	0	0	0	0	0	2
15	2	2	3	3	2	2	2	2	3	1	0	0	0	0	0	0	0	0	0	0	0	0	0	0
16	0	0	0	0	0	0	0	0	0	0	0	0	0	0	0	0	0	0	0	0	0	0	0	0
17	0	0	0	0	0	0	0	0	0	0	0	0	0	0	0	0	0	0	0	0	0	0	0	0
18	0	0	0	0	0	0	0	0	0	0	0	0	0	0	0	0	0	0	0	0	0	0	0	0
19	0	0	0	0	0	0	0	0	0	0	0	0	0	0	0	0	0	0	0	0	0	0	0	0
20	0	0	0	0	0	0	0	0	0	0	0	0	14	15	15	0	0	0	0	0	0	0	0	0
21	0	0	0	0	0	0	0	0	0	0	0	0	0	0	0	0	0	0	0	0	0	0	0	0
22	0	0	0	0	0	0	0	0	0	0	0	1	0	0	0	0	0	0	0	0	0	0	0	0
23	0	0	0	0	0	0	0	0	0	0	0	0	0	0	0	0	0	0	0	0	0	0	0	0
24	0	0	0	0	0	0	0	0	0	0	-1	-1	-1	-2	-1	-2	-2	-1	-1	-2	-1	-1	-1	0
25	0	-1	-1	0	0	0	0	0	0	0	0	0	0	0	0	0	0	0	0	0	0	0	0	0
26	0	0	0	0	0	0	0	0	0	0	0	0	0	0	0	0	0	0	0	0	0	0	0	0
27	0	0	0	0	0	0	0	0	0	0	0	0	0	0	0	0	0	0	0	0	0	0	0	0
28	0	0	0	0	0	0	0	0	0	0	0	0	0	0	0	0	0	0	0	0	0	0	0	0
29	0	0	0	0	0	0	0	0	0	0	0	0	0	0	0	0	0	0	0	0	0	0	0	0
30	0	0	0	0	0	0	0	-1	0	0	0	0	0	0	0	0	0	0	0	0	-1	0	0	0

Unit 1 = SA185-2A Analyzer
 Unit 2 = SA185-2 Analyzer

Mean .289
 Standard Deviation = 1.34

Table A6.2,1-3b

DIURNAL VARIATION OF SO2 DIFFERENCE OF UNIT2 - UNIT1 (UG/M3)

STATION AB23

May 1977

HOUR

DAY	1	2	3	4	5	6	7	8	9	10	11	12	13	14	15	16	17	18	19	20	21	22	23	24
1	0	0	0	0	0	0	0	0	0	0	0	0	0	0	0	0	0	0	0	0	0	0	0	0
2	-1	0	0	0	0	0	0	0	0	0	0	0	0	0	0	0	0	0	0	0	0	0	0	0
3	3	3	2	0	0	0	0	0	0	0	0	0	0	0	0	0	0	0	0	0	0	0	0	0
4	0	0	0	0	0	0	0	1	1	0	0	0	1	3	2	3	2	3	2	2	4	4	5	5
5	5	5	5	6	4	4	6	6	6	2	0	0	0	0	0	0	0	0	0	1	0	2	2	2
6	2	2	2	2	1	0	0	1	2	1	0	0	0	0	2	0	0	0	0	1	2	2	4	3
7	3	4	4	2	0	0	0	1	0	0	0	0	0	0	0	0	0	0	0	0	0	0	0	0
8	0	0	0	0	0	0	0	0	0	0	0	0	0	0	0	0	0	0	0	0	0	0	0	0
9	0	0	0	0	0	0	0	0	0	0	0	0	0	0	0	0	0	0	0	0	0	0	0	0
10	0	0	-1	-1	-1	-1	0	-1	-1	0	0	0	0	0	0	0	0	0	0	0	-1	0	0	0
11	0	0	0	0	0	0	0	0	0	0	0	0	0	0	0	0	0	0	0	0	0	0	0	0
12	0	0	0	0	0	0	0	0	-1	0	0	0	0	0	0	0	0	0	0	0	0	0	0	0
13	0	0	0	0	0	0	0	0	0	0	0	0	0	0	0	0	0	0	0	0	0	0	0	0
14	0	0	0	0	0	0	0	0	0	0	0	0	0	0	0	0	0	0	0	0	0	0	0	0
15	0	0	0	0	0	0	0	0	0	0	0	0	0	0	0	0	0	0	0	0	0	0	0	0
16	0	0	0	0	0	0	0	0	0	0	0	0	0	0	0	0	0	0	0	0	0	0	0	0
17	3	0	0	6	3	1	3	3	2	0	0	0	0	0	3	9	10	6	2	1	2	3	5	7
18	0	0	0	2	1	0	0	0	0	-2	-2	-2	0	0	0	0	0	0	0	0	0	0	0	0
19	0	0	0	0	0	0	0	0	0	0	0	0	0	0	0	0	0	0	0	0	0	0	0	0
20	0	0	0	0	0	0	0	0	0	0	0	0	0	0	0	0	0	0	0	0	0	0	0	0
21	0	0	0	0	0	0	0	0	0	0	0	0	0	0	0	0	0	0	0	0	0	0	0	0
22	0	0	0	0	0	0	0	0	0	0	0	0	0	0	0	0	0	0	0	0	0	0	0	0
23	0	0	0	0	0	0	0	0	0	0	0	0	0	0	0	0	0	0	0	0	0	0	0	0
24	6	6	6	6	0	0	0	0	0	0	0	0	0	0	0	0	0	0	0	0	0	0	0	0
25	6	6	6	6	0	0	0	0	0	0	0	0	0	0	0	0	0	0	0	0	0	0	0	0
26	0	0	0	0	0	0	0	0	0	0	0	0	0	0	0	0	0	0	0	0	0	0	0	0
27	0	0	0	0	0	0	0	0	0	0	0	0	0	0	0	0	0	0	0	0	0	0	0	0
28	0	0	0	0	0	0	0	0	0	0	0	0	0	0	0	0	0	0	0	0	0	0	0	0
29	2	2	2	2	0	0	0	0	0	0	0	0	0	0	0	0	0	0	0	0	0	0	0	0
30	0	0	0	0	0	0	0	0	0	0	0	0	0	0	0	0	0	0	0	0	0	0	0	0
31	0	0	0	3	2	1	2	3	2	0	0	0	0	0	0	0	0	0	0	0	0	0	0	0

Unit 1 - SA185-2A Analyzer
Unit 2 - SA185-2 Analyzer

Mean = .535
Standard deviation = 1.48

Table A6.2-1-3c

DIURNAL VARIATION OF SO₂ DIFFERENCE OF UNIT2 - UNIT1 (UG/M3)
 STATION AB23
 June 1977
 HOUR

DY	1	2	3	4	5	6	7	8	9	10	11	12	13	14	15	16	17	18	19	20	21	22	23	24
1	3	0	0	0	0	0	0	0	0	0	0	0	0	0	0	0	0	0	0	0	0	0	0	0
2	0	0	0	-2	0	0	0	0	0	0	1	1	1	0	0	0	0	0	0	0	0	0	0	0
3	0	0	0	0	-2	0	-2	-2	-1	-1	-1	-1	-2	-1	0	-1	0	0	0	0	-2	0	-2	-2
4	-2	-2	-2	0	0	0	0	0	0	0	0	0	0	0	0	0	0	0	-2	0	0	0	0	0
5	0	0	0	0	0	0	0	0	0	0	0	0	0	0	0	0	0	0	0	0	0	0	0	0
6	0	0	0	0	0	0	0	0	0	0	0	0	0	0	0	1	0	0	1	0	0	0	0	0
7	0	0	0	0	0	0	0	0	0	0	7	6	4	5	5	5	5	4	5	5	4	5	6	6
8	6	7	6	0	0	0	0	0	6	2	0	0	0	0	0	0	0	0	0	0	0	0	0	0
9	0	0	0	0	0	0	0	0	0	0	1	2	1	2	2	2	1	0	1	0	2	3	3	2
10	2	4	5	0	0	0	0	0	0	0	0	0	0	0	0	0	0	0	0	0	0	0	0	0
11	0	0	0	0	0	0	0	0	0	0	0	0	0	0	0	0	0	0	0	0	0	0	0	0
12	0	0	0	1	0	0	1	0	0	0	0	0	0	0	0	0	0	0	0	0	0	0	0	0
13	0	0	0	0	0	0	0	2	0	0	0	0	0	0	0	0	0	0	0	0	0	0	0	0
14	2	2	2	0	0	0	0	0	0	0	0	0	0	0	0	0	0	0	0	0	0	0	0	0
15	0	0	0	0	0	0	0	0	0	0	0	0	0	0	0	0	0	0	0	0	0	0	0	0
16	0	0	0	0	0	0	0	0	0	0	0	0	0	0	0	0	0	0	0	0	0	0	0	0
17	0	0	0	2	2	2	2	3	5	2	2	2	0	0	0	0	0	0	0	0	0	0	0	0
18	0	0	0	2	1	0	2	2	1	0	0	0	0	0	0	0	0	0	0	0	0	0	0	0
19	2	2	3	0	1	7	18	26	29	13	3	0	0	0	0	0	0	0	0	0	0	0	0	0
20	0	0	0	2	5	2	2	2	2	1	0	2	2	2	2	3	3	3	2	2	3	4	5	5
21	5	5	6	2	4	6	8	6	6	5	3	2	1	0	1	2	2	1	0	0	0	0	0	0
22	8	9	11	1	4	6	10	11	12	0	0	0	0	0	0	0	0	0	0	0	0	0	0	0
23	0	0	0	0	1	10	19	25	32	24	10	4	1	0	0	0	0	0	0	0	0	0	0	0
24	0	0	0	1	7	9	6	3	0	0	0	0	0	0	0	0	0	0	0	0	0	0	0	0
25	0	0	0	0	0	0	0	0	0	0	0	0	0	0	0	0	0	0	0	0	0	0	0	0
26	0	0	0	0	0	0	0	0	0	0	0	0	0	0	0	0	0	0	0	0	0	0	0	0
27	0	0	0	0	0	0	0	0	1	0	0	0	0	0	0	0	0	0	0	0	0	0	0	0
28	0	0	0	0	0	0	0	0	0	0	0	0	0	0	0	0	0	0	0	0	0	0	0	0
29	0	0	0	0	0	0	0	0	0	0	0	0	0	0	0	0	0	0	0	0	0	0	0	0
30	0	0	0	0	0	0	0	0	0	0	0	0	0	0	0	0	0	0	0	0	0	0	0	0

Unit 1 = SA185-2A Analyzer
 Unit 2 = SA185-2 Analyzer

Mean = .96
 Standard Deviation = 3.17

Table A6.2.1-3d

DIURNAL VARIATION OF SO₂ DIFFERENCE OF UNIT2 - UNIT1 (UG/M3)
 STATION AB23
 July 1977
 HOUR

DAY	1	2	3	4	5	6	7	8	9	10	11	12	13	14	15	16	17	18	19	20	21	22	23	24
1	0	0	0	0	0	0	0	0	0	0	0	0	0	0	0	0	0	0	0	0	0	0	0	0
2	0	0	0	1	0	0	0	0	1	0	0	0	0	0	0	0	0	0	0	0	0	0	0	0
3	0	0	1	0	0	0	0	0	0	0	1	0	1	0	0	0	0	0	0	0	1	0	0	0
4	0	0	0	0	0	0	0	0	1	0	0	1	1	0	0	0	0	0	0	0	0	0	0	0
5	0	0	0	0	0	0	0	0	0	1	1	1	0	0	0	1	1	0	1	0	0	0	0	0
6	0	0	0	1	0	0	0	0	0	0	1	0	0	1	0	0	0	0	1	0	0	0	0	0
7	0	0	0	0	0	0	0	0	0	1	1	0	0	0	0	0	0	0	0	0	0	0	0	0
8	2	2	5	5	5	2	6	4	0	0	2	0	0	1	0	0	0	0	0	0	0	0	0	0
9	0	0	0	0	0	0	0	0	0	7	0	0	0	0	0	0	0	0	0	0	0	0	0	0
10	0	5	7	7	6	3	5	6	5	1	0	0	1	1	0	0	0	0	0	0	0	0	0	0
11	6	8	8	8	7	7	9	0	2	0	1	0	0	1	0	1	0	0	0	0	1	0	0	0
12	3	5	4	6	6	5	7	7	6	0	0	1	1	0	1	1	1	2	2	2	2	1	2	1
13	1	0	1	0	0	1	0	1	0	0	0	0	0	0	-1	0	0	0	0	0	0	0	0	0
14	0	0	0	0	0	0	0	0	0	0	0	0	0	0	0	0	0	0	0	0	0	0	0	0
15	0	0	0	0	0	0	0	0	0	0	0	0	0	0	0	0	0	0	0	0	0	0	0	0
16	0	0	0	0	0	0	0	0	0	0	0	0	0	0	0	0	0	0	0	0	0	0	0	0
17	0	0	0	0	0	0	0	0	0	0	0	0	0	0	0	0	0	0	0	0	0	0	0	0
18	0	0	0	0	0	0	0	0	0	0	0	0	-1	0	0	0	0	0	0	0	0	0	0	0
19	0	0	0	0	0	0	0	0	0	0	0	0	0	0	0	0	0	0	0	0	0	0	0	0
20	0	0	0	0	0	0	0	0	0	0	0	0	0	0	0	0	0	0	0	0	0	0	0	0
21	0	0	0	0	0	0	0	0	0	0	0	0	0	0	0	0	0	0	0	0	0	0	0	0
22	0	0	0	0	0	0	0	0	0	0	0	0	0	0	0	0	0	0	0	0	0	0	0	0
23	0	0	0	0	0	0	0	0	0	0	0	0	0	2	0	0	0	0	0	0	0	0	0	0
24	0	0	0	0	0	0	0	0	0	0	0	0	0	0	0	0	0	0	0	0	0	0	0	0
25	0	0	0	0	0	0	0	0	0	0	0	0	0	0	0	0	0	0	0	0	0	0	0	0
26	0	0	0	0	0	0	0	0	0	0	0	0	0	1	1	0	0	1	0	0	0	0	0	0
27	0	0	0	0	0	0	0	0	0	0	1	1	2	0	0	1	1	1	1	0	0	0	0	0
28	0	0	0	0	0	0	0	0	0	0	1	0	0	0	0	1	1	2	2	2	2	1	0	0
29	0	1	0	1	1	0	0	1	2	0	0	0	0	0	0	0	0	0	0	0	0	0	0	0
30	0	0	0	0	0	0	0	0	0	0	0	0	0	0	0	0	0	0	0	0	0	0	0	0
31	0	0	0	0	0	0	0	0	0	17	0	0	0	0	0	0	0	0	0	0	0	0	0	0

Mean = 0.47
 Standard Deviation = 1.49

Unit 1 - SA185-2A Analyzer
 Unit 2 - SA185-2 Analyzer

FIGURE A6.2.1-5

QUARTERLY SO₂ CONCENTRATION ROSES, STATION AB23 (1976-1978)

QUARTERLY SO₂ CONCENTRATION ROSE
DEC '76 - FEB '77

TOTAL % OF CALMS DISTRIBUTED (0000%)
TOTAL NO. OF 1 HOUR SAMPLES -2078

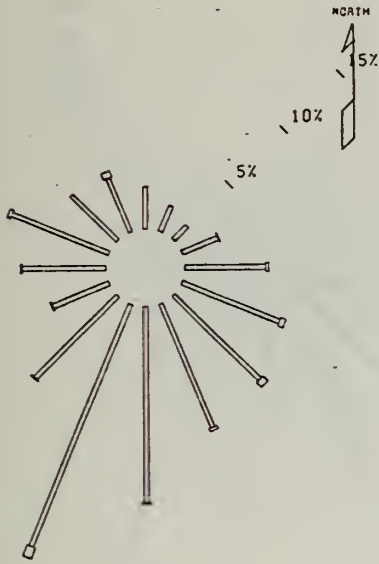

QUARTERLY SO₂ CONCENTRATION ROSE
MAR '77 - MAY '77

TOTAL % OF CALMS DISTRIBUTED (0000%)
TOTAL NO. OF 1 HOUR SAMPLES -2129

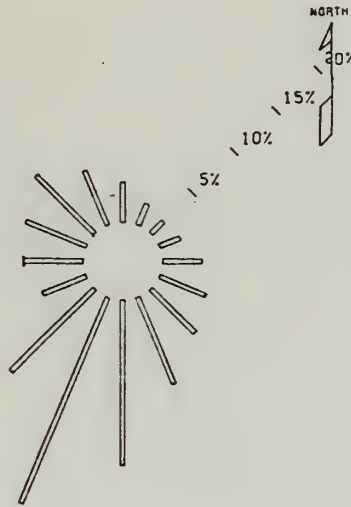

QUARTERLY SO₂ CONCENTRATION ROSE
JUN '77 - AUG '77

TOTAL % OF CALMS DISTRIBUTED (0.00%)
TOTAL NO. OF 1 HOUR SAMPLES -1538

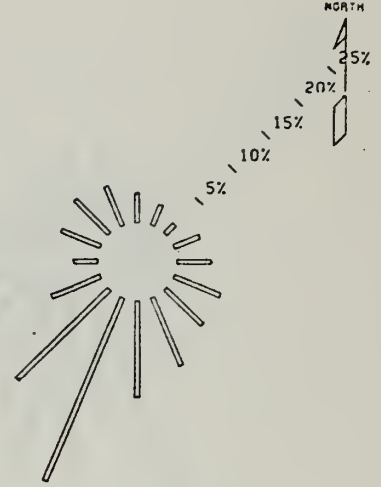

QUARTERLY SO₂ CONCENTRATION ROSE
SEP '77 - NOV '77

TOTAL % OF CALMS DISTRIBUTED (0000%)
TOTAL NO. OF 1 HOUR SAMPLES -1391

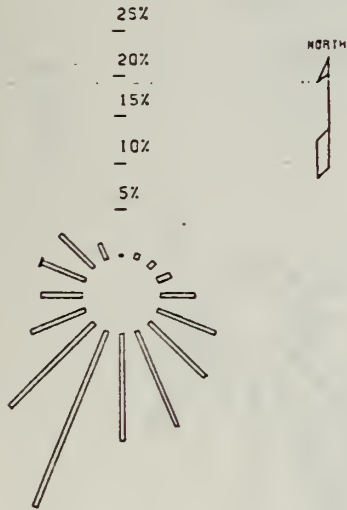

QUARTERLY SO₂ CONCENTRATION ROSE
DEC '77 - FEB '78

TOTAL % OF CALMS DISTRIBUTED (0000%)
TOTAL NO. OF 1 HOUR SAMPLES -1147

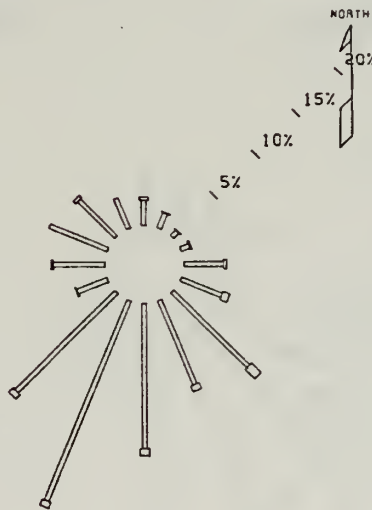

QUARTERLY SO₂ CONCENTRATION ROSE
MAR '78 - APR '78

TOTAL % OF CALMS DISTRIBUTED (0000%)
TOTAL NO. OF 1 HOUR SAMPLES -1272

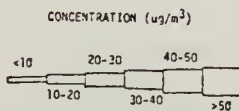
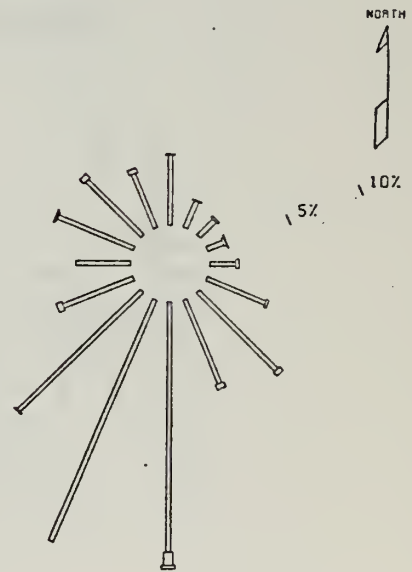

QUARTERLY H₂S CONCENTRATION ROSES, STATION AB23 (1976-1978)

QUARTERLY H₂S CONCENTRATION ROSE
DEC '76 - FEB '77

TOTAL % OF CALMS DISTRIBUTED (0000%)
TOTAL NO. OF 1 HOUR SAMPLES -2050

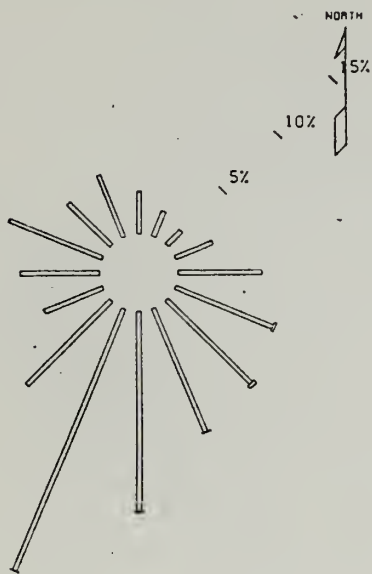

QUARTERLY H₂S CONCENTRATION ROSE
MAR '77 - MAY '77

TOTAL % OF CALMS DISTRIBUTED (0000%)
TOTAL NO. OF 1 HOUR SAMPLES -2114

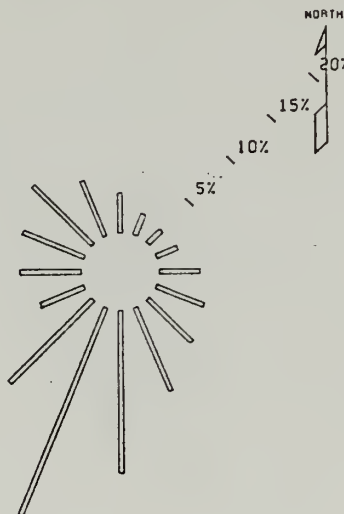

QUARTERLY H₂S CONCENTRATION ROSE
JUN '77 - AUG '77

TOTAL % OF CALMS DISTRIBUTED (0.00%)
TOTAL NO. OF 1 HOUR SAMPLES -1469

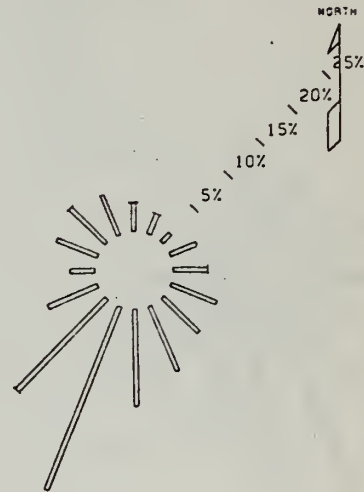

QUARTERLY H₂S CONCENTRATION ROSE
SEP '77 - NOV '77

TOTAL % OF CALMS DISTRIBUTED (0000%)
TOTAL NO. OF 1 HOUR SAMPLES -1405

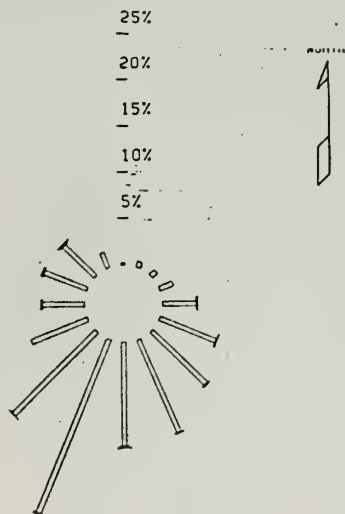

QUARTERLY H₂S CONCENTRATION ROSE
MAR '78 - APR '78

TOTAL % OF CALMS DISTRIBUTED (0000%)
TOTAL NO. OF 1 HOUR SAMPLES -1254

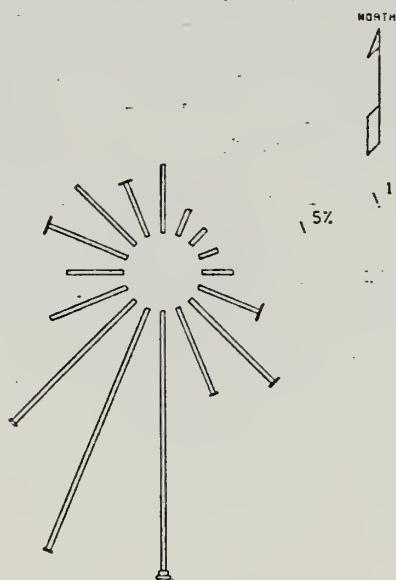

QUARTERLY H₂S CONCENTRATION ROSE
DEC '77 - FEB '78

TOTAL % OF CALMS DISTRIBUTED (0000%)
TOTAL NO. OF 1 HOUR SAMPLES -1127

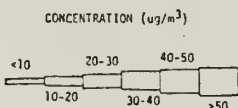
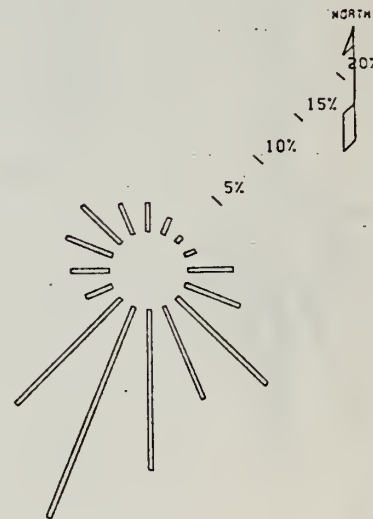
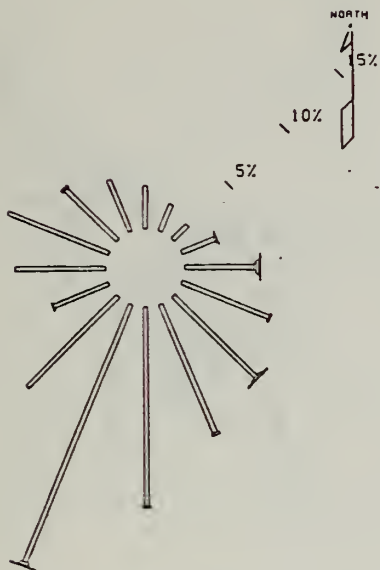

FIGURE A6.2.1-7

QUARTERLY NOX CONCENTRATION ROSES, STATION AB23 (1976-1978)

QUARTERLY NOX CONCENTRATION ROSE
DEC '76 - FEB '77

TOTAL % OF CALMS DISTRIBUTED (0000%)
TOTAL NO. OF 1 HOUR SAMPLES -1773



QUARTERLY NOX CONCENTRATION ROSE
MAR '77 - MAY '77

TOTAL % OF CALMS DISTRIBUTED (0000%)
TOTAL NO. OF 1 HOUR SAMPLES -2048

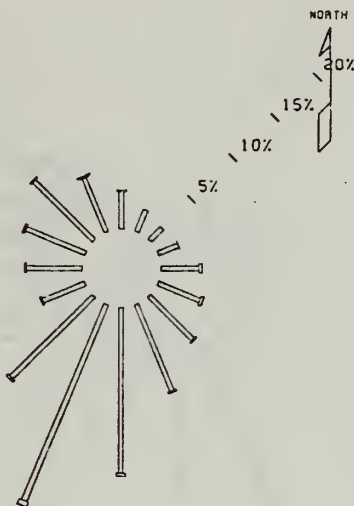

QUARTERLY NOX CONCENTRATION ROSE
JUN '77 - AUG '77

TOTAL % OF CALMS DISTRIBUTED (0.00%)
TOTAL NO. OF 1 HOUR SAMPLES -1182

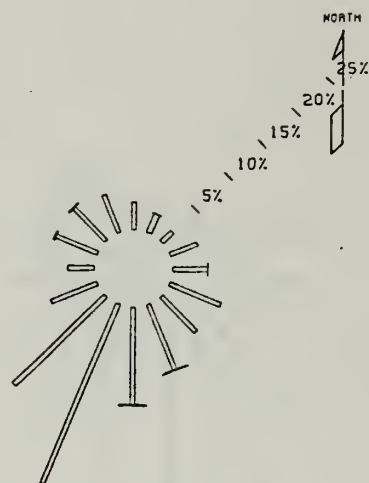

QUARTERLY NOX CONCENTRATION ROSE
SEP '77 - OCT '77

TOTAL % OF CALMS DISTRIBUTED (0000%)
TOTAL NO. OF 1 HOUR SAMPLES -93

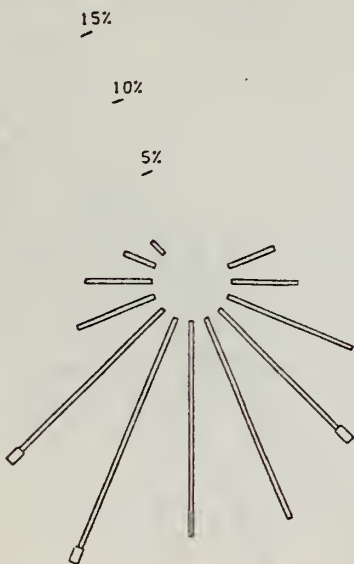

QUARTERLY NOX CONCENTRATION ROSE
MAR '78 - APR '78

TOTAL % OF CALMS DISTRIBUTED (0000%)
TOTAL NO. OF 1 HOUR SAMPLES -114

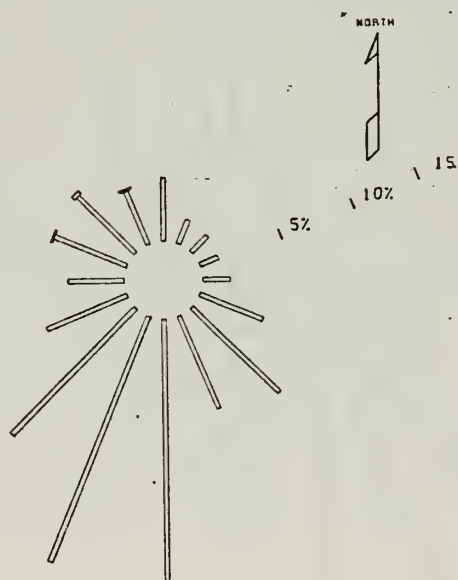

CONCENTRATION ($\mu\text{g}/\text{m}^3$)

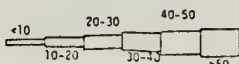
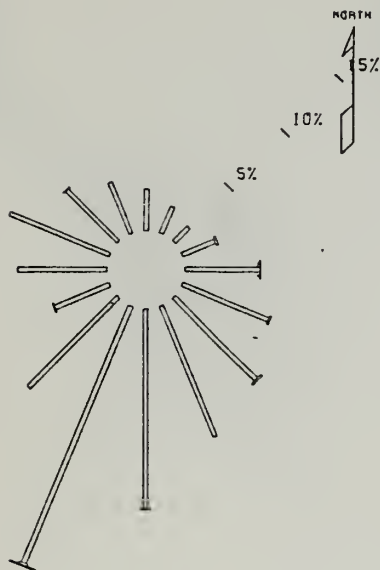

FIGURE A6.2.1-8

QUARTERLY NO₂ CONCENTRATION ROSES, STATION AB23 (1976-1978)

QUARTERLY NO₂ CONCENTRATION ROSE
DEC '76 - FEB '77

TOTAL % OF CALMS DISTRIBUTED (0000%)
TOTAL NO. OF 1 HOUR SAMPLES -1773



QUARTERLY NO₂ CONCENTRATION ROSE
MAR '77 - MAY '77

TOTAL % OF CALMS DISTRIBUTED (0000%)
TOTAL NO. OF 1 HOUR SAMPLES -2048

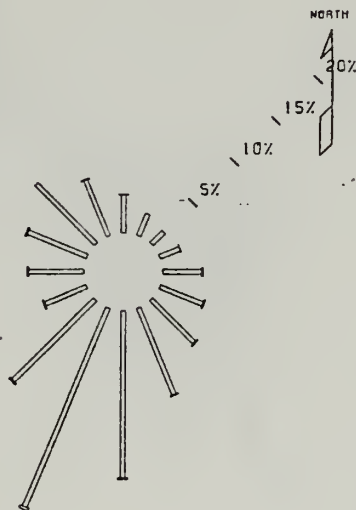

QUARTERLY NO₂ CONCENTRATION ROSE
JUN '77 - AUG '77

TOTAL % OF CALMS DISTRIBUTED (0.00%)
TOTAL NO. OF 1 HOUR SAMPLES -1182

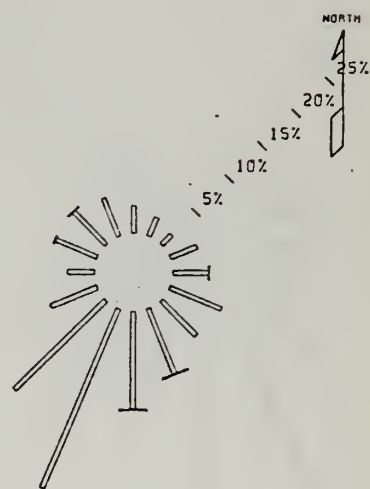

QUARTERLY NO₂ CONCENTRATION ROSE
SEP '77 - OCT '77

TOTAL % OF CALMS DISTRIBUTED (0000%)
TOTAL NO. OF 1 HOUR SAMPLES -93

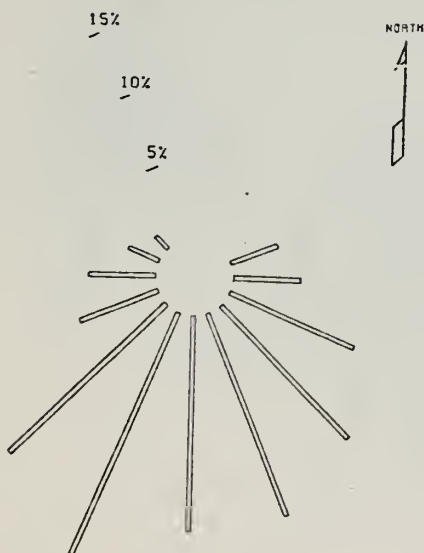

QUARTERLY NO₂ CONCENTRATION ROSE
MAR '78 - APR '78

TOTAL % OF CALMS DISTRIBUTED (0000%)
TOTAL NO. OF 1 HOUR SAMPLES -1143

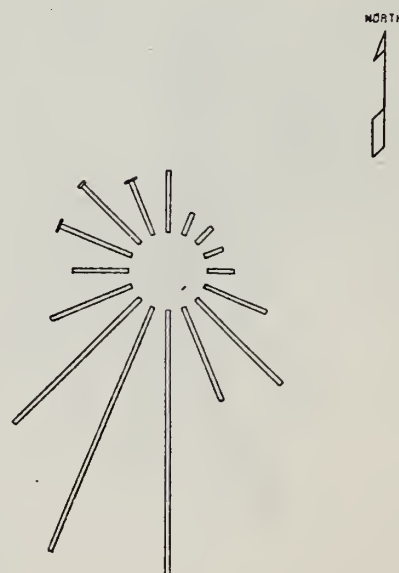

QUARTERLY CO CONCENTRATION ROSES, STATION AB23 (1976-1978)

QUARTERLY CO CONCENTRATION ROSE
DEC '76 - FEB '77

TOTAL % OF CALMS DISTRIBUTED (0000%)
TOTAL NO. OF 1 HOUR SAMPLES -1513

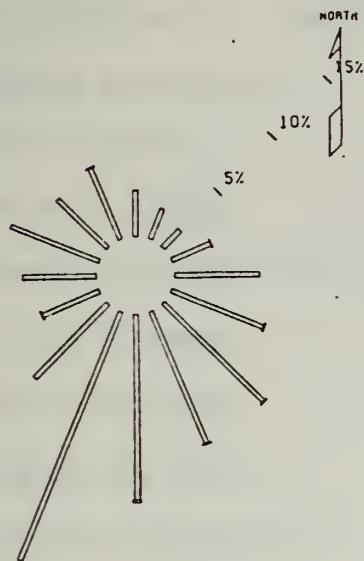

QUARTERLY CO CONCENTRATION ROSE
MAR '77 - MAY '77

TOTAL % OF CALMS DISTRIBUTED (0000%)
TOTAL NO. OF 1 HOUR SAMPLES -1161

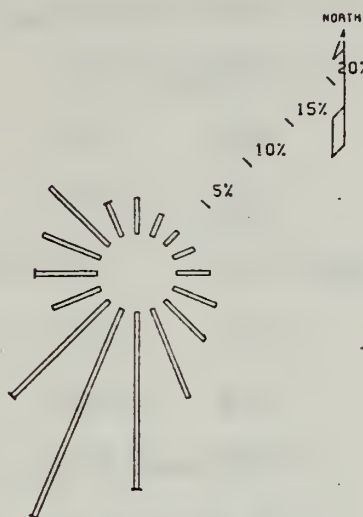

QUARTERLY CO CONCENTRATION ROSE
JUN '77 - AUG '77

TOTAL % OF CALMS DISTRIBUTED (0.00%)
TOTAL NO. OF 1 HOUR SAMPLES -1246

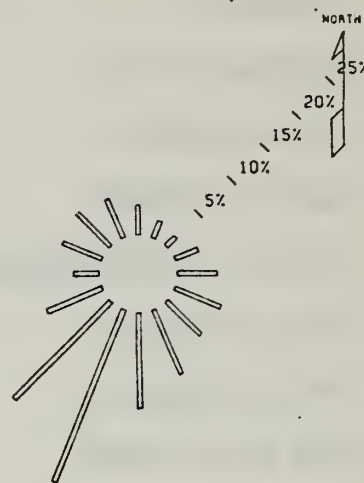

QUARTERLY CO CONCENTRATION ROSE
SEP '77 - NOV '77

TOTAL % OF CALMS DISTRIBUTED (0000%)
TOTAL NO. OF 1 HOUR SAMPLES -288

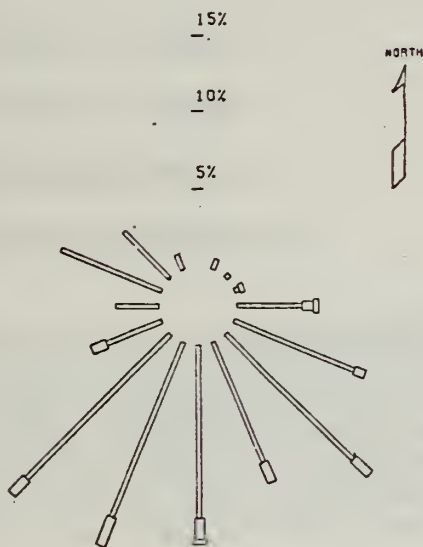

QUARTERLY CO CONCENTRATION ROSE
MAR '78 - APR '78

TOTAL % OF CALMS DISTRIBUTED (0000%)
TOTAL NO. OF 1 HOUR SAMPLES -817

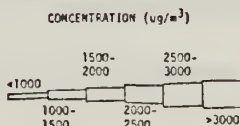
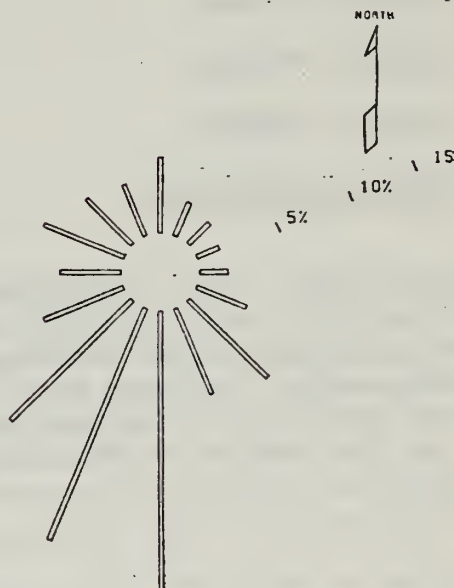

Table A6.2.1-4

UNIVARIATE TIME SERIES ANALYSIS FOR OZONE AUGUST 1975Station AB20

Parameter:	Ozone (8/75)(hours 433-744)	312 data points
Series:	Original	Differenced by 1 and 24
Series Mean:	42.6	0.101
Series Variance:	278.9	34.84
Trend at 95% Confidence Level:	0.0	0.0
Series Minimum:	8.0	-23.0
Series Maximum:	78.0	30.0
Chi-Sq. for Data:	2776. with 47 d.f.	99.4 with 47 d.f.
<u>Chi-Sq. at 95% Level:</u>	64.001 with 47 d.f.	64.001 with 47 d.f.
Model: (0,24,24)	$(1-B)^1(1-B)^2 z_t = 0.090239 + (1-.21382B^2)(1-.74195B^{24})a_t$	
Coef. of Det:	0.917 for original series	0.311
Residual Mean:		.179
Residual Variance:		23.77
Residual Minimum:		-17.0
Residual Maximum:		28.0
Residual Chi-Sq.:		28.09 with 21 d.f.
<u>Chi-Sq. at 95% Level:</u>		32.671 with 21 d.f.

Discussion: This is an ARIMA model based on a twice differenced series by lags of 1 and 24. The form of the model is (0,24,24). The autocorrelation function of the differenced series contained significant spikes at lags 2, 24, and 25. The trend term (.090239) was retained in the model even though it was not significant. The model has probably been overspecified in this case since the first difference of order 24 provided an autocorrelation function of lumpy, decaying exponential form similar to the hourly ozone series modeled for station AB23 August 1977 series.

Based on autocorrelation function comparison, this series is judged equivalent to AB23 August 1977 series except that the mean value is much lower.

NOTE: See Appendix A5.2.1D for discussion of Univariate Time Series Analysis.

Table A6.2.1-5

UNIVARIATE TIME SERIES ANALYSIS FOR OZONE AUGUST 1977

	<u>Station AB23</u>	
Parameter:	Ozone 8/77 (116-403)	
Series:	Original (288 hours)	Differenced by 24
Series Mean:	96.1	0.443
Series Variance:	333.75	287.37
Trend at 95% Confidence Level:	0.0	0.0
Series Minimum:	31.0	
Series Maximum:	129.0	
Chi-Sq. for Data:	1480.3 with 47 d.f.	690.00 with 46 d.f.
<u>Chi-Sq. at 95% Level:</u>	64.001 with 47 d.f.	62.830 with 46 d.f.
Model: (1,24,24)	$(1-.86896B^1)(z_t)=(1-.70217B^{24})a_t$	
Coef. of Det.		
Residual Mean:	0.24221	
Residual Variance:	66.313	
Residual Minimum:		
Residual Maximum:		
Residual Chi-Sq.:	47.884	
<u>Chi-Sq. at 95% Level:</u>	62.830 with 46 d.f.	

Discussion: This is an ARIMA model of the form (1,24,24). The model was based on differencing once by 24 lags to obtain an autocorrelation function of a lumpy, decaying exponential form. Significant lags occurred in the PACF of the differenced series at lags 1 and 24. Lag 1 was retained in the autoregressive term and lag 24 retained in the moving average term. Trend was insignificant for both original and differenced series. Forecast model fits data well and accounts for diurnal cycle of 24 hours.

NOTE: See Appendix A5.2.1D for discussion of Univariate Time Series Analysis.

Table A6.2.1-6

UNIVARIATE TIME SERIES ANALYSIS FOR OZONE AUGUST 1975Station AB23

Parameter:	Ozone 8175 (hours 433-744)	312 data points
Series:	Original	Differenced by 1 and 24
Series Mean:	52.3	.167
Series Variance:	204.57	36.34
Trend at 95% Confidence Level:		0.0
Series Minimum:	18.	
Series Maximum:	126.	
Chi-Sq. for Data:	1298 with 47 d.f.	
<u>Chi-Sq. at 95% Level:</u>	64.001 with 47 d.f.	
Model: (0,24,24)	$(1-B)^1(1-B)^2 z_t = .11026 + (1 + .24528B - .10950B^6 - .65533B^{24})a_t$	
Coef. of Det:	.784	.275
Residual Mean:		.0772
Residual Variance:		25.97
Residual Minimum:		-43.
Residual Maximum:		+36.
Residual Chi-Sq.:		27.87 with 28 d.f.
<u>Chi-Sq. at 95% Level:</u>		41.337 with 28 d.f.

Discussion: This is an ARIMA model based on twice differenced series by lags of 1 and 24. The form of the model is (0,24,24) with the moving term containing three parameters of order 1, 6, and 24. The autocorrelation function of the differenced series contained random spikes that were significant at lags 1, 6, and 24. The trend parameter of .11026 was not significant but was retained in the final model. The model has probably been overspecified and could have been based on differencing by 24 only. The model and series is equivalent to that of ozone series for AB20, August 1975.

A model based on differencing once by 24 lags would likely yield a form similar to that of ozone series for AB23, August 1977 except for a much lower mean value.

NOTE: See Appendix A5.2.1D for discussion of Univariate Time Series Analysis.

Table A6.2.1-7

UNIVARIATE TIME SERIES ANALYSIS FOR PARTICULATESStation AB23

Parameter:	Particulates (41 monthly data points)
Series Mean:	8.83171
Series Variance:	25.3322
Trend:	0.0 at 95% confidence level
Series Minimum:	1.10
Series Maximum:	19.30
Chi-Sq. for Data:	70.7666 with 39 d.f.
<u>Chi-Sq. at 95% Level:</u>	54.572 with 39 d.f.
Model: (12,0,0)	$(1-.60112B^1)(1-.24026B^12)(z_t-8.83171)=a_t$
Coef. of Det:	.402223
Residual Mean:	-.496612 = 0 at 95% confidence level
Residual Variance:	9.41857
Residual Minimum:	-4.71776
Residual Maximum:	10.9535
Residual Chi-Sq.:	13.4723 with 25 d.f.
<u>Chi-Sq. at 95% Level:</u>	37.652 with 25 d.f.

Discussion: This is an ARIMA (p,d,q) model where $p = 12$, $d = 0$, and $q = 0$. The partial-autocorrelation function of the data showed significant lags at times one and twelve. The trend term was insignificant at the 95% confidence level. Although the chi-square statistic for the data was significant, the residual chi-square was not significant, indicating that the model has successfully reduced the residuals to uncorrelated white noise. No actual forecasting was done using this model.

NOTE: See Appendix A5.2.1D for discussion of Univariate Time Series Analysis.

Table A6.2.1-8

UNIVARIATE TIME SERIES ANALYSIS FOR CARBON MONOXIDEStation AB23

Parameter:	Carbon Monoxide (31 monthly data points filled in via forecasting.)
Series Mean:	816.040
Series Variance:	278064.
Trend:	0 at 95% confidence level
Series Minimum:	239.3
Series Maximum:	1847.30
Chi-Sq. for Data:	68.3723 with 15 d.f.
<u>Chi-Sq. at 95% Level:</u>	24.996 with 15 d.f.
Model: (1,0,0)	$(1 - .81378B)(z_t - 816.040) = a_t$
Coef. of Det:	0.637104
Residual Mean:	0 at 95% confidence level
Residual Variance:	98534.9
Residual Minimum:	-675.863
Residual Maximum:	661.020
Residual Chi-Sq.:	7.29373 with 14 d.f.
<u>Chi-Sq. at 95% Level:</u>	23.685 with 14 d.f.

Discussion: The above model is an ARIMA (p,d,q) model where p, the order of the AR term = 1, and d and q, the order of the differencing and MA terms, respectively = 0.

This data is considered too limited for a meaningful time series. However, modeling of the "filled in" data showed a residual mean of 0 and an insignificant trend term at 95% confidence level. The residual chi-square was not significant showing that the residuals had been reduced to noise.

NOTE: See Appendix A5.2.1D for discussion of Univariate Time Series Analysis.

APPENDIX A6.2.3

Site Log Sheets for 1978 Visibility Study

SITE LOG SHEETS

4/06/78

MST

- 0750 - Arrived site. Windy not to cold. Some sunshine but cloudy overhead. All views good visibility. Clouds on H on View 4. Road dry.
- 0830 - All views good - cl on hz on View 4 only. Real overcast on View 4. No haze anywhere. Still windy from southeast. Kinda unusual? Sun behind large cloud.
- 0930 - No haze. Clouds on H on View 4 only. Still windy, a little more sunshine.
- 1030 - Some haze, View 1 & 2. Shadows on View 1 & 2. Still windy, some sunshine with high wispy clouds.
- 1130 - High cloudiness, sun shining. Light hz on View 1 & 2. Cl on H on View 1, 2, 3.
- 1300 - High cloudiness, sun shining. Lt hz. View 1. Cl on H on View 1, 2, 3. Warm 50+ and windy.
- 1400 - High clouds. with sun, real light hz. View 1 & 2. Real clear on View 3 & 4. Shadows on View 1 & 2.
- 1500 - High clouds, general overcast, not too much sun. Light hz View 1 & 2 clear on View 3 & 4. Has been windy, blustry type spring day.

SITE LOG SHEETS

4/12/78

MST

- 0800 - Arrived site. Fantastic morning. Not a cloud in sky. Sunny.
- 0830 - No change. Light hz all views snow on View 3 & 4. Not too cold. No breeze. Hz a little more to the west.
- 0930 - Nice - slight breeze - SW. View 1 & 2. Have lt hz while View 3 & 4. Not too cold no breeze hz a little more to the west.
- 1030 - Same as 0930. Breeze picking up a little.
- 1130 - Lt Hz View 1. View 2, 3, 4 clear few scattered clouds. No cl on H some breeze from SW - Nice out.
- 1200 - Getting windy. Some scattered clouds. Very little hz on View 1 & 2. 3 & 4 clear. Still sunny most times clouds coming from east.
- 1400 - Windy with some pretty good gusts. Lt hz on View 1. View 2, 3, & 4 clear. More clouds.
- 1500 - Still windy - Snow on View 3. Almost gone. Some hz View 1. All other views clear. Not too warm now, otherwise real nice day.

Depart site

SITE LOG SHEETS

4/18/78

MST

- 0800 - Arrived site. Calm, mostly clear. All views visible.
- 0830 - Sunny with some cl. Lt hz all views. Cl on Hz on Views 2,3, 4. No cl on View 1, a patch of shadow between site & View 1. Not too cold. Snow on View 4.
- 0930 - Cl on H on View 3 & 4. Calm and real nice. Snow is gone on all views except View 4. Seem hazy in all directions today - windy yesterday.
- 1030 - Has turned windy, hz is almost gone except View 1. Cl on H on View 3 & 4. A few scattered cl now to the N.
- 1130 - Still windy, shadow on View 2. Ht hz. View 1 - Rest are clear scattered cl and sunny.
- 1300 - Continues to be windy - Lt hz View 1 & 2. Clear to the east.
- 1400 - No change - very few clouds left in sky now.
- 1500 - Same - Windy but otherwise has been a real nice day.

Depart site

SITE LOG SHEETS

4/24/78

MST

- 0800 - Calm, sunny day. All views visible. Some hz all views
- 0830 - No change. A few high wispy cl. Snow on View 4. No cl on H. Some dust or smoke in area of C-b worksite.
- 0930 - Cl on H View 1, 2, 3 - lt hz 1, 2, 3. No much Hz on View 4. Always heavier to the west. Small amount of dust can be seen from C-b work site. Sunny & lt. wind.
- 1030 - Cl on H View 1 & 2 lt hz west, View 3 & 4 not bad. Lt. wind has started.
- 1130 - Cl on horizon all views. Lt hz View 1 and 2. 3 & 4 mostly clear wind is picking up a little more. Sunny.
- 1300 - Quite a bit of wind, gusty. Cl on H all view lt hz. View 1 & 2 View 3 & 4 mostly clear becoming overcast.
- 1400 - Gusty winds at time. Cl on H all views. Shadow on View 3. Lt hz to the west, better to the east. Not as overcast as 1300.
- 1500 - Cl on H all views, Wind isn't quite as gusty, cloudy to the south Sunny - lt hz View 1 & 2, 3 & 4 pretty good.

Real nice day

SITE LOG SHEETS

4/30/78

MST

- 0805 - View 1 & 2 covered with clouds View 3 & 4 can be seen but not too clear. Overcast with some sun, light wind blowing from SW. Rain last night some shower to west and northwest.
- 0830 - Same as 0805. Some clearing on skyline to west.
- 0930 - No sun. Light rain total overcast. Can see View 4 only clouds on View 1, 2, & 3. Pictures taken from inside cabin.
- 1030 - All views in clouds, however close objects all view are visible. Sunny to south. Windy. Not raining at site now.
- 1130 - View 2 & 4 visible. Rain showers. Some sun to south. View 3 heavy clouds. View 1 clouds.
- 1300 - Good rain at site - overcast can see View 1. View 2, 3, & 4 covered with clouds. Wind, light out of SW. No sun now.
- 1400 - View 1 - Visible - some light cls on View 2. View 3 & 4 are covered with clouds. Rain showers to View 4 sun shining again. But mostly overcast.
- 1500 - View 1 & 2 visible. View 3 & 4 in clouds. Some sun, but mostly cloudy. About same all day.

Depart site

SITE LOG SHEETS

5/6/78

MST

- 0800 - 1" snow at site - overcast - with some sunshine. View 2 & 4 visible with cl on View 1 & 4. Calm. Some blue skys too mostly overhead.
- 0830 - Cl on H all views. View 1, 2, 3 visible. View 4 in clouds. Calm. Overcast right now. Radio says 100% for showers & or snow today.
- 0930 - View 1 & 2 visible. View 3 just barely visible. View 4 snowing. Wind calm, a bit more cloudy - seems to be closing in a bit.
- 1030 - Weather getting worse. Can only see View 2. Storm moving west to east. Real light wind. No sun. Light snow on all higher areas.
- 1130 - View 1, 2, 3 visible. Snowing View 4. No sun. No wind. No warmth. Light snow & rain showers at sight. Not much change.
- 1300 - View 1 & 2 visible. Snowing elsewhere. Just minutes after pictures were taken a snowstorm at site.
- 1400 - All views snowing. Some sun overhead good snowstorm from NW.
- 1400 - Snowing all views. Sun overhead some wind. Not too hot a day.

Depart site

NOTE: Forgot to change the month on calibration card!

SITE LOG SHEETS

5/12/78

MST

- 0805 - Sunny with a few scattered clouds on horizon to North & NE. Breeze from SW. Nice morning.
- 0830 - Cl on H on View 3 & 4. Lt hz on View 1, 2, 3. View 4 real clear, snow on View 4. A low cl on 4 north & east. Sunny with breeze from SW. Some gusts.
- 0930 - Cl on H all views. Lt hz. View 1, 2, 3. View 4 clear. Light breeze and sunny. No dust at all from C-b work site, or from Ca either.
- 1030 - View 4 clearest I have ever seen. Cl on horizon View 1, 2, 3. Lt hz View 1 & 2. Sunny with breeze & some gusts from SW.
- 1130 - Cl on Horizon, View 1, 2, 3. View 4 real clear. Lt hz on 1 & 2. 3 is not bad. Sunny, light wind and some gusts.
- 1300 - Clear H on View 3. Lt hz View 1 and 2. View 3 and 4 clear. Almost a cloudless day - sunny - some wind and gusts.
- 1400 - No cl on H all views. View 1 light hz. View 2, 3, 4 are clean. Breeze blowing from W with some gusts. Clear & sunny.
- 1500 - No cl on H all views. Lt hz in west, cleaner to the east. Wind almost calm. Real nice day.

Depart site 1510

SITE LOG SHEETS

5/18/78

MST

- 0800 - Skiff of snow on ground at site. Breeze from west, cool, scattered clouds. Some sunshine. View 1, 2, 3 visible, hz to the northwest. View 4 in clouds. Road has been graded.
- 0830 - View 1, 2, 3 visible, some hz. Cl on 4. All views - scattered cls some sun, breeze (cool) from west.
- 0930 - All views visible. Lt hz in east to considerable amounts in west — snow on View 4. Scattered cl, some sun.
- 1030 - Same as 0930 but a little more wind. Some gusts.
- 1130 - Quite a bit of hz to the west and clear to the east. Mostly overcast with shadows from sun. Lt breeze from W.
- 1300 - Not much change.
- 1400 - Overcast at site, with shadows View 3 & 4. Lt. breeze with gusts.
- 1500 - View 4 in sunshine, overcast rest of views. Not much haze as wind is stronger now.

Depart site 1510

SITE LOG SHEETS

5/24/78

MST

- 0800 - Only 2 cl in sky - wind from SE? Quite a bit of haze seems heaviest to the NW.
- 0830 - Heavy HZ on View 1 & 2. Moderate hz on View 3 & 4. View 4 has snow. Windy - out of SE. Sunny. Sometimes gusty.
- 0930 - Note quite as hazy as 0830 still windy. Not much change.
- 1030 - View 4 is clearing up. Must be the wind. Still hard to see View 1. Windy from SE with some good gusts. Sunny & nice.
- 1130 - Same as 1030, but starting to get some scattered clouds mostly north.
- 1300 - Fairly clear to the east but gets hazy to a point in where you can hardly see View 1. Wind is shaking the shelter? Real gusty. Quite a few clouds from the south.
- 1400 - Real hazy View 1, View 2 not quite so bad, light hz. View 3, to almost clear View 4. Windy, clouds are making some shadows.
- 1500 - Same as 1400 - However cl are no on H on View 1, 2, 3, very windy day storm moving in from NW.

Depart Site 1515

SITE LOG SHEETS

5/30/78

MST

- 0755 - Pretty sunny morning. Light breeze from NE. All view visible
Snow on View 4. All views lt. hz.
- 0830 - No cl or H View 1 & 2, 4, cl or h View 3, sunny with breeze from
NW. Seems to be more hz in the NE than even before. Snow on
View 4.
- 0930 - Weather about the same. No cl on h now. Some cl to the north.
Light hz all views.
- 1030 - Not much change. View 4 may be a bit clearer. Seems like more hz
in area of Rio Blanco.
- 1130 - Cloudy to the east. Wind from west. Lt hz all views. Cool
outside.
- 1300 - Wind from NW. Cloudy over much of the south and east. View
4 much clearer and View 1 has more hz.
- 1400 - Overcast - some shadows. Cl on 4. All views moderate hz to the
west to lt hz in the East. Still windy looks like some showers to
the East.
- 1500 - Overcast - generally cloudy everywhere. Still windy getting
pretty hazy in the east, View 4.

Depart site 1510

SITE LOG SHEETS

10/05/78

MST

- 0755 - Sunny morning. Calm. All views visable.
- 0830 - No CL. on H. Sunny & no haze. Calm.
- 0930 - Some clouds on Hor. to N. but not in picture area. Slight haze all views. Slight wind from east.
- 1030 - Same as at 0930. Still some haze. Wind now in west. Slightly cooler.
- 1130 - Some clouds on H. - N.W., but not in picture area. Slight haze all views. Wind from west.
- 1300 - CL. on H. views 1,2,4. Haze still exists. Wind from west. More haze on views 1 & 2.
- 1400 - CL on H. views 1,2,3. Haze still exists. Wind from N.W.
- 1500 -- CL. on H. views 1,2,3,4. Has been a nice day.
- 1510 - Departed site.

SITE LOG SHEETS

10/11/78

MST

- 0800 - Arrived on sight. CL. on Hr. sights 1,2,3,4. Calm & warm. All views visable but haze on all sights.
- 0830 - CL. on Hr all views. Still sunny & warm. No wind.
- 0930 - More CL. on views 1,2,3. Not yet heavy on view 4. No wind. some haze. Looks like change of weather from N.W.
- 1030 - About same as 0930. Clouds slowly rising. Still no wind.
- 1130 - Getting quite a lot of haze, views 1,2,3. Breeze blowing from N.W. CL on Hr all views. Very clear south & east.
- 1300 - Haze has lifted. All sights still CL. on Hr, but clouds more broken. Slight breeze from N.W.
- 1400 - Clouds more broken. Haze has lifted. CL on Hr. Wind from N.W. Sunny & warm.
- 1500 - Some CL. on Hr. Views 1,2,4. Clear on view 3. Wind stronger. Still warm & sunny.
- 1510 - Departed site.

SITE LOG SHEETS

10/17/78

MST

- 0800 - Arrived at sight. Cloudy all directions. Sights are visible, but all have haze.
- 0830 - Cloudy all directions. All sights barely visible. Southeast wind. All sights have haze.
- 0930 - Same as at 0830. No wind. #4 barely visible.
- 1030 - Some broken clouds overhead. Still cloudy to sights. Wind from south.
- 1130 - Clouds more broken. All sights, clouds and haze. Wind stronger from south.
- 1300 - Variable high cloudiness. Haze on sights 1,2,3. Cannot see #4. Wind stronger from south.
- 1400 - Seems darker all sights. But high clouds so that all sights are visible.
- 1500 - About the same. More haze in picture areas. Wind strong.
- 1507 - Dearted site.

SITE LOG SHEETS

10/23/73

MST

- 0800 - Arrived on sight. Sunny & very clear to views 1 & 2. Views 3 & 4 cannot see due to low clouds. No wind. Cloudy to N & W.
- 0830 - Very clear, views of 1 & 2. Views 3 & 4 still covered with clouds. No wind.
- 0930 - Same as at 0830. Slight breeze from east.
- 1030 - Sights 1 & 2 still very clear. #3 can now be seen under clouds. #4 still covered with clouds. Clouds seem to be breaking up.
- 1130 - All sights now visible. Some haze on view 1. View 4, snow on peak.
- 1300 - Slight haze, views 1 & 2. Views 3 & 4 extremely clear. Slight breeze from west.
- 1400 - Same as at 1300. Slight breeze from west. Seems some cooler. Some haze #3 & 4. (No heat in shelter)
- 1500 - All locations very clear. Very nice day. Sunny & cool.
- 1510 - Departed site.

SITE LOG SHEETS

10/29/78

MST

- 0810 - Arrived at sight. All sights very clear. Sunny & Bright. Moderate wind from S.E.
- 0830 - Conditions same. Slight haze views 1 & 2. Views 3 & 4 very clear. Wind from S.E. cool. (No heat at location)
- 0930 - Same as at 0830. Wind much stronger.
- 1030 - More haze, views 1,2,3. Quite clear on view 4. Still very windy. A few high clouds forming.
- 1130 - More haze, all four locations. Very windy.
- 1300 - Still haze, all four locations. Strong & gusty wind from S.E.
- 1400 - Cl. on Hr views 1,2,3. Haze on view 4. Strong wind from S.E.
- 1500 - Cl. on Hr. Views 1,2,3. Haze on view 4. Wind still strong from S.E.
- 1515 - Departed site.

SITE LOG SHEETS

11/04/78

MST

- 0800 - Arrived at sight. Some high clouds. No wind. Light clouds all directions (trying new equipment today). Conditions same. Light clouds all directions. But sights are visable.
- 0930 - Condition same. Little more haze. Slight breeze from S.E.
- 1030 - Light clouds & haze, views 1 & 2. A little less haze, views 3 & 4. Slight breeze from S.E.
- 1130 - Conditions same. Clouds in background, all locations. Views 1 & 2 more haze. Wind has gotten stronger.
- 1300 - High clouds & haze, views 1,2,3. Clearer on view 4. Conditions about same all day.
- 1400 - Conditions same. Wind has let up some.
- 1500 - Haze has lifted some. High clouds on all locations. Conditions have remained same all day.
- Tried new equipment today. Am sure I need more instruction. No consistancy to readings.
- 1515 - Departed site.

SITE LOG SHEETS

11/10/78

MST

- 0800 - Arrived at sight. Snowing lightly. Light snow cover at sight. No sights are visible.
- 0830 - Conditions same. Light snow. No wind. Visibility about 2 miles.
- 0930 - Visibility has lifted some. Still no sights visible. Not snowing at present.
- 1030 - Little more visibility. No sights yet visible.
- 1130 - Clouds all locations. Getting much colder.
- 1300 - Cloudy views 1-2-3. View 4 barely visible - (Tested this view with new instrument). First reading I have taken today. View 4 only.
- 1400 - CL views 1-23. #4 barely visible. Took reading on instrument view, 4 only.
- 1500 - Cloudy. Conditions same as at 1400. Reading of new instrument on view 4 only.
- This has been a cloudy, cold day.
- 1515 - Departed site.

SITE LOG SHEETS

11/16/78

MST

- 0810 - Arrived at sight. About 8" of snow on ground. Completely socked in. Visibility all directions about 100 yards. No wind.
- 0830 - Conditions same.
- 0930 - Conditions same.
- 1030 - Fog has lifted some. Visibility now about $\frac{1}{2}$ mile.
- 1130 - Still no sights visible. Visibility about 1 mile. No wind.
- 1300 - Visibility much greater. Still no sights visible. No wind. Partly cloudy.
- 1400 - Conditions about same as at 1300. View #4 slightly visible. CL on Hr. all directions.
- 1500 - CL obstruct views 1-23. #4 slightly visible. View 4 is only time I could take reading on new instrument.

Has been a cold day. No wind. Departed sight 1520.

SITE LOG SHEETS

11/22/78

MST

- 0820 - Arrived a little late. Slipped off road on way in. Snowing hard at present. About 1 inch of new snow on ground. Looks like it will be another bad day.
- 0830 - Conditions same. Snowing hard. Visability about $\frac{1}{2}$ mile all directions. Slight wind from S.E.
- 0930 - Still snowing, but is clearing. Some blue sky overhead. Slight wind from south.
- 1030 - View #1 not visable. Views 2-34 barely visable. Wind strong from south. Very cold. No haze in clearing areas.
- 1130 - Views 1 & 2-4 not visable. View 3 is visable. Cloudy all directions. Strong wind from south. Cold.
- 1300 - Views 1 & 2 not visable. Snowing to the west & N.W. Views 3 & 4 visable with clouds overhead. Wind is strong from south with some drifting now to 2'.
- 1400 - All sights visable with background & HR of clouds. Still very windy and cold.
- 1500 - All sights visable. CL on HR. No haze but clouds all around. Windy and cold.
- 1520 - Departed site.

SITE LOG SHEETS

11/28/78

MST

- 0800 - Snowing lightly. Completely overcast. About 6" new snow on ground. Cold wind from south.
- 0830 - Snowing harder. Visability about $\frac{1}{2}$ mile. Completely overcast. About a foot of snow on ground.
- 0930 - Conditions same. Snowing. Wind from south. Looks like another bad day. "4th day in a row."
- 1030 - Snowing very light. No sights yet visable. Wind strong from south. Cloud cover not so heavy now.
- 1130 - No sights yet visable. Strong wind from south and very cold.
- 1300 - No sights visable. Snowing lightly again. Wind strong. Extremely cold.

Because of poor visibility - blowing and drifting snow - decided to leave now rather than take a chance on getting caught in worse weather.

- 1345 - Departed site.

Table A6.3.1-1

UNIVARIATE TIME SERIES ANALYSIS FOR TEMPERATUREStation AB23

Parameter:	Temperature (41 monthly data points)
Series Mean:	6.04651
Series Variance:	68.3787
Trend:	0 at 95% confidence level
Series Minimum:	-5.0
Series Maximum:	21.0
Chi-Sq. for Data:	232.294 with 41 d.f.
<u>Chi-Sq. at 95% Level:</u>	60.561 with 41 d.f.
Model: (12,0,0)	$(1 - 0.089864B - 0.84552B^{12})(z_t - 6.04651) = a_t$
Coef. of Det:	0.849677
Residual Mean:	0 at 95% confidence level
Residual Variance:	
Residual Minimum:	
Residual Maximum:	
Residual Chi-Sq.:	9.86816 with 45 d.f.
<u>Chi-Sq. at 95% Level:</u>	61.656 with 45 d.f.

Discussion: This is an ARIMA (12,0,0) model where 12 = the order of the autoregressive terms, 0 = the order of the difference term (there is no differencing), and the last 0 = the order of the moving average terms (there are no moving average terms). The trend was not significant at the 95% confidence level. Although the chi-square statistic for the data is significant at the 95% level, the residual chi-square is not significant, indicating that the residuals have been reduced to uncorrelated white noise. The partial autocorrelation function of the actual data had significant spikes at lags 1, 2, 3, and nine. Insignificant parameters were discarded to obtain the current model which fits the data well and accounts for an annual cycle of 12 months.

NOTE: See Appendix A5.2.1D for discussion of Univariate Time Series Analysis.

TABLE A6.3.1-2

AIR TEMPERATURE, 10m (°C)

STA.	ITEM	SEASONAL YEAR	MONTH												ANNUAL	
			DEC	JAN	FEB	MAR	APR	MAY	JUN	JUL	AUG	SEP	OCT	NOV	MAX. AVG.	MIN.
AB20 AB23	HOURLY MAX.	1975	7	10	8	15	21	26	31	32	28	25	18	32		
	"	1975	9	6	6	10	20	22	28	29	26	22	17	29		
	HOURLY AVG.	1975	-11	-9	-7	0	2	9	14	19	12	6	-3	4		
	"	1975	-4	-5	-4	-1	2	8	13	19	13	8	0	6		
	HOURLY MIN.	1975	-34	-43	-31	-33	-28	-9	-1	-2	-8	-18	-27	-43		
AB23	"	1975	-18	-21	-18	-21	-14	-6	1	11	-2	-10	-16	-21		
AB20 AB23	HOURLY MAX.	1976	11	8	11	13	20	27(1)	30	34	30	25	(2)	34		
	"	1976	10	8	9	11	17	23	28	31	27	22	15	31		
	HOURLY AVG.	1976	-6	-9	-3	-4	4	11	15	21	13	3	(2)	7		
	"	1976	-2	-4	-1	-2	6	16	21	21	13	6	1	7		
	HOURLY MIN.	1976	-26	-41	-29	-32	-9	-7(1)	-8	4	-4	-14	(2)	-41		
AB23	"	1976	-14	-21	-14	-15	-6	-3	-6	10	-9	-19	-21			
AB20 AB23	HOURLY MAX.	1977	8	7	12	12	19	22(1)	28(1)	28(1)	34	22	18	34		
	"	1977	8	7	12	12	19	22(1)	28(1)	28(1)	29	22	18	34		
	HOURLY AVG.	1977	-3	-5	-2	-2	6	9(1)	20(1)	21(1)	15	5	3	7		
	"	1977	-3	-5	-2	-2	6	9(1)	20(1)	21(1)	19	5	3	7		
	HOURLY MIN.	1977	-13	-20	-13	-16	-11	-2(1)	7(1)	11(1)	-4	-12	-17	-20		
AB23	"	1977	-13	-20	-13	-16	-11	-2(1)	7(1)	11(1)	-4	-12	-17	-20		
AB20 AB23	HOURLY MAX.	1978	13	13	6	15	18	24	28	(2)	27	27	31	31		
	"	1978	13	13	6	15	18	24	28	(2)	27	27	31	31		
	HOURLY AVG.	1978	4	7	-3	2	6	9	17	(2)	14	15	15	15		
	"	1978	4	7	-3	2	6	9	17	(2)	14	15	15	15		
	HOURLY MIN.	1978	-8	-2	-15	-11	-5	-4	2	(2)	-4	-4	-4	-15		
AB23	"	1978	-8	-2	-15	-11	-5	-4	2	(2)	-4	-4	-15			

(1) Partial Data Only

(2) Station Inoperative

TABLE A6.3.1-3

GROWING SEASON AND DEGREE-DAYS BY YEAR

YEAR	GROWING SEASON*			DEGREE-DAYS** (°C-DAYS) IN				
	START	STOP	LENGTH (days)	GROWING SEASON	APR-MAY-JUN	MAY-JUN-JUL	JUN-JUL-AUG	JUL-AUG-SEPT
1975	May 26	Sept 21	118	84	8	57	84	76
1976	June 14	Oct 5	111	111	15	87	108	93
1977	Apr 21	Sept 14	144	110	23	70	110	87
1978	May 15	Sept 17	124	223	33	121	169	163

* Hourly minimum air temperature always >0°C

** $\frac{5}{9} [T_{av} - 65^{\circ}F]$ X (No. of days in month for which T_{av} applies) Summed over appropriate number of months

Where T_{av} = daily average temperature (°F) specifically for those days whose average is over 65°F

(Ref: Munn (1970))

TABLE A6.3.1-4
DIRECT SOLAR RADIATION

MONTH	TOTAL LANG. FOR MONTH		'AVG. DAY-LIGHT HRS/DAY	DAYLIGHT HRS PER MONTH	UPTIME DAYLIGHT HRS/MO.	CORR. FACTOR = (5)/(6)	AVG. LANG/DAY (MOD.)	DAILY TOTAL/DATE	
	UNMOD.	MOD.*						HIGHEST	LOWEST
①	②	③ = ② x ⑦	④	⑤	⑥	⑦	⑧ (Days Per Mo.)	⑨	⑩
11/74	4121	4256	10	300	291	1.031	141.9	225/11	1/3
12/74	1878	3500	10	310	167	1.856	112.9	164/9	0/7
01/75	4036	4396	10	310	284	1.092	141.8	266/1	22/28
02/75	6880	7305	11	308	291	1.058	260.9	416/24	100/15
03/75	7586	10076	12	372	280	1.329	325.0	479/19	142/9
04/75	10940	11325	13	390	375	1.040	377.5	550/25	65/7
05/75	14559	14559	14	434	434	1.000	496.6	706/26	94/28
06/75	13762	15667	15	450	395	1.139	522.2	737/26	166/18
07/75	16079	16659	15	465	447	1.040	537.4	687/6	227/16
08/75	15005	15670	14	434	409	1.061	511.9	665/3	324/13
09/75	11849	12324	13	390	375	1.040	410.8	545/6	180/11
10/75	10089	10114	12	372	372	1.000	326.3	446/1	28/31
11/75	4615	4670	10	300	297	1.010	155.7	279/1	11/28
12/75	3957	4007	10	310	307	1.010	129.3	207/18	13/25
01/76	6166	6176	10	310	310	1.000	199.2	303/29	85/5
02/76	8102	8102	11	308	308	1.000	279.4	393/22	59/6
03/76	11856	12046	12	372	365	1.019	388.6	567/30	133/25
04/76	11990	13225	13	390	355	1.099	440.8	656/28	187/17
05/76	14693	15198	14	434	421	1.031	490.3	732/16	224/6
06/76	18674	18689	15	450	450	1.000	623.0	741/21	227/22
07/76	17102	17292	15	465	460	1.011	557.8	720/4	229/5
08/76	15351	15961	14	434	417	1.041	514.9	665/5	193/1
09/76	11477	11477	13	390	390	1.000	382.6	558/2	155/24
10/76	10178	10178	12	372	372	1.000	328.3	440/7	143/26
11/76	6725	6725	10	300	299	1.003	224.9	307/1	75/13
12/76	5685	5685	10	310	310	1.000	183.4	242/1	73/5
01/77	6043	6043	10	310	309	1.003	194.9	376/25	54/5
02/77	7850	7850	11	308	308	1.000	280.4	409/27	92/22
03/77	10737	11059	12	372	360	1.033	356.7	523/27	110/17
04/77	12870	12870	13	390	390	1.000	429.0	598/10&24	90/19
05/77	16228	16390	14	434	431	1.007	528.7	717/18	209/14
06/77	18590	18590	15	450	450	1.000	619.7	744/19	381/7
07/77	14256	16124	15	465	420	1.107	520.1	731/10	269/4
08/77	13970	14249	14	434	424	1.024	459.6	674/1	172/17
09/77	11904	12380	13	390	375	1.040	412.7	568/2	121/28
10/77	9676	9870	12	372	365	1.019	318.4	667/2	89/31
11/77	5580	6026	10	300	279	1.075	200.9	323/1	36/19
12/77	1328	-	10	310	81	-	-	229/5	75/3
01/78	1147	-	10	310	98	-	-	249/13	67/18
02/78	4508	8250	11	308	168	1.833	294.6	404/18	90/3
03/78	954	-	12	372	22	-	-	101/30	67/31
04/78	-	-	13	390	-	-	-	-	-
05/78	7587	-	14	434	183	-	-	714/12	5/21
06/78	-	-	15	450	-	-	-	-	-
07/78	1835	-	15	465	55	-	-	646/30	366/29
08/78	16327	16441	14	434	431	1.007	530.4	663/3	234/14
09/78	12107	12557	13	390	376	1.037	418.6	483/22	126/18
10/78									
11/78									
12/78									

* "Modified" by the ratio of total-daylight to uptime-daylight hrs/mo for cases where uptime \geq 50% of total.

TABLE A6.3.1-5

RELATIVE HUMIDITY (%)

STA.	ITEM	SEASONAL YEAR	RELATIVE HUMIDITY (%)												ANN. MAX. AVG. MIN.	
			DEC	JAN	FEB	MAR	APR	MAY	JUN	JUL	AUG	SEP	OCT	NOV		
AB23	HOURLY MAX.	1975	100	100	100	100	100	100	100	100	100	87	93	100	100	100
AB23	HOURLY AVG.	1975	69	68	72	72	67	64	54	54	54	29	35	40	53	56
AB23	HOURLY MIN.	1975	25	26	32	37	32	28	25	28	28	12	16	15	19	12
AB23	HOURLY MAX.	1976	90	90	89	30	98	90	99	96	96	100	99	94	97	100
AB23	HOURLY AVG.	1976	62	62	57	56	53	51	44	47	50	50	59	51	56	54
AB23	HOURLY MIN.	1976	34	25	22	23	21	24	27	29	32	32	32	32	32	21
AB23	HOURLY MAX.	1977	96(1)	(2)	(2)	74(1)	100	(2)	80	(2)	(2)	(2)	99(1)	(2)	(2)	100
AB23	HOURLY AVG.	1977	58(1)	(2)	(2)	56(1)	67	(2)	24	(2)	(2)	(2)	37(1)	(2)	(2)	(1)
AB23	HOURLY MIN.	1977	30(1)	(2)	(2)	41(1)	37	(2)	1	(2)	(2)	(2)	15(1)	(2)	(2)	1
AB23	HOURLY MAX.	1978	99	97	96	96	95	94	96	94	94	94	97			99
AB23	HOURLY AVG.	1978	65	74	71	66	53	49	42	38	38	38	45			
AB23	HOURLY MIN.	1978	10	32	25	20	14	13	12	9	9	9	8			8

(1) Partial Data Only

(2) Missing Data

TABLE A6.3.1-6a
MONTHLY PRECIPITATION FOR 1975

STATION	COM- PUTER CODE	MONTHLY TOTAL (cm)												ANN- TOTAL ACTUAL (EST)			
		JAN	FEB	MAR	APR	MAY	JUN	JUL	AUG	SEP	OCT	NOV	DEC				
USGS 022	WU22		2.54	2.74	0.71							2.87	1.22	2.54			
USGS 015	WU15		1.27	1.22	2.54	2.57	5.18	2.36				0.30	0.66	2.79	2.79	2.03	
USGS 058	WU58											1.65	1.09	2.29			
USGS 050	WU50		1.27	1.52	1.65	0.28		1.27	0.51					1.65	1.78	2.01	
USGS 070	WU70		5.74	4.01	5.21			2.54	0.43				1.02	4.85	4.95	4.01	
AQ Sta 020	AB20																
AQ Sta 023	AB23																
MC Sta 1	BC01							1.80	1.00	0.08	0.43	0.76	1.15				
MC Sta 2	BC02							1.80	0.80	0.20	0.41	1.42	1.35				
MC Sta 3	BC03					2.62	2.49	0.60	0.40	1.19	0.46	1.27	1.15				
MC Sta 4	BC04					2.59	4.62	2.50	1.00	0.36	0.50	1.14	1.52				
MC Sta 5	BC05						2.18	1.30	1.10	0.13	0.10	2.49	1.10				
MC Sta 6	BC06					3.40	6.99	2.40	0.70	0.61	0.48	3.07	1.37				
MC Sta 7	BC07					0.53	3.28	4.60	0.40	0							
MC Sta 8	BC08					0.64	1.52	3.20	0	0	0						
MC Sta 9	BC09						3.05	1.00	3.40	0.86	0.43	0.97	1.50				
MC Sta 13	BC13						5.59	3.30	4.30	0.03	0.66	1.50	1.65				
AVERAGE*		(1)	(2.42)	1.66	1.83	1.63	2.28	3.62	2.16	1.32	0.49	0.98	1.48	(24.86)			
AVERAGE EXCL. MC		(2.42)	1.69	1.83	1.63	1.43	5.18	1.82	1.33	0.99	2.32	2.29	2.02	(24.95)			

*EXCL WU70

(1) Estimated "Tract" average from ratio of WU70 to the average of WU15, WU50, and WU22 for the month of February, i.e.:
 $5.74 \times \frac{1.69}{4.01} = 2.42$

TABLE A6.3.1-6b
MONTHLY PRECIPITATION FOR 1976

STATION	COM- PUTER CODE	MONTHLY TOTAL (cm)												ANN. TOTAL ACTUAL (EST)			
		JAN	FEB	MAR	APR	MAY	JUN	JUL	AUG	SEP	OCT	NOV	DEC				
USGS 022	WU22					4.06	2.01	4.24	2.26	2.79	0.51						
USGS 015	WU15		4.06	4.29	1.78	3.05	2.01	2.92	0.13	2.46				0.10	0		
USGS 058	WU58						2.90	4.09	1.12								
USGS 050	WU50		4.32	4.32	1.65	3.48	1.60	2.41	Tr.	2.03				0	0		
USGS 070	WU70	1.47	8.71	5.82				4.62	1.68	4.29	1.47	0.79	0.84				
AQ Sta 020	AB20															0.74	
AQ Sta 023	AB23															0.99	
MC Sta 1	BC01	3.90		4.10		0.79	0.97	0	1.30								
MC Sta 2	BC02	3.40		4.60		1.52	1.80	0	0.76								
MC Sta 3	BC03	4.13	4.60	9.22	4.90	6.30	1.63	1.63	1.30					0.11	0		
MC Sta 4	BC04	2.29	2.48	0	0		1.88	0.36	1.47	0.79	0	0	0				
MC Sta 5	BC05	4.30	3.09	3.20		0.97	0.91	0.20	0.71					2.87	0.43		
MC Sta 6	BC06	2.20	0.99	2.63	0.79	1.68	2.29	3.56	0.56	0.91	2.14						
MC Sta 7	BC07	2.20	1.41						1.78	0.72							
MC Sta 8	BC08	1.10	0.64	2.40	2.16	0.91	1.57	1.32	1.55								
MC Sta 9	BC09	2.00	4.19	2.90		2.01	0.74	0.25	1.73								
MC Sta 13	BC13	3.10	2.59	4.80		1.19	1.37	0.25	1.73								
AVERAGE*		2.86	2.84	3.86	1.88	2.30	1.67	1.63	1.17	1.62	1.03	0.25	0.29	0.10	0.43		
AVERAGE EXCL. MC		0	4.19	4.31	1.72	3.53	2.13	3.42	0.87	2.43	0.51	0.10	0.43				

*EXCL WU70

TABLE A6.3.1-6c
MONTHLY PRECIPITATION FOR 1977

() = Estimate

STATION	COM- PUTER CODE	MONTHLY TOTAL (cm)												ANN. TOTAL ACTUAL (EST)			
		JAN	FEB	MAR	APR	MAY	JUN	JUL	AUG	SEP	OCT	NOV	DEC				
USGS 022	WU22					2.03	0.28	6.05	6.50	5.84	2.84						
USGS 015	WU15	1.09	0.38	2.9	0.53	1.85	0.08	5.05	5.18	3.40	2.84	4.22					
USGS 058	WU58					2.36	0.51	1.68	6.15	5.14	1.55						
USGS 050	WU50	1.09	0.30	2.18	1.70	2.34	0.25	4.17	5.36	2.83	1.32	4.29	2.74				
USGS 070	WU70	1.98	1.70	7.39		3.40	0.28	1.52	6.05	3.71	2.36	4.98	3.28				
AQ Sta 020	AB20	2.31	1.19	4.24	3.15	2.39	0.38	3.91	5.18	9.27	2.57	4.37	3.43				
AQ Sta 023	AB23	2.03	1.35	4.01	3.18	2.79	0.41	4.70	5.66	3.73	2.24	3.66	2.16				
MC Sta 1	BC01										4.32	0.86					
MC Sta 2	BC02										1.90	0.56					
MC Sta 3	BC03	0.05	0.03	0.04	0.15	0.03	0.02	17.80			4.70	1.02					
MC Sta 4	BC04	0.04	0.03	0.06	0.13	0.10	0.03				2.79	0.74					
MC Sta 5	BC05										2.16	0.36					
MC Sta 6	BC06	0.12	0	0.03	0.09	0.08	0	8.72			3.91	0.97					
MC Sta 7	BC07	0	0	0	0.38	0.25					1.52	0.66					
MC Sta 8	BC08										4.44	0.63					
MC Sta 9	BC09										1.47	0.46					
MC Sta 13	BC13										4.01	1.14					
AVERAGE*		0.84	0.41	2.06	0.88	1.42	0.22	6.51	5.67	5.04	2.79	1.71	2.78	(30.35)			
AVERAGE EXCL. MC		2.21	0.81	3.33	2.14	2.75	0.38	4.26	5.67	5.04	2.23	4.14	2.78	(35.74)			

*EXCL WU70

TABLE AG.3.1-6d
MONTHLY PRECIPITATION FOR 1978

STATION	COM- PUTER CODE	MONTHLY TOTAL (cm)												ANN. TOTAL ACTUAL (EST)			
		JAN	FEB	MAR	APR	MAY	JUN	JUL	AUG	SEP	OCT	NOV	DEC				
USGS 022	WU22						0	1.40	0.53	1.02							
USGS 015	WU15	2.67	2.08	7.37	0	1.57	0.05	1.78	0.79	3.23	0	4.83					
USGS 058	WU58						0.71	0.43	0.46								
USGS 050	WU50	1.93	1.57	5.79	0	1.68	0.05	2.77	0.64	1.27	0	3.89					
USGS 070	WU70	4.88			3.51	3.38	1.03	3.22	1.50	0.97	0.86	7.90	5.89				
AQ Sta 020	AB20	3.02	2.11	8.13	1.70	3.99	2.57	2.18	2.36	1.83	0.58	4.83					
AQ Sta 023	AB23	1.65	2.64	8.36	2.29	3.94	1.30	1.98	0.48	1.40	0.20	4.50					
MC Sta 1	BC01	6.60	6.60		7.72	2.36	2.51	1.22	0.87	1.45	0.28	2.69	1.78				
MC Sta 2	BC02	6.86	6.86	4.14	4.75	2.18	2.67	2.57	0.94	1.52	0.10	3.76	9.98				
MC Sta 3	BC03	6.86	6.86	4.70	4.70	2.62	2.77	1.83	1.27	1.20	0	3.66	1.80				
MC Sta 4	BC04	6.60	6.60	3.56	5.31	2.44	2.84	2.06	1.12	1.35	0.10	3.55	1.57				
MC Sta 5	BC05	6.60	6.60		7.19	1.60	2.79	0.33	0.36	1.24	0.30	3.86	1.83				
MC Sta 6	BC06			4.83	5.87	2.49	2.26	0.66	1.20	1.53	0	2.85	4.95				
MC Sta 7	BC07	6.86	6.86	3.63	4.70	1.98	3.00	1.71	1.05	1.62	0.33	3.22	1.37				
MC Sta 8	BC08	6.98		3.66	3.71	1.80	3.86	0.38	0.99	1.22	1.12	3.56	1.57				
MC Sta 9	BC09	7.62		3.68	5.36	2.26	2.95	0.41	1.12	1.32	0.25	3.08	1.88				
MC Sta 13	BC13			4.19	6.10	2.59	3.05	1.43	1.47	1.62	0.25	2.87					
AVERAGE*		5.35	4.88	5.17	4.24	2.39	2.09	1.45	0.98	1.52	0.25	3.65	2.97	(34.94)			
AVERAGE EXCL. MC		2.32	2.10	7.41	1.00	2.80	0.78	1.76	0.88	1.75	0.20	4.51	0	(25.51)			

*EXCL WU70

TABLE A6.3.1-7

EVAPORATION (cm) @ STATION AB23

1978

	MONTH				
	MAY	JUNE	JULY	AUGUST	SEPTEMBER
<u>PAN</u>					
MONTHLY TOTAL	20.8	22.5	27.0	24.2	17.7
DAILY AVERAGE	0.67	0.75	0.87	0.78	0.59
<u>LAKE</u> ⁽¹⁾					
MONTHLY TOTAL	14.6	15.8	18.9	16.9	12.4
DAILY AVERAGE	0.47	0.53	0.61	0.55	0.41

(1) Assumes a pan coefficient of 0.7

TABLE A6.3.1-8

BAROMETRIC PRESSURE, MILLIBARS (DAILY EXTREMA)

STA.	ITEMS	SEASONAL YEAR	DEC	JAN	FEB	MAR	APR	MAY	JUN	JUL	AUG	SEP	OCT	NOV	ANN.	
															MAX.	MIN.
AB24	DAILY MAX.	1975						795	796	799	798	803	802	803		803(1)
AB23	"	1975			794(1)	790	790	792	793	794	794	799	798	800		800
AB24	DAILY AVG.	1975						790(1)	791(1)	795	796	797	794	793(1)		
AB23	"	1975				782(1)	782	786	778(1)	791	792	794	791	789		
AB24	DAILY MIN.	1975						776	781	792	792	792	782	772		772(1)
AB23	"	1975			777	769	771	773	778	788	789	789	782	770		770
AB24	DAILY MAX.	1976	802	802	804	796	799	798	799	799	801	803	800	(3)		804
AB23	"	1976	798	799	799	793	790	795	795	796	797	799	797	798		799
AB24	DAILY AVG.	1976	794	795	791	788	789	793(1)	793	796	797	796	795	(3)		
AB23	"	1976	791	791	788	785	786(1)	790(1)	790	792(1)	793	793	792	792		790
AB24	DAILY MIN.	1976	776	785	778	778	776	787	787	791	792	790	789	(3)		776
AB23	"	1976	780	781	775	775	781	784(1)	784	789	787	787	786	777		775
AB23	DAILY MAX.	1977	798	797	797	793	796	795	795	797	796	(2)	(2)	(2)		798(1)
AB23	DAILY AVG.	1977	790	788	790	784	789	786	791	794	794	(2)	(2)	(2)		
AB23	DAILY MIN.	1977	779	773	774	771	775	776	786	789	789	(2)	(2)	(2)		771(1)
AB23	DAILY MAX.	1978	(2)	784(1)	788	787	771	771	795	793	796	792				796(1)
AB23	DAILY AVG.	1978	(2)	773(1)	775	777	764	764	789	787	789	785				
AB23	DAILY MIN.	1978	(2)	758(1)	760	765	757	753	782	773	776	770				753(1)

(1) Partial Data Only

(2) Missing Data

(3) Station Inoperative

APPENDIX A6.3.2

This Appendix consists of two parts:

A6.3.2A - Wind Fields Summaries

A6.3.2B - Tracer Test Results

APPENDIX A6.3.2A

Wind Fields Summaries

List of Figures Appearing in Appendix A6.3.2A

<u>FIGURE NO.</u>		<u>PAGE</u>
A6.3.2A-1	Meteorological Tower 10M Elevation, Quarterly Wind Roses 1976-1977	225
A6.3.2A-2	Meteorological Tower 10M Elevation, Quarterly Wind Roses 1977-1978	226
A6.3.2A-3	Meteorological Tower 30M Elevation, Quarterly Wind Roses 1976-1977	227
A6.3.2A-4	Meteorological Tower 30M Elevation, Quarterly Wind Roses 1977-1978	228
A6.3.2A-5	Station AB20 Quarterly Wind Rose at 10M, 1976	229
A6.3.2A-6	Station AB20 Quarterly Wind Rose at 10M, 1978	230
A6.3.2A-7	Station AD42 Quarterly MRI Wind Roses at 10M, 1978	231
A6.3.2A-8	Station AD56 Quarterly MRI Wind Roses at 10M, 1978	232
A6.3.2A-9	C-b Average Hourly Inversion Height by Quarter for 1978, Station AB20	233
A6.3.2A-10	June 1976 Inversion Heights Plotted with Constant Potential Temperature Surfaces through Stations AB20 and AB23 on 24 June 1976, 0400-0600 MST	234
A6.3.2A-11	October 1976 Inversion Heights Plotted with Constant Potential Temperature Surfaces the Morning of 14 September 1978	235
A6.3.2A-12	Pibal Altitude - Temperature Profiles for Single and Double Theodolite Observations, (Early Morning)	236
A6.3.2A-13	Pibal Altitude - Temperature Profiles for Single and Double Theodolite Observations, (Afternoon)	237

Figure A6.3.2A-1

Meteorological Tower Quarterly Wind Roses - 10M Level (1976-1977)

QUARTERLY WIND ROSE-10M LEVEL
SEP '76 - NOV '76

TOTAL % OF CALMS DISTRIBUTED (0.00%)
TOTAL NO. OF 1 HOUR SAMPLES -2148

QUARTERLY WIND ROSE-10M LEVEL
DEC '76 - FEB '77

TOTAL % OF CALMS DISTRIBUTED (0.00%)
TOTAL NO. OF 1 HOUR SAMPLES -2147

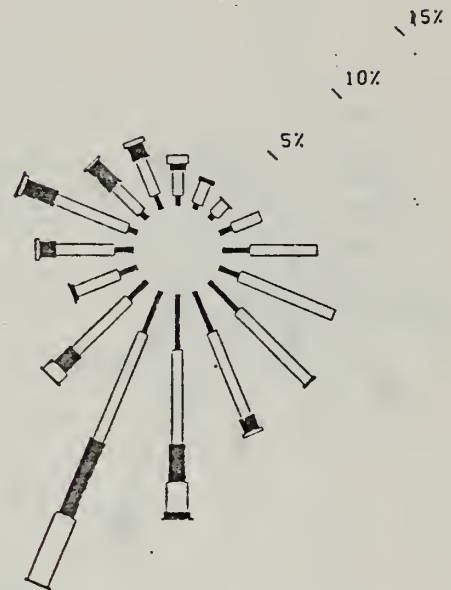
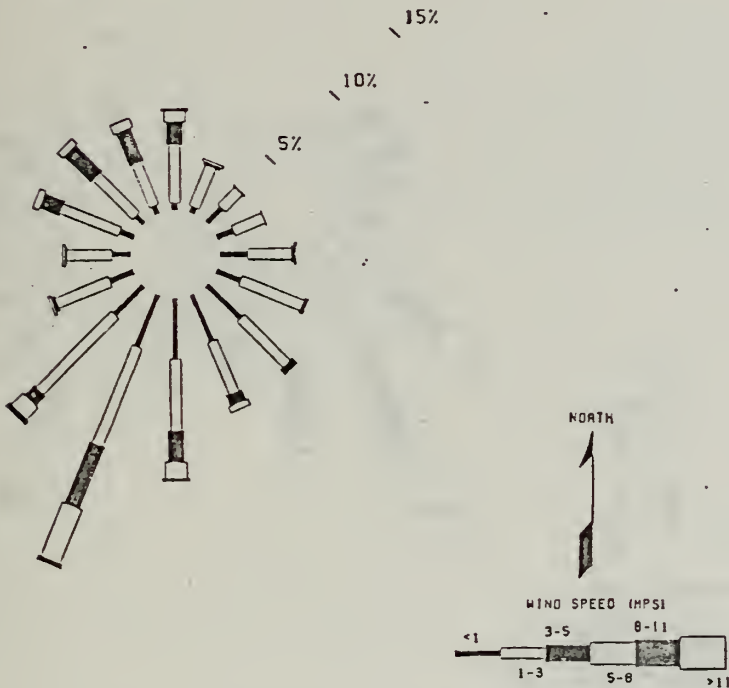

QUARTERLY WIND ROSE-10M LEVEL
MAR '77 - MAY '77

TOTAL % OF CALMS DISTRIBUTED (0.00%)
TOTAL NO. OF 1 HOUR SAMPLES -2147

QUARTERLY WIND ROSE-10M LEVEL
JUN '77 - AUG '77

TOTAL % OF CALMS DISTRIBUTED (0.00%)
TOTAL NO. OF 1 HOUR SAMPLES -1973

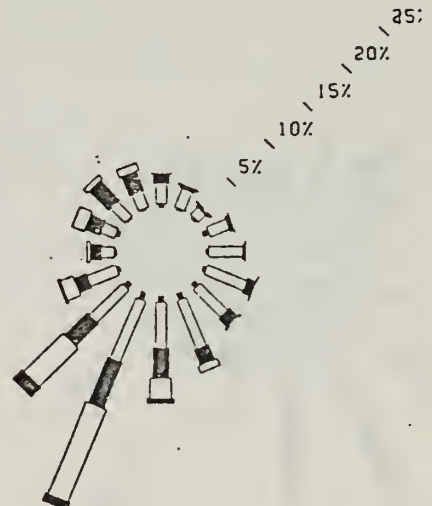
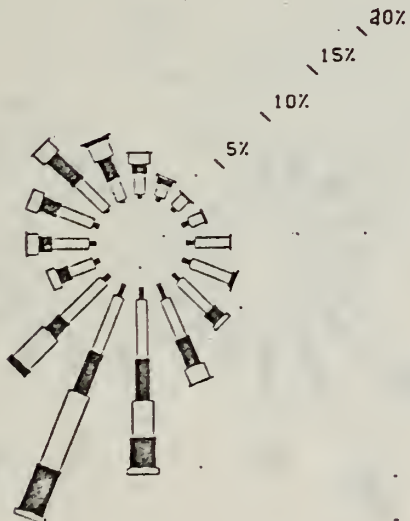
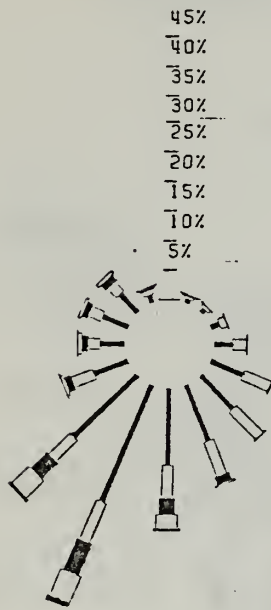

Figure A6.3.2A-2

Meteorological Tower Quarterly Wind Roses - 10M Level (1977-1978)

QUARTERLY WIND ROSE-10M LEVEL
SEP '77 - NOV '77

TOTAL % OF CALMS DISTRIBUTED (0.14%)
TOTAL NO. OF 1 HOUR SAMPLES -2072



QUARTERLY WIND ROSE-10M LEVEL
DEC '77 - FEB '78

TOTAL % OF CALMS DISTRIBUTED (4.43%)
TOTAL NO. OF 1 HOUR SAMPLES -1805

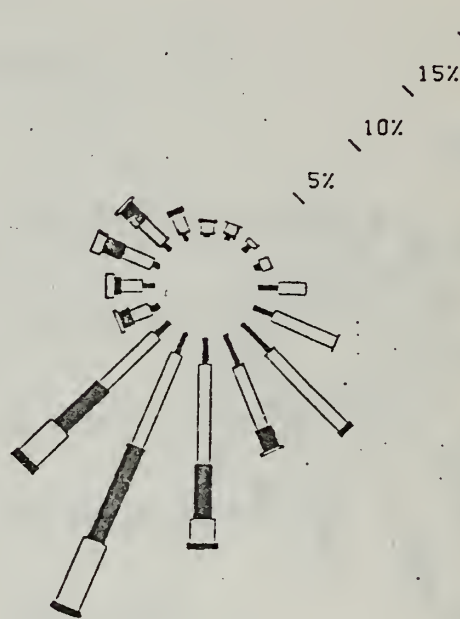

NORTH

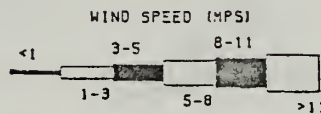

QUARTERLY WIND ROSE-10M LEVEL
MAR '78 - MAY '78

TOTAL % OF CALMS DISTRIBUTED (3.87%)
TOTAL NO. OF 1 HOUR SAMPLES -2043

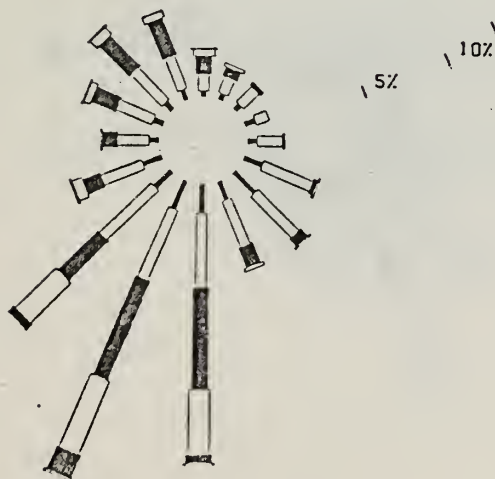

QUARTERLY WIND ROSE-10M LEVEL
JUN '78 - AUG '78

TOTAL % OF CALMS DISTRIBUTED (1.71%)
TOTAL NO. OF 1 HOUR SAMPLES -2159

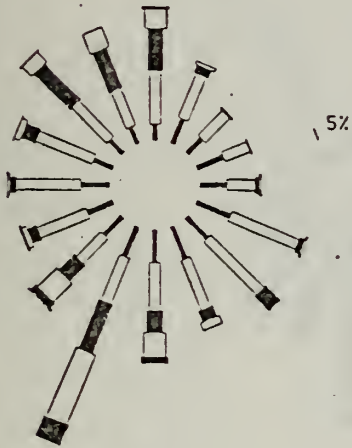

Figure A6.3.2A-3

Meteorological Tower Quarterly Wind Roses - 30M Level (1976-1977)

QUARTERLY WIND ROSE - 30M LEVEL
SEP '76 - NOV '76

TOTAL % OF CALMS DISTRIBUTED (0.0 %)
TOTAL NO. OF 1 HOUR SAMPLES -2152



QUARTERLY WIND ROSE - 30M LEVEL
DEC '76 - FEB '77

TOTAL % OF CALMS DISTRIBUTED (0.0 %)
TOTAL NO. OF 1 HOUR SAMPLES -2145

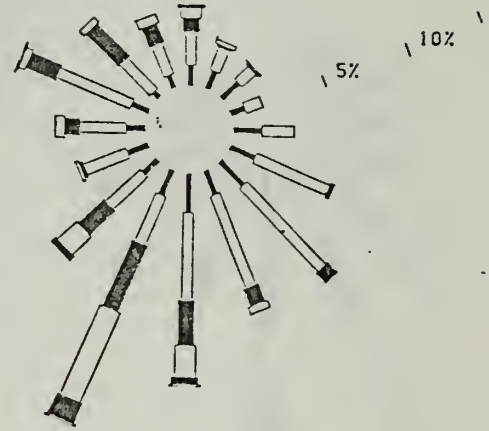

NORTH

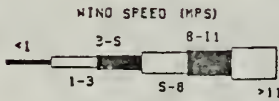

QUARTERLY WIND ROSE - 30M LEVEL
MAR '77 - MAY '77

TOTAL % OF CALMS DISTRIBUTED (0.0 %)
TOTAL NO. OF 1 HOUR SAMPLES -2162



QUARTERLY WIND ROSE - 30M LEVEL
JUN '77 - AUG '77

TOTAL % OF CALMS DISTRIBUTED (0.0 %)
TOTAL NO. OF 1 HOUR SAMPLES -1334

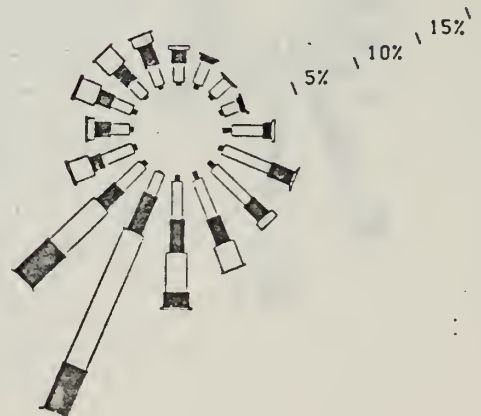

QUARTERLY WIND ROSE - 30M LEVEL
SEPT'77 - NOV'77

TOTAL % OF CALMS DISTRIBUTED (0.00%)
TOTAL NO. 1 - HR SAMPLES (2075)

15%
10%
5%

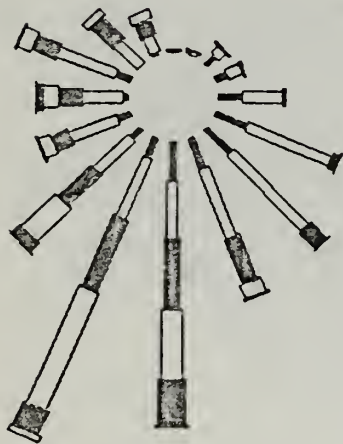

QUARTERLY WIND ROSE - 30M LEVEL
DEC'77 - FEB'78

TOTAL % OF CALMS DISTRIBUTED (3.73%)
TOTAL NO. 1 - HR SAMPLES (1770)

25%
20%
15%
10%
5%



ANNUAL WIND ROSE - 30M LEVEL
SEPT'77 - AUG'78

TOTAL % OF CALMS DISTRIBUTED (2.24%)
TOTAL NO. 1-HR SAMPLES (7335)

20%
15%
10%
5%

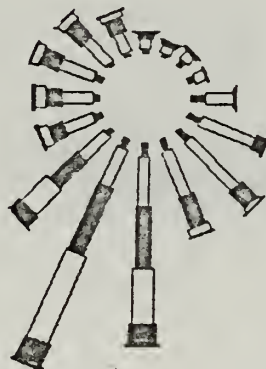

QUARTERLY WIND ROSE - 30M LEVEL
MAR'78 - APR'78

TOTAL % OF CALMS DISTRIBUTED (4.20%)
TOTAL NO. 1 - HR SAMPLES (1333)

20%
15%
10%
5%

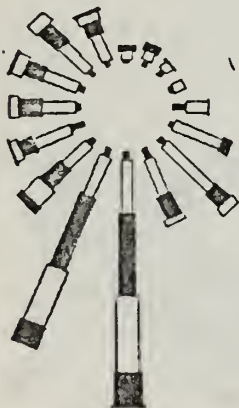

QUARTERLY WIND ROSE - 30M LEVEL
JUNE'78 - AUG'78

TOTAL % CALMS DISTRIBUTED (1.95%)
TOTAL NO. 1 - HR SAMPLES (2158)

15%
10%
5%



Figure A6.3.2A-4

METEOROLOGICAL TOWER 30M ELEVATION
QUARTERLY AND ANNUAL WIND ROSES
1977 - 1978

Figure A6.3.2A-5

Station AB20 Quarterly Wind Rose - 10M Level (1976)

AB20 QUARTERLY WIND ROSE @10M
SEP '76 - OCT '76

TOTAL % OF CALMS DISTRIBUTED (0.0 %)
TOTAL NO. OF 1 HOUR SAMPLES -1401

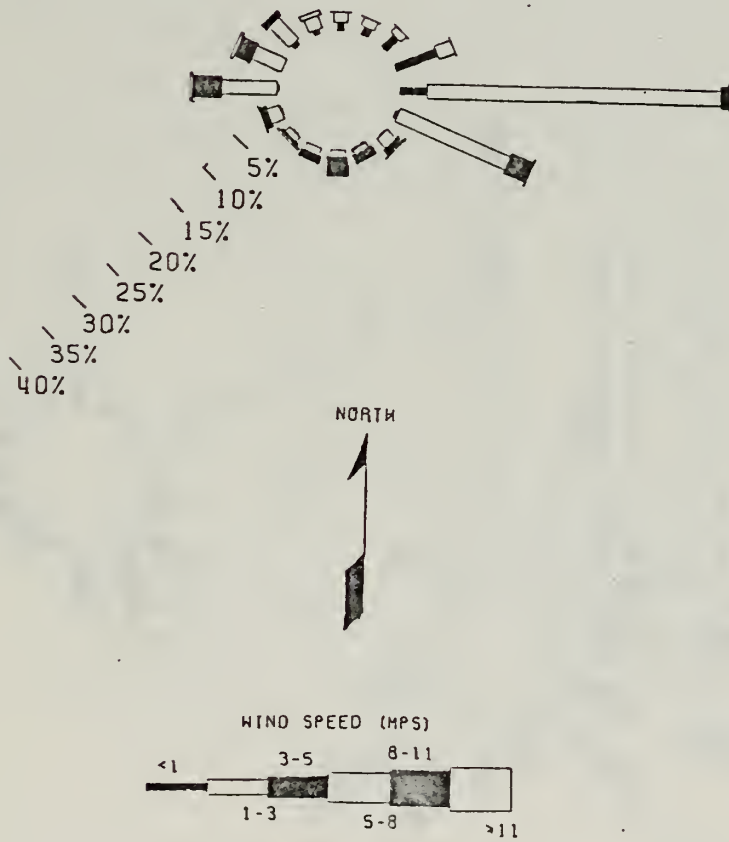
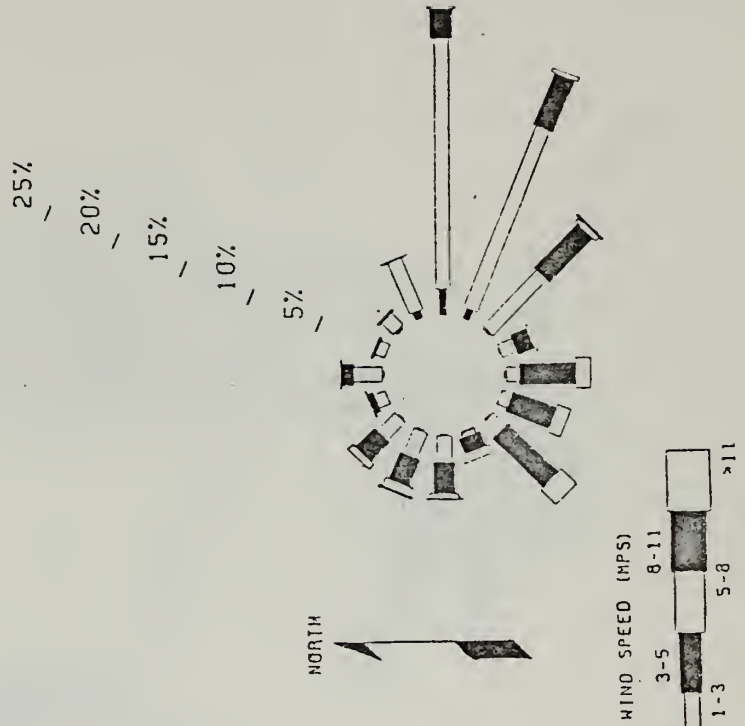

Figure A6.3.2A-6

Station AB20 Quarterly Wind Rose - 10M Level (1978)

AB20 QUARTERLY WIND ROSE @10M
 JUN '78 - AUG '78

TOTAL % OF CALMS DISTRIBUTED (2.99%)
 TOTAL NO. OF 1 HOUR SAMPLES -1939



AB20 QUARTERLY WIND ROSE @10M
 MAR '78 - APR '78

TOTAL % OF CALMS DISTRIBUTED (4.28%)
 TOTAL NO. OF 1 HOUR SAMPLES -1356

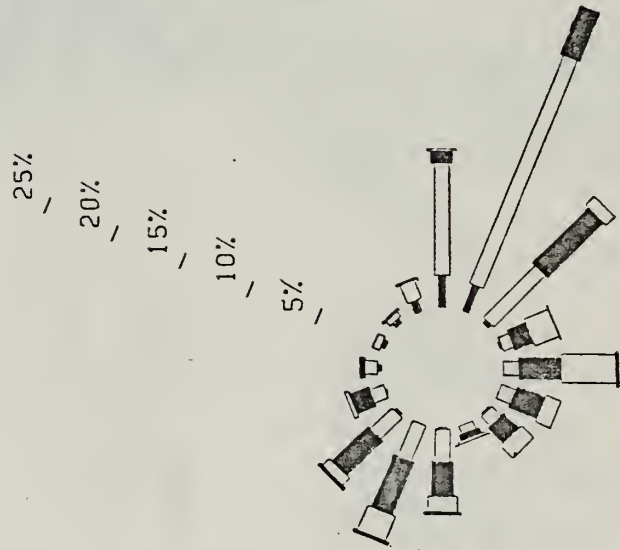

Station AD42 Quarterly MRI Wind Roses - 10M Level (1978)

QUARTERLY MRI WIND ROSE AD42

MAR '78 - MAY '78

TOTAL % OF CALMS DISTRIBUTED (0.00%)

TOTAL NO. OF 1 HOUR SAMPLES -582

15%

10%

5%

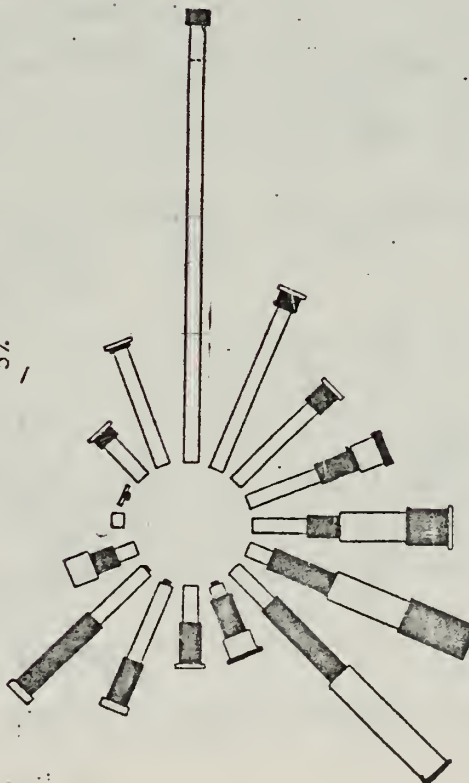

QUARTERLY MRI WIND ROSE AD42

JUN '78 - AUG '78

TOTAL % OF CALMS DISTRIBUTED (0.00%)

TOTAL NO. OF 1 HOUR SAMPLES -2198

15%

10%

5%

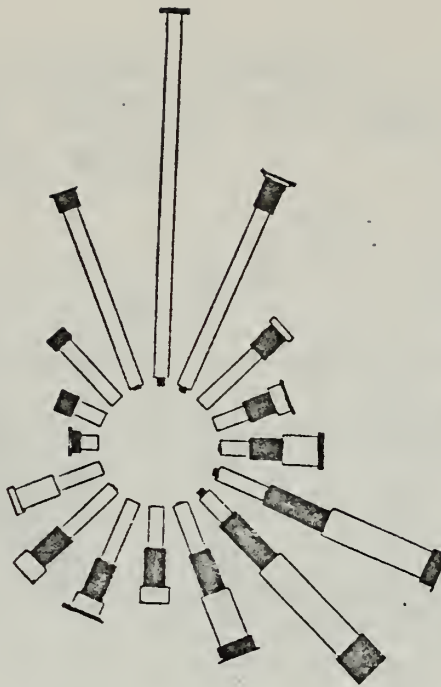

NORTH

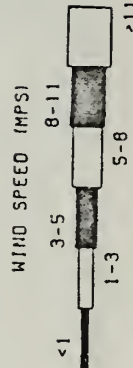
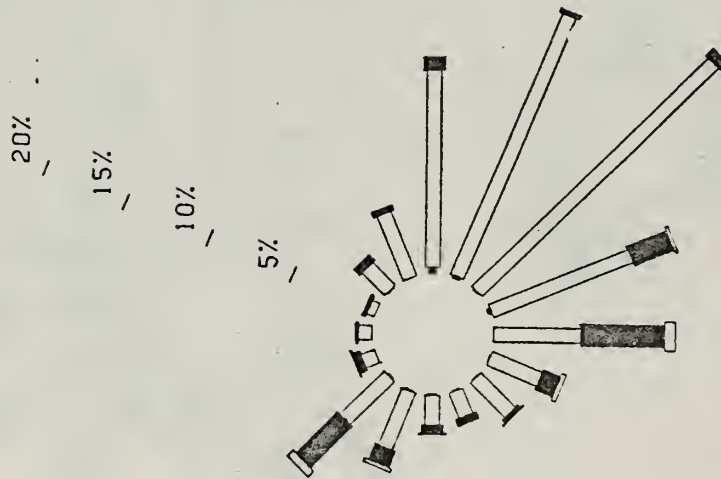

Figure A6.3.2A-8

Station AD56 Quarterly MRI Wind Roses - 10M Level (1978)

QUARTERLY MRI WIND ROSE AD56
MAR '78 - MAY '78

TOTAL % OF CALMS DISTRIBUTED (0.00%)
TOTAL NO. OF 1 HOUR SAMPLES - 1874



QUARTERLY MRI WIND ROSE - AD56
JUL '78 - AUG '78

TOTAL % OF CALMS DISTRIBUTED (0.0%)
TOTAL NO. OF 1 HOUR SAMPLES - 517

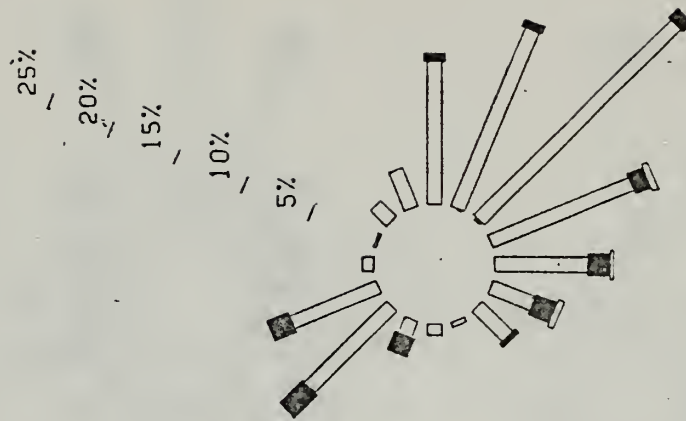

NORTH

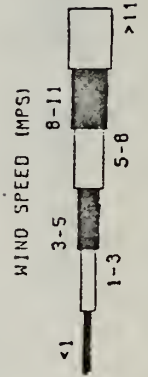
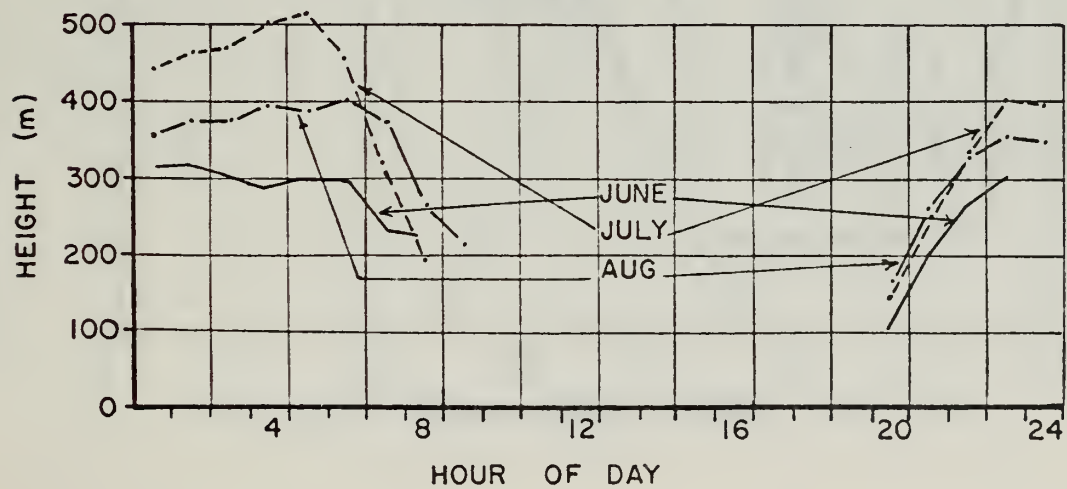
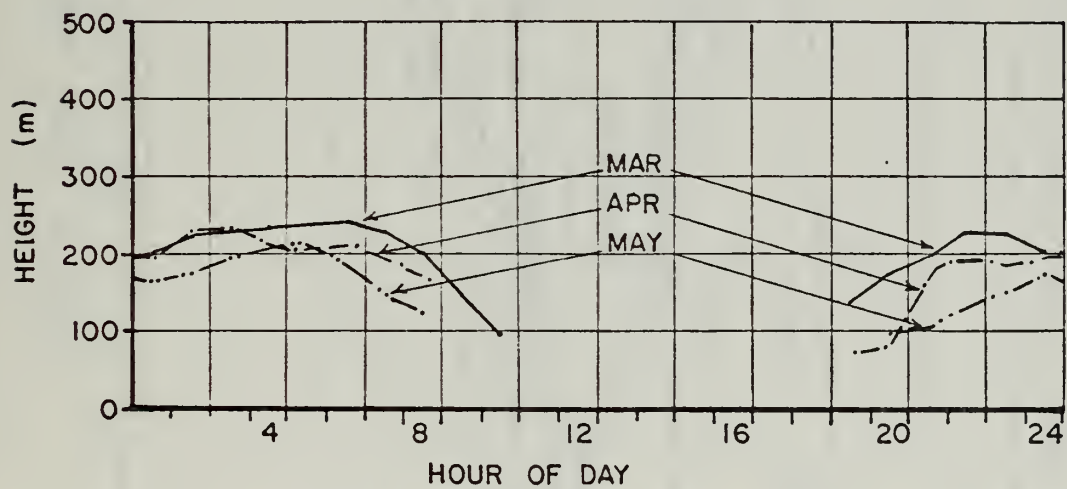
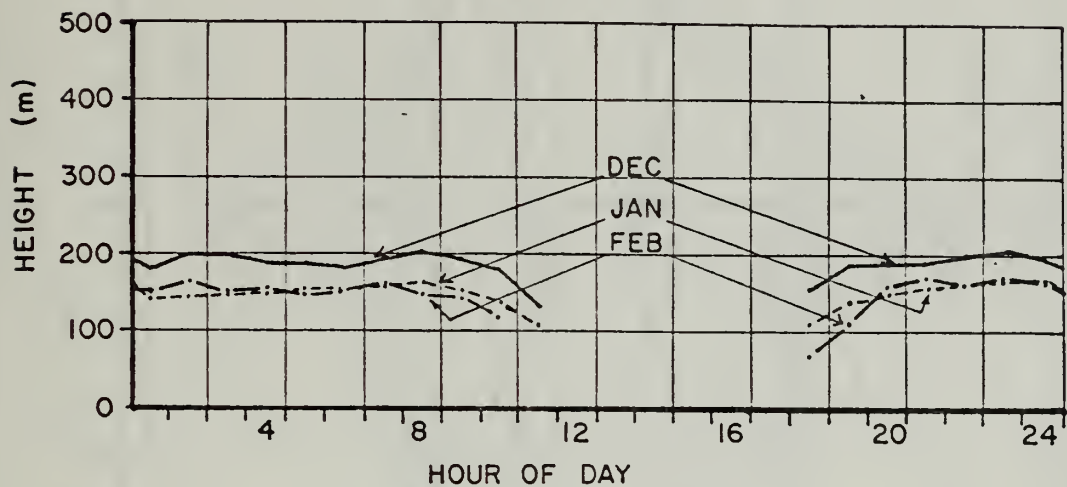

FIGURE A6.3.2A-9 C-b AVERAGE HOURLY
 INVERSION HEIGHT - BY QUARTER FOR 1978
 STATION AB20



KEY

- CONSTANT PRESSURE LINES (P)(mb)
- CONSTANT POTENTIAL TEMPERATURE LINE (θ)(°K)

□ JUNE 1976 MAXIMUM, MEAN, AND MINIMUM INVERSION HEIGHTS

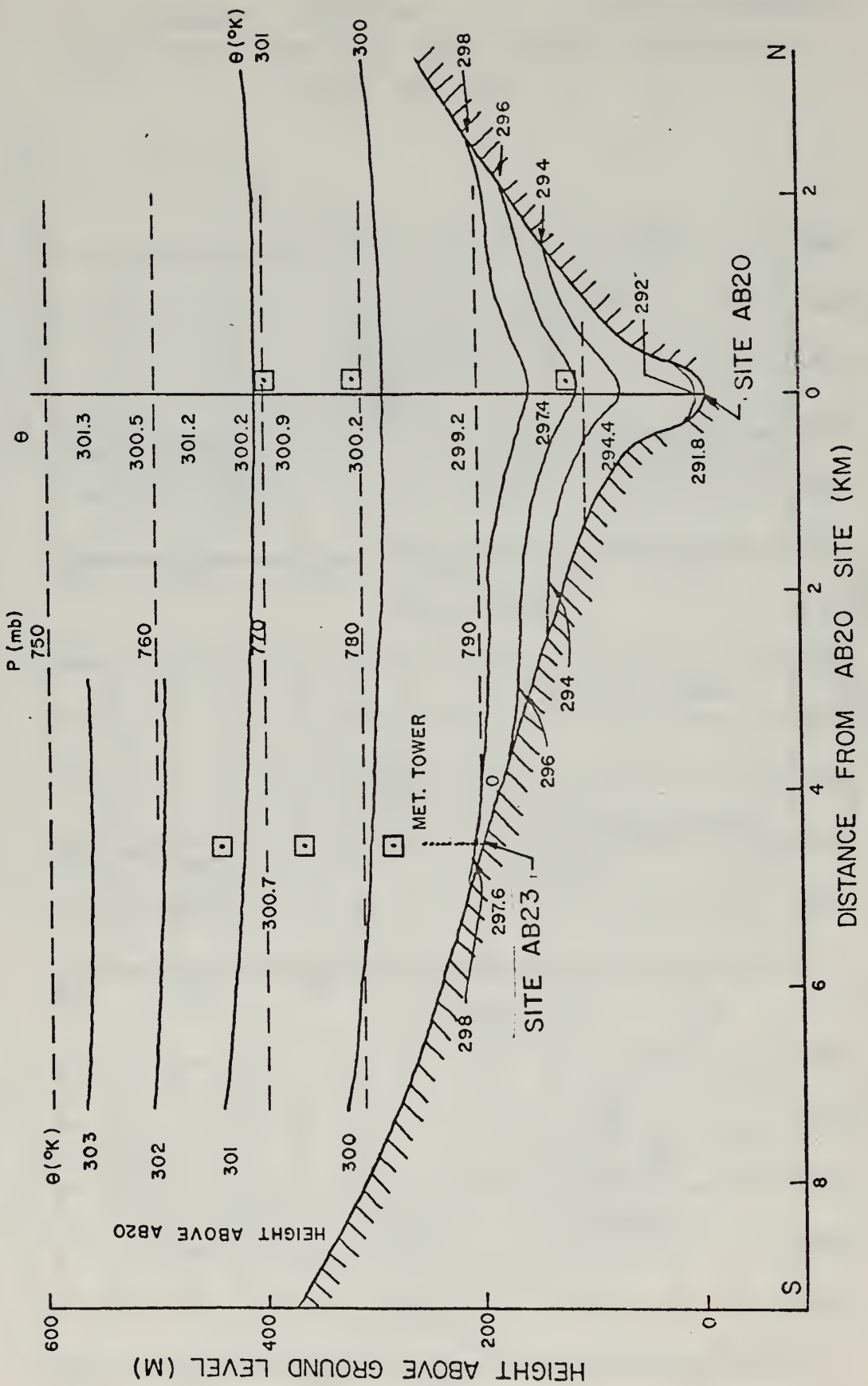
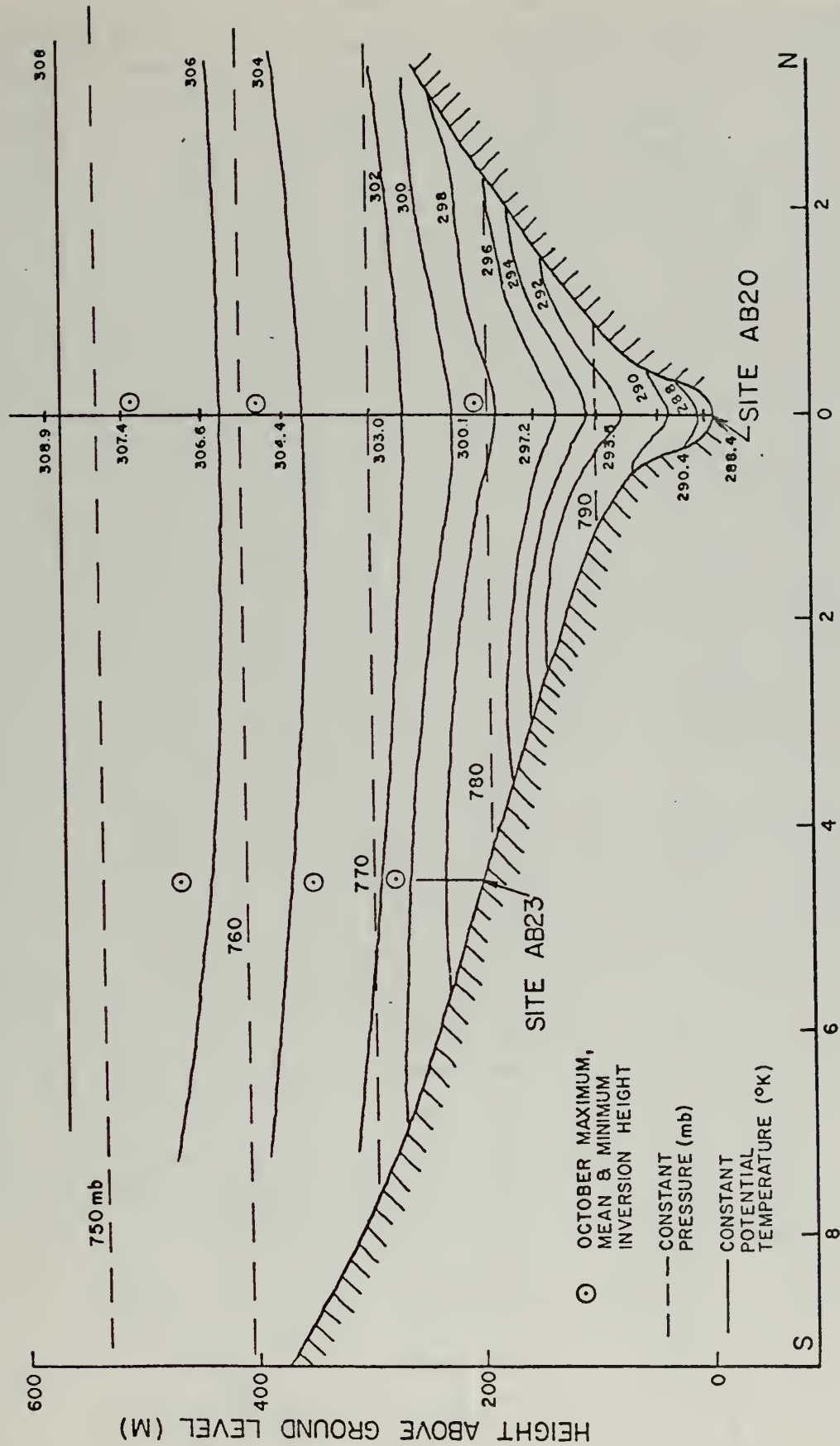

FIGURE A6.3.2A-10 JUNE 1976 INVERSION HEIGHTS PLOTTED WITH CONSTANT POTENTIAL TEMPERATURE SURFACES THROUGH STATIONS AB20 AND AB23 ON 24 JUNE 1976, 0400-0600 MST.



DISTANCE FROM AB20 SITE (KM)

FIGURE A6.3.2A-11 OCTOBER 1976 INVERSION HEIGHTS PLOTTED WITH CONSTANT POTENTIAL TEMPERATURE SURFACES THE MORNING OF SEPTEMBER 14, 1978

FIGURE A6.3.2A-12 PIBAL ALTITUDE-TEMPERATURE
FOR SINGLE AND DOUBLE THEODOLITE OBSERVATIONS (EARLY MORNING)

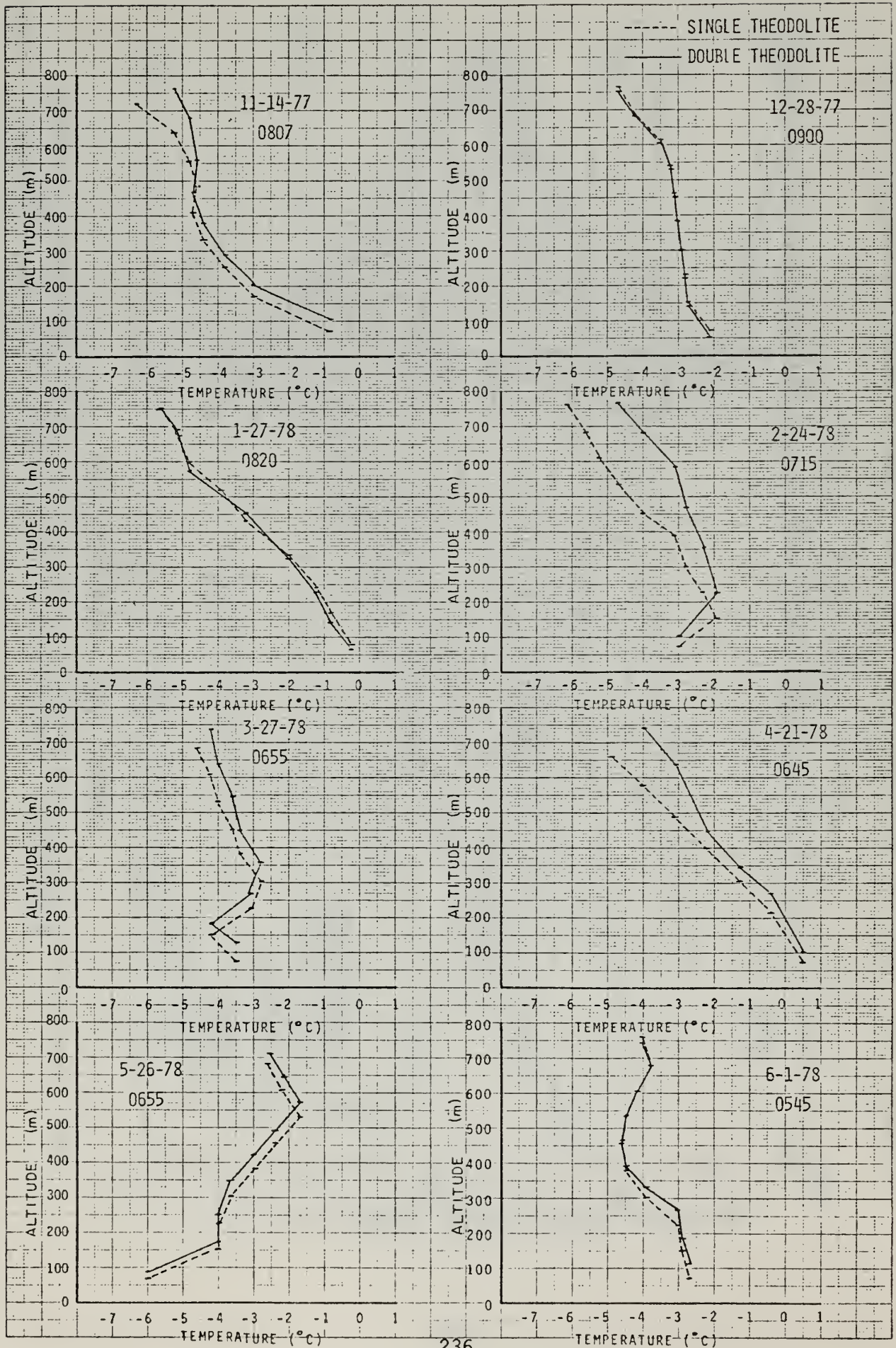
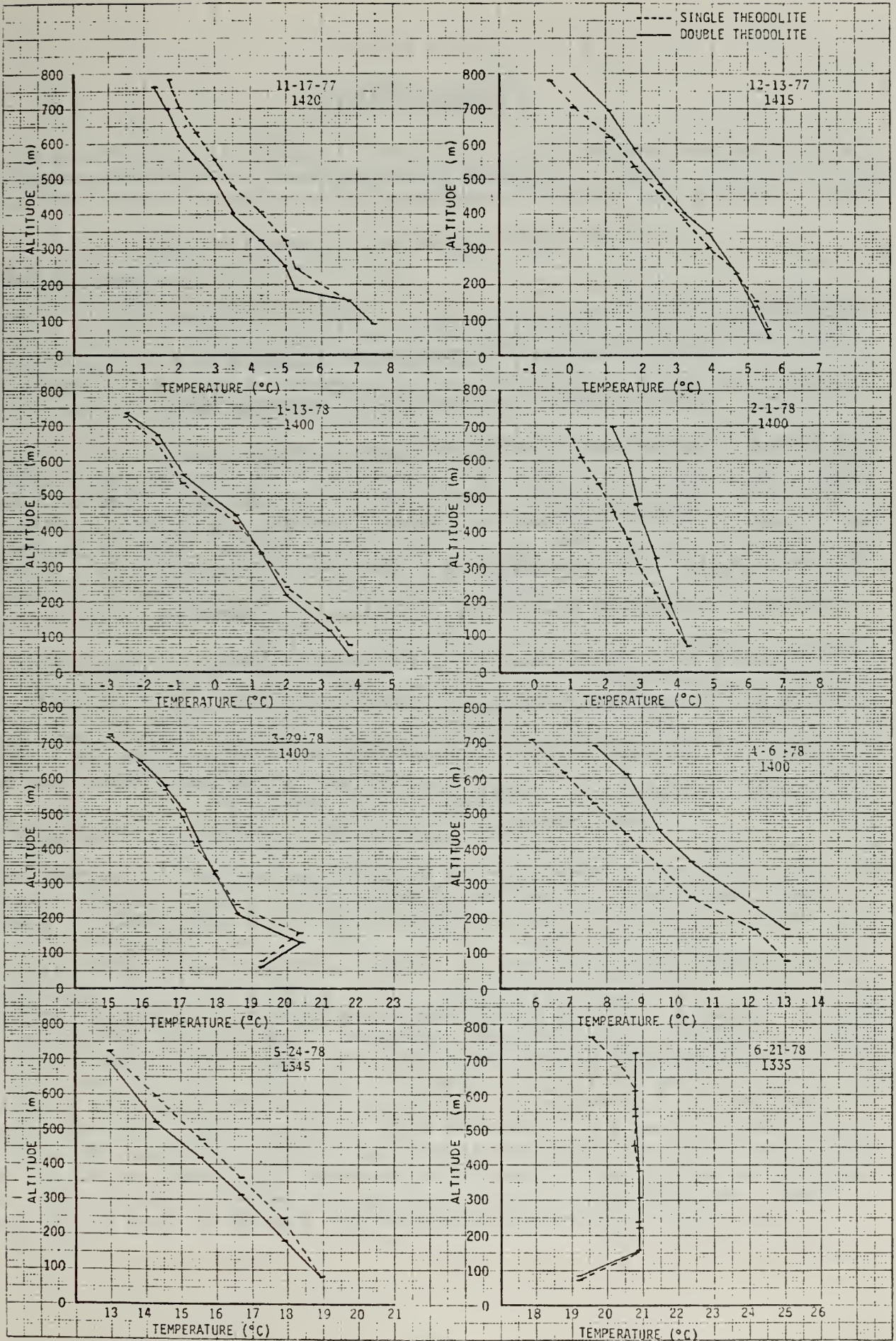

FIGURE A6.3.2A-13 PIB.M ALTITUDE - TEMPERATURE PROFILE FOR SINGLE AND DOUBLE THEODOLITE OBSERVATIONS (AFTERNOON)



APPENDIX A6.3.2B

Tracer Test Results

List of Figures Appearing in Appendix A6.3.2B

<u>FIGURE NO.</u>		<u>PAGE</u>
A6.3.2B-1	Synoptic Weather Situation on 14 September 1978	240
A6.3.2B-2	Synoptic Weather Situation on 15 September 1978	240
A6.3.2B-3	Temperature Soundings Taken on 14 September 1978	241
A6.3.2B-4	Constant Potential Temperature Surfaces Constructed From Soundings Taken on 14 September 1978	241
A6.3.2B-5	Wind Soundings Taken on 14 September 1978	243
A6.3.2B-6	Streamlines of Drainage Situation Over Tract C-b	243
A6.3.2B-7	A Cross-Sectional View of the Drainage Flow	244
A6.3.2B-8	Streamlines of Upslope Flow Over Tract C-b	245
A6.3.2B-9	A Cross-Sectional View of the Upslope Flow	245
A6.3.2B-10	Streamlines of Synoptic Flow Over Tract C-b	246

APPENDIX A6.3.2B

TRACER TEST RESULTS

To understand the distribution of tracer gas concentrations, one has to first understand the factors affecting such a distribution - namely, the meteorological conditions that existed during and immediately preceding the release of tracer gas.

Synoptic Weather Situation

After a frontal passage on September 11, a closed upper-level low formed north of Tract C-b. By the morning of September 14, a general northeast-southwest trough situation had developed from Manitoba to Nevada (See Figure A6.3.2B-1). Two distinct low pressure centers were centered in these areas with Colorado in between. Pressure gradients became weak over the tract.

After sunrise on the 14th, an anomalous blocking pattern with a warm high over Western Canada formed. By the morning of the 15th (Figure A6.3.2B-2) a fast west-east jet stream had set up along the U.S.-Canadian border. At the surface a rapidly moving, weak, dry front passed mainly south of the tract during the afternoon and early evening of the 14th. Clouds from this system cleared away shortly after midnight but the pressure maintained its weak pattern. By the afternoon of the 15th, clouds and a strong southwest flow preceding another weather front were becoming established over the tract area.

The weak pressure gradients and the lack of clouds allowed the formation of strong drainage, particularly along Piceance Creek, on the morning of September 14. Although clouds formed during the afternoon of September 14, they cleared away shortly after midnight, allowing radiative cooling of the ground to take place. The drainage that developed on the morning of September 15, however, was much weaker than that of the 14th.

Meteorological Conditions on C-b Tract, 14 September 1978

The atmospheric structure over Piceance Creek as well as over the entire tract is best illustrated by soundings taken by tether sonde near Piceance Creek. Figure A6.3.2B-3 shows three soundings of temperature taken on September 14.

As a result of strong radiative cooling, a very deep surface-based inversion appeared in the pre-dawn hours. This inversion was quite strong close to the surface but gradually weakened until about 500 m AGL, when it became isothermal. This situation was observed in soundings through 0700 MDT. Beginning at about 0800 MDT, the inversion lost more of its strength and the base of the isothermal layer lowered to about 350 m AGL. The destruction of the surface-based inversion began at about 0900 MDT and the top of the isothermal layer was detected at about 450 m AGL. This isothermal layer was topped by a neutral lapse layer. Further destruction of the surface-based inversion and lowering of the base of the neutral lapse layer continued until about 1100 MDT, when the inversion totally disappeared and was replaced by a neutral lapse condition. Similar conclusions could be derived from data collected by the acoustic radar at Site AB20.

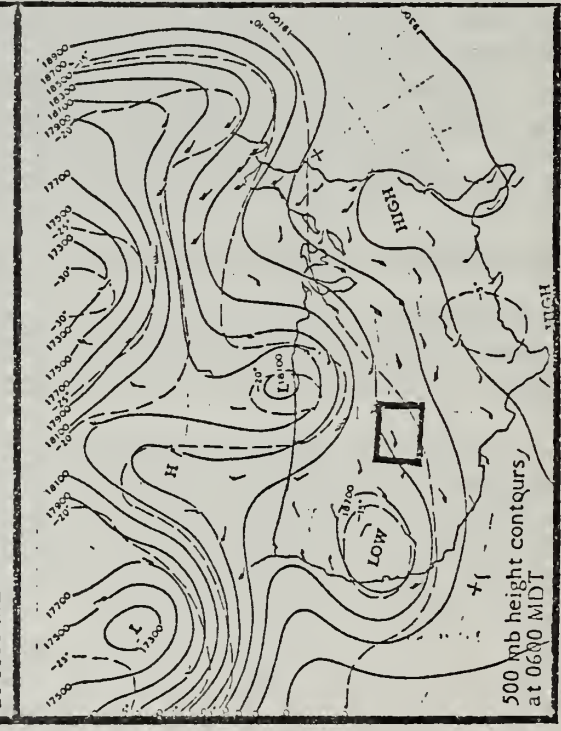
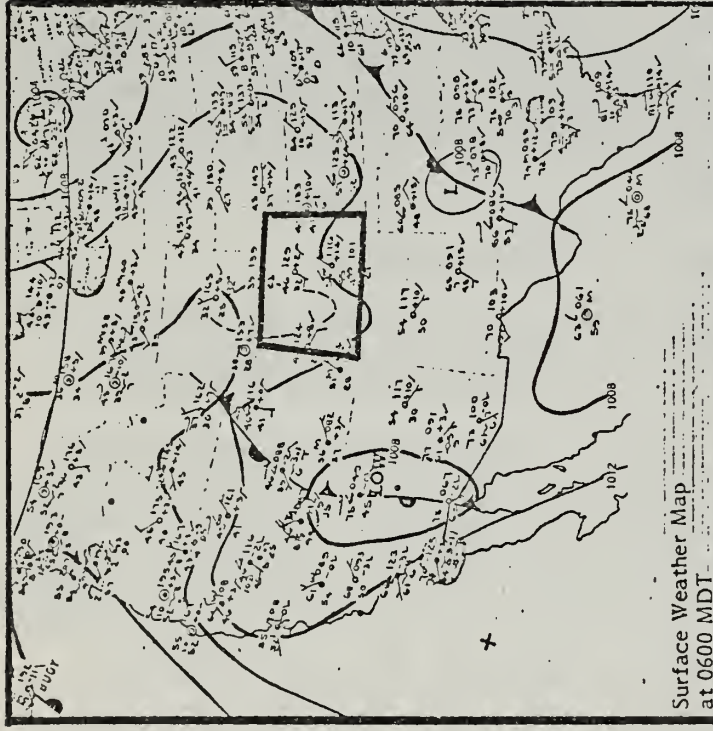
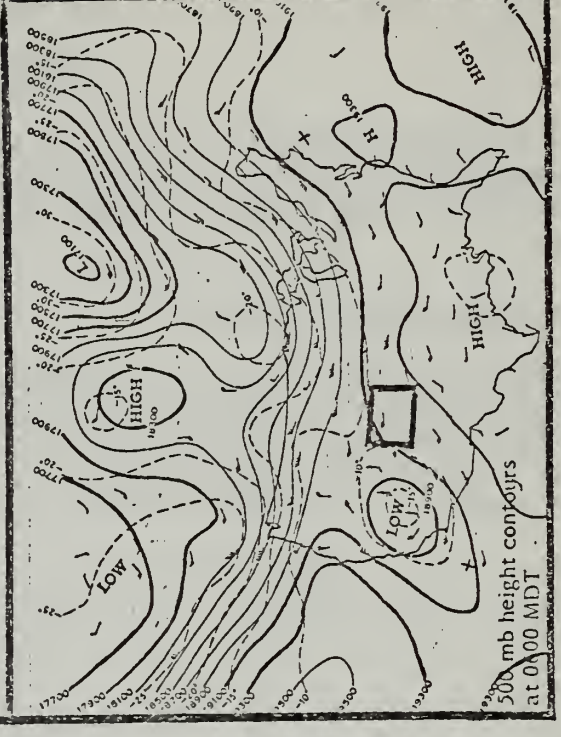
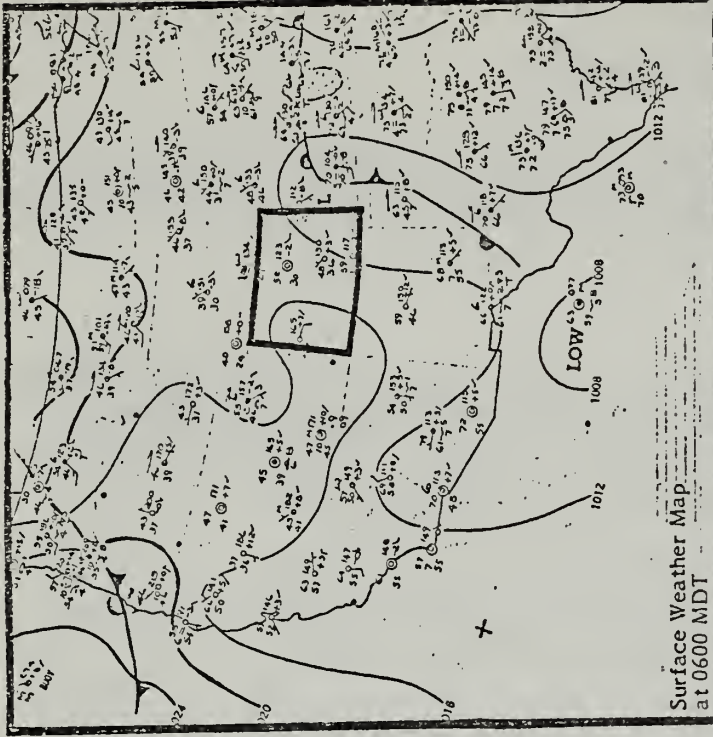

Fig. A6.3.2B-2 Synoptic weather situation on 15 September 1978.

Fig. A6.3.2B-1 Synoptic weather situation on 14 September 1978.

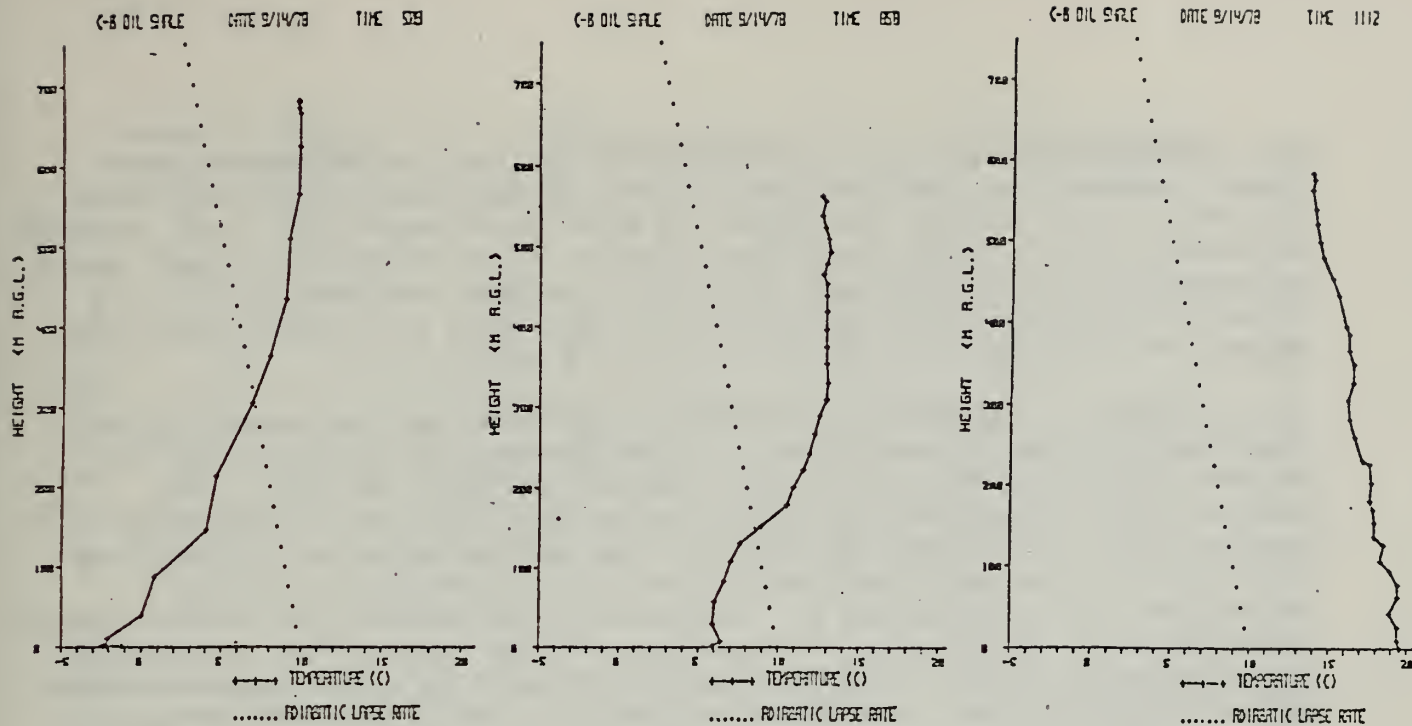

Figure A6.3.2B-3 Temperature soundings taken on 14 September 1978.

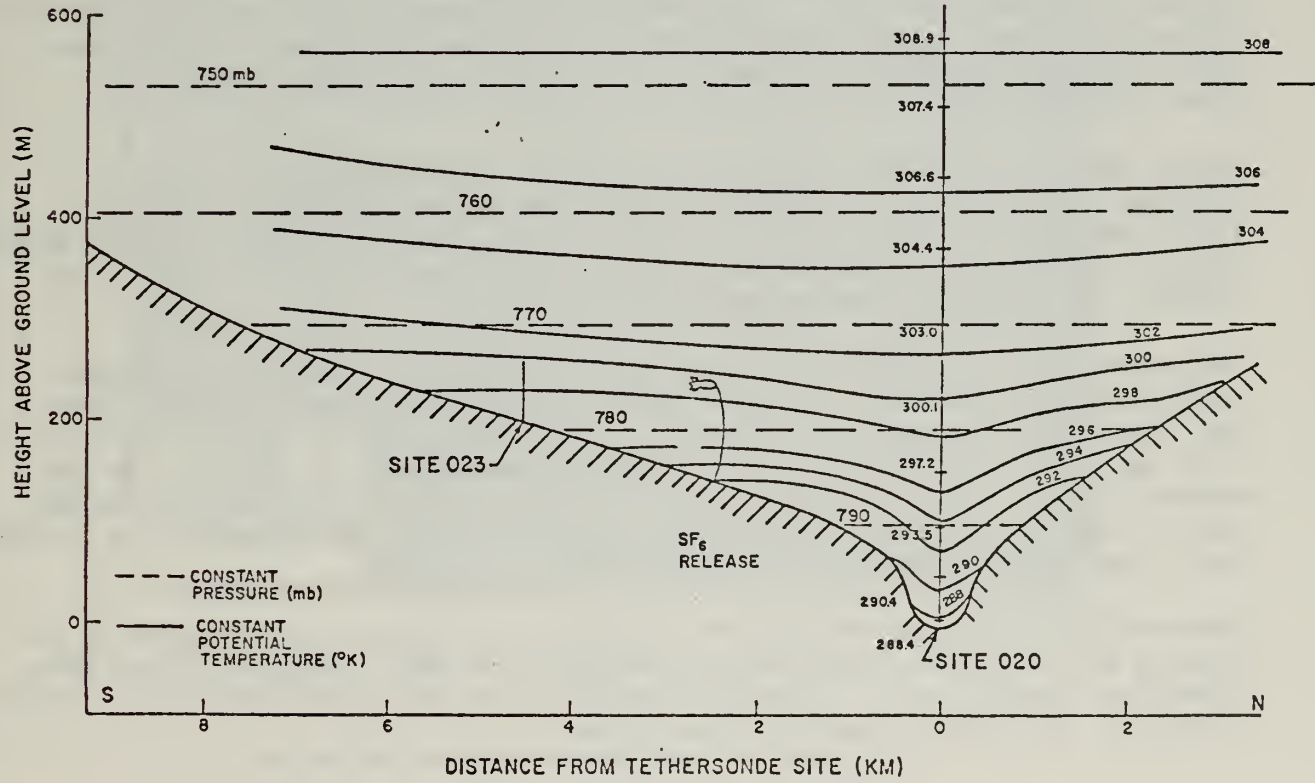

Figure A6.3.2B-4 Constant potential temperature surfaces constructed from sounding taken on the morning of 14 September 1978.

This atmospheric structure would, of course, apply only along the Piceance Creek. However, one can infer that a surface-based inversion did exist over the entire tract, even on the ridges and above the release site. This inference is supported by the delta-temperature data collected at Site AB23 as well as by tether sonde profiles taken over the tract at various locations in 1976 (C-b Shale Oil Venture, 1976) Figure A6.3.2B-4 shows what the constant potential temperature surfaces should look like over the tract.

The soundings at Site 048 also provided valuable information concerning the wind flow above the Piceance Creek. Strong drainage was evident, with the maximum speed appearing shortly after 0600 MDT at about 150 m AGL. The synoptic flow pattern was not observed below about 600 m AGL in the early morning hours. As the morning advanced, the heat gained by the surface from solar radiation exceeded that lost by terrestrial radiation and the soil temperature rose, warming the air just above. This created pressure differences resulting in an upslope flow. The evidence of this upslope flow showed up at about 0900 MDT. At this time there were still remnants of the nighttime drainage on top of this newly developed upslope flow. The strongest shear appeared at around 200 m AGL. It was not until the end of the experiment, around 1100 MDT, that the drainage flow system was totally destroyed. Even at 1100 MDT, there was still a surface layer of upslope flow to about 150 m, above which existed the synoptic flow. This wind flow picture is illustrated in Figure A6.3.2B-5. It is interesting to note that at about 300 m AGL, the wind speed was virtually zero at 0600-0700 MDT, the first hour of the sampling period.

The wind flow over the rest of the tract (other than over Piceance Creek) followed a similar pattern. Strong drainage prevailed between 0400-0600 MDT. Figure A6.3.2B-6 shows streamlines of the drainage situation while Figure A6.3.2B-7 shows what the drainage looks like in a cross-section between Sites AB23 and AB20.

During the first hour of sampling, the overall pattern was still of the drainage type although almost calm conditions were detected at various locations over the tract. At the release site, the kytoon was observed to head towards the west, then rotated clockwise during the hour to finally end up pointing towards the south-southeast direction.

The second hour of sampling saw the head of the kytoon meandering between south-southeast to east. In other words, the wind at the level of release was from the south-southeast to east. Over other parts of the tract, the wind was light and often variable, with the predominant direction from the eastern sector. This is probably due to the fact that the tract is located west of the Continental Divide and in the macroscale, there would be a drainage that flows generally from east to west over the tract.

Between 0800-0900 MDT, the wind at the point of release, as indicated by the heading of the kytoon, was from the southeast to east. Meteorological data from other wind stations indicated that the wind was still light and variable, without a definitely organized flow system.

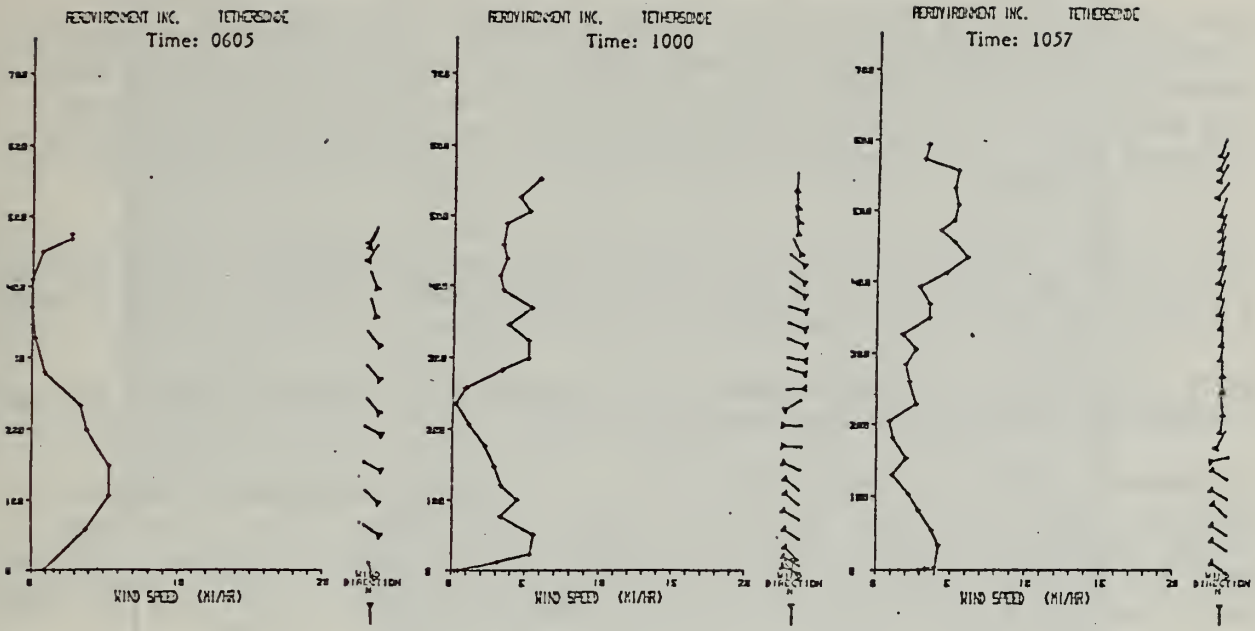

Figure A6.3.2B-5 Wind soundings taken on 14 September 1978.

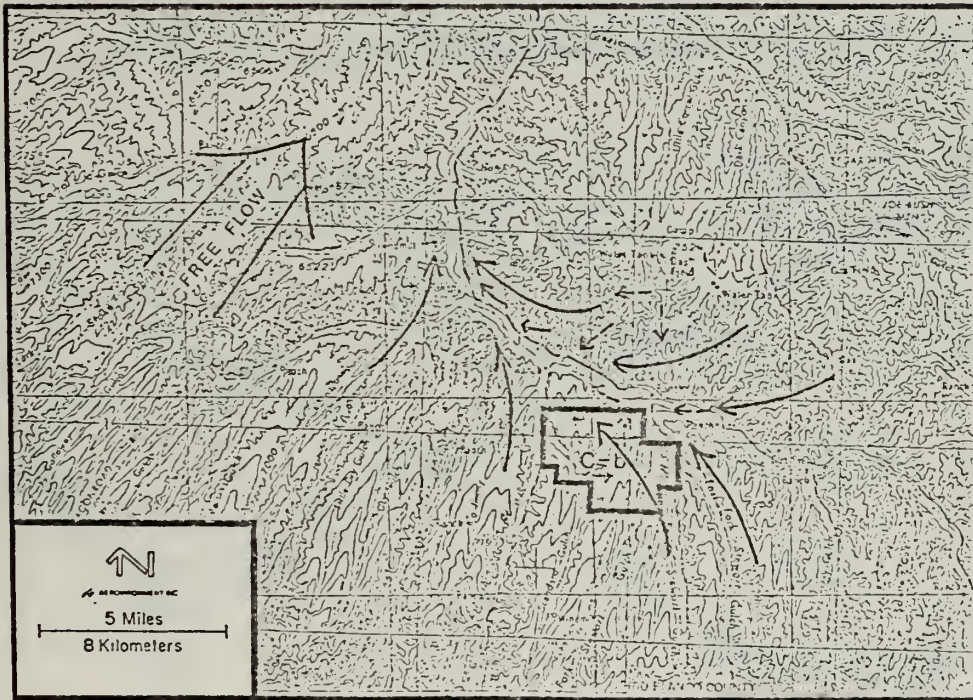

Figure A6.3.2B-6 Streamlines of drainage situation over Tract C-b.

During the last two hours of the sampling period, the heading of the kytoon indicated that the wind at the point of release was from the north to east quadrant. Data collected also indicated that the wind was generally from the north in areas south of the Piceance Creek and from areas north of the Piceance Creek. This phenomenon is generalized in Figure A6.3.2B-8 and Figure A6.3.2B-9.

The synoptic flow (winds from the south) was never established at the surface during the sampling period. It appeared around noon. Figure A6.3.2B-10 shows a picture of the synoptic pattern in the afternoon.

Data collected at Site AB23 showed that turbulence was weak throughout the period of sampling, especially between 0600-0800 MDT.

In summary, during the first three hours of sampling drainage was evident along Piceance Creek and the gulches leading to Piceance Creek. Over the ridges and higher ground, the surface flow was disorganized and weak. In the last two hours of sampling, an upslope flow was discernible all over the tract. Turbulence was weak, especially between 0600-0800 MDT.

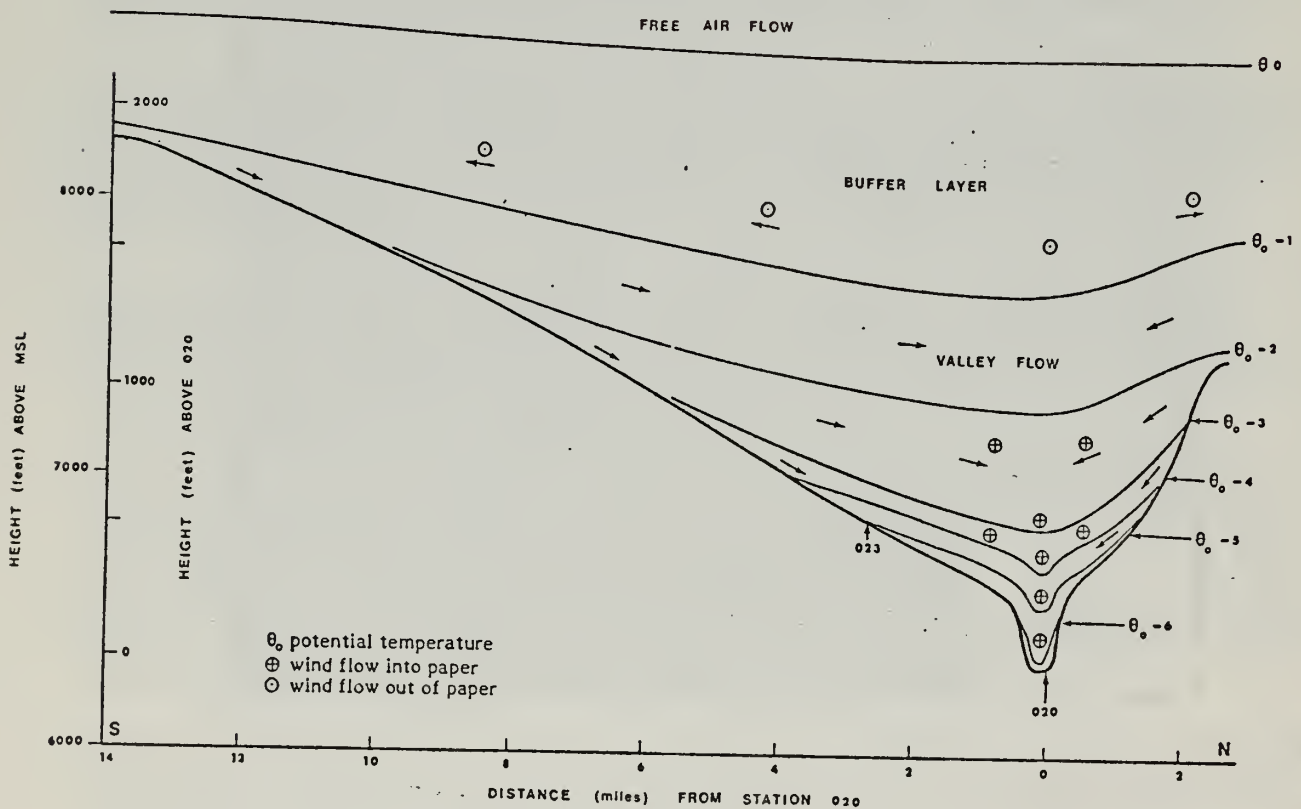

Figure A6.3.2B-7 A cross-sectional view of the drainage flow.

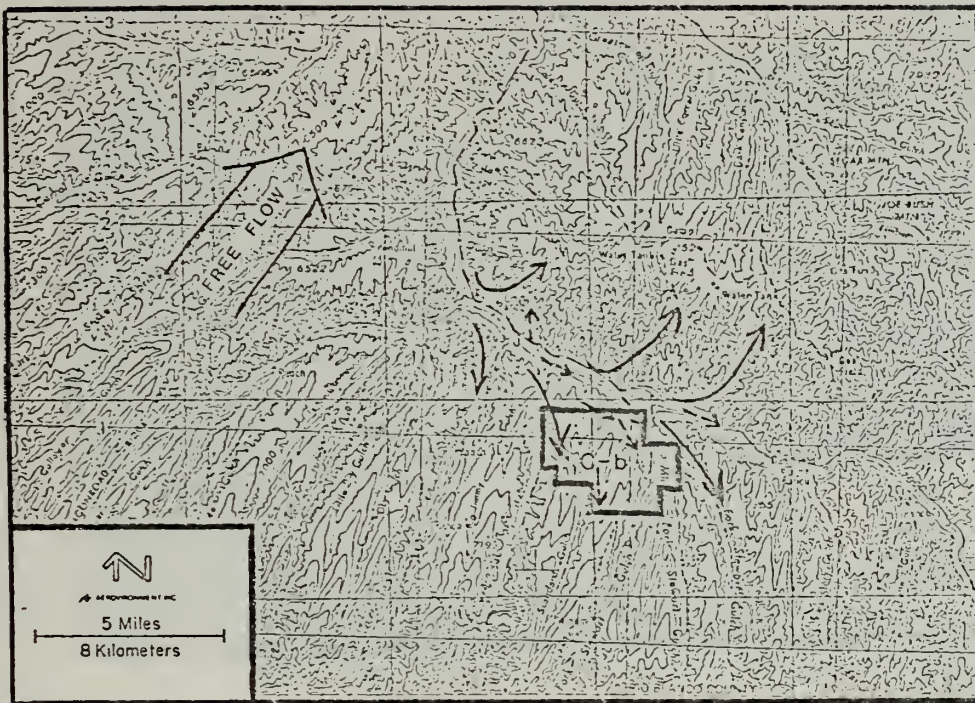

Figure A6.3.2B-8 Streamlines of upslope flow over Tract C-b.

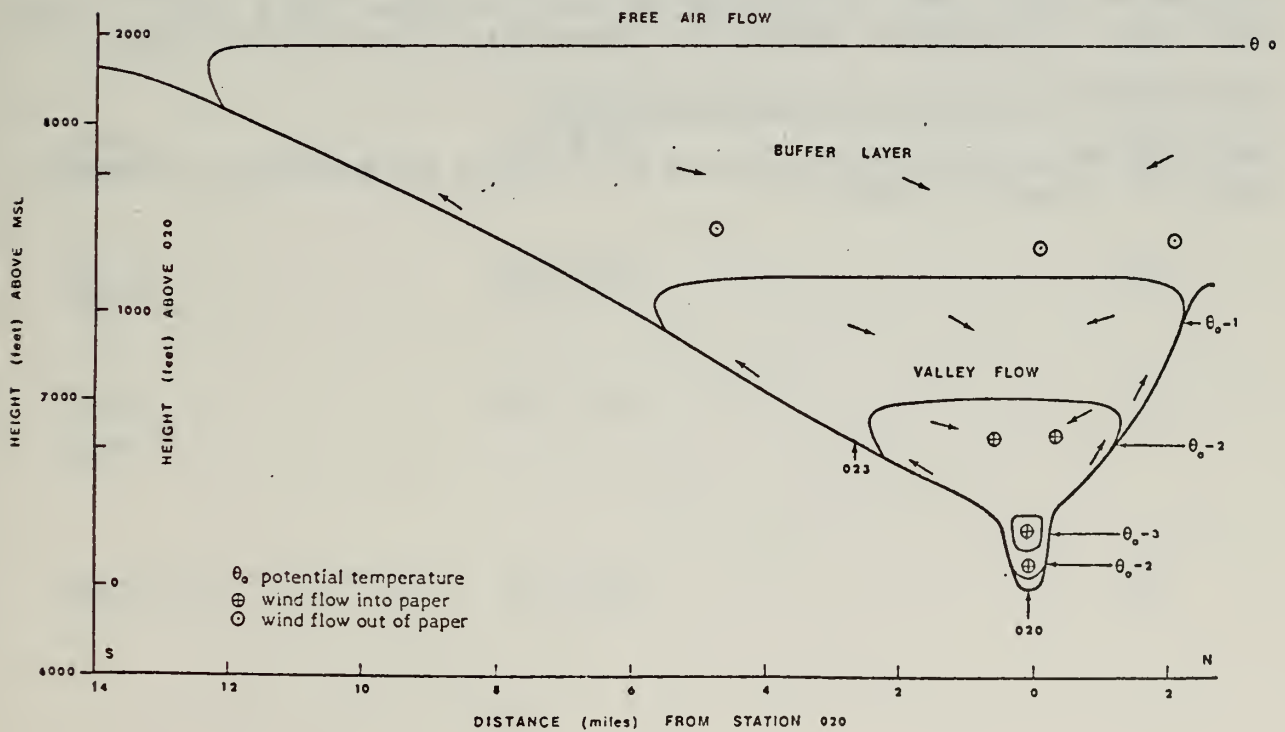

Figure A6.3.2B-9 A cross-sectional view of the upslope flow.

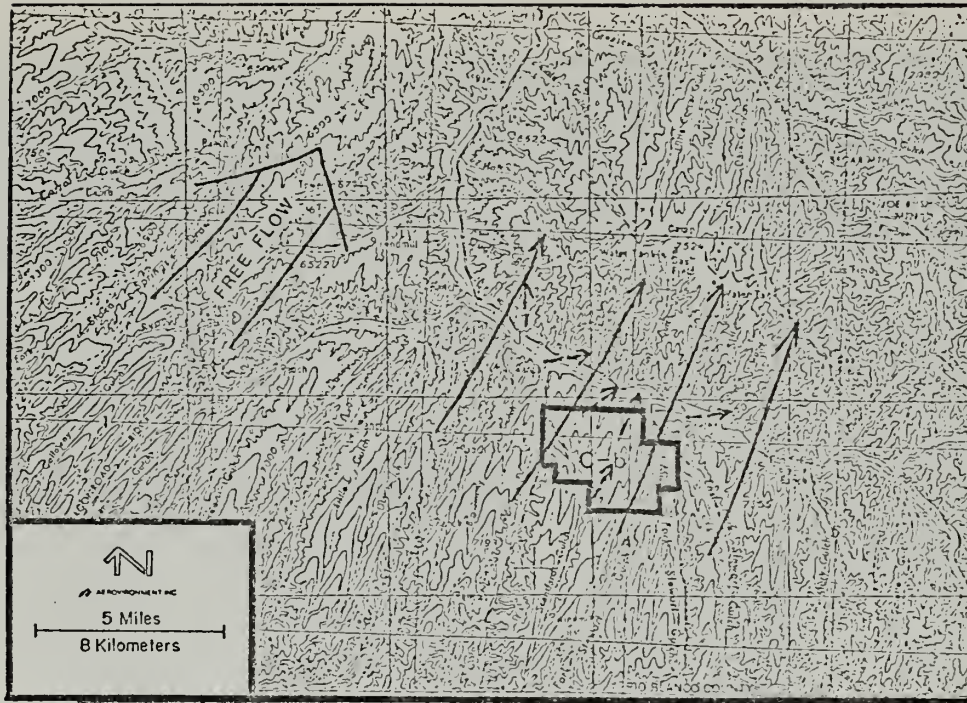

Figure A6.3.2B-10 Streamlines of synoptic flow over Tract C-b.

Tracer Gas Release Data

The release rate was kept fairly constant during the experiment, at about 3.21 gm/sec (28.8 lb/hr) in the first day and 3.14 gm/sec (28.0 lb/hr) in the second day. The height of release was approximately 100 m (330 ft) AGL.

Distribution of Ground Level SF₆ Concentration

The actual observed SF₆ concentrations at all sites are presented in the data report for January 15, 1978.

Table A8.2.1-1a

Deer pellet-group densities in the chained rangeland habitat,
1977-78.

Transect	Mean pellet-groups per acre \pm SE	No. of 0.01 acre plots
BA 17 (CH-C-1)	235 \pm 56	20
BA 18 (CH-C-2)	245 \pm 52	20
BA 25 (CH-C-3)	385 \pm 62	20
Combined	288 \pm 33	60
BA 21 (CH-T-1)	495 \pm 67	20
BA 20 (CH-T-2)	535 \pm 72	20
BA 23 (CH-T-3)	274 \pm 38	19
Combined	437 \pm 38	59

Table A8.2.1-1b

Deer pellet-group densities in the pinyon-juniper habitat,
1977-78.

Transect	Mean pellet-groups per acre \pm SE	No. of 0.01 acre plots
BA 19 (PJ-C-1)	360 \pm 56	20
BA 26 (PJ-C-2)	110 \pm 34	20
BA 27 (PJ-C-3)	245 \pm 53	20
Combined	238 \pm 31	60
BA 16 (PJ-T-1)	310 \pm 77	20
BA 22 (PJ-T-2)	195 \pm 38	19
BA 24 (PJ-T-3)	90 \pm 16	20
Combined	198 \pm 31	59

Table A8.2.1-1c

Deer pellet-group densities in the chained rangeland habitat on Big Jimmy ridge, 1977-78.

Transect	Mean pellet-groups per acre \pm SE	No. of 0.01 acre plots
BA 01	355 \pm 60	20
BA 02	420 \pm 73	20
BA 03	430 \pm 66	20
BA 04	360 \pm 41	20
BA 05	580 \pm 88	20
BA 06	205 \pm 44	20
BA 07	210 \pm 69	20
BA 08	415 \pm 61	20
BA 09	610 \pm 90	20
Combined	398 \pm 24	180

Table A8.2.1-1d

Deer pellet-group densities in the pinyon-juniper habitat north of Piceance Creek, 1977-78.

Transect	Mean pellet-groups per acre \pm SE	No. of 0.01 acre plots
BA 10	95 \pm 26	20
BA 11	90 \pm 22	20
BA 12	130 \pm 31	20
Combined	105 \pm 15	60
BA 13	345 \pm 69	20
BA 14	440 \pm 47	20
BA 15	285 \pm 48	20
Combined	357 \pm 33	60

Table A8.2.2-1

Mule deer road counts conducted from Fall 1977 to Spring 1978.

Location	SEP.		OCT				NOV				Fall Totals	
	22	29	6	13	20	24	27	3	10	17		24
White River												
Little Hills											4	4
												3
								15	13		19	87
												12
					3	7						10
						5			8	7		20
						7	9					16
						5	42	24				71
Rock School							4			21		25
											5	5
				4	18	51	23			24	10	130
Hunter Creek									83	10	6	133
PL Gate			14	15	126	150	7	72	57	7		448
AQ 020				8	106	205	96		61			476
Sorghum, Cottonwood					115	122	41	60	45	9		392
Stewart Gulch Rd.					30	101	236	138	8	5		518
AQ Trailer 021					25	28	25	21	8	17		124
					6	25	5		6			42
						3	15					18
						6						6
Sprague Gulch								3	2			5
								8				8
												6
												8
						3	3					6
Rio Blanco							2					2
AL	0	0	0	14	30	480	837	498	418	226	82	

Table A8.2.2-1 (Continued)

Mile	Location	DEC					JAN				Winter Totals
		3	8	15	21	29	5	12	19	25	
41	White River										
40											
39										5	5
38											
37											
36											
35											
34	Little Hills				1						1
33			1			2					3
32			7	3							10
31		13	15	5		8				5	46
30			10								10
29											
28					5	3					8
27			6	15							21
26					3						3
25			4		6						10
24	Rock School				5	5					10
23							1			1	2
22		9	68	34	4	18	12	1		8	154
21	Hunter Creek	19	16							4	39
20	PL Gate		2	23			2				27
19	AQ 020		4								4
18	Sorghum, Cottonwood										
17	Stewart Gulch Rd.										
16	AQ Trailer 021						1				1
15						2					2
14											
13			5								5
12	Sprague Gulch										
11				5							5
10							3				3
9							2				2
8											
7							6				6
6											
5										1	1
4											
3											
2											
1											
0	Rio Blanco						2				2
TOTAL		41	138	85	24	38	29	1	0	24	

Table A8.2.2-1 (Continued)

Mile	Location	FEB				MAR					Spring Totals
		2	9	16	23	2	9	16	23	30	
41	White River										
40							23		48		71
39					17	7		13	6		43
38					3		9	10	11		33
37				3	17		1	21	24		66
36					11				28		39
35			2	15	7				1	1	26
34	Little Hills			3	2						5
33					13			5			18
32					3	6	4	2		5	20
31					13	2	7	59	41	14	136
30				21	20	2	18	9	38		108
29					26	10		55	11	15	117
28			5	8	18	28	18			25	102
27					23			21	24	5	73
26					2		7	10	20	40	79
25				13	40		12	27	113	88	293
24	Rock School	6		11	53	2	17	40	39	58	226
23				3	11		8	13	19	17	71
22		2	13	9	23		37	9	81	61	235
21	Hunter Creek			8	74		61	62	12		217
20	PL Gate			31	13		24	45	25	75	213
19	AQ 020		3	18			13	22	49	47	152
18	Sorghum, Cottonwood		3	6			3	43	8	57	120
17	Stewart Gulch Rd.		4		20	3	10	15		18	70
16	AQ Trailer 021				5			5	4	12	26
15				10	4			33	3	2	52
14			3	4	8			20		10	45
13			21	18	13	8	1	21		21	103
12	Sprague Gulch		26	5	41	1	11	67		20	171
11		1	8	36	22	1	4	79		12	163
10			14	51	24			23		6	118
9		5	3	9	7	7	8	50	14	27	130
8		21	9	13	31	11	54	37	15		191
7			4	4	19	3	21	42	3	30	126
6			16		16		9	50		3	94
5						3		22			25
4					9		23	18	1		51
3		2		25	6			21			54
2			1	23	28	3	18	39			112
1				14	8			26			48
0	Rio Blanco										
TOTAL		37	135	361	650	97	421	1034	638	669	

BIRD SPECIES OBSERVED ON TRACT C-b DURING SPRING 1978 CENSUS

ORDER Family Species	Common Name	Observed		
		Pinyon-juniper	Chained pinyon-juniper	Fly over
FALCONIFORMES ACCIPITRIDAE <u>Buteo jamaicensis</u>	red-tailed hawk			X
COLUMBIFORMES COLUMBIDAE <u>Zenaida macroura</u>	mourning dove	X		X
APODIFORMES APODIDAE <u>Aeronautes saxatalis</u>	white-throated swift			X
TROCHILIDAE <u>Şelasphorus platycercus</u>	broad-tailed hummingbird	X		X
PICIFORMES PICIDAE <u>Colaptes auratus</u> <u>Sphyrapicus thyroideus</u> <u>Picoides villosus</u>	common flicker Williamson's sapsucker hairy woodpecker		X	X
PASSERIFORMES TYRANNIDAE <u>Myiarchus cinerascens</u> <u>Empidonax hammondi</u> <u>Empidonax oberholseri</u>	ash-throated flycatcher Hammond's flycatcher dusky flycatcher		X	X

ORDER Family Species	Common Name	Observed		
		Pinyon-juniper	Chained pinyon-juniper	Fly over
PASSERIFORMES (cont.)				
CORVIDAE				
<u>Gymnorhinus cyanocephalus</u>	pinyon jay	X	X	
<u>Corvus corax</u>	common raven			X
PARIDAE				
<u>Parus gambeli</u>	mountain chickadee	X		
<u>Parus inornatus</u>	plain titmouse	X		
<u>Psaltriparus minimus</u>	bushtit	X		
SITTIDAE				
<u>Sitta carolinensis</u>	white-breasted nuthatch	X		
TROGLODYTIDAE				
<u>Troglodytes aedon</u>	house wren	X		X
TURDIDAE				
<u>Myadestes townsendi</u>	Townsend's solitaire	X		
<u>Catharus guttata</u>	hermit thrush	X		
<u>Sialia currucoides</u>	mountain bluebird	X		X
VIREONIDAE				
<u>Vireo solitarius</u>	solitary vireo	X		
PARULIDAE				
<u>Vermivora virginiae</u>	Virginia's warbler	X		
<u>Dendroica coronata</u>	yellow-rumped warbler			X
<u>Dendroica nigrescens</u>	black-throated gray warbler	X		X

ORDER Family Species	Common Name	Observed		
		Pinyon-juniper	Chained pinyon-juniper	Fly over
FRINGILLIDAE				
<u>Pheucticus melanocephalus</u>	black-headed grosbeak	X		
<u>Carpodacus cassinii</u>	Cassin's finch	X		
<u>Carpodacus mexicanus</u>	house finch		X	
<u>Carduelis pinus</u>	pine siskin	X		
<u>Pipilo chlorura</u>	green-tailed towhee	X		
<u>Pipilo erythrophthalmus</u>	rufous-sided towhee	X		
<u>Passerculus sandwichensis</u>	savannah sparrow		X	
<u>Poocetes gramineus</u>	vesper sparrow		X	
<u>Junco caniceps</u>	gray-headed junco	X		
<u>Spizella passerina</u>	chipping sparrow	X		
<u>Spizella breweri</u>	Brewer's sparrow	X		X

TABLE A8.5.1-2a

AVIFAUNA ESTIMATES AT TRACT C-b FOR SPRING SAMPLE PERIOD, 1978

TRANSECT 1, CHAINED PINYON-JUNIPER RANGELAND (CONTROL).

Species	# Obs	Coeff det	Basal adj	Density /ha	%Relative (1) abundance
Mourning dove	1	1.00	*	0.02	0.9
Broad-tailed hummingbird	1	0.28	*	0.09	4.1
Ash-throated flycatcher	1	0.63	*	0.04	1.8
House wren	2	0.65	*	0.08	3.6
Mountain blue bird	8	*	*	0.20	9.1
Black-throated gray warbler	1	1.00	*	0.03	1.4
House finch	1	0.62	*	0.04	1.8
Green-tailed towhee	8	0.57	*	0.36	16.4
Savannah sparrow	5	0.63	*	0.20	9.1
Chipping sparrow	1	0.63	*	0.04	1.8
Brewer's sparrow	21	0.49	*	1.10	50.0
	Total			2.20	

(1) $\frac{\text{Species density/ha}}{2.20} \times 100\%$

TABLE A8.5.1-2b

AVIFAUNA ESTIMATES AT TRACT C-b FOR SPRING SAMPLE PERIOD, 1978

TRANSECT 2, PINYON-JUNIPER WOODLAND (DISTURBED)

Species	# Obs	Coeff det	Basal adj	Density /ha	% Relative abundance	(1)
Broad-tailed hummingbird	1	0.73	*	0.04	2.1	
Common flicker	1	0.90	*	0.03	1.5	
Ash-throated flycatcher	2	0.50	*	0.10	5.2	
Pinyon jay	2	1.00	*	0.05	2.6	
Mountain chickadee	5	0.56	*	0.23	11.8	
Plain titmouse	1	0.31	*	0.08	4.1	
Bushtit	3	0.22	*	0.35	18.0	
White-breasted nuthatch	1	0.59	*	0.04	2.1	
Mountain bluebird	3	0.42	*	0.18	9.2	
Solitary vireo	2	0.59	*	0.09	4.6	
Virginia's warbler	7	0.75	*	0.24	12.4	
Black-throated gray warbler	8	0.60	*	0.34	17.5	
Black-headed grosbeak	1	0.75	*	0.03	1.5	
Gray-headed junco	1	0.43	*	0.06	3.1	
Brewer's sparrow	2	0.62	*	0.08	4.1	
		Total		1.94		

(1) $\frac{\text{Species density/ha}}{2.20} \times 100\%$

TABLE A8.5.1-2c

AVIFAUNA ESTIMATES AT TRACT C-b FOR SPRING SAMPLE PERIOD, 1978

TRANSECT 3, CHAINED PINYON-JUNIPER RANGELAND (DISTURBED)

Species	# Obs	Coeff det	Basal adj	Density /ha	% Relative (1) abundance
Broad-tailed hummingbird	1	0.28	*	0.09	2.3
Common flicker	2	1.00	*	0.05	1.3
Ash-throated flycatcher	3	0.63	*	0.12	3.1
Pinyon jay	4	0.25	*	0.41	10.7
House wren	2	0.65	*	0.08	2.1
Mountain bluebird	10	*	*	0.26	6.8
Yellow-rumped warbler	2	0.19	*	0.27	7.0
Green-tailed towhee	24	0.57	*	1.08	28.2
Vesper sparrow	3	0.57	*	0.10	2.6
Chipping sparrow	3	0.63	*	0.12	3.1
Brewer's sparrow	24	0.49	*	1.25	32.6
			Total	3.83	

(1) $\frac{\text{Species density/ha}}{2.20} \times 100\%$

TABLE A8.5.1-2d

AVIFAUNA ESTIMATES AT TRACT C-b FOR SPRING SAMPLE PERIOD, 1978

TRANSECT 4, PINYON-JUNIPER WOODLAND (CONTROL)

Species	# Obs	Coeff det	Basal adj	Density /ha	% Relative (1) abundance
Mourning dove	5	0.74	*	0.17	4.2
Williamson's sapsucker	1	0.38	*	0.07	1.7
Hammond's flycatcher	1	0.25	*	0.10	2.5
Dusky flycatcher	7	0.44	*	0.41	10.2
Mountain chickadee	5	0.56	*	0.23	5.7
Bush-tit	2	0.22	*	0.23	5.7
House wren	5	0.45	*	0.28	6.9
Hermit thrush	4	0.66	*	0.16	4.0
Mountain bluebird	10	0.42	*	0.61	15.1
Solitary vireo	7	0.59	*	0.30	7.4
Black-throated gray warbler	16	0.60	*	0.68	16.9
Black-headed grosbeak	2	0.75	*	0.07	1.7
Cassin's finch	1	0.50	*	0.05	1.2
Pine siskin	1	0.43	*	0.06	1.5
Green-tailed towhee	2	0.54	*	0.10	2.5
Rufous-sided towhee	1	0.54	*	0.05	1.2
Chipping sparrow	5	0.34	*	0.38	9.4
Brewer's sparrow	2	0.62	*	0.08	2.0
			Total	4.03	

(1) $\frac{\text{Species density/ha}}{2.20} \times 100\%$

Table A8.6.2-1

Abundance (units/cm²), percent relative abundance (%RA), and species diversity of periphyton from artificial substrates on Piceance Creek, Colorado at Stewart and Hunter Stations, May 18, 1978

Taxon	Stewart				Hunter					
	Rep 4	Rep 5	Rep 6	Mean	%RA	Rep 4	Rep 5	Rep 6	Mean	%RA
DIVISION BACILLARIOPHYTA (Diatoms)										
<u>Achnanthes lanceolata</u> var. <u>dubia</u>	6	16	18	13.3	2.0	6	4	6	5.3	1.1
<u>A. minutissima</u>	10	16	16	14.0	2.1	16	38	28	27.3	5.8
<u>Amphora</u> sp.							4	2	2.0	0.4
<u>Cocconeis placentula</u>	P	6	2	2.7	0.4	6	2		2.7	0.6
<u>Cymbella minuta</u>	2	4	2	2.7	0.4					
<u>C. tumida</u>						4	2	2	2.7	0.6
<u>Denticula</u> sp.								2	0.7	0.1
<u>Fragilaria crotonensis</u>			2	0.7	0.1					
<u>F. vaucheriae</u>			P	P				2	0.7	0.1
<u>Gomphonema gracile</u>										
<u>G. olivaceum</u>	2	6	6	4.7	0.7	20	4		8.0	1.7
<u>G. parvulum</u>	12		16	9.3	1.4	42	28		23.3	3.0
<u>G. subclavatum</u> var. <u>commutatum</u>						2	4	4	3.3	0.7
<u>G. spp.</u>	10	6		5.3	0.8		12	2	4.7	1.0
<u>Cyrosigma</u> sp.			6	2.7	0.4	16			5.3	1.1
<u>Hantzschia amphioxys</u>	6	4	8	6.0	0.9	4		2	2.0	0.4
<u>Melosira varians</u>			P	P						
<u>Meridion circulare</u>		P	4	1.3	0.2					
<u>Navicula accomoda</u>	4	2		2.0	0.3					
<u>N. capitata</u>	2		2	1.3	0.2			4	1.3	0.3
<u>N. cryptocephala</u>	P		2	0.7	0.1	P	P	P	P	
<u>N. cryptocephala</u> var. <u>veneta</u>	85	89	87	87.0	13.0	12	10	12	11.3	2.4
<u>N. cuspidata</u>			2	0.7	0.1					
<u>N. nr. menisculus</u> var. <u>upsaliensis</u>						2	4		2.0	0.4
<u>N. minima</u>	4		2	2.0	0.3			8	2.7	0.6
<u>N. mutica</u>										P

Table A8.6.2-1 (Continued)

Taxon	Stewart			Mean	%RA	Hunter			Mean	%RA
	Rep 4	Rep 5	Rep 6			Rep 4	Rep 5	Rep 6		
<u>Navicula mutica</u> var. <u>undulata</u>			2	0.7	0.1					
<u>N. secreta</u> var. <u>apiculata</u>	71	85	83	79.7	11.9	57	63	40	53.3	11.4
<u>N. tripunctata</u> var. <u>schizonemoides</u>	40	55	32	42.3	6.3	55	81	69	68.3	14.6
<u>N. viridula</u> var. <u>avenacea</u>	6	32	20	19.3	2.9	P	P	P	P	
<u>N. spp.</u>	47	51	55	51.0	7.6	34	16	20	23.3	5.0
<u>Neidium</u> sp.	2			0.7	0.1					
<u>Nitzschia acicularis</u>	12	16	8	12.0	1.8	12	20	24	18.7	4.0
<u>N. apiculata</u>	P			P				2	0.7	0.1
<u>N. dissipata</u>	P			P			4		1.3	0.3
<u>N. hungarica</u>	2	4	4	3.3	0.5					
<u>N. palea</u>	26	63	42	43.7	6.5	16	36	34	28.7	6.1
<u>N. siemoidea</u>	2		4	2.0	0.3	P			P	
<u>N. tryblionella</u> var. <u>levidensis</u>		2	2	1.3	0.2					
<u>N. spp.</u>	142	206	199	182.3	27.2	97	145	122	121.3	26.0
<u>Pinnularia borealis</u>			2	0.7	0.1					
<u>P. sp.</u>			4	1.3	0.2					
<u>Rhopaledia gibba</u> var. <u>ventricosa</u>			P	P						
<u>R. ruscus</u>	2			0.7	0.1					
<u>Stephanodiscus hantzschii</u>			P	P						
<u>Surirella angustata</u>	P	2		0.7	0.1					
<u>S. ovalis</u>	10			3.3	0.5		2		0.7	0.1
<u>S. ovata</u>	26	38	32	32.0	4.8	P	8	4	4.0	0.8
<u>Synedra delicatissima</u>	6			2.0	0.3					
<u>S. fasciculata</u>						P			P	
<u>S. ulna</u>			P	P						
<u>S. sp.</u>		2	4	2.0	0.3	2			0.7	0.1
Unidentified centrics								2	0.7	0.1

Table A8.6.2-1 (Continued)

Taxon	Stewart			Mean	%RA	Hunter			Mean	%RA
	Rep 4	Rep 5	Rep 6			Rep 4	Rep 5	Rep 6		
Unidentified pennates	43	43	16	34.0	5.1	38	36	26	33.3	7.1
Total Bacillariophyta	579	749	682	670.0	99.9	439	520	417	458.7	98.2
DIVISION CHLOROPHYTA (Green algae)										
<u>Crucigenia quadrata</u>						2		2	1.3	0.3
<u>Stigeoclonium</u> sp.						4	8	P	4.0	0.8
Unidentified coccoids						8			2.7	0.6
Total Chlorophyta						14	8	2	8.0	1.7
DIVISION CYANOPHYTA (Blue-green algae)										
<u>Oscillatoria</u> sp.	2			0.7	0.1					
Total Cyanophyta	2			0.7	0.1					
DIVISION CRYPTOPHYTA										
<u>Cryptomonas ovata</u>							2		0.7	0.1
Total Cryptophyta							2		0.7	0.1

Total Individuals	581	749	682	670.7		453	530	419	467.3	
Total Taxa	32	24	36	46		28	25	26	39	
Diversity (\bar{d})	3.64	3.48	3.52	3.67		3.69	3.50	3.42	3.70	
Maximum diversity (\bar{d} max)	4.75	4.52	4.95	5.28		4.46	4.52	4.58	5.09	
Equitability (%)	76.60	76.97	73.18	69.39		82.85	77.39	74.67	72.63	

P = present

Table A8.6.2-2

Abundance (units/cm²), percent relative abundance (%RA), and species diversity (\bar{d}) of periphyton from artificial substrates on Piceance Creek, Colorado at Stewart and Hunter Station, June 20, 1978

Taxon	Stewart				Hunter					
	Rep 4	Rep 5	Rep 6	Mean	%RA	Rep 4	Rep 5	Rep 6	Mean	%RA
DIVISION BACILLARIOPHYTA (Diatoms)										
<u>Achnanthes lanceolata</u>						2,270			756	0.1
<u>A. lanceolata</u> var. <u>dubia</u>	6,190	39,200	41,200	28,070	3.8	79,400	43,100	61,200	61,250	7.6
<u>A. minutissima</u>	39,200	53,600	70,100	54,310	7.2	68,000	70,300	49,900	62,760	7.8
<u>Amphora</u> sp.		2,060		687	0.1	4,540		6,810	2,269	0.3
<u>Coconeis pediculus</u>	P	P	2,060	687	0.1	2,270	2,270		1,513	0.2
<u>C. placentula</u>						6,810	P	4,540	3,781	0.5
<u>Cyclotella meneghiniana</u>	2,060	P	10,300	4,120	0.5					
<u>Cymbella minuta</u>	P		P	P						
<u>C.</u> sp.		P		P						
<u>Fragilaria crotonensis</u>			P	P						
<u>F.</u> sp.	2,060			687	0.1		6,810		2,269	0.3
<u>Comphonema intricatum</u> var. <u>vibrif</u>	P			P				2,270	756	0.1
<u>G. olivaceum</u>	14,400	18,600	8,250	13,750	1.8	25,000	4,540	6,810	12,100	1.5
<u>G. parvulum</u>	6,190	6,190	2,060	4,812	0.6		P	2,270	756	0.1
<u>G.</u> spp.	2,060	4,120		2,060	0.3	9,070			3,025	0.4
<u>Hantzschia arcus</u>		P		F						
<u>Hantzschia amphioxys</u>		P	P	P						
<u>Navicula cryptocephala</u> var. <u>veneta</u>	18,600	26,800	26,800	24,060	3.2	6,810			2,269	0.3
<u>N. minima</u>	12,400	14,400	18,600	15,120	2.0	4,540	6,810	13,600	8,320	1.0
<u>N. secreta</u> var. <u>apiculata</u>	57,700	74,200	66,000	66,000	8.8	22,700	22,700	34,000	26,470	3.3
<u>N. tripunctata</u> var. <u>schizonemoides</u>							2,270		756	0.1
<u>N. viridula</u> var. <u>avenacea</u>	16,500	16,500	33,000	22,000	2.9	95,300	86,200	79,400	86,960	10.7
<u>N.</u> spp.	37,100		6190	14,440	1.9		6810		2269	0.3

Table A8.6.2-2 (Continued)

Taxon	Stewart			Mean	%RA	Hunter			Mean	%RA
	Rep 4	Rep 5	Rep 6			Rep 4	Rep 5	Rep 6		
<u>Nitzschia acicularis</u>	53,600	53,600	82,500	63,250	25.2	216,000	284,000	263,000	254,100	31.4
<u>N. apiculata</u>			P							
<u>N. dissipata</u>		4,120	2,060	2,060	0.3	13,600	2,270	15,900	10,590	1.3
<u>N. hungarica</u>	2,060	2,060	4,120	2,750	0.4		2,270		756	0.1
<u>N. linearis</u>			6,190	2,062	0.3					
<u>N. Palea</u>	72,200	78,400	51,600	67,370	8.9	61,200	122,000	93,000	92,200	11.4
<u>N. sigmoidea</u>								P		
<u>N. spp.</u>	315,500	338,200	286,700	313,500	41.6	83,900	188,000	141,000	137,600	17.0
<u>Surirella angustata</u>	P		P	P				2,270	756	0.1
<u>S. ovalis</u>	P	P	2,060	687	0.1			P	1,512	0.2
<u>S. ovata</u>	8,250	4,120	8,250	6,875	0.9	13,600	4,540	4,540	7,562	0.9
<u>Synedra ulna</u>	6,190	P		2,062	0.3					
<u>S. sp.</u>		4,120		1,406	0.2	2,270			756	0.1
Unidentified centrics	2,060	2,060		1,375	0.2			2,270	756	0.1
Unidentified pennates	22,700	43,300	24,700	30,250	4.0	9,070	13,600	31,800	18,150	2.2
Total Bacillariophyta	660,600	823,000	753,000	745,200	98.4	726,000	869,000	819,000	804,600	99.4
DIVISION CHLOROPHYTA (Green algae)										
<u>Oedogonium sp.</u>			2,060	687	0.1					
<u>Scenedesmus sp.</u>						2,270			756	0.1
<u>Stigeoclonium sp.</u>		2,060		687	0.1	2,270	4,540		2,269	0.3
<u>Ulothrix sp.</u>		2,060	P	687	0.1					
Unidentified filament	16,500	2,060	P	6,187	0.8					
Total Chlorophyta	16,500	6,190	2,060	8,249	1.1	4,540	4,540		3,025	0.4

Table A8.6.2-2 (Continued)

Taxon	Stewart						Hunter			
	Rep 4	Rep 5	Rep 6	Mean	%RA	Rep 4	Rep 5	Rep 6	Mean	%RA
DIVISION CYANOPHYTA (Blue-green algae)										
<u>Chroococcus sp.</u>		P		P			4,540		1,512	0.2
<u>Oscillatoria sp.</u>		P		P			4,540		1,512	0.2
Total Cyanophyta										
Total Individuals	676,000	829,000	755,000	753,400	730,000	878,000	819,000	809,100		
Total Taxa	25	31	28	39	21	23	19	32		
Diversity (\bar{d})	2.87	3.13	3.17	3.15	3.27	2.86	3.09	3.14		
Maximum diversity (\bar{d} max)	4.32	4.52	4.39	4.95	4.39	4.25	4.25	4.95		
Equitability (%)	66.44	69.29	72.17	63.55	74.40	67.45	72.65	63.35		

P = present

Table A8.6.2-3

Abundance (units/cm²), Percent Relative Abundance (%RA), and Species Diversity of Periphyton from Artificial Substrates on Piceance Creek, Colorado, at Stewart and Hunter Stations, July 19, 1978

Taxon	Stewart			Mean	%RA	Hunter			Mean	%RA
	Rep 1	Rep 2	Rep 3			Rep 1	Rep 2	Rep 3		
DIVISION BACILLARIOPHYTA (Diatoms)										
<u>Achnanthes lanceolata</u>	18,974	22,769	92,972	44,905.0	9.0	34,153	18,974	14,230	22,452.3	5.9
<u>A. lanceolata</u> var. <u>dubia</u>	177,406	200,175	235,276	204,285.7	41.1	83,485	124,279	93,921	100,561.7	26.4
<u>A. minutissima</u>	203,021	123,330	192,585	172,978.7	34.8	135,663	142,304	159,380	145,782.3	38.3
<u>Amphora perpusilla</u>	2,846	1,897	5,692	3,478.3	0.7	949	949		632.7	0.2
<u>A. sp.</u>		P	P	P	-	P	P		P	-
<u>Cocconeis pediculus</u>	P	949	17,077	6,008.7	1.2	P	949	P	316.3	0.1
<u>C. placentula</u> var. <u>euglypta</u>	3,795	1,897	1,897	2,529.7	0.5	15,179	13,282	12,333	13,598.0	3.6
<u>Cyclotella meneghiniana</u>			949	316.3	0.1		P	2,846	948.7	0.2
nr. <u>Cylindrotheca gracilis</u>						P		P	P	-
<u>Cymbella affinis</u>	P			P	-					
<u>C. minuta</u>	949	P		316.3	0.1					
<u>C. sp.</u>			2,846	948.7	0.2					
<u>Fragilaria vaucheriae</u>	949			316.3	0.1					
<u>Gomphonema gracile</u>						P			P	-
<u>G. olivaceum</u>						949	2,846	P	1,265.0	0.3
<u>G. parvulum</u>	19,923	11,384	7,590	12,965.7	2.6	4,743	3,795	949	3,162.3	0.8
<u>Navicula cryptocephala</u> var. <u>veneta</u>		949	9,487	3,478.7	0.7	4,743	1,897	2,846	3,162.3	0.8
<u>N. nr. luzonensis</u>	6,641	4,743	10,436	7,273.3	1.5	18,025	13,282	3,795	11,700.7	3.1
<u>N. notha</u>		2,846		948.7	0.2					
<u>N. secreta</u> var. <u>apiculata</u>	3,795	3,795	7,590	5,060.0	1.0	12,333	16,128	14,230	14,230.3	3.7
<u>N. tripunctata</u> var. <u>schizonemoides</u>	P		949	316.3	0.1		P		P	-
<u>N. viridula</u> var. <u>avenacea</u>	2,846		P	948.7	0.2	8,538	6,641	7,590	7,589.7	2.0

Table A8.6.2-3 (Continued)

Taxon	Stewart			Mean	%RA	Hunter			Mean	%RA
	Rep 1	Rep 2	Rep 3			Rep 1	Rep 2	Rep 3		
<u>N. spp.</u>	2,846	949		1,265.0	0.2	7,590	4,743		4,111.0	1.1
<u>Nitzschia acicularis</u>						P		.949	316.3	0.1
<u>N. amphibia</u>	949	2,846	949	1,581.3	0.3		949		632.7	0.2
<u>N. apiculata</u>	P	P	P	P	-	P		1,897	632.3	0.2
<u>N. linearis</u>		949	P	316.3	0.1	P		P	P	-
<u>N. spp.</u>	1,897	3,795	6,641	4,111.0	0.8	8,538	5,692	9,487	7,905.7	2.1
<u>Rhoicosphenia curvata</u>		1,897	949	948.7	0.2	1,897	1,897		1,264.7	0.3
<u>Surirella ovalis</u>	949	P	P	316.3	0.1	949	949	.949	949.0	0.2
<u>S. ovata</u>	P	949	P	316.3	0.1		P		P	-
<u>S. sp.</u>							P		P	-
<u>Synedra ulna</u>			P	P	-			P	P	-
<u>Unidentified pennates</u>	1,897	1,897	1,897	1,897.0	0.4	5,692	949	3,795	3,478.7	0.9
Total Bacillariophyta	449,683	388,017	595,780	477,826.7	96.0	343,428	360,504	330,146	44,692.7	90.5

DIVISION CHLOROPHYTA (Green algae)

<u>Cladophora sp.</u>			2,846	948.7	0.2			P	P	-
<u>Stigeoclonium sp.</u>	5,692	8,538	13,282	9,170.7	2.0	11,384	38,896	49,332	33,204.0	8.7
<u>Unidentified coccoid</u>							949		316.3	0.1
<u>Unidentified filament</u>	18,025	5,692	2,846	8,854.3	1.8	2,846	949	3,795	2,530.0	0.7
Total Chlorophyta	23,717	14,230	18,974	18,973.7	3.8	14,230	40,794	53,127	36,050.3	9.5

Table A8.6.2-3 (Continued)

Taxon	Stewart			Hunter					
	Rep 1	Rep 2	Rep 3	Rep 1	Rep 2	Rep 3	Mean	%RA	
DIVISION CYANOPHYTA (Blue-green algae)									
<u>Chroococcus</u> sp.			P					-	
<u>Merismopedia tenuisima</u>			P					-	
<u>Oscillatoria</u> sp.		949	949				316.3	0.1	
<u>Phormidium</u> sp.		949	P			P	316.3	0.1	
Total Cyanophyta		949	949			P	632.7	0.1	
<hr/>									
Total Individuals	473,399	403,196	615,703	497,432.7		357,658	401,298	383,273	380,743.0
Total Taxa	23	25	31	36		25	26	25	34
Diversity (\bar{d})	2.16	2.18	2.44	2.37		2.88	2.69	2.59	2.78
Maximum diversity (\bar{d}_{max})	4.17	4.39	4.39	4.91		4.17	4.39	4.17	4.58
Equitability (%)	51.70	49.63	55.60	48.35		69.06	61.31	62.05	60.68

P = present but not in count

Table A8.6.2-4

Abundance (units/cm²), Percent Relative Abundance (%RA), and Species Diversity of Periphyton from Artificial Substrates on Piceance Creek, Colorado, at Stewart and Hunter Stations, August 18, 1978

Taxon	Stewart			Hunter			Mean	%RA		
	Rep 1	Rep 2	Rep 3	Rep 1	Rep 2	Rep 3				
DIVISION BACILLARIOPHYTA (Diatoms)										
<u>Achnanthes lanceolata</u>	1,107	2,372	1,739	1,739.3	3.3	9,487	7,590	9,487	8,854.7	3.1
<u>A. lanceolata</u> var. <u>dubia</u>	16,760	13,756	20,081	16,865.7	32.0	36,999	100,562	61,665	66,408.7	23.2
<u>A. minutissima</u>	3,953	5,099	11,226	6,759.3	12.8	116,690	41,742	116,690	91,707.3	32.1
<u>Amphora perpusilla</u>	632	593	158	461.0	0.9	16,128	4,743	8,538	9,803.0	3.4
<u>A. sp.</u>	474	949	949	790.7	1.5	949	P	P	316.3	0.1
<u>Coconeis pediculus</u>	1,739	4,743	10,594	5,692.0	10.8	61,665	14,230	30,358	35,417.7	12.4
<u>C. piacentula</u> var. <u>euglypta</u>	4,111	4,506	6,166	4,927.7	9.4	12,333	28,461	11,384	17,392.7	6.1
<u>Cyclotella meneghiniana</u>	790	356	316	487.3	0.9	949	2,846	2,846	2,213.7	0.8
<u>Cymatopleura elliptica</u>						P			P	-
<u>Cymbella affinis</u>		118		39.3	0.1			949	316.3	0.1
<u>C. minuta</u>		237		79.0	0.2					
<u>Fragilaria vaucheriae</u>		474	316	263.3	0.5	1,897	949	4,744	632.3	0.2
<u>Gomphonema olivaceum</u>	474	712	1,265	817.0	1.6	2,846	3,795	2,846	1,897.7	0.6
<u>G. parvulum</u>			316	105.3	0.2	949			3,162.3	1.1
<u>G. spp.</u>			158	52.7	0.1		P		316.3	0.1
<u>Gyrosigma</u> sp.	P			P	-				P	-
<u>Hantzschia amphioxys</u>						P			P	-
<u>Meridion circulare</u>										
<u>Navicula capitata</u>		P		P	-					
<u>N. cryptocephala</u>						949			316.3	0.1
<u>N. cryptocephala</u> var. <u>veneta</u>	474	2,846	3,637	2319.0	4.4		1,897	949	948.7	0.3
<u>N. nr. luzonensis</u>	474	356	1,107	645.7	1.2					
<u>N. notha</u>	158	1,067	474	566.3	1.1	2,846	1,897	P	1,581.0	0.6
<u>N. secreta</u> var. <u>apiculata</u>	1,107	4,981	4,269	3,452.3	6.6	3,795	9,487	8,538	7,273.3	2.5

Table A8.6.2-4 (Continued)

Taxon	Stewart			Mean	%RA	Hunter			Mean	%RA
	Rep 1	Rep 2	Rep 3			Rep 1	Rep 2	Rep 3		
<u>N. tripunctata</u> var. <u>schizonemoides</u>	632	356	474	487.3	0.9	P		2,846	948.7	0.3
<u>N. viridula</u> var. <u>avenacea</u>		356	158	171.3	0.3	6,641	10,436	15,179	10,752.0	3.8
<u>N. spp.</u>	632	1,186		606.0	1.2		4,743	2,846	2,529.7	0.9
<u>Nitzschia acicularis</u>						P		949	316.3	0.1
<u>N. amphibia</u>		P	158	52.7	0.1	949	949	949	949.0	0.3
<u>N. aciculata</u>		118	316	144.7	0.3	1,897	2,846	2,846	2,529.7	0.9
<u>N. dissinata</u>						949			316.3	0.1
<u>N. linearis</u>						P	1,897		632.3	0.2
<u>N. vermicularis</u>						P			P	-
<u>N. spp.</u>	1,265	1,542	1,581	1,462.7	2.8	5,692	7,590	10,436	7,906.0	2.8
<u>Rhicospheria curvata</u>	158		158	105.3	0.2					
<u>Surirella ovalis</u>	P	474	158	210.7	0.4	P	949	P	316.3	0.1
<u>S. ovata</u>		118		39.3	0.1	P	1,897	3,795	1,497.3	0.7
<u>S. spp.</u>								P	P	-
<u>Synedra ulna</u>						949	949	P	632.7	0.2
Unidentified centrics	158	118	474	250.0	0.5					
Unidentified pennates	1,107	1,542	790	1,146.3	2.2	5,692	10,436	10,436	5,376.0	1.9
Total Bacillariophyta	36,210	48,977	67,042	50,743.0	96.4	291,249	250,455	309,275	283,659.7	99.2
DIVISION CHLOROPHYTA (Green algae)										
<u>Characium</u> sp.			474	158.0	0.3					
<u>Cladophora</u> sp.	158		316	158.0	0.3	949		1,897	948.7	0.3
<u>Closterium</u> sp.		118		39.3	0.1					
<u>Stigeoclonium</u> sp.	632	118		250.0	0.4					
Unidentified filament	790	712	1,265	922.3	1.5		949	2,846	1,265.0	0.4
Total Chlorophyta	1,580	948	2,055	1,527.7	2.6	949	949	4,743	2,213.7	0.8

Table A8.6.2-4 (Continued)

Taxon	Stewart			Mean	%RA	Hunter			Mean	%RA
	Rep 1	Rep 2	Rep 3			Rep 1	Rep 2	Rep 3		
DIVISION CYANOPHYTA (Blue-green algae)										
<u>Merismopedia punctata</u>		118		39.3	0.1					
<u>Phormidium</u> sp.						P	P		P	-
Total Cyanophyta		118		39.3	0.1	P	P		P	-
DIVISION CHRYSOPHYTA (Yellow-brown algae)										
<u>Dinobryon borgei</u>	316	356	316	329.3	0.6					
Total Chrysoophyta	316	356	316	329.3	0.6					
Total Individuals	38,106	50,399	69,413	52,639.3		292,198	251,404	314,018	285,873.3	
Total Taxa	26	32	29	39		30	25	28	37	
Diversity (\bar{d})	3.15	3.72	3.39	3.59		2.83	3.04	3.15	3.32	
Maximum diversity (\bar{d}_{max})	4.52	4.91	4.86	5.17		4.46	4.46	4.52	5.04	
Equitability (R)	69.54	75.77	69.73	69.51		63.46	68.21	69.58	65.88	

P = present but not in count

Table A8.6.2-5

Abundance (units/cm²), Percent Relative Abundance (%RA) and Species Diversity of Periphyton from Artificial Substrates on Piceance Creek, Colorado, at Stewart and Hunter Stations, September 20, 1978

Taxon	Stewart			Hunter						
	Rep 1	Rep 2	Rep 3	Mean	%RA	Rep 1	Rep 2	Rep 3	Mean	%RA
DIVISION BACILLARIOPHYTA										
<u>Achnanthes lanceolata</u>	10,587	7,562	4,537	7,562.0	1.8					
<u>A. lanceolata</u> var. <u>dubia</u>	3,025	P	1,512	1,512.3	0.4					
<u>A. minutissima</u>	323,656	302,482	453,724	359,954.0	83.7					
<u>Amphora veneta</u>		1,512		504.0	0.1					
<u>A. sp.</u>	P	P	1,512	503.3	0.1					
<u>Cocconeis pediculus</u>	48,397	13,612	19,661	27,223.3	6.3					
<u>C. placentula</u> var. <u>euglypta</u>	6,050	6,050	3,025	5,041.7	1.2					
<u>Cymbella minuta</u>	3,025	P	P	1,008.3	0.2					
<u>Gomphonema subclavatum</u>		P		P						
<u>G. truncatum</u>			4,537	1,512.3	0.4					
<u>G. spp.</u>	1,512	3,025	1,512	2,016.3	0.5					
<u>Navicula cryptocephala</u> var. <u>veneta</u>	12,099	P	3,025	5,041.3	1.2					
<u>N. secreta</u> var. <u>spiculata</u>	1,512	1,512	3,025	2,016.3	0.5					
<u>N. viridula</u> var. <u>avenacea</u>		P		P						
<u>N. spp.</u>	3,025			1,008.3	0.2					
<u>Nitzschia</u> spp.	7,562	15,124	4,537	9,074.3	2.1					
Unidentified pennates	4,537	4,537	1,512	3,528.7	0.8					
Total Bacillariophyta	424,988	355,417	502,121	427,508.7	99.4					
DIVISION CHLOROPHYTA										
<u>Oedogonium</u> sp.		P								
<u>Stigeoclonium</u> sp.	P	P	1,512	504.0	0.1					
Unidentified coccoid		6,050		2,016.7	0.5					
Total Chlorophyta	P	6,050	1,512	2,520.7	0.6					

SAMPLER DESTROYED

Table A8.6.2-5 (Continued)

Taxon	Stewart			Mean	%RA	Hunter			Mean	%RA
	Rep 1	Rep 2	Rep 3			Rep 1	Rep 2	Rep 3		
DIVISION CYANOPHYTA										
<u>Merismopedia punctata</u>			P	P						
<u>Phormidium</u> sp.	P	P		P						
Total Cyanophyta	P	P	P	P						
DIVISION CHRYSOPHYTA										
<u>Dinobryon</u> sp.			P	P						
Total Chrysoophyta			P	P						

Total Individuals	424,988	361,467	503,633	430,029.3
Total Taxa	15	19	16	22
Diversity (\bar{d})	1.40	1.10	0.76	1.14
Maximum Diversity (\bar{d} max)	3.58	3.32	3.70	4.09
Equitability (%)	39.19	33.20	20.55	27.77

P = Present

Table A8.6.2-6

Abundance (units/cm²), Percent Relative Abundance (%RA) and Species Diversity of Periphyton from Artificial Substrates on Piceance Creek, Colorado, at Stewart and Hunter Stations, October 18, 1978

Taxon	Stewart			Mean	%RA	Hunter			Mean	%RA
	Rep 1	Rep 2	Rep 3			Rep 1	Rep 2	Rep 3		
DIVISION BACILLARIOPHYTA (Diatoms)										
<u>Achnanthes lanceolata</u>		2,269	P	756.3	0.2		1,138		379.3	0.6
<u>A. lanceolata</u> var. <u>dubia</u>	3,403	4,537		2,646.7	0.7	9,107	3,415	3,890	5,470.7	8.5
<u>A. minutissima</u>	284,712	309,666	243,876	279,418.0	74.8	1,708	1,328	569	1,201.7	1.9
<u>Amphora ovalis</u>	P	1,134	2,269	1,134.3	0.3		190	95	95.0	0.1
<u>A. perusilla</u>						379			126.3	0.2
<u>Caloneis amphibaena</u>		P		P		P		95	31.7	<0.1
<u>Cocconeis pectidulus</u>	28,358	23,820	29,492	27,223.3	7.3	4,933	3,605	2,656	3,731.3	5.8
<u>C. placentula</u>	5,672	18,149	3,403	9,074.7	2.4	P			P	
<u>C. placentula</u> var. <u>euglypta</u>		P		P		17,076	20,871	14,230	17,329.3	26.9
<u>Cyclotella meneghiniana</u>		2,269	3,403	1,890.7	0.5	1,897	1,138	1,138	1,391.0	2.2
<u>Cylindrotheca gracilis</u>								P	P	
<u>Cymatopleura elliptica</u>								P	P	
<u>Cymbella minuta</u>	2,269	1,134	5,672	3,025.0	0.8					
<u>C. tumida</u>	P	P	3,403	1,134.3	0.3					
<u>Diatoma tenue</u> var. <u>elongatum</u>	4,537	P	P	1,512.3	0.4					
<u>D. vulgare</u>		P	P	P						
<u>Epithemia turgida</u>		P		P						
<u>Fragilaria crotonensis</u>		P		P						
<u>Gomphonema acuminatum</u>	1,134			378.0	0.1					
<u>G. olivaceum</u>	1,134		3,403	1,512.3	0.4	949	569	379	623.3	1.0
<u>G. parvulum</u>	1,134	1,134		756.0	0.2	190		95	95.0	0.1
<u>G. subclavatum</u>	P			P						
<u>G. truncatum</u>	1,134	5,672	22,686	9,830.7	2.6					

Table A8.6.2-6 (Continued)

Taxon	Stewart			Mean	%RA	Hunter			Mean	%RA
	Rep 1	Rep 2	Rep 3			Rep 1	Rep 2	Rep 3		
<u>C</u> spp.	7,940	2,269	2,269	4,159.3	1.1					
<u>Cyrosigma</u> sp.						P	379	569	316.0	0.5
<u>Melosira</u> <u>varians</u>							P	95	31.7	<0.1
<u>Navicula</u> <u>capitata</u>		P						95	31.7	<0.1
<u>N.</u> <u>cryptocephala</u> <u>var.</u> <u>veneta</u>	7,940	1,134	17,015	8,696.3	2.3	2,467	759	3,131	2,119.0	3.3
<u>N.</u> <u>pupula</u> <u>var.</u> <u>rectangularis</u>								95	31.7	<0.1
<u>N.</u> <u>secretata</u> <u>var.</u> <u>apiculata</u>	2,269	10,209	21,418	10,965.3	2.9	8,918	4,174	6,356	6,482.7	10.0
<u>N.</u> <u>tripunctata</u> <u>var.</u> <u>schizonemoides</u>	1,134	2,269	1,134	1,512.3	0.4					
<u>N.</u> <u>viridula</u> <u>var.</u> <u>avenacea</u>	P	P	P			24,097	18,974	11,479	18,183.3	28.2
<u>N.</u> spp.						1,328	379	1,423	1,043.3	1.6
<u>Nitzschia</u> <u>acicularis</u>	P	P	1,134	378.0	0.1	190		190	126.7	0.2
<u>N.</u> <u>apiculata</u>		P	P			190	P	379	189.7	0.3
<u>N.</u> <u>dissipata</u>		P								
<u>N.</u> <u>hungarica</u>		P				190			63.3	0.1
<u>N.</u> <u>sigmoidea</u>						379	379	285	347.7	0.5
<u>N.</u> <u>vitrea</u>										
<u>N.</u> spp.	3,403	3,403	4,537	3,781.0	1.0	2,467	3,415	1,423	2,435.0	3.8
<u>Pinnularia</u> sp.	P	P	1,134	378.0	0.1					
<u>Rhoicospheria</u> <u>curvata</u>			P			379	190	190	253.0	0.4
<u>Rhopalodia</u> <u>gibba</u> <u>var.</u> <u>ventricosa</u>		P	P							
<u>Stauroneis</u> <u>anceps</u>										
<u>Surirella</u> <u>ovalis</u>							P		P	
<u>S.</u> <u>ovata</u>						379	190	95	221.3	0.3
<u>S.</u> sp.						P	P	P	P	
<u>Synedra</u> <u>ulna</u>							P		P	
<u>S.</u> sp.	3,403	P	P			759	759	2,087	1,201.7	1.9
Unidentified pennates			1,134	1,512.3	0.4			P	P	
Total Bacillariophyta	359,576	389,068	367,516	372,053.3	99.6	77,982	61,852	51,039	63,624.3	98.6

Table A8.6.2-6 (Continued)

Taxon	Stewart			Mean	%RA	Hunter			Mean	%RA
	Rep 1	Rep 2	Rep 3			Rep 1	Rep 2	Rep 3		
DIVISION CHLOROPHYTA (Green algae)										
<u>Closterium</u> sp.				P		P	P	P		
<u>Oedogonium</u> sp.		P		P		379	P		.126.3	0.2
<u>Scendesmus acutus</u>			P	P						
<u>Stigeoclonium</u> sp.	2,269	1,134	1,134	1,512.3	0.4			190	63.3	0.1
<u>Ulothrix</u> sp.		P	P	P						
Unidentified flagellate		P		P						
Unidentified filament	P			P		379			126.3	0.2
Total Chlorophyta	2,269	1,134	1,134	1,512.3	0.4	758	P	190	316.0	0.5
DIVISION CYANOPHYTA (Blue-green algae)										
<u>Chroococcus</u> sp.				P				285	95.6	0.1
Unidentified filament			P	P						
Total Cyanophyta			P	P				285	95.0	0.1
DIVISION CHRYSOPHYTA										
Unidentified coccoid							1,518		506.0	0.8
Total Chrysophyta							1,518		506.0	0.8
Total Individuals	361,845	390,202	368,651	373,566.0		78,742	63,373	51,514	64,543.0	
Total Taxa	24	34	31	44		27	26	30	40	
Diversity (\bar{d})	1.43	1.37	2.03	1.7057		3.08	2.87	3.25	3.15	
Maximum diversity (\bar{d} max)	4.09	4.00	4.25	4.58		4.46	4.25	4.70	5.00	
Equitability (%)	35.06	34.32	47.89	37.20		68.99	67.62	69.10	69.92	

P = present but not encountered while counting

Table A8.6.2-7

Summary Species List of Periphyton Collected at Stewart and Hunter Stations, Piceance Creek, Colorado, 1978

Taxon	Stewart						Hunter					
	May	June	July	Aug	Sept	Oct	May	June	July	Aug	Sept	Oct
Division Bacillariophyta												
<u>Achnanthes lanceolata</u>			D	+	+	+		+	D	+		+
<u>A. lanceolata</u> var. <u>dubia</u>	+	+	D	D	+	+	+	D	D	D		D
<u>A. minutissima</u>	+	D	D	D	D	D	D	D	D	D		+
<u>Amphora ovalis</u>						+						+
<u>A. perpusilla</u>			+	+					+	+		+
<u>A. veneta</u>					+							
<u>A. sp.</u>		+	+	+	+		+	+	+	+		
<u>Caloneis amphisbaena</u>						+						+
<u>Cocconeis pediculus</u>		+	+	D	D	D		+	+	D		D
<u>C. placentula</u>	+					+	+	+				+
<u>C. placentula</u> var. <u>euglypta</u>			+	D	+	+			+	D		D
<u>Cyclotella meneghiniana</u>		+	+	+		+			+	+		+
nr. <u>Cylindrotheca gracilis</u>									+			+
<u>Cymatopleura elliptica</u>										+		+
<u>Cymbella affinis</u>			+	+						+		
<u>C. minuta</u>	+	+	+	+	+	+						
<u>C. tumida</u>						+	+					
<u>C. sp.</u>		+	+									
<u>Denticula</u> sp.							+					
<u>Diatoma tenue</u> var. <u>elongatum</u>						+						
<u>D. vulgare</u>												+
<u>Epithemia turpida</u>												+
<u>Fragilaria crotonensis</u>	+	+				+						
<u>F. vaucheriae</u>	+		+									
<u>F. sp.</u>		+						+		+		
<u>Gomphonema acuminatum</u>						+						
<u>G. gracile</u>							+		+			
<u>G. intricatum</u> var. <u>vibrio</u>		+						+				
<u>G. olivaceum</u>	+	+		+		+	+	+	+	+		+
<u>G. parvulum</u>	+	+	+	+		+	+	+	+	+		
<u>G. subclavatum</u>					+	+						
<u>G. subclavatum</u> var. <u>commutatum</u>							+					
<u>G. truncatum</u>					+	+						
<u>G. spp.</u>	+	+		+	+	+	+	+		+		+
<u>Gyrosigma</u> sp.		+										+
<u>Hantzschia amphioxys</u>	+	+		+			+					
<u>Melosira varians</u>	+											+
<u>Meridion circulare</u>	+								+			
<u>Navicula accomoda</u>	+											
<u>N. capitata</u>	+			+		+	+					
<u>N. cryptocephala</u>	+			+		+	+			+		
<u>N. cryptocephala</u> var. <u>veneta</u>	D	+	+	+	+	+	D	+	+	+		+
<u>N. cuspidata</u>	+											
<u>N. nr. luzonensis</u>			+	+					+			
<u>N. nr. menisculus</u> var. <u>upsalicensis</u>												
<u>N. minima</u>	+	+					+	+				
<u>N. mutica</u>								+				
<u>N. mutica</u> var. <u>undulata</u>	+											
<u>N. notha</u>			+	+						+		
<u>N. pupula</u> var. <u>rectangularis</u>												+
<u>N. secreta</u> var. <u>apiculata</u>	D	D	+	D	+	+	D	+	+	+		D
<u>N. tripunctata</u> var. <u>schizonemoides</u>	D		+	+		+	D	+	+	+		
<u>N. viridula</u> var. <u>avenacea</u>	+	+	+	+	+	+	+	D	+	+		D
<u>N. spp.</u>	D	+	+	+	+	+	D	+	+	+		+
<u>Neidium</u> sp.	+											
<u>Nitzschia acicularis</u>	+	D				+	+	D	+	+		+
<u>N. amphibia</u>			+	+					+	+		
<u>N. apiculata</u>	+	+	+	+		+	+		+	+		+
<u>N. dissipata</u>	+	+				+	+	+	+	+		
<u>N. hungarica</u>	+	+				+		+				+
<u>N. linearis</u>		+	+						+	+		
<u>N. palca</u>	D	D					D	D				
<u>N. sigmoidea</u>	+						+	+				+
<u>N. tryblionella</u> var. <u>levidensis</u>	+											
<u>N. vermicularis</u>										+		
<u>N. vitrea</u>						+						
<u>N. spp.</u>	D	D	+	+	+	+	D	D	+	+		+

SAMPLER DESTROYED

Table A8.6.2-7 (Continued)

Taxon	Stewart						Hunter					
	May	June	July	Aug	Sept	Oct	May	June	July	Aug	Sept	Oct
Division Sacchariophyta (cont'd)												
<u>Pinnularia borealis</u>	+											
<u>P. sp.</u>	+					+						
<u>Rhoicosphenia curvata</u>			+	+				+				+
<u>Rhopalodia gibb. var. ventricosa</u>	+					+						
<u>R. musculus</u>	+											
<u>Stauroneis anceps</u>						+						
<u>Stephanodiscus hantzschii</u>	+											
<u>Surirella angustata</u>	+	+						+				
<u>S. ovalis</u>	+	+	+	+			+	+	+	+		+
<u>S. ovata</u>	+	+	+	+			+	+	+	+		+
<u>S. sp.</u>								+	+			+
<u>Synedra delicatissima</u>	+											
<u>S. fasciculata</u>							+					
<u>S. ulna</u>	+	+	+			+			+	+		+
<u>S. sp.</u>	+	+				+	+	+				+
Unidentified centrics		+		+			+	+				
Unidentified pennates	D	+	+	+	+		D	+	+	+		+
Division Chlorophyta												
<u>Characium sp.</u>				+								
<u>Cladophora sp.</u>			+	+								
<u>Closterium sp.</u>				+								+
<u>Crucigenia quadrata</u>							+					
<u>Oedogonium sp.</u>		+			+	+						+
<u>Scenedesmus acutus</u>						+						+
<u>S. sp.</u>								+				
<u>Stigeoclonium sp.</u>		+	+	+	+	+	+	+	+			+
<u>Ulothrix sp.</u>		+				+						+
Unidentified coccoid					+		+		+			
Unidentified filament		+	+	+		+			+	+		+
Unidentified flagellate						+						+
Division Cyanophyta												
<u>Chroococcus sp.</u>		+	+									+
<u>Merismopedia punctata</u>				+	+							
<u>Merismopedia tenuissima</u>			+									
<u>Oscillatoria sp.</u>	+		+					+				
<u>Phormidium sp.</u>			+	+					+	+		
Unidentified filament						+						
Division Cryptophyta												
<u>Cryptomonas ovata</u>							+					
Division Chrysophyta												
<u>Dinobryon borgei</u>				+								
<u>D. sp.</u>					+							+
Unidentified coccoid												+

SAMPLER DESTROYED

+ = Present

D = Present as dominant (greater than 5% of the mean total abundance)

Table A8.6.2-8

Summary of Species Diversity (\bar{d}) of the Mean for
Periphyton Collected at Stewart and Hunter
Stations, Piceance Creek, Colorado, 1978.

Date	Stewart	Hunter
May	3.67	3.70
June	3.15	3.14
July	2.37	2.78
August	3.59	3.32
September	1.14	Sampler Destroyed
October	1.70	3.15

Table A8.6.2-9

Summary of Mean Biomass (mg/cm^2) Expressed as Ash-free Dry Weight for Periphyton Collected at Stewart and Hunter Stations, Piceance Creek, Colorado, 1978.

Date	Stewart	Hunter
May	0.52	0.66
June	0.42	1.66
July	0.24	0.37
August	0.05	0.28
September	0.35	Sampler Destroyed
October	0.13	0.22

TABLE A8.6.2-10

Station

P-3	TAXA	1974					1975					1976				
		AUG	SEP	OCT	NOV	DEC	JAN	MAR	MAY	JUL	SEP	NOV	JAN	MAR	MAY	JUL
CHLOROPHYCEAE																
	<i>Actinastrum</i> sp.															
	<i>Cladophora</i> sp.															
	<i>Chaetophora</i> sp.															
	<i>Closterium</i> sp.				X											
	<i>Closterium liebleinii</i>															
	<i>Closterium lunula</i>															
	<i>Closterium gracilis</i>															
	<i>Cosmarium</i> sp.															
	<i>Enteromorpha</i> sp.															
	<i>Microspora</i> sp.															
	<i>Pediastrum</i> sp.															
	<i>Protococcus</i> sp.															
	<i>Protococcus viridis</i>															
	<i>Protoderma viride</i>												X			
	<i>Scenedesmus</i> sp.			X												
	<i>Spirogyra</i> sp.															
	<i>Stigoclonium</i> sp.				X											
	<i>Ulothrix</i> sp.												X			
	<i>Ulothrix zonata</i>															
	<i>Vaucheria</i> sp.				X											
	<i>Zygnema</i> sp.															
	<i>Draparnaldia</i> sp.															
	Unidentified Zygnemataceae															
	Unidentified Green Cocoid															
BACILLARIOPHYCEAE																
	<i>Achnanthes</i> sp.											X	X			X
	<i>Achnanthes lanceolata</i>															
	<i>Achnanthes lanceolata</i> var. <i>Dubia</i>															
	<i>Amphora</i> sp.	X	X	X												
	<i>Amphora ovalis</i>								X		X		X	X	X	
	<i>Amphiphora ornata</i>															
	<i>Asterionella</i> sp.															
	<i>Caloneis</i> sp.	X	X													
	<i>Caloneis amphisbaena</i>								X							
	<i>Caloneis sillicula</i>								X							
	<i>Ceratoneis</i> sp.															
	<i>Cocconeis</i> sp.			X	X											
	<i>Cocconeis placentula</i>								X	X	X	X		X	X	
	<i>Cymbella</i> sp.	X	X													
	<i>Cymbella affinis</i>								X							
	<i>Cymbella ventricosa</i>									X	X					
	<i>Cymbella tumida</i>															X
	<i>Cyclotella</i> sp.															
	<i>Cyclotella meneghiniana</i>															
	<i>Cymatopleura</i> sp.				X											
	<i>Cymatopleura solea</i>								X				X			
	<i>Deploneis</i> sp.															
	<i>Diatoma</i> sp.				X											
	<i>Diatoma vulgare</i>								X				X		X	
	<i>Diatoma tenua</i> var. <i>longatum</i>															
	<i>Eunotia</i> sp.															
	<i>Eunotia pretinalis</i>												X			
	<i>Fragilaria</i> sp.				X											
	<i>Fragilaria crotonensis</i>								X							X
	<i>Fragilaria construens</i>	X														

TABLE A8.6.2-10 (CONTINUED)

Station

P-3	TAXA	1974				1975				1976						
		AUG	SEP	OCT	NOV	DEC	JAN	MAR	MAY	JUL	SEP	NOV	JAN	MAR	MAY	JUL
	<i>Frustulia</i> sp.		X	X	X											
	<i>Gomphonema</i> sp.		X													
	<i>Gomphonema</i> sp.		X	X	X											
	<i>Gomphonema olivaceum</i>									X		X				
	<i>Gomphonema constrictum</i>								X				X	X		
	<i>Gyrosigma</i> sp.		X	X	X											
	<i>Gyrosigma acuminatum</i>															
	<i>Hannaea arcus</i>															
	<i>Melosira</i> sp.															
	<i>Meridion</i> sp.															
	<i>Meridion circulare</i>								X							
	<i>Navicula</i> sp.		X	X	X											
	<i>Navicula cryptocephala</i>								X	X	X		X	X	X	X
	<i>Navicula rhynchocephala</i>									X		X	X	X	X	X
	<i>Navicula viridula</i>								X	X	X	X	X			
	<i>Nedium</i> sp.															
	<i>Nitzschia</i> sp.		X		X											
	<i>Nitzschia gracilis</i>												X			
	<i>Nitzschia sigmaidea</i>															
	<i>Nitzschia acicularis</i>															
	<i>Nitzschia palea</i>								X						X	
	<i>Nitzschia paleacea</i>															
	<i>Pinnularia</i> sp.															
	<i>Pinnularia viridis</i>								X						X	
	<i>Rhoicosphenia</i> sp.		X													
	<i>Rhoicosphenia curvata</i>			X												
	<i>Rhopalodia</i> sp.															
	<i>Stauroneis</i> sp.				X											
	<i>Stephanodiscus hantzschii</i>								X			X				
	<i>Surirella</i> sp.		X	X	X											
	<i>Surirella ovata</i>								X							
	<i>Synedra</i> sp.		X	X	X											
	<i>Synedra ulna</i>								X			X				X
	<i>Synedra ulna</i> var. <i>Impressa</i>															
	<i>Synedra rupens</i>															
	<i>Tabellaria</i> sp.		X	X	X											
	CYANOPHYTA															
	<i>Agmenellum</i> sp.															
	<i>Anabaena</i> sp.															
	<i>Lyngbya</i> sp.															
	<i>Lyngbya spirulinoides</i>															
	<i>Nodularia</i> sp.															
	<i>Oscillatoria</i> sp.															
	<i>Oscillatoria limnetica</i>															
	<i>Oscillatoria limosa</i>															
	<i>Phormidium</i> sp.			X												
	EUGLENOPHYCEAE															
	<i>Euglena acus</i>															
	TRACHEOPHYTA															
	<i>Naja</i> sp.															
	<i>Ranuculus</i> sp.															
	<i>Potamogeton</i> sp.															
	<i>Mimulus</i> sp.															
	<i>Porippa</i> sp.															
	TOTAL NUMBER SPECIES/STATION		13	15	17					17	6	5	7	12	7	9

TABLE A8.6.2-11

Station

P-6	TAXA	1974					1975					1976				
		AUG	SFP	OCT	NOV	DEC	JAN	MAR	MAY	JUL	SEP	NOV	JAN	MAR	MAY	JUL
CHLOROPHYCEAE																
	<i>Actinastrum</i> sp.			X	X											
	<i>Cladophora</i> sp.		X		X											
	<i>Chaetophora</i> sp.															
	<i>Closterium</i> sp.															
	<i>Closterium liebleinii</i>															
	<i>Closterium lunula</i>															
	<i>Closterium gracilis</i>									X						
	<i>Cosmarium</i> sp.															
	<i>Enteromorpha</i> sp.															
	<i>Microspora</i> sp.															
	<i>Pediastrum</i> sp.															
	<i>Protococcus</i> sp.															
	<i>Protococcus viridis</i>															
	<i>Protoderma viride</i>										X					
	<i>Scenedesmus</i> sp.															
	<i>Spirogyra</i> sp.															
	<i>Stigoclonium</i> sp.															
	<i>Ulothrix</i> sp.										X			X		
	<i>Ulothrix zonata</i>															
	<i>Vaucheria</i> sp.															
	<i>Zygnema</i> sp.															
	<i>Draparnaldia</i> sp.															
	Unidentified Zygnemataceae															
	Unidentified Green Coccoid									X						
BACILLARIOPHYCEAE																
	<i>Achnanthes</i> sp.				X											
	<i>Achnanthes lanceolata</i>								X				X	X		
	<i>Achnanthes lanceolata</i> var. <i>Dubia</i>															
	<i>Amphora</i> sp.															
	<i>Amphora ovalis</i>										X			X		X
	<i>Amphiphora ornata</i>															
	<i>Asterionella</i> sp.															
	<i>Caloneis</i> sp.		X	X	X											
	<i>Caloneis amphisbaena</i>									X					X	
	<i>Caloneis silicula</i>															
	<i>Ceratoneis</i> sp.															
	<i>Cocconeis</i> sp.		X	X	X											
	<i>Cocconeis placentula</i>								X	X		X	X	X		X
	<i>Cymbella</i> sp.		X	X												
	<i>Cymbella affinis</i>															
	<i>Cymbella ventricosa</i>									X	X					
	<i>Cymbella tumida</i>													X		
	<i>Cyclotella</i> sp.															
	<i>Cyclotella meneghiniana</i>															
	<i>Cymatopleura</i> sp.			X												
	<i>Cymatopleura solea</i>															X
	<i>Deploneis</i> sp.		X													
	<i>Diatoma</i> sp.		X													
	<i>Diatoma vulgare</i>								X							
	<i>Diatoma tenue</i> var. <i>Elongatum</i>										X					
	<i>Eunotia</i> sp.															
	<i>Eunotia pectinalis</i>															
	<i>Fragilaria</i> sp.															
	<i>Fragilaria crotonensis</i>											X	X			
	<i>Fragilaria construens</i>									X						

TABLE A8.6.2-11 (CONTINUED)

Station

P-6	TAXA	1974					1975					1976				
		AUG	SEP	OCT	NOV	DEC	JAN	MAR	MAY	JUL	SEP	NOV	JAN	MAR	MAY	JUL
	<i>Frustulia</i> sp.		X	X	X											
	<i>Comphonens</i> sp.															
	<i>Comphonema</i> sp.		X		X											
	<i>Comphonema olivaceum</i>								X			X				
	<i>Comphonema constrictum</i>										X					X
	<i>Gyrosigma</i> sp.		X	X	X											
	<i>Gyrosigma acuminatum</i>															
	<i>Hantzaca arcus</i>															
	<i>Melosira</i> sp.															
	<i>Meridion</i> sp.		X													
	<i>Meridion circulare</i>															
	<i>Navicula</i> sp.		X	X	X											
	<i>Navicula cryptocephala</i>							X	X	X	X	X		X	X	X
	<i>Navicula rhynchocephala</i>											X	X			X
	<i>Navicula viridula</i>							X	X	X		X	X	X		
	<i>Nedium</i> sp.				X											
	<i>Nitzschia</i> sp.		X	X	X											
	<i>Nitzschia gracilis</i>							X								
	<i>Nitzschia sigmoidea</i>															
	<i>Nitzschia acicularis</i>								X							X
	<i>Nitzschia palea</i>								X		X					X
	<i>Nitzschia paleacea</i>															
	<i>Pinnularia</i> sp.			X	X											
	<i>Pinnularia viridis</i>															X
	<i>Rhoicosphenia</i> sp.															
	<i>Rhoicosphenia curvata</i>															
	<i>Rhopalodia</i> sp.			X												
	<i>Stauroneis</i> sp.															
	<i>Stephanodiscus hantzschii</i>									X	X	X				
	<i>Surirella</i> sp.		X		X											
	<i>Surirella ovata</i>			X				X	X							
	<i>Synedra</i> sp.		X		X											
	<i>Synedra ulna</i>								X							X
	<i>Synedra ulna</i> var. <i>Impressa</i>															
	<i>Synedra rupens</i>							X	X							
	<i>Tabellaria</i> sp.			X	X											
	CYANOPIHYTA															
	<i>Agmenellum</i> sp.															
	<i>Anabaena</i> sp.			X				X	X							
	<i>Lyngbya</i> sp.															
	<i>Lyngbya spirulinoides</i>									X						
	<i>Nodularia</i> sp.															
	<i>Oscillatoria</i> sp.															
	<i>Oscillatoria limnetica</i>															
	<i>Oscillatoria limosa</i>															
	<i>Phormidium</i> sp.															
	EUGLENOPHYCEAE															
	<i>Euglena acus</i>															
	TRACHELOPHYTA															
	<i>Naja</i> sp.															
	<i>Ranunculus</i> sp.															
	<i>Polamoucten</i> sp.															
	<i>Mimulus</i> sp.															
	<i>Rorippa</i> sp.															
	TOTAL NUMBER SPECIES/STATION		14	14	15			10	17	5	6	9	7	3	10	

PERIPHYTON PRODUCTIVITY¹ ESTIMATES FOR PICEANCE BASIN STATIONS, MAY 1975 - JULY 1976

Station	Months												
	May	July	Sept	Nov	Jan	March	May	July					
P-1		.1136*	.7964	.0071									
P-2		.0852	.0520	.0074									
P-3		.1429	.4936	.0092	.0614	.3029	.8425	.0232					
P-5		.2906	.1832*	.0255									
P-5A			1.9059	.9596									.4528
P-6	.0192	.0258	.0116	.0067	.0070	.1698	.0142	.0339					
P-7	.0088	.0473	.2459	.0235**			1.0738	.0310					
S-1	.1310	.0276	.0089	.1380	.0567	1.375	2.4874						
S-2	.0063	.0708	.0164				.7598	.0247					
USL		.0283	.0249***	.1676									
L ²			H = .2866 V = .0930	H = .2189 V = .1196	H = .1584 V = .2301**	H = .4601 V = .2575							
W-1	.0964		.0418	.2659									
W-2													
W-3	.0215		.0758	.1648	.1025		.1411	.2365					
UWL			.0360	.2780	.7124	1.8139	.3658**	.0640					
LWL			.0641	.0713	.0594	.1129	.1819	.0165					
WR-1			.4693	.1383**									
WR-2			.1893	.0613**			4.4029						

1. Grams ash-free weight/m²/day (average of three replicates exposed for approximately 30 days).
 2. H = Horizontal slide, V - Vertical slide.

* One slide only

** Two slides only

*** Exposed for two months

Table A8.7.1-1 . Herb quadrat summaries for Plot 1-0. Based on data from 25 permanently located quadrats. June 1978. Values in percents. "?" indicates uncertain identification. \pm Values are equal to the standard error of the mean.

Species	Mean Cover	Relative Cover	Range of Cover Values	Frequency
Agoseris glauca	0.1	0.01	0-1	16
Agropyron desertorum	3.6	0.25	0-20	40
Agropyron smithii	1.7	0.12	0-15	52
Antennaria rosea	0.7	0.05	0-6	20
Arabis holboellii	0.1	0.01	0-1	8
Artemisia ludoviciana	0.4	0.03	0-6	12
Aster fendleri	<0.1	<0.01	0-<1	4
Bouteloua gracilis	0.6	0.04	0-15	8
Bromus tectorum	0.8	0.06	0-3	88
Carex pennsylvanica	0.3	0.02	0-4	20
Chaenactis douglasii	0.1	0.01	<1-1	24
Chenopodium album	<0.1	<0.01	0-<1	12
Cryptantha sp.	0.1	0.01	<1-1	16
Descurainia pinnata	<0.1	<0.01	0-<1	8
Euphorbia robusta	<0.1	<0.01	0-<1	3
Festuca brachyphylla (?)	0.2	0.02	0-6	8
Gayophytum ramocissimum	<0.1	<0.01	0-<1	32
Ipomopsis aggregata	<0.1	<0.01	0-<1	4
Lappula redowskii	0.1	0.01	0-1	12
Lepidium densiflorum	<0.1	<0.01	0-<1	4
Lomatium orientale	<0.1	<0.01	0-<1	8
Lupinus argenteus	<0.1	<0.01	0-<1	4
Mentzelia dispersa	0.1	0.01	0-1	12
Oryzopsis hymenoides	3.2	0.22	0-15	76
Phlox longifolia	<0.1	<0.01	0-<1	8
Poa fendleriana	0.1	0.01	0-3	4
Polygonum sawatchense	<0.1	<0.01	0-<1	28
Sitanion longifolium	0.4	0.03	0-2	32
Stipa comata	1.6	0.11	0-9	28
Townsendia sericea	<0.1	<0.01	0-<1	4
Unknown grass	0.1	0.01	0-3	4
Artemisia tridentata	<0.1	<0.01	0-<1	20
Gutierrezia sarothrae	0.2	1.10	0-2	20
Pinus edulis			0-<1	4
Total Herb	12.3		1-30	100
Total Woody	0.2		0-2	40
Mosses	0.3		0-5	12
Crustose Lichen	1.0		0-10	40
Litter	76.0		8-100	100
Bare Soil	21.4		0-89	96
Rock	2.5		0-25	56

Mean No. of Herb Species per $m^2 = 6.32 \pm 0.55$

Mean No. of Species per $m^2 = 6.56 \pm 0.55$

Table A8.7.1-2 . Herb quadrat summaries for Plot 1-F. Based on data from 25 permanently located quadrats. June 1978. Values in percents. "?" indicates uncertain identification. ±Values are equal to the standard error of the mean.

Species	Mean Cover	Relative Cover	Range of Cover Values	Frequency
<i>Agoseris glauca</i>	0.1	0.38	0-1	12
<i>Agropyron dasystachyum</i>	0.3	1.54	0-5	8
<i>Agropyron desertorum</i>	4.2	20.35	0-30	44
<i>Agropyron smithii</i>	0.8	3.65	0-11	16
<i>Antennaria parvifolia</i>	<0.1	<0.01	0-<1	8
<i>Antennaria rosea</i>	0.1	0.58	0-2	12
<i>Arabis holboellii</i>	<0.1	<0.01	0-<1	8
<i>Artemisia ludoviciana</i>	0.1	0.19	0-1	4
<i>Aster fendleri</i>	0.2	0.96	0-4	16
<i>Astragalus ceramicus</i>	0.1	0.19	0-1	32
<i>Bromus tectorum</i>	0.6	2.69	0-5	68
<i>Carex pennsylvanica</i>	0.3	1.34	0-4	12
<i>Chaenactis douglasii</i>	<0.1	<0.01	0-<1	4
<i>Chenopodium album</i>	<0.1	<0.01	0-<1	12
<i>Collinsia parviflora</i>	0.0	0.19	0-1	4
<i>Cryptantha</i> sp.	<0.1	<0.01	0-<1	4
<i>Delphinium nelsoni</i>	0.0	0.19	0-1	4
<i>Descurainia pinnata</i>	<0.1	<0.01	0-<1	8
<i>Draba reptans</i>	<0.1	<0.01	0-<1	4
<i>Erigeron nematophyllus</i>	0.1	0.19	0-1	4
<i>Festuca brachyphylla</i> (?)	0.4	2.11	0-6	20
<i>Gayophytum ramocissimum</i>	<0.1	<0.01	0-<1	8
<i>Haplopappus nuttallii</i>	0.2	1.15	0-4	12
<i>Koeleria gracilis</i>	2.0	9.79	0-14	28
<i>Lappula redowskii</i>	0.3	1.34	0-5	20
<i>Lepidium densiflorum</i>	<0.1	<0.01	0-<1	4
<i>Mentzelia dispersa</i>	0.2	1.15	0-6	8
<i>Microsteris micrantha</i>	<0.1	<0.01	0-<1	4
<i>Oryzopsis hymenoides</i>	7.4	35.51	0-45	84
<i>Phlox hoodii</i>	1.1	5.18	0-8	36
<i>Physaria floribunda</i>	0.1	0.19	0-1	8
<i>Poa fendleriana</i> (?)	1.0	4.80	0-12	24
<i>Polygonum sawatchense</i>	<0.1	<0.01	0-<1	8
<i>Senecio multilobatus</i>	0.1	0.38	0-2	8
<i>Sitanion longifolium</i>	0.5	2.50	0-5	40
<i>Stipa comata</i>	0.1	0.58	0-3	8
<i>Taraxacum officinale</i>	<0.1	<0.01	0-<1	4
<i>Tragopogon dubius</i>	0.1	0.19	0-1	4
<i>Zigadenus venenosus</i>	<0.1	<0.01	0-<1	4

Table A8.7.1-2 . (Continued)

Species	Mean Cover	Relative Cover	Range of Cover Values	Frequency
<i>Artemisia tridentata</i>	<0.1	<0.01	0-<1	12
<i>Chrysothamnus nauseosus</i>	<0.1	<0.01	0-<1	4
<i>Gutierrezia sarothrae</i>	0.6	2.69	0-5	16
Total Herb	18.9		1-55	100
Total Woody	0.6		0-5	44
Mosses	0.1		0-1	4
Crustose Lichen	0.2		0-5	16
Litter	77.8		20-99	100
Bare Soil	20.8		0-80	96
Rock	1.4		0-30	12

Mean No. of Herb Species per m² = 6.48 ± 0.69

Mean Total No. of Species per m² = 6.64 ± 0.68

Table A8.7.1-3 . Herb quadrat summaries for Plot 2-0. Based on data from 25 permanently located quadrats. June 1978. Values in percents. "?" indicates uncertain identification. Values are equal to the standard error of the mean.

Species	Mean Cover	Relative Cover	Range of Cover Values	Frequency
<i>Agoseris glauca</i>	0.1	0.24	0-1	4
<i>Agropyron desertorum</i>	3.8	22.82	0-16	36
<i>Agropyron smithii</i>	0.8	5.10	0-12	16
<i>Antennaria rosea</i>	<0.1	<0.01	0-<1	4
<i>Artemisia ludoviciana</i>	0.1	0.24	0-1	4
<i>Aster fendleri</i>	0.1	0.73	0-2	24
<i>Aster glaucodes</i> (?)	0.2	1.21	0-5	4
<i>Astragalus ceramicus</i>	<0.1	<0.01	0-<1	4
<i>Bouteloua gracilis</i>	0.4	2.43	0-9	12
<i>Bromus tectorum</i>	4.7	28.64	0-15	96
<i>Carex pennsylvanica</i> (?)	1.2	7.28	0-30	4
<i>Chenopodium album</i>	<0.1	<0.01	0-<1	16
<i>Crepis acuminata</i>	0.1	0.24	0-1	8
<i>Descurainia pinnata</i>	<0.1	<0.01	0-<1	8
<i>Festuca brachyphylla</i> (?)	0.4	2.67	0-6	16
<i>Gayophytum ramocissimum</i>	0.1	0.73	0-1	48
<i>Heterotheca villosa</i>	1.2	7.28	0-30	4
<i>Koeleria gracilis</i>	0.5	3.16	0-8	8
<i>Lappula redowskii</i>	0.2	1.21	0-3	40
<i>Lepidium montanum</i>	<0.1	<0.01	0-<1	4
<i>Microsteris micrantha</i>	<0.1	<0.01	0-2	16
<i>Oenothera trichocalyx</i>	<0.1	<0.01	0-<1	4
<i>Oryzopsis hymenoides</i>	0.2	0.97	0-2	16
<i>Phlox longifolia</i>	0.5	2.91	0-10	12
<i>Poa</i> sp.	0.1	0.49	0-1	8
<i>Polygonum sawatchense</i>	<0.1	<0.01	0-<1	16
<i>Salsola iberica</i>	<0.1	<0.01	0-<1	8
<i>Sisymbrium altissimum</i>	0.2	0.97	0-4	4
<i>Sisymbrium officinale</i>	0.1	0.24	0-1	4
<i>Sitanion longifolium</i>	1.1	6.55	0-8	44
<i>Sphaeralcea coccinea</i>	0.1	0.49	0-2	4
<i>Taraxacum officinale</i>	0.1	0.49	0-2	4
<i>Tragopogon dubius</i>	<0.1	<0.01	0-<1	4
Unknown composite	0.2	1.21	0-5	4
Unknown mustard	0.1	0.49	0-2	8
<i>Artemisia tridentata</i>	0.2	1.21	0-2	28
<i>Chrysothamnus nauseosus</i>	<0.1	<0.01	0-1	24

Table A8.7.1-3. (Continued)

Species	Mean Cover	Relative Cover	Range of Cover Values	Frequency
Total Herbs	15.8		1-35	100
Total Woody	0.4		0-2	36
Mosses	0.1		0-3	4
Crustose Lichen	0.1		0-2	20
Litter	82.4		45-100	100
Bare Soil	15.9		0-45	84
Rock	1.6		0-25	24

Mean No. of Herb Species per m² = 5.04 ± 0.45

Mean Total No. of Species per m² = 5.56 ± 0.49

Table A8.7.1-4. Herb quadrat summaries for Plot 2-F. Based on data from 25 permanently located quadrats. June 1978. Values in percents. "?" indicates uncertain identification. (\pm values are equal to the standard error of the mean).

Species	Mean Cover	Relative Cover	Range of Cover Values	Frequency
<i>Agoseris glauca</i>	0.1	0.54	0-1	8
<i>Agropyron dasystachyum</i>	5.7	38.69	0-35	44
<i>Agropyron desertorum</i>	0.8	5.45	0-20	4
<i>Agropyron smithii</i>	0.6	4.36	0-6	24
<i>Antennaria rosea</i>	0.2	1.09	0-4	4
<i>Aster fendleri</i>	0.1	0.54	0-2	16
<i>Astragalus ceramicus</i>	<0.1	<0.01	0-<1	4
<i>Astragalus diversifolius</i>	0.1	0.27	0-1	4
<i>Bouteloua gracilis</i>	0.2	1.63	0-3	16
<i>Bromus tectorum</i>	2.7	18.53	0-20	76
<i>Calochortus nuttallii</i>	<0.1	<0.01	0-<1	4
<i>Chenopodium album</i>	<0.1	<0.01	0-<1	20
<i>Erysimum asperum</i>	<0.01	<0.01	0-<1	4
<i>Festuca brachyphylla</i> (?)	0.1	2.18	0-3	16
<i>Gayophytum ramocissimum</i>	0.1	0.82	0-1	32
<i>Koeleria gracilis</i>	0.6	3.81	0-9	12
<i>Lappula redowskii</i>	0.1	0.27	0-1	12
<i>Lomatium grayi</i>	0.1	0.27	0-1	4
<i>Mentzelia dispersa</i>	<0.1	<0.01	0-<1	4
<i>Microsteris micrantha</i>	<0.1	<0.01	0-<1	4
<i>Phlox longifolia</i>	0.1	0.27	0-1	8
<i>Poa fendleriana</i>	0.4	3.00	0-6	8
<i>Poa pratensis</i>	0.1	0.82	0-3	4
<i>Polygonum sawatchense</i>	<0.1	<0.01	0-<1	20
<i>Oryzopsis hymenoides</i>	0.9	5.99	0-5	24
<i>Sitanion longifolium</i>	1.0	7.08	0-7	36
<i>Sphaeralcea coccinea</i>	0.1	0.54	0-1	8
<i>Stipa comata</i>	0.2	1.63	0-6	4
Unknown mustard	<0.1	<0.01	0-4	4
<i>Artemisia tridentata</i>	0.2	1.63	0-3	44
<i>Chrysothamnus nauseosus</i>	0.1	0.27	0-1	12
<i>Pinus edulis</i>	0.1	0.27	0-1	4
<i>Purshia tridentata</i>	<0.1	<0.01	0-<1	4
Total Herb	12.6		1-40	100
Total Woody	0.3		0-3	56
Mosses	0.4		0-5	8
Crustose Lichen	0.6		0-8	20
Litter	81.8		25-100	100
Bare Soil	16.6		0-75	76
Rock	1.7		0-14	32

Mean No. of Herb Species per m^2 = 4.36 ± 0.44
Mean Total No. of Species per m^2 = 4.96 ± 0.46

Table A8.7.1-5 . Frequency, mean cover, and relative cover values for shrub species in plot 1-0, 1974-1978. Based on data from 20 10m x 4m line strip transects.

Species	Frequency (%)		Mean Cover (%)		Relative Cover (%)				
	1974	1976	1978	1974	1976	1978			
Anelanchier spp.	40	30	35	0.3	0.3	0.4	2.1	1.9	2.3
Artemisia tridentata	100	100	100	9.6	10.3	9.6	66.8	58.5	64.0
Cercocarpus montanus	65	65	70	0.4	0.3	0.2	3.1	1.9	1.1
Chrysothamnus nauseosus	30	45	40	0.4	0.2	0.2	2.8	1.2	1.0
Chrysothamnus viscidiflorus	5	15	15	<0.1	<0.1	<0.1	<0.1	<0.1	<0.1
Juniperus osteosperma	40	35	45	0.6	0.4	2.0	3.8	2.3	13.1
Juniperus scopulorum	5	15		1.0	1.4		6.6	7.9	
Opuntia polyacantha	20	10	35	<0.1	<0.1	<0.1	<0.1	<0.1	<0.1
Pinus edulis	55	70	75	0.8	1.6	1.2	5.5	9.2	8.1
Purshia tridentata	65	80	75	1.2	1.9	1.1	8.3	10.9	7.4
Symphoricarpos oreophilus	30	30	40	0.2	0.2	0.4	1.0	0.8	2.9
Total				14.5	16.6	15.1			

Table A8.7.1-6 . Frequency, mean cover, and relative cover values for shrub species in plot 1-F, 1974-1978. Based on data from 20 10m x 4m line strip transects.

Species	Frequency (%)		Mean Cover (%)		Relative Cover (%)				
	1974	1976	1978	1974	1976	1978	1974	1976	1978
Amelanchier spp.	10	10	15	0.6	0.8	0.7	6.6	6.3	7.0
Artemisia tridentata	80	80	100	5.3	7.4	6.4	58.6	58.6	61.7
Cercocarpus montanus	50	55	50	0.1	0.1	0.2	1.1	0.7	1.9
Chrysothamnus nauseosus	50	50	55	1.4	1.5	1.3	15.5	12.1	12.5
Chrysothamnus viscidiflorus	5	5		<0.1	<0.1		<0.1	<0.1	
Juniperus osteosperma	25	20	40	0.2	0.2	0.4	2.2	1.7	3.7
Juniperus scopulorum	5	5		<0.1	0.1		<0.1	1.0	
Opuntia polyacantha	10		20	<0.1		<0.1	<0.1		<0.1
Pinus edulis	25	25	25	0.2	0.2	0.3	2.8	1.9	2.6
Purshia tridentata	50	65	55	0.6	1.6	1.0	6.6	12.5	9.5
Symphoricarpos oreophilus	20	20	35	0.1	<0.1	0.1	1.1	<0.1	1.1
Total				8.5	11.9	10.4			

Table A8.7.1-7. Frequency, mean cover, and relative cover values for shrub species in plot 2-0, 1974-1978. Based on data from 20 10m x 4m line strip transects.

Species	Frequency (%)		Mean Cover (%)		Relative Cover (%)				
	1974	1976	1978	1974	1976	1978			
Amelanchier spp.	20	10	10	0.2	0.6	0.7	3.7	7.4	7.8
Artemisia tridentata	50	50	75	0.3	0.9	1.7	5.5	12.0	19.2
Cercocarpus montanus	25	25	25	0.3	0.2	0.2	5.5	1.9	2.5
Chrysothamnus nauscosus	85	90	95	2.6	3.4	4.2	46.7	42.8	46.9
Chrysothamnus viscidiflorus	5	10		<0.1	<0.1		<0.1	<0.1	
Juniperus osteosperma	50	60	60	1.3	1.2	0.9	23.9	15.6	10.6
Opuntia polyacantha	35		20	<0.1		<0.1	<0.1		<0.1
Pinus edulis	65	60	60	0.8	0.5	0.3	13.8	5.9	3.7
Purshia tridentata	20	25	35	<0.1	0.6	0.4	<0.1	7.0	4.6
Symphoricarpos oreophilus	10	20	35	0.1	0.1	0.4	0.9	0.8	4.6
Total				5.6	7.5	8.8			

Table A8.7.1-8. Frequency, mean cover, and relative cover values for shrub species in plot 2-F, 1974-1978. Based on data from 20 10m x 4m line strip transects.

Species	Frequency (%)		Mean Cover (%)		Relative Cover (%)	
	1974	1976	1978	1974	1976	1978
Amelanchier spp.	30	10	10	<0.1	<0.1	<0.1
Artemisia tridentata	35	65	70	1.1	1.6	2.6
Artemisia sp.		5		<0.1	<0.1	<0.1
Cercocarpus montanus	10	25	20	0.4	0.5	0.5
Chrysothamnus nauseosus	50	70	75	0.6	1.8	1.4
Chrysothamnus viscidiflorus	5	10	5	<0.1	<0.1	<0.1
Juniperus osteosperma	70	80	85	2.8	4.0	3.4
Opuntia polyacantha	10		15	<0.1	<0.1	<0.1
Pinus edulis	65	65	70	1.2	1.9	1.9
Purshia tridentata	35	55	40	3.2	3.8	4.8
Symphoricarpos oreophilus		30	25	<0.1	<0.1	0.1
Total				9.3	13.6	14.7

Table A8.7.1-9. Density values (No. per hectare) for shrub species at plots 1-0, 1-F, 2-0, and 2-F; chained pinyon-juniper rangeland. Values based on 20 10m x 4m belt transects. Height class 1 = 0.25m - 0.75m; class 2 = 0.76m - 1.50m; class 3 = 1.51m - 2.25m; class 4 = <2.26m. 1974-1978.

Height Class	Plot 1-0		Plot 1-F		Plot 2-0		Plot 2-F		
	1974	1976	1978	1974	1976	1978	1974	1976	1978
<i>Amelanchier</i> spp.	1	162	99	163	25	88	62	75	25
	2	25	49	113	12	13	12	25	12
	3						12		13
	4								
	Total	187	148	276	37	101	74	100	37
<i>Artemisia</i> <i>tridentata</i>	1	2162	2561	2350	988	1138	138	212	388
	2	712	1074	1363	600	863	62	50	200
	3	12	25	38	12	150	12	49	63
	4			13		13			
	Total	2886	3661	3764	1600	2164	200	262	637
<i>Artemisia</i> sp.	1								12
	Total								12
<i>Cercocarpus</i> <i>montanus</i>	1	262	375	350	138	100	38	50	62
	2	88	114	150	112	188	25	12	12
	3				49	63	12	12	12
	4								12
	Total	350	489	500	250	351	75	62	99
<i>Chrysothamnus</i> <i>nauseosus</i>	1	175	212	138	262	200	388	175	262
	2	25	12	13	12	50	100	50	114
	3						25		100
	Total	200	224	151	272	250	488	225	376

Table A8.7.1-9. (Continued)

Height Class	Plot 1-0		Plot 1-F		Plot 2-0		Plot 2-F		
	1974	1976	1978	1974	1976	1978	1974	1976	1978
<i>Chrysothamnus viscidiflorus</i>									
1	12	49	63	12	12	12	12	25	13
Total	12	49	63	12	12	12	12	25	13
<i>Juniperus osteosperma</i>									
1	75	37	88	38	49	88	75	74	75
2	62	62	75	50	12	38	162	175	138
3			50				12	37	50
4			13						
Total	137	99	226	88	61	126	249	286	263
<i>Juniperus scopulorum</i>									
1	25	12		12					
2	25	25							
Total	50	37		12					
<i>Opuntia polyacantha</i>									
1	100	25	75	125		50	200		35
Total	100	25	75	125		50	200		35
<i>Pinus edulis</i>									
1	138	188	163	125	114	150	212	114	138
2	125	200	125	38	49	38	75	126	75
3	38	49	63	12	25	13	25	49	50
4			25			13		12	38
Total	301	437	376	175	188	214	312	301	301
<i>Purshia tridentata</i>									
1	588	874	938	225	299	200	88	74	88
2	12	1000	125	50	212	188	12	37	13
3						13		12	13
Total	600	1874	1063	275	511	401	100	123	114
<i>Symphoricarpos oreophilus</i>									
1	150	262	438	112	62	188	112	99	188
2			13		25	38			13
Total	150	262	451	112	87	226	112	99	201

Table A8.7.2-1. Oven dry weights (grams) for range cages and adjacent open areas in the pinyon-juniper woodland community type. 1978.

	Quadrat Number	<u>Agropyron smithii</u>	<u>Bromus tectorum</u>	<u>Oryzopsis hymenoides</u>	Other Perennial Grasses	Perennial Forbs	Annual Forbs	Half Shrubs	Total Biomass
OPEN AREA	1	1.513	0.068		17.647	0.418	5.456		25.102
	2	0.281			2.037	0.261			2.579
	3	0.191			7.901	9.377	0.334		17.803
	4			4.931	2.560	0.880			8.371
	5				2.152	2.518			4.670
	6		0.011		3.597	0.188		2.926	6.722
	7				2.188	0.062	0.139		2.389
	8		0.645	8.968	4.483	0.248	0.771		15.115
	9								
	10				2.631		3.148		5.779
RANGE CAGES	1	6.488			55.936	6.000	2.249		70.673
	2			7.909	0.597	3.329			11.835
	3	0.427			7.002	8.197	1.059		16.685
	4			9.988	20.771	1.580	0.015		32.354
	5				12.719	5.970	0.002		18.691
	6				6.657	0.079	0.002		6.738
	7	0.212			6.848	0.222	0.139		7.421
	8				1.002	7.997			8.999
	9								
	10	0.631			10.669	8.034	0.008		19.342

Table A8.7.2-2. Mean production \pm the standard error of the mean (S.E.), frequency, and range of observed values for clipped plots in the pinyon-juniper woodland community. Production values in grams/m². 1978.

	Mean \pm S.E.	Sample Size	Frequency (%)	Range of Values
<u>RANGE CAGES</u>				
<u>Agropyron smithii</u>	0.862 \pm 0.707	9	44	0-6.488
<u>Oryzopsis hymenoides</u>	1.989 \pm 1.327	9	22	0-9.988
Other perennial grasses	13.578 \pm 5.674	9	100	0.597-55.936
Perennial forbs	4.601 \pm 1.121	9	100	0.079-8.197
Annual forbs	0.386 \pm 0.260	9	78	0-2.249
Total	21.415 \pm 6.705	9	100	6.738-70.673
<u>OPEN AREAS</u>				
<u>Agropyron smithii</u>	0.221 \pm 0.165	9	33	0-1.513
<u>Bromus tectorum</u>	0.080 \pm 0.071	9	33	0-0.645
<u>Oryzopsis hymenoides</u>	1.837 \pm 1.063	9	33	0-8.968
Other perennial grasses	4.729 \pm 1.770	9	89	0-17.647
Perennial forbs	1.900 \pm 1.006	9	100	0.062-9.377
Annual forbs	0.744 \pm 0.595	9	44	0-5.456
Half shrubs	0.325 \pm 0.325	9	11	0-2.926
Total	9.837 \pm 2.602	9	100	2.389-25.102

Table A8.7.2-3. Oven dry weights (grams) for range cases and adjacent open areas in the chained pinyon-juniper rangeland community type. 1978.

	Quadrat Number	<u>Agropyron smithii</u>	<u>Bromus tectorum</u>	<u>Oryzopsis hymenoides</u>	Other Perennial Grasses	Perennial Forbs	Annual Forbs	Half Shrubs	Total Biomass
OPEN AREA	1		10.766	7.433	5.489	3.855	0.460		28.003
	2	0.359	0.166		17.501	5.563	0.068		23.657
	3	11.931		0.699	47.329				59.959
	4	17.499	1.329	49.617	20.729				89.174
	5	3.646		65.528	16.432	0.398			86.004
	6		0.460	4.388	15.209	11.170	0.088		31.315
	7	52.547	0.551		7.339	0.015	0.006		60.458
	8	8.873			30.574	3.852	0.111		43.410
	9		0.058	0.877	30.417	25.785	0.076		57.213
	10								
RANGE CAGES	1	15.961	7.354	1.726	1.564		0.348		26.953
	2	4.816	0.483	7.894	13.087	0.363	0.028		26.671
	3	27.529		74.478	15.095				117.102
	4	6.747		52.070	75.576	9.018			143.411
	5	1.349		3.286	33.656				38.291
	6		0.425	55.143	10.048	4.145			69.761
	7	19.576	0.017	0.181	20.069	6.500	0.640		46.983
	8	9.696			59.015	1.014	0.147		69.872
	9	0.444			24.491	7.880			32.815
	10								

Table A8.7.2-4 . Mean production \pm the standard error of the mean (S.E.), frequency, and range of observed values for clipped plots in the chained pinyon-juniper rangeland. Production values in grams/m². 1978.

	Mean \pm S.E.	Sample Size	Frequency (%)	Range of Values
<u>RANGE CAGES</u>				
<u>Agropyron smithii</u>	9.569 \pm 3.198	9	89	0-27.529
<u>Bromus tectorum</u>	0.920 \pm 0.807	9	44	0-7.354
<u>Oryzopsis hymenoides</u>	21.642 \pm 9.972	9	78	0-74.478
Other perennial grasses	28.067 \pm 8.116	9	100	1.564-75.576
Perennial forbs	3.213 \pm 1.242	9	67	0-9.018
Annual forbs	0.129 \pm 0.075	9	44	0-0.640
Total	63.540 \pm 13.885	9	100	26.671-143.411
<u>OPEN AREAS</u>				
<u>Agropyron smithii</u>	19.428 \pm 10.358	9	67	0-52.547
<u>Bromus tectorum</u>	1.481 \pm 1.169	9	67	0-10.766
<u>Oryzopsis hymenoides</u>	14.282 \pm 8.330	9	67	0-65.528
Other perennial grasses	21.224 \pm 4.357	9	100	5.489-47.329
Perennial forbs	5.626 \pm 2.803	9	78	0-25.785
Annual forbs	0.090 \pm 0.049	9	67	0-0.460
Total	53.244 \pm 7.964	9	100	23.657-89.174

Table A8.7.2-5. Oven dry weights (grams) for range cages and adjacent open areas in the upland sagebrush community type. 1978.

	Quadrat Number	<u>Agropyron smithii</u>	<u>Bromus tectorum</u>	<u>Oryzopsis hymenoides</u>	Other Perennial Grasses	Perennial Forbs	Annual Forbs	Half Shrubs	Total Biomass
OPEN AREA	1	1.513			24.274	8.691		46.447	80.925
	2	1.981			13.875	0.105	0.005		15.966
	3	7.975	1.387	0.021	13.936	0.155	0.008		23.482
	4	29.125	0.807	1.765	28.673	2.886			63.256
	5	15.313	0.003		11.507	11.194	0.068		38.085
	6	4.252			81.377	6.931	0.023		92.583
	7	3.179	0.317		54.047	0.138	0.004		57.685
	8	9.584			11.209	4.420	0.123		25.336
	9	3.735			17.336	3.709		6.992	31.772
	10	13.852	0.192		27.445	1.178			42.667
RANGE CAGES	1				69.652	13.926	1.807	54.519	139.904
	2	3.143		2.443	25.071	0.191			30.848
	3	30.171			74.087	3.358	0.829		108.445
	4	18.072			34.241	0.499	0.003		52.815
	5	16.777			17.931	7.189			41.897
	6	12.633			43.941	1.258			57.832
	7	2.575			80.774	1.905	0.072		85.326
	8	23.282			23.215	0.281	0.270		47.048
	9	0.508			39.421	8.877			48.806
	10	12.916			41.559	12.853			67.328

Table A8.7.2-6. Mean production \pm the standard error of the mean (S.E.), frequency, and range of observed values for clipped plots in the upland sagebrush community. Production values in grams/m². 1978.

	Mean \pm S.E.	Sample Size	Frequency (%)	Range of Values
<u>RANGE CAGES</u>				
<u>Agropyron smithii</u>	12.008 \pm 3.269	10	90	0-30.171
<u>Oryzopsis hymenoides</u>	0.244 \pm 0.244	10	10	0-2.443
Other perennial grasses	44.989 \pm 7.069	10	100	17.931-80.774
Perennial forbs	5.034 \pm 1.677	10	100	0.191-13.926
Annual forbs	0.298 \pm 0.187	10	50	0-1.807
Half shrubs	5.452 \pm 5.452	10	10	0-54.519
Total	68.025 \pm 10.703	10	100	30.848-139.904
<u>OPEN AREAS</u>				
<u>Agropyron smithii</u>	9.051 \pm 2.706	10	100	1.513-29.125
<u>Bromus tectorum</u>	0.271 \pm 0.148	10	50	0-1.387
<u>Oryzopsis hymenoides</u>	0.179 \pm 0.176	10	20	0-1.765
Other perennial grasses	28.368 \pm 7.154	10	100	11.209-81.377
Perennial forbs	3.941 \pm 1.232	10	100	0.105-11.194
Annual forbs	0.023 \pm 0.013	10	60	0-0.123
Half shrubs	5.344 \pm 4.620	10	20	0-46.447
Total	47.176 \pm 8.112	10	100	15.966-92.583

Table A8.7.2-7 . Oven dry weights (grams) for range cages and adjacent open areas in the bottomland sagebrush community type. 1978.

	Quadrat Number	<u>Agropyron smithii</u>	<u>Bromus tectorum</u>	<u>Oryzopsis hymenoides</u>	Other Perennial Grasses	Perennial Forbs	Annual Forbs	Half Shrubs	Total Biomass
OPEN AREA	1	1.144	2.566		12.138	7.799	11.485		35.132
	2	3.089	1.337		0.379				4.805
	3	9.624	5.012		0.299	5.288	1.405		21.628
	4		4.688		9.339		0.057	0.889	14.973
	5		1.714		0.702	2.219	0.849		5.484
	6		10.539						10.539
	7	2.203	3.954			0.249	0.123		6.529
	8	1.126	0.610	17.927	14.579	1.922	0.044		36.208
	9	0.522	2.992		2.902	0.338	0.086		6.840
	10	0.328	22.758			0.022	0.480		23.588
RANGE CAGES	1		8.863		15.956	16.439	0.074		41.332
	2	15.629			8.588		0.334		24.551
	3	14.435	3.691		0.029	28.408	5.202		51.765
	4		25.903		1.057	16.089	2.558	4.148	49.755
	5		24.151		3.858	0.107	0.521		28.637
	6		7.081		0.294		0.135		7.510
	7	3.450	2.112		38.429	0.018	0.113		44.122
	8	1.175	3.283		0.138	0.209	0.014	0.229	5.048
	9	2.411	13.581		0.701		0.115		16.808
	10		58.747			0.111	0.596		59.454

Table A8.7.2-8. Mean production \pm the standard error of the mean (S.E.), frequency, and range of observed values for clipped plots in the bottomland sagebrush community. Production values in grams/m². 1978.

	Mean \pm S.E.	Sample Size	Frequency (%)	Range of Values
<u>RANGE CAGES</u>				
<u>Agropyron smithii</u>	3.710 \pm 1.927	10	50	0-15.629
<u>Bromus tectorum</u>	14.741 \pm 5.651	10	90	0-58.747
Other perennial grasses	6.905 \pm 3.866	10	90	0-38.429
Perennial forbs	6.138 \pm 3.265	10	70	0-28.408
Annual forbs	0.966 \pm 0.528	10	100	.014-5.202
Half shrubs	0.438 \pm 0.413	10	20	0-4.148
Total	32.898 \pm 6.064	10	100	5.048-59.454
<u>OPEN AREAS</u>				
<u>Agropyron smithii</u>	1.804 \pm 0.928	10	70	0-9.624
<u>Bromus tectorum</u>	5.617 \pm 2.100	10	100	0.610-22.758
<u>Oryzopsis hymenoides</u>	1.793 \pm 1.793	10	10	0-17.927
Other perennial grasses	4.032 \pm 1.806	10	70	0-14.579
Perennial forbs	1.784 \pm 0.855	10	70	0-7.799
Annual forbs	1.453 \pm 1.124	10	80	0-11.485
Half shrubs	0.089 \pm 0.089	10	10	0-0.887
Total	16.573 \pm 3.802	10	100	4.805-36.208

Table A8.7.2-9. Regression equations used for converting fresh weight estimates to oven dry weights for the intensive study plots, May 1977.

Species / Species Group	Regression Equation	Correlation Coefficient
<u>Agropyron smithii</u>	$y = 0.512x + 0.717$	0.70
<u>Bromus tectorum</u>	$y = 0.435x + 0.185$	0.62
<u>Oryzopsis hymenoides</u>	$y = 0.362x + 1.134$	0.84
Other perennial grasses	$y = 0.543x + 0.720$	0.80
Perennial forbs	$y = 0.431x - 0.228$	0.62
Annual forbs	$y = 0.372x - 0.028$	0.68
Half shrubs*	$y = 0.379x$	
Total biomass	$y = 0.529x + 0.948$	0.82

*Only one data point

Table A8.7.2-10 Regression equations used for converting fresh weight estimates to oven dry weights for the intensive study plots, June 1977.

Species / Species Group	Regression Equation	Correlation Coefficient
<u>Agropyron smithii</u>	$y = 0.711x + 1.519$	0.75
<u>Bromus tectorum</u> [*]	$y = 0.435x + 0.185$	0.62
<u>Oryzopsis hymenoides</u>	$y = 0.920x + 0.065$	0.80
Other perennial grasses	$y = 0.323x + 1.554$	0.55
Perennial forbs	$y = 0.624x + 0.464$	0.86
Annual forbs	$y = 0.701x - 0.234$	0.99
Half shrubs	$y = 0.439x - 0.240$	0.92
Total biomass	$y = 0.697x + 1.517$	0.77

*Same equation as used for May data.

Table A8.7.2-11 Regression equations used for converting fresh weight estimates to oven dry weights for the intensive study plots, July 1977.

Species / Species Group	Regression Equation	Correlation Coefficient
<u>Agropyron smithii</u>	$y = 0.505x + 0.807$	0.70
<u>Bromus tectorum*</u>	$y = 0.435x + 0.185$	0.62
<u>Oryzopsis hymenoides</u>	$y = 0.870x - 0.592$	0.93
Other perennial grasses	$y = 0.605x + 0.512$	0.95
Perennial forbs	$y = 0.618x - 0.157$	0.94
Annual forbs	$y = 0.338x - 0.189$	0.96
Half shrubs	$y = 0.236x + 0.436$	0.98
Total biomass	$y = 0.591x + 0.805$	0.91

*Same equation as used for May data.

Table A8.7.2-12. Mean production \pm the standard error of the mean (S.E.), frequency, and range of observed values for quadrats in Plots 1-0 and 1-F, May 1977. Based on data derived from regression equations. Production values in grams/m².

	Mean \pm S.E.	Sample Size	Frequency (%)	Range of Values
<u>PLOT 1-0</u>				
<u>Agropyron smithii</u>	0.025 \pm 0.025	50	2	0-1.229
<u>Bromus tectorum</u>	0.067 \pm 0.037	50	8	0-1.490
<u>Oryzopsis hymenoides</u>	1.089 \pm 0.185	50	46	0-4.389
Other perennial grasses	5.992 \pm 0.686	50	92	0-22.452
Perennial forbs	0.868 \pm 0.229	50	58	0-6.238
Total	8.220 \pm 0.689	50	96	0-22.106
<u>PLOT 1-F</u>				
<u>Agropyron smithii</u>	0.054 \pm 0.040	50	4	0-1.741
<u>Oryzopsis hymenoides</u>	1.477 \pm 0.219	50	62	0-5.836
Other perennial grasses	5.657 \pm 0.682	50	96	0-22.452
Perennial forbs	1.112 \pm 0.270	50	50	0-9.413
Total	8.465 \pm 0.629	50	100	1.213-22.106

Table A8.7.2-13 Mean production \pm the standard error of the mean (S.E.), frequency, and range of observed values for quadrats in Plots 1-O and 1-F, June 1977. Based on data derived from regression equations. Production values in grams/m².

	Mean \pm (S.E.)	Sample Size	Frequency (%)	Range of Values
<u>PLOT 1-O</u>				
<u>Agropyron smithii</u>	0.415 \pm 0.255	50	10	0-12.180
<u>Oryzopsis hymenoides</u>	0.479 \pm 0.196	50	30	0-9.263
Other perennial grasses	3.609 \pm 0.310	50	92	0-8.010
Perennial forbs	0.492 \pm 0.156	50	24	0-5.458
Half shrubs	0.190 \pm 0.117	50	6	0-5.069
Total	7.418 \pm 0.673	50	100	1.865-21.024
<u>PLOT 1-F</u>				
<u>Agropyron smithii</u>	1.181 \pm 0.324	50	30	0-9.337
<u>Bromus tectorum</u>	0.008 \pm 0.008	50	2	0-0.403
<u>Oryzopsis hymenoides</u>	0.824 \pm 0.199	50	36	0-6.504
Other perennial grasses	4.227 \pm 0.586	50	88	0-24.151
Perennial forbs	2.261 \pm 0.631	50	42	0-25.436
Half shrubs	0.460 \pm 0.180	50	16	0-6.387
Total	9.825 \pm 1.218	50	92	0-50.285

Table A8.7.2-14. Mean production \pm the standard error of the mean (S.E.), frequency, and range of observed values for quadrats in Plots 1-0 and 1-F, July 1977. Based on data derived from regression equations. Production values in grams/m².

	Mean \pm S.E.	Sample Size	Frequency (%)	Range of Values
<u>PLOT 1-0</u>				
<u>Agropyron smithii</u>	0.047 \pm 0.033	50	4	0-1.312
<u>Oryzopsis hymenoides</u>	2.057 \pm 0.629	50	30	0-17.991
Other perennial grasses	5.902 \pm 0.639	50	92	0-15.648
Perennial forbs	0.593 \pm 0.274	50	24	0-11.587
Annual forbs	0.005 \pm 0.004	50	4	0-0.150
Half shrubs	0.233 \pm 0.181	50	8	0-8.943
Total	8.751 \pm 0.803	50	98	0-26.197
<u>PLOT 1-F</u>				
<u>Agropyron smithii</u>	0.407 \pm 0.161	50	16	0-4.345
<u>Oryzopsis hymenoides</u>	2.084 \pm 0.481	50	42	0-17.121
Other perennial grasses	7.623 \pm 0.836	50	94	0-24.729
Perennial forbs	1.584 \pm 0.639	50	46	0-22.095
Annual forbs	0.002 \pm 0.002	50	2	0-0.100
Half shrubs	0.107 \pm 0.043	50	12	0-1.145
Total	11.064 \pm 0.928	50	98	0-31.807

Table A8.7.2-15 Mean production \pm the standard error of the mean (S.E.), frequency, and range of observed values for quadrats in Plots 2-O and 2-F, May 1977. Based on data derived from regression equations. Production values in grams/m².

	Mean \pm S.E.	Sample Size	Frequency (%)	Range of Values
<u>PLOT 2-O</u>				
<u>Agropyron smithii</u>	0.548 \pm 0.131	50	30	0-3.276
<u>Bromus tectorum</u>	0.497 \pm 0.157	50	36	0-6.709
<u>Oryzopsis hymenoides</u>	0.488 \pm 0.139	50	22	0-3.666
Other perennial grasses	7.324 \pm 1.003	50	80	0-27.885
Perennial forbs	0.398 \pm 0.127	50	46	0-4.945
Annual forbs	0.077 \pm 0.034	50	16	0-1.460
Half shrubs	0.038 \pm 0.038	50	2	0-1.895
Total	9.482 \pm 0.888	50	98	0-27.660
<u>PLOT 2-F</u>				
<u>Agropyron smithii</u>	0.843 \pm 0.260	50	34	0-10.955
<u>Bromus tectorum</u>	0.702 \pm 0.171	50	48	0-5.405
<u>Oryzopsis hymenoides</u>	0.799 \pm 0.161	50	36	0-3.666
Other perennial grasses	5.306 \pm 0.510	50	94	0-18.649
Perennial forbs	3.043 \pm 0.642	50	88	0-27.359
Annual forbs	0.045 \pm 0.030	50	12	0-1.460
Half shrubs	0.857 \pm 0.540	50	8	0-20.845
Total	12.500 \pm 1.215	50	100	1.213-39.033

Table A8.7.2-16 Mean production \pm the standard error of the mean (S.E.), frequency, and range of observed values for quadrats in Plots 2-O and 2-F, June 1977. Based on data derived from regression equations. Production values in grams/m².

	Mean \pm S.E.	Sample Size	Frequency (%)	Range of Values
<u>PLOT 2-O</u>				
<u>Agropyron smithii</u>	0.684 \pm 0.290	50	16	0-12.180
<u>Bromus tectorum</u>	0.016 \pm 0.011	50	4	0-0.403
<u>Oryzopsis hymenoides</u>	0.124 \pm 0.084	50	6	0-3.745
Other perennial grasses	3.412 \pm 0.345	50	86	0-12.853
Perennial forbs	1.291 \pm 0.497	50	28	0-16.072
Annual forbs	0.129 \pm 0.070	50	10	0-3.039
Half shrubs	0.031 \pm 0.031	50	2	0-1.557
Total	7.921 \pm 0.849	50	96	0-25.552
<u>PLOT 2-F</u>				
<u>Agropyron smithii</u>	0.793 \pm 0.220	50	26	0-5.073
<u>Oryzopsis hymenoides</u>	0.879 \pm 0.309	50	22	0-9.263
Other perennial grasses	2.004 \pm 0.211	50	76	0-7.365
Perennial forbs	1.365 \pm 0.371	50	44	0-12.950
Annual forbs	0.035 \pm 0.020	50	6	0-0.585
Half shrubs	0.040 \pm 0.040	50	2	0-1.996
Total	5.585 \pm 0.551	50	94	0-16.147

Table A8.7.2-17. Mean production \pm the standard error of the mean (S.E.), frequency, and range of observed values for quadrats in Plots 2-O and 2-F, July 1977. Based on data derived from regression equations. Production values in grams/m².

	Mean \pm S.E.	Sample Size	Frequency (%)	Range of Values
<u>PLOT 2-O</u>				
<u>Agropyron smithii</u>	1.024 \pm 0.261	50	28	0-5.861
<u>Bromus tectorum</u>	0.009 \pm 0.009	50	2	0-0.453
<u>Oryzopsis hymenoides</u>	0.480 \pm 0.226	50	12	0-9.291
Other perennial grasses	4.746 \pm 0.707	50	72	0-15.648
Perennial forbs	0.685 \pm 0.240	50	32	0-9.114
Annual forbs	0.299 \pm 0.203	50	20	0-9.957
Half shrubs	0.013 \pm 0.013	50	2	0-0.672
Total	7.460 \pm 0.832	50	92	0-22.063
<u>PLOT 2-F</u>				
<u>Agropyron smithii</u>	0.372 \pm 0.152	50	16	0-5.861
<u>Bromus tectorum</u>	0.014 \pm 0.010	50	4	0-0.453
<u>Oryzopsis hymenoides</u>	1.621 \pm 0.557	50	24	0-17.991
Other perennial grasses	4.819 \pm 0.743	50	78	0-24.729
Perennial forbs	1.152 \pm 0.405	50	34	0-13.441
Annual forbs	0.267 \pm 0.201	50	12	0-9.957
Half shrubs	0.032 \pm 0.032	50	2	0-1.617
Total	8.073 \pm 0.942	50	94	0-24.425

Table A8.7.2-18 Mean production \pm the standard error of the mean (S.E.), frequency, and range of observed values for quadrats in Plots 3-O and 3-F, May 1977. Based on data derived from regression equations. Production values in grams/m².

	Mean \pm S.E.	Sample Size	Frequency (%)	Range of Values
<u>PLOT 3-O</u>				
<u>Agropyron smithii</u>	0.898 \pm 0.133	50	56	0-3.276
Other perennial grasses	7.576 \pm 0.282	50	100	3.980-12.672
Perennial forbs	3.066 \pm 0.171	50	100	1.065-5.807
Annual forbs	0.016 \pm 0.007	50	10	0-0.158
Total	12.215 \pm 0.361	50	100	7.296-17.875
<u>PLOT 3-F</u>				
<u>Agropyron smithii</u>	4.607 \pm 0.301	50	100	1.741-9.931
Other perennial grasses	8.913 \pm 0.387	50	100	1.807-14.846
Perennial forbs	3.981 \pm 0.266	50	100	1.065-9.686
Annual forbs	0.029 \pm 0.010	50	16	0-0.344
Half shrubs	0.008 \pm 0.008	50	2	0-0.379
Total	18.160 \pm 0.615	50	100	9.940-25.809

Table A8.7.2-19. Mean production \pm the standard error of the mean (S.E.), frequency, and range of observed values for quadrats in Plots 3-0 and 3-F, June 1977. Based on data derived from regression equations. Production values in grams/m².

	Mean \pm S.E.	Sample Size	Frequency (%)	Range of Values
<u>PLOT 3-0</u>				
<u>Agropyron smithii</u>	4.263 \pm 0.207	50	100	1.875-9.337
Other perennial grasses	2.942 \pm 0.115	50	100	1.877-5.428
Perennial forbs	1.457 \pm 0.121	50	96	0-4.210
Half shrubs	0.076 \pm 0.041	50	8	0-1.557
Total	8.421 \pm 0.345	50	100	3.955-14.754
<u>PLOT 3-F</u>				
<u>Agropyron smithii</u>	4.337 \pm 0.245	50	96	0-8.626
Other perennial grasses	3.258 \pm 0.109	50	100	2.199-6.396
Perennial forbs	1.617 \pm 0.162	50	82	0-5.458
Half shrubs	0.164 \pm 0.076	50	10	0-2.874
Total	9.633 \pm 0.364	50	100	4.304-18.934

Table A8.7.2-20. Mean production \pm the standard error of the mean (S.E.), frequency, and range of observed values for quadrats in Plots 3-O and 3-F, July 1977. Based on data derived from regression equations. Production values in grams/m².

	Mean \pm S.E.	Sample Size	Frequency (%)	Range of Values
<u>PLOT 3-O</u>				
<u>Agropyron smithii</u>	3.011 \pm 0.186	50	100	1.060-5.861
Other perennial grasses	4.181 \pm 0.183	50	100	2.328-6.566
Perennial forbs	0.622 \pm 0.089	50	88	0-2.933
Half shrubs	0.067 \pm 0.029	50	10	0-0.909
Total	7.743 \pm 0.319	50	100	4.643-14.387
<u>PLOT 3-F</u>				
<u>Agropyron smithii</u>	2.920 \pm 0.144	50	100	1.312-5.861
Other perennial grasses	4.011 \pm 0.228	50	100	1.723-9.593
Perennial forbs	0.616 \pm 0.122	50	80	0-4.170
Half shrubs	0.056 \pm 0.028	50	8	0-0.909
Total	7.448 \pm 0.267	50	100	4.348-12.025

Table A8.7.2-21. Mean production \pm the standard error of the mean (S.E.), frequency, and range of observed values for quadrats in Plots 4-0 and 4-F, May 1977. Based on data derived from regression equations. Production values in grams/m².

	Mean \pm S.E.	Sample Size	Frequency (%)	Range of Values
<u>PLOT 4-0</u>				
<u>Agropyron smithii</u>	1.242 \pm 0.170	50	64	0-4.300
<u>Bromus tectorum</u>	0.020 \pm 0.015	50	4	0-0.620
<u>Oryzopsis hymenoides</u>	0.294 \pm 0.157	50	10	0-6.921
Other perennial grasses	1.263 \pm 0.416	50	60	0-8.869
Perennial forbs	0.015 \pm 0.013	50	4	0-0.634
Annual forbs	0.036 \pm 0.013	50	16	0-0.344
Total	2.782 \pm 0.306	50	92	0-9.676
<u>PLOT 4-F</u>				
<u>Agropyron smithii</u>	0.741 \pm 0.117	50	52	0-2.764
<u>Bromus tectorum</u>	0.008 \pm 0.008	50	2	0-0.403
<u>Oryzopsis hymenoides</u>	0.726 \pm 0.188	50	28	0-5.474
Other perennial grasses	0.809 \pm 0.165	50	46	0-6.153
Other annual grasses	0.021 \pm 0.021	50	2	0-1.055
Perennial forbs	0.054 \pm 0.025	50	18	0-1.065
Annual forbs	0.074 \pm 0.034	50	16	0-1.460
Total	2.541 \pm 0.225	50	90	0-7.296

Table A8.7.2-22. Mean production \pm the standard error of the mean (S.E.), frequency, and range of observed values for quadrats in Plots 4-0 and 4-F, June 1977. Based on data derived from regression equations. Production values in grams/m².

	Mean \pm S.E.	Sample Size	Frequency (%)	Range of Values
<u>PLOT 4-0</u>				
<u>Agropyron smithii</u>	1.074 \pm 0.152	50	52	0-2.941
<u>Oryzopsis hymenoides</u>	0.236 \pm 0.119	50	10	0-4.665
Other perennial grasses	1.015 \pm 0.197	50	40	0-4.782
Perennial forbs	0.037 \pm 0.026	50	4	0-1.088
Annual forbs	0.012 \pm 0.012	50	2	0-0.585
Half shrubs	0.177 \pm 0.093	50	8	0-3.752
Total	2.849 \pm 0.324	50	84	0-10.574
<u>PLOT 4-F</u>				
<u>Agropyron smithii</u>	1.205 \pm 0.136	50	62	0-2.230
<u>Oryzopsis hymenoides</u>	0.652 \pm 0.179	50	30	0-5.584
Other perennial grasses	0.745 \pm 0.171	50	34	0-4.782
Perennial forbs	0.081 \pm 0.042	50	8	0-1.713
Annual forbs	0.030 \pm 0.022	50	4	0-0.936
Half shrubs	0.396 \pm 0.117	50	22	0-3.313
Total	3.058 \pm 0.321	50	84	0-9.180

Table A8.7.2-23 Mean production \pm the standard error of the mean (S.E.), frequency, and range of observed values for quadrats in Plots 4-0 and 4-F, July 1977. Based on data derived from regression equations. Production values in grams/m².

	Mean \pm S.E.	Sample Size	Frequency (%)	Range of Values
<u>PLOT 4-0</u>				
<u>Agropyron smithii</u>	1.202 \pm 0.246	50	50	0-9.904
<u>Bromus tectorum</u>	0.009 \pm 0.009	50	2	0-0.453
<u>Oryzopsis hymenoides</u>	0.593 \pm 0.297	50	12	0-11.031
Other perennial grasses	2.070 \pm 0.728	50	40	0-32.600
Perennial forbs	0.012 \pm 0.010	50	4	0-0.461
Annual forbs	0.006 \pm 0.003	50	6	0-0.100
Half shrubs	0.352 \pm 0.212	50	8	0-7.525
Total	4.605 \pm 0.858	50	82	0-32.102
<u>PLOT 4-F</u>				
<u>Agropyron smithii</u>	0.870 \pm 0.167	50	42	0-3.839
<u>Oryzopsis hymenoides</u>	1.175 \pm 0.292	50	28	0-6.681
Other perennial grasses	1.363 \pm 0.391	50	38	0-13.831
Perennial forbs	0.015 \pm 0.010	50	6	0-0.461
Annual forbs	0.007 \pm 0.004	50	6	0-0.150
Half shrubs	0.594 \pm 0.241	50	18	0-9.888
Total	4.483 \pm 0.709	50	86	0-27.968

Table A8.7.2-24. Mean production \pm the standard error of the mean (S.E.), frequency, and range of observed values for quadrats in Plots 5-0 and 5-F, May 1977. Based on data derived from regression equations. Production values in grams/m².

	Mean \pm S.E.	Sample Size	Frequency (%)	Range of Values
<u>PLOT 5-0</u>				
<u>Agropyron smithii</u>	0.025 \pm 0.025	50	2	0-1.229
<u>Oryzopsis hymenoides</u>	1.882 \pm 0.336	50	62	0-13.794
Other perennial grasses	2.201 \pm 0.439	50	40	0-18.649
Other annual grasses	0.039 \pm 0.038	50	2	0-1.925
Perennial forbs	0.529 \pm 0.367	50	12	0-17.014
Total	5.071 \pm 1.038	50	98	0-43.264
<u>PLOT 5-F</u>				
<u>Agropyron smithii</u>	0.697 \pm 0.174	50	38	0-5.836
<u>Oryzopsis hymenoides</u>	1.613 \pm 0.240	50	58	0-5.474
Other perennial grasses	3.211 \pm 0.383	50	80	0-11.586
Perennial forbs	0.599 \pm 0.135	50	50	0-4.083
Annual forbs	0.010 \pm 0.008	50	4	0-0.344
Total	6.238 \pm 0.508	50	100	1.213-16.817

Table A8.7.2-25 Mean production \pm the standard error of the mean (S.E.), frequency, and range of observed values for quadrats in Plots 5-O and 5-F, June 1977. Based on data derived from regression equations. Production values in grams/m².

	Mean \pm S.E.	Sample Size	Frequency (%)	Range of Values
<u>PLOT 5-O</u>				
<u>Agropyron smithii</u>	0.232 \pm 0.090	50	12	0-2.230
<u>Oryzopsis hymenoides</u>	2.404 \pm 0.417	50	62	0-11.103
Other perennial grasses	0.728 \pm 0.151	50	34	0-3.491
Perennial forbs	0.031 \pm 0.022	50	4	0-0.776
Annual forbs	0.012 \pm 0.012	50	2	0-0.585
Total	3.573 \pm 0.365	50	84	0-9.877
<u>PLOT 5-F</u>				
<u>Agropyron smithii</u>	0.941 \pm 0.221	50	32	0-6.494
<u>Oryzopsis hymenoides</u>	1.839 \pm 0.310	50	70	0-7.424
Other perennial grasses	1.911 \pm 0.212	50	70	0-4.782
Perennial forbs	0.330 \pm 0.109	50	20	0-3.586
Annual forbs	0.012 \pm 0.012	50	2	0-0.585
Half shrubs	0.093 \pm 0.054	50	6	0-1.996
Total	5.474 \pm 0.453	50	100	1.865-19.631

Table A8.7.2-26. Mean production \pm the standard error of the mean (S.E.), frequency, and range of observed values for quadrats in Plots 5-O and 5-F, July 1977. Based on data derived from regression equations. Production values in grams/m².

	Mean \pm S.E.	Sample Size	Frequency (%)	Range of Values
<u>PLOT 5-O</u>				
<u>Agropyron smithii</u>	0.748 \pm 0.316	50	22	0-13.441
<u>Oryzopsis hymenoides</u>	2.098 \pm 0.414	50	62	0-13.641
Other perennial grasses	2.460 \pm 0.668	50	56	0-22.913
Perennial forbs	0.080 \pm 0.041	50	16	0-1.697
Total	4.902 \pm 0.854	50	94	0-28.559
<u>PLOT 5-F</u>				
<u>Agropyron smithii</u>	0.440 \pm 0.094	50	32	0-1.818
<u>Oryzopsis hymenoides</u>	2.115 \pm 0.482	50	56	0-15.381
Other perennial grasses	3.161 \pm 0.430	50	84	0-18.520
Perennial forbs	0.268 \pm 0.134	50	18	0-6.024
Annual forbs	0.002 \pm 0.002	50	2	0-0.100
Half shrubs	0.983 \pm 0.052	50	18	0-1.697
Total	5.029 \pm 0.539	50	90	0-18.520

Table A8.7.2-27. Mean production \pm the standard error of the mean (S.E.), frequency, and range of observed values for quadrats in Plots 6-O and 6-F, May 1977. Based on data derived from regression equations. Production values in grams/m².

	Mean \pm S.E.	Sample Size	Frequency (%)	Range of Values
<u>PLOT 6-O</u>				
<u>Agropyron smithii</u>	1.238 \pm 0.582	50	42	0-28.631
<u>Oryzopsis hymenoides</u>	0.052 \pm 0.052	50	2	0-2.581
Other perennial grasses	6.224 \pm 0.600	50	88	0-17.019
Perennial forbs	2.012 \pm 0.469	50	70	0-14.859
Total	9.965 \pm 1.039	50	92	0-32.685
<u>PLOT 6-F</u>				
<u>Agropyron smithii</u>	0.191 \pm 0.059	50	18	0-1.229
<u>Oryzopsis hymenoides</u>	0.400 \pm 0.120	50	20	0-3.304
Other perennial grasses	3.440 \pm 0.314	50	96	0-11.586
Perennial forbs	0.544 \pm 0.240	50	48	0-10.548
Total	4.695 \pm 0.414	50	98	0-15.494

Table A8.7.2-28. Mean production \pm the standard error of the mean (S.E.), frequency, and range of observed values for quadrats in Plots 6-O and 6-F, June 1977. Based on data derived from regression equations. Production values in grams/m².

	Mean \pm S.E.	Sample Size	Frequency (%)	Range of Values
<u>PLOT 6-O</u>				
<u>Agropyron smithii</u>	0.546 \pm 0.180	50	20	0-5.783
<u>Oryzopsis hymenoides</u>	0.030 \pm 0.022	50	4	0-0.985
Other perennial grasses	3.456 \pm 0.337	50	88	0-11.238
Perennial forbs	1.471 \pm 0.423	50	44	0-12.950
Total	7.531 \pm 0.896	50	90	0-30.778
<u>PLOT 6-F</u>				
<u>Agropyron smithii</u>	0.418 \pm 0.124	50	20	0-3.651
<u>Oryzopsis hymenoides</u>	0.498 \pm 0.144	50	30	0-4.664
Other perennial grasses	2.259 \pm 0.125	50	92	0-4.136
Perennial forbs	0.270 \pm 0.085	50	26	0-3.586
Total	3.857 \pm 0.266	50	94	0-7.787

Table A8.7.2-29. Mean production \pm the standard error of the mean (S.E.), frequency, and range of observed values for quadrats in Plots 6-O and 6-F, July 1977. Based on data derived from regression equations. Production values in grams/m².

	Mean \pm S.E.	Sample Size	Frequency (%)	Range of Values
<u>PLOT 6-O</u>				
<u>Agropyron smithii</u>	0.677 \pm 0.438	50	10	0-21.022
Other perennial grasses	6.305 \pm 1.375	50	94	0-67.109
Perennial forbs	1.497 \pm 0.381	50	62	0-12.205
Total	8.686 \pm 1.609	50	96	0-75.209
<u>PLOT 6-F</u>				
<u>Agropyron smithii</u>	0.093 \pm 0.071	50	4	0-3.334
<u>Oryzopsis hymenoides</u>	1.586 \pm 0.407	50	46	0-15.381
Other perennial grasses	4.307 \pm 0.403	50	94	0-12.015
Perennial forbs	0.886 \pm 0.254	50	46	0-8.496
Annual forbs	0.003 \pm 0.003	50	2	0-0.150
Half shrubs	0.016 \pm 0.014	50	4	0-0.672
Total	6.430 \pm 0.546	50	96	0-16.158

Table A8.7.2-30. Fresh weight estimates (grams) for intensive study plot 1-F, chained pinyon-juniper rangeland. July, 1978.

Quadrat Number	1	2	3	4	5	6	7	8	9	10	11	12	13	14	15	16	17	18	19	20	21	22	23	24	25
	26	27	28	29	30	31	32	33	34	35	36	37	38	39	40	41	42	43	44	45	46	47	48	49	50
<u>Agropyron smithii</u>	<1					<1										18						6		11	
<u>Bromus tectorum</u>	1				1	<1	<1			<1	<1	<1	<1												
<u>Oryzopsis hymenoides</u>	35	17	27		40	2	100	10	17	10	30	12	30	7			50	45	50	65	13	80		7	25
Perennial grasses	6																	5		40	<1	40			
Perennial forbs	3		11	12	3	35	20	12	12		3	13	8	6	37	28	30	5		45	83	2	4		
	55	12	40		3	35	13	15	5	3	1	40	10	5	40	55	85	13	18	5	15	10		10	20
					3	40			1			5	1	2	2	<1	3			10					
Annual forbs																									
Half shrubs																									
Total Biomass	20	39	17	38	15	75	30	29	10	33	70	13	36	46	28	30	52	50	50	112	96	2	125	0	11
	1	61	12	40	51	37	118	27	71	13	1	73	14	70	97	55	141	36	18	63	15	10	40	17	90

Table A8.7.2.31 . Fresh weight estimates (grams) for intensive study plot 2-F, chained pinyon-juniper rangeland. July, 1978

Quadrat Number	1	2	3	4	5	6	7	8	9	10	11	12	13	14	15	16	17	18	19	20	21	22	23	24	25
	26	27	28	29	30	31	32	33	34	35	36	37	38	39	40	41	42	43	44	45	46	47	48	49	50
<u>Agropyron smithii</u>	13	2	14	5	20	23	2	1	25	18	1	18	27	6	11	25	6	11	26	80	20	20	40	5	
	6	40	19				20	33																	
<u>Bromus tectorum</u>	<1	1	3	<1	<1	3	<1	<1	1	<1	4	2	<1	6	4	3	6	1	1	2	1	3	5	7	
	<1		5	<1	5	<1	3		4	9	5	1	<1	<1	6	4	6	<1	2	1	3	5			
<u>Oryzopsis hymenoides</u>	17						33		33		8						4	3	8	7	10	30			
	16																35	55							
Perennial grasses	30	35	55	55	2	2	70	15	6	1	27	60	45	6	2	3	35	5	20	2	70	17	52	6	
	2	25	30	7	30	12	5	18	1																
Perennial forbs	18	2			4	2	1	20	2	16	37	1	2	1	2	2	37	1	2	2	4				
	1	2																							
Annual forbs	<1				1		<1	<1	4	<1	1	1	1	1	1	2	<1	2	1	1	1	1	1	1	
									2	7	2														
Half shrubs					3		11														4				
Total Biomass	43	55	35	60	23	29	39	73	53	38	14	4	27	60	35	45	73	6	19	11	45	28	83	37	61
	23	3	67	49	12	<1	53	45	42	13	12	29	<1	7	5	43	43	62	24	9	1	74	15	72	13

Table A8.7.2-32 . Fresh weight estimates (grams) for intensive study plot 5-F, pinyon-juniper woodland. July 1978.

Quadrat Number	1	2	3	4	5	6	7	8	9	10	11	12	13	14	15	16	17	18	19	20	21	22	23	24	25
	26	27	28	29	30	31	32	33	34	35	36	37	38	39	40	41	42	43	44	45	46	47	48	49	50
<u>Agropyron smithii</u>	2	5	<1			2	2										2					1	1	3	3
<u>Bromus tectorum</u>																	3					8	3	2	
<u>Oryzopsis hymenoides</u>	2						<1						1	<1							<1		<1		<1
Perennial grasses	35	13	10			5	7				<1	4	3			5		2			2	20	16	1	1
	1	2	4	18		50		15			7					6		13	5				18		18
Perennial forbs	20	<1	8	<1	25	22	20	8	5	15	3	1	6	18	8					10	5	2	40	15	
	5	3	8	9	15	4	35	11	8	13	25	19	20	3	6	7	80	40	1			12	32	50	200
Annual forbs																									
Half shrubs																									
Total Biomass	55	2	26	10	27	22	7	29	8	5	15	3	3	10	3	18	8	5	0	4	14	8	23	63	16
	6	7	12	20	12	18	60	35	14	23	13	26	26	22	3	7	16	80	57	14	9	20	38	78	200

Table A.8.7.2-33. Fresh weight estimates (grams) for intensive study plot 6-F, pinyon-juniper woodland. July, 1978.

Quadrat Number	1	2	3	4	5	6	7	8	9	10	11	12	13	14	15	16	17	18	19	20	21	22	23	24	25
<u>Agropyron smithii</u>	3			3	4	3	4	3	<1	6	20	2	9	3	6	1	4	35	1	5	40	9	3	45	9
<u>Bromus tectorum</u>			2										<1	4											
<u>Oryzopsis hymenoides</u>			30								13		2	3	45	65		35		15	47	40			10
Perennial grasses	70	55	20	95	100	30	60	50	20		<1	13	10	40	28	45	60	100	7	100	110	40	45	65	45
	50	20	150	55	60	85	110	50	120	85	17	30	85	35	5	50	55	35	30	100	30	40	45	60	14
Perennial forbs	2	15	30	20	55	25	18	2	32	7	35	18	7	6	30	35	22	10	12	20	22	60	25	50	30
	15	30	20	55	25	18	2	32	7	35	18	7	6	6	15	6	33	30	1	6	12	20	15		
Annual forbs								<1		11			<1										1	<1	
Half shrubs																									
Total Biomass	72	130	20	125	104	36	67	98	45	11	<1	29	20	54	64	146	86	145	20	135	179	140	79	116	85
	65	53	170	122	129	109	112	85	142	139	55	47	96	43	60	65	81	68	65	153	45	57	140	80	29

Table A8.7.2-34. Oven dry weights (grams) for chained pinyon-juniper rangeland plots 1-F and 2-F. 1978.

	Quadrat Number	<u>Agropyron smithii</u>	<u>Bromus tectorum</u>	<u>Oryzopsis hymenoides</u>	Other Perennial Grasses	Perennial Forbs	Annual Forbs	Half Shrubs	Total Biomass
Plot 1-F	2		3.820	38.283	9.301	0.037			51.404
	5				9.597		0.547		10.144
	10			21.505	1.071				22.576
	16		0.336		29.040	0.149	0.158		29.525
	20			38.994	40.052		2.356		81.402
	21			6.114	64.422				70.536
	30		3.929	23.056	3.846		1.229	4.361	36.421
	32		0.115	62.142	10.861			2.301	75.419
	39		0.312	37.307	2.619				39.926
40		0.787	22.570	37.541	1.435			62.333	
Plot 2-F	6	25.321	3.755		1.096		0.064		30.236
	12		3.398		1.531		0.143		5.072
	15	33.175	0.120			9.202	0.914		43.291
	16		0.095		51.016	0.172			51.188
	21		4.143		17.633		2.010	1.642	25.428
	28	17.526			18.794	0.542			36.862
	34		7.982	15.106	5.685		0.237		29.010
	35		29.132			0.228	2.515		31.875
	36		7.970				3.859		11.829
48		7.509	5.396					12.905	

Table A8.7.2-35. Oven dry weights (grams) for pinyon-juniper woodland plots 5-F and 6-F. 1978.

	Quadrat Number	<u>Agropyron smithii</u>	<u>Bromus tectorum</u>	<u>Oryzopsis hymenoides</u>	Other Perennial Grasses	Perennial Forbs	Annual Forbs	Half Shrubs	Total Biomass
Plot 5-F	7	1.573		4.089	0.372		0.179		5.841
	9				3.776				3.776
	12				1.199		0.157		1.356
	14			1.787	3.859				5.646
	31				3.819		1.073		4.892
	35			10.729	3.109				13.838
	41		0.087		2.144		0.152		2.383
	44				20.260	4.358			24.618
46			0.242	3.941		0.173	0.702		5.058
48					21.615	1.776	0.471		23.862
Plot 6-F	6	0.396			7.489	1.210			9.095
	13	1.989			5.911	0.148			8.048
	21	4.441		24.508	55.049	15.879	0.025		95.461
	28	4.903			56.719	5.568			62.287
	33	3.570			27.376	14.751	0.875		46.572
	38	3.194			67.699	1.755			72.648
	43	1.344			22.264	26.876	0.199		49.140
	47	3.374	0.020	0.373	22.784	8.857			35.388
	49				28.806	11.719	0.415		40.940
	50				5.448	7.123			12.571

Table A8.7.2-36. Regression equations used for converting fresh weight estimates to oven dry weights in plots 1-F, 2-F, 5-F, and 6-F. 1978.

Species / Species Group	Regression Equation	Correlation Coefficient
<u>Agropyron smithii</u>	$y = 0.650x + 2.503$	0.70
<u>Bromus tectorum</u>	$y = 2.748x - 1.543$	0.93
<u>Oryzopsis hymenoides</u>	$y = 0.586x + 0.565$	0.95
Other perennial grasses	$y = 0.520x + 3.415$	0.88
Perennial forbs	$y = 0.616x - 0.893$	0.91
Annual forbs	$y = 0.537x + 0.234$	0.81
Half shrubs	$y = 0.924x - 2.160$	0.99
Total Biomass	$y = 0.518x + 6.597$	0.89

Table A8.7.2-37. Mean production \pm the standard error of the mean (S.E.), frequency, and range of observed values for quadrats at chained pinyon-juniper rangeland Plots 1-F and 2-F, 1978. Production data are in grams/m² based on data derived from regression equations.

	Mean \pm S.E.	Sample Size	Frequency (%)	Range of Values
<u>PLOT 1-F</u>				
<u>Agropyron smithii</u>	0.838 \pm 0.370	50	14	0-14.201
<u>Bromus tectorum</u>	0.092 \pm 0.041	50	26	0-1.205
<u>Oryzopsis hymenoides</u>	12.115 \pm 2.098	50	64	0-59.125
Other perennial grasses	12.077 \pm 1.579	50	84	0-47.636
Perennial forbs	1.164 \pm 0.668	50	24	0-23.747
Annual forbs	0.107 \pm 0.038	50	16	0-1.307
Half shrubs	2.500 \pm 1.119	50	22	0-39.420
Total	29.461 \pm 2.542	50	100	6.597-79.635
<u>PLOT 2-F</u>				
<u>Agropyron smithii</u>	7.800 \pm 1.539	50	52	0-54.495
<u>Bromus tectorum</u>	3.968 \pm 0.796	50	74	0-23.189
<u>Oryzopsis hymenoides</u>	3.180 \pm 1.005	50	26	0-32.733
Other perennial grasses	9.338 \pm 1.615	50	62	0-39.832
Perennial forbs	1.161 \pm 0.547	50	32	0-21.900
Annual forbs	0.411 \pm 0.105	50	38	0-3.992
Half shrubs	0.382 \pm 0.238	50	8	0-8.928
Total	24.406 \pm 1.707	50	100	6.856-49.591

Table A8.7.2-38. Mean production \pm the standard error of the mean (S.E.), frequency, and range of observed values for quadrats at pinyon-juniper woodland Plots 5-F and 6-F, 1978. Production data are in grams/m² based on data derived from regression equations.

	Mean \pm S.E.	Sample Size	Frequency (%)	Range of Values
<u>PLOT 5-F</u>				
<u>Agropyron smithii</u>	1.036 \pm 0.277	50	24	0-7.702
<u>Bromus tectorum</u>	0.113 \pm 0.082	50	14	0-3.953
<u>Oryzopsis hymenoides</u>	3.357 \pm 0.823	50	50	0-29.846
Other perennial grasses	11.724 \pm 2.287	50	88	0-107.464
Perennial forbs	0.433 \pm 0.213	50	28	0-9.579
Annual forbs	0.323 \pm 0.062	50	44	0-2.381
Half shrubs	0.004 \pm 0.003	50	4	0-0.100
Total	19.169 \pm 2.332	50	100	6.597-110.197
<u>PLOT 6-F</u>				
<u>Agropyron smithii</u>	4.721 \pm 1.031	50	58	0-31.750
<u>Bromus tectorum</u>	0.272 \pm 0.203	50	8	0-9.449
<u>Oryzopsis hymenoides</u>	5.076 \pm 1.374	50	34	0-38.630
Other perennial grasses	30.654 \pm 2.556	50	98	0-81.452
Perennial forbs	9.566 \pm 1.307	50	88	0-36.068
Annual forbs	0.183 \pm 0.124	50	14	0-6.139
Half shrubs	1.293 \pm 1.074	50	6	0-53.280
Total	50.306 \pm 3.303	50	100	6.856-99.319

Table A8.7.2-39. Oven dry weights (grams) for range cages and adjacent open areas in the pinyon-juniper woodland treatment (development) site north of Piceance Creek. 1978.

	Quadrat Number	<u>Agropyron smithii</u>	<u>Bromus tectorum</u>	<u>Oryzopsis hymenoides</u>	Other Perennial Grasses	Perennial Forbs	Annual Forbs	Half Shrubs	Total Biomass
OPEN AREA	1		0.366	4.515	3.098	0.133	0.069		8.181
	2			1.806				1.403	3.209
	3			2.571	8.848		0.465		11.884
	4	0.378		3.391	4.084		0.660		8.513
	5		0.048	1.558		0.049	0.077	2.921	4.653
	6			0.648	3.891		0.098		4.637
	7				12.104	0.729	0.567		13.400
	8	2.158			1.375	0.048	0.016		3.577
	9		8.606	4.672	6.279	0.169	5.644		25.370
	10		0.071	4.198	9.465	1.341	0.050		15.125
RANGE CAGES	1			1.649	19.731	0.763			22.143
	2			1.590	28.659	2.967	0.012	0.691	33.919
	3		0.018	1.745	6.834		0.557		9.154
	4	0.424	2.971	7.971	35.753	0.388	2.859		50.366
	5			3.365			0.052	1.278	4.695
	6	2.337			1.036				3.373
	7		0.907	18.739	12.863	0.049	1.165	0.474	34.197
	8	0.488		12.971			0.015		13.474
	9		3.731	6.907	3.853		1.646		16.137
	10		0.017	9.379					9.396

Table A8.7.2-40 . Oven dry weights (grams) for range cages and adjacent open areas in the pinyon-juniper woodland control site north of Piceance Creek. 1978.

	Quadrat Number	<u>Agropyron smithii</u>	<u>Bromus tectorum</u>	<u>Oryzopsis hymenoides</u>	Other Perennial Grasses	Perennial Forbs	Annual Forbs	Half Shrubs	Total Biomass
OPEN AREA	1			5.648		0.049			5.697
	2			10.816			0.024		10.840
	3	3.339		2.964	1.347	0.447		3.769	11.866
	4		0.041		4.271	0.159		0.983	5.454
	5			0.430		0.042		0.492	0.964
	6			5.057	5.309	2.077		1.073	13.516
	7		0.037	2.436		0.920			3.393
	8			3.796					3.796
	9			0.011	0.168		3.395		3.574
	10				6.749				6.749
RANGE CAGES	1		0.791	13.983	4.815		0.078		19.667
	2			24.159		0.014			24.173
	3	0.084		5.207	8.961	0.306		0.417	14.975
	4			0.563	9.198	6.506		5.739	22.006
	5				22.659	5.137		0.148	27.946
	6			1.488	9.459	0.497		1.359	12.803
	7			8.416		0.370	0.142		8.928
	8			9.730				1.565	11.295
	9			3.633	1.943		0.003	0.248	5.827
	10			2.915	25.130	1.809		0.024	29.878

Table A8.7.2-41. Mean production \pm the standard error of the mean (S.E.), frequency, and range of observed values for clipped plots in the piñon-juniper woodland development (treatment) site north of Piceance Creek. Production values in grams/m². 1978.

	Mean \pm S.E.	Sample Size	Frequency (%)	Range of Values
<u>RANGE CAGES</u>				
<u>Agropyron smithii</u>	0.325 \pm 0.232	10	30	0-2.337
<u>Bromus tectorum</u>	0.764 \pm 0.444	10	50	0-3.731
<u>Oryzopsis hymenoides</u>	6.433 \pm 1.899	10	90	0-18.739
Other perennial grasses	10.873 \pm 4.130	10	70	0-35.753
Perennial forbs	0.417 \pm 0.294	10	40	0-2.967
Annual forbs	0.631 \pm 0.309	10	70	0-2.859
Half shrubs	0.244 \pm 0.139	10	30	0-1.278
Total	19.685 \pm 4.853	10	100	3.373-50.366
<u>OPEN AREAS</u>				
<u>Agropyron smithii</u>	0.252 \pm 0.213	10	20	0-2.138
<u>Bromus tectorum</u>	0.909 \pm 0.856	10	40	0-8.606
<u>Oryzopsis hymenoides</u>	2.336 \pm 0.572	10	80	0-4.672
Other perennial grasses	4.914 \pm 1.315	10	80	0-12.104
Perennial forbs	0.247 \pm 0.140	10	60	0-1.341
Annual forbs	0.765 \pm 0.548	10	90	0-5.644
Half shrubs	0.432 \pm 0.310	10	20	0-2.921
Total	9.855 \pm 2.180	10	100	3.209-25.370

Table A8.7.2-42. Mean production \pm the standard error of the mean (S.E.), frequency, and range of observed values for clipped plots in the pinyon-juniper woodland control site north of Piceance Creek. Production values in grams/m². 1978.

	Mean \pm S.E.	Sample Size	Frequency (%)	Range of Values
<u>RANGE CAGES</u>				
<u>Agropyron smithii</u>	0.008 \pm 0.008	10	10	0-0.084
<u>Bromus tectorum</u>	0.079 \pm 0.079	10	10	0-0.791
<u>Oryzopsis hymenoides</u>	7.009 \pm 2.368	10	90	0-24.159
Other perennial grass	8.216 \pm 2.889	10	70	0-25.130
Perennial forbs	1.464 \pm 0.753	10	70	0-6.506
Annual forbs	0.022 \pm 0.015	10	30	0-0.142
Half shrubs	0.950 \pm 0.562	10	70	0-5.739
Total	17.750 \pm 2.599	10	100	5.827-29.878
<u>OPEN AREAS</u>				
<u>Agropyron smithii</u>	0.334 \pm 0.334	10	10	0-3.339
<u>Bromus tectorum</u>	0.008 \pm 0.005	10	20	0-0.041
<u>Oryzopsis hymenoides</u>	3.116 \pm 1.089	10	80	0-10.816
Other perennial grasses	1.784 \pm 0.830	10	50	0-6.749
Perennial forbs	0.369 \pm 0.211	10	60	0-2.077
Annual forbs	0.342 \pm 0.339	10	20	0-3.395
Half shrubs	0.632 \pm 0.374	10	40	0-3.769
Total	6.585 \pm 1.311	10	100	0.964-13.516

Table A8.7.3-1

Production and utilization of bitterbrush in the chained rangeland habitat, 1977-78.

Transect	A	B	C
	PRODUCTION: length of new shoots in fall (mm) Mean \pm SE (N)	Length of shoots remaining in spring (mm) Mean \pm SE (N)	UTILIZATION: in percent $C = \frac{A-B}{A} \times 100$
BA 17 (CH-C-1)	42 \pm 3.8 (100)	3 \pm 0.6 (90)	92
BA 18 (CH-C-2)	75 \pm 9.0 (100)	4 \pm 0.9 (100)	94
BA 25 (CH-C-3)	73 \pm 8.3 (100)	5 \pm 0.8 (100)	94
Combined	63 \pm 4.3 (300)	4 \pm 0.5 (290)	93
BA 21 (CH-T-1)	73 \pm 6.4 (100)	9 \pm 1.1 (100)	88
BA 20 (CH-T-2)	145 \pm 11.2 (100)	10 \pm 1.5 (100)	93
BA 23 (CH-T-3)	143 \pm 10.6 (100)	16 \pm 2.3 (100)	89
Combined	120 \pm 5.9 (300)	12 \pm 1.0 (300)	90

Table A8.7.3-2

Production and utilization of bitterbrush in the pinyon-juniper habitat, 1977-78.

Transect	A	B	C
	PRODUCTION: length of new shoots in fall (mm) Mean \pm SE (N)	Length of shoots remaining in spring (mm) Mean \pm SE (N)	UTILIZATION: in percent $C = \frac{A-B}{A} \times 100$
BA 19 (PJ-C-1)	48 \pm 3.9 (100)	9 \pm 2.1 (100)	81
BA 26 (PJ-C-2)	43 \pm 3.9 (100)	4 \pm 0.9 (100)	91
BA 27 (PJ-C-3)	29 \pm 3.1 (100)	4 \pm 1.0 (100)	85
Combined	40 \pm 2.2 (300)	6 \pm 0.8 (300)	85
BA 16 (PJ-T-1)	28 \pm 2.6 (99)	5 \pm 0.8 (80)	82
BA 22 (PJ-T-2)	94 \pm 7.1 (100)	15 \pm 1.8 (100)	84
BA 24 (PJ-T-3)	36 \pm 2.4 (100)	9 \pm 1.5 (90)	75
Combined	53 \pm 3.2 (299)	10 \pm 0.9 (270)	81

Table A8.7.3-3

Production and utilization of mountain mahogany in the chained rangeland habitat, 1977-78.

Transect	A	B	C
	PRODUCTION: length of new shoots in fall (mm) Mean \pm SE (N)	Length of shoots remaining in spring (mm) Mean \pm SE (N)	UTILIZATION: in percent $C = \frac{A-B}{A} \times 100$
BA 17 (CH-C-1)	5 \pm 0.4 (100)	0.5 \pm 0.13 (100)	91
BA 18 (CH-C-2)	16 \pm 4.2 (100)	3.5 \pm 1.23 (100)	79
BA 25 (CH-C-3)	13 \pm 1.5 (50)	1.4 \pm 0.38 (50)	89
Combined	11 \pm 1.7 (250)	1.8 \pm 0.51 (250)	83
BA 21 (CH-T-1)	9 \pm 1.0 (100)	0.7 \pm 0.28 (80)	92
BA 20 (CH-T-2)	15 \pm 2.7 (100)	0.9 \pm 0.21 (100)	94
BA 23 (CH-T-3)	44 \pm 6.6 (98)	4.5 \pm 0.80 (100)	90
Combined	23 \pm 2.5 (298)	2.1 \pm 0.32 (280)	91

Table A8.7.3-4

Production and utilization of mountain mahogany in the pinyon-juniper habitat, 1977-78.

Transect	A	B	C
	PRODUCTION: length of new shoots in fall (mm) Mean \pm SE (N)	Length of shoots remaining in spring (mm) Mean \pm SE (N)	UTILIZATION: in percent $C = \frac{A-B}{A} \times 100$
BA 19 (PJ-C-1)	4 \pm 0.2 (100)	1.0 \pm 0.18 (100)	72
BA 26 (PJ-C-2)	8 \pm 1.1 (100)	1.4 \pm 0.38 (100)	82
BA 27 (PJ-C-3)	12 \pm 2.2 (100)	2.5 \pm 0.90 (100)	80
Combined	8 \pm 0.8 (300)	1.6 \pm 0.33 (300)	79
BA 16 (PJ-T-1)	2 \pm 0.3 (20)	1.5 \pm 0.58 (20)	37
BA 22 (PJ-T-2)	23 \pm 4.7 (40)	4.6 \pm 1.82 (30)	80
BA 24 (PJ-T-3)	19 \pm 2.2 (99)	4.6 \pm 1.05 (100)	76
Combined	18 \pm 1.9 (159)	4.2 \pm 0.79 (150)	77

Table A8.7.3-5

Production of bitterbrush, 1978.

Transect	Habitat	PRODUCTION:
		length of new shoots in fall (mm) Mean \pm SE (N)
BA 18	chained rangeland	266 \pm 16.6 (100)
BA 25	"	174 \pm 11.7 (100)
BA 21	"	211 \pm 17.2 (100)
BA 20	"	246 \pm 18.8 (100)
BA 23	"	274 \pm 25.4 (100)
BA 19	pinyon-juniper	123 \pm 7.7 (100)
BA 26	"	133 \pm 8.3 (100)
BA 27	"	154 \pm 8.7 (100)
BA 16	"	149 \pm 9.8 (100)
BA 22	"	179 \pm 14.2 (100)
BA 24	"	120 \pm 8.2 (100)

Table A8.7.3-6

Baseline evaluation of bitterbrush on Big Jimmy ridge. Twenty 0.04 acre plots occurred along each transect.

Transect	Density: No. of shrubs per acre	No. of shrubs counted	Height class (cm)			Percent live tissue on individual shrubs <25 25 50 75 100	No. of seedlings encountered in twenty 0.003 acre plots
			<15	15-40	>40		
BA 01	49	39	3	30	6	0 3 16 19 1	0
BA 02	61	49	7	36	6	2 5 24 15 3	1
BA 03	30	24	1	13	10	1 0 6 10 7	0
BA 04	144	115	24	54	37	16 22 34 34 9	0
BA 05	114	91	10	45	36	0 20 45 22 4	0
BA 06	113	90	2	35	53	3 5 33 42 7	0
BA 07	29	23	0	7	16	0 0 4 13 6	0
BA 08	34	27	2	8	17	0 0 6 14 7	0
BA 09	6	5	0	2	3	0 0 2 3 0	0

Table A8.7.3-7

Baseline evaluation of mountain mahogany on Big Jimmy ridge. Twenty 0.04 acre plots occurred along each transect.

Transect	Density: No. of shrubs per acre
BA 01	56
BA 02	0
BA 03	3
BA 04	29
BA 05	3
BA 06	0
BA 07	9
BA 08	0
BA 09	3

Table A8.7.3-8

Sagebrush Ocular Estimates - Fall 1978

Sagebrush Habitat

Transect	Paces	Sample Size	Young	Mature	Decadent	Low	Medium	High	Density
BA01	2	50	10	40	---		48	2	
BA02	2	50	12	38	---	34	16	---	
BA03	2	50	11	39	---	40	10	---	
BA04	3	50	1	48	1	22	24	4	5, 3, 3, 4, 4
BA05	3	50	1	41	8	10	21	19	7, 9, 11, 5, 9
BA06	3	50	2	47	1	21	10	19	9, 9, 6, 4, 14
BA07	3	50	1	47	2	32	13	5	10, 8, 12, 8, 5
BA08	3	50	3	39	8	12	20	18	9, 3, 4, 11, 7
BA09	2	50	1	37	12	7	8	35	7, 6, 2, 11, 6
BA17	2	50	1	49	---	41	9	---	3, 2, 1, 4, 7
BA18	3	50	8	42	---	27	23	---	1, 2, 1, 3, 1
BA20	3	50	1	47	2	15	20	15	5, 2, 3, 7, 3
BA21	3	50	2	47	1	17	27	6	2, 1, 3, 1, 2
BA23	3	50	--	50	---	25	22	3	2, 3, 7, 6, 4
BA25	2	50	--	49	1	11	24	15	4, 9, 7, 1, 1
TOTAL		750	54	660	36	314	295	141	
PERCENT			7.2	88	4.8	41.9	39.3	18.8	

Pinyon Juniper Habitat

Transect	Paces	Sample Size	Young	Mature	Decadent	Low	Medium	High	Density
BA10	5	25	--	15	10	2	10	13	1, 1, 1
BA11	5	25	--	17	8	---	19	6	1, 1, 1
BA12	3	40	--	22	18	5	20	15	1, 2, 1, 1
BA13	3	50	--	30	20	7	20	23	4, 3, 6, 2, 1
BA14	3	50	--	37	13	3	25	22	3, 4, 4, 1, 1
BA15	3	50	--	31	19	3	22	25	1, 5, 5, 1, 3
BA16	3	50	--	20	30	---	13	37	4, 3, 4, 1, 2
BA19	5	25	--	3	22	1	10	14	1, 2, 1
BA22	5	25	--	4	21	1	9	15	2, 1
BA24	5	25	--	2	23	2	3	20	0, 1
BA26	3	50	--	20	30	1	17	32	1, 2, 1, 1, 0
BA27	3	50	--	25	25	2	20	28	1, 1, 2, 1, 1
TOTAL		465	0	226	239	27	188	250	
PERCENT				48.6	51.4	5.8	40.4	53.8	

Table A8.7.3-9

Production of bitterbrush and mountain mahogany treated with fertilizer, 1978. All transects are located in the chained rangeland habitat.

Transect	PRODUCTION: length of new shoots in fall (mm)	Treatment
	Mean \pm SE (N)	
Bitterbrush:		
BA 28	185 \pm 16 (99)	ammonia nitrate
BA 31	260 \pm 20 (100)	ammonia nitrate
BA 17	223 \pm 21 (100)	nitrogen and phosphorus
BA 30	201 \pm 17 (100)	nitrogen and phosphorus
Mountain mahogany:		
BA 28	132 \pm 7 (100)	ammonia nitrate
BA 17	114 \pm 7 (100)	nitrogen and phosphorus

THIS PAGE
INTENTIONALLY LEFT BLANK

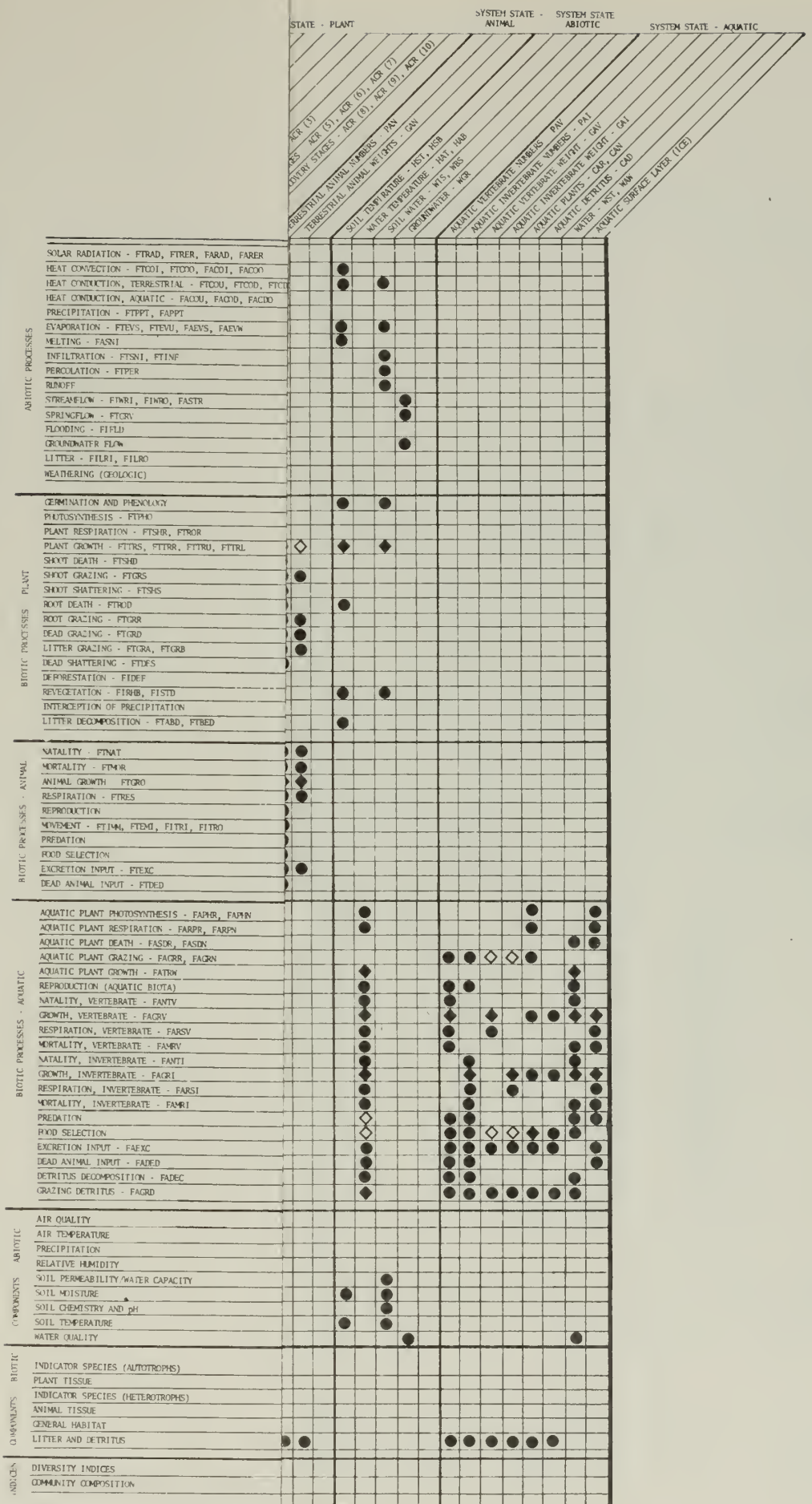
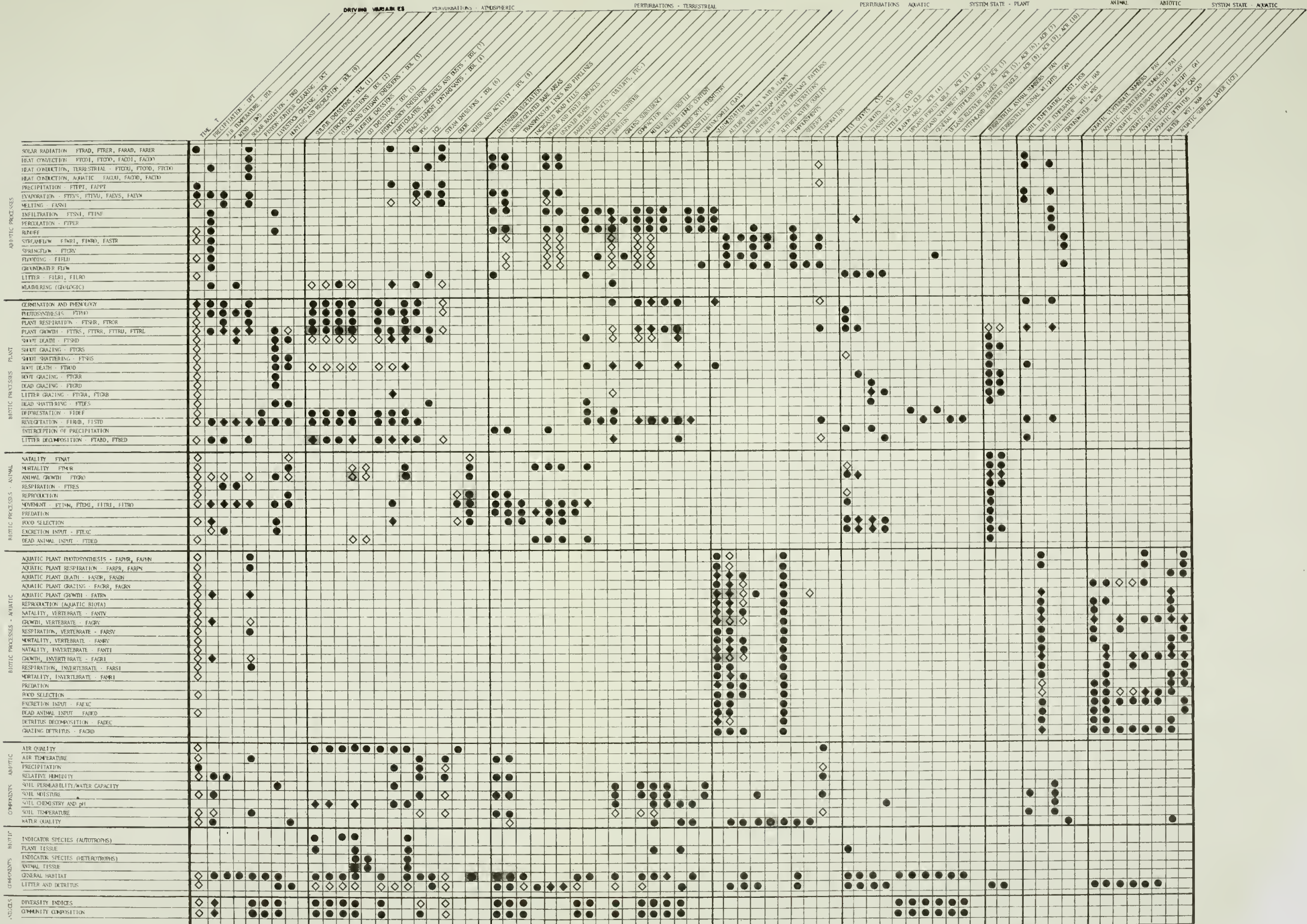

FIGURE A12.1-1

THIS PAGE
INTENTIONALLY LEFT BLANK



EFFECTS MATRIX. EFFECT GENERATORS ARE LISTED ACROSS TOP, AND EFFECT RECEPTORS ARE LISTED DOWN THE SIDE.

- DIRECT EFFECT
- ◆ BOTH DIRECT AND INDIRECT EFFECTS
- ◇ INDIRECT EFFECT
- EFFECT OF PARTICULAR CONCERN

FIGURE A12.1-1

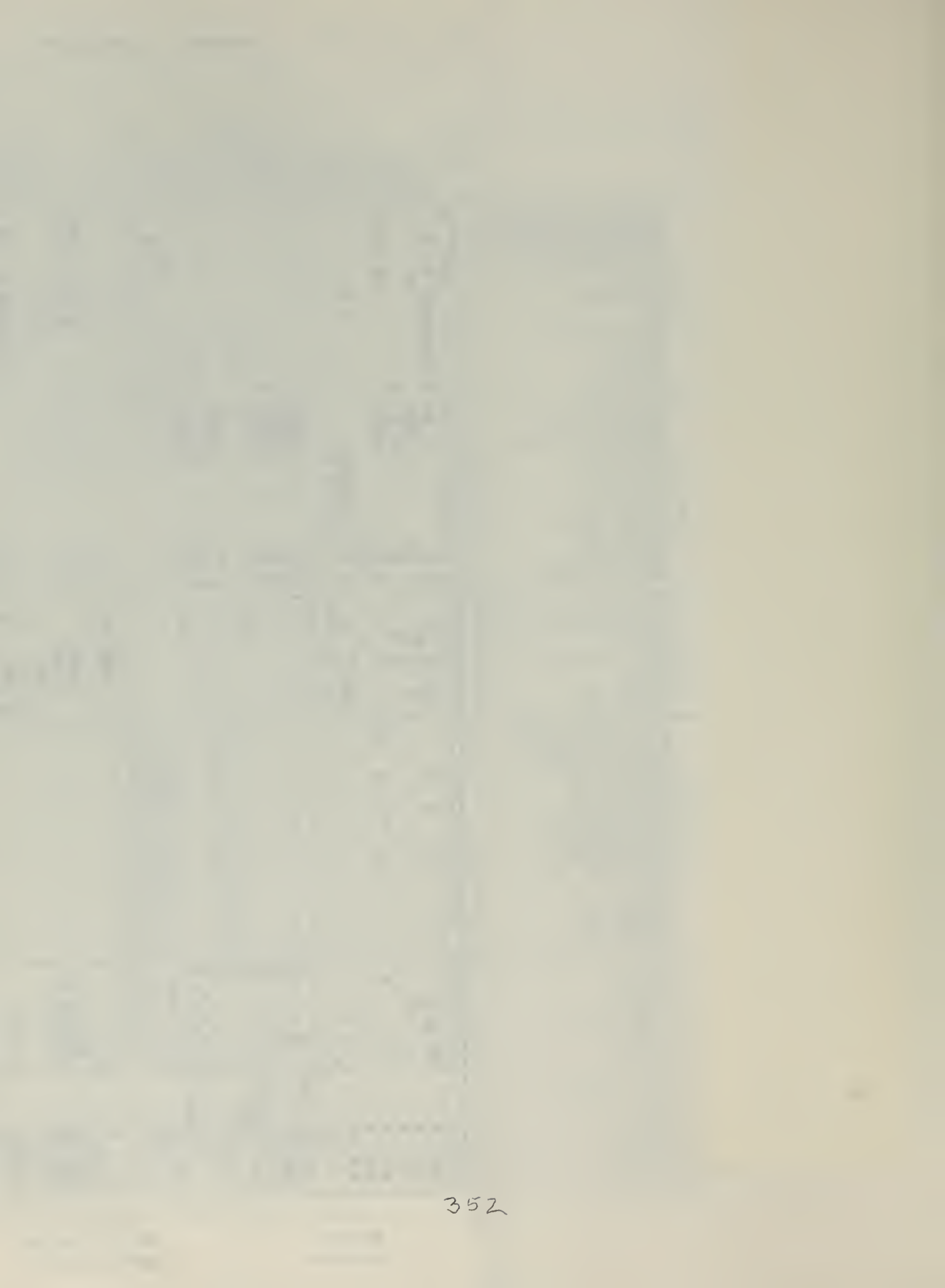

A = SINGLE POINT
 B = TWO POINTS OVERLAID

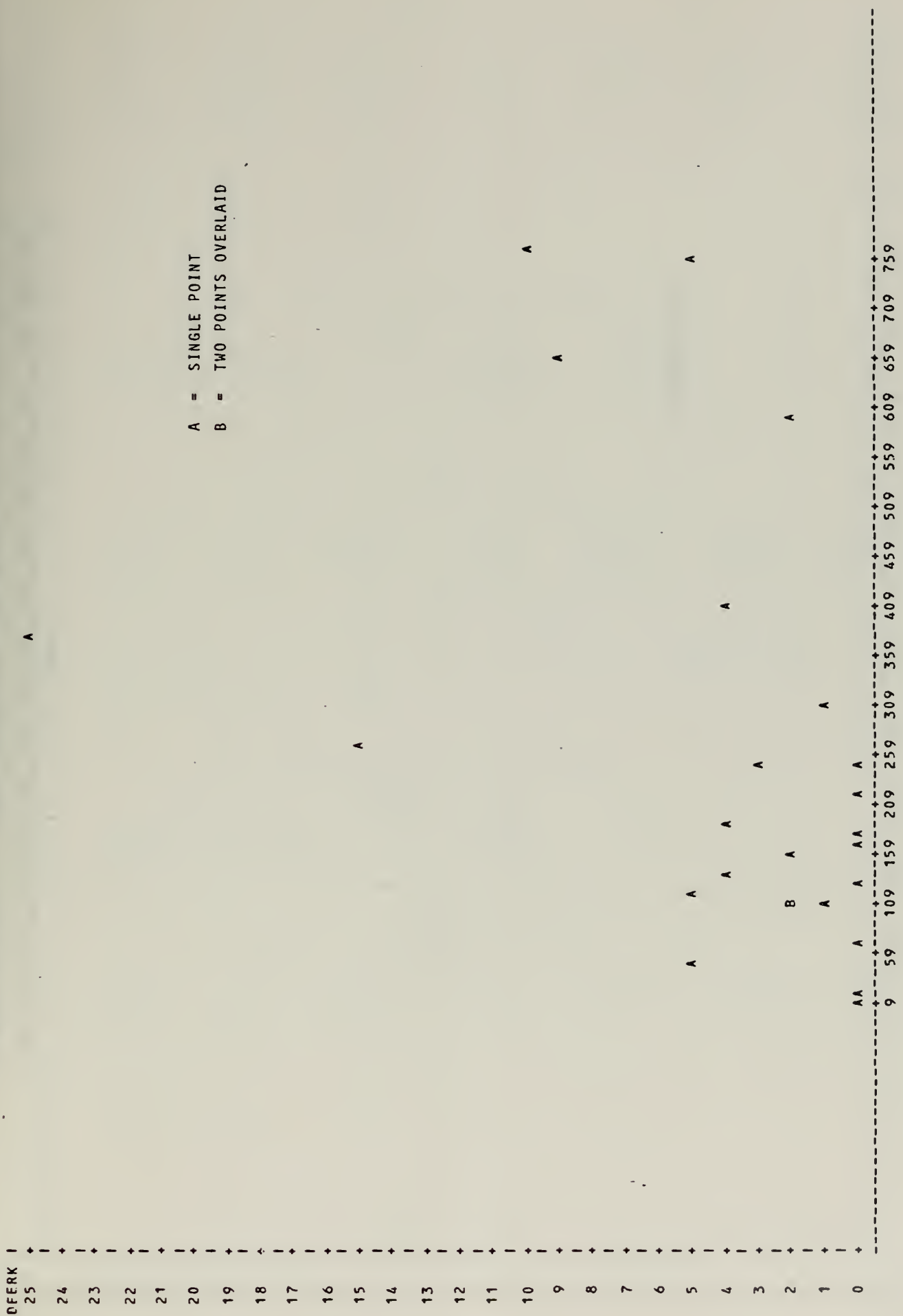

DEERC

Figure A12.3.2-2 PLOT OF DEER KILL AND INCOMING CARS AT GUARD SHACK

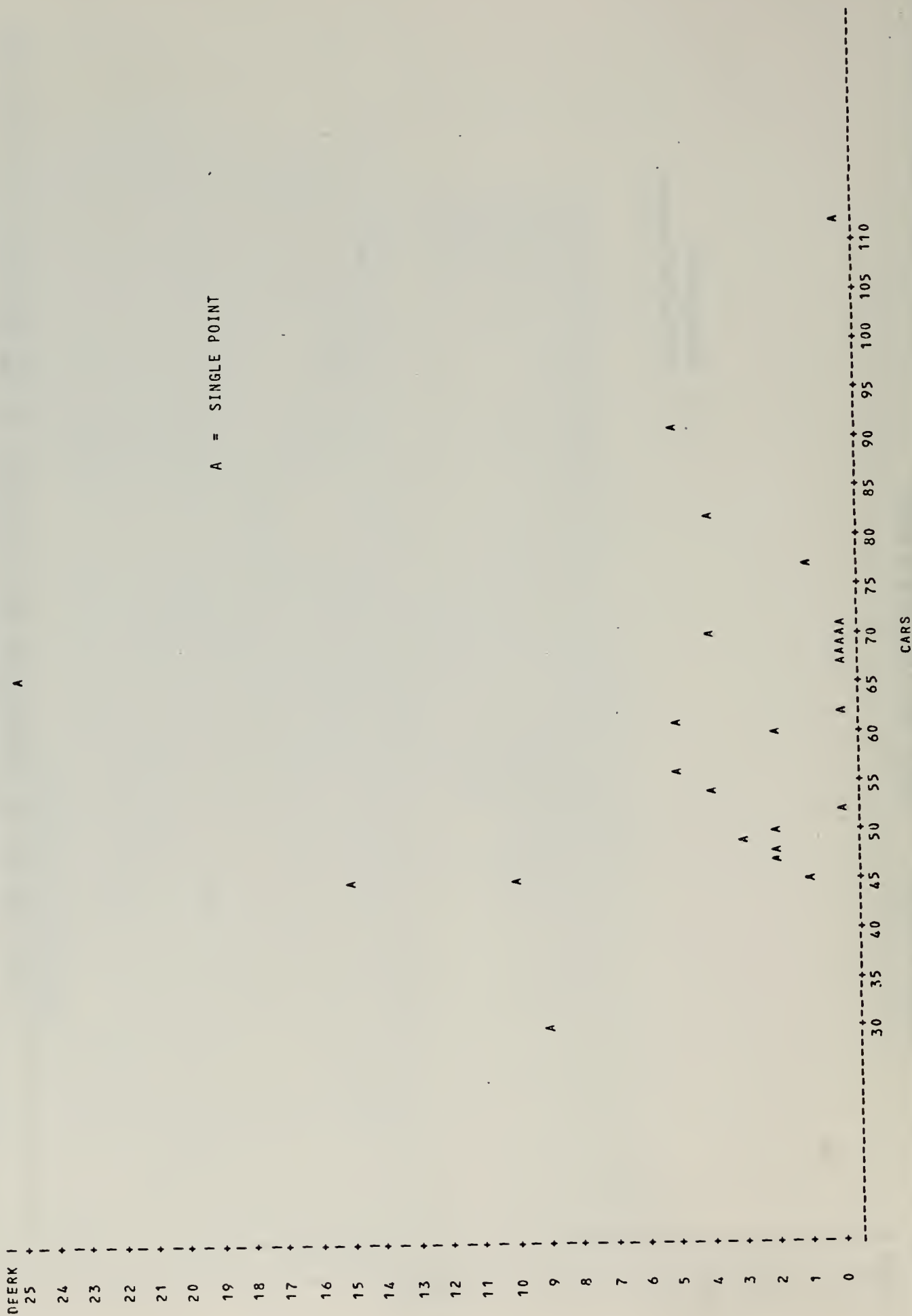

Figure A12.3.2-3 PLOT OF DEER KILL AND SNOW DEPTH

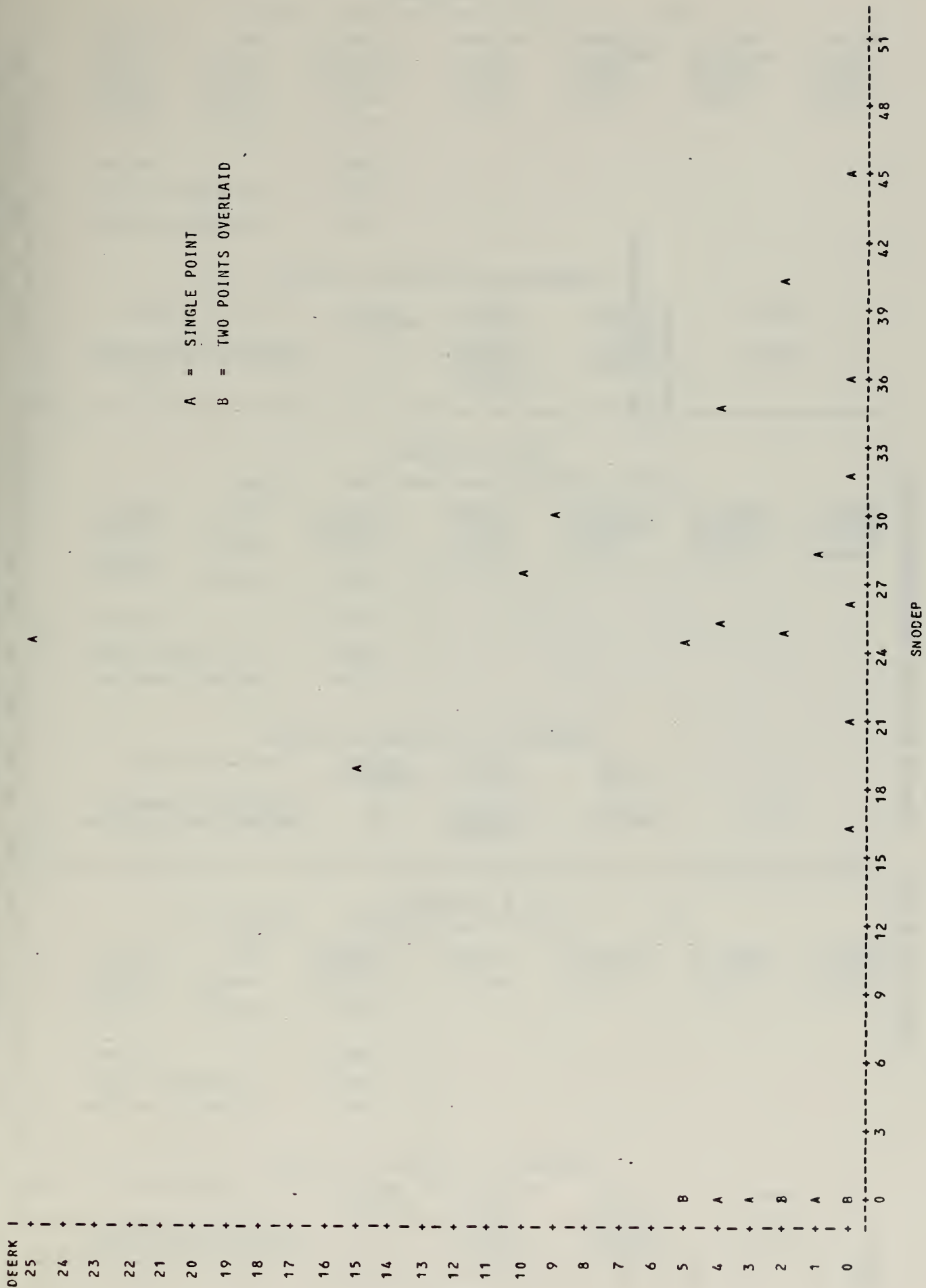

Figure A12.3.2-4 PLOT OF DEER KILL AND PRECIPITATION

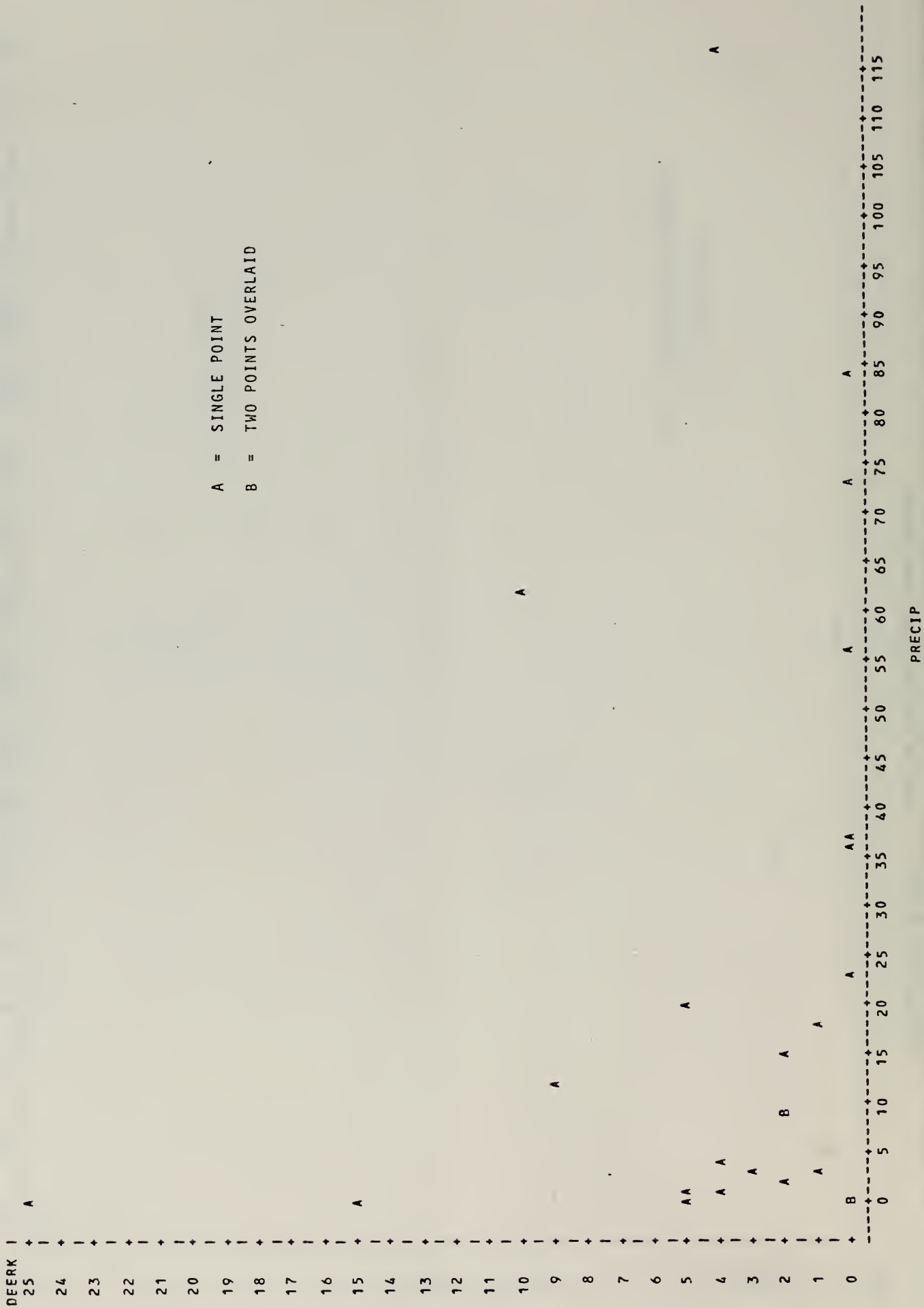

Table A12.3.2-1

STEPWISE		REGRESSION ANALYSIS STATISTICS - STEP 1				
VARIABLE NO. NAME	MEAN	STANDARD DEVIATION	CORRELATION X VS Y	REGRESSION COEFFICIENT	ST. ERROR, OF REG. COEF.	COMPUTED T VALUE
3 OCT1	256.75977	221.43738	0.40638	0.00959	0.00602	1.59243
5 CART	61.87999	17.23685	-0.22698	-0.01038	0.07677	-0.13516
DEPENDENT 9 PREC 2 KILL	23.39999 3.96000	31.52641 5.73352	-0.20645	-0.02918	0.03604	-0.20956
INTERCEPT		2.82307				
MULTIPLE CORRELATION		0.43667				
STD. ERROR OF ESTIMATE		5.51412				

ANALYSIS OF VARIANCE FOR THE REGRESSION

SOURCE OF VARIATION	DEGREES OF FREEDOM	SUM OF SQUARES	MEAN SQUARES	F VALUE
ATTRIBUTABLE TO REGRESSION	3	150.44177	50.14725	1.64928
DEVIATION FROM REGRESSION	21	638.51709	30.40556	
TOTAL	24	788.95874		

Table A12.3.2-2

STEPWISE		REGRESSION ANALYSIS STATISTICS - STEP 2				
VARIABLE NO. NAME	MEAN	STANDARD DEVIATION	CORRELATION X VS Y	REGRESSION COEFFICIENT	ST. ERROR, OF REG. COEF.	COMPUTED T VALUE
3 OCT1	256.75977	221.43738	0.40638	0.01026	0.00592	1.73318
5 CART	61.87999	17.23685	-0.22688	-0.00654	0.07602	-0.08608
DEPENDENT 2 KILL	3.96000	5.73352				
INTERCEPT		1.73167				
MULTIPLE CORRELATION		0.40673				
STD. ERROR OF ESTIMATE		5.47077				

ANALYSIS OF VARIANCE FOR THE REGRESSION

SOURCE OF VARIATION	DEGREES OF FREEDOM	SUM OF SQUARES	MEAN SQUARES	F VALUE
ATTRIBUTABLE TO REGRESSION	2	130.51462	65.25731	2.18038
DEVIATION FROM REGRESSION	22	658.44434	29.92928	
TOTAL	24	788.95874		

Table A12.3.2-3

STEPWISE		REGRESSION ANALYSIS STATISTICS - STEP 3				
VARIABLE NO. NAME	MEAN	STANDARD DEVIATION	CORRELATION X VS Y	REGRESSION COEFFICIENT	ST. ERROR, OF REG. COEF.	COMPUTED T VALUE
3 OCT1	256.75977	221.43738	0.40638	0.01052	0.00493	2.13300
DEPENDENT 2 KILL	3.96000	5.73352				
INTERCEPT		1.25534				
MULTIPLE CORRELATION		0.40638				
STD. ERROR OF ESTIMATE		5.35142				

ANALYSIS OF VARIANCE FOR THE REGRESSION

SOURCE OF VARIATION	DEGREES OF FREEDOM	SUM OF SQUARES	MEAN SQUARES	F VALUE
ATTRIBUTABLE TO REGRESSION	1	130.29294	130.29294	4.54971
DEVIATION FROM REGRESSION	23	658.66602	28.63765	
TOTAL	24	788.95874		

THIS PAGE
INTENTIONALLY LEFT BLANK

Form 1279-3
(June 1984)

BORROWER

TN 859 .064 03
C-b Shale 0111
C.B. annual rep

DATE LOANED	BORROWER

USDI - ELM

