

FOR THE PEOPLE
FOR EDVCATION
FOR SCIENCE

LIBRARY
OF
THE AMERICAN MUSEUM
OF
NATURAL HISTORY

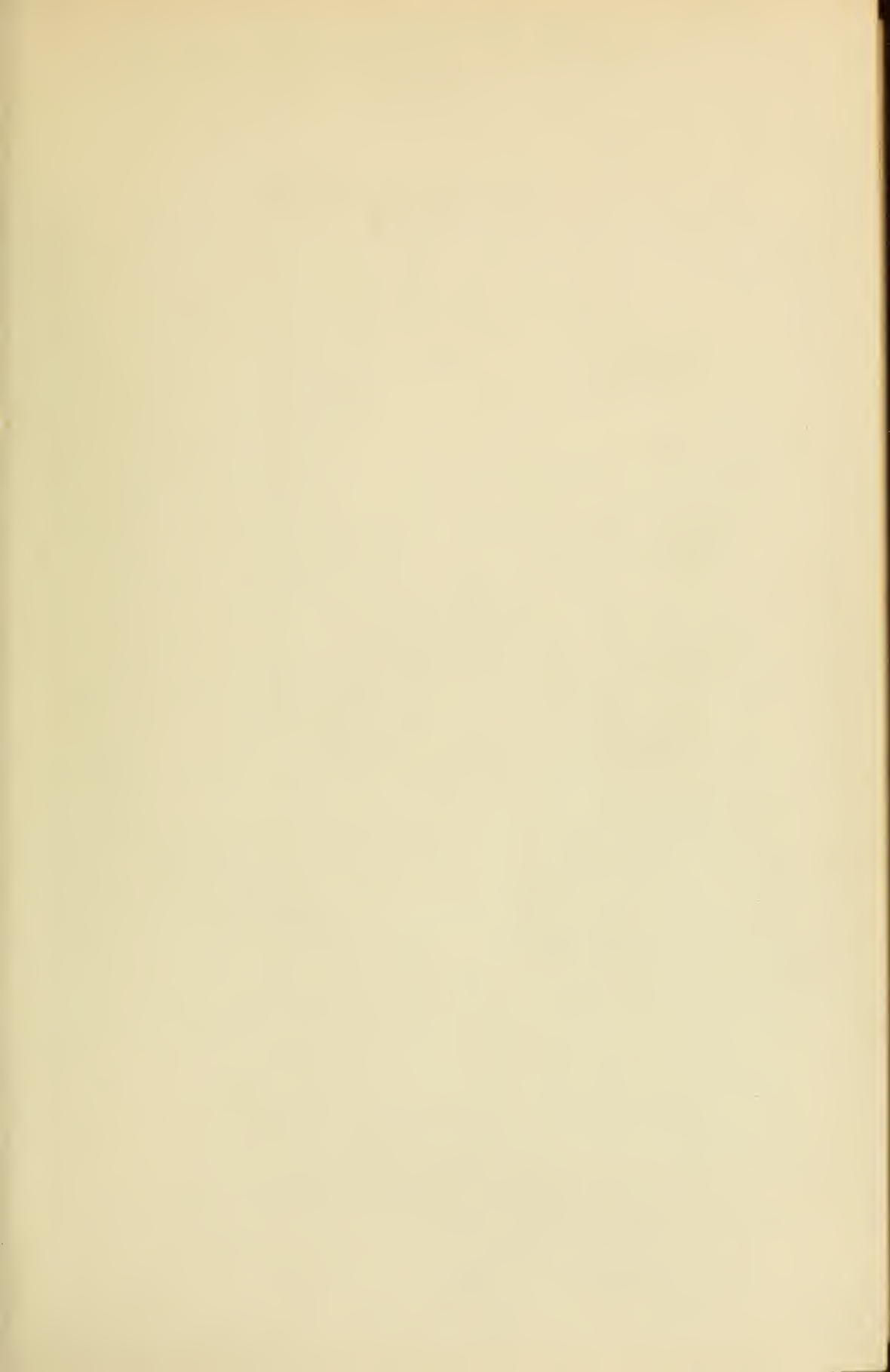







GUIDE TO THE HALL OF BIOLOGY OF MAMMALS

BY ROBERT T. HATT



THE AMERICAN MUSEUM OF NATURAL HISTORY
NEW YORK CITY

THE MAMMAL HALLS OF
THE AMERICAN MUSEUM OF NATURAL HISTORY

1. Hall of the Biology of Mammals. Third Floor, Sec. 3.
2. North American Mammals. Second Floor, Sec. 3.
3. South Asiatic Mammals. Second Floor, Sec. 9.
4. Marine Mammals. First Floor, Sec. 10.
5. North Asiatic Mammals. In Preparation.
6. African Mammals. In Preparation.
7. Primates. Third Floor, Sec. 2.
8. Mammal Photographs. Third Floor, Sec. 2.
9. Horses. Fourth Floor, Sec. 2 West
10. Fossil Mammals. Fourth Floor, Secs. 2 and 3.
11. Introduction to Anthropology. Third Floor, Sec. 4.

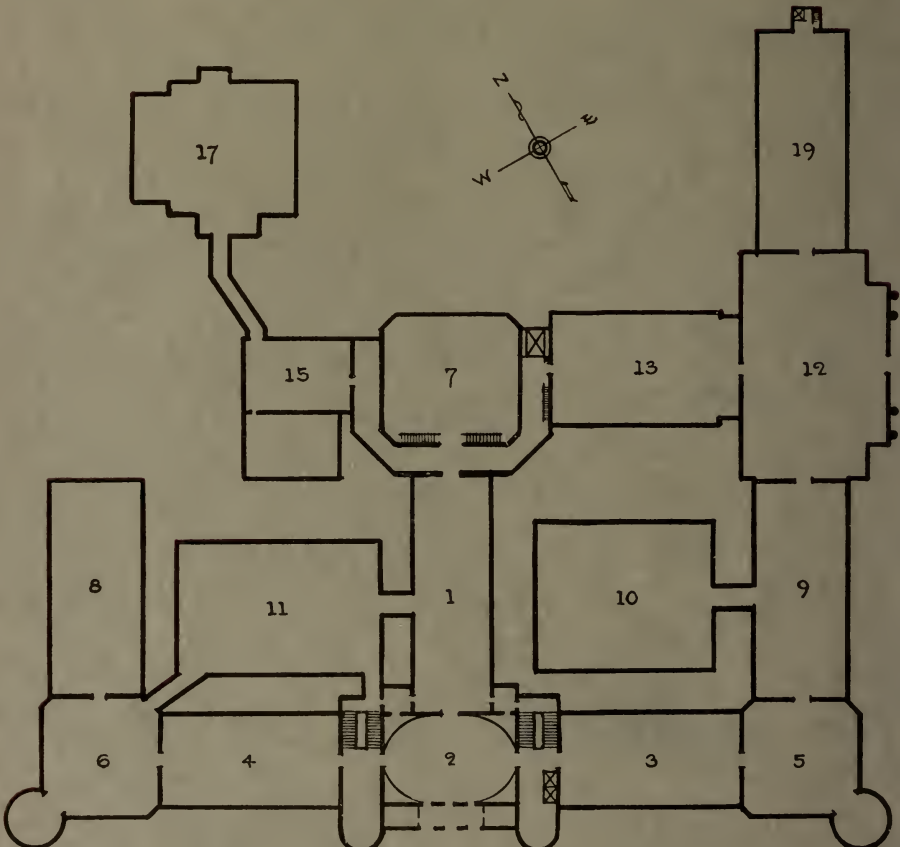

FLOOR PLAN OF THE MUSEUM

GUIDE TO THE HALL
OF
BIOLOGY OF MAMMALS



E.S. Lucas - del.

R. THATT - 1932

THE FAMILY TREE OF MAMMALS

GUIDE TO THE HALL OF
BIOLOGY OF MAMMALS

IN
THE AMERICAN MUSEUM
OF NATURAL HISTORY

By ROBERT T. HATT



GUIDE LEAFLET SERIES No. 76

PUBLISHED BY THE MUSEUM PRESS
NEW YORK
1933

FLOOR PLAN OF THE HALL

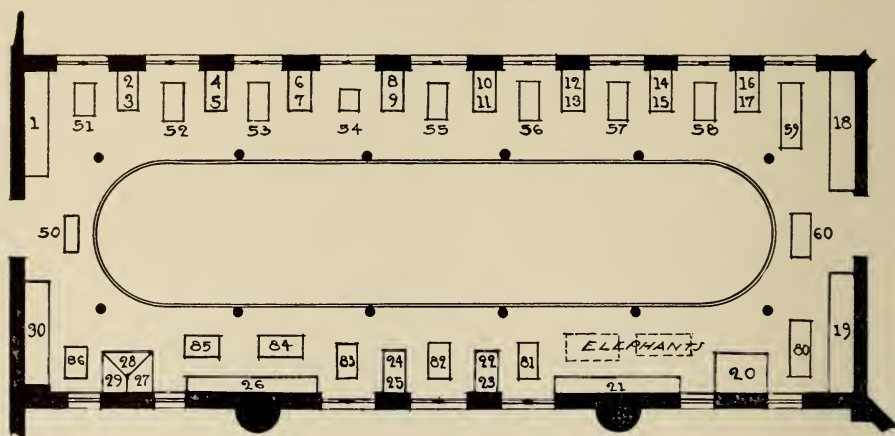

The numbers are those which may be found marked on the cases. Reference to these cases is given in bold faced type in this Guide.

GUIDE TO THE HALL OF THE BIOLOGY OF MAMMALS

BY ROBERT T. HATT

This booklet is intended primarily as a guide to the synoptic series of mammals and the exhibits of mammalian biology that constitute the "Hall of the Biology of Mammals." It is hoped, however, that enough information is contained within the covers to make its interest extend beyond the walls of this Museum and that it may serve to refresh the memory of the visitor whose stay at the Museum was all too brief.

The visitor will find it convenient to study the exhibits from left to right. Doing this he will view in approximate order of specialization the larger natural groups or ORDERS of mammals. The exhibits pertaining to general mammalian biology are not, because of the limitations of space, grouped in any systematic order, but by following this guide much of broad interest may be found in the Hall that might otherwise escape notice.

THE MAMMALS PLACE IN THE ANIMAL KINGDOM

The animal kingdom is composed of an infinite variety of species which may be divided into about twenty major groups or phyla whose interrelationships are obscured by the antiquity of their origin. Some of these are structurally very simple and are thus called primitive. Others are of extreme complexity. A world-famed exhibit of these phyla may be seen in Darwin Hall on the first floor of the Museum. The mammals clearly belong among the phylum Chordata of which the chief examples are the vertebrates or back-boned animals, a group which contains five classes, the fishes, amphibians, reptiles, birds and mammals. Since the Chordata are the most highly organized of the phyla, and the mammals the most highly organized of the chordates, it is customary to place them at the head of the animal kingdom as is done in the "Tree of Animal Life" illustrated in Case 2. It must, however, be borne in mind that every living animal is in its own way greatly specialized for its particular mode of life and that the terms "highest" and "most primitive" are only relative.

What is a Mammal?

A mammal may be defined as any species of animal in which the young are nourished for a time on milk, a secretion of specialized cutaneous glands. The mammals constitute a natural though widely diversified, group of the vertebrate or backboned animals. All, at some period in their existence, bear a coat of hair, though in some groups such as the whale and man, this is largely lost before birth. In contrast to lower classes of vertebrates (fishes, amphibians and reptiles) the mammals have a comparatively constant body temperature, which is different for different species but notably lower in the primitive group, the monotremes (3). The body temperature may rise above normal in disease or become considerably lowered in a state of hibernation. The adrenal glands appear to act as the thermostat which coordinates the various elements of control.

This high and constant body temperature is associated with a complicated heat regulating mechanism. Among the mammalian characters composing this complex is a muscular sheet, the diaphragm, which by rhythmic pumping movements furnishes a more constant air supply than is enjoyed by other vertebrates.

A richly glandular skin by controlling surface evaporation aids in regulating body temperature. The skin contains two main types of glands, the sudoriparous or sweat glands, and the sebaceous or oil glands. These latter are ordinarily associated with hair follicles, and their secretion aids in keeping hair in good condition. The sudoriparous glands control evaporation and eliminate waste. They are regionally differentiated to several uses. The lacteal or milk glands are specialized sweat glands.

Mammals all possess a four chambered heart which keeps the well oxygenated blood coming from the lungs completely separated from the poorly oxygenated blood entering the heart from the body circulation. This efficient arrangement occurs only among the birds and mammals.

The brain is proportionately larger in the mammals than in other vertebrates by reason of enlargement of the fore brain or cerebrum. It is this part of the brain which accounts for the greater intelligence of the mammals and which is proportionately larger in man than in most other animals.

The skulls of mammals have the brain case comparatively larger than the skulls of other vertebrates, except certain birds which is an accommodation to increased brain size. The roof of the skull is simplified

by the loss of a number of bones found in more primitive vertebrates. Similarly the mandible or lower jaw has had the number of bones reduced to one.

In mammals there has developed a secondary bony palate in the roof of the mouth. The skull is hinged on the vertebral column by a pair of condyles in contrast to the single condyle of reptiles.

Mammals have three minute bones in the inner ear which are not represented as such in other vertebrates. The history of these bones has,

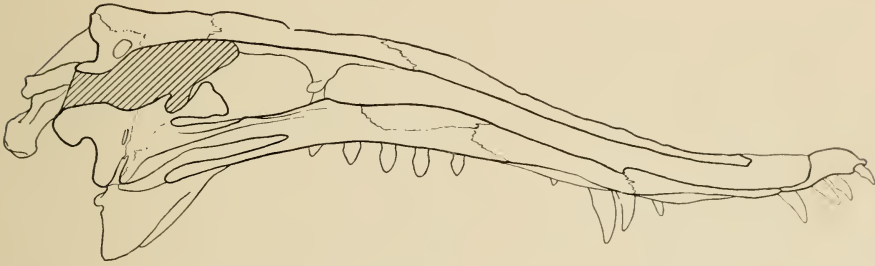

THE BRAIN CAVITY OF A REPTILE SKULL

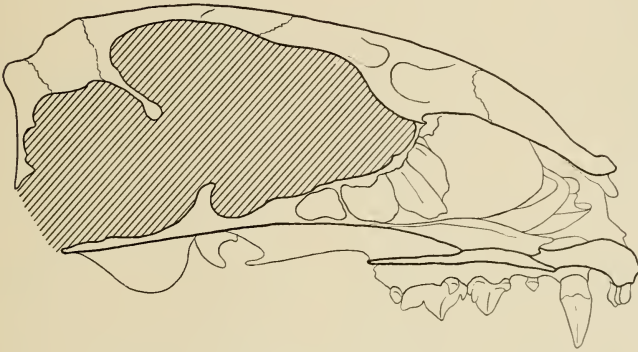

THE BRAIN CAVITY OF A MAMMAL SKULL

however, been traced. The *incus* or anvil bone is represented in other vertebrates as the *quadrate*; the *malleus* or hammer bone by the *articular* bone of the lower jaw. The *stapes* or stirrup bone occurs in fishes as the *hyomandibular*, and in other vertebrates as the *columella*.

The teeth of mammals are usually more highly differentiated than are those of more primitive vertebrates. Typically they are regionally differentiated from front to rear into incisors, canines, premolars and

molars. In such an animal as a monkey the incisors are used chiefly to cut off food, the canines for fighting, the premolars for further breaking up of food, and the molars for the final crushing. In various types of mammals the teeth are variously modified for special purposes. (83).

The mammals it is clear, evolved from the reptiles through a fossil group, the Theriomorpha, of which fossils are found in the Permian beds of South Africa. These animals possessed characters of the teeth and skeleton which are distinctly intermediate between those of reptiles and primitive mammals. The exhibits in Case 1 show the skulls of some Theriomorpha and many of the anatomical features by which the mammals and reptiles differ.

In mammals the vertebral column is typically well differentiated into five regions, the *cervical* or neck, the *thoracic* or rib bearing, the *lumbar*, the *sacral* which forms part of the pelvis, and the *caudal* or tail.

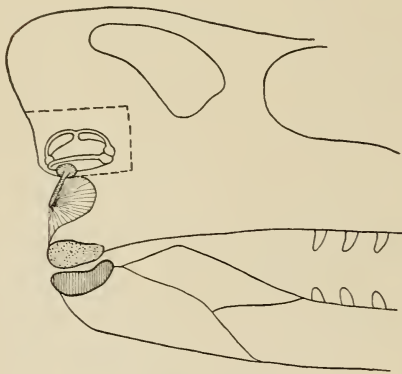

REPTILIAN

The forerunners of the mammalian ear ossicles as they lie in the reptile skull. The columella is indicated by horizontal hatching; the quadrate by stippling, the articular by vertical lines

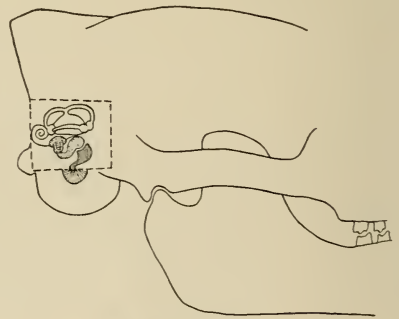

MAMMALIAN

The ear ossicles of mammals. The stapes is the equivalent of the columella, the incus is derived from the quadrate, and the malleus from the articular

In almost all mammals there are seven cervical vertebræ. In the giraffe these are excessively elongated and in the whales excessively compressed. Only in the manatee (21) and a species of two-toed sloth (16) is the number reduced to six and only in the three-toed sloths is the number increased, here to nine.

The mammals develop bony ends or *epiphyses* on the limb bones (rare in reptiles) and on the vertebræ. It is between these epiphyses and

the shafts of the bones that growth in length takes place. When the sutures between them close growth stops (23).

The limbs of mammals are more efficiently constructed for rapid and sustained locomotion than are those of the other quadrupedal land vertebrates. The legs are brought more directly under the body, the length of the bones is usually increased and the joints tend more and more to limit motion to a fore and aft direction.

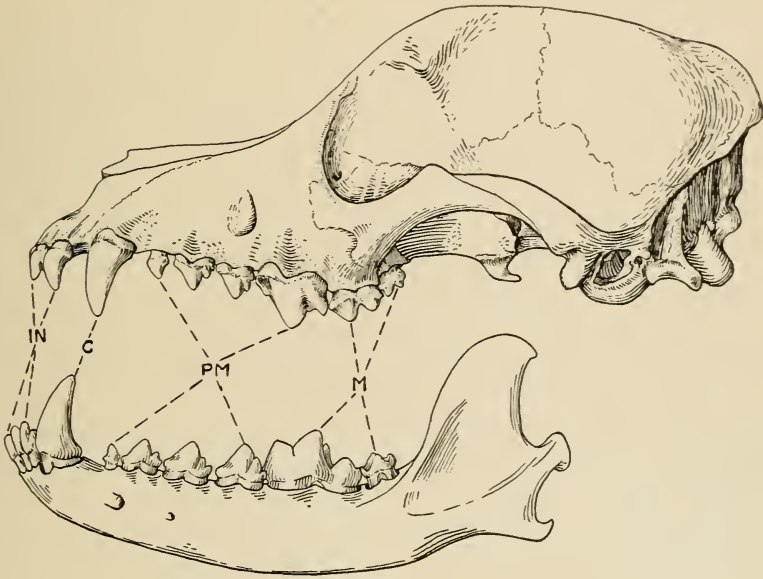

THE DENTITION OF A DOG

In generalized mammals the teeth are differentiated into incisors (IN), canines (C), premolars (PM), and molars (M)

THE LIVING ORDERS OF MAMMALS

MONOTREMATA



ECHIDNA

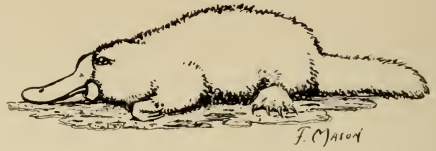

PLATYPUS

Monotremata. Egg laying mammals. Monotremes. (3). The monotremes are a small group of archaic mammals confined to the Australian region. They are considered the most primitive of all living mammals because they retain a number of reptilian characters among which are the reptile-like shoulder girdle, low body temperature, and egg laying habit. All higher animals and most primitive forms develop from fertilized eggs. In the monotremes, as in the birds, these eggs are surrounded with a shell and passed from the body shortly after fertilization. They are equipped with a large amount of yolk which serves as a food supply for the developing embryo. Among the higher mammals the fertilized egg contains little yolk and is retained within the body of the mother for the early period of development. The embryo here obtains nourishment from the maternal blood supply. The eggs of such mammals are never equipped with a shell.

The only representatives of the order Monotremata are the echidna or spiny anteater and the duck-billed platypus. These animals, though retaining primitive structures, are highly specialized to particular modes of life. The spines and toothlessness of Echidna are not primitive, nor are the poison secreting fighting spurs, the duck-like bill, webbed feet and horny teeth of the platypus.

Marsupalia. Pouched mammals. (4, 5, 52, 28, 29). The marsupials retain more primitive characters in their structures than any order except the monotremes. They are an interesting and diversified group confined at present to the Australian region except for the opossums and Cœnolestidæ which occur in the Western Hemisphere. In the mammals of this Order the young are born at a very early stage of development and make their way into the pouch of their mother where they become fastened to nipples. In this pouch they are carried until they are able to shift for themselves. (See well-case opposite 4).

MARSUPIALIA

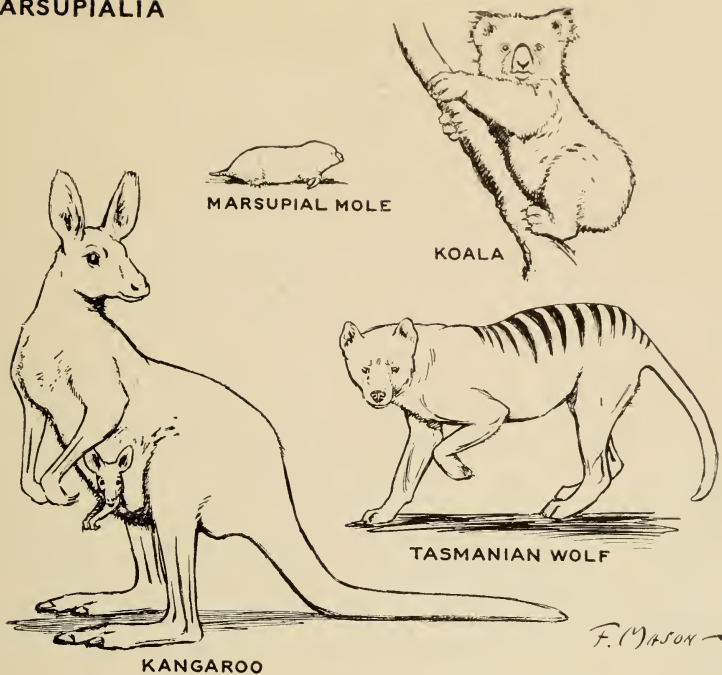

The marsupials have successfully invaded almost every realm of specialization except that of flying. Some leap, others climb, run, sail in the air, swim or dig like moles. Some eat flesh, some insects and others grass. One member of the Order, *Myrmecobius*, the marsupial anteater, possesses 54 to 56 teeth, the greatest number found in any land mammal. Marsupials are the only land mammals of Australia other than monotremes, man, bats, rats and mice, and the wild dog or dingo.

Insectivora. Insectivores. (6, 7). The insectivores are small primitive mammals, generally of flesh eating habits, that have survived the struggle for existence in part by the advantage of a high birth rate and the specialization to feeding habits in which few mammals compete with them. The members of the Order obtain their prey of beetles, grubs, worms and snails by burrowing in the earth, by hunting along its surface, by climbing trees, or by swimming. The muzzles of most of them are sharply pointed, a shape adapted to seeking out insects in the small cracks and holes in which they are apt to conceal themselves. Burrowing is best developed among the Talpidæ or moles, and the Chrysochloridæ or golden moles. These animals have modified the feet

into powerful digging members. An opposite extreme of locomotion is attained by the Macroscelididæ or jumping shrews which bound along in kangaroo fashion on their elongated rear legs. The Potomogalidæ or African water shrews have webbed feet and a powerful sculling tail. The tree shrews or Tupaidæ are remarkably like tree squirrels in habits and in appearance. They are of unusual interest to us in that they are probably descendants of the same stock from which the Primates (lemurs, monkeys, apes and men) originated. The hedgehogs or Erinaceidæ are spiny creatures of the old world, and externally resemble some members

INSECTIVORA

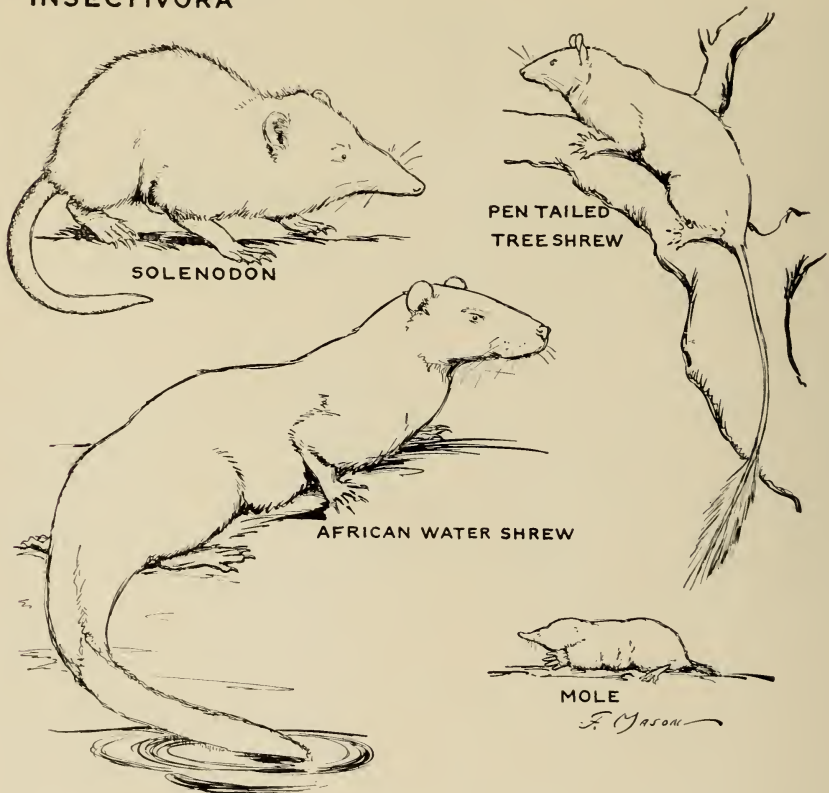

of a Madagascar family of insectivores, the Tenrecidæ. The shrews or Soricidæ, whose soft velvety pelage is in extreme contrast to the spiny armour of the hedgehogs, contain among them the smallest mammals of the world. One other family, the Solenodontidæ is confined to a single genus of an ancient stock surviving because of its isolation from modern enemies on the two islands of Cuba and Haiti.

DERMOPTERA

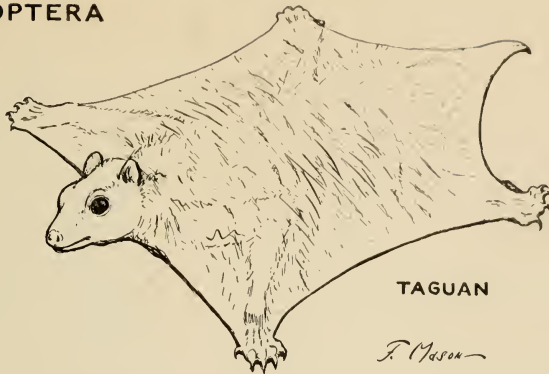

TAGUAN

Dermoptera. Taguans. (7). The members of this Order are a strange group of oriental mammals which are equipped with large skin folds stretched between the legs and tail by which they glide through the air from tree to tree in the manner of our flying squirrels. One of the peculiarities of the taguans is the unique comb-like edge of the incisor teeth. Their molars are multi-cusped and suited to cutting up the leaves upon which they feed. Though having some characters of the insectivores, the Dermoptera are so entirely different from this group that they are usually placed in an order by themselves. It has been assumed that they are descendants of the same primitive stock as the bats, the tree shrews and the primates. The only English name for the taguans is "flying lemur" which is inappropriate inasmuch as they are not lemurs and do not fly.

Chiroptera. Bats. (8, 9, 20). The bats are the only flying mammals. They are not birds in any sense, but like other mammals give birth to living young which feed on milk. Their flying habits limit their modifications, but in spite of this they present a strong diversity, several hundred species having been described. In size they range from the "flying foxes" of the Philippines (20) whose wings attain a five foot spread to tiny insect eating bats which with wings folded could rest on a silver dollar. Bats may be fruit eaters, insect eaters, blood-suckers (the vampires) or, in the case of an Indian bat, may feed on frogs, lizards, small birds, mice and even other bats. A bat of the West Indies has specialized

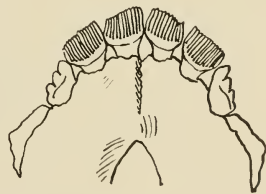
The comb-like incisor teeth
of a taguan

CHIROPTERA



BAT

for fish-eating. Bats' teeth present many modifications of this primitive formula and range in number from 38 to 20.

Some bats are noteworthy for the peculiar skin structures developed on the face. These carry sensory nerve endings which are doubtless of great importance to them while flying in the dark. One group of bats bear suction cups on their wings, which enable them to cling to smooth surfaces.

Carnivora. Flesh eating mammals. (10-13, 51, 53-56). The carnivores fall naturally into two large groups that are by some consid-

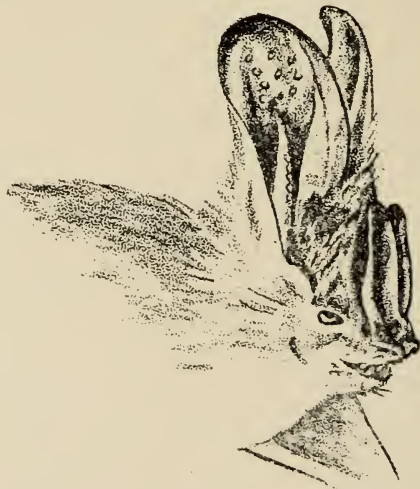

The sensitive ears and skin folds of a leaf-nosed bat

CARNIVORA
FISSIPEDIA



GIANT PANDA



CHEETAH



AARD WOLF



MONGOOSE



COATI MUNDI



MALAY BEAR



SEA OTTER

F. Mason

ered separate orders. These are the Fissipedia or terrestrial carnivores, and the Pinnipedia or aquatic carnivores.

The Fissipedia are divided into a number of families which are of such universal interest that they may be separately characterized.

The Viverridæ, which are not represented in the New World, are

typified by the civets, genets and mongooses. One form, the fossa (*Cryptoprocta*, 53) found in Madagascar is very cat-like. The mongoose of India is famous as a snake killer. From the civets comes a powerful musk used as the base for many perfumes.

The Hyænidæ include several African and Asiatic species which on occasion take living game but typically live off such carrion as they find at the kills of the big cats or other predators. A small relative of the hyænas, the aardwolf of Africa, subsists largely on white-ants and as other animals of similar food habits has a reduced dentition. This animal is placed in a family of its own, the Protelidæ.

The Felidæ or cats, lions, tigers, lynxes, leopards, cheetahs and others are lightly built carnivores with claws which (except in the cheetah) are retractible. They have short heads and, usually, long tails which, however, are never prehensile. The canine teeth of cats are unusually long and well suited to seizing and killing their victims. The cheek teeth are modified into sharp edged shears for slicing up the meat on which they feed. The most aberrant of the family is the cheetah or hunting leopard of Africa and Asia. It is capable of great speed and is sometimes trained to hunt with men.

Amongst the Canidæ are wolves, jackals, dogs and foxes. They are all predatory creatures who usually obtain their prey by running it down rather than by using stealth. Among the more interesting species are the large eared fennec foxes, the short legged, web toed bush dog (*Icticyon*) of South America, and the hunting dogs of Africa, whose coat resembles that of a hyæna.

Exhibits of domestic dogs may be found in Section I on this floor, and also in the Darwin Hall on the first floor.

The Mustelidæ are differentiated as weasels, skunks, badgers, otters, wolverines and others. The family produces some of the finest furs, of which the ermine, sable and mink are well known examples. The most valuable skin individually is that of the sea otter, an animal that is as independent of land as a sea lion. Though once abundant in the North Pacific, this animal is now almost extinct as a result of exploitation. A single hide of this animal has been sold for as much as \$1,400.

The Ursidæ or bears, are large massive animals with rudimentary tails and, ordinarily, shaggy fur. They are omnivorous in their feeding habits and their teeth, in consequence, are not highly specialized. Interesting members of this group are the polar bear, most aquatic of its family, the spectacled bear of the Andes, the little Malay bear which feeds mostly on fruits, and the giant brown bears of Alaska, the largest of living carnivores.

The Procyonidæ are American and Asiatic. The raccoon is here the most familiar member. The kinkajou, or honey bear (54), is a prehensile tailed species living in the American tropics, where one also finds the coati-mundi (54), a form with a long pig-like snout of good service in foraging along the forest floor. The panda, a handsome long-haired animal, brilliantly marked in red, black and white, lives in the Himalayas. In neighboring territory is found the giant panda (56) a rare bear-like

CARNIVORA
PINNIPEDIA

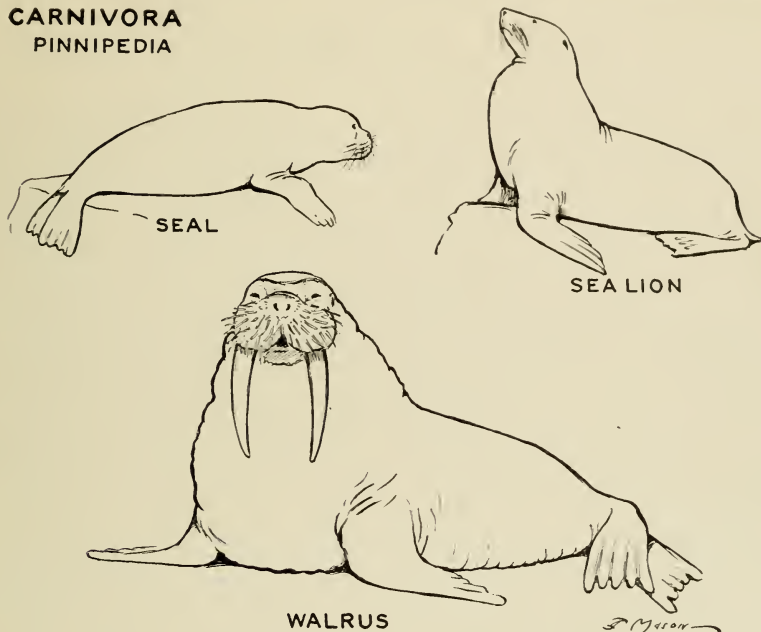

creature, said to feed largely on bamboo shoots. This unique animal, now placed in a family to itself (Aeluropidæ) combines characters of bears and procyonids.

The Pinnipedia or fin-footed carnivores are animals which have taken to aquatic life but which have not lost their dependence of land or ice fields for the birth of their young. The seals, sea lions and walrus which compose this suborder, represent well separated natural groups.

The true seals or Phocidæ are the most aquatic members of the order. Their hind feet are so bound together that they are unable to put them forward and can use them only for sculling action. The teeth which are sharp and often recurved are useful for seizing fish and other creatures upon which they prey, but are useless for cutting up the food.

RODENTIA



BEAVER

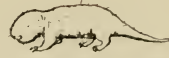

SOMALI BLIND RAT



JERBOA

J. Mason

The eared seals or sea lions (*Otariidæ*) have small external ears and like land mammals can place their hind feet forward for walking. The fur seals of the Pribilof Islands, of which good photographs are on exhibition in Sec. 2 on this floor, are commercially important members of this family. The California sea lion, often seen in circuses and on the stage, can be trained to do a remarkable series of tricks. The walrus (*Odobænidæ*) are somewhat intermediate between the eared seals and the earless seals. They are noteworthy chiefly for their long-upper canine teeth (tusks), which are used for digging up the clams on the ocean floor and for fighting. The flat and massive cheek teeth are adapted to breaking up the heavy shelled molluscs upon which they live. At present they survive only in the Arctic Seas.

Rodentia. Gnawing animals. (14, 15, 57). The rodents are to the Mammalia what the insects are to all the animal kingdom, each eminently the most successful group in its field. Over 2000 species have been described, and these are spread all over the world with the exception of the Antarctic continent and a few remote Pacific islands inhabited only by bats. The rodents have adapted themselves to almost all types of life that other mammals have mastered. The great majority are however small inconspicuous rat-like creatures. The beaver, the muskrat and some others have taken to water life. The pocket gophers and mole rats have become almost as specialized for tunneling habits as have the moles. The jerboas, kangaroo rats and springhaas hop along on their rear feet as do the kangaroos. Some squirrels and other rodents are well adapted to tree living.

The diet of rodents does not vary to extremes. The dental equipment of all of them consists of four large chisel-like incisor teeth in front, a toothless diastema in the region of the lost canine, and a set of

grinding cheek teeth. The incisors consist of a strong band of enamel on the front surface backed by a core of dentine. The teeth working against each other wear away the soft dentine and leave cutting edges of enamel in front. As these teeth grow throughout life the rodent must gnaw to keep them in working order. When anything occurs to interrupt gnawing the teeth grow out in circles, which eventually prevent the animal from obtaining enough food to sustain life. Such deformed teeth may be seen in Case 67. To the rear of the gnawing teeth the lips fold in to form a curtain of skin which prevents splinters of wood, earth or other unwanted material which the animal is cutting, from entering the mouth.

The rodents are divided into many divergent groups. The most important of the sections of the Order are the following:

LAGOMORPHA. Hares, rabbits, pikas. These animals, which are so distinct from the other rodents, that it is sometimes questioned that they arose from the same stock, are characterized by the presence of two minute peg-like teeth immediately behind the large upper incisors.

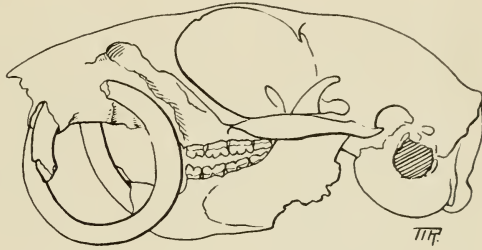

RODENT INCISORS GROW THROUGHOUT LIFE
This squirrel suffered an accident to its mandible which resulted in faulty occlusion of its chiseling teeth. When these no longer wore against each other the teeth grew in circles

Rabbits and hares are known to all. The pikas are small relatives with short legs, short ears, and no tail. Usually, the pikas live among the rock slides of mountains, though they are occasionally found at low altitudes.

SCIUROIDEA. Squirrel tribe. This group of rodents contains such diverse types of animals as squirrels, woodchucks, kangaroo rats, pocket gophers and beavers.

MUROIDEA. Rat tribe. The most wide spread of the rodents are the Muroidea. While the best known types, the house rat and the house mouse are unattractive and are serious pests, numerous others, such as the European dormice are very pretty and interesting. By far the greater number of species are not enemies of man but are either neutral, or his benefactors.

DIPODOIDEA. Jerboa tribe. Though the long legged bipedal jerboas are the characteristic members of this sub-order, several other

TUBULIDENTATA



AARD VARK

families of rodents, among them the scaly tailed flying squirrels of Africa, the American sewellel, and the horned rodents of the Miocene age seem to belong here as distant relatives.

HYSTRICOIDEA. Porcupine tribe. The rat tribe is currently the most successful of the rodents, but the porcupine tribe seems to represent the culmination of rodent evolution inasmuch as its members are most highly adapted to the life of cutting and grinding vegetable matter. The porcupines are not the only members of the group. Others are guinea pigs, chinchillas, agoutis, and the largest of all rodents, the capybara (57). Though almost world-wide in distribution they are predominantly South American.

Tubulidentata. Aard varks. (58). The aard varks, (the name means "earth pig" and was applied to them by the Dutch colonists of South Africa) constitute the only instance of an order being represented by a single living genus. These animals feed almost exclusively on white ants or termites which they dig out with their powerful fore legs. The teeth of the aard-vark are simple cylinders of dentine which are traversed from base to crown by hundreds of minute passages.

The principal foes of the aard-arks, other than arch-destroyer man, are the lions, the wart hog and the python. The lions feed upon the succulent aard varks and the latter two dispossess these termite eaters of their extensive underground retreats.

Aard varks, though known as fossils from Madagascar, Greece, India and Wyoming, are today confined to Africa. Their palaeontological record is, however, fragmentary, and offers little evidence as to their immediate antecedents. The evidence of comparative anatomy indicates that this Order arose from the fore-runners of the ungulates and that the early tube-toothed termite eaters followed an evolutionary course not dissimilar to that of the hyraxes.

Xenarthra. American edentates. (16, 50). The anteaters, sloths and armadillos, though all related, externally have little in common. In spite of the fact that they are called edentates, only the anteaters are truly toothless.

The anteaters have long heads which accommodate the long sticky tongue with which they catch ants. The giant anteater or ant-bear (50) of South America, the largest of the order, attains a length of about five feet, much of which is in its great, bristly, brush-like tail. The tamandua (16) or arboreal anteater, is smaller and carries a prehensile tail. The two toed anteater is also prehensile tailed and arboreal, but is only as large as a squirrel.

The sloths are so modified for tree life that they habitually hang back downwards and walk with great difficulty on the ground. The feet and

XENARTHRA

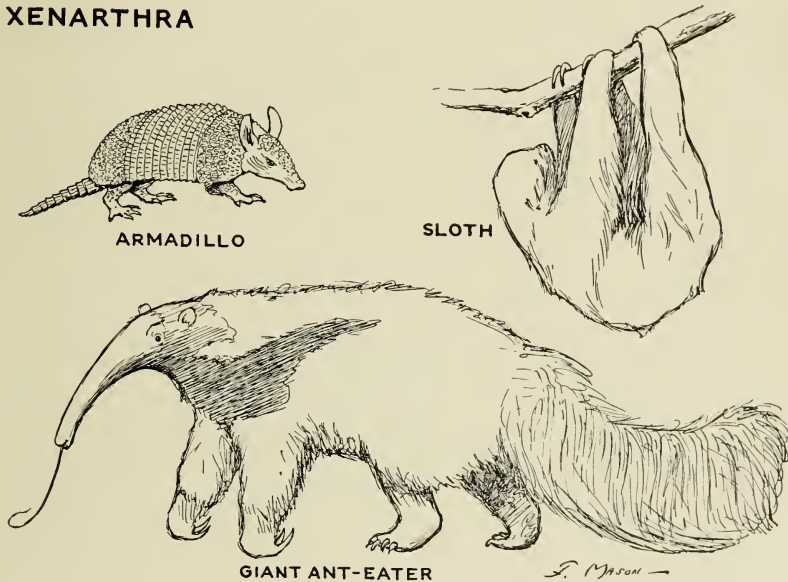

claws are modified into great hooks that circle the branches. The fur which is long and coarse, in one species harbors a growing green plant, (alga) which gives the animal a greenish tinge and makes it very inconspicuous up in the foliage.

Ground-living sloths existed in North and South America until recent times. Some of these grew to be as large as Indian elephants. Skeletons of these are on view in the Hall of the Age of Man.

The armadillos carry on their backs a jointed armour that contains bone. When attacked they roll up in this shelly armour and form an almost impregnable ball.

Only one species is found in the United States, the nine-banded armadillo. In South America lives a pygmy armadillo, the pichiciago (16) which dwells under ground, and carries on its rump a solid plate of bone firmly attached to the pelvis. With this it is said to block up its burrow. The largest armadillo attains a length of about three feet. A fossil related group, the Glyptodonts, sometimes attained a length of sixteen feet. Their great shells lying on the Pampas are said to have served as shelters to the first white visitors.

Pholidota. Scaly anteaters. (17). In Asia and Africa occur animals known as scaly anteaters, manids or pangolins. Externally they are all

PHOLIDOTA

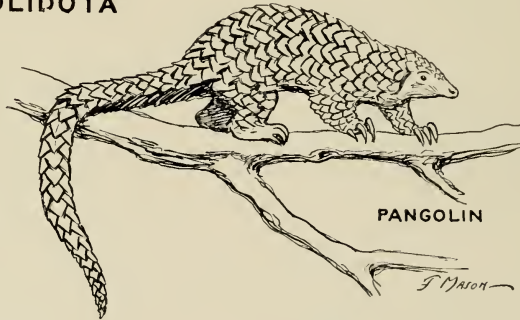

much alike and bear a curious flexible coat of horny scales which probably represent fused bundles of hair or hair rudiments. The scaly coat of the pangolins serves them in many ways. Like the armadillos when attacked, they will curl up into a round ball that presents no soft parts to the enemy. When one of the tree climbing species falls it quickly curls up into a ball, and so efficient are the scales in absorbing shock that even a drop from a great height inflicts no injury. Feeding on ants as they do, pangolins are subject to the vicious attacks of swarming hoards of these biting stinging insects. Here again the smooth scales serve their wearer in good stead for a rapid quivering movement of the body sends the ants flying in all directions. The sharp edged scales of the tail are sometimes used against larger foes, and a hand caught between the scales of the tail and the body may be badly lacerated. Some of the pangolins are arboreal. In these forms the tail acts as a prop when they are climbing, and is so prehensile that it is used as a fifth arm.

Artiodactyla. Even-toed hoofed animals. (18, 60). The artiodactyls are usually large animals, important to mankind in the region in which they inhabit. In the Order the main axis of the foot always passes between the third and fourth digits which are capped with hoofs. The following families constitute the group:

The Suidæ and their close relatives the Tayassuidæ are the pigs and the peccaries which may be identified by their flat-ended snouts and short tails. The diet of all of them is omnivorous.

The Hippopotamidæ are almost hairless, thick skinned aquatic vegetarians. The only living forms are the giant hippopotamus, widespread in Africa, and the pygmy hippopotamus of Liberia. Though these animals secrete a carmine colored fluid from the sweat glands they do not sweat blood as is commonly supposed.

The Tragulidæ or chevrotains (sometimes called mouse deer) are diminutive creatures living in southern Asia and West Africa. They are somewhat intermediate between pigs and deer. Their feet are pig-like, their stomachs have three divisions and the upper jaw bears long saber-like canine teeth.

The Camelidæ are two-toed artiodactyls with a long prehensile upper lip, long necks and legs. They all have thick, long hair which is extensively used for wool. The feet are protected by soft pads of skin.

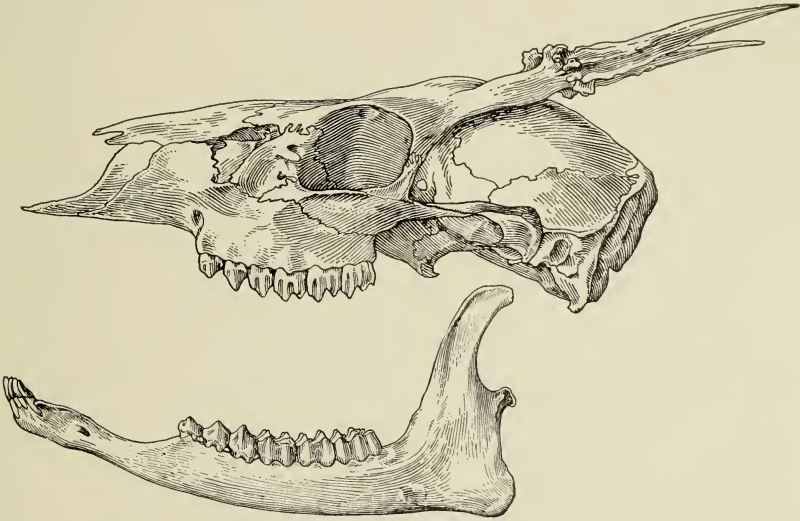

The deer skull typifies the ruminants in which group there are no upper incisors to oppose those in the mandible

ARTIODACTYLA



WART HOG



HIPPOTAMUS



DEER



IBEX

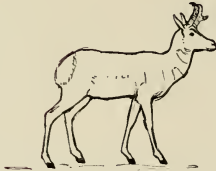

PRONG HORN



CHEVROTAIN

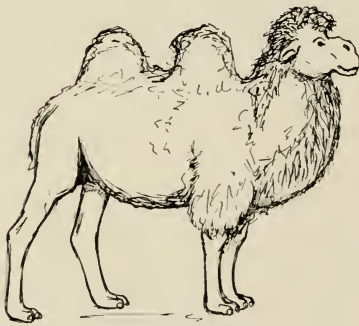

BACTRIAN CAMEL



GIRAFFE

F. MASON

PERISSODACTYLA

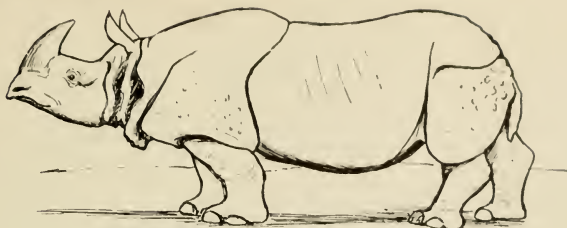

RHINOCEROS



ZEBRA

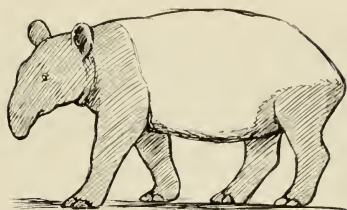

TAPIR

The two species of camel are domesticated. The one-humped species ranges from North Africa to Central Asia. The two-humped or bactrian camel is exclusively Asiatic. In South America the llamas and several allied animals inhabit chiefly the Andean region where two of them, the llamas and vicunia are used as beasts of burden.

The Cervidæ, a family composed of the deer, the moose, reindeer and their allies, are typically species which develop bony antlers which are shed annually. In the caribou and reindeer, both sexes bear antlers, but in other Cervidæ the males only have these fighting weapons. Two aberrant forms, the musk deer and water deer do not have antlers but are equipped with fighting tusks.

A wide variety of the deer of the world is shown in the Hall of Asiatic Mammals and the Hall of North American Mammals.

The Giraffidæ have skin covered antlers on the skulls. In the okapi, a little known animal of the Congo, these occur on the male only. In the giraffes they are found on both sexes.

The Antilocapridæ contains only the American pronghorn, the only animal which has branched hollow horns, and the only hollow horned mammal in which the horns are periodically shed.

The Bovidæ, a family including the oxen, antelopes, sheep and goats, are the hollow horned ruminants whose horns are not periodically shed.

PROBOSCIDEA

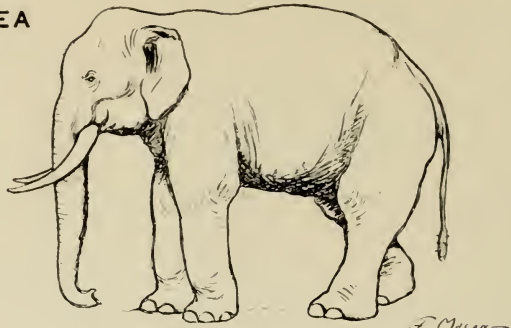

INDIAN ELEPHANT

These horns are in most species present in both sexes, though they are larger in the male. As in the Giraffidæ and Cervidæ, teeth are absent in the front of the upper jaw. The stomach, as in other animals which "chew the cud" is a complicated organ with four compartments, and the intestines are extremely long. This sort of digestive apparatus enables the possessor to get the most out of the flesh-making constituents of the vegetation.

Perissodactyla. Odd-toed ungulates. (19, 59, 80). The Perissodactyla, or tapirs, rhinoceroses and horses, are hoofed animals in which the central axis of the foot passes through the third digit which is always large and symmetrically shaped. In the Equidæ, or horses and zebras, this is the only digit left. The tapirs have four toes on the front feet and three on the rear. Among the rhinoceroses there are three toes on each foot.

The tapirs, horses and rhinoceroses, though now most diverse, were in Eocene time very much alike.

Proboscidea Elephants. (19). The African and Indian elephants are the largest land living mammals, but they do not compare in bulk to the whales. Their exceptional tusks, trunk and many other character-

HYRACOIDEA



HYRAX

SIRENIA

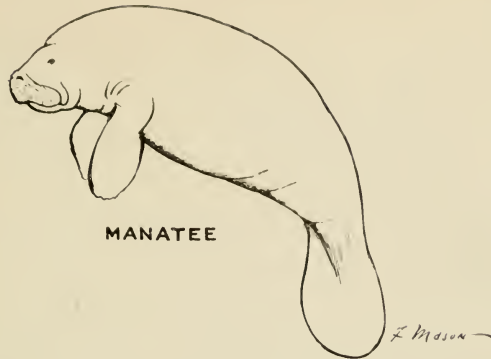

istics set them widely apart from all other mammals. The trunk, which has evolved from a shorter proboscis such as that of the tapirs, is the elephant's indispensable possession. With it he can pick up anything from a peanut to a heavy log. It serves him when he raises water for drinking, dusts or fans himself.

The evolution of the elephant is well illustrated by an extensive series of fossil elephants which may be seen on the fourth floor.

Hyracoidea. Hyraxes. (19). These small rabbit-like animals are, strange though it may seem more closely related to the elephants than to any other existing mammals. On their toes are small rounded hoofs, and on the soles are singular suction pads which give the hyraxes the power to climb trees and rocky surfaces. Their range covers most of Africa and Arabia. It is these animals that are called conies in the Bible.

Sirenia. Sea cows, manatees, dugongs. (21). The Sirenia are naked-skinned aquatic animals that, like the whales have lost their rear limbs and have developed a horizontal fleshy paddle on the end of the tail. Their bones especially in the manatee, are dense and heavy a condition suited to their bottom feeding habits. In contrast to other mammals, their vertebræ lack epiphyses. The existing species all have teeth, but the rhytina had in their place heavy horny pads. The Sirenia are today inhabitants of warm quiet seas and tropical rivers, but the rhytina, which was exterminated by man less than two hundred years ago, lived among the Aleutian Islands.

It is probable that the myth of the mermaids had origin in distant glimpses which sailors had of these animals. With their heads out of water, and sea weed streaming from their mouths, or with a young one held up to the breast, the animals could easily give the illusion of being half human.

CETACEA

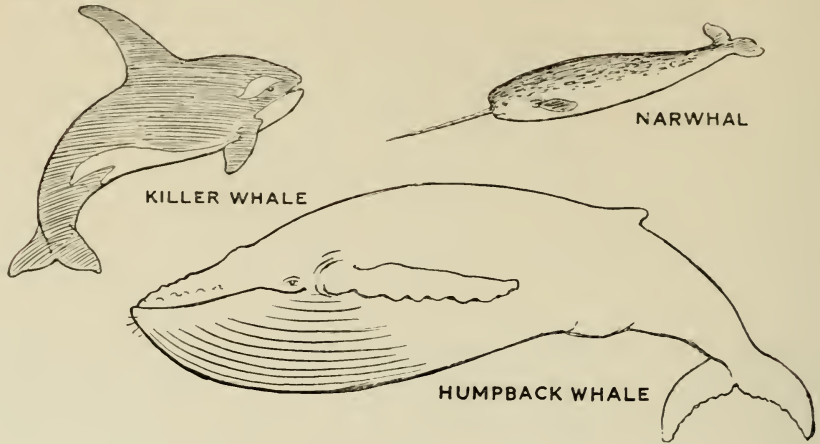

Cetacea. Whales, porpoises, dolphins. (26). The Cetacea are exclusively aquatic mammals which have completely lost their rear limbs, but which in some forms retain a small pair of bony rods deeply imbedded in the flesh that from muscular relations are recognized as the ischia of the pelvic girdle. The tail bears a pair of horizontal flukes that are without bony support, but which probably do all the work of propelling. Unlike the fishes, the whales breathe air into the lungs and do not possess gills. The "spouting" of certain species of whales is due to the condensation of water vapor leaving the lungs and striking the cold air. As other mammals, the whales are warm blooded, their young are born alive and are nourished on milk. The few hairs of the adults are found about the head.

Among the Cetacea are the largest mammals that have ever lived. The longest specimen ever measured was a blue whale of one hundred and three feet.

Primates. Lemurs, monkeys, apes and men. (30). The Primates are, on the whole, a primitive group, but certain specialized forms occur among them. Within the Order the orbit of the eye is protected by a ring of bone or is completely walled off.

Most Primates live an active life in the trees and this environment has left an indelible stamp on the whole group. All four feet are more or less hand-like, the thumb and great toe being set off at an angle to the others so that the feet are able to grasp limbs quickly and firmly. The feet of man are modified for terrestrial existence and the great toe is

PRIMATES

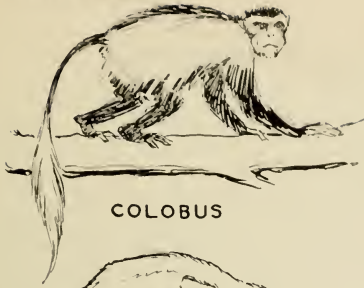

COLOBUS

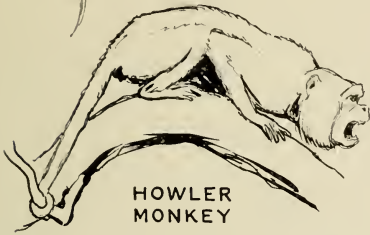

HOWLER
MONKEY



ORANG UTAN



LEMUR



TARSIER



MARMOSET

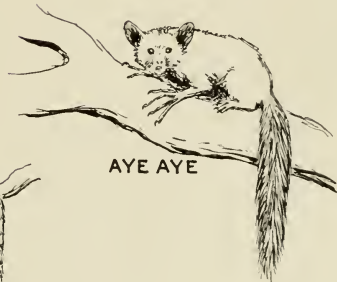

AYE AYE



MANDRIL

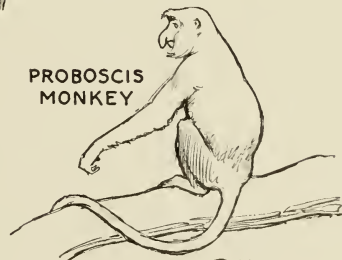

PROBOSCIS
MONKEY

F. Mason

held parallel to the others, but there are still vestiges of the muscles that in our ancestors made this great toe an efficient grasping organ

The brain also reflects the arboreal life of the Primates. Centers of alertness, of intelligence and sight are large, while the brain center connected with smell is poorly developed.

The Lemuridæ are the most primitive members of the Order, the less modified of them have long fox-like skulls, and long tails and are arboreal in their habits. Though found chiefly in Madagascar, specialized forms such as the pottos and galagos, (bush babies) are found in Africa, while others, the lorises, occur in southern Asia. As fossils the lemurs are known from America and Europe as well as from the lands they now inhabit.

The most remarkable of the lemurs is the aye aye (*Daubentonia*) whose rodent-like incisor teeth are used to tear open the tunnels of wood-inhabiting insects, and whose third finger is transformed into a long thin searching probe for extracting the grubs upon which it feeds.

Most aberrant of the primates, possibly excepting man, is the tarsius (*Tarsius spectrum*) which has the hind feet extraordinarily elongated and possesses eyes that are so large that they very nearly touch in the middle. It is also noteworthy for its ability to turn its head in so great an arc that it is able to look directly backwards without twisting its body.

The monkeys of the New World are easily separated from those of the Old World by the character of their noses. In the former group (Platyrrhines) the nostrils are broadly separated, while in the Old World monkeys (Catarrhines) the nostrils, as in men, are close together. Other characters which are chiefly internal also separate the groups.

The New World monkeys may be divided into two families, the Hapalidæ and the Cebidæ. The Hapalidæ or marmosets are small creatures with non-prehensile tails and thumbs which are nonopposable and which, except on the great toe, bear claws instead of nails. The Cebidæ are South and Central American monkeys which usually have prehensile tails. The most familiar are the little capuchin monkeys (*Cebus*) which are common objects in zoological parks. The male howling monkeys possess enormous bony throat pouches which give their voices such tremendous power, that their calls may be heard for two miles. The spider monkeys are species with very long arms, legs and tails. The night monkeys are forms with large eyes that aid in the nocturnal wanderings.

The Old World monkeys (Cercopitheciæ) are most typically represented by the macaques of Asia and the members of the genus *Cercopithecus* of Africa. These animals have ischial callosities and, occasionally, cheek pouches, but never have prehensile tails. Specialized forms of interest are the baboons, dog-like semiterrestrial forms with long faces, powerful bodies and, usually, bad tempers. The mandril of West Africa is the most colorful of all mammals. The Abyssinian colobus monkeys are strikingly furred in black and white. It is the long hair of these animals that is sometimes used for trimming of women's wraps. A group of these monkeys may be seen at the entrance to the Primate Hall. The proboscis monkeys of Borneo are leaf eaters with enormous abdomens. Their name is given for the noses of the males which are very long and pendulous. A rare Asiatic primate, the snub nosed or golden monkey has a short nose turned up at the tip.

The remaining group of sub-human primates, the Anthropoid apes (Pongidæ) contains but five genera, the gibbon (*Hylobates*), the closely related siamang (*Symphalangus*), the orang utan (*Pongo*), the chimpanzee (*Pan*) and the gorilla (*Gorilla*). As man is so closely related to these animals some authors include him in the family, but usually he is placed in one apart, the Hominidæ, characterized by unusual enlargement of the forebrain, and upright posture.

The gibbons and siamang are extremely arboreal types whose hands almost touch the ground when the animal is standing upright. Both genera live in the Malayan countries. The orang utan is a large, tree living, red-haired ape inhabiting Borneo and Sumatra. Chimpanzees and gorillas are closely related forms living in the forested regions of central Africa. The gorilla attains the greatest bulk of any primate. Though features of advanced age mask the similarity, gorilla and man are much alike and probably arose from the same primate stocks in Miocene time.

The visitor who wishes a more comprehensive view of the primates than is obtainable in this Hall may see a wide variety of representative types mounted and as skeletons in the adjoining Primate Hall. One interested in the record of fossil man would do well to visit the Hall of the Age of Man on the fourth floor.

MAMMALIAN BIOLOGY ILLUSTRATED IN THIS HALL

Though the greater part of this Hall is devoted to a systematic arrangement of the principal orders and families of mammals, it has also been attempted to illustrate a few of the more interesting aspects of mammalian biology.

The synoptic series of mammals illustrates to some extent the range of variation in adaptation to environment. In addition to this there are special exhibits which illustrate particular phases of the adaptive radiation of mammals.

ADAPTIVE RADIATION IN THE LOCOMOTOR APPARATUS

As animals of different ancestry have adopted similar modes of life they have tended to become similar in some of their features. Thus the whales and the manatees, mammals of totally different ancestry have both lost the greater part of their hairy coats, rear limbs and external ears, while both have modified the fore limbs into paddles and developed a horizontal fluke on the tail. There are innumerable instances in the animal kingdom of animals that look alike externally and yet are fundamentally different. Several examples of this principle have been assembled in case 29. This approximation of dissimilar stocks is called *convergence*.

Aquatic Adaptations

The most specialized aquatic mammals are the Cetacea, or whales and porpoises, illustrated by the life-sized model of a sulphur-bottom whale suspended from the ceiling, the porpoises above the cases, and by scale models of other whales in Case 26. Other less modified aquatic animals illustrated are the seals and sea lions (12, 28), the otter (29), the Congo water shrew (6, 29), the desman, an European insectivore (29), the manatees and dugongs (21), muskrat (29) beaver, and platypus (3). Specialization for aquatic life results in modification for warmth in cold water which may be a thick layer of fat, as in whales where it is known as blubber, or the development of a thick water resisting fur, as in the muskrat. Food habits become specialized too, and the food catching structures are modified accordingly. One group of whales has developed horny plates of baleen (26) for straining minute animal life from the water. The teeth of the seals are specialized for catching fish, while the teeth of the walrus are heavy and plate-like for cracking clams. The rhytina (21) which fed on soft marine plants, had lost all of its teeth.

The locomotor apparatus is highly modified. The fore limbs may become paddles (Sirenia, Pinnipedia) and the hind feet may be bound together (seals) or entirely lost (Cetacea, Sirenia). In less specialized aquatic animals the toes become webbed. The tail is often an important propulsive organ (Cetacea, *Potomogale*). The bones of the manatee are very dense and heavy to enable it to remain submerged while feeding.

Skeletons of aquatic animals are displayed in Cases 6, 21, 22, 26. Skeletons of the larger whales are on view in the Hall of Ocean Life.

Fossorial or Digging Adaptations

In the soil lies a rich food supply of plants and animals on which many mammals are partially or totally dependent for sustenance. Several groups have become so specialized for this type of feeding that they spend virtually their whole lives in tunnels which they make under the earth. This has resulted in the reduction or total loss of their visual powers which are of no use in their dark world. The fore feet are always shortened and enlarged for digging, while the muscles that operate them are powerful. The neck becomes shortened, and the tail, which can be of little use, is usually short. The best representatives of this type of specialization are the marsupial-mole (*Notoryctes*, 29, 4), the insectivorous garden moles and golden moles (29, 6), the mole-rats (14) and sand rats (15) of the Old World, and the pocket gophers (14) of the New World.

Scansorial or Climbing Adaptations

Many animals are capable of climbing trees, but for obvious reasons large animals are not successful in this life. Animals take to the trees for food to escape enemies, and to build their nests. It would be difficult to name the most successful of tree-living creatures, but without question the sloths are the most highly specialized.

Tree living requires modification of the hands and feet or claws that enable an animal to catch hold of the bark or encircle the limbs. Cats, squirrels and many others have sharp claws for catching in the bark. The sloths (16) have sickle-shaped fingers and claws which enable their bearers to hang below the branches. Tree living primates (30) phalangiers (52) and opossums (4) have strongly divergent great toes that aid the animal in grasping. Some primates such as the spider monkey and gibbon, which are capable of rapid swinging (brachiating) passage through the trees, have the thumb reduced so that it is not in the way when the hand takes hold of a limb in rapid progress. The tree hyrax, (19) tarsius (30) and a bat (*Thyroptera*) are equipped with suction

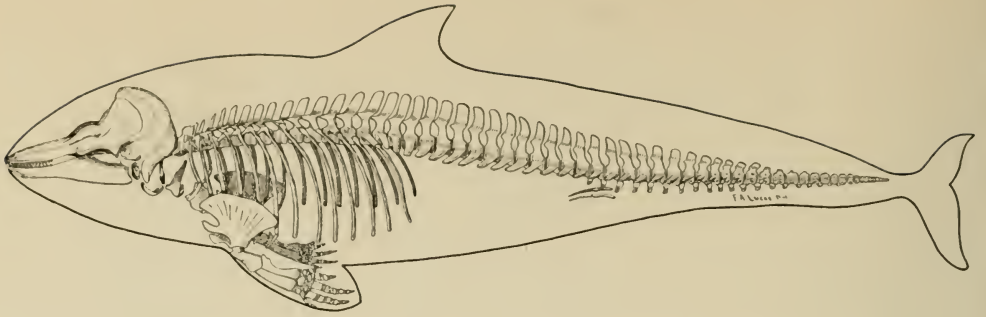

The skeleton of a porpoise, highly specialized for an aquatic life

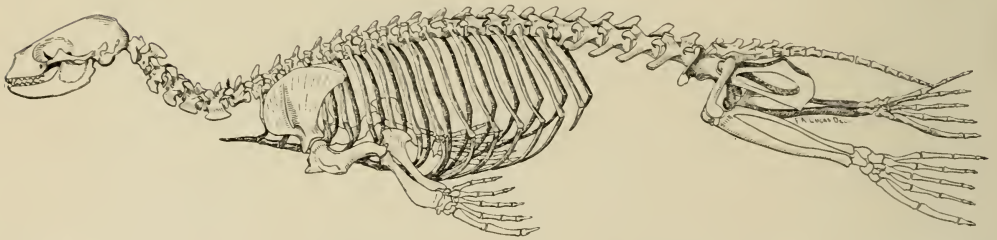

The skeleton of a seal, specialized for an aquatic life but retaining many primitive characters of a land living ancestor

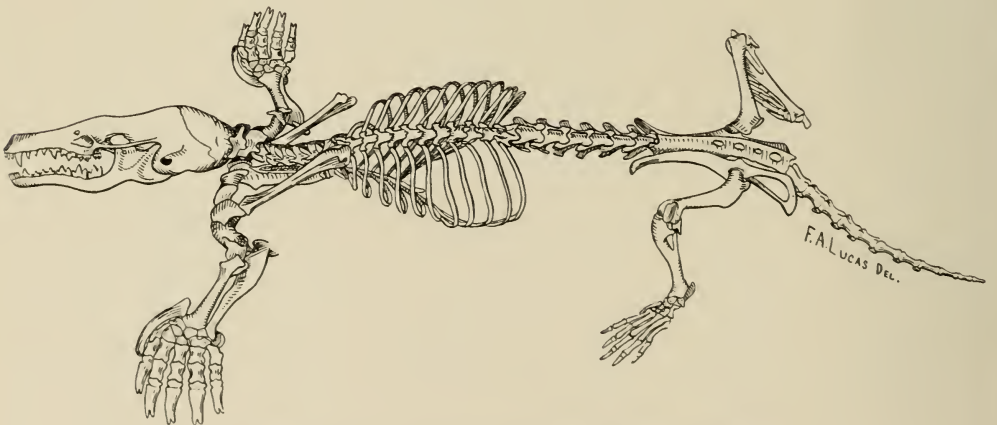

The skeleton of a mole, modified for burrowing in the earth

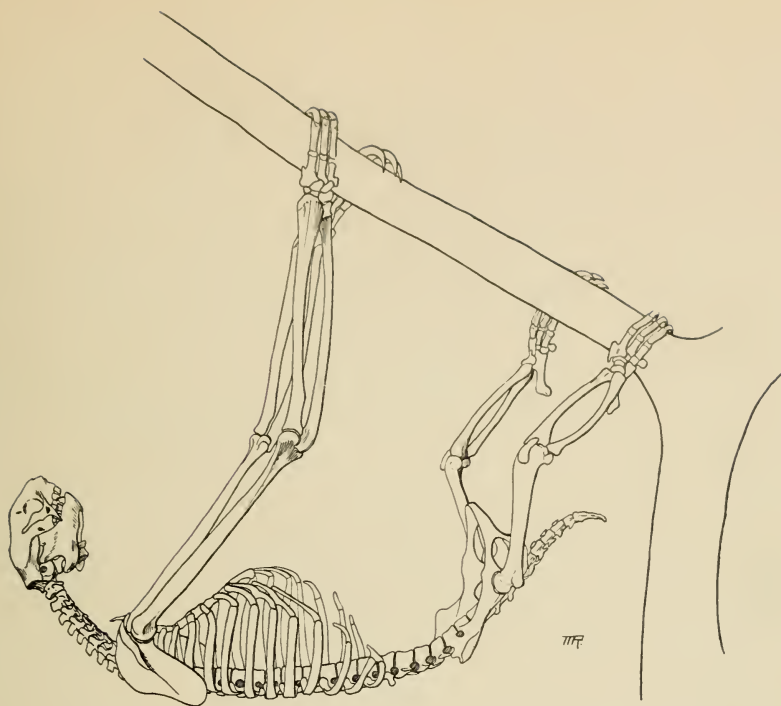

The sloth skeleton adapted to an inverted posture

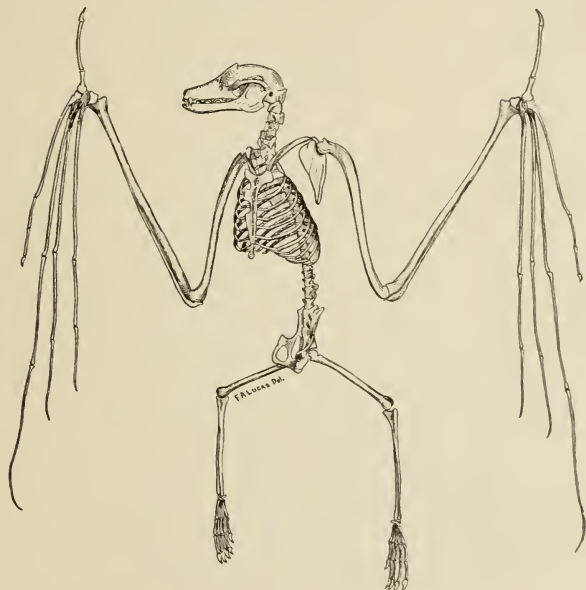

The bat skeleton, specialized for flight

devices that enable them to cling to smooth surfaces. In the hyrax the middle of the fleshy foot pad may be drawn up to create a vacuum, by which means they are said to ascend vertical tree trunks.

Many animals in many orders have developed prehensile tails that act as a fifth suspensive organ. This is found in the opossum (4) and phalangers (52), the kinkajou (54), the tree porcupine, the arboreal manises (17), the tamandua (16), and some New World monkeys (30).

Some of the animals have strong tails with which they may prop themselves against the tree when ascending. The climbing pangolins and the scaly-tailed flying squirrels (14, 29) have not only this adaptation, but in addition possess horny scales which effectively prevent the tail from slipping.

Volant or Flying Adaptations

Only the bats among mammals have developed into true flyers. Their evolution was so remote and the fossil record so poor that we do not know the steps by which this specialization arose. In artful dodging they are not surpassed by the birds, but when not in flight they are very awkward.

In the bats the anatomical specializations for flying have been the tremendous lengthening of the fore arms (8, 9, 20, 22), and the second to the fifth fingers, the great enlargement of the chest muscles which operate the wings, and the growth of the skin to form a web stretching between the fingers and the rear legs. In many of the species the skin extends between the legs and out to the tip of the tail.

Gliding Adaptations

Though only the bats among mammals have mastered true flight, other groups have developed membranes between the fore and hind legs that enable them to glide through the air from a high point to a lower one. This modification has given all of them a superficial resemblance. No one closely acquainted with the animals or seeing them divested of their skins would, however, think of them as related. Here again is illustrated the principle of convergence. Three unrelated types, the flying phalanger, the flying squirrel and the scaly tailed flying squirrel are exhibited in Case 29. Another, the taguan is to be seen in Case 28.

Cursorial or Running Adaptations

Cursorial adaptation implies ability to move not only rapidly but to sustain high speed for a long distance. To do this the limbs must be long and straight (81, 22) the joints must have the movements restricted

chiefly to the fore and aft plane, and the fore and hind limbs must both be strongly developed. The adaptation is best if the point of contact with the ground is limited. The horses (19) are possibly the most perfect examples of this type of adaptation, though many of the artiodactyls (18, 60), particularly antelopes, are excellent runners. In the marsupials the Tasmanian "wolf" (52), is the best cursorial type while among the carnivores, the cheetah and the dogs (53) are the best examples.

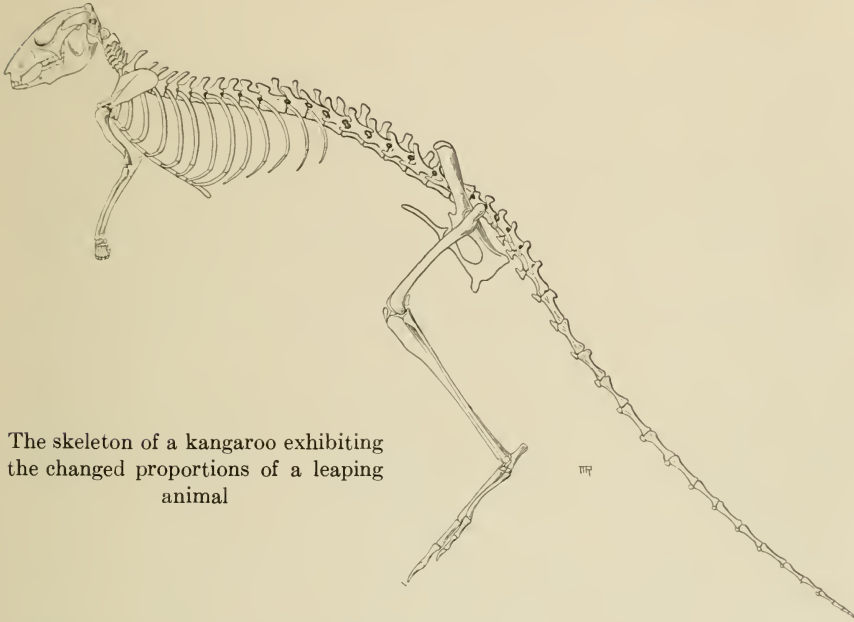

The skeleton of a kangaroo exhibiting the changed proportions of a leaping animal

Saltatory or Leaping Adaptations

Some animals that are defenceless and much preyed upon are modified for great speed, though along lines that are not conducive to the conservation of energy. These animals progress by long bounds and some use only the rear feet when moving most rapidly. In correlation with this the animals have the hind legs greatly elongated. In some the fore legs are remarkably shortened. The tails of the bipedal animals are elongated and serve to counterbalance the body.

The kangaroos (5), are the most widely known of the bipedal leaping animals, but other smaller forms such as the jerboas, (*Jaculus orientalis*, 14) are more highly modified. Other examples are the kangaroo rats (*Dipodomys*, 29, 51), the jumping shrews (*Rhyncocyon*, 7) and *Tarsius* (30).

The giant dinosaur *Tyrannosaurus*, exhibited on the fourth floor, though possessing the exaggerated proportions of a jerboa, was not a leaping animal, but like man, was a bipedal runner.

ADAPTIVE RADIATION INTO AREAS OF EXTREME CLIMATE

Desert Adaptations (51)

In deserts, conditions are unfavorable to ordinary mammals. The heat during the day is apt to be extreme; the food supply is often limited to a short portion of the year, as is too, the water supply; there is little vegetation to furnish concealment or nesting sites, and the light color of the background is such as to render most mammals conspicuous.

To escape the desert heat all of the smaller species are nocturnal in habits, and during the day most of them live in burrows, where the temperature is not excessive. To adapt themselves to the short season when food and water are present in sufficient abundance, some of them spend over half the year underground in a state of dormancy called *æstivation*. For this period of prolonged fast they lay up some stores and put on a large amount of fat.

A few animals, such as the jerboas (14, 29) and kangaroo rats (29), require exceptionally little moisture and may never drink, obtaining what they need from their food. In order to be as inconspicuous as possible desert animals are harmoniously light colored.

Arctic Adaptations

On the Antarctic continent there are no land mammals, but over the ice of the Arctic ocean some foraging species wander and in the land areas well within the Arctic Circle there is a rich fauna. The adverse conditions which the mammals must meet here are but an exaggeration of those found in the cold temperate zones; a period of cold weather which is accompanied by a failing food supply, and a transformation of the landscape into an almost unbroken white expanse against which a dark coat is too conspicuous for the success of predator or the preyed upon.

As protection against the cold, northern animals build a layer of fat which acts as an insulator and a reserve food supply. They also have luxurious fur coats for which they are relentlessly pursued by man. To become inconspicuous, some, such as the weasel or ermine, the snowshoe hare (86), Arctic hares and the Arctic fox change the dark coat of summer to a white coat. The polar bear and Arctic wolf remain light colored the entire year.



Seasonal coat change in some animals, as the weasel is accompanied by a color change which is protective in the harmony it shows in relation to the usual background

The adverse winter conditions are avoided by many animals by migration or by hibernation. Hibernation resembles a deep sleep, in which the pulse rate and body temperature are greatly lowered and the animal's resources are conserved to the utmost.

ADAPTATIONS TO SPECIAL FEEDING HABITS

Carnivorous or Flesh Eating Adaptations

Animals that prey on others must have locomotor and sensory adaptation that will enable them to come upon the other creature. In some cases such as among wolves hunting in packs, the predator depends upon long sustained pursuit to wear down the prey. In cats where hunting is usually done by solitary animals the success of the pursuit is generally dependent on a stalk which culminates in a final quick rush or spring. Once upon the prey the animal must be able to overcome and kill it, strong jaw muscles or a blow from powerful fore legs usually accomplishing this object. Most carnivores are provided with long and strong fangs (canine teeth), (1, 22, 83) with which they may seize and kill the victim. The incisors are short that they may not interfere with the action of the canines. The jaws are short so that leverage is at its best. The Felidæ (10), representing the ultimate carnivorous type, have a pair of cheek teeth modified into large slicing blades that cut the flesh into sizes that may be conveniently swallowed.

Piscivorous or Fish Eating Adaptations

Fish catching animals must first of all be efficient swimmers, and must then be able to seize and hold their slippery, elusive but not powerful prey. For this all of them have sharp recurved teeth which are eminently adapted to this end. Since most piscivorous animals swallow their

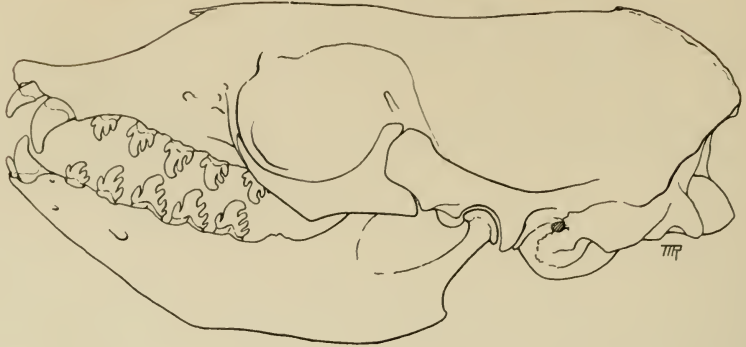

The crab-eater seal has teeth admirably suited to seizing and breaking up the hard shelled crustaceans upon which it feeds

prey whole, the teeth are not adapted to cutting up the fish. This is an advantage for fish bones are sharp and could be troublesome in the throat.

Noteworthy fishers are the otter (27, 29), whose smooth body form webbed feet and muscular tail make it one of the most successful of the group, the seals (13, 28), and porpoises (26). The porpoises are unique in the large number of teeth they possess, over two hundred sometimes being present. It has been suggested that this multiplication of teeth is due to the separation of the lobes of the teeth somewhat similar to those of the sea leopard (13).

Blood Sucking Adaptations

Three genera of tropical American bats live by sucking the blood of other animals which range from chickens to horses. They also are not averse to feeding on men which they attack while asleep. The victim of

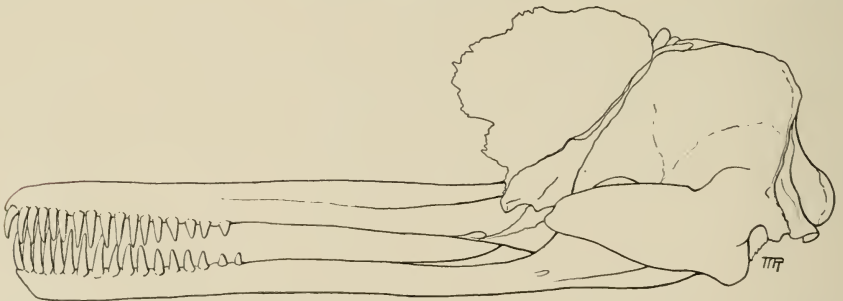

The Ganges River porpoise possesses many needle-like teeth with which it seizes its slippery prey, the fish

such a bleeding does not discover the injury until he awakens the next morning and suffers little inconvenience from it.

The upper incisors of such bats are a pair of large knife-like teeth with which they slice off a bit of the skin of the victim. The molars are small, and the stomach is a thin simple tube no larger than the intestine.



The front teeth of the vampire bat are sharp blades, which cut into the shallow-lying blood vessels of its victim

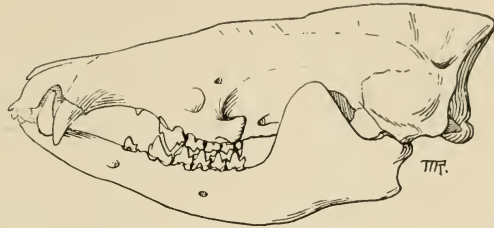

The tenrec, in common with most other insectivores has sharp teeth and a pointed nose, features attendant upon its insectivorous habits

Insectivorous or Insect Eating Adaptations

Insects are preyed upon not only by a host of small animals typically the order Insectivora and the bats, but also by many larger creatures such as baboons and bears. Such omnivorous species, as the latter, are not primarily adapted to an insect diet and may be omitted from consideration.

Insects are of diverse habits and live in many environments. Though some are soft bodied, many of them have hard shells so that insect eating species must be capable not only of catching the insects but also of breaking this shell. It is for this reason that the little insectivorous bats and the shrews have sharp teeth suited to seizing and breaking up the catch, (6, 7, 8). The teeth at the front of the mouth of such insectivores as shrews and hedgehogs are enlarged to enable the animals to seize quickly such active prey. Usually their muzzles are sharply pointed which allows them to seek insects that are in small cavities.

Though all primates probably eat insects, there is only one the aye aye (30) which is primarily adapted to such a diet. This animal has large squirrel-like incisor teeth with which it tears open branches that contain burrowing grubs. The second finger is thin and elongated that it may be introduced into insect burrows for extracting the animal. The large

ears of the eye eye may serve to improve the hearing and aid the animal in locating its food.

Certain species living chiefly on ants and termites are considered below.

Myrmecophagous or Ant Eating Adaptations

Several groups of animals have more or less independently become specialized for feeding upon ants or the somewhat similar termites. This has involved the development of strong digging claws to open up the nests, a long tongue for securing the ants, a lengthened skull for the



The giant ant eater has lost all its teeth and its skull is elongated to house the long sticky tongue

housing of such a tongue, and has resulted in the reduction or loss of teeth. Examples are the giant anteater (50), the pangolin (17), the aardvark (58), marsupial anteater (4), and the sloth bear which may be seen in the Hall of South Asiatic Mammals. The reader is referred to page 20 of this manual for notes on highly developed ant eating specializations of the manis.

Plankton Eating Adaptations

The whale-bone whales (*Mysticeti*, 26) are the only mammals equipped to feed on the minute animal life of the sea (plankton). They have lost all teeth but have developed great fringed, horny plates with which they may strain out these minute animals from the sea water as they swim along with mouth open. The gullets of these largest of all whales are very small and suited only to swallowing of small animals. To swallow a creature the size of a man would be an impossible feat.

Herbivorous or Plant Eating Adaptations

In typical herbivorous forms such as the horse and kangaroo the incisors are well developed for cutting off the vegetation, the canines are suppressed, or if present are used only for fighting, and the cheek teeth are large and have broad surfaces.

Animals such as the manatee (21), which live on soft aquatic plants have a tendency to tooth reduction, though in some cases, as in the hippopotamus (18), the front teeth are strong for digging up the plants.

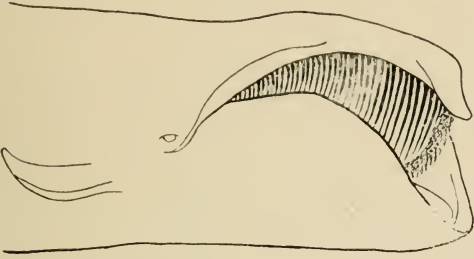

The whale bone whales have substituted baleen for teeth. This serves as a sieve for the water passing through the mouth and strains out the minute animals which are the food of these whales



A sheet of baleen

Species eating tree fruits must be climbers or fliers. Their teeth are usually simple for breaking up or crushing soft plant tissues. The taguans (7) and the fruit bats (9, 20) are good examples. The fruit bats are often large, slow flying and colonial. They do so much damage in their native countries that their importation into the United States is prohibited. One tribe of Madagascar natives evens up accounts by eating the bats.

Animals living on the bark, buds and roots of trees, and many that have softer fare, are equipped with chisel-like incisors that grow from persistent pulps. The whole group of rodents (14) are of this type. Their cheek teeth are typically modified to flat grinding surfaces which finely comminute the food before it is swallowed. The beaver exemplifies the power of the rodent chisel. Trees three feet in diameter have been felled by these rodents.

ADAPTATION FOR PROTECTION

Armor

Though most mammals are covered with soft hair some for protective reasons, have developed an effective armor. The armadillos (16) possess a jointed carapace that is reinforced by bony nodules. The pangolins (17) are covered with hard horny scales. The porcupines (15, 29) are protected by strong, sharp barbed quills which become imbedded in the flesh of an attacking animal but which cannot be thrown at the enemy. Hedgehogs (29), tenrees (6) and the echidna (3) are other groups of animals defended by spiny coats that repel an attacker. All of these animals are unprotected on their ventral surface and will usually curl up when attacked, leaving only a forbidding prickly surface to the enemy.

Offensive Odor

The animal kingdom is replete with creatures that make themselves offensive by bad odors. Some of the mammals are justly famed for these special powers of protection. The llamas have the habit of spitting their unpleasant smelling saliva in the face of any one who proves obnoxious to them. Other mammals, find their defence in specialized glands, which in such an animal as the skunk, become invested with a sphincter muscle capable of ejecting the accumulated secretion of the glands. A powerful fluid ejected by the pangolins effects the mucous membranes of dogs or other creatures it strikes and causes serious illness.

Coloration

The concealing coloration of such an animal as the cottontail rabbit or a polar bear seems obvious. Other types of color patterns are, however, apparently conspicuous. The tiger, for example, in a museum case is an exhibit that would be conspicuous in the largest hall. However, when in high grass the tiger's stripes blend in with the vertical lights and shadows of its environment. The skunk with broad white bands is a conspicuous animal to us who stand above it, but the skunk does not need to hide from us. It is by its prey, such as the mice, that it must be unseen. To these smaller creatures of the ground the skunk's dark under parts and light upper parts must blend into the background with some success, the black into the heavy shadows of evening, the skunks hunting time, and the white stripes into the lighter sky. The sloth (16) has growing in its hair a microscopic green plant that aids the animal in concealment.

Some cases of supposed concealing coloration are open to question as to the correctness of the interpretation of concealment, but certainly

in the great majority of mammals the coat pattern and color, when seen against the animal's usual background, are concealing. If an animal is a vegetarian it has carnivorous enemies from which it must hide. If it is a meat eater it must be relatively inconspicuous in order to come up to its prey. The usual darker shades of the upper side of an animal may originally have arisen as a protection against over exposure to ultra-violet rays, or other factors. But whatever the original cause for the pattern and coloration, the result has favored concealment.

Escape

The animal that has been discovered by an enemy must defend itself, escape or be taken. The majority of animals invariably attempt to make escape. Burrowing animals scurry to their holes, arboreal creatures dash up the nearest tree, swimmers plunge into the water. Goats and sheep run to the rocky slopes where their enemies cannot keep up with them. Many species not protected by such special environments have only recourse to speed or to artful dodging. Such are the hares, the jerboas, the gazelles and the horses. The greatest speed of few animals is known. The best horses on a short course cannot exceed the rate of thirty-six miles an hour, while racing whippets attain about the same speed. The American pronghorn is reported to attain on occasion a speed of forty-three miles an hour.

Special Weapons

Horns, which may be defined as hard outgrowths of the epidermis occur in the Bovidae (18), Antilocapridae (18) and Rhinocerotidae (19). In the first two families these horns are paired, hollow structures growing over a bony core. In the rhinoceros they are solid and grow along the mid-line. In most of the species which bear them they are used effectively against their enemies and in fighting amongst themselves. The Bovidae present the greatest variation in horns. These range in shape from the long straight spears of the oryx to the massive coils of the mountain sheep. Only the four horned antelope and a variety of domestic sheep have more than one pair of horns.

Antlers are the periodically shed, branched, bony appendages found on the heads of the Cervidae (18). Though used as defensive weapons, they are commonly employed in fighting amongst the males during breeding season, at which time they have reached their greatest development.

Tusks and fangs are enlarged canine or incisor teeth which are usually food catching organs, but which are also brought into play for

fighting. The elephant, wild boar, chevrotain, (18), musk-deer, walrus (12), and narwhal (26) possess impressive structures of this sort.

Claws and hoofs though fundamentally locomotor and food getting organs, are also important in defense. The defense of the giant ant-eater (50) lies in the use of its huge digging claws. Ungulates which do not bear horns, antlers or tusks have only their hard tipped feet with which to defend themselves. A giraffe may kill a lion by the forceful blows of the hoofs, and the kicking ability of the horse tribe has saved many of its members from death.

Poison glands emptying through a hollow spur are found only on the hind feet of the male duckbilled platypus and echidna (3). It is supposed that these are used principally in fighting among the males.

Autotomy

Many of the lower animals such as crabs may break their own appendages at will in order to free themselves from an enemy. There is no comparable phenomenon among mammals except in certain rodents, among them the pocket mice (*Perognathus*, 14), where the animals may break off their tails, when seized by that member, by running in small circles. The skin covering the tails of many other rodents will slip off if the animal is held by the tail.

Size

Some of the animals are practically immune to attack because of their size. An adult elephant or rhinoceros has nothing to fear from any mammal other than man. The largest whales, though are subject to attack by the killer-whales which run in packs and tear out the tongues of their larger relatives.

Social and Mental Traits

Mammals of some species protect themselves by pugnacity, charging any potential enemy on little provocation. An enemy is less likely to trouble an animal that is always ready to fight than one whose habit is to flee. It takes a brave animal to attack a big baboon who is equipped to fight and is ready to do so. Herbivorous animals herd together that the enemy will be the more likely to be discovered and that it may be successfully repulsed by the concerted action of the herd. Among some species a few members of the large herd will act as sentinels and give warning to others that are feeding. When wolves attack musk oxen the adults form a ring around the younger ones and all face outward so that the enemy must brave a continuous circle of forbidding sharp horns

VARIATION AND HEREDITY

The development of an individual is an exceedingly complex matter the nature of which we are only beginning to understand. The wonder grows that we are so closely alike, that variation is so small in extent. Variation is, however, of many sorts. In part it is due to changes in the germ cells and these we call genetic. Such changes are the ones that natural selection and other evolutionary processes must work from.

Other changes are due to environment, to give this term a significance so broad that it includes anything from sunlight to the influence of surrounding organs. These variations so far as we know, are never hereditary. The exact mechanism by which genetic and environmental variations are produced is imperfectly understood in all but an infinitely small number of special cases. Such variations as occurs between different races of dogs, though genetic in its background, is in some features attributable to the inheritance of certain types of glands of internal secretion. This effect is shown in Case 23 where a bulldog, a blood hound and a borzoi represent glandular strains. The bulldogs are typical achondroplastic dwarfs that owe their condition to deficient thyroid activity. This condition produces in dogs or men a stocky body with short twisted limbs and muscles that are short, thick and knotty. The base of the skull is short, the nose bridge low, and sunken, the forehead overhanging, the jaw undershot and the face flat.

The bozoi and the bloodhound are races in which the anterior lobe of the pituitary, a gland associated with the base of the brain, is overactive during part of the life. The secretion (hormone) of this gland, tethelin, stimulates growth, and when released in such quantities as to over-balance its natural checks, produces gigantism. This gland is overactive in the borzoi before the bone sutures close and as a result the bones grow to great length. In the bloodhound this same gland is overactive before the bone sutures close, with the result that these dogs develop large coarse features and loose skin, a condition named acromegaly.

The gonads of each sex secrete special hormones which produce the secondary sexual characteristics.

The environment may act directly on an animal to produce other variations. The tail length of rats is determined, within limits, by the temperature of the environment during growing period. The coat color of Siamese cats is similarly controlled by temperature.

Considering the end result, variation is correlated with several factors which may be considered separately.

Age Variation

From birth to death every mammal undergoes pronounced changes of size, proportion, coloration, habit and other characters. Striking changes in color pattern often occur. The young of the wild boar are prominently striped, as are those of the tapir. The young of many deer and cats are spotted when adults of these same species are not (84). Age changes in the skull (24), usually include the increase in size, closure of sutures, appearance and loss of a first or milk dentition, and the appearance and loss of a second set. As age progresses the ridges of the skull tend to become more pronounced in accommodation to increased muscle size.

Seasonal Variation

Animals in temperate and polar climates often undergo two complete changes of pelage annually, one of which is adapted to winter cold and the other of which is lighter for summer warmth. Frequently a color change accompanies this change in coats (84). The winter coat occasionally, as in the hare (86) the weasel and Arctic fox, is white in contrast to a dark summer coat. Other examples of seasonal variations are the growth and shedding of antlers among the deer, and the many changes due to seasonal differences in habits and nutrition.

Sexual Differentiation

Though the sexes of most mammals are colored alike, there are often differences in size and fighting equipment.

The male and female nilgai and black buck to be seen in the Hall of South Asiatic Mammals, are differently colored, as are some of the primates such as the mandril and gibbon. Male mammals are usually larger and more powerful than their mates. Instances of this disparity in size may be noted in the Virginia deer (84), and in many of the habitat groups of mammals in other halls. Fighting weapons such as the spurs of the platypus (3), the antlers of most deer (18, 84), and the tusks of the boar (18, 83) are either developed only on the males, or are better developed in that sex. The fighting among males during the breeding season is conducive to racial betterment, for in this manner the stronger males more frequently produce offspring and the weak individuals are either killed or kept from the females.

Geographical Variation

Geographic variation is intimately tied up with environmental change. Species with broad geographic spread are in most cases distinctly different in various parts of their ranges. These differences

concern coat color, size and proportions. When a form becomes isolated, as on an island, the fortuitous genetic variation arising within the species are likely to become fixed more readily than they would be within the main range of the species where greater mixture and, possibly, different enemies weaken the chance of survival of changed types. Geographic variation among mammals, notably among the white-footed mice (*Peromyscus*), is associated with change in backgrounds. Species inhabiting areas of white sands have become extremely light in color, while forms living on areas of black lava reach the opposite extreme of dark coloration.

Mutational Variation

There is a tendency for the structure upon which heredity depends to change or mutate from time to time. These changes which take place in the germ cell give rise to changes in the individuals. Should these changes be favorable the animal's chance of survival to breed and transmit the new character will be enhanced and by such changes evolution takes place. Not all such mutations are, however, favorable. Some, such as those responsible for the disappearance of pigment (albinism, 27, 85) are unfavorable since the albino animal is more conspicuous and has eyes that cannot function well due to lack of protective pigment. As a result albino strains do not become established except where they are protected from enemies by isolation. The over production of pigment or melanin, produced occasionally by mutation, gives rise to black animals or melanos (27), which for one reason or another rarely become established.

The lineal transmission of mutations among mammals is illustrated in Darwin Hall on the first floor.

Size

The size of mammals is adapted to the feeding and locomotor habits, and to the environment. Burrowing mammals are small because of the mechanical difficulties attending the construction of large tunnels, and because of the impossibility of securing a large amount of food underground. The size of arboreal mammals is limited by the strength of the trees which support them. Aquatic mammals reach the extreme of size because in their environment food is plentiful and the density of the water medium buoys up the great weight of the animals.

The smallest mammal is probably a Virginian shrew, *Microsorex hoyi winnemana*, with a body length of two inches and a weight no greater than that of a slightly worn American dime. The largest mammals that exist or ever lived are the blue whales, which may attain a length of 103

feet. Their maximum weight is not known, but the 70 foot whale whose model is exhibited in the middle of this Hall weighed $61\frac{1}{4}$ tons.

The largest living land mammals are the African elephants, the tallest measured specimen having attained eleven and one half feet at the shoulder. "Jumbo" a famous captive elephant whose skeleton is exhibited in this Hall, stood ten feet ten inches at the shoulder and weighed four tons. A few fossil land mammals are known that are larger than this.

PRINCIPLES OF THE CLASSIFICATION OF MAMMALS

In order that the relationships of animals may be understood it is self-evident that we must first know the existing species of animals. It is to this end that the efforts of many of the departments of the Museum are largely devoted. Because of the enormous numbers and infinite geographical variations of mammals it is necessary to collect large series of specimens from all parts of the world. To exhibit such a wealth of material would not be feasible, nor would anything be gained by it. The great majority of specimens go into study collections of the Museum where they are studied and classified. These specimens form raw material on which all critical studies of animal distribution and relationships must ultimately rest.

Modern methods of classification aim not only to so describe and classify forms that they may not be confused, but attempt as well to express the evolutionary relationship of an animal to other species.

The system of naming which all workers now follow was founded by Linnaeus in 1757. All species are given a *specific* name which is always combined with another name, the *generic*, which it shares with other closely related species. Thus the lion and domestic cat both bear the same generic name, *Felis*. The domestic cat, however, is known under the name of *Felis domesticus* whereas the lion is named *Felis leo*. To this combination is sometimes added a third name which designates a geographical variety or subspecies of the species. Thus the Asiatic lion is named *Felis leo persicus*. The genera of mammals may be readily associated with other related genera and such groups form families. The genus *Felis* and the genus *Lynx* (lynxes and bobcats) are clearly related and are placed in the same family, the Felidæ. The family Felidæ is only one of several families of flesh-eating mammals which together constitute one of the orders of mammals the carnivora. The entire range of orders shown in the Hall together with certain extinct orders constitute the class Mammalia, while the mammals, birds, reptiles,

amphibians and fishes are all classes of the phylum Chordata, a group composed of the vertebrated animals and certain aberrant sea living animals which show affinities with the vertebrates.

WHY A SCIENTIFIC NAME?

To many people a scientific name appears as an unnecessary and cumbersome appellation. It has proved impossible to use common names for animals since one species may bear a half dozen common names in a single country, and one name is often applied to several species of mammals. As examples, the rabbit's small cousin *Ochotona* (14) is known in the western United States as pika, rock-rabbit, haymaker and cony, whereas cony is used not only for *Ochotona*, but also for the hyraxes (order Hyracoidea, 19). *Ochotona*, on the other hand, applies to all and only those of a group of related species whose distribution extends over two continental masses where it probably has as many as thirty "Common" names. The rules of scientific nomenclature specify that a name used for one genus of animals cannot be used for any other.

That scientific names are not necessarily too difficult is shown by the popular adoption of such scientific names as *Rhinoceros* and *Hippopotamus*. Some scientific names may be of extreme shortness such as that of a Philippine bat which is called *Ia io*. Others, it is true, are more formidable as may be illustrated by the name of a fossil mammal, *Brachydiastematherium transilvanicum*.



HOW TO REACH THE MUSEUM

Sixth or Ninth Avenue Elevated to Eighty-first Street
Independent Subway to Eighty-first Street
Broadway (Seventh Avenue) Subway to Seventy-ninth Street
Eighth or Columbus Avenue Surface Cars

ALWAYS FREE

Open Weekdays, 9 A.M., to 5 P.M., Sundays, 1 to 5.

Membership

The great collections and exhibitions of the Museum are the gifts of public-spirited citizens and friends. Over twelve thousand members are now contributing to explorations in America and other parts of the World.

THE MEMBERSHIP CLASSES AND FEES ARE:

ASSOCIATE MEMBER (ANNUALLY).....	\$3
ANNUAL MEMBER (ANNUALLY).....	10
SUSTAINING MEMBER (ANNUALLY).....	25
LIFE MEMBER.....	200
FELLOW.....	500
PATRON.....	1,000
ASSOCIATE BENEFACTOR.....	10,000
ASSOCIATE FOUNDER.....	25,000
BENEFACTOR.....	50,000
ENDOWMENT MEMBER.....	100,000

For further information address the Secretary of

THE AMERICAN MUSEUM OF NATURAL HISTORY
77TH STREET AND CENTRAL PARK WEST
NEW YORK, N. Y.



THE AMERICAN MUSEUM OF NATURAL HISTORY
NEW YORK CITY

COMETS, METEORS, AND METEORITES



By CHESTER A. REEDS

CURATOR OF GEOLOGY AND INVERTEBRATE PALAEOLOGY



AHNIGHITO, A CAPE YORK, GREENLAND METEORITE

*Reprinted from Natural History Magazine
for May-June, 1933*



GUIDE LEAFLET SERIES, No. 77

THE AMERICAN MUSEUM OF NATURAL HISTORY
NEW YORK, 1933



COMETS, METEORS, AND METEORITES

By CHESTER A. REEDS

CURATOR OF GEOLOGY AND INVERTEBRATE PALAEOLOGY

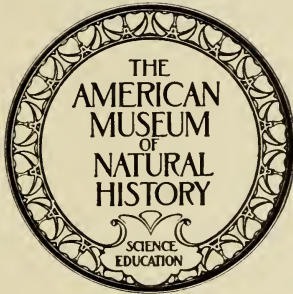

*Reprinted from Natural History Magazine
for May-June, 1933*

GUIDE LEAFLET SERIES, No. 77

THE AMERICAN MUSEUM OF NATURAL HISTORY
NEW YORK, 1933





Artist's Sketch of Successive Explosions of a Meteor. By T. W. Voter

COMETS, METEORS, AND METEORITES

Mysterious Travelers of the Sky—Their Origin, Action, and Composition

By CHESTER A. REEDS

Curator of Geology and Invertebrate Palæontology, American Museum of Natural History

COMETS, meteors, and meteorites are usually regarded as three distinct cosmic phenomena. They seem to be connected, however, by relations of origin and association founded upon well authenticated observational evidence. These phenomena appear but occasionally and are singular and mysterious in aspect. In appearance comets and meteors resemble one another, for they both have luminous heads and nebulous tails, but as far as space relations are concerned they are separated by millions of miles. Comets, which are the most distant, are those erratic members of the solar system which move in elongated orbits about the sun. Their masses are exceedingly small when compared to their size, for they are generally surrounded by hazy or nebulous envelopes. Meteors, on the other hand, are transient cosmical bodies which enter

the earth's atmosphere from without and become luminous as they shoot across the sky. Meteorites are masses of matter from outer space which have fallen upon the earth's surface. They consist usually of stony matter with varying amounts of metallic iron and nickel; more rarely of nickeliferous iron and much more rarely of stony matter with little or no metal.

For untold centuries man has looked at the starry canopy of the heavens at night and marveled at the wondrous display of the moon, the planets, and the multitude of stars set in constellations or in the Milky Way. During the day this same canopy impresses him in a different manner, for, due to the strong light from the sun, the zenith appears to be sky-blue and a sense of emptiness and vacancy is in evidence everywhere except for the clouds that may form in the lower levels of the



HOBA WEST SIDERITE

This fell near Grootfontein, Southwest Africa. This find (1920) is reported to be the largest single mass of meteoric iron known ($3 \times 9 \times 9.67$ feet) 60 metric tons, 132,300 lbs. Iron 83.44%, nickel 16.24%. It shows no lines—an ataxite

daily and yearly movements of the earth, as one of the planets of the solar system, for he, with his buildings, railroads and other works, is carried along unconsciously with the earth as the entire solar system moves

through space towards the star Vega. The earth rotates on its axis at the rate of 17.28 miles a minute at the equator and travels at a speed of more than 1000 miles a minute along its path around the sun.

While these celestial and terrestrial phenomena are profound and have engaged the attention of scientific men and philosophers for more than two millenia, the occasional appearance of comets, and the not infrequent flight of meteors and meteorites have aroused special attention, for these phenomena are as yet not fully understood. Comets, meteors, and meteorites appear by day or by night. They are seen in flight more clearly by

atmosphere called the troposphere. The stars and planets which are prominent on clear nights can seldom be seen in the daytime except from the depths of a well, a cave, a cañon or through a telescope.

Man has discovered from such observations spread over many centuries that these various celestial objects have regular yearly movements, that they are governed in their course by definite physical laws, and consequently he has grown accustomed to their regular movements, for he sets his clocks and watches by sidereal time, predicts the time of eclipses to within a few seconds of their happening, plants and harvests his crops according to the seasons, makes his home on the earth and plans his business undertakings for the coming year with full confidence that these bodies will continue their accustomed movements and functions.

On the other hand it has been more difficult for man to visualize the

OLLAQUE SIDEROLITE, OLLAQUE, BOLIVIA

The polished surface shows olivine masses filling meshes of nickel-iron network

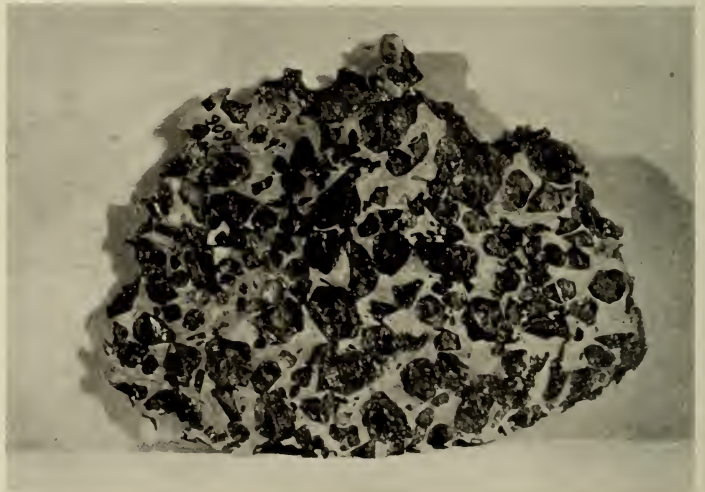



ARTIST'S SKETCH OF METEOR FALLING AT NIGHT. BY T. W. VOTER

Meteors pass through the atmosphere at speeds varying from eight to fifty miles per second

night than during the day for at night their light is apparently stronger.

Comets are rarely conspicuous, for less than ten per cent of the several hundred thousand in the solar system can be seen with the naked eye. They vary considerably in size, some of the smallest have approximately the diameter of the earth; while the Great Comet of 1811 exceeded the size of the sun and had a diameter of fully 1,000,000 miles. The average size of many of them is 80,000 miles. Comets, which move in highly elliptical orbits of great extent are, according to Kepler's laws, much more rapid in their motion when near the sun than when far away. Moreover, since most of them are illuminated only during the short interval when they are near the sun, they travel most of the time in the cold realms of space as dark objects or faintly luminous bodies.

Comets usually have a brilliant head and tail when seen near the sun. The long tail, if present, generally streams

across the sky for millions of miles in directions away from the sun. The brilliant head is hazy and nebulous in appearance and may change in size when swinging through that portion of its elliptical orbit nearest the sun, called perihelion. Although the head may be great in size its mass is exceedingly small, being less than that of the major planets. Within the head a sharply defined star-like nucleus is usually visible. This nucleus is generally believed to be composed of a swarm of meteors and meteorites, whereas spectrum analyses show that the outer portion of the head consists of the extremely rarefied gases cyanogen and carbon monoxide. The tail is not in evidence when the comet is far from the sun, but, as the sun is approached, an atomic activity is set up within the head and electrons are driven off into space to form the tail. Some force, perhaps the sun's light pressure, radiation pressure or electrical repulsion within the comet's

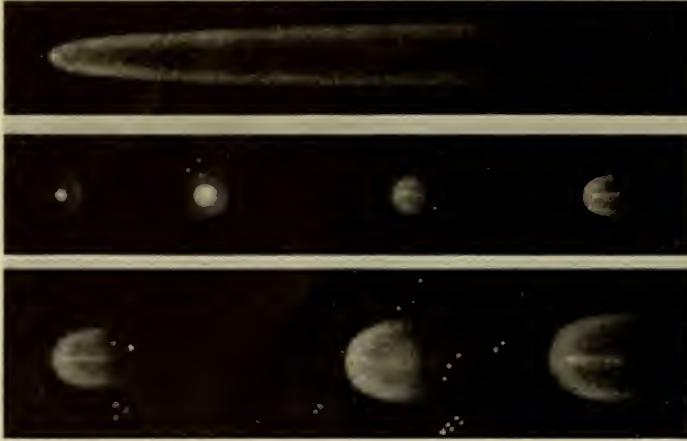

HALLEY'S COMET

C. P. Smyth's drawings of Halley's comet, 1835-1836. From Chamber's *Story of the Comets*

head, is responsible for the lighted tail. As shown by an accompanying drawing, the tail points away from the sun even after the comet has passed around the sun and starts on its return trip. Then the tail precedes the body of the comet. At various times the tail has been observed to consist of various streamers emanating from the head.

It would seem that those particles of matter which are driven out of the head to form the tail are lost and must be constantly renewed, for it has been noted that comets whose orbits are small and pass frequently about the sun are relatively faint and often devoid of a tail. May it not be that their frequent passage about the sun has deprived them of the gaseous tail-forming material?

Comets or at least some of them follow regular orbits. Newton, in studying the comet of 1680, ascertained that, according to the laws of gravitation, the path of a comet should be an elongated curve, and represented the course of such a body mathematically. Halley, in 1704, collected the observations on 24 comets, calculated their orbits, and found that the comet of 1682 had a path round the sun similar to that of the comets of 1456, 1531, and 1607. He recognized them as recurrences of the same comet and, although their periods were not exactly

equal, due to interference by the planets Jupiter and Saturn, he predicted that this comet would return, subject to the influences of the planets, about 1758. Other astronomers took up the calculations of the algebraical and numerical

formulae and determined that Saturn would delay the return of Halley's comet 100 days and Jupiter 518 days, a total of 618 days. The comet was observed to pass perihelion on March 12, 1759. It returned again on November 15, 1835, after completing its course in 28,006 days. In 1873 it reached aphelion and returned once more in 1910. Halley's comet thus has an average period of about



Photograph by Max Wolf

COMET MOREHOUSE (1908 III)

Discovered November, 1908, by D. W. Morehouse at Yerkes Observatory, Wisconsin. A series of parabolic hoods enclose the head of the comet. From *Handbuch der Astrophysik*, Band IV

COMET RORDAME

July, 13, 1893. The camera moved with the comet, hence, the stationary stars show as short white lines



Photograph by E. E. Barnard, Lick Observatory, Calif.

76 $\frac{1}{6}$ years. These calculations and observations removed comets from the domain of legend and established them as part of our solar system.

The periodicity of a considerable number of comets has been confirmed. Of these Encke's comet, discovered November 26, 1818, is the "Mercury of Comets." It completes its elliptical orbit of 2,324,060,000 miles in 3.3 years. It is brightly lit up when it passes within 31 million miles of the sun and may then be readily seen with a telescope. In its revolutions it is also affected by planetary disturbances as are some 60 other comets with known periods of less than 80 years. Astronomers divide

this assemblage of comets into four groups and name them after the four major planets, Jupiter, Saturn, Uranus, and Neptune. Jupiter's family, the largest, has some fifty members including Encke's comet, with periods 3.3 to 8.9 years; Saturn's family has four members with periods 13.1 to 17.7 years; Uranus has two with an average period of 36.6 years; Neptune's family has nine members including Halley's comet with a mean period of 70.0 years. The influence of Jupiter on the first group has been for the most part established, but the connection of other planets with their assigned members is not universally recognized.

There are a number of instances on record which show that not only the orbits, but also the comets themselves, may be considerably affected by passing near the planet Jupiter. For instance, the orbit of Lexell's comet of 1770 was so changed in 1779 that it could not be seen. In 1770 it passed within one and a half million miles of the earth. Changes have also been noted in d'Arrest's comet 1860, Brook's 1886, Wolf's 1875 and 1922. The 1922 perturbations of Wolf's comet modified the orbit to such an extent that it took a course nearly the reverse of that of 1875. Biela's comet whose period of 6.75 years was established in 1826 had been seen in 1772 and 1805. Its orbit

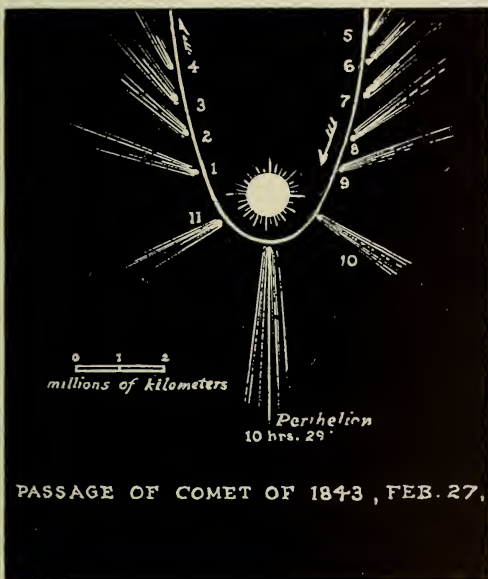

SECTION OF A COMET'S PATH

Passage of the comet 1843 about the sun. This comet covered the perihelion portion of its orbit, twelve million kilometers, in ten hours. The tail pointed away from the sun

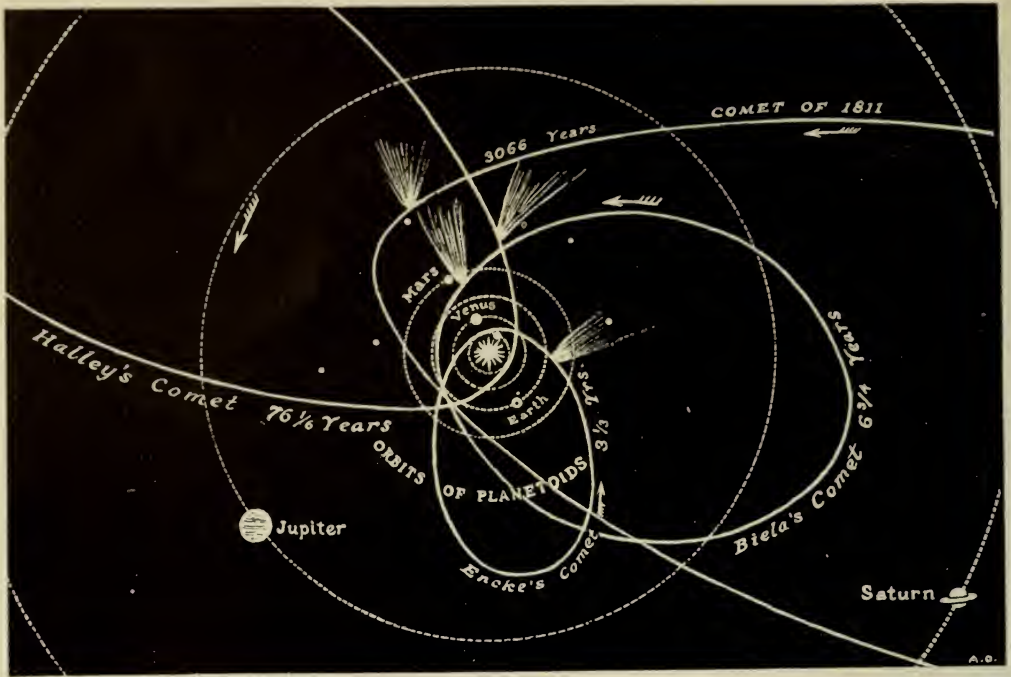

ORBITS OF SOME COMETS AND PLANETS

While the earth encircles the sun in one year, Encke's comet takes three and one-third years, and other comets a longer period. Most comets have paths which do not lie in the plane of the earth's orbit

was found to intersect that of the earth's, and in 1832, when it returned, there were many needless apprehensions. It was not seen in 1839, but in 1846 it was found to have split into two comets, which travelled side by side. In 1852 it reappeared with the two comets farther apart. It was not seen in 1859 or in 1866, and for the years 1872, 1885, 1892 and 1898, there was no comet, but instead brilliant showers of meteors. Other known comets have also disappeared, namely: Brorsen and Temple I, in 1879. The Pons-Winnecke comet with a period of 5.6 years has also attracted considerable attention because of irregularities in its orbit and its period. Discovered in 1819, its perihelion distance, although changed every alternate revolution by Jupiter, remained within the earth's orbit up to 1915, when it went outside. In June, 1916, and June, 1927, there were meteoric showers, which were associated with this comet. Some astronomers would

also connect this comet with the great meteoric fall, which crashed into an uninhabited region of central Siberia in 1908, where, after the reported appearance of a great light followed by many detonations, an area of some 1,000 square miles, was completely devastated.

The most prominent member of Saturn's family is Tuttle's comet, discovered in 1858, with a period of $13\frac{1}{2}$ years. It has been seen at every return since 1858.

Temple's comet, discovered in 1866, is the more notable of the two comets of Uranus. Its period of 33 years and its orbit coincides with that of the Leonid meteors with brilliant displays in November, 1833, 1866, and less so in 1899, since perturbations of Jupiter had changed its course. Its motion is retrograde to that of the planets. Stephan's comet seen 1867, but not since, is the other member.

Of Neptune's nine comets five have been seen a second time. Halley's is the best known. It has been traced back to

IRON METEORITE FROM
GIBEON, SOUTHWEST
AFRICA

A black carbon nodule appears near the center of the polished and etched surface; Widmanstätten figures cover the remaining portion of the slice

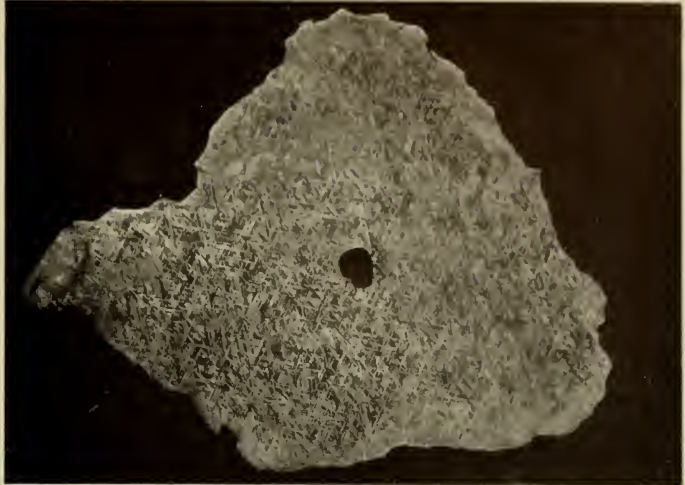

240 B.C. On various occasions it has approached near enough to the earth to give meteor showers. It was observed in 467, 1066, 1456, 1531, 1607, 1759, 1835 and 1910. It crossed the sun in 1910, but since it was then in-

visible, it demonstrates the very small amount of matter remaining in it.

Other comets with periods ranging from 119 to 165 years have been observed, and one with a period of 335 years suggests a family belonging to an extra Neptune planet.

In this connection it should be stated that while comets may be seen at various times as they pass about the sun, meteors can be seen only when they enter the earth's atmosphere. In various instances it has been noted that where comets approach or cross the orbit of the earth, or disintegrate, meteoric displays have been observed.

Not infrequently on clear nights faint moving sparks of light may be seen to emanate sporadically from the starry canopy and increase in brightness as they move rapidly towards the earth, but seldom reach it before quickly and silently disappearing. Such objects are called "shooting stars" or small meteors. Occasionally, a brilliant streak of light with a more or less well-defined head called a "fireball" or "bolide," accompanied by a hissing sound and detonations, will light the sky momentarily and strike the earth at a place near or beyond the range of vision of the observer.

These are also meteors, but of a larger size than the shooting star type. Perhaps a cloud of dust will be seen to rise from the place where it struck and its lodgment can be definitely located. When the spot is approached, there may be seen a newly made hole, one or more feet in



A PORTION OF THE
ROSE CITY, MICHIGAN,
METEORITE

Composed of a network of stone and metallic masses with a black crust appearing on the upper and lower margins

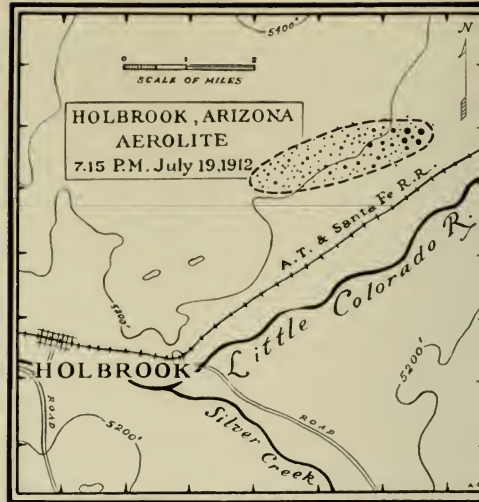
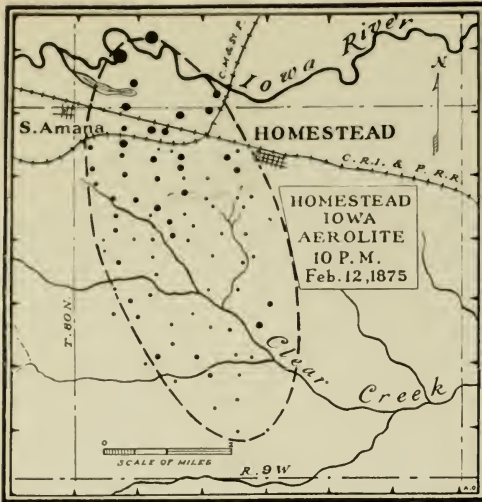

(Left) THE HOMESTEAD, IOWA, SHOWER.—Showing a characteristic ellipsoidal area, 3×6 miles. Pieces weighing 32 kilograms were found along the northern margin. (Right) THE HOLBROOK, ARIZONA, SHOWER.—The ellipsoidal area is 1×3 miles in extent. Many thousands of small fragments have been recovered.

depth with an object in the bottom of it. The object may be either a stone with a blackened surface or an irregular mass of metal marked on the front or “brust-seite” with shallow furrows and subconical pits, and on the rear side with depressions called thumb-marks or “piezoglyphs.” Sometimes the thumb-marks are found on all surfaces. These markings are due to superficial heating produced by friction with the air. Whether the object has a stony or metallic aspect its appearance will be unlike any terrestrial rock or stone and may be called a meteorite.

Stony meteorites often fall as showers due to the fact that the original mass explodes or bursts one or more times before reaching the earth. The areal distribution of the stony fragments on the surface of the ground usually assumes the form of an ellipse varying in size from one-half mile in width to three in length as in the 1912 Holbrook, Arizona, fall, or three by six miles as in the 1875 Homestead, Iowa, fall, or three by ten miles as in the 1924 Johnstown, Colorado, fall, as shown diagrammatically in this article. The individuals of a shower are distributed

according to their momentum, those of small size with less momentum will reach the ground first, while those of large size and greater momentum will be carried farther. This fact affords corroborative evidence in determining the direction of the path of the meteor. A comparison of the diagrams will show that the Homestead meteor traveled in a N.N.W. direction, the Holbrook in an E.N.E. direction and the Johnstown in a N.E. direction.

Nickel-iron meteorites are often found in single masses, yet in the case of the Cape York, Greenland, irons two large masses were found on one island, and one each on two near-by islands, suggesting a single fall. The large mass, Ahnighito, 36½ tons, the Woman, 3 tons, and the Dog, 90 pounds, are in the American Museum. The other piece, 3.4 metric tons, is in the Royal Museum at Copenhagen, Denmark. The Bethany irons in southwest Africa have been found singly in rather widely separated areas, yet when their distribution is plotted it suggests a shower. The most recent find in this region is that of the Hoba West iron near Grootfontein, Southwest Africa. It is estimated to weigh 6

metric tons and is reported to be the largest single mass known.

Mr. Hirn, writing in *L'Astronomie*, June, 1883, calculated that a bolide entering the upper regions of the atmosphere with a relative velocity of 18.64 miles per second, compressed the air in front of its path from one-hundredth of an atmosphere on entering to 56 atmospheres at a height of 23 miles. He also determined that with increase of pressure there is an increase of heat and a rise of temperature on the exterior surface to points higher than can be produced in the laboratory. The temperature of space is 273° below zero Centigrade. It is assumed that the bolide had this temperature before entering the earth's atmosphere. If so, then its surficial temperature was raised from -273° C. to $3,340^{\circ}$ C. in the few seconds of its flight. If this calculation be true it is readily understood why a meteor becomes visible on account of this transformation of its motion into heat and light. Neither is it difficult to perceive why the small masses of "shooting stars" are consumed, why the larger stony masses with low conductivity are rent into fragments by explosions, and why the more tenacious

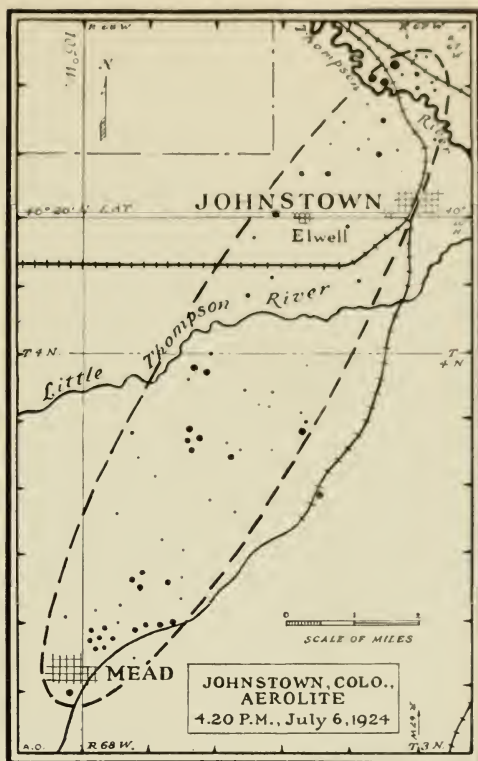

THE JOHNSTOWN, COLORADO, SHOWER

Four terrific explosions were heard accompanied by "smoke" puffs, before the fragments were spread over an ellipsoidal area some 3×10 miles in extent

irons usually remain intact and have irregular outlines and pitted surfaces.

It is also known that the greater the air pressure the more the velocity of the meteor is checked. This fact would explain the shallow depth of the holes made in the ground by most meteorites. The height at which some meteorites lose their initial velocity is quite variable. On the basis of some nine, which have been studied, it varies between 2 and

THE JOHNSTOWN, COLORADO, AEROLITE

One of the thirteen pieces found showing a thin black crust and a gray stony interior. Rounded and angular particles of greenish-gray pyroxene are in evidence in the gray field



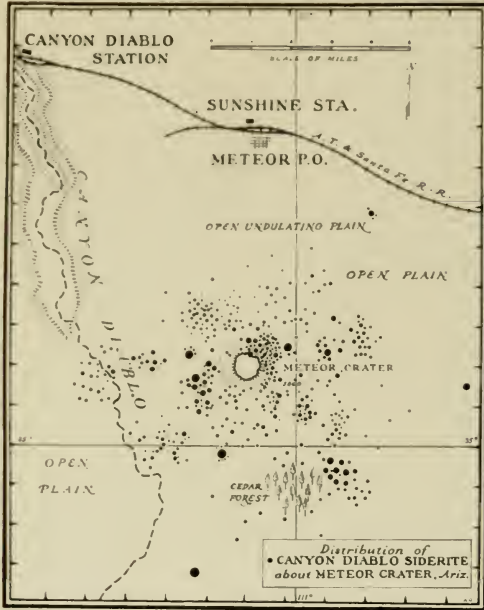

SKETCH MAP

Showing position of Meteor Crater and the Canyon Diablo Meteorites

29 miles above the surface of the earth. Some few meteors, however, have made great holes in the ground.

The most remarkable occurrence of iron meteorites associated with a meteor crater is in Yavapai County, Arizona, near the intersection of the 111th meridian and 35th parallel. The meteorite, which is called Canyon Diablo, after a near-by erosion feature, consists of thousands of pieces of variable sizes scattered over an oval area about nine miles in diameter. A depression known as Meteor Crater

THE CANYON DIABLO METEORITE

A large mass of the Canyon Diablo siderite in the American Museum. Total weight of fall unknown; six tons preserved in collections

lies in the center of the meteorite field. This crater is quite large being 4150 feet in diameter and 570 feet deep. It is surrounded by a parapet 150 feet in height composed of rock débris thrown out of the crater. The crater has been studied at various times from different stand-points and the present general consensus of opinion is that it was formed by the impact of a great meteor or comet with the earth some 50,000 years ago, and that immediately following the impact there was a tremendous explosion which not only scattered the meteorites and rock débris over the surrounding plain, but gouged out the crater pit and greatly disturbed the normal disposition of the thick limestone and sandstone beds in the margins of the crater. Borings have been made within and about the margins of the crater in an endeavor to locate a possible larger meteoric mass, but so far they have yielded only inconclusive results.

Other meteor craters and associated



meteoric material have recently been found at Henbury, Australia and Odessa, Texas. No meteorite fragments, however, have been found near the meteor craters of Tunguska, Siberia, and Kaali, Esthonia.

So seldom are meteorites seen to fall that it is not strange that such phenomena should attract widespread attention whenever and wherever they occur. Neither is it strange that skepticism should arise in the minds of non-witnesses regarding the existence of objects which are reported to have fallen from the heavens.

Early records show that meteoric showers were regarded as supernatural. According to the late G. P. Merrill of the Smithsonian Institution, such phenomena are referred to in Revelations VI, 13; VIII, 10; and XII, 3, 4. E. F. F. Chladin in 1819 stated that one of the oldest meteoric falls on record is that of Crete, 1478 B.C. Pliny in his second book, *Naturale Historie*, mentions that in 468 B.C. a Greek



Photograph by Clyde Fisher
METEOR CRATER, ARIZONA, FROM THE RIM
Looking across the crater pit, 570 feet deep and
4150 feet in diameter

philosopher, Anaxagoras Clazomenius, foretold that with the appearance of a comet a stone should fall from the sun. Such a stone did fall at Abydos and was held in great reverence. Records also show that at 11:30 P.M., on November 7, 1492, a meteorite fell at Ensisheim in Ober-Elsass, Germany. This stone was regarded as a miracle of God and by order of King Maximilian the main mass, weighing 260 pounds, was placed in the church at Ensisheim. This meteorite is of interest in that it constitutes



AIRPLANE VIEW OF
METEOR CRATER, ARIZONA
Taken by Clyde Fisher,
January 12, 1933, with snow
on the ground. Canyon
Diablo and the San Francisco
Mountains in the background

the oldest known fall of which samples of the specimen have been preserved.

As noted by Dr. O. C. Farrington, 1915, the first stony meteorite observed to fall in America, and which was described, was that of Weston, which fell 6:30 A.M., December 14, 1807, in Fairfield County, Connecticut. In commenting upon this fall Thomas Jefferson, President of the United States, expressed the prevailing opinion in regard to meteorites when he said that it was easier to believe that Yankee professors would lie than to believe that stones would fall from heaven.

The brilliant display in November, 1833, of shooting stars, later known as Leonid meteors, associated with Temple's comet, brought forth a decided change in

the general attitude of the public in regard to meteoric phenomena.

With this change in attitude it is interesting to note by centuries the record of meteorites which were seen to fall and portions of which have been preserved. Referring to G. P. Merrill's 1929 list of 482 falls, we note that for the 15th and 16th Centuries there is one each; for the 17th, three; for the 18th, nineteen; for the 19th, three hundred forty-two; and for the first third of the 20th, one hundred sixteen. This shows quite conclusively that during the centuries when meteorites were regarded as being supernatural, few specimens were found, and that during the 19th and 20th Centuries, when they received attention, many were recovered.

Out of a total of 482 seen to fall, 458



A GREAT BOLIDE OR METEOR, AS SEEN THROUGH A TELESCOPE

Photograph by Josef Klepesta at the Prague Observatory, September 12, 1923. The white spots are stars. The bolide is the white streak of varying width. It crossed the field of the camera as the great spiral nebula in Andromeda (center) was being photographed

SHOOTING STAR AS
SEEN THROUGH A
TELESCOPE

Nebulae in Cygnus to the right. The stars show as white dots. Photograph by E. E. Barnard, Yerkes Observatory, Wisconsin, July 15, 1909

represent stony meteorites, 5 stony-irons, and 22 nickel-iron meteorites. Stony meteorites are thus seen to fall more frequently than the iron meteorites, of which 350 had been found to 1929, but only 22 seen to fall. The number of falls and finds known in 1929 was 832. The list has been considerably increased during the following four years. The American Museum Collection of meteorites (March, 1933) contained 2640 specimens, representing 569 falls and finds.

Large collections of meteorites reveal that the specimens of no two falls are exactly alike in structure or composition, yet it has been observed that they may be arranged into three principal groups or kinds, as noted by Merrill namely:

1. Aërolites, or stony meteorites, consisting essentially of silicate minerals with minor amounts of the metallic alloys and sulphides.
2. Siderolites or stony-iron meteorites, consisting of an extremely variable network or sponge of metal, the interstices of which are occupied by one or more silicate minerals.
3. Siderites or iron meteorites, consisting essentially of an alloy of nickel-iron with iron phosphides and sulphides.



Technical students of meteorites have subdivided each of these groups. The aërolites and siderites are, however, the more common kinds. When cut, polished and etched, the siderites, or iron meteorites, usually show peculiar markings of crossed lines, and thus can be easily distinguished from the terrestrial irons.

Some siderites have the nickel-iron alloys arranged in the form of plates parallel with the faces of an octahedron. These lamellae may be of different degrees of thickness and composed of one, two or three kinds of metal. On etching with acid these metallic bands react unequally

and show characteristic figures known as Widmanstätten lines.

Another group of iron meteorites, composed of homogeneous masses of nickel-iron, show cleavage and lamellae parallel to the faces of a hexahedron. This is due to the twinning of a cube on an octahedral face. On etching with dilute nitric acid the structures show Neumann lines. Such forms are known as hexahedral irons.

A third group of irons are called massive irons or ataxites because their structure is amorphous and shows neither Neumann or Widmanstätten lines or other pronounced features.

The structure of the aërolites is quite different. They resemble the light colored felsitic rocks of the earth's crust, but they are unlike them. Aërolites may be granular, crystalline, chondritic, basaltic, tuff-like or breccia-like and with or without veins. Metallic shreds may or may not be scattered through the mass. While the color is usually light gray, it may vary through various shades of gray to black. A characteristic feature of aërolites is that while their interiors may be gray in tone,

with various chondrules or mineral grains in evidence, their exterior surfaces are always coated with a thin black crust, which varies in thickness from $\frac{1}{64}$ to $\frac{1}{32}$ of an inch.

Astronomers tell us that about 400,000,000 celestial objects enter the earth's atmosphere every day, that about 20,000,000 are large enough to form shooting stars or meteors, and that of this number a minimum of but one per day is of sufficient size to reach the earth and constitute a meteorite. At first it may seem strange that so many meteors enter the atmosphere and so few reach the earth. When it is recalled, however, that meteorites vary from sizes microscopic to objects measured in tens of cubic feet, that they enter the upper rarefied layers of the earth's atmosphere at speeds varying from 8 to 50 miles per second, and that the atmosphere offers great resistance to their passage, it is not surprising that in the few seconds of their flight through the atmosphere that most of them are heated

to the point of incandescence and consumed before they reach the earth.

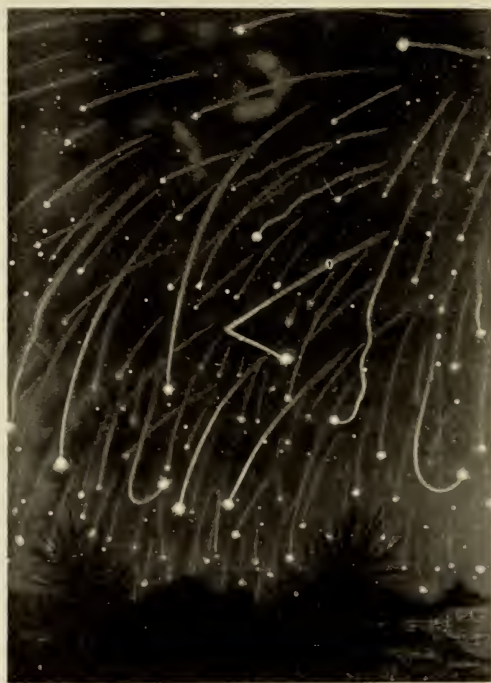

ARTIST'S CONCEPTION OF NOVEMBER METEORS
NOVEMBER 13-14, 1866





FORTY TONS OF CORAL

by

ROY WALDO MINER

CURATOR OF LIVING INVERTEBRATES, AMERICAN MUSEUM



*Reprinted from Natural History Magazine
for July-August, 1931*

GUIDE LEAFLET SERIES, No. 78

THE AMERICAN MUSEUM OF NATURAL HISTORY
NEW YORK, 1933



FORTY TONS OF CORAL

by

ROY WALDO MINER

CURATOR OF LIVING INVERTEBRATES, AMERICAN MUSEUM

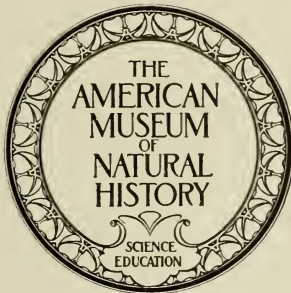

*Reprinted from Natural History Magazine
for July-August, 1931*

GUIDE LEAFLET SERIES, No. 78

THE AMERICAN MUSEUM OF NATURAL HISTORY
NEW YORK, 1933



Fantastic Growths of Coral in Weird Formations Crowd the Sea Bottom

FORTY TONS OF CORAL

The Story of the Preparation of the Immense Coral Reef Exhibit Now Under Construction in the New Hall of Ocean Life at the American Museum

By ROY WALDO MINER

Curator of Living Invertebrates, American Museum

FORTY tons of coral trees growing on the ocean floor, bathed in the crystal waters of tropic seas, three fathoms below the surface, amid waving sea plumes and schools of brilliantly colored fishes flitting between their branches!

Forty tones of coral ripped from the heart of a hundred-mile submarine forest of tinted limestone, hauled to a snowy beach, bleached, embedded in sponge clippings, packed in huge crates, and shipped to the American Museum!

Forty tons of coral rising from the floor of the Hall of Ocean Life, their serrated branches interlaced as of old and once more invested with the delicate hues that gave them their pristine beauty, while above them again spreads the mirroring quicksilver of a simulated watery surface overarched by the blue of a painted tropic sky!

Such, in brief, is the story of the great Bahaman Coral Reef Group which, for several years past, gradually but steadily, has been approaching realization in the largest and most imposing of the Museums's exhibition halls. The expeditions which secured the specimens and other data for the group, replete with romance and adventure, have been described in previous issues of *NATURAL HISTORY*. It is not my purpose in this article to repeat these incidents in detail, but, though the exhibit, which is their fruit, is not yet completed, it may be of interest to summarize briefly the chief events of these voyages and then to recount the principal steps in the actual building of the group itself, an undertaking of unusual magnitude.

The idea of building a replica of a Bahaman coral reef had been in my mind

for a number of years, but first took definite shape during the year 1922 when the steel structure for the new Hall of Ocean Life was in process of erection and I was informed by President Osborn that the department of lower invertebrates was to have an important share in the exhibits to be housed in it. At the same time he requested me to submit suggestions for an invertebrate exhibit of outstanding character which also should be typical of oceanic life.

The reef-building coral polyp with its associates, has probably produced the most significant and conspicuous results of all the lower inhabitants of the seas. Its castellated structures of limestone may rise from depths of twenty or thirty fathoms to the ocean surface, and, in the case of the Great Barrier Reef of Australia, extend for more than fourteen hundred miles in length. They are dotted over tropic seas where they are perilous to vessels approaching them from without, while the difficult entrances through their submerged barrier walls, when mastered, lead to harbors of safety. Hence, they must be accurately mapped on navigators' charts. As world-builders, the coral and its associates

have taken part in the construction of many oceanic islands forming the abode of men, and during past geologic ages, were an important source of the continental limestone deposits of the world.

It was natural that I should jump at the opportunity of building a coral reef exhibit for the new hall, and so, under my direction, Chris E. Olsen, modeler in my department, prepared a scale model of a proposed installation for the new group adapted to the architecture of the hall and embodying my ideas for the exhibit. This was presented to the President and Board of Trustees early in 1923 and was unanimously accepted by them, and I was authorized to prepare plans and to make negotiations for



SKETCH MODEL OF THE
CORAL REEF GROUP

Designed by Doctor Miner and modeled by Chris Olsen on the scale of $\frac{3}{4}$ inch to the foot. The model represents the central portion of the western end of the Hall of Ocean Life, showing a representation of the proposed coral reef group in position



PALMATE CORAL WITH BEAM-SHAPED BRANCHES

A characteristic growth of coral under exposed condition near the surface of the sea. This ten-foot specimen was collected by B. E. Dahlgren and Herman Mueller from the Andros Reef in 1908, and was brought to New York by Joshua Slocum in his famous sloop "Spray," in which he had just returned from his remarkable voyage around the world

the necessary expeditionary work.

Four expeditions to the Island of Andros in the Bahamas were undertaken in the interests of the group between the years 1923 and 1930. The first, in December, 1923, was of a preliminary and exploratory character, in which I made arrangements for the first main trip which took place during the summer of 1924.

Early in June, I arrived in Nassau, accompanied by three artists and modelers of the American Museum staff: Messrs. Herman Mueller, Chris Olsen, and Dr. George H. Childs of the department of lower invertebrates. We allied ourselves there with Mr. J. Ernest Wil-

FAN CORAL

This fragile variety (*Acropora muricata* var. *prolifera*) often is found clustering thickly on the floor of the sea outside the great forests of elkhorn, in strangely exposed positions without danger to its fairy-like beauty



liamson, who generously put himself and his wonderful under-sea tube at our disposal, and with the cordial coöperation of the Bahaman Government we set sail for Andros.

Here, skirting the eastern shore for more than one hundred miles, is the finest coral barrier reef in the West Indies, and here, seated in the spherical steel submarine chamber of the tube, we gazed out through a plate glass window at a magnificent submarine forest

towering above us everywhere. We made water-color sketches, instantaneous photographs and motion pictures through water so transparent that we could see one hundred and fifty feet through the weird tangle of sea growths before our vision was obscured by the luminous, pearly blue fog beyond.

Aided by diving helmets and a chain hoist mounted on pontoons, we attached chain or rope slings to the coral masses

we desired, and dragged them to the surface. Our largest specimen weighed two tons and was twelve feet in length. We towed our catches to the sheltered beach of our little Cay and there we bleached them. This process consists in keeping the surface of the corals wet until the thin outer layer of animal tissue decays and sloughs off, leaving the white limestone skeleton exposed.

When we had completely covered the beach with gnarled and

twisted branches of elk-horns, spike-like tangles of stag-horns and the delicate and fragile clusters of fan corals standing out among dome-shaped specimens of orb and brain corals, we sent natives to Nassau to bring us boatloads of heavy pine timber, from which we constructed crates and packed our specimens in them, embedded in sponge clippings. These were finally shipped safely to New York.

The third expedition was devoted to



PALMATE ELKHORN CORAL

This beautifully symmetrical specimen (*Acropora muricata* var. *palmata*) grow in a sheltered position, so that its branches spread out evenly in broad fronds, contrasting sharply with the twelve-foot specimen shown on page 378 which grew in an exposed position on the outer reef, in which case the most rapid growth is with the direction of the prevailing oceanic currents

obtaining the reef fishes for the group. It was conducted with the coöperation of Mr. John S. Phipps, who lent us his fine houseboat yacht, "Seminole," and several smaller motor boats. The sea-going motor launch, "Iolanthe," was also with us during part of the time. Mr. Phipps' son, John H. Phipps, accompanied the expedition, and was in general charge of the fleet. Mr. Phipps, Senior, and several members of his family and

guests visited us while at work. I was accompanied by my wife, son, Roy W. Miner, Jr., Chris Olsen of the Museum modeling staff, and Mr. J. L. Jaques, Museum artist. We were on the Andros Reefs from the latter part of June until

FINGER CORAL

This species (*Porites clavaria*) grows so prolifically that it sometimes rises in dome-shaped colonies thirty feet in diameter. The finger-shaped branches are closely set. A detail of the Coral Reef Group





THE TWO-TON CORAL SPECIMEN IN PLACE

This immense coral tree rises from a contorted cluster of trunks and now dominates the entire summit of the stony forest forming the center of the group. This specimen, with branches spreading twelve feet horizontally, was torn from the sea bottom in front of the coral barrier reef at Andros

the end of July. We set fish traps among the reefs, and used granges, gill nets, hand nets, and hook and line to obtain our specimens.

As soon as the fish were caught, living specimens were placed in aquaria and sketched in colors by Mr. Jaques before their brilliant hues faded. These and other specimens then passed through the hands of Mr. Olsen and my son who constructed plaster molds from them, and the specimens themselves were preserved in alcohol and formaldehyde for future reference.

In this way we secured molds and sketches of sixty-five different species of typical reef fishes. Later on, wax casts will be constructed from these molds, which, colored from the data furnished

by Mr. Jaques' accurate sketches, will bring to life once more in the Museum group the multitudinous gaily colored fish population of the Andros Reef. During this expedition, Mr. Jaques made sketches for the cyclorama to form the great above-water background of the future group.

During our stay we experienced a severe hurricane but came through without damage to ourselves or our collections, and reached New York just in time to escape the second hurricane of that year which wrought such havoc in Miami.

The fourth trip was undertaken during the early spring of 1930, when Mrs. Miner again shared my experiences with me. We spent the month of March as



MAKING THE SKETCH-MODEL FOR THE CORAL REEF GROUP

Chris Olsen is modeling the coral specimens in miniature under Doctor Miner's direction. They are placed in their correct position in the model; measurements are taken with reference to fixed points; and then the massive corals of the real exhibit are hoisted into exactly corresponding positions guided by similar measurements in the large group



LOOKING OVER A PART OF THE FORTY TONS OF CORAL

It took six months to clean the specimens in preparation for coloring. Those shown here have received a thin coating of wax, colored to simulate the living animal tissue covering the corals in life



MODELING "DEAD CORAL" ARCHES OVER STEEL WORK

Plaster of Paris over wire screening is used for this purpose. Later on a thin coating of beeswax and oil colors gives the surface effect of the natural formations as they appear on the sea bottom. The steel worker is constructing steel supports



ELKHORN CORAL

This unusually perfect specimen shows the typical method of branching

guests of Mr. and Mrs. Daniel Bacon on their interesting island camp, "Pirates' Nest." Through their courtesies, we established our headquarters here while gathering and preparing sea plumes and sea bushes for the new group.

Later on, we were joined in Nassau by Dr. and Mrs. Charles J. Fish, of the Buffalo Museum of Science, and with them explored the beautiful coral reef at Rose Island. This work was greatly facilitated by Mr. Hugh Matheson, of Coconut Grove, who put his ketch, the "Marmion," at our disposal. Utilizing diving helmets, we descended to the base of the reef at a depth of three fathoms, and made many observations and motion pictures of great value for the group.

So much for the field work. Difficult and arduous as it often is, and beset with unexpected and unusual problems, the work in the field is nevertheless the most romantic and enjoyable stage in the

preparation of Museum groups. More than this, however, it is absolutely essential for the production of museum groups conceived in the modern spirit.

The ideal museum group is not merely a work of art. It is a record of living beings in their natural state and environment, depicted in their proper relations to their surroundings, and emphasizing the truth that the real unit in nature is the association rather than the individual.

To make these groups accurate portrayals of reality, the modern Museum finds it necessary to send out well equipped expeditions to all parts of the world to gather the facts of nature at first hand. Consequently, if it is desired to build a group which will faithfully depict the life of the sea bottom, one must descend to the bottom of the sea to obtain the material and the observations to make this possible.

The preparation of the group in the



A DETAIL OF THE GROUP
Showing the steel framework anchoring a specimen of elkhorn coral in position



BRAIN CORALS GROWING AT THE BASE OF DEAD CORAL BEAMS

Welded together by overgrowths of *Lithothamnion*, a calcareous alga, or sea plant, which encrusts the dead coral with an overlying blanket of additional limestone, thus adding materially to the bulk of the reef

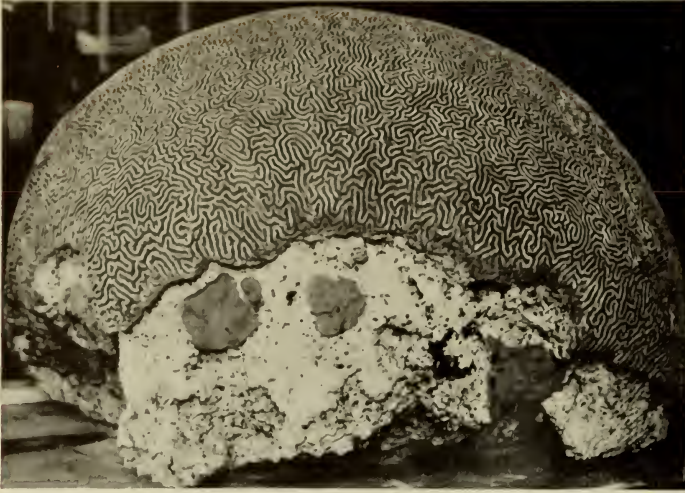

A LARGE HEAD OF BRAIN CORAL (*Maandra cerebriformis*)
Showing the intricate pattern produced on the surface of the coral
limestone built up by the rapidly dividing coral polyps

Museum, while not so romantic as the field work, nevertheless is full of interest and is beset with fascinating problems. Often these present special difficulties involving original and unprecedented methods, which, however, give greater zest to the work. This has been especially true of the Coral Reef Group.

In order better to understand our aims, let us first try to visualize the exhibit as it will appear when finished. We pass through the archway leading to the Hall of Ocean Life and find ourselves standing on the gallery surrounding an enormous hall 160 feet long and 130 feet wide. The lofty ceiling is surrounded by skylights and springs from a series of arches enclosing lunettes. These form the settings for murals depicting on one side of the hall various species of whales in their oceanic environment, and on the other, scenes illustrating the capture of whales by the old-fashioned whaling ship of by-gone days. Skeletons and models of whales are suspended from the ceiling. An extensive shell collection occupies the gallery, and beneath it are caught glimpses of a series of pictorial groups illustrating the life of walruses, sea ele-

phants, seals, and other marine mammals.

These features become apparent as the visitor has time to examine the hall in detail, but what first strikes his attention and holds his eye as he enters the hall is the enormous, brilliantly lighted group immediately facing him at the farther end.

The exhibit is framed in a great arch rising from the floor of the hall sixteen feet below the gallery and, passing through the latter, it

sweeps in an enormous half-circle thirty-five feet above the main floor. Apparently one looks through the portion of the arch above the gallery into a tropical lagoon overarched by a brilliant sapphire sky with towering trade-wind clouds



TOUCHING UP THE MENDED BRANCHES
Doctor Childs is skilfully repairing an elk horn
coral specimen that was broken in transit

drifting by. In the foreground is a cay overgrown with shrubbery and plumed with wind-blown coconuts. In the distance is the long, low-lying shore of Andros.

We walk around the gallery and approach the arch from the right. The half-domed cyclorama, the masterpiece of F. L. Jaques, depicting the scene, discloses a new vista with every step. Now, we are looking out across the coral barrier marked by long

lines of gleaming white breakers at the dark-blue, deep waters of the Tongue of the Ocean. As we come nearer, the emerald green shallows just within the reef meet our view, intersected with long, arching lines of rippling wavelets

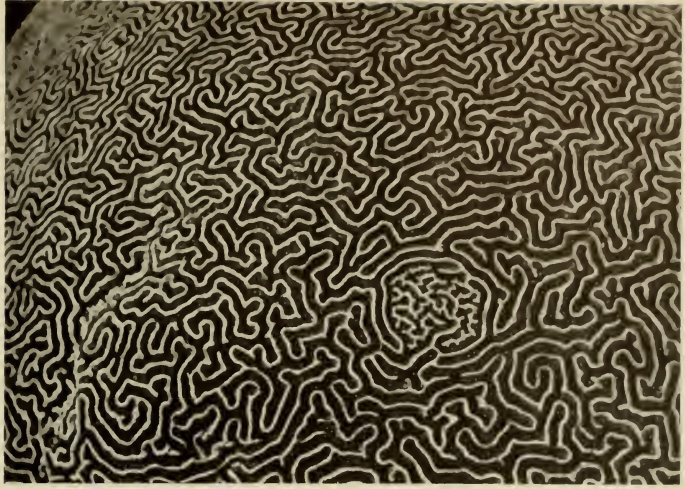

A "CLOSE-UP" VIEW OF BRAIN CORAL
Showing a remarkable labyrinthine growth around an enclosed nodule of more closely contorted pattern

caused by the surges dying out over the obstructing barrier.

As we face the arch, turquoise and green slicks of quiet waters spread out beyond the white, sandy point on the inner side of the cay, mirroring in the distance the alternating clouds and luminous sky colors along the horizon. Overhead, a long line of roseate flamingos sails above the palm trees, the birds lazily and majestically flapping their black-bordered wings as they follow the direction of the wind toward Middle Bight, an inland sea piercing the distant land-mass with its quiet waters.

Glancing downward, we see that the foreground is of transparent glass simulating the water surface, through which penetrate the tips of submerged elk-horn corals. We are looking into the heart of a coral reef, the treelike growths giving us glimpses of a fairy world between their branches. Our curiosity whetted, we note there are descending staircases on either hand. Down one of these we pass beneath the gallery and find ourselves looking through a coral forest, the tangled branches of which rise above our heads. We are standing on the floor of the sea!



COLORING A HEAD OF ORBICELLA CORAL
Chris Olsen is not only an expert modeler but also an artist of unusual attainments

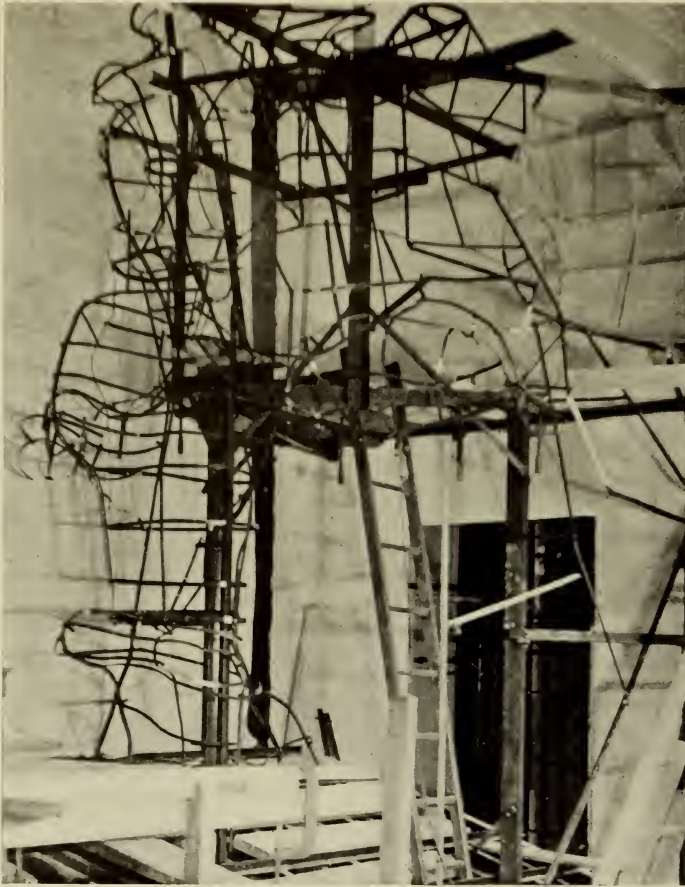

THE STEEL FRAMEWORK OF THE "CORAL CAVE"

The heavier channel irons form the main structure and the lighter framework gives shape to the outline of the submerged coral cliffs, shown in nearly completed condition on the opposite page

I shall leave a further description of this weird and strangely beautiful world until the group has reached its completion. At the present time we are still struggling with the problems of partial accomplishment, and our imagination has filled in the unfinished details, as we are continually doing in the actual process of preparing the group. Let us now review some of the steps which have brought it to its present stage of preparation.

Let us imagine we have just returned from the expedition of 1924. Our forty tons of coral have arrived. In the courtyard outside the Hall of Ocean Life are thirty-one huge cases of hard pine. Our

men carefully remove the planks from the tops of the cases, and disclose the soft masses of closely packed sponge clippings in which our corals are imbedded. Each case contains a large specimen blocked and braced in its center, while around it the lighter and more fragile specimens are closely packed, separated from one another by the elastic cushion of the sponges. As the specimens are laid out in long rows in the courtyard, we are delighted to find that but very few of them are broken after their long voyage of a thousand miles over a rough sea.

After all are unpacked, the next step is to clean the specimens thoroughly. There are so many of them, and they are frequently so complicated in their

branching structure, that it takes six months of industrious work to accomplish this process properly.

Next, each specimen is coated with a thin layer of beeswax to simulate the animal layer, which in life invests the coral. This also serves to fill and seal the minute crevices with which coral is permeated, thus keeping the crumbling limestone dust within and furnishing a proper surface substance for coloring.

Now, each specimen is colored with oil colors, following sketches made from life. Each species has its appropriate color combinations and it is necessary that they should be faithfully represented to give

a lifelike appearance. Some of the brain corals are peculiarly difficult, for three main colors are involved, one of which, a green hue, must be applied in the bottom of the sinuous winding valleys with which the huge heads are covered in a most complicated pattern.

Some of the delicate fan corals were quite broken, and these had to be mended. All the broken tips had to be saved and carefully matched to their proper stumps, drilled and pegged with wire pegs, cemented with litharge, and the joints colored so that they could not be detected when finished. This was accomplished most successfully, Doctor Childs and Bruce Brunner showing an especial aptitude for this work, while the coloring by Mr. Olsen and Mr. W. H. Southwick is remarkably true to nature.

Meanwhile, Olsen busied himself in constructing miniature models of each essential coral mass on the scale of three-fourths of an inch to a foot, and these were built up into a miniature composition according to the design which I had projected. This gave us a working model. Fixed points were designed upon this model and corresponding points were plotted in the great space 30×16×16 feet which the group was destined to occupy.

A skilled iron-worker was assigned to our work, and began erecting a sloping steel framework in the form of a grid,



LOOKING INTO THE HEART OF THE CORAL CAVE
A detail of the group in an advanced state of completion. The cave shows in the center of the picture, its entrance overarched by a projecting shelf of sage green brain coral (*Maandra*)

to hold our heavy but fragile corals.

The largest coral masses were suspended by powerful chain-hoists in their proper places above this, using the sketch-model strictly as a guide. Each was carefully adjusted in a lifelike position, with due regard to the growth of each branch as determined by the prevailing oceanic currents, and then the steel structure was built up to support it properly, each piece, whether I-beam, channel iron, or T-iron, being carefully cut to fit.

It was always a case of try and cut and try again, bending and fitting according to need, remembering always the over-



PREPARING THE HUGE TWELVE-FOOT SPECIMEN

The artists are mending and touching up the coral branches, while the iron worker is working with an electric drill on the supporting steel armature

hangs and caverns planned in the composition of the group, and yet compensating by braces judiciously placed according to need, or concealed rods bolted into the floor to act as check reins with turn-buckles adjusted to give the right tension.

This was a steel structure which no blue-print could map out beforehand and required the most continuous impromptu exercise of engineering ability and adaptable ingenuity, qualities for which Louis Beauvais has shown especial capacity during the three years in which he has been patiently fitting six tons of steel parts into this group with which to

support our forty tons of coral in its proper anchorage.

Early in the construction of this part of the work two huge sheets of plate glass were raised into place to serve finally as translucent backgrounds. One of these is eleven feet in height and the two are together so contrived as to form a continuous backing for the group. On these finally will be painted a continuation of the submarine vista. A great curving opaque background behind them will depict the still more distant prospect. This will be illuminated by soft, concealed lights which, shining through the translucent screen in front, will give the soft, watery effect of the under-sea. Chris Olsen has been painting many studies of submarine

effects most successfully in preparation for coloring these backgrounds.

The principal mass of coral trees rises in the left center of the foreground, the steel supports completely concealed by modeling representing eroded masses of dead coral branches forming arches and caverns.

To the right of the group a great cavern of eroded and welded limestone and coral has been modelled. This reaches the surface to form a cay of grotesquely eroded rock awash at low tide. These features have been modeled over the iron framework by Mr. Olsen, using first a base of stiff wire screening,

over which is spread plaster of Paris mixed with excelsior, forming a rigid matrix. Over this, in turn, is brushed a layer of bees' wax to form a finished surface, and finally the whole is colored with oil colors to represent dead coral limestone, coated with encrusting algæ, bryozoa, sponges, and other living forms of beautiful color tones, as in the actual reef.

Thousands of smaller and more delicate corals have been colored to be inserted at the proper time. Hundreds of sea fans, sea plumes, sea bushes, and sea whips have been prepared by special processes and colored, ready for placing. Our skillful glass-modeler, Herman Mueller, is constructing fragile glass polyps and other organisms for assembling in the foreground. Olsen is coloring, modeling, and assembling assorted varieties of details, and is devoting his ingenuity to the solution of all kinds of problems. Great sheets of rippled glass have been prepared, and a complex yet unobtrusive structure has been contrived to support them in such fashion as to simulate the water surface.

A carefully worked out system of light boxes with special illuminating units of daylight lamps is being installed, and two immense glass fronts are being ordered to enclose and protect the group both above and below the gallery.

Within the coral forest beneath the crystal water-surface, hundreds of reef fishes of all the typical species will be seen disporting themselves between the branches or darting in and out of the coral arches and caverns. These, as above mentioned, will be cast in wax, from the plaster molds made from actual fishes in the field, and colored to the verisimilitude of life.

Finally, it is hoped that the group, when finished, will create in the visitor the illusion that he has actually descended beneath the tropic seas—that, without leaving the metropolis, he has been able to witness a world of life that would otherwise require long voyages, special equipment, and the willingness to don diving helmet and leaden weights in order to lower himself into Davy Jones's Locker!



Coating the coral surface with melted beeswax



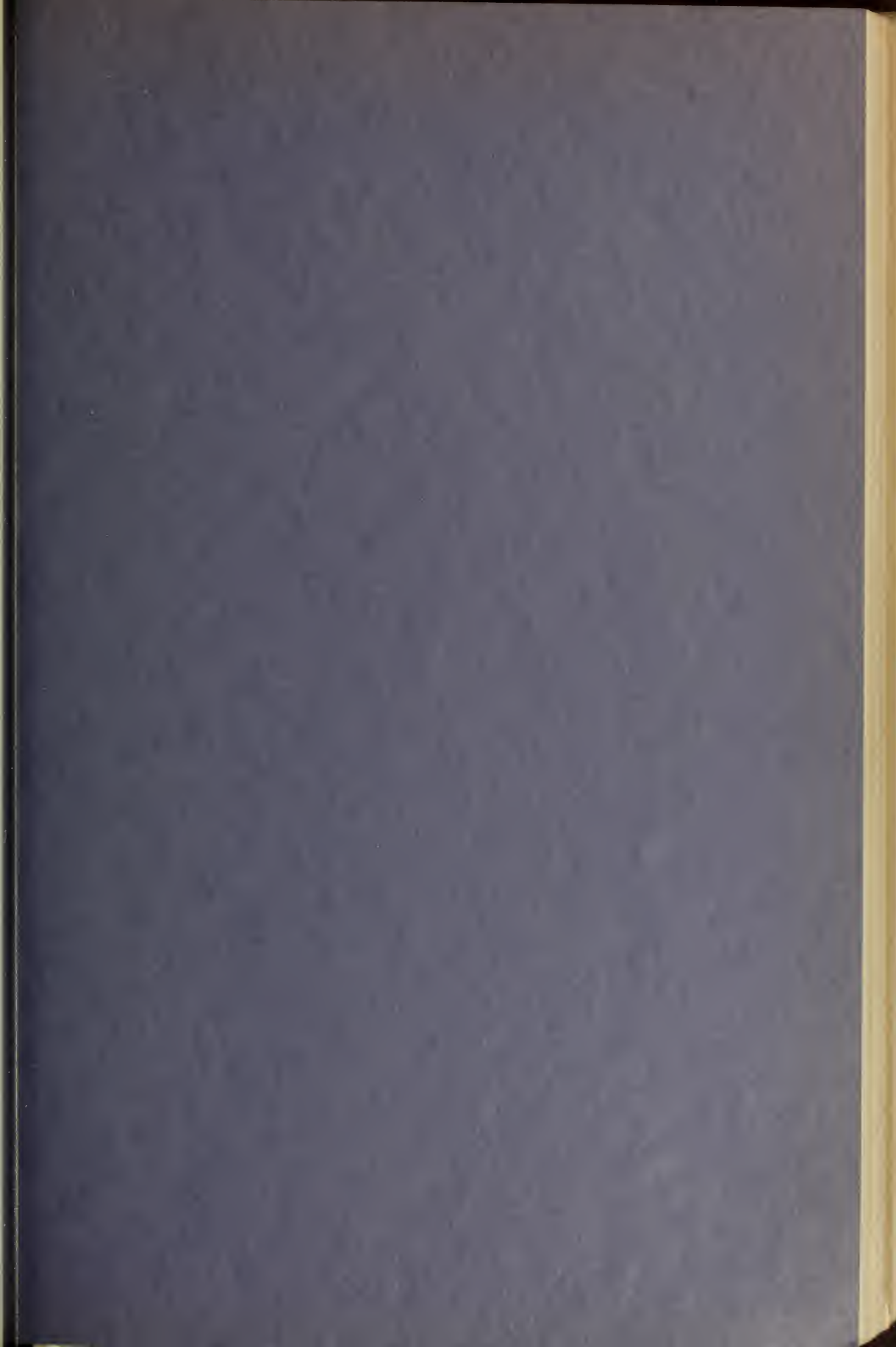



JADE
AND
THE ANTIQUE USE
OF GEMS

By HERBERT P. WHITLOCK

Curator of Minerals and Gems, American Museum



*Reprinted from Natural History Magazine for
July-August and September-October, 1932*

GUIDE LEAFLET SERIES, No. 79

THE AMERICAN MUSEUM OF NATURAL HISTORY

NEW YORK, 1934



JADE
AND
THE ANTIQUE USE
OF GEMS

By Herbert P. Whitlock

Curator of Minerals and Gems, American Museum



*Reprinted from Natural History Magazine for
July-August and September-October, 1932*

GUIDE LEAFLET No. 79
THE AMERICAN MUSEUM OF NATURAL HISTORY
NEW YORK, 1934

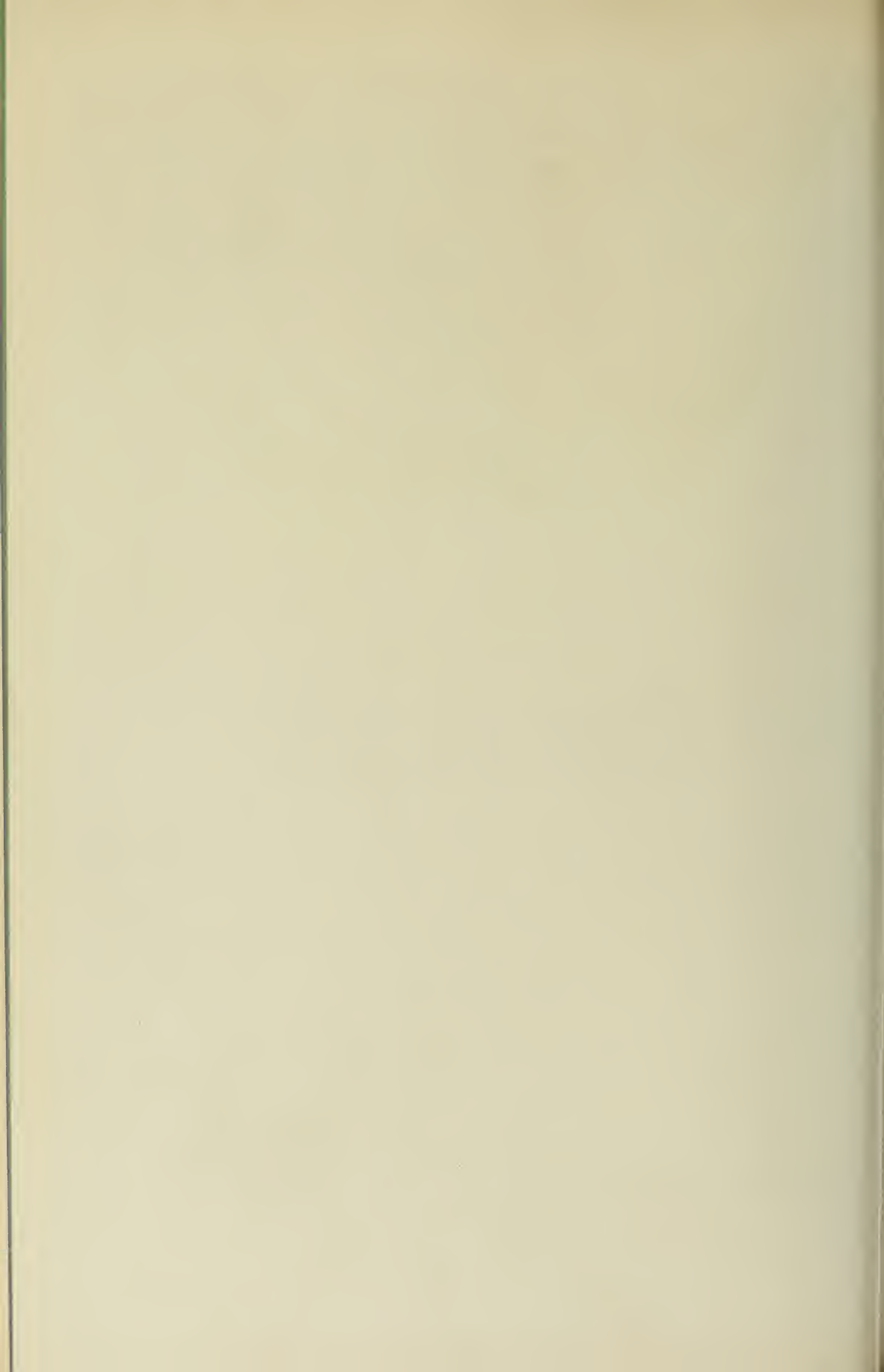

THE ANTIQUE USE OF GEMS

The Appeal of Color and Rarity of Certain Minerals to Primitive as Well as Modern Man—Their Use as Charms, Symbols, and for Personal Adornment

By H. P. WHITLOCK

Curator of Minerals and Gems, American Museum

AMONG the ancient expressions of human culture which have been handed down to us throughout the ages, we find ample evidence that our prehistoric forebears began to appreciate the decorative value of gems and precious stones at an extremely early stage in their development.

The subtle charm that holds a Twentieth Century woman spellbound before a jeweler's window doubtless prompted Mother Eve to devise ways of hanging these vivid scraps of color about her person, and of these decorative devices which have developed into our present day forms of jewelry, the necklace is without question the most ancient. From such rough assemblages of strung-together gem pebbles as the garnets found in a Bohemian grave of the Bronze Age to the most elaborate creations of the modern jeweler's art, we can trace in unbroken sequence throughout the ages, and in most of the countries of the ancient world, the evolution of the necklace.

It would be highly interesting if we could conjure up a pageant of necklace wearers of all periods and races, but since

this is beyond the powers of even our modern magic, we must content ourselves with the consideration of those relics that have come down to us from the past, a handful of beads here, a tarnished and battered brooch there, all that is left to tell us of forgotten beauties whose charms they enhanced before Helen wore her star-sapphires or Cleopatra her emeralds or Mary Stuart her garnets.

Among the Germanic tribes that roamed over Central Europe half a millenium before our era, amber washed up on the eastern shore of the Baltic and roughly shaped into round beads was a standard medium of exchange. A necklace of these rude, uneven, amber lumps was found in a grave of the period of about 300 B.C., in Hallstatt, Austria. Surely it would require but little imagination to picture such a barbaric trophy as the im-

mortal necklace of the goddess, Freyja, the famous "Brisingamen" of Norse mythology.

The Gallo-Roman inhabitants of France in the Third and Fourth Centuries A.D. were lovers of fine apparel and jewels. The necklace beads of delicately colored



THE MOST PRIMITIVE NECKLACE

This small handful of rough garnet pebbles was found in a Bohemian grave of the Bronze Age. Aside from the fact that every pebble is drilled, there was no attempt to shape them into beads. (Specimen in the N. Y. State Museum, Albany)



ROCK CRYSTAL BEADS FROM CENTRAL AMERICA

Representing a very early stage in the evolution of the necklace. They were probably made about the beginning of our era

agate and orange-red carnelian of this period show a wide range in quality of workmanship but are, on the whole, much better shaped than those of the softer amber of the previous example. Moreover, the heavier strings, some of which contain beads as large as an inch and a half in diameter, were undoubtedly worn by men.

The agate, carnelian, and rock crystal used by these early French lapidaries may well have come from France, since these stones are to be found today on French soil.

Turning to Persia we find necklace beads, fashioned out of a number of stones, whose rough shape and lack of finish indicate an early period in the development of this civilization. From Afghanistan came the deep blue lapis lazuli, one of the earliest stones to be used by man, and here wrought into roughly angular unpolished forms, mere lumps of stone with the sides rubbed smooth. From Europe came caravans bearing amber from the Baltic which was carved into flat cylindrical beads with rounded

sides, quite different in appearance from those of Central and Northern Europe. And most important and significant of all, from the ancient mines near Nishapur in northeastern Persia came the turquois which has so long been associated with Iranian culture, and which was carved into necklace beads, whose rude, thickened disks suggest those made today by the Navajo and Pueblo Indians of our own Southwest.

Almost incredibly old are the long, cylindrical beads of Chinese jade which represent one of the earliest uses to which inhabitants of the "Flowery Kingdom" put their national gem stone.

Only one civilization other than China has made use of jade for personal adornment. Necklace beads of jade, irregularly



AN EARLY PERSIAN NECKLACE

This string of necklace beads was fashioned from rough lumps of lapis lazuli, brought by the trading caravans from Afghanistan

rounded but nicely polished, have been found among the remains of the Zapotec culture of ancient Mexico which flourished at about the beginning of our era. Earlier beads from Central America are very roughly fashioned out of rock crystal, and a very recent excavation has brought to light beautiful necklace jewelry from Mexico in which brilliant, translucent, green jade has been combined with gold in a manner that would do credit to a modern designer.

In the bazaars of India, Ceylon, and Burmah, there sit today, as their forebears have sat for centuries, the East Indian gem cutters, fashioning necklace beads from the gem stones of their countries. Sapphires, rubies, garnets, a rich wealth of color go into these necklaces, the elements of which are sometimes roughly faceted, but more often of somewhat irregular rounded shape, following the time-honored custom of the East, that strives to produce the largest and heaviest gem possible from the fragment of material used.

The necklaces which have come down to us from the higher development in culture of the later Egyptian dynasties show a very considerable scope in the materials used. Amethyst, lapis lazuli, carnelian, turquoise, jasper, rock crystal, garnet, and even emerald were freely combined with gold to produce bead jewelry forms of great taste and charm.

It is quite significant that Egyptian gem cutters seemed unwilling to alter such regular crystal forms as the hexagonal prism of emerald by cutting them into round or prolate beads. These forms were usually preserved intact in the bead design, and whereas the beads fashioned from amethyst, carnelian, or amazon stone were made spherical or cylindrical, the six-sided prisms of emerald were simply pierced in the direction of their axes, and left otherwise unworked.

The reason for this may lie in the reluc-



AN ANCIENT CHINESE NECKLACE

These cylindrical beads are roughly carved from Chinese jade. They belong to the legendary past of that fascinating old corner of the Orient. (Specimen from the Drummond Gift)

tance of the artificer to waste any of the material of the rarer and consequently more precious stone, or possibly some symbolism may have been attached to its regular natural shape. At least this treatment of emerald may be observed not only in Egyptian jewelry but also in that of Cyprus and Etruria.

From the necklace composed of strung beads it is but a step to one in which the roughly shaped stones were encased in a metal setting. In Egypt we find this advance taking place at quite an early stage, as instanced by an example in the collection of the Metropolitan Museum of Art, where a small, square plaque of gold enclosing an oval carnelian forms the middle element of a double string of *unset* carnelian beads.

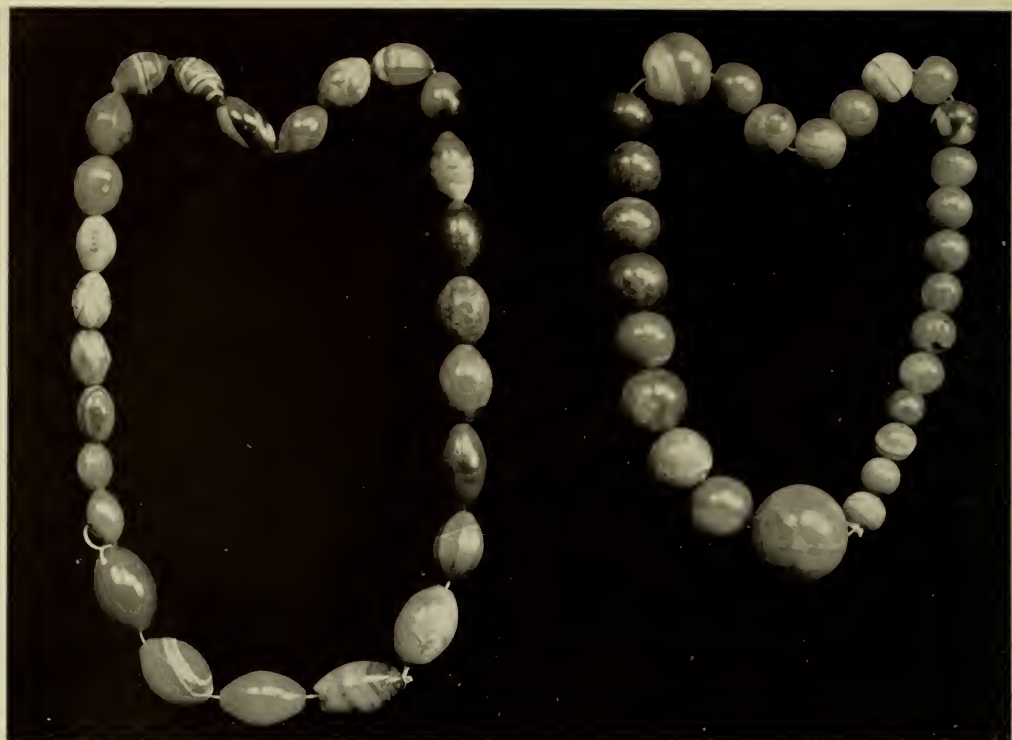

TWO NECKLACES OF AGATE

The Gallo-Roman people of France in the early centuries of our era fancied agate for their necklaces, some of the heavier of which were worn by men. These two come from the Department of Gard in Languedoc

From very early times until approximately the period of Ptolemaic kings we find the Egyptians making use of a sort of mosaic of gem stones, turquois, and lapis lazuli, set in thin gold boxes, the latter being shaped to the design so that, when the whole was polished, it had somewhat the aspect of the cloisonné work of Russia.

The transition from such primitive combinations of gem stones with the precious metals, to the more elaborate settings of Greece, Rome, and the later cultures of Europe and Asia is both easy and obvious, and once made, the development of jewelry forms was simply a matter of that artistic progress which follows so closely upon historic and political progress. As the needs of an ever advancing civilization called for more and more varied ornamentation of

dress and person in gold and silver, it was inevitable that these ornaments should be embellished with gem stones that had already become familiar to man through the medium of earlier and simpler jewelry forms.

A striking instance of this adaptation of the earlier to the later usage is to be found in the necklace that constitutes the ceremonial trapping of a Vizier of Morocco of the middle of the Eighteenth Century. The roughly rounded aquamarines that furnish the larger jewels for the medallion settings that constitute this regalia are pierced, clearly indicating that they were once strung together to form a necklace of beads of a much earlier and more primitive type; how much earlier we can only conjecture.

The use of various minerals as materials from which objects for personal adorn-

ment were made, ancient though this use is, does not constitute the only, nor even the most deep-seated side of the question of the antique use of gems. It is safe to assume that from the very earliest period, when people began to recognize the beauty of certain stones, they also began to ascribe to them certain supernatural properties as amulets and talismans. And as far back as we can trace, they wore some material token in the form of a stone to guard them from the ills of life, real or imaginary. The wearing of such amulets is, in all probability, older than the wearing of jewelry, and, no doubt, the one grew by insensible steps out of the other. It was essentially a natural and logical act for the primitive man who found an



BEADS OF DEEP, FIERY, INDIAN GARNETS
The necklace beads cut by the native gem cutters of India, Burmah, or Ceylon have a character of their own



DEEP BROWN COPAL BEADS

The natives of the west coast of Africa, the country of "Trader Horn," made and wore this necklace of copal, which was their substitute for amber

attractive or unusual bit of stone to ascribe to it occult powers. As he advanced in culture, he shaped these bits of stone into increasingly regular forms, and finally as an added fetish, he scratched on them images of his gods and invocations to them. A talisman was supposed to be endowed with wider and more general powers than was an amulet, the function of the latter being to ward off evil. The addition of a magical combination of words would make either a talisman or an amulet a "charm."

Some of the earliest amulets of which we have any knowledge are the little stone cylinders that were used among the Assyrians, Babylonians, Persians, and Hittites, as seals. These cylinders, some of which date as far back as 4000 B.C., are carved from various minerals, such as steatite, serpentine, hermatite, lapis lazuli, jasper, amazon stone, chalcedony, marble, and rock crystal. Many of these materials

are esteemed today for their beauty as mediums for small carvings, proving that modern taste in this matter is at least founded upon ancient precedent.

The engraving was of course incised, both because this was the easiest and most obvious way of engraving hard materials, and because the impression made by rolling such a seal over a suitable soft substance was more natural and more easily read.

Considerable skill was displayed by these early lapidaries in cutting their

designs, which included figures of gods, men, and animals, as well as inscriptions in cuneiform characters. The inscription often gave the name of the wearer, the name of his father, and the name of his god. The significance of this sequence becomes apparent when we consider that the official name given to every man upon coming of age placed him under the protection of a god, who forthwith made his abode in the body of this particular man subject to his good behavior. But should he be so unfortunate as to sin against his

fellow men or against the gods, the divine presence left him and he immediately became the prey of some one of the seven devils.

Asiatic cylindrical seals of this type were not set in rings as are those of our day, but were hung around the neck, or fastened on the arm. A typical example of a Babylonian cylinder from among the small but representative series in the Morgan Gem Collection, is carved from limpid rock crystal and is approximately 3000 years old. This is engraved with an image of the storm god Rammon, who was identical with the Rimmon of the Old Testament (2 Kings, v. 18). He is here represented in a short robe holding a scepter in one hand, and accompanied by his wife, Sahla, whose figure in a long, flounced dress is shown on both sides of him.



FROM NORTH AFRICA

A string of old and crudely shaped necklace beads. The pale green aquamarines which compose its elements are similar to those which adorn the large medallions in the necklace on page 9



RICH AND COLORFUL

The necklace of a Vizier of Morocco of the period of about 1750. The aquamarine gems of the large medallions have been pierced and were at one time a string of beads like that shown on page 8

In Egypt the most popular amulet was the well known scarabæus or scarab, the somewhat conventionalized image of a large black beetle regarded as a symbol of resurrection and immortality, since it was believed that no female of this insect existed. These carved beetles were engraved, as were the Asiatic seals, the inscription being cut on the oval underside of the conventionalized figure in ideographic characters.

Scarabs were even more typically amulets than were the cylinder seals of Babylon and Assyria, for although they commonly bore the name of the wearer, they were in many instances inscribed with magical charms taken from the Book of the Dead. Beautifully worked funeral or heart scarabs were often made from green jasper, amethyst, lapis lazuli, amazon stone, carnelian and serpentine, while the more precious emerald and turquoise were not without representation

among these figures of the sacred beetle that replaced the heart in the mummies of the Egyptian dead.

It was believed that when the soul of the deceased came to be judged before Osiris, his heart was weighed in the balance held by Anubis against his good or evil deeds in life. Consequently the charm inscribed on a heart scarab invoked the gods of the underworld to deal leniently with the heart of the dead. An example inscribed on a scarab of green feldspar would read¹

Oh ye gods who seize upon Hearts, and pluck out the whole Heart, and whose hands fashion anew the Heart of a person according to what he hath done, Lo now let that be forgiven to him by you.

Hail to you, Oh ye Lords of Everlasting time and Eternity.

Let not my Heart be torn from me by your fingers.

¹Quoted from *The Magic of Jewels and Charms* by Dr. George F. Kunz, p. 319.



A NECKLACE FROM ANCIENT CYPRUS

Showing a charming combination of gold with agate and carnelian beads carved as turtles. This use of gold and gem stones reflects strongly Egyptian influence. (Specimen in Metropolitan Museum of Art)



EGYPTIAN OR SYRIAN NECKLACE

Of the Sixth Century A.D., Rough prisms of light-colored enamel are used as beads, alternated with pearls in a gold setting. (Specimen in Metropolitan Museum of Art)

Let not my Heart be fashioned anew according to the evil things said against me.

For this Heart of mine is the Heart of the god of mighty names, of the great god, whose words are in his members, and who giveth free course to his Heart, which is within him. And most keen of insight is his Heart among the gods.

Ho to me, Heart of mine; I am in possession of thee, I am they master and thou art by me; fall not away from me; I am the dictator to whom thou shalt obey in the Netherworld.

Among the peoples that were influenced by Egyptian culture, the scarab gradually became more highly conventionalized, losing much of its resemblance to a beetle as it lost its symbolic and esoteric significance. Thus we have the scaraboid, an oval dome-shaped seal, inscribed on the flat underside as was the scarab, but no longer with the magic charms of Egypt. In other words the scaraboid, a purely ornamental engraved stone, is literally the "stepping stone" between the scarab and the modern form of seal. A form of engraved amulet that came into use in Persia about the Eighth Century, and

that reached its culmination in elaboration from the Sixteenth to the Seventeenth Centuries, was made from polished, flat slabs of chalcedony and carnelian, varying in size and shape, but rarely more than two and a half inches in longest dimensions. These Persian seals belonged to the Moslem culture, and since the Mohammedan code forbids the depicting of natural objects, the engravers of these amulets were restrained from using the symbolism employed by peoples of other faiths. As a consequence they all bear texts from the Koran inscribed in Arabic characters, the engraving in many instances being beautifully executed. The quaint Arabic letters that look like some glorified kind of shorthand, are highly decorative, and were embellished with loving care by the Moslem engravers.

The smaller and older examples are mostly oval or more rarely cushion-shaped and were lettered with incised



AMETHYST BEADS

A necklace of the early Christian Era (4th-6th Centuries) showing strong Egyptian influence. (Specimen in Metropolitan Museum of Art)



AN EARLY EGYPTIAN BROOCH

Here the design is formed by carefully shaped pieces of turquoise and lapis lazuli, each set in a little box of gold. This gem mosaic was the forerunner of jewel settings. (Specimen in the Museum of the New York Historical Society)

characters often deeply cut as though for use as seals. The larger and more elaborate forms have a broad, heart-shaped outline, and are representative of the later period. In these the lettering of the central panel is very slightly raised against a matte background composed of fine

crossed lines, so that the inscription stands out on a polished surface against a dead one. The surrounding border is lettered with a longer text in smaller incised characters.

Nothing can be more appealing than the exquisite delicacy and detail of this engraving as revealed when the light strikes across the polished face of the lettering. The effect is much the same, and achieved in the same way, as that which one sees on an old engraved sword blade.

It is quite frequent among the engraved chalcedony amulets of both the oval and the heart-shaped types to find a short text, or sometimes only the name of the Prophet, occupying the center of the design, and a longer text wrought as a border or panel



A CYLINDER SEAL

Carved from rock crystal in Babylon about 2000 B.C. At the left is shown the impression made by rolling the cylinder over a piece of soft clay

around it. Also we meet with considerable repetition, a text of notable efficacy as a charm being used on many amulets. Here is one from one of the later seals, now a part of the Morgan Gem Collection.

CENTER: And the Thunder declares His Glory with His Praise, and the an-

gels also for awe of Him.

BORDER: In the name of Allah, the compassionate, the Merciful. Allah is He besides whom there is no god, the Everliving, the Self-subsisting by whom all subsist. Slumber does not overtake him nor sleep. Whatever is in the Heavens, and whatever is in the Earth is His. Who is he that can intercede with Him but by His permission? He knows what hath been before them, and what shall be after them, and they cannot comprehend anything out of His knowledge except what he pleases. His knowledge extends over the

Heavens and the Earth, and the upholding of them both burdens Him not. And He is the most high, the great

A notable exception to the almost universal use of quartz for these Moslem seals, is an irregular slab of turquoise in the Morgan Gem Collection, five inches by three, engraved with about two thousand words.



A PERSIAN AMULET

Carved from chalcedony and engraved with texts from the Koran. The Arabic lettering has the effect of an intricate and beautiful decoration.



THE FIVE HAPPINESSES

JADE

The Mythology and Symbolism Expressed in the Carvings
of the Jewel of Heaven

By HERBERT P. WHITLOCK
Curator of Minerals and Gems, American Museum

NEARLY twenty-four hundred years ago Confucius, speaking of the "jewel of Heaven" said, "In Ancient times men found the likeness of all excellent qualities in jade."

Perhaps nothing can so vividly present to us the remote antiquity to which we must turn to find the beginnings of Chinese carved jade than the words "in ancient times" from the lips of this old sage. And it may not be amiss for us to enquire into the questions of how and why these orientals should regard this stone as the embodiment of all virtues.

Under the general

term "jade" are included massive varieties of at least two mineral species,—a massive pyroxene known as jadeite, having

the composition of a soda alumina silicate, and a tough, compact amphibole, called nephrite, and corresponding in composition to a lime magnesia iron silicate. So closely do these mineral materials resemble each other in texture and outward characteristics that it is often difficult to distinguish them apart, especially when carved.

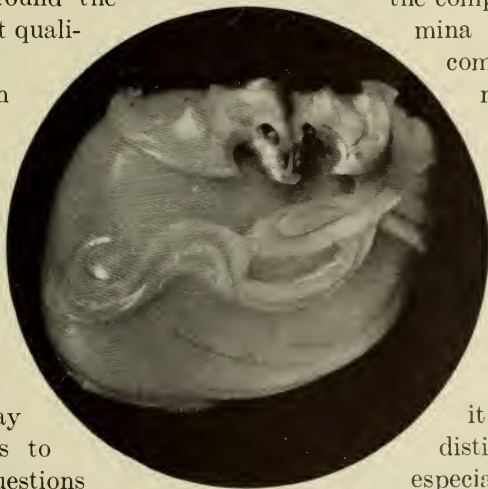

A FINGERING PIECE

Of white jade, in which a brown-colored area has been used for the ears and face of the "happiness" bat. The bulk of the piece represents a bag of grain (for prosperity). Below the bat may be seen the cords which tie the mouth of the bag. The whole carving is wonderfully smooth to the touch. Whitlock Collection

Of the two, jadeite is slightly the harder, having a hardness of 7 in the Mohs scale as compared with about 6.5 for nephrite.

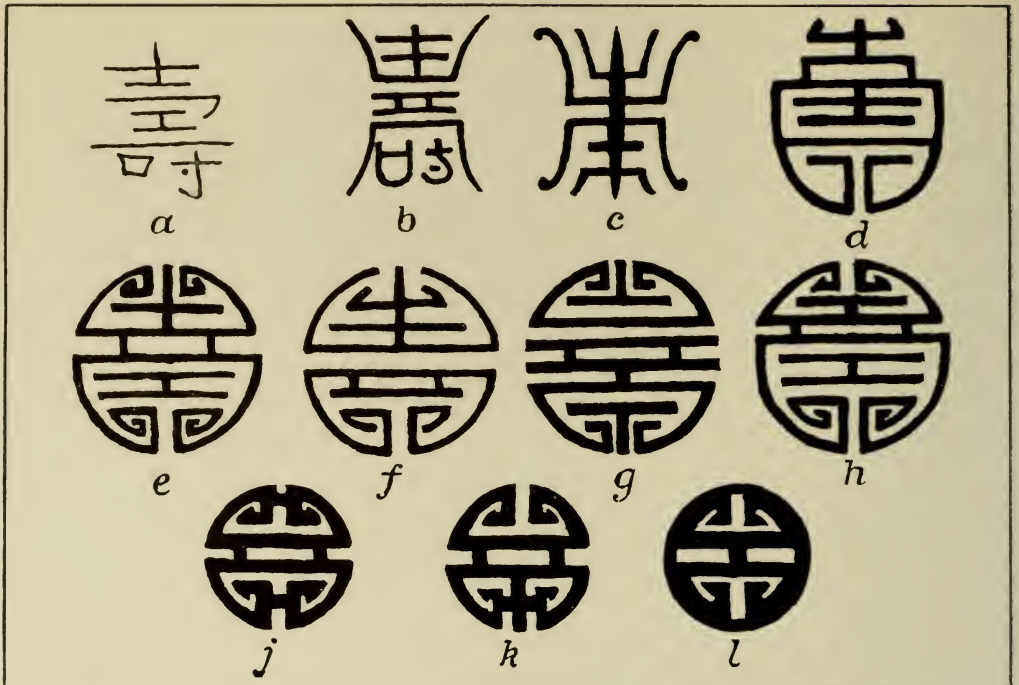

THE CHINESE CHARACTER MEANING IMMORTALITY

With some of the conventionalized variations (Shou marks). *a* Written character. *b* From an old embroidered silk. *c* From a suit of armor of the imperial guard. *d* From a jade wine pot (Tang dynasty). *e-h* Variations mostly in raised carvings on jade. *j, k* From jade pendants (K'ien Lung period). *l* Movable pivot from a jade prayer wheel

Also the specific gravity of jadeite is rather higher than that of nephrite; 3.34 as compared with about 2.95-3.00.

By reason of its toughness and relative hardness, jade was a favorite material for the fashioning of implements employed by primitive man. Wherever jade was obtainable, either from a native source or through trade, we find men of the cultural stage corresponding to the late Neolithic era employing nephrite, and occasionally jadeite, as materials for celts, axes, and other primitive tools and weapons, much as the natives of New Zealand at present make use of their local nephrite. But, although such jade implements of early man have been found in many places

throughout the world, there are but two regions where the use of this material has risen in cultural degree from the purely utilitarian to the decorative stage that places it among the ornamental stones.



WHITE JADE CARVING REPRESENTING THE IMMORTAL WARRIOR CHUN T'I RIDING ON THE ONE-EYED PEACOCK. WHITLOCK COLLECTION

In the portions of the tropical Americas comprising Southern Mexico, Yucatan, Guatemala, Costa Rica, Panama, Colombia, and possibly Ecuador and Peru, the pre-Columbian cultures furnished many carved jade objects of decoration well within the scope of ancient jewelry. There are now no known deposits of either jadeite or nephrite in these countries, and at the time of the conquest of Mexico by Cortez, jade was so rare and so highly esteemed by the Aztecs that it

constituted their most precious possession, worth many times its weight in gold.

It is, however, among the Chinese that the high estimation of jade places it above all other gem stones. And it is in China that we find the use of jade not only extending back into vast antiquity, but furnishing us with a means of tracing through the countless examples of both ancient and modern carved objects the development of a highly interesting and attractive expression of the lapidary art.

As far back as the period of the Chow dynasty of the Eleventh Century B.C., we find nephrite used for carved designs, decorated chiefly with geometric motives.

Although jade of this early period was originally of some shade of green, corresponding to nephrite as we know it today, the green color has, in many instances been altered to some shade of brown, ocher, or dull red. This change is purely superficial, affecting only a very thin layer of the surface, and is due to the action of the weather during long periods of time, the iron oxides, which originally colored the stone green or grayish-green, having been replaced by higher oxides

of the ocher or umber shades. Since the oxidizing agencies producing this surface change of color are those that operate best in the upper layers of the soil, it follows that jade pieces which have been buried for long periods of time exhibit it in the highest degree.

Nephrite from local sources in Shensi and other Chinese provinces, or brought from Eastern Turkestan, or possibly from a deposit near Lake Baikal, furnished most of the jade of this period. In color the stone from these deposits varied from white and gray-green, through leaf-green to dark laurel-leaf-green, the depth of color increasing with the amount of iron contained in the nephrite. Some jadeite from Shensi and Yunnan provinces of China, and from Tibet was no doubt also used for Chow carvings, as for the worked jade of later periods. It is however, difficult to separate the jadeite of this culture from nephrite on a basis of color alone, particularly as many of the carvings in both materials have been altered in color through having been buried.

The tendency to supplant the geometric formality, characteristic of early jade carv-



A GIRDLER PENDANT CARVED FROM WHITE JADE SHOWING THE IMMORTAL CHANG-KUO, RIDING HIS MAGIC COLLAPSIBLE MULE. WHITLOCK COLLECTION

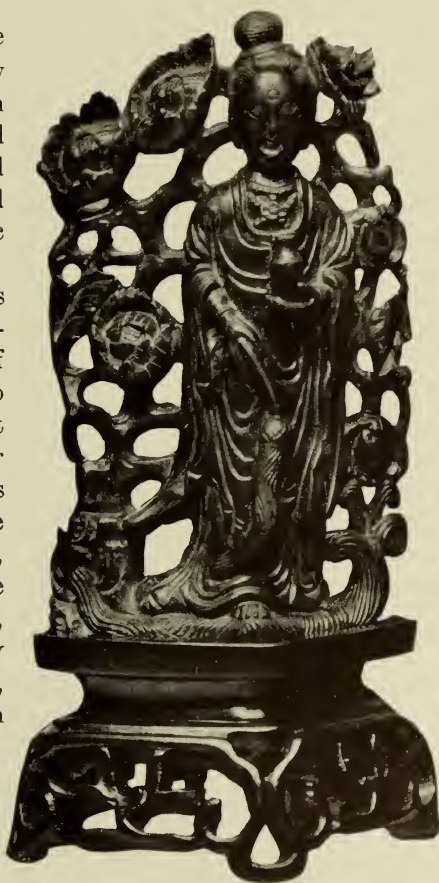

A FIGURINE REPRESENTING KWAN YIN, THE GODDESS OF MERCY, CARVED FROM DARK-GREEN YUNNAN JADE. AMERICAN MUSEUM GEM COLLECTION



THE FIVE POISONS

An amulet carved from white jade, representing a toad, a serpent, a spider, a lizard, and a centipede, the five venomous creatures whose images protect from evil. Whitlock Collection

eties through various shades of green, to deep "spinach"-green heavily mottled, and even to the black of *chloromelanite*.

Among the rarer colors may be ranked the light ochre yellow of some Burmese jadeite, a blood red, met with in patches in white jadeite, and a still rarer light violet or mauve. A beautiful jadeite from Yunnan province is colored a mottled, opaque, grass-green, very much

ing, with a freer and more graceful ornamentation culminated in the highly elaborate carving of the K'ien Lung period (1644-1912), with its undercut relief and open-work patterns. At this time also the beautiful green jadeite, from the Mogaung district in Upper Burmah, began to be imported into China, and much enriched the materials available for Chinese expression in carved jade. This choicest of the jade varieties is also the best known to the western world under the name of "imperial jade." It is never found in large masses, always in relatively small areas disseminated through white jadeite which fact accounts for the mottled and streaked distribution of color observed even in some of the finest and most highly prized pieces.

Aside from the semitransparent apple-green of the imperial jade, the colors that characterize this ornamental stone run the gamut of tints from the translucent white of "melting snow" or the more opaque "mutton fat" vari-

WHITE JADE DISK REPRESENTING THE MOON

The white rabbit, symbolizing the Yin principle, is compounding the pills of immortality in a mortar. Drummond Gift Collection





A DRAGON

A white jade figurine of a dragon with somewhat lion-like proportions. Whitlock Collection

like the color of malachite, but differing from the latter stone in texture.

With increased elaboration in the carving of jade by the Chinese lapidaries there grew up a symbolism involving the subjects depicted in this art. Just as among more primitive people we find glyptic artists depicting gods and heroes, sacred animals and supernatural attributes, so among the Chinese carvers of jade we find myth and legend, philosophic principle and ritualistic symbols used freely and developed with increasing conventionalization as the forms and patterns were



A HORNED AND WINGED DRAGON

Intricately carved belt ornament of white jade. Note the elaborate pierced carving in the background. Drummond Collection Gift

handed down through many generations of artists.

To those of us who have seen large assemblages of Chinese carved jade a very familiar figure is that of a tall, graceful woman, represented seated or standing, and holding either a vase or a lotus flower in her hand. She is Kwan Yin, the Goddess of Mercy, one who hears the cry or prayer of the world. According to the beautiful legend of the Chinese Buddhists,



DRAGON, HIGHLY CONVENTIONALIZED

Carved in old jade; of the period of the Chow dynasty. Note the archaic square turns of the body and the birdlike head substituted for a tail.

Drummond Gift Collection

she was about to become an immortal, but turned back from the very gateway of the Western Paradise, when she heard a cry of anguish rising from earth. So by renunciation she achieved immortality in the hearts of the sorrowing throughout the centuries. Her shrine and her image is to be found in every Chinese temple, as

her prayer is always on the lips of countless mothers: "Great mercy, great pity, save from misery, save from evil, broad, great, efficacious, responsive Kwan Yin Buddha."

Whenever one finds six little men and two women carved in jade be sure that they are the famous Eight Immortals of Taoism. These legendary characters probably at one time actually lived, at least we have excellent reasons to regard some of them as historical personages. According to very old Taoist legends all of the Eight became immortal and each may be recognized by some article that he or she wears or carries, as the crutch and gourd full of magic medicines of Li T'ich-Kuai, or the magic feather fan with which Chung-li Ch'uan fans the souls of those who are to be immortalized back into their bodies. Some of the Eight Immortals are depicted alone, as Chang-Kuo who is shown seated on his marvelous donkey, which folds up like a piece of paper when not in use, and his bundle of magic rods, with which he wrought all manner of necromancy.

Chinese legend relates that long ago in

the nebulous period that preceded the Chow dynasty there occurred a tremendous battle of the Gods in which demigods, Buddhas, and Immortals, not to mention fire dragons and other wonderful creatures, participated. It was an

epic struggle, a sort of Chinese Siege of Troy or Mahabharata in the course of which Chun T'i, a Taoist warrior much gifted in magic, transformed his adversary into a red, one-eyed peacock upon whose back he rode through the sky to the Western Paradise. A little jade carving, no larger than a half dollar depicts this episode with detail and fidelity, even to the single eye of the peacock.

Disks of white jade sometimes show carved in relief a rabbit standing on its hind legs beside a conventionalized tree, engaged in pounding something in a mortar. The subject of this design emanates from the legend of Heng O, the wife of Shen I, the divine archer. She ate one of the pills of immortality and flew to the moon. Seized with a violent fit of coughing, she presently coughed up the coating of the pill she had eaten, which immediately became a rabbit as white as purest

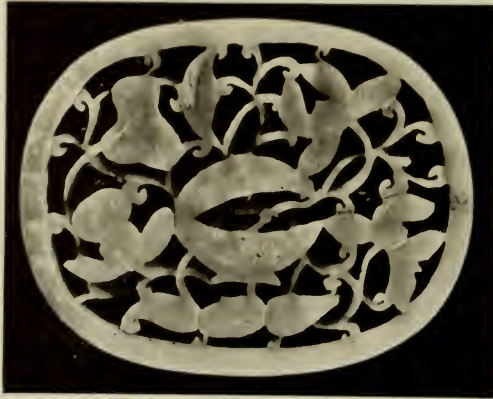

THE LOTUS

An open carving in white jade showing the lotus, one of the "eight auspicious signs," growing from a vase formed from one of its own pods. Whitlock Collection



WHITE JADE GIRDLE PENDANT

Representing a conventionalized dragon on the left, and a phoenix on the right. Both embody the *Yang* or male principle, and in this design support the disk of the sun. Whitlock Collection

jade. Thus was created the ancestor of the *yin*, the negative or female principle of universal life, whose prototype is the moon.

The essence of the *Yang* or male principle resides in the person of the dragon, that mythical animal or being endowed by the Chinese mind with supernatural powers which are generally assumed to be exercised for good rather than evil, as when a dragon was invoked in times of drought to bring fertilizing rain. In this sense dragons were looked upon as veritable deities, and according to Berthold Laufer¹ the manifold types and variations of dragons met with in ancient Chinese art are representative of different forces of nature, that is, of different deities. In a measure this would explain why dragons are so univer-

sally represented in jade carvings, and why they vary so richly and amazingly. Some are full-bodied like lions, while some are attenuated, convoluted, and very reptilian indeed. Some have branching horns and others are decorated with manes that are singularly like human hair. An old Chinese classic ascribes nine "resemblances" to the dragon; its horns are like those of a deer, its head that of a camel, its eyes are those of a devil, it has the neck of a snake, the abdomen of a cockle shell, the scales of a carp, the claws of an eagle, the soles of its feet are like those of a tiger, and its ear like those of an ox. Even in the matter of claws this miraculous beast holds to no fixed rule for, although the imperial dragon has five to each of its four feet, ordinary dragons have but four.

Perhaps because of the fact that Chinese designs and decorative motives

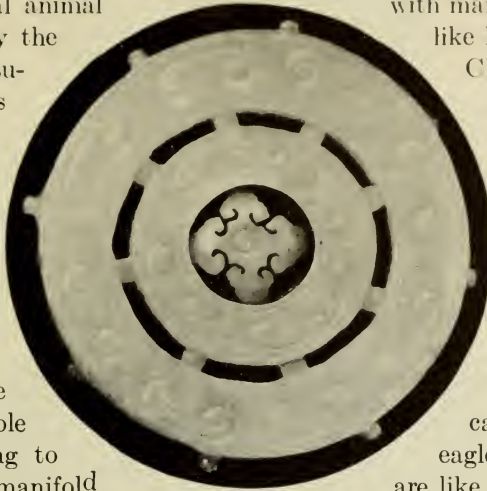

¹"Jade: A Study in Chinese Archæology and Religion." Field Museum of Natural History Publication 154, 1912.



A GROUP OF "WHEELS OF LIFE" CARVED IN WHITE JADE

Two have movable centers and can be rotated by holding the loose central piece between thumb and forefinger. The other one has a swastika for a center. Whitlock Collection

have been handed down from very ancient times, Chinese artists have learned to express these designs in highly conventionalized treatment. In no instance is this more obvious than in the treatment of the dragon in carved jade. His sinuous body has taken on angular bends

or perhaps more frequently has divided and branched like a heraldic mantle. His feet have disappeared, or where present, the toes sometimes spread like the spokes of a wheel, the claws joining on to each other in a circle. Often a dragon holds or supports a round object like a pearl, which really represents the sun, phototype of the *Yang*.

Often associated with a dragon in designs of carved jade, is the phoenix, a highly conventionalized bird which ordinarily symbolizes prosperity. The phoenix, however, also stands for passionate love and is consequently an appropriate and symbolic love gift.

Much the same symbolism is attached



A SYMBOL OF IMMORTALITY
Highly conventionalized butterfly carved from white jade

to a pair of fishes or carp, whereas one carp often stands for power or literary eminence. Chang Tao-ling, who may be considered the actual founder of modern Taoism, is represented as riding on a tiger under whose paw are crushed the five venomous creatures: the

lizard, snake, spider, toad, and centipede. Sometimes these five are represented together in carved jade in an amulet known as the "Five Poisons."

When Buddhism was introduced into

China from India in the Han dynasty in the first century of our era, it brought with it a very interesting series of symbols, known as the "auspicious signs," most of which were said to have been stamped in the footprint of Buddha. These Buddhist symbols were favorite forms



TWO AUSPICIOUS SYMBOLS
A peach blossom, also symbolic of immortality has been made a part of this butterfly design

among the lapidaries of the Kien Lung period, and are often met with carved in white jade of that epoch. One of the most characteristic of them is the Wheel of Life, a disk represented within a disk, often

THE MYSTIC KNOT

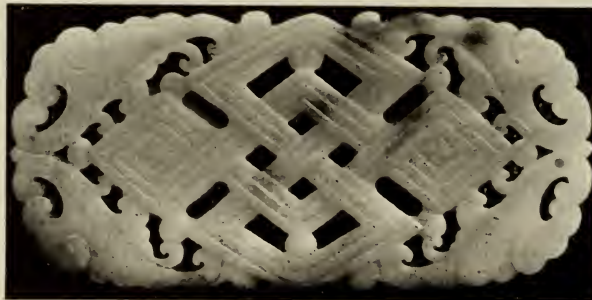

A very popular Buddhist symbol, carved as a buckle in white jade

Note the swastika in the center of the closed loops. Whitlock Collection

wrought with a very cleverly executed movable center about which the whole device may be turned. In this way we have the so-called "prayer wheels" dear to the hearts of Tibetan Buddhists in whose reverend fingers they revolve, in a measure taking the place of the bead rosary. The "spokes" connecting the two disks may number six or eight and the design of the central movable disk may represent the swastika, or the immortality symbol, or even the mystic *yang yin*.

Another very popular auspicious sign is the lotus, either represented with its leaves, embellishing other designs, or growing from a jar or vase, the jar being yet another of the eight treasures of Buddha.

A symbol much in favor is that "mystic knot" which is represented as having no beginning and no end. Not only was this sign one of those found in Buddha's footprint, but it is also said to have appeared on the breast of Vishnu. The Chinese, who love to ascribe auspicious meaning to their symbols, sometimes call it the "Knot of Everlasting Happiness."

Returning to the Taoist type of symbols,

The simplest form of the happiness character



THE HAPPINESS SYMBOLS
Note the "bat of happiness" above the "happiness" character



This girdle pendant illustrates another variation of the happiness character surmounted by the bat of happiness



we have the magic gourd, sometimes depicted alone and sometimes accompanied by a monkey. In the legend of the monkey that became a god this famous gourd was the prized possession of the Demons who opposed Sun Hou-tzu, the Monkey Fairy, and his master, and was capable of containing a thousand people. Sun by a clever device exchanged it for a worthless gourd, which he made the Demons believe could contain the entire universe.

Because butterflies symbolize immortality in Chinese, as they do in Greek mythology, carvings of butterflies were buried with the dead, and no doubt the beautiful white jade butterflies of the K'ien Lung period are survivals of a symbol handed down from Han time. Like most of the other Chinese carved forms they have become highly conventional, often with peach blossoms and swastikas represented on the extended wings.

In the midst of the Western Paradise on the border of the Lake of Gems is the orchard of immortal peach trees whose fruit ripens every six thousand years. These celestial peaches have the mystic virtue

It is surmounted by the sun disk between dragons

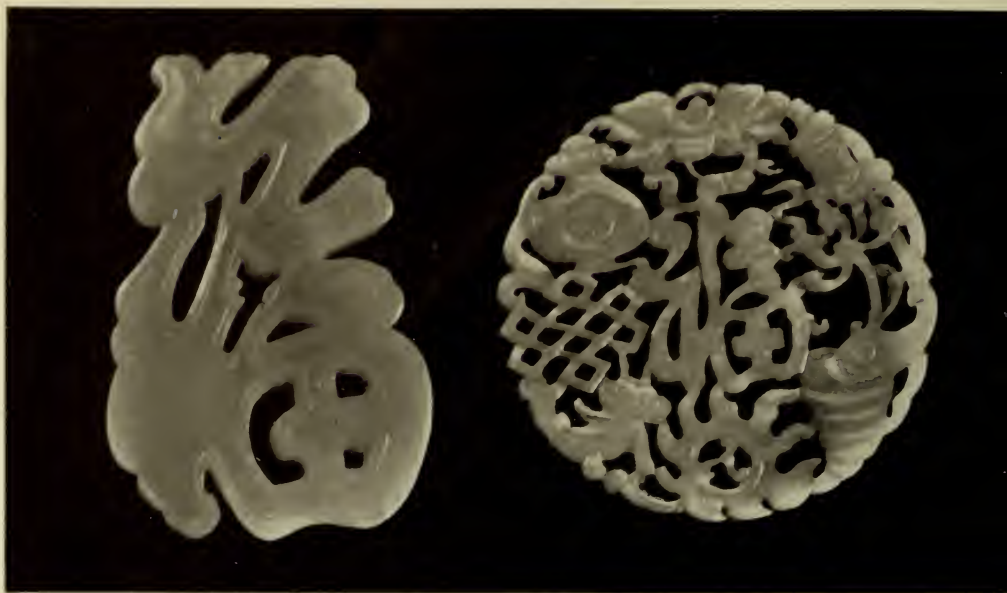

WHITE JADE GIRDLE PENDANTS

Carved with the luck character. To the left is shown the character unembellished, on the right it occupies the center of the design surrounded by a gourd, a mystic knot, a sun disk, etc. Whitlock Collection

of conferring long life, and thus by eating them the Immortals renew their immortality. That is why the Peach of Immortality is so often carved in jade, and why the immortal peach blossom is such an auspicious symbol.

Almost equally auspicious as one of the magic emblems of Taoism, is the Fungus of Immortality which was supposed to grow only on the sacred mountain Hua Shan in the province of Shensi. The contorted and involved shape of this miraculous plant lends itself well to the designs of girdle pendants and it was often carved in the white jade of the K'ien Lung period.

Not only are the Chinese fond of auspicious symbols, but they love a rebus, or as we would say, a pun. The Chinese word for happiness is *fu*, and the same word pronounced a little differently means a bat. So a carved bat becomes a symbol of happiness, and is very generally used either alone or combined with other favorable symbolic designs. Should you meet a design involving *five* bats you are to read it as meaning the "Five Happinesses,"

that is to say "Old Age, wealth, health, love of virtue, and a natural death."

It would probably never occur to any one but a Chinese to use the somewhat complex graphic symbols of the Chinese language in a decorative way. And yet treated conventionally, as the Chinese treat all of their designs, these characters are capable of developing into balanced and well proportioned decorative forms.

One of the oldest as well as one of the most decorative of these "Sho marks" is the character that stands for longevity, or to give it a more mystic significance, immortality. The figure on page 14 shows the modern Chinese character for longevity and a series of its conventionalized variants mostly derived from jade carvings. This seems to be a favorite symbol for use as the movable center of the "prayer wheels" mentioned a few pages back.

Another character very popular with the carvers of girdle pendants in white jade is that which signifies happiness. This is, of course, often combined with

the happiness bat, as well as with dragons and other auspicious symbols. An interesting variation is the "doubling" of the symbol by representing two happiness characters side by side, adjacent parts being connected.

The jade pieces carved with this "double happiness" are appropriate gifts for newly married couples, and convey a wish that their union may be a long and felicitous one.

A somewhat rare conventionalized character in carved jade, rare because it does not lend itself readily to symmetrical

design, is the one that signifies luck or good fortune. In the writer's experience it has been used either alone, without decorative embellishments, or in a somewhat haphazard assemblage of symbols.

Certain designs lend themselves specially to the smooth, rounded contours of fingering pieces, such as are dear to the hearts of contemplative Celestials, who love to sense their cool, delicious feeling through what is to an Occidental the least developed of the senses. Perhaps if we cultivated a love for jade fingering pieces we would think more. Who knows?



A LARGE BUTTON OR STUD CARVED FROM WHITE JADE WITH A HIGHLY CONVENTIONALIZED "SWIRLING" FLORAL FORM, IN THE CENTER OF WHICH IS THE FAMOUS "YIN YANG" MARK.
WHITLOCK COLLECTION

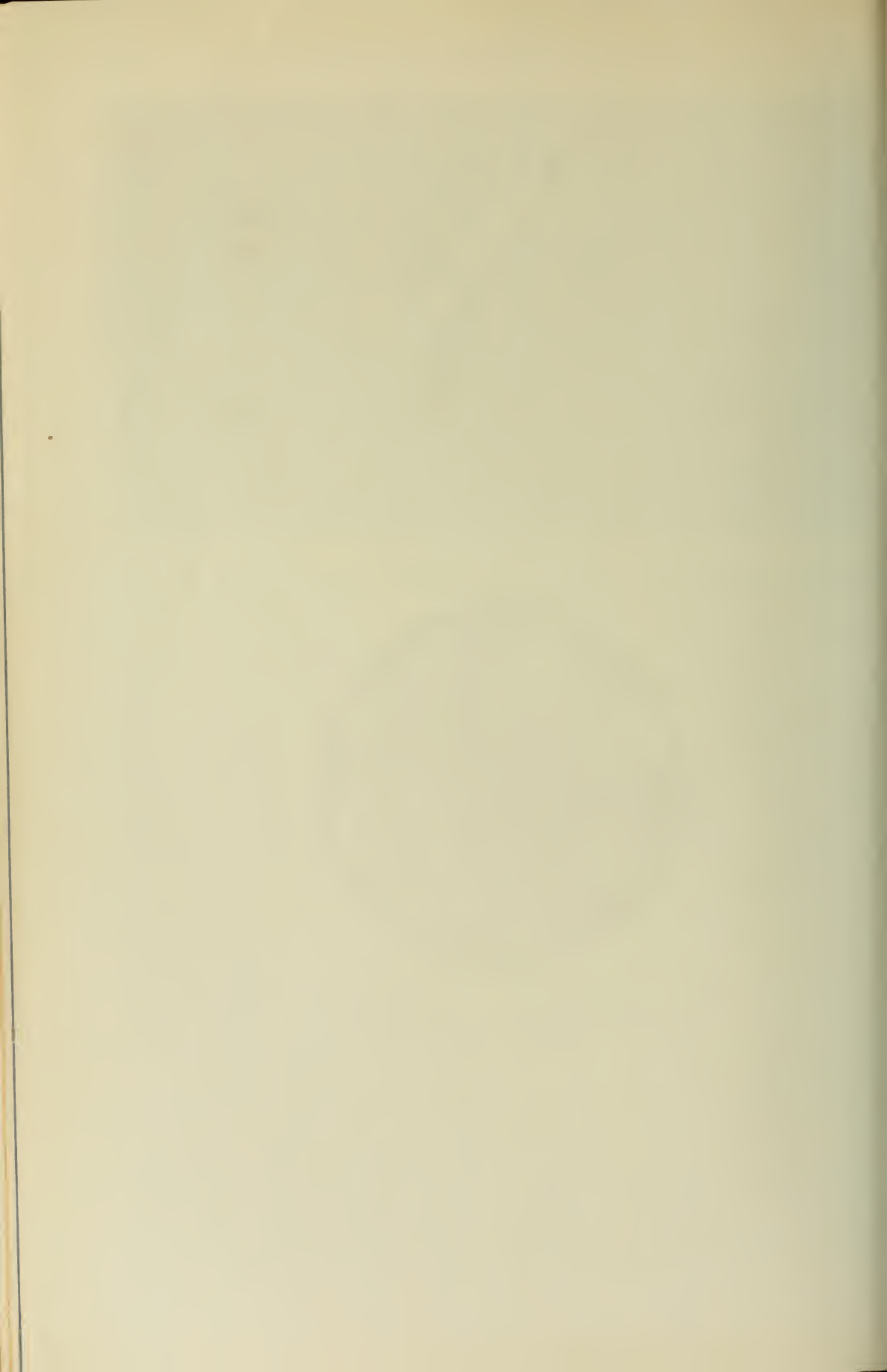



DIVING IN CORAL GARDENS

By ROY WALDO MINER

CURATOR OF LOWER INVERTEBRATES



A BAHAMAN CORAL GARDEN

GUIDE LEAFLET SERIES, No. 80

THE AMERICAN MUSEUM OF NATURAL HISTORY
NEW YORK, 1933





Diving in Coral Gardens

By ROY WALDO MINER

CURATOR OF LOWER INVERTEBRATES



*Reprinted from Natural History Magazine
for September-October, 1933*

GUIDE LEAFLET SERIES, No. 80

The American Museum of Natural History
New York, 1933

THE PHOTOGRAPHS IN THIS ARTICLE WERE
TAKEN BY DR. MINER, MR. AND MRS. ROSWELL
MILLER, MR. AND MRS. ARTHUR N. PACK AND
MR. CHRIS OLSEN



Typical Coral Polyps (*Astrangia danae*)

DIVING IN CORAL GARDENS

A Scientist Works Beneath the Clear Waters of the Coral Reefs of the Bahamas

BY ROY WALDO MINER

Curator, Living Invertebrates, American Museum

After ten years of work on the great Coral Reef Group which is now approaching completion in the Hall of Ocean Life in the American Museum of Natural History, Doctor Miner, the author of this article, took his fifth expedition to the Bahaman coral reefs in order to make another underwater study and to compare the artificially colored corals that will be used in the group with the natural coral growths. This article describes the work accomplished during the time spent in Bahaman waters by this latest of American Museum submarine expeditions.—THE EDITORS.

THE steady hum of the engine of the "Standard J." ceased as the bow anchor went overboard.

"Hey there, you Moxie!" shouted Captain Joe Bethell, "Haul up that dinghy! You and Sweeting carry out the other anchor and hook it over that coral in the yellow patch! Hustle 'er out now!"

Soon the graceful launch was floating close to the reef, anchored securely fore and aft. The brass rope ladder splashed into the water from the starboard gangway and I was standing on it submerged to my neck. Sweeting started one of the pumps going while Moxie carefully lowered the helmet over my head. I thrust my right arm through the loop of the air-hose.

The steady clinkety-clank of the pump

sounded close to my ear as I adjusted the weight of the helmet to my shoulders and started down the ladder. The edge of the water-surface appeared momentarily through the window of the helmet and vanished upward as I passed beneath it. Immediately the weight was lifted from my shoulders and the helmet seemed as light as a feather. I counted the rungs of the ladder as I descended, marking the number of feet from the surface. I swallowed once or twice to relieve the increasing pressure on my ear-drums, and at the twenty-second rung stepped off the ladder on to the white sand of the seabottom. A huge, black sting-ray rose from almost under my feet and swam slowly off with graceful undulations. I had missed him by inches!



A SUBMARINE VISTA ON THE ANDROS REEF

Sunlit aisles of the sea forest floor with reef fishes swimming among the fronds of the tree-like gorgonians

Steadying myself by grasping a ladder-rung, I looked about me. A short distance away rose the coral reef, tier on tier, to the surface. Clusters of mushroom-like coral growths capped with gray-green and pink *Orbicella* formed the bulk of the reef. Purple and yellow sea-fans swayed back and forth with the motion of the water, while sea-bushes of soft and varied hue rose from slender stocks, their waving branches, extending upward in widely expanding parallel ranks, starred with hosts of feathery polyps. Caverns and arches of eroded coral, fantastic in form, showed clearly through the unbelievably transparent water or melted into the pearly blue liquid mist in the distance.

I took a few steps forward leaning against the push of the current, and glanced up to see the keel and underside of the launch bulking above my head with propeller and rudder looking very formi-

dable from below. My air-hose floated coiling to the surface, while clouds of silvery bubbles, released momentarily from my shoulders, rose in expanding clouds. A disturbance of the water at the summit of the ladder attracted my attention. A pair of legs appeared weirdly on the rungs. The body was not visible, being concealed by the liquid mirror of the water surface. This was impenetrable to the view, but reflected an inverted image of the legs, giving the odd effect of a St. Andrew's cross! In a few minutes the rest of the figure and a helmeted head succeeded the legs, descended the ladder, and stood on the sea floor beside me. Looking through the window of the helmet, I perceived the smiling features of Roswell Miller, who, with Mrs. Miller and my artist, Chris Olsen, completed the personnel of my expedition for the American Museum of Natural History.

I motioned toward the reef and we advanced slowly in the direction of an outlying brain-coral that towered above us on a fantastically carved pedestal, with a cloud of bright yellow fishes flitting around its summit like canary birds. Rounding this mass, we entered a crooked passageway which led toward one of the great overhanging arches of coral rock. As we peered within, a moving form became visible in the watery shadows, then another.

Presently, a huge parrot fish, brilliantly blue, varied with deep violet, swam slowly out of the cavern, followed by two others in stately procession. Back and forth they sailed, staring toward us, occasionally nibbling at a bit of loose coral, portions of which they crushed with their white, parrot-like beaks, releasing powdery fragments which rose in clouds as they masticated them for the filmy nourishment they afforded. We signaled to each other and edged back toward the boat. The window of a water-glass penetrated the surface beside the bottom of a floating dinghy. We motioned with our arms, and the undersea tripod splashed down through the water to settle bottom side up at our feet, its legs extending upward from the square metal top. The heavy camera-box now came gliding down, hooked on the end of a cord. We slowly and painfully erected the tripod, carefully adjusting it in a favorable position. One must move with deliberation at the bottom of the sea. Attempts at rapid motion were futile and exhausting, but if we moved slowly, the water supported us in half floating fashion and we progressed easily with the effect of a slow-motion film. A little push with the foot and we glided over an obstruction to a considerable distance and settled down slowly and gently. After the tripod was erected satisfactorily, we returned for the camera-box. I reached for it but miscalculated the distance, and my hand

grasped empty water about two feet in advance of it. Distances under water are deceptive to the vision, because of the unaccustomed density. Groping forward, I felt the handle of the camera-box, and had no difficulty in lifting, with one extended hand, a weight that both hands could scarcely raise from the boat's deck, in the open air. We carried the box over to the tripod, placed it in position, and took turns pressing the lever that actuated the mechanism of the camera. Unfortunately, by this time the parrot fishes had disappeared, though swarms of blue-heads and schools of jacks swam into focus.

As the focus of the camera had to be set at a predetermined distance before sending it down, it was impossible to focus on a fish directly, and it was tantalizing to see beautiful queen triggers, blue angel fishes, and grotesque trumpet fishes come into plain view at a distance of twenty-five feet, when we had carefully arranged our focus at ten feet.

After fifty feet of motion picture film had been taken, we carried the box back to the cord which hung suspended from the launch and sent it up for Captain Bethell to rewind and return to us again. When the film had completely run out, it was sent up for Mrs. Miller to change, and a second undersea box containing color film was sent down. This was Roswell Miller's specialty, and through its means he obtained beautiful motion pictures depicting the soft colors of the living corals and gorgonians and the brilliant hues of the fishes which lived among them. After a time, Chris Olsen took his turn with the helmet, and we worked our way carefully through the tortuous aisles of this undersea fairyland to observe more intimately the multitudinous variety of the creatures composing the closely interlocked association of forms characteristic of the living coral reef.

Our attention was attracted by a

COLLECTING "HONEY-
COMB" ROCK ON SPRUCE
CAY

Many of the smaller cays of the Bahamas are composed of eroded limestone rock honey-combed with cavities and winding passages of fantastic form, resembling a petrified sponge



SCOUTING FOR A
FAVORABLE LOCATION
TO DIVE

Members of the expedition using water-glasses to examine the sea-bottom for an advantageous position from which to study and photograph the coral reefs from the sea-floor





**THE "STANDARD J." THE
FLOATING HEADQUARTERS
OF THE EXPEDITION**

This forty-eight-foot gasoline launch, commanded by Captain Joe Bethell of Nassau, is well adapted for coral reef work. She has been used by Doctor Miner on two expeditions to obtain the material and observations for the American Museum's Coral Reef Group



**ROSWELL MILLER AND
HIS UNDERSEA COLOR
CAMERA**

The brass water-tight box contains a motion-picture camera adapted for Kodachrome. Mr. Miller succeeded in obtaining submarine color films of great beauty



MRS. ROSWELL MILLER DESCENDS
BENEATH THE SURFACE

The heavily weighted helmet is being lowered over her head as she prepares to submerge

ridges exquisitely wrought with radiating star-shaped calices. Hues of delicate rosy pink shaded into cream-yellow tints, suffused at intervals with areas of orange and purple. We had brought with us specimens of this coral which had been colored artificially by our artists for use in the Coral Reef Group being constructed in the American Museum. We now took these with us down under the sea, and placed them beside the living specimens for comparison so as to test the accuracy of our colors. The result was very gratifying. At arm's length, they looked exactly like the real coral and blended with their living

wonderful cluster of golden yellow *Porites* coral which rose in an enormous dome above our heads. It was composed of a succession of expanded mushroom-like caps, completely covered with small conical mounds which gleamed in the sunlight flickering through the ripples overhead. Like most such growths, the caps were supported by eroded columns of dead coral limestone overgrown with encrusting sponges of scarlet, or green and yellow. Clusters of *Agaricia* coral grew vertically from the sides of the columns sculptured on both sides of their thin leaf-like expansions with close-set series of fine parallel

DOCTOR MINER ABOUT TO DIVE
He stands on a rope ladder while the helmet is being adjusted. The rungs of the ladder are a foot apart, enabling him to measure his depth as he descends



neighbors so perfectly that they could not be told apart!

As we stood looking at the coral, we suddenly became aware of a beautiful sight. From the open ends of a cluster of little whitish tubes, soft tufts, for all the world like penciled color brushes, came into view, slowly unfolding until flower-like heads of violet and purple spread themselves wide open from every tiny aperture. Even while this transformation was taking place, another cluster began to expand, and then another, until the dead and eroded rocky shafts of coral became alive with the bursting bloom of animal flowers. For these were the heads of beautiful sabellid sea-worms which are crowned with circlets of delicate petal-like breathing organs expanding to receive through their thin, translucent walls life-giving oxygen from the watery flood in which they are bathed.

One stands amazed at the wealth of detail which gradually dawns upon the vision as the attention is directed to the multitudinous forms of which the reef is composed. Here, a magnificent purple sea-bush spreads its comblike fronds before us. Every branch is covered with thousands of transparent cream-colored polyps each spreading eight raylike tentacles around a tiny dot of a mouth, so small that it can be seen only upon close examination. The sunlight shining through their translucent crowded bodies outlines every twig of their waving,



MANNING THE PUMPS ABOARD THE "STANDARD J."
Moxie, in the center, acts as tender. It is his duty to watch the divers and to pay out and take in the air-hose as needed

treelike home with a multiple margin of glory.

A cluster of fluffy green clubs rises from a crevice between two rounded brain-corals. The starry blanket covering them seems to be very soft and deep. I touched it with a speculative finger. The soft clubs magically transformed themselves into a cluster of hard, finger-shaped projections of bright purple! Looking closely, I saw that the fingers were covered with thousands of pinholes, and, as I watched, one filmy form after another peered forth and gradually elongated until the purple surface of the fingers became clothed once more with fluffy green.



The sea-clubs, sea-bushes, sea-whips, sea-feathers, and sea-fans are all grouped together by scientists under the name, *Gorgonia*. Unlike the corals, their tree-like skeletal support is flexible, being composed of a tough, horny substance invested with a crust of felted calcareous needles, irregularly shaped and of extremely small size. A labyrinth of canals penetrates this crust, opening frequently to the outside by means of circular or oval apertures about the size of a pinhole. The living substance of the polyps is tubular and invests the canals throughout, projecting through the pinholes, when expanded, as tiny tube-shaped creatures crowned by a circlet of eight threadlike tentacles surrounding the central mouth-opening. If touched, they contract and withdraw into their hollow retreats.

The reef-forming corals resemble the gorgonian polyps in appearance and

DOCTOR MINER FOUR
FATHOMS BELOW
THE SURFACE

His sixty-five-pound helmet rests lightly on his shoulders, because of the supporting power of the sea water

TWENTY-FIVE FEET
BELOW THE SEA SURFACE
The motion-picture camera is enclosed in a water-tight box and is actuated by a lever from the outside

structure except that their cylindrical polyps are surmounted by many tentacles in multiples of six, and have the power of laying down a skeletal structure of carbonate of lime beneath and around their soft bodies. The concerted action of millions of coral polyps builds

up the immense and complicated limestone structures which form the coral reef. The coral skeletons may form crusts over the sea bottom, or may rise in dome-shaped masses like the brain and star corals (*Mæandra* and *Siderastræa*), or postlike growths capped like mushrooms, as in the case of the orb corals (*Orbicella*). They may be leaf-shaped, as in *Agaricia*, or like rosettes, or sinuously petalled flower-like colonies, characteristic of *Isophyllia* and *Mussa*. Among the most beautiful and striking corals of the Bahaman reefs are three species of *Acropora*, which forms branching structures, the most delicate and fragile of which is the fan coral



(*Acropora prolifera*). The staghorn coral (*Acropora cervicornis*) builds loosely branching many-tined skeletons reminding one of the antlers of a stag, from which its name is derived. The largest and most massive of the three is the great elkhorn, or palmate coral (*Acropora palmata*) which forms gigantic growths with branches like beams, expanding into broad, palmate tips, reminding one of the antlers of an elk. This species dominates the great Andros barrier reef, where the scene of the American Museum's Coral Reef Group is laid. All the other species of coral are found there, but are overshadowed by the great orchard-like groves of the elkhorn, which rise in tangled thickets of marble trees tinted with saffron.



COMING TO THE SURFACE AFTER A DIVE
Moxie reaches down to remove the helmet as the head of the diver appears above the water

Of the five expeditions I have led to obtain the material and observations for the Coral Reef Group, the first three centered around the Andros reef. The two latest, including that of the present year, concentrated on the beautiful reefs of Rose Island. Here, again, all the species characteristic of Andros are present, but the elkhorn coral is relatively rare, while the dome-shaped corals and the gorgonians are particularly abundant. The Rose Island reefs thus form a strongly contrasting association as compared with the Andros Barrier Reef. The latter is massive, wild, and grotesquely beautiful in its effect, as the coral growths run riot in protean variety and menacing grandeur.

The Rose Island reefs, on the other hand, are filled with soft and colorful beauties, due to the rising terraces of rounded species, cap beyond cap, dome beyond dome, their foundations columned and buttressed, pierced by caverns, arches, and winding passages. Their ethereal beauty is heightened by the multitude of waving gorgonians; sea-plumes, sea-feathers, and sea-bushes of many soft and varied hues—purple, violet, brown, tan, yellow, and lavender—waving back and forth in the sunlight which descends through the heavenly blue waters in beams of light. When the water surface is roughened, these sunbeams may be seen flickering and dancing



A PURPLE SEA-FAN WITH FULLY EXPANDED POLYPS
Waves back and forth in the sunlight glinting through the lacy openings of the delicate meshwork composing its flexible fan-shaped "skeleton"

up and down, piercing the water in shining spear-shafts, advancing and retreating like Northern Lights. Out from behind the clustered domes dart fishes of every brilliant hue, in almost every unbelievable contrast of pattern and color, while from coral arch and deep, dark cavern, the bulky, bright-colored parrot fishes, the huge, somber jew-fish, and the variegated and changeable Nassau grouper, peer and nose and glide in slow and stately parade. Now and then a great school of silver-blue jacks with clean-cut bodies and small-peduncled, slender-finned tails will glide across the view and even surround us completely. Hundreds of them! All glide by, swimming in the same direction, passing out of sight, their silvery-blue bodies suddenly vanishing in the silvery-blue haze of the undersea. Suddenly they appear again out of nowhere and sail past in the opposite direction. This will happen several times, as if

GOLDEN YELLOW
PORITES CORALS

Like nuggets of gold, they are massed together in immense clusters, capping irregular columns of eroded limestone



the entire school were formed into a committee of the whole to inquire into the doings of their strange, helmeted visitors from the upper world.

It is true that there are fish-serpents in this coral paradise of the fish world. Long and slinky

green or spotted morays with small serpent-like heads and sharp needle-like teeth lurk among deep crevices of coral. But they are seldom seen, and if we are careful not to thrust hand or foot into an unexplored hiding place, there is little danger. Once, a barracuda, more to be dreaded than sharks, swam over my head while I was engaged with a camera; but I didn't know it till I came to the surface, when Captain Joe told me about it. However, it did not disturb me and went about its business elsewhere. As for sharks, one is occasionally seen about the reef, but both sharks and barracudas are open-water fishes. They seem to need



A CORAL FOREST ON THE ANDROS REEF

Stone trees, fifteen feet in height, with closely interlacing branches, present weird undersea prospects, in striking contrast to the dome-shaped coral growths characteristic of the Rose Island reef

sea-room, and do not usually bother with the serrated entanglements of coral reefs. So, if one is careful about crevices, and watches not to step on a sting-ray, and keeps one's ankles away from the needle-like spines of "sea-eggs," as the natives ironically call the big black sea-urchin (*Centrechinus antillarum*), there is not much to fear, not nearly so much as there is in crossing Broadway during the rush hour.

Day after day, whenever the weather permitted, the good launch "Standard J." took us from clump to clump of the reefs at Rose Island, Athol Island, and Long Shoal. We had three undersea cameras, two for black and white motion pictures, and one for color film. The latter and one of the former were the ingenious contrivances of Roswell Miller. There were also two helmets and pumps, which thus enabled two persons to get under the sea at a time. We could walk

about together and converse simply, by means of predetermined signs which enabled us to compare notes for our work. At times Chris Olsen would go down with palette and easel constructed of non-corrosive metal. He would set up his easel on a convenient clump and fasten into it an oiled canvas securely mounted on a sheet of plate glass. Then he would actually make sketches with oil colors directly from nature, undersea, at a depth of fifteen or twenty feet. At first, he used the regulation artists' brushes with wooden handles, but whenever, inadvertently, he let go his hold on one, it would float to the surface and Moxie would have to row out with a dinghy to get it. Besides, in the wash of the tide, a brush is not steady enough for applying color. So Olsen finally used a palette knife instead, which was much easier to manage.

I succeeded in getting motion pictures



MANY-BRANCHED GORGONIAN SEA-BUSHES

Their vertical fingers, extending upward in closely parallel ranks, are covered with feathery white polyps, which outline the slender subdivisions like a halo of light as the sun shines through them.



DETAIL OF A CORAL CLUSTER ON A ROSE ISLAND REEF

Huge dome-shaped masses of tawny or gray-green *Orbicella* corals, suffused with delicate pink, rise in towering clusters to the water surface, interspersed with patches of fluffy red and green algae and branching gorgonia.



NUMEROUS SPECIES OF GORGONIANS GROW AMONG THE CORALS

These are flexible coral trees each built up by thousands of tiny polyps, constructed by them of a horny substance, in contrast to the limestone "skeleton" built by stony coral polyps



CHRIS OLSEN PAINTING AT THE BOTTOM OF THE SEA

Equipped with diving helmet, monel metal palette and easel, the expeditionary artist made sketches of coral reefs twenty-five feet below the surface. He used oil-colors on an oiled canvas stretched over a sheet of glass



A GREAT ELK-HORN
CORAL

High on the summit of the reef, close under the water surface. The spreading tips resemble the antlers of an elk

of him at work, by going down in another helmet for the purpose and mounting an undersea camera on the tripod at a carefully measured distance. An enlargement from a portion of one of these films is shown in this article.

Of course, it was possible to make only the preliminary sketches undersea. The finished studies were made at our headquarters in Nassau, where our studio was established at the hospitable home of Mr. Edward S. Toothe.

Mr. and Mrs. Roswell Miller were splendid coworkers on this trip. They are excellent swimmers and occasionally, while both helmets were in use, I would sense a splash above my head and look up to see a graceful, red-clad figure break through the mirrored water-film, and Mrs. Miller would come diving down in a stream of silvery bubbles, or we could see her partly penetrating the surface as she

swam about the boat for long periods, looking down at Mr. Miller and myself as we worked, peering through a water-glass held in front of her.

At other times we had the pleasure of introducing His Excellency Sir Bede Clifford, the Governor of the Bahamas,

and Lady Clifford to the undersea world. They came down in turn, and explored the face of the reef, working their way through the crevices between the coral clumps, facing the inevitable camera at a depth of twenty feet. The Bahaman officials were all greatly interested in our work, both in this and in all the previous expeditions, and did everything in their power to assist us.

Occasionally, when the weather was too rough for diving, we went ashore on one of the rocky cays which abound in the waters near Nassau, and, by means of hammer and hatchet, hacked off huge fragments of the eroded "honeycomb

CORAL GROWTHS LIKE
GIANT PETRIFIED
MUSHROOMS

Rise above waving fronds of sea-fans and sea-bushes, melting into the luminous blue of the distant watery prospect



A SCHOOL OF SILVERY
JACKS

They swam solemnly past the undersea workers, as if to examine the intruders into their submarine Paradise



rock" of which they are composed. This rock is wrought by wave and weather into most fantastic forms; in fact, the whole surface of the cays is full of holes and passages contorted and twisted and anastomosing like a petrified sponge. We obtained more than a ton

of this rock and shipped it to the Museum, where we are now reproducing a portion of such a rocky cay as a part of the foreground in the upper section of the group, using the original material in the process.

This group is now nearly finished. A few months more and the exhibit will be complete, after ten years of arduous work. During that time, five expeditions have been undertaken to the Bahamas, the first, in December, 1923, for preliminary observations and arrangements; the second, in 1924, secured forty tons of coral, many feet of undersea photographs and motion pictures of the Andros reef, and many water-color studies from

life, using the Williamson undersea tube and diving helmets for the purpose; the third, in 1926, obtained the casts and sketches of the fishes for the group, as well as sketches for the great cyclorama representing the scene of the coral lagoon above the water; the fourth, in 1930, procured the gorgonians needed, properly prepared, and additional undersea motion pictures and observations, utilizing diving helmets; the fifth, during the spring of the present year, also utilizing diving helmets, a check-up expedition, made final observations and additional motion pictures from the sea-bottom, and obtained rock for the coral island.

These five expeditions have been interpolated between long periods of work at the Museum, preparing and coloring corals, erecting the elaborate framework to support them in the group, consisting of more than seven tons of structural steel.

SIR BEDE CLIFFORD,
GOVERNOR OF THE
BAHAMAS

Inspecting the Rose Island gardens on the sea bottom. Governor and Lady Clifford were enthusiastic divers



modeling and coloring fishes and the other multitudinous forms of undersea life composing the coral reef association. The great upper and lower backgrounds had to be colored for this huge two-storied group which exhibits the above-water and under-water scene simultaneously. Eleven-foot plate-glass backgrounds had to be inserted and colored, and the under-water illusion

had to be worked out. Various items remain to be completed. When finished, it is estimated that the exhibit will be the equivalent of thirty ordinary Museum groups in size and difficulty of preparation. It will occupy one-third of the entire farther end of the great Hall of Ocean Life, probably the largest museum exhibition hall in the world.



LANDING THE "HONEY-COMB" ROCK
AT NASSAU

The expedition brought back more than a ton of this rock to build a rocky cay as a part of the Coral Reef Group in the American Museum







THE WORLD OF FISHES

Guide to the Fish Collections of
The American Museum of Natural History

By WILLIAM KING GREGORY

and FRANCESCA LA MONTE



GUIDE LEAFLET SERIES No. 81

THE AMERICAN MUSEUM OF NATURAL HISTORY
NEW YORK, N. Y.



The Sea Rovers.

An undersea scene, showing a number of sharks attacking a sea turtle. In the lead is a twelve-foot Tiger Shark; on the left, a Hammerhead, and in the background, the White Shark or Man-Eater.

THE WORLD OF FISHES

Guide to the Fish Collections
of the
American Museum of Natural History

by
WILLIAM KING GREGORY
and
FRANCESCA LAMONTE

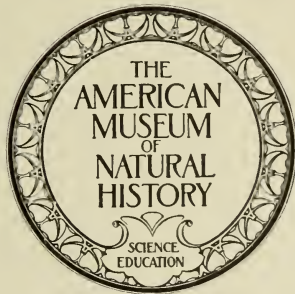

GUIDE LEAFLET SERIES No. 81
NEW YORK, 1934

TABLE OF CONTENTS

	PAGE
INTRODUCTION.....	7, 8
Part I. Recent Fishes.....	9-49
Section I. Archaic Fishes.....	9-18
Sharks.....	9-14
Rays.....	14, 15
Chimæroids.....	15, 16
Lampreys and Hags.....	16
Lungfishes.....	16-18
Section II. The Biology of Fish.....	19-23
Reproduction.....	19-21
Parental Care.....	21
Locomotion and Body Form.....	22, 23
Section III. Deep Sea and Reef Fishes.....	24-26
Section IV. Gamefishes.....	27
Section V. The Higher Fishes.....	29-49
Ganoids.....	29
Teleosts.....	29-49
Part II. Fossil Fishes.....	53-64
INDEX.....	65-90



Fig. 2. Remora, the Shipholder. (After Camerarius, 1654).

INTRODUCTION

“**F**ISH stories” have been cheerfully told by romancers of all ages, and a public that loves to be humbugged has greedily believed them.

The mermaid, the sea-serpent, and the giant “devil fish” that threw its slimy tentacles around a Chinese junk are among the more famous narratives of marine life, but there are others equally ancient and astonishing.

The myth of the Shipholder, for instance, lasted from Aristotle’s time to the end of the Middle Ages. This slender, smallish fish with an adhesive disc on top of its flattened head, according to Pliny “bridles the impetuous violence of the deep” and stops large vessels in their course merely by fastening itself to them. To this fish, the Remora, prominent roles in ancient naval encounters have been assigned by credulous authors who should have known better.

In the same delightful manner, a learned gentleman named Conrad Wolffhart rose in the sixteenth century to announce a “downpouring from heaven” of little fishes, illustrating his story with a woodcut of the fishes dropping as a gentle rain from heaven upon a village in Saxony.

Man’s small imaginative efforts have, however, been put to shame by nature’s own inventions. No sixteenth century collection of zoological yarns could rival the contents of nature’s unique collection. For here are fishes with bifocal spectacles, or four eyes—two for looking above water and two for seeing below the water line; fishes fully equipped with

rod, line, hooks and dangling bait; fishes that can shoot—water—with deadly aim; fishes carrying electric batteries on their backs or tails; fishes that drown if prevented from rising to the surface for atmospheric air; fishes that hop about on land. “Believe it or not,” there is a species of black, deep-sea Anglers in which the female is sometimes a thousand times heavier than the male, who dangles like a pendant from the cheek of his huge mate.

Our object, however, is not to lay undue emphasis on the numerous freaks and oddities of nature’s Cabinet of Curiosities, but to exhibit fish life in its more truly representative phases. The Hall of Fishes of the World contains representatives of only a very small fraction of the twenty thousand already known species of fishes. It aims, however, to present a selection of the better known families, classified and arranged according to their natural blood relationships with each other.

Under Biology of Fishes, we consider the fish as a natural mechanism. Here our object is to look below the surface and see the wheels go round,—to see how the fish lives, moves, eats, etc.

The collection of Game Fishes appeals not only to the student, but to everyone who loves fishing as a sport. It contains several of the biggest fish ever caught on rod and reel, according to available records. The Sailfish Group and the gigantic Marlins caught by Dr. Zane Grey form the chief features of this exhibit.

In general, the arrangement of this guide follows that of the Hall.

SECTION I

ARCHAIC FISHES

(Sharks, Rays, Lampreys, Lungfishes)

[Cases, 7, 11, 5, 3, 1; groups; inner room]

SHARKS

The Sharks of the present are the survivors and descendants of sharks that lived many millions of years ago in the Devonian age of the earth's history. [See Fossil Fishes]. They differ from ordinary fishes especially in the gristly or cartilaginous state of the skeleton, which is not strengthened by bony tissue, but by deposits of calcium carbonate and calcium phosphate. The skeleton as a whole is in a primitive or generalized state as compared with that of higher vertebrates and the same is true of the brain, blood vessels, digestive system, etc. Hence a study of the anatomy of the shark forms an excellent introduction to the anatomy of higher vertebrates, including man.

The diagram in Case 11 attempts to visualize the evolution of the body forms of the higher sharks from some ancient central stock which is most nearly typified by the existing Sand Shark (fig. 1 of diagram). Each figure stands for a family or group of related forms, and the branching of the lines indicates the relationships.

The whole surface of the shark's body is covered, not by scales, but by denticles or little teeth, or plates, called "shagreen." Because of its roughness and durability, the skin of the shark has been considerably used in place of sandpaper for polishing wood and ivory, as well as for ornamental purposes. The commercial leather known as "galuchat" is shark skin. Around the mouth of the shark, these denticles become enlarged and give rise to the teeth.

The swifter sharks, like the Mackerel Shark (Case 11), pursue and devour live fish, but the more sluggish ones, like the Nurse Shark are content with offal. Some with blunt teeth, like the Port Jackson Shark (Case 7), crush shellfish, while some with very large mouths and reduced teeth, such as the Whale Shark (*see* separate case) and the Basking Shark, (above Case 11), feed like whales on small copepods and other floating, shrimp-like forms.

Reproduction: Sharks produce but a few eggs at a time, in contrast to the hundreds of thousands produced by a single Codfish; hence they can afford, so to speak, to invest a large amount of capital in each egg, that is, to endow the young with a very large yolk. This nourishes the young for a long time, so that they are well equipped to take care of themselves when they are hatched. In some sharks, however, the eggs

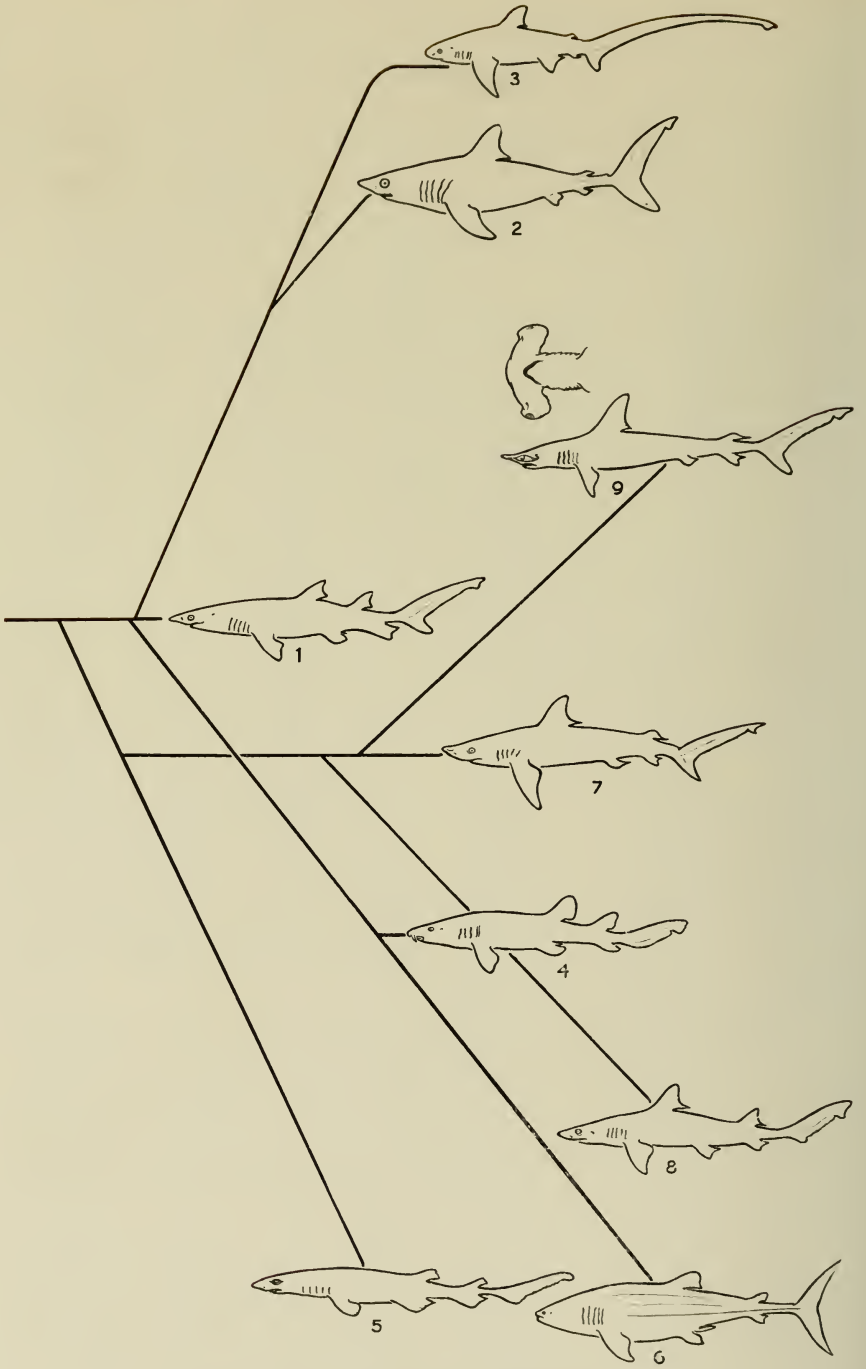

Fig. 3. Evolution of the Body Form of Sharks.

develop within the oviducts or egg ducts, and the young draw nourishment from the mother by means of root-like outgrowths from the region of their gills.

The Port Jackson Sharks (Heterodontidæ). [Case 7]: During and before that ancient period of the earth's history in which the vast swamps and forests of Pennsylvania were accumulating their stores of coal-forming vegetation, the shallow seas of the world swarmed with ancient sharks, many of which bore curved spikes on the front margins of their fins. The more specialized forms of these early sharks became extinct, but one family survives,—the Port Jackson Sharks—which are still found living in the Pacific Ocean. These retain the stout fin spines and whorl-like crushing teeth of their vastly distant ancestors. They lay eggs which are enclosed in a spirally twisted egg case.

The Spined Dogfishes or Squaloid Sharks (Squalidæ). [Case 7]: These sharks are far removed from the higher sharks and appear to be related to the ancestral stock of the Rays. They have lost the anal fin; the teeth are usually closely packed and more or less uniform. Some of the deep-sea members of the family are only a few inches long, while the Greenland Shark is said to reach a length of twenty-four feet. In the common Spiny Dogfish, the eggs are surrounded by a horny shell, but they are not laid; the egg shells break down within the egg duct in which the young are retained until fully developed.

The Notidanoid Group. [Case 11]: This group includes the long-bodied, deep sea Frilled Shark (*Chlamydoselache*), the Cow Sharks, and their allies. The Frilled Shark has trident-shaped teeth, but in the Cow Sharks and their allies the lower teeth are saw-like. Very large yolked eggs are laid. There are not less than six large gill clefts, and but one dorsal fin.

The True Dogfishes or Cat Sharks. [Case 7]: These sharks are variously called Scylliidæ, Scilliorhinidæ, and Catulidæ. As in all the higher sharks, there are two dorsal fins without spines. These are displaced backward, and the lower lobe of the caudal fin is not much produced. Their teeth are many-pointed. The egg cases are elongate and quadrangular with the corners produced into long, curling filaments. This family dates from the Jurassic period. The common "Dogfish" (*Mustelus*) does not belong to this family but is related to the Requiem Shark group. (*See below*).

The Sand Sharks (Odontaspidæ, Carchariidæ). [Case 11]: These are perhaps the most central or generalized of the higher sharks. The body is perfectly normal or shark-like, with none of the fins reduced or displaced. The teeth have needle-sharp points with small accessory cusps on either side of the yoke-like base. The gill slits are of ample

size and lie entirely in front of the pectoral fin. The checker-like centra of the backbone are of the asterospondyl or star type, with four uncalcified streaks radiating outward from the center. The family of the Sand Sharks dates from the Cretaceous. A deep sea member of it, *Scapanorhynchus*, has an elongate, depressed snout.

The Nurse Sharks (Orectolobidæ). [Case 11]: The Nurse Sharks are related to the Sand Sharks but are specialized for a more sluggish life. The head is typically broad and more or less depressed; the teeth closely packed, flattened, or not needle-like; the dorsal fins more or less displaced backward. There are one or more flaps or projections of skin around the mouth. The eggs of the Nurse Shark are about as large as goose eggs, with a delicate, horny shell. It is believed that these eggs are retained in the body during the entire incubation period and free young released as in the Requiem or Carcharinid sharks. In this respect the Nurse Sharks are intermediate between the true Dogfishes (Scyllidæ) which are oviparous or egg-laying, and the Requiem Sharks which are viviparous (producing living young). Fossil representatives of the Nurse Shark family date from the Eocene.

The Mackerel Sharks (Isuridæ). [Case 11]: represent a swift-swimming adaptation from some ancient relative of the Sand Sharks. The contour of the body recalls that of the swift-swimming Bonitos [Case 32]. The upper lobe of the tail-fin is turned sharply upward; its lower lobe is produced downward so that the tail as a whole is more or less lunate. Its base is supported by lateral keels. The second dorsal and anal fins are much reduced. The teeth range from simple bodkin points in the Cretaceous *Orthacodus* [see Fossil Fishes] to the broad, serrate triangles of the Whale Shark and the far larger teeth of the gigantic extinct *Carcharodon* shown at the entrance of the Fossil Fish Exhibit. The gill slits are very large, wholly in front of the pectoral fins. The White Shark, or Man-Eater, is a gigantic member of this family. The whale-like Basking Shark [above Case 11] is another giant, with the gill rakers prolonged into a sieve for straining from the water multitudes of minute floating crustaceans.

The Thresher Sharks (Alopiidæ). [Case 11, also above elevator]: These are heavy-bodied derivatives of the Mackerel Shark group, in which the enormous tail is used for rounding up the schools of fish upon which the Thresher feeds.

The Requiem Sharks (Carcharinidæ). [Case 7]: The most numerous and dominant group of the present day, these sharks arose later than most of the other families, their fossil teeth dating back at most to the Eocene epoch. They have advanced beyond the lower sharks (such as the true Dogfishes) by retaining the eggs within the egg-tube until the

young are well developed; the young are, therefore, born alive. The Requiem Sharks may be distinguished from the Sand Sharks (*Carcharias*) by the fact that the last one or two of the rather small gill slits lie above the base of the pectoral fin. The base of the tail is notched above and below; the upper lobe of the tail is turned partly upward and the lower lobe is more or less produced. The body form is long and slender in the Blue Shark (*Prionace glauca*). A group at the southwest end of the hall shows a Blue Shark surrounded by its new-born young, swimming about under Sargasso weed and among the wreckage which drifts into the comparatively currentless ocean area known as the Sargasso Sea.

In the New York Ground Shark (*Carcharinus milbertii*) [Case 7], the body is stout, with a massive snout.

The Smooth Dogfish (*Galeorhinus* or *Mustelus*) somewhat resembles the true Dogfishes (Scylliidæ), but differs from them in the more normal position of the first dorsal fin which is not displaced backward. The teeth also are flattened and the fish feeds on crabs, squid and many other creatures. The type represents a bottom-living adaptation of the free-swimming Carcharinid stock.

The strange Hammerhead Sharks (*Sphyrna zygaena*) appear to have derived from some more normal member of the Requiem Shark or Carcharinid group, in which the snout was broad and shovel-like. The Bonnet Shark (*Sphyrna tiburo*) shows an intermediate stage in the widening of the head. The Hammerhead is a swift swimmer and makes sharp turns with great agility, apparently using the flattened head as a "bow rudder."

The Japanese Sawfishes (Pristiophoridae) [Case 7], like the true Sawfishes (*Pristis pectinatus*) [above Case 7], have their nose produced into a very long, flat rostrum, armed on each side with a row of teeth. But a comparative study of the skeleton and internal anatomy of these forms shows that the Japanese Sawfish is more nearly related to the spiny-finned sharks, while the true Sawfish is closely related to the Guitar Fishes [Case 5]. In other words, the saw-like rostrum has been acquired independently in two distantly related groups.

The Whale Shark (*Rhineodon typus*): In a case near the entrance to the Hall of Ocean Life stands a scale model of the Whale Shark, the largest living fish. This fish has been measured up to 45 feet in length, and is estimated to reach 70 feet. It resembles a whale in manner of feeding as well as in size. Its teeth, about $\frac{3}{16}$ of an inch in height and 5000 in number in each jaw, are set in many card-like rows, but are useless for biting. Its food consists of small organisms filtered out of the water by its sieve-like gill rakers. Despite its huge size, this fish is harmless. It occurs in warm waters of the ocean.

The specimen of which this is a model ($\frac{1}{8}$ scale) was 32 feet long. It was captured near Long Key, Florida, June 9, 1923.

Recent investigations indicate that the Whale Shark represents a peculiar family which is a specialized derivative of the Mackerel Shark group.

SKATES AND RAYS

"Winged Sharks"

[Case 5 and Inner Room]

The strange looking Skates and Rays of the present time may be regarded as transformed Sharks, in which the body became greatly



Fig. 4. Russell J. Coles harpooning a Devilfish.

flattened and the pectoral fins enlarged and widened into "wings" which finally became the principal organs of locomotion. The tail is reduced to a long, trailing rudder. The gill slits have been displaced onto the lower side and the water for the gills is pumped in and out through the large spiracles behind the eyes.

Several still existing forms show some of the stages by which this transformation has been brought about. The Monkfish (*Rhina squatina*) is, in fact, more or less intermediate between the Spiny Dogfishes and the Rays. Its pectoral fins are enlarged, but are still separated from the head by the gill slits, which remain lateral in position. The skull and jaws also are of the primitive shark-like type. In the Guitarfishes

(*Rhinobatus*) the front part of the enlarged pectoral fins is fastened to the side of the head and the gill slits are on the lower surface.

The true Sawfishes (Pristidæ) are essentially *Rhinobatus*-like forms in which the greatly prolonged snout has acquired a row of "teeth" on either side. These, like the teeth in the mouth of sharks, have been evolved out of the tooth-like denticles on the surface of the skin.

In the Electric Rays or Torpedoes [case 5 and Inner Room], part of the enlarged muscles of the breast fins have been transformed into electric batteries which consist of layers of alternating tissues of different electric potential, like the plates of a voltaic pile. These fishes are capable of giving a powerful electric shock.

In certain Eagle Rays [Case 5 and Inner Room], the front ends of the breast fins begin to project beyond the mouth, and in the Manta or Devil Fish these forward projections give rise to movable flaps or "horns" which appear to assist the fish in scooping into the broad mouth the small floating creatures upon which it feeds. The large central fish of the Inner Room is the model of a Manta taken off the west coast of Florida in 1915. It measures 17 feet across the outstretched wings. Also in this room, against the wall, is a Sting Ray, its whip tail bearing at the base a strong saw-edged spine which can inflict a severe and irritating, but not specifically poisonous, wound.

The Skates lay eggs enclosed in tough, horny coverings, the four corners of which are prolonged into filaments. These egg cases are frequently washed up on northern beaches. In the Sting Rays and Eagle Rays the young are developed in the egg duct and the embryos draw their nourishment from the mother by means of filaments that extend from their gill openings.

CHIMAERIDS

Silver Sharks

[Case 3]

The existing Chimaeroids, or Silver Sharks, nearly all deep-sea forms, are the descendants of certain specialized sharks of the Jurassic period. [See Fossil Exhibit, case 6]. The living *Rhinochimæra*, for instance, with its long rostrum and tapering tail, strongly recalls this ancient stock, while *Harriotta*, a black fish from the great depths of the Atlantic and Pacific, is a caricature of *Rhinochimæra*.

The Chimæroids progress chiefly by means of their wing-like pectoral fins. Their teeth and powerful jaws are adapted for biting and crushing. In external appearance, as well as in their cartilaginous skeleton and general anatomy, they are clearly allied with the sharks although in

certain other features they parallel the higher fishes. Their mode of development is shark-like. Their eggs are enclosed in tough, horny egg cases which probably lie on the sea bottom. When the young are ready to escape, the egg case opens along hinge-like folds.¹

CYCLOSTOMATA

Lampreys and Hags

[Case 3 and group]

This class includes the two groups of fishes known as the Hags and the Lampreys, eel-like forms with jawless, sucking mouths. With these mouths they fasten themselves on larger fishes and feed upon them until nothing is left of their prey but an empty skin.

The Hagfishes are the vampires of the ocean, a career for which their sucking mouth and their tongues armed with rasping teeth well fit them. The body of the Hagfish is heavily covered with mucous which it also exudes in quantity as a defense when caught, giving it the popular name of "Slime Eel."

These fishes appear to be the highly modified and degraded descendants of the Ostracoderms, the oldest known forerunners of the backboned animals; the intervening stages are missing from the record.

The Sea Lamprey and its Nest: The group to the left of the Cyclostome case was brought as a unit from a stream near Smithtown, Long Island. These fishes, by means of their suctorial mouths, root up and push about the pebbles of clear, shallow streams in order to make a nest in which to spawn.

DIPNOANS

Lungfishes

[Case 1]

All fish breathe oxygen, which is dissolved in the water that passes over their gills, but a few fishes also have true lungs, by means of which they can breathe even when the water in which they live gets foul or dries up. These are the famous Lungfishes of Australia, Africa, and South America.

These interesting relics of long past ages also have four limbs, in the shape of paddles, which are equivalent to the fore and hind limbs of land-living animals.

¹These fishes and their development have been described in detail by Bashford Dean, in his "Chimæroid Fishes and their Development." Publications of the Carnegie Institution of Washington, 1906, number 32. 195 pages, plate, 144 figures.

The Lungfishes are distantly related to the ancestors of the swamp and land-living amphibians.

The Australian Lungfish (*Neoceratodus*) is found today only in the Burnett and Mary Rivers in Queensland, Australia, but many millions

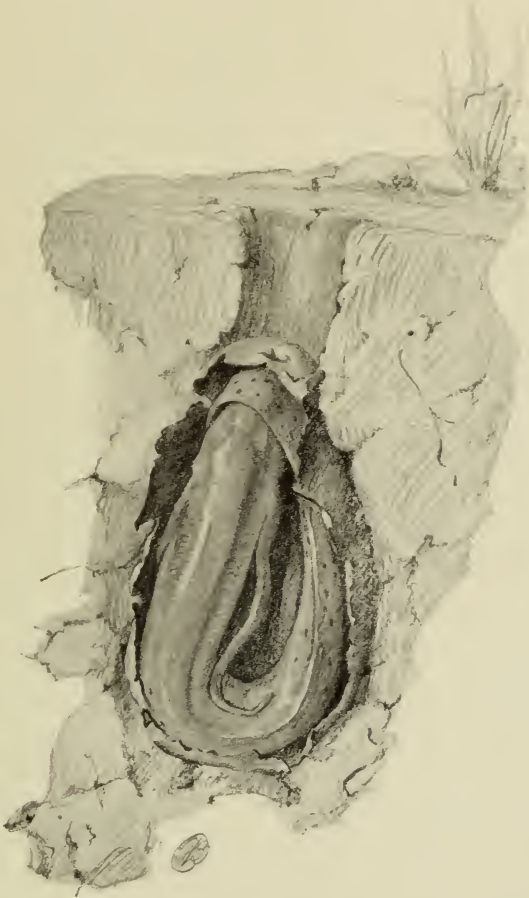

Fig. 5. A Lungfish in its Burrow. Drawn by D. Blakely.

of years ago its ancestors left their peculiar fan-like dental plates and other traces in the swamps of the Devonian and subsequent ages in many parts of the world, from India to Pennsylvania and from Great Britain to Australia.

The modern fish lives in stagnant pools or waterholes. At irregular intervals, it rises to the surface and protrudes its snout in order to

empty its lung and take in fresh air. The development of this fish from the egg is shown on the wall chart nearby.

The African Lungfish (*Protopterus*) has the fore and hind limbs prolonged into tapering filaments, which may be useful in creeping over the bottom of the marshes in which it lives. When the dry summer season comes on and the marshes are drying up, the lungfish buries itself in the mud, excavating a burrow in which it lies coiled up. The glands of the skin secrete a thick mucous, which, when dry, covers the fish like a bag, only a little hole being left around the mouth, through which the fish breathes. For many months the fish lives on its own fat, in a torpid state. When the rainy season returns, the water dissolves the cocoon-like bag and the fish escapes, none the worse for its long fast. A model of the Lungfish in its mud ball may be seen in Case 53.

The South American Lungfish (*Lepidosiren*) is even more eel-like in appearance than its African relative. It also lives in swamps and buries itself in the mud in a tubular burrow during the dry season, escaping when the rainy season returns.

The eggs are deposited in underground burrows at the bottom of the swamp; the male fish standing guard over them. During this period its hind limbs become enlarged and covered with a rich growth of blood-red filaments. These are thought to serve as an accessory breathing organ which enables the male to guard the nest without being forced to leave it and go to the surface to breathe air.

SECTION II

THE BIOLOGY OF FISH

[Cases 53, 54]

Development of Fish from the Egg: [Case 53 and wall chart]: Fishes, like all other backboned animals, reproduce themselves from a *zygote* which results from the union of two germ cells, one from the female, the other from the male parent.

The female germ cell is called an *ovum*, or egg, (plural *ova*); the male germ cell is called a *spermatozoon* (plural *spermatozoa*), or sperm. The egg is commonly said to be "fertilized" by the male element because the male cell starts the process of development. But the male cell does much more than this since it brings with it all the hereditary tendencies derived through the father, while the egg carries the hereditary tendencies derived through the mother.

Spawning (External Fertilization): In the higher fishes, the union of the male and female germ cells usually takes place in the water, into which they are discharged by the parents at the time of mating. In this case, fertilization is said to be external. When the eggs are discharged into the water and fertilized, they either float near the surface (pelagic eggs) or sink to the bottom (demersal eggs).

The pelagic eggs are very small, often less than a millimeter in diameter. They are transparent and often contain a large globule of oil. Such eggs are produced in countless numbers by pelagic fishes of many families (cods, flounders, mackerels, some herrings, etc.).

The demersal eggs are larger, heavier and more opaque. Those of the salmon, for example, are about 5 millimeters ($\frac{3}{16}$ of an inch) in diameter. In many demersal eggs, the outer egg membrane is viscid and adhesive, so that the eggs readily stick to each other or to rocks, stones, or bits of seaweed.

When fertilization is external, the eggs extruded at one time are usually very numerous, sometimes amounting to many millions, in order to compensate for the wholesale destruction of the eggs and young by other creatures or by unfavorable conditions of the environment. The rate of development is dependent upon the size of the egg (large eggs with much yolk tend to develop slowly); the temperature (cold water slows down the development), and racial tendencies which tend to retard or accelerate development. In the small eggs of the anchovy, development from the time of fertilization to hatching takes only two or three days, while the larger yolked eggs of the salmon develop in colder water in 35 to 148 days. After perhaps several weeks, a tiny larval fish is ready to start life on its own account. It begins by taking in only very small

DEVELOPMENT OF FISH FROM THE EGG

"OMNE VIVUM EX OVO"

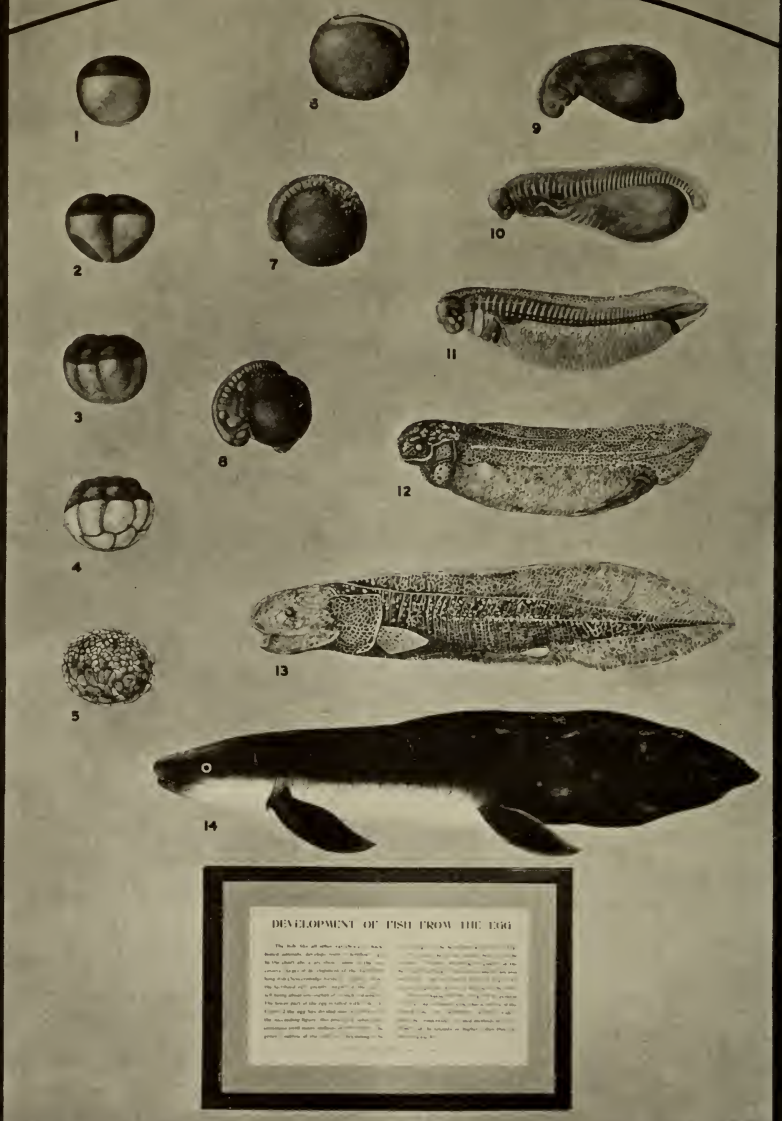

DEVELOPMENT OF FISH FROM THE EGG

The fish, like all other vertebrates, has a head, tail, and dorsal fin. The head is the part of the organism that contains the brain, eyes, and mouth. The tail is the part of the organism that contains the tail fin. The dorsal fin is the part of the organism that contains the dorsal fin. The fish is a vertebrate, and it has a backbone. The fish is a vertebrate, and it has a backbone. The fish is a vertebrate, and it has a backbone.

W. B. BENCKERT

Fig. 6. Development of the Fish from the Egg. The Australian Lungfish. Chart drawn by W. Benckert.

organisms and then passes step by step to larger and larger kinds of food as its size and strength increase.

Differing widely from the modernized methods of development of the Teleosts or higher fishes [Case 53], is the old-fashioned type of development characteristic of the Ganoids, the Lungfishes and the amphibians. On the chart to the left of the Shark Group, are shown some of the successive stages in the development of the Australian Lungfish, *Neoceratodus forsteri*. Figure 1 shows the fertilized egg, greatly magnified, the egg itself being about one-eighth of an inch in diameter. The lower part of it is filled with yolk. In Figure 2, the egg has divided into halves. In the succeeding figures, this process of subdivision continues until many millions of cells result. The general outline of the embryo is beginning to be seen in Figure 7, the head being at the left. In Figure 10, we note the already swollen brain, with the eyeball. The heart, the muscle segments of the body, and the blocks of the spinal column are also indicated. The baby fish is shown in Figure 13, greatly magnified. Figure 14 represents the adult. [See also Case 1.]

Viviparity (Internal Fertilization): The eggs of sharks, chimæroids, and rays are frequently covered with a horny shell which is secreted by the walls of the egg duct. In "oviparous" sharks, such as the European Dogfish, these eggs are laid and the young, in due time, hatch out from them. In many other kinds of sharks, however, the young are long retained within the enlarged egg duct and the egg shell is either broken up or absorbed so that the young are "born alive," or released in an advanced stage of development.

Parental Care: In many cases, one or both parents, instead of abandoning their progeny to be the sport of the elements and the prey of innumerable enemies, either construct a nest, as in the case of the Bowfins and the Sticklebacks, or in some other way guard and protect the young. For example, the eggs may be deposited in some secure retreat, as in old oyster shells, or the gill cavities of clams, mussels or oysters. Among the Sea Horses, the males of certain species receive the eggs in a brood pouch of skin beneath the abdomen, where they undergo their development, while in the Cichlids, and certain Catfishes, one or the other parent takes the eggs in its mouth or pharynx and does not eat anything until the young are large enough to be released safely. In such cases, the number of eggs produced at one time may be small, since the parental care greatly improves the chances of survival for the offspring, while the eggs themselves may be large to increase the food for the young.

Adaptive Radiation in Jaws:¹ On the right of Case 53, is an exhibit showing how, in many groups, the jaws, starting with a primitive or normal type, tend to become very long and highly predacious or very short, nibbling, pinching or crushing in type.

Locomotion of Fish. [Case 54]: *Engines of the Fish's Body*: As a living, self-directing machine with a mind of its own, the fish needs all the complex apparatus shown in the models in Case 54. Its jaws, mouth, and digestive system capture and prepare its fuel. Its heart and circulatory system distribute the fuel to its engines and propellers (the muscles and the fins). By means of the oxygen absorbed by its gills from the water, it consumes the fuel, and releases the necessary energy which is expended in driving the body forward and is lost in the form of heat.

Millions of delicate sense organs are constantly recording the changes in the surrounding medium and in the position of the various parts of the body, while the nose, eyes, internal ears, brain and spinal nerve cord also act as an automatic control or steering system. Its framework, the skeleton, consists of a system of jointed levers and supports. The rear part of the hold of this living ship is freighted with live eggs.

The locomotor machinery takes up the greater part of the entire body of the normal fish. This, in brief, consists of a close-set series of zig-zag muscle segments running along the sides of the body from the head to the tail, making undulation possible. The fins act as keels, rudders, and brakes, and partly as paddles; the swim bladder as an additional balance.

*Types of locomotion*²: The Eel and the Trunkfish illustrate two extremely different methods of locomotion which have been named, respectively, the *anguilliform* and the *ostraciiform* types. The Eel has very numerous joints in its backbone, with an equally high number of zig-zag muscle segments on the sides of the body. By means of these, the eel throws its long, slender body into a series of small waves which pass backward faster than the fish moves forward. The Trunkfish, on the other hand, has a rigid body which swings from side to side with the sculling movement of the flexible tail.

Almost exactly between these two extremes stands the *carangiform* movement, as typified in the Crevalle or Horse Mackerel (*Caranx*). The body is short, but not rigid. The movement is essentially the same

¹For monograph, see Gregory, William King. "Fish Skulls: a Study of the Evolution of Natural Mechanisms." Trans. Amer. Philos. Soc., 1933, vol. 23, pp. 75-481. 302 figs.

²For detailed article see: C. M. Breder, Jr. "The Locomotion of Fishes." Zoologica, 1926, vol. 4, no. 5; pp. 159-297. 44 figs.

as in the Eel, except that only one large curve can be formed at a time. Movement starts by throwing the head to one side, the tail being then drawn in toward midline. The movements of the fins follow the same principles as do those of the body. Thus very long fins may be thrown into eel-like or anguilliform movement, while short, paddle-like fins recall the movement of the tail in the Trunkfish or ostraciiform type.

*Streamline Body Forms*¹: Ships, submarines, torpedoes, airplanes, etc., are designed and built with "streamline" bodies which slip through the water or air with the least resistance from eddies that can be planned for under the given conditions of speed, displacement, etc. The typical fish body has streamline contours in the top, side, front, bottom, and rear views. Even aberrant body forms seem to conform to the same principle. A potent factor in determining the various streamline body forms of fishes is the universal force of gravitation which causes the pressure to increase as we descend beneath the surface of the water. The proportions of the body vary enormously in different fishes, *i.e.*, the proportion of the body length to the body height, the width, the relative size of any single part, as of the jaws or any one of the fins. Between any two extremely unlike body forms there are many intermediate conditions even among still existing species and we realize that the differences have probably grown greater with the passage of geologic time, and that such extremes have probably been derived from parent stocks of more normal shape.

¹For further data see: William King Gregory. "Studies on the Body Forms of Fishes." *Zoologica*, 1928, vol. 8, no. 6, pp. 325-341. 35 figs.

SECTION III

DEEP-SEA AND REEF FISHES

[Case 52 and Inner Room]

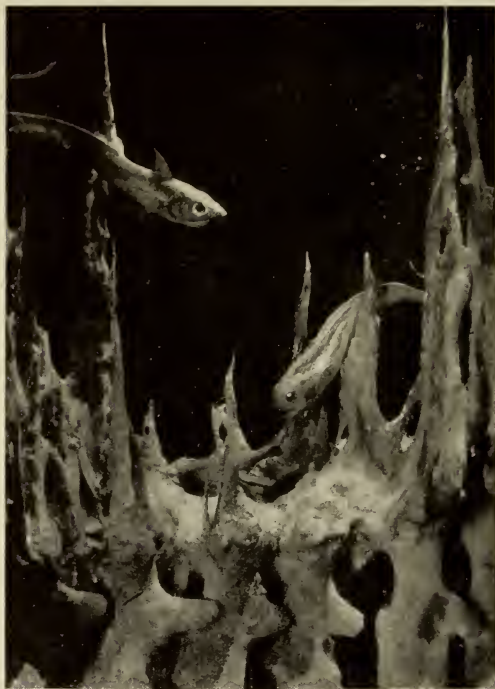

Fig. 7. Wandering Ghosts.

The walls of the inner room represent, on one side, the vividly colored fishes of a coral reef, and, on the other side, the silvery fishes of a black volcanic reef. Space in this room is being reserved for a future reef group.

The Rays and Skates shown here are discussed on pages 14 and 15.

Oarfish: Above the inner doorway, hangs the model of a rare and highly specialized deep sea fish, remarkable for its peculiar skull structure and its fragility and flatness of body in proportion to the great length. The length of body, the peculiar upturned mouth, and the crest of scarlet fin rays rising from the top near the head have supplied picturesque detail to the stories of fishermen who believed they had seen a "sea serpent" rising beside their boat.

The Sargasso Fish: This is a small exhibit showing a characteristic few inches of those miles of golden weed which stretch from south and east of Bermuda out toward Africa. Picking its way among this weed, is found the small fish known as the Sargasso Fish, *Pterophryne*.

Deep Sea Fishes: Case 52 contains enlarged models of Deep-Sea Anglers (Ceratioids). Other examples will be found in Case 35, where they are shown in their proper systematic position, and in the Deep-Sea Panels. On the northwest wall of the Hall is a case containing a model of one of these fishes, with a parasitic male fish attached to her cheek.

These strange black monsters of the deep are living fish-traps. Above or below the cavernous mouth with its long, bristling teeth, dangles a lure that in the darkness glows with a phosphorescent light. When smaller fishes draw near, attracted by this bait, they are engulfed by the large black mouth.

In some Ceratioid genera the males are free-swimming; in others they are parasitic upon the larger females and spend their lives attached to some portion of her body. In *Photocorynus* the male, two-fifths of an inch long, is attached to the top of the two and one-half inch female's head, above the right eye; in *Cerantias*, the parasitic male hangs from her cheek; parasitic males have been found attached to the abdomen of *Linophryne*.

In the outer room of the enclosure stands the old Deep Sea Group, now replaced by the Deep Sea Panels at the other end of the room. Since this old group was made it has been possible to make more accurate models of these fishes through material studied on various deep sea expeditions and investigations. A series of transparencies at one end of the room show photographs of one of these expeditions, that of the "Arcturus" in 1925, under the leadership of Dr. William Beebe and of under water exploration in the "bathysphere." In a nearby case are some of the actual specimens of these incredibly fragile fishes which live in the black depths of a mile or more under the surface of the ocean, where every square inch of their body is exposed to a water pressure of over a ton. Enlarged drawings of the same specimens are also shown here. The recently invented bathysphere,—a steel sphere with quartz windows—is so made and equipped that it has been possible for two investigators to descend in it to over 2200 feet beneath the surface of the sea. By its means Dr. Beebe has invaded the black depths in which deep sea fishes live and has seen them there with his own eyes.

The bathysphere, was first used off Nonsuch Island, Bermuda, during the summer of 1930.

Deep Sea Panels: Through the doorway underneath the Oarfish is a group of seven panels representing a descending series of zones of fish

life. The original material and data for these were, for the most part, collected by the Arcturus Expedition, in the Pacific near the Galapagos Islands. The exhibit was designed by William King Gregory and Dwight Franklin and executed by the latter with the cooperation of the Museum's Department of Preparation. The models are wax, the skins of most deep sea fishes being too flimsy to mount. The lighting of the three groups on the left (luminous fishes) is designed to first show the visitor the color and shape of the fishes, and then to exhibit these luminous fishes as they probably appear to each other in the dense blackness in which they live, only the luminous spots being visible.

Beginning at the right end of the groups, we see first the bottom of the ocean, gradually progressing until at the left end we are shown some of the fishes which live in the great depths, but occasionally come near enough the surface at night to be caught in nets.

Groups 1 and 2. "The Country of Perpetual Night," "Wandering Ghosts": These two groups show the ocean floor, 1000 fathoms down, where deep sea fishes wander about the bleached skeleton of a whale in total darkness, water pressure of over a ton, and a temperature around freezing.

Group 3. "Little Sea Devils": These are some of the small Oceanic Anglers. Their trap-like mouths are open to catch the prey attracted by the bit of luminous skin at the end of their rod-like appendages.

Group 4. "Black Pirates": These degraded eels have lost almost everything but their voracious appetites, for which their enormous mouths and distensible stomachs are well equipped. One of them has just swallowed a fish larger than himself.

Groups 5, 6, 7 (Luminous Fishes): "The Dragon Strikes" represents a group of Big Heads being pursued by a dragon-like fish, *Chauliodus*. "Blazing Jewels" shows the Jewel Fishes, flashing, luminous fishes living far down where the last feeble light from the surface merges into the blackness of the depths. "Neptune's Fireflies" shows the Lantern Fishes, rows of phosphorescent spots on their sides and head, with *Astronesthes* in pursuit.

SECTION IV GAMEFISHES

[North end of Hall]

This collection forms the north end of the Hall and includes the results of cruises and fishing trips from Mexico to Maine and even farther afield.

A 74 lb. Channel Bass, 588 lb. Broadbill, 758 lb. Tuna, and a 2000 lb. Ocean Sunfish, looking down from the walls would seem like the answer to the fisherman's prayer:

“Lord, grant to me to catch a fish
So big, that even I
In talking of it to my friends
May never need to lie!”

In 1928, Zane Grey gave his gamefish collection of rod and reel catches to the Museum. This, with the Sailfish Group, forms the bulk of the Gamefish Section. The Sailfish in this group is the mounted skin of a fish caught off the rocky coast of Cape San Lucas, Lower California. Many other fishes well known to anglers and sportsmen, or greatly desired as closer acquaintances, hang in these cases,—Salmon, Trout, Perch, Muskellunge, Barracuda, Yellowjack, Bonefish, etc. Of the last named, we have a world record of 13¾ lb., from Bimini, Bahamas.

Dr. Grey's collection is especially noteworthy for its superb Tunas and Marlins. On the wall nearby hang colored photographs of the capture of some of these fishes and of some of his more recent Tahitian catches.

Charts of the World Record rod and reel catches hang on the wall in this section.



Fig. 8. Zane Grey and a Giant Tahitian Marlin. By permission Dr. Grey.

SECTION V

THE HIGHER FISHES

Ganoids and Teleosts

[Cases 18-38 and Groups]

THE GANOIDS, "LIVING FOSSILS"

[Case 18; groups]

Possibly three hundred million years ago, the remote ancestors of these living fossils were the Old Ganoid fishes of the Devonian period. These were, in general, shark-like forms, but with the body covered with an armor of shiny "ganoid" scales. (See Fossil Fish Exhibit.) Louis Agassiz, a famous American authority on fossil fishes, in 1833 classified them according to the character of their scales. His Ganoid group included all those in which the scales were covered externally with a thick, shiny, enamel-like layer (whence the name 'Ganoid,' meaning 'glistening'). Such scales were usually rhombic, or lozenge-shaped, with stratified bony tissue beneath the surface.

Each living survivor of this ancient world retains some of the features of the olden time, but has acquired certain specializations of its own. The Paddlefish of the lower Mississippi River (Group 1) retains the ancient shark-like body, but has lost most of its scales and acquired a spoonbill snout. The Sturgeon (group 2), well known commercially because of the use of its roe as caviar and of its air bladder as isinglass, also retains the shark-like form, but its mouth is sucking in type and its body covered with bony plates.

Two mounts of Russian sturgeon, from which most caviar is obtained, are shown in a northwest wall case. Only the Garpike (group 3) has inherited the complete armor of rhombic, enamel-covered scales, but its jaws are snipe-like and its skeleton completely bony. The Bowfin (*Amia*) (group 4) which is a descendant of the later, or New Ganoid, stock, is the most advanced of the series and has almost attained the rank of the Teleosts or higher fishes. This group shows the nest made by the Bowfin in which to deposit its eggs.

THE TELEOSTS

[Cases 16-36]

During the Cretaceous period, when the giant dinosaurs ruled the land, the mail-clad Ganoid fishes were largely crowded out by their more highly evolved descendants, the Teleosts, who at present constitute about ninety percent of the fish fauna of the world. The name Teleost, meaning 'completely bony,' refers to the fact that the notochord, or

primitive axial rod, of the larval stages of development is replaced in the adult fishes of this division by complete, bony, checker-like vertebral bodies or centra.

ORDER ISOSPONDYLI. (Tarpons, Herrings, Trouts, etc.). [Cases 16, 17]: This order, a main subdivision of the Teleost series, is a rather loose assemblage of fishes that are higher in rank than the Ganoids but lower than the spiny-finned fishes (Acanthopterygii). It comprises first such veterans as the Bonefish (*Albula*), the Tarpon, and the Herrings,—all survivors from the dawn of Teleost history in the Cretaceous, and, secondly, the more modernized Trouts, Salmon, etc., which are the younger scions of an ancient branch and date only from the Miocene



Fig. 10. Tarpon leaping. Drawn by D. Blakely.

epoch. Between these two divisions come the Osteoglossids, dating from the Eocene.

Beneath a great diversity of outward form, these essentially conservative fishes retain the soft or branched fin rays of the Ganoids; the air bladder retains the primitive duct that connects it with the throat, and the ventral fins are abdominal (*i.e.*, inserted under the abdomen). The name Isospondyli, meaning 'equal vertebræ,' refers to the fact that, in contrast with the fishes of the Carp-Catfish order, the first four vertebræ behind the skull are not strongly modified.

The oldest members of this order are the Leptolepidæ of the Jurassic,—small, herring-like Teleost fishes of very generalized type. Next in line come the existing Bonefishes and their Cretaceous and Eocene ancestors, while the Herrings and Tarpons follow at no great distance. The Tarpons are related to the Herrings through the fossil *Thrissopater* from the Cretaceous.

The order Isospondyli, while vastly outnumbered in species by the higher orders of Teleosts, includes a very wide range of body form, in

adaptation to different modes of locomotion, and of jaws, teeth and snouts, in adaptation to different methods of feeding.

The Elephant Fishes (Mormyridæ) are a highly specialized fresh-water group, apparently allied with the Albulidæ. These strange fishes of the River Nile were venerated by the ancient Egyptians who believed that the Mormyrids had eaten a piece of the body of the god Osiris.

The Moon-Eyes or Gold-Eyes (Hyodontidæ) are herring-like fishes of the fresh waters of North America. They stand near the common center of a number of other specialized relics of long past ages, such as the Featherbacks (Notopteridæ) of West Africa, India and Sumatra, and the Osteoglossidæ from eastern South America, West Africa and the Malay-Australian region.

The Dorab (*Chirocentrus*) of the Indian Ocean is the dwarfed survivor of a Cretaceous family that includes the gigantic *Portheus*. (See Fossil Fish Exhibit).

The Salmon and Trout (Salmonidæ) are the highest and most beautiful members of the soft-rayed group of fishes. They are limited to the northern world, except those that have been transplanted to New Zealand and Tasmania, and delight in cool waters, many species of trout being found in the lakes and streams that were left as remnants of the great glaciers of the Glacial period.

The Salmons are famous for their habit of coming up from the sea to spawn, travelling upstream sometimes for hundreds of miles, jumping the rapids and penetrating as far as possible toward the purer waters of the north. At the end of this journey they release the eggs and milt that give rise to the next generation and, having done so, perish by the thousands until, in Alaska, the streams are choked with their dead bodies and the sea gulls fly miles inland to feed upon them. The young Salmon, or Smolts, gradually make their way down to the sea.

Unlike their relatives the Herrings, the Salmons and Trouts are predacious fishes with strong teeth. The family, as far as known, dates only from the Miocene.

Deep Sea Relatives of the Salmon and Trout: The fantastic forms and coloring of the deep sea relatives of the Salmon and Trout (the Alepocephalidæ, Gonorhynchidæ and Stomiidæ) are in keeping with the world of darkness and cold in which they live and rear their sensitive young. Their large eyes serve to catch the phosphorescent glow produced by other creatures, while their own light-producing organs (marked by light spots on the sides of the body) serve to attract their prey.

ORDER OSTARIOPHYSI. (Characins, Carps, Catfishes, etc.). [Cases 19, 20]: The members of this order are nearly all fresh-water fishes and to

this group belong most of the fresh-water fishes of the world. The Catfishes, its most specialized members, date from the Eocene epoch, so the earlier ancestral forms must be sought perhaps in the Cretaceous. Thus the group may have been derived from some very early Teleosts, perhaps the Leptolepidæ of the Jurassic.

The Weberian Apparatus: The members of this group possess one of the most remarkable of all animal mechanisms,—the Weberian Apparatus. This consists chiefly of a linked series of small, bony levers and springs which is attached at the lower end to the swim bladder and at the upper end to the back of the so-called inner ears, or organs of balance. Some authors hold that this apparatus serves to collect pulsations coming in from the water, to magnify them and to transmit them to the nerves of the internal ears. Others hold that its chief function is to transmit not sounds, but sensations of varying pressure. The small, bony levers and springs represent highly modified ribs and other parts of the first four vertebræ behind the skull. This apparatus is found in no other order of fishes.

Carps and Loaches (Sub-order Eventognathi): Everyone who has watched a living Goldfish must have noticed how it can shoot out its toothless jaws and draw in bits of food; but not everyone knows that the Goldfish, like all other members of the Carp family, carries an elaborate dental apparatus in its throat. This apparatus consists of four series of finger-like teeth located on the upper and lower pharyngeal bones, which are the rear segments of the jointed gill arches. It is to this peculiar arrangement that the name 'Eventognathi,' meaning 'wholly internal jaws,' refers.

Carps are mostly sluggish fish that feed on vegetable matter found on the muddy bottom. The carps form one of the dominant fresh-water families of Asia, Europe and North America and have undergone a wide adaptive radiation in body form as may be seen in this exhibit. To this order belongs the Bleak, *Alburnus*, the silvery substance of whose scales is used by the Japanese in the manufacture of artificial pearls. In the wall case opposite hangs a mounted skin of a giant member of this family,—the Mahseer, *Barbus tor*, or Giant Carp, found in India where it occupies probably the highest rank as a game fish.

Fossil Carps are not yet known below the Miocene of Europe.

Chinese Carps: The carps of China are related to the Suckers and Carps of North America, but whereas in the latter country the representatives of other fresh-water families are far more numerous, in China the Carps are dominant and have given rise to a great variety of forms which in external appearance recall diverse fishes of other parts of the world.

Characins (Sub-order Heterognathi): The vicious Piranha, or so-called "Man-eating Fish," forms the central type of this South American and African group. Unlike their distant relatives the Carps, the Characins are mostly carnivorous and have well developed teeth on the outer jaws, but no carp-like teeth in the throat. The name Heterognathi refers to their various kinds of jaws and teeth. They may also be distinguished from the Carps by the possession of a small adipose fin on the back, in front of the tail.

Electric Eels (Sub-order Gymnonoti): *Electrophorus electricus*, the eel-like fish from South America, is able to give a strong electric shock to any animal that touches it. Its electric organs, which fill long strips on either side of the body, represent highly modified muscle plates, richly provided with nerves. This fish is not related to the true eels, which it resembles only in general appearance, but is really an eel-like Characin.

Catfishes (Sub-order Nematognathi). [Case 20]: Catfishes for the most part are the scavengers of the river bottoms where they lurk in the mud and feed upon offal. Their scaleless, slimy bodies are covered with sensory cells that taste the food dissolved in the water. The long black barbels around their mouth doubtless aid them in feeling their way about in the semi-darkness and partly compensate for their very small eyes. The teeth in their jaws are small or lacking, and their mouth serves as a wide scoop. The maxillary, or rear upper jaw bone, is reduced to a small movable base for the main barbel (whence the name Nematognathi, meaning 'thread-jaw'). Catfishes have lost their scales, but some of them, especially the Armored Catfishes (family Loricariidæ), have acquired secondary derm bone plates covering the body. The pectoral and dorsal fins bear strong single spines which are often dangerous weapons.

ORDER HAPLOMI. (Pikes, Killifishes, etc.). [Case 21]: The Pike-Killifish order is intermediate in its anatomical characters between the Isospondyli or the lower Teleosts and the spiny-finned or higher Teleosts. The name Haplomi (simple shoulder) is given in allusion to the simplified character of the shoulder girdle which lacks the "mesocoracoid" arch, or middle inner brace of the bony base of the pectoral fin. This structure is possessed by all Ganoids and lower Teleosts in which the pectorals are held in a more horizontal plane, but is lost in the higher Teleosts in which the resting pectorals are held in a more vertical plane.

The Pikes and Pickerels which are the typical forms of this order, lie in wait for their prey and make swift rushes to snap it up with their long, sharp-toothed jaws. Their whole appearance is in keeping with their piratical life. Their small relatives, the Killifishes, are chubby caricatures

of the Pikes, with tiny mouths instead of gaping jaws, but they retain the pike-like backwardly placed dorsal and anal fins, and broad tails that enable them to make very quick turns.

[Several members of the Killifish family have been successfully used in destroying mosquitoes.

ORDER INIOMI. (Lizardfishes). [Case 21]: These large-mouthed, needle-toothed fishes are in certain respects intermediate between the Salmon-like forms of the soft-rayed order and the Pikes and their allies of the order Haplomi. Many of the deep sea members of the family (Myctophids) have a series of light-producing spots on the body and head. These light organs, which are described in other exhibits, have been developed independently in different groups of deep-sea fish.

In some of the Lizardfishes that live at great depths, *e.g.*, *Bathypterois*, the eyes are reduced or absent, while the rays of the breast fins are prolonged into delicate feelers. The family is an ancient one, dating from the Upper Cretaceous period.

ORDER HETEROMI. (Halosaurs). [Case 21]: These distant relatives of the isospondyls reveal their deep sea habit in the combination of very dark colors, eel-like form with very long tapering tail, and small eyes. Only the lower part of the tail fin is developed.

ORDER THORACOSTRACI. (Sticklebacks, Tubefish, Seahorses.) [Case 21]: This order includes a number of very peculiarly formed fishes.

The Sticklebacks (Gasterosteidæ): These fishes are so called because of the three isolated spines which represent the spinous dorsal. The small two and three-spined Sticklebacks can be moved from fresh to salt water or vice versa without harm. The larger fifteen-spined *Spinachia* is entirely marine. The male fish builds the nest of weeds, held together by a thread-like secretion from the kidneys, and then guards the eggs deposited by the female. These fishes are short-lived and probably only breed once.

Fishes with Tubiform Snouts. (Aulorhynchidæ, Aulostomatidæ, Centriscidæ): These fishes have elongate bodies and produced, tubiform snouts. The Aulorhynchidæ are closely related to the Sticklebacks. Their elongate snouts approach those of the Trumpet Fishes, or Aulostomatidæ, of the West Indies, Polynesia and Asia. A species of *Aulostomus* is found in the Eocene of Italy. The Shrimp Fishes, Centriscidæ, possess a transparent bony cuirass covering their back and extending beyond the tail. The small, toothless mouth is at the end of a long snout.

Fishes that Swim Vertically. (Amphisilidæ, Syngnathidæ): The Syngnathidæ, including the pipefishes and seahorses, are more or less

elongate, and protected by an exoskeleton forming rings. The snout is somewhat produced and tubiform and the tail sometimes prehensile. In most species, the male takes charge of the eggs in a pouch under the tail or on the abdomen. (See p. 21.) The Australian Seahorse, *Phyllopteryx*, is remarkable for its seaweed-like appendages. The Northern Seahorse is common to our coast in summer, from Charleston, South Carolina to Cape Cod, Massachusetts. Where it goes in winter is as yet unknown.

Like the Seahorses, the Amphisilidæ swim vertically. There are three or four species of this family, found in the Pacific and Indian Oceans. The body is much compressed and completely enclosed in a thin, bony armor which is fused with the endoskeleton.

ORDER APODES. (The Eels). [Case 22]: The Eels have cast aside all superfluous fins, drawn out the smooth cylindrical body into a compressed tapering end, and multiplied the muscle segments until they can undulate as easily as a streamer waves in the wind. (See p. 22.). In some families of Eels, the scales are entirely lacking, but in the most common eel, *Anguilla*, they are present, although rudimentary and imbedded.

The true Eels of Europe and America all go to the deep sea to spawn. There is one area south of Bermuda where all such Eels have been thought to spawn, and certainly they seek either this or similar ocean conditions. The eggs hatch flat, translucent, un-eel-like larvæ known as *Leptocephali*. These are so unlike the adult that they have sometimes been classified as distinct fishes. Those to the westward gradually drift, as they grow, toward America; those to the eastward toward Europe. When they approach the shore, they are several inches long. On entering coastal waters they shrink to a smaller size and take on the appearance of Eels, though still more or less transparent. Some of these remain and grow in coastal salt or brackish waters, and others penetrate far inland becoming the Fresh-water Eels of the interior.

The Conger Eel does not enter fresh water; it moves away from the shore to spawn but it too dies after spawning.

The Morays are typically reef fishes. They are the largest of the Eel tribe and have powerful jaws armed with sharp teeth.

ORDER SYNENTOGNATHI. (Flying Fishes, Needlefishes, etc.) [Wall Case]: Several unrelated groups of fishes have developed independently the ability to fly, but the *Exocætidæ*, or Marine Flying Fishes, characteristic of the trade wind belts of open, tropical oceans, excel all others in aërial powers. These, of all flying animals, most closely re-

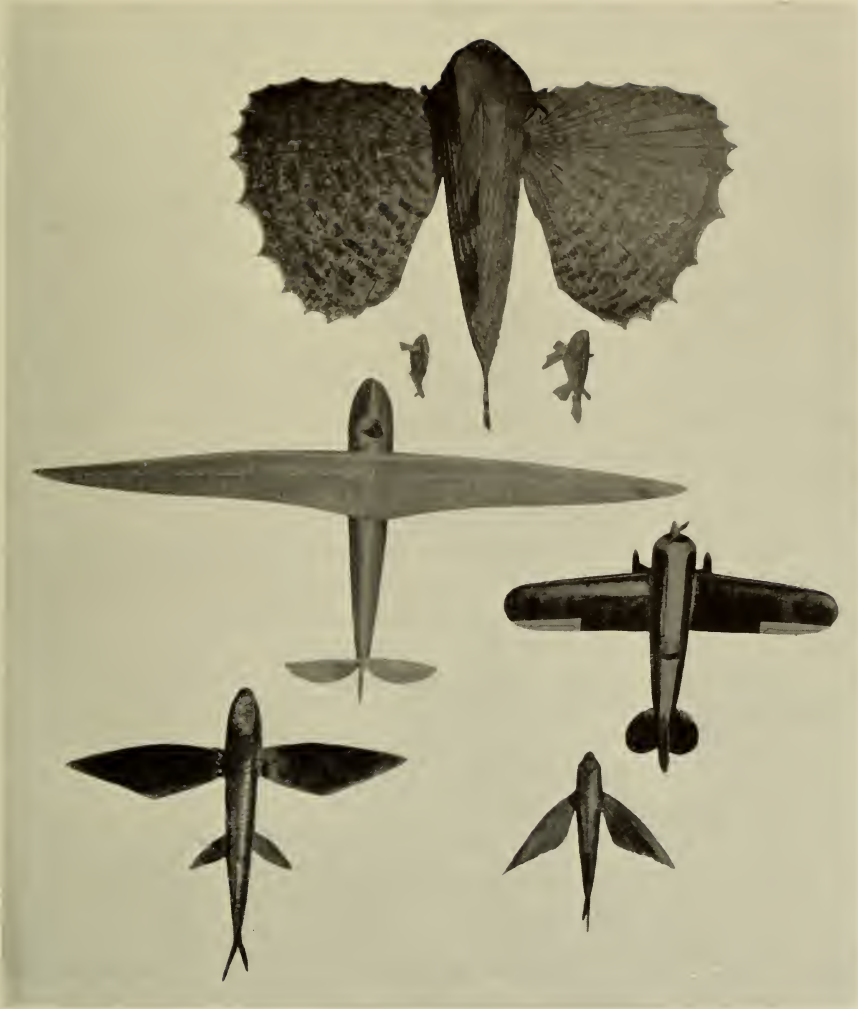

Fig. 11. Flying Fish and Airplane Compared.

semble the modern airplane. The proportions of flying fish and airplane are very close in spite of the disparity in size.

Being an organic unit and not a rigidly articulated machine, the fish is capable of greater flexibility of movement and possesses some adjustments not yet possible in a plane.

The camber of the wings, their placement and the presence of stabilizer fins at their proper places, considering the form, size and landing requirements of each, are remarkably similar. One of the most striking differences is the complete absence of any landing gear on the fish. This is a notable economy, possible because the fish can plunge into the water head-first or drop without injury in a manner that would wreck a plane.

The average rise of these fishes is about five feet, although they occasionally rise higher; the length of flight varies from fifty to three hundred feet, and, when with the wind, has been observed to attain a quarter mile. Turning is accomplished by use of the body muscles and tail fin. The wings, when in flight, remain like the wings of a glider. The larger the fish, the longer the flight will be and the fewer the dippings of the tail into the water for added power.

About twice as many flying fishes fly in schools of two or more as fly alone. *Parexocetus mesogaster* is the predominant form in the Gulf Stream.

The Flying Fish group appears to be an offshoot from some early member of the spiny-finned order.

Other Flying Fishes: Three other fishes not related to the Synentognaths have powers of flight. These are:

The South American Fresh-Water Flying Fish (Gasteropelecus), a small fish related to the Piranha of the family Characinidae. This fish is able to make a flight of from five to ten feet.

The African Fresh-Water Flying Fish (Pantodon), a small Isospondyl related to the Herring-Trout group. This fish has very slight powers of flight.

(?) *The Flying Gurnard (Dactylopterus)*, one of the mail-checked fishes, related to the Sea Robins and Sculpins. The Flying Gurnard has been said to leap into the air, where its relatively large breast fins are able to support it for a short journey.

ORDER PERCESOCES. (Barracuda, Mulletts, etc.) [Case 27]: The Barracuda (*Sphyræna*) is one of the most piratical looking of all sea-going crafts, and its record of attacks on human beings justifies its evil reputation. While in general appearance it recalls the Pikes, it may be recognized readily by its separate spiny dorsal fin. This fin is also possessed

by such peaceful kinsfolk of the Barracuda as the Silversides (*Atherinidæ*), and Mulletts (*Mugilidæ*). The latter feed on other small animals, algæ and occasionally vegetable matter. They resemble the Flying Fishes in the high position of their breast fins, and the group as a whole may be distantly related to that assemblage.

ORDER ACANTHOPTERYGII. (The Spiny-Finned Fishes.) [Cases 24–36]: The vast majority of existing species of fishes belong to the “spiny-finned” order, the peculiar features of which are illustrated in the skeleton of a Striped Bass. The word ‘spiny-finned’ is a translation of *Acanthopterygii*. The first few bony rays of the dorsal fin are tipped with sharp points and there are also such points on the first ray of the pectoral and ventral fins and on the first few rays of the anal fin.

The typical spiny-finned fish has a fairly stout body with a broad strong tail base and broad tail,—all signs of vigorous swimming ability. The pelvis or bony base of the ventral fins is prolonged forward and fastened between the ploughshare-like lower end of the pectoral girdle. This arrangement facilitates quick turning and stability. These fishes usually have strong jaws and teeth, and prey upon other fish. The front upper jaw bone (premaxilla) is prolonged backward and downward so as to shut out the second upper jaw bone (maxilla) from the corner of the mouth. The maxilla is thus toothless and acts only as a lever for pushing forward the premaxilla.

The bony operculum, or chief gill-cover, usually has a point or spike on its hinder end. The supraoccipital bone usually forms a prominent crest above the back of the skull. To this crest on either side are attached the muscles that run along the top of the back.

The skull forms a strong wedge which is pushed through the water by the forward thrust of the backbone. The skull may also be considered as the pivot upon which the body is thrown into waves. Even without the tail fin, the fish can move forward by waving the body. The tail fin serves both as a flexible paddle and as a rudder. The other fins serve as keels, brakes and rudders.

The Basses and their Allies: (Sub-Order *Percoidæ*). [Cases 23, 24, 25]: The true Basses (*Serranidæ*) and their allies stand near the center of the great assemblage of spiny-finned fishes. They are mostly stout-bodied fishes, usually swift and voracious. Most of them prey upon smaller fishes, crabs, shrimps and other crustaceans. Many are brilliantly colored and some, such as the Rockfishes, can change their colors to suit the color of their background.

Snappers, Grunts and Porgies. [Case 23]: The Snappers (Lutianidæ) are carnivorous food fishes, closely allied to the true Basses, but often having a longer face from the tip of the upper jaw to the lower border of the eye. The back part of the upper jaw slips under the lower border of the enlarged front suborbital bone and is thus concealed when the mouth is closed. Above the ventral fins there is often a scaly flap. These fishes are usually very brightly colored.

The Grunts (Hæmulidæ) are also called Roncos, from the Spanish word, *roncar*—to grunt or snore, referring to the noise they make either with the very large pharyngeal teeth or the complicated air bladder. These also are tropical fishes.

The Porgies (Sparidæ) are well known in our markets through the Northern Porgy, commercially called Porgy. In these fishes, the pharyngeal, or throat, teeth become very large, and in one form, the Sheepshead, the front teeth of the upper and lower jaws are also strongly developed so that with them the fish can pluck up crustaceans which are then crushed by the teeth in the throat. The Porgies occur chiefly in warm waters and many of them are vividly colored, the common Mediterranean species being crimson with blue spots.

The Basses. [Case 24]: The true Basses (Serranidæ) include the Sea Bass, Striped Bass, White Perch of this vicinity, the Rockfish and the Groupers of the Florida Keys and Cuba, besides many others in various parts of the world.

Most of these have three well developed spines in the anal fin, and the back part of the upper jaw is quite distinct when the mouth is closed. The upper corner of the gill cover often has one or two spines.

Fishermen apply the name Bass indiscriminately to bass-like fishes belonging to other families as well as to the fishes above named, such as the Large-mouth Black Bass and the Small-mouth Black Bass, both of which actually belong to the Sunfish family (Centrarchidæ), and the Channel Bass and California Sea Bass which belong to the Weakfish family (Sciænidæ).

The White Perch (*Morone*) is not, strictly speaking, a Perch at all, but a Bass.

The Perches and Darters. [Case 24]: These fishes of the family Percidæ have more joints in the backbone than the Basses and differ in other ways.

The Bluefishes (Pomatomidæ). These are swift, carnivorous fishes which approach the Mackerels in appearance.

The Triple-tails (Lobotidæ) are powerful, deep-bodied fishes.

The Berycids are chiefly deep sea forms, near relatives of the Squirrel Fishes.

Croakers and Weakfishes. [Case 25]: The Croakers (Sciaenidæ) are closely related to the true Basses, but differ in their small anal fins in which the spines are reduced. In the long dorsal fins there is a deep notch between the spiny and soft parts, but the two are in contact at the base. A system of large pits on the top of the skull lodges sacs containing the sense organs of the lateral line system.

Local members of this marine family are the Weakfish, Channel Bass, Spot, Croaker, Kingfish (*Menticirrhus*), and Sea Drum. The latter has strong, paved teeth in its throat for crushing shellfish and makes a loud grunting sound with them.

Crab-Eaters, Shark Suckers, etc. (Sub-order Discocephali) (Case 25]: This sub-order includes the Crab-eater, Cobia, and the Shark Sucker, *Echeneis*. The latter has an adhesive disc on top of its head, by means of which it is able to cling to the sides of larger fishes, particularly the sharks.

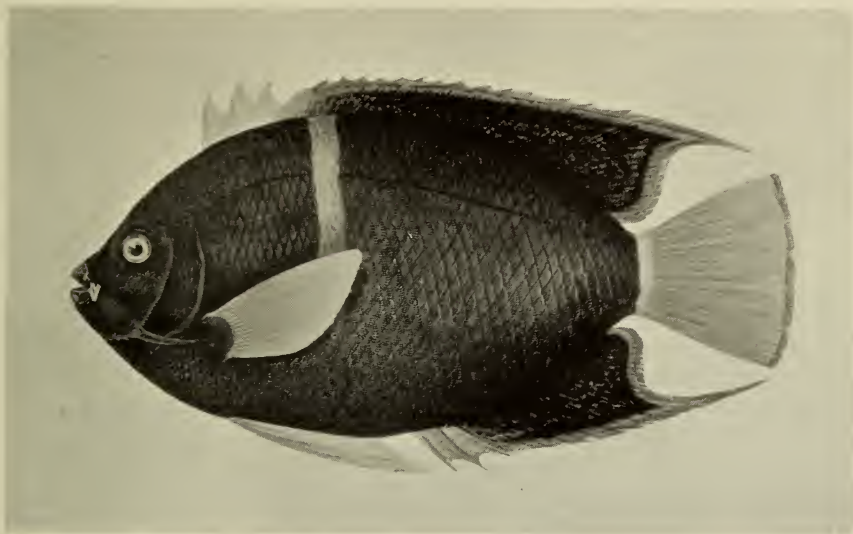

Fig. 12. Galapagos Angelfish. From painting by W. Belanske. From W. K. Vanderbilt collection of scientific paintings of fishes caught from his yacht, the *Ara*.

Angel, Butterfly and Surf Fishes. (Sub-Order Squamipinnes). [Case 27]: The Angelfishes (*Holacanthus*, *Pomacanthus*, *Angelichthys*) and their relatives the Butterflyfishes (Chætodontidæ) have small, nibbling mouths which act like pincers in plucking off small living organisms from the rocks and coral reefs. The great depth of the body and the strength of the fins give the fish a very firm stance and power in

plucking. The brilliant or dense colors are in wide contrast to the pale or silver hue of open-sea fishes. In the Butterfly Fishes, the teeth are very fine and brush-like.

The Viviparous Surf Fishes. (Embiotocidæ): The Surf Fishes are deep-bodied offshoots of the Bass stock which develop the young within the body of the mother. This is very unusual among Teleost fishes.

Fighting Fish, Climbing Perch and Snake Heads. (Sub-Order Labyrinthici). [Case 27]: The Labyrinthici are so-called because of the peculiar structure of the pharyngeal bones and respiratory apparatus. In these labyrinth-gilled fishes, the gill filaments discharge their normal function, but in addition, the fourth branchial arch is extremely developed and provided with thin folds forming chambers in which air is retained for respiration.

Betta pugnax, the Fighting Fish of Siam, is said to be used by the natives in the same way cocks are used for cock fights, only in this case the combat takes place in a glass aquarium bowl. The various species of this genus are popular as aquarium fishes, more because of their extremely bright and beautiful colors than because of their pugnacity.

The Climbing Perch, *Anabas scandens*, has been credited with the ability to climb trees. This is an exaggeration, but the fish is able to move rapidly overland by means of the mobility and sharp spines of its gill cover, aided by its strong pectoral fins and tail. *Channa*, the Snake-head Mullet, is a native of Ceylon and China.

The Osphronemidæ (Snake-heads) have not such a complicated accessory breathing structure as the others and are probably degraded descendants of the Labyrinthici.

Abudefdufs and Cichlids. (Sub-Order Chromides). [Case 28]: The strange name *Abudefduf* is Arabic in origin, coming from two words meaning literally, 'father,' and 'side' or 'flank,' *i.e.*, something with prominent sides. These jolly little fishes of the coral reefs are always bustling about after the small pickings on which they feed. They are related to both the Cichlids and the Wrasses, and, like them, have crushing teeth in the throat.

The Cichlids are especially plentiful in Lake Tanganyika, Africa. They are small relatives of the Wrasses and have invaded the brackish and fresh waters of Africa, Madagascar, Syria, India, Ceylon, South America and Central America, and as far north as Texas. The duty of caring for the eggs and young is performed by the females in certain species; in others, the males take over this responsibility. In either case, the eggs and young are sheltered in the mouth or in the pharynx of the self-denying parent who is necessarily deprived of food until the young are able to take care of themselves.

Wrasses and Parrot Fishes. (Sub-Order Labroidei). [Case 28]: Apparently nature grew reckless when she colored the Wrasses and Parrot Fishes, for these are among the most bizarre sights that bewilder the eye of the visitor to undersea gardens in tropical waters. Only the Cunner and the Tautog, among the northern outliers of the family, have been toned down into sobriety and sombreness in the chill waters of New England. The Cunner retains the loose, protruding lips and retreating forehead of its tropical ancestors, but the Tautog has acquired a short stiff mouth, a prominent chin and a generally determined countenance.

The Wrasses are more or less omnivorous, nibbling and biting with their strong incisors and crushing with the remarkable pebble-coated millstones in their throats. In the Parrot Fishes, the front teeth have fused into a large, nipper-like beak, while the mill in the throat is surmounted by cylindrical teeth of oval or flattened section. The origin of this apparatus may be traced to the simple conical teeth clustered on the surface of the gill skeleton in primitive Wrasses. In leisurely swimming, many of the Wrasses and their allies use chiefly the pectoral fins, holding the large tail fin as a rudder.

Sculpins, Gurnards, Scorpion Fishes, etc. (Sub-Order Scorpenoidei). [Case 29]: This group of fishes is generally known as the Cheek-Armored Fishes, in reference to the fact that one of the bones surrounding the eye is much enlarged and arches backward over the cheek so as to gain a broad contact with the forepart of the bony gill cover. Thus it forms the so-called "bony stay" that strengthens the skull in this group.

The Gurnards, or Sea-Robins, with their broad heads enclosed in this bony shield, bear little resemblance to the Basses, yet the Sculpins and the Rose Fishes tend to connect them with the primitive Sea Bass stock.

Most of the fishes of this group are marine forms, living either among the rocks, or on or near the bottom, sometimes at considerable depths. The most primitive forms are the Rose Fishes; the most advanced the Flying Gurnards.

The Gurnards have the first three rays of the breast fins specialized as 'legs.' Due to this specialization, their movement among seaweed or along any surface much resembles walking on these fins.

In the Lumpfishes and Sea Snails, the ventral fins are modified into a sucker, by means of which these fishes cling to the rocks.

In the Platycephalids, the flattened head presents a curious resemblance to that of bottom-living forms of widely different groups, such as the extinct Ostracoderms (*see* Fossil Exhibit), and the Armored Catfishes (case 20).

The Gobies. (Sub-Order Gobioidi). [Case 29]: The Gobies have pushed their way into all the seas outside the Arctic and Antarctic circles, and have representatives in the fresh waters of all parts of the world. The central form, *Gobius*, is not very different from the Johnny Darters of the Perch-Bass group, except that the ventral fins together tend to form a sucking disc by means of which the fish clings to rocks. In the Mud Skipper, *Periophthalmus*, the breast fins are modified into flippers and the fish skips about on these over the mud flats of



Fig. 13. *Periophthalmus*, the Mud-Skipper. Drawn by D. Blakely.

eastern tropical rivers. Its eyes are greatly enlarged and protruding. In the Blind Goby of California, on the other hand, the eyes are reduced to mere vestiges and the fish lives like a slug under the rocks.

In size the Gobies vary from the minute *Mistichthys* of the Philippines, which measures only twelve to fourteen millimeters in length, to the *Eleotris marmorata* of Siam, which grows to nearly three feet. The Gobies differ from the cheek-armored group in lacking the bony stay of the cheek.

Cods, Hakes, Rat-tails, etc. (Sub-Order Anacanthini). [Case 30] These mulluscous, obese offshoots of the vigorous spiny-finned order are

highly specialized, and in many respects degraded. Even in the rat-tailed Grenadiers (Macrurids) which are less specialized than the Cods, the true tail fin has been lost and the hind end of the body has been prolonged into a trailing wisp. In the Cods and their allies, the tail, while outwardly not unlike that of more normal fishes, appears to be merely an imitation, fashioned from the rear parts of the elongated, subdivided soft dorsal and anal fins, as shown by the construction of the bony rods supporting the tail. In the Grenadiers and Cods the ventral fins are normal, but in the Hakes they have been reduced to greatly elongate feelers.

This group as a whole is essentially marine and ranges from the greatest depths to the shallower waters of the coastal belt. The abundance of these fishes is truly astounding. For example, 14,000,000 pounds of Silver Hake were marketed in Massachusetts and Maine in 1919. As to their fertility,—the roe of a seventy-five pound Cod contained, according to a careful estimate, no less than nine million, one hundred thousand eggs.

Long before the landing of the Pilgrims at Plymouth, boats had come from Europe to the New England coasts and north to the Grand Banks to fish for cod. These fisheries, which have now been developed into a huge industry, were of the utmost economic importance in the life of the early settlers in New England. They center at present in Boston and Gloucester, Massachusetts. The Cod fisheries are also a big industry in France which sends a large fleet to the Iceland fishing grounds, and in Norway which carries on big fisheries in the Lofoten Islands.

Blennies. (Sub-Order Blennioidei). [Case 30]: The Blennies are active little fishes living around rocky or coral reef shores. Certain Blennies, for instance the Lizard Skipper of Samoa, even leap from rock to rock at low water, in this respect paralleling the unrelated mud-skipping Goby. Most of them are small, but there is one gigantic and ferocious-looking marine Blenny, with strong tusk-like front teeth. This is the Sea Wolf, *Anarrhichas*. It also has large, rounded crushing teeth on the roof of the mouth and inner side of the jaw, enabling it to devour crabs and shelled molluscs.

The Eel-Pouts are elongate derivatives of the Blenny stock.

The Weavers. (Sub-Order Jugulares). [Case 30]: The Weavers are distant relatives of the Perch-like fishes. Some of them have poisonous spikes on the gill-covers. The Electric Star-gazers of this group have a pair of powerful electric organs behind the eyes.

Mackerels, Tunas, Dolphins, etc. (Sub-Order Scombroidei). [Cases 31, 32, 33]: The Mackerel group represents one of the culminating phases in the evolution of the Bass-like fishes from which group its more

typical members are distinguished by the torpedo-like body, the delicate, thin-boned skull, absence of spines on the gill cover, reduction of the scales, presence of a horizontal keel at the base of the tail, and the symmetrical arrangement of rear fins above and below the horizontal axis.

Pedigree of the Mackerels and their Allies. [Case 31]: This Sub-Order divides itself into four principal lines: (1) The Mackerel Series, culminating in the Albacores and Bonitos. These are the swiftest and most active of all the Mackerels, with beautifully streamlined bodies. (2) The Spanish Mackerels and Wahoos, chiefly distinguished by their pointed snouts, their long, low body and long dorsal fin. (3) The Swordfish and Sailfish in which the forepart of the skull is produced into a long, sharply pointed beak. In the Sailfishes, the dorsal fin is of enormous size. (4) The Escolar-Cutlass Fish line which runs out into fierce eel-like forms.

Bonitos, Tunas and Mackerels. [Case 32]: The acme of speed, of "fineness" and of streamline form is attained by the Bonitos, Tunas, Mackerels and their allies. In the Bonitos and Tunas the body is short and comparatively stiff; the tail large and lunate but with a slender, strong base. These fishes often leap from the water like Dolphins, or like a projectile that strikes and ricochets from the surface. In the Mackerels the body is more elongate and torpedo-like, with forked tail. In the Cutlass Fishes, the body has become eel-like and the tail is reduced to a point. The Oil Fish, *Ruvettus*, a deep-sea relative of the Mackerels, is here shown with the wooden hook used for its capture in the South Seas.

Dolphins, Pompanos, Moonfishes. [Case 33]: The central type of these pearly, silvery fishes is the Pompano, from whose orb-like body we may derive, on one hand, the much deepened disc of the Moonfish and Lookdown, and, on the other, the progressively elongate form of the Jacks, or Amberfishes.

The ornate Roosterfish may be regarded as an Amberfish with an enlarged and plume-like first dorsal fin. The Dolphin (*Coryphæna*), another long-bodied offshoot of the Pompano stock, is famous for its brilliant and changing blue and golden hues. The Dolphin of heraldry and sculpture is a composite of this fish and the true Dolphin which is a kind of porpoise or toothed whale.

In the wall case opposite this alcove is a cast of the Opah or Moonfish, *Lampris luna*, a round, iridescent fish with scarlet fins, a very rare visitor on our coasts. This fish reaches a length of six feet and a weight of five hundred to six hundred pounds.

Flatfishes. (Sub-Order Heterosomata). [Case 38]: In this group belong the Flounders, Halibuts, Turbots and their allies,—fishes which habitually lie on one side on sandy bottoms. They have been derived

from deep-bodied fishes allied to the John Dory (*Zeus faber*). The oldest known member of the group, *Amphistium* of the Upper Eocene, was a deep-bodied, symmetrically built form which had not yet become twisted for lying on its side.

It is to this group that the Soles belong. The "filet of sole" of American restaurants is usually made of the Winter Flounder, *Pseudopleuronectes americanus*. The European Sole belongs to the same family as the American Sole, but none of the American species are particularly valued as food.

Migration of the Eye in Flatfishes: When the Flatfish are hatched, the young are normal in appearance, with even coloration and an eye on either side. They swim in a normal, fish-like way. However, as the fish begins to develop, it tilts over toward one side, and finally becomes adapted for resting and swimming in this position. One result of this is that the color on the more exposed side grows deeper, while that on the under side remains light. Meanwhile, the eye of the down-turned side migrates over the top of the skull, so that, in the adult, both eyes lie on the upper side of the head. The mouth also is partly twisted onto the upper surface.

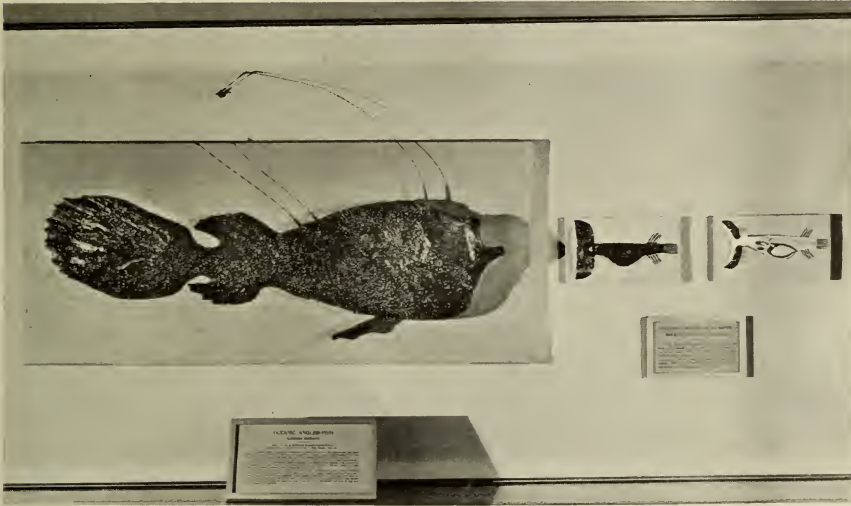

Fig. 14. *Ceratias*, the Oceanic Angler and Parasitic Male.

ORDER PEDICULATI. (Anglers, Batfishes, etc. See also Section III).
 [Case 35]: The terrible living trap set by the Angler Fish lies concealed in wait for the unwary fish that stops to examine its dangling bait.

This trap consists of the sharp-toothed jaws and cavernous interior of its enormous mouth, and the bait is a bit of skin floating from the top of a movable fishing rod which is made from an enlarged and separated ray of the dorsal fin. In the Oceanic Deep Sea Anglers (Ceratiidæ), living in abyssal darkness, the "bait" becomes luminous.

The males in several species of Oceanic Anglers are of extremely small size and live dangling like pendants from the side of the head of the gigantic females. An exhibit in a window case shows a replica of a cast in the British Museum (Natural History) of *Ceratias holboelli*, the Oceanic Angler, with its parasitic male. We quote from the original British Museum label:

"The female Angler Fish with attached parasitic male from which the original cast was made, was taken near Iceland. It is 40 inches long and has a male 4 inches long attached in the mid ventral line a little behind the head. Unlike the female, the male has no fin ray on the head; its mouth is small, toothless and closed in front, and the alimentary canal is vestigial. Fleishy outgrowths from the face of the male unite in front of the mouth and fuse with a projection from the skin of the female. Dissection reveals that both the outgrowth from the male and the projection from the female are formed of fibrous tissue with numerous small blood vessels. The union is complete so that it is impossible to say where one fish begins and the other ends. The blood system appears to be continuous with that of the female, from which the male derives its nourishment. The Ceratioids are unique among backboned animals in having dwarfed males of this kind."

The habits and conditions of life of the Ceratioids—few in numbers, solitary, slow swimmers, floating about in the darkness of the middle depths of the ocean—would make it difficult for a mature fish to find a mate. It is probable that the males, as soon as they are hatched, when they are relatively numerous, see the females and if they find one become attached to her and remain attached for life. Probably the male first nips a piece of skin of the female, and then its lips fuse with the papillæ so formed.

In the Batfishes the body is flattened and the fins serve as limbs for moving about on the sea-bottom.

The Angler group may be regarded as excessively specialized relatives of the Blennies [case 30], the Toadfishes being in some respects intermediate between the two groups.

ORDER PLECTOGNATHI. (Puffers, Trigger Fishes, etc.). [Cases 35, 36]: This group as a whole appears to be derived from the stem of the Trigger Fishes.

The Puffers and Porcupine Fishes. [Case 35]: The frog that tried to swell to the size of an ox finds a certain parallel in the Puffers (Tetrodontidæ) and Porcupine Fishes (Diodontidæ), which, however, unlike the frog, do not burst, but readily deflate themselves before their elastic limit is reached. They puff themselves out by pumping in water through the mouth by means of the action of certain specialized muscles behind the enlarged shoulder plates. Apparently it is as hard for a larger fish to bite an inflated Puffer as it is for a boy to bite an apple floating in the water. In both the Puffers and the Porcupine Fishes, the fore part of the jaws are modified into powerful nippers for biting and crushing resistant objects. In the Puffers the beaks of the opposite sides are separate; in the Porcupine Fishes they are fused together.

The Ocean Sunfish (*Mola*), of which there is a large specimen in the Gamefish section, is a gigantic relative of the Porcupine Fish. It is a slow-swimming, lethargic fish, fond of coming to the surface of warm waters to sun itself, and easily caught.

The Trigger Fishes. [Case 36]: The Trigger Fish is an inoffensive fish which goes bustling around the coral reefs searching for something good to nibble, but if a larger fish attempts to swallow him, he erects his tall spike, stretches his leathery skin and awaits developments. His "trigger" is the small spike on his back, lying behind the large one. When it is pulled into place by the muscles beneath, it serves to lock the larger spike in an erect position so that the latter cannot be lowered until the trigger is withdrawn. The Triggers are more specialized relatives of the Surgeon Fishes.

The Surgeon Fishes. [Case 36]: The Surgeon Fishes, or Xesuri, are so called because they carry sharp knives, one on either side of the base of the tail. These actually represent a greatly enlarged scale which is sometimes depressible in a case or groove. The fish seems to be able to give a vicious "side swipe" with its tail.

In *Xesurus* and related genera, the knife is replaced by three or more forwardly-directed spikes. Probably the 'knife' of the true Surgeon Fishes represents a specialized survivor of one of these three spikes.

The group as a whole constitutes a specialized offshoot from the stem of the Butterfly and Angel Fishes.



THE BASHFORD DEAN MEMORIAL EXHIBIT
OF
FOSSIL FISHES

Southeast Pavilion
Fourth Floor

FIVE HUNDRED MILLION YEARS OF FISH LIFE

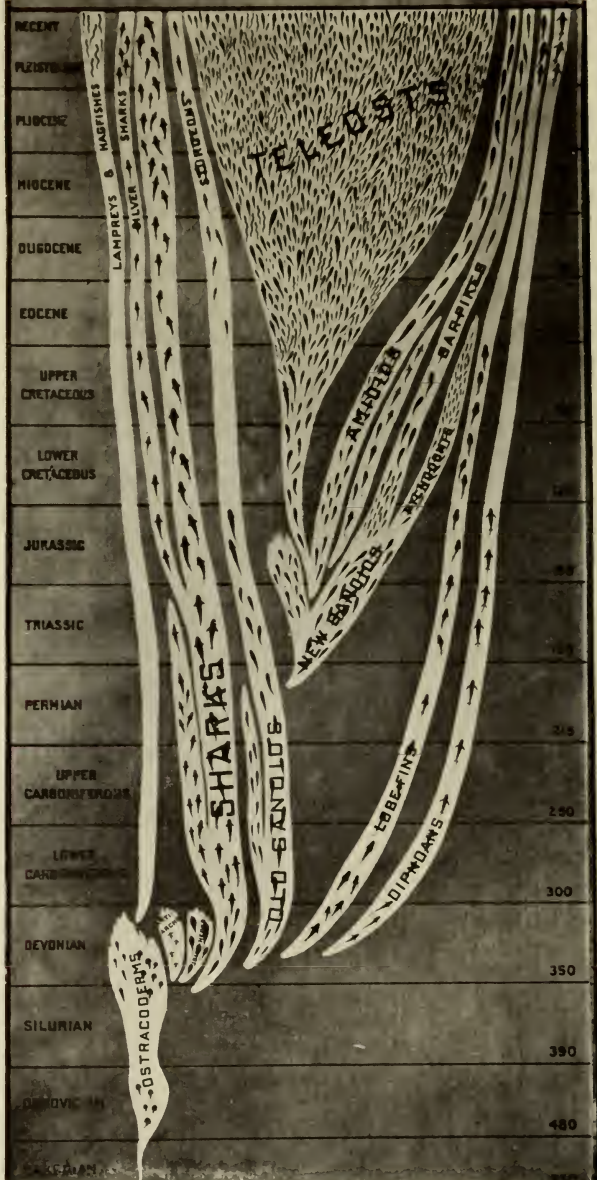

Fig. 15. Five Hundred Million Years of Fish Life. Chart drawn by W. Benckert.

THE BASHFORD DEAN MEMORIAL EXHIBIT OF FOSSIL FISHES

Southeast Pavilion
Fourth Floor

This exhibit of Fossil Fishes was rearranged in 1929 as a memorial to Dr. Bashford Dean (1867–December 1928), first Curator of the Department of Fishes in this Museum; later its Honorary Curator; always its friend and contributor, and author of many authoritative works on fishes living and fossil.

The bronze portrait plaque of Dr. Dean, hanging to the right of the entrance, is the memorial gift of friends and colleagues in America, Europe and Asia. Below is a small case containing a monograph by Dr. Dean, one of his field notebooks and a letter from him written from Japan to his friend and colleague Professor Henry Fairfield Osborn.

On the left of the entrance is a bronze portrait plaque of Professor John Strong Newberry (1822–1892), professor of geology at Columbia College; well-known for his studies on the fossil fishes of the Devonian, and the friend and teacher of Bashford Dean. His collection, the property of Columbia University, is deposited in this museum.

The fossil fish exhibit consists of selected material from the museum's large study collection. It includes parts of the following collections as well as important single specimens:

Newberry Collection: deposited by Columbia University in 1903. Brought together by Professor J. S. Newberry. About 3350 specimens.

Cope Collection: presented by the late president of this Museum, Morris K. Jesup. About 2425 specimens.

Dodge Collection: presented by William E. Dodge. About 100 specimens of Placoderm fishes from Ohio, collected by Mr. Jay Terrell.

Day Collection: presented by Rev. D. Stuart Dodge. About 1200 specimens collected in the Cretaceous of Syria by the late Dr. Alfred Ely Day.

Hall Collection: brought together by Professor James Hall. About 250 specimens.

Stuart Collection: presented by Robert L. Stuart. 40 specimens.

Kepler Collection: 75 specimens of Placoderms and primitive sharks, collected in Ohio by Rev. William Kepler and purchased by the Museum in 1904.

American Museum Collection: specimens collected in the field by various expeditions, and otherwise obtained by purchase, gift, exchange, etc.

NOTE: The guide to this exhibit is based on the explanatory labels found in each case.

FIVE HUNDRED MILLION YEARS OF FISH LIFE

[Wall Chart, Case 11]

The class of Fishes was the first of the vertebrates to appear in the history of the earth, fragmentary fossil remains of Ostracoderms having been found in rocks of the Lower Ordovician Age near Canyon City, Colorado.

According to the most recent geological estimates, the age in years of these rocks would be about four hundred million years. It is not improbable that even in the Lower Cambrian (five hundred and fifty million years) the predecessors of the Ostracoderms were already distinct from the trilobites, worms, molluscs and other animals of that far-off time. This chart represents in a general way the main branches of fish life as indicated by fossils from successive geological horizons.

Sequence of Fishes in Geologic Time. [Case 11]: Many hundreds of extinct species of fishes are already on record. Nevertheless, the history of each of the main divisions of the fishes is very defective at many points, the forces of destruction having completely wiped out both the fossil-bearing beds and their contained fossils. The diagram in this case indicates only a few of the better known species of fossil fishes. Each group is derived from a central or generalized type. This, then, gives rise to many peculiar specialized side lines which sooner or later become extinct. Meanwhile, the central stock gradually progresses to the next higher grade.

OSTRACODERMS

(The Oldest Fossil Fishes)

[Cases 1 and 3]

Near Canyon City, Colorado, are found red sandstones of the Ordovician period containing small fragments of the most ancient and most primitive of all known fossil fishes. Better preserved specimens of this class occur in the mudstones of the succeeding Silurian period, in Scotland, Norway and New York State. It is estimated that the oldest of these specimens lived about four hundred million years ago. They belong to a large class of extinct, fish-like animals called Ostracoderms.

These fossils are of great interest because they illustrate the 'basic patents' of the vertebrate type of animal. That is, even at that remote period, they already had a fish-like body which moved by lateral undulations caused by the zig-zag muscle segments arranged along the sides of the body; the head comprised three pair of capsules for the nostrils, eyes, and internal ears respectively; behind the mouth was a cavity for

the gills, and presumably the back was stiffened by a simple axial rod or notochord—the forerunner of the complex backbone of vertebrates.

In some Ostracoderm fossils, the fine silt on which the animal died finally penetrated into the blood vessels along the bony channels of its main nerves and into the interior of the brain chamber. Thus, after the silt turned to stone, a natural cast of the brain and of the cranial nerves and blood vessels was left. These casts have been intensively studied by the Swedish palæontologist, Dr. Erik A. Stensiö. He has thus been enabled to compare much of the internal anatomy of these Silurian Ostracoderms with that of the lowest existing fishes, especially the lampreys and hag fishes, which are the nearest living relatives of the Ostracoderms.

The Anaspida. The Ostracoderms differed widely among themselves in external body form and in other details. In the primitive Anaspida, the body was fish-like, the head not enclosed in a single shield, and the eyes were on the side of the head.

The Cephalaspida. In this group, the head and branchial chamber together were enclosed in a large, more or less semicircular bony shield. This shield was produced by the ossification of the many-layered skin covering the forepart of the body. The eyes were on the top of the head.

The Pteraspida. The shield of the Pteraspida was formed without true bone cells. The small eyes were at the sides of the head. In some of these forms, the fine ridges on the surface of the shield in the fossil condition refract the light and give rise to a pearly lustre, hence the name “Ostracoderm,” meaning ‘shell-skin,’ originally applied to members of the Pteraspid group only, and afterward expanded to include the entire class.

THE CYCLIAE

[Case 3]

This is a special group of early chordates, of unknown kinship. The representative is *Palæospondylus*, the “fossil lamprey-eel” much discussed in the literature of fossil fishes. It is characterized by well-marked vertebræ, a prominent head terminating in barbel-like processes, and a paddle-shaped (diphycercal) tail. It was found in the Middle Devonian of Scotland. Recent studies by Professor Graham Kerr of Glasgow and one of his students indicate that “*Palæospondylus*” is a larval lung-fish, the adults of which are found in formations of equivalent age.

ARTHRODIRA

[Cases 2 and 3]

Evolution of the Arthrodira [Case 2]: This exhibit illustrates the evolution of the Arthrodira, or Joint-Necked Fishes, as shown by changes in the size and structure of the head.

The Arthrodira were fish-like animals whose head, shoulders and abdomen were armored with plates of bone; their mouth was provided with powerful "teeth" or cutting plates. They ranged from a few inches to twenty feet in length and lived abundantly in the seas and rivers of the Devonian, becoming extinct during the beginning of the Coal Period (Carboniferous).

The earliest and most primitive type was the small *Phlyctænaspis*, ten or fifteen inches in length, represented both in Europe and America (Old Red Sandstone, Scotland; Lower Devonian, Canada). From a type like this, all other Arthrodira were descended. Among these we note: *Homosteus*, a large form found in the Old Red Sandstone of Scotland; *Coccosteus*, a small fish (one or two feet), most abundant in species of all earlier forms and surviving to the close of the Devonian; *Dinichthys* and *Titanichthys*, *Coccosteus*-like forms found in the Upper Devonian shales near Cleveland, Ohio, including examples twenty feet in length, the largest of this group.

Titanichthys: On the wall is mounted the head and front portion of the body of the giant Arthrodira, *Titanichthys clarkii* Newberry. The complete animal was probably fifteen to twenty feet in length. It came from the Cleveland shale.

Dinichthys: Below *Titanichthys*, in the cases between cases 2 and 3, are shown restorations of the head and front portion of the body of one of the larger arthrodira, *Dinichthys terrelli* Newberry. The pieces were found in the Cleveland shale of the Upper Devonian. The entire animal must have measured about fifteen feet in length. These two restorations have been followed, in 1930-31, by the latest restoration, made by Dr. Anatol Heintz of Oslo. A metal model showing roughly the arrangement of the armor plates of the head and thorax in this new restoration is to be seen in the case with the mounted head. This model illustrates the unique jaw mechanism of these fishes who opened their jaws by throwing the head back and drawing down the lower jaw. Four pair of muscles, worked respectively to lift the head roof, to move the head roof downward, to move the lower jaw upward, and to move the lower jaw downward. That is, the first and fourth pair operated to open the mouth and the second and third pair to shut it. This unusual mouth mechanism has never before been observed in any fossil or living animals.

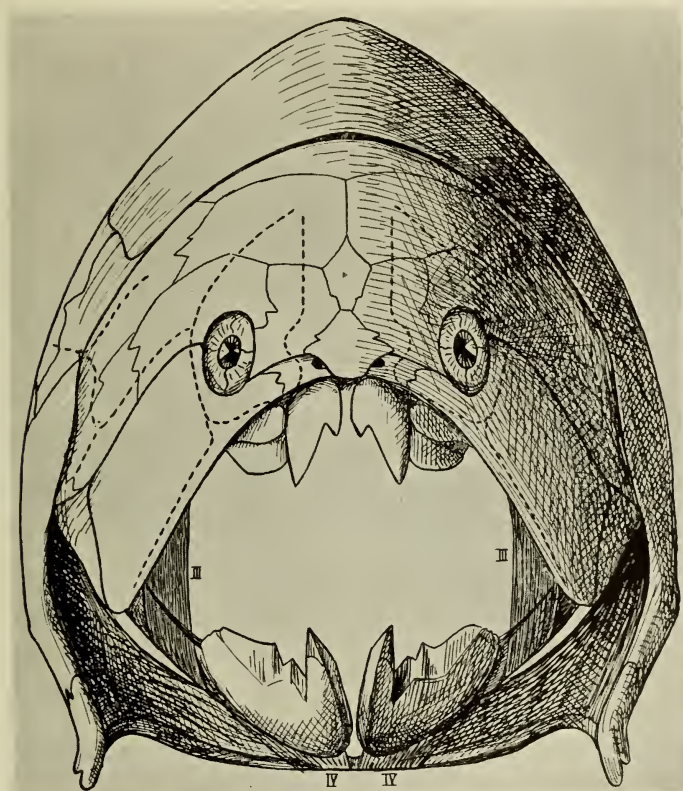
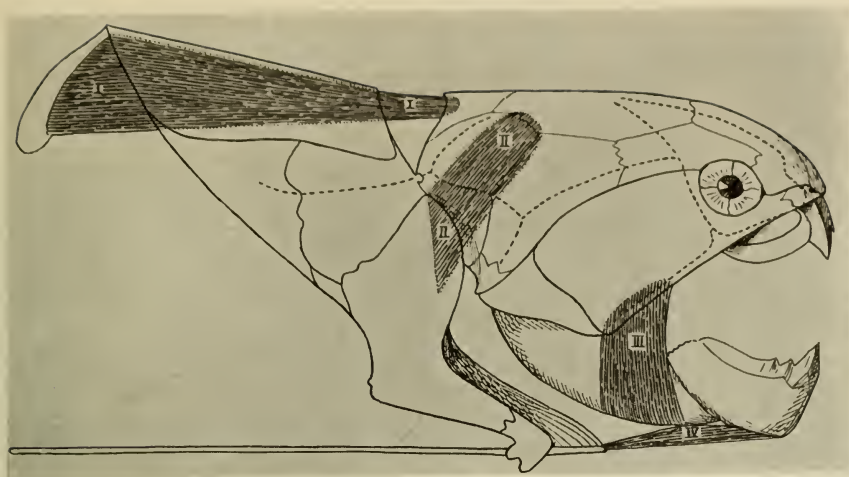

Fig. 16. Restoration of *Dinichthys*. Front and Side Views. By Anatol Heintz.

SHARKS

[Cases 3, 4, 5]

Sharks were among the first vertebrates to appear and have survived throughout all later geologic ages.

Giant Fossil Shark, *Carcharodon megalodon*. [Above entrance to exhibit]: About the time when the glaciers covered the northern part of North America, the seas were inhabited by gigantic sharks. The actual teeth of one of these monsters are shown above the entrance to the alcove. They are from the Tertiary of North Carolina. Their average height is $4\frac{1}{4}$ inches. They have been set in jaws modelled after those of the Man-Eater Shark, which is the nearest relative of the giant extinct species (*Carcharodon carcharias*). The estimated length of this fish in life is 46 feet. A scale drawing below the jaws shows its size as compared with that of the Man-Eater and that of the average man.

The Fin-Fold Shark, *Cladoselache*. [Case 4]: *Cladoselache* is one of the most primitive known types of shark. It lived in the sea during the Devonian. It was characterized by notochordal skeleton, fin-fold type of fins (embryonic fold of skin in which fin rays are developed), and eyes protected by many enlarged shagreen scales. The specimens in this case are from the Upper Devonian of Ohio. In some of the specimens the myotomes, or muscle segments, on the side of the body are preserved.

Pleuracanthidæ. [Case 3]: These are extinct primitive sharks. Their characters include a notochordal backbone, a strong spine at the back of the head, peculiar forked teeth and paddle-shaped pectoral and ventral fins. They have been found from the Carboniferous and Permian of Europe and North America.

Acanthodia. [Case 3]: The leading characteristics of this order of primitive sharks are shagreen close set and scale-like, each web-like fin supported by a spine, eye protected by a ring of bony plates, backbone cartilaginous (notochordal). They appeared in the Silurian and became extinct in the Permian.

Edestidæ. [Case 5]: These are extinct sharks whose nearest living relative is probably the Port Jackson Shark (*Heterodontus*). Of *Edestus*, the only structures preserved have long been regarded as spirals of teeth which projected in front of the mouth. They have been found in the Carboniferous and Permian of Europe and North America. In most sharks the most used teeth come to lie in the front line and eventually get broken off. In *Edestus*, however, the teeth of the symphyseal region of the lower jaw had such long stout "roots" that they could not break off but gradually grew outward into a tightly wound spiral in which the older and smaller teeth are nearer the center.



Fig. 17. Jaws of *Carcharodon megalodon*.

Skates and Rays. [Case 5]: Skates and rays are characterized by a cartilaginous skeleton; the skin is often studded with small tubercle-shaped scales; the teeth are flattened, often fused into pavement-like crushing plates; the gills open in separate slits on the under side of the neck. They were dominant in the Carboniferous and are greatly reduced at the present time. The early forms show many curious specializations in fin-spines and teeth, some of the latter pavement or plate-like.

ICHTHYODORULITES

[Case 5]

Ichthyodorulites are spines and spine-like structures of fossil fishes, many of which cannot as yet be associated with any particular kinds of fishes.

CHIMAEROIDS

(Silver Sharks)

[Case 6]

Chimæroids appeared in early geologic times and were most numerous and diversified during the Cretaceous. They form a small group of shark-like fishes whose existing forms with few exceptions inhabit the deep sea. Some extinct species grew to a length of over fifteen feet. Complete fossil Chimæroids are rare. They are mainly known from detached plates and spines. The living genera representing this group are also shown in this case.

This group is interesting to zoologists as survivors of an ancient stock more closely akin to primitive sharks than to any other fishes. In general they retain shark-like features, but in highly modified form. Their head is typically rat-shaped; their body tapering, with a wisp-like tail and large pectoral fins which are the main organs of swimming. The numerous scales of the shark have in large measure disappeared; the many small teeth are represented usually in three pair of dental plates; the many small valves of the base of the main artery become fewer and larger; the intestinal valve is present, not in many low ridges, but in a few ridges of great width, and the upper jaw, instead of being separate from the skull, as in sharks, is fused with it. The skeleton is cartilaginous and the dorsal spines strong.

Ptyctodonts: These fishes shown at the bottom of Case 6 probably belong to the group of Arthrodira, but by some are regarded as Chimæroids. They have been extinct since the Devonian and are known only from dental plates.

DIPNOANS

[Case 7]

These fishes are provided with a lung as well as with gills. They breathe through nostrils; have three pair of dental plates, and paddle-like paired limbs. At present they are represented by but a few species (see Hall of Fishes, Case 1), two of which, *Protopterus* and *Neoceratodus*, the African and Australian Lungfishes, are shown here.

The lungfishes, are, in many regards, like Salamanders. They appeared in the early Devonian and attained their greatest development at the close of the Palæozoic. Complete fossil specimens are rare. In early periods of the world's history the Dipnoans were a large and important group, abounding in nearly all fresh water. At present they are represented only by three genera, *Protopterus*, living in the rivers of Africa, *Lepidosiren* in South America, and *Neoceratodus* in Australia.

The structures which distinguish them are a lung, which may be single or double-lobed and which enables the fish to withstand the long rainless season when the rivers in which it lives become dry; teeth which are crushing or cutting plates, each with ridges extending crosswise over its surface, and the paired fins of the kind known as "archipterygia," *i.e.*, with an internal structure consisting of a jointed rod of cartilage having similar or smaller rods branching from it on either side.

The most ancient fossil lungfish is *Dipterus* which lived in the Devonian. It is well known by fossil remains from the Old Red Sandstone of Scotland. It had two separate dorsal fins and its head was covered with numerous small, enamel-coated bones.

It gave rise to *Phaneropleuron* which resembled it in the main, except that it was more slender and the two dorsal fins were united into a single long fin. The family to which *Phaneropleuron* belongs gave rise to two types of lungfishes, one a rather stout form, *Scaumenacia*; the other a more slender fish, *Uronemus*. These two types became in time more and more differentiated, gradually leading up to the families of lungfishes existing at the present time, the one including the Triassic *Ceratodus* and *Neoceratodus* of Australia; the other including the slender, eel-like *Protopterus* of Africa, and *Lepidosiren* of South America.

CROSSOPTERYGII

(Lobe-fins)

[Case 7]

The oldest of this group, from the Old Red Sandstone of Europe were long-bodied, pipe-like fishes with voracious mouths. Their pectoral and pelvic fins however were lobate or fringe-finned, that is with a more or less elongate bony and fleshy core surrounded on the front and

rear borders by long, fringing bony and dermal rays. The shorter lobe-like fins resembled the paired limbs of amphibians in having only a single bone, representing the humerus or the femur respectively at the proximal end of each paddle or limb. These forms (Rhipidistia) also approached the amphibians in skull structure and are believed to have stood close to the ancestral line of the latter. The Rhipidists have two dorsal fins and a peculiar type of tail. Among modern fishes two genera, the *Polypterus* and *Erpetoichthys* of Africa were formerly believed to be the direct descendants of the Devonian Crossopterygians, but Professor E. S. Goodrich has adduced evidence for his conclusion that they differ from the latter in many important structural features and that they may rather have been derived from ancient ganoids of the palæoniscoid type.

One branch of the Rhipidists gave rise to the strange Cœlacanths which lasted from Devonian to Cretaceous times.

GANOIDS

[Cases 8, 9, 12]

The Ganoids comprise an extensive group of fishes whose survivors include the Sturgeon, Garpike and Bowfin. The fossil members of this group were numerous during the late Palæozoic and early Mesozoic. They have prominent enamelled and bony scales and in many structural features are intermediate between Sharks and Teleosts. The specimens in these cases are mainly from the celebrated lithographic stone in Solenhofen, Bavaria. (Jurassic).

Pycnodonts. [Case 8]: The Pycnodonts (*pynos*-crowded; *odous*—teeth) are extinct Ganoids with deep compressed body, persistent notochord, and numerous small grinding teeth. They were abundant and widely distributed during the Mesozoic era, but gradually became extinct, disappearing in the early Tertiary. Some specimens reached a length of three feet. Other typical extinct Ganoid fishes are shown in Case 9.

The Saw-finned Fish, *Protosphyræna nitida* Cope. [Case 12]: Among the strange fishes that swarmed in the ancient seas of Kansas, none are more noteworthy than the Amioid fish, *Protosphyræna*. Its bony snout was prolonged like that of a Gar; there were two tusk-like teeth in the upper jaw and very sharp teeth in the lower jaw like those of a living Barracuda. The front edge of the enormous pectoral fins was serrated, and it is supposed that the fish used these in attacking its enemies. On the left side of this case is a sketch of the skeleton of this fish; below it a sketch of the skull, and to one side a reconstruction made from the actual parts shown on the plaque with it. Across the bottom of the case stretch the huge, saw-edged pectoral fins.

THE FOSSIL AQUARIUM

The aquarium at the back of the exhibit alcove is a restoration of early fossil fishes from the Old Red Sandstone of Cromarty, Scotland. This group represents fossil fishes which flourished in the ages preceding the appearance of land-living animals such as frogs, reptiles, and mammals. The aquarium is designed as an aid in interpreting the fossils in adjoining cases, and it probably gives the more accurate picture since all the fishes shown were found in a single locality and in a single layer of Old Red Sandstone (Lower Devonian). In their coloring, they have been made to correspond with their nearest living relatives.

The present models show several kinds of sharks, a lungfish, two lobe-finned ganoids, and the earliest form of ganoid, *Cheirolepis*. In addition, there appear two fishes whose race is extinct, and whose relationships are obscure. These are the Placoderms, *Coccosteus* and *Pterichthys*. The habitat of these fishes appears to have been estuarine, fresh water, or brackish. The plants represented are from the same age and two of them from the same locality. The background was made by Charles R. Knight under the direction of Bashford Dean, in 1909.

TELEOSTS

(Bony fishes)

[Case 10:]

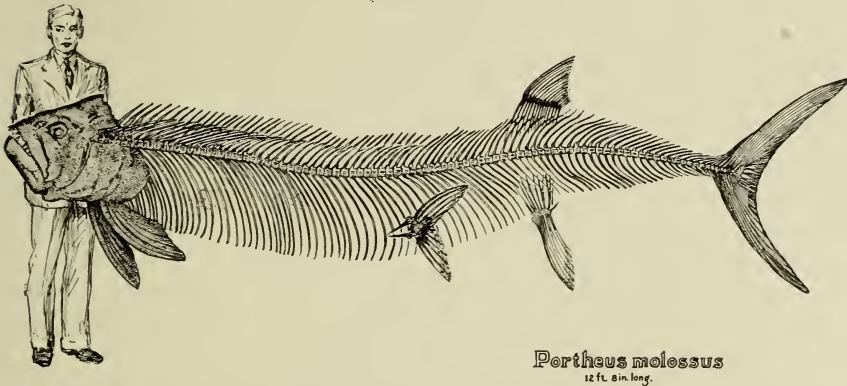

Fig. 18. *Porthetus*, the Giant Bulldog Fish. Drawn by Louise Nash from a photograph of a specimen 12 feet 8 inches long, discovered by George F. Sternberg in the Kansas Chalk (Cretaceous).

To this group belong the majority of food and game fishes of the world—the Bass, Carp, Cod, Eel, Herring, etc. They are the dominant type of fishes at the present time. They are descended from and have supplanted the Ganoids. Many of their forms, including several orders, appeared during the Chalk Period,—the earliest being the Herrings

(Clupeoids) and the Ten Pounders (Elopidæ). An interesting series of transition stages of connecting links can be arranged leading by almost imperceptible degrees from Ganoids to Teleosts.

Structure: The Teleosts are exceedingly diverse in form, size, coloring and anatomical structure, having become adapted to the most varied conditions in seas and lakes and rivers. In size they range from the half-inch *Mistichthys luzonensis* of the Philippines—the smallest vertebrate known, to the gigantic Arapaima of the Amazon, which attains a length of over fifteen feet.

In typical Teleosts, the skeleton is bony or calcified; the fins light, flexible, and provided with complex muscles which insure rapid and diversified movement. The body is covered with thin, flexible, overlapping scales; the brain and sense organs are well developed, especially for sight and hearing.

Fossil localities: Fossil Teleosts are widely distributed. Most of those in this case are from the Green River shales of Wyoming. This geological formation consists of soft, buff-colored shales which appear to have been deposited in an estuary, or in a landlocked bay during the Middle Eocene. The fishes found in these shales are of great variety and beautifully preserved. These formed part of the collection brought together by the distinguished palæontologist, Professor E. D. Cope; the remaining specimens are from various localities and geological ages, as indicated on the labels. Among them are examples of the earliest Teleosts from the Cretaceous of Mt. Lebanon, Syria, also fossils from the Eocene of Monte Bolca, near Verona, Italy.

The Giant Bulldog Fish, *Portheus molossus* Cope. [Above back center of alcove, also Case 12]: This gigantic fossil fish occurs in the Cretaceous of Kansas. Its skull is shown in Case 12, and below it a key to the parts, also a restoration sketch to scale from a photograph of a specimen 12 feet 8 inches long. The specimen on the wall at the back of the alcove measures 15 feet 8 inches in length. The *Portheus* is remotely related to the existing Tarpon, its nearest living relative is the tiny *Chirocentrus dorab* of the Indian Ocean.

For a full description of this fish, see Bulletin American Museum of Natural History, 1904, volume 20, article by Henry Fairfield Osborn.

Recommended books for reference:

- JORDAN, D. S. "Fishes." D. Appleton, New York, 1925.
NORMAN, J. R. "A History of Fishes." London, 1931.
NICHOLS, J. T., and C. M., BREDER, JR. "The Marine Fishes of New York and Southern New England." Zoologica, 1927, IX, No. 1.
BREDER, C. M., JR. "Field Book of Marine Fishes of the Atlantic Coast." G. P. Putnam, New York, 1929.

INDEX

Explanation of abbreviations used below: ew=east wall, Hall of Fishes; F=Fossil Fish Alcove, fourth floor; ff=Flying Fish Case, east wall, Hall of Fishes; p=paintings; V=Vanderbilt collection of paintings, Hall of Fishes; ww=west wall, Hall of Fishes.

	Page	Case
<i>Ablennes</i>		ff (p)
<i>Abramis</i>		19
<i>Abudefduf</i>	42	28
<i>Acanthocybium</i>	46	31 (p); 42
<i>Acanthodia</i>	58	F3
<i>Acanthopterygii</i>	31, 39-47	23-38
<i>Acanthorhodeus</i>		19
<i>Acanthurus</i>		36; V
<i>Achirus</i>		38
<i>Acipenser</i>	29, 62	18; ww; ew; F8
<i>Actinophorus</i>		F8
Adhesive disc.....	5, 41	
<i>Aëtobatus</i>	15	Inner Room
Agassiz, Louis.....	29	
Agonidae.....		29
<i>Agonus</i>		29
Air bladder.....	22, 31, 40	
Airplanes.....	23, 37, 38	ff
Albacore.....	46	32; 46
False.....		31 (p); 50
Long-finned.....		31 (p)
Yellow-fin.....		46
<i>Albula</i>	27, 31	17; 42; 50
Albulidae.....	32	17
<i>Alburnus</i>	33	
Aldrovandia.....		21
Alepocephalidae.....	32	16
<i>Alepocephalus</i>		16
<i>Alestes imberi</i>		19
<i>Aletodus</i>		F6
Alewife.....		17
<i>Alopias</i>		11; entrance
Alopiidae.....		11
<i>Alosa</i>		17
<i>Alutera</i>		36
Amberjack.....	46	33; 42; 48
Ambicoloration.....	47	
<i>Ambloplites</i>		23
<i>Amblypterus</i>		F8
<i>Ameiurus</i>		20
<i>Amia</i>	21, 29, 62	18; ew; F9
<i>Amiatus</i> see <i>Amia</i>		
Amioidei.....	62	18; ew
<i>Ammodytes</i>		30
<i>Amphisile</i>		21

	Page	Case
Anaphisilidae.....	35, 36	21
<i>Amphistium</i>	47	
<i>Anabas</i>	42	27
<i>Anableps</i>	5	21
Anacanthini.....	44, 45	30
<i>Anarrhichas</i>	45	30
Anaspida.....	55	F1
<i>Anchovia</i>	19	17
Anchovy, Striped.....	19	17
<i>Ancyllopsetta</i>		38
Angelfish.....	41, 42	27; V
<i>Angelichthys</i>	41, 42	27
Anglers, Oceanic.....	6, 25, 26, 47, 48	35; 52; ew; Inner; Deep-Sea.
Angling <i>see</i> Gamefish.		
<i>Anguilla</i>	22, 36	22; 54
<i>Anisotremus</i>		23
<i>Anogmius</i>		F10
<i>Anoplopoma</i>		29
Antennariidae.....		35
<i>Antigonia</i>		38, V
<i>Aphyonus</i> (blind).....		30
<i>Aphredoderus</i>		24
<i>Aplodinotus</i>		25
Apodes.....	36	22
<i>Apogon</i>		24
<i>Aprion</i>		23
Aquarium fishes <i>see</i> under their <i>individual names</i> .		
Aquarium, fossil.....	62	F
"Ara" (paintings).....	41	V
<i>Arapaima</i>	64	17
<i>Archaeobatis</i> <i>see</i> <i>Psammodus</i> .		
Archer Fish.....	6	24
Archipterygia.....	61	
<i>Archosargus</i>	40	23
Arcturus Expedition.....	25, 26	Inner
Argenteum.....	33	
<i>Argyropelecus</i>		16, V, Inner
Armor.....	34, 36	
Arthrodira.....	56-57, 60	F (wall); F2; F3
<i>Aspidorhynchus</i>		F8
<i>Aspredo sexcirrhus</i>		20
<i>Asteracanthus</i>		F5
<i>Astronesthes</i>	26	16; Inner
<i>Astroscopus</i>		30
Atherinidae.....	39	
<i>Auchenaspis</i>		F3
<i>Aulorhynchus</i>		21

	Page	Case
Aulostomatidae	35	21
<i>Auxis</i>		31 (p), 32
<i>Balistapus</i>		V
Balistidae	48, 49	36
Ballyhoo.....		ff; ff (p)
Bandfish, Red.....		24
<i>Barathronus diaphanus</i>		Inner
Barb, Caldwell's.....		19
Barbels.....	34	
<i>Barbus</i>	33	ew, 19
Barracuda.....	38, 39, 62	27; 42; 48
Barton, O. <i>see</i> Bathysphere.		
Bass, Calico.....		23
Channel.....	27, 40	ww
Large-Mouth Black.....	40	23; 40; F10
Rock		23
Sea	40, 43	24
Small-Mouth Black.....	40	23; 40
Striped.....	39, 40	ww; 24; 53; 54
White Lake		24
Batfish.....	47, 48	35
<i>Bathypterois longicauda</i>	35	21; Inner
<i>Bathysaurus mollis</i>		21
Bathysphere.....	25	Inner
Batrachidae		35
<i>Bdellostoma</i> <i>see</i> <i>Homea</i> .		
Beebe, William <i>see</i> Areturus Expedition; Bathysphere.		
<i>Bellotia apoda</i>		30
Belonidae.....		ff
<i>Belonorhynchus</i>		F8
<i>Belonostomus</i>		F8
Bermuda <i>see</i> Bathysphere.		
Berycidae.....	40	24
<i>Betta</i>	42	27
Big-eye.....		24
Big-heads <i>see</i> <i>Plectromus</i> .		
Biology.....	19-23	53; 54
Bitterling.....		53
Blackfish, Alaska.....		21
Bladder	22, 31, 40	
Bleak.....	33	
Blenniidae.....	45, 48	30, V
Bluefish.....	40	24; 54
Boarfish.....		38, V
<i>Bodianus</i>		24, 28
Body form.....	22, 23	53 ;54
of Sharks	9, 10	11
Bogue.....		23

	Page	Case
<i>Boleophthalmus</i>		29
<i>Boleosoma olmstedii</i>	42	
Bonefish.....	27, 31, 32	17; 42; 50
Bonito.....	12, 46	31 (p), 32
Bony Fishes <i>see</i> Teleosts.....		
<i>Bothriolepis</i>		F3
<i>Bothrocarra mollis</i>		30
Bowfin.....	21, 29, 62	ew; 18; F9
<i>Bor</i>		23
Boxfish.....		35
<i>Brachyplatystoma filamentosum</i>		20
Bream, Chinese.....		19
Sea.....		23
Breder, C. M., Jr.....	22	
Brood pouch.....	21, 36	
Brotulidae.....		30
Buffalo Fish.....		19
Bulldog Fish, Giant.....	32, 63, 64	F wall; F12
Burnett River.....	17	
Butterfish.....		54
Red.....		24
Butterfly Fish.....	41, 42	27, V
<i>Bythiacanthus</i>		F5
<i>Calamoichthys calabaricus</i>		18
<i>Calamus taurinus</i>		23
<i>Callionymus</i>		V, 30
<i>Callorhynchus</i>		3, 53, F6
<i>Cantharus vulgaris</i>		23
<i>Canthidermis sobaco</i>		36
<i>Canthigaster rostratus</i>		V
Canyon City, Colorado, fossils from.....	54	
Cape San Lucas.....	27	
Caproidea.....		38
Carangidae.....	22, 46	33
<i>Caranx</i>		33, 50, 54
<i>Carassius</i>		19
Carcharhinidae.....	11, 12, 13	7
<i>Carcharhinus</i>	13	7; Group
<i>Carcharias</i>	9; 13	11; group; F5
Carchariidae.....	11; 12; 13	11
<i>Carcharodon carcharias</i>	12, 58	entrance; group
<i>C. megalodon</i> (jaws).....	12, 58, 59	F
<i>Careproctus melanurus</i>	43	29
Caretta.....		group
Carp.....	31, 32-34	19
Catfish.....	21, 31, 32-34, 43	20; 53
Catfish Sucker.....		20
<i>Catostomus commersonii</i>		19

	Page	Case
Catulidae <i>see</i> Seylliidae.		
<i>Catulus retifer</i>	11, 15	11
<i>Caturus</i>		F9
Caviar.....	29	
Centrarchidae.....	40	23
Centriscidae.....	35	21
<i>Centriscus scolopax</i> <i>see</i> <i>Macror-</i> <i>hamphosus</i> .		
<i>Centropomus undecimalis</i>		24; 50
<i>Centropristes striatus</i>	40, 43	24
<i>Cephalacanthus</i> <i>see</i> <i>Dactylopterus</i> .		
Cephalaspida.....	55	F1; F3
<i>Cephalaspis</i>		F1; F3
<i>Cepola rubescens</i>		24
Cepolidae.....		24
<i>Ceratias holboelli</i>	6, 25, 47, 48	ew
Ceratioids.....	25, 26, 47, 48	ew; 35; 52; Inner
Cero (Florida Mackerel).....		42
Cestraciontidae.....		7
<i>Cetorhinus maximus</i>	9	above 11
<i>Chaetodipterus faber</i>		27, V
<i>Chaetodon</i>		V
Chaetodontidae.....	41, 42	27
<i>Chalcinus elongatus</i>		19
<i>Channa ocellata</i>	42	27
Characidae.....	32-34, 38	19
<i>Chauliodus sloanei</i>	26	16; Inner
<i>Chaunax pictus</i>		35
<i>Cheilinus lunifer</i>		V
<i>Cheilodactylus variegatus</i>		29
<i>Cheilodipterus octovittatus</i>		24
<i>Cheiracanthus</i>		F3
<i>Cheirodus</i>		F8
<i>Cheirolepis</i>	63	Foss. Aq.
<i>Chiasmodon niger</i>		27
<i>Chilomycterus schoepfi</i>		35
<i>Chimaera</i>	15	3; F6
Chimaeroids.....	15, 16, 60	3; F6
<i>Chimaeropsis</i>		F6
<i>Chirocentrus</i>	32, 64	17
<i>Chlamydoselachus anguineus</i>	11	11; 53
Chondrostei.....		18
<i>Chriodorus</i>		ff (p)
Chromides.....		28
<i>Chrysophrys bifasciatus</i>		23
Chub.....		19, 24
Cichlidae.....	21, 42	28
<i>Cirrhitites rivulatus</i>		29
Cladistia.....		18

	Page	Case
<i>Cladodus mortifer</i>		F5
<i>Cladoseleche</i>	58	F4
"Claret Jock Scott" (artificial fly).		wall beyond 36
<i>Clarias</i>		20
Cleveland Shale.....	56	F4
<i>Climatius</i>		Foss. Aq.
Climbing Perch.....	42	27
<i>Clupea harengus</i>		53
Clupeidae.....	19, 31, 32, 63, 64	17
Cobia or Crab-eater.....	41	25; 50
Cobitidae.....		19
<i>Coccodus</i>		F8
<i>Cocosteus</i>	56, 63	F2; F3; Foss. Aq
Cod.....	19, 44, 45	29, 30
Coelacanthidae.....	62	
<i>Coelacanthus</i>		F7
Coelolepidae.....		F3
Columbia University.....	53	
Conant, Isabel Fiske (poem by)...		Inner
Conger Eel.....	36	22
Cope, Edward Drinker (Collection)	53, 64	F
<i>Coregonus clupeaformis</i>		16
<i>Coreus styani</i>		19
<i>Coreoperca whiteheadi</i>		24
Cornet Fish.....		21
<i>Coryphaena</i>	46	ww; 33; 48
Cottidae.....		29
Cowfish.....		35
Crab-eater <i>see</i> Cobia.		
Crappie.....		23
<i>Crenicichla saxatilis</i>		28
<i>Crenilabrus pavo</i>		28
Creole Fish.....		V
Crevalle (<i>see also</i> Jackfish).....	22	33; 54
<i>Cristivomer namaycush</i>		16
Croaker.....	41	25
Crossopterygians.....	61-62	F7; 18
<i>Crossostoma</i>		19
<i>Cryptosparas</i>		3; Inner
<i>Ctenacanthus</i>		F4, F5
Cunner.....	43	28
Cutlass Fish (<i>see also</i> Silvery Hair- tail).....		31 (p); 32
<i>Cybbium chinense</i>		31 (p)
Cycliae.....	55	
<i>Cyclobatis</i>		F5
<i>Cyclopterus lumpus</i>	43	29
Cyclostomata.....	16	3
<i>Cymatogaster aggregatus</i>		27

INDEX

71

	Page	Case
<i>Cynoscion nebulosus</i>		25
<i>C. nobilis</i>	40	
<i>C. regalis</i>	41	25
Cyprinidae.....	31, 32-34	19
Cyprinodontes.....	34, 35	21
<i>Cypselurus</i>		ff; ff (p)
<i>Dactylopterus volitans</i>	38, 43	29; ff
<i>Dallia pectoralis</i>		21
Damsel.....		V
<i>Dapedius</i>		F8
Darter.....	40	
<i>Dasyatis</i>		5, Inner, F5
Dasybatidae.....	15	5
Dasybatus.....	15	
Day, Alfred Ely (Collection).....	53	F
Dean, Bashford.....	16	
Memorial Exhibit.....	52-64	F
Deep-Sea Fishes.....	24-26, 32, 35, 40	16; 35; 52; Inner
Dentition. <i>See</i> Teeth		
Development <i>see</i> Biology.		
Devilfish (Manta).....	14, 15	Inner
Small (<i>Mobula olfersi</i>).....		Above 3; 5
Devonian Fossils.....	53	F
<i>Diacranodus</i>		F3
<i>Dicrolene niger</i>		30
<i>Dictyorbatus</i>		F3
<i>Dinichthys</i>	56, 57	F2 and wall.
<i>Dinomylostoma</i>		F2
Diodontidae.....	49	35
<i>Diplacanthus</i>		F3, Foss. Aq.
<i>Diplectrum formosum</i>		24
<i>Diplodus</i>		F3
<i>Diplognathus</i>		F2
<i>Diplomystus</i>		F10
<i>Diplurus</i>		F7
Dipnoans.....	16-18, 20, 21, 55, 61,	
63		1; F7
<i>Dipterus</i>	61	F7; Foss. Aq.
<i>Discobatus sinensis</i>		5
Discocephali.....	41	25
<i>Distichodus</i>		19
Dodge, D. Stuart.....	53	
Dodge, William E. (Collection)...	53	F
Dogfish, Reticulated.....		11
Smooth.....	13	7
Spined.....	11, 14	5; 7
Spotted.....		V
<i>Dolopichthys</i>		V
Dolphin.....	45, 46	ww; 33; 48

	Page	Case
Dómine.....		31 (p)
Doncella.....		28
Dorab.....	32	17
Doree <i>see</i> John Dory.		
<i>Dorosoma</i>		F10
Dory, Deep-water.....		38
Dragon Fish.....		29
Dragonet.....		30, V
<i>Drepanaspis gemündensis</i>		F3
Drum.....	41	25
Duskfish.....		16; 52
<i>Echeneis</i>	5, 41	25
<i>Echiostoma</i>		26; Inner (p)
<i>Edaphodon</i>		F6
Edestidae.....	58	F5
<i>Edestus</i>		F5
Eel, Common.....	22, 36	22, 54
Conger.....	36	22
Electric.....	34	19
Giant Slime.....		3
Pointed-finned.....		22
Slime.....	16	3
Snipe.....		54; Inner
Snout.....		19
Snub-nosed.....		22
Thread (<i>see also</i> Snipe Eel)...		54; Inner
Eel Herring.....		17
Eel Polypterus.....		18
Eel-pout.....	45	30
Egg.....	19, 20, 21, 45	
Elasmobranchii <i>see</i> Sharks.		
<i>Elasmodus</i>		F6
Electric Fishes.....	34	
<i>Electrophorus electricus</i>	34	19
<i>Elegatis</i>		50
<i>Eleotris potamophila</i>	44	29
Elephant Fishes.....	32	17
<i>Elonichthys</i>		F8
Elopidae.....	31, 64	16
<i>Elops saurus</i>	64	50; F10
<i>Embassichthys bathibius</i>		38
Embiotocidae.....	41, 42	27
<i>Embryx crassilabrus</i>		30
Engraulidae.....	19	17
<i>Epibulus insidiator</i>		28
<i>Epinephelus</i>		24, V
<i>Epinnula magistralis</i>		31 (p)
<i>Eques lanceolatus</i>		25
<i>Erpetoichthys</i>	62	

	Page	Case
Escolar <i>see</i> Ruvettus.		
Esoces.....		21
Esocidae.....	36, 37, 38	21
<i>Esox</i>		21; 40
<i>Etmopterus lucifer</i>		7
<i>Euchilichthys guentheri</i>		20
<i>Eugnathus</i>		F9
<i>Euleptorhamphus</i>		ff (p)
<i>Euphyacanthus</i>		F5
<i>Eupomacentrus partitus</i>		V
<i>Eurypholis</i>		F10
<i>Eusthenopteron</i>		F7
<i>Euthynnus yaito</i>		31 (p)
<i>Euthynotus</i>		F9
<i>Eutropius</i>		20
Eventognathi.....	33	19
<i>Evoplites viridis</i>		23
<i>Eronautes</i>		ff; ff (p)
Eye, migration of.....	47	
Fanfish.....		5
Featherback.....	32	
<i>Felichthys felis</i>	21	20; 53
Fertilization.....	19, 21	
Fighting Fish of Siam.....	42	27
Filefish.....		V, 36
Filet of Sole.....	47	
Fins. <i>See also</i> Locomotion.....	22	
adipose.....	34	
(archipterygia).....	61	
prehensile caudal.....	36	
Fisheries.....	45	
Fistulariidae.....		21
Flasher. <i>See</i> <i>Lobotes</i> .		
Flatfishes.....	46, 47	38
Flathead, Indo-Pacific.....		29
Flounder.....	46, 47	38
Fly, artificial.....		wall beyond 36
Flying Fish.....	36, 37, 38	17, ww; ff; ff (p), 46
<i>Fodiator</i>		ff (p)
"Fossil Aquarium".....	62, 63	F
Fossil Fishes.....	52-64	F
<i>Forcipiger longirostris</i>		V
Four-eyed Fish.....		21
Frog Fish, Deep-water.....		35
<i>Fundulus majalis</i>		21
Gadidae.....	44, 45	30
<i>Gadus callarias</i>		30
<i>Gadus morrhua</i>	19, 44, 45	30
<i>Galeocerdo</i>		Group

	Page	Case
Galeorhinidae.....		7
<i>Galeorhinus</i> see <i>Mustelus</i> .		
"Galuchat".....	9	
Gamefishes.....	9, 27-28, 63	40; 42; 46; 48; 50
Ganoidei.....	21, 29, 31, 62, 63, 64	18; groups (ew); F8; F9
Garpike.....	29, 62	18, above 18, 53, groups, F9
<i>Gasteropelecus</i>	38	ff
Gasterosteidae.....	21, 35	21, 53
<i>Gastromyzon leveretti</i>		19
<i>Gastrosomus</i>		Inner
<i>Gempyla serpens</i>		31 (p); 32
Geology see Fossil Fishes.		
<i>Geotria</i>		3
<i>Germo</i>	46	31 (p); 32; 46
Gerridae.....		25
Gigantactinidae.....		35; 52; Inner
<i>Gigantura</i>		30
Gill-cover see Operculum.		
Gills.....	42	
<i>Ginglymostoma cirratum</i>	9, 12	11
Gloucester, Mass., fleet.....	45	
<i>Gnathonemus</i>		17
Gobioidei.....	44	29
<i>Gobius niger</i>	44	29
Goby, Black.....		29
Blind.....	44	29
Gold-eye.....	32	17
Goldfish.....	33	19, 28
Gonorhynchidae.....	32	16
Goodrich, E. S.....	62	
<i>Grammatorcynus</i>		31 (p)
Grand Banks.....	45	
Grayling, Michigan.....		16
Green River Shales.....	64	F10
Green's Labeo.....		19
Gregory, William King.....	21, 26	
Grenadier.....	44, 45	
Grey, Zane see Gamefishes.		
Grouper.....	40	23; 24; V
Grunt.....	40	23
Guita fish.....	13, 14, 15	5
Gunnel.....		30; 53
Gurnard.....	38, 43	29; ff
<i>Gymnosarda</i>		31 (p); 50
Gymnotidae.....	34	19
<i>Gyrcanthus</i>		F5
<i>Gyrodus</i>		F8
<i>Gyroleurotus francisci</i>	9, 11, 58	7; 53; 54; F5

	Page	Case
Haddock.....		30
Haemulidae.....	40	23
Hagfish.....	16	3
Hairtail, Silvery.....		31; (p); 32
Hake.....	45	30
Halibut.....	46	above 30
<i>Halichaeres bivittatus</i>		28
<i>Halimochirurgus centriscoides</i>		36
Hall, James (Collection).....	53	F
<i>Halocypselus evolan</i>		ff (p)
Halosauridae.....	35	21
Haplodoci.....		35
<i>Haplolepis</i>		F8
Haplomi.....	34-35	21
<i>Harriotta</i>	15	3
Hatchetfishes <i>see</i> <i>Argyropelecus</i> and <i>Sternoptyx</i> .		
Heintz, Anatol.....	56, 57	
<i>Helicoprion</i>		F5
Hemibranchii.....		21
<i>Hemimyzon zebroides</i>		19
<i>Hemiramphus</i>		ff; ff (p)
<i>Hemitripteris americanus</i>		29
<i>Heniochus</i>		V
<i>Hepatus</i>		V; 36
<i>Heptranchus perlo</i>		11
Herring.....	19, 31, 32, 63, 64	17; 53
Herring Mackerel.....		31 (p)
Heterodontidae.....	11	7
<i>Heterodontus</i> <i>see</i> <i>Gyropleurodus</i> .		
Heterognathi.....	34	19
Heteromi.....	35	21
Heterosomata.....	46, 47	38
<i>Hexagrammus</i>		29
<i>Himantolophus groenlandicus</i>		52
Hind, Rock.....		24
<i>Hiodon alosoides</i>	32	17
<i>Hippocampus</i>	21, 35, 36	21; 53
<i>Histrio</i>		35
<i>Hippoglossus</i>	46	above 30
<i>Hoelaspis</i>		F1
Hogfish.....		28
<i>Holacanthus passer</i>	41, 42	27; V
<i>Holocentru</i>	40	24
<i>Holoptychius</i>		F7; Foss. Aq.
Holostei.....		18
<i>Homea</i>	16	3
<i>Homosteus</i>	56	F2
<i>Hoplias malabaricus</i>		19

	Page	Case
<i>Hoplopteryx</i>		F10
<i>Hoplosternum littorale</i>		20
Houndfish.....		ff
<i>Hybodus</i>		F5
<i>Hynnix cubensis</i>		33; 48
<i>Hyperprosopon argenteus</i>		27
<i>Hypophthalmichthys molitrix</i>		19
<i>Hypoplectrus unicolor</i>		V
<i>Hypoprion brevirostris</i>		7
<i>Hyporhamphus</i>		ff
<i>Hypsocormus</i>		F9
<i>Hypsypops rubicundus</i>		28
Ichthyodorulites.....	60	F5
<i>Ictiobus cyprinella</i>		19
Iniomi.....	35	21
<i>Iridio garnoti</i>		28
<i>Ischnacanthus</i>		F3
<i>Ischyodus</i>		F6
Isospondyli.....	31-32; 38	16-17
<i>Istiophorus</i>	27, 46	31 (p), 42; above 40; above 48; above 50; group.
Isuridae.....	9, 12, 14	11
<i>Isurus</i>	9	11
Jack Fish.....	46	33; 54
Jaws of fishes.....	21, 39, 49, 58, 59	53
Jesup, Morris K.....	53	
Jewelfish.....	26	
Jewfish.....		ww, 42
John Dory.....	47	38; V
Johnny Darter.....	44	
Joint-necked Fishes <i>see</i> Arthrodira.		
Jugulares.....	45	30
<i>Julis</i>		V
Kansas, Cretaceous Fishes of.....	62, 64	F12
Kepler, William (Collection).....	53	F
<i>Katsuwonus</i>		31 (p); 32
<i>Kiaeraspis</i>		F1
Kerr, J. Graham.....	55	
Killifish.....	34, 35	21
Kingfish, Florida.....		32
Whiting.....	41	25
Kisugo.....		25
Knifefish.....		19
<i>Knightia</i>		F10
Kyphosidae.....		24
<i>Labeo</i>		19
Labridae.....	43	28
Labyrinthici.....	42	27

INDEX

77

	Page	Case
Lacerto.....		21
<i>Lachnolaimus maximus</i>		28
<i>Lactophrys</i>		35; 54
<i>Laemargus borealis</i>	11	7
<i>Laemonema barbatulum</i>		V
<i>Lagocephalus laevigatus</i>		35
<i>Lampetra</i>		3
Lamprey.....	16	3, 16; group.
<i>Lampris</i>	46	ew
<i>Lanarkia</i>		F3
Lanternfish, Dark.....	26	V
<i>Lasiognathus</i>		35; 52; Inner
Lateral line.....	41	
<i>Lates</i>		F10
Leather Jacket.....		33
Lebanon, Mt.....	53, 64	F
<i>Leiostomus</i> see Spot.		
<i>Lepidopus</i>		31 (p)
<i>Lepidosiren</i>	16, 18, 61	1
<i>Lepidosteus</i>	29, 62	18; above 18; 53; Group; F9
<i>Lepidotus</i>		F9
<i>Lepisosteus</i> see <i>Lepidosteus</i> .		
<i>Lepomis pallidus</i>		23
Leptocephali.....	36	22
Leptolepidae.....	31, 33	
<i>Leptolepis</i>		F10
<i>Leuciscus</i>		F10
Ling, Fresh-water.....		30
<i>Linophryne</i>	25	35; 52 Inner; Inner (p).
<i>Liognathus</i>		F2
Lionfish.....		29; V
<i>Listracanthus</i>		F5
Lizard Fish.....	35	21
Loaches.....		19
Lobe-fins see Crossopterygians.		
<i>Lobotes</i>	40	24
Locomotion.....	22, 23, 35, 36, 39, 43	54
Lookdown see Vomer.		
<i>Lophius</i>		35
Lophobranchii.....		21
<i>Lopholatilus chamaeleonticeps</i>		23
<i>Lophopsetta maculata</i>		38
Loricariidae.....	34	20
<i>Lota maculosa</i>		30
Lousefish.....		30
<i>Luciocharax</i>		19
Luminous fishes.....	26, 32, 35	Inner
Lumpfish.....	43	29

	Page	Case
Lungfish.....	16-18, 21, 55, 61, 63	1; 53; panel; F7
<i>Lutianus</i>	40	23; 50
<i>Lycodontis</i>		22; above 22
Mackerel.....	19, 40, 45, 46	29; 31 (p); 32
Florida <i>see</i> Cero.		
Horse (<i>see also</i> Tuna).	22	
<i>Macrorhamphosus scolopax</i>		21
<i>Macrourus</i>		30; Inner
Macruridae.....	26, 44, 45	30
Mahseer.....	33	ew
<i>Makaira</i>	27	
<i>Malacanthus</i>		23
<i>Malucoctenus</i>		V
<i>Malopterurus electricus</i>		20
<i>Malthopsis</i>		35; Inner (p)
"Man-eating Fish".....	34	
Man of War, Portuguese.....		Inner
Mandarin Fish.....		24
Manta.....	14, 15	Inner
<i>Marcusenius psittacus</i>		17
Marlin, Black. <i>See also</i> Swordfish	6, 27	46
Tahitian.....	28	
Mary River.....	17	
Mebachi.....		31
<i>Megalobrama macrops</i>		19
<i>Megalurus</i>		F9
<i>Melamphaes</i> <i>see</i> <i>Plectromus</i> .		
<i>Melanocetus</i>		35; 52; Inner
<i>Melanogrammus aeglefinus</i>		30
<i>Melanostomias</i>		Inner
<i>Melichthys bispinosus</i>		36
<i>Menidia menidia notata</i>		27
<i>Mene</i>		F10
<i>Menticirrhus americanus</i>	41	2
<i>Mesacanthus</i>		F3
<i>Mesodon</i>		F8
<i>Microdon</i>		F8
<i>Microgadus</i>		30
<i>Micropogon</i>	41	25
<i>Micropterus</i>	40	23; 40; F10
Midshipman.....		35
<i>Misgurnus</i>		19
Mississippi R.....	29	
<i>Mistichthys</i>	44, 64	
<i>Mobula</i>		above 3; 5
<i>Moebia promelas</i>		30
Mojarra, Long-spined Silvery....		25
<i>Mola</i>	49	north center; above 38.
<i>Monacanthus</i>		36; V

	Page	Case
Monkfish.....	14	5
<i>Monocentris japonicus</i>		24
Monte Bolea.....	64	F10
Moon-eyes.....	32	
Moonfish (<i>Lampris</i>).....	46	ew
Moonfish (<i>Vomer</i>).....	46	33
Moorish Idol.....		27; 54; V
Moray.....	36	22; above 22
Mormyridae.....	32	17
<i>Mormyrops</i>		17
<i>Mormyrus</i>		17
<i>Morone</i>	40	24
Mosquitoes.....	35	
Mt. Lebanon.....		F10
Mouse Fish.....		35
Mouth Fish, Black Bellied.....		V
<i>Moxostoma</i>		19
Mud Minnow, Barred.....		21
Mud Skipper.....	44	29
<i>Mugil</i>	38, 39	27
Mullet.....	38; 39; 42	27
<i>Mullus</i>		25
Muraenidae.....	36	22
Muskallunge.....		21; 40
<i>Mustelus canis</i>	11	7
Muttonfish.....		23; 50
<i>Mycteroperca</i>	40	24; 48
<i>Myctophum</i>	26, 35	Inner
<i>Myliobatis</i>	15	54; F5
<i>Myleleuciscus aethiops</i>		19
<i>Mylostoma</i>		F2
<i>Myoplosus</i>		F10
<i>Myoxocephalus</i>	43	29; 54
<i>Myzine</i>	16	3
<i>Myxocyprinus asiaticus</i>		19
<i>Narcacion torpedo</i>		5; Inner
<i>Naucrates ductor</i>		33
Needlefishes.....	36	
<i>Nematistius pectoralis</i>	46	33; 46
Nematognathi.....	34	20
<i>Nemichthys</i>		54; Inner
<i>Neoceratodus</i>	16-18, 20, 21, 61	1; panel; F7
<i>Neomaenis</i>		23
<i>Neoscopelus</i>		21; Inner
<i>Neothunnus</i>		31 (p)
Nests.....	21, 29	
Newberry, John Strong (Collection).....	53	F
Nichols, John Treadwell.....	4	

	Page	Case
Niobrara formation.....		F10
<i>Nomeus gronovii</i>		Inner
Nonsuch Island.....	25	
Notothenidae.....		29
Notidanidae.....	11	11
<i>Notogoneu</i>		F10
Notopteridae.....	32	17
<i>Notorhynchus</i>	11	11
Oarfish.....	24	Inner
<i>Ochetobius elongatus</i>		19
<i>Ocyurus chrysurus</i>		23; 50
<i>Odaxothrissa</i>		17
Odontaspidae.....	11, 12	11
<i>Ogocephalus</i>		35
Oilfish.....	46	31 (p); 32
Old Red Sandstone.....	62	
<i>Oligoplites saurus</i>		33
<i>Oncorhynchus tshawytscha</i>		16
<i>Onychostoma</i>		19
Opah.....	46	ew
Operculum.....	39, 40, 42, 43, 46	
<i>Ophicephalus</i>		27
Ophidiidae.....		30
<i>Ophiodon</i>		29
<i>Opisthoproctus</i>		Inner
<i>Opsanus tau</i>		35
<i>Opsariichthys</i>		19
<i>Oracanthus</i>		F5
Oral gestation.....	42	
Ordovician (fossils of the).....	54, 55	F
<i>Orectolobus</i>		11
<i>Orthacodus</i>	12	
Osborn, Henry Fairfield.....	53	
Osëtr.....	29	ww
<i>Osmerus</i>		16
Osphronemidae.....	42	27
Ostariophysi.....	31, 32-34	19; 20
Osteoglossidae.....	31, 32	17
<i>Osteoglossum</i>		17
<i>Osteolepis</i>		F7; Foss. Aq
Ostraciontidae.....	22, 23	35
Ostracoderms.....	43, 54-55	F1; F3
Oviparity.....	21	
<i>Ovoides</i>		V
Ovum.....	19	
<i>Oxynotus</i>		7
<i>Pachycormus</i>		F9
Paddlefish.....	29	18; group; F8
<i>Pagellus (Sparus)</i>		23

	Page	Case
<i>Palaeomytilus</i>		F6
<i>Palaeoniscus</i>		F8
<i>Palaeospondylus</i>	55	F3
<i>Pantodon</i>	38	17; ff
Papagallo <i>see</i> Roosterfish.		
Paperhead.....		24; V
<i>Parabramis pckinensis</i>		19
<i>Paralichthys dentatus</i>		38
<i>Parali parisi</i>		29
<i>Paramyxine atami</i>		3
<i>Paranthias</i>		V
<i>Parasilurus asotus</i>		20
Parasitic males.....	47, 48	
<i>Parathunnus</i>		31 (p)
Parental care.....	21, 36, 42	
<i>Parexocoetus</i>	37	ff (p)
<i>Parophrys</i>		38
Parrotfish.....	43	28
Pearls, artificial.....	33	
Pediculati.....	47, 48	35; 52
<i>Pegasus draconis</i>		29
Penfish, Pacific.....		23
<i>Perca flavescens</i>		24; 40; F10
Percesoces.....	38, 39	27
Perch, Climbing.....	42	27
Pike <i>see</i> <i>Stizostedion</i> .		
Pirate.....		24
White.....	40	24
Yellow.....		24; 40; F10
Percoidei.....	39-41, 44	23; 24; 25
<i>Periophthalmus</i>	44, 45	29
<i>Peristedion miniatum</i>		29
<i>Petalodus alleghaniensis</i>		F5
<i>Petromyzon marinus</i>	16	3; V
<i>Phago boulengeri</i>		19
<i>Phaneropleuron</i>	61	F7
<i>Phareodus</i>		F10
Pharyngeal teeth.....	33, 40	
<i>Pharyngolepis</i>		F1
<i>Phlyctaenaspis</i>	56	F2
<i>Pholidophorus</i>		F9
<i>Pholis gunnellus</i>		30; 53
<i>Photocornylus</i>	25	52
<i>Phtheirichthys</i>		V
<i>Phycis</i>		30
<i>Phylactaenaspis</i>	56	
<i>Phyllopteryx</i>	36	21
Pickerel.....	34	
Pike.....	34, 35, 38	21; 40

	Page	Case
Saury.....		ff; ff (p)
Pike Perch.....		24
Pilot Fish.....		33
Pinecone Fish.....		24
Pintadilla.....		29
Pintado <i>see</i> Cero.		
Pipefish, Northern.....	35, 36	21
Piranha.....	34, 38	
Pirate Perch.....		24
Placoderms.....	53, 63	F1; F3; Foss. Aq.
Plagiostomi.....		5; 7; 11; Groups
<i>Platichthys stellatus</i>		38
<i>Platycephalus indicus</i>	43	29
<i>Platycormus</i>		F9
Platysomidae.....		F8
<i>Plecostomus</i>		20
Plectognathi.....	48-49	35; 36
<i>Plectromus (Melamphaes)</i>		24; Inner; V
<i>Pleuracanthus</i>	58	F3
<i>Pleurogrammus monoptyerygius</i>		29
Pleuronectidae.....	19, 46, 47	38
<i>Pliotrema</i>		5
Pogge.....		29
<i>Pogonias</i>	41	25
<i>Polydactylus octonemus</i>		27
Polynemidae.....		27
<i>Polyodon</i>	29	18; group; F8
<i>Polyprion americanus</i>		24
Polypterus, Eel.....		18
<i>Polypterus</i>	62	18; F7
<i>Polyrhizodus</i>		F5
<i>Pomacanthus</i>	41, 42	27
Pomacentridae.....		28
<i>Pomatomus</i>	40	24; 54
<i>Pomolobus</i>		17
<i>Pomoxis</i>		23
Pompano.....	46	33; 48; 50
Pompon.....		23
Pond Skipper.....		29
Porcupine Fish.....	48, 49	35
Porgy.....	40	23
Red Sea.....		23
<i>Porichthys porosissimus</i>		35
<i>Poronotus triacanthus</i>		54
<i>Portheus</i>	32, 63, 64	F12; centre
Pout, Horned.....		20
<i>Priacanthus arenatus</i>		24
Prionace.....	13	Group
Prionodes.....		V

	Page	Case
<i>Prionotus</i>	43	29
<i>Priscacara</i>		F10
Pristidae.....	15	5
Pristiophoridae.....	13	7
<i>Pristiophorus</i>		7
<i>Pristis</i>	13, 15	5; 7
<i>Pristiurus</i>		V; F5
<i>Prochilodus</i>		19
<i>Prolebias</i>		F10
<i>Promicrops</i>		ww
<i>Propterus</i>		F9
<i>Protopterus</i>	16, 18, 61	1; F7
<i>Protosphyraena</i>	62	F12
<i>Psammodus</i>		F5
<i>Psephorus</i>		18
<i>Psetta maxima</i>		38
<i>Pseudoberyx</i>		F10
<i>Pseudopleuronectes</i>	47	38
<i>Pseudoscarus</i>		28
Pteraspida.....	55	F1; F3
<i>Pteraspis</i>		F1
<i>Pterichthys</i>	63	F3; Foss. Aq.
<i>Pterois</i>		29; V
<i>Pterolepis</i>		F1
<i>Pterophryne</i>	25	Inner
<i>Pterophyllum</i>		28
<i>Pteroplatea maclura</i>		5
Ptyctodonts.....	60	F6
Puffer.....	48, 49	V
Pycnodonts.....	62	F8
<i>Rachycentron</i>		25; 50
Rains of Fishes.....	5	
<i>Raja</i>		5; 54; F5
<i>Rastrelliger</i>		31 (p)
Ratfish.....		3; F6
Rat-tail.....	44, 45	30
Ray.....	11, 14, 15, 60	5; 54; Inner; F5
Giant <i>see</i> Manta.		
Record Catches.....	27	Northwest
Red Horse, Common.....		19
Red Sea Porgy.....		23
Red Sea Soldierfish.....		24
Reef Fishes.....	24, 26	Inner
<i>Regalecus</i>	24	Inner
Remora.....	5, 41	25; V
Reproduction.....	19-21	
Respiration.....	16, 42	
<i>Rhadinacanthus</i>		F3
<i>Rhamphichthys</i>		19

	Page	Case
<i>Rhamphocottus</i>		29
<i>Rhina</i>	14	
<i>Rhincodon</i>	9, 12, 13, 14	North
<i>Rhinobatus</i>	13, 14, 15	5; F5
<i>Rhinochimaera</i>	15	3
<i>Rhinogobio</i>		19
<i>Rhinoptera</i>		5
Rhipidistia.....	62	
<i>Rhodeus amarus</i>		53
<i>Rhombeus</i>		F10
<i>Rhomboidichthys</i>		38
<i>Rhynchaetis</i>		35
<i>Rhynchodus</i>		F6
<i>Rhyncholepis</i>		F1
Ribbon Fish.....		25
<i>Roccus</i>	39, 40	ww; 24; 53; 54
Rockfish.....	39, 40	48
Rock Pilot, Particolored.....		V
Rod and Reel Catches.....		Northwest
Ronco.....	40	23
Roosterfish.....	46	33; 46
Rosefish.....	43	29
Runner.....		50
Russia.....	29	
<i>Ruvettus</i>	46	31 (p); 32
<i>Rypticus</i>		24
<i>Saccopharynx</i>		22; Inner
Sailfish.....	6, 27, 46	Group; 31 (p); 42; above 40; above 48; above 50
<i>Salmo</i>	19; 32	16; 40; 53
Salmon.....	19, 31, 32	16; 40; 53
<i>Salpa</i>		23
<i>Salvelinus</i>		16; 40; 53
Sandfish.....		24
Sand Launce.....		30
<i>Sarcocheilichthys sinensis sinensis</i>		19
<i>Sarda</i>	12, 46	31 (p); 32
Sargasso.....	13	
Sargasso Fish.....	25	Inner
<i>Sargus rondeletii</i>		23
<i>Saurocephalus</i>		F10
<i>Saurogobio dumerili</i>		19
Saury Pike.....		ff; ff (p)
Saw-finned Fish.....	62	F12
Sawfish.....	13, 15	5; above 7
Scabbard Fish.....	W 41	31 (p)
Scales.....	29, 33, 36, 62	
<i>Scapanorhynchus</i>	12	11
<i>Scaphyrhynchus</i>		18; 54; group

	Page	Case
<i>Scarus caeruleus</i>		28
<i>Scaumenacia</i>	61	F7
Sciaenidae.....	40, 41	25
<i>Sciaenops ocellatus</i>	27, 40, 41	ww
Scylliorhinidae <i>see</i> Scylliidae.		
<i>Scolopsis ghanam</i>		24
<i>Scomber</i>	45, 46	31 (p); 32
<i>Scomberesox saurus</i>		ff; ff (p)
<i>Scomberoides</i>		33
<i>Scomberomorus cavalla</i>		32
<i>S. maculatus</i>	46	32
<i>S. regalis</i>		42
Scombridae.....	19, 40	32
Scombriformes.....		52
<i>Scombroclupea</i>		F10
<i>Scombrocypris styani</i>		19
Scombroidei.....	45, 46	31 (p); 32; 33
<i>Scopelengys</i>		V
Scopelidae.....		21
Scorpaenoidei.....	43	29
Scorpion Fish, Pacific Deep-water.	43	29
Sculpin, Greenland.....	38, 43	29; 54
Scuppang.....		23
Scylliidae.....	11, 12, 13	11
Sea Cat. <i>See</i> <i>Chimaera collei</i> .		
Sea Devil, Deep-sea. <i>See</i> Ceratioids.		
<i>See also</i> Devil Fish.		
Sea Horse.....	21, 35, 36	21; 53
Sea Raven.....		29
Sea Robin.....	38, 43	29
"Sea Serpent".....	24	
Sea Snail, Deep-water.....	43	29
Sea Wolf.....	45	30
<i>Sebastes marinus</i>	43	29
<i>Sebastolobus</i>		29
<i>Selene vomer</i>	46	33
<i>Semionotus</i>		F8
<i>Semotilus</i>		19
Sergeant Fish.....		28
<i>Seriola</i>	46	33; 42; 46; 48
Serranidae.....	39, 40, 41	24
Serrano, Banded.....		V
<i>Serranus scriba</i>		24
Sevruga.....	29	ww
Shad.....		17
Gizzard.....		F10
Shagreen.....	9, 58	
Shark.....	9-14, 21, 58-59, 60-63	7; 11; groups; above 11; F3; F4; F5; F entrance; Foss. Aq.

	Page	Case
Shark, Basking.....	above 11	
Bearded <i>see</i> Carpet.		
Blue.....	13	Group
Bonnet.....	13	
Box.....		7
Carpet.....		11
Cow.....	11	11
Cat <i>see</i> Dogfish.		
Eel.....		11
Fat.....		11
Fin Fold.....	58	F4
Fossil.....	58-59, 60, 63	F3; F4; F5; F entrance; Foss. Aq.
Fox <i>see</i> Thresher.		
Fried.....	11	11
Greenland.....	11	7
Ground, New York.....		7; group
Ground, Southern.....		group
Hammerhead.....	13	7; group
Japanese Long-nosed.....	12	11
Japanese Mackerel.....	9, 12, 14	11
Japanese Sand.....		7
Man-eater.....	12, 58	entrance; group
New York Ground.....	13	7; group
Nurse.....	9, 12	11
Port Jackson.....	9, 11, 58	7; 53; 54; F5
Priest.....		7
Requiem.....	11, 12, 13	7
Sand.....	9, 11, 12, 13	11; group; F5
Silver.....	15, 16, 60	3; 53; F6
Six-gilled.....		5
Southern Ground.....		Group
Spot Fin <i>see</i> New York Ground		
Thresher.....		11; entrance
Tiger.....		Group
Whale.....	9, 12, 13, 14	North
Whip Tail <i>see</i> Thresher.		
White <i>see</i> Man-eater.		
Yellow.....		7
Shark Sucker.....	41	25
Sheepshead.....	40	23
Shiner, Golden.....		19
Shipholder <i>see</i> Remora.		
Shrimpfish.....	35	21
Siam, Fighting Fish of.....	42	27
<i>Sillago</i>		25
Siluridae.....	21, 31, 32-34	20
Silver Shark.....	15, 16, 60	3; 53; F6
Silverside.....	39	27

	Page	Case
<i>Siniperca</i>		24
Skate <i>see</i> Ray.		
Skipper, Lizard.....	45	
Mud.....		29
Pond.....		29
Skull.....	39	
Slangdang.....		23
Slippery Dick.....		28
Smelt, Japanese.....		16
Snake Fish.....		21
Snakehead, Spotted.....	42	27
Snapper.....	40	23; 50
Snipefish.....		21
Snook.....		24; 50
Snout Eel.....		19
Soapfish.....		24
Soldierfish, Red Sea.....		24
Sole.....	47	38
<i>Solea</i>	47	38
Soleidae.....	47	38
Solenhofen, Germany.....	62	F9
<i>Solenostomus</i>		21
Sounds.....	40, 41	
Spadefish.....		27
Sparada.....		27
Sparidae.....	40	23
<i>Sparisoma</i>		28
<i>Sparus</i> <i>see</i> <i>Pagellus</i> .		
Spawning.....	19, 32, 36	
Spearfish.....		31 (p)
<i>Sphyraena</i>	38, 39, 62	27; 42; 48
Sphyraenidae.....	38, 39	27
<i>Sphyrna</i>	13	7; group
<i>Spinachia</i> <i>see</i> <i>Gasterosteus</i> .		
Spongehead, West Coast.....		30
Spoonbill Cat Sturgeon.....		18; Group; F8
Sport <i>see</i> Gamefish.		
Spot.....	41	
Squalidae.....	11	5; 7
<i>Squaloraja</i>		F6
<i>Squalus acanthias</i>	11	5; 7
Squamipinnes.....		27
<i>Squatina</i>		5; F5
Squirrel Fish.....	40	24
Star Gazer.....	45	30
<i>Stenesthes chrysoptera</i>		23
Stensiö, Eric A.....	55	
Stephanobercyidae.....		24
<i>Stephanoberyx</i>		24

	Page	Case
<i>Stereolepis gigas</i>		42
<i>Sternoptyx</i>		Inner; V
Stickleback.....	21, 35	21; 53
<i>Stizostedion</i>		24
<i>Stomias</i>		V
Stomiidae.....	32	16
Streamline.....	23, 46	
<i>Strongylura</i>		ff (p)
Stuart, Robert L. (Collection)....	53	
Sturgeon.....	29, 62	18; 54; ww; above entrance to H. O. L.; group; above group; F8
<i>Stylophthalmus</i>		16; Inner
Sucker, Cat fish.....		20
Chinese.....		19
Shark.....		25
White.....		19
Sucking disc.....	44	
Sucking Fish.....		25
Sun Dial.....		38
Sunfish, Blue-Gill.....	40	23
Ocean.....	49	North centre; above 38
Surf-fish.....	41, 42	27
Surgeon Fish.....	49	V; 36
Surmullet.....		25
Swellfish.....		35
Swimming <i>see</i> Locomotion.		
Swordfish, Broadbill.....	27, 46	31 (p); above 52; above 53
Marlin.....		42; 46
<i>Synphobranchus</i>		22
Synentognathi.....	36, 37, 38	ff
Syngnathidae.....	21, 35, 36	21
<i>Syngnathus fuscus</i>		21
<i>Synodontis</i>		20
<i>Synodus</i>		21
Syria, fossils from.....	53, 64	F
<i>Taenianotus</i>		29
Tang.....		V
Tanganyika, Lake.....	42	
<i>Tarpon</i>	31, 64	16; 42; 48; ew
<i>Tautoga onitis</i>	43	28
<i>Tautoglabrus</i>	43	28
Teasdale, Sara (poem by).....		entrance (left)
Teeth.....	58, 59, 60	
pharyngeal.....	33, 40, 41, 43	
Teleosts.....	21, 29-49, 63-64	16-36; F10
Ten Pounder.....	64	50; F10
Terrell, J.....	53	

	Page	Case
<i>Tetraodon maculatus</i>		35
<i>T. setosus</i> see <i>Ovooides setosus</i> . . .		
<i>Tetrapturus</i>		31 (p); 42
Tetrodontidae	48, 49	35
<i>Tetronarce</i>		above 1
Teuthididae		36
<i>Teuthis hepatus</i>		V
<i>Thalassoma</i>		28; V
<i>Thelodus</i>		F3
Thoracostraci	35-36	21
Threadfin		27
South American		28
<i>Thrissopater</i>	31	
"Throat Whisker"		V
<i>Thynnus macropterus</i>		46
<i>T. thynnus</i>	27, 46	31 (p); 32; above 42; above 46
<i>Thymallus</i>		16
<i>Tilapia melanopleura</i>		28
Tilefish		23
<i>Titanichthys</i>	56	F wall; F2
Toadfish	48	35
Tomcod		30
Torpedo	15	above 1; above 5; 54. Inner; F1
<i>Toxotes</i>	6	24
<i>Trachinocephalus</i>		21
<i>Trachinotus goodei</i>	46	33; 50
<i>Trachinus draco</i>		30
<i>Tremataspis</i>		F1
Triacanthidae		36
<i>Trichiurus</i>		31 (p); 22
Triggerfish	46, 48, 49	36; V
Triglidae		29
Triple-tail Flasher	40	24
<i>Tristichopterus</i>		F7
Trout	31, 32	16; 29; 40; 53
Trumpet Fish	35	21
Trumpet Stickleback, California . . .		21
Trunkfish, Common	22, 23	35; 54
Tubefish	35	
Tuna	27, 45, 46	31 (p); 32; above 42; above 46
Tunny see Tuna		
Turbot	46	38
Turtle, Loggerhead		Shark group
<i>Tylosurus</i>		ff
<i>Umbra limi</i>		21
Unicorn Fish		36

	Page	Case
<i>Uranoscopus</i>		30
<i>Uronemus</i>	61	F7
Vanderbilt, William K.....	41	
Vaca.....		V
Vertebrae.....	31, 33, 58	
Viper Fish.....		16
Viviparity.....	21, 42	
<i>Vomer setapinnis</i>	46	33
Vulpeculidae <i>see</i> Alopiidae.		
Wahoo.....	46	31 (p); 42
Weakfish.....	40, 41	25
Weaver, Greater.....	45	30
Weberian Ossicles.....	33	
Whitefish.....		16
Wolf Fish.....	45	30
Wrasse.....	42, 43	28; V
Wreckfish.....		24
<i>Xanclus see Zanclus</i> .		
<i>Xenocypris davidi</i>		19
Xenomi.....		21
<i>Xesurus</i>	49	36
<i>Xiphias gladius</i>	27, 46	31 (p); above 52; above 53
Yellow Jack.....		50
Yellowtail.....		46
Yellowtail Snapper.....		23; 50
<i>Zacco asperus</i>		19
<i>Zanclus</i>		27; 54; V
<i>Zembrasoma</i>		F10
Zeidae.....		38
<i>Zenopsis</i>		38
<i>Zeus</i>	47	38; V
<i>Zoarcis</i>	45	30
Zygaenidae.....		7
Zygote.....	19	

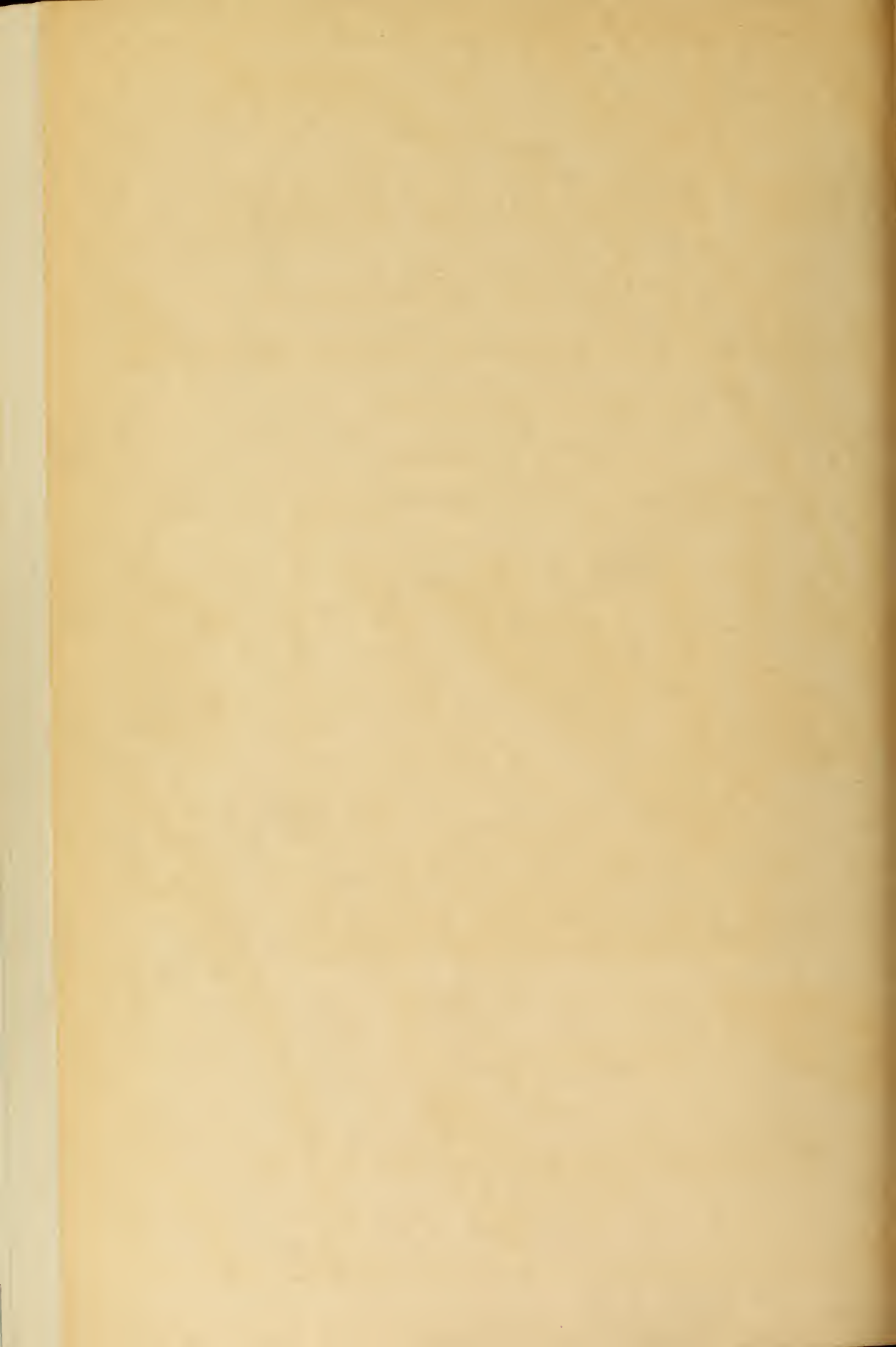

Building the Museum Group

BY ALBERT E. BUTLER

Associate Chief, Department of Preparation and Exhibition



GUIDE LEAFLET SERIES, No. 82

THE AMERICAN MUSEUM OF NATURAL HISTORY

NEW YORK, N. Y., 1934



Building the Museum Group

BY ALBERT E. BUTLER

Associate Chief, Department of Preparation and Exhibition



GUIDE LEAFLET SERIES, No. 82

THE AMERICAN MUSEUM OF NATURAL HISTORY

NEW YORK, N. Y., 1934

INDEX

	PAGE
INTRODUCTION.....	5
I. MAKING LEAVES OF WAX.....	5
a. Making a Plaster Mold of a Leaf.....	5
b. Preparing Wire for Ribs.....	6
c. Preparing the Cotton Base.....	7
d. Preparing the Wax.....	7
e. Casting the Leaf.....	7
f. Finishing and Trimming.....	7
g. Assembling.....	9
II. MAKING LEAVES OR PETALS OF CELLULOID.....	9
III. MAKING LEAVES OF PAPER OR WOOD.....	9
a. Commercial Methods.....	10
IV. CASTING FRUITS AND LIKE OBJECTS.....	10
V. MAKING FLOWERS.....	11
a. Flowers of Wax-saturated Muslin.....	11
b. Flowers of Wax-saturated Cotton.....	11
c. Flowers of Celluloid.....	11
d. Making the Calyx.....	13
e. Making the Stamens and Pistil.....	13
f. Choosing the Proper Medium.....	13
VI. COLORING LEAVES AND FLOWERS.....	13
VII. REPRODUCING TREES.....	13
VIII. PRESERVING GRASSES AND MOSSES.....	14
IX. REPRODUCING ROCKS.....	15
a. Casting a Rock.....	15
b. Modeling a Rock.....	15
c. Texturing a Modeled Rock.....	15
d. Coloring a Plaster Rock.....	15
e. Reproducing a Large Section of Rock Work.....	15
X. PREPARING DRY LEAVES FOR GROUNDWORK.....	17
XI. BUILDING THE BACKGROUND.....	17
a. Laying Out the Hall.....	17
b. Determining Size and Arrangement of Group.....	17
c. Laying Out the Curve.....	17
d. Coving the Ceiling.....	17
e. Methods of Construction.....	17
f. Applying the Canvas or Surfacing.....	17
g. Calking.....	17
h. Installing the "Breather Tube".....	17
XII. DETERMINING THE CASE OPENING.....	19
XIII. SCALE MODELS OR MINIATURE GROUPS.....	21
XIV. LIGHTING THE GROUP.....	21
XV. MAKING A REMOVABLE FRONT.....	22
XVI. MAKING THE GROUP BASE.....	22
XVII. EQUIPMENT FOR COLLECTING ACCESSORIES.....	24
XVIII. SELECTING AND COLLECTING THE GROUP MATERIAL.....	25
XIX. FORMULAS.....	27
XX. COMMON TROUBLES AND THEIR CAUSES.....	28
XXI. WHERE TO GET MATERIALS.....	29

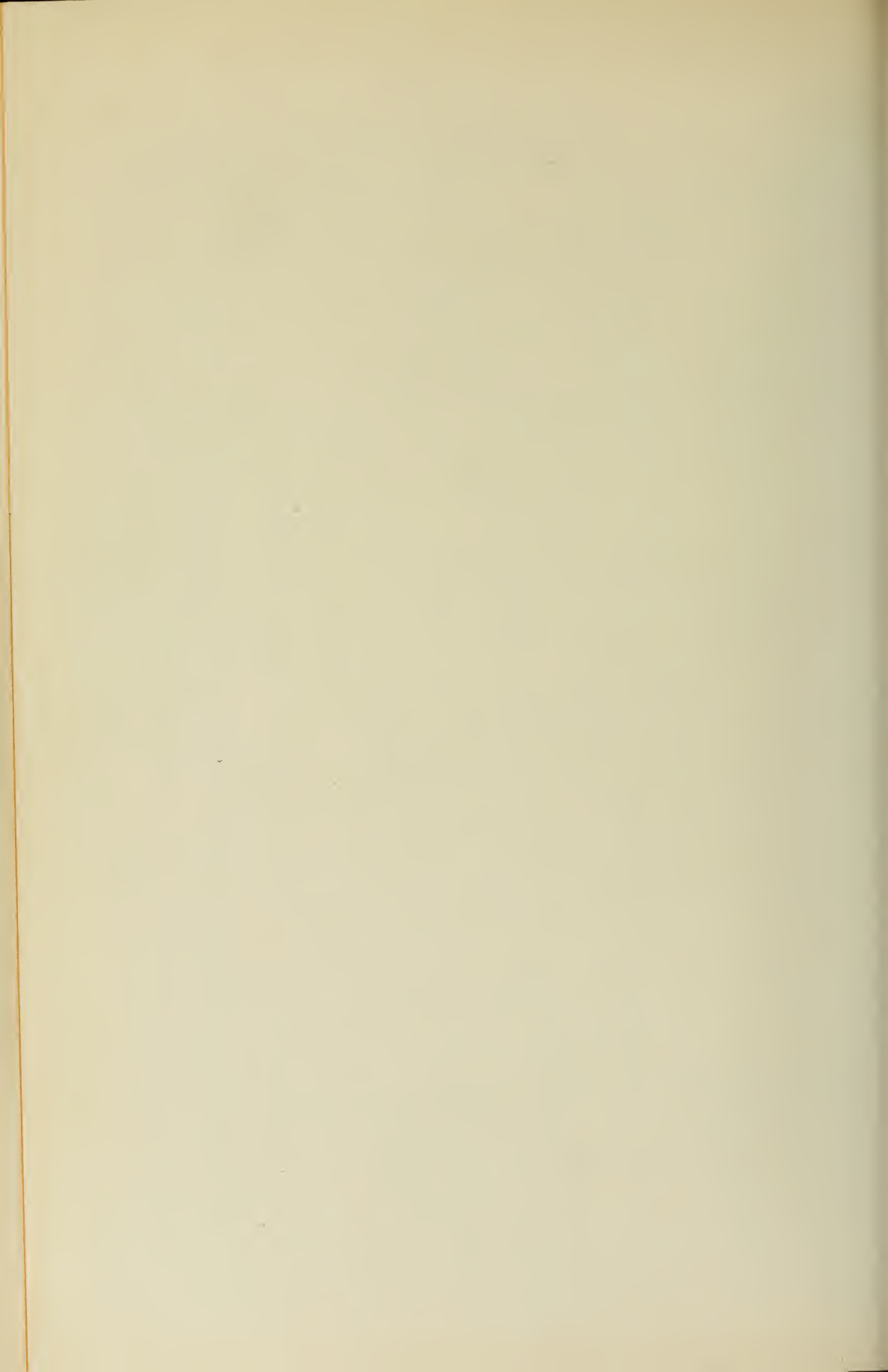

BUILDING THE MUSEUM GROUP

By Albert E. Butler

Associate Chief, Department of Preparation and Exhibition,
The American Museum of Natural History

The Habitat Group, which first made its appearance less than forty years ago, has, in the past twenty years, become a recognized factor in arousing the public interest in Museums. Even the smallest museum has adopted this method of displaying specimens, and the frequent calls from these, as well as from individuals, for information on the procedure of Group building has led the writer to prepare this pamphlet. The information presented herein, while brief, is sufficiently broad to give the uninitiated or the comparatively new worker a basis upon which to proceed. It is the author's desire to pass on the results of a long and varied experience in this field, giving such information as has been found to produce excellent results with economy and simplicity.

A successful Group requires the consideration and coöperation of the Curator, the Artist, the Taxidermist and the Accessory-man. This insures a plan which will not only be comprehensive and accurate, but will bring the utmost in interest to the museum visitor. This paper concerns chiefly the Accessory-man's work, which is the building and housing of the setting.

The successful worker in this field must possess ability to model, draw and color, and, in addition, have some knowledge of Botany and a mechanical sense. The plant life and other accessories should convey the same degree of accuracy and beauty as the subject of the Group, and this is possible only when the worker possesses all of the qualifications named.

I. Perhaps the simplest task in the accessory field is the reproducing of foliage. But even this, at times, may present difficulties.

a. In reproducing a simple leaf, such as an apple leaf, a plaster mold is first made. For this purpose a fresh leaf, or one preserved in its fresh form, is posed face up on a bed of soft water clay, which can be molded to support the contour and undulations without pressing on the surface of the leaf and thereby destroying its detail. When satisfactorily posed, after cleaning the leaf surface with a soft brush and water, a clay dam is built around the leaf, leaving a margin of about three-quarters of an inch. Plaster of Paris, mixed to a creamy consistency, is poured over the surface to a depth of about one inch. Spraying the surface lightly with water before pouring plaster will prevent bubbles; or brushing on the first coat of plaster will bring the same result. When the plaster is "set," lift it from the clay and remove the leaf; ream out two or three

"keys" on the margin of the mold and, after soaking thoroughly in water, brush the whole surface with heavy soap water, a soft mixture of stearine and kerosene or with lard oil to prevent sticking. Build a clay dam about this and again flow with an inch of plaster. When this is set, you will have a two-piece mold with surfaces in perfect contact. Where the under side of a leaf will show in the Group, the leaf should be left on the first mold and the second layer of plaster flowed over this. However, the leaf is removed preferably where at all possible, because a thinner wax impression will result from molds with surfaces in perfect contact.



Molds mounted in a clamp. Materials used and successive stages in leaf making.

It will be necessary to gouge out the plaster where the midrib occurs on the half representing the back of the leaf, and in some cases the more prominent lateral ribs should be accentuated by the same means.

Where many leaves are to be made, the molds should be mounted in hinged clamps in perfect alignment. This will eliminate unnecessary wear and imperfect impressions. A plaster mold should stand about fifty impressions. Where a great number of leaves are to be made, it will be found more satisfactory to use type-metal molds. (See Directions for Making Metal Molds.) *b*. Wire is used to support the leaf, and should be cut into lengths about an inch longer than the leaf from tip to end of

petiole, and of sufficient size to support the leaf without sagging. The wires should be tapered by tying into bunches and dipping into nitric acid and draining alternately until the desired taper is obtained. Wash off the acid and rub with fine sandpaper to remove the rusty deposit. Wind each wire with a film of cotton, and, if the mold is undulated, bend to the contour of the midrib before beginning to press.

c. Jeweler's, or Johnson's, absorbent cotton forms the base for the leaf, and should be torn into thin slabs, each piece just large enough to cover well the leaf surface.

d. Beeswax, never paraffin, is used to give the leaf body and detail, and should be liquified by heating in a double-boiler.

When the molds are soaked in water as hot as the hand can stand, the preparation for pressing is now complete.

e. A cotton-wound wire is placed in the groove which represents the midrib, a sheet of cotton placed over this and a sufficient amount of the hot wax poured over this to insure the leaf surface being wholly covered. The clamp must be closed as speedily as possible after pouring the wax, as this alone is the secret of making thin leaves. Very little pressure is required. If two or three clamps are manipulated in series, the first impression will have cooled properly for removing by the time the second or third is poured. Moisten the mold surface after each impression.

The hot wax may be given a body color by dissolving oil color in it. Care should be used not to overload with the paint, which may cause the wax to emulsify and make it unfit for use. Use Flake or Permalba white; never zinc. Wax, once melted, should be kept on a very low fire, with water barely simmering. This gives the proper temperature for pressing.

Experience and a careful study of results will soon show the proper amount of cotton and wax required for perfect results. A good general rule is, "Use a maximum of cotton and a minimum of wax."

f. The excess wax is trimmed from the margin of the leaf by using slightly warmed scissors. If the margin is smooth, then the trimming is accomplished by a sliding motion of the scissors. If serrate, the result is effected by a choppy motion. There is a knack in this operation which will be acquired only through considerable practice. Every Accessory-worker has, I believe, at some time attempted to simplify the serrating operation by inventing a special tool, but its very mechanical nature defeats the object, which is to gain a natural finish. The amount of finishing required on a tool-trimmed leaf more than offsets any possible saving of time in trimming.

The edges of the finished leaves should be thinned sufficiently to give a natural appearance, and this is best done by pinching the barest margin between the thumb and fore-finger. A sliding motion of the thumb on the

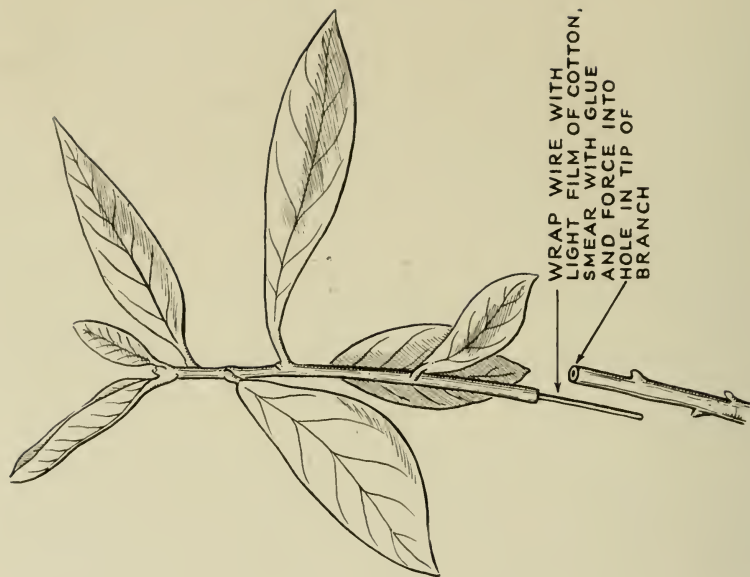
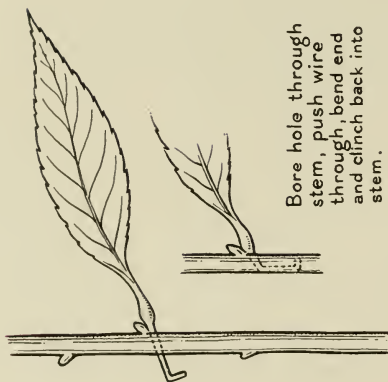

METHODS FOR SECURING LEAVES OR
BRANCH TIPS TO REAL BRANCH

back of the leaf and the natural warmth of the hand accomplishes the result.

g. In most cases, leaves are built into clusters after the character of the plant, and these "tips" secured to the real branch. If the plant be a small succulent one, then the whole assembly is built onto a wire stalk, which is modeled and bent, as the assembly progresses, to give the character of the plant.

Too much stress cannot be given the importance of lightness all the way through. Keep all materials to a minimum, so that the finished branch will rigidly support the weight placed upon it.

II. Materials other than wax may be used in leaf making, such as celluloid and paper. Celluloid possesses advantages in special instances, and there are two methods in common use. The first requires a plaster mold of the upper surface of the leaf and sheet celluloid of a thickness suitable to the subject to be reproduced. The celluloid is dipped into diluted acetone, or other solvent, then dipped into water and applied to the water-soaked mold surface with a backing of water clay to hold it in contact until "set." When removed, a tapered wire is dipped into celluloid or acetone solution, and applied to the back along the midrib.

The second method requires metal molds, set in clamps. (See Metal Molds.) A piece of sheet celluloid placed between the molds and clamped tightly under very hot water will take the impression. For making petals of flowers such as the Dogwood or Magnolia, this process has a distinct advantage in that it has the required rigidity without the use of wire. However, in leaf work, neither process is practical where many leaves are to be made because of the inflexibility of the material. To obtain a desirable variation of form and size, many molds would be required, and there is a stiffness in the finished work which cannot be entirely lost. Wax, on the other hand, requires few molds because each impression may be varied in form, and slightly in size, without losing the character of the leaf. Further, wax permits of alteration even after assembling.

III. The use of paper in making leaves is confined to occasions where an effect is best obtained by its use and the position of the plant in the Group permits it. As an example, a banana plant well back in the Group space where small imperfections would not be seen might be made by using a plaster mold of the surface of the leaf and applying wet paper, after the manner of making paper forms of dolls, globes, etc. Apply each successive layer with a paste made of flour and a little liquid Plaster of Paris added before applying. This gives a stiffness and "set" in a short time. A midrib of split bamboo or flattened wire should be placed in position between the layers during the process of building. When dry, this form

may be given a coat of varnish and color, producing a very satisfactory effect with little labor. Another paper method may be illustrated in the making of a pinnate palm leaf. Here the leaf form is drawn out on a sheet of cardboard of suitable thickness and quality. The cutout is best made with a razor blade, and when a tapered piece of split bamboo is applied along the midrib to near the tip and all secured with Du Pont's cement, the result is a leaf with a droop very like that of a palm. The detail may be suggested by scratching the upper surface with sandpaper. Similarly, bamboo lends itself to this method, using a tough paper in place of the cardboard. The finished cutouts are pasted to the real bamboo branches. In either case, the cutouts should be coated with liquid celluloid. Paper is also an excellent medium for reproducing long lanceolate leaves, such as occur on reeds or small cat-tails. For long cat-tail leaves and similar subjects, wood (straight grained pine or basswood) is very satisfactory. It should be cut into very thin strips and shaped to desired form. Sandpaper will produce the detail.

The methods used in making artificial flowers and foliage for commercial use are adaptable in many cases to the requirements of Group accessories, particularly where a large number of impressions are to be made. As has been stated, nothing is of greater importance than choice of just the proper material and method for the subject to be reproduced, and paper or cloth will often produce more satisfactory results than either wax or celluloid.

a. The equipment required for the commercial method may be obtained from any artificial Flower Tool Company, and is as follows: Cutting dies, veining dies, cutting block, stamping press and mallet. The last three are permanent equipment, and will last for many years. The dies vary in cost, but will always be found to more than offset this cost wherever the impressions to be made run well into the hundreds. All prepared cloths for this work are starched, and it will be found necessary to dip the material in hot wax to give it a thin protective coating, which will prevent warping. For very small leaves or petals no waxing is necessary. Paper should be sealed from atmospheric changes by coating on either side with liquid cellulose. If a waxy texture is desired, the paper may also be given a coat of wax. Experience in this field to date points to paper as the preferred medium, because of its lower cost and the variety of textures and quality available. Further, it will stand up better than cloth.

IV. Objects, such as fruits, should be cast while fresh since these will not preserve satisfactorily in solution. It is usually necessary to make "piece mold" of such things. An apple, for instance, would require a mold of two pieces, or perhaps three. A more irregular object might

require several pieces in order to insure the mold releasing without breaking because of undercuts. Agar is sometimes used for casting objects where a piece mold is required. Hot wax may be used in an agar mold, and for the novice the process is perhaps simpler. (See Agar Formula.)

V. Petals of flowers are most often made in wax, using the same process as in leaf-making, except that wire is seldom used in petals. In other words, only such flower petals as will reproduce in wax without wire support are made by that method.



Piece mold showing how an apple is cast.

a. A flower of the dandelion or wild aster type may be closely imitated by using mousseline dipped in wax of the color desired. This is cut into strips slightly wider than the length of the petals, and then cut fringe-like, with each segment the width and length of the petals. When this fringe is wound tightly about the tip of a wire, it resembles the composite structure of the flower.

b. Most small flowers are best reproduced by the use of wax-saturated cotton made in squeeze molds with flat contacting surfaces. This gives a tough, thin material, which will easily mold into shape in the palm of the hand with the aid of a tool. The petal forms should be cut to a carefully drawn pattern. A wooden tool, shaped for the particular job on hand, and kept moist, will be found most satisfactory for molding the wax petals.

c. The celluloid processes, already mentioned, cover all other petal reproduction. The fine, frost-like texture characteristic of some flowers is readily imitated by dipping the celluloid petals in hot wax.



Flowers made of sheet celluloid pressed in metal molds.

Flower made of cotton and wax in plaster molds; pistil of wax on tip of wire stem, with stamens of wax-tipped thread.



Steel dies may be used for stamping out flower parts, or leaves where the commercial method is used. The material may be waxed cloth, paper or celluloid.

d. The calyx may be cast in wax by the same process as that used in making leaves. Or, if many are to be made, the form may be stamped out of wax-saturated cotton or waxed mousseline with a steel die made to pattern. *e.* Stamens are commonly made by drawing thread through hot wax and, after cutting into proper lengths, dipping the tips into hot wax until a little ball, the size of the anther, appears. For more accurate work the stamens may be made in glass by drawing to proper thinness in a blow-flame and shaping the tip, while malleable, to form the anther. The pistil is usually modeled on the tip of a wire, which is to form the flower stem. The stamens and other parts are secured to this with wax applied with a heated metal tool.

f. Success in making artificial flowers comes rapidly with experience, for when one has learned how to handle wax, he quickly recognizes its possibilities and limitations and can readily judge which process is best suited to the subject at hand. Ability to judge the best medium for each problem is as important as ability to attain a technically satisfactory result.

VI. The finished coloring of both leaves and flowers is best done with an air brush. Where this is not available, the coloring may be applied with a brush by hand, or by spattering from a brush. The latter method may be developed to a remarkable degree of fineness. Coloring of the veins requires a fine line brush. It is often desirable to coat the wax with French varnish before coloring. This will prevent wax from absorbing the color.

The soft, downy hair sometimes found on leaves is represented by blowing fine cotton flock over the surface after applying a thin coat of varnish. Likewise, the hair on a leaf stem is very well imitated by either silk or cotton flock. These materials may be obtained in several degrees of fineness.

There are several ways in which a tree trunk may be represented in a Group. It is seldom practical to use the real tree. Wherever this is done, however, the wood should be thoroughly poisoned or otherwise treated to make sure the insect life in it has been destroyed.

VII. Wherever the bark can be readily removed, this is undoubtedly the most satisfactory for the purposes of reproduction. (See Photo Plate No. 5.) This should be poisoned by dipping in or painting with arsenic solution to prevent development of any insect life which may be in the bark. With the aid of good photographs of the original, the bark can be fitted to a wood frame with such accuracy as to make it undistinguishable from the original. Where it is impossible or impractical to take either the tree or its bark, then a complete set of photographs from all angles, together with a sample of the bark, will insure a faithfully reproduced

tree in the laboratory. For this method a wood frame, made slightly under the measurements of the tree, is covered with wire mesh, burlap and plaster. This is given a coat of shellac and the detail applied with slow-drying papier maché. (Formula—Dextrine Maché.)

VIII. Most grasses are easily preserved (See Formula for Glycerine and Formaline Solution) and in most cases, this is the best procedure. This, as well as other material preserved in this solution, loses its color and



Trees are reproduced by using original bark, wherever possible, as shown above, but more often must be entirely modeled in maché or plaster from photographs.

emerges darker. When all excess moisture is evaporated, the grass should be wiped carefully to remove dust, and a coat of oil color applied, preferably with an air brush. This first coat should be much lighter in tone than the final color, and contain some body white. When this is thoroughly dry, apply the finish coat with transparent, or nearly transparent, color. Oil paint is heavy, and should be used as sparingly as possible on delicate preserved grasses, or they will sag into unnatural position. In drying, it is good practice to hang the grass clumps upside

down. Sometimes it may be desirable to artificially produce grass. This is accomplished by cutting wax-dipped mousseline, or very thin celluloid, into grass-shaped strips and securing these to a wire. Fresh Spring grass will not preserve, and should be reproduced by the latter method.

Mosses preserve readily in the glycerine solution. This is done either by immersing the fresh moss for about twenty-four hours, or by spraying several times a day for a few days. Both mosses and grasses may be restored even after dried from age by first soaking in very warm water, and then immersing in solution for about a day. In fact, in most cases these things preserve better after having dried first. Mosses are colored after the manner of grasses, or by dusting on dry color.

IX. Rocks of any appreciable size are never used in Groups. Either they are reproduced by making plaster molds from the original, or by carefully modeling after photographs. A combining of the two processes may be found most practicable where there is a great amount to be made.

a. To make a plaster mold from a rock, the subject must first be well oiled, so that the plaster will readily release from it when set. *b.* If the work is to be done by modeling alone from photographs, then a form of wire mesh is molded after the contour of the rock, and this is covered with burlap dipped in plaster. The details of modeling and texture are added with plaster. *c.* A wet sponge, dipped in thin plaster, if skillfully handled, will give a rock texture of considerable variation. Other methods will suggest themselves to the resourceful worker. Ground cork mixed with the finishing plaster coat will be found useful in obtaining a coarse granite texture. Dry color is sometimes mixed with plaster to give a base color, but the author does not recommend its use. It is more satisfactory and much less expensive to paint the white plaster with Diamond Dyes, after it has set.

d. When the plaster is thoroughly dry, give it a light coat of shellac, and then paint with oil colors. Spattering the color from a brush is usually more effective than spraying, especially on granite or like rocks. The spattering adds to the effect of texture. Dry colors mixed with Dextrine Solution are ideal for coloring rockwork. Apply Dextrine size to plaster surface first.

e. A large section of rockwork may be reproduced to perfection by making piece molds of the original and setting these up in position and building into the mold a mixture of cement and dry color with fine ashes (1 cement to 4 ashes). When the plaster mold is chipped away, the result is a completely finished, colored rock. Cement has a natural texture similar to rock, as well as a gray base color, which is desirable.

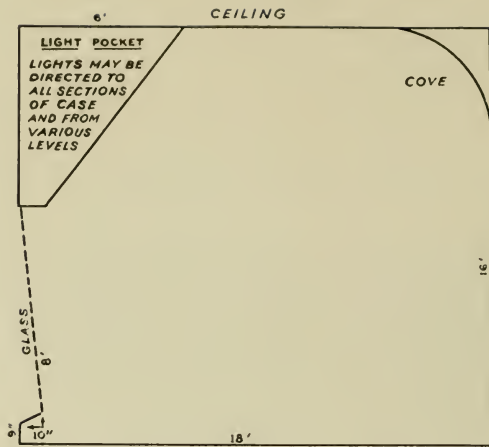

CROSS SECTION OF 18'X30' GROUP WITH 16' CEILING, LIGHT POCKET AND OPENING. ❖ ❖ ❖ ❖ ❖ ❖

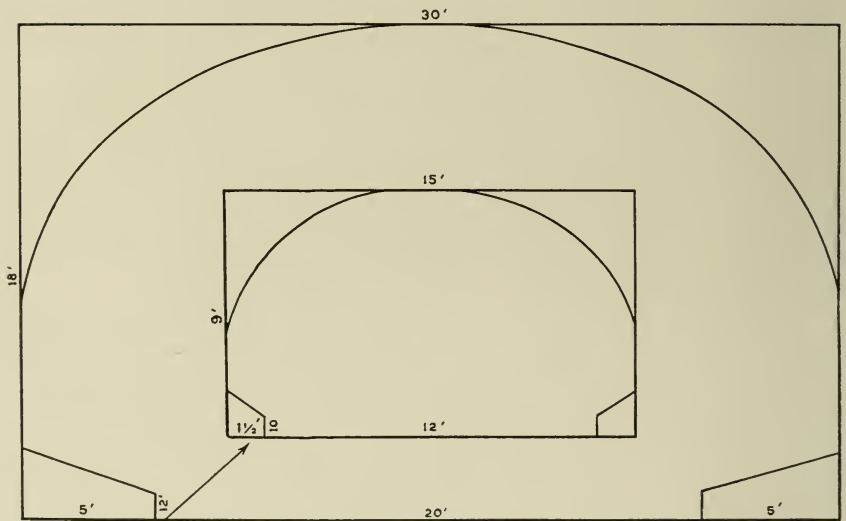

CORNER SPACES MAY BE USED FOR LABELS, SMALLER GROUPS, MINIATURE GROUPS, OR ADDITIONAL LIGHTS IF DESIRED. ❖ ❖ ❖ ❖ ❖

SHOWING WELL PROPORTIONED GROUP AREA, CURVE OF BACKGROUND AND OPENINGS IN GROUPS 18'X30' AND 9'X15'.

X. Dry leaves for the ground may be preserved by soaking in fairly hot water and then immersing in glycerine solution for a day. When thoroughly drained and excess moisture is evaporated, the leaves will be sufficiently flexible to stand handling without breaking.

XI. The curved panoramic background, which is now in universal use for museum Groups, may be adapted to almost any architectural condition with more or less success. *a.* However, for best results, any hall of Group exhibits should be laid out on paper to determine requirements in advance of the drawing of the architectural plans. It does not follow



Under structure for a background. Metal may be substituted for wood.

that an already existing Hall may not be suited to Group exhibits. Indeed, it may be admirably so. Much depends upon the size of the Groups desired. *b.* For instance, in a Hall of North American Mammals, where there must be shown buffalo, moose, elk and other large animals, the Group area should be from approximately 18×30 feet for the largest animals to perhaps 10×15 for the Virginia deer. Smaller animals would require a proportionately smaller area, always keeping the horizontal depth at about 60% of the width. Not less than a 16 foot ceiling can give a wholly satisfactory effect to a Group of 18×30 feet. Therefore,

even the smaller Groups in the same Hall will have an equal height, which is rather an advantage than otherwise.

c. The curve of the background should be continuous, but not a perfect arc. A sharp break in the shoulders of the curve should be avoided. In others words, do not make the form a horse-shoe. d. It will be found advantageous, though not absolutely necessary, to cover the background, not too sharply, slightly below the ceiling line, especially in open Groups where much of the sky shows. This will carry the eye beyond the frame as the Group is approached, and give a feeling of greater area.

e. Methods of constructing backgrounds for Groups are so variable that it seems advisable to give details only of those which are obviously practical from the point of view of durability and low cost.

Preferably the Group case should be fireproof. Therefore, wherever possible, the framework should be made of light metal, covered with

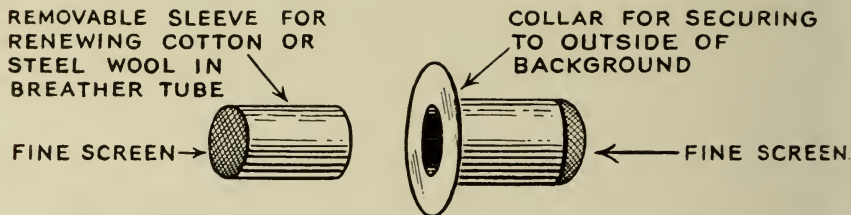

"BREATHER" TUBE

metal lath or galvanized wire mesh. Apply to this a hair and mortar mixture, just as for ordinary wall finish. When thoroughly dry, coat the back with asphaltum and the front with shellac. f. Apply the canvas to this surface with a mixture of spar varnish and white lead of thick creamy consistency. However, if wood is used for the framework, the back should be covered with sheet asbestos. The canvas covering may be omitted, in which case the mortar is given the usual plaster smooth coat. This, when dry, is coated with shellac, and this followed with two coats of white lead, the first brushed on, and the second stippled. This will give a canvas-like texture. In any case, the background form should be free floating; that is, not secured to either ceiling or floor. With such construction, no cracking should ever develop. g. The floor and ceiling lines should be well calked to insure against dust entering the Group.

h. A "breather-tube" installed near the base of the background will further insure against dust. Such a tube is made in two sections, so

that the cotton or steel wool filler, which is used in it to catch the dust, may be replaced from time to time. The tube forms a "point of least resistance," which takes care of contraction and expansion within the Group due to temperature changes, and thus prevents cracks which might otherwise develop.

XII. The opening in the case front varies with the size of the case, the size of the animals to be shown and the character of the exhibit. For entirely satisfactory results it is necessary to lay out on paper the whole hall plan. This insures symmetry of the architecture in the inner hall, and a favorable relation of the Groups, one to another. The 18×30 foot Moose Group mentioned should have an opening approximately 8 feet



Scale model of a hall. This layout assists materially in deciding best possible arrangement of groups.

high × 20 feet long (here the great width influences the size of the opening because of the difficulty and hazard of handling large glasses), the top of the glass being about 9 feet and 3 inches from the floor. These dimensions may be shaded some to meet the requirements of the hall as a unit.

In the case of a Group of foxes, where the floor area might be approximately 6×10 feet, a better picture effect will result if the groundwork is raised to about 2 or 2½ feet from the floor. In this instance, the glass area would be 7 feet × 6 feet 9 inches, if the top line were to be maintained to that of the Moose Group. These proportions obviously would be better if the top line could be dropped to 8 feet, giving a glass 7 feet × 5 feet 9 inches. If the entire hall plan is laid out before proceeding with any one Group, the problems are known, and it will be possible



The above photographs show the miniature model and the finished group. While the original character of the model has been maintained certain changes were necessary to achieve the desired effect.

to keep a balance architecturally and at the same time display each Group to best advantage. To avoid reflections, it is desirable to install the glass on a slant, as shown in Cut No. 1.

XIII. Miniature group models are helpful in planning a Group if carefully worked out in scale. However, the usual procedure of modeling carefully the required animals to scale, and then sticking in anything to represent the trees, etc., without regard to scale, is misleading and a waste of time. A good Accessory-man will be able to portray character in a scale model of a tree or other accessory so that it will bear a proper relation to the animals. Leaves for trees in scale work are easily made by cutting the forms, many at a time, from a sheet of folded paper and the veining indicated by scoring with a tool over a blotter. These are readily attached to the miniature tree branches by the use of Du Pont's cement. Branches of small shrubs may often be used to represent branches of scale trees. Smaller plants are readily mimicked by paper cut-outs secured to broom straws or any slender frond which answers to the scale and character required. Scale grass of various heights, in most cases, is best imitated by excelsior. It is obtainable in several degrees of fineness, and is easily manipulated to give grass character.

Galvanized sheet metal is ideal for backgrounds of miniature Groups, as it will readily bend to the required curve. The surface to be painted on should be washed with vinegar, and then coated with two or three coats of white lead, all coats stippled on, except the first.

A scale model, in which every part has been worked out in proper relation, will give all concerned some conception of the effect and character of the finished Group. However, one should keep in mind that in making the scale model he has himself remained full scale, and should therefore be prepared to make any deviation from the model that may seem advisable or necessary in the course of assembling the finished Group. In other words, be guided by the working out of the Group, rather than by the model.

XIV. The lighting of a Group is done mainly from the space directly above the window where an enclosure is built, for the purpose of excluding the heat of the lamps from the Group proper. A ventilator tube should be installed at either end for carrying off the heat. The enclosure will be as wide at the base as the opening of the Group will permit, and slant outward into the case as far as possible and yet not be seen from within two or three feet of the Group. Provision for reaching the lights for replacing must be made. Such a light pocket makes possible the lighting of the entire foreground, either directly or indirectly, as required. However, it is desirable at times to place lights in other parts of the case, but, if avoidable, none ever should be so placed as to make it necessary to

enter the case for replacement. For the average Group, a pleasing effect is obtainable from the latitude of the front light pocket, as outlined. Sunlit spots are very effectively simulated, either by the use of spot lights or reflected light from a mirror.

XV. A case front can be, and should be, constructed so that it is removable, for it will be found that the inner surface of the glass needs cleaning at last once a year. To go into the Group space for this cleaning will, in time, seriously damage the groundwork of the Group and whatever accessories are near the front. If the front is mounted on casters, and so designed that it can be readily detached, a wheeled truss, constructed so that it can be attached to the front, will make a complete unit which can be moved easily and with safety.

XVI. The base on which the groundwork of the Group is to be constructed is made according to the character of the setting, the size of the Group and the construction of the case front. Wherever possible, the Group front should be left entirely open, a dummy front being used during installation whenever necessary. This permits the building of the base in one piece. If the case front is installed, it becomes necessary to build the base in three sections, the centre section wedge-shaped, since it will be found desirable to remove the base frequently during assembly. Swivel roller-bearing casters should be installed on all base sections, to permit easy handling. The framework lumber should be proportionate to the load it is to carry. Frequent uprights are nailed to this, following the determined contour of the Group base. Iron wire mesh is nailed over the uprights, and this surface covered with burlap dipped in plaster. This should be made sufficiently strong to support one's weight. Reinforcing the underside will accomplish this. Or, where greater strength is required, sisal fibre may be substituted for the burlap. Where large rocks occur, these should be built as a part of the groundwork structure. Large trees and necessary anchorage for animals must be placed before laying the wire mesh. Usually, it is best to permanently place the animals before the accessories are installed. It is also best, in assembling, to place the material nearest to the background first, in order to enable the artist to connect his painting with the foreground without walking over any finished part. Naturally, if the case front has been left open, there will be no difficulty in joining, since the groundwork may be removed whenever necessary.

The surface of earth, twigs, dry leaves, etc., is the last operation in finishing any part of a Group. A mixture of cement and sifted ashes, about one to four, with dry color added if desired, is applied to the plaster surface, and the earth, etc. worked into this sufficiently to hold it in place and obtain a natural effect. Dry, preserved leaves may be scat-



The base for groundwork should be made strong and follow closely the finished contour. In this case the form was slatted to give the flowing form of drifted snow.

tered over this loosely; or, if necessary to secure them, dip into a diluted solution of glycerine and gelatine before applying. The solution should be of such consistency as to leave no gloss on the leaves when dry, yet retain sufficient adhesive quality to hold the leaves in place.

The "tying-up" of the foreground to the background and the successful portrayal of the character of a setting are so greatly influenced by the placing of the horizon line in the painting, that it should be considered along with the business of building the foreground. It should be kept in mind that we are building dimensional "pictures." Size, character, dimensions and placement of Groups are all factors in determining the placing of the horizon. Let the requirements and specifications of the individual Group determine the most effective point for the horizon, and never be influenced by "actual eye level," a thing which cannot exist in a Group picture because of the great variation in height of the Museum visitors for whom the exhibits are produced.

In building a Group base where water is to be shown, the procedure is as follows: The under-water portion is worked out up to the water level, where a sheet of glass is installed. The shore-line above water is built separately from the main Group base, so that it may be removed as often as necessary in working out the under-water effect, including the installing of whatever forms are to appear as projecting from the pool. The glass usually requires some additional treatment. Painting or flowing the surface with celluloid (colored as desired) gives a watery texture. Or, the effect may be obtained as described in "Gelatin-Glycerine Formula." A slight clouding of the under-surface of the glass will produce a deceptive effect of depth, or of cloudy water.

Snow is best represented by spraying hot paraffin onto a white plaster base, which has been carefully modelled to the desired finished contour. Any coarse atomizing apparatus may be used for this. The plaster must be dry, and the first spray applied with the paraffin well heated and the spray nozzle fairly close to the surface. As the spray is thrown further, it will deposit in fine, snow-like particles. For coarser textures, use the paraffin less hot. Varying results may be obtained by regulating the heat of the liquid and the flow of air. The soft puffs of snow sometimes seen on branches may be reproduced by securing a fluffy bunch of cotton to the branch and spraying with paraffin. In small Groups, the paraffin may be spattered from a small hand scrub-brush to give the same effect as atomizing.

XVII. The equipment for collecting Group material should be carefully planned, and to do this it is essential to have as definite an idea of the Group plan as possible and a knowledge of the locality in which the collecting is to be done.

Excessive equipment is as annoying in the field as a lack of it. Simple tools, such as saw, hammer, screw-driver, pliers, hand-ax, solder-iron and knife, should always be included. Ordinary materials which are commonly needed on any expedition are: plaster of Paris, plasticene, formaline, solder, solder-paste, burlap, cheese-cloth, twine (medium and heavy, with large spaying needle), water colors and brushes, stencil outfit and adhesive tape. The tanks for preserving leaf and other material

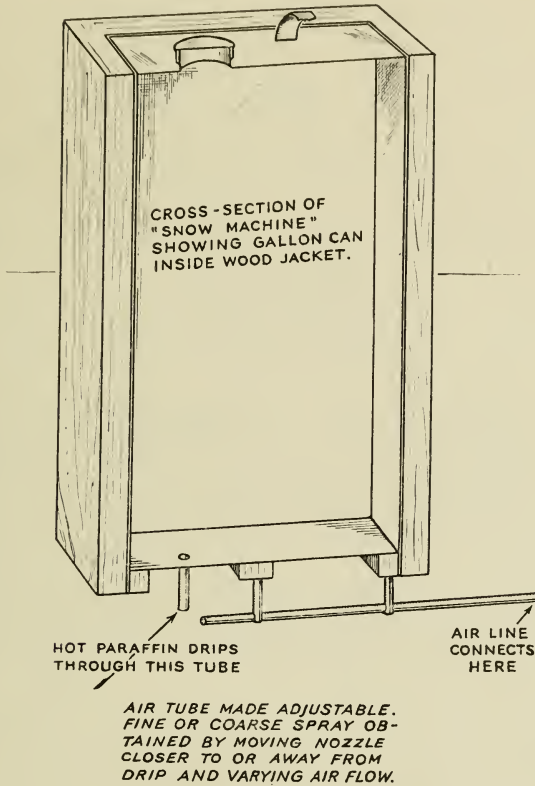

should be cylindrical. Material is more apt to jam in square tanks. Where more than one tank is required, the sizes may be graded so as to pack one inside the other. Much of the other equipment can be packed inside the innermost tank and in the corners of the box in which the tanks are packed. Thus, virtually the entire equipment may be taken into the field in one unit.

XVIII. The first work of an expedition is that of selecting the locality which is to form the basis for the Group. The plant life and other

accessories selected will be only such as are common to that particular locality. Those forms most typical and, at the same time, most practical for reproducing are chosen. Fresh leaves and flowers, together with small branches, or plants entire, are put into a solution of 3% formaline. Leaves carefully chosen for variety of character and size are stacked, card-like, and wrapped in cheese-cloth and dropped into the solution. All tender parts or plants should be wrapped in the cloth before placing

METHODS COMMONLY USED IN JOINING BRANCHES



STRIPS OF METAL COUNTERSUNK IN BRANCHES AND SCREWED IN PLACE OR BOLTED THROUGH THE BRANCH. (FOR LARGE BRANCHES)

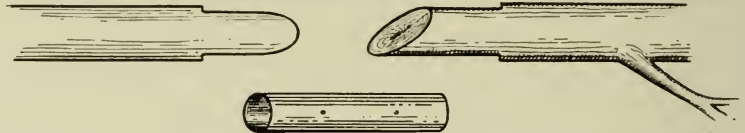

BRANCHES REAMED DOWN AND JOINED BY BRASS TUBE. NAILS OR SCREWS HOLD TUBING IN PLACE AND PREVENT BRANCHES FROM TWISTING.



ALL BRANCHES ARE CUT BIAS. HELPS TO PREVENT TWISTING AND IS GUIDE TO PROPER JOINING OF BRANCH.



THIS METHOD FOR LARGE BRANCHES

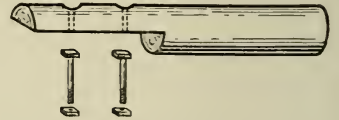

in the tank. Short, brittle grasses require the same treatment. All this material, after remaining immersed for a few days, may safely be drained, leaving only a quart or two of solution in the tank. If the tank is well soldered, this will remain in good condition indefinitely, and the lightened tanks will transport more easily. As an additional precaution, plaster molds of leaves and petals are made in case anything should go wrong with the tank material. Water color notes should be made of all plants while fresh. Careful pattern drawings of flower petals and parts should be made.

Tree or shrub branches should be taken, as far as is practical, and cut suitably for packing, keeping always in mind that these are again to be joined in the laboratory. Long grass will ship in very good condition if strapped to a board or slab of bark for stiffener and wrapped snugly in burlap.

The necessary operations in taking records of rocks and trees have been covered in another section. Dry leaves and twigs should be taken from an area corresponding in size with the Group area. These will ship safely if wrapped in burlap and packed in a box. If the ground is more or less bare, a good amount of the surface silt should be taken—a sufficient amount to cover the floor of the Group. Always a goodly sample of the earth is taken; this will be ample for the worker to properly match at home for use in the Group. Too many notes and photographs cannot be taken.

Finally, all material should be inspected immediately upon arrival at destination. All dry material should be preserved or poisoned, and the material in tanks should be examined to make sure it is in good condition.

AGAR AGAR

XIX. To 6 oz. Agar add 1 qt. water. When thoroughly soaked, boil in double boiler and add 3 lbs. glycerine. Continue cooking until water is well evaporated. Add a few drops carbolic acid. Allow to stand until evaporation is complete. The resulting rubbery mass should be cut into small cubes and is ready for use. Heat, as before, until liquified and, after cooling somewhat, pour over the object to be cast. Harden the inner mold surface by coating with alum water before pouring hot wax into it. It may be used for casting objects in either wax or plaster.

GELATIN-GLYCERINE SOLUTION FOR WATER AND OTHER USES

To 1 lb. of gelatine add 1 qt. of water. When all water has been taken up, boil in double boiler until about 1 qt. of bulk remains. Add 13 fluid oz. of glycerine and 10 drops of carbolic acid. This solution should be made in advance of requirements, so that all water will have evaporated. It may then be blown over a glass base to give a water effect, or be blown into a mold which has been made from a surface representing disturbed water. This slab, when set, may be laid on a glass surface. In either case, the gelatine surface should be varnished when thoroughly set.

This solution may also be diluted for immersing leaves to be fastened to a Group base.

GLYCERINE SOLUTION FOR PRESERVING LEAVES, BRANCHES,
GRASSES, ETC.

33 parts glycerine
2 parts formaline
65 parts water

DEXTRINE MACHÉ FOR MODELING OR POINTING UP TREE BARK

4 measures Dextrine }
4 measures cold water }boil

Add

5 measures dry paper pulp
1 measure manikin sawdust
7 measures whiting }
7 measures plaster } mixed thoroughly together
first

The "set" may be varied by using more or less plaster.

In mixing plaster, fill the pan with water to about half the bulk of plaster required. Sift the plaster into this until it stands dry above the water level. Let stand until the whole is wet, then mix thoroughly with the hand until smooth and creamy. If too thin, the plaster will be weak; if too thick, it will not flow easily.

Never remove plaster from the object being cast until the mixture has become quite warm. At this point it has sufficient "set" to be removed without breaking.

Always wet a plaster surface where a fresh plaster coat is to be applied.

METAL MOLDS

Any metal casting process may be used for making metal molds, but it will suffice to give here one of the simpler methods.

First, make a plaster mold as already described. When this is thoroughly dry, build a dam close about the margin with molding sand, and pour heated type-metal over the mold surface. When cold, smoke the surface with a sooty deposit and enclose in a dam, as before. Pour metal onto this, and the result is two metal molds in perfect contact.

XX. COMMON TROUBLES AND THEIR CAUSES

Leaves stick to the mold—

Wax too hot

Molds not thoroughly soaked

Leaves do not fill out—

Too little wax

Wet cotton

- Leaves too thick—
 Too slow in closing clamp after pouring wax
 Wax too cold
 Mold too cold
 Wire rib out of midrib groove
 Midrib groove not deep enough for wire
- Leaves tear easily—
 Too little cotton
- Leaves slip from midrib wire—
 Cotton on wire is wet
 Too little cotton on wire
- Molds wear too fast—
 Not in alignment
 Soaking in too hot water
 Wax too hot.

XXI

- | | |
|--|---|
| Agar Agar | Any wholesale druggist |
| Air Brush | Spray Products Co., 756 Tenth Ave., New York City. |
| Burlap | Hoffman-Lion Mills, 542 West Broadway, New York City. |
| Calking Compound | Any building materials store. |
| Celluloid (Liquid) | Celluloid Corp., 290 Ferry St., Newark, N. J. |
| Celluloid (Sheet) | Celluloid Corp., 290 Ferry St., Newark, N. J. |
| Clay (Water) | Ettl Studios, 227 West 13th St., New York City. |
| Color (Dry) | Behlen Bros., 10 Christopher St., New York City. |
| Color (Oil) | Windsor Newton, at any artists' supply store. |
| Compressor and Tank Unit
for Air Brush Work | General Air Brush Co., 129 Lexington Ave., New York City. |
| Cotton (Jewelers) | Dennison Mfg. Co., 220 Fifth Ave., New York City. |
| Cotton Flock | Mark Jacobs, 20 East 17th St., New York City. |
| Dextrine | Behlen Bros., 10 Christopher St. or Ehrmann-Strauss Co., 200 W. Houston St., New York City. |
| Duco Cement | Patterson Bros., 27 Park Row, New York City. |
| Formaline | Any drug store. |
| Glycerine | Wholesale drug store, for large quantity |
| Green Soap | Ehrmann-Strauss Co., 200 W. Houston St., New York City. |
| Paraffin | Asiatic Petroleum Co., 80 Broad St., New York City. |
| Plaster of Paris | Any building materials store. |
| Plasticene | Schneider & Co., 128 W. 68th St., New York City.
or any artists' supply store. |
| Sand, Moulders | Any Bronze Foundry |
| Scissors | Kny-Scheerer Co., 21-27 Borden Ave., Long Island City, N. Y. |
| Silk Flock | Mark Jacobs, 20 E. 17th St., New York City. |
| Stearine | Ehrmann-Strauss Co., 200 W. Houston St., New York City. |

Steel Dies	New York Die Co., 245 Centre St., New York City
Steel Wax Tools	Ettl Studios, 227 W. 13th St., New York City.
Wax	Theo. Leonhard, Paterson, N. J.
Whiting	Behlen Bros., 10 Christopher St., New York City.
Wire (Galvanized)	Any hardware store.
Wire (Iron Mesh)	Estey Wire Works, 34 Cliff St., New York City.





THE KINGDOM OF THE TIDES

*Invertebrate
zoology*

By
ROY WALDO
MINER

LEAFLET SERIES

No. 83

AMERICAN MUSEUM

OF NATURAL HISTORY

NEW YORK, 1934

*Reprinted from Natural History Magazine
for July-August, 1934*



A STUDY IN LOCOMOTION AMONG MARINE ANIMALS

Detail of Wharf-Pile Group in the Darwin Hall of the American Museum

The stationary animals of the wharf piles are contrasted, on the one hand, with the jellyfish (*Dactylometra quinquecirra*), which swims aimlessly without power of direction, and on the other, with the squid (*Loligo pealii*) and cummer (*Tautoglabrus adspersus*), both of which possess highly coordinated and efficiently controlled swimming organs.

The Kingdom of the Tides

By

Roy Waldo Miner

Curator, Living Invertebrates
American Museum

Some of the Creatures One May Find
along the Shore Line of New England

WHEN we look at maps and charts, we see the boundary between land and sea marked by a definite line, but if we search for its exact location as we stroll along the beach, we cannot find it. The incoming waves rush up over the sands until they flatten out, lose their momentum, hesitate, and stream back into the flood whence they came. As the tide rises, the sea gradually advances farther inshore, but finally a limit is reached at high water. At certain seasons, and at times of storm, a greater area of land is covered, but the recession always takes place and the territory won by the ocean is abandoned, until, at the very lowest ebb, a strip of sea-bottom, in turn, is conquered by the land.

The strand slides under water at the same general slope, and, though diversified by sand bars and shoals, the sea-bottom sinks at a uniform rate, until, at a greater or less distance offshore, at a depth of about six hundred feet, it dives at a more rapid gradient into the depths of the sea. Here, at the edge of this steep slope, is the first indication of a line of separation. It is said that, ages ago, the real boundary of the land was to be found here, and the continents were much larger. Now the seas have flooded over the edges of this ancient land, forming a comparatively shallow border or rim, varying in width from thirty to one hundred miles, which we call the continental shelf.

This shallow area, well lighted by the sun, and warmer than the oceanic deeps, is the real theater of the life of the sea-bottom. In the sunlight the sea-plants, or algæ, abound, and feeding among them are myriads of small oceanic creatures,

which, in turn, form the food of the larger inhabitants of the sea.

Here are gathered living hordes of fishes, mollusks, crustaceans, sea-worms, echinoderms, and the lower forms of life. From this shallow zone, in the course of time, many species have invaded the deeper waters and have become adapted for the dark abysses beyond the edge of the continental shelf. Myriads of others have crowded into the warm, sun-lit shallows near the shore and have even sought the intertidal stretch which is laid bare twice daily by the ebbing tide.

As we walk along the shore at low tide or wade in the shallows, we invade the edge of this teeming world of sea-creatures and see many signs of their activities. Along our coast from New York to the Bay of Fundy, the aspect of the ocean margin presents many contrasts. Long Island and Connecticut are characterized by stretches of exposed sand beaches, sheltered mud flats and sand spits. Here and there may be found out-croppings of rocks or tide-rips where glacial boulders have been laid bare, but the chief character of the coast is low and free from rock. This condition becomes intensified as we reach and round the curving arm of Cape Cod, which is nothing but a huge sand spit. North of Massachusetts Bay and Boston, bold headlands of rocky cliff jut out into the sea, as at Nahant, Marblehead, Gloucester, and Cape Ann generally. Along the coast of Maine, high, rocky cliffs become the rule, lining and limiting deep bays, sown with jagged islands, and hemming in the estuaries of great rivers.

The height to which the tide may flow

Sea Shore Warfare

The five pictures at the right show, first, a colony of oysters on a mud flat. The second picture shows a mass of invading mussels which, in the third photograph, are pictured after they have overwhelmed the oysters. The fourth view depicts the mussel colony being invaded, in turn, by barnacles which, in the fifth view, are shown completely victorious





A barnacle extending its feathery feet from its limestone wigwam

Creatures of the Sandy Beach



At the left on the opposite page are two pictures of *Natica*, the sand collar snail, which hides in mound-shaped burrows or crawls over the sand, pushing its fleshy apron before it. Next comes a lady crab up to her eyes in sand; a "sand bug" preparing to "dig in"; a rock crab, and finally another lady crab showing its paddle-shaped hind legs

shows great variation. Along the exposed sandy shores of southern New England it ranges from two to five feet in height, except where the incoming seas are forced into narrowing bodies of water like Long Island Sound, where it rises six to seven feet, as at New Haven and Bridgeport.

HIGH TIDES AND LOW

On the outer side of Cape Cod, the rise is but two feet, but the masses of water that crowd into Cape Cod Bay reach nine feet at Plymouth. North of Boston this height continues, becoming gradually increased along the Maine coast. The Gulf of Maine is a huge, curving and tapering funnel, guarded by Cape Cod to the southward and the peninsula of Nova Scotia to the northeast.

The tides entering this huge gulf are shunted along the hollow curve of the Maine shore line and Bay of Fundy, rising at high water eighteen feet at Bar Harbor, twenty-eight feet at St. Andrews, New Brunswick, and the enormous height of forty-five feet during spring tides at Amherst and Truro, where, at the double apex of the funnel-shaped Bay, the Nova Scotian isthmus ties the peninsula of that name to the mainland of North America.

Naturally the combination of high, swift-running tides and rocky coasts has a far-reaching effect on the animal and plant life inhabiting the impetuous waters of northern New England, compared with the low-lying, quiet, sandy and muddy coasts of the more southerly portions.

The temperature of the waters in the two regions also is of great influence. Southern New England is washed by spurs from the warm waters of the Gulf Stream, especially in the Cape Cod region which, with the outlying Elizabeth Islands, as well as Marthas Vineyard and Nantucket, juts boldly out into the sea. But farther north, the cold Arctic Current pushes its way in close to the shore, and creatures which, in southerly waters, are

found only in the deeper, colder seas, here occur near the surface and are able to live in shallow waters near the rocky shore.

If we could stroll along the entire New England coast in a few hours, we should find ourselves passing over regions continually changing in character, and the species of animals populating the shallow waters around the low-tide limit also would be seen to vary in harmony with the changing environment. The forces of inanimate nature sift out all individuals that invade regions to which their bodily structures and habits are not adapted.

As it is out of the question to cover so much territory in one journey, let us transport ourselves in imagination from place to place and sample a number of contrasting typical localities to become acquainted with the shallow-water animals characteristic of them.

AN EXPOSED SANDY BEACH

The white sand stretches out before us for miles, heaped high into dunes at our left or extending over into broad flats covered with beach grass and low shrubbery. At our right, the surf breaks thundering on the shore, washing to our very feet and bringing quantities of loose sand along with it. Here and there, with a rattle and a roar, the waves bombard the coast with masses of rounded pebbles, spreading them over the strand in assorted sizes ranging from gravel to bowlders.

We pick up dead and empty shells on the beach, many of them broken and beach-worn. Ruffled fronds of kelp are washed up and other flotsam from the sea, but, for the most part, life is conspicuous by its absence, and the sandy shore seems barren indeed. This is not to be wondered at. The shifting sand gives little opportunity for harboring animal life which otherwise might burrow within it, and the force of the waves transforms into grindstones the pebbles and rocks which, in quieter waters, would give

shelter to all sorts of sea-creatures. The siliceous sand grains are barren of food material and could support no life even if any could find foothold among them.

Nevertheless, at the upper tide limit, long lines of beach wrack mark the boundary of the ocean's surge, and as we stir up the decaying and drying fragments of seaweed, swarms of beach-fleas (*Orchestia agilis*) come to life and jump hither and thither in clouds. If we are quick, we can capture them and put them into a glass jar, where we can examine them at leisure. They are olive green in color. Now, as we look closely at the sand not far from the high-tide mark, struggling forms emerge from tiny little holes that are almost invisible, and go leaping about, their grayish, sand-colored bodies closely resembling their environment. They, too, are sand-fleas of two different species (*Talorchestia megalophthalma* and *longicornis*) somewhat larger than their green brethren and distinguished by unusually large eyes and long feelers, respectively.

THE LADY CRAB

At low tide, when the sea is calm, one may wade in the shallows with a water glass and find other evidences of life. Yonder a lady crab (*Ovalipes ocellatus*) goes swimming by sidewise, waving its paddle-shaped hind legs over its back as a means of propulsion. A short distance away it settles down on the sea-bottom, raises its stalked eyes, and regards us warily. We approach with stealth, to get a good view of its carapace gayly spotted with irregular purplish pink dots, and the sharp pincer-like claws, striped also in purple and pink, which wave menacingly toward us. It is all a bluff! For as we cautiously wade nearer, the crab shoves the hinder margin of its carapace down into the sand, and rapidly digs itself under till only the frontal edge, the ends of the stalked eyes, and the waving, threadlike antennæ are visible.

The rock crab (*Cancer irroratus*) is also abundant here, scuttling over the sandy floor, as it has no paddles to swim with like its more fortunate cousin. We catch glimpses of the slender almost transparent boatlike bodies of the common shrimp (*Crangon vulgaris*) darting here and there like phantoms.

SAND-COLLAR SNAILS

A number of sand-collar snails of two species (*Natica heros* and *duplicata*) have started a settlement yonder where the sandy floor is nearly level and is laid bare only at the lowest tide. Low, rounded mounds scattered over the wet sand betray their habitat, and, as we watch, there is a disturbance in one of them which is still under water, and we see a round, almost globular shell, about as large as a tennis ball, break through. A fleshy foot protrudes itself from the shell opening and extends forward and back over the sand until it seems impossible that so much animal could be packed so tightly within the spire of the shell. Now it begins to travel forward, pushing before it an apron-like flap, above which waves a pair of antennæ, each with an eye-spot at its base.

As the creature slowly progresses, a transparent, jelly-like ribbon emerges from under the right side of the apron and is slowly pushed around the lower margin of the shell, where it is overlapped by a fold of the broad, fleshy body. Soon it completely surrounds the shell like a border. The snail continues to creep forward and leaves the transparent ribbon behind it on the sandy sea-floor. The sand washes against it and sticks to it. We pick it up and find it is a delicate little collar-shaped arrangement, open in front and slightly ruffled at the lower margin. The sand which has stuck to the outer surface covers it in a single layer, giving it an appearance of fine sandpaper. If we examine the under side with a hand lens, we find that it is entirely lined with a

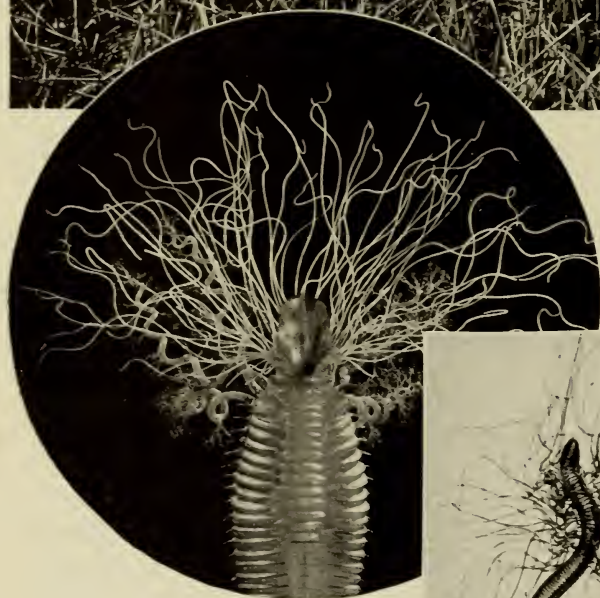

Tidal Water and Marsh Grass

In settings such as the one shown at the top of the page, fiddler crabs dig burrows among the grass roots.

The sectional view above at the right shows a fiddler-crab burrow, together with a starfish preparing to feed on an oyster. Marvelously adorned seaworms dig in the mud, as well. In the circle the ornate worm (*Amphitrite ornata*) spreads its delicate tentacles; in the center rectangle a fringed worm (*Cirratulus grandis*) extends its threadlike filaments; at the left is pictured the head of a plumed worm (*Diopatra cuprea*). Except for the view at the top, these photographs are of models at the American Museum

A Ripple-Marked Mud Flat

Prolific sea worms make their homes and dig their subways in the tide-washed mud. In the circle, a clam worm (*Nereis*) appears to be attacking an opal worm. At the upper right a trumpet-worm model is shown, surrounded by the sand grains that it has built into a home. The center rectangle shows a model of a "beak thrower," pictured also in the circle "throwing its beak." Below at the left the head of an opal worm is shown, gleaming with iridescent hues. The tracks shown crossing the ripple marks in the bottom picture have been made by black mud-snails

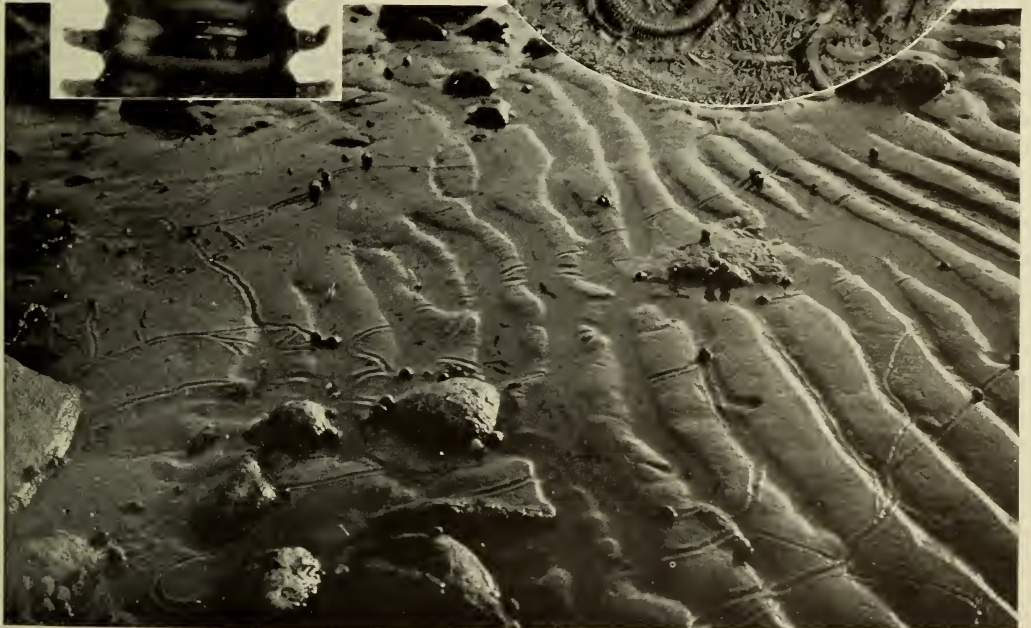
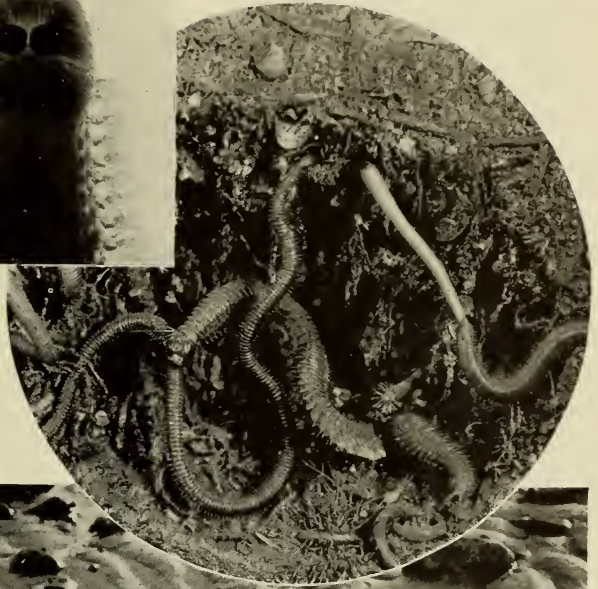

delicate layer of transparent eggs, each like a tiny bead of jelly, all closely set together in a finely wrought mosaic. As the collar dries in the sun, it becomes so fragile that it crumbles to sand in our fingers.

We now turn our attention to the snail itself and see that it is rapidly creeping through the shallow water toward a group of little flattened sticks standing up from the sand at an abrupt angle. The snail seems much interested in them. As we examine them with attention we see that their sides are formed of two long, narrow, slightly curving shells which somewhat suggest the size and shape of the old-fashioned razor handle. We recognize the razor-shell clam (*Ensis directus*). The shells stand half-buried in the sand, showing the ends of their short siphon-tubes at the top bordered with fringelike papillæ. Apparently they are aware either of us or of the approaching snail, for suddenly first one, then another, shoots down into the sand until the siphon-openings are barely even with the surface. They are great diggers, for their lower end is equipped with a powerful curved and tapering foot, which is used as a very efficient digging organ.

These inhabitants of the exposed sandy beaches, together with certain others, such as the soft clam (*Mya arenaria*), the surf clam (*Spisula solidissima*), the "sand bug" (*Hippa talpoida*), the sand dollar (*Echinarachnius parma*), and a few sea-worms, are able to endure the difficult conditions of exposure to the open sea. Most of them also occur in the more sheltered regions described below, but they are the hardy explorers of the shallow seas, and form the scattered population of a region which is otherwise without abundant visible life.

SHELTERED SAND AND MUD FLATS

As we walk along the beach, we may find our progress stopped by an inlet through which the tide flows into more

sheltered waters. In such places the currents wash the sand and mud away from the boulders embedded therein and much of the mud is carried into the sheltered waters of the bay, to be deposited upon its floor, mingled with sand to a greater or less degree.

AMONG THE EELGRASS

This mud is filled with nutritive material in which eelgrass grows readily and which also provides sustenance for all sorts of burrowing sea animals, and many others which lurk among the weed. Hosts of tiny creatures grow on the eelgrass blades, hide under the stones in the bottom and edges of the tidal channel, and cling to the seaweeds growing in such places.

Depending on the amount of exposure to the open sea, the soil grades from gravel, through sand, sandy mud of various degrees of admixture, and pure mud, abounding in inhabitants which thrive best in each special environment as well as those ubiquitous creatures which range over the whole field.

The little hermit crabs (*Pagurus longicarpus*) are among the latter. These may be seen scuttling back and forth in shallow water. They are small shrimplike creatures with a pair of heavily armored, formidable claws and four spiny walking legs, but with a soft, tapering abdomen which is their weak point and is entirely unprotected. Attached to this are a few pairs of small holding claws. To make good their deficiency, the hermit crabs appropriate abandoned snail shells, backing their soft abdomen into the spiral chamber of the shell, into which it neatly fits. They hold the shell in place by gripping the central columella of the spire with their weak abdominal claws, and then boldly run around with their castles on their backs. If assailed by an enemy, they retreat within the shell, closing the opening with one of their large claws. However, certain species of fish eat them, shell

and all. The hermits are the scavengers of the shallow seas and always gather together in great numbers to feast upon dead and decaying plants and animals. On muddy bottoms they are joined by the black mud snails (*Nassa obsoleta*), whose progress over the mud can be traced by their undulating groovelike trails.

A POPULOUS CITY ON A SHELL

The hermit crab is also interesting, because, in many cases, the dead shell that it carries may become covered with a soft substance appearing at first glance like the pile of coarse velvet. If we place such a crab in a small dish of sea water and look at it under a magnifying glass, this covering resolves itself into a city of tiny hydroids (*Hydractinia echinata*), little flower-like creatures with slender tube-shaped bodies, some of them with terminal mouths surrounded with grasping tentacles; others with no mouths but carrying quantities of egg-producing organs looking like tiny clusters of grapes; and still others near the edge of the shell with no mouths, but with their heads crowned with beadlike batteries of sting cells. Obviously this is a community of specialists, some members of which are the feeders for the colony, others, the reproducers and nursemaids, and the rest the fighters. Each has its special work to do. All the individuals are connected by a network of tubes, so that food may be supplied to the members that have no mouths by those which secure and digest it.

Larger species of hermits (*Pagurus bernhardus* and *pollicaris*) hide in the eelgrass, where also may be found the great whelks (*Fulgur canaliculata* and *carica*), which bear large, coiled shells on their backs with a pointed siphon in front. The females of these whelks manufacture egg-strings, two or more feet in length, looking like strings of spiny, yellow pill boxes, in which the eggs hatch into baby snails with tiny shells like those of their

parents. After a time the little snails emerge from a hole in the edge of each pill box and take up an independent life. The whelks prowl around, in the hope of capturing one of the scallops (*Pecten gibbus*) which abound in the eelgrass. This is a game of stalking, for the latter possess a hundred or more gleaming, steely blue eyes around the edge of the mantles, and, when alarmed by a shadow, will spring up in the water and flit out of the way, opening and closing their shells rapidly as a means of locomotion.

The green crab (*Carcinides mænas*), conspicuous with its bright green, yellow, and black markings, and the blue crab (*Callinectes sapidus*), familiar to us in the markets, frequent the sheltered mud flats in shallow water, while the small mud crabs (*Panopeus herbstii* and *sayi*) with their black-fingered claws are everywhere at the water's edge. The large spider crabs (*Libinia emarginata* and *dubia*), with their long legs and small, spiny, rounded carapaces, hide in the eelgrass and are hard to see on muddy bottoms.

OYSTERS AND MUSSELS

On mud-flats laid bare at low tides one may chance upon occasional oyster beds, though these are usually cultivated at some depth. More frequently huge flats may be covered with edible mussels (*Mytilus edulis*). These black mussels are a potential article of food, now much neglected, but, when properly prepared, they rival the succulent oyster and little-neck clam in delicacy of flavor and nutritious value. On Marthas Vineyard Island, literally acres of mussels are laid bare at low tide. They multiply so rapidly that, if by chance they come in contact with a bed of oysters, they will overspread it and completely smother it. The rock barnacles, in turn, reproduce even faster than the mussels, and, by sheer force of numbers, given an opportunity, will invade a mussel colony and overwhelm it,



Above: A giant whelk pursues a scallop, which swims by opening and closing its shell



Above: A hermit crab in his borrowed and "velvet"-covered shell

Below: The familiar edible blue crab



Photograph by M. C. Dickerson



*Photographs,
M. C. Dickerson*

Above: The green crab above is not edible, but is a pugnacious fighter

Below:
A spider crab, which has camouflaged himself by plucking tufts of *Bugula* and placing them on his back



A rough-spined spider crab, which has lost one claw



Below: A lady crab is shown swimming vigorously in an attempt to escape from a lobster



thus rendering poetic justice to the former conquering horde.

ENEMIES OF MOLLUSKS

These beds of shellfish, of course, attract the enemies of bivalve mollusks in great abundance. The most important of these are the oyster drill (*Urosalpinx cinerea*) and the common sea stars (*Asterias vulgaris* and *forbesi*). The former bores neat little pinholes in an oyster shell, and sucks out the contents, while the latter mounts the oyster, applies the pneumatic disks of its tube-feet to the two valves, and, bracing the tips of its arms against surrounding objects, pulls the shells open by main force and proceeds to devour their contents.

The oysters are not naturally found in muddy localities, but have been transplanted there by man, by spreading shells to form a "clutch." They belong more properly on a rocky bottom.

The animals most typically associated with more or less muddy regions are the sea worms. Burrowing in the soil everywhere, they construct tubes of greater or less consistency, or, in some cases, no tubes at all. They hide under flat stones, or dig among the roots of eelgrass. In localities rich in mud the fringed worm (*Cirratulus grandis*) burrows in great abundance, its reddish body adorned with a multiplicity of long, threadlike, breathing organs on the forward third of its body, each filament of golden yellow with a brilliant red thread of blood showing through the translucent walls. The plumed worm (*Diopatra cupræa*) constructs tough, parchment-like tubes in sandy mud, showing like chimneys above the sea-bottom, to which bits of shell and seaweed are cemented. The worm has a bluish iridescent body equipped on the forward part with marvelous blood-red plumes with spirally arranged branches. The ornate worm (*Amphitrite ornata*) builds tubes of sand and mud. It is a

wonderful creature with three pairs of intricately branched gill-plumes on its shoulders and numerous flesh-colored tentacles extending in all directions from its head. Its body is beautifully marked with reddish brown, and a broadly tapering upper lip is colored from rich rose to violet. The opal worm (*Arabella opalina*) has an orange head with four eyes, and a long, slender body composed of brilliantly opalescent rings. The trumpet worm (*Pectinaria belgica*) digs with a pair of golden combs and constructs a trumpet-shaped tube of neatly matched sand grains arranged in a delicate mosaic.

Scores of other species occur, all remarkable for beauty, grotesqueness, or strange habits, but it is impossible to mention them all here. Needless to say, the sheltered mud- and sand-flat is one of the most fruitful fields for the study of the strange creatures of the sea.

ROCKY SHORES AND HIGH TIDES

Let us now transport ourselves to the north shore of Massachusetts or the coast of Maine. We are on a rock-bound coast, hemmed in by high cliffs, against the base of which the incoming tide breaks in masses of foam, which scour through every crevice and rush back into the sea. The tide rises and falls nine feet or more, according to the locality, and, farther north, several times that distance.

At low tide the vertical walls of the cliffs are seen to be broken into shelving terraces, draped and festooned with rock-weed, bordered above with a long frieze of white barnacles. The basin-like hollows on the rocky terraces are filled with water, even when the tide is at its lowest, and each one glows with submerged colors like an aquatic sea-garden. There is no soil for burrowing like that on sand- and mud-flats, and all animals having no adequate clinging organs, or requiring a soft substratum for burrowing are eliminated here by the force of the elements, and yet

Left: The only coral (*Astrangia danae*) of the New England coast is shown growing over a rocky bottom

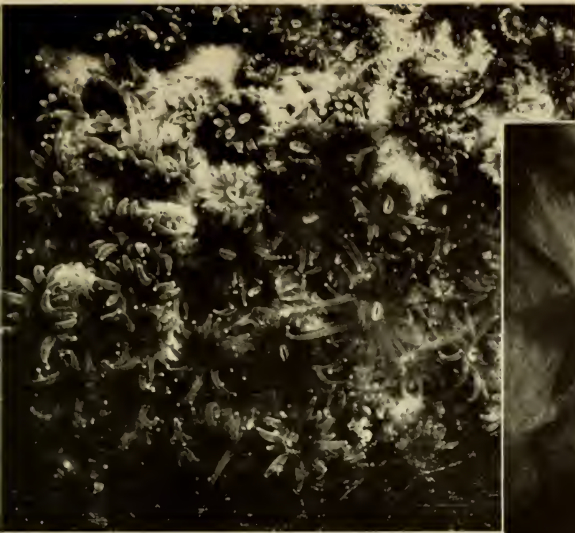

Photographs, M. C. Dickerson

In the small rectangle a common starfish (*Asterias vulgaris*) is portrayed. Below: A

starfish is shown attacking a small fish. The "tube-feet" are equipped with sucking discs by means of which the fish is dragged into its attacker's central mouth



Above: A sea anemone (*Metridium marginatum*) expands its feathery crown, which is armed with sting-cells with which it slays small fish for food





The rocky coast at low tide. The white band is made up of barnacles. Below these, festoons of rock weed partly cover crowded masses of mussels. In the water, starfish and green sea urchins abound

Right: The little red sea star (*Henricia sanguinolenta*), which is abundant in the tide pools of rocky coasts. Photograph by M. C. Dickerson

Below: A view looking through the clear water of a pool replete with Irish moss, coralline dulse, kelp, rockweed, and sponges



Seaweed drapes the rocks of a beautiful pool at Nahant, Massachusetts. In these clear, quiet waters are displayed a magnificent sea garden in which the observer may find a rich field for observation



Left: Purple snails (*Thais lapillus*) are shown feasting on mussels. These snails produce a beautiful purple dye similar to the ancient Tyrian purple. A cluster of eggs is also visible

Below: A corner of the Nahant pool showing green sea urchins, sea stars, and green crabs on the coralline covered rocks



certain creatures familiar to the southern shores adapt themselves to these trying conditions and survive.

BLACK MUSSELS AND PURPLE SNAILS

The same kind of black mussel (*Mytilus edulis*) that covers the mud-flats of the southern coast to so great an extent, clings to the rocks in broad bands below the barnacle zone and underneath the rockweed, but, in exposed situations, the shells are always very small, for when they reach a size to present resistance to the force of the waves, the silken strands of their tough byssus threads give way and they are stripped from their anchorage by the rushing water. They also must dispute their territory with the purple snails (*Thais lapillus*), which cluster in numerous colonies and feed on the little mussels. These snails derive their name from the fact that they exude a purple fluid, allied to the Tyrian purple of Mediterranean snails. Their shells, however, are gayly banded with red or yellow spirals, or the entire shell may vary from white, through orange, red, and brown. They lay their eggs in little pink or yellowish vase-shaped capsules, which stand on slender stems and are grouped together in small patches in the crevices of the rocks.

At low tide multitudes of sea stars familiar to the southern shore (*Asterias vulgaris*) but varying greatly in color from purple, through blue, crimson, and yellow, feed on the mussels and on the little green sea urchin with the long scientific name (*Strongylocentrotus droehbachiensis*), which is very abundant here. Another sea star characteristic of rocky coasts is a small, deep-red species (*Henricia sanguinolenta*), bright yellow beneath and at the tips of its curving arms. The Jonah crab (*Cancer borealis*) is very common, crouching and hiding in rocky dens. It is larger and with much rougher carapace than the rock crab of Southern New England (*Cancer irroratus*), which also is

found on the northern coast, but more sparingly.

The tide pools on the terraces show remarkable concentrations of sea life. As the sun slants through one of these flooded basins at low tide, it lights up tangles of rich brown, brilliant green, purple, pink, and red algæ, their graceful fronds clustering and overarching miniature vistas, in which acorn snails (*Littorina litorea*), green crabs (*Carcinides mænas*), and tiny red or variegated chitons (*Chiton ruber* and *apiculatus*) creep about amid fairy clusters of pink-hearted hydroids (*Tubularia crocea*), gray-green chimney sponges (*Hali-chondria panicea*), and pink finger sponges (*Chalina oculata*).

SEA ANEMONES AND SEAWEEDS

Sea anemones (*Metridium dianthus*) expand their broad, flower-like, fringed disks, and cylindrical bodies, brown, pink and white, and bright orange in color. Even the rocky basin itself is enameled with encrustations of red-purple *Melobesia* and brick-red *Lithothamnion*,—calcareous seaweeds, that spread thin, stony layers of color over the underlying rock. Clusters of huge horse-mussels (*Modiola modiola*) covered with purple and red bryozoa, open their shells slightly, exposing their orange-colored mantles.

It seems impossible that there should be such an abundant association of living forms in so small a space, but the secret lies in the flood of aerated and food-laden waters that twice a day overwhelms these tidal pools and brings the inhabitants everything on which their life depends.

These associations of the animal life of the seas, whether on sandy shore, mud-flat, or rock-bound coast, are but glimpses of an almost infinite kingdom of creatures under the rule of the tide, which sweeps over the great oceanic shelf, bringing life or death to its subjects, depending upon how they adapt themselves to its laws.

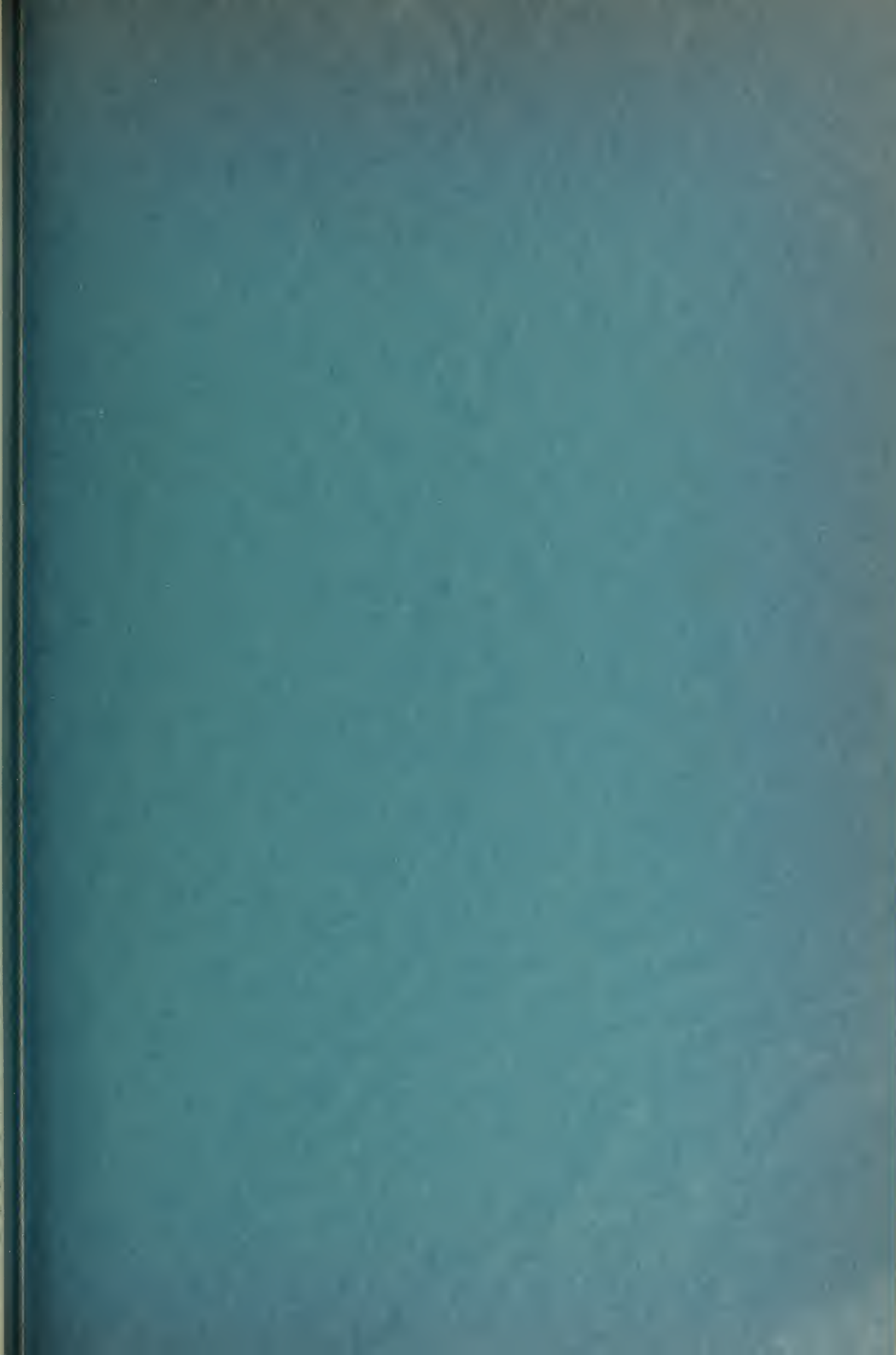



JADE, AMBER, AND IVORY

By HERBERT P. WHITLOCK

Curator of Minerals and Gems, American Museum



*Reprinted from Natural History Magazine
for September, 1934*

GUIDE LEAFLET SERIES, No. 84

THE AMERICAN MUSEUM OF NATURAL HISTORY
NEW YORK, 1934



JADE, AMBER, AND IVORY

By HERBERT P. WHITLOCK

Curator of Minerals and Gems, American Museum



*Reprinted from Natural History Magazine
for September, 1934*

GUIDE LEAFLET SERIES, No. 84

THE AMERICAN MUSEUM OF NATURAL HISTORY
NEW YORK, 1934

Jade, Amber, and Ivory

by

Herbert P. Whitlock

Curator of Minerals and Gems,
American Museum

26 Photographs
by the American Museum
Staff Photographers

AMONG the court officials who attended the Chinese emperors of the Chou dynasty (B.C. 1122-255) there was, it is said, a steward of the treasury whose task it was to attend to the preservation of the Hall of the Ancestor of the Imperial House, in which were kept all the precious objects handed down from generation to generation. This stewardship of the treasury, however, has long since been abolished. Even the latest dynasty of Chinese emperors has passed away and with it much of the tradition and romance that are always attached to what is old and what is regal. Yet, although there is no longer an imperial treasury in Peiping, there has been created during the past six months, in the American Museum in New York, a veritable "Hall of Ancestors," a treasure house in which are gathered the beautiful and precious objects representative of Chinese and Japanese culture brought together through the life work of a man whose knowledge and taste in these matters rendered him an authority of high standing.

This new acquisition of the American Museum is the collection of the late Dr. I. Wyman Drummond, which came to the Museum through the gift of his sister, Mrs. Katherine W. D. Herbert. In reality it is not merely a collection. Instead, it is a group of collections, each correlated with and supplementing the others; and with so keen an appreciation and such ripened knowledge have these units been chosen, that it seems

Precious and beautiful carvings of the Drummond Collection depicting not only the art, but also the ancient myths and legends of China and Japan

as though the touch of beauty passing from hard, cold jade to glowing amber and vitalized ivory, carries with it all the wealth of tradition and symbolism of the two great oriental races.

In the matter of jade alone the Drummond Collection, which is now the Drummond Memorial, is a rich and well balanced series, representative of all periods, and covering a cultural range of more than thirty centuries. Exceptional indeed is the splendid group of ancient jade ceremonial weapons which has no counterpart in other museums of the world. By far the most important piece in the series of carved jade, however, is the superb composite piece of white jade that constituted the gift to the Emperor Kien lung by the officials of his court upon the event of his fiftieth birthday.

In solving the problem of the display of the Drummond Memorial in the round tower room at the southwest corner of the fourth floor of the American Museum, this famous piece of jade has been made the center of the installation. From it, like the spokes of a wheel, radiate the eight upright cases, some of which are equipped with glass shelves, while others are treated in panel fashion.

The left half of the room is devoted to jade arranged by periods, and the right half is given over to amber, ivory, lacquer, and bronze sword guards. Around the walls between the window spaces are ranged the cabinets which contain the units of the Drummond Collection as they were formerly displayed at Doctor Drummond's residence. With these latter cases care has been taken to retain the original arrangement, so that every piece occupies exactly the position with respect to its neighbors that it did in the



The ivory statuette of K'wan Yin of the Fish is characteristically Japanese both in conception and rendering. It immortalizes in ivory the story of the princely fisherman who set up a shrine to this goddess after her image had repeatedly appeared in his net, taking the place of the fish he sought.

K'wan Yin of the Fish

Japanese

Figurines



Left:—A miniature carving in ivory of the celebrated Buddha of Kama-kara sitting in eternal meditation. Behind the master spread the wonderful conventionalized flames symbolizing purification



Above:—An elaborately carved ivory figure of Kwan Yin, the Goddess of Mercy, holding a vase which is one of the traditional objects associated with her. The wealth of detail and marked realism of this Japanese figurine is in strong contrast with the formal conventionality that stamps the Chinese rendition of such a subject



Left:—A charming and elaborately wrought figure of Lan Ts'ai-Ho, the work of a Japanese ivory carver. Lan Ts'ai-Ho was one of the Taoist immortals who wandered through the streets singing of the futility of earthly pleasures

Carved In Ivory

Right

Wang Mu, the Chinese Queen of the Fairies, attended by one of her jewel maidens, who holds a basket filled with the immortal peaches. A very charming little group in Japanese carved ivory



Left

The Three Heroes of Han, legendary Chinese warriors of the Han dynasty (200 B.C. to 250 A.D.). They are represented in this ivory carving as drinking sake in a kind of Japanese Valhalla

Chinese and Japanese Ivory

Left:—This intricate Japanese carving in ivory represents the Dragon Boat, laden with immortals and magical treasures. It is being guided to the Western Paradise by the crane, the messenger of the gods



Below:—The reverse of the group representing the Chinese Zodiac pictured at the left of the opposite page



Above:—Among the outlandish animals originating in Chinese mythology, one of the strangest is the Baku, the creature that feeds upon the bad dreams of mortals. This Baku is carved from ivory by a Japanese artist

Right.—The miniature figure of Ho Hsien-ku (only three inches high) is carved from ivory and dark wood. She is supposed to have lived in the Seventh Century, and, having attained immortality, became a fairy. In her hand she carries a fly whisk



Above:—This little masterpiece in ivory pictures a realistic group of the twelve creatures (the back of the group is shown on the opposite page) that represent the Twelve Terrestrial Branches, the Chinese zodiac. As seen they are the dragon, the rat, the cock, the monkey, the ox, the serpent, the goat, and the dog

The carving of a "puzzle ball," such as this one, is a feat of ivory carving performed only by Chinese artists. Carved from a single piece of ivory, this ball incloses eight others, each smaller than and separated from the next outer one

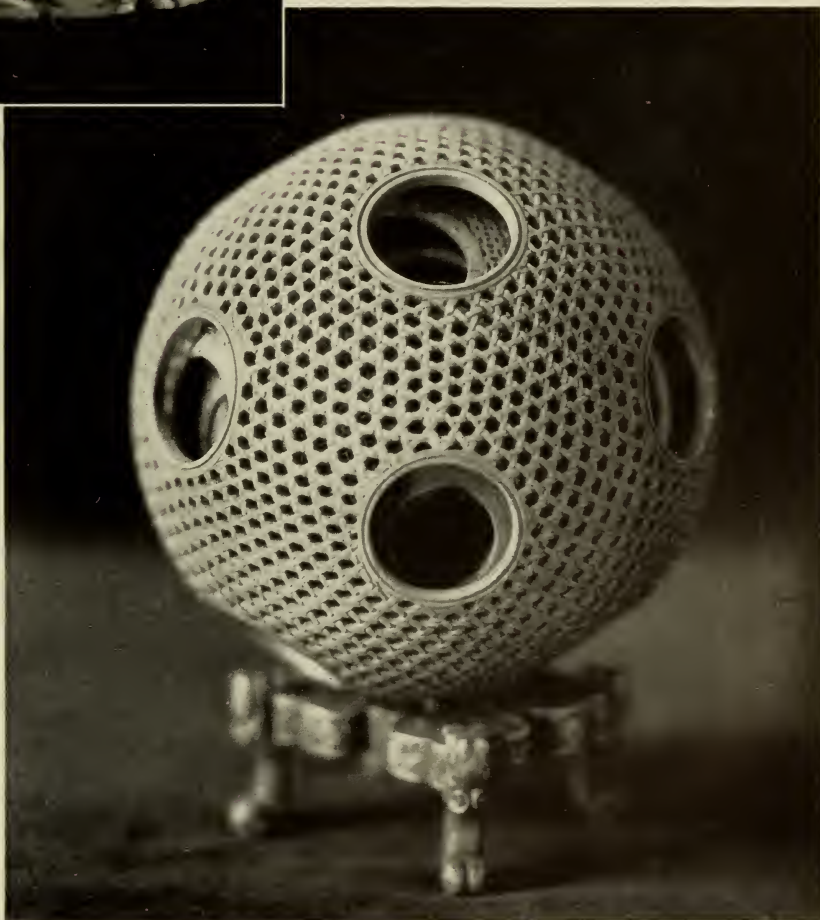

lifetime of this famous connoisseur, the charming taste and sense of color that have always characterized his displayed collection thus being retained.

Particularly is this the case with the series illustrating the various colors of jade of relatively modern date, which includes among others the rare lavender tint very much prized among collectors.

The magnificent suite of Burmese amber, which also speaks eloquently of Doctor Drummond's taste in color arrangement, has been conceded to be the finest assemblage of oriental amber in the world. Here ruby-red colors contrast with limpid honey-yellow and mottled orange in wonderful and intricate carvings.

Of the six wall cases that contain the varied and important collection of Chinese snuff bottles, one is filled with those fashioned almost exclusively of oriental amber.

JADE

Perhaps no one material other than jade can turn back so successfully the pages of time and permit us to read the record of a culture that was old when our own was struggling to emerge out of barbarism. Here, among these old jade objects, many of which have been buried for centuries, we find the beginnings of a philosophy, cosmic in its inception, that in China has outlasted dynasties.

Among the most ancient of the symbols carved in antique jade is the group of designs called the Twelve Ornaments. More than 2000 years B.C. the Emperor Shun, referring to these designs, said, "I wish to see the emblematic figures of the ancients embroidered in five colors to decorate the official robes." Only the Emperor had the right to wear the complete set of twelve emblems on his ceremonial robes. Nobles of the first rank were restricted from using the symbols of the highest order. With decreasing rank further restrictions in the display of the remaining nine ornaments defined five sets of official robes. In the Drummond Collection an ancient and beautifully carved jade piece,

representing the deity Earth, expressed by the Chinese as being square outside and round inside, represents on one of its faces these ancient Twelve Ornaments.

A very fine piece of white jade of the Kien lung period of renaissance in glyptic art is in the form of a "Scepter of Good Luck" (Joo-i scepter). On the long handle of this piece are carved in high relief the figures of the Eight Immortals, the half mythical, half historical personages so often represented in Taoist art. Each of these carries some characteristic object, such as the flute of Han Hsiang-tzu, whose marvelous tone caused flowers to grow and blossom instantly.

Singularly enough, there is, in the Drummond Collection, a Chinese flute carved from pure white jade, and while those of us who were privileged to hear M. Georges Barrère play upon it at the opening of the Drummond Hall, might need to stretch our imaginations a little in order to credit it with causing the spring flowers to bloom, it nevertheless has a remarkable tone, quite capable of producing exquisite music. Incidentally, it was made in 1488 in the Studio of the Eternal Spring. Many symbolic designs, have, through the reverence that all Chinese have for what is old and traditional, persisted throughout jade and amber carvings down to the present day. (See the author's article on "Jade" in NATURAL HISTORY for September-October, 1932.)

JAPANESE CARVINGS

In sharp contrast to the conventional treatment and traditional recurrence of designs in Chinese carving, is the realistic freedom that characterizes the work of Japanese carvers in ivory and wood, scores of examples of which are included in the Drummond Collection. Hampered by no such formalism as that which has been handed down through generations of Chinese lapidaries, the Japanese artists, working in ivory, produce graceful and impressive figures of the sages and immortals, charming and often grotesque statuettes,



Above:—A general view of the Drummond Hall

Circle:—A portrait head of the late Doctor Drummond, modeled by James Drummond Herbert

Below:—In the center stands the assemblage of jade pieces which was presented to the Chinese emperor Kien lung on his fiftieth birthday





Jade
and
Amber

This white jade incense burner is a superb example of the open work carving that reached its height in Kien lung's time. Both the bowl and the cover were reduced to about the thickness of a piece of heavy cardboard before the intricate lacelike pattern was executed with hundreds of cleverly shaped holes.

The dragons on this jade cup are of the form which developed in China in the Ming dynasty. The perfection in carving, however, shows the piece to be of later date, probably early Kien lung

Of a wonderful rich orange is this piece of Burmese amber carved to resemble a huge peach, to which is added the "long life" symbol, showing that it is a "Peach of Immortality." Two bats, signifying happiness, flutter above

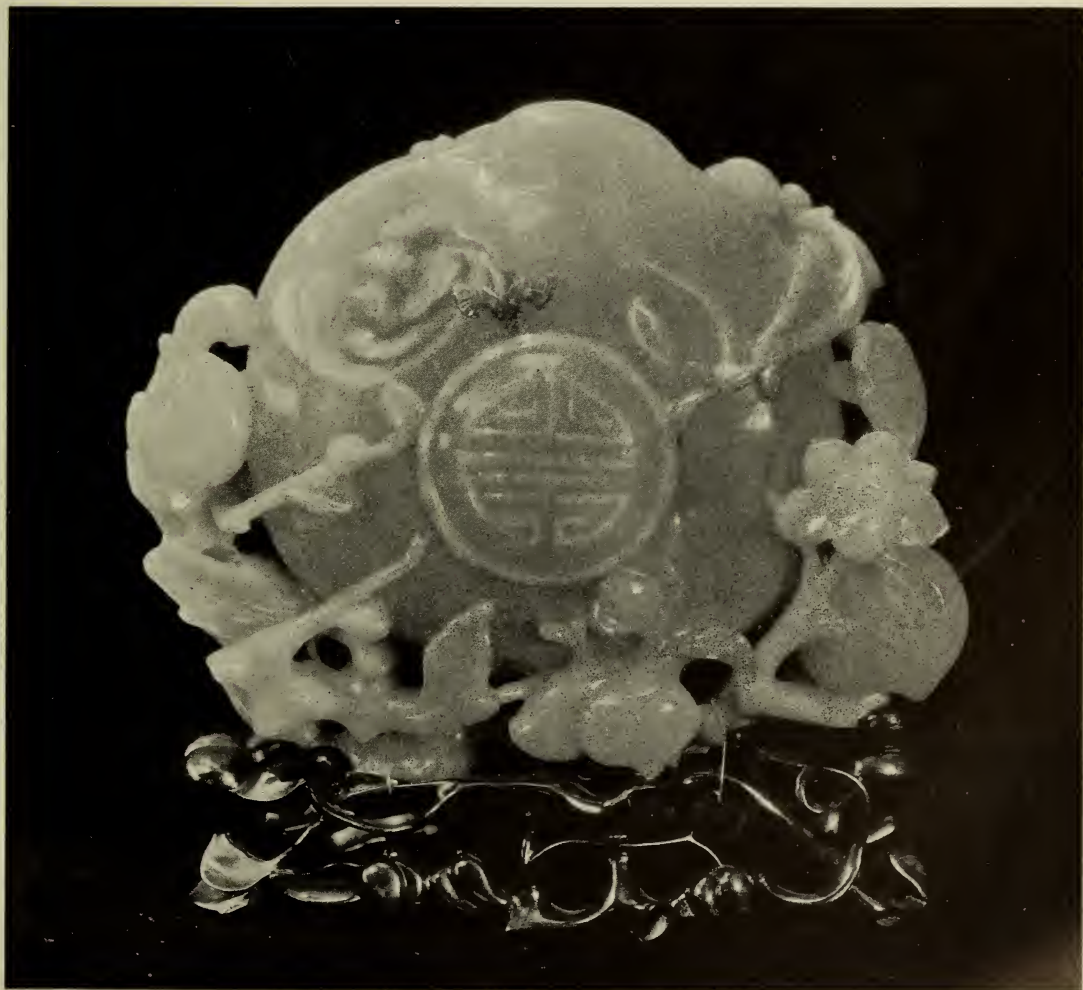

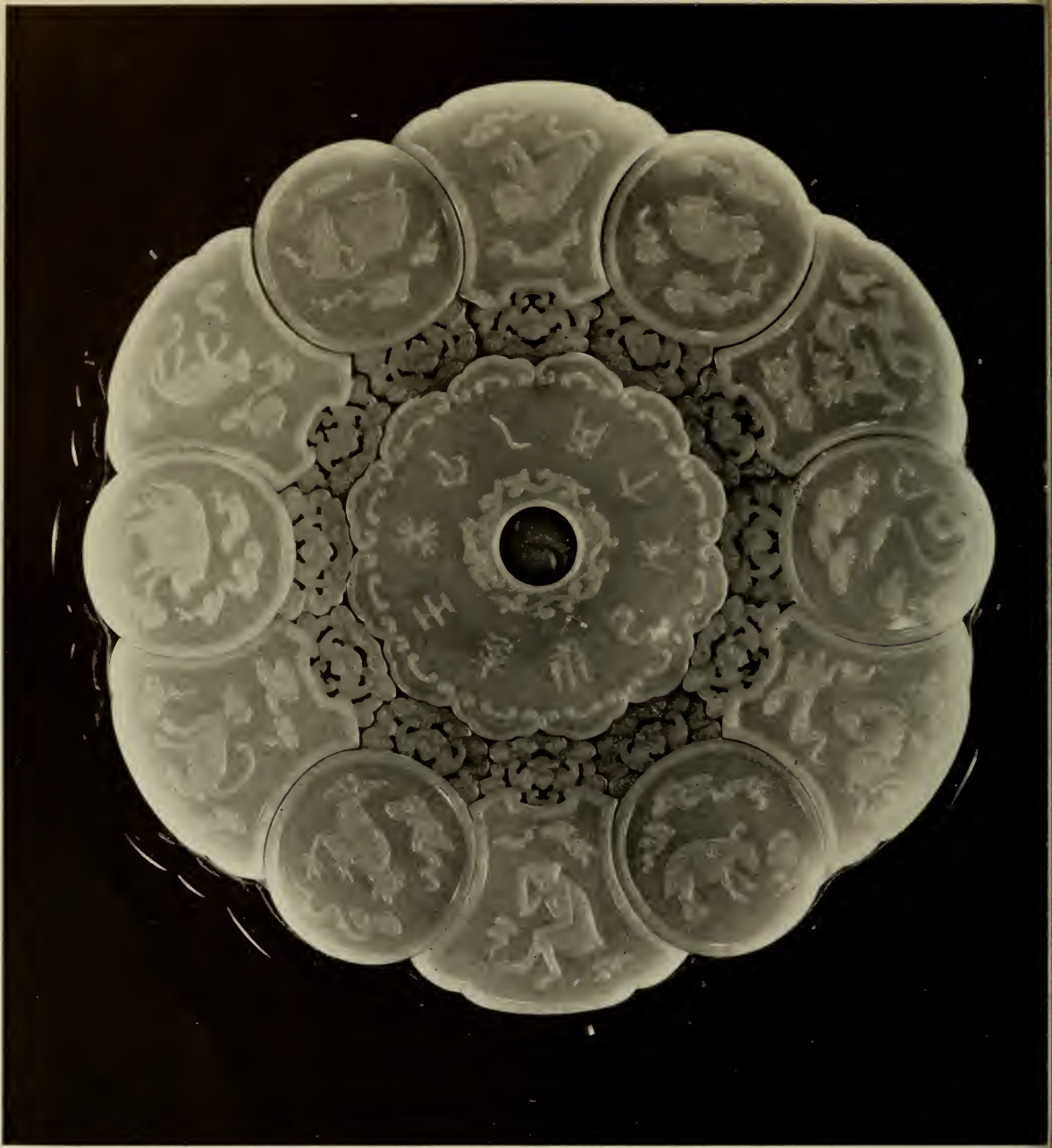

An Emperor's Birthday Gift

A masterpiece of modern carving in white jade was selected for this gift to a famous emperor—Kien lung. The central piece has a loose button decorated with the yang yin (universal life symbol). Surrounding the central piece are twelve pieces fitted together, each of which is carved with a representation of one of the twelve creatures which in China correspond to the signs of the zodiac as used by Westerners

A very ancient jade image of the deity Earth carved with representations of the Twelve Ornaments. Reading from the top downward these are: The sun, the moon, the stars, mountains, dragon, pheasant, the cups, pond weed, fire, grain, the axe, and the symbol of distinction. The Twelve Ornaments are of great antiquity and signified authority and power



Highly conventionalized dragons as well as a bat meaning happiness mark this elaborately carved disk of white jade

Sword Guards

A magnificent gold dragon decorates this Japanese sword guard, and since this is a "dragon of the air" he is surrounded by conventional clouds



The subject pictured on this sword guard in bronze of various colors and in gold inlay is from the Japanese fairy tale of the sparrows who entertained their human friend in a manner singularly human, even for fairy-tale sparrows

The maker of this magnificent Japanese sword guard chose for his subject the fairy tale that recounts the adventures of Momotaro, who, with the aid of a dog, a monkey, and a pheasant, overcame the demons and took their treasure for ransom





A Traveling Shrine

This lacquered box is in reality a traveling shrine. The wooden interior displays a figure of Amitabha, the Buddha of Enlightenment, beautifully carved and gilded

A Crystal Snuff Bottle

Among the almost miraculous feats of dexterity practiced by Chinese artists is that of painting the inside surface of a glass or rock crystal snuff bottle. This delightful little painting was executed by passing a very minute brush through the neck of the bottle and reversing the strokes, somewhat in the manner of a "looking-glass" painting



and groups illustrating folk lore and legend dear to the hearts of Japanese boys and girls.

Among the ivory figures of appealing beauty from the Drummond Collection, is the "K'wan Yin of the Fish" in which the goddess is poised with great freedom of action upon the back of a huge carp. The legend that inspired this masterpiece relates how a banished Japanese prince, who was forced to earn his living by fishing, on one occasion found in his net no fish but instead a small image of the Goddess of Mercy. This he threw back into the sea only to find it again when he next cast his net. So he kept the image and with his own hands fashioned a shrine for it on a hill overlooking the sea, where the Goddess of the Fish was continually worshiped.

Another charming figurine to which a story is attached, is Hsi Wang Mu, the Chinese Queen of the Fairies, whose legend, like many other Taoist myths, was brought into Japan from China. It is said that the palace of Wang Mu is in the Kuen-lun Mountains, where she guards the Tree of Immortal Peaches that grows beside the Lake of Gems, whose fruit ripens upon her birthday, every 3000 years. Here gather to the Feast of Peaches all the immortals to renew their immortality by eating the celestial fruit.

CARVING IN IVORY

A small but extremely intricate ivory carving shows the Dragon Boat laden with sages and immortals and freighted with the fabulous treasures of Takaramono, which include the hat of invisibility, the purse whose wealth never fails, not to mention many other remarkable things. Above flies the crane, the messenger of the gods guiding the vessel to the Western Paradise. With such wealth of detail are all of these ivory pieces wrought that such matters as necklaces and headdresses are rendered with the greatest fidelity. In fact, whole costumes might be copied to the last clasp and fold from these authentic sources. And such costumes! It would seem as though the

divine K'wan Yin, and Lan Ts' ai-Ho, the immortal flower girl, were especially created to grace costume balls and pageants.

SWORD GUARDS

Much as the Japanese carver in ivory loved to draw his subjects from the legends and myths of Japan, he was probably no match in this respect for his brother craftsman whose art consisted in fashioning sword guards from iron, bronze, and other alloys, some of which are not used outside of Japan. These were inlaid in gold and silver with great skill and artistry. A large and very handsome example from the Drummond Collection depicts an incident from the fairy tale of Monotaro, the boy who was found inside a peach, and who grew to be a sort of Japanese "Jack the Giant Killer." Accompanied by a dog, a monkey, and a pheasant, he invaded the island of the devils and, having overcome them in battle, returned to his astonished foster parents with all of their fabulous treasure.

Another beautifully inlaid sword guard illustrates the fairy tale of "The Tongue-cut Sparrow" who, after sumptuously entertaining his benefactors with food and *sake*, rewarded them for their charitable deeds with a basket filled with treasure. Needless to say the spirited designs which picture these folk tales are wrought by master artists whose names inscribed on little gold inlaid plates actually add to the attractiveness of their designs.

In order to describe in detail the hundreds of works of art that make up this extraordinary collection, one would almost require the magic aid of the gods and devils that are so generously portrayed among them. Nor, even then, could words picture these beautiful objects satisfactorily. Color, form, patina, subject matter—all require first-hand visual examination, before their beauty and their rarity can be made manifest.

They are, however, now on permanent display, and are ready, always, to offer their beauty to any who care to see.

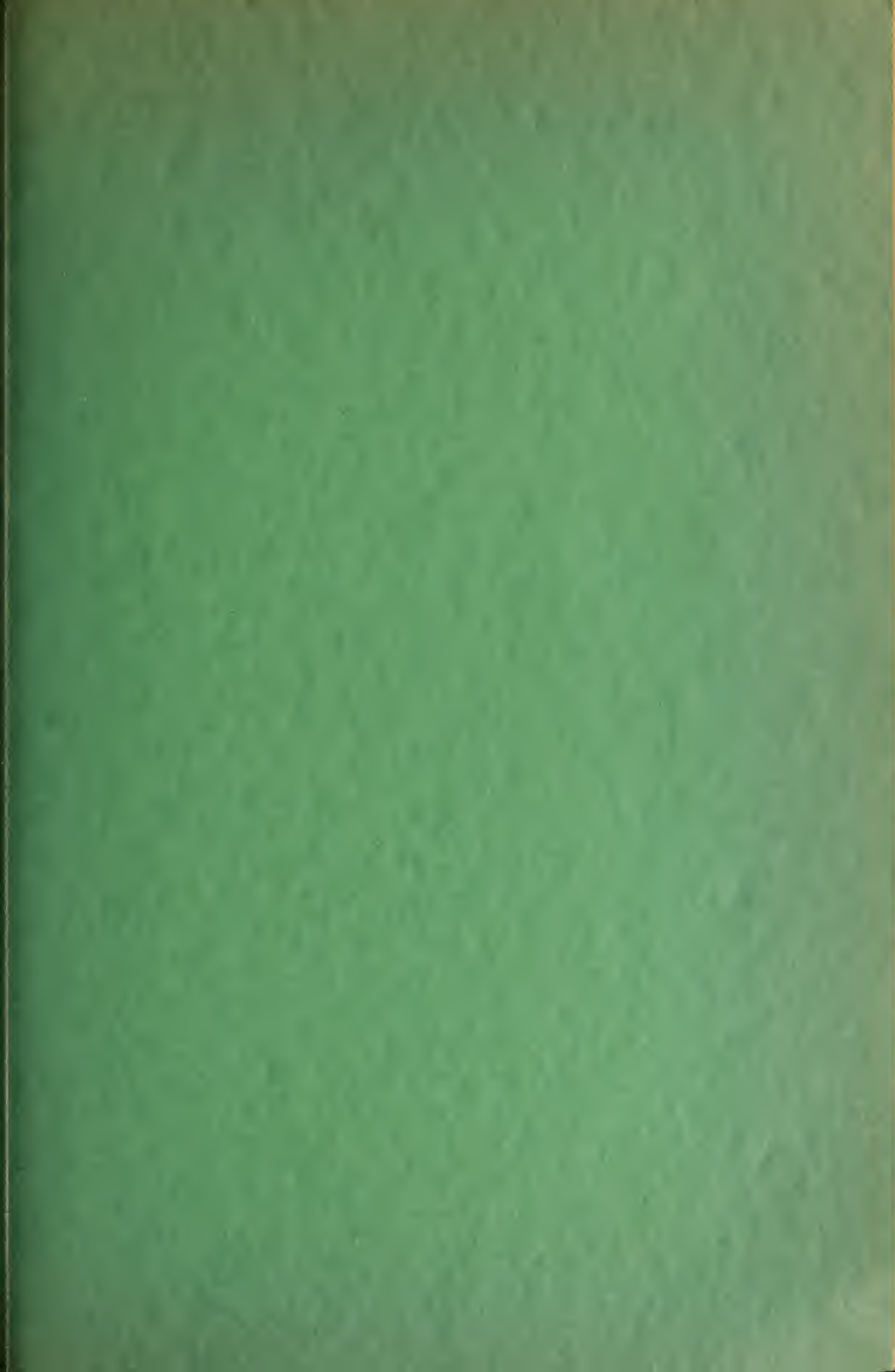

New Piers for Giant Ships

By

CHESTER A. REEDS

Curator of Geology, American Museum of Natural History



REPRINTED FROM

NATURAL HISTORY

The Journal of The American Museum of Natural History

VOL. XXXIV
No. 2

84 B
COPYRIGHT, 1934

MARCH-APRIL
1934

NEW YORK, N. Y.



From Fwing Galloway, N. Y.

Lower Manhattan, New York, 1933; Left, Hudson River Piers; Right, East River Piers

NEW PIERS FOR GIANT SHIPS

The Geologic and Engineering Problems Involved in the Construction of New 1100-Foot Piers in the Port of New York Are Briefly Considered

By CHESTER A. REEDS

Curator of Geology, American Museum of Natural History

To John McKenzie, Commissioner of Docks of the City of New York, Francis T. O'Keefe, Chief Engineer, and Alfred J. Duggan, Resident Engineer, I express my thanks for their kind coöperation, and for the loan of various charts, sketches, and photographs prepared by the Dock Department in the course of the investigation of the physical conditions of the rock in the site for the new piers. I also express my gratitude to the Board of Trustees, to Dr. F. Trubee Davison, President, and to Dr. George H. Sherwood, Director, of the American Museum of Natural History, for allowing me time from my duties as Curator of Geology, to make this investigation. To Mr. Ray N. Spooner, and Mr. F. R. W. Cleverdon, Vice-President of the Allen N. Spooner & Son Construction Company, I express my thanks for courtesies received when visiting the excavations, and for the loan of a set of photographs.—C. A. R.

THE construction of new piers for giant ships in New York is in keeping with the remarkable growth of the City. Situated on a number of islands facing the Upper and Lower bays, and being surrounded by deep estuaries leading inland in various directions, New York has been ideally placed to handle commodities by water. Having been blessed with one of the best natural harbors in the world, New York, with more than ten million people in its metropolitan district, has grown to be the

chief port of the North American continent.

The Hudson, the principal waterway of the harbor, being a drowned river with tides extending to Troy, provides a natural entrance into the interior of the United States. Some 25,000 to 35,000 years ago the coast line of the region at the mouth of the river subsided, and the course of the Hudson, for approximately 151 miles inland and 100 miles across the continental shelf, was submerged. With the drowning of the river only a few



© Brown Bros., N. Y.

LOWER MANHATTAN, NEW YORK, 1876

East River with wharves and sailing vessels in foreground; Upper Bay and Hudson River in mid-distance; New Jersey shoreline in the background

natural impediments to navigation remained in the harbor. These consisted of occasional fogs, scattered rocks, and the mud flats across the mouth of the river. Progress has been made in remedying these defects, namely: The harbor has been well lighted and fog horns established. The rocks have been blasted away. The mud flats, which arise by the natural tendency of the river to drop its load of silt where its current meets the ocean waters, have been removed in part. From 1899 to 1914 the Federal Government dredged the Ambrose Channel across the Lower Bay at a cost of \$5,000,000. The Channel extends in a nearly southeasterly direction from the inner harbor to the ocean and has a length of seven miles, a width of 2000 feet, and a depth at mean low tide of 40 feet. This channel permits the largest of ocean vessels to enter the harbor without difficulty. For many years the Old Main Ship-Bayside-Gedney Channel, width 1000 feet, depth 30 feet, sufficed. It is horseshoe-shaped in outline and follows the natural course of the river channel across the Lower Bay. It is five miles longer, however, than the Ambrose Channel. The new Anchorage Channel in the Upper Bay, which is 2000 feet wide and 40 feet deep at mean low water, continues

the course of the Ambrose Channel. The mean range of tide is about 4.5 feet.

When Hendrick Hudson anchored the "Half Moon," the first ship to visit the harbor, off the west shore of Manhattan Island on September 13, 1609, a row boat and a sandy beach served for a landing. The first wharf erected by the early Dutch settlers was built 1648-1649 on the East River at the end of Schreyer's Hook. It seems to have been the first and only pier in New Amsterdam until a larger one known as "The Bridge" was built in 1659, near the foot of the present Moore Street. In 1695 the City, then under English rule, had a great dock which extended along Water Street from Coenties Slip to Whitehall Street. By the amended charter of 1730, the docks, slips and wharves, with all the profits arising from them, were granted to the City. By the time of the Revolution there were six slips on the East River, and two docks and one slip on the North River at the foot of Oswego, now Liberty Street. After the Revolution, New York grew to be one of the leading cities of the United States.

During the Nineteenth Century, the low areas along the shore line were filled in and an extensive line of wharves were developed. On the west side of Manhattan

Island a continuous line of dock buildings was built for a distance of about four miles. On the eastern shore numerous piers were erected. In Brooklyn piers and docks were extended along the greater part of the shore opposite the lower end of Manhattan and farther south in Gowanus Bay. With the completion of the Erie Canal in 1825, New York became the center of commerce for half the continent. With the phenomenal growth of the great trunk-line railroads, 1840-1860, most of which built their terminals at tidewater on the New Jersey shore opposite Manhattan, there developed the car-float lirage system of freight transfer. Although there was a radical change about 1860 from canal to railroad transportation, New York retained her position as the chief shipping and industrial center of the United States. In fact, the ocean, the rivers, the canals, the railroads, and a productive hinterland continued to transform the life of the harbor, increase the waterfront developments, add value to property, and make New York great.

In 1860, the combined exports and imports of New York were valued at \$311,358,064, with New York handling twice as much of the country's import trade as all the other American ports combined. The population of the City at that time was 800,000, the five boroughs more than 1,000,000, and the New York region more than 1,800,000. Throughout the remainder of the Nineteenth Century and up to the present, the City has continued to grow in two directions—vertically and horizontally. The population of the five boroughs of New York in 1900 was 2,507,414; in 1930, 6,930,446. The population of the metropolitan area in 1930 was 10,901,424.

With the continued growth of the City and its metropolitan district there has been an increasing demand for New York waterfront property. In 1870, the Department of Docks of the City of New York was created. It is charged with the construction, care, and maintenance of the City's waterfront. More than a half million people are directly occupied in



© Brown Bros., N. Y.

HUDSON RIVER DOCKS LOOKING NORTH ON WEST STREET, 1906

The west side of Manhattan Island is lined with piers from the Battery to 72d Street, New York. Groups of docks appear at points beyond



From Ewing Galloway, N. Y.

DOCKS AND WAREHOUSES OF THE BUSH TERMINAL, BROOKLYN, N. Y.
Air view of one of the most active sections of the Port of New York

all-the-year round employment on the waterfront. By 1930 it had made improvements having a value of more than \$250,000,000. The direct waterfront of Greater New York is 587.4 miles in length. A considerable portion of it is as yet undeveloped. The improved waterfront around piers and bulkhead lines in 1924 measured 275 miles. In 1930 the number of piers, both public and private, was 722. Of these, 277 were owned by the City of New York, 409 privately, 27 by the United States Government, and 9 by the State of New York.

Throughout the history of the Port, river and harbor developments have been subject to some sort of official control. The first systematic attempt to authorize and regulate the building of piers along the waterfront was by the New York State Legislature in 1796. In the course of time, however, piers were built in more or less haphazard fashion and with the overlapping jurisdiction of two states, New York and New Jersey, and the

various municipalities, the Federal Government, by an Act of Congress passed in 1888, assumed the authority to fix bulkhead and pierhead lines throughout the Port in the interests of commerce and navigation, and created a Board for that purpose under the War Department. This was one of the first steps taken toward the coördination of port facilities. Since that date the Department of Docks of the City of New York has frequently been given permission to extend the pier head line outward. Since 1921, the affairs of the Port have been under the Port of New York Authority, a body created by special agreement between the states of New York and New Jersey, and the Federal Government. It has under its supervision 1463 square miles of territory, containing 771 miles of waterfront, 341 miles of which are improved. The City has control of all water inside the pier-head line.

In 1930 New York collected more than \$7,000,000 as rental for the piers and

bulkheads it owns. The revenue for 1928 was \$7,725,479.96, while the expenditure for maintenance was \$1,600,000. The highest rental, \$300,000 a year, is received for Pier 86, North River, with Pier 84 next at \$270,000. Both piers are leased to the United American Lines. The vessels that entered the Port in 1930 numbered 4997; their cargo amounted to 43,244,036 long tons, which was valued at \$1,882,187,459. During the same year, the 5366 ships which cleared the port carried a cargo of 15,422,962 long tons valued at \$1,699,794,188. The total imports and exports thus amounted to 58,666,998 tons, valued at \$3,581,981,647. Although these figures are considerably under those for 1920, it may be noted that nearly one-half the foreign commerce of the United States is now handled by the Port of New York, that more than two hundred companies and agencies operate to foreign ports, and at least sixty lines are employed in coastwise and river trade.

While the New York waterfront has not

yet been fully developed, the traffic conditions in the Port have been so congested at times that special regulations have been suggested. The commerce of the Port is not only immense, but more than 350,000 people are carried daily in the ferries which ply back and forth.

Of the 5000 to 6000 vessels which enter the Port in the course of a year, some 200 are great ocean steamships with tonnages ranging from 14,000 to 56,000 tons. The six largest vessels according to Lloyd's Register of Shipping 1932-1933, have the following dimensions:

	<i>Length</i> ¹	<i>Breadth</i>	<i>Depth</i>	<i>Flag</i>
Majestic	915'5"	100'1"	58'2"	British
Leviathan	907'6"	100'3"	58'2"	U. S.
Bremen	898'7"	101'9"	48'2"	German
Europa	890'2"	102'1"	48'0"	German
Berengaria	883'6"	98'3"	57'1"	British
Rex	833'8"	97'1"	47'3"	Italian

These ocean liners are, of course, a very small minority of the ships that use the harbor facilities of New York, but they

¹Note: Length between perpendiculars, that is, from the stem to the fore part of the rudder post.



From Ewing Galloway, N. Y.

THE SOUTH STREET DOCKS ON EAST RIVER, LOWER MANHATTAN, NEW YORK
The wharves and skyline of Brooklyn appear in the background

are both dramatic and important, and their enormous size creates, in the mind of the traveling public, an impression greatly disproportionate to their number. Their dimensions, too, are so great that the normal facilities of the Port are inadequate. Consequently, with each new and larger ship that is launched, new and larger piers and docks must be constructed, in order that the floating giants may be docked properly.

For this reason the City was forced to consider the problem presented by the two enormous ships now being built by the Cunard Line and the French Line, each of which is more than a thousand feet in length, for no piers now in use could care adequately for vessels so enormous.

The restrictions imposed by the War Department on bulkhead and pierhead lines made impossible the construction of piers of the required length, without

cutting deeply into the shoreline. Piers have already grown so long and the traffic in the North, or Hudson River, has grown so heavy, that further extensions of the piers into the river would tend to obstruct the port's proper operation. Consequently, with piers 1100 feet in length absolutely essential, the shore line would either have to be moved back sufficiently to build such piers behind the established pierhead line, or, if this was found impracticable, to move the shore line as far back as possible and make up the deficiency by moving the pierhead line out.

The only site in the waters surrounding Manhattan Island that came near fulfilling these specifications extended from the foot of West 47th Street to West 56th Streets, North River. The use of this site, however, required (1) that the pier slips would have to be cut out of solid rock for a distance of at least 305 feet,

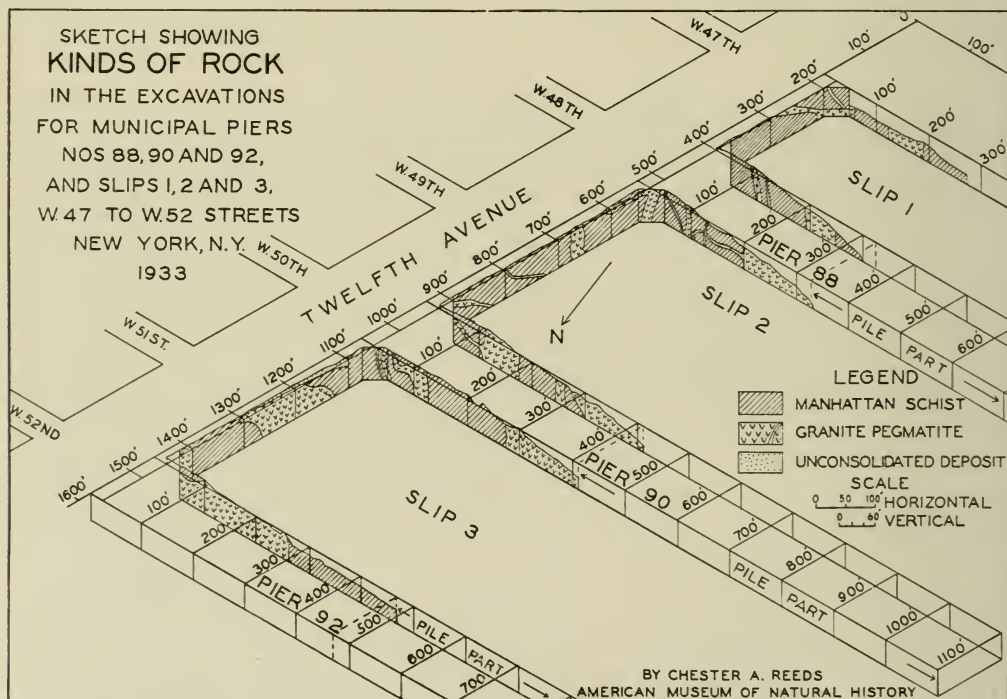

SKETCH SHOWING KINDS OF ROCKS IN 1100-FOOT PIERS, 88, 90 AND 92, NEW YORK. The metamorphosed Manhattan schist and the intruded granite pegmatites show a mixed relation. The unconsolidated deposits consisting of glacial deposits and river silt occur on the surface

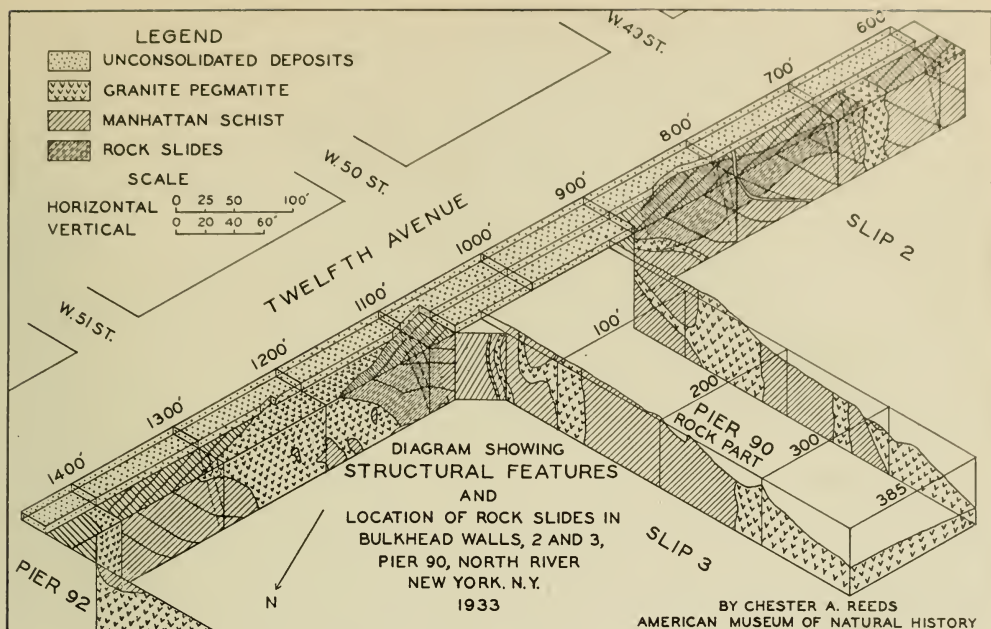

DIAGRAM OF THE ROCK STRUCTURE, PIER 90, NORTH RIVER, NEW YORK

An isometric sketch showing the structural features and relations of the rocks in Pier 90, and adjacent bulkhead walls. Rock slides occurred in the more densely shaded areas

and for some slips more; (2) that a slight extension outward of the existing pierhead line would have to be obtained from the War Department; and (3) that the course of Twelfth Avenue would have to be extended northward for nine blocks from West 47th Street across grounds occupied in part by privately owned buildings.

After due consideration new bulkhead and pierhead lines for the above mentioned site were established by the Secretary of War on January 13, 1931. The territory within the newly approved lines permitted of the erection of five new piers each 1100 feet long and 125 feet wide with accompanying slips each 1100 feet long and 400 feet wide. Plans for the immediate construction of three of the piers and accompanying slips were approved by the Dock Department of the City of New York on July 1, 1931. The contract for the construction of them, however, was not let until November 14, 1931, when the Allen N. Spooner and Son

Construction Company started work on this huge undertaking.

The site faces the Hudson River estuary, which is a drowned river channel filled for the most part with sand, clay, and silt, to a depth near mid-channel, at 32d Street, of approximately 350 feet. Soundings off shore from the pier sites show the depth of the river water to be 60 feet. The concrete wall on the old bulkhead line, established April 25, 1890, by the Secretary of War and which has been for the most part removed, extended in a nearly north-south direction, about 325 feet west of the bulkhead wall of the new slips. A westwardly sloping bed rock surface served as the foundation for this old bulkhead wall. The footing consisted of bags of concrete laid by divers on the natural rock. The wall itself consisted of huge blocks of precast concrete set upon the concrete bags. When removed from the pier slips, the concrete bags and the blocks showed no signs of deterioration although they had been submerged in



PIER 86, AND SITE OF
NEW 1100-FOOT PIERS
Cofferdam, mid center, being
erected; undrained and un-
excavated rock to right

By Ewing Galloway, N.Y.

For the landward or easterly part of each of the slips 1, 2, and 3, earth and rock had to be removed to a depth of 46 feet below mean low tide level. To permit the removal of this rock, a cofferdam 2079 feet long,

brackish water for more than forty years. The part of this wall which extended across the site of Pier 90, has been left standing and will be used as part of the fill required to complete the pier.

Each of the new piers will consist structurally of two parts, namely: (a) the outermost part made of timber piles driven into the river silt, and (b) the landward part composed of natural rock, and rock fill retained by concrete walls. For the southernmost pier, No. 88, the pile part is 795 feet long, the natural rock and fill part 305 feet; for pier 90, the parts are 715 and 385 feet, respectively; and for pier 92, 655 and 445 feet, respectively. Both parts of each pier will have a concrete deck. Above this deck will appear a two-story standard pier-shed superstructure. It will be supported by concrete footings which will be independent of the deck. Reinforced concrete cross-wall fire stops will appear at intervals of 140 feet on the timber portion of the piers.

SITE OF NEW 1100-FOOT
PIERS, OCTOBER, 1933

Rock portions of piers 88 and 90 are completed; concrete facing for pier 92 under way

Courtesy Dock Department, N. Y.



constructed of steel pile cells, was erected in the Hudson River along a line having a depth of 60 feet. The pile cells of the cofferdam were filled with clayey sand; the inshore side was also reinforced by a riprap embankment. When the river water, amounting to about 200,000,000 gallons, was pumped out behind the cofferdam, an area of about 15 acres was laid bare.

The surface of the rock as exposed over this area was somewhat uneven, but in general it sloped westward from 10 feet above sea level at the easterly margin of the pier sites to 46 feet below sea level along the inner margin of the rock fill behind the cofferdam. The amount of earth and rock which had to be removed from this area was immense. It com-



Fairchild Aerial Surveys, Inc.

VIEW OF PIERS 88, 90 AND 92, NORTH RIVER, NEW YORK, MAY 17, 1933

Pile part of piers, in river, outside cofferdam; rock portions of piers and excavations for slips, within a 15-acre enclosure. Photograph supplied by Allen N. Spooner and Son, contractors

prised 648,000 cubic yards, 508,000 cubic yards of rock, and 140,000 cubic yards of earth overburden. The methods used have been described in the August 3, 1933, issue of the *Engineering News Record*. It was accomplished by using a number of air compressors, a large number of drilling machines, a fleet of 30 ten-ton trucks, and a large force of men who worked day and night in three shifts of eight hours each, except from midnight Saturday to midnight Sunday. Along the pier and bulkhead walls the rock was line drilled to a depth of 46 feet with drill holes about 12 inches apart for a distance of about 2900 feet. Between these deep holes intermediate holes were drilled to a depth of 15 feet. The Jackhammer drill was the principal type of drill used in drilling the rock in the pier slips. The blasted rock was dumped by trucks on scows berthed outside the cofferdam. The excavation in Slip 3, the most northerly slip, was carried to a depth of

32 feet below sea level by June, 1933, and then delayed until October, 1933, when an additional 14 feet were removed to provide fill for those parts of the piers which are constructed of rock and reinforced concrete. The floor of each of the three slips is now 46 feet below mean low tide level.

During the excavation of the slips, the natural rock composing the bulkhead walls and intervening piers was left standing as nearly vertical as the conditions of the rock would permit. These rock precipices vary in height from 56 feet at the inshore end to zero at the distal ends near the cofferdam. The rock walls were excavated and benched to sound rock, upon which were built heavy gravity retaining walls. Where conditions made it necessary, battered walls were constructed, and in some portions, steel reinforcements were placed. The engineers propose that these concrete walls built upon the solid rock shall form the foundation for the concrete



By C. A. Reeds, N. Y.

WEDGE-SHAPED LEDGES OF MANHATTAN SCHIST, BULKHEAD WALL, NO. 3

Such V-shaped masses of hanging rock, thick at the top, and often unsupported at the bottom, gave rise to three rock slides along the bulkhead walls, extending from the foot of West 47th to West 52d Streets, New York City

deck and pier buildings which are to be erected.

The composition and structure of the rock varied from place to place in the excavations, and since rock slides occurred in the bulkhead walls of slips 2 and 3, geologists were called to examine and report upon the physical conditions of the rock. For this investigation the Allen N. Spooner & Son Construction Company, contractors, engaged the services of Dr. Charles P. Berkey of Columbia University, and Mr. John McKenzie, Commissioner of Docks of the City of New York, prevailed upon Dr. George H. Sherwood, Director of the American Museum of Natural History, to permit the present writer to represent the City.

In the discussion which follows, special consideration is given to the problem involved, the kinds of rock encountered, and an explanation is offered as to why the slides occurred.

The rock walls left standing for the pier

foundations were found to consist of two kinds of ancient rocks, each having a different origin. They may be designated the *Manhattan schist* and the *granite pegmatite*. The original characters of each of these kinds of rock have been changed or altered by processes of metamorphism. In addition to these two kinds of rock, a third kind was encountered on the surface, which may be called *unconsolidated deposits*, and described as follows:

When the river water behind the cofferdam was pumped out, it was found that the pier sites were covered with a mantle of loose rock composed of layers of glacial drift, river silt, and artificial fill, the combined thickness of which varied from five to more than ten feet. As this unconsolidated material was removed from the pier sites, glaciated rock surfaces were exposed. Many of these surfaces were uneven and exhibited typical rock hummocks, caused by the grinding and scouring action of glacial ice on rocks having

varied structures and different degrees of hardness.

The Manhattan schist which is the predominant rock at the pier site, is the chief bed rock of Manhattan Island. It is frequently met in digging for the foundations of buildings and other structures. Its thickness at the pier site is not known. Borings in this rock in various parts of New York City have reached depths of 1224 feet, and in places it is estimated to be 3000 feet thick.

It is characterized by the following features: It is a dark schistose rock, streaked, strongly micaceous, coarsely crystalline, markedly foliated, and is composed essentially of the minerals biotite, quartz, and feldspar. Red garnet in small crystals is the chief accessory mineral. In places epidote, cyanite, staurolite, and fibrolite are also present. The mineral combination and its structural features indicate that the schist was formed in ancient times by the metamorphism of sediments. This metamorphism of the original sediments must have taken place in the depths of a geosyncline, one of the stages in the evolution of mountains. To produce these features the materials must have been buried some five miles or more below the present surface of the earth, for in addition to closely appressed folds, they show flowage structures and oftentimes segregation of the quartz, feldspar, and mica ingredients into separate bands.

Where the Manhattan schist is unweathered, it affords good foundations for buildings. Where it is weath-

ered, it shows a brownish to rusty appearance caused by the oxidation of the iron present in the biotite. Weathered surfaces appear in the rock along joint planes and on surfaces which have been exposed for a long time. Where the surfaces show glacial markings, the weathering is slight and of no consequence. In long exposed surfaces the weathering may have reached depths of two to four feet, and in some narrow zones, even to forty feet. In fact, in some cases, the decay of the various mineral ingredients may have progressed to such an extent that the rock may be crumbled in the hand. On flat surfaces the decayed rock will carry a load, but on exposed vertical walls it will

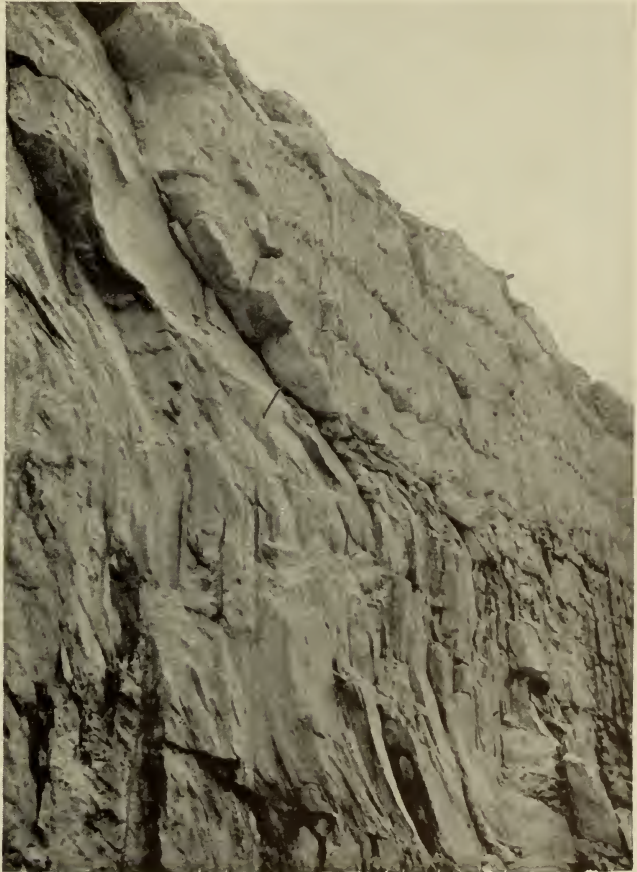

By C. A. Reeds, N. Y.

WEDGE-SHAPED HANGING MASS OF GRANITE PEGMATITE Showing bulkhead wall, slip No. 3, foot of West 51st Street, New York City. The rock is steeply inclined and jointed



By Eric J. Baker, Elizabeth, N. J.

ROCK SLIDE, BULKHEAD WALL, SLIP NO. 2, FOOT OF WEST 49TH STREET, N. Y.

A hanging wedge-shaped mass of Manhattan schist, 75 feet long, slid into the 46-foot-deep excavation on April 28, 1933. Photograph supplied by Allen N. Spooner and Son, contractors

not do this unless it is reinforced.

The granite pegmatites, which are igneous in origin, are abundant in the pier walls, but they do not represent the major portion of the rock mass. They appear in the form of large and small dikes, sills, stringers, veins, and lenses cutting and penetrating the schist. Some of the dikes are from six inches to four feet across, others twelve to one hundred fifty feet in width. The more prominent of these features have been sketched diagrammatically in the accompanying isometric drawing of the pier and bulkhead walls.

The granite pegmatites invaded the Manhattan schist as molten masses of

rock and cooled slowly in the positions they now occupy. In some places the mineral ingredients are typical of a coarse-grained pinkish granite with the grains of quartz, feldspar, and mica scattered uniformly throughout the mass. In other areas they are abnormal in size, being one to two inches across, and appear as bands one or more feet in width, which run up and down through the rock. These large crystal developments are the typical pegmatites. They represent the ducts through which the hot vapors and gases escaped as the molten rock was cooling.

The presence of reddish orthoclase in the granite pegmatites suggest that they have sprung from a source common to the numerous dikes of red pegmatite

found elsewhere in New York City. Their geologic age is still problematical. If they are of the same age as the pegmatites at Bedford, Westchester County, New York, which have recently been determined by the radioactive method to be 380,000,000 years old, then these intrusive igneous rocks are of early Silurian age according to a recent radioactive chart of geologic time.¹ A like age has been recently determined by the same method for similar igneous rocks, namely: for the pegmatites at Branchville, Connecticut, 374,000,000 years, and for the granite at Fitchburg, Massa-

¹Reeds, Chester A., 1931. "How Old Is the Earth?" NATURAL HISTORY, Vol. XXXI, No. 2, and Guide Leaflet Series No. 75. American Museum of Natural History.

PEGMATITE SILL

Undulating surface exposed by rock slide, October, 1933. Bulkhead wall, No. 3, foot of W. 50th Street, New York, N. Y.

Courtesy of Dock Department, N. Y.

achusetts, 360,000,000 years.

The kinds of rock exposed in the site of the 1100-foot piers having been considered, it is well now to dwell briefly on the structural features of the area. The rocks have not only been folded and metamorphosed, but the folds have been so appressed that the rock ledges of the schist stand nearly on edge. The tops of the folds, moreover, have been so completely carried away by river and glacial ice erosion that only the basal parts of the former great folds remain. The axial trend of these folds is slightly east of north (N. 14° E.). In the Manhattan schist, the only rock present which shows banded structures, there are numerous pressure planes and foliation ledges. These dip westward toward the Hudson River at high angles which vary from 55 to 85 degrees, average 78 degrees. These structural features are more noticeable



in the bulkhead walls than in the rock faces left standing for the piers, for in the pier walls the ledges have been cut in cross section and are supported by adjacent ledges. In the bulkhead walls the ledges have been cut on a bevel and appear as sharply pointed long rock slivers, having wide tops and thin lower edges which, in walls 46 feet high, may remain unsupported for distances of 60 to 75 feet.

This slivered appearance of the schist in the bulkhead walls has come about through drilling the rock face in a north-east direction (N. 29° E.), and cutting the ledges at an angle of 15 degrees. Furthermore, the drill has gone vertically downward and cut across successive ledges pitched steeply toward the river; consequently, in the upper part of these newly made walls the ledges were cut, and wedge-shaped masses

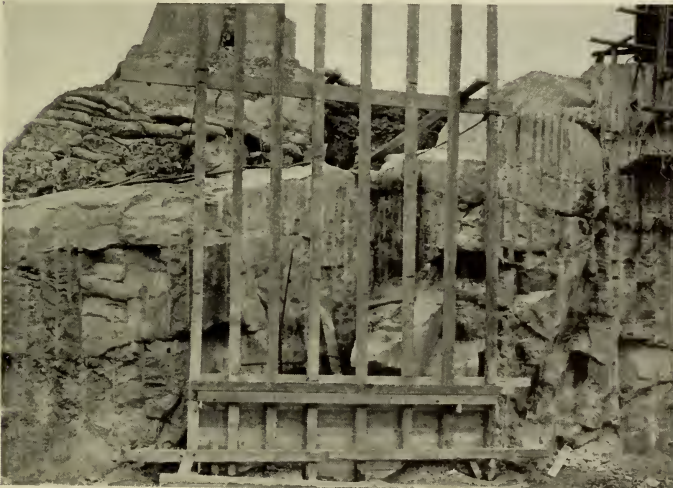

BULKHEAD WALL OF 1890

Resting on bags of concrete, laid by divers on glaciated surface of granite pegmatite, Pier 90, foot of W. 50th Street, New York, N. Y. Photograph supplied by Allen N. Spooner and Son, contractors

By Eric J. Baker, Elizabeth. N.J.



Courtesy Cunard Line

By Airmap Corporation of America, N. Y.

S. S. BERENGARIA DOCKING AT PIER 54, NORTH RIVER, NEW YORK

Large transatlantic liners require numerous tug boats to warp them into position alongside the pier

of rock were left hanging on their schistose surfaces without sufficient basal support to insure a stable wall. The V-shaped outline of these attenuated hanging ledges is shown in cross section in accompanying photographs taken by the author, and in the diagrammatic representation of the structural features in slips 2 and 3.

These structural features, together with the presence of numerous intersecting joint planes, have caused slides to occur in some places along the bulkhead walls. In the northeast corner of slip 2 a large slide occurred April 28, 1933, which was some 75 feet in length and extended from Stations 800 to 875. The part of the wall which slid out was wedge-shaped in cross section, wide at the top with dimensions 15 to 25 feet in width, about 30 feet high, and intersected by a joint plane along the lower margin. When seen in May, 1933, the

inclined schistose plane was highly micaceous and wet with seeping ground water.

Just to the south of the great slide, evidence of another slide appeared between Stations 750 and 800. Here a comparatively smooth inclined surface intersected the line of the wall at an angle of about 15 degrees. A narrow pegmatite dike crossed it obliquely. Since drill marks showed only in the lower part of the wall, and the face of a prominent vertical joint appeared at Station 750, it was apparent that this smooth surface was a plane of schistosity, and that either at the time of blasting, or shortly after, a V-shaped mass of rock, wider at the top than at the bottom, slid into the excavation from the upper portion of the wall.

A slide of large proportions also developed in October, 1933, along the southeast part of the bulkhead wall of

slip 3. Steeply inclined schist ledges, which were unsupported along their lower margins for a distance of 75 feet, slid into the excavation. The inclined surface, which remained, was highly micaceous. An examination of the rock showed that it was the outer surface of an intruded sill of granite pegmatite. The thick sill extended to the bottom of the excavation and was found to be quite stable. In order that the wall line might be straight, this section, as well as the other places where slides occurred has now been faced with battered concrete walls.

Since all of the principal difficulties encountered in the construction of the new 1100-foot piers have now been briefly considered, it may be said that the excavation of the rock in the pier slips and the preparation of the foundations for the new piers have been large, expensive, and noteworthy undertakings. The engineering problems, although great, have not been insurmountable. The chief source of trouble was met in the bulkhead walls where wedge-shaped masses of rock unsupported at the base for distances of 60 to 75 feet either slid or had a tendency to slide into the excavation, some 46 to 56

feet in depth. These features together with numerous joints, which cut the ledges at intervals, caused at least three rock slides. These sections and some other parts of the pier and bulkhead rock-walls have now been reinforced with concrete walls, and it is not expected that any additional geologic or engineering problems will arise.

As this article goes to press, the rock foundations for the three new piers have been completed, the cofferdam is being removed, and the water is gradually being let into the pier slips. As the water rises, a man in a power boat with acetylene torch constantly skirts the pier and bulkhead walls. The blue flame which we see here and there denotes that he is cutting off bits of steel and iron, which project from the face of the reinforced concrete walls. Great skill, constant forethought, and supervision have entered into the construction of these huge structures. They are nearing completion, and as giant ships tie up alongside, incoming or departing passengers will seldom realize what the hand of man has wrought in building these new piers for the Port of New York.



S. S. MAJESTIC, Outward Bound, Hudson River, New York City



EARTHQUAKES

By CHESTER A. REEDS



THE LIBRARY BUILDING, STANFORD UNIVERSITY, CALIFORNIA, AS IT APPEARED
AFTER THE SAN FRANCISCO EARTHQUAKE OF APRIL 18, 1906

Reprinted from Natural History Magazine, December, 1934

GUIDE LEAFLET SERIES, No. 85

THE AMERICAN MUSEUM OF NATURAL HISTORY
NEW YORK, 1934



Earthquakes

An account of the sharp movements of the earth that often bring tragedy to the inhabitants of certain regions, together with an explanation of the instruments that record these movements

by
Chester A. Reeds

Curator of Geology and
Invertebrate Palæontology,
American Museum

THE needles on the seismograph in the American Museum may suddenly, without a moment's notice, begin to trace on moving sheets of paper a threefold series of wavy lines, which represent vibrations that have passed through the earth—somewhere there has been an earthquake and the seismograph is making a graphic record of it. If the shock is sufficiently strong, other seismographs in various parts of the world will inscribe a record of the same quake at approximately the same time. The vibrations from a strong distant quake may continue to arrive for an hour or more; those from a small near-by quake will be recorded in a much shorter time.

An earthquake is produced when the materials composing the earth are broken or displaced. The materials are hard, brittle, and elastic, and they will resist change until the forces acting upon them develop stresses greater than their strength, then they will yield suddenly and produce not only a fracture, but a shock. A sudden yielding of rocks to earth strains may give rise either to a new fracture or to movements along a previously existing fault. When a sudden movement does occur along a new or old fault, the frictional resistance offered by the opposing rock walls no doubt contributes its share to the development of vibrations. Whatever happens, the sudden shock releases energy, vibrations are set up and waves are transmitted through the earth in various directions to seismographs situated at different distances from the point of origin. The greater the dislocation, the greater the vibrations set up, and the greater the distance the waves will travel.

In the United States 62 major earthquakes and many smaller ones were recorded

instrumentally for the year 1933. The average annual number of earthquakes locally sensible to human beings is about 4000. Of this number, about 70 are major quakes capable of instrumental registration over a hemisphere or the entire globe. There are some 200-odd seismological stations scattered over the surface of the earth. Many of these stations contain only a pair of seismographs, the larger stations contain three, four, or more makes of instruments, each with a different degree of sensitivity, and capable of registering, not only the horizontal, but also the vertical components of an earth shock. It has been recently estimated that the number of earthquakes, which probably occur annually, and which are susceptible of instrumental registration, approximate 8000. A limited number of modern seismographs have been in use for the past 35 years. During this period, it has been estimated that nearly 2500 major earthquakes have been recorded, and about 140,000 smaller ones, which may have been felt locally. The number which probably occurred, both large and small, and which may have been strong enough for registration by present-day instruments, may have amounted to 240,000. It may be noted thus that earthquakes are not of infrequent occurrence.

In recent years the citizens of the United States and of other countries have manifested a widespread interest in the occurrence and distribution of earthquakes and in the kinds of instruments which have been devised for recording them. With the gradual increase in the number of seismological stations in various parts of the



Wide World Photograph

A view of the wreckage of the city of Melfi, Italy, after the earthquake of July 23, 1930. Almost the entire Mediterranean is included in the geologically "young" zone that continues across Asia Minor and the Himalayas to the East Indies and beyond

Italy

Taormina, Sicily, looking toward the active volcano, Mt. Aetna, and with the ruins of an ancient Greek theater in the foreground. Taormina and Messina were severely shaken in 1908. The loss of life exceeded 100,000. The famous volcano of Sicily and the fact that earthquakes are not uncommonly felt in the island, demonstrate its geologic youth

Publishers Photo Service





Wide World Photograph

An aerial view showing the ruins of Miyagi, Japan, as they were burning, following the destructive earthquake of March 3, 1933

Japan



Looking across Shoji Lake toward Fujiyama. This particular volcano is quiescent but others in Japan have played their part in the periodic earthquakes that are common in the Japanese archipelago

civilized world, together with the improvements that have been made in the different types of self-recording instruments, there has been a marked increase in the number of earthquakes recorded.

THE COMPOSITION OF THE EARTH

The study which has been made during the past few decades of seismograph records has revealed that the earth has a crust composed of solid material, and that it has a thickness variously interpreted as being 40 to 60 miles in depth. The irregular configuration of the earth's outer surface is a matter of common knowledge. The highest point of land, represented by Mount Everest, has an elevation of 29,141 feet; the greatest depth of the sea, known as the Swire Deep, off the east coast of the Philippines, measures 35,433 feet. The maximum relief of the earth's surface is thus approximately $12\frac{1}{4}$ miles. The average height of the land, however, is but 2,300 feet above sea level, or nearly a half mile, while the oceans have an average depth of 11,500 feet, or a little more than two miles. The difference in relief between the average height of land and the average depth of the oceans is thus 2.6 miles. Only 28 per cent of the earth's surface is above sea level, the remaining 72 per cent being below. In other words, one part is land while nearly three parts are covered by water. This relative distribution of land and water is in keeping with the location of earthquakes, for maps showing the distribution of earthquake epicenters, for periods of one or more years, show that earthquakes are far more abundant at sea than on the land. It has been recognized by geologists and other scientists that the earth's surface has an irregular relief, because of the presence of materials of different densities near the earth's surface. Under the continents the densities, which average 2.67 times an equal volume of fresh water, are less than they are for the materials under the oceans, which are of the order of 3. The average density of the entire earth is considerably greater. It is 5.6 times as much as

an equal volume of water. As a consequence, the materials of the inner parts of the earth must be denser and heavier than those of the outer crust.

We know, too, that the crust of the earth is rigid, although it is composed of materials of different consistencies, for, otherwise, the high areas would slump down and the materials composing them would move forward to fill the valleys, the ocean basins and their deeps, and produce a true spheroid, which would be covered with water to an average depth of about 7,500 feet.

The length of time during which the earth has had this irregular configuration is not definitely known. It has been long and may be of the order of the oldest known rocks, which are now regarded as exceeding a billion and a half years. High mountains such as the Alps, Andes, Caucasus, Himalayas, Rocky Mountains, and Sierra Nevadas have not always been high, for they are of comparatively recent origin geologically speaking; older mountains, such as the Appalachians of the United States, the Caledonian and Hercynians of Europe, have been greatly reduced in height by the action of the agents of erosion during many millions of years. The still older Laurentides of Canada, and the upturned strata of Manhattan Island and the adjacent mainland of New York have been reduced by these same agents of erosion to rolling uplands. Their present relief does not suggest mountains, but their geologic structure does. We may conclude from this evidence that while the high spots of the land and the low places of the sea have not always been where they are now, the relative distribution of the continental land masses and the oceanic basins has, with minor variations, remained more or less constant for vast geologic ages.

WHAT HAPPENS WHEN THE EARTH QUAKES

In regions where large earthquakes occur, it has been noted that either vertical or horizontal changes, or both, take place in the crust of the earth. The amount of change produced at any one time may be of

the order of a few inches or a small number of feet, and have a lineal extent of either a few miles, or as in the San Francisco earthquake of 1906, of several hundred miles. In the course of irregular periods, of long or short duration, earthquakes may recur in the same place or in closely adjacent areas; the combined result of a number of such recurring earthquakes is to produce a well marked change in the configuration of the earth's surface at that place. Earthquakes, which accompany either vertical or horizontal changes in the surface of the earth, are not only happening now, but they have occurred frequently during the past history of the earth. In fact, there is no portion of the earth's surface which is absolutely free of faults, those large fractures, which appear as mute evidence that earthquakes have occurred along them at one time or another during the past history of the earth.

It is also true that during past geologic ages parts of the earth's crust have been either down-warped, uplifted or broken, and in many cases, tilted. Evidence of this may be seen in many of our highest mountains where beds of limestone, sandstone, or shale, which contain fossil remains of shells that once lived in the sea, have been found at high elevations. Volcanoes also periodically bring up molten materials from great depths and pour them out at different elevations on the earth's surface. It would be of interest in this connection if we knew more precisely from what depth this white hot lava arises.

WHERE EARTHQUAKES ORIGINATE

The depth at which earthquakes originate is a problem concerning which we would like to have more precise data. Many earthquakes produce evidence of shift of earth-blocks at the surface of the earth, others leave no trace of such movements. While some earthquakes undoubtedly occur near the surface, with movements extending downward, others appear to be deep-seated. A study of Japanese earthquakes by K. Wadati, 1928, shows that they may be either

shallow or deep-seated. The shallow ones have an average depth of 25 miles, while the deep-seated ones may originate at depths of more than 186 miles. A few other investigators have made studies of this problem with varying results. The studies of B. Gutenberg in 1929 of sixteen different earthquakes show that the focus or point of origin of these quakes lies, with a few exceptions, at a depth of 28 miles or less. Some investigators of this problem say that, if the velocity of propagation of seismic waves through the uppermost layers of the earth's crust were more precisely known, there would be less uncertainty in determining the depth at which earthquakes originate.

SEISMOGRAPHS AND EARTH VIBRATIONS

Seismographs are instruments designed to record the vibrations transmitted through the ground. During a great earthquake two things are apt to happen, namely: (1) There will be a lurch or displacement of the ground, either horizontal or vertical, or horizontal and vertical, the range of which may amount to 20 feet or more. The amount of displacement will not be recorded by the seismograph. It may be determined by resurveying the ground. (2) Vibrations will be set up in the ground.

All earthquakes develop vibrations. The period of the vibrations may vary from a fraction of a second in near earthquakes to 20 or 30 seconds in distant earthquakes. No one seismograph will record all of these varied tremors. Due to limitations in construction and recording, different types of instruments are required for the registration of near and distant earthquakes. A third type of instrument, known as a tromometer, is needed for registering the minute tremors which precede and accompany volcanic eruptions. A fourth type of seismograph is required for those regions where great earthquakes occur, for there the motion is apt to be so strong and vigorous that any machine designed for the registration of other types of earthquakes would be damaged or thrown out of action.

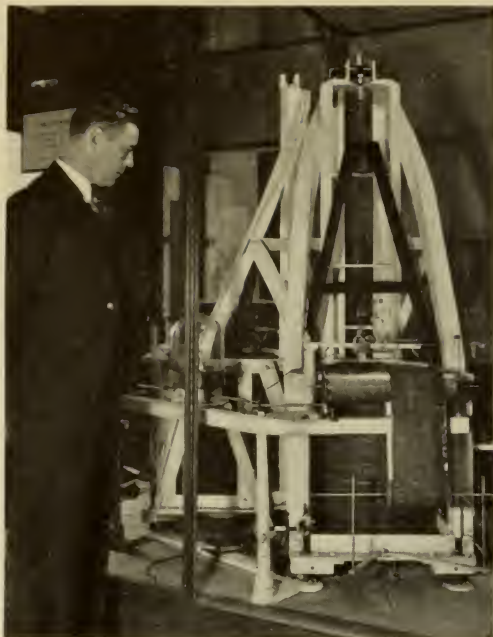

Seismograph

The photographs at the left and below show the seismograph at the American Museum of Natural History. The record which is being examined by the observer below records an earthquake of moderate intensity in the ocean bed on August 29, 1934. So accurate and sensitive are these instruments that though thousands of miles may separate them from the center of the earthquake shock, a study of the record will often determine the quake's location

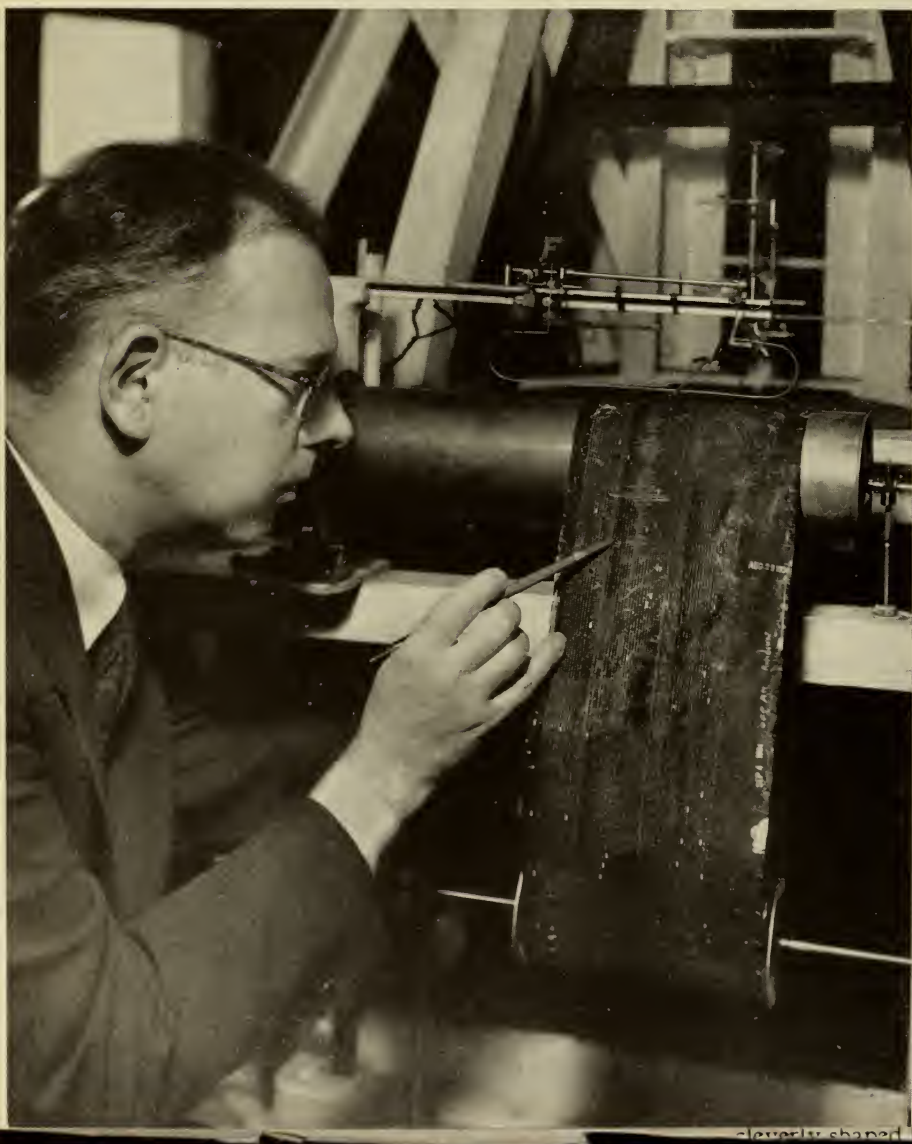

Above: The seismographic record above and the one parallel to it on the opposite page are in reality two parts of one record, made on November 20, 1933, on the American Museum seismograph, recording a quake in Baffin Bay. Seismological stations have reported these shocks as being among the strongest ever recorded

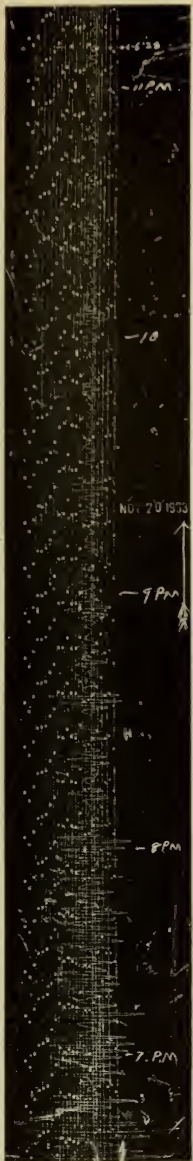

Photograph by Charles C. Mook
 Above: Trouble for a railroad. This view, taken immediately after the earthquake of July, 1925, at Three Forks, Montana, shows the havoc wrought on a railroad line by the displaced masses of rock loosened by the earthquake



Earthquake

A crack in the earth photographed after the earthquake of July, 1925, at Three Forks, Montana, not far from the spot pictured above. Such cracks in the earth are not uncommon after earthquake shocks, and sometimes can be traced for considerable distances

Photograph by Charles C. Mook

Each kind of seismograph consists of five essential parts, namely. (1) the "steady mass" which remains or should remain quiet during the time of an earthquake; (2) the framework which supports the "steady mass"; (3) the recording apparatus; (4) a damping device whose function is to keep the "steady mass" quiet; and (5) a pier constructed in such a manner that it stands free of buildings and is firmly connected to the ground.

THE MAINKA SEISMOGRAPH

In the American Museum installation there are two horizontal pendulums, known as the Mainka seismograph and built precisely alike and set at right angles to each other. One is placed in a N-S direction the other in an E-W plane. The N-S instrument registers the E-W component, the E-W instrument the N-S component of an earthquake movement. The "steady masses" in these two seismographs have been painted black. Each consists of a series of 16 alternating iron and lead discs which have been stacked in such a way that they make a cylinder $15\frac{1}{2}$ inches in diameter and 22 inches high. The weight of each "steady mass" is 450 kilograms or nearly 1000 pounds. Each "steady mass" is suspended from a sturdy angle-iron frame, painted white, which rests upon a concrete pier. The top of the pier, which has dimensions $3' 8'' \times 5' 8''$ and supports both instruments, is level with the first floor of the Museum building. It is not connected with the building, however, for an air space separates them. The pier, which extends downward 24 feet, has its lower half firmly imbedded in Manhattan schist. The upper half of the pier passes through the basement of the building and there it is surrounded by a wall of hollow tile. This tile wall not only protects the pier, but it keeps the air surrounding the pier of a uniform temperature. Air conditioning of seismograph piers is an important matter, for, if not attended to, the seismograph records are apt to show unnatural earth tilts brought about by un-

equal changes in temperature in the piers.

The mode of suspension of the "steady masses" varies in different types of instruments. The "steady mass" may be supported in such a manner that it represents either a common pendulum, an inverted pendulum, or a horizontal pendulum. In these various types of suspension, the equilibrium of the "steady mass" is respectively stable, unstable, and neutral. Of these three types of pendulum the horizontal one offers the least amount of difficulty in providing a "steady mass," which is essential in an accurate seismograph. The horizontal pendulum, therefore, is the one generally used in the construction of seismographs. A door or gate swung on two hinges is a common example of this type of pendulum.

In order that the horizontal pendulum may have a small amount of stability and may return to its initial position after displacement, the axis of support is tilted slightly toward the center of gravity of the "steady mass." Swinging doors and gates also readily come to rest when they are not hung perfectly true.

THE ARRANGEMENT OF THE "STEADY MASS"

In a simply constructed horizontal pendulum the "steady mass" is usually firmly attached to one end of a boom; the other end of the boom, which is free, ends in a steel point which is pivoted in an agate cup near the base of the mast or supporting frame. The weight of the "steady mass" is supported in mid air by a wire stay, which is attached at one end to the weight and at the other to the top of the mast. This mode of attachment not only keeps the "steady mass" free of its supporting frame, but it permits adjustment of the angle which the boom makes to a horizontal plane passing through its pivoted end. This angle affects the period of the instrument, in other words, the number of vibrations which the "steady mass" will make in a second, when touched lightly with the finger. For near earthquakes a period of four to six seconds is suitable; for distant earthquakes one of thirty seconds or even greater is desirable.

In the American Museum installation of the Mainka seismograph the "steady mass" is kept free of the supporting frame by a Y-shaped yoke, the two distal ends of which are attached to the sides of the mass, while the free proximal end is fastened to the frame in such a way that a knife-blade spring is kept under tension. The lower end of the supporting stay consists of a bridle fastened to the two ends of a pipe which passes through the center of gravity of the "steady mass"; the upper end of this support terminates in a wire which is attached to the top of the supporting frame. The suspension is so delicately adjusted that, if the "steady mass" is slightly touched with the finger, it will swing back and forth in a horizontal plane and the vibrations will be registered by the recording needle on smoked paper. From such a registration the natural period of the instrument can be obtained. In this connection it may be stated that a seismograph is most sensitive to those waves which correspond to its own natural period of vibration. The period of the machine is noted at the beginning of every record. New sheets of paper are placed on the instruments, usually at the end of every forty-eight hours.

THE "DAMPER"

The movement of the "steady mass" when touched is just the contrary of what happens when an earthquake occurs; then the earth, the concrete pier, and the white supporting frame vibrate as a unit while the "steady mass" remains quiet, at least for a time, when it may begin, if not damped, to pick up the earth's vibrations transmitted through the supporting boom and stay.

The damper which is placed upon the side of each supporting frame consists of a rectangular metal box, a pair of round air holes near the top with adjustable covers, a sheet of metal within the box which acts as a diaphragm, and a set of rods which connect the diaphragm with the center of the "steady mass." This is an air damper; oil and magnetic dampers are also used on some types of seismographs. The damper

offers resistance to any sudden movement which may take place, especially the tendency of the pendulum to swing in its own natural period when an earthquake occurs.

HOW THE RECORDING APPARATUS OPERATES

The recording apparatus in each instrument consists of a connected series of multiplying levers. One end is attached to the center of gravity of the "steady mass"; the other end is a freely moving well-balanced recording needle which lightly touches a moving sheet of smoked paper. These levers magnify the earth tremors 100 times. In order that the earth movements which pass through the pier and supporting frame may be registered with reference to the "steady mass" which remains quiet, the recording levers are also attached to the center of the "steady mass," the diaphragm of the damper, and to the supporting frame. In addition to the multiplying levers, the recording apparatus in the Mainka seismograph consists of a pair of revolving drums on which sheets of smoked paper 15×90 centimeters in size, and joined at the ends, rotate past the point of the recording needles. The movement of the drums and smoked paper, which is at the rate of 15 mm. per minute, is controlled by a weight and governor. Minute and hour dots are marked on the sheets of smoked paper by a pointer, which is controlled by a master wall clock having electrical contacts.

Normal registration of a Mainka seismograph appears to consist of a series of parallel lines traced by the needle on smoked paper. Actually the needle traces a continuous line of closely appressed spirals, as when a garden hose is coiled up, for the paper moves over slightly as it climbs the higher side of the gently inclined drums.

During an earthquake the needle swings back and fourth across the paper and thus inscribes the vibrations of the earth which usually arrive in three phases known as the First Preliminary tremors, *P*; the Second Preliminary tremors, *S*; and the Main Waves, *L*. In distant earthquakes one or

Publishers Photo Service

The photograph at the left, taken at Compton, California, shows how the wall of a building crumbled away as the result of a quake. Below is a view of San Francisco which in 1906 was fearfully damaged by an earthquake followed by fire

California



cleverly shaped holes

New Zealand

Publishers Photo Service

The photograph at the right was taken at Napier, New Zealand, Feb 3, 1931, while an earthquake was still in action in the vicinity. The view below is at Auckland, which was shaken by the great quake of 1931. New Zealand is periodically subject to earthquake shocks []



two reflections of these waves at the earth's surface may occur, at one-third and two-thirds the distance, and be recorded as superimposed phases. The first case may be designated as PR1, SR1, and the latter as PR2 and SR2. The seismograph record of such tremors indicates not only the paths by which the various kinds of waves reached the instrument, but also the properties of the materials through which the waves passed. The earth thus not only writes its own epitaph, but this inscription is full of meaning and is worthy of our careful inspection. For distant earthquakes, the beginnings as well as the continuation of the different phases of the record are indicated on the seismogram by sudden or gradual increases of amplitude, by sudden change of period, or both, and by the order of succession in which they occur. For instance, it has been determined that the P-waves, the first to arrive, are longitudinal or compressional waves with vibrations in the direction of progress. They are fast and of small amplitude, usually less than a millimeter. Their velocity near the surface is 7 to 8 kilometers per second and their period varies from 5 to 7 seconds. They usually follow a direct path from the point of origin to the recording seismograph, but a curved one, since in passing through, they dip toward the center of the earth where the rocks are denser and their rate of propagation is faster.

WAVES AND VIBRATIONS

The S-waves are transverse or distortional with vibrations at right angles to the direction of progress. They are slower than the P-waves, and have a velocity near the surface of about 4.5 kilometers per second. Their period is 11 to 13 seconds. They follow approximately the same path as the P-waves.

The main or long waves, L, which pass around the surface are complex longitudinal waves. Their velocity is 3 to 4 kilometers per second, depending on conditions. According to N. H. Heck, chief seismologist of the U. S. Coast and Geodetic Survey,

their velocity under the Pacific ocean is about 20 per cent greater than under the continents. Their periods vary greatly and may be as large as 40 or 60 seconds.

The P and S waves of sharp, well defined single shocks can be definitely differentiated on a seismograph record for those earthquakes which originate at places more than 700 miles and less than 7000 miles distant from the recording instrument. Furthermore, with an accurate timing apparatus the times of arrival of these waves can usually be definitely determined on the record, the difference noted, and the distance from the receiving station to the point of origin (epicenter) calculated, or read off from an empirical table or its graph, with an error not greater than 25 to 50 miles. By using the determined distance as a radius, and the location of the station as a center, a circle may be inscribed on a globe, or scaled map, which will pass through the epicenter. Its location on the circle may be determined by applying the same method to distances obtained from two other widely separated stations, using one or the other of those stations as the center of the second and third circles. The point of intersection of the three circles, or the center of the triangle formed by them, will be the location of the epicenter. The use of the duration of the first preliminary tremor for determining the position of the epicenter of a distant earthquake is known as the Zeissig method. It is the one used by most observers. Other methods are sometimes used but they require special apparatus.

Whatever method is used it may be noted that since 1899 there has been an ever-increasing accuracy in locating earthquakes, especially those 700 to 7000 miles distant from recording stations. The location of the main seismic areas is now well known—one belt extends around the margins of the Pacific Ocean, another forms a great circle about the earth through the Mediterranean-Caribbean regions. Other areas of frequency are less well defined, for isolated occurrences are common in many parts of the world, except

H. Armstrong Roberts, photo

Extending in a vast horseshoe from Cape Horn up the coast of the Americas across to Asia and down to the East Indies is a great band which includes mountains and islands of geologically recent formation. Most of the West Indies also are included in this region throughout which earthquakes are occasionally experienced. The view on the right was taken on the island of Puerto Rico, and the photograph below shows the Chilean Andes rising abruptly from the sea



Publishers Photo Service





Athens

A view of the city from the top of the Stadium. Both Greece and Palestine occasionally feel the effects of earthquakes, for old though these regions are in the history of civilization, they are comparatively young as the geologist measures the age of the earth.

Right: A view of the Temple of Jupiter with some of its fallen columns. Many of the Greek ruins have been brought to their present condition by earthquakes

Publishers Photo Service



in the polar regions, where few earthquakes have been registered during the past thirty-five years.

For near-earthquakes, that is, those that occur within 10° , or 700 miles, of the epicenter, there is no separation, on most seismograph records, of the primary waves, P, and of the secondary waves, S, and it has been suggested that for this distance each wave possesses both types of characters. In other words, the characteristic features of these waves, condensational on the one hand and distortional on the other, are not differentiated on seismograph records made by instruments designed and set for those quakes originating 700 to 7000 miles away and known as distant quakes. Specially constructed instruments are required to separate P and S waves of near-earthquakes.

Those far distant earthquakes, which originate 7000 to 10,000 miles or farther from a recording station, do not register the P waves, as the first recorded impulses, since these waves are refracted at a depth of 2900 kilometers (1802 miles) into the inner core of the earth and produce by their refractions what is known as the "blind zone." Such refracted waves, when recorded, are designated at P' waves. The velocity of these waves just outside the central core is 13 kilometers (8 miles) per second; inside it is 8.5 km. (5.3 miles) per second.

So far as we know the S-waves originating 7000 to 10,000 miles distant do not emerge from the inner core and we may assume, since they are not transmitted through substances in a liquid or gaseous state, that the inner core, with radius 3470 km. (2157 miles) or .55 of the radius of the earth, is in a liquid or gaseous condition and composed of a molten mixture of the heavy metals iron and nickel.

The study of distant earthquake records has indicated that the surface of the inner core is a well marked surface of discontinuity, and that it refracts or reflects the waves which meet it. Some four other less pronounced discontinuities separate the zones of the earth which appear above it.

The one appearing at a depth of about 60 kilometers (37 miles) is well marked in many seismograph records. It is the lower margin of the crust of the earth.

These planes of discontinuity change the path and energy of earthquake waves.

PROBLEMS TO BE SOLVED

The foregoing discussion gives a brief resumé of the general status of our knowledge concerning the earth's interior, the propagation of earthquake waves, and the significance of seismograph records. While various seismological investigations have been carried on during the past thirty-five years, which have thrown a flood of light upon hitherto unsolved problems and hidden features of the earth, we would like to know more about the earth's interior, the elastic properties of the earth, the conditions which produce earthquakes, and the composition and structure of the layers composing the crust. Geological observations on surface indications during the past 150 years lead us to believe that the crust is composed of numerous layers of rock which are variable in number, extent, origin, structure, and composition. The recent development of seismic prospecting for oil and other minerals and the effect of the propagation of earthquake waves on buildings and other structures emphasize the importance of these researches. Daily observation and studies are being conducted by various organizations. In the United States they are being carried on by the National Government through the Coast and Geodetic Survey with the cooperation of the Weather Bureau, the Geological Survey, the Bureau of Standards, and the National Research Council. Other organizations are also cooperating, such as the Carnegie Institution of Washington, the Jesuit Seismological Association, and the various universities, colleges, and museums in different parts of the country. The ultimate aim of this study is a better understanding of the elastic conditions of the earth.

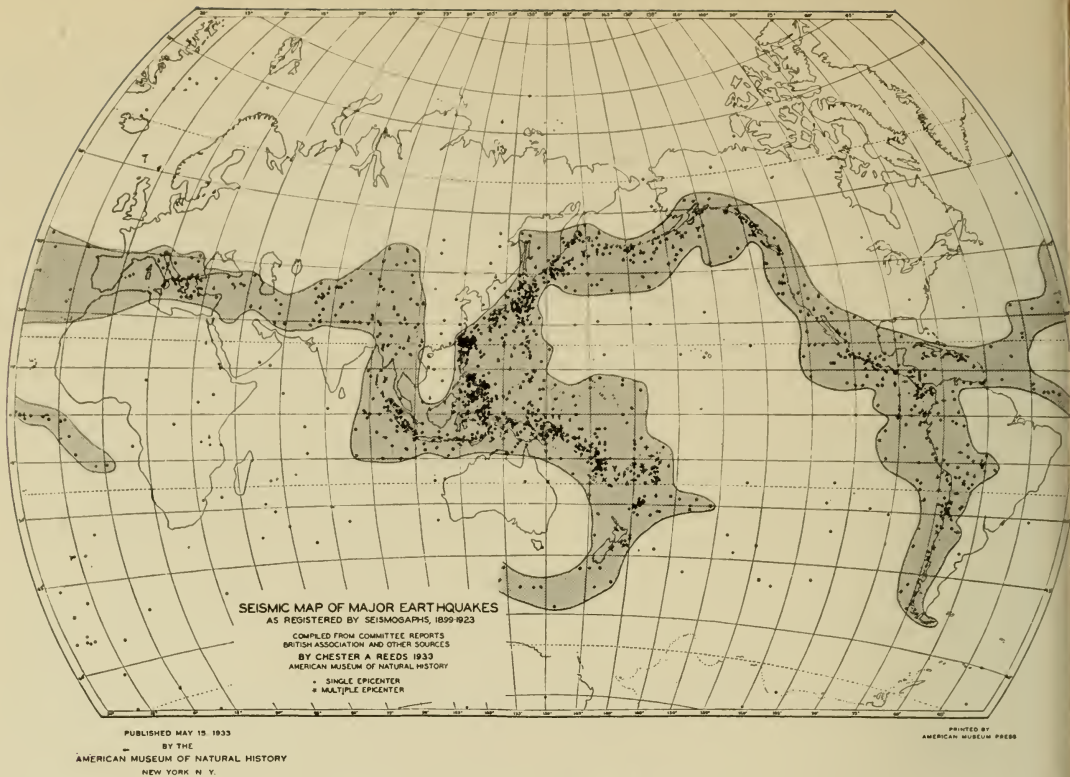

A SEISMIC MAP OF THE WORLD

BY CHESTER A. REEDS

This map shows the epicenters of 1783 major earthquakes. These large earthquakes were recorded at various seismological stations during the twenty-five-year period 1899-1923. The data for the map were compiled from the reports of the Seismological Committee of the British Association, the Canadian Observatory, the Seismological Society of America and other organizations.

The solid black dots show the location of single major disturbances. The circles with one or more radiating rays indicate places where large earthquakes have been repeated at different times during the twenty-five-year period. Each ray represents a recurrence. Some circles have as many as sixteen rays. Major earthquakes are usually produced by pronounced movements along fault planes. They generate waves of sufficient intensity to pass through the earth and be recorded at seismological stations situated at points more than half way around the earth from the place of origin. Those numerous minor quakes which are recorded by nearby stations and which may have exceeded 100,000 in number during the twenty-five-year period, are not shown on the map. If they had been plotted they would show a more widespread distribution. Most of them, however, would be confined to the shaded zone which represents those belts of the earth where the highest and youngest mountains and deepest troughs of the oceans occur.

The map shows that most earthquakes originate in rocks beneath the oceans and that they are confined for the most part to two great belts, one running from west to east through the Mediterranean and Caribbean Seas and the other adhering to the margins of the Pacific Ocean. The ancient shields of the continental masses, which include the great ice wastes of the polar regions, are underlaid by old rocks which are, for the most part, free of earthquakes.

Prior to the development of modern seismology by John Milne and his associates in the late Nineties, our knowledge of the occurrence of earthquakes was confined to the destruction wrought by them on land. From instrumental records, we now know that most earthquakes originate beneath the oceans and in those parts of the land where geomorphic changes are taking place in the crust of the earth.



INTRODUCTION TO HUMAN ANATOMY

By

WILLIAM K. GREGORY

and

MARCELLE ROIGNEAU

GUIDE TO SECTION I OF THE HALL OF NATURAL HISTORY OF MAN

SCIENCE GUIDE No. 86

THE AMERICAN MUSEUM
OF
NATURAL HISTORY

1947

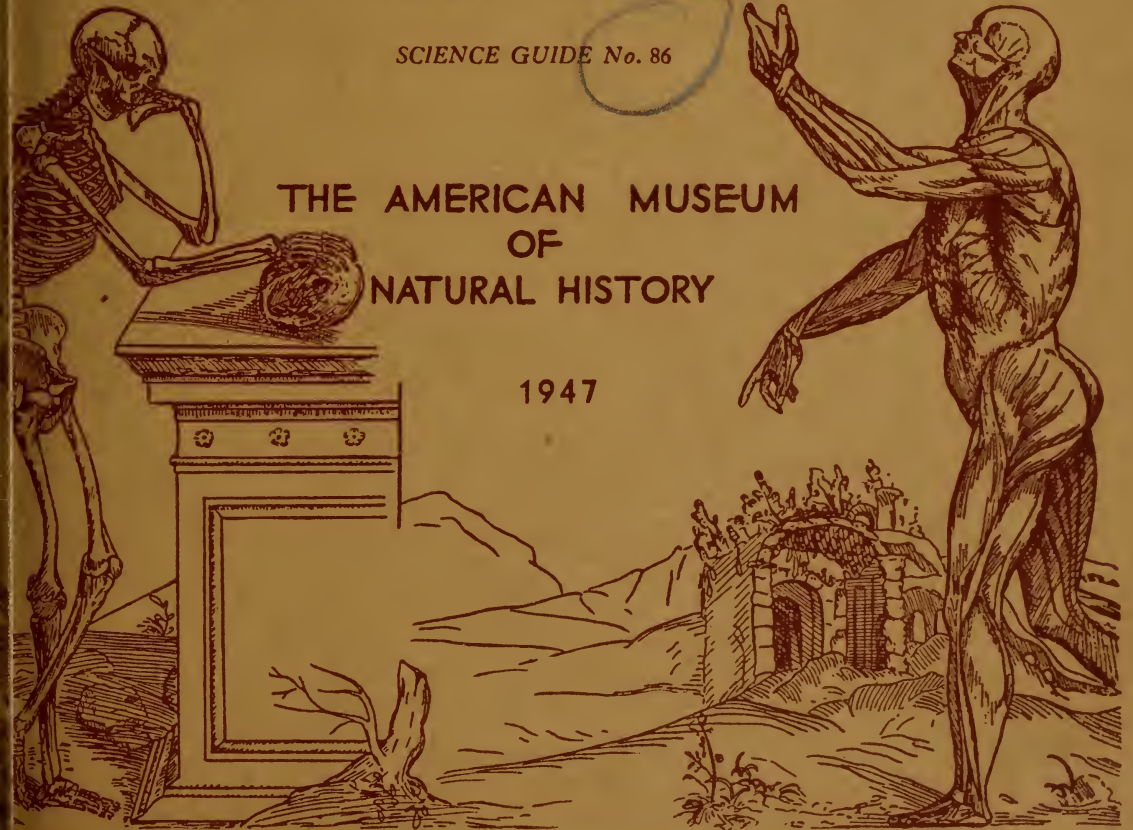

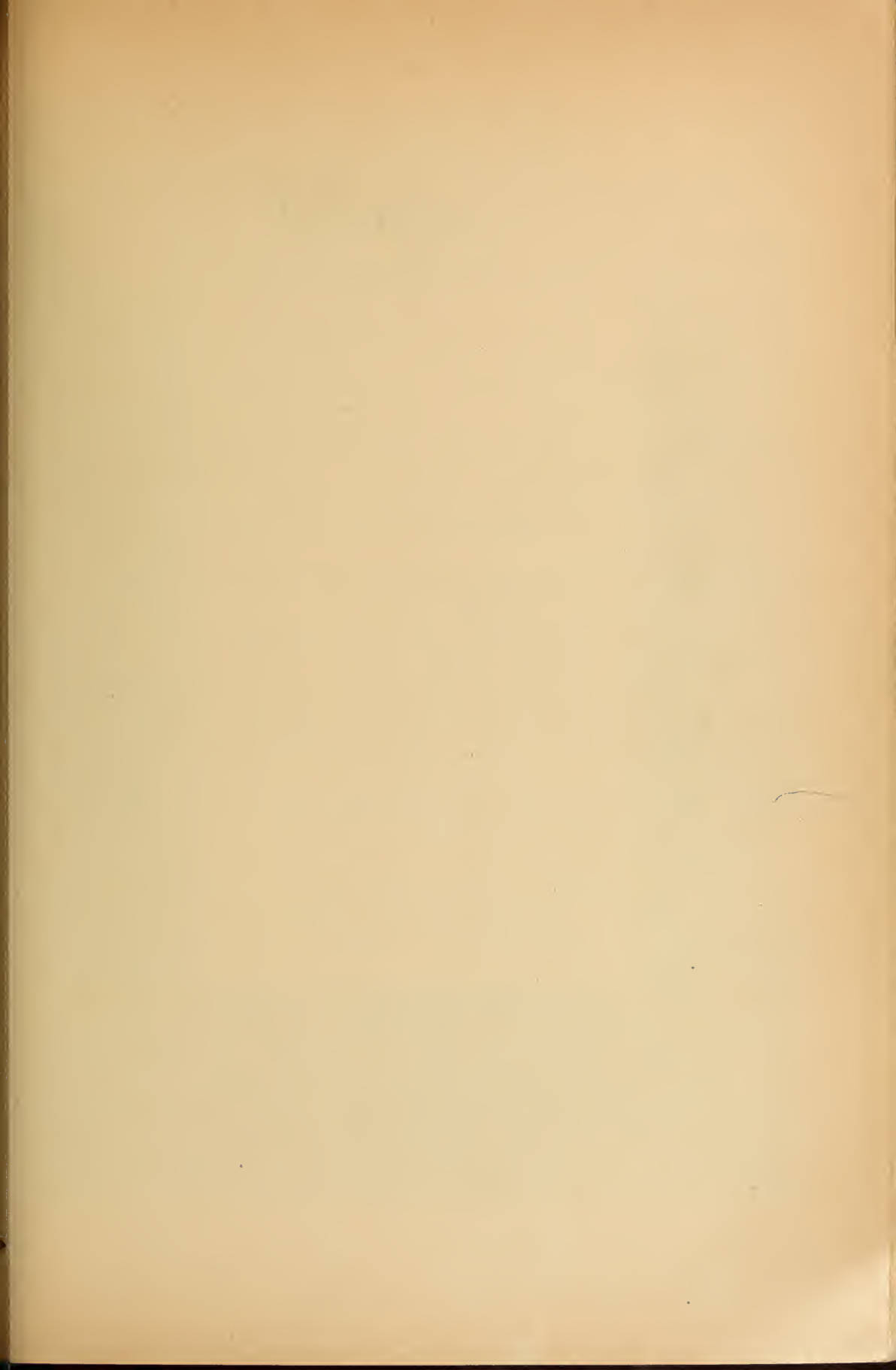

The EVOLUTION OF ANATOMY



THE SCIENCE OF ANATOMY SPRINGS FROM TWO MAIN SOURCES: FIRST, MAN'S SEARCH FOR THE CAUSES OF HIS BODILY PAIN; SECONDLY, FROM HIS CURIOSITY ABOUT HIMSELF. THE FIRST MOTIVE GIVES RISE TO SURGERY, OR APPLIED ANATOMY, AND MEDICINE; THE SECOND TO COMPARATIVE ANATOMY, OR MORPHOLOGY. THIS DEALS WITH THE STAGES THROUGH WHICH A GIVEN ORGAN HAS PASSED DURING ITS EVOLUTION.

AMONG THE ANCIENTS ANATOMY WAS LARGELY MIXED UP WITH ASTROLOGY AND OTHER FORMS OF FORTUNE TELLING AND MADE COMPARATIVELY LITTLE PROGRESS UNTIL ARISTOTLE (BORN 384 B.C.) LAID THE FOUNDATIONS OF COMPARATIVE ANATOMY, AND GALEN (129-199 A.D.) FAIRLY OPENED UP THE SCIENCE OF ANATOMY, PARTLY ON THE BASIS OF HIS DISSECTIONS OF THE BARBARY APE.

AFTER A LONG ECLIPSE OF ANATOMY DURING THE DARK AGES (200 TO 1050 A.D.) THE SCIENCE WAS REVIVED AT BOLOGNA, PADUA AND OTHER UNIVERSITIES OF THE MIDDLE AGES.

THE GREAT ARTIST LEONARDO DA VINCI (1452-1519) LEFT BEHIND HIM A SERIES OF WONDERFUL DRAWINGS OF HUMAN ANATOMY. HE WAS FOLLOWED BY VESALIUS (1514-1564) THE FOUNDER OF MODERN ANATOMY.

AMONG THE GREATEST ADVANCES IN MODERN ANATOMICAL KNOWLEDGE MAY BE MENTIONED THE FOLLOWING:

- (1) THE DISCOVERY OF THE CIRCULATION OF THE BLOOD BY WILLIAM HARVEY (1616).
- (2) THE INVENTION AND DEVELOPMENT OF THE MICROSCOPE AND OF MICROSCOPIC ANATOMY, OR HISTOLOGY BY LEEUWENHOEK (1632-1723) AND HIS SUCCESSORS. THIS HAS MADE POSSIBLE THE MODERN SCIENCE OF EMBRYOLOGY, GENETICS, EXPERIMENTAL BIOLOGY, ENDOCRINOLOGY, ETC.
- (3) THE FOUNDED OF MODERN COMPARATIVE ANATOMY AND PALAEOLOGY BY CUVIER.
- (4) THE DISCOVERY OF THE "ECHELLE DES ETRES" OR SCALE OF LIFE AMONG RECENT FORMS, BY BUFFON, LAMARCK, DARWIN AND THEIR SUCCESSORS. THIS GAVE NEW LIFE AND MEANING TO COMPARATIVE AND HUMAN ANATOMY.
- (5) THE DISPROOF OF THE DOCTRINE OF THE FIXITY OF SPECIES AND THE ACCUMULATION OF PROOF THAT DURING THE COURSE OF AGES THE HIGHER ANIMALS HAVE BEEN DERIVED FROM LOWER TYPES BY DESCENT WITH MODIFICATION, BY CHARLES DARWIN (1859) AND HIS SUCCESSORS.

THUS THE HISTORY OF THE STRUCTURE OF MAN BECOMES PART OF THE HISTORY OF THE VERTEBRATES IN GEOLOGIC TIME.

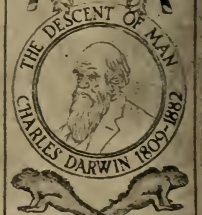

INTRODUCTION
TO HUMAN ANATOMY

A GUIDE TO SECTION I
OF THE HALL OF THE NATURAL HISTORY OF MAN

By
WILLIAM K. GREGORY

and
MARCELLE ROIGNEAU

REVISED BY W. K. GREGORY AND H. C. RAVEN

Fourth Printing

Science Guide No. 86

NEW YORK CITY
The American Museum of Natural History
1947

CONTENTS

	PAGE
PREFACE	3
THE SUN, SOURCE OF ENERGY	4
THE LIVING CHEMICAL ENGINE	6
What the Body is made of	8
Digestion and Absorption	10
Blood Corpuscles	11
The Solar Energy utilized by the Muscles	14
Heat Regulation	14
The Main Pump of the Body	15
The Living Bellows	16
The Ductless or Endocrine Glands	16
MAN AMONG THE VERTEBRATES	20
Organ Systems of Shark and Man	21
Elements of the Locomotor System	25
The Skeleton from Fish to Man	28
Upright Posture and its Maintenance	30
The Pectoral and Pelvic Girdles	32
Hands and Feet	36
THE FACE FROM FISH TO MAN	42
Facial Muscles	43
Evolution of the Human Skull	45
Evolution of the Jaw Muscles	47
Evolution of the Jaws	49
Evolution of the Auditory Ossicles	51
Evolution of the Molar Teeth	52
THE NERVOUS SYSTEM AND ITS FUNCTIONS	54
Elements of the Nervous System	54
The Brain	57
Sensation	57
Response	66
EPITOME	68
SELECTED REFERENCES	71
CHARTS—Showing Comparative Embryology and Phylogeny	75-76-77

PREFACE

The exhibits on the south side of the hall are designed to give an introduction to human anatomy, to show by simple examples how the machinery of the body works, and especially to trace the origin and rise of the principal systems of organs.

The synopsis of the exhibits is as follows:

How man, like other organisms, derives his life-energy from the sun and how he spends it (Case I).

The ground-plan of each of the main organ systems of man is present in such a primitive form as a shark (Case IIA).

The evolution of the motor system, from its simple beginnings in the fish to the upright-walking motor system of man (Cases IIB, III, IV, and VA).

Embryology, or development of the body before birth (Case VB).

The history and origin of the human face, the skull, jaws and teeth (Cases VI and VIIA).

Chief characters of the nervous system, including the organs of sensation and response (Cases VIIB and VIII).

The wall charts show man's place among the vertebrates.

This Hall, although not completed, was opened to the Public in August 1932, in connection with the Third International Congress of Eugenics.

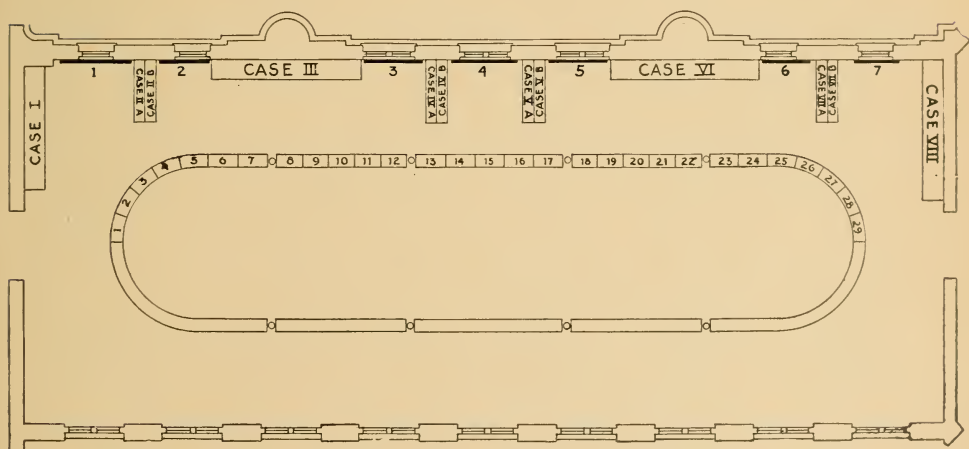

FLOOR PLAN OF THE HALL. The numbers are those which may be found marked on the cases



THE SUN

Chief Source of Human Energy

Man, like other animals, draws his supply of energy from the sun.

The sun is the source of the energy stored up in plants. It is the leading factor in the forces which have made the earth fit for human habitation. Without the sun man could never have appeared; without it he could not survive a moment.

Man, however, cannot absorb the sun's energy directly, as the plants do; he must take it in his food, thus appropriating it from other animals and from plants.

The green coloring matter (chlorophyll) of plants has the power of absorbing some of the red, blue and violet rays of the sun, using them to transform raw materials into food for the plant's growth.

These raw materials are carbon dioxide, which the plant takes from the atmosphere, water, dissolved nitrates and other salts, which it draws up from the soil.

When the chlorophyll, with the aid of the sun's rays, breaks up these substances, the carbon is pulled out of the carbon dioxide and the hydrogen out of the water.

After a complex series of chemical reactions the finished products appear as sugar, starch and other carbohydrates, fats and proteins, which are the food-stuffs of both plants and animals.

Every animal is endowed with the power of locomotion so that he may either pursue the prize or flee from those who would wrest it from him. And when he has overtaken it he devours it, that it may sustain his life. But that he may know what to eat and what not to eat, when to run and when to fight, Nature has bestowed upon him a keen eye and an understanding brain.

Thus the energy of the sunlight, stored up in the substance of plants and animals, becomes a hidden treasure of great worth, to obtain which all animal life labors and struggles unceasingly.

THE LIVING CHEMICAL ENGINE

(CASE I)

The human body is often compared to an automobile: the consumption of food recalls the combustion of the fuel; the contraction of the muscles is like the action of a piston on a shaft; also unless the products of combustion are thoroughly eliminated the machine becomes choked with its own waste. Such a comparison, however useful, is quite inadequate, for the body, considered as a living organism dominated by its own control system, is infinitely more complex than a lifeless machine.

The body has also been likened to a whirlpool, which is constantly seizing upon new inert matter from the outside, whirling it around and then ejecting it. The body is also like the flame of a candle, which lives only as long as its food supply lasts and its wick holds out. But it is rather to be considered as a conscious flame that seeks out suitable fuel and makes its own wick.

By means of its cells the body as a whole has the properties of IRRITABILITY, MOTION, METABOLISM¹, GROWTH and REPRODUCTION, common to living organisms.

The body is first of all a commonwealth of active living cells that dwell in the midst of non-living substances which they have secreted; or they float in a watery fluid or lymph.

A cell is normally a mass of protoplasm containing a nucleus, or center of cell activities. Protoplasm itself in its most typical form is a colloidal or jelly-like substance permeated with globules. It contains much water, a little salt in solution and chiefly proteins, or nitrogenous compounds, in suspension and fat droplets in emulsion. The cells are separated by membranes or walls; these membranes permit varying concentrations of certain chemical compounds in the cell; they are also like filters in straining out insoluble substances; by OSMOSIS the membranes also permit the passage of fluids of different degrees of acidity in opposite directions. The motive force of all these movements, as well as the contractility of muscle cells, is to be found in the various electric charges of the different kinds of aggregates of molecules, especially of the very complex protein molecules.

All the activities of the body are dependent upon these and similar conditions.

¹The process of breaking down and building up organic substances.

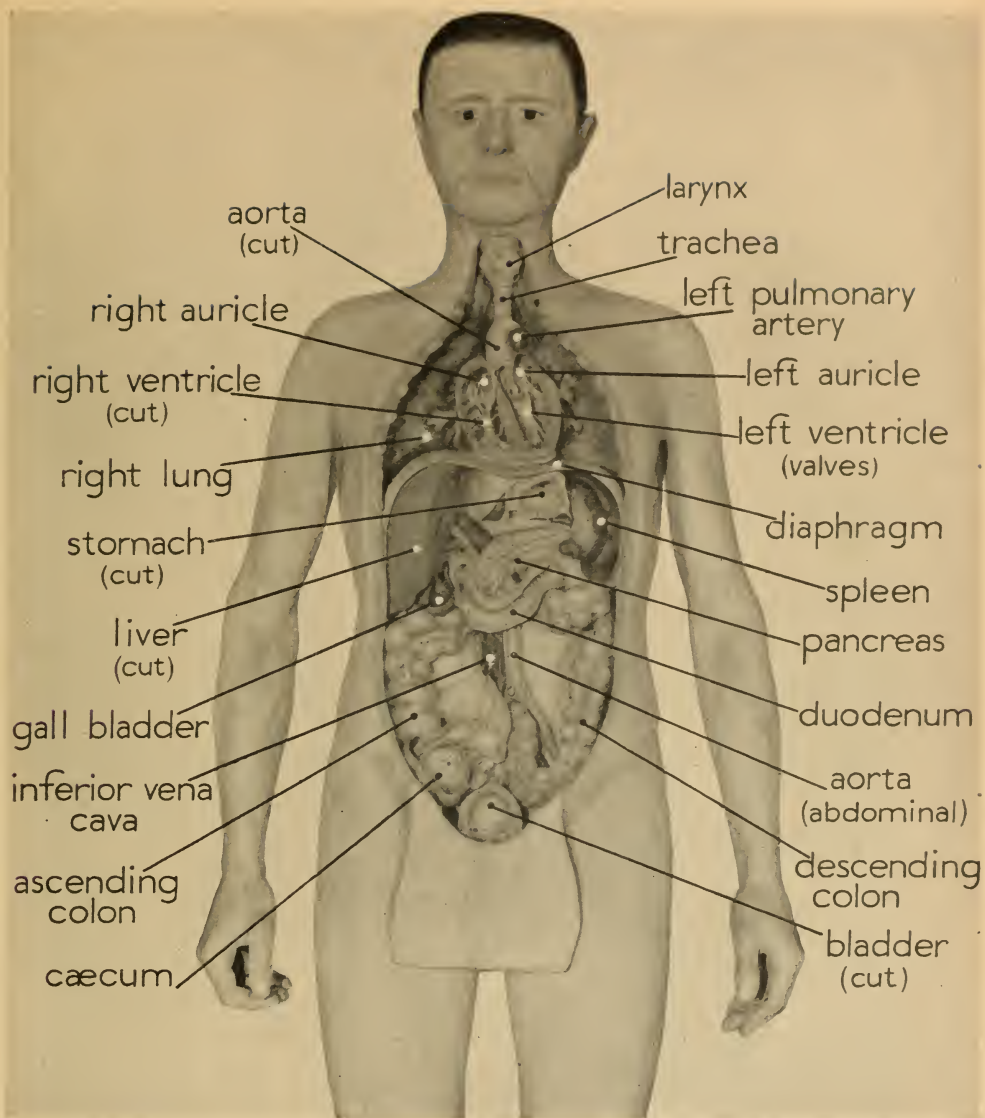

FIG. 1. THE HIDDEN PARTS OF THE HUMAN ENGINE. Model showing the interior of the chest and abdomen, after the removal of the stomach and other organs. Based chiefly on the plates in Spalteholz' Hand Atlas of Human Anatomy. Model by Christopher Marguglio

INTRODUCTION TO HUMAN ANATOMY

All cells in the body have been derived by subdivision from the single zygote or combined male and female sex-cell; nevertheless they have become differentiated by regions into manifold tissues, with diverse chemical and physical properties.

WHAT THE BODY IS MADE OF

WATER	FATS
CARBOHYDRATES	INORGANIC SALTS
PROTEINS	VITAMINS

These chemicals make up the food we eat and are therefore what we ourselves are made of.

Water heads the list, forming about 65 per cent of the body weight. Water circulates in all our arteries, veins and lymph vessels, carrying other substances in solution and in combination; it dissolves the food and is an indispensable element in digestion; it washes out injurious products through the kidneys; it forms a greater or lesser part of all the bodily tissues. Water comes into the body in all food and drink; it escapes as vapor from the lungs and skin and goes out as liquid in the urine and feces.

Carbohydrates. The energy of the sun's rays, when passed through the green coloring matter of plants, builds up water and carbon dioxide (CO₂) into glucose and other forms of sugar, and into starches. These carbohydrates taken in as food must all be reduced, through the process of digestion, to glucose, a simple sugar, before being carried by the blood stream to the liver and the muscles. Most of the energy of the carbohydrates is used as fuel for the muscle engines.

Proteins. Proteins are very complex compounds of carbon, hydrogen, oxygen, and nitrogen; most of them also contain sulphur and some contain phosphorus. Albumen, or white of eggs, is a protein in a weak salt solution.

Plants draw up nitrates from the soil and combine their nitrogen with carbon dioxide and water to form amino-acids, which are in turn built up into different plant proteins.

The animals, including man, are not able to form amino-acids from such simple materials; herbivorous animals must obtain amino-acids in the form of "vegetable proteins"; carnivorous animals rely chiefly on "animal proteins"; omnivorous animals, including man, can use both.

In the course of digestion these proteins taken in as food are decomposed by a series of hydrolyses¹, into their respective amino-acids, which are then

¹*Hydrolysis*: from Greek *hydros*, water and *lysein*, to loose.

INTRODUCTION TO HUMAN ANATOMY

absorbed into the blood stream and carried first to the liver; then they are distributed from the liver to the various tissues of the body, where they are built up into the characteristic proteins of the particular tissues.

The wide geographic distribution of mankind is partly dependent upon man's ability to eat many kinds of food and to utilize them all either for work or for the storage of energy.

Fats. These are compounds of carbon, hydrogen and oxygen. By the action of the pancreatic juice and the bile the fats taken in as food are split into glycerol $C_3H_5(OH)_3$ and fatty acids; these are then absorbed by the intestinal epithelium where they are recombined into neutral fats. Then instead of passing directly into the blood stream, they are taken up by the lymph vessels as chyle and are poured with the lymph into the blood from the thoracic lymph duct.

However, most of the fat stored in the body is the product of the synthesis of any excess of carbohydrates that may occur.

INORGANIC OR MINERAL SALTS

(Not Sources of Energy)

Calcium. When bone is burned, lime (calcium oxide) is left in the ash along with other "earthy salts." Calcium phosphate ($Ca_3(PO_4)_2$) forms most of the hard parts of the skeleton. Also to a less extent calcium carbonate ($CaCO_3$). Weak solutions of calcium chloride ($CaCl_2$), sodium chloride ($NaCl$) and potassium chloride (KCl) are essential for alternate contraction and relaxation, or tonus, of the heart muscles. That is, the rhythmic beating of the heart depends partly on the antagonistic action between these salts. Such antagonistic reactions between salts are probably requisite for the maintenance of the proper degree of permeability in cells. For example, calcium has a balancing or compensating effect on metabolism. Milk is especially rich in calcium; but many other foods contain small amounts of it.

Sodium chloride, or common salt, occurs in the blood plasma and other fluids of the body. *Potassium*, on the other hand, occurs most abundantly in the soft solid tissues, the corpuscles of the blood, the protoplasm of the muscles, also in certain secretions, e.g., milk. Most vegetables are rich in potassium.

A conspicuous function of the salts in the tissues is the maintenance of the normal osmotic pressure. The plasma, or clear fluid of the blood, consists of about 90 per cent water, 9 per cent proteins and .09 per cent salts. Sodium chloride is excreted through the kidneys. Potash (potassium) salts

INTRODUCTION TO HUMAN ANATOMY

tend to cause the loss of sodium and chlorine. The craving for common salt (sodium chloride), when one is eating vegetable food, especially potatoes, tends to correct undue loss of chlorine and sodium.

Phosphorus enters into the nucleo-proteins of the cell nuclei, which are very active in metabolism and growth. Phosphorus is an important element of the nerve cells, and particularly of the skeleton. Many foods contain phosphorous compounds, especially milk and egg yolks.

Chlorine is found both in the chlorides of the blood stream and in the hydrochloric acid of the stomach. This acid seems to be formed through the decomposing action of a certain protein on sodium chloride in the presence of carbon dioxide.

Iron is present in excessively small quantities in red blood corpuscles, where in combination with carbon, hydrogen, nitrogen and oxygen it forms hæmatin, which in turn is united with a protein, "globin," to form hæmoglobin. This extremely complex substance contains several thousands of atoms of carbon, hydrogen, nitrogen and oxygen to every one of iron. Hæmoglobin carries oxygen from the lungs to the tissues of the body. Iron is present in certain foods, especially in egg-yolk, barley, spinach and liver.

Iodine. This element is very important in the secretions of the thyroid gland.

Vitamins ("accessory food-stuffs") are organic food materials, not in themselves significant sources of energy but essential, in some way not yet definitely known, to normal metabolism; e.g., children whose food lacks vitamin D develop rickets, while want of vitamin C causes scurvy.

DIGESTION AND ABSORPTION

In chemistry a substance is said to be "digested" when it is exposed to the action of hot liquid. Digestion is also defined as a process of HYDROLYSIS, the breaking-up or decomposition of a complex substance, some of whose parts unite with the hydrogen and oxygen of water. Water is therefore an absolute necessity for digestion.

The diagrams (Fig. 2A, B) indicate how the several divisions of the digestive tract pour certain reagents into the food-containing solution.

The complex carbohydrates, fats and proteins of the food are thus broken down into simpler substances, such as glucose, fatty acids, amino-acids, etc. These soak through the mucous membrane of the intestine and are reconverted into such forms of carbohydrates, fats and proteins as can be assimilated by the body; after being absorbed by the walls of the capil-

INTRODUCTION TO HUMAN ANATOMY

lary blood-vessels of the digestive tract (except the fats which are first taken up by the lymph vessels), they are carried eventually to the heart, whence they are pumped to all parts of the body.

BLOOD CORPUSCLES

(The Currency of the Body)

The energy contained in the food-stuffs is carried to the billions of the body's cells by the circulating medium, including the blood and lymph streams. The blood stream also carries the oxygen from the lungs to all the tissues of the body. The principal units of the circulation are: the red blood corpuscles, the white blood corpuscles and the blood-platelets. All these float in the watery plasma of the blood.

The red blood corpuscles (erythrocytes) are extremely minute, there being about five million in one fifteen-thousandth of a cubic inch (= 1 cubic millimeter); also they are so numerous that a man weighing 154 pounds has in his blood about 30,000,000,000,000 of them, which if spread out side by side would cover about 4,400 square yards.

The red coloring matter, or hæmoglobin, consists of an iron-containing pigment combined with a protein. Hæmoglobin has the power of carrying oxygen from the lungs, of giving it up to the tissues and of receiving from them the waste gas, or carbon dioxide, which is again carried to the lungs to be given off into the outer air. The red blood corpuscles originate in the red marrow of certain limb bones.

In man, as in other mammals, the red corpuscles at first have a nucleus but later expel it.

The white blood corpuscles (leucocytes) are amœba-like cells which can pass through the walls of the capillary blood vessels to form the pus or matter of inflamed parts. There are several kinds of leucocytes. One kind, called microphages, derived from cells in the red bone-marrow, engulfs and devours foreign bacteria in the blood stream and thus protects the body against certain diseases. Others, called lymphocytes, are necessary in elaborating some of the food-products so that they can be taken up by the tissues. These originate in the lymph glands.

The blood-platelets are exceedingly minute. They have the important function of assisting in the clotting of the blood.

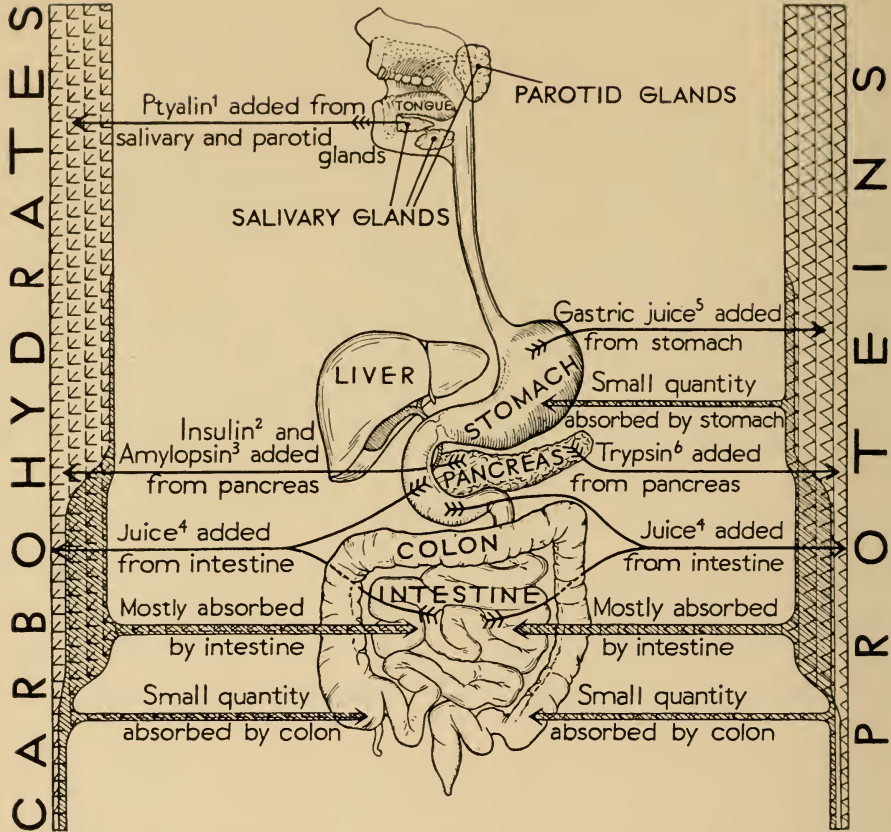

FIG. 2A. DIGESTION AND ABSORPTION OF FOODS. 1. Ptyalin (salivary diastase) turns starch into soluble sugar (maltose). 2. "Islands of Langerhans" (in pancreas) give insulin, a hormone which enables tissues to take up sugar actively. 3. Amylopsin (pancreatic diastase) splits starches. 4. Intestinal juice continues digestion of carbohydrates and proteins. 5. Gastric juice=free hydrochloric acid + pepsin (from stomach) converts proteins to intermediate products. 6. Trypsin (pancreatic juice) splits proteins

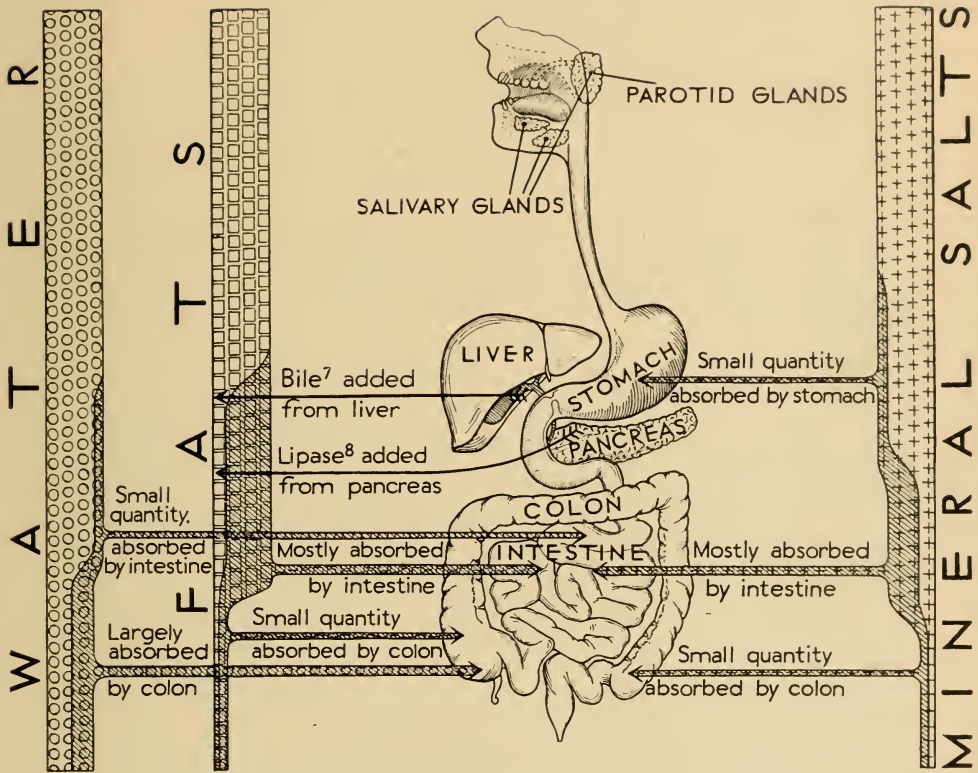

FIG. 2B. DIGESTION AND ABSORPTION OF FOODS (continued). 7. Bile, or gall (from gall bladder in liver) greatly accelerates action of lipase in splitting fats. 8. Lipase (pancreatic juice) splits fats, converting them to fatty acid and glycerol. Diagrams based on the illustrations and data published in *Der Mensch* by Martin Vogel

INTRODUCTION TO HUMAN ANATOMY

THE SOLAR ENERGY IS UTILIZED BY THE MUSCLES

The chlorophyll of the plant, as already shown, utilizes the energy of the sunlight to build up sugar and starch out of water and carbon dioxide. These carbohydrates taken in as food are turned into glucose by the digestive juices of the intestine. The blood stream carries the glucose to the liver, where it is converted into glycogen or animal starch (which is the anhydride of glucose).

The liver then stores up the glycogen for future use.

Indirectly, the combustion of glycogen furnishes the heat and energy necessary for the life of the higher animals, but the direct energy of the muscles is due to the breaking down of a creatine-phosphoric acid compound.

Creatine is an amino-acid which is present in muscle tissue.

Insulin, a hormone manufactured by the Islands of Langerhans in the pancreas, is also essential for the proper combustion of carbohydrates in the animal body.

HEAT REGULATION

The chemical processes involved in the capture and use of solar energy by the body all generate heat. Overheating of the body, which would finally cause heat-stroke, is normally prevented largely by the radiation of heat from the surface of the skin. Also when the body gets too hot the "temperature sense-organs" in the skin send messages up the afferent nerves to the "temperature center" in the brain stem; this in turn sends currents down the nerves to the muscular sheaths of the capillary blood vessels, causing them to become dilated and the sweat glands to pour out sweat. This, being a slightly salt solution, evaporates quickly and causes a rapid cooling of the heated blood in the skin. On the other hand, excessive loss of heat is checked in most mammals by the furry undercoat of the skin, and in man especially by the secretion of the adrenal glands; this secretion unites with the free oxygen in the blood, thus producing heat. Additional heat is generated also by shivering, but chiefly by muscular exercise.

Thus we see that man, like other mammals, possesses various mechanisms for maintaining a relatively high and stable temperature (about 98.4° Fahrenheit in man) in spite of wide variations in the temperature of the environment. The lower vertebrates (reptiles, amphibians), on the other hand, have a more variable body temperature and are more at the mercy of changes in the environment.

INTRODUCTION TO HUMAN ANATOMY

THE MAIN PUMP OF THE BODY

The heart is the motor that drives the blood through all the circulatory system and keeps it on its ceaseless round. It is an automatic double pump operated by involuntary muscles and by nervous reflexes. The minute muscular engines which contract and expand this double pump are built into its walls.

The two bag-like pumps, which work in unison, are placed side by side with a single muscular partition between them (Fig. 1). The left, or SYSTEMIC HEART, sends fresh arterial blood from the lungs to the body; the right, or RESPIRATORY HEART, receives venous blood from the body and sends it to be renewed, or oxygenated, in the lungs. Each half consists of an atrium (auricle) or thin-walled receiving chamber and of a ventricle, or thick-walled pumping chamber.

Thus the four main divisions of the heart are as follows: (1) the LEFT AURICLE receives freshly oxygenated or arterial blood from the lungs through the right and left pairs of pulmonary veins; when the heart expands this blood is drawn through a one-way valve from the left auricle to the left ventricle; (2) the LEFT VENTRICLE then contracts, driving the blood through the aorta to the capillaries of the head and body. Here the blood loses its surplus oxygen and after absorbing the free carbon dioxide passes from the capillaries into the veins; these drain into the upper and lower venæ cavæ, which open into (3) the bag-like RIGHT AURICLE or atrium; the latter in turn passes the blood through another valve into (4) the RIGHT VENTRICLE, which pumps it through the right and left pulmonary arteries to the lungs.

Nerve fibers are diffused through the heart muscles. At each beat contraction begins in the "pace-maker," or sino-auricular node, and spreads thence to other parts of the heart.

While the rhythmical expansion and contraction of the heart is largely automatic, the beat is retarded by branches of the vagus nerve and accelerated by branches of the thoraco-lumbar nerves of the sympathetic system. The brain centers for regulating the heart beat are in the medulla.

INTRODUCTION TO HUMAN ANATOMY

THE LIVING BELLOWS

Air is drawn into the chest cavity and forced out of it again by rhythmical movements of the ribs and diaphragm (Fig. 3). The scalenus and intercostal muscles pull the obliquely-set ribs upward and outward, the abdominal muscles pull them forward and downward. As they move upward they rotate slightly outward and thus increase the volume of the chest cavity; this reduces the air pressure in its interior and so draws fresh air into the lungs.

The diaphragm is a muscular and tendinous dome which, with the aid of the abdominal muscles, acts both as a bellows for the chest cavity and as a piston for the abdominal cavity. When it descends the abdomen expands; when it moves upward the abdomen contracts; thus it assists the circulation of the blood in the liver and digestive tract.

In the living bellows formed by the diaphragm, thorax and abdominal muscles, the great multitude of muscular engines are built into the wall of the bellows.

In the ascending series of vertebrates from fish to man the breathing muscles of the ribs have experienced a change of function, having arisen from the lateral muscles of the body-walls, which were originally locomotor muscles. The main muscle of the diaphragm represents a backward extension of one of the ventral neck muscles of the lower vertebrates; the diaphragm as a whole is a secondary partition, completed in the mammals, which separates the heart and lungs from the abdominal cavity.

THE DUCTLESS OR ENDOCRINE GLANDS

(See also exhibit on opposite side of hall.)

The ductless or endocrine glands play an important part in metabolism (the breaking down and building up of the cell materials of the body), also in reproduction and in growth from infancy to old age.

The ductless glands secrete substances called hormones because they act as "chemical messengers," which are carried by the blood and activate other tissues. While each particular gland has a certain measure of independence, they all act together more or less like an orchestra, the pituitary often taking the role of director, or perhaps regulator.

Pineal. This gland represents a stalk-like outgrowth from the roof of the third ventricle of the brain. In some of the lower vertebrates it is the stalk of the pineal eye, but in the mammals, including man, it has lost its eye and shriveled into a mere remnant. In young children with diseased pineal gland the sex glands develop at a very early age and there is a precocious

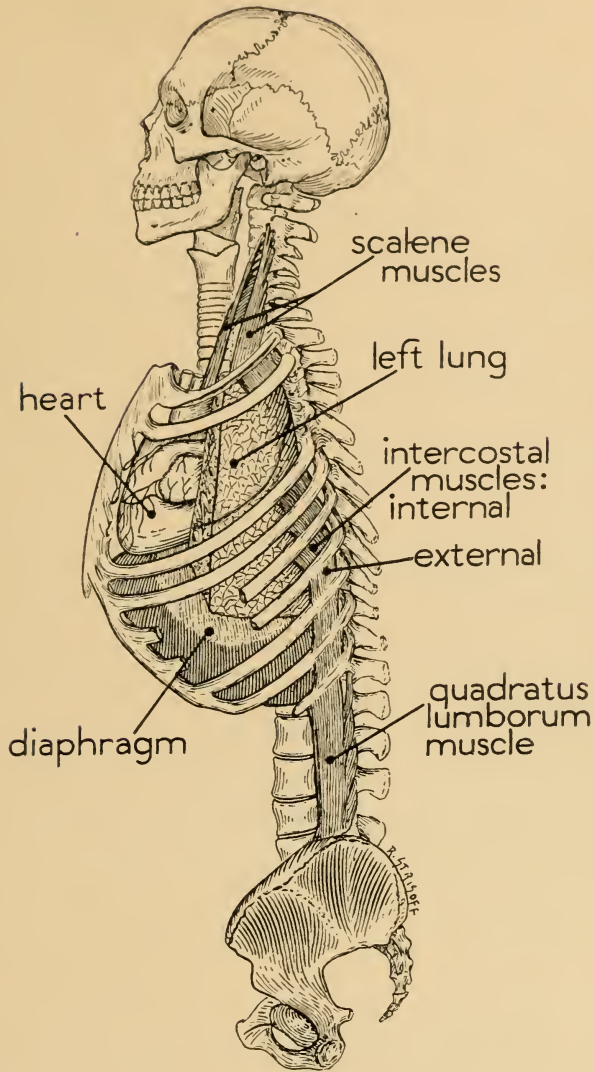

FIG. 3. THE LIVING BELLOWS. Sketch model showing the position of the muscles that cause the bellows-like action of the chest in breathing. Based on data from Sir Arthur Keith's "Engines of the Human Body"

INTRODUCTION TO HUMAN ANATOMY

abnormal growth of the long bones. However, later investigations suggest that there may be other factors in this complex.

Pituitary. This gland fits in the "sella turcica" or "Turkish saddle" in the middle of the base of the skull. It comprises three parts, the anterior, intermediate, and posterior lobes. The hormone of the anterior lobe, called *TETHELIN*, stimulates growth and the healing of wounds. Extracts of the middle and posterior lobes, containing *PITUITRIN*, produce a rise in blood pressure, increased activity of the kidneys and milk glands, and also stimulate contraction of the muscles of the uterus. On the other hand, pituitrin inhibits the secretions of the salivary glands, stomach and pancreas.

Deficiency in the secretion of the anterior lobe of the pituitary causes a child to become a diminutive dwarf. Early overactivity of the same gland makes him a "symmetrical" giant. If the activity begins after puberty, well rounded development is no longer possible, but the resulting overgrowth (acromegaly) takes place only in such parts of the body as are still susceptible to the influence of the hormone. The pituitary body is found in all the vertebrates.

The pituitary gland is of complex origin. In the human embryo the anterior lobe originates from a pouch-like projection of the outer layer of the embryonic mouth or stomodeum. The posterior lobe originates from the base of the mid-brain.

Thyroid. Chemical analysis of the thyroid gland reveals the presence of compounds of carbon, hydrogen, oxygen, nitrogen, sulphur, phosphorus, sodium, calcium, iodine and other elements.

Thyroxin, the most widely known derivative of the thyroid gland, is a crystalline body with a relatively high iodine content. Extremely small quantities of thyroxin stimulate metabolic processes, while a deficiency of thyroxin is one of the causes of cretinism, myxoedema and other abnormal conditions.

"Hyperthyroid" persons have an excess of thyroid secretion and are extremely energetic. In "hypothyroid" persons the opposite symptoms appear.

Parathyroids. These small glands, although closely associated with the thyroid, have a different function. They are indispensable for the assimilation of calcium. In rabbits from which the parathyroids have been removed the bones become soft and brittle and the teeth break easily, since they lack calcium. Complete removal of human parathyroids causes a tetany followed by death.

Thymus. This "gland of childhood" is also highly necessary for the building of bone, especially the long bones of the limbs. The thymus shrinks

INTRODUCTION TO HUMAN ANATOMY

when the sex-glands develop and becomes very small or vestigial in normal adults.

The thyroid, parathyroids and thymus are derived from different pockets of the embryonic gill structures.

Adrenals. These glands are hat-like bodies, one on top of each kidney. The sponge-like medulla, or core, of the suprarenals forms adrenalin, or epinephrine. One part of adrenalin in four hundred million parts of water checks the action of the intestinal muscles, makes the heart beat faster, causes the liver to discharge its glycogen and prevents fatigue. The suprarenals have thus been called the "fighting glands" and they are relatively large in both fighting and swift fleeing animals, which require sudden outbursts of energy. Adrenalin also inhibits the action of insulin from the pancreas. The cortex, or rind, of the suprarenals contains many delicate blood vessels, fat droplets, blood spaces and cells containing dark fatty pigments.

In Addison's disease the cortex of the suprarenals is affected so that an excess of dark brown pigment is deposited in the skin and the mucous membranes.

Islands of Langerhans. These very minute glands in the pancreas secrete insulin, a hormone indispensable for the "combustion" of glucose in the production of muscular energy.

Sex-glands. The primary sex-glands (ovaries in females, testes in males) begin to appear at any early stage of embryonic development and to produce "hormones" which determine the subsequent development of either the female (egg-producing) or the male (sperm-producing) sex. In the males the secretions of the interstitial glands of the testes produce certain male characters. In the females the secretions of the yellow-bodies (corpora lutea) of the ovaries affect various changes in the uterus during menstruation and pregnancy.

MAN AMONG THE VERTEBRATES

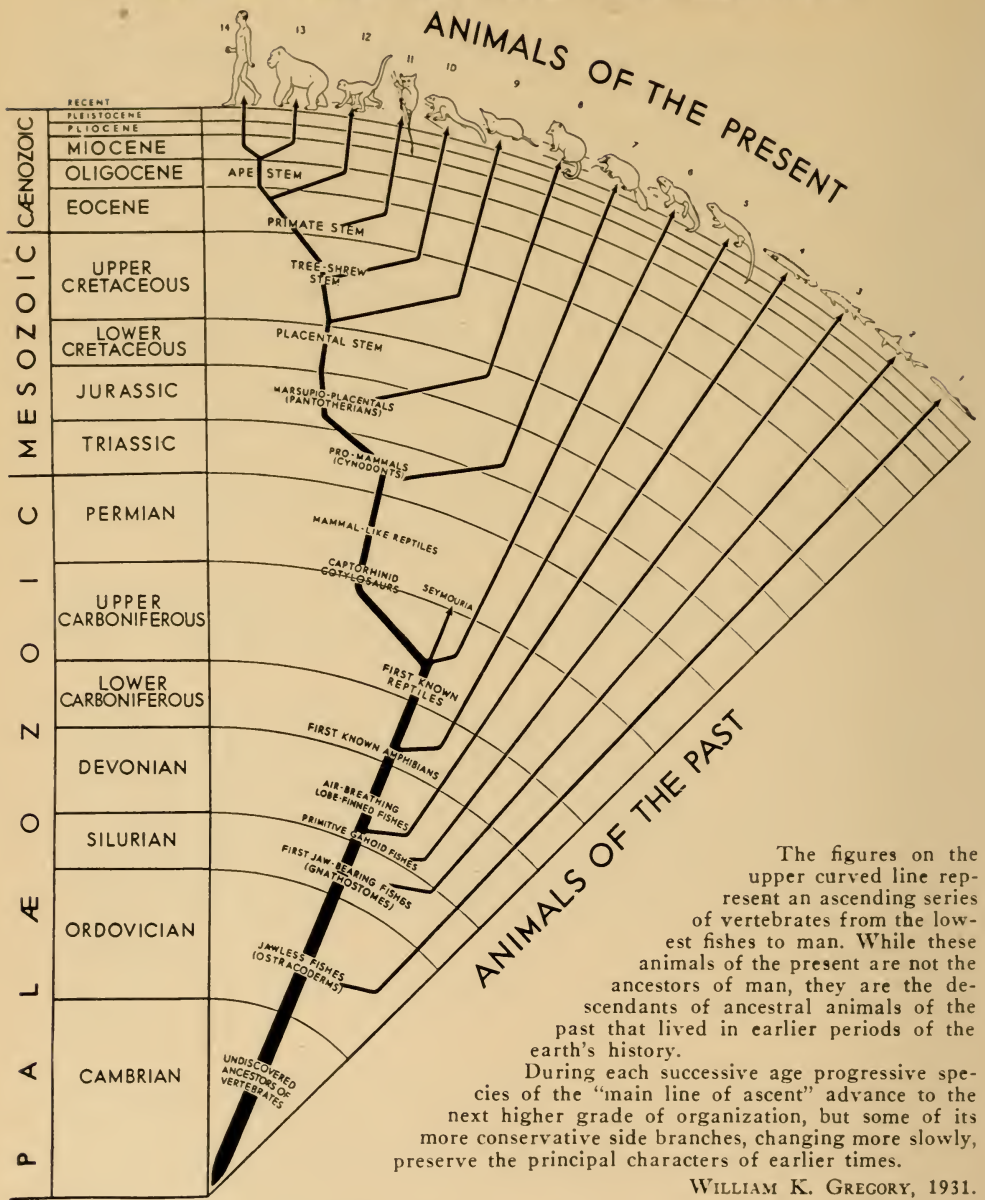

The figures on the upper curved line represent an ascending series of vertebrates from the lowest fishes to man. While these animals of the present are not the ancestors of man, they are the descendants of ancestral animals of the past that lived in earlier periods of the earth's history.

During each successive age progressive species of the "main line of ascent" advance to the next higher grade of organization, but some of its more conservative side branches, changing more slowly, preserve the principal characters of earlier times.

WILLIAM K. GREGORY, 1931.

FIG. 4. MAN AMONG THE VERTEBRATES (Wall Chart 2). 1. Lamprey. 2. Shark. 3. Sturgeon. 4. *Polypterus*. 5. Newt. 6. *Sphenodon*. 7. Platypus. 8. Opossum. 9. Ground Shrew. 10. Tree Shrew. 11. *Tarsius*. 12. Monkey. 13. Anthropoid. 14. Man

ORGAN SYSTEMS OF SHARK AND MAN

(CASE IIA)

Man, like other animals, captures and utilizes the life-giving energy of the sunlight (contained in food) by means of a complex anatomical equipment, which includes the following systems:

- (1) THE ALIMENTARY SYSTEM
(Mouth, jaws, teeth, tongue, digestive tract, salivary glands, liver, pancreas, etc.)
- (2) THE BLOOD-STREAM SYSTEM
(Red corpuscles, white corpuscles, blood platelets: manufactured in the spleen, marrow, and elsewhere)
- (3) THE CIRCULATORY SYSTEM
(Heart, arteries, capillaries, veins, lymphatics)
- (4) THE RESPIRATORY SYSTEM
(Lungs, windpipe, bronchial tubes, breathing muscles)
- (5) THE MOTOR SYSTEM
(Locomotor muscles, bones, joints, ligaments, etc.)
- (6) THE EXCRETORY SYSTEM
(Kidneys, bladder, skin)
- (7) THE HEAT-PRODUCING AND REGULATING SYSTEM
(Temperature receptors in skin, sweat glands, etc.)
- (8) THE ENDOCRINE OR DUCTLESS GLAND SYSTEM
(Thymus, thyroids, parathyroids, pituitary, adrenals, etc.)
- (9) THE RECEPTOR SYSTEM
(Sense organs, afferent nerves and nerve centers)
- (10) THE AUTOMATIC NERVOUS SYSTEM
(Sympathetic and parasympathetic nerves, plexuses and their connections)
- (11) THE CENTRAL CONTROL SYSTEM
(Spinal cord, brain, etc., controlling the motor system and coördinating all other systems)
- (12) THE REPRODUCTIVE SYSTEM
(Ovaries, testes and associated parts)

INTRODUCTION TO HUMAN ANATOMY

Digestive System. In both shark and man the digestion and absorption of food takes place in a long winding tube, the alimentary canal or gut; this is subdivided into œsophagus, stomach and intestine, and bears as appendages a liver and a pancreas. In both cases the stomach secretes an enzyme and a small quantity of hydrochloric acid. The other main divisions likewise secrete several enzymes or ferments, which split up the food into glucose, glycerol, fatty acids, amino-acids, etc., and thus prepare it for absorption by the capillary blood-vessels in the wall of the gut.

Although the shark's gut is thus an epitome of that of man, it also has certain peculiarities. Its stomach is subdivided into a swollen cardiac portion, separated by a valve from the tubular pyloric section; the intestine is filled with a great spiral fold, which greatly increases the absorptive area.

Circulatory and Oxygenating Systems. The circulatory and oxygenating systems in both shark and man have the same functions, namely:

- (1) to deliver to all parts of the body the energy-bearing food products from the digestive system;
- (2) likewise to distribute everywhere the oxygen-bearing red blood corpuscles;
- (3) to deliver the waste products to the excretory system.

In both shark and man the main muscular pump, or heart, drives the blood to the capillary vessels of the body, whence the veins return it to the heart, whence the heart sends it respectively to the gills or to the lungs. In the shark, however, the heart is a relatively simple pump, consisting of auricle, ventricle and conus arteriosus arranged in a fore-and-aft series; these drive the blood forward to the gills. In man, as in other mammals, a median partition divides the heart into a double or four-chambered pump, the right side sending venous blood to the lungs, the left, pure blood through the aorta to the body (see Case I). Intermediate conditions are found in lung-fish, amphibians, reptiles and in the embryonic stages of man.

In a human embryo 4 millimeters long the shark-like ground-plan of the human circulatory system is more evident than in the adult. In the shark the aortic arches give off vessels to the gills; in the human embryo gills are absent but the gill-pouches, which are still represented (see Case 18), are likewise supplied by aortic arches. The heart of the human embryo is also simpler, more shark-like, than in the adult.

Comparative Anatomy of the Heart. The four-chambered heart of man is constructed on the same plan as that of other mammals, but in some of the lower vertebrates, especially the amphibians, the right and left halves are more or less incompletely divided from each other, so that the venous

INTRODUCTION TO HUMAN ANATOMY

and arterial blood are mingled in the single ventricle. In the shark, representing primitive fishes, there is no median partition of the auricle and ventricle; in other words, the heart is single not double.

The transition from the single to the double-chambered heart is seen in the developmental stages of the heart of man and other mammals.

Urinogenital System. In AMPHIOXUS, the most primitive known pre-vertebrate, the waste products of the blood are excreted through about ninety pairs of small nephridia, or bent tubes situated above the pharynx. The gonads (producing eggs or sperm respectively) are about twenty-six pairs of pouches arranged metamericly (in series) along the body wall. Thus the excretory and reproductive systems are separate in this very primitive type.

In the shark and higher vertebrates, however, the excretory tubules are united into a pair of organs, the kidneys, and the organs of excretion and of reproduction form a complex urino-genital system.

Each kidney consists of an immense number of coiled tubules, forming a "living high-pressure filter" that separates the clear blood plasma from the nitrogenous wastes, including urea, that have been received from the liver, etc., by way of the blood-stream. The kidneys also help to maintain the proper volume and composition of the blood partly by eliminating excess water, and rid the body of undesirable salts and foreign substances in the blood.

In the females of the lower vertebrates the ova, or eggs, after escaping from the ovaries are usually carried out by separate right and left oviducts. In the primates, including man, the lower parts of these ducts are united into a median thick-walled pouch, the uterus or womb, in which the fertilized egg develops into an embryo (Fig. 33).

In the males of many of the higher mammals, including man, the testes, containing the spermatozoa or male elements, descend during individual development (i.e., before or after birth) from the abdominal cavity into a pouch, or scrotum. Hence the ductus deferens through which the spermatozoa pass out, ascends from the testis, looping over the ureter or tube from the bladder and opening into the urethra. Thus in the higher mammals, including man, the male genital products and the urine pass out through a single tube, the urethra.

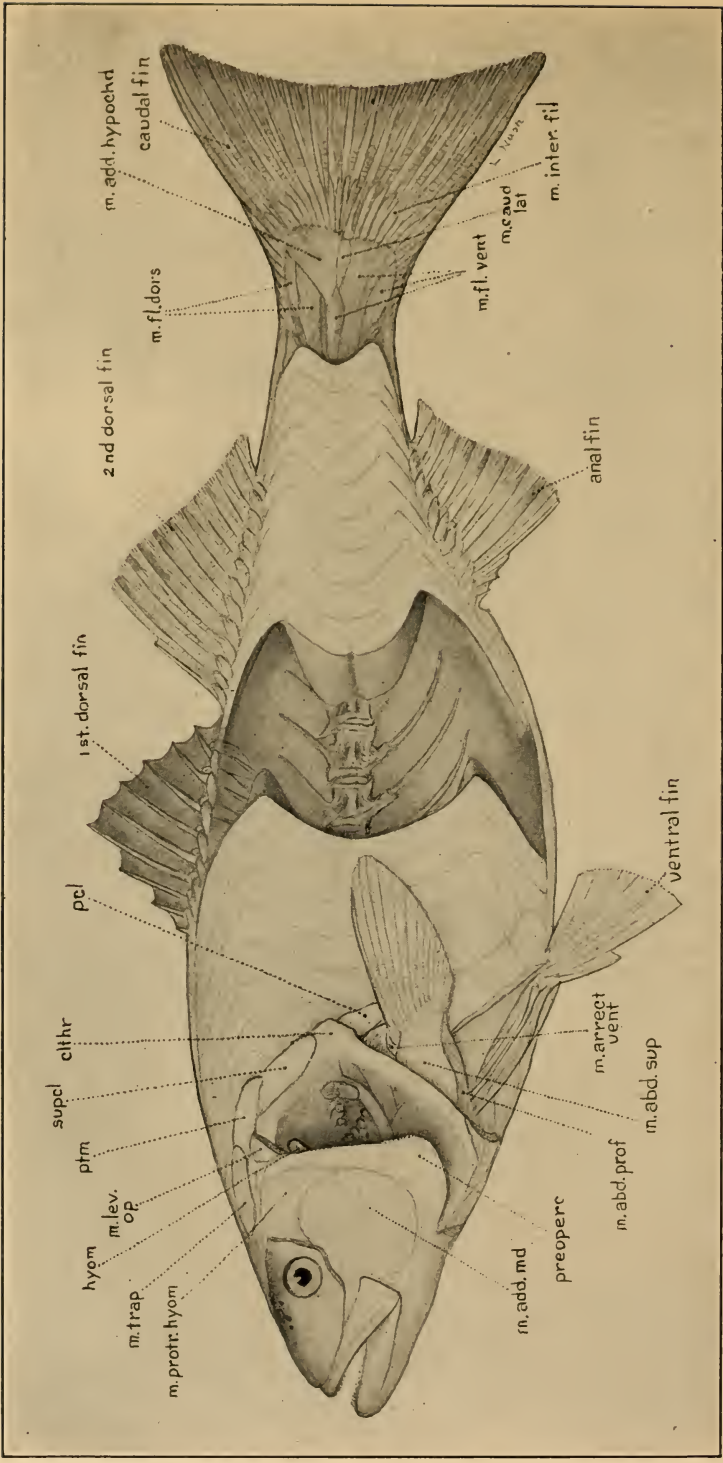

FIG. 5. THE LOCOMOTOR APPARATUS OF A TYPICAL FISH (STRIPED BASS). The myomeres or muscle segments are arranged in zig-zags closely fitting one behind the other. These are the main locomotor organs of the fish, the fins being of secondary importance. Drawn from dissections by M. Roigneau

ELEMENTS OF THE LOCOMOTOR SYSTEM

(CASE IIB)

To explain how a man moves we begin with a fish. A fish moves through the water by turning his head first to one side, then to the other, and by sending one wave of contraction after the other along his tapering body. As these muscular waves flow backward they push against the water and drive the fish forward.

The body muscles of fish and other vertebrates are arranged in segments, one behind the other (Fig. 5). Immediately after the segment on one side contracts the nerves carry the message up to the spinal nerve cord and thence downward to the next segment on the same side; another set of nerves carries the message to the other side and starts a wave going on that side; and so on.

The human embryo passes through a stage in which the somites or segments are arranged in a fore-and-aft series, like the locomotor segments of a fish.

Although the muscle fibrils are so minute that the human body contains many billions of them, they are composed of molecules and atoms which are incomparably smaller still. When a muscle contracts it does so because its nerve fibres have discharged into it a current of some sort which suddenly upsets the equilibrium of the muscle's atoms and molecules. A chemical reaction takes place, the molecules shrink, causing contraction of the muscle, and lactic acid is set free in the tissues. Some of the oxygen carried by the red blood corpuscles is then used in restoring the muscle molecules and in oxidizing the waste products.

The Backbone. The backbone arose as a flexible elastic rod (the notochord), which enabled the fish to thrust its undulating body forward through the water. As time went on the notochord became strengthened by bony rings or centra, which, being separated by elastic discs, enabled the backbone to bend. Bony arches were added to protect the spinal nerve cord.

In man the backbone, held at right angles to its original position, supports the skull, ribs and internal organs.

Vertebrae, or units of the backbone, are the essential and original core of the skeleton of vertebrates, or animals that are provided with a backbone, or vertebral column.

MAN'S HERITAGE FROM QUADRUPEDAL ANCESTORS

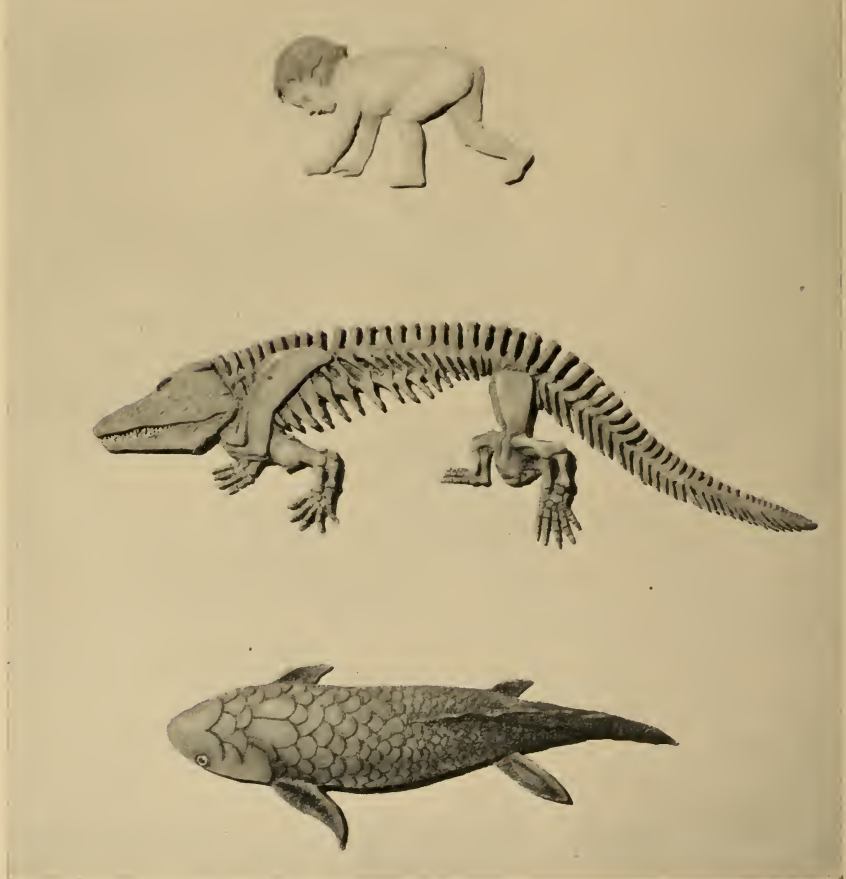

FIG. 6. MAN'S HERITAGE FROM QUADRUPEDAL ANCESTORS. *Below.* Air-breathing fish (*Ceratodus*) with paired paddles. After Dean. *Center.* Fossil amphibian (*Eryops*) from the Permian of Texas. *Above.* Human infant running on all fours. After Hrdlička. Note the comparison between the paired paddles of the fish, the fore and hind limbs of the quadruped and the arms and legs of man

STUDENTS IN NATURE'S TRAINING SCHOOL.



Neanderthal
cave-man

In the present and past ages of the earth Nature has kept a physical and mental training-school of many grades. Her examinations have always been practical ones, the prize of survival being awarded to the "fittest" in each successive grade.

In the primary school the lower grades were passed through under water. Here one learned to swim and steer in the currents, to lurk quietly, to strike successfully. A few grades further on the pupils were equipped with air-sacs, so that they could wriggle out on the banks and use their fore-and-hind paddles as limbs.

After acquiring the physique to withstand hardships of heat and cold, some of the more advanced candidates were admitted to the school of the forests and to the uncertainties of life in the trees, where a practical course in the care and feeding of infants was required of all mothers.

At last the most intelligent pupils ventured out into the open and went into training both for short sprints and



Miocene anthropoid



Early lemuroid
primate



Archaic mammal



Cynodont reptile



Primitive terrestrial
reptile



Generalized
amphibian

with these, before they retired to their dormitories at night, they prepared for themselves their simple meal of bear's meat.

Thus they were trained for the degree of H. S. (*Homo sapiens*), which was eventually won by their descendants.

W. K. GREGORY, 1931.
F. L. JAUQUES, pinx.

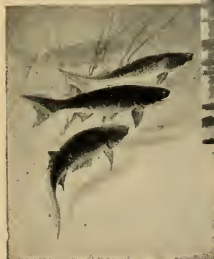

Primitive ganoid fish

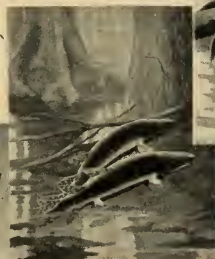

Lobe-finned fish

FIG. 7. STUDENTS IN NATURE'S TRAINING-SCHOOL (Wall Chart 3)

THE skeleton of man, like that of all other vertebrate animals, is the passive part of the locomotor machinery, while the muscles and nerves are the active part. Comparative study of the skeletons of all known types of fossil and modern animals has made it possible to decipher the record of progress from fish to man. The series of forms here shown does not form a *direct* line of descent from fish to man, but each stage shown is the nearest to the direct line so far discovered.

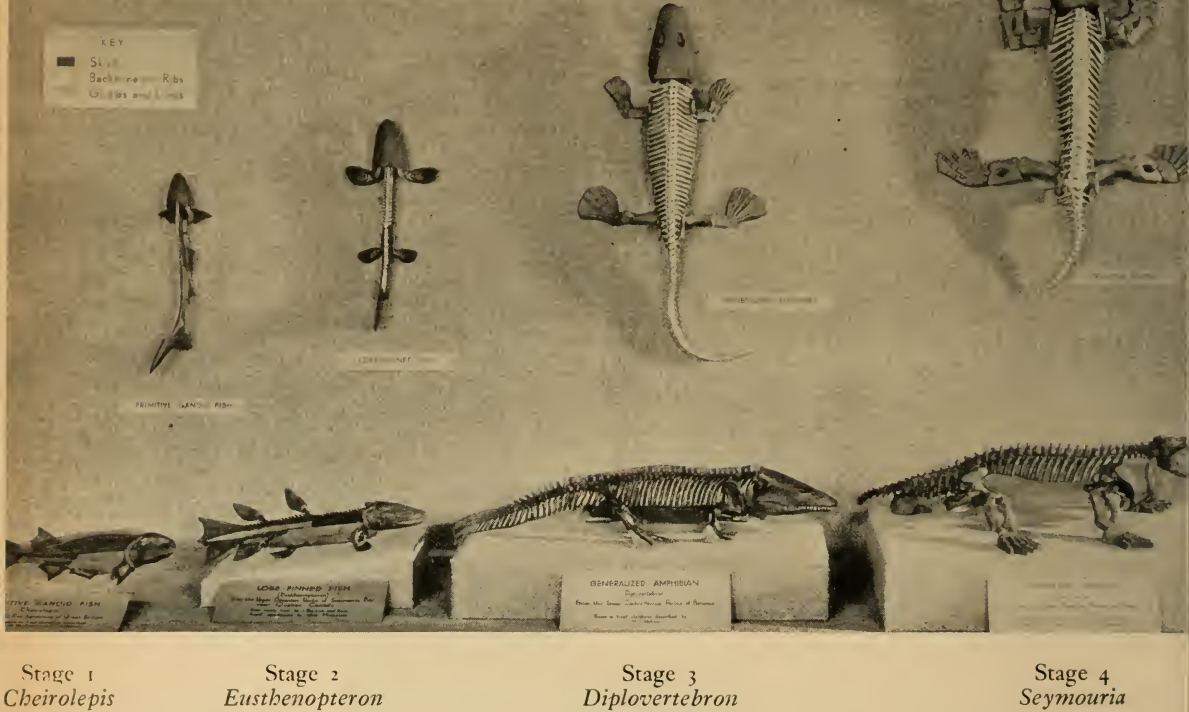

FIG. 8A. THE FIRST FOUR STAGES FROM FISH TO MAN. (From water-living to land-living)

THE SKELETON FROM FISH TO MAN

(From "Exhibition Halls of the American Museum of Natural History"
by Roy W. Miner, Editor)

The judgment of science is that our pre-human ancestors reached the grade of humanity only after millions of years of slow promotion from lower to higher grades of life.

Owing to the enormous number and variety of living forms in all ages and to the wholesale destruction of their skeletons by natural agencies, only about thirty of the fossil forms which we have discovered to date happen to lie in or near the direct line of ascent from fish to man. Nevertheless the story of the evolution of the skeleton from fish to man is already clear in its main outlines as shown by this exhibit prepared under the direction of Dr. William K. Gregory.

The First Stage represents the earliest true fishes by a model based on a fossil fish from the Old Red Sandstone (Devonian of Scotland) named *Cheirolepis*. This fish, which breathed by gills in the normal fish way, must have looked somewhat like a trout, but its tail was more like that of a shark. The body moved forward in the water by a wriggling movement caused by the regularly arranged muscle flakes along either side of the body. The axis of the body was an elastic rod called the notochord (similar to that which appears in the embryonic stages of all higher vertebrates, including man). The fins were folds of skin, serving as keels and rudders.

The Second Stage, of Upper Devonian age, represents a long step in advance. It is based on a fossil fish named *Eusthenopteron*, from the Upper Devonian of Canada. This fish still had gills but there is evidence that it also possessed an air-sac or lung. It had two pairs of paddles, corresponding to the fore and hind limbs respectively of four-footed animals.



Stage 5
Cynognathus

Stage 6
Opossum

Stage 7
Notharctos

Stage 8
Gibbon

FIG. 8B. THE SECOND FOUR STAGES FROM FISH TO MAN. (From ground-dwelling to tree-dwelling)

The Third Stage, from the Carboniferous age, represents the oldest known type of four-footed animals. The skeleton of the hands, feet and limbs is much more developed than in the previous stage. There are five digits on each of the hands and feet.

The Fourth Stage represents the primitive reptilian or lizard-like stage, from the Lower Permian of Texas. The skeleton on the whole is not greatly different from the preceding stage (except in detail) but the limbs were better developed.

The Fifth Stage represents an advanced mammal-like reptile (*Cynognathus*) from the Upper Triassic of South Africa. In this form the limbs were better adapted for running and there are many features of the skull, backbone and limbs that approach those of mammals.

For the Sixth Stage the skeleton of a modern opossum was used. It retains in the main the leading characters of the skeletons of the older fossil mammals. This form has five-toed grasping hands and feet, by means of which it climbs about in the trees. It has retained a relatively low type of skull, teeth and brains.

In the Seventh Stage we come to a form that lies near the lower limits of the order of Primates. These were thoroughly adapted for life in the trees but they had much larger eyes and bigger brains than any of the preceding stages.

The Eighth Stage is represented by the skeleton of the gibbon, an east Asiatic ape which is a tree-living descendant of the first family of the tail-less or man-like apes. When on the ground he is the only existing man-ape which normally walks on his hind legs. His skeleton begins to be almost human in many ways but his arms are excessively long.

The Ninth Stage is represented by our distant cousins the gorilla (below) and chimpanzee (above). These apes retain the essential characters of the fossil apes of



Stage 9
Chimpanzee and Gorilla

Stage 10
Man

FIG. 8C. THE TWO FINAL STAGES FROM FISH TO MAN. (On the ground again, and attainment of erect posture)

India and South Africa, some of which in turn approached quite near to the oldest known fossil men. The ape brain is much more developed than the brains of lower animals and ape intelligence at times is almost human.

In the Tenth Stage we see that the human skeleton is built upon the same general plan as those of the chimpanzee, gorilla and gibbon, but that in man the backbone, pelvis and limbs are modified to enable him to walk on his hind legs and to use his forelegs as arms and hands rather than as supports. His brain is much larger and more highly developed than in the apes.

THE UPRIGHT POSTURE AND ITS MAINTENANCE (CASE IVA)

From fish to man there is still a chain of living forms, in spite of all the devastation and wholesale extinction of the present and past ages. As the skeleton of man testifies to his derivation from lower forms of vertebrates (Fig. 8) so also does his muscular system, and through this orderly and intelligible series of stages we can follow the main changes of posture as our ancestors learned first to swim, then to crawl, to run, to climb and finally to walk erect.

In the swimming stages (see Fig. 8A) the segmental muscles of the backbone and ribs were dominant, the fin-muscles being subordinate extensions of the body. Then the paddles grew outward and were eventually moulded into the new and highly organized limbs of land-living vertebrates.



FIG. 9. MUSCULAR ANATOMY OF CHIMPANZEE AND MAN, showing principal muscles used in maintaining upright posture. The model of the chimpanzee, by G. D. Christensen, was based on dissections by H. C. Raven

These limbs are compound levers with the muscles arranged on opposite sides of the pivots and acting in pairs as antagonists to produce extension or flexion, abduction or adduction, twisting and untwisting, etc. In walking and running each limb alternately pulls and pushes on the ground. When in early stages the limbs sprawled widely at the sides, the muscles were very thick. In the course of ages, as the feet were gradually brought in toward the midline and the body was raised off the ground, the limbs grew longer and more graceful.

The Superficial Musculature of the Chimpanzee. When running on the ground the chimpanzee usually goes on all fours, supporting the fore part of the body on the fingers, sharply bent at the middle joints. The muscular anatomy, however, is well adapted also for a semi-erect posture, as well as for sitting upright and for brachiating, or swinging with the arms (Fig. 9).

Among the more conspicuous differences from man are: the very short neck, the long arms and short legs, the long fingers, the short thumb and the inwardly-directed great toe. The loins (lumbar region) are extremely short and broad, the hip bones (ilia) long. The hind limb is habitually flexed at the hip and knee.

There are corresponding differences in the proportions of the muscles: for example, the limb muscles of the chimpanzee are more fleshy, with shorter tendons, than in man. A peroneus tertius muscle is usually lacking.

These and many other such differences between chimpanzee and man relate to the wide contrast in their present methods of locomotion, but in spite of these adaptive differences there is a remarkable unity in the plan and arrangement of the muscles in these two forms.

Man. Man is a fully erect bipedal mammal whose entire weight is carried by his long hind limbs (Figs. 8C, 9). Consequently his superficial gluteal muscles are relatively enormous as compared with those of the chimpanzee, since they assist alternately in holding the body aloft on one side, while the opposite leg swings off the ground.

INTRODUCTION TO HUMAN ANATOMY

For similar reasons his erector spinae muscles are much widened, especially at the lower end, his gastrocnemius muscle is very thick and short with a long tendon, and the biceps femoris muscle extends only a little way below the knee.

His long loins (lumbar region) form a flexible lever on which the whole weight of the upper part of the body is poised. In order to give better balance the back is curved in at the lumbar region and the hip bones are widened greatly.

Another consequence of the upright posture is that the fore limbs of man are completely suspended from the skull, the backbone and the ribs, since they no longer serve as limbs but as levers for moving things.

In spite of these and many other special adaptations to the upright posture, man has inherited from his remote pre-human ancestors a great many characters which have also been retained in the existing anthropoid apes. For example, his shoulders are held far away from the neck by means of the long curved clavicle, his arms can be swung around in a complete circle, his hands can be freely turned up, or supinated; his thumb, however, has progressed beyond the grasping stage that is now represented in the ape's thumb.

THE PECTORAL AND PELVIC GIRDLES

(CASE IVB)

A well-known dictionary defines the term girdle in the anatomical sense as "The ring-like arrangement of bones by which the limbs of a vertebrate animal are attached to the trunk." The pectoral and pelvic girdles might better be defined as originally U-shaped or V-shaped bony supports by which the trunk is suspended between the limbs (Fig. 12).

In the oldest and most primitive known fossil fishes the body moved forward through the water by waving from side to side by means of the contraction of successive muscle segments (Fig. 10). At that time the fins were merely keel-like projections from the body, which were stiffened internally by rod-like skeletal supports, and externally by spines formed in the skin. All the fins functioned as keels and rudders rather than as paddles. Between the pectoral and the pelvic fins in certain primitive fishes there were several other pairs of fins. Evidently the paired fins were similar both in origin and in construction to the median or unpaired fins.

The fins in ancient and modern sharks were supported by skeletal rods which were laid down in the membranes between adjacent muscle segments.

The anal, pelvic and pectoral fins of early fossil sharks (Fig. 10) exhibit progressive stages in the squeezing together of the basal rods into a U-shaped girdle.

The subsequent history of the shoulder girdle from fish to man is summarized in Figs. 11-13. In typical fish the pectoral girdle consisted of: (1) an outer or dermal series of bony plates (including the cleithra, clavicles, etc.) and (2) an inner or primary shoulder girdle, including the scapula and coracoid.

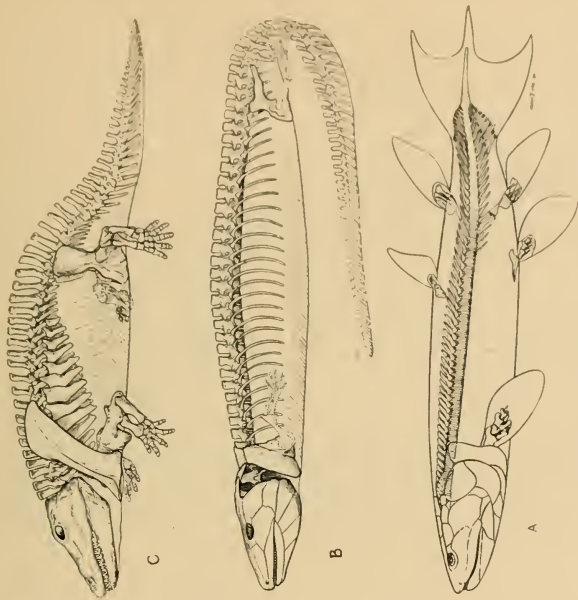

FIG. 11. THE SHOULDER GIRDLE, ORIGINALLY ATTACHED TO THE SKULL BY A BONY LINK, BECOMES FREE FROM IT IN LAND ANIMALS. A. Reconstructed skeleton of *Eusthenopteron foordi*, based on the data of Bryant, Husakof, Goodrich. B. *Eogyrinus*. Reconstruction slightly modified from Watson. C. *Eryops megacephalus*. Based chiefly on the mounted skeleton in the American Museum of Natural History. Details of pectoral girdle and limb after Mimer

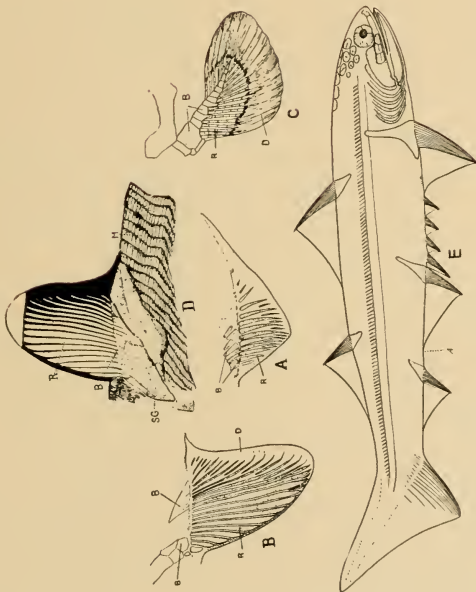

FIG. 10. EARLIEST KNOWN STAGES IN THE ORIGIN OF THE FINS AND GIRDLES. A. Ventral fins of Devonian shark (*Cladotelache*), showing separate rod-like supports of "fin-fold" fin. B. Pectoral fin of *Cladotelache*, showing pectoral girdle and basal pieces presumably derived from fusion of separate rods. C. Pectoral fin of Permian *Pleuracanthus*, showing fully developed paddle-like fin with jointed axis. D. Pectoral fin of *Cladotelache*, partly covered by preserved myomeres. E. Restoration of generalized acanthodian by Dean

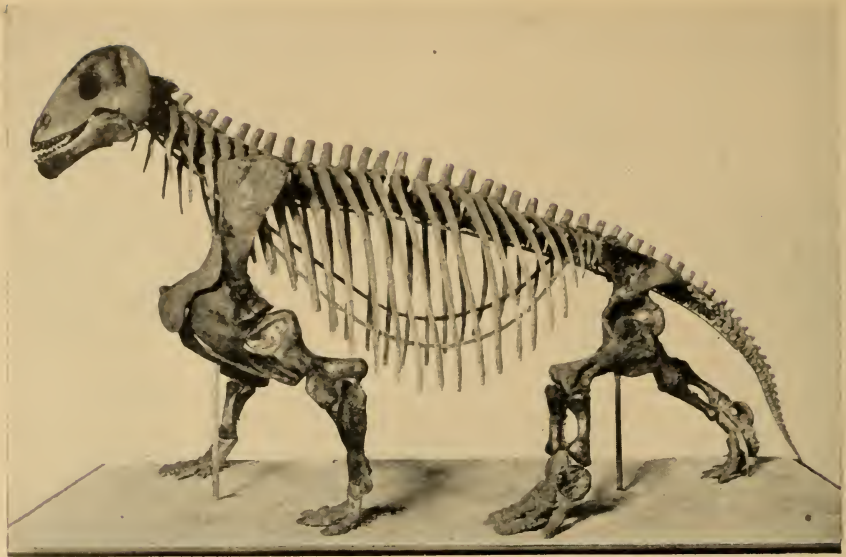

FIG. 12. SKELETON OF *MOSCHOPS CAPENSIS* BROOM. In this fossil mammal-like reptile the shoulder girdle retained the cleithra (reduced), clavicles and inter-clavicles, representing the outer layer of the fish girdle, and the coracoids and scapulae (shoulder blades) of the inner layer of the fish girdle

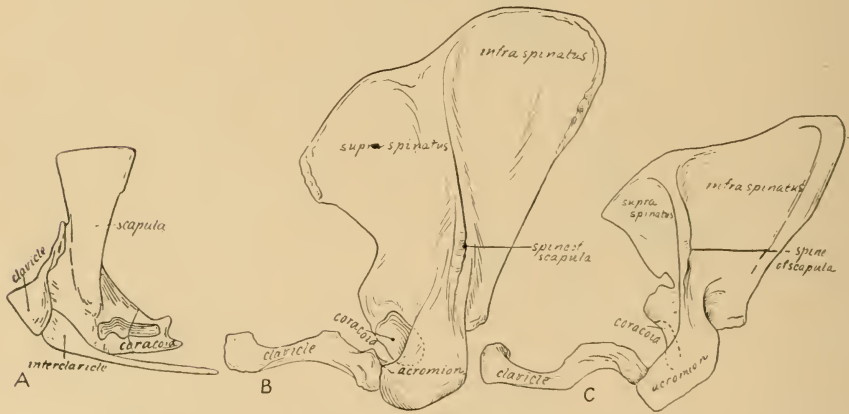

FIG. 13. IN HIGHER MAMMALS THE SHOULDER GIRDLE CONSISTS ON EACH SIDE ONLY OF A SHOULDER BLADE (SCAPULA) AND A COLLAR BONE (CLAVICLE), THE REMAINING PARTS HAVING BEEN LOST. A. Typical early reptilian type, after the loss of the cleithrum. B. Gorilla. C. Man. The shoulder girdle of man is very like that of the gorilla

INTRODUCTION TO HUMAN ANATOMY

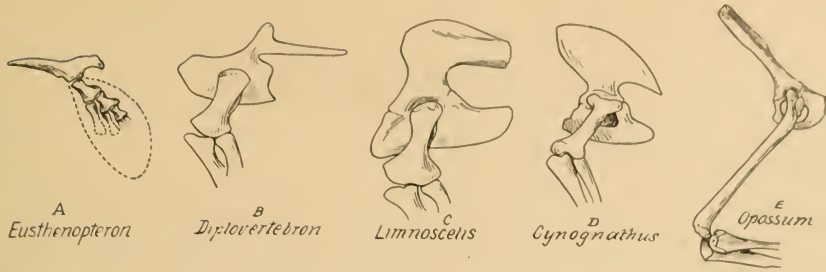

FIG. 14. SERIES OF PELVES AND PELVIC LIMBS, from lobe-finned fish to primitive mammal. The pelvis (Figs. 14, 15) arose as a pair of bony rods on either side of the cloaca, or exit of the digestive and reproductive tubes. It supported the pelvic fins. After the lobe-finned fishes came out on land the iliac blades of the pelvis grew upward, becoming attached to the sacral ribs and thus to the vertebral column. A. Lobe-finned ganoid (*Eusthenopteron*) of the Devonian period; B. *Diplovertebron*, early tetrapod; C. *Limnoscelus*, primitive reptile; D. *Cynognathus*, advanced mammal-like reptile; E. Opossum, primitive mammal

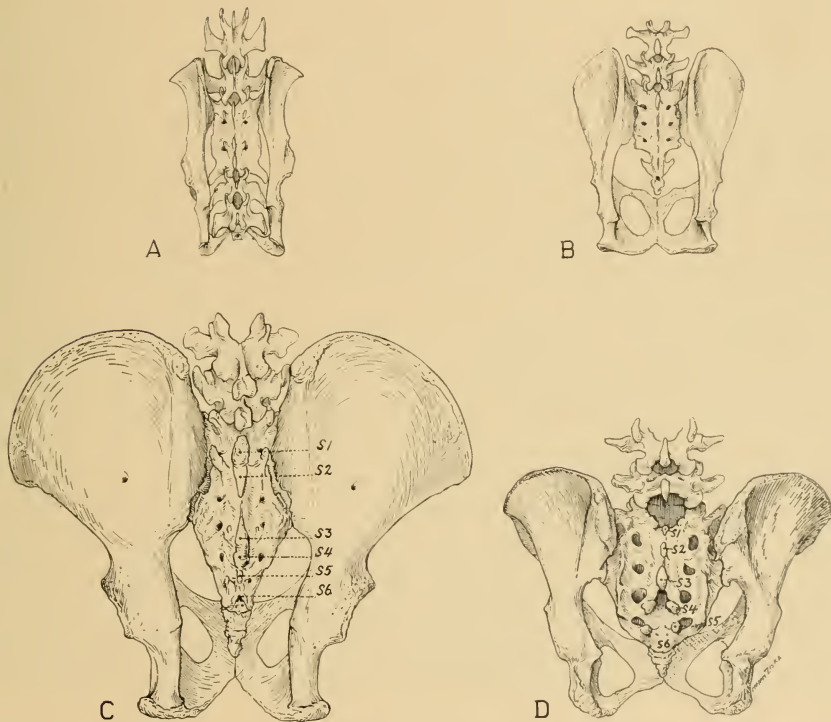

FIG. 15. PROGRESSIVE WIDENING OF THE PELVIS AND SACRUM IN PRIMATES. A. Lemur, with long narrow ilia adapted for leaping. B. Gibbon. Incipient widening of the iliac blade. C. Gorilla. D. Man

HANDS AND FEET

(CASE VA)

Hands of Primates. The hands and feet of most mammals are provided with digits that are tipped with either claws or hoofs, but in the primates the digits usually bear nails. These nails appear to be relics of an ancient arboreal habitus, which, as the fossils show, had already been assumed by the early primates of the Eocene epoch. The most primitive existing primates are the lemurs of Madagascar, which have a strongly grasping type of hand with the fourth digit the longest and partly opposable to the thumb. In the most specialized of the lemurs, the potto of Africa, these characters are greatly emphasized, while the second finger has become vestigial (Fig. 16).

The hand of *TARSIVUS* retains the primitive five digits but the ends of the fingers bear large flattened discs like those of tree-frogs.

The New World monkeys, or platyrrhines, exhibit considerable skill in handling objects and their hands are more mobile and less clamp-like than those of lemurs. Most of these animals have five fingered hands, but in the spider monkeys, which use the hands as hooks to swing with, the thumb is lost.

In most of the South American monkeys the nails are strongly folded; in the marmosets this tendency gives rise to false claws.

In the Old World monkeys, or catarrhines, the hands are intermediate between paws and true hands. In the species of *COLOBUS* monkeys the thumb is variously reduced, sometimes almost to the vanishing-point, doubtless in connection with the use of the hands as hooks.

In most of the anthropoid apes the hands have become elongate and specialized, with a more or less feeble thumb. These tendencies terminate in the orang-utan. In the gorilla the hands are very broad and massive, in keeping with the burly proportions of the body as a whole. In man the hand far surpasses those of other primates as an organ for picking up food and other things. The thumb is larger than in the anthropoids and is more easily opposable to the other digits.

However, the human hand inherits a generally anthropoid type of musculature and the thumb springs from the root of the hand as in the anthropoids, not from near the end of the metacarpals as in Old World monkeys.



FIG. 16. HANDS OF PRIMATES. Man inherits a five-rayed plan of the hands and feet, which has been specially modified so that the fore feet ordinarily have to do only with the handling of objects

INTRODUCTION TO HUMAN ANATOMY

Feet of Primates. The five-toed feet of the lemurs have a large sharply-offset great toe tipped with a broad flat nail (Fig. 17). The clawed second digit is used for scratching the fur. The long fourth digit coöperates with the great toe in firmly clamping the branches. In the foot of the potto these grasping characters are further emphasized. In TARSIVUS the foot is spreading, with delicate digits, flattened discs and more or less clawlike nails.

In the New World monkeys the foot is more mobile, less clamp-like than in the lemurs, and the same is true in the Old World monkeys, although all retain the divergent great toe.

In the anthropoid apes the foot is often used for suspension, especially in the orang-utan, in which the foot becomes extremely long and narrow. In the gorilla the toes have begun to shorten and the great toe begins to resemble that of man, except that it is still offset from the other digits. In the orang, chimpanzee and gorilla the heel is placed on the ground in walking, as in man.

In man the great toe has become drawn in toward the other digits and the latter have become very short.

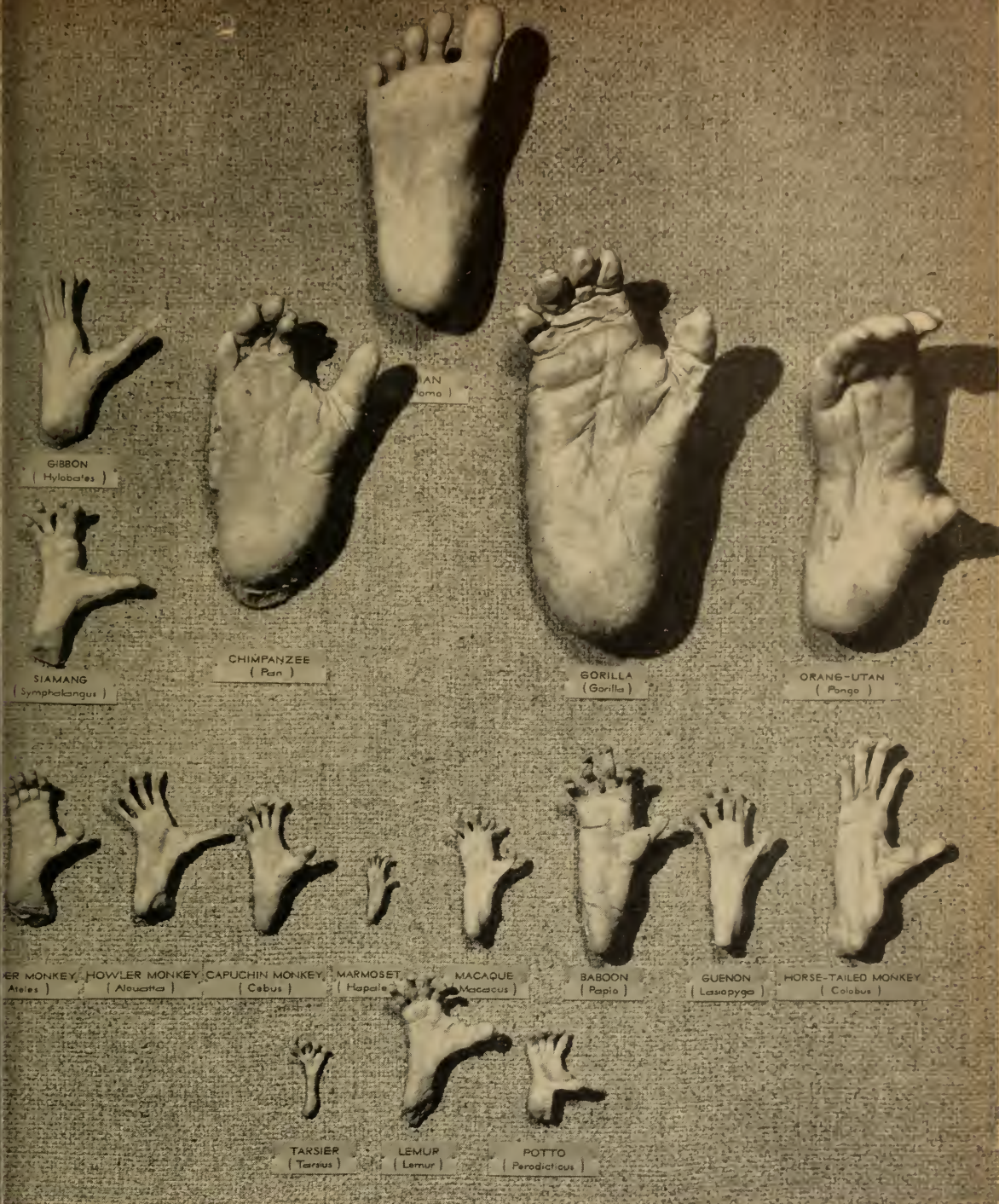

FIG. 17. FEET OF PRIMATES. Casts showing the sole of the foot. In the lower primates the big toe branches off at a sharp angle from the rest of the foot but in man it has been drawn forward so as to be nearly parallel with the other toes

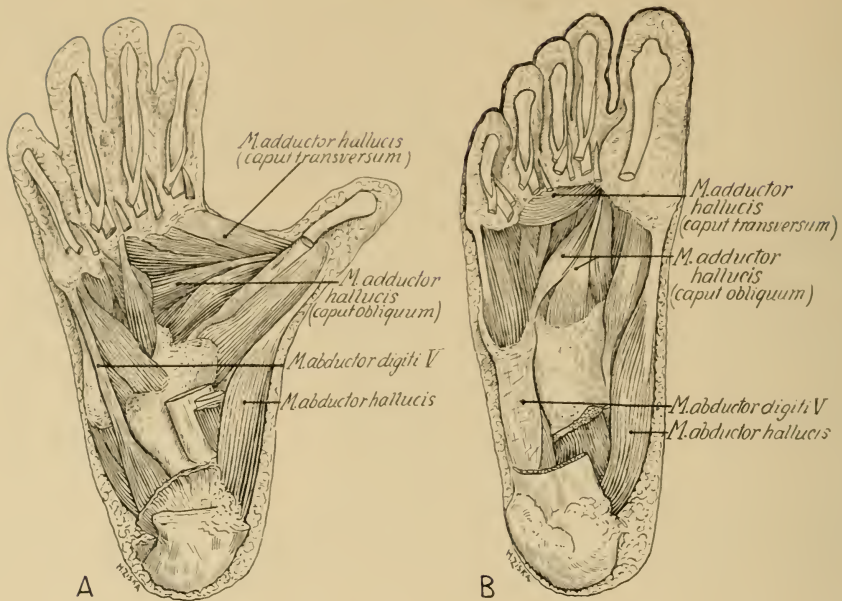

FIG. 18. GRASPING MUSCLES OF THE GREAT TOE AND THEIR OP-
 PONENTS AS SEEN ON THE SOLE OF THE FOOT IN (A) GORILLA,
 (B) MAN. After dissections by H. C. Raven. In man the transverse adductor of
 the great toe is still present essentially in the anthropoid position though much
 reduced. The oblique adductors of the great toe are well developed in both man
 and anthropoids. The abductor of the great toe is almost identical in man and
 anthropoids. The same is true of the abductor of the little toe

Comparative Anatomy of the Sole of the Human Foot. The superficially hand-like appearance of the feet of the chimpanzee and gorilla was viewed in earlier times as an important and fundamental point of difference from the foot of man, but dissections of the sole musculature show that the foot of the chimpanzee and of the gorilla is operated by muscles which correspond, not to the muscles of the human hand, but to those of the human foot (Fig. 18). In brief, the musculature as well as the skeleton of the human foot is fundamentally of the biramous anthropoid type.

INTRODUCTION TO HUMAN ANATOMY

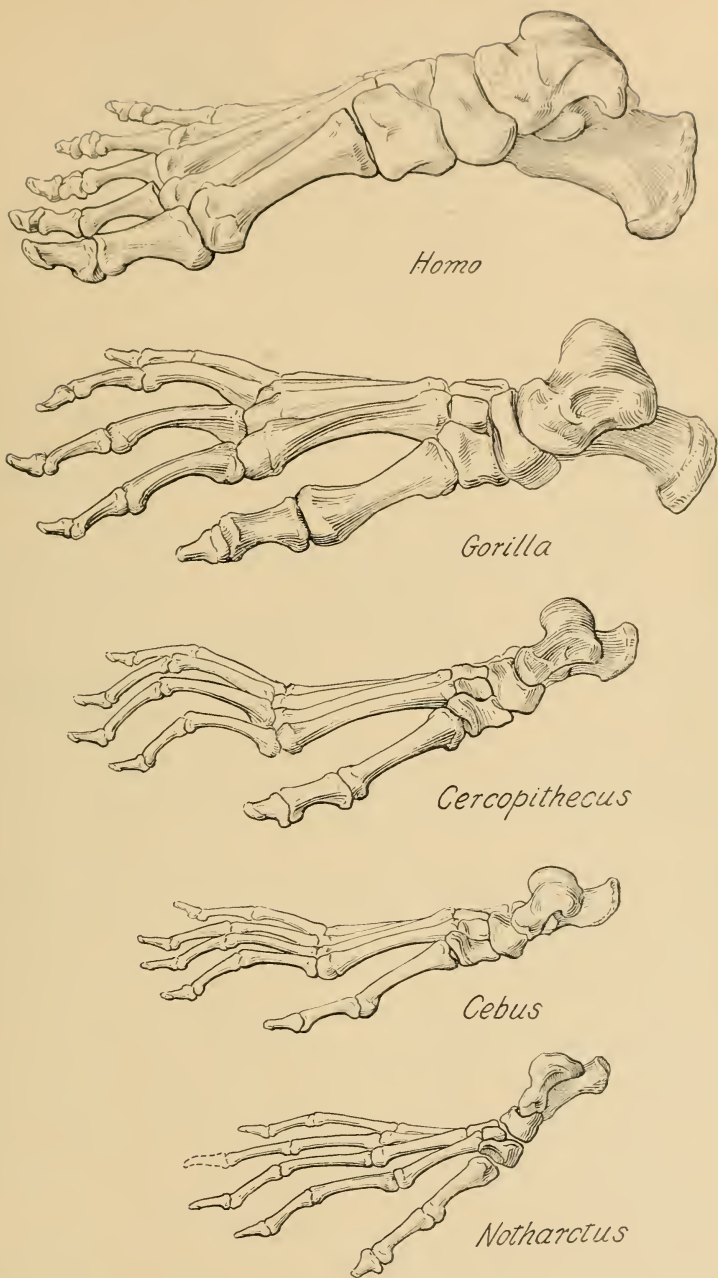

FIG. 19. A STRUCTURAL SERIES OF FEET OF PRIMATES FROM THE EOCENE *NOTHARCTUS* TO MAN

THE FACE FROM FISH TO MAN

(CASE VI)

A comparative series of models, including living and extinct forms and showing a general progress from fish to man (Fig. 20).

These forms do not lie in the direct line of descent to man but are the nearest to the direct line yet discovered.

The lower forms contrast with man in the following characters:

	LOWER FORMS	MAN
Normal position of backbone	Horizontal	Vertical
Position of eyes	On side of head	In front
Direction of eyes	Outward, forward and upward	Forward and slightly downward
Position of mouth	Largely in front of eyes	Largely beneath eyes
Direction of mouth	Somewhat downward	Horizontal
Muzzle	Large	Much reduced
Nose	Not lifted above muzzle	Prominent, narrow
Nostrils	More or less separated	Close together
Upper lip	Separated by nose	Continuous beneath nose

Intermediate stages in the shifting and development of the parts of the face are seen in the monkeys and apes.

Taken as a whole, the series indicates that in the earlier forms the brain-case was low; the forehead first begins to be lifted up in the monkeys but it is not until man himself appears that the brain swells up to produce an almost vertical forehead.

The eyes first appear on the side of the head and gradually shift around to the front, so that by the stage of the anthropoid ape they can both be focussed at once on an object held in the hand or near the face.

The nostrils also are originally wide apart and come together into a true nose only in the anthropoid stage. The nose is at first not differentiated from the projecting muzzle, but in the anthropoids it becomes separated from the mouth by the broad upper lip and begins to take on its human character.

The mouth is at first only the opening to a sort of fish-trap set with sharp teeth, but in the anthropoids it becomes adapted for a diet chiefly of tender shoots and herbs. In man the mouth finally becomes relatively very small and delicate.

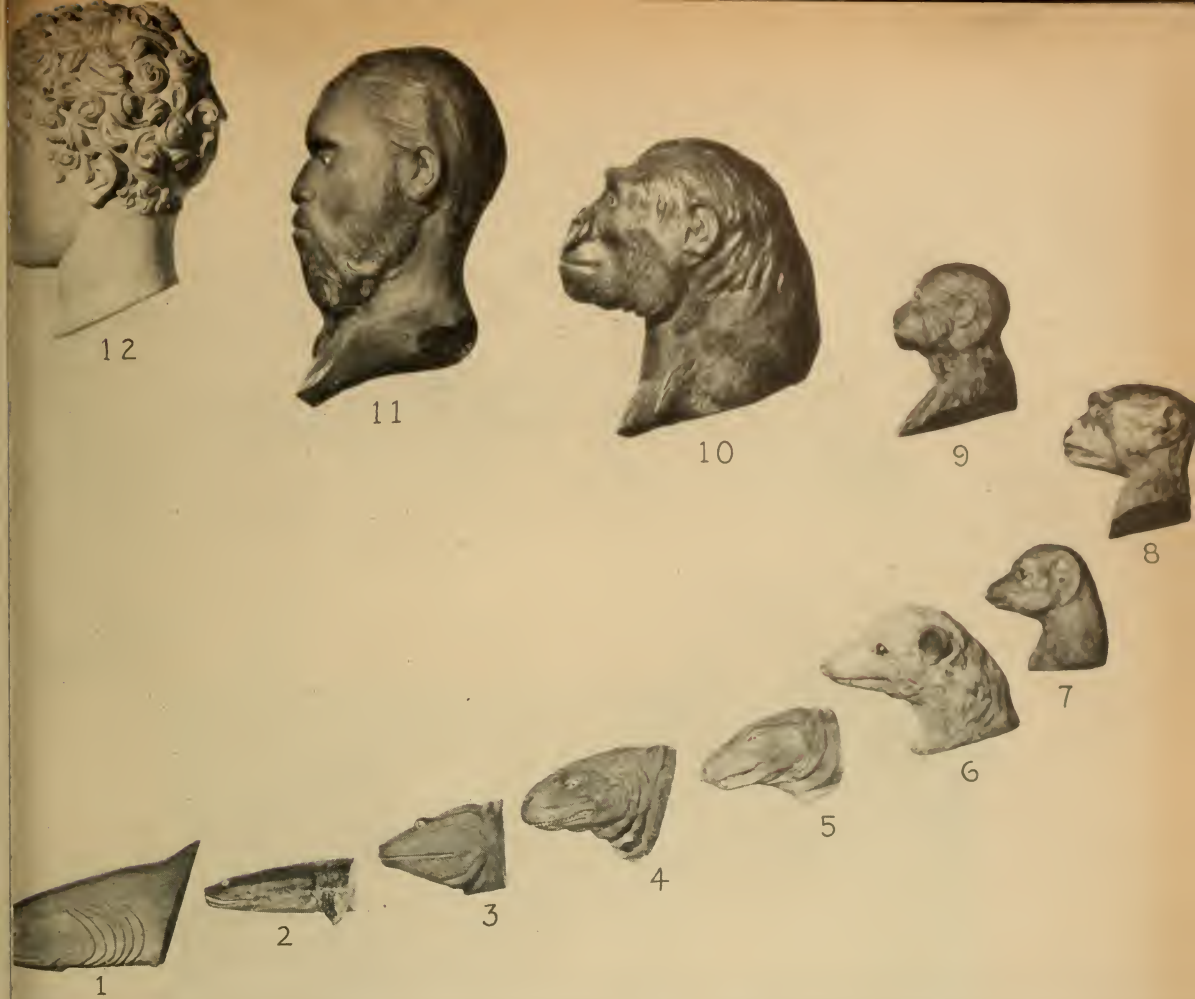
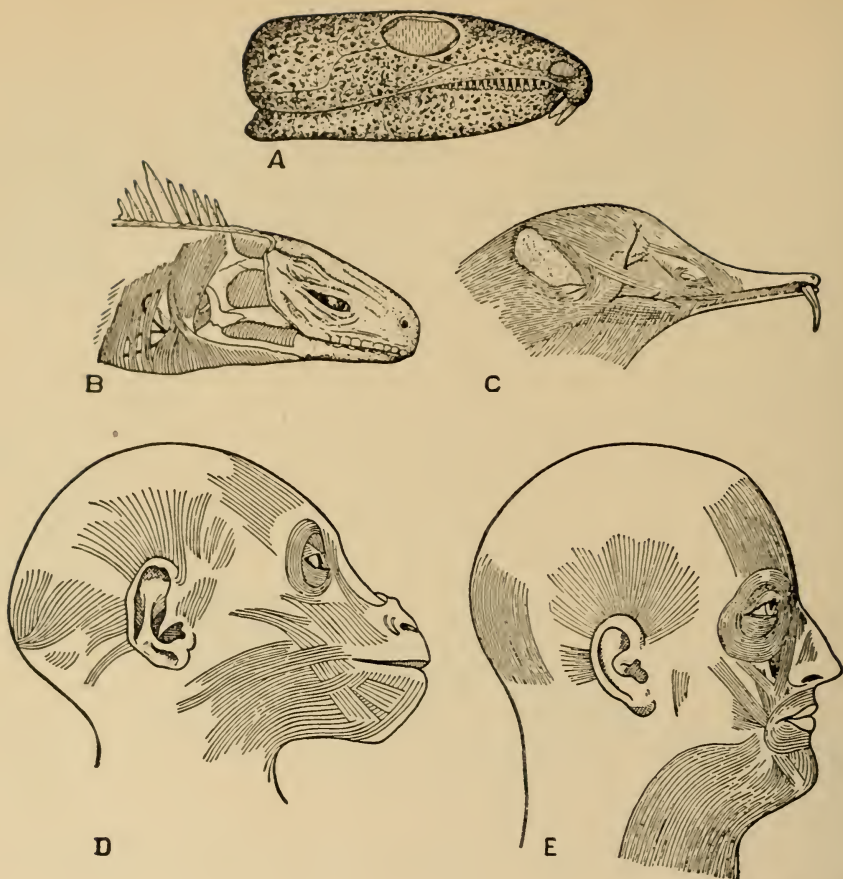

FIG. 20. A COMPARATIVE SERIES OF CASTS AND MODELS INCLUDING LIVING AND EXTINCT FORMS AND SHOWING A GENERAL PROGRESS FROM FISH TO MAN. 1. Ancient Shark (*Cladosebe*); 2. Lobe-finned Fish (*Eusthenopteron*); 3. Earliest Amphibian (*Eogyrinus*); 4. Stem Reptile (*Seymouria*); 5. Pro-Mammal or Cynodont (*Cynognathus*); 6. Common Opossum (*Didelphys*); 7. Recent Lemur; 8. Old World monkey (*Erythrocebus*); 9. Siamang (*Symphalangus*); 10. Young Gorilla; 11. Australian Bushman; 12. Greek Athlete

Thus the face has undergone great changes in adaptation to successively different modes of life; but, from first to last, the mouth, which is the gateway to the stomach, has been assisted by the nose, the eyes, and the ears. And as our brains have improved, our eyes and ears have told us more and more about the world of nature and of men.

THE FACIAL MUSCLES FROM FISH TO MAN (CASE VI)

The human face owes to its facial muscles the ability to smile or to frown and to express such emotions as joy, fear, dislike and their opposites. The facial muscles also take part in other movements of the lips, mouth, nostrils,



Courtesy G. P. Putnam's Sons

FIG. 21. ORIGIN OF THE FACIAL MUSCLES OF MAN. A. Primitive reptile with continuous bony mask covering skull. The mask was covered with thick skin without muscles, as in the alligator. (After Williston.) B. Modern reptile with an open or fenestrated skull covered with thick, non-muscular skin. (From Fürbringer, modified from Ruge.) C. Primitive mammal in which the sphincter colli system has grown forward over the face. D. Gorilla. E. Man: (C, D and E after Ruge). From "Our Face from Fish to Man" by William K. Gregory.

ears and scalp. In mammals, including man, they extend over the face and around the scalp, ears and neck, but in the vertebrates below the mammals they are confined to the neck and throat.

The series of models (Case VI) in low relief illustrates some of the steps by which the complex conditions in mammals are believed to have arisen out of the more simple conditions in man's less progressive relatives. The models (except No. 3) are based on a few of the numerous dissections and illustrations prepared by the late Professor Ernst Huber of Johns Hopkins University and described by him in his book on "The Evolution of Facial Musculature and Facial Expression" (1931).

EVOLUTION OF THE HUMAN SKULL

(CASES VI, VIIA AND 20)

During the evolution of the skull from that of a primitive lobe-finned fish to that of man (Fig. 23), many changes have taken place in the number, proportions and relations of the bones.

In the skull of the primitive Devonian fish, *Eusthenopteron*, there are about 145 bones, while in man (Fig. 22) the number is reduced to 27 or fewer. In the living codfish the skull is made up of 68 bones, not including the hyoid and branchial arches.

This reduction in number, as well as the striking great increase in the size of the brain-case and the reduction in the size of the jaws, well illustrates the principle recognized by Stromer and Williston, that as we pass from primitive to specialized vertebrates the number of primary skull elements is reduced, while those that remain become more highly differentiated.



FIG. 22. DISARTICULATED HUMAN SKULL, EXCLUSIVE OF HYOID AND LARYNGEAL ELEMENTS



A

B

C

D

FIG. 23. EVOLUTION OF THE HUMAN SKULL. This exhibit is designed to show ten structural stages in the evolution of the skull from fish to man, represented by known fossil and recent specimens. I. Devonian crossopterygian fish, *Rhizodopsis*. II. Carboniferous amphibian, *Eogyrinus*. III. Permo-Carboniferous reptile, *Scymouria*. IV. Permo-Carboniferous theromorph reptile, *Mycterosaurus*. V. Permian reptile, *Scynnognathus*. VI. Triassic cynodont reptile, *Ictidopsis*. VII. Recent opossum representing Upper Cretaceous marsupials. VIII. Eocene primate, *Notharctus*. IX. Recent anthropoid, chimpanzee, immature female.

(Continued on opposite page.)

INTRODUCTION TO HUMAN ANATOMY

Evolution of Jaw Muscles. The temporal and masseter muscles of man are homologous with similarly situated muscles in lower animals (Fig. 24). The temporal muscle arises on the side of the skull, passes down beneath the cheek arch and is inserted into the upper part of the mandible. The masseter arises from the lower border of the cheek arch and is inserted into the outer, rear part of the mandible.

In the shark (1) the temporal and masseter are represented by part of the adductor mandibulae mass, which in turn is in series with the deep flexor muscles of the gill arches.

The temporal muscle has played a prominent part in the perforation of the bony shell behind the eyes to form the temporal opening and cheek arch (see "Evolution of the Human Skull," Fig. 23).

The two pterygoid muscles (external and internal) although usually small in the mammals are of great importance in the opening and closing of the jaw. They also counterbalance the pull of the masseter, which might tear the jaws apart at the symphysis.

The digastric muscle of mammals is a compound muscle and it, together with one of the muscles of the throat region, represents part of the second constrictor of the fishes.

FIG. 23 (*continued*). X. Man. Column A. Evolution of the skull roof. The paired nasal, frontal and parietal bones of the primitive vertebrates (I-V) are passed on by heredity to the lower mammals (VII, VIII) and finally to man (X). In man (top) the upgrowth of the brain is reflected in the dome-like cranium. Column B. Evolution of the bones around the eye. In lower vertebrates (I-V) there was a series of five bones around the orbits or eye-sockets. In the mammals (VII-X) only two of these bones (the malar and the lacrymal) remain. In the lower forms the eyes are on the sides of the muzzle behind the upper jaw, and they look sideways. In anthropoids and man they are above the upper jaw and are directed forward. Column C. Evolution of the jaws. In adult man the upper jaw on each side is composed of two fused bones, the premaxilla (intermaxillary) and the maxilla. The lower jaw on each side is composed of a single bone, the dentary. These bones are present in the lower vertebrates. As we pass from fish to man the maxilla and the dentary become larger and the dentary at Stage VII effects a new contact (the temporo-mandibular joint) with the skull. In the anthropoid and man the jaws become deepened and shortened in front beneath the eyes. Column D. Evolution of the temporo-mandibular bones. In the fish (I) the cheek plates cover the jaw muscles and are continuous below with the infra-dentary bones. In the reptiles this series is represented especially by the squamosal and angular bones. In mammals (VII-X) only the squamosal remains visible, to form the squamous portion of the temporal bone

INTRODUCTION TO HUMAN ANATOMY

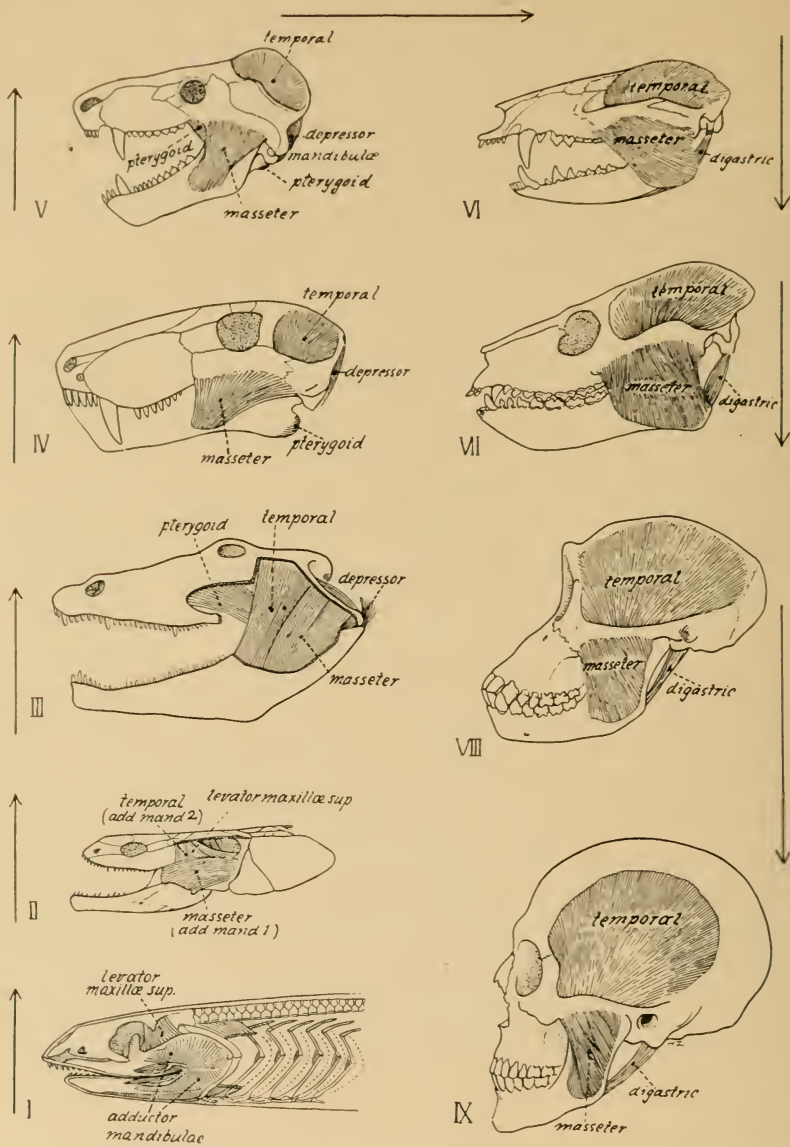

Courtesy G. P. Putnam's Sons

FIG. 24. EVOLUTION OF THE JAW MUSCLES. I. Shark (*Chlamydoselachus*). II. Lobe-finned ganoid (*Polypterus*). III. Primitive amphibian (*Eryops*). IV. Primitive mammal-like reptile (*Scymnognathus*). V. Advanced mammal-like reptile (*Cynognathus*). VI. Opossum. VII. Primitive primate (*Notharctus*). VIII. Chimpanzee. IX. Modern Man. From "Our Face from Fish to Man" by William K. Gregory.

INTRODUCTION TO HUMAN ANATOMY

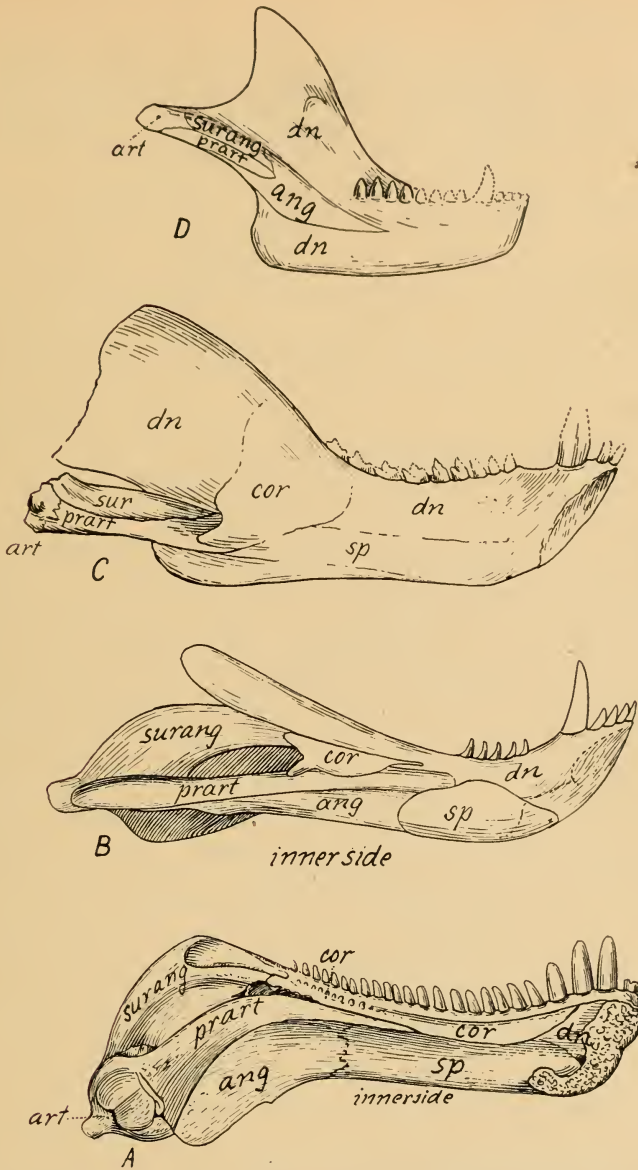
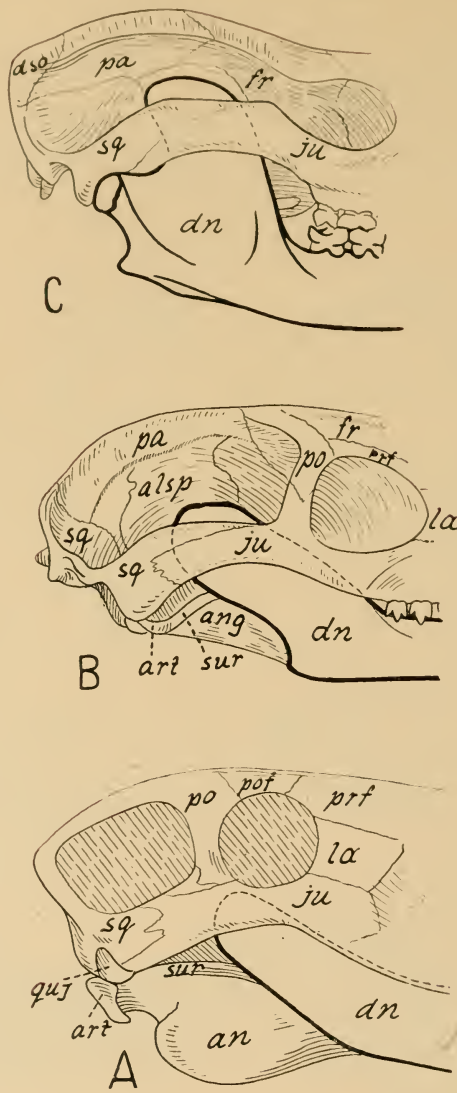

FIG. 25. PROGRESSIVE INCREASE OF THE DENTARY (*dn*) and reduction of the elements behind the dentary, leading to the mammalian jaw, which has formed a new articulation with the skull (see Fig. 26). Inner side of left half of mandible. A. Primitive theromorph reptile, *Dimetrodon*. After Williston. B. Primitive gorgonopsian, *Cynarioides*. After Broom. C. Progressive cynodont, *Cynognathus*. Partly after Watson. D. Ictidosaurian. After Broom

INTRODUCTION TO HUMAN ANATOMY



Courtesy G. P. Putnam's Sons

FIG. 26. PROGRESSIVE UPGROWTH (A, B) OF THE ASCENDING BRANCH OF THE DENTARY BONE OF THE LOWER JAW, which eventually, in the early mammals (C), effected a contact with the skull, thus forming a new joint. Meanwhile the old joint (at the back of A) dwindled away. A. Primitive mammal-like reptile; B. Advanced mammal-like reptile; C. Primitive mammal. From "Our Face from Fish to Man" by William K. Gregory.

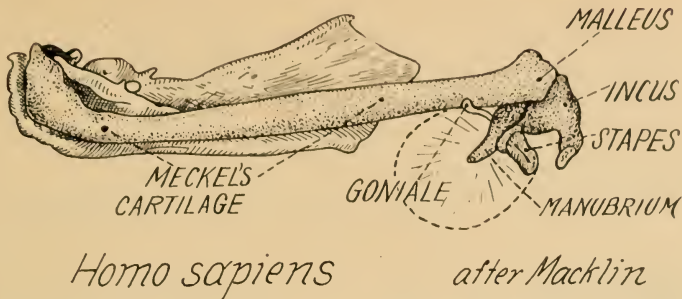

Courtesy G. P. Putnam's Sons. After W. K. Gregory

FIG. 27. AUDITORY OSSICLES OF FOETAL STAGE FORMED FROM JAW ELEMENTS BEHIND THE DENTARY

EVOLUTION OF THE AUDITORY OSSICLES

(CASE 25)

The auditory ossicles of man, like those of mammals, are derived in the course of embryonic development from parts of the "visceral arches" corresponding to the cartilaginous jaws, hyoid arch and branchial arches of the fish. Thus in the human embryo the future incus (anvil) is represented by a little cartilage that has the precise position and spatial relations of the quadrate bone of the lower vertebrates; the malleus (hammer) is a part of the Meckel's cartilage, or core of the lower jaw; while the stapes represents the upper part of the hyoid arch (Fig. 27). This interpretation of the origin of the mammalian ossicles was first put forward by the embryologist C. Reichert in 1837, but it has been greatly extended and confirmed by modern investigators, especially E. Gaupp of Fribourg.

In the series of fossil vertebrates from fish to man, the cynodonts, or pro-mammals of the Triassic age of South Africa, show a critical stage in the evolution of the auditory ossicles, immediately preceding the mammalian condition (Fig. 25 C, D). The dentary bone of the lower jaw has increased in size and the bones behind it have become much smaller. As in modern reptiles, the tympanum, or ear-drum, was very probably connected by ligaments with the back part of the lower jaw. Hence in these animals the articular, quadrate and columella auris had already begun to function respectively as the malleus, incus and stapes.

This amazing but now fully documented transformation of jaw elements into auditory ossicles affords an excellent example of the principle of the "change of function."

For the relations of the auditory ossicles to other parts of the organ of hearing, see Fig. 32 and page 64.

INTRODUCTION TO HUMAN ANATOMY

Evolution of Molar Teeth. It has been shown by palæontologists that the more complex forms of the crowns of the molar teeth of mammals have evolved from a simple triangular or tritubercular pattern. This was the most important part of the "Cope-Osborn Theory of Trituberculy," developed by the American palæontologists Edward D. Cope and Henry Fairfield Osborn between 1883 and 1907.

The series of enlarged models of teeth of fossil and living mammals (Fig. 28) represents eight stages of advancement from the Jurassic period to the present time.

The series as a whole shows the transformation of the upper molars from an irregular cutting and piercing triangle to a rounded, four-cusped grinding tooth.

In the lower molars the progress is from small cutting triangles with very small posterior heels to large oval grinders with low conical cusps and a large central basin.

Noteworthy details of this transformation are as follows:

In the second stage (B) the tip of the upper premolars is represented in the molars by a large conical cusp (solid black) called the amphicone. In the later stages the amphicone divides into two cusps (paracone and metacone), which move apart as the hypoconid of the lower molars comes to fit between them.

The "protocone" of Osborn is apparently not the oldest cusp of the upper molars but arises as a swelling or bud on the inner side of the base of the crown.

In the earlier stages the outer part of the crown, called the cingulum, is very large, but after the fourth stage (from the bottom) it disappears, leaving the paracone and metacone on the outer border of the crown.

In the fifth stage a new cusp, the hypocone, grows up, filling the space between the upper molars and changing a triangular into a roundly quadrangular crown.

In the lower molars we observe that in the earlier stages the talonids or heels are small, but finally they become larger than the trigonids (or lower triangles). As this happens, the protocones of the upper teeth enlarge to fit into the expanded talonid basins. The paraconids, or antero-internal cusps of the lower molars, disappear at the fifth stage, while the hypocones of the upper molars become enlarged.

INTRODUCTION TO HUMAN ANATOMY



FIG. 28. EVOLUTION OF MOLAR TEETH ILLUSTRATED BY FOSSIL AND RECENT MAMMALS. Upper teeth left, lower teeth right half of picture. A. Pantotherian. B. Deltatheridium. C. Potamogale. D. Didelphodus. E. Pronycticebus. F. Dryopithecus. G. Le Moustier. H. Man (modern White)

THE NERVOUS SYSTEM AND ITS FUNCTIONS

ELEMENTS OF THE NERVOUS SYSTEM

(CASE VIIIB)

Man, like other organisms, is a living solar engine, run by the energy of the sunlight that is stored in plant and animal food (see Case I).

This stolen energy may easily drive its user to destruction unless quick adjustments are constantly being made against dangerous forces both inside and outside the body.

The nervous system makes these adjustments possible; it also determines which one of several alternatives shall be followed when competing interests are at stake. In very simple animals a good adjustment is presumably rewarded by a sense of well-being or pleasure, while a bad adjustment gives rise to a sense of pain. In the higher animals the immediate pursuit of pleasure and the avoidance of pain is complicated by memories of the good or bad consequences of past behavior.

This exhibit is intended to show how the simplest elements of the nervous system are built up into the amazing complexities of the brain; similarly, the science of psychology strives to trace an orderly historical sequence from the elementary reactions of an amœba to the most abstruse reasonings of mathematicians.

A few of the myriads of vibrations which constantly rain down upon us are caught by tens of thousands of sense organs, or receptors, scattered almost everywhere on the surface of the body and in its interior. The receptors for smell and taste are able to catch chemical stimuli; the receptors for touch, pressure, hearing, receive mechanical or physical stimuli; the receptors for light, color-waves, heat and cold, are sensitive to radiant energy.

The position of the body in reference to the direction of the force of gravity (balance), as well as the position of the different organs and parts to each other, is indicated by several kinds of "receptor organs" sensitive to pressure and located in the skin, in the tendons of the muscles, in the joints and elsewhere.

When a receptor is excited it starts a current of "negativity" in the ions of the neurons. The discharge of the current at the end of a neuron starts a current in the one above it, and so on by relays along afferent nerves up to the brain; then other currents start in various directions in the cortex of the brain; thence new currents pass down the efferent neurons to the effectors, or motor organs, including muscles around the glands.

INTRODUCTION TO HUMAN ANATOMY

The "Sympathetic" (Autonomic) Nervous System. The nervous system as a whole is composed of two main divisions: (1) the cerebro-spinal system, including (A) the brain, (B) the cranial nerves, (C) the spinal cord, (D) the spinal nerves; (2) the autonomic nervous system, including a vast network of fibers ending in the unstriated muscular coats of the blood-vessels and in the mucous membranes and other parts of the glands and other internal organs.

The autonomic system comprises two main divisions, sympathetic and para-sympathetic, which oppose each other in regulating the action of the ductless glands, viscera, blood-vessels, etc.

The larger branches of the sympathetic nervous system unite to form a series of ganglia on each side of the spinal cord. Each of these ganglia is connected by delicate branches with the corresponding spinal nerve of the cerebro-spinal system. The ganglia of the sympathetic system arise in the mammalian, human and other embryos from the lateral margins of the neural crests. Hence the sympathetic ganglia are really only differentiated portions of the central nervous system.

Spinal Nerves. In such a primitive vertebrate as a shark the muscular part of the body is divided into a series of segments called somites, which surround the non-segmental digestive tract and spinal cord. Each somite contains one vertebra and one pair of spinal nerves.

Each spinal nerve issues by two roots, dorsal and ventral, from the spinal cord between the neural arches of the vertebræ. The motor (ventral) root is so called because it motivates the muscles of the trunk and limbs. The dorsal and ventral roots unite to form a common trunk. This subdivides into a dorsal and ventral primary division, both carrying motor and sensory nerve fibers. Smaller branches finally supply the sense organs in the skin and the skeletal muscles beneath. This arrangement, which makes possible the spinal reflex, is found in all vertebrates from fish to man. In certain vertebrates, especially reptiles, those spinal reflexes that cause wriggling of the body may continue long after the cord has been severed, but in the mammals these reflexes are more or less under the control of nerve centers in the brain-stem.

Reflex Action. In the "knee-jerk reflex" a slight tap just below the knee stimulates the sense organs of pressure in the tendon of the extensor muscle of the leg. Nervous impulses then travel up the afferent nerves through the posterior or sensory root of the spinal nerves into the spinal cord itself; there the afferent currents pass into fine terminal nerve branches which come very near to, but do not actually cross over into, equally fine terminal branches of the descending or efferent nerves. Somehow the currents in the afferent branches induce corresponding currents in the efferent

INTRODUCTION TO HUMAN ANATOMY

branches and these travel out through the anterior or motor root down the efferent nerves to the nerve endings, or end-plates, which are fastened to the sides of the muscle fibers. The discharge in these end-plates initiates the contraction of the extensor muscles on the thigh and the lower leg suddenly kicks forward.

This reflex is practically automatic or involuntary, since the reaction between afferent and efferent impulses takes place in the spinal cord with little or no control from the brain.

Cranial Nerves. The "cranial nerves" are paired nerves that issue from the brain and brain-stem in front of the spinal cord. In all vertebrates from fish to man the cranial nerves are arranged in the following traditional sequence:

NERVE PAIR	NAME	FUNCTION
I	Olfactory	Nerves of smell
II	Optic	Nerves of sight
III	Oculomotor	Motor nerves to four out of the six muscles of the eye-balls, as well as the ciliary muscles and muscles of the iris in the interior of the eyes
IV	Pathetic or Trochlear	Motor nerves to superior oblique muscle of eye-balls
V	Trigeminal	
V ₁	Ophthalmic branch	Sensory nerves to front of head
V ₂	Superior maxillary branch	Sensory nerves to face, palate
V ₃	Mandibular branch	Motor nerves to jaw muscles; sensory nerves to teeth, anterior part of tongue
VI	Abducent	Motor nerves to external rectus muscle of eye-balls
VII	Facial	In fish the sensory branches go mostly to the lateral line organs of the face, the motor branches to the muscles of the neck and gill covers
VIII	Acoustic	Sensory nerves of the inner ear or labyrinth
IX	Glosso-pharyngeal	Sensory branches to taste organs of the tongue and pharynx Mixed branches to second gill cleft
X	Pneumogastric or Vagus	Sensory and motor branches to lateral line, branchial arches, lungs, heart, stomach
XI	Spinal accessory	Motor nerves to branchial arches and muscles of the neck
XII	Hypoglossal	Motor nerves to muscle of tongue

INTRODUCTION TO HUMAN ANATOMY

In mammals nerve XI is derived from part of X, while XII represents one or more of the spinal nerves of lower vertebrates.

In mammals, including man, the general arrangement and distribution of the cranial nerves are substantially the same as in fish but with these important exceptions:

(1) With the abandonment of aquatic life the lateral line system of sense organs has disappeared from the head and neck, and with it the corresponding branches of the seventh cranial nerve.

(2) The gill covers, their sensory organs and special nerves have also disappeared but some of the muscles of the hyoid arch are still present and function in operating the larynx, or voice mechanism.

(3) In the ancestors of the mammals some of the superficial muscles of the neck grew forward under the skin to form the facial or mimetic muscles, carrying with them branches of the seventh or facial nerve (see Case VI).

Modern anatomists have discovered that there are several additional pairs of cranial nerves, not noticed by the older anatomists.

THE BRAIN

(CASE VIII)

SENSATION

Palæokinesis: Action Controlled by the Senses. The main divisions of the shark's brain correspond to the organs for smelling, seeing, balancing, touching and tasting. The brain is surrounded by these organs and consists of bundles of nerves that come from them and from the spinal cord, the latter being the main mass of nerves from the internal organs, muscles and skin of the body.

The reactions of the shark to its environment are controlled directly by its senses. Thus pleasure and pain produce opposite and immediate direct response. This type of reaction is called *palæokinesis* (ancient action) in contrast with the more deliberate response of the highest animals, which is more or less controlled by ideas (*neokinesis*) (Figs. 29 and 30).

Touch, Pressure, Pain, Heat, Cold, etc. In the skin of vertebrate animals we find several kinds of sense organs which may be called CONTACT receptors, in contrast to DISTANCE receptors, including the eye and ear. The contact receptors give rise to the senses of touch, pressure, pain, heat, cold and perhaps other sensations. They are widely distributed over the skin

PALÆOKINESIS

ACTION CONTROLLED
BY THE SENSES

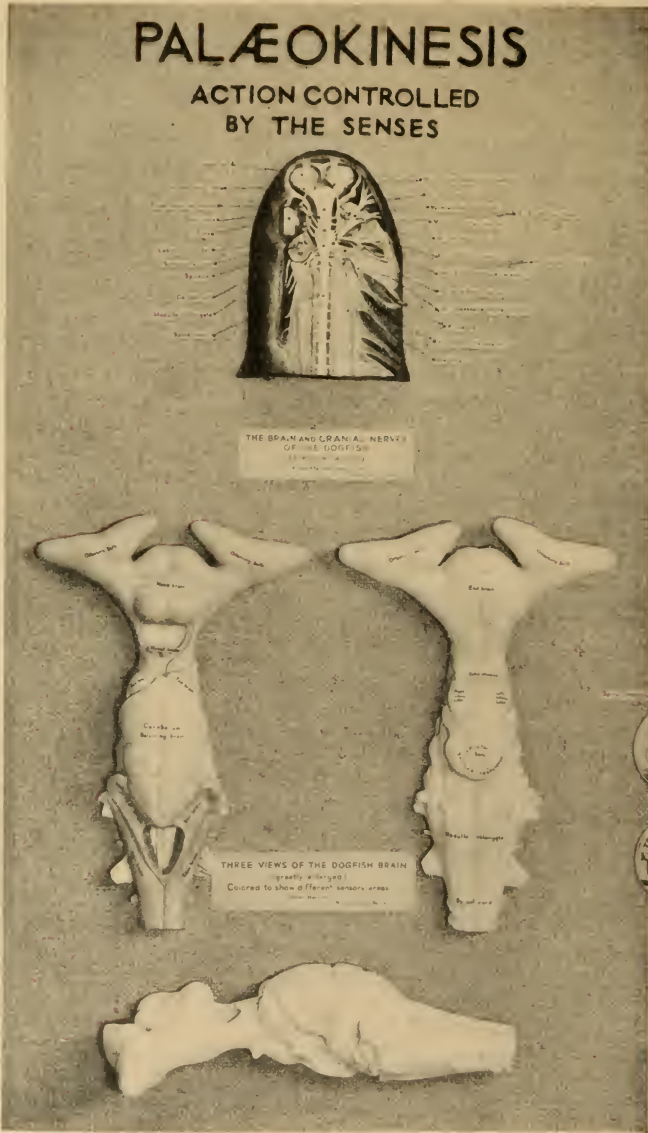

FIG. 29. IN THE SHARK THE NOSE BRAIN, EAR BRAIN AND CEREBELLUM DOMINATE THE MIDBRAIN, WHICH IN THE FISH IS THE MAIN CENTER OF CONTROL

NEOKINESIS

ACTION CONTROLLED
BY IDEAS

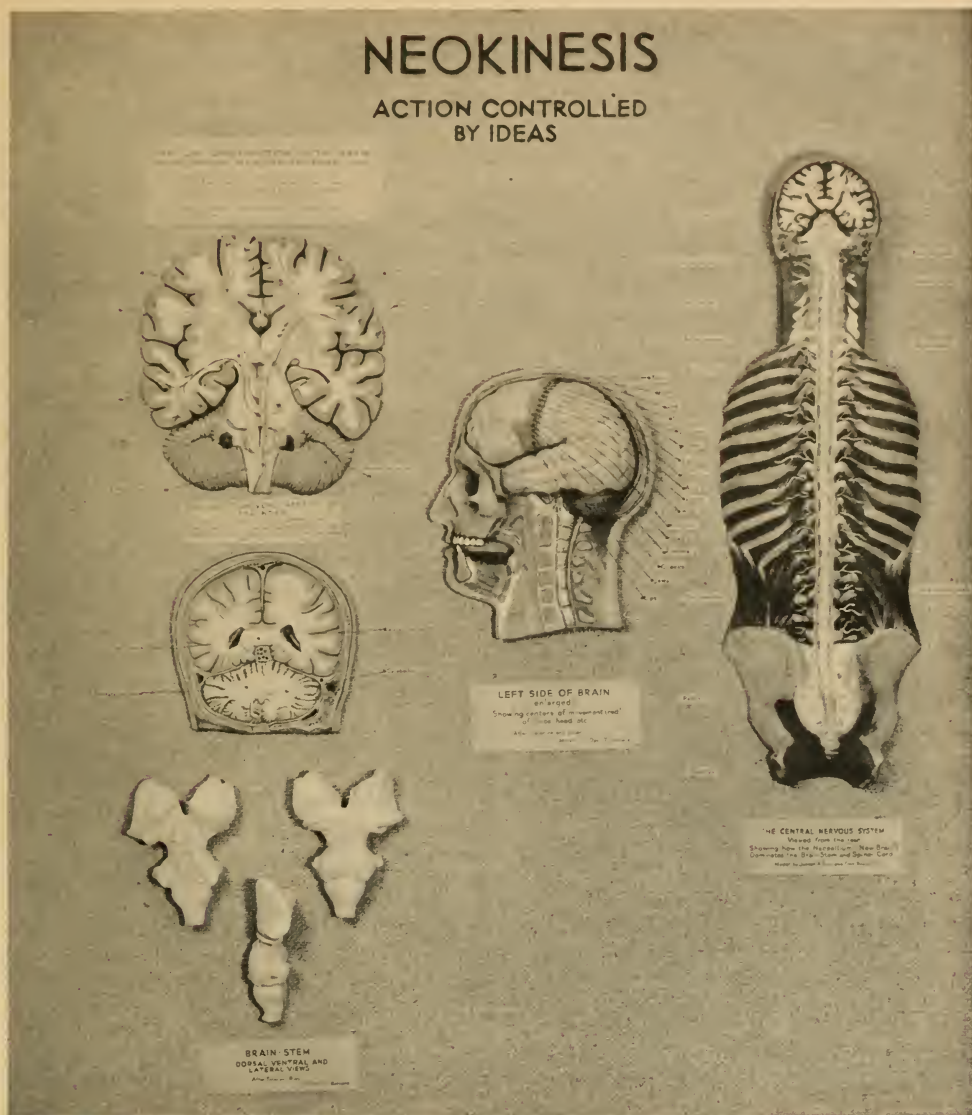

FIG. 30. IN MAN THE CENTER OF CONTROL HAS MOVED UPWARD INTO THE CEREBRAL CORTEX, WHICH DOMINATES ALL THE PARTS BELOW IT

INTRODUCTION TO HUMAN ANATOMY

and are supplied by the cutaneous nerves. The latter lead back to the dorsal roots of the spinal nerves and thence up the spinal cord to the medulla oblongata of the brain-stem, where the centers for these senses are located.

The muscles, tendons and joints of the body are also supplied with end organs that are sensitive to pressure. Movements of one part on another, or even the arrest of movements as in fixed postures, stimulate the end organs in the tendons and joints and thus inform the brain of the position and state of tension of each part. These receptors are innervated by branches of the spinal nerves.

Other receptors, called enteroceptors, located in the viscera and in the muscular parts of the heart and blood-vessels, appear to be sensitive to the pressure of gases and liquids, while still other receptors in the intestines may be sensitive to chemical stimuli of the body fluids. The viscera are innervated by the vagus nerve (parasympathetic) and sympathetic systems.

Smell. The olfactory receptors, or organs for the sense of smell, are classed as chemo-receptors because they are stimulated by certain chemical substances dissolved in olfactory mucus, a watery solvent. These solutions affect the sensory hairs of the olfactory epithelium, perhaps by reacting with the solutions contained therein.

There is evidence that the sense of smell was very highly developed in the oldest types of fishes and that there has been a marked reduction of this power in the nearer ancestors of man. In a certain large shark, according to Haldane and Huxley, the olfactory epithelium (which is greatly infolded and packed into the olfactory capsules) had an immense area, estimated at twenty-four square feet. In a dog, which like most ordinary mammals has a relatively keen sense of smell, the olfactory epithelium if unfolded would cover about ten or more square inches. In man, although the nasal cavity is lined with mucous membrane, only a very small area (about one-fourth of a square inch) is supplied with the branches of the olfactory nerve, all the rest being insensitive to smell.

Similarly, those parts of the brain which relate to the sense of smell have become much reduced in man and his nearest relatives, the anthropoid apes.

Taste. "Taste buds," or receptors for taste stimuli, in the human adult are located in several places, chiefly on the tongue, epiglottis and soft palate.

The four principal tastes are differently distributed on the surface of the tongue: "sour" is best noted on the sides of the tongue; "saline" on the sides and tip; "sweet" at the tip; and "bitter" at the base.

Three, or possibly four, of the paired cranial nerves include gustatory fibers. The chorda tympani branch of the seventh nerve separates from

INTRODUCTION TO HUMAN ANATOMY

the lingual nerve (a branch of the fifth) and sends gustatory fibers to the anterior two-thirds of the tongue. The glosso-pharyngeal, or ninth, supplies the posterior third of the tongue, including the foliate and vallate papillæ, while branches of the tenth (vagus) are distributed to the larynx, the epiglottis and to a small area at the most posterior part of the tongue itself. In human fetuses and babes taste buds are more widely distributed than in the adult.

In the brain afferent nerve fibers from the taste buds discharge their currents into "nuclei," or centers in the medulla oblongata. Then by relays the gustatory messages are conveyed to the brain. The kind of response of the brain as a whole to these stimuli will depend in part upon the data supplied by the various centers of memory and association (see Fig. 30, Neokinesis).

Sight. The "basic patent," or most fundamental feature of the eye, is the battery of light-cells (rods and cones) in the retina, whereby the energy of the light waves is converted into visual nerve impulses which travel along the optic nerve to the brain.

The rods of the retina contain "rhodopsin," or visual purple, and it is possible that the decomposition of visual purple under the influence of light causes excitation of the rods. The cones have no visual purple but probably do contain some other photo-sensitive compound.

The efficiency of the light-cells is immensely increased by the fact that the eye as a whole is a natural camera, whose chief parts are as follows: (1) a dark chamber, in which the light is admitted only through a small circular aperture called the pupil; (2) a sensitive plate called the retina; (3) a lens for focussing the image; (4) muscles of accommodation for altering the curvature and focal length of the lens; (5) a contractile iris for regulating the amount of light admitted to the chamber.

But the eye is a living camera, all of whose parts have to be fed with materials for maintenance and growth. Hence it possesses a great many features not found in an ordinary camera. The retina, for example, is crowded with nutrient blood vessels, which supply the many layers of rods and cones.

A small circular spot called the fovea, which lies within the macula on the back of each retina, is far more sensitive to light than is the surrounding area. These sensitive spots enable the two eyes to converge on a single small object. This convergence is effected by the coöperation of the two sets of eye muscles. Each eye is moved by six muscles, which together form a cone surrounding the optic nerve. Focussing is done by muscles attached to the lens.

The cornea, or transparent front window of the eye, is continuous with

INTRODUCTION TO HUMAN ANATOMY

the sclerotic coat. Specks of dirt, sand, etc., are washed off by tears from the lacrimal gland in the outer corner of the eye.

In primitive vertebrates the optic lobes on the upper part of the mid-brain were the chief receiving centers for visual stimuli, but as the neopallium, or higher brain, became larger and more complex (Fig. 31), the "optic radiation" on the occipital surface of the cerebrum became increasingly important; in the mammals the old optic lobes serve as reflex centers for the eye muscles.

In the anthropoids and man nerve fibers from each eye cross over to the opposite half of the brain; others go directly to the same side of the brain. This makes possible complete overlap of the two visual fields, resulting in "stereoscopic vision."

The position of the paired eyes in primitive vertebrates is on the sides of the head but in the mammals there is a tendency for the eyes to be directed forward. Finally in the anthropoid apes and man the eyes look wholly forward and are not only capable of converging on an object but can both follow an object moving in any direction within the combined field of vision (biconjugate movement) (Case 26).

In the vertebrates the eyes arise in the embryo as pockets in the medullary folds of the future brain. The optic stalk and cup then grow outward from the base of the rapidly swelling midbrain. When the optic cup touches the outer layer it gives out a chemical substance that causes the ectoderm to thicken into a lens.

The general structure of the eye throughout the vertebrates is remarkably constant, the chief differences between the eyes of fishes and those of land-living vertebrates being that in the former the lens is more convex and its focal distance shorter.

FIG. 31. THE RISE OF THE HUMAN BRAIN (Wall Chart 7). From fish to man the brain increases in complexity and in the size of certain parts, especially the forebrain. In the lower forms the forebrain functions chiefly in connection with the "olfactory bulbs," and smelling nerves. In the mammals the upper part of the forebrain becomes differentiated as the neopallium, or new brain, gradually assumes control and finally becomes greatly convoluted or infolded, largely concealing, especially in the side and top views, the older parts of the brain. Although the forms whose brains are figured on the opposite page are all living at the present day and therefore not ancestral one to the other, their brains represent a progressive series from lower to higher types

BASE

LEFT SIDE

TOP



MAN



ANTHROPOID APE
(GORILLA)



PRIMITIVE ANTHROPOID
(GIBBON)



PREPRIMATE
(TREE-SHREW)



LOWLY MAMMAL
(OPOSSUM)



GENERALIZED REPTILE
(SPHENODON)



TAILED AMPHIBIAN
(NEWT)



PRIMITIVE FISH
(SHARK)

FIG. 31

INTRODUCTION TO HUMAN ANATOMY

Hearing. The organ of hearing (Fig. 32) is classed among the mechanical receptors because it responds to mechanical stimuli, which in this case are the pulsations of sound waves in the air against the tympanum, or ear-drum. The outer ear (concha) and its tube (the external auditory meatus) serve merely to collect and conduct the sound waves to the tightly stretched ear-drum. The latter is located at the entrance to the tympanic cavity, which in turn leads to the Eustachian tube (tuba auditiva), connecting with the throat. The degree of tension of the ear-drum is regulated by the tensor tympani muscle, the tendon of which is fastened into the handle of the hammer, or malleus. The latter is the outermost of a chain of three little bones (ossicula auditus) that transmit vibrations of the ear-drum to the membrane of the oval window (fenestra ovalis) of the inner ear (see p. 51).

The three little bones are geared together in such a way that the relatively wide but weak oscillations of the ear-drum are transformed into much shorter but more powerful thrusts of the foot-plate of the stirrup, or stapes. The vibrations of the latter start waves in the liquid that fills the snail-shell, or cochlea; this in turn contains the organ of Corti, or true organ of hearing.

The waves of pressure travel up the liquid in the coils of the cochlea in the upper division thereof (scala vestibuli), passing over the sensory hairs of the acoustic epithelium and thus initiating nerve currents which pass through the afferent acoustic nerves to their centers in the brain-stem. Numerous relays pass thence to and from the temporal lobe and other parts of the brain. After reaching the top of the cochlea the pressure waves come down the lower division of the coil (scala tympani) and appear to escape through the vibrations of the membrane covering the round window (fenestra rotunda) at the lower end of the cochlea. The cochlea seems to analyze sound waves by some mechanism for sympathetic vibrations. Since the sensory cells of the organ of Corti are arranged in a spirally-wound series, it is possible that they are sensitive, like the wires of a piano, to different wave lengths. Other structures in the ear, for example the basilar membrane, have been considered as the significant part in the resonating apparatus.

The semicircular canals are sometimes called the chief organs of balance, or equilibration, because they supply sensory stimuli that vary according to the inclination of the head toward the pull of the earth's gravitation. There are three semicircular canals, the anterior vertical, posterior vertical, and external or horizontal canals, arranged at right angles to each other in the three planes of space. They are supposed to act like spirit-levels. The canals are filled with liquid and lined with sensory hair-cells, which are connected with nerve fibers from the upper division of the eighth

INTRODUCTION TO HUMAN ANATOMY

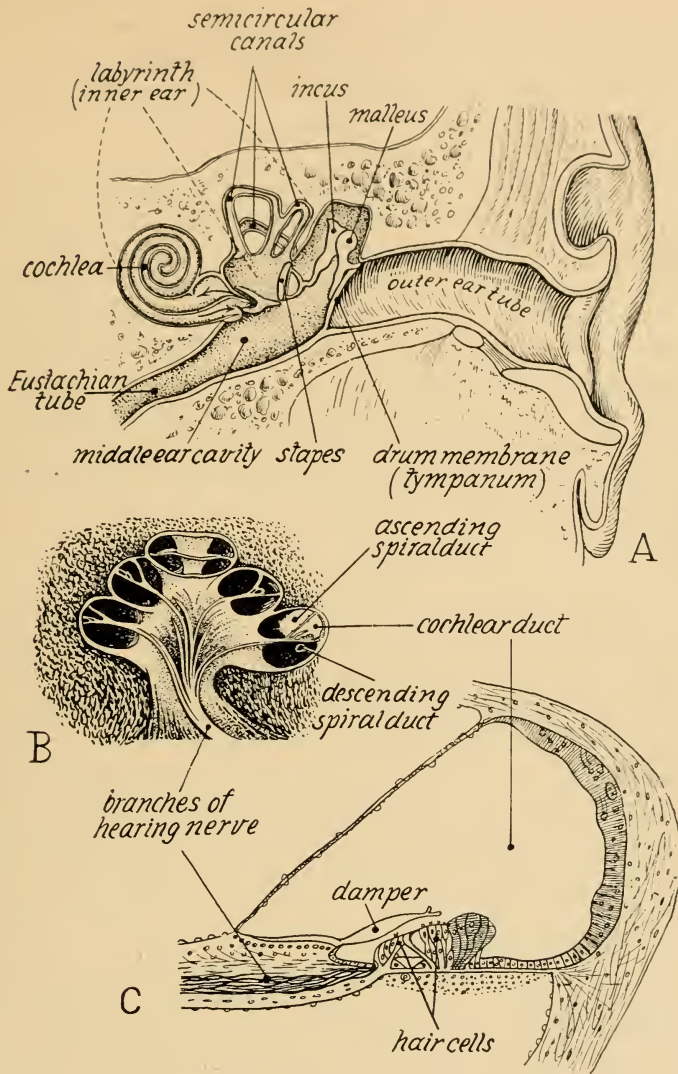

Courtesy G. P. Putnam's Sons

FIG. 32. THE HUMAN ORGAN OF HEARING AND BALANCE. A. Transverse section. B. Diagram, section of the cochlea, showing the ascending and descending spiral duct and the cochlear duct containing the organ of Corti, or true organ of hearing. C. Greatly enlarged view of the cochlear duct, showing the organ of Corti with its damper, hair cells and hearing nerves. (A and C, after Cunningham.) From "Our Face from Fish to Man" by William K. Gregory.

INTRODUCTION TO HUMAN ANATOMY

cranial nerve. The chief centers of balance are in the medulla and cerebellum. The absence of direct connections with the cortex of the cerebrum indicates that the mechanism for equilibration is largely reflex.

Semicircular canals were present in the very oldest known fossil vertebrates and are remarkably constant in their general arrangement in the existing vertebrates from fish to man.

The cochlea, or organ of hearing, on the other hand, first appears in the higher reptiles and becomes fully developed only in the highest vertebrates, which are the birds and mammals.

The acoustic, or eighth pair of cranial nerves, is in series with the vagus, or tenth, and the entire labyrinth, including its nerves, is regarded as a highly differentiated and specialized portion of the lateral line organ system of fishes.

The entire labyrinth, or inner ear, arises in the early embryo as a pocket of ciliated epithelium, an infolding of ectoderm. In later stages this pocket becomes divided: the dorsal half gives rise to the canals and the utriculus; the ventral, to the cochlea.

RESPONSE

Memory. The first "basic patent" for memory is the fact that when a nerve current comes up to the brain from a sense organ, it induces another discharge or series of discharges, in the cortex of the brain itself, and that these discharges appear to leave some physical traces behind them, analogous perhaps to stains. To use a crude analogy, the more intense and wide-spread the sensory discharges, the deeper the stains will be and the longer time it will take to wash them out. In this connection it is an interesting fact that there is a close resemblance between the "curve of forgetting" and the curve of times necessary for washing out dye-stains in certain tissues.

The second physical basis of memory is the fact that every "center" in the brain is connected with many other centers by "association fibers." Adjacent sensory and motor areas on the surface of the cortex are connected by short association fibers, while long association fibers connect the occipital, parietal and temporal lobes with each other and with the frontal lobe, toward which the association fibers converge. The millions of "afferent" fibers come up to the cortex from the sense organs, passing through such crowded pathways as the thalamus, the lenticulate nucleus and the corona radiata, and the currents that they discharge leave their traces in many parts of the brain.

Memory, both conscious and unconscious, is the first basis of the "conditioned reflex," and eventually of habit-forming and the learning process.

INTRODUCTION TO HUMAN ANATOMY

"The burnt child fears the fire," and even a pike will soon learn not to strike his nose against the glass in an aquarium.

Memory is of the highest value in all vertebrates, including man, because it enables its possessor to profit by experience, to "see things coming" and to make effective adjustments before the storm breaks or before a given course of action leads to disaster.

Speech. While all the senses such as touch, taste, smell, sight and hearing are constantly pouring their stimuli into the brain, the brain also responds in various ways, as by bodily movements, by an increased glandular secretion, or perhaps by arrested movement with heightened internal pressure. Finally, in the case of man, response may issue in speech or in its short-hand record which is called thinking. Spoken words, considered as purely physical events, are merely noises caused by puffs of air rushing across the vocal cords of the larynx and variously checked or otherwise modified by the action of the larynx, tongue, palate, teeth and lips.

The larynx represents a highly specialized derivative of the complex gill-arch apparatus of the fish. The several bones of the larynx may be followed backward along the descending scale of living vertebrates to the corresponding parts in the branchial skeleton of the fish, and this is true of each of the muscles of the larynx. The skeleton of the tongue is derived from parts of the hyoid arch and of the median bars of the branchial arches. The muscles of the tongue are innervated by branches of the hypoglossal, the twelfth cranial nerve, while those of the larynx are supplied by the tenth. It is noteworthy that these same cranial nerves, the tenth and the twelfth, also supply the tongue and branchial muscles of lower vertebrates.

Thought. In neurological terms, thinking may be defined as a more or less organized series of discharges, in the surface layers of the brain, of the various "association systems" acting in unison with each other, reacting to present sensory patterns but always conditioned by emotional stresses left over from past sensory, motor and associational discharges.

Due to these diversely conditioned reactions established by past experience and habit, similar sensory-motor patterns do not always induce the same associational responses. On the other hand, a characteristic part of a pattern often induces the same response as does the whole pattern.

Thinking involves a process which may be compared with the projection of two streams of pictures upon the same screen. The first stream includes such reflections of the outer world as are transmitted by the sense organs and their nerves; the second stream is composed of the blurred, distorted images furnished by memory. The "screen" is found in the projection areas of the "association systems," especially those on the frontal lobes of the brain.

INTRODUCTION TO HUMAN ANATOMY

Thinking may be defined as the process of matching new sensory patterns with the memories of past ones and of responding in different ways to identities and differences between these patterns. Thinking, in this sense, apparently goes on in all the higher animals, including man, and is developed with the increase in size and complexity of the prefrontal, parietal, temporal and other projection centers of the neocortex.

In verbalized thinking, which is peculiar to man, complex sensory patterns are represented by relatively simple auditory and visual verbal symbols. These symbols, through a series of historical events, now have a more or less uniform significance to all normal persons speaking the same language. Hence words are the currency of thought.

In scientific thinking there is an emotional stress or passion to analyze sensory patterns, to make close comparisons and measurements, to distinguish between symbols or identical wholes and symbols of wholes that are superficially similar but fundamentally distinct, and finally to trace historical and causal sequences in all fields open to human investigation.

Neokinesis: Action Controlled by Ideas. In the lower vertebrates, as typified by the shark, response to sensory stimuli is largely direct. A "good" smell in the water causes the animal to turn toward the sources of the pleasant stimulus, to swim toward it and to devour it. Memory of past results plays comparatively little part in modifying behavior. In higher animals, on the other hand, only "reflex" acts are free from the restraining or encouraging influence of memory. Perhaps all conscious acts are "conditioned" by memories or ideas, which are generated or conveyed by the complex association tracts of the neopallium, or higher brain (Fig. 30).

The peculiarly human power of speech has made it possible for ideas to be handed down from generation to generation and to be built up into systems of social control that tend either to encourage or to inhibit particular responses to sensory stimuli.

EPITOME

THE RISING SCALE OF LIFE

The existence of a rising scale of life ("l'échelle des êtres") leading from the lowest one-celled organisms to man was suspected by some of the ancient Greeks and demonstrated by the naturalists of the eighteenth and nineteenth centuries, especially Lamarck, Darwin and Haeckel. It remained for the palæontologists of the nineteenth and twentieth centuries to discover a long series of extinct vertebrates from successive ages of the

INTRODUCTION TO HUMAN ANATOMY

earth, forms which carry forward the story of the origin and rise of prehuman and human characteristics in an orderly and well established sequence (Fig. 4).

The earliest known forerunners of the vertebrates were the ostracoderms, or jawless fishes, whose fossil remains are found in rocks of the Ordovician and Silurian periods; the age of the oldest of these fossils is estimated at nearly five hundred millions of years. From this time onward the vertebrates are known from more and more branches. Many of these branches became extinct, but others went on and gave rise to new branches; both old and new branches together form the Tree of Life. The definition and classification of these larger and smaller branches belong in the fields of zoölogy and palæontology, but a practical knowledge of the Tree of Life is a necessary prerequisite for correct appreciation of the fossil record of evolution, from fish to man (Figs. 8, 23, 35).

NATURE'S "BASIC PATENTS"

When Nature at last works out a new and successful mechanical device in one group of animals and in one part of the world, she bequeaths this treasure to their diversified descendants in many lands. The "one-piece jaw" arose among the earliest mammals of the Triassic age (Figs. 25, 26) and was transmitted with innumerable modifications in detail to countless millions of later mammals, including man. Another example of an important "basic patent" is the neopallium, or higher brain, which likewise arose in the earliest mammals as a super-control system (see Fig. 31); in the higher mammals it has become the organ of intelligence.

Resemblance between relatives is normally due to inheritance from one or more common ancestors. Therefore when two animals of different species resemble each other in possessing numerous "basic patents" in common, it is inferred that they are more or less closely related by descent from a common ancestor.

MAN'S HABITUS AND HERITAGE

The later additions to an animal's capital stock of "basic patents" usually fit him for some special way of locomotion, such as climbing, running, walking, swimming, flying, or for some particular range of food habits. The totality of these newer adaptations is called the *HABITUS*. The older adaptations, which he has inherited from very distant ancestors, are grouped together as his *ANATOMICAL HERITAGE*.

Man's *HABITUS* includes his fully erect posture and all that this implies in the unique details of his backbone, pelvis and feet. His habitus also includes his enormous brain, his diminished jaws and his power of speech.

INTRODUCTION TO HUMAN ANATOMY

AS to his ANATOMICAL HERITAGE, he shares a very great number of deep-seated anatomical and physiological characters with the anthropoid apes, especially the gorilla and the chimpanzee.

THE PRINCIPLE OF CHANGING FUNCTION AND STRUCTURE

Many of the most striking of man's characteristics have arisen by "descent with modification" and through "change of function and structure."

Thus man's skilful hands, with which he has built up his civilizations, represent the modified fore feet of remote quadrupedal ancestors (Fig. 8). His feet, which are now so well adapted for supporting the body in an upright posture, have been derived by "descent with modification" and through "change of function" from grasping organs not unlike those of the gorilla (Figs. 17, 18).

During such changes in function there are marked changes in the relative sizes of certain parts. Thus in the immediate ancestors of man the thumb (Fig. 16) became longer, the hand wider, the outer toes (Fig. 17) shorter, the femur (Fig. 8 C) longer, while opposite changes took place in the orang-utan, which became highly specialized for arboreal life.

Man's much admired face is molded upon the fish-trap of a creature that was no higher than a shark; his voice, which he now broadcasts over the world, issues from an apparatus originally made out of the gill-bars of a fish; his very brain, by means of which he has discovered space-time and plumbed the depth of the atom, began as a simple automatic mechanism for directing his motor and digestive apparatus toward his next meal.

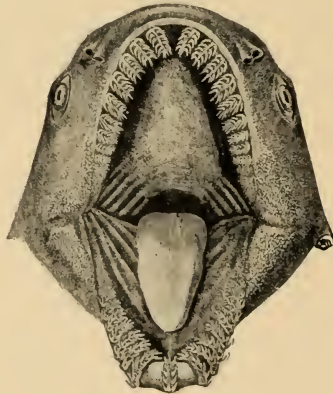

SELECTED REFERENCES

- ADDISON, WILLIAM H. F.
1927. Piersol's normal histology with special reference to the structure of the human body. Philadelphia and London.
- BERRY, R. J. A.
1928. Brain and mind, or the nervous system of man. New York.
- BREDER, C. M., JR.
1926. The locomotion of fishes. *Zoologica*, vol. IV, No. 5, pp. 157-297.
- BROOM, ROBERT
1932. The mammal-like reptiles of South Africa and the origin of mammals. London.
- BRYANT, W. L.
1919. Structure of *Eusthenopteron*. Bull. of the Buffalo Society of Natural Sciences, vol. XIII, No. 1.
- CONANT, JAMES B.
1933. The chemistry of organic compounds. New York.
- DANIEL, FRANK J.
1928. The Elasmobranch fishes. 2nd edition, Berkeley, California.
- DEAN, BASHFORD
1895. Fishes, living and fossil. New York.
- ELWYN, ADOLPH
1930. Yourself, Inc.: The story of the human body. New York.
- GREGORY, WILLIAM K.
1922. The origin and evolution of the human dentition. Baltimore.
1928. Were the ancestors of man primitive brachiators? Proceedings American Philosophical Society, vol. LXVII, No. 2, pp. 129-150.
1928. The upright posture of man: a review of its origin and evolution. Proceedings American Philosophical Society, vol. LXVII, No. 4, pp. 339-376.
1929. Our face from fish to man. New York.
1934. Man's place among the anthropoids. Oxford, England.
1934. A half century of trituberculy. The Cope-Osborn theory of dental evolution. Proceedings American Philosophical Society, vol. LXXVIII, No. 4, pp. 169-317.
- GREGORY, WILLIAM K. AND C. L. CAMP
1918. Studies in comparative myology and osteology, No. III.
Part I. A comparative review of the muscles of the shoulder-girdle and pelvis of reptiles and mammals with an attempted reconstruction of these parts in *Cynognathus*, an extinct therapsid reptile. Bull. Amer. Mus. Nat. Hist., vol. XXXVIII, art. XV, pp. 447-563.

INTRODUCTION TO HUMAN ANATOMY

GREGORY, WILLIAM K. AND MILO HELLMAN

1926. The dentition of *Dryopithecus* and the origin of man. Anthropological Papers, Amer. Mus. Nat. Hist., vol. XXVIII, part I, pp. 1-123.

GREGORY, WILLIAM K. AND HENRY C. RAVEN

1941. Studies on the origin and early evolution of paired fins and limbs:
Part I. Paired fins and girdles in ostracoderms, placoderms, and other primitive fishes.
Part II. A new restoration of the skeleton of *Eusthenopteron* (Pisces Crossopterygii, Devonian, Quebec) with remarks on the origin of the tetrapod stem.
Part III. On the transformation of pectoral and pelvic paddles of *Eusthenopteron* type into pentadactylate limbs.
Part IV. A new theory of the origin of the pelvis of tetrapods. Ann. New York Acad. Sci., vol. XLII, art. 3, pp. 273-360.

HERRICK, C. JUDSON

1926. Brains of rats and men. Chicago.

HILL, J. P.

1932. The developmental history of the primates. Croonian Lecture. Philosophical Transactions Royal Society, London, Series B, vol. CCXXI, pp. 45-178.

HOWELL, WILLIAM H.

1931. A text-book of physiology. 11th edition, Philadelphia and London.

HRDLIČKA, ALES

1931. Children who run on all fours. New York.

HUBER, ERNST

1931. Evolution of facial musculature and facial expression. Baltimore.

KEITH, ARTHUR

1919. The engines of the human body. London.
1933. Human embryology and morphology. 5th edition, London.

MARTIN, H. NEWELL

1926. The human body. 11th edition, New York.

MAXIMOW, ALEXANDER

1931. A text-book of histology. Completed and edited by Wm. Bloom, Philadelphia.

OSBORN, HENRY FAIRFIELD

1907. Evolution of mammalian molar teeth. New York.

PARKER, T. JEFFREY AND WILLIAM A. HASWELL

1940. A text-book of zoology. 6th edition. 2 vols. Vol. II. Revised by C. Forster-Cooper. Macmillan and Co., Ltd., London.

RANSON, STEPHEN WALTER

1925. The anatomy of the nervous system. Philadelphia and London.

INTRODUCTION TO HUMAN ANATOMY

RASMUSSEN, ANDREW THEODORE

1932. The principal nervous pathways, neurological charts and schemes with explanatory notes. New York.

ROBERTSON, T. BRAILSFORD

1924. Principles of biochemistry. Philadelphia and New York.

ROMER, A. S.

1933. Vertebrate paleontology. Chicago.

SÄVE-SÖDERBERGH, G.

1933. The dermal bones of the head and the lateral line system in *Osteolepis macrolepidotus* Ag. with remarks on the terminology of the lateral line system and on the dermal bones of certain other crossopterygians. Nova Acta Regiae Societatis Scientiarum Upsaliensis, (4), vol. IX, No. 2, pp. 1-129.
1936. On the morphology of Triassic stegocephalians from Spitzbergen and the interpretation of the endocranium in the Labyrinthodontia. Kungl. Svenska Vetenskapsakademiens Handl. (3), Band XVI, No. 1, pp. 1-181.

SCHULTZ, ADOLPH H.

1930. The skeleton of the trunk and limbs of higher primates. Human Biology, vol. II, No. 3, pp. 303-438.

SHERMAN, HENRY C.

1911. The chemistry of food and nutrition. New York.

SINGER, CHARLES

1925. The evolution of anatomy. New York.

SMITH, G. ELLIOTT

1924. The evolution of man. Essays. Oxford University Press.
1929. Human history. New York.

SOBotta, JOHANNES AND J. PLAYFAIR McMURRICK

1930. Atlas of human anatomy. 3rd edition, 3 vols. New York.

SPALTEHOLZ, WERNER

1901. Hand atlas of human anatomy. Translated from 3rd German edition by Lewellys F. Barker. 3 vols. Leipzig.

STERNBERG, R. M.

1941. Cranial morphology of the Devonian crossopterygian *Eusthenopteron* Univ. Toronto Studies, Geol. Surv., No. 45, pp. 3-48.

STIEGLITZ, JULIUS (Editor)

1928. Chemistry in medicine: A coöperative treatise intended to give examples of progress made in medicine with the aid of chemistry. The Chemical Foundation, New York.

TILNEY, FREDERICK

1928. The brain from ape to man. 2 vols. New York.
1930. The master of destiny. New York.

INTRODUCTION TO HUMAN ANATOMY

TILNEY, F. AND H. A. RILEY

1923. The form and functions of the central nervous system. 2nd edition, New York.

VESALIUS, ANDREAS

1543. De humani corporis fabrica. Basle.

VOGEL, MARTIN

1930. Der Mensch vom Werden, Wesen und Wirken des menschlichen Organismus. Leipzig.

WATSON, D. M. S.

1919. On *Seymouria*, the most primitive known reptile. Proceedings of the Zoological Society of London. pp. 267-301.
1919. The structure, evolution and origin of the Amphibia. The "Orders" Rachitomi and Stereospondyli. Philosophical Transactions Royal Society of London, Series B, vol. CCIX, pp. 1-73.
1926. The evolution and origin of the Amphibia. Croonian Lecture. Philosophical Transactions Royal Society, London, Series B, vol. CCXIV, pp. 189-257.
1937. The acanthodian fishes. Philos. Trans. Roy. Soc. London, Series B, No. 549, vol. 228, pp. 49-146.

WHITE, T. E.

1939. Osteology of *Seymouria baylorensis* Broili. Bull. Mus. Comp. Zool. Harvard Coll., vol. LXXXV, No. 5, pp. 325-409.

ZITTEL, KARL A. VON

1932. Text-book of palæontology. Translated and edited by Charles R. Eastman. Vol. II. 2nd English edition revised with additions by Sir Arthur Smith Woodward. Macmillan and Co., Ltd., London.



Dept. of Comparative and Human Anatomy 1932

FIG. 33. COMPARATIVE EMBRYOLOGY FROM FISH TO MAN (Wall Chart 5). Man, like other vertebrates, develops from a zygote or fertilized egg, which divides and subdivides as it grows until it eventually gives rise to the millions of cells in the adult body. In order to facilitate comparison the corresponding stages in the different lines of development have been enlarged to about the same size, regardless of "scale." Thus the human egg, which measures only about 1/250 of an inch in diameter, is here shown nearly as big as the egg of the Port Jackson shark, which measures about two inches (bottom row). The picture shows seven out of the innumerable stages of development. The second row illustrates late cleavage stages. In the third row note the beginning of somites (body segments); in the fourth row gill slits and the beginning of the fore limbs are indicated; the fifth row shows late embryos with fore and hind limb buds; sixth row, late foetal, newly hatched, or new-born stages; top row, adults

MAN AMONG THE PRIMATES

Mans position on the tree of life is among the primates
and his branch is next to that of the anthropoid apes

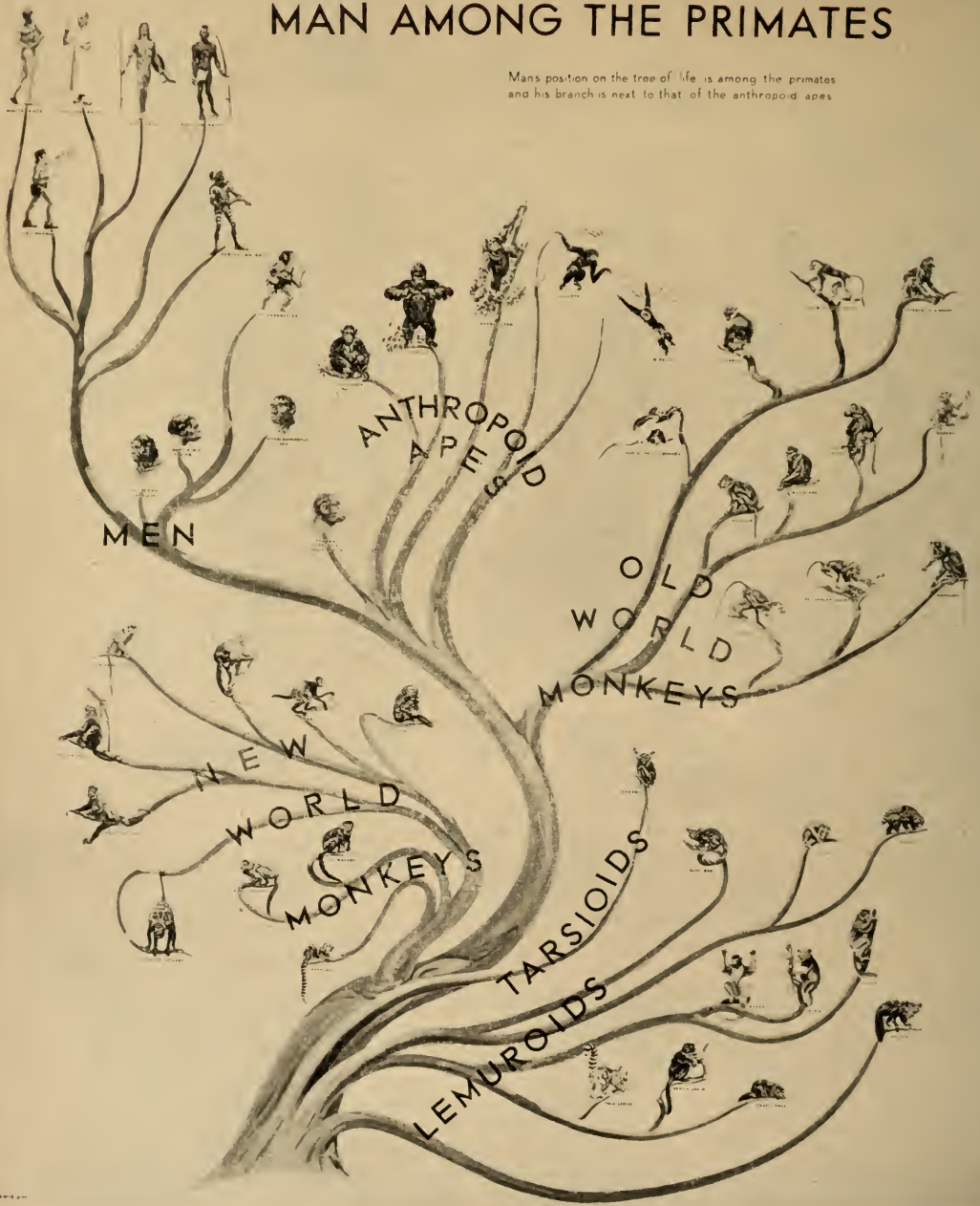
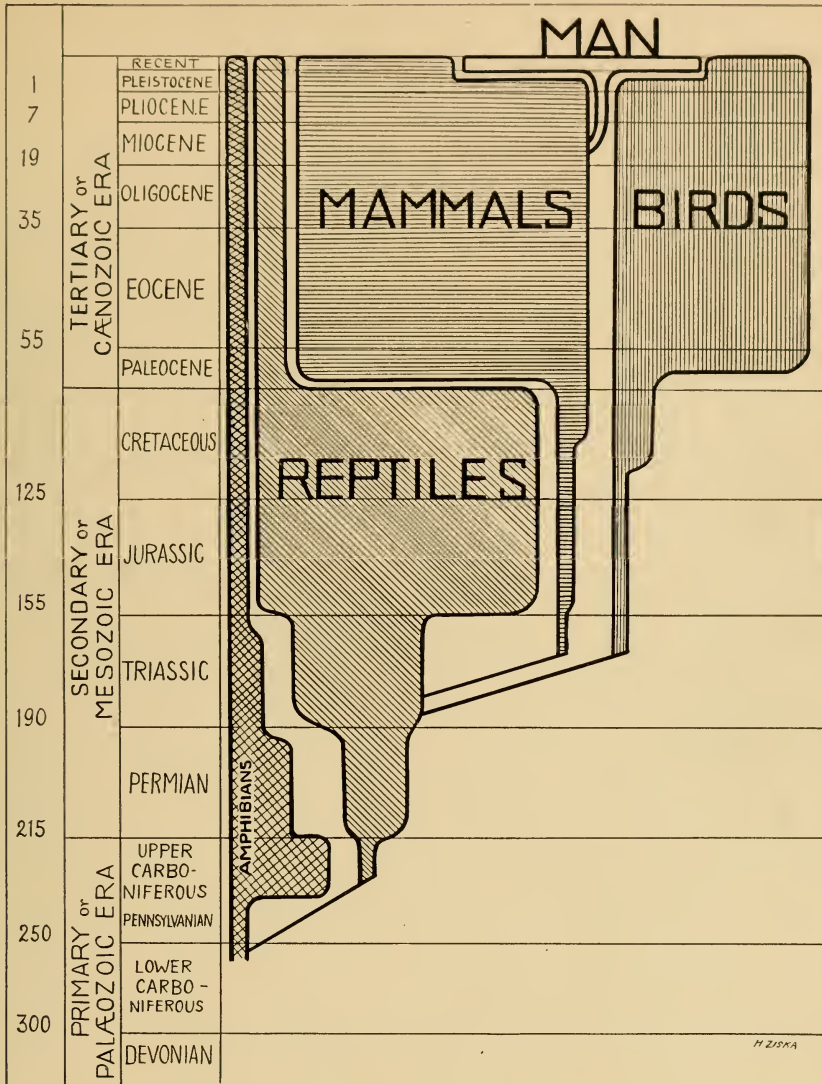

Fig. 34. MAN AMONG THE PRIMATES (Wall Chart 6)

INTRODUCTION TO HUMAN ANATOMY



Courtesy G. P. Putnam's Sons

FIG. 35. MAN'S EMERGENCE IN GEOLOGIC TIME. Numerals at left stand for millions of years since beginning of period, according to rate of "radium emanation" from uranium minerals, based on Barrell's estimates



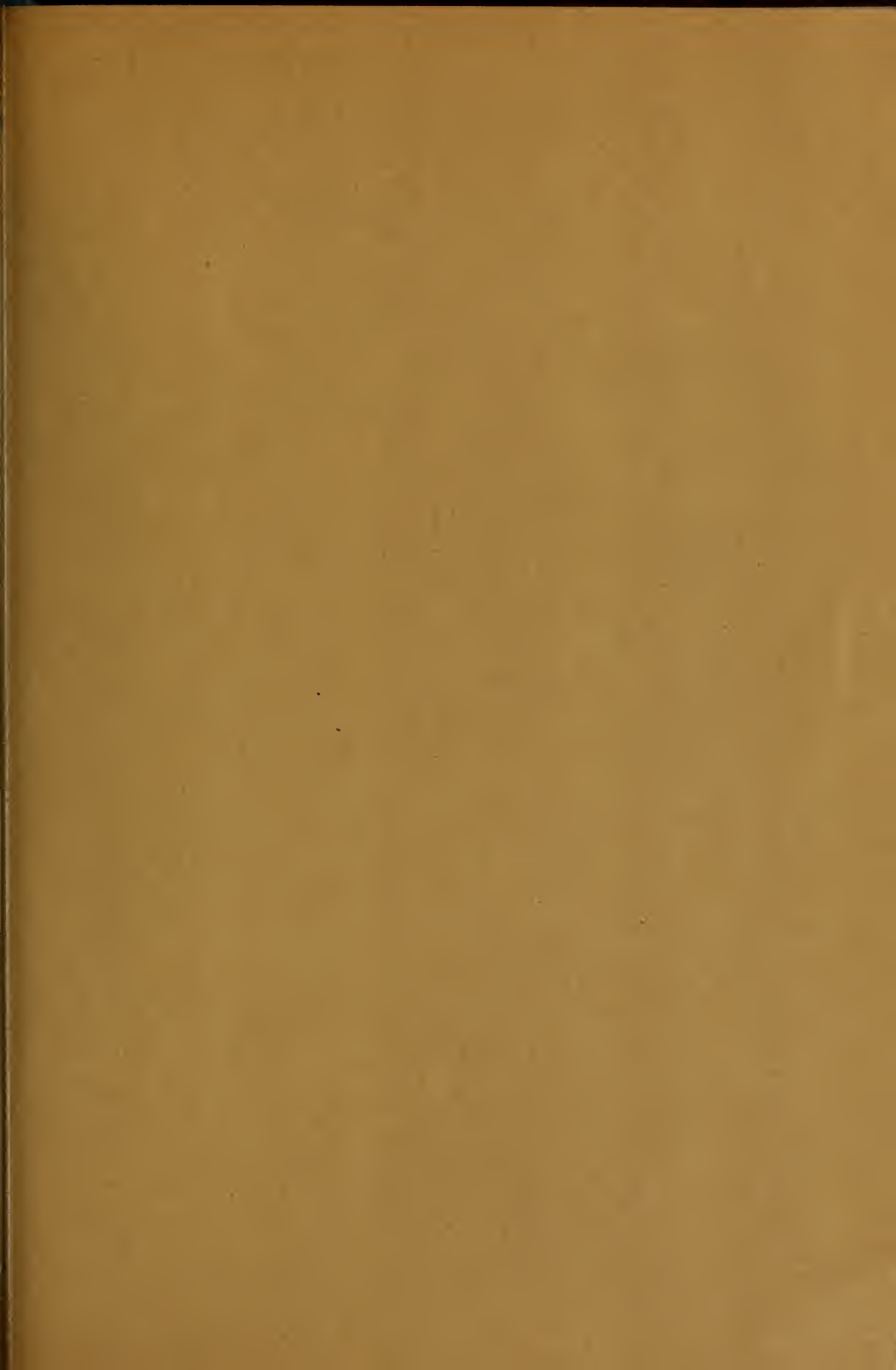



MAN AND NATURE
PUBLICATIONS

Science Guide No. 86

THE NETSUKE OF JAPAN

By HERBERT P. WHITLOCK

Curator of Minerals and Gems, American Museum



*Reprinted from Natural History Magazine
for February, 1935*

GUIDE LEAFLET SERIES, No. 87
THE AMERICAN MUSEUM OF NATURAL HISTORY
NEW YORK, 1935

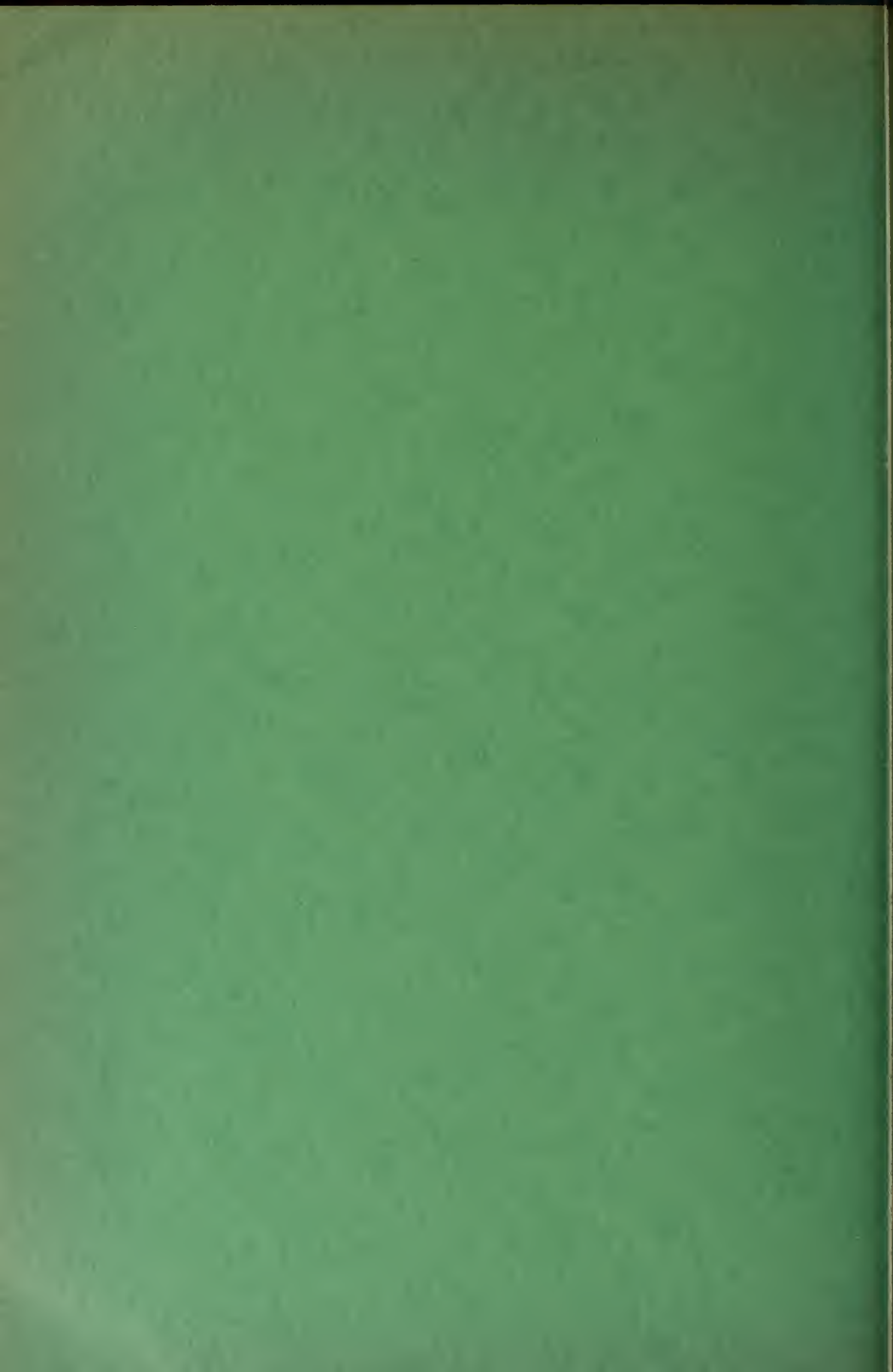

The Netsuke of Japan

An account of certain miniature Japanese carvings featuring the mythical stories they tell

BY HERBERT P. WHITLOCK

Curator, Department of Minerals and Gems, American Museum

In Japan, where the art of carving both beautifully and delicately in ivory and wood has been carried to such extraordinary perfection, a particular type of carving is unique. The Japanese costume is devoid of pockets, with the result that each person usually carries a handsome bag or detached "pocket" which he attaches to his girdle by means of a "netsuke." This decorative piece, usually of ivory or of wood, is almost invariably a little work of art, and the specimens that illustrate the following article are from the Drummond Collection which recently has been put on display at the American Museum. The word is not pronounced as it is spelled. An approximation of the Japanese pronunciation might be written phonetically as follows: Netski.

—THE EDITORS.

THE Japanese carver in ivory practices an art which is in many respects essentially different from that of his brother craftsman, the Chinese lapidary who works in the harder mediums. His is a handicraft allied in material and technique with that of the wood carver, and, indeed, he often resorts to wood and handles it with the same facility with which he uses ivory.

Unlike the Chinese carver of jade, whose tools are few and simple, the Japanese ivory carver produces his small, realistic works of art with the aid of a multitude of knives, burins, gravers, chisels, drills, files, and saws. A full set of these implements contains upward of fifty pieces, including right-handed and left-handed burins, whose purpose would be obvious to a golfer who uses a left-handed club when the golf ball lies close to the right side of an obstacle, such as a tree root.

Such an array of carving paraphernalia has rendered possible a perfection in the representation of detail which in many cases is little short of microscopic. So meticulous indeed is the work of the Japanese ivory carver, that it often includes a completeness of rendition undreamed of by an Occidental artist. One of the pieces in the Drummond Collection, for instance,

depicts a huddle of twenty mice which not only are reproduced to the last hair on the exposed or upper side, but whose feet and claws, not to mention the articulations of the tails, also are faithfully shown on the *under* side, which is usually hidden from view.

Ingenuity as well as skill is shown by these clever craftsmen, as when they represent a monkey that is capable of running in and out of a hollow log, or an ivory toy representing a street actor that is actually capable of changing his masks by means of the flick of one's finger.

Much of the finest ivory carving in miniature pieces takes the form of netsuke, the buttons or bobs that terminate the cords to which the various girdle appendages are attached, and prevent these cords, when passed through the girdle, from slipping out again. These netsuke, although varying somewhat in size, are, from the nature of their use, small and compact, and are of almost infinite variety in design. There is hardly a legend or folk story known to Japanese legendary lore which has not at some time or other inspired the design of one or more of these clever little carvings. They are dramatic, they are philosophic, and very often they are highly humorous,



Skulls are very popular subjects for netsuke among Japanese ivory carvers. The decidedly macabre sentiment which attaches to a medicine box (inro), such a forceful reminder of mortality, is thoroughly consistent with an art that emphasizes the grotesque and the abnormal



The legless Daruma is a favorite toy among Japanese young people, and is often reproduced as a snow man by Japanese boys. The little netsuke above does not, however, depict such a snow man, but a toy Daruma of heroic size made of papier-mâché

The odd little figure of Daruma is one very often met with among ivory netsuke. Daruma was a sage who, according to tradition, introduced the Zen sect of Buddhism into China. It is said that he remained seated, immovable, absorbed in meditation, for a period of nine years, at the end of which time his legs had "rotted away." He is usually represented in the act of stretching his arms at the conclusion of his long meditation, with his body enveloped in a garment like a bag





Among the many legends to be found in Japanese folklore is one relating to the "foreigners," strange races of people which like Othello's "men whose heads do grow beneath their shoulders" have some singular physical abnormality. By far the most famous of these and the ones most often represented in ivory and wood carvings are Ashinaga and Tanaga. Ashinaga has tremendously long legs and carries on his back Tanaga, whose enormously long arms reach down into the water, when Ashinaga wades out with him in order that they may gather the sea food upon which this cooperative pair lives.



The fantastic figure above, executed in wood, represents one of the attendants of Riujin, The Dragon King of the Sea. He wears upon his head a sea dragon, and holds in his hands the fabulous jewel that controls the tides.



The Palace of Riujin is shown in this ivory netsuke as being entirely included between the shells of a clam. Another conception makes it a sort of "cloud castle" that materializes from the "breath of a clam"



This ivory netsuke depicts the grotesque figure of Kosensei the Gama Sen-nin, or the Sage with the Toad. He is always represented with a toad crawling over his person. Sometimes this is represented as the mystic three-legged toad, but oftener it has its full complement of legs

Upon the broad surface of this ivory lotus leaf a priest and an oni, the Japanese word for devil, are engaged in a match of *udeoshi* — arm wrestling. The identity of the oni is very apparent because, besides having rudimentary horns, he has only three fingers on each hand, and three toes on each foot. We are almost led to wonder if the priest really knows with whom he is contending



A Japanese street actor is called *Shishimai*, and plies his trade about New Year festival-time much as does a London "Punch-and-Judy-Show" man. The little ivory carving below is in reality a toy representing *Shishimai*, and is quite as capable of changing its mask as is the actor himself. A clever little wheel inside the figure revolves to a flick of the finger so as to show successively five entirely different masks. The illustrations show two of these





Like the Chinese, the Japanese are fond of depicting fabulous animals. One of the most richly variant of these is the Kirin, derived from the Chinese K'ilin or unicorn. The illustration at the left shows a standing Kirin executed in light-colored wood. This variety of unicorn has two horns instead of one, and seems to be covered with scales



Many of the dances, of which countless numbers are performed in Japan, are religious in character. The subject of the tiny netsuke above is performing Sambaso, the Earthquake Dance, said to have originated early in the Ninth Century to stop the disastrous effect of an earthquake. The mitre-like cap worn by the dancer is decorated with the red disk of the sun



Raiden, the Thunder God, depicted in this little ivory netsuke, has a distinct demonic aspect. The face and rudimentary horns are those of an oni, as are the two claws that decorate each foot, and the three fingers on each hand. He is shown with the drum that he beats to produce thunder



The monkey depicted in this highly humorous netsuke is looking through a magnifying glass at a netsuke carved to represent himself. One could almost imagine the monkey at which he is looking to be looking at a smaller monkey, and so on as far as one cares to carry the illusion

Hotei, the most popular of the seven "Gods of Luck" among Japanese netsuke carvers, is always represented, as in the example below, with a superabundance of flesh, and a very winning smile. Indeed, his generously extensive stomach furnishes a wrestling ground for the two little oni who are entertaining him. He may truly be described as carrying his Madison Square Garden with him

Masks are indispensable adjuncts to the Japanese Nō dances as well as to other theatrical performances. Consequently, they are very often depicted in ivory by the netsuke carvers, either singly or in such groupings as shown in the example below, which presents one or more grotesque faces on whatever side is turned to the observer





Wrestling is as popular in Japan as dancing. This ivory netsuke represents a throw invented by a celebrated wrestler who overcame his opponent when lifted by the loin cloth. This is known as Kawasu's throw

The subject of this beautifully carved ivory netsuke group is none other than Emma, the august Regent of Hell. He is represented as taking a bath while two attendant oni faithfully scrub him. It would be interesting to know whether the liquid is melted sulphur or boiling oil





Shoki,
Queller
of Demons

Intimately associated with the demonology of Japanese myth is Shoki the Demon Queller. This mythical being, who has furnished the subject of many netsuke, was known in China as early as the Tang dynasty, and was the sworn foe of all the oni or devils. In this netsuke he is depicted as hunting down and capturing several oni in a covered tub



Kijohima, the heroine of this netsuke story, was the daughter of an innkeeper, who fell in love with a holy monk, named Anchin. Upon her advances being met with stern refusal, the love of Kijohima turned to passionate hate, and she summoned to her aid the infernal deities. She pursued Anchin into the temple, where he took refuge under the great bell, which was ten feet in height and enormously heavy. Kijohima, now consumed by a fury of baffled passion, began to undergo a change, her face became a witch's mask, her body became sinuous and dragon-like, and, as she wrapped herself around the great temple bell, flames, emitted from her person, melted it, effectually consuming the unfortunate object of her literally "burning passion"

The subject of this ivory netsuke is Benkei, a hero of the Twelfth Century, famous in Japanese legend. It is said that he was eight feet in height and had the strength of one hundred men. One of his celebrated feats of strength was the carrying away of the temple bell of Miidera. This incident is depicted with great wealth of detail in the carving shown below



because the pursuit of realism in art leads to the grotesque and the abnormal.

It may seem odd to us that the total absence of pockets in Japanese attire has so enriched an art, to say nothing of having produced a devoted band of netsuke collectors. Among these latter were the late Dr. I. Wyman Drummond and his father, James F. Drummond, and it is from Doctor Drummond's collection, now in the Drummond Memorial Hall of the American Museum, that the illustrations for this article are taken. In making a selection from the wealth of material contained in this famous collection, which includes more than 500 carefully selected netsuke, the writer has been at pains to choose those which have a story to tell rather than those whose high artistic worth transcends their mere interest. But, since the ivory artists of Japan never produce an unworthy work, choose as we may, these charming little carvings always appeal to our sense of beauty and fitness.

Even the grotesque ugliness of Tanaga or one of the attendants of Riugin has its enigmatic charm no less than has the captivating serenity of Wang Mu (pictured in "Jade, Amber, and Ivory," *NATURAL HISTORY*, September, 1934), or the infectious joviality of Hotei. We come to feel that these fabulous worthies have a reality akin to Peter Pan or Long John Silver, and as we all are well aware, that reality constitutes the acme of art.

A question that is often asked and that is somewhat hard to answer is "How old is the oldest ivory netsuke?" One does not hear of any antedating the Eighteenth Century; in fact, it is said that ivory netsuke carving began with the work of Yoshimura Shuzan of Osaka, who lived and worked early in that century. The Eighteenth Century ivory netsuke, however, supplanted similar work in wood, which latter dated from the Ashikaga period (1394-1573 A. D.).

All of the best ivory carvings of Japan are signed by the artists who made them. Tiny characters, usually filled in with red, appear in inconspicuous places on even the smallest carvings, and announce to the discerning eye of the expert that Masatoshi or Tomotane of Kyoto created the particular masterpiece.

Even in the matter of subject it is possible to recognize the work of a certain artist specializing in the portrayal of warriors, as contrasted with the work of one whose forte is the carving of demons or masks. And, as in all Japanese art, throughout this handicraft runs the touch of realism like the golden thread of Truth.

A story that the late Doctor Drummond delighted to tell (I have heard it many times from him), runs something like this:

A wealthy Japanese nobleman once said to a craftsman in bronze, who belonged to his entourage:

"I wish you to make for me a sword guard that shall depict a crane flying across the disk of the full moon."

"Very well, Master," replied the artist.

Many months elapsed before the nobleman again summoned the sword guard maker.

"And have you yet made for me the flying crane and the moon disk?" said he.

"Not yet, Master," was the reply.

Years passed and finally the noble patron said to his servant:

"Why have you not fulfilled my wish and executed in bronze a crane flying by moonlight?"

"Master," replied this supreme realist, "every moonlit night have I watched the face of the moon these many years, but never have I had the fortune to see a crane flying across its silvery disk."

And so well did his master sympathize with the high ideals of his art that the matter was dropped and the sword guard was never made.



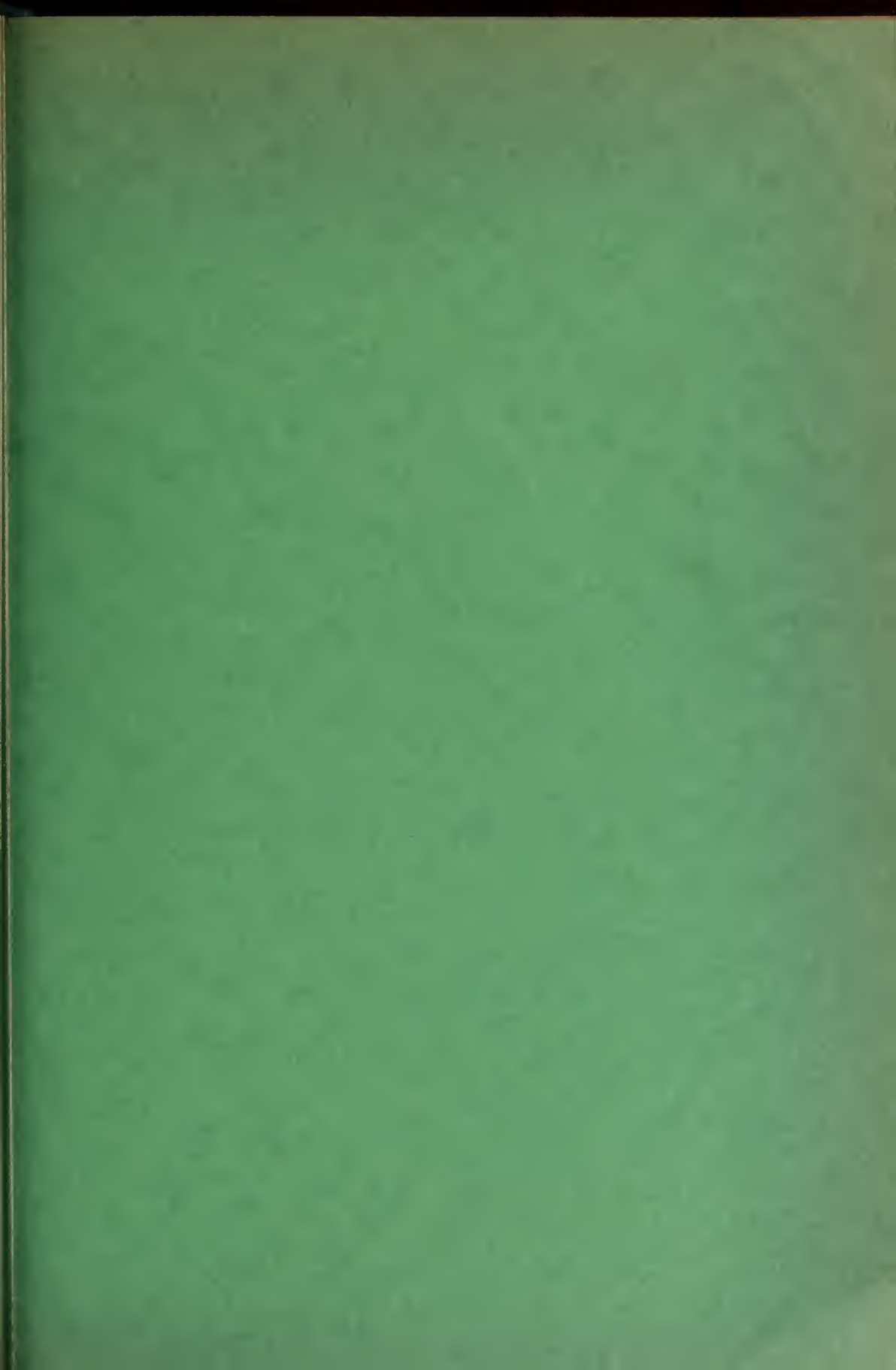



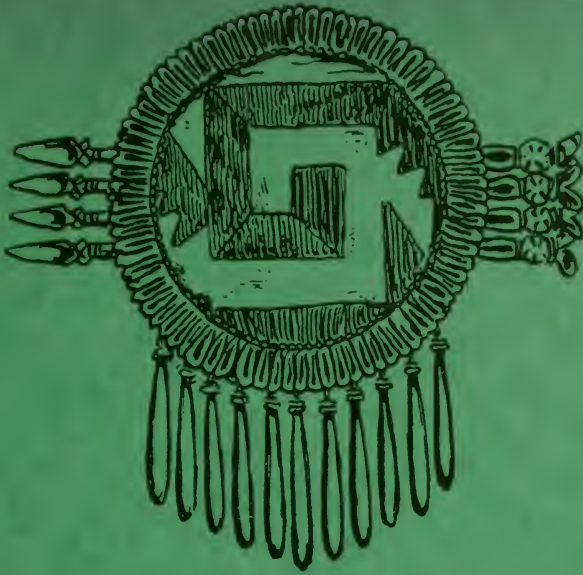

Artists and Craftsmen in Ancient Central America

By George C. Vaillant

THE AMERICAN MUSEUM OF NATURAL HISTORY

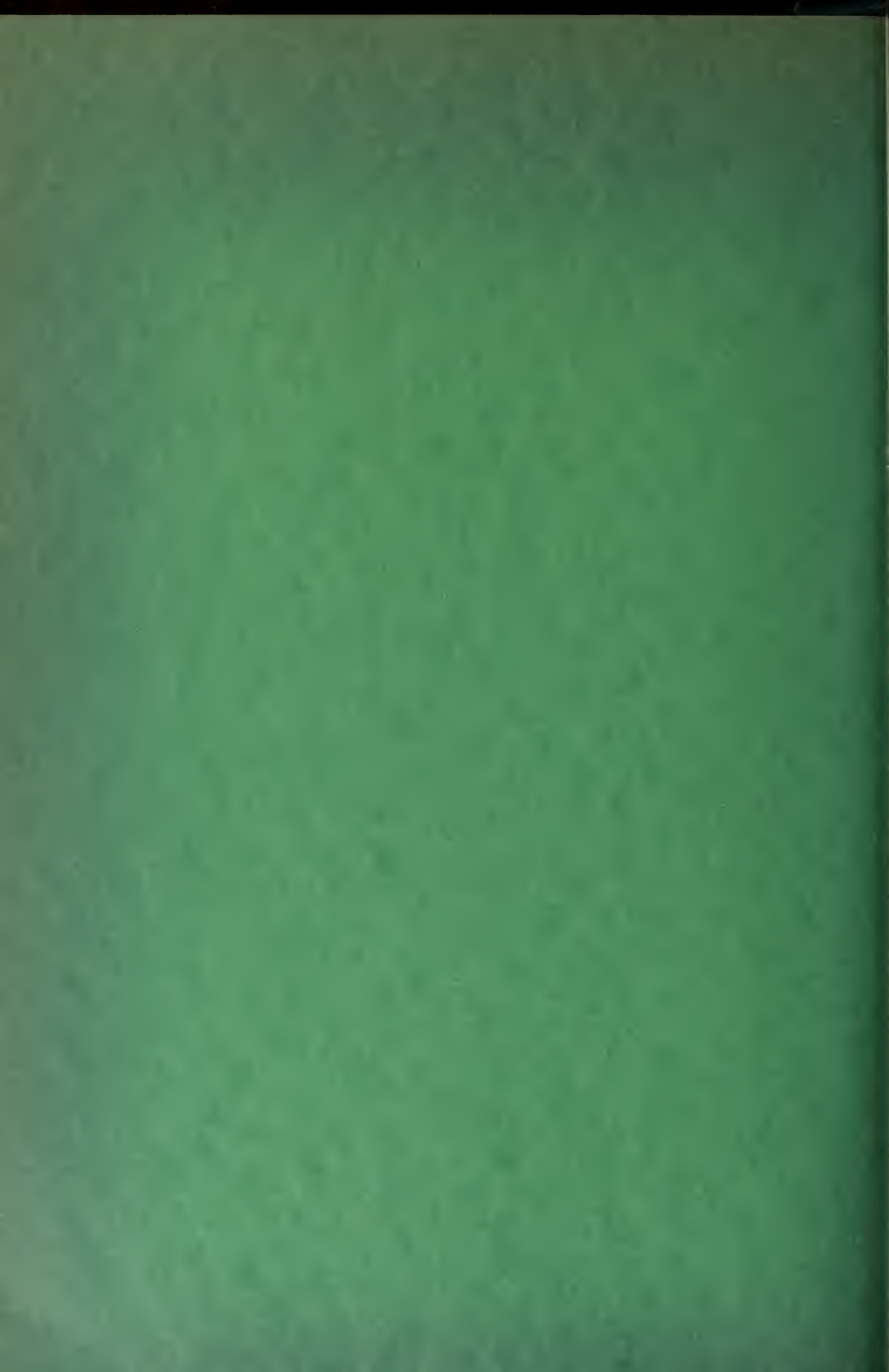

ARTISTS AND CRAFTSMEN
in
ANCIENT CENTRAL AMERICA

by
GEORGE C. VAILLANT
Associate Curator of Mexican Archaeology



Guide Leaflet Series, No. 88
THE AMERICAN MUSEUM OF NATURAL HISTORY
New York, 1935

Second Printing, 1940



THE FEATHERED SERPENT

Detail from relief at the temple of Quetzalcoatl, Teotihuacan, Mexico. Teotihuacan is the site of the first real civilization in the Valley of Mexico. After Lehmann, 1933

PREFACE

The seven articles grouped in this pamphlet are reprinted from *Natural History*. The last six appeared successively as a connected series on the art of pre-Columbian Central America. The first paper, the *Worshippers of the Aztec War Gods*, came out earlier and has been included to give a glimpse of the physical and social background against which these arts flourished.

The purpose of this pamphlet is to provide examples of the extraordinary range of Central American art forms, which are too often buried in technical publications inaccessible to the general public. While there are a number of books which describe vividly and accurately the social customs of the Aztec, Maya, and their neighbors, the high cost of reproduction has prevented a presentation of their art commensurate with its importance. In view of the considerable interest shown in Central American aesthetics, we have tried to give a general picture of art from the artistic rather than the historical point of view.

The American Museum of Natural History has in its halls of anthropology many rare and beautiful examples of human handiwork, chiefly from peoples not blessed by the term "civilized." Since anthropology is concerned with man more as a social organism than as a creator of masterpieces, presentation of exhibits cannot solely be confined to aboriginal fine arts. Yet it is to be hoped that through the media of articles of this nature, the visitor and student will be guided to the riches contained in the halls, the result of centuries of effort by many peoples in many lands to achieve aesthetic satisfaction.

February, 1935.

These articles are reprinted from the following issues of *Natural History*.

Vol. 33, No. 1, pp. 17-30

Vol. 34, No. 2, pp. 117-132

Vol. 34, No. 3, pp. 258-272

Vol. 34, No. 4, pp. 389-402

Vol. 34, No. 5, pp. 485-496

Vol. 34, No. 6, pp. 578-586

Vol. 34, No. 7, pp. 662-673

CONTENTS

	PAGE
Preface	1
The Worshippers of the Aztec War Gods	5
The Architecture of Pre-Columbian Central America	19
The Sculpture of Pre-Columbian Central America	35
The Art of Painting in Pre-Columbian Central America	49
The Crafts of Pre-Columbian Central America	63
Ornaments of Pre-Columbian Central America	75
The Pottery of Pre-Columbian Central America	84
Bibliography	97



AFTER SAVILLE,
*Gold Workers Art in
Ancient Mexico*



BREAST ORNAMENT OF
GOLD WITH TURQUOISE
MOSAIC, MIXTEC CULTURE,
MUSEO NACIONAL MEXICO

The Worshippers of the Aztec War Gods¹

A Brief Description of Tenochtitlan, the Ancient Mexico City at the
Time of the Landing of Cortes

WHEN we realize that the Mayas were in a state of decadence at the time of the Spanish Conquest, and that we recreate much of the splendor of their civilization from the eloquent silence of their ruined architecture, it is well to consider the aspect of the Aztecs who were at their zenith in 1519. Although the Spaniards and their myriad allies so thoroughly razed Tenochtitlan that only a few foundations now remain, there fortunately exists much descriptive information gathered by such eye-witnesses as the Spanish soldiers and the missionary friars, as well as the testimony offered by the documents of the Aztecs themselves.

Bernal Diaz tells how his comrades-in-arms on first beholding Tenochtitlan exclaimed, "It is like the enchantments they tell of in the Legend of Amadis. Are not the things we see a dream?"

This is lyric language from hard-bitten

men-at-arms whose chief avocations, while engaged in converting the heathen, lay in acquiring booty and enjoying the charms of dusky Dulcineas. Yet in contrast to the drab towns and tawny hills of Spain, Tenochtitlan must have appeared a Paradise indeed, with its green gardens and white buildings set against the blue of the lakes. "Gazing on such wonderful sights," writes Bernal Diaz, "we did not know what to say or whether what appeared before us was real, for on one side on the land there were great cities and in the lake ever so many more, and the lake itself was crowded with canoes, and in the causeway were many bridges at intervals and in front of us stood the great City of Mexico, and we—we did not even number four hundred soldiers!"

Although socially and governmentally Tenochtitlan was distinctly American Indian, outwardly it appeared the capital

¹Drawings reproduced from the Codex Florentino, edited by Sahagun in the Sixteenth Century and published by Paso y Troncoso, Madrid, 1907.

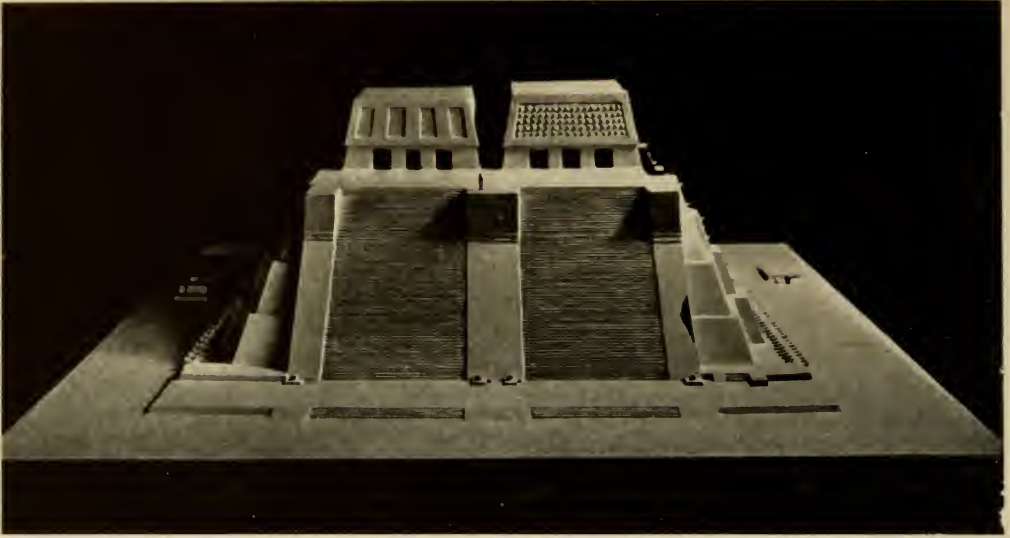

MODEL OF THE PYRAMID AT TENAYUCA, FEDERAL DISTRICT, MEXICO

The original temple epitomizes the history of the Valley of Mexico. According to tradition, after the Tenth Century, a tribe of fierce nomads, the Chichimecs, filtered into the Valley and brought about the downfall of its civilized occupants, the Toltecs. The Chichimecs took over elements of the Toltec culture and began a sedentary life. Later, other tribes like the Tepanecs and the Acolhuas entered the Valley and, fusing with the Chichimecs, built up a civilization. Finally came the Aztecs, who, absorbing this Chichimec-Acolhua culture, became strong enough to dominate the Valley tribes.

At Tenayuca six temples were found superimposed, the upper two of typical Aztec architecture. Excavations near by revealed three layers of pottery, the upper of Aztec date, the second probably to be correlated with the Tepanec-Acolhua people, and the crude styles of the lowest layer assignable perhaps to the Chichimec. While it was not possible specifically to correlate the ceramic styles with the individual buildings, yet it is very probable, to judge from the changes in the profiles of the buildings, that they were made by these successive peoples.

The symbolism of the temple involves the worship of the natural forces governing agriculture. Enough stone ornaments were found to reveal the presence of two temples, one honoring the goddess of the Earth and the other the god of War, who was also connected with the Sun. The serpents ornamenting the sides symbolize the earth, and the two connected with the altars flanking the pyramid represent the 52-year calendric cycle which the Aztecs considered much as we do our century.

The excavations were carried out by the Department of Prehistoric Monuments of the Mexican Government during the years 1925-32 as part of their program of reconstruction and research on their antiquities. In making this model, Mr. Shoichi Ichikawa, of the division of anthropology, followed the plans of Mr. Ignacio Marquina, head of the Department of Prehistoric Monuments, under the supervision of Mr. Hay and Doctor Vaillant.

city of an empire. A bird's-eye view would reveal an oval island connected with the mainland by three causeways which were pierced by bridges and which converged at the center of the city. The edges of the island were fringed by the green of the "floating gardens," while toward its center the shiny white of roof-tops predominated, the green being reduced to the little squares of the patio gardens. Thrust above the quadrate masses of the roof-tops loomed the various clan temples, each set on its pyramid. There were few streets or open spaces in

the city, which was gridded with canals crossed by drawbridges, but the plazas of the temple of Tlalotelco and of the religious center of Tenochtitlan stood out from the pyramids and official palaces clustered about them. There must have been a curiously living quality about this grouping, the temples seeming to ride like horsemen among the serrated ranks of the houses.

A visitor would be struck by the rich variety of the sights were he to transverse Tenochtitlan from south to north. Approaching along the causeway, the

SAHAGUN'S MAP OF MEXICO CITY

A.—GREAT TEOCALLI OF HUITZILOPOCHTLI AND TLALOC. B.—PRIEST OFFERING A SACRIFICE. C.—PRIEST QUARTERS. E.—EAGLE WARRIORS' QUARTERS. F.—BALL COURT. G.—SKULL-RACK. H.—TEMPLE OF XIPE. I.—SACRIFICIAL STONE, POSSIBLY STONE OF TIZOC. K.—TEMPLE OF HUITZILOPOCHTLI, THE ORIGIN PLACE OF WORSHIP OF THIS GOD. LATER BUILDING "A" SUPPLANTED IT. L.—5 LIZARD (DATE) AND STATUE OF MACUILXOCHITL, GOD OF FLOWERS. M.—5 HOUSE (DATE) AND STATUE OF MACUILXOCHITL, GOD OF FLOWERS. N.—DANCING PLACES, THREE ENTRANCES TO THE TEMPLE ENCLOSURE ARE SHOWN IN THE SURROUNDING WALL, WHICH WAS ADORNED WITH SERPENT HEADS

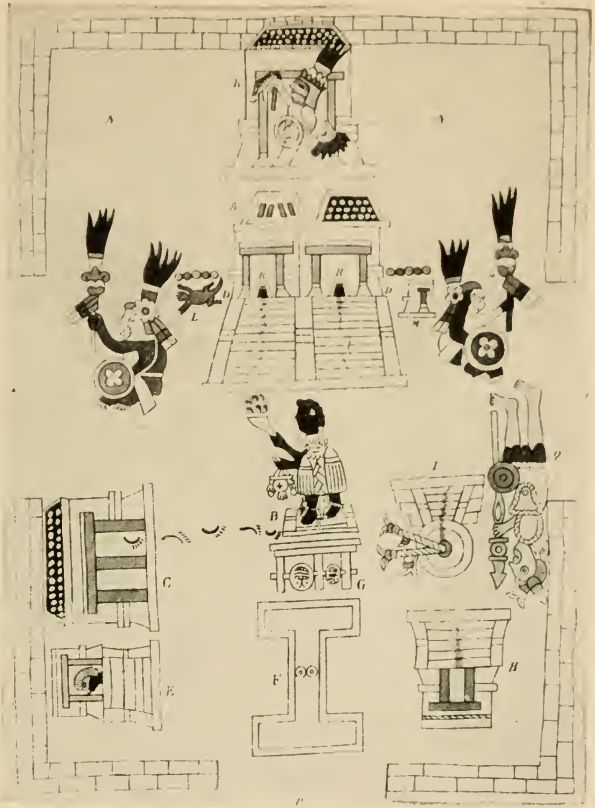

traveler of that time passed first between expanses of open water. Then gradually tiny islands of green appeared, the so-called floating gardens, made of masses of mud heaped up from the bottom of the lake and spread on reed rafts. White-clad farmers dexterously poled their tiny dugouts through the maze on their way to cultivate their garden truck. These irregular islets merged gradually into orderly groups, where the roots had established anchorage in the lake bottom and made more solid ground. Open water remained only in the narrow canals. Save for the broad causeways, roads there were none, and along the waterways one saw in increasing numbers boatloads of produce headed in toward the city. Here and there among the green one caught glimpses of thatched roofs and wattled walls, the huts of the farmers. Then adobe walls of more substantial dwellings began to encroach on the gardens, and the waters of the lake shrunk to a canal following the roadway. The adobe walls gradually were replaced by the fronts of houses plastered white or with the rich dull red of powdered pumice. For the first time the visitor realized how the city expanded through the artificial creation of beds of vegetation which in solidifying bore first a crop, then a modest hut, and finally became integral with the masonry of the city.

The causeway had now changed from a

simple means of communication into the social complexity of a principal street. Since canals took the place of roads, space for a saunter was so rare that the causeways were as much recreation grounds as arteries of traffic. Thus people out to see the sights, people on errands, people on the way to the myriad functions of religious import swallowed up the long lines of trotting carriers who, bowed under their burdens, went to the city with produce and tribute, or left it with goods for barter. Outside the city limits the ant-like streams of laden folk had been but rarely relieved by the rare passage of a civil functionary, all feathers and pomp in his litter, or of a stern merchant with a handful of fighting men followed by a chain of apprentices, showing the whites of their eyes as they peered from under the press of the tumplines.



100.
INVESTITURE OF WARRIORS WITH TRAPPINGS OF CASTE

Now could be seen men in rich mantles, smiling flowers as they watched the milling crowd and black-robed priests whose hair was matted with the blood of self-inflicted penance. There was little sound, there was little hurry, save for the carriers, trotting to reach relief from their burdens. But there was great vitality, that of a multitude of units participating

in complex action, knowing each its allotted part but not the substance of the whole.

A glance into the doorway of a dwelling gave relief from the cold-blooded, almost insect-like quality of the life outside. A shaded patio was blocked in with buildings with cool and spacious interiors. Mats and straw cushions on the polished floor welcomed one to repose, while the rhythmic clap of hands and the scrape of stone on stone told that tortillas were being made and corn meal ground in a kitchen at the back. In a corner an elderly man was talking to two small boys, whose serious faces showed that, already conscious of their participation in the tribal life, they heeded their uncle's precepts. In a doorway a fat little girl vainly tried to imitate with her stubby fingers and toy instruments the graceful movements of her mother as she produced fine thread by the cunning manipulation of her spindle. Lolling on a



Photograph from Ewing Galloway

THE "FLOATING GARDENS" OF MEXICO

A scene that might well represent the days before the Conquest. The people in the district of Xochimilco, where this picture was taken, still speak Aztec and live much as did their ancestors

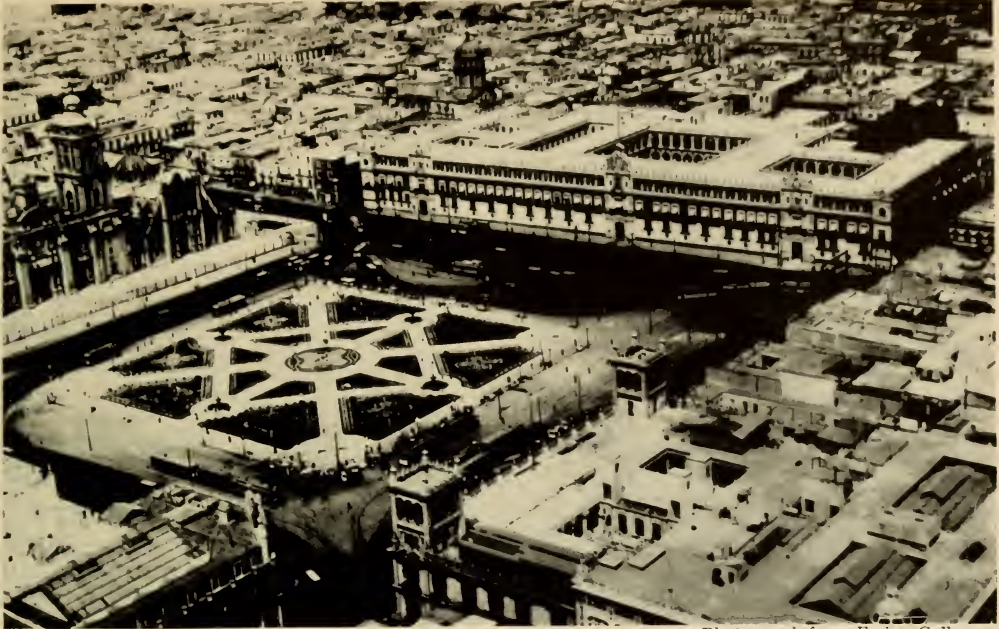

Photograph from Ewing Galloway

THE ZOCCALO, MEXICO CITY

The site of the ancient temple enclosure of Mexico as it looks today. The Cathedral is built in front of the great Temple of Huitzilopochtli

cushion, a young man idly smoked, picking thoughtfully at the scarcely healed lobe of his ear, tattered by penitential blood-letting with cactus spine and obsidian blade.

A fiesta was going on in another house and one heard music, the rich vibration of wooden drums and the gay squeal of reed flutes. The patio was full of people gay in the bright colors of their holiday clothes, and the air was heavy with the cloying scent of lilies. The sharp smells of rich sauces cunningly mixed from many peppers embroidered this odor, and occasionally a light breeze wafted the cool, mystic scent of incense. Somebody was celebrating his birthday, since in the background one saw a painted figure adorned with maguey paper representing the titular deity for the day. A little apart from the feasters, who partook of their entertainment with dignified pleasure, clustered a group of old men whose clownish gestures and burlesque solemnity could be easily associated with

the cups that a slave was industriously filling for them. Not for nothing had they passed through the rigid self-denial of young manhood to be permitted alcoholic indulgence in their old age, whenever a feast came around. A last backward glance revealed the musicians, garlanded with flowers, blowing their flutes and conch shells, while one beat on the head of a cylindrical drum and another the wooden tongues in the side of the two-toned *teponaztle*.

Farther up the street the priests seemed to increase in numbers and more individuals wore the trappings of high office, such as the nodding panaches of quetzal plumes and cloaks the designs of which were worked in feathers like the clan insignia on their circular shields.

Presently the causeway ended in a great open square where rose the majestic planes of the pyramids. In the hard, bright light of early afternoon, heat waves joined with smoke of incense in rendering

902.



HOUSE OF WATTLE AND DAUB, USED BY THE POORER FARMERS

indistinct and unearthly the outlines of the temples, and the short, black shadows suggested unspeakable things. Was it imagination or reality, that sickening odor of a filthy butcher shop, in bitter contrast to the immaculate pavement of the courtyard? Imagination was too personal a sensation for an Indian community and the great block of the skull-rack gave the answer. Thousands of skulls were piled up in orderly symmetry, and the blacks of the eye sockets and nostrils of these sacrificed victims suggested heaps of infernal dice. A few young men were practising in a ball court near by, thrusting at the ball with agile hips while striving to propel

891.

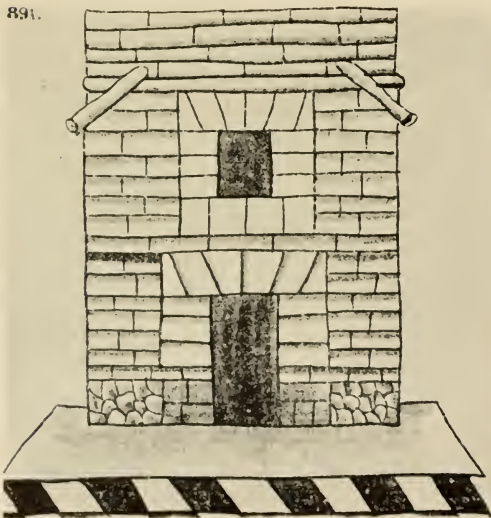

TWO-STORY HOUSE OF STONE AND ADOBE

it through the rings set transversely to the walls along the length of the courts.

A circular stone set a short distance away was the scene of a most cruel game. Here on certain ceremonial days a tethered captive was allowed to defend himself with a wooden club against the onslaught of an adversary whose weapon was set with razor-sharp obsidian blades. Sometimes a victim would resist so successfully that he gained a pardon. The great disc of the calendar stone was

889.



A NOBLE'S HOUSE. NOTE FRESCO AND STONE COLUMNS

placed vertically on another platform. Carved with consummate mastery of design, it represented the symbolic history of the world. A third great disc, carved on its face and edges, commemorated the far-flung conquests of the War Chief Tizoc.

A sacrifice was to be made. Before a small temple dedicated to one of the gods, a group was gathered, some in the gay panoply of merchants and others wearing the sinister black of the priesthood. Among them, tightly-pinioned, stood a slave, who looked unseeingly about him, resignation, not fear, in his face. The priests rushed him up the steep steps to the temple, the merchants following at

more leisurely pace. Two priests, seizing the slave by either arm, forced him backward while two others pulled his legs out from under, until his body curved, belly upward, over the altar. A fifth priest dragged his knife in a long sweep from the breast-bone to the base of the stomach and, reaching into the aperture, with a dexterous twist tore out the heart. They burned this on the altar, and the mer-

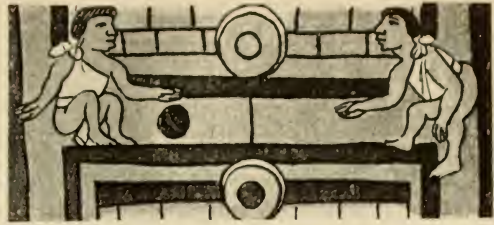

A BALL COURT. THE POINT OF THE GAME IS TO PASS THE BALL THROUGH THE RINGS

Then bare-headed and barefooted, with downcast eyes, they made their way before the throne where sat the slim figure of Montezuma the War Chief, who was simply dressed but for the jade earrings and gold crown of his exalted office.

The austerity of the council chamber was not borne out by Montezuma's other apartments, which contained all the appurtenances of luxurious potency. Magnificent quarters were occupied by the War Chief's two wives and his many concubines. Kitchens and store houses were spread over another great space, for

18.



BOYS GOING TO SCHOOL. NOTE THAT THE PARENTS WEAR THE DRESS OF POOR FOLK

chants, swinging long ladles of smoking incense, chanted their thanks for a safe and profitable excursion to the hot country.

Paying no attention to this pious little scene, knots of chiefs were converging on a large building at a corner of the plaza. The War Chief Montezuma was planning an attack on a neighboring town remiss in its tribute and there must be a gathering of the clan leaders. Adorned with helmets like the heads of jaguars, eagles, and wolves, girt with armor of wadded cotton brocaded in many colors or embroidered with feathers, their faces set with nose and lip ornaments of jade and gold, these fierce-faced chiefs passed through the door, but before entering the council chamber they stripped off this finery.

79.



WARRIORS. NOTE RICII TRAPPINGS AND VICIOUS CLUBS OF WOOD, TOOTHED WITH OBSIDIAN



A PRODUCE MARKET. THE NEAT ARRANGEMENT OF WARES MAY BE SEEN IN ANY MEXICAN MARKET TODAY

not only were some three hundred guests served at each meal but also a thousand attendants and guards. In contrast to the profusion within, outside the kitchen door squatted patiently a meager group of countrymen from whose carrying bags swayed the mottled heads of trussed turkeys to be offered to the larder.

Other apartments in Montezuma's palace contained the tribal treasure composed of the tribute wrung from many pueblos. Gold, jade, rich feather mantles, baskets of produce were heaped in abundance. Clerks were listing the goods to see that each subject town had contributed its

quota, or calculating the share that should be turned over to the various clan stewards. Another patio presented a more animated scene. Here acrobats were practising their feats and poor, warped dwarfs were composing grosser contortions to win a chiefly smile. In another set of buildings was housed the zoo, where serpents undulated sluggishly, and where from behind wooden bars peered the greedy, yellow eyes of jaguars and ocelots. In a side room, a human



PUNISHING MALEFACTORS. FOUR JUDGES SUPERVISE EXECUTIONS BY NOOSE AND CLUB

hand projecting from a basket of raw meat showed how the bodies of some of the sacrificed victims were utilized.

Extending north from this great plaza, which even today is the center of the city, stretched the highway to Tlaltelolco. This wide road with a canal beside it was filled with the same indecisive multitude that filled the southern artery. The sinking sun had brought people out on their roof tops. Some leaned over parapets to watch the throng below, even as idlers squatting in a shaded bit of the street took equal interest in the slow movements of the householders above them.

A path and canal debouching into the main avenue led to a small square, in the



A GROUP OF JUGGLERS. OBSERVE THE HUNCHBACKS IN THE LOWER ROW



STAIRWAY OF THE PYRAMID OF TENAYUCA

Near Mexico City. This is an excellent illustration of the dramatic quality of Aztec architecture

center of which loomed a pyramid. From the patio of a large building shrill cries arose and the dull clash of wooden instruments. Within, a number of boys were receiving instruction in the manual of arms. Each equipped with a small buckler and a flat club of wood, they learned the art of cut and parry under the scornful eye of a warrior. They dealt and received severe blows, but the clubs were not toothed with the wedges of obsidian, the volcanic glass that made hand-to-hand combat so vicious in war. Another group were practising with the atlatl or throwing stick. The marksman laid his spear along a narrow wooden trough hooked at the farther end, the nearer end being grasped in the hand. By lengthening the arm in this way it was possible to attain a greater propulsive force.

A less animated scene took place among the boys of the religious training school on the other side of the plaza. Their little legs and faces lacerated by maguey spines,

their bodies thin from penance, and their eyes dulled by the monotony of self-denial, these children were chanting strophes from a ritual. The preceptor who led the singing showed in his own scarred and emaciated body that the propitiation of the gods was a relentless and never-ending task. Priest, chief, warrior, or husbandman, every Aztec from boyhood on, spent much of his life either in a kind of beseeching penance to ensure his future or in a state of grateful atonement for not having had a worse past. The Aztecs lived on intimate if uncomfortable terms with the supernatural powers.

Another aspect of this lack of individualism was to be seen in the tecpan or clan building. Here elders of the clan were arranging the affairs of the group. One old man by means of maps adjusted a question of land tenure between two contesting families, making his judgment on the basis of how much land each family could cultivate by its own efforts.



TRADE FROM THE HOT COUNTRY. JAGUAR SKINS, JADE, AND FEATHERS ARE OFFERED FOR SALE

Another old man was distributing some pottery, given up as tribute from a town across the lake, to some of the poorer members of the community. None of these people bestowed more than an occasional glance into the back courtyard where an adulterer was being stoned to death by the members of the affronted family. Urban existence contained too many interests and life was too cheap for them to view as an excitement the inevitable result of wrongdoing.

In many such centers each phratry regulated its own affairs. The great plaza where Montezuma had his palace and where the gods were worshipped in many temples was for the use of all the clans together. Yet in spite of the importance of this center, the great plaza of Tlatelolco near the northern edge of the island was almost as striking. The self-contained nature of a Mexican tribe did not diminish the governmental functions of a conquered people, who were supposed to furnish fighting men and tribute, once they acknowledged the sway of a superior power. Thus the recently conquered Tlatelolco had a communal center as

majestic as that of Tenochtitlan. It seemed more dramatic to Spanish eyes, perhaps because its great temple to Huitzilopochtli was thrust into prominence by the wide spread of the market place, while in Tenochtitlan the great buildings were so close together that it was hard to gain an impression of their size.

The open space was divided into two sections. A large area of smoothly polished pavement was bordered by arcades which sheltered many of the merchants. At one edge was a basin opening from the canal beside the northern causeway, where the boats bringing goods and produce could find an anchorage. Each kind of product was concentrated in a special place. Thus one section was devoted to vegetables, and compactly squatting women sat watching their goods, which were arranged in symmetrical heaps on woven mats. In



TRADE FROM THE HIGHLANDS. GOLD, COPPER, OBSIDIAN, AND MANTLES ARE OFFERED IN EXCHANGE FOR TROPICAL PRODUCTS



A SLAVE FAMILY. THE BARS ACROSS THE NECKS ARE THE SIGN OF BONDAGE

another section cotton mantles were being sold, some being spread to show the full design, and others neatly folded. Elsewhere was a row where tools were for sale, obsidian blades, spindle whorls of pottery carved and burnished, spoons of deer horn, bodkins of bone, and a few copper axes. A brilliant mass of color characterized the row of the feather salesmen. Some sold merely bunches of the feathers, the green of the trogon and the multi-colored plumage of the parrots, while at the booths of the others cloaks, mats, and shields gave evidence of charming fancy and patient toil. Jewelers displayed ornaments of jade and gold worked into precious rings of filigree or massive, beaten gorgets. It was the jade, however, that caught the envious eye and was produced with furtive circumspection as material of great price. Other merchants sold ornaments of shell, and the pinks, whites, and subtle mottled browns of sea shells contrasted with the rich, dark sheen of the tortoise carapace. At one booth a rich warrior earnestly chattered with the proprietor for an exquisite pair of earplugs,



FEATHER WORKERS. IN THE DISTANCE A MERCHANT BRINGS THE RAW MATERIALS FROM THE TROPICS



GOLD WORKER MAKING A MOSAIC DESIGN LIKE THE BREAST ORNAMENT ON PAGE 5

cunningly inlaid with a mosaic of turquoise and shell.

The smiling whispers and admiring glances of the crowd when at the jewelers' abruptly changed in the slave quarter to appraising stares. Some of the chattels wore wooden collars and stared blankly with brutish eyes. These had reached their servitude through penalties for crime or by capture in war. Others were thin and emaciated, and did not wear the collar of bondage. They had met with misfortune and were selling themselves to ensure food and shelter.

A low hum rose from the market place; there was none of the strident shouting of a European fair. The bargaining for goods was carried on slowly, quietly, but none the less keenly. The Aztecs had no money, so that barter was the usual means of purchase. The cocoa bean, however, had a standard value and this, in equalizing exchanges, performed the nearest approach to the function of currency. Passing through the crowd were warriors who acted as police, and should a dispute arise, they haled the disputants to a court where one of the tribal elders settled the question.

96.



FARMER PLANTING CORN. NOTE THE USE OF THE PLANTING STICK

Beyond the market was a double line of walls which divided off the religious part of the plaza of Tlatelolco from the market. Rectangular buildings, with patios in their centers, housed the priests and the various schools and councils of the central organizations of the Tlatelolcans. Farther on were grouped the main temples of the various divinities. In the center the great temple shouldered its bulk into the sky. There was a skull-rack like the one in Tenochtitlan, and another heap was made of the bones of the victims. Near the great pyramid stood a circular temple, the door of which was built to resemble the mouth of a serpent: the place of worship for the god Quetzalcoatl. The sacrificial block in front was black with the smoke of incense and the encrusted blood of victims. A pile of stone knives and axes gave a sinister indication of what rites were practised there.

Pools of water fed by pipes from the aqueduct gave an impression of quiet peace and the reflections of the temples, distorted by an occasional breeze, intensi-

fied the brooding mysticism of the sacred enclosure. As a relief to the austerity of the scene young girls with downcast eyes slipped back and forth on the various errands of their training school within the enclosure. The great pyramid, that of Huitzilopochtli, the war god, completely dominated the place. Terraces breaking at intervals the line of the sloping sides increased the impression of its size. A wide staircase of one hundred and fourteen narrow steps led up the western side, and so steep was this stair that not until one's head rose clear of the platform, did the temple itself come into view.

The temple was, in reality, two shrines, built side by side, each having stone walls and soaring roofs of wood. Through the right-hand door, one could dimly see the squat figure of Huitzilopochtli carved in stone and then covered with a paste in which were set jade, turquoise, gold, and seed pearls. A girdle of snakes in gold picked out by precious stones adorned its waist, and around its neck hung a string of gold masks with turquoise mosaic. By its side stood the statue of an attendant deity with a short lance and a gold



101.

FARMER STORING CORN FOR WINTER. POTTERY JARS LIKE THOSE SHOWN HERE ARE USED FOR STORAGE TODAY



A FIESTA. HERE A DRUMMER AND SINGERS WITH RATTLES, FLOWERS, AND FEATHER FANS MAKE MERRY



MUSICIANS SINGING A DUET. THE SCROLLS HERE SHOW THE LYRICAL OF SONG. NOTE DETAILS OF DRUM AND RATTLE

shield richly decorated with a turquoise mosaic.

In the other temple was an image of Tezcatlipoca, one of the most prominent Aztec gods. Its eyes were inlaid with mirrors of obsidian that gleamed reddishly in the afternoon light. This statue, too, was adorned with gold and precious stones. High in the wooden roof of the temple was a small statue of the god of seedtime. Braziers of incense discharged greasy coils of smoke which plunged into deeper gloom the temples whose walls were already black with the blood of many victims. In dim corners stood heaps of paraphernalia, conch-shell

trumpets, knives, banners, and baskets of shapeless human hearts that had not yet been placed upon the braziers. The priests gliding in this murk seemed fitting satellites to the diabolic gods they served. In front of the

temple stood the great drum that was soon to throb across the lake the death throes of a nation.

It was from this point that Montezuma showed Cortes his empire, and Bernal Diaz, who witnessed the scene, has left an unforgettable description, which is the best conclusion to this brief sketch of Tenochtitlan, the ancient Mexico City.

"Then Montezuma took Cortes by the hand and told him to look at his great city and all the other cities that were standing in the water and the many other towns and the land round the lake. . . . So we stood looking about us for that huge

and cursed temple stood so high that from it one could see over everything very well and we saw the three causeways which led into Mexico . . . , and we saw the (aqueduct of) fresh water that comes from Chapultepec which supplies the city and we

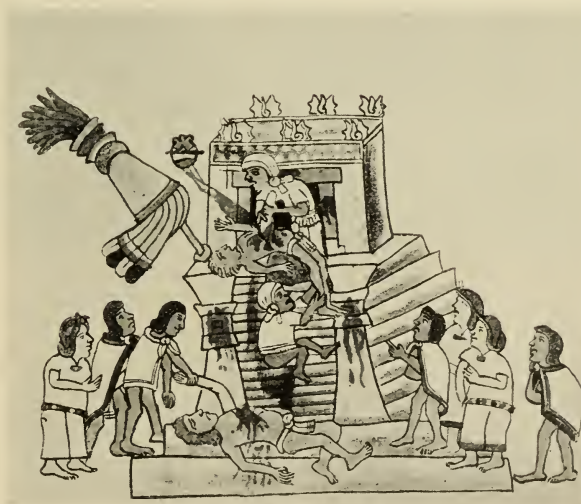

PRIESTS, MEN, AND WOMEN WITNESSING HUMAN SACRIFICES AT THE SHRINE OF THE WARRIOR GOD HUTZILOPOCHTLI

saw the bridges on the three causeways which were built at certain distances apart . . . and we beheld on the lake a great multitude of canoes, some coming with supplies of food, others returning loaded with cargoes of merchandise, and we saw that from every house of that great city and of all the other cities that

were built in the water it was impossible to pass from house to house except by drawbridges which were made of wood, or in canoes; and we saw in those cities Cues (temples) and oratories like towers and fortresses and all gleaming white, and it was a wonderful thing to behold!"



CAST OF THE NATIONAL STONE

AN AZTEC SCULPTURE WHICH MIGHT BE CALLED A MODEL, SINCE IT PROBABLY REPRESENTS THE CALENDAR STONE SET ON A PYRAMID. THE ORIGINAL IS ABOUT A METER SQUARE AND IS RICHLY ADORNED WITH CARVINGS PERTAINING TO WORSHIP OF THE SUN GOD.



Temple, Nahuatl Style, Santiago Huatusco, Vera Cruz. After Dupaix, 1834

The Architecture of Pre-Columbian Central America

THE art of Central America is as baffling as it is impressive. Completely a product of the Indians of the New World, it cannot be fitted into the customary canons of European aesthetics. The higher expressions of Central American art are far from primitive, the modern American, missing the emotional appeal of his own art, feels something remote and undeveloped in Pre-Columbian civilizations. Yet, since we ourselves are immigrants in a new land who built up our own civilization, the cultural and artistic achievements of previous immigrants, of different race, to the same continent should be as worthy of our knowledge as the culture of the ancient Egyptians, which is part of all our courses in ancient history.

In the preceding chapter we have tried to describe the life in a typical Central American community and in the

following pages the art that flourished amid such surroundings, in an effort to bring into sharper focus the more tangible aspects of Central American art. But before we begin to discuss these various manifestations, let us roughly sketch the historical background of these civilizations.

The first immigrants from Asia entered America by way of Alaska toward the close of the last glaciation, and this infiltration of peoples probably continued up to the time of European colonization. Since no traces of Asiatic civilization are found in North America, the cultural plane of which is relatively low, there are no good grounds for assuming that these immigrants brought an art with them. At some time during this population of the New World, groups of people in Central America and northern South America began to develop an agriculture based on



Photograph by La Rochester, Mexico

PYRAMID OF CUICUILCO, VALLEY OF MEXICO

This oval structure of adobe studded with uncut stone is completely surrounded by the lava flow at the left. It is probably the oldest building in Central Mexico.

native plants like corn, potatoes, and manioc, which were unknown to the Old World until after the discovery of the New. This food supply is one of the most important proofs that the New World civilizations were uninfluenced by those of the Old. A contact with the Old World close enough to permit absorption of its art styles would also utilize its food plants and domestic animals.

Once a stable food supply was assured them, the tribes in Central America had an opportunity to develop their culture. Perhaps more conscious of the novelty of

agriculture than the Asiatics, the Central Americans worshipped those natural forces which controlled the harvest, and evolved a religion in their honor.

The broken mountainous country stretching from the Rio Grande to Panama has several distinct climates, according to the altitude. Great forests and mountains tended to isolate inhabited communities. Consequently small groups of people could retain their language and develop dialects as well as evolve distinctive customs and art forms. Some of these tribes developed most sophisticated civilizations, while others lagged, retaining a primitive culture. To thread our way through the tortuous mazes of the cultures of these tribelets is beyond our purpose, nor have we the knowledge to do so even if we wished.

Two major artistic developments can be discerned, however, the art of the Maya-speaking people of the low, hot country of Guatemala and Yucatan, and that of the Nahua tribes of the Mexican Highlands. Combinations and transitions between Maya and Nahua art may be seen in the civilizations of the tribes in adjoining regions. Maya art is the aesthetic of a gentle people, whereas Nahua art is the product of a more austere and warlike folk.

The period of Central American art covers the first fifteen hundred years of the Christian era. Previous to that time

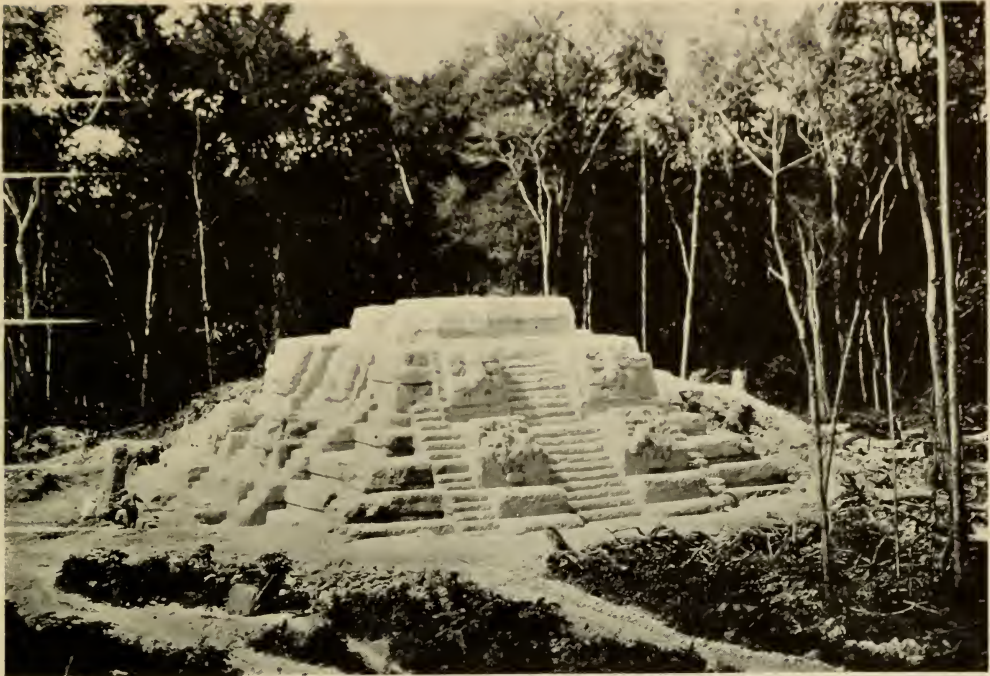

Photograph by S. G. Morley

TEMPLE EVI SUB, UAXACTUN, GUATEMALA

This oldest Maya building yet found is made of rubble with a plaster covering. It is a platform without any trace of a temple. Note the masks carved at the sides (See p. 57)

the tribes of Central America were making the slow climb from a hunting stage and inventing agriculture anew, while some of the Old World nations had already embarked on the preliminary stages of civilization. The Maya seem to have been first to produce a really fine art in Central America, but, by the Tenth Century, the Nahua had also developed a concrete aesthetic expression. While in the first ten centuries of the Christian era the Maya were artistically predominant, they afterward began to decline, so that at the time of the Spanish Conquest in 1519, Nahua tribes, like the Aztec and Mixtec, produced the major examples of Central American art.

Having roughly oriented ourselves in time and space, we can now examine the various expressions of Central American aesthetics. We can appreciate a little more clearly the circumstances under which groups of people, without steel

tools and without draught animals, were able to create a civilization that glorified not themselves but the gods who permitted them to exist. Living in subservience to their divinities, the Central Americans seemed little interested in their own emotional weaknesses or sentimentality, and this impersonality, often austere, defines their art.



Architecture, more than any other art, symbolizes the pitiless quality of Central American civilization. However, as coldness also characterizes our own modern buildings, the architecture of the ancient Mexicans and Mayas gives us the most comprehensive approach to their art. We can also understand, since the major architecture of Central America is dominantly religious, how ritualistic and ceremonial requirements permeate the other arts like sculpture, painting, textiles, jewelry, and pottery.

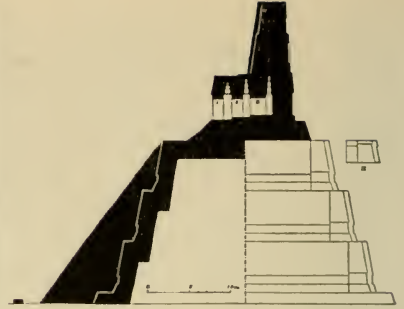

TEMPLE II, TIKAL GUATEMALA,
MODEL AND SECTION

The decorative emphasis has passed from the platform (p. 21) to the temple proper. The rooms are mere slits in the solid masonry mass supporting the roof comb on which decoration is concentrated. It can be readily seen that the basic idea is to construct a monument rather than a place to house a congregation. Temple II is one of the oldest Maya religious structures, and illustrates one of the fundamental principles of the religious architecture. The succeeding photographs trace the evolution of religious monuments like this into temples. Section after Maler, 1911 (See also p. 56)

Religion was the most vigorous social force in Central America. Priests, not chiefs, governed the various tribal groups, and these hierarchs were ever conscious that they must placate the gods who controlled all natural phenomena. This philosophy caused the tribal leaders to organize ceremonies and establish places of worship in order to cultivate the favor of their divinities. Religious demands so completely absorbed the surplus energy of the Central American people, once they had met their needs for subsistence, that, except in the highest civilizations, one can discern few traces of specific civil government.

Under such conditions it is not surprising that the ceremonial architecture was tremendously developed, while dwelling houses, made of adobe or wattle and daub, were of the simplest nature. Only the Aztecs and their neighbors in the Valley of Mexico seem to have produced a

domestic architecture at all complex. Discussion of the artistic evolution of architecture naturally centers around the buildings used directly and indirectly for religious purposes.

We do not know the point of origin for Central American architecture, or whether it had been evolved at a single place or in several. But the most common type of ruin comprises a group of mounds, set sometimes around a central plaza, sometimes without an obviously formal plan. Quite commonly in the mountainous regions collections of mounds are strung along ridges or mesas, which have been graded to provide level surfaces for living and to give a solid basis for the erection of platforms. Very often these terraces and substructures were faced with stone over a hearting of adobe or rubble, when a suitable quarry was readily accessible.

The groundplans of Central American cities differ, but in two respects only.—formal or informal grouping. Yet, the arrangement of the plan seems to depend

on local conditions of terrain or order of construction, rather than on the scale of cultural evolution. The architecturally very developed Chichen Itza has a haphazard distribution, while the older and structurally much simpler Teotihuacan is most elegant in its orderly design.

Preservation is an extremely important factor in our estimates of architectural values. The stone-faced temple of Yucatan which has resisted the elements seems to us more worthy of admiration than the battered adobe or rubble buildings on the Mexican Highlands which have capitulated to the elements. For all we know there may have been superb buildings of wood representing an interesting and imposing architectural order which, being incapable of preservation, is lost to us. We cannot, then, judge build-

ings en masse, but must trace by individual temples the course of Central American architecture.

The fundamental idea in Central American architecture was to create a focal point for ceremonies which took place outside the buildings. The temples were seldom intended to house congregations, as were the cathedrals of Europe or the great temples of Egypt, nor in shape or purpose do they resemble those colossal mortuary chambers, the Pyramids. Maya and Mexican ceremonial structures were true monuments to the glory of the gods.

In view of this dominant interest, the constant enlargement of buildings is not surprising. Moreover, in several regions, the termination of a fifty-two year cycle was the occasion for renovating all possessions, ceremonial and personal, even

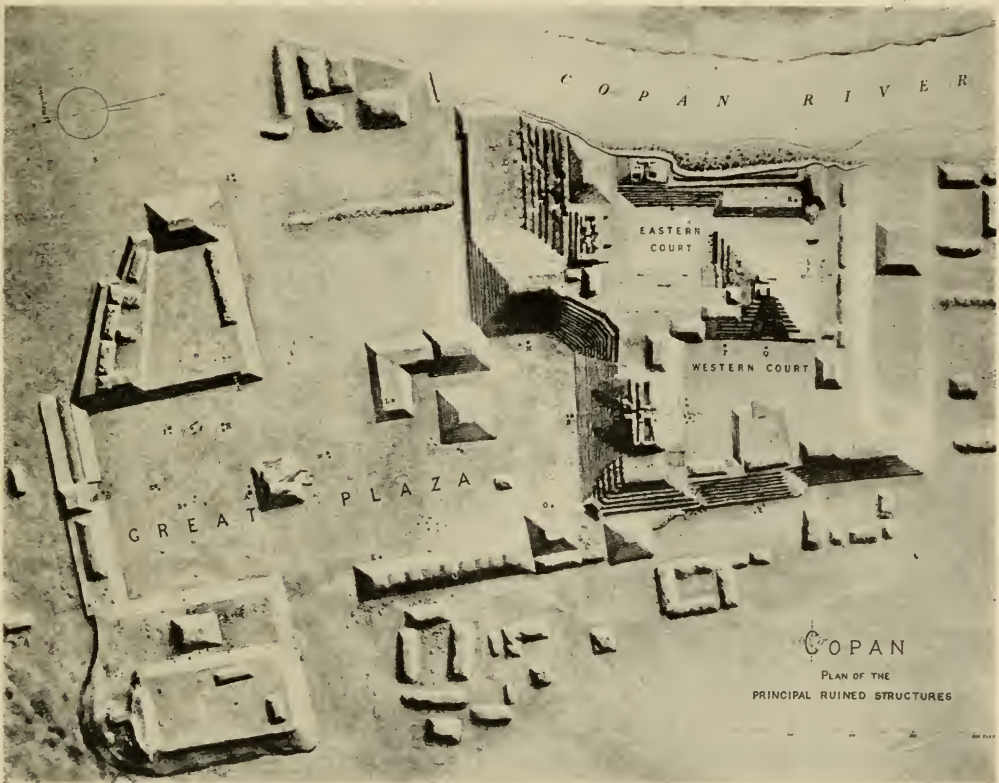

RELIEF MAP OF COPAN, HONDURAS

Showing the plan of this ancient Maya city. Note the amount of grading done before construction of buildings began. After Maudslay, 1899



THE GATEWAY AT LABNAH, YUCATAN

A magnificent example of northern Maya architecture. The corbel vault is composed of overlapping stones which are supported by the weight of the masonry above, and are not united by a keystone, as in the true arch. Photograph by the Department of Historical Monuments, Mexico

to the destruction of household articles used up to that time. This aggrandizement was accomplished in two ways. The simpler method was to build over the original structure, filling in the temple and adding to the platform until both were converted into a foundation on which a new temple could be erected. Due to this custom many buildings that would otherwise have been lost are now preserved within the sheathing of the later additions. The second way was to add a wing or an ell to the original structure, a method of addition well known to us today. Sometimes the two methods were combined.

The two oldest buildings known to us in Central America were platforms, probably without temples. One of these is the oval mound of Cuicuilco in the south of the Valley of Mexico. This was built of adobe bricks arranged in several ascending terraces, and two staircases were disposed at either end. The outside of the

structure was faced with river boulders, over which a later enlargement had been made, utilizing lava blocks as a veneer. An altar in horse-shoe shape surmounted the earlier building, but no trace remains of whatever construction crowned the later mound. While it is possible that this earlier altar was enclosed, its size and shape suggest that it was built in the open. The antiquity of Cuicuilco is incontestable, first because a lava flow surrounded the building after it had been abandoned, and second, because the associated objects tie in with the remains of one of the Early Cultures of the Valley.

The other temple, EVII-sub, at Uaxactun in the heart of the Maya country, was a quadrangular structure of rubble coated with a thick layer of plaster. Stairs ascended the sides, flanked by broad buttresses carved into grotesque masks. There was no trace of any construction on top of the platform. The

CHICHEN ITZA, YUCA-TAN

In this panorama of a late Maya city may be seen how formal groundplan was seldom a primary consideration with the Maya. The temples of the Mexican period in the background show a more orderly arrangement than do the Maya buildings in the foreground. After Holmes, 1895



preservation of this perishable structure was accomplished by a later platform which effectively sealed it from destructive natural agencies, such as roots and rains. That temple EVII-sub is of substantial antiquity there can be little doubt, as the outer building was associated with some of the earliest time-markers found in the Maya area.

Both of these early structures were platforms, not temples. The underlying idea was definitely to attain elevation, and thus to dramatize the ceremony. The open summits show that there was no idea of enclosing the ritual, so that temple construction must have been a secondary factor. Already we can discern in the carved surfaces of the Uaxactun temple the Maya preoccupation with design, and in the unadorned surfaces of Cuicuilco

the Mexican emphasis on mass and treatment of planes.

The need of a place to house the image of a god must soon have made itself felt, and soon the custom of a temple or shrine surmounting the mound must have arisen. The earliest Maya temples preserved were of rubble faced with plaster, and were intended to be seen rather than used. The carving which had embellished the side walls of the platform, as at Uaxactun, was transferred to the temple, leaving the substructure bare. To receive this decoration a masonry block was built on the roof, but the weight of this mass necessitated extremely thick walls to support it. Furthermore, the Maya used a corbel or false arch, incapable of bearing a heavy weight. As a result we find massive buildings with rooms only two or three feet wide.

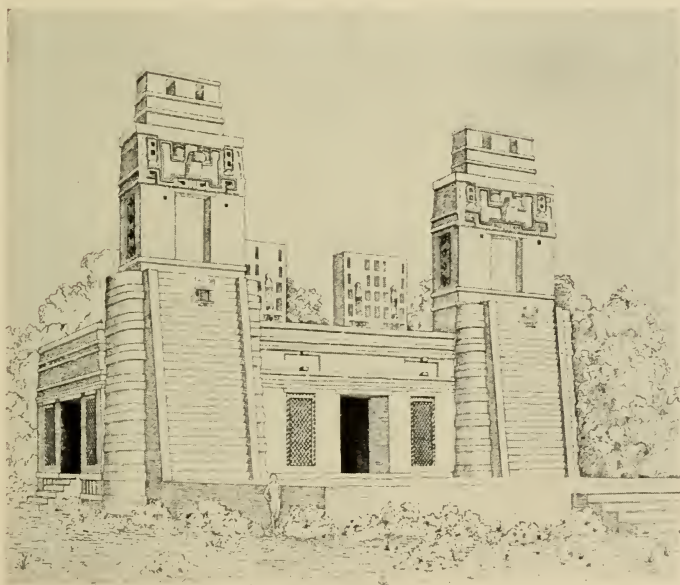

In time the Maya learned how to lighten the burden of the roof-comb by rearing a narrow perforated wall directly above the partition walls of the temple. By so doing, no weight fell directly on the arch of the roof, and it became possible to

TEMPLE AT RIO BEC. QUINTANA ROO

This Maya temple shows the transition from a religious monument to a shrine with usable rooms. The towers are conventionalized reproductions of the Tikal type of temple (p. 22), while the building proper is not unlike the Yucatan structures shown above and on page 26

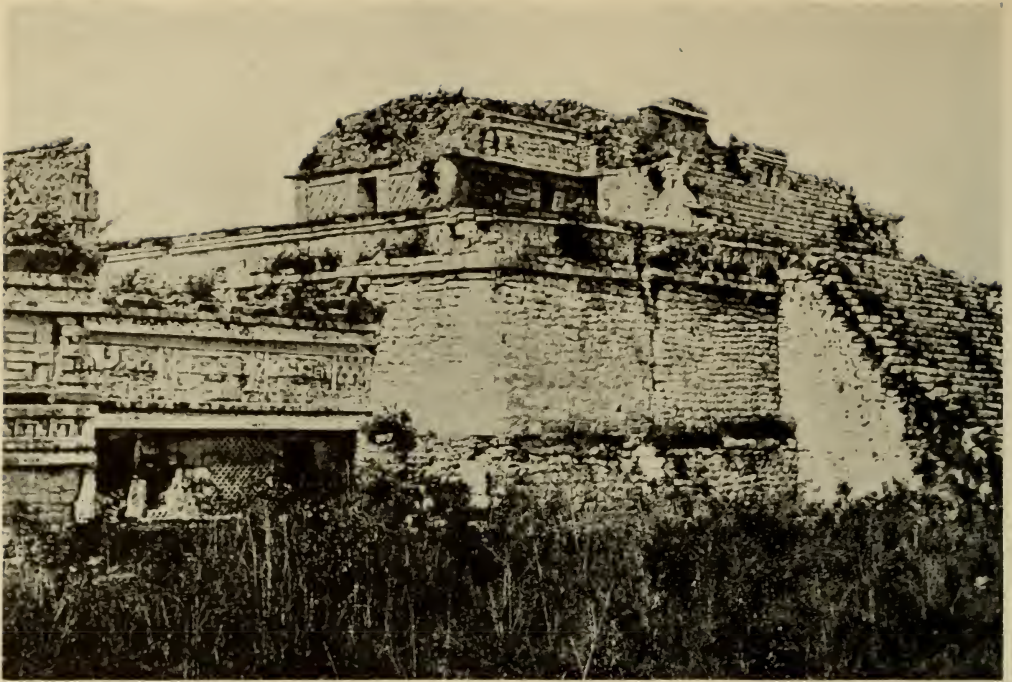

THE "NUNNERY." CHICHEN ITZA

A building of Yucatan Maya type (see also p. 25, upper). Stone is used as facing and elaborate ornament relieves the outer surfaces. Note how this solid construction resists decay and renders possible an accurate appraisal of the architecture. After Totten, 1926

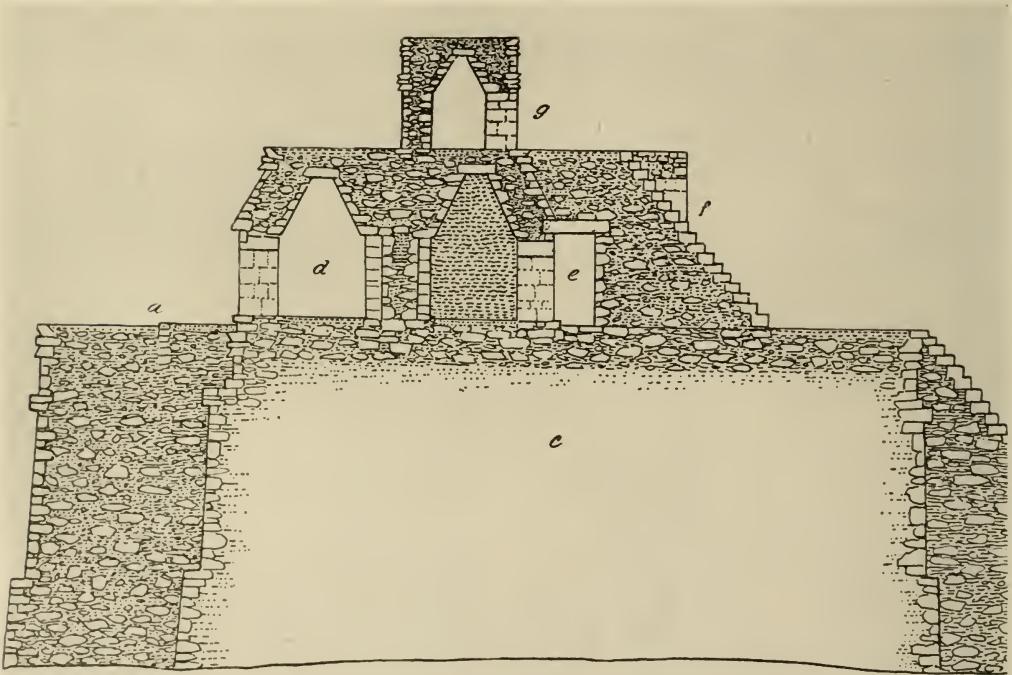

CROSS-SECTION OF THE "NUNNERY"

Showing structural detail and method of accretion. The platform, *c*, was built to add a second story, *d*, to the wing at the left of the photograph above. The third story, *g*, reached by the stair, *f*, was added later, after filling in one rank of the *d* series of rooms. After Holmes, 1895



THE CASTILLO, CHICHEN ITZA, A MEXICAN PERIOD TEMPLE

Showing this foreign influence in the dramatic treatment of the stair and the serpent columns and balustrade. The Temple of the Warriors, a notable companion building, is shown on p. 34.
 Photograph by Department of Historic Monuments

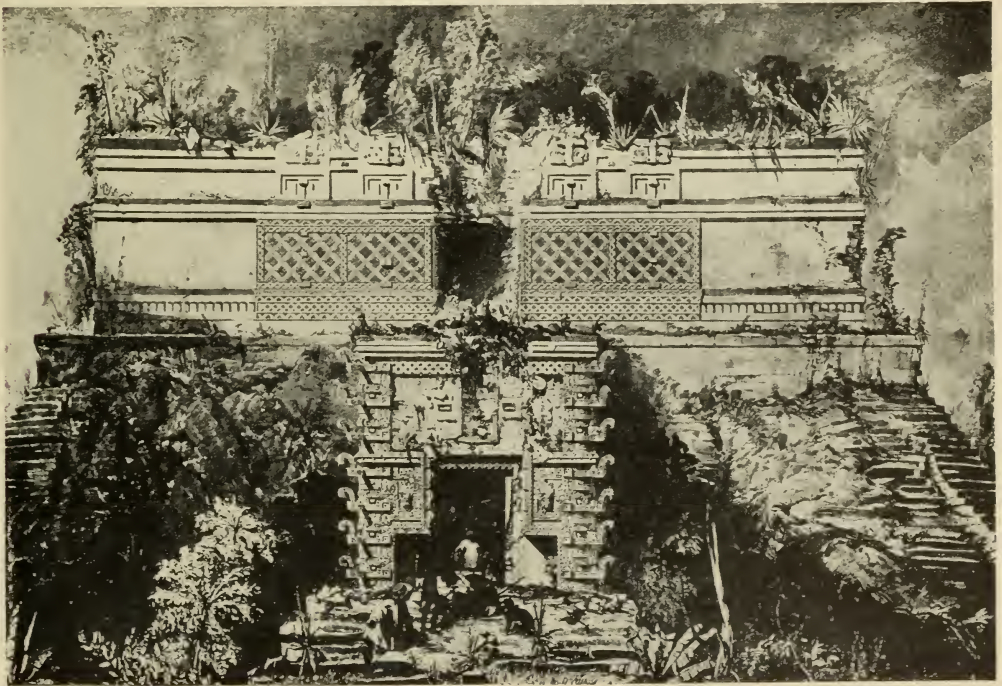

HOUSE OF THE DWARF, UXMAL

Compare the ornate treatment of the ornament on this Maya temple with the simplicity of the Mexican-influenced Castillo above. Note how the portal represents a serpent mouth. Totten, 1926.
 after Catherwood, 1841



RECONSTRUCTION OF TEOTIHUACAN

In the Toltec city of the Mexican Highlands, groundplan is very important. The temples are grouped in precincts, which in turn are arranged in axes. After Gamio, 1922



PYRAMID OF THE SUN, TEOTIHUACAN

This central structure in the panorama above is made of adobe with a stone facing and was the foundation for a temple. Note the size in contrast with the buildings near by. Photograph by Fairchild Aerial Surveys de Mexico, S. A.

have wider rooms. Once room plan became a primary consideration, it was possible to give the rooms a more varied use instead of confining them to the support of a heavy roof-comb. At Palenque we find an outer and an inner shrine, the latter containing a small sanctuary, and at the Castillo in Chichen Itza an outer corridor surrounds the shrine. The culmination of the temple idea is the great Temple of the Warriors at Chichen Itza and its various annexes. Here the roof-comb was dispensed with, and rows of elaborately carved columns supported a series of arches. This building, strongly affected by influence from Mexico, is the most important Central American example of a temple which afforded space for a congregation within its confines.

The essence of Maya architecture may be seen in the evolution of the offering platform into a pyramid surmounted by an ornamented shrine which finally, through increased knowledge of construction, is developed into a temple. Paralleling this development is that of the associated buildings which presumably were to house the temple staff. Without the necessity of supporting an elaborate ornamental crest, the rooms could be as wide as a corbel vault could conveniently be made, a space of some eight to thirteen feet, depending on the length of the tails of the roofing stones and the height of the vault. But the long axes of the build-



TEMPLE OF THE SUN, PALENQUE

The most evolved type of Maya building. Compare the wide rooms here with the narrow slots at Tikal (p. 22). Notice also the shrine in the back room, and the division of the door into a colonnade

ing could be indefinitely prolonged. At first these houses seem to have been composed of three or four oblong rooms fitted together to form a rectangle. Later, when size began to be more esteemed, ranks of rooms were strung together like beads.

The highest development of this kind of building was found in Yucatan. Instead of a plaster façade, the facing of these houses was of stone, which was elaborately carved. The general field of decoration was between the top wall and the roof. Now a large building of several ranks of rooms was extremely unsatisfactory, since the inner rooms were deprived of light and air. To overcome this, the idea of creating second and third stories was



THE GREAT TEMPLE AT TENOCHTITLAN, THE ANCIENT MEXICO CITY

This building and that on page 27 show the Mexican emphasis on planes in contrast to the Maya use of ornament. The double temple is in honor of the Rain and War Gods. (See *NATURAL HISTORY* Volume XXXIII, pp. 18-19). Reconstruction by Ignacio Marquina

evolved. As we have seen in the temple architecture, it was incompatible with Maya idea of safety to support a great weight on a hollow foundation. In building a second story the Maya usually filled in the rooms immediately beneath the projected upper floor. To keep the maximum number of rooms in use, each of the rooms was stepped back from the one below. Another method of constructing an edifice of more than one story was to surround with ranks of rooms the platform supporting a building.

We have seen that at first the conception of an enclosed space was predominant, and that later air and light began to be considered by erecting several tiers of rooms. As a corollary of this, the simple doorway began to be split up into several portals, leading to an eventual evolution of the column. Toward the close of the Mexican occupation of Chichen Itza, the ranks of rooms so characteristic of Yucatan gave way to colonnades. Here wooden lintels strung from column to column carried the weight of the vaults.



HALL OF THE COLUMNS, MITLA, OAXACA

This is one of the largest completely walled buildings in Central America. Note the ingenious mosaic of separate blocks of stone. After Charnay and Viollet le Duc, 1862

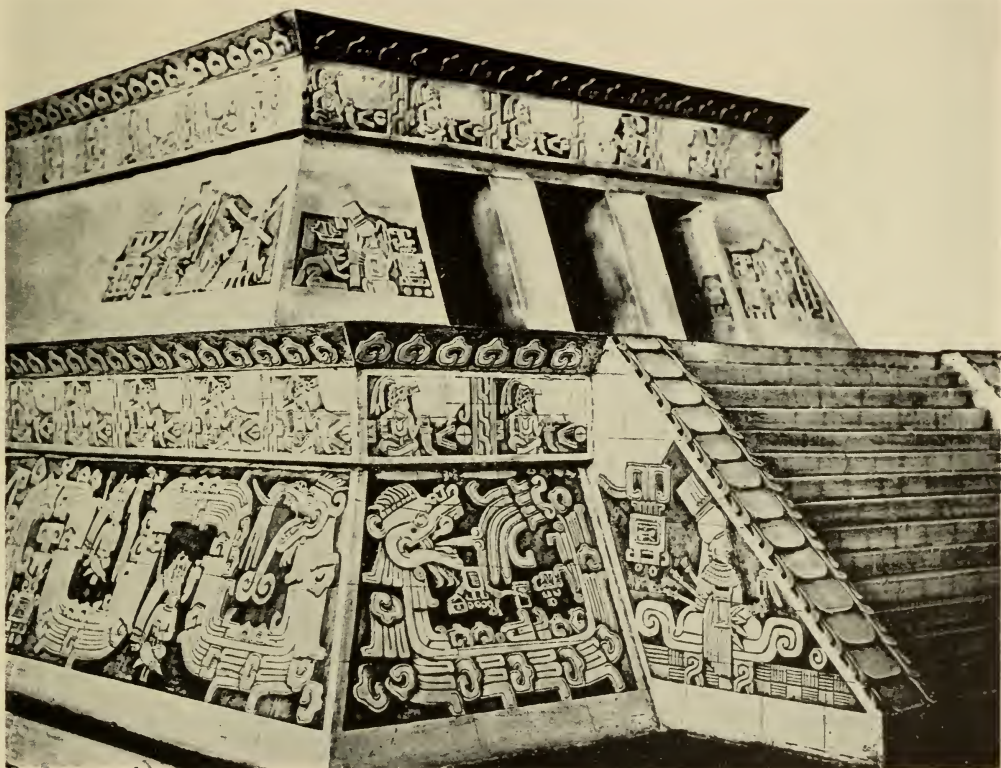

TEMPLE AT XOCHICALCO, MORELOS

Another ornate example of Nahuatl architecture wherein the temple and platform are treated as a unit. The frieze falls into the Mixtec-Zapotec art style. After Totten, 1926

Perhaps because of accident of preservation, but more probably because of increased light, in buildings of this late period we begin to find interior ornament such as frescoes and carved and plastered columns. Unless designs could be seen, there would be no purpose in creating them, for the inner apartments of a simple collection of ranked rooms must have been almost pitch black.

The essential success of Maya architecture from the dramatic point of view was the invention of a monolithic type of construction involving the false arch, which rendered it possible to combine mass, height, and field for ornament, with inner space for the performance of cult practice. On the highlands of Mexico the basis of construction was much simpler. The false arch was unknown, and there was no such mastery of stone and concrete construction. Unfortunately, very few Mexican temples have been preserved.

In the first place, the people on the Mexican Highlands commonly used adobe and piled stone faced with cement, a type of construction that resists very poorly the destructive action of time. Instead of covering their buildings with corbel vaults, they erected flat roofs of plaster spread on beams, or pitched roofs of thatch or wood. Consequently we have no such obvious point of interest as in the miraculously preserved Maya buildings. However, one does have the impression that the effect of awe was gained by the vast, imposing mass of the substructure rather than the building on top.

Decorative treatment of the side walls of the platform was emphasized very rarely to the point of obscuring the central planes. While the most ornate frieze known from the Highland region is the deeply cut Temple of Quetzalcoatl at Teotihuacan, more often carvings like snakes' or death's-heads were inserted in

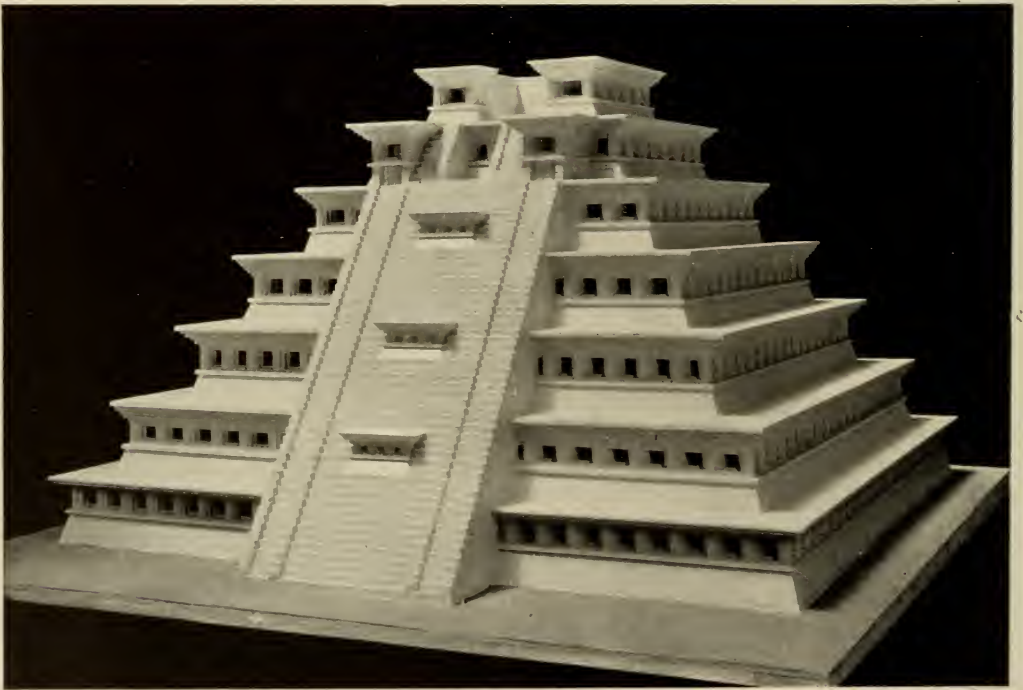

TEMPLE OF TAJIN, VERA CRUZ

As at Xochicalco (p. 31) the platform and temple are built as a unit. The apertures are small niches for statues. This temple is most readily adaptable to European architectural ideas

the walls. The major ornament seems to have been the stair which was treated as a center of interest and not as a mere communication.

The plans of the temples were not so rigidly controlled by structural factors as in the Maya area. Roofs supported by wooden beams could cover wider spaces than stone slabs inched out to meet in a corbel vault. Under such circumstances an inner and an outer chamber of substantial size could be made. Sometimes the temples had stone walls and the roofs were lofty structures of wooden crib-work. A

feature of many Aztec temples was the erection of two temples on a platform for whichever two gods in their pantheon were especially to be venerated. At Tenochtitlan there was a notable pair of shrines in honor of the Gods of War and Rain.

Palaces and priestly dwellings followed domestic architecture more closely. A number of rooms were grouped around courts, and colonnades were not uncommon. In some places, as at Teotihuacan, by using interior columns a large central room could be formed. Two-story houses are described in accounts of Mexico, but at the earlier site of Teotihuacan, our best source for priestly dwellings, platforms were used to elevate one room above another. As in the Maya area, there was the same mistrust of using the roof and walls of one room to support another.

A blending of Mexican and Mayan architectural ideas existed at Chichen Itza and at Tuloom. At Chichen Itza

the Castillo showed a dramatic treatment of the substructure and stair, although the emphasis on the temple was in part Maya. More specifically the Temple of the Warriors resembled Mexico in the ornate friezes around the platform, and perhaps the use of the colonnade in the

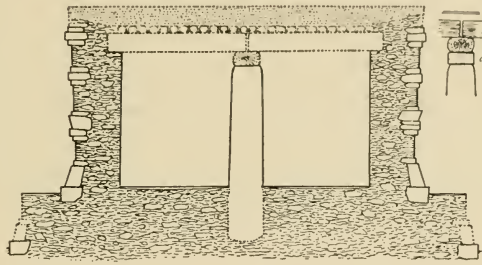

CROSS SECTION OF A TEMPLE AT MITLA, OAXACA

(See p. 31 upper)

Compare this Mexican roof with the corbel vaults of the Maya (p. 26 lower). This structural method makes it possible to have wider rooms than under the Maya system. After Holmes, 1897

temple proper. However, the vaulting and general exterior treatment are Maya. At Tuloom we find an emphasis on mass and plane surfaces, as well as the flat roof of the Highlands. Conceivably this is the ultimate southeastern swing of the Mexican school of architecture.

These types of architecture, the Maya and the Mexican, express the two major styles of Central America. There are, however, certain other buildings which suggest the existence of different architectural evolutions.

Especially notable is the temple of Tajin near Papantla in Vera Cruz. In this case the temple was made one of the successive rising stages of the platform, thus creating a unified harmony between fane and substructure. There was no carving, although in niches set throughout the sides idols were placed; but these cannot have detracted from the essential unity of plane and mass. Another case where the temple was treated in terms of the platform was at Xoehicalco. Here the planes of the building were subordinated as fields for an exquisitely carved relief, which suggested a Maya inspiration.

At Mitla, in Oaxaca, we have the three great "Palace" groups, each composed of oblong buildings on the three sides of a sunken court. The walls were ornamented



TULOOM, QUINTANA ROO, A FUSION OF MEXICO AND MAYA ARCHITECTURE. AFTER LOTHROP, 1924

with a mosaic of cut stones composing a lovely fretwork design. The flat roofs were partly supported by massive stone columns and include the largest completely walled floor spaces found in Central America.

This résumé has covered briefly the principal aspects of Central American architecture. Maya architecture emerged as triumphant glorification of design, as opposed to the Mexican emphasis on

massive planes. Certain specialized buildings were mentioned which, although belonging to neither of these major styles, were none the less noteworthy. At the same time it must not be forgotten that Central America is spattered with mounds, the details of which are either irremediably destroyed or else have to be studied by excavation, so that only the broadest outlines of Central American architecture are visible to us.

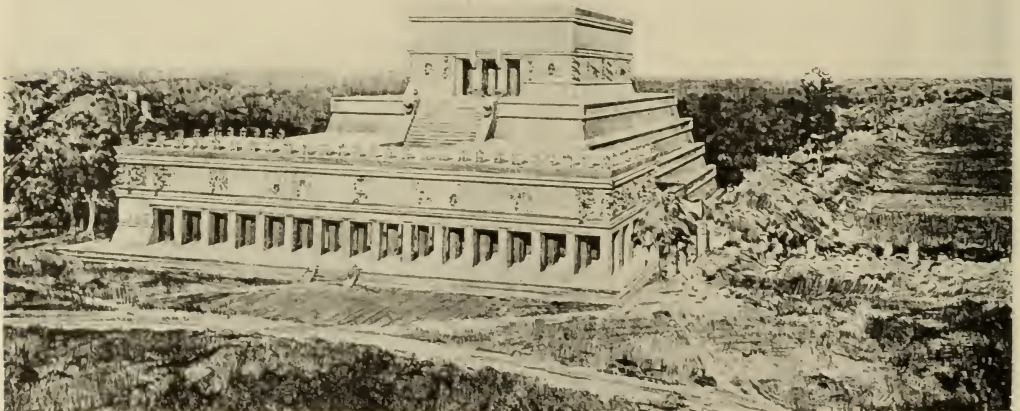

THE TEMPLE OF THE WARRIORS, RECONSTRUCTED BY PROF. K. CONANT, AFTER MORRIS, 1931



MASK OF GREEN STONE.
TOTONAC (?) CULTURE.
NEAR TEAYO, VERA CRUZ

The Sculpture of Pre-Columbian Central America

The sculpture of Central America expresses in a more subtle and varied form the quality of impersonality noticeable in the architecture. The arts were created by nameless craftsmen to enrich their tribal ceremony, and were not expressions of the individual as they are today. Thus we see the Central American arts as a communal production, not the aesthetic reactions of a number of individual artists. Whereas the major buildings were the foci of the highly ceremonialized group religion, sculpture had a more diffuse function. Not only did it adorn the temples and explain their purpose but also it depicted the god honored within the shrine. Plastic forms were also utilized in the creation of incense burners and other temple furniture. Sculpture had its place in the life of the individual, who fashioned from various substances his household gods and votive offerings. Again, images of people and animals were sometimes made to put into graves as equipment for the next world.

If the plastic arts of the Central Americans were not entirely religious, their inspiration, at least, must have originated in ritualistic necessity, to judge from the all-permeating effect of religion on tribal life.

This religious domination makes Central American art seem to us cold, unsympathetic, and confused. Accustomed as we are to completely untrammelled artistic forms and to the glorification of the individual, it is hard for us to conceive how an art could be so imprisoned by ritual. Yet if we think back to the slow emergence of European art from the formulae of religious teaching, Central American sculpture becomes more conceivable. Its lack of emotional appeal is a question of racial interest. The Central Americans, to judge from their art, considered awe the proper emotional relation between the worshipper and his god. If European art had followed the Old Testament conceptions of religion instead of the New, the artistic forms of Europe and



**"HOUSE OF THE
NUNS," AT UXMAL,
YUCATAN, MEXICO**

Late Maya period. Detail of the inner facade. Note the conventionalization of the superimposed serpent masks. Here religious symbolism has all but obscured the direct visual image, but there is complete mastery of design. After Holmes, 1915



**CENTRAL VERA
CRUZ SCULPTURE**

In this carving of a wild turkey, the requirements of design are met, although the presentation is naturalistic. To represent it more dramatically, the figure is shown base upward



**TEMPLE OF
THE CHACMOOL,
CHICHEN ITZA,
YUCATAN**

Period of Mexican influence. These pilaster figures represent a stage midway between the complete religious symbolism (page 36, upper) of the late Maya and the more naturalistic treatment of the Nahuatl peoples. After Morris, Charlott, and Morris, 1931



**CLAY TIGER FROM
OAXACA, MEXICO**

Zapotec culture. A tiger god is represented by this clay figure. The attributes of divinity detract little from the lively realism of the figure proper which has been humanized to some extent

Central America might have produced a very similar emotional effect.

Another conflict between the modern observer and ancient American art is the variation in the ethnic ideal of beauty. Consequently, it is well to remember that the Central Americans were reproducing their own racial type.

The confused quality of the art arises from two factors, the presentation of the attributes and symbols of the various gods and the extreme fascination which complicated design held for the Central American. After all, if we examined me-

dieval painting according to its original purpose instead of from our modern technical and aesthetic point of view, we would be infinitely bewildered trying to understand the attributes of the various individuals and the exact significance of the scene. Furthermore, simplicity or complexity in plastic design veers from one extreme to the other in the history of European art, so that Central American art cannot be justly dismissed by us on the ground of complexity alone. Therefore, if we discount our racial and emotional prejudices, aroused all too quickly by

the unfamiliar, we find in Central American sculpture a competent and versatile art, well adapted to the portrayal of human beings, as well as the relationship between them and their gods.

This sculpture is known to us chiefly by examples in stone and clay. Because of their perishability, few carvings in wood have been found, and shell, owing to its size, was used only for the making of ornaments. The carving of semi-precious stones like jade we shall defer to a later article on jewelry.

The earliest sculptures found are small figurines of clay. Their evolution can be traced fairly accurately through ascending stages wherein experiment and variety alternate with conventionalization arising from the attainment of temporarily satisfactory forms. The human form engaged the attention of these



GUERRERO, MEXICO

Unknown culture. This head of a monkey in black stone presents a happy balance between design and reproduction of a living form

early sculptors and there was a sustained effort to give the little figurines vitality by countless experiments in depicting the features. Owing to the difficulty of supporting strips of wet clay, arms and legs had to be disposed in more or less passive positions so that little action could ever be shown. Usually there is an underlying stylistic unity between the plastic product of each tribe, but occasionally individual expression obtrudes.

In the early culture groups clay sculpture was the dominating artistic medium, and, seemingly, the religion in those days must have been a simple anthropomorphism. With the rise of civilization the art was transformed to meet the requirements of religion, and the clay sculpture was no longer a dominant plastic medium. The development of a pantheon composed of different divinities atrophied the simple naturalism of the earlier art, and the invention of the clay mould made it possible to cast myriads of figures scrupulously defined by their attributes. Thus the craftsman tended to abandon this mechanical reproduction of divinities and utilize stone as a medium of expression, although he occasionally worked in clay with the most harmonious results. Conceivably, the increased specialization of individual activity in a developed civilization allowed men the opportunity to dedicate themselves to religious art, and



OAXACA, MEXICO

Zapotec culture. This clay figure in the Oaxaca Museum is a striking example of Central American art, when allowed to express itself without religious symbolism. Photograph by Miguel Covarrubias

to utilize materials like stone, which required time to shape.

We know on archaeological grounds that stone sculpture developed later than clay in the Maya and the Mexican regions. While it began like the clay plastic, in the round, it took a somewhat different course. Where clay could be readily shaped, stone had to be laboriously pecked and ground into the desired form. On the basis of the earliest stone carvings recovered from Central American sites, there seems to have been no inheritance



COPAN, HONDURAS

Early Maya culture. One of the best examples of Maya sculpture is this magnificent limestone head in the Peabody Museum. Compare it with the racial types shown on pages 35 and 39. This photograph and that on the opposite page are by Dr. Clarence Kennedy



COPAN, HONDURAS

Early Maya culture. This conventionalized serpent head, also in the Peabody Museum, expresses vividly the ceremonial preoccupation of the Central American sculptors, which all but extinguished their extraordinary naturalistic gifts, as exemplified on the opposite page



CUERNAVACA, MORELOS

Gualupita I culture. The genesis of the sculptor's art lay in the development of clay figurines like this in the Bourgeois collection in Mexico

from a former wood-carver's technique of which such strong traces exist in the sculpture of the archaic Greeks and ancient Egyptians. Wood-carving, on the contrary, appears to have followed in the path of the stone-work. Such a condition could well arise from the absence of adequate metal cutting tools, which so hampered the Central American sculptor.

It is perhaps owing to this circumstance that we note one of the most striking differences between Egypto-Grecian and Central American carving. The insistence in Old World art on anatomy would result from *hewing* out the rough outline of the figure, but the Central American preoccupation with external contour would arise from pecking and smoothing down the resistant stone surfaces. Probably the fleshy physical type of the Central American, in contrast to the

muscular and bony European, also contributed to this divergence in presentation.

Once the Central American sculptors had mastered their material sufficiently to fulfill their conceptions of gods, men, and animals, they began to develop the various applications of sculpture and also to establish regional styles. Even as in architecture, there is discernible the cleavage between the gentle Maya and the fierce Highland tribes like the Nahuas and the Zapotecs.

Maya sculpture in stone is chiefly to be found enriching buildings or composing those great monoliths on which the priests caused to be inscribed the ceremonial pattern of their calendar. But scarcely a specimen exists of complete sculpture in the round, such as might be enthroned on the central altar of a temple to symbolize a god.



CUERNAVACA, MORELOS

Gualupita II culture. This clay figure represents an advance over the crude work of the preceding period. It is but a short step from this figure to the skilful presentation on page 39

The most impressive sculpture comes from Copan, Honduras, where exquisitely carved figures ornamented an architecture that, compared to other Maya cities, was inferior. Great skill was shown in bringing out the soft outlines of human faces, and, in the depiction of bodies, real anatomical skill was displayed. Grotesque beings were conceived with equal imagination and artistry. The great stone blocks of the stelae or time markers also presented majestic figures, carved in such deep relief that only the back of the block, containing the inscription, disqualified them from being sculpture in the round. To the north at Quirigua this art reached its zenith in gigantic stelae, twenty-five feet high, and in those fantastic boulders, ornamented and reornamented into an essence of ceremonial involution.

To the west, across the lowlands of



PUEBLA, MEXICO

Unknown culture. This simple and vigorous presentation of a Highland face is characteristic of Nahuatl stonework. The eyes were probably inlaid with shell and obsidian



TEOTIHUACAN, MEXICO

Teotihuacan culture. This crude figure more than ten feet high represents an early stage in stone carving, which seems not to have been developed until long after modeling in clay

Guatemala. is another style of Maya sculpture, that of the cities of the Usumacintla River. Here, at Yaxchilan and Piedras Negras, lintels of hard zapote wood or of limestone were adorned by scenes in low relief. Stelae, too, were decorated in the same manner, and, although some of the relief is very deep, nowhere does it approach sculpture in the round. The finest examples of this school come from downstream, at Palenque. So low is the relief and so firm the line, that the sculpture almost enters into the realm of drawing and painting. Especially interesting in this Usumacintla art is the naturalistic treatment of the figures which are framed by the hieroglyphic text.

To the north, in Yucatan, the sculptures are largely reduced to theological abstractions, wherein the gods are depicted by a harmonious disposal of their



SEIBAL, PETEN
DISTRICT,
GUATEMALA

Maya culture. This detail from a stone time-marker is a magnificent example of Maya low relief carving. Note the combination of naturalism in the figure proper with the pure design of the disposal of the headdress and the hieroglyphs. Especially graceful are the headdress and its pendant plumes. After Maler 1908



VALLEY
OF MEXICO.
AZTEC CULTURE

This colossal head of the Goddess Coyolxauhqui in the Mexican National Museum is a masterpiece of Highland art. Compare the simple strength of this goddess, depicted as dead, with the softer elaboration of the Maya carving above

**PIEDRAS
NEGRAS, PETEN
DISTRICT,
GUATEMALA**

Maya culture. One of the loveliest Maya treatments of life forms is this detail from a door lintel. Comparing it with the relief on the opposite page, one can see the difficulty in using modern European aesthetics to choose the best examples of an art based on totally different canons. Photograph by Dr. Clarence Kennedy



**PANTALEON,
GUATEMALA**

Pipil (?) culture. This detail from a massive carving seems to represent a blending of Maya artistic formulae with the rugged strength of the Highland sculpture. Little is known of the ethnic affiliations of this distinctive school of stone carving



COSTA RICA

Guetar culture. This almost life-size stone figure comes from one of the cultures peripheral to the great Central American civilizations. It has a crude vigor, unobscured by the detail of religious symbolism

attributes. Such treatment precludes an appreciation of this carving as true sculpture, since it is, in reality, pure design. With the intrusion of the Mexicans and the rise of Chichen Itza, naturalistic reliefs again found favor, but they also had a strong theological flavor in their involved ornament.

Bordering on the Maya area to the south in Costa Rica and Nicaragua is a sculpture that represents a stylistic midpoint between the civilized conceptions of the Maya and the somewhat fumbling naturalism of the early cultures. Although probably contemporaneous with the best art of the Maya, it shows the archaism of provincial districts. There is, however, a rugged boldness about the major sculptures that establishes

them as highly significant forms.

The sculpture of the Mexican Highland at the outset seems to have fallen under rigid theological control. The sculptures at San Juan Teotihuacan and the grotesque divinities of the later Aztecs reflect the elements of pure design arising from the theological use of form. Yet occasionally one finds superb naturalistic treatment of divine subjects. Nowhere on the Central Plateau does that balance between the intrinsic beauty of natural forms and the harmonious design of theological conception obtain as in the Maya sculptures of Copan and the Usumacintla region. However, the art of this people freshly endowed with the paraphernalia of civilization has an undoubted strength and vigor that one does not feel in the gradual unfolding of the older and softer Maya civilization.

This conflict in Aztec art between the grotesque conventionalization of religious dogma and the

naturalism arising from increased skill in portraying human forms may be seen reduced to its essential constituents in the arts of the Zapotec and the Totonac. The Zapotec of Oaxaca practised an extremely formalized art best exemplified in their clay funerary urns. In these specimens ritual is apparent in every line. Clay models were used to build up the ornaments and attributes of the divinities portrayed. Human or animal forms were used as a terrifying background for the addition of ceremonial features. Yet excellent naturalistic sculptures occur scattered infrequently through this art.

Among the Totonac of Vera Cruz we find the reverse, that the conventionalization of religious formulae is subordinated to a rich portrayal of the human form.

Whenever conventionalization is deemed necessary, it is concentrated on some object like a ceremonial yoke, but it is nowhere used to throttle a naturalistic expression. Extremely entertaining are the clay "laughing heads," which grin with a blissful good humor. A number of the heads from the Totonac region were shown with oblique eyes, and created the belief in some quarters that this was Chinese influence. Since the American Indian is of Mongoloid stock, it is not surprising that such traits as the epicanthic fold should be reproduced in the sculpture, but it by no means implies that Chinese art had any connection with Central American.

From the point of view of the European, these east coast Mexican forms are the most satisfying of all the various Central American sculptures, since there is a minimum of theological grotesqueness. Closely connected with this Totonac art is that of the Huastecs at the north of



TEMPOAL, VERA CRUZ, MEXICO
Huastec culture. This seated female figure is a survival of the most primitive art in clay

Vera Cruz. Although Maya-speaking, their sculpture shows no artistic influence from the parent stock and is noteworthy in its appreciation of youth.

An exquisite group of sculptures comes from a strip of territory that runs from coast to coast between the lands of the Aztecs and the Zapotecs. Conjecture might attribute these marvellous carvings to the Olmec, who appear in the dim background of mythological history. It is a perplexing paradox that the creators of the beautiful heads and ornaments from this area, which were traded far and wide, must rest in anonymity, unless further research can define them. Much of the sculpture belongs to the lapidary's art.

Another important style of sculpture comes from the Pacific slopes of Guatemala and expresses a fusion of Nahua vigor and Maya mastery of ritualistic design. This plastic style suggests a sudden genesis, rather than the slow evolution of a self-contained tribal art.

Finally, the rich clay plastic of Western Mexico gives us an idea of the utmost



GUIAROO, OAXACA, MEXICO
Zapotec (?) culture. The rugged racial type of the Mexican Highlands is shown vividly by this small stone head

development of a people who were subjected neither to the discipline of complicated ritual nor to the stimulation of a highly organized religion. While there is great variety in subject and attitudes, the characteristic one would expect from an art in the hands of the people, there is none of the finish of the Central American arts under hierarchical control. If these western Mexican sculptures are basically religious and intended for use as mortuary offerings, they are nevertheless worked out by lay methods. They are in reality survivals of an older aesthetic system.

However unified the purpose of Central American sculpture, it is not the product of a single people and should not be so considered. It is the product of a number of tribal groups, of different language and physical types, striving to glorify their religion, according to their various abilities. Yet there is, none the less, a generic resemblance in the sculpture as a

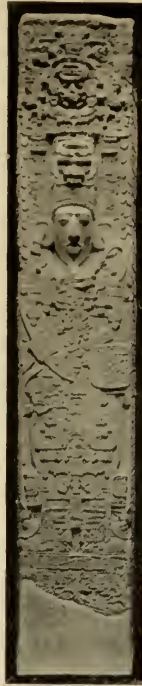

QUIRIGUA, GUATEMALA. MAYA CULTURE. THIS STELE OR TIME-MARKER IS SOME 25 FEET HIGH AND SHOWS THE CEREMONIAL ART OF THE MAYA AT ITS BEST. AFTER MAUDSLAY, 1889-1902

whole, which lies in the absence of those sensual and emotional features that characterize our own. It is not to be expected that people of one race can derive from the art of another the same psychological reaction, particularly if it is religious. However, the detached and impersonal repose of the Central American sculptures has a soothing effect in this modern era where intensely independent individuals strive to perpetuate their personalities in the face of mass production. While there is conflict in Central American sculptures between the freedom necessary for naturalism and the conventionalization dictated by theology, it is a struggle of technique. The creators of the sculptures were harmonizing their tribal life with the rhythms of nature. They expressed their gratitude for divine favors through the skilled anonymity of their craftsmen, and their works registered complete content without a sign of the fickle protest in our modern art.



WESTERN MEXICO. THESE CLAY FIGURES ENEMPLIFY THE VITALITY AND HUMOR OF A FOLK ART UNAFFECTED BY REQUIREMENTS OF RITUAL



Fresco, Tizatlan, Tlaxcala, Mexico. After Caso, 1927

The Art of Painting in Pre-Columbian Central America

CENTRAL American painting does not show the same masterly control over subject and material that is so evident in the architecture and sculpture. Perhaps this inferiority may be due to the rarity of examples. Frescos and deerskin or paper manuscripts are extremely perishable, so that few specimens have survived the action of the weather or the destructive fanaticism of the Spanish priesthood. Much more probably, however, the ritualistic restrictions which controlled the architecture and sculpture have limited painting even more, for this art was confined to a didactic or explanatory supplement to the religious symbolism expressed by the stone carving, or else was used for simple narrative purposes in connection with the historical annals.

The term "painting" we are using in the common sense of the word, to mean a picture, not the mere laying on of colors. Hence we shall not consider the designs on pottery vessels nor touch on the coloring

of sculpture, which was a universal Central American practice. On the border line of this subject are the low reliefs of Chichen Itza and the Usumacintla River sites. These sculptured friezes were coated and corrected with plaster before they were painted, but they do not really fall within the scope of *painting and draughtsmanship*. Therefore we shall confine ourselves to the examples of frescos, manuscripts, and vases which depict actual scenes, in distinction to designs.

Few frescos have survived, since those natural agencies which have caused whole buildings to crumble, attack first the paintings on their walls. The surviving examples display colors such as red, blue, yellow, and green, obtained from ochreous earths and sometimes from vegetable dyes. Occasionally scarlet cochineal, obtained from insects, was employed. The earliest examples known to us are from San Juan Teotihuacan in the Highlands of Mexico, where the painter, despite



Caracol,
Chichen Itza,
Yucatan

This circular astronomical observatory is shown partly restored by the Carnegie Institution of Washington. The disintegration by natural forces that ruins massive buildings like this offers scant chance of survival to perishable materials like frescos and manuscripts. The wonder of Central American painting is that any examples survived at all

This limestone low relief from Tabasco illustrates the transition between drawing and sculpture. The Central American never could suggest by his brush the delicate contours he achieved in modeling



The painter of the vase from Guatemala, a detail of which is shown below, lacked only an accurate knowledge of perspective to equal the masterly result of the sculptor whose work is shown above. After Gordon, 1925-28



his rude drawing, has caught in lively terms a ceremonial scene. Especially noteworthy is a conventionalized design combining various fruits and plants.

Most of the frescos presumably date from the time immediately preceding the Conquest, and come from Yucatan where the rugged stone architecture resisted the elements, and in consequence preserved the fragile paintings within the rooms of the buildings. A number of the subjects seem to be secular. At the Temple of the Warriors, in Chichen Itza, two animated scenes were reconstructed by Ann Axtell Morris from the fallen blocks of the temple vault. In one a seaside village is shown, and in the other the defeat of a foray by marauding strangers. There is no real grasp of foreshortening, but the arrangement of the figures suggests a dawning knowledge of perspective. In the Temple of the Tigers at the same site there is a fresco depicting another attack, and in this case some rather successful attempts at foreshortening have been achieved. At other sites like Chacmultun scenes have been attempted but the draughtsmanship is crude.

RELIGIOUS FRESCOS

There are a number of purely religious frescos, without the secular element introduced by the presence of human beings. The most celebrated are found at Santa Rita in northern British Honduras and at Tuloom on the east coast of Yucatan. In this group the element of design is dominant, and the divinities are arranged according to the dictates of ceremonial pattern. Curiously enough, although found in Maya territory, these frescos have strong affinities in subject and style to the paintings at Mitla in distant Oaxaca.

The Mitla frescos are entirely ceremonial, being composed of divinities and their attributes, and they are closely related to the codices or ritualistic books of

that area. Other Oaxacan examples are extremely rare, and in Central Mexico, save for the frescos at Teotihuacan already mentioned, the painted altars at Tizatlan, near Tlaxcala, alone are worth consideration. These designs are composed in brilliant colors, but the content is purely ritualistic and ceremonial. Like the Mitla frescos, the draughtsmanship is closely related to that of the manuscripts.

ILLUMINATED MANUSCRIPTS

By one of those constant paradoxes in Central America, codices abound where frescos are few, and vice-versa. Thus on the Mexican Highlands there are many illuminated manuscripts, but, as we have seen, few frescos have survived. On the other hand, in the Maya country, the source of most of our knowledge of fresco painting, only three books have been preserved. For a knowledge of draughtsmanship, the manuscripts are a most valuable source of information. They include ritualistic and divinatory manuals, historical annals, tribute rolls, maps, and the like. Thus in the rendition of the subjects chosen, artistic considerations were always secondary to the needs of exposition.

Middle American writing was at a relatively primitive stage. It was ideographic and phonetic, the principle being that of our modern rebus. There was, however, no means of conjugating verbs or declining nouns. Consequently action had to be expressed by pictures. It is quite probable that long recitations learned by rote and passed on from generation to generation supplemented the picture writings which served as a mnemonic aid. A great many of these documents gave calendric and astronomical calculations, and the inscriptions are largely composed of the names and numbers of the various dates, the pictures of the gods presiding over the various days, and the ceremonies associated with them.



Painted Relief
from
Chichen Itza

This carved wall from the lower chamber, Jaguar Temple, was covered with plaster and then painted. A procession of priests and warriors converges on an altar in honor of their god Quetzalcoatl, the Feathered Serpent. The warriors carry spears and spear-throwers, and the two priests have feathered robes in their hands



Ritualistic uses of painting. The upper picture, an altar at Teotihuacan (Gamio, 1922), shows religious formulae reduced to pure design. The middle picture from the Codex Florentino describes a ceremony in which people dressed as birds or gods participate. At the bottom is a scene from the Vienna Codex after Humboldt, 1814. The content is partly ceremonial and partly historic



Descriptive uses of painting include this woodland scene from the Temple of the Warriors at Chichen Itza. The panther in the tree suggests that the artist cared more about defining his genera than drawing them naturally. After Maudslay, 1889-1902



Detail from a battle scene, Temple of the Warriors, Chichen Itza, shows considerable animation in the house to house fighting and the captives being led off for sacrifice by the black-painted priests. After Morris, Charlot and Morris, 1931





Tikal

This dramatic model constructed by Herbert Maier, aided by H. Marchand and H. B. Wright, for the Buffalo Museum shows a typical early Maya ceremonial center. The jungle has wreaked havoc with the site so that now little except the architecture remains of the achievements of its builders. Thus the incomplete patchwork comprising present knowledge of Central America utilizes scraps from many sources

Perishable remains like this plaster temple at Uaxactun, Peten District, Guatemala, are sometimes miraculously preserved. This model cross-section shows how a later building sheathed the earlier structure and protected it (See p. 21)



This fresco from Teotihuacan, perhaps the earliest in this series, was saved in the same way. Men and women offer gifts to the statues of two gods at either side of the picture. On the altars before them burn sacred fires. After Gamio, 1922



The three Maya books fall into this last category. As the Maya had developed an extremely conventionalized way of depicting word symbols, the pages, from an artistic point of view, do not compare with the Highland documents. Among the latter the manuscripts assignable to the Mixtec civilization are especially handsome. The day signs and the representations of the divinities are carefully, one might say arduously, drawn. Proportions are based upon the ritualistic importance of the details shown rather than their anatomical symmetry. Colors are used not only to reproduce natural tones but also to define the object ceremonially, since colors had a strong ritualistic significance in Central American religion. Permeating all the symbols, and their distribution on the page, is design, which follows closely in the train of the order implicit in ritual.

AZTEC PAINTING

In comparison to the Mixtec documents, the painting in Aztec manuscripts seems barbaric, but because it is less confined by ceremonial restrictions it has a freshness rather engaging to our eyes. Furthermore, the Aztec system of writing was incorporated into the Spanish colonial administration, both as a method for keeping legal records pertaining to Indian affairs and as a means for disseminating Christianity among the natives. It is, therefore, possible to see in a number of drawings the transition from a purely Indian to quasi-European style of draughtsmanship.

In the purely ceremonial documents, like the *tonalamall* or sacred almanac, there was a close connection with the extremely stylized documents of the south, but there is more immediate interest to the casual reader in the annals. These follow two forms. One is in the nature of a map, where the events are set forth much as are localities. A knowledge

of the symbols defining personages and tribes does not explain the action entirely, so that manuscripts of this type must have been supplements to oral tradition. The other class is more self-contained. The symbols for the years were set down successively, and lines connect the various events pictured with the year glyphs. Some of these records, like the *Annals of 1576*, were kept well into Colonial times, but the text gradually shifted from picture-writing to Nahuatl words transliterated into Spanish characters.

Another category of documents is composed of the tribute rolls, land grants, and similar administrative records. The Aztecs kept careful account of the toll to be exacted from the towns they conquered. Pictures of the objects with symbols for the quantity are set down together with the hieroglyphs designating the tributary pueblos. Other records show the land held by individuals and the rent payable, and, as these records were retained in colonial times, there is often a gloss in European characters, describing in Spanish or Nahuatl the significance of the document. A few colonial manuscripts exist wherein the symbols were rearranged into a sort of phonetic writing, suitable to record prayers. The Spanish priests broke down the ideographs into a system of actual writing, but the greater serviceability of Spanish characters caused this attempt soon to be abandoned.

CODEx FLORENTINO

The most diverting document from Central America is the Codex Florentino, a collection of pictures illustrating Father Bernardino Sahagun's exhaustive work, *A General History of the Things of New Spain*, written about 1565. These drawings depict every detail of Aztec social life and religion, not to speak of delightful excursions into natural history. The draughtsmanship suggests the phrase



This mortuary bowl from Uaxactun shows great ease and freedom in drawing. The hole in the center of the vessel was made to kill the pot, so that it could pass with its owner to the next world.

After Smith, 1932

The detail shown below from another Maya vase commemorates the meeting between a Maya chief (at the left) and a noble stranger. The features are accentuated to express racial differences. The glyphs doubtless give explanatory details.

After Dieseldorff, 1904



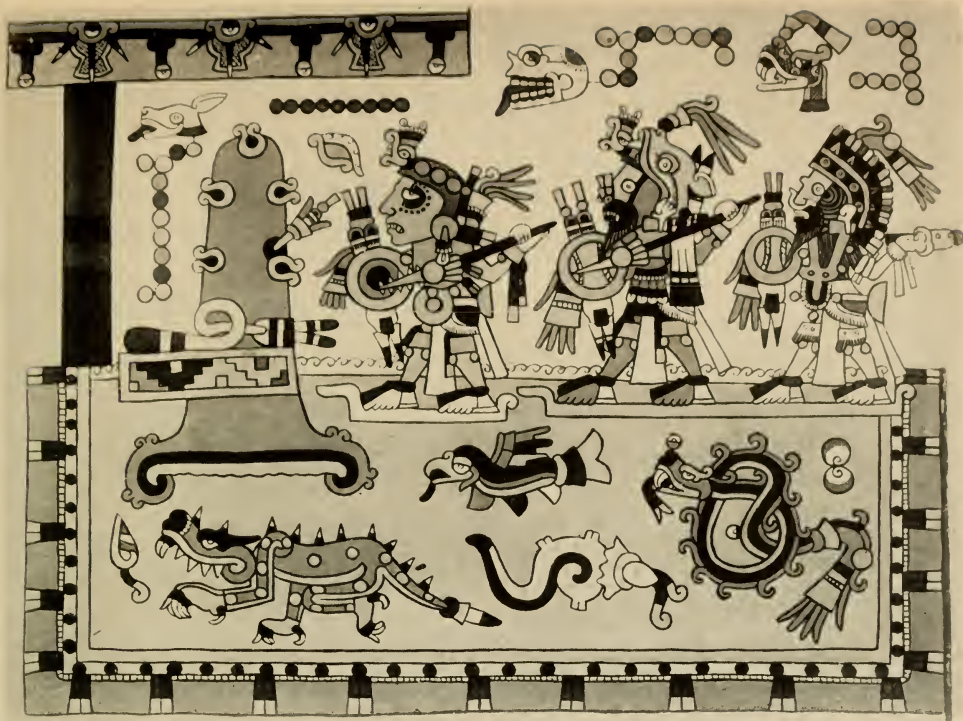

This painting from a Mixtec history, the Codex Nuttall, involves a group of warriors in canoes, who are attacking a town on an island in a lake. Note the ingeniously stylized wild life which inhabits the water. After Joyce, 1927



No such schematic drawings as shown above mar this Maya vase from Copan, which represents a quetzal or trogon, the sacred bird of the Maya. After Gordon, 1928

"old wine in new bottles," since despite the influence of European methods of drawing, the content and psychology are Aztec.

The preceding pages have outlined the two principal sources for Central American painting, the frescos and the manuscripts. While the frescos show a certain fresh ability in presentation, the manuscripts on the whole exhibit the lifelessness that one would expect from the standardized repetition of signs and symbols already defined by ritual. The draughtsmanship does not equal the sculpture and the architecture. Yet there is the inevitable exception to every generalization, and this is to be found in a small group of Maya vases, where a lively and subtle style of drawing is to be found.

Human figures, naturalistically presented, are extremely rare in Central American pottery decoration, and are confined almost exclusively to the Maya region. The style commences at Copan in a vigorous shorthand and finally blossoms into its fullest flower in the Chama region of Guatemala, although there seems to have been a sub-center in the Peten district of the same country.

The scenes are apparently purely descriptive. A notable receiving an embassy from another tribe is depicted on one vase. On another a high personage is borne on a litter, and a third vessel is decorated by a scene wherein a chief

seated on a throne holds a levee. The racial types are exaggerated, but the positions of the body are as graceful in carriage as they are harmonious in design. The strong, sure outlines recall the best of the low reliefs from the Usumacinta River region, and it is apparent that the same school of draughtsmanship which inspired the vase painting controlled also the outlines of the reliefs. When we remember that sculpture was always painted in Central America, it will be seen that here painting and sculpture blend. In the Maya vase painting we have at last found an approximation to the beauties of the stone carving.

The art of painting in Central America exists for us by implication, much as does the delineative art of the ancient Greeks for which vase painting and literary description are the principal sources since the paintings themselves have disappeared.

The frescos are not really representative, because either, as in the case of the Teotihuacan examples, they came from a primitive civilization, or, as in the Yucatan, they were the product of a decadent one. In the codices, the draughtsman's skill, because of delineative and ritualistic conventions, had no opportunity to express itself save in design. Only in Mayan vase painting do we find that the painters

give indications of a skill equal to that of the architects and the sculptors.



Maya vase,
from Nebaj,
Guatemala.
After Gordon,
1928

The Crafts of Pre-Columbian Central America

MANY of the crafts of ancient Central America have persisted to the present day in spite of the transformations which the Spanish Colonial Empire and modern industry have wrought on the native civilizations. The major arts of the ancient peoples now exist more as an heirloom than a useful heritage. The modern artists from the Central American republics have recently utilized aboriginal themes, but between them and their source material stretch four hundred years of European artistic inspiration. In the crafts, however, there are connections, oftentimes tenuous to be sure, with the aboriginal industries. Sometimes only the technique survives, and the subject matter is completely Spanish Colonial or modern Republican. None the less, it is in the crafts that we feel most strongly the influence of the Indian past.

The applied arts of the ancient civilizations embodied many of those characteristics noted in architecture, sculpture, and painting. The same religious purpose that dominated the stone carving not only extended to ceremonial dress and temple paraphernalia, but even penetrated into secular possessions. Thus the elaborate decorative expression of ceremonial values influenced the craftsman as much as it did the creator of artistic masterpieces. Such a result, however, is natural, for there are no sharply drawn distinctions between the two spheres of action. Skilful workers were drafted to enhance the religious ceremonial, which gave the chief outlet for aesthetic expression. Wealth and social position, which make possible the private possession of fine things, were inextricably combined with the gradations of the religious hierarchy.

Surviving examples of these ancient arts

must often take the place of selected masterpieces, for most of the perishable material has disappeared, owing to natural decay or to the willful destruction of war and conquest. Often the written descriptions of the Spanish Conquerors or the crabbed drawings in the native documents offer the sole testimony of remarkable craftsmanship in ancient Central America. Descriptions of the jewelry and pottery we shall reserve for succeeding chapters, since much of this material is wrought of imperishable substances and has survived in far greater quantities than examples of weaving, featherwork, wood carving, and the like.

Weaving was an important art in Central America, but few examples have resisted decay. To determine its degree of excellence we must rely on knowledge derived from other areas, where arid climates have preserved textiles and other perishable materials. The Basket Makers of the Southwestern United States, the earliest agriculturists discovered in that region, developed great skill in weaving cloths, sandals, and baskets, before they learned how to make pottery. Thus we can postulate with some confidence that weaving in the New World was well advanced on a very early cultural horizon. At the other extreme we find the magnificent textile art of ancient Peru, miraculously available to posterity, because the arid climate preserved thousands of burials, each enveloped in several lovely fabrics. That distinguished authority, Mr. M. D. C. Crawford, said of Peruvian weaving, "No single people we know ever invented and perfected so many forms of textiles." and again, "In tapestry Peru reached its highest textile development. The harmony of color, the beauty and the fastness of the dyes, and the perfection of

Costumes

The richness of Aztec costume deeply impressed the Spanish Conquistadores, but the contemporary drawings do scant justice to the originals. These illustrations by Keith Henderson for Prescott's *Conquest of Mexico*, published by Henry Holt in 1922, recapture the splendor of the Aztec scene, thanks to the artist's study of native source material



This drawing of the Aztec ambassadors to Cortes shows the dress of high officials. Note the elaborate coiffure and the ornamental mantles. The feather fans further add to the splendor of the costumes



This procession of warriors shows the imagination that governed gala dress. As this is a peacetime occasion, they are carrying flowers and standards in the place of weapons. Cotton, skins, feathers, and paper were utilized in composing these outfits

Women's dress, as exemplified by these Totonac girls, was relatively simple, yet with a little tailoring these lovely fabrics would not be out of place as sports costumes today



spinning and weaving, place these fabrics in a class by themselves, not only as compared to other textiles of this land, but as regards those of any other people."

Although we have scant means of judging the relative merits of the fabrics of Central America and Peru on the basis of weaving technique, we can compare their designs. The Mexican tribute rolls list mantles in many patterns, and on the great Maya sculptures we see evidence of the most elaborately decorated vestments. These designs are by no means inferior to those adorning the textiles of Peru. If the actual weaving processes were less developed in Central America than in Peru, the decorative aspects must have been very nearly equal.

ENRICHMENT OF FABRICS

The greatest development of the Central American textile art lay in dress. Although the quality of the garments depended on the station of the wearer, the basic costume was the same for all classes. Men wore a breech clout and mantle, knotted at the neck, both made of cotton or maguey fiber. Women usually were clothed in a skirt and a long blouse, the *huipil* which is still worn in parts of Central America. Such costumes could be varied or enriched by the quality of the fabric or by its decoration of brocade, openwork patterns, or embroidery. Additional means of enriching the fabrics were provided by tie-dyeing, batik, and complete dyeing in colors made of various vegetable and animal substances like logwood or cochineal. Clay stamps were used to print designs either on the fabrics or on the skins of the wearers.

The accessories of dress called into play much cunning craftsmanship, since for ceremonial occasions and warfare dazzling costume was demanded. A conspicuous element of ceremonial dress involved the use of feathers. Sometimes the feathers were attached to a loosely woven fabric in such a way that they made an actual cloth, with the designs worked out in various colors. The plumage of different birds was also employed

as a mosaic adorning shields and helmets. Long plumes of tropical birds furnished crests on headgear or formed part of the standards which picked warriors wore on their backs to distinguish various clan and tribal units.

FEATHERWORK AND WOOD CARVING

Today the finer types of weaving and featherwork have disappeared with the destruction of the ancient religion, and the adoption of European costumes for gala occasions. An attractive embroidery still lingers on the Highlands of Guatemala, although many European motives have entered the designs. The featherwork, too, has almost ceased to exist, but, during the Colonial and early Republican period in Mexico, a sort of landscape painting in feather inlay survived.

Wood carving, like weaving, would be difficult to appraise, had not a number of examples found their way to Europe as trophies of the Conquest. Other specimens have either been guarded as heirlooms, or discovered by chance in dry caves. Prof. M. H. Saville, in his *Wood Carvers' Art in Ancient Mexico*, has gathered together all the available information on this art. The most intricate work is represented on several atlats or throwing sticks, which must have been reserved for state occasions. The same mastery of design which distinguishes the major works of art characterizes this carving. Wooden drums show equal artistic ability and the human and animal forms of several belong properly to the realm of sculpture. The construction of one type, the *teponaztli*, required considerable ability, for the sounding board consisted of two tongues of wood which were partly freed from the hollowed block of the drum and gave different notes. Although the tone of the drums varied considerably, the interval between the notes of each was always the same.

MOSAIC WORK

Masks of wood for religious purposes were frequently made, since the gods were im-

turquoise mosaic mirror, which Itza, Yucatan. The reflecting surface was probably made of a number of fragments of iron pyrites laid against the sandstone center. The elaborateness of the fitting together with its discovery beneath an altar indicates that its use was ritualistic. After Morris, Charlot and Morris, 1931



Right:—Obsidian mirror with gilded wooden frame, Mexico. This exceedingly rare specimen was purchased in Europe and may well have been among the presents sent to Charles V by Cortes



Lacquer tray. These gay utensils were a characteristic product of Mexican Indians during the Colonial period, and in recent years their manufacture has been revived in various villages in western Mexico. It is probable that their origin is Pre-Columbian

Pages From



Rich Man



Poor Man



53.

Gold Worker



Beggar Man

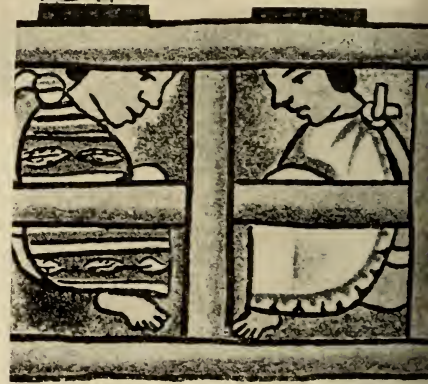

Thief



107

Soldiers



The Codex Florentino consists of several hundred paintings by Aztec artists to illustrate Father Sahagun's great work on the Aztec civilization. The pictures shown here give an idea of the complexity of the civilization. Besides the divisions expressed by the nursery rhyme, "Rich man, poor man,— there was a great variety of other trades and professions, some of which

Mexican Album

are shown at the bottom of these pages. Since the illustrations were intended for secular consumption, naïve vivacity (see "Bathers") replaces the usual ritualistic formality. Compare these drawings with those of Keith Henderson on pages 64-65, to see how faithfully that artist caught the native spirit, and to guide the eye in perceiving the subject matter which is depicted in this group



Chief



Merchant



Lawyer



Women



Doctor



58.



Bathers

personated in a number of ceremonies. Warfare, too, created a function for the wood carver in providing helmets which frequently took the form of animal heads. Yet such work was really the base for another distinctive Mexican craft, mosaic work, for knowledge of which we are again indebted to the erudition of Professor Saville. Fragments of turquoise, jade, obsidian, and shell were inlaid with consummate skill, and this art was a favorite method of embellishing a multitude of implements and jewelry. One of the most extraordinary examples of the craft is a shield in the Museum of the American Indian, where a scene in low relief is carried out in turquoise mosaic. The temples at Mitla show an adaptation of this mosaic technique in the creation of decorative friezes. Today, however, little or nothing survives of this industry.

A craft much more widely practised was the cutting of shell. The demand for this easily manufactured substance was enormous. Few indeed were the New World peoples, however primitive and however distant from the coast, who did not barter for their quota. Shell most frequently was made into beads or pendants, and perhaps because of its almost universal use, seldom received the attention of the more skilful craftsmen. Yet conch shells were sometimes ground and carved into handsome trumpets, while some were covered with plaster and painted with ritualistic designs. A few engraved gorgets show how readily this material responded to a skilled craftsman, but such ornaments are rare. Evidence exists that the carapaces of turtles and armadillos were also worked in ancient times. Some very beautiful objects are made of tortoise shell, today, but it is problematical whether this can be called a legitimate survival, or is of European introduction. Far to the south, in Panama, there occur splendid bone carvings that are reminiscent of major sculptures. Mention should also be made of carved whale teeth in the same region, and carved jaguar fangs in the Maya country, a type of work which

showed considerable ingenuity in adapting the design to the natural form.

Horn and bone were substances perhaps too work-a-day for the highly skilled artisan. Needles, awls, flakers for stone tools, and many other household implements were made of bone, but seldom does one find a beautifully worked example. The most notable exceptions are the jaguar bones from the priestly tomb at Monte Alban. These were split and polished, and on their convex surfaces inscriptions of a ceremonial character were chased, with a minute precision worthy of the Japanese. The backgrounds of these patterns were picked out in turquoise mosaic. Engraved human femora, sometimes ornamented in mosaic, are grim reminders of the exigencies of Nahua religion.

STONE ARTIFACTS

Work in stone we have considered in respect to architecture and sculpture, and shall describe again in connection with jewelry. Yet to manufacture the ordinary implements of everyday life required a consummate mastery of an obdurate material. To detach in a single effort the thin blades of obsidian used as razors and scalpels for ceremonial blood letting necessitated as skilful a coördination of strength and skill as did the patient flaking of the great leaf-shaped sacrificial knives. Some of the axes ground from hard stones like jade and serpentine are aesthetically satisfying in their useful symmetry. This same pride in craftsmanship, which was not unlike that of a medieval smith, seems to have dominated even the manufacture of an arrowhead every facet of which shows the skilled impress of the worker's hand.

ANCIENT MIRRORS

The manufacture of mirrors gives yet another aspect of Central American capability. There were in that region relatively few substances that could take a polish high enough to give a reflection. Glass and bronze were unknown, and copper never seems to

Mosaic

Mosaic working was one of the most elegant of Central American crafts, and color reproductions alone can give its true value. The wooden mask (taken like the two other illustrations on this page from Saville, 1922) was purchased from Cosimo de Medici for the Prehistoric and Ethnographic Museum in Rome, for two and one half francs. It must have been part of the loot from the conquest

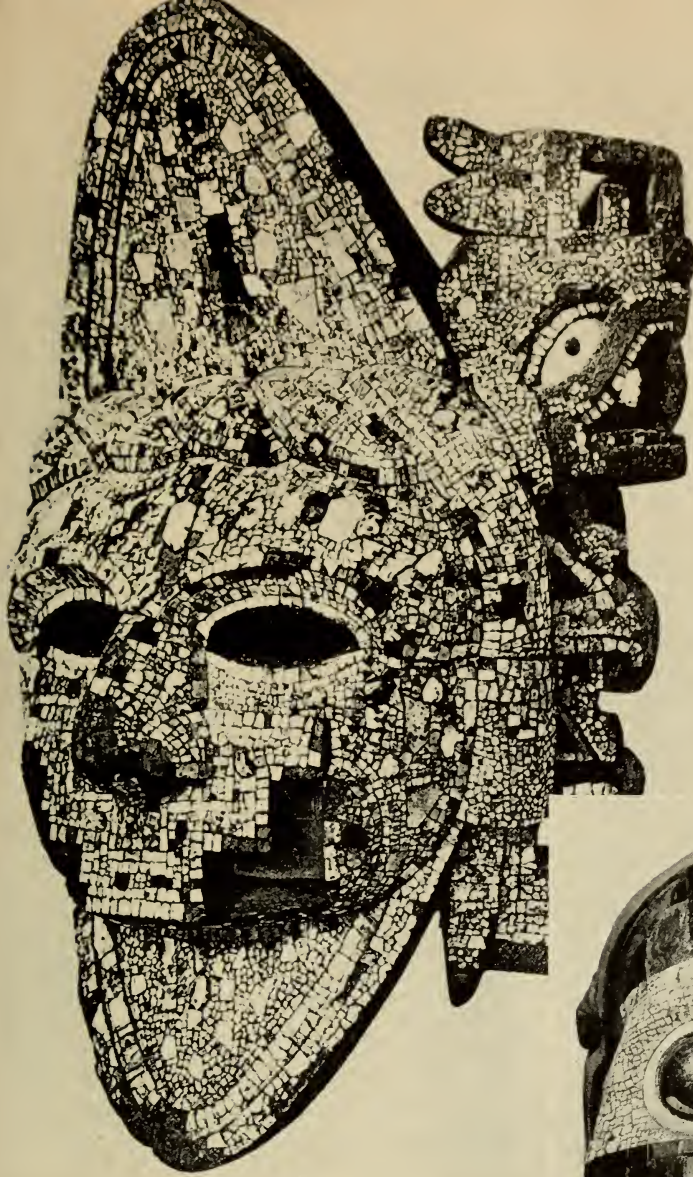

Right:—This mosaic has as its matrix a human skull cut away in back to form a mask. It is one of the treasures of the British Museum. The lighter bands are turquoise and the darker, lignite



Left:—This sacrificial knife in the British Museum is a little more than a foot long. Turquoise, malachite, and variously colored shells compose the mosaic work which depicts an Eagle Knight

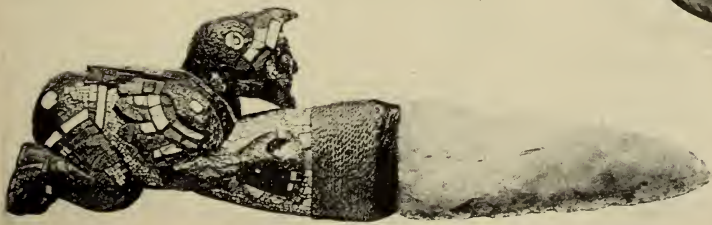



Featherwork is so extremely perishable that almost no Pre-Columbian examples survive. Under Spanish colonial influence, a sort of genre painting in feathers was developed which continued in Mexico until the middle of the last century. Examples of this feather painting in its degenerate state are shown at the left and on the opposite page. At the bottom of page 68 is shown a featherworker practising his craft, and from the pictures on pages 64 and 65 one can judge how important an adjunct to costume feathers were

This headdress (from Heger, 1908) originally belonged to the ill-fated Montezuma and was sent by Cortes to the Emperor Charles V, who in turn gave it to his nephew Ferdinand II of Tyrol. Kept in Ferdinand's castle at Ambras, this unique headdress finally became part of the collections of the Natural History Museum in Vienna

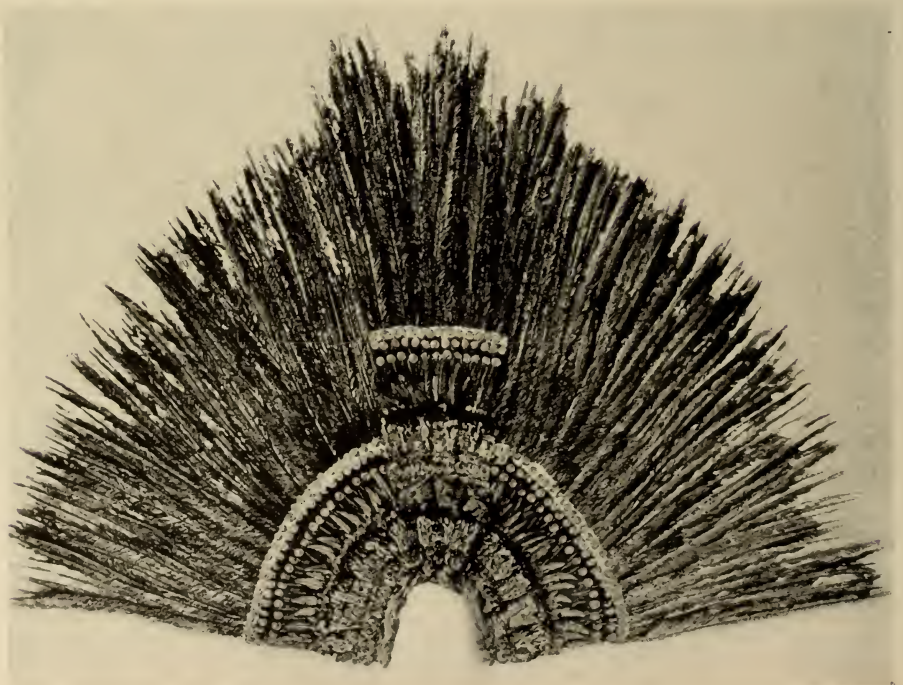



Feather- Work

The patient selection of different colored feathers and the care in joining them, as exemplified by this picture, made during the last century, is a direct expression of the Indian heritage in Mexico. It is curious to see in comparing this and the feather painting opposite with the costumes on pages 64 and 65 how little the dress of the Indian has changed with the ages. Only the trousers and the hat distinguish these people of 1850 from their ancestors of three centuries and a half before

have been used for such a purpose. The inhabitants did, however, make mirrors of iron pyrites and obsidian. Iron pyrites sometimes occur in small nodules on which a plane surface could be ground, giving a very satisfactory reflection. Another type of mirror consisted of thin plates of pyrites, laid like a mosaic on a backing of pottery or stone. Few complete specimens are known, but there do exist a number of stone discs which may well have been backs for such mirrors. It is quite probable that the celebrated mosaic disc from Chichen Itza could have had a mosaic of iron pyrites in its center. A unique mirror in the American Museum of Natural History utilizes iron pyrites in their original slate matrix, the pyrites being polished as a surface and the slate carved as an ornamental back. The obsidian mirrors of Central Mexico are among the wonders of ancient technology, since even a modern lapidary, with his diamond drills and carborundum wheels, has difficulty in grinding down this volcanic glass to the lustrous sheen of early times. Mirrors of both materials must have been very precious, and it is not surprising that they were used as much for divining purposes as to cater to the vanity of their owners.

The introduction of iron and steel tools has largely destroyed the ancient crafts of wood carving and stone work. Yet two very flourishing crafts survive that may well have

had a pre-Columbian origin. A plaster-cloisonné decoration of gourds is carried out at several points along the Central American Highland, and its prototype may be represented in pottery vessels from northwestern Mexico, which are ornamented by similar means. No example of the beautiful lacquer trays from Guerrero and Jalisco survives from the indigenous civilization, but although their pre-Columbian origin may be doubtful, their manufacture was an exclusive Indian property in Colonial times.

ART IN EVERY-DAY LIFE

Thus vestiges of the ancient civilization exist today in some of the modern crafts. Those carvings and buildings which we have grouped under the Fine Arts were really projections of the common technical skill of the people. The virtual anonymity of most religious art fuses the humble crafts with the highest aesthetic expression. The attempts to inculcate "Art in the Home," so often made in modern times, would have been unnecessary in ancient Central America. While the little-known may well present fictitious advantages, particularly in the case of civilizations viewed through the mouse-holes of archaeological research, yet one feels that the Central Americans individually participated in their civilization to a greater extent than we do in ours.

Ornaments of Pre-Columbian Central America

CENTRAL American ornaments resemble the antique jewelry of Europe in that skillful workmanship contributed more to the value of a piece than the intrinsic worth of the stone or metal. The cost of a jewel was not expressed by its size, as in the case of those modern diamond rings which reflect so clearly the bank notes tendered in payment.

The ancient Central Americans worked, as precious, such stones as jade, turquoise, obsidian, rock crystal, amethyst, opal, beryl, onyx, and carnelian, not to speak of other stones resembling these in textures and color. Around the Isthmus of Panama emeralds were used as ornament, and they have been reported also among the Aztecs. Metals employed for jewelry included gold and copper, but silver ornaments are extremely rare, owing to the metallurgical skill required for extracting the ore. If few of the stones which we moderns consider precious are represented in this list, it should be recalled that the ancient Mediterranean peoples, notably the Egyptians, Greeks, and Romans, knew equally little of our modern gem stones. Their ideas of value were certainly as developed as our own, but to them the sources for modern precious stones were almost completely closed.

The stone most generally esteemed by the Central Americans was jade. The New World varieties are distinguishable from the Asiatic jade, not only in chemical composition, but also in that elusive trait called "feel." Considerable mystery surrounds the exact origin of American jade, because no natural deposits have yet been found in Central America. The few specimens that reveal the original shape of the

raw product suggest that jade was collected in boulder form from stream beds but was not mined from the veins. It is quite possible that the more accessible places producing jade have been effectually gleaned of the precious substance by the ancient inhabitants, even as the Spaniards in the Colonial period exhausted the gold deposits which could be worked by hand. From the general distribution of jade objects according to the towns listed in the native manuscripts as paying tribute in that medium, the chief source must have been within the limits of the modern states of Oaxaca, Guerrero, Chiapas, and southern Vera Cruz. Costa Rica also produced much jade ornament, but the workmanship is not comparable to that of the north.

The value of jade to the Central Americans can be authenticated in various ways. The finest work and most skillful sculpture are lavished on objects of this stone. The tribute rolls show a constant demand for jade beads and ornaments. The Nahuatl word for jade "chalchihuitl" and its hieroglyph were used with the connotation of "precious," and in describing the adornments of gods and chieftains, the chroniclers refer to jade in the same luscious way that we describe the diamonds of the mighty in our own society. Jade was prominent in the lists of gifts made by the native rulers to the Spaniards at the time of the Conquest. Finally, we have the testimony of the Conquistador, Bernal Diaz, our most engaging first-hand source on the Ancient Mexicans. In describing how the Spaniards looted the treasure of Montezuma's father, previous to their disastrous sortie from Mexico City during the Noche Triste, he says,

" . . . Many of the soldiers of Narvaez and some of our people loaded themselves with it (gold). I declare that I had no other desire, but the desire to save my life, but I did not fail to carry off from some small boxes that were there four chalchihuites (jades) which are stones very highly prized among the Indians, and I quickly placed them in my bosom under my armor, and later on the price of them served me well in healing my wounds and getting me food." No one who has read *The True History of the Conquest of New Spain* would ever doubt Bernal Diaz's practical sense of economic values.

USES OF JADE IN CENTRAL AMERICA

The uses of jade were manifold. Axes and chisels were ground out that were not only aesthetically pleasing in their polished symmetry, but also, due to their hardness, extremely useful in carving softer stones for major sculptures. Ornaments comprised sets of beads, often matched as to color and size, ear-plugs, and pendants. Some of the ear-plugs were too large for human use, and this type of jewelry must have been made especially for the statues of the gods. Little pendants often engraved with floral designs or human figures are most pleasing, since they combine the natural luster of the stone with the balance of design inherent in Central American craftsmanship.

The process of manufacture must have been laborious, to judge from the unfinished fragments that have been found. The jade pebbles were often sawed into slabs by means of a string of rawhide used in connection with a rude abrasive like sand and water. Pecking and grinding must also have helped to reduce the irregularities of the natural stone. In the Oaxaca specimens especially, one sees evidence that a circular drill of bone or reed was used to engrave many elements of the decorative design. Some of the secondary details may have been brought out by sharp-

edged flakes of obsidian. Finally the artisan imparted a lustrous polish to the specimen.

MAIN STEPS IN WORKING STONE

Prof. M. H. Saville acquired for this Museum a series of onyx vases that illustrate very neatly the main processes in working stone. First there was the primary stage of pecking out the block into the desired external form. The next stage lay in hollowing the interior by isolating with a tubular drill thin columns of stone, which could be readily broken out. A third step consisted of smoothing off the irregularities left by pecking and boring. Then the final details were added, and a general burnish completed the vessel. There is no doubt that this general method applied to the working of all the harder stones, with the substitution of sawing for drilling when the need demanded.

Yet the true beauty of jade is expressed by a series of small sculptures that bring out in miniature all the consummate design of the major plastic art. These small idols, like the Necaxa "tiger" and the larger votive axe from Vera Cruz, illustrate that element of monumentality which the better examples of Central American sculpture possess. By the term "monumentality" I mean the capacity of a carved figure to be indefinitely enlarged or reduced so that the sculpture, due to the balance of the elements involved in the composition, is neither distorted by the one nor diminished in dignity by the other. The Necaxa tiger, although only three inches high, is as impressive as if it were thirty feet. The Ocosingo jades, representing softer influences from the Maya country, lose nothing in comparison with the monumental reliefs with which the Mayas enhanced their stelae and temple walls. In fact, from our modern point of view, we can comprehend these minor carvings more readily than the great, since a *bibelot* one can keep and handle, but mas-

Jade is among the hardest of stones, and was most precious to the ancient Central Americans. They worked it without metal tools, so that the manufacture of ornaments like these must have required months of labor. New World jade can readily be distinguished from the Old World variety



Jade and Jadeite



The three jade sculptures shown on this page are among the treasures of the American Museum of Natural History. The middle photograph represents a small figure in the Maya style from Ocosingo, Chiapas. The top and bottom figures represent the same tiger-faced divinity. The seated figure is a little more than three inches high, but the upper one is more than a foot, and is the largest carved jade from Central America. Both carvings may be the work of the semi-mythical Olmecs of Vera Cruz

sive religious sculpture seems to belong to the god in whose honor it was created.

SUBSTITUTES FOR JADE

Many greenish stones, like porphyry, serpentine, and wernerite, the native jewelers worked in a manner similar to jade. Perhaps they could not distinguish these minerals from jade, or perhaps they knew that through the substitution of softer stones they could attain the same effect achieved in the harder and rarer medium. That extraordinary group of sculptures attributable perhaps to the legendary Olmecs depicts people with tiger and baby faces, both in jade and other stones.

The work in rock crystal, due to the excessive hardness of the material, is from the technical point of view even more impressive than the jade sculpture. A few examples exist from various sites of beads and pendants. The most famous example, however, is the nearly life-size skull in the British Museum, and a miniature, illustrated for the first time in these pages, is one of the treasures of the American Museum of Natural History. The rock crystal vase, found by Doctor Caso in Tomb 4 at Monte Alban, represents even more strikingly the days of patient work that the creation of one of these masterpieces must have consumed in the absence of any of our modern mechanical aids.

Ear-plugs and labrets of obsidian (volcanic glass), ground so thin as to be almost transparent, indicate that this useful substance was treated on occasion as a gemstone, and sometimes it was used as a material for sculpture. Even iron pyrites, commonly ground to make mirrors, was at least in one instance carved, as is attested by a lovely example in the Trocadero. Amethyst, opal, carnelian, and the like have been utilized as beads, while turquoise was used above all for mosaic work. The accounts of the loot of the Conquistadores mention emeralds, but they may have been exceptionally fine jades. In fact, of all the stones treated as precious

by the Central Americans, jadeite and nephrite produce the most conspicuous examples of the lapidary's finesse. In civilizations so essentially religious in character as those in Central America, it is to be expected that the work in their most precious stone would produce a sculpture comparable in every way, except size, to the best monumental examples.

Although we have insisted that jade was more valuable than gold to the ancient Central Americans, and Bernal Diaz quotes Montezuma's ambassador as saying "that these rich stones of chalchihuite (jade) . . . were of the highest value, each one being worth more and being esteemed more highly than a great load of gold," this precious metal none the less had value among the Central Americans. Copper was also worked as ornament, but it was more commonly fashioned into tools. On the other hand, gold, save for some sporadic mentions of fishhooks, seems to have been reserved for ornament.

THE ORIGIN OF GOLD WORK TECHNIQUE

The techniques for working gold were apparently invented in northern South America. Indeed, Colombia and Ecuador have produced in sheer bulk the greatest Indian treasures exhumed in the New World. From these countries the gold worker's art spread through Panama to Costa Rica. Perhaps because the sources of the raw metal were negligible, there is no further great development of gold working, until one reaches southern and central Mexico. There we find the cleverest goldsmithing in the New World, although no addition seems to have been made to the fundamental techniques of manufacture imported from the South.

HOW GOLD ORNAMENTS WERE MADE

The Central Americans apparently knew nothing of smelting or other methods of separating the metal from the ore, for they extracted grains and nuggets of gold from river beds. This raw metal they melted



This tiny rock crystal skull represents countless hours of labor, and is one of the three finest specimens in the world. It is probably the work of an Aztec lapidary

Crystal,
Copper, and
Serpentine



Copper was occasionally used for ornament, as is attested by this large bell sculptured in repoussé. The negroid features suggest a point of origin in southeastern Mexico



The little baby-faced figure to the left resembles the jade figure on page 77. The statuette is of serpentine, and the technique of carving suggests an imitation of the effects obtainable in the harder green stone, jade

This ornament (after Saville, 1920) is an exquisite example of Mixtec jewelry in the National Museum of Mexico. It imitates a feather-mosaic shield and the background of the design is turquoise inlay



Central
American
Goldwork

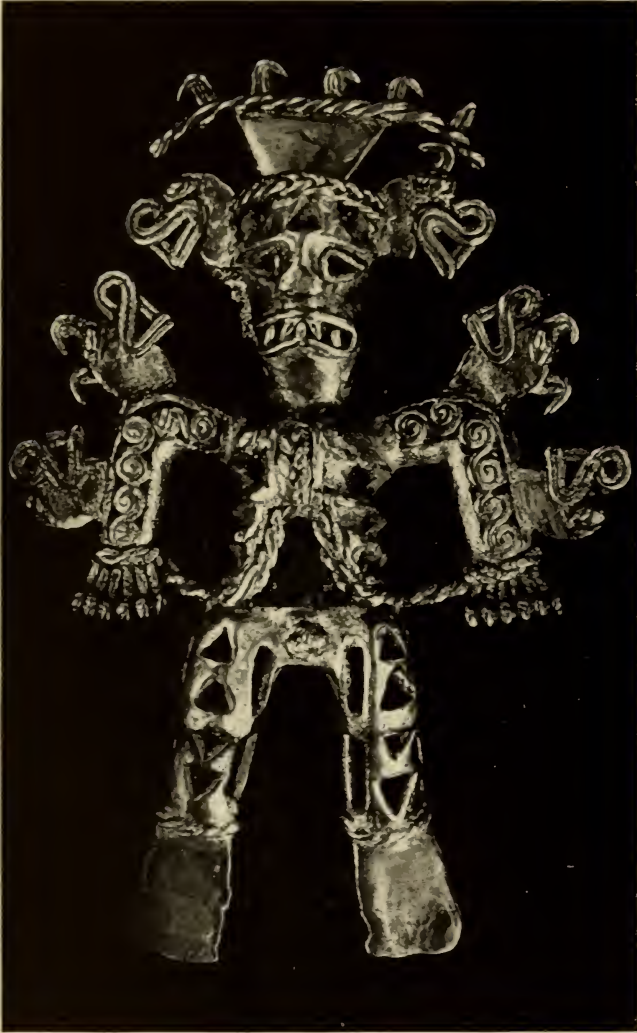

The gold ornaments in the photograph above and at the lower right illustrate the barbaric jewels of Panama and Costa Rica. However, a strong sense of design gives to the four massive brooches a highly decorative effect. The group of five little animals (right, above) is more naturalistic in treatment, although a bird-headed monkey is a beast met more commonly in mythology than in a zoo





The three little ornaments above (after Saville, 1920) came from Oaxaca, and show the extraordinary skill of the Mixtec goldworkers in their reproduction of a harpy eagle, a monkey, and a horned owl. Note especially the treatment of the owl's feathers. It is a tragedy that so much of this lovely ornament found its way to the Spanish melting pot



down and worked either by hammering or casting. This latter method is extremely ingenious, since it is like the European *cire-perdue* process. The pattern to be cast was engraved on specially treated clay over which was spread a layer of wax. The wax-covered pattern was then coated with more clay through which a wax-filled aperture was made. The mold was then baked, during which process the wax melted and ran out. The molten metal was poured into the resultant cavity, and when the gold had cooled, the mold was broken in order to extract the ornament which, save for a final polishing, was then ready for use.

The Central American goldsmiths knew how to plate copper with gold, and in Mexico they sometimes fused gold and silver into a single ornament. According to contemporary accounts, animals were made with movable legs, and fish with the scales so cunningly jointed that they wriggled. In Mexico they knew how to beat out gold leaf and apply it to objects of wood and stone, while there was considerable work in repoussé, which involves the beating out of a pattern in relief from the reverse of a gold or copper plate.

The regions producing gold ornaments are characterized by various types and styles of presentation. A rich gold art emanates from a chieftain's tomb in the province of Coelé, Panama, scientifically excavated by the archaeologists of the Peabody Museum of Harvard University. Here delightful animal figures contrast with the austerity of heavy ornaments and ceremonial discs in repoussé. Another group of gold objects comes from Costa Rica in the magnificent collection of Minor C. Keith, half of which is on view in the American Museum of Natural History. There are close parallels between this art and that of Panama, and here also one may enjoy the fresh vitality of little animals like frogs, crabs, and armadillos, as well as marvel at the bulk of formal ornament. An carrying representing an animal

seated in a swing indicates a quaint humanitarianism unwilling to allow even an ornamental beast to dangle by its neck. A whole collection of birds of various sizes could serve as models to jewelers today, so marked is the *chic* of the cleverly conventionalized forms. There is a considerable amount of copper plating and copper alloy that attest to some skill in metallurgy.

In the region occupied by the great Maya cities, there has appeared even less gold than jade, and both seem to owe their presence to trade. The Sacred Well at Chichen Itza, source of the greatest treasure hitherto found in the Maya area, yielded gold ornaments obtained from as far as Costa Rica to the southeast and southern Mexico to the southwest. It is not until the frontier between the Highland and Maya cultures is reached that we find the great development of gold working.

NOTABLE EXAMPLES OF GOLD WORK

According to Prof. M. H. Saville, whose *Goldsmith's Art in Ancient Mexico* is the authoritative work on this subject, northern Oaxaca produced more notable gold objects than any other section of Mexico, and this statement was made before the discovery of the treasure in Tomb 7 at Monte Alban. Nor can this rich harvest be entirely due to the drain put by the Spaniards on other parts of Mexico, since they were as active in Oaxaca as anywhere else. A soldier named Figueroa, according to Bernal Diaz, gave up trying to conquer the Indian tribes of Mixteca and "determined to undertake the excavation of graves in the burial places of the Caciques of these provinces, for he found in them a quantity of gold jewels . . . and he attained such dexterity that he took out from these over five thousand pesos de oro in addition to other jewels obtained from the pueblos." The enormous yield of Doctor Caso's remarkable discovery at Monte Alban gives an idea of the scope of the gold-worker's industry there. Fin-

ger rings, to wear below the knuckle and at the first joint, bore representations of eagles executed in filigree. Necklaces arranged in decorative tiers and massive gorgets depicting gods and religious symbols gave evidence of a sumptuous ceremonialism. Pearls also were scattered about the tomb and innumerable fragments of turquoise attested to disintegrated mosaics. Sophisticated as was the subject matter of the Monte Alban jewels, the outlines of some of the gorgets show the southern ancestry of the goldsmith's art in Oaxaca.

MUSEUM PIECES

The collections of the American Museum reveal a few consummate examples of gold work. A small owl's head, complete even to the overlapping feathers, corroborates the tales of the Conquistadores and shows a technical precision not unworthy to be compared with Benvenuto Cellini's artistry. A haughty little harpy eagle head combines naturalism with a strong sense of decorative values, and a large lip ornament representing an eagle head subordinates naturalistic detail to design, without distorting the essential realism of the reproduction. Even beads are carefully worked into forms which are as satisfactory individually as they are when grouped as a necklace.

The Aztec gold work, thanks to the assiduous looting of the Spaniards, has almost completely disappeared. We know that there was a guild of goldsmiths, high in social standing, who inhabited a special quarter of Azcapotzalco and claimed descent from the legendary Toltecs. Conspicuous

in the tribute sent by Cortes to his king was a golden "wheel" six and a half feet in diameter, inscribed like the famous "calendar stone" with the sun, day signs, and other symbolic elements relating to time as recorded by the Aztecs. Cortes was also the recipient of a necklace in which golden scorpions were a conspicuous element. How far the Aztec goldsmiths were influenced by Oaxacan styles the dearth of specimens from the Valley of Mexico prevents our saying, but in the lists of Spanish loot there is a general correspondence between the descriptions of the Aztec treasure and the different types of ornament recovered in Oaxaca.

The jeweler's art in Central America, as can be seen by the illustrations accompanying this article, is capably developed and appears less alien to our modern tastes than the major arts. Personal eclecticism and the joy of individual possession influence one's taste in ornament to a great degree. A contributory factor in the appreciation of an art is the possibility of incorporating examples in one's own milieu, a condition difficult to envisage with the major examples of Central American arts. However, to keep as a *biblot* a jade ornament, or to wear a gold idol as a brooch or charm is perfectly feasible, since such an action involves no violent adjustment of aesthetic or ideological conceptions. Perhaps the sheer craftsmanship of the Central American jewel worker will lead us to as close an appreciation of Central American art as any other factor in these remarkable civilizations.

The Pottery of Pre-Columbian Central America

THE potter's art in Central America reveals an extraordinary development of imaginative skill. It seems little bound by those set requirements of ritual which governed artistic expression in the arts we have considered in the five preceding chapters. Humble as are the uses of pottery, an almost infinite invention is displayed by the multiplicity of forms and decorative styles. The work in clay suggests that here the oppressive grasp of religion was relinquished, releasing the fancy thwarted in other directions. No other part of the world, China not excepted, shows such diverse forms and decorations as those displayed by pre-Columbian ceramics in the area between Chile and the Rio Grande.

In Central America, as elsewhere, the invention and practice of agriculture relieved man from his unremitting search for food, since the harvest created a store to satisfy his needs for months to come. The leisure thus gained gave him a chance to use his mind in directions other than the hunt, and led to the series of inventions and intellectual conceptions which culminated in the handful of great World Civilizations. One of the first steps taken by the early farmer was to devise means of conserving his winter food supply and of preparing it for palatable consumption. In the attainment of these ends, the development of containers of baked clay played a significant and highly important part.

Apart from its importance as an invention, pottery has a more complete historical record than any other phase of early culture in Central America. The hardness of baked clay renders it relatively immune from the destructive action of rot or fire, which have so affected textiles and wooden objects.

Even when a vessel is broken, the fragments survive among the ruins of a building or in the village refuse heap. The lack of intrinsic value secured pottery from the cupidity of invaders, greedy for treasure. The common household functions of ceramic products cleared them of the stigma of heretical barbarism, which impelled the Conquistadores to destroy so much of the native religious art in Central America. The usefulness of pottery made it a usual equipment for the dead in their life beyond the grave, so that many complete examples have been conserved in burials, to satisfy later the rapacious curiosity of excavators. Thus the study of pottery, because it is both prevalent and indestructible, has become the backbone of archaeological technique, and by means of the local and tribal decorative styles it is possible to trace the history of early peoples by the fragments of their vessels. Unfortunately, the involved descriptions of pots and pans, which in consequence fill professional reports on excavations, effectively quench whatever interest the layman might take in them.

To absorb the full beauty of Central American ceramic form and design, one must look beyond the borders of the Greek aesthetic ideal. The exquisite shapes of Greek vases resulted from the harmonious principles devised to govern the proportions of their vessels, but lovely as were the results, these formulae restricted the range of forms. Central American pottery, in contrast, seems completely without such laws, so varied are the shapes. A more detailed examination discloses, however, the operation of rigorous local customs to which the potters strictly adhered. As the pueblo, or town, was the chief unit of group organization, there arose almost innumerable local



This vase from Miahuatlan, Oaxaca, represents Macuilxochitl, the Mexican god of games and feasting. The simple lines of the vessel throw into vivid prominence the lively figure of the divinity. The design on his loincloth and his necklace of gold and jade are faithfully represented

Ceremonial Vessel from Mexico

Left: This vase from Tepic, Mexico, (after Lumholtz, 1902) represents a turkey. The wing feathers and wattles of the neck are picked out in gold leaf



Below: Guatemala was the source of this elaborately carved vase (after Saville 1919) which is a masterpiece of Maya ceramics



Below: The glazed effect of this type of Salvador pottery was so greatly admired in ancient Central America that it was traded far and wide. This delightful example shows how successfully the potter animated the vessel by the use of a few simple lines





Above: This sturdy jar from western Mexico illustrates the architectural proportions of much Central American pottery. Structure is stressed, rather than concealed, as Central American art is relatively little concerned with ephemeral grace



Above: This vase from one of the earliest Central American cultures shows how excellent decorative effects could be attained by the use of a lustrous surface and a few simple lines

Below: The pottery of Costa Rica is often lavishly ornamented, but in these examples painted designs are used to emphasize simple effigy forms. Note how the jars are supported in one case by a tripod, in the other by an annular base



styles, differing widely from one another and giving to the whole of Central America the effect of aesthetic anarchy, so far as pottery is concerned.

While the shapes of Greek vases give the effect of defeating gravity by their graceful upward curves, the Central American potters seem to stress the difficulty of keeping their vessels erect. The greatest dimension is apt to be horizontal, rather than vertical, and emphasis is placed on the support which in the smaller vessels is usually a ring base or three or (less commonly) four legs. So constant is the use of a low center of gravity that vases with the "soaring" quality of the Greek urn are almost unknown. It is possible that the technical difficulties of building up a vessel with strips of wet clay may have necessitated a more solid structure than that demanded by the more rapid Greek process of throwing up a vessel on the potter's wheel.

The shapes of Central American pottery are as eminently satisfying as the forms of natural objects. Some bowls are almost spherical and others have the form of a pear. Cylindrical vases of varying dimensions express a delicate grace if tall and narrow, or practical solidity if short and wide. By curving the walls slightly inward or outward, beautiful variations are obtained. Again, a bowl may be grooved to give the effect of a gourd, or else ridged spirally to bring up the high lights on its surface. Many vessels are made in two sections, a wall and base, and, by increasing the size of one or the other, not only are various delightful proportions attained, but also fields are created for a rich variety of decorative effects. In western Mexico occur especially attractive forms, which involve a curved base, with an almost horizontal shoulder, out of which protrudes a flaring neck.

The simplest form of decoration is to polish the exterior of the vessel. The methods of firing the pots seldom produce an absolutely even color, so that the glossy surfaces suggest the tones of polished fruits or the glossy coats of animals. Black, for

example, is seldom jet black, but more the shade of well-used walnut furniture. Reds range from the brown tones of a russet apple to the solid shades of red peppers, dried and polished. Browns merge into black at one extreme and dwindle through imperceptible gradations to a matt yellow. Warm orange tones characterize the clays of several ceramic families, while others show steely gray shades. Such lustrous tones enhance the pure forms in a way that painting never can.

There are numerous cases of effigy vessels, where in the simplest stages, a head, limbs, and tail, added to the pot, give it a pleasingly alive appearance. Sometimes the head alone is added and the anatomical details are incised. In extreme cases the animation of a pot is carried so far that it becomes a sculpture in clay, like the figures of western Mexico mentioned in a previous chapter. The most consistent use of effigy pottery is in the Plumbate Ware of Salvador, which has a vitreous surface and is the nearest approach to true glaze in Central America.

Since the tripod support was so important in keeping a vessel on an even keel, the Central American potter gave vent to his imagination in constructing this useful adjunct. One way was to make the legs hollow and insert pellets of clay, so that they became rattles. Often the supports were modeled into imitations of animal or human legs, and sometimes, in Costa Rica, Atlantean figures supported the bowl. The modeling of bird and animal heads was also thought a suitable means of transforming a functional necessity into an ornament. When a ring base was used, it was often painted or carved, and sometimes by closing the bottom, it was converted into a rattle.

Two other methods of decoration were in general use. One was to produce a decorative effect on the surface of the pot by incision or applying bits of clay. The second was to add a painted design. Which of the two was the earlier there is no means of knowing, since no really primitive culture has yet been discovered in Central America. If the cultures of the Southwestern United States, which

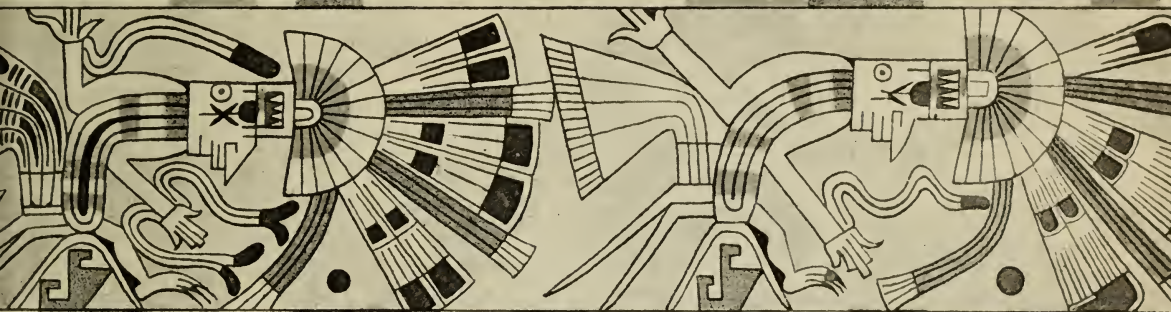

Mexican Design

The sources for Mexican pottery designs are many and varied. In the upper right hand picture the purely conventional *grecque* is used, whereas the vase at the lower right is ornamented by the hieroglyph for one of the days of their month, which is a conventional representation of the reed. The jar at the upper left is ornamented in plaster cloisonné, and the central band (after Lumholtz, 1902) reproduces the design from a similar vessel. Such stylized human figures are rare in Mexican ornament





Above: This cover from a Zapotec incense burner shows the transformation of a vessel into a ceremonial sculpture



Left: The incensario at the left is much restored and comes from the Teotihuacan culture of the Valley of Mexico. It shows the building-up process utilized in this class of religious vessel

Below: This clay mask from Vera Cruz is a simple and straightforward piece of sculpture, yet it may have been used in connection with some elaborate creation like that on the left





Above: This life-sized figure from the Valley of Mexico is a remarkable technical achievement, requiring great skill in building up the sections so that they would not collapse of their own weight



The head at the upper right was one of a pair of effigy vases found with a burial of the Mazapan culture at Teotihuacan. Although treated sculpturally it is none the less a container. The large figure at its left, and the seated figure from Nayarit are pure sculptures. The photographs on these pages show in striking fashion the contrast between convention and naturalism in Central American art

showed the transition between hunters and agriculturists, produced painted designs as the earliest ceramic decoration, the Argentine and the Eastern United States were the home of primitive tribes who incised and stamped their rude vessels. Therefore, in describing Central American ceramic decoration, we cannot follow an evolutionary plan.

Incising and carving the surface of a bowl were especially common. The cruder examples, from the earliest cultures yet found, show simple geometric patterns made sometimes after sun drying and occasionally after the pot was baked. A striking development of this process was the Teotihuacan method of *champlevé*, in which, after a vessel had been fired and burnished, the polished surface was cut away to leave a figure in relief. Sometimes the effect was enhanced by rubbing red pigment into this roughened background. Some of the finest reliefs in the Maya country may be found on carved vases of this type from Yucatan, where great skill in sculpture and drawing raised the *champlevé* work from the secondary field of decoration to the primary one of Fine Art.

A type of decoration which is found in western Mexico and perhaps derived from this work in *champlevé* approaches the technique of *cloisonné*. In the Mexican examples a completed pot was covered with plaster and the desired design outlined by scraping the soft exterior down to the original surface of the pot. Into these scraped zones, plaster strips of different colors were laid, creating a harmonious, if fragile, decoration. Another method of ornament involved a covering of plaster, which was then painted in fresco. These plaster decorations could not have survived daily use and must have required special treatment for mortuary or ceremonial use. In fact, in several examples, a painted design has been concealed by a covering of fresco or plaster *cloisonné*.

Another decorative style consisted of pressing a stamped design on to the wet surface of a bowl. This process, when repeated, gave a symmetrical series of orna-

ments in relief or *intaglio*. Even commoner was the attachment of decorative elements made in moulds, which might represent floral patterns, human and animal heads, or else purely conventional designs. Clay vessels were sometimes touched up with gold leaf, like the celebrated Tepic effigy vase, and clay beads treated in the same way were thrifty imitations of the real thing.

Painted decoration involved a prevalent use of geometric design. As we have suggested in the section on Crafts, there is very strong evidence that the textile art with its complementary ornamental patterns was developed long before pottery. Since, in the Southwestern United States the designs painted on pottery are in direct imitation of the earlier basketry patterns, there is considerable likelihood that this practice was quite general in the New World. There was no orderly evolution of design from naturalism into conventionalization. The use of naturalistic elements appeared late, strictly governed by the requirements of harmonious design.

The arrangement of the design in most localities was in panels. Frequently these design units, when on the outside of the bowl, were arranged in threes, so that a complete pattern could be seen. This principle is based on a "rule of thumb" geometry, since a little less than a third of a cylindrical body can be viewed from the side. Continuous patterns, except for borders, are much less common. Besides the steps, grecques and volutes of geometric design, there were also conventionalizations of natural forms. Flowers, animals, hieroglyphs, religious symbols, were cunningly treated to make decorative effects. In the Maya pottery of Copan and Salvador the monkey was often used, since its elongated arms and tail were readily adaptable to the needs of design.

The colors include shades of white, red, yellow, orange, black, with occasional uses of blue and green. The disposition of the colors usually involves one for the background, another to outline the design, and a third to fill the patterns. Sometimes when

Elaborate painted designs come from the Maya country. The two circular patterns (after Merwin and Vaillant, 1932) adorned a plate and a bowl cover from Holmul, in the Peten district of Guatemala. They are in polychrome



The realism of the two Maya vase paintings is skilfully adjusted to decorative needs. Extraordinary as is the fancy shown in their creations, the two designs from Cholula bowls are equally original in conception. The pattern shown in the central rectangle was inspired by a feather headdress placed against an ocelot skin, and the decoration below utilizes a feather fan



Maya Pottery Designs



Left: The Maya used their script in decorative fashion. This vase from Guatemala, like the Holmul plate on the preceding page, utilizes bands of glyphs to divide off design fields



Below: The conventionalized pelican on this vase is carried out in red tones on a white background. This and the upper vase are after Gordon, 1925-28

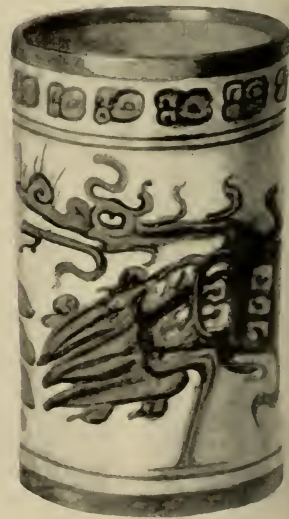

Left: This vase from Salvador is ornamented by designs in black and orange on a yellow field, while the Maya bowls on the preceding page show similar uses of warm red and orange tones with black outlines

realistic elements like a headdress or a butterfly are portrayed, they are used naturalistically. The fullest use of naturalism in color and design is in the celebrated "picture" vases from the Maya country which we have considered under Painting.

Besides pottery vessels, the work in baked clay extends to many other types of objects. The figurine cult, which contributes so much to the plastic art of Central America, absorbed much of the potter's inventiveness. Spindle whorls, the weights used for the wooden shafts in spinning cotton, become, in the hands of Central Mexican clay workers, beautiful little creations, with their lustrous red or black slips and delicately worked reliefs. The stamps for adorning cloth or the skin are often of clay, and represent in their cutting skilful judgment of balanced design. Musical instruments like whistles, flutes and ocarinas require of the potter a knowledge of the physical properties of tone, while the cylindrical drums of Central America are often beautifully ornamented by carving or painting. A curious musical instrument, very rarely found, is the whistling jar which gives out a note by the air expelled when the liquid is poured out. The massive incensarios, used to burn incense before the temples, are as imposing from a structural point of view as from one of ceremonial art. Pipes, used presumably for ceremonial smoking, since cigarettes and cigars were the usual method for consuming tobacco, are frequently exquisitely polished and very well proportioned. Censers or incense ladles often received treatment comparable to the best of the ceremonial art.

The relationship of these Central American clay forms to the art of the present day brings one face to face with the besetting difficulty of modern European art. We are

in an age of revolution, intellectual and artistic as well as political and technical. There is a tendency to abandon individualism for group action, and, in the fields of architecture and the decorative arts, function and the relationship between the material and the form tend to suppress the individualism of the craftsman's personal expression. The copying of alien art forms is arid when it is not jarring, so that it would be stupid to utilize in our art today the *content* of Central American aesthetic expression. On the other hand, the impersonality of Central American art, which expresses a mass life under divine direction, dovetails well with our modern disciplines under mass production and mass movement.

Our recent World Fairs, intended for the absorption of millions of people, produces the anonymous effect of the work of thousands of artisans and engineers, but not the genius of an individual. Much this same spirit permeates the art of Central America. The principles of design and form are no less inherent in our discipline by graph, blue print, and mathematical formula than in the ancient Central American rule by ritual.

This and the preceding chapters have been intended to show the various aspects of Central American art without insistence on the complicated historical background. The relationship of the individual Central American to his art we can probably never know precisely, although we can be certain it was not aesthetic in our modern sense of the word. On the other hand, we moderns can extract a great deal of pleasure, even inspiration, from the contemplation of the works of these gifted people, if we lay aside the tenets and traditions of our past art history to examine Central American art from the viewpoint of our modern industrial age.

BIBLIOGRAPHY

The following list of books on Central American archaeology comprises volumes in English of general interest to the layman which are likely to be accessible in public libraries or else purchasable at moderate cost. Many of these volumes contain extensive bibliographies, so that the more deeply interested reader may find his way to the more technical publications in English and foreign languages. By far the best introduction to Central American archaeology is Doctor H. J. Spinden's *Ancient Civilizations of Mexico and Central America*, published in the Handbook Series of this Museum. Many articles of popular interest on Central America are to be found in *Natural History*.

- BANCROFT, H. H.
1883. The Native Races. 5 vols. San Francisco, 1883.
- BLOM, F. AND LA FARGE, O.
1926. Tribes and Temples. A Record of the Expedition to Middle America Conducted by the Tulane University of Louisiana in 1925 (The Tulane University of Louisiana, 2 vols., New Orleans, 1926).
- CAHILL, HOLGER
1933. American Sources of Modern Art (The Museum of Modern Art, May 11 to June 30, 1933. Catalogue of Exhibition, New York, 1933).
- CILARNAY, DÉSIÉ
1888. The Ancient Cities of the New World, being Voyages and Explorations in Mexico and Central America from 1857-1882. New York, 1888.
- CORTES, HERNANDO
1908. Letters of Cortes (Translated and edited by F. A. MacNutt), 2 vols. New York, 1908.
- DAVIS, EMILY C.
1931. Ancient Americans. The Archaeological Story of Two Continents. New York, 1931.
- DIAZ DEL CASTILLO, B.
1908-1916. The True History of the Conquest of New Spain, 5 vols. Edited and published in Mexico by Genaro Garcia. Translated by A. P. Maudslay (Hakluyt Society, Series II, vols. 23-25, 30, 40, London, 1908-1916).
- GANN, T. W. AND THOMPSON, J. E.
1931. History of the Maya; from the Earliest Times to the Present Day. New York, 1931.
- HOLMES, W. H.
1895 and 1897. Archaeological Studies Among the Ancient Cities of Mexico (Field Columbian Museum, Anthropological Series No. 8, vol. 1, parts 1 and 2, Chicago, 1895 and 1897).
- JOYCE, T. A.
1920. Mexican Archaeology. An introduction to the Archaeology of the Mexican and Mayan Civilizations of Pre-Spanish America. London, 1920.

- JOYCE, T. A.
1927. Maya and Mexican Art. London, 1927.
- LINNÉ, S.
1934. Archaeological Researches at Teotihuacan, Mexico (The Ethnographical Museum of Sweden, new series. Publication No. 1, Stockholm, 1934).
- LOTHROP, S. K.
1926. Pottery of Costa Rica and Nicaragua (Contributions, Museum of the American Indian, Heye Foundation, vol. 8, 2 vols., New York, 1926).
- LUMHOLTZ, C.
1902. Unknown Mexico. 2 vols. New York, 1902.
- MORLEY, S. G.
1915. An Introduction to the Study of Maya Hieroglyphs (Bulletin 57, Bureau of American Ethnology, Washington, 1915).
1920. The Inscriptions at Copan (Carnegie Institution of Washington, Publication 219, Washington, 1920).
- MORRIS, ANN AXTELL
1931. Digging in Yucatan. New York, 1931.
- PRESCOTT, W. H.
1922. The Conquest of Mexico. Edited by T. A. Joyce and illustrated by Keith Henderson. 2 vols. New York, 1922.
- RADIN, P.
1920. The Sources and Authenticity of the History of the Ancient Mexicans (University of California Publications in American Archaeology and Ethnology, vol. 17, no. 1, pp. 1-150, Berkeley, 1920).
- REDFIELD, R.
1930. Tepoztlan: a Mexican Village. A Study of Folk Life (The University of Chicago Publications in Anthropology, Ethnological Series, Chicago, 1930).
- SPENCE, L.
1923. The Gods of Mexico. London, 1923.
- SPINDEN, H. J.
1913. A Study of Maya Art, its Subject Matter and Historical Development (Memoirs, Peabody Museum of American Archaeology and Ethnology, Harvard University, vol. 6, Cambridge, 1913).
1928. Ancient Civilizations of Mexico and Central America (Handbook Series, no. 3, American Museum of Natural History. Third and revised edition. New York, 1928).
- STEPHENS, J. L.
1841. Incidents of Travel in Central America, Chiapas, and Yucatan. 2 vols. New York, 1841.
1843. Incidents of Travel in Yucatan. 2 vols. New York, 1843.
- TRIPLE, J. E.
1930. Maya Astronomy (Contributions to American Archaeology, No. 2, Carnegie Institution of Washington, Publication 403, pp. 29-115, Washington, 1930).

- THOMPSON, J. ERIC
1933. Mexico Before Cortez. An Account of the Daily Life, Religion,
and Ritual of the Aztecs and Kindred Peoples. New York,
1933.
- TOTTEN, GEORGE OAKLEY
1926. Maya Architecture. Washington, 1926.
- VAILLANT, GEORGE C.
1939. Indian Arts in North America. New York, 1939.
- WILLARD, T. A.
1926. The City of the Sacred Well. Being a Narrative of the Dis-
coveries and Excavations of Edward Herbert Thompson
in the Ancient City of Chi-Chen Itza with some Discourse
on the Culture and Development of the Mayan Civiliza-
tion as Revealed by Their Art and Architecture. New
York, 1926.
- WISSELER, CLARK
1938. The American Indian. An introduction to the Anthropology
of the New World. Third Edition. New York, 1938.

SOURCES OF ILLUSTRATIONS REPRODUCED IN THE TEXT

- CASO, A.
1927. Las Ruinas de Tizatlan, Tlaxcala (*Revista Mexicana de Estudios Historicos*, vol. 1, pp. 139-172, Mexico, 1927).
- CATHERWOOD, F.
1844. Views of Ancient Monuments in Central America, Chiapas and Yucatan. London, 1844.
- CHARNAY, DÉSIRÉ
1862-1863. Cités et Ruines Américaines. Mitla, Palenqué, Izamal, Chichen-Itza, Uxmal. Recueillies et Photographiées par Désiré Charnay. Avec un Texte par (Eugène Emmanuel) Viollet-Le-Duc, Ferdinand Denis. Suivi du Voyage et des Documents de l'Auteur. Paris, 1862-1863.
- CODICES
- Codex Borbonicus
1899. Manuscrit Mexicain de la Bibliothèque du Palais-Bourbon, publié en fac-simile, avec un commentaire explicatif par E. T. Hamy. Paris, 1899.
- Codex Boturini
Reproduced in Radin, P., Sources and Authenticity of the History of Ancient Mexico (University of California Publications in American Archaeology and Ethnology, vol. 17, no. 1, pp. 1-150, Berkeley, 1920).
- Codex Nuttall or Codex Zouche
1902. Facsimile of an Ancient Mexican Codex belonging to Lord Zouche of Harynworth, with an introduction by Zelia Nuttall (Peabody Museum of Archaeology and Ethnology, Harvard University, Cambridge, 1902).
- Codex Telleriano-Remensis
1899. Codex Telleriano Remensis, Manuscrit Mexicain. Reproduit en photochromographie aux frais du Duc de Loubat et précédé d'une Introduction contenant la Transcription complète des Anciens Commentaires Hispano-Mexicans. . . . par E. T. Hamy. Paris, 1899.
- Codex Vindobonensis (Vienna Codex) Codex Vindobonensis Mexic. 1. Facsimileausgabe der Mexikanischen Bilder-Handschrift der Nationalbibliothek in Wien (Lehmann, Walter und Smital, Ottokar). Wien, 1929.
- Lienzo de Tlaxcala
Reproduced in Antiquedades Mexicanas publicadas por la Junta Colombina de Mexico en el cuarto centenario de descubrimiento de América. Mexico, 1892.
- Tribute Roll of Montezuma
Reproduced in Peñafiel, A. Monumentos del Arte Mexicano Antiguo. 3 vols. Berlin, 1890.

- DIESELDORFF, E. P.
1904. A Pottery Vase with Figure Painting, from a Grave in Chama (Bulletin 28, Bureau of American Ethnology, pp. 635-644, Washington, 1904).
- DUPAIX, G.
1834. Antiquités Mexicaines. Relation des Trois Expéditions du Capitaine Dupaix ordonnées en 1805, 1806, et 1807, pour la Recherche des Antiquités du Pays, notamment celles de Mitla et de Palenque. 2 vols. and atlas. Paris, 1834.
- GAMIO, M.
1922. La Poblacion del Valle de Teotihuacan (Secretaria de Agricultura y Fomento, Direccion de Antropologia, tomo 1, vols. 1 and 2, tomo 2, Mexico, 1922).
- GORDON, G. B. (editor)
1925-1928 Examples of Maya Pottery in the Museum and other Collections (The University Museum, University of Pennsylvania, Philadelphia, 1925-1928).
- HEGER, FRANZ
1908. Der Altamerikanische Federschmuck in den Sammlungen der anthropologisch-ethnographischen Abteilung des k. k. naturhistorischen Hofmuseums in Wien (Festschrift herausgegeben anlässlich d. Tagung d. XVI Internationalen Amerikanisten-Kongresses in Wien. September 1908. vom Organisations-komitee. Wien, 1908).
- HOLMES, W. H.
1895 and 1897. Archaeological Studies among the Ancient Cities of Mexico (Field Columbian Museum, Publication No. 8, Anthropological Series, vol. 1, no. 1, parts 1 and 2, Chicago, 1895 and 1897).
1914-1915. Masterpieces of Aboriginal American Art (Art and Archaeology, vol. 1, pp. 1-12, 91-102, 243-255, Washington, 1914-1915).
- HUMBOLDT, A.
1810. Vues des Cordillères et Monuments des Peuples Indigènes de l'Amérique. Paris, 1810.
- JOYCE, T. A.
1927. Maya and Mexican Art. London, 1927.
- LEHMANN, W.
1933. Aus den Pyramidenstädten in Alt-Mexiko. Berlin, 1933.
- LOTHROP, S. K.
1924. Tulum. An Archaeological Study of the East Coast of Yucatan (Carnegie Institution of Washington, Publication 335, Washington, 1924).
- LUMHOLTZ, C.
1902. Unknown Mexico. 2 vols. New York, 1902.

- MALER, T.
 1908. Explorations in the Department of Peten, Guatemala, and Adjacent Region (Memoirs, Peabody Museum of American Archaeology and Ethnology, vol. 4, no. 1, Cambridge, 1908).
 1911. Explorations in the Department of Peten, Guatemala. Tikal (Memoirs, Peabody Museum of American Archaeology and Ethnology, Harvard University, vol. 5, no. 1, Cambridge, 1911).
- MASON, J. A. (editor)
 1928. Examples of Maya Pottery in the Museum and other Collections (The University Museum, University of Pennsylvania, Philadelphia, 1928).
- MAUDSLAY, A. P.
 1889-1902. *Biologia Centrali-Americana*, or Contributions to the Knowledge of the Flora and Fauna of Mexico and Central America. Archaeology, 4 vols. of text and plates. London, 1889-1902.
- MERWIN, B. E. AND VAILLANT, G. C.
 1932. The Ruins of Holmul, Guatemala (Memoirs, Peabody Museum of Harvard University, vol. 3, no. 2, Cambridge, 1932).
- MORRIS, E. H., WITH CHARLOT, J., AND MORRIS, A. A.
 1931. The Temple of the Warriors at Chichen Itza, Yucatan (Carnegie Institution of Washington, Publication 406, 2 vols. Washington, 1931).
- PRESCOTT, W. H.
 1922. The Conquest of Mexico. Edited by T. A. Joyce and illustrated by Keith Henderson. 2 vols. New York, 1922.
- SAVILLE, M. H.
 1919. A Sculptured Vase from Guatemala (Leaflets, no. 1, Museum of the American Indian, Heye Foundation, New York, 1919).
 1920. The Goldsmith's Art in Ancient Mexico (Indian Notes and Monographs, Museum of the American Indian, Heye Foundation, New York, 1920).
 1922. Turquoise Mosaic Art in Ancient Mexico (Contributions, Museum of the American Indian, Heye Foundation, vol. 6, New York, 1922).
 1925. The Wood-Carver's Art in Ancient Mexico (Contributions, Museum of the American Indian, Heye Foundation, vol. 9, New York, 1925).
- SMITH, A. LEDYARD
 1932. Two Recent Ceramic Finds at Uaxactun (Contributions to American Archaeology, no. 5, Carnegie Institution of Washington, Publication 436, pp. 1-25, Washington, 1932).
- TOTTEN, GEORGE OAKLEY
 1926. Maya Architecture. Washington, 1926.





Issued under the direction of the Committee on
Popular Publications.

ROY W. MINER, *Chairman*

A TRANSPLANTED CORAL REEF

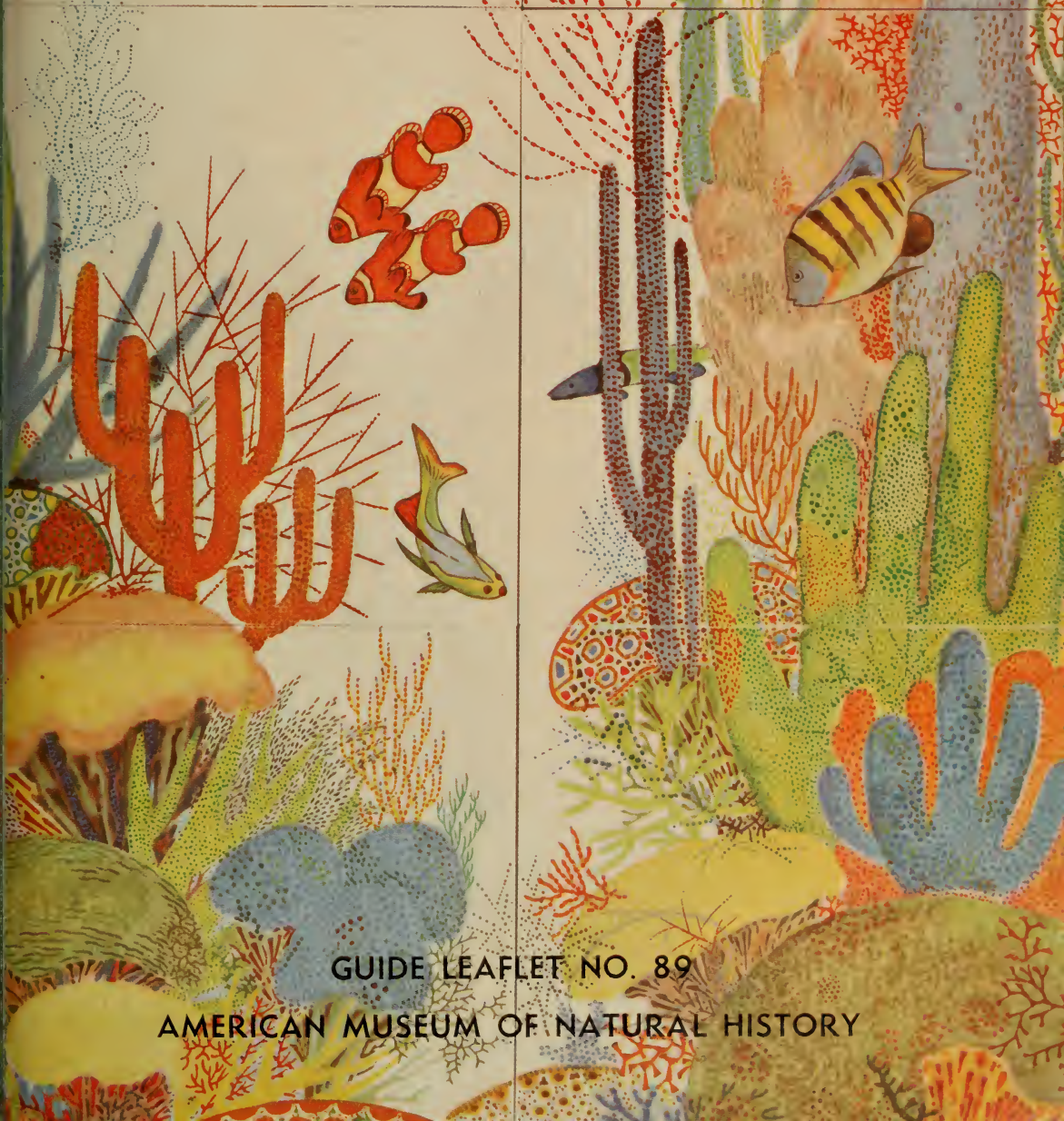

By
ROY WALDO MINER



GUIDE LEAFLET NO. 89

AMERICAN MUSEUM OF NATURAL HISTORY



THE COVER



*A SUBMARINE
DESIGN*

on Tile

by

W. H. SOUTHWICK



A Submarine
Coral Forest on the
Andros Reef

*Photograph taken twenty-five feet
below the surface. The studies for
the Coral Reef Group were made not
far from this spot*

A Transplanted Coral Reef

A description of the Bahaman Coral Reef Group in the Hall of Ocean Life at the American Museum

BY ROY WALDO MINER

Curator, Living Invertebrates, American Museum

After twelve years of complicated and difficult work, the department of living invertebrates at the American Museum has opened to the public what is, perhaps, the most remarkable museum "group" ever constructed. Created from forty tons of coral that was gathered from the sea bottom in the Bahamas, this elaborate exhibit is tied together and supported by an intricate fabric of structural steel which, in itself, weighs eight tons. In the course of the work, Doctor Miner, the author of the following article and the originator and designer of the exhibit, has led five expeditions to the Bahamas during which the studies and the collections utilized in building the group have been made. His account and description, therefore, are of special interest and value. — THE EDITORS

AS you enter the Hall of Ocean Life on the gallery level at the American Museum, the new Bahaman Coral Reef Group may be seen at the farther end directly opposite the observer. Its proscenium arch rises from the main floor of the hall, passes through the gallery, and surrounds the upper part of the group in a half-circle at a height of thirty-five feet.

The portion of the group above the gallery presents a vista of coral island with waving palm trees, quiet lagoon, and tropical sky with trade-wind clouds drifting across it. A flight of flamingos dots the background of snowy clouds with flecks of rosy color. On the distant horizon, apparently a mile or so away, the low-lying shore of Andros is visible, soft with its long fringe of coconut palms. For the scene is laid in the Bahamas, along the eastern coast of its largest island mass, where the finest coral barrier reef in the West Indies parallels the shore. The small island in the foreground is Goat Cay, just back of the main reef, the location of which, at the left, may be seen more clearly, at closer view.

The section of the group below the gallery, even at this distance, obviously depicts the coral forest as seen from the bottom of the sea. On either side, staircases permit visitors to descend from the gallery, and, as it were, plunge beneath the waves to stand on the ocean floor and study the coral reef from that point of vantage, as the members of the Museum's expeditions did in obtaining the material and observations for this group.

Now let us pass around the gallery and view the upper scene at close range. We are looking over the rail of a yacht which has been anchored fore and aft in a channel of the reef. The wind-swept vegetation of Goat Cay and its shore of eroded limestone are now clearly visible. At the left, the dark blue waters of the Tongue of the Ocean, an arm of the sea more than a mile in depth, roll in, breaking heavily upon the barrier reef in long lines of white foam. The coral barrier rising from the crest of a submerged precipice, the summit of which is from twenty to forty feet below the water surface, consists largely of huge branching

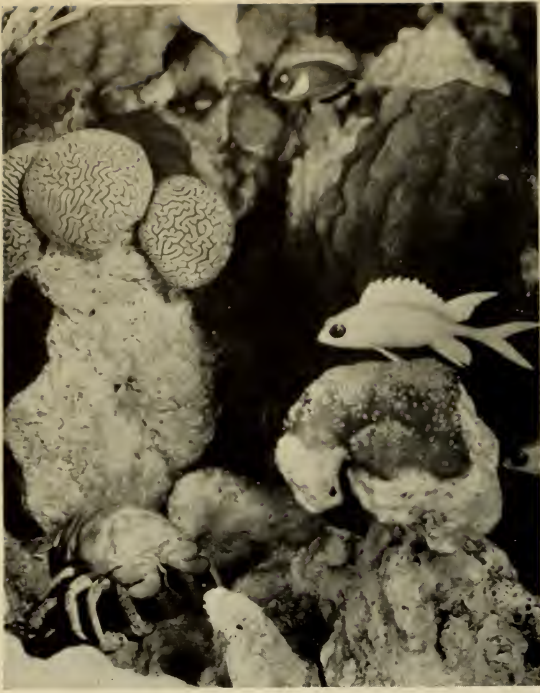

A squirrel-fish swims over a post of orb coral toward a triple-headed brain coral, below which crawls a bear-crab



(Above) The Cave of the Blue Parrot-fish guarded by its white-jawed denizens

(Below) Two members of a school of black angel fish, with spadelike bodies, their dorsal fins with trailing filaments



*A spiny lobster
peers forth from
its den among the
corals, waving its
prickly antennæ*



*A vista through branching
elkhorn corals. Black angel
fish swim by in stately
procession. In the fore-
ground is a group of three
mushroom-like orb corals*



trees of the elkhorn coral, the tips of which break the water surface at low tide. The trade winds, blowing continuously from the southeast, dash the waters of the Tongue of the Ocean against the face of the submarine precipice and the tangled growth of the stony coral trees, causing upwelling currents which mingle with the ranks of snow-crested surf.

THE UPPER SCENE

Inside the reef the force of the waves is broken, and they slide with diminishing force in intersecting cross currents across the quiet waters of the sheltered lagoon, where vessels may lie safely at anchor, except in times of hurricane.

In the distance the shore of Andros shows native villages snuggling among the coconuts, while, at the right, the open waters of a wide strait, Middle Bight, lead the eye into the quiet peace of a broad inland sea, dotted with islands.

The towering trade-wind clouds rise on the heated air currents of a June day 25,000 feet into the air, where their fleecy summits stand out against the deep blue of the tropic sky. Outlined against them, the long file of scarlet flamingos flies in stately procession inland to follow the coast to the great flamingo colony in southern Andros.

Our boat is anchored close to a little rocky cay, a point of which projects in the right foreground, carved and honeycombed in fantastic hollows.

Looking over the rail, our eyes penetrate the transparent waters right down to the bottom of the sea, and, through their lucid depths the wondrous submarine gardens are disclosed with all their beauty of form and color, tempting us to a closer view.

So, descending the staircase, we pass beneath the gallery level, and well may we imagine that we have donned diving helmets and have penetrated the depths, for all the glory of the coral world bursts upon the view. We are gazing into the heart of a magnificent coral forest. The branching trees of the elkhorn coral (*Acropora palmata*) rise, tier on tier, above our heads, breaking the water-surface sixteen feet above. An arching sea cave at the right, piercing a fantastically carved and eroded

submarine ledge, leads into a tortuous tunnel filled with mysterious purple shadows and soft lights filtering through an opening in the rear. This is the Cave of the Blue Parrot-fishes, and two of the heavy-bodied cerulean tenants may be seen nosing their way out of the cavern entrance, while a third swims slowly back and forth as if guarding the back door.

Between the rocky wall and the spreading tangle of the coral forest a vista opens out into the watery world, melting by degrees into the opalescent and luminous blue mist which everywhere terminates our vision in the distance. The light of the sun filters through the aqueous depths, lighting up vague forms of grotesque outline. The waters in the Bahamas are of unbelievable transparency. Crystal clear in the foreground, everything stands out as sharply as in the open air. Under favorable circumstances, at depths ranging from fifteen to twenty-five feet, one can see a hundred feet or more before visual penetration is limited by the gathering density of the sun-lit azure fog.

The sea floor, around one's feet, blooms with every variety of stony splendor in crowded array. Not an inch is wasted. As far as the eye can see through the watery aisles the abundant coral growths stand in shouldering clusters. Here is a group of three green, dome-shaped caps rising close together on stony pedestals for all the world like giant mushrooms. They are the annular orb corals (*Orbicella annularis*), their green summits suffused with delicate clouds of rose, where areas of the tiny flower-like polyps show their expanded tentacles. Near by, a double-ridged brain coral (*Diploria cerebriformis*), bright orange in color, projects its rounded knoblike head, mounted on a contorted column, its surface covered with complicated meandering sculpture, suggesting the convolutions of the human brain. A little farther to the left another growth of the same species has developed an odd triple cluster of heads upon the same stem. A beautiful elkhorn immediately behind it spreads an unusually symmetrical frond of broad palmate branches like a giant fan. Crowding upon this from the rear, phalanxes of orb coral



Nassau

Grouper

This great, striped and mottled fish is often so camouflaged among its surroundings as to be practically invisible. Should it swim over a patch of white sand, its colors fade to harmonize. Opposite the grouper a giant sea anemone spreads its waving tentacles. At the lower right is a fragile bush coral

posts stand, grouped like sentinels, among golden yellow nuggets of pore corals (*Porites astreoides*) which cover every available space on the sea floor between their stately neighbors.

In the center foreground, spreading clusters of the fragile, finely divided bush coral (*Acropora prolifera*) overarch the hiding place of the spiny lobster or crawfish (*Panulirus argus*), while on a little sandy patch at the lower left a bear-crab (*Scyllarides aquinoctialis*) is warily inspecting a large spiny sea urchin (*Centrochinus antillarum*) which radiates its black, needle-like spines in all directions, reminding one of a submarine porcupine. Clusters of yellow-tipped finger corals (*Porites clavaria*) are crowded at the base of a great dome of sidereal coral (*Siderastrea siderea*), most massive of all species. This particular specimen weighs a ton and a half, and, when collected, required the combined efforts of twelve men to roll it up the beach.

THE LAIR OF THE MORAY

Behind the finger corals arches a low cavern, the home of the dreaded green moray (*Gymnothorax funebris*), which inhabits crevices of this sort. It is a heavy-bodied eel with small head furnished with sharp, needle-like teeth. It is well for a diver not to thrust hand or foot into such a crevice without first investigating with a lance, for the creature will dart out its head, biting viciously at any intruder. The eroded coral forming the arch and sides of this cavern is overgrown with purple, green, and yellow sponges, some forming clusters of chimneys, others made up of low, rounded mounds crowded closely together.

Everywhere among the stony coral structures rise dense growths of gorgonians. These are the plantlike sea-bushes, sea whips, sea feathers, and sea fans. When one observes them through a glass-bottomed boat, one can see them wave back and forth with the ocean currents, and they are often mistaken for vegetation by the casual observer. Nevertheless, they are animal structures with a core built of horny material, instead of having a limy "skeleton," as with the reef-building corals. There are some gorgonians, known as

"sea clubs," with fully expanded polyps, shown in the group near the moray's den. The clubs are purple, but, when the light-green polyps are fully expanded, that color is concealed and the clusters appear to be masses of heavy, feathery plumes. When one touches them, however, the green polyps are suddenly withdrawn within the clubs, and the color seems to change into purple as if by magic.

The sea feathers (*Gorgonia acerosa*) are large, heavy, magenta-purple plumes reminding one of ostrich feathers. Many of them can be seen in the group. When fully expanded, the fine branchlets are covered with rows of tiny corn-yellow polyps suggesting the florets of goldenrod.

The sea fans (*Gorgonia flabellum*) are strikingly conspicuous on the reef. As their name implies, they are broad fanlike expansions, characterized by a lacy texture of fine meshes. Purple and yellow sea fans are seen growing side by side and are of the same species.

The fish-life of the coral reef is very abundant and characteristic. When, equipped with diving helmets, we wandered, half walking, half gliding, through the coral forests of Andros, or the sea gardens of Rose Island, we seemed to be in another planet, where trees were of tinted marble and grew with interlacing branches gnarled in weird contortions from a forest floor beset with enormous mushrooms, also of stone; where animal flowers expanded and contracted on every hand, and dim figures moved silently in dark, mysterious caverns. We ourselves glided almost as in a dream, for, though we wore helmets weighing sixty-five pounds in the world above, down here among the corals we seemed to have lost all weight, and, borne up by the aqueous medium, became part and parcel of our ethereal environment.

Then, suddenly, almost out from nothingness, our watery atmosphere became shot with living jewels, brilliant colors scintillated in the sunlight that came dancing down from the motile liquid silver film of the water surface above. Fishes of every hue were all about us. Chromids shone with sapphire, blueheads, — the males, true to their name, hooded with rich azure, col-

Transplanters of the Coral Reef. Doctor Miner conversing with Chris Olsen, chief modeler of the group. At left, Herman Mueller, glass modeler, Dr. George Childs, scientific artist; at right, Worthington Southwick, colorist, Bruce Brunner, assistant modeler



General view of the Coral Reef Group seen beneath the pontoons of the Lindbergh plane. (Above) the Coral Lagoon at Andros Island. (Below) view into the heart of the coral barrier from the sea floor



lared with black and snowy white, with bodies of a brilliant emerald-green; the females, with salmon-colored cheeks, their bodies green and white, with black stripes; the young, yellow like canary birds, often variegated with black blotches and areas of green and pink. As we wandered about, larger species sailed into view, gaudily decked out in gay patterns.

FISHES OF THE CORAL REEF

Let us return to our group, for here we have endeavored to give a similitude of life as faithfully as possible, though with a feeling of despair at the inadequacy of our efforts.

Many blueheads (*Thalassoma bifasciatum*), as described above, may be seen flitting about in various parts of the group, especially toward the right. The sergeant-majors or cock-eye pilots (*Abudefduf marginatus*), are the rather deep-bodied little fishes, with vertical black bars over a body shading from yellow to white, in the upper right-hand corner, near the top of the rocky ledge. They must not be confused with the banded butterfly-fishes (*Chaetodon striatus*). These are thin, flat, and much smaller. They are seen as if flitting like butterflies, in the lower part of the group, to the right of the center, where they are associated with blueheads and slippery dicks (*Iridio bivittata*). These latter are little, elongate fishes, with a continuous fin along the back, their color blending through pale tints of rose, green, blue, and black markings on an orange and yellow ground.

The large fishes swimming in a school down past the upper portion of the cliff are yellowtails (*Ocyurus chrysurus*), so-called because they have a bright yellow stripe along the side of the body continued into a completely yellow tail. They are excellent foodfishes and are eaten throughout the West Indies.

An interesting situation is occurring in the upper part of the group. A school of houndfishes (*Tylosurus raphidoma*), conspicuous because of their slender, silvery bodies and long pointed beaks, is being broken up, the fishes scattering desperately through the coral branches. The reason is not far to seek. Lurking just under the

water-surface, at the upper left, and gliding through the coral branches, is a large barracuda (*Sphyræna barracuda*), four and one-half feet in length. Its baleful eyes are fixed on its prey as it slides swiftly toward them, the undershot jaw slightly open, showing an irregular assortment of long, cruel teeth. The barracuda are abundant in tropical waters, where they are dreaded even more than sharks. Fortunately, they seem to prefer open lagoons, and only occasionally visit the reefs.

In the middle distance, below the houndfishes, a large school of black angel fishes (*Pomacanthus arcuatus*) sails slowly by in stately procession. They are deep-bodied, dark gray in color, often with indefinite vertical bands, and with trailing filaments prolonging their large, flat, dorsal and anal fins. Compare them with the blue angel (*Angelichthys ciliaris*), a brilliantly blue, flat-bodied fish, in the middle part of the group, nibbling at a purple sea feather. The remarkable peacock blue of its body and fins is narrowly bordered with scarlet which shades into trailing, bright yellow filaments above and below. Near by, a school of yellow and black rock beauties (*Holacanthus tricolor*) flits in and out among the corals.

NATURE'S CAMOUFLAGE

Slightly to the left of the lower center, just behind a growth of the fragile bush coral, a large Nassau grouper has emerged halfway from under a coral arch. Its brown-and-tan striped and mottled color pattern acts as a camouflage with the variegated surroundings and so completely conceals it that one can gaze directly toward the fish for several minutes without noticing it, in spite of its size. The Nassau grouper is one of the prized foodfishes of the Bahamas, and the people of Nassau pride themselves on the savory chowders made from it. When exploring a reef with diving helmet, one should be wary of cornering one of these groupers, for when irritated, they are capable of suddenly turning and giving a vigorous nip. It is interesting to watch a grouper swim out over a patch of white sand. As it does so, the mottled color pattern fades out before one's eyes and the

fish becomes pale and sandy in color, completely harmonizing with its background. As it turns and goes into the reef again the color pattern returns with all its original vividness.

Around the grouper's arched hiding place, several clumps of the beautiful lettuce coral (*Agaricia agaricites*) are attached to the dead coral rock. They have beautifully foliated expansions in undulating clusters, richly tinted with rose-madder, pink, and purplish-blue, often with suggestions of yellow. On one of our trips, our artists made careful color sketches of these corals in the living state. Then the specimens were collected, bleached, and brought back to the Museum, where the color was restored artificially in oils. On a subsequent expedition, we carried samples of these painted corals back with us, took them down undersea, and placed them on the reef, beside living specimens. We were greatly gratified to find that the artists had copied the colors so faithfully that they could not be told apart when viewed at arm's length.

CORAL GARDENS

Almost directly opposite the nose of the grouper, a beautiful red-tipped sea anemone (*Condylactis gigantea*) of large size expands its cream-colored, petal-like tentacles above a scarlet body. The sea anemones are closely related to coral polyps, but, unlike them, are incapable of building a stony skeleton.

At the extreme right of the group, a series of great domelike heads of brain coral (*Mæandra*) and purple sidereal coral (*Siderastrea*) rise in a clustered terrace of massive outline. Among them tower post-like pinnacles of tree-stump coral (*Dendrogyra cylindrus*), with meandriiform patterns completely covering their shafts. Butterfly fishes flutter about, their light delicacy in strong contrast to the massive roundness of the coral heads.

The loosely branching antlers of staghorn coral (*Acropora cervicornis*) grow out from the narrow crevices between the heads, their sharp points menacing like *chevaux-de-frise*. Immediately before one's eyes, the striking color pattern and unbelievable form of the

queen trigger fish (*Balistes vetula*) startle the gaze of the onlooker. Various individuals are differently colored, but all are equally surprising.

STARTLING COLOR COMBINATIONS

The most brilliant combination starts with velvety bright green on the upper part, shading into equally bright purple below. The lower part of the face may be pink or yellow, and two extraordinarily brilliant blue streaks are slashed across the face. Radiating irregular lines of black outlined with cream dart in all directions like lightning streaks from the very bright eyes with their little, black, beadlike pupils. The body of the fish is so narrow that when it turns toward you it seems almost to disappear. Its little, absurdly puckered mouth is furnished with white, close-set teeth. The fish is not shy, but will swim directly up to your helmet and peer in at you, moving its pursed up mouth as if it were trying to kiss you. If you try to grab at it with your hands you find it always just beyond your grasp.

Above it is another surprise, — a fish that we often see nosing about the reef, always singly. It is the equally absurd trumpet fish (*Aulostomus maculatus*). It grows to a yard or more in length, and is equipped with a ridiculous elongated snout, flattened vertically with a small mouth at the extreme end which is always in motion. It has a pulled-out caricature of a horselike face with small eyes set far back. The paired fins are very small, — almost insignificant, but the vertical dorsal and anal fins are broad and set so far back on the body as to seem about to slide off on to the fan-shaped almost arrow-headed tail. The color-pattern is quite as surprising. It is faintly suggestive of a Scotch plaid, being composed of vertical brown bands crossing longitudinal yellow stripes at right angles, against a light tan background. Small black dots are sprinkled over this array in longitudinal rows. As the fish progresses, it may expand its mouth like a trumpet, or the whole snout will droop in elephantine fashion. Sometimes it swims nearly upright, with head either up or down.

It is refreshing to turn from this out-



(Left) The weird trumpet fish, with its elongate, extensible snout and Zeppelin-like body, floats slowly through a school of spotted hinds



(Below) A cluster of tube-building marine worms expands purple, flower-like heads on the side of an eroded coral pedestal





A green moray lurks within an arched cavern, ready to attack any passing creature with its array of needle-sharp teeth

(Below) Around a fanlike elkhorn flit banded butterfly fish, slippery dicks, female and young blueheads. A surgeon fish swims below them

(Above) Gnarled, interlacing branches of the elkhorn coral form dense forests of stone trees rising to the water surface from the sea floor

(Below) A gray snapper (upper left) darts down among the smaller blueheads. A blue-striped grunt swims in from the right





Queen

Trigger

Fish

Its striking colors and unbelievable form startle the observer. Bright green blends into equally bright purple. Part of the face is yellow, slashed by blue lines of the utmost brilliancy. Lightning-like streaks of black and yellow radiate from the eyes

landish affair to the school of more normal looking rock hinds (*Epinephalus ascensionis*) swimming near and above it, their bodies patterned with reddish, oval spots.

The trumpet fish is headed toward a growth of sea feathers. Let us look in the same direction downward to the right and behind the beautifully symmetrical growth of elkhorn coral with the clustered sea fans at its base. Peering in here carefully, we see two huge, rainbow parrot-fishes (*Pseudoscarus guacamaia*) lurking in the shadows. Their name is quite appropriate, for they have conspicuous blue teeth, continuing the shape of the head in parrot-like profile. The scales of the hinder portion of the body are green edged with brown, while the forward part is of variable reddish brown. Let us compare them with the blue parrot-fish (*Scarus cæruleus*), in the cave at the extreme right of the group. These fish are uniformly blue, though in some individuals this may shade into dark indigo.

The conspicuous teeth are white and are very powerful grinders. I have watched these creatures through the windows of my helmet, as they swam out of their cavern and nosed about the rocky surface flanking it. They would actually bite off pieces of the limestone, grind them between their powerful teeth, presumably to get at the boring worms, sponges, and other nutriment permeating the porous substratum. After the rock was ground to powder, they would eject it from their mouths, and I could see the clouds of pulverized limestone rising toward the surface.

A school of gray snappers (*Lutianus griseus*) edges out of the lower part of the cave below the blue parrots and turns to the right where blue tangs or surgeon fish (*Acanthurus cæruleus*) are circling uncertainly. These are vertically flattened fishes, rounded in outline. Their color is a chocolate-brown with fine blue lines running through it. The edge of the dorsal fin is lined with blue. Their name is derived from the sharp curved lancet on either side of the peduncle of the tail. This may be erected and will lacerate the hand to such an extent that there would be no doubt about its capacity for blood-letting.

Blue-striped grunts (*Hæmulon sciurus*)

are swimming out from the extreme lower right of the group, past posts of *Dendrogyra* coral, their flat-nosed bodies adorned with a striking pattern of narrow, alternating blue and yellow stripes. The blue lines often gleam as the fish turns in the sunlight, so as to appear almost iridescent. Above the ledge where they are swimming is an obliquely sloping shelf capped with encrusting green brain coral (*Mæandra viridis*), from which a small forest of gorgonian sea bushes is growing, partly obscuring the entrance to the Cavern of the Blue Parrot-fishes. A closely packed school of spotted hinds (*Epinephalus guttatus*) swims downward past the clump, keeping in ordered phalanx as though it were perilous to direct their course past the den of the larger fish.

A MARINE KALEIDOSCOPE

Before we turn away from the group, our eyes catch a flash of color, and we stoop to examine at close range a squadron of squirrel-fishes (*Holocentrus ascensionis*) sliding past in front of the cluster of mushroom-like orb corals already mentioned. These little fishes are brilliant scarlet in color with darker stripes running the length of their body. Their huge, dark-red eyes seem out of all proportion to their size.

These are only a few of the multitudinous fishes ordinarily associated with a Bahaman coral reef. The entire number of species recorded from the Bahamas mounts up to more than a thousand. The Coral Reef Group is carefully planned to display a balanced association of reef-life, occurring at a definite locality, with the number of species likely to be noticed readily during an average trip to the sea bottom if one were observant and had time to take stock of his surroundings. It must be remembered that the scene would be changing constantly, and the observations of successive visits to the same locality would never be identical. Then, as we moved from place to place along the same reef, every location would be different from the rest. The character and arrangements of the coral growths and associated forms would change kaleidoscopically, one factor becoming dominant in a given region, while in another place it would be of secondary importance.



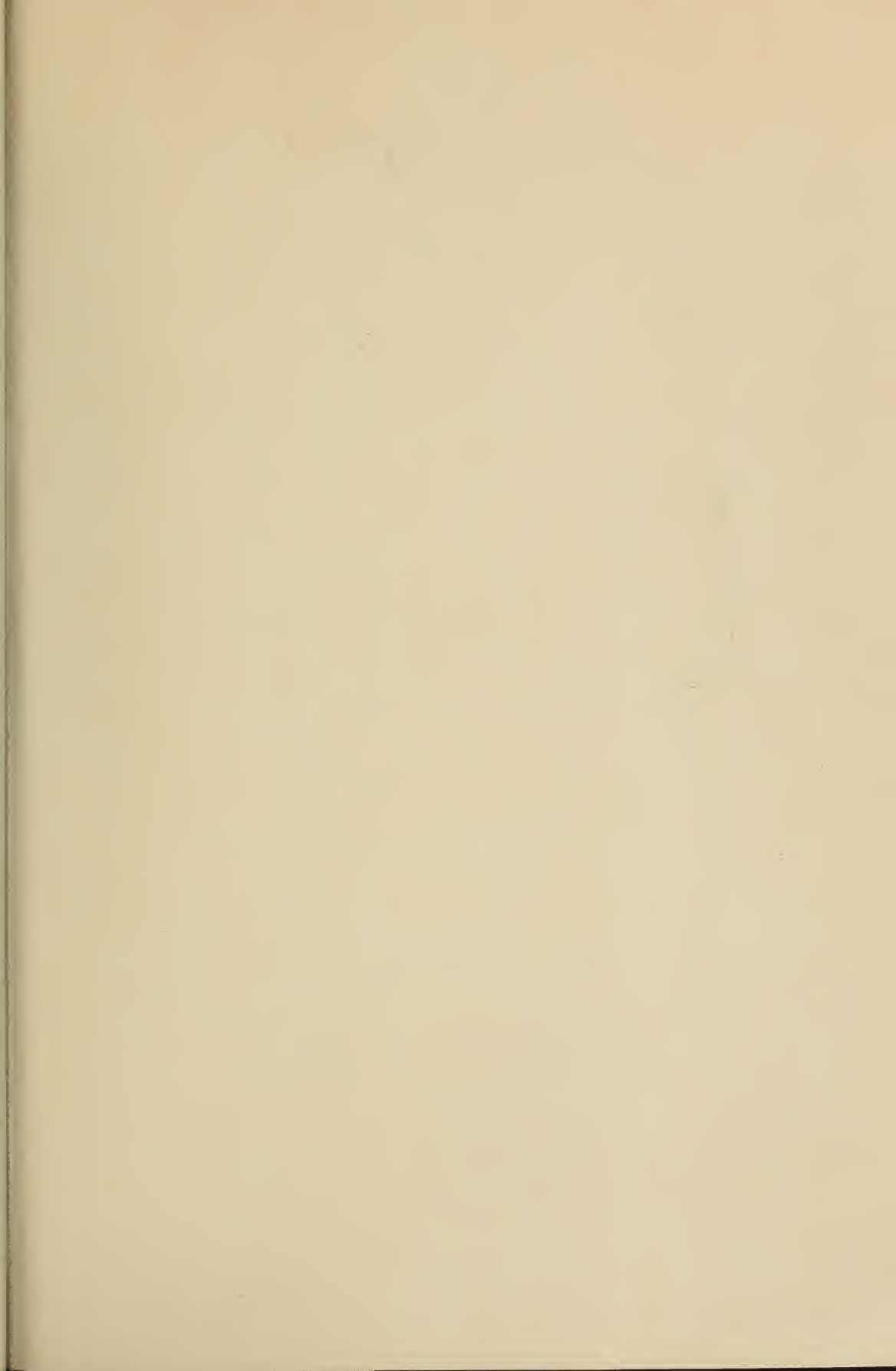

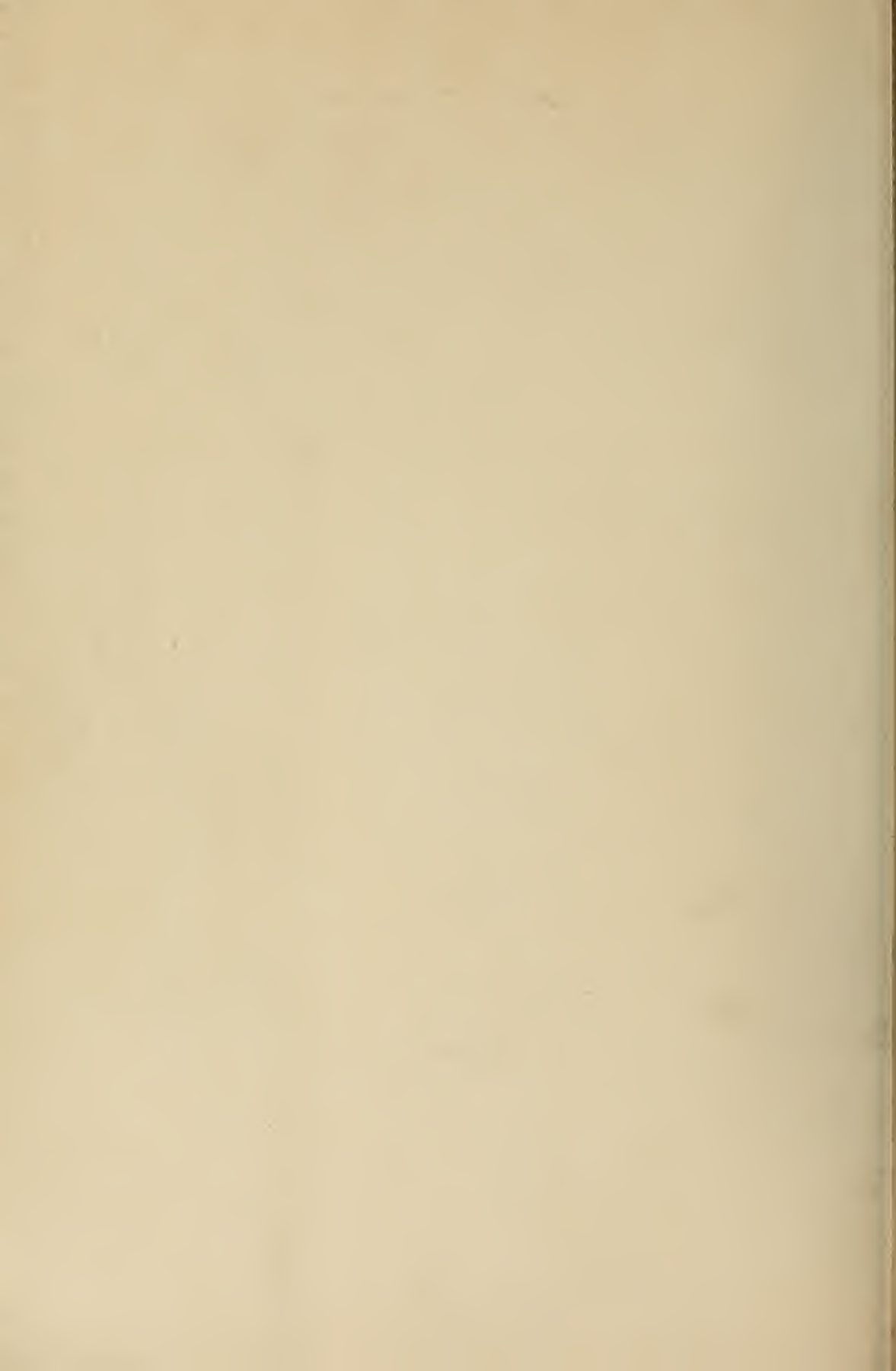

ALPHABETICAL GUIDE
TO
THE BIRD EXHIBITS

IN THE AMERICAN MUSEUM
OF NATURAL HISTORY

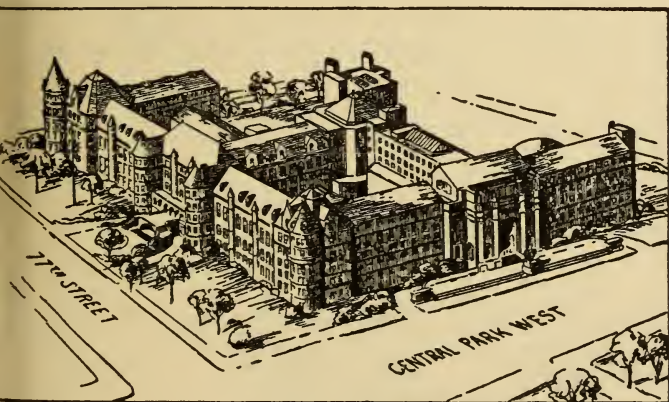

Guide Leaflet Series No. 90
Fourth Printing

MARCH, 1942

NEW YORK CITY

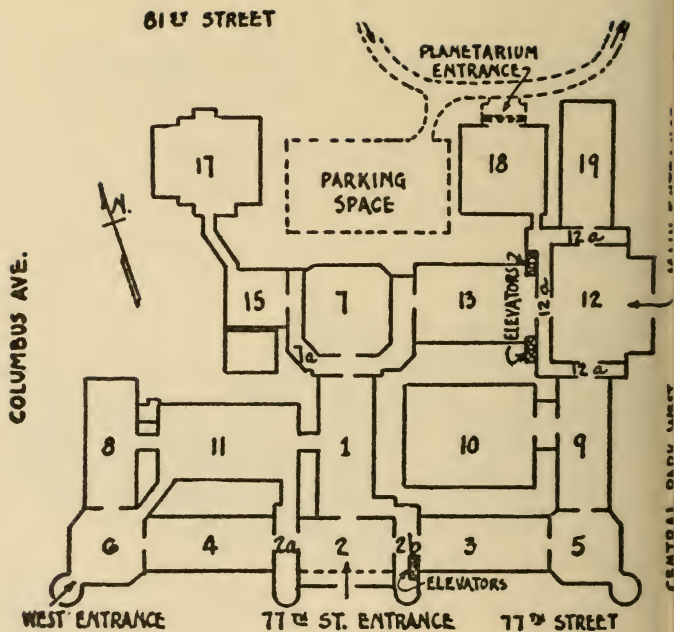

FLOOR PLAN

THE AMERICAN MUSEUM OF NATURAL HISTORY

THE Museum's bird exhibits are displayed in the corridor of floor **I** of the Roosevelt Memorial and in halls **1** and **2** of floors **II** and **III** in the central part of the building. They include many habitat groups showing birds in their natural surroundings, nest and subject groups, a systematic collection of the leading types of birds and their skeletons arranged to show the most approved classification, and about 10,000 birds arranged according to the Faunal Regions they inhabit.

To acquaint you with the nature and extent of these exhibits and to tell you where they may be found, this alphabetical guide to them has been made. When you have learned the Museum geography and the meaning of the location symbols here used, it is believed that you will have no difficulty in finding your way to any subject listed in this guide.

This leaflet does not pretend to be a complete guide to the bird exhibits; to include them all would require a volume. It lists only all the groups, large and small, some places and subjects, the various collections, as a whole, and the more widely known species. When a bird is not found entered under its specific title, look for it under its family name. Thus Hermit Thrush will be found under "Thrushes, North American, **II, 1, L-3**": meaning floor **II**, hall **1**, case **L**, section **3**.

- Acadian Flycatcher and nest, **II, 1**, alcove D-E.
 Aconcagua birds, **II, 2, 2**.
 Africa, British East, birds, **II, 2, 5**.
 Africa, western, birds, **II, 2, 6**.
 African Region birds, **II, 1**, O-11, P, Q-1-3.
 Aigrettes, **III, 1, 10**.
 Albatross in flight, **II, 1**, dome; label, alcove N-O.
 II, 19, dome.
 Albino birds, **II, 1**, alcove P-Q.
 Albino Pheasants, **II, 1**, A.
 Alpine birds, **II, 2, 10**.
 Altitude and bird distribution, **III, 1, 1**.
 Altitudinal life zones, origin of, **II, 2, 2**.
 American Tropical Region birds, **II, 1**, E-12, 13; F, G.
 H-1, 2, 3, 4; **II, 2, 3**.
 Andean birds, **II, 2, 2**.
 Anhinga nest and young, **III, 1, 7**.
 Ani nesting, **II, 1**, end of hall.
 Antarctic birds, **II, 1**, E-1, 2; **II, 2, 4**.
 Ant-birds, **II, 1**, G-10.
 Arctic-Alpine birds, **III, 1, 24**.
 Arctic Region birds, **II, 1**, M-1-4; **III, 1, 16**.
 Arctic Tundra at Port Churchill, **II, 2, 12**.
 Argentine birds, **II, 1**, E-3-12; **2, 2**.
 Argus Pheasant, **II, 1**, B-17.
 Arizona bird group, **III, 1, 12**.
 Audubon Gallery, paintings, souvenirs, **IV, 12a**.
 Auk, Great and skeleton, **II, 1**, alcove S-T.
 Australian Barrier Reef birds, **II, 19, 15**.
 Australian birds, **II, 2, 7**.
 II, 1, S-T.

- Bahaman birds, **III, 1, 17, 18**.
 Bald Eagle in flight, **II, 1**, dome, label D-E.
 Bank Swallow nesting, **II, 2**, near 12.
 Barro Colorado and birds, **II, 2, 3**.
 Bellbirds, **II, 1**, G-12.
 Bill and food, **II, 1**, alcove C-D; development with use
 in Flamingo, **III, 1, 17**; types of, **II, 1**, alcove B-C.

- Bird Rock, Magdalen Island birds, **III, 1, 30.**
 Birds and insects, **III, 5, 18.**
 Birds and Man, **I, 19.**
 Birds, in art, paintings, etc., **IV, 19.**
 Birds of the Month, **I, 12a**, corridor.
 Birds of World, **II, 1; 2.**
 Blackbirds, European, **II, 2, 11.**
 Blackbirds, North American, **II, 1, L-13.**
 Black Duck, nest and young, **II, 1**, alcove D-E.
 Black Grouse, **II, 1, M-6**; alcove M-N.
 Black Rail, nest and young, **II, 1**, alcove I-J.
 Black Skimmers, nests and young, **III, 1, 2.**
 Black Terns and nest, **III, 1, 15.**
 Black and White Warbler nesting, **II, 1**, passage **1-2.**
 Blue-winged Warbler nesting, **II, 1**, passage **1-2.**
 Bobwhite, **II, 1, T.**
 Booby nesting, **III, 1, 18.**
 Boreal birds in Mexico, **III, 1, 1** (label).
 Brain of bird, **II, 1**, alcove A-B.
 Brandt's Cormorant at Monterey, Cal., **III, 1, 14.**
 Brown Pelicans in flight, **II, 1**, dome; nest and young,
III, 1, 9.
 Brown Thrasher nesting, **II, 1**, alcove P-Q.
 Bullfinch, **II, 1, O-10; 2, 11.**
 Bustards, **II, 1, N-2; 2, 5, 9.**
- Cactus desert birds, **III, 1, 12.**
 California Condor, **II, 1, K-6**; nesting, **III, 1, 13.**
 California Gull nesting, **III, 1, 23.**
 California Valley Quail, nest and young, **II, 1**, alcove
F-G.
 Canada Geese flying, **II, 1**, dome; label, alcove G-H.
 Canadian Rockies, birds, **III, 1, 24.**
 Canvasbacks in flight, **II, 1**, dome (painting).
 Capercaillie, **II, 1, M-6**; alcove N-O.
 Cardinal nesting, **II, 1**, alcove O-P passage.
 Carolina Paroquet, **II, 1, K-1.**
 Caspian Terns nesting, **III, 1, 23.**

- Cassiques nesting, **II, 1**, alcove L-M.
 Catbird nesting, **II, 1**, alcove G-H.
 Chaffinch, **II, 2**, 11.
 Chascomus, Argentine, birds, **II, 2**, 1.
 Chickens, domestic, **I, 5**, entrance, right.
 Chimney Swift nesting, **II, 1**, alcove M-N.
 China desert, bird-life of, **II, 2**, 9.
 Clapper Rail nesting, **II, 1**, alcove G-H.
 Classification, **II, 1**, A-D.
 Cliff Swallow nesting, **II, 2**, near 1.
 Cobb's Island, Va., birds, **III, 1**, 2.
 Cockatoos, **II, 1**, S-12.
 Color of feathers, **II, 1**, alcove A-B, central case.
 Coloration, protective, **II, 1**, alcove N-O (Ptarmigan).
 Colors of desert birds, **III, 1**, 12; of forest birds, **II, 2**,
 (label).
 Condor in Andes, **II, 2**, 2; in flight, **II, 1**, dome; label
 N-O.
 Congo forest birds, **II, 2**, 6.
 Cormorants, American, **II, 1**, alcove I-J.
 Courtship of Prairie Hen, **III, 1**, 26; of Sage Grouse
III, 1, 25.
 Crane, Demoiselle, **II, 2**, 5.
 Cranes, American, **II, 1**, I-6; compared with herons
III, 1, 8 (label).
 Creepers, North American, **II, 1**, L-4.
 Crows, North American, **II, 1**, L-6.
 Cuckoo, European, **II, 1**, O-4; **II, 2**, 11.
 Cuckoos, North American, **II, 1**, L-1; Tropical Ameri-
 can, **II, 1**, G-6.

 Destruction of birds on Cobb's Island, **III, 1**, 2 (label).
 Dichromatism, Screech Owl, group, **II, 1**, alcove B-C.
 Diomedes Island, Bering Sea and birds, **III, 1**, 16.
 Dipper, American, nesting, **II, 1**, alcove K; Eurasian,
 O-4
 Distribution, altitudinal in southern Andes, **II, 2**, 2
 (label).
 Dodo (restoration) and skeleton, **II, 1**, alcove S-T.

Domestic fowls, **II, 1**, alcove P-Q.
Domestic pigeons, **II, 1**, alcove P-Q.
Doves, **I, 12a**, corridor.
Duck Hawk, nest and young, **III, 1, 3**.
Ducks, American, **II, 1**, I-12-13; J-1-2; 1-4; Eurasian,
II, 1, N, 8-11

Eagle, Bald, in flight, **II, 1**, dome.
Eggs and nests of the New York City region, **I, 12**.
Eggs of North American birds, **II, 1**, alcoves H-I; I-J.
Eggs and nests of North American birds, **II, 1**, alcove
H-J.
Eggs, Synoptic collection of, **II, 1**, alcove E-F.
Egrets nest and young, **III, 1**, 10, 19.
Embryo of bird, **II, 1**, alcove A-B.
English birds, **II, 2**, 11.
Eurasian Region birds, **II, 1**, M-6; Q-10.
European Robin, **II, 2**, 11.
Extinct American birds, **II, 1**, alcoves R-S; S-T.

Falconry, **II, 1**, alcove L-M; **III, 1, 3**.
Faunal areas of the world, **II, 1**; see maps above cases.
Feathers, Colors of, **II, 1**, alcove A-B; types of, **II, 1**,
alcove B-C.
Feeding habits of birds, **II, 1**, alcove C-D; of young
penguins, **II, 2**, 4; of young Water-Turkey, **III, 1, 7**;
of young Pelicans, **III, 1, 9, 23**; of young Flamingoes,
III, 1, 17.
Feet of birds, **II, 1**, alcove B-C.
Field Sparrow and nest, **II, 1**, alcove B-C.
Fiji birds, **II, 19**, 16.
Finches, North American, **II, 1**, L-8; **I, 12a**, corridor.
Flamingo, young feeding, **III, 1, 17**; nesting, **III, 1, 17**.
Flock formation, **II, 1**, dome.
Florida bird groups, **III, 1, 6-9, 19**.
Flycatchers, North American, **II, 1**, L-2; Tropical
American, **II, 1**, G-11.
Flying birds, **II, 1**, dome.
Forest birds, African, **II, 2, 6**; South American, **II, 2, 3**.

- Galapagos birds, **II, 19, 6.**
Galapagos Finches, **I, 5,** entrance, left.
Gannets nesting, **III, 1, 30.**
Geese, American, **II, 1, I-11;** Eurasian, N-8-9.
Geese, flying, label, **II, 1,** alcove G-H.
Georgia Island birds, **II, 2, 4.**
Glacial Period, influence of, on bird distribution, Group,
label, **III, 1, 24.**
Gnatcatchers, North American, **II, 1, L-3.**
Goatsuckers, North American, **II, 1, K-1;** **I, 12a,** corri-
dor.
Gobi Desert birds, **II, 2, 9.**
Golden Eagle nesting, **III, 1, 22.**
Great Auk, **II, 1, H-13;** alcove S-T.
Grebes, **II, 1, H-12;** M-10; **I, 12a,** corridor.
Grebes' nests and young, **III, 1, 28.**
Grey, Lord Edward of Fallodon, group dedicated to,
II, 2, 11
Grosbeaks, American, **II, 1, L-8.**
Grouse, American, **II, 1, H-7-10;** **I, 12a,** corridor; Euro-
pean, **II, 1, M-6-7.**
Grouse, Sierra nest and young, **II, 1,** alcove C-D.
Growth of Pigeon, **II, 1,** alcove A-B.
Guillemots nesting, **III, 1, 16, 30.**
Guinea Hen, **II, 2, 6.**
Gulls, American, **II, 1, I-1, 2;** **I, 12a,** corridor; Eurasian,
II, 1, M-11-12.
- Hackensack Marsh birds, **III, 1, 4.**
Hawaiian birds, **II, 19, 7.**
Hawks, North American, **II, 1, K-2-6;** **I, 12a,** corridor;
Eurasian, **II, 1, O-1-3.**
Heath Hen nesting, **II, 1,** alcove R-S.
Hérons, American, **II, 1, I-7-8.**
Hoopoe, **II, 2, 5, 9.**
Hornbill nesting, **II, 1,** alcove Q-R.
Horned Larks, North American, **II, 1, L-7.**
House Sparrow, **II, 1, O-10.**
Hudson Bay birds, **II, 2, 12.**

Hudson, William Henry, group dedicated to, **II, 2, 1**.
Hummingbirds, **II, 1, G-3, 4**; North American, K-1.
Hybrids, **II, 1, alcove P-Q**.

Ibises, American, **II, 1, F-4; I-4**.
Incubation of Golden Eagle, **III, 1, 22**.
Indigo Bunting and nest, **II, 1, alcove O-P, passage**.
Indo-Malayan birds, **II, 1, Q-4-13**.
Irrigation and bird-life, **III, 1, 15**.
Island bird-life, **III, 1, 30**.
Island variation, **I, 5, entrance, left**.
Ivory-billed Woodpecker, **II, 1, L-2**.

Jabiru, **II, 1, F-4**.
Jackdaw, **II, 1, O-8; II, 2, 11**.
Jaegers, **II, 1, M-12**.
Jays, North American, **II, 1, L-4-6; I, 12a, corridor**.

Killdeer, **III, 1, 15**.
Kingbird and nest, **II, 1, alcove H-I**.
Kingfisher, North American, **II, 1, K-1**.
Kinglets, North American, **II, 1, L-3**.
King Vulture, **II, 1, E-8**.
Kittiwakes nesting, **III, 1, 16, 30**.
Kiwi, **II, 1, A-3-5**.
Klamath Lake, Oregon, bird-life, **III, 1, 23**.

Labrador Duck, **II, 1, alcove, S-T**.
Lake Umbagog, N. H.-Me., and loons, **III, 1, 29**.
Lapwing, **II, 2, 11**.
Laughing Gull and nest, **II, 1, alcove E-F**.
Laughing Jackass, **II, 1, T-1**.
Laysan birds, **II, 19, 8**.
Little Blue Herons, **III, 1, 19**.
Local birds, **I, 12a, corridor**.
Long-billed Marsh Wren and nest, **II, 1, alcove B-C**.
Loons, **II, 1, H-12; nesting, III, 1, 29**.
Louisiana Heron nesting, **III, 1, 19**.

Louisiana Water-Thrush and nest, **II, 1**, alcove N-O
Lyre-bird, **II, 1**, T-2.

Magpie, North American, **II, 1**, L-6; Eurasian, O-8; **2**
11.

Magpie, Yellow-billed, nesting, **II, 1**, alcove N-O.

Manakins, **II, 1**, G-11.

Man-o'-war-birds in flight, **II, 1**, dome; **II, 19**, dome
label, alcove N-O; nesting, **III, 1**, 18.

Marquesas birds, **II, 19**, 4.

Maryland Yellow-throat nest, **II**, passage **1-2**.

Migration; North American Shorebirds in Argentine
II, 2, 1.

Mockingbird, **II, 1**, L-3.

Motmots, **II, 1**, G-1.

Mountain Quail, California, nesting, **II, 1**, alcove F-G

Murres nesting, **III, 1**, 16, 30.

Nebraska prairies, **III, 1**, 26.

Nest and eggs of the New York City region, **I, 12**.

Nests, types of, **II, 1**, alcoves F-G; G-H.

New Caledonia birds, **II, 19**, 9.

New Forest birds, **II, 2**, 11.

New Guinea birds, **II, 19**, 14.

Nightingale, **II, 1**, O-6; **II, 2**, 11.

North American habitat groups, **III, 1**; **II, 2**, 12.

North American Temperate Region birds, **II, 1**, H-L.

Nuptial plumage of Cormorant, **III, 1**, 14.

Nuthatches, North American, **II, 1**, L-4.

Orchard Oriole and nest, **II, 1**, alcove D-E.

Orioles, North American, **II, 1**, L-12; **I, 12a**, corridor;

Tropical American, **II, 1**, H-1, 2.

Orizaba, Mexican Group, **III, 1**, 1.

Oropéndolas nesting, **II, 1**, alcove L-M.

Osprey and nest, **II, 2**, near 7; in flight, **II, 1**, dome.

Ostrich, **II, 1**, A; **II, 2**, 7; fossil egg of, **II, 1**, A.

Ovenbird and nest, **II, 1**, alcove B-C.

Owls, North American, **II, 1, K-1-2**; Eurasian, O-3.

Oyster Bay birds, **I, 12**.

Oyster-catcher on Cobb's Island, **III, 1, 2**.

Pacific Island birds, **II, 19**.

Palaearctic Region birds, **II, 2, 10**; 11.

Panama Canal Zone birds, **II, 2, 3**.

Paradise birds, **II, 1**, end of hall.

Páramo Zone birds, **II, 2, 2**.

Parrot, Double Yellow-head, nesting, **II, 1**, alcove M-N.

Parrot, Gray African, **II, 2, 6**.

Parrots, African, **II, 1, P-11**; American, **II, 1, F-12-13-G-1**; Australian, **II-1, S-12-13**.

Passenger Pigeon, group of, **II, 1**, alcove R-S.

Peacock, **II, 1, B, Q**; **I, 5**, left of entrance.

Penguin, Emperor, **II, 1**, alcove A-B; King, **II, 2, 4**.

Permanent resident birds, **I, 12a**, corridor.

Peruvian Guano Island birds, **II, 19, 5**.

Petrels nesting, **III, 1, 30**.

Pheasants, **II, 1, M-7-8**; **II, 2, 11**; Indo-Malayan, **II, 1, Q-4-10**.

Pied-billed Grebe, nest and young, **II, 1**, alcove H-I.

Pigeons, American, **II, 1, F-3-H-11**.

Pigeons, domestic, **I, 5**, entrance, right; Wild, **II, 1**, alcove R-S.

Pine Siskin and nest, **II**, passage **1-2**.

Pipits, North American, **II, 1, L-7**.

Pipit and nest, **III, 1, 24**.

Plovers, see Shorebirds.

Plumage, growth of in Brown Pelican, **III, 1, 9**.

Prairie Hen Courtship, **III, 1, 26**.

Prairie Warbler and nest, **II**, alcove O-P, passage.

Protective coloration shown by young skimmers, **III, 1, 2**.

Ptarmigan, molt of, **II, 1**, alcove N-O; nest, **III, 1, 24**.

Puffins nesting, **III, 1, 16, 30**.

Quail, American, **II, 1, F-1**; H-6; Eurasian, **II, 1, M-7**.

Quetzal, **II, 1, G-2**.

- Rails, North American, **II, 1, H-11**; **I, 12a**, corridor;
 Eurasian, **II, 1, M-10**.
 Raven, North American, **II, 1, L-6**; Eurasian, **M-10**.
 Razor-billed Auks nesting, **III, 1, 30**.
 Red-eyed Vireo and nest, **II, 1**, alcove O-P, passage.
 Red Grouse, **II, 1**, alcove M-N.
 Red-head Duck and nest, **III, 1, 27**; in flight, **II, 1**, dome
 (painting).
 Red-shouldered Hawk, **II, 1**, alcove K-L.
 Redstart and nest, **II, 1**, alcove R-S.
 Red-winged Blackbird and nest, **II, 1**, alcove B-C.
 Reedbird in Hackensack Marshes, **III, 1, 4**.
 Rhea, **II, 2, 1, 2**; **II, 1, A**.
 Roadrunner, **III, 1, 12**.
 Robin, American and nest, **II, 1**, alcove Q-R.
 Robin, European, **II, 1, O-6**; **2, 11**.
 Rook, **II, 1, O-8**.
 'Rookery' in Florida, **III, 1, 19**.
 Roosevelt Bird Sanctuary group, **I, 12**.
 Roosevelt Bird Walk in England, **II, 2, 11**.
 Roseate Spoonbill nesting, **III, 1, 19**.
 Rose-breasted Grosbeak and nest, **II, 1**, alcove O-P,
 passage.
 Ruby-throated Hummingbird and nest, **II, 1**, alcove
 O-P, passage.
 Ruffed Grouse, nest and young, **II, 1**, alcove F-G.
 Ruff group, **II, 1**, end of hall.
- Sage Grouse nesting, **III, 1, 25**.
 Samoan birds, **II, 19, 2**.
 Sand Grouse, **II, 2, 9**.
 Sandhill Crane and nest, **III, 1, 8**.
 Sandpipers, see Shorebirds.
 San Joaquin Valley birds, **III, 1, 15**.
 Scarlet Ibis, **II, 1, F-4**.
 Scarlet Tanager and nest, **II, 1**, alcove H-I.
 Scaup Ducks in flight, **II, 1**, dome.
 Screech Owl, nest and young, **II, 1**, alcove B-C.
 Sea birds, **II, 19, 1**.

- Seaside Sparrow and nest, **II, 1**, alcove R-S.
- Season, birds of, **I, 12a**, corridor.
- Seasonal plumage changes, **II, 1**, alcove N-O.
- Secondary sexual characters in Man-o'-war-bird, **III, 1**, 18 (label).
- Secretary-bird, **II, 2, 7**.
- Sexual characters of Prairie Hen, **III, 1**, 26 (label).
- Sharp-tailed Sparrow and nest, **II, 1**, alcove R-S.
- Ship-Followers, birds, **II, 19**, 1.
- Shorebirds, American, **II, 1**, I-3-4; **I, 12a**, corridor; European, **II, 1**, M-13; N-1.
- Shrikes, North American, **II, 1**, L-4; **I, 12a**, corridor; Eurasian, O-7.
- Skeleton of bird, **II, 1**, alcove A-B.
- Skuas, **II, 2, 4**.
- Skuas, in flight, **II, 19**, dome.
- Skylark, **II, 1**, O-10; **2**, 11.
- Snake-bird, nest and young, **III, 1**, 7.
- Snow Mountain, New Guinea, birds, **II, 19**, 14.
- Snow Petrel, flying, **II, 19**, dome.
- Snowy Egrets, nesting, **III, 1**, 19.
- Solomon Island birds, **II, 19**, 10.
- Song Sparrow and nest, **II**, passage **1-2**.
- Song Thrush, **II, 2**, 11.
- Sora in Hackensack Marshes, **III, 1**, 4.
- South American Temperate Region birds, **II, 1**, E-3-12; **II, 2**, 1.
- Sparrows, North American, **II, 1**, L-10-11.
- Starling, **II, 1**, L-13; **I, 12a**, corridor, Permanent Residents.
- Stilts and young, **III, 1**, 15.
- Storks, **II, 1**, N-3-4.
- Structure and habit in Woodpeckers, **II, 1**, alcove D-E.
- Swallows in Hackensack Marshes, **III, 1**, 4; North American, **II, 1**, L-2.
- Swamp Sparrow and nest, **II**, passage **1-2**.
- Swan, Black-necked, **II, 2**, 1.
- Swans, American, **II, 1**, I-10; Eurasian, N-7.
- Swifts, North American, **II, 1**, K-1.

Swiss Alps, birds, **II, 2, 10.**

Systematic collection, Birds of World, **II, 1, A-D.**

Tails, types of, **II, 1, alcove B-C.**

Tanagers, **II, 1, H-3-4; L-8; I, 12a, corridor.**

Terns, American, **II, 1, I-2; I, 12a, corridor.**

Terns, in flight, **II, 19, dome.**

Thrushes, European, **II, 1, O-4; North American, L-3
I, 12a, corridor.**

Timberline, altitude of, label, **III, 1, 24.**

Titmice, Eurasian, **II, 1, O-7; North American, L-4;
I, 12a, corridor.**

Toucans, **II, 1, G-7.**

Towhee and nest, **II, 1, alcove O-P, passage.**

Trogon, **II, 1, G-2.**

Tropic-birds, in flight, **II, 19, dome.**

Tropical American birds, **II, 2, 3; II, 1, E-12-H-4.**

Tropical Mexico, birds, **II, 1, 1.**

Tuamotu birds, **II, 19, 3.**

Tucson, Arizona bird group, **III, 1, 12.**

Turkey Buzzard and nest, **III, 1, 11.**

Umbrella bird, **II, 1, G-12.**

Variation in Ruff, **II, 1, end of hall.**

Veery and nest, **II, passage 1-2.**

Vireos, North American **II, 1, L-3.**

Vultures, African, **II, 1, P-6-7; Eurasian, N-13; North
American, K-6.**

Warblers, North American, **II, 1, L-7-8; I, 12a, corridor.**

Warbling Vireo and nest, **II, passage, 1-2.**

Ward's Great Blue Heron, nest and young, **III, 1, 6.**

Waxwings, North American, **II, 1, L-3.**

West Virginia, Wild Turkey in, **III, 1, 5.**

Whale-birds, in flight, **II, 19, dome.**

Whale-headed Stork, **II, 1, P-3.**

Whistling Swan nesting, **III, 1, 20.**

- White-crowned Pigeon nesting, **II, 1**, alcove K-L.
 White-eyed Vireo and nest, **II, 1**, alcove O-P, passage.
 White Pelican nesting, **III, 1**, 23.
 Whooping Crane on Heron Lake, Minn., **III, 1**, 21.
 Wild Geese in flight, **II, 1**, dome; nest and young, **III, 1**,
 27.
 Wild Turkeys, **II, 1**, F-1; H-10; nesting, **III, 1**, 5.
 Wilson's Phalarope nesting, **II, 1**, alcove I-J.
 Wings, types of, **II, 1**, alcove B-C.
 Woodcock and nest, **II, 2**, near 6.
 Woodcreepers, **II, 1**, G-10.
 Woodpeckers, structure and habit of, **II, 1**, alcove D-E;
 American, **II, 1**, L-1-2; G-8; **I, 12a**, corridor; Eura-
 sian, **II, 1**, O-4.
 Wood Thrush and nest, **II, 1**, alcove K-L.
 Worm-eating Warbler and nest, **II, 1**, alcove N-O.
 Wrens, North American, **II, 1**, L-2; **I, 12a**, corridor.
 Wyoming and Sagebrush, **III, 1**, 25.
 Yellow-billed Cuckoo and nest, **II, 1**, alcove G-H.
 Yellow Warbler and nest, **II, 1**, alcove R-S.
 Young birds and their nest-types, **II, 1**, alcove F-G.

*Issued under the direction of
 the Committee on Popular Publications.*

ROY W. MINER, *Chairman.*

EXHIBITION HALLS
of the
American Museum of Natural History

A fully illustrated and comprehensive
souvenir-guide and manual to the
Museum exhibits

Price, 75 cents

Also
Special Handbooks and Guide Leaflets based on
Museum exhibits and subjects
for sale at the
Book Shop and Information Desk
or by addressing
The Committee on Popular Publications
Price Lists on Request

STAR LEGENDS

AMONG THE AMERICAN INDIANS

By CLARK WISSLER





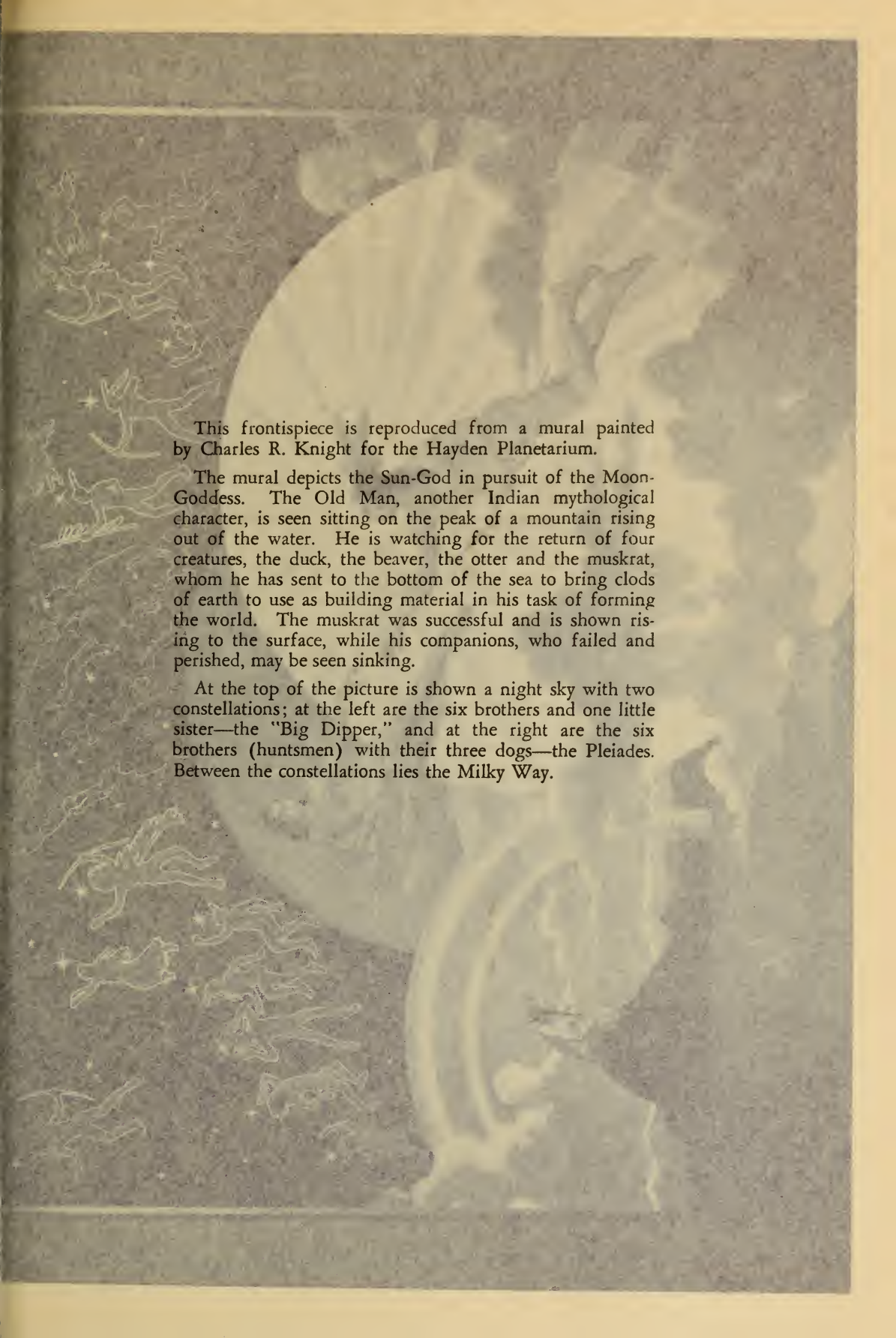

This frontispiece is reproduced from a mural painted by Charles R. Knight for the Hayden Planetarium.

The mural depicts the Sun-God in pursuit of the Moon-Goddess. The Old Man, another Indian mythological character, is seen sitting on the peak of a mountain rising out of the water. He is watching for the return of four creatures, the duck, the beaver, the otter and the muskrat, whom he has sent to the bottom of the sea to bring clods of earth to use as building material in his task of forming the world. The muskrat was successful and is shown rising to the surface, while his companions, who failed and perished, may be seen sinking.

At the top of the picture is shown a night sky with two constellations; at the left are the six brothers and one little sister—the "Big Dipper," and at the right are the six brothers (huntsmen) with their three dogs—the Pleiades. Between the constellations lies the Milky Way.

This frontispiece is reproduced from a mural painted by Charles R. Knight for the Hayden Planetarium.

The mural depicts the Sun-God in pursuit of the Moon-Goddess. The Old Man, another Indian mythological character, is seen sitting on the peak of a mountain rising out of the water. He is watching for the return of four creatures, the duck, the beaver, the otter and the muskrat, whom he has sent to the bottom of the sea to bring clods of earth to use as building material in his task of forming the world. The muskrat was successful and is shown rising to the surface, while his companions, who failed and perished, may be seen sinking.

At the top of the picture is shown a night sky with two constellations; at the left are the six brothers and one little sister—the "Big Dipper," and at the right are the six brothers (huntmen) with their three dogs—the Pleiades. Between the constellations lies the Milky Way.



STAR LEGENDS

Among the American Indians



By
CLARK WISSLER
Curator of Anthropology

THE AMERICAN MUSEUM OF NATURAL HISTORY

Guide Leaflet Series No. 91

NEW YORK, N. Y.

1936

Second Printing, 1937

Third Printing, 1937

Fourth Printing, 1940

C O N T E N T S

Introduction	5
Foreword	6
The Sun and the Moon	7
The Creation of the Earth	7
The Six Brothers.....	8
The Seven Brothers.....	9
Other Star Myths	11
The Fixed Star.....	11
Blood-Clot, or Smoking-Star	13
Scar-Face	17
The Twin Brothers.....	20

INTRODUCTION

IT HAS been said that man first began to study the things farthest away from him and so astronomy is the oldest science and psychology the most recent. Perhaps the heavenly bodies were by far the greatest mysteries and appealed to primitive man as the most desirable forms of existence; anyway, in many lands and ages the dead are believed to become stars. Our Indians gave a great deal of attention to the heavens as revealed in the many beautiful stories told around their camp fires. So it seems peculiarly appropriate that this Planetarium should record a few masterpieces in Indian creative literary art.

Mr. Charles R. Knight, who conceived and executed the murals in the Planetarium, chose his themes from a series of star myths known to the Blackfoot Indians of Montana. In the following pages we print English versions of these myths in order that the reader may come to realize that what Mr. Knight did was to set himself the task of illustrating a few of these aboriginal classics. It is hoped that the reader may sense the simple beauty in the narratives which inspired the artist to execute these appealing murals.

FOREWORD

THE star myths in this booklet were narrated to the writer by Wolf-head, a Blackfoot Indian. An oral translation was made by an English-speaking Indian which the writer recorded as given. The narrative follows closely the style of the narrator and the translator, we hoping that in this way something of the personality of the narrator might be retained. Wolf-head understood that these myths would be published eventually and as he proceeded we realized that he was making the artistic effort of his life. The story of the Twin Brothers was the last and evidently regarded by him as his masterpiece. The reader may prefer the simpler tale of the Fixed Star or perhaps Scar-Face, but to one understanding what Blackfoot life was like forty or more years ago, the Twins will make a strong appeal. George Bird Grinnell, Walter McClintock and J. W. Schultz have published interesting books about the Blackfoot Indians.

These myths were recorded in 1903. Even then Wolf-head was an elderly man, his death occurring two years later. No Indian of his age knew the date of his birth, as there were no true calendars, but Wolf-head believed he was born about 1840. So he, as a young man, went to war, hunted buffalo and lived the life of an aboriginal before his tribe was settled upon a reservation.

STAR LEGENDS among the American Indians



The Sun and the Moon

THE center of the picture represents the artist's interpretation of a myth explaining how the sun and moon came to be. One version of the myth states that the sun was the brother and the moon the sister in a family of the long ago. Often they quarreled. Upon one occasion the sister was so outraged over the treatment she received at the hands of her brother, that she grasped a burning stick from the house fire and rushed up through the smoke hole of the tipi. The brother shouted that she could not escape him in that way, caught up a larger fire brand and followed in pursuit. So they continue to this day, the moon with the fainter light moving across the sky at night, the sun with his great fire brand still pursuing, causing the day.

The theme of this myth is not peculiar to the Blackfoot Indians but was spread among Indian tribes ranging from Cape Cod to Alaska. The details of the myth vary as in all unwritten literature but the essentials of the plot are the same. The Blackfoot Indians, however, preferred to look upon the Sun and Moon as their chief deities. The Sun was the most sacred and powerful of all and the Moon was his wife. They lived in a tipi in the sky country. So it is fitting that the Sun and the Moon should occupy the center of the mural and dominate the other parts of the painting.

The Creation of the Earth

THE scene beneath the rainbow on the left represents a Culture-Hero of the Blackfoot Indians known as Napi or the Old Man. He is not only credited with making the earth as we now see it, but the people and everything else in the world. He is called a Culture-Hero because before he left the world he taught the people how to live and to order their daily lives. The earliest record of this Blackfoot conception is a statement in the diary of Alexander Henry under the date of 1809. Henry was the head of a large fur-trading company operating posts in all parts of the northern plains country, especially in Canada. He says that from one of the Blackfoot Chiefs visiting his post he obtained the following:

At first the world was one body of water inhabited by only one great white man and his wife, who had no children. This man, in the course of time, made the earth, dividing the waters into lakes and rivers, and formed the range of the Rocky Mountains; after which he made the beasts, birds, fishes, and every other living creature.

A later version collected by the writer contains the following plot:

A great flood came and the waters began to rise over the hills. The Old Man was running from one height to another to escape it. At last he climbed to the top of the highest mountain. Here he was joined by four of the

animals, beaver, otter, duck and muskrat. The water rose almost to the top of the mountain but could go no farther for the Old Man was too powerful. For a long time he waited but the waters did not recede. At last the Old Man said that if he had some mud, even a speck of it, he could create dry land. Then he ordered the beaver to dive to the bottom but after a long time his lifeless body floated to the surface. Next the otter tried but with the same tragic result. Then the Old Man sent the duck down but it came up unconscious. It was now the turn of the muskrat. He was gone a long time and when he did appear he, too, was unconscious but held fast in his front paws the precious particle of mud. The Old Man put the mud on the palm of his hand and blew upon it. It began to grow bigger and bigger until it spread out upon and into the water, finally forming the land as we see it to-day. Then he made the plants, then all the living things.

The rainbow does not have a place in this myth but the Blackfoot speak of it in mythical terms. Thus among its numerous names are Rain's Hat, Old Man's Fish Line, Lariat, and so forth. It is, therefore, appropriate that the artist should paint this brilliant arch over the Old Man creating the world. We say creating the earth but that is not quite right. Not only the Blackfoot Old Man, but all similar characters in American Indian mythology, are really transformers. They take things as they find them and merely change them into the forms known to us. They do not make something out of nothing.

The Six Brothers

THE Blackfoot speak of the Pleiades as the Six Brothers and again as the Bunched Stars. In some versions of this myth the boys take their dogs with them to the sky land, so in the mural we see the stars in position and the shadowy forms of the six boys and three dogs.

The version of this myth, narrated to us by Wolf-Head, ran thus:

In a camp of our people there was a family of six boys. Their parents were very poor. Every spring the people went out to hunt for buffalo. At this time of the year, the buffalo calves are red, and their skins are much desired for children's robes. Now as the parents of these children were very poor and not able to do much hunting, these boys had to wear brown robes or those made of old buffalo-skins. As the children grew up, they were constantly reminded of the fact that they had no red robes. The other children of the camp sometimes made fun of them because of this. So one day one of the boys said to his brothers, "Why is it that we never get any red robes? If we do not get any next spring, let us leave the camp and go up into the sky." Then the boys went out to a lonely place to talk the matter over. Finally they agreed that, if they did not get red robes in the following spring, they would go up to the sky country. The spring hunting-season passed, but no red robes came to the boys. Then the oldest brother said, "Now I shall take you all up to the sky." The fourth brother said, "Let us also take all the water away from the people, because they have been bad to us." Another brother said, "We must take our dogs with us."

Then the oldest brother took some weasel-hair, placed a little on the backs of his brothers and upon their dogs. Then he took another bunch of hair, put it first into his mouth, then rubbed it on his palm. "Now shut your eyes," he said. Then he blew the weasel-hair up, and, when the brothers opened their eyes, they found themselves in the house of the Sun and Moon. The Sun, who was an old man, and the Moon, who was his wife, said, "Why have you come?" "We left the earth," said the oldest brother, "because the people never gave us red robes. All the other children had red robes to wear, but we had only brown ones. So we have come to you for help." "Well," said the Sun, "what do you want?" The fourth brother

said, "We should like to have all the water taken away from the people for seven days." Now the Sun made no answer to this; but the Moon took pity on the poor boys and said, "I will help you; but you must stay in the sky." The Moon pitied the boys so much that she cried. She asked the Sun to aid her in taking away the water from the people; but the Sun made no answer. She asked him seven times. At last he promised to aid her.

The next day on the earth was very hot. The water in the streams and lakes boiled, and in a short time it all evaporated. The next night was very warm and the moonlight strong. When the water was gone, the people in the camp said, "Let us take two dogs with us out to the river-bed." When they came to the bank of the river, the two dogs began to dig a hole in the side of the bank. When they had dug a long time, water came out of the hole like a spring. This is the way springs were made. Even to this day, people have great respect for their dogs because of this. The days were so hot that the people were forced to dig holes into the hills and crawl into them. They would have died, if they had remained on top of the ground. When the water in the springs gave out, the dogs made other springs. Now the leader of the dogs was a medicine-dog. He was old and white. On the seventh day he began to howl and look at the sky. He was praying to the Sun and the Moon. He explained to the Sun and Moon why it was that the boys got no red robes. He asked them to take pity on the dogs below. (This is why dogs sometimes howl at the moon.) On the eighth day the Sun and Moon gave the people rain. It was a great rain, and it rained for a long time.

The six boys remained in the sky, where they may be seen every night. They are the Bunched Stars (Pleiades).

The Seven Brothers

THE Great Dipper has always intrigued the human mind. The Milky Way which was used by the artist as a part of the decoration is rarely the subject of a myth but often spoken of as the sky-trail and sometimes as the wolf-trail. The Blackfoot did not know that the Milky Way is composed of stars, since they had no telescopes, hence their explanation is natural enough.

A young woman had seven brothers and a little sister. One of the brothers was still too young to go about alone, so the little sister carried him upon her back. Their parents were dead and since they had no relations they lived alone.

One day the little sister said to the older sister, "Now you be a bear and we will go out into the brush to play." The older sister agreed to this, but said, "Little sister, you must not touch me over my kidneys." So the big sister acted as a bear and they played in the brush. While they were playing, the little sister forgot what she had been told, and touched her older sister in the wrong place. At once she turned into a real bear, ran into the camp, and killed many of the people. After she had killed a large number, she turned back into her former self. Now, when the little sister saw the older run away as a real bear, she became frightened, took up her little brother, and ran into their lodge. Here they waited, badly frightened, but were very glad to see their older sister return after a time as her true self.

Now the older brothers were out hunting, as usual. As the little sister was going down for water with her little brother on her back, she met her six brothers returning. The brothers noted how quiet and deserted the camp seemed to be. So they said to their little sister, "Where are all our people?" Then the little sister explained how she and her sister were playing, when the elder turned into a bear, ran through the camp, and killed many people. She told her brothers that they were in great danger, as

their sister would surely kill them when they came home. So the six brothers decided to go into the brush. One of them had killed a jack-rabbit. He said to the little sister, "You take this rabbit home with you. When it is dark, we will scatter prickly-pears all around the lodge, except in one place. When you come out, you must look for that place, and pass through."

When the little sister came back to the lodge, the elder sister said, "Where have you been all this time?" "Oh, my little brother mused himself and I had to clean him," replied the little sister. "Where did you get that rabbit?" she asked. "I killed it with a sharp stick," said the little sister. "That is a lie. Let me see you do it," said the older sister. Then the little sister took up a stick lying near her, threw it at the rabbit, and it stuck in the wound in his body. "Well, all right," said the elder sister. Then the little sister dressed the rabbit and cooked it. She offered some of it to her older sister, but it was refused; so the little sister and her brother ate all of it. When the elder sister saw that the rabbit had all been eaten, she became very angry, and said, "Now I have a mind to kill you." So the little sister arose quickly, took her little brother on her back, and said, "I am going out to look for wood." As she went out, she followed the narrow trail through the prickly-pears and met her six brothers in the brush. Then they decided to leave the country, and started off as fast as they could go.

The older sister, being a powerful medicine-woman, knew at once what they were doing. She turned herself into a bear. The prickly-pears stopped her for a time but at last she found the trail and started in pursuit. Soon she was about to overtake them, when one of the boys tried his power. He took a little water in the hollow of his hand and sprinkled it around. At once it became a great lake between them and the bear. Then the children hurried on while the bear went around. After a while the bear caught

up with them again, when another brother threw a porcupine-tail (a hairbrush) on the ground. This became a great thicket; but the bear forced its way through, and again overtook the children. This time they all climbed a high tree. The bear came to the foot of the tree, and, looking up at them, said, "Now I shall kill you all." So she took a stick from the ground, threw it into the tree and knocked down four of the brothers. While she was doing this, a little bird flew around the tree, calling out to the children, "Shoot her in the head! Shoot her in the head!" Then one of the boys shot an arrow into the head of the bear, and at once she fell dead. Then they came down from the tree.

Now the four brothers were dead. The little brother took an arrow, shot it straight up into the air, and when it fell one of the dead brothers came to life. This he repeated until all were alive again. Then they held a council, and said to each other, "Where shall we go? Our people have all been killed, and we are a long way from home. We have no relatives living in the world." Finally they decided that they preferred to live in the sky. Then the little brother said, "Shut your eyes." As they did so, they all went up. Now you can see them every night. The little brother is the North Star. The six brothers and the little sister are seen in the Great Dipper. The little sister and the eldest brother are in a line with the North Star, the little sister being nearest it because she used to carry her little brother on her back. The other brothers are arranged in order of their age, beginning with the eldest. This is how the seven stars (Great Dipper) came to be.

* * *

We heard different interpretations as to the position of the sister and her little brother. The foregoing is the way the narrator told it to us and is the version used by the artist; but we heard another narrator say that the sister is Mizar in the handle of the dipper and that the little brother is the small star near the

sister but not a part of the handle. This would be consistent. Again another said that Mizar was the little brother and the star near-by was the sister. Such variations are common in folk lore. The star at the end of the handle is spoken of as the Last Brother. The revolving of the dipper around the North Star served the Blackfoot as a night clock, its position indicating the passing of time, so one might say, "Now the Last Brother is pointing downward," or "upward."

Other Star Myths

THE Blackfoot Indians have other myths about the stars. In fact their belief was that every star was once a human being. They thought of the stars as not fixed in number, but as ever increasing, for when any of their people died they believed that their spirits ascended to become stars. A sorrowing mother would watch the sky for what she believed to be a new star and finding one would say, "Now my child is looking down upon me." It was a beautiful belief, that when one walked abroad at night his relatives and all the old ones were looking down upon him with kindness and sympathy.

So it is not strange that the most prominent stars in the heavens were given personal names. As illustrations we add a few more myths, most of which were known to many other Indian tribes as well as to the Blackfoot.

Incidentally, we remark that many stars had symbolic names without an associated story, though it is possible there was once a story later lost to memory. Thus, Mars was the Big Fire Star; Venus the Day Star because it was occasionally seen during the day; a comet was "a star feeding"; and so on.

The Fixed Star

BLACKFOOT narrators sometimes designated the North Star as the Fixed Star.

In the story of the Seven Stars it was said to be one of the brothers, though not

always so considered; however, myths need not be consistent, for they are literature, and even the most devout Blackfoot recognized the legitimacy of these different versions. For example, we now give a story accounting for the North Star in a different way. Incidentally, we note that this story is found among the mythological collections from many tribes throughout the United States. Everywhere it was a favorite and so is an Indian literary classic.

* * *

One summer night when it was very hot inside the lodge, two young women went outside to sleep. They woke up before daylight and were looking up at the sky, when one of them saw the Morning Star. She said to her companion, "That is a very bright star. I should like him for a husband." She soon forgot what she had said. In a few days these two young women went out from the camp to gather wood. When they had made up their packs and were drawing them up on their shoulders with the pack-straps, the strap broke that belonged to the girl who said she wished the Morning Star for her husband. Every time she made up her bundle and raised it to her back, the strap would break. Her companion, who was standing by her side with her pack on her shoulders, began to grow weary. She said, "I shall go on with my load; you can follow."

When the young woman was left alone, and had made up her bundle again, a handsome young man came out of the brush. He wore a fine robe made of beaver-skins, and had an eagle-plume in his hair. When the young woman started to go on, he stepped in front of her. Whichever way she turned, he headed her off. Finally she said to him, "Why do you head me off?" The young man replied, "You said you would take me for your husband." "No," said the young woman, "you must be mistaken. I never had anything to do with you. I do not know you." "I am the Morning Star," said the stranger, "and one night, when you looked up at me, you said that you wished me for a hus-

band. Now I have come for you." "Yes, I did say that," said the young woman. So she consented to go away with him. Then Morning Star put an eagle-plume in her hair, and told her to shut her eyes. Then they went up into the sky.

Now the Sun was the father of the Morning Star and the Moon was his mother. When they came into the lodge, Morning Star said to his parents, "I have brought a wife with me." The parents were pleased with what their son had done. Moon gave the young wife four berries and a few drops of water in a little shell. These were given to her to eat and to drink. Though the young woman was very hungry, she could neither eat all of the berries nor drink all of the water, because these berries stood for all the food there was in the world and the shell symbolized all the water there was in the ocean.

After a time, Moon said to her daughter-in-law, "Now I shall give you a root-digger, and you may go out to dig roots; but you are not to dig that big turnip there, because it is sacred." So the young woman went about the sky country digging roots for their food. She often looked at that fine large turnip growing there, and was curious to know why she was forbidden to dig it up. In course of time she gave birth to a child. One day, when it was old enough to sit alone, she said to herself as she went out to dig roots, "Now no one will know about it if I dig it up." So she stuck her digging-stick into the ground under the turnip; but, when she tried to raise it, the stick would not move. When she found that she could not get the stick out, she began to cry. Then two large white cranes flew down; one was a male and the other a female. The young woman prayed to them for help to get her root-digger out of the ground. Then the Crane-Woman said, "When I married I was true to my vow. I never had anything to do with any other man than my husband. It is because of this that I have power to help you. Your mother gave you this digging-stick. Now I shall teach you the songs that go with it." Then Crane-Woman

burned incense, took the hands of the woman into her own, and, while she sang the songs, placed them upon the digging-stick. Then Crane-Woman pulled out the stick, and, marching around in the direction of the sun, made three movements toward the turnip, and with the fourth dug it out. Now the young woman took the digging-stick and the turnip home with her. When her family saw what she had, they reprimanded her. Morning Star said to her, "What did you see when you dug out this turnip?" The woman replied, "I looked down through the hole and saw the earth, the trees, the rivers, and the lodges of my people."

"Now," said Morning Star, "I cannot keep you any longer. You must take the boy with you and go back to your people; but when you get there you must not let him touch the ground for two-seven (fourteen) days. If he should touch the ground before that time, he will become a puff-ball (a fungus), go up as a star, and fit into the hole from which you dug the turnip. He will never move from that place, like the other stars, but will always be still."

Sun said to her, "I shall call in a man to help you down to the earth." After a while a man came with a strong spiderweb, to one end of which he tied the woman and the boy, and let them down through the hole from which the turnip was taken. The woman came down over the camp of her own people. The young men of the camp were playing at the wheel-game. One of them happened to look up into the sky, where he saw something coming down. Now this young man was known to have poor eyesight, so when he told his companions that something was coming down from the sky, they looked, and, seeing nothing, made sport of him. As he still insisted, they, in derision, threw dirt into his eyes. But after a while they, too, saw something coming down from the sky. As the woman reached the ground in the centre of the camp, some one, recognizing her, called out, "Here is the woman who never came back with her wood." Then all her friends came out to meet her, and her mother took her home.

Now, before the woman left the sky, Morn-

ing Star told her, that, since she had made one mistake in digging up the turnip, she would no doubt make another mistake, and allow the child to touch the ground before the time was up. So he advised her to make the sign of the Morning Star on the back of her lodge, so that she might be reminded daily of her duty. (The doors of the lodges at that time faced the sun, and the sign of the Morning Star was to be made upon the back of the lodge, because he always travels on the other side from the sun.)

The young woman kept careful watch over the boy for thirteen days. On this day her mother sent her out for water. Before going out, the young woman cautioned her mother to keep the child upon the bed, and not allow him to touch the ground. Now the grandmother was not so careful, because she did not understand the reason for watching the child; and while her back was turned he crawled out upon the ground. When she saw him, she caught him up, putting him back on the bed as quickly as she could. This seemed to make the child angry, for he pulled the robe up over himself. The grandmother paid no further attention to him.

Now, when the boy's mother came back, she looked around, and said, "Where is my child?" "Oh, he covered himself up with a robe," said the grandmother. The young mother rushed to the bed, pulled back the robe, and found nothing but a puff-ball (fungus). She caught this up, and carried it in her bosom all the time.

That evening when the stars came out, she looked up into the sky. A new star stuck in the hole from which she pulled the turnip. Then she knew what had become of her child.

This is the way the Fixed Star came to be.

After this the woman painted circles around the bottom of her lodge to represent the puff-ball, or the Fallen Star (the one that came down). She had already painted the Morning Star on the back of her lodge. This is why the people paint their lodges in the way that

you see them. Also this woman brought down the sacred turnip and the digging-stick. Crane-Woman taught her the songs that go with them and their use in the sun-dance. This was the beginning of the medicine-woman (leader in the sun-dance).

* * *

The Blackfoot believe that the puff-ball fungus is what is left after a star falls. Probably suggested by the genus of puff-balls, called by botanists *Geasters* or earth-stars, having double walls, the outer one of which bursts open and spreads out, presenting the appearance of a conventional star. The narrator is using a literary touch in referring to the fact that the child came from the sky and so was a fallen star. The large tipi in the Plains Indian Hall of the Museum has circular spots around its base representing these "fallen stars" lying on the ground. At the top the Seven Stars, the Six Brothers, and the Morning Star are represented. If the reader will visit this tipi with this charming legend in mind, he will catch some of the spirit of the Blackfoot Indian woman who made the skin cover of the tipi and decorated it. She, like the painter of the mural on the Planetarium wall, was interpreting in form and color a legend of the olden time.

Blood-Clot, or Smoking-Star

ONCE there was an old man and woman whose three daughters married the same young man. The old people lived in a lodge by themselves. The young man was supposed to hunt buffalo, and feed them all. Early in the morning the young man invited his father-in-law to go out with him to kill buffalo. The old man was then directed to drive the buffalo through a gap where the young man stationed himself to kill them as they went by. As soon as the buffalo were killed, the young man requested his father-in-

law to go home. He said, "You are old. You need not stay here. Your daughters can bring you some meat." Now the young man lied to his father-in-law; for when the meat was brought to his lodge, he ordered his wives not to give meat to the old folks. Yet one of the daughters took pity on her parents, and stole meat for them. The way in which she did this was to take a piece of meat in her robe, and as she went for water drop it in front of her father's lodge.

Now every morning the young man invited his father-in-law to hunt buffalo and, as before, sent him away and refused to permit his daughters to furnish meat for the old people. On the fourth day, as the old man was returning, he saw a clot of blood in the trail, and said to himself, "Here at least is something from which we can make soup." In order that he might not be seen by his son-in-law, he stumbled, and spilt the arrows out of his quiver. Now, as he picked up the arrows, he put the clot of blood into the quiver. Just then the young man came up and demanded to know what it was he picked up. The old man explained that he had just stumbled, and was picking up his arrows. So the old man took the clot of blood home and requested his wife to make blood-soup. When the pot began to boil, the old woman heard a child crying. She looked all around, but saw nothing. Then she heard it again. This time it seemed to be in the pot. She looked in quickly, and saw a boy baby: so she lifted the pot from the fire, took the baby out and wrapped it up.

Now the young man, sitting in his lodge, heard a baby crying, and said, "Well, the old woman must have a baby." Then he sent his oldest wife over to see the old woman's baby, saying, "If it is a boy, I will kill it." The woman came in to look at the baby, but the old woman told her it was a girl. When the young man heard this, he did not believe it. So he sent each wife in turn; but they all came back with the same report. Now the young man was greatly pleased, because he could look for-

ward to another wife. So he sent over some old bones, that soup might be made for the baby. Now, all this happened in the morning. That night the baby spoke to the old man, saying, "You take me up and hold me against each lodge-pole in succession." So the old man took up the baby, and, beginning at the door, went around in the direction of the sun, and each time that he touched a pole, the baby became larger. When halfway around, the baby was so heavy that the old man could hold him no longer. So he put the baby down in the middle of the lodge, and, taking hold of his head, moved it toward each of the poles in succession, and, when the last pole was reached, the baby had become a fine young man. Then this young man went out, got some black flint (obsidian) and, when he returned to the lodge, said to the old man, "I am the Smoking Star. I came down to help you. When I have done this, I shall return to the sky."

When morning came, Blood-Clot (the name his father gave him) arose and took his father out to hunt. They had not gone far when they killed a scabby cow. Then Blood-Clot lay down behind the cow and requested his father to wait until the son-in-law came to join him. He also requested that he stand his ground and talk back to the son-in-law. Now, at the usual time in the morning, the son-in-law called at the lodge of the old man, but was told that he had gone out to hunt. This made him angry, and he struck at the old woman, saying, "I have a notion to kill you." So the son-in-law went out.

Blood-Clot had directed his father to be eating a kidney when the son-in-law approached. When the son-in-law came up and saw all this, he was very angry. He said to the old man, "Now you shall die for all this." "Well," said the old man, "you must die too, for all that you have done." Then the son-in-law began to shoot arrows at the old man, and the latter, becoming frightened, called on Blood-Clot for help. Then Blood-Clot sprang up and

upbraided the son-in-law for this cruelty. "Oh," said the son-in-law, "I was just fooling." At this Blood-Clot shot the son-in-law through and through. Then Blood-Clot said to his father, "We will leave this meat here, it is not good. Your son-in-law's house is full of dried meat. Which one of your daughters helped you?" The old man told him that it was the youngest. Then Blood-Clot went to the lodge, killed the two older women, brought up the body of the son-in-law, and burned them together. Then he requested the younger daughter to take care of her old parents and to be kind to them. "Now," said Blood-Clot, "I shall go to visit other Indians."

So he started out, and finally came to a camp. He went into the lodge of some old women, who were surprised to see such a fine young man. They said, "Why do you come here, among such old women as we? Why don't you go where there are young people?" "Well," said Blood-Clot, "give me some dried meat." Then the old women gave him some meat, but no fat. "Well," said Blood-Clot, "you did not give me the fat to eat with my dried meat." "Hush!" said the old women. "You must not speak so loud. There are bears here that take all the fat and give us the lean, and they will kill you, if they hear you." "Well," said Blood-Clot, "I will go out tomorrow, do some butchering, and get some fat." Then he went out through the camp, telling all the people to make ready in the morning, for he intended to drive the buffalo over the cliff.

Now there were some bears who ruled over this camp. They lived in a bear-lodge (painted lodge), and were very cruel. When Blood-Clot had driven the buffalo over, he noticed among them a scabby cow. He said, "I shall save this for the old women." Then the people laughed and said, "Do you mean to save that poor old beast? It is too poor to have fat." However, when it was cut open it was found to be very fat. Now, when the bears heard the buffalo go

over the drive, they as usual sent out two bears to cut off the best meat, especially all the fat; but Blood-Clot had already butchered the buffalo, putting the fat upon sticks. He hid it as the bears came up. Also he had heated some stones in a fire. When they told him what they wanted, he ordered them to go back. Now the bears were very angry, and the chief bear and his wife came up to fight, but Blood-Clot killed them by throwing hot stones down their throats. Then he went down to the lodge of the bears and killed all, except one female who was about to become a mother. She pleaded so pitifully for her life, that he spared her. If he had not done this, there would have been no more bears in the world. The lodge of the bears was filled with dried meat and other property. Also all the young women of the camp were confined there. Blood-Clot gave all the property to the old women, and set free all the young women. The bears' lodge he gave to the old women. It was a bear painted lodge.

"Now," said Blood-Clot, "I must go on my travels." He came to a camp and entered the lodge of some old women. When these women saw what a fine young man he was, they said, "Why do you come here, among such old women? Why do you not go where there are younger people?" "Well," said he, "give me some meat." The old women gave him some dried meat, but no fat. Then he said, "Why do you not give me some fat with my meat?" "Hush!" said the women, "you must not speak so loud. There is a snake-lodge here, and the snakes take everything. They leave no fat for the people." "Well," said Blood-Clot, "I will go over to the snake-lodge to eat." "No, you must not do that," said the old women. "It is dangerous. They will surely kill you." "Well," said he, "I must have some fat with my meat, even if they do kill me." Then he entered the snake-lodge. He had his white rock knife ready. Now the snake, who was the head man in this lodge, had one horn on his head. He was lying with his head in the lap of a beauti-

ful woman. He was asleep. By the fire was a bowl of berry-soup ready for the snake when he should wake. Blood-Clot seized the bowl and drank the soup. Then the woman warned him in whispers, "You must go away: you must not stay here." But he said, "I want to smoke." So he took out his knife and cut off the head of the snake, saying as he did so, "Wake up! light a pipe! I want to smoke." Then with his knife he began to kill the other snakes. At last there was one snake who was about to become a mother, and she pleaded so pitifully for her life that she was allowed to go. From her descended all the snakes that are in the world. Now the lodge of the snakes was filled up with dried meat of every kind and fat. Blood-Clot turned all this over to the people, the lodge and everything it contained. Then he said, "I must go away and visit other people."

So he started out. Some old women advised him to keep on the south side of the road, because it was dangerous the other way. But Blood-Clot paid no attention to their warning. As he was going along, a great windstorm struck him and at last carried him into the mouth of a great fish. This was a sucker-fish and the wind was its sucking. When he got into the stomach of the fish, he saw a great many people. Many of them were dead, but some were still alive. He said to the people, "Ah, there must be a heart somewhere here. We will have a dance." So he painted his face white, his eyes and mouth with black circles, and tied a white rock knife on his head, so that the point stuck up. Some rattles made of hoofs were also brought. Then the people started in to dance. For a while Blood-Clot sat making wing-motions with his hands, and singing songs. Then he stood up and danced, jumping up and down until the knife on his head struck the heart. Then he cut the heart down. Next he cut through between the ribs of the fish, and let all the people out.

Again Blood-Clot said he must go on his travels. Before starting, the people warned him, saying that after a while he would see a

woman who was always challenging people to wrestle with her, but that he must not speak to her. He gave no heed to what they said, and after he had gone a little way, saw a woman who called him to come over. "No," said Blood-Clot. "I am in a hurry." However, at the fourth time the woman asked him to come over, he said, "Yes, but you must wait a little while, for I am tired. I wish to rest. When I have rested, I will come over and wrestle with you." Now, while he was resting, he saw many large knives sticking up from the ground almost hidden by straw. Then he knew that the woman killed the people she wrestled with by throwing them down on the knives. When he was rested, he went over. The woman asked him to stand in the place where he had seen the knives; but he said, "No, I am not quite ready. Let us play a little, before we begin." So he began to play with the woman, but quickly caught hold of her, threw her upon the knives, and cut her in two.

Blood-Clot took up his travels again, and after a while came to a camp where there were some old women. The old women told him that a little farther on he would come to a woman with a swing, but on no account must he ride with her. After a time he came to a place where he saw a swing on the bank of a swift stream. There was a woman swinging on it. He watched her a while, and saw that she killed people by swinging them out and dropping them into the water. When he found this out, he came up to the woman. "You have a swing here; let me see you swing," he said. "No," said the woman, "I want to see you swing." "Well," said Blood-Clot, "but you must swing first." "Well," said the woman, "now I shall swing. Watch me. Then I shall see you do it." So the woman swung out over the stream. As she did this, he saw how it worked. Then he said to the woman, "You swing again while I am getting ready," but as the woman swung out this time, he cut the vine and let her drop into the water.

"Now," said Blood-Clot, "I have rid the

world of all the monsters, I will go back to my old father and mother." So he climbed a high ridge, and returned to the lodge of the old couple. One day he said to them, "I shall go back to the place from whence I came. If you find that I have been killed, you must not be sorry, for then I shall go up into the sky and become the Smoking-Star." Then he went on and on, until he was killed by some Crow Indians on the war-path. His body was never found, for the moment he was killed he ascended to the sky, where he now appears as the Smoking-Star.

* * *

This star has not been positively identified. Formerly the Blackfoot practised a ceremonial dance in which a dancer impersonating Blood-Clot wore a stone knife on his head from which the light flashed as he jumped up and down; the Smoking-Star was thought to look like this. Some informants placed the star in Orion, probably the Great Nebula in Orion. To the naked eye, this is a hazy (smoky) spot surrounding what appears to be a single star, the middle one of the sword.

Scar-Face

SCAR-FACE was a favorite mythical character among the Blackfoot Indians. They used to refer to him in conversation, and skillful narrators always did their best when rendering the myth. Arthur Nevin wrote an opera based on the adventures of Scar-Face.*

The alternate name for Scar-Face is Mistaken Morning Star. The belief is that often near dawn a bright star will appear which is sometimes mistaken for the true Morning Star. A little later the Morning Star will rise and reveal the mistake. Two planets approaching conjunction would invite such confusion. Any-

way the creator of the story used this concept skillfully.

* * *

Once there was a very poor young man who lived with his sister. He had a chum. In the camp was a very fine girl, the daughter of a chief, with whom all the young men were in love. Now the poor young man was in love with her also, but he had a long, ugly scar on his cheek. One day he asked his sister to go over to the chief's lodge to persuade the girl to marry him. Accordingly, the sister went over; but when the girl found out what she wanted, she said that she was willing to marry Scar-Face whenever that ugly scar disappeared. She made all manner of fun of Scar-Face.

The sister returned and told Scar-Face what the girl had said. He was very much hurt, and decided to go away to seek some one who could aid him in removing the scar. Yet, though he traveled far, no one could tell him where to go for aid. At last he decided to go to the Sun. So he traveled on and on, and the farther he went, the blacker the people became. As he went along, he inquired for the Sun's house. Always he was told to go on, until he came to a very high ridge where some people lived who could tell him the whereabouts of the Sun's house. At last Scar-Face came to this ridge. There he saw a nude man with very black skin and curly hair. Scar-Face called to him. "Where is the Sun's lodge?" "It is at the end of this ridge," said the black man. "But go back! go back! You will be burned very badly!" Scar-Face said, "Well, I shall go on anyway; it is better to die than to go back." "Look at me!" said the black man. "You can see how I have been burned black. You had best take my advice and go no farther." "Where do you live?" asked Scar-Face. "I have a cave to live in," replied the black man. "I stay in this cave when the sun is hot, otherwise I should be burned up." (It was just about sun-

*The title of the opera is "Poia," the Indian name for Scar-Face. The music was played in 1907 in Pittsburgh, and the Opera was produced in the Berlin Royal Opera House, the first performance having been given on April 23, 1910.

down that Scar-Face met the black man.) The black man advised him to travel only at night.

Now Scar-Face went on towards the place where the Sun lived. Presently he saw a young man standing alone. The young man called to Scar-Face, "Where are you going?" "I am going to the Sun," said Scar-Face. "Oh!" said the young man. "Sun is my father, this is his house." (This young man was Morning Star.) "My father is a strong willed man. He is not at home now, but when he comes he will surely kill you. However, I will talk with my mother, who is a tender hearted woman and will treat you kindly." Then Morning Star took Scar-Face up to his father's lodge, and addressed his mother, saying, "Mother, I have brought a strange young man here. I wish him for a companion. He has come a long way to find us, and I wish you would take pity on him, that I may enjoy his company." "Well," said his mother, "bring him in. We will talk to your father when he returns; but I fear we shall not be able to keep the young man."

When Scar-Face was taken into the lodge, he saw on the ground a kind of earthen square, with some cedar-brush, and buffalo-chips. This was the altar or sacred place, where Sun burned incense. After a time the old woman who was Moon, said to Scar-Face, "Is there anything that you especially care for?" "Yes," answered Scar-Face, "I want this scar taken from my face." "Well," replied Moon, "it is about time for my husband to come in. If he takes pity on you—well, we shall see." In a little while Moon said, "Now he is coming." Then she took Scar-Face to one side of the lodge and covered him up with cedar. Scar-Face began to feel very warm, because Sun was approaching. He began to shift about under the cedar, but Moon whispered that he must be quiet. So he lay very still, but became very hot as Sun came up. Finally Moon said to Scar-Face. "Now Sun is at the door." Sun looked into the lodge and said, "Oh, my, this lodge smells bad!" "Yes," Moon replied. "Morning Star has a chum here." "Well,"

said Sun, "make a smudge with cedar (burn it on the altar)."

After this had been done, Sun entered the lodge. Now Scar-Face was very hot. Finally Sun said, "Where is that young man?" "We covered him up," said Moon. "Come," said Sun, "get up." Then Scar-Face came out from under the cedar. He could not look Sun in the face. As Sun looked upon him, he knew that this was a poor unfortunate boy, and took pity on him. The heat then grew gradually less.

Now it seems that Morning Star was out on one of his journeys, and Sun waited for his return. When Morning Star came into the lodge and sat down in his usual place, Sun addressed him, saying, "My son, do you wish this young man for a companion?" Then Morning Star said that he did very much, as he wished for a companion to go about with him. He was lonesome on his journeys through the sky. "Well," said Sun, "you must make a sweat-house." Then Morning Star went out and prepared a sweat-house. When all was ready, Sun went out. He had a disk of metal at the back of his head. This disk looked like brass. Then Sun went into the sweat-house and began to wipe off the metal disk. Then he brought Morning Star and Scar-Face into the sweat-house. When they were in, the covers were closed down. At last, when all was ready the covers were raised and the light let in. The two boys now looked alike.

Now, Moon came out, and Sun said to her, "Which is Morning Star?" Moon looked at them for a moment, then pointed at one; but she made a mistake, for she pointed at Scar-Face. "Oh!" said Sun, "you are a foolish woman! This is the star you mistook for Morning Star. After this, his name shall be Mistaken-for-Morning Star."

Scar-Face stayed with his new companion at Sun's house. Sun told him that he could go anywhere in the sky-land except straight west or straight down: he could go in any other direction. One morning, when Morn-

ing Star and Scar-Face were out together, Scar-Face said, "Let us go that way," pointing to the west. "No," replied Morning Star. "It is dangerous. My father said we must not go there." "Oh," said Scar-Face, "let us go anyway." Morning Star refused, but at the fourth request he said, "All right, let us go." So the two boys went in the forbidden direction, and presently they came to a place where there were seven large white geese. At once the birds attacked them. Morning Star ran, calling out, "Now you see." Scar-Face did not run, but killed the seven geese with his club, then ran home. Before he reached home, he overtook Morning Star, and said to him, "There is no danger now. I killed all of those birds."

When they reached home, Morning Star told his mother what Scar-Face had done, but she said to Scar-Face, "I will not believe you until you get their heads." So the boys returned and took the heads of the seven birds. (This is supposed to be the origin of scalping, and no one will believe that an enemy is killed until his scalp is produced.)

Some time after this, Scar-Face and Morning Star went out together as before, and Scar-Face said, "Let us go that way again." "No," said Morning Star. "It will be more dangerous than before." Scar-Face insisted, and at the fourth request, Morning Star consented. As they were going along, they saw seven cranes. When the cranes saw the boys, they took after them. Morning Star ran away as fast as he could. These cranes were terrible looking birds, and Scar-Face was badly frightened; but he took off his robe and held it in front of him. As the cranes came up, they began to peck at the robe, whereupon Scar-Face struck them one by one with his club.

Now when Scar-Face reached home, Sun was there and asked where he had been. Scar-Face said that he was walking along when some large cranes took after him, and that he had killed them all with his club. "Oh!" said Sun, "I will not believe it until you have shown me their heads." So Scar-Face returned to the scene

of his conflict, and brought away the heads of the cranes. When Sun saw the heads, he believed him. Sun was greatly pleased at the courage of Scar-Face, and brought out a bundle. "Here," said he, "are some clothes for you,—a shirt and leggings. These I give you because you have killed some very dangerous and troublesome birds." Then Sun took up the leggings, and painted seven black stripes on them, saying, "I make these here as a sign that you killed enemies. All your people shall wear black stripes on their leggings when they kill enemies." Then Sun sang some songs which were to go with the clothes.

After a time, Scar-Face said to Sun, "Now I should like to return to my people. I have been here long enough." "All right," said Sun. "You may go." Then Sun took Scar-Face out, put a hoop or ring of cedar around his head, and, as soon as the hoop was on, Scar-Face found that he could see down to his people. "Now," said Sun, "shut your eyes." Scar-Face shut his eyes. When he opened them, he found himself down by the camp of his people. Now in the camp at that time there were some Indians who were playing at the wheel-and-arrow game; and one of the players, looking up, saw a black object coming down from the sky. He called out, "Oh, look at that black thing!" Then all stopped to look. They saw the object coming closer and closer. At last it reached the ground, some distance from them. It appeared to be a person. Then the old chum of Scar-Face, who was among the young men playing at the wheel-game, recognized Scar-Face, and rushed up to him; but, as he approached, Scar-Face said, "Go back! Go back! Do not touch me. You must get some willows, and make a sweat-house out here from the camp."

Then the chum went back to the people of the camp and explained to them. A sweat-house was prepared. When all was ready, Scar-Face went into the sweat-house with the bundle containing the suit of clothes given him by the Sun. When the bath had been taken, Scar-Face

came out, carrying the bundle in his arm. He said to his chum, "My friend Sun gave me a suit of clothes: now I will give them to you."

Now this is why our people say that the sweat-house came from the sun. The medicine-lodge we make at the sun-dance is the lodge of the sun where Scar-Face had been. The weasel-tail suit which Scar-Face brought to his chum was just like those you see to-day. There was a disk on the back and one on the front. There were seven black stripes on each sleeve. These were for the groups of seven birds that Scar-Face killed. Sometimes the feet of these birds are painted on the shirt. The seven bands on the leggings are for the seven other birds that Scar-Face killed. Scar-Face directed that only such persons as performed great deeds were to be allowed to wear such a suit.

After a time Scar-Face longed to see his friend Morning Star and so returned to the sky where he has been ever since. He is sometimes called the chum of Morning Star, or the Mistaken Morning Star, but usually just Scar-Face.

The Twin Brothers

A LONG time ago there was a man by the name of Smart-Crow. When he traveled, he always went by himself. One day after he was married he told his wife that in the future two children would be born to them, both boys. He predicted that one of them would be disobedient and the other reliable. Smart-Crow knew this, because a crow had given him the information in a dream. This crow also told him that, before his two children were born, an evil man would try to kill their mother. The crow told the man that he must warn his wife. It said, "This man will come to the lodge when you are away, and ask to come inside. Your wife must say nothing to him. He will repeat the visit four times." The next time Smart-Crow went out to hunt, he told his wife about this dream, and warned her not to speak to the strange man.

While Smart-Crow was away, the strange

man came and stood before the lodge. After a while the woman thought to herself, "Why does not this man come in?" Now, the stranger had great power. He read the woman's thoughts, and, as soon as she thought this, the man answered by saying, "I will tell you why." So he entered the lodge and sat down, saying as he did so, "I knew you wished me to come in." Now the woman began to cook some meat for the stranger, and when it was ready, she put it in some wooden bowls, and placed it before him. There were four kinds of bowls in the house. Some were made of hard knots of wood; some of bark; some of buffalo-horn; and some of mountain-sheep horn. After the woman had cooked the meat, she placed it before the stranger in a wooden bowl. The stranger looked at it and said, "That is not the kind of bowl from which I take my food." Then the woman took the food, and, putting it into a bark bowl, offered it to him again. "No," he said, "I do not take my food from bark." So the woman took the food, placed it in a bowl of buffalo-horn, and offered it to him for the third time. Again he refused, saying that he did not take food from horns. The woman took back the food, and, putting it in a bowl of sheep-horn placed it before him; but he refused to take food in such a dish. Now the woman was troubled, and looked about the lodge for something in which to serve the food. Finally she saw a piece from the horn of a moose, and offered him food upon it. This he refused also. As she looked about for something else, she happened to see a blanket. "That will do not, either," said the stranger. Then she offered her dress. "That is near the kind I must have," he said. Then the woman said, "Oh, well, I will put the meat on my breast." "All right," said the stranger. The woman then lay down on her back, and placed the meat on her breast. The stranger had a white stone knife, which he sharpened and began to cut the meat. Three times he cut the meat; but the fourth time he said, "I came near cutting you." The fifth time he cut the woman open,

killing her. Then the stranger saw two infants in the lodge. They were twin brothers.

The stranger took one of them, put him down near the ashes, and as he did so said, "You shall be called Ashes-Chief." Then he took the other, stuck him behind the lining of the lodge, and said, "You shall be called Stuck-Behind." Then the man went away. He carried a small lodge, with the skin of a running-fisher for a pennant.

After a while Smart-Crow returned from his hunt, bringing much buffalo-meat. As he came over the hill near his lodge, he saw no smoke rising from the smoke-hole. "Now," he said to himself, "I know what has happened. I knew that woman would invite the stranger in." When he entered the lodge, he saw Ashes-Chief lying by the fire. While he was looking at his wife's body he heard the other infant crying behind the lodge-lining.

Now Smart-Crow was very angry, and rushed out in pursuit of the stranger. He followed his trail and soon overtook him. As he came up, he said to the stranger, "Now I shall kill you." "My friend," said the stranger, "I will restore her to you." "I do not believe you," said Smart-Crow. "My friend, I tell you I will restore her," repeated the stranger. "I cannot believe it," said Smart-Crow. "My friend," said the stranger, "I will restore her to you." "You are a liar," said Smart-Crow. Then the stranger began to sing a song. The words of this song were as follows:—

"I am a great medicine (powerful.)
Everything in the ground hears me.
Everything in the sky hears me."

When Smart-Crow heard this song, he believed in the promise of the stranger. Then the stranger took the bundle from his back, and said, "I give you this lodge and the running-fisher skin." The stranger set up the lodge. There were four buffalo-tails hanging to its sides. Two of these were cow-tails, and two were bull-tails. One of each hung in front, and also behind. This lodge was called the Four-Tail Lodge. The stranger told Smart-Crow that the hanging of the buffalo-tails on the lodge

would make the buffalo range near it, so that the people would always have meat. The stranger transferred this lodge to Smart-Crow. He sat down upon a stump, explained the ritual to him, and also taught him the songs. Among other things he said, "The punk which you use to make fires is made of bark, and does not kindle quickly; take puff-balls (fungus) instead, for they are much better. They are the Dusty Stars. You are to paint these stars around the bottom of the lodge. At the top of the lodge you are to paint the Seven Stars on one side and the Bunch Stars on the other. At the back of the lodge, near the top, you must make a cross to represent the Morning Star. Then around the bottom, above the Dusty Stars, you shall mark the mountains. Above the door, make four red stripes passing around the lodge. These are to represent the trails of the buffalo."

When Smart-Crow had received all of the instructions belonging to the new lodge, and had learned all the songs, he went away with it and returned to his own lodge. He picked up Ashes-Chief, and said to a large rock lying near by, "I give you this child to raise." Then he pulled down the lining of the lodge, picked up Stuck-Behind, and called out to his friend the beaver, "I give you this child to raise." So the rock and the beaver took the boys away.

The boys grew up. When they were about six years old, Smart-Crow began to wish that he might have them with him again. He went out to get them back; but the boys were wild, and knew nothing about people. So, when the boys saw him coming, Ashes-Chief ran into the rock and Stuck-Behind into the beaver's house. Then Smart-Crow took some arrows from his quiver, laid them down near the rock, and concealed himself in the bushes. After a while, Ashes-Chief came out, saw the arrows, and looked curiously at them. As the boy was about to pick them up, Smart-Crow sprang out and caught him. Now Ashes-Chief had been raised by the rock, and was so strong for his

age that Smart-Crow was scarcely able to hold him. He saw that his son would soon break away; so he said, "Ashes-Chief, lick my hand, and you will know that I am your father." Then Ashes-Chief licked his hand, stopped struggling, and said, "Yes, you are my father, and I will go with you."

Now Smart-Crow was anxious to secure Stuck-Behind, and advised with Ashes-Chief as to how to proceed. Finally they decided to draw him out of the beaver's house by playing the hoop-game. Smart-Crow concealed himself near the house while Ashes-Chief began to roll the hoop back and forth near the door. Stuck-Behind became curious to know about the hoop, and ventured out to play. When he was outside, Smart-Crow sprang upon him, and held him fast. Now, Stuck-Behind had been raised by the beaver, and for that reason was very hard to hold. Smart-Crow said to him, "Lick my hand, and you will know that I am your father." He did so, and recognized his father.

When the boys were at home with their father, their names were changed. Ashes-Chief was now called Rock, and Stuck-Behind was called Beaver. Thus were they separated from the rock and the beaver. Rock was the adventurous one, and Beaver the good one, as the crow had told their father in the dream. One day Rock said to his father, "Make me a bow and two arrows." "What do you want with bows and arrows?" said Smart-Crow. "Well," said Rock, "Beaver and I wish to go out to hunt buffalo. While we are gone, you must go back to our old lodge where the bones of our mother lie, and cut a stick such as she used for stirring the meat when cooking. Wait there for us until we bring the meat." Then Rock and Beaver went on their way to hunt.

Now, at this time, the people cooked in pots of clay. These were shaped out of mud by the hands, and put in the sun to dry; then the kettle was rubbed all over with fat inside and out, and placed in the fire. When it was red hot, it was taken out, and allowed to cool. Such

a pot was good for boiling. Rock told his father to take one of his mother's pots, fill it with water, and put it over the fire so that it might be ready for his mother to boil meat.

After a while the boys came up to their mother's lodge, where the skeleton lay. They had a great deal of meat with them. Rock said, "Now, I shall take a little meat from each part of the buffalo, boil it in the pot, and then make medicine to put over the skeleton of our mother." Beaver said, "I shall help mother with the heart, the brains, and the marrow." Rock took up the tongue, blew his breath on it four times, and put it into the pot. Then he took up the other parts, one at a time, and did the same. The brains and marrow, however, he laid to one side, and did not put them into the pot. Rock said to Beaver, "I will help mother in two things and you may help her in the other two things." Now Smart-Crow was lying down in bed. The boys took his robe, and covered their mother's bones. Then the pot began to boil more than ever, and Rock said to his father, "Get up, call mother, and tell her that her pot is about to boil over."

The father arose from his bed, went over to the place where the robe lay, and said, "Get up, woman! Your pot is about to boil over." The bones did not move. Then Beaver called, "Mother, get up quick! Your pot is boiling over." At this there was a little movement under the robe. Then Rock called out, "Mother, get up quick, and feed us!" At this there was much movement under the robe, and parts of the woman's feet could be seen beneath the edge. Now Beaver called to her, which made the fourth time, saying, "Mother, get up quick! I have a heart, brains, and marrow for you to eat."

The woman sat up and drew a deep breath. "I have had a long sleep," she said. "I am very hungry; I shall eat." The boys gave her some of each part of the buffalo to restore her to life. For eyes, they gave her the inside of the eyes; for brains, they gave her the brains;

for tongue, part of the tongue; for heart, part of the heart, and so on. When she had eaten all of these, she got up and set food before her children and Smart-Crow, as she had always done.

Then Smart-Crow said to his wife, "Let us move from this place; it is an unlucky place for us. Let us leave this lodge here and take the new one given me by the stranger. When this new lodge is up in a new place, make a sweat-house, that I may go through it, for we have a medicine-lodge now. I did not kill the stranger, because he promised to restore you to me, and gave me this new lodge. After all I have seen, I believe that this lodge is very powerful. You have been asleep for a long time. Your bones were bleached, now you are alive; and it is the power of this lodge that made you so. When we are old, we will give this lodge to Beaver; he is a good man. Rock, on the other hand, is no good, and he will not live long."

When the mother had put up the new lodge in a new place, she made a sweat-house. Smart-Crow put the skin of the running-fisher around his shoulders, painted his face, took off his breech-cloth and moccasins, and was ready to go through the sweat-house. Then he covered the sweat-house with the skin of the new lodge, that it also might be purified. When he came out of the sweat-house, he painted his wife and children, and, taking up the lodge, put it in place. When all this was arranged, the woman looked at the lodge, admiring it. "What are those round things at the bottom?" she said.

"Those," said Smart-Crow, "are for two purposes. They will help us to live long and to make fire quickly." When they had gone inside of the lodge, Smart-Crow said to his wife, "Now I shall teach you how to use the smudge." Then he took some moss from the pine-tree and laid it upon the fire, singing a song. "You are to do this," he said, "every morning and every night. Also you must sing two-seven songs (fourteen) that I shall teach you."

Now all this time Smart-Crow had been away from his people; but now he returned with his family and the new lodge. This created a great sensation.

The hoop that was used in catching Beaver was the big game-hoop. Rock and Beaver often played at this game. One day their father told them that they must not roll the hoop in the same direction as the wind. Then they went out to play. Now Rock said to Beaver, "There is no reason why we should not roll this hoop with the wind. Nothing will happen if we do." "Oh," said Beaver, "our father requested us not to do this, and we should obey him." However, Rock paid no attention to what he said, and started the hoop in the direction of the wind. Now, the hoop continued to roll and roll. It would not stop, and as the boys followed along, waiting for it to fall, they were brought near a rock lodge. As the hoop rolled by, an old woman came out, took it in her hands, and invited the boys inside. They both went in.

This old woman had some kind of power. She killed people by suffocating them with smoke. As soon as the boys were seated, she took out a large pipe with a man's head for a bowl. Then she placed a great heap of wood on the fire, and, after shutting the door and the ears (smoke-hole) of the lodge, lighted the pipe and made a great smoke. Then the old woman said to the boys, "Smoke with me." "No," said Rock. "You must," said the old woman, "because it is the custom for the guest to smoke with the head of the lodge."

Now this old woman was a cannibal, and the boys knew it. So Rock said to the old woman, "Well, I will smoke with you." But Beaver refused. Then the old woman gave back the hoop, which Beaver took and put over his head. Rock took out a yellow plume and tied it to his hair. Both of these things had power. The hoop kept the smoke away from Beaver's head, so that his head was in a hollow place surrounded by thick smoke. The plume in

Rock's hair whirled in the air, and kept the smoke from his face. Now the smoke was so thick that the old woman could not see. She did not know that the boys had such great power. It became so thick at last that she was almost suffocated herself. "Oh!" she said, "there is too much smoke." She tried to rise to open the door, but fell down dead. Then the boys went outside of the lodge, and called out as if talking to the old woman. In this way they made all manner of fun of her great power. Looking around, they found themselves near the rock that had raised Rock. Then Rock took an arrow from his quiver, spit upon the point, and, pointing toward the rock, asked it for help, saying, "Make the arrow do what I wish." Then he threw the arrow at the lodge in which the old woman lived. It struck at the bottom, making a hole from which the water began to flow. The stream continued to increase in size until it carried the lodge and rock away. Then the boys went home. Rock told his father everything that had happened, and laughed a great deal.

There was a tall tree upon which grew some fine berries. Their father said to them, "You must not eat those berries." Some time after, when the boys were out by themselves, Rock looked up at the tree, and said to Beaver, "Come, let us get some of those berries." But Beaver said, "No. Every time father requests us to do a thing, you do the opposite." But as Rock insisted upon getting the berries, Beaver consented. Now, beneath this tree lived a snake with a large horn in the middle of his head. When they came near the tree, Beaver was afraid, and said to Rock, "I do not wish to climb the tree. You get the berries." Then Rock began to climb the tree, and, when he was up in the branches, the snake came out of the bushes and began to climb the tree. When the snake came within reach, he tried to hook Rock; but missing, his horn struck the tree and stuck fast. Then Rock broke the tree and twisted the trunk, which pulled out the snake's

brains. This snake always killed people who came to gather berries. Then the boys took some of the berries and went home. Rock related the adventure to his father, and laughed as if it were but an incident.

Once they were forbidden to shoot at the morning-bird. Now the morning-bird was a very powerful creature; every one was afraid to do anything to him. One day when the boys were out, they saw this bird, but could not get at him as he was high in the air. Later they saw the bird near the ground, and Rock suggested to Beaver that they send an arrow after it. Again Beaver tried to persuade Rock to heed the commands of their father; but without success. So Rock shot an arrow into the bird. It fell into the branches of a tree, almost within their reach. Rock stood upon a log and tried to reach the bird, but every time he tried, the bird got a little higher. Then he got upon a limb, and finally into the tree itself. Then, as he climbed the tree, the bird went higher and higher, and the tree became taller and taller, until Beaver, who stood upon the ground, could not see them. Now Beaver felt very much ashamed that he had yielded to his brother's folly. He did not feel like going home to tell his father, so he sat down by the tree and began to cry. When this happened, the boys were men, but Beaver cried so much at the foot of the tree that he became a dirty little ragged boy.

At this time the Blackfoot were out looking for buffalo, but could find none. They were forced to live upon such berries as they could find. One day an old woman gathering berries heard a child crying. Looking around, she found Beaver at the foot of the tree. He was almost starved. The old woman felt sorry for him, picked him up and took him home. She gave him to her daughter to care for, saying, "Here is my grandson. When he grows up, he will run errands for us. You must feed him." Now, as they had no meat from which to make soup for the child, the daughter gathered some old bones around the camp and boiled them in

a kettle. A few days after this the chief of the camp, who had two beautiful daughters for whom there were many suitors, made a public announcement. He said, "To-morrow morning a prairie chicken will sit upon a tall tree near the camp, and all the young men are to shoot at it with bows and arrows. The man who hits it first shall receive my eldest daughter for a wife."

Now Beaver was a very dirty little fellow; every one in the camp talked about his uncleanliness. When he heard what the chief said, he said to the old woman who found him, "Make me some arrows and I will try to hit the bird." "Oh, you dirty thing!" said the woman in disgust. "You are a disgrace to the camp; you would nauseate everybody. The girl would not have you anyway." The boy insisted that the arrows should be made for him; and, the fourth time he made the request, she made him a bow and four arrows. All were very poorly constructed.

When the time came for the young men to try their skill at shooting, the little boy came among the crowd, wearing an old piece of skin for a robe. He was pot-bellied. His eyes were sore and dirty. The people made fun of him. "What can you do?" they said. "What brought you anyway?" So they threw dirt at him and mocked him. Then the shooting began. One after the other, the young men discharged their arrows at the bird, but no one made a hit. Beaver looked at the bird in the tree, then discharged one of his arrows, which came near hitting the bird.

Now there was a man in the crowd called Crow-Arrow, who had never been able to get a wife. He observed that the boy had some kind of power, and envied his success. He got his bow ready to discharge an arrow at the same time as the boy, and, in case the bird was hit, he would dispute the ownership of the arrow. When the boy discharged his second arrow Crow-Arrow discharged his also. The boy's arrow struck the bird, and it fell to the ground. Crow-Arrow, who was very swift,

ran at once to the spot, pulled out the boy's arrow and put in his own. The people, who were all looking on, said, "No, it was the boy who hit the bird." Then they all went before the chief, and announced to him that the little dirty boy had won; but Crow-Arrow insisted that it was his arrow that killed the bird. The chief looked at the small dirty boy with disgust, and said to himself, "I cannot have him for my son-in-law, even if he did hit the bird." Then he said to the people, "Since there is a dispute about this, we will try something else. All the young men shall set wolf-traps, and whoever gets a black one or a white one shall be my son-in-law."

Beaver went home and asked his grandmother to make him a wolf-trap. The grandmother said, "Oh, you get away from here, you dirty boy! No wolf would ever go into a trap you touched." But as Beaver insisted, she fixed up a trap just back of the lodge. In the evening, Beaver went out to fix his trap, and when morning came there was both a black and a white wolf in his trap. Now Crow-Arrow had set a trap also, and in the morning found a black wolf in his trap. Crow-Arrow hurried to the chief with his prize; but when he got there he found Beaver with two wolves, one black and one white. "Well," said the chief, "there is no dispute about it this time. The little dirty boy must be my son-in-law."

So the eldest daughter was dressed up, her face painted, and taken over to the lodge where Beaver lived.

Now Beaver always defecated and urinated in his bed. When the girl saw him she was disgusted, for his eyes were dirty and his abdomen was very large; but she gave him some food. As he ate, the girl noticed how filthy and repulsive he really was and became nauseated. She said she would not live with such a husband as this, and went over to live with Crow-Arrow. When the chief heard this, he was angry, because he knew that the little dirty boy possessed some kind of power, for which reason his daughter should have kept

her promise. So, to make amends, he sent his youngest daughter over to be the wife of Beaver. Now this girl was rather bashful, and when she came to the lodge where Beaver lived, she got behind the old woman, and, peeping out at him, whispered, "I think that boy is very pretty. I shall stay with him because he is so nice, and I see no reason why my sister left him."

Now all this time the people had been without meat, and the chief sent out the young men in every direction to look for buffalo, but none were seen. Beaver said to his wife, "You are to go home to-night and stay with your mother until I send for you." He said to his grandmother, "You also must go away from this lodge and not return until I call you. You must leave me alone here." As soon as they were gone, Beaver took some yellow paint, put in it the hollow of his hand, mixed it with water, and painted his entire body. Then he took hold of his hair, pulled it down and painted it. At once he became a man, as before. Before him stood the Four-Tail Lodge of his father. In it was a dress covered with elk-teeth for his wife, also a fine white robe for himself. There were beds and other furniture in the lodge. Then Beaver sent out for the old woman, his grandmother, and when she came up directed her to wait outside of the door. Then he brought out a fine dress covered with elk-teeth, and told her to put it on. As soon as she did this she became a young woman again. Then he sent the grandmother over to the lodge of the chief to call his wife. The young woman did not recognize the grandmother, but followed her as requested; and when she came to the strange lodge she also failed to recognize Beaver. Beaver explained to her what had happened, and told her that she was to be rewarded for her kindness to him when he was such a dirty little boy. He brought out to her a fine dress covered with elk-teeth, and, rubbing paint upon her hair, pulled it gently until it became very long. Then he sent his wife to her father. When she came in, she said, "Father, my hus-

band is about to go out to drive the buffalo over into the enclosure. There will be one white buffalo in the herd, and my husband requests that no one shoot it, but that it be roped and then knocked on the head so that no injury be done to the skin, for it is to be made into a robe."

All the young men of the camp went out with Beaver to drive the buffalo. Crow-Arrow also went. Beaver took a white rock and placed it near the edge of the enclosure, then he took up a rock colored like the beaver, and placed it on the other side. Then he directed the young men to lay rows of rock spreading outward from these two. Then they laid down between them some buffalo-chips. As they were putting down the last, Beaver shouted four times. Everybody looked around. They saw a herd of buffalo, a white one and a beaver-colored one in the lead. Then the men hid behind the rocks. This was a buffalo-drive.

When the people were going out with Beaver to prepare the buffalo-drive, Crow-Arrow came upon an old buffalo-carcass. He cut out some of the spoiled meat, and carried it back to the chief to make him believe that he had the power to get meat first. While Crow-Arrow was on his way back, he heard the shouting and the noise of the buffalo going over. He ran up as quickly as he could, and saw the white buffalo already roped and about to be knocked upon the head. Looking around, he saw the beaver-colored one and shot it. When the buffalo were killed, Beaver called to his wife, directed her to take his arrows, rub them over the skin of the white buffalo, and throw them away. These arrows were feathered with eagle-tails. As the woman threw them from her, all the young men fought for them, because they were regarded as very good medicine. When Crow-Arrow saw this, he directed his wife to take his arrows and do likewise with the skin of the beaver-colored buffalo. Crow-Arrow's arrows were made of crow-feathers. Now when Beaver's wife rubbed the arrows over the skin of the white buffalo, it was made smooth and

clean; but when the wife of Crow-Arrow rubbed the skin of the beaver-colored buffalo, it did not change. So when she threw her arrows away, no one seemed anxious to pick them up. Now the wife of Crow-Arrow, the same one who deserted Beaver, felt ashamed. She came close to Beaver, and said, "I wish you would give me some of your arrows to clean the skin." "No," said Beaver. "Once I married you, but you refused to live with me or to clean me: now I shall not help you clean skins." When Crow-Arrow saw what had happened he was angry, and went home with his wife. He was angry because Beaver seemed to have greater power than he. Now Crow-Arrow was a great medicine-man, and so he transformed himself and his family into crows, and they flew out at the top of their lodge. Then these crows flew around over the lodges and mocked the people in crow-language, "We shall starve you; we shall take all the buffalo away from you, and starve you to death."

After this no buffalo were seen in the country; because the crows took the buffalo over the mountains. Beaver and his people were soon driven to starvation; but the crows returned, flew around over the lodges and mocked them. So Beaver called the people together in council and said to the young men, "What can you do? Has any one power to bring back the buffalo?" No one seemed to have such power. This was in the winter. Then Beaver said, "Let two young men go to the place where the beaver lives, cut a hole in the ice, build a fire and try to smoke the beaver out. Then I shall transform myself into a beaver and lie by the hole as if dead." The young men did as directed. During the night, Beaver went down to the place, transformed himself into a beaver and lay down upon the ice as if dead. Part of the skin was pulled away, and his entrails could be seen. While he was lying there, Crow flew up, looked down, and said, "Oh, yes! I know your game. I know you. It is no use for you to try to get me in this way. Your people will starve. You think you are very smart, but you

cannot get me. It is no use to try me in that way, because I know too much." None of this made any impression upon Beaver, who looked precisely like a corpse. Then Crow said to himself, "Well, after all, I believe it is a real dead beaver." He came down and looked closely at the corpse, and pecked at the breast and eyes. They were all frozen hard: he could not make a dent in them. So Crow took up a piece of fat from the entrails. He flew to a place and began to eat. Then he said, "Yes, it is a real beaver." Then Crow went back to the corpse and began to eat. Beaver lay still for a while, but suddenly transformed himself into a man, sprang upon Crow and caught him. As he struggled, Crow cried, "Let me go! let me go! I will get buffalo for you." "No," said Beaver, "you are a liar. I shall hold on to you this time. I shall surely punish you." So he broke the wing of Crow, took him home and tied him to the smoke-hole of the lodge. Then Beaver gathered a lot of birch-wood and threw it into the fire, making a very black smoke. Now, up to this time, all crows were white; and while Crow was crying in the top of the lodge, "Oh, let me go! let me go! I will bring you buffalo surely," the smoke made him black, and crows have been black ever since. After Crow was as black as he could be, Beaver consented to let him go if he would call the buffalo. Crow promised, but, as soon as he was released, he flew to the top of a lodge and called back, "I shall let you starve; I shall let you starve. I was just fooling."

Then the people of the camp scolded Beaver. They said, "You knew that he was a liar. You knew that he would not keep his word. You should have kept him fast until he produced the buffalo." "Well," said Beaver, "I will get the buffalo myself." One of the men said, "I should like to go with you." "What kind of power have you?" said Beaver. "Well, I have some power," said the man. "I can transform myself into a swallow, a pup, and a spider." "Well, you have some power," said Beaver, "but I have greater power. I can transform my-

self into anything, but you may come with me."

The name of this man was Little-Dog. He transformed himself into a swallow, and Beaver became a prairie-chicken. Then they started out to look for buffalo. As they went along, Little-Dog saw Crow's camp in the distance. Then he transformed himself into a spider, and, coming up to a man belonging to Crow's camp, inquired of him the whereabouts of Crow. The man informed him that he had gone over the mountain to live, and that there was a very high cliff behind them. Then Little-Dog transformed himself into a swallow, and Beaver into a horse-fly. Together they flew over the cliff. Here they saw Crow's camp. While they were looking, Crow's people moved their camp. The Little-Dog transformed himself into a spider, and Beaver became a pine-tree. Now the two watched a long time for the buffalo; but they saw no trace of them around Crow's camp. One day they saw Crow go away. Then they went to the place where the camp was first seen, and Beaver transformed himself into a digging-stick, and Little-Dog became a pup. After a while the young daughter of Crow came out to look around the old camping-place. She found the digging-stick and the pup, and carried them home with her. When she came up to the lodge, her mother was tanning a hide. The girl said to her, "Mother, these things were left behind when we moved camp." So the woman thought no more of it, and the girl took the two into the lodge to play. Now the girl was very fond of the pup, and carried it about in her arms, with the digging-stick stuck on her back in the way that women carry babies. While the girl was playing with the pup, as children do, she raised up the edge of the bed. There was a deep hole under it, and holding the pup over it, she said, "Pup, do you see that deep hole? Do you see all the buffalo down there?" Now Little-Dog and Beaver looked down into the hole and saw where the buffalo were hidden. As the girl was leaning over, the digging-stick slipped from her back into the hole, and pup grew into

a large dog, so large that he slipped down of his own weight. The girl was frightened, but went away without saying anything to her mother.

So Beaver and Little-Dog fell down into the hole. Beaver transformed himself into a man, and Little-Dog became a monstrous dog. At once he began to bark and chase the buffalo, and Beaver ran after them shouting. This frightened the buffalo so much that they dashed up through the hole and out upon the earth. There were so many buffalo that it took them a long time to get out; so that Crow returned while Beaver and Little-Dog were still driving buffalo. Crow knew who was driving them out, and took his station by the side of the hole, waiting to kill them. However, they were not to be caught so easily. Beaver caught hold of a buffalo, transformed himself into a stick, and concealed himself in the long hair of the neck. Little-Dog became a pup once more, and fastened his teeth in the long hair of the breast of a buffalo. Thus they were carried out, unobserved by Crow.

Now the buffalo were running over the earth; they were restored to the people once more.

After this, Beaver returned to his people. One day he told his wife that she must never put sagebrush on the fire as it was against his medicine; but one day his wife forgot this, and threw sagebrush into the fire while Beaver was away. When Beaver came in, he knew what had been done. He said to his wife, "Now, since you have used the sagebrush for the fire, I must leave you and go to my brother. You will never see me here again." Then he took his white robe and a plume. He blew the plume up into the air and rose to the sky. His brother had been carried to the sky on the branches of a tree, and Beaver went up to him. Now they are both stars. Every night we see two large stars side by side: these are the two brothers, Ashes-Chief and Stuck-Behind. They became the Twin Stars (Castor and Pollux).

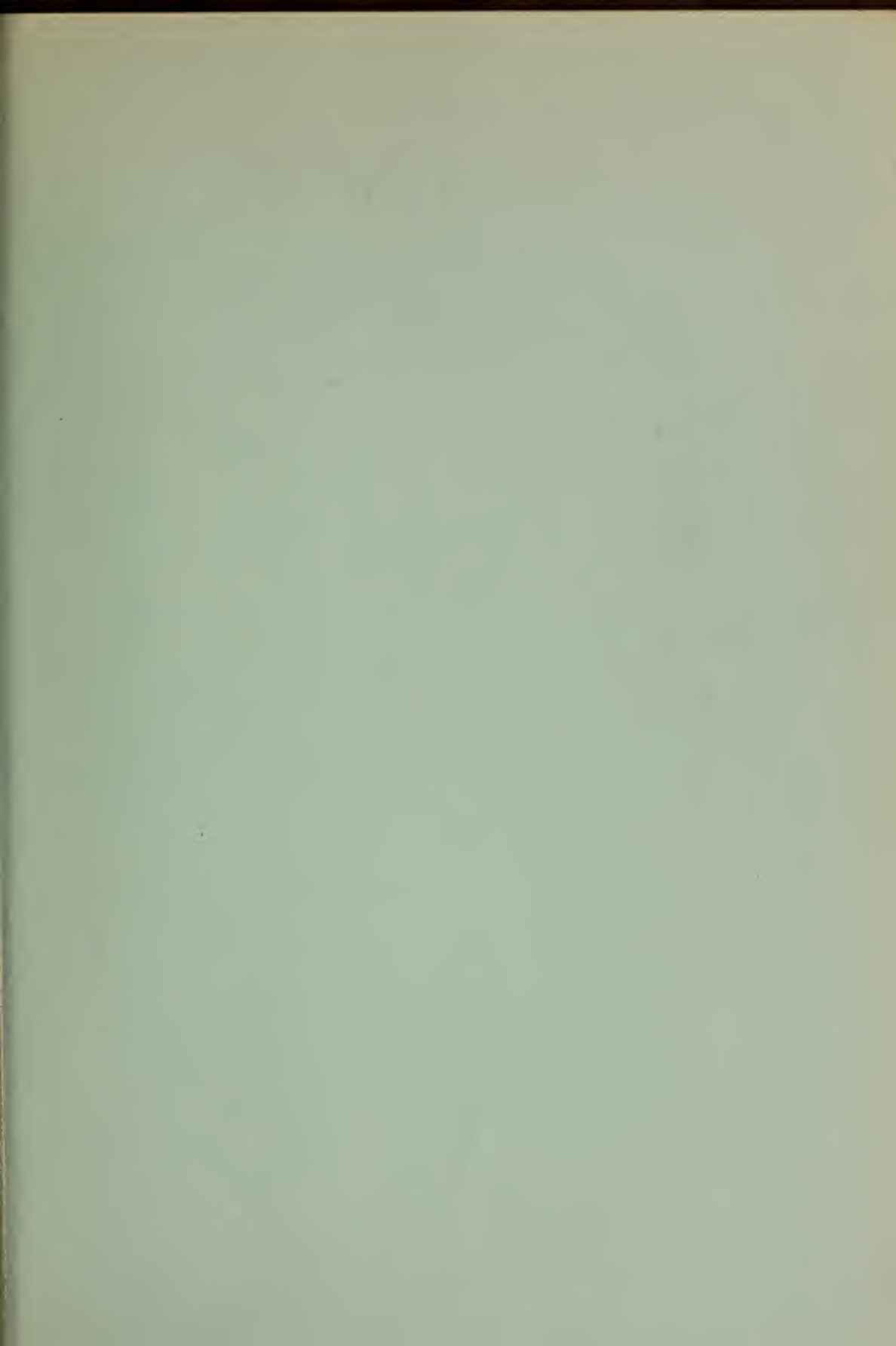



meteor crater,
arizona

BY CLYDE FISHER

METEOR CRATER, ARIZONA

By CLYDE FISHER

*Honorary Curator, Department of Astronomy
and the Hayden Planetarium*

*Reprinted with some modifications from
The Barnwell Addresses, Philadelphia, 1934*

Science Guide No. 92

THIRD PRINTING

THE AMERICAN MUSEUM OF NATURAL HISTORY

New York, New York

1946



THE METEOR SHOWER OF 1833.

An old wood-cut from Grondal's *"Music of the Spheres"* illustrating the Leonid shower of November 13, 1833, the greatest phenomenon of the kind on record. Compared to a fall of snowflakes. (See cut at top of page 13.)

Meteor Crater, Arizona

Where a huge, dense mass of iron meteorites struck the earth, probably 50,000 years ago, the impact of which crushed and dislodged some 300,000,000 tons of rock

By CLYDE FISHER,

*Honorary Curator, Department of Astronomy
and the Hayden Planetarium*

A METEOR shower is one of the most impressive phenomena in the whole realm of nature. Its sudden appearance, together with the suggestion of falling or shooting stars, excites wonder and fear, especially in untutored and primitive minds. Various tribes of American Indians used the November shower of 1833, the greatest meteor shower on record—"the rain of stars,"—as a milestone in their calendars.

While showers or swarms of meteors are comparatively infrequent, the adventitious or occasional meteors are extremely common. It is estimated that about 100,000,000,000 meteors and micrometeors enter the earth's atmosphere every twenty-four hours. Most of these are exceedingly small, weighing perhaps only a few grains each. When we recall that there are 7,000 grains in a pound, avoirdupois, we realize how tiny these meteors must be. Practically all of the meteors that penetrate the earth's atmosphere, day after day, are burned up due to the heat generated by friction with the air, and consequently do not reach the earth.

Few fall to the earth

Occasionally, of course, one comes clear through to the earth, and, if found, it is called arbitrarily a "meteorite", the name "meteor" usually being reserved for those which enter the earth's atmosphere, but which do not come through to the earth. Nearly 1,350 falls of meteorites are known, of which more than 550 are represented in the collections of the American Museum of Natural History.

Half the falls observed

Although nearly 500 falls of meteorites have actually been observed, the phenomenon still attracts much attention,—and well it might, for these are the only direct messengers from space that come to the earth, the only heavenly bodies besides the earth that we can actually touch. A recent fall to be observed was that of July 1, 1933, when two masses of stony meteorite were seen to fall near Spartanburg, South Carolina, one weighing about twelve pounds and the other about half as much. This fall occurred in the daytime, and was observed by several persons.

During the last few years it seems that more than the usual number of large meteors, sometimes called fire-balls, have been observed. On March 24, 1933, a gigantic meteor flashed across five southwestern states. An airmail pilot flying near Amarillo, Texas, declared that it looked as big as the hangar at the Wichita Airport. Some most unusual and striking photographs of the train left by this fire-ball were secured at Timpas, Colorado, by Mr. C. R. West. In northeastern New Mexico Mr. Charles M. Brown succeeded in photographing the meteor, which showed a cork-screw train at the moment,—securing an absolutely unique photograph. Dr. H. H. Nininger succeeded in locating a number of pieces of this fall in northeastern New Mexico, along a line twenty-nine miles long, for which success he deserves much credit. It proved to be a stone meteorite or rather a group of meteorites, one specimen of which, picked up near Pasamonte, New Mexico, has been acquired from Dr. Nininger for the collections of the American Museum of Natural History. On September 27, 1934, another huge meteor was observed in California by an airplane pilot who thought it

necessary to swerve his plane to keep from colliding with it. In this case no meteoric material constituting a fall has been located. On July 11, 1939, just at dusk, a brilliant fire-ball startled the residents of several northern states from Wisconsin to Pennsylvania, and also Ontario, Canada. Practically the entire town of Dresden, Ontario, saw this meteor fall. It consisted of several fragments of stone, now known as the Dresden meteorite.

Most great falls prehistoric

The greatest falls of meteoric material known on the face of the earth were not observed. In fact, with the exception of the Siberian fall of June 30, 1908, all of these occurred without much doubt in prehistoric times. The first crater, the cause of which was determined to be due to the impact of a meteorite or mass of meteorites, was Meteor Crater in Arizona. It was not until the early years of this century that the theory that this crater was caused by the impact of meteoric or cometary material was set forth by Mr. Daniel Moreau Barringer, geologist and mining engineer of Philadelphia, and to him must be given the credit for convincing scientists of the truth of his theory.

Meteor Crater is best seen from the air, and consequently the most satisfactory photographs have been made from an airplane. A huge circular crater, nearly a mile in diameter and nearly six hundred feet deep, with a conspicuous elevated rim, formed in solid limestone and sandstone, constitutes an impressive challenge to one's innate desire to understand the causes of things. Svante Arrhenius, the great Swedish scientist, author of the electrolytic theory of matter, is said to have declared that Meteor Crater is the most interesting spot on Earth.

Located in Coconino County, in north-central Arizona, about twenty miles west of Winslow and thirty-five miles east of Flagstaff, the crater is easily reached by the Santa Fé Railroad or by U. S. Highway 66.

First seen by white men some sixty years ago, although doubtless known to the Indians long before, it was formerly known as Coon Butte or Coon Mountain, the latter part of the name referring to the elevated rim.

Dr. Charles R. Toothaker, Curator of the Philadelphia Commercial Museum, who had much to do with the Meteor Crater iron in the early days, writes me as follows:

"It appears that in 1886 some shepherds were in the neighborhood of Cañon Diablo, Arizona, and one of them named Mathias Armijo found a piece of this iron and thought it was silver. Some time later, a man staked a claim and put the samples in the hands of a chemical firm named M. B. Booth & Co., in Albuquerque, New Mexico, in March 1891.

"Dr. A. E. Foote of Philadelphia was at that time a dealer in mineral specimens and I was employed by him. I remember when the first news of this matter reached Dr. Foote. He went to Cañon Diablo at once and sent back a piece of the iron which was immediately put in the hands of Professor G. A. Koenig, Professor of Chemistry in the University of Pennsylvania. Koenig analyzed it and discovered diamonds in this iron."

Crater at first misunderstood

This crater was at first explained by the scientists of the U. S. Geological Survey as the result of a steam or gaseous blow-out. Because of the absence of lava and other evidence of volcanism, no scientists have believed it to be a volcanic crater. One writer advanced the theory that it was a limestone-sink. But the credit for the conception and establishment of the theory that is now well-nigh universally accepted goes to Mr. Barringer,—and a magnificent conception it was. He set forth the idea that this crater was the result of the impact of a huge, dense mass of iron meteorites, possibly the head of a small comet, and this theory has now come to be held by nearly all geologists, physicists and astronomers.

This meteoric mass penetrated 40 to 50 feet of purplish-red sandstone (Moencopie Formation—Triassic), which lies next below the thin soil of the surrounding plain; then crashed through some 300 feet of Kaibab Limestone (Permian Age), the same rock that outcrops in the Grand Canyon of the Colorado in north-western Arizona, then it plowed into the Coconino Sandstone (Permian Age), which underlies the Kaibab Limestone, shattering this

stratum to a depth of some 600 feet, or practically to the Supai Sandstone or "Red Beds" (Permian) underneath.

The meteoric origin of the Crater is suggested by the occurrence of literally thousands of pieces of meteoric iron around the crater. These fragments were found as far as four or five miles from the crater on all sides, but the nearer the Crater, the more numerous they were. In other words, Meteor Crater is about in the exact center of an area from which have been collected many more specimens of meteoric iron than have ever been found on all of the rest of the earth's surface.

The larger specimens

The largest piece of which I have knowledge is in the Colorado Museum of Natural History in Denver, and it weighs 1,406 pounds. For this information I am indebted to Dr. H. H. Nininger, Curator of Meteorites in that Museum. The second-largest piece is in the American Museum of Natural History and weighs 1,055 pounds (re-weighed in 1935 upon removal into the Hayden Planetarium). The third-largest piece, now in the Chicago Natural History Museum, weighs 1,013 pounds, according to the late Dr. O. C. Farrington, Curator of Geology in that Museum. The fourth-largest piece of which I have knowledge is in the Smithsonian Institution collection in charge of Mr. E. P. Henderson, Assistant Curator of Physical Geology. It is labeled and recorded as weighing 1,000 pounds. Mr. Henderson informs me that they also have in their collection another piece weighing 960 pounds and still another weighing 746 pounds, besides a great many others of lesser weight. Another large piece is located near the front door of the Fred Harvey Indian Building in Albuquerque, New Mexico, which, according to Mr. H. Schweizer, weighs 625 pounds. It is estimated that between ten and fifteen tons of meteoric iron have been shipped away from Meteor Crater, all of which has been collected within about five miles of the crater, most of it in the immediate vicinity.

Meteorites have been known to burst in the air just before striking the earth, but very few, if any, of the individual pieces of Meteor

Crater iron, whether large or small, show evidence of the bursting in air of an enormous meteorite. For this reason it is believed that the crater was formed by a huge meteorite accompanied by thousands of small ones, or more probably by a huge, dense mass of comparatively small, iron meteorites.

It is noteworthy, according to Russell, Dugan and Stewart "*Astronomy*," (p. 455), that nearly every one of the large iron meteorites found on the earth's surface lies on the side of our planet which, at the time of the great impact, faced in the direction from which this swarm came. They *may* all have belonged to one large swarm.

Composition

The meteoric iron from the vicinity of Meteor Crater, known as Canyon Diablo iron, named from a gorge located about three miles to the westward, is remarkable in its composition, for it contains 91 to 92 per cent of iron, some 7 per cent of nickel (always present in meteoric iron), traces of cobalt (also common in meteoric iron), silicon, sulphur, phosphorus, carbon, iridium, and platinum, as well as traces of a few other elements. Troilite, a sulphide of iron, found only in meteorites, occurs. Silicon carbide (moissanite) occurs in this iron, and for a time was not known to occur elsewhere in nature. Silicon carbide is manufactured under the trade name of "Carborundum," at Niagara Falls, New York. It is next to diamond in hardness, with the exception of boron carbide. Probably correlated with the silicon carbide is the occurrence of diamonds, all extremely small. As stated in Dr. Toothaker's letter quoted above, Dr. G. A. Koenig, Professor of Chemistry in the University of Pennsylvania, was the first to isolate diamonds from this meteoric iron, and this was in 1891. These diamonds were very small, one mentioned in the report having a diameter of one-half millimeter. The material analyzed was from a forty-pound meteorite brought from Meteor Crater by Dr. A. E. Foote of Philadelphia, who, in this same year, was the first to bring this crater prominently before the scientific world. Later five diamonds were secured from this iron by Dr. J. W. Mallet, F.R.S., Professor of Chem-



Photograph from Yerkes Observatory

Craters of the Moon

Above: The moon at gibbous phase between first quarter and full, showing many of the 30,000 craters on the side which is always turning toward the earth. The similarity of these lunar craters to Meteor Crater in Arizona is evident

Below: The elevated rim of Meteor Crater from a distance of two or three miles. It varies in height from 130 to 160 feet

Photograph by Clyde Fisher



*Photograph by
Clyde Fisher*

Right: Meteor Crater, blanketed with snow, as seen from a plane; San Francisco Peaks, from forty to fifty miles distant, are shown in the background; Canyon Diablo, about three miles to the westward, may be seen in the middle ground



Meteor Crater

Below:

Meteor Crater from a plane on an early summer morning. The automobile road connecting U. S. Highway 66 with the north rim shows in the lower right-hand corner.

*Photograph by
Clyde Fisher*



istry, University of Virginia. It was thought that the platinum, along with the nickel, would promise a profitable commercial enterprise. In fact, it was this idea that prompted the mining ventures and the explorations which have given us so much interesting information. Considering its composition, it is not surprising to know that the late Dr. George P. Merrill, Head Curator of Geology in the U. S. National Museum, and one of the leading authorities on Meteorites, stated that Canyon Diablo iron is one of the hardest and toughest of all known meteoric irons.

Widmannstätten lines

When polished and etched with nitric acid, the Canyon Diablo iron shows definite and pronounced Widmannstätten figures. These are the geometrical markings on the polished surface which are caused by internal crystallization. In this form they are found only in meteorites.

Besides the unoxidized meteoric iron, there have been found at the Crater many so-called "shale-balls," which are generally rounded or globular masses of disintegrating meteoric iron and nickel oxide, many of them containing solid nickel-iron centers. The late Dr. O. C. Farrington, one of the leading students of meteorites, believed the shale-balls to be the result of terrestrial oxidation, and not that of oxidation occurring when passing through the air.

More than one hundred shale-balls have been found, the heaviest weighing more than forty pounds. Some contain microscopic diamonds. Besides the typical shale-balls there are in and about the crater great quantities of oxidized iron-shale, which without much doubt came from shale-balls. This gives a suggestion as to the fate of some of the Meteor Crater iron. That most of these irons are the residuals of shale-balls, was the confident opinion of Mr. D. M. Barringer, who pointed out that the rounded shape of the latter was probably due to the gentle abrasive action of the members of the cluster during their years of journeying through space.

In determining the origin of the crater, the composition of the elevated rim is significant. This rim, which is 130 to 160 feet higher than

the surrounding plain, and one and one-half miles in outside diameter, can easily be seen from more than ten miles away. It is made up largely of boulders and smaller fragments of Kaibab limestone and Coconino sandstone. Some huge boulders were ejected from the crater and thrown over the rim to the distance of a mile or more. It is true, of course, that the ejected boulders occur more abundantly as one approaches the crater.

Much of the Coconino sandstone has been reduced to a fine rock-flour, so fine that it requires a microscope to show that it consists of shattered or pulverized sand-grains. This rock-flour or "star-dust," as it has been called, composes a great part of the rim, nearly three miles in circumference, and it has also been found 850 feet deep in the crater. There are literally millions of tons of this fine powder, white as snow. It is estimated that it constitutes 15 to 20 per cent of all material thrown out by the impact.

Of all the evidence that Meteor Crater was caused by impact, perhaps the most convincing to geologists is the fact that some of the Coconino sandstone was changed into a vesicular, metamorphosed rock, looking not unlike pumice stone and very light. In fact the quartz has been fused and is now amorphous and not crystalline. This silica-glass or fused quartz has been named by the mineralogists "Le Chatelierite."

Exploded theories

The limestone-sink theory could not explain the elevated rim made up of boulders, fragments and rock-flour. It could not explain the presence of rock-flour and fused quartz at all. It could not explain the presence, in the rim, of Coconino sandstone boulders which came from a stratum that underlies the Kaibab limestone.

A steam blow-out theory might account for the rock-flour, although this seems to the writer extremely doubtful, but it seems certain that no scientist would maintain that it is competent to account for the silica-glass or Le Chatelierite. Dr. George P. Merrill states that there is no record of a sudden outburst of volcanic action wherein the heat generated was sufficient to fuse crystalline quartz. The steam blow-out

Photograph by Clyde Fisher

Right:

Meteor Crater in Arizona, located about twenty miles west of Winslow and thirty-five miles east of Flagstaff, photographed from a plane in winter, when snow covered the landscape, including the bottom of the crater



Photograph by Ruth Anna Fisher

Left: Clyde Fisher with Jack Irish, the pilot on his first flight over Meteor Crater



Below: Clyde Fisher surveying the Crater from the north rim. Note the sizable buildings of the mining company on the crater floor

Photograph by Te Ata



theory is further weakened by the fact that there are no igneous or eruptive rocks in or around the Crater or in the neighborhood, and by the fact that there is no evidence of solfataric activity, and by the finding of unaltered sandstone (Supai) in place in the bottom of the crater in its proper stratigraphical position, shown by the cores of numerous drill-holes sunk in the floor of the crater.

Probability

The fact that the crater is in the center of a meteor fall, would be looked upon as a coincidence by the advocates of both the limestone-sink theory and the steam blow-out theory. But the finding of meteoric material mixed with the ejected rock, and underneath the lake deposits in the bottom of the crater, and even 500 or 600 feet below the crater floor, indicates that the meteor fall occurred at the same time that the crater was formed, that is, that the excavated material and the meteorites got there at the same time. The probability that these two unusual phenomena occurred at the same time and at the same place is infinitesimal.

The question that naturally arises is how large a mass of meteoric iron would be necessary to produce the result,—to plow into solid rock and form a crater about four-fifths of a mile in diameter and nearly 600 feet deep!

It has been variously estimated that the mass of meteoric iron weighed from 100,000 tons to as much as 10,000,000 tons, that it was several hundred feet in diameter if the larger estimates are correct, and that it was moving from seven to forty miles a second.

The amount of rock dislodged and partly thrown out of the crater has been estimated at over 300,000,000 tons. The true crater is filled to one-half its depth with rock fragments which rolled or fell back.

On the bottom of Meteor Crater there are now 70 to 90 feet of lacustrine or lake sediments formed when this was a small lake. In these deposits many fossil shells were found, which were identified by Dr. William H. Dall, Curator, Division of Mollusks, U. S. National Museum, as "all recent species local to the region of southwestern United States."

While it is now true that practically all astronomers, physicists and geologists agree that this crater was caused by the impact of a huge mass of meteoric iron, the testimony of a few of the leading scientists in these fields, given before such unanimity of opinion had been reached, would not be out of place. Following are verbatim statements from a few:

Dr. Elihu Thomson, Director of the Thomson Laboratory of the General Electric Company,—"There can be no question of the Crater being made by masses of meteoric iron, and that an enormous mass of such iron remains buried under the south wall of the Crater."

Dr. W. F. Magie, former head of the Palmer Physical Laboratory, and Dean of the Faculty of Princeton University, who spent two weeks at the Crater making careful studies,—"There is no reasonable doubt that the Crater was formed by the fall of a meteor and this meteor is buried in it."

Dr. Henry Norris Russell, Head of the Department of Astronomy, Princeton University,—"I have examined the Crater on the ground, as well as the other evidence, and I am thoroughly convinced of its meteoric origin."

Position of meteorite

If this crater was formed by impact, where is the main mass of the meteoric iron? Mr. Barringer and his associates first attempted to answer this question by drilling some twenty-five holes in the floor of the crater. These holes were drilled in the bottom of the crater because it was then believed that the nearly circular shape of the crater indicated that the meteorite had descended vertically or nearly so. No large piece of meteoric material was ever struck in these holes. Mr. Barringer's son, Daniel Moreau Barringer, Jr., tells us how his father was accidentally led to the discovery that the fall of this meteorite was not vertical, but at an angle. The son writes as follows: "Largely by accident, my father observed one day that by firing a rifle into mud he could make an excellent replica of the Crater, and, moreover, that the rifle need not be fired vertically downward, but might be held even less than 45 degrees from the horizontal. Naturally one would suppose that a shot at such an angle

would make an elongated hole. But it will not. The hole will be just as round as though the shot had come straight down, although the projectile will lodge under one edge of the hole instead of in the center. A charge of shot fired from a shotgun at close range will produce the same effect." This observation led the elder Mr. Barringer to make a closer examination of the crater, the results of which indicated with great certainty that the mass had come from the north at a comparatively low angle.

Thereupon a drill-hole some 1400 feet deep was sunk on the south rim. Beginning at a depth of 1000 feet, a series of hard bodies carrying nickel, and clearly meteoric in origin, were struck. Of this boring, Mr. Barringer reported, "Eventually this hole (the last boring sunk through the south rim, it having been determined that the mass approached from the north at an angle of approximately 45°) encountered what is beyond doubt the upper part of the buried cluster of iron meteorites, finding it exactly in the predicted position." It is significant that geophysical investigations, both magnetic and electrical, as well as the geological evidence, all pointed to a large mass of meteoric iron under the southern rim; and two recent drill-holes in the southwestern part of the bowl about 1000 feet from the previous drill-hole on the rim, have also encountered numerous meteorites.

Volatilization?

It has been suggested that the energy of onward motion, when the meteoric body was suddenly stopped, would have been transformed into sufficient heat to vaporize all or part of the main body. Mr. Barringer believed, however, that due largely to being checked by the air, the meteoric body struck at too low a velocity to have been vaporized. The absence of stains, such as would be caused by the vapor which would have been formed by volatilization of the iron, he believed, strongly supported this view.

Dr. F. R. Moulton, formerly Professor of Astronomy in the University of Chicago, co-author of the Planetesimal Hypothesis, and leading student of celestial mechanics, arrived at the following conclusions:

"My interpretation of the probable event is roughly as follows: The dense part of the swarm was something like 2,000 feet in diameter and its mass was from 100,000 to 500,000 tons. It crashed into the rock to a depth of something like 800 to 1000 feet, carrying with it a large mass of greatly condensed (and consequently heated) air, which was further condensed on penetrating the rock. Ejected rock was thrown out not only by the condensed air and the steam generated, but also by volatilization of a considerable amount of the meteor and rock materials with which it came in contact."

Explosion?

Dr. Moulton discusses the fate of meteors of various masses in his *ASTRONOMY* (1931), closing with the following sentences: "But a meteorite weighing thousands of tons would not be greatly retarded by the air and would strike the surface at a high velocity. At a speed of 20 kilometers per second the resistance of surface soil or rock, due to its inertia alone, would amount to 32×10^9 grams per square centimeter; at 14 kilometers per second the resistance would be about half as great. Either of these pressures would be sufficiently great to cause the material of the meteorite to flow as though it were a gas. The energy given up in a tenth of a second would be sufficient to vaporize both the meteorite and the material it encountered—there would be in effect a violent explosion that would produce a circular crater, regardless of the direction of impact, which alone would remain as evidence of the event." The recent studies of Professor C. C. Wylie, of the University of Iowa, on the explosive effects of high-speed bullets upon striking a target evidently support the conclusions of Dr. Moulton. The stubborn reply to these theoretical conclusions, however, is the fact that thousands of meteorites of the original mass, several of which are mentioned on pages 4 and 5, *did remain* about the crater.

An inevitable question arises: What is the age of Meteor Crater? It is certainly young, geologically speaking. The sharp angles of the boulders and smaller fragments in the rim and talus indicate that. A Juniper tree growing on



Above: THE HOBA METEORITE. The largest known meteorite, located near Grootfontein, S. W. Africa, estimated to weigh from 50 to 70 tons. The second person from the left is Dr. L. J. Spencer, who was there in charge of the meteorites in the British Museum of Natural History.

Below: THE AHNIGHITO METEORITE. The Ahnighito, weighing 36½ tons, the largest meteorite in any museum, brought from Greenland in 1897 by Peary. Three other large iron meteorites, pretty surely of the same fall as the Ahnighito, were found nearby. Pieces of one of these had been laboriously hammer off by the Eskimos for knives. Clyde Fisher in foreground.



Photograph by Thane Bierwert, American Museum of Natural History

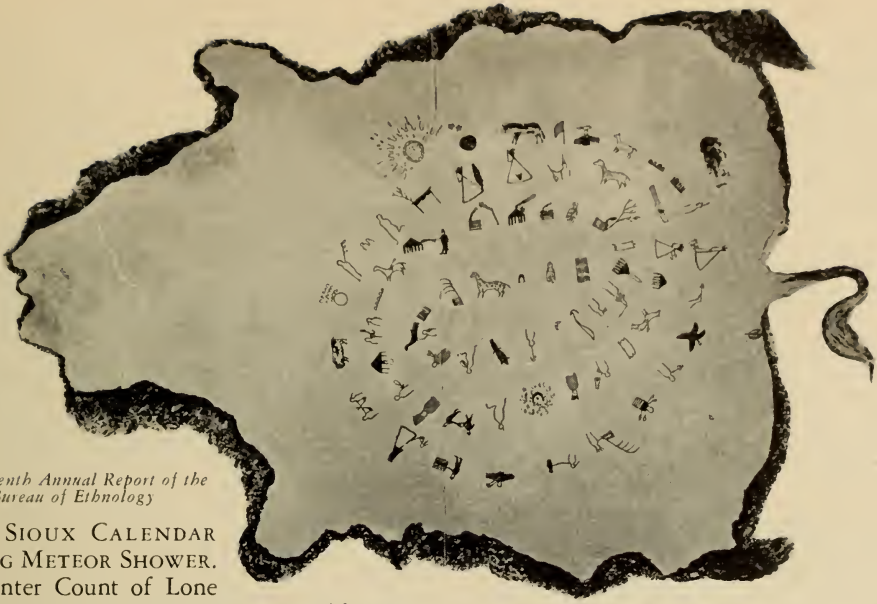

*From Tenth Annual Report of the
Bureau of Ethnology*

**Above: SIOUX CALENDAR
SHOWING METEOR SHOWER.**

The Winter Count of Lone Dog, a Sioux warrior, showing the Leonid meteor shower of November, 1833,—when "the stars fell," as the Indians all agreed. The record is in the middle of second coil of the spiral from the bottom. In the original, in the Smithsonian Institution, the crescent moon is black and the meteors are red. (See cut on page 2.)

**Below: BOULDERS IN THE WALL OF METEOR
CRATER.** Portion of the wall of the crater showing some of the larger boulders left as a result of the impact.

Photograph by Clyde Fisher



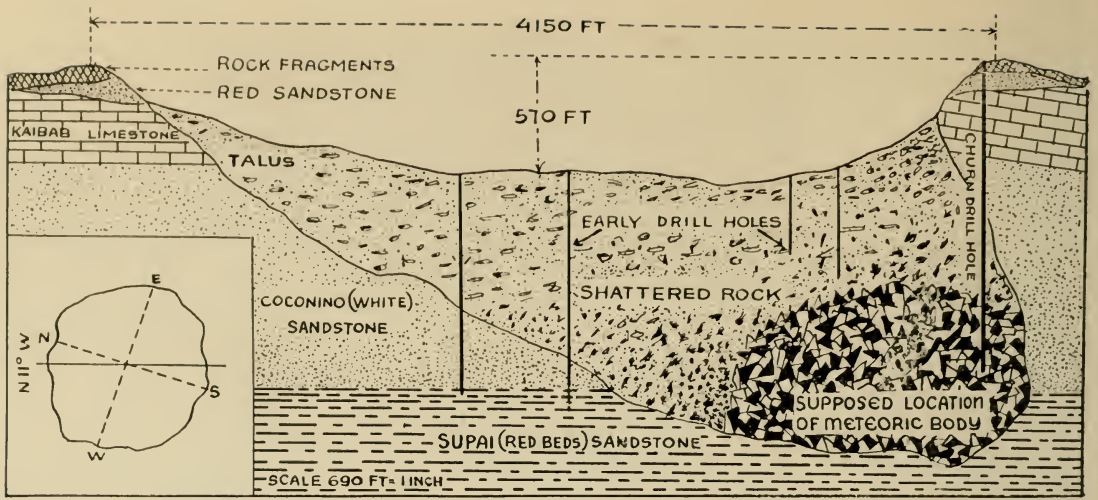

Cross-Section of Meteor Crater

the south rim is said to put it back at least 700 years, because it had that number of annual rings. The presence of lapilli and volcanic ash found in the lake deposits in the bottom of the crater correlate it with the last volcanic eruptions in the nearby mountains of Arizona. These, together with other evidences of the lake deposits, etc. point to a probable age of 40,000 to 75,000 years,—a conclusion arrived at by Dr. Eliot Blackwelder, Professor of Geology in Stanford University, who has made careful studies on two visits to the crater.

Craters of the moon

A comparison of Meteor Crater with the craters on the moon has led some scientists to believe that the latter were also caused by impact. While it is probably true that the majority of astronomers accept the volcanic theory of the origin of the moon's craters, there is much evidence in favor of the impact theory.

The difference in opinion among scientists can well be illustrated by the fact that the authors of the Planetesimal Hypothesis of the origin of the Solar System disagree. Professor T. C. Chamberlin was definitely opposed to the impact theory for the origin of the lunar craters, while Professor F. R. Moulton says that these craters may have been caused by the impact of planetesimals.

Some of the difficulties with the volcanic theory are as follows: volcanic craters on the earth are far less numerous than the craters on the moon, and yet the former belong to several

types, while nearly all of those on the moon show great similarity, none on the earth being like the typical craters on the moon.

There are 30,000 craters on this side of the moon, and yet not a single lava-flow can be seen. There are no fissures on the moon from which lava has flowed.

As pointed out by Mr. D. M. Barringer, in his thorough-going work on this subject, there is not a single conical mountain peak on the moon which is similar to Fuji, Aetna, Vesuvius, Orizaba and other volcanoes of this type, made by the effusion of lava from a central vent and the building up of the mountain mass higher and higher as it flows down the sides.

Volcanic craters on the earth do not have central conical hills like those in so many of the lunar craters.

Finally the fact that the moon is not large enough ever to have held an atmosphere indicates that it could never have had enough water or oxygen to cause either the types of volcanic craters found on the earth or the far more abundant craters on the moon. Scientists who have studied volcanism hardly need to assure us, as they unanimously do, that there can be no volcanic phenomena in the absence of water and oxygen.

On the other hand, the impact theory, set forth by Richard A. Proctor in his book entitled "The Moon," has other facts in its favor.

The floors of the craters on the moon, as Mr. Barringer has stated, are usually far below the surrounding surface, as is true in Meteor

Crater in Arizona, whereas the floor of a terrestrial volcanic crater is usually above the original surface surrounding the volcano.

The only explanation that has come to the writer's knowledge for the formation of the rift through the lunar Alps is that it may have been caused by a huge meteorite or planetesimal which struck the moon tangentially.

The central peaks

The central conical hills furnish strong evidence of the impact theory of the origin of the craters on the moon, as a study of splashes has shown. This is made clear by high-speed motion pictures of drops of liquids or, of small solid bodies, falling into liquids at rest. It is also shown by miniature craters produced by shooting bullets, or charges of shot from a shotgun at close range, into mud or other plastic media. At first, the circular shape of the craters on the moon did not seem to fit in with this theory, but experiment has shown that the craters would be circular even when the projectile arrives at a rather low angle.

The impact theory would explain the light-colored streaks which radiate from the craters

Copernicus, Tycho, and others, in that they are probably made of rock-flour produced in exactly the same way as that at Meteor Crater in Arizona, and splashed out at the time of the impact. The great length of these streaks on the moon, and also the large size of the lunar craters are probably correlated with the small surface gravity on the moon, which is about one-sixth that on the earth, and with the absence of atmosphere on the moon.

The fact that there are so few impact craters on the earth as compared with those on the moon,—assuming that those on the moon were caused by impact,—is probably due to erosion. Water erosion, wind erosion, freezing and thawing, etc., have been active on the earth for millions of year, while on the moon, since there is no water and no air, there has been no erosion, except that very slight effect caused by the impact of meteors in the absence of the cushion of air, as pointed out in his book entitled "Meteors" (p. 254), by Dr. Charles P. Olivier, Professor of Astronomy in the University of Pennsylvania and President of the American Meteor Society.

Until recently it was believed that Meteor

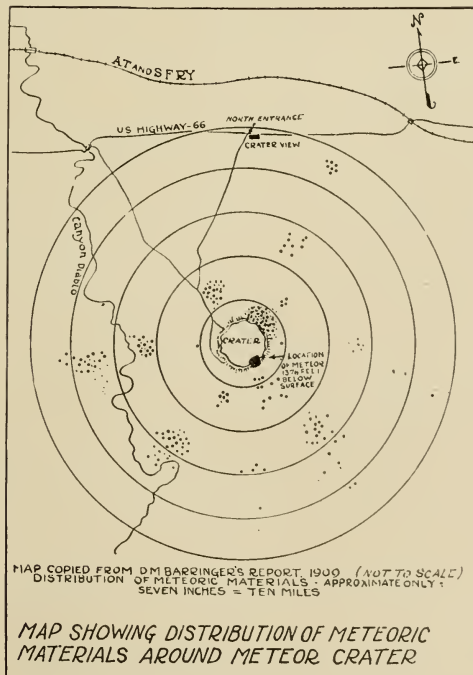

Crater was the only one of its kind on the face of the earth, while there are 30,000 on the side of the moon turned toward the earth. But more and more are being identified on the earth. The meteorite craters so far studied are distributed as follows: one near Winslow, Arizona; one near Odessa, Texas, identified as a meteor crater by Mr. Daniel Moreau Barringer, Jr. (within the past few years, Dr. E. H. Sellards has unearthed four smaller craters in the immediate vicinity of the main Odessa crater.); one near Haviland, Kiowa County, Kansas, identified as a meteor crater by Dr. H. H. Nininger; a group of some thirteen near Henbury in Central Australia; a very small crater which contained the Huckitta Meteorite in Central Australia; a group of seven craters on the Baltic island of Saaremaa (Oesel) belonging to Estonia, which the writer had the opportunity of visiting in the summer of 1936,

identified as meteor craters by Mr. I. Reinvald in 1927; the Wabar craters in Arabia; the Siberian craters; a doubtful one at Ashanti, in West Africa; a very doubtful group near the coast of South Carolina; a supposed crater in Persian Baluchistan; and the Campo del Cielo craters in Argentina. No meteorites have been found at the Siberian craters, and none at the South Carolinian craters.

Certainly no other meteor crater has been so thoroughly studied as the one in Arizona, and judging from a comparison of these studies with the published descriptions of meteor craters in other parts of the world, certainly none is more interesting or impressive.

Our poet-astronomer, William Tyler Olcott, has paid tribute to this gigantic bowl in the following lines, titled "Meteor Crater, Arizona."

You were a black moth winging through the night,
A bit of cosmos shorn from molten matter,
One of a swarm with beating wings that batter
The source and all reflections of the light.

You were the silent echo of a voice,
A slave to might beneath the lashes bending,
And then you plunged to death in flames descending,
In answer to predestinated choice.

You now within a mausoleum lie,
And men gaze on your sepulchre in wonder,
Far down beneath the earth you rent asunder,
You rest secure and dream of star and sky.

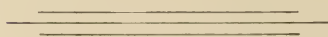

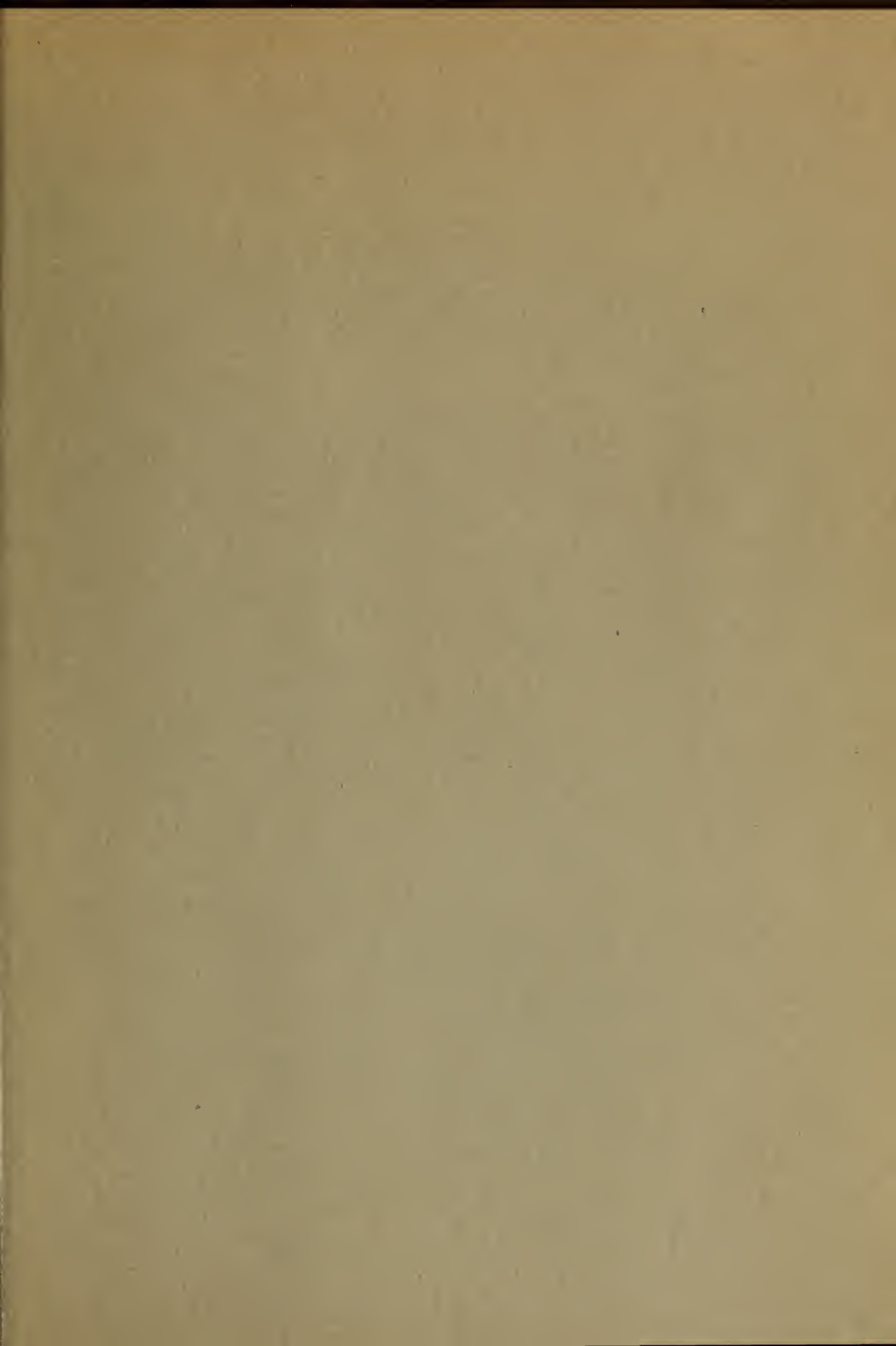



MAN AND NATURE
PUBLICATIONS



Reference

THE  BOUND TO PLEASE
Heckman Bindery INC.
APR. 65
N. MANCHESTER,
INDIANA



AMNH LIBRARY

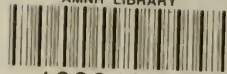

100048776