





STANDARD STEEL CONSTRUCTION

A MANUAL FOR
ARCHITECTS, ENGINEERS
AND CONTRACTORS
CONTAINING USEFUL TABLES
FORMULAS AND OTHER INFORMA-
TION RELATING TO THE USE OF
BEAMS, CHANNELS AND
STRUCTURAL SHAPES

REVISED BY F. L. GARLINGHOUSE, *C. E.*, *Member A. S. C. E.*

SIXTH EDITION

1908

AS MADE BY

JONES & LAUGHLIN STEEL
COMPANY

AMERICAN IRON AND STEEL WORKS

PITTSBURGH

CHICAGO

LIBRARY of CONGRESS
Two Copies received
SEP 12 1908
JULY 16 1908
CLASS a XG. No.
212096
COPY B.

Copyrighted, 1896
Jones & Laughlins, Limited

Copyrighted, 1898
Jones & Laughlins, Limited

Copyrighted, 1900
Jones & Laughlins, Limited

Copyrighted, 1903
Jones & Laughlin Steel Co.

Copyrighted, 1908
Jones & Laughlin Steel Co.

8-26021

PRICE, \$1.50

Preface to Sixth Edition

IN submitting this revised edition of Standard Steel Construction, it is our aim to put in concise form such information as should prove most useful to Structural Engineers, Architects and Contractors.

We have thoroughly revised all data relating to steel shapes manufactured by us, which shapes conform with the standard sections adopted by the American Association of Steel Manufacturers, omitting sections we no longer make, and adding a few new shapes.

We have discontinued manufacturing corrugated steel, but give a table conforming with the most approved practice.

We state in this edition the extreme length of beams, channels, angles, tees, bars and plates which we are willing to make, but we call attention that these lengths might be exceeded in some special cases, and would invite correspondence on this subject in cases where longer lengths are imperative.

The Standard Specifications for Structural Steel correspond with those adopted February, 1903, by the Association of American Steel Manufacturers.

The permissible working shear and bearing for rivets has, in many handbooks, been kept the same as when in former times wrought iron was used instead of steel. This is inconsistent with the balance of unit loads which are universally used in proportioning steel structures. We therefore give tables where the shear and bearing for rivets are given, which are permissible for quiescent loads such as in buildings, and for moving loads as in bridges, craneways, motor supports, or for similar purposes.

We have inserted data relating to chains which we manufacture, pages 40 and 41. Also a table of wrought steel pipe for steam, gas and water, which we do not manufacture, for reference only; and a table of the Metric System compared with the U. S. Standard weights and measures. Other data will be noticed not contained in former editions.

Pittsburgh, July, 1908.

STANDARD SECTIONS

Steel Beams

B. O.

80, 85, 90, 95 and 100 lbs.

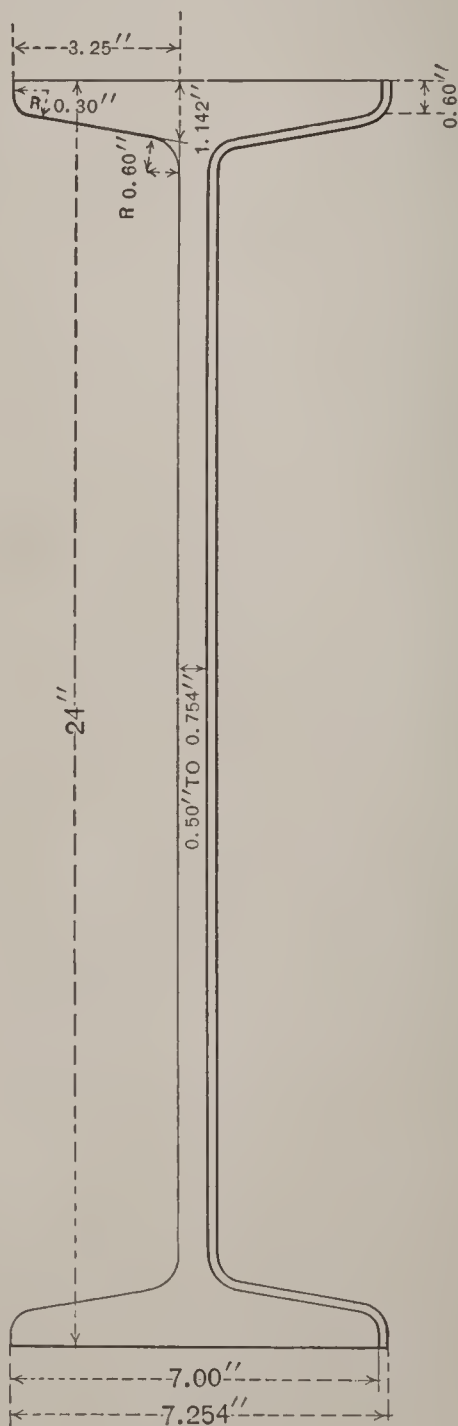

STANDARD SECTIONS

Steel Beams

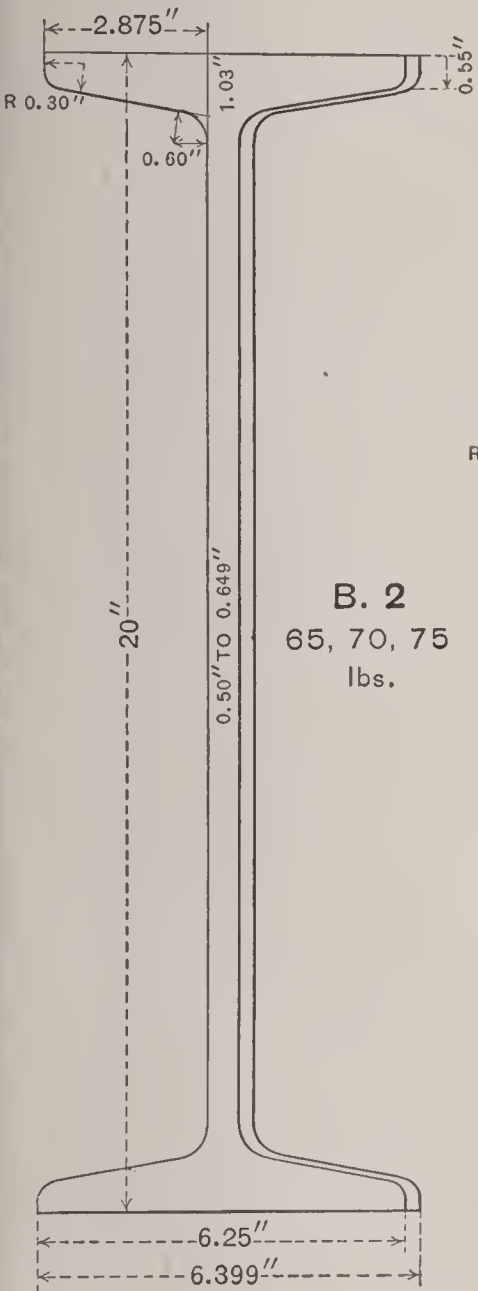

B. 2
65, 70, 75
lbs.

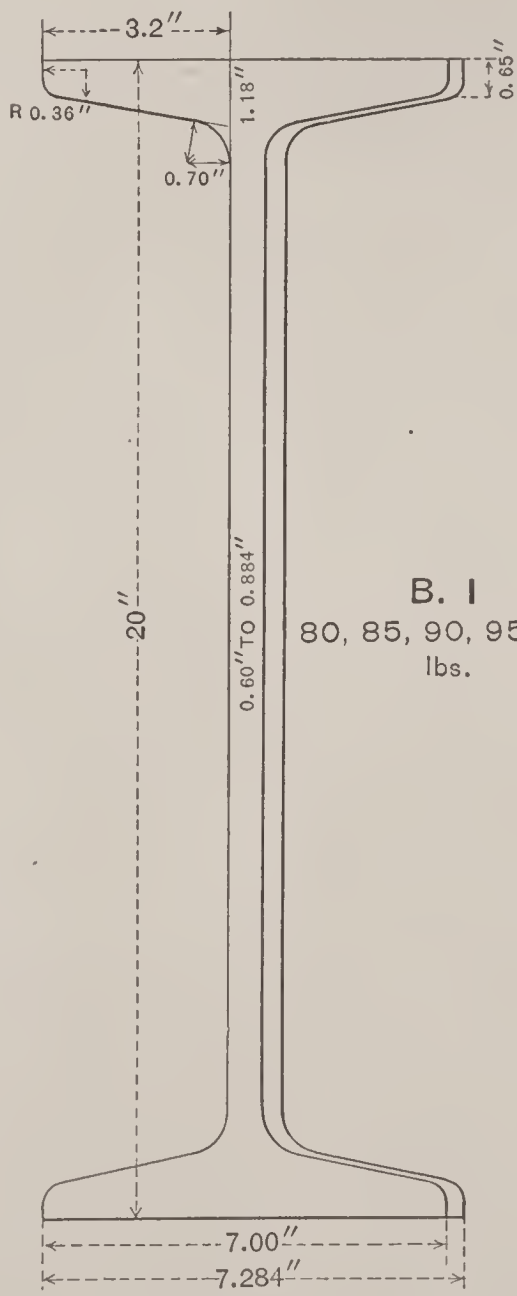

B. 1
80, 85, 90, 95, 100
lbs.

STANDARD SECTIONS

Steel Beams

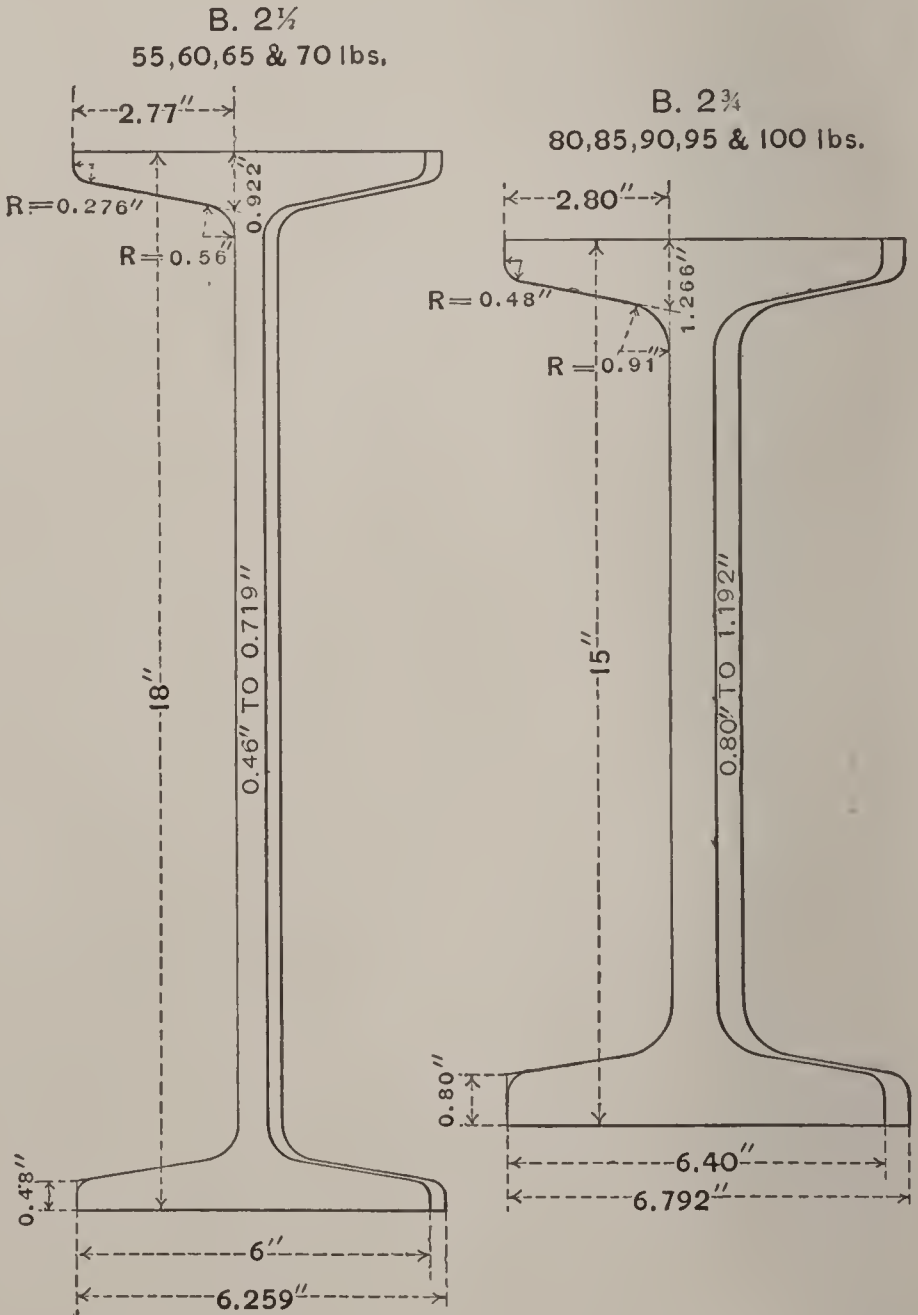

STANDARD SECTIONS

Steel Beams

B. 3.

60,65,70 & 75 Lbs.

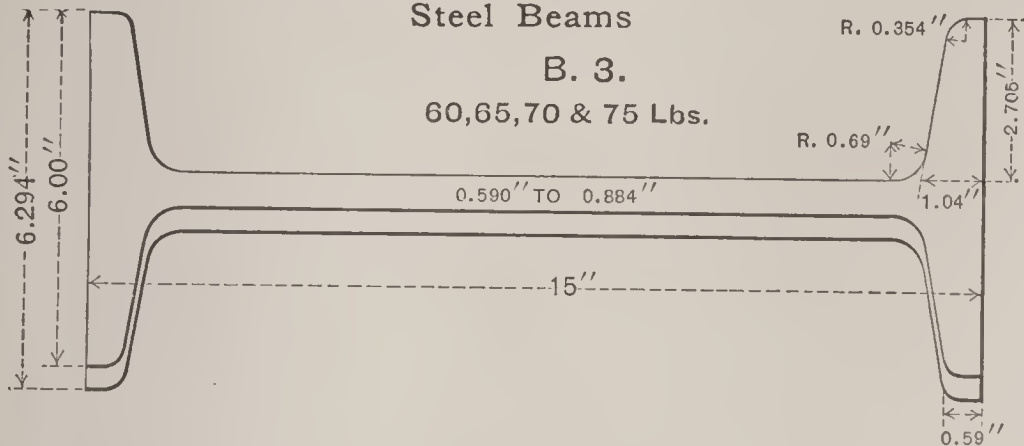

B. 4.

42,45,50 & 55 Lbs.

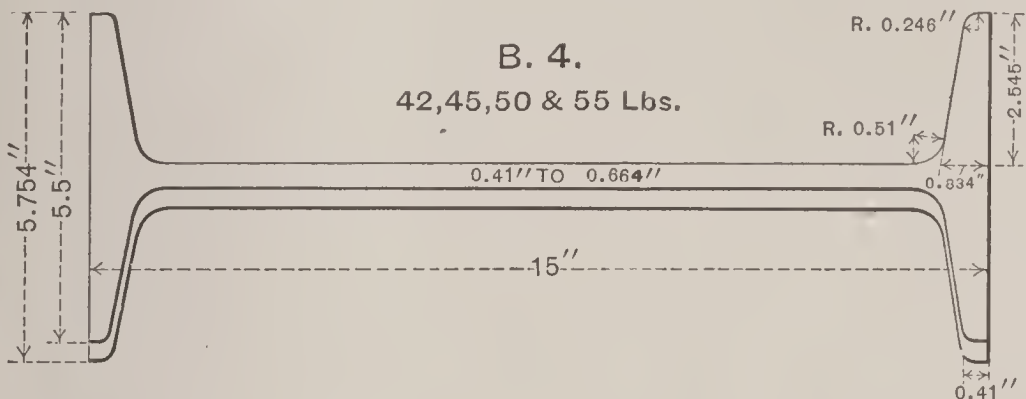

B. 5.

40,45,50 & 55 Lbs.

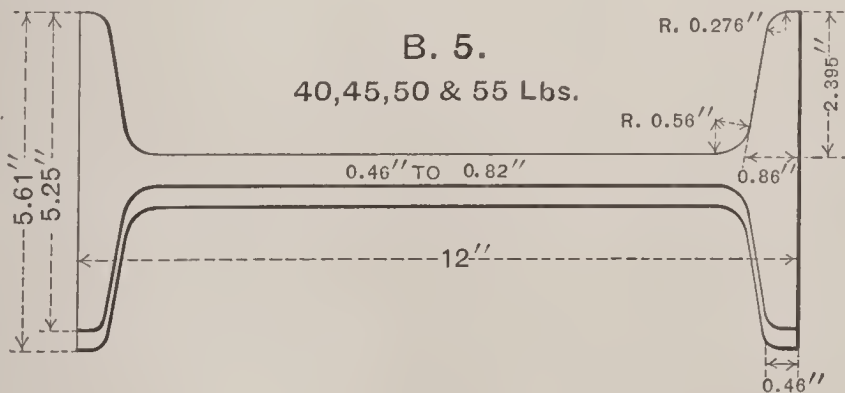

B. 6.

31 1/2 & 35 Lbs.

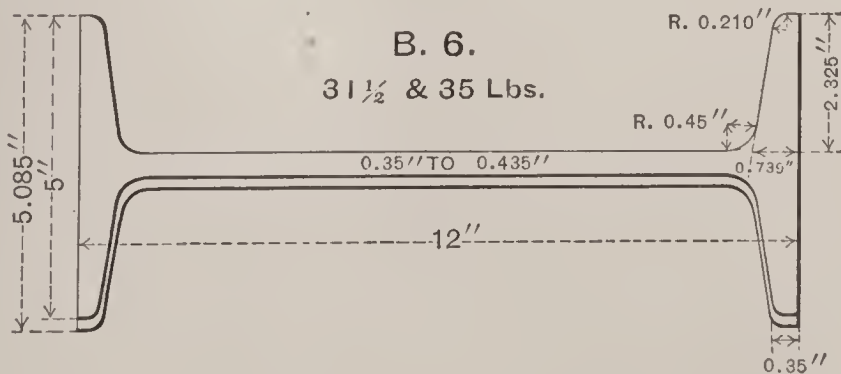

STANDARD SECTIONS

Steel Beams

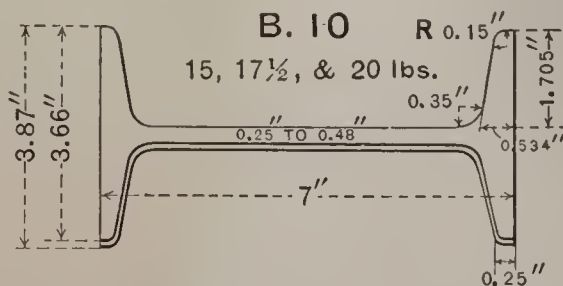
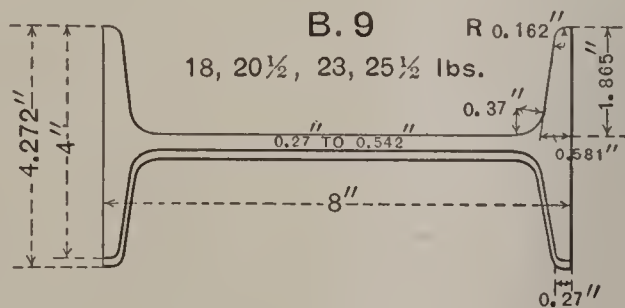
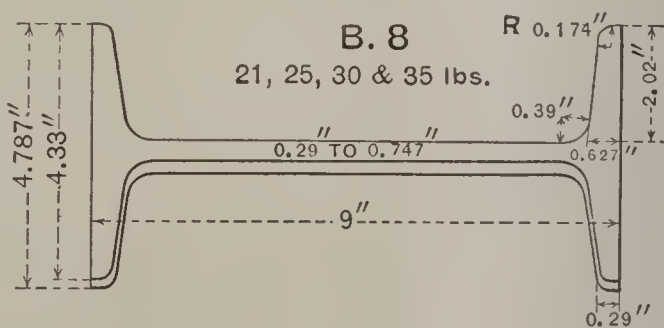
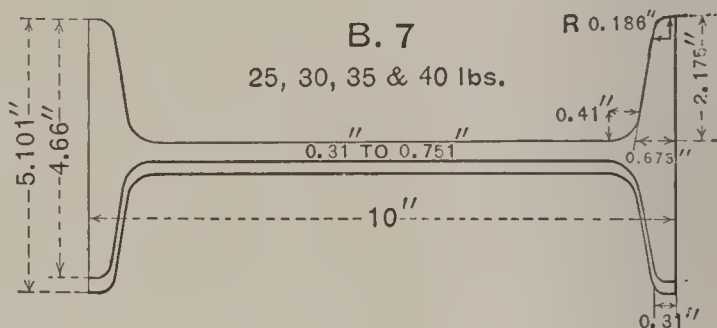

STANDARD SECTIONS

Steel Beams

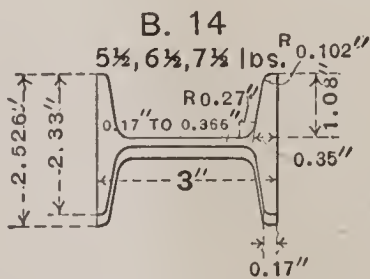
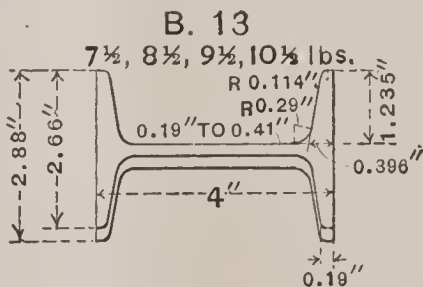
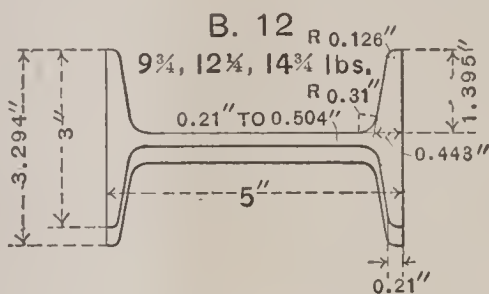
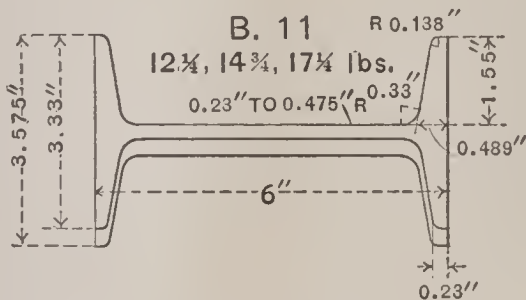

3" SPECIAL BEAM

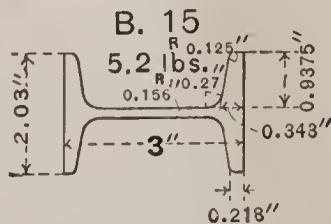

STANDARD SECTIONS
Steel Channels

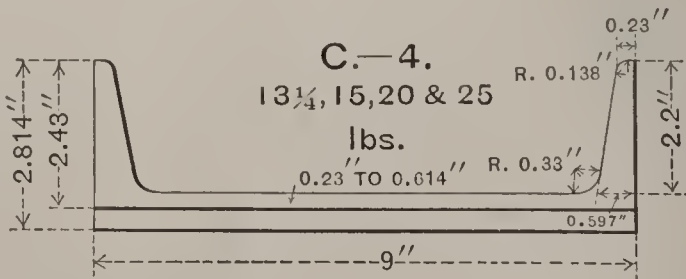
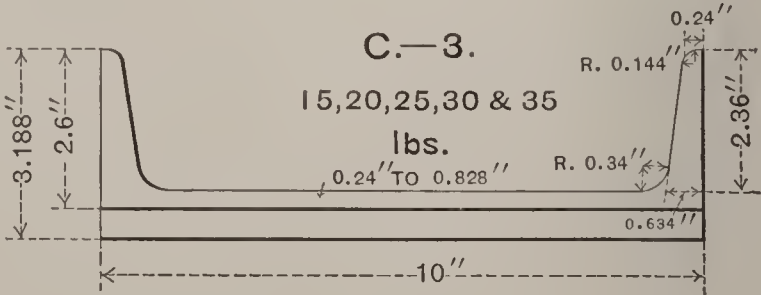
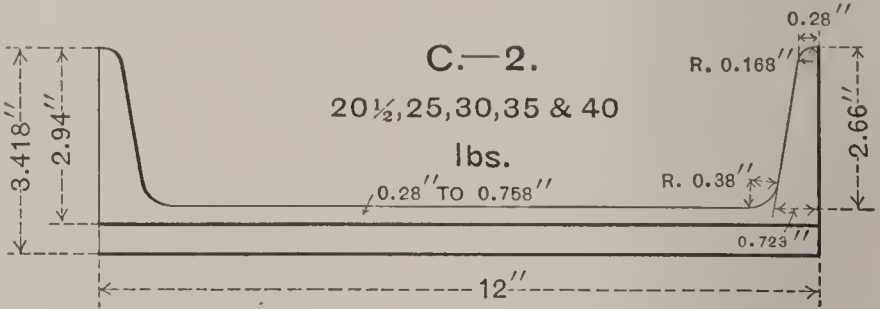
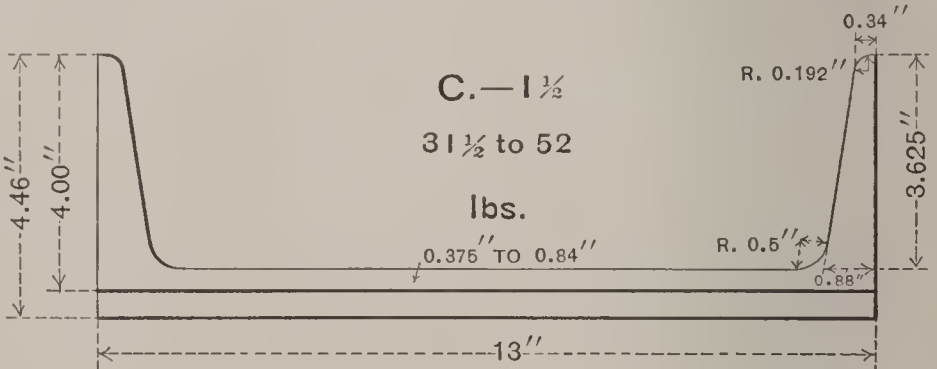
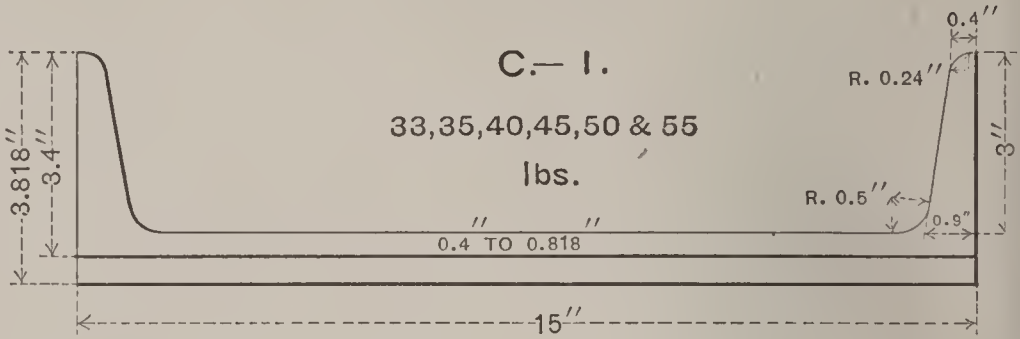

STANDARD SECTIONS

Steel Channels

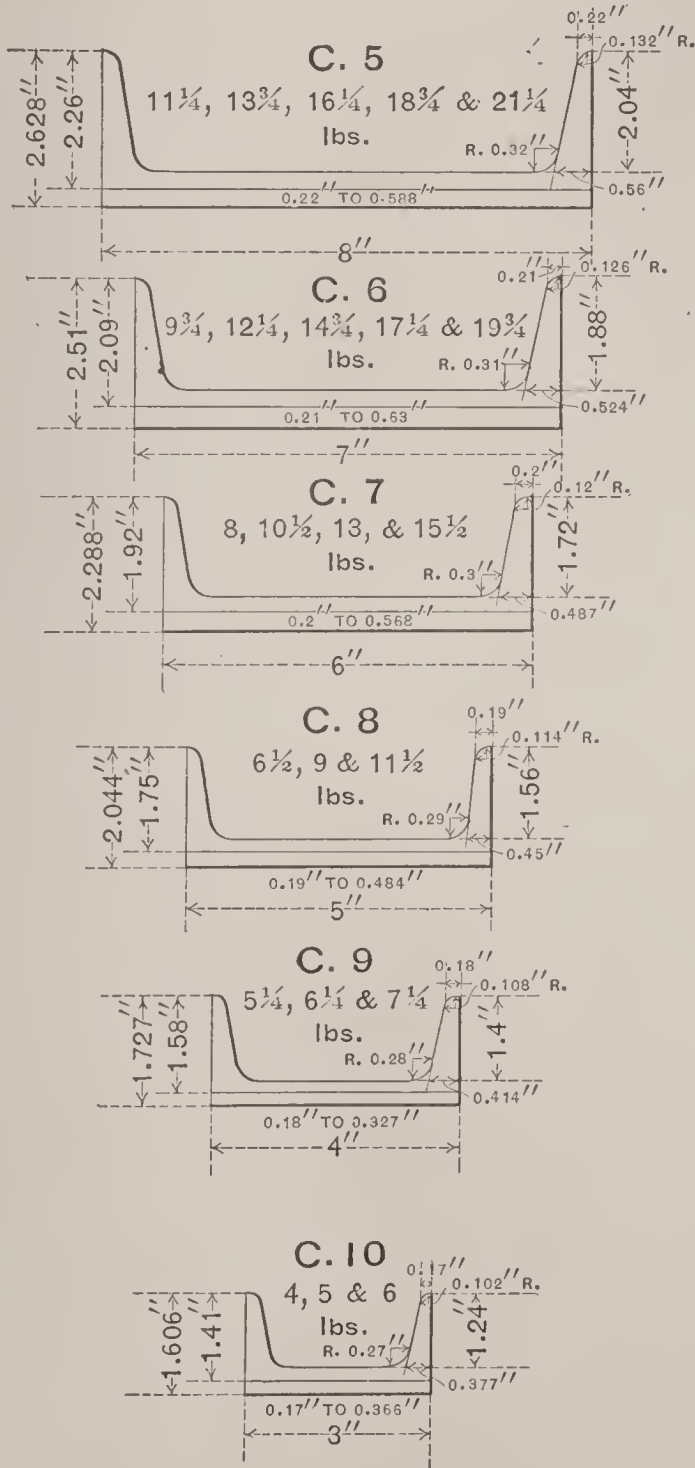

SPECIAL CHANNELS

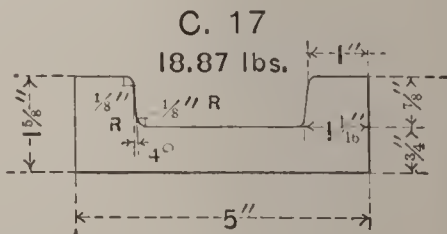
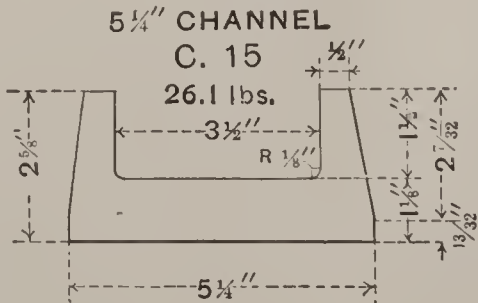
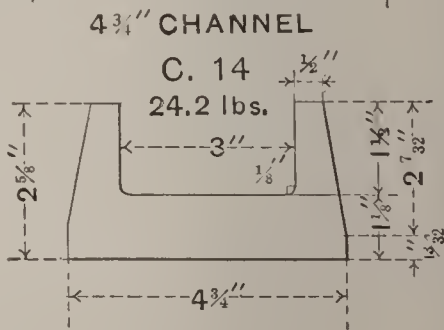
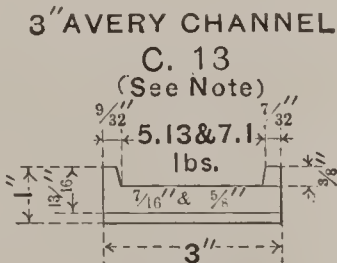
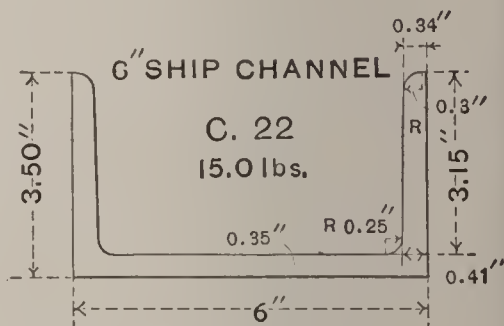
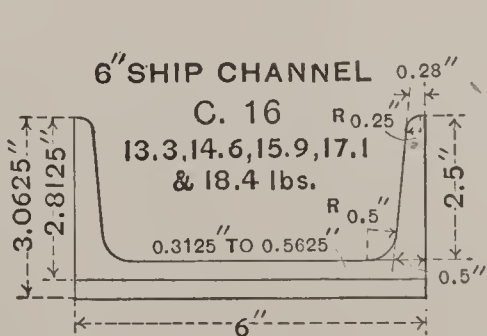
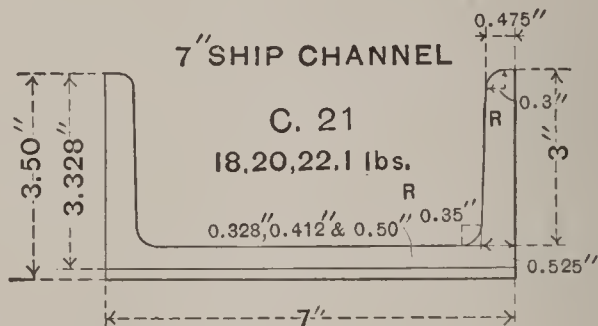

Note: C 13 made only by special arrangement

ANGLES WITH EQUAL LEGS

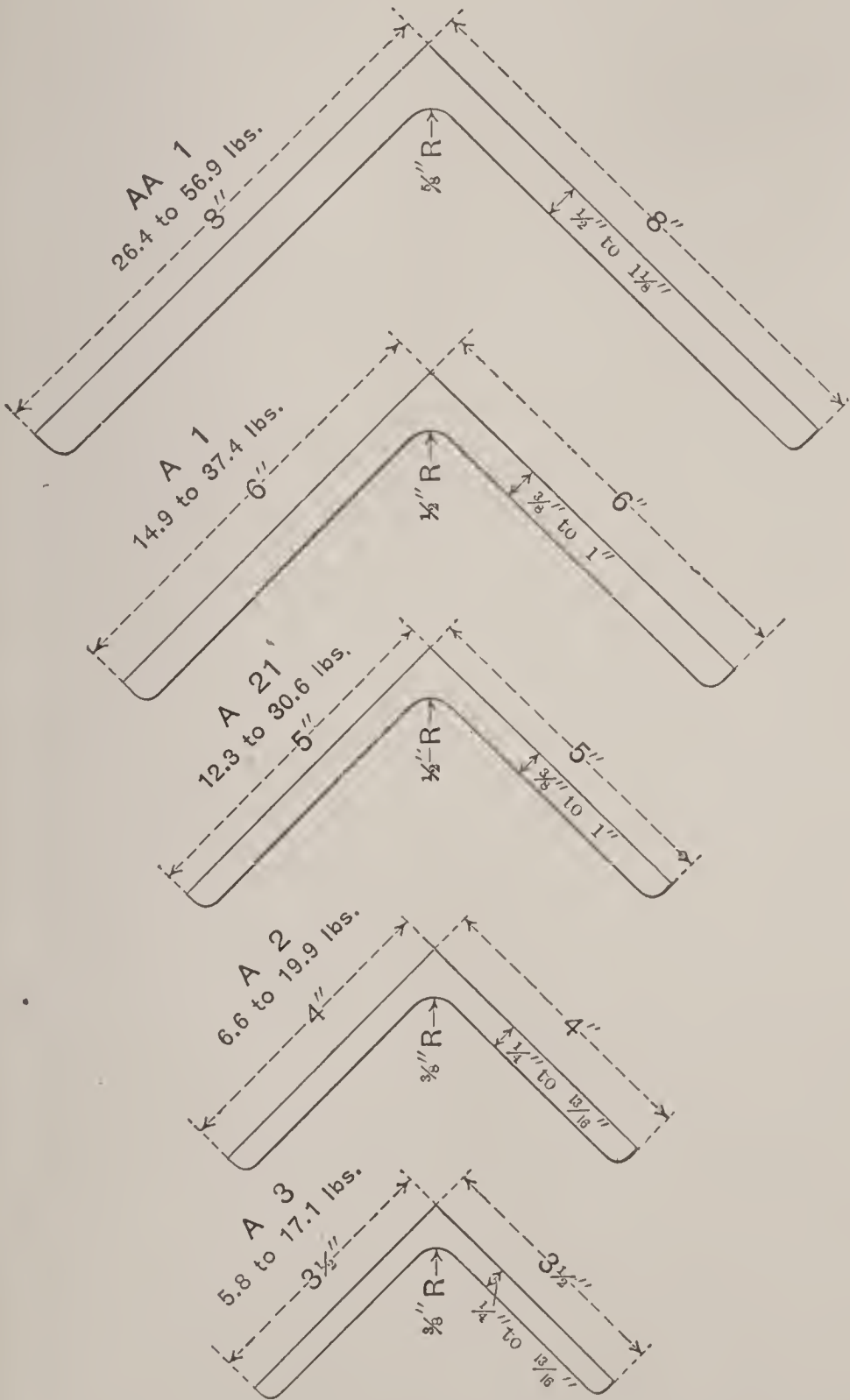

ANGLES WITH EQUAL LEGS

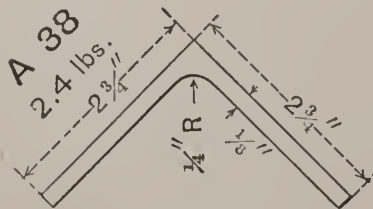
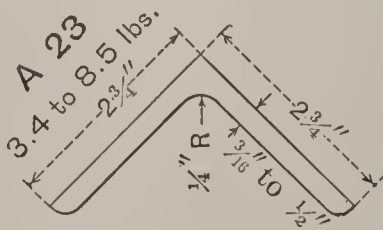
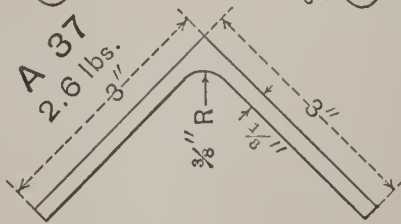
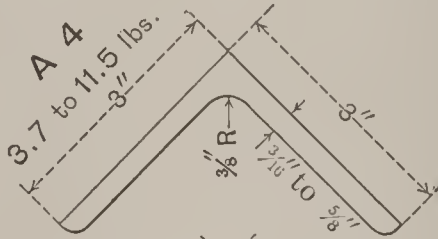
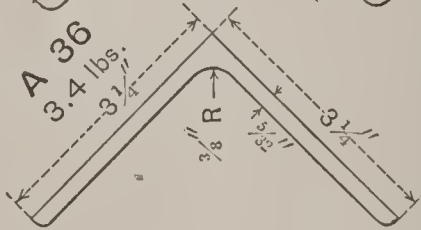
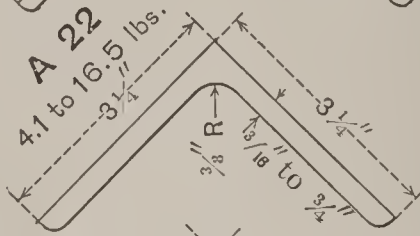
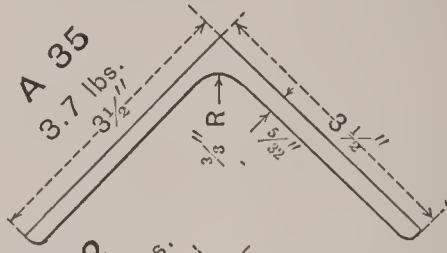

ANGLES WITH EQUAL LEGS

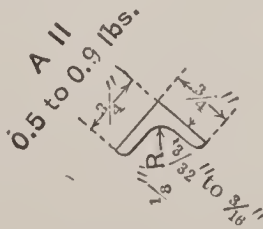
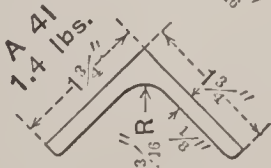
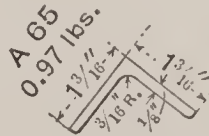
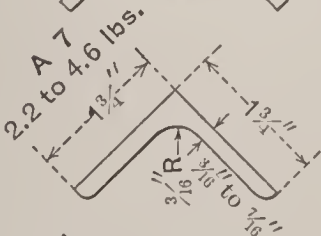
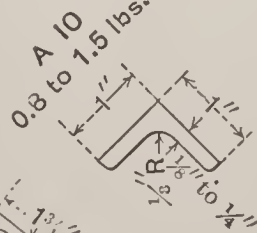
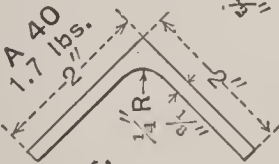
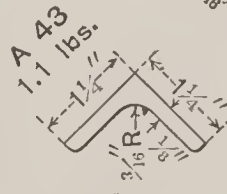
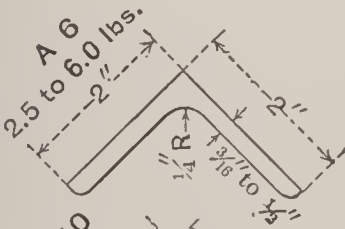
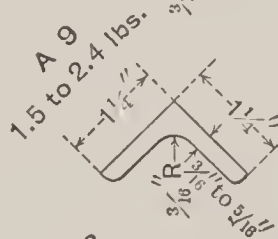
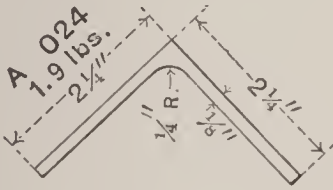
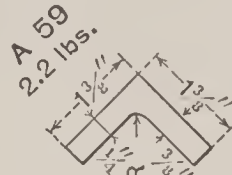
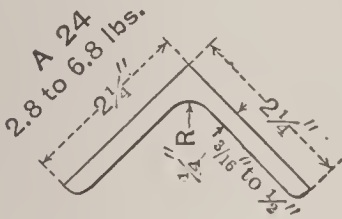
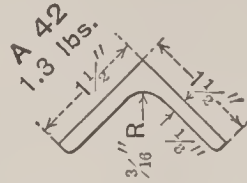
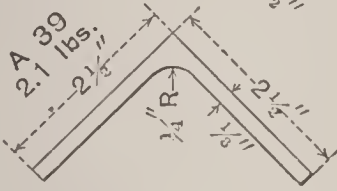
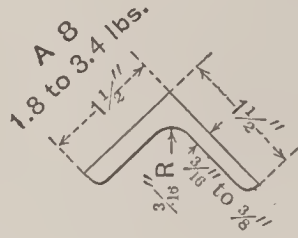
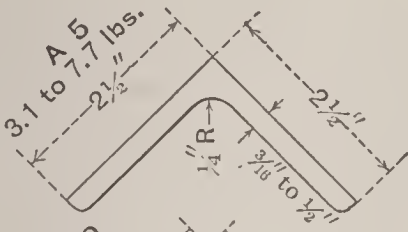

ANGLES WITH UNEQUAL LEGS

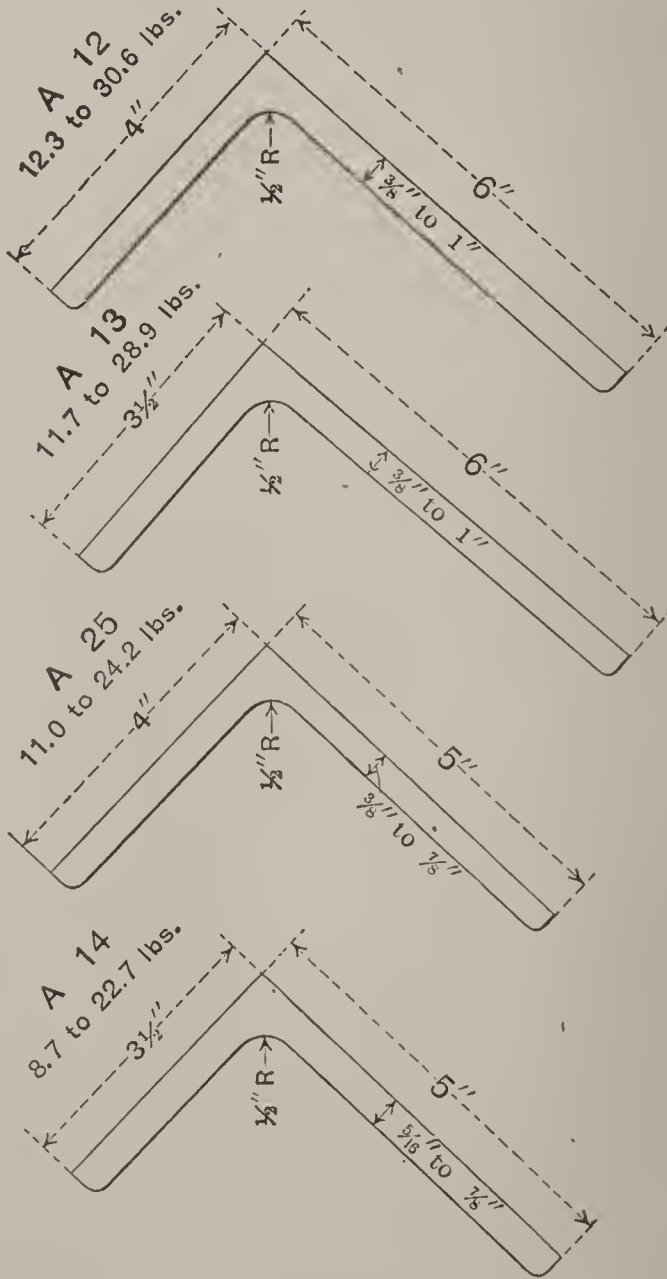

ANGLES WITH UNEQUAL LEGS

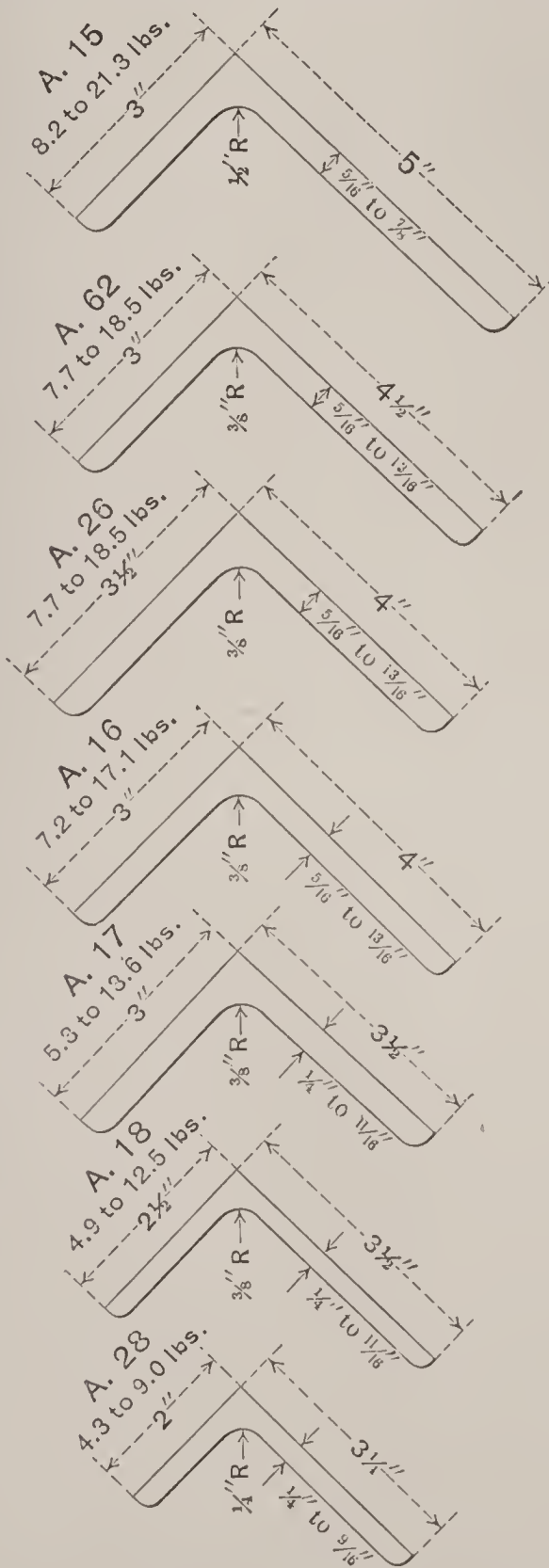

ANGLES WITH UNEQUAL LEGS

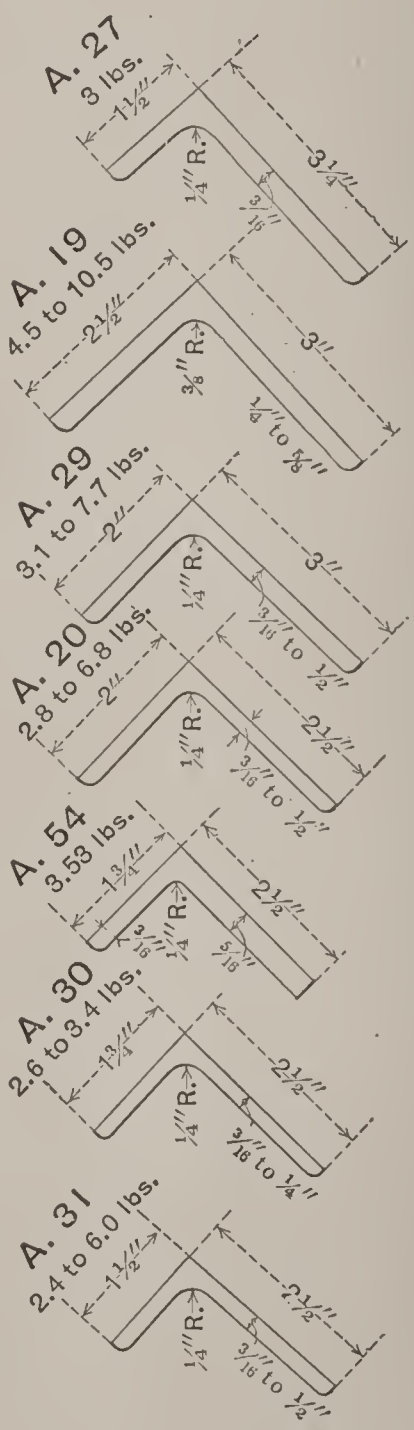

UNEQUAL LEGGED TEES — STEEL

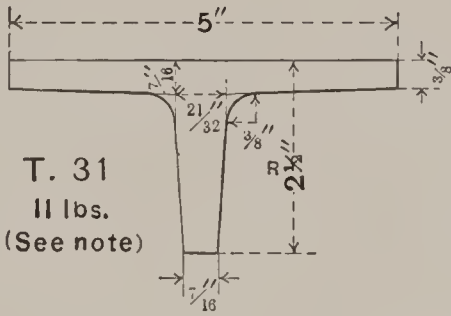

T. 31
11 lbs.
(See note)

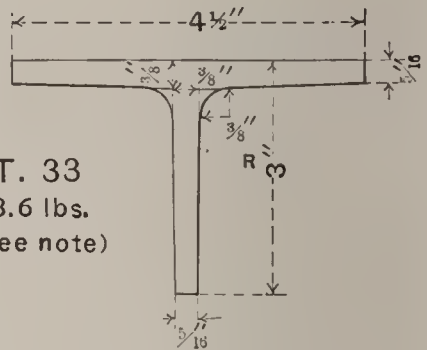

T. 33
8.6 lbs.
(See note)

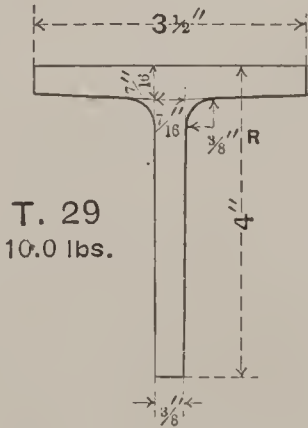

T. 29
10.0 lbs.

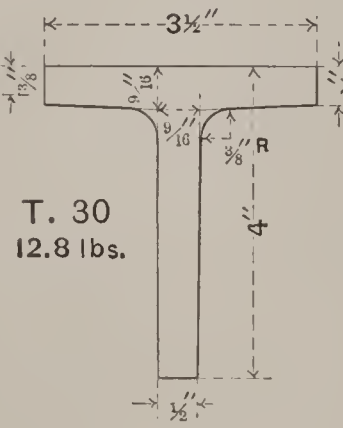

T. 30
12.8 lbs.

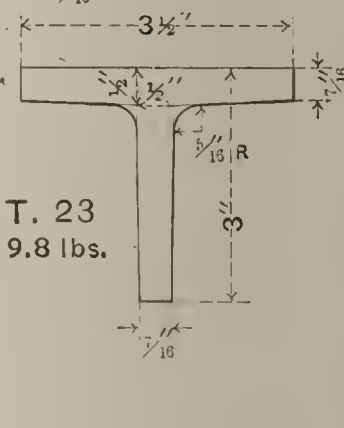

T. 23
9.8 lbs.

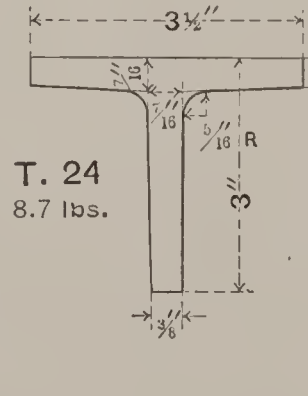

T. 24
8.7 lbs.

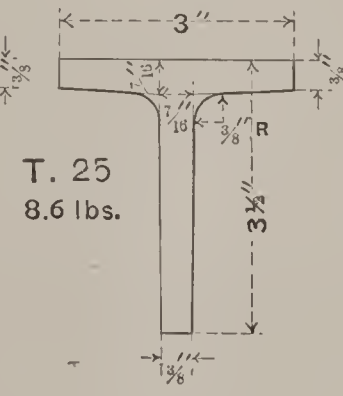

T. 25
8.6 lbs.

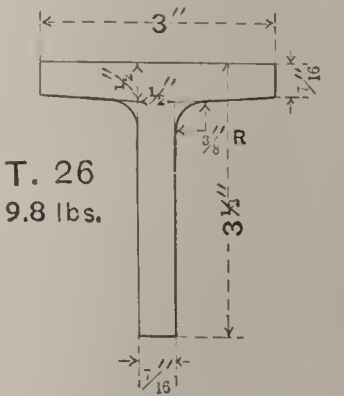

T. 26
9.8 lbs.

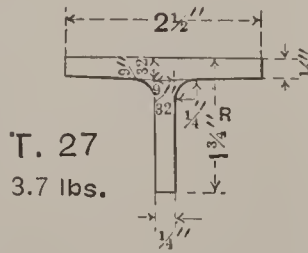

T. 27
3.7 lbs.

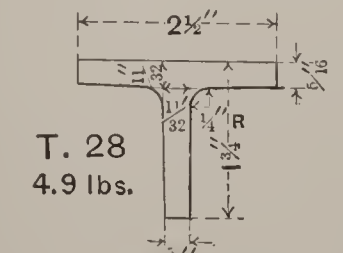

T. 28
4.9 lbs.

Note: T 31 & T 33 made only by special arrangement

EQUAL LEGGED TEES—STEEL

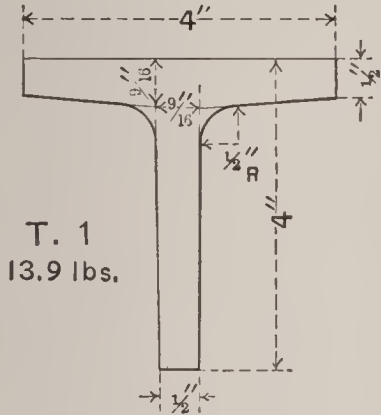

T. 1
13.9 lbs.

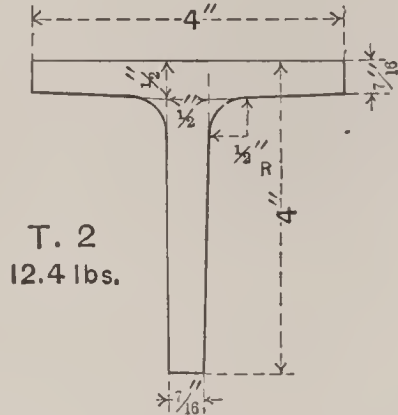

T. 2
12.4 lbs.

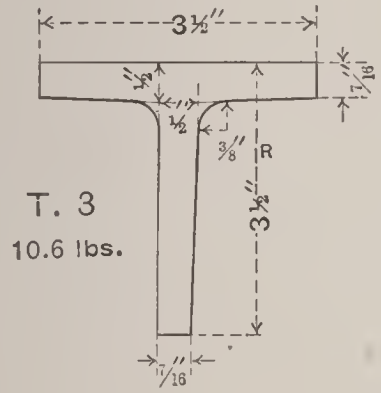

T. 3
10.6 lbs.

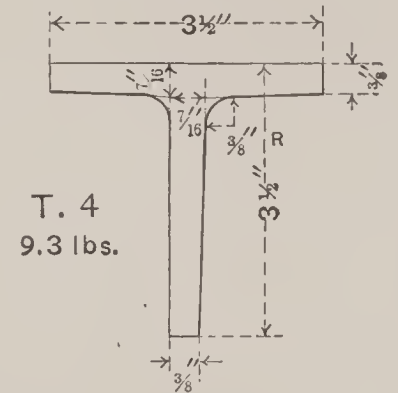

T. 4
9.3 lbs.

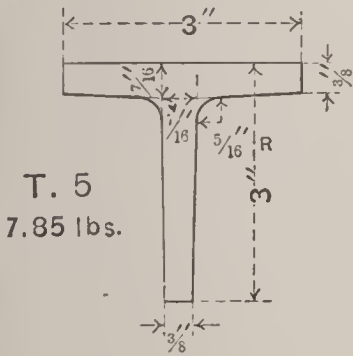

T. 5
7.85 lbs.

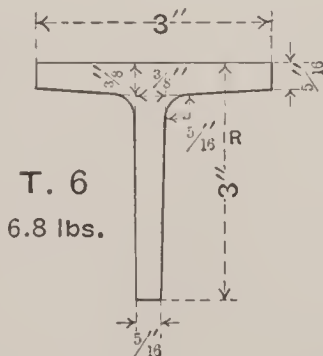

T. 6
6.8 lbs.

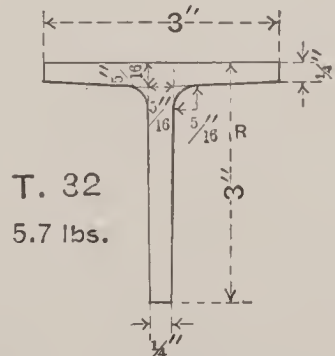

T. 32
5.7 lbs.

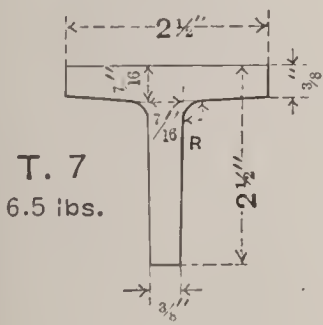

T. 7
6.5 lbs.

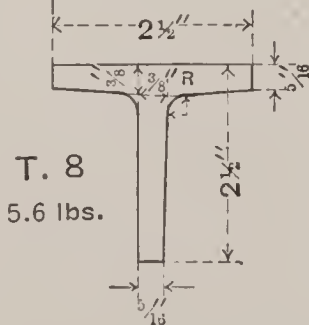

T. 8
5.6 lbs.

EQUAL LEGGED TEES—STEEL

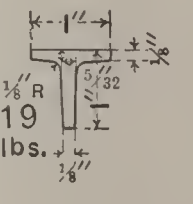
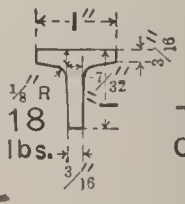
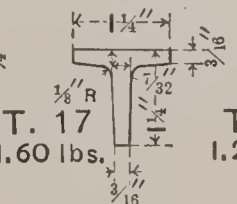
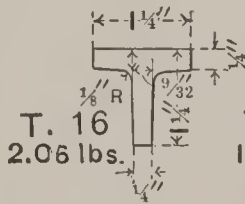
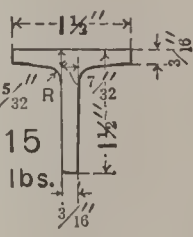
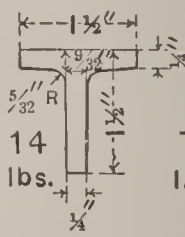
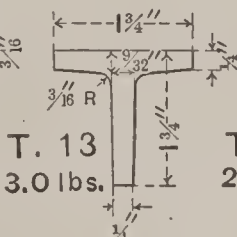
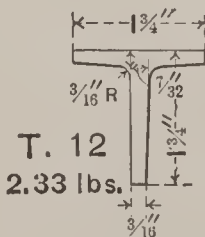
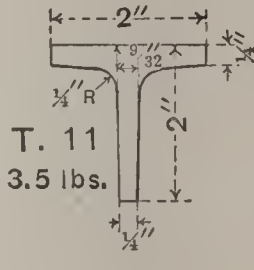
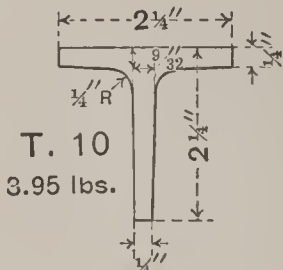
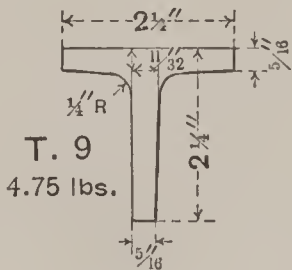

STEEL Z BARS

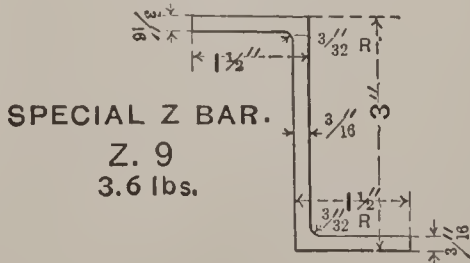
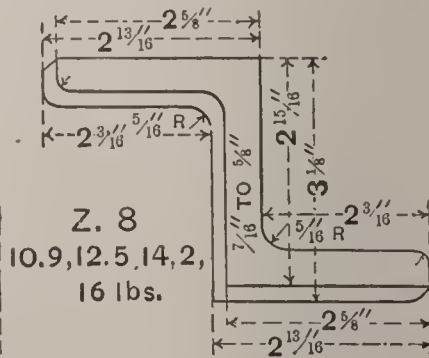
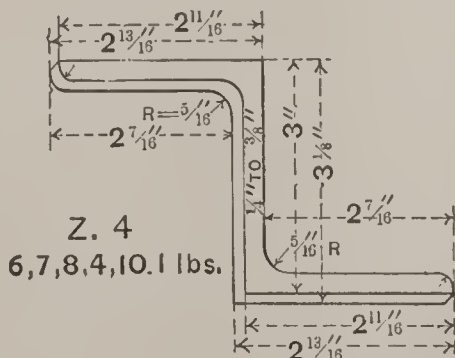

GROOVED STEEL

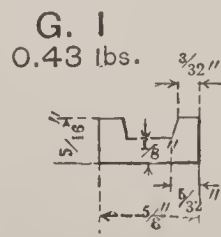
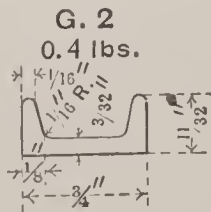
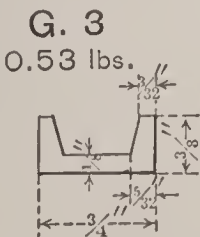
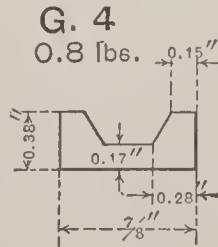
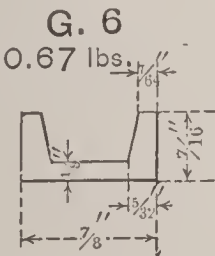
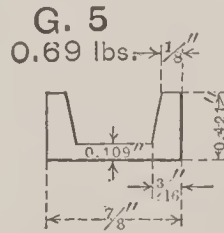
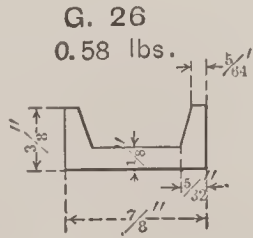
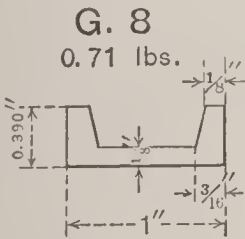
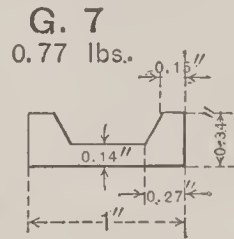
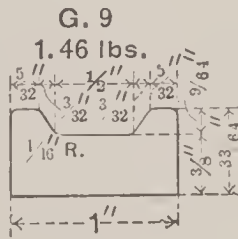
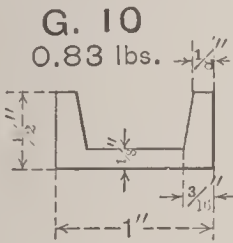
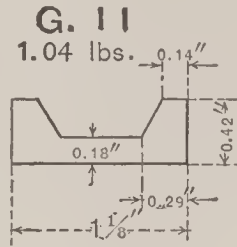
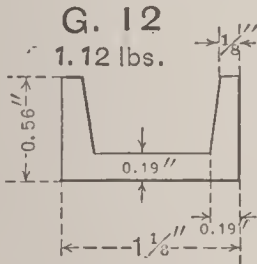
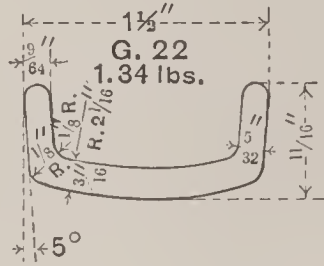
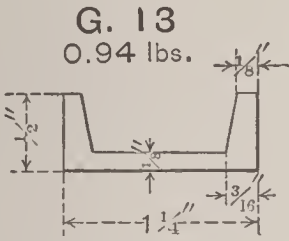

GROOVED STEEL

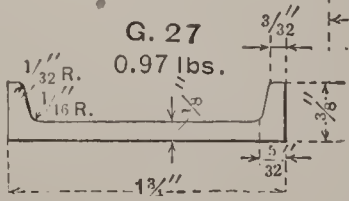
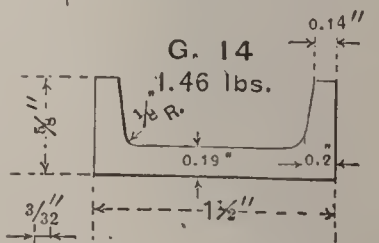
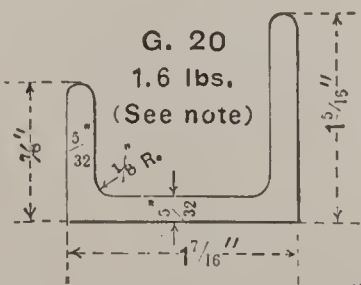
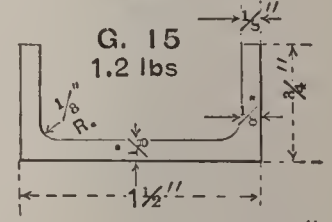
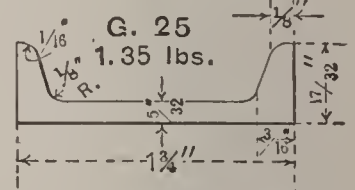
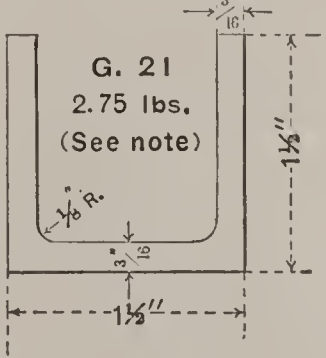
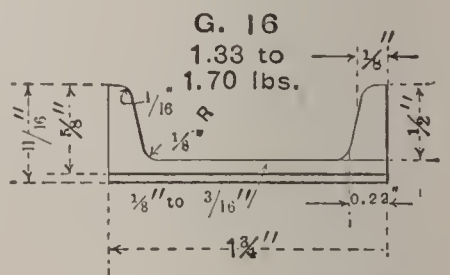
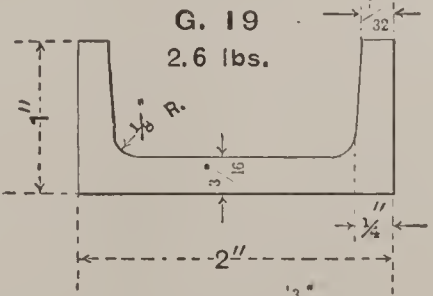
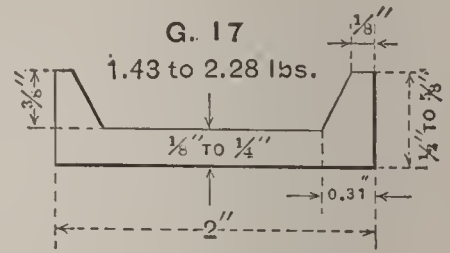
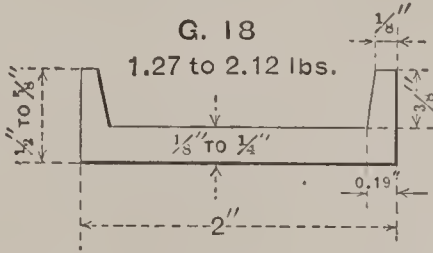
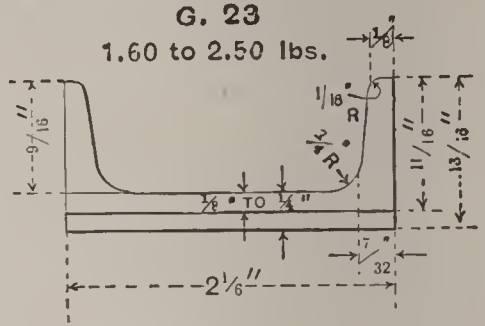
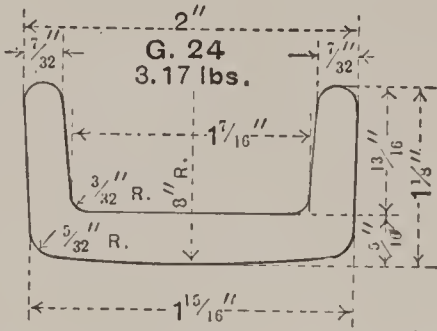

Note: G 20 and G 21 made only by special arrangement

MISCELLANEOUS SHAPES—STEEL
Channel Tires

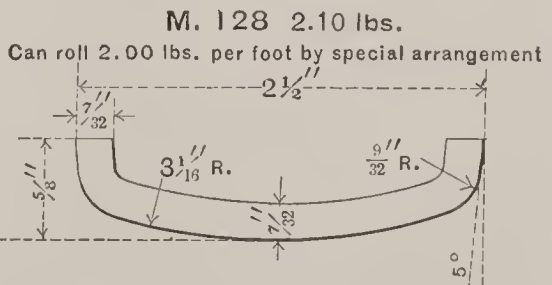
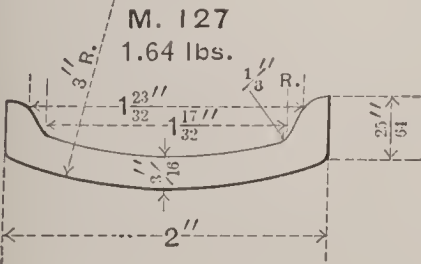
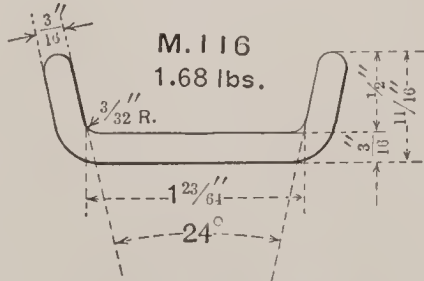
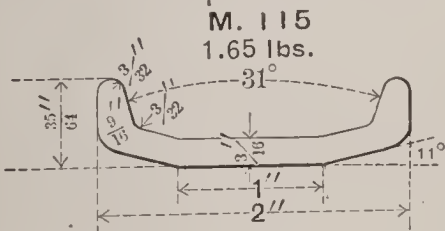
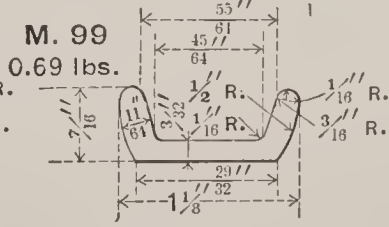
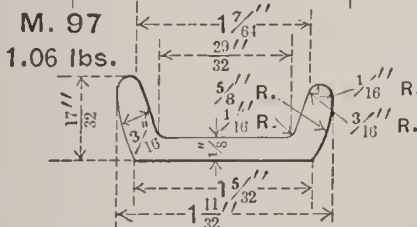
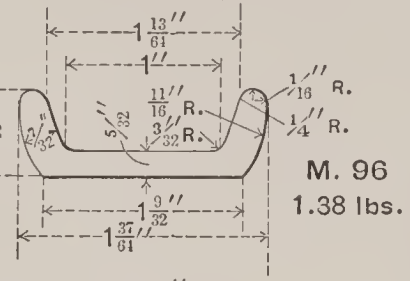
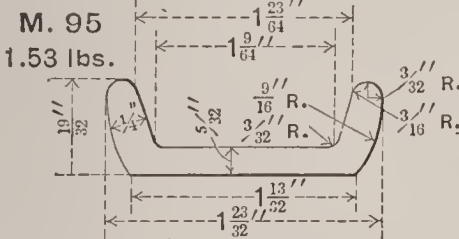
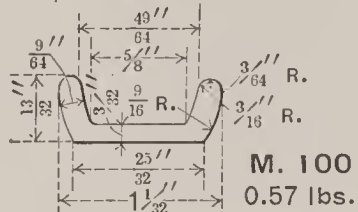
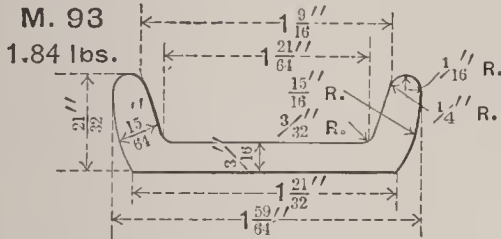
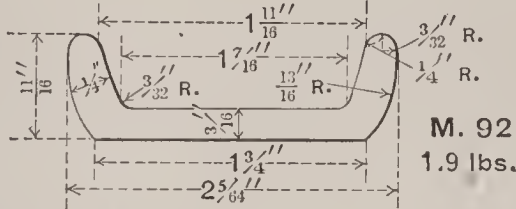

MISCELLANEOUS SHAPES—STEEL

Harvester Tires

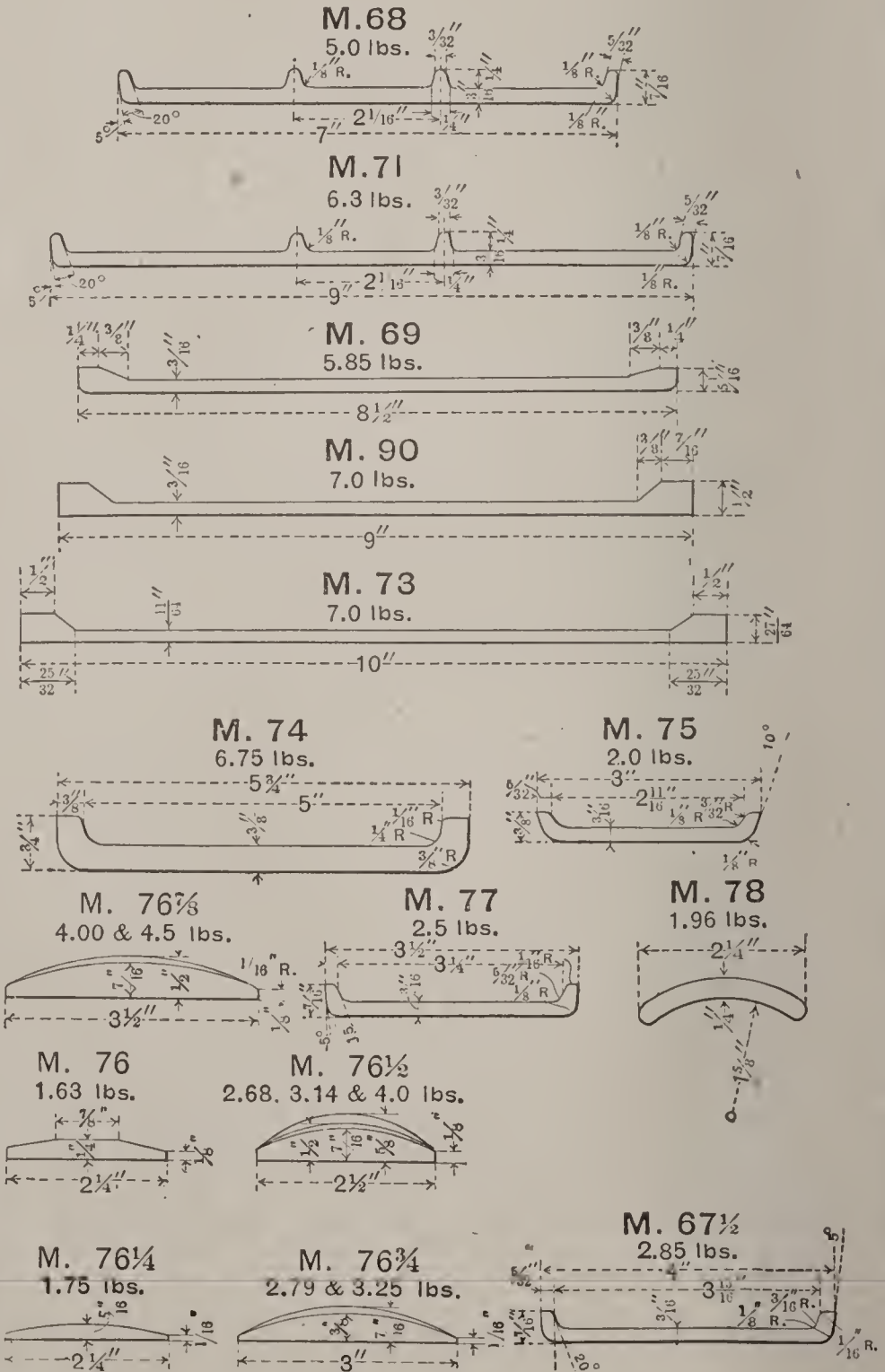

MISCELLANEOUS SHAPES—STEEL

M. 123
0.30 lbs.

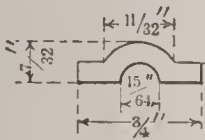

M. 124
0.89 lbs.

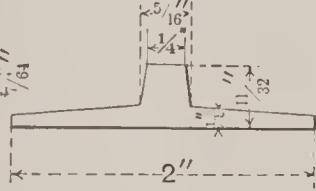

DASH CHANNEL

M. 126
0.72 lbs.

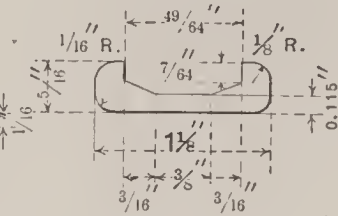

SCREEN BARS

M. 22

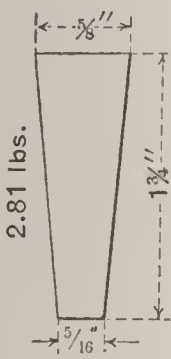

M. 23

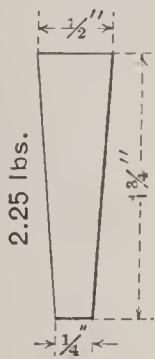

M. 24

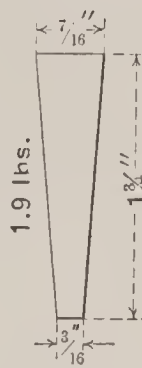

M. 25

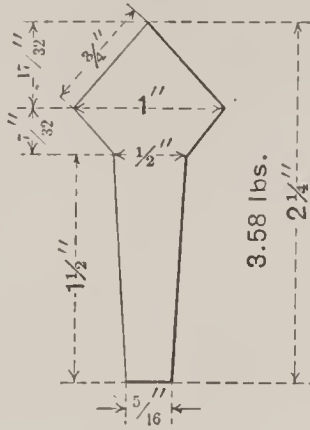

M. 26

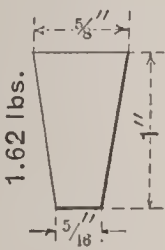

M. 27

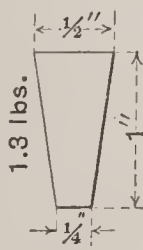

M. 28

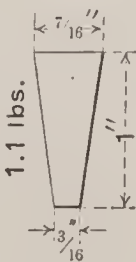

M. 122
0.95 lbs.

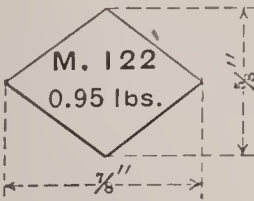

ICE SLIDE
M. 29

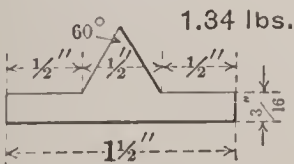

SASH BAR

M. 110
1.66 lbs.

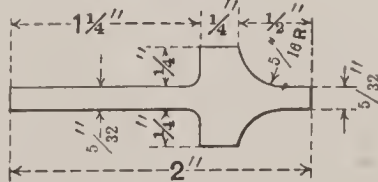

MISCELLANEOUS SHAPES—STEEL

Curved Sled Shoe

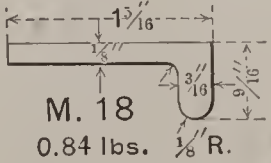
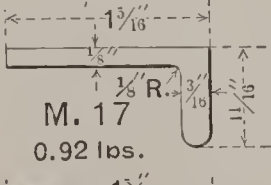
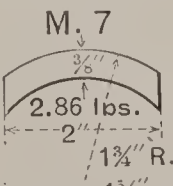
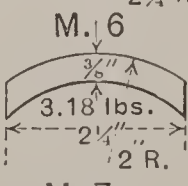
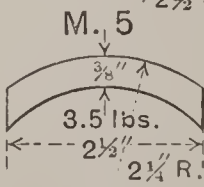
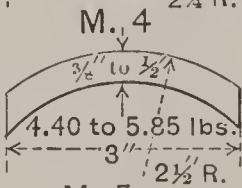
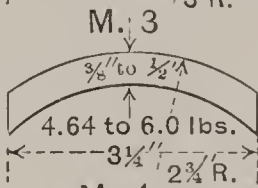
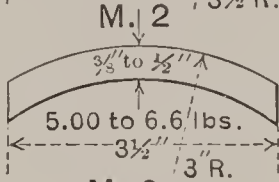
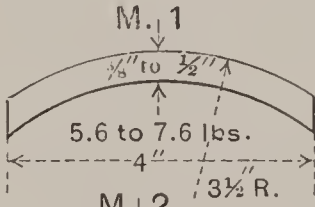

Dropper Bar

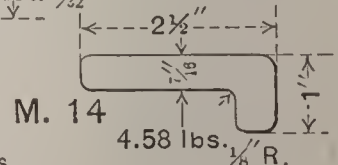
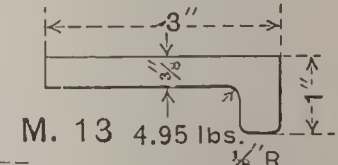
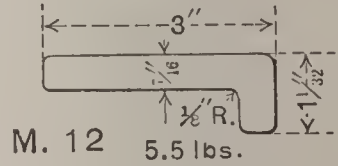
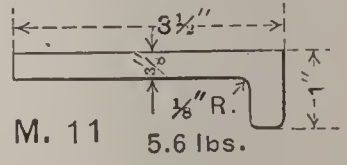
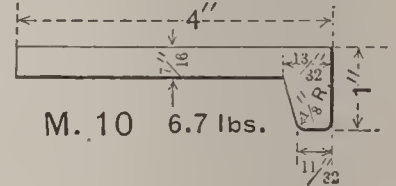
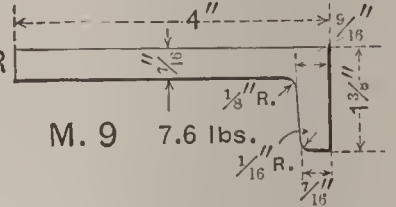

CYLINDER

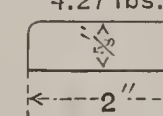
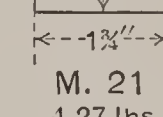
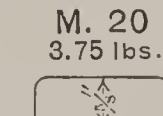
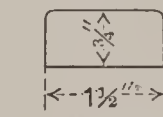
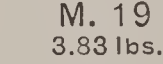

WAGON BOX
 Complete Lists of Sizes
 on page 43

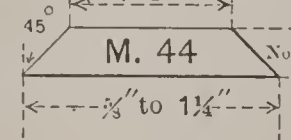

OVAL EDGE
 Complete Lists of Sizes
 on page 43

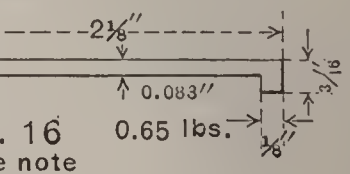
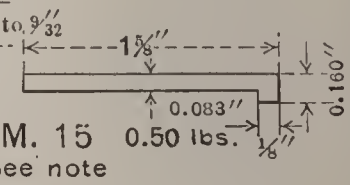
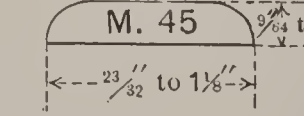

Note: M 15 & M 16 made only by special arrangement.

MISCELLANEOUS SHAPES—STEEL

M. 62

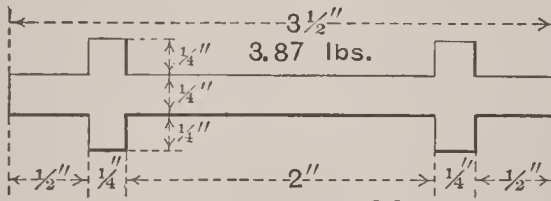

M. 64

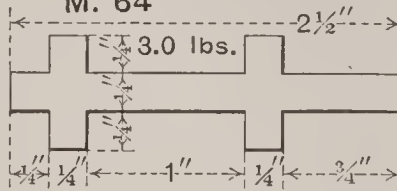

M. 65 4.25 lbs.

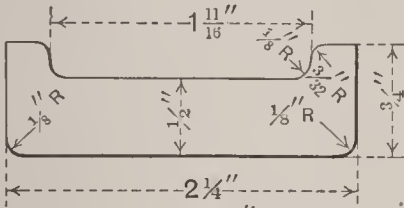

M. 67
2.78 lbs.

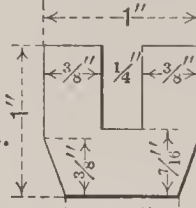

M. 87
4.25 lbs.

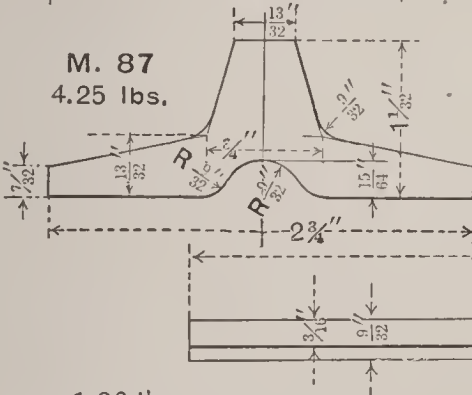

J BAR
M. 102
3.35 &
5.06 lbs.
(See note)

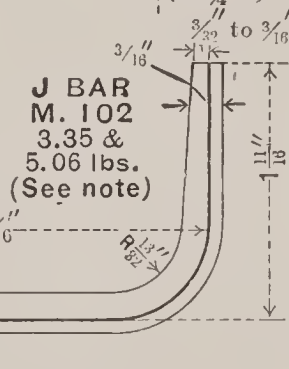

1.86 lbs.
(See note)

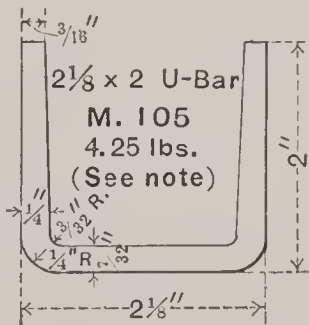
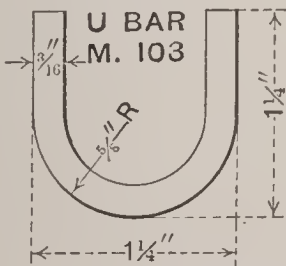

1 1/8" ROUND
BACK CHANNEL

M. 104
1.00 lbs.

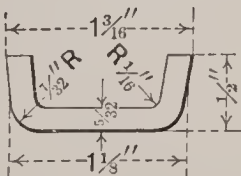

HOE POINT
M. 117 0.73 lbs.

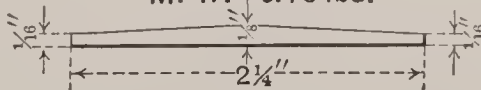

Note: M 102, M 103 and M 105 made only by special arrangement

MISCELLANEOUS SHAPES—STEEL

Cultivator Beams

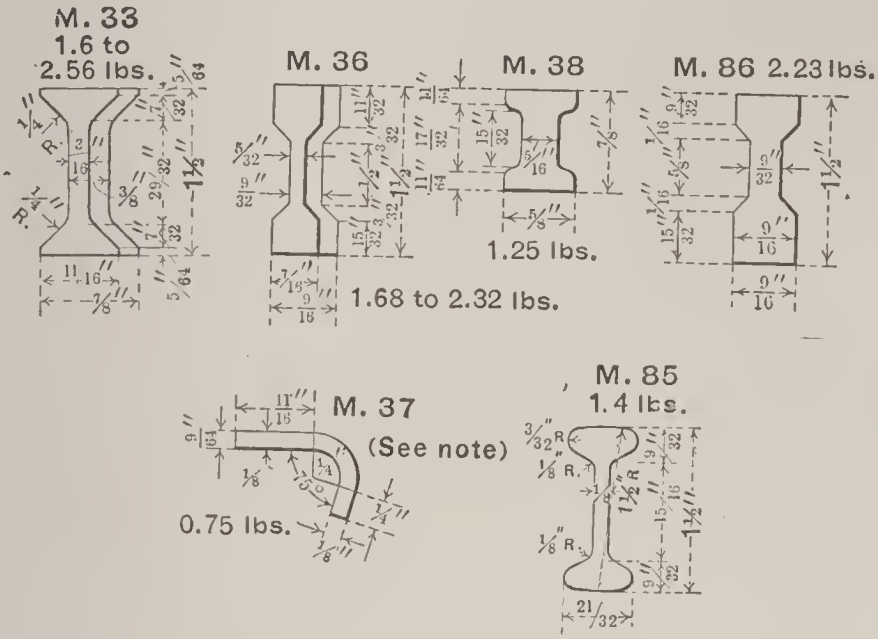

Rack Rails

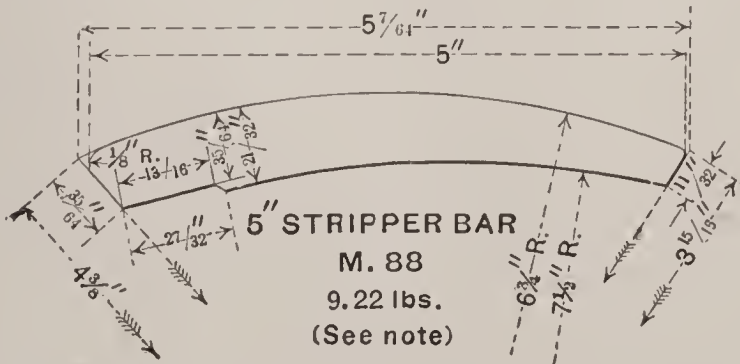
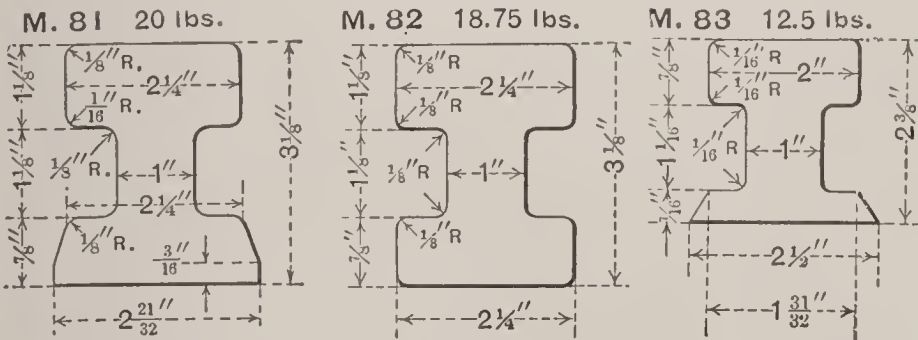

Note: M 37 and M 88 made only by special arrangement

COLD-ROLLED REAPER AND HARVESTER FINGER BARS

Accurately Finished and Straightened

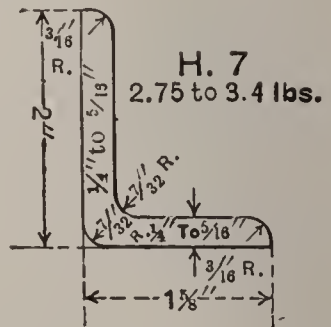
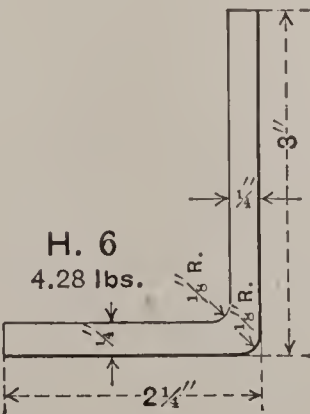
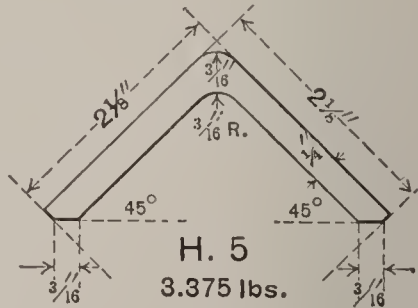
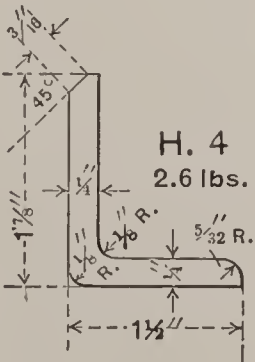
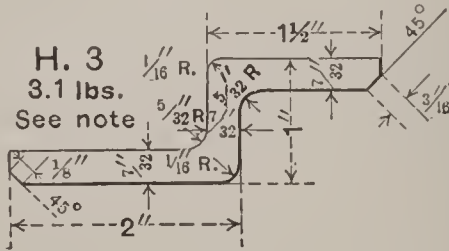
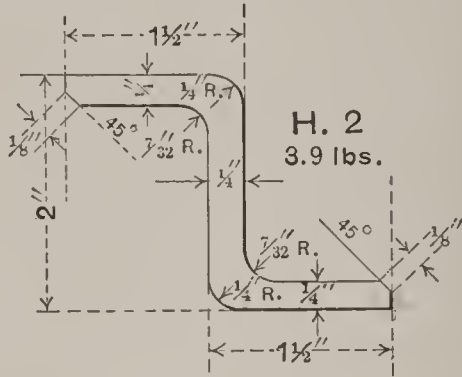

Note: H 3 made only by special arrangement

COLD-ROLLED REAPER AND HARVESTER FINGER BARS

Accurately Finished and Straightened

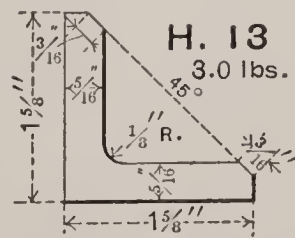
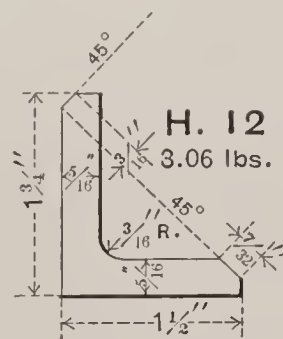
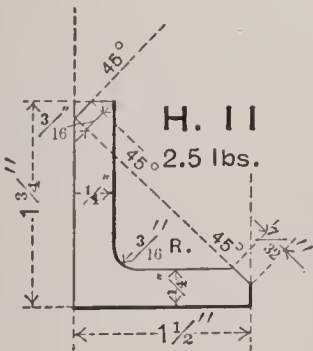
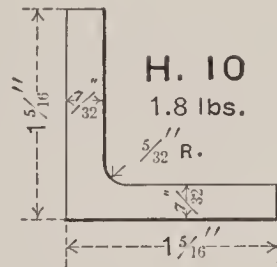
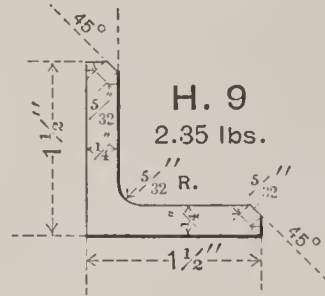
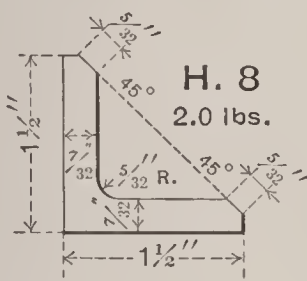

HOT-ROLLED REAPER AND HARVESTER FINGER BARS

H. 17
3.8 lbs.

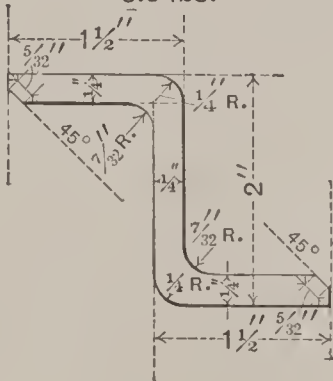

H. 19 (see note)
3.1 lbs.

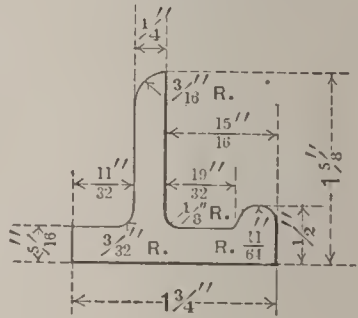

H. 20 (see note)
4.34 lbs.

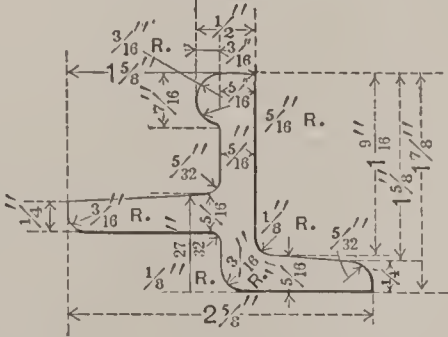

H. 21 (see note)
4.0 lbs.
Hot or Cold Rolled

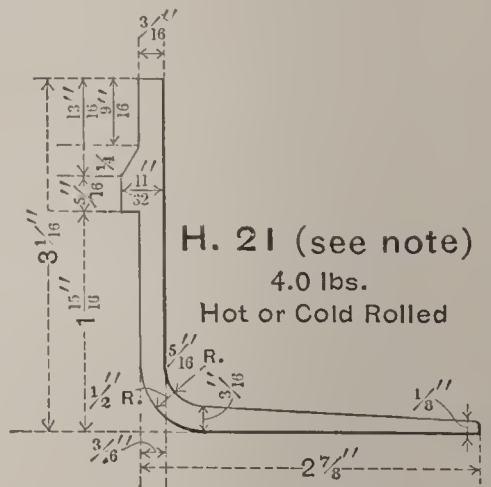

NOTE: H. 19, 20 & 21 made only by special arrangement.

STEEL T RAILS

SECTION R. 1

40 lbs.

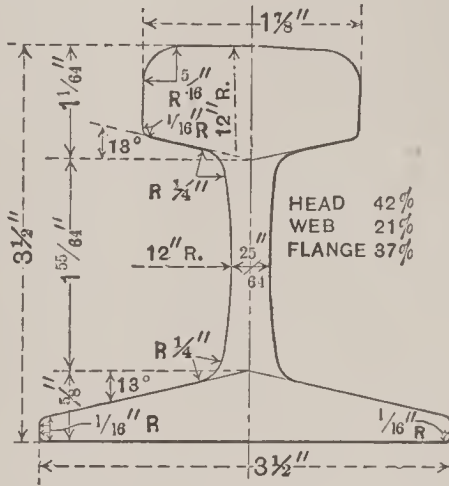

SECTION R. 2

35 lbs.

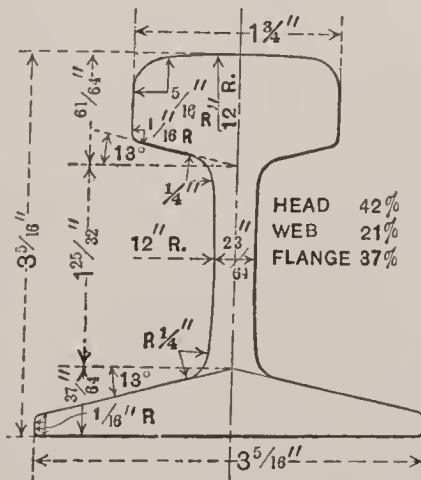

STEEL TEE RAILS

SECTION R. 3

30 lbs.

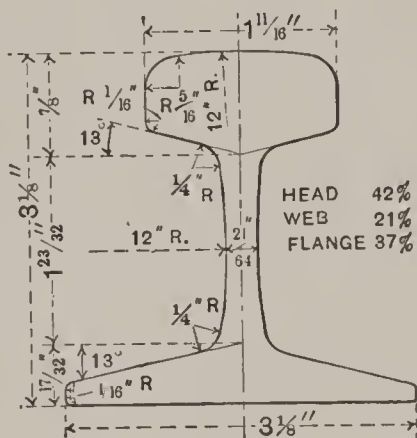

SECTION R. 8

8 lbs.

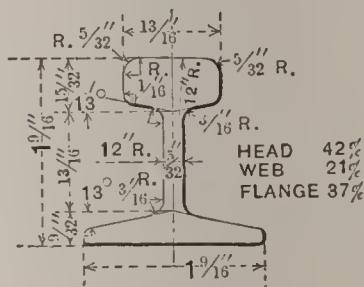

SECTION R. 4

25 lbs.

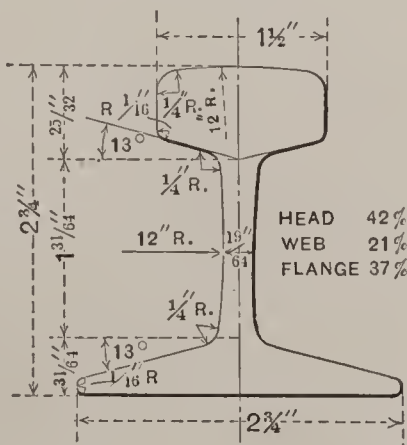

SECTION R. 7

12 lbs.

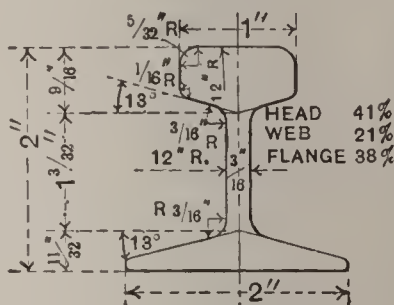

SECTION R. 5

20 lbs.

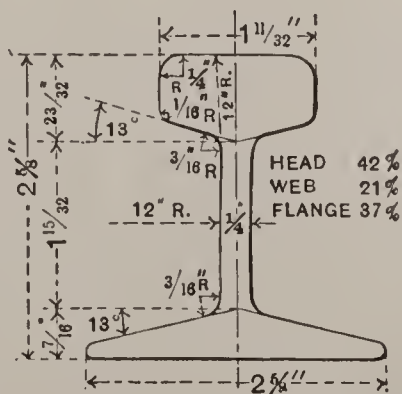

SECTION R. 6

16 lbs.

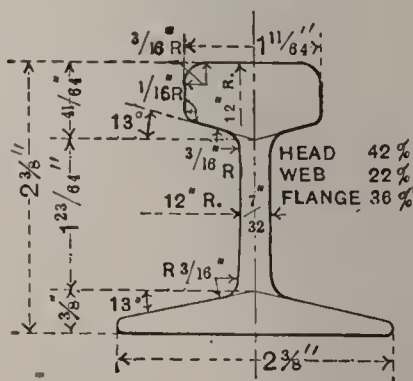

FOR REFERENCE ONLY

Not Rolled by Jones & Laughlin Steel Co.

Rail sections recommended as standard by the Committee on Standard Rail Sections of the American Society of Civil Engineers. Dimensions which are constant for all sections are shown only on the 100-pound section. On other sections the dimensions special to each are alone shown.

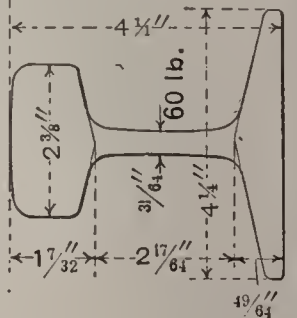
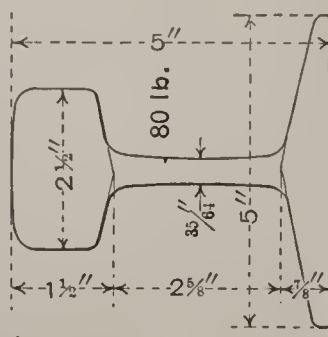
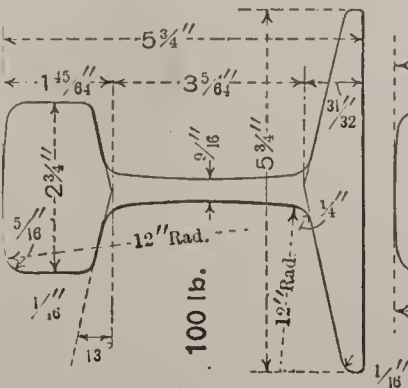
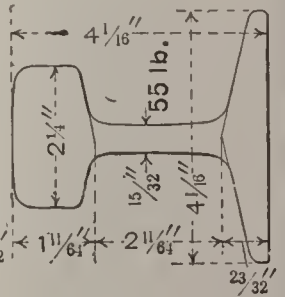
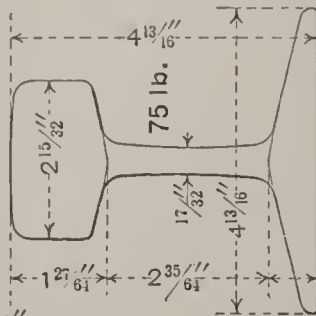
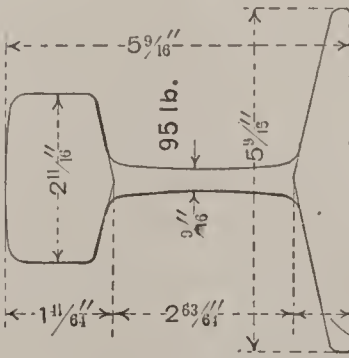
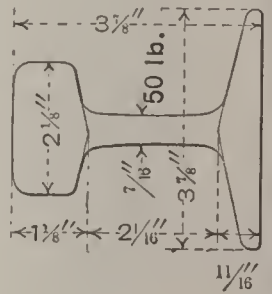
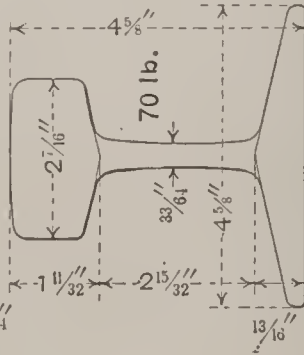
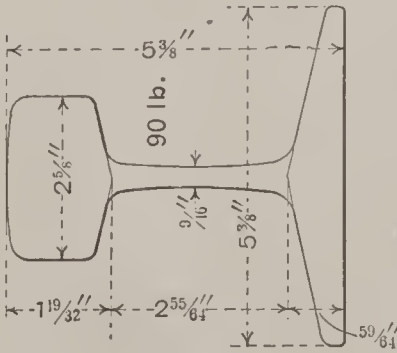
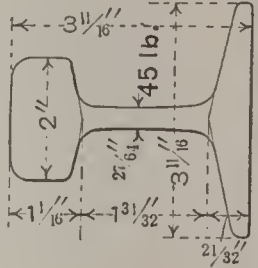
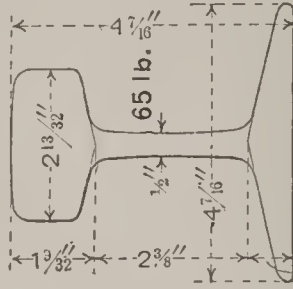
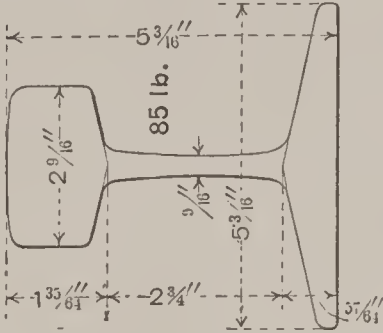

METHOD OF INCREASING SECTIONAL AREAS

Dark portions represent the minimum sections, and the blank portions the added areas

No. 1

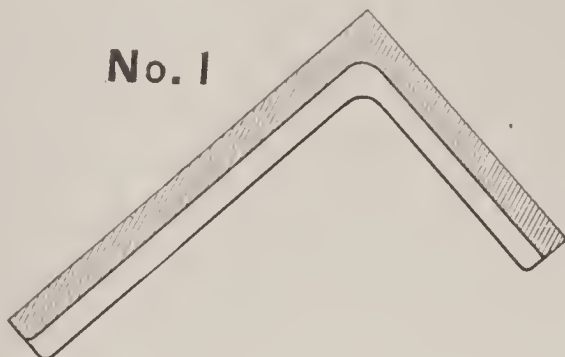

No. 2

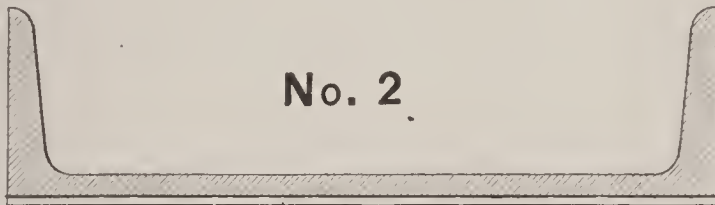

No. 3

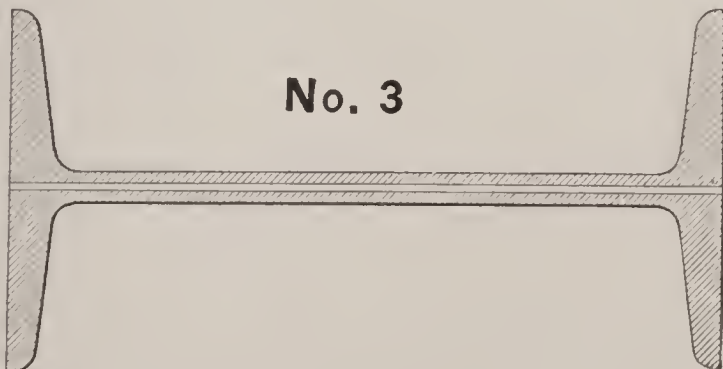

CHAINS

Straight Link Coil Chain.

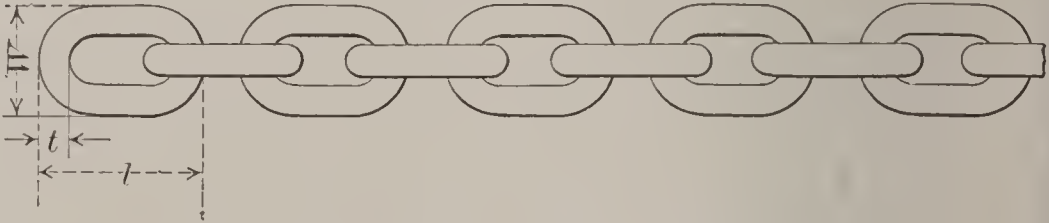

Standard Close Link Cable Chain.

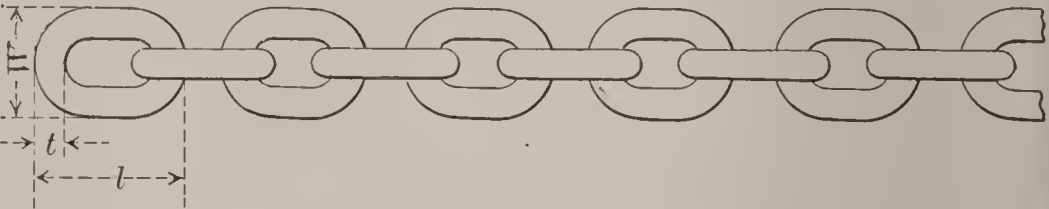

Standard Stud Link Cable Chain.

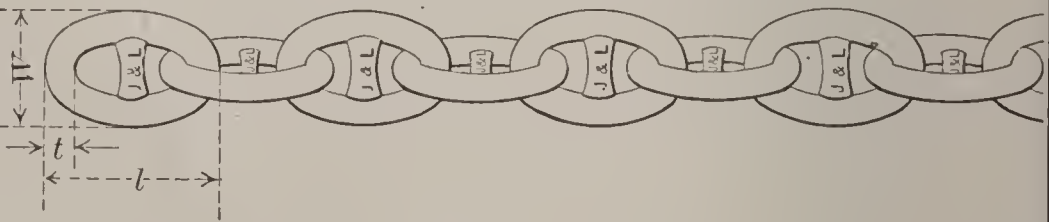

Conveyor or Sprocket Wheel Chain.

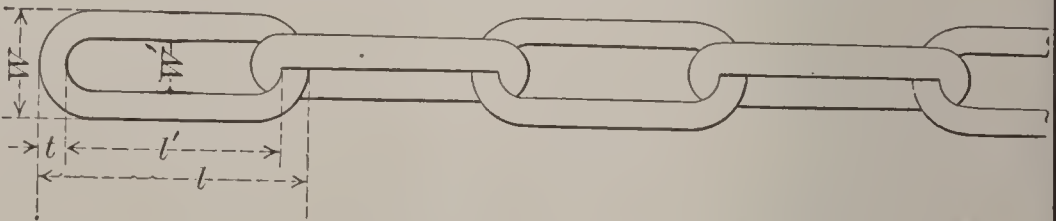

Twist Coil Chain.

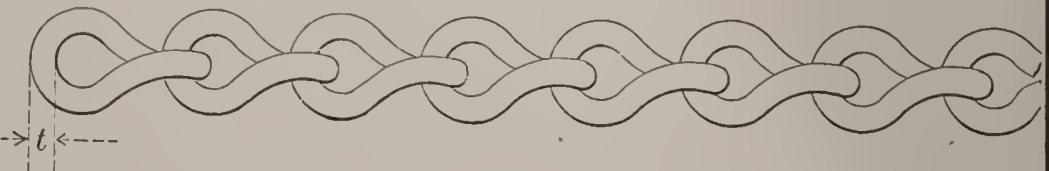

For sizes, dimensions and notes on the above chains, see page 41.



CHAINS

Sizes, Weights, Dimensions and Proof Tests of Chains Manufactured by Jones & Laughlin Steel Co.

SIZE OF CHAIN IN INCHES	STRAIGHT LINK COIL CHAIN						S'T'D CLOSE LINK CABLE CHAIN				S'T'D STUD LINK CABLE CHAIN			
	Length of Link Inches	Width of Link Inches	Weight per Ft. of Chain	Proof Test for BB Chain	Proof Test for BBB Chain	Proof Test for Dredge Chain	Length of Link Inches	Width of Link Inches	Weight per Ft. of Chain	Proof Test	Length of Link Inches	Width of Link Inches	Weight per Ft. of Chain	Proof Test
t	l	w	Lbs.	Tons	Tons	Tons	l	w	Lbs.	Tons	l	w	Lbs.	Tons
3/8	1 3/8	1 1/8	.5	.39	.45	.5
1/4	1 1/2	1	.75	.66	.75	.8
5/16	1 3/4	1 1/8	1.10	1.37	1.6	1.7
3/8	2	1 3/8	1.55	1.92	2.21	2.36
7/16	2 1/4	1 9/16	2.00	2.64	3.05	3.33
1/2	2 1/2	1 3/4	2.65	3.41	3.92	4.42
9/16	2 7/8	1 11/8	3.25	4.29	4.93	5.53
5/8	3 1/4	2 1/8	4.2	5.28	6.07	6.67
11/16	3 1/2	2 5/8	5.0	6.32	7.28	8.02
3/4	3 3/4	2 1/2	5.9	7.59	8.74	9.24	4 3/8	2 3/4	5.5	10.1
13/16	4	2 11/16	7.0	8.91	10.3	10.7	4 3/4	3	6.3	12.0
7/8	4 1/4	3	8.0	10.3	11.9	12.1	5	3 1/4	8.2	13.7
15/16	4 1/2	3 1/4	9.0	11.8	13.6	14.5	5 3/8	3 1/2	9.2	15.7
1	4 3/4	3 1/2	10.0	13.5	15.6	16.3	4 5/8	3 1/2	10.3	12.0	5 7/8	3 3/4	10.2	18.0
1 1/16	5	3 5/8	11.8	12.5	6 1/4	3 7/8	11.5	20.3
1 1/8	5 1/2	3 7/8	12.5	16.2	18.6	19.6	5 3/8	3 7/8	12.7	15.1	6 1/2	4 1/8	12.3	22.8
1 1/4	5 1/2	4 1/8	13.7	16.9	6 3/4	4 1/4	13.5	25.5
1 1/2	6	4 1/4	16.0	20.1	23.1	24.0	5 3/4	4 1/4	15.2	18.7	7 1/8	4 1/2	15.0	28.1
1 5/8	6	4 1/2	16.5	20.6	7 3/8	4 5/8	16.2	31.0
1 3/4	6 1/2	4 3/4	19.0	24.2	27.8	28.7	6 1/4	4 3/4	18.8	22.6	7 3/4	4 7/8	18.3	34.0
1 7/8	6 5/8	5	19.7	24.7	8 1/8	5 1/8	18.8	37.2
1 1/2	7 1/4	5 1/4	21.0	28.9	33.2	34.6	6 7/8	5 1/4	21.7	27.0	8 1/2	5 3/8	21.2	40.5
1 9/8	7 1/4	5 1/2	23.0	29.2	8 7/8	5 5/8	23.8	44.0
1 5/8	7 7/8	5 3/4	35.0	34.9	39.0	41.0	7 1/2	5 3/4	25.3	31.6	9 1/4	5 7/8	25.0	47.5
1 11/8	9 3/8	6	26.2	51.2
1 3/4	10	6 1/4	28.8	55.2
1 7/8	10 1/2	6 3/4	33.8	63.3
1 15/8	10 3/4	7	35.8	67.5
2	11 1/8	7 1/4	38.8	72.0
2 1/16	11 1/2	7 1/2	42.3	76.5
2 1/8	12	7 3/4	46.0	81.2
2 3/16	12 1/2	8	48.3	86.1
2 1/4	13	8 1/4	50.0	91.0

NOTES.—Safe working loads of chains are one-half of Proof Test Loads. Twist Coil Chains are made in all sizes from 3/8 to 2-inch, inclusive. Conveyor or Sprocket Wheel Chains are made to any dimensions required, and in ordering give dimensions of links wanted, or preferably a sketch of same.

ROUND BARS
 Sizes Rolled by Jones & Laughlin Steel Co.

 DIAMETER INCHES	WEIGHT PER FOOT POUNDS	MAXIMUM LENGTH FEET	 DIAMETER INCHES	WEIGHT PER FOOT POUNDS	MAXIMUM LENGTH FEET	 DIAMETER INCHES	WEIGHT PER FOOT POUNDS	MAXIMUM LENGTH FEET	
								Straight	Coiled
7 ⁵ / ₁₆	142.8	23	3 ⁷ / ₈	40.10	45	1 ¹ / ₈	3.379	60	
7 ¹ / ₄	140.4	23	3 ³ / ₄	37.56	45	1 ¹ / ₁₆	3.014	60	
7 ¹ / ₈	135.6	23	3 ⁵ / ₈	35.09	45	1	2.670	60	
7	130.9	25	3 ¹ / ₂	32.71	45				
			3 ³ / ₈	30.42	45	1 ⁵ / ₁₆	2.347	60	
6 ⁷ / ₈	126.2	25	3 ¹ / ₄	28.20	45	7 ⁷ / ₈	2.044	60	
6 ³ / ₄	121.7	27	3 ¹ / ₈	26.08	45	1 ¹ / ₈	1.763	60	
6 ⁵ / ₈	117.2	27	3	24.03	45	3 ³ / ₄	1.502	60	225
6 ¹ / ₂	112.8	30				1 ¹ / ₁₆	1.262	40	265
6 ³ / ₈	108.5	30	2 ⁷ / ₈	22.07	45	5 ⁵ / ₈	1.043	40	315
6 ¹ / ₄	104.3	32	2 ³ / ₄	20.20	45	9 ⁹ / ₁₆	0.845	40	285
6 ¹ / ₈	100.2	32	2 ⁵ / ₈	18.40	45	1 ¹ / ₃	0.754	40	395
6	96.14	34	2 ¹ / ₂	16.69	45	1 ¹ / ₂	0.667	40	450
			2 ³ / ₈	15.07	45				
5 ⁷ / ₈	92.17	34	2 ¹ / ₄	13.52	60	1 ⁵ / ₃	0.587	40	255
5 ³ / ₄	88.29	38	2 ¹ / ₈	12.06	60	7 ⁷ / ₁₆	0.511	40	295
5 ⁵ / ₈	84.49	38	2	10.68	60	1 ¹ / ₃	0.441	40	340
5 ¹ / ₂	80.77	42				1 ¹ / ₃	0.375	40	400
5 ³ / ₈	77.15	42	1 ¹⁵ / ₁₆	10.02	60	1 ¹ / ₃	0.316	40	475
5 ¹ / ₄	73.60	45	1 ⁷ / ₈	9.388	60	5 ⁵ / ₁₆	0.261	40	575
5 ¹ / ₈	70.14	45	1 ¹³ / ₁₆	8.773	60	9 ⁹ / ₃₂	0.211	30	90
5	66.76	45	1 ³ / ₄	8.178	60	1 ¹ / ₄	0.167	30	90
			1 ¹¹ / ₁₆	7.604	60	7 ⁷ / ₃₂	0.128	30	85
4 ⁷ / ₈	63.46	45	1 ⁵ / ₈	7.051	60	3 ³ / ₁₆	0.094	30	65
4 ³ / ₄	60.25	45	1 ⁹ / ₁₆	6.520	60				
4 ⁵ / ₈	57.12	45	1 ¹ / ₂	6.008	60				
4 ¹ / ₂	54.07	45	1 ⁷ / ₁₆	5.518	60				
4 ³ / ₈	51.11	45	1 ³ / ₈	5.049	60				
4 ¹ / ₄	48.24	45	1 ⁵ / ₁₆	4.600	60				
4 ¹ / ₈	45.44	45	1 ¹ / ₄	4.173	60				
4	42.73	45	1 ³ / ₁₆	3.766	60				

NOTE.—Maximum lengths denote shipping lengths.

SQUARE BARS

Sizes Rolled by Jones & Laughlin Steel Co.

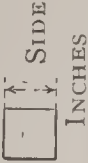
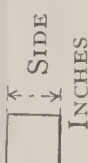
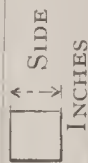
 SIDE INCHES	WEIGHT PER FOOT POUNDS	MAXIMUM LENGTH FEET	 SIDE INCHES	WEIGHT PER FOOT POUNDS	MAXIMUM LENGTH FEET	 SIDE INCHES	WEIGHT PER FOOT POUNDS	MAXIMUM LENGTH FEET	
								Straight	Coiled
4 1/4	61.41	45	1 3/4	10.41	60	3/4	1.913	60	
4	54.40	45	1 11/16	9.682	60	11/16	1.607	40	
3 3/4	47.82	45	1 5/8	8.978	60	5/8	1.328	40	
3 1/2	41.65	45	1 9/16	8.301	60	9/16	1.076	40	
3 1/4	35.92	45	1 1/2	7.650	60	1 1/32	0.960	40	
3	30.60	45	1 7/16	7.026	60	1/2	0.850	40	
2 3/4	25.71	45	1 3/8	6.428	60	15/32	0.747	40	
2 5/8	23.43	45	1 5/16	5.857	60	7/16	0.651	40	70
2 1/2	21.25	45	1 1/4	5.313	60	1 1/32	0.561	40	70
2 3/8	19.18	45	1 3/16	4.795	60	3/8	0.478	40	75
2 1/4	17.21	45	1 1/8	4.303	60	1 1/32	0.402	30	75
2 1/8	15.35	45	1 1/16	3.838	60	5/16	0.332	30	80
2	13.60	60	1	3.400	60	9/32	0.269	30	80
1 15/16	12.76	60	15/16	2.988	60	1/4	0.212	30	75
1 7/8	11.95	60	7/8	2.603	60	7/32	0.163	30	70
1 13/16	11.17	60	13/16	2.245	60	3/16	0.120	30	70

OVAL EDGE OR REACH PLATE

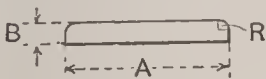

BEVEL EDGE OR WAGON BOX

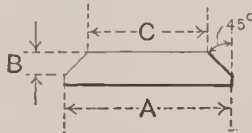

A Ins.	B Ins.	R Ins.	A Ins.	B Ins.	C Ins.	A Ins.	B Ins.	C Ins.
2 3/32	9/32	1/8	5/8	No. 12		7/8	1/4	11/16
3/4	1/8	1/8	3/4	No. 12		1	1/2	9/16
3/4	3/16	1/8	3/4	No. 14		1	No. 12	
2 7/32	11/64	1/8	3/4	3/16		1	1/4	
7/8	3/16	1/8	3/4	1/4		1 1/8	No. 12	
7/8	1/4	1/8	13/16	No. 13		1 1/8	1/4	
1	1/4	1/8	7/8	No. 14		1 1/4	5/16	
1 1/8	9/32	1/8	7/8	1/4		1 1/4	11/32	

NOTE.—Maximum lengths denote shipping lengths.

OVALS, HALF OVALS, HALF ROUNDS, HEXAGONALS AND BLUNT OVALS

Sizes Rolled by Jones & Laughlin Steel Company

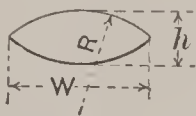
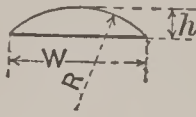
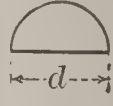
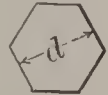
OVALS				HALF OVALS				HALF ROUNDS		HEXAGONALS	
											
W Inches	$\frac{1}{2}$ Inches	R Inches	Weight Pounds	W Inches	$\frac{1}{2}$ Inches	R Inches	Weight Pounds	d Inches	Weight Pounds	d Inches	Weight Pounds
$\frac{1}{2}$	$\frac{1}{4}$	$\frac{5}{16}$	0.297	$\frac{3}{8}$	$\frac{3}{16}$	$\frac{1}{8}$	0.084	$\frac{5}{16}$	0.131	$\frac{5}{16}$	0.283
$\frac{9}{16}$	$\frac{3}{8}$	$\frac{11}{16}$	0.376	$\frac{7}{16}$	$\frac{5}{16}$	$\frac{3}{8}$	0.114	$\frac{3}{8}$	0.187	$\frac{3}{8}$	0.414
$\frac{5}{8}$	$\frac{5}{16}$	$\frac{3}{2}$	0.465	$\frac{1}{2}$	$\frac{1}{8}$	$\frac{5}{8}$	0.149	$\frac{7}{16}$	0.256	$\frac{7}{16}$	0.564
$\frac{3}{4}$	$\frac{5}{16}$	$\frac{17}{16}$	0.551	$\frac{9}{16}$	$\frac{1}{8}$	$\frac{5}{8}$	0.170	$\frac{1}{2}$	0.334	$\frac{1}{2}$	0.736
$\frac{3}{4}$	$\frac{3}{8}$	$\frac{3}{2}$	0.669	$\frac{5}{8}$	$\frac{3}{8}$	$\frac{11}{8}$	0.198	$\frac{5}{8}$	0.522	$\frac{9}{16}$	0.932
$\frac{7}{8}$	$\frac{5}{16}$	$\frac{11}{16}$	0.632	$\frac{5}{8}$	$\frac{3}{8}$	$\frac{3}{2}$	0.232	$\frac{11}{16}$	0.631	$\frac{5}{8}$	1.150
$\frac{7}{8}$	$\frac{3}{8}$	$\frac{3}{2}$	0.774	$\frac{5}{8}$	$\frac{3}{16}$	$\frac{3}{2}$	0.282	$\frac{3}{4}$	0.751	$\frac{11}{16}$	1.392
$\frac{7}{8}$	$\frac{1}{2}$	$\frac{3}{2}$	0.910	$\frac{3}{4}$	$\frac{3}{16}$	$\frac{3}{2}$	0.335	$\frac{7}{8}$	1.032	$\frac{3}{4}$	1.656
1	$\frac{1}{2}$	$\frac{11}{16}$	1.030	$\frac{7}{8}$	$\frac{3}{2}$	$\frac{3}{2}$	0.455	1	1.335	$\frac{13}{16}$	1.944
1	$\frac{1}{2}$	$\frac{5}{8}$	1.170	1	$\frac{1}{4}$	$\frac{5}{8}$	0.585	$\frac{11}{8}$	1.690	$\frac{7}{8}$	2.254
$\frac{11}{8}$	$\frac{9}{16}$	$\frac{4}{5}$	1.508	$\frac{11}{8}$	$\frac{9}{16}$	$\frac{4}{5}$	0.754	$\frac{11}{4}$	2.086	$\frac{15}{16}$	2.588
$\frac{11}{4}$	$\frac{5}{8}$	$\frac{3}{2}$	1.860	$\frac{11}{4}$	$\frac{5}{16}$	$\frac{3}{2}$	0.930	$\frac{11}{2}$	3.004	1	2.945
$\frac{11}{2}$	$\frac{3}{4}$	$\frac{15}{16}$	2.670	$\frac{11}{2}$	$\frac{1}{4}$	$\frac{11}{4}$	0.876	$\frac{13}{4}$	4.089	$\frac{1}{16}$	3.324
				$\frac{11}{2}$	$\frac{5}{16}$	$\frac{1}{16}$	1.100	2	5.34	$\frac{11}{8}$	3.727
				$\frac{11}{2}$	$\frac{3}{8}$	$\frac{15}{16}$	1.335			$\frac{1}{16}$	4.152
				$\frac{13}{4}$	$\frac{7}{16}$	$\frac{3}{2}$	1.825			$\frac{1}{4}$	4.601
				2	$\frac{1}{2}$	$\frac{11}{4}$	2.380			$\frac{5}{16}$	5.072
				2	$\frac{3}{8}$	$\frac{3}{2}$	1.751			$\frac{3}{8}$	5.567
				$\frac{21}{4}$	$\frac{5}{16}$	$\frac{3}{16}$	1.623			$\frac{7}{16}$	6.085
				$\frac{21}{2}$	$\frac{1}{2}$	$\frac{13}{16}$	2.915			$\frac{1}{2}$	6.625
				$\frac{21}{2}$	$\frac{5}{8}$	$\frac{9}{16}$	3.716			$\frac{9}{16}$	7.189
				3	$\frac{3}{8}$	$\frac{3}{2}$	2.584			$\frac{5}{8}$	7.775
				3	$\frac{7}{16}$	$\frac{5}{2}$	3.006			$\frac{11}{16}$	8.385
										$\frac{3}{4}$	9.018
										$\frac{13}{16}$	9.673
										$\frac{7}{8}$	10.352
										$\frac{15}{16}$	11.053

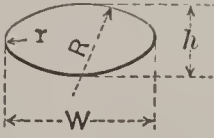
BLUNT OVALS			
			
W—Inches	$\frac{1}{2}$ —Inches	R—Inches	Weight Pounds
$\frac{5}{8}$	$\frac{11}{16}$	$\frac{7}{16}$	0.557
$\frac{7}{8}$	$\frac{5}{8}$	$\frac{15}{16}$	0.735
$\frac{7}{8}$	$\frac{7}{16}$	$\frac{11}{16}$	1.020

STEEL HOOPS

Sizes Rolled by Jones & Laughlin Steel Company

WIDTH INCHES	GAUGE	WIDTH INCHES	GAUGE
$\frac{1}{2}$	13 to 19	$1\frac{3}{4}$	13 to 19
$\frac{5}{8}$	13 to 19	2	13 to 18
$\frac{3}{4}$	13 to 19	$2\frac{1}{8}$	13 to 16
$\frac{7}{8}$	13 to 19	$2\frac{1}{4}$	13 to 16
1	13 to 19	$2\frac{3}{8}$	13 to 16
$1\frac{1}{8}$	13 to 19	$2\frac{1}{2}$	13 to 16
$1\frac{1}{4}$	13 to 19	$2\frac{5}{8}$	13 to 16
$1\frac{3}{8}$	13 to 19	$2\frac{3}{4}$	13 to 16
$1\frac{1}{2}$	13 to 19	3	13 to 16
$1\frac{5}{8}$	13 to 19		

ROUND EDGE STEEL FLATS

(Measurement Over All)

$\frac{1}{2}$ to $3\frac{1}{2}$ in. wide by $\frac{3}{16}$ to 1 in. thick . { Advancing in width and thickness by 16ths.

ROUND EDGE STEEL TIRE

(Measurement on Flat)

$\frac{3}{4}$ to 3 in. wide by $\frac{3}{16}$ to 1 in. thick . { Advancing in width and thickness by 16ths.

FLATS

Sizes Rolled by Jones & Laughlin Steel Co.

WIDTH INCHES	THICKNESS INCHES	WIDTH INCHES	THICKNESS INCHES	WIDTH INCHES	THICKNESS INCHES
$\frac{1}{2}$	No. 12 to $\frac{7}{16}$	$\frac{3}{8}$	No. 12 to $\frac{3}{8}$	7	No. 11 to 2
$\frac{5}{8}$	No. 12 to $\frac{9}{16}$	$\frac{3}{2}$	No. 12 to $\frac{3}{4}$	$7\frac{1}{4}$	No. 11 to 2
$\frac{3}{4}$	No. 12 to $\frac{11}{16}$	$\frac{5}{8}$	No. 12 to 3	$7\frac{1}{2}$	No. 11 to 2
$\frac{7}{8}$	No. 12 to $\frac{13}{16}$	$\frac{3}{4}$	No. 12 to $\frac{3}{2}$	$7\frac{3}{4}$	No. 11 to 2
1	No. 12 to $\frac{15}{16}$	$\frac{3}{7}$	$\frac{1}{4}$ to $\frac{3}{8}$	$7\frac{7}{8}$	No. 10 to 3
$1\frac{1}{8}$	No. 12 to 1	4	No. 12 to $\frac{3}{2}$	8	No. 11 to 2
$1\frac{1}{4}$	No. 12 to $1\frac{1}{8}$	$4\frac{1}{8}$	No. 11 to 2	$8\frac{1}{2}$	No. 11 to 2
$1\frac{3}{8}$	No. 12 to $1\frac{1}{4}$	$4\frac{1}{4}$	No. 12 to 2	9	No. 11 to 2
$1\frac{1}{2}$	No. 12 to $1\frac{3}{8}$	$4\frac{3}{8}$	No. 11 to 2	$9\frac{1}{2}$	$\frac{5}{8}$ to 2
$1\frac{5}{8}$	No. 12 to $1\frac{1}{2}$	$4\frac{1}{2}$	No. 11 to 2	$9\frac{3}{4}$	$\frac{1}{8}$ to 3
$1\frac{3}{4}$	No. 12 to $1\frac{5}{8}$	$4\frac{5}{8}$	No. 11 to 2	10	$\frac{5}{2}$ to 2
$1\frac{7}{8}$	No. 12 to $1\frac{3}{4}$	$4\frac{3}{4}$	No. 11 to 2	11	$\frac{1}{4}$ to 2
2	No. 12 to $1\frac{7}{8}$	$4\frac{7}{8}$	No. 11 to 2	12	$\frac{1}{4}$ to 2
$2\frac{1}{8}$	No. 12 to $1\frac{1}{2}$	5	No. 11 to 2	13	$\frac{1}{4}$ to 2
$2\frac{1}{4}$	No. 12 to 2	$5\frac{1}{4}$	No. 11 to 2	14	$\frac{1}{4}$ to 2
$2\frac{3}{8}$	No. 12 to $1\frac{1}{2}$	$5\frac{1}{2}$	No. 11 to 2	15	$\frac{3}{8}$ to 2
$2\frac{1}{2}$	No. 12 to $2\frac{1}{4}$	$5\frac{3}{4}$	No. 11 to 2	16	$\frac{3}{8}$ to 2
$2\frac{5}{8}$	No. 12 to $1\frac{1}{2}$	6	No. 11 to 2		
$2\frac{3}{4}$	No. 12 to $2\frac{1}{2}$	$6\frac{1}{4}$	No. 11 to 2		
$2\frac{7}{8}$	No. 12 to $2\frac{3}{4}$	$6\frac{1}{2}$	No. 11 to 2		
3	No. 12 to $2\frac{7}{8}$	$6\frac{3}{4}$	No. 11 to 2		
$3\frac{1}{8}$	$\frac{1}{4}$ to $2\frac{1}{2}$				
$3\frac{1}{4}$	No. 12 to 3				

NUT STEEL

WIDTH INCHES	THICKNESS INCHES	WEIGHT PER FOOT	WIDTH INCHES	THICKNESS INCHES	WEIGHT PER FOOT	WIDTH INCHES	THICKNESS INCHES	WEIGHT PER FOOT
$\frac{5}{8}$	$\frac{5}{16}$	0.664	$1\frac{1}{8}$	$\frac{11}{16}$	2.630	$1\frac{1}{8}$	$1\frac{1}{8}$	5.757
$\frac{3}{4}$	$\frac{7}{16}$	0.767	$1\frac{1}{4}$	$\frac{11}{16}$	2.776	$1\frac{1}{4}$	$1\frac{1}{8}$	7.192
$\frac{7}{8}$	$\frac{9}{16}$	1.080	$1\frac{3}{8}$	$\frac{11}{16}$	3.280	$1\frac{3}{8}$	$1\frac{1}{8}$	8.785
$1\frac{1}{8}$	$\frac{11}{16}$	1.162	$1\frac{1}{2}$	$\frac{11}{16}$	3.237	$1\frac{1}{2}$	$1\frac{1}{8}$	10.69
$1\frac{1}{4}$	$\frac{13}{16}$	1.434	$1\frac{3}{4}$	$\frac{11}{16}$	3.367	$1\frac{3}{4}$	$1\frac{1}{8}$	12.61
$1\frac{1}{2}$	$\frac{15}{16}$	1.580	$1\frac{7}{8}$	$\frac{11}{16}$	3.410	$1\frac{7}{8}$	$1\frac{1}{8}$	
$1\frac{3}{4}$	$\frac{17}{16}$	2.483	$1\frac{1}{2}$	$\frac{11}{16}$	4.482	$1\frac{1}{2}$	$1\frac{1}{8}$	

NOTE.—See page 46 for maximum lengths of flats.

SHEARED STEEL PLATES
 Sizes of Rectangular Plates Rolled on 108" Mill by Jones & Laughlin Steel Co.

THICKNESS INCHES	WIDTH AND LENGTH OF PLATES																		
	102	98	94	90	88	84	80	76	72	68	64	60	56	52	48	44	40	36	24
1/4	*192	192	216	228	240	252	264	288	300	300	312	336	348	360	360	360
5/16	...	240	240	252	264	264	276	282	300	340	360	360	360	360	360	360	360	360	360
3/8	168	180	192	240	240	252	264	300	340	360	360	360	360	360	360	360	360	360	360
7/8	174	180	198	240	252	264	276	300	340	360	360	360	360	360	360	360	360	360	360
1 1/2	180	192	228	240	252	288	312	340	360	360	360	360	360	360	360	360	360	360	360
1 3/4	180	198	216	240	252	300	324	340	360	360	360	360	360	360	360	360	360	360	360
1 5/8	180	198	216	240	252	300	324	340	360	360	360	360	360	360	360	360	360	360	360
1 1/2	180	192	204	216	240	276	300	340	360	360	360	360	360	360	360	360	360	360	360
1 3/4	180	192	204	216	240	276	300	340	360	360	360	360	360	360	360	360	360	360	360
1 5/8	180	192	204	216	240	276	300	340	360	360	360	360	360	360	360	360	360	360	360
1 7/8	180	180	192	204	216	240	276	288	300	324	340	360	360	360	360	360	360	360	360
1	180	180	180	192	192	216	216	240	264	276	288	300	324	340	360	360	360	360	360
1 1/4	156	156	156	168	180	192	192	204	216	216	228	240	252	264	300	300	300	300	300
1 3/8	132	132	144	144	156	168	168	180	192	204	216	228	240	252	300	300	300	300	300
1 1/2	132	132	132	144	144	156	156	168	180	192	204	228	240	252	300	300	300	300	300
1 5/8	120	120	120	132	132	144	144	156	168	180	192	204	216	228	240	252	252	252	240
1 3/4	108	108	108	120	120	132	132	144	144	156	156	168	174	180	204	228	240	240	204
1 7/8	108	108	108	120	120	132	132	144	144	144	156	156	168	180	204	216	216	216	204
2	96	108	114	120	126	132	138	144	150	156	162	168	192	192	192	192	192

Plates of greater width than shown in this schedule may be submitted for special consideration.
 *Plates 192" x 90" x 1/4" rolled by special arrangement.

RECTANGULAR PLATES ROLLED ON 78-INCH
MILL

Sizes Rolled by Jones & Laughlin Steel Company

THICKNESS	WIDTH AND LENGTH OF PLATES IN INCHES										
	66	60	56	52	48	44	40	36	32	28	24
No. 11	144	168	180	192	204	216	228	240	252	264
No. 10	120	168	180	192	204	216	228	240	252	264	276
No. 9	120	168	180	192	204	216	228	240	252	264	276
No. 8	120	168	180	192	216	228	240	252	264	276	288
$\frac{3}{16}$ inch	120	192	204	216	228	240	264	288	300	300	300
$\frac{7}{32}$ and $\frac{1}{4}$ inch	120	192	204	216	228	240	252	264	276	288	300
$\frac{5}{16}$ inch	108	144	156	168	180	192	204	216	264	300	300
$\frac{3}{8}$ inch	96	120	144	156	180	192	216	240	252	264	276

CIRCULAR PLATES

THICKNESS IN INCHES	MAXIMUM DIAMETER IN INCHES	THICKNESS IN INCHES	MAXIMUM DIAMETER IN INCHES
$\frac{1}{8}$	65	$\frac{9}{16}$	103
$\frac{3}{16}$	65	$\frac{5}{8}$	103
$\frac{1}{4}$	90	$\frac{11}{16}$	103
$\frac{5}{16}$	100	$\frac{3}{4}$	103
$\frac{3}{8}$	103	up to	
$\frac{7}{16}$	103	$1\frac{1}{2}$	
$\frac{1}{2}$	103		

Plates of greater width than shown in this schedule may be submitted for special consideration.

All our plates are accurately straightened by the most improved straightening methods known.

WEIGHTS AND DIMENSIONS OF STEEL TEES

With Equal Legs

SECTION No.	SIZE IN INCHES		THICKNESS OF METAL, INCHES		WEIGHT PER FOOT
	Flange	Stem	Flange	Stem	
T 1	4	4	$\frac{1}{2}$ to $\frac{9}{16}$	$\frac{1}{2}$ to $\frac{9}{16}$	13.90
T 2	4	4	$\frac{7}{16}$ to $\frac{1}{2}$	$\frac{7}{16}$ to $\frac{1}{2}$	12.40
T 3	$3\frac{1}{2}$	$3\frac{1}{2}$	$\frac{7}{16}$ to $\frac{1}{2}$	$\frac{7}{16}$ to $\frac{1}{2}$	10.40
T 4	$3\frac{1}{2}$	$3\frac{1}{2}$	$\frac{3}{8}$ to $\frac{7}{16}$	$\frac{3}{8}$ to $\frac{7}{16}$	9.30
T 5	3	3	$\frac{3}{8}$ to $\frac{7}{16}$	$\frac{3}{8}$ to $\frac{7}{16}$	7.85
T 6	3	3	$\frac{5}{16}$ to $\frac{3}{8}$	$\frac{5}{16}$ to $\frac{3}{8}$	6.60
T32	3	3	$\frac{1}{4}$ to $\frac{5}{16}$	$\frac{1}{4}$ to $\frac{5}{16}$	5.68
T 7	$2\frac{1}{2}$	$2\frac{1}{2}$	$\frac{3}{8}$ to $\frac{7}{16}$	$\frac{3}{8}$ to $\frac{7}{16}$	6.32
T 8	$2\frac{1}{2}$	$2\frac{1}{2}$	$\frac{5}{16}$ to $\frac{3}{8}$	$\frac{5}{16}$ to $\frac{3}{8}$	5.40
T 9	$2\frac{1}{4}$	$2\frac{1}{4}$	$\frac{5}{16}$ to $\frac{11}{32}$	$\frac{5}{16}$ to $\frac{11}{32}$	4.62
T10	$2\frac{1}{4}$	$2\frac{1}{4}$	$\frac{1}{4}$ to $\frac{9}{32}$	$\frac{1}{4}$ to $\frac{9}{32}$	4.12
T11	2	2	$\frac{1}{4}$ to $\frac{9}{32}$	$\frac{1}{4}$ to $\frac{9}{32}$	3.50
T12	$1\frac{3}{4}$	$1\frac{3}{4}$	$\frac{3}{16}$ to $\frac{7}{32}$	$\frac{3}{16}$ to $\frac{7}{32}$	2.33
T13	$1\frac{3}{4}$	$1\frac{3}{4}$	$\frac{1}{4}$ to $\frac{9}{32}$	$\frac{1}{4}$ to $\frac{9}{32}$	3.00
T14	$1\frac{1}{2}$	$1\frac{1}{2}$	$\frac{1}{4}$ to $\frac{9}{32}$	$\frac{1}{4}$ to $\frac{9}{32}$	2.50
T15	$1\frac{1}{2}$	$1\frac{1}{2}$	$\frac{3}{16}$ to $\frac{7}{32}$	$\frac{3}{16}$ to $\frac{7}{32}$	1.95
T16	$1\frac{1}{4}$	$1\frac{1}{4}$	$\frac{1}{4}$ to $\frac{9}{32}$	$\frac{1}{4}$ to $\frac{9}{32}$	2.04
T17	$1\frac{1}{4}$	$1\frac{1}{4}$	$\frac{3}{16}$ to $\frac{7}{32}$	$\frac{3}{16}$ to $\frac{7}{32}$	1.60
T18	1	1	$\frac{3}{16}$ to $\frac{7}{32}$	$\frac{3}{16}$ to $\frac{7}{32}$	1.25
T19	1	1	$\frac{1}{8}$ to $\frac{7}{32}$	$\frac{1}{8}$ to $\frac{7}{32}$	0.90

With Unequal Legs

SECTION No.	SIZE IN INCHES		THICKNESS OF METAL, INCHES		WEIGHT PER FOOT
	Flange	Stem	Flange	Stem	
T31	5	$2\frac{1}{2}$	$\frac{3}{8}$ to $\frac{7}{16}$	$\frac{7}{16}$ to $\frac{21}{32}$	11.00
T33	$4\frac{1}{2}$	3	$\frac{5}{16}$ to $\frac{3}{8}$	$\frac{5}{16}$ to $\frac{3}{8}$	8.60
T30	$3\frac{1}{2}$	4	$\frac{1}{2}$ to $\frac{9}{16}$	$\frac{1}{2}$ to $\frac{9}{16}$	12.80
T29	$3\frac{1}{2}$	4	$\frac{3}{8}$ to $\frac{7}{16}$	$\frac{3}{8}$ to $\frac{7}{16}$	9.90
T23	$3\frac{1}{2}$	3	$\frac{7}{16}$ to $\frac{1}{2}$	$\frac{7}{16}$ to $\frac{1}{2}$	9.80
T24	$3\frac{1}{2}$	3	$\frac{3}{8}$ to $\frac{7}{16}$	$\frac{3}{8}$ to $\frac{7}{16}$	9.00
T25	3	$3\frac{1}{2}$	$\frac{3}{8}$ to $\frac{7}{16}$	$\frac{3}{8}$ to $\frac{7}{16}$	8.60
T26	3	$3\frac{1}{2}$	$\frac{7}{16}$ to $\frac{1}{2}$	$\frac{7}{16}$ to $\frac{1}{2}$	9.80
T27	$2\frac{1}{2}$	$1\frac{3}{4}$	$\frac{1}{4}$ to $\frac{9}{32}$	$\frac{1}{4}$ to $\frac{9}{32}$	3.90
T28	$2\frac{1}{2}$	2	$\frac{5}{16}$ to $\frac{11}{32}$	$\frac{5}{16}$ to $\frac{11}{32}$	4.80

NOTE.—The maximum length in which we can furnish tees is 35 feet. In ordering extreme lengths a leeway of five feet will facilitate the execution of orders.

Z BARS

Sizes, Weights, Dimensions and Maximum Lengths,
Rolled by Jones & Laughlin Steel Co.

SECTION NUMBER	THICKNESS OF METAL, INCHES	SIZE IN INCHES			WEIGHT PER FOOT	AREA OF SECTION	MAXIMUM LENGTH, FEET
		Flange	Web	Flange			
Z4	$\frac{1}{4}$	$2\frac{11}{16}$	3	$2\frac{11}{16}$	6.7	1.97	54
Z4	$\frac{5}{16}$	$2\frac{3}{4}$	$3\frac{1}{16}$	$2\frac{3}{4}$	8.4	2.48	50
Z4	$\frac{3}{8}$	$2\frac{13}{16}$	$3\frac{1}{8}$	$2\frac{13}{16}$	10.1	3.00	41
Z8	$\frac{7}{16}$	$2\frac{5}{8}$	$2\frac{15}{16}$	$2\frac{5}{8}$	10.9	3.20	34
Z8	$\frac{1}{2}$	$2\frac{11}{16}$	3	$2\frac{11}{16}$	12.5	3.69	30
Z8	$\frac{9}{16}$	$2\frac{3}{4}$	$3\frac{1}{16}$	$2\frac{3}{4}$	14.2	4.18	26
Z8	$\frac{5}{8}$	$2\frac{13}{16}$	$3\frac{1}{8}$	$2\frac{13}{16}$	16.0	4.69	23
Z9	$\frac{3}{16}$	$1\frac{1}{2}$	3	$1\frac{1}{2}$	3.6	1.06	

LONGEST LENGTHS IN FEET OF ANGLES

Rolled by Jones & Laughlin Steel Co.

SIZE INCHES	THICKNESS IN INCHES																
	$\frac{1}{8}$	$\frac{3}{16}$	$\frac{1}{4}$	$\frac{5}{16}$	$\frac{3}{8}$	$\frac{7}{16}$	$\frac{1}{2}$	$\frac{9}{16}$	$\frac{5}{8}$	$\frac{11}{16}$	$\frac{3}{4}$	$\frac{13}{16}$	$\frac{7}{8}$	1	$1\frac{1}{8}$	$1\frac{1}{2}$	
8 X8	95	95	95	95	95	95	95	95	95	95	95
6 X6	100	100	100	100	100	100	100	100	100	100	100	100	100
6 X4	100	100	100	100	100	100	100	100	100	100	100	100	100
6 X3 $\frac{1}{2}$	100	100	100	100	100	100	100	100	100	100	100	100	100
5 X5	100	100	100	100	100	100	100	100	100	100	100	100	100
5 X4	100	100	100	100	100	100	100	100	100	100	100	100	100
5 X3 $\frac{1}{2}$	100	100	100	100	100	100	100	100	100	100	100	100	100	100
5 X3	100	100	100	100	100	100	100	100	100	100	100	100	100	100
4 $\frac{1}{2}$ X3	54	54	54	54	54	54	50	46	44					
4 X4	54	54	54	54	54	52	47	44	42					
4 X3 $\frac{1}{2}$	54	54	54	54	54	54	50	46	42					
4 X3	54	54	54	54	54	54	54	50	46					
3 $\frac{1}{2}$ X3 $\frac{1}{2}$...	54	54	54	54	54	54	54	54	54	50	46					
3 $\frac{1}{2}$ X3	54	54	54	54	54	54	54	54	54						
3 $\frac{1}{2}$ X2 $\frac{1}{2}$	54	54	54	54	54	54	54	54	54						
3 $\frac{1}{4}$ X3 $\frac{1}{4}$...	54	54	54	54	54	54	54	54	54							
3 X3	54	54	54	54	54	54	54	54	54	54							
3 X2 $\frac{1}{2}$	54	54	54	54	54	54	54	54							
3 X2	...	50	50	50	40	35	31										
2 $\frac{3}{4}$ X2 $\frac{3}{4}$	50	50	50	44	38	32	28										
2 $\frac{1}{2}$ X2 $\frac{1}{2}$	50	50	50	50	40	35	31										
2 $\frac{1}{2}$ X2	...	50	50	50	45	45	35										
2 $\frac{1}{2}$ X1 $\frac{1}{2}$...	50	50	50	45	45	45										
2 $\frac{1}{4}$ X1 $\frac{1}{2}$...	50	50	50	45	45	45										
2 $\frac{1}{4}$ X2 $\frac{1}{4}$	50	50	50	50	45	40	35										
2 X2	50	50	50	50	45	45	45										
2 X1 $\frac{1}{2}$...	35	35	35	35	...											
2 X1 $\frac{3}{8}$...	35	35	35	35	...											
1 $\frac{3}{4}$ X1 $\frac{3}{4}$	35	35	35	35	35	35											
1 $\frac{1}{2}$ X1 $\frac{1}{2}$	35	35	35	35	35												
1 $\frac{1}{4}$ X1 $\frac{1}{4}$	35	35	35	35													
1 X1	45	45	45														
$\frac{3}{4}$ X $\frac{3}{4}$	45	45															

Lengths given are in feet. In ordering extreme lengths, a leeway of five feet will facilitate the execution of orders.

AREAS OF ANGLES

SIZE INCHES	1/8	3/16	1/4	5/16	3/8	7/16	1/2	9/16	5/8	11/16	3/4	13/16	7/8
8 X 8	7.75	8.68	9.61	10.53	11.44	12.34	13.23
6 X 6	4.36	5.06	5.75	6.43	7.11	7.78	8.44	9.09	9.74
6 X 4	3.61	4.18	4.75	5.31	5.86	6.41	6.94	7.47	7.99
6 X 3 1/2	3.42	3.97	4.50	5.03	5.55	6.06	6.56	7.06	7.55
5 X 5	3.61	4.18	4.75	5.31	5.86	6.41	6.94	7.47	7.99
5 X 4	3.24	3.76	4.26	4.74	5.24	5.71	6.18	6.65	7.12
5 X 3 1/2	3.05	3.53	4.00	4.47	4.92	5.37	5.81	6.25	6.67
5 X 3	2.40	2.86	3.31	3.75	4.18	4.61	5.03	5.44	5.84	6.28
4 1/2 X 3	2.25	2.68	3.09	3.50	3.91	4.29	4.68	5.06	5.44	
4 X 4	1.94	2.40	2.86	3.31	3.75	4.18	4.61	5.03	5.44	5.84	
4 X 3 1/2	2.68	3.09	3.50	3.91	4.29	4.68	5.06	5.44	
4 X 3	2.09	2.48	2.87	3.25	3.62	3.98	4.34	4.69	5.03	
3 1/2 X 3 1/2	1.09	1.69	2.09	2.48	2.87	3.25	3.62	3.98	4.34	4.69	5.03		
3 1/2 X 3	1.93	2.30	2.65	3.00	3.34	3.67	4.00		
3 1/2 X 2 1/2	1.44	1.78	2.11	2.43	2.75	3.06	3.36	3.60			
3 1/4 X 3 1/4	1.00	1.56	1.93	2.30	2.65	3.00	3.34	3.67					
3 1/4 X 2	1.26	1.56	1.82	2.11	2.38	2.64					
3 1/4 X 1 1/2	0.88											
3 X 3	0.76	1.44	1.78	2.11	2.43	2.75	3.06	3.36				
3 X 2 1/2	1.31	1.62	1.92	2.22	2.50	2.78	3.06				
3 X 2	0.91	1.19	1.47	1.73	2.00	2.25						
2 3/4 X 2 3/4	0.71	1.31	1.62	1.92	2.22	2.50						
2 1/2 X 2 1/2	0.62	0.88	1.19	1.47	1.73	2.00	2.25						
2 1/2 X 2	0.81	1.06	1.31	1.55	1.78	2.00						
2 1/2 X 1 3/4	0.76	1.00										
2 1/2 X 1 1/2	0.71	0.94	1.15	1.36	1.56	1.76						
2 1/4 X 2 1/4	1.06	1.31	1.55	1.78	2.00						
2 X 2	0.48	0.71	0.94	1.15	1.36	1.56	1.75						
2 X 1 1/2	0.62	0.81	1.00	1.17								
2 X 1 3/8	0.59	0.79	0.97	1.12								
1 3/4 X 1 3/4	0.42	0.62	0.81	1.00	1.17	1.30							
1 3/4 X 1 1/2	0.57	0.76	0.92	1.09								
1 1/2 X 1 1/2	0.36	0.53	0.69	0.84	0.99								
1 1/4 X 1 1/4	0.30	0.43	0.56	0.71									
1 X 1	0.24	0.34	0.44										
1 X 5/8	0.19	0.27											
3/4 X 3/4	0.17	0.25											

SIZE INCHES	15/16	1	1 1/8	1 1/8
8 X 8	14.12	15.00	15.87	16.73
6 X 6	10.37	11.00		
6 X 4	8.50	9.00		
6 X 3 1/2	8.03	8.50		
5 X 5	8.50	9.00		

SIZE OF HOLE	AREA TO BE DEDUCTED FOR ONE HOLE																
	1/8	3/16	1/4	5/16	3/8	7/16	1/2	9/16	5/8	11/16	3/4	13/16	7/8	15/16	1	1 1/8	1 1/8
1/16	.07	.11	.14	.18	.21	.25	.28	.32	.35	.39	.42	.46	.49	.53	.56	.60	.64
1/8	.09	.13	.17	.21	.25	.30	.34	.39	.43	.47	.52	.56	.60	.64	.69	.73	.77
3/16	.10	.15	.20	.25	.30	.36	.41	.46	.51	.56	.61	.66	.71	.76	.81	.86	.91
1/4	.12	.18	.23	.29	.35	.40	.47	.53	.59	.64	.70	.76	.82	.88	.94	1.00	1.06

Above table gives area of angles corresponding to thickness varying by 1/16-inch.

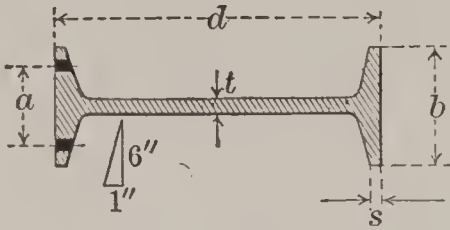

DIMENSIONS OF STANDARD STEEL BEAMS, AND MAXIMUM LENGTHS

<i>d</i> Inches	Weight per Foot	<i>b</i> Inches	<i>t</i> Inches	<i>s</i> Inches	<i>a</i> Inches	Size of Flange Holes, Inches	Max. Length, Ft.	<i>d</i> Inches	Weight per Foot	<i>b</i> Inches	<i>t</i> Inches	<i>s</i> Inches	<i>a</i> Inches	Size of Flange Holes, Inches	Max. Length, Ft.										
24	100	7.254	0.754	0.60	4	1 13/16	57	12	35	5.085	0.436	0.35	2 3/4	1 13/16	75										
	95	7.192	0.692				60		31.5	5.000	0.350				75										
	90	7.131	0.631				62		10	40	5.101				0.751	0.31	2 5/8	1 13/16	75						
	85	7.070	0.570				65												35	4.954	0.604	75			
	80	7.000	0.500				69												30	4.807	0.457	75			
				25	4.660	0.310	75																		
20	100	7.284	0.884	0.65	4	1 13/16	45	9	35	4.787	0.747	0.29	2 1/2	1 13/16	75										
	95	7.210	0.810				47								30	4.624	0.584	75							
	90	7.137	0.737				50								25	4.461	0.421	75							
	85	7.063	0.663				50								21	4.330	0.290	75							
	80	7.000	0.600				53								8	25.5	4.272	0.542	0.27	2 1/4	1 13/16	75			
18	75	6.399	0.649	0.55	3 1/2	1 13/16	60	23	4.181	0.451	75														
	70	6.325	0.575				64	20.5	4.090	0.360	75														
	65	6.250	0.500				60	18	4.000	0.270	75														
	60	6.098	0.555				63	7	20	3.870	0.460	0.25	2 1/4	1 11/16								75			
	55	6.000	0.460				70								17.5	3.765	0.355	75							
15	100	6.792	1.192	0.80	3 3/4	1 13/16	43								6	17.25	3.575	0.475	0.23	2	1 11/16	75			
	95	6.694	1.094				45															14.75	3.453	0.353	75
	90	6.596	0.996				48															12.25	3.330	0.230	75
	85	6.498	0.898				51	5	14.75	3.294	0.504	0.21	1 3/4	1 9/16								75			
	80	6.400	0.800				55															12.25	3.147	0.357	75
12	75	6.294	0.884	0.59	3 1/4	1 13/16	56								9.75	3.000	0.210	75							
	70	6.196	0.786				60								4	10.5	2.880	0.410	0.19	1 1/2	1 9/16	50			
	65	6.098	0.688				64															9.5	2.806	0.366	50
	60	6.000	0.590				70	8.5	2.733	0.263	50														
	15	55	5.754				0.664	0.41	3	1 13/16	75	7.5	2.660	0.190								50			
50		5.656	0.566	75	3	7.5	2.526				0.366	0.17	1 7/16	7/16								50			
45		5.558	0.468	75											6.5	2.428	0.268	50							
42		5.500	0.410	75											5.5	2.330	0.170	50							
60		5.740	0.950	55											3	7.5	2.526	0.366	0.17	1 7/16	7/16	50			
55	5.618	0.828	60	6.5				2.428	0.268	50															
50	5.496	0.706	65	5.5	2.330	0.170	50																		
45	5.373	0.583	65																						
40	5.250	0.460	75																						

Lengths given are in feet. In ordering extreme lengths, a leeway of five feet will facilitate the execution of orders.

DIMENSIONS OF STANDARD STEEL CHANNELS AND MAXIMUM LENGTHS

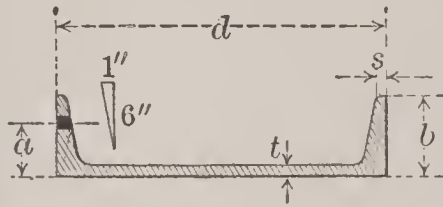

<i>d</i> Inches	Weight per Foot	<i>b</i> Inches	<i>t</i> Inches	<i>s</i> Inches	<i>a</i> Inches	Flange Holes, In.	Max. Length, Ft.	<i>d</i> Inches	Weight per Foot	<i>b</i> Inches	<i>t</i> Inches	<i>s</i> Inches	<i>a</i> Inches	Flange Holes, In.	Max. Length, Ft.	
15	55	3.836	0.831	0.40	2 1/4	7/8	75	7	19.75	2.510	0.630	0.21	1 1/2	7/8	75	
	50	3.733	0.733		2 1/4	7/8	75		17.25	2.405	0.525		1 1/2	7/8	75	
	45	3.638	0.636		2 1/4	7/8	75		14.75	2.300	0.420		1 1/4	1 1/8	75	
	40	3.538	0.538		1 7/8	1 1/8	75		12.25	2.195	0.315		1 1/4	1 1/8	75	
	35	3.440	0.440		1 7/8	1 1/8	75		9.75	2.090	0.210		1 1/4	1 1/8	75	
	33	3.400	0.400		1 7/8	1 1/8	75									
13 to 31.5	52 to 4.000	0.840 to 0.375	0.34	2 1/4	1 1/8 to 1 3/8	60 to 75	Ship 7	22.0	3.5	0.50	0.475	2	1 1/8	90		
								20.5	3.43	0.43		2	1 3/8	90		
								18.0	3.33	0.33		2		90		
12	40	3.410	0.758	0.28	2	7/8	75	6	15.50	2.288	0.568	0.20	1 3/8	7/8	75	
	35	3.290	0.636		2	7/8	75		13.00	2.166	0.446		1 3/8	1 1/8	75	
	30	3.170	0.513		2	1 1/8	75		10.50	2.043	0.323		1 1/8	1 1/8	75	
	25	3.050	0.390		1 3/4	7/8	75		8.00	1.920	0.200		1 1/8		75	
	20.5	2.940	0.280		1 3/4	7/8	75									
10	35	3.188	0.828	0.24	2	7/8	75	Ship 6	18.40	3.062	0.562	0.28	1 3/4	1 1/8	58	
	30	3.041	0.681		2	7/8	75		17.10	3.000	0.500					
	25	2.894	0.534		2	1 1/8	75		15.90	2.936	0.437					
	20	2.747	0.378		1 1/2	7/8	75		14.60	2.874	0.375					
	20	2.747	0.378		1 1/2	7/8	75		13.30	2.812	0.312					
	15	2.600	0.240		1 1/2	7/8	75		15.0	3.5	0.35		0.34	2	1 3/8	90
9	25	2.814	0.614	0.23	1 3/4	7/8	75	5	11.50	2.044	0.484	0.19	1 1/4	7/8	75	
	20	2.651	0.451		1 3/4	1 1/8	75		9.00	1.897	0.337		1 1/4	9/16	75	
	15	2.478	0.288		1 3/8	7/8	75		6.50	1.750	0.190		1		75	
	13.25	2.430	0.230		1 3/8	7/8	75									
8	21.25	2.628	0.588	0.22	1 1/2	7/8	75	4	7.25	1.727	0.327	0.18	1	9/16	50	
	18.75	2.536	0.496		1 1/2	7/8	75		6.25	1.654	0.254				50	
	16.25	2.444	0.404		1 1/2	1 1/8	75		5.25	1.580	0.180				50	
	13.75	2.352	0.312		1 1/4	7/8	75		6.00	1.606	0.366		0.17	1 1/8	7/16	50
	11.25	2.260	0.220		1 1/4	7/8	75		5.00	1.508	0.268			1 1/8	7/16	50
															50	

Lengths given are in feet. In ordering extreme lengths, a leeway of five feet will facilitate the execution of orders.

CAST SEPARATORS FOR BEAMS

Separators with Two Bolts

DESIGNATION OF BEAM			DISTANCES		BOLTS			WEIGHTS			
Depth Inches	Number of Shape	Weight Pounds	Out to Out of Flanges of Beams Inches	Center to Center of Beam Inches	Size Inches	Distance, Center to Center, Inches	Length Inches	Bolts and Nuts Pounds	Increase of Bolts for 1 inch Additional Spread of Beams Pounds	Separator Pounds	Add to Separator Weight for each Inch Spread of Beams Pounds
24	B 0	80	14 $\frac{3}{4}$	7 $\frac{3}{4}$	$\frac{3}{4}$	12	9 $\frac{1}{4}$	3 $\frac{3}{4}$	0.25	29 $\frac{3}{4}$	5 $\frac{1}{2}$
20	B 1	80	14 $\frac{3}{4}$	7 $\frac{3}{4}$	$\frac{3}{4}$	10	9 $\frac{1}{4}$	3 $\frac{3}{4}$	0.25	24 $\frac{3}{4}$	3 $\frac{1}{8}$
20	B 2	65	13 $\frac{1}{4}$	7	$\frac{3}{4}$	10	8 $\frac{1}{2}$	3 $\frac{1}{2}$	0.25	22	3 $\frac{1}{8}$
18	B 2 $\frac{1}{2}$	55	12 $\frac{3}{4}$	6 $\frac{3}{4}$	$\frac{3}{4}$	9	8 $\frac{1}{2}$	3 $\frac{1}{2}$	0.25	19	2 $\frac{3}{4}$
15	B 2 $\frac{3}{4}$	80	13 $\frac{5}{8}$	7 $\frac{1}{4}$	$\frac{3}{4}$	7	9	3 $\frac{1}{2}$	0.25	13 $\frac{1}{4}$	1 $\frac{3}{4}$
15	B 3	60	12 $\frac{3}{4}$	6 $\frac{3}{4}$	$\frac{3}{4}$	7	8	3 $\frac{1}{4}$	0.25	12 $\frac{1}{4}$	1 $\frac{3}{4}$
15	B 4	42	11 $\frac{1}{2}$	6	$\frac{3}{4}$	7	7 $\frac{1}{2}$	3	0.25	11 $\frac{1}{2}$	1 $\frac{3}{8}$
12	B 6	31 $\frac{1}{2}$	10 $\frac{3}{4}$	5 $\frac{3}{4}$	$\frac{3}{4}$	6 $\frac{1}{2}$	7 $\frac{1}{8}$	3	0.25	9 $\frac{1}{2}$	1 $\frac{1}{2}$

Separators with One Bolt

12	B 5	40	11	5 $\frac{3}{4}$	$\frac{3}{4}$	7 $\frac{1}{4}$	1 $\frac{1}{2}$	0.12	9 $\frac{1}{4}$	1 $\frac{7}{16}$
12	B 6	31 $\frac{1}{2}$	10 $\frac{3}{4}$	5 $\frac{3}{4}$	$\frac{3}{4}$	7 $\frac{1}{8}$	1 $\frac{1}{2}$	0.12	9 $\frac{1}{2}$	1 $\frac{1}{2}$
10	B 7	40	11	6	$\frac{3}{4}$	7 $\frac{3}{4}$	1 $\frac{3}{8}$	0.12	7	1 $\frac{3}{16}$
10	B 7	25	10 $\frac{1}{4}$	5 $\frac{1}{2}$	$\frac{3}{4}$	6 $\frac{7}{8}$	1 $\frac{3}{8}$	0.12	7 $\frac{1}{4}$	1 $\frac{1}{4}$
9	B 8	35	10 $\frac{1}{4}$	5 $\frac{1}{2}$	$\frac{3}{4}$	7 $\frac{1}{4}$	1 $\frac{3}{8}$	0.12	6 $\frac{1}{2}$	1 $\frac{1}{16}$
9	B 8	21	9 $\frac{3}{8}$	5	$\frac{3}{4}$	6 $\frac{1}{4}$	1 $\frac{3}{8}$	0.12	6	1 $\frac{1}{4}$
8	B 9	25 $\frac{1}{4}$	9 $\frac{1}{4}$	5	$\frac{3}{4}$	6 $\frac{1}{2}$	1 $\frac{3}{8}$	0.12	5 $\frac{1}{2}$	1 $\frac{5}{16}$
8	B 9	17 $\frac{3}{4}$	8 $\frac{3}{4}$	4 $\frac{3}{4}$	$\frac{3}{4}$	6	1 $\frac{3}{8}$	0.12	5 $\frac{1}{2}$	1 $\frac{5}{16}$
7	B10	20	8 $\frac{5}{8}$	5	$\frac{3}{4}$	6 $\frac{1}{4}$	1 $\frac{1}{4}$	0.12	4 $\frac{1}{2}$	1 $\frac{13}{16}$
7	B10	15	8 $\frac{1}{4}$	4 $\frac{1}{2}$	$\frac{3}{4}$	5 $\frac{3}{4}$	1 $\frac{1}{4}$	0.12	4 $\frac{1}{2}$	1 $\frac{13}{16}$
6	B11	17 $\frac{1}{4}$	7 $\frac{1}{2}$	4	$\frac{3}{4}$	5 $\frac{1}{2}$	1 $\frac{1}{4}$	0.12	2 $\frac{1}{4}$	$\frac{1}{2}$
6	B11	12 $\frac{1}{4}$	7 $\frac{1}{8}$	3 $\frac{3}{4}$	$\frac{3}{4}$	5	1 $\frac{1}{4}$	0.12	2 $\frac{1}{4}$	$\frac{9}{16}$
5	B12	14 $\frac{3}{4}$	7	3 $\frac{3}{4}$	$\frac{3}{4}$	5 $\frac{1}{4}$	1 $\frac{1}{8}$	0.12	1 $\frac{3}{4}$	$\frac{7}{8}$
5	B12	9 $\frac{3}{4}$	6 $\frac{1}{2}$	3 $\frac{1}{2}$	$\frac{3}{4}$	4 $\frac{3}{4}$	1 $\frac{1}{8}$	0.12	1 $\frac{3}{4}$	$\frac{7}{8}$
4	B13	7 $\frac{1}{2}$	5 $\frac{7}{8}$	3 $\frac{1}{4}$	$\frac{3}{4}$	4 $\frac{1}{2}$	1 $\frac{1}{8}$	0.12	1 $\frac{1}{2}$	$\frac{3}{8}$
3	B14	5 $\frac{1}{2}$	5 $\frac{1}{4}$	3	$\frac{3}{4}$	4 $\frac{1}{4}$	$\frac{3}{4}$	0.12	1 $\frac{1}{2}$	$\frac{1}{4}$

Separators for 18, 20 and 24-inch beams are made of $\frac{5}{8}$ -inch metal.
 Separators for 6 to 15-inch beams are made of $\frac{1}{2}$ -inch metal.
 Separators for 5-inch beams and under are made of $\frac{3}{8}$ -inch metal.
 Minimum widths given. Separators can be made wider.

STANDARD SPACING AND DIMENSIONS OF RIVET AND BOLT HOLES

Through Flanges of Beams, Channels, Connection Angles

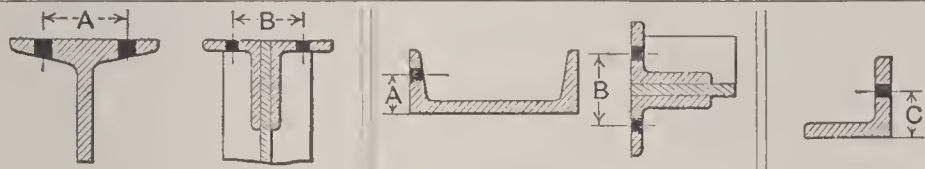

STEEL BEAMS					STEEL CHANNELS					ANGLES		
Depth in Inches	Weight per Foot, Pounds	Diameter of Bolt or Rivet, Inches	A Inches	B Inches	Depth in Inches	Weight per Foot, Pounds	Diameter of Bolt or Rivet, Inches	A Inches	B Inches	Depth of Leg, Inches	Max. Diam. of Bolt or Rivet, Inches	C Inches
24	80.	3/4	4	5 1/2	15	45.	3/4	2 1/4	5 5/8	6	1	3 1/2
20	80.	3/4	4	5 5/8	15	33.	3/4	1 7/8	5 7/16	5	1	2 3/4
20	65.	3/4	3 1/2	5 1/2	13	31.5	3/4	2 1/4	5 3/8	4	1	2 1/4
18	55.	3/4	3 1/4	5 1/2	12	30.	3/4	2	5 1/2	3 1/2	1	2
15	80.	3/4	3 3/4	5 13/16	10	25.	3/4	2	5 9/16	3 1/4	7/8	1 3/4
15	60.	3/4	3 1/4	5 5/8	10	15.	3/4	1 1/2	5 1/4	3	7/8	1 3/4
15	42.	3/4	3	5 7/16	9	20.	3/4	1 3/4	5 7/16	3	7/8	1 3/4
12	40.	3/4	3	5 1/2	9	13.25	3/4	1 3/8	5 1/4	2 3/4	3/4	1 1/2
12	31.5	3/4	2 3/4	5 3/8	8	16.25	3/4	1 1/2	5 7/16	2 1/2	3/4	1 3/8
10	25.	3/4	2 5/8	5 5/16	8	11.25	3/4	1 1/4	5 1/4	2 1/2	3/4	1 3/8
9	21.	3/4	2 1/2	5 5/16	7	17.25	3/4	1 1/2	5 9/16	2 1/4	3/4	1 1/4
8	17.75	3/4	2 1/4	5 1/4	7	9.75	3/4	1 1/4	5 1/4	2	5/8	1 1/8
8	17.75	3/4	2 1/4	5 1/4	7	Ship	3/4	2	5 5/16	2	5/8	1 1/8
7	15.	5/8	2 1/4	5 1/4	6	13.	5/8	1 3/8	5 7/16	1 3/4	5/8	1 5/16
7	15.	5/8	2 1/4	5 1/4	6	8.	5/8	1 1/8	5 3/16	1 1/2	1/2	1 3/16
6	12.25	5/8	2	5 1/4	6	Ship	3/4	2	5 3/8	1 1/2	1/2	1 3/16
5	9.75	1/2	1 3/4	5 1/4	5	9.	1/2	1 1/4	5 3/8	1 1/4	1/2	1 1/16
5	9.75	1/2	1 3/4	5 1/4	5	6.5	1/2	1	5 3/16	1 1/4	1/2	1 1/16
4	7.5	1/2	1 1/2	5 3/16	4	5.25	1/2	1	5 3/16	1	3/8	9/16
4	7.5	1/2	1 1/2	5 3/16	4	5.25	1/2	1	5 3/16	1	3/8	9/16
3	5.5	3/8	1 7/16	5 3/16	3	4.	3/8	1 5/16	5 3/16	3/4	1/4	7/16

The spaces "B" correspond with spacing given on page 61 for Standard Connection Angles.

Notes on Standard Connection Angles for Jones & Laughlin Steel Co.'s Beams

The Standard Connection Angles for Jones & Laughlin Steel Co.'s Steel Beams, illustrated on next page, are designed for an allowed shearing strain of 10,000 pounds per square inch, and a bearing strain for 20,000 pounds per square inch on rivets or bolts, corresponding with an extreme fiber strain of 16,000 pounds per square inch in the beam. The minimum span length at and above which the standard connections can be used with safety (the beam being loaded with its full capacity) are shown in the tables below. For shorter spans (the beam being loaded with its full capacity) additional strength in the connection should be made.

Table of Minimum Spans for Jones & Laughlin Steel Co.'s Steel Beams for which Standard Connection Angles may be Safely Used with Beams Loaded to their Full Capacity.

Section No.	Size of Beam Inches	Weight per Foot	Minimum Safe Span in Feet	Section No.	Size of Beam Inches	Weight per Foot	Minimum Safe Span in Feet
B 0	24	80	18.0	B 8	9	25	9.6
B 1	20	80	16.0	B 8	9	21	8.6
B 2	20	65	14.0	B 9	8	25 $\frac{1}{4}$	7.6
B 2 $\frac{1}{2}$	18	55	14.0	B 9	8	17 $\frac{3}{4}$	7.0
B 2 $\frac{3}{4}$	15	80	12.6	B 10	7	20	6.0
B 3	15	70	12.0	B 10	7	15	5.6
B 4	15	60	11.6	B 11	6	17 $\frac{1}{4}$	6.6
B 4	15	50	11.0	B 11	6	12 $\frac{1}{4}$	6.0
B 4	15	42	10.6	B 12	5	14 $\frac{3}{4}$	4.0
B 5	12	40	8.6	B 12	5	9 $\frac{3}{4}$	4.0
B 6	12	31 $\frac{1}{2}$	7.6	B 13	4	10 $\frac{1}{2}$	3.0
B 7	10	35	10.6	B 13	4	7 $\frac{1}{2}$	3.0
B 7	10	25	9.0				

STANDARD CONNECTION ANGLES
For I Beams and Channels

For 24" I

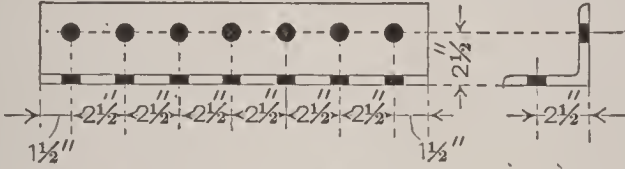

4" x 4" x 3/8" L - 1' 6"
Weight 40 lbs.

For 20" I

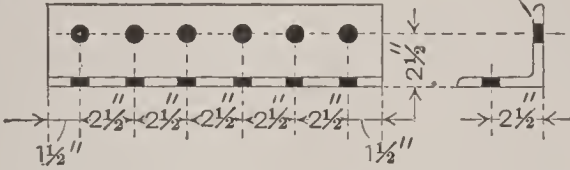

4" x 4" x 3/8" L - 1' 3 1/2"
Weight 34.3 lbs.

For 18" I

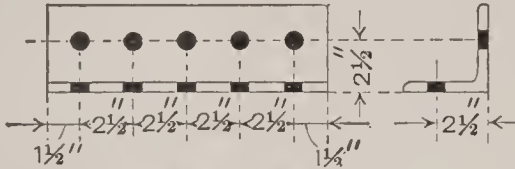

4" x 4" x 3/8" L - 1' 1"
Weight 28.7 lbs.

For 15" I's & L's

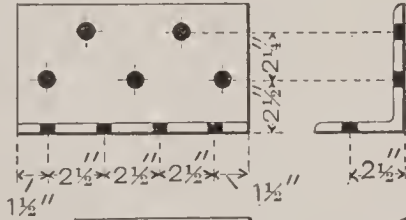

6" x 4" x 3/8" L - 0' - 10 1/2" lg.
Weight 28 lbs.

For 12" I's & L's

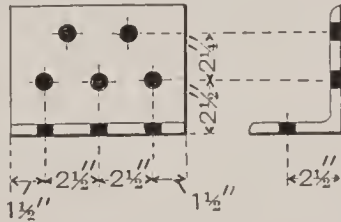

6" x 4" x 3/8" L - 0' - 8" lg.
Weight 21.9 lbs.

For 7" 8" 9" & 10" I's & L's

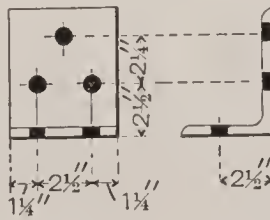

6" x 4" x 3/8" L - 0' - 5" lg.
Weight 13.8 lbs.

For 5" & 6" I's & L's

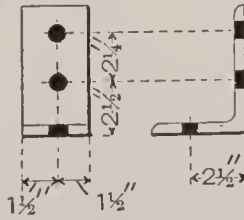

6" x 4" x 3/8" L - 0' - 3" lg.
Weight 8.2 lbs.

For 3" & 4" I's & L's

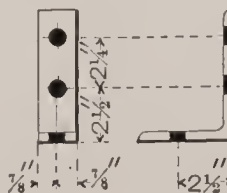

6" x 4" x 3/8" L - 0' - 1 3/4" lg.
Weight 5.6 lbs.

All holes for 3/4-inch bolts or rivets. The weights of connections include shop and field rivets.

LOCATION OF CONNECTION ANGLES

(For Beams of Different Sizes Framing opposite, Bottoms or Tops being Flush)

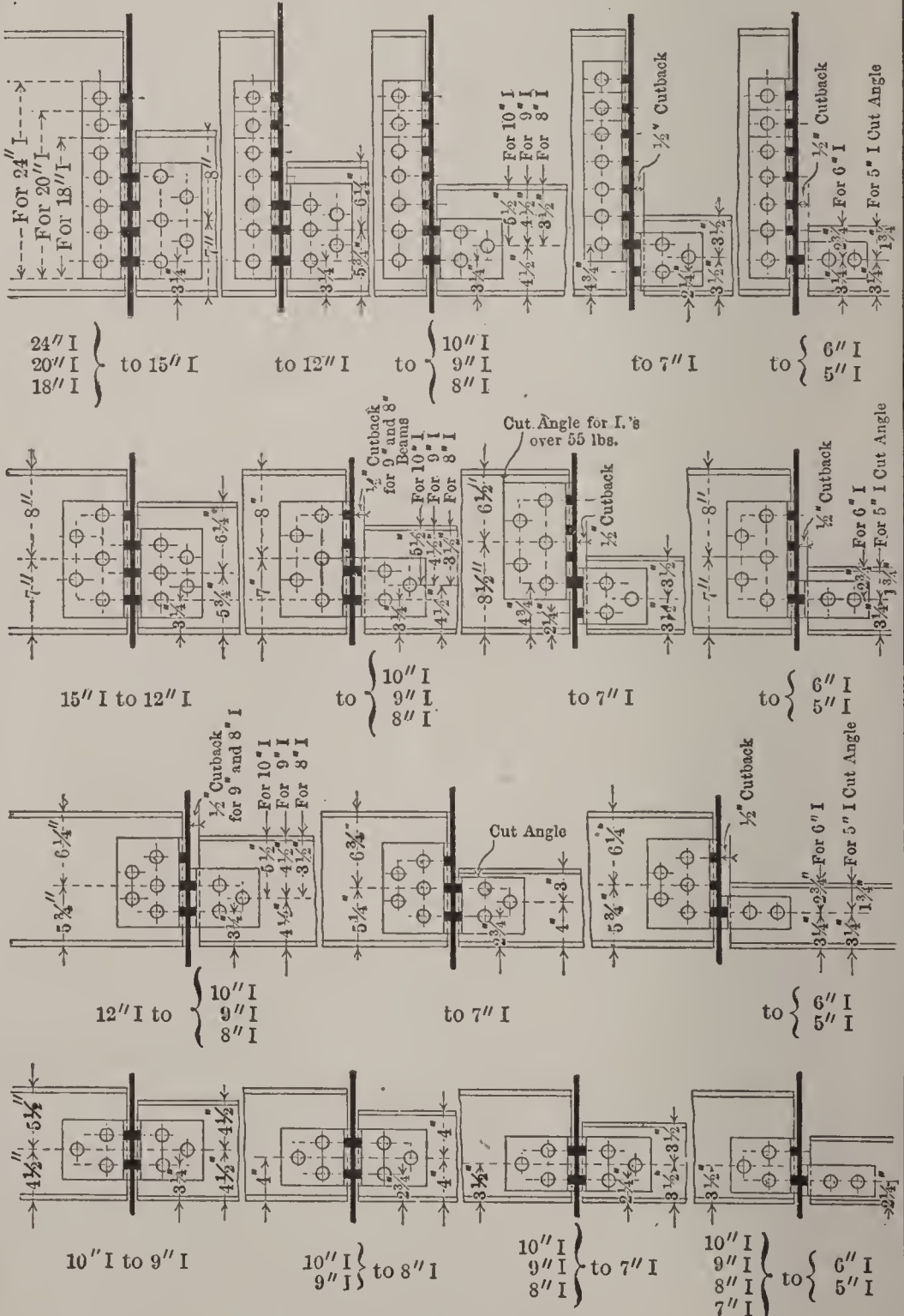

See Punching of Connection Angles on page 61.

**BEARING PLATES FOR BEAMS
AND CHANNELS ON BRICK OR MASONRY**

SIZE OF BEAM OR CHANNEL	BEARING ON WALL INCHES	SIZE OF BEARING PLATES	WEIGHT IN POUNDS	SAFE BEARING VALUES IN TONS FOR PLATES RESTING ON		
				Common Brick	First Class Brick	Ordinary Masonry
3 4 5 & 6 inch	6	6× 6× ³ / ₈	4	1.8	2.7	4.5
	6	6× 6× ¹ / ₂	5			
7 & 8 inch	8	8× 8× ¹ / ₂	9	3.2	4.8	8.0
	8	8× 8× ³ / ₄	14			
9 & 10 inch	8	8× 12× ¹ / ₂	14	4.8	7.2	12.0
	8	8× 12× ³ / ₄	20			
12 inch 31.5 pounds	12	12× 12× ¹ / ₂	20	7.2	10.8	18.0
	12	12× 12× ³ / ₄	31			
12 inch 40 pounds and up 15 inch 42 pounds	12	12× 16× ³ / ₄	41	9.6	14.4	24.0
	12	12× 16× 1	54			
15 inch 60 and 80 pounds	12	12× 18× ³ / ₄	46	10.8	16.2	27.0
	12	12× 18× 1	61			
18 20 24 inch	16	16× 16× 1	73	12.8	19.2	32.0

Above bearing values are based on the following table :

Allowable load on brick work	100 pounds per square inch
Allowable load on first class work	150 pounds per square inch
Allowable load on masonry	250 pounds per square inch

Use the thicker plate for bearing values exceeding those given under common brick work.

When end reaction exceeds the above safe bearing values, special plates will be provided. 20-inch and 24-inch beams will usually require special calculations.

BUILT COLUMN SECTIONS

Fig. 1



Fig. 2



Fig. 3



Fig. 4



Fig. 5



Fig. 6



Fig. 7



Fig. 8



Fig. 9



Fig. 10



Fig. 11



Fig. 12

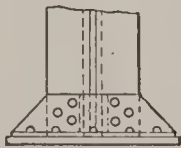

Column Base for light loads.

Fig. 13

Fig. 14

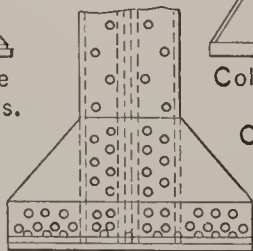

Built up Column Base for heavy loads.

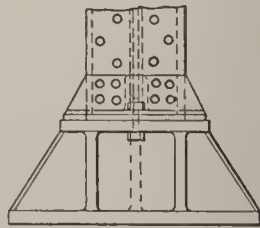

Column Base with Cast Iron or Cast Steel Base.

Fig. 15

Dotted lines indicate lattice.

GENERAL DETAILS

of Column Splices and of Connections for I Beams to Plate and Angle Columns

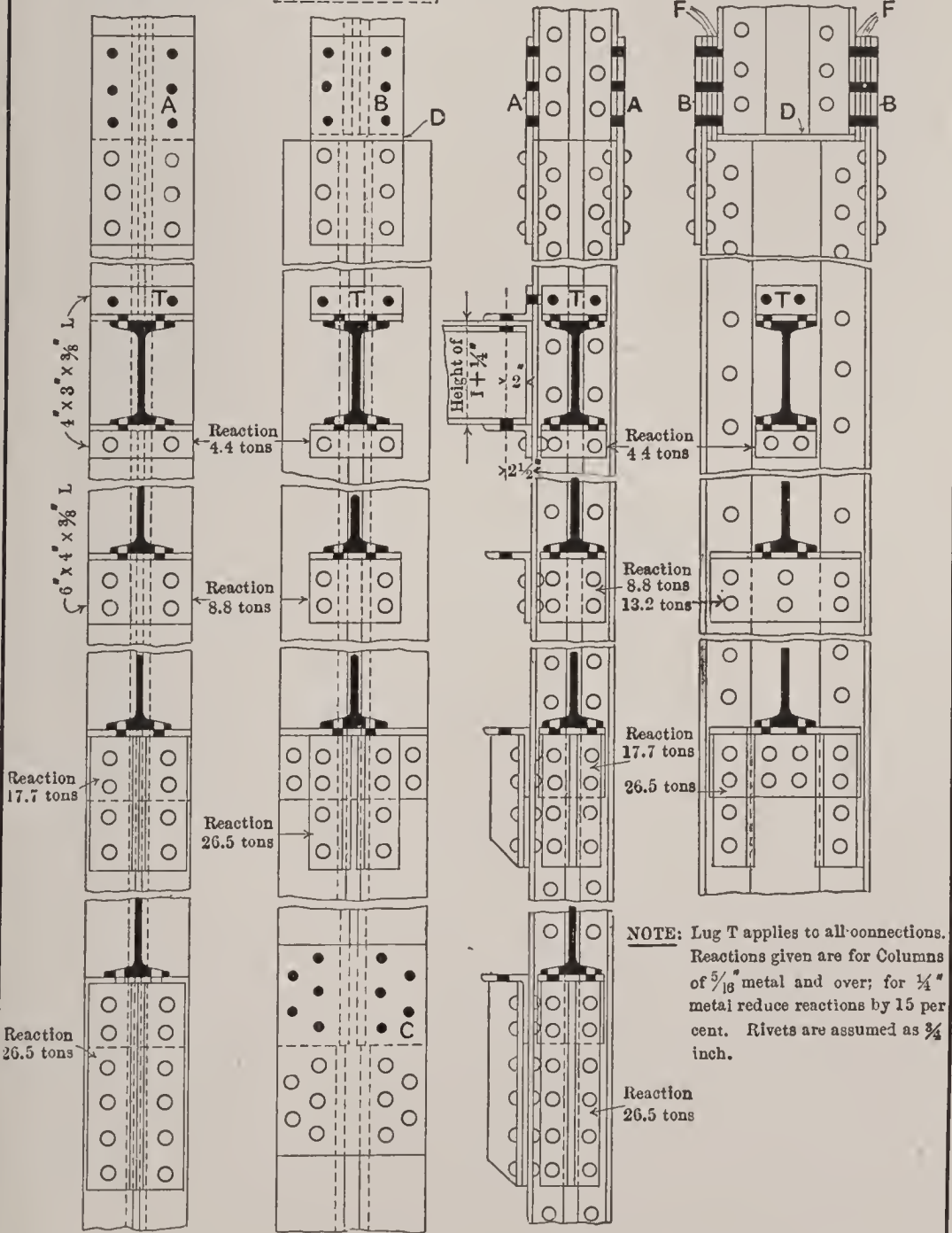
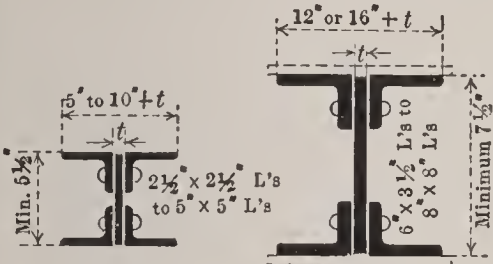

NOTE: Lug T applies to all connections. Reactions given are for Columns of $\frac{5}{16}$ " metal and over; for $\frac{1}{4}$ " metal reduce reactions by 15 per cent. Rivets are assumed as $\frac{3}{4}$ inch.

Notes on Splicing of Columns and Connection of Beams to Columns

Page 65 illustrates manner of splicing columns and also methods of attaching floor beams and girders to columns.

It will be noted that the columns are composed of four angles and one web plate.

Experience in the construction of skeleton steel frames for buildings, in the past ten years, has plainly demonstrated that columns so constructed are generally as economical in the use of material as when composed of zees or other shapes. Besides, the angles are easier to get from the mills and the connections on such columns are more simple and accessible.

In the fabrication of plate and angle columns less trouble is encountered in keeping them straight and out of wind. The designer has at his command a large list of sizes and weights of angles, so that the proper strength can be easily attained either with the four shaft angles or by the addition of flange plates.

Three kinds of splices are shown, designated as A, B and C. The first and last are for light and heavy columns of same widths of web plates, while that marked B is for columns of different widths of web plates, necessitating the use of pressure plates D and fillers F.

Pressure plates are commonly $\frac{3}{4}$ -inch thick, and splice plates $\frac{3}{8}$ -inch to $\frac{1}{2}$ -inch; the latter being about eighteen inches long; the columns being spliced about 1 foot 3 inches above finished floor level.

The beam connections illustrated will cover most cases occurring in practice.

The reactions given for the various connections apply to columns with metal $\frac{3}{8}$ -inch thick or more. With shafts $\frac{1}{4}$ -inch thick, the reaction must be reduced accordingly.

The bearing value of rivets should equal the double shearing value, where beams or girders connect on each side of column webs. See tables on pages 184 and 185.

FIREPROOF FLOOR CONSTRUCTION

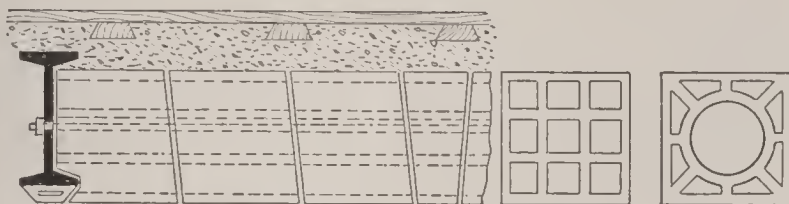

Fig. 1. End Construction. Fig. 4 Fig. 5

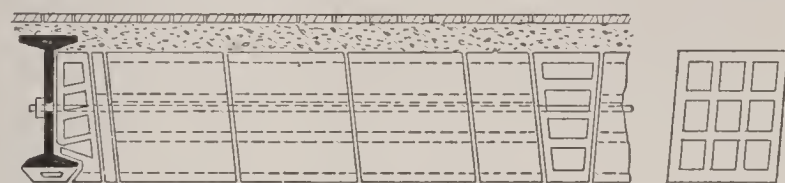

Fig. 2. Combination Construction. Fig. 6

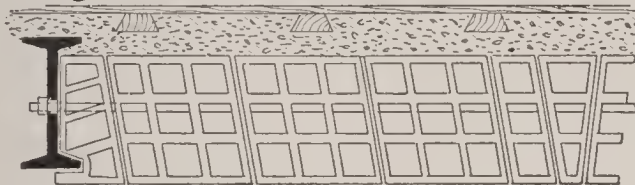

Fig. 3. Parallel Web or Side Construction.

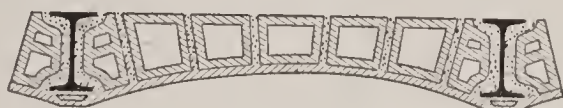

Fig. 7

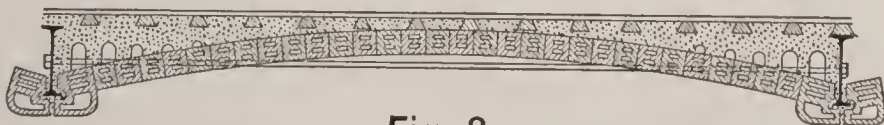

Fig. 8

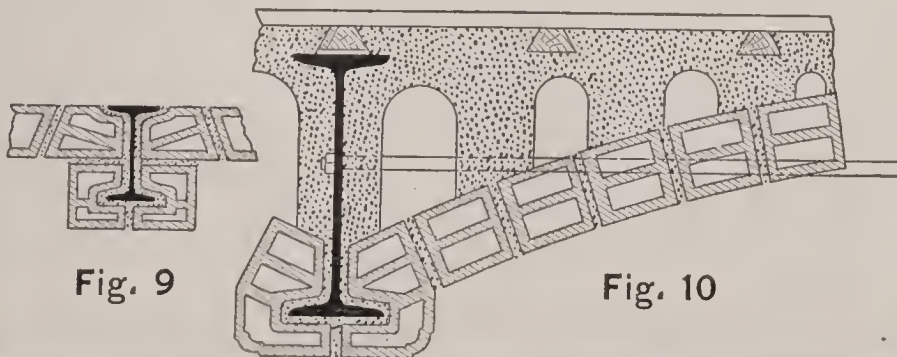

Fig. 9

Fig. 10

FIREPROOF FLOORS, PARTITIONS, CEILING AND ROOFS

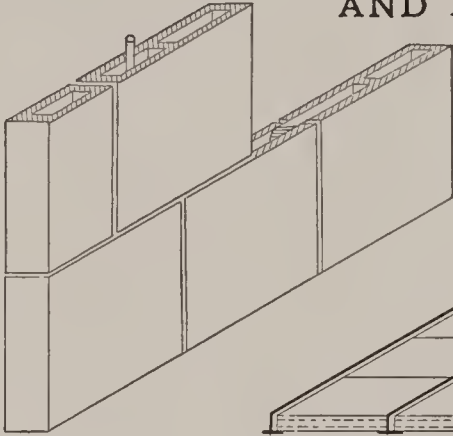

Fig. 7

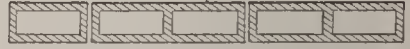

Fig. 8

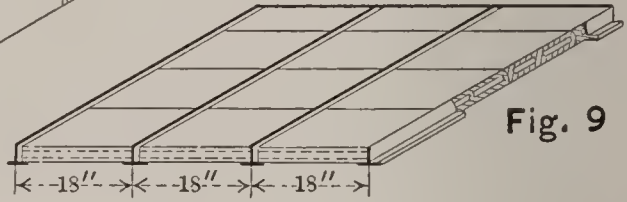

Fig. 9

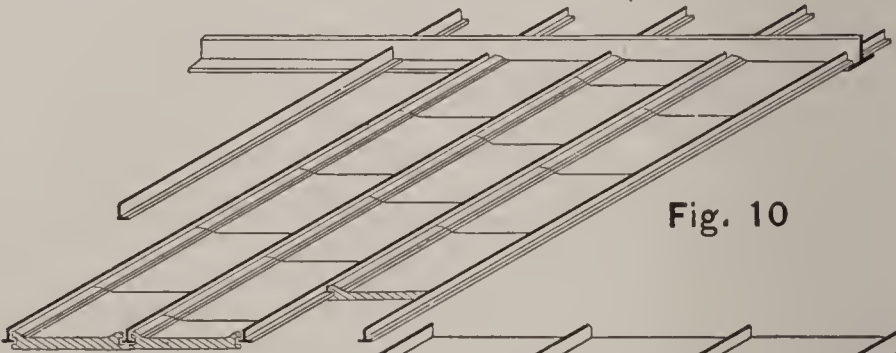

Fig. 10

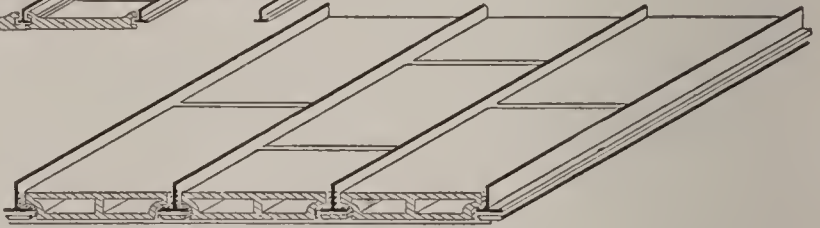

Fig. 11

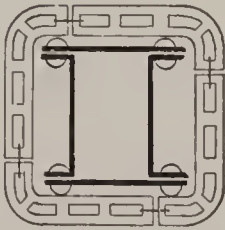

Fig. 12

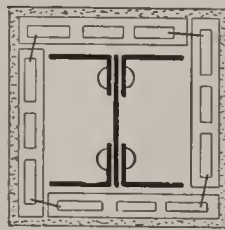

Fig. 13

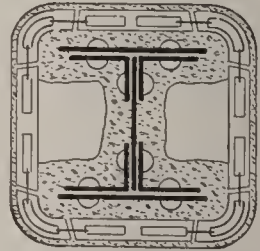

Fig. 14

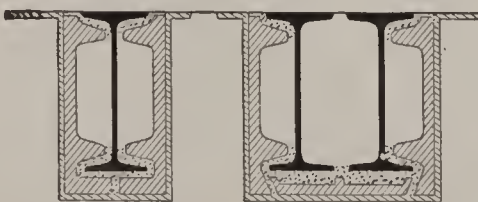

Fig. 15

Fig. 16

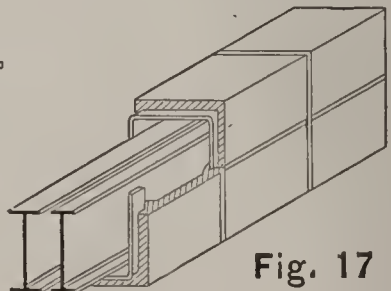

Fig. 17

GENERAL DETAILS OF FLOORS AND CONNECTIONS

Fig. 1

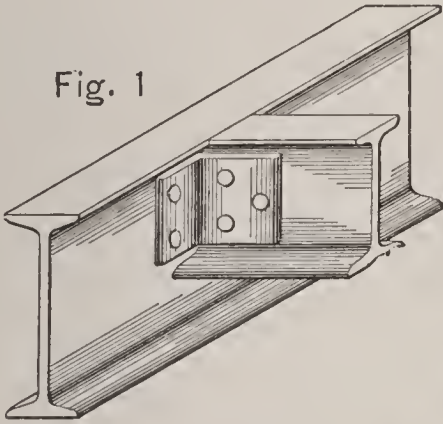

Fig. 2

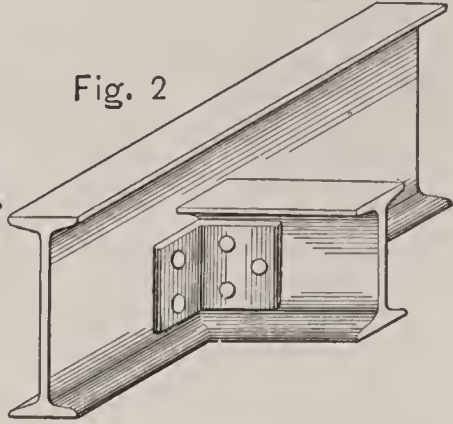

Fig. 3

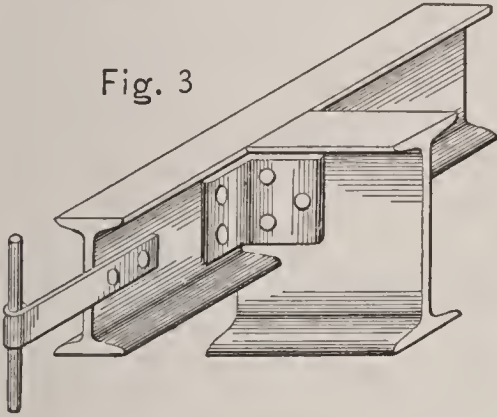

Fig. 4

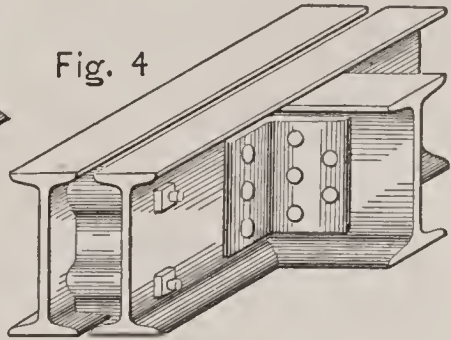

Fig. 5



Fig. 6



Fig. 8



Fig. 9



GENERAL DETAILS OF CEILINGS

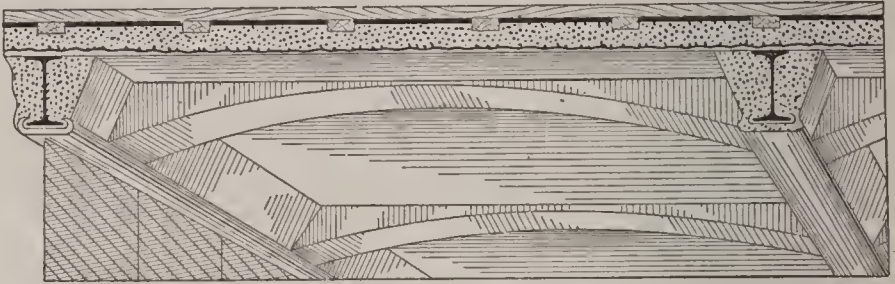

Fig. 1

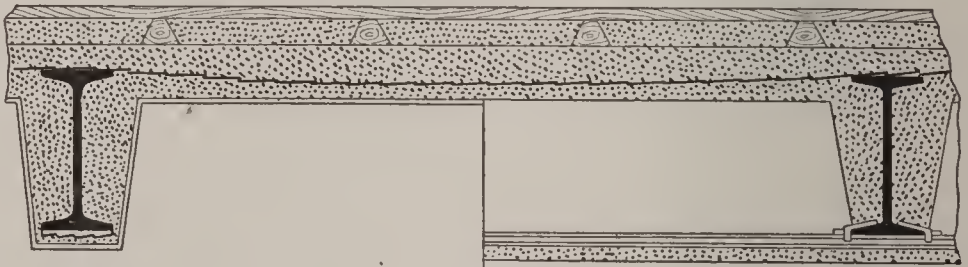

Fig. 2



Fig. 3

DETAILS OF PARTITIONS

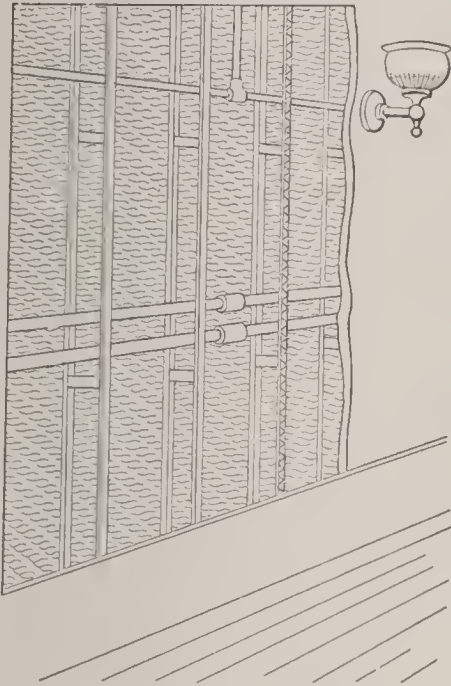

Fig. 4

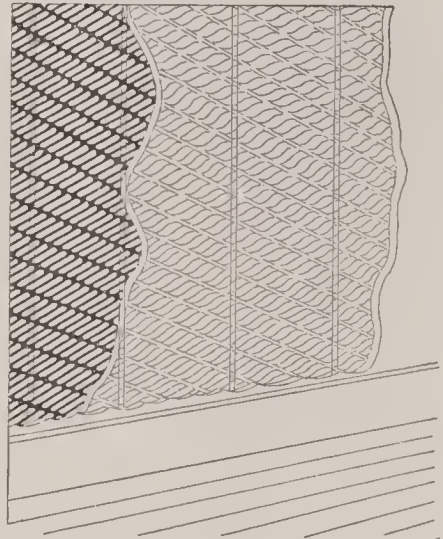

Fig. 6

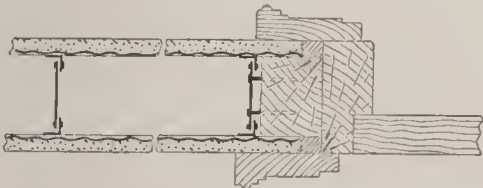

Fig. 5

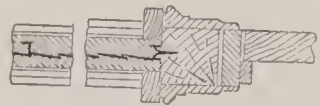

Fig. 7

FIREPROOFING COLUMNS



Fig. 8

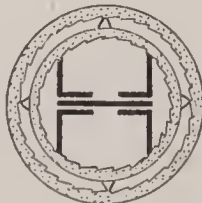

Fig. 9



Fig. 10

General Notes on Floors and Fireproofing

Floors

Examples of girders and joists and their connections, as they most commonly occur, are shown on page 69, Figs. 1, 2 and 4, although we occasionally have cases where a large beam frames into a smaller beam, as in Fig. 3. This is somewhat objectionable and should be avoided as much as possible. Girders consisting of two or more beams side by side, as in Fig. 4, should be connected by means of cast-iron separators, using either 1-bolt separators or 2-bolt separators, according to the size of the beams. These separators in a measure hold in position the compression flanges of the beams, preventing side deflections or buckling. They also unite the two beams and cause them to act in unison as regards vertical deflection. Separators should be placed near the supports and then spaced at regular intervals of about 6 feet. Figs. 5 and 6 show cuts of separators. (For weights of separators for different sizes of beams, see page 58.)

Figs. 1, 2, 3 and 4 show different methods of framing joists into girders. Figs. 1 and 2 represent the joist framed into single girders, with standard angle connections, flush either top or bottom as the case may be. In this case the girders are of a greater depth than the joists. Fig. 4 represents joist framed into double girders, flush top and bottom. In this case the joists are of the same depth as the girders, connection being made as before with standard connection angles. Joist or floor beams should be placed about 5 or 6 feet center to center.

Information regarding standard sizes of connection angles for the different sizes of beams is given on pages 60, 61 and 62. The anchors shown in Figs. 3 and 8 are in the wall end of the beams and are embedded in the stone or brick work, thus tying walls together. Fig. 9 shows tie rods used between floor beams. They are usually made of $\frac{3}{4}$ -inch diameter rods and should be spaced about 6 feet apart.

Fireproofing

Within a few years, great improvements have been made in the methods and materials employed for the interior construction of buildings; especially is this true of the arch filling between the steel floor members of the skeleton frame.

Formerly ordinary brick arches, or corrugated sheets, curved to proper radii and filled up level with concrete to tops of floor beams, were used.

This construction being too heavy for high buildings, has been discarded, and the hollow tile arches, shown on page 67, (Figs. 1 to 6) are generally used.

The material is well-burned terra cotta blocks, with voids formed in them to decrease the weight. The result is that the blocks consist of a series of ribs, over which the pressure, from their own weight and the super-imposed loads, is distributed as uniformly as is practicable.

Figs. 1, 4 and 5 show the ribs running lengthwise of the blocks or arches.

In Figs. 2 and 6 the voussoirs have the ribs longitudinal as before, but the keys, springers or skewbacks have the ribs parallel with the axis of the arch or supporting beams. Sometimes solid-bearing tiles are inserted between the skewbacks and voussoirs or at intervals between the various voussoirs; the object being to secure a better bearing for the ribs.

Fig. 3 illustrates all ribs parallel with axis of arch or supporting beams. The first is styled "end" construction; the second "combination" construction, being a combination of the first and third, while the last is termed "side" construction.

Practically, it is easier to get better joints with the "side" construction, which is certainly a great desideratum in a good solid floor.

The tiles are made of suitable strength to meet conditions imposed by varying the thickness of the ribs.

The following formula is used in calculating the strength of flat arches:

$$L = \frac{208 A. D.}{S^2} \quad \text{in which}$$

L=Safe load in pounds per square foot of floor.

A=Least effective area of terra cotta in square inches in section of arch 12 inches wide.

D=Total depth of arch in *feet*.

S=Span of arch in feet.

Two hundred and eight pounds is the permissible compression per square inch on terra cotta, or brick work laid in cement mortar, according to New York and Philadelphia building laws; and is equivalent to a factor of safety of 7.

From the safe load thus obtained should be deducted the dead weight, consisting of the terra cotta arch, concrete filling over same, floor finish and ceiling.

The weights of terra cotta arches, of various spans and depths, are given in table in column marked "W."

The total dead weight made up as stated will vary from 22 to 35 pounds per square foot of floor area, dependent upon depth and span of arch, nature of filling over same and kind of finish used for floors and ceilings.

The net permissible live loads thus obtained should be as follows, to accord with the New York building laws:

For dwellings and hotels	70 lbs. per sq. ft.
For office buildings	100 lbs. per sq. ft.
For places of public assembly	120 lbs. per sq. ft.
For stores, factories and warehouses	150 lbs. per sq. ft. (or more)
For roofs	50 lbs. per sq. ft.

FLAT ARCHES

D INCHES	END CONSTRUCTION				PARALLEL WEB OR SIDE CONSTRUCTION			
	Max. S Feet and Inches	W	L	A and End Section Square Inches	Max. S Feet and Inches	W	L	A and Cross Section Square Inches
4	3 0	16 1/2	215	28 	2 9	16 1/4	138	15
5	4 0	18 1/2	163	32 "	3 8	19	98	15 "
6	5 0	19 3/4	150	36 "	4 6	23 3/4	116	22 1/2
7	5 9	22	147	40 	5 6	25 1/2	90	22 1/2 "
8	6 6	24	145	44 	6 3	26 3/4	80	22 1/2 "
9	7 3	25 1/2	142	48 	7 0	28 3/4	72	22 1/2 "
9	8 0	26 1/2	141	52 	7 0	31 1/4	96	30
10	8 6	28	148	56 	7 9	33 1/4	87	30 "
11	9 0	29 3/4	158	60 	8 9	36 3/4	82	30 "
12	9 4	33 1/4	165	64	9 10	46	100	37 1/2
13	9 8	35	177	68				
14	10 0	36 1/2	187	72				
15	10 3	41	200	76				

A great many tests have been made as to strength of hollow tile arches, both by quiescent load and by dropping of heavy weights, and in every case the "end section" method has demonstrated its greater efficiency over the older systems. The usual manner of setting tile arches is by the use of portable scaffolds formed of 2×10 plank, supported underneath by "center stringers," which in turn are carried by bolts attached to cross pieces resting on the tops of the beams. After the tile arches have been set in cement mortar for thirty-six hours, the center scaffolding is removed and the tops of the arches are then filled in with cement concrete to the required level, 2×4 wooden sleepers being embedded in the concrete to afford nailing surface for the wood flooring; or if marble or mosaic flooring is required, the wood strips are omitted.

Fig. 7 illustrates a hollow tile arch between beams with a segment soffit and flat top. This form of arch has been extensively used in breweries, warehouses, etc., where the necessity for a level ceiling did not exist.

Fig. 8 represents a segment hollow tile arch set in place between beams spaced 18 feet from center to center. The tiles forming this arch are 6×6 inches square with outside shell $\frac{7}{8}$ -inch thick, and center web $\frac{3}{4}$ -inch thick. This form of arch costs less than the flat systems shown in Figs. 1 and 2, effecting as it does a considerable saving in steel beams. Its use is becoming general for warehouses, malt houses and also office structures, although great care is necessary in the arrangement of steel framing to anticipate the thrust by the proper distribution of tie rods.

Fig. 10 shows in detail the abutment piece completely enclosing the steel beam, also the concrete filling in haunches cored out with metallic cores to lighten the weight of the floor; the wood strips are shown embedded in the concrete, same as described above.

Segment arches the sizes described have been built of 6-inch tile with a span of 18 feet, having 14 inches rise in the center, and tested to carry 300 pounds per foot, with factor of 6 for

safety. Segment arches of 5-inch and 4-inch thick tile are used for smaller spans, and effect considerable saving when a level ceiling is not essential. The weight of a 5-inch segment arch is about 28 pounds per square foot; that of a 6-inch arch, 35 pounds.

Fig. 9 shows method of fireproofing a beam or girder built in a floor that projects below the ceiling line. When desired special formed tile can be made to suit the outline required for ornamental cornices, etc.

On page 68, Figs. 15, 16 and 17 illustrate single and double isolated steel girders enclosed with fireproofing material, and finished out to the plaster line. On same page, Fig. 9 illustrates method of constructing mansard or flat fireproof roofs. For this purpose tees of the required weight are used, spaced 18 inches from center to center. Between the tees hollow tiles 12×18 inches are bedded in cement mortar and left ready for the weathering. On steep pitched and mansard roofs the porous tiles are preferable, as the slates or roofing tiles can be nailed directly to the same. Fig. 10 illustrates a fireproof ceiling constructed by a combination of steel and tile. The main supports are constructed of 3×3 angles spaced 6 feet from center to center, punched at regular intervals of 12-inch centers, with triangular holes of sufficient size to permit 1×1 -inch tees passing through the same. The 3×3 angles are supported by rods of the required length from the roof rafters at intervals of 8 feet. After the 1×1 -inch tees are set in place $\frac{1}{2}$ -inch thick flat tiles with grooved edges are set in place between same and the under surface left ready for the receipt of the plaster. This form of fireproof ceiling is sufficiently strong to bear the weight of a man, but should not be used if required to carry anything but its own weight.

Fig. 11 shows tees and tile construction suited for ceilings or attic floors of fireproof buildings. The tees are spaced 16 inches from center to center, 3-inch thick tiles being bedded between same; the soffits of the tees are protected with a slab of tile. A thin coat of cement mortar spread upon the tops

of the tile leaves a finished surface suitable for attic floor. Figs. 12, 13 and 14 illustrate three different forms of fireproof covering applied to steel columns. These tiles are molded to suit any size or form of column, and are secured to each other with steel clamps, and to the column with suitable fastenings. Any form of steel column can be fireproofed in a like manner.

Fig. 14 shows a steel column first enclosed in a few inches of cement concrete, protecting the steel against corrosion and then encased by hollow tiles as a protection against fire and also to obtain the desired shape of column.

By fireproofing columns as shown, a channel or duct between the column and tile is formed, thus allowing space for pipes, etc., to be carried up through the building without increasing the exterior dimensions of the column.

Figs. 7 and 8 show an isometrical view and plan of hollow tile partition. These tiles are manufactured from 2 to 6 inches thick, and are 12 inches square. They are laid in place in cement mortar, joints being regularly broken in every course. Steel clamps are used to tie the tiles together whenever the walls are of unusual heights.

In addition to the well known systems of terra cotta and hollow tile construction, we show on pages 70 and 71 examples of one of the standard systems of concrete construction and different methods of building fireproof partitions under what is known as the expanded metal system of fireproofing. This system is well beyond the experimental stage, having been used in different classes of buildings upwards of twelve years in different cities of the United States.

Page 70, Fig. 1 shows a method of construction where the floor beams are dispensed with and suitable steel channels substituted in their stead. These channels are sprung in arch form from girder to girder and are spaced generally about four feet on centers.

Concrete is filled on top of these channels by means of centering, and over the whole structure is then laid a slab of concrete of the required thickness, in which are imbedded sheets of expanded metal.

Fig. 2 is in all respects similar to Fig. 1, except that the channel arches are left out and the floor beams are spaced from 5 feet to 8 feet on centers.

One-half of the cut shows the method of floor construction giving paneled ceiling effect, and is the type generally used in warehouses where flat ceilings are not especially required.

The other half of the cut shows the method of construction to give flat ceiling effect. This is accomplished by attaching small channel or angle irons spaced 12 inches to 16 inches on centers to the bottom of the beam with malleable iron clamps, to which the expanded metal lathing is attached with No. 19 annealed wire, the space between the ceiling and the floor plate being used to conceal the pipes, speaking tubes and electric wires. This method is generally used for office and public buildings, schools, etc.

This system can be made to carry almost any weight that may be imposed upon it by simply using a thicker concrete plate and a heavier form of expanded metal. The usual requirement for a warehouse load to carry 250 pounds live load would be a plate 4 inches thick, with one sheet of No. 10 gauge, 3-inch mesh expanded metal.

Fig. 3 shows the common type of floor used in apartment houses, office buildings, etc.

This system is generally used where 5-inch to 7-inch beams are used spaced about 4 feet on centers.

This is a very economical system, as it gives a flat ceiling effect without the additional expense of furring and lathing.

This system may be used on floors where not more than 150 pounds per square foot, live load, is required.

Page 71, Fig. 4 shows a very light and economical method of construction for partitions.

The studding is made with two bars of light angle irons riveted together with pieces of strap iron every 2 or 3 feet, and expanded metal lathing tied on both sides with annealed wire. This affords an air space of 3 or 4 inches, depending

upon the width of the partitions in which the piping may be concealed as shown in the cut.

It has a unique advantage, possessed by no other partition, in the fact that the pipes may be run either vertically or horizontally, as may be desired.

Another advantage possessed by this partition is the fact that it may be plastered with common mortar, the framework being made very rigid and stiff.

Fig. 5 shows detail of framing around door openings for these partitions.

Fig. 6 shows the well known type of solid partition which has been in use throughout the United States for some time.

This partition is so well and favorably known that no explanation is necessary further than to say that the studding is made of light channel or angle irons, generally three-quarters of an inch, set about 16 inches on centers, on one side of which expanded metal lathing is securely tied.

It is then plastered on both sides with any one of the patent hard mortars to a total thickness of $1\frac{1}{2}$ to 2 inches.

Fig. 8 shows a method of fireproofing steel columns.

Light angle iron uprights are placed at each corner and expanded metal lathing is then bent around and securely tied. Plastering is then applied in the usual manner.

Fig. 9 shows the method of fireproofing columns with a double air space, which is considered preferable by many prominent engineers.

Fig. 10 shows the method of fireproofing round cast-iron columns.

The lathing in this case is tied on as tightly as possible to the column, the peculiar shape of the strands giving it ample set-off so that mortar will be securely keyed on the back.

Girders in Buildings

In the design of a building cases may occur where a single beam girder will not answer. It may be found desirable to increase the lengths of the spans so as to reduce the number of supporting columns to a minimum, or it often occurs that heavy concentrated loads, such as vaults, brick walls, etc., will render single beam girders inadequate. Various forms of girders may be used in such cases. Where the ends of the girders rest upon the wall, bearing plates should be used to distribute the pressure over a greater surface and thereby prevent the crushing of the material in the wall directly under the girder (see page 63).

The allowed pressure per square foot for brick work should not exceed six tons, and for stone twelve to twenty tons, according to its character.

For spanning openings in brick walls, girders composed of two or more I-beams connected by bolts and separators are most commonly used.

The probable line of rupture where the bricks have been laid regularly, if the girders should fail, will be found to be inside the sides of an isosceles triangle, whose base is the span, and whose height is one-third of the span. In order to be entirely on the safe side, the weight of wall between vertical lines directly over the girder for a height equal to that of the triangle is frequently adopted as the load to be carried. It should be noted, however, that for green walls, or walls having openings, this rule does not apply.

Placing the weight of brick work at 112 pounds per cubic foot, the weights per superficial foot for different walls are as follows:

For 9-inch wall	84 pounds
For 13-inch wall	121 pounds
For 18-inch wall	168 pounds
For 22-inch wall	205 pounds
For 26-inch wall	243 pounds

Explanation of Tables

Jones & Laughlin's Steel Co.'s Sections

The tables on pages 86 to 105, for beams and channels, give the loads which a beam or channel will carry safely (distributed uniformly over its length) for the distances between supports indicated. These loads include the weight of the beam or channel, which must be deducted in order to arrive at the net load which the beam or channel will carry. On pages 106 to 110 will also be found the safe loads for other sections; and on pages 140 to 148 for built-up girders.

The values given are based on a maximum fiber strain of 16,000 lbs. per square inch.

It has been assumed in these tables that proper provision is made for preventing the compression flanges of the beams from deflecting sideways. They should be held in position at distances not exceeding twenty times the width of the flange, otherwise the strain allowed should be reduced as per table, page 84.

In some instances deflection, rather than absolute strength, may become the governing consideration in determining the size of beam to be used. For beams carrying plastered ceilings, for example, it has been found by practical tests that if the deflection exceeds $\frac{1}{300}$ of the distance between supports, or $\frac{1}{30}$ of an inch per foot of the distance, there is danger of the ceiling cracking. This limit is indicated in the following tables by cross lines, beyond which the beams should not be used, if intended to carry plastered ceilings, unless the allowable loads given in the tables are reduced. There is an element of safety not taken into account in the tables, viz., the fact that the dead load of the floor is carried by the beams before the plaster is applied; consequently, only the deflection due to the live load is liable to cause damage to the plaster. The following method can be used to obtain the reduced loads:

Multiply the load given immediately above the cross line by the square of the corresponding span and divide by the square

of the required span; the result will be the required load. See example II. on page 84.

A table of deflection of Jones & Laughlin Steel Co.'s sections is given on page 85. It may generally be assumed, both for rolled and built beams, that the above limit is not exceeded so long as the depth of the beam is not less than $\frac{1}{20}$ of the distance between supports ($\frac{5}{8}$ -inch per foot).

Inasmuch as the carrying capacity of beams increases largely with their depth, and it is therefore economical to use the greatest depth of beam consistent with the other conditions to which it is necessary to conform (as clear height, etc.), the above cases of extreme deflection will rarely be met with in practice.

As the deflection of beams is not very uniform either in iron or steel, the question of the relative deflection of iron and steel beams can be decided only from the average results of a large number of tests. Such experiments as have been made, though insufficient in number to be conclusive, indicate that a steel beam will deflect slightly less than an iron beam of the same section, under the same load, in about the inverse ratio of the moduli of elasticity for these materials as generally assumed, or say as 14 to 15.

Examples of Application of Tables

I. What size and weight of beam 19 feet 6 inches long in clear between walls, and therefore 20 feet long between centers of supports, will be required to carry safely a uniformly distributed load of 16 tons, the weight of the beam included?

ANSWER: From the table for safe loads of beams, a 15-inch beam, 42 lbs., will carry safely for a span of 20 feet, 15.71 tons, or .29 tons less than required in this case. Therefore, a beam of this size and weight will be sufficient to carry the load. Otherwise use beam weighing 45 lbs., which will carry 16.29 tons.

II. What load uniformly distributed, including its own weight, will a 15-inch beam, weighing 50 lbs. per foot, carry for a span of 30 feet, without deflecting sufficiently to endanger a plastered ceiling?

ANSWER: From the table for safe loads of beams we find, at the limit indicated for plastered ceilings, that a 15-inch, 50-lb. beam will carry safely a uniform load of 11.91 tons over a span of 29 feet. In order not to give rise to undue deflection, the safe load for a 30-foot span, according to the rule given on page 82, will be

$$\frac{11.91 \times 29^2}{30^2} = 11.12 \text{ tons.}$$

BEAMS WITHOUT LATERAL SUPPORT

LENGTH OF BEAM	PROPORTION OF TABULAR LOAD FORMING GREATEST SAFE LOAD
20 times flange width	Whole tabular load
30 times flange width	9-10 tabular load
40 times flange width	8-10 tabular load
50 times flange width	7-10 tabular load
60 times flange width	6-10 tabular load
70 times flange width	5-10 tabular load

DEFLECTION COEFFICIENTS

For Different Shapes, Given in 64ths of an Inch

COEFFICIENT INDEX	DISTANCE BETWEEN SUPPORTS IN FEET								
	6	8	10	12	14	16	18	20	22
C	38.0	68.0	106.0	152.5	208.0	271.0	343.0	424.0	513.0
C'	30.0	53.0	83.0	119.0	162.0	212.0	268.0	331.0	400.5
COEFFICIENT INDEX	DISTANCE BETWEEN SUPPORTS IN FEET								
	24	26	28	30	32	34	36	38	40
C	610.0	716.0	830.5	953.0	1085.0	1225.0	1373.0	1530.0	1695.0
C'	477.0	559.0	649.0	748.0	847.0	957.0	1073.0	1195.0	1324.0

The figures given opposite C and C' are the deflection coefficients for steel shapes subject to transverse strain for varying spans, under their maximum uniformly distributed safe loads, derived from a fiber strain of 16,000 and 12,500 respectively, the modulus of elasticity being taken at 29,000,000.

To find the deflection of any symmetrical shape used as a beam, under its corresponding safe load, divide the coefficients given in the above tables by the depth of the beam. This applies to such shapes as beams, channels, etc. For those shapes having unsymmetrical axes, such as tees, angles, etc., divide by twice the greatest distance of the neutral axis from the outside fiber.

Example: Required, the deflection of a 10-inch beam, 25 lbs. per foot, 20-foot span, under its maximum uniformly distributed safe load of 6.51 tons as given on page 94. The above tables give 424.0 as the deflection coefficient; dividing this by 10 gives 42 as the required deflection in 64ths of an inch. For deflections due to different systems of loading, see page 115.

SAFE LOADS IN TONS OF 2000 POUNDS
 Uniformly Distributed, for Jones & Laughlin Steel Co.'s
 Steel Beams

DISTANCE IN FEET BETWEEN SUPPORTS	24-INCH BEAM, STANDARD					
	100 Pounds	95 Pounds	90 Pounds	85 Pounds	80 Pounds	Deflection Inches
10	105.32	102.18	99.04	95.90	92.76	.07
11	95.74	92.89	90.04	87.18	84.33	.09
12	87.76	85.15	82.53	79.92	77.30	.10
13	81.01	78.60	76.18	73.77	71.36	.12
14	75.23	72.99	70.74	68.50	66.26	.14
15	70.21	68.12	66.03	63.93	61.84	.16
16	65.82	63.86	61.90	59.90	57.97	.18
17	61.95	60.10	58.26	56.41	54.57	.21
18	58.51	56.76	55.02	53.28	51.53	.23
19	55.42	53.78	52.13	50.47	48.82	.26
20	52.66	51.09	49.52	47.95	46.38	.29
21	50.15	48.66	47.16	45.67	44.17	.31
22	47.87	46.44	45.02	43.59	42.16	.35
23	45.79	44.43	43.06	41.69	40.33	.38
24	43.88	42.57	41.27	39.96	38.65	.41
25	42.13	40.87	39.62	38.36	37.11	.45
26	40.51	39.30	38.09	36.88	35.68	.48
27	39.01	37.84	36.68	35.52	34.36	.52
28	37.61	36.49	35.37	34.25	33.13	.56
29	36.31	35.23	34.15	33.07	31.99	.60
30	35.11	34.06	33.01	31.97	30.92	.64
31	33.97	32.96	31.95	30.94	29.92	.69
32	32.91	31.93	30.95	29.97	28.98	.73
33	31.91	30.96	30.01	29.06	28.11	.78
34	30.98	30.05	29.13	28.20	27.28	
35	30.09	29.19	28.30	27.40	26.50	
36	29.25	28.38	27.51	26.64	25.76	

Safe load includes weight of beam. Maximum fiber strain of 16,000 pounds per square inch.

SAFE LOADS IN TONS OF 2000 POUNDS
Uniformly Distributed, for Jones & Laughlin Steel Co.'s
Steel Beams

DISTANCE IN FEET BETWEEN SUPPORTS	20-INCH BEAM, HEAVY SECTION					
	100 Pounds	95 Pounds	90 Pounds	85 Pounds	80 Pounds	Deflection Inches
10	88.66	86.05	83.43	80.82	78.21	.09
11	80.59	78.22	75.84	73.47	71.10	.10
12	73.88	71.70	69.53	67.35	65.17	.12
13	68.20	66.19	64.18	62.17	60.16	.14
14	63.33	61.46	59.59	57.73	55.86	.17
15	59.11	57.36	55.62	53.88	52.14	.19
16	55.41	53.78	52.15	50.51	48.88	.22
17	52.15	50.61	49.08	47.54	46.00	.25
18	49.25	47.80	46.35	44.90	43.45	.28
19	46.66	45.29	43.91	42.54	41.16	.31
20	44.33	43.02	41.72	40.41	39.10	.34
21	42.22	40.97	39.70	38.49	37.24	.38
22	40.30	39.11	37.93	36.74	35.55	.41
23	38.55	37.41	36.28	35.14	34.00	.45
24	36.94	35.85	34.76	33.68	32.59	.49
25	35.46	34.42	33.37	32.33	31.28	.54
26	34.10	33.09	32.09	31.08	30.08	.58
27	32.83	31.87	30.90	29.93	28.97	.62
28	31.66	30.73	29.80	28.87	27.93	.67
29	30.57	29.67	28.77	27.87	26.97	.72
30	29.55	28.68	27.81	26.94	26.07	.77
31	28.60	27.76	26.91	26.07	25.23	.82
32	27.70	26.89	26.07	25.25	24.44	.88
33	26.86	26.07	25.31	24.49	23.70	.93
34	26.07	25.31	24.52	23.77	23.00	
35	25.33	24.58	23.84	23.09	22.33	
36	24.63	23.90	23.18	22.45	21.72	

Safe load includes weight of beam. Maximum fiber strain of 16,000 pounds per square inch.

NOTE.—Use spans above horizontal black line for plastered ceilings.

SAFE LOADS IN TONS OF 2000 POUNDS
Uniformly Distributed, for Jones & Laughlin Steel Co.'s
Steel Beams

DISTANCE IN FEET BETWEEN SUPPORTS	20-INCH BEAM, STANDARD			
	75 Pounds	70 Pounds	65 Pounds	Deflection Inches
10	68.13	65.51	62.90	.09
11	61.93	59.56	57.18	.10
12	56.82	54.59	52.41	.12
13	52.40	50.39	48.38	.14
14	48.66	46.79	44.93	.17
15	45.42	43.67	41.93	.19
16	42.58	40.94	39.31	.22
17	40.07	38.54	37.00	.25
18	37.85	36.40	34.94	.28
19	35.86	34.48	33.10	.31
20	34.06	32.76	31.45	.34
21	32.44	31.20	29.95	.38
22	30.97	29.78	28.59	.41
23	29.62	28.48	27.35	.45
24	28.41	27.29	26.21	.49
25	27.25	26.20	25.16	.54
26	26.20	25.19	24.19	.58
27	25.23	24.26	23.29	.62
28	24.33	23.45	22.46	.67
29	23.49	22.59	21.69	.72
30	22.71	21.83	20.97	.77
31	21.98	21.13	20.29	.82
32	21.29	20.47	19.66	.88
33	20.64	19.85	19.06	.93
34	20.04	19.27	18.50	
35	19.46	18.72	17.97	
36	18.94	18.20	17.47	

Safe load includes weight of beam. Maximum fiber strain of 16,000 pounds per square inch.

NOTE.—Use spans above horizontal black line for plastered ceilings.

SAFE LOADS IN TONS OF 2000 POUNDS
 Uniformly Distributed, for Jones & Laughlin Steel Co.'s
 Steel Beams

DISTANCE IN FEET BETWEEN SUPPORTS	18-INCH BEAM, STANDARD				Deflection Inches
	70 Pounds	65 Pounds	60 Pounds	55 Pounds	
10	54.52	52.16	49.80	47.06	.10
11	49.56	47.42	45.27	42.78	.12
12	45.43	43.47	41.50	39.22	.14
13	41.94	40.12	38.30	36.20	.16
14	38.94	37.26	35.57	33.62	.19
15	36.34	34.77	33.20	31.38	.21
16	34.07	32.60	31.12	29.42	.24
17	32.07	30.68	29.29	27.68	.28
18	30.29	28.98	27.66	26.14	.31
19	28.70	27.46	26.21	24.77	.34
20	27.26	26.08	24.90	23.53	.38
21	25.97	24.84	23.71	22.41	.42
22	24.78	23.71	22.63	21.39	.46
23	23.70	22.68	21.65	20.46	.50
24	22.71	21.73	20.75	19.61	.55
25	21.81	20.86	19.92	18.82	.60
26	20.97	20.06	19.15	18.10	.64
27	20.19	19.32	18.44	17.43	.69
28	19.47	18.63	17.78	16.81	.75
29	18.80	17.99	17.17	16.23	.80
30	18.17	17.39	16.60	15.69	.86
31	17.58	16.83	16.06	15.18	.92
32	17.04	16.30	15.56	14.71	.98
33	16.52	15.81	15.09	14.27	1.04
34	16.03	15.34	14.65	13.84	
35	15.58	14.91	14.23	13.45	
36	15.14	14.49	13.83	13.07	

Safe load includes weight of beam. Maximum fiber strain of 16,000 pounds per square inch.

NOTE.—Use spans above horizontal black line for plastered ceilings.

SAFE LOADS IN TONS OF 2000 POUNDS
 Uniformly Distributed, for Jones & Laughlin Steel Co.'s
 Steel Beams

DISTANCE IN FEET BETWEEN SUPPORTS	15-INCH BEAM, HEAVY SECTION					
	100 Pounds	95 Pounds	90 Pounds	85 Pounds	80 Pounds	Deflection Inches
10	63.96	62.00	60.04	58.08	56.11	.11
11	58.14	56.36	54.58	52.80	51.01	.14
12	53.30	51.66	50.03	48.40	46.76	.16
13	49.20	47.69	46.18	44.67	43.17	.19
14	45.68	44.28	42.88	41.48	40.08	.22
15	42.64	41.33	40.02	38.72	37.41	.26
16	39.97	38.75	37.52	36.30	35.07	.29
17	37.62	36.47	35.32	34.16	33.01	.33
18	35.53	34.44	33.35	32.26	31.17	.37
19	33.66	32.63	31.60	30.57	29.52	.41
20	31.98	31.00	30.02	29.04	28.06	.46
21	30.45	29.52	28.59	27.66	26.73	.50
22	29.07	28.18	27.29	26.40	25.51	.55
23	27.81	26.96	26.10	25.25	24.40	.60
24	26.65	25.83	25.01	24.20	23.38	.66
25	25.58	24.80	24.01	23.23	22.45	.71
26	24.60	23.84	23.09	22.34	21.58	.77
27	23.69	22.96	22.24	21.51	20.78	.83
28	22.84	22.14	21.44	20.74	20.04	.90
29	22.05	21.38	20.70	20.03	19.35	.96
30	21.32	20.67	20.01	19.36	18.70	1.03
31	20.63	20.00	19.37	18.73	18.10	1.10
32	19.99	19.37	18.76	18.15	17.54	1.17
33	19.38	18.79	18.19	17.60	17.00	1.24
34	18.81	18.23	17.66	17.08	16.50	
35	18.27	17.71	17.15	16.59	16.03	
36	17.76	17.22	16.68	16.13	15.59	

Safe load includes weight of beam. Maximum fiber strain of 16,000 pounds per square inch.

NOTE.—Use spans above horizontal black line for plastered ceilings.

SAFE LOADS IN TONS OF 2000 POUNDS
 Uniformly Distributed, for Jones & Laughlin Steel Co.'s
 Steel Beams

DISTANCE IN FEET BETWEEN SUPPORTS	15-INCH BEAM, LIGHT SECTION					
	80 Pounds	75 Pounds	70 Pounds	65 Pounds	60 Pounds	Deflection Inches
10	51.15	49.19	47.23	45.27	43.31	.11
11	46.50	44.72	42.93	41.15	39.37	.14
12	42.62	40.99	39.36	37.72	36.09	.16
13	39.35	37.84	36.33	34.82	33.31	.19
14	36.54	35.13	33.73	32.33	30.93	.22
15	34.10	32.79	31.49	30.18	28.87	.26
16	31.97	30.74	29.52	28.29	27.07	.29
17	30.09	28.93	27.78	26.63	25.47	.33
18	28.42	27.33	26.24	25.15	24.06	.37
19	26.92	25.89	24.86	23.82	22.79	.41
20	25.57	24.59	23.61	22.63	21.65	.46
21	24.36	23.42	22.49	21.56	20.62	.50
22	23.25	22.36	21.47	20.58	19.69	.55
23	22.24	21.39	20.53	19.68	18.83	.60
24	21.31	20.50	19.68	18.86	18.04	.66
25	20.46	19.68	18.89	18.11	17.32	.71
26	19.67	18.92	18.16	17.41	16.66	.77
27	18.95	18.22	17.49	16.77	16.04	.83
28	18.27	17.57	16.87	16.17	15.47	.90
29	17.64	16.96	16.29	15.61	14.93	.96
30	17.05	16.40	15.74	15.09	14.44	1.03
31	16.50	15.87	15.23	14.60	13.97	1.10
32	15.98	15.37	14.76	14.14	13.53	1.17
33	15.50	14.91	14.31	13.72	13.12	1.24
34	15.04	14.47	13.89	13.31	12.74	
35	14.61	14.05	13.49	12.93	12.36	
36	14.21	13.66	13.12	12.57	12.03	

Safe load includes weight of beam. Maximum fiber strain of 16,000 pounds per square inch.

NOTE.—Use spans above horizontal black line for plastered ceilings.

SAFE LOADS IN TONS OF 2000 POUNDS
 Uniformly Distributed, for Jones & Laughlin Steel Co.'s
 Steel Beams

DISTANCE IN FEET BETWEEN SUPPORTS	15-INCH BEAM, STANDARD				
	55 Pounds	50 Pounds	45 Pounds	42 Pounds	Deflection Inches
10	36.52	34.55	32.59	31.41	.11
11	33.19	31.41	29.63	28.56	.14
12	30.42	28.79	27.16	26.18	.16
13	28.08	26.58	25.07	24.16	.19
14	26.08	24.68	23.28	22.44	.22
15	24.34	23.03	21.73	20.94	.26
16	22.82	21.59	20.37	19.63	.29
17	21.49	20.32	19.17	18.48	.33
18	20.28	19.19	18.10	17.45	.37
19	19.21	18.18	17.15	16.53	.41
20	18.26	17.26	16.29	15.71	.46
21	17.38	16.45	15.52	14.96	.50
22	16.59	15.70	14.81	14.28	.55
23	15.87	15.02	14.17	13.66	.60
24	15.21	14.40	13.58	13.09	.66
25	14.60	13.82	13.04	12.56	.71
26	14.04	13.29	12.53	12.08	.77
27	13.52	12.80	12.07	11.63	.83
28	13.04	12.34	11.64	11.22	.90
29	12.59	11.91	11.24	10.83	.96
30	12.17	11.52	10.86	10.47	1.03
31	11.78	11.14	10.51	10.13	1.10
32	11.41	10.80	10.18	9.82	1.17
33	11.06	10.47	9.88	9.52	1.24
34	10.74	10.16	9.58	9.24	
35	10.43	9.87	9.31	8.97	
36	10.14	9.60	9.05	8.73	

Safe load includes weight of beam. Maximum fiber strain of 16,000 pounds per square inch.

NOTE.—Use spans above horizontal black line for plastered ceilings.

SAFE LOADS IN TONS OF 2000 POUNDS

Uniformly Distributed, for Jones & Laughlin Steel Co.'s Steel Beams

DISTANCE IN FEET BETWEEN SUPPORTS	12-INCH BEAM, SPECIAL SECTION					12-INCH BEAM STANDARD		
	60 Pounds	55 Pounds	50 Pounds	45 Pounds	40 Pounds	35 Pounds	31½ Pounds	Def. Inches
10	30.18	28.61	27.04	25.48	23.91	20.28	19.18	.14
11	27.44	26.01	24.58	23.16	21.73	18.44	17.44	.17
12	25.14	23.84	22.54	21.23	19.92	16.90	15.99	.21
13	23.22	22.01	20.80	19.60	18.39	15.60	14.76	.24
14	21.56	20.44	19.32	18.20	17.08	14.49	13.70	.28
15	20.13	19.08	18.03	16.98	15.94	13.52	12.79	.32
16	18.86	17.88	16.90	15.92	14.94	12.68	11.99	.37
17	17.75	16.83	15.91	14.99	14.06	11.93	11.28	.41
18	16.78	15.90	15.02	14.15	13.28	11.27	10.66	.46
19	15.89	15.06	14.23	13.41	12.58	10.67	10.10	.52
20	15.10	14.31	13.52	12.74	11.95	10.14	9.59	.57
21	14.38	13.63	12.88	12.13	11.38	9.66	9.14	.63
22	13.73	13.01	12.29	11.58	10.87	9.22	8.72	.69
23	13.12	12.44	11.76	11.08	10.39	8.82	8.34	.76
24	12.57	11.92	11.27	10.61	9.96	8.45	7.99	.82
25	12.08	11.45	10.82	10.19	9.56	8.11	7.67	.89
26	11.62	11.01	10.40	9.80	9.19	7.80	7.38	.97
27	11.18	10.60	10.02	9.43	8.85	7.51	7.10	1.04
28	10.78	10.22	9.66	9.10	8.54	7.24	6.85	1.12
29	10.41	9.87	9.33	8.78	8.24	6.99	6.62	1.20
30	10.07	9.54	9.01	8.48	7.97	6.76	6.39	1.29
31	9.74	9.23	8.72	8.21	7.71	6.54	6.19	1.37

Safe load includes weight of beam. Maximum fiber strain of 16,000 pounds per square inch.

NOTE.—Use spans above horizontal black line for plastered ceilings.

SAFE LOADS IN TONS OF 2000 POUNDS

Uniformly Distributed, for Jones & Laughlin Steel Co.'s
Steel Beams

DISTANCE IN FEET BETWEEN SUPPORTS	10-INCH BEAM, STANDARD					9-INCH BEAM, STANDARD				
	40 Pounds	35 Pounds	30 Pounds	25 Pounds	Deflection Inches	35 Pounds	30 Pounds	25 Pounds	21 Pounds	Deflection Inches
10	16.94	15.64	14.33	13.02	.17	13.35	12.18	11.00	10.06	.19
11	15.40	14.22	13.03	11.85	.21	12.14	11.07	10.00	9.15	.23
12	14.12	13.03	11.94	10.85	.25	11.12	10.15	9.17	8.39	.27
13	13.03	12.03	11.02	10.02	.29	10.27	9.36	8.46	7.74	.32
14	12.10	11.17	10.24	9.30	.34	9.53	8.70	7.86	7.19	.37
15	11.30	10.42	9.55	8.68	.39	8.90	8.12	7.34	6.71	.43
16	10.59	9.77	8.96	8.14	.45	8.34	7.61	6.88	6.29	.49
17	9.97	9.20	8.43	7.66	.50	7.85	7.16	6.47	5.92	.55
18	9.41	8.69	7.96	7.24	.56	7.42	6.76	6.11	5.60	.62
19	8.92	8.23	7.54	6.85	.62	7.03	6.41	5.79	5.30	.69
20	8.47	7.82	7.16	6.51	.69	6.67	6.09	5.50	5.03	.76
21	8.07	7.45	6.82	6.20	.76					
22	7.71	7.11	6.51	5.92	.83					
23	7.37	6.80	6.23	5.66	.91					
24	7.06	6.52	5.97	5.43	.99					
25	6.78	6.25	5.73	5.21	1.07					

Safe load includes weight of beam. Maximum fiber strain of 16,000 pounds per square inch.

NOTE.—Use spans above horizontal black line for plastered ceilings.

SAFE LOADS IN TONS OF 2000 POUNDS

Uniformly Distributed, for Jones & Laughlin Steel Co.'s Steel Beams

DISTANCE IN FEET BETWEEN SUPPORTS	8-INCH BEAM, STANDARD					7-INCH BEAM, STANDARD			
	25½ Pounds	23 Pounds	20½ Pounds	18 Pounds	Deflection Inches	20 Pounds	17½ Pounds	15 Pounds	Deflection Inches
5	18.31	17.26	16.21	15.17		12.87	11.95	11.04	
6	15.26	14.38	13.51	12.64	.08	10.73	9.96	9.20	.09
7	13.08	12.33	11.58	10.83	.10	9.19	8.53	7.89	.12
8	11.44	10.79	10.13	9.48	.14	8.04	7.47	6.90	.16
9	10.17	9.59	9.01	8.43	.17	7.15	6.64	6.13	.20
10	9.15	8.63	8.11	7.58	.21	6.44	5.98	5.52	.24
11	8.32	7.85	7.37	6.89	.26	5.85	5.43	5.02	.30
12	7.63	7.19	6.76	6.32	.31	5.36	4.98	4.60	.35
13	7.04	6.64	6.24	5.83	.36	4.95	4.60	4.25	.41
14	6.54	6.16	5.79	5.42	.42	4.60	4.26	3.94	.48
15	6.10	5.75	5.40	5.06	.48	4.29	3.99	3.68	.55
16	5.72	5.39	5.07	4.74	.55	4.02	3.74	3.45	.63
17	5.38	5.08	4.76	4.46	.62				
18	5.08	4.79	4.50	4.21	.69				

Safe load includes weight of beam. Maximum fiber strain of 16,000 pounds per square inch.

NOTE.—Use spans above horizontal black line for plastered ceilings.

SAFE LOADS IN TONS OF 2000 POUNDS

Uniformly Distributed, for Jones & Laughlin Steel Co.'s
Steel Beams

DISTANCE IN FEET BETWEEN SUPPORTS	6-INCH BEAM, STANDARD				5-INCH BEAM, STANDARD			
	17 $\frac{3}{4}$ Pounds	14 $\frac{3}{4}$ Pounds	12 $\frac{1}{4}$ Pounds	Deflection Inches	14 $\frac{3}{4}$ Pounds	12 $\frac{1}{4}$ Pounds	9 $\frac{3}{4}$ Pounds	Deflection Inches
5	9.31	8.53	7.74		6.47	5.81	5.16	.09
6	7.76	7.11	6.45	.10	5.39	4.84	4.30	.12
7	6.65	6.09	5.53	.14	4.62	4.15	3.68	.17
8	5.82	5.33	4.84	.18	4.04	3.63	3.22	.22
9	5.17	4.74	4.30	.23	3.59	3.23	2.87	.28
10	4.66	4.26	3.87	.29	3.23	2.91	2.58	.34
11	4.23	3.88	3.52	.35	2.94	2.64	2.34	.41
12	3.88	3.55	3.23	.41	2.69	2.42	2.15	.49
13	3.58	3.28	2.98	.48				
14	3.33	3.05	2.77	.56				
15	3.10	2.84	2.58	.64				
16	2.91	2.66	2.42	.73				

Safe load includes weight of beam. Maximum fiber strain of 16,000 pounds per square inch.

NOTE.—Use spans above horizontal black line for plastered ceilings.

SAFE LOADS IN TONS OF 2000 POUNDS

Uniformly Distributed, for Jones & Laughlin Steel Co.'s
Steel Beams

DISTANCE IN FEET BETWEEN SUPPORTS	4-INCH BEAM, STANDARD					3-INCH BEAM, STANDARD			
	10½ Pounds	9½ Pounds	8½ Pounds	7½ Pounds	Deflection Inches	7½ Pounds	6½ Pounds	5½ Pounds	Deflection Inches
5	3.81	3.60	3.39	3.18	.11	2.08	1.92	1.76	.14
6	3.17	3.00	2.82	2.65	.15	1.73	1.60	1.47	.21
7	2.72	2.57	2.42	2.27	.21	1.49	1.39	1.26	.28
8	2.38	2.25	2.12	1.99	.27	1.30	1.20	1.10	.37
9	2.12	2.00	1.88	1.77	.35				
10	1.90	1.80	1.70	1.59	.43				

Safe load includes weight of beam. Maximum fiber strain of 16,000 pounds per square inch.

NOTE.—Use spans above horizontal black line for plastered ceilings.

SAFE LOADS IN TONS OF 2000 POUNDS
 Uniformly Distributed, for Jones & Laughlin Steel Co.'s
 Steel Channels

DISTANCE IN FEET BETWEEN SUPPORTS	15-INCH CHANNEL, STANDARD					
	55 Pounds	50 Pounds	45 Pounds	40 Pounds	35 Pounds	33 Pounds
10	30.85	28.80	26.93	24.97	23.01	22.22
11	28.05	26.27	24.48	22.70	20.92	20.20
12	25.71	24.08	22.44	20.81	19.17	18.52
13	23.73	22.22	20.72	19.21	17.70	17.10
14	22.04	20.64	19.24	17.84	16.44	15.87
15	20.57	19.26	17.96	16.65	15.34	14.82
16	19.28	18.06	16.83	15.61	14.38	13.89
17	18.15	16.99	15.84	14.69	13.53	13.07
18	17.14	16.05	14.96	13.87	12.78	12.35
19	16.24	15.21	14.17	13.14	12.11	11.69
20	15.43	14.45	13.47	12.48	11.50	11.11
21	14.69	13.76	12.82	11.89	10.96	10.58
22	14.02	13.13	12.24	11.35	10.46	10.10
23	13.41	12.56	11.71	10.86	10.00	9.66
24	12.86	12.04	11.22	10.40	9.59	9.26
25	12.34	11.56	10.77	9.99	9.20	8.89
26	11.87	11.11	10.36	9.60	8.85	8.55
27	11.43	10.70	9.97	9.25	8.52	8.23
28	11.02	10.32	9.62	8.92	8.22	7.94
29	10.64	9.96	9.29	8.61	7.93	7.66
30	10.28	9.63	8.98	8.32	7.67	7.41

Safe load includes weight of channel. Maximum fiber strain of 16,000 pounds per square inch.

NOTE.—Use spans above horizontal black line for plastered ceilings.

SAFE LOADS IN TONS OF 2000 POUNDS
 Uniformly Distributed, for Jones & Laughlin Steel Co.'s
 Steel Channels

DISTANCE IN FEET BETWEEN SUPPORTS	12-INCH CHANNEL, STANDARD				
	40 Pounds	35 Pounds	30 Pounds	25 Pounds	20½ Pounds
10	17.50	15.93	14.36	12.80	11.38
11	15.91	14.49	13.06	11.64	10.35
12	14.59	13.28	11.97	10.67	9.48
13	13.46	12.25	11.05	9.85	8.76
14	12.50	11.38	10.26	9.14	8.13
15	11.67	10.62	9.58	8.53	7.59
16	10.94	9.96	8.98	8.00	7.12
17	10.30	9.37	8.45	7.53	6.69
18	9.72	8.85	7.98	7.11	6.33
19	9.21	8.39	7.56	6.74	5.99
20	8.75	7.97	7.18	6.40	5.69
21	8.34	7.59	6.84	6.09	5.42
22	7.96	7.24	6.53	5.82	5.18
23	7.61	6.93	6.25	5.56	4.95
24	7.29	6.64	5.99	5.33	4.74
25	7.00	6.37	5.75	5.12	4.55
26	6.73	6.13	5.53	4.92	4.38
27	6.48	5.90	5.32	4.74	4.22
28	6.25	5.69	5.13	4.57	4.07
29	6.04	5.49	4.95	4.41	3.92
30	5.83	5.31	4.79	4.27	3.79

Safe load includes weight of channel. Maximum fiber strain of 16,000 pounds per square inch.

NOTE.—Use spans above horizontal black line for plastered ceilings.

SAFE LOADS IN TONS OF 2000 POUNDS

Uniformly Distributed, for Jones & Laughlin Steel Co.'s
Steel Channels

DISTANCE IN FEET BETWEEN SUPPORTS	10-INCH CHANNEL, STANDARD				
	35 Pounds	30 Pounds	25 Pounds	20 Pounds	15 Pounds
10	12.36	11.06	9.75	8.44	7.13
11	11.24	10.05	8.86	7.67	6.49
12	10.30	9.21	8.12	7.03	5.94
13	9.51	8.50	7.50	6.49	5.49
14	8.83	7.90	6.96	6.03	5.10
15	8.24	7.37	6.50	5.63	4.75
16	7.73	6.91	6.09	5.28	4.46
17	7.27	6.50	5.73	4.97	4.20
18	6.87	6.14	5.42	4.69	3.96
19	6.51	5.82	5.14	4.44	3.75
20	6.18	5.53	4.87	4.22	3.57
21	5.89	5.26	4.64	4.02	3.44
22	5.62	5.03	4.43	3.84	3.24
23	5.37	4.81	4.24	3.67	3.10
24	5.15	4.61	4.06	3.52	2.97
25	4.95	4.42	3.90	3.38	2.85

Safe load includes weight of channel. Maximum fiber strain of 16,000 pounds per square inch.

NOTE.—Use spans above horizontal black line for plastered ceilings.

SAFE LOADS IN TONS OF 2000 POUNDS

Uniformly Distributed, for Jones & Laughlin Steel Co.'s
Steel Channels

DISTANCE IN FEET BETWEEN SUPPORTS	9-INCH CHANNEL, STANDARD			
	25 Pounds	20 Pounds	15 Pounds	13¼ Pounds
10	8.37	7.20	6.02	5.61
11	7.61	6.54	5.47	5.10
12	6.98	6.00	5.02	4.67
13	6.44	5.54	4.63	4.31
14	5.98	5.14	4.30	4.01
15	5.58	4.80	4.01	3.74
16	5.23	4.50	3.76	3.51
17	4.92	4.23	3.54	3.30
18	4.65	4.00	3.34	3.12
19	4.41	3.79	3.17	2.95
20	4.19	3.60	3.01	2.80
21	3.99	3.43	2.87	2.67

Safe load includes weight of channel. Maximum fiber strain of 16,000 pounds per square inch

NOTE.—Use spans above horizontal black line for plastered ceilings.

SAFE LOADS IN TONS OF 2000 POUNDS

Uniformly Distributed, for Jones & Laughlin Steel Co.'s
Steel Channels

DISTANCE IN FEET BETWEEN SUPPORTS	8-INCH CHANNEL, STANDARD				
	21¼ Pounds	18¾ Pounds	16¼ Pounds	13¾ Pounds	11¼ Pounds
10	6.40	5.88	5.35	4.83	4.32
11	5.82	5.34	4.87	4.39	3.93
12	5.33	4.90	4.46	4.03	3.60
13	4.92	4.52	4.12	3.72	3.32
14	4.57	4.20	3.82	3.45	3.08
15	4.27	3.92	3.57	3.22	2.88
16	4.00	3.67	3.35	3.02	2.70
17	3.76	3.46	3.15	2.84	2.54
18	3.56	3.28	2.97	2.68	2.40

Safe load includes weight of channel. Maximum fiber strain of 16,000 pounds per square inch.

NOTE.—Use spans above horizontal black line for plastered ceilings.

SAFE LOADS IN TONS OF 2000 POUNDS

Uniformly Distributed, for Jones & Laughlin Steel Co.'s Steel Channels

DISTANCE IN FEET BETWEEN SUPPORTS	7-INCH CHANNEL, STANDARD				
	19 $\frac{3}{4}$ Pounds	17 $\frac{1}{4}$ Pounds	14 $\frac{3}{4}$ Pounds	12 $\frac{1}{4}$ Pounds	9 $\frac{3}{4}$ Pounds
5	10.09	9.17	8.26	7.35	6.43
6	8.41	7.64	6.88	6.12	5.36
7	7.20	6.55	5.90	5.25	4.59
8	6.30	5.73	5.16	4.59	4.02
9	5.61	5.10	4.59	4.08	3.57
10	5.04	4.59	4.13	3.67	3.22
11	4.58	4.17	3.75	3.34	2.92
12	4.20	3.82	3.44	3.06	2.68
13	3.88	3.53	3.18	2.82	2.47
14	3.60	3.27	2.95	2.62	2.29
15	3.36	3.06	2.75	2.45	2.14
16	3.15	2.86	2.58	2.29	2.01

Safe load includes weight of channel. Maximum fiber strain of 16,000 pounds per square inch.

NOTE.—Use spans above horizontal black line for plastered ceilings.

SAFE LOADS IN TONS OF 2000 POUNDS
 Uniformly Distributed, for Jones & Laughlin Steel Co.'s
 Steel Channels

DISTANCE IN FEET BETWEEN SUPPORTS	6-INCH CHANNEL, STANDARD				5-INCH CHANNEL, STANDARD		
	15½ Pounds	13 Pounds	10½ Pounds	8 Pounds	11½ Pounds	9 Pounds	6½ Pounds
5	6.97	6.19	5.41	4.62	4.47	3.82	3.16
6	5.81	5.16	4.50	3.85	3.73	3.18	2.64
7	4.98	4.42	3.86	3.30	3.19	2.73	2.26
8	4.36	3.87	3.38	2.89	2.79	2.39	1.98
9	3.87	3.44	3.00	2.57	2.48	2.12	1.76
10	3.49	3.09	2.73	2.31	2.23	1.92	1.58
11	3.17	2.81	2.45	2.10	2.03	1.75	1.44
12	2.91	2.58	2.25	1.93	1.86	1.59	1.32
13	2.68	2.38	2.08	1.78			
14	2.49	2.21	1.93	1.65			
15	2.32	2.06	1.80	1.54			
16	2.18	1.93	1.69	1.44			

Safe load includes weight of channel. Maximum fiber strain of 16,000 pounds per square inch.

NOTE.—Use spans above horizontal black line for plastered ceilings.

SAFE LOADS IN TONS OF 2000 POUNDS
 Uniformly Distributed, for Jones & Laughlin Steel Co's.
 Steel Channels

DISTANCE IN FEET BETWEEN SUPPORTS	4-INCH CHANNEL STANDARD			3-INCH CHANNEL STANDARD		
	7¼ Pounds	6¼ Pounds	5¼ Pounds	6 Pounds	5 Pounds	4 Pounds
5	2.44	2.23	2.02	1.48	1.32	1.16
6	2.04	1.86	1.69	1.23	1.10	.97
7	1.74	1.59	1.44	1.06	.94	.83
8	1.53	1.39	1.26	.92	.82	.73
9	1.36	1.24	1.12			
10	1.22	1.12	1.01			

Safe load includes weight of channel. Maximum fiber strain of 16,000 pounds per square inch.

NOTE.—Use spans above horizontal black line for plastered ceilings.

SAFE LOADS IN TONS OF 2000 POUNDS
 Uniformly Distributed, for Jones & Laughlin Steel Co's.
 Angles with Equal Legs

.SIZE OF ANGLE	DISTANCE BETWEEN SUPPORTS IN FEET									
	1	2	3	4	5	6	7	8	9	10
8 × 8 × 1/2	44.64	22.32	14.88	11.16	8.93	7.44	6.38	5.58	4.96	4.46
8 × 8 × 1 1/8	93.49	46.74	31.16	23.37	18.70	15.58	13.36	11.69	10.39	9.35
6 × 6 × 7/16	21.71	10.85	7.24	5.43	4.34	3.62	3.10	2.71	2.41	2.17
6 × 6 × 7/8	40.75	20.37	13.58	10.18	8.15	6.79	5.82	5.09	4.53	4.08
5 × 5 × 1 1/2	11.84	5.92	3.95	2.96	2.37	1.97	1.69	1.48	1.32	1.18
5 × 5 × 3/4	24.11	12.05	8.04	6.03	4.82	4.02	3.44	3.01	2.68	2.41
4 × 4 × 3/8	8.11	4.05	2.70	2.03	1.62	1.35	1.16	1.01	0.90	0.81
4 × 4 × 3/4	14.99	7.49	5.00	3.75	3.00	2.50	2.14	1.87	1.67	1.50
3 1/2 × 3 1/2 × 3/8	6.13	3.07	2.04	1.53	1.23	1.02	0.88	0.77	0.68	0.61
3 1/2 × 3 1/2 × 3/4	10.83	5.41	3.61	2.71	2.17	1.81	1.55	1.35	1.20	1.08
3 1/4 × 3 1/4 × 3/8	5.28	2.64	1.76	1.32	1.05	0.88	0.75	0.66	0.59	0.53
3 1/4 × 3 1/4 × 3/4	7.25	3.62	2.42	1.81	1.45	1.21	1.04	0.91	0.81	0.73
3 × 3 × 1/4	3.09	1.54	1.03	0.77	0.62	0.51	0.44	0.39	0.34	0.31
3 × 3 × 5/8	6.93	3.47	2.31	1.73	1.39	1.16	0.99	0.87	0.77	0.69
2 3/4 × 2 3/4 × 1/4	2.56	1.28	0.85	0.64	0.51	0.43	0.37	0.32	0.28	0.26
2 3/4 × 2 3/4 × 1/2	4.75	2.37	1.58	1.19	0.95	0.79	0.68	0.59	0.53	0.48
2 1/2 × 2 1/2 × 1/4	2.13	1.07	0.71	0.53	0.43	0.36	0.30	0.27	0.24	0.21
2 1/2 × 2 1/2 × 1/2	3.89	1.94	1.30	0.97	0.78	0.65	0.56	0.49	0.43	0.39
2 1/4 × 2 1/4 × 1/4	1.71	0.85	0.57	0.43	0.34	0.29	0.24	0.21	0.19	0.17
2 1/4 × 2 1/4 × 1/2	3.09	1.54	1.03	0.77	0.62	0.52	0.44	0.39	0.34	0.31
2 × 2 × 1/8	0.80	0.40	0.27	0.20	0.16	0.13	0.11	0.10	0.09	0.08
2 × 2 × 7/16	2.13	1.06	0.71	0.53	0.43	0.36	0.30	0.27	0.24	0.21
1 3/4 × 1 3/4 × 1/8	0.59	0.30	0.20	0.15	0.12	0.10	0.08	0.07	0.07	0.06
1 3/4 × 1 3/4 × 7/16	1.60	0.80	0.53	0.40	0.32	0.27	0.23	0.20	0.18	0.16
1 1/2 × 1 1/2 × 1/8	0.41	0.21	0.14	0.10	0.08	0.07	0.06	0.05	0.05	0.04
1 1/2 × 1 1/2 × 3/8	1.03	0.52	0.34	0.26	0.21	0.17	0.15	0.13	0.11	0.10
1 1/4 × 1 1/4 × 1/8	0.27	0.135	0.090	0.067	0.054	0.045	0.039	0.034	0.030	0.027
1 1/4 × 1 1/4 × 1/4	0.48	0.24	0.16	0.12	0.096	0.080	0.069	0.060	0.053	0.048
1 × 1 × 1/8	0.17	0.085	0.057	0.042	0.034	0.028	0.024	0.021	0.019	0.017
1 × 1 × 3/16	0.23	0.115	0.077	0.057	0.046	0.038	0.033	0.029	0.025	0.023
3/4 × 3/4 × 1/8	0.09	0.045	0.030	0.022	0.018	0.015	0.013	0.011	0.010	0.009
3/4 × 3/4 × 3/16	0.127	0.063	0.042	0.032	0.025	0.021	0.018	0.016	0.014	0.013

Safe loads include weight of angle. Maximum fiber strain of 16,000 pounds per square inch. Neutral axis through center of gravity parallel to one leg.

For safe loads to the right of heavy line the deflection will be greater than allowable for plastered ceiling. Limit for 8 x 8-inch L, 23 feet; for 6 x 6-inch L, 17 feet; for 5 x 5-inch L, 13 feet; for 4 x 4-inch L, 11 feet.

SAFE LOADS IN TONS OF 2000 POUNDS
 Uniformly Distributed, for Jones & Laughlin Steel Co's.
 Angles with Unequal Legs

Long Leg Vertical

SIZE OF ANGLE	DISTANCE BETWEEN SUPPORTS IN FEET									
	1	2	3	4	5	6	7	8	9	10
6 × 4 × 3/8	17.71	8.85	5.91	4.43	3.55	2.95	2.53	2.21	1.96	1.77
6 × 4 × 1/2	35.47	17.73	11.83	8.87	7.09	5.91	5.07	4.44	3.95	3.55
6 × 3 1/2 × 3/8	17.33	8.67	5.77	4.33	3.47	2.89	2.48	2.17	1.92	1.73
6 × 3 1/2 × 1/2	33.07	16.53	11.03	8.27	6.61	5.51	4.72	4.13	3.68	3.31
5 × 4 × 3/8	12.53	6.27	4.17	3.13	2.51	2.09	1.79	1.57	1.39	1.25
5 × 4 × 1/2	22.99	11.49	7.67	5.75	4.60	3.83	3.28	2.88	2.56	2.29
5 × 3 1/2 × 3/8	12.21	6.11	4.07	3.05	2.44	2.04	1.75	1.53	1.36	1.23
5 × 3 1/2 × 1/2	22.51	11.25	7.51	5.63	4.51	3.75	3.21	2.81	2.51	2.25
5 × 3 × 3/8	11.89	5.95	3.96	2.97	2.37	1.99	1.69	1.49	1.32	1.19
5 × 3 × 1/2	22.03	11.01	7.35	5.51	4.40	3.67	3.15	2.76	2.45	2.20
4 1/2 × 3 × 5/16	8.21	4.11	2.74	2.05	1.64	1.37	1.17	1.03	0.91	0.82
4 1/2 × 3 × 1/8	19.31	9.65	6.44	4.83	3.86	3.22	2.76	2.41	2.15	1.93
4 × 3 1/2 × 3/8	8.00	4.00	2.66	2.00	1.60	1.33	1.15	1.00	0.90	0.80
4 × 3 1/2 × 1/2	14.56	7.28	4.85	3.64	2.91	2.43	2.08	1.83	1.61	1.45
4 × 3 × 3/8	7.63	3.81	2.55	1.91	1.52	1.27	1.09	0.96	0.85	0.76
4 × 3 × 1/2	14.19	7.09	4.73	3.55	2.84	2.36	2.03	1.77	1.57	1.41
3 1/2 × 3 × 3/8	5.81	2.91	1.93	1.45	1.16	0.97	0.83	0.73	0.64	0.59
3 1/2 × 3 × 1/2	10.83	5.41	3.61	2.71	2.16	1.80	1.55	1.36	1.20	1.08
3 1/2 × 2 1/2 × 1/4	4.00	2.00	1.33	1.00	0.80	0.66	0.57	0.51	0.44	0.40
3 1/2 × 2 1/2 × 1/2	7.79	3.89	2.60	1.95	1.56	1.29	1.11	0.97	0.87	0.77
3 × 2 1/2 × 1/4	2.99	1.49	1.00	0.75	0.60	0.50	0.43	0.38	0.33	0.29
3 × 2 1/2 × 1/2	5.49	2.75	1.83	1.37	1.10	0.92	0.79	0.69	0.61	0.55
3 1/4 × 2 × 1/4	2.72	1.36	0.91	0.68	0.55	0.45	0.39	0.35	0.31	0.27
3 1/4 × 2 × 1/2	6.19	3.09	2.07	1.55	1.24	1.03	0.88	0.77	0.64	0.61
3 × 2 × 3/16	1.75	0.87	0.58	0.44	0.35	0.29	0.25	0.22	0.19	0.17
3 × 2 × 1/2	5.33	2.66	1.77	1.33	1.07	0.89	0.76	0.67	0.59	0.53
2 1/2 × 2 × 3/16	1.55	0.77	0.52	0.39	0.31	0.25	0.22	0.19	0.17	0.16
2 1/2 × 2 × 1/2	3.79	1.89	1.26	0.95	0.76	0.63	0.54	0.47	0.42	0.38
1 3/4 × 1 1/8 × 5/16	1.11	0.56	0.37	0.28	0.22	0.19	0.16	0.14	0.12	0.11
1 3/8 × 7/8 × 1/8	0.35	0.15	0.10	0.08	0.06	0.05	0.04	0.04	0.03	0.03
1 × 5/8 × 1/8	0.12	0.08	0.05	0.04	0.03	0.03	0.02	0.02	0.02	0.02

Safe loads include weight of angle. Maximum fiber strain of 16,000 pounds per square inch. Neutral axis through center of gravity parallel to short leg.

See notes on page 106.

SAFE LOADS IN TONS OF 2000 POUNDS
Uniformly Distributed, for Jones & Laughlin Steel Co's.
Angles with Unequal Legs

Short Leg Vertical

SIZE OF ANGLE	DISTANCE BETWEEN SUPPORTS IN FEET									
	1	2	3	4	5	6	7	8	9	10
6 × 4 × $\frac{3}{8}$	8.53	4.27	2.84	2.13	1.71	1.43	1.22	1.07	0.95	0.85
6 × 4 × $\frac{1}{2}$	16.80	8.40	5.60	4.20	3.36	2.80	2.40	2.10	1.87	1.68
6 × 3½ × $\frac{3}{8}$	6.56	3.28	2.19	1.64	1.31	1.09	0.94	0.82	0.73	0.66
6 × 3½ × $\frac{1}{2}$	12.85	6.43	4.28	3.21	2.57	2.14	1.84	1.61	1.43	1.28
5 × 4 × $\frac{3}{8}$	8.37	4.19	2.79	2.09	1.68	1.40	1.20	1.05	0.93	0.84
5 × 4 × $\frac{1}{2}$	15.25	7.63	5.08	3.81	3.05	2.54	2.18	1.91	1.69	1.52
5 × 3½ × $\frac{3}{8}$	6.40	3.20	2.13	1.60	1.28	1.07	0.92	0.80	0.71	0.64
5 × 3½ × $\frac{1}{2}$	11.63	5.81	3.88	2.91	2.32	1.94	1.66	1.45	1.29	1.16
5 × 3 × $\frac{3}{8}$	4.75	2.37	1.59	1.19	0.95	0.79	0.68	0.60	0.53	0.48
5 × 3 × $\frac{1}{2}$	8.59	4.29	2.87	2.15	1.72	1.43	1.23	1.08	0.96	0.86
4½ × 3 × $\frac{5}{16}$	4.05	2.03	1.35	1.01	0.81	0.68	0.58	0.51	0.45	0.41
4½ × 3 × $\frac{3}{8}$	9.12	4.56	3.04	2.28	1.82	1.52	1.30	1.14	1.01	0.91
4 × 3½ × $\frac{3}{8}$	6.29	3.15	2.09	1.57	1.25	1.05	0.90	0.79	0.70	0.63
4 × 3½ × $\frac{1}{2}$	11.36	5.68	3.79	2.84	2.27	1.89	1.62	1.42	1.27	1.14
4 × 3 × $\frac{3}{8}$	4.53	2.27	1.51	1.13	0.91	0.76	0.65	0.57	0.50	0.45
4 × 3 × $\frac{1}{2}$	8.32	4.16	2.77	2.08	1.67	1.39	1.19	1.04	0.92	0.83
3½ × 3 × $\frac{3}{8}$	4.43	2.21	1.48	1.11	0.88	0.74	0.63	0.56	0.49	0.44
3½ × 3 × $\frac{1}{2}$	8.11	4.05	2.70	2.03	1.62	1.35	1.16	1.01	0.90	0.81
3½ × 2½ × $\frac{1}{4}$	2.19	1.09	0.73	0.55	0.44	0.36	0.31	0.28	0.24	0.22
3½ × 2½ × $\frac{1}{2}$	4.32	2.16	1.44	1.08	0.87	0.72	0.62	0.54	0.48	0.43
3 × 2½ × $\frac{1}{4}$	2.13	1.07	0.71	0.53	0.43	0.36	0.32	0.27	0.24	0.21
3 × 2½ × $\frac{1}{2}$	3.89	1.95	1.29	0.97	0.78	0.65	0.56	0.49	0.43	0.39
3¼ × 2 × $\frac{1}{4}$	1.12	0.56	0.37	0.28	0.23	0.19	0.16	0.14	0.12	0.11
3¼ × 2 × $\frac{1}{2}$	2.56	1.28	0.85	0.64	0.51	0.43	0.36	0.32	0.28	0.26
3 × 2 × $\frac{3}{16}$	1.07	0.53	0.36	0.27	0.21	0.18	0.15	0.13	0.12	0.11
3 × 2 × $\frac{1}{2}$	2.51	1.25	0.84	0.63	0.50	0.42	0.36	0.32	0.28	0.25
2½ × 2 × $\frac{3}{16}$	1.01	0.51	0.33	0.25	0.20	0.17	0.15	0.13	0.11	0.10
2½ × 2 × $\frac{1}{2}$	2.49	1.25	0.83	0.62	0.50	0.41	0.36	0.31	0.28	0.25
1¾ × 1½ × $\frac{5}{16}$	0.49	0.25	0.16	0.12	0.10	0.08	0.07	0.06	0.05	0.05
1¾ × 1½ × $\frac{3}{8}$	0.13	0.07	0.04	0.03	0.03	0.02	0.02	0.02	0.02	0.01
1 × ¾ × $\frac{1}{8}$	0.064	0.032	0.021	0.016	0.013	0.011	0.009	0.008	0.007	0.006

Safe loads include weight of angle. Maximum fiber strain of 16,000 pounds per square inch. Neutral axis through center of gravity parallel to long leg.

See notes on page 106.

SAFE LOADS IN TONS OF 2000 POUNDS
 Uniformly Distributed, for Jones & Laughlin Steel Co's.
 Tees

SECTION No.	SIZE FLANGE BY STEM	DISTANCE BETWEEN SUPPORTS IN FEET									
		1	2	3	4	5	6	7	8	9	10
T 1	4 × 4	11.67	5.83	3.89	2.92	2.33	1.95	1.67	1.45	1.29	1.17
T 2	4 × 4	10.28	5.15	3.43	2.57	2.05	1.72	1.47	1.28	1.15	1.03
T31	5 × 2½	4.59	2.29	1.53	1.15	0.92	0.76	0.66	0.57	0.51	0.46
T29	3½ × 4	8.27	4.13	2.76	2.07	1.65	1.37	1.19	1.04	0.92	0.83
T33	4½ × 3	4.32	2.16	1.44	1.08	0.86	0.72	0.62	0.54	0.48	0.43
T30	3½ × 4	10.56	5.28	3.52	2.64	2.11	1.76	1.51	1.32	1.17	1.05
T 3	3½ × 3½	7.37	3.69	2.45	1.84	1.48	1.23	1.05	0.92	0.81	0.74
T 4	3½ × 3½	6.39	3.19	2.13	1.60	1.28	1.07	0.92	0.80	0.71	0.64
T23	3½ × 3	5.45	2.72	1.81	1.36	1.09	0.91	0.77	0.68	0.60	0.55
T24	3½ × 3	4.72	2.36	1.57	1.18	0.95	0.79	0.68	0.59	0.52	0.47
T26	3 × 3½	7.19	3.59	2.40	1.80	1.44	1.20	1.03	0.89	0.80	0.72
T25	3 × 3½	6.23	3.11	2.08	1.56	1.24	1.04	0.89	0.78	0.69	0.63
T 5	3 × 3	4.77	2.39	1.59	1.20	0.96	0.80	0.68	0.60	0.53	0.48
T 6	3 × 3	4.11	2.05	1.37	1.03	0.83	0.68	0.59	0.51	0.45	0.41
T32	3 × 3	3.30	1.65	1.10	0.82	0.66	0.55	0.47	0.41	0.37	0.33
T 7	2½ × 2½	3.25	1.63	1.08	0.81	0.65	0.55	0.47	0.40	0.36	0.32
T 8	2½ × 2½	2.79	1.39	0.93	0.69	0.56	0.47	0.40	0.35	0.31	0.28
T28	2½ × 2	1.69	0.85	0.56	0.42	0.33	0.28	0.24	0.21	0.19	0.17
T 9	2¼ × 2¼	2.13	1.07	0.71	0.53	0.43	0.36	0.31	0.27	0.24	0.21
T10	2¼ × 2¼	1.75	0.87	0.59	0.44	0.35	0.29	0.25	0.21	0.20	0.17
T11	2 × 2	1.36	0.68	0.45	0.34	0.27	0.23	0.20	0.17	0.15	0.14
T27	2½ × 1¾	1.03	0.52	0.35	0.26	0.20	0.17	0.15	0.13	0.12	0.10
T13	1¾ × 1¾	1.03	0.51	0.35	0.26	0.20	0.17	0.15	0.13	0.12	0.10
T12	1¾ × 1¾	0.68	0.34	0.23	0.17	0.13	0.12	0.09	0.08	0.08	0.07
T14	1½ × 1½	0.73	0.37	0.24	0.19	0.15	0.12	0.11	0.09	0.08	0.07
T15	1½ × 1½	0.61	0.31	0.20	0.15	0.12	0.11	0.09	0.08	0.07	0.06
T16	1¼ × 1¼	0.52	0.26	0.17	0.13	0.11	0.09	0.08	0.07	0.06	0.05
T17	1¼ × 1¼	0.39	0.20	0.13	0.10	0.08	0.07	0.05	0.05	0.04	0.04
T18	1 × 1	0.25	0.13	0.08	0.07	0.05	0.04	0.04	0.03	0.03	0.03
T19	1 × 1	0.19	0.09	0.06	0.05	0.04	0.03	0.03	0.03	0.02	0.02

Safe loads include weight of tees. Maximum fiber strain, 16,000 pounds per square inch.

For safe loads to the right of heavy lines the deflection will be greater than allowable for plastered ceilings.

SAFE LOADS IN TONS OF 2000 POUNDS

Uniformly Distributed, for Jones & Laughlin Steel Co.'s
Steel Z Bars

SECTION No.	SIZE, INCHES	THICKNESS OF METAL INCHES	DISTANCE BETWEEN SUPPORTS, FEET									
			4	5	6	7	8	9	10	12	14	16
Z4	3	$\frac{1}{4}$	2.56	2.05	1.71	1.46	1.28	1.14	1.02	0.85	0.73	0.64
	$3\frac{1}{16}$	$\frac{5}{8}$	3.17	2.54	2.12	1.81	1.59	1.41	1.27	1.06	0.91	0.70
	$3\frac{1}{8}$	$\frac{3}{8}$	3.77	3.02	2.51	2.16	1.88	1.68	1.51	1.26	1.08	0.94
Z8	$2\frac{15}{16}$	$\frac{7}{16}$	3.57	2.86	2.38	2.04	1.79	1.59	1.43	1.19	1.02	0.89
	3	$\frac{1}{2}$	4.08	3.26	2.72	2.33	2.04	1.81	1.63	1.36	1.16	1.02
	$3\frac{1}{16}$	$\frac{9}{16}$	4.57	3.66	3.05	2.61	2.29	2.03	1.83	1.52	1.31	1.14
	$3\frac{1}{8}$	$\frac{5}{8}$	5.08	4.05	3.39	2.90	2.54	2.26	2.03	1.69	1.45	1.27
Z9	3	$\frac{3}{16}$	1.24	0.99	0.82	0.71	0.62	0.55	0.50	0.41	0.36	0.31

Safe loads include weight of Z bar. Maximum fiber stress, 16,000 pounds per square inch.

CORRUGATED SHEETS.—(Not Manufactured by Jones & Laughlin Steel Co.)

NOTE.—Allowing a lap of one and one-half corrugations, one sheet will cover 24 inches.

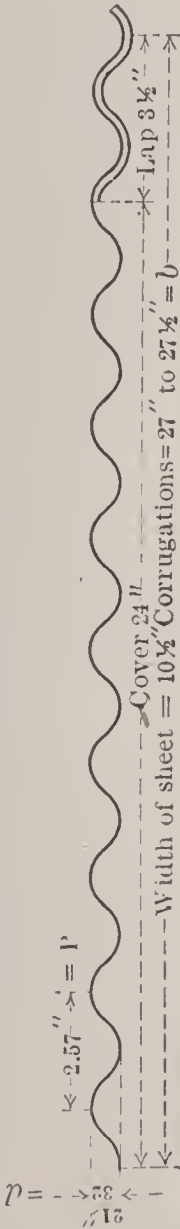

No. by Birmingham Gauge	Thickness in Inches = t	Weights of Sheets Black				Weights of Sheets Galvanized			Weight per square of 100 square feet of corrugated sheets (black) when laid, allowing 6-inch lap in length and 3 1/2 inches or 1 1/2 corrugations in width of sheet for sheet length of :											
		Per Sq. Ft. Corrugated	Per Sq. Ft. Corrugated and Painted	Per Lin. Ft. of Sheet Painted	Per Sq. Ft. Flat	Per Sq. Ft. Corrugated	Per Lin. Ft. of Sheet	5'	6'	7'	8'	9'	10'	5'	6'	7'	8'	9'	10'	
16	.065	2.65	2.95	3.02	6.95	2.99	3.32	7.64	370	364	359	357	353	351	379	374	368	366	362	360
18	.049	2.00	2.22	2.29	5.27	2.34	2.60	5.98	279	274	271	269	266	265	288	283	280	278	275	274
20	.035	1.43	1.59	1.66	3.82	1.77	1.96	4.51	200	196	194	192	190	189	209	205	203	201	199	198
22	.028	1.14	1.27	1.34	3.08	1.48	1.64	3.77	160	157	155	154	152	151	169	166	164	163	161	160
24	.022	0.90	1.00	1.07	2.46	1.24	1.38	3.17	126	124	122	121	120	119	135	133	131	130	129	128
26	.018	0.73	0.81	0.88	2.02	1.07	1.19	2.74	102	100	99	98	97	97	111	109	108	107	106	106

NOTE.—For weights per square laid with two laps, add to above five per cent.

Sheets are 30 1/2 inches wide before, and 27 to 27 1/2 inches wide after corrugating.
 Sheets can be corrugated any length not exceeding 10 feet.
 It is not advisable to use over six feet clear spans on roofs.

L = Unsupported length of sheet in inches.
 t = Thickness of sheet in inches.
 b = Width of sheet in inches.
 d = Depth of corrugations in inches.
 W = Breaking weight distributed in pounds.

$$W = \frac{99900tb}{L}$$
 Safe loads per sheet between supports = $\frac{W}{4}$

Use of Tables on the Properties of Rolled Shapes

(Pages 118 to 139.)

These tables afford a ready means of determining the safe uniformly distributed load a particular shape will sustain, by making one division only.

Refer to columns headed "Coefficient of Strength" C and C' and divide the numbers therein found by the length of span measured between centers of bearings. The first column gives safe uniformly distributed loads with fiber stress at 16,000 pounds per square inch. The second with fiber stress at 12,500 pounds for beams and channels and 12,000 pounds for tees and zees.

Referring to 24-inch beam, 80 pounds per foot, in table under C is found 1,855,900 and under C' 1,449,900. If span is thirty feet divide said numbers by 30, giving 61,863 and 48,330 respectively, or the number of pounds uniformly distributed which a 24-inch beam, 80 pounds per foot, will safely support 30 feet between supports, the extreme fibers of beam being stressed 16,000 pounds per square inch in first case and 12,500 pounds in second.

Suppose we wish to know the safe load a tee will support ten feet long, section T-30. We find, page 127, under C and C', 21,160 and 15,870. Dividing same by ten we have 2116 and 1587 pounds, respectively, as safe loads, stressing material 16,000 pounds per square inch in first case and 12,000 pounds in second.

With any complicated system of loading it is only necessary to determine the moment, multiply same by eight and look up nearest number corresponding to this in columns C and C', when proper beam, channel, tee or zee will be indicated.

For example, if a beam is loaded at the center with 10,000 pounds and the span is twenty feet, the reaction at each end of beam is 5000 pounds and eight times the moment or $M=8 \times 10 \times 500=400,000$.

Under column C we find 405,800, which corresponds to a 12-inch 35-pound beam.

Under column C' we find 396,800, which corresponds to a 12-inch, 40-pound beam.

Where two beams or two channels are connected together by latticing or stay plates, column 14 will be useful in spacing them to make radii of gyration equal.

The value of I , I' , r , r' , R , R' will be found convenient in applying the general formulæ on the flexure' of beams of any cross-section, given on page 114, to particular sections.

General Formulas on the Flexure of Beams of any Cross-Section

Let A = area of section, in square inches.

l = length of span, in inches.

W = load, uniformly distributed, in pounds.

M = bending moment, in inch-pounds.

h = height of cross-section, out-to-out, in inches.

n = distance of center of gravity of section, from top or from bottom, in inches.

s = strain per square inch in extreme fibers of beam, either top or bottom, in pounds, according as n relates to distance from top or from bottom of section.

D = maximum deflection, in inches.

I = moment of inertia of section, neutral axis through center of gravity.

I_a = moment of inertia of section, neutral axis parallel to above, but not through center of gravity.

d = distance between these neutral axes.

R = section factor.

r = radius of gyration, in inches.

E = modulus of elasticity (for wrought iron, assume 27,000,000; for steel, 29,000,000).

$$\text{Then: } R = \frac{I}{n} \qquad r = \sqrt{\frac{I}{A}}$$

$$M = \frac{sI}{n} = sR$$

$$s = \frac{Mn}{I} = \frac{M}{R}$$

$$W = \frac{8sI}{ln} = \frac{8s}{l} R$$

$$s = \frac{Wln}{8I} = \frac{Wl}{8R}$$

$$I_a = I + Ad^2$$

$$D = \frac{5Wl^3}{384EI} \text{ for beam supported at both ends and uniformly loaded.}$$

$$D = \frac{Pl^3}{48EI} \text{ for beam supported at both ends and loaded with a single load } P \text{ at middle.}$$

$$D = \frac{Wl^3}{8EI} \text{ for beam fixed at one end and unsupported at the other and uniformly loaded.}$$

$$D = \frac{Pl^3}{3EI} \text{ for beam fixed at one end and unsupported at the other, and loaded with a single load } P \text{ at the latter end.}$$

BENDING MOMENTS AND DEFLECTIONS OF BEAMS UNDER VARIOUS SYSTEMS OF LOADING

W = total load.
 l = length of beam.

- (1) Beam fixed at one end and loaded at the other.

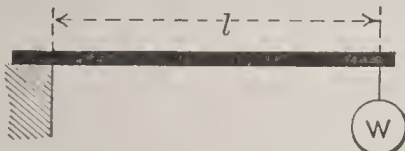

Safe load = $\frac{1}{8}$ that given in tables.
 Maximum bending moment at point of support = Wl .
 Maximum shear at point of support = W .

$$\text{Deflection} = \frac{Wl^3}{3EI}$$

- (3) Beam supported at both ends, single load in the middle.

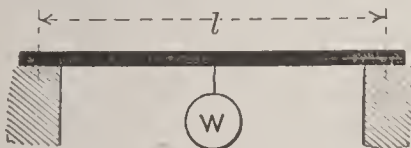

Safe load = $\frac{1}{2}$ that given in tables.
 Maximum bending moment at middle of beam = $\frac{Wl}{4}$

Maximum shear at points of support = $\frac{1}{2}W$.

$$\text{Deflection} = \frac{Wl^3}{48EI}$$

- (5) Beams supported at both ends, single unsymmetrical load.

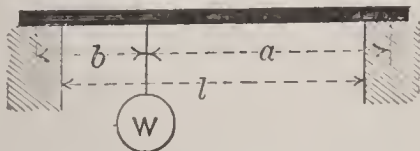

Safe load = that given in tables $\times \frac{l^2}{8ab}$

Maximum bending moment under load = $\frac{Wab}{l}$

Maximum shear: at support near $a = \frac{Wb}{l}$; at other support = $\frac{Wa}{l}$

$$\text{Maximum deflection} = \frac{Wab(2l-a)}{9EI} \sqrt{\frac{1}{3}a(2l-a)}$$

I = moment of inertia.
 E = modulus of elasticity.

- (2) Beam fixed at one end, and uniformly loaded.

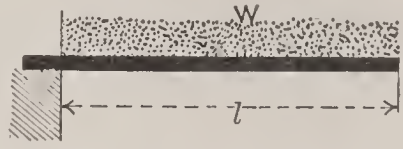

Safe load = $\frac{1}{4}$ that given in tables.
 Maximum bending moment at point of support = $\frac{Wl}{2}$

Maximum shear at point of support = W .

$$\text{Deflection} = \frac{Wl^3}{8EI}$$

- (4) Beam supported at both ends and uniformly loaded.

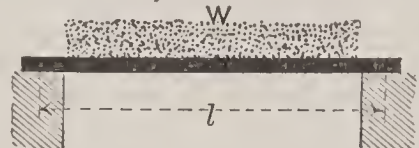

Safe load = that given in tables.
 Maximum bending moment at middle of beam = $\frac{Wl}{8}$

Maximum shear at points of support = $\frac{1}{2}W$.

$$\text{Deflection} = \frac{Wl^3}{768EI}$$

- (6) Beam supported at both ends, two symmetrical loads.

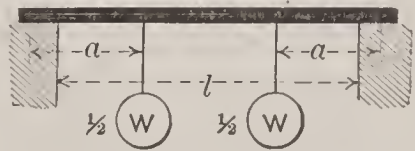

Safe load = that given in tables $\times \frac{l}{4a}$

Maximum bending moment between loads = $\frac{1}{2}Wa$.

Maximum shear between load and nearer support = $\frac{1}{2}W$.

$$\text{Maximum deflection} = \frac{Wa}{48EI} (3l^2 - 4a^2)$$

VALUES OF MOMENTS OF INERTIA

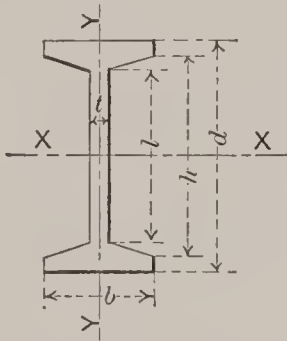

$$I, \text{ axis X-X} = \frac{b d^3 - \frac{1}{4r} (h^4 - t^4)}{12}$$

$$I, \text{ axis Y-Y} = \frac{b^3 (d-h) + l t^3 + \frac{r}{4} (b^4 - t^4)}{12}$$

$$\text{Batter} = r = \frac{h-l}{b-t}$$

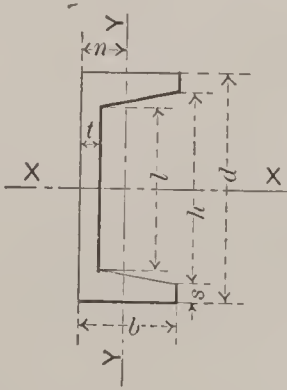

$$I, \text{ axis X-X} = \frac{b d^3 - \frac{1}{8r} (h^4 - t^4)}{12}$$

$$I, \text{ axis Y-Y}$$

$$= \frac{2 s b^3 + l t^3 + \frac{r}{2} (b^4 - t^4) - A n^2}{3}$$

$$n = [b^2 s + \frac{h t^2}{2} + \frac{r}{3} (b-t)^2 (b+2t)] \div A$$

$$\text{Area} = A = 2 b s + h t + \frac{h-l}{2} (b-t)$$

$$\text{Batter} = r = \frac{h-l}{2 (b-t)}$$

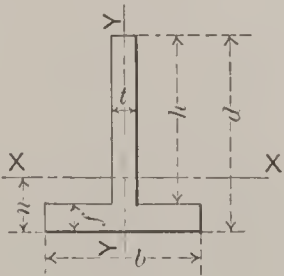

$$I, \text{ axis X-X} = \frac{b n^3 + t (d-n)^3 - (b-t) (n-f)^3}{3}$$

$$I, \text{ axis Y-Y} = \frac{f b^3 + (d-f) t^3}{12}$$

$$n = \frac{b f^2 + t (d^2 - f^2)}{2 (h t + b f)}$$

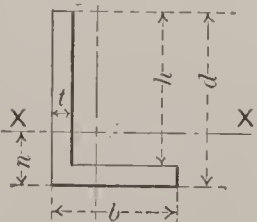

$$I, \text{ axis X-X} = \frac{b n^3 + t (d-n)^3 - (b-t) (n-t)^3}{3}$$

for uneven and even angles.

$$I, \text{ axis Y-Y} = \frac{d n^3 + t (b-n)^3 - (d-t) (n-t)^3}{3}$$

for uneven angles.

$$2 n^4 - 2 (n-t)^4 + t [b - (2n - \frac{t}{2})]^3,$$

$$I, \text{ axis U-U} = \frac{\quad}{3}$$

for even angles.

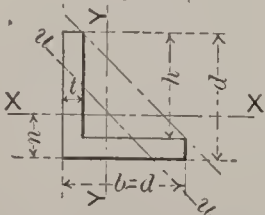

$$n = \frac{t (2h+b) + h^2}{2 (h+b)}, \text{ for uneven and even angles.}$$



VALUES OF MOMENTS OF INERTIA

I = Moment of Inertia

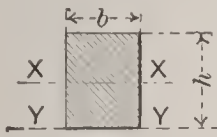
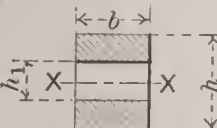
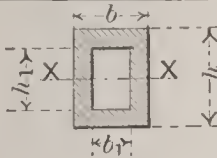
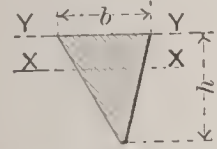
R = Moment of Resistance

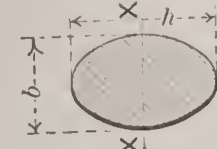
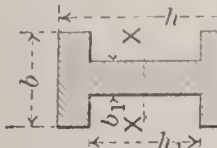
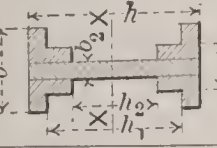
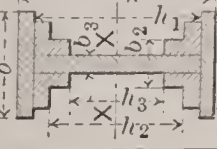
Sections	I	R
	For axis X-X = $\frac{b h^3}{12}$ For axis Y-Y = $\frac{b h^3}{3}$	$\frac{b h^2}{6}$
	$\frac{b (h^3 - h_1^3)}{12}$	$\frac{b (h^3 - h_1^3)}{6 h}$
	$\frac{b h^3 - b_1 h_1^3}{12}$	$\frac{b h^3 - b_1 h_1^3}{6 h}$
	For axis X-X = $\frac{b h^3}{36}$ For axis Y-Y = $\frac{b h^3}{12}$	Min. = $\frac{b h^2}{24}$
	$\frac{\pi d^4}{64}$	$\frac{\pi d^3}{32}$
	$\frac{\pi (d^4 - d_1^4)}{64}$	$\frac{\pi (d^4 - d_1^4)}{32 d}$
	$\frac{\pi b h^3}{64}$	$\frac{\pi b h^2}{32}$
	$\frac{b h^3 - (b - b_1) h_1^3}{12}$	$\frac{2 I}{h}$
	$\frac{b h^3 - (b - b_1) h_1^3 - (b_1 - b_2) h_2^3}{12}$	$\frac{2 I}{h}$
	$\frac{b h^3 - (b - b_1) h_1^3 - (b_1 - b_2) h_2^3 - (b_2 - b_3) h_3^3}{12}$	$\frac{2 I}{h}$

PROPERTIES OF

1	2	3	4	5	6	7	8	9
Section Number	Depth of Beam Inches	Weight per Foot Pounds	Area of Section Square Inches	Thickness of Web Inches	Width of Flange Inches	Mom. of Inertia Neutral Axis Perpendicular to Web at Center	Mom. of Inertia Neutral Axis Coincident with Center Line of Web	Radius of Gyration Neutral Axis Perpen- dicular to Web at Center
						I	I'	r
B0	24	100.	29.41	.754	7.254	2380.3	48.56	9.00
		95.	27.94	.692	7.192	2309.6	47.10	9.09
		90.	26.47	.631	7.131	2239.1	45.70	9.20
		85.	25.	.570	7.070	2168.6	44.35	9.31
		80.	23.53	.500	7.000	2087.9	42.86	9.46
B1	20	100.	29.41	.884	7.284	1655.8	52.65	7.50
		95.	27.94	.810	7.210	1606.8	50.78	7.58
		90.	26.47	.737	7.137	1557.8	48.98	7.67
		85.	25.	.663	7.063	1508.7	47.25	7.77
		80.	23.53	.600	7.000	1466.5	45.81	7.86
B2	20	75.	22.06	.649	6.399	1268.9	30.25	7.58
		70.	20.59	.575	6.325	1219.9	29.04	7.70
		65.	19.08	.500	6.250	1169.6	27.86	7.83
B2½	18	70.	20.59	.719	6.259	921.3	24.62	6.69
		65.	19.12	.637	6.177	881.5	23.47	6.79
		60.	17.65	.555	6.095	841.8	22.38	6.91
		55.	15.93	.460	6.000	795.6	21.19	7.07
B2¾	15	100.	29.41	1.184	6.792	900.5	50.98	5.53
		95.	27.94	1.085	6.694	872.9	48.37	5.59
		90.	26.47	.987	6.596	845.4	45.91	5.65
		85.	25.	.889	6.498	817.8	43.57	5.72
		80.	23.53	.810	6.400	795.5	41.76	5.78
B3	15	75.	22.06	.882	6.274	691.2	30.68	5.60
		70.	20.59	.784	6.183	663.6	29.00	5.68
		65.	19.12	.686	6.091	636.0	27.42	5.77
		60.	17.67	.590	6.000	609.0	25.96	5.87
B4	15	55.	16.18	.656	5.754	511.0	17.06	5.62
		50.	14.71	.558	5.669	483.4	16.04	5.73
		45.	13.24	.460	5.585	455.8	15.00	5.87
		42.	12.48	.410	5.500	441.7	14.62	5.95
B5	12	55.	16.18	.822	5.612	321.0	17.46	4.45
		50.	14.71	.699	5.489	303.3	16.12	4.54
		45.	13.24	.576	5.366	285.7	14.89	4.65
		40.	11.84	.460	5.250	268.9	18.81	4.77
B6	12	35.	10.29	.436	5.086	228.3	10.07	4.71
		31.50	9.26	.350	5.000	215.8	9.50	4.83
B7	10	40.	11.84	.749	5.099	158.7	9.50	3.67
		35.	10.29	.602	4.952	146.4	8.52	3.77
		30.	8.82	.455	4.806	134.2	7.65	3.90
		25.	7.37	.310	4.660	122.1	6.89	4.07
B8	9	35.	10.29	.732	4.772	111.8	7.31	3.29
		30.	8.82	.569	4.609	101.9	6.42	3.40
		25.	7.35	.406	4.446	91.9	5.65	3.54
		21.	6.81	.290	4.330	84.9	5.16	3.67

L=Safe load in pounds uniformly distributed. I=Span in feet.

M=Moment of forces in foot pounds. C and C'=Coefficients given on opposite page. Weights in heavy print are standard ; others are special.

STEEL BEAMS

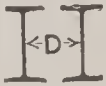
10	11	12	13	14	15
Radius of Gyration Neutral Axis Coincident with Center Line of Web r'	Section Factor Neutral Axis Perpendicular to Web at Center R	Coefficient of Strength for Fiber Stress of 16,000 Pounds per Square Inch. Used for Buildings C	Coefficient of Strength for Fiber Stress of 12,500 Pounds per Square Inch. Used for Bridges C'	Distance Center to Center Required to Make Radii of Gyration Equal 	Section Number
1.28	198.4	2,115,800	1,653,000	17.82	
1.30	192.5	2,052,900	1,603,900	17.99	
1.31	186.6	1,990,300	1,554,900	18.21	B0
1.33	180.7	1,927,600	1,505,900	18.43	
1.36	174.0	1,855,900	1,449,900	18.72	
1.34	165.6	1,766,100	1,379,800	14.76	
1.35	160.7	1,713,900	1,339,000	14.92	
1.36	155.8	1,661,600	1,298,100	15.10	B1
1.37	150.9	1,509,300	1,257,200	15.30	
1.39	146.7	1,564,300	1,222,100	15.47	
1.17	126.9	1,353,500	1,057,400	14.98	
1.19	122.0	1,301,200	1,016,600	15.21	B2
1.21	117.0	1,247,600	974,700	15.47	
1.09	102.4	1,091,900	853,000	13.20	
1.11	97.9	1,044,800	816,200	13.40	B2½
1.13	93.5	997,700	779,500	13.63	
1.15	88.4	943,000	736,700	13.95	
1.31	120.1	1,280,700	1,000,600	10.75	
1.32	116.4	1,241,500	969,900	10.86	
1.32	112.7	1,202,300	939,300	10.99	B2¾
1.32	109.0	1,163,000	908,600	11.13	
1.32	106.1	1,131,300	883,900	11.25	
1.18	92.2	983,000	768,000	10.95	
1.19	88.5	943,800	737,400	11.11	
1.20	84.8	904,600	706,700	11.29	B3
1.21	81.2	866,100	676,600	11.49	
1.02	68.1	726,800	567,800	11.05	
1.04	64.5	687,500	537,100	11.27	B4
1.07	60.8	648,200	506,400	11.54	
1.08	58.9	628,300	490,800	11.70	
1.04	53.5	570,600	445,800	8.65	
1.05	50.6	539,200	421,300	8.83	B5
1.06	47.6	507,900	396,800	9.06	
1.08	44.8	478,100	373,500	9.29	
0.99	38.0	405,800	317,000	9.21	B6
1.01	36.0	383,700	299,700	9.45	
0.90	31.7	338,500	264,500	7.12	
0.91	29.3	312,400	244,100	7.32	B7
0.93	26.8	286,300	223,600	7.57	
0.97	24.4	260,500	203,500	7.91	
0.84	24.8	265,000	207,000	6.36	
0.85	22.6	241,500	188,700	7.58	B8
0.88	20.4	217,900	170,300	6.86	
0.90	18.9	201,300	157,300	7.12	

$$L = \frac{C \text{ or } C'}{1} \quad M = \frac{C \text{ or } C'}{8} \quad C \text{ or } C' = L \quad 1 = 8M = \frac{8 s R}{12}$$

PROPERTIES OF

1	2	3	4	5	6	7	8	9
Section Number	Depth of Beam Inches	Weight per Foot Pounds	Area of Section Square Inches	Thickness of Web Inches	Width of Flange Inches	Mom. of Inertia Neutral Axis Perpendicular to Web at Center I	Mom. of Inertia Neutral Axis Coincident with Center Line of Web I'	Radius of Gyration Neutral Axis Perpen- dicular to Web at Center r
B 9	8	25.50	7.50	.541	4.271	68.4	4.75	3.02
		23.00	6.76	.449	4.179	64.5	4.39	3.09
		20.50	6.03	.357	4.087	60.6	4.07	3.17
		18.00	5.33	.270	4.000	56.9	3.78	3.27
B10	7	20.00	5.88	.458	3.868	42.2	3.24	2.68
		17.50	5.15	.353	2.763	39.2	2.94	2.76
		15.00	4.42	.250	3.660	36.2	2.67	2.85
B11	6	17.25	5.07	.475	3.575	26.2	2.36	2.27
		14.75	4.34	.352	3.452	24.0	2.09	2.35
		12.25	3.61	.230	3.330	21.8	1.85	2.46
B12	5	14.75	4.34	.504	3.294	15.2	1.70	1.87
		12.25	3.60	.357	3.147	13.6	1.45	1.94
		9.75	2.87	.210	3.000	12.1	1.28	2.05
B13	4	10.50	3.09	.410	2.880	7.1	1.01	1.52
		9.50	2.79	.337	2.807	6.7	0.93	1.55
		8.50	2.50	.268	2.733	6.4	0.85	1.59
		7.50	2.21	.190	2.660	6.0	0.77	1.64
B14	3	7.50	2.21	.361	2.521	2.9	0.60	1.15
		6.50	1.91	.263	2.423	2.7	0.53	1.19
		5.50	1.63	.170	2.330	2.5	0.46	1.23

PROPERTIES OF SPECIAL

1	2	3	4	5	6	7	8	9
Section Number	Depth of Channel Inches	Weight per Foot Pounds	Area of Section Square Inches	Thickness of Web Inches	Width of Flange Inches	Mom. of Inertia Neutral Axis Perpendicular to Web at Center I	Mom. of Inertia Neutral Axis Parallel with Center Line of Web I'	Radius of Gyration Neutral Axis Perpen- dicular to Web at Center r
*C 1½	13	52.	15.3	.84	4.46	318.2	13.07	4.56
		31.5	9.27	.375	4.	233.	10.39	5.01
†C21	7	22.1	6.50	.50	3.50	46.04	7.04	2.67
		18.	5.29	.33	3.33	41.30	5.80	2.79
†C16	6	18.4	5.41	.562	3.06	25.44	3.66	2.17
		13.3	3.91	3.12	2.81	20.94	2.65	2.31
†C22	6	15.	4.41	.35	3.50	25.02	4.25	2.38

* Special channels. † Ship channels.

STEEL BEAMS

10	11	12	13	14	15
Radius of Gyration Neutral Axis Coincident with Center Line of Web r'	Section Factor Neutral Axis Perpendicular to Web at Center R	Coefficient of Strength for Fiber Stress of 16,000 Pounds per Square Inch. Used for Buildings C	Coefficient of Strength for Fiber Stress of 12,500 Pounds per Square Inch. Used for Bridges C'	Distance Center to Center Required to Make Radii of Gyration Equal 	Section Number
.80	17.1	182,500	142,600	5.82	B 9
.81	16.1	172,000	134,400	5.96	
.82	15.1	161,600	126,200	6.12	
.84	14.2	151,700	118,500	6.32	
.74	12.1	128,600	100,400	5.15	B10
.76	11.2	119,400	93,300	5.31	
.78	10.4	110,400	86,300	5.50	
.68	8.7	93,100	72,800	4.33	B11
.69	8.0	85,300	66,600	4.49	
.72	7.3	77,500	60,500	4.70	
.63	6.1	64,600	50,500	B12
.63	5.4	55,100	45,400	
.65	4.8	51,600	40,300	3.88	
.57	3.6	38,100	29,800	B13
.58	3.4	36,000	28,100	
.58	3.2	33,900	26,500	
.59	3.0	31,800	24,900	3.07	
.52	1.9	20,700	16,200	B14
.52	1.8	19,100	15,000	
.53	1.7	17,600	15,800	2.24	

AND SHIP STEEL CHANNELS

10	11	12	13	14	15	16
Radius of Gyration Neutral Axis Parallel with Center Line of Web r'	Section Factor Neutral Axis Perpendicular to Web at Center R	Coefficient of Strength for Fiber Stress of 16,000 Pounds per Square Inch. Used for Buildings C	Coefficient of Strength for Fiber Stress of 12,500 Pounds per Square Inch. Used for Bridges C'	Distance Required to make Radii of Gyration Equal 	Distance of Center of Gravity from Outside of Web	Section Number
.924	48.95	522,100	407,900	6.72	1.114	C 1½
1.059	35.85	382,400	298,800	7.66	10.72	
1.04	13.15	140,300	109,600	2.83	1.05	C21
1.04	11.80	125,800	98,300	3.01	1.09	
.80	8.48	90,500	70,700	2.45	0.78	C16
.823	6.98	74,500	58,200	2.75	0.79	
.98	8.34	88,960	69,500	2.24	1.05	C22

PROPERTIES OF

1	2	3	4	5	6	7	8	9
Section Number	Depth of Channel Inches	Weight per Foot Pounds	Area of Section Square Inches	Thickness of Web, Inches	Width of Flange Inches	Mom. of Inertia Neutral Axis Perpendicular to Web at Center	Mom. of Inertia Neutral Axis Parallel with Center Line of Web	Radius of Gyration Neutral Axis Perpendicular to Web at Center
						I	I'	r
C 1	15	55.	16.18	.818	3.818	430.2	12.19	5.16
		50.	14.71	.720	3.720	402.7	11.22	5.23
		45.	13.24	.622	3.622	375.1	10.29	5.32
		40.	11.76	.524	3.524	347.5	9.39	5.43
		35.	10.29	.426	3.426	320.0	8.48	5.58
		33.	9.90	.400	3.400	312.6	8.23	5.62
C 2	12	40.	11.76	.758	3.418	197.0	6.63	4.09
		35.	10.29	.636	3.296	179.3	5.90	4.17
		30.	8.82	.513	3.173	161.7	5.21	4.28
		25.	7.35	.390	3.050	144.0	4.53	4.43
		20.5	6.03	.280	2.940	128.1	3.91	4.61
		35.	10.29	.828	3.188	115.5	4.66	3.35
C 3	10	30.	8.82	.676	3.036	103.2	3.90	3.42
		25.	7.35	.529	2.889	91.0	3.40	3.52
		20.	5.88	.382	2.742	78.7	2.85	3.66
		15.	4.46	.240	2.600	66.9	2.30	3.87
		25.	7.35	.614	2.815	70.7	2.98	3.10
C 4	9	20.	5.88	.452	2.652	60.8	2.45	3.21
		15.	4.41	.288	2.488	50.9	1.95	3.40
		13.25	3.89	.230	2.430	47.3	1.77	3.49
		21.25	6.25	.588	2.628	47.8	2.25	2.77
C 5	8	18.75	5.51	.490	2.530	43.8	2.01	2.82
		16.25	4.78	.399	2.439	39.9	1.78	2.89
		13.75	4.04	.307	2.347	36.0	1.55	2.98
		11.25	3.35	.220	2.260	32.3	1.33	3.11
		19.75	5.81	.633	2.513	33.2	1.85	2.39
C 6	7	17.25	5.07	.528	2.408	30.2	1.62	2.44
		14.75	4.34	.423	2.303	27.2	1.40	2.50
		12.25	3.60	.318	2.198	24.2	1.19	2.50
		9.75	2.85	.210	2.090	21.1	0.98	2.72
		15.5	4.56	.568	2.288	19.5	1.28	2.07
C 7	6	13.	3.82	.440	2.160	17.3	1.07	2.13
		10.5	3.09	.318	2.038	15.1	0.88	2.21
		8.00	2.38	.200	1.920	13.0	0.70	2.34
		11.5	3.38	.484	2.044	10.4	0.82	1.75
C 8	5	9.	2.65	.330	1.890	8.9	0.64	1.83
		6.5	1.95	.190	1.750	7.4	0.48	1.95
		7.25	2.13	.327	1.727	4.6	0.44	1.46
C 9	4	6.25	1.84	.252	1.652	4.2	0.38	1.51
		5.25	1.55	.180	1.580	3.8	0.32	1.56
		6.	1.76	.366	1.606	2.1	0.31	1.08
C10	3	5.	1.47	.264	1.504	1.8	0.25	1.12
		4.	1.19	.170	1.410	1.6	0.20	1.17

L=Safe load in pounds uniformly distributed. I=Span in feet.

M=Moment of forces in foot pounds. C and C'=Coefficients given on opposite page. Weights in heavy type are standard; others are special.

STEEL CHANNELS

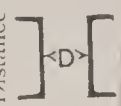
10	11	12	13	14	15	16
Radius of Gyration Neutral Axis Parallel to Line of Web r'	Section Factor Neutral Axis Perpendicular to Web at Center R	Coefficient of Strength for Fiber Stress of 16,000 lbs. per Square Inch. Used for Buildings C	Coefficient of Strength for Fiber Stress of 12,500 lbs. per Square Inch Used for Bridges C'	Distance Required to make Radii of Gyration Equal 	Distance of Center of Gravity from Outside of Web	Section Number
.868	57.4	611,900	478,000	8.53	.823	
.873	53.7	572,700	447,400	8.71	.803	
.882	50.0	533,500	416,800	8.92	.788	
.893	46.3	494,200	386,100	9.15	.783	C 1
.905	42.7	455,000	355,500	9.43	.789	
.912	41.7	444,500	347,300	9.50	.794	
.751	32.8	350,200	273,600	6.60	.722	
.757	29.9	318,800	249,100	6.81	.694	
.768	26.9	287,400	224,500	7.07	.677	C 2
.785	24.0	256,100	200,000	7.36	.678	
.805	21.4	227,800	178,000	7.67	.704	
.672	23.1	246,400	192,500	5.17	.695	
.672	20.6	220,300	172,100	5.40	.651	
.680	18.2	194,100	151,700	5.67	.620	C 3
.696	15.7	168,000	131,200	5.97	.609	
.718	13.4	142,700	111,500	6.33	.639	
.637	15.7	167,600	130,900	4.84	.615	
.646	13.5	144,100	112,600	5.12	.585	C 4
.665	11.3	120,500	94,200	5.49	.590	
.674	10.5	112,200	87,600	5.63	.607	
.600	11.9	127,400	99,500	4.23	.587	
.603	11.0	116,900	91,300	4.38	.567	
.610	10.0	106,400	83,200	4.54	.556	C 5
.619	9.0	96,000	75,000	4.72	.557	
.630	8.1	86,100	67,300	4.94	.576	
.565	9.5	107,700	79,000	3.48	.583	
.564	8.6	91,000	71,800	3.64	.555	
.568	7.8	81,800	64,700	3.80	.535	C 6
.575	6.9	73,700	57,500	3.99	.528	
.586	6.0	66,800	52,200	4.22	.546	
.529	6.5	69,500	54,300	2.91	.546	
.529	5.8	61,600	48,100	3.09	.517	
.534	5.0	53,800	42,000	3.28	.503	C 7
.542	4.3	46,200	36,100	3.52	.517	
.493	4.2	44,400	34,700	2.34	.508	
.493	3.5	37,900	29,600	2.56	.481	C 8
.498	3.0	31,600	24,700	2.79	.489	
.455	2.3	24,400	19,000	1.85	.463	
.454	2.1	22,300	17,400	1.96	.458	C 9
.453	1.9	20,200	15,800	2.06	.464	
.421	1.4	14,700	11,500	1.07	.459	
.415	1.2	13,100	10,300	1.19	.443	C10
.409	1.1	11,600	9,100	1.31	.443	

$$L = \frac{C \text{ or } C'}{1}$$

$$M = \frac{C \text{ or } C'}{8}$$

$$C \text{ or } C' = L1 = 8M = \frac{8sR}{12}$$

PROPERTIES OF

1	2	3	4	5	6	7	8
Section Number	Depth of Web Inches	Width of Flange Inches	Thickness of Metal Inches	Weight per Foot Pounds	Area of Section Square Inches	Moments of Inertia	
						I	I'
						Neutral Axis through Center of Gravity Perpendicular to Web	Neutral Axis through Center of Gravity Coincident with Web
Z4	3	$2\frac{11}{16}$	$\frac{1}{4}$	6.7	1.97	2.87	2.81
	$3\frac{1}{16}$	$2\frac{3}{4}$	$\frac{5}{16}$	8.4	2.48	3.64	3.64
	$3\frac{1}{8}$	$2\frac{13}{16}$	$\frac{3}{8}$	10.1	3.00	4.43	4.53
	$2\frac{15}{16}$	$2\frac{5}{8}$	$\frac{7}{16}$	10.9	3.20	3.94	4.08
Z8	3	$2\frac{11}{16}$	$\frac{1}{2}$	12.5	3.69	4.59	4.85
	$3\frac{1}{16}$	$2\frac{3}{4}$	$\frac{9}{16}$	14.2	4.18	5.26	5.70
	$3\frac{1}{8}$	$2\frac{13}{16}$	$\frac{5}{8}$	16.0	4.69	5.95	6.56
Z9	3	$1\frac{1}{2}$	$\frac{3}{16}$	3.6	1.06	1.40	0.35

STANDARD AND SPECIAL Z BARS

9	10	11	12	13	14	15	16
Section Factors		Radii of Gyration			Coefficient of Strength		Section Number
R	R'	r	r ¹	r ²	C	C'	
Neutral Axis through Center of Gravity Perpendicular to Web	Neutral Axis through Center of Gravity Coincident with Web	Neutral Axis through Center of Gravity Perpendicular to Web	Neutral Axis through Center of Gravity Coincident with Web	Least Radius Neutral Axis Diagonal	For Fiber Stress of 16,000 Pounds per Sq. In. Axis Perpendicular to Web at Center	For Fiber Stress of 12,000 Pounds per Sq. In. Axis Perpendicular to Web at Center	
1.92	1.10	1.21	1.19	0.55	20,500	15,400	Z4
2.38	1.40	1.21	1.21	0.56	25,400	19,000	
2.83	1.73	1.22	1.23	0.57	30,190	22,600	
2.68	1.70	1.10	1.13	0.54	28,600	21,440	Z8
3.06	1.99	1.12	1.15	0.55	32,600	24,500	
3.43	2.31	1.12	1.17	0.56	36,600	27,400	
3.81	2.62	1.13	1.18	0.57	40,600	30,480	
0.93	0.25	1.15	0.57	0.40	9,900	7,400	Z9

PROPERTIES OF

1	2	3	4	5	6	7
Section Number	Size Flange by Stem Inches	Weight per Foot Pounds	Area of Section Square Inches	Distance of Center of Gravity from Outside of Flange Inches	Mom. of Inertia	Least Section Factor Neutral Axis as before
					Neutral Axis through Center of Gravity Parallel to Flange	
T31	5 × 2½	11.	3.24	.65	1.60	.86
T 1	4 × 4	13.9	4.08	1.20	6.12	2.19
T 2	4 × 4	12.4	3.63	1.19	5.42	1.93
T30	3½ × 4	12.8	3.75	1.25	5.50	1.98
T29	3½ × 4	9.9	2.91	1.19	4.30	1.55
T33	4½ × 3	8.6	2.55	.73	1.80	.81
T 3	3½ × 3½	10.4	3.06	1.00	3.46	1.33
T 4	3½ × 3½	9.3	2.73	.91	3.09	1.20
T23	3½ × 3	9.8	2.88	.83	2.22	1.02
T24	3½ × 3	9.	2.65	.75	1.99	.88
T26	3 × 3½	9.8	2.88	1.06	3.29	1.35
T25	3 × 3½	8.6	2.50	.98	2.94	1.17
T 5	3 × 3	7.85	2.30	.89	1.88	.89
T 6	3 × 3	6.6	1.94	.87	1.63	.77
T32	3 × 3	5.68	1.67	.83	1.35	.62
T 7	2½ × 2½	6.32	1.86	.79	1.04	.61
T 8	2½ × 2½	5.4	1.59	.74	.92	.52
T28	2½ × 2	4.8	1.41	.54	.46	.32
T 9	2¼ × 2¼	4.62	1.36	.68	.63	.40
T10	2¼ × 2¼	4.12	1.21	.67	.49	.33
T11	2 × 2	3.5	1.03	.56	.37	.25
T27	2½ × 1¾	3.9	1.15	.44	.25	.19
T13	1¾ × 1¾	3.	.88	.51	.24	.19
T12	1¾ × 1¾	2.33	.69	.50	.16	.13
T14	1½ × 1½	2.5	.77	.46	.14	.14
T15	1½ × 1½	1.95	.56	.47	.12	.11
T16	1¼ × 1¼	2.04	.60	.42	.08	.097
T17	1¼ × 1¼	1.6	.45	.40	.062	.073
T18	1 × 1	1.25	.36	.33	.032	.047
T19	1 × 1	.90	.26	.30	.024	.034

STEEL T'S

8	9	10	11	12	13
Radius of Gyration Neutral Axis as before r	Mom. of Inertia Neutral Axis through Center of Gravity Coincident with Center Line of Stem I'	Section Factor Neutral Axis as before R'	Radius of Gyration Neutral Axis as before r'	Coefficient of Strength for Fiber Stress of 16,000 Pounds per Square Inch Neutral Axis through Center of Gravity Parallel to Flange C	Coefficient of Strength for Fiber Stress of 12,000 Pounds per Square Inch Neutral Axis as before C'
.71	4.9	1.70	1.16	9,200	6,900
1.21	3.05	1.52	.85	23,320	17,490
1.22	2.61	1.31	.85	20,560	15,420
1.21	1.89	1.08	.72	21,160	15,870
1.22	1.42	.81	.70	16,500	12,380
.87	2.60	1.16	1.03	8,650	6,490
1.04	1.70	.97	.73	14,740	11,060
1.01	1.47	.84	.70	12,760	9,570
.87	1.70	.97	.76	10,890	8,170
.84	1.47	.84	.72	9,420	7,070
1.06	1.08	.71	.60	14,360	10,770
1.03	.93	.62	.58	12,440	9,330
.91	.93	.62	.64	9,550	7,160
.92	.78	.52	.63	8,200	6,150
.90	.64	.43	.62	6,610	4,960
.75	.54	.43	.54	6,490	4,870
.75	.45	.36	.53	5,560	4,170
.57	.43	.34	.55	3,390	2,540
.67	.32	.28	.48	4,270	3,200
.67	.25	.23	.48	3,480	2,610
.59	.18	.18	.41	2,700	2,040
.48	.37	.29	.58	2,050	1,540
.51	.12	.14	.36	2,040	1,530
.48	.092	.10	.36	1,360	1,020
.44	.076	.10	.32	1,470	1,100
.47	.058	.077	.33	1,210	910
.37	.045	.072	.28	1,040	780
.37	.034	.054	.27	770	580
.29	.017	.035	.22	510	380
.30	.012	.024	.21	360	270

PROPERTIES OF STANDARD ANGLES

Equal Legs

1	2	3	4	5	6	7	8
Section No.	Dimensions Inches	Thickness Inch	Weight per Foot Pounds	Area of Section Square Inches	Distance of Center of Gravity from Back of Leg Inches	Moment of Inertia Axis Y-Y	Section Factor Axis Y-Y
	h x h	t		A	n	I	R
A 11	$\frac{3}{4} \times \frac{3}{4}$	$\frac{1}{8}$.6	.18	.23	.009	.017
		$\frac{3}{16}$.9	.25	.25	.012	.024
A 10	1 x 1	$\frac{1}{8}$.8	.24	.30	.022	.031
		$\frac{3}{16}$	1.2	.34	.32	.030	.044
		$\frac{1}{4}$	1.5	.44	.34	.037	.056
A 9	$1\frac{1}{4} \times 1\frac{1}{4}$	$\frac{1}{8}$	1.1	.30	.36	.044	.049
		$\frac{3}{16}$	1.5	.44	.38	.061	.071
		$\frac{1}{4}$	2.0	.57	.40	.077	.091
		$\frac{5}{16}$	2.4	.69	.42	.090	.109
A 8	$1\frac{1}{2} \times 1\frac{1}{2}$	$\frac{1}{8}$	1.3	.36	.42	.08	.072
		$\frac{3}{16}$	1.8	.53	.44	.11	.104
		$\frac{1}{4}$	2.4	.69	.47	.14	.134
		$\frac{5}{16}$	2.9	.84	.49	.16	.162
		$\frac{3}{8}$	3.4	.99	.51	.19	.188
		$\frac{7}{16}$	3.9	1.13	.53	.21	.214
A 7	$1\frac{3}{4} \times 1\frac{3}{4}$	$\frac{3}{16}$	2.2	.63	.51	.18	.14
		$\frac{1}{4}$	2.8	.82	.53	.23	.19
		$\frac{5}{16}$	3.4	1.00	.55	.27	.23
		$\frac{3}{8}$	4.0	1.18	.57	.31	.26
		$\frac{7}{16}$	4.6	1.34	.59	.35	.30
		$\frac{1}{2}$	5.1	1.50	.61	.38	.33
A 6	2 x 2	$\frac{3}{16}$	2.5	.72	.57	.27	.19
		$\frac{1}{4}$	3.2	.94	.59	.35	.25
		$\frac{5}{16}$	4.0	1.16	.61	.42	.30
		$\frac{3}{8}$	4.7	1.36	.64	.48	.35
		$\frac{7}{16}$	5.3	1.56	.66	.54	.40
		$\frac{1}{2}$	6.0	1.75	.68	.59	.45
A 5	$2\frac{1}{2} \times 2\frac{1}{2}$	$\frac{3}{16}$	3.1	.91	.69	.55	.30
		$\frac{1}{4}$	4.1	1.19	.72	.70	.39
		$\frac{5}{16}$	5.0	1.47	.74	.85	.48
		$\frac{3}{8}$	5.9	1.74	.76	.98	.57
		$\frac{7}{16}$	6.8	2.00	.78	1.11	.65
		$\frac{1}{2}$	7.7	2.25	.81	1.23	.72
		$\frac{9}{16}$	8.5	2.50	.83	1.34	.80
A 4	3 x 3	$\frac{1}{4}$	4.9	1.44	.84	1.24	.58
		$\frac{5}{16}$	6.1	1.78	.87	1.51	.71
		$\frac{3}{8}$	7.2	2.11	.89	1.76	.83
		$\frac{7}{16}$	8.3	2.44	.91	1.99	.95
		$\frac{1}{2}$	9.4	2.75	.93	2.22	1.07
		$\frac{9}{16}$	10.4	3.06	.95	2.43	1.19
		$\frac{5}{8}$	11.5	3.36	.98	2.62	1.30
		$\frac{11}{16}$	12.5	3.66	1.00	2.81	1.40

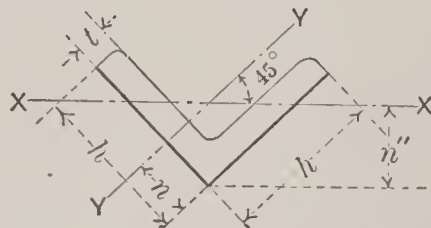

9	10	11	12	13	1	
Radius of Gyration Axis Y-Y Inches	Distance of Center of Gravity from External Apex Inches	Least Moment of Inertia Axis X-X	Section Factor Axis X-X	Least Radius of Gyration Axis X-X	Section No.	
r	n''	I''	R''	r''		
.22	.33	.004	.011	.14	A-11	
.22	.36	.005	.014	.14		
.30	.42	.009	.021	.19	A-10	
.30	.45	.013	.028	.19		
.29	.48	.016	.034	.19		
.38	.51	.018	.035	.24	A-9	
.38	.54	.025	.047	.24		
.37	.57	.033	.057	.24		
.36	.60	.040	.066	.24		
.47	.60	.031	.053	.30	A-8	
.46	.63	.045	.072	.29		
.45	.66	.058	.088	.29		
.44	.69	.070	.101	.29		
.44	.72	.082	.114	.29		
.43	.75	.094	.126	.29		
.54	.72	.073	.10	.34		A-7
.53	.75	.094	.13	.34		
.52	.78	.118	.15	.34		
.51	.81	.133	.16	.34		
.51	.84	.152	.18	.34		
.50	.87	.171	.20	.34		
.62	.80	.11	.14	.39	A-6	
.61	.84	.14	.17	.39		
.60	.87	.17	.20	.39		
.59	.90	.20	.22	.39		
.59	.93	.23	.25	.38		
.58	.96	.26	.27	.38		
.78	.98	.22	.22	.49		A-5
.77	1.01	.29	.28	.49		
.76	1.05	.35	.33	.49		
.75	1.08	.41	.38	.48		
.75	1.11	.46	.42	.48		
.74	1.14	.52	.46	.48		
.73	1.17	.58	.49	.48		
.93	1.19	.50	.42	.59	A-4	
.92	1.22	.61	.50	.59		
.91	1.26	.72	.57	.58		
.91	1.29	.82	.64	.58		
.90	1.32	.92	.70	.58		
.89	1.35	1.02	.76	.58		
.88	1.38	1.12	.81	.58		
.88	1.41	1.22	.86	.58		

PROPERTIES OF STANDARD ANGLES

Equal Legs

1	2	3	4	5	6	7	8
Section No.	Dimensions Inches	Thickness Inches	Weight per Foot Pounds	Area of Section Square Inches	Distance of Center of Gravity from Back of Legs Inches	Moment of Inertia Axis Y-Y	Section Factor Axis Y-Y
	h x h	t		A	n	I	R
A 3	3½ × 3½	5/16	7.2	2.09	0.99	2.45	0.98
		3/8	8.5	2.49	1.01	2.87	1.15
		7/16	9.8	2.88	1.04	3.26	1.32
		1/2	11.1	3.25	1.06	3.64	1.49
		9/16	12.4	3.63	1.08	3.99	1.65
		5/8	13.6	3.99	1.10	4.33	1.81
		11/16	14.8	4.34	1.12	4.65	1.96
		3/4	16.0	4.69	1.15	4.96	2.11
		13/16	17.1	5.03	1.17	5.25	2.25
		7/8	18.3	5.36	1.19	5.53	2.39
A 2	4 × 4	5/16	8.2	2.41	1.12	3.71	1.29
		3/8	9.8	2.86	1.14	4.36	1.52
		7/16	11.3	3.31	1.16	4.97	1.75
		1/2	12.8	3.75	1.18	5.56	1.97
		9/16	14.3	4.19	1.21	6.12	2.19
		5/8	15.7	4.62	1.23	6.66	2.40
		11/16	17.1	5.03	1.25	7.17	2.61
		3/4	18.5	5.44	1.27	7.66	2.81
		13/16	19.9	5.84	1.29	8.14	3.01
		7/8	21.2	6.24	1.31	8.59	3.20
A 1	6 × 6	3/8	14.9	4.36	1.64	15.39	3.53
		7/16	17.2	5.06	1.66	17.68	4.07
		1/2	19.6	5.75	1.68	19.91	4.61
		9/16	21.9	6.44	1.71	22.07	5.14
		5/8	24.2	7.11	1.73	24.16	5.66
		11/16	26.5	7.78	1.75	26.19	6.17
		3/4	28.7	8.44	1.78	28.15	6.66
		13/16	31.0	9.09	1.80	30.06	7.15
		7/8	33.1	9.74	1.82	31.92	7.63
		15/16	35.3	10.38	1.84	33.72	8.11
1	37.4	11.00	1.86	35.46	8.57		
AA 1	8 × 8	1/2	26.4	7.75	2.19	48.65	8.37
		9/16	29.6	8.69	2.21	54.09	9.34
		5/8	32.7	9.61	2.23	59.43	10.30
		11/16	35.8	10.53	2.25	64.64	11.25
		3/4	38.9	11.44	2.28	69.74	12.18
		13/16	42.0	12.34	2.30	74.72	13.11
		7/8	45.0	13.24	2.32	79.58	14.02
		15/16	48.1	14.13	2.34	84.34	14.91
		1	51.0	15.00	2.37	88.98	15.80
		1 1/8	54.0	15.88	2.39	93.58	16.67
1 1/8	56.9	16.74	2.41	97.97	17.53		

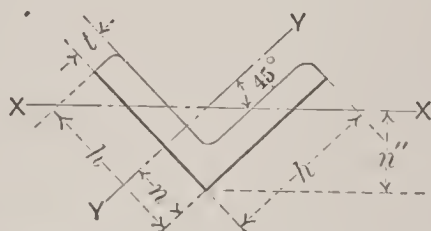

9	10	11	12	13	1
Radius of Gyration Axis Y-Y Inches	Distance of Center of Gravity from External Apex Inches	Least Moment of Inertia Axis X-X	Section Factor Axis X-X	Least Radius of Gyration Axis X-X	Section No.
r	n''	I''	R''	r''	
1.08	1.40	.99	.71	.69	A 3
1.07	1.43	1.16	.81	.68	
1.07	1.46	1.33	.91	.68	
1.06	1.50	1.50	1.00	.68	
1.05	1.53	1.66	1.09	.68	
1.04	1.56	1.82	1.17	.68	
1.04	1.59	1.97	1.24	.67	
1.03	1.62	2.13	1.31	.67	
1.02	1.65	2.28	1.38	.67	
1.02	1.68	2.43	1.45	.67	
1.24	1.58	1.50	.95	.79	A 2
1.23	1.61	1.77	1.10	.79	
1.23	1.64	2.02	1.23	.78	
1.22	1.67	2.28	1.36	.78	
1.21	1.71	2.52	1.48	.78	
1.20	1.74	2.76	1.59	.77	
1.19	1.77	3.00	1.70	.77	
1.19	1.80	3.23	1.80	.77	
1.18	1.83	3.46	1.89	.77	
1.17	1.86	3.69	1.99	.77	
1.88	2.32	6.19	2.67	1.19	A 1
1.87	2.34	7.13	3.04	1.19	
1.86	2.38	8.04	3.37	1.18	
1.85	2.41	8.94	3.70	1.18	
1.84	2.45	9.81	4.01	1.17	
1.83	2.48	10.67	4.31	1.17	
1.83	2.51	11.52	4.59	1.17	
1.82	2.54	12.35	4.86	1.17	
1.81	2.57	13.17	5.12	1.16	
1.80	2.60	13.98	5.37	1.16	
1.80	2.64	14.78	5.61	1.16	
2.51	3.09	19.56	6.33	1.59	AA 1
2.50	3.12	21.79	6.98	1.58	
2.49	3.16	23.97	7.60	1.58	
2.48	3.19	26.13	8.20	1.58	
2.47	3.22	28.24	8.77	1.57	
2.46	3.25	30.33	9.33	1.57	
2.45	3.28	32.38	9.86	1.56	
2.44	3.32	34.40	10.38	1.56	
2.44	3.35	36.40	10.88	1.56	
2.43	3.38	38.38	11.36	1.56	
2.42	3.41	40.33	11.83	1.55	

PROPERTIES OF SPECIAL ANGLES

Equal Legs

1	2	3	4	5	6	7	8
Section No.	Dimensions Inches h x h	Thickness Inches t	Weight per Foot Pounds	Area of Section Square Inches A	Distance of Center of Gravity from Back of Leg Inches n	Moment of Inertia Axis Y-Y I	Section Factor Axis Y-Y R
A 24	2¼ × 2¼	⅜	2.8	.81	.63	.39	.24
		¼	3.7	1.07	.65	.50	.32
		⅙	4.5	1.31	.68	.61	.39
		⅜	5.3	1.55	.70	.70	.45
		⅙	6.1	1.78	.72	.79	.52
		½	6.8	2.00	.74	.87	.58
A 23	2¾ × 2¾	⅜	3.4	1.00	.76	.73	.37
		¼	4.5	1.32	.78	.95	.48
		⅙	5.6	1.63	.80	1.15	.59
		⅜	6.6	1.93	.82	1.33	.69
		⅙	7.6	2.22	.85	1.51	.79
		½	8.5	2.50	.87	1.67	.89
A 21	5 × 5	⅜	12.3	3.61	1.39	8.74	2.42
		⅙	14.3	4.19	1.41	10.02	2.79
		½	16.2	4.75	1.43	11.25	3.16
		⅙	18.1	5.31	1.46	12.44	3.51
		⅜	20.0	5.86	1.48	13.58	3.86
		⅙	21.8	6.41	1.50	14.68	4.20
		¾	23.6	6.94	1.52	15.75	4.53
		⅙	25.4	7.46	1.55	16.77	4.85
		⅜	27.2	7.99	1.57	17.75	5.17
		⅙	28.9	8.50	1.59	18.71	5.49
		1	30.6	9.00	1.61	19.64	5.80

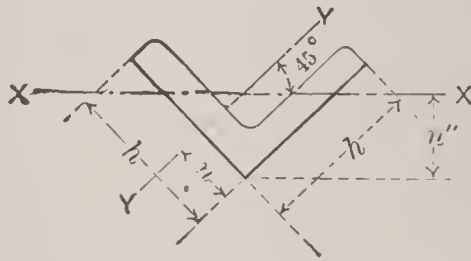

9	10	11	12	13	1
Radius of Gyration Axis Y-Y Inches	Distance of Center of Gravity from External Apex Inches	Least Moment of Inertia Axis X-X	Section Factor Axis X-X	Least Radius of Gyration Axis X-X	Section No.
r	n''	I''	R''	r''	
.70	.89	.16	.18	.44	A 24
.69	.92	.21	.22	.44	
.68	.96	.25	.26	.44	
.67	.99	.29	.30	.43	
.67	1.02	.33	.33	.43	
.66	1.05	.37	.37	.43	
.86	1.07	.30	.28	.54	A 23
.85	1.10	.38	.35	.54	
.84	1.13	.47	.41	.54	
.83	1.17	.55	.47	.53	
.83	1.20	.63	.52	.53	
.82	1.23	.70	.57	.53	
1.56	1.96	3.53	1.79	.99	A 21
1.55	2.00	4.05	2.03	.98	
1.54	2.03	4.56	2.25	.98	
1.53	2.06	5.06	2.46	.98	
1.52	2.09	5.55	2.66	.97	
1.51	2.12	6.03	2.84	.97	
1.51	2.15	6.50	3.01	.97	
1.50	2.18	6.96	3.16	.96	
1.49	2.21	7.41	3.30	.96	
1.48	2.24	7.85	3.42	.96	
1.48	2.27	8.28	3.55	.95	

PROPERTIES OF STANDARD ANGLES
Unequal Legs

1	2	3	4	5	6	7	8
Section No.	Dimensions Inches d x b	Thickness Inches t	Weight per Foot Pounds	Area of Section Square Inches A	Distance of Center of Gravity from Back of Longer Leg Inches	Moment of Inertia Axis Y-Y I	Section Factor Axis Y-Y R
					n		
A 20	2½ × 2	3/16	2.8	.81	.51	.29	.20
		1/4	3.7	1.07	.54	.37	.25
		5/16	4.5	1.31	.56	.45	.31
		3/8	5.3	1.55	.58	.51	.36
		7/16	6.1	1.78	.60	.58	.41
		1/2	6.8	2.00	.63	.64	.46
		9/16	7.6	2.22	.65	.69	.51
A 19	3 × 2½	1/4	4.5	1.32	.66	.74	.40
		5/16	5.6	1.63	.68	.90	.49
		3/8	6.6	1.93	.71	1.04	.58
		7/16	7.6	2.22	.73	1.18	.66
		1/2	8.5	2.50	.75	1.30	.74
		9/16	9.5	2.78	.77	1.42	.82
		5/8	10.4	3.05	.79	1.53	.90
A 18	3½ × 2½	1/4	4.9	1.44	.61	.78	.41
		5/16	6.1	1.78	.64	.94	.50
		3/8	7.2	2.11	.66	1.09	.59
		7/16	8.3	2.44	.68	1.23	.68
		1/2	9.4	2.75	.70	1.36	.76
		9/16	10.4	3.06	.73	1.49	.84
		5/8	11.5	3.36	.75	1.61	.92
A 17	3½ × 3	5/16	6.6	1.94	.81	1.58	.72
		3/8	7.9	2.30	.83	1.85	.85
		7/16	9.1	2.66	.85	2.09	.98
		1/2	10.2	3.00	.88	2.33	1.10
		9/16	11.4	3.34	.90	2.55	1.21
		5/8	12.5	3.68	.92	2.76	1.33
		11/16	13.6	4.00	.94	2.96	1.44
A 16	4 × 3	3/8	7.2	2.09	.76	1.65	.73
		7/16	8.5	2.49	.78	1.92	.87
		1/2	9.8	2.88	.80	2.18	.99
		9/16	11.1	3.25	.83	2.42	1.12
		5/8	12.4	3.63	.85	2.66	1.23
		11/16	13.6	3.99	.87	2.87	1.35
		3/4	14.8	4.34	.89	3.08	1.46
		13/16	16.0	4.69	.92	3.28	1.57
		7/8	17.1	5.03	.94	3.47	1.68
			18.3	5.36	.96	3.66	1.79

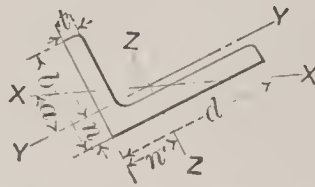

9	10	11	12	13	14	15	1
Radius of Gyration Axis Y-Y Inches r	Distance of Center of Gravity from Back of Shorter Leg Inches n'	Moment of Inertia Axis Z-Z I'	Section Factor Axis Z-Z R'	Radius of Gyration Axis Z-Z r'	Tangent of Angle a	Least Radius of Gyration Axis X-X Inches r''	Section No.
.60	.76	.51	.29	.79	.632	.43	A20
.59	.79	.65	.38	.78	.626	.42	
.58	.81	.79	.47	.78	.620	.42	
.58	.83	.91	.55	.77	.614	.42	
.57	.85	1.03	.62	.76	.607	.42	
.56	.88	1.14	.70	.75	.600	.42	
.56	.90	1.24	.77	.75	.592	.42	
.75	.91	1.17	.56	.95	.684	.53	A19
.74	.93	1.42	.69	.94	.680	.53	
.74	.96	1.66	.81	.93	.676	.52	
.73	.98	1.88	.93	.92	.672	.52	
.72	1.00	2.08	1.04	.91	.666	.52	
.72	1.02	2.28	1.15	.91	.661	.52	
.71	1.04	2.46	1.26	.90	.655	.52	
.74	1.11	1.80	.75	1.12	.506	.54	A18
.73	1.14	2.19	.93	1.11	.501	.54	
.72	1.16	2.56	1.09	1.10	.496	.54	
.71	1.18	2.91	1.26	1.09	.491	.54	
.70	1.20	3.24	1.41	1.09	.486	.53	
.70	1.23	3.55	1.56	1.08	.480	.53	
.69	1.25	3.85	1.71	1.07	.472	.53	
.69	1.27	4.13	1.85	1.06	.468	.53	
.68	1.29	4.40	1.99	1.06	.461	.54	
.90	1.06	2.33	.95	1.10	.724	.63	A17
.90	1.08	2.72	1.13	1.09	.721	.62	
.89	1.10	3.10	1.29	1.08	.718	.62	
.88	1.13	3.45	1.45	1.07	.714	.62	
.87	1.15	3.79	1.61	1.07	.711	.62	
.87	1.17	4.11	1.76	1.06	.707	.62	
.86	1.19	4.41	1.91	1.05	.703	.62	
.85	1.21	4.70	2.05	1.04	.698	.62	
.85	1.23	4.98	2.20	1.04	.694	.62	
.84	1.25	5.24	2.33	1.03	.689	.62	
.89	1.26	3.38	1.23	1.27	.554	.65	A16
.88	1.28	3.96	1.46	1.26	.551	.64	
.87	1.30	4.52	1.68	1.25	.547	.64	
.86	1.33	5.05	1.89	1.25	.543	.64	
.86	1.35	5.55	2.00	1.24	.538	.64	
.85	1.37	6.03	2.30	1.23	.534	.64	
.84	1.39	6.49	2.49	1.22	.529	.64	
.84	1.42	6.93	2.68	1.22	.524	.64	
.83	1.44	7.35	2.87	1.21	.518	.64	
.83	1.46	7.75	3.05	1.20	.512	.64	

PROPERTIES OF STANDARD ANGLES

Unequal Legs

1	2	3	4	5	6	7	8
Section No.	Dimensions Inches	Thickness Inches	Weight per Foot Pounds	Area of Section Square Inches	Distance of Center of Gravity from Back of Longer Leg Inches	Moment of Inertia Axis Y-Y	Section Factor Axis Y-Y
	d x b	t		A	n	I	R
A 15	5x3	5/16	8.2	2.41	.68	1.75	.75
		3/8	9.8	2.86	.70	2.04	.89
		7/16	11.3	3.31	.73	2.32	1.02
		1/2	12.8	3.75	.75	2.58	1.15
		9/16	14.3	4.19	.77	2.83	1.27
		5/8	15.7	4.61	.80	3.06	1.39
		11/16	17.1	5.03	.82	3.29	1.51
		3/4	18.5	5.44	.84	3.51	1.62
		13/16	19.9	5.84	.86	3.71	1.74
		1/2	21.2	6.24	.88	3.91	1.85
A 14	5x3 1/2	5/16	8.7	2.56	.84	2.72	1.02
		3/8	10.4	3.05	.86	3.18	1.21
		7/16	12.0	3.53	.88	3.63	1.39
		1/2	13.6	4.00	.91	4.05	1.56
		9/16	15.2	4.47	.93	4.45	1.73
		5/8	16.8	4.93	.95	4.83	1.90
		11/16	18.3	5.38	.97	5.20	2.06
		3/4	19.8	5.82	1.00	5.55	2.22
		13/16	21.3	6.25	1.02	5.89	2.37
		1/2	22.7	6.68	1.04	6.21	2.52
A 13	6x3 1/2	3/8	11.7	3.43	.79	3.34	1.23
		7/16	13.5	3.97	.81	3.81	1.41
		1/2	15.3	4.50	.83	4.25	1.59
		9/16	17.1	5.03	.86	4.67	1.77
		5/8	18.9	5.55	.88	5.08	1.94
		11/16	20.6	6.06	.90	5.47	2.11
		3/4	22.4	6.57	.93	5.84	2.27
		13/16	24.0	7.06	.95	6.20	2.43
		7/8	25.7	7.55	.97	6.55	2.59
		1/2	27.3	8.03	.99	6.88	2.74
A 12	6x4	1	28.9	8.50	1.01	7.21	2.90
		3/8	12.3	3.61	.94	4.90	1.60
		7/16	14.3	4.19	.96	5.60	1.85
		1/2	16.2	4.75	.99	6.27	2.08
		9/16	18.1	5.31	1.01	6.91	2.31
		5/8	20.0	5.86	1.03	7.52	2.54
		11/16	21.8	6.41	1.06	8.11	2.76
		3/4	23.6	6.94	1.08	8.68	2.97
		13/16	25.4	7.47	1.10	9.23	3.18
		7/8	27.2	7.99	1.12	9.75	3.39
1		15/16	28.9	8.50	1.14	10.26	3.59
		1	30.6	9.00	1.17	10.75	3.79

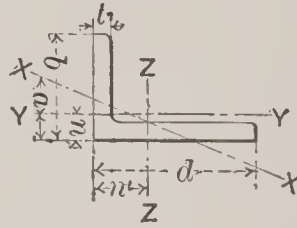

9	10	11	12	13	14	15	1
Radius of Gyration Axis Y-Y Inches r	Distance of Center of Gravity from Back of Shorter Leg Inches n'	Moment of Inertia Axis Z-Z I'	Section Factor Axis Z-Z R'	Radius of Gyration Axis Z-Z r'	Tangent of Angle a	Least Radius of Gyration Axis X-X r''	Section No.
.85	1.68	6.26	1.89	1.61	.368	.66	A15
.84	1.70	7.37	2.24	1.61	.364	.65	
.84	1.73	8.43	2.58	1.60	.361	.65	
.83	1.75	9.45	2.91	1.59	.357	.65	
.82	1.77	10.43	3.23	1.58	.353	.65	
.82	1.80	11.37	3.55	1.57	.349	.64	
.81	1.82	12.28	3.86	1.56	.345	.64	
.80	1.84	13.15	4.16	1.55	.340	.64	
.80	1.86	13.98	4.46	1.55	.336	.64	
.79	1.88	14.78	4.75	1.54	.331	.64	
1.03	1.59	6.60	1.94	1.61	.489	.77	A14
1.02	1.61	7.78	2.29	1.60	.485	.76	
1.01	1.63	8.90	2.64	1.59	.482	.76	
1.01	1.66	9.99	2.99	1.58	.479	.75	
1.00	1.68	11.03	3.32	1.57	.478	.75	
.99	1.70	12.03	3.65	1.56	.472	.75	
.98	1.72	12.99	3.97	1.56	.468	.75	
.98	1.75	13.92	4.28	1.55	.464	.75	
.97	1.77	14.81	4.58	1.54	.460	.75	
.96	1.79	15.67	4.88	1.53	.455	.75	
.96	1.81	16.49	5.17	1.53	.451	.75	
.99	2.04	12.86	3.24	1.94	.350	.77	A13
.98	2.06	14.76	3.75	1.93	.347	.76	
.97	2.08	16.59	4.24	1.92	.344	.76	
.96	2.11	18.37	4.72	1.91	.341	.75	
.96	2.13	20.08	5.19	1.90	.338	.75	
.95	2.15	21.74	5.65	1.89	.334	.75	
.94	2.18	23.34	6.10	1.89	.331	.75	
.94	2.20	24.89	6.55	1.88	.327	.75	
.93	2.22	26.39	6.98	1.87	.323	.75	
.93	2.24	27.84	7.41	1.86	.320	.75	
.92	2.26	29.15	7.80	1.85	.317	.75	
1.17	1.94	13.47	3.32	1.93	.446	.88	A12
1.16	1.96	15.46	3.83	1.92	.443	.87	
1.15	1.99	17.40	4.33	1.91	.440	.87	
1.14	2.01	19.26	4.83	1.90	.438	.87	
1.13	2.03	21.07	5.31	1.90	.434	.86	
1.13	2.06	22.82	5.78	1.89	.431	.86	
1.12	2.08	24.51	6.25	1.88	.428	.86	
1.11	2.10	26.15	6.70	1.87	.425	.86	
1.11	2.12	27.73	7.15	1.86	.421	.86	
1.10	2.14	29.26	7.59	1.86	.418	.86	
1.09	2.17	30.75	8.02	1.85	.414	.86	

PROPERTIES OF SPECIAL ANGLES

Unequal Legs

1	2	3	4	5	6	7	8
Section No.	Dimensions Inches d x b	Thickness Inches t	Weight per Foot Pounds	Area of Section Square Inches A	Distance of Center of Gravity from Back of Longer Leg Inches n	Moment of Inertia Axis Y-Y I	Section Factor Axis Y-Y R
A 31	2½ × 1½	⅜	2.5	.72	.35	.13	.11
		¼	3.2	.94	.38	.16	.14
		⅙	4.0	1.16	.40	.19	.17
		⅜	4.7	1.36	.42	.22	.20
		⅙	5.3	1.56	.44	.24	.23
A 29	3 × 2	⅜	3.1	.91	.47	.31	.20
		¼	4.1	1.19	.49	.39	.26
		⅙	5.0	1.47	.51	.47	.32
		⅜	5.9	1.74	.54	.54	.37
		⅙	6.8	2.00	.56	.61	.42
A 28	3¼ × 2	¼	4.3	1.25	.48	.40	.26
		⅙	5.3	1.54	.50	.48	.32
		⅜	6.3	1.83	.52	.55	.37
		⅙	7.2	2.11	.54	.62	.43
		½	8.1	2.38	.57	.69	.48
A 26	4 × 3½	⅙	7.7	2.25	.93	2.59	1.01
		⅜	9.1	2.67	.96	2.99	1.18
		⅙	10.6	3.09	.98	3.40	1.35
		½	11.9	3.50	1.00	3.79	1.52
		⅙	13.3	3.90	1.02	4.17	1.68
A 62	4½ × 3	⅙	14.7	4.30	1.04	4.52	1.84
		⅜	16.0	4.68	1.07	4.86	2.00
		⅙	17.3	5.06	1.09	5.18	2.15
		¾	18.5	5.43	1.11	5.49	2.30
		⅙	7.7	2.25	.72	1.73	.76
A 62	4½ × 3	⅜	9.1	2.67	.74	1.98	.88
		⅙	10.6	3.09	.76	2.25	1.01
		½	11.9	3.50	.79	2.51	1.13
		⅙	13.3	3.90	.81	2.75	1.25
		⅜	14.7	4.30	.83	2.98	1.37
A 25	5 × 4	⅙	16.0	4.68	.85	3.19	1.49
		¾	17.3	5.06	.88	3.40	1.60
		⅙	18.5	5.43	.90	3.60	1.71
		⅜	11.0	3.24	1.03	4.66	1.57
		⅙	12.8	3.74	1.05	5.32	1.81
A 25	5 × 4	½	14.5	4.25	1.07	5.96	2.04
		⅙	16.2	4.75	1.10	6.56	2.26
		⅜	17.8	5.24	1.12	7.14	2.48
		⅙	19.5	5.72	1.14	7.70	2.69
		¾	21.1	6.19	1.16	8.23	2.90
A 25	5 × 4	⅙	22.7	6.65	1.18	8.74	3.11
		⅜	24.2	7.11	1.21	9.23	3.31

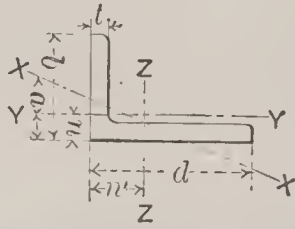

9	10	11	12	13	14	15	1
Radius of Gyration Inches	Distance of Center of Gravity from Back of Shorter Leg Inches	Moment of Inertia Axis Z-Z	Section Factor Axis Z-Z	Radius of Gyration Axis Z-Z	Tangent of Angle	Least Radius of Gyration Axis X-X Inches	Section No.
r	n'	I'	R'	r'	a	r''	
.42	.85	.46	.28	.80	.364	.33	A31
.41	.88	.55	.36	.79	.357	.32	
.41	.90	.71	.44	.79	.349	.32	
.40	.92	.82	.52	.79	.340	.32	
.40	.94	.92	.59	.77	.331	.32	
.58	.97	.84	.41	.97	.446	.44	A29
.57	.99	1.09	.54	.96	.440	.43	
.56	1.02	1.32	.66	.95	.434	.43	
.55	1.04	1.53	.78	.94	.428	.43	
.55	1.06	1.73	.89	.93	.421	.43	
.55	1.08	1.92	1.00	.92	.414	.43	
.57	1.09	1.36	.63	1.04	.380	.45	A28
.56	1.12	1.65	.77	1.03	.375	.45	
.55	1.15	1.92	.91	1.02	.369	.44	
.54	1.17	2.18	1.05	1.02	.363	.44	
.54	1.19	2.42	1.17	1.01	.357	.44	
.53	1.21	2.64	1.30	1.00	.351	.44	
1.07	1.18	3.56	1.26	1.26	.757	.73	A26
1.06	1.21	4.18	1.50	1.25	.755	.73	
1.05	1.23	4.76	1.72	1.24	.753	.72	
1.04	1.25	5.32	1.93	1.23	.750	.72	
1.03	1.27	5.86	2.15	1.23	.747	.72	
1.03	1.29	6.37	2.35	1.22	.742	.72	
1.02	1.32	6.86	2.56	1.21	.738	.72	
1.01	1.34	7.32	2.75	1.20	.734	.72	
1.01	1.36	7.77	2.92	1.19	.730	.72	
.88	1.47	4.69	1.54	1.44	.444	.66	
.86	1.49	5.50	1.83	1.44	.440	.66	
.85	1.51	6.29	2.10	1.43	.437	.65	
.85	1.54	7.04	2.37	1.42	.431	.65	
.85	1.56	7.75	2.64	1.41	.428	.64	
.83	1.58	8.44	2.89	1.40	.424	.64	
.83	1.60	9.10	3.14	1.39	.419	.64	
.82	1.63	9.73	3.38	1.39	.414	.64	
.81	1.65	10.33	3.62	1.38	.410	.64	
1.20	1.53	8.14	2.34	1.59	.631	.85	A25
1.19	1.55	9.32	2.70	1.58	.629	.85	
1.18	1.57	10.46	3.05	1.57	.626	.85	
1.18	1.60	11.55	3.39	1.56	.623	.85	
1.17	1.62	12.61	3.73	1.55	.620	.84	
1.16	1.64	13.62	4.05	1.54	.617	.84	
1.15	1.66	14.60	4.37	1.54	.614	.84	
1.15	1.68	15.54	4.69	1.53	.611	.84	
1.14	1.71	16.42	4.99	1.52	.608	.84	

SAFE LOADS IN TONS OF 2000 POUNDS
 Uniformly Distributed, for Box Girders Composed of
 Two 10'' Beams and Two 12'' x 1/2'' Plates

Distance, Center to Center of Bearings, Feet	2-10'' Beams 25 Pounds per Foot					
	Safe Load Including Weight of Girder Tons	Weight of Girder Pounds	Add to Safe Load for 5 Pounds Increase in Weight of Beam	Add to Safe Load for 1/8'' Increase in Thickness of Plates	Add to Weight of Girder for 5 Pounds Increase in Weight of Beam	Add to Weight of Girder for 1/8'' Increase in Thickness of Plates
12	40.0	1114	1.92	2.89	120	61
13	36.9	1206	1.77	2.67	130	66
14	34.3	1299	1.64	2.48	140	71
15	32.0	1392	1.54	1.31	150	77
16	30.0	1485	1.44	1.16	160	82
17	28.2	1578	1.35	1.04	170	87
18	26.7	1670	1.28	1.93	180	92
19	25.3	1763	1.20	1.82	190	97
20	24.0	1856	1.14	1.73	200	102
21	22.8	1949	1.09	1.64	210	107
22	21.7	2042	1.04	1.57	220	112
23	20.9	2134	1.00	1.51	230	117
24	20.0	2227	0.96	1.44	240	122
25	19.2	2320	0.92	1.39	250	128
26	18.5	2413	0.89	1.33	260	133
27	17.8	2506	0.84	1.28	270	138
28	17.1	2598	0.82	1.24	280	143
29	16.5	2691	0.79	1.19	290	148
30	16.0	2784	0.76	1.16	300	153
31	15.5	2877	0.74	1.12	310	158
32	15.0	2970	0.71	1.08	320	163
33	14.5	3062	0.70	1.04	330	168
34	14.1	3155	0.68	1.02	340	173
35	13.7	3248	0.65	1.00	350	179
36	13.3	3341	0.64	0.96	360	184
37	13.0	3434	0.62	0.93	370	189
38	12.6	3526	0.60	0.86	380	194

Above values are based on maximum fiber strain of 16,000 pounds per square inch, 13/16-inch rivet holes deducted. Weights correspond to lengths, center to center of bearings.

SAFE LOADS IN TONS OF 2000 POUNDS
 Uniformly Distributed, for Box Girders Composed of Two
 12" Steel Beams and Two 14" x 1/2" Steel Plates

Distance, Center to Center of Bearings, Feet	2-12" Beams, 3 1/2" Pounds per Foot			2-12" Beams, 40 Pounds per Foot			Add to Safe Load for 1/16" Increase in Thickness of Plates	Add to Weight of Girder for 1/16" Increase in Thickness of Flange Plates
	Safe Load Including Weight of Girder Tons	Weight of Girder Pounds	Add to Safe Load for 3 1/2" Pounds Increase in Weight of Beam	Safe Load Including Weight of Girder Tons	Weight of Girder Pounds	Add to Safe Load for 40 Pounds Increase in Weight of Beam		
12	58.7	1351	1.82	65.2	1555	2.62	4.47	71
13	54.2	1464	1.68	60.2	1685	2.42	4.12	77
14	50.3	1576	1.57	55.9	1814	2.24	3.83	83
15	46.9	1689	1.46	52.1	1944	2.08	3.57	89
16	44.0	1802	1.38	48.9	2074	1.96	3.35	95
17	41.4	1914	1.30	46.0	2203	1.86	3.15	101
18	39.1	2027	1.22	43.5	2333	1.74	2.98	107
19	37.1	2139	1.14	41.2	2462	1.66	2.82	113
20	35.2	2252	1.10	39.1	2592	1.58	2.68	119
21	33.5	2365	1.04	37.2	2722	1.50	2.56	125
22	32.0	2477	1.00	35.5	2851	1.42	2.44	131
23	30.6	2590	0.96	34.0	2981	1.38	2.33	137
24	29.3	2702	0.92	32.6	3110	1.30	2.24	143
25	28.2	2815	0.87	31.3	3240	1.26	2.15	149
26	27.1	2928	0.82	30.1	3370	1.22	2.06	155
27	26.1	3040	0.78	29.0	3499	1.16	1.98	161
28	25.1	3153	0.76	27.9	3629	1.12	1.91	167
29	24.3	3265	0.74	27.0	3758	1.08	1.84	173
30	23.5	3378	0.72	26.1	3888	1.02	1.78	179
31	22.7	3491	0.70	25.2	4018	1.00	1.73	184
32	22.0	3603	0.68	24.4	4147	0.98	1.68	190
33	21.3	3716	0.66	23.7	4277	0.96	1.63	196
34	20.7	3828	0.64	23.0	4406	0.92	1.58	202
35	20.1	3941	0.62	22.3	4536	0.90	1.53	208
36	19.5	4054	0.60	21.7	4666	0.88	1.49	214
37	19.0	4166	0.58	21.1	4795	0.86	1.45	220
38	18.5	4279	0.57	20.6	4925	0.84	1.41	226



Above values are based on maximum fiber strain of 16,000 pounds per square inch, 1 1/8-inch rivet holes deducted. Weights correspond to length, center to center of bearings.

SAFE LOADS IN TONS OF 2000 POUNDS
 Uniformly Distributed, for Box Girders Composed of Two
 15" Steel Beams and Two 14" x 5/8" Steel Plates

Distance, Center to Center of Bearings, Feet	2-15" Beams 42 Pounds per Foot			2-15" Beams 60 Pounds per Foot			Add to Safe Load for 1/16" Increase in Thickness of Plates	Add to Weight of Girder for 1/16" Increase in Thickness of Flange Plates
	Safe Load Including Weight of Girder Tons	Weight of Girder Pounds	Add to Safe Load for 1 Pound Increase in Weight of Beam	Safe Load Including Weight of Girder Tons	Weight of Girder Pounds	Add to Safe Load for 5 Pounds Increase in Weight of Beam		
12	94.3	1746	0.60	111.0	2178	3.03	5.17	72
13	87.1	1891	0.55	102.4	2359	2.80	4.77	78
14	80.8	2037	0.51	95.1	2541	2.60	4.43	84
15	75.5	2182	0.48	88.8	2722	2.43	4.13	90
16	70.7	2328	0.45	83.2	2904	2.27	3.87	96
17	66.6	2473	0.42	78.3	3085	2.14	3.65	102
18	62.9	2619	0.40	74.0	3267	2.02	3.44	108
19	59.6	2764	0.38	70.1	3448	1.91	3.26	114
20	56.6	2910	0.36	66.6	3630	1.82	3.10	120
21	53.9	3055	0.34	63.4	3811	1.73	2.95	126
22	51.4	3201	0.33	60.5	3993	1.65	2.82	132
23	49.2	3346	0.31	57.9	4174	1.58	2.70	138
24	47.1	3492	0.30	55.5	4356	1.51	2.58	144
25	45.3	3637	0.29	52.2	4537	1.45	2.48	150
26	43.5	3783	0.28	51.2	4719	1.40	2.38	156
27	41.9	3928	0.27	49.3	4900	1.35	2.29	162
28	40.4	4074	0.26	47.5	5082	1.30	2.21	168
29	39.0	4219	0.25	46.1	5263	1.25	2.14	174
30	37.7	4365	0.24	44.4	5445	1.21	2.07	180
31	36.5	4510	0.23	42.9	5626	1.17	2.00	186
32	35.4	4656	0.22	41.6	5808	1.13	1.94	192
33	34.3	4801	0.22	40.3	5989	1.10	1.88	198
34	33.3	4947	0.21	39.1	6171	1.07	1.82	204
35	32.3	5092	0.20	38.0	6352	1.04	1.77	210
36	31.4	5238	0.20	37.0	6534	1.01	1.72	216
37	30.6	5383	0.19	36.0	6715	0.98	1.67	222
38	29.8	5529	0.19	35.0	6897	0.95	1.63	228

Above values are based on maximum fiber strain of 16,000 pounds per square inch, 13/16-inch rivet holes deducted. Weights correspond to lengths, center to center of bearings.

SAFE LOADS IN TONS OF 2000 POUNDS
 Uniformly Distributed, for Box Girders Composed of Two
 18" Steel Beams and Two 16" x 3/4" Steel Plates

Distance, Center to Center of Bearings, Feet	 2-18" Beams 70 Pounds per Foot 2-16" x 3/4" Steel Plates			 2-18" Beams 55 Pounds per Foot 2-16" x 3/4" Steel Plates			Add to Safe Load for 1/16" Increase in Thickness of Plates	Add to Weight of Girder for 1/16" Increase in Thickness of Plates
	Safe Load Including Weight of Girder Tons	Weight of Girder Pounds	Add to Safe Load for 1/16" Increase in Thickness of Plates	Safe Load Including Weight of Girder Tons	Weight of Girder Pounds	Add to Safe Load for 5 Pounds Increase in Weight of Beam		
12	162.6	2712	6.68	151.3	2352	3.92	6.68	82
13	150.1	2938	6.17	139.7	2548	3.62	6.17	88
14	139.4	3164	5.73	129.7	2744	3.36	5.73	95
15	130.1	3390	5.35	121.1	2940	3.14	5.35	102
16	121.9	3616	5.01	113.5	3136	2.94	5.01	109
17	114.8	3842	4.72	106.8	3332	2.77	4.72	116
18	108.4	4068	4.45	100.9	3528	2.61	4.45	122
19	102.7	4294	4.22	95.6	3724	2.47	4.22	129
20	97.5	4520	4.01	90.8	3920	2.35	4.01	136
21	92.9	4746	3.82	86.5	4116	2.24	3.82	143
22	88.7	4972	3.64	81.7	4312	2.14	3.64	150
23	84.8	5198	3.49	78.9	4508	2.04	3.49	156
24	81.3	5424	3.34	75.7	4704	1.96	3.34	163
25	78.0	5650	3.21	72.6	4900	1.88	3.21	170
26	75.0	5876	3.08	69.8	5096	1.81	3.08	177
27	72.2	6102	2.97	67.2	5292	1.74	2.97	184
28	69.7	6328	2.86	64.8	5488	1.68	2.86	190
29	67.3	6554	2.76	62.6	5684	1.62	2.76	197
30	65.0	6780	2.67	60.5	5880	1.57	2.67	204
31	62.9	7006	2.58	58.6	6076	1.52	2.58	211
32	61.0	7232	2.50	56.7	6272	1.47	2.50	218
33	59.1	7458	2.43	54.5	6468	1.42	2.43	224
34	57.4	7684	2.36	53.4	6664	1.38	2.36	231
35	55.7	7910	2.29	51.9	6860	1.34	2.29	238
36	54.2	8136	2.23	50.4	7056	1.30	2.23	245
37	52.7	8362	2.17	49.1	7252	1.26	2.17	252
38	51.3	8588	2.11	47.8	7448	1.23	2.11	258

Above values are based on maximum fiber strain of 16,000 pounds per square inch, 13/32-inch rivet holes deducted. Weights correspond to lengths, center to center of bearings.

SAFE LOADS IN TONS OF 2000 POUNDS
 Uniformly Distributed, for Box Girders Composed of Two
 Steel Beams and Two 16" Steel Plates

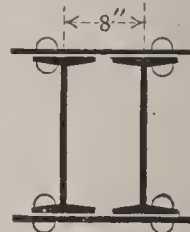
Distance, Center to Center of Bearings, Feet	 2-20" Steel Beams 65 Pounds per Foot 2-16" x 3/4" Steel Plates				 2-24" Steel Beams 80 Pounds per Foot 2-16" x 3/4" Steel Plates				
	Safe Load, Including Weight of Girder Tons	Weight of Girder, Pounds	Add to Safe Load for 5 Pounds Increase in Weight of Beams	Add to Safe Load for 1/8" Increase in Thickness of Plates	Safe Load, Including Weight of Girder Tons	Weight of Girder, Pounds	Add to Safe Load for 5 Pounds Increase in Weight of Beams	Add to Safe Load for 1/8" Increase in Thickness of Plates	Add to Weight of Girder for 1/8" Increase in Thickness of Plates
12	183.0	2563	4.36	8.00	256.6	2923	5.23	9.58	82
13	168.8	2777	4.02	7.38	236.8	3167	4.83	8.84	88
14	156.8	2990	3.74	6.85	219.9	3410	4.48	8.21	95
15	146.4	3204	3.48	6.40	205.2	3654	4.18	7.66	102
16	137.2	3418	3.26	6.00	192.4	3898	3.92	7.18	109
17	129.2	3631	3.02	5.64	181.1	4141	3.70	6.76	116
18	122.0	3845	2.90	5.33	171.0	4385	3.49	6.39	122
19	115.5	4058	2.76	5.05	162.1	4628	3.30	6.05	129
20	109.8	4272	2.62	4.80	153.9	4872	3.14	5.75	136
21	104.5	4486	2.50	4.56	146.6	5116	2.99	5.47	143
22	99.8	4699	2.38	4.36	139.9	5359	2.85	5.22	150
23	95.4	4913	2.28	4.17	133.9	5603	2.73	5.00	156
24	91.5	5126	2.18	4.00	128.3	5846	2.61	4.79	163
25	87.8	5340	2.08	3.84	123.1	6090	2.51	4.60	170
26	84.4	5554	2.00	3.69	118.4	6334	2.41	4.42	177
27	81.3	5767	1.92	3.55	114.0	6577	2.32	4.25	184
28	78.4	5981	1.86	3.43	109.9	6821	2.24	4.10	190
29	75.7	6194	1.80	3.31	106.1	7064	2.16	3.96	197
30	73.2	6408	1.74	3.20	102.6	7308	2.09	3.83	204
31	70.8	6622	1.68	3.09	99.3	7552	2.02	3.71	211
32	68.6	6835	1.62	3.00	96.2	7795	1.96	3.59	218
33	66.5	7049	1.58	2.91	93.3	8039	1.90	3.48	224
34	64.6	7262	1.52	2.82	90.5	8282	1.85	3.38	231
35	62.7	7476	1.46	2.74	88.0	8526	1.79	3.28	238
36	61.0	7690	1.40	2.66	85.5	8770	1.74	3.19	245
37	59.3	7903	1.38	2.59	83.2	9013	1.70	3.10	252
38	57.7	8117	1.36	2.52	81.0	9257	1.65	3.02	258

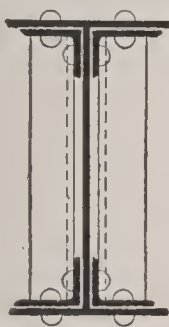
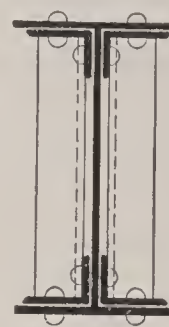

Above values are based on maximum fiber strain of 16,000 pounds per square inch, 13/16-inch rivet holes deducted. Weights correspond to lengths, center to center of bearings.

SAFE LOADS IN TONS OF 2000 POUNDS
 Uniformly Distributed, for Steel Plate Girders

Distance Center to Center of Bearings Feet	 <p>30" x 1/2" Web Plate 1 1/2" x 3/8" Flange Plates 5" x 3 1/2" x 1/2" Angles</p>				 <p>33" x 1/2" Web Plate 1 1/2" x 3/8" Flange Plates 5" x 3 1/2" x 1/2" Angles</p>			
	Safe Load, Including Weight of Girder Tons	Weight of Girder Tons	Increase in Safe Load for 1/16" Increase in Thickness of Flange Plates	Increase in Weight of Girder for 1/16" Increase in Thickness of Flange Plates	Safe Load, Including Weight of Girder Tons	Weight of Girder Tons	Increase in Safe Load for 1/16" Increase in Thickness of Flange Plates	Increase in Weight of Girder for 1/16" Increase in Thickness of Flange Plates
20	99.91	1.62	4.92	.05	112.87	1.70	5.41	.05
21	95.15	1.69	4.67	.05	107.49	1.77	5.13	.05
22	90.82	1.76	4.46	.06	102.60	1.84	4.90	.06
23	86.87	1.86	4.26	.06	98.14	1.95	4.68	.06
24	83.25	1.93	4.08	.06	94.05	2.02	4.48	.06
25	79.92	2.01	3.92	.06	90.29	2.09	4.31	.06
26	76.85	2.07	3.77	.07	86.82	2.17	4.14	.07
27	74.00	2.14	3.63	.07	83.60	2.24	3.99	.07
28	71.36	2.21	3.50	.07	80.63	2.31	3.85	.07
29	68.90	2.31	3.38	.07	77.84	2.42	3.71	.07
30	66.60	2.38	3.27	.08	75.24	2.49	3.59	.08
31	64.45	2.45	3.17	.08	72.82	2.56	3.48	.08
32	62.44	2.52	3.07	.08	70.55	2.64	3.37	.08
33	60.55	2.59	2.97	.08	68.41	2.71	3.26	.08
34	58.77	2.66	2.87	.09	66.40	2.78	3.16	.09
35	57.08	2.73	2.79	.09	64.49	2.85	3.07	.09
36	55.50	2.83	2.72	.09	62.70	2.96	2.99	.09
37	54.00	2.90	2.65	.09	61.01	3.03	2.91	.09
38	52.58	2.97	2.58	.10	59.40	3.11	2.84	.10
39	51.23	3.04	2.52	.10	57.88	3.18	2.77	.10
40	49.95	3.11	2.46	.10	56.43	3.25	2.70	.10

The above values are founded on the moments of inertia of the sections using a maximum fiber strain of 16,000 pounds per square inch for steel; 1/16-inch rivet holes in both flanges deducted. Weights of girders correspond to lengths center to center of bearings and include rivet heads, stiffeners and fillers.

SAFE LOADS IN TONS OF 2000 POUNDS
 Uniformly Distributed, for Steel Plate Girders

Distance Center to Center of Bearings Feet	 36" x 1/2" Web Plate 12" x 3/8" Flange Plates 5" x 3 1/2" x 1/2" Angles				 42" x 5/8" Web Plate 14" x 3/8" Flange Plates 6" x 6" x 7/16" Angles			
	Safe Load, Including Weight of Girder Tons	Weight of Girder Tons	Increase in Safe Load for 1/16" Increase in Thickness of Flange Plates	Increase in Weight of Girder for 1/16" Increase in Thickness of Flange Plates	Safe Load, Including Weight of Girder Tons	Weight of Girder Tons	Increase in Safe Load for 1/16" Increase in Thickness of Flange Plates	Increase in Weight of Girder for 1/16" Increase in Thickness of Flange Plates
20	126.24	1.77	5.90	.05	187.74	2.72	8.25	.06
21	120.23	1:85	5.63	.05	178.80	2.84	7.85	.06
22	114.76	1.92	5.37	.06	170.67	2.95	7.49	.07
23	109.77	2.04	5.14	.06	163.12	3.12	7.17	.07
24	105.20	2.17	4.93	.06	156.45	3.24	6.86	.07
25	100.99	2.19	4.73	.06	150.19	3.36	6.59	.07
26	97.10	2.26	4.55	.07	144.41	3.48	6.34	.08
27	93.51	2.34	4.37	.07	139.06	3.59	6.11	.08
28	90.17	2.41	4.21	.07	134.10	3.71	5.88	.08
29	87.06	2.53	4.07	.07	129.47	3.88	5.69	.09
30	84.16	2.60	3.94	.08	125.16	4.00	5.51	.09
31	81.44	2.68	3.81	.08	121.12	4.12	5.32	.09
32	78.90	2.75	3.69	.08	117.33	4.23	5.15	.10
33	76.81	2.82	3.58	.08	113.78	4.35	5.00	.10
34	74.26	2.89	3.47	.09	110.43	4.47	4.85	.10
35	72.13	2.98	3.37	.09	107.28	4.59	4.71	.10
36	70.13	3.09	3.27	.09	104.30	4.76	4.58	.11
37	68.23	3.16	3.18	.09	101.48	4.87	4.45	.11
38	66.44	3.24	3.10	.10	98.81	4.99	4.32	.11
39	64.74	3.31	3.03	.10	96.27	5.11	4.21	.12
40	63.12	3.39	2.95	.10	93.87	5.23	4.12	.12

The above values are founded on the moments of inertia of the sections using a maximum fiber strain of 16,000 pounds per square inch for steel; 13/16-inch rivet holes in both flanges deducted. Weights of girders correspond to lengths center to center of bearings and include rivet heads, stiffeners and fillers.

SAFE LOADS IN TONS OF 2000 POUNDS
Uniformly Distributed, for Steel Box Girders

Distance Center to Center of Bearings
Feet

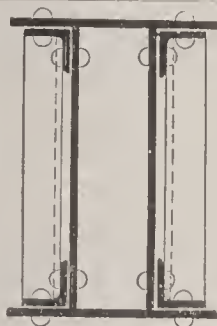

30" x 1/2" Web Plates
16" x 3/8" Flange Plates
3 1/2" x 3 1/2" x 1/2" Angles

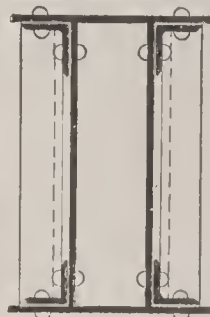

33" x 1/2" Web Plates
20" x 7/16" Flange Plates
3 1/2" x 3 1/2" x 1/2" Angles

Distance Center to Center of Bearings Feet	30" x 1/2" Web Plates 16" x 3/8" Flange Plates 3 1/2" x 3 1/2" x 1/2" Angles				33" x 1/2" Web Plates 20" x 7/16" Flange Plates 3 1/2" x 3 1/2" x 1/2" Angles			
	Safe Load, Including Weight of Girder Tons	Weight of Girder Tons	Increase in Safe Load for 1/16" Increase in Thickness of Flange Plates	Increase in Weight of Girder for 1/16" Increase in Thickness of Flange Plates	Safe Load, Including Weight of Girder Tons	Weight of Girder Tons	Increase in Safe Load for 1/16" Increase in Thickness of Flange Plates	Increase in Weight of Girder for 1/16" Increase in Thickness of Flange Plates
20	120.00	2.13	7.04	.07	160.2	2.44	9.54	.09
21	114.28	2.23	6.70	.07	152.6	2.55	9.08	.09
22	109.09	2.32	6.40	.08	145.6	2.66	8.67	.09
23	104.34	2.45	6.12	.08	139.3	2.80	8.29	.10
24	100.00	2.54	5.86	.08	133.5	2.91	7.95	.10
25	96.00	2.64	5.63	.09	128.2	3.03	7.63	.11
26	92.30	2.74	5.41	.09	123.2	3.14	7.34	.11
27	88.88	2.83	5.21	.09	118.7	3.25	7.07	.12
28	85.71	2.93	5.03	.10	114.4	3.36	6.82	.12
29	82.76	3.06	4.85	.10	110.5	3.50	6.58	.12
30	80.00	3.16	4.69	.10	106.8	3.61	6.36	.13
31	77.42	3.25	4.54	.11	103.3	3.72	6.15	.13
32	75.00	3.35	4.40	.11	100.1	3.83	5.96	.14
33	72.72	3.50	4.26	.11	97.1	3.95	5.78	.14
34	70.59	3.54	4.14	.12	94.2	4.06	5.60	.14
35	68.57	3.64	4.02	.12	91.5	4.17	5.44	.15
36	66.66	3.76	3.91	.12	89.0	4.31	5.29	.15
37	64.86	3.86	3.80	.13	86.6	4.41	5.14	.16
38	63.16	3.95	3.70	.13	84.3	4.53	5.01	.16
39	61.54	4.05	3.61	.13	82.1	4.65	4.88	.17
40	60.00	4.15	3.52	.14	80.1	4.76	4.77	.17

The above values are founded on the moments of inertia of the sections using a maximum fiber strain of 16,000 pounds per square inch for steel; 13/16-inch rivet holes in both flanges deducted. Weights of girders correspond to lengths center to center of bearings and include rivet heads, stiffeners and fillers.

SAFE LOADS IN TONS OF 2000 POUNDS
Uniformly Distributed, for Steel Box Girders

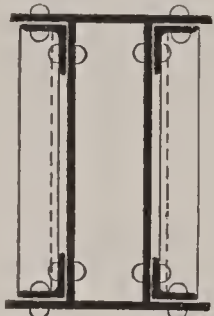
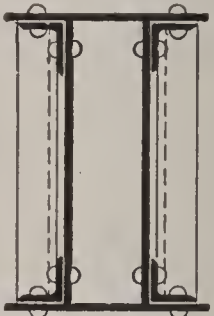
Distance Center to Center of Bearings Feet								
	Safe Load, Including Weight of Girder Tons	Weight of Girder Tons	Increase in Safe Load for $\frac{1}{16}$ " Increase in Thickness of Flange Plates	Increase in Weight of Girder for $\frac{1}{16}$ " Increase in Thickness of Flange Plates	Safe Load, Including Weight of Girder Tons	Weight of Girder Tons	Increase in Safe Load for $\frac{1}{16}$ " Increase in Thickness of Flange Plates	Increase in Weight of Girder for $\frac{1}{16}$ " Increase in Thickness of Flange Plates
20	227.5	2.92	12.92	.10	355.0	3.78	19.43	.13
21	216.7	3.06	12.30	.11	338.1	3.95	18.50	.13
22	206.9	3.19	11.74	.11	322.8	4.13	17.66	.14
23	197.9	3.36	11.23	.12	308.7	4.34	16.89	.15
24	189.6	3.49	10.76	.12	296.0	4.52	16.19	.15
25	182.0	3.63	10.33	.13	284.0	4.69	15.54	.16
26	175.0	3.76	9.94	.13	273.1	4.87	14.94	.17
27	168.5	3.89	9.57	.14	263.0	5.04	14.39	.17
28	162.6	4.03	9.22	.14	253.6	5.21	13.88	.18
29	156.9	4.15	8.91	.15	244.8	5.43	13.40	.19
30	151.7	4.33	8.61	.15	236.7	5.61	12.95	.19
31	146.8	4.45	8.33	.16	229.0	5.78	12.53	.20
32	142.2	4.60	8.07	.16	221.9	5.95	12.14	.20
33	137.9	4.74	7.83	.17	215.2	6.12	11.77	.21
34	133.8	4.87	7.60	.17	208.8	6.29	11.43	.22
35	130.0	5.00	7.38	.18	202.9	6.47	11.10	.22
36	126.4	5.17	7.17	.18	197.2	6.69	10.79	.23
37	123.0	5.31	6.98	.19	191.9	6.86	10.50	.24
38	119.7	5.44	6.80	.19	186.8	6.94	10.22	.24
39	116.7	5.58	6.62	.20	182.1	7.20	9.96	.25
40	113.8	5.71	6.46	.20	177.5	7.38	9.71	.26

The above values are founded on the moments of inertia of the sections using a maximum fiber strain of 16,000 pounds per square inch for steel; $\frac{13}{16}$ " rivet holes in both flanges deducted. Weights of girders correspond to lengths center to center of bearings and include rivet heads, stiffeners and fillers.

Steel Columns in Fireproof Buildings

The construction of steel-frame fireproof buildings is becoming general in cities and towns. In the business centers of our great cities no other form can be used to advantage, and the architects who are keeping pace with improvements recognize the desirability of the improved construction. This change has been facilitated in no small degree by the great improvements made in the art of fireproof construction, insuring not only a higher degree of efficiency, but a considerable reduction in cost, as compared with methods formerly practiced.

The old style of solid brick or stone arch, at one time so common, has been almost wholly supplanted by the modern forms of hollow tile and terra cotta, and roofs, ceilings and partition walls are now largely constructed of these refractory materials.

The substitution of steel for iron in beams has hastened this radical improvement. Our patterns of beams and channels, having the highest efficiency, are well adapted for this purpose.

For some time past another change which has gradually taken place has been the substitution of steel for cast-iron in the composition of columns, cast-iron being a material so uncertain in character that its use in bridge construction has long since been abandoned. In buildings the loads are generally quiescent, and the liability of sudden shocks is more remote than in bridges; yet on the other hand, the columns seldom receive their loads as favorably as in bridges. In many cases there exists considerable eccentricity, that is, the loads on one side of the column are heavier than on the other side, and the bending strains arising therefrom increase the strains from direct compression materially.

The following are some of the contingencies which may arise in the manufacture of castings, and which preclude anything approaching uniformity in the product:

In the case of hollow cast-iron columns, while the metal is yet in a molten state, the buoyancy of the central core tends to cause it to rise, thereby reducing the thickness of the metal above and increasing the same below. When columns are of

such lengths as to make it necessary to pour the metal into the molds from both ends, it sometimes occurs that the iron becomes too much chilled on the surface to properly mix and unite, thus creating a weak seam at the very point where the greatest strength will be needed. The presence of confined air, producing "blowholes" and "honeycomb," and the collection of impurities at the bottom of the mold, may be further mentioned as frequent sources of weakness in cast-iron.

The most critical condition, however, is that due to the unequal contraction of the metal during the process of cooling, thereby giving rise to initial strains, at times of sufficient force to produce rupture in the column or in its lugs on the slightest provocation. In many cases the trouble can be ascribed to faulty designing or carelessness in the execution of the work, yet even under favorable conditions it is so difficult to secure equal radiation from the molds in all directions, that castings, entirely exempt from inherent shrinkage strains, are probably seldom produced.

As a protection against these contingencies, resort must be had either to the crude or uncertain expedient of a high safety factor, not less than 8 or 10, or a material, such as rolled steel, must be adopted, of a more uniform and reliable character than cast-iron.

Steel columns fail either by deflecting bodily out of a straight line, or by buckling of the metal between rivets or other points of support. Both actions may take place at the same time, but if the latter occurs alone, it may be an indication that the rivet spacing or the thickness of the metal is insufficient.

The rule has been deduced from actual experiments upon steel columns, that the distance between centers of rivets should not exceed, in the line of strain, sixteen times the thickness of metal of the parts joined, and that the distance between rivets or other points of support, at right angles to the line of strain, should not exceed thirty-two times the thickness of the metal.

On page 64 are shown sections of some of the most common forms of built columns. Figs. 5, 6 and 7 are known as closed columns. As it is impracticable to repaint the inner surface of such columns, it is preferable to use them only for interior

work where the changes in temperature are not considerable and the air is dry. In places exposed to the extremes of temperature and unprotected from rain, the paint on the inner surface of the column will sooner or later cease to be a protection. Corrosion will set in, and, once begun, will continue as long as there is unoxidized metal left in the column. The remaining figures on this page represent columns with open sections or latticed columns, which admit of repainting and are suitable for out-of-door work.

Cast and steel bases are shown on page 64. Complete tables giving the safe loads in tons for plate and channel columns or plate and angle columns shown by Figures 5 and 10 on same page, are given on pages 152 to 169.

SAFE LOADS IN TONS OF 2000 POUNDS
6" Channel Column. Square Ends.

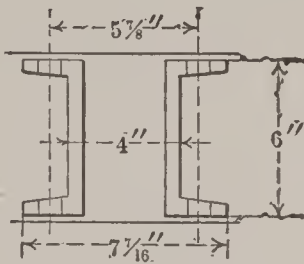

Allowable strain per square inch equals
 12,000 pounds for lengths of 90 radii
 or less; $17,100 - 57\frac{1}{r}$ for lengths over
 90 radii. Safety factor = 4.

Section: 2-6" — laced with $1\frac{1}{2}'' \times \frac{5}{16}''$ bars;
 or 2-6" — and 2-8" wide side plates.

Holes in flanges, $\frac{1}{16}''$ or less. Rivets in flanges, $\frac{5}{8}''$ or less.

Section	Area in Sq. Inches	Weight in Pounds per Lineal Foot of Columns	Least r	Unsupported Column Lengths Feet					
				14	16	18	20	22	24
2-6" — 8 laced...	4.76	22.75	2.34	...	28.6	28.2	26.8	25.4	24.0
2-6" — 8 2-8x1/4"	8.76	31.6	2.32	...	52.6	51.6	49.1	46.5	44.0
2-6" — 8 2-8x5/16"	9.76	35.0	2.32	...	58.6	57.5	54.7	51.8	49.0
2-6" — 8 2-8x3/8"	10.76	38.4	2.32	...	64.6	63.4	60.3	57.1	54.0
2-6" — 8 2-8x7/16"	11.76	41.8	2.32	...	70.6	69.3	65.9	62.4	59.0
2-6" — 8 2-8x1/2"	12.76	45.2	2.32	...	76.6	75.2	71.5	67.7	64.0
2-6" — 8 2-8x9/16"	13.76	48.6	2.32	...	82.6	81.1	77.1	73.0	69.0
2-6" — 8 2-8x5/8"	14.76	52.0	2.32	...	88.6	87.0	82.7	78.3	74.0
2-6" — 8 2-8x11/16"	15.76	55.4	2.32	...	94.6	92.9	88.3	83.6	79.1
2-6" — 10 1/2 laced...	6.18	27.75	2.21	...	37.1	35.6	33.7	31.8	29.9
2-6" — 10 1/2 2-8x1/4"	10.18	36.6	2.25	...	61.1	59.2	56.1	52.9	49.9
2-6" — 10 1/2 2-8x5/16"	11.18	40.0	2.25	...	67.1	65.0	61.6	58.1	54.8
2-6" — 10 1/2 2-8x3/8"	12.18	43.4	2.26	...	73.1	70.9	67.3	63.6	59.9
2-6" — 10 1/2 2-8x7/16"	13.18	46.8	2.26	...	79.1	76.8	72.8	68.8	64.8
2-6" — 10 1/2 2-8x1/2"	14.18	50.2	2.26	...	85.1	82.6	78.3	74.0	69.7
2-6" — 10 1/2 2-8x9/16"	15.18	53.6	2.26	...	91.1	88.4	83.8	79.3	74.7
2-6" — 10 1/2 2-8x5/8"	16.18	57.0	2.27	...	97.1	94.5	89.6	84.5	79.8
2-6" — 10 1/2 2-8x11/16"	17.18	60.4	2.27	...	103.1	100.3	95.1	89.9	84.7
2-6" — 13 laced...	7.64	32.75	2.13	45.8	45.7	43.3	40.8	38.3	35.9
2-6" — 13 2-8x5/16"	12.64	45.0	2.20	...	75.8	72.7	68.8	64.8	60.9
2-6" — 13 2-8x3/8"	13.64	48.4	2.21	...	81.8	78.6	74.4	70.2	65.9
2-6" — 13 2-8x7/16"	14.64	51.8	2.22	...	87.8	84.5	80.0	75.4	70.9
2-6" — 13 2-8x1/2"	15.64	55.2	2.22	...	93.8	90.4	85.5	80.7	75.9
2-6" — 13 2-8x9/16"	16.64	58.6	2.23	...	99.8	96.3	91.1	85.9	80.8
2-6" — 13 2-8x5/8"	17.64	62.0	2.23	...	105.8	102.2	96.7	91.3	85.8
2-6" — 13 2-8x11/16"	18.64	65.4	2.24	...	111.8	108.1	102.3	96.6	90.8
2-6" — 13 2-8x3/4"	19.64	68.8	2.24	...	117.8	114.0	107.9	101.9	95.8
2-6" — 15 1/2 laced...	9.12	37.75	2.06	54.7	53.7	50.7	47.7	44.6	41.6
2-6" — 15 1/2 2-8x5/16"	14.12	50.0	2.15	...	84.7	80.3	75.8	71.3	66.8
2-6" — 15 1/2 2-8x3/8"	15.12	53.4	2.17	...	90.7	86.4	81.5	76.7	71.8
2-6" — 15 1/2 2-8x7/16"	16.12	56.8	2.17	...	96.7	92.1	87.0	82.0	76.9
2-6" — 15 1/2 2-8x1/2"	17.12	60.2	2.18	...	102.7	98.0	92.6	87.3	81.9
2-6" — 15 1/2 2-8x9/16"	18.12	63.6	2.19	...	108.7	104.0	98.3	92.7	87.0
2-6" — 15 1/2 2-8x5/8"	19.12	67.0	2.20	...	114.7	109.9	104.0	98.0	92.0
2-6" — 15 1/2 2-8x11/16"	20.12	70.4	2.20	...	120.7	115.8	109.6	103.3	97.1
2-6" — 15 1/2 2-8x3/4"	21.12	73.8	2.21	...	126.7	121.7	115.2	108.6	102.1

NOTE.—Weights of column shafts include rivets.

SAFE LOADS IN TONS OF 2000 POUNDS
7" Channel Column. Square Ends

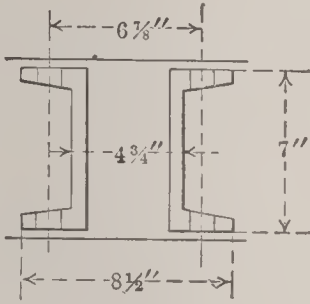

Allowable strain per square inch equals 12,000 pounds for lengths of 90 radii or less; $17,100 - 57 \frac{1}{r}$ for lengths over 90 radii. Safety factor = 4.
Section: 2-7" — laced with $1 \frac{3}{4}$ " x $\frac{5}{16}$ " bars; or 2-7" — and 2-9" bars. Holes, $\frac{13}{16}$ "; rivets, $\frac{3}{4}$ " diameter.

Section	Area in Sq. Inches	Weight, Lbs. per Lin. Ft.	Least r	Unsupported Column Lengths Feet					
				18	20	22	24	26	28
2-7" — $9 \frac{3}{4}$ " laced	5.70	27.1	2.72	34.2	33.0	31.5	30.1	28.7
2-7" — $9 \frac{3}{4}$ " 2-9" x $\frac{1}{4}$ "	10.20	36.8	2.67	61.2	58.5	55.9	53.2	50.6
2-7" — $9 \frac{3}{4}$ " 2-9" x $\frac{5}{16}$ "	11.32	40.6	2.67	67.9	64.9	62.0	59.0	56.1
2-7" — $9 \frac{3}{4}$ " 2-9" x $\frac{3}{8}$ "	12.45	44.5	2.66	74.7	71.2	68.0	64.7	61.5
2-7" — $9 \frac{3}{4}$ " 2-9" x $\frac{7}{16}$ "	13.58	48.3	2.66	81.5	77.6	74.1	70.5	67.0
2-7" — $9 \frac{3}{4}$ " 2-9" x $\frac{1}{2}$ "	14.70	52.1	2.65	88.2	87.8	83.9	80.1	76.3	72.5
2-7" — $9 \frac{3}{4}$ " 2-9" x $\frac{9}{16}$ "	15.85	55.9	2.65	95.0	94.4	90.3	86.2	82.0	77.9
2-7" — $9 \frac{3}{4}$ " 2-9" x $\frac{5}{8}$ "	16.95	59.8	2.64	101.7	101.0	96.6	92.2	87.8	83.4
2-7" — $12 \frac{1}{4}$ " laced	7.20	32.1	2.59	43.2	42.5	40.6	38.7	36.8	34.9
2-7" — $12 \frac{1}{4}$ " 2-9" x $\frac{1}{4}$ "	11.70	41.8	2.59	70.2	69.1	66.0	62.9	59.9	56.8
2-7" — $12 \frac{1}{4}$ " 2-9" x $\frac{5}{16}$ "	12.82	45.6	2.59	76.9	75.8	72.4	69.0	65.7	62.3
2-7" — $12 \frac{1}{4}$ " 2-9" x $\frac{3}{8}$ "	13.95	49.5	2.59	83.7	82.4	78.7	75.0	71.4	67.7
2-7" — $12 \frac{1}{4}$ " 2-9" x $\frac{7}{16}$ "	15.08	53.3	2.59	90.5	89.1	85.1	81.1	77.2	73.2
2-7" — $12 \frac{1}{4}$ " 2-9" x $\frac{1}{2}$ "	16.20	57.1	2.59	97.2	95.7	91.4	87.2	82.9	78.6
2-7" — $12 \frac{1}{4}$ " 2-9" x $\frac{9}{16}$ "	17.35	60.9	2.59	104.0	102.4	97.8	93.2	88.7	84.1
2-7" — $12 \frac{1}{4}$ " 2-9" x $\frac{5}{8}$ "	18.45	64.8	2.59	110.7	109.0	104.1	99.3	94.4	89.5
2-7" — $14 \frac{3}{4}$ " laced	8.68	37.1	2.50	52.1	50.5	48.1	45.7	43.3	41.0
2-7" — $14 \frac{3}{4}$ " 2-9" x $\frac{1}{4}$ "	13.18	46.8	2.53	79.1	77.0	73.5	69.9	66.4	62.9
2-7" — $14 \frac{3}{4}$ " 2-9" x $\frac{5}{16}$ "	14.30	50.6	2.54	85.8	83.7	79.9	76.0	72.2	68.4
2-7" — $14 \frac{3}{4}$ " 2-9" x $\frac{3}{8}$ "	15.43	54.5	2.54	92.6	90.4	86.3	82.1	78.0	73.8
2-7" — $14 \frac{3}{4}$ " 2-9" x $\frac{7}{16}$ "	16.56	58.3	2.55	99.4	97.1	92.7	88.2	83.8	79.3
2-7" — $14 \frac{3}{4}$ " 2-9" x $\frac{1}{2}$ "	17.68	62.1	2.55	106.1	103.8	99.0	94.3	89.6	84.8
2-7" — $14 \frac{3}{4}$ " 2-9" x $\frac{9}{16}$ "	18.81	65.9	2.55	112.9	110.5	105.4	100.4	95.4	90.2
2-7" — $14 \frac{3}{4}$ " 2-9" x $\frac{5}{8}$ "	19.93	69.8	2.56	119.6	117.2	111.8	106.5	101.2	95.7
2-7" — $17 \frac{1}{4}$ " laced	10.14	42.1	2.43	60.8	58.3	55.4	52.5	49.6	46.7
2-7" — $17 \frac{1}{4}$ " 2-9" x $\frac{1}{4}$ "	14.64	51.8	2.49	87.8	85.0	80.9	76.9	72.9	68.9
2-7" — $17 \frac{1}{4}$ " 2-9" x $\frac{3}{8}$ "	16.89	59.5	2.50	101.3	98.2	93.6	89.0	84.4	79.8
2-7" — $17 \frac{1}{4}$ " 2-9" x $\frac{1}{2}$ "	19.14	67.1	2.51	114.8	111.5	106.3	101.1	95.9	90.7
2-7" — $17 \frac{1}{4}$ " 2-9" x $\frac{5}{8}$ "	21.39	74.8	2.52	128.3	124.8	119.0	113.2	107.4	101.6
2-7" — $19 \frac{3}{4}$ " laced	11.62	47.1	2.39	69.7	66.1	62.8	59.5	56.2	52.8
2-7" — $19 \frac{3}{4}$ " 2-9" x $\frac{1}{4}$ "	16.12	56.8	2.45	96.7	92.8	88.3	83.8	79.3	74.8
2-7" — $19 \frac{3}{4}$ " 2-9" x $\frac{3}{8}$ "	18.37	64.5	2.46	110.2	106.0	100.9	95.8	90.7	85.7
2-7" — $19 \frac{3}{4}$ " 2-9" x $\frac{1}{2}$ "	20.62	72.1	2.47	123.7	119.2	113.6	107.8	102.1	96.5
2-7" — $19 \frac{3}{4}$ " 2-9" x $\frac{5}{8}$ "	22.87	79.8	2.48	137.2	132.5	126.2	119.9	113.6	107.4
2-7" — $19 \frac{3}{4}$ " 2-9" x $\frac{3}{4}$ "	25.12	87.4	2.49	150.7	145.8	138.9	132.0	125.1	118.2

NOTE.—Weights of column shafts include rivets.

SAFE LOADS IN TONS OF 2000 POUNDS

8" Channel Column. Square Ends

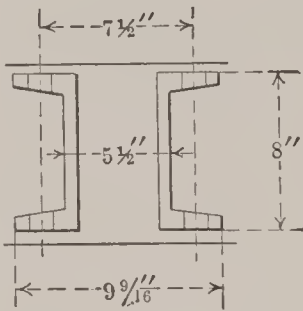

Allowable strains per square inch = 12,000 pounds for lengths of 90 radii or less. 17,100 pounds — $57 \frac{1}{r}$ for lengths over 90 radii.

Safety factor = 4.

Section: 2-8" — laced with $1 \frac{3}{4}$ " x $\frac{5}{16}$ " bars. Holes, $\frac{1}{16}$ "; rivets, $\frac{3}{4}$ " diameter, or 2-8" — and 2-10" bars.

Section	Area in Sq. Inches	Weight, Lbs. per Lin. Ft.	Least	Unsupported Column Lengths Feet					
				20	22	24	26	28	30
Pounds Bars									
2-8" — 11 1/4 laced.....	6.70	30.13	13.11	40.2	39.6	38.1	36.7	35.2
2-8" — 11 1/4 2-10 x 1/4"	11.70	41.53	3.03	70.2	68.3	65.7	63.0	60.4
2-8" — 11 1/4 2-10 x 5/16"	12.95	45.73	3.02	77.7	75.5	72.6	69.6	66.7
2-8" — 11 1/4 2-10 x 3/8"	14.20	50.03	3.02	85.2	82.7	79.5	76.2	73.0
2-8" — 11 1/4 2-10 x 7/16"	15.45	54.23	3.01	92.7	89.9	86.4	82.8	79.3
2-8" — 11 1/4 2-10 x 1/2"	16.70	58.53	3.00	100.2	97.1	93.3	89.5	85.7
2-8" — 11 1/4 2-10 x 9/16"	17.95	62.73	3.00	107.7	104.3	100.2	96.1	92.0
2-8" — 11 1/4 2-10 x 5/8"	19.20	67.02	2.99	115.2	111.5	107.1	102.7	98.3
2-8" — 13 3/4 laced.....	8.08	35.12	2.98	48.5	46.8	45.0	43.1	41.3
2-8" — 13 3/4 2-10 x 1/4"	13.08	46.53	3.00	78.5	76.0	73.0	70.1	67.1
2-8" — 13 3/4 2-10 x 5/16"	14.33	50.72	2.99	86.0	83.2	79.9	76.6	73.4
2-8" — 13 3/4 2-10 x 3/8"	15.58	55.02	2.98	93.5	90.3	86.7	83.2	79.6
2-8" — 13 3/4 2-10 x 7/16"	16.83	59.22	2.98	101.0	97.5	93.5	89.8	85.9
2-8" — 13 3/4 2-10 x 1/2"	18.08	63.52	2.97	108.5	104.6	100.4	96.3	92.1
2-8" — 13 3/4 2-10 x 9/16"	19.33	67.72	2.96	116.0	111.7	107.2	102.8	98.3
2-8" — 13 3/4 2-10 x 5/8"	20.58	72.02	2.96	123.5	118.9	114.1	109.4	104.6
2-8" — 16 1/4 laced.....	9.56	40.12	2.89	57.4	56.8	54.6	52.3	50.1	47.8
2-8" — 16 1/4 2-10 x 3/8"	17.06	60.02	2.93	102.4	102.1	98.1	94.1	90.1	86.2
2-8" — 16 1/4 2-10 x 7/16"	18.31	64.22	2.93	109.9	109.5	105.3	101.0	96.7	92.5
2-8" — 16 1/4 2-10 x 1/2"	19.56	68.52	2.92	117.4	117.0	112.4	107.9	103.3	98.7
2-8" — 16 1/4 2-10 x 9/16"	20.81	72.72	2.92	124.9	124.4	119.6	114.7	109.9	105.0
2-8" — 16 1/4 2-10 x 5/8"	22.06	77.02	2.92	132.4	131.8	126.7	121.5	116.4	111.2
2-8" — 16 1/4 2-10 x 1/6"	23.33	81.22	2.92	139.9	139.3	133.9	128.4	123.0	117.5
2-8" — 16 1/4 2-10 x 3/4"	24.56	85.52	2.92	147.4	146.7	140.9	135.2	129.4	123.7
2-8" — 18 3/4 laced.....	11.02	45.12	2.82	66.1	64.8	62.2	59.5	56.8	54.1
2-8" — 18 3/4 2-10 x 3/8"	18.52	65.02	2.89	111.1	110.1	105.7	101.4	97.0	92.6
2-8" — 18 3/4 2-10 x 1/2"	21.02	73.52	2.89	126.1	125.0	120.0	115.0	110.1	105.1
2-8" — 18 3/4 2-10 x 5/8"	23.52	82.02	2.89	141.1	139.8	134.3	128.7	123.2	117.6
2-8" — 18 3/4 2-10 x 3/4"	26.02	90.52	2.89	156.1	154.7	148.6	142.4	136.3	130.1
2-8" — 21 1/4 laced.....	12.5	50.12	2.77	75.0	72.9	69.8	66.7	63.7	60.6
2-8" — 21 1/4 2-10 x 3/8"	20.0	70.02	2.83	120.0	117.9	113.1	108.2	103.4	98.5
2-8" — 21 1/4 2-10 x 1/2"	22.5	78.52	2.83	135.0	132.8	127.4	121.9	116.5	111.0
2-8" — 21 1/4 2-10 x 5/8"	25.0	87.02	2.84	150.0	147.6	141.6	135.6	129.5	123.5
2-8" — 21 1/4 2-10 x 3/4"	27.5	95.52	2.84	165.0	162.5	155.9	149.3	142.6	135.0
2-8" — 21 1/4 2-10 x 7/8"	30.0	104.02	2.85	180.0	177.3	170.1	162.9	155.7	148.5

NOTE.—Weights of column shafts include rivets.

SAFE LOADS IN TONS OF 2000 POUNDS
9" Channel Column. Square Ends

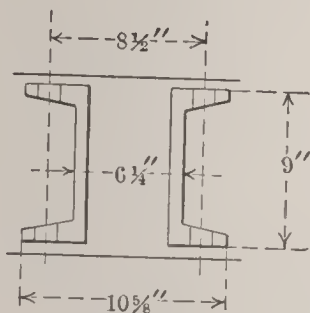

Allowable strain per square inch =
 12,000 pounds for lengths of 90 radii
 or less. 17,100 pounds — $57 \frac{1}{r}$ for
 lengths over 90 radii.
 Safety factor = 4.
 Section: 2-9" — laced with 2" x $\frac{5}{16}$ "
 bars. Holes, $\frac{13}{16}$ "; rivets, $\frac{3}{4}$ " diameter,
 or 2-9" — and 2-11" bars.

Section	Area in Sq. Inches	Weight, Lbs. per Lin. Ft.	Least r	Unsupported Column Lengths Feet					
				22	24	26	28	30	32
2-9" — 13 1/4 laced.....	7.78	34.93.49	46.7	46.7	45.2	43.6	42.1	
2-9" — 13 1/4 2-11 x 1/4"	13.28	47.23.41	79.7	78.9	76.3	73.6	70.9	
2-9" — 13 1/4 2-11 x 5/16"	14.66	57.93.40	88.0	86.8	83.9	80.9	78.0	
2-9" — 13 1/4 2-11 x 3/8"	16.03	56.63.38	96.2	94.7	91.5	88.3	85.0	
2-9" — 13 1/4 2-11 x 7/16"	17.41	61.23.37	104.5	102.6	99.1	95.6	92.1	
2-9" — 13 1/4 2-11 x 1/2"	18.78	65.93.35	112.7	110.6	106.7	102.9	99.1	
2-9" — 13 1/4 2-11 x 9/16"	20.16	70.63.34	121.0	118.5	114.4	110.3	106.2	
2-9" — 13 1/4 2-11 x 5/8"	21.53	75.33.32	129.2	126.4	122.0	117.6	113.2	
2-9" — 15 laced.....	8.82	38.43.40	52.9	52.3	50.6	48.8	47.0	
2-9" — 15 2-11 x 1/4"	14.32	50.73.36	85.9	84.5	81.7	78.8	75.9	
2-9" — 15 2-11 x 5/16"	15.70	55.43.34	94.2	92.5	89.3	86.1	82.9	
2-9" — 15 2-11 x 3/8"	17.07	60.13.33	102.4	100.4	96.9	93.4	89.9	
2-9" — 15 2-11 x 7/16"	18.45	64.73.32	110.7	108.3	104.5	100.7	96.9	
2-9" — 15 2-11 x 1/2"	19.82	69.43.31	118.9	116.2	112.1	108.0	103.9	
2-9" — 15 2-11 x 9/16"	21.20	74.13.30	127.2	124.1	119.7	115.3	110.9	
2-9" — 15 2-11 x 5/8"	22.57	78.83.29	135.4	132.0	127.3	122.6	117.9	
2-9" — 20 laced.....	11.76	48.43.21	70.6	68.0	65.5	63.0	60.5	
2-9" — 20 2-11 x 5/16"	18.64	65.43.27	111.8	108.7	104.8	100.9	97.0	
2-9" — 20 2-11 x 3/8"	20.01	70.13.26	120.1	116.6	112.4	108.2	104.0	
2-9" — 20 2-11 x 7/16"	21.39	74.73.26	128.3	124.5	120.0	115.5	111.0	
2-9" — 20 2-11 x 1/2"	22.76	79.43.25	136.6	132.4	127.6	122.8	118.1	
2-9" — 20 2-11 x 9/16"	24.14	84.13.25	144.8	140.3	135.3	130.2	125.1	
2-9" — 20 2-11 x 5/8"	25.51	88.83.25	153.1	148.2	142.9	137.5	132.1	
2-9" — 20 2-11 x 11/16"	26.89	93.43.24	161.3	156.2	150.5	144.8	139.1	
2-9" — 20 2-11 x 3/4"	28.26	98.13.24	169.6	164.1	158.1	152.1	146.2	
2-9" — 25 laced.....	14.70	58.43.10	88.2	86.8	83.5	80.3	77.0	73.8	
2-9" — 25 2-11 x 3/8"	22.95	80.13.18	137.8	137.0	132.1	127.1	122.2	117.2	
2-9" — 25 2-11 x 7/16"	24.33	84.73.18	146.0	145.2	140.0	134.7	129.5	124.3	
2-9" — 25 2-11 x 1/2"	25.70	89.43.18	154.2	153.4	147.9	142.3	136.8	131.3	
2-9" — 25 2-11 x 9/16"	27.08	94.13.18	162.5	161.6	155.8	150.0	144.1	138.3	
2-9" — 25 2-11 x 5/8"	28.45	98.83.18	170.7	169.8	163.7	157.6	151.5	145.3	
2-9" — 25 2-11 x 11/16"	29.83	103.43.18	179.0	178.0	171.6	165.2	158.8	152.4	
2-9" — 25 2-11 x 3/4"	31.20	108.13.18	187.2	186.3	179.5	172.8	166.1	159.4	
2-9" — 25 2-11 x 13/16"	32.58	112.83.18	195.5	194.5	187.4	180.4	173.4	166.4	
2-9" — 25 2-11 x 7/8"	33.95	117.53.18	203.7	202.7	195.4	188.1	180.7	173.4	
2-9" — 25 2-11 x 15/16"	35.33	122.13.18	212.0	210.9	203.3	195.7	188.1	180.5	

NOTE.—Weights of column shafts include rivets.

SAFE LOADS IN TONS OF 2000 POUNDS

10" Channel Column. Square Ends

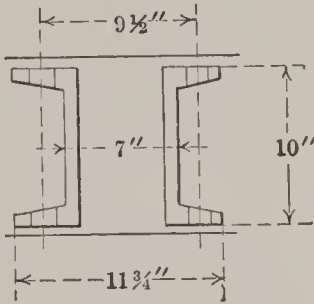

Allowable strain per square inch = 12,000 pounds for lengths of 90 radii or less. $17,100 - 57 \frac{1}{r}$ for lengths over 90 radii.

Safety factor = 4.

Section: 2-10" \lrcorner laced with 2" x $\frac{5}{16}$ " bars. Holes, $\frac{13}{16}$ "; rivets, $\frac{3}{4}$ " diameter, or 2-10" \lrcorner and 2-12" plates.

Section	Area in Sq. Inches	Weight, Lbs. per Lin. Ft.	Least r	Unsupported Column Lengths Feet					
				24	26	28	30	32	34
Pounds Plates									
2-10" \lrcorner 15 laced.....	8.92	38.43	87.....			53.5	52.6	51.0	49.5
2-10" \lrcorner 15 2-12 x $\frac{1}{4}$ "	14.92	52.43	76.....			89.5	86.9	84.2	82.5
2-10" \lrcorner 15 2-12 x $\frac{5}{16}$ "	16.42	57.53	74.....			98.5	95.4	92.3	89.3
2-10" \lrcorner 15 2-12 x $\frac{3}{8}$ "	17.92	62.63	73.....		107.5	107.2	103.8	100.5	97.2
2-10" \lrcorner 15 2-12 x $\frac{7}{16}$ "	19.42	67.73	71.....	116.5	115.9	112.2	108.6	105.0	
2-10" \lrcorner 15 2-12 x $\frac{1}{2}$ "	20.92	72.83	69.....	125.5	124.6	120.6	116.7	112.8	
2-10" \lrcorner 15 2-12 x $\frac{9}{16}$ "	22.42	77.93	68.....	134.5	133.2	129.0	124.8	120.7	
2-10" \lrcorner 15 2-12 x $\frac{5}{8}$ "	23.92	83.03	66.....	143.5	141.9	137.5	133.0	128.5	
2-10" \lrcorner 20 laced.....	11.76	48.43	66.....	70.6	69.8	67.6	65.4	63.2	
2-10" \lrcorner 20 2-12 x $\frac{3}{8}$ "	20.75	72.63	65.....	124.5	123.0	119.1	115.2	111.3	
2-10" \lrcorner 20 2-12 x $\frac{7}{16}$ "	22.26	77.73	64.....	133.5	131.7	127.5	123.3	119.1	
2-10" \lrcorner 20 2-12 x $\frac{1}{2}$ "	23.76	82.83	63.....	142.6	140.4	135.9	131.5	127.0	
2-10" \lrcorner 20 2-12 x $\frac{9}{16}$ "	25.26	87.93	62.....	151.6	149.1	144.4	139.6	134.8	
2-10" \lrcorner 20 2-12 x $\frac{5}{8}$ "	26.76	93.03	61.....	160.6	157.8	152.8	147.7	142.6	
2-10" \lrcorner 20 2-12 x $\frac{11}{16}$ "	28.26	98.13	61.....	169.6	166.6	161.2	155.9	150.5	
2-10" \lrcorner 20 2-12 x $\frac{3}{4}$ "	29.76	103.23	60.....	178.6	175.3	169.6	164.0	158.3	
2-10" \lrcorner 25 laced.....	14.70	58.43	52.....	88.2	85.7	82.8	80.0	77.1	
2-10" \lrcorner 25 2-12 x $\frac{1}{4}$ "	26.70	92.83	57.....	160.2	156.7	151.5	146.4	141.2	
2-10" \lrcorner 25 2-12 x $\frac{5}{16}$ "	28.20	97.93	57.....	169.2	165.4	159.9	154.5	149.0	
2-10" \lrcorner 25 2-12 x $\frac{3}{8}$ "	29.70	103.03	56.....	178.2	174.0	168.3	162.5	156.8	
2-10" \lrcorner 25 2-12 x $\frac{7}{16}$ "	31.20	108.13	56.....	187.2	182.7	176.7	170.6	164.6	
2-10" \lrcorner 25 2-12 x $\frac{1}{2}$ "	32.70	113.23	55.....	196.2	191.4	185.1	178.7	172.4	
2-10" \lrcorner 25 2-12 x $\frac{9}{16}$ "	34.20	118.33	55.....	205.2	200.1	193.5	186.8	180.2	
2-10" \lrcorner 25 2-12 x $\frac{5}{8}$ "	35.70	123.43	54.....	214.2	208.7	201.8	194.9	188.0	
2-10" \lrcorner 30 laced.....	17.64	68.43	42.....	105.8	101.4	97.9	94.4	90.8	
2-10" \lrcorner 30 2-12 x $\frac{5}{8}$ "	32.64	113.03	50.....	195.8	189.8	183.4	177.0	170.6	
2-10" \lrcorner 30 2-12 x $\frac{3}{4}$ "	35.64	123.23	50.....	213.8	207.1	200.1	193.1	186.2	
2-10" \lrcorner 25 2-12 x $\frac{7}{8}$ "	38.64	133.43	50.....	231.8	224.4	216.9	209.3	201.7	
2-10" \lrcorner 30 2-12 x 1"	41.64	143.63	49.....	249.8	241.8	233.6	225.4	217.3	
2-10" \lrcorner 35 laced.....	20.58	78.43	35	123.5	121.3	117.2	113.0	108.9	104.7
2-10" \lrcorner 35 2-12 x $\frac{5}{8}$ "	35.58	124.03	45	213.5	212.5	205.5	198.4	191.3	184.3
2-10" \lrcorner 35 2-12 x $\frac{3}{4}$ "	38.58	133.23	45	231.5	230.4	222.8	215.1	207.5	199.8
2-10" \lrcorner 35 2-12 x $\frac{7}{8}$ "	41.58	143.43	45	249.5	248.3	240.1	231.8	223.6	215.4
2-10" \lrcorner 35 2-12 x 1"	44.58	153.63	45	267.5	266.2	257.4	248.6	239.7	230.9
2-10" \lrcorner 35 2-12 x $1\frac{1}{8}$ "	47.58	163.83	45	285.5	284.1	274.7	265.3	255.8	246.4

NOTE.—Weights of column shafts include rivets.

SAFE LOADS IN TONS OF 2000 POUNDS
12" Channel Column. Square Ends

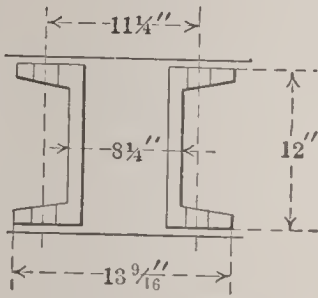

Allowable strain per square inch = 12,000 pounds for lengths of 90 radii or less. $17,100 - 57 \frac{1}{r}$ for lengths over 90 radii.

Safety factor = 4.

Section: 2-12" \lrcorner laced with 2" x $\frac{5}{16}$ " bars. Holes, $\frac{13}{16}$ "; rivets, $\frac{3}{4}$ " diameter, or 2-12" \lrcorner and 2-14" plates.

Section	Area in Sq. Inches	Weight, Lbs. per Lin. Ft.	Least r	Unsupported Column Lengths Feet					
				30	32	34	36	38	40
Pounds Plates									
2-12" \lrcorner 20 $\frac{1}{2}$ laced.....	12.06	49.44	4.61	72.4	70.9	69.1	67.3
2-12" \lrcorner 20 $\frac{1}{2}$ 2-14 x $\frac{5}{16}$ "	20.81	72.74	4.39	124.9	122.8	119.6	116.3	113.1
2-12" \lrcorner 20 $\frac{1}{2}$ 2-14 x $\frac{3}{8}$ "	22.56	78.74	4.37	135.4	132.7	129.2	125.7	122.1
2-12" \lrcorner 20 $\frac{1}{2}$ 2-14 x $\frac{7}{16}$ "	24.31	84.64	4.35	145.9	142.7	138.9	135.0	131.2
2-12" \lrcorner 20 $\frac{1}{2}$ 2-14 x $\frac{1}{2}$ "	26.06	90.64	4.33	156.4	152.6	148.5	144.4	140.3
2-12" \lrcorner 20 $\frac{1}{2}$ 2-14 x $\frac{9}{16}$ "	27.81	96.54	4.32	166.9	162.6	158.2	153.7	149.3
2-12" \lrcorner 20 $\frac{1}{2}$ 2-14 x $\frac{5}{8}$ "	29.56	102.54	4.30	177.4	172.5	167.8	163.1	158.4
2-12" \lrcorner 20 $\frac{1}{2}$ 2-14 x $\frac{11}{16}$ "	31.31	108.44	4.28	187.9	182.5	177.1	172.5	167.4
2-12" \lrcorner 20 $\frac{1}{2}$ 2-14 x $\frac{3}{4}$ "	33.06	114.44	4.26	198.4	192.4	187.1	181.8	176.5
2-12" \lrcorner 25 laced.....	14.70	58.44	4.43	88.2	87.1	84.8	82.6	80.3
2-12" \lrcorner 25 2-14 x $\frac{3}{8}$ "	25.20	87.74	4.30	151.2	147.3	143.3	139.3	135.3
2-12" \lrcorner 25 2-14 x $\frac{7}{16}$ "	26.95	93.64	4.29	161.7	157.3	153.0	148.7	144.4
2-12" \lrcorner 25 2-14 x $\frac{1}{2}$ "	28.70	99.64	4.28	172.2	167.2	162.6	158.0	153.4
2-12" \lrcorner 25 2-14 x $\frac{9}{16}$ "	30.45	105.54	4.27	182.7	177.2	172.3	167.4	162.5
2-12" \lrcorner 25 2-14 x $\frac{5}{8}$ "	32.20	111.54	4.26	193.2	192.6	187.1	181.9	176.8	171.5
2-12" \lrcorner 25 2-14 x $\frac{11}{16}$ "	33.95	117.44	4.25	203.7	202.8	197.0	191.6	186.1	180.6
2-12" \lrcorner 25 2-14 x $\frac{3}{4}$ "	35.70	123.44	4.23	214.2	212.9	207.0	201.2	195.5	189.7
2-12" \lrcorner 25 2-14 x $\frac{13}{16}$ "	37.45	129.34	4.22	224.7	223.1	216.9	210.9	204.8	198.7
2-12" \lrcorner 25 2-14 x $\frac{7}{8}$ "	39.20	135.34	4.21	235.2	233.3	226.9	220.5	214.2	207.8
2-12" \lrcorner 30 laced.....	17.64	68.44	4.28	105.8	102.9	100.1	97.3	94.4
2-12" \lrcorner 30 2-14 x $\frac{1}{2}$ "	31.64	109.64	4.22	189.8	188.5	183.3	178.2	173.1	168.0
2-12" \lrcorner 30 2-14 x $\frac{5}{8}$ "	35.14	121.54	4.21	210.8	209.0	203.2	197.5	191.8	186.1
2-12" \lrcorner 30 2-14 x $\frac{3}{4}$ "	38.64	133.44	4.19	231.8	229.5	223.2	216.9	210.5	204.3
2-12" \lrcorner 30 2-14 x $\frac{7}{8}$ "	42.16	145.34	4.18	252.8	249.9	243.1	236.2	229.2	222.4
2-12" \lrcorner 30 2-14 x 1"	45.64	157.24	4.17	273.8	270.4	263.0	255.5	247.9	240.5
2-12" \lrcorner 35 laced.....	20.58	78.44	4.17	123.5	121.9	118.6	115.2	111.8	108.5
2-12" \lrcorner 35 2-14 x $\frac{5}{8}$ "	38.08	113.54	4.16	228.5	224.4	218.4	212.4	206.4	200.3
2-12" \lrcorner 35 2-14 x $\frac{3}{4}$ "	41.58	125.44	4.15	249.5	245.2	238.5	231.8	225.1	218.4
2-12" \lrcorner 35 2-14 x $\frac{7}{8}$ "	45.08	137.34	4.14	270.5	265.9	258.5	251.1	243.8	236.4
2-12" \lrcorner 35 2-14 x 1"	48.58	149.24	4.13	291.5	286.6	278.6	270.5	262.5	254.4
2-12" \lrcorner 40 laced.....	23.52	88.44	4.09	141.1	138.2	134.2	130.3	126.4	122.8
2-12" \lrcorner 40 2-14 x $\frac{3}{4}$ "	44.52	153.44	4.10	267.1	261.8	254.4	247.0	239.5	232.1
2-12" \lrcorner 40 2-14 x $\frac{7}{8}$ "	48.02	165.34	4.10	288.1	282.3	274.3	266.3	258.3	250.2
2-12" \lrcorner 40 2-14 x 1"	51.52	177.24	4.10	309.1	302.8	294.2	285.6	277.0	268.4
2-12" \lrcorner 40 2-14 x $1\frac{1}{8}$ "	55.02	189.14	4.09	330.1	323.3	314.1	304.9	295.7	286.5
2-12" \lrcorner 40 2-14 x $1\frac{1}{4}$ "	58.52	201.04	4.09	351.1	343.7	334.0	324.2	314.4	304.6

NOTE.—Weights of column shafts include rivets.

SAFE LOADS IN TONS OF 2000 POUNDS

15" Channel Column. Square Ends

Allowable strains per square inch = 12,000 pounds for lengths of 90 radii or less. $17,100 - 57 \frac{1}{r}$ for lengths over 90 radii.

Safety factor = 4.

Section: 2-15" \perp laced with $2 \frac{1}{4}$ " x $\frac{3}{8}$ " bars. Holes, $\frac{13}{16}$ "; rivets, $\frac{3}{4}$ " diameter, or 2-15" \perp and 2-16" plates.

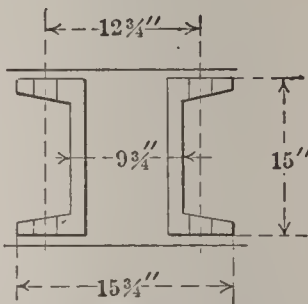

Section	Area in Sq. Inches	Weight, Lbs. per Lin. Ft.	Least r	Unsupported Column Lengths Feet					
				35	37	39	41	43	45
Pounds Plates									
2-15" \perp 33 laced.....	19.80	76.65	5.35	118.8	117.4	114.9	112.3
2-15" \perp 33 2-16 x $\frac{3}{8}$ "	31.80	108.85	5.08	190.8	188.4	184.1	179.8	175.6
2-15" \perp 33 2-16 x $\frac{7}{16}$ "	33.80	115.65	5.07	202.8	199.8	195.2	190.6	186.0
2-15" \perp 33 2-16 x $\frac{1}{2}$ "	35.80	122.45	5.05	214.8	211.2	206.3	201.4	196.5
2-15" \perp 33 2-16 x $\frac{9}{16}$ "	37.80	129.25	5.03	226.8	222.6	217.4	212.2	207.0
2-15" \perp 33 2-16 x $\frac{5}{8}$ "	39.80	136.05	5.01	238.8	233.9	228.5	223.0	217.5
2-15" \perp 33 2-16 x $\frac{11}{16}$ "	41.80	142.85	5.00	250.8	245.3	239.5	233.8	228.0
2-15" \perp 33 2-16 x $\frac{3}{4}$ "	43.80	149.64	4.98	262.8	256.7	250.6	244.6	238.5
2-15" \perp 33 2-16 x $\frac{13}{16}$ "	45.80	156.44	4.96	274.8	268.1	261.7	255.4	249.0
2-15" \perp 33 2-16 x $\frac{7}{8}$ "	47.80	163.24	4.94	286.8	279.4	272.8	266.2	259.5
2-15" \perp 33 2-16 x 1"	51.80	176.84	4.91	310.8	310.8	302.2	295.0	287.7	280.5
2-15" \perp 35 laced.....	20.58	80.65	5.32	123.5	121.7	119.1	116.4
2-15" \perp 35 2-16 x $\frac{3}{8}$ "	32.58	112.85	5.07	195.5	192.9	188.5	184.1	179.7
2-15" \perp 35 2-16 x $\frac{1}{2}$ "	36.58	126.45	5.04	219.5	215.6	210.6	205.6	200.6
2-15" \perp 35 2-16 x $\frac{5}{8}$ "	40.58	140.05	5.00	243.5	238.3	232.7	227.1	221.6
2-15" \perp 35 2-16 x $\frac{3}{4}$ "	44.58	153.64	4.97	267.5	261.0	254.8	248.7	242.5
2-15" \perp 35 2-16 x $\frac{7}{8}$ "	48.58	167.24	4.94	291.5	283.7	277.0	270.2	263.5
2-15" \perp 35 2-16 x 1"	52.58	180.84	4.90	315.5	313.8	306.4	299.1	291.8	284.4
2-15" \perp 40 laced.....	23.52	90.65	5.21	141.1	137.8	134.7	131.6
2-15" \perp 40 2-16 x $\frac{1}{2}$ "	39.52	136.44	4.98	237.1	232.0	226.6	221.2	215.8
2-15" \perp 40 2-16 x $\frac{3}{4}$ "	47.52	163.64	4.94	285.1	277.4	270.8	264.2	257.6
2-15" \perp 40 2-16 x 1"	55.52	190.84	4.90	333.1	330.6	322.8	315.0	307.3	299.5
2-15" \perp 40 2-16 x $1 \frac{1}{4}$ "	63.52	218.04	4.86	381.1	377.2	368.2	359.3	350.3	341.4
2-15" \perp 40 2-16 x $1 \frac{1}{2}$ "	71.52	245.24	4.82	429.1	423.8	413.6	403.5	393.3	383.2
2-15" \perp 45 laced.....	26.48	100.65	5.12	158.9	157.4	153.9	150.3	146.8
2-15" \perp 45 2-16 x $\frac{1}{2}$ "	42.48	146.44	4.94	254.5	248.5	242.6	236.8	230.9
2-15" \perp 45 2-16 x $\frac{3}{4}$ "	50.48	173.64	4.90	302.5	300.8	293.8	286.8	279.7	272.7
2-15" \perp 45 2-16 x 1"	58.48	200.84	4.87	350.5	347.4	339.2	330.9	322.7	314.4
2-15" \perp 45 2-16 x $1 \frac{1}{4}$ "	66.48	228.04	4.84	398.5	393.9	384.5	375.1	365.7	356.2
2-15" \perp 45 2-16 x $1 \frac{1}{2}$ "	74.48	255.24	4.80	446.5	440.5	429.8	419.2	408.6	398.0
2-15" \perp 50 laced.....	29.42	110.65	5.02	176.5	173.4	169.4	165.4	161.4
2-15" \perp 50 2-16 x $\frac{3}{4}$ "	53.42	183.64	4.84	320.5	317.1	309.5	302.0	294.4	286.8
2-15" \perp 50 2-16 x 1"	61.42	210.84	4.82	368.5	363.7	355.0	346.2	337.5	328.8
2-15" \perp 50 2-16 x $1 \frac{1}{4}$ "	69.42	238.04	4.80	416.5	410.3	400.4	390.5	380.6	370.7
2-15" \perp 50 2-16 x $1 \frac{1}{2}$ "	77.42	265.24	4.78	464.5	457.0	445.9	434.8	423.7	412.6
2-15" \perp 55 laced.....	32.36	120.64	5.06	194.2	189.6	185.1	180.6	176.2
2-15" \perp 55 2-16 x $\frac{3}{4}$ "	56.36	193.64	4.82	338.2	333.9	325.9	318.0	310.0	302.0
2-15" \perp 55 2-16 x 1"	64.36	220.84	4.80	386.2	380.4	371.3	362.1	352.9	343.8
2-15" \perp 55 2-16 x $1 \frac{1}{4}$ "	72.36	248.04	4.78	434.2	426.9	416.6	406.2	395.9	385.6
2-15" \perp 55 2-16 x $1 \frac{1}{2}$ "	80.36	275.24	4.76	482.2	473.4	461.9	450.4	438.9	427.4

NOTE.—Weights of column shafts include rivets.

SAFE LOADS IN TONS OF 2000 POUNDS

Single Beam Columns. Square Ends

$$\left. \begin{array}{l} \text{Assumed strains per square inch} \\ \text{Factor of safety}=4 \end{array} \right\} = \frac{50000}{1 + \frac{(121)^2}{36000r^2}} \times \frac{1}{4}$$

DEPTH OF BEAM INCHES	WEIGHT PER FOOT POUNDS	LEAST r	UNSUPPORTED LENGTH OF BEAM IN INCHES									
			4	6	8	10	12	14	16	18	20	22
24	100	1.29	148	135	124	113	102	93	84
24	80	1.36	117	110	102	94	86	78	71
20	100	1.34	151	140	129	117	108	98	89
20	80	1.39	123	114	105	97	89	81	74
20	65	1.21	94	86	78	70	63	57	..
18	70	1.09	106	96	87	78	69	62
18	55	1.15	83	77	70	63	56	50
15	100	1.31	160	149	138	126	115	105	95	86
15	80	1.32	128	120	111	102	93	85	77	70
15	60	1.22	94	87	80	72	65	59	53	
15	42	1.08	64	58	53	47	42	37		
12	55	1.04	..	89	81	74	66	58	52	46		
12	40	1.08	..	66	60	55	50	44	40	35		
12	31½	1.01	..	51	47	42	37	33	29	26		
10	40	0.90	..	62	56	49	43	37	32			
10	25	0.97	..	40	36	32	28	25	22			
9	35	0.84	..	53	47	41	35	30				
9	21	0.90	..	34	30	26	23	20				
8	25½	0.80	..	38	33	28	24	21				
8	18	0.84	..	27	24	21	18	15				
7	20	0.74	33	29	25	21	18					
7	15	0.78	25	22	20	17	14					
6	17¼	0.68	28	24	20	17	14					
6	12¼	0.72	20	17	15	13	11					
5	14¾	0.63	24	20	16	12						
5	9¾	0.65	15	13	11	9						
4	10½	0.57	16	13	11	9						
4	7½	0.59	12	10	8	6						
3	7½	0.52	11	9	7							
3	5½	0.53	9	7	5							

SAFE LOADS IN TONS OF 2000 POUNDS

For radius of gyration axis X-X using
 12,000 pounds per square inch for
 lengths of 90 radii or less. Over 90 radii
 $17,100 - 57 \frac{1}{r} =$ pounds per square inch.

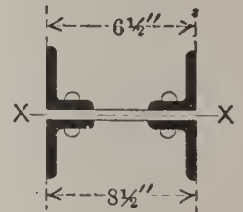

Size of Angles Inches	Size of Web Plates Inches	Area of Column Square Inches	Weight per Foot of Column Pounds	Radius of Gyration Axis X-X Inches
$3 \times 2\frac{1}{2} \times \frac{1}{4}$	$6 \times \frac{1}{4}$	6.78	23.1	1.24
$3 \times 2\frac{1}{2} \times \frac{5}{16}$	$6 \times \frac{5}{16}$	8.40	28.6	1.27
$3 \times 2\frac{1}{2} \times \frac{3}{8}$	$6 \times \frac{3}{8}$	9.97	33.9	1.30
$3 \times 2\frac{1}{2} \times \frac{7}{16}$	$6 \times \frac{7}{16}$	11.51	39.1	1.33
$3 \times 2\frac{1}{2} \times \frac{1}{2}$	$6 \times \frac{1}{2}$	13.00	44.2	1.36
$3 \times 2\frac{1}{2} \times \frac{9}{16}$	$6 \times \frac{9}{16}$	14.50	49.3	1.39
$3 \times 2\frac{1}{2} \times \frac{5}{8}$	$6 \times \frac{5}{8}$	15.95	54.2	1.43
$4 \times 3 \times \frac{5}{16}$	$8 \times \frac{5}{16}$	10.86	36.9	1.67
$4 \times 3 \times \frac{3}{8}$	$8 \times \frac{3}{8}$	12.96	44.1	1.70
$4 \times 3 \times \frac{7}{16}$	$8 \times \frac{7}{16}$	15.02	51.07	1.73
$4 \times 3 \times \frac{1}{2}$	$8 \times \frac{1}{2}$	17.00	57.8	1.76
$4 \times 3 \times \frac{9}{16}$	$8 \times \frac{9}{16}$	19.02	64.7	1.79
$4 \times 3 \times \frac{5}{8}$	$8 \times \frac{5}{8}$	20.96	71.3	1.82
$4 \times 3 \times \frac{11}{16}$	$8 \times \frac{11}{16}$	22.86	77.7	1.86
$4 \times 3 \times \frac{3}{4}$	$8 \times \frac{3}{4}$	24.76	84.2	1.89
$4 \times 3 \times \frac{13}{16}$	$8 \times \frac{13}{16}$	26.62	90.5	1.92

FOR PLATE AND ANGLE COLUMNS

Square Ends

Rivets, $\frac{3}{4}$ " diameter. Holes, $\frac{13}{16}$ " diameter.

Short legs of angles riveted to web plates.

Column weights do not include rivets.

Length in Feet

9	10	12	14	16	18	20	22	24
40.4	39.0	37.6	36.2	34.8	33.4
50.1	49.0	46.5	44.0	41.6	39.2
59.6	58.7	55.3	51.9	48.4	44.9
69.0	68.7	64.2	59.7	55.1	50.7
.....	78.0	73.1	67.5	61.9	56.4
.....	86.9	81.9	75.4	68.7	62.2
.....	95.9	90.8	83.2	75.5	67.9
.....	65.2	61.7	57.3	52.9	48.4	44.0	39.6
.....	77.5	74.1	69.1	64.1	58.9	53.9	48.9
.....	89.9	86.6	80.9	75.2	69.5	63.8	58.1
.....	102.0	99.0	92.7	86.4	80.0	73.7	67.7
.....	113.9	111.5	104.5	97.5	90.6	83.6	76.7
.....	125.5	123.9	116.3	108.7	101.1	93.5	86.0
.....	137.2	136.3	128.1	119.9	111.6	103.5	95.2
.....	148.6	139.9	131.0	122.2	113.4	104.5
.....	159.7	151.7	142.2	132.7	123.3	113.8

SAFE LOADS IN TONS OF 2000 POUNDS

For radius of gyration axis X-X using
12,000 pounds per square inch for
lengths of 90 radii or less. Over 90 radii
 $17,100 - 57 \frac{1}{r} =$ pounds per square inch.

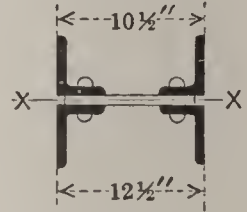

Size of Angles Inches	Size of Web Plates Inches	Area of Column Square Inches	Weight per Foot of Column Pounds	Radius of Gyration Axis X-X Inches
5×3× $\frac{5}{16}$	10× $\frac{5}{16}$	12.77	43.4	2.13
5×3× $\frac{3}{8}$	10× $\frac{3}{8}$	15.19	51.6	2.15
5×3× $\frac{7}{16}$	10× $\frac{7}{16}$	17.62	59.9	2.18
5×3× $\frac{1}{2}$	10× $\frac{1}{2}$	20.00	68.0	2.21
5×3× $\frac{9}{16}$	10× $\frac{9}{16}$	22.38	76.1	2.24
5×3× $\frac{5}{8}$	10× $\frac{5}{8}$	24.69	83.9	2.27
5×3× $\frac{11}{16}$	10× $\frac{11}{16}$	27.00	91.8	2.30
5×3× $\frac{3}{4}$	10× $\frac{3}{4}$	29.26	99.5	2.34
5×3× $\frac{13}{16}$	10× $\frac{13}{16}$	31.48	107.0	2.37
5×3× $\frac{7}{8}$	10× $\frac{7}{8}$	33.71	114.6	2.40
6×4× $\frac{3}{8}$	12× $\frac{3}{8}$	18.94	64.4	2.51
6×4× $\frac{7}{16}$	12× $\frac{7}{16}$	22.01	74.8	2.54
6×4× $\frac{1}{2}$	12× $\frac{1}{2}$	25.00	85.0	2.57
6×4× $\frac{9}{16}$	12× $\frac{9}{16}$	27.99	95.2	2.60
6×4× $\frac{5}{8}$	12× $\frac{5}{8}$	30.94	105.2	2.63
6×4× $\frac{11}{16}$	12× $\frac{11}{16}$	33.89	115.2	2.66
6×4× $\frac{3}{4}$	12× $\frac{3}{4}$	36.76	125.0	2.69
6×4× $\frac{13}{16}$	12× $\frac{13}{16}$	39.63	134.7	2.72
6×4× $\frac{7}{8}$	12× $\frac{7}{8}$	42.46	144.4	2.75
6×4× $\frac{15}{16}$	12× $\frac{15}{16}$	45.25	153.9	2.78
6×4×1	12×1	48.00	163.2	2.81

FOR PLATE AND ANGLE COLUMNS

Square Ends

Rivets, $\frac{3}{4}$ " diameter. Holes, $\frac{13}{16}$ " diameter.

Short legs of angles riveted to web plates.

Column weights do not include rivets.

Length in Feet

16	18	20	22	24	26	28	30	32	34
76.3	72.0	67.9	63.8	59.8	55.7	51.6
91.1	86.4	81.7	77.0	72.3	67.6	62.9
105.7	100.8	95.5	90.2	84.9	79.6	74.3
120.0	115.2	109.3	103.3	97.4	91.5	85.6
134.1	129.2	123.0	116.5	110.0	103.4	96.9
148.1	143.9	136.8	129.7	122.5	115.4	108.2
162.0	158.3	150.6	142.8	135.1	127.3	119.5
175.6	172.7	164.4	156.0	147.6	139.3	130.9
188.9	187.1	178.1	169.2	160.2	151.2	142.2
202.0	201.5	191.9	182.3	172.7	163.1	153.5
.....	113.7	108.2	105.3	102.3	99.4	96.5	93.6	90.7	87.7
.....	131.8	126.7	122.9	119.1	115.3	111.6	107.8	104.0	100.2
.....	150.0	145.2	140.6	135.9	131.3	126.6	121.9	117.3	112.6
.....	167.9	163.8	158.2	152.7	147.2	141.6	136.1	130.6	125.0
.....	185.6	182.3	175.9	169.5	163.1	156.7	150.3	143.9	137.0
.....	203.3	200.8	193.5	186.3	179.0	171.7	164.4	157.2	149.9
.....	220.6	211.2	203.1	194.9	186.8	178.6	170.5	162.3
.....	237.8	228.9	219.8	210.8	201.8	192.8	183.8	174.8
.....	254.8	246.5	226.6	226.7	216.8	207.0	197.1	187.2
.....	271.5	264.2	253.4	242.6	231.9	221.1	210.4	199.6
.....	288.0	281.8	270.2	258.6	246.9	235.3	223.7	212.0

SAFE LOADS IN TONS OF 2000 POUNDS

For radius of gyration axis X-X using
 12,000 pounds per square inch for
 lengths of 90 radii or less. Over 90 radii
 $17,100 - 57 \frac{l}{r}$ = pounds per square inch.

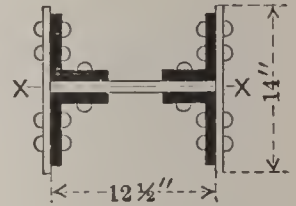

Size of Angles Inches	Size of Web Plates Inches	Size of Cover Plates Inches	Area of Column Square Inches	Weight per Foot of Column Pounds	Radius of Gyration of Axis X-X Inches
6×4× 3/8	12× 3/8	14× 1/4	25.94	88.2	3.00
6×4× 3/8	12× 3/8	14×1	46.94	159.6	3.50
6×4× 7/16	12× 7/16	14× 1/4	29.01	98.6	3.00
6×4× 7/16	12× 7/16	14×1	50.01	170.0	3.48
6×4× 1/2	12× 1/2	14× 1/4	32.00	108.8	3.00
6×4× 1/2	12× 1/2	14×1	53.00	180.2	3.46
6×4× 9/16	12× 9/16	14× 1/4	34.99	119.0	3.00
6×4× 9/16	12× 9/16	14×1	55.99	190.4	3.44
6×4× 5/8	12× 5/8	14× 1/4	37.94	129.0	3.00
6×4× 5/8	12× 5/8	14×1	58.94	200.4	3.42
6×4× 11/16	12× 11/16	14× 1/4	40.89	139.0	3.00
6×4× 11/16	12× 11/16	14×1	61.89	210.4	3.41
6×4× 3/4	12× 3/4	14× 1/4	43.76	148.8	3.00
6×4× 3/4	12× 3/4	14×1	64.76	220.2	3.39
6×4× 7/8	12× 7/8	14× 1/4	49.46	168.2	3.00
6×4× 7/8	12× 7/8	14×1	70.46	239.6	3.35
6×4×1	12×1	14× 1/4	55.00	187.0	3.00
6×4×1	12×1	14×1	76.00	258.4	3.31
Additional for		2-14× 1/16	1.75	5.95

FOR PLATE AND ANGLE COLUMNS

Square Ends

Rivets, $\frac{3}{4}$ " diameter. Holes, $\frac{13}{16}$ " diameter.

Short legs of angles riveted to web plates.

Column weights do not include rivets.

Length in Feet

22	24	26	28	30	32	34	36	38	40
155.6	150.8	144.9	139.0	133.1	127.2	121.2	115.3	109.4	103.5
281.6	281.6	281.6	272.9	263.7	254.6	245.5	236.3	227.2	218.0
173.8	167.6	161.1	154.5	147.9	136.1	134.8	128.2	121.7	115.1
300.0	300.0	299.8	288.7	278.8	269.0	259.2	249.4	239.6	229.8
192.0	184.5	177.2	170.0	162.8	150.9	148.3	141.1	133.9	126.7
318.0	318.0	318.0	304.4	293.9	283.5	273.0	262.5	252.0	241.6
209.9	201.3	193.4	185.5	177.6	165.8	161.9	154.0	146.1	138.3
335.9	335.9	335.9	320.2	309.0	297.9	286.8	275.6	264.5	253.4
227.6	218.1	209.6	201.0	192.5	180.7	175.5	166.9	158.4	149.9
353.6	353.6	353.6	335.9	324.1	312.3	300.5	288.7	276.9	265.1
245.3	234.9	225.7	216.6	207.4	195.5	189.0	179.8	170.6	161.5
371.3	371.3	364.1	351.7	339.2	326.7	314.3	301.8	289.3	276.9
262.6	251.7	241.9	232.1	222.2	210.4	202.6	192.7	182.9	173.1
388.6	388.6	380.5	367.4	354.2	341.2	328.0	314.9	301.8	288.7
296.8	285.4	274.2	263.1	251.9	240.1	229.7	218.5	207.4	196.3
422.8	422.8	413.4	398.9	384.5	370.0	355.5	341.1	326.6	312.2
330.0	319.0	306.6	294.1	281.7	269.2	256.8	244.3	231.9	219.4
456.0	456.0	446.2	430.4	414.6	398.8	383.1	367.3	351.5	335.7
10.5	10.5	11.5	11.3	11.0	10.7	10.4	10.2	9.9	9.6

SAFE LOADS IN TONS OF 2000 POUNDS

For radius of gyration axis X-X using
 12,000 pounds per square inch for
 lengths of 90 radii or less. Over 90 radii
 $17,100 - 57 \frac{1}{r} =$ pounds per square inch.

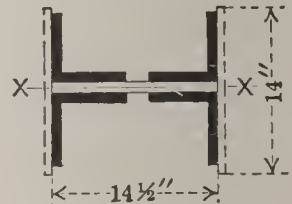

Size of Angles Inches	Size of Web Plates Inches	Size of Cover Plates Inches	Area of Column Square Inches	Weight per Foot of Column Pounds	Radius of Gyration Axis X-X Inches
6×6× $\frac{3}{8}$	14× $\frac{3}{8}$	14× $\frac{5}{16}$	31.44	106.9	2.89
6×6× $\frac{3}{8}$	14× $\frac{3}{8}$	14× $\frac{3}{4}$	43.69	148.5	3.25
6×6× $\frac{7}{16}$	14× $\frac{7}{16}$	14× $\frac{5}{16}$	35.12	119.4	2.85
6×6× $\frac{7}{16}$	14× $\frac{7}{16}$	14× $\frac{3}{4}$	47.37	161.1	3.20
6×6× $\frac{1}{2}$	14× $\frac{1}{2}$	14× $\frac{5}{16}$	38.75	131.8	2.82
6×6× $\frac{1}{2}$	14× $\frac{1}{2}$	14× $\frac{3}{4}$	51.00	173.4	3.16
6×6× $\frac{9}{16}$	14× $\frac{9}{16}$	14× $\frac{5}{16}$	42.39	144.1	2.80
6×6× $\frac{9}{16}$	14× $\frac{9}{16}$	14× $\frac{3}{4}$	54.64	185.8	3.12
6×6× $\frac{5}{8}$	14× $\frac{5}{8}$	14× $\frac{5}{16}$	45.94	156.2	2.79
6×6× $\frac{5}{8}$	14× $\frac{5}{8}$	14× $\frac{3}{4}$	58.19	197.8	3.10
6×6× $\frac{11}{16}$	14× $\frac{11}{16}$	14× $\frac{5}{16}$	49.50	168.3	2.79
6×6× $\frac{11}{16}$	14× $\frac{11}{16}$	14× $\frac{3}{4}$	61.75	209.9	3.08
6×6× $\frac{3}{4}$	14× $\frac{3}{4}$	14× $\frac{5}{16}$	53.01	180.2	2.79
6×6× $\frac{3}{4}$	14× $\frac{3}{4}$	14× $\frac{3}{4}$	65.26	221.9	3.06
6×6× $\frac{13}{16}$	14× $\frac{13}{16}$	14× $\frac{5}{16}$	56.49	192.1	2.79
6×6× $\frac{13}{16}$	14× $\frac{13}{16}$	14× $\frac{3}{4}$	68.74	233.0	3.05
6×6× $\frac{7}{8}$	14× $\frac{7}{8}$	14× $\frac{5}{16}$	59.96	203.9	2.80
6×6× $\frac{7}{8}$	14× $\frac{7}{8}$	14× $\frac{3}{4}$	72.21	245.5	3.04
Additional for		2-14× $\frac{1}{16}$	1.75	5.95

FOR PLATE AND ANGLE COLUMNS

Square Ends

Rivets, $\frac{3}{4}$ " diameter.

Holes, $\frac{1\frac{3}{8}}$ " diameter.

Column weights do not include rivets.

Length in Feet

20	22	24	26	28	30	32	34	36	38	40
188.6	187.0	179.6	172.2	164.7	157.3	149.8	142.4	134.9	127.4	120.0
262.1	262.1	262.1	254.0	244.8	235.6	222.4	217.2	208.0	198.8	189.6
210.7	207.4	198.9	190.5	182.0	173.6	165.1	156.7	148.2	139.8	131.3
284.2	284.2	284.2	273.3	263.2	253.1	243.0	232.9	222.8	212.7	202.6
232.5	227.9	218.5	209.1	199.8	190.4	181.0	171.6	162.2	152.9	143.5
306.0	306.0	303.6	292.5	281.5	270.4	259.4	248.3	237.3	226.2	215.2
254.0	248.5	238.2	227.9	217.6	207.3	197.0	186.6	176.3	166.0	155.7
327.8	327.6	323.4	311.5	299.5	287.6	275.6	263.7	251.7	239.8	227.8
275.6	269.0	257.8	246.5	235.3	224.0	212.8	201.5	190.3	179.0	167.7
349.1	349.1	343.4	330.6	317.7	304.9	292.0	279.2	266.3	253.5	240.6
297.0	289.5	277.4	265.3	253.2	241.1	229.0	216.8	204.7	192.6	180.5
370.5	370.5	363.1	349.4	335.7	322.0	308.3	294.6	280.8	267.1	253.4
318.0	310.0	297.0	284.0	271.0	258.0	245.0	232.0	219.0	206.0	193.0
391.5	391.5	383.3	368.6	354.0	339.3	324.7	310.0	295.4	280.7	266.1
338.9	330.6	316.8	302.9	289.1	275.3	261.4	247.6	233.8	219.9	206.1
412.4	412.4	402.6	387.2	371.8	356.4	341.0	325.6	310.2	294.8	279.4
359.7	351.5	336.8	322.2	307.5	292.8	278.2	263.5	248.8	234.1	219.5
433.2	433.2	422.6	406.4	390.2	374.1	357.9	341.7	325.5	309.3	293.2
10.5	10.5	12.0	11.8	11.6	11.4	11.2	11.0	10.8	10.6	10.4

SAFE LOADS IN TONS OF 2000 POUNDS

For radius of gyration axis X-X using 12,000 pounds per square inch for lengths of 90 radii or less. Over 90 radii $17,100 - 57 \frac{1}{r} =$ pounds per square inch.

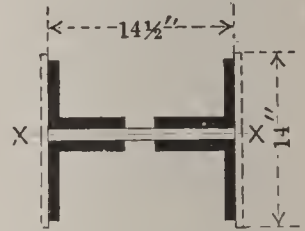

Size of Angles Inches	Size of Web Plates Inches	Size of Cover Plates Inches	Area of Column Square Inches	Weight per Foot of Column Pounds	Radius of Gyration Axis X-X Inches
6×6× 3/8	14× 3/8	22.69	77.15	2.29
6×6× 7/16	14× 7/16	26.37	89.66	2.32
6×6× 1/2	14× 1/2	30.00	102.00	2.35
6×6× 9/16	14× 9/16	33.64	114.38	2.38
6×6× 5/8	14× 5/8	37.19	126.45	2.41
6×6× 11/16	14× 11/16	40.75	138.55	2.44
6×6× 3/4	14× 3/4	44.26	150.48	2.47
6×6× 13/16	14× 13/16	47.74	162.32	2.50
6×6× 7/8	14× 7/8	51.21	174.11	2.53
6×6× 15/16	14× 15/16	54.65	185.81	2.56
6×6×1	14×1	58.00	197.20	2.59
6×6×1	14×1	14× 1/4	65.00	221.00	2.78
6×6×1	14×1	14× 3/8	68.50	232.90	2.86
6×6×1	14×1	14× 1/2	72.00	244.80	2.93
6×6×1	14×1	14× 5/8	75.50	256.70	2.99
6×6×1	14×1	14× 3/4	79.00	268.60	3.04
6×6×1	14×1	14× 7/8	82.50	280.50	3.09
6×6×1	14×1	14×1	86.00	292.40	3.14

FOR PLATE AND ANGLE COLUMNS

Square Ends

Rivets, $\frac{3}{4}$ " diameter.

Holes, $\frac{1}{8}$ " diameter.

Column weights do not include rivets.

Length in Feet

16	18	20	22	24	26	28	30	32	34	36	38	40
136	133	126	119	113	106	99	92	86	79			
158	156	148	140	133	125	118	111	103	94			
180	178	170	161	153	145	137	129	119	108			
202	201	191	182	173	165	156	148	135	123			
223	223	213	202	193	184	175	166	152	138			
245	245	235	223	213	204	194	184	168	153			
266	266	256	244	233	223	213	203	185	167			
286	286	278	264	254	243	232	221	202	182			
307	307	300	285	274	262	251	240	218	197			
328	328	321	306	294	283	270	258	235	212			
348	348	343	327	314	301	289	276	251	226			
390	390	390	380	364	348	332	316	300	284	268	252	236
411	411	411	405	388	372	355	339	323	306	290	273	257
432	432	432	429	413	397	379	362	345	328	311	295	278
453	453	453	453	437	420	402	385	368	350	333	316	299
474	474	474	474	461	444	426	408	390	373	355	337	320
495	495	495	495	486	467	449	431	413	395	377	359	340
516	516	516	516	510	491	473	454	436	417	399	380	361

6" Z Bar Column Formed of 4 3" Z Bars and I Web Plate 5 3/4" X Thickness of Z Bars

Diameter of Bolt or Rivet = 3/4-inch	Thick- ness of Metal	A	B	C	D	E	F	G	H	I	Thick- ness of Metal	A	B	C	D	E	F	G	H	I	Diameter of Bolt or Rivet = 3/4-inch	
1/4	12 5/16	3 1/8	5 5/16	2 7/8	2 1/2	1 5/8	2 1/16	8 1/2	3 1/4	11 1/16	7/16	11 1/16	3 5/16	5 1/16	2 7/8	2 1/2	1 5/8	2 5/8	8 1/8	3 3/8	3 3/8	33/8
1/8	12 3/8	3 3/16	5 1/16	2 7/8	2 1/2	1 5/8	2 1/16	8 3/8	3 3/4	12	1/2	12	3 1/4	5 1/16	2 7/8	2 1/2	1 5/8	2 1/16	8	3 1/2	3 1/2	3 1/2
3/8	12 1/2	3 1/8	5 1/16	2 7/8	2 1/2	1 5/8	2 1/16	8 1/4	3 1/2	12 1/8	1/16	12 1/8	3 1/2	5 1/16	2 7/8	2 1/2	1 5/8	2 3/4	7 7/8	3 5/8	3 5/8	3 5/8
			5 1/16	2 7/8	2 1/2	1 5/8	2 1/16	8 1/4	3 1/16	12 1/4	5/8	12 1/4	3 1/16	5 1/16	2 7/8	2 1/2	1 5/8	2 1/16	7 3/4	3 3/4	3 3/4	3 3/4

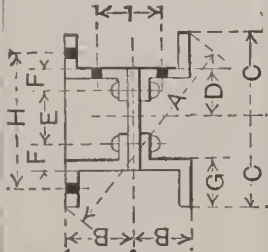

SAFE LOADS IN TONS OF 2000 POUNDS. For Z Bar Columns with Square Ends

Allowable strains per square inch=12,000 pounds for lengths of 90 radii or under. 17,100-57 1/r for lengths over 90 radii. Safety factor=4

6" Z BAR COLUMN	LENGTH OF COLUMN IN FEET									
	12 and under	14	16	18	20	22	24	26	28	30
1/4" Metal = 31.7 Lbs. = 9.31 Sq. In. R Minimum = 1.88	55.9	55.7	52.3	48.8	45.4	42.0	38.6	35.2	31.7	28.3
1/8" Metal = 39.8 Lbs. = 11.7 Sq. In. R Minimum = 1.90	70.3	70.3	66.5	62.3	58.1	53.9	49.7	45.5	41.3	37.1
3/8" Metal = 47.8 Lbs. = 14.1 Sq. In. R Minimum = 1.94	84.6	84.6	80.8	75.8	70.8	66.0	61.0	56.0	51.0	46.0
1/2" Metal = 52.1 Lbs. = 15.3 Sq. In. R Minimum = 1.85	91.8	91.2	85.6	79.9	74.2	68.6	62.9	57.3	51.6	46.0
3/4" Metal = 59.9 Lbs. = 17.6 Sq. In. R Minimum = 1.90	105.7	105.7	99.9	93.6	87.2	80.9	74.6	68.2	61.9	55.5
1" Metal = 67.9 Lbs. = 20.0 Sq. In. R Minimum = 1.95	119.8	119.8	114.8	107.8	100.8	93.8	86.8	79.8	72.8	65.8
5/8" Metal = 76.0 Lbs. = 22.4 Sq. In. R Minimum = 2.00	134.4	134.4	130.2	122.6	114.9	107.3	99.6	91.9	84.3	76.6

SAFE LOADS IN TONS OF 2000 POUNDS
Hollow Cylindrical Cast-Iron Columns

OUTSIDE DIAMETER INCHES	THICKNESS OF METAL	LENGTH OF COLUMNS IN FEET									SECTIONAL AREA INCHES	WEIGHT PER FOOT OF LENGTH OF COLUMNS, POUNDS
		8	10	12	14	16	18	20	22	24		
6	1/2	26.2	23.0	20.1	17.5	15.2	13.2	11.5	8.6	26.95
6	3/4	37.5	33.0	28.8	25.0	21.7	18.9	16.5	12.4	38.59
6	7/8	42.7	37.6	32.8	28.5	24.7	21.5	18.8	14.1	43.96
6	1	47.6	41.9	36.5	31.8	27.6	24.0	21.0	15.7	49.01
6	1 1/8	52.2	46.0	40.1	34.8	30.2	26.3	23.0	17.2	53.76
7	3/4	47.7	43.1	38.5	34.3	30.4	26.9	23.9	21.2	18.9	14.7	45.96
7	1	61.1	55.2	49.3	43.8	38.9	34.4	30.6	27.1	24.2	18.9	58.90
7	1 1/8	67.2	60.8	54.3	48.3	42.8	37.9	33.7	29.9	26.7	20.8	64.77
8	3/4	57.9	53.3	48.6	44.1	39.7	35.8	32.2	28.9	26.1	17.1	53.29
8	1	74.6	68.7	62.5	56.7	51.1	46.0	41.4	37.3	33.6	22.0	68.64
8	1 1/4	89.9	82.8	75.5	68.4	61.7	55.5	49.9	44.9	40.5	26.5	82.71
9	3/4	68.1	63.6	58.9	54.2	49.6	45.2	41.2	37.5	34.1	19.4	60.65
9	1	88.0	82.3	76.2	70.0	64.1	58.4	53.2	48.4	44.1	25.1	78.40
9	1 1/4	106.6	99.6	92.2	84.8	77.6	70.8	64.4	58.7	53.4	30.4	94.94
9	1 1/2	123.8	115.7	107.1	98.5	90.1	82.2	74.8	68.1	62.0	35.3	110.26
9	1 3/4	139.6	130.5	120.8	111.1	101.6	92.7	84.4	76.8	69.9	39.9	124.36
10	1	101.4	95.9	89.8	83.6	77.4	71.5	65.8	60.5	55.5	28.3	88.23
10	1 1/4	123.3	116.5	109.1	101.6	94.1	86.8	79.9	73.4	67.5	34.4	107.23
10	1 1/2	143.7	135.8	127.3	118.5	109.7	101.2	93.2	85.6	78.7	40.1	124.99
10	1 3/4	162.7	153.8	144.1	134.1	124.2	114.6	105.5	97.0	89.1	45.4	141.65
11	1	114.8	109.4	103.5	97.3	91.0	84.8	80.2	73.3	67.7	31.4	98.03
11	1 1/4	139.9	133.3	126.1	118.6	110.9	103.3	97.8	89.4	82.5	38.3	119.46
11	1 1/2	163.5	155.9	147.5	138.6	128.7	120.8	114.3	104.1	96.4	44.8	139.68
11	1 3/4	185.7	177.1	167.5	157.5	147.3	137.2	129.8	118.3	109.5	50.9	158.68
11	2	206.6	196.9	186.3	175.1	163.8	152.6	144.4	131.5	121.8	56.6	176.44
12	1	128.0	122.9	117.2	111.0	104.7	98.4	92.2	86.1	80.4	34.6	107.51
12	1 1/4	156.4	150.1	143.1	135.7	127.9	120.2	112.6	105.2	98.2	42.2	131.41
12	1 1/2	183.3	175.9	167.7	159.0	149.9	140.9	132.0	123.3	115.1	49.5	154.10
12	1 3/4	208.7	200.4	191.0	181.1	170.7	160.4	150.3	140.5	131.1	56.4	175.53
12	2	232.7	223.4	213.0	201.9	190.4	178.9	167.6	156.6	146.1	62.8	195.75
13	1	141.2	136.3	130.7	124.7	118.5	112.1	105.8	99.5	93.5	37.7	117.53
13	1 1/4	172.8	166.8	160.0	152.7	145.0	137.2	129.4	121.8	114.4	46.1	143.86
13	1 1/2	203.0	195.9	187.9	179.3	170.3	161.1	152.0	143.1	134.3	54.2	168.98
13	1 3/4	231.6	223.6	214.5	204.7	194.4	183.9	173.5	163.3	153.3	61.9	192.88
13	2	258.9	249.9	239.7	228.7	217.3	205.5	193.9	182.5	171.3	69.1	215.56
14	1	154.3	149.6	144.3	138.5	132.3	125.9	119.5	113.1	106.8	40.8	127.60
14	1 1/4	189.2	183.4	176.9	169.7	162.2	154.4	146.5	138.6	131.0	50.1	156.31
14	1 1/2	222.6	215.8	208.1	199.7	190.8	181.7	172.3	163.1	154.1	58.9	183.67
14	1 3/4	254.4	246.7	237.9	228.3	218.1	207.6	197.0	186.5	176.2	67.4	210.00
14	2	284.8	276.2	266.4	255.6	244.2	232.4	220.6	208.8	197.2	75.4	235.12
15	1	167.4	162.9	157.8	152.1	146.0	139.7	133.3	126.8	120.4	44.0	137.28
15	1 1/4	205.5	200.0	193.7	186.7	179.3	171.5	163.6	155.7	147.9	54.0	168.48
15	1 1/2	242.1	235.7	228.2	220.0	211.2	202.1	192.8	183.5	174.2	63.6	198.74
15	1 3/4	277.2	269.8	261.3	251.9	241.9	231.4	220.7	210.1	199.5	72.9	227.45
15	2	310.8	302.5	293.0	282.5	271.2	259.5	247.5	235.5	223.6	81.7	254.90

ULTIMATE STRENGTH OF STEEL STRUTS

For different proportions of length in feet= l .
 To least radius of gyration in inches= r .
 Ultimate strength in pounds per square inch= S

Column Square Bearing 50000 <hr style="width: 80%; margin: 0 auto;"/> $1 + \frac{(12 l)^2}{36000r^2}$	Column Pin and Square Bearing 50000 <hr style="width: 80%; margin: 0 auto;"/> $1 + \frac{(12 l)^2}{24000r^2}$	Column Pin Bearing 50000 <hr style="width: 80%; margin: 0 auto;"/> $1 + \frac{(12 l)^2}{18000r^2}$
--	--	---

To obtain safe { For quiescent loads, as in buildings, divide by 4.
 resistance { For moving loads, as in bridges, divide by 5.

Ultimate Strength per Square Inch, Pounds				Ultimate Strength per Square Inch, Pounds			
l	Square	Pin and Square	Pin	l	Square	Pin and Square	Pin
r				r			
3.0	48262	47437	46637	11.6	32500	27662	24087
3.2	48037	47100	46212	11.8	32112	27250	23662
3.4	47787	46750	45762	12.0	31725	26825	23237
3.6	47537	46387	45300	12.2	31337	26412	22825
3.8	47275	46012	44825	12.4	30962	26012	22425
4.0	46987	45625	44325	12.6	30587	25612	22025
4.2	46700	45212	43812	12.8	30212	25225	21637
4.4	46400	44800	43300	13.0	29837	24825	21250
4.6	46087	44375	42762	13.2	29462	24450	20887
4.8	45775	43925	42212	13.5	28925	23887	20350
5.0	45450	43475	41662	13.8	28375	23337	19812
5.2	45112	43025	41112	14.0	28025	22975	19475
5.4	44775	42562	40550	14.2	27687	22625	19137
5.6	44425	42087	39975	14.5	27175	22112	18650
5.8	44075	41600	39400	14.8	26650	21612	18162
6.0	43706	41112	38825	15.0	26312	21275	17862
6.2	43337	40625	38237	15.2	25987	20950	17550
6.4	42962	40137	37662	15.5	25362	20487	17112
6.6	42575	39637	37087	15.8	25025	20012	16687
6.8	42187	39137	36500	16.0	24700	19712	16400
7.0	41800	38637	35925	16.2	24387	19425	16137
7.2	41412	38137	35337	16.5	23937	18987	15737
7.4	41012	37637	34775	16.8	23487	18562	15350
7.6	40612	37137	34200	17.0	23187	18287	15100
7.8	40212	36637	33637	17.2	22900	18012	14850
8.0	39812	36125	33075	17.5	22475	17625	14487
8.2	39400	35625	32512	17.8	22050	17237	14150
8.4	38987	35125	31962	18.0	21775	16987	13925
8.6	38587	34625	31412	18.2	21500	16737	13700
8.8	38175	34137	30875	18.5	21100	16375	13375
9.0	37762	33650	30337	18.8	20712	16025	13062
9.2	37350	33162	29812	19.0	20462	15787	12862
9.4	36937	32675	29287	19.2	20212	15562	12662
9.6	36537	32200	28785	19.5	19837	15237	12362
9.8	36125	31712	28275	19.8	19462	14912	12087
10.0	35712	31250	27775	20.0	19225	14700	11900
10.2	35312	30787	27287	20.2	19000	14500	11725
10.4	34900	30325	26800	20.5	18650	14200	11462
10.6	34500	29862	26325	20.8	18312	13900	11212
10.8	34087	29412	25862	21.0	18140	13710	11040
11.0	33687	28962	25412	21.2	17870	13520	10880
11.2	33300	28525	24950	21.5	17550	13250	10640
11.4	32900	28087	24512	21.8	17240	12980	10410

RADI OF GYRATION

For Two Equal Legged Angles, Placed Back to Back

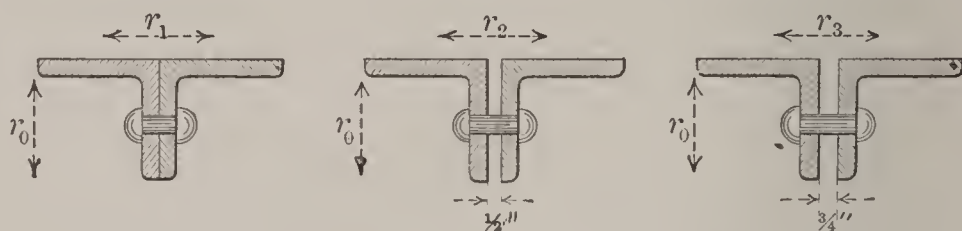

Size Inches	Thickness Inches	Weight per Foot of Single Angle Pounds	Radii of Gyration			
			r_0	r_1	r_2	r_3
8 × 8	$\frac{1}{2}$	26.4	2.50	3.32	3.49	3.58
	$1\frac{1}{8}$	56.9	2.42	3.42	3.60	3.69
6 × 6	$\frac{3}{8}$	14.9	1.88	2.49	2.67	2.76
	1	37.4	1.80	2.59	2.77	2.87
5 × 5	$\frac{3}{8}$	12.3	1.56	2.09	2.26	2.35
	1	30.6	1.48	2.19	2.38	2.48
4 × 4	$\frac{1}{4}$	6.6	1.25	1.65	1.84	1.93
	$\frac{13}{16}$	19.9	1.18	1.75	1.94	2.04
$3\frac{1}{2} \times 3\frac{1}{2}$	$\frac{1}{4}$	7.2	1.09	1.46	1.64	1.73
	$\frac{13}{16}$	17.1	1.02	1.55	1.74	1.85
3 × 3	$\frac{1}{4}$	4.9	0.93	1.25	1.43	1.53
	$\frac{5}{8}$	11.5	0.88	1.32	1.51	1.62
$2\frac{3}{4} \times 2\frac{3}{4}$	$\frac{1}{4}$	4.5	0.84	1.15	1.34	1.44
	$\frac{1}{2}$	8.5	0.80	1.18	1.38	1.48
$2\frac{1}{2} \times 2\frac{1}{2}$	$\frac{3}{16}$	3.1	0.78	1.04	1.22	1.32
	$\frac{1}{2}$	7.7	0.74	1.10	1.29	1.40
$2\frac{1}{4} \times 2\frac{1}{4}$	$\frac{3}{16}$	2.7	0.70	0.94	1.12	1.23
	$\frac{1}{2}$	6.8	0.65	0.98	1.18	1.29
2 × 2	$\frac{3}{16}$	2.5	0.62	0.84	1.03	1.13
	$\frac{1}{2}$	6.0	0.58	0.89	1.09	1.20

RADII OF GYRATION

For Two Unequal Legged Angles, Placed with Longer Legs Back to Back

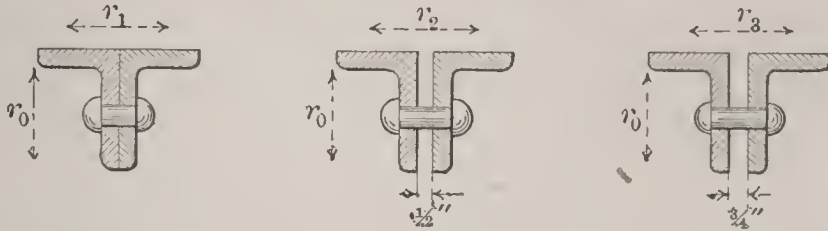

Size Inches	Thickness Inches	Weight per Foot of Single Angle Pounds	Radii of Gyration			
			r ₀	r ₁	r ₂	r ₃
6 × 4	3/8	12.3	1.93	1.50	1.67	1.76
	1	30.6	1.85	1.60	1.79	1.89
6 × 3 1/2	3/8	11.7	1.94	1.26	1.43	1.53
	1	28.9	1.85	1.37	1.56	1.67
5 × 4	3/8	11.0	1.59	1.58	1.75	1.85
	7/8	24.2	1.52	1.66	1.85	1.95
5 × 3 1/2	5/16	8.7	1.61	1.33	1.50	1.59
	7/8	22.7	1.53	1.42	1.61	1.71
5 × 3	5/16	8.2	1.61	1.09	1.26	1.35
	7/8	21.3	1.54	1.20	1.39	1.49
4 × 3 1/2	5/16	7.7	1.26	1.42	1.60	1.69
	13/16	18.5	1.19	1.50	1.69	1.79
4 × 3	5/16	7.2	1.27	1.17	1.35	1.44
	13/16	17.1	1.21	1.25	1.45	1.55
3 1/2 × 3	1/4	5.3	1.11	1.20	1.38	1.47
	11/16	13.6	1.02	1.28	1.48	1.58
3 1/2 × 2 1/2	1/4	4.9	1.12	0.96	1.13	1.23
	11/16	12.5	1.06	1.03	1.23	1.33
3 × 2 1/2	1/4	4.5	0.95	1.00	1.18	1.28
	5/8	10.5	0.90	1.06	1.26	1.36
3 1/4 × 2	1/4	4.3	1.04	0.74	0.92	1.02
	9/16	9.0	1.00	0.79	0.99	1.10
3 × 2	3/16	3.1	0.97	0.75	0.93	1.03
	1/2	7.7	0.92	0.80	1.00	1.10
2 1/2 × 2	3/16	2.8	0.79	0.79	0.97	1.07
	1/2	6.8	0.75	0.84	1.04	1.15

RADII OF GYRATION
For Two Unequal Legged Angles, Placed with Shorter
Legs Back to Back

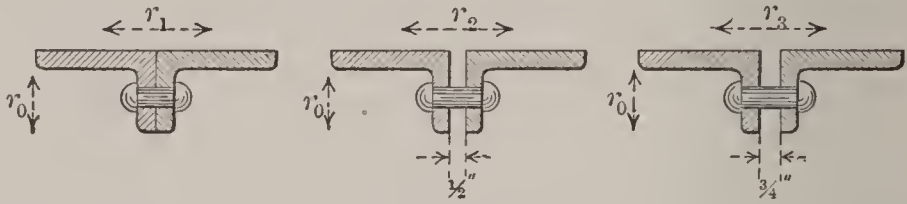

Size Inches	Thickness Inches	Weight per Foot of Single Angle Pounds	Radii of Gyration			
			r_0	r_1	r_2	r_3
6 × 4	$\frac{3}{8}$	12.3	1.17	2.74	2.92	3.01
	1	30.6	1.09	2.85	3.04	3.14
6 × 3½	$\frac{3}{8}$	11.7	0.99	2.81	3.00	3.10
	1	28.9	0.92	2.93	3.13	3.23
5 × 4	$\frac{3}{8}$	11.0	1.20	2.20	2.38	2.48
	$\frac{7}{8}$	24.2	1.14	2.29	2.48	2.58
5 × 3½	$\frac{5}{16}$	8.7	1.03	2.26	2.44	2.54
	$\frac{7}{8}$	22.7	0.96	2.36	2.55	2.65
5 × 3	$\frac{5}{16}$	8.2	0.85	2.33	2.51	2.61
	$\frac{7}{8}$	21.3	0.79	2.43	2.64	2.74
4 × 3½	$\frac{5}{16}$	7.7	1.07	1.73	1.91	2.00
	$\frac{13}{16}$	18.5	1.01	1.81	2.01	2.11
4 × 3	$\frac{5}{16}$	7.2	0.89	1.79	1.97	2.07
	$\frac{13}{16}$	17.1	0.83	1.88	2.08	2.18
3½ × 3	$\frac{1}{4}$	5.3	0.91	1.51	1.70	1.79
	$\frac{11}{16}$	13.6	0.86	1.59	1.78	1.88
3½ × 2½	$\frac{1}{4}$	4.9	0.74	1.58	1.76	1.86
	$\frac{11}{16}$	12.5	0.67	1.66	1.86	1.96
3 × 2½	$\frac{1}{4}$	4.5	0.75	1.31	1.50	1.59
	$\frac{5}{8}$	10.5	0.72	1.38	1.57	1.67
3¼ × 2	$\frac{1}{4}$	4.3	0.57	1.51	1.70	1.80
	$\frac{9}{16}$	9.0	0.53	1.57	1.77	1.88
3 × 2	$\frac{3}{16}$	3.1	0.59	1.37	1.55	1.65
	$\frac{1}{2}$	7.7	0.55	1.42	1.62	1.73
2½ × 2	$\frac{3}{16}$	2.8	0.60	1.10	1.28	1.39
	$\frac{1}{2}$	6.8	0.56	1.16	1.35	1.46

CAST WASHERS

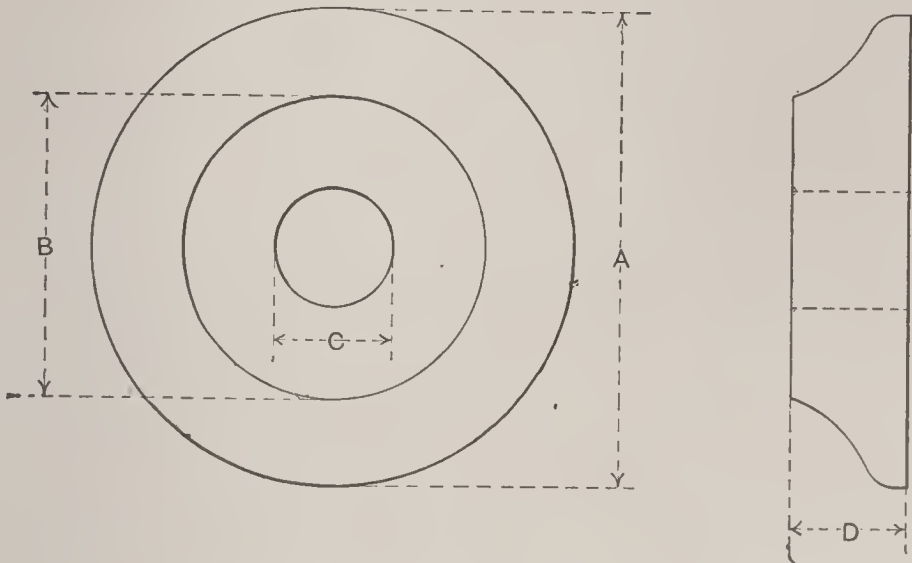

Diameter of bolt = d
 $A = 4d + \frac{1}{4}$ -inch $C = d + \frac{1}{8}$ -inch
 $B = 2d + \frac{1}{4}$ -inch $D = d$

For sizes not given below.

STANDARD CAST WASHER

Diameter of Bolt=d-inch	A	B	C	D	Weight in Pounds
$\frac{1}{2}$	$2\frac{5}{8}$	$1\frac{3}{4}$	$\frac{9}{16}$	$\frac{5}{8}$	$\frac{1}{2}$
$\frac{5}{8}$	3	$1\frac{7}{8}$	$\frac{11}{16}$	$\frac{3}{4}$	$\frac{3}{4}$
$\frac{3}{4}$	$3\frac{1}{4}$	$2\frac{1}{8}$	$\frac{13}{16}$	$\frac{7}{8}$	$1\frac{1}{4}$
$\frac{7}{8}$	$3\frac{3}{4}$	$2\frac{1}{2}$	$\frac{15}{16}$	$\frac{7}{8}$	$1\frac{1}{2}$
1	4	$2\frac{3}{4}$	$1\frac{1}{16}$	$1\frac{1}{8}$	$2\frac{1}{2}$
$1\frac{1}{8}$	$4\frac{3}{4}$	$2\frac{3}{4}$	$1\frac{3}{16}$	$1\frac{1}{8}$	3
$1\frac{1}{4}$	6	3	$1\frac{5}{16}$	$1\frac{3}{8}$	$5\frac{3}{4}$
$1\frac{1}{2}$	$6\frac{1}{4}$	$3\frac{1}{4}$	$1\frac{5}{8}$	$1\frac{1}{2}$	6
$1\frac{3}{4}$	$7\frac{1}{4}$	$3\frac{3}{4}$	$1\frac{7}{8}$	$1\frac{3}{4}$	$9\frac{1}{2}$
2	$8\frac{1}{4}$	$4\frac{1}{4}$	$2\frac{1}{8}$	2	$17\frac{1}{4}$
$2\frac{1}{4}$	$9\frac{1}{4}$	$4\frac{3}{4}$	$2\frac{3}{8}$	$2\frac{1}{4}$	20
$2\frac{1}{2}$	$10\frac{1}{4}$	$5\frac{1}{4}$	$2\frac{5}{8}$	$2\frac{1}{2}$	$27\frac{1}{4}$
$2\frac{3}{4}$	$11\frac{1}{4}$	$5\frac{3}{4}$	$2\frac{7}{8}$	$2\frac{3}{4}$	36
3	$12\frac{1}{4}$	$6\frac{1}{4}$	$3\frac{1}{8}$	3	46

WOODEN BEAMS

Table of safe quiescent loads in pounds for horizontal rectangular beams of white pine or spruce one inch broad, supported at both ends, the load being equally distributed over the span.

SPAN IN FEET	DEPTH OF BEAM IN INCHES										
	6	7	8	9	10	11	12	13	14	15	16
5	800	1090	1420	1800	2220	2690	3200	3750	4350	5000	5690
6	670	910	1180	1500	1850	2240	2670	3130	3630	4170	4740
7	570	780	1010	1290	1590	1920	2280	2680	3110	3570	4060
8	500	680	890	1120	1390	1680	2000	2350	2720	3130	3560
9	440	600	790	1000	1210	1490	1780	2090	2420	2780	3160
10	400	540	710	900	1110	1340	1600	1880	2180	2500	2840
11	360	490	650	820	1010	1220	1450	1710	1980	2270	2590
12	330	450	590	750	930	1120	1330	1560	1810	2080	2370
13	310	420	550	690	850	1030	1230	1440	1680	1920	2190
14	290	390	510	640	790	960	1140	1340	1560	1790	2030
15	270	360	470	600	740	900	1070	1250	1450	1670	1900
16	250	340	440	560	690	840	1000	1170	1360	1560	1780
17	230	320	420	530	650	790	940	1100	1280	1470	1670
18	220	300	400	500	620	750	890	1040	1210	1390	1580
19	210	290	380	470	590	710	840	990	1150	1320	1500
20	200	270	360	450	560	670	800	940	1090	1250	1420
21	190	260	340	430	530	640	760	890	1040	1190	1350
22	180	250	320	410	500	610	730	850	990	1140	1290
23	170	240	300	390	480	580	700	810	950	1090	1230
24	160	230	290	370	460	560	670	780	910	1040	1180
25	160	220	280	350	440	540	640	750	870	1000	1130
26	150	210	270	340	420	520	610	720	840	960	1090
27	150	200	260	330	400	500	590	690	810	920	1050
28	140	190	250	320	390	480	570	670	780	890	1010
29	140	190	250	310	380	460	550	650	750	860	980
30	130	180	240	300	370	450	530	630	730	830	950

This table has been calculated for extreme fiber strain of 1000 pounds per square inch, being one-sixth the breaking strain, ordinary building timber of fair quality.

Oak and yellow pine will carry a load one-fourth greater.

When more accuracy is required, the weight of the beam itself must be deducted.

Care must be taken to let the beams rest for a sufficient distance on their supports to guard against crushing at the ends, especially in placing very heavy loads upon short but deep and strong beams.

SAFE LOADS IN TONS OF 2000 POUNDS
Square Wooden Posts

Half seasoned white or common yellow pine

C. Shaler Smith's Formula. Safe load in pounds per square inch

$$= \frac{1250}{1 \times \left(\frac{l^2}{d^2} \times .004 \right)}$$

l=Length of post in inches. d=Width of side in inches

HEIGHT FEET	SIDE OF SQUARE POST INCHES								
	4	6	8	10	12	14	16	18	20
4	6.4	17.8	35.0	57.2	84.6	117.0	154.6	196.8	244.2
6	4.4	14.3	30.2	51.6	78.7	110.0	147.3	189.3	237.2
8	3.0	11.1	25.4	45.7	71.4	102.8	140.0	181.7	229.0
10	2.2	8.6	21.1	39.7	64.3	94.9	130.5	171.4	218.4
12	1.6	6.8	17.5	34.2	57.1	86.0	121.0	161.3	207.2
14	1.2	5.4	14.5	29.4	50.5	77.6	111.2	150.1	194.9
16	1.0	4.4	12.2	25.3	44.5	70.0	101.6	139.2	182.6
18	.8	3.6	10.2	21.8	39.2	62.7	92.7	128.2	170.2
20	.6	3.0	8.7	18.9	34.6	56.3	84.3	118.2	158.5
22	2.6	7.5	16.5	30.7	51.0	76.7	108.6	147.3
24	2.2	6.5	14.5	27.2	45.6	69.7	100.0	136.6
26	1.9	5.6	12.8	24.3	41.4	63.3	91.8	126.8
28	1.6	5.0	11.3	21.8	37.2	57.7	84.6	117.6
30	1.5	4.4	10.1	19.6	33.9	52.9	77.8	108.9
32	1.3	3.9	9.0	17.6	30.5	48.4	71.7	101.1
34	1.1	3.5	8.2	16.0	27.7	44.5	66.4	93.8
36	1.0	3.2	7.4	14.5	25.5	40.9	61.3	87.4
389	2.9	6.7	13.3	23.5	37.5	56.8	81.2
408	2.6	6.1	12.2	21.6	34.7	52.6	75.6
42	2.4	5.6	11.2	19.9	32.2	49.0	70.8
44	2.2	5.1	10.3	18.5	30.0	45.6	66.1
46	2.0	4.7	9.5	17.1	27.7	42.6	61.9
48	1.8	4.4	8.8	16.0	25.8	39.8	58.0
50	1.7	4.2	8.2	14.8	24.1	37.2	54.3
52	7.6	14.0	22.7	34.7	51.0
54	7.1	13.2	21.3	32.8	48.2
56	6.6	12.3	19.9	30.8	45.4
58	6.2	11.5	18.8	28.8	42.8
60	5.9	10.6	17.6	27.4	40.3

NOTE.—Oak posts will carry loads 15 per cent greater than given above. Southern yellow pine will carry loads 40 per cent greater than given above. The loads given in table are for posts in permanent structures. For posts in temporary structures add 25 per cent to the above loads.

STANDARD DETAIL FOR ROOF TRUSSES

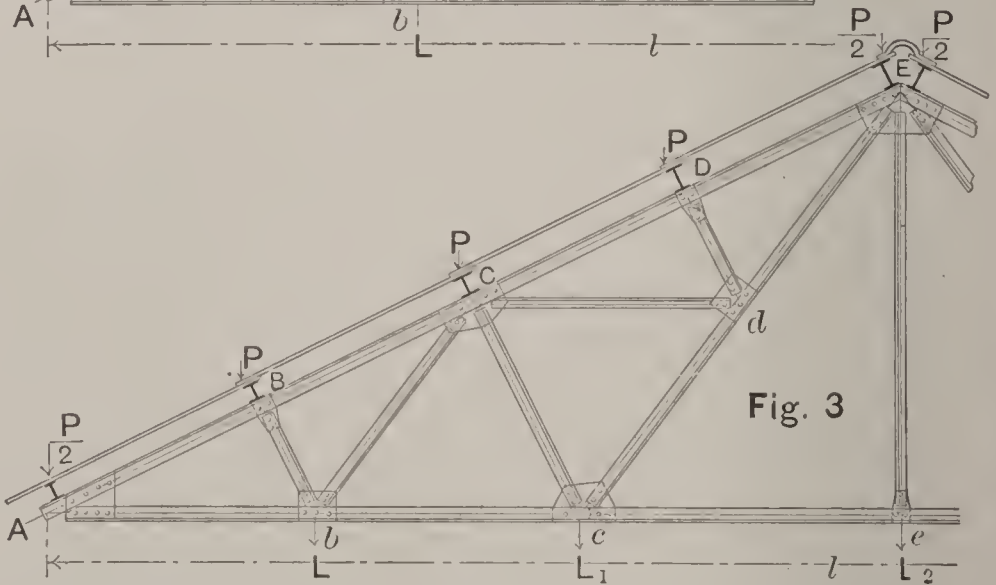
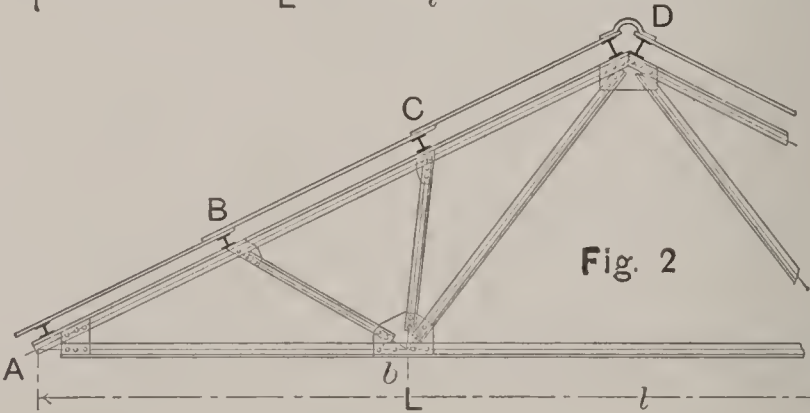
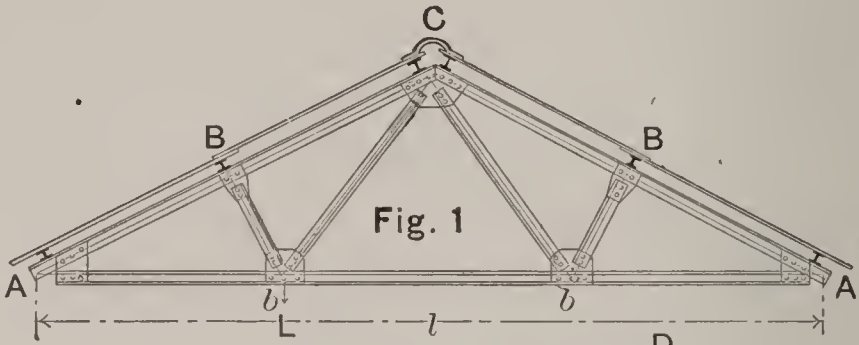

Load per square foot of roof (horizontal) = W
 Distance center to center of trusses = m
 Number of panels in truss = n
 Length of span in feet = l

$$\text{Load on purlin} = P = \frac{W \times m \times l}{n}$$

$$\text{Load on truss} = W \times m \times l$$

W is usually 30 to 40 lbs.

NOTES.—Coefficients given in table on opposite page are for dead load on roof from purlins and for additional stress from concentrated loads, L , L_1 and L_2 , suspended from bottom chord as shown.

Distance from center to center of purlins should not exceed six feet.

Roof covering generally used, No. 20 corrugated steel.

ROOF TRUSSES

Table of Coefficients for Finding Stresses in Members of Roof Trusses of Any Span

NOTE.—For loads corresponding to coefficients, see opposite page.

To find stresses in pounds in roof truss members, multiply the coefficients sub. dead load with load on one truss (= span in feet \times distance between the trusses in feet \times weight per square foot = $l \times m \times w$).

To find the maximum stresses from concentrated loads, multiply coefficients sub. L_1 or L_2 with corresponding actual suspended loads in pounds.

These stresses have to be added to those obtained from dead load to get the total stresses in roof truss members.

PITCH	Member of Truss	1/3			30°			1/4			1/2		
		Dead Load on Roof	L	L ₁	L ₂	Dead Load on Roof	L	L ₁	L ₂	Dead Load on Roof	L	L ₁	L ₂
FIGURE 1	AB	.675	1.15	.750	1.33	.838	1.54	1.010	1.91	.838	1.54	1.010	1.91
	BC	.537	1.15	.625	1.33	.726	1.54	.917	1.91	.726	1.54	.917	1.91
	Ab	.563	.96	.650	1.15	.750	1.38	.938	1.78	.750	1.38	.938	1.78
	Bb	.375	.54	.433	.57	.500	.62	.625	.73	.500	.62	.625	.73
	Bb	.208	0.00	.217	.00	.224	.00	.232	.00	.224	.00	.232	.00
	Cb	.188	1.09	.217	1.16	.250	1.25	.313	1.45	.250	1.25	.313	1.45
	AB	.750	1.15	.833	1.33	.930	1.54	1.120	1.91	.930	1.54	1.120	1.91
	BC	.589	1.15	.666	1.33	.757	1.54	.928	1.91	.757	1.54	.928	1.91
	CD	.568	1.15	.666	1.33	.783	1.54	.995	1.91	.783	1.54	.995	1.91
	Ab	.625	.96	.721	1.15	.833	1.38	1.042	1.78	.833	1.38	1.042	1.78
	Bb	.375	.54	.433	.57	.500	.62	.625	.73	.500	.62	.625	.73
	Bb	.155	0.00	.167	.00	.180	.00	.202	.00	.180	.00	.202	.00
Cb	.155	0.00	.167	.00	.180	.00	.202	.00	.180	.00	.202	.00	
Db	.250	1.09	.288	1.16	.333	1.25	.417	1.45	.333	1.25	.417	1.45	
AB	.788	1.47	.874	1.66	1.33	1.87	1.54	2.30	1.178	1.87	1.54	2.30	
BC	.718	1.47	.812	1.66	1.33	1.87	1.54	2.30	1.131	1.87	1.54	2.30	
CD	.649	.58	.750	.66	1.33	.76	1.54	1.12	1.085	.95	1.910	1.35	
DE	.580	.58	.687	.66	1.33	.76	1.54	1.12	1.038	.95	1.910	1.35	
Ab	.655	1.23	.758	1.44	1.15	1.68	1.38	1.00	1.094	2.14	1.775	1.25	
bc	.562	.81	.650	.86	1.15	.93	1.38	1.00	.938	1.08	1.775	1.25	
ce	.375	.27	.433	.29	.57	.30	.62	1.00	.625	.36	.730	1.25	
Bb	.104	0.00	.108	.00	.112	.00	.116	.00	.116	.00	.116	.00	
Cb	.093	1.09	.108	1.15	.125	1.25	.156	.00	.156	1.45	.00	.00	
Cc	.208	.60	.216	.58	.224	.56	.232	.00	.232	.54	.00	.00	
Cd	.093	0.00	.108	.00	.125	.00	.156	.00	.156	.00	.00	.00	
Dd	.104	0.00	.108	.00	.112	.00	.116	.00	.116	.00	.00	.00	
Ed	.280	.54	.325	.58	1.16	.63	1.25	.00	.469	.73	1.45	.00	
dc	.187	.54	.217	.58	1.16	.63	1.25	.00	.313	.73	1.45	.00	
Ee	.00	.00	.00	.00	.00	.00	.00	1.00	.00	.00	.00	1.00	

LENGTH OF RIVETS FOR VARIANT GRIPS

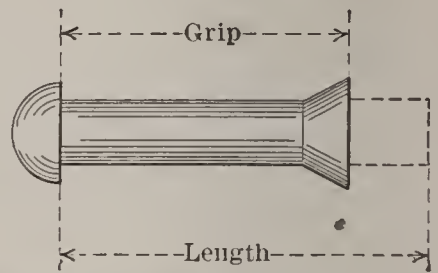
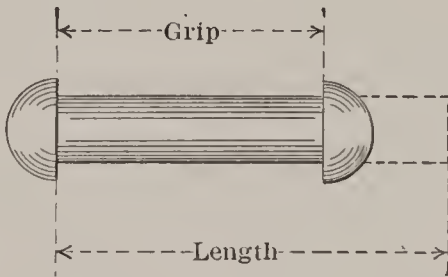

GRIP IN INCHES	DIAMETER IN INCHES					GRIP IN INCHES	DIAMETER IN INCHES				
	1/2	5/8	3/4	7/8	1		1/2	5/8	3/4	7/8	1
	Length in Inches						Length in Inches				
1/2	15/8	17/8	2	2 1/8	2 1/4	1/2	1 1/4	1 3/8	1 3/8	1 1/2	1 1/2
5/8	1 3/4	2	2 1/8	2 1/4	2 3/8	5/8	1 3/8	1 1/2	1 1/2	1 5/8	1 5/8
3/4	1 7/8	2 1/8	2 1/4	2 3/8	2 1/2	3/4	1 1/2	1 5/8	1 5/8	1 3/4	1 3/4
7/8	2	2 1/4	2 3/8	2 1/2	2 5/8	7/8	1 5/8	1 3/4	1 3/4	1 7/8	1 7/8
1	2 1/8	2 3/8	2 1/2	2 5/8	2 3/4	1	1 3/4	1 7/8	1 7/8	2	2
1 1/8	2 1/4	2 1/2	2 3/8	2 3/4	2 7/8	1 1/8	1 7/8	2	2	2 1/8	2 1/8
1 1/4	2 3/8	2 5/8	2 3/4	2 7/8	3	1 1/4	2	2 1/8	2 1/8	2 1/4	2 1/4
1 3/8	2 1/2	2 3/4	2 7/8	3	3 1/8	1 3/8	2 1/8	2 1/4	2 1/4	2 3/8	2 3/8
1 1/2	2 3/4	3	3 1/8	3 1/4	3 3/8	1 1/2	2 1/4	2 3/8	2 1/2	2 1/2	2 5/8
1 5/8	2 7/8	3 1/8	3 1/4	3 3/8	3 1/2	1 5/8	2 3/8	2 1/2	2 5/8	2 5/8	2 3/4
1 3/4	3	3 1/4	3 3/8	3 1/2	3 5/8	1 3/4	2 1/2	2 5/8	2 3/4	2 3/4	2 7/8
1 7/8	3 1/8	3 3/8	3 1/2	3 5/8	3 3/4	1 7/8	2 5/8	2 3/4	2 7/8	2 7/8	3
2	3 1/4	3 1/2	3 5/8	3 3/4	3 7/8	2	2 3/4	2 7/8	3	3	3 1/8
2 1/8	3 3/8	3 5/8	3 3/4	3 7/8	4	2 1/8	2 7/8	3	3 1/8	3 1/8	3 1/4
2 1/4	3 1/2	3 3/4	3 7/8	4	4 1/8	2 1/4	3	3 1/4	3 1/4	3 1/4	3 3/8
2 3/8	3 5/8	3 7/8	4	4 1/8	4 1/4	2 3/8	3 1/8	3 1/4	3 3/8	3 3/8	3 1/2
2 1/2	3 3/4	4	4 1/8	4 1/4	4 3/8	2 1/2	3 1/4	3 3/8	3 1/2	3 1/2	3 5/8
2 5/8	3 7/8	4 1/8	4 1/4	4 3/8	4 1/2	2 5/8	3 3/8	3 1/2	3 5/8	3 5/8	3 3/4
2 3/4	4	4 1/4	4 3/8	4 1/2	4 5/8	2 3/4	3 1/2	3 3/8	3 3/4	3 3/4	3 7/8
2 7/8	4 1/8	4 3/8	4 1/2	4 5/8	4 3/4	2 7/8	3 5/8	3 3/4	3 7/8	3 7/8	4
3	4 3/8	4 5/8	4 3/4	4 7/8	5	3	3 7/8	3 7/8	4	4 1/8	4 1/4
3 1/8	4 1/2	4 3/4	4 7/8	5	5 1/8	3 1/8	4	4	4 1/8	4 1/4	4 3/8
3 1/4	4 5/8	4 7/8	5	5 1/8	5 1/4	3 1/4	4 1/8	4 1/4	4 1/4	4 3/8	4 1/2
3 3/8	4 3/4	5	5 1/8	5 1/4	5 3/8	3 3/8	4 1/4	4 3/8	4 3/8	4 1/2	4 5/8
3 1/2	4 7/8	5 1/8	5 1/4	5 3/8	5 1/2	3 1/2	4 3/8	4 1/2	4 1/2	4 5/8	4 3/4
3 5/8	5	5 1/4	5 3/8	5 1/2	5 5/8	3 5/8	4 1/2	4 5/8	4 5/8	4 3/4	4 7/8
3 3/4	5 1/8	5 3/8	5 1/2	5 5/8	5 3/4	3 3/4	4 5/8	4 3/4	4 3/4	4 7/8	5
3 7/8	5 1/4	5 1/2	5 5/8	5 3/4	5 7/8	3 7/8	4 3/4	4 7/8	4 7/8	5	5 1/8
4	5 3/8	5 5/8	5 3/4	5 7/8	6	4	4 7/8	5	5 1/8	5 1/8	5 1/4
4 1/8	5 1/2	5 3/4	5 7/8	6	6 1/8	4 1/8	5	5 1/8	5 1/4	5 1/4	5 3/8
4 1/4	5 5/8	5 7/8	6	6 1/8	6 1/4	4 1/4	5 1/8	5 1/4	5 3/8	5 3/8	5 1/2
4 3/8	5 3/4	6	6 1/8	6 1/4	6 3/8	4 3/8	5 1/4	5 3/8	5 1/2	5 1/2	5 5/8
4 1/2	6	6 1/4	6 3/8	6 1/2	6 5/8	4 1/2	5 5/8	5 3/4
4 5/8	6 1/8	6 3/8	6 1/2	6 3/8	6 3/4	4 5/8	5 3/4	5 7/8
4 3/4	6 1/4	6 1/2	6 5/8	6 3/4	6 7/8	4 3/4	5 7/8	6
4 7/8	6 3/8	6 5/8	6 3/4	6 7/8	7	4 7/8	6	6 1/8
5	6 1/2	6 3/4	6 7/8	7	7 1/8	5	6 1/8	6 1/4
5 1/8	6 5/8	6 7/8	7	7 1/8	7 1/4	5 1/8	6 1/4	6 3/8
5 1/4	6 3/4	7	7 1/8	7 1/4	7 3/8	5 1/4	6 3/8	6 1/2
5 3/8	6 7/8	7 1/8	7 1/4	7 3/8	7 1/2	5 3/8	6 1/2	6 5/8

CONVENTIONAL SIGNS FOR RIVETING

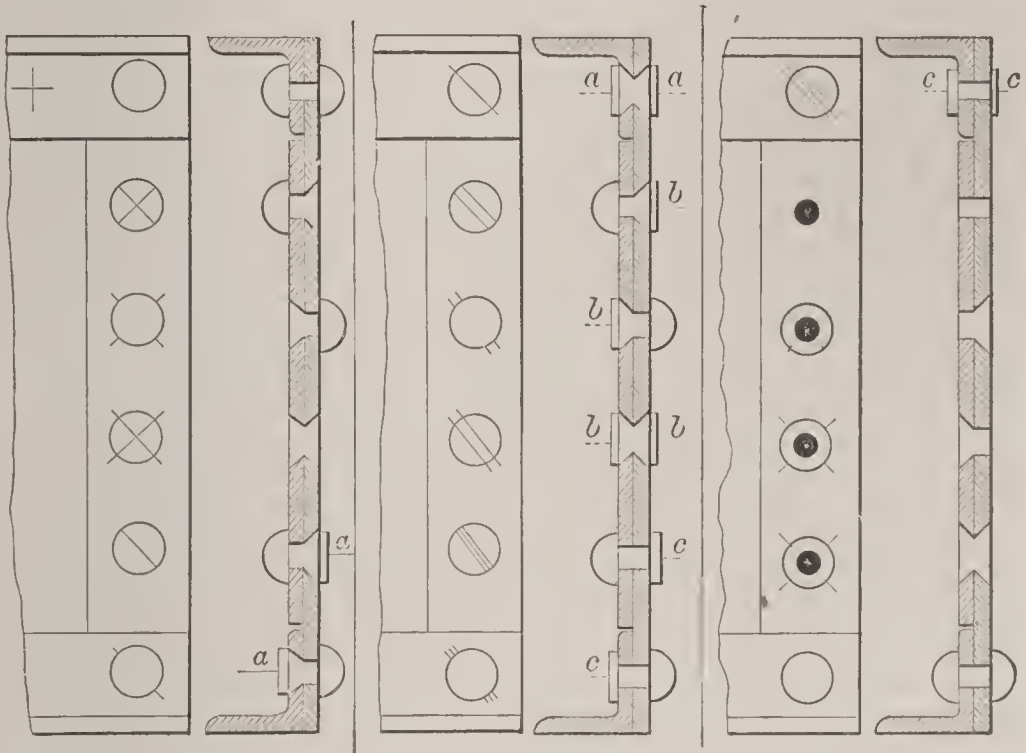

Maximum height of heads marked $a = \frac{1}{8}''$

;; " " " " $b = \frac{1}{4}''$

" " " " " $c = \frac{3}{8}''$

		Shop	Field
Two full heads	\perp or		
Countersunk and chipped other side (or side not visible)			
Countersunk and chipped this side (or side visible)			
Countersunk and chipped both sides			
		Other side (Not Visible)	This side (Visible)
Countersunk but not chipped limit $\frac{1}{8}''$ high			
Flattened head $\frac{1}{4}''$ high and countersunk			
Flattened head $\frac{3}{8}''$ high and not countersunk			

SHEARING AND BEARING VALUE OF RIVETS FOR QUIESCENT LOADS AS USED IN BUILDINGS

Diameter of Rivet in Ins.	Area of Rivet	Single Shear at 10,000 lbs. per sq. inch	Bearing Value for Different Thicknesses of Plate at 20,000 lbs. per square inch (= Diameter of Rivet X Thickness of Plate X 20,000 lbs.)														
			Decimal	1/4 Inch	5/16 Inch	3/8 Inch	7/16 Inch	1/2 Inch	9/16 Inch	5/8 Inch	11/16 Inch	3/4 Inch	13/16 Inch	7/8 Inch			
3/8	.1104	1100	1880														
7/16	.1503	1500	2190	2730													
1/2	.1963	1960	2500	3130	3750												
9/16	.2485	2490	2810	3520	4220	4920											
5/8	.3068	3070	3130	3910	4690	5470											
11/16	.3712	3710	3440	4300	5160	6020	6880										
3/4	.4418	4420	3750	4690	5630	6560	7500	8440									
13/16	.5185	5190	4060	5080	6090	7110	8130	9140	10160								
7/8	.6013	6010	4380	5470	6570	7660	8750	9840	10940								
15/16	.6903	6900	4690	5860	7030	8200	9380	10550	11720	12890							
1	.7854	7850	5000	6250	7500	8750	10000	11250	12500	13750	15000						
1 1/16	.8866	8870	5310	6640	7970	9300	10630	11950	13280	14610	15940	17270					
1 1/8	.9940	9940	5630	7030	8440	9840	11250	12660	14060	15470	16880	18280	19690				
1 3/16	1.1075	11080	5940	7420	8910	10390	11880	13360	14840	16330	17810	19300	20780				

SHEARING AND BEARING VALUE OF RIVETS AS USED FOR MOVING LOADS
IN BRIDGES, CRANEWAYS, ETC.

Diam. of Rivet in Inches		Area of Rivet	Single Shear at 7500 lbs. per sq. inch	Bearing Value for Different Thicknesses of Plate at 15,000 lbs. per square inch. (= Diameter of Rivet × Thickness of Plate × 15,000 lbs.)														
Frac- tion	Decimal			¼ Inch	⅕ Inch	⅜ Inch	½ Inch	⅞ Inch	1 Inch	1 ⅛ Inch	1 ¼ Inch	1 ½ Inch	1 ¾ Inch	2 Inch				
3/8	.375	.1104	828	1410														
7/16	.4375	.1503	1130	1640	2050													
1/2	.5	.1963	1470	1880	2340	2810												
9/16	.5625	.2485	1860	2110	2640	3160	3690											
5/8	.625	.3068	2300	2340	2930	3520	4100											
11/16	.6875	.3712	2780	2580	3220	3870	4510	5160										
3/4	.75	.4418	3310	2810	3520	4220	4920	5630	6330									
13/16	.8125	.5185	3890	3050	3810	4570	5330	6090	6860	7620								
7/8	.875	.6013	4510	3280	4100	4920	5740	6560	7380	8200								
15/16	.9375	.6903	5180	3520	4390	5270	6150	7030	7910	8790	9670							
1	1	.7854	5890	3750	4690	5620	6560	7500	8440	9380	10310	11250						
1 1/16	1.0625	.8866	6650	3980	4980	5980	6970	7970	8960	9960	10960	11950	12950					
1 1/8	1.125	.9940	7460	4220	5270	6330	7380	8440	9490	10550	11600	12660	13710	14770				
1 3/16	1.1875	1.1075	8310	4450	5570	6680	7790	8910	10020	11130	12250	13360	14470	15590				

I BEAM BRIDGES

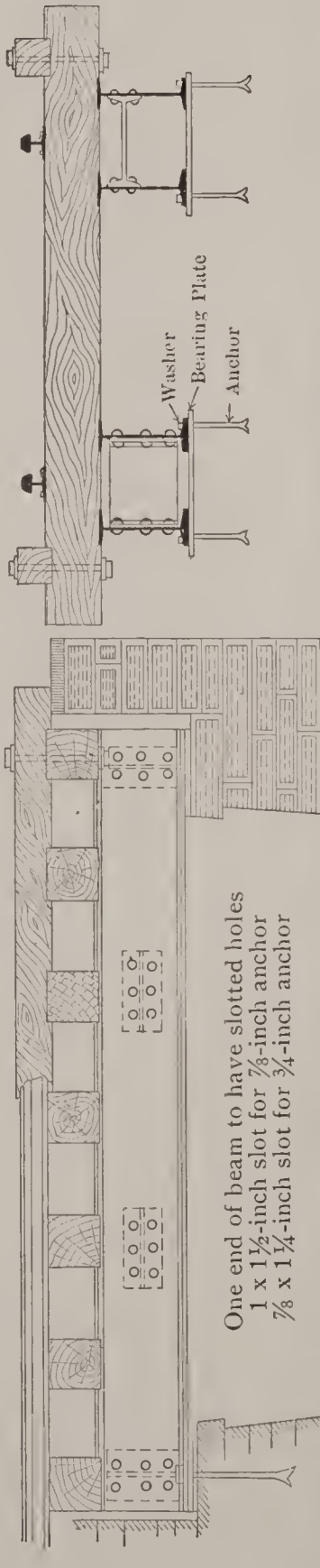

One end of beam to have slotted holes
 1 x 1 1/2-inch slot for 7/8-inch anchor
 7/8 x 1 1/4-inch slot for 3/4-inch anchor

DOUBLE

Size Ins.	Separators Inches	Bearing Plates, Ins.	Wedge and Anchors, Ins	Washers Inches	Size Ins.	Separators Inches	Bearing Plates, Ins.	Wedge and Anchors, Ins	Washers Inches
24	20 I 65 lbs. 18 	18 x 3/4 x 32	7/8 x 12	2 1/2 x 2 1/2 x 1/2 x 1/4	24	10 I 25 lbs. 18	18 x 3/4 x 32	7/8 x 12	2 1/2 x 2 1/2 x 1/2 x 1/4
20	20 I 65 lbs. 15 	12 x 3/4 x 30	7/8 x 12	2 1/2 x 2 1/2 x 1/2 x 1/4	20	10 I 25 lbs. 15	12 x 3/4 x 30	7/8 x 12	2 1/2 x 2 1/2 x 1/2 x 1/4
15	15 I 42 lbs. 11 	12 x 3/4 x 24	7/8 x 12	2 1/2 x 2 1/2 x 1/2 x 1/4	15	10 I 25 lbs 11	12 x 3/4 x 30	7/8 x 12	2 1/2 x 2 1/2 x 1/2 x 1/4
12	12 I 31 1/2 lbs. 9 	12 x 3/4 x 21	3/4 x 10	2 x 1/2 x 1/4 x 2 1/2					
10	10 I 25 lbs. 7 	12 x 1/2 x 18	3/4 x 10	2 x 1/2 x 1/4 x 2 1/2					

TRIPLE

Size Ins.	Separators Inches	Bearing Plates, Ins.	Wedge and Anchors, Ins	Washers Inches

Standard specifications governing the chemical and physical properties of structural and special open-hearth plate and rivet steel, as adopted by the Association of American Steel Manufacturers.— Revised February 6, 1903.

STRUCTURAL STEEL

PROCESS OF MANUFACTURE

1. Steel may be made by either the open-hearth or Bessemer process.

TESTING AND INSPECTION

2. All tests and inspections shall be made at the place of manufacture prior to shipment.

TEST PIECES

3. The tensile strength, limit of elasticity and ductility shall be determined from a standard test piece cut from the finished material. The standard shape of the test piece for sheared plates shall be as shown by the following sketch:

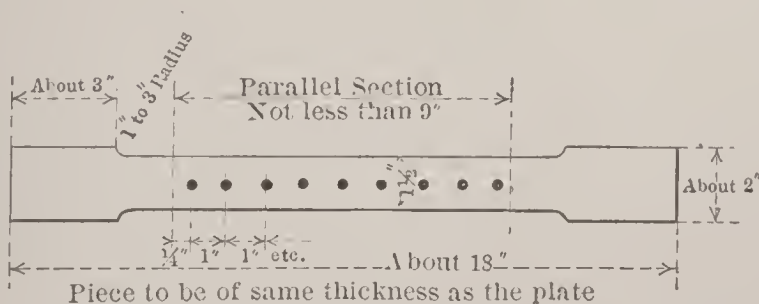

On tests cut from other material the test piece may be either the same as for sheared plates or it may be planed or turned parallel throughout its entire length, and in all cases where possible two opposite sides of the test piece shall be the rolled

surfaces. The elongation shall be measured on an original length of 8 inches, except as modified in section 12, paragraph *c*. Rivet rounds and small bars shall be tested of full size as rolled.

Two test pieces shall be taken from each melt or blow of finished material, one for tension and one for bending; but in case either test develops flaws, or the tensile test piece breaks outside of the middle third of its gauged length, it may be discarded and another test piece substituted therefor.

ANNEALED TEST PIECES

4. Material which is to be used without annealing or further treatment shall be tested in the condition in which it comes from the rolls. When material is to be annealed or otherwise treated before use, the specimen representing such material shall be similarly treated before testing.

MARKING

5. Every finished piece of steel shall be stamped with the blow or melt number, and steel for pins shall have the blow or melt number stamped on the ends. Rivet and lacing steel, and small pieces for pin plates and stiffeners, may be shipped in bundles securely wired together, with the blow or melt number on a metal tag attached.

FINISH

6. Finished bars shall be free from injurious seams, flaws or cracks, and have a workmanlike finish.

CHEMICAL PROPERTIES

7a. Steel for buildings, train sheds, highway bridges and similar structures, maximum phosphorus .10 per cent.

7b. Steel for railway bridges, maximum phosphorus .08 per cent.

PHYSICAL PROPERTIES

8. Structural steel shall be of three grades, Rivet, Railway Bridge and Medium.

RIVET STEEL

9. Ultimate strength, 48,000 to 58,000 pounds per square inch. Elastic limit, not less than one-half the ultimate strength. Percentage of elongation, $\frac{1,400,000}{\text{ultimate strength}}$. Bending test, 180 degrees flat on itself, without fracture on outside of bent portion.

STEEL FOR RAILWAY BRIDGES

10. Ultimate strength, 55,000 to 65,000 pounds per square inch. Elastic limit, not less than one-half the ultimate strength. Percentage of elongation, $\frac{1,400,000}{\text{ultimate strength}}$. Bending test, 180 degrees to a diameter equal to thickness of piece tested, without fracture on outside of bent portion.

MEDIUM STEEL

11. Ultimate strength, 60,000 to 70,000 pounds per square inch. Elastic limit, not less than one-half the ultimate strength. Percentage of elongation, $\frac{1,400,000}{\text{ultimate strength}}$. Bending test, 180 degrees to a diameter equal to thickness of piece tested, without fracture on outside of bent portion.

MODIFICATIONS IN ELONGATION FOR THIN AND THICK MATERIAL

12. For material less than $\frac{5}{16}$ -inch and more than $\frac{3}{4}$ -inch in thickness, the following modifications shall be made in the requirements for elongation:

a. For each increase of $\frac{1}{8}$ -inch in thickness above $\frac{3}{4}$ -inch, a deduction of 1 per cent. shall be made from the specified elongation, except that the minimum elongation shall be 20 per cent. for eye-bar material and 18 per cent. for other structural material.

b. For each decrease of $\frac{1}{16}$ -inch in thickness below $\frac{5}{16}$ -inch, a deduction of $2\frac{1}{2}$ per cent. shall be made from the specified elongation.

c. In rounds of $\frac{5}{8}$ -inch or less in diameter, the elongation shall be measured in a length equal to eight times the diameter of section tested.

d. For pins made from any of the before-mentioned grades of steel, the required elongation shall be 5 per cent. less than that specified for each grade, as determined on a test piece, the center of which shall be 1 inch from the surface of the bar.

VARIATION IN WEIGHT

13. The variation in cross-section or weight of more than $2\frac{1}{2}$ per cent. from that specified will be sufficient cause for rejection except in the case of sheared plates, which will be covered by the following permissible variations:

a. Plates $12\frac{1}{2}$ pounds per square foot or heavier, up to 100 inches wide, when ordered to weight, shall not average more than $2\frac{1}{2}$ per cent. variation above or $2\frac{1}{2}$ per cent. below the theoretical weight. When 100 inches wide and over, 5 per cent. above or 5 per cent. below the theoretical weight.

b. Plates under $12\frac{1}{2}$ pounds per square foot, when ordered to weight, shall not average a greater variation than the following:

Up to 75 inches wide, $2\frac{1}{2}$ per cent. above or $2\frac{1}{2}$ per cent. below the theoretical weight. 75 inches wide up to 100 inches wide, 5 per cent. above or 3 per cent. below the theoretical weight. When 100 inches wide and over, 10 per cent. above or 3 per cent. below the theoretical weight.

c. For all plates ordered to gauge there will be permitted an average excess of weight over that corresponding to the dimensions on the order equal in amount to that specified in the following table:

TABLE OF ALLOWANCES FOR OVERWEIGHT FOR RECTANGULAR PLATES WHEN ORDERING TO GAUGE

Plates will be considered up to gauge if measuring not over $\frac{1}{100}$ -inch less than the ordered gauge

PLATES $\frac{1}{4}$ -INCH AND OVER IN THICKNESS

THICKNESS OF PLATE INCH	WIDTH OF PLATE			
	Up to 75 Inches Per Cent	75 Inches to 100 Inches Per Cent	Over 100 to 115 Inches Per Cent	Over 115 Inches Per Cent
$\frac{1}{4}$	10	14	18	..
$\frac{5}{16}$	8	12	16	..
$\frac{3}{8}$	7	10	13	17
$\frac{7}{16}$	6	8	10	13
$\frac{1}{2}$	5	7	9	12
$\frac{9}{16}$	$4\frac{1}{2}$	$6\frac{1}{2}$	$8\frac{1}{2}$	11
$\frac{5}{8}$	4	6	8	10
Over $\frac{5}{8}$	$3\frac{1}{2}$	5	$6\frac{1}{2}$	9

PLATES UNDER $\frac{1}{4}$ -INCH IN THICKNESS

THICKNESS OF PLATE INCH	WIDTH OF PLATE		
	Up to 50 inches Per Cent	50 Inches to 70 Inches Per Cent	Over 70 inches Per Cent
$\frac{1}{8}$ up to $\frac{5}{32}$	10	15	20
$\frac{5}{32}$ up to $\frac{3}{16}$	$8\frac{1}{2}$	$12\frac{1}{2}$	17
$\frac{3}{16}$ up to $\frac{1}{4}$	7	10	15

NOTE.—The weight of 1 cubic inch of rolled steel is assumed to be 0.2833 pound.

STRUCTURAL CAST-IRON

1. Except when chilled iron is specified, all castings shall be tough gray iron, free from injurious cold-shuts or blow-holes, true to pattern, and of a workmanlike finish. Sample pieces one inch square, cast from the same heat of metal in sand molds, shall be capable of sustaining on a clear span of 4 feet 8 inches a central load of 500 pounds when tested to the rough bar.

SPECIAL OPEN-HEARTH PLATE AND RIVET STEEL-

TESTING AND INSPECTION

1. All tests and inspections shall be made at the place of manufacture prior to shipment.

TEST PIECES

2. The tensile strength, limit of elasticity and ductility shall be determined from a standard test piece cut from the finished material. The standard shape of the test piece for sheared plates shall be as shown by the following sketch:

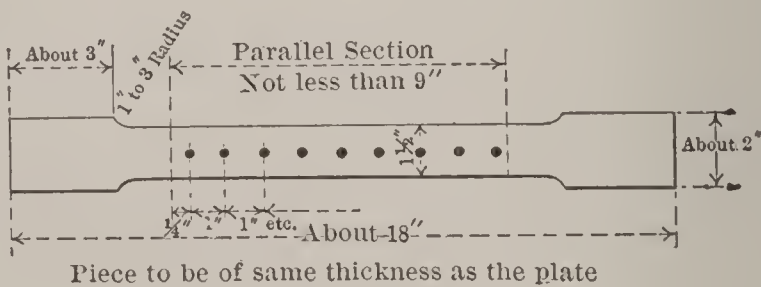

On tests cut from other material the test piece may be either the same as for sheared plates or it may be planed or turned parallel throughout its entire length, and in all cases where possible two opposite sides of the test piece shall be the rolled surfaces. The elongation shall be measured on an original length of 8 inches, except as modified in section 12, paragraph *c*. Rivet rounds and small bars shall be tested of full size as rolled. Four test pieces shall be taken from each melt of finished material, two for tension and two for bending; but in case either test develops flaws, or the tensile test piece breaks outside of the middle third of its gauged length, it may be discarded and another test piece substituted therefor.

ANNEALED TEST PIECES

3. Material which is to be used without annealing or further treatment shall be tested in the condition in which it comes from the rolls. When material is to be annealed or otherwise

treated before use, the specimen representing such material shall be similarly treated before testing.

MARKING

4. Every finished piece of steel shall be stamped with the melt number. Rivet steel may be shipped in bundles securely wired together, with the melt number on a metal tag attached.

FINISH

5. All plates shall be free from injurious surface defects and have a workmanlike finish.

CHEMICAL PROPERTIES

6a. Flange or Boiler Steel, maximum phosphorus .06 per cent., maximum sulphur .04 per cent.

6b. Extra Soft and Fire Box Steel, maximum phosphorus .04 per cent., maximum sulphur .04 per cent.

PHYSICAL PROPERTIES

7. Special Open-hearth Plate and Rivet Steel shall be of three grades, **Extra Soft, Fire Box and Flange or Boiler Steel.**

EXTRA SOFT STEEL

8. Ultimate strength, 45,000 to 55,000 pounds per square inch. Elastic limit, not less than one-half the ultimate strength. Elongation, 28 per cent. Cold and Quench Bends, 180 degrees flat on itself, without fracture on outside of bent portion.

FIRE BOX STEEL

9. Ultimate strength, 52,000 to 62,000 pounds per square inch. Elastic limit, not less than one-half the ultimate strength. Elongation, 26 per cent. Cold and Quench Bends, 180 degrees flat on itself, without fracture on outside of bent portion.

FLANGE OR BOILER STEEL

10. Ultimate strength, 55,000 to 65,000 pounds per square inch. Elastic limit, not less than one-half the ultimate strength.

Elongation, 25 per cent. Cold and Quench Bends, 180 degrees flat on itself, without fracture on outside of bent portion.

BOILER RIVET STEEL

11. Steel for boiler rivets shall be made of the extra soft grade specified in paragraph No. 8.

MODIFICATIONS IN ELONGATION FOR THIN AND THICK MATERIAL

12. For material less than $\frac{5}{16}$ -inch and more than $\frac{3}{4}$ -inch in thickness, the following modifications shall be made in the requirements for elongation:

a. For each increase of $\frac{1}{8}$ -inch in thickness above $\frac{3}{4}$ -inch, a deduction of 1 per cent. shall be made from the specified elongation.

b. For each decrease of $\frac{1}{16}$ -inch in thickness below $\frac{5}{16}$ -inch, a deduction of $2\frac{1}{2}$ per cent. shall be made from the specified elongation.

c. In rounds of $\frac{5}{8}$ -inch or less in diameter, the elongation shall be measured in a length equal to eight times the diameter of section tested.

VARIATION IN WEIGHT

13. The variation in cross-section or weight of more than $2\frac{1}{2}$ per cent. from that specified will be sufficient cause for rejection except in the case of sheared plates, which will be covered by the following permissible variations:

a. Plates $12\frac{1}{2}$ pounds per square foot or heavier, up to 100 inches wide, when ordered to weight, shall not average more than $2\frac{1}{2}$ per cent. variation above or $2\frac{1}{2}$ per cent. below the theoretical weight. When 100 inches wide and over, 5 per cent. above or 5 per cent. below the theoretical weight.

b. Plates under $12\frac{1}{2}$ pounds per square foot, when ordered to weight, shall not average a greater variation than the following:

Up to 75 inches wide, $2\frac{1}{2}$ per cent. above or $2\frac{1}{2}$ per cent. below the theoretical weight. 75 inches wide up to 100 inches

wide, 5 per cent. above or 3 per cent. below the theoretical weight. When 100 inches wide and over, 10 per cent. above or 3 per cent. below the theoretical weight.

c. For all plates ordered to gauge there will be permitted an average excess of weight over that corresponding to the dimensions on the order equal in amount to that specified in the following table:

TABLE OF ALLOWANCES FOR OVERWEIGHT FOR RECTANGULAR PLATES WHEN ORDERED TO GAUGE

Plates will be considered up to gauge if measuring not over $\frac{1}{100}$ -inch less than ordered gauge

PLATES $\frac{1}{4}$ -INCH AND OVER IN THICKNESS

THICKNESS OF PLATES INCHES	WIDTH OF PLATE			
	Up to 75 Inches Per Cent	75 Inches to 100 Inches Per Cent	Over 100 Inches to 115 Inches Per Cent	Over 115 Inches Per Cent
$\frac{1}{4}$	10	14	18	..
$\frac{5}{16}$	8	12	16	..
$\frac{3}{8}$	7	10	13	17
$\frac{7}{16}$	6	8	10	13
$\frac{1}{2}$	5	7	9	12
$\frac{9}{16}$	4 $\frac{1}{2}$	6 $\frac{1}{2}$	8 $\frac{1}{2}$	11
$\frac{5}{8}$	4	6	8	10
Over $\frac{5}{8}$	3 $\frac{1}{2}$	5	6 $\frac{1}{2}$	9

PLATES UNDER $\frac{1}{4}$ -INCH IN THICKNESS

THICKNESS OF PLATE INCHES	WIDTH OF PLATE		
	Up to 50 Inches Per Cent	50 Inches to 70 Inches Per Cent	Over 70 Inches Per Cent
$\frac{1}{8}$ up to $\frac{5}{32}$	10	15	20
$\frac{5}{32}$ up to $\frac{3}{16}$	8 $\frac{1}{2}$	12 $\frac{1}{2}$	17
$\frac{3}{16}$ up to $\frac{1}{4}$	7	10	15

NOTE.—The weight of 1 cubic inch of rolled steel is assumed to be 0.2833 pound.

WEIGHTS OF FLAT ROLLED STEEL Per Lineal Foot

For thicknesses from $\frac{3}{16}$ " to 2" and widths from 1" to 12 $\frac{3}{4}$ "

THICKNESS INCHES	WIDTH IN INCHES								
	1	1 $\frac{1}{4}$	1 $\frac{1}{2}$	1 $\frac{3}{4}$	2	2 $\frac{1}{4}$	2 $\frac{1}{2}$	2 $\frac{3}{4}$	12
$\frac{3}{16}$.638	.797	.957	1.11	1.28	1.44	1.59	1.75	7.65
$\frac{1}{4}$.850	1.06	1.28	1.49	1.70	1.91	2.12	2.34	10.20
$\frac{5}{16}$	1.06	1.33	1.59	1.86	2.12	2.39	2.65	2.92	12.75
$\frac{3}{8}$	1.28	1.59	1.92	2.23	2.55	2.87	3.19	3.51	15.30
$\frac{7}{16}$	1.49	1.86	2.23	2.60	2.98	3.35	3.72	4.09	17.85
$\frac{1}{2}$	1.70	2.12	2.55	2.98	3.40	3.83	4.25	4.67	20.40
$\frac{9}{16}$	1.92	2.39	2.87	3.35	3.83	4.30	4.78	5.26	22.95
$\frac{5}{8}$	2.12	2.65	3.19	3.72	4.25	4.78	5.31	5.84	25.50
$\frac{11}{16}$	2.34	2.92	3.51	4.09	4.67	5.26	5.84	6.43	28.05
$\frac{3}{4}$	2.55	3.19	3.83	4.47	5.10	5.75	6.38	7.02	30.60
$\frac{13}{16}$	2.76	3.45	4.14	4.84	5.53	6.21	6.90	7.60	33.15
$\frac{7}{8}$	2.98	3.72	4.47	5.20	5.95	6.69	7.44	8.18	35.70
$\frac{15}{16}$	3.19	3.99	4.78	5.58	6.38	7.18	7.97	8.77	38.25
1	3.40	4.25	5.10	5.95	6.80	7.65	8.50	9.35	40.80
1 $\frac{1}{16}$	3.61	4.52	5.42	6.32	7.22	8.13	9.03	9.93	43.35
1 $\frac{1}{8}$	3.83	4.78	5.74	6.70	7.65	8.61	9.57	10.52	45.90
1 $\frac{3}{16}$	4.04	5.05	6.06	7.07	8.08	9.09	10.10	11.11	48.45
1 $\frac{1}{4}$	4.25	5.31	6.38	7.44	8.50	9.57	10.63	11.69	51.00
1 $\frac{5}{16}$	4.46	5.58	6.69	7.81	8.93	10.04	11.16	12.27	53.55
1 $\frac{3}{8}$	4.67	5.84	7.02	8.18	9.35	10.52	11.69	12.85	56.10
1 $\frac{7}{16}$	4.89	6.11	7.34	8.56	9.78	11.00	12.22	13.44	58.65
1 $\frac{1}{2}$	5.10	6.38	7.65	8.93	10.20	11.48	12.75	14.03	61.20
1 $\frac{9}{16}$	5.32	6.64	7.97	9.30	10.63	11.95	13.28	14.61	63.75
1 $\frac{5}{8}$	5.52	6.90	8.29	9.67	11.05	12.43	13.81	15.19	66.30
1 $\frac{11}{16}$	5.74	7.17	8.61	10.04	11.47	12.91	14.34	15.78	68.85
1 $\frac{3}{4}$	5.95	7.44	8.93	10.42	11.90	13.40	14.88	16.37	71.40
1 $\frac{13}{16}$	6.16	7.70	9.24	10.79	12.33	13.86	15.40	16.95	73.95
1 $\frac{7}{8}$	6.38	7.97	9.57	11.15	12.75	14.34	15.94	17.53	76.50
1 $\frac{15}{16}$	6.59	8.24	9.88	11.53	13.18	14.83	16.47	18.12	79.05
2	6.80	8.50	10.20	11.90	13.60	15.30	17.00	18.70	81.60

WEIGHTS OF FLAT ROLLED STEEL
Per Lineal Foot

THICKNESS INCHES	WIDTH IN INCHES								
	3	3¼	3½	3¾	4	4¼	4½	4¾	12
3/16	1.91	2.07	2.23	2.39	2.55	2.71	2.87	3.03	7.65
1/4	2.55	2.76	2.98	3.19	3.40	3.61	3.83	4.04	10.20
5/16	3.19	3.45	3.72	3.99	4.25	4.52	4.78	5.05	12.75
3/8	3.83	4.15	4.47	4.78	5.10	5.42	5.74	6.06	15.30
7/16	4.46	4.83	5.20	5.58	5.95	6.32	6.70	7.07	17.85
1/2	5.10	5.53	5.95	6.38	6.80	7.22	7.65	8.08	20.40
9/16	5.74	6.22	6.70	7.17	7.65	8.13	8.61	9.09	22.95
5/8	6.38	6.91	7.44	7.97	8.50	9.03	9.57	10.10	25.50
11/16	7.02	7.60	8.18	8.76	9.35	9.93	10.52	11.11	28.05
3/4	7.65	8.29	8.93	9.57	10.20	10.84	11.48	12.12	30.60
13/16	8.29	8.98	9.67	10.36	11.05	11.74	12.43	13.12	33.15
7/8	8.93	9.67	10.41	11.16	11.90	12.65	13.39	14.13	35.70
15/16	9.57	10.36	11.16	11.95	12.75	13.55	14.34	15.14	38.25
1	10.20	11.05	11.90	12.75	13.60	14.45	15.30	16.15	40.80
1 1/16	10.84	11.74	12.65	13.55	14.45	15.35	16.26	17.16	43.35
1 1/8	11.48	12.43	13.39	14.34	15.30	16.26	17.22	18.17	45.90
1 3/16	12.12	13.12	14.13	15.14	16.15	17.16	18.17	19.18	48.45
1 1/4	12.75	13.81	14.87	15.94	17.00	18.06	19.13	20.19	51.00
1 5/16	13.39	14.50	15.62	16.74	17.85	18.96	20.08	21.20	53.55
1 3/8	14.03	15.20	16.36	17.53	18.70	19.87	21.04	22.21	56.10
1 7/16	14.66	15.88	17.10	18.33	19.55	20.77	21.99	23.22	58.65
1 1/2	15.30	16.58	17.85	19.13	20.40	21.68	22.95	24.23	61.20
1 9/16	15.94	17.27	18.60	19.92	21.25	22.58	23.91	25.24	63.75
1 5/8	16.58	17.96	19.34	20.72	22.10	23.48	24.87	26.25	66.30
1 11/16	17.22	18.65	20.08	21.51	22.95	24.38	25.82	27.26	68.85
1 3/4	17.85	19.34	20.83	22.32	23.80	25.29	26.78	28.27	71.40
1 13/16	18.49	20.03	21.57	23.11	24.65	26.19	27.73	29.27	73.95
1 7/8	19.13	20.72	22.31	23.91	25.50	27.10	28.69	30.28	76.50
1 15/16	19.77	21.41	23.06	24.70	26.35	28.00	29.64	31.29	79.05
2	20.40	22.10	23.80	25.50	27.20	28.90	30.60	32.30	81.60

WEIGHTS OF FLAT ROLLED STEEL Per Lineal Foot

THICKNESS INCHES	WIDTH IN INCHES								
	5	5¼	5½	5¾	6	6¼	6½	6¾	12
$\frac{3}{16}$	3.19	3.35	3.51	3.67	3.83	3.99	4.14	4.30	7.65
$\frac{1}{4}$	4.25	4.46	4.67	4.89	5.10	5.31	5.53	5.74	10.20
$\frac{5}{16}$	5.31	5.58	5.84	6.11	6.38	6.64	6.90	7.17	12.75
$\frac{3}{8}$	6.38	6.69	7.02	7.34	7.65	7.97	8.29	8.61	15.30
$\frac{7}{16}$	7.44	7.81	8.18	8.56	8.93	9.29	9.67	10.04	17.85
$\frac{1}{2}$	8.50	8.93	9.35	9.77	10.20	10.63	11.05	11.48	20.40
$\frac{9}{16}$	9.57	10.04	10.52	11.00	11.48	11.95	12.43	12.91	22.95
$\frac{5}{8}$	10.63	11.16	11.69	12.22	12.75	13.28	13.81	14.34	25.50
$\frac{11}{16}$	11.69	12.27	12.85	13.44	14.03	14.61	15.20	15.78	28.05
$\frac{3}{4}$	12.75	13.39	14.03	14.67	15.30	15.94	16.58	17.22	30.60
$\frac{13}{16}$	13.81	14.50	15.19	15.88	16.58	17.27	17.95	18.65	33.15
$\frac{7}{8}$	14.87	15.62	16.36	17.10	17.85	18.60	19.34	20.08	35.70
$\frac{15}{16}$	15.94	16.74	17.53	18.33	19.13	19.92	20.72	21.51	38.25
1	17.00	17.85	18.70	19.55	20.40	21.25	22.10	22.95	40.80
$1\frac{1}{16}$	18.06	18.96	19.87	20.77	21.68	22.58	23.48	24.39	43.35
$1\frac{1}{8}$	19.13	20.08	21.04	21.99	22.95	23.91	24.87	25.82	45.90
$1\frac{3}{16}$	20.19	21.20	22.21	23.22	24.23	25.23	26.24	27.25	48.45
$1\frac{1}{4}$	21.25	22.32	23.38	24.44	25.50	26.56	27.62	28.69	51.00
$1\frac{5}{16}$	22.32	23.43	24.54	25.66	26.78	27.90	29.01	30.12	53.55
$1\frac{3}{8}$	23.38	24.54	25.71	26.88	28.05	29.22	30.39	31.56	56.10
$1\frac{7}{16}$	24.44	25.66	26.88	28.10	29.33	30.55	31.77	32.99	58.65
$1\frac{1}{2}$	25.50	26.78	28.05	29.33	30.60	31.88	33.15	34.43	61.20
$1\frac{9}{16}$	26.57	27.89	29.22	30.55	31.88	33.20	34.53	35.86	63.75
$1\frac{5}{8}$	27.63	29.01	30.39	31.77	33.15	34.53	35.91	37.29	66.30
$1\frac{11}{16}$	28.69	30.12	31.55	32.99	34.43	35.86	37.30	38.73	68.85
$1\frac{3}{4}$	29.75	31.24	32.73	34.22	35.70	37.19	38.68	40.17	71.40
$1\frac{13}{16}$	30.81	32.35	33.89	35.43	36.98	38.52	40.05	41.60	73.95
$1\frac{7}{8}$	31.87	33.47	35.06	36.65	38.25	39.85	41.44	43.03	76.50
$1\frac{15}{16}$	32.94	34.59	36.23	37.88	39.53	41.17	42.82	44.46	79.05
2	34.00	35.70	37.40	39.10	40.80	42.50	44.20	45.90	81.60

WEIGHTS OF FLAT ROLLED STEEL
Per Lineal Foot

THICKNESS INCHES	WIDTH IN INCHES								
	7	7¼	7½	7¾	8	8¼	8½	8¾	12
3/16	4.46	4.62	4.78	4.94	5.10	5.26	5.42	5.58	7.65
1/4	5.95	6.16	6.36	6.58	6.80	7.01	7.22	7.43	10.20
5/16	7.44	7.70	7.97	8.23	8.50	8.76	9.03	9.29	12.75
3/8	8.93	9.25	9.57	9.88	10.20	10.52	10.84	11.16	15.30
7/16	10.41	10.78	11.16	11.53	11.90	12.27	12.64	13.02	17.85
1/2	11.90	12.32	12.75	13.18	13.60	14.03	14.44	14.87	20.40
9/16	13.39	13.86	14.34	14.82	15.30	15.78	16.26	16.74	22.95
5/8	14.87	15.40	15.94	16.47	17.00	17.53	18.06	18.59	25.50
11/16	16.36	16.94	17.53	18.12	18.70	19.28	19.86	20.45	28.05
3/4	17.85	18.49	19.13	19.77	20.40	21.04	21.68	22.32	30.60
13/16	19.34	20.03	20.72	21.41	22.10	22.79	23.48	24.17	33.15
7/8	20.83	21.57	22.32	23.05	23.80	24.55	25.30	26.04	35.70
15/16	22.32	23.11	23.91	24.70	25.50	26.30	27.10	27.89	38.25
1	23.80	24.65	25.50	26.35	27.20	28.05	28.90	29.75	40.80
1 1/16	25.29	26.19	27.10	28.00	28.90	29.80	30.70	31.61	43.35
1 1/8	26.78	27.73	28.68	29.64	30.60	31.56	32.52	33.47	45.90
1 3/16	28.26	29.27	30.28	31.29	32.30	33.31	34.32	35.33	48.45
1 1/4	29.75	30.81	31.88	32.94	34.00	35.06	36.12	37.20	51.00
1 5/16	31.23	32.35	33.48	34.59	35.70	36.81	37.93	39.05	53.55
1 3/8	32.72	33.89	35.06	36.23	37.40	38.57	39.74	40.91	56.10
1 7/16	34.21	35.44	36.66	37.88	39.10	40.32	41.54	42.77	58.65
1 1/2	35.70	36.98	38.26	39.53	40.80	42.08	43.35	44.63	61.20
1 9/16	37.19	38.51	39.84	41.17	42.50	43.83	45.16	46.49	63.75
1 5/8	38.67	40.05	41.44	42.82	44.20	45.58	46.96	48.34	66.30
1 11/16	40.16	41.59	43.03	44.47	45.90	47.33	48.76	50.20	68.85
1 3/4	41.65	43.14	44.63	46.12	47.60	49.09	50.58	52.07	71.40
1 13/16	43.14	44.68	46.22	47.76	49.30	50.84	52.38	53.92	73.95
1 7/8	44.63	46.22	47.82	49.40	51.00	52.60	54.20	55.79	76.50
1 15/16	46.12	47.76	49.41	51.05	52.70	54.35	56.00	57.64	79.05
2	47.60	49.30	51.00	52.70	54.40	56.10	57.80	59.50	81.60

WEIGHTS OF FLAT ROLLED STEEL
Per Lineal Foot

THICKNESS INCHES	WIDTH IN INCHES								
	9	9¼	9½	9¾	10	10¼	10½	10¾	12
$\frac{3}{16}$	5.74	5.90	6.06	6.22	6.38	6.54	6.70	6.86	7.65
$\frac{1}{4}$	7.65	7.86	8.08	8.29	8.50	8.71	8.92	9.14	10.20
$\frac{5}{16}$	9.56	9.83	10.10	10.36	10.62	10.89	11.16	11.42	12.75
$\frac{3}{8}$	11.48	11.80	12.12	12.44	12.75	13.07	13.39	13.71	15.30
$\frac{7}{16}$	13.40	13.76	14.14	14.51	14.88	15.25	15.62	15.99	17.85
$\frac{1}{2}$	15.30	15.73	16.16	16.58	17.00	17.42	17.85	18.28	20.40
$\frac{9}{16}$	17.22	17.69	18.18	18.65	19.14	19.61	20.08	20.56	22.95
$\frac{5}{8}$	19.13	19.65	20.19	20.72	21.25	21.78	22.32	22.85	25.50
$\frac{11}{16}$	21.04	21.62	22.21	22.79	23.38	23.96	24.54	25.13	28.05
$\frac{3}{4}$	22.96	23.59	24.23	24.86	25.50	26.14	26.78	27.42	30.60
$\frac{13}{16}$	24.86	25.55	26.24	26.94	27.62	28.32	29.00	29.69	33.15
$\frac{7}{8}$	26.78	27.52	28.26	29.01	29.75	30.50	31.24	31.98	35.70
$\frac{15}{16}$	28.69	29.49	30.28	31.08	31.88	32.67	33.48	34.28	38.25
1	30.60	31.45	32.30	33.15	34.00	34.85	35.70	36.55	40.80
$1\frac{1}{16}$	32.52	33.41	34.32	35.22	36.12	37.03	37.92	38.83	43.35
$1\frac{1}{8}$	34.43	35.38	36.34	37.29	38.25	39.21	40.17	41.12	45.90
$1\frac{3}{16}$	36.34	37.35	38.36	39.37	40.38	41.39	42.40	43.40	48.45
$1\frac{1}{4}$	38.26	39.31	40.37	41.44	42.50	43.56	44.63	45.69	51.00
$1\frac{5}{16}$	40.16	41.28	42.40	43.52	44.64	45.75	46.86	47.97	53.55
$1\frac{3}{8}$	42.08	43.25	44.41	45.58	46.75	47.92	49.08	50.25	56.10
$1\frac{7}{16}$	44.00	45.22	46.44	47.66	48.88	50.10	51.32	52.54	58.65
$1\frac{1}{2}$	45.90	47.18	48.45	49.73	51.00	52.28	53.55	54.83	61.20
$1\frac{9}{16}$	47.82	49.14	50.48	51.80	53.14	54.46	55.78	57.11	63.75
$1\frac{5}{8}$	49.73	51.10	52.49	53.87	55.25	56.63	58.02	59.40	66.30
$1\frac{11}{16}$	51.64	53.07	54.51	55.94	57.38	58.81	60.24	61.68	68.85
$1\frac{3}{4}$	53.56	55.04	56.53	58.01	59.50	60.99	62.48	63.97	71.40
$1\frac{13}{16}$	55.46	57.00	58.54	60.09	61.62	63.17	64.70	66.24	73.95
$1\frac{7}{8}$	57.38	58.97	60.56	62.16	63.75	65.35	66.94	68.53	76.50
$1\frac{15}{16}$	59.29	60.94	62.58	64.23	65.88	67.52	69.18	70.83	79.05
2	61.20	62.90	64.60	66.30	68.00	69.70	71.40	73.10	81.60

WEIGHTS OF FLAT ROLLED STEEL
Per Lineal Foot

THICKNESS INCHES	WIDTH IN INCHES							
	11	11¼	11½	11¾	12	12¼	12½	12¾
3/16	7.02	7.17	7.32	7.49	7.65	7.82	7.98	8.13
1/4	9.34	9.57	9.78	10.00	10.20	10.42	10.63	10.84
5/16	11.68	11.95	12.22	12.49	12.75	13.01	13.28	13.55
3/8	14.03	14.35	14.68	14.99	15.30	15.62	15.94	16.26
7/16	16.36	16.74	17.12	17.49	17.85	18.23	18.60	18.97
1/2	18.70	19.13	19.55	19.97	20.40	20.82	21.25	21.67
9/16	21.02	21.51	22.00	22.48	22.95	23.43	23.90	24.39
5/8	23.38	23.91	24.44	24.97	25.50	26.03	26.56	27.09
11/16	25.70	26.30	26.88	27.47	28.05	28.64	29.22	29.80
3/4	28.05	28.68	29.33	29.97	30.60	31.25	31.88	32.52
13/16	30.40	31.08	31.76	32.46	33.15	33.83	34.53	35.22
7/8	32.72	33.47	34.21	34.95	35.70	36.44	37.19	37.93
15/16	35.06	35.86	36.66	37.46	38.25	39.05	39.84	40.64
1	37.40	38.25	39.10	39.95	40.80	41.65	42.50	43.35
1 1/16	39.74	40.64	41.54	42.45	43.35	44.25	45.16	46.06
1 1/8	42.08	43.04	44.00	44.94	45.90	46.86	47.82	48.77
1 3/16	44.42	45.42	46.44	47.45	48.45	49.46	50.46	51.48
1 1/4	46.76	47.82	48.88	49.94	51.00	52.06	53.12	54.19
1 5/16	49.08	50.20	51.32	52.44	53.55	54.67	55.78	56.90
1 3/8	51.42	52.59	53.76	54.93	56.10	57.27	58.44	59.60
1 7/16	53.76	54.99	56.21	57.43	58.65	59.87	61.10	62.32
1 1/2	56.10	57.37	58.65	59.93	61.20	62.48	63.75	65.03
1 9/16	58.42	59.76	61.10	62.43	63.75	65.08	66.40	67.74
1 5/8	60.78	62.16	63.54	64.92	66.30	67.68	69.06	70.44
1 11/16	63.10	64.55	65.98	67.42	68.85	70.29	71.72	73.15
1 3/4	65.45	66.93	68.43	69.92	71.40	72.90	74.38	75.87
1 13/16	67.80	69.33	70.86	72.41	73.95	75.48	77.03	78.57
1 7/8	70.12	71.72	73.31	74.90	76.50	78.09	79.69	81.28
1 15/16	72.46	74.11	75.76	77.41	79.05	80.70	82.34	83.99
2	74.80	76.50	78.20	79.90	81.60	83.30	85.00	86.70

The weights for 12-inch width are repeated on each page to facilitate making the additions necessary to obtain the weights of plates wider than 12 inches. Thus, to find the weight of 15½ X ¾ inches, add the weights to be found in the same line for 3½ X ¾ inches and 12 X ¾ inches = 10.41 + 35.70 = 46.11 pounds

WEIGHTS AND AREAS
Square and Round Steel, and also Circumference of
Round Bars

Thickness or Diameter Inches	Weight of Square Bar 1 Foot Long	Weight of Round Bar 1 Foot Long	Area of Square Bar Square Inches	Area of Round Bar Square Inches	Circumference of Round Bar Inches
$\frac{3}{16}$.120	.094	.0352	.0276	.5890
$\frac{1}{4}$.213	.167	.0625	.0491	.7854
$\frac{5}{16}$.332	.261	.0977	.0767	.9817
$\frac{3}{8}$.478	.375	.1406	.1104	1.1781
$\frac{7}{16}$.651	.511	.1914	.1503	1.3744
$\frac{1}{2}$.851	.668	.2500	.1963	1.5708
$\frac{9}{16}$	1.076	.845	.3164	.2485	1.7671
$\frac{5}{8}$	1.329	1.044	.3906	.3068	1.9635
$\frac{11}{16}$	1.608	1.263	.4727	.3712	2.1598
$\frac{3}{4}$	1.914	1.503	.5625	.4418	2.3562
$\frac{13}{16}$	2.246	1.764	.6602	.5185	2.5525
$\frac{7}{8}$	2.605	2.046	.7656	.6013	2.7489
$\frac{15}{16}$	2.990	2.348	.8789	.6903	2.9452
1	3.402	2.672	1.0000	.7854	3.1416
$\frac{1}{16}$	3.841	3.017	1.1289	.8866	3.3379
$\frac{1}{8}$	4.306	3.382	1.2656	.9940	3.5343
$\frac{3}{16}$	4.798	3.768	1.4102	1.1075	3.7306
$\frac{1}{4}$	5.316	4.175	1.5625	1.2272	3.9270
$\frac{5}{16}$	5.861	4.603	1.7227	1.3530	4.1233
$\frac{3}{8}$	6.432	5.052	1.8906	1.4849	4.3197
$\frac{7}{16}$	7.030	5.521	2.0664	1.6230	4.5160
$\frac{1}{2}$	7.655	6.012	2.2500	1.7671	4.7124
$\frac{9}{16}$	8.306	6.524	2.4414	1.9175	4.9087
$\frac{5}{8}$	8.984	7.056	2.6406	2.0739	5.1051
$\frac{11}{16}$	9.688	7.609	2.8477	2.2365	5.3014
$\frac{3}{4}$	10.419	8.183	3.0625	2.4053	5.4978
$\frac{13}{16}$	11.177	8.778	3.2852	2.5802	5.6941
$\frac{7}{8}$	11.961	9.394	3.5156	2.7612	5.8905
$\frac{15}{16}$	12.772	10.031	3.7539	2.9483	6.0868

In the above table one cubic foot is assumed to weigh 490 pounds.

WEIGHTS AND AREAS

Square and Round Steel, and also Circumference of Round Bars

Thickness or Diameter Inches	Weight of Square Bar 1 Foot Long	Weight of Round Bar 1 Foot Long	Area of Square Bar Square Inches	Area of Round Bar Square Inches	Circumference of Round Bar Inches
2	13.61	10.69	4.0000	3.1416	6.2832
$\frac{1}{16}$	14.47	11.36	4.2539	3.3410	6.4795
$\frac{1}{8}$	15.36	12.06	4.5156	3.5466	6.6759
$\frac{3}{16}$	16.28	12.79	4.7852	3.7583	6.8722
$\frac{1}{4}$	17.22	13.52	5.0625	3.9761	7.0686
$\frac{5}{16}$	18.19	14.29	5.3477	4.2000	7.2649
$\frac{3}{8}$	19.19	15.07	5.6406	4.4301	7.4613
$\frac{7}{16}$	20.21	15.87	5.9414	4.6664	7.6576
$\frac{1}{2}$	21.26	16.70	6.2500	4.9087	7.8540
$\frac{9}{16}$	22.34	17.55	6.5664	5.1572	8.0503
$\frac{5}{8}$	23.44	18.41	6.8906	5.4119	8.2467
$\frac{11}{16}$	24.57	19.30	7.2227	5.6727	8.4430
$\frac{3}{4}$	25.73	20.21	7.5625	5.9396	8.6394
$\frac{13}{16}$	26.91	21.14	7.9102	6.2126	8.8357
$\frac{7}{8}$	28.12	22.09	8.2656	6.4918	9.0321
$\frac{15}{16}$	29.36	23.06	8.6289	6.7771	9.2284
3	30.62	24.05	9.0000	7.0686	9.4248
$\frac{1}{16}$	31.91	25.06	9.3789	7.3662	9.6211
$\frac{1}{8}$	33.23	26.10	9.7656	7.6699	9.8175
$\frac{3}{16}$	34.57	27.15	10.160	7.9798	10.014
$\frac{1}{4}$	35.94	28.23	10.563	8.2958	10.210
$\frac{5}{16}$	37.33	29.32	10.973	8.6179	10.407
$\frac{3}{8}$	38.75	30.43	11.391	8.9462	10.603
$\frac{7}{16}$	40.20	31.57	11.816	9.2806	10.799
$\frac{1}{2}$	41.68	32.74	12.250	9.6211	10.996
$\frac{9}{16}$	43.17	33.91	12.691	9.9678	11.192
$\frac{5}{8}$	44.71	35.12	13.141	10.321	11.388
$\frac{11}{16}$	46.26	36.33	13.598	10.680	11.585
$\frac{3}{4}$	47.84	37.57	14.063	11.045	11.781
$\frac{13}{16}$	49.45	38.84	14.535	11.416	11.977
$\frac{7}{8}$	51.09	40.13	15.016	11.793	12.174
$\frac{15}{16}$	52.75	41.43	15.504	12.177	12.370

In the above table one cubic foot is assumed to weigh 490 pounds.

WEIGHTS AND AREAS

Square and Round Steel, and also Circumference of Round Bars

Thickness or Diameter Inches	Weight of Square Bar 1 Foot Long	Weight of Round Bar 1 Foot Long	Area of Square Bar Square Inches	Area of Round Bar Square Inches	Circumference of Round Bar Inches
4	54.45	42.77	16.000	12.566	12.566
$\frac{1}{8}$	57.90	45.47	17.016	13.364	12.959
$\frac{1}{4}$	61.47	48.28	18.063	14.186	13.352
$\frac{3}{8}$	65.13	51.15	19.141	15.033	13.744
$\frac{1}{2}$	69.81	54.83	20.250	15.904	14.137
$\frac{5}{8}$	72.79	57.17	21.391	16.800	14.530
$\frac{3}{4}$	76.78	60.30	22.563	17.721	14.923
$\frac{7}{8}$	80.87	63.52	23.766	18.665	15.315
5	85.08	66.82	25.000	19.635	15.708
$\frac{1}{8}$	89.38	70.20	26.266	20.629	16.101
$\frac{1}{4}$	93.80	73.67	27.563	21.648	16.493
$\frac{3}{8}$	98.31	77.21	28.891	22.691	16.886
$\frac{1}{2}$	102.94	80.85	30.250	23.758	17.279
$\frac{5}{8}$	107.67	84.56	31.641	24.850	17.671
$\frac{3}{4}$	112.52	88.37	33.063	25.967	18.064
$\frac{7}{8}$	117.45	92.25	34.516	27.109	18.457
6	122.51	96.22	36.000	28.274	18.850
$\frac{1}{8}$	127.66	100.26	37.516	29.465	19.242
$\frac{1}{4}$	132.94	104.41	39.063	30.680	19.635
$\frac{3}{8}$	138.30	108.62	40.641	31.919	20.028
$\frac{1}{2}$	143.78	112.92	42.250	33.183	20.420
$\frac{5}{8}$	149.35	117.30	43.891	34.472	20.813
$\frac{3}{4}$	155.05	121.78	45.563	35.785	21.206
$\frac{7}{8}$	160.84	125.32	47.266	37.122	21.598
7	166.75	130.97	49.000	38.485	21.991
$\frac{1}{8}$	172.75	135.68	50.766	39.871	22.384
$\frac{1}{4}$	178.87	140.48	52.563	41.282	22.777
$\frac{3}{8}$	185.08	145.36	54.391	42.718	23.169
$\frac{1}{2}$	191.42	150.34	56.250	44.179	23.562
$\frac{5}{8}$	197.85	155.39	58.141	45.664	23.955
$\frac{3}{4}$	204.39	160.53	60.063	47.173	24.347
$\frac{7}{8}$	211.03	165.74	62.016	48.707	24.740

In the above table one cubic foot is assumed to weigh 490 pounds.

WEIGHTS AND AREAS

Square and Round Steel, and also Circumference of Round Bars

Thickness or Diameter Inches	Weight of Square Bar 1 Foot Long	Weight of Round Bar 1 Foot Long	Area of Square Bar Square Inches	Area of Round Bar Square Inches	Circumference of Round Bar Inches
8	217.78	171.04	64.000	50.265	25.133
1/8	224.64	176.43	66.016	51.849	25.525
1/4	231.61	181.91	68.063	53.456	25.918
3/8	238.68	187.46	70.141	55.088	26.311
1/2	245.86	193.10	72.250	56.745	26.704
5/8	253.14	198.82	74.391	58.426	27.096
3/4	260.54	204.63	76.593	60.132	27.489
7/8	268.03	210.51	78.766	61.862	27.882
9	275.64	216.49	81.000	63.617	28.274
1/8	283.34	222.54	83.266	65.397	28.667
1/4	291.16	228.68	85.563	67.201	29.060
3/8	299.08	234.90	87.891	69.029	29.452
1/2	307.11	241.20	90.250	70.882	29.845
5/8	315.24	247.59	92.641	72.760	30.238
3/4	323.49	254.07	95.063	74.662	30.631
7/8	331.83	260.62	97.516	76.589	31.023
10	340.29	267.16	100.00	78.540	31.416
1/8	348.85	273.99	102.52	80.516	31.809
1/4	357.52	280.80	105.06	82.516	32.201
3/8	366.29	287.68	107.64	84.541	32.594
1/2	375.17	294.66	110.25	86.590	32.987
5/8	384.15	301.71	112.89	88.664	33.379
3/4	393.25	308.86	115.56	90.763	33.772
7/8	402.44	316.08	118.27	92.886	34.165
11	411.75	323.39	121.00	95.033	34.558
1/8	421.16	330.78	123.77	97.205	34.950
1/4	430.68	338.26	126.56	99.402	35.343
3/8	440.30	345.81	129.39	101.62	35.739
1/2	450.03	353.45	132.25	103.87	36.128
5/8	459.87	361.18	135.14	106.14	36.521
3/4	469.81	368.99	138.06	108.43	36.914
7/8	479.86	376.88	141.02	110.75	37.306

In the above table one cubic foot is assumed to weigh 490 pounds.

AVERAGE WEIGHT PER 100
Round Head Rivets

LENGTH INCHES	DIAMETER							
	3-8	1-2	5-8	3-4	7-8	1	1 1-8	1 1-4
1 1/4	5.5	12.9	21.9	29.3	44.0	66.6	93.3	125.5
1 1/2	6.3	14.2	24.2	32.4	48.2	72.1	100.4	135.7
1 3/4	7.0	15.6	26.3	35.6	52.4	77.7	107.1	144.8
2	7.9	16.9	28.4	38.7	56.7	83.2	114.2	153.0
2 1/4	8.7	18.4	30.6	41.8	61.0	88.8	121.4	162.2
2 1/2	9.4	19.8	32.8	45.0	64.3	94.4	128.5	170.3
2 3/4	10.2	21.1	35.0	48.0	69.5	100.0	135.7	179.5
3	11.0	22.5	37.1	51.2	73.7	105.1	142.8	187.7
3 1/4	11.7	24.0	39.4	54.4	78.0	111.2	149.9	196.9
3 1/2	12.5	25.3	41.5	57.5	82.3	116.3	157.1	205.0
3 3/4	13.4	26.7	43.7	60.6	86.5	122.4	164.2	214.2
4	14.1	28.1	45.9	63.8	90.8	127.5	170.3	222.4
4 1/4	14.9	29.5	48.0	66.9	95.1	133.6	177.5	231.5
4 1/2	15.7	30.9	50.2	70.0	99.3	138.7	184.6	240.7
4 3/4	16.5	32.2	52.4	73.1	104.0	144.8	191.8	248.9
5	17.2	33.7	54.6	76.3	108.1	149.9	198.9	258.1
5 1/4	18.1	35.1	56.7	79.4	112.2	156.1	206.0	266.2
5 1/2	18.8	36.4	58.9	82.5	116.3	161.2	213.2	275.4
5 3/4	19.6	37.8	61.1	85.7	120.4	166.3	220.3	283.6
6	20.4	39.3	63.2	88.7	124.4	172.4	227.5	292.7
6 1/2	21.9	42.0	67.6	95.1	133.6	183.6	240.7	310.1
7	23.5	44.8	71.9	101.3	141.8	194.8	255.0	327.4
7 1/2	25.1	47.5	76.3	108.1	149.9	206.0	269.3	344.8
8	26.6	50.4	80.6	114.2	159.1	217.3	283.6	362.1
8 1/2	28.2	53.1	85.0	120.3	167.3	227.5	297.8	379.4
9	29.8	55.9	89.4	126.5	176.5	238.7	312.1	396.8
9 1/2	31.3	58.8	93.6	132.6	184.6	249.9	325.4	410.1
10	32.8	61.5	98.0	138.7	192.8	261.1	339.7	431.5
Heads..	1.8	5.8	11.1	13.7	22.6	38.8	58.1	83.6

In the above table the length is from under the head.

**AVERAGE WEIGHT PER 100
Square Head Machine Bolts**

LENGTH	DIAMETER								
	1-4	5-16	3-8	7-16	1-2	5-8	3-4	7-8	1
1½	4.0	6.8	10.6	15.0	23.9	40.5	70.0
1¾	4.4	7.3	11.3	16.1	25.1	42.7	73.1
2	4.7	7.8	12.0	17.2	26.3	44.8	76.2
2¼	5.1	8.4	12.6	18.2	27.7	47.0	79.3
2½	5.4	8.9	13.3	19.2	29.0	49.2	82.4	120.5
2¾	5.8	9.5	14.0	20.2	30.4	51.4	85.5	124.7
3	6.1	10.0	14.7	21.2	31.8	53.5	88.7	128.9	185.0
3½	6.8	11.1	16.0	23.2	34.7	57.9	95.0	137.4	196.0
4	7.5	12.2	17.4	25.2	37.5	62.3	101.2	145.8	207.0
4½	8.2	13.2	18.7	27.2	40.2	66.7	107.5	159.2	218.0
5	8.9	14.3	20.0	29.1	43.0	71.0	113.7	167.7	229.0
5½	9.6	15.4	21.4	31.2	45.7	75.4	120.0	176.1	240.0
6	10.3	16.5	22.8	33.1	48.4	79.8	126.2	184.6	251.0
6½	11.0	17.6	24.1	35.1	51.2	84.1	132.5	193.0	262.0
7	11.7	18.6	25.9	37.1	54.0	88.5	138.7	201.4	273.0
7½	12.4	19.7	27.7	39.1	56.7	92.9	145.0	209.9	284.0
8	13.1	20.8	29.5	41.0	59.4	97.2	151.2	218.3	295.0
9	33.1	45.0	64.8	106.0	163.7	240.2	317.0
10	36.7	49.0	70.3	114.7	176.2	257.1	339.0
11	40.4	53.0	75.8	123.5	188.7	273.9	360.0
12	44.0	57.0	81.3	132.2	201.0	290.0	382.0
13	86.7	140.7	213.4	307.7	404.0
14	92.2	149.2	225.9	324.5	426.0
15	97.7	157.6	238.3	341.4	448.0
16	103.1	166.1	250.8	358.3	470.0
17	108.6	174.6	263.2	375.2	492.0
18	114.1	183.1	275.6	392.0	514.0
19	119.5	191.5	288.1	408.9	536.0
20	125.0	200.0	300.5	425.8	558.0
Per inch additional	1.4	2.2	3.6	4.0	5.5	8.5	12.4	16.9	22.0

**APPROXIMATE WEIGHT IN POUNDS
Nuts and Bolt Heads**

Diameter of Bolt, Inches	¼	⅕	⅜	⅞	½	⅝	¾
Weight of Hexagon Nut and Head.....	.017	.042	.057	.109	.128	.267	.43
Weight of Square Nut and Head.....	.021	.049	.069	.120	.164	.320	.55
Diameter of Bolt, Inches	¾	1	1¼	1½	1¾	2	2½
Weight of Hexagon Nut and Head.....	.73	1.10	2.14	3.78	5.6	8.75	17.0
Weight of Square Nut and Head.....	.88	1.31	2.56	4.42	7.0	10.5	21.0

SIZES AND WEIGHTS, U. S. STANDARD
Hot Pressed Square Nuts

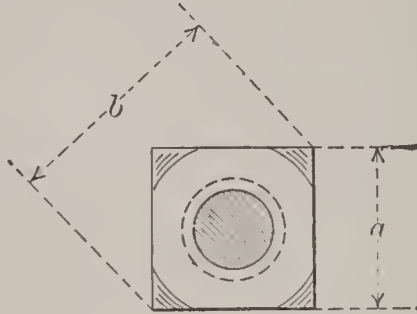

DIMENSIONS		THICKNESS	SIZE OF HOLE		SIZE OF BOLT	WEIGHT OF 100 NUTS	NUMBER OF NUTS IN 100 POUNDS
a	b						
$\frac{1}{2}$.71	$\frac{1}{4}$	0.185	$\frac{3}{16}$ scant	$\frac{1}{4}$	1.4	7270
$\frac{19}{32}$.84	$\frac{5}{16}$	0.240	$\frac{1}{4}$ scant	$\frac{5}{16}$	2.2	4700
$\frac{11}{16}$.97	$\frac{3}{8}$	0.294	$\frac{19}{64}$ scant	$\frac{3}{8}$	4.3	2350
$\frac{25}{32}$	1.11	$\frac{7}{16}$	0.344	$\frac{11}{32}$ scant	$\frac{7}{16}$	6.1	1630
$\frac{7}{8}$	1.24	$\frac{1}{2}$	0.400	$\frac{13}{32}$ scant	$\frac{1}{2}$	9.0	1120
$\frac{31}{32}$	1.37	$\frac{9}{16}$	0.454	$\frac{29}{64}$ scant	$\frac{9}{16}$	11.2	890
$1\frac{1}{16}$	1.50	$\frac{5}{8}$	0.507	$\frac{1}{2}$ full	$\frac{5}{8}$	15.6	640
$1\frac{1}{4}$	1.77	$\frac{3}{4}$	0.620	$\frac{5}{8}$ scant	$\frac{3}{4}$	26.3	380
$1\frac{7}{16}$	2.03	$\frac{7}{8}$	0.731	$\frac{7}{16}$ scant	$\frac{7}{8}$	35.7	280
$1\frac{5}{8}$	2.30	1	0.837	$\frac{33}{64}$ scant	1	58.8	170
$1\frac{13}{16}$	2.56	$1\frac{1}{8}$	0.940	$\frac{15}{16}$ full	$1\frac{1}{8}$	76.9	130
2	2.83	$1\frac{1}{4}$	1.065	$1\frac{1}{16}$ full	$1\frac{1}{4}$	104.2	96
$2\frac{3}{16}$	3.09	$1\frac{3}{8}$	1.160	$1\frac{5}{32}$ full	$1\frac{3}{8}$	142.8	70
$2\frac{3}{8}$	3.36	$1\frac{1}{2}$	1.284	$1\frac{9}{32}$ full	$1\frac{1}{2}$	172.4	58
$2\frac{9}{16}$	3.62	$1\frac{5}{8}$	1.389	$1\frac{25}{64}$ scant	$1\frac{5}{8}$	227.3	44
$2\frac{3}{4}$	3.89	$1\frac{3}{4}$	1.491	$1\frac{1}{2}$ scant	$1\frac{3}{4}$	294.1	34
$2\frac{15}{16}$	4.15	$1\frac{7}{8}$	1.616	$1\frac{5}{8}$ scant	$1\frac{7}{8}$	370.4	27
$3\frac{1}{8}$	4.42	2	1.712	$1\frac{23}{32}$ scant	2	416.7	24
$3\frac{5}{16}$	4.68	$2\frac{1}{8}$	1.836	$1\frac{27}{32}$ scant	$2\frac{1}{8}$	500.0	20
$3\frac{1}{2}$	4.95	$2\frac{1}{4}$	1.962	$1\frac{11}{8}$ scant	$2\frac{1}{4}$	588.2	17

NOTE.—Both weights and sizes are for unfinished nuts.

SIZES AND WEIGHTS, U. S. STANDARD
Hot Pressed Hexagon Nuts

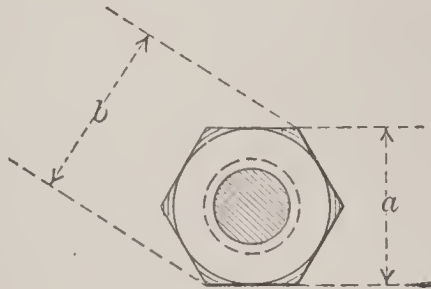

DIMENSIONS		THICKNESS	SIZE OF HOLE		SIZE OF BOLT	WEIGHT OF 100 NUTS	NUMBER OF NUTS IN 100 POUNDS
a	b						
1/2	.58	1/4	0.185	3/16 scant	1/4	1.3	7615
19/32	.68	5/16	0.240	1/4 scant	5/16	1.9	5200
11/16	.79	3/8	0.294	19/64 scant	3/8	3.3	3000
25/32	.90	7/16	0.344	1 1/2	7/16	5.0	2000
7/8	1.01	1/2	0.400	13/32 scant	1/2	7.0	1430
31/32	1.12	9/16	0.454	29/64	9/16	9.1	1100
1 1/16	1.23	5/8	0.507	1/2 full	5/8	13.5	740
1 1/4	1.44	3/4	0.620	5/8 scant	3/4	22.2	450
1 7/16	1.66	7/8	0.731	47/64 scant	7/8	32.4	309
1 5/8	1.88	1	0.837	27/32 scant	1	46.3	216
1 13/16	2.09	1 1/8	0.940	15/16 full	1 1/8	67.6	148
2	2.31	1 1/4	1.065	1 1/16 full	1 1/4	90.1	111
2 3/16	2.53	1 3/8	1.160	1 5/32 full	1 3/8	117.5	85
2 3/8	2.74	1 1/2	1.284	1 9/32 full	1 1/2	147.1	68
2 9/16	2.96	1 5/8	1.389	1 25/64 scant	1 5/8	178.6	56
2 3/4	3.18	1 3/4	1.491	1 1/2 scant	1 3/4	250.0	40
2 15/16	3.39	1 7/8	1.616	1 5/8 scant	1 7/8	285.7	35
3 1/8	3.61	2	1.712	1 23/32 scant	2	344.8	29
3 5/16	3.82	2 1/8	1.836	1 27/32 scant	2 1/8	384.6	26
3 1/2	4.04	2 1/4	1.962	1 31/32 scant	2 1/4	434.8	23

NOTE.—Both weights and sizes are for unfinished nuts.

UPSET SCREW ENDS

For Round and Square Bars

DIAMETER OF ROUND OR SIDE OF SQUARE BAR, INCHES	ROUND BARS				SQUARE BARS			
	Diameter of Upset Screw End Inches	Diameter of Screw at Root of Thread Inches	Threads per Inch No.	Excess of Effective Area of Screw End over Bar, Per Cent	Diameter of Upset Screw End Inches	Diameter of Screw at Root of Thread Inches	Threads per Inch No.	Excess of Effective Area of Screw End over Bar, Per Cent
$\frac{1}{2}$	$\frac{3}{4}$.620	10	54	$\frac{3}{4}$.620	10	21
$\frac{9}{16}$	$\frac{3}{4}$.620	10	21	$\frac{7}{8}$.731	9	33
$\frac{5}{8}$	$\frac{7}{8}$.731	9	37	1	.837	8	41
$\frac{11}{16}$	1	.837	8	48	1	.837	8	17
$\frac{3}{4}$	1	.837	8	25	$1\frac{1}{8}$.940	7	23
$\frac{13}{16}$	$1\frac{1}{8}$.940	7	34	$1\frac{1}{4}$	1.065	7	35
$\frac{7}{8}$	$1\frac{1}{4}$	1.065	7	48	$1\frac{3}{8}$	1.160	6	38
$\frac{15}{16}$	$1\frac{1}{4}$	1.065	7	29	$1\frac{3}{8}$	1.160	6	20
1	$1\frac{3}{8}$	1.160	6	35	$1\frac{1}{2}$	1.284	6	29
$1\frac{1}{16}$	$1\frac{3}{8}$	1.160	6	19	$1\frac{5}{8}$	1.389	$5\frac{1}{2}$	34
$1\frac{1}{8}$	$1\frac{1}{2}$	1.284	6	30	$1\frac{5}{8}$	1.389	$5\frac{1}{2}$	20
$1\frac{3}{16}$	$1\frac{1}{2}$	1.284	6	17	$1\frac{3}{4}$	1.490	5	24
$1\frac{1}{4}$	$1\frac{5}{8}$	1.389	$5\frac{1}{2}$	23	$1\frac{7}{8}$	1.615	5	31
$1\frac{5}{16}$	$1\frac{3}{4}$	1.490	5	29	$1\frac{7}{8}$	1.615	5	19
$1\frac{3}{8}$	$1\frac{3}{4}$	1.490	5	18	2	1.712	$4\frac{1}{2}$	22
$1\frac{7}{16}$	$1\frac{7}{8}$	1.615	5	26	$2\frac{1}{8}$	1.837	$4\frac{1}{2}$	28
$1\frac{1}{2}$	2	1.712	$4\frac{1}{2}$	30	$2\frac{1}{8}$	1.837	$4\frac{1}{2}$	18
$1\frac{9}{16}$	2	1.712	$4\frac{1}{2}$	20	$2\frac{1}{4}$	1.962	$4\frac{1}{2}$	24
$1\frac{5}{8}$	$2\frac{1}{8}$	1.837	$4\frac{1}{2}$	28	$2\frac{3}{8}$	2.087	$4\frac{1}{2}$	30
$1\frac{11}{16}$	$2\frac{1}{8}$	1.837	$4\frac{1}{2}$	18	$2\frac{3}{8}$	2.087	$4\frac{1}{2}$	20
$1\frac{3}{4}$	$2\frac{1}{4}$	1.962	$4\frac{1}{2}$	26	$2\frac{1}{2}$	2.175	4	21
$1\frac{13}{16}$	$2\frac{1}{4}$	1.962	$4\frac{1}{2}$	17	$2\frac{5}{8}$	2.300	4	26
$1\frac{7}{8}$	$2\frac{3}{8}$	2.087	$4\frac{1}{2}$	24	$2\frac{5}{8}$	2.300	4	18
$1\frac{15}{16}$	$2\frac{1}{2}$	2.175	4	26	$2\frac{3}{4}$	2.425	4	23
2	$2\frac{1}{2}$	2.175	4	18	$2\frac{7}{8}$	2.550	4	28
$2\frac{1}{16}$	$2\frac{5}{8}$	2.300	4	24	$2\frac{7}{8}$	2.550	4	20
$2\frac{1}{8}$	$2\frac{5}{8}$	2.300	4	17	3	2.629	$3\frac{1}{2}$	20
$2\frac{3}{16}$	$2\frac{3}{4}$	2.425	4	23	$3\frac{1}{8}$	2.754	$3\frac{1}{2}$	24

UPSET SCREW ENDS
For Round and Square Bars

DIAMETER OF ROUND OR SIDE OF SQUARE BAR, INCHES	ROUND BARS				SQUARE BARS			
	Diameter of Upset Screw End Inches	Diameter of Screw at Root of Thread Inches	Threads per Inch No.	Excess of Effective Area of Screw End over Bar, Per Cent	Diameter of Upset Screw End Inches	Diameter of Screw at Root of Thread Inches	Threads per Inch No.	Excess of Effective Area of Screw End over Bar, Per Cent
2 1/4	2 7/8	2.550	4	28	3 1/8	2.754	3 1/2	18
2 5/16	2 7/8	2.550	4	22	3 1/4	2.879	3 1/2	22
2 3/8	3	2.629	3 1/2	23	3 3/8	3.004	3 1/2	26
2 7/16	3 1/8	2.754	3 1/2	28	3 3/8	3.004	3 1/2	19
2 1/2	3 1/8	2.754	3 1/2	21	3 1/2	3.100	3 1/4	21
2 9/16	3 1/4	2.879	3 1/2	26	3 5/8	3.225	3 1/4	24
2 5/8	3 1/4	2.879	3 1/2	20	3 5/8	3.225	3 1/4	19
2 11/16	3 3/8	3.004	3 1/2	25	3 3/4	3.317	3	20
2 3/4	3 3/8	3.004	3 1/2	19	3 7/8	3.442	3	23
2 13/16	3 1/2	3.100	3 1/4	22	3 7/8	3.442	3	18
2 7/8	3 5/8	3.225	3 1/4	26	4	3.567	3	21
2 15/16	3 5/8	3.225	3 1/4	21	4 1/8	3.692	3	24
3	3 3/4	3.317	3	22	4 1/8	3.692	3	19
3 1/8	3 7/8	3.442	3	21	4 3/8	3.923	2 7/8	24
3 1/4	4	3.567	3	20	4 1/2	4.028	2 3/4	21
3 3/8	4 1/8	3.692	3	20	4 5/8	4.153	2 3/4	19
3 1/2	4 1/4	3.798	2 7/8	18				
3 5/8	4 1/2	4.028	2 3/4	23				
3 3/4	4 5/8	4.153	2 3/4	23				
3 7/8	4 3/4	4.255	2 5/8	21				

REMARKS.—As upsetting reduces the strength of iron, bars having the same diameter at root of thread as that of the bar invariably break in the screw end, when tested to destruction, without developing the full strength of the bar. It is therefore necessary to make up for this loss in strength by an excess of metal in the upset screw ends over that in the bar.

The screw threads in the above table are the Franklin Institute standard.

To make one upset end for 5-inch length of thread, allow 6-inch length of rod additional.

STANDARD SCREW THREADS, NUTS AND BOLT HEADS

Recommended by Franklin Institute, December 15, 1864, and adopted by Navy Department of the United States, by the R. R. Master Mechanics' and Master Car-Builders' Associations, by the Jones & Laughlin Steel Company, and by many other of the prominent engineering and mechanical establishments of the country.

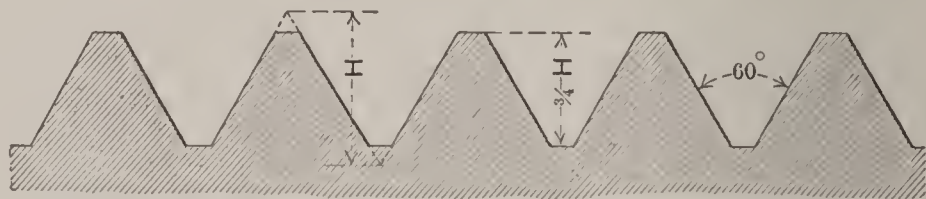

Angle of thread 60°. Flat at top and bottom $\frac{1}{8}$ of pitch.

Diameter of Screw	Threads per Inch	Diameter at Root of Thread	Diameter of Screw	Threads per Inch	Diameter at Root of Thread
$\frac{1}{4}$	20	.185	2	$4\frac{1}{2}$	1.712
$\frac{5}{16}$	18	.240	$2\frac{1}{4}$	$4\frac{1}{2}$	1.962
$\frac{3}{8}$	16	.294	$2\frac{1}{2}$	4	2.176
$\frac{7}{16}$	14	.344	$2\frac{3}{4}$	4	2.426
$\frac{1}{2}$	13	.400	3	$3\frac{1}{2}$	2.629
$\frac{9}{16}$	12	.454	$3\frac{1}{4}$	$3\frac{1}{2}$	2.879
$\frac{5}{8}$	11	.507	$3\frac{1}{2}$	$3\frac{1}{4}$	3.100
$\frac{3}{4}$	10	.620	$3\frac{3}{4}$	3	3.317
$\frac{7}{8}$	9	.731	4	3	3.567
1	8	.837	$4\frac{1}{4}$	$2\frac{7}{8}$	3.798
$1\frac{1}{8}$	7	.940	$4\frac{1}{2}$	$2\frac{3}{4}$	4.028
$1\frac{1}{4}$	7	1.065	$4\frac{3}{4}$	$2\frac{5}{8}$	4.256
$1\frac{3}{8}$	6	1.160	5	$2\frac{1}{2}$	4.480
$1\frac{1}{2}$	6	1.284	$5\frac{1}{4}$	$2\frac{1}{2}$	4.730
$1\frac{5}{8}$	$5\frac{1}{2}$	1.389	$5\frac{1}{2}$	$2\frac{3}{8}$	4.953
$1\frac{3}{4}$	5	1.491	$5\frac{3}{4}$	$2\frac{3}{8}$	5.203
$1\frac{7}{8}$	5	1.616	6	$2\frac{1}{4}$	5.423

Nuts and bolt heads are determined by the following rules, which apply to both square and hexagon nuts :

Short diameter of rough nut = $1\frac{1}{2} \times$ diameter of bolt + $\frac{1}{8}$ -inch.

Short diameter of finished nut = $1\frac{1}{2} \times$ diameter of bolt + $\frac{1}{16}$ -inch.

Thickness of rough nut = diameter of bolt.

Thickness of finished nut = diameter of bolt - $\frac{1}{16}$ -inch.

Short diameter of rough head = $1\frac{1}{2} \times$ diameter of bolt + $\frac{1}{8}$ -inch.

Short diameter of finished head = $1\frac{1}{2} \times$ diameter of bolt + $\frac{1}{16}$ -inch.

Thickness of rough head = $\frac{1}{2}$ short diameter of head.

Thickness of finished head = diameter of bolt - $\frac{1}{16}$ -inch.

The long diameter of a hexagon nut may be obtained by multiplying the short diameter by 1.155 and the long diameter of a square nut by multiplying the short diameter by 1.414.

WEIGHT PER SUPERFICIAL FOOT
Sheet Iron and Steel

BIRMINGHAM GAUGE	WEIGHT POUNDS		BIRMINGHAM GAUGE	WEIGHT POUNDS	
	Iron	Steel		Iron	Steel
No. 1=.3	12.12	12.36	No. 16=.065	2.63	2.68
" 2=.284	11.48	11.71	" 17=.058	2.34	2.39
" 3=.259	10.47	10.68	" 18=.049	1.98	2.02
" 4=.238	9.62	9.81	" 19=.042	1.70	1.73
" 5=.22	8.89	9.07	" 20=.035	1.56	1.59
" 6=.203	8.20	8.36	" 21=.032	1.40	1.43
" 7=.18	7.27	7.42	" 22=.028	1.25	1.28
" 8=.165	6.67	6.80	" 23=.025	1.12	1.14
" 9=.148	5.98	6.10	" 24=.022	1.	1.02
" 10=.134	5.42	5.53	" 25=.02	.9	.92
" 11=.12	4.85	4.95	" 26=.018	.8	.82
" 12=.109	4.41	4.50	" 27=.016	.72	.73
" 13=.095	3.84	3.92	" 28=.014	.64	.65
" 14=.083	3.35	3.42	" 29=.013	.56	.57
" 15=.072	2.91	2.97	" 30=.012	.5	.51

Tank Iron and Steel

THICKNESS INCHES	WEIGHT POUNDS		THICKNESS INCHES	WEIGHT POUNDS	
	Iron	Steel		Iron	Steel
$\frac{1}{32} = .03125$	1.27	1.30	$\frac{5}{16} = .3125$	12.63	12.88
$\frac{1}{16} = .0625$	2.52	2.57	$\frac{3}{8} = .375$	15.16	15.46
$\frac{3}{32} = .09375$	3.79	3.87	$\frac{7}{16} = .4375$	17.68	18.03
$\frac{1}{8} = .125$	5.05	5.15	$\frac{1}{2} = .5$	20.21	20.61
$\frac{5}{32} = .15625$	6.32	6.45	$\frac{9}{16} = .5625$	22.73	23.19
$\frac{3}{16} = .1875$	7.58	7.73	$\frac{5}{8} = .625$	25.26	25.77
$\frac{7}{32} = .21875$	8.84	9.02	$\frac{3}{4} = .75$	30.31	30.92
$\frac{1}{4} = .25$	10.10	10.30	$\frac{7}{8} = .875$	35.37	36.08
$\frac{9}{32} = .28123$	11.38	11.61	1 = 1	40.42	41.23

The low temperature (as compared with iron) at which steel plates have to be finished, causes a slight springing of the rolls, leaving the plate thicker in the center. This, combined with greater density, causes steel plates, if kept up to full thickness on the edges, to weigh more than iron. Both iron and steel over 72 inches wide are apt to run even heavier than the weights given above.

STANDARD STEAM, GAS AND WATER PIPE

Not Manufactured by Jones & Laughlin Steel Co.

SIZE IN INCHES	ORDINARY PIPE			X STRONG PIPE			XX STRONG PIPE		
	Nominal Inside Diameter	Actual Outside Diameter	Weight per Foot	Nominal Inside Diameter	Actual Outside Diameter	Weight per Foot	Nominal Inside Diameter	Actual Outside Diameter	Weight per Foot
$\frac{1}{8}$.27	.405	.24	.205	.405	.29			
$\frac{1}{4}$.364	.540	.42	.294	.540	.54			
$\frac{3}{8}$.494	.675	.56	.421	.675	.74			
$\frac{1}{2}$.623	.84	.84	.542	.84	1.09	.244	.84	1.70
$\frac{3}{4}$.824	1.05	1.12	.736	1.05	1.39	.422	1.05	2.44
1	1.048	1.315	1.67	.951	1.315	2.17	.587	1.315	3.65
$1\frac{1}{4}$	1.38	1.66	2.24	1.272	1.66	3.00	.885	1.66	5.20
$1\frac{1}{2}$	1.611	1.90	2.68	1.494	1.90	3.63	1.088	1.90	6.40
2	2.067	2.375	3.61	1.933	2.375	5.02	1.491	2.375	9.02
$2\frac{1}{2}$	2.468	2.875	5.74	2.315	2.875	7.67	1.755	2.875	13.68
3	3.067	3.50	7.54	2.892	3.50	10.25	2.284	3.50	18.56
$3\frac{1}{2}$	3.548	4.00	9.00	3.358	4.00	12.47	2.716	4.00	22.75
4	4.026	4.50	10.66	3.818	4.50	14.97	3.136	4.50	27.48
$4\frac{1}{2}$	4.508	5.00	12.49	4.28	5.00	18.22	3.564	5.00	32.53
5	5.045	5.563	14.50	4.813	5.563	20.54	4.063	5.563	38.12
6	6.065	6.625	18.76	5.75	6.625	28.58	4.875	6.625	53.11
7	7.023	7.625	23.27	6.625	7.625	37.67	5.875	7.625	62.38
8	7.982	8.625	28.18	7.625	8.625	43.00	6.875	8.625	71.62
9	8.937	9.625	33.70						
10	10.019	10.75	40.00						

WEIGHT PER CUBIC FOOT OF SUBSTANCES

Name of Substances	Average Weight Pounds
Aluminum, cast	160
Aluminum, rolled	167
Anthracite, solid, of Pennsylvania	93
Anthracite, broken, loose	54
Anthracite, broken, moderately shaken	58
Anthracite, heaped bushel, loose	(80)
Ash, American white, dry	38
Asphaltum	87
Brass (copper and zinc), cast	504
Brass, rolled	524
Brick, best pressed	150
Brick, common hard	125
Brick, soft, inferior	100
Brickwork, pressed brick	140
Brickwork, ordinary	112
Cement, hydraulic, ground, loose, American Rosendale	56
Cement, hydraulic, ground, loose, American Louisville	50
Cement, hydraulic, ground, loose, English Portland	90
Concrete	148 to 160
Cinder concrete	98 to 102
Cherry, dry	42
Chestnut, dry	41
Clay, potters', dry	119
Clay, in lumps, loose	63
Coal, bituminous, solid	84
Coal, bituminous, broken, loose	49
Coal, bituminous, heaped bushel, loose	(74)
Coke, loose, of good coal	26
Coke, loose, heaped bushel	(40)
Copper, cast	549
Copper, rolled	556
Earth, common loam, dry, loose	76
Earth, common loam, dry, moderately rammed	95
Earth, as a soft flowing mud	108
Ebony, dry	76
Elm, dry	35
Flint	162
Glass, common window	157
Gneiss, common	168

WEIGHT PER CUBIC FOOT OF SUBSTANCES.

Name of Substances	Average Weight Pounds
Gold, cast pure, or 24-carat	1204
Gold, pure hammered	1217
Grain, at 60 pounds per bushel	48
Granite	170
Gravel, about the same as sand (see Sand)	
Gypsum (plaster of paris)	142
Hemlock, dry	25
Hickory, dry	53
Hornblende, black	203
Ice	58.7
Iron, cast	450
Iron, wrought, purest	485
Iron, wrought, average	480
Iron, ore	175
Ivory	114
Lead	711
Lignum-vitæ, dry	83
Lime, quick, ground, loose, or in small lumps	53
Lime, quick, ground, loose, thoroughly shaken	75
Lime, quick, ground, loose, per struck bushel	(66)
Limestones and marbles	168
Limestones and marbles, loose, in irregular fragments	96
Magnesium	109
Mahogany, Spanish, dry	53
Mahogany, Honduras, dry	35
Maple, dry	49
Marbles (see Limestones)	
Masonry, of granite or limestone, well dressed	165
Masonry, of mortar rubble	154
Masonry, of dry rubble, well scabbled	138
Masonry, of sandstone, well dressed	144
Mercury, 32° Fahrenheit	849
Mica	183
Mortar, hardened	103
Mud, dry, close	80 to 110
Mud, wet, fluid, maximum	120
Oak, live, dry	59
Oak, white, dry	50
Oak, other kinds	32 to 45

WEIGHT PER CUBIC FOOT OF SUBSTANCES

Name of Substances	Average Weight Pounds
Paper	48 to 50
Petroleum	55
Pine, white, dry	25
Pine, yellow, Northern	34
Pine, yellow, Southern	45
Platinum	1342
Quartz, common, pure	165
Resin	69
Salt, coarse, Syracuse, N. Y.	45
Salt, fine, Liverpool, for table use	49
Sand, of pure quartz, dry, loose	90 to 106
Sand, well shaken	99 to 117
Sand, perfectly wet	120 to 140
Sandstones, fit for building	151
Shales, red or black	162
Silver	655
Slate	175
Snow, freshly fallen	5 to 12
Snow, moistened and compacted by rain	15 to 50
Spruce, dry	25
Steel	490
Sulphur	125
Sycamore, dry	37
Tar	62
Tin, cast	459
Turf or peat, dry, unpressed	20 to 30
Walnut, black, dry	38
Water, pure rain or distilled at 60° Fahrenheit	62 $\frac{1}{3}$
Water, sea	64
Wax, bees	60.5
Zinc or spelter	437.5

Green timbers usually weigh from one-fifth to one-half more than dry.

AREAS AND CIRCUMFERENCES OF CIRCLES

DIAM.	AREA	CIRCUM.	DIAM.	AREA	CIRCUM.
0.0			4.0	12.5664	12.5664
.1	.007854	.31416	.1	13.2025	12.8805
.2	.031416	.62832	.2	13.8544	13.1947
.3	.070686	.94248	.3	14.5220	13.5088
.4	.12566	1.2566	.4	15.2053	13.8230
.5	.19635	1.5708	.5	15.9043	14.1372
.6	.28274	1.8850	.6	16.6190	14.4513
.7	.38485	2.1991	.7	17.3494	14.7655
.8	.50266	2.5133	.8	18.0956	15.0796
.9	.63617	2.8274	.9	18.8574	15.3938
1.0	.7854	3.1416	5.0	19.6350	15.7080
.1	.9503	3.4558	.1	20.4282	16.0221
.2	1.1310	3.7699	.2	21.2372	16.3363
.3	1.3273	4.0841	.3	22.0618	16.6504
.4	1.5394	4.3982	.4	22.9022	16.9646
.5	1.7671	4.7124	.5	23.7583	17.2788
.6	2.0106	5.0265	.6	24.6301	17.5929
.7	2.2698	5.3407	.7	25.5176	17.9071
.8	2.5447	5.6549	.8	26.4208	18.2212
.9	2.8353	5.9690	.9	27.3397	18.5354
2.0	3.1416	6.2832	6.0	28.2743	18.8496
.1	3.4636	6.5973	.1	29.2247	19.1637
.2	3.8013	6.9115	.2	30.1907	19.4779
.3	4.1548	7.2257	.3	31.1725	19.7920
.4	4.5239	7.5398	.4	32.1699	20.1062
.5	4.9087	7.8540	.5	33.1831	20.4204
.6	5.3093	8.1681	.6	34.2119	20.7345
.7	5.7256	8.4823	.7	35.2565	21.0487
.8	6.1575	8.7965	.8	36.3168	21.3628
.9	6.6052	9.1106	.9	37.3928	21.6770
3.0	7.0686	9.4248	7.0	38.4845	21.9911
.1	7.5477	9.7389	.1	39.5919	22.3053
.2	8.0425	10.0531	.2	40.7150	22.6195
.3	8.5530	10.3673	.3	41.8539	22.9336
.4	9.0792	10.6814	.4	43.0084	23.2478
.5	9.6211	10.9956	.5	44.1786	23.5619
.6	10.1788	11.3097	.6	45.3646	23.8761
.7	10.7521	11.6239	.7	46.5663	24.1903
.8	11.3411	11.9381	.8	47.7836	24.5044
.9	11.9459	12.2522	.9	49.0167	24.8186

For diameters from $\frac{1}{16}$ to 100, advancing by tenths.

AREAS AND CIRCUMFERENCES OF CIRCLES

DIAM.	AREA	CIRCUM.	DIAM.	AREA	CIRCUM.
8.0	50.2655	25.1327	12.0	113.0973	37.6991
.1	51.5300	25.4469	.1	114.9901	38.0133
.2	52.8102	25.7611	.2	116.8987	38.3274
.3	54.1061	26.0752	.3	118.8229	38.6416
.4	55.4177	26.3894	.4	120.7628	38.9557
.5	56.7450	26.7035	.5	122.7185	39.2699
.6	58.0880	27.0177	.6	124.6898	39.5841
.7	59.4468	27.3319	.7	126.6769	39.8982
.8	60.8212	27.6460	.8	128.6796	40.2124
.9	62.2114	27.9602	.9	130.6981	40.5265
9.0	63.6173	28.2743	13.0	132.7323	40.8407
.1	65.0388	28.5885	.1	134.7822	41.1549
.2	66.4761	28.9027	.2	136.8478	41.4690
.3	67.9291	29.2168	.3	138.9291	41.7832
.4	69.3978	29.5310	.4	141.0261	42.0973
.5	70.8822	29.8451	.5	143.1388	42.4115
.6	72.3823	30.1593	.6	145.2672	42.7257
.7	73.8981	30.4734	.7	147.4114	43.0398
.8	75.4296	30.7876	.8	149.5712	43.3540
.9	76.9769	31.1018	.9	151.7468	43.6681
10.0	78.5398	31.4159	14.0	153.9380	43.9823
.1	80.1185	31.7301	.1	156.1450	44.2965
.2	81.7128	32.0442	.2	158.3677	44.6106
.3	83.3229	32.3584	.3	160.6061	44.9248
.4	84.9487	32.6726	.4	162.8602	45.2389
.5	86.5901	32.9867	.5	165.1300	45.5531
.6	88.2473	33.3009	.6	167.4155	45.8673
.7	89.9202	33.6150	.7	169.7167	46.1814
.8	91.6088	33.9292	.8	172.0336	46.4956
.9	93.3132	34.2434	.9	174.3662	46.8097
11.0	95.0332	34.5575	15.0	176.7146	47.1239
.1	96.7689	34.8717	.1	179.0786	47.4380
.2	98.5203	35.1858	.2	181.4584	47.7522
.3	100.2875	35.5000	.3	183.8539	48.0664
.4	102.0703	35.8142	.4	186.2650	48.3805
.5	103.8689	36.1283	.5	188.6919	48.6947
.6	105.6832	36.4425	.6	191.1345	49.0088
.7	107.5132	36.7566	.7	193.5928	49.3230
.8	109.3588	37.0708	.8	196.0668	49.6372
.9	111.2202	37.3850	.9	198.5565	49.9513

For diameters from $\frac{1}{10}$ to 100, advancing by tenths.

AREAS AND CIRCUMFERENCES OF CIRCLES

DIAM.	AREA	CIRCUM.	DIAM.	AREA	CIRCUM.
16.0	201.0619	50.2655	20.0	314.1593	62.8319
.1	203.5831	50.5796	.1	317.3087	63.1460
.2	206.1199	50.8938	.2	320.4739	63.4602
.3	208.6724	51.2080	.3	323.6547	63.7743
.4	211.2407	51.5221	.4	326.8513	64.0885
.5	213.8246	51.8363	.5	330.0636	64.4026
.6	216.4243	52.1504	.6	333.2916	64.7168
.7	219.0397	52.4646	.7	336.5353	65.0310
.8	221.6708	52.7788	.8	339.7947	65.3451
.9	224.3176	53.0929	.9	343.0698	65.6593
17.0	226.9801	53.4071	21.0	346.3606	65.9734
.1	229.6583	53.7212	.1	349.6671	66.2876
.2	232.3522	54.0354	.2	352.9894	66.6018
.3	235.0618	54.3496	.3	356.3273	66.9159
.4	237.7871	54.6637	.4	359.6809	67.2301
.5	240.5282	54.9779	.5	363.0503	67.5442
.6	243.2849	55.2920	.6	366.4354	67.8584
.7	246.0574	55.6062	.7	369.8361	68.1726
.8	248.8456	55.9203	.8	373.2526	68.4867
.9	251.6494	56.2345	.9	376.6848	68.8009
18.0	254.4690	56.5486	22.0	380.1327	69.1150
.1	257.3043	56.8628	.1	383.5963	69.4292
.2	260.1553	57.1770	.2	387.0756	69.7434
.3	263.0220	57.4911	.3	390.5707	70.0575
.4	265.9044	57.8053	.4	394.0814	70.3717
.5	268.8025	58.1195	.5	397.6078	70.6858
.6	271.7164	58.4336	.6	401.1500	71.0000
.7	274.6459	58.7478	.7	404.7078	71.3142
.8	277.5911	59.0619	.8	408.2814	71.6283
.9	280.5521	59.3761	.9	411.8707	71.9425
19.0	283.5287	59.6903	23.0	415.4756	72.2566
.1	286.5211	60.0044	.1	419.0963	72.5708
.2	289.5292	60.3186	.2	422.7327	72.8849
.3	292.5530	60.6327	.3	426.3848	73.1991
.4	295.5925	60.9469	.4	430.0526	73.5133
.5	298.6477	61.2611	.5	433.7361	73.8274
.6	301.7186	61.5752	.6	437.4354	74.1416
.7	304.8052	61.8894	.7	441.1503	74.4557
.8	307.9075	62.2035	.8	444.8809	74.7699
.9	311.0255	62.5177	.9	448.6273	75.0841

For diameters from $\frac{1}{16}$ to 100, advancing by tenths.

AREAS AND CIRCUMFERENCES OF CIRCLES

DIAM.	AREA	CIRCUM.	DIAM.	AREA	CIRCUM.
24.0	452.3893	75.3982	28.0	615.7522	87.9646
.1	456.1671	75.7124	.1	620.1582	88.2788
.2	459.9606	76.0265	.2	624.5800	88.5929
.3	463.7698	76.3407	.3	629.0175	88.9071
.4	467.5947	76.6549	.4	633.4707	89.2212
.5	471.4352	76.9690	.5	637.9397	89.5354
.6	475.2916	77.2832	.6	642.4243	89.8495
.7	479.1636	77.5973	.7	646.9246	90.1637
.8	483.0513	77.9115	.8	651.4407	90.4779
.9	486.9547	78.2257	.9	655.9724	90.7920
25.0	490.8739	78.5398	29.0	660.5199	91.1062
.1	494.8087	78.8540	.1	665.0830	91.4203
.2	498.7592	79.1681	.2	669.6619	91.7345
.3	502.7255	79.4823	.3	674.2565	92.0487
.4	506.7075	79.7965	.4	678.8668	92.3628
.5	510.7052	80.1106	.5	683.4928	92.6770
.6	514.7185	80.4248	.6	688.1345	92.9911
.7	518.7476	80.7389	.7	692.7919	93.3053
.8	522.7924	81.0531	.8	697.4650	93.6195
.9	526.8529	81.3672	.9	702.1538	93.9336
26.0	530.9292	81.6814	30.0	706.8583	94.2478
.1	535.0211	81.9956	.1	711.5786	94.5619
.2	539.1287	82.3097	.2	716.3145	94.8761
.3	543.2521	82.6239	.3	721.0662	95.1903
.4	547.3911	82.9380	.4	725.8336	95.5044
.5	551.5459	83.2522	.5	730.6167	95.8186
.6	555.7163	83.5664	.6	735.4154	96.1327
.7	559.9025	83.8805	.7	740.2299	96.4469
.8	564.1044	84.1947	.8	745.0601	96.7611
.9	568.3220	84.5088	.9	749.9060	97.0752
27.0	572.5553	84.8230	31.0	754.7676	97.3894
.1	576.8043	85.1372	.1	759.6450	97.7035
.2	581.0690	85.4513	.2	764.5380	98.0177
.3	585.3494	85.7655	.3	769.4467	98.3319
.4	589.6455	86.0796	.4	774.3712	98.6460
.5	593.9574	86.3938	.5	779.3113	98.9602
.6	598.2849	86.7080	.6	784.2672	99.2743
.7	602.6282	87.0221	.7	789.2388	99.5885
.8	606.9871	87.3363	.8	794.2260	99.9026
.9	611.3618	87.6504	.9	799.2290	100.2168

For diameters from 1₁₀ to 100, advancing by tenths.

AREAS AND CIRCUMFERENCES OF CIRCLES

DIAM.	AREA	CIRCUM.	DIAM.	AREA	CIRCUM.
32.0	804.2477	100.5310	36.0	1017.8760	113.0973
.1	809.2821	100.8451	.1	1023.5387	113.4115
.2	814.3322	101.1593	.2	1029.2172	113.7257
.3	819.3980	101.4734	.3	1034.9113	114.0398
.4	824.4796	101.7876	.4	1040.6212	114.3540
.5	829.5768	102.1018	.5	1046.3467	114.6681
.6	834.6898	102.4159	.6	1052.0880	114.9823
.7	839.8185	102.7301	.7	1057.8449	115.2965
.8	844.9628	103.0442	.8	1063.6176	115.6106
.9	850.1229	103.3584	.9	1069.4060	115.9248
33.0	855.2986	103.6726	37.0	1075.2101	116.2389
.1	860.4902	103.9867	.1	1081.0299	116.5531
.2	865.6973	104.3009	.2	1086.8654	116.8672
.3	870.9202	104.6150	.3	1092.7166	117.1814
.4	876.1588	104.9292	.4	1098.5835	117.4956
.5	881.4131	105.2434	.5	1104.4662	117.8097
.6	886.6831	105.5575	.6	1110.3645	118.1239
.7	891.9688	105.8717	.7	1116.2786	118.4380
.8	897.2703	106.1858	.8	1122.2083	118.7522
.9	902.5874	106.5000	.9	1128.1538	119.0664
34.0	907.9203	106.8142	38.0	1134.1149	119.3805
.1	913.2688	107.1283	.1	1140.0918	119.6947
.2	918.6331	107.4425	.2	1146.0844	120.0088
.3	924.0131	107.7566	.3	1152.0927	120.3230
.4	929.4088	108.0708	.4	1158.1167	120.6372
.5	934.8202	108.3849	.5	1164.1564	120.9513
.6	940.2473	108.6991	.6	1170.2118	121.2655
.7	945.6901	109.0133	.7	1176.2830	121.5796
.8	951.1486	109.3274	.8	1182.3698	121.8938
.9	956.6228	109.6416	.9	1188.4724	122.2080
35.0	962.1128	109.9557	39.0	1194.5906	122.5221
.1	967.6184	110.2699	.1	1200.7246	122.8363
.2	973.1397	110.5841	.2	1206.8742	123.1504
.3	978.6768	110.8982	.3	1213.0396	123.4646
.4	984.2296	111.2124	.4	1219.2207	123.7788
.5	989.7980	111.5265	.5	1225.4175	124.0929
.6	995.3822	111.8407	.6	1231.6300	124.4071
.7	1000.9821	112.1549	.7	1237.8582	124.7212
.8	1006.5977	112.4690	.8	1244.1021	125.0354
.9	1012.2290	112.7832	.9	1250.3617	125.3495

For diameters from $\frac{1}{10}$ to 100, advancing by tenths.

AREAS AND CIRCUMFERENCES OF CIRCLES

DIAM.	AREA	CIRCUM.	DIAM.	AREA	CIRCUM.
40.0	1256.6371	125.6637	44.0	1520.5308	138.2301
.1	1262.9281	125.9779	.1	1527.4502	138.5442
.2	1269.2348	126.2920	.2	1534.3853	138.8584
.3	1275.5573	126.6062	.3	1541.3360	139.1726
.4	1281.8955	126.9203	.4	1548.3025	139.4867
.5	1288.2493	127.2345	.5	1555.2847	139.8009
.6	1294.6189	127.5487	.6	1562.2826	140.1153
.7	1301.0042	127.8628	.7	1569.2962	140.4292
.8	1307.4052	128.1770	.8	1576.3255	140.7434
.9	1313.8219	128.4911	.9	1583.3706	141.0575
41.0	1320.2543	128.8053	45.0	1590.4313	141.3717
.1	1326.7024	129.1195	.1	1597.5077	141.6858
.2	1333.1663	129.4336	.2	1604.5999	142.0000
.3	1339.6458	129.7478	.3	1611.7077	142.3142
.4	1346.1410	130.0619	.4	1618.8313	142.6283
.5	1352.6520	130.3761	.5	1625.9705	142.9425
.6	1359.1786	130.6903	.6	1633.1255	143.2566
.7	1365.7210	131.0044	.7	1640.2962	143.5708
.8	1372.2791	131.3186	.8	1647.4826	143.8849
.9	1378.8529	131.6327	.9	1654.6847	144.1991
42.0	1385.4424	131.9469	46.0	1661.9025	144.5133
.1	1392.0476	132.2611	.1	1669.1360	144.8274
.2	1398.6685	132.5752	.2	1676.3853	145.1416
.3	1405.3051	132.8894	.3	1683.6502	145.4557
.4	1411.9574	133.2035	.4	1690.9308	145.7699
.5	1418.6254	133.5177	.5	1698.2272	146.0841
.6	1425.3092	133.8318	.6	1705.5392	146.3982
.7	1432.0086	134.1460	.7	1712.8670	146.7124
.8	1438.7238	134.4602	.8	1720.2105	147.0265
.9	1445.4546	134.7743	.9	1727.5697	147.3407
43.0	1452.2012	135.0885	47.0	1734.9445	147.6550
.1	1458.9635	135.4026	.1	1742.3351	147.9690
.2	1465.7415	135.7168	.2	1749.7414	148.2832
.3	1472.5352	136.0310	.3	1757.1635	148.5973
.4	1479.3446	136.3451	.4	1764.6012	148.9115
.5	1486.1697	136.6593	.5	1772.0546	149.2257
.6	1493.0105	136.9734	.6	1779.5237	149.5398
.7	1499.8670	137.2876	.7	1787.0086	149.8540
.8	1506.7393	137.6018	.8	1794.5091	150.1681
.9	1513.6272	137.9159	.9	1802.0254	150.4823

For diameters from $\frac{1}{16}$ to 100, advancing by tenths.

AREAS AND CIRCUMFERENCES OF CIRCLES

DIAM.	AREA	CIRCUM.	DIAM.	AREA	CIRCUM.
48.0	1809.5574	150.7964	52.0	2123.7166	163.3628
.1	1817.1050	151.1106	.1	2131.8926	163.6770
.2	1824.6684	151.4248	.2	2140.0843	163.9911
.3	1832.2475	151.7389	.3	2148.2917	164.3053
.4	1839.8423	152.0531	.4	2156.5149	164.6195
.5	1847.4528	152.3672	.5	2164.7537	164.9336
.6	1855.0790	152.6814	.6	2173.0082	165.2479
.7	1862.7210	152.9956	.7	2181.2785	165.5619
.8	1870.3786	153.3097	.8	2189.5644	165.8761
.9	1878.0519	153.6239	.9	2197.8661	166.1903
49.0	1885.7409	153.9380	53.0	2206.1834	166.5044
.1	1893.4457	154.2522	.1	2214.5165	166.8186
.2	1901.1662	154.5664	.2	2222.8653	167.1327
.3	1908.9024	154.8805	.3	2231.2298	167.4469
.4	1916.6543	155.1947	.4	2239.6100	167.7610
.5	1924.4218	155.5088	.5	2248.0059	168.0752
.6	1932.2051	155.8230	.6	2256.4175	168.3894
.7	1940.0042	156.1372	.7	2264.8448	168.7035
.8	1947.8189	156.4513	.8	2273.2879	169.0177
.9	1955.6493	156.7655	.9	2281.7466	169.3318
50.0	1963.4954	157.0796	54.0	2290.2210	169.6460
.1	1971.3572	157.3938	.1	2298.7112	169.9602
.2	1979.2348	157.7080	.2	2307.2171	170.2743
.3	1987.1280	158.0221	.3	2315.7386	170.5885
.4	1995.0370	158.3363	.4	2324.2759	170.9026
.5	2002.9617	158.6504	.5	2332.8289	171.2168
.6	2010.9020	158.9646	.6	2341.3976	171.5310
.7	2018.8581	159.2787	.7	2349.9820	171.8451
.8	2026.8299	159.5929	.8	2358.5821	172.1593
.9	2034.8174	159.9071	.9	2367.1979	172.4735
51.0	2042.8206	160.2212	55.0	2375.8294	172.7876
.1	2050.8395	160.5354	.1	2384.4767	173.1017
.2	2058.8742	160.8495	.2	2393.1396	173.4159
.3	2066.9245	161.1637	.3	2401.8183	173.7301
.4	2074.9905	161.4779	.4	2410.5126	174.0442
.5	2083.0723	161.7920	.5	2419.2227	174.2584
.6	2091.1697	162.1062	.6	2427.9485	174.6726
.7	2099.2829	162.4203	.7	2436.6899	174.9867
.8	2107.4118	162.7345	.8	2445.4471	175.3009
.9	2115.5563	163.0487	.9	2454.2200	175.6150

For diameters from $\frac{1}{10}$ to 100, advancing by tenths.

AREAS AND CIRCUMFERENCES OF CIRCLES

DIAM.	AREA	CIRCUM.	DIAM.	AREA	CIRCUM.
56.0	2463.0086	175.9292	60.0	2827.4334	188.4956
.1	2471.8130	176.2433	.1	2836.8660	188.8097
.2	2480.6330	176.5575	.2	2846.3144	189.1239
.3	2489.4687	176.8717	.3	2855.7784	189.4380
.4	2498.3201	177.1858	.4	2865.2582	189.7522
.5	2507.1873	177.5000	.5	2874.7536	190.0664
.6	2516.0701	177.8141	.6	2884.2648	190.3805
.7	2524.9687	178.1283	.7	2893.7917	190.6947
.8	2533.8830	178.4425	.8	2903.3343	191.0088
.9	2542.8129	178.7566	.9	2912.8926	191.3230
57.0	2551.7586	179.0708	61.0	2922.4666	191.6372
.1	2560.7200	179.3849	.1	2932.0563	191.9513
.2	2569.6971	179.6991	.2	2941.6617	192.2655
.3	2578.6899	180.0133	.3	2951.2828	192.5796
.4	2587.6985	180.3274	.4	2960.9197	192.8938
.5	2596.7227	180.6416	.5	2970.5722	193.2079
.6	2605.7626	180.9557	.6	2980.2405	193.5221
.7	2614.8183	181.2699	.7	2989.9244	193.8363
.8	2623.8896	181.5841	.8	2999.6241	194.1504
.9	2632.9767	181.8982	.9	3009.3395	194.4646
58.0	2642.0794	182.2124	62.0	3019.0705	194.7787
.1	2651.1979	182.5265	.1	3028.8173	195.0929
.2	2660.3321	182.8407	.2	3038.5798	195.4071
.3	2669.4820	183.1549	.3	3048.3580	195.7212
.4	2678.6476	183.4690	.4	3058.1520	196.0354
.5	2687.8289	183.7832	.5	3067.9616	196.3495
.6	2697.0259	184.0973	.6	3077.7869	196.6637
.7	2706.2386	184.4115	.7	3087.6279	196.9779
.8	2715.4670	184.7256	.8	3097.4847	197.2920
.9	2724.7112	185.0398	.9	3107.3571	197.6062
59.0	2733.9710	185.3540	63.0	3117.2453	197.9203
.1	2743.2466	185.6681	.1	3127.1492	198.2345
.2	2752.5378	185.9823	.2	3137.0688	198.5487
.3	2761.8448	186.2964	.3	3147.0040	198.8628
.4	2771.1675	186.6106	.4	3156.9550	199.1770
.5	2780.5058	186.9248	.5	3166.9217	199.4911
.6	2789.8599	187.2389	.6	3176.9043	199.8053
.7	2799.2297	187.5531	.7	3186.9023	200.1195
.8	2808.6152	187.8672	.8	3196.9161	200.4336
.9	2818.0165	188.1814	.9	3206.9456	200.7478

For diameters from $\frac{1}{16}$ to 100, advancing by tenths.

AREAS AND CIRCUMFERENCES OF CIRCLES

DIAM.	AREA	CIRCUM.	DIAM.	AREA	CIRCUM.
64.0	3216.9909	201.0620	68.0	3631.6811	213.6283
.1	3227.0518	201.3761	.1	3642.3704	213.9425
.2	3237.1285	201.6902	.2	3653.0754	214.2566
.3	3247.2222	202.0044	.3	3663.7960	214.5708
.4	3257.3289	202.3186	.4	3674.5324	214.8849
.5	3267.4527	202.6327	.5	3685.2845	215.1991
.6	3277.5922	202.9469	.6	3696.0523	215.5133
.7	3287.7474	203.2610	.7	3706.8359	215.8274
.8	3297.9183	203.5752	.8	3717.6351	216.1416
.9	3308.1049	203.8894	.9	3728.4500	216.4556
65.0	3318.3072	204.2035	69.0	3739.2807	216.7699
.1	3328.5253	204.5176	.1	3750.1270	217.0841
.2	3338.7590	204.8318	.2	3760.9891	217.3982
.3	3349.0085	205.1460	.3	3771.8668	217.7124
.4	3359.2736	205.4602	.4	3782.7603	218.0265
.5	3369.5545	205.7743	.5	3793.6695	218.3407
.6	3379.8510	206.0885	.6	3804.5944	218.6548
.7	3390.1633	206.4026	.7	3815.5350	218.9690
.8	3400.4913	206.7168	.8	3826.4913	219.2832
.9	3410.8350	207.0310	.9	3837.4633	219.5973
66.0	3421.1944	207.3451	70.0	3848.4510	219.9115
.1	3431.5695	207.6593	.1	3859.4544	220.2256
.2	3441.9603	207.9734	.2	3870.4736	220.5398
.3	3452.3669	208.2876	.3	3881.5084	220.8540
.4	3462.7891	208.6017	.4	3892.5590	221.1681
.5	3473.2270	208.9159	.5	3903.6252	221.4823
.6	3483.6807	209.2301	.6	3914.7072	221.7964
.7	3494.1500	209.5442	.7	3925.8049	222.1106
.8	3504.6351	209.8584	.8	3936.9182	222.4248
.9	3515.1359	210.1725	.9	3948.0473	222.7389
67.0	3525.6524	210.4867	71.0	3959.1921	223.0531
.1	3536.1845	210.8009	.1	3970.3526	223.3672
.2	3546.7324	211.1150	.2	3981.5289	223.6814
.3	3557.2960	211.4292	.3	3992.7208	223.9956
.4	3567.8754	211.7433	.4	4003.9284	224.3097
.5	3578.4704	212.0575	.5	4015.1518	224.6239
.6	3589.0811	212.3717	.6	4026.3908	224.9380
.7	3599.7075	212.6858	.7	4037.6456	225.2522
.8	3610.3497	213.0000	.8	4048.9160	225.5664
.9	3621.0075	213.3141	.9	4060.2022	225.8805

For diameters from $\frac{1}{10}$ to 100, advancing by tenths.

AREAS AND CIRCUMFERENCES OF CIRCLES

DIAM.	AREA	CIRCUM.	DIAM.	AREA	CIRCUM.
72.0	4071.5041	226.1947	76.0	4356.4598	238.7610
.1	4082.8217	226.5088	.1	4548.4057	239.0752
.2	4094.1550	226.8230	.2	4560.3673	239.3894
.3	4105.5040	227.1371	.3	4572.3446	239.7035
.4	4116.8687	227.4513	.4	4584.3377	240.0177
.5	4128.2491	227.7655	.5	4596.3464	240.3318
.6	4139.6452	228.0796	.6	4608.3708	240.6460
.7	4151.0571	228.3938	.7	4620.4110	240.9602
.8	4162.4846	228.7079	.8	4632.4669	241.2743
.9	4173.9279	229.0221	.9	4644.5384	241.5885
73.0	4185.3868	229.3363	77.0	4656.6257	241.9026
.1	4196.8615	229.6504	.1	4668.7287	242.2168
.2	4208.3519	229.9646	.2	4680.8474	242.5310
.3	4219.8579	230.2787	.3	4692.9818	242.8451
.4	4231.3797	230.5929	.4	4705.1319	243.1592
.5	4242.9172	230.9071	.5	4717.2977	243.4734
.6	4254.4704	231.2212	.6	4729.4792	243.7876
.7	4266.0394	231.5354	.7	4741.6765	244.1017
.8	4277.6240	231.8495	.8	4753.8894	244.4159
.9	4289.2243	232.1637	.9	4766.1181	244.7301
74.0	4300.8403	232.4779	78.0	4778.3624	245.0442
.1	4312.4721	232.7920	.1	4790.6225	245.3584
.2	4324.1195	233.1062	.2	4802.8983	245.6725
.3	4335.7827	233.4203	.3	4815.1897	245.9867
.4	4347.4616	233.7345	.4	4827.4969	246.3009
.5	4359.1562	234.0487	.5	4839.8198	246.6150
.6	4370.8664	234.3628	.6	4852.1584	246.9292
.7	4382.5924	234.6770	.7	4864.5128	247.2433
.8	4394.3341	234.9911	.8	4876.8828	247.5575
.9	4406.0916	235.3053	.9	4889.2685	247.8717
75.0	4417.8647	235.6194	79.0	4901.6699	248.1858
.1	4429.6535	235.9336	.1	4914.0871	248.5000
.2	4441.4580	236.2478	.2	4926.5199	248.8141
.3	4453.2783	236.5619	.3	4938.9685	249.1283
.4	4465.1142	236.8761	.4	4951.4328	249.4425
.5	4476.9659	237.1902	.5	4963.9127	249.7566
.6	4488.8332	237.5044	.6	4976.4084	250.0708
.7	4500.7163	237.8186	.7	4988.9198	250.3850
.8	4512.6151	238.1327	.8	5001.4469	250.6991
.9	4524.5296	238.4469	.9	5013.9897	251.0133

For diameters from $\frac{1}{16}$ to 100, advancing by tenths.

AREAS AND CIRCUMFERENCES OF CIRCLES

DIAM.	AREA	CIRCUM.	DIAM.	AREA	CIRCUM.
80.0	5026.5482	251.3274	84.0	5541.7694	263.8938
.1	5039.1225	251.6416	.1	5554.9720	264.2079
.2	5051.7124	251.9557	.2	5568.1902	264.5221
.3	5064.3180	252.2699	.3	5581.4242	264.8363
.4	5076.9394	252.5840	.4	5594.6739	265.1514
.5	5089.5764	252.8982	.5	5607.9392	265.4646
.6	5102.2292	253.2124	.6	5621.2203	265.7787
.7	5114.8977	253.5265	.7	5634.5171	266.0929
.8	5127.5819	253.8407	.8	5647.8296	266.4071
.9	5140.2818	254.1548	.9	5661.1578	266.7212
81.0	5152.9973	254.4690	85.0	5674.5017	267.0354
.1	5165.7287	254.7832	.1	5687.8614	267.3495
.2	5178.4757	255.0973	.2	5701.2367	267.6637
.3	5191.2384	255.4115	.3	5714.6277	267.9779
.4	5204.0168	255.7256	.4	5728.0345	268.2920
.5	5216.8110	256.0398	.5	5741.4569	268.6062
.6	5229.6208	256.3540	.6	5754.8951	268.9203
.7	5242.4463	256.6681	.7	5768.3490	269.2345
.8	5255.2876	256.9823	.8	5781.8185	269.5486
.9	5268.1446	257.2966	.9	5795.3038	269.8628
82.0	5281.0173	257.6106	86.0	5808.8048	270.1770
.1	5293.9056	257.9247	.1	5822.3215	270.4911
.2	5306.8097	258.2389	.2	5835.8539	270.8053
.3	5319.7295	258.5531	.3	5849.4020	271.1194
.4	5332.6650	258.8672	.4	5862.9659	271.4336
.5	5345.6162	259.1814	.5	5876.5454	271.7478
.6	5358.5832	259.4956	.6	5890.1407	272.0619
.7	5371.5658	259.8097	.7	5903.7516	272.3761
.8	5384.5641	260.1239	.8	5917.3783	272.6902
.9	5397.5782	260.4380	.9	5931.0206	273.0044
83.0	5410.6079	260.7522	87.0	5944.6787	273.3186
.1	5423.6534	261.0663	.1	5958.3525	273.6327
.2	5436.7146	261.3805	.2	5972.0420	273.9469
.3	5449.7915	261.6947	.3	5985.7472	274.2610
.4	5462.8840	262.0088	.4	5999.4681	274.5752
.5	5475.9923	262.3230	.5	6013.2047	274.8894
.6	5489.1163	262.6371	.6	6026.9570	275.2035
.7	5502.2561	262.9513	.7	6040.7250	275.5177
.8	5515.4115	263.2655	.8	6054.5088	275.8318
.9	5528.5826	263.5796	.9	6068.3082	276.1460

For diameters from $\frac{1}{16}$ to 100, advancing by tenths.

AREAS AND CIRCUMFERENCES OF CIRCLES

DIAM.	AREA	CIRCUM.	DIAM.	AREA	CIRCUM.
88.0	6082.1234	276.4602	92.0	6647.6101	289.0265
.1	6095.9542	276.7743	.1	6662.0692	289.3407
.2	6109.8008	277.0885	.2	6676.5441	289.6548
.3	6123.6631	277.4026	.3	6691.0347	289.9690
.4	6137.5411	277.7168	.4	6705.5410	290.2832
.5	6151.4348	278.0309	.5	6720.0630	290.5973
.6	6165.3442	278.3451	.6	6734.6008	290.9115
.7	6179.2693	278.6593	.7	6749.1542	291.2256
.8	6193.2101	278.9740	.8	6763.7233	291.5398
.9	6207.1666	279.2876	.9	6778.3082	291.8540
89.0	6221.1389	279.6017	93.0	6792.9087	292.1681
.1	6235.1268	279.9159	.1	6807.5250	292.4823
.2	6249.1304	280.2301	.3	6822.1569	292.7964
.3	6263.1498	280.5442	.3	6836.8046	293.1106
.4	6277.1849	280.8584	.4	6851.4680	293.4248
.5	6291.2356	281.1725	.5	6866.1471	293.7389
.6	6305.3021	281.4867	.6	6880.8419	294.0531
.7	6319.3843	281.8009	.7	6895.5524	294.3672
.8	6333.4822	282.1150	.8	6910.2786	294.6814
.9	6347.5958	282.4292	.9	6925.0205	294.9956
90.0	6361.7251	282.7433	94.0	6939.7782	295.3097
.1	6375.8701	283.0575	.1	6954.5515	295.6239
.2	6390.0309	283.3717	.2	6969.3106	295.9380
.3	6404.2073	283.6858	.3	6984.1453	296.2522
.4	6418.3995	284.0000	.4	6998.9658	296.5663
.5	6432.6073	284.3141	.5	7013.8019	296.8805
.6	6446.8309	284.6283	.6	7028.6538	297.1947
.7	6461.0701	284.9425	.7	7043.5214	297.5088
.8	6475.3251	285.2566	.8	7058.4047	297.8230
.9	6489.5958	285.5708	.9	7073.3033	298.1371
91.0	6503.8822	285.8849	95.0	7088.2184	298.4513
.1	6518.1843	286.1991	.1	7103.1488	298.7655
.2	6532.5021	286.5133	.2	7118.1950	299.0796
.3	6546.8356	286.8274	.3	7133.0568	299.3938
.4	6561.1848	287.1416	.4	7148.0343	299.7079
.5	6575.5498	287.4557	.5	7163.0276	300.0221
.6	6589.9304	287.7699	.6	7178.0366	300.3363
.7	6604.3268	288.0840	.7	7193.0612	300.6504
.8	6618.7388	288.3982	.8	7208.1016	300.9646
.9	6633.1666	288.7124	.9	7223.1577	301.2787

For diameters from $\frac{1}{16}$ to 100, advancing by tenths.

AREAS AND CIRCUMFERENCES OF CIRCLES

DIAM.	AREA	CIRCUM.	DIAM.	AREA	CIRCUM.
96.0	7238.2295	301.5929	98.0	7542.9640	307.8761
.1	7253.3170	301.9071	.1	7558.3656	308.1902
.2	7268.4202	302.2212	.2	7573.7830	308.5044
.3	7283.5391	302.5354	.3	7589.2161	308.8186
.4	7298.6737	302.8405	.4	7604.6648	309.1327
.5	7313.8240	303.1637	.5	7620.1293	309.4469
.6	7328.9901	303.4779	.6	7635.6095	309.7610
.7	7344.1718	303.7920	.7	7651.1054	310.0752
.8	7359.3693	304.1062	.8	7666.6170	310.3894
.9	7374.5824	304.4203	.9	7682.1444	310.7035
97.0	7389.8113	304.7345	99.0	7697.6893	311.0177
.1	7405.0559	305.0486	.1	7713.2461	311.3318
.2	7420.3162	305.3628	.2	7728.8206	311.6460
.3	7435.5922	305.6770	.3	7744.4107	311.9602
.4	7450.8839	305.9911	.4	7760.0166	312.2743
.5	7466.1913	306.3053	.5	7775.6382	312.5885
.6	7481.5144	306.6194	.6	7791.2754	312.9026
.7	7496.8532	306.9336	.7	7806.9284	313.2168
.8	7512.2078	307.2478	.8	7822.5971	313.5309
.9	7527.5780	307.5619	.9	7838.2815	313.8451
			100.0	7853.9816	314.1593

For diameters from $\frac{1}{10}$ to 100, advancing by tenths.

To compute the area or circumference of a diameter greater than 100 and less than 1001:

Take out the area or circumference from table as though the number had one decimal, and move the decimal point two places to the right for the area, and one place for the circumference.

EXAMPLE.—Wanted, the area and circumference of 567. The tabular area for 56.7 is 2524.9687, and circumference 178.1283. Therefore area for 567=252496.87 and circumference=1781.283.

To compute the area or circumference of a diameter greater than 1000:

Divide by a factor, as 2, 3, 4, 5, etc., if practicable, that will leave a quotient to be found in table, then multiply the tabular area of the quotient by the *square* of the factor, or the tabular circumference by the factor.

EXAMPLE.—Wanted, the area and circumference of 2109. Dividing by 3, the quotient is 703, for which the area is 388150.84, and the circumference 2208.54. Therefore area of 2109=388150.84×9=3493357.56 and circumference=2208.54×3=6625.62.

RAILROAD SPIKES

SIZE MEASURED UNDER HEAD INCHES	AVERAGE NUMBER PER KEG OF 200 POUNDS	NUMBER REQUIRED PER MILE, FOR TIES 2 FEET ON CENTERS, 4 SPIKES PER TIE	USED FOR RAILS OF WEIGHT PER YARD
5½ × 9/16	360	5920 lbs. = 29 1/3 kegs	45 to 100
5 × 9/16	405	5230 lbs. = 26 kegs	40 to 56
4½ × 9/16	460	4606 lbs. = 23 kegs	35 to 40
5 × 1/2	475	4460 lbs. = 23 3/10 kegs	35 to 40
4½ × 1/2	518	4080 lbs. = 20 4/10 kegs	28 to 35
4 × 1/2	605	3515 lbs. = 17 1/2 kegs	24 to 35
3½ × 1/2	670	3180 lbs. = 15 7/8 kegs	20 to 30
4½ × 7/16	690	3090 lbs. = 15 1/2 kegs	20 to 30
4 × 7/16	780	2730 lbs. = 13 3/5 kegs	20 to 30
3½ × 7/16	890	2377 lbs. = 12 kegs	16 to 25
4½ × 3/8	780	2730 lbs. = 13 3/5 kegs	16 to 25
4 × 3/8	1025	2044 lbs. = 10 1/5 kegs	16 to 25
3½ × 3/8	1250	1740 lbs. = 8 1/2 kegs	16 to 20
3 × 3/8	1380	1592 lbs. = 8 kegs	16 to 20
2½ × 3/8	1650	1280 lbs. = 6 2/5 kegs	12 to 16
3 × 5/16	1880	1152 lbs. = 5 3/4 kegs	12 to 16
2½ × 5/16	2230	948 lbs. = 4 3/4 kegs	8 to 12

BOAT SPIKES

- 3/4 inch square, 12 to 24 inches in length
- 5/8 inch square, 8 to 16 inches in length
- 1/2 inch square, 8 to 16 inches in length
- 7/16 inch square, 6 to 12 inches in length
- 3/8 inch square, 4 to 12 inches in length
- 5/16 inch square, 4 to 12 inches in length
- 1/4 inch square, 3 to 8 inches in length

TWISTED BARS

SIZE OF SQUARE BAR IN INCHES	NUMBER OF TURNS PER FOOT	ELASTIC LIMIT			ULTIMATE TENSILE STRENGTH		
		Before Twisting	Twisted	Increase due to Twisting Per Cent	Before Twisting	Twisted	Increase due to Twisting Per Cent
1/4	4	38400	78400	104	68800	91200	32
3/8	3½	39130	71160	82	61180	85380	39
1/2	3	38600	66000	71	60400	83200	38
3/4	1½	39120	72720	86	60080	81060	35
1	1	37400	67500	80	61000	74000	21
1¼	¾	38250	62510	63	61300	79270	29

WEIGHTS OF ROLLED STEEL PLATES

THICKNESS INCHES	WIDTH, INCHES								
	12	13	14	15	16	17	18	19	20
$\frac{3}{16}$	7.65	8.28	8.92	9.56	10.2	10.84	11.48	12.1	12.76
$\frac{1}{4}$	10.2	11.05	11.9	12.75	13.6	14.44	15.3	16.16	17.0
$\frac{5}{16}$	12.75	13.81	14.88	15.94	17.0	18.06	19.12	20.2	21.24
$\frac{3}{8}$	15.3	16.58	17.86	19.14	20.4	21.68	22.96	24.25	25.5
$\frac{7}{16}$	17.85	19.34	20.82	22.32	23.8	25.28	26.76	28.28	29.75
$\frac{1}{2}$	20.4	22.1	23.8	25.5	27.2	28.89	30.6	32.31	34.0
$\frac{9}{16}$	22.95	24.86	26.78	28.7	30.6	32.52	34.44	36.34	38.27
$\frac{5}{8}$	25.5	27.62	29.74	31.88	34.0	36.12	38.25	40.37	42.5
$\frac{11}{16}$	28.05	30.39	32.72	35.06	37.4	39.72	42.08	44.42	46.74
$\frac{3}{4}$	30.6	33.16	35.71	38.26	40.8	43.36	45.92	48.46	51.0
$\frac{13}{16}$	33.15	35.91	38.67	41.43	44.2	46.96	49.72	52.48	55.25
$\frac{7}{8}$	35.7	38.62	41.65	44.62	47.6	50.6	53.56	56.52	59.5
$\frac{15}{16}$	38.25	41.44	44.63	47.82	51.0	54.2	57.38	60.57	63.76
1	40.8	44.2	47.63	51.0	54.4	57.8	61.2	64.6	68.0
$1\frac{1}{16}$	43.35	46.96	50.57	54.2	57.8	61.4	65.02	68.64	72.25
$1\frac{1}{8}$	45.9	49.72	53.55	57.37	61.2	65.04	68.85	72.68	76.5
$1\frac{3}{16}$	48.45	52.48	56.52	60.56	64.6	68.64	72.68	76.72	80.75
$1\frac{1}{4}$	51.0	55.25	59.5	63.76	68.0	72.26	76.5	80.74	85.0
$1\frac{5}{16}$	53.55	58.02	62.47	66.95	71.4	75.86	80.33	84.8	89.28
$1\frac{3}{8}$	56.1	60.77	65.45	70.12	74.8	79.48	84.15	88.83	93.5
$1\frac{7}{16}$	58.65	63.54	68.42	73.32	78.2	83.08	88.0	92.88	97.75
$1\frac{1}{2}$	61.2	66.3	71.4	76.51	81.6	86.7	91.8	96.9	102.0
$1\frac{9}{16}$	63.75	69.06	74.38	79.69	85.0	90.31	95.63	100.9	106.3
$1\frac{5}{8}$	66.3	71.83	77.35	82.88	88.4	93.93	99.45	105.0	110.5
$1\frac{11}{16}$	68.85	74.58	80.33	86.06	91.8	97.54	103.3	109.0	114.8
$1\frac{3}{4}$	71.4	77.35	83.3	89.25	95.2	101.5	107.1	113.1	119.0
$1\frac{13}{16}$	73.95	80.11	86.28	92.44	98.6	104.8	110.9	117.1	123.3
$1\frac{7}{8}$	76.5	82.88	89.25	95.63	102.0	108.4	114.8	121.1	127.5
$1\frac{15}{16}$	79.05	85.64	92.23	98.81	105.4	112.0	118.6	125.2	131.8
2	81.6	88.4	95.2	102.0	108.8	115.6	122.4	129.2	136.0

WEIGHTS OF ROLLED STEEL PLATES

WIDTH, INCHES

21	22	23	24	25	26	27	28	29	30
13.4	14.04	14.64	16.85	17.56	18.22	18.92	19.62	20.32	21.03
17.84	18.69	19.56	22.44	23.39	24.33	25.26	26.18	27.1	28.05
22.32	23.36	24.44	27.56	27.89	29.83	30.97	32.14	33.26	34.43
26.78	28.06	29.36	32.74	34.11	35.48	36.85	38.22	39.56	40.96
31.24	32.72	34.24	37.86	39.43	41.0	42.58	44.15	45.73	47.32
35.7	37.4	39.1	42.82	44.62	46.41	48.21	49.98	51.74	53.55
40.16	42.04	44.0	47.99	49.95	51.97	53.97	55.97	57.98	59.98
44.64	46.76	48.88	53.01	55.25	57.45	59.66	61.87	64.06	66.31
49.08	51.4	53.76	58.09	60.49	62.91	65.32	67.73	70.14	72.59
53.56	56.1	58.66	63.34	65.99	68.64	71.29	73.92	76.56	79.21
58.01	60.79	63.53	68.61	71.48	74.34	77.19	80.05	82.9	85.76
62.49	65.44	68.43	73.90	76.99	80.07	83.14	86.22	89.31	92.37
66.96	70.13	73.32	79.18	82.47	85.78	89.08	92.39	95.68	99.99
71.4	74.8	78.2	84.46	87.98	91.5	95.01	98.53	102.1	105.6
75.85	79.48	83.08	89.74	93.48	97.21	101.0	104.7	108.4	112.2
80.33	84.16	88.0	95.01	98.99	102.9	106.9	110.9	114.8	118.7
84.79	88.83	92.88	100.3	104.5	108.6	112.8	117.0	121.2	125.4
89.26	93.52	97.76	105.6	110.0	114.4	118.8	123.2	127.6	132.0
93.72	98.16	102.6	110.9	115.6	120.1	124.7	129.3	133.9	138.6
98.17	102.8	107.5	116.1	121.0	125.8	130.7	135.5	140.3	145.2
102.7	107.5	112.4	121.4	126.5	131.5	136.6	141.6	146.7	151.8
107.1	112.2	117.3	126.7	132.0	137.2	142.5	147.8	153.1	158.4
111.6	116.9	122.2	132.0	137.5	143.0	148.5	154.0	159.5	164.9
116.0	121.6	127.1	137.2	143.0	148.7	154.4	160.1	165.8	171.6
120.5	126.2	132.0	142.5	148.5	154.4	160.3	166.3	172.2	178.2
125.0	130.9	136.9	147.8	154.0	160.1	166.3	172.4	178.6	184.1
129.4	135.6	141.8	153.1	159.5	165.8	172.2	178.6	185.0	191.4
133.9	140.3	146.5	158.4	164.9	171.6	178.2	184.8	191.4	198.0
138.3	144.9	151.5	163.6	170.5	177.3	184.1	190.9	197.7	203.6
142.8	149.6	156.4	168.9	176.0	183.0	190.0	197.1	204.1	211.1

Allowances for overweight added to plates 24 inches wide and upwards, according to Manufacturers' Standard Specifications on page 191.

WEIGHTS OF ROLLED STEEL PLATES

THICKNESS INCHES	WIDTH, INCHES								
	31	32	33	34	35	36	38	40	42
$\frac{3}{16}$	21.73	22.44	23.14	23.85	24.55	25.26	26.62	28.07	29.48
$\frac{1}{4}$	29.0	29.92	30.84	31.77	32.69	33.65	35.55	37.04	39.25
$\frac{5}{16}$	35.57	36.72	37.84	39.0	40.13	41.3	43.62	45.88	48.21
$\frac{3}{8}$	42.31	43.66	45.03	46.39	47.76	49.14	51.87	54.57	57.31
$\frac{7}{16}$	48.89	50.46	52.03	53.6	55.2	56.80	59.95	63.07	66.23
$\frac{1}{2}$	55.34	57.12	58.91	60.67	62.48	64.26	67.85	71.4	74.97
$\frac{9}{16}$	61.99	63.98	65.96	67.97	69.97	70.98	75.95	79.99	83.95
$\frac{5}{8}$	68.52	70.72	72.94	75.13	77.33	79.56	83.97	88.44	92.85
$\frac{11}{16}$	75.02	77.43	79.82	82.22	84.66	87.11	91.95	96.75	101.6
$\frac{3}{4}$	81.85	84.47	87.11	89.75	92.43	95.07	100.3	105.6	110.9
$\frac{13}{16}$	88.62	91.48	94.34	97.2	100.1	102.9	108.6	114.4	120.1
$\frac{7}{8}$	95.43	98.53	101.6	104.8	107.8	110.9	117.0	123.2	129.4
$\frac{15}{16}$	102.3	105.6	108.9	112.2	115.5	118.8	125.4	132.0	138.6
1	109.1	112.6	116.1	119.7	123.2	126.7	133.7	140.8	147.8
$1\frac{1}{16}$	115.9	119.6	123.4	127.1	130.8	134.6	142.1	149.6	157.0
$1\frac{1}{8}$	122.7	126.7	130.7	134.6	138.6	142.5	150.4	158.4	166.3
$1\frac{3}{16}$	129.5	133.7	137.9	142.1	146.3	150.5	158.8	166.7	175.5
$1\frac{1}{4}$	136.4	140.8	145.2	149.6	154.0	158.4	167.0	176.0	184.8
$1\frac{5}{16}$	143.2	147.8	152.4	157.0	161.7	166.2	175.5	184.8	194.0
$1\frac{3}{8}$	150.0	154.8	160.7	164.4	169.4	174.2	183.9	193.6	203.3
$1\frac{7}{16}$	156.8	161.9	166.9	172.0	177.1	182.2	192.3	202.3	212.5
$1\frac{1}{2}$	163.6	168.9	174.2	179.5	184.8	190.0	200.6	211.1	221.7
$1\frac{9}{16}$	170.5	176.0	181.5	186.5	192.4	198.0	208.9	219.9	231.0
$1\frac{5}{8}$	177.3	183.0	188.7	194.4	200.2	205.9	218.0	228.7	240.2
$1\frac{11}{16}$	184.1	190.0	196.0	201.9	207.8	213.8	225.7	237.5	249.4
$1\frac{3}{4}$	190.9	197.1	203.2	209.3	215.5	221.7	234.0	246.3	258.6
$1\frac{13}{16}$	197.7	204.1	210.5	216.9	223.3	229.6	242.4	255.1	267.9
$1\frac{7}{8}$	204.6	211.1	217.8	224.3	231.0	237.5	250.7	263.9	277.1
$1\frac{15}{16}$	211.4	218.2	225.0	231.8	238.7	245.5	259.1	272.7	286.4
2	218.2	225.2	232.3	239.3	246.3	253.4	267.5	281.5	295.6

Allowances for overweight added to plates 24 inches wide and upwards, according to Manufacturers' Standard Specifications on page 191.

WEIGHTS OF ROLLED STEEL PLATES

WIDTH IN INCHES

44	46	48	50	52	54	56	58	60
30.89	32.22	33.7	35.11	36.43	37.84	39.25	40.66	42.06
41.12	43.02	44.88	46.77	48.66	50.51	52.36	54.21	56.10
50.46	52.79	55.13	57.37	59.66	61.95	64.27	66.53	68.86
60.05	62.82	65.48	68.22	70.96	73.7	76.44	79.18	81.92
69.37	72.58	75.73	78.86	82.01	85.16	88.3	91.46	94.64
78.54	82.11	85.68	89.25	92.82	96.43	99.96	103.5	107.1
87.88	91.96	95.97	99.9	103.9	107.9	111.9	116.0	120.0
97.26	101.7	105.1	110.5	114.9	119.3	123.7	128.1	132.6
106.4	111.3	116.2	121.0	125.8	130.6	135.5	140.3	145.2
116.1	121.4	126.7	132.0	137.3	142.6	147.9	153.1	158.4
125.8	131.5	137.2	143.0	148.7	154.4	160.1	165.8	171.5
135.5	141.7	147.8	154.0	160.1	166.3	172.4	178.6	184.7
145.2	151.8	158.4	164.9	171.6	178.2	184.8	191.4	198.0
154.8	161.9	168.9	176.0	183.0	190.0	197.1	204.1	211.1
164.6	172.0	179.5	187.0	194.4	201.9	209.3	216.8	224.3
174.2	182.1	190.0	198.0	205.8	213.8	221.7	229.6	237.5
183.9	192.3	200.6	208.9	217.3	225.7	234.0	242.4	250.7
193.6	202.4	211.1	219.9	228.8	237.6	246.3	255.1	264.0
203.2	212.5	221.7	230.9	240.2	249.4	258.6	267.9	277.2
212.9	222.6	232.4	241.9	251.6	261.3	271.0	280.7	290.3
222.6	232.7	242.8	253.0	263.1	273.2	283.3	293.4	303.5
232.3	242.8	253.8	263.9	274.5	285.1	295.6	306.2	316.7
241.9	252.9	263.9	274.9	285.9	296.9	307.9	318.9	329.9
251.6	263.1	274.5	285.9	297.4	308.8	320.2	331.7	343.1
261.3	273.2	285.0	296.9	308.8	320.7	332.6	344.4	356.3
271.0	283.3	295.6	307.9	320.2	332.6	344.9	357.2	369.5
280.7	293.4	306.1	318.9	331.7	344.4	357.2	370.0	382.7
290.3	303.5	316.7	329.9	343.1	356.3	369.5	382.7	385.9
300.0	313.6	326.3	340.9	354.5	368.2	381.8	395.5	409.1
309.7	323.8	337.8	351.0	366.0	380.1	394.1	408.2	422.3

Allowances for overweight added to plates 24 inches wide and upwards, according to Manufacturers' Standard Specifications on page 191.

RADII OF GYRATION
Two Equal Legged Angles—Star Section

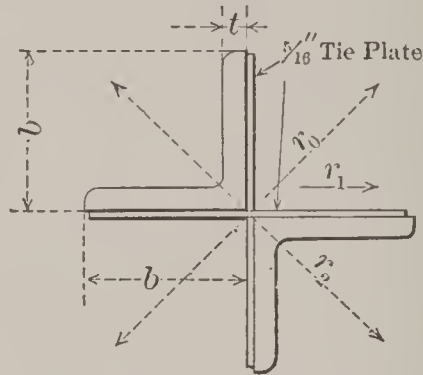

Radii corresponding to direction of arrows

$b \times b$, Inches	t Inches	Area 2 Angles	Weight per Ft. 2 Angles	r_0	r_1	r_2
2 × 2	$\frac{1}{4}$	1.88	6.4	.75	.96	1.12
	$\frac{5}{16}$	2.30	8.0	.74	.97	1.15
	$\frac{3}{8}$	2.72	9.4	.73	.99	1.17
	$\frac{1}{2}$	3.12	10.6	.72	1.00	1.20
$2\frac{1}{2} \times 2\frac{1}{2}$	$\frac{1}{4}$	2.38	8.2	.96	1.16	1.32
	$\frac{5}{16}$	2.94	10.0	.95	1.17	1.35
	$\frac{3}{8}$	3.46	11.8	.94	1.18	1.38
	$\frac{7}{16}$	4.00	13.6	.93	1.20	1.41
	$\frac{1}{2}$	4.50	15.4	.92	1.21	1.43
3 × 3	$\frac{1}{4}$	2.88	9.8	1.17	1.36	1.52
	$\frac{5}{16}$	3.56	12.2	1.16	1.37	1.55
	$\frac{3}{8}$	4.22	14.4	1.14	1.38	1.59
	$\frac{7}{16}$	4.86	16.6	1.13	1.39	1.61
	$\frac{1}{2}$	5.50	18.8	1.12	1.40	1.64
	$\frac{9}{16}$	6.12	20.8	1.11	1.42	1.67
	$\frac{5}{8}$	6.72	23.0	1.10	1.43	1.70
$3\frac{1}{2} \times 3\frac{1}{2}$	$\frac{1}{4}$	3.38	11.6	1.37	1.56	1.72
	$\frac{5}{16}$	4.18	14.4	1.36	1.57	1.75
	$\frac{3}{8}$	4.96	17.0	1.35	1.58	1.78
	$\frac{7}{16}$	5.74	19.6	1.34	1.59	1.81
	$\frac{1}{2}$	6.50	22.2	1.32	1.60	1.84
	$\frac{9}{16}$	7.24	24.8	1.31	1.62	1.87
	$\frac{5}{8}$	7.96	27.2	1.30	1.63	1.90

RADIi OF GYRATION
Two Equal Legged Angles—Star Section

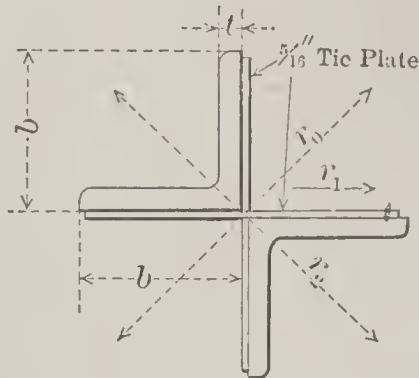

Radii corresponding to direction of arrows

$b \times b$, Inches	t Inches	Area 2 Angles	Weight per Ft. 2 Angles	r_0	r_1	r_2
4×4	$\frac{5}{16}$	4.80	16.4	1.57	1.78	1.96
	$\frac{3}{8}$	5.72	19.6	1.55	1.79	1.98
	$\frac{7}{16}$	6.62	22.6	1.54	1.80	2.01
	$\frac{1}{2}$	7.50	25.6	1.53	1.81	2.04
	$\frac{9}{16}$	8.36	28.6	1.51	1.82	2.07
	$\frac{5}{8}$	9.22	31.4	1.50	1.83	2.10
	$\frac{11}{16}$	10.06	34.2	1.49	1.84	2.13
	$\frac{3}{4}$	10.88	37.0	1.48	1.85	2.16
5×5	$\frac{3}{8}$	7.22	24.6	1.96	2.19	2.39
	$\frac{7}{16}$	8.36	28.6	1.95	2.20	2.42
	$\frac{1}{2}$	9.50	32.4	1.94	2.21	2.45
	$\frac{9}{16}$	10.62	36.2	1.92	2.22	2.47
	$\frac{5}{8}$	11.72	40.0	1.91	2.23	2.50
	$\frac{11}{16}$	12.82	43.6	1.90	2.24	2.53
	$\frac{3}{4}$	13.88	47.2	1.89	2.25	2.56
	$\frac{13}{16}$	14.94	50.8	1.88	2.26	2.59
	$\frac{7}{8}$	15.98	54.4	1.86	2.27	2.62

RADI OF GYRATION

Two Equal Legged Angles—Star Section

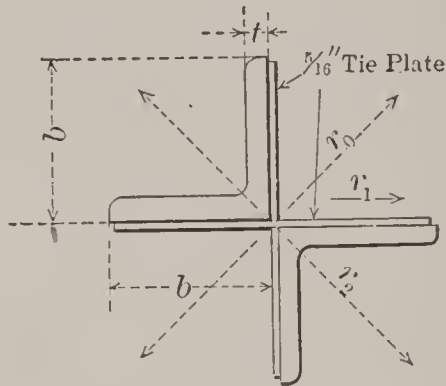

Radii corresponding to direction of arrows

$b \times b$, Inches	t Inches	Area 2 Angles	Weight per Ft. 2 Angles	r_0	r_1	r_2
6×6	$\frac{3}{8}$	8.72	29.8	2.36	2.59	2.80
	$\frac{7}{16}$	10.12	34.4	2.35	2.60	2.82
	$\frac{1}{2}$	11.50	39.2	2.34	2.61	2.85
	$\frac{9}{16}$	12.86	43.8	2.33	2.63	2.88
	$\frac{5}{8}$	14.22	48.4	2.32	2.64	2.91
	$\frac{11}{16}$	15.56	53.0	2.31	2.65	2.94
	$\frac{3}{4}$	16.88	57.4	2.30	2.66	2.96
	$\frac{13}{16}$	18.18	62.0	2.28	2.67	2.99
	$\frac{7}{8}$	19.48	66.2	2.27	2.68	3.02
8×8	$\frac{1}{2}$	15.50	52.8	3.16	3.42	
	$\frac{9}{16}$	17.36	59.2	3.15	3.43	
	$\frac{5}{8}$	19.22	65.4	3.14	3.44	
	$\frac{11}{16}$	21.06	71.6	3.12	3.45	
	$\frac{3}{4}$	22.88	77.8	3.11	3.46	
	$\frac{13}{16}$	24.68	84.0	3.10	3.48	
	$\frac{7}{8}$	26.46	90.0	3.09	3.49	
	$\frac{15}{16}$	28.24	96.2	3.08	3.50	
	1	30.00	102.0	3.06	3.51	
	$1\frac{1}{16}$	31.74	108.0	3.05	3.52	
$1\frac{1}{8}$	33.46	113.8	3.04	3.53		

METRIC CONVERSION TABLE

Arranged by C. W. Hunt, New York

Millimetres $\times .03937 =$ inches.
 Millimetres $\div 25.4 =$ inches
 Centimetres $\times .3937 =$ inches.
 Centimetres $\div 2.54 =$ inches.
 Metres $\times 39.37 =$ inches. (Act Congress.)
 Metres $\times 3.281 =$ feet.
 Metres $\times 1.094 =$ yards.
 Kilometres $\times .621 =$ miles.
 Kilometres $\div 1.6093 =$ miles.
 Kilometres $\times 3280.8693 =$ feet.
 Square millimetres $\times .00155 =$ square inches.
 Square millimetres $\div 645.1 =$ square inches.
 Square centimetres $\times .155 =$ square inches.
 Square centimetres $\div 6.451 =$ square inches.
 Square metres $\times 10.764 =$ square feet.
 Square kilometres $\times 247.1 =$ acres.
 Hectare $\times 2.471 =$ acres.
 Cubic centimetres $\div 16.383 =$ cubic inches.
 Cubic centimetres $\div 3.69 =$ fluid drams (U. S. Phar.).
 Cubic centimetres $\div 29.57 =$ fluid ounce (U. S. Phar.).
 Cubic metres $\times 35.315 =$ cubic feet.
 Cubic metres $\times 1.308 =$ cubic yards.
 Cubic metres $\times 264.2 =$ gallons (231. cubic inches).
 Litres $\times 61.022 =$ cubic inches (Act Congress).
 Litres $\times 33.84 =$ fluid ounces (U. S. Phar.).
 Litres $\times .2642 =$ gallons (231. cubic inches).
 Litres $\div 3.78 =$ gallons (231. cubic inches)
 Litres $\div 28.316 =$ cubic feet.
 Hectolitres $\times 3.531 =$ cubic feet.
 Hectolitres $\times 2.84 =$ bushels (2150.42 cubic inches).
 Hectolitres $\times .131 =$ cubic yards.
 Hectolitres $\times 26.42 =$ gallons (231. cubic inches).
 Grammes $\times 15.432 =$ grains (Act Congress).
 Grammes $\div 981. =$ dynes.
 Grammes (water) $\div 29.57 =$ fluid ounces.
 Grammes $\div 28.35 =$ ounces avoirdupois.
 Grammes per cubic centimetre $\div 27.7 =$ pounds per cubic inch.
 Joule $\times .7373 =$ foot pounds.
 Kilo-grammes $\times 2.2046 =$ pounds.
 Kilo-grammes $\times 35.3 =$ ounces avoirdupois.
 Kilo-grammes $\div 907.2 =$ tons (2000 pounds).
 Kilo-grammes per square centimetre $\times 14.223 =$ pounds per square inch.
 Kilo-gram-metres $\times 7.233 =$ foot pounds.
 Kilo-grammes per metre $\times .672 =$ pounds per foot.
 Kilo-grammes per cubic metre $\times .062 =$ pounds per cubic foot.
 Kilo-grommes per cheval $\times 2.235 =$ pounds per horse-power.
 Kilo-watts $\times 1.34 =$ horse-power.
 Watts $\div 746. =$ horse-power.
 Watts $\times .7373 =$ foot pounds per second.
 Calorie $\times 3.968 =$ B. T. U.
 Cheval vapeur $\times .9863 =$ horse-power.
 (Centigrade $\times 1.8$) $+ 32 =$ degrees Fahrenheit.
 Franc $\times .193 =$ dollars.
 Gravity Paris $= 980.94$ centimetres per second.
 Tonneau $\times 1.1023 =$ tons (2000 pounds).

AREAS OF ANGLES AND PLATES

Plate and Angle Columns

THICKNESS OF METAL, INCHES	SIZE OF ANGLES INCHES	AREA		AREA 13-INCH PLATE		AREA 14-INCH PLATE		THICKNESS OF METAL, INCHES
		2 Angles	4 Angles	1 Plate	2 Plates	1 Plate	2 Plates	
$\frac{3}{8}$ $\frac{1}{2}$ $\frac{5}{8}$ $\frac{3}{4}$ $\frac{7}{8}$ $\frac{1}{1}$	6×6 	8.72	17.44	4.88	9.76	5.25	10.50	$\frac{3}{8}$ $\frac{1}{2}$ $\frac{5}{8}$ $\frac{3}{4}$ $\frac{7}{8}$ $\frac{1}{1}$
		10.12	20.24	5.69	11.38	6.13	12.26	
		11.50	23.00	6.50	13.00	7.00	14.00	
		12.88	25.76	7.31	14.62	7.88	15.76	
		14.22	28.44	8.13	16.26	8.75	17.50	
		15.56	31.12	8.94	17.88	9.63	19.26	
		16.88	33.76	9.75	19.50	10.50	21.00	
		18.18	36.36	10.56	21.12	11.38	22.76	
		19.48	38.96	11.38	22.76	12.25	24.50	
		20.76	41.52	12.19	24.38	13.13	26.26	
1	22.00	44.00	13.00	26.00	14.00	28.00	1	

THICKNESS OF METAL, INCHES	SIZE OF ANGLES INCHES	AREA		AREA 13-INCH PLATE		AREA 12-INCH PLATE		THICKNESS OF METAL, INCHES
		2 Angles	4 Angles	1 Plate	2 Plates	1 Plate	2 Plates	
$\frac{3}{8}$ $\frac{1}{2}$ $\frac{5}{8}$ $\frac{3}{4}$ $\frac{7}{8}$ $\frac{1}{1}$	6×4 or 5×5	7.22	14.44	4.88	9.76	4.50	9.00	$\frac{3}{8}$ $\frac{1}{2}$ $\frac{5}{8}$ $\frac{3}{4}$ $\frac{7}{8}$ $\frac{1}{1}$
		8.38	16.76	5.69	11.38	5.25	10.50	
		9.50	19.00	6.50	13.00	6.00	12.00	
		10.62	21.24	7.31	14.62	6.75	13.50	
		11.72	23.44	8.13	16.26	7.50	15.00	
		12.82	25.64	8.94	17.88	8.25	16.50	
		13.88	27.76	9.75	19.50	9.00	18.00	
		14.94	29.88	10.56	21.12	9.75	19.50	
		15.98	31.96	11.38	22.76	10.50	21.00	
		17.00	34.00	12.19	24.38	11.25	22.50	
1	18.00	36.00	13.00	26.00	12.00	24.00	1	

AREAS OF ANGLES AND PLATES
Plate and Angle Columns

THICKNESS OF METAL, INCHES	SIZE OF ANGLES INCHES	AREA		AREA 12-INCH PLATE		AREA 13-INCH PLATE		THICKNESS OF METAL, INCHES
		2 Angles	4 Angles	1 Plate	2 Plates	1 Plate	2 Plates	
$\frac{3}{8}$	6 × 3½	6.86	13.78	4.50	9.00	4.88	9.76	$\frac{3}{8}$
$\frac{7}{16}$		7.94	15.88	5.25	10.50	5.69	11.38	$\frac{7}{16}$
$\frac{1}{2}$		9.00	18.00	6.00	12.00	6.50	13.00	$\frac{1}{2}$
$\frac{9}{16}$		10.06	20.12	6.75	13.50	7.31	14.62	$\frac{9}{16}$
$\frac{5}{8}$		11.10	22.20	7.50	15.00	8.13	16.26	$\frac{5}{8}$
$\frac{11}{16}$		12.12	24.24	8.25	16.50	8.94	17.88	$\frac{11}{16}$
$\frac{3}{4}$		13.14	26.28	9.00	18.00	9.75	19.50	$\frac{3}{4}$
$\frac{13}{16}$		14.12	28.24	9.75	19.50	10.56	21.12	$\frac{13}{16}$
$\frac{7}{8}$		15.10	30.20	10.50	21.00	11.38	22.76	$\frac{7}{8}$
$\frac{15}{16}$		16.06	32.12	11.25	22.50	12.19	24.38	$\frac{15}{16}$
1		17.00	34.00	12.00	24.00	13.00	26.00	1

THICKNESS OF METAL, INCHES	SIZE OF ANGLES INCHES	AREA		AREA 10-INCH PLATE		AREA 12-INCH PLATE		THICKNESS OF METAL, INCHES
		2 Angles	4 Angles	1 Plate	2 Plates	1 Plate	2 Plates	
$\frac{5}{16}$	5 × 3½	5.12	10.24	3.13	6.26	3.75	7.50	$\frac{5}{16}$
$\frac{3}{8}$		6.10	12.20	3.75	7.50	4.50	9.00	$\frac{3}{8}$
$\frac{7}{16}$		7.06	14.12	4.38	8.76	5.25	10.50	$\frac{7}{16}$
$\frac{1}{2}$		8.00	16.00	5.00	10.00	6.00	12.00	$\frac{1}{2}$
$\frac{9}{16}$		8.94	17.88	5.63	11.26	6.75	13.50	$\frac{9}{16}$
$\frac{5}{8}$		9.86	19.72	6.25	12.50	7.50	15.00	$\frac{5}{8}$
$\frac{11}{16}$		10.76	21.52	6.88	13.76	8.25	16.50	$\frac{11}{16}$
$\frac{3}{4}$		11.64	23.28	7.50	15.00	9.00	18.00	$\frac{3}{4}$
$\frac{13}{16}$		12.50	25.00	8.13	16.26	9.75	19.50	$\frac{13}{16}$
$\frac{7}{8}$		13.36	26.72	8.75	17.50	10.50	21.00	$\frac{7}{8}$
$\frac{15}{16}$		14.18	28.36	9.38	18.76	11.25	22.50	$\frac{15}{16}$

AREAS OF ANGLES AND PLATES
Plate and Angle Columns

THICKNESS OF METAL, INCHES	SIZE OF ANGLES INCHES	AREA		AREA, 8-INCH PLATE		AREA 10-INCH PLATE		THICKNESS OF METAL, INCHES
		2 Angles	4 Angles	1 Plate	2 Plates	1 Plate	2 Plates	
$\frac{5}{16}$	5×3	4.82	9.64	2.50	5.00	3.13	6.26	$\frac{5}{16}$
	or	5.72	11.44	3.00	6.00	3.75	7.50	
$\frac{3}{8}$	4×4	6.62	13.24	3.50	7.00	4.38	8.76	$\frac{3}{8}$
		7.50	15.00	4.00	8.00	5.00	10.00	
$\frac{7}{16}$		8.38	16.76	4.50	9.00	5.63	11.26	$\frac{7}{16}$
		9.22	18.44	5.00	10.00	6.25	12.50	
$\frac{1}{2}$		10.06	20.12	5.50	11.00	6.88	13.76	$\frac{1}{2}$
		10.88	21.76	6.00	12.00	7.50	15.00	
$\frac{9}{16}$		11.68	23.36	6.50	13.00	8.13	16.26	$\frac{9}{16}$
		12.48	24.96	7.00	14.00	8.75	17.50	
$\frac{5}{8}$								$\frac{5}{8}$
$\frac{11}{16}$								$\frac{11}{16}$
$\frac{3}{4}$								$\frac{3}{4}$
$\frac{13}{16}$								$\frac{13}{16}$
$\frac{7}{8}$								$\frac{7}{8}$

THICKNESS OF METAL, INCHES	SIZE OF ANGLES INCHES	AREA		AREA, 8-INCH PLATE		AREA 10-INCH PLATE		THICKNESS OF METAL, INCHES
		2 Angles	4 Angles	1 Plate	2 Plates	1 Plate	2 Plates	
$\frac{5}{16}$	4×3	4.18	8.36	2.50	5.00	3.13	6.26	$\frac{5}{16}$
	or	4.98	9.96	3.00	6.00	3.75	7.50	
$\frac{3}{8}$	$3\frac{1}{2} \times 3\frac{1}{2}$	5.76	11.52	3.50	7.00	4.38	8.76	$\frac{3}{8}$
		6.50	13.00	4.00	8.00	5.00	10.00	
$\frac{7}{16}$		7.26	14.52	4.50	9.00	5.63	11.26	$\frac{7}{16}$
		7.98	15.96	5.00	10.00	6.25	12.50	
$\frac{1}{2}$		8.68	17.36	5.50	11.00	6.88	13.76	$\frac{1}{2}$
		9.38	18.76	6.00	12.00	7.50	15.00	
$\frac{9}{16}$		10.06	20.12	6.50	13.00	8.13	16.26	$\frac{9}{16}$
		10.72	21.44	7.00	14.00	8.75	17.50	
$\frac{5}{8}$								$\frac{5}{8}$
$\frac{11}{16}$								$\frac{11}{16}$
$\frac{3}{4}$								$\frac{3}{4}$
$\frac{13}{16}$								$\frac{13}{16}$
$\frac{7}{8}$								$\frac{7}{8}$

AREAS OF ANGLES AND PLATES
Plate and Angle Columns

THICKNESS OF METAL, INCHES	SIZE OF ANGLES INCHES	AREA		AREA, 8-INCH PLATE		AREA, 10-INCH PLATE		THICKNESS OF METAL, INCHES
		2 Angles	4 Angles	1 Plate	2 Plates	1 Plate	2 Plates	
		$\frac{5}{16}$	$3\frac{1}{2} \times 3$	3.88	7.76	2.50	5.00	
$\frac{3}{8}$		4.60	9.20	3.00	6.00	3.75	7.50	$\frac{3}{8}$
$\frac{7}{16}$		5.32	10.64	3.50	7.00	4.38	8.76	$\frac{7}{16}$
$\frac{1}{2}$		6.00	12.00	4.00	8.00	5.00	10.00	$\frac{1}{2}$
$\frac{9}{16}$		6.68	13.36	4.50	9.00	5.63	11.26	$\frac{9}{16}$
$\frac{5}{8}$		7.36	14.72	5.00	10.00	6.25	12.50	$\frac{5}{8}$
$\frac{11}{16}$		8.00	16.00	5.50	11.00	6.88	13.76	$\frac{11}{16}$
$\frac{3}{4}$		8.64	17.28	6.00	12.00	7.50	15.00	$\frac{3}{4}$
$\frac{13}{16}$		9.26	18.52	6.50	13.00	8.13	16.26	$\frac{13}{16}$
$\frac{7}{8}$		9.86	19.72	7.00	14.00	8.75	17.50	$\frac{7}{8}$

THICKNESS OF METAL, INCHES	SIZE OF ANGLES INCHES	AREA		AREA, 8-INCH PLATE		AREA, 10-INCH PLATE		THICKNESS OF METAL, INCHES
		2 Angles	4 Angles	1 Plate	2 Plates	1 Plate	2 Plates	
		$\frac{1}{4}$	$3\frac{1}{2} \times 2\frac{1}{2}$	2.88	5.76	2.00	4.00	
$\frac{5}{16}$	or	3.56	7.12	2.50	5.00	3.13	6.26	$\frac{5}{16}$
$\frac{3}{8}$	3×3	4.22	8.44	3.00	6.00	3.75	7.50	$\frac{3}{8}$
$\frac{7}{16}$		4.88	9.76	3.50	7.00	4.38	8.76	$\frac{7}{16}$
$\frac{1}{2}$		5.50	11.00	4.00	8.00	5.00	10.00	$\frac{1}{2}$
$\frac{9}{16}$		6.12	12.24	4.50	9.00	5.63	11.26	$\frac{9}{16}$
$\frac{5}{8}$		6.72	13.44	5.00	10.00	6.25	12.50	$\frac{5}{8}$
$\frac{11}{16}$		7.32	14.64	5.50	11.00	6.88	13.76	$\frac{11}{16}$
$\frac{3}{4}$		7.88	15.76	6.00	12.00	7.50	15.00	$\frac{3}{4}$

AREAS OF ANGLES AND PLATES

Plate and Angle Columns

THICKNESS OF METAL, INCHES	SIZE OF ANGLES INCHES	AREA		AREA, 6-INCH PLATE		AREA, 8-INCH PLATE		THICKNESS OF METAL, INCHES
		2Angles	4Angles	1Plate	2Plates	1Plate	2Plates	
$\frac{1}{4}$ $\frac{5}{16}$ $\frac{3}{8}$ $\frac{7}{16}$ $\frac{1}{2}$ $\frac{9}{16}$ $\frac{5}{8}$	3 × 2½	2.64	5.28	1.50	3.00	2.00	4.00	$\frac{1}{4}$
		3.26	6.52	1.88	3.76	2.50	5.00	$\frac{5}{16}$
		3.86	7.72	2.25	4.50	3.00	6.00	$\frac{3}{8}$
		4.44	8.88	2.63	5.26	3.50	7.00	$\frac{7}{16}$
		5.00	10.00	3.00	6.00	4.00	8.00	$\frac{1}{2}$
		5.56	11.12	3.38	6.76	4.50	9.00	$\frac{9}{16}$
6.10	12.20	3.75	7.50	5.00	10.00	$\frac{5}{8}$		
$\frac{1}{4}$ $\frac{5}{16}$ $\frac{3}{8}$ $\frac{7}{16}$ $\frac{1}{2}$ $\frac{9}{16}$	2½ × 2½	2.38	4.76	1.50	3.00	2.00	4.00	$\frac{1}{4}$
		2.94	5.88	1.88	3.76	2.50	5.00	$\frac{5}{16}$
		3.48	6.96	2.25	4.50	3.00	6.00	$\frac{3}{8}$
		4.00	8.00	2.63	5.26	3.50	7.00	$\frac{7}{16}$
		4.50	9.00	3.00	6.00	4.00	8.00	$\frac{1}{2}$
		5.00	10.00	3.38	6.76	4.50	9.00	$\frac{9}{16}$
$\frac{1}{4}$ $\frac{5}{16}$ $\frac{3}{8}$ $\frac{7}{16}$ $\frac{1}{2}$ $\frac{9}{16}$	2½ × 2	2.14	4.28	1.50	3.00	2.00	4.00	$\frac{1}{4}$
		2.62	5.24	1.88	3.76	2.50	5.00	$\frac{5}{16}$
		3.10	6.20	2.25	4.50	3.00	6.00	$\frac{3}{8}$
		3.56	7.12	2.63	5.26	3.50	7.00	$\frac{7}{16}$
		4.00	8.00	3.00	6.00	4.00	8.00	$\frac{1}{2}$
		4.44	8.88	3.38	6.76	4.50	9.00	$\frac{9}{16}$

LOGARITHMS OF NUMBERS

No.	0	1	2	3	4	5	6	7	8	9	Diff.
10	0000	0043	0086	0128	0170	0212	0253	0294	0334	0374	40
11	0414	0453	0492	0531	0569	0607	0645	0682	0719	0755	37
12	0792	0828	0864	0899	0934	0969	1004	1038	1072	1106	33
13	1139	1173	1206	1239	1271	1303	1335	1367	1399	1430	31
14	1461	1492	1523	1553	1584	1614	1644	1673	1703	1732	29
15	1761	1790	1818	1847	1875	1903	1931	1959	1987	2014	27
16	2041	2068	2095	2122	2148	2175	2201	2227	2253	2279	25
17	2304	2330	2355	2380	2405	2430	2455	2480	2504	2529	24
18	2553	2577	2601	2625	2648	2672	2695	2718	2742	2765	23
19	2788	2810	2833	2856	2878	2900	2923	2945	2967	2989	21
20	3010	3032	3054	3075	3096	3118	3139	3160	3181	3201	21
21	3222	3243	3263	3284	3304	3324	3345	3365	3385	3404	20
22	3424	3444	3464	3483	3502	3522	3541	3560	3579	3598	19
23	3617	3636	3655	3674	3692	3711	3729	3747	3766	3784	18
24	3802	3820	3838	3856	3874	3892	3909	3927	3945	3962	17
25	3979	3997	4014	4031	4048	4065	4082	4099	4116	4133	17
26	4150	4166	4183	4200	4216	4232	4249	4265	4281	4298	16
27	4314	4330	4346	4362	4378	4393	4409	4425	4440	4456	16
28	4472	4487	4502	4518	4533	4548	4564	4579	4594	4609	15
29	4624	4639	4654	4669	4683	4698	4713	4728	4742	4757	14
30	4771	4786	4800	4814	4829	4843	4857	4871	4886	4900	14
31	4914	4928	4942	4955	4969	4983	4997	5011	5024	5038	13
32	5051	5065	5079	5092	5105	5119	5132	5145	5159	5172	13
33	5185	5198	5211	5224	5237	5250	5263	5276	5289	5302	13
34	5315	5328	5340	5353	5366	5378	5391	5403	5416	5428	13
35	5441	5453	5465	5478	5490	5502	5514	5527	5539	5551	12
36	5563	5575	5587	5599	5611	5623	5635	5647	5658	5670	12
37	5682	5694	5705	5717	5729	5740	5752	5763	5775	5786	12
38	5798	5809	5821	5832	5843	5855	5866	5877	5888	5899	12
39	5911	5922	5933	5944	5955	5966	5977	5988	5999	6010	11
No.	0	1	2	3	4	5	6	7	8	9	Diff.

LOGARITHMS OF NUMBERS

No.	0	1	2	3	4	.5	6	7	8	9	Diff.
40	6021	6031	6042	6053	6064	6075	6085	6096	6107	6117	11
41	6128	6138	6149	6160	6170	6180	6191	6201	6212	6222	10
42	6232	6243	6253	6263	6274	6284	6294	6304	6314	6325	10
43	6335	6345	6355	6365	6375	6385	6395	6405	6415	6425	10
44	6435	6444	6454	6464	6474	6484	6493	6503	6513	6522	10
45	6532	6542	6551	6561	6571	6580	6590	6599	6609	6618	10
46	6628	6637	6646	6656	6665	6675	6684	6693	6702	6712	9
47	6721	6730	6739	6749	6758	6767	6776	6785	6794	6803	9
48	6812	6821	6830	6839	6848	6857	6866	6875	6884	6893	9
49	6902	6911	6920	6928	6937	6946	6955	6964	6972	6981	9
50	6990	6998	7007	7016	7024	7033	7042	7050	7059	7067	9
51	7076	7084	7093	7101	7110	7118	7126	7135	7143	7152	8
52	7160	7168	7177	7185	7193	7202	7210	7218	7226	7235	8
53	7243	7251	7259	7267	7275	7284	7292	7300	7308	7316	8
54	7324	7332	7340	7348	7356	7364	7372	7380	7388	7396	8
55	7404	7412	7419	7427	7435	7443	7451	7459	7466	7474	8
56	7482	7490	7497	7505	7513	7520	7528	7536	7543	7551	8
57	7559	7566	7574	7582	7589	7597	7604	7612	7619	7627	7
58	7634	7642	7649	7657	7664	7672	7679	7686	7694	7701	8
59	7709	7716	7723	7731	7738	7745	7752	7760	7767	7774	8
60	7782	7789	7796	7803	7810	7818	7825	7832	7839	7846	7
61	7853	7860	7868	7875	7882	7889	7896	7903	7910	7917	7
62	7924	7931	7938	7945	7952	7959	7966	7973	7980	7987	6
63	7993	8000	8007	8014	8021	8028	8035	8041	8048	8055	7
64	8062	8069	8075	8082	8089	8096	8102	8109	8116	8122	7
65	8129	8136	8142	8149	8156	8162	8169	8176	8182	8189	6
66	8195	8202	8209	8215	8222	8228	8235	8241	8248	8254	7
67	8261	8267	8274	8280	8287	8293	8299	8306	8312	8319	6
68	8325	8331	8338	8344	8351	8357	8363	8370	8376	8382	6
69	8388	8395	8401	8407	8414	8420	8426	8432	8439	8445	6
No.	0	1	2	3	4	5	6	7	8	9	Diff.

LOGARITHMS OF NUMBERS

No.	0	1	2	3	4	5	6	7	8	9	Diff.
70	8451	8457	8463	8470	8476	8482	8488	8494	8500	8506	7
71	8513	8519	8525	8531	8537	8543	8549	8555	8561	8567	6
72	8573	8579	8585	8591	8597	8603	8609	8615	8621	8627	6
73	8633	8639	8645	8651	8657	8663	8669	8675	8681	8686	6
74	8692	8698	8704	8710	8716	8722	8727	8733	8739	8745	6
75	8751	8756	8762	8768	8774	8779	8785	8791	8797	8802	6
76	8808	8814	8820	8825	8831	8837	8842	8848	8854	8859	6
77	8865	8871	8876	8882	8887	8893	8899	8904	8910	8915	6
78	8921	8927	8932	8938	8943	8949	8954	8960	8965	8971	5
79	8976	8982	8987	8993	8998	9004	9009	9015	9020	9025	6
80	9031	9036	9042	9047	9053	9058	9063	9069	9074	9079	6
81	9085	9090	9096	9101	9106	9112	9117	9122	9128	9133	5
82	9138	9143	9149	9154	9159	9165	9170	9175	9180	9186	5
83	9191	9196	9201	9206	9212	9217	9222	9227	9232	9238	5
84	9243	9248	9253	9258	9263	9269	9274	9279	9284	9289	5
85	9294	9299	9304	9309	9315	9320	9325	9330	9335	9340	5
86	9345	9350	9355	9360	9365	9370	9375	9380	9385	9390	5
87	9395	9400	9405	9410	9415	9420	9425	9430	9435	9440	5
88	9445	9450	9455	9460	9465	9469	9474	9479	9484	9489	5
89	9494	9499	9504	9509	9513	9518	9523	9528	9533	9538	4
90	9542	9547	9552	9557	9562	9566	9571	9576	9581	9586	4
91	9590	9595	9600	9605	9609	9614	9619	9624	9628	9633	5
92	9638	9643	9647	9652	9657	9661	9666	9671	9675	9680	5
93	9685	9689	9694	9699	9703	9708	9713	9717	9722	9727	4
94	9731	9736	9741	9745	9750	9754	9759	9763	9768	9773	4
95	9777	9782	9786	9791	9795	9800	9805	9809	9814	9818	5
96	9823	9827	9832	9836	9841	9845	9850	9854	9859	9863	5
97	9868	9872	9877	9881	9886	9890	9894	9899	9903	9908	4
98	9912	9917	9921	9926	9930	9934	9939	9943	9948	9952	4
99	9956	9961	9965	9969	9974	9978	9983	9987	9991	9996	4
No.	0	1	2	3	4	5	6	7	8	9	Diff.

NATURAL SINES, TANGENTS AND SECANTS
Advancing by 10 Minutes

DEGREES	MINUTES	SINE	TANGENT	SECANT	DEGREES	MINUTES	SINE	TANGENT	SECANT
0	00	.0000	.0000	1.0000	5	00	.0872	.0875	1.0038
	10	.0029	.0029	1.0000		10	.0901	.0904	1.0041
	20	.0058	.0058	1.0000		20	.0929	.0934	1.0043
	30	.0087	.0087	1.0000		30	.0958	.0963	1.0046
	40	.0116	.0116	1.0001		40	.0987	.0992	1.0049
	50	.0145	.0145	1.0001		50	.1016	.1022	1.0052
1	00	.0175	.0175	1.0002	6	00	.1045	.1051	1.0055
	10	.0204	.0204	1.0002		10	.1074	.1080	1.0058
	20	.0233	.0233	1.0003		20	.1103	.1110	1.0061
	30	.0262	.0262	1.0003		30	.1132	.1139	1.0065
	40	.0291	.0291	1.0004		40	.1161	.1169	1.0068
	50	.0320	.0320	1.0005		50	.1190	.1198	1.0072
2	00	.0349	.0349	1.0006	7	00	.1219	.1228	1.0075
	10	.0378	.0378	1.0007		10	.1248	.1257	1.0079
	20	.0407	.0407	1.0008		20	.1276	.1287	1.0082
	30	.0436	.0437	1.0010		30	.1305	.1317	1.0086
	40	.0465	.0466	1.0011		40	.1334	.1346	1.0090
	50	.0494	.0495	1.0012		50	.1363	.1376	1.0094
3	00	.0523	.0524	1.0014	8	00	.1392	.1405	1.0098
	10	.0552	.0553	1.0015		10	.1421	.1435	1.0102
	20	.0581	.0582	1.0017		20	.1449	.1465	1.0107
	30	.0610	.0612	1.0019		30	.1478	.1495	1.0111
	40	.0640	.0641	1.0021		40	.1507	.1524	1.0116
	50	.0669	.0670	1.0022		50	.1536	.1554	1.0120
4	00	.0698	.0699	1.0024	9	00	.1564	.1584	1.0125
	10	.0727	.0729	1.0027		10	.1593	.1614	1.0129
	20	.0756	.0758	1.0029		20	.1622	.1644	1.0134
	30	.0785	.0787	1.0031		30	.1650	.1673	1.0139
	40	.0814	.0816	1.0033		40	.1679	.1703	1.0144
	50	.0843	.0846	1.0036		50	.1708	.1733	1.0149

NATURAL SINES, TANGENTS AND SECANTS
Advancing by 10 Minutes

DEGREES	MINUTES	SINE	TANGENT	SECANT	DEGREES	MINUTES	SINE	TANGENT	SECANT
10	00	.1736	.1763	1.0154	15	00	.2588	.2679	1.0353
	10	.1765	.1793	1.0160		10	.2616	.2711	1.0361
	20	.1794	.1823	1.0165		20	.2644	.2742	1.0369
	30	.1822	.1853	1.0170		30	.2672	.2773	1.0377
	40	.1851	.1883	1.0176		40	.2700	.2805	1.0386
	50	.1880	.1914	1.0181		50	.2728	.2836	1.0394
	11	00	.1908	.1944		1.0187	16	00	.2756
10		.1937	.1974	1.0193	10	.2784		.2899	1.0412
20		.1965	.2004	1.0199	20	.2812		.2931	1.0421
30		.1994	.2035	1.0205	30	.2840		.2962	1.0429
40		.2022	.2065	1.0211	40	.2868		.2994	1.0439
50		.2051	.2095	1.0217	50	.2896		.3026	1.0448
12		00	.2079	.2126	1.0223	17		00	.2924
	10	.2108	.2156	1.0230	10		.2952	.3089	1.0466
	20	.2136	.2186	1.0236	20		.2979	.3121	1.0476
	30	.2164	.2217	1.0243	30		.3007	.3153	1.0485
	40	.2193	.2247	1.0249	40		.3035	.3185	1.0495
	50	.2221	.2278	1.0256	50		.3062	.3217	1.0505
	13	00	.2250	.2309	1.0263		18	00	.3090
10		.2278	.2339	1.0270	10	.3118		.3281	1.0525
20		.2306	.2370	1.0277	20	.3145		.3314	1.0535
30		.2334	.2401	1.0284	30	.3173		.3346	1.0545
40		.2363	.2432	1.0291	40	.3201		.3378	1.0555
50		.2391	.2462	1.0299	50	.3228		.3411	1.0566
14		00	.2419	.2493	1.0306	19		00	.3256
	10	.2447	.2524	1.0314	10		.3283	.3476	1.0587
	20	.2476	.2555	1.0321	20		.3311	.3508	1.0598
	30	.2504	.2586	1.0329	30		.3338	.3541	1.0608
	40	.2532	.2617	1.0337	40		.3365	.3574	1.0619
	50	.2560	.2648	1.0345	50		.3393	.3607	1.0631

NATURAL SINES, TANGENTS AND SECANTS

Advancing by 10 Minutes

DEGREES	MINUTES	SINE	TANGENT	SECANT	DEGREES	MINUTES	SINE	TANGENT	SECANT
20	00	.3420	.3640	1.0642	25	00	.4226	.4663	1.1034
	10	.3448	.3673	1.0653		10	.4253	.4699	1.1049
	20	.3475	.3706	1.0665		20	.4279	.4734	1.1064
	30	.3502	.3739	1.0676		30	.4305	.4770	1.1079
	40	.3529	.3772	1.0688		40	.4331	.4806	1.1095
	50	.3557	.3805	1.0700		50	.4358	.4841	1.1110
21	00	.3584	.3839	1.0711	26	00	.4384	.4877	1.1126
	10	.3611	.3872	1.0723		10	.4410	.4913	1.1142
	20	.3638	.3906	1.0736		20	.4436	.4950	1.1158
	30	.3665	.3939	1.0748		30	.4462	.4986	1.1174
	40	.3692	.3973	1.0760		40	.4488	.5022	1.1190
	50	.3719	.4006	1.0773		50	.4514	.5059	1.1207
22	00	.3746	.4040	1.0785	27	00	.4540	.5095	1.1223
	10	.3773	.4074	1.0798		10	.4566	.5132	1.1240
	20	.3800	.4108	1.0811		20	.4592	.5169	1.1257
	30	.3827	.4142	1.0824		30	.4617	.5206	1.1274
	40	.3854	.4176	1.0837		40	.4643	.5243	1.1291
	50	.3881	.4210	1.0850		50	.4669	.5280	1.1308
23	00	.3907	.4245	1.0864	28	00	.4695	.5317	1.1326
	10	.3934	.4279	1.0877		10	.4720	.5354	1.1343
	20	.3961	.4314	1.0891		20	.4746	.5392	1.1361
	30	.3987	.4348	1.0904		30	.4772	.5430	1.1379
	40	.4014	.4383	1.0918		40	.4797	.5467	1.1397
	50	.4041	.4417	1.0932		50	.4823	.5505	1.1415
24	00	.4067	.4452	1.0946	29	00	.4848	.5543	1.1434
	10	.4094	.4487	1.0961		10	.4874	.5581	1.1452
	20	.4120	.4522	1.0975		20	.4899	.5619	1.1471
	30	.4147	.4557	1.0989		30	.4924	.5658	1.1490
	40	.4173	.4592	1.1004		40	.4950	.5696	1.1509
	50	.4200	.4628	1.1019		50	.4975	.5735	1.1528

NATURAL SINES, TANGENTS AND SECANTS
Advancing by 10 Minutes

DEGREES	MINUTES	SINE	TANGENT	SECANT	DEGREES	MINUTES	SINE	TANGENT	SECANT
30	00	.5000	.5774	1.1547	35	00	.5736	.7002	1.2208
	10	.5025	.5812	1.1566		10	.5760	.7046	1.2233
	20	.5050	.5851	1.1586		20	.5783	.7089	1.2258
	30	.5075	.5890	1.1606		30	.5807	.7133	1.2283
	40	.5100	.5930	1.1626		40	.5831	.7177	1.2309
	50	.5125	.5969	1.1646		50	.5854	.7221	1.2335
31	00	.5150	.6009	1.1666	36	00	.5878	.7265	1.2361
	10	.5175	.6048	1.1687		10	.5901	.7310	1.2387
	20	.5200	.6088	1.1707		20	.5925	.7355	1.2413
	30	.5225	.6128	1.1728		30	.5948	.7400	1.2440
	40	.5250	.6168	1.1749		40	.5972	.7445	1.2467
	50	.5275	.6208	1.1770		50	.5995	.7490	1.2494
32	00	.5299	.6249	1.1792	37	00	.6018	.7536	1.2521
	10	.5324	.6289	1.1813		10	.6041	.7581	1.2549
	20	.5348	.6330	1.1835		20	.6065	.7627	1.2577
	30	.5373	.6371	1.1857		30	.6088	.7673	1.2605
	40	.5398	.6412	1.1879		40	.6111	.7720	1.2633
	50	.5422	.6453	1.1901		50	.6134	.7766	1.2661
33	00	.5446	.6494	1.1924	38	00	.6157	.7813	1.2690
	10	.5471	.6536	1.1946		10	.6180	.7860	1.2719
	20	.5495	.6577	1.1969		20	.6202	.7907	1.2748
	30	.5519	.6619	1.1992		30	.6225	.7954	1.2778
	40	.5544	.6661	1.2015		40	.6248	.8002	1.2808
	50	.5568	.6703	1.2039		50	.6271	.8050	1.2837
34	00	.5592	.6745	1.2062	39	00	.6293	.8098	1.2868
	10	.5616	.6787	1.2086		10	.6316	.8146	1.2898
	20	.5640	.6830	1.2110		20	.6338	.8195	1.2929
	30	.5664	.6873	1.2134		30	.6361	.8243	1.2960
	40	.5688	.6916	1.2158		40	.6383	.8292	1.2991
	50	.5712	.6959	1.2183		50	.6406	.8342	1.3022

NATURAL SINES, TANGENTS AND SECANTS
Advancing by 10 Minutes

DEGREES	MINUTES	SINE	TANGENT	SECANT	DEGREES	MINUTES	SINE	TANGENT	SECANT
40	00	.6428	.8391	1.3054	45	00	.7071	1.0000	1.4142
	10	.6450	.8441	1.3086		10	.7092	1.0058	1.4183
	20	.6472	.8491	1.3118		20	.7112	1.0117	1.4225
	30	.6494	.8541	1.3151		30	.7133	1.0176	1.4267
	40	.6517	.8591	1.3184		40	.7153	1.0235	1.4310
	50	.6539	.8642	1.3217		50	.7173	1.0295	1.4352
41	00	.6561	.8693	1.3250	46	00	.7193	1.0355	1.4396
	10	.6583	.8744	1.3284		10	.7214	1.0416	1.4439
	20	.6604	.8796	1.3318		20	.7234	1.0477	1.4483
	30	.6626	.8847	1.3352		30	.7254	1.0538	1.4527
	40	.6648	.8899	1.3386		40	.7274	1.0599	1.4572
	50	.6670	.8952	1.3421		50	.7294	1.0661	1.4617
42	00	.6691	.9004	1.3456	47	00	.7314	1.0724	1.4663
	10	.6713	.9057	1.3492		10	.7333	1.0786	1.4709
	20	.6734	.9110	1.3527		20	.7353	1.0850	1.4755
	30	.6756	.9163	1.3563		30	.7373	1.0913	1.4802
	40	.6777	.9217	1.3600		40	.7392	1.0977	1.4849
	50	.6799	.9271	1.3636		50	.7412	1.1041	1.4897
43	00	.6820	.9325	1.3673	48	00	.7431	1.1106	1.4945
	10	.6841	.9380	1.3711		10	.7451	1.1171	1.4993
	20	.6862	.9435	1.3748		20	.7470	1.1237	1.5042
	30	.6884	.9490	1.3786		30	.7490	1.1303	1.5092
	40	.6905	.9545	1.3824		40	.7509	1.1369	1.5141
	50	.6926	.9601	1.3863		50	.7528	1.1436	1.5192
44	00	.6947	.9657	1.3902	49	00	.7547	1.1504	1.5243
	10	.6967	.9713	1.3941		10	.7566	1.1571	1.5294
	20	.6988	.9770	1.3980		20	.7585	1.1640	1.5345
	30	.7009	.9827	1.4020		30	.7604	1.1708	1.5398
	40	.7030	.9884	1.4061		40	.7623	1.1778	1.5450
	50	.7050	.9942	1.4101		50	.7642	1.1847	1.5504

NATURAL SINES, TANGENTS AND SECANTS
 Advancing by 10 Minutes

DEGREES	MINUTES	SINE	TANGENT	SECANT	DEGREES	MINUTES	SINE	TANGENT	SECANT
50	00	.7660	1.1918	1.5557	55	00	.8192	1.4281	1.7434
	10	.7679	1.1988	1.5611		10	.8208	1.4370	1.7507
	20	.7698	1.2059	1.5666		20	.8225	1.4460	1.7581
	30	.7716	1.2131	1.5721		30	.8241	1.4550	1.7655
	40	.7735	1.2203	1.5777		40	.8258	1.4641	1.7730
	50	.7753	1.2276	1.5833		50	.8274	1.4733	1.7806
51	00	.7771	1.2349	1.5890	56	00	.8290	1.4826	1.7883
	10	.7790	1.2423	1.5948		10	.8307	1.4919	1.7960
	20	.7808	1.2497	1.6005		20	.8323	1.5013	1.8039
	30	.7826	1.2572	1.6064		30	.8339	1.5108	1.8118
	40	.7844	1.2647	1.6123		40	.8355	1.5204	1.8198
	50	.7862	1.2723	1.6183		50	.8371	1.5301	1.8279
52	00	.7880	1.2799	1.6243	57	00	.8387	1.5399	1.8361
	10	.7898	1.2876	1.6303		10	.8403	1.5497	1.8443
	20	.7916	1.2954	1.6365		20	.8418	1.5597	1.8527
	30	.7934	1.3032	1.6427		30	.8434	1.5697	1.8612
	40	.7951	1.3111	1.6489		40	.8450	1.5798	1.8699
	50	.7969	1.3190	1.6553		50	.8465	1.5900	1.8783
53	00	.7986	1.3270	1.6616	58	00	.8480	1.6003	1.8871
	10	.8004	1.3352	1.6681		10	.8496	1.6107	1.8959
	20	.8021	1.3432	1.6746		20	.8511	1.6213	1.9048
	30	.8039	1.3514	1.6812		30	.8526	1.6319	1.9139
	40	.8056	1.3597	1.6878		40	.8542	1.6426	1.9230
	50	.8073	1.3680	1.6945		50	.8557	1.6534	1.9323
54	00	.8090	1.3764	1.7013	59	00	.8572	1.6643	1.9416
	10	.8107	1.3848	1.7081		10	.8587	1.6753	1.9511
	20	.8124	1.3934	1.7151		20	.8601	1.6864	1.9606
	30	.8141	1.4019	1.7221		30	.8616	1.6977	1.9703
	40	.8158	1.4106	1.7291		40	.8631	1.7090	1.9801
	50	.8175	1.4193	1.7362		50	.8646	1.7205	1.9900

NATURAL SINES, TANGENTS AND SECANTS

Advancing by 10 Minutes

DEGREES	MINUTES	SINE	TANGENT	SECANT	DEGREES	MINUTES	SINE	TANGENT	SECANT
60	00	.8660	1.7321	2.0000	65	00	.9063	2.1445	2.3662
	10	.8675	1.7437	2.0101		10	.9075	2.1609	2.3811
	20	.8689	1.7556	2.0204		20	.9088	2.1775	2.3961
	30	.8704	1.7675	2.0308		30	.9100	2.1943	2.4114
	40	.8718	1.7796	2.0413		40	.9112	2.2113	2.4269
	50	.8732	1.7917	2.0519		50	.9124	2.2286	2.4426
61	00	.8746	1.8040	2.0627	66	00	.9135	2.2460	2.4586
	10	.8760	1.8165	2.0736		10	.9147	2.2637	2.4748
	20	.8774	1.8291	2.0846		20	.9159	2.2817	2.4912
	30	.8788	1.8418	2.0957		30	.9171	2.2998	2.5078
	40	.8802	1.8546	2.1070		40	.9182	2.3183	2.5247
	50	.8816	1.8676	2.1185		50	.9194	2.3369	2.5419
62	00	.8829	1.8807	2.1301	67	00	.9205	2.3559	2.5593
	10	.8843	1.8940	2.1418		10	.9216	2.3750	2.5770
	20	.8857	1.9074	2.1537		20	.9228	2.3945	2.5949
	30	.8870	1.9210	2.1657		30	.9239	2.4141	2.6131
	40	.8884	1.9347	2.1786		40	.9250	2.4342	2.6316
	50	.8897	1.9486	2.1902		50	.9261	2.4545	2.6504
63	00	.8910	1.9626	2.2027	68	00	.9272	2.4751	2.6695
	10	.8923	1.9768	2.2153		10	.9283	2.4960	2.6888
	20	.8936	1.9912	2.2282		20	.9293	2.5172	2.7085
	30	.8949	2.0057	2.2412		30	.9304	2.5386	2.7285
	40	.8962	2.0204	2.2543		40	.9315	2.5605	2.7488
	50	.8975	2.0353	2.2677		50	.9325	2.5826	2.7695
64	00	.8988	2.0503	2.2812	69	00	.9336	2.6051	2.7904
	10	.9001	2.0655	2.2949		10	.9346	2.6279	2.8117
	20	.9013	2.0809	2.3088		20	.9356	2.6511	2.8334
	30	.9026	2.0965	2.3228		30	.9367	2.6746	2.8555
	40	.9038	2.1123	2.3371		40	.9377	2.6985	2.8779
	50	.9051	2.1283	2.3515		50	.9387	2.7228	2.9006

NATURAL SINES, TANGENTS AND SECANTS
 Advancing by 10 Minutes

DEGREES	MINUTES	SINE	TANGENT	SECANT	DEGREES	MINUTES	SINE	TANGENT	SECANT
70	00	.9397	2.7475	2.9238	75	00	.9659	3.7321	3.8637
	10	.9407	2.7725	2.9474		10	.9667	3.7760	3.9061
	20	.9417	2.7980	2.9713		20	.9674	3.8208	3.9495
	30	.9426	2.8239	2.9957		30	.9681	3.8667	3.9939
	40	.9436	2.8502	3.0206		40	.9689	3.9136	4.0394
	50	.9446	2.8770	3.0458		50	.9696	3.9617	4.0859
71	00	.9455	2.9042	3.0716	76	00	.9703	4.0108	4.1336
	10	.9465	2.9319	3.0977		10	.9710	4.0611	4.1824
	20	.9474	2.9600	3.1244		20	.9717	4.1126	4.2324
	30	.9483	2.9887	3.1515		30	.9724	4.1653	4.2837
	40	.9492	3.0178	3.1792		40	.9730	4.2193	4.3362
	50	.9502	3.0475	3.2074		50	.9737	4.2747	4.3901
72	00	.9511	3.0777	3.2361	77	00	.9744	4.3315	4.4454
	10	.9520	3.1084	3.2653		10	.9750	4.3897	4.5022
	20	.9528	3.1397	3.2951		20	.9757	4.4494	4.5604
	30	.9537	3.1716	3.3255		30	.9763	4.5107	4.6202
	40	.9546	3.2041	3.3565		40	.9769	4.5736	4.6817
	50	.9555	3.2371	3.3881		50	.9775	4.6382	4.7448
73	00	.9563	3.2709	3.4203	78	00	.9781	4.7046	4.8097
	10	.9572	3.3052	3.4532		10	.9787	4.7729	4.8765
	20	.9580	3.3402	3.4867		20	.9793	4.8430	4.9452
	30	.9588	3.3759	3.5209		30	.9799	4.9152	5.0159
	40	.9596	3.4124	3.5559		40	.9805	4.9894	5.0886
	50	.9605	3.4495	3.5915		50	.9811	5.0658	5.1636
74	00	.9613	3.4874	3.6280	79	00	.9816	5.1446	5.2408
	10	.9621	3.5261	3.6652		10	.9822	5.2257	5.3205
	20	.9628	3.5656	3.7032		20	.9827	5.3093	5.4026
	30	.9636	3.6059	3.7420		30	.9833	5.3955	5.4874
	40	.9644	3.6470	3.7817		40	.9838	5.4845	5.5749
	50	.9652	3.6891	3.8222		50	.9843	5.5764	5.6653

NATURAL SINES, TANGENTS AND SECANTS

Advancing by 10 Minutes

DEGREES	MINUTES	SINE	TANGENT	SECANT	DEGREES	MINUTES	SINE	TANGENT	SECANT
80	00	.9848	5.6713	5.7588	85	00	.9962	11.430	11.474
	10	.9853	5.7694	5.8554		10	.9964	11.826	11.868
	20	.9858	5.8708	5.9554		20	.9967	12.251	12.291
	30	.9863	5.9758	6.0589		30	.9969	12.706	12.745
	40	.9868	6.0844	6.1661		40	.9971	13.197	13.235
	50	.9872	6.1970	6.2772		50	.9974	13.727	13.763
81	00	.9877	6.3138	6.3925	86	00	.9976	14.301	14.336
	10	.9881	6.4348	6.5121		10	.9978	14.924	14.958
	20	.9886	6.5606	6.6363		20	.9980	15.605	15.637
	30	.9890	6.6912	6.7655		30	.9981	16.350	16.380
	40	.9894	6.8269	6.8998		40	.9983	17.169	17.198
	50	.9899	6.9682	7.0396		50	.9985	18.075	18.103
82	00	.9903	7.1154	7.1853	87	00	.9986	19.081	19.107
	10	.9907	7.2687	7.3372		10	.9988	20.206	20.230
	20	.9911	7.4287	7.4957		20	.9989	21.470	21.494
	30	.9914	7.5958	7.6613		30	.9990	22.904	22.926
	40	.9918	7.7704	7.8344		40	.9992	24.542	24.562
	50	.9922	7.9530	8.0156		50	.9993	26.432	26.451
83	00	.9925	8.1443	8.2055	88	00	.9994	28.636	28.654
	10	.9929	8.3450	8.4047		10	.9995	31.242	31.258
	20	.9932	8.5555	8.6138		20	.9996	34.368	34.382
	30	.9936	8.7769	8.8337		30	.9997	38.188	38.202
	40	.9939	9.0098	9.0652		40	.9997	42.964	42.976
	50	.9942	9.2553	9.3092		50	.9998	49.104	49.114
84	00	.9945	9.5144	9.5668	89	00	.9998	57.290	57.299
	10	.9948	9.7882	9.8391		10	.9999	68.750	68.757
	20	.9951	10.0780	10.1275		20	.9999	85.940	85.946
	30	.9954	10.3854	10.4334		30	1.0000	114.589	114.593
	40	.9957	10.7119	10.7585		40	1.0000	171.885	171.888
	50	.9959	11.0594	11.1045		50	1.0000	343.774	343.775
					90	00	1.0000	Infinite	Infinite

SQUARES, CUBES, SQUARE ROOTS AND CUBE ROOTS

NUMBERS	SQUARES	CUBES	SQUARE ROOT	CUBE ROOT	NUMBERS	SQUARES	CUBES	SQUARE ROOT	CUBE ROOT
1	1	1	1.000	1.000	51	26 01	132 651	7.141	3.708
2	4	8	1.414	1.260	52	27 04	140 608	7.211	3.733
3	9	27	1.732	1.442	53	28 09	148 877	7.280	3.756
4	16	64	2.000	1.537	54	29 16	157 464	7.349	3.780
5	25	125	2.236	1.710	55	30 25	166 375	7.416	3.803
6	36	216	2.449	1.817	56	31 36	175 616	7.483	3.826
7	49	343	2.646	1.913	57	32 49	185 193	7.550	3.849
8	64	512	2.823	2.000	58	33 64	195 112	7.616	3.871
9	81	729	3.000	2.080	59	34 81	205 379	7.681	3.893
10	1 00	1 000	3.162	2.154	60	36 00	216 000	7.746	3.915
11	1 21	1 331	3.317	2.224	61	37 21	226 981	7.810	3.937
12	1 44	1 728	3.464	2.289	62	38 44	238 328	7.874	3.958
13	1 69	2 197	3.606	2.351	63	39 69	250 047	7.937	3.979
14	1 96	2 744	3.742	2.410	64	40 96	262 144	8.000	4.000
15	2 25	3 375	3.873	2.466	65	42 25	274 625	8.062	4.021
16	2 56	4 096	4.000	2.520	66	43 56	287 496	8.124	4.041
17	2 89	4,913	4.123	2.571	67	44 89	300 763	8.185	4.062
18	3 24	5 832	4.243	2.621	68	46 24	314 432	8.246	4.082
19	3 61	6 859	4.359	2.668	69	47 61	328 509	8.307	4.102
20	4 00	8 000	4.472	2.714	70	49 00	343 000	8.367	4.121
21	4 41	9 261	4.583	2.759	71	50 41	357 911	8.426	4.141
22	4 84	10 648	4.690	2.802	72	51 84	373 248	8.485	4.160
23	5 29	12 167	4.796	2.844	73	53 29	389 017	8.544	4.179
24	5 76	13 824	4.899	2.885	74	54 76	405 224	8.602	4.198
25	6 25	15 625	5.000	2.924	75	56 25	421 875	8.660	4.217
26	6 76	17 576	5.099	2.963	76	57 76	438 976	8.718	4.236
27	7 29	19 683	5.196	3.000	77	59 29	456 533	8.775	4.254
28	7 84	21 952	5.292	3.037	78	60 84	474 552	8.832	4.273
29	8 41	24 389	5.385	3.072	79	62 41	493 039	8.888	4.291
30	9 00	27 000	5.477	3.107	80	64 00	512 000	8.944	4.309
31	9 61	29 791	5.568	3.141	81	65 61	531 441	9.000	4.327
32	10 24	32 768	5.657	3.175	82	67 24	551 268	9.055	4.345
33	10 89	35 937	5.745	3.208	83	68 89	571 737	9.110	4.362
34	11 56	39 304	5.831	3.240	84	70 56	592 704	9.165	4.380
35	12 25	42 875	5.916	3.271	85	72 25	614 125	9.220	4.397
36	12 96	46 656	6.000	3.302	86	73 96	636 056	9.274	4.414
37	13 69	50 653	6.083	3.332	87	75 69	658 503	9.327	4.431
38	14 44	54 872	6.164	3.362	88	77 44	681 472	9.381	4.448
39	15 21	59 319	6.245	3.391	89	79 21	704 969	9.434	4.465
40	16 00	64 000	6.325	3.420	90	81 00	729 000	9.487	4.481
41	16 81	68 921	6.403	3.448	91	82 81	753 571	9.539	4.498
42	17 64	74 088	6.481	3.476	92	84 64	778 688	9.592	4.514
43	18 49	79 507	6.557	3.503	93	86 49	804 357	9.644	4.531
44	19 36	85 184	6.633	3.530	94	88 36	830 584	9.695	4.547
45	20 25	91 125	6.708	3.557	95	90 25	857 375	9.747	4.563
46	21 16	97 336	6.782	3.583	96	92 16	884 736	9.798	4.579
47	22 09	103 823	6.856	3.609	97	94 09	912 673	9.849	4.595
48	23 04	110 592	6.928	3.634	98	96 04	941 192	9.900	4.610
49	24 01	117 649	7.000	3.659	99	98 01	970 299	9.950	4.626
50	25 00	125 000	7.071	3.684	100	1 00 00	1 000 000	10.000	4.642

SQUARES, CUBES, SQUARE ROOTS AND CUBE ROOTS

NUMBERS	SQUARES	CUBES	SQUARE ROOT	CUBE ROOT	NUMBERS	SQUARES	CUBES	SQUARE ROOT	CUBE ROOT
101	1 02 01	1 030 301	10.0499	4.6570	151	2 28 01	3 442 951	12.2882	5.3251
102	1 04 04	1 061 208	10.0995	4.6723	152	2 31 04	3 511 808	12.3288	5.3368
103	1 06 09	1 092 727	10.1489	4.6875	153	2 34 09	3 581 577	12.3693	5.3485
104	1 08 16	1 124 864	10.1980	4.7027	154	2 37 16	3 652 264	12.4097	5.3601
105	1 10 25	1 157 625	10.2470	4.7177	155	2 40 25	3 723 875	12.4499	5.3717
106	1 12 36	1 191 016	10.2956	4.7326	156	2 43 36	3 796 416	12.4900	5.3832
107	1 14 49	1 225 043	10.3441	4.7475	157	2 46 49	3 869 893	12.5300	5.3947
108	1 16 64	1 259 712	10.3923	4.7622	158	2 49 64	3 944 312	12.5698	5.4061
109	1 18 81	1 295 029	10.4403	4.7769	159	2 52 81	4 019 679	12.6095	5.4175
110	1 21 00	1 331 000	10.4881	4.7914	160	2 56 00	4 096 000	12.6491	5.4288
111	1 23 21	1 367 631	10.5357	4.8059	161	2 59 21	4 173 281	12.6886	5.4401
112	1 25 44	1 404 928	10.5830	4.8203	162	2 62 44	4 251 528	12.7279	5.4514
113	1 27 69	1 442 897	10.6301	4.8346	163	2 65 69	4 330 747	12.7671	5.4626
114	1 29 96	1 481 544	10.6771	4.8488	164	2 68 96	4 410 944	12.8062	5.4737
115	1 32 25	1 520 875	10.7238	4.8629	165	2 72 25	4 492 125	12.8452	5.4848
116	1 34 56	1 560 896	10.7703	4.8770	166	2 75 56	4 574 296	12.8841	5.4959
117	1 36 89	1 601 613	10.8167	4.8910	167	2 78 89	4 657 463	12.9228	5.5069
118	1 39 24	1 643 032	10.8628	4.9049	168	2 82 24	4 741 632	12.9615	5.5178
119	1 41 61	1 685 159	10.9087	4.9187	169	2 85 61	4 826 809	13.0000	5.5288
120	1 44 00	1 728 000	10.9545	4.9324	170	2 89 00	4 913 000	13.0384	5.5397
121	1 46 41	1 771 561	11.0000	4.9461	171	2 92 41	5 000 211	13.0767	5.5505
122	1 48 84	1 815 848	11.0454	4.9597	172	2 95 84	5 088 448	13.1149	5.5613
123	1 51 29	1 860 867	11.0905	4.9732	173	2 99 29	5 177 717	13.1529	5.5721
124	1 53 76	1 906 624	11.1355	4.9866	174	3 02 76	5 268 024	13.1909	5.5828
125	1 56 25	1 953 125	11.1803	5.0000	175	3 06 25	5 359 375	13.2288	5.5934
126	1 58 76	2 000 376	11.2250	5.0133	176	3 09 76	5 451 776	13.2665	5.6041
127	1 61 29	2 048 383	11.2694	5.0265	177	3 13 29	5 545 233	13.3041	5.6147
128	1 63 84	2 097 152	11.3137	5.0397	178	3 16 84	5 639 752	13.3417	5.6252
129	1 66 41	2 146 689	11.3578	5.0528	179	3 20 41	5 735 339	13.3791	5.6357
130	1 69 00	2 197 000	11.4018	5.0658	180	3 24 00	5 832 000	13.4164	5.6462
131	1 71 60	2 248 091	11.4455	5.0788	181	3 27 61	5 929 741	13.4536	5.6567
132	1 74 24	2 299 968	11.4891	5.0916	182	3 31 24	6 028 568	13.4907	5.6671
133	1 76 89	2 352 637	11.5326	5.1045	183	3 34 89	6 128 487	13.5277	5.6774
134	1 79 56	2 406 104	11.5758	5.1172	184	3 38 56	6 229 504	13.5647	5.6877
135	1 82 25	2 460 375	11.6190	5.1299	185	3 42 25	6 331 625	13.6015	5.6980
136	1 84 96	2 515 456	11.6619	5.1426	186	3 45 96	6 434 856	13.6382	5.7083
137	1 87 69	2 571 353	11.7047	5.1551	187	3 49 69	6 539 203	13.6748	5.7185
138	1 90 44	2 628 072	11.7473	5.1676	188	3 53 44	6 644 672	13.7113	5.7287
139	1 93 21	2 685 619	11.7898	5.1801	189	3 57 21	6 751 269	13.7477	5.7388
140	1 96 00	2 744 000	11.8322	5.1925	190	3 61 00	6 859 000	13.7840	5.7489
141	1 98 81	2 803 221	11.8743	5.2048	191	3 64 81	6 967 871	13.8203	5.7590
142	2 01 64	2 863 288	11.9164	5.2171	192	3 68 64	7 077 888	13.8564	5.7690
143	2 04 49	2 924 207	11.9583	5.2293	193	3 72 49	7 189 057	13.8924	5.7790
144	2 07 36	2 985 984	12.0000	5.2415	194	3 76 36	7 301 384	13.9284	5.7890
145	2 10 25	3 048 625	12.0416	5.2536	195	3 80 25	7 414 875	13.9642	5.7989
146	2 13 16	3 112 136	12.0830	5.2656	196	3 84 16	7 529 536	14.0000	5.8088
147	2 16 09	3 176 523	12.1244	5.2776	197	3 88 09	7 645 373	14.0357	5.8186
148	2 19 04	3 241 792	12.1655	5.2896	198	3 92 04	7 762 392	14.0712	5.8285
149	2 22 01	3 307 949	12.2066	5.3015	199	3 96 01	7 880 599	14.1067	5.8383
150	2 25 00	3 375 000	12.2474	5.3133	200	4 00 00	8 000 000	14.1421	5.8480

SQUARES, CUBES, SQUARE ROOTS AND CUBE ROOTS

NUMBERS	SQUARES	CUBES	SQUARE ROOT	CUBE ROOT	NUMBERS	SQUARES	CUBES	SQUARE ROOT	CUBE ROOT
201	4 04 01	8 120 601	14.1774	5.8578	251	6 30 01	15 813 251	15.8430	6.3080
202	4 08 04	8 242 408	14.2127	5.8675	252	6 35 04	16 003 008	15.8745	6.3164
203	4 12 09	8 365 427	14.2478	5.8771	253	6 40 09	16 194 277	15.9060	6.3247
204	4 16 16	8 489 664	14.2829	5.8868	254	6 45 16	16 387 064	15.9374	6.3330
205	4 20 25	8 615 125	14.3178	5.8964	255	6 50 25	16 581 375	15.9687	6.3413
206	4 24 36	8 741 816	14.3527	5.9059	256	6 55 36	16 777 216	16.0000	6.3496
207	4 28 49	8 869 743	14.3875	5.9155	257	6 60 49	16 974 593	16.0312	6.3579
208	4 32 64	8 998 912	14.4222	5.9250	258	6 65 64	17 173 512	16.0624	6.3661
209	4 36 81	9 129 329	14.4568	5.9345	259	6 70 81	17 373 979	16.0935	6.3743
210	4 41 00	9 261 000	14.4914	5.9439	260	6 76 00	17 576 000	16.1245	6.3825
211	4 45 21	9 393 931	14.5258	5.9533	261	6 81 21	17 779 581	16.1555	6.3907
212	4 49 44	9 528 128	14.5602	5.9627	262	6 86 44	17 984 728	16.1864	6.3988
213	4 53 69	9 663 597	14.5945	5.9721	263	6 91 69	18 191 447	16.2173	6.4070
214	4 57 96	9 800 344	14.6287	5.9814	264	6 96 96	18 399 744	16.2481	6.4151
215	4 62 25	9 938 375	14.6629	5.9907	265	7 02 25	18 609 625	16.2788	6.4232
216	4 66 56	10 077 696	14.6969	6.0000	266	7 07 56	18 821 096	16.3095	6.4312
217	4 70 89	10 218 313	14.7309	6.0092	267	7 12 89	19 034 163	16.3401	6.4393
218	4 75 24	10 360 232	14.7648	6.0185	268	7 18 24	19 248 832	16.3707	6.4473
219	4 79 61	10 503 459	14.7986	6.0277	269	7 23 61	19 465 109	16.4012	6.4553
220	4 84 00	10 648 000	14.8324	6.0368	270	7 29 00	19 683 000	16.4317	6.4633
221	4 88 41	10 793 861	14.8661	6.0459	271	7 34 41	19 902 511	16.4621	6.4713
222	4 92 84	10 941 048	14.8997	6.0550	272	7 39 84	20 123 648	16.4924	6.4792
223	4 97 29	11 089 567	14.9332	6.0641	273	7 45 29	20 346 417	16.5227	6.4872
224	5 01 76	11 239 424	14.9666	6.0732	274	7 50 76	20 570 824	16.5529	6.4951
225	5 06 25	11 390 625	15.0000	6.0822	275	7 56 25	20 796 875	16.5831	6.5030
226	5 10 76	11 543 176	15.0333	6.0912	276	7 61 76	21 024 576	16.6132	6.5108
227	5 15 29	11 697 083	15.0655	6.1002	277	7 67 29	21 253 933	16.6433	6.5187
228	5 19 84	11 852 352	15.0997	6.1091	278	7 72 84	21 484 952	16.6733	6.5265
229	5 24 41	12 008 989	15.1327	6.1180	279	7 78 41	21 717 639	16.7033	6.5343
230	5 29 00	12 167 000	15.1658	6.1269	280	7 84 00	21 952 000	16.7332	6.5421
231	5 33 61	12 326 391	15.1987	6.1358	281	7 89 61	22 188 041	16.7631	6.5499
232	5 38 24	12 487 168	15.2315	6.1446	282	7 95 24	22 425 768	16.7929	6.5577
233	5 42 89	12 649 337	15.2643	6.1534	283	8 00 89	22 665 187	16.8226	6.5654
234	5 47 56	12 812 904	15.2971	6.1622	284	8 06 56	22 906 304	16.8523	6.5731
235	5 52 25	12 977 875	15.3297	6.1710	285	8 12 25	23 149 125	16.8819	6.5808
236	5 56 96	13 144 256	15.3623	6.1797	286	8 17 96	23 393 656	16.9115	6.5885
237	5 61 69	13 312 053	15.3948	6.1885	287	8 23 69	23 639 903	16.9411	6.5962
238	5 66 44	13 481 272	15.4272	6.1972	288	8 29 44	23 887 872	16.9706	6.6039
239	5 71 21	13 651 919	15.4596	6.2058	289	8 35 21	24 137 569	17.0000	6.6115
240	5 76 00	13 824 000	15.4919	6.2145	290	8 41 00	24 389 000	17.0294	6.6191
241	5 80 81	13 997 521	15.5242	6.2231	291	8 46 81	24 642 171	17.0587	6.6267
242	5 85 64	14 172 488	15.5563	6.2317	292	8 52 64	24 897 088	17.0880	6.6343
243	5 90 49	14 348 907	15.5885	6.2403	293	8 58 49	25 153 757	17.1172	6.6419
244	5 95 36	14 526 784	15.6205	6.2488	294	8 64 36	25 412 184	17.1464	6.6494
245	6 00 25	14 706 125	15.6525	6.2573	295	8 70 25	25 672 375	17.1756	6.6569
246	6 05 16	14 886 936	15.6844	6.2658	296	8 76 16	25 934 336	17.2047	6.6644
247	6 10 09	15 069 223	15.7162	6.2743	297	8 82 09	26 198 073	17.2337	6.6719
248	6 15 04	15 253 992	15.7480	6.2828	298	8 88 04	26 463 592	17.2627	6.6794
249	6 20 01	15 439 249	15.7797	6.2912	299	8 94 01	26 730 899	17.2916	6.6869
250	6 25 00	15 625 000	15.8114	6.2996	300	9 00 00	27 000 000	17.3205	6.6943

SQUARES, CUBES, SQUARE ROOTS AND CUBE ROOTS

NUMBERS	SQUARES	CUBES	SQUARE ROOT	CUBE ROOT	NUMBERS	SQUARES	CUBES	SQUARE ROOT	CUBE ROOT
301	9 06 01	27 270 901	17.3494	6.7018	351	12 32 01	43 243 551	18.7350	7.0540
302	9 12 04	27 543 608	17.3781	6.7092	352	12 39 04	43 614 208	18.7617	7.0607
303	9 18 09	27 818 127	17.4069	6.7166	353	12 46 09	43 986 977	18.7883	7.0674
304	9 24 16	28 094 464	17.4356	6.7240	354	12 53 16	44 361 864	18.8149	7.0740
305	9 30 25	28 372 625	17.4642	6.7313	355	12 60 25	44 738 875	18.8414	7.0807
306	9 36 36	28 652 616	17.4929	6.7387	356	12 67 36	45 118 016	18.8680	7.0873
307	9 42 49	28 934 443	17.5214	6.7460	357	12 74 49	45 499 293	18.8944	7.0940
308	9 48 64	29 218 112	17.5499	6.7533	358	12 81 64	45 882 712	18.9209	7.1006
309	9 54 81	29 503 629	17.5784	6.7606	359	12 88 81	46 268 279	18.9473	7.1072
310	9 61 00	29 791 000	17.6068	6.7679	360	12 96 00	46 656 000	18.9737	7.1138
311	9 67 21	30 080 231	17.6352	6.7752	361	13 03 21	47 045 881	19.0000	7.1204
312	9 73 44	30 371 328	17.6635	6.7824	362	13 10 44	47 437 928	19.0263	7.1269
313	9 79 69	30 664 297	17.6918	6.7897	363	13 17 69	47 832 147	19.0526	7.1335
314	9 85 96	30 959 144	17.7200	6.7969	364	13 24 96	48 228 544	19.0788	7.1400
315	9 92 25	31 255 875	17.7482	6.8041	365	13 32 25	48 627 125	19.1050	7.1466
316	9 98 56	31 554 496	17.7764	6.8113	366	13 39 56	49 027 896	19.1311	7.1531
317	10 04 89	31 855 013	17.8045	6.8185	367	13 46 89	49 430 863	19.1572	7.1596
318	10 11 24	32 157 432	17.8326	6.8256	368	13 54 24	49 836 032	19.1833	7.1661
319	10 17 61	32 461 759	17.8606	6.8328	369	13 61 61	50 243 409	19.2094	7.1726
320	10 24 00	32 768 000	17.8885	6.8399	370	13 69 00	50 653 000	19.2354	7.1791
321	10 30 41	33 076 161	17.9165	6.8470	371	13 76 41	51 064 811	19.2614	7.1855
322	10 36 84	33 386 248	17.9444	6.8541	372	13 83 84	51 478 848	19.2873	7.1920
323	10 43 29	33 698 267	17.9722	6.8612	373	13 91 29	51 895 117	19.3132	7.1984
324	10 49 76	34 012 224	18.0000	6.8683	374	13 98 76	52 313 624	19.3391	7.2048
325	10 56 25	34 328 125	18.0278	6.8753	375	14 06 25	52 734 375	19.3649	7.2112
326	10 62 76	34 645 976	18.0555	6.8824	376	14 13 76	53 157 376	19.3907	7.2177
327	10 69 29	34 965 783	18.0831	6.8894	377	14 21 29	53 582 633	19.4165	7.2240
328	10 75 84	35 287 552	18.1108	6.8964	378	14 28 84	54 010 152	19.4422	7.2304
329	10 82 41	35 611 289	18.1384	6.9034	379	14 36 41	54 439 939	19.4679	7.2368
330	10 89 00	35 937 000	18.1659	6.9104	380	14 44 00	54 872 000	19.4936	7.2432
331	10 95 61	36 264 691	18.1934	6.9174	381	14 51 61	55 306 341	19.5192	7.2495
332	11 02 24	36 594 368	18.2209	6.9244	382	14 59 24	55 742 968	19.5448	7.2558
333	11 08 89	36 926 037	18.2483	6.9313	383	14 66 89	56 181 887	19.5704	7.2622
334	11 15 56	37 259 704	18.2757	6.9382	384	14 74 56	56 623 104	19.5959	7.2685
335	11 22 25	37 595 375	18.3030	6.9451	385	14 82 25	57 066 625	19.6214	7.2748
336	11 28 96	37 933 056	18.3303	6.9521	386	14 89 96	57 512 456	19.6469	7.2811
337	11 35 69	38 272 753	18.3576	6.9589	387	14 97 69	57 960 603	19.6723	7.2874
338	11 42 44	38 614 472	18.3848	6.9658	388	15 05 44	58 411 072	19.6977	7.2936
339	11 49 21	38 958 219	18.4120	6.9727	389	15 13 21	58 863 869	19.7231	7.2999
340	11 56 00	39 304 000	18.4391	6.9795	390	15 21 00	59 319 000	19.7484	7.3061
341	11 62 81	39 651 821	18.4662	6.9864	391	15 28 81	59 776 471	19.7737	7.3124
342	11 69 64	40 001 688	18.4932	6.9932	392	15 36 64	60 236 288	19.7990	7.3186
343	11 76 49	40 353 607	18.5203	7.0000	393	15 44 49	60 698 457	19.8242	7.3248
344	11 83 36	40 707 584	18.5472	7.0068	394	15 52 36	61 162 984	19.8494	7.3310
345	11 90 25	41 063 625	18.5742	7.0136	395	15 60 25	61 629 875	19.8746	7.3372
346	11 97 16	41 421 736	18.6011	7.0203	396	15 68 16	62 099 136	19.8997	7.3434
347	12 04 09	41 781 923	18.6279	7.0271	397	15 76 09	62 570 773	19.9249	7.3496
348	12 11 04	42 144 192	18.6548	7.0338	398	15 84 04	63 044 792	19.9499	7.3558
349	12 18 01	42 508 549	18.6815	7.0406	399	15 92 01	63 521 199	19.9750	7.3619
350	12 25 00	42 875 000	18.7083	7.0473	400	16 00 00	64 000 000	20.0000	7.3681

SQUARES, CUBES, SQUARE ROOTS AND CUBE ROOTS

NUMBERS	SQUARES	CUBES	SQUARE ROOT	CUBE ROOT	NUMBERS	SQUARES	CUBES	SQUARE ROOT	CUBE ROOT
401	16 08 01	64 481 201	20.0250	7.3742	451	20*34 01	91 733 851	21.2368	7.6688
402	16 16 04	64 964 808	20.0499	7.3803	452	20 43 04	92 345 408	21.2603	7.6744
403	16 24 09	65 450 827	20.0749	7.3864	453	20 52 09	92 959 677	21.2838	7.6801
404	16 32 16	65 939 264	20.0998	7.3925	454	20 61 16	93 576 664	21.3073	7.6857
405	16 40 25	66 430 125	20.1246	7.3986	455	20 70 25	94 196 375	21.3307	7.6914
406	16 48 36	66 923 416	20.1494	7.4047	456	20 79 36	94 818 816	21.3542	7.6970
407	16 56 49	67 419 143	20 1742	7.4108	457	20 88 49	95 443 993	21.3776	7.7026
408	16 64 64	67 917 312	20.1990	7.4169	458	20 97 64	96 071 912	21.4009	7.7082
409	16 72 81	68 417 929	20.2237	7.4229	459	21 06 81	96 702 579	21.4243	7.7138
410	16 81 00	68 921 000	20.2485	7.4290	460	21 16 00	97 336 000	21.4476	7.7194
411	16 89 21	69 426 531	20.2731	7.4350	461	21 25 21	97 972 181	21.4709	7.7250
412	16 97 44	69 934 528	20.2978	7.4410	462	21 34 44	98 611 128	21.4942	7.7306
413	17 05 69	70 444 997	20.3224	7.4470	463	21 43 69	99 252 847	21.5174	7.7362
414	17 13 96	70 957 944	20.3470	7.4530	464	21 52 96	99 897 344	21.5407	7.7418
415	17 22 25	71 473 375	20.3715	7.4590	465	21 62 25	100 544 625	21.5639	7.7473
416	17 30 56	71 991 296	20.3961	7.4650	466	21 71 56	101 194 696	21.5870	7.7529
417	17 38 89	72 511 713	20.4206	7.4710	467	21 80 89	101 847 563	21.6102	7.7584
418	17 47 24	73 034 632	20.4450	7.4770	468	21 90 24	102 503 232	21.6333	7.7639
419	17 55 61	73 560 059	20.4695	7.4829	469	21 99 61	103 161 709	21.6564	7.7695
420	17 64 00	74 088 000	20.4939	7.4889	470	22 09 00	103 823 000	21.6795	7.7750
421	17 72 41	74 618 461	20.5183	7.4948	471	22 18 41	104 487 111	21.7025	7.7805
422	17 80 84	75 151 448	20.5426	7.5007	472	22 27 84	105 154 048	21 7256	7.7860
423	17 89 29	75 686 967	20.5670	7.5067	473	22 37 29	105 823 817	21.7486	7.7915
424	17 97 76	76 225 024	20.5913	7.5126	474	22 46 76	106 496 424	21.7715	7.7970
425	18 06 25	76 765 625	20.6155	7.5185	475	22 56 25	107 171 875	21.7945	7.8025
426	18 14 76	77 308 776	20.6398	7.5244	476	22 65 76	107 850 176	21.8174	7.8079
427	18 23 29	77 854 483	20.6640	7.5302	477	22 75 29	108 531 333	21.8403	7.8134
428	18 31 84	78 402 752	20.6882	7.5361	478	22 84 84	109 215 352	21.8632	7.8188
429	18 40 41	78 953 589	20.7123	7.5420	479	22 94 41	109 902 239	21.8861	7.8243
430	18 49 00	79 507 000	20.7364	7.5478	480	23 04 00	110 592 000	21.9089	7.8297
431	18 57 61	80 062 991	20.7605	7.5537	481	23 13 61	111 284 641	21.9317	7.8352
432	18 66 24	80 621 568	20.7846	7.5595	482	23 23 24	111 980 168	21.9545	7.8406
433	18 74 89	81 182 737	20.8087	7.5654	483	23 32 89	112 678 587	21.9773	7.8460
434	18 83 56	81 746 504	20.8327	7.5712	484	23 42 56	113 379 904	22.0000	7.8514
435	18 92 25	82 312 875	20.8567	7.5770	485	23 52 25	114 084 125	22.0227	7.8568
436	19 00 96	82 881 856	20.8806	7.5828	486	23 61 96	114 791 256	22.0454	7.8622
437	19 09 69	83 453 453	20.9045	7.5886	487	23 71 69	115 501 303	22.0681	7.8676
438	19 18 44	84 027 672	20.9284	7.5944	488	23 81 44	116 214 272	22.0907	7.8730
439	19 27 21	84 604 519	20.9523	7.6001	489	23 91 21	116 930 169	22.1133	7.8784
440	19 36 00	85 184 000	20.9762	7.6059	490	24 01 00	117 649 000	22.1359	7.8837
441	19 44 81	85 766 121	21.0000	7.6117	491	24 10 81	118 370 771	22.1585	7.8891
442	19 53 64	86 350 888	21.0238	7.6174	492	24 20 64	119 095 488	22.1811	7.8944
443	19 62 49	86 938 307	21.0476	7.6232	493	24 30 49	119 823 157	22.2036	7.8998
444	19 71 36	87 528 384	21.0713	7.6289	494	24 40 36	120 553 784	22.2261	7.9051
445	19 80 25	88 121 125	21.0950	7.6346	495	24 50 25	121 287 375	22.2486	7.9105
446	19 89 16	88 716 536	21.1187	7.6403	496	24 60 16	122 023 936	22.2711	7.9158
447	19 98 09	89 314 623	21.1424	7.6460	497	24 70 09	122 763 473	22.2935	7.9211
448	20 07 04	89 915 392	21.1660	7.6517	498	24 80 04	123 505 992	22.3159	7.9264
449	20 16 01	90 518 849	21.1896	7.6574	499	24 90 01	124 251 499	22.3383	7.9317
450	20 25 00	91 125 000	21.2132	7.6631	500	25 00 00	125 000 000	22.3607	7.9370

SQUARES, CUBES, SQUARE ROOTS AND CUBE ROOTS

NUMBERS	SQUARES	CUBES	SQUARE ROOT	CUBE ROOT	NUMBERS	SQUARES	CUBES	SQUARE ROOT	CUBE ROOT
501	25 10 01	125 751 501	22.3830	7.9423	551	30 36 01	167 284 151	23.4734	8.1982
502	25 20 01	426 506 008	22.4054	7.9476	552	30 47 04	168 196 608	23.4947	8.2031
503	25 30 09	127 263 527	22.4277	7.9528	553	30 58 09	169 112 377	23.5160	8.2081
504	25 40 16	128 024 064	22.4499	7.9581	554	30 69 16	170 031 464	23.5372	8.2130
505	25 50 25	128 787 625	22.4722	7.9634	555	30 80 25	170 953 875	23.5584	8.2180
506	25 60 36	129 554 216	22.4944	7.9686	556	30 91 36	171 879 616	23.5797	8.2229
507	25 70 49	130 323 843	22.5167	7.9739	557	31 02 49	172 808 693	23.6008	8.2278
508	25 80 64	131 096 512	22.5389	7.9791	558	31 13 64	173 741 112	23.6220	8.2327
509	25 90 81	131 872 229	22.5610	7.9843	559	31 24 81	174 676 879	23.6432	8.2377
510	26 01 00	132 651 000	22.5832	7.9896	560	31 36 00	175 616 000	23.6643	8.2426
511	26 11 21	133 432 831	22.6053	7.9948	561	31 47 21	176 558 481	23.6854	8.2475
512	26 21 44	134 217 728	22.6274	8.0000	562	31 58 44	177 504 328	23.7065	8.2524
513	26 31 69	135 005 697	22.6495	8.0052	563	31 69 69	178 453 547	23.7276	8.2573
514	26 41 96	135 796 744	22.6716	8.0104	564	31 80 96	179 406 144	23.7487	8.2621
515	26 52 25	136 590 875	22.6936	8.0156	565	31 92 25	180 362 125	23.7697	8.2670
516	26 62 56	137 388 096	22.7156	8.0208	566	32 03 56	181 321 496	23.7908	8.2719
517	26 72 89	138 188 413	22.7376	8.0260	567	32 14 89	182 284 263	23.8118	8.2768
518	26 83 24	138 991 832	22.7596	8.0311	568	32 26 24	183 250 432	23.8328	8.2816
519	26 93 61	139 798 359	22.7816	8.0363	569	32 37 61	184 220 009	23.8537	8.2865
520	27 04 00	140 608 000	22.8035	8.0415	570	32 49 00	185 193 000	23.8747	8.2913
521	27 14 41	141 420 761	22.8254	8.0466	571	32 60 41	186 169 411	23.8956	8.2962
522	27 24 84	142 236 648	22.8473	8.0517	572	32 71 84	187 149 248	23.9165	8.3010
523	27 35 29	143 055 667	22.8692	8.0569	573	32 83 29	188 132 517	23.9374	8.3059
524	27 45 76	143 877 824	22.8910	8.0620	574	32 94 76	189 119 224	23.9583	8.3107
525	27 56 25	144 703 125	22.9129	8.0671	575	33 06 25	190 109 375	23.9792	8.3155
526	27 66 76	145 531 576	22.9347	8.0723	576	33 17 76	191 102 976	24.0000	8.3203
527	27 77 29	146 363 183	22.9565	8.0774	577	33 29 29	192 100 033	24.0208	8.3251
528	27 87 84	147 197 952	22.9783	8.0825	578	33 40 84	193 100 552	24.0416	8.3300
529	27 98 41	148 035 889	23.0000	8.0876	579	33 52 41	194 104 539	24.0624	8.3348
530	28 09 00	148 877 000	23.0217	8.0927	580	33 64 00	195 112 000	24.0832	8.3396
531	28 19 61	149 721 291	23.0434	8.0978	581	33 75 61	196 122 941	24.1039	8.3443
532	28 30 24	150 568 768	23.0651	8.1028	582	33 87 24	197 137 368	24.1247	8.3491
533	28 40 89	151 419 437	23.0868	8.1079	583	33 98 89	198 155 287	24.1454	8.3539
534	28 51 56	152 273 304	23.1084	8.1130	584	34 10 56	199 176 704	24.1661	8.3587
535	28 62 25	153 130 375	23.1301	8.1180	585	34 22 25	200 201 625	24.1868	8.3634
536	28 72 96	153 990 656	23.1517	8.1231	586	34 33 96	201 230 056	24.2074	8.3682
537	28 83 69	154 854 153	23.1733	8.1281	587	34 45 69	202 262 003	24.2281	8.3730
538	28 94 44	155 720 872	23.1948	8.1332	588	34 57 44	203 297 472	24.2487	8.3777
539	29 05 21	156 590 819	23.2164	8.1382	589	34 69 21	204 336 469	24.2693	8.3825
540	29 16 00	157 464 000	23.2379	8.1433	590	34 81 00	205 379 000	24.2899	8.3872
541	29 26 81	158 340 421	23.2594	8.1483	591	34 92 81	206 425 071	24.3105	8.3919
542	29 37 64	159 220 088	23.2809	8.1533	592	35 04 64	207 474 688	24.3311	8.3967
543	29 48 49	160 103 007	23.3024	8.1583	593	35 16 49	208 527 857	24.3516	8.4014
544	29 59 36	160 989 184	23.3238	8.1633	594	35 28 36	209 584 584	24.3721	8.4061
545	29 70 25	161 878 625	23.3452	8.1683	595	35 40 25	210 644 875	24.3926	8.4108
546	29 81 16	162 771 336	23.3666	8.1733	596	35 52 16	211 708 736	24.4131	8.4155
547	29 92 09	163 667 323	23.3880	8.1783	597	35 64 09	212 776 173	24.4336	8.4202
548	30 03 04	164 566 592	23.4094	8.1833	598	35 76 04	213 847 192	24.4540	8.4249
549	30 14 01	165 469 149	23.4307	8.1882	599	35 88 01	214 921 799	24.4745	8.4296
550	30 25 00	166 375 000	23.4521	8.1932	600	36 00 00	216 000 000	24.4949	8.4343

SQUARES, CUBES, SQUARE ROOTS AND CUBE ROOTS

NUMBERS	SQUARES	CUBES	SQUARE ROOT	CUBE ROOT	NUMBERS	SQUARES	CUBES	SQUARE ROOT	CUBE ROOT
601	36 12 01 217 081 801	24.5153	8.4390	651	42 38 01 275 894 451	25.5147	8.6668		
602	36 24 04 218 167 208	24.5357	8.4437	652	42 51 04 277 167 808	25.5343	8.6713		
603	36 36 09 219 256 227	24.5561	8.4484	653	42 64 09 278 445 077	25.5539	8.6757		
604	36 48 16 220 348 864	24.5764	8.4530	654	42 77 16 279 726 264	25.5734	8.6801		
605	36 60 25 221 445 125	24.5967	8.4577	655	42 90 25 281 011 375	25.5930	8.6845		
606	36 72 36 222 545 016	24.6171	8.4623	656	43 03 36 282 300 416	25.6125	8.6890		
607	36 84 49 223 648 543	24.6374	8.4670	657	43 16 49 283 593 393	25.6320	8.6934		
608	36 96 64 224 755 712	24.6577	8.4716	658	43 29 64 284 890 312	25.6515	8.6978		
609	37 08 81 225 866 529	24.6779	8.4763	659	43 42 81 286 191 179	25.6710	8.7022		
610	37 21 00 226 981 000	24.6982	8.4809	660	43 56 00 287 496 000	25.6905	8.7066		
611	37 33 21 228 099 131	24.7184	8.4856	661	43 69 21 288 804 781	25.7099	8.7110		
612	37 45 44 229 220 928	24.7386	8.4902	662	43 82 44 290 117 528	25.7294	8.7154		
613	37 57 69 230 346 397	24.7588	8.4948	663	43 95 69 291 434 247	25.7488	8.7198		
614	37 69 96 231 475 544	24.7790	8.4994	664	44 08 96 292 754 944	25.7682	8.7241		
615	37 82 25 232 608 375	24.7992	8.5040	665	44 22 25 294 079 625	25.7876	8.7285		
616	37 94 56 233 744 896	24.8193	8.5086	666	44 35 56 295 408 296	25.8070	8.7329		
617	38 06 89 234 885 113	24.8395	8.5132	667	44 48 89 296 740 963	25.8263	8.7373		
618	38 19 24 236 029 032	24.8596	8.5178	668	44 62 24 298 077 632	25.8457	8.7416		
619	38 31 61 237 176 659	24.8797	8.5224	669	44 75 61 299 418 309	25.8650	8.7460		
620	38 44 00 238 328 000	24.8998	8.5270	670	44 89 00 300 763 000	25.8844	8.7503		
621	38 56 41 239 483 061	24.9199	8.5316	671	45 02 41 302 111 711	25.9037	8.7547		
622	38 68 84 240 641 848	24.9399	8.5362	672	45 15 84 303 464 448	25.9230	8.7590		
623	38 81 29 241 804 367	24.9600	8.5408	673	45 29 29 304 821 217	25.9422	8.7634		
624	38 93 76 242 970 624	24.9800	8.5453	674	45 42 76 306 182 024	25.9615	8.7677		
625	39 06 25 244 140 625	25.0000	8.5499	675	45 56 25 307 546 875	25.9808	8.7721		
626	39 18 76 245 314 376	25.0200	8.5544	676	45 69 76 308 915 776	26.0000	8.7764		
627	39 31 29 246 491 883	25.0400	8.5590	677	45 83 29 310 288 733	26.0192	8.7807		
628	39 43 84 247 673 152	25.0599	8.5635	678	45 96 84 311 665 752	26.0384	8.7850		
629	39 56 41 248 858 189	25.0799	8.5681	679	46 10 41 313 046 839	26.0576	8.7893		
630	39 69 00 250 047 000	25.0998	8.5726	680	46 24 00 314 432 000	26.0768	8.7937		
631	39 81 61 251 239 591	25.1197	8.5772	681	46 37 61 315 821 241	26.0960	8.7980		
632	39 94 24 252 435 968	25.1396	8.5817	682	46 51 24 317 214 568	26.1151	8.8023		
633	40 06 89 253 636 137	25.1595	8.5862	683	46 64 89 318 611 987	26.1343	8.8066		
634	40 19 56 254 840 104	25.1794	8.5907	684	46 78 56 320 013 504	26.1534	8.8109		
635	40 32 25 256 047 875	25.1992	8.5952	685	46 92 25 321 419 125	26.1725	8.8152		
636	40 44 96 257 259 456	25.2190	8.5997	686	47 05 96 322 828 856	26.1916	8.8194		
637	40 57 69 258 474 853	25.2389	8.6043	687	47 19 69 324 242 703	26.2107	8.8237		
638	40 70 44 259 694 072	25.2587	8.6088	688	47 33 44 325 660 672	26.2298	8.8280		
639	40 83 21 260 917 119	25.2784	8.6132	689	47 47 21 327 082 769	26.2488	8.8323		
640	40 96 00 262 144 000	25.2982	8.6177	690	47 61 00 328 509 000	26.2679	8.8366		
641	41 08 81 263 374 721	25.3180	8.6222	691	47 74 81 329 939 371	26.2869	8.8408		
642	41 21 64 264 609 288	25.3377	8.6267	692	47 88 64 331 373 888	26.3059	8.8451		
643	41 34 49 265 847 707	25.3574	8.6312	693	48 02 49 332 812 557	26.3249	8.8493		
644	41 47 36 267 089 984	25.3772	8.6357	694	48 16 36 334 255 384	26.3439	8.8536		
645	41 60 25 268 336 125	25.3969	8.6401	695	48 30 25 335 702 375	26.3629	8.8578		
646	41 73 16 269 586 136	25.4165	8.6446	696	48 44 16 337 153 536	26.3818	8.8621		
647	41 86 09 270 840 023	25.4362	8.6490	697	48 58 09 338 608 873	26.4008	8.8663		
648	41 99 04 272 097 792	25.4558	8.6535	698	48 72 04 340 068 392	26.4197	8.8706		
649	42 12 01 273 359 449	25.4755	8.6579	699	48 86 01 341 532 099	26.4386	8.8748		
650	42 25 00 274 625 000	25.4951	8.6624	700	49 00 00 343 000 000	26.4575	8.8790		

SQUARES, CUBES, SQUARE ROOTS AND CUBE ROOTS

NUMBERS	SQUARES	CUBES	SQUARE ROOT	CUBE ROOT	NUMBERS	SQUARES	CUBES	SQUARE ROOT	CUBE ROOT
701	49 14 01 344	472	101 26.4764	8.8833	751	56 40 01 423	564	751 27.4044	9.0896
702	49 23 04 345	948	408 26.4953	8.8875	752	56 55 04 425	259 008	27.4226	9.0937
703	49 42 09 347	428	927 26.5141	8.8917	753	56 70 09 426	957 777	27.4408	9.0977
704	49 56 16 348	913	664 26.5330	8.8959	754	56 85 16 428	661 064	27.4591	9.1017
705	49 70 25 350	402	525 26.5518	8.9001	755	57 00 25 430	368 875	27.4773	9.1057
706	49 84 36 351	895	816 26.5707	8.9043	756	57 15 36 432	081 216	27.4955	9.1098
707	49 98 49 353	393	243 26.5895	8.9085	757	57 30 49 433	798 093	27.5136	9.1138
708	50 12 64 354	894	912 26.6083	8.9127	758	57 45 64 435	519 512	27.5318	9.1178
709	50 26 81 356	400	829 26.6271	8.9169	759	57 60 81 437	245 479	27.5500	9.1218
710	50 41 00 357	911	000 26.6458	8.9211	760	57 76 00 438	976 000	27.5681	9.1258
711	50 55 21 359	425	431 26.6646	8.9253	761	57 91 21 440	711 081	27.5862	9.1298
712	50 69 44 360	944	128 26.6833	8.9295	762	58 06 44 442	450 728	27.6043	9.1338
713	50 83 69 362	467	097 26.7021	8.9337	763	58 21 69 444	194 947	27.6225	9.1378
714	50 97 96 363	994	344 26.7208	8.9378	764	58 36 96 445	943 744	27.6405	9.1418
715	51 12 25 365	525	875 26.7395	8.9420	765	58 52 25 447	697 125	27.6586	9.1458
716	51 26 56 367	061	696 26.7582	8.9462	766	58 67 56 449	455 096	27.6767	9.1498
717	51 40 89 368	601	813 26.7769	8.9503	767	58 82 89 451	217 663	27.6948	9.1537
718	51 55 24 370	146	232 26.7955	8.9545	768	58 98 24 452	984 832	27.7128	9.1577
719	51 69 61 371	694	959 26.8142	8.9587	769	59 13 61 454	756 609	27.7308	9.1617
720	51 84 00 373	248	000 26.8328	8.9628	770	59 29 00 456	533 000	27.7489	9.1657
721	51 98 41 374	805	361 26.8514	8.9670	771	59 44 41 458	314 011	27.7669	9.1696
722	52 12 84 376	367	048 26.8701	8.9711	772	59 59 84 460	099 648	27.7849	9.1736
723	52 27 29 377	933	067 26.8887	8.9752	773	59 75 29 461	889 917	27.8029	9.1775
724	52 41 76 379	503	424 26.9072	8.9794	774	59 90 76 463	684 824	27.8209	9.1815
725	52 56 25 381	078	125 26.9258	8.9835	775	60 06 25 465	484 375	27.8388	9.1855
726	52 70 76 382	657	176 26.9444	8.9876	776	60 21 76 467	288 576	27.8568	9.1894
727	52 85 29 384	240	583 26.9629	8.9918	777	60 37 29 469	097 433	27.8747	9.1933
728	52 99 84 385	828	352 26.9815	8.9959	778	60 52 84 470	910 952	27.8927	9.1973
729	53 14 41 387	420	489 27.0000	9.0000	779	60 68 41 472	729 139	27.9106	9.2012
730	53 29 00 389	017	000 27.0185	9.0041	780	60 84 00 474	552 000	27.9285	9.2052
731	53 43 61 390	617	891 27.0370	9.0082	781	60 99 61 476	379 541	27.9464	9.2091
732	53 58 24 392	223	168 27.0555	9.0123	782	61 15 24 478	211 768	27.9643	9.2130
733	53 72 89 393	832	837 27.0740	9.0164	783	61 30 89 480	048 687	27.9821	9.2170
734	53 87 56 395	446	904 27.0924	9.0205	784	61 46 56 481	890 304	28.0000	9.2209
735	54 02 25 397	065	375 27.1109	9.0246	785	61 62 25 483	736 625	28.0179	9.2248
736	54 16 96 398	688	256 27.1293	9.0287	786	61 77 96 485	587 656	28.0357	9.2287
737	54 31 69 400	315	553 27.1477	9.0328	787	61 93 69 487	443 403	28.0535	9.2326
738	54 46 44 401	947	272 27.1662	9.0369	788	62 09 44 489	303 872	28.0713	9.2365
739	54 61 21 403	583	419 27.1846	9.0410	789	62 25 21 491	169 069	28.0891	9.2404
740	54 76 00 405	224	000 27.2029	9.0450	790	62 41 00 493	039 000	28.1069	9.2443
741	54 90 81 406	869	021 27.2213	9.0491	791	62 56 81 494	913 671	28.1247	9.2482
742	55 05 64 408	518	488 27.2397	9.0532	792	62 72 64 496	793 088	28.1425	9.2521
743	55 20 49 410	172	407 27.2580	9.0572	793	62 88 49 498	677 257	28.1603	9.2560
744	55 35 36 411	830	784 27.2764	9.0613	794	63 04 36 500	566 184	28.1780	9.2599
745	55 50 25 413	493	625 27.2947	9.0654	795	63 20 25 502	459 875	28.1957	9.2638
746	55 65 16 415	160	936 27.3130	9.0694	796	63 36 16 504	358 336	28.2135	9.2677
747	55 80 09 416	832	723 27.3313	9.0735	797	63 52 09 506	261 573	28.2312	9.2716
748	55 95 04 418	508	992 27.3496	9.0775	798	63 68 04 508	169 592	28.2489	9.2754
749	56 10 01 420	189	749 27.3679	9.0816	799	63 84 01 510	082 399	28.2666	9.2793
750	56 25 00 421	875	000 27.3861	9.0856	800	64 00 00 512	000 000	28.2843	9.2832

SQUARES, CUBES, SQUARE ROOTS AND CUBE ROOTS

NUMBERS	SQUARES	CUBES	SQUARE ROOT	CUBE ROOT	NUMBERS	SQUARES	CUBES	SQUARE ROOT	CUBE ROOT
801	64 16 01	513 922 401	28.3019	9.2870	851	72 42 01	616 295 051	29.1719	9.4764
802	64 32 04	515 849 608	28.3196	9.2909	852	72 59 04	618 470 208	29.1890	9.4801
803	64 48 09	517 781 627	28.3373	9.2948	853	72 76 09	620 650 477	29.2062	9.4838
804	64 64 16	519 718 464	28.3549	9.2986	854	72 93 16	622 835 864	29.2233	9.4875
805	64 80 25	521 660 125	28.3725	9.3025	855	73 10 25	625 026 375	29.2404	9.4912
806	64 96 36	523 606 616	28.3901	9.3063	856	73 27 36	627 222 016	29.2575	9.4949
807	65 12 49	525 557 943	28.4077	9.3102	857	73 44 49	629 422 793	29.2746	9.4986
808	65 28 64	527 514 112	28.4253	9.3140	858	73 61 64	631 628 712	29.2916	9.5023
809	65 44 81	529 475 129	28.4429	9.3179	859	73 78 81	633 833 779	29.3087	9.5060
810	65 61 00	531 441 000	28.4605	9.3217	860	73 96 00	636 056 000	29.3258	9.5097
811	65 77 21	533 411 731	28.4781	9.3255	861	74 13 21	638 277 381	29.3428	9.5134
812	65 93 44	535 387 328	28.4956	9.3294	862	74 30 44	640 503 928	29.3598	9.5171
813	66 09 69	537 367 797	28.5132	9.3332	863	74 47 69	642 735 647	29.3769	9.5207
814	66 25 96	539 353 144	28.5307	9.3370	864	74 64 96	644 972 544	29.3939	9.5244
815	66 42 25	541 343 375	28.5482	9.3408	865	74 82 25	647 214 625	29.4109	9.5281
816	66 58 56	543 338 496	28.5657	9.3447	866	74 99 56	649 461 896	29.4279	9.5317
817	66 74 89	545 333 513	28.5832	9.3485	867	75 16 89	651 714 363	29.4449	9.5354
818	66 91 24	547 343 432	28.6007	9.3523	868	75 34 24	653 972 032	29.4618	9.5391
819	67 07 61	549 353 259	28.6182	9.3561	869	75 51 61	656 234 900	29.4788	9.5427
820	67 24 00	551 368 000	28.6356	9.3599	870	75 69 00	658 503 000	29.4958	9.5464
821	67 40 41	553 387 661	28.6531	9.3637	871	75 86 41	660 776 311	29.5127	9.5501
822	67 56 84	555 412 248	28.6705	9.3675	872	76 03 84	663 054 848	29.5296	9.5537
823	67 73 29	557 441 767	28.6880	9.3713	873	76 21 29	665 338 617	29.5466	9.5574
824	67 89 76	559 476 224	28.7054	9.3751	874	76 38 76	667 627 624	29.5635	9.5610
825	68 06 25	561 515 625	28.7228	9.3789	875	76 56 25	669 921 875	29.5804	9.5647
826	68 22 76	563 559 976	28.7402	9.3827	876	76 73 76	672 221 376	29.5973	9.5683
827	68 39 29	565 609 283	28.7576	9.3865	877	76 91 29	674 526 133	29.6142	9.5719
828	68 55 84	567 663 552	28.7750	9.3902	878	77 08 84	676 836 152	29.6311	9.5756
829	68 72 41	569 722 789	28.7924	9.3940	879	77 26 41	679 151 439	29.6479	9.5792
830	68 89 00	571 787 000	28.8097	9.3978	880	77 44 00	681 472 000	29.6648	9.5828
831	69 05 61	573 856 191	28.8271	9.4016	881	77 61 61	683 797 841	29.6816	9.5865
832	69 22 24	575 930 368	28.8444	9.4053	882	77 79 24	686 128 968	29.6985	9.5901
833	69 38 89	578 003 537	28.8617	9.4091	883	77 96 89	688 465 387	29.7153	9.5937
834	69 55 56	580 093 704	28.8791	9.4129	884	78 14 56	690 807 104	29.7321	9.5973
835	69 72 25	582 182 875	28.8964	9.4166	885	78 32 25	693 154 125	29.7489	9.6010
836	69 88 96	584 277 056	28.9137	9.4204	886	78 49 96	695 506 456	29.7658	9.6046
837	70 05 69	586 376 253	28.9310	9.4241	887	78 67 69	697 864 103	29.7825	9.6082
838	70 22 44	588 480 472	28.9482	9.4279	888	78 85 44	700 227 072	29.7993	9.6118
839	70 39 21	590 589 719	28.9655	9.4316	889	79 03 21	702 595 369	29.8161	9.6154
840	70 56 00	592 704 000	28.9828	9.4354	890	79 21 00	704 969 000	29.8329	9.6190
841	70 72 81	594 823 321	29.0000	9.4391	891	79 38 81	707 347 971	29.8496	9.6226
842	70 89 64	596 947 688	29.0172	9.4429	892	79 56 64	709 732 288	29.8664	9.6262
843	71 06 49	599 077 107	29.0345	9.4466	893	79 74 49	712 121 957	29.8831	9.6298
844	71 23 36	601 211 584	29.0517	9.4503	894	79 92 36	714 516 984	29.8998	9.6334
845	71 40 25	603 351 125	29.0689	9.4541	895	80 10 25	716 917 375	29.9166	9.6370
846	71 57 16	605 495 733	29.0861	9.4578	896	80 28 16	719 323 136	29.9333	9.6406
847	71 74 09	607 645 423	29.1033	9.4615	897	80 46 09	721 734 273	29.9500	9.6442
848	71 91 04	609 800 192	29.1204	9.4652	898	80 64 04	724 150 792	29.9666	9.6477
849	72 08 01	611 960 049	29.1376	9.4690	899	80 82 01	726 572 699	29.9833	9.6513
850	72 25 00	614 125 000	29.1548	9.4727	900	81 00 00	729 000 000	30.0000	9.6549

SQUARES, CUBES, SQUARE ROOTS AND CUBE ROOTS

NUMBERS	SQUARES	CUBES	SQUARE ROOT	CUBE ROOT	NUMBERS	SQUARES	CUBES	SQUARE ROOT	CUBE ROOT
901	81 18 01	731 432 701	30.0167	9.6585	951	90 44 01	860 085 351	30.8383	9.8339
902	81 36 04	733 870 808	30.0333	9.6620	952	90 63 04	862 801 408	30.8545	9.8374
903	81 54 09	736 314 327	30.0500	9.6656	953	90 82 09	865 523 177	30.8707	9.8408
904	81 72 16	738 763 264	30.0666	9.6692	954	91 01 16	868 250 664	30.8869	9.8443
905	81 90 25	741 217 625	30.0832	9.6727	955	91 20 25	870 983 875	30.9031	9.8477
906	82 08 36	743 677 416	30.0998	9.6763	956	91 39 36	873 722 816	30.9192	9.8511
907	82 26 49	746 142 643	30.1164	9.6799	957	91 58 49	876 467 493	30.9354	9.8546
908	82 44 64	748 613 312	30.1330	9.6834	958	91 77 64	879 217 912	30.9516	9.8580
909	82 62 81	751 089 429	30.1496	9.6870	959	91 96 81	881 974 079	30.9677	9.8614
910	82 81 00	753 571 000	30.1662	9.6905	960	92 16 00	884 736 000	30.9839	9.8648
911	82 99 21	756 058 031	30.1828	9.6941	961	92 35 21	887 503 681	31.0000	9.8683
912	83 17 44	758 550 528	30.1993	9.6976	962	92 54 44	890 277 128	31.0161	9.8717
913	83 35 69	761 048 497	30.2159	9.7012	963	92 73 69	893 056 347	31.0322	9.8751
914	83 53 96	763 551 944	30.2324	9.7047	964	92 92 96	895 841 344	31.0483	9.8785
915	83 72 25	766 060 875	30.2490	9.7082	965	93 12 25	898 632 125	31.0644	9.8819
916	83 90 56	768 575 296	30.2655	9.7118	966	93 31 56	901 428 696	31.0805	9.8854
917	84 08 89	771 095 213	30.2820	9.7153	967	93 50 89	904 231 063	31.0966	9.8888
918	84 27 24	773 620 632	30.2985	9.7188	968	93 70 24	907 039 232	31.1127	9.8922
919	84 45 61	776 151 559	30.3150	9.7224	969	93 89 61	909 853 209	31.1288	8.8956
920	84 64 00	778 688 000	30.3315	9.7259	970	94 09 00	912 673 000	31.1448	9.8990
921	84 82 41	781 229 961	30.3480	9.7294	971	94 28 41	915 498 611	31.1609	9.9024
922	85 00 84	783 777 448	30.3645	9.7329	972	94 47 84	918 330 048	31.1769	9.9058
923	85 19 29	786 330 467	30.3809	9.7364	973	94 67 29	921 167 317	31.1929	9.9092
924	85 37 76	788 889 024	30.3974	9.7400	974	94 86 76	924 010 424	31.2090	9.9126
925	85 56 25	791 453 125	30.4138	9.7435	975	95 06 25	926 859 375	31.2250	9.9160
926	85 74 76	794 022 776	30.4302	9.7470	976	95 25 76	929 714 176	31.2410	9.9194
927	85 93 29	796 597 983	30.4467	9.7505	977	95 45 29	932 574 833	31.2570	9.9227
928	86 11 84	799 178 752	30.4631	9.7540	978	95 64 84	935 441 352	31.2730	9.9261
929	86 30 41	801 765 089	30.4795	9.7575	979	95 84 41	938 313 739	31.2890	9.9295
930	86 49 00	804 357 000	30.4959	9.7610	980	96 04 00	941 192 000	31.3050	9.9329
931	86 67 61	806 954 491	30.5123	9.7645	981	96 23 61	944 076 141	31.3209	9.9363
932	86 86 24	809 557 568	30.5287	9.7680	982	96 43 24	946 966 168	31.3369	9.9396
933	87 04 89	812 166 237	30.5450	9.7715	983	96 62 89	949 862 087	31.3528	9.9430
934	87 23 56	814 780 504	30.5614	9.7750	984	96 82 56	952 763 904	31.3688	9.9464
935	87 42 25	817 400 375	30.5778	9.7785	985	97 02 25	955 671 625	31.3847	9.9497
936	87 60 96	820 025 856	30.5941	9.7819	986	97 21 96	958 585 256	31.4006	9.9531
937	87 79 69	822 656 953	30.6105	9.7854	987	97 41 69	961 504 803	31.4166	9.9565
938	87 98 44	825 293 672	30.6268	9.7889	988	97 61 44	964 430 272	31.4325	9.9598
939	88 17 21	827 936 019	30.6431	9.7924	989	97 81 21	967 361 669	31.4484	9.9632
940	88 36 00	830 584 000	30.6594	9.7959	990	98 01 00	970 299 000	31.4643	9.9666
941	88 54 81	833 237 621	30.6757	9.7993	991	98 20 81	973 242 271	31.4802	9.9699
942	88 73 64	835 896 888	30.6920	9.8028	992	98 40 64	976 191 488	31.4960	9.9733
943	88 92 49	838 561 807	30.7083	9.8063	993	98 60 49	979 146 657	31.5119	9.9766
944	89 11 36	841 232 384	30.7246	9.8097	994	98 80 36	982 107 784	31.5278	9.9800
945	89 30 25	843 908 625	30.7409	9.8132	995	99 00 25	985 074 875	31.5436	9.9833
946	89 49 16	846 590 536	30.7571	9.8167	996	99 20 16	988 047 936	31.5595	9.9866
947	89 68 09	849 278 123	30.7734	9.8201	997	99 40 09	991 026 973	31.5753	9.9900
948	89 87 04	851 971 392	30.7896	9.8236	998	99 60 04	994 011 992	31.5911	9.9933
949	90 06 01	854 670 349	30.8058	9.8270	999	99 80 01	997 002 999	31.6070	9.9967
950	90 25 00	857 375 000	30.8221	9.8305	1000	100 00 00	1000 000 000	31.6228	10.0000

PATENT COLD ROLLED STEEL SHAFTING,
Piston Rods, Etc.

ROUND						SQUARE	
Diameter Inches	Weight Per Foot	Diameter Inches	Weight Per Foot	Diameter Inches	Weight Per Foot	Side Inches	Weight Per Foot
6	96.22	2 ³ / ₈	15.07	1 ¹ / ₁₆	2.35	4	54.45
5 ¹ / ₈	94.23	2 ¹ / ₈	14.29	1 ¹ / ₈	2.27	3 ³ / ₄	47.84
5 ¹ / ₂	80.85	2 ¹ / ₄	13.52	1 ¹ / ₄	2.19	3 ¹ / ₂	41.68
5 ⁷ / ₈	79.01	2 ³ / ₈	12.79	1 ³ / ₈	2.05	3 ¹ / ₄	35.94
5	66.82	2 ¹ / ₈	12.06	2 ⁷ / ₈	1.90	3	30.62
4 ¹ / ₈	65.15	2 ¹ / ₈	11.36	1 ⁵ / ₈	1.83	2 ³ / ₄	25.73
4 ³ / ₄	60.30	2	10.69	1 ³ / ₈	1.76	2 ¹ / ₂	21.26
4 ¹ / ₂	54.83	1 ⁵ / ₈	10.03	1 ¹ / ₈	1.70	2 ¹ / ₄	17.22
4 ⁷ / ₈	52.62	1 ⁷ / ₈	9.39	2 ⁵ / ₈	1.63	2	13.61
4 ¹ / ₄	48.28	1 ³ / ₄	9.09	1 ³ / ₄	1.50	1 ³ / ₄	10.42
4 ³ / ₈	46.87	1 ¹ / ₂	8.78	1 ¹ / ₂	1.44	1 ⁵ / ₈	8.98
4	42.77	1 ³ / ₄	8.18	1 ¹ / ₂	1.38	1 ¹ / ₂	7.66
3 ¹ / ₈	41.43	1 ¹ / ₈	7.61	1 ¹ / ₈	1.26	1 ³ / ₈	6.43
3 ⁷ / ₈	40.13	1 ⁵ / ₈	7.06	1 ¹ / ₄	1.21	1 ¹ / ₄	5.32
3 ³ / ₄	37.57	1 ¹ / ₈	6.52	1 ¹ / ₄	1.15	1 ¹ / ₈	4.31
3 ¹ / ₂	36.33	1 ¹ / ₂	6.01	1 ¹ / ₄	1.10	1 ¹ / ₈	3.84
3 ⁵ / ₈	35.12	1 ¹ / ₂	5.77	5/8	1.04	1	3.40
3 ⁹ / ₈	33.91	1 ⁹ / ₈	5.52	19/32	.94	15/16	2.99
3 ¹ / ₂	32.74	1 ¹ / ₂	5.29	9/16	.85	7/8	2.61
3 ⁷ / ₈	31.57	1 ³ / ₈	5.05	13/32	.74	13/16	2.25
3 ³ / ₈	30.43	1 ⁵ / ₈	4.60	1/2	.67	3/4	1.91
3 ¹ / ₄	28.23	1 ⁹ / ₈	4.38	15/32	.59	11/16	1.61
3 ³ / ₈	27.15	1 ¹ / ₄	4.18	7/16	.51	5/8	1.33
3 ¹ / ₈	26.10	1 ⁷ / ₃₂	3.97	13/32	.44	9/16	1.08
3	24.05	1 ² / ₁₀	3.85	3/8	.38	1/2	.85
2 ¹ / ₈	23.06	1 ³ / ₁₆	3.77	11/32	.32	7/16	.65
2 ⁷ / ₈	22.09	1 ⁵ / ₃₂	3.57	1/8	.26	3/8	.48
2 ¹ / ₂	21.14	1 ¹ / ₈	3.38	1/4	.17	1/2	.40
2 ³ / ₄	20.21	1 ³ / ₂	3.20	7/32	.13	5/16	.33
2 ¹ / ₄	19.30	1 ⁵ / ₆₄	3.11	3/16	.09	9/32	.27
2 ⁵ / ₈	18.41	1 ¹ / ₁₆	3.02			1/4	.21
2 ⁹ / ₁₆	17.55	1 ¹ / ₃₂	2.84			7/32	.16
2 ¹ / ₂	16.70	1	2.67				
2 ⁷ / ₁₆	15.87	3/4	2.51				

Made to Whitworth's Standard Gauge, and accurately straightened.
The shafts are kept on hand at the mill, in lengths of 24 feet, and are cut to any length desired.

SEND FOR OUR SHAFTING CATALOGUE.

STANDARD TURNBUCKLES

Cleveland City Forge and Iron Company

(For reference only. Not made by Jones & Laughlin Steel Co.)

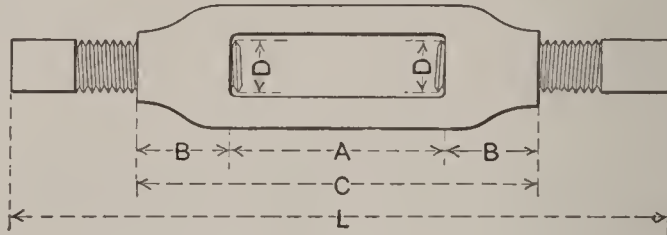

Size D Inches	Length L Inches	Weight of Buckle Pounds	Weight of Buckle and Bolt Ends Pounds	Size D Inches	Length L Inches	Weight of Buckle Pounds	Weight of Buckle and Bolt Ends Pounds
$\frac{3}{8}$	22	1	$1\frac{1}{2}$	2	29	14	35
$\frac{7}{16}$	22	1	$1\frac{3}{4}$	$2\frac{1}{8}$	29	17	41
$\frac{1}{2}$	22	1	2	$2\frac{1}{4}$	30	20	47
$\frac{9}{16}$	22	$1\frac{1}{4}$	$2\frac{1}{2}$	$2\frac{3}{8}$	31	22	53
$\frac{5}{8}$	22	$1\frac{1}{2}$	3	$2\frac{1}{2}$	32	25	61
$\frac{3}{4}$	23	2	4	$2\frac{5}{8}$	32	30	70
$\frac{7}{8}$	24	3	6	$2\frac{3}{4}$	33	33	78
1	25	4	8	$2\frac{7}{8}$	33	36	86
$1\frac{1}{8}$	25	5	11	3	34	40	96
$1\frac{1}{4}$	26	6	13	$3\frac{1}{8}$	36
$1\frac{3}{8}$	27	7	16	$3\frac{1}{4}$	36	50	120
$1\frac{1}{2}$	27	8	19	$3\frac{3}{8}$	37
$1\frac{5}{8}$	28	10	23	$3\frac{1}{2}$	37	65	150
$1\frac{3}{4}$	28	11	26	$3\frac{3}{4}$	39
$1\frac{7}{8}$	29	12	30	4	41

D. Size = Outside diameter of screws.

A. Length in clear between heads = 6 inches first length for all sizes.

B. Length of tapped heads = $1\frac{1}{2}$ D.

C. Total length of buckle without bolt ends = 6 inches + 3 D, nearly.

L. Total length of buckle and stub ends when open.

L.—A = Length of two stub ends.

The "size" of the buckle is the outside diameter of the screw, same as bolts, nuts, etc.

STANDARD CLEVISES

King Bridge Company, Cleveland, Ohio

(For reference only. Not made by Jones & Laughlin Steel Co.)

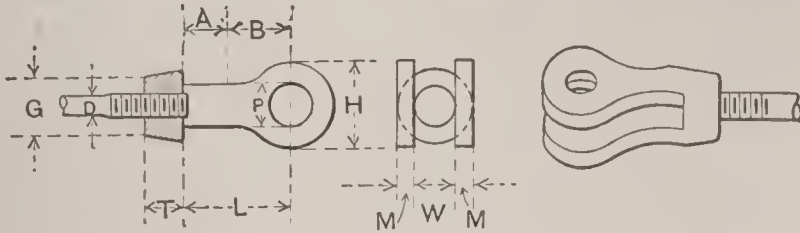

W varies to suit connections

DIMENSIONS IN INCHES

D	P		H	M	L	T	G	A
	Min.	Max.						
1	1 5/16	2 5/16	4 1/4	3/8	5	1 1/2	1 1/2	2 1/8
1 1/8	1 5/16	2 5/16	4 1/4	3/8	5	1 1/2	1 1/2	2 1/8
1 1/4	1 5/16	2 5/16	4 1/4	3/8	5	1 1/2	1 1/2	2 1/8
1 3/8	1 9/16	2 9/16	4 3/4	1/2	5 1/2	2	2	2 1/8
1 1/2	1 9/16	2 9/16	4 3/4	1/2	5 1/2	2	2	2 1/8
1 5/8	1 13/16	2 13/16	5 1/4	9/16	6	2 1/4	2 1/4	2 1/8
1 3/4	1 13/16	2 13/16	5 1/4	9/16	6	2 1/4	2 1/4	2 1/8
1 7/8	2 1/16	3 1/16	5 3/4	5/8	6 1/4	2 1/2	2 1/2	2 1/8
2	2 1/16	3 1/16	5 3/4	5/8	6 1/4	2 1/2	2 1/2	2 1/8
2 1/8	2 5/16	3 5/16	6 1/4	11/16	6 1/2	2 3/4	2 3/4	2 1/8
2 1/4	2 5/16	3 5/16	6 1/4	11/16	6 1/2	2 3/4	2 3/4	2 1/8
2 3/8	2 9/16	3 9/16	6 3/4	3/4	7	3	3	2 1/8
2 1/2	2 9/16	3 9/16	6 3/4	3/4	7	3	3	2 1/8
2 5/8	2 13/16	3 13/16	7 1/4	13/16	7 1/2	3 1/4	3 1/4	2 1/8
2 3/4	2 13/16	3 13/16	7 1/4	13/16	7 1/2	3 1/4	3 1/4	2 1/8
2 7/8	3 1/16	4 1/16	8	7/8	8	3 1/2	3 1/2	2 1/8
3	3 1/16	4 1/16	8	7/8	8	3 1/2	3 1/2	2 1/8

STANDARD SLEEVE NUTS

King Bridge Company, Cleveland, Ohio

(For reference only. Not made by Jones & Laughlin Steel Co.)

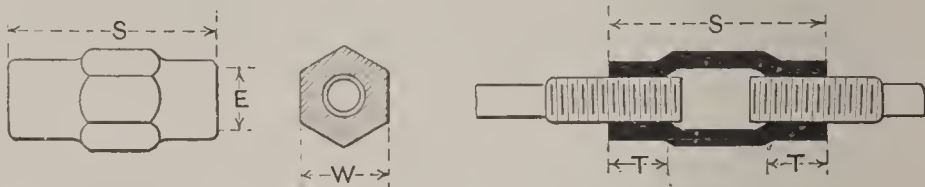

Threads, U. S. Standard

E DIAMETER OF SCREW INCHES	S LENGTH OF NUT INCHES	T LENGTH OF THREAD INCHES	W DIAMETER OF HEXAGON INCHES	WEIGHT OF ONE NUT POUNDS	WEIGHT OF ONE NUT AND TWO SCREW ENDS POUNDS
$\frac{3}{4}$	8	1			
$\frac{7}{8}$	8	$1\frac{1}{8}$			
1	8	$1\frac{1}{4}$			
$1\frac{1}{8}$	8	$1\frac{3}{8}$			
$1\frac{1}{4}$	8	$1\frac{1}{2}$			
$1\frac{3}{8}$	8	$1\frac{5}{8}$			
$1\frac{1}{2}$	8	$1\frac{3}{4}$			
$1\frac{5}{8}$	8	$1\frac{7}{8}$			
$1\frac{3}{4}$	8	2			
$1\frac{7}{8}$	8	$2\frac{1}{8}$			
2	10	$2\frac{1}{4}$			
$2\frac{1}{8}$	10	$2\frac{3}{8}$			
$2\frac{1}{4}$	10	$2\frac{1}{2}$			
$2\frac{3}{8}$	10	$2\frac{5}{8}$			
$2\frac{1}{2}$	10	$2\frac{3}{4}$			
$2\frac{5}{8}$	10	$2\frac{7}{8}$			
$2\frac{3}{4}$	10	3			
$2\frac{7}{8}$	10	$3\frac{1}{8}$			
3	10	$3\frac{1}{4}$			
$3\frac{1}{8}$	12	$3\frac{3}{8}$			
$3\frac{1}{4}$	12	$3\frac{1}{2}$			
$3\frac{3}{8}$	12	$3\frac{5}{8}$			
$3\frac{1}{2}$	12	$3\frac{3}{4}$			
$3\frac{5}{8}$	12	$3\frac{7}{8}$			
$3\frac{3}{4}$	12	4			
$3\frac{7}{8}$	12	$4\frac{1}{8}$			
4	12	$4\frac{1}{4}$			
$4\frac{1}{8}$	12	$4\frac{3}{8}$			

STANDARD SHOULDERED PINS

King Bridge Company, Cleveland, Ohio

(For reference only. Not made by Jones & Laughlin Steel Co.)

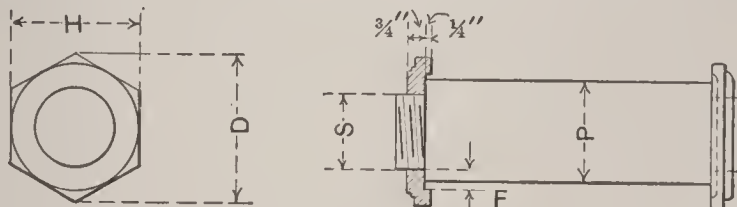

Eight threads per inch.

DIMENSIONS IN INCHES					DIMENSIONS IN INCHES				
P	S	D	F	H	P	S	D	F	H
1 1/4	3/4	2 7/8	3/8	2 1/2	5 1/2	4	7 3/4	7/8	6 3/4
1 3/8	3/4	2 7/8	3/8	2 1/2	5 5/8	4	7 3/4	7/8	6 3/4
1 1/2	1	3 1/8	3/8	2 3/4	5 3/4	4 1/2	8 1/8	3/4	7
1 5/8	1	3 1/8	3/8	2 3/4	5 7/8	4 1/2	8 1/8	3/4	7
1 3/4	1 1/4	3 1/2	3/8	3	6	4 1/2	8 3/8	7/8	7 1/4
1 7/8	1 1/4	3 1/2	3/8	3	6 1/8	4 1/2	8 3/8	7/8	7 1/4
2	1 1/2	4	1/2	3 1/2	6 1/4	4 1/2	8 5/8	1	7 1/2
2 1/8	1 1/2	4	1/2	3 1/2	6 3/8	4 1/2	8 5/8	1	7 1/2
2 1/4	1 1/2	4	1/2	3 1/2	6 1/2	4 1/2	8 5/8	1	7 1/2
2 3/8	1 3/4	4 3/8	1/2	3 3/4	6 5/8	4 1/2	9	1 5/8	7 3/4
2 1/2	1 3/4	4 3/8	1/2	3 3/4	6 3/4	4 1/2	9	1 5/8	7 3/4
2 5/8	1 3/4	4 3/8	1/2	3 3/4	6 7/8	4 1/2	9	1 5/8	7 3/4
2 3/4	2	4 5/8	1/2	4	7	4 1/2	9	1 5/8	7 3/4
2 7/8	2	4 5/8	1/2	4	7 1/4	5	9 7/8	1 3/8	8 1/2
3	2 1/4	4 7/8	1/2	4 1/4	7 1/2	5	9 7/8	1 3/8	8 1/2
3 1/8	2 1/4	4 7/8	1/2	4 1/4	7 3/4	5	9 7/8	1 3/8	8 1/2
3 1/4	2 1/2	5 1/8	1/2	4 1/2	8	5	10 3/4	1 3/4	9 1/4
3 3/8	2 1/2	5 1/8	1/2	4 1/2	8 1/4	5	10 3/4	1 3/4	9 1/4
3 1/2	2 3/4	5 1/2	1/2	4 3/4	8 1/2	5	10 3/4	1 3/4	9 1/4
3 5/8	2 3/4	5 1/2	1/2	4 3/4	8 3/4	6	11 5/8	1 5/8	10
3 3/4	3	5 3/4	1/2	5	9	6	11 5/8	1 5/8	10
3 7/8	3	5 3/4	1/2	5	9 1/4	6	11 5/8	1 5/8	10
4	3 1/4	6 1/8	1/2	5 1/4	9 1/2	6	12 1/8	1 7/8	10 1/2
4 1/8	3 1/4	6 1/8	1/2	5 1/4	9 3/4	6	12 1/8	1 7/8	10 1/2
4 1/4	3 1/4	6 1/8	1/2	5 1/4	10	7	13 1/4	1 7/8	11 1/2
4 3/8	3 1/2	6 5/8	5/8	5 3/4	10 1/4	7	13 1/4	1 7/8	11 1/2
4 1/2	3 1/2	6 5/8	5/8	5 3/4	10 1/2	7	13 1/4	1 7/8	11 1/2
4 5/8	3 1/2	6 5/8	5/8	5 3/4	10 3/4	7	13 1/4	1 7/8	11 1/2
4 3/4	3 1/2	7	5/8	6	11	8	14 3/4	2	12 3/4
4 7/8	3 1/2	7	5/8	6	11 1/4	8	14 3/4	2	12 3/4
5	4	7 1/4	5/8	6 1/4	11 1/2	8	14 3/4	2	12 3/4
5 1/8	4	7 1/4	5/8	6 1/4	11 3/4	8	14 3/4	2	12 3/4
5 1/4	4	7 1/2	3/4	6 1/2	12	8	14 3/4	2	12 3/4
5 3/8	4	7 1/2	3/4	6 1/2					

STANDARD LOOPED EYES AND UPSETS

King Bridge Company, Cleveland, Ohio

(For reference only. Not made by Jones & Laughlin Steel Co.)

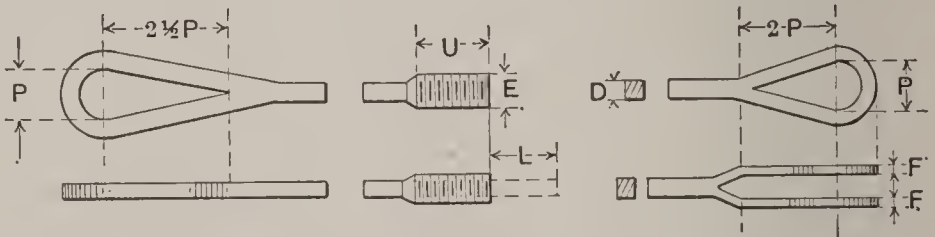

P = Diameter of pin. Threads, U. S. Standard.

D, Side of Square, Inches	E, Diameter of Upset, Inches	U, Length of Upset, Inches	L, Add for Upset, Inches	F, Square for Double Loop, Inches	Length of Material for Double Loop Feet and Inches	D, Side of Square, Inches	E, Diameter of Upset, Inches	U, Length of Upset, Inches	L, Add for Upset, Inches	F, Square for Double Loop, Inches	Length of Material for Double Loop Feet and Inches
1/2	3/4	5	5	3/8	2 9	1 13/16	25/8	6	5	1 5/8	3 0
5/8	7/8	5	5	7/8	2 9	7/3	25/8	6	5	1 3/8	3 0
1	1	5	5	1 1/2	2 9	1 5/8	2 3/4	6	5	1 3/8	3 0
1 1/4	1 1/8	5	5	1 1/2	2 9	2	27/8	6	5	1 7/8	3 0
1 1/2	1 1/4	5	5	1 5/8	2 9	1 1/8	27/8	6	5	1 1/2	3 0
1 5/8	1 3/8	5	5	1 5/8	2 9	1 1/8	3	6	5	1 7/8	3 0
1 3/4	1 3/8	5	5	1 1/2	2 9	1 3/8	3 1/8	7	6	1 7/8	3 6
1	1 1/2	6	5	3/4	3 0	1 1/4	3 1/8	7	6	1 5/8	3 6
1 1/8	1 5/8	6	5	3/4	3 0	1 5/8	3 1/4	7	6	1 11/16	3 6
1 1/8	1 5/8	6	5	1 3/4	3 0	3/8	3 3/8	7	6	1 11/16	3 6
1 3/8	1 3/4	6	5	1 1/2	3 0	1 1/2	3 3/8	7	6	1 3/4	3 6
1 1/4	1 7/8	6	5	1 3/8	3 0	1 1/2	3 1/2	7	6	1 11/16	3 6
1 1/4	1 7/8	6	5	1 3/8	3 0	1 5/8	3 5/8	7	6	1 11/16	3 6
1 5/8	2	6	5	1 5/8	3 0	1 5/8	3 5/8	7	6	1 7/8	3 6
1 5/8	2 1/8	6	5	1	3 0	1 1/8	3 3/4	7	6	1 11/16	3 6
1 7/8	2 1/8	6	5	1 1/8	3 0	3/4	3 7/8	7	6	2	3 6
1 7/8	2 1/8	6	5	1 1/8	3 0	1 1/8	3 7/8	7	6	2	3 6
1 1/2	2 1/8	6	5	1 1/8	3 0	1 1/8	4	7	6	2 1/4	3 6
1 1/2	2 1/4	6	5	1 1/8	3 0	1 1/8	4 1/8	7	6	2 1/8	3 6
1 5/8	2 3/8	6	5	1 3/8	3 0	1 5/8					
1 5/8	2 3/8	6	5	1 1/4	3 0	3	4 1/8	7	6	2 1/8	3 6
1 3/4	2 1/2	6	5	1 1/4	3 0						

ADJUSTABLE EYE BARS

King Bridge Company, Cleveland, Ohio

(For reference only. Not made by Jones & Laughlin Steel Co.)

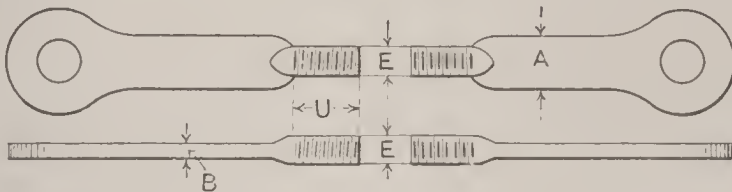

Lengths of upsets are for King Bridge Company's standard sleeve nuts.
Add two inches for Cleveland turnbuckles.

A, Inches	B, Inches	E, Inches	Area of Bar	Area at Root of Thread	U, Inches	Add for Upset Inches	A, Inches	B, Inches	E, Inches	Area of Bar	Area of Root of Thread	U, Inches	Add for Upset Inches
7	1 1/2	4 1/2	10.5	12.57	9	18	4	1 3/4	3 3/4	7.	8.64	7 1/2	15
7	1 3/8	4 1/4	9.63	12.41	8 1/2	17	4	1 5/8	3 1/2	7.	8.64	7 1/2	15
7	1 1/4	4	8.75	9.99	8	16	4	1 1/2	3 1/2	7.	8.64	7 1/2	15
7	1 1/8	4	7.88	9.99	8	16	4	1 3/8	3 1/4	7.	8.64	7 1/2	15
7	1	3 3/4	7.	8.64	7 1/2	15	4	1 1/4	3 1/4	7.	8.64	7 1/2	15
6	1 5/8	4 1/2	9.75	12.57	9.	18	4	1	2 3/4	4.5	5.43	6	12
6	1 1/2	4 1/4	9.	11.41	8 1/2	17	4	7/8	2 5/8	4.5	5.43	6	12
6	1 3/8	4	8.25	9.99	8	16	4	3/4	2 1/2	4.5	5.43	6	12
6	1 1/4	3 3/4	7.5	8.64	7 1/2	15	3 1/2	1 1/4	3	4.38	5.43	6	12
6	1 1/8	3 3/4	6.75	8.64	7 1/2	15	3 1/2	1 1/8	2 3/4	3.94	4.62	6	12
6	1	3 1/2	6.	7.55	7	14	3 1/2	1	2 5/8	3.5	4.16	6	12
6	7/8	3 1/4	5.25	6.51	6 1/2	13	3 1/2	7/8	2 1/2	3.06	3.72	6	12
6	3/4	3	4.5	5.43	6	12	3 1/2	3/4	2 3/8	2.63	3.30	6	12
5	1 3/4	4 1/4	8.75	11.41	8 1/2	17	3	1 1/2	3	4.5	5.43	6	12
5	1 5/8	4	8.13	9.99	8	16	3	1 3/8	2 7/8	4.13	4.92	6	12
5	1 1/2	3 3/4	7.5	8.64	7 1/2	15	3	1 1/4	2 3/4	3.75	4.62	6	12
5	1 3/8	3 3/4	6.88	8.64	7 1/2	15	3	1 1/8	2 5/8	3.38	4.16	6	12
5	1 1/4	3 1/2	6.25	7.55	7	14	3	1	2 1/2	3.	3.72	6	12
5	1 1/8	3 1/4	5.63	6.51	6 1/2	13	3	7/8	2 1/4	2.63	3.02	6	12
5	1	3 1/4	5.	6.51	6 1/2	13	3	3/4	2 1/4	2.25	3.02	6	12
5	7/8	3	4.38	5.43	6	12	3	3/4	2 1/4	2.25	3.02	6	12
5	3/4	2 3/4	3.75	4.62	6	12	2 1/2	1 1/4	2 1/2	3.13	3.72	6	12
4 1/2	1 1/2	3 3/4	6.75	8.64	7 1/2	15	2 1/2	1 1/8	2 3/8	2.81	3.30	6	12
4 1/2	1 3/8	3 1/2	6.19	7.55	7	14	2 1/2	1	2 1/4	2.5	3.02	6	12
4 1/2	1 1/4	3 1/4	5.63	6.51	6 1/2	13	2 1/2	7/8	2 1/8	2.19	2.65	6	12
4 1/2	1 1/8	3 1/4	5.06	6.51	6 1/2	13	2 1/2	3/4	2	1.88	2.30	6	12
4 1/2	1	3	4.5	5.43	6	12	2	1	2 1/8	2.	2.65	6	12
4 1/2	7/8	2 7/8	3.94	4.92	6	12	2	7/8	2	1.75	2.30	6	12
4 1/2	3/4	2 5/8	3.38	4.16	6	12	2	3/4	1 7/8	1.5	2.05	6	12

STANDARD EYE BARS

King Bridge Company
Cleveland, Ohio

For refer-
ence only.
Not made
by Jones &
Laughlin
Steel Co.

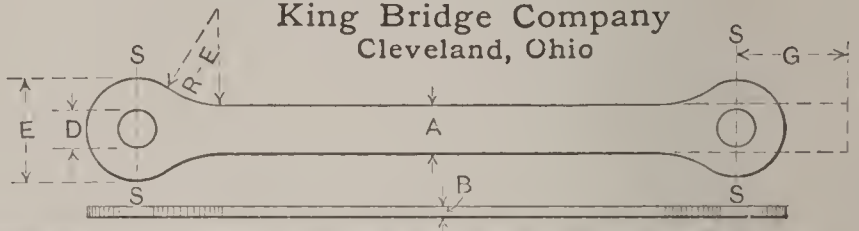

DIMENSIONS IN INCHES

DIMENSIONS IN INCHES

A	B Minimum	E	D Maximum	Excess Section S-S	C For Eye	A	B Minimum	E	D Maximum	Excess Section S-S	G For Eye
12	1 3/4	24	7 2/8	40%	31	4	3/4	10	4 3/8	40%	17
12	1 3/4	22	5 1/8	40%	25 1/2	4	3/4	9 1/2	3 7/8	40%	15 1/2
12	1 3/4	26 1/2	9 3/4	40%	39 1/4	4	3/4	9	3 3/8	40%	14 1/2
10	1 3/4	24	10	40%	39	4	3/4	8 1/2	2 7/8	40%	13
10	1 3/4	22	8	40%	32	4	3/4	8	2 3/8	40%	12
10	1 3/4	21	7	40%	29	3 1/2	3/4	10	5 1/8	40%	20 1/2
10	1 3/4	20	6	40%	26	3 1/2	3/4	9 1/2	4 1/8	40%	18
9	1 1/2	21	8 3/8	40%	31	3 1/2	3/4	9	4 1/8	40%	16
9	1 1/2	20	7 7/8	40%	30	3 1/2	3/4	8 1/2	3 3/8	40%	14
8	1 3/8	20	8 1/8	40%	34 1/2	3 1/2	3/4	8	3 1/8	40%	13
8	1 3/8	19	7 1/8	40%	30 1/2	3 1/2	3/4	7 1/2	2 1/8	40%	12
8	1 3/8	18	6 1/8	40%	27	3 1/2	3/4	7	2 1/8	40%	11
7 1/2	1 3/8	14	3 1/2	40%	19	3	3/4	10	5 1/8	40%	27
7	1 1/4	18	8 3/8	40%	32	3	3/4	9 1/2	5 1/8	40%	24
7	1 1/4	17	7 3/8	40%	28 1/2	3	3/4	9	4 3/4	40%	19
7	1 1/4	16	6 1/8	40%	24 1/2	3	3/4	8 1/2	4 1/8	40%	17
7	1 1/4	15	5 1/8	40%	21	3	3/4	8	3 1/8	40%	16
6	1	17 1/2	9 1/8	40%	35 1/2	3	3/4	7 1/2	3 5/8	40%	14
6	1	16 1/2	8 1/8	40%	32	3	3/4	7	2 1/8	40%	13
6	1	16	7 5/8	40%	29	3	3/4	6 1/2	2 5/8	40%	12
6	1	15 1/2	7 1/8	40%	27	3	3/4	6	1 1/8	40%	10 3/4
6	1	15	6 5/8	40%	25	2 1/2	3/4	7 1/2	4	40%	17
6	1	14 1/2	6 1/8	40%	24	2 1/2	3/4	7	3 1/2	40%	14 1/2
6	1	14	5 5/8	40%	21 1/2	2 1/2	3/4	6 1/2	3	40%	13
6	1	13 1/2	5 1/8	40%	20 1/2	2 1/2	3/4	6	2 1/2	40%	12
5	1	15	8	40%	32	2 1/2	3/4	5 1/2	2	40%	11
5	1	14 1/2	7 1/2	40%	30	2 1/2	3/4	5	1 1/2	40%	10
5	1	14	7	40%	27 1/2	2 1/2	3/4	4 3/4	1 1/4	40%	9
5	1	13	6	40%	25	2	3/4	6 1/2	3 1/8	40%	19
5	1	12 1/2	5 1/2	40%	22	2	3/4	6	3 1/8	40%	15
5	1	12	5	40%	20	2	3/4	5 1/2	2 1/8	40%	13
5	1	11 1/2	4 1/2	40%	18 1/2	2	3/4	5	2 3/8	40%	11
5	1	11	4	40%	16 1/2	2	3/4	4 3/4	1 1/8	40%	10
5	1	9 1/2	2 1/2	40%	10 1/2	2	3/4	4	1 3/8	40%	7 1/2
4 1/2	3/4	11 1/2	5 3/8	40%	20	2	3/4	3 3/4	1 5/8	40%	7
4 1/2	3/4	11	4 1/8	40%	18	2	3/4	3 1/2	1 1/8	40%	4
4 1/2	3/4	10 1/2	4 3/8	40%	16	1 1/2	5/8	6	3 7/8	40%	18
4 1/2	3/4	10	3 1/8	40%	15	1 1/2	5/8	5 1/2	3 3/8	40%	16 1/2
4 1/2	3/4	9 1/2	3 1/8	40%	14	1 1/2	5/8	5	2 7/8	40%	14
4 1/2	3/4	9	2 1/8	40%	12	1 1/2	5/8	4 3/4	2 5/8	40%	12 1/2
4	3/4	13	7 3/8	40%	30 1/2	1 1/2	5/8	4	1 7/8	40%	9
4	3/4	12 1/2	6 7/8	40%	28	1 1/2	5/8	3 3/4	1 5/8	40%	8
4	3/4	12	6 3/8	40%	26 1/2	1 1/4	5/8	3 3/4	2	40%	9
4	3/4	11 1/2	5 7/8	40%	24	1 1/8	5/8	3 3/4	2 1/8	40%	10 1/2
4	3/4	11	5 3/8	40%	22	1	5/8	3 3/4	2 1/8	40%	12
4	3/4	10 1/2	4 7/8	40%	20						

DECIMALS OF A FOOT FOR EACH 1-64 INCH

INCH	INCHES											
	0	1	2	3	4	5	6	7	8	9	10	11
0	.0	.0833	.1667	.2500	.3333	.4167	.5000	.5833	.6667	.7500	.8333	.9167
$\frac{1}{64}$.0013	.0846	.1680	.2513	.3346	.4180	.5013	.5846	.6680	.7513	.8346	.9180
$\frac{1}{32}$.0026	.0859	.1693	.2526	.3359	.4193	.5026	.5859	.6693	.7526	.8359	.9193
$\frac{3}{64}$.0039	.0872	.1706	.2539	.3372	.4206	.5039	.5872	.6706	.7539	.8372	.9206
$\frac{1}{16}$.0052	.0885	.1719	.2552	.3385	.4219	.5052	.5885	.6719	.7552	.8385	.9219
$\frac{5}{64}$.0065	.0898	.1732	.2565	.3398	.4232	.5065	.5898	.6732	.7565	.8398	.9232
$\frac{3}{32}$.0078	.0911	.1745	.2578	.3411	.4245	.5078	.5911	.6745	.7578	.8411	.9245
$\frac{7}{64}$.0091	.0924	.1758	.2591	.3424	.4258	.5091	.5924	.6758	.7591	.8424	.9258
$\frac{1}{8}$.0104	.0937	.1771	.2604	.3437	.4271	.5104	.5937	.6771	.7604	.8437	.9271
$\frac{9}{64}$.0117	.0951	.1784	.2617	.3451	.4284	.5117	.5951	.6784	.7617	.8451	.9284
$\frac{5}{32}$.0130	.0964	.1797	.2630	.3464	.4297	.5130	.5964	.6797	.7630	.8464	.9297
$\frac{11}{64}$.0143	.0977	.1810	.2643	.3477	.4310	.5143	.5977	.6810	.7643	.8477	.9310
$\frac{3}{16}$.0156	.0990	.1823	.2656	.3490	.4323	.5156	.5990	.6823	.7656	.8490	.9323
$\frac{13}{64}$.0169	.1003	.1836	.2669	.3503	.4336	.5169	.6003	.6836	.7669	.8503	.9336
$\frac{7}{32}$.0182	.1016	.1849	.2682	.3516	.4349	.5182	.6016	.6849	.7682	.8516	.9349
$\frac{15}{64}$.0195	.1029	.1862	.2695	.3529	.4362	.5195	.6029	.6862	.7695	.8529	.9362
$\frac{1}{4}$.0208	.1042	.1875	.2708	.3542	.4375	.5208	.6042	.6875	.7708	.8542	.9375
$\frac{17}{64}$.0221	.1055	.1888	.2721	.3555	.4388	.5221	.6055	.6888	.7721	.8555	.9388
$\frac{9}{32}$.0234	.1068	.1901	.2734	.3568	.4401	.5234	.6068	.6901	.7734	.8568	.9401
$\frac{19}{64}$.0247	.1081	.1914	.2747	.3581	.4414	.5247	.6081	.6914	.7747	.8581	.9414
$\frac{5}{16}$.0260	.1094	.1927	.2760	.3594	.4427	.5260	.6094	.6927	.7760	.8594	.9427
$\frac{21}{64}$.0273	.1107	.1940	.2773	.3607	.4440	.5273	.6107	.6940	.7773	.8607	.9440
$\frac{11}{32}$.0286	.1120	.1953	.2786	.3620	.4453	.5286	.6120	.6953	.7786	.8620	.9453
$\frac{23}{64}$.0299	.1133	.1966	.2799	.3633	.4466	.5299	.6133	.6966	.7799	.8633	.9466
$\frac{3}{8}$.0312	.1146	.1979	.2812	.3646	.4479	.5312	.6146	.6979	.7812	.8646	.9479
$\frac{25}{64}$.0326	.1159	.1992	.2826	.3659	.4492	.5326	.6159	.6992	.7826	.8659	.9492
$\frac{13}{32}$.0339	.1172	.2005	.2839	.3672	.4505	.5339	.6172	.7005	.7839	.8672	.9505
$\frac{27}{64}$.0352	.1185	.2018	.2852	.3685	.4518	.5352	.6185	.7018	.7852	.8685	.9518
$\frac{7}{16}$.0365	.1198	.2031	.2865	.3698	.4531	.5365	.6198	.7031	.7865	.8698	.9531
$\frac{29}{64}$.0378	.1211	.2044	.2878	.3711	.4544	.5378	.6211	.7044	.7878	.8711	.9544
$\frac{15}{32}$.0391	.1224	.2057	.2891	.3724	.4557	.5391	.6224	.7057	.7891	.8724	.9557
$\frac{31}{64}$.0404	.1237	.2070	.2904	.3737	.4570	.5404	.6237	.7070	.7904	.8737	.9570
$\frac{1}{2}$.0417	.1250	.2083	.2917	.3750	.4583	.5417	.6250	.7083	.7917	.8750	.9583

DECIMALS OF AN INCH FOR EACH 1-64TH

$\frac{1}{32}$ DS	$\frac{1}{64}$ THS	DECIMAL	FRACTION	$\frac{1}{32}$ DS	$\frac{1}{64}$ THS	DECIMAL	FRACTION
	1	.015625			33	.515625	
1	2	.03125		17	34	.53125	
	3	.046875			35	.546875	
2	4	.0625	1-16	18	36	.5625	9-16
	5	.078125			37	.578125	
3	6	.09375		19	38	.59375	
	7	.109375			39	.609375	
4	8	.125	1-8	20	40	.625	5-8
	9	.140625			41	.640625	
5	10	.15625		21	42	.65625	
	11	.171875			43	.671875	
6	12	.1875	3-16	22	44	.6875	11-16
	13	.203125			45	.703125	
7	14	.21875		23	46	.71875	
	15	.234375			47	.734375	
8	16	.25	1-4	24	48	.75	3-4
	17	.265625			49	.765625	
9	18	.28125		25	50	.78125	
	19	.296875			51	.796875	
10	20	.3125	5-16	26	52	.8125	13-16
	21	.328125			53	.828125	
11	22	.34375		27	54	.84375	
	23	.359375			55	.859375	
12	24	.375	3-8	28	56	.875	7-8
	25	.390625			57	.890625	
13	26	.40625		29	58	.90625	
	27	.421875			59	.921875	
14	28	.4375	7-16	30	60	.9375	15-16
	29	.453125			61	.953125	
15	30	.46875		31	62	.96875	
	31	.484375			63	.984375	
16	32	.5	1-2	32	64	1.	1

TABLE CONVERTING INCHES AND FEET TO METRIC MEASURES

INCHES	METRES	FEET	METRES	FEET	METRES	FEET	METRES
$\frac{1}{64}$.000397	1	.3048	36	10.9727	71	21.6406
$\frac{1}{32}$.000794	2	.6096	37	11.2775	72	21.9454
$\frac{1}{16}$.001588	3	.9144	38	11.5823	73	22.2502
$\frac{1}{8}$.003175	4	1.2192	39	11.8871	74	22.5550
$\frac{3}{16}$.004763	5	1.5240	40	12.1919	75	22.8598
$\frac{1}{4}$.006350	6	1.8288	41	12.4967	76	23.1646
$\frac{5}{16}$.007938	7	2.1336	42	12.8015	77	23.4694
$\frac{3}{8}$.009525	8	2.4384	43	13.1063	78	23.7742
$\frac{7}{16}$.011113	9	2.7432	44	13.4111	79	24.0790
$\frac{1}{2}$.012700	10	3.0480	45	13.7159	80	24.3838
$\frac{9}{16}$.014287	11	3.3528	46	14.0207	81	24.6886
$\frac{5}{8}$.015875	12	3.6576	47	14.3255	82	24.9934
$\frac{11}{16}$.017462	13	3.9624	48	14.6303	83	25.2982
$\frac{3}{4}$.019050	14	4.2672	49	14.9351	84	25.6030
$\frac{13}{16}$.020637	15	4.5720	50	15.2399	85	25.9078
$\frac{7}{8}$.022225	16	4.8768	51	15.5447	86	26.2126
$\frac{15}{16}$.023812	17	5.1816	52	15.8495	87	26.5174
1	.0254	18	5.4864	53	16.1543	88	26.8222
2	.0508	19	5.7912	54	16.4591	89	27.1270
3	.0762	20	6.0959	55	16.7638	90	27.4318
4	.1016	21	6.4007	56	17.0686	91	27.7366
5	.1270	22	6.7055	57	17.3734	92	28.0414
6	.1524	23	7.0103	58	17.6782	93	28.3461
7	.1778	24	7.3151	59	17.9830	94	28.6509
8	.2032	25	7.6199	60	18.2878	95	28.9557
9	.2286	26	7.9247	61	18.5926	96	29.2605
10	.2540	27	8.2295	62	18.8974	97	29.5653
11	.2794	28	8.5343	63	19.2022	98	29.8701
12	.3048	29	8.8391	64	19.5070	99	30.1749
		30	9.1439	65	19.8118	100	30.4797
		31	9.4487	66	20.1166	101	30.7845
		32	9.7535	67	20.4214	102	31.0893
		33	10.0583	68	20.7262	103	31.3941
		34	10.3631	69	21.0310	104	31.6989
		35	10.6679	70	21.3358	105	32.0037

Example for explanation : 90 ft. = 27.4318 m. = 27 m. 43 cm. 1.8 mm., or = 27 metres, 43 centimetres, $1\frac{8}{10}$ millimetres.

METRIC MEASURE CONVERTED INTO INCHES

CENTI- METRES	MILLIMETRES									
	0	1	2	3	4	5	6	7	8	9
0	.00	.04	.08	.12	.16	.20	.24	.28	.31	.35
1	.39	.43	.47	.51	.55	.59	.63	.67	.71	.75
2	.79	.83	.87	.91	.94	.98	1.02	1.06	1.10	1.14
3	1.18	1.22	1.26	1.30	1.34	1.38	1.42	1.46	1.50	1.54
4	1.57	1.61	1.65	1.69	1.73	1.77	1.81	1.85	1.89	1.93
5	1.97	2.01	2.05	2.09	2.13	2.17	2.20	2.24	2.28	2.32
6	2.36	2.40	2.44	2.48	2.52	2.56	2.60	2.64	2.68	2.72
7	2.76	2.80	2.83	2.87	2.91	2.95	2.99	3.03	3.07	3.11
8	3.15	3.19	3.23	3.27	3.31	3.35	3.39	3.43	3.46	3.50
9	3.54	3.58	3.62	3.66	3.70	3.74	3.78	3.82	3.86	3.90
10	3.94	3.98	4.02	4.06	4.09	4.13	4.17	4.21	4.25	4.29
11	4.33	4.37	4.41	4.45	4.49	4.53	4.57	4.61	4.65	4.69
12	4.72	4.76	4.80	4.84	4.88	4.92	4.96	5.00	5.04	5.08
13	5.12	5.16	5.20	5.24	5.28	5.32	5.35	5.39	5.43	5.47
14	5.51	5.55	5.59	5.63	5.67	5.71	5.75	5.79	5.83	5.87
15	5.91	5.95	5.98	6.02	6.06	6.10	6.14	6.18	6.22	6.26
16	6.30	6.34	6.38	6.42	6.46	6.50	6.54	6.57	6.61	6.65
17	6.69	6.73	6.77	6.81	6.85	6.89	6.93	6.97	7.01	7.07
18	7.09	7.13	7.17	7.20	7.24	7.28	7.32	7.36	7.40	7.44
19	7.48	7.52	7.56	7.60	7.64	7.68	7.72	7.76	7.80	7.83
20	7.87	7.91	7.95	7.99	8.03	8.07	8.11	8.15	8.19	8.23
21	8.27	8.31	8.35	8.39	8.43	8.46	8.50	8.54	8.58	8.62
22	8.66	8.70	8.74	8.78	8.82	8.86	8.90	8.94	8.98	9.02
23	9.06	9.09	9.13	9.17	9.21	9.25	9.29	9.33	9.37	9.41
24	9.45	9.49	9.53	9.57	9.61	9.65	9.69	9.72	9.76	9.80
25	9.84	9.88	9.92	9.96	10.00	10.04	10.08	10.12	10.16	10.20
26	10.24	10.28	10.32	10.35	10.39	10.43	10.47	10.51	10.55	10.59
27	10.63	10.67	10.71	10.75	10.79	10.83	10.87	10.91	10.95	10.98
28	11.02	11.06	11.10	11.14	11.18	11.22	11.26	11.30	11.34	11.38
29	11.42	11.46	11.50	11.54	11.58	11.61	11.65	11.69	11.73	11.77
30	11.81	11.85	11.89	11.93	11.97	12.01	12.05	12.09	12.13	12.17
31	12.20	12.24	12.28	12.32	12.36	12.40	12.44	12.48	12.52	12.56
32	12.60	12.64	12.68	12.72	12.76	12.80	12.83	12.87	12.91	12.95
33	12.99	13.03	13.07	13.11	13.15	13.19	13.23	13.27	13.31	13.35
34	13.39	13.43	13.46	13.50	13.54	13.58	13.62	13.66	13.70	13.74
35	13.78	13.82	13.86	13.90	13.94	13.98	14.02	14.06	14.09	14.13
36	14.17	14.21	14.25	14.29	14.33	14.37	14.41	14.45	14.49	14.53
37	14.57	14.61	14.65	14.69	14.72	14.76	14.80	14.84	14.88	14.92
38	14.96	15.00	15.04	15.08	15.12	15.16	15.20	15.24	15.28	15.32
39	15.35	15.39	15.43	15.47	15.51	15.55	15.59	15.63	15.67	15.71
40	15.75	15.79	15.83	15.87	15.91	15.95	15.98	16.02	16.06	16.10
41	16.14	16.18	16.22	16.26	16.30	16.34	16.38	16.42	16.46	16.50
42	16.54	16.58	16.61	16.65	16.69	16.73	16.77	16.81	16.85	16.89
43	16.93	16.97	17.01	17.05	17.09	17.13	17.17	17.20	17.24	17.28
44	17.32	17.36	17.40	17.44	17.48	17.52	17.56	17.60	17.64	17.68
45	17.72	17.76	17.80	17.84	17.87	17.91	17.95	17.99	18.03	18.07
46	18.11	18.15	18.19	18.23	18.27	18.31	18.35	18.39	18.43	18.47
47	18.50	18.54	18.58	18.62	18.66	18.70	18.74	18.78	18.82	18.86
48	18.90	18.94	18.98	19.02	19.06	19.09	19.13	19.17	19.21	19.25
49	19.29	19.33	19.37	19.41	19.45	19.49	19.53	19.57	19.61	19.65
50	19.69	19.72	19.76	19.80	19.84	19.88	19.92	19.96	20.00	20.04
	0	1	2	3	4	5	6	7	8	9

NOTE.— mm. = millimetre ; 10 mm. = 1 cm. (centimetre) ; 100 cm. = 1 m. (metre).

METRIC MEASURE CONVERTED INTO INCHES

CENTI- METRES	MILLIMETRES									
	0	1	2	3	4	5	6	7	8	9
50	19.69	19.72	19.76	19.80	19.84	19.88	19.92	19.96	20.00	20.04
51	20.08	20.12	20.16	20.20	20.24	20.28	20.32	20.35	20.39	20.43
52	20.47	20.51	20.55	20.59	20.63	20.67	20.71	20.75	20.79	20.83
53	20.87	20.91	20.95	20.98	21.02	21.06	21.10	21.14	21.18	21.22
54	21.26	21.30	21.34	21.38	21.42	21.46	21.50	21.54	21.58	21.61
55	21.65	21.69	21.73	21.77	21.81	21.85	21.89	21.93	21.97	22.01
56	22.05	22.09	22.13	22.17	22.21	22.24	22.28	22.32	22.36	22.40
57	22.44	22.48	22.52	22.56	22.60	22.64	22.68	22.72	22.76	22.80
58	22.84	22.87	22.91	22.95	22.99	23.03	23.07	23.11	23.15	23.19
59	23.23	23.27	23.31	23.35	23.39	23.43	23.47	23.50	23.54	23.58
60	23.62	23.66	23.70	23.74	23.78	23.82	23.86	23.90	23.94	23.98
61	24.02	24.06	24.09	24.13	24.17	24.21	24.25	24.29	24.33	24.37
62	24.41	24.45	24.49	24.53	24.57	24.61	24.65	24.69	24.72	24.76
63	24.80	24.84	24.88	24.92	24.96	25.00	25.04	25.08	25.12	25.16
64	25.20	25.24	25.28	25.32	25.35	25.39	25.43	25.47	25.51	25.55
65	25.59	25.63	25.67	25.71	25.75	25.79	25.83	25.87	25.91	25.95
66	25.98	26.02	26.06	26.10	26.14	26.18	26.22	26.26	26.30	26.34
67	26.38	26.42	26.46	26.50	26.54	26.58	26.61	26.65	26.69	26.73
68	26.77	26.81	26.85	26.89	26.93	26.97	27.01	27.05	27.09	27.13
69	27.17	27.21	27.24	27.28	27.32	27.36	27.40	27.44	27.48	27.52
70	27.56	27.60	27.64	27.68	27.72	27.76	27.80	27.84	27.87	27.91
71	27.95	27.99	28.03	28.07	28.11	28.15	28.19	28.23	28.27	28.31
72	28.35	28.39	28.43	28.47	28.50	28.54	28.58	28.62	28.66	28.70
73	28.74	28.78	28.82	28.86	28.90	28.94	28.98	29.02	29.06	29.10
74	29.13	29.17	29.21	29.25	29.29	29.33	29.37	29.41	29.45	29.49
75	29.53	29.57	29.61	29.65	29.69	29.73	29.76	29.80	29.84	29.88
76	29.92	29.96	30.00	30.04	30.08	30.12	30.16	30.20	30.24	30.28
77	30.32	30.35	30.39	30.43	30.47	30.51	30.55	30.59	30.63	30.67
78	30.71	30.75	30.79	30.83	30.87	30.91	30.95	30.98	31.02	31.06
79	31.10	31.14	31.18	31.22	31.26	31.30	31.34	31.38	31.42	31.46
80	31.50	31.54	31.58	31.61	31.65	31.69	31.73	31.77	31.81	31.85
81	31.89	31.93	31.97	32.01	32.05	32.09	32.13	32.17	32.21	32.24
82	32.28	32.32	32.36	32.40	32.44	32.48	32.52	32.56	32.60	32.64
83	32.68	32.72	32.76	32.80	32.84	32.87	32.91	32.95	32.99	33.03
84	33.07	33.11	33.15	33.19	33.23	33.27	33.31	33.35	33.39	33.43
85	33.47	33.50	33.54	33.58	33.62	33.66	33.70	33.74	33.78	33.82
86	33.86	33.90	33.94	33.98	34.02	34.06	34.10	34.13	34.17	34.21
87	34.25	34.29	34.33	34.37	34.41	34.45	34.49	34.53	34.57	34.61
88	34.65	34.69	34.73	34.76	34.80	34.84	34.88	34.92	34.96	35.00
89	35.04	35.08	35.12	35.16	35.20	35.24	35.28	35.32	35.36	35.40
90	35.43	35.47	35.51	35.55	35.59	35.63	35.67	35.71	35.75	35.79
91	35.83	35.87	35.91	35.95	35.98	36.02	36.06	36.10	36.14	36.18
92	36.22	36.26	36.30	36.34	36.38	36.42	36.46	36.50	36.54	36.58
93	36.61	36.65	36.69	36.73	36.77	36.81	36.85	36.89	36.93	36.97
94	37.01	37.05	37.09	37.13	37.17	37.21	37.24	37.28	37.32	37.36
95	37.40	37.44	37.48	37.52	37.56	37.60	37.64	37.68	37.72	37.76
96	37.80	37.84	37.87	37.91	37.95	37.99	38.03	38.07	38.11	38.15
97	38.19	38.23	38.27	38.31	38.35	38.39	38.43	38.47	38.50	38.54
98	38.58	38.62	38.66	38.70	38.74	38.78	38.82	38.86	38.90	38.94
99	38.98	39.02	39.06	39.10	39.13	39.17	39.21	39.25	39.29	39.33
100	39.37	39.41	39.45	39.49	39.53	39.57	39.61	39.65	39.69	39.73
	0	1	2	3	4	5	6	7	8	9

NOTE.—mm. = millimetre; 10 mm. = 1 cm. (centimetre); 100 cm. = 1 m. (metre).

TABLE OF WEIGHTS

Interchangeable between U. S. and Metric Systems

NUMBER	AVOIRDUPOIS OUNCES TO GRAMS	KILOGRAMS TO OUNCES AVOIRDUPOIS	AVOIRDUPOIS POUNDS TO KILOGRAMS	KILOGRAMS TO POUNDS AVOIRDUPOIS	NET TONS TO METRIC TONS	METRIC TONS TO NET TONS
1	28.3495	35.274	0.4536	2.2046	0.9072	1.1023
2	56.6990	70.548	0.9072	4.4092	1.8144	2.2046
3	85.0485	105.822	1.3608	6.6138	2.7216	3.3069
4	113.3980	141.096	1.8144	8.8184	3.6288	4.4092
5	141.7475	176.370	2.2680	11.0230	4.5360	5.5115
6	170.0970	211.644	2.7216	13.2276	5.4432	6.6138
7	198.4464	246.918	3.1752	15.4322	6.3504	7.7161
8	226.7959	282.192	3.6288	17.6368	7.2576	8.8184
9	255.1454	317.466	4.0824	19.8414	8.1648	9.9207
10	283.4949	352.740	4.5360	22.0460	9.0720	11.0230
11	311.8444	388.014	4.9896	24.2506	9.9792	12.1253
12	340.1939	423.288	5.4432	26.4552	10.8864	13.2276
13	368.5434	458.562	5.8968	28.6598	11.7936	14.3299
14	396.8928	493.836	6.3504	30.8644	12.7008	15.4322
15	425.2423	529.110	6.8040	33.0690	13.6080	16.5345
16	453.5918	564.384	7.2576	35.2736	14.5152	17.6368
17	7.7112	37.4782	15.4224	18.7391
18	8.1648	39.6828	16.3296	19.8414
19	8.6184	41.8874	17.2368	20.9437
20	9.0720	44.0920	18.1440	22.0460
21	9.5256	46.2966	19.0512	23.1483
22	9.9792	48.5012	19.9584	24.2506
23	10.4328	50.7058	20.8656	25.3529
24	10.8864	52.9104	21.7728	26.4552
25	11.3400	55.1150	22.6800	27.5575

1 metric ton=1000 kg. (kilograms).

1 kilogram =1000 g. (grams).

1 gram=10 dg. (decigrams)=100 cg. (centigrams)=1000 mg. (milligrams).

Weight of 1 cubic mm. of water=1 milligram.

Weight of 1 cubic cm. of water=1 gram.

Weight of 1 cubic dm. of water (=1000 grams) =
1 litre=1 kg.Weight of 1 cubic m. of water (=1000 dm³)=1
metric ton.1 cubic cm. =
1 cm³.NOTE.—10 mm.=1 cm; 10 cm.=1 dm. (decimetre);
10 dm.=1 m. (metre); mm = millimetre; cm. = centi-
metre.

TABLE OF LIQUID AND DRY MEASURE
Interchangeable between U. S. and Metric Systems

NUMBER	LITRES TO QUARTS		QUARTS TO LITRES		CUBIC METRES TO GALLONS LIQUID	GALLONS TO CUBIC METRES LIQUID	HECTOLITRES TO BUSHELS DRY	BUSHELS TO HECTOLITRES DRY
	Liquid	Dry	Liquid	Dry				
1	1.0567	0.908	0.9463	1.1013	264.17	0.0038	2.8375	0.3524
2	2.1134	1.816	1.8927	2.2026	528.35	0.0076	5.6750	0.7048
3	3.1701	2.724	2.8390	3.3040	792.52	0.0114	8.5125	1.0573
4	4.2268	3.632	3.7854	4.4053	1056.70	0.0151	11.3500	1.4097
5	5.2835	4.540	4.7317	5.5066	1320.87	0.0189	14.1875	1.7621
6	6.3402	5.448	5.6781	6.6079	1585.05	0.0227	17.0250	2.1145
7	7.3969	6.356	6.6244	7.7093	1849.22	0.0265	19.8625	2.4669
8	8.4536	7.264	7.5707	8.8106	2113.40	0.0303	22.7000	2.8194
9	9.5103	8.172	8.5171	9.9119	2377.57	0.0341	25.5375	3.1718
10	10.5670	9.080	9.4634	11.0132	2641.75	0.0379	28.3750	3.5242
11	11.6237	9.988	10.4098	12.1145	2905.92	0.0416	31.2125	3.8766
12	12.6804	10.896	11.3561	13.2158	3170.10	0.0454	34.0500	4.2290
13	13.7371	11.804	12.3024	14.3172	3434.27	0.0492	36.8875	4.5815
14	14.7938	12.712	13.2488	15.4185	3698.45	0.0531	39.7250	4.9339
15	15.8505	13.620	14.1951	16.5198	3962.62	0.0569	42.5625	5.2863
16	16.9072	14.528	15.1415	17.6211	4226.80	0.0606	45.4000	5.6387
17	17.9639	15.436	16.0878	18.7224	4490.97	0.0644	48.2375	5.9911
18	19.0206	16.344	17.0341	19.8238	4755.15	0.0682	51.0750	6.3436
19	20.0773	17.252	17.9805	20.9251	5019.32	0.0720	53.9125	6.6960
20	21.1340	18.160	18.9268	22.0264	5283.50	0.0758	56.7500	7.0484
21	22.1907	19.068	19.8732	23.1277	5547.67	0.0796	59.5875	7.4008
22	23.2474	19.976	20.8195	24.2290	5811.85	0.0833	62.4250	7.7532
23	24.3041	20.884	21.7658	25.3304	6076.02	0.0871	65.2625	8.1057
24	25.3608	21.792	22.7122	26.4317	6340.20	0.0909	68.1000	8.4581
25	26.4175	22.700	23.6585	27.5330	6604.37	0.0947	70.9375	8.8105

1 cu. metre (m³) = 1000 l. (litres) = 1000 dm³ (cu. decimetres).

1 hectolitre (hl.) = 100 litres.

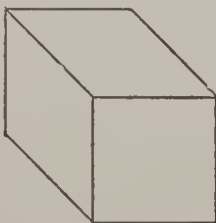
1 litre = 1 dm³ (cu. decimetre) = 10 dl. (decilitre) = 100 cl. (centilitre) = 1000 ml. (millilitres).

1 millilitre = 1 cm³ (cu. centimetre).

MENSURATION

$\pi = 3.1415926536$

$\frac{\pi}{2} = 1.5708$

$\frac{\pi}{3} = 1.0472$

$\frac{\pi}{4} = 0.7854$

$\frac{\pi}{12} = 0.2618$

$\frac{\pi}{64} = 0.04909$

$\frac{1}{\pi} = 0.31831$

$\frac{1}{\pi^2} = 0.10132$

$\pi^2 = 9.86960$

$\pi^3 = 31.00628$

log. $\pi = 0.4971499$

$\sqrt{\pi} = 1.77245$

$\sqrt{\frac{1}{\pi}} = 0.56419$

log. $\sqrt{\pi} = 0.2485749$

$c = 2 \pi r \times \frac{c \text{ in degrees}}{360} = .01745 \times r \times c \text{ in degrees}$

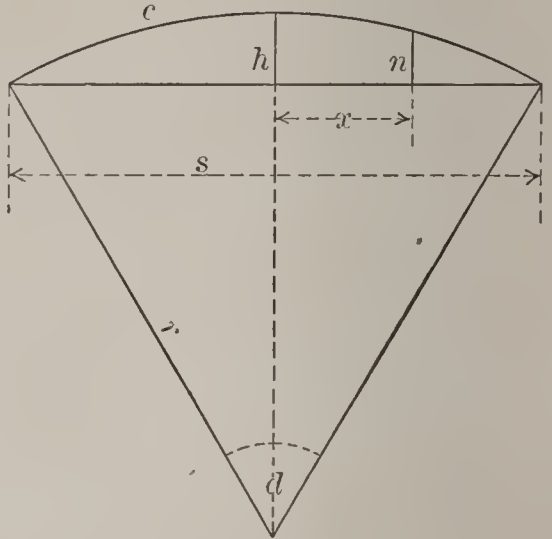

$$r = \frac{h^2 + \frac{s^2}{4}}{2h}$$

or very nearly $= \frac{s^2}{8h}$

$n = \sqrt{r^2 - x^2} - (r - h)$

$h = r - \sqrt{r^2 - \frac{s^2}{4}}$

or very nearly $= \frac{s^2}{8r}$

Circle

$A = \text{area}$ $d = \text{diameter}$ $r = \text{radius}$

$A = \frac{\pi \times d^2}{4} = 0.7854 d^2$ $d = 1,12838 \sqrt{A}$

Circumference $= 2 \pi r = \pi d$

Sector of circle $= \text{length of arc} \times \text{half radius.}$

Segments of circle $= \text{area of sector less triangle, also for}$

flat segments very nearly $= \frac{4h}{3} \sqrt{0.388h^2 + \frac{s^2}{4}}$

MENSURATION

Triangle

$$A = \sqrt{s \times (s-a) (s-b) (s-c)}$$

if s is half of the sum of the sides a , b , and c ,
or = base \times half perpendicular height.

Polygons

Area of any regular or irregular polygon can be found by dividing the polygon into triangles and taking the sum of the areas. Area of any regular polygon

$$= \frac{\text{No. of sides}}{2} \times (\text{circumscribed rad.})^2 \times \sin. \frac{2\pi}{(\text{No. sides})}$$

Ellipse. $A = \pi a b$

Parabola. $A = \frac{2}{3} s h$

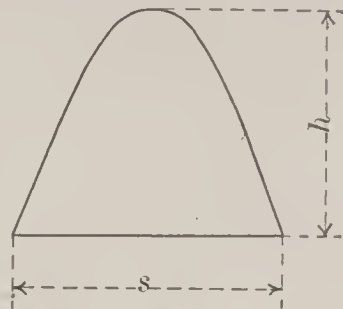
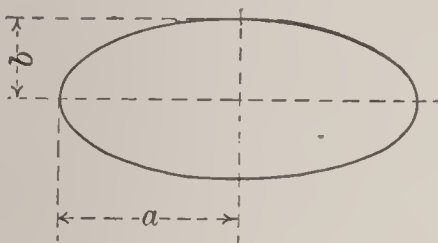

Area of any Irregular Plane Surface

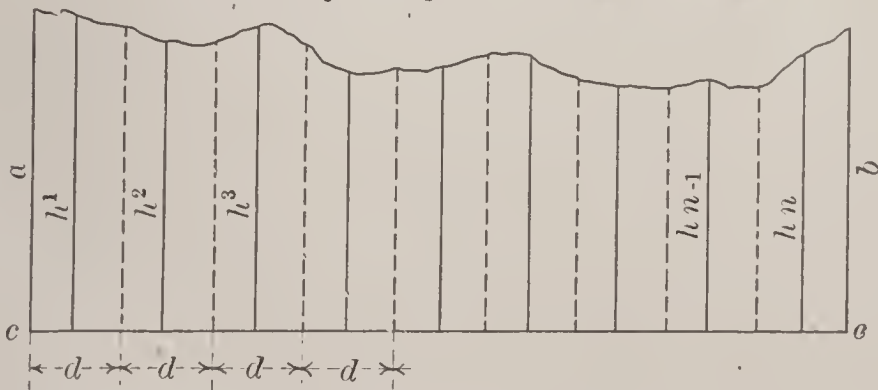

Divide the surface into any number, say n , parallel strips of equal widths, d , whose middle ordinates are represented by

$$\begin{matrix} h & h & h & h & \dots & h & h \\ 1 & 2 & 3 & 4 & & n-1 & n \end{matrix}$$

then is, after Poncelet's rule,

$$A = d \sum h + \frac{1}{12} d (a-h) + \frac{1}{12} d (b-h)$$

but more exact after Francke's rule,

$$A = d \sum h + \frac{1}{72} d (8a + h - 9h) + \frac{1}{72} d (8b + h - 9h)$$

MENSURATION

Cylinder

$$A = \pi d h + \left[\frac{\pi d^2}{4} \right] 2 \quad V = \text{contents}$$

$$V = \frac{\pi d^2}{4} h$$

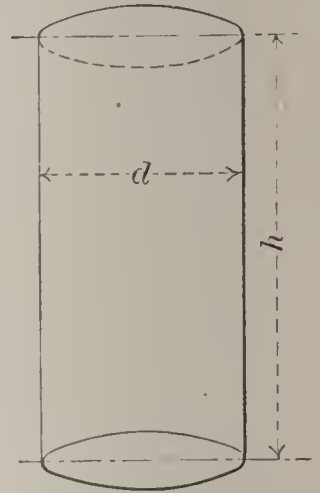

Sphere

$$A = \pi d^2$$

$$V = \frac{\pi d^3}{6}$$

Pyramid and Cone

$A =$ periphery or circumference of base \times half slant height.
 $V =$ area of base $+ \frac{1}{3}$ perpendicular height.

Frustum

$A =$ sum of peripheries or circumferences of the two ends
 \times half slant height $+ \text{area of both ends.}$

Frustum of a cone. $V = \frac{1}{3} \pi h (R^2 + r^2 + Rr)$

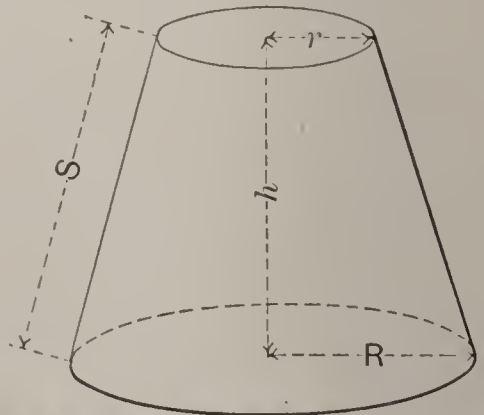
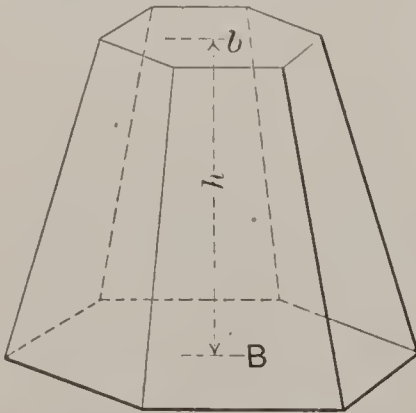

Frustum of pyramid. $V = \frac{1}{3} h (B + \sqrt{Bb} + b)$
 (h being the distance of the two parallel end surfaces
 B and b).

MENSURATION .

Properties of the Circle

Circumference = Diam. \times 3.1416 or $3\frac{1}{7}$.

Diam. \times .8862 = Side of an equal square.

Diam. \times .7071 = Side of an inscribed square.

Diam. $^2 \times$.7854 = Area of circle.

Radius \times 6.2832 = Circumference.

Circumference = 3.5446 \sqrt area of circle.

Diam. = 1.1283 \sqrt area of circle.

Length of arc = No. of degrees \times .017453 radius.

Degrees in arc whose length equals radius = 57.2957°.

Length of an arc of 1° = Radius \times .017453.

Length of an arc of 1' = Radius \times .0002909.

Length of an arc of 1'' = Radius \times .0000048.

π = Proportion of circumference to diam. = 3.1415926.

π^2 = 9.8696044.

$\sqrt{\pi}$ = 1.7724538.

Log. π = 0.4971499.

$\frac{1}{\pi}$ = 0.3183001.

$\frac{1}{360}$ = .002778.

$\frac{360}{\pi}$ = 114.59.

Trigonometrical Formulæ

General Equivalents

The diagram shows the different trigonometrical expressions in terms of the angle *A*.

In the following formulæ Radius = 1.

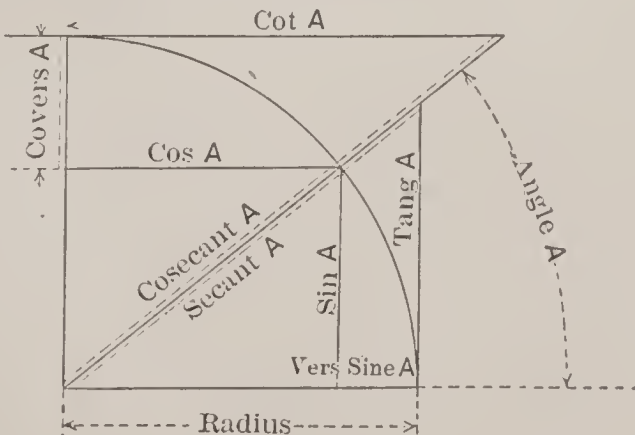

MENSURATION

Complement of an angle = its difference from 90° .

Supplement of an angle = its difference from 180° .

$$\text{Sin.} = \frac{1}{\text{cosec.}} = \frac{\text{cos.}}{\text{cot.}} = \sqrt{(1 - \text{cos.}^2)}$$

$$\text{Tan.} = \frac{\text{sin.}}{\text{cos.}} = \frac{1}{\text{cot.}}$$

$$\text{Sec.} = \sqrt{\text{Rad}^2 + \text{tan}^2} = \frac{1}{\text{cos.}} = \frac{\text{tan.}}{\text{sin.}}$$

$$\text{Cos.} = \sqrt{(1 - \text{sin.}^2)} = \frac{\text{sin.}}{\text{tan.}} = \text{sin.} \times \text{cot.} = \frac{1}{\text{sec.}}$$

$$\text{Cot.} = \frac{\text{cos.}}{\text{sin.}} = \frac{1}{\text{tan.}} \quad \text{Cosec.} = \frac{1}{\text{sin.}}$$

Versin. = Rad. — cos. Coversin. = Rad. — sin.

$$\text{Rad.} = \text{tan.} \times \text{cot.} = \sqrt{\text{sin.}^2 + \text{cos.}^2}$$

Solution of Right-Angled Triangles

$$\text{Hypoth.}^2 = \text{base}^2 + \text{perpend.}^2$$

$$\text{Base}^2 = (\text{hyp.} + \text{perp.}) \times (\text{hyp.} - \text{perp.})$$

$$\text{Perp.}^2 = (\text{hyp.} + \text{base}) \times (\text{hyp.} - \text{base}).$$

$$\text{Sin. } a = \frac{A}{C}$$

$$\text{Cot. } a = \frac{B}{A}$$

$$\text{Cos. } a = \frac{B}{C}$$

$$\text{Cos. } b = \frac{A}{C}$$

$$\text{Tan. } a = \frac{A}{B}$$

$$\text{Cot. } b = \frac{A}{B}$$

$$\text{Cosec. } a = \frac{C}{A}$$

$$b = 90^\circ - a$$

$$A = B \tan. a$$

$$\text{Sec. } a = \frac{C}{B}$$

$$A = C \sin. a$$

$$B = C \cos. a = A \cot. a =$$

$$\sqrt{(C+A)(C-A)}$$

$$C = \sqrt{A^2 + B^2} = \frac{A}{\text{sin. } a} = \frac{B}{\text{cos. } a}$$

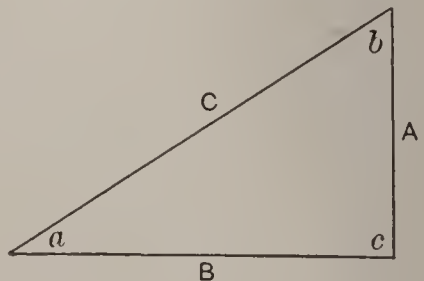

MENSURATION

Solution of Oblique-Angled Triangles

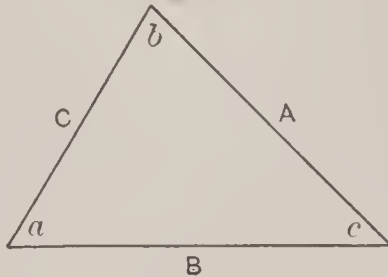

Value of any side C is:

$$C = \frac{A \sin. c}{\sin. a} = \frac{B \sin. c}{\sin. b} = \frac{A}{\cos. b + \sin. b \cot. c}$$

$$C = \frac{B}{\cos. a + \sin. a \cot. c} = A \cos. b + A$$

$$C = \sqrt{A^2 + B^2 - 2AB \cos. c} = B \cos. a + B \sin. a \cot. b$$

Value of any angle a is:

$$\sin. a = \frac{A \sin. c}{c} = \frac{A \sin. b}{B} = \sin. (b + c)$$

$$\sin. a = \sin. b \cos. c + \cos. b \sin. c$$

$$\cos. a = \sin. b \sin. c - \cos. b \cos. c$$

$$\cos. a = \frac{C^2 + B^2 - A^2}{2BC}$$

$$\tan. a = \frac{A \sin. c}{B - A \cos. c} = \frac{A \sin. b}{C - A \cos. b}$$

$$\tan. a = \frac{\tan. b + \tan. c}{\tan. b \tan. c - 1}$$

STRENGTH OF MATERIALS

Ultimate Resistance to Tension in Pounds per
Square Inch

Metals and Alloys

	AVERAGE
Aluminum Bronze,	
10 per cent Al. and 90 per cent copper	85000
1¼ per cent Al. and 98¾ per cent copper	28000
Brass, cast	18000
Brass, wire	49000
Bronze or gun metal	36000
Copper, cast	19000
Copper, sheet	30000
Copper, bolts	36000
Copper, wire, unannealed	60000
Iron, cast, 13,400 to 29,000	16500
Iron, wrought, round or square bars of 1 to 2-inch diameter, double refined	50000 to 54000
Iron, wrought specimens ½-inch square, cut from large bars of double refined iron	50000 to 53000
Iron, wrought, double refined, in large bars of about 7-square-inch section	46000 to 47000
Iron, wrought, universal mill plates, angles and other shapes	48000 to 51000
Iron, wrought plates over 36 inches wide	46000 to 50000
The modulus of elasticity of double refined bar iron is 25,000,000 to 27,000,000 ; of steel bars, 29,000,000 to 42,000,000.	
Iron wire	70000 to 100000
Iron wire ropes	90000
Lead, sheet	3300

STRENGTH OF MATERIALS

AVERAGE

Steel	65000 to 120000
Tin, cast	4600
Zinc	7000 to 8000

Timber, Seasoned, and other Organic Fiber

Taken largely from Trautwine's pocket book (edition of 1902).

Ash, English	16000
Ash, American	16500
Beech, English	11500
Birch	15000
Cedar of Lebanon	11400
Cedar, American, red	10300
Fir or Spruce	10000
Hempen Ropes	12000 to 15000
Hickory, American	11000
Mahogany	8000 to 16000
Oak, American white	10000
Oak, European	10000
Pine, American white, red and pitch, Memel, Riga	10000
Pine, American long leaf yellow	12600 to 19200
Poplar	7000
Silk fiber	52000
Walnut, black	8000

Stone, Natural and Artificial

Brick	40 to 400	220
Glass	2500 to 9000	5700
Slate	2400 to 3800	
Mortar, ordinary	10 to 20	15

STRENGTH OF MATERIALS

Ultimate Resistance to Compression

Metals

AVERAGE

Brass, cast, reduced	$\left\{ \begin{array}{l} \frac{1}{10} \text{ part in length by } 51000 \\ \frac{1}{2} \text{ part in length by } 16500 \end{array} \right.$	
Iron, cast		82000 to 125000
Iron, wrought, within elastic limit		22400 to 35800
Steel, rolled, within elastic limit		47000

General Instructions to Customers Ordering Structural Material

Architect's and engineer's drawings and specifications are usually definite enough to enable us to execute them without loss of time in correspondence. Small orders from contractors and others are frequently very indefinite in specifying just what is desired, making correspondence necessary and often resulting in great loss of time in shipping the material. We therefore invite your attention to the following data which should accompany the order:

1. Size of holes should be given, or better, the size of bolts or rivets to be used. If same are not especially specified, we will punch all beams and channels $1\frac{3}{8}$ -inch holes for $\frac{3}{4}$ -inch rivets or bolts in webs. Flange holes we will punch of size given in table of beams and channels on pages 56 and 57.

2. In ordering beams to be punched for and provided with separators, state width of walls to be supported, or give width lintel should be over all after assembling. Further, state if separator bolts are to be used only to assemble lintel, or if some wood furring, either on one or both sides of lintel or twin beam, has to be fastened to beam webs by said bolts, in which case we would add to length of bolts 2 inches or 4 inches respectively.

3. If beam ends are not to be square, it would be well to distinguish between mitered as per sketch No. 1, or beveled as per sketch No. 2. Better still, to accompany same with a clear sketch, giving the required angle either in degrees or in proportion of 12-inch to x as shown on sketch.

4. In ordering bent beams or channels, state if same are to be

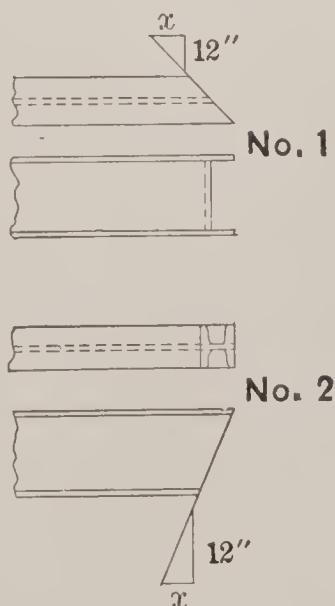

cambered as per sketch No. 3, giving besides the required length, L , either height of camber, h , or radius, r or R . Further state if ends have to be cut off square to chord, on line nn , or radial, on line mm .

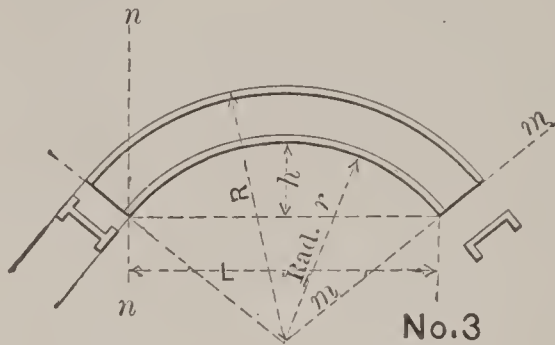

No.3

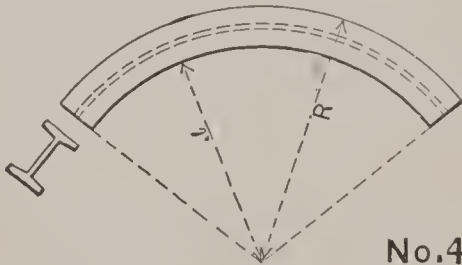

No.4

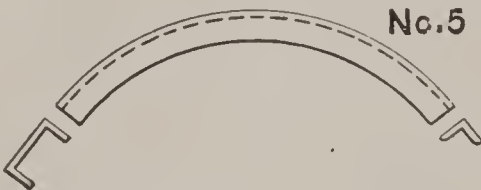

No.5



No.6

When beams or channels are to be bent vertical to their web as in sketch Nos. 4, 5 or 6, similar data should be given as for cambered beams or channels, but in this case for channels or angles it is necessary to state if web of channel or vertical leg of angle is to be outside, as in sketch No. 5, or inside as in No. 6; further, in case of angles of unequal legs, state which leg is to be vertical to curve. In all these cases, a simple sketch will explain more than many words.

5. State in each order if steel should be painted before shipment, and if field connections are to be bolts or rivets.

INDEX

INDEX

	PAGE
Anchors :	
Standard types	69
Angles :	
Areas of	55
Diagrams of	13-19
Equal legs	52
Maximum lengths	54
Maximum size of rivets and gauge for punching	59
Minimum spans for Standard connection angles	60
Properties of	128-139.
Radii of gyration, two angles back to back	174-176
Radii of gyration, two angles star section	236-238
Radii of gyration, single angle	128-139
Safe loads for	106-108
Safe loads, single angle struts	172
Standard connections, notes on	60
Standard connections, details of	61
Standard connections for opposite framing	62
Arches :	
Types of fireproof	67
Weights of	74
Areas :	
Of angles and plates for columns	240-244
Of circles	218-230
Methods of increasing for shapes	39
Bars :	
Beveled edges	43
Flat—sizes and maximum lengths	46, 47
Flat—sizes and weights	196-201
Half rounds	44
Hexagons	44
Ovals and half-ovals	44
Round	42

	PAGE
Round edges	43, 45
Twisted	235
 Beams :	
Bending moments and deflections of	115
Deflection coefficients	85
Diagrams of	4-9
Formulæ on flexure	114
Properties of	118-121
Sizes and maximum lengths	56
Standard framing of	62
Standard gauges for punching	59
Tables of safe loads	86-97
Tables, explanation of	81-84
Without lateral support	84
Wooden, strength of	178
 Bearing Plates	 63
 Beveled Edged Bars	 43
 Boat Spikes :	
Weights and sizes	235
 Bolts :	
Machine, weights of	207
Standard screw threads, nuts and heads	212
 Brick Walls :	
Weight of	80
 Bridges :	
Beam, details of	186
 Cast Washers :	
Table of	177
 Chains :	
Diagrams of	40
Sizes, strength and weights of	41

	PAGE
Channels :	
Diagrams of	10-12
Properties of	120-123
Sizes and maximum lengths	57
Tables of safe loads	98-105
Channel Tires	25
Circles :	
Areas and circumferences of	218-230
Circular Plates :	
Sizes	49
Clevises	269
Columns :	
Areas of angles and plates for	240-244
Details of concrete fireproofing	71
Diagrams of sections	64
General notes on	149-151
Notes on splicing and connections	66
Strength and weights of angle and plate	160-169
Strength and weights of channel	152-158
Strength and weights of cast-iron	171
Strength and weights of single angle	172
Strength and weights of single beams	159
Strength and weights of Z bar	170
Strength of wooden	179
Cold Rolled :	
Reaper and harvester finger bars	32, 33
Shafting, etc.	267
Corrugated Sheets :	
Weights and strength of	111
Cubic Foot of Substances :	
Weights of	215-217
Decimals of a Foot for each $\frac{1}{64}$ of an Inch	276, 277

	PAGE
Decimals of an Inch for each $\frac{1}{64}$ of an Inch .	278
Expansion Coefficients	85
Explanation of Tables	112, 113
Eye Bars :	
Standard	274
Adjustable	273
Notes on	275
Finger Bars	32, 33
Fireproofing :	
General notes on	72-79
Styles of floors	68-70
Floors :	
Details of connections	69
General notes on fireproof construction	72-79
Girders for	80
Styles of fireproofing	67, 70
Formulæ :	
General	114
Framing :	
Standard diagrams of	62
General Instructions for Ordering Material .	293, 294
Girders :	
Beam, strength and weight of	140-144
Built, strength and weight of	145-148
Grooved Steel	23, 24
Half Rounds	44
Harvester Tires	25
Hexagons	44

	PAGE
Hoops	45
Inertia, Moments of	116, 117
Logarithms	245-247
Looped Eyes	272
Manufacturers' Standard Specifications	187-195
Mensuration	284-289
Metric Conversion Table	239
Miscellaneous Steel	27-31
Moments of Inertia	116, 117
Natural Sines, etc.	248-256
Nuts :	
Sizes and weights of square	208
Sizes and weights of hexagon	209
Pin	271
Sleeve	270
Nut Steel	47
Ovals and Half-Ovals	44
Partitions :	
Details of construction	71
Plates :	
Bearing	63
Circular	49
Rolled edges	46
Sheared edges	48, 49
Weights of	231-234
Pipe :	
For steam, water and gas	214

	PAGE
Pins and Pin Nuts	271
Radii of Gyration :	
Angles	128-139
Beams, single and double	118-121
Channels, single and double	120-123
Plate and angle columns	160-169
Tees	126, 127
Two angles, back to back	174-176
Two angles, star section	236-238
Zees	124, 125
Rails :	
Diagrams and weights of	35-38
Splices for	37
Railroad Spikes :	
Weight of	235
Reaper and Harvester Finger Bars :	
Diagrams of cold rolled	32, 33
Diagrams of hot rolled	34
Rivets :	
Conventional signs for	183
Lengths of	182
Shearing and bearing values	184, 185
Weights of round headed	206
Roof Trusses :	
Details of	180
Stresses in	181
Round Bars :	
Sizes of	42
Round Edge Steel Flats :	
Sizes	45
Round Edge or Reach Plate	43

	PAGE
Round Edge Steel Tires :	
Sizes	45
Sectional Areas :	
Methods of increasing	39
Separators :	
Standard sizes and weights	58
Types of cast	69
Sheared Plates :	
Sizes	48, 49
Shafting :	
Cold rolled	267
Sheet Iron and Steel :	
Weights of	213
Sleeve Nuts	270
Specifications, Manufacturers' Standard	187-195
Spikes :	
Boat	235
Railroad	235
Square Bars :	
Sizes	43
Squares, Cubes, etc.	257-266
Standard Framing :	
Diagrams of	62
Spacing in flanges of rolled sections	59
Screw threads	212
Strength of Material	290-292
Struts :	
Ultimate strength of	173

	PAGE
Substances :	
Weights per cubic foot	215-217
Tables :	
Converting inches and feet to metric measure	279
Converting metric measure into inches .	280, 281
Of weights, interchanging U. S. and Metric systems	282
Of liquid and dry measure, interchanging U. S. and Metric systems	283
Of strength of materials	290-292
Tank Iron and Steel .	
Weights of	213
Tees :	
Diagrams of	20-22
Properties of	126, 127
Sizes and weights of	50
Table of safe loads	109
Tires :	
Channel	25
Harvester	25
Round edge	45
Twisted Bars	235
Upset Screw Ends for Round and Square Bars	210, 211
Weights :	
Bolts, machine	207
Brick walls	80
Cubic foot of substances	215-217
Flat bars	146-201
Nuts	208, 209
Nuts and bolt heads	207
Pipe for steam, water and gas	214
Rivets, round headed	206
Separators	58

	PAGE
Sheet and tank steel	213
Terra cotta arches	74
Wooden Posts :	
Strength of	179
Zees :	
Diagrams of	20-22
Properties of	124, 125
Sizes and weights	51
Table of safe loads	110

We Manufacture the Following Articles

Bessemer, Basic and Acid Open Hearth Steel Blooms	Tee Rails (8 to 40 pounds per yard)
Slabs and Billets	Railroad Spikes
Beams	Structural and Boiler Rivets
Channels	Boat and Barge Spikes
Angles	Cold Rolled Shafting
Tees and Zees	Squares
Rounds and Squares	Hexagons
Flats	Flats
Hexagons	Zees
Sheets	Angles
Rectangular and Circular Plates	Finger Bars and Special Shapes
Hoops and Bands	Couplings
Chains	Hangers
Special Sections for Structural and Agricultural pur- poses	Pillow Blocks
	Pulleys
	Forgings, etc., etc.

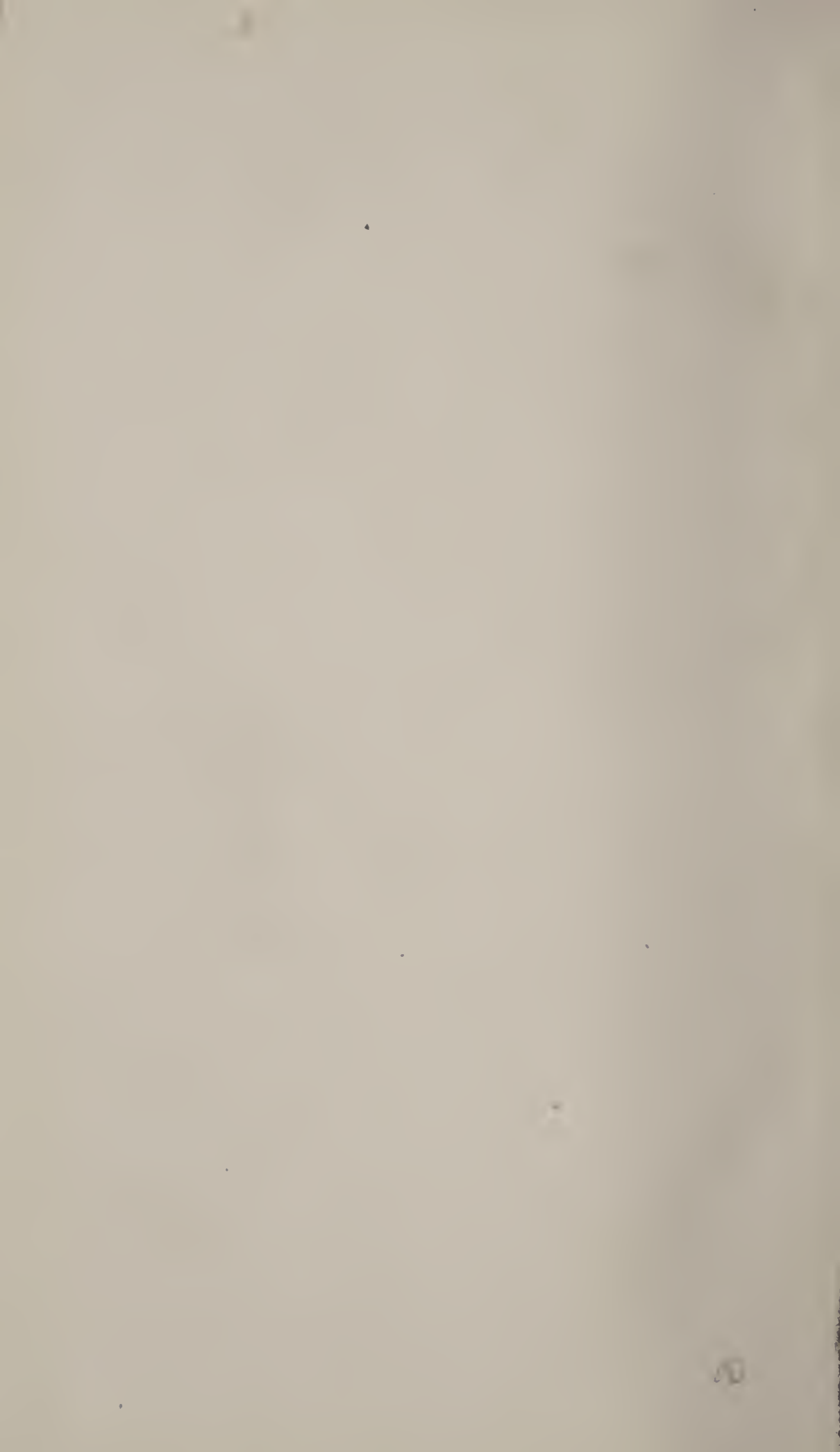





LIBRARY OF CONGRESS

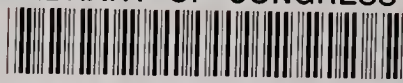

0 021 622 715 3