

Scanned from the collections of The Library of Congress



Packard Campus
for Audio Visual Conservation
www.loc.gov/avconservation

Motion Picture and Television Reading Room
www.loc.gov/rr/mopic

Recorded Sound Reference Center
www.loc.gov/rr/record

Cinematographer

THE MAGAZINE OF MOTION PICTURE PHOTOGRAPHY

THEATRE
TELEVISION
INDUSTRIAL
AMATEUR



This Issue . . .

- Pictorial Continuity
- Filming A Water Ski Ballet
- Simple Sound Recorder For Amateurs

25c

\$3.00 YEARLY

“To attain brutal realism in the story of ‘Martin Luther,’ we chose a film known for exceptional contrast, speed and wide latitude,”

declared cameraman
Joseph Brun, ASC.



Joseph Brun, left, confers with assistant on location during filming of the story. Note the Eclair Come "300" reflex studio camera used by Mr. Brun.

Inspired career of Martin Luther filmed on DU PONT "SUPERIOR" 2

In discussing the film story of "Martin Luther," proudly produced and released by Louis de Rochemont Associates for Lutheran Church Productions, Inc., cameraman Joseph Brun enthusiastically praised the qualities of Du Pont Motion Picture Film: "We required a film which would enable us to create an artistic portrayal of the man and the issues involved in this theological picturization.

"Because the story was filmed in locales where the original action took place, in Germany during the 16th century, many of our sets were huge naves, unending corridors, and immense halls. Some of the action took place at night and with snow on the ground. It proved a challenge in lighting . . . and, quite understandably, necessitated a film that would capture every detail."

That Du Pont "Superior" 2 was the film selected to photograph this outstanding production further testifies to its wide acceptance by many of the country's foremost cinematographers. That the picture won immediate acclaim as a photographic achievement, and is being extensively shown, although not originally produced for general distribution, is proof anew of the fine work an artist can achieve with the best of tools.



Niall MacGinnis, at table, played the role of Martin Luther in this masterful Louis de Rochemont production now enthraling audiences everywhere.



Typical scene from the authentic story produced by Lothar Wolff. All backgrounds and settings were those actually used in the 16th century, when the action originally occurred.

DU PONT
MOTION PICTURE FILM

NEW YORK • CHICAGO • LOS ANGELES



REG. U.S. PAT. OFF.

BETTER THINGS FOR BETTER LIVING... THROUGH CHEMISTRY

SALES • SERVICE • RENTALS



TR845
A55

2

357
JAN 26 1954

THE WORLD'S MOST COMPLETE ASSORTMENT
OF PHOTOGRAPHIC EQUIPMENT FOR

T.V. and Motion Picture Studios

13

MICROPHONE BOOMS

FOR ALL PURPOSES

SMALL, MEDIUM, LARGE



M-R Microphone Boom with Perambulator. Quiet in operation. Also lightweight Models C-12, C-17 and Century Mike Boom. Beautifully engineered for TV and motion pictures.

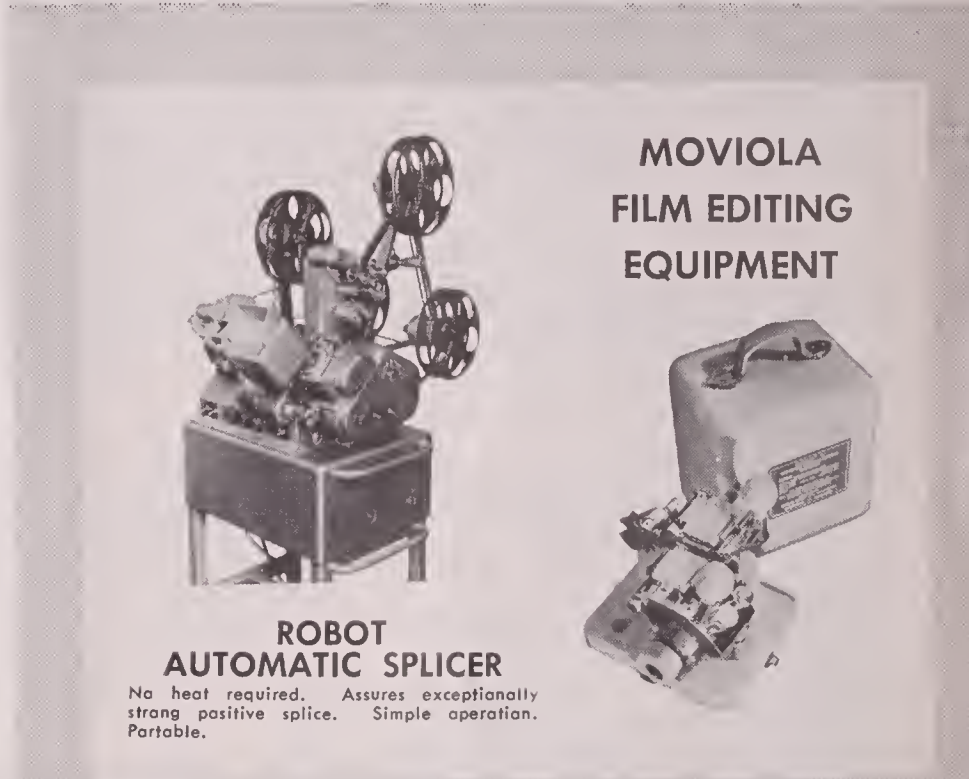

MOVIOLA
FILM EDITING
EQUIPMENT

ROBOT AUTOMATIC SPLICER

No heat required. Assures exceptionally strong positive splice. Simple operation. Portable.



AURICON CAMERAS

Illustrated: Cinevoice with 3-lens turret, Zoom Finder and 400 ft. Magazine.

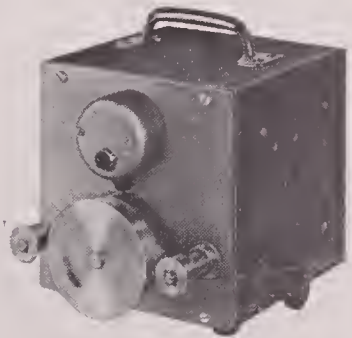

PRECISION SOUND READER

(16-35 COMBINATION)

Simple threading. Polished Stabilizer drum with needle bearings. Surface cannot damage film. Precision ground shafts. Dimensions—6" x 6" x 7 1/2". AMPLIFIER: 117 volt, 60 cycle, AC. Power output 4 Watts. Heavy duty Alnico V. Speaker. Safety fused.

LIGHTWEIGHT ALUMINUM SHOULDER BRACE

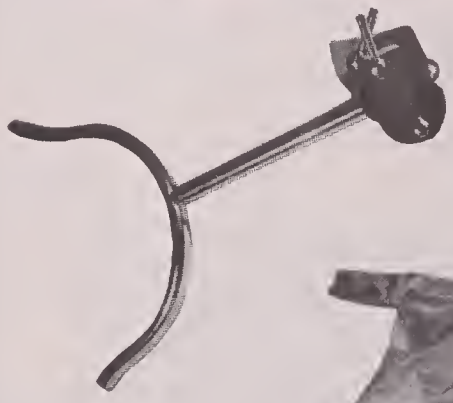

... for 16mm and 35mm cameras. Sturdy, yet light enough not to tire user. Easy panning and tilting. For all hand-held cameras.

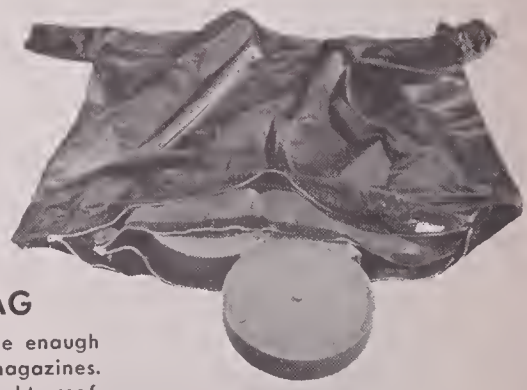

CHANGING BAG

— a portable darkroom. Large enough to take 1000 ft. 35mm magazines. Double zipper. Completely light-proof.

9.5mm Lenses in 16mm C mount. 18.5mm (extreme wide angle-flat field) Lenses available in mounts for all 35 mm Motion Picture Cameras. PHOTO RESEARCH Color Temperature Meters. *Electric Footage Timers Neumade and Hollywood Film Company cutting room equipment. Griswold & B.&H. Hot Splicers. *DOLLIES—Bardwell-McAlister, Mole Richardson, Century and Colortran Lighting Equipment.

Complete line of 16mm and 35mm Cameras

FRANK C. ZUCKER

CAMERA EQUIPMENT ©

1600 BROADWAY NEW YORK CITY

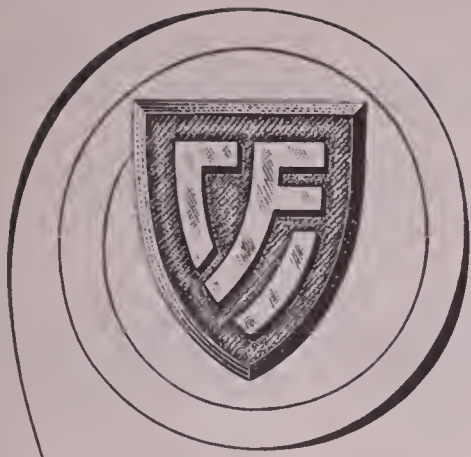

The Seal of Our Pledge to You . . .

... to bring to the screen in flawless manner the artistry of your photography

Hollywood's only complete

LABORATORY SERVICE

CONSOLIDATED FILM INDUSTRIES

A DIVISION OF REPUBLIC PICTURES CORPORATION

959 N. SEWARD ST. PHONE HO 9-1441

AMERICAN

Cinematographer

THE MAGAZINE OF MOTION PICTURE PHOTOGRAPHY
PUBLICATION OF THE AMERICAN SOCIETY OF CINEMATOGRAPHERS

ARTHUR E. GAVIN, *Editor*

EMERY HUSE, *Technical Editor*

GLENN R. KERSHNER, *Art Editor*

MARGUERITE DUERR, *Circulation*

EDITORIAL ADVISORY BOARD: John Arnold, Arthur Edeson, Lee Garmes, Charles Rosher, Leon Shamroy, Fred Gage, Dr. L. A. Jones

Editorial and Business Office: 1782 N. Orange Dr., Hollywood 28, Calif.
Telephone: HOLLYWOOD 7-2135

VOL. 35

JANUARY

1954

NO. 1

CONTENTS

ARTICLES

FILMING A WATER SKI BALLET—By Arthur Rowan	18
1953 BOX SCORE (YEAR'S ASSIGNMENTS FOR ASC CAMERAMEN)	20
PROJECTION VIEWING WITH THE WESTREX EDITER—By Leigh Allen	23
THE ZOOMAR VARIFOCAL LENS FOR 16MM CAMERAS—By Alvin D. Roe	27
PICTORIAL CONTINUITY—By Charles Loring	30
CAMERA CREWS GO TO COLLEGE TO GET MATERIAL FOR NEW TV FILM SERIES —By Joseph W. MacDonald	32

AMATEUR CINEMATOGRAPHY

RECORD SOUND AS YOU SHOOT—By George W. Cushman	34
SIMPLE LENS ASSEMBLY FOR MAKING SPECIAL EFFECTS	36

FEATURES

INDUSTRY NEWS	6
WHAT'S NEW IN EQUIPMENT, ACCESSORIES, SERVICE	3
HOLLYWOOD BULLETIN BOARD	12
SWAP YOUR ODD SHOTS	40
CURRENT ASSIGNMENTS OF A.S.C. MEMBERS	52
ROSTER OF AMERICAN SOCIETY OF CINEMATOGRAPHERS	53

ON THE COVER

ESTHER WILLIAMS is the focus of attention on the Cypress Gardens, Florida, location of MGM's "Easy To Love," as director of photography Ray June, ASC, checks his light readings. Tony Martin and members of the MGM crew watch. The Technicolor musical features an unusual water ski ballet, the photography of which is described in an article beginning on page 18 of this issue.

—Photo by Eric Carpenter.

AMERICAN CINEMATOGRAPHER, established 1920, is published monthly by the A. S. C. Agency, Inc., 1782 N. Orange Dr., Hollywood 28, Calif. Entered as second class matter Nov. 18, 1937, at the postoffice at Los Angeles, Calif., under act of March 3, 1879. SUBSCRIPTIONS: United States and Pan-American Union, \$3.00 per year; Canada, \$3.00 per year; Foreign, \$4.00. Single copies, 25 cents; back numbers, 30 cents; foreign single copies, 35 cents; back numbers, 40 cents. Advertising rates on application. Copyright 1954 by A. S. C. Agency, Inc.

Mitchell *

PROFESSIONAL EQUIPMENT
FOR PROVEN
PROFESSIONAL RESULTS

*World's Finest
16mm and 35mm
Cameras!*



35mm BNC MODEL

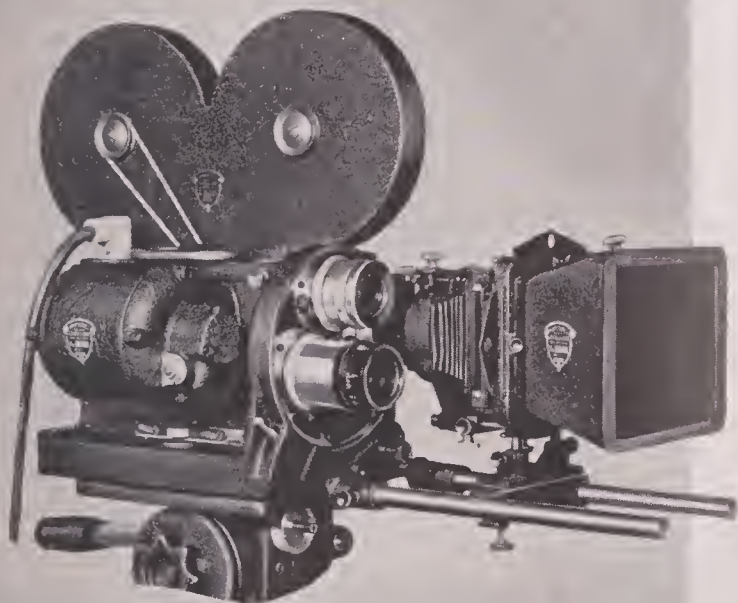

16mm PROFESSIONAL

IMPORTANT NEWS

ABOUT THE WORLD'S
MOST FAMOUS 16mm CAMERAS

Immediate Delivery

of the Mitchell 16mm Professional Cameras currently being made. Write today for Complete Information.

THE **I** AND ONLY *Mitchell*

Mitchell Camera CORPORATION

666 WEST HARVARD STREET • GLENDALE 4, CALIFORNIA • CABLE ADDRESS: "MITCAMCO"

EASTERN REPRESENTATIVE: THEODORE ALTMAN • 521 FIFTH AVENUE • NEW YORK CITY 17 • MURRAY HILL 2-7038



85% of the motion pictures shown in theatres throughout the world are filmed with a Mitchell

mitchell

CAMERA STORES, INC.

HAPPY NEW YEAR

May we take the opportunity presented to us only once each year, to extend to all of our wonderful friends and customers the very best wishes for a successful and prosperous New Year.

And may we ask you to bear in mind that next year as in past years we are at your disposal to render you our usual courteous prompt and efficient services.

- Rental and Sales —
Mitchells — Woll — Bell & Howell —
Akeley — Arri & Eclair Cameras, Etc.
Roby Blimps — Dollies — Houston —
etc.
- Professional Lenses for 16mm and
35mm, supplied and mounted to
Mitchell and all other Motion Picture
Cameras: Boltor — Goerz American —
Cooke — Angenieux — Wollensok —
Eastman — Zeiss — Astro — etc.
- Lens Cooling and Colibration.
- Synchronous, Variable Speed and
other special duty motors supplied for
all motion picture cameras.
- "T" Stop Colibration for all lenses
- Repair Service —
Complete service for Mitchell — Bell
& Howell — Woll — Akeley —
Eastman — Arri — Eclair — and
Auricon Cameras, etc.
- Only Authorized Mitchell camera re-
pair service station on Eastern Sea-
board.
- We ship anywhere.
- Write for information and rental price
list to the attention of: Dept. T.C. —
Professional Service.

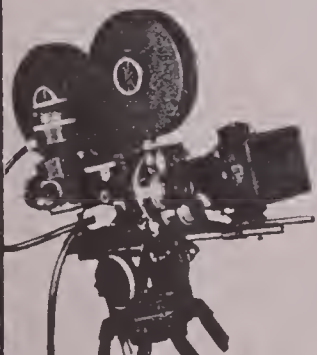

● Phone
PL 7-6812
CI 5-9372

● Warehouse
Address
110 West
51st Street,
New York
19, N. Y.

127 West 50th St. (At Radio City)
New York 19, N. Y.

INDUSTRY NEWS

Irving Browning, president of The Camera Mart, Inc., New York City, and founder of the Society of Cinema Collectors and Historians has recently presented two film subjects to the Museum of Modern Art for its film library. One is a two-reel short he produced in 1930 titled "City of Contrasts"; the second is a film report of the work of famed photographer Edward Steichen titled "Master of The Camera."

The coming year is likely to see renewed interest on part of studios in production of short subjects. "Too many exhibitors have been ignoring the big money-making potential in the promotion of one-and-two-reelers," according to Paramount's Oscar A. Morgan. With the growing trend toward single-bills, there will be increasing need for short subjects, cartoons, etc., to round out programs.

Newsreels are going wide-screen, and it is predicted that there will also be a general swing by all news films to color, now that there is more ample supply of Eastman color single-negative, necessary to newsreel color operations.

As for the trend of newsreels to wide screen, here are latest steps: Paramount began turning out newsreels on January 2nd in the standard Paramount wide-screen aspect ratio of 1.66 to 1. Footage is shot in standard manner, but with transparent masks in camera finders showing the 1.66 to 1 ratio.

MGM's "News of the Day" has begun issuing a wide-screen version, using the aspect ratio of 1.85 to 1.

Warner's Pathe News is using a ratio of 1.66 to 1—same as Paramount.

Fred Quimby, MGM's short subjects production head, has installed CinemaScope lenses on cameras of studio's cartoon department, and will henceforth turn out CinemaScope versions of a number of its pen-and-ink-and-color subjects. First three will be "Touche Pussy Cat," "South Bound Duckling" and "Brave Little Mouseketeer," all Tom and Jerry subjects.

Quimby also has started production on two new Tom and Jerry cartoons, "Robin Hoodwink," and "Ivan Whoa Whoa," using wide-screen technique. "A much broader range of story action is possible when a cartoon is drawn to wide screen proportion throughout," he said.

Warner Brothers has set January 4th as the date for resumption of production of animated cartoons. The studio plans to turn out between 25 and 30 cartoons during 1954.

A new all-purpose cartoon camera and crane has been installed. Larger swivel units for the animation, inking and painting desks have also been added, all of which will enable the studio to produce its new series of cartoons for both standard screens and the new WB screen ratio of 1.75 to 1.

Short Subjects in CinemaScope, a necessary adjunct to rounding out a theatre program where the feature is in CinemaScope, is now a major project on the 20th Century-Fox lot. Charles G. Clarke, ASC, photographed "Vesuvius Express," the studio's first. It's a travelogue-type subject filmed for the most part aboard one of the world's most famous railroad trains as it runs between Milan and Naples, Italy. Other CinemaScope shorts are now in production.

Three Appointments in Eastman Kodak Company's film processing organization has been announced. They are Earl R. Ruckdeschel, manager of company's new processing station to open at Chamblee, Georgia in June; Donald R. Brown, who becomes assistant service manager of the processing division in Rochester; and Harry G. Cooke, named general supervisor of engineering for the color print and processing organization in Rochester.

Advent of new dimensions in film production has brought still another advantage to the studios—that of cashing in on many of their best "old" story properties by re-making them in CinemaScope and other wide-screen systems. Paramount, for example is readying a new, revised script on "The Covered Wagon," one of the industry's all-time great pictures. Other major studios are similarly active.

"Wonder if it were just bad habits that rolled up movie budgets so high? Many TV film producers are using the same crews, equipment, and methods and are turning out footage in one-tenth the time and consequently one-tenth the money." Leo Guild, in his column "On The Air" in a recent issue of the "Hollywood Reporter."



35 and 16/35 mm



reflex viewing



divergent turret



40° to 200° adjustable shutter



lightweight - 14 lbs.



100' to 400' magazine



instantaneous loading



dovetail mounting



camerette

patents Coutant-Mathot
manufactured by Eclair, Paris

for descriptive brochure write U.S. representative

Benjamin Berg Agency, 1410 No. Van Ness Avenue, Hollywood 28, Calif.

in Canada: B.O.P. Co. Ltd., 455 Craig Street West, Montreal, P.Q.

ARRIFLEX

35mm
Model 11

**A TRULY GREAT
CAMERA**

for TV, Newsreel
and commercial
films

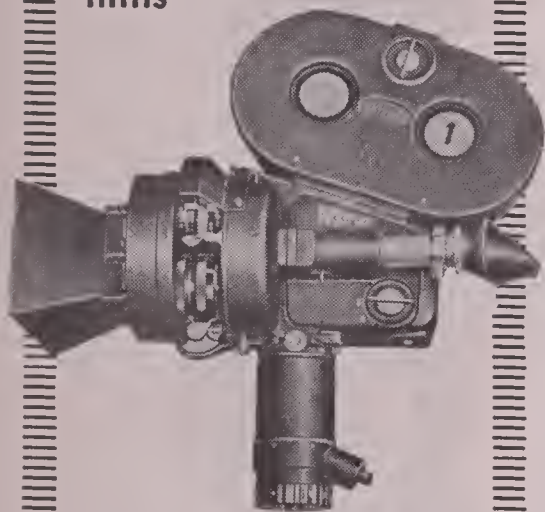

For tough and trying assignments, ARRIFLEX 35 is in a class by itself. Reflex focusing through photographing lens while camera is operating—this is just one outstanding ARRIFLEX feature.

Equipped with bright, right-side-up image finder, 6½ x magnification. Solves all parallax problems. 3 lens turret. Variable speed motor built into handle operates from lightweight battery. Tachometer registering from 0 to 50 frames per second. Compact, lightweight for either tripod or hand-held filming. Takes 200' or 400' magazine. Write for free folder.

COMPLETE REPAIR FACILITIES

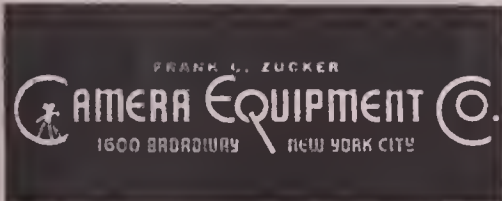

WHAT'S NEW in equipment, accessories and service

Time Lapse Device — Photovision Company, 1636 Washington Ave., Wilmette, Ill., announces a time lapse device for use with Bell & Howell 16mm Filmo and 35mm Eyemo cameras. The unit provides automatic picture cycling in a wide range of timing from two frames per second to one every four minutes.

Device consists of two units: the solenoid and timer. The former is a self-con-

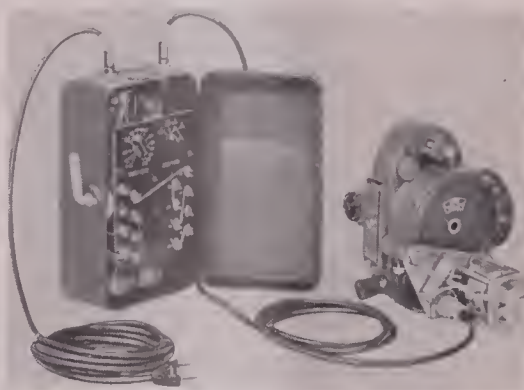

tained drive unit which drives the camera in place of the spring motor or auxiliary motor drive. Thus it is possible to maintain more even exposures from frame to frame, than when the camera spring motor is used.

The timer, an electronic intervalometer, has two dial controls, permitting unlimited selection of cycling intervals. This unit plugs into any standard 110-v. 60 cycle AC current supply.

Price of Solenoid unit is \$175; the Intervalometer, \$185.00. Delivery 60 days from order. Further information is available by writing the manufacturer.



Carrying Case — Crownlite, Inc., Brooklyn, N. Y., manufacturers of barlite units for cine cameras, announces a new carry carton for its Foldmaster and Foldmaster Deluxe units. It is an attractive cardboard case having a plastic handle. Price of the Foldmaster with carry case is \$12.95; the Foldmaster Deluxe with case is \$19.95.

Optical and Filter Glass—Alfa Photo Corp., 303 West 42nd St., N. Y. City has been appointed American agents for the line of optical and filter glass manufactured by Chance Brothers Ltd., Birmingham, England. Company is one of the oldest manufacturers of these materials.

The New York office will function as liaison to the American users of optical glass, answer inquiries, and expedite orders. Catalogs and price information are available on request.

Optical-Magnetic Reader—Precision Laboratories, 1139 Utica Ave., Brooklyn 3, N. Y., announces a new combination optical-magnetic sound track reader. Equipped with combination 16mm/35mm film rollers, these are machined to SMPTE standards and equipped with oilless bearings. The stabilizer drum has needle bearings and a highly pol-



ished surface to prevent scratching of film.

Changing from optical to magnetic is simply a matter of flicking a switch. The magnetic head mount has adjustment for track location and magnetic film thickness. Head is disengaged from contacting the optical film by mechanical means. Price is \$259.50, FOB factory.

Color Projection Guide—Radiant Manufacturing Corp., 2627 West Roosevelt Rd., Chicago 8, Ill., offers a free 16-page booklet on the preparation and projection of color pictures entitled "Secrets of Good Color Projection." Among the wealth of information it contains are data on complimentary colors with ex-

(Continued on Page 14)

Here is amazing

MANEUVERABILITY

never before achieved!

NEW!

for Film and TV Cameras

NEW! CIRCULAR STEERING

Entirely new steering mechanism makes possible easy, smooth, sharp turning on own axis or in any desired arc. Wheels can also be locked parallel for straight tracking in any direction.

VERSATILE WHEEL POSITIONS

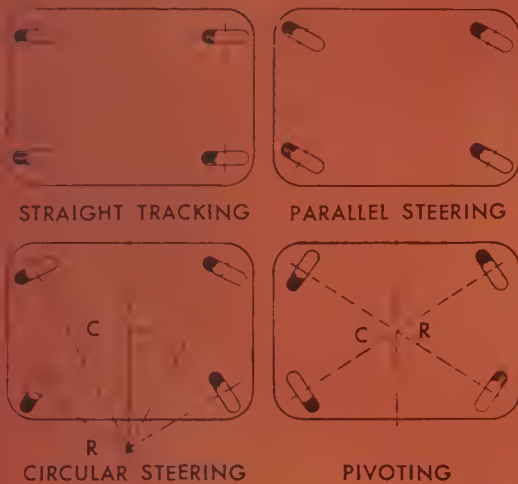

NEW! MANEUVERABILITY

The extreme flexibility of the steering mechanism makes possible fast positioning in small, crowded studios.

NEW! HANDLING EASE

Weighs only 500 pounds. Cameramen and grips appreciate easy dollying, turning, raising and lowering boom.

NEW! LOW SLUNG CHASSIS

Cinemobile is built low down for better balance, greater stability and smoother rolling.

NEW! VERSATILITY

Makes possible a wide range of camera effects formerly achieved only with larger, heavier equipment. Priced to fit the budget of smaller studios.

HOUSTON-FEARLESS CINEMOBILE



NEW! HYDRAULIC BOOM LIFT

Camera boom is raised and lowered smoothly, quietly, effortlessly, automatically by hydraulic system. Extreme high and low lens heights are readily achieved even when dolly is in motion.

SEND FOR FULL INFORMATION NOW!

The
HOUSTON FEARLESS
Corporation

THE HOUSTON-FEARLESS CORPORATION
11809 W. Olympic Blvd. • Los Angeles 64, California
Send information on Cinemobile Film Processors All Metal Tripod
 Panaram Dolly Camera Crane TV Pedestal
Name _____
Firm _____
Address _____
City _____ Zone _____ State _____

NOW...UNLIMITED HORIZONS

With a Flick of Your Finger

ZOOMAR 16

ZOOMS FROM NORMAL
... TO TELEPHOTO
... TO WIDE ANGLE

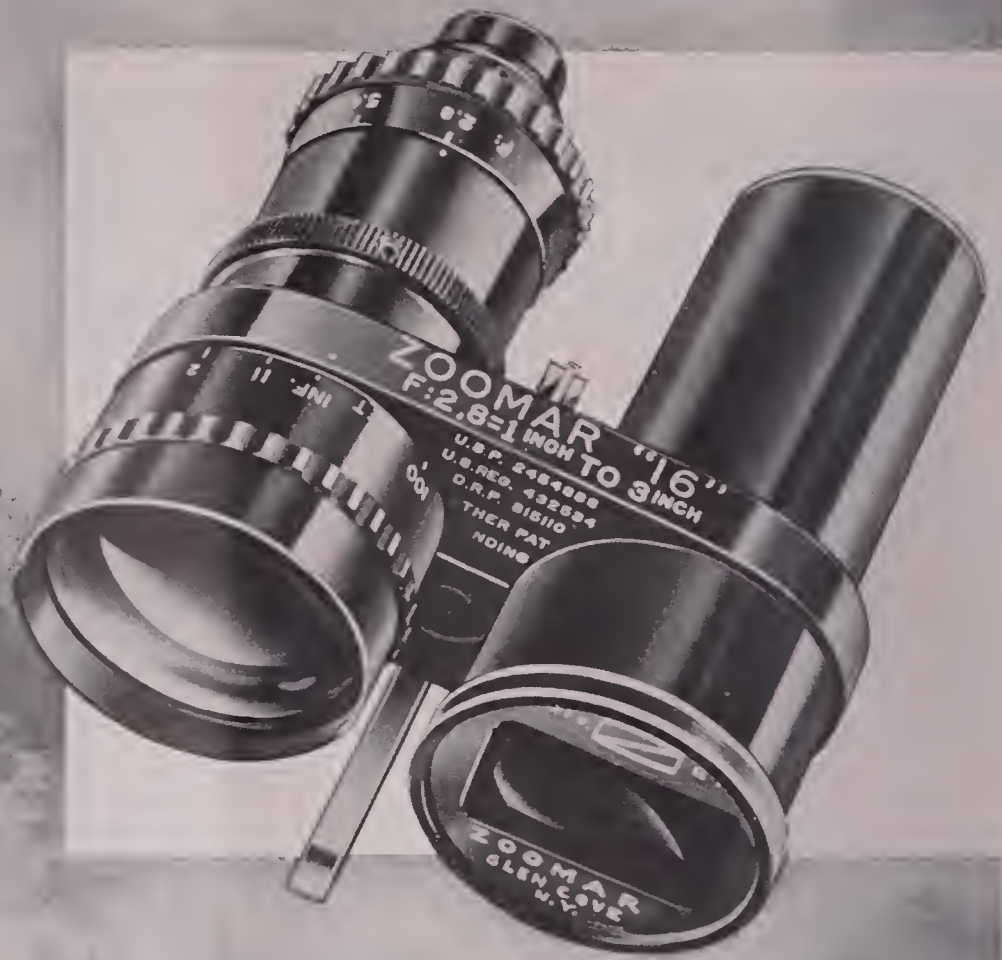

APERTURE RANGE F/2.8 to F/16
 ZOOM RANGE 1" to 3" (25mm to 75mm)
 DIFFERENCE IN FIELD nine times in one continuous zoom
 DISTANCE RANGE 8 ft. to infinity
 COUPLED VIEWFINDER.....large eye relief, no change in apparent frame size
 Weight 20 ounces
 Standard Series VII Filters and Short Range Adapters
\$600

ONLY ZOOMAR 16 FITS ALL 16MM MOTION PICTURE CAMERAS

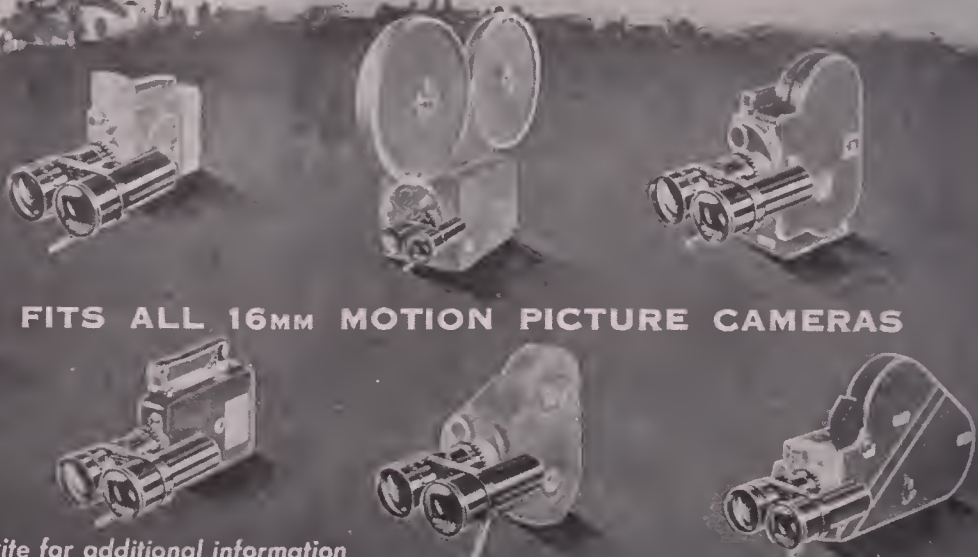

See Your Dealer, or write for additional information

ZOOMAR, Glen Cove, Long Island, N. Y. In Canada: ZOOMAR, Canada Ltd., Montreal, Quebec

It's here! new Westrex **Editer**

... the finest film editing machine
for studios everywhere!



Westrex Editer equipped for magnetic and photographic sound tracks synchronized with picture. 3-3/4" x 5" translucent screen shows bright, clear picture.

Designed and engineered by the Westrex Hollywood Laboratories—in cooperation with leading studios—the new Westrex Editer is an advanced machine that meets every film editing need.

The Westrex Editer can handle both standard and the new small-hole perforated 35mm films—film strips—motion picture films—magnetic or photographic sound films (single or multiple)—composite release prints—and for the first time it makes possible "projection viewing" of an enlarged image on a wall or screen without extra attachments.

The Westrex Editer is quiet in operation—no intermittent, hence less noise and less film damage—speedy and efficient. Among its advanced features are simplified threading—automatic fast stop—synchronization while running—improved sound—lower flutter.

The Westrex Editer—available in both 35mm and 16mm models—is the latest in a long line of notable Westrex contributions to the motion picture industry. A new illustrated folder that describes in detail its many

technical and operating advantages is yours for the asking.

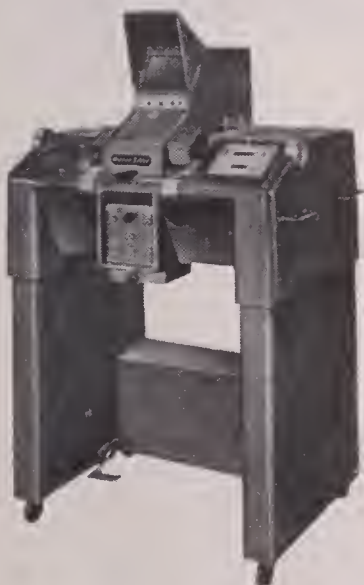

The basic Westrex Editer, for use with film strips—vertical film handling method—faster and more practical for either film strips or reels of film.



The Westrex Editer features "projection viewing" on wall or screen without disturbing the adjustments of the normal optical system.

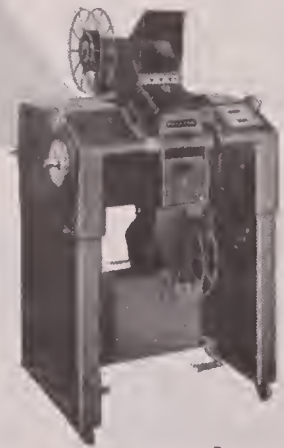

Research, Distribution and Service for the Motion Picture Industry.



Westrex Corporation

111 EIGHTH AVENUE, NEW YORK 11, N. Y.
HOLLYWOOD DIVISION: 6601 ROMAINE STREET. HOLLYWOOD 38. CAL.



Hollywood Bulletin Board



Primar Reflex Photo
normal 105 mm. lens

"Impossible"
distances
become
close-ups



Primar Reflex Photo
Astro 640 mm. lens
taken simultaneously
by Hans Namuth

with **ASTRO**®

LONG DISTANCE LENSES
FOCAL LENGTHS TO 1000 mm.!

Used by the world's foremost explorers, scientists and news services, Astro lenses have been making photographic history all over the globe. Special formulas have produced resolving powers up to 100 lines to the mm. And these superb lenses are *fast enough for action color work*—focal lengths from 300 to 800 mm. rated at F/5, the giant 1000 mm. (40 in.) at F/6.3.

FOR STILL CAMERAS Leica, Exakta, Primar-Reflex, Master Reflex, Hasselblad, Proklico, Contax-S

FOR MOVIE CAMERAS 16 & 35 mm. Bolex, Mitchell, Eyemo, Debrise, Askania, E.K., Arriflex, etc.

DUAL PURPOSE MOUNTS allow interchanging movie and still.



SUPER SPEED TELEPHOTOS

5 in. F/2.3
6 in. F/2.3
6 in. F/1.8

Made by Germany's foremost specialists in long-range optics, Astro lenses are available on order from franchised dealers only.

Write for brochure and prices

ERCONA CAMERA CORP.

Dept. A-19, 527 Fifth Ave., New York 17, N.Y.



IRMIN ROBERTS, ASC, and Peruvian topper.

Irmin Roberts, ASC, special photographic effects specialist at Paramount Studios, picked up a typical peasant rain hat in Peru, while photographing "The Story of The Incas." With a little blocking and the addition of a llama cord, the headgear was high style enough to start a fad that spread to other Paramount executives and to Lima, Peru where a store started turning them out by the gross.

Photo of Roberts above was taken by Sun Valley news bureau photographer Reid Rowland, while Mr. and Mrs. Roberts were guests at the resort over the holidays.

Karl Struss, ASC, in Italy for the past year, has photographed three 3-D films in Ferrania Color, which he says is similar to Eastman Color negative. It was just 29 years ago that Karl photographed the first movie of "Ben Hur" in Italy. MGM is currently preparing to re-make the picture.

Jack Greenhalgh, ASC, resumes shooting television films for Family Films the first week in February.

Mack Stengler, ASC, has been signed by Guild Films, Inc., to photograph both the "Liberace Show," and "Life With Elizabeth" during 1954.

David P. Boyle, ASC, son of John Boyle, secretary of the American Society of Cinematographers, died January 6th following a brief illness. At the time of his death, he was electrical engineer for Pathe Industries' Hollywood laboratories. Surviving besides his parents, are his wife and two daughters.

First International Film Festival of Brazil will take place in Sao Paulo from the 12th to the 26th of February. Film producers in all countries have been invited to participate, and a number of important personages from the Hollywood studios have been invited as special guests. The event will commemorate the fourth Centennial of the city of Sao Paulo.

Benjamin Berg, ASC, accompanied by Mrs. Berg, are enroute to Paris, France, on a combined vacation and business trip. Berg is U. S. representative for Eclair-Paris, manufacturers of the Eclair Camerette, with offices in Hollywood.

Ray Fernstrom, ASC, who recently severed connections with Reid Ray Film Productions in Minneapolis, has been signed as director of photography by Valiant Productions, makers of TV and industrial films in Houston, Texas.

A Total of 425 Films—10 less than last year, have been approved by the Academy of Motion Picture Arts and Sciences as contenders for the 1953 Academy Awards. This is the lowest number of films making the "eligible" list in four years.

Of these, 28 black-and-white and 24 color productions are currently being voted upon by industry cinematographers to select the 10 films in each group that will be nominated for Cinematography Awards.

In the meantime there is marked interest by the industry in pre-Award polls which have been conducted throughout the U. S., naming the "best" or "10 best" pictures of the year, etc.

In San Francisco, critics named "Moulin Rouge" (a contender for 1952 Oscars last year) as best for 1953, with "From Here To Eternity" next best.

MGM's New York publicity head, Russ Stewart sees the studio's "Julius Caesar," "Knights Of The Round Table," and "Lili" as leading the nominations for best picture and for technical Awards.

The New York Film Critics gave the nod to "From Here To Eternity" and "Roman Holiday" as top pictures of the year at the 19th annual voting at the Newspaper Guild club December 28th.

Metro-Goldwyn-Mayer studios will celebrate 1954 as the 30th Jubilee of the merger of the old silent-era Metro, Goldwyn and Mayer studios. An interesting note is the fact that old Metro employees, such as John Arnold, ASC, and Irving Ries, ASC, who went along with others in the move from Hollywood to Culver City, are still with MGM. Arnold is executive director of photography, and Ries is head of the optical effects department.

Hollywood Foreign Correspondents Assn., at a banquet January 22 at the Del Mar Hotel, Del Mar, Calif., will present its annual Golden Globe Awards, including that for best cinematography.



FILMEFFECTS OF HOLLYWOOD

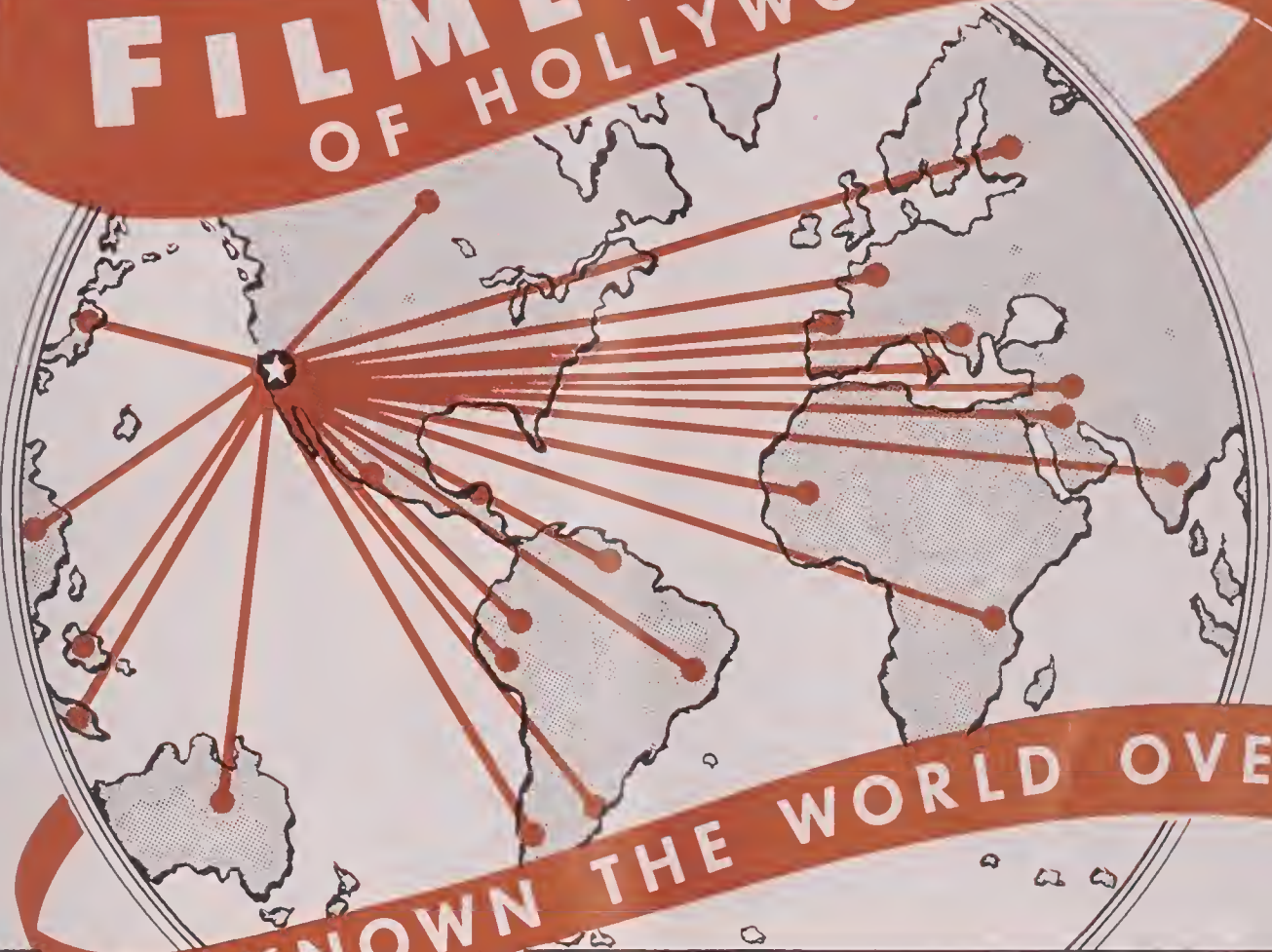

KNOWN THE WORLD OVER

35mm Color Prints from 16mm Originals

- ★ Direct Reversal Blow-Up Prints
- ★ Blow-Up Color Negatives
- ★ Blow-Up Separation Negatives

For the past six years our Color Prints have been acclaimed by leading producers in the United States as well as in other countries.

- | | | | |
|-----------|--------------|-------------|------------------|
| ● CANADA | ● FINLAND | ● NICARAGUA | ● JAPAN |
| ● MEXICO | ● JUGOSLAVIA | ● ECUADOR | ● ISRAEL |
| ● ITALY | ● BRAZIL | ● VENEZUELA | ● IRAN |
| ● SPAIN | ● CHILE | ● AFRICA | ● PHILLIPINES |
| ● FRANCE | ● ARGENTINA | ● INDIA | ● BRITISH MALAYA |
| ● ENGLAND | ● COLOMBIA | ● CHINA | ● AUSTRALIA |

LOOK TO FILMEFFECTS FOR QUALITY LEADERSHIP

Unsurpassed!

Eastman or Ansco color dupe negatives made on our new triple-head precision registration printer.

Write For Complete Information

**- 35MM -
SPECIALIZED
LABORATORY
SERVICES
- 16MM -**

FILMEFFECTS of Hollywood

1153 N. Highland Ave., Hollywood 38, Calif. • HO 9-5808

OPTICAL EFFECTS

COLOR PRINTING MASTERS • TELEVISION FILM SERVICES

16mm Film Achievements



"The Look of Things"

It is a truism that the most perfect printing and projection in the world cannot make up for uninteresting subject matter in a film. But the opposite also holds true. The finer the subject, the more it deserves—and needs—perfect laboratory duplication to set it forth.

This is why we feel that the finest combination of every factor won for the notable 16mm film subject **THE LOOK OF THINGS** the first prize in the Public Relations Category of the recent Cleveland Film Festival. The competition was keen, but this winner was outstanding. Every producer, every film man and, indeed, every individual with an interest in viewing a superior motion picture should make it his business to see this film. The producer would be pleased to arrange for screenings through inquiries directed to us.

Precision Film Laboratories doffs its hat to this unusual example of a fine industrial 16mm color and sound production.

Precision Film Laboratories—a division of J. A. Maurer, Inc., has 16 years of specialization in the 16mm field, consistently meets the latest demands for higher quality and speed.

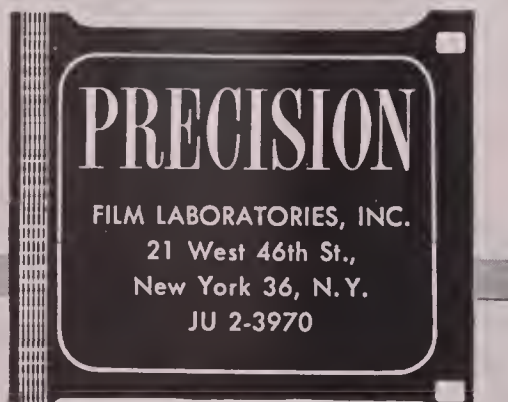

WHAT'S NEW

(Continued From Page 8)

planatory charts, projection room screen sizes, audience capacities, and projection length distances. Also included are helpful hints on regular and stereo color projection. Copies may be obtained by writing the company direct.

Automatic Dual Sixtomat—Photoptic Corp., 235 Fourth Ave., New York, N. Y., announces the new Automatic Dual Sixtomat exposure meter which features automatic hi-low light intensity switch, built-in roll diffuser for incident light measurement, scale magnifier, and a

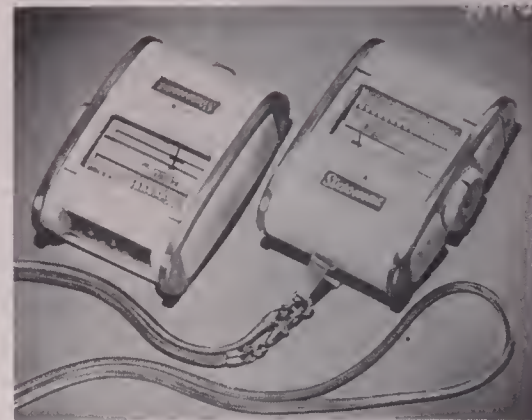

number of other features for easy reading and one-hand operation. Photocell is fitted with a honeycomb lens and a baffle to match its angular field to standard camera lenses. It renders accurate readings in brightest sunshine as well as dim interiors. Proper shutter speeds and lens openings for still and movie cameras are clearly indicated. Price, including chrome neck chain, is \$27.50.



Pen-Size Oil Can—Pell-i-can, a new pen-sized oiler with a long, narrow "beak" now makes it easy to fill small out-of-the-way oil holes in movie cameras and projectors, tape recorders, electric shavers, etc. New oiler features a visible oil supply and handy pocket clip. Spilling of contents is avoided by delivering its fine, light-weight oil one drop at a time. Pell-i-can is leakproof, easy to refill and unbreakable in normal use. It is available for \$1.49 postpaid, from the Lofthouse Company, Box 832, Binghamton, N. Y.

AURICON brings The GI's home— — on Talking Picture Film!



Hello Folks!

NOTE: "Cine-Voice" Camera is being operated from 6 volt "Jeep" battery, using Auricon PS-14 Power Converter.



AURICON "Cine-Voice" Sound-On-Film 16mm Camera... Shoots Talking Pictures for release on Television!

The parents of American GI's overseas are today visiting with their sons through the medium of "Talking-Pictures" shown on Television. The men are interviewed and filmed by the major News Services and Broadcasting Networks operating from military outposts all over the world. Auricon Equipment is providing high-fidelity, trouble-free operation under the most rigorous conditions of climate and travel. At home or overseas, Auricon Cameras are proving over and over again, that they can "take it!"

Auricon 16 mm Sound-On-Film Cameras are ideal working tools for the production of Television Newsreels, Film Commercials, Dramatic Inserts and local Candid-Camera programming. Write for complete Auricon Catalog.

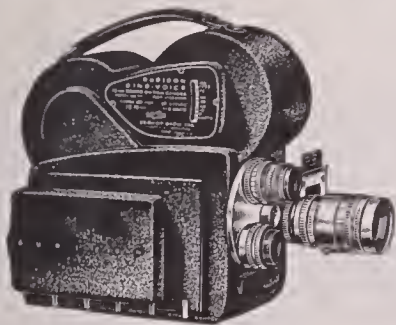

AURICON CINE-VOICE 16 mm CAMERA...

\$695.00 (and up), with a 30-day money-back guarantee. You must be satisfied. Write today for free illustrated "Cine-Voice" Folder describing this newest 16 mm optical sound-on-film Camera.

AURICON

BERNDT-BACH, INC.

7381 BEVERLY BLVD., LOS ANGELES 36, CALIF.



MANUFACTURERS OF SOUND-ON-FILM RECORDING EQUIPMENT SINCE 1931

SEEING IS BELIEVING!

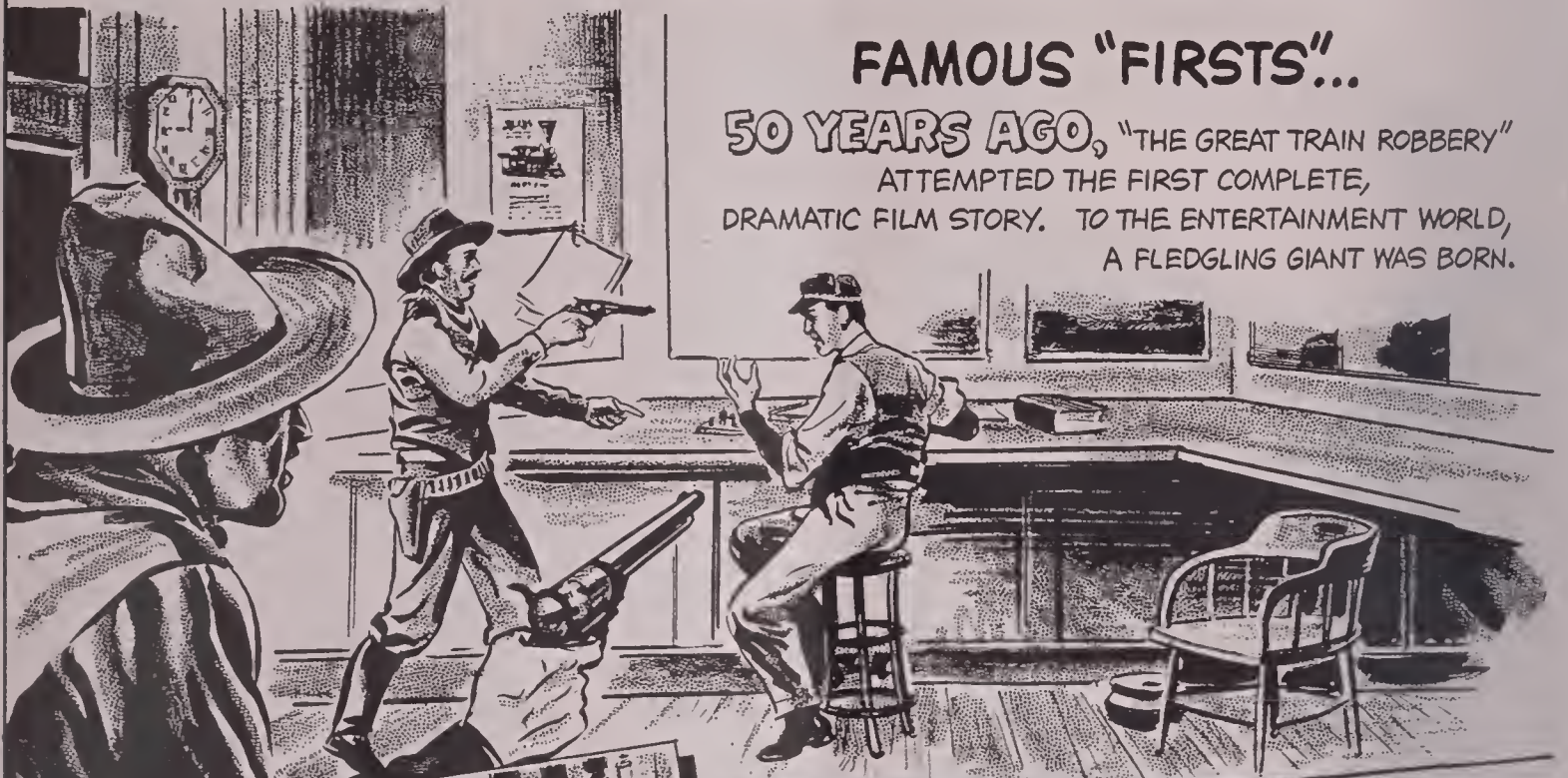

FAMOUS "FIRSTS"...

50 YEARS AGO, "THE GREAT TRAIN ROBBERY"
ATTEMPTED THE FIRST COMPLETE,
DRAMATIC FILM STORY. TO THE ENTERTAINMENT WORLD,
A FLEDGLING GIANT WAS BORN.

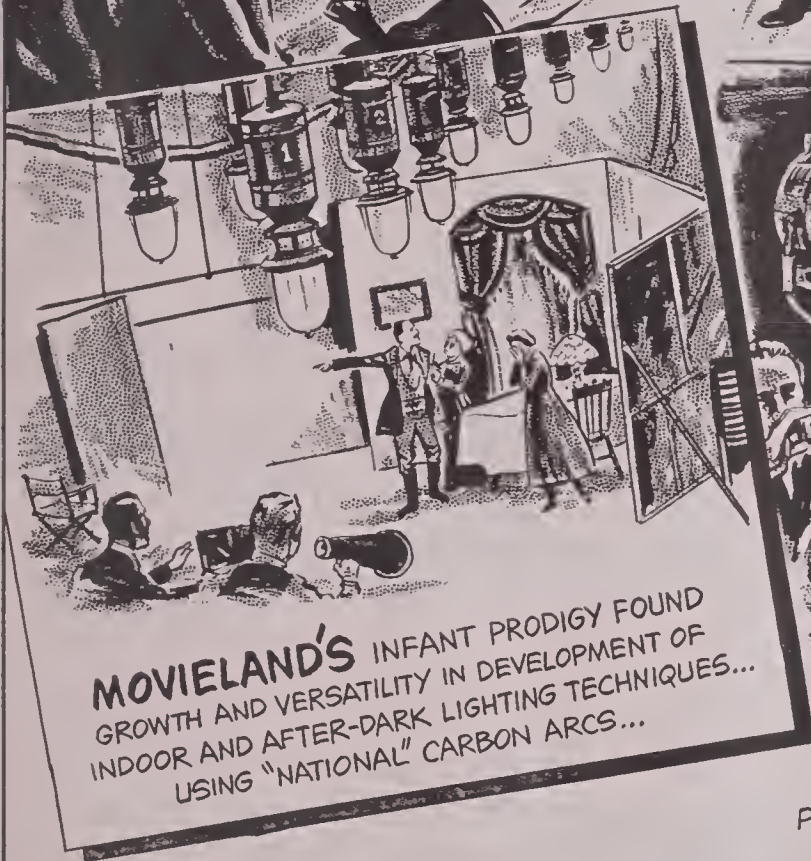

MOVIELAND'S INFANT PRODIGY FOUND
GROWTH AND VERSATILITY IN DEVELOPMENT OF
INDOOR AND AFTER-DARK LIGHTING TECHNIQUES...
USING "NATIONAL" CARBON ARCS...



TODAY...IMPROVED "NATIONAL"
CARBONS CONTINUE TO PAY OFF IN DEEP SET
PENETRATION, BROAD COVERAGE, SHARP SHADOWS
AND COOL BRILLIANCE.

THE "NATIONAL" CARBON ARC...NOTHING BRIGHTER UNDER THE SUN

The term "National" is a registered trade-mark of Union Carbide and Carbon Corporation

NATIONAL CARBON COMPANY

A Division of Union Carbide and Carbon Corporation, 30 East 42nd Street, New York 17, New York

District Sales Offices: Atlanta, Chicago, Dallas, Kansas City, New York, Pittsburgh, San Francisco

IN CANADA: National Carbon Limited, Montreal, Toronto, Winnipeg



Great equipment makes great cameramen

BALANCED TRIPOD HEAD

and

PROFESSIONAL JUNIOR TRIPOD

are the standbys of the masters

You'll never hear Fritz Kreisler playing on a scratchy fiddle . . . or Louis Armstrong on a \$7 trumpet. Good craftsmen need good tools.

Camera Equipment Company makes, sells, services and rents the world's finest quality TV and Motion Picture Equipment.



More professional cameramen use The PROFESSIONAL JUNIOR Tripod than any other tripod in the world.



New "BALANCED" Tripod—for the world's smoothest pan and tilt action.

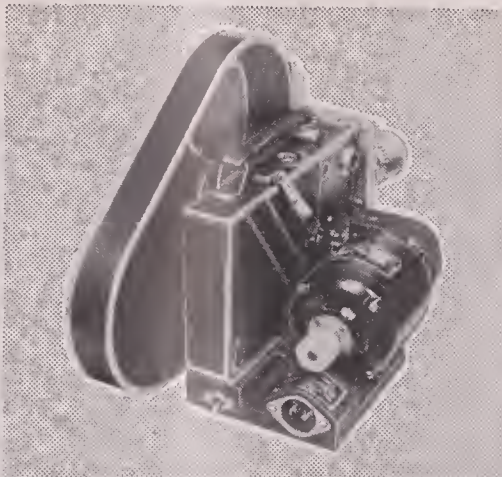

SYNCHRONOUS MOTOR DRIVE — 110 Volt AC—Single phase, 60 Cycle. Runs in perfect synchronization with either 16mm or 35mm Sound Recorders. Mounting platform permits removal of magazine while camera remains mounted on motor. Spring steel drive fin coupling prevents damage if film jam occurs.

Knurled knob on armature permits rotating for threading. "On-Off" switch in base. Platform base threaded for 1/4" or 3/8" tripod tie-down screw. Rubber covered power cable with plugs included.

The new "BALANCED" Tripod, perfect for every photographic and video need. The result—a revelation in effortless operation, super-smooth tilt and 360° pan action.

PERFECT BALANCE prevents mishap if the lock lever is not applied. Quick release pan handle locks into desired position. Mechanism is enclosed, rustproof, needs no lubrication. Tension adjustment for Camera Man's preference. Built-in spirit level. Telescoping extension pan handle. We defy you to get anything but the smoothest, most efficient operation out of this famous precision-engineered BALANCED Tripod.

Let's face it. You need a first class tripod to make better pictures. PROFESSIONAL JUNIOR has the rigidity, the range, and the ease of operation that better pictures demand. See this tripod beauty—and you'll never be without it. PROFESSIONAL JUNIOR TRIPOD—Friction Type. Handles all 16mm cameras, with or without motor. Also 35mm DeVry, Bell & Howell and without motor, and 400' magazines. Tripod base interchangeable with Professional Junior gear drive head. "Baby" tripod base and "Hi-Hat" base available.

FRANK C. ZUCKER

CAMERA EQUIPMENT CO.
1600 BROADWAY NEW YORK CITY

SALES • SERVICE • RENTALS — CAMERAS * MOVIOLES * DOLLIES

Complete line of 35mm and 16mm equipment available for rental.

MITCHELL: Standard, Hi-Speed, BNC, NC, 16mm

BELL & HOWELL: Standard, Shiftover, Eyemo

ARRIFLEX: 35mm and 16mm

MAURER: 16mm Cameras

MOVIOLE: Editing machines, Synchronizers

Design and manufacture Lens Mounts and camera equipment for 16mm—35mm and TV cameras.

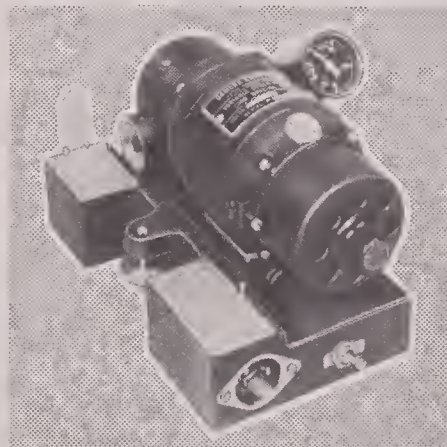

VARIABLE SPEED MOTOR — 110 Volt AC/DC with Tachometer for EK Cine Special Motor drive your Cine Special with confidence! Tachometer is mounted in clear view of operator. Calibrated from 16 to 64 frames per second. Definite RED marking for 24 fps. Electrical governor adjusts speeds. Steady operation at all speeds. No adaptors needed. Motor coupling attaches to camera and couples to motor. Spring steel drive arm shears if film jam occurs. Easily replaced.

We calibrate lenses—Precision "T" Stop Calibration of all type lenses, any focal length. Our method is approved by Motion Picture Industry and Standard Committee of SMPTE. For proper exposure density, it is important that you have your lens "T" stop calibrated. Lenses coated for photography. Special TV coating. Rapid service.



FIG. 1—Water ski routines for MGM's "Easy To Love" were carefully planned in advance. Here director Busby Berkeley (R) briefs Esther Williams on her routine by means of blackboard diagrams.



FIG. 2—One of the spectacular water ski numbers photographed by Ray June from helicopter. Countless rehearsals were required to obtain the precision that made number so colorful.



FIG. 3—Esther Williams, standing to right of camera boat, makes ready to don skis for a series of shots at Cypress Gardens.



FIG. 4—Miss Williams holding tow rope extended from boom of boat is shot in closeup doing ski routine filmed earlier in long shot.

FIG. 7—Rough going in turbulent water churned up by tow boats and wind which prevailed daily. Here figure dives from 'copter trapeze.



FIG. 8—Unique arrangement for filming Esther Williams taking off from water on trapeze of helicopter.



Filming A Water Ski Ballet

How cinematographer Ray June and his camera crew filmed the spectacular and colorful sequence for MGM's "Easy To Love," from motorboat and helicopter at Cypress Gardens, Florida.

By ARTHUR ROWAN

ONE OF THE MOST fascinating, exciting and certainly the most daring of photographic assignments ever undertaken by a studio cinematographer was the filming early last year at Cypress Gardens, Florida, of the water ballet sequence of the Metro-Goldwyn-Mayer Technicolor production, "Easy To

Love," starring Esther Williams and Van Johnson.

The assignment involved for director of photography Ray June, ASC. such unorthodox operations as shooting from a helicopter and from the swaying deck of a 12-foot parallel mounted on a

motorboat skimming along at 40 miles per hour.

The ballet, said to be the greatest performance of massed water skiers ever attempted, formed the grand finale of the picture and featured the aqua-skiing prowess of Esther Williams and some

(Continued On Page 42)



FIG. 5—Ray June atop 12-foot parallel on speeding motorboat shoots formation of water skiers in one of several numbers for production.

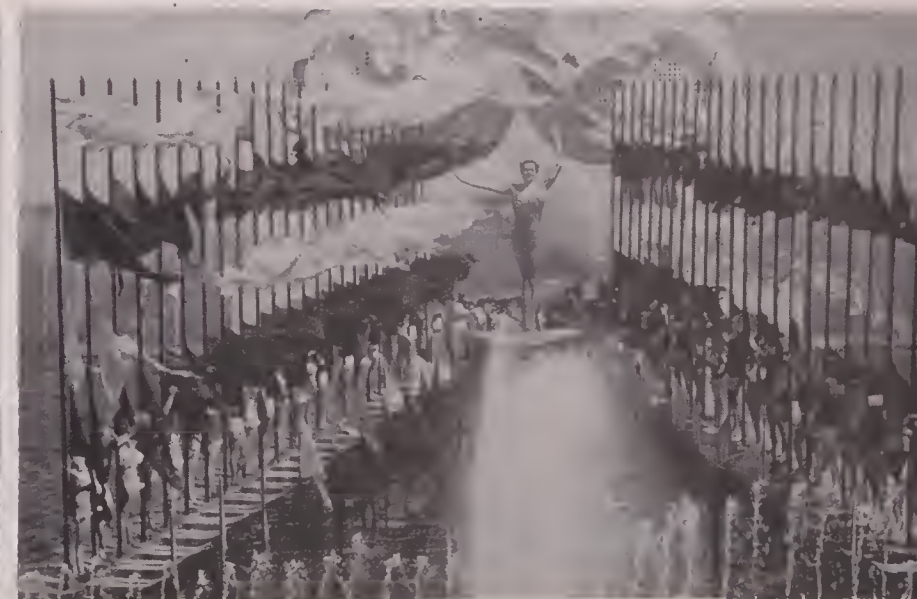

FIG. 6—Scene as filmed by second camera in same boat (Fig. 5). Tow lines lend unusual compositional touch to scene.

FIG. 9—The camera 'copter was employed often in shooting scenes such as this of water ski groups in formation.



FIG. 10—The grand finale shot, made on MGM's back lot, in which Esther Williams makes spectacular entrance on skis.



1953 BOX SCORE

76
A. S. C.
CAMERAMEN

filmed

236
HOLLYWOOD
FEATURE FILMS

White, Guthrie and

OF SOME 250 feature films produced in Hollywood during 1953, 236 were photographed by 76 ASC cameramen. High man in the number of features filmed for the year is Lester White who directed the photography of nine. Right behind him with a total of eight features each are Carl Guthrie and Harry C. Neumann—the latter one of the top men also in 1952. With the exception perhaps of those ASC cameramen who were under contract to photograph the popular series of television films, the three named above were the busiest cinematographers in the Hollywood studios during the past year.

Despite the general industry-wide recession that set in early during 1953, the number of productions

Lloyd Ahern

"Gorilla At Large," Fox.
"Princess Of The Nile," Fox.

John Alton

"The San Quentin Story," Ind.
"Take The High Ground," MGM.
"I, the Jury," Ind.
"Witness To Murder," Ind.
"Desperate Men," Ind.

Arthur Arling

"Red Garters," Para.

Lucien Ballard

"The Desert Rat," Fox.
"Inferno," Fox.
"Prince Valiant," Fox.
"New Faces," Fox.

George Barnes

"Little Boy Lost," Para.

Joseph Biroc

"Harness Bull," Ind.
"Donovan's Brain," Ind.
"The World For Ransom," Ind.
"Rage Of The Jungle," Ind.

Charles Boyle

"The Stand At Apache River," U-I.

John Boyle

"The 3-D Follies," Ind.

William Bradford

"Saginaw Trail," Col.
"Last Of The Pony Express," Col.
"Top Banana," Ind.

Robert Burks

"The Grace Moore Story," W.B.
"The Boy From Oklahoma," W.B.
"Dial M For Murder," W.B.
"Rear Window," Para.

Ellis Carter

"Captain John Smith and Pocahontas," Ind.
"The Royal African Rifles," Allied Artists.
"Arrow In The Dust," Allied Artists.

Charles G. Clarke

"Fight Town," Fox.
"Night People," Fox.

Wilfrid Cline

"Calamity Jane," W.B.
"Rear Guard," W.B.
"Lucky Me," W.B.

Stanley Cortez

"China Gold," Ind.
"The Neanderthal Man," Ind.
"Shark River," Ind.
"Riders To The Stars," Ind.
"Broncho Apache," Ind.

Edward Cronjager

"Twelve-Mile Reef," Fox.
"Gatling Gun," Fox.

Floyd Crosby

"The Man Who Lived Twice," Col.

William Daniels

"Drifting," U-I.
"Brady's Bunch," U-I.
"The Glenn Miller Story," U-I.
"The Far Country," U-I.

Robert DeGrasse

"Marry Me Again," Ind.

Edwin B. Du Par

"The System," W.B.
"The Eddie Cantor Story," W.B.
"The Bounty Hunter," W.B.
"Ring Of Fear," W.B.

Elmer Dyer

"Hollywood Stunt Man," Ind.

Daniel Fapp

"Money From Home," Ind.
"Knock On Wood," Para.
"Living It Up," Para.

George Folsey

"The Band Wagon," MGM.
"All The Brothers Were Valiant," MGM.
"Tennessee Champ," MGM.
"Executive Suite," MGM.
"Panther Squadron," MGM.
"A Bride For Seven Brothers," MGM.

Henry Freulich

"Conquest Of Cochise," Col.
"Charge Of The Lancers," Col.
"The Nebraskan," Col.
"Battle Of Rogue River," Col.
"Saracen Blade," Col.
"The Miami Story," Col.
"Jungle Man-Eaters," Col.

Lee Garmes

"Outlaw Territory," Ind.
"Hannah Lee," Ind.

Maury Gertsman

"The Golden Blade," U-I.
"Back To God's Country," U-I.
"The Glass Webh," U-I.
"Fort Laramie," U-I.
"Tanganyika," U-I.

Irving Glassberg

"Walkin' My Baby Back Home," U-I.
"Border River," U-I.
"Ride Clear Of Diablo," U-I.
"The Black Shield of Falworth," U-I.

Loyal Griggs

"Elephant Walk," Para.
"White Christmas," Para.

Burnett Guffey

"From Here To Eternity," Col.
"The Human Beast," Col.

Carl Guthrie

"All I Desire," U-I.
"Three Sailors And A Girl," U-I.
"Ma And Pa Kettle Hit The Road Home," U-I.
"Bowery Bloodhounds," Allied Artists.
"Tabloid," Allied Artists.
"Yankee Pasha," U-I.
"Johnny Dark," U-I.
"Playgirl," U-I.

Ernest Haller

"Carnival," Ind.

Sidney Hickox

"Blowing Wild," W.B.
"Them," W.B.

Winton Hoch

"A Star Is Born," W.B.

James Wong Howe

"Main Street To Broadway," Ind.
"Jennifer," Ind.

Harry Jackson

"The Kid From Left Field," Fox.
"Rhapsody," MGM.

Ray June

"A Slight Case Of Larceny," MGM.
"Easy To Love," MGM.

Benjamin Kline

"No Escape," Ind.

Milton Krasner

"Vicki," Fox.
"The Story of Demetrius," Fox.
"We Believe In Love," Fox.

Charles Lan

"The Big Heat," Col.
"It Should Happen To You," Col.
"Sabrina Fair," Para.

Joseph La Shelle

"Dangerous Crossing," Fox.
"Be Prepared," Fox.
"River Of No Return," Fox.

Ernest Laszlo

"The Moon Is Blue," Ind.
"The Naked Jungle," Para.
"About Mrs. Leslie," Para.
"Broncho Apache," Ind.

ummann Lead In 1953 Assignments...

and number of cinematographers employed were only slightly less than during the previous year. In 1952, 79 ASC cameramen photographed 290 feature film productions.

Whereas major studios like Metro-Goldwyn-Mayer and Twentieth Century-Fox, disrupted sharply by the advent of new formats such as 3-D and CinemaScope, greatly curtailed production, production among independent producers maintained a steady pace, and provided employment for many cinematographers dropped from major studio contracts.

This survey does not reflect the increased employment of cinematographers in the production of television films, which increased sharply during 1953.

Many directors of photography, such as Philip Tannura, Hal Mohr, Karl Freund, William Mellor, Virgil Miller, and Gilbert Warrenton who were associated with major studio production the year before, transferred their talents and activities to television film production exclusively.

This survey does not include the assignments of ASC members located outside Hollywood, such as Jack Cardiff and Freddie Young of England, and Joseph Brun and Don Malkames of New York City — all of whom were consistently active during the year.

The ASC cameramen of Hollywood and their feature film assignments during 1953 follow:

Charles (Buddy) Lawton, Jr.
 "Cruisin' Down The River," Col.
 "Miss Sadie Thompson," Col.
 "Little Giant," Col.
 "The Wood Hawk," Col.

Lionel (Curley) Lindon
 "Here Come The Girls," Para.
 "Sangaree," Para.
 "Those Sisters From Seattle," Para.
 "Lost Treasure Of The Amazon," Para.
 "Casanova's Big Night," Para.
 "Legend Of The Incas," Para.
 "Conquest Of Space," Para.

Harold Lipstein
 "The Great Diamond Robbery," MGM.
 "Big Leaguer," MGM.
 "Gypsy Colt," MGM.
 "Three Young Texans," Fox.
 "Drums Across The River," U-I.

Joseph MacDonald
 "Nearer My God To Thee," Fox.
 "How To Marry A Millionaire," Fox.
 "Hell and High Water," Fox.

Peeverell Marley
 "House of Wax," W.B.
 "The Charge at Feather River," W.B.
 "The Phantom Ape," W.B.
 "The Talisman," W.B.

Ted McCord
 "Sulu Sea," W.B.

William Mellor
 "Give A Girl A Break," MGM.
 "Affairs of Dobie Gillis," MGM.
 "Alaska Seas," Para.

Russell Metty
 "The Prince of Bagdad," U-I.
 "It Happens Every Thursday," U-I.
 "Three Were Renegades," U-I.
 "Tumbleweeds," U-I.
 "Son of Cochise," U-I.
 "Magnificent Obsession," U-I.
 "Sign of the Pagan," U-I.

Ernest Miller
 "Vigilante Terror," Allied Artists.
 "The Forty-Niners," Allied Artists.

Virgil E. Miller
 "Crazylegs—All-American," Ind.

Hal Mohr
 "The Wild One," Col.

Nick Musuraca
 "The Blue Gardenia," Ind.
 "Arizona Outpost," RKO.
 "Susan Slept Here," RKO.

Harry C. Neumann
 "Jalopy," Allied Artists.
 "Bowery Nights," Allied Artists.
 "The Maze," Allied Artists.
 "Fighter Attack," Allied Artists.
 "Pride of the Bluegrass," Allied Artists.
 "Dragonfly Squadron," Allied Artists.
 "Bomba and the Green Idol," Allied Artists.
 "Paris Bombshell," Allied Artists.

Robert Planck
 "Torch Song," MGM.
 "The Prisoner of War Story," MGM.

Frank Planer
 "Scalpel," Col.
 "The Caine Mutiny," Col.

Ray Rennahan
 "Arrowhead," Para.
 "Flight To Tangier," Para.

George Robinson
 "Abbott and Costello Meet Jekyll & Hyde," U-I.
 "Echo Canyon," U-I.

Charles Rosher
 "Kiss Me Kate," MGM.

Hal Rosson
 "Fame and Fortune," MGM.

John L. "Jack" Russell, Jr.
 "City That Never Sleeps," Rep.
 "The Champ from Brooklyn," Rep.
 "Geraldine," Rep.
 "Hell's Half Acre," Rep.
 "The Outcast," Rep.

Joseph Ruffenberg
 "Latin Lovers," MGM.
 "The Great Diamond Robbery," MGM.
 "Miss Baker's Dozen," MGM.
 "Brigadoon," MGM.

John Seitz
 "Fort Algiers," Ind.
 "Saskatchewan," U-I.
 "The Kid From Outer Space," Fox.

Leon Shamroy
 "White Witch Doctor," Fox.
 "The Robe," Fox.
 "King of the Khyber Rifles," Fox.

William Sickner
 "Northern Patrol," Allied Artists.
 "Mexican Quest," Allied Artists.
 "Slade," Allied Artists.
 "Off The Record," Allied Artists.

William Snyder
 "Second Chance," RKO.

"Son of Sinbad," RKO.
 "Rangers of the North," RKO.
 "Black Lagoon," U-I.

Cliff Stine
 "East of Sumatra," U-I.
 "It Came From Outer Space," U-I.
 "Wings of the Hawk," U-I.
 "Americano," Ind.
 "Fireman Save My Child," U-I.

Archie Stout
 "Island In The Sky," W.B.
 "Hondo," W.B.
 "The High and the Mighty," W.B.

Harry Stradling
 "A Lion Is In The Streets," Ind.
 "Johnny Guitar," Rep.

Robert Surtees
 "Mogambo," MGM.
 "Fort Bravo," MGM.
 "The Long, Long Trailer," MGM.
 "Valley of the Kings," MGM.

Leo Tover
 "Blueprint for Murder," Fox.
 "Man In The Attic," Fox.

Thomas Tutwiler
 "The Bridges of Toko Ri," Para.

Paul C. Vogel
 "Arena," MGM.
 "Half a Hero," MGM.
 "Rose Marie," MGM.
 "The Student Prince," MGM.

Gilbert Warrenton
 "The Great Jesse James Raid," Ind.
 "Sins of Jezebel," Ind.
 "Deputy Marshall," Allied Artists.
 "West of Texas," Allied Artists.

Lester White
 "Forty-nine Men," Col.
 "Renegade Canyon," Col.
 "I Ride Alone," Col.
 "Gun Fury," Col.
 "Drums of Tahiti," Col.
 "Jesse James versus the Daltons," Col.
 "Silver Dollar," Ind.
 "Adios My Texas," Col.
 "The White Stallion," Col.

Harry Wild
 "Gentlemen Prefer Blondes," Fox.
 "The French Line," RKO.
 "The Big Rainbow," RKO.

for filming

CINEMASCOPE



Scene from "THE ROBE," 20th Century-Fox CinemaScope Epic

... the world's finest lens

BALTAR



Bausch & Lomb
BALTAR
Cinematography Lenses



Bausch & Lomb
Anamorphic Adapter
for filming
CinemaScope

It's only natural that 20th Century-Fox looked to Bausch & Lomb for the optical know-how to achieve "the most significant movie development since sound." 20th Century-Fox and other studios use B&L Baltar Lenses with B&L anamorphic adapter in filming CinemaScope productions . . . for breathtaking brilliance and detail . . . for superb correction and definition . . . for today's finest image quality. Because today, just as when it pioneered America's first ciné lenses, Bausch & Lomb sets the industry's standard . . . in CinemaScope, 2-D, expanded 2-D, and 3-D. For your finest work, order Baltar Lenses from your professional camera manufacturer.

BAUSCH & LOMB

OPTICAL COMPANY



ROCHESTER 2, N. Y.

Projection Viewing With The Westrex Editer

Latest editing equipment offers choice of viewing film images projected on wall or screen or on conventional shadow-box screen.

By LEIGH ALLEN



FIG. 1—The Westrex Editer, newest film editing equipment for sound or silent 35mm films. A Unique feature is a device which permits operator to synchronize the sound and picture films while machine is in motion or at rest.

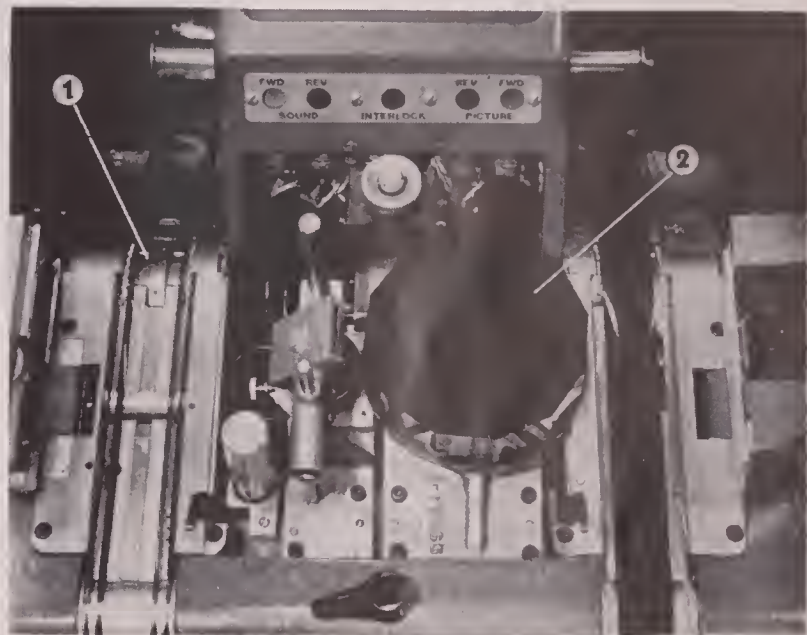

FIG. 2—Film is locked automatically to the drive sprocket (1) and may be removed just as quickly by touch of the hand on the release lever. The picture system employs continuous non-intermittent projection by means of a rotary 12-sided prism (2).

THE NEW WESTREX EDITER for motion picture film, designed and engineered in the Hollywood laboratories of Westrex Corporation, is a single integrated unit which offers many improvements and innovations. One of its more important features is the system of continuous optical projection without use of an intermittent, also the substitution of timing belt drives for gear driven mechanisms, both of which make operation of the Editer virtually noiseless. Of further interest is the fact the equipment can handle both standard and the new small-hole (Cinemascope-Stereophonic) perforated films, film strips, picture films, magnetic or photographic sound films, (single or multiple), and composite release prints.

For the first time, the Westrex Editer makes possible projection viewing of an enlarged image on a wall or screen (Fig. 3) without extra attachments. The projection distance and the resultant picture size are determined according to the auxiliary lens used.

Considerable attention has been given to simplicity and efficiency in operation and to the convenience of the operator. Elimination of the intermittent avoids necessity of a loop between the operator's hand and the machine.

Threading the film has been reduced to a minimum of effort. Due to the smoothness of operation of the rotating prism mechanism, it is possible to feed the film into the Editer without regard to critical entrance angles. Placing the film in the film trap locks the film automatically to the drive sprocket (1, Fig. 2) so that the position of the film cannot be lost. Closing the film gate completes the operation. Removal of the film is accomplished with one sweeping motion of the hand.

As the hand approaches the film, a flat lever is depressed which completely releases the film. The hand continues in the same direction and removes the film. Touching a different lever opens the film gate without releasing the film from the sprocket to permit inspection of or marking the film without possible loss of its position in the film trap.

A differential synchronizer permits continuously changing the position of the sound film with respect to the picture film while the machine is either in motion or at rest. Associated with the differential synchronizer is a dial which counts the number of frames required for synchronism in either direction.

The sound sprocket is driven by a constant-speed motor which is controlled by a foot-pedal switch operated by the left foot. The picture sprocket is driven by a variable-speed torque motor which is controlled by a foot-pedal switch and rheostat operated by the right foot. The film sprockets can be operated independently by their respective motors, or the two sprockets can be mechanically interlocked by the operation of a lever and driven by either motor in the forward or reverse direction. Four illuminated arrows on the front

(Continued On Next Page)

panel (Fig. 1) indicate whether each motor circuit is set for forward or reverse operation and a fifth arrow indicates whether the two sprockets are interlocked.

The height of the Westrex Editor is adjustable over a range of 5 inches to accommodate the individual operator in seated or standing position. The two foot pedals are also adjustable back and forth to accommodate the operator's position. Four castors provide mobility while two jack screws insure operation in a stationary position when desired.

An incandescent lamp located within the housing of the $3\frac{3}{4}$ inch by 5 inch view screen provides a shadow box for viewing film.

All of the controls are conveniently located for efficient operation. The center panel contains sound and projection lamp switches, a photographic to magnetic sound transfer switch, a switch which operates the constant speed motor or transfers the control to the foot pedal, a main power switch, a volume control, and a jack for phones. To the left of the center section of the machine are the reversing switch and handwheel for the constant speed motor and the differential-synchronizing control. In front of these is the monitor loudspeaker. To the right of the center section are the reversing switch and handwheel for the variable-speed motor, and the framing control. In front of these is the footage counter reading in feet and frames. An optional, additional counter reading in seconds of time is mounted just below the footage counter. The sound and projection lamps are mounted in cartridge type lamp mountings and are quickly removable from the front of the machine for replacement of lamps.

Just above the control panel is a lever which rotates through 180° to interlock the sound and picture drive mechanisms. The lever operates a coupling consisting of an internal gear meshing with an external gear of the same number of teeth — a one-tooth interval in mesh is equivalent to one sprocket hole. The engagement is spring-loaded by the control lever and the indicator light is lighted only when actual mesh is achieved, which may require the rotation of one shaft by a fractional tooth pitch. A high speed rewind flange is located on the left side of the machine and is normally operated by the constant speed motor.

The picture system employs continuous projection by means of a rotating 12-sided prism, (2, Fig. 2) thus eliminating the noise introduced by the conventional type of intermittent movement. The function of the prism in this system is similar to that employed in highspeed cameras and is proposed for use as film

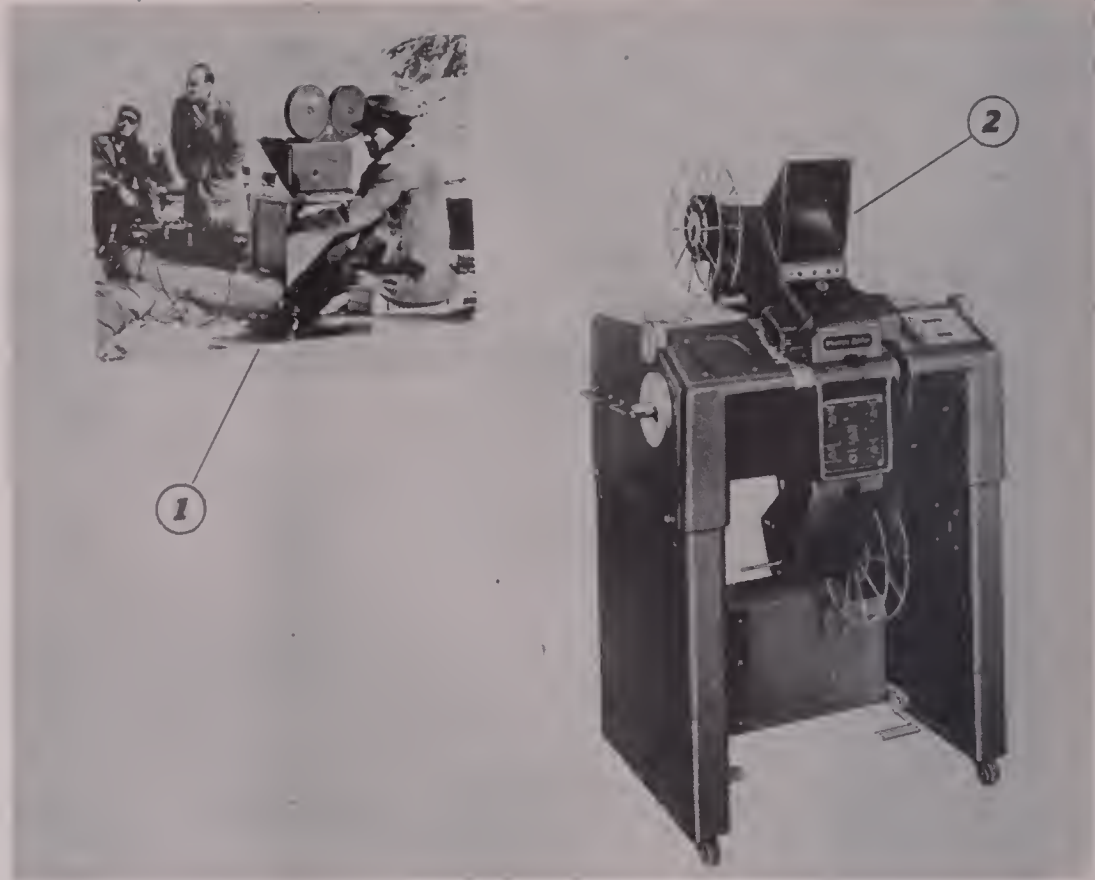

FIG. 3—Another Westrex feature enables operator to project film image on wall or screen (1) instead of viewing it on small Editor screen (2).

scanners for television. The picture image is projected from the rear on a translucent screen with sufficient light intensity to permit operation in the presence of normal room illumination. The image is $3\frac{3}{4}$ " X 5" and of the same orientation as image on the film; that is, the film in the gate is threaded so as to appear upright and properly oriented from left to right and this relationship is maintained in the projected image on the screen. The movement of a lever shifts the picture to the right to include a view of the sound tracks of a composite print.

Projection of the enlarged image on a wall or screen as shown in Fig. 3, is easily accomplished by operating two controls. A knob control inserts a simple spectacle lens in the optical path below the projection lens, and a second knob tilts one mirror. This second lens is introduced to focus the projected picture without disturbing adjustments of the normal optical system, and its focal length may be chosen to accommodate any given distance.

The optical scanning system is substantially the same as that in general use in theatre reproducers. The magnetic sound head is the conventional commercial type. A four-stage amplifier is used for photographic sound reproduction. One additional stage is added for magnetic reproduction with magnetic reproducing equalization provided. The

photographic input circuit contains a narrow dip filter tuned to 120 cycles to attenuate the light modulation resulting from operating the sound lamp on a-c. This feature combined with the relatively high thermal inertia of the 7.5 ampere lamp gives a satisfactory signal-to-noise ratio for this use. A tone control is provided on the amplifier, and there is also an output jack provided at this point to accommodate an extension speaker to be used with wall projection if desired.

The picture film is driven by a variable speed torque motor which, in combination with the foot pedal resistance control, is capable of driving the film at variable speeds from essentially standstill to double normal speed and is instantly reversible while running.

The sound film is driven by an induction motor, which is substantially constant speed, and is equipped with an electrical brake, so that the motor can be stopped within two picture frames. This type of braking is fully automatic and has the advantage of having no braking torque applied when the machine is turned by the handwheel.

Optional equipment includes the stereophonic sound kit, the upper and lower film take-up assemblies, the seconds counter, frame and bag for film strips, and additional sound heads for reproduction of films having sound on multiple tracks.

END.

EASTMAN

**PROFESSIONAL
MOTION PICTURE
FILMS**

W. J. GERMAN, INC.

Fort Lee

Chicago

Hollywood

MODEL SW-602
PORTABLE RECORDING SYSTEM



MODEL SW-602-RP
RACK-MOUNT RECORDER
IN PORTABLE CASE



MODEL SW-602-D3
THREE INTERLOCKED DUMMIES
WITH PLAYBACK PRE-AMPLIFIERS

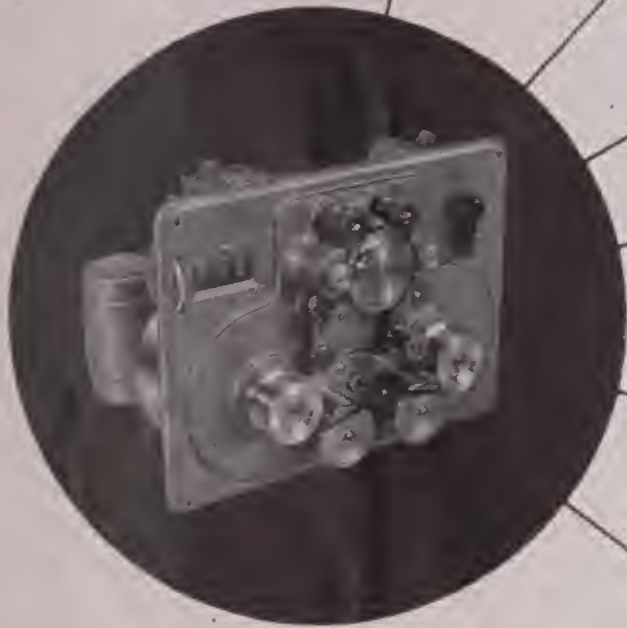
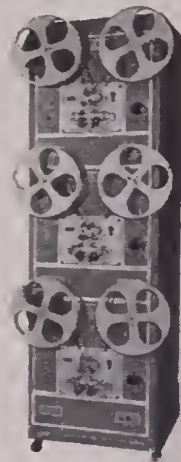

MODEL SW-335
35mm STEREO
PHONIC
THEATRE
PLAYBACK SYSTEM

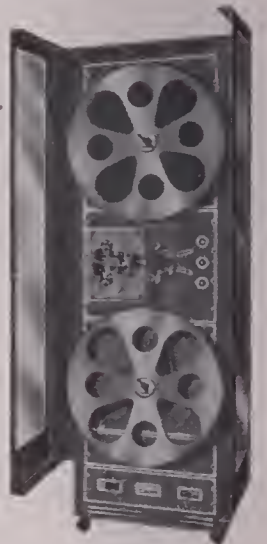

RACK-MOUNT AMPLIFIER WITH SPEAKER



EQUALIZED PLAYBACK PRE-AMPLIFIER

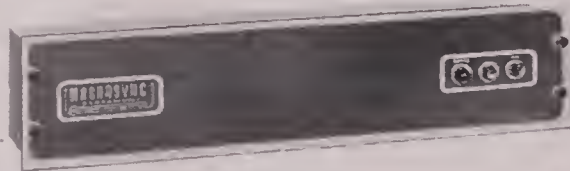

UNITIZED CONSTRUCTION

Designed around this famous "SYNKINETIC" film transport, all MAGNASYNC equipment is built to PERFORM.

You can depend on MAGNASYNC!

16mm CENTER TRACK 16mm EDGE TRACK
17½mm 35mm MULTI-CHANNEL



NORTH HOLLYWOOD, CALIFORNIA

Send for complete technical data

DISTRIBUTORS

MAGNETIC RECORDERS COMPANY
7120 Melrose Ave., Los Angeles 46, Calif.
WEBster 3-5545

CAMERA EQUIPMENT COMPANY
1600 Broadway, New York 19, New York
Judson 6-1420 Cable Address: CINEQUIP

ZENITH CINEMA SERVICE, INC.

3252 Foster Ave., Chicago 25, Illinois
IRving 8-2104

Manufactured by:

MAGNASYNC MFG. CO., Ltd. • P.O. Box 707, North Hollywood, Calif.

MICROPHONE MIXERS • PORTABLE SUPPLIES • SPLIT-APART REELS • BULK ERASERS



THE ZOOMAR in place on the Cine Special camera. No alterations are required in fitting the lens to a wide-range of 16mm cameras. Its total weight is only 1¼ pounds; length 5 inches.



THE ZOOMAR varifocal lens can do the work of all lenses from 1" to 3" focal length. It is not only a special-effects lens, but a high-speed, all-purpose lens as well.

THE ZOOMAR "16", a new varifocal lens for 16mm motion picture cameras, has been designed to give the 16mm camera user—whether he be an industrial photographer, a scientist, a news cameraman, an explorer, a TV movie maker, or an amateur intent on building up his own film library—a single all-purpose lens to take care of the majority of his picture-making assignments, including special effects. It has been designed for ease of operation, ease of mountability and ease of portability.

Almost eight years ago, in the spring of 1946, the first Zoomar varifocal lens was introduced and demonstrated at the annual convention of the Society of Motion Picture Engineers. It was hailed as a revolutionary development in the fields of scientific, educational, industrial and commercial motion-picture production.

No sooner had the Zoomar lens become a valuable tool in the motion picture industry when television bloomed into reality. To meet the specific needs of this growing industry, Zoomar engineers created and produced the Television Zoomar. This lens is now standard equipment on television cameras in over 100 TV stations throughout the country. More recently, the Studio Zoomar was introduced. This is a

The Zoomar Varifocal Lens For 16mm Cameras

Equipped with a coupled finder that is an integral part of the lens, it has a zoom range from 1" to 3" and an aperture range from f/2.8 to f/16.

By ALVIN D. ROE

smaller more compact version of the Standard Zoomar for use in telecasting studio shows. Now, out of the same laboratories in Glen Cove, Long Island, has come the new Zoomar varifocal lens for 16mm motion-picture cameras.

Extremely light and compact, it brings to all 16mm camera users, amateur as well as professional, a new height in lens and camera flexibility. For by design, it is not only a special effects lens but a high-quality, high-speed all-purpose lens as well. By being capable of taking the place of all conventional lenses from 1 in. to 3 in. on

the camera turret, it makes the long-dreamed-of "one-lens camera" an actuality.

Weighing only 1¼ pounds and measuring 5 in. in overall length, the new Zoomar 16 can be mounted on any 16mm movie camera without altering the camera or the lens. Once in place, picture-taking is easy. Lens settings are clearly visible. The zoom lever is conveniently located under the lens where it is out of the way yet easy to reach and to operate. Simply pushing the lever forward zooms in; pulling it back zooms out. During all zooming operations, the

(Continued On Page 50)

For PERFORMANCE... PORTABILITY... PRICE...

it's

KINEVOX

Right Down The Line!



SYNCHRONOUS MAGNETIC
FILM RECORDER

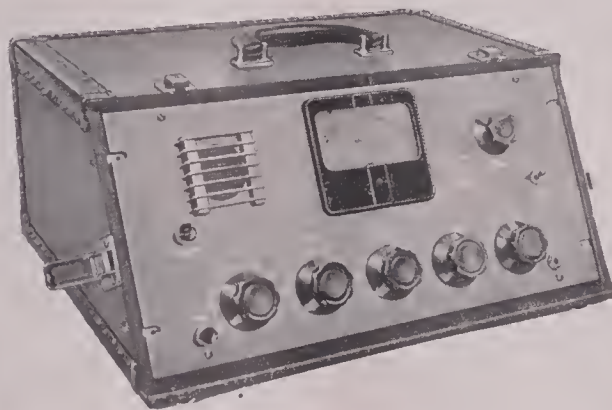

4-POSITION AMPLIFIER-MIXER



FILM PHONOGRAPH



MAGNETIC FILM SPLICER

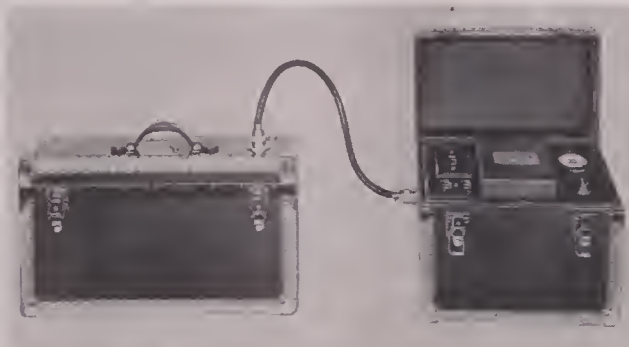

FIELD POWER SUPPLY



MAGNETIC FILM READER

Descriptive Catalog of Complete Kinevox Equipment Available on Request

Licensed under R.C.A., Western Electric, Armour Research Foundation and Kinevox Patents.

KINEVOX BUILDING
116 SO. HOLLYWOOD WAY
TELEPHONE: ROCKWELL 9-3291
ROME • BOMBAY

KINEVOX

I N C O R P O R A T E D
NEW YORK • RIO DE JANEIRO

BURBANK
CALIFORNIA
CABLE: Kinevox, Burbank
CANADA

KINEVOX "know-how"

Expedites Foreign Shipments



Kinevox magnetic recording equipment, properly packed and documented for fast shipment to a customer in South America.

YEARS of experience in supplying the foreign market with Kinevox magnetic recording equipment enables us to properly pack and ship orders promptly for fastest possible delivery. Our service includes:

- Immediate translation of orders regardless of language.
- Preparation of proper documentation.
- Selection of best shipping route.
- Packing for Air or Sea transport.
- Attending to **all** details.

IN ADDITION—we will act as your purchasing agent for other equipment, carefully pack same with your order of Kinevox equipment, and make the entire shipment on one letter of credit.

NOTE—Kinevox equipment can be supplied in any voltage and frequency to suit your local needs. Please specify when ordering.

KINEVOX BUILDING
116 SO. HOLLYWOOD WAY
TELEPHONE: ROCKWELL 9-3291
ROME • BOMBAY

KINEVOX

I N C O R P O R A T E D
NEW YORK •

BURBANK
CALIFORNIA
CABLE: Kinevox, Burbank
RIO DE JANEIRO • CANADA



WHEN IT BECOMES necessary to change locales in a sequence in which the subject is moving, let subject WALK out of one scene and INTO the next, thus maintaining a smooth flow of action continuity.

Pictorial Continuity

Camera movement is one of the most effective means of preserving pictorial continuity — so necessary to a coherent, smooth-flowing story.

By CHARLES LORING

PICTORIAL CONTINUITY, in simple language, means the correct *visual* tying together of separate scenes and sequences to form a coherent, smoothly flowing motion picture. It is the factor that gives a pattern of unity to the whole production; it is the blending ingredient which allows the audience to lose itself in the screen narrative, undistracted by the mechanics of the medium.

In the planning of pictorial continuity, the film maker shapes and molds the various scenes so that they will fit into the cinematic whole as smoothly as the pieces of a jig-saw puzzle dovetail together. Each scene is planned so that it contains elements that link it visually with the scenes that precede and follow it.

Pictorial continuity depends upon two factors: composition and pattern of action. The first is the function of camera and lens; the second stems from the movement of characters about the set; but the two are closely inter-related and depend upon each other for force.

When photographing a scene for a motion picture, the cameraman can see at a glance the entire situation and the locale in which it is taking place. In addition, he is able from time to time to take his eye away from the viewfinder and the action which it confines, and refresh his memory as to the general surroundings.

Not so the audience. It sees only what the camera lens allows it to see, and unless the overall locale is first

clearly presented or suggested, the audience may feel cheated and remain curious as to the context of the action shown. For this reason, the cinematographer must first clearly establish the general locale of a fresh situation whenever it arises. Since the audience's memory is short, usually retaining the details of only the preceding two or three scenes, the locale must also be *re-established* from time to time.

This re-establishing can be done in a variety of ways — first, by simply backing away to take in a wider angle of the action and surroundings with the lens, or, secondly, by *panning* the subject from one location to another that has been previously established. A third and perhaps the most cinematic method is to link up two elements of the same scene to show their spatial relationship. Here the foreground might include some object or character, previously introduced, so that the audience is able at once to re-orient itself by means of this element.

It is all too easy to "lose" one's audience by concentrating on medium and closeup shots too long. Action should be so staged that occasionally long shots fall naturally into the pattern. Thus, closeups should be saved for emphasis, and medium shots used for general action, with cutting to long shots for the purpose of establishing and re-establishing in order to maintain the sweep of the overall scene.

A good example to follow is the basic sequence pattern of long shot, medium shot, closeup, and re-establishing shot. This more or less duplicates the normal concentration of a person viewing a new situation for the first time. Our first glimpse of a subject is normally a long shot. Then, without changing position, we narrow our vision down to a point of view that can be compared with a medium shot. Ultimately, we move in closer for a more concentrated view corresponding to the closeup — the shot, which in any film, is the most emphatic. Finally, we move back or glance about to reappraise the surroundings of the subject.

While this basic sequence pattern is effective and uncomplicated, it is by no means an iron-clad formula; and it should never be followed so rigidly that the sense of the action is lost. In the final analysis, it is the action within the scene that should determine the camera angle and image size to be selected in photographing that particular scene.

The lens, acting as the eye of the camera, adopts a certain point of view for each scene, depending upon the angle and image size which the cinematographer feels best portrays the action.

(Continued On Page 46)

Colortran Converters

High powered studio illumination from ordinary house current.

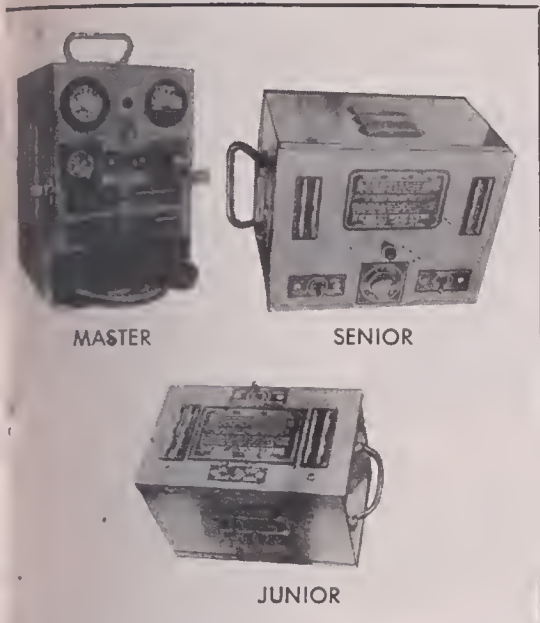

WRITE FOR COMPLETE CATALOG

F & B Film Footage Counter

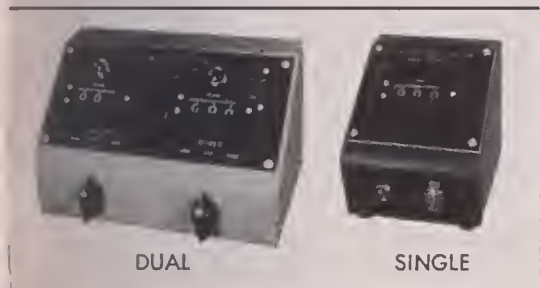

Write For Brochure

NEW F & B LEG-LOK TRIANGLE

WITH LEG-LOK CLAMPS AND REINFORCED CENTER CASTING

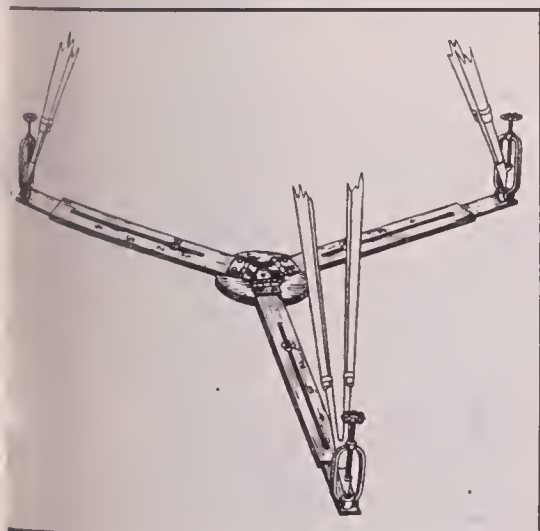

WRITE FOR BROCHURE

F & B 600-Ft. Magazine

for
Auricon
Cinevoice
Camera
At Low Cost

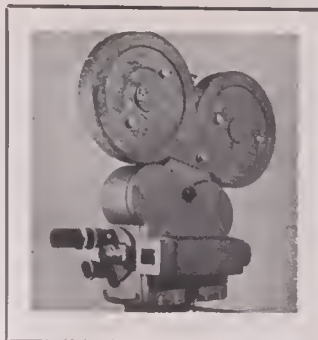

600 Ft. Cinevoice Magazine

NOW IN USE BY: TV STATIONS, TV NEWSREELS, LOCAL NEWSPAPERS, TV FILM PRODUCERS, POLITICAL ORGANIZATIONS, FRATERNAL ORGANIZATIONS, COLLEGES, UNIVERSITIES, SCHOOLS, CHURCHES, RELIGIOUS ORGANIZATIONS, GOVERNMENT AGENCIES, WEDDING AND SOCIAL EVENTS FILM PRODUCERS.

WRITE FOR COMPLETE DETAILS

NEW F & B SPLIT REELS

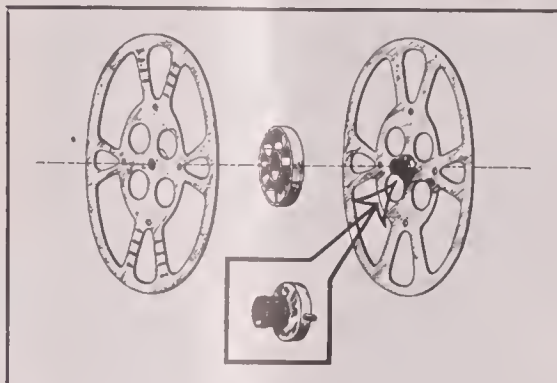

NOW — you can project 16mm film in a case without rewinding. Simply open split reel, slip film in and close reel.

- 400 ft. split reels — 16mm..... \$4.50
- 800 ft. split reel — 16mm..... \$6.00
- 1200 ft. split reel — 16mm..... \$7.50
- 1600 ft. split reel — 16mm..... \$9.00

NEW F & B GATOR CLIPLITE WITH BARN DOOR

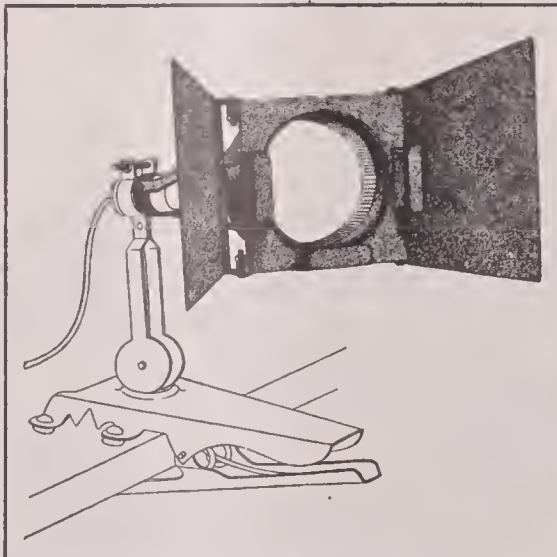

WRITE FOR BROCHURE

F & B 3rd Annual Clearance Sale!

(Most items are one-of-a-kind. First check buys it.)

- WALL 35mm SINGLE SYSTEM CAMERA, less galva, with 25, 40, 50, 75mm lenses, rackover, 2 1000-ft. mags, 12v. motor, cases **2975.00**
 - MOVIOLA 35mm UDPV3S, 1 pic & 3 sound heads, large preview screen, with ampl., rolling stand, perfect cand. **BEST OFFER**
 - MAURER 16mm CAMERA, latest model, 2 motors, 400-ft. mag., Maurer viewfinder, sunshade & filter holder, perfect cand. **3485.00**
 - BELL & HOWELL 35mm exchange model hat splicer, foot pedals **619.75**
 - BERNDT-MAURER 16 mm single system sound camera, rackover, complete production outfit for TV. VERY REASONABLE **WRITE FOR DETAILS**
 - BELL & HOWELL model H FILMO, with PAR 4-lens turret incl. pas. finders, PAR rackover and groundglass focus magnifier, MAIER-HANCOCK side viewfinder, 400-ft. mag., 110v. sync motor, deluxe case like new ... beautiful production outfit, worth over \$2000.00 **995.00**
 - ASTRO TELEPHOTO LENSES for Arriflex 35 camera, 300mm f5 \$145.00, 125mm f2.3 **115.00**
 - 16mm TELEPHOTO LENSES, 138mm Berthiot f3.5, "C" mt. **\$62.50**, 4" Goerz Hypar f2.7, "C" mt. **\$69.50**; 6" KA f4.5 Cine Spec. mt. **\$49.50**; 10.5 cm Xenar f3.8 "C" mt. **\$57.50**; 114mm KA f4.5 Cine Spec. mt. **\$32.50**; 3" KA f4.5 Cine Spec mt **\$22.50**; 76mm KA f4.5 Cine Spec mt **\$27.50**; 3 1/4 cm Tessar f2.8 Cine Spec mt **\$21.50**
 - SPECIAL*** 9.5mm ANGENIEUX WIDE ANGLE f2.2 "C" mt **89.50**
 - FILMO SUPERSPEED 128 fps., less lens, excellent cond. **157.50**
 - BOLEX 16mm STANDARD, 15mm f2.8, 25mm f1.9, 3" f2.9 **195.50**
 - AURICON outa-parallax viewfinder mtd. for Cine Spec. **147.50**
 - KINEVOX 17 1/2 mm sync magnetic recorder, List \$1500 **\$875.00**
 - SPECIAL***** FLANGES FOR 16mm & 35mm, 10" dia, aluminum **7.95**
 - EYEMO 71M, 35mm, 3-lens compact turret, filter slot, Pas. finders, 2" f2.8, LIKE NEW **645.00**
 - CONTINUOUS 16MM SOUND PROJECTORS — COMPLETE AND PERFECT
 - DeVRY — 400 ft. cap **\$245.00**
 - MOVIEMITE — 400 ft. cap **\$195.00**
 - AMPRO — 800 ft.-3-way — continuous or regular projection **\$295.00**
 - MAC VAN 16mm printer — reduced to **\$395.00**
- WANTED TO BUY
AURICON CAMERAS — MOVIOLAS — PAN CINOR LENSES
EDITING EQUIPMENT — LARGE QUANTITIES, REELS, CANS
CASES — LIGHTING EQUIPMENT

F & B USED EQUIPMENT

Always in stock . . . THOUSANDS OF ITEMS . . . cameras, projectors, lenses, accessories, rewinds, splicers, synchronizers, editing, lighting and laboratory equipment . . . ALL AT REASONABLE PRICES. We are always glad to quote lowest prices for specific items.
WE WILL BUY . . . FOR CASH . . . all kinds of used items as listed above. F&B is noted for paying FAIR prices.
LARGE LOTS OR COMPLETE STUDIOS solicited. We will gladly send our buyer to your studio for accurate appraisals and immediate cash payment.
TRADES . . . CONSIGNMENTS ACCEPTED

F & B Rental Equipment

35mm & 16mm

- MITCHELL CAMERAS, 16mm, NC, BNC
- AURICON SUPER 1200 SOUND CAMERA
- AURICON PRO, CINEVOICE, FILMO
- MAURER 16, ARRIFLEX 16 & 35
- EYEMOS, CINE KODAK SPECIALS
- MOVIOLAS 16 & 35, SYNCHRONIZERS,
- SYNC RECORDERS, SYNC PROJECTORS,
- SOUND READERS, HOT SPLICERS, DOLLIES,
- BLIMPS, MIKE BOOMS, TRIPODS, ZOOM LENSES
- BARDWELL-McALISTER LIGHTS, COLORTRANS

Write For Price Lists

FLORMAN & BABB

70 West 45th Street, New York 19, N. Y.

Phone: Murray Hill 2-2928

Cable Address — FLORBABB, N. Y.

MAY WE WISH A MOST PROSPEROUS AND

Happy New Year

to all our friends in the UNITED STATES, CANADA and all over the world.

We sincerely thank you for your past patronage and hope to serve you well in the years to come.

ART FLORMAN

JOHN BABB

Camera Crews Go To College To Get Material For New TV Film Series

By JOSEPH W. MacDONALD
Staff Cinematographer, Motion Picture Division, Ohio State University



USING A MITCHELL 35mm camera and compact, portable lighting equipment, the crew shot scenes in classrooms and on campus for CBS' new TV film series. Here, checking script, is (l to r) Leo Seltzer, director; cameraman Frank Follette, ASC; assistant Manuel Longinera, and Dr. Samuel Renshaw, psychologist, whose work at Ohio State University was subject of one film in series.

IT HAS OFTEN BEEN SAID, by discriminating members of television audiences and TV critics, that programs of an educational and cultural nature are sadly lacking. Now CBS is doing something about that and it is hoped others will follow their example pending, of course, the success of a recent new venture.

When the Columbia Broadcasting System decided a few months ago to do a series of twenty-six film programs on the subject of the nation's institutions of higher learning, preparation soon got underway to organize technical crews, directors, and production managers to go into the field and film these stories on the spot, using the actual people involved and no actors.

This new TV film series is appropriately titled "The Search," because it depicts the search for greater knowledge that is being conducted in higher educational circles today. Norton Bloom, speaking for Irving Gitlin producer, was excited about the series. He sees the programs possessing a wide mass appeal, but only time will tell. A serious effort was made to select twenty-six examples of outstanding educational achievement and research which would be interesting and comprehensive to the lay public. Thus far they seem to have succeeded in capturing some of the best of such activity. Films have been made at Yale of the child study center, at the University of Michigan's English Institute (spoken English taught in

eight weeks), at the University of Minnesota, where five-hundred men are submitting to annual checkups in a study of cardiovascular heart disease, and at Columbia where Oceanography is a big study project.

After several weeks of investigating work at Ohio State University, it was decided to do "Visual Perception" which delineates the work of Dr. Samuel Renshaw, well-known in the field of experimental psychology for his investigations in visual perception. The course of training which he designed to increase visual acuity and speed of perception was used to great advantage by the armed services in World War II. This subject seems ideal for television. Many of the devices Dr. Renshaw has invented or is using are eminently "photogenic", and besides the program will have one thing that probably none of the other twenty-five will have—a sense of audience participation, since many of the visual exercises used in this research can be employed and enjoyed by the audience.

Jerry Bronfield, on loan-out from the RKO-Pathe east coast office, where he is story editor and subject head for short stories, was picked to write the script not only for his writing ability, but because of his familiarity with the Ohio State campus. Jerry received his BSc in Journalism here in 1936.

A company of nine arrived in Columbus late in November expecting to stay for two weeks, but they were able to complete the shooting in seven and one-half days. Leo Seltzer, free-lance motion-picture producer and instructor at Columbia handled the directorial assignment; and Walter Cronkite CBS newsmen and commentator came along and remained for three days to appear in some lip-sync sequences with Dr. Ren-

(Continued On Page 42)



USING Stancil-Hoffman portable magnetic recording equipment, sync-sound was recorded for all takes by sound technician Clarence Wall.

DEDICATED TO BETTER PERFORMANCE



COLLAPSIBLE 3-WHEEL DOLLY

For motion picture and TV cameras. Sturdy cast aluminum. For standard or baby tripods. Additional baby tripod point holders to control spread of tripod legs. Adjustable spring seat. Extra wide rubber wheels. Bronze tie down clamps and other features.

For studio or location. Folds into one compact unit. Can be used with professional or semi-professional tripods.

'HYDROLLY'

TV OR
CAMERA DOLLY

The advanced dolly for instant moveability — streamlined, light-weight, exceptionally sturdy. Nothing to get out of order. Many new advantages for easy operation. Hydraulic lift type for fast upward and downward motion of TV and motion picture cameras.



Swivel seat. Adjustable leveling head. Seat for assistant. In-line wheels for track use. Steering wheel, rigid floor locks. Hand pump or combination hand and motor pump. Easily transported in a station wagon. Fits through a 28" door.

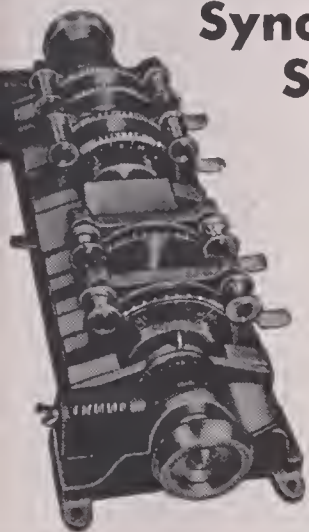

Synchro-film-ed Synchronizer

Our Exclusive Distributor
NEUMADE PRODUCTS CORP.

Any combination of 16mm and/or 35mm sprockets assembled to specification. Cast aluminum. Foot linear type, adjustable frame dial. Fast finger roller release. Contact rollers adjusted individually for positive film contact. Sprocket shaft slip lock, foot-age counter, etc.

RENTALS

SALES • REPAIRS • SERVICE

LENS COATING

"T" STOP CALIBRATION

DESIGNING and MANUFACTURING

lens mounts & camera equipt.
for 16mm, 35mm, TV cameras.

BAUSCH & LOMB "BALTA" LENSES and others

for motion picture, TV cameras.
15mm to 40" focal length.

COMPLETE LINE OF: 16mm, 35mm cameras, dollies, synchronizers, animation stands, cutting room and time lapse equipment.

BELL & HOWELL: Standard, Eyemos, Filmos. MITCHELL: Standard, Hi-speed, BNC, NC, 16mm.

SEND FOR CATALOGUE

Synchro-film-Slate

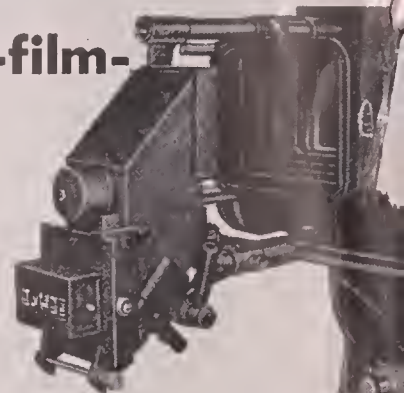

Pays for itself in production savings on the set. A New Development! Eliminates clap stick synch and slate on set. Mounts on double arm bracket to work with BNC, NC, Standard, 16mm Mitchell and all types of blimps and Geared Head. Interlocks with Sound Recorder.



PORTABLE MICROPHONE BOOM

For Studio or on Location. Light-weight — collapsible — for TV and motion picture production. Sturdy construction. Boom telescopes 7 to 17 ft. Rear handle for directional mike control. A remote control permits 360° rotation of the microphone.

Operator can push the boom and operate microphone swivel simultaneously. Extension rods make it simple to operate microphone rotation from floor. Microphone cable hangs outside of boom, preventing cable from tangling with the rotation mechanism. Ball bearing casters, rigid foot locks, pneumatic drop check for lowering the boom, etc.

VARIABLE-SPEED MOTOR with TACHOMETER

for Cine Special or Maurer Cameras

115 V. Universal Motor — AC-DC
Separate Base for Cine Special.
Variable Speed 8-64 frames.
Adapter for Maurer Camera.

INTERCHANGEABLE MOTORS: 12 volt DC Variable Speed 8-64 frames. 115 Volt AC 60 Cycles, Synchronous Motor, Single Phase.

ANIMATION MOTORS: Cine Special, Maurer, Mitchell, B & H Motors, for Bolex and Filmo Cameras.



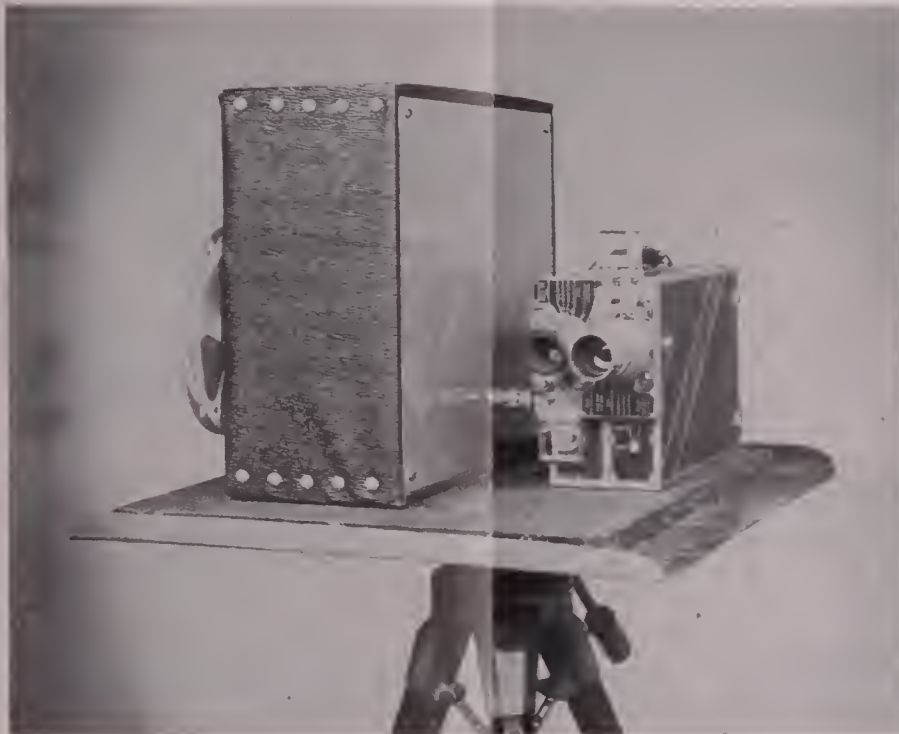

FIG. 1—Author's homemade magnetic film recorder coupled to a Cine Special camera. Sync motor of recorder drives both the recorder and camera. Magnetic film speed is 4.8 inches per second.



FIG. 2—The same unit shown at left covered with a blimp made of Celotex. Equipment and blimp rest on metal base which has fitting for mounting on conventional camera tripod.

Record Sound As You Shoot

With this homemade magnetic film recorder, which couples directly to and drives the camera, positive synchronization is assured.

By GEORGE W. CUSHMAN

THE ADVENT OF practical sound recording on tape and film has opened the door for the amateur movie maker who long has sought a simple and relatively low-cost method of recording and reproducing synchronized sound for his films. Today, it is a simple matter for the cine amateur with a leaning also toward mechanics to construct a magnetic recorder that can be coupled to his camera for the purpose of recording a sound track in complete sync with his picture film.

One such piece of equipment is pictured on this and the adjoining page. It is the culmination of four year's work and trial-and-error testing by the writer and Earl Everley, a brother cine enthusiast. In this equipment, we have a recorder which is entirely satisfactory in performance, is easy and economical to

operate, and it does practically anything that larger and more costly apparatus will do.

In our early attempts to achieve synchronized sound, we tried a number of ideas including that of coupling the camera and projector to a conventional home tape recorder by means of flexible shafts, etc., only to learn that conventional non-perforated tape will stretch with use and also slip, making accurate synchronization impossible.

Thus we discovered the answer to our problem was perforated tape, or more properly magnetic recording film. The medium we are presently using is made by Minnesota Mining and Manufacturing Company. It has as its base standard DuPont 16mm film, which is coated with iron oxide. It is available in either sin-

gle or double perforation. We use the latter and split it down the middle, using an 8mm film splitter, so that we obtain two strips of perforated film the width of conventional 8mm movie film, but having 16mm perforations along one edge.

The basic recorder, which appears here as a mechanism enclosed in a box or cabinet, actually has most of its mechanism on the outside panel. There is no amplifying apparatus in the recorder cabinet; instead, we use the amplifier of a conventional home tape recorder, as will be described later. Inside the cabinet is the synchronous electric motor which drives both the recorder and the camera—the latter by means of the coupling shown in Fig. 1.

A shaft extends out from each side of the motor. One end of the shaft is

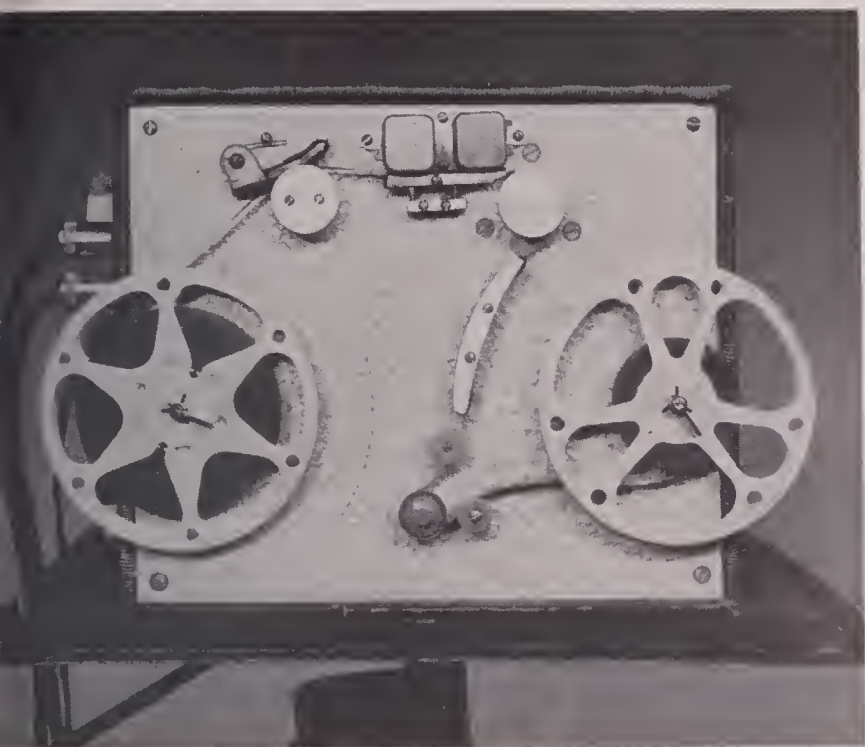

FIG. 3—Front view of recorder. Film travels from left to right. Magnetic recording and monitor heads are at top center. Unit is approximately 10" X 12" X 4 1/2" in size, weighs about 10 pounds.

coupled to the camera, while the other engages the drive mechanism of the recorder, shown in Fig. 3. The motor—a Bodine synchronous, rated at 1/75th h.p.—has been geared down to 120 rpm, which is equivalent to the 16 fps film speed (silent) for the 8-tooth sprocket of a 16mm camera. Since an 8-tooth sprocket is used in the camera, and another is used in the recorder to drive the magnetic film, both the picture and recording film travel at uniform speed and cannot get out of sync.

An aluminum panel is mounted on front of the recorder cabinet and carries the film transporting mechanism, recording head, flywheel, dampeners, and spindles for takeup and supply reels. We selected aluminum for the panel because it is light in weight and non-magnetic. The recording head is a Shure model 815, which is one of the few commercially available heads that will accommodate the film width that we use—which is roughly 5/16 inch. Thus far.

FIG. 4—An early model of author's magnetic film recorder is shown here coupled to a 16mm Bolex camera by means of flexible cable and a reversing gear. Camera operator is Earl Everley of Long Beach (Calif.) Camera Club.

the head has proven entirely satisfactory.

Construction of the film transport mechanism was not difficult. Our earlier

attempts failed mainly because we attempted something more complicated. We found that simplicity was the key to success. In laying out the panel for equipment of this kind, a study of the photographs (Figs. 1 to 3) will provide the reader with a good idea of what is required. It should be noted that the direction of film travel is from left to right—i.e., from the left hand reel in Fig. 3, thence upward to the guide roller with its felt-covered dampener, thence to the recording head, and over the flywheel and down and past another felt-covered dampener. From here the film travels to the drive sprocket (actually is *pulled* by it) and proceeds then to the takeup reel at the right.

This recorder was originally designed to accommodate 400 foot reels of recording film; however, it will also take 200 foot reels, which is the size of the reels shown in the photographs. The latter size are used whenever the recorder is to be used with the blimp, shown in Fig. 2.

The function of the felt-covered dampeners is to smooth out the film flow and prevent any jerky motion which would affect the sound quality.

At the left of the recorder, in Fig. 3, may be seen three power cables. One connects the recording head to the electronic end of the unit; the second connects the monitor head to a small am-

(Continued On Page 38)





TYPICAL DISTORTION EFFECT that can be achieved in 8mm and 16mm movies with the addition of a homemade distortion lens before camera lens.

Simple Lens Assembly For Making Special Effects

Using low-cost spectacle lenses, you can make a distortion effects device for your camera.

THE VERSATILITY of the amateur movie maker—the serious and inventive amateur, that is—is often exemplified in the unique special effects he achieves with his camera. Whereas the professional has the studio's special effects department to take this work off his hands, the amateur invariably must make his effect shots himself, using his camera plus other items of equipment made for the purpose or improvised.

In this sphere of effects work, the amateur often finds need for a distortion effect—so ideal for enhancing a mystery or "horror" film, or pointing up a

comedy sequence. Here the simple, easy-to-acquire auxiliary lens can pave the way to easy accomplishment of such effects.

"Diopter" lenses—the inexpensive spectacle-lenses that can be picked up at dime stores or at any optician's—are familiar to most amateur cinematographers. They're useful as supplementary lenses to correct the focus of camera lenses for extreme close-up work, such as making titles or extreme full screen close-ups of flowers and insects.

But they have another use, too: in the proper combination, they can be used

to produce deliberately distorted optical effects on the screen. This distortion can be either small or great, as the scene demands. It can be just a slight compression of a scene in one plane (either vertical or horizontal) with an accompanying spread in the other plane, in order to make a landscape composition fill the frame more pleasingly, or to give a close-up something of the lengthened perspective you see in fashion sketches. In this case, the distortion would probably pass unnoticed. Or it can be exaggerated for special effects, such as making a Boris Karloff-like character more menacing, or adding either menace or grotesque to a nightmare sequence.

First of all, though, let's get started with a good understanding of what a "diopter" lens really is, and what it does. "Diopter" is simply the term used by opticians to designate the magnifying power of a spectacle-lens. One diopter is the reciprocal of a focal length of one meter; thus a 10 diopter (10 D) lens would have a focal length of 1/10 meter or 100mm. Diopter lenses are available both as positive lenses, rated as *plus* so many D, and negative lenses, rated as *minus* so many D.

For distortion, we make use of a somewhat more complicated supplementary lens set-up, using two cylindrical diopter lenses—one positive, and one negative—assembled like a simple Galilean telescope. A plus diopter cylinder occupies the objective position, while a minus cylinder of greater power takes the place of the telescope eyepiece, and is placed as close as possible to the camera's lens. Both the axes and the focal points of the two cylinder lenses must coincide. The separation between the two should be equal to the difference in their focal lengths. The magnification produced may be determined by dividing the focal length of the plus lens by that of the minus lens.

(Continued On Page 50)

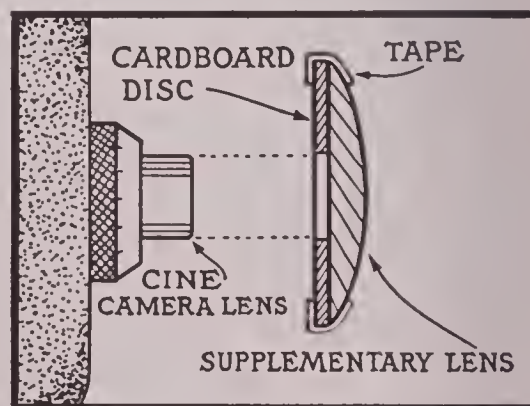

METHOD of mounting a single spectacle lens on camera lens for ultra-closeup shots. Thick cardboard disc, same diameter as spectacle lens, is pierced in middle to slip over barrel of the camera lens.



*Get SHARPER screen images
with Ansco Hypan Film*

Now you can increase the enjoyment of your films by using Ansco Hypan. Its ability to record fine detail and its brilliant projection characteristics make your screen images ever-so-much-sharper.

Indoors or out, Ansco Hypan Film is a *modern* panchromatic film; it gives you new sparkle in your black-

and-white movies. Its inherently brilliant gradation coupled with a speed of 40 daylight and 32 tungsten makes it the perfect all 'round movie film.

Ansco Hypan comes in both 8mm and 16mm rolls and magazines. Get some today and capture more of the scenes you and your family enjoy so much.

ANSCO Binghamton, N. Y.
A Division of General Aniline & Film Corporation. "From Research to Reality."

Important Announcement

regarding

American Cinematographer's

3-D FILM FESTIVAL

for

16mm Stereoscopic
Motion Pictures

Due to the increasing number of applications received from film makers in foreign countries who wish to participate in the Festival, and because the previously announced closing date would preclude getting these entries into the committee's hands in time, the Festival Committee announces that

Date For The Festival

has been set ahead to

MARCH 4, 1954

We are delighted that so many foreign film makers wish to participate in this first of stereoscopic film festivals, and in view of this extraordinary interest the Committee believes that an extension of the Festival date is justified.

The extension will also give many film makers in this country who wish to participate additional time in which to complete and submit their film.

Participation in this Festival is open to all makers of amateur, semi-professional, and professional 16mm single-film three-dimensional motion pictures, black-and-white or color. Those whose films are accepted for Festival screenings will receive the distinguished American Cinematographer Merit Filming Award.

Festival Committee

RECORD SOUND

(Continued From Page 34)

plifier, and the third supplies power for the 110-volt 60-cycle synchronous motor. Immediately above is the power on-off switch.

The electronic section of this unit, which is not pictured, is a Brush model BK-401 home tape recorder. Here we have simply disconnected the two wires leading to the recording head of the instrument and in place have connected the leads from our recording head. Any good magnetic tape recorder can be used for this purpose and in a similar way. Some mis-match will occur in this arrangement since the recording heads are of different manufacture, and also because the magnetic film travels past the heads at a speed of 4.8 inches per second in our recorder, whereas the tape speed established for our Brush recorder is 7.5 inches per second. When a recorder such as we have built is made to run at standard sound speed of 24 fps instead of 16 fps, the film speed is increased to 7.2 inches per second, which is close enough for all practical purposes. But even without working over the Brush recording unit to compensate for the slower film speed we use, the results obtained are excellent; it takes a trained ear of an experienced sound technician to detect any difference in quality.

About the cable which runs to the monitor head, which was previously mentioned — this leads to a small amplifier sufficient to "magnify" or intensify the recorded signal on the magnetic film and thence to the monitor headset. The sound operator, wearing the headset, can thus hear the recorded signal an instant after it is recorded. Where the sound is unsatisfactory, or for any other reason, the operator can stop the recorder and camera promptly by flicking the control switch on the recorder. The monitor head is not absolutely necessary, yet it is a safety precaution that we have found paid for itself many times over in the saving of picture film.

You may have noticed that no mention has been made here of the erase head. We do not use one, following the current trend in professional recording circles to omit it, but instead use a "bulk" eraser — a piece of equipment which enables one to erase a roll of magnetic film in a matter of seconds instead of by the old method of running the whole roll of tape or film through the recorder for this purpose. Bulk erasing is highly satisfactory, does a clean job and leaves no sound of any kind or degree on the tape.

No less important component of the recorder is the flywheel, which is the

secret of good, flutter-free sound recording. The one we have installed was made to our special order, although any good, heavy, well-balanced flywheel such as commonly used in 16mm sound projectors will work just as well. Our flywheel is free floating, and is not connected to any motor, belt, pulley or any other component of the recorder. The travel of the magnetic film is all that turns it. The wheel is inside the recorder cabinet, just back of the panel, with its shaft protruding. Mounted on this shaft is a hub over which the film rides, and which may be seen in Fig. 3, just to the right and slightly below the recording head. The function of the flywheel is to smooth out the flutter and vibration normally introduced in the magnetic film as it engages the film sprocket. The better the flywheel is engineered, the more efficient it will operate.

Besides the stabilizing effect imparted to the moving film by the flywheel, there is need for still other flutter retarders. Professional magnetic recorders usually employ the patented Davis Flutter Suppressor. We have simply used a curved surface in the path of film travel, just before the film engages the drive sprocket, and which is covered with felt. This simple gadget, which may be seen to the left of the takeup reel in Fig. 3, eliminates a surprising amount of flutter and vibration, yet puts little if any strain on the film. And this was one of the major problems that confronted us—how to introduce flutter suppressors which would do the work expected yet not induce undue pull on the film. For if there is too much pull on the film anywhere along the forward path, the sprocket teeth will tear the perforations and render the film worthless. This is not as important during recording as it is in projection of the film, where repeated use would soon ruin the magnetic film.

By comparison, the film is subject to only moderate strain during recording because it passes through the recorder only once, or twice at the most; for this reason, we have loaded the recorder with pressure in the path of film travel. The first pressure pads, plus the pressure applied under the two heads, plus the inertia of starting the flywheel, plus the pull of the felt-covered curved track is just about all the film will take. We have run the same film through the recorder as many as 30 times without even the slightest damage evident in the perforations.

As for other components in the recorder, the sprocket wheel used is one commonly used on an 8mm movie projector. Originally, it had 16 teeth (for 8mm film perforations), so it was necessary to file off every other tooth, leav-

(Continued On Page 41)

PERFECT COLOR EXPOSURES as simple as

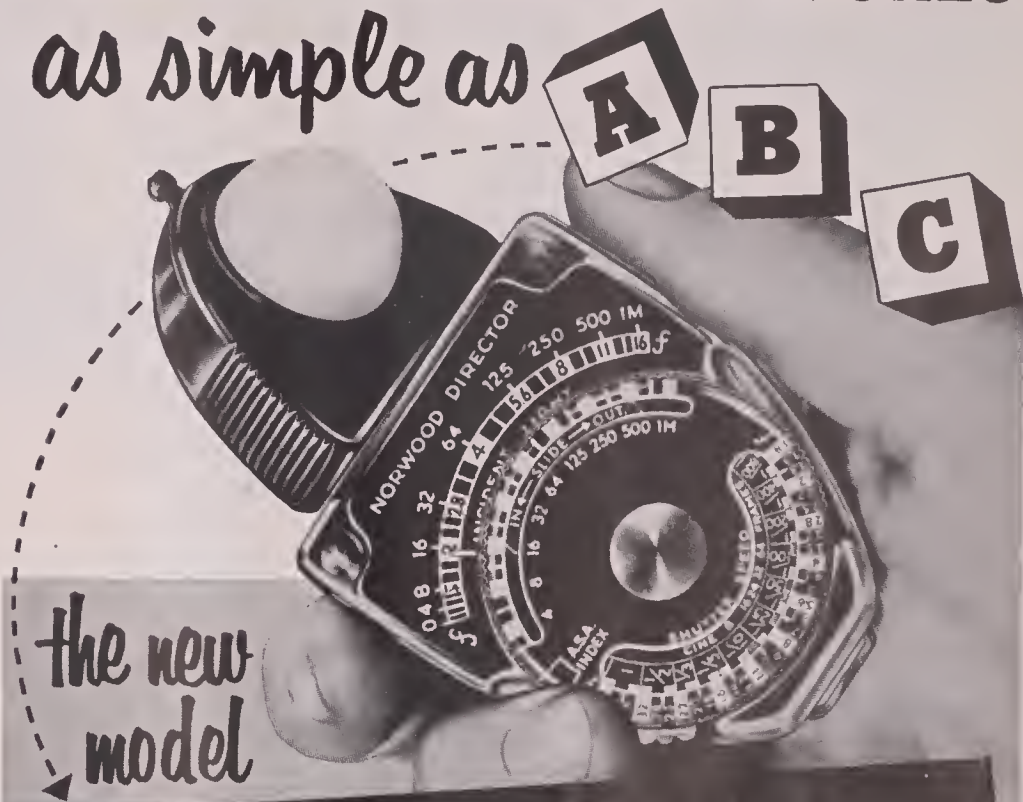

the new
model

NORWOOD Director INCIDENT LIGHT EXPOSURE METER

with the Exclusive *Color-Matic* CONTROL
and Sensational CONTROL
For Simplified Direct Reading When Taking Color Pictures

COLOR-MATIC Control provides the simplest, most accurate way of taking color pictures ever devised. No other meter can match the NORWOOD DIRECTOR for versatility — for color, black-and-white, stereo, still, movie. In addition to COLOR-MATIC Control, the new model features a new dial with larger, easier-to-read numbers. Of course, the PHOTOSPHERE and other famous features have been retained. And still only \$32.95, with Photosphere, Photodisk, Photogrid and COLOR-MATIC Control. See Your Photo Store, or Write For Literature to DIRECTOR PRODUCTS CORP., 570 Fifth Ave., New York 36.

"The Standard Of The Studios"

... And for Better Flash Pictures!

NORWOOD Flashrite, the world's only automatic exposure meter for flash photography.....\$11.95
NORWOOD Speedrite, the world's only automatic exposure meter for electronic flash.....\$11.95

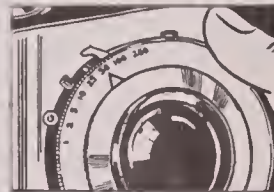

With COLOR-MATIC Control you set the camera at 1/50th second

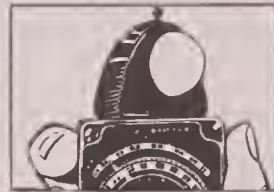

You point the Photosphere at the camera position



The needle indicates the proper "f" stop for perfect color exposure

No need to set for film speed, no need to use or look at the computer when shooting in color—the COLOR-MATIC Control does the job for you — quickly, easily, beautifully.

MOTION PICTURE and TV EQUIPMENT

NEW MACHINE SHOP, facilities for all types of camera repairs and modifications. Lens mounts, T-stop and lens calibrations.

RENTALS and SALES

16-35mm CAMERAS

MITCHELL MAURER AURICON SUPER 1200's
ARRIFLEX FILMO CINE SPECIAL

HALLEN 16mm MAGNETIC FILM RECORDERS

COLORTRAN LIGHTING and CONVERTERS

BARDWELL-McALISTER EQUIPMENT

REGEL LIGHTS

MOVIOLA FILM EDITING machines for 16mm and 35mm, re-winds, synchronizers, readers.

OUR RENTAL DEPARTMENT will ship to any part of the country in time for your shooting schedule.

WATCH for our big, new 1954 Catalogue, out soon.

THE CAMERA MART, INC.
1845 Broadway, near 60th Street
New York 23, N.Y. Circle 6-0930
Cable Address: Cameramart

Precision Built Combination MAGNETIC FILM AND TAPE SOUND READER

Features: Simple threading . . . polished stabilizer drum with needle bearings . . . combination film rollers for 16mm, 17.5mm, 35mm and 1/4-inch tape, machined to conform with SMPTE standards, and equipped with oilless bearings . . . precision ground shafts . . . Magnetic head mount with adjustments for track locations, azimuth, and magnetic film and tape thickness . . . dimensions 6"x6"x7 1/2".

Amplifier: 117-volt—60-cycle—AC . . . power output—4 watts . . . heavy duty Alnico V speaker . . . safety fused . . . pilot light . . . 6-ft heavy duty line cord

Net Price \$198.00 F.O.B., Factory, N. Y.

PRECISION LABORATORIES
1139 Utica Ave., Brooklyn 3, N. Y.



EVERYTHING PHOTOGRAPHIC AND CINEMATIC

FOR PROFESSIONAL AND AMATEUR

The World's Largest Variety of Cameras and Projectors. Studio and Laboratory Equipment with Latest Improvements as Used in the Hollywood Studios. New and Used . . . BARGAINS.

HOLLYWOOD CAMERA EXCHANGE
1600 Cahuenga Boulevard
HO 9-3651 • Hollywood, Calif. • Cable Hacamex

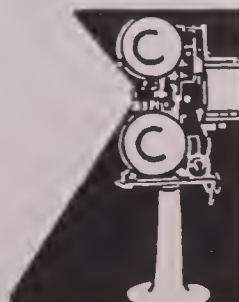

SWAP YOUR ODD SHOTS

with other readers of
American Cinematographer

Need some special footage in 8mm or 16mm, color or black-and-white? Got odd footage or stock shots you'd like to swap? Want to shoot local scenes or subjects for other cine amateurs? Then tell them about it in the Odd Shot Column. This service is free to amateur movie makers.

Editor:—

I have the following odd footage in 16mm color to offer. Will trade depending on what footage is offered in exchange:

125 ft. of scenes at amusement park at Long Beach, Calif.; 25 ft. of boats passing through government locks at Seattle, Wash.; 10 ft. of hair seals sunning on rock-bound coast of Oregon; 45 ft. Alcatraz Island prison, San Francisco skyline, and Bay Bridge taken from a ferry boat; 30 ft. Navajo Indian woman weaving a small rug; 100 ft. native Indian tribes staging costume dances on South Rim of Grand Canyon, Arizona; and 90 ft. of ASC-member Tom Tutwiler shooting scenes for the U.S. Air Force in Fairbanks, Alaska in wintertime.

—Harry R. Reynolds,
906 Marshall Drive,
Midwest City, Okla.

Editor:—

I have for years collected 16mm film of interesting and unusual railroad scenes, especially narrow-gauge railroads. Please list me in your "Odd Shots" column as desiring 16mm black-and-white footage of interesting railroad subjects. Especially want footage of the suspended monorail railway in Wupertal, Germany and narrow-gauge railroad scenes from any foreign country, including the Darjeeling & Himalayan Ry., in India.

—Charles Keevil,
1841 Lincoln St.,
Evanston, Ill.

Editor:—

I have 16mm negative and/or positive, single and double-perforated film, of a wide range of subjects, which I have been accumulating during the past 15 years. Footage includes war subjects, Italian subjects, cultural pageants, interesting places, sporting events, folklore subjects, etc. Will also shoot footage of local scenes or subjects in most areas of Italy, Switzerland, and Germany on request.

—Enzo Monachesi,
5 Via Poliziano,
Milano, Italy.

RECORD SOUND

(Continued From Page 39)

ing the required 8 to engage the perforations of our magnetic film.

The magnetic heads are "split heads" — that is, they are intended for dual tracking. The perforations of our recording film pass over the dead half of the head, leaving the live half free to contact the usable portion of the sprocketed magnetic film.

The takeup reel spindle is connected by belt and pulley at rear of the panel to the motor shaft. The sync motor has sufficient power to handle this slight extra load without affecting the film speed or recording results.

A synchronous motor was selected for two reasons: first, we wanted absolute uniform film speed in both camera and recorder; second, we wanted the unit to be able to operate with other units which also operate with synchronous motors. At one time, we intended to install a separate sync motor on the camera, but since the present setup is so compact and operates so successfully, it is doubtful that we shall ever consider the more complicated method of operating the two units separately, thus necessitating the use of clapsticks and tedious editing and syncing problems.

In using the recorder with camera, our procedure is to mark the first frame (actually the point of contact with the head) of the magnetic film with a grease pencil. This coincides with the first exposed frame of the picture film, making it easy to match up the starting point on each film when it comes time to edit or project. In playing back the picture and sound films, they are set to start at the marked "start" frames. Because both camera and recorder are mechanically interlocked and operated by the same sync motor, complete synchronization is assured throughout the screening of the entire reel of film, regardless of how many times the camera was stopped or started during production — a most economical feature no other double system provides.

Fig. 2 shows the blimp constructed for use when the equipment is being employed in filming action at close range to the microphone. It is made of panels of Celotex, securely bound at the corners with metal strips. The porthole for the camera lens is of high-quality plate glass, and there is another and smaller glass-covered port at the rear which affords the cameraman a view through the camera finder during filming. The blimp simply rests on the sheet-metal base which has a Celotex pad on which is mounted the coupled recorder and camera. There is accommodation for the tripod screw underneath the base, which permits mounting the whole

ANIMATION EQUIPMENT SPECIAL EFFECTS OPTICAL PRINTERS

- ANIMATION
- TITLES
- STILLS
- CARTOONS
- TRICK PHOTOGRAPHY

For

- INDUSTRIAL MOTION PICTURES
- EDUCATIONAL MOTION PICTURES
- TV MOTION PICTURES
- ENTERTAINMENT MOTION PICTURES

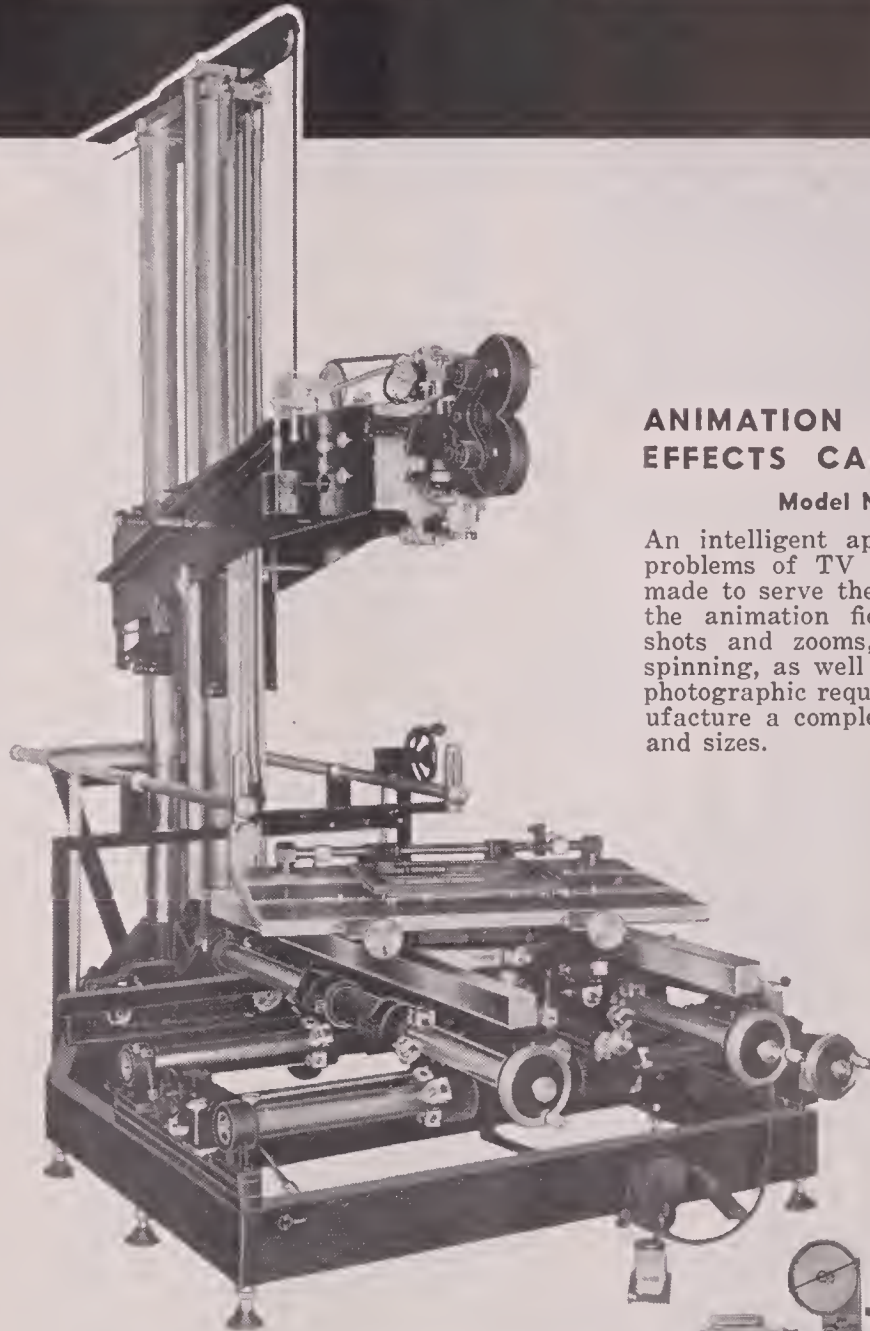

ANIMATION AND SPECIAL EFFECTS CAMERA STAND

Model No. 111-E

An intelligent approach to today's problems of TV commercials. It is made to serve the multiple tasks of the animation field to take angle shots and zooms, matching zooms, spinning, as well as countless other photographic requirements. We manufacture a complete range of styles and sizes.

OPTICAL PRINTER FOR SPECIAL EFFECTS WORK

Prints from one picture to another or one size picture to another. Zoom can be added to the picture without an exposure crew. Foreign titles can be added to bottom of any picture. The machine has a ball bearing mounted zoom for 4 to 1 blow-up or reduction.

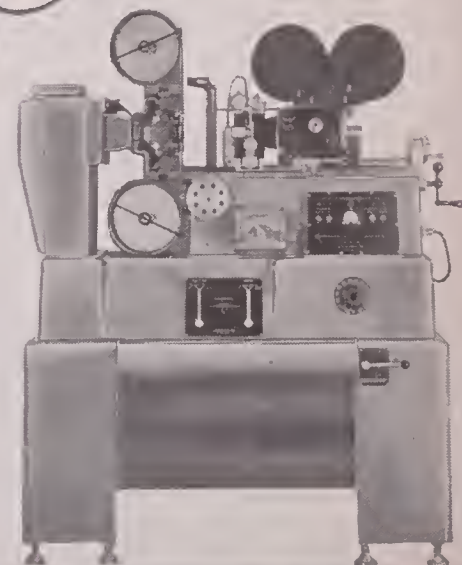

WRITE FOR COMPLETE LITERATURE

Distributed by

J. G. SALTZMAN, INC.

480 Lexington Avenue, New York 17, N. Y.

A 400-ft. Magazine for Your BOLEX H-16



Complete with Synchronous Motor and Base . . . Includes Installation and Case

Permits continuous run of 400 feet of 16mm film, or—the 200 ft. daylight loading spool may be used in the 400 ft. magazine. The 100 ft. daylight loading spool can be used in the camera without removing the external magazine. In block wrinkle finish to match camera. Fully guaranteed.

See your Bolex dealer or order direct. Immediate delivery.

TOLEDO CINE ENGINEERING
1309 Milburn Ave. Toledo 6, Ohio

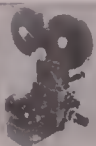

PUMPS

for . . .
CHEMICALS
DEVELOPER
HYPO



Centrifugal Pumps for Circulation, Transfer, Mixing, Agitation, Temperature Control. Corrosion-proof pump of plastic & stainless steel. Rotary seal of inert carbon & ceramic. 115 v. 1/4 h.p., pumps up to 20 G.P.M. Inlet 1" hose or 3/4" pipe. Outlet for 3/4" hose. Some type in 1/2, 3/4, and 1 h.p. size. Write for prices. Satisfaction guaranteed.

Also
Complete DEVELOPING MACHINES
with Wall Micro-Tension Drive.

METAL MASTERS
5599 University Ave., San Diego 15, Calif.

Ready-Eddy

U. S. Registered Trademark
EASY READABLE • ACCURATE
FOR EVERY DAY USE

1001 Ready Sound-Film
Editing Data:
• Footage • Frame
Count • Screen Time
• 35mm and 16mm
equivalents.

Plastic computer for
everyone in movies
and TV, from script to
screen.

\$2.00 Prepaid

(Delivered in U.S.A.)

ASK FOR REPRINT OF ARTICLE
IN AMERICAN CINEMATOGRAPHER.

Write or ask your dealer

READY-EDDY, Sandy Hook, Conn.



unit on a camera tripod, as pictured.

Coupling the recorder to the camera has not presented any serious problems. Thus far, it has been used with a Cine Special and a 16mm Bolex. Direct coupling is achieved with the Cine Special through the camera's 8 fps shaft. With the Bolex, a reversing gear is necessary—a simple mechanical device which is shown just to left of the camera in Fig. 4.

The equipment which we designed for playing back and projecting the sound films made with this apparatus will be the subject of an article next month.

CAMERA CREWS GO TO COLLEGE FOR TV FILMS

(Continued From Page 32)

shaw. Later he will record the off-screen narration to the edited work print.

Photographic and sound recording equipment was shipped out from New York via air express and the company traveled by train. Camera equipment consisted of a Mitchell NC and a Bell & Howell Eyemo. The Mitchell, of course, was used with a blimp for sound takes, and the Eyemo proved very useful for high-angle closeups and other "wild" insert shots. Eastman 35mm Plus-X film stock was used and about twenty thousand feet was exposed. Lighting equipment was held to a minimum. Several colortran units and about a half dozen 750-watt spots, occasionally supplemented by daylight coming through the laboratory windows, proved adequate.

Veteran cameraman Frank R. Follette, ASC, and his assistant Manuel Longinera performed some amazing feats of cinematography under rather difficult conditions where camera movement was very restricted. Each evening the day's exposed film was air-expressed to the laboratory in New York and the following afternoon a report on the negative was received. All reports were favorable and shooting proceeded smoothly.

Sound man Clarence Wall was forced to make some improvisations. A more versatile mike boom than the one brought along was borrowed from the local CBS affiliate WBNS-TV. It was also necessary to bring in a number of floor pads and to purchase some soft Celotex panels to improve the acoustics and extend the reverberation time of the laboratory and class room walls.

Two electricians were recruited from the local stagehand's union to handle the lights and make the necessary connections for electric power. And from time to time it was necessary to call on the Service Department of the Univer-

sity for the use of trucks, and two to four men to move equipment.

Miss Daisy Sickles, writer and editor for the University's Motion Picture Department, acted as script girl. She turned in an excellent job daily and worked extra evening hours typing script changes and revisions.

I was temporarily relieved from my job as staff cinematographer to act as assistant director. The work proved very interesting and many valuable tips were received from cameraman Follette.

Mr. Seltzer and Mr. Kandel, unit manager, both expressed their appreciation to those on the campus who, on very brief notice, helped with the numerous details involved in the undertaking.

Exact scheduling is incomplete for the presentation of this series, but it is believed the programs will take the air late in January or early February in a choice Sunday afternoon spot.

WATER SKI BALLET

(Continued From Page 19)

forty expert skiers recruited from the famed Cypress Gardens water show and from aquatic carnivals throughout the nation. In the picture story, Miss Williams is star of the Cypress Gardens show managed by Van Johnson. In love with the unresponsive Johnson, Miss Williams—while both are in New York on a business trip—arouses Johnson's jealousy when a nightclub singer (Tony Martin) makes a play for her. But she returns to Cypress Gardens and to Johnson, and gives her all in the stunning water ballet, which ends with Johnson finally admitting his love for her.

It is the big, spectacular ballet that is easily the film's outstanding attraction, and Ray June and his camera crew did a remarkable job in filming so vividly the pageant of skiers, with their colorful costumes, backdropped by grand Florida scenery and the sparkling green waters of Winterhaven's Cypress Gardens.

Only a cameraman of June's ability and experience could have filmed it so successfully, and particularly with the skill he has demonstrated for implementing continuity of action.

The ballet sequence, which runs for seven minutes on the screen, required approximately four weeks to produce, including time spent in shooting tests and rehearsals.

"To start with," said June, "we had to do a lot of testing of helicopters and pilots. We finally chose a man from Ventura, California, who had a 'copter that operated with the minimum of

vibration." The helicopter was a vital cog in the studio's plan to give spectacular scope to the water skiing numbers by shooting them from the air. This could not be done satisfactorily from a plane, and could only be done from a helicopter that was in excellent condition mechanically.

"It was necessary to mount the camera on the 'copter," June explained, "so that we could shoot towards the rear. In this way, we could travel just ahead of the skiers and film them in a running shot. To mount the camera, it was necessary first to extend a heavy plank out from the pilot's compartment and secure the camera to it by means of a hi-hat mount. Obviously, this meant little room for the camera operator, and because the weight capacity of the 'copter was limited to the equivalent of the pilot, the camera, and one camera operator, it was obvious that I would have to serve as operator in most of the shots — which I did."

Of course, not all the shots were made from the air. A larger percentage of the action in this sequence was shot from a motor-boat — which became virtually a water-borne camera car. This boat is the property of the Cypress Gardens operators, who employ it in their own vast photographic operations, and who loaned it to the studio for shooting the water ballet scenes. Thus the company found itself better prepared to shoot the water scenes perhaps, than if it had brought along its own equipment or improvised after arriving on the location. The boat was fitted out especially for photographic work and included such equipment as a tubular metal parallel, adjustable from four to twelve feet in height. The boat operator had a wealth of experience in piloting the boat for motion picture photography, which greatly simplified filming operations on the water for June.

Filming from this boat, especially from atop the twelve foot parallel, proved to be the toughest part of the whole picture assignment. "It was the most difficult photographic job I have undertaken," said June. "It was real tough trying to keep my balance and run the camera at the same time. We couldn't have two men on the parallel, so I handled the camera myself most of the time on these shots. There was always a lot of side-sway to fight, and at the same time there was always the fear that the camera would be jolted from its moorings, although it was tied down as securely as it was humanly possible to do.

"Believe me, I was a busy guy! We put a double head on the tripod so I could keep the horizon line level at all times. I had the freehead handle under one arm, and operated the tilt crank

"IN THE EAST"

it's



For COMPLETE FILM PROCESSING

ROUND THE CLOCK SERVICE

- Negative Developing
- First Print Department
- Ultra Violet & Flash Patch Track Printing
- 16mm & 35mm Release Printing
- Quality Control
- Title Department
- 22 Cutting Rooms

FOR COLOR

it's

Rainbowlab Inc.

AN ADDED FEATURE "FOR THE PRODUCER"

Up-to-the-minute advances in motion picture techniques demand radical innovations in projection equipment ... Movielab's new preview theatre brings TO THE EAST the ultimate in theatre projection.

- Three dimensional projection
- 16mm interlock projection

FEATURING 35mm THREE CHANNEL INTERLOCK PROJECTION



MOVIELAB FILM LABORATORIES, INC.

619 West 54th Street, New York 19, N. Y. JUDSON 6-0360



GEO. W. COLBURN LABORATORY INC.
164 NORTH WACKER DRIVE • CHICAGO 6
TELEPHONE STATE 2-7316

**8 and 16mm
SERVICES**

**SPARKLING COLOR
FOR YOUR PRINTS**

Expert timing by color craftsmen plus the careful attention accorded your film in our famous "personalized service" will give you unsurpassed prints whose brilliance makes them alive on the screen.

Write for Information

Dept. C-11
TELEFILM, INC.
6039 Hollywood Boulevard
Hollywood 28, California

Where SPEED is essential use
CAMART
SLATE AND CLAPSTICK

PROD. NO.		
DIRECTOR		
CAMERA		
SOUND	SCENE	TAKE
DATE		

The kind used professionally in most studios and an location. Special slate finish with silk-screen processed characters.

Price \$11.75
THE CAMERA MART, INC.
1845 Broadway • New York 23, N. Y.

with one hand and the pan crank with the other — all the time trying to keep my balance atop the parallel — a matter which injured the metatarsal arch in my left foot."

From the standpoint of photography, the company really had only one good day when the weather was calm and the water smooth. All the rest of the time the wind blew strong and the water was so rough that often there was doubt that the water skiers could remain long on their skis.

"I still marvel at how those kids could stay on their feet!" said June. "In doing the big numbers, there were eight motor boats pulling the skiers, and the camera boat and three pickup boats all on the water at the same time. What the wind didn't do to churn the water, the boats did, making it difficult for the skiers to execute their routines."

Perhaps the reader can get a more vivid picture of this unique photographic undertaking by reviewing the photos at the beginning of this article. For instance, before Miss Williams and the skiers took to the water, the routine they were to follow was first explained by the director, using diagrams on a blackboard. Fig. 1 shows director Busby Berkeley explaining a routine to Esther Williams. Because of such careful planning, retakes were kept to a minimum.

Fig. 2 is a shot from the helicopter and shows the tow boats and three

groups of skiers in formation for the big massed number, which marked the closing footage of the picture. It is one of the most spectacular aerial scenes ever photographed. The waterspouts shown here are two of a series and were produced by an unusual arrangement worked out by the studio. They contributed a breathtaking pictorial touch to this particular routine.

For this, the studio drove a row of telegraph poles into the bed of the lake at intervals, leaving the tops just a foot or so beneath the water surface. On top of each was mounted an assembly of twelve short water nozzles, each of which was attached to a length of fire-hose which ran to a pipeline on shore. Through this network of pipes, hose, and nozzles a battery of water pumps powered by 200 hp motors generated the tremendous flow necessary to create the artificial geysers. As the skier groups approached each geyser, a switch automatically started the flow of water. This entire routine was filmed from the air with the aid of the helicopter.

Fig. 3 is a closeup view of the camera boat with the unblimped Mitchell camera mounted on the four-foot parallel. Miss Williams, standing with water skis submerged, is ready to take off for a closeup shot.

How such closeups were filmed is shown in Fig. 4. Here a short boom

New Norwood Meter Features 'Color-Matic' Control



REDESIGNED Norwood "Director" Meter

both professional and amateur camera-men, has recently been improved to render simplified direct readings for color photography.

A new feature of the meter is the Color-Matic control, a small perforated tab which slips into a slot in the head of the meter.

According to Director Products Corporation, makers of the meter, after the Color-Matic control is in place, you simply set your camera to expose at 1/50th of a second. Meter readings are then taken the same as before, by pointing the Photosphere of the meter toward the camera position, except that now the meter needle points to the proper "f" stop to use for correct color picture exposure. You don't have to set the meter for film speed.

In addition to the new Color-Matic control, the new model Norwood "Director" meter features a redesigned dial face having larger, more easily-read figures than in previous models. The new meter, which operates on the incident light reading principle, can also be used for all types of black-and-white photography, still or motion pictures.

THE NORWOOD "Director" exposure meter which has become the most popular photoelectric exposure meter for



TEWE MOTIVEFINDER

— like a "right arm" for the creative MP and TV Director

TEWE MOTIVEFINDER is a wizard that solves scores of set problems. This Director's Zoom-type Finder reveals the most suitable focal length, the proper camera position, the effects of dolly shots, etc. It is invaluable to a creative Director who likes to plan optical tricks and special effects. Combination Finder zooms from 25mm to 135mm for 35mm Motion Picture and zooms from 28mm to 150mm for TV. Complete with leather carrying case and neck band. **Only \$75**

Other Versatile Viewfinders — each a honey for the money!



ZOOM DIRECTOR'S FINDER for 16mm and 35mm. . . . 16mm zooms from 13mm to 75mm. 35mm zooms from 25mm to 6". **\$15.50**

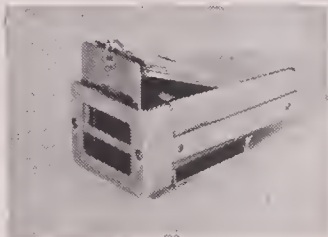

WATSON Director's type finder, pocket size, with mattes from 30mm to 100mm for 35mm cameras. Also for 16mm cameras. **\$35**

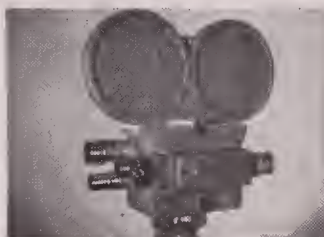

ZOOM Finder for Auricon Cine Voice . . . zooms from 15mm to 12". **\$60**
Available for Filmo and Eyemo. **\$39.50**

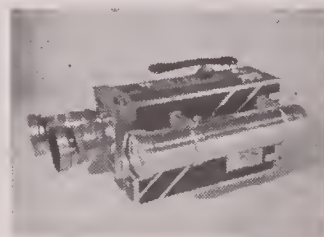

ZOOM Finder for Cine Kodak Special . . . zooms from 15mm to 150mm, with parallax adjustment. **\$75**
Template supplied for mounting Finder on magazine. Additional brackets for magazines available at \$7.50 per set.

FRANK C. ZUCKER
CAMERA EQUIPMENT CO.
1600 BROADWAY NEW YORK CITY

extends from prow of camera boat, to the end of which extends a short length of tow line held by Miss Williams. As the boat moved in the water, Miss Williams glided along with it, so that there was no problem of keeping her uniformly in focus and in frame during the shot. Both closeups and full figure shots of Miss Williams were filmed with this setup by changing lenses and using two cameras.

Note also the reflector which is being held with difficulty by members of the camera crew, and which furnished the necessary booster light. Reflectors, incidentally, were the main source of fill light on all shots of this kind; but they proved a serious problem when used in high winds, which made them almost unmanageable. Three were lost when they were torn from the hands of crewmen and flung overboard by the wind.

The manner in which the follow shots of the skiing groups were made is shown in Fig. 5. Here two cameras are mounted on the camera boat — one on the twelve foot platform of the parallel, and the other at a lower level on a tripod secured to the deck of the boat. Here it is easy to imagine the operational problems encountered by Ray June, who is behind the camera in this shot, up on the twelve-foot parallel.

The unique pictorial composition secured by the lower camera in this

C. ROSS

FOR

LIGHTING EQUIPMENT

Inkie and Arc Lamps including Required Accessories
Generators—Cables—Boards—Boxes

Raby Camera Crane—Dollies—Blimps—Geared Heads

GRIP EQUIPMENT

FOR LOCATION AND STUDIO

Parallels—Steps—Platform Ladders
Century Stands—Reflectors—Flags—Scrim

SOLE EASTERN MOLE-RICHARDSON CO. DISTRIBUTOR

RENTALS • SALES • SERVICE

CHARLES ROSS, Inc.

333 WEST 52nd STREET

NEW YORK 19, N.Y.

Circle 6-5470-1

RUBY CAMERA EXCHANGE

Rents . . . Sells . . . Exchanges

Everything You Need for the

Production & Projection

of Motion Pictures Provided
by a Veteran Organization
of Specialists

35 mm. . . . 16 mm.
Television

IN BUSINESS SINCE 1910

729 Seventh Ave., New York 19, N. Y.
Tel.: Circle 5-5640
Cable address: RUBYCAM

Color Train

THE New Master Model
Converter

LIGHTING



PROVEN BY TEN YEARS ACCEPTANCE
OF MAJOR STUDIOS AND TOP FLIGHT
PHOTOGRAPHERS THE WORLD OVER!

*Don't Blow
Your Time!*

Let the "Color Train Man"
show you the way to
high powered
studio illumination from
ordinary house current!

ask your
dealer What it will do for YOU!

WRITE FOR FURTHER INFORMATION
GENERAL 5
CALIFORNIA

EQUIPMENT

NATURAL LIGHTING CORP.

WORLD FAMOUS

S-5

synchronous
magnetic film
recorder for
motion pictures
and television



STANCIL - HOFFMAN

921 N. Highland Hollywood 38, Calif. send
for
particulars

Scheibe

FILTERS

In World-Wide Use

Produce moonlight and night effects
in daytime • fog scenes • diffused focus
and many other effects.

Information mailed on request.

SCHEIBE FILTERS COMPANY
ORIGINATORS OF EFFECT FILTERS
P.O. Box 16834, Hollywood 46, Calif.

1000 W. 11TH ST.
HOLLYWOOD
MOVING PICTURES
PRODUCTION

operation is pictured in Fig. 6. Here Miss Williams leads a group of skiers in one of several routines as the camera boat moves close to shore in order to get the picturesque trees for a backdrop. Note how the tow ropes form an interesting compositional pattern.

The rough going encountered by the intrepid water skiers in many of the routines is pictured in Fig. 7. This scene depicts Miss Williams (a double was used here) diving from trapeze of a helicopter, in what is the beginning of the grand finale shot of the picture.

Fig. 8 shows how the action of Miss Williams coming up out of the water to grasp trapeze of the 'copter was filmed in closeup. Special rigging mounted atop the twelve-foot parallel extends out to one side. From this is suspended the trapeze, which was progressively shortened in length by crewmen operating ropes from within the boat, thus lifting Miss Williams out of the water, as though by the helicopter itself. Ray June filmed this action with the Mitchell camera mounted on tripod just under the parallel.

For aerial shots of the massed water skiers, the helicopter mounting the camera was invaluable, as shown in Fig. 9. Its wide range of maneuverability enabled June to get shots that would have been impossible from a plane.

The grand finale of all this was staged and shot on the back lot at MGM studio. The setting, pictured in Fig. 10, was erected on the studio lake on the lot. In this shot, Miss Williams comes through the opening at the rear and lands with skis on the water, from where she is immediately elevated on the rising pylon in center of the pool, seen just behind the large geyser of water. This setting, as well as the geyser formation described earlier, was the incredible work of the highly imaginative MGM art director Jack Smith and his crew.

Ray June credits Bob Eastman, technical man at Cypress Gardens, for easing the way for him and his camera crew. It was Eastman who made the camera boat and the parallel available, and who aided in rigging up the tow boats and other craft necessary to filming the water scenes. Eastman said that when the big group scenes were

being filmed, it was the first time that so many people performed on water skis at one time at Cypress Gardens — perhaps anywhere in the world. When MGM technical men first proposed it, the Cypress Gardens management said it simply couldn't be done.

It was a monumental task keeping forty skiers, eight tow boats, two camera boats, and three pickup boats in line and performing to plan. Just keeping all forty skiers on their feet during the routines was a tremendous task in itself. "It required an awful lot of rehearsing just for the boat drivers alone," said June. "They had wind, rough water and currents to contend with. Also, although all tow boats were of the same type and size and were all powered by the same type motor, it was sometimes difficult to keep all of them moving at uniform speed, thus creating a tedious job for the drivers."

Although Technicolor 3-strip film was used on the rest of the picture, the studio elected to shoot the ballet sequence with Ansco Color, which would enable June to use a lighter, single-negative camera instead of the heavier and bulkier Technicolor camera. In cutting the picture, the studio was obliged to intercut some three-strip footage with the Ansco Color, which caused some difficulty in making the final release prints. The color characteristics of the two films are quite different.

All footage for the water ballet sequence was shot with Mitchell 35mm cameras and a Bell & Howell 35mm studio camera, the latter used in shooting from the helicopter. No hand-held cameras were used at any time. All film was shot at standard sound speed of 24 fps — that is, none of the footage was shot at other than normal speed in order to gain some special effect.

"All in all, we had a lot of fun doing the sequence, despite the disappointing Florida weather," said June.

PICTORIAL CONTINUITY

(Continued From Page 30)

Therefore, every transition to another scene or sequence represents a shift in point of view. These changes should be clean and definite, but made with a sense of flow from one to the other, permitting an uninterrupted unfolding of the story.

In order for the two scenes to cut together smoothly, the composition must be changed, either by moving in closer to the subject, by using a different focal length lens, or by chang-

TITLES • OPTICAL EFFECTS

35 mm & 16 mm MOTION PICTURES and TELEVISION

NO rmandie

3-9331

ray mercer & co.

4241 NORMAL AVE • HOLLYWOOD 29, CALIF.
(1½ BLOCKS EAST OF VERMONT, OPP. L. A. CITY COLLEGE)

NO rmandie

3-9331

FADES • LAP DISSOLVES • INSERTS • MATTE SHOTS • MINIATURES • 3-D

ing angle completely. If two scenes showing continuous action are shot from the same or very similar angles, a disturbing "jump" cut will result.

If, on the other hand, too great a change of angle is made in cutting to another scene, the audience will be jolted and momentarily lost. Therefore, should it be necessary for a radical change of angle to be made, the jolt may be minimized either by momentarily cutting away from the scene, or by using a *dolly*, *pan*, or *follow* shot to lead the audience smoothly from one composition to another.

Here, the moving camera comes into its own, for it is the smoothest possible way to change composition without losing the audience. Used correctly, it can link up two to ten or more separate compositions within a single scene, at all times preserving the relationship of one component with the rest.

In sequences which show a subject moving or facing in a certain direction, it is important that each scene preserve a consistency of screen direction, regardless of the size of the shot.

For example, where a character is shown walking down the street from right to left, it would be a disturbing jolt to the audience if in the following scene he were shown going from left to right. It would appear as though he

CAMART SCOUT TRIPOD



THE SCOUT
Includes head
Measures from
42" closed to
72" fully ex-
tended. Weighs
9½ pounds.

\$104.50

THE CUB
Baby Tripod

\$35.00

HI-HAT
Ideal for
low angle
cinematography

\$16.00

A PROVEN LEADER!

Sturdy tripod for 16mm or 35mm cameras. Well balanced removable friction head for smooth pan and tilt action. Water level. Specially treated wood prevents warping. Fibre boot covers available.

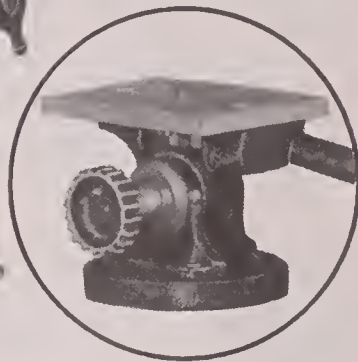

REMOVABLE HEAD

Model A, narrow plate for Cine-Special. Model B, wide plate for other cameras.

Send for
descriptive literature

THE CAMERA • MART INC.

1845 BROADWAY at 60th ST.
NEW YORK 23, N. Y.

Phone: Circle 6-0930
Cable Address CAMERAMART



frost lights the nation!

MOTION PICTURE STUDIO •
THEATRICAL • DISPLAY
RENTAL EQUIPMENT

WHEREVER YOU ARE—WHATEVER YOU NEED

... in the way of unusual, specialized lighting, call on Jack Frost! For movie-making, stage lighting, feature exhibits, large conventions ... for *any* location that requires exceptional lighting, Jack Frost is ready to serve you! And Jack Frost's unequalled national service includes complete installation and removal *wherever* you are. Rent all your specialized lighting equipment from Jack Frost ... famous for lighting the nation's greatest shows ... most spectacular displays.

FOR FULL INFORMATION ON
RENTAL EQUIPMENT
MAIL COUPON, OR CALL
DETROIT, TRINITY 3-8030

JACK A. FROST, DEPT. J,
234 PIQUETTE AVE.
DETROIT 2, MICHIGAN

Please send me full information on
your rental service.

Name _____
Address _____
City _____ Zone _____ State _____

MOVIOLA

FILM EDITING
EQUIPMENT
16MM - 35MM

- PICTURE SOUND Photo and Magnetic
- SYNCHRONIZERS
- REWINDERS

One of the new series 20 Moviolos for picture and sound.

Write for Catalogue

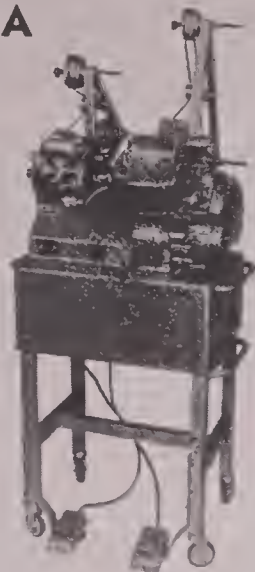

MOVIOLA MANUFACTURING CO.
1451 Garden St. • Hollywood 28, Calif.

AUTOMATIC DAYLIGHT PROCESSING EQUIPMENT DEVELOPING TANK

- Processes up to 200 Ft.
- 8mm-16mm-35mm
- Movie—X-Ray—Microfilm
- Motor Driven, Portable
- Tough Plastic Tonks
- Uniform Density Assured
- 70mm tonk also available

FILM DRYER

- Motor driven—Heated
- Speedy drying
- Automatic shrinkage allowance
- Stainless steel and aluminum construction
- Easily assembled without Tools
- Compact, Portable

Guaranteed. Write for Free Literature

MICRO RECORD CORP.

Dept. AC 225 W. 28th St., N.Y. 1, N.Y.



New Shutter Converts Auricons For TV Recording



SCHEMATIC at left shows method of using Auricon "1200" camera with "TV-T" shutter for kinescope recording. Photo at right is the Auricon "1200" equipped with "TV-T" shutter and 1200-ft. film magazine, which provides 30 minutes of continuous filming.

PELLEGRINI

VARIABLE SHUTTER UNITS
FOR THE BOLEX H-16



The real answer to complete FADES and LAP DIS- SOLVES. Faster shutter speeds and many other advantages. Prices within U. S. \$99.60. Cameras with outside frame counter \$109.80. Tax extra. One year guarantee and camera transportation back included. Send for free informative booklet.

Prices subject to change without notice.

TULLIO PELLEGRINI

1545 Lombard St.
San Francisco 23, California



ADVERTISERS—

... let us tell you how **American Cinematographer** can sell more of your products to advanced movie amateurs — the group that buys the most and uses the most amateur cine equipment and films!

AMERICAN CINEMATOGRAHER
1782 N. Orange Dr., Hollywood 28, Calif.

were retracing his steps. Actually, this is an error which is all too common in the films of many professionals as well as amateurs.

If, however, it should become necessary to change direction suddenly, the jump can be minimized by showing the subject turning a corner, by cutting to a neutral (straight-on) shot of the subject, or by cutting away momentarily to another segment of the situation.

The reverse of this approach can sometimes be used to good advantage in order to show conflict between two opposing elements, such as a couple of locomotives rushing toward each other from different directions (as in Paramount's "Denver & Rio Grande"). By *intercutting* shots of the two locomotives roaring toward each other, a certain forceful suspense is created.

Where it is desired to change locales in a sequence in which the subject is moving, let him walk *out* of one scene

and *into* the next. Unless this is done, there will be a disturbing jolt as the background behind subject suddenly changes completely in character. If this change also involves a lapse of time, it is better to *dissolve* or use a *wipe* effect rather than *cut* directly from the one scene to the other. In such case, the subject should *not* leave the frame.

Sometimes the entrance and exit of a character or subject into and out of a scene involve diagonal lines of action, so that the subject enters or leaves from one corner of the screen. In such a case, it is important that a consistency of screen geography be maintained. Thus, if subject leaves the frame (facing the camera) at the lower right corner of the screen, he should enter the frame of the following scene (facing the camera) from the upper left hand corner. But if, in the second scene, he is walking away from the camera, he

AURICON CAMERAS are now available with a special shutter for use in making kinescope recordings in industrial and commercial television. Known as the "TV-T" or Television Transcription shutter, the development makes it possible to use Auricon cameras so modified to photograph television pictures from the face of a receiver tube. The pictures, which occur at a rate of 30 frames per second, are recorded on 16mm film at the rate of 24 fps without any loss of picture quality such as occurs when conventional motion picture cameras are used for this purpose.

Auricon cameras equipped with the "TV-T" shutter, according to Berndt-Bach, Inc., the manufacturer, may also be used to film conventional live action 16mm SOF pictures without any camera

modification or change in the "TV-T" shutter.

The Auricon "1200" equipped with the "TV-T" shutter can make a kinescope record of a continuous 30 minute operation or program, using 1200 foot film magazines. The dual-purpose "TV-T" shutter is also available for the Auricon-Pro and Cine-Voice cameras.

Other important applications of Auricon "TV-T" kinescopes are delayed broadcasting, sponsor presentations, competition checks, pilot kinescopes, showcase films, film library, "hot kines." and TV air checks.

The company has available for free loan a 50-ft. kinescope "TV-T" demonstration film. For further details, write the company at 7377 Beverly Blvd., Los Angeles 36, Calif.

again available-

OUR FAMOUS
"controlled action"
small GYRO tripod

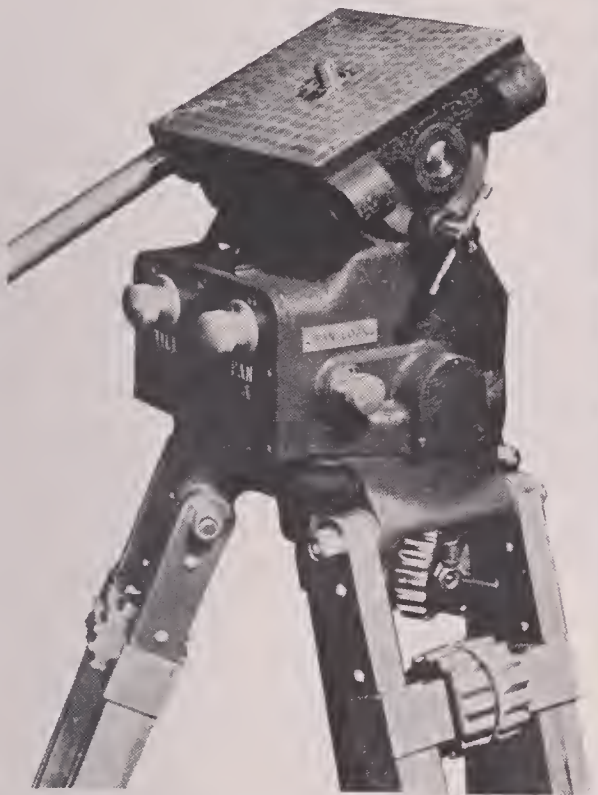

Here is exciting news for many Motion Picture Cameramen. . . . We are happy to announce that we are again in production on our popular Small Gyro Tripod.

If you have used our Gyro, of course no description is necessary. But if you know it only from hearsay, you have an interesting experience ahead of you. You will be delighted with this "Action Controlled" job which is precision-engineered with gears and flywheels like a fine clock.

It has two speeds—slow and fast—for both panning and tilting, and is equipped with a long pan handle which enables you to control the pan and tilt action—helps you capture fine scenic views and fast moving sports events with ease.

Our GYRO is especially recommended for such cameras as the 16mm Mitchell, the 16mm Murer, the Bell & Howell Eyemo with 400 foot magazine and motor and similar cameras.

If you appreciate lightweight convenience in a versatile tripod, lose no time in seeing our Gyro. We predict you will be fascinated by it.

FRANK C. ZUCKER
CAMERA EQUIPMENT CO.
1600 BROADWAY NEW YORK CITY

should enter from the lower left corner.

Pictorial continuity depends upon the proper build-up to the main point of the sequence. This simply means that if you have a striking closeup as the "punch line" of the sequence, don't haphazardly throw it into the film, but build up to it with carefully planned and executed long and medium shots.

The device known as *juxtaposition*, if correctly and not too frequently used, provides a smooth and original transition between scenes. Simply defined, the term means the matching up for effect of two separate scenes, each of which has different subject matter, but a similar compositional pattern. For example, if at the close of one scene we move into a spinning roulette wheel, and then dissolve to a spinning car wheel to introduce the next scene, an effective transition is made. Similarly, if we concentrate on the flame of a burning match and then dissolve to flames leaping in a fireplace, we have another forceful example of juxtaposition of compositional elements. This device can be used to add variety, to create smooth transitions, and to create a symbolic connection between two subjects of different meaning but similar form.

As stated before, camera movement is one of the most effective means of pre-

Model 35-16C

SENSITESTER

★ IMMEDIATE DELIVERY
to the lab owners interested in—

QUALITY
EFFICIENCY
ECONOMY

- DUAL MACHINE
1—Sensitometer
2—Scene Tester
- HIGHLY ACCURATE
Electronic timer unaffected
by climatic changes.
- NEW TYPE LONG-LIFE
Cold Light Exposure Unit
- WITHOUT ADDITIONAL
EXPENSE will match any
printer

Combination 35mm-16mm

ART REEVES MOTION PICTURE EQUIP.

7512 Santa Monica Blvd.

Hollywood 46

California

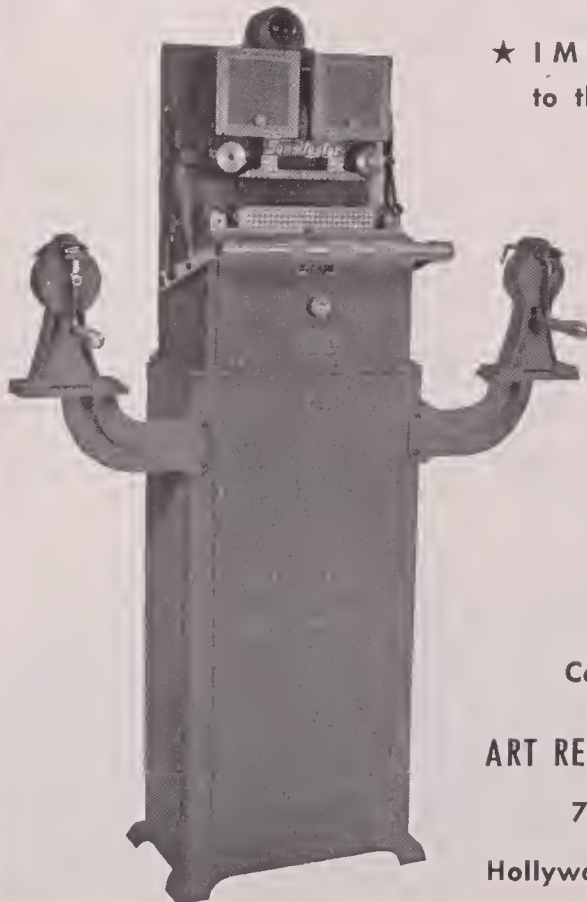

erving pictorial continuity — its strongest point being that changes in composition can be made without the audience becoming confused as to the physical relationship of different parts of the setting or action.

The straight *tilt* or horizontal *pan* is used to follow the action of the moving object, while tripod remains stationary.

The *follow shot* (also known as *dolly shot*, *trucking shot*, or *perambulator shot*) is executed by mounting the camera on a movable base so that it actually follows along with the subject as it moves.

A *pull-in* is a shot in which the camera starts with a long or medium shot and gradually moves into a closeup of a particular segment of the scene. It is one effective means of establishing a new scene and then getting to the most important element quickly and smoothly.

The *pull-back* shot, a direct reverse of the above technique, starts with the camera in closeup, and then moves back

to a medium or long shot to show the general surroundings. This is effective when it is necessary to impress a certain segment of the situation on the minds of the audience before the overall setting is shown.

Camera movement should never be used merely for the sake of movement, or for the purpose of forcing action into an otherwise static treatment. Like any other pictorial continuity device, it should always be used with a definite effect in mind.

Pictorial continuity should originate in the script. The director should be careful that the pattern follows through in the action as he stages it. The cameraman, above all, should use his camera to enhance the flow of one scene into the other, so that the audience will gain the impression of a freely moving story unhampered by jumpy transitions or gaps in the narrative.

Reprinted from "Cinema Workshop" by Charles Loring.

SIMPLE LENS FOR SPECIAL EFFECTS

(Continued From Page 36)

From these facts, it is easy to calculate any type of system you want. Suppose you use a +10D cylinder for your plus lens, and a -D cylinder for your minus lens. The plus cylinder will have a focal length of 100mm; the minus cylinder will have a focal length of 50mm. The magnification or distortion should equal the focal length of the difference in their focal lengths, that is, 100mm minus 50mm, which equals 50 mm. The magnification or distortions produced is equal to the focal length of the plus lens divided by that of the minus lens, in this case $100 \div 50$, which equals 2.

Mounting a supplementary lens system like this involves accuracy, since the tube that holds the lens elements should keep them accurately aligned, and yet permit adjusting the separation between the two, and also permit one of the lenses to be rotated with respect to the other, so that the final adjustments can be made with the device in position on the camera.

The housing for this auxiliary lens system can be made from tubes of cardboard or metal. One should be slightly smaller in diameter so that it will fit fairly snugly within the larger tube — so that it may be moved in and out for focusing. In a mount like this, one can hold the spectacle-lenses in place either by using cardboard retaining-rings, which can be glued into place, or Scotch tape.

For long-shots, this system is complete in itself. But if you are going to use it

making closer shots, you'll need to add a spherical auxiliary lens (not a cylinder lens as in the distorting system) in front of the plus cylinder to correct your focus. The focal length of this supplement should be equal to the distance between camera and subject: that is, if the subject is $6\frac{1}{2}$ feet from the camera, use an auxiliary with a focal length of 2 meters — or a plus 0.50 D spectacle-lens — to refocus your optical system at $6\frac{1}{2}$ feet.

The amount of distortion is determined by the overall power of the supplementary-lens system. For most purposes a set of these cylinder-distortion supplementaries ranging in magnifying power from 1.2 to 1.6 will prove satisfactory. More powerful units can be made easily enough, but they're not so convenient; if you use strong lenses, aberrations will be introduced which will be sharp, but the separation between them must be so large that you will have a long tube which will cut into the field of any but very long-focus camera-lenses.

Here are the specifications with which to build a set of three of these distorting-lens systems, which will give you a convenient range in power from 1.2 to 1.6, enough for most requirements. For a magnification of 1.2, use a plus 5 diopter lens and a minus 6 diopter lens, spaced 33.33mm apart. For a magnification of 1.5, use a plus 8 D lens and a minus 12 D lens, spaced 41.67mm apart. For a magnification of 1.66, use a plus 9 diopter lens and a minus 15

diopter lens, spaced 43.34mm apart.

In this connection, the term "magnification" is used advisedly, for these cylinder-distortion systems produce the effect of distortion by magnifying the image in one plane or direction — either horizontal or vertical — and leaving the other vertically unchanged. The axis or direction of distortion is determined by the inclination of the axes of the two lens-cylinders of the distorting combination. If both axes are vertical, the image is distorted horizontally, and vice-versa. By revolving both units together, it should be possible to make the distortion change from horizontal to vertical during a scene, as when producing some very bizarre effects for nightmare or drunken scenes.

ZOOMAR LENS

(Continued From Page 27)

physical length of the lens as well as that of the coupled finder remains the same.

Built as an integral part of the lens assembly, the coupled finder is a wide-vision finder. It has no peephole to make "nose-to-the-camera" operation necessary. As a result, the cameraman has the maximum freedom of movement while filming, and the image he sees in the finder is just as it will appear later on the projection screen. It puts the cameraman in the unique position of being able to compose and edit his shooting on the spot, instead of later on the cutting and splicing board.

The operation of the new Zoomar 16 is smooth and continuous. The zoom mechanism does not rely on the operation of cams or gears which would be subject to wear. Adjusted carefully at the factory, it remains in perfect adjustment.

The technical data for the Zoomar 16 is as follows:

Aperture Range:	f/2.8 to f/16
Zoom Range:	1 in. to 3 in. (25mm to 75mm)
Distance Range:	8 ft. to Infinity (short-range adapters are available for shorter distances)
Weight:	1 $\frac{1}{4}$ pounds
Overall Dimensions:	5 $\frac{1}{2}$ in. long 4 $\frac{1}{2}$ in. wide 2 in. high

All optical elements are fluoride coated; also the highest resolving power ever built into any varifocal lens, according to the manufacturer, assures

Film Editing Made Easy
with NEW

professional film viewer

for 35mm and 16mm

Every film editor will appreciate a viewer that enables him to view his film from left to right—on a large, brilliantly illuminated screen.

The PROFESSIONAL FILM VIEWER makes film editing a breeze. Easy threading, portable, will not scratch film. Put this viewer between your rewinders and speed up your editing. Size of Viewing Screen 5¾ x 4¾.



35mm Model \$375

16mm Model \$350

FRANK C. ZUCKER
CAMERA EQUIPMENT ©
1600 BROADWAY NEW YORK CITY

brilliance, detail, and picture contrast over the entire picture frame. Furthermore, there are no cemented elements so thermic stability is assured.

The new Zoomar 16 is the result of more than seven years of intensive research and development in the field of varifocal lenses, the manufacturer has stated. Into it has been built all the know-how and experience which company engineers gathered during the development of the earlier television and newsreel varifocal lenses. Thus, all the long sought-for advantages of a compact, versatile varifocal lens is now available for the 16mm cinematographer. The Zoomar 16 can be used with the following professional and amateur 16mm cameras: Arriflex, Auricon, Cine Kodak, Bell & Howell, Bolex, Keystone, Maurer, Mitchell, Morton, Pathe, and Revere. It may also be used with the Dage and RCA industrial television cameras.

You are able to see movies and TV as motion pictures because your "flicker fusion" frequency is slow. Such insects as bees, flies, and shore slaters see them as a rapid procession of stills, reports Philip R. Ruck, U.S. Public Health Service.

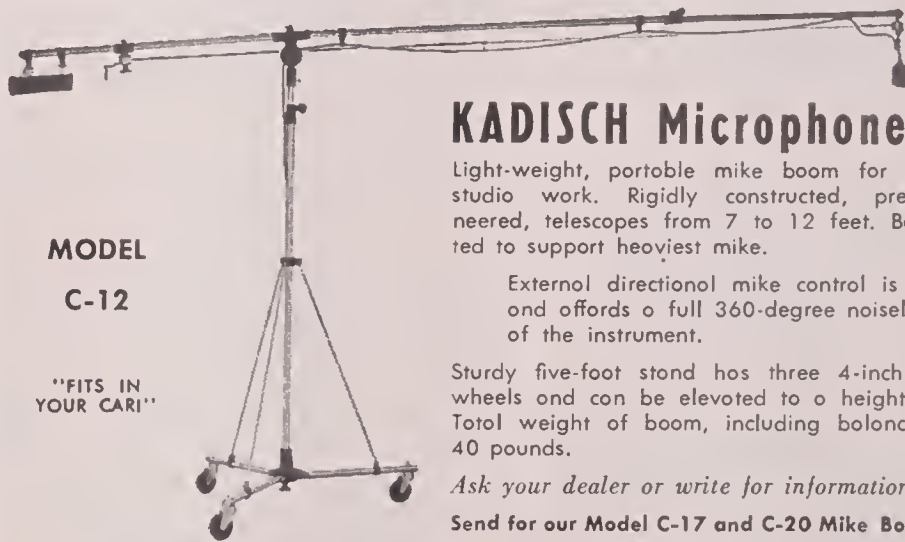

MODEL

C-12

"FITS IN
YOUR CAR!"

KADISCH Microphone Boom

Light-weight, portable mike boom for location and studio work. Rigidly constructed, precision engineered, telescopes from 7 to 12 feet. Boom is strutted to support heaviest mike.

External directional mike control is at rear and affords a full 360-degree noiseless turn of the instrument.

Sturdy five-foot stand has three 4-inch rubber-tired wheels and can be elevated to a height of ten feet. Total weight of boom, including balance weight, is 40 pounds.

Ask your dealer or write for information and prices.

Send for our Model C-17 and C-20 Mike Booms Catalog.

KADISCH CAMERA AND SOUND ENGINEERING CO.

Designers and Manufacturers of Motion Picture and TV Equipment

500 West 52nd Street

New York 19, N. Y.

Phone PLaza 7-3511

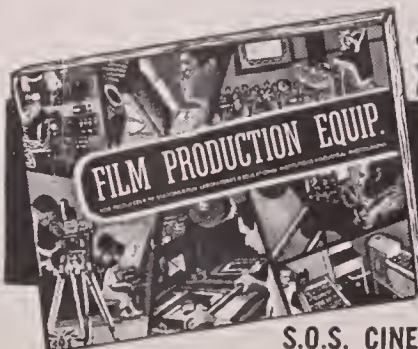

FREE! CATALOG

THE BIGGEST OF ITS KIND!!
80 pages, more than 1000
different items with prices
and over 300 illustrations. For
Producers, TV Stations, Film
Labs., Industrial Photography,
Educational Institutions, etc.

**MOTION
PICTURE
PRODUCTION
EQUIPMENT**

S.O.S. CINEMA SUPPLY CORP., Dept. F, 602 West 52nd St., N. Y. C.

Current Assignments of A.S.C. Members



Major film productions on which members of the American Society of Cinematographers were engaged as directors of photography during the past month.

AMERICAN SOCIETY OF CINEMATOGRAPHERS

FOUNDED January 8, 1919, The American Society of Cinematographers is composed of the leading directors of photography in the Hollywood motion picture studios. Its membership also includes non-resident cinematographers and cinematographers in foreign lands. Membership is by invitation only.

ARTHUR EDESON, President
 MILTON KRASNER, First Vice-President
 ARTHUR MILLER, Second Vice-President
 HAL MOHR, Third Vice-President
 WILLIAM SKALL, Treasurer
 JOHN W. BOYLE, Secretary
 ROBERT DE GRASSE, Sergeant-At-Arms
 JOHN ARNOLD
 CHARLES G. CLARKE
 LEE GARMES
 ALFRED GILKS
 VICTOR MILNER
 RAY RENNAHAN
 JOSEPH RUTTENBERG
 LEON SHAMROY

Alternate Board Members

JOSEPH BIROC
 WILLIAM DANIELS
 PAUL EAGLER
 SOL HALPRIN
 WINTON HOCH
 CHARLES LANG
 JOSEPH LA SHELLE
 SOL POLITO
 JOHN SEITZ
 JAMES VAN TREES

ALLIED ARTISTS

• ERNEST MILLER, "The Forty-Niners," with Wild Bill Elliott, Virginia Grey, Thomas Carr, director.

COLUMBIA

• HENRY FREULICH, "The Miami Story," with Barry Sullivan. Fred F. Sears, director.
 • CHARLES LAWTON, "The Wood Hawk," (Technicolor) with Robert Francis, Donna Reed. Phil Karlson, director.
 • HENRY FREULICH, "Jungle Man-Eaters," with Johnny Weismuller, Karin Booth. Lee Sholem, director.
 • LESTER WHITE, "The White Stallion," with Phil Carey, Dorothy Patrick. Fred Sears, director.
 • BURNETT GUFFEY, "The Human Beast," with Glenn Ford and Gloria Grahame. Fritz Lang, director.

METRO-GOLDWYN-MAYER

• GEORGE FOLSEY, "A Bride for Seven Brothers," (CinemaScope, Eastman Color) with Jane Powell, Howard Keel. Stanley Donen, director.
 • ROBERT SURTEES, "Valley of the Kings," (Eastman Color, Wide-screen; shooting in Egypt) with Robert Taylor, Eleanor Parker. Robert Pirosh, director.

• JOSEPHINE RUTTENBERG, "Brigadoon," with Gene Kelly, Van Johnson, Cyd Charisse. Vincente Minnelli, director.
 • PAUL C. VOGEL, "The Student Prince," (Ausco Color, CinemaScope) with Ann Blythe, Edmund Purdom. Richard Thorpe, director.
 • ROBERT PLANCK, "The Prisoner of War Story," (Ausco Color, Wide-screen) with Ronald Reagan, Dewey Martin. Andrew Marton, director.

PARAMOUNT

• LOYAL GRIGGS, "White Christmas," (Technicolor) with Bing Crosby. Michael Curtiz, director.
 • DANIEL FAPP, "Living It Up," (Technicolor, Wide-screen) with Dean Martin, Jerry Lewis. Norman Taurog, director.
 • ROBERT BURKS, "Rear Window," (Wide-screen, Technicolor) with James Stewart. Alfred Hitchcock, producer-director.
 • LIONEL LINDON, "Conquest of Space," (Color, Wide-screen) with Eric Fleming, William Redfield. Byron Haskin, director.
 • THOMAS TUTWILER, "The Bridges of Toko Ri," (Perlborg-Seaton Prod.; color) with Wm. Holden and Robert Strauss. Mark Robson, director.

REPUBLIC

• HARRY STRADLING, "Johnny Guitar," (Tricolor) with Joan Crawford, Sterling Hayden. Nick Ray, producer-director.

R.K.O.

• HARRY WILD, "The Big Rainbow," (Technicolor) with Jane Russell. John Sturges, director.
 • NICK MUSURACA, "Susan Slept Here," with Dick Powell, Debbie Reynolds. Frank Tashlin, director.

20th CENTURY-FOX

• MILTON KRASNER, "Garden of Evil," (Technicolor, CinemaScope, shooting in Mexico) with Gary Cooper, Susan Hayward. Henry Hathaway, director.
 • LLOYD AHERN, "Princess of the Nile," (Panoramic Prods.; Technicolor) with Debra Paget, Jeffrey Hunter. Harmon Jones, director.
 • JOHN SEITZ, "The Kid from Outer Space," (Panoramic Prods.) with Charles Coburn, Spring Byington. Oscar Rudolph, director.

UNIVERSAL-INTERNATIONAL

• CLIFF STINE, "Fireman Save My Child," (Wide-screen) with Hugh O'Brian, Buddy Hackett. Leslie Goodwins, director.
 • CARL GUTHRIE, "Playgirl," with Shelley Winters. Colleen Miller. Joseph Pevney, director.
 • IRVING GLASSBERG, "The Black Shield of Falworth," (Technicolor, CinemaScope) with Tony Curtis and Janet Leigh. Rudolph Mate, director.
 • RUSSELL METTY, "Sign of The Pagan," (Technicolor, CinemaScope) with Jeff Chandler, Jack Palance. Douglas Sirk, director.

WARNER BROS.

• WILFRED CLINE, "Lucky Me," (Warner-Color, CinemaScope) with Doris Day, Robert Cummings. Jack Donohue, director.

• ARCHIE STOUT, "The High and the Mighty," (Wayne-Fellows Prods.; Warner-Color, CinemaScope) with John Wayne, Claire Trevor. William A. Wellman, director.
 • EDWARD DU PAR, "Ring of Fear," (Wayne-Fellows Prods.; Warner-Color, CinemaScope) with Clyde Beatty, Micky Spillane. James Edward Grant, director.
 • PEVERELL MARLEY, "The Talisman," (Warner-Color, CinemaScope) with Virginia Mayo, Rex Harrison. David Butler, director.

INDEPENDENT

• STANLEY CORTEZ, "Broncho Apache," (Hecht-Lancaster Prods.; Technicolor, Wide-screen) with Burt Lancaster, Jean Peters. Robert Aldrich, director.
 • FRANZ PLANER, "The Long Wait," retitled "A Bullet Is Waiting," (Parklane Prods.; Wide-screen) with Anthony Quinn, Charles Coburn. Victor Saville, director.
 • ERNEST LASZLO, "Bronco Apache," (Hecht-Lancaster Prod.; Technicolor, Wide-screen) with Burt Lancaster, Jean Peters. Robert Aldrich, director.
 • JOHN ALTON, "Desperate Men," (Benedict Bogeaus Prod., Eastman Color, ScenicScope) with John Payne, Elizabeth Scott. Allan Dwan, director.

TELEVISION

(The following directors of photography were active last month in photographing films for television, or were on contract to direct the photography of television films for the producers named.)

• LUCIEN ANDRIOT, "The Life of Riley" series for Hal Roach Prods.
 • NORBERT BRODINE, "Letters To Loretta" series for Lewislor Enterprises, Inc.
 • DAN CLARK, "Cisco Kid," and "I Led Three Lives," series for ZIV TV.
 • EDWARD COLMAN, "Dragnet," Mark VII Prods.
 • ROBERT DEGRASSE, "Make Room For Daddy," D.P.I. and Marterto Prods., Inc.;
 • GEORGE DISKANT, "Four Star Playhouse," Four Star Prods.
 • KARL FREUND, "I Love Lucy" and "Our Miss Brooks," for Desilu Prods.
 • FRED GATELY, "Big Town," Gross-Krasne Productions.
 • RUSSELL HARLAN, "Playhouse of Stars" for Meridian Productions.
 • JACK MACKENZIE, "The Hank McCune Show" for Video Pictures, Inc.
 • WILLIAM MELLOR, "Adventures of Ozzie and Harriett," Stage 5 Productions.
 • VIRGIL MILLER, "You Bet Your Life," (the Groucho Marx Show), Filmcraft Productions.
 • HAL MOHR, "The Joan Davis Show," Joan Davis Productions.
 • ROBERT PITTACK, "Cavalcade of America," Jack Chertok Productions.
 • MACK STENGLER, "Life With Elizabeth," Snader Telescription Corporation.
 • HAROLD STINE, "Cavalcade of America," series for Jack Denove Prods., Inc.
 • WALTER STRENCE, "My Little Margie," Roland Reed Productions.
 • STUART THOMPSON, "Topper" series of 1/2-hr. telepix for Loveton-Schubert Prods.
 • GILBERT WARRENTON, "Chevron Theatre," Revue Productions.

ROSTER

American Society of Cinematographers

JANUARY 1, 1954

RESIDENT MEMBERS

L. B. Abbott
David Abel
Lloyd Ahern
John Alton
Lucien Andriot
Arthur Arling

Lucien Ballard
R. O. Binger
Joe Biroc
Charles P. Boyle
John W. Boyle
Wm. W. Bradford
Elwood Bredell
Norbert Brodine
Robert Burks

Elis W. Carter
Walter Castle
Dan Clarke
Charles G. Clarke
Wilfrid Cline
Russell Collings
Edward Coleman
Stanley Cortez
Ray Cory
Edward Cronjager
Floyd Crosby

Wm. H. Daniels
Mark Davis
Robert deGrasse
George E. Diskant
Linwood Dunn
E. B. DuPar
Elmer Dyer

Paul E. Eagler
Arthur Edeson
A. Faricot Edouart

Max Fabian
Daniel L. Fapp
Ray Fernstrom
Frank Finger
George J. Folsey, Jr.
Henry Freulich
Karl Freund
John P. Fulton

Lee Garmes
Fred Gately
Maury Gertsman
Alfred L. Gilks
Irving Glassberg
Donald C. Glouner
James Gordon
W. Howard Greene
Jack Greenhalgh
Loyal Griggs
Burnett Guffey
Carl Guthrie

Ernest Haller
Sol Halprin
Edwin Hammeras
Ralph Hammeras
Russell Harlan
Sid Hickox
Robert Hoag

Winton Hoch
David S. Horsley
James Wong Howe

Allan E. Irving

Fred H. Jackman, Jr.
Fred W. Jackman
Ray June

W. Wallace Kelley
Benj. H. Kline
Lloyd Knechtel
H. F. Koenekamp
Milton Krasner

Charles B. Lang, Jr.
Joe LaShelle
Ernest Laszlo
Charles C. Lawton, Jr.
Paul K. Lerpae
Lionel Lindon
Leo Lippe
Harold Lipstein
Arthur Lloyd
Walter Lundin
Warren E. Lynch

Joe MacDonald
Jack MacKenzie
Fred Mandl
J. Peverell Marley
Charles A. Marshall
Harold J. Marzorati
Rudolph Mate
Ted McCord
Wm. C. Mellor
Ray Mercer
R. L. Metty
Arthur Miller
Ernest W. Miller
Virgil Miller
Victor Milner
Hol Mohr
Ira H. Morgan
Nick Musuraca

Harry C. Neumann

Roy Overbaugh

Ernest Palmer
Kenneth Peach
Harry Perry
R. W. Pittack
Robert H. Planck
Frank Planer
Sol Polito

Frank Redman
Ray Rennahan
Irving Ries
Irmin Roberts
George H. Robinson
Guy Roe
Len H. Roos
Jackson Rose
Charles Rosher
Harold Rosson
John L. Russell, Jr.
Joseph Ruttenberg

Charles Salerno, Jr.
John Seitz
Leon Shamroy
Henry Sharp
William A. Sickner
Allen Sigler
Wm. V. Skall
Edward Snyder
Wm. F. Snyder
Ralph Staub
Mack Stengler
Clifford Stine
Harold Stine
Archie J. Stout
Harry Stradling
Walter Streng
Karl Struss
Robert L. Surtees

Philip Tannura
Ted Tetzlaff
Stuart Thompson
Robert Tobey
Leo Tover
Thomas Tutwiler

James C. Van Tres
Paul C. Vogel

Joseph Walker
Gilbert Warrenton
Harold E. Wellman
Albert Wetzell
Lester White
Harry Wild
Wm. N. Williams
Rex Wimpy

ASSOCIATE MEMBERS

Herbert Aller
Simeon Aller
Mark Armistead
Cecil Bardwell
Benj. Berg
Edgar Bergen
John Bishop
Louis A. Bonn
David Boyle
L. M. Combs
J. L. Courcier
George Crane
Edward P. Curtis
Wm. A. Cushman
Dr. C. R. Daily
John DuVall
William Eglinton
Ferdinand Eich
Ralph Farnham
Rolla Flora
Fred W. Gage
Wm. J. German
George H. Gibson
Henry Goldfarb
Alan Gundelfinger
Charles Handley
Robert Hansard
Ted Hirsch
Wilton R. Holm
Emery Huse
Lloyd A. Jones
W. F. Kelley
Wilson Leahy
Sidney Lund

Dr. C. E. K. Mees
Lewis L. Mellor
Garland C. Misener
Peter Mole
Hollis Moyse
O. W. Murray
Capt. Don Norwood
Norman F. Oakley
Val E. Osborne
Emil Oster
Harry E. Pratt
H. W. Remerscheid
Robert Riley
Loren Ryder
Sidney P. Solow
John J. Swain
Randall Terraneau
Albert Tondreau
Wm. J. Wade
Jack Webb
Robert Young

NON-RESIDENT MEMBERS

Charles E. Bell—St. Paul, Minnesota
O. H. Borradaile—Canada
Joseph Brun—Forest Hills, New York
Jack Cardiff—England
S. C. Chuck—Formosa
Olle Comstedt—New York
J. Burgi Contner—New Canaan, Conn.
John Dored—Halden, Norway
Max B. DuPont—Tahiti
Higino J. Fallorina—Quezon City, P. I.
Frank R. Follette—Sparta, New Jersey
Charles Harten—New York, N. Y.
Reed N. Haythorne—Tucson, Arizona
Charles W. Herbert—Tucson, Arizona
John L. Herrman—New Orleans, La.
Gerald Hirschfeld—Port Wash., N. Y.
Eric Horvitch—South Africa
Wm. H. Jansen—Manila, P. I.
Don Malkames—Tuckahoe, N. Y.
Ricardo Marcelino—Manila, P. I.
Louis Page—France
Ted Pahle—Spain
J. F. Painter—N. Y.
Paul Perry—California
Bob Roberts—Brazil
Robert Sable—Chicago, Ill.
James Seeley—Penna.
Harry Squire—New York
William Steiner, Jr.—New Jersey
Frederick A. Young—England
Frank C. Zucker—New York, N. Y.

INACTIVE MEMBERS

Russell Cully
Faxon Dean
Harry Hallenberger
G. Floyd Jackman
Glenn Kershner
Gordon B. Pollock
George Schneiderman
Douglas Shearer

HONORARY MEMBERS

E. O. Blackburn
A. S. Howell
David MacDonald
G. A. Mitchell

CLASSIFIED ADVERTISING

RATE: 10c per word—minimum ad \$1.00. Words set in capital letters, 15c per word. Display format 90c per line.

STUDIO & PRODN. EQUIP.

DEPT. STORE OF THE INDUSTRY 1954 SPECIALS

HEAVY DUTY ESCALATOR TRIPOD with large freehead on rolling dolly. \$1250 val. \$ 595.00
 CINE SPECIAL with 2 lenses. Excellent 419.50
 DEPUE 35/16mm SOUND REDUCTION Printer, rebuilt 2995.00
 ANSCO-SWEET COLOR DENSITOMETER, \$B50 value 367.50
 3 Digit Counters for printers, etc. 4.95
 American Cinematographer Handbooks, early 1953 edition. Publ. overstock 2.50
 BERNDT-MAURER SINGLE SYSTEM 16mm Sound Camera, turret, 4 lenses, finder, 400' magazine, amplifier, power supply, fair 1295.00
 SPIDER TURET for EYEMO with 3 lens, f2.3 Pentachar 40/50/75mm 395.00
 ELECTRIC FILM FOOTAGE COUNTERS — starts, stops, continues automatically. Comb. 16/35mm, \$119.50; 16 or 35 mm 67.50
 NEW STRIPPING FLANGES, 6" comb. 16/35mm, rd. keyway 5.95
 HOUSTON 16mm KIA REVERSAL DEVELOPER, reconditioned 3250.00
 HOUSTON 35mm PROCESSOR Model 10 combination, negative/positive. Originally \$13,250. Reconditioned 7500.00
 NEW FILM EDGE NUMBERING MACHINES, 16 or 35 mm 2250.00
 ARRIFLEX 35mm CAMERA, 3 lenses, tripod, adapter, batteries, etc. 895.00
 EYEMO NEWSREEL CAMERAS Model 71 less lens, as is 99.50
 EYEMO SPIDER TURRET Newsreel Cameras, Model 71 less lens, as is 295.00
 WALL MOVIE TONE 35mm Single System outfit, \$7000 value 3995.00
 NEW 500/750W FRESNEL SPOTS, 6" lens, med. pref. 19.95
 CASH PAID FOR USED EQUIPMENT. TRADES TAKEN Dept. fc Coble: SOSOUND

S. O. S. CINEMA SUPPLY CORPORATION
 602 W. 52nd Street New York 19, N. Y.

BASS . . . CHICAGO. Cinema headquarters for 43 years offers money saving buys in guaranteed used equipment. B. & H. 70 DE, hond crank, back wind, 1" F:1.5 Cooke, 15mm. F:2.7 Kodak w.a., 4" F:4.5 Cooke, \$399.50; Bolex H-16, 1" Primoplan F:1.5, 17 mm. F:2.7 Wollensak w.a.; 2" F:1.6 Kodak, case, \$299.50; B. & H. 70 E, 1" F:2.7 Cooke, case, \$122.50; Kodak Model K, 1" F:1.9, case, \$82.50; B. & H. Auto Master, 1" F:1.9 Wollensak, 15mm. F:2.5 Ektor, 4" F:4.5 Wollensak, case, \$267.50; 16mm. Mogaize Kodak, F:1.9, case, \$92.50; Bmm. Magazine Kodak, F:1.9, case, \$92.50; Bmm. Revere 99 Turret, F:2.B, case, \$52.50; 8mm. Revere Magazine 70, F:2.B, case, \$67.50; B. & H. Foton, gun, case—\$543.00 value for \$250.00. Best buys . . . Best trades always. BASS CAMERA CO., Dept. AC-1, 179 W. Madison St., Chicago 2, Illinois.

16mm. LAB AND MOVIE EQUIPMENT

LATE AURICON PRO—including redesigned amplifier for superior sound, mike, ear-phones cables, AC-DC inverter, case, parallex viewfinder, lens shade, two daylight load magazines, 3 lenses, double system recorder. Cost \$2,900.00. Now \$1,450.00
 HEAVY DUTY ALUMINUM TRIPOD—all metal. Cost \$300.00. Now 150.00
 UHLER CINE PRINTER—sonud ond silent, with redesigned contact shoes including air jets for contact. Cost \$1,200.00. Now 600.00
 K-1 HOUSTON DEVELOPER. Cost \$2,600.00. Now 1,300.00

FILM-ART, INC.,
 3407 Clifton Ave., Cincinnati 20, Ohio. CApitol 4158

WALL S. S. 35MM. SOUND CAMERA

COMPLETE with Galvanometer, amplifier, portable power supply, 40-50-75 and 100mm. lenses, erect image viewfinder, complete front attachments, two 1000 ft. magazines, Balanced Tripod, necessary carrying cases. Overhauled. Guaranteed perfect. Reasonable.

CAMERA EQUIPMENT COMPANY
 1600 Broadway New York 19, N. Y.

AUDIO AKELEY single system camera complete with Akeley sound head, Gyro tripod, 3 lenses, view finder, Maurer mixing amplifier. Complete with cables, power supply and W. E. microphone. CAMERA EQUIPMENT CO., 1600 Broadway, New York 19, N.Y. Cable Cinequip.

WE BUY, SELL AND RENT PROFESSIONAL AND 16mm. EQUIPMENT, NEW AND USED. WE ARE DISTRIBUTORS FOR ALL LEADING MANUFACTURERS. RUBY CAMERA EXCHANGE, 729 Seventh Ave., New York City. Established since 1910.

STUDIO & PRODN. EQUIP.

35MM CINEPHON Camera, 5 Calibrated Coated Lenses, Mitchell type Focusing shift. 7 magazines, electric motor, Matte box, cases. Used in Theatrical Film Production. CARL-FREDRIK NELSON, 164-12 110th Road, Jamaica 33, N. Y.

CINE SPECIAL II, 200' mogozine F1.9 25 mm. Ektor lens, used only 8,000 feet, \$B50.00. Auricon blimp for Cine, Synchronous motor, parallex viewfinder \$440.00. Auricon tripod \$250.00. Package price for all three \$1,475.00. GEORGE PALMER, 3580 Washington Ave., Cincinnati 29, Ohio.

FOR SALE—Cine Kodak Special, 3 lenses, two 200-ft. magazines, deluxe case, perfect condition, \$1100.00. CHARLES CLARKE, 328 So. Bedford Drive, Beverly Hills, Calif.

BELL & HOWELL 35mm standard camera with high-speed movement, 6 lenses, matt box, viewfinder, 110-volt synchronous motor, two 1000-ft. magazines, two 200-ft. mogazines, tachometer, etc., with cases. Excellent condition. \$1950.00 cash. BOX 11B2, American Cinematographer.

LABORATORY & SOUND

SOUND RECORDING at a reasonable cost. High Fidelity 16 or 35. Quality guaranteed. Complete studio and laboratory services. Color printing and lacquer coating. ESCAR MOTION PICTURE SERVICE, INC., 7315 Carnegie Avenue, Cleveland 3, Ohio. Phane Endicott 1-2707.

RECORDING and sound editing. 16 or 17½mm. Magnetic tracks. Music recorded in sync to your work print. L.A. and Harbor area producers call Don Dunn — Davenport 6-4925, EL RANCHO AUDIO, 26236 Fairview Avenue, Lomita, California.

WANTED

IMMEDIATE CASH PAYMENT FOR CAMERAS AND EQUIPMENT

NEED EYEMOS (SINGLE LENS AND TURRET), MITCHELLS, ARRIFLEX, DE BRIES, B&H STANDARDS AND HI-SPEEDS, WALLS, AKELEYS, CINE SPECIALS, AJURICONS, MAURERS, FILMOS. ALSO BALTARS, COOKES AND OTHER LENSES. SOUND STAGE, LABORATORY AND EDITING EQUIPMENT OF ALL TYPES REQUIRED. PLEASE SHIP INSURED OR FORWARD DESCRIPTIONS AIRMAIL. IMMEDIATE PAYMENT.

GORDON ENTERPRISES • 5362 N. Cahvenga NORTH HOLLYWOOD, CALIFORNIA

WANTED TO BUY FOR CASH

CAMERAS AND ACCESSORIES

MITCHELL, B & H, EYEMO, DEBRIE, AKELEY ALSO LABORATORY AND CUTTING ROOM EQUIPMENT

CAMERA EQUIPMENT COMPANY

1600 BROADWAY, NEW YORK CITY 19

CABLE: CINEQUIP

WANTED

PRODUCTION EQUIPMENT, LABORATORY EQUIPMENT, EDITING EQUIPMENT, 16mm. and 35mm. FROM SINGLE ITEMS TO COMPLETE STUDIOS. TRADES ACCEPTED.

THE CAMERA MART, INC.

1845 Broadway Circle 6-0930 New York 23, N.Y.

WANTED

Mitchell — Akeley — B & H — Wall — Eyemo Cameras — Lenses — Equipment

NATIONAL CINE EQUIPMENT, INC.

209 West 48th St. New York, N.Y.

F & B PAYS MORE

FOR USED 16/35MM EQUIPMENT

WRITE — WIRE — PHONE

FOR OUR CASH OFFER

FLORMAN & BABB MU. 2-2928
 70 W. 45TH ST. NEW YORK 36, N.Y.

SOS ARE SPECIALISTS ON SALES

If You Can't Get Your Price We Can Do It For You

Cameras, Dollies, Lenses Lights
 Moviolas, Printers, Recorders,
 Studio or Laboratory Equipment
 Western Union Private Wire — WUX New York

S. O. S. CINEMA SUPPLY CORPORATION
 Dept. fc Coble: SOSOUND
 602 W. 52nd Street New York 19, N. Y.

WANTED GOOD used 16mm. sound films, cortoon, sport, etc. Will pay highest prices. FILM SERVICE, Box 625 Industrial Branch, Hillside, New Jersey.

COLOR SLIDES, PHOTOS & FILMS

NATURAL COLOR SLIDES, Scenic, National Parks, Cities, Animals, Flowers, etc. Set of eight \$1.95. Sample and List 25c. SLIDES, P.O. Box 26, Gordena, Calif.

BUGS, SNAIL, LIZARD, etc. Extreme closeups of various insects, 400 ft. MISS UNIVERSE PARADE, 300 ft. All original color film, 24 f.p.s. professionally filmed. Can be made into excellent TV subjects. LEO CALOIA, 10521 Ruthelen St., Los Angeles 47, Calif. PL. 4-5842 after 6 p.m.
 PL-45B42 after 6 P.M.

CAMERA & SOUND MEN

ASSIGNMENTS FOR INDIA or nearby territories for any type of films, 16 or 35mm, B&W or Color, write to KANU PATEL, A.R.P.S., The Clorion Productions, 34, Park Mansions, CALCUTTA-16.

SKILLED CINEMATOGRAPHER available, 16mm.-35mm. Well traveled—has made many 'travelogues'. Work U. S. or anywhere in world. Has 16mm. equipment Passport. EMERSON, 224 Noples Terrace, Bronx (63), New York.

Here . . .

on this page
 you'll find

BARGAINS GALORE

in

New and Used Equipment

of all kinds.

A good place for YOU

to sell, too!

Rates Are Low!

Only

10c a word.

practically
every film producer
in the western
hemisphere is **a client**
of
byron



byron production services

script — *titling*

animation — *location photography*

sound stage — *music library*

editing — *recording*

color-correct prints* — *complete black-and-white laboratory facilities*

art — *sound effects*

When you want the best quality and service —
use swift, economical Byron production facilities!
Visit our studios, discuss your plans with us,
or ask for our illustrated brochure and price list.

*Reg. U.S. Patent Office

byron Studios and Laboratory

1226 Wisconsin Avenue, N.W., Washington 7, D.C. DUpont 7-1800

550 Fifth Avenue, New York 36, N.Y. Circle 5-8188

ULTRA-SHARP DETAIL

...in

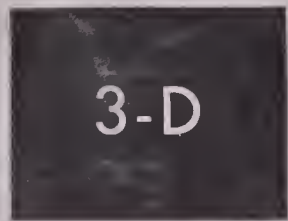

3-D

...in



T-V

...and in

CINEMA SCOPE



...with Taylor, Taylor and Hobson Speed Panchro Lenses

T-T-H Speed Panchro lenses again meet the demands of a fast-growing industry—supplying the high degree of sharpness needed for CinemaScope, 3-D and television films. A complete set of eight fully color corrected lenses matched for

perfection is now available from Bell & Howell. Each lens is accurately calibrated by scientific measurement of light actually transmitted. Consistent negative densities regardless of which lens is used. For full details, write to Bell & Howell.



100mm T3 (f/2.5)



75mm T2.3 (f/2)



50mm T2.3 (f/2)



40mm T2.3 (f/2)

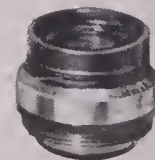

35mm T2.3 (f/2)



25mm T2.3 (f/2)

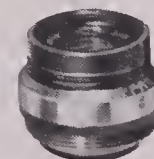

32mm T2.3 (f/2)

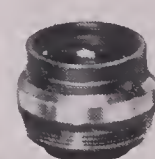

28mm T2.3 (f/2)

Also 8½", 12½", and 20" F/5.6 T-T-H Telephotos

Look for Bell & Howell's new 35mm anamorphic lens for studio and theater projection.



Bell & Howell

Professional Equipment Department
7148 McCormick Road, Chicago 45, Ill.

Cinematographer

THE MAGAZINE OF MOTION PICTURE PHOTOGRAPHY

THEATRE
TELEVISION
INDUSTRIAL
AMATEUR



In This Issue . . .

Photographing "Rear Window" . . . The New Arriflex Cameras
. . . Disney's Naturalist-Cinematographers . . . Magnetic Sound
With Any Cine Projector.

25c

\$3.00 YEARLY

Here is amazing

MANEUVERABILITY

never before achieved!

NEW!

For Film and TV Cameras

NEW! CIRCULAR STEERING

Entirely new steering mechanism makes possible easy, smooth, sharp turning on own axis or in any desired arc. Wheels can also be locked parallel for straight tracking in any direction.

VERSATILE WHEEL POSITIONS

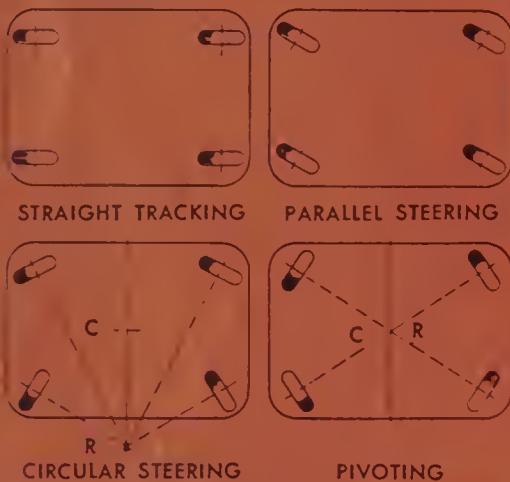

NEW! MANEUVERABILITY

The extreme flexibility of the steering mechanism makes possible fast positioning in small, crowded studios.

NEW! HANDLING EASE

Weighs only 500 pounds. Cameramen and grips appreciate easy dollying, turning, raising and lowering boom.

NEW! LOW SLUNG CHASSIS

Cinemobile is built low down for better balance, greater stability and smoother rolling.

NEW! VERSATILITY

Makes possible a wide range of camera effects formerly achieved only with larger, heavier equipment. Priced to fit the budget of smaller studios.

HOUSTON-FEARLESS CINEMOBILE



NEW! HYDRAULIC BOOM LIFT

Camera boom is raised and lowered smoothly, quietly, effortlessly, automatically by hydraulic system. Extreme high and low lens heights are readily achieved even when dolly is in motion.

The
HOUSTON FEARLESS
Corporation

SEND FOR FULL INFORMATION NOW!

THE HOUSTON-FEARLESS CORPORATION
 11809 W. Olympic Blvd. • Los Angeles 64, California
 Send information on Cinemobile Film Processors All Metal Tripod
 Panoram Dolly Camera Crane TV Pedestal

Name _____
 Firm _____
 Address _____
 City _____ Zone _____ State _____

MAR -1 1954



THE WORLD'S MOST COMPLETE ASSORTMENT
OF PHOTOGRAPHIC EQUIPMENT FOR

T.V. and Motion Picture Studios

MICROPHONE BOOMS

FOR ALL PURPOSES

SMALL, MEDIUM, LARGE

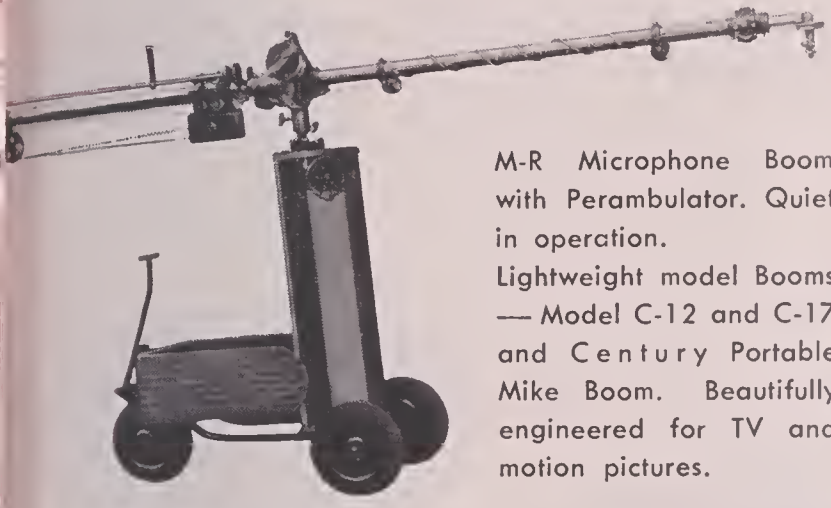

M-R Microphone Boom with Perambulator. Quiet in operation. Lightweight model Booms — Model C-12 and C-17 and Century Portable Mike Boom. Beautifully engineered for TV and motion pictures.

MOVIOLA FILM EDITING EQUIPMENT

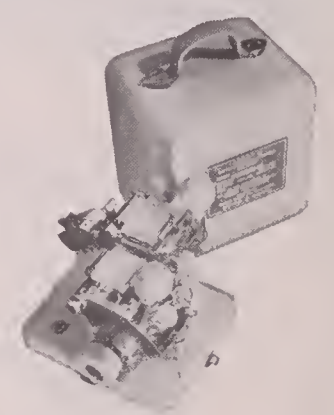
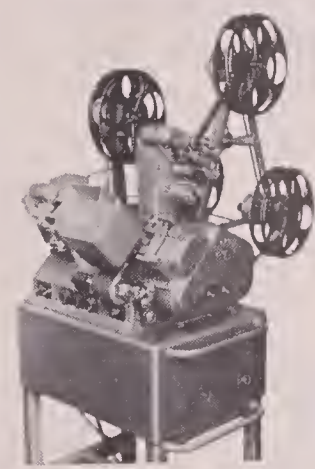

ROBOT AUTOMATIC SPLICER

No heat required. Assures exceptionally strong positive splice. Simple operation. Portable.



AURICON CAMERAS

Illustrated: Cinevoice with 3-lens turret, Zoom Finder and 400 ft. Magazine.

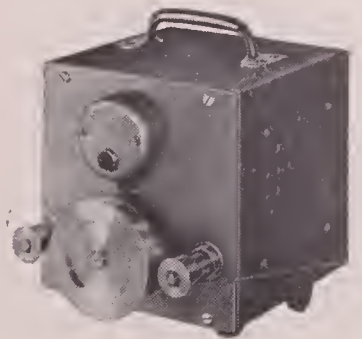

PRECISION SOUND READER

(16-35 COMBINATION)

Simple threading. Polished Stabilizer drum with needle bearings. Surface cannot damage film. Precision ground shafts. Dimensions—6" x 6" x 7 1/2". AMPLIFIER: 117 volt, 60 cycle, AC. Power output 4 Watts. Heavy duty Alnico V. Speaker. Safety fused.

LIGHTWEIGHT ALUMINUM SHOULDER BRACE

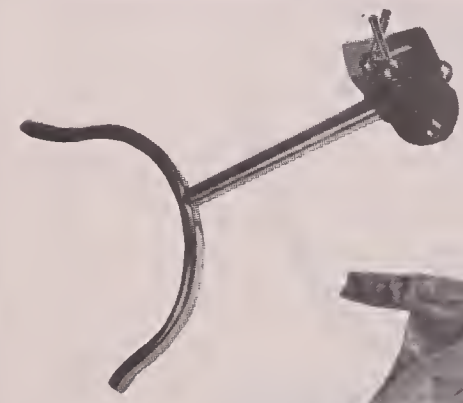

... for 16mm and 35mm cameras. Sturdy, yet light enough not to tire user. Easy panning and tilting. For all hand-held cameras.

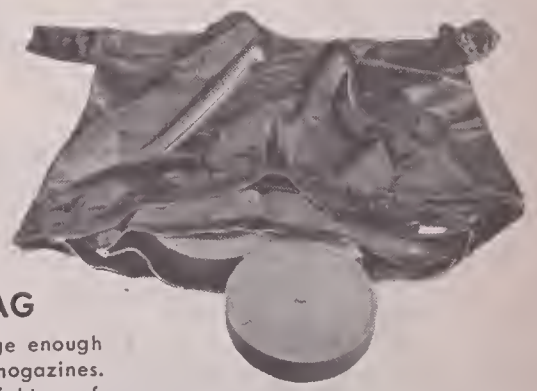

CHANGING BAG

— a portable darkroom. Large enough to take 1000 ft. 35mm magazines. Double zipper. Completely light-proof.

9.5mm Lenses in 16mm C mount. 18.5mm (extreme wide angle-flat field) Lenses available in mounts for all 35 mm Motion Picture Cameras. PHOTO RESEARCH Color Temperature Meters. *Electric Footage Timers Neumade and Hollywood Film Company cutting room equipment. Griswold & B.&H. Hot Splicers. *DOLLIES—Bardwell-McAlister, Mole Richardson, Century and Colortran Lighting Equipment.

Complete line of 16mm and 35mm Cameras

FRANK C. ZUCKER
CAMERA EQUIPMENT CO.
 1600 BROADWAY NEW YORK CITY

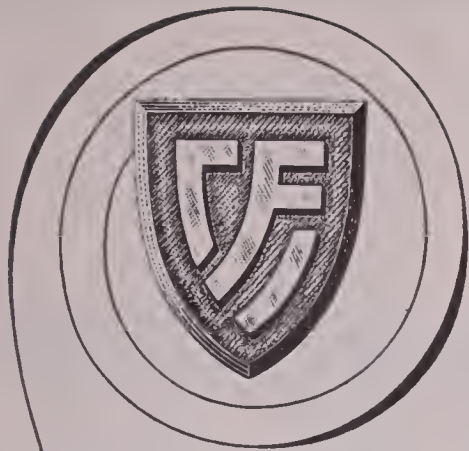

**The Seal of Our
Pledge to You**

**... to bring
to the screen
in flawless manner
the artistry
of your
photography**

*Hollywood's
only complete*

**LABORATORY
SERVICE**

**CONSOLIDATED
FILM INDUSTRIES**

A DIVISION OF REPUBLIC PICTURES CORPORATION

**959 N. SEWARD ST.
PHONE HO 9-1441**

AMERICAN

Cinematographer

THE MAGAZINE OF MOTION PICTURE PHOTOGRAPHY
PUBLICATION OF THE AMERICAN SOCIETY OF CINEMATOGRAPHERS

ARTHUR E. GAVIN, *Editor*

EMERY HUSE, *Technical Editor*

GLENN R. KERSHNER, *Art Editor*

Circulation, MARGUERITE DUERR

EDITORIAL ADVISORY BOARD: John Arnold, Arthur Edeson, Lee Garmes, Charles Roshier, Leon Shamroy, Fred Gage, Dr. L. A. Jones

Editorial and Business Office: 1782 N. Orange Dr., Hollywood 28, Calif.

Telephone: HOLLYWOOD 7-2135

VOL. 35

FEBRUARY

• 1954

NO. 2

CONTENTS

ARTICLES

WALT DISNEY'S NATURALIST-CINEMATOGRAPHERS—By <i>Frederick Foster</i>	74
REAR WINDOW—By <i>Arthur E. Gavin</i>	76
NEW ARRIFLEX CAMERAS FEATURE MANY IMPROVEMENTS—By <i>Arthur Rowan</i>	80
FINISHING THE PRODUCTION—By <i>Herb A. Lightman</i>	82
ACCENTING TEMPO WITH LIGHTING	87

AMATEUR CINEMATOGRAPHY

CARE AND HANDLING OF FILM IN THE TROPICS—By <i>John Forbes</i>	89
MAGNETIC SOUND FOR ANY PROJECTOR—By <i>George W. Cushman</i>	90
3-D FILM FESTIVAL	92

FEATURES

INDUSTRY NEWS	62
WHAT'S NEW IN EQUIPMENT, ACCESSORIES, SERVICE	66
BULLETIN BOARD	72
SWAP YOUR ODD SHOTS	92
CURRENT ASSIGNMENTS OF ASC MEMBERS	106

ON THE COVER

ONE OF THE MOST interesting of photographic assignments was undertaken by director of photography Robert Burks, ASC, last month when he began filming "Rear Window," his fourth production for Alfred Hitchcock, at Paramount Studios. Here, Burks (right) has lined up his camera on action taking place in an apartment across courtyard, as observed by Jimmy Stewart seated in rear window of his Greenwich Village apartment. Director Hitchcock (left) uses P-A system to direct players in distant set. Story about the photography begins on page 76 in this issue.—*Photo by Glen E. Richardson.*

AMERICAN CINEMATOGRAPHER, established 1920, is published monthly by the A. S. C. Agency, Inc., 1782 N. Orange Dr., Hollywood 28, Calif. Entered as second class matter Nov. 18, 1937, at the postoffice at Los Angeles, Calif., under act of March 3, 1879. SUBSCRIPTIONS: United States and Pan-American Union, \$3.00 per year; Canada, \$3.00 per year; Foreign, \$4.00. Single copies, 25 cents; back numbers, 30 cents; foreign single copies, 35 cents; back numbers, 40 cents. Advertising rates on application. Copyright 1954 by A. S. C. Agency, Inc.

IMPORTANT ANNOUNCEMENT

re: the *Mitchell*
16mm Professional Camera

IMMEDIATE SHIPMENTS

are currently
being made



...with this announcement
the Mitchell
Camera Corporation,
for the first time
in history,
now offers you
shipment of the
famed Mitchell 16mm
Professional Camera
on receipt
of your order.



THE CAMERA WITH A HERITAGE

There is no substitute for a heritage of GREAT ENGINEERING. No 16mm motion picture camera made anywhere in the world can match the technical perfection which a Mitchell 16 brings to your film. Each 16mm camera has the same supreme custom workmanship and Mitchell's exclusive, positive operation that is today world-famous ... wherever truly professional films are made.

Mitchell Camera CORPORATION

666 West Harvard Street • Glendale 4, Calif. • Cable Address: "MITCAMCO"



85% of the professional motion pictures shown throughout the world are filmed with a Mitchell

ARRIFLEX

35mm
Model 11

**A TRULY GREAT
CAMERA**

for TV, Newsreel
and commercial
films

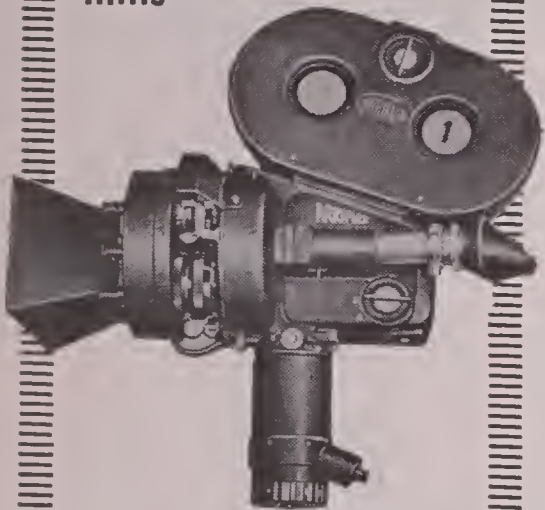

For tough and trying assignments, ARRIFLEX 35 is in a class by itself. Reflex focusing through photographing lens while camera is operating—this is just one outstanding ARRIFLEX feature.

Equipped with bright, right-side-up image finder, $6\frac{1}{2}x$ magnification. Solves all parallax problems. 3 lens turret. Variable speed motor built into handle operates from lightweight battery. Tachometer registering from 0 to 50 frames per second. Compact, lightweight for either tripod or hand-held filming. Takes 200' or 400' magazine. Write for free folder.

COMPLETE REPAIR FACILITIES

FRANK C. ZUCKER
CAMERA EQUIPMENT CO.
1600 BROADWAY NEW YORK CITY

INDUSTRY NEWS

In all the big changes which have been wrought in the production of motion pictures in recent months, photography has been a dominant factor. The introduction of 3-D, CinemaScope, and the various wide-screen formats all began with camera and/or lens modifications; all involved some change in photographic procedure.

While the resultant upheaval in studio programs temporarily displaced some cinematographers and camera crews, most of the displaced have found interesting new employment in the bustling, ever-growing TV film industry.

Hal Roach, Jr., in a recent address before members of the American Society of Cinematographers, in Hollywood, hinted at plentiful assignments in TV film making yet to come.

Last month, the Roach Studio in Culver City, revealed that over 3,500,000 feet of negative was exposed in 250 telepix produced at that studio during 1953.

The studio, which has a capacity for turning out 400 TV pictures per year, anticipates greatly increased activity there during 1954.

There's a lot of business in store for film manufacturers the next 10 months—just in the TV film production field.

Most of the major studios already are shifting into high gear, production-wise. Those that shut down or approached that status last year, did so only to get their bearings during the "confusion in formats" period. Now, with few if any studios worrying about the importance of 3-D, with most all settled in their minds as to which wide-screen formats to follow, the production train is surely but cautiously being accelerated again.

One thing is certain: there won't be as many feature films made during 1954. But those that will, will be made with care; with bigger budgets; with more film; and in most cases with greater casts and personnel.

Color in feature pictures, which has shown a steady increase in the past twelve months, is expected to take an even greater jump this year. Almost two-thirds of the major studios will shoot their feature productions in Technicolor, Eastman color negative, or Ansco Color. Production of short subjects in CinemaScope and color will in-

crease color film use over that of last year.

Production of TV spot commercials last year showed an increase of about 20% over 1952, according to "The TV Reporter," industry trade paper, with the upward trend continuing. Though there are over 80 companies currently engaged in this field on west coast, as compared to about 50 in New York area, the eastern output is heavier. Budgets for "spots" vary widely from \$600 to \$10,000.

Said to be one of the most consistently active producers of TV commercials is the Universal-International Pictures' subsidiary, United-World Pictures. Using U-I's studio facilities, company has turned out more than 300 TV commercials ranging in length from 20 seconds to five minutes.

Crawley Films Limited, of Ottawa, Canada's largest private producer of motion pictures, for the 15th consecutive year reports an upswing in business. Gross business in 1953 was up 22% over 1952. A total of 52 major productions were completed. In addition, 100 smaller assignments were handled. The company, incidentally, received eight new film citations during the year, bringing the total to 35 awards received in five years.

A course in TV advertising is being offered by the University of California Extension, in Los Angeles, for the first time. Evening classes will start February 15th at 7 p.m. in a Royce Hall classroom. The courses will deal with the economics and effectiveness of TV film commercials and will include laboratory work in writing film and live-commercial copy. Course will extend over period of eight weeks.

Following a filming recess, to begin about mid-February, when all productions for its 1954-54 releasing season are completed, Metro-Goldwyn-Mayer will launch its 1954-55 releasing season with eight big pictures to start shooting in April and May. More than 22 writers are currently at work on scripts for those and other MGM productions scheduled to go before the cameras this year.

MODEL SW-602
PORTABLE RECORDING SYSTEM

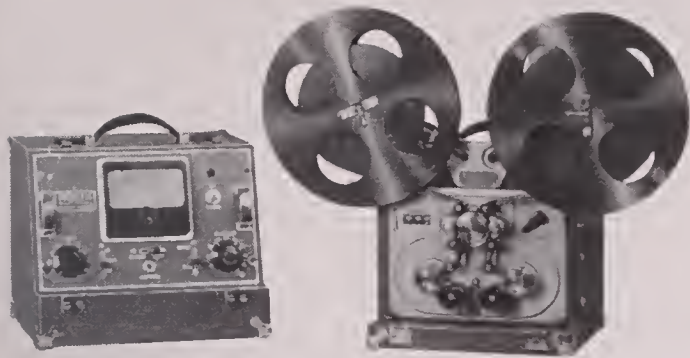

MODEL SW-602-RP
RACK-MOUNT RECORDER
IN PORTABLE CASE



MODEL SW-602-D3
THREE INTERLOCKED DUMMIES
WITH PLAYBACK PRE-AMPLIFIERS

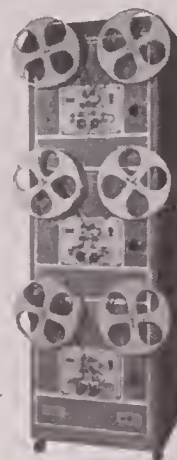

MODEL SW-335
35mm STEREOPHONIC
THEATRE
PLAYBACK SYSTEM

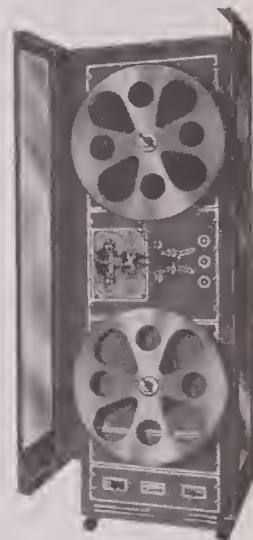

RACK-MOUNT AMPLIFIER WITH SPEAKER



UNITIZED CONSTRUCTION

Designed around this famous "SYNKINETIC" film transport, all MAGNASYNC equipment is built to PERFORM.

You can depend on MAGNASYNC!

16mm CENTER TRACK 16mm EDGE TRACK
17½mm 35mm MULTI-CHANNEL



NORTH HOLLYWOOD, CALIFORNIA

EQUALIZED PLAYBACK PRE-AMPLIFIER



Send for complete technical data

DISTRIBUTORS

MAGNETIC RECORDERS COMPANY
7120 Melrose Ave., Los Angeles 46, Calif.
WEbster 3-5545

CAMERA EQUIPMENT COMPANY
1600 Broadway, New York 19, New York
Judson 6-1420 Cable Address: CINEQUIP

ZENITH CINEMA SERVICE, INC.
3252 Foster Ave., Chicago 25, Illinois
IRving 8-2104

Manufactured by:

MAGNASYNC MFG. CO., Ltd. • P.O. Box 707, North Hollywood, Calif.

MICROPHONE MIXERS • PORTABLE SUPPLIES • SPLIT-APART REELS • BULK ERASERS

SEEING IS BELIEVING!

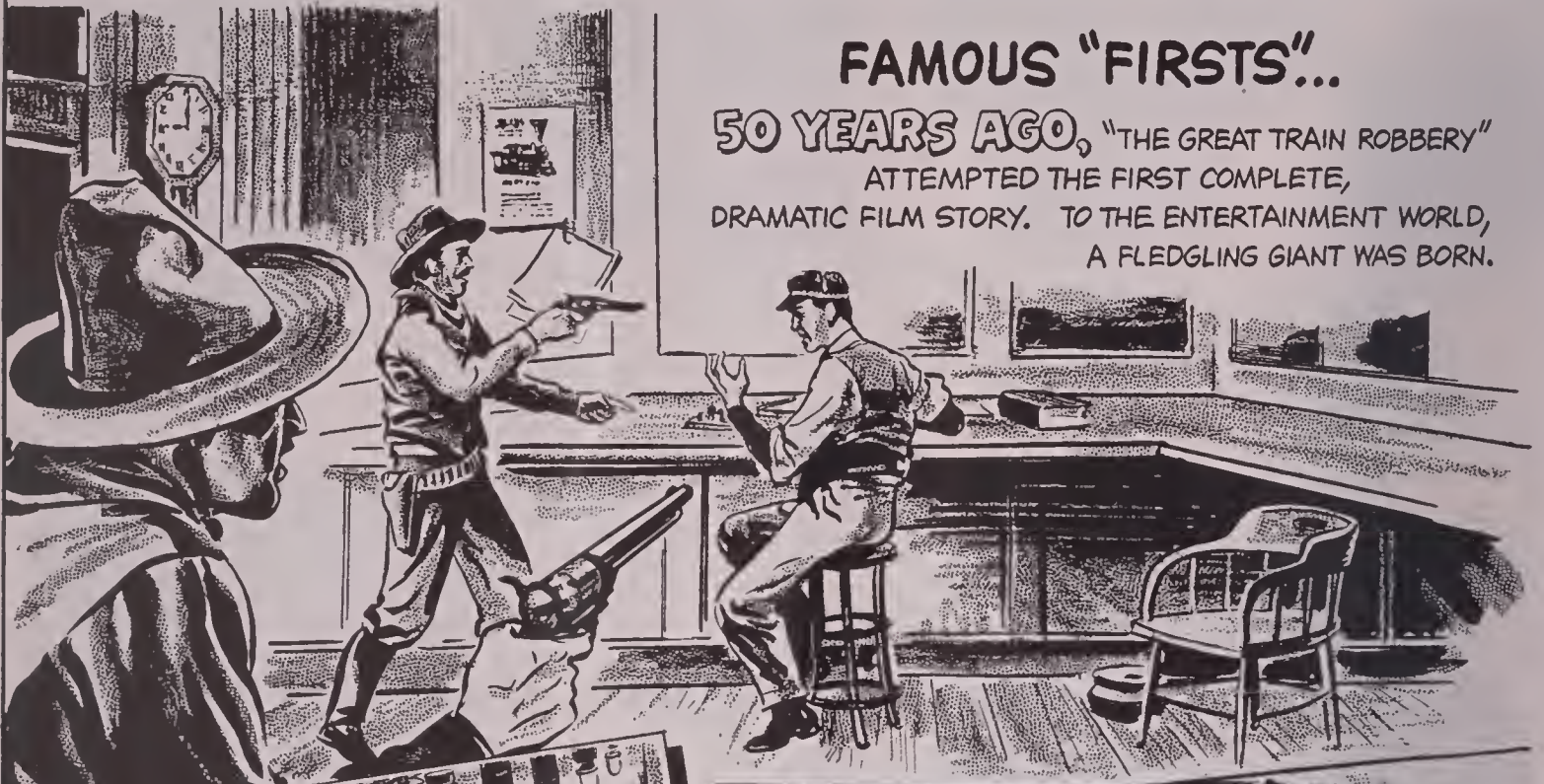

FAMOUS "FIRSTS"...

50 YEARS AGO, "THE GREAT TRAIN ROBBERY" ATTEMPTED THE FIRST COMPLETE, DRAMATIC FILM STORY. TO THE ENTERTAINMENT WORLD, A FLEDGLING GIANT WAS BORN.

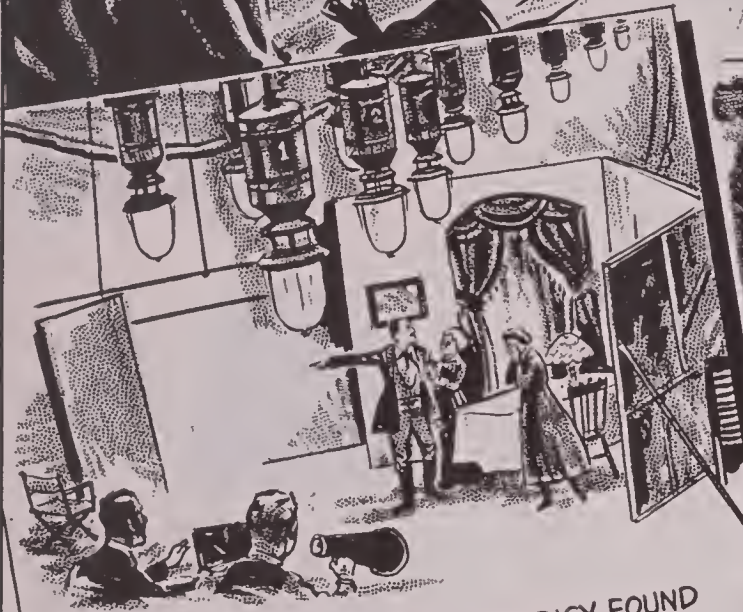

MOVIELAND'S INFANT PRODIGY FOUND GROWTH AND VERSATILITY IN DEVELOPMENT OF INDOOR AND AFTER-DARK LIGHTING TECHNIQUES... USING "NATIONAL" CARBON ARCS...



TODAY...IMPROVED "NATIONAL" CARBONS CONTINUE TO PAY OFF IN DEEP SET PENETRATION, BROAD COVERAGE, SHARP SHADOWS AND COOL BRILLIANCE.

THE "NATIONAL" CARBON ARC...NOTHING BRIGHTER UNDER THE SUN

The term "National" is a registered trade-mark of Union Carbide and Carbon Corporation

NATIONAL CARBON COMPANY

A Division of Union Carbide and Carbon Corporation, 30 East 42nd Street, New York 17, New York

District Sales Offices: Atlanta, Chicago, Dallas, Kansas City, New York, Pittsburgh, San Francisco

IN CANADA: National Carbon Limited, Montreal, Toronto, Winnipeg



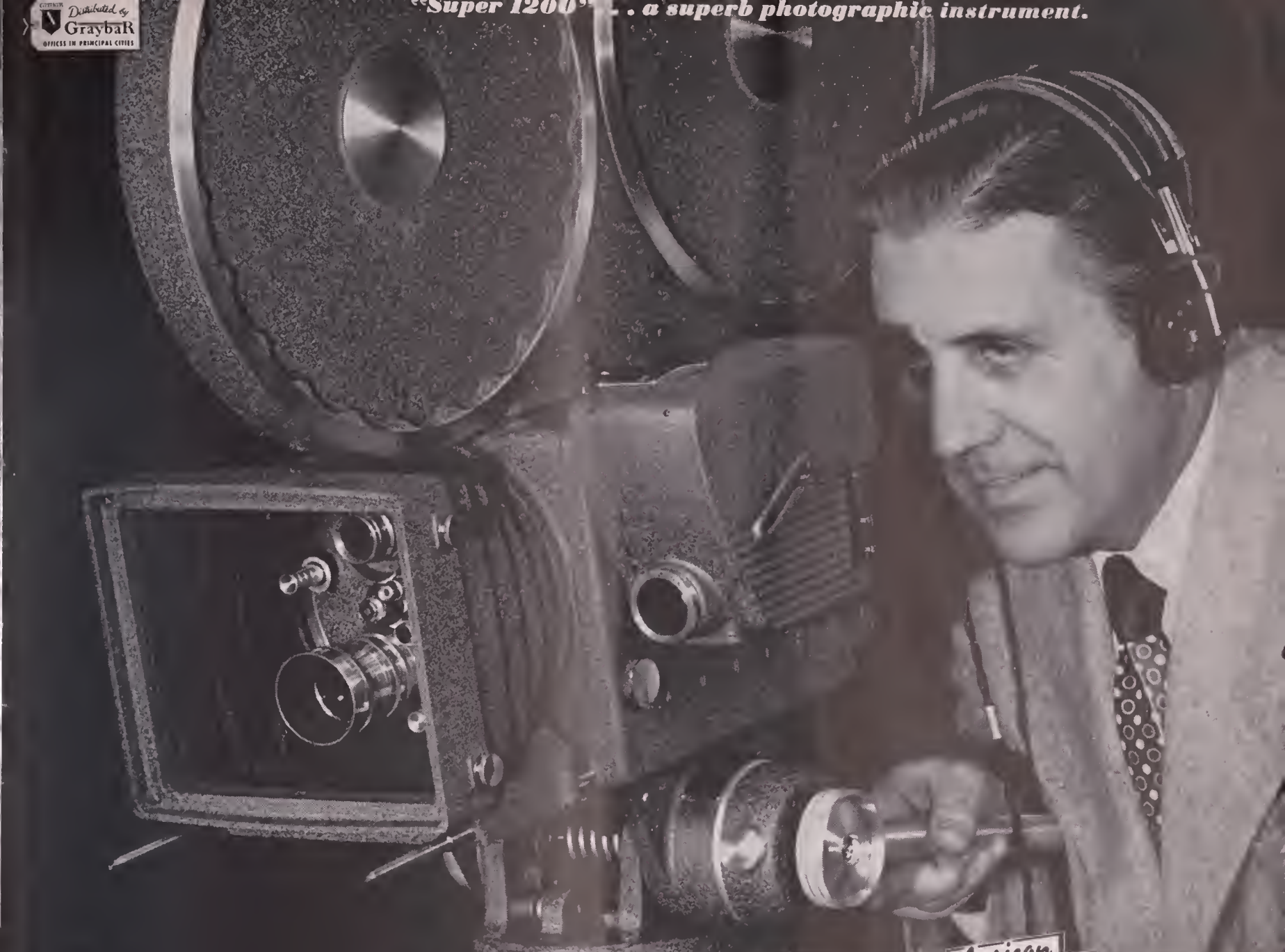

16 MM SOUND-ON-FILM CAMERA

Auricon "Super 1200"

with new Model "CM-74A" features . . .

- ★ During picture exposure, your film runs through the New Auricon "Super 1200" Film-Gate with the light-sensitive film emulsion accurately positioned on jewel-hard Sapphire surfaces, an exclusive Berndt-Bach feature (U.S. Patent No. 2,506,765). This polished Sapphire Film-Gate is guaranteed frictionless and wear-proof for in-focus and scratch-free pictures, regardless of how much film you run through the camera!
- ★ Built-in Electric Camera Heater with automatic Thermostat-Control, provides reliable cold-weather Camera operation.
- ★ Geared Footage & Frame Counter with built-in neon-glow indirect light.
- ★ Two independent Finder systems (in addition to Reflex Ground-Glass Focussing through the Camera lens); a brilliant upright-image Studio Finder, plus a "Rifle-Scope" precision-matched Telephoto Finder.
- ★ Records "rock-steady" picture and High Fidelity Optical Sound-Track on same film at same time, with "whisper-quiet" Camera & Sound Mechanism synchronously driven by precision-machined Nylon gears.
- ★ 400 and 1200 ft. film Magazines available. Up to 33 minutes continuous filming.
- ★ "Super 1200" is self-Blimped for completely quiet studio use.
- ★ Now priced from \$4,652.15 complete for sound-on-film; \$3,755.65 without sound; choice of "C" Mount lenses and Carrying Cases extra.
- ★ Sold with a 30 day money-back Guarantee and One Year Service Guarantee; you must be satisfied. Write today for your free Auricon Catalog...

Auricon
Hollywood

Shown here is a cutaway view of the "Super 1200" Optical System for Reflex Ground-Glass Focussing through the Camera lens. Also provided are two other finder systems, a telephoto-lens "Rifle-Scope" Finder synchronized with the Camera Turret, and a brilliant upright-image Studio Finder.

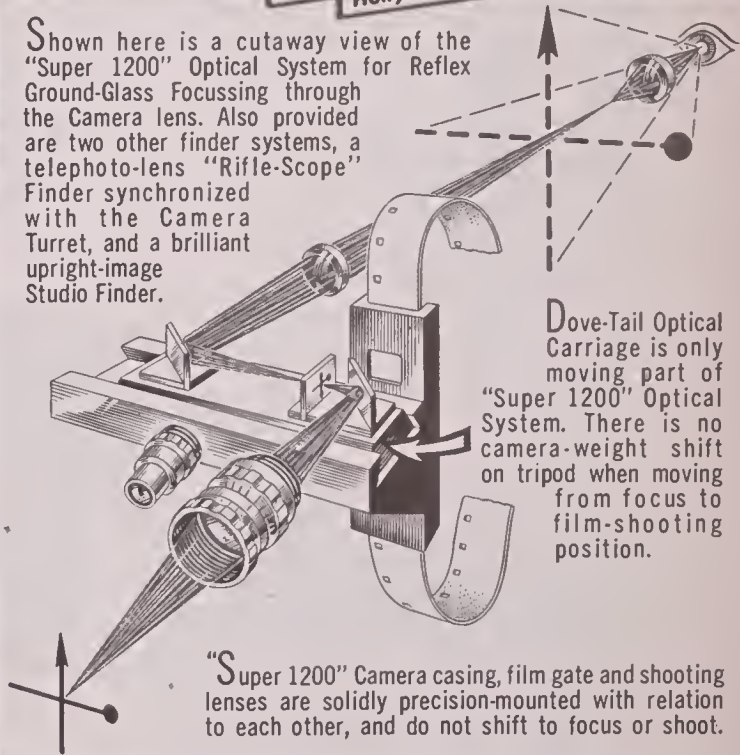

Dove-Tail Optical Carriage is only moving part of "Super 1200" Optical System. There is no camera-weight shift on tripod when moving from focus to film-shooting position.

"Super 1200" Camera casing, film gate and shooting lenses are solidly precision-mounted with relation to each other, and do not shift to focus or shoot.

BERNDT-BACH, INC.
7381 Beverly Blvd., Los Angeles 36, Calif.

The **Auricon** Hollywood Line
SOUND-ON-FILM CAMERAS SINCE 1931



CINE-VOICE



AURICON-PRO



SUPER 1200

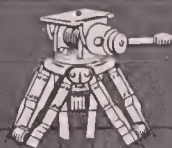

TRIPOD

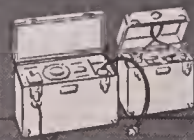

PORTABLE POWER UNIT

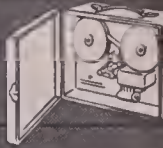

SOUND RECORDER

We
are
proud
of our
appointment
as exclusive
eastern
United States
agent for
camerette

patents Coutant-Mathat
manufactured by Eclair, Paris

and

came' - 300

We have been chosen exclusive distributor in the Eastern United States for the Camerette and Came 300 motion picture cameras.

If you are located between the Atlantic Coast and the Mississippi, look to us for full information, sales, and service on these most modern and versatile motion picture cameras.

Our facilities will assure Camerette and Came 300 users in the Eastern states of rapid service for their equipment.

We look forward to serving you.

FRANK C. ZUCKER
CAMERA EQUIPMENT CO.
1600 BROADWAY NEW YORK



WHAT'S NEW

in equipment, accessories and service

Flutter Meter—S.O.S. Cinema Supply Corp., 602 W. 52nd St., New York City, N. Y. has been appointed U. S. distributor of the Gaumont-Kalee flutter meter, an electronic device for measuring small frequency variations of a



given carrier frequency in the recording or reproduction of sound. Instrument operates at normal c.f. of 3000 cycles per second. The meter consists of a narrow-band amplifier, a limiter, a discriminator and detector, and a metering system. The whole unit is self contained. More complete details may be had by writing S.O.S. and mentioning *American Cinematographer*.



Kodascope Analyst Projector — Eastman Kodak Co., Rochester, N. Y., announces a new 16mm film projector specifically designed for analytical study of films. Featuring a constant-speed motor for the blower cooling system, and a two-speed governor-controlled motor for the film moving mechanism, projector has a reversing switch which enables operator to stop and back up, then re-run

film for close study. No darkened room is required for projection. Image is thrown on a translucent screen which is part of the carrying case. Film capacity is 400 ft. Price of unit is \$295.00.

Mobile Camera Units—Comprehensive brochures illustrating and describing the various types of camera cranes, dollies, and camera pedestals, as well as film processing equipment, offered by the Houston-Fearless Corporation, are now available to responsible persons in the film industry by writing the manufacturer at 11809 West Olympic Blvd., Los Angeles 64, Calif., and mentioning *American Cinematographer*.



DeLuxe Studio Tripod—Kling Photo Corp., 235 Fourth Ave., New York 3, N. Y., announces the new Linhof deLuxe Studio Tripod for light-weight motion picture cameras. Employing a new type of tripod construction, the tripod is available in a choice of two- or three-section models affording camera positions from floor level up to 60 and 73 inches respectively. Tripod folds to a minimum length of 30"; weighs 6½ lbs. The 60" model is priced at \$69.95; the 73", \$79.95.

New Westrex Recording Equipment—Westrex Corp., 111 Eighth Ave., New York 11, N. Y., announces its new

(Continued On Page 68)

CAMERETTE 35 & 16/35

THE MOST VERSATILE CAMERA IN THE WORLD



BENJAMIN BERG

U.S. DISTRIBUTOR FOR ECLAIR, PARIS

is pleased to announce
the appointment of



as Eastern Sales and Service
Representative For The

Camerette 35 & 16/35

and

Camé-300

Customers located east of the Mississippi River will find complete Camerette sales, service and supply facilities, assuring rapid and convenient attention to their needs.

The Camerette represents the greatest advance in motion picture camera design in the past decade . . . Reflex Viewing, seeing through the taking lens at all times . . . The more critical requirements of the new techniques for accurate framing and focusing DEMAND this modern motion picture camera.

Precise, rugged movement . . . Divergent 3 lens turret . . . 200 degree adjustable shutter . . . Automatic film gate . . . 400' and 200' magazines . . . Light weight, only 14 pounds with 3 lenses, 400' magazine and 6/8 volt motor.

Some Recent Camerette Users:

20th Century-Fox
Paramount Pictures, Inc.
Metro-Goldwyn-Mayer
Republic Studios
Raphael G. Wolff Studios
Lockheed Aircraft Corp.

Affiliated Film Producers, Inc.
Beelond-King Film Prod.
Encyclopaedia Britannica Films
Herbert Kerkow, Inc.
Fox Movietone News
RKO-Pathé News

for descriptive brochure write U.S. distributor

Benjamin Berg, 1410 No. Van Ness Avenue, Hollywood 28, Calif.

in Canada: B.O.P. Co. Ltd., 455 Craig Street West, Montreal, P.Q.



Camerette 35 & 16/35

patents coutant-mathot • manufactured by Eclair, Paris

Precision Prints

**YOUR PRODUCTIONS
BEST REPRESENTATIVE**

CLOSE CHECK ON PROCESSING

Picture and sound results are held to the closest limits by automatic temperature regulation, spray development, electronically filtered and humidity controlled air in the drying cabinets, circulating filtered baths, Thymatrol motor drive, film waxing and others. The exacting requirements of sound track development are met in PRECISION'S special developing machinery.

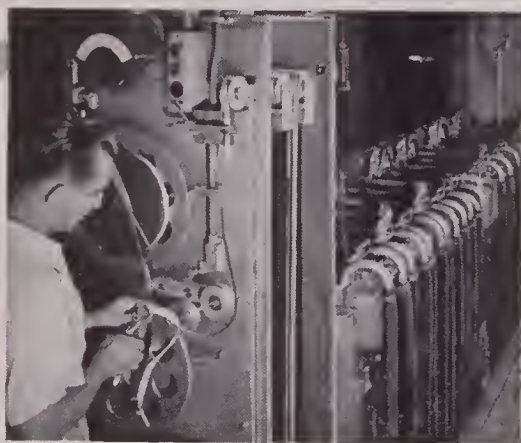

YOUR ASSURANCE OF BETTER 16mm PRINTS

16 Years Research and Specialization in every phase of 16mm processing, visual and aural. So organized and equipped that all Precision jobs are of the highest quality.

Individual Attention is given each film, each reel, each scene, each frame — through every phase of the complex business of processing — assuring you of the very best results.

Our Advanced Methods and our constant checking and adoption of up-to-the-minute techniques, plus new engineering principles and special machinery enable us to offer service unequalled anywhere!

Newest Facilities in the 16mm field are available to customers of Precision, including the most modern applications of electronics, chemistry, physics, optics, sensitometry and densitometry — including exclusive Maurer-designed equipment — your guarantee that only the *best* is yours at Precision!

Precision Film Laboratories — a division of J. A. Maurer, Inc., has 16 years of specialization in the 16mm field, consistently meets the latest demands for higher quality and speed.

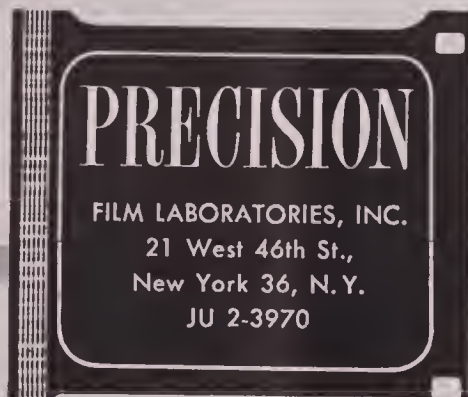

WHAT'S NEW

(Continued from Page 66)

"Penthouse" stereophonic modification unit for its 1035 single-track magnetic recording system. New unit adds the facility for recording and monitoring of three or four magnetic tracks to the basic single magnetic track RA-1467A Westrex recorder. The new unit is



mounted between the recorder and the reel assembly, as illustrated, and contains a film-driven filter and the magnetic heads. Complete technical data and price may be had by writing the manufacturer and mentioning *American Cinematographer*.



Bertram Exposure Meter—Willoughby's, 110 W. 32nd St., New York 1, N. Y., announce a new model Bertram exposure meter which features a new type,

(Continued on Page 109)

Great equipment makes great cameramen

BALANCED TRIPOD HEAD

and

PROFESSIONAL JUNIOR TRIPOD

are the standbys of the masters

You'll never hear Fritz Kreisler playing on a scrotchy fiddle . . . or Louis Armstrong on a \$7 trumpet. Good craftsmen need good tools.

Comero Equipment Company makes, sells, services and rents the world's finest quality TV and Motion Picture Equipment.



More professional cameramen use The PROFESSIONAL JUNIOR Tripod than any other tripod in the world.



New "BALANCED" Tripod—for the world's smoothest pan and tilt action.

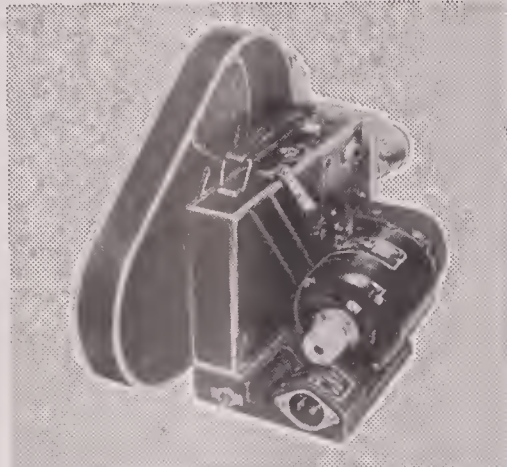

SYNCHRONOUS MOTOR DRIVE—110 Volt AC—Single phase, 60 Cycle. Runs in perfect synchronization with either 16mm or 35mm Sound Recorders. Mounting platform permits removal of magazine while camera remains mounted on motor. Spring steel drive fin coupling prevents damage if film jam occurs.

Knurled knob on armature permits rotating for threading. "On-Off" switch in base. Platform base threaded for 1/4" or 3/8" tripod tie-down screw. Rubber covered power cable with plugs included.

The new "BALANCED" Tripod, perfect for every photographic and video need. The result—o revelation in effortless operation, super-smooth tilt and 360° pan action.

PERFECT BALANCE prevents mishap if the lock lever is not applied. Quick release pan handle locks into desired position. Mechanism is enclosed, rustproof, needs no lubrication. Tension adjustment for Comero Man's preference. Built-in spirit level. Telescoping extension pan handle. We defy you to get anything but the smoothest, most efficient operation out of this famous precision-engineered BALANCED Tripod.

It's face it. You need a first class tripod to make better pictures. PROFESSIONAL JUNIOR has the rigidity, the range, and the ease of operation that better pictures demand. See—try this tripod beauty—and you'll never be without it. PROFESSIONAL JUNIOR TRIPOD—Friction Type. Handles all mm cameras, with or without motor. Also 35mm DeVry, & H Eyemo with and without motor, and 400' magazines. Tripod base interchangeable with Professional Junior gear drive head. "Baby" tripod base and "Hi-Hat" base available.

FRANK C. ZUCKER

CAMERA EQUIPMENT CO.
1600 BROADWAY NEW YORK CITY

SALES • SERVICE • RENTALS — CAMERAS * MOVIOLAS * DOLLIES

Complete line of 35mm and 16mm equipment available for rental.

MITCHELL: Standard, Hi-Speed, BNC, NC, 16mm

BELL & HOWELL: Standard, Shiftover, Eyemo

ARRIFLEX: 35mm and 16mm

MAURER: 16mm Cameras

MOVIOLA: Editing machines, Synchronizers

We design and manufacture Lens Mounts and camera equipment for 16mm—35mm and TV cameras.

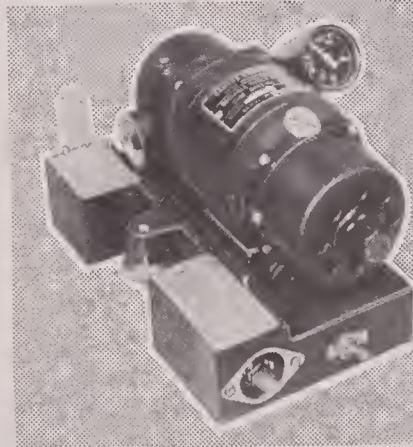

VARIABLE SPEED MOTOR—110 Volt AC/DC with Tachometer for EK Cine Special Motor drive your Cine Special with confidence! Tachometer is mounted in clear view of operator. Calibrated from 16 to 64 frames per second. Definite RED marking for 24 fps. Electrical governor adjusts speeds. Steady operation of all speeds. No adapters needed. Motor coupling attaches to camera and couples to motor. Spring steel drive arm shears if film jam occurs. Easily replaced.

We calibrate lenses—Precision "T" Stop Calibration of all type lenses, any focal length. Our method is approved by Motion Picture Industry and Standard Committee of SMPTE. For proper exposure density, it is important that you have your lens "T" stop calibrated. Lenses coated for photography. Special TV coating. Rapid service.



Give your movies life-like sparkle by loading with *finer* Ansco Hypan Film!

• This famous Ansco black-and-white film can bring to your home movie screen images whose bright crispness rivals the original scenes. Yes, those memorable moments you'll want to record will photograph on Hypan film with amazingly little loss of sharpness from what your eye sees.

That's because Ansco Hypan Film is made with an inherently brilliant contrast which imparts a characteristic snap and luminosity to your pictures, whether they're taken inside or outdoors. And Hypan's good speed (Exposure Index of 40 for daylight, 32 for tungsten) allows you to capture fine-grain images rarely seen in home movies.

Priced low, Hypan lets you take *more* high-quality movies for your money, too. Photo dealers everywhere stock this *finer* Ansco Hypan Reversible Film for 8 and 16mm cameras.

People Who Know Buy Ansco

ANSCO, Binghamton, N.Y. A Division of General Aniline & Film Corporation.
"From Research to Reality."

Ask for
**ANSCO
HYPAN
FILM**



NEW AND USED EQUIPMENT

FOR MOTION PICTURE & TV FILM PRODUCTION

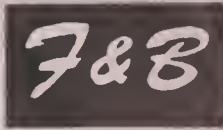

Colortran Converters

High powered studio illumination from ordinary house current.

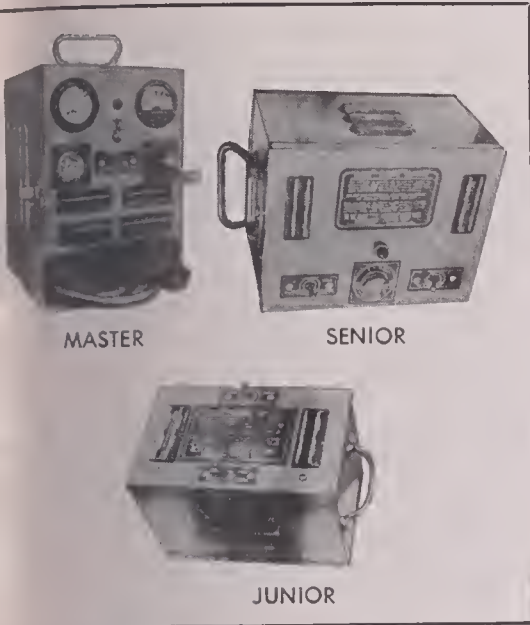

WRITE FOR COMPLETE CATALOG

F & B Film Footage Counter

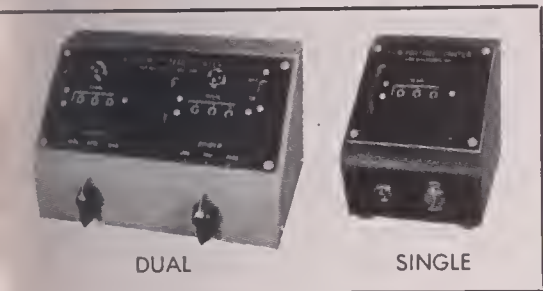

Write For Brochure

NEW F & B LEG-LOK TRIANGLE

WITH LEG-LOK CLAMPS AND REINFORCED CENTER CASTING

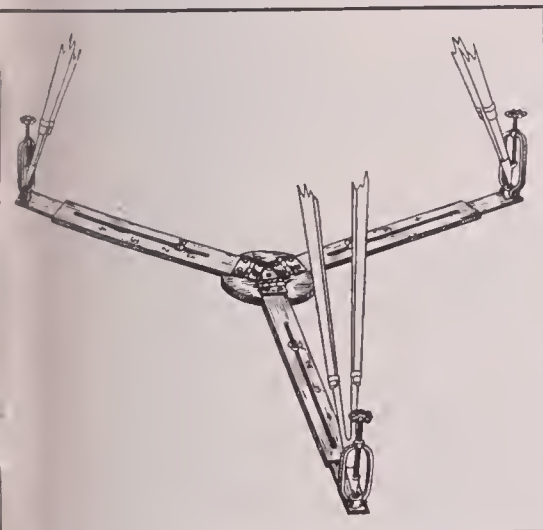

WRITE FOR BROCHURE

F & B 600-Ft. Magazine

for
Auricon
Cinevoice
Camera
At Low Cost

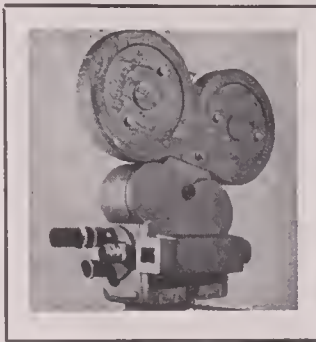

600 Ft. Cinevoice Magazine

NOW IN USE BY: TV STATIONS, TV NEWSREELS, LOCAL NEWSPAPERS, TV FILM PRODUCERS, POLITICAL ORGANIZATIONS, FRATERNAL ORGANIZATIONS, COLLEGES, UNIVERSITIES, SCHOOLS, CHURCHES, RELIGIOUS ORGANIZATIONS, GOVERNMENT AGENCIES, WEDDING AND SOCIAL EVENTS FILM PRODUCERS.

WRITE FOR COMPLETE DETAILS

NEW F & B SPLIT REELS

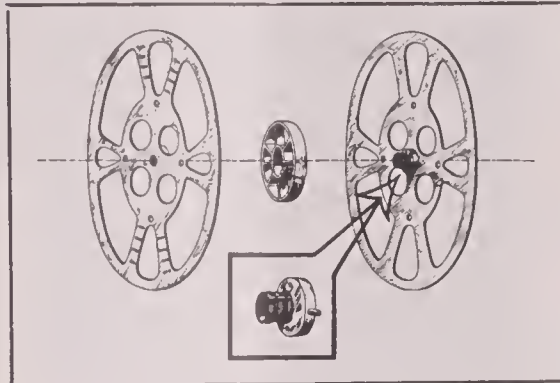

NOW — you can project 16mm film in cases without rewinding. Simply open split reel, slip film in and close reel.

- 400 ft. split reels — 16mm..... \$4.50
- 800 ft. split reel — 16mm..... \$6.00
- 1200 ft. split reel — 16mm..... \$7.50
- 1600 ft. split reel — 16mm..... \$9.00

NEW F & B GATOR CLIPLITE WITH BARN DOOR

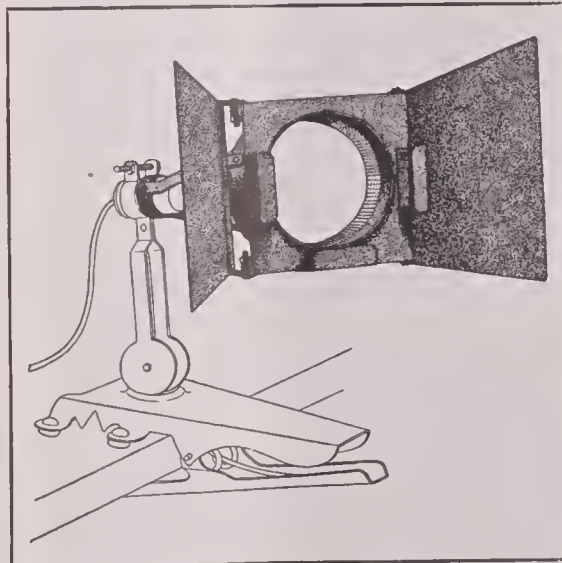

WRITE FOR BROCHURE

F & B 3rd Annual Clearance Sale!

(Most items are one-of-a-kind. First check buys it.)

- WALL 35mm SINGLE SYSTEM CAMERA, less galvo, with 25, 40, 50, 75mm lenses, rackover, 2 1000-ft. mags, 12v. motor, cases **2975.00**
 - MOVIOLA 35mm UDPV3S, 1 pic & 3 sound heads, large preview screen, with ompl., rolling stand, perfect cand. **BEST OFFER 3485.00**
 - MAURER 16mm CAMERA, latest model, 2 motors, 400-ft. mag., Maurer viewfinder, sunshade & filter holder, perfect cand. **3485.00**
 - BELL & HOWELL 35mm exchange model hot splicer, foot pedals **619.75**
 - BERNDT-MAURER 16 mm single system sound camera, rackover, complete production outfit for TV. VERY REASONABLE **WRITE FOR DETAILS**
 - BELL & HOWELL model H FILMO, with PAR 4-lens turret incl. pas. finders, PAR rackover and groundglass focus magnifier, MAIER-HANCOCK side viewfinder, 400-ft. mag., 110v. sync mota, deluxe case like new beautiful production outfit, worth over \$2000.00 **995.00**
 - ASTRO TELEPHOTO LENSES for Arriflex 35 camera, 300mm f5 \$145.00, 125mm f2.3 **115.00**
 - 16mm TELEPHOTO LENSES, 138mm Berthiot f3.5, "C" mt. **\$62.50**, 4" Gaerz Hypar f2.7, "C" mt. **\$69.50**; 6" KA f4.5 Cine Spec. mt. **\$49.50**; 10.5 cm Xenar f3.8 "C" mt. **\$57.50**; 114mm KA f4.5 Cine Spec. mt. **\$32.50**; 3" KA f4.5 Cine Spec mt **\$22.50**; 76mm KA f4.5 Cine Spec mt **\$27.50**; 3 1/4 cm Tessar f2.8 Cine Spec mt **\$21.50**
 - SPECIAL*** 9.5mm ANGENIEUX WIDE ANGLE F2.2 "C" mt **89.50**
 - FILMO SUPERSPEED 128 fps., less lens, excellent cand. **157.50**
 - BOLEX 16mm STANDARD, 15mm f2.8, 25mm f1.9, 3" f2.9 **195.50**
 - AURICON auto-parallax viewfinder mtd. for Cine Spec. **147.50**
 - KINEVOX 17 1/2 mm sync magnetic recarder, List **\$1500** **\$875.00**
 - SPECIAL***** FLANGES FOR 16mm & 35mm, 10" dia, aluminum **7.95**
 - EYEMO 71M, 35mm, 3-lens compact turret, filter slot, Pos. finders, 2" f2.8, LIKE NEW **645.00**
 - CONTINUOUS 16MM SOUND PROJECTORS — COMPLETE AND PERFECT
 - DeVRY — 400 ft. cap **\$245.00**
 - MOVIEMITE — 400 ft. cap **\$195.00**
 - AMPRO — 800 ft. 3-way — continuous or regular projection **\$295.00**
 - MAC VAN 16mm printer — reduced to **\$395.00**
- WANTED TO BUY
AURICON CAMERAS — MOVIOLAS — PAN CINOR LENSES
EDITING EQUIPMENT — LARGE QUANTITIES, REELS, CANS
CASES — LIGHTING EQUIPMENT

F & B USED EQUIPMENT

Always in stock . . . THOUSANDS OF ITEMS . . . cameras, projectors, lenses, accessories, rewinds, splicers, synchronizers, editing, lighting and laboratory equipment . . . ALL AT REASONABLE PRICES. We are always glad to quote lowest prices for specific items.
WE WILL BUY . . . FOR CASH . . . all kinds of used items as listed above. F&B is noted for paying FAIR prices.
LARGE LOTS OR COMPLETE STUDIOS solicited. We will gladly send our buyer to your studio for accurate appraisals and immediate cash payment.
TRADES . . . CONSIGNMENTS ACCEPTED

F & B Rental Equipment

35mm & 16mm

- MITCHELL CAMERAS, 16mm, NC, BNC
- AURICON SUPER 1200 SOUND CAMERA
- AURICON PRO, CINEVOICE, FILMOS
- MAURER 16, ARRIFLEX 16 & 35
- EYEMOS, CINE KODAK SPECIALS
- MOVIOLAS 16 & 35, SYNCHRONIZERS,
- SYNC RECORDERS, SYNC PROJECTORS,
- SOUND READERS, HOT SPLICERS, DOLLIES,
- BLIMPS, MIKE BOOMS, TRIPODS, ZOOM LENSES
- BARDWELL-McALISTER LIGHTS, COLORTRANS

Write For Price Lists

FLORMAN & BABB

70 West 45th Street, New York 19, N. Y.

Phone: Murray Hill 2-2928

Cable Address — FLORBABB, N. Y.

F&B HAS A COMPLETE STOCK OF NEW AND USED CAMERAS, PRODUCTION, LIGHTING, EDITING & LABORATORY EQUIPMENT

Visit our new larger showroom or WRITE—WIRE—PHONE

EVERY ITEM SOLD IS MONEYBACK GUARANTEED

WE BUY — SELL — RENT



Hollywood Bulletin Board



ONE OF "Filmdom's Famous Five" is Leon Shamroy, ASC, (L) who was recently awarded the Film Daily Award as best cinematographer of 1953 for his outstanding camera work on "The Robe." Fox's camera department head Sol Halprin, ASC, holds Cinemascope lens like one Shamroy used for shooting the picture.

Academy Awards for the best cinematography of 1953 came a step nearer reality last month. The directors of photography of the Hollywood motion picture studios, in a preliminary balloting, selected ten black-and-white and ten color productions of 1953 as candidate entries for nominations for Academy photographic achievement awards.

Nomination ballots were subsequently mailed to all directors of photography. Latter will vote to select, from among the preliminary 20 productions, five films in each class as the 1953 Awards nominees. The balloting closed on February 6th, and results will be announced publicly on February 15th.

The twenty candidate films and the names of the directors of photography who filmed them follow:

BLACK-AND-WHITE PRODUCTIONS

"The Cruel Sea," Gordon Dines, FRPS. (Rank-U-I).

"The Desert Rats," Lucien Ballard, ASC. (Fox).

"The Four Poster," Hal Mohr, ASC, (Kramer-Col.).

"From Here to Eternity," Burnett Guffey, ASC. (Col.).

"Island in the Sky," Archie Stout, ASC. (Warners).

"Julius Caesar," Joseph Ruttenberg, ASC. (MGM).

"The Little World of Don Camillo," Nicholas Hayer, (I.F.E. Releasing Corp., Italy).

"Martin Luther," Joseph Brun, ASC, (L. deRochemont).

"Roman Holiday," Frank Planer, ASC, and Henri Alekan. (Para.).

"So Big," Ellsworth Fredericks, (Warners).

COLOR PRODUCTIONS

"All the Brothers Were Valiant," George Folsey, ASC. (MGM).

"Beneath the Twelve Mile Reef," Joseph Cronjager, ASC. (Fox).

"Hondo," Robert Burks, ASC, and Archie Stout, ASC. (Wayne-Fellows-W.B.).

"Gentlemen Prefer Blondes," Harry Wild, ASC. (Fox).

"Knights of the Round Table," Freddie Young, ASC. (MGM).

"Lili," Robert Planck, ASC. (MGM).

"The Mississippi Gambler," Irving Glassberg, ASC. (U-I).

"Mogambo," Robert Surtees, ASC, and Freddie Young, ASC. (MGM).

"The Robe," Leon Shamroy, ASC. (Fox).

"Shane," Loyal Griggs, ASC. (Para.).

The five films nominated in each classification will be announced here next month.

In the meantime, the Academy of



BENJAMIN KLINE, ASC, (R) last month started his sixth consecutive year as director of photography for Frank Wisbar, TV film producer of the popular "Fireside Theatre" series of half-hour dramas.



LOYAL GRIGGS, ASC, shows Marla English, new Paramount starlet, some of the fine points about a cameraman's job. Miss English will be crowned "Miss PSA Movie Queen of 1954" at forthcoming Second Annual Town Meeting of Motion Picture Photography, March 27-28, in Hollywood.

Motion Picture Arts and Sciences is proceeding with plans to hold its "Oscar" presentation ceremonies at the Hollywood Pantages Theatre the evening of March 25th.

BRIEFLY—Donald E. Hyndman, salesmanager of Eastman Kodak motion picture film department, Rochester, was elected to Associate Membership in the ASC last month . . . Sam Leavitt, who just finished shooting "A Star Is Born" at Warners, has been re-admitted to membership in the ASC . . . Edward J. Snyder, ASC, has been re-pacted by 20th-Fox for another year . . . Ted McCord, ASC, is in Puerto Rico on a new picture assignment for Warner Brothers . . . John W. Boyle, ASC secretary, has been appointed to Program Committee of the forthcoming Academy Awards presentations . . . Art Arling, ASC, goes to Columbia along with Betty Grable, to film her new picture there . . . Gil Warrenton, ASC, on leave from Revue (TV) Productions, is in Mexico shooting a feature for Cosmo Productions . . . Omitted last month from "Box Score" pages were following credits: Stanley Cortez, ASC, "Diamond Queen"; Bob Burks, ASC, "Hondo." (with Archie Stout).

DEDICATED TO BETTER PERFORMANCE

COLLAPSIBLE 3-WHEEL DOLLY



For motion picture and TV cameras. Sturdy cast aluminum. For standard or baby tripods. Additional baby tripod point holders to control spread of tripod legs. Adjustable spring seat. Extra wide rubber wheels. Bronze tie down clamps and other features.

For studio or location. Folds into one compact unit. Can be used with professional or semi-professional tripods.

'HYDROLLY'

TV OR
CAMERA DOLLY



The advanced dolly for instant moveability — streamlined, light-weight, exceptionally sturdy. Nothing to get out of order. Many new advantages for easy operation. Hydraulic lift type for fast upward and downward motion of TV and motion picture cameras.

Swivel seat. Adjustable leveling head. Seat for assistant. In-line wheels for track use. Steering wheel, rigid floor locks. Hand pump or combination hand and motor pump. Easily transported in a station wagon. Fits through a 28" door.

Synchro-film-ed Synchronizer

Our Exclusive Distributor
NEUMADE PRODUCTS CORP.



Any combination of 16mm and/or 35mm sprockets assembled to specification. Cast aluminum. Foot linear type, adjustable frame dial. Fast finger roller release. Contact rollers adjusted individually for positive film contact. Sprocket shaft slip lock, foot-age counter, etc.

RENTALS

SALES · REPAIRS · SERVICE

LENS COATING

"T" STOP CALIBRATION

DESIGNING and MANUFACTURING

lens mounts & camera equipt.
for 16mm, 35mm, TV cameras.

BAUSCH & LOMB "BALTAR"
LENSES and others

for motion picture, TV camer-
as. 15mm to 40" focal length.

COMPLETE LINE OF: 16mm, 35mm
cameras, dollies, synchronizers,
animation stands, cutting room
and time lapse equipment.

BELL & HOWELL: Standard, Eye-
mos, Filmos. MITCHELL: Standard,
Hi-speed, BNC, NC, 16mm.

SEND FOR CATALOGUE

Synchro-film- Slate



Pays for itself
in production
savings on the
set. A New De-
velopment! Elim-
inates clap stick synch and slate on set. Mounts
on double arm bracket to work with BNC, NC,
Standard, 16mm Mitchell and all types of blimps
and Geared Head. Interlocks with Sound Recorder.

PORTABLE MICROPHONE BOOM



For Studio or on Location. Light-weight — collapsible — for TV and motion picture production. Sturdy construction. Boom telescopes 7 to 17 ft. Rear handle for directional mike control. A remote control permits 360° rotation of the microphone. Operator can push the boom and operate

microphone swivel simultaneously. Extension rods make it simple to operate microphone rotation from floor. Microphone cable hangs outside of boom, preventing cable from tangling with the rotation mechanism. Ball bearing casters, rigid foot locks, pneumatic drop check for lowering the boom, etc.

VARIABLE- SPEED MOTOR with TACHOMETER

for Cine Special or Maurer Cameras

115 V. Universal Motor — AC-DC
Separate Base for Cine Special.
Variable Speed 8-64 frames.
Adapter for Maurer Camera.

INTERCHANGEABLE MOTORS: 12
volt DC Variable Speed 8-64 frames.
115 Volt AC 60 Cycles, Synchron-
ous Motor, Single Phase.

ANIMATION MOTORS: Cine Spe-
cial, Maurer, Mitchell, B & H Motors,
for Bolex and Filmo Cameras.

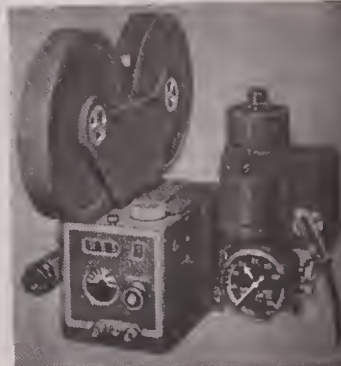

Walt Disney's Naturalist-Cinematographers

The cameramen who gather the interesting footage for Walt Disney's "True-Life Adventures" are essentially naturalists or scientists who made the motion picture camera a vital tool in their studies.

By FREDERICK FOSTER



STUART JEWELL and his telephoto-mounted Special camera filming wild bee life for coming Disney "True-Life Adventure"

MAKING POSSIBLE the "True-Life Adventure" series of films which Walt Disney has been turning out the past few years are a new breed of motion picture cameramen.

All are essentially naturalists, scientists or folk authorities first, and cameramen by accident. That is, it was their zeal for recording as well as observing the facts of life as uncovered in their scientific probings that led most of them to taking up cinematography as the recording medium.

Their ability as cinematographers is attested in the wealth of rare and unusual 16mm color film they have contributed to such Disney subjects as "Seal Island" (1948), "Beaver Valley" (1950), "Nature's Half Acre" (1951), "Water Birds" (1952), and to his most recent, "The Living Desert," currently in release.

"The Living Desert" marks the first of the "True Life Adventures" to be presented in the newer 60 to 70 minute format—twice the length of previous releases.

"The 'True Life Adventures' have been logically expanded," says Walt Disney, "because the volume of fine material coming in from our collaborative naturalist-photographers could no longer be cramped into the original format."

In "The Living Desert," there is unreeled the most exciting drama of wild-life and primitive passions ever brought to the screen. It goes far down the ladder of existence for its theme. Here, against the majestic background of the Great American Desert, are seen the animals, birds, reptiles and bizarre insects which have learned to exist and thrive in the hardest of all environ-

CAMERAMAN Bob Crandall (L) and Paul Kenworthy filmed the thrilling scenes of a bobcat treed by a family of sturdy peccaries, which highlight "Living Desert."



B CRISLER and wife Lois are in Alaska filming grizzly bears and their activities Disney's forthcoming "Northern Tundra."



ALFRED AND ELMA MILOTTE training their special Arriflex camera through window of their armored truck on a herd of elephants in Africa.



JIM SIMON, with his telephoto-equipped Arriflex, filming a scene for Disney's forthcoming "The Vanishing Prairie" in Kodachrome.

ments on this continent. They offered the wildlife cinematographers their toughest challenge and tasks.

Highlighting the picture are ancient feuds, now instinctive. A redtailed hawk battles a rattlesnake to the death. A shiny black wasp called the pepsis fights a great tarantula with abysmal ferocity. A valiant little kangaroo rat mother dares the fangs of a sidewinder in defense of her babies by kicking dust into the viper's eyes. Two jealous male tortises contend for the favor of a shellbacked siren of the sands.

In an amorous recess from feudal furies, a pair of scorpions tread a giddy wedding dance. A skinny little ground squirrel brazenly defies the lethal gila monster. And a family of sturdy pecararies, wild cousins of the barnyard pig, chase an impertinent bobcat up a spiny cactus dome in another feud much older than the Montagues and Capulets. And there are others, far too many to mention in the space allotted here. However, mention must be made of the magnificent sequence toward the close of the picture of a flash flood rolling over the desert floor, the aftermath of a sudden storm miles away. It is a rare pictorial record filmed unexpectedly by chance by Tad Nichols who was on the scene filming other material.

Chief photographic credits for "The Living Desert" go to N. Paul Kenworthy, Jr., and Robert Crandall, with additional footage by Nichols, Stuart V. Jewell, Don Arlen, and Jack C. Couffer. These cameramen gave themselves tough assignments. Hardship had to be expected, for this remote wildlife frontier in the still wild west is far from highways and gas stations and drinking water. Here, by the naturalist's passion and the wildlife photographer's particular zeal, half a dozen top naturalist-cameramen caught the spirit as well as the physical character



DR. O. S. PETTINGILL and wife Eleanor are in Falkland Isles lensing penguins and other bird life.



JOHN NASH OTT, JR., in his Winnetka, Ill., time-lapse lab., is filming life span of an apple from dormant tree to ripened fruit for Disney.

of the desert itself in magnificent landscape and gargoyle shapes. The shots they brought back of creature life—much of it never heretofore recorded by the motion picture camera—has the impact and intense interest of a news event, which indeed it is in the arena of universal life.

Paul Kenworthy, Jr., who, with Robert H. Crandall, shared the major photographic credits in "The Living Desert," is a graduate of the University of Southern California. He started his searching study of the western desert as a university thesis, then continued it for a two-year period with Crandall as a Disney project.

Jack Couffer contributes one of the sensational highlights, the bat sequence, showing uncounted myriads of these eerie, primitive creatures swirling in great clouds from desert caverns on their nightly hunting flight for insects.

Stuart V. Jewell, expert on bees and floral time-lapse cinematography, contributed the strikingly beautiful scenes of desert flowers, especially the gorgeous cactus blooms rivaling any orchids.

Tad Nichols, who photographed the previously mentioned desert flash flood, has worked with the U. S. Department of the Interior in the Colorado River basin.

Don Arlen achieved a strange kind of comedy with his camera filming bubbling mudpots making odd sounds on the edge of Death Valley.

In all, more than twenty-four such 16mm cinematographers have photographed or are photographing material for Disney "True Life Adventure" films. In addition to those already mentioned are James Simon, Tom McHugh, Cleveland Grant, Lloyd Beebe, Warren Gorst, Dick Borden, C. A. Harwell, John Nash Ott, Jr., Karl Maslowski, Murl Deu-

(Continued On Page 104)



ABOVE and at right are Paramount's art director Mac Johnson's "visuals" of the overall set on which 95% of action for "Rear Window" was filmed. Top sketch shows lighting scheme for day; sketch at right the lighting for night. Director of photography Robert Burks, ASC, pre-lit the set so that it could be illuminated for night or day by throwing combination of remote switches. The project involved use of almost every lighting unit, switch and piece of cable on the Paramount lot.



JIMMY STEWART'S Greenwich Village apartment is illustrated in this art department "visual." The set was constructed in replica. Sitting at the rear window of this apartment, the injured Stewart looks idly out on courtyard scene below (pictured in sketches above), where a murder has taken place. His analytical study of suspect's movements from the single vantage point leads to solution of the crime.

Hitchcock's latest mystery drama is told through the eyes of one man, with the camera shooting from one and the same point of view in his apartment — the

REAR WINDOW

By ARTHUR E. GAVIN

THE PHOTOGRAPHY of "Rear Window," Alfred Hitchcock's latest production, tops anything ever attempted in his previous pictures, every one of which involved some new or unusual photographic innovation. For director of photography Robert Burks, ASC, "Rear Window" was perhaps the toughest assignment of his career, although he wouldn't exactly put it that way. He'd say it was "the most challenging."

"Rear Window," completed last month at Paramount Studios, was shot in its entirety on one sound stage and in one set—but a set of which Hollywood has never before seen the like.

The story, which stars James Stewart, Grace Kelly and Wendell Corey, is one of the tightest suspense stories ever written. It has Stewart cast as a photographer for a national picture magazine who is confined to a wheel-chair with a broken leg suffered in his last assignment. Throughout the entire picture he remains grounded to his wheel-chair, which is placed in the rear window of his Greenwich Village apartment. From this vantage point, and with little else to do, he gazes idly at the apartments and their occupants opposite and to both sides of him.

After a few days, he has reason to believe that one of the apartment dwellers has murdered his wife, sliced up her body, and disposed of it in a flower bed in the courtyard below. At this point, Stewart uses binoculars to study the suspect at closer range, and later he scans the scene even more minutely through the telephoto lens attached to his reflex-type camera.

Although evidence he gathers points to a correct summation on his part, it is up to him to prove his case to his fiancée, Grace Kelly; his war-time buddy, now a detective, portrayed by Wendell Corey; and to his nurse, Thelma Ritter. As the story progresses, occupants of the 31 apartments within his vantage point continue their various ways of life. But Stewart's chief interest is in the activities of Raymond Burr, who plays the part of the salesman-murderer, and he eventually brings about his arrest.

(Continued on Next Page)

HOW some of the action in apartments across courtyard from Stewart's window was filmed. With 6-inch telephoto on camera mounted on boom, scene is recorded as viewed from window by Stewart. Director Alfred Hitchcock (left foreground) looks on as action is being filmed by camera crew.



WHEN murder suspect's actions arouse his suspicions, Stewart, a photographer, takes a closer look through telephoto lens of his reflex-type camera, makes incriminating photos of what he sees. Reflected in lens of telephoto is scene he observes across courtyard.



HOW reflection on lens (above) was photographed is shown here. A transparency of the scene is illuminated from rear and set up out of camera range a few feet in front of Stewart. Burk's camera is in shadows just below the bright light to left of transparency.



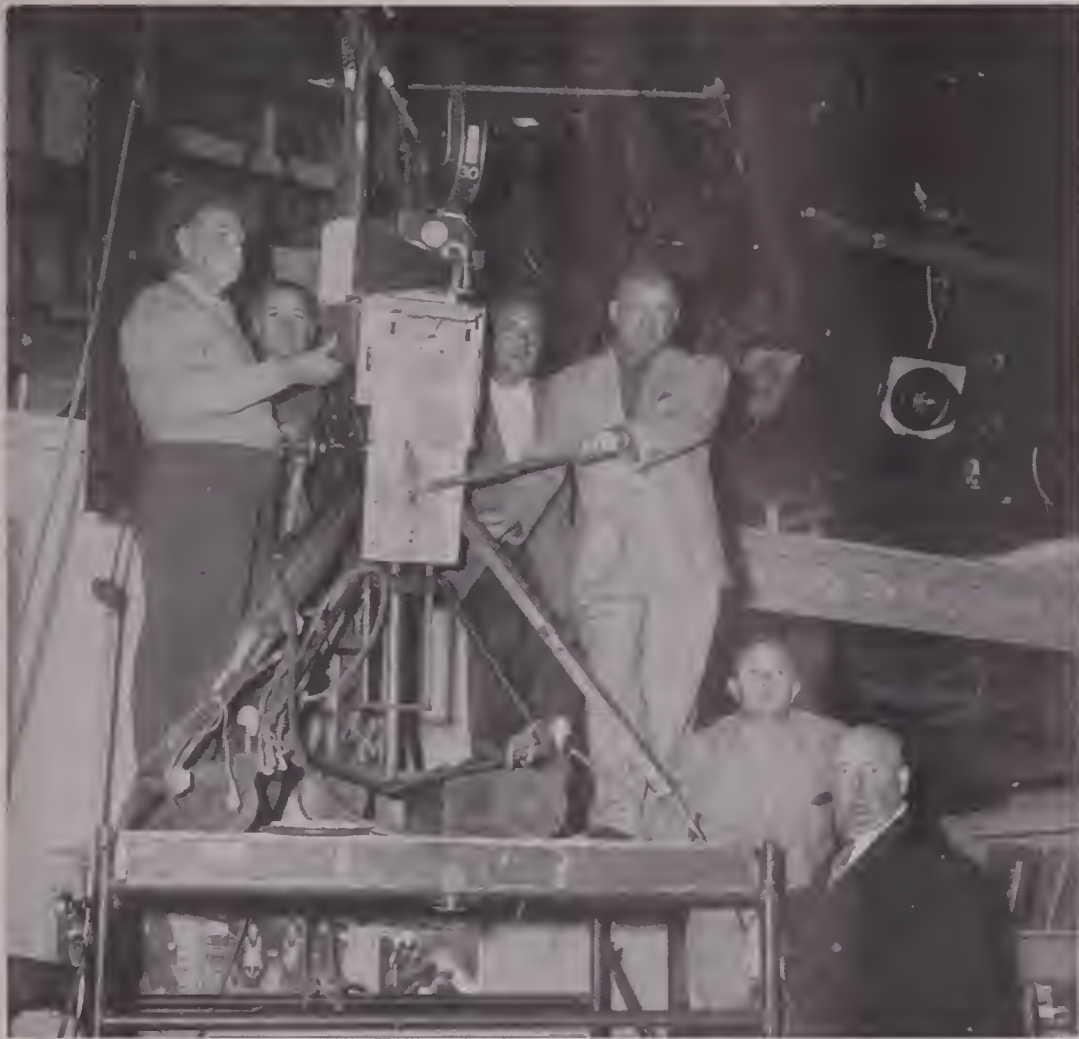

MOST SPECIAL EFFECTS for "Rear Window" were filmed right on the set, whenever possible. Here a unique device is used in conjunction with camera in filming the illusion of Stewart studying and comparing, with the actual scene in the courtyard, the 35mm transparencies he made of murder suspect's actions. Irmin Roberts, ASC, (standing on parallel in front of Burks) is shown operating the gadget he devised for the effect and which involved prisms, short range projection and quick-focus changes.

Because all shots had to be taken as from Stewart's eye-level as he looked across the courtyard to the apartments beyond, oftentimes pinpointing small objects, Burks, shooting the picture in Eastman Color negative and for the wide-screen, had to use a variety of lenses, including the very powerful six-inch telephoto. The latter was used in shooting a great deal of the picture because so much of the action took place across the courtyard—at distances ranging from 40 to 80 feet away.

"Our chief problem here," said Burks, "was definition. Try to visualize shooting scenes in which the players never get any closer to the camera than 70 feet; where our objective is to convey purely by pantomime what is taking place; and you'll understand what problems we had to contend with. All these shots were silent because it would be illogical for Stewart to hear any of the conversations of people inside the distant apartments."

In the beginning, Burks used a 10-inch telephoto; but because the depth of field obtained at the distance was only about a foot and a half or so, the lens was abandoned in favor of a 6-inch

telephoto, and the camera moved out over the courtyard on a boom. Other lenses used were a 2-inch and a 3-inch.



CIRCLE in photo (above left) indicates living room of murder suspect—60 feet away from the camera at all times—where some of the most important action of story takes place, which is filmed by Burk's camera

These three lenses recorded the action as seen by Stewart with the naked eye or with the aid of binoculars or camera telephoto lens.

"We used the 2-inch lens for scenes representing Stewart's naked eye point of view," said Burks. "The 3-inch lens was also used for this purpose where double cutting was involved; that is, say, where Stewart studies a certain action across the courtyard, then the camera cuts back to him momentarily, and then back to what he sees. To lend variety, the 3-inch lens was used for the cut-back shots."

"When I started to make the series of telephoto shots," Burks continued, "I began working with the set illumination at a very high key in order to be able to stop down the lens as much as possible to gain depth and definition. Here I was working at 1600 foot candles and shooting at f/5.6."

"We had one shot in the picture that was a key shot in the plot, and it illustrates a typical experience in our use of telephotos. The salesman-murderer is observed by Stewart from his window vantage point going through his wife's effects during her absence. He takes her wedding ring out of her purse and looks at it. Now ordinarily, a shot of this kind would be handled by moving in close and making an insert shot; but we had to sell the idea of seeing the ring from Stewart's vantage point—about 70 feet away on the other side of the courtyard.

"The first time we attempted the shot, we made it with a 10-inch lens. On the

(Continued On Page 97)



set at Stewart's eye point of view. At right is view of interior of same room showing some of the numerous lighting units, scrims, etc., necessary to providing the precise lighting for both day and night effects.

EASTMAN

PROFESSIONAL

MOTION PICTURE

FILMS

W. J. GERMAN, Inc.

Fort Lee

Chicago

Hollywood



ON HAND, when the new Arriflex cameras were demonstrated recently for members of the American Society of Cinematographers, was Dr. Robert Richter (second from left), president of Arnold & Richter, makers of the camera. Others in photo admiring features of the new Arriflex blimp are (L. to R.) R. D. Pestonji, Bangkok, Siam; John Boyle, ASC, and Karl Freund, ASC.

New Arriflex Cameras Feature Many Improvements

Both the 35mm and 16mm models have features which make them ideal cameras for the most exacting of professional film making.

By ARTHUR ROWAN

AT THE NOVEMBER meeting of the American Society of Cinematographers in Hollywood, the industry's leading directors of photography were given a preview of the new Arriflex 35mm and 16mm cameras. Present to explain the many new improvements in the cameras was Dr. Robert Richter, president of Arnold & Richter, the West Germany company which manufactures the Arriflex and other motion picture

equipment under the well-known trade name of "Arri."

The Arriflex has long been one of the most popular of portable professional motion picture cameras. Now, with the addition of several improved features including a soundproof blimp of advanced design, the 35mm Arriflex becomes an important camera for all-around production use.



1 OUTSTANDING feature of the New Arriflex is the new Arri blimp, designed especially for the camera using 400 foot magazines and sync motor.



2 AT REAR is telephone-dial type threading knob (A), and windows affording observation of tachometer (C) and footage counter (B).



3 EXTERNAL focusing knobs (D and E) afford follow focus control of blimp-mounted Arriflex, while a unique focusing scale (F) affords quick check of f/ stop through small window just above focus control knob (E).

The new model 11A 35mm Arriflex features four important improvements. These are: a new 180° shutter, which increases exposure to 1/48 second at 24 fps.; a new intermittent system that assures rock-steady pictures and perfect frame registration; a new precision-lapped, chrome-finished, stainless steel film gate, which assures absolute focus and frame registration, and prevents film "breathing"; and a new synchronous motor unit. The latter is a smooth-running, constant-speed hysteresis motor for 115-volt, 60-cycle AC operation. This motor is mounted on a base-plate housing (see Fig. 6) which contains the gear mechanism that connects directly to the main drive shaft of the camera. The base plate has a tripod-socket. The motor unit includes a built-in footage counter and a safety slip-clutch which automatically disengages motor from camera should the film "jam."

The synchronous motor unit is easily and quickly attached to the 35mm Arriflex camera without the need for special tools.

Other features, for which the Arriflex 35mm camera is famous include the mirror reflex shutter, which affords through-the-taking lens viewing of the scene during shooting—ideal for follow-focus shots; this unique viewing system eliminates parallax and the need for accessory finders, and affords a bright, uninverted image on the ground glass, magnified 6½ times.

Quick-change, geared film magazines of both 200-ft. and 400-ft. capacity; a variable-speed 8-12 volt DC motor mounted in the grip handle; a tachometer, which registers film speed from 1 to 50 frames per second; a matte-box-filter-holder that is quickly and easily detachable; and a three lens revolving



4 FOR 16MM PHOTOGRAPHY, Arriflex offers its latest model 16mm camera featuring such improvements as "button-on" 400 ft. external film magazine, divergent 3-lens rotary turret, registration pin, and built-in electric motor drive.

turret are favorable features of this well-balanced camera which is ideal for tripod or hand-held filming.

Fig. 5 shows how the Arriflex reflex shutter operates. The shutter surface nearest the lens is a front-surface mirror set on a 45° angle so that, when the shutter is momentarily closed, it reflects the image from the lens to a set of prisms at the right and thence through the finder optical system, as shown by the dotted lines.

Perhaps the outstanding feature of the new Arriflex 35mm camera is the new Arri sound-proof blimp (Figs. 1 to 3) which has been tailor-made for the camera. Designed especially for use with the camera mounting the 400-foot magazine and synchronous motor unit (already described), the blimp housing is cast of magnesium alloy; the exterior finish is black crackle. The manufacturer claims the most advanced acous-

(Continued On Page 108)

5 HOW REFLEX shutter of Arriflex cameras operates to afford through-the-taking lens viewing of the scene as it is being photographed, is shown in illustrations below.

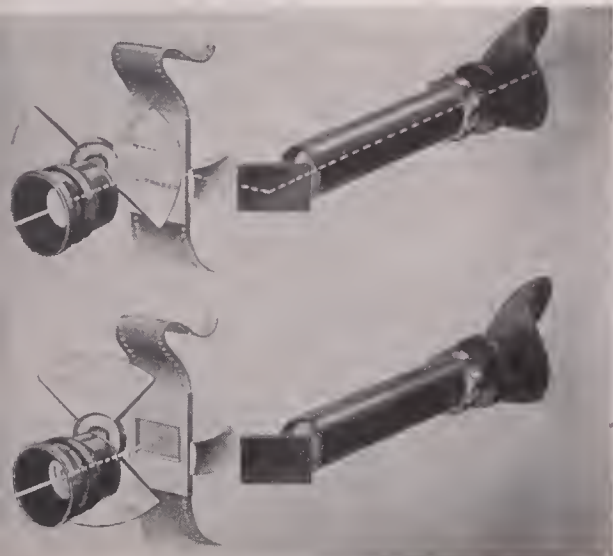

6 REAR VIEW of the 35mm Arriflex with 400 ft. magazine and synchronous motor. Motor is quickly demountable without tools.



7 THE BASIC new model 11A 35mm Arriflex camera for handheld or tripod shooting. Variable-speed motor is mounted in grip.



IN THE CRUCIBLE of the film editing department, the many takes are evaluated, trimmed and spliced together to form the final production. Here the work print is scanned countless times in an effort to impart the desired dramatic tempo and story value to the production.

Finishing The Production

After photography is completed, the real work begins in molding the footage into the screen success the producer expects.

By HERB. A. LIGHTMAN

IT IS A BALMY night in Hollywood. The sky is slashed by the frosty beams of giant searchlights. An exquisitely-groomed crowd of brilliant celebrities moves into the theatre to see a gala premiere of "The Robe," "Miss Sadie Thompson" or "Julius Caesar." Everyone interviewed by the man at the microphone is sure the picture will be great—and it probably will. But while the stars, the producer and the director will receive the major credit for a fine job, there is another group of men far behind the scenes whose contributions were indispensable to the picture's success, but whose names may not even be mentioned. These are the men who put the finishing touches to the movies after they are photographed.

When the cameras have stopped rolling, and the last scene of a film is "in

the can," the real work of picture-making then begins. Up to this point the weeks, months or years of preparation that have gone into the writing and shooting of the script, remain creatively unrealized. The separate bits and pieces of film—often photographed at the expense of much blood, sweat and tears—do not, as yet, have meaning or coherence. It yet remains for a staff of highly skilled technicians to lend their special know-how to the crucial operation—the finishing of the film.

In the production of the average Hollywood feature, several hundred thousand feet of picture and sound track are shot. This tremendous mass of original material must be "boiled down" in an editing process to produce a picture that will run the required eight or nine thousand feet in length. The operative

steps in between amount to a great deal more than (as the layman says) "cutting out the bad parts."

The dramatic and artistic values achieved by the editing, scoring and dubbing processes are as important as those conceived and executed in the writing and directing phases. The finishing of a film is no mere mechanical accomplishment, but rather a highly creative process of selection and arrangement of dramatic elements to capture and hold audience attention.

Effective editing begins with careful pre-planning. The script writer, for example, does not merely write words on paper. He must first "see" a sequence as it will play upon the screen, then set down the blueprint of that sequence in terms of action and dialogue. In his script, he breaks the sequence down into separate scenes and camera set-ups—and if he has visualized the situations in their proper cinematic relationship to each other, then he can be said to have pre-edited the film on paper.

The director then takes the script and, using it as a blueprint, interprets the meaning of the printed word in the kinetic language of screen action. It is his prerogative to stage a sequence precisely as indicated in the script, or to use the script as a starting point and allow his creative imagination to soar beyond the literal blueprint.

Whichever may be the case, the film editor inherits the many fragments of celluloid thus exposed and assumes the task of fitting the huge jigsaw puzzle together to crystallize the original conception of the writer and/or director. In so doing, he adds something of his own interpretation to the story, since it is a fact that the same batch of exposed film can be put together in so many different ways that there would be a vast difference in pace, tempo and emphasis in each separate version.

Throughout the filming of a picture in Hollywood, the supervising film editor spends a great deal of time on the set, working closely with the director to see that the various angles and action patterns as staged will later cut together smoothly. Very often he will request, for protective coverage, photographing additional angles or scenes not indicated in the script, or he may suggest methods of staging that will permit more effective cutting.

The film exposed during each shooting day is usually processed the same night and prints known as "dailies" or "rushes" are available next day for screening before the director, editor and other technicians concerned. This provides a constant check on technical quality, actors' performances and photographic coverage of the action. At these

(Continued On Page 94)

The New
Revolutionary

ARRIFLEX 16

®

The Only 16mm Camera with
MIRROR REFLEX SHUTTER
for Continuous Thru-the-Lens
Focusing and Viewing.

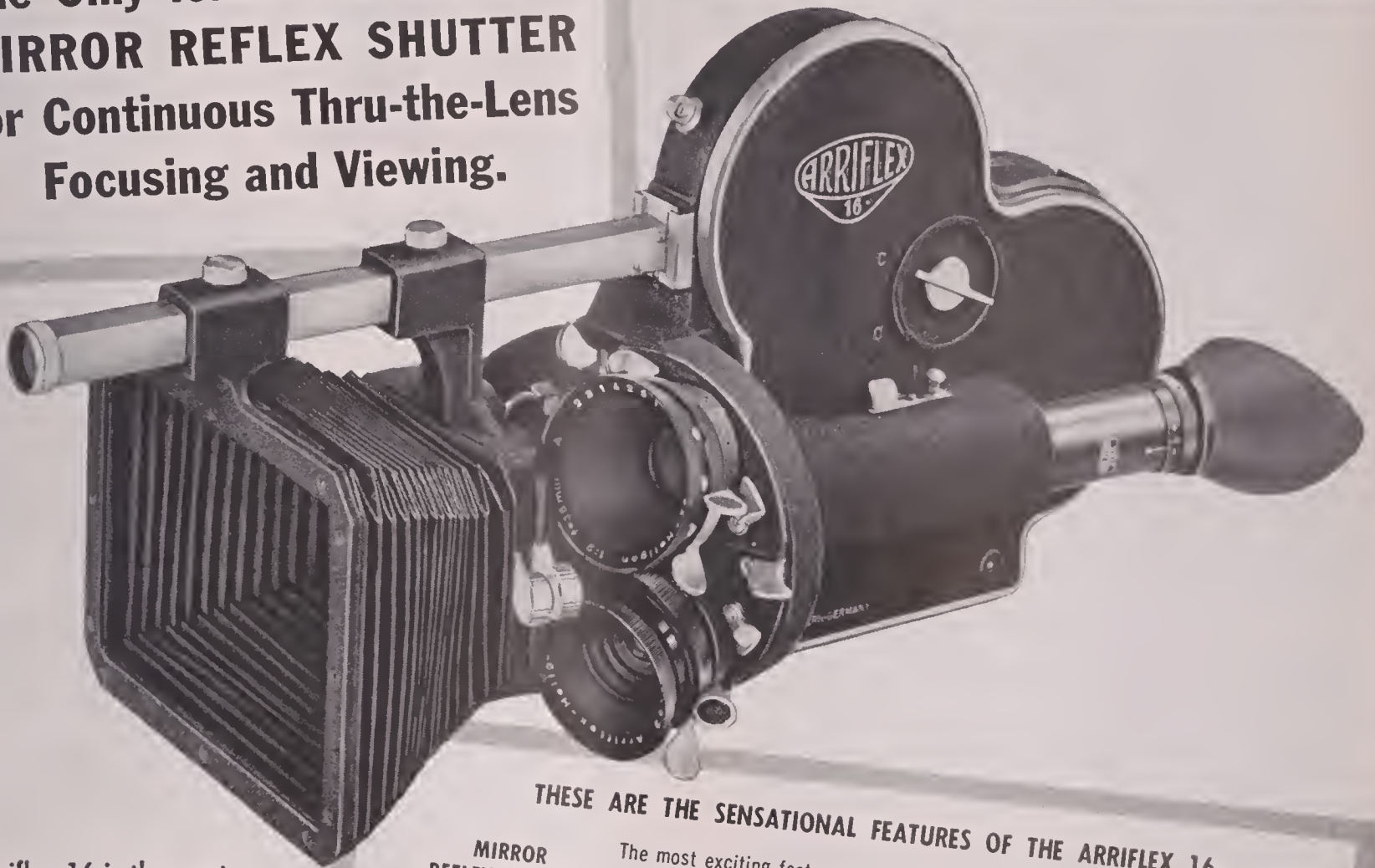

The Arriflex 16 is the most advanced camera in the 16mm field. No comparison can be made with any existing equipment. It is in a class by itself... unique for its features, and outstanding for its workmanship.

THESE ARE THE SENSATIONAL FEATURES OF THE ARRIFLEX 16

MIRROR REFLEX SHUTTER

The most exciting feature of them all: for accurate framing and critical follow-focus, through the taking lens, even during the actual shooting. Image on ground glass is brilliant, uninverted and right-side-up, magnified 10x through a highly corrected optical system. No parallax, and no need for accessory finders.

REGISTRATION PIN

Found only in cameras selling for \$3000 or more. Automatically engages and locks film during exposure. Assures absolute frame registration, and picture steadiness.

ELECTRIC MOTOR DRIVE

No need to stop a scene to wind a spring. Has variable-speed 6-volt DC motor with forward and reverse switch. Operates from portable, rechargeable battery pack, dry cell batteries, or with Transformer-Rectifier Unit on 115 volts AC. Easily interchangeable with Synchronous Motor Unit (available as accessory).

DIVERGENT 3-LENS TURRET

Accommodates lenses from 11.5mm extreme wide angle to longest telephotos. Lenses quickly interchangeable. Wide angle and 300mm telephoto can be mounted simultaneously without mechanical or optical interference.

OTHER ARRIFLEX PROFESSIONAL FEATURES

FOOTAGE & FRAME COUNTERS — for forward and reverse action.

TACHOMETER — indicates speeds from 1 to 50 frames-per-second.

CONTOUR GRIP — provides a natural and firm grip for handheld shooting.

DETACHABLE NECKSTRAP — for handheld filming.

LIGHTWEIGHT — camera with Matte Box weighs only 7½ pounds.

FILM CAPACITY — 50 and 100-foot standard daylight spools.

400-FOOT MAGAZINE — accommodates External Film Magazine. (This accessory will be available at a later date.)

DETACHABLE MATTE BOX-FILTER HOLDER — has stationary and rotating filter stages for color filters, polarizing filters, fades, dissolves, and other effects.

SINGLE SPROCKET DRIVE — for either silent or sound-perforated film.

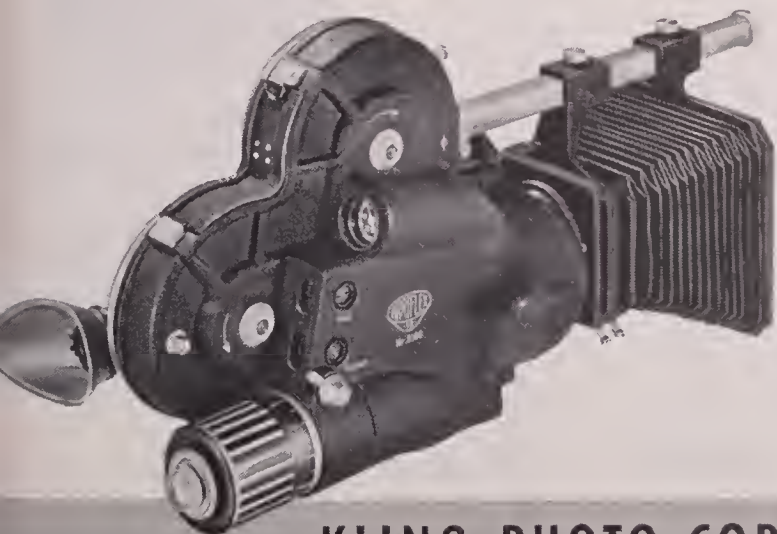

KLING PHOTO CORPORATION

235 Fourth Ave., New York 3, N. Y. • GRamercy 5-1120
7303 Melrose Ave., Hollywood 46, Calif. • WYoming 9026

NOW GREATER

THE **NEW** MODEL IIA

ARRIFLEX 35

MIRROR REFLEX CAMERA



With the new Model IIA, the Arriflex 35 attains undisputed first place among all 35mm hand cameras in the professional field. Easily convertible into an efficient studio camera, its versatility is amazing. In addition to the many features which made the earlier model a favorite among top-ranking cameramen, the improvements and engineering advances embodied in the new Model IIA, make the Arriflex 35 greater than ever.



FAMOUS ARRIFLEX FEATURES IN THE NEW MODEL IIA

- Mirror Reflex Shutter for through-the-taking-lens follow-focus and viewing even during actual shooting.
- Bright, uninverted viewing image on ground glass, magnified 6½ times.
- Eliminates parallax and the need for accessory finders.
- Quick-change, geared Film Magazines (200 and 400 feet). No belts used.
- Variable-Speed DC Motor mounted in Grip Handle... operates from 6-8 volts.
- Tachometer — registers from 1 to 50 frames-per-second.
- Matte Box-Filter Holder — quickly and easily detachable.
- Three-lens Revolving Turret.
- Perfect for tripod and handheld filming.

NEW 180° SHUTTER
Increases exposure to 1/48th second at 24 frames.

NEW INTERMITTENT SYSTEM
Rock-steady pictures. Perfect frame registration.

NEW FILM GATE
Precision-lapped, chrome-finished, stainless steel gate assures absolute focus, and frame registration. Prevents film breathing!

NEW SYNCHRONOUS MOTOR & BLIMP OPERATION
Incorporates all necessary fittings for use with Arri Synchronous Motor Unit and Arri Sound-Proof Blimp.



THE NEW ARRI SYNCHRONOUS MOTOR UNIT for ARRIFLEX 35

A smooth-running, constant-speed hysteresis motor for 115-volt, 60-cycle AC operation. Motor is mounted on base-plate housing containing the gear mechanism which connects directly to the main drive-shaft of the camera. Motor Unit has a built-in tripod socket and a built-in footage counter. A safety slip-clutch automatically disengages the motor should the film 'jam'. The Synchronous Motor Unit is easily and quickly attached to the camera without the need for special tools.

BETTER THAN EVER

The NEW ARRI® Sound-Proof Blimp for ARRIFLEX 35

Designed for the Arriflex 35 with 400-foot Magazine, and Synchronous Motor Unit. Blimp housing is cast magnesium alloy, finished in black crackle. The most advanced accoustical damping techniques have been employed. Internal walls are lined with corduroy velvet over six alternate layers of foam plastic and lead. For complete soundproofing, all door members are sealed with foam rubber gaskets, and close by means of heavy, 'knee-action' clamp locks. Camera is cushion-mounted.



BLIMP DOORS OPEN

Showing easy access to camera, lenses, and magazine.

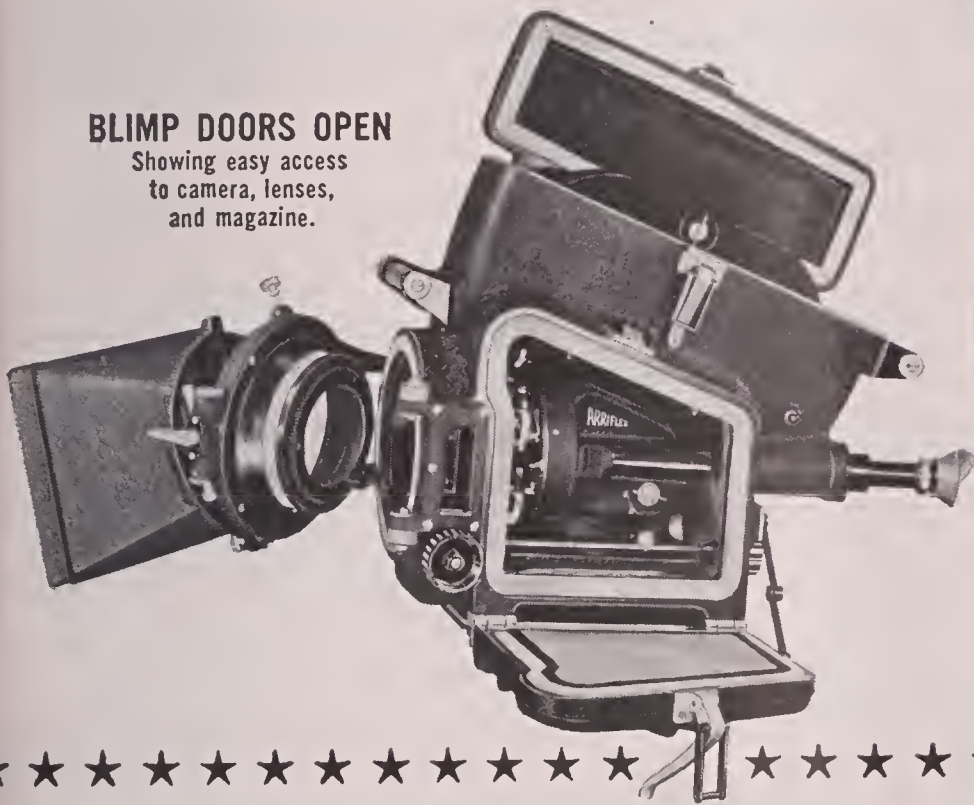

REAR VIEW

Showing convenient controls.



The important reflex-viewing feature of the Arriflex 35 is still retained while it is used in the Blimp. The regular cover and optical system is removed from the camera and replaced with a special cover which connects to the optical viewing system built into the Blimp. Follow-focus is then accomplished by means of either of two controls... located at the front side and in the back of the Blimp. These controls connect directly to the focusing mount of any lens in taking position,

equipped with Arri Follow-Focus Grips. No gears are required around the lens mounts.

An oversized focusing scale for any lens in use can be set behind, and viewed through the control window located over the focusing knob. Other observation windows are conveniently located to permit viewing the footage counter and checking the tachometer. The lens window is made of optically flat glass, shielded by a detachable matte box.

Two heavy-duty handles facilitate lifting and carrying. A Fingertip Diol permits shutter to be 'turned over' manually for preliminary focusing. A hook is provided in the exact film plane for attaching a measuring tape. A pulsating pilot light indicates that the camera is in operation.

Weight of Blimp with Arriflex 35, lenses, Synchronous Motor Unit, and 400-foot Magazine is approximately 55 pounds.



Write for Complete Details to:

KLING PHOTO CORPORATION

235 Fourth Ave., New York 3, N. Y. • GRamercy 5-1120
7303-Melrose Ave., Hollywood 46, Calif. • WYoming 9026



FILM LAB EQUIPMENT

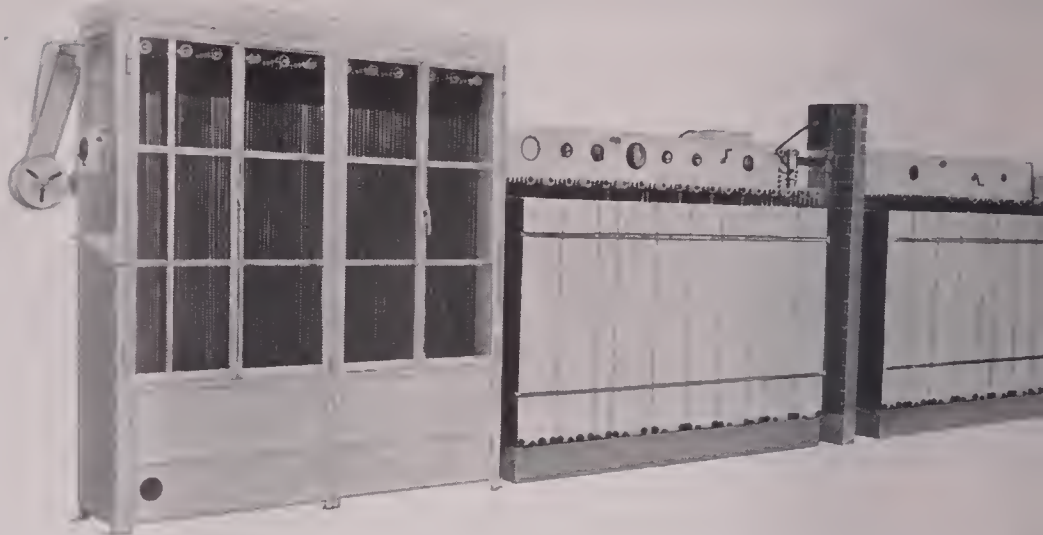
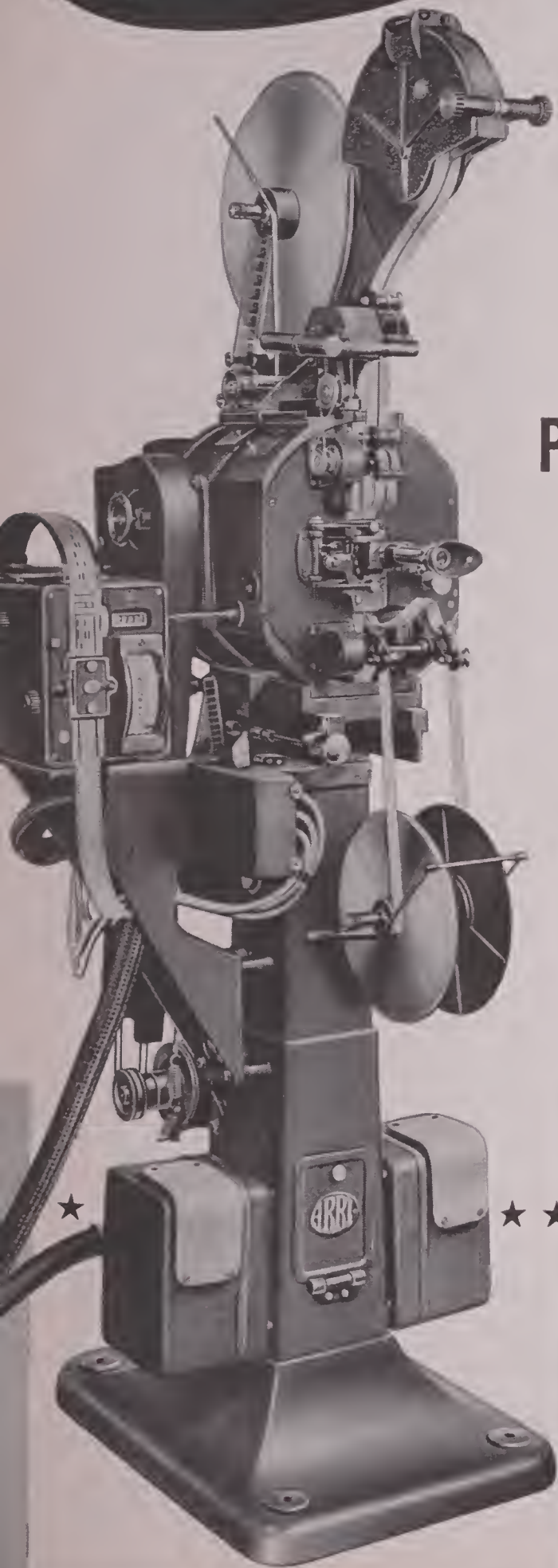

Printers and Developing Machines

Arnold & Richter, established in 1919, is West Germany's leading manufacturer of professional motion picture equipment. In addition to the Arriflex 16 and Arriflex 35 cameras, this firm is known throughout the world for high quality printers and developing machines.

Arnold & Richter also operates a large film processing laboratory which serves as a proving ground for its own products. Here, each design and development is rigidly tested under actual working conditions before it is approved and released for the general market.

MOTION PICTURE PRINTERS

Available for 35mm and 16mm film . . . sound and silent . . . black-and-white or color. Also optical printers and sound reduction printers, 35mm to 16mm.

MOTION PICTURE PROCESSING MACHINES

Available in all sizes and capacities, for 16mm and 35mm film . . . black-and-white or color. Installations planned to suit space conditions

Complete data on request.

NEW SERVICE FACILITIES for **ARRI** PRODUCTS

Complete facilities have been created for factory-approved service and maintenance of Arriflex 16 and Arriflex 35 cameras, Arri printers, and other Arri products. These facilities, located at our New York headquarters, are staffed by factory trained personnel. Special tools have been installed, and are now in use in this expanded service department.

Owners of Arriflex cameras and other Arri products are urged to avail themselves of our specialized services to insure proper maintenance of their equipment.



ACTION which is slow in its dramatic tempo is often best treated with somber, low-key lighting; while a more swiftly-paced narrative tempo is better served by brighter, higher-key lighting.



COMEDIES, which are dramatically exaggerated in both narrative and physical tempo, usually require exaggeration in lighting. An example is "The 5000 Fingers of Dr. T," photographed by Frank Planer.

Accenting Tempo With Lighting

When lighting is carefully planned to suit the mood or action set by the script, it can enhance the progressive flow of the story.

THE AFFINITY between tempo and lighting in motion picture photography is sometimes difficult to define. It exists, yet it is not easy to describe in concrete terms.

Tempo is essentially dynamic; lighting is generally static. And there is a fundamental point of contact between the two in that both are means of producing, visually, positive psychological responses. Therefore, as such, they must be closely coordinated.

We think of tempo in motion pictures as indicating the degree of swiftness or slowness with which a scene or sequence moves. It may be subdivided into two interdependent categories: 1) physical tempo, and 2) dramatic or narrative tempo.

The former refers to the physical pace of the action filmed. Obviously, if action moves at a swift physical pace, it will consume less screen time. The eye of the viewer must react more swiftly, in order to perceive and transmit to the brain a clear mental image of the action in the brief time allowed. Here the cinematographer's presentation of the action must be such as to assist in this quick visual reaction. The composition

should be simple, allowing the eye at once to focus attention on the salient action. The lighting should aid in this—be incisive and brilliant, though not necessarily of a high key, in order to facilitate quick perception of motives in the action or scene.

Let us take a swift-moving battle sequence as an example. Here the visual treatment should be such as to reveal the vital points of the action at a glance. Primarily, this would be achieved by maintaining a low visual key demanded by the action, and by increasing scene brilliance; or by simplifying the visual scale to a readily-perceived range of positive highlights and shadows, with a minimum of intermediate halftones.

By contrast, quick visual perception is not so vital in an essentially slow-moving sequence. Here the photographic tempo may be slower paced. A greater degree of visual softness is possible, and the lighting and compositional treatment may become more intricate.

Where there is a definite sense of physical movement to be conveyed, proper set lighting can do a great deal to enhance the effect. For example, let us consider filming a scene of a parade,

or of a company of soldiers on the march. Both are examples of forward physical movement which can be heightened visually through lighting. Few directors of photography shooting such a scene for a studio production would light it flatly. No matter whether nat-

(Continued On Page 96)



AN OUTSTANDING example of tempo in lighting is "The Four Poster," which Hal Mohr, ASC, (left, in background) photographed for Stanley Kramer.

SPECTRA

TELESCOPIC

BRIGHTNESS SPOT METER

NO MORE GUESSWORK IN
SCREEN BRIGHTNESS READINGS



STANDARD MODEL

- Telescopic—measures screen brightness from any point in theatre
- Indispensable for measuring drive-in theatre screen brightness
 - Reads direct in foot lamberts. Small angle
 - Locking micrometer retains readings until released
 - Sensitivity from 0.1 to 1,000,000 ftls. in 6 ranges
 - Self-contained; requires no external power or wiring
 - Completely portable; small in size; lightweight
 - Accuracy better than 5% over entire sensitivity range
 - Dependability—battery replacement only maintenance
 - Focusing from 4-ft. to infinity by rotating lens barrel
 - Supplementary lens available for measuring 1/10" at 2"

Photo Research Corp. is proud to include the following wellknown organizations among the users of the SPECTRA Brightness Spot Meter:

A & M College of Texas
Admiral Corporation
Army & Air Force Motion Picture Service
Asvin Film & Theatrical Production
Camera Equipment Co.
Chicago Park District
Columbia Broadcasting System, Inc.
Consolidated Film Industries
Daybrite Lighting, Inc.
Eastman Kodak Company
Frazar & Hansen, Ltd.
General Electric Company
Harrison Wholesale Company
The Hydro-Electric Power Comm. of Ontario
Ingersoll Products Division
Kistner, Wright & Wright
Libbey-Owens-Ford Glass Co.
Metro-Goldwyn-Mayer Studio
The Miller Company

Motion Picture Research Council, Inc.
National Broadcasting Company, Inc.
National Carbon Company
National Film Board, Canada
National Research Council, Canada
Pittsburg Corning Corp.
Portsmouth Naval Shipyard
Society of Motion Picture & Television Engineers
Stanford University
The Strong Electric Corp.
Sunbeam Lighting Company
Sylvania Electric Products, Inc.
United States Navy
U. S. Naval Academy
University of Kentucky
University of Michigan
Virginia Polytechnic Institute
Westinghouse Electric Corp.



*Other models available to meet the requirements of a wide range of light-evaluating problems.
Write for illustrated brochure.*

PHOTO RESEARCH CORP.

KARL FREUND, President

127 W. ALAMEDA AVE., BURBANK, CALIF.

Care And Handling Of Film In The Tropics

Some pointers that will insure complete film safety for those planning a filming expedition to tropic climes.

By JOHN FORBES

TOO OFTEN the amateur venturing into tropic lands for the first time to make movies suffers irreparable loss of valuable footage because of ignorance in caring for film—both unexposed and exposed—when in tropic climes. This is perhaps the most important consideration when planning a filming venture, be it a vacation trip or a carefully prepared filming expedition, which will take you and your camera and film into tropical regions.

The dangerous element in the tropics is the combination of extreme heat and equal extremes of humidity. Where the climate is both hot and dry, the amateur filmer's problem is reduced to the relatively simple one of protecting his film from direct sunlight, keeping it as cool as possible. Where there is both

heat and humidity the film must be guarded against damage from mildew, which has a deteriorating effect on unexposed emulsions.

When exposed film is kept for long periods in high temperatures, a chemical fog is generated; and in addition the latent image is deteriorated to such extent that in many cases it is scarcely visible after development.

All motion picture film intended for use in the tropics, or which is to be transported through the tropics, should be purchased in the special hermetically-sealed tropical packing. It is advisable also to purchase your film supply in small rolls, i.e., in 400 or even 200 foot rolls rather than in 1000-foot rolls—so that only the film necessary for any

given day's shooting need be unpacked at one time.

On the tropical location, care must be taken to keep all exposed and unexposed film in dry, cool storage, and never in contact with damp ground or in places where the hot rays of the sun can fall on the film container.

Film magazines, where such are used, should not be loaded until immediately before use, and should be wrapped carefully in waxed paper where some time will elapse before using. Exposed film should be packed in dry black paper, without rewinding.

The filmer should exercise care, when loading and unloading film from his camera, to make sure that perspiration does not fall on the film or on the paper in which it is wrapped. The best precaution against this is to wrap several layers of cheesecloth about the wrists and forehead, which will absorb perspiration during the film-handling period. The hands, of course, should also be kept dry by wiping them frequently.

All camera accessories should also be kept away from the direct rays of hot sun or other excessive heat. This is especially true of lenses and filters, which are easily ruined by intense heat or direct, strong sunlight.

After movie film has been exposed, it should be dehydrated or dissicated (the moisture removed) before it is canned and packed for shipment to the laboratory. However, this does not mean the film should be dehydrated to the point that it becomes dangerously brittle. If it does, it may crack or break, and it is certain also to develop static marks when unrolled.

There are two general ways of dehydrating film, writes Jackson J. Rose, ASC., in the latest edition of his "American Cinematographer Handbook and Reference Guide." The procedures are as follows:

1) Take black paper (the kind used by film manufacturers in packing film)

(Continued On Page 93)



TED PHILLIPS' highly successful motion pictures of Jamaica in 16mm Kodachrome were due in no small part to infinite care in protecting his film supply from the effects of heat and moisture of the tropics.

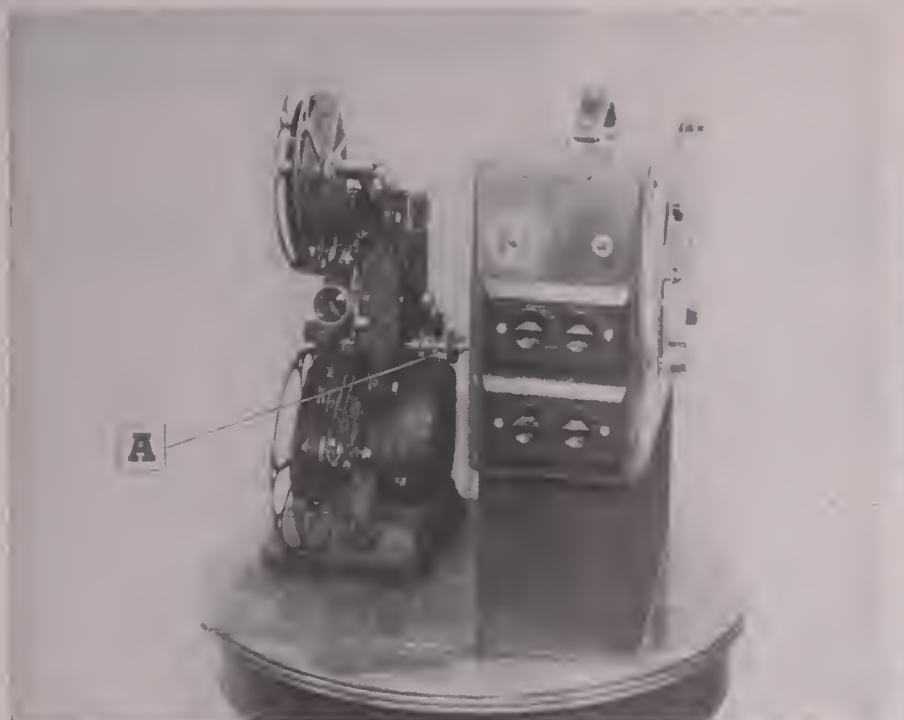

FIG. 1—Author's original adaptation had the recording unit used with the camera coupled to a 16mm Ampro projector by means of a shaft "A." Playback head was wired to a Brush home recorder which served as amplifier and speaker during projection of sound films.

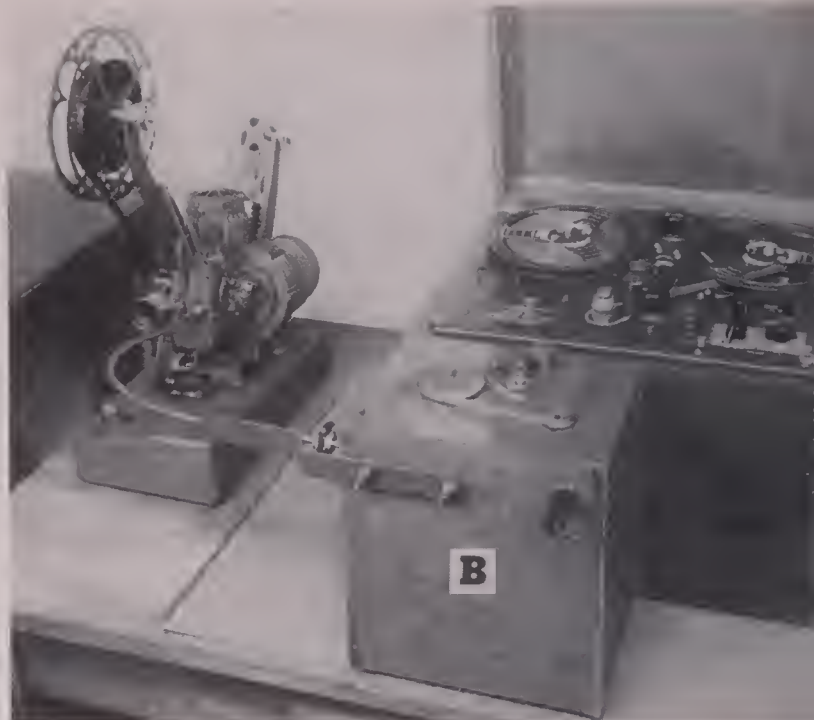

FIG. 2—This adaptation employed Bell & Howell 16mm projector driving special gear box with playback head on top. As before, Brush tape recorder served as electronics system and the speaker. Method of threading magnetic sound film utilized Brush unit for takeup.

Magnetic Sound For Any Projector

This month George Cushman describes three methods of linking up a homemade magnetic film reproducer with projector to play back sound recorded with the camera unit described here last month.

By GEORGE W. CUSHMAN

LAST MONTH, in response to increasing demand by readers for practical information regarding the application of magnetic sound to home movie films, I discussed a method of recording lip-sync sound with simple homemade recording equipment coupled directly to the camera, and described the recording equipment designed and built by the author.

This month, I shall deal with the apparatus necessary to playing back the sound tracks made with the camera equipment, and describe some of the systems with which the author has experimented.

Three different methods employing three different hookups between the playback instrument and the projector, are pictured in the photos above.

To play back a sound track recorded by the equipment described last month,

the recording unit itself may be converted as a playback unit and coupled to the projector (as it was with the camera) by a single drive shaft, as shown at "A" in Fig. 1 above.

As the illustration shows, a shaft extending from the recorder is joined to a shaft extending from the projector, with a flexible coupling in between.

In the recording-photography stage, the shaft of the recorder was coupled directly to the camera, which operated at 16 fps. For use of the recorder with the projector, the shaft is coupled to either the upper or lower 8-tooth sprocket shaft, which moves the film through the projector at the same speed it was photographed—16 frames per second. The projector in Fig. 1 is an old silent 16mm Ampro, Model J.

In projection, as in the recording stage, I use the amplifying system of

a home tape recorder. In my case, as explained last month, the amplifying system of a Brush Model 401 tape recorder served this purpose. I merely disconnected the two wires leading to the Brush recording head and connected them to the leads of the head on my recorder.

In using this equipment, my Brush tape recorder amplifying system serves for both recording and playback. If you own one of the modern home tape recorders, it can be similarly adapted for this purpose, and thus save you the expense of building (or buying) an amplifier. Excellent sound quality can be obtained if the Shure head on the recording or playback unit is equalized to match the circuit of the home recorder being used for an amplifier.

All of the projectors which I have used in conjunction with my equipment

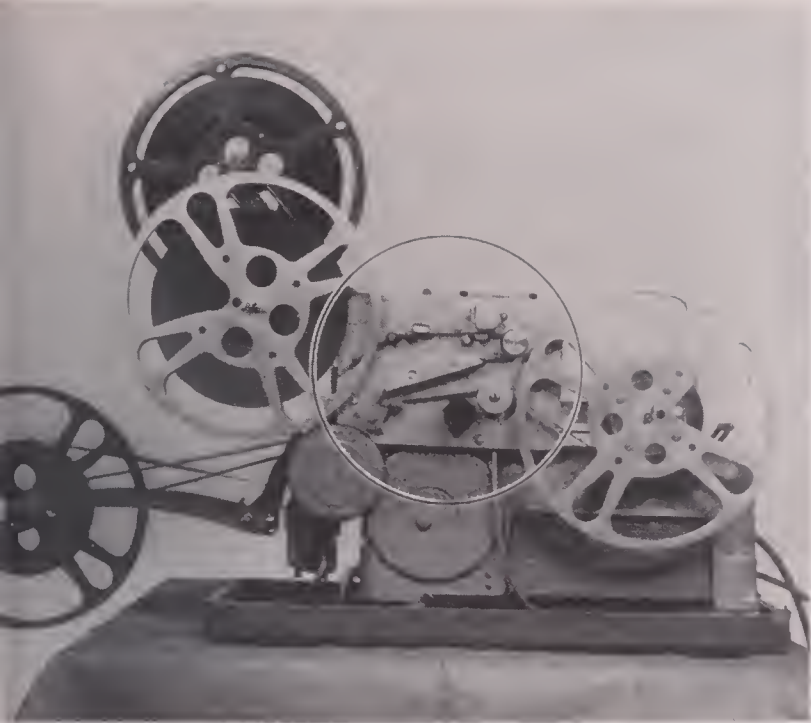

FIG. 3—Author's latest adaptation. Here, magnetic film playback unit (not shown) is mounted at rear of an Ampro Model 30 Premier sound projector, and plays through the projector amplifier system. Volume is ample for use in auditoriums of moderate size.

for playing back magnetic sound films have been 16mm Ampros, except one. Ampro projectors proved most ideal because the shaft which drives the 8-frame-per-revolution sprockets can be easily extended as required. It is necessary to install a longer shaft in order to be able to link the projector with the recorder. To do this, the side panel of the Ampro projector must be removed. The 8-tooth sprocket of the projector is also removed, which permits the shaft to come out easily. Next, the drive gear, which has been pressed onto the other end of the shaft, is removed by gently tapping with a small hammer.

The new shaft, which may be made from a piece of 1/4-inch drill rod, should be approximately 3 inches longer than the original shaft—or long enough to protrude beyond the projector to permit coupling with the recorder.

Before replacing side panel on the projector it will be necessary to drill a hole for the new shaft to extend through. A template carefully prepared for this will insure proper centering of the hole.

In the project pictured in Fig. 1, it was necessary also to build a support for the recorder, to lift it so that the shafts of the instruments were on the same level, and thus easily coupled together by means of a collar and set screw.

In this arrangement, the motor of the projector is disengaged from the film transport mechanism. This leaves it free

to be driven by the motor of the recorder, which drives both units in synchronism. With some projectors, this method might place too great a load on the recorder motor, resulting in the two units turning slower than normal speed. In some cases, the projector motor can be re-engaged with the mechanism and turned on to supplement the recorder motor. Here, patience and experimentation will solve the problem.



FIG. 4—Another Ampro sound projector adaptation. Playback unit is mounted at rear, and sound plays back through the projector augmented with a pre-amplifier.

Needless to say, this simple coupling of recorder-playback unit with projector assures complete synchronization between picture and sound track, and after using the combination for more than a year, I found little to be desired. In time, however, this "little" became "big," due mostly to the bulkiness of the equipment. Each time I wanted to screen one of my pictures with sound away from home, I had to carry three units—sound recorder, my home tape recorder, and the projector.

To get around this problem, there was only one answer: build the three components into a single unit, or rather—start with a 16mm sound projector (which incorporated two components, including the very important amplifier) and add on a compact unit for transporting the magnetic sound film in sync with the picture film. This I did, and the results may be seen in Fig. 3. However, there was an intermediate project before this was completed. My first efforts were with a model UA Ampro-sound projector (Figs. 4 and 5). Here the recording unit, consisting of a panel carrying the film transport mechanism and recording head, was mounted on the far side of the projector. The panel was made of 1/4-inch aluminum plate, approximately 7 inches square. In mounting it to the projector, the existing four screw-holes in the chassis necessary to mounting the projector side

(Continued On Page 102)



FIG. 5—Detailed view of the playback unit film transport system and head. Arrangement is essentially the same as that described for camera unit last month.

SWAP YOUR ODD SHOTS

with other readers of
American Cinematographer

Need some special footage in 8mm or 16mm, color or black-and-white? Got odd footage or stock shots you'd like to swap? Want to shoot local scenes or subjects for other cine amateurs? Then tell them about it in the Odd Shot Column. This service is free to amateur movie makers.

Editor:—

I need extra footage for a 16mm film of the North Woods. I need any and all kinds of shots in 16mm of wildlife; common animals of the North Woods and of Wisconsin, Minnesota, and Michigan, such as beaver, otter, squirrels, porcupines, etc., also footage of birds. I am particularly interested in footage of 25 ft. or more of each subject, either black-and-white or color, silent or sound. All such footage must have been shot in the "wilds," with cottages, telephone poles, etc., omitted from scenes.

Will buy footage, or shoot "swap" footage in trade for any subjects in the Chicago area.

—Richard Dix,
3042 N. Sawyer Ave.,
Chicago 18, Ill.

Editor:—

I have 16mm Kodachrome footage available of the Skagway, Alaska, area and also of the Chillkoot Pass, scene of the '98 Gold Rush. Will also shoot footage in this area on assignment for cine amateurs.

—Wesley W. Patterson,
P. O. Box 332,
Skagway, Alaska.

Editor:—

New York State—western part. Have some 16mm Kodachrome. Can get or will shoot anything reasonable. Want Florida and other scenes in 16mm color to fill in for shots missed on recent 4200 mile tour.

—Bert Patterson,
133 Dean Road,
Spenceport, N. Y.

Editor:—

I have 16 mm footage of the famous Macy Thanksgiving Day parade; also other scenes of New York city to swap with other cine filmers who wish to add footage to their travel films. Will also shoot footage in New York City on special assignment.

—Irving Brady,
331 E. 18th St.,
Brooklyn 26, N. Y.

3-D Film Festival To Be Held At A. S. C. Clubhouse In Hollywood

Jury of prominent Hollywood directors of photography will evaluate films for the Festival screening beginning this month.

HOLLYWOOD will have opportunity next month to see for the first time the sort of three-dimensional movies that are being made by 16mm movie makers, both amateur and professional, when the best of the 3-D films entered in the *American Cinematographer's* first 3-D Film Festival will be screened.

The program will take place at the clubhouse of the American Society of Cinematographers in Hollywood the evening of March 4.

Films have been entered by movie makers of several foreign countries, as well as those in the United States, and cover a wide range of subjects. Some have synchronized sound, while others are the usual "silent" type amateur movies. All films submitted thus far are in color.

The festival has been limited to films made with the aid of any one of three single-film, single-projector systems, i.e., Bolex, Nord, or Elgeet. There is likelihood that one or two other films, made with other systems, will be screened purely as demonstration of the results to be had with other types of 3-D filming equipment; but they will not be considered as competition for regular festival films.

Unlike in movie-making contests or competitions, none of the Festival Films will be rated for "First," "Second" or "Third" choice, etc.; instead each film chosen by the panel of judges will win for its maker the Merit Filming Award of *American Cinematographer magazine*.

The judging panel is made up of four prominent Hollywood directors of photography who have themselves photographed some of the industry's most successful 3-D motion pictures. Thus, those who submit 3-D films in this Festival will enjoy the opportunity of having their work evaluated by professionals in the same field of cinematography.

The judging panel includes Peverell Marley, ASC, who photographed "House of Wax"; Ellis W. Carter, ASC, who photographed the currently popular "Cease Fire" in actual locales in Korea; Charles Lawton, Jr., ASC, who photographed "Miss Sadie Thompson" for Columbia Pictures; and Lester White,

ASC, another Columbia Pictures' cinematographer who has photographed a score of 3-D productions for that studio. This illustrious group will begin screening and evaluating Festival entries immediately following the closing date for entries—February 15th.

As far as is known, this is the first time that a competitive event of any kind has been conducted anywhere for 16mm 3-D motion pictures. *American Cinematographer's* 3-D Film Festival is open to all makers of amateur, semi-professional and professional 16mm single-film, three-dimensional motion pictures, black-and-white or color, sound or silent.

Only 16mm 3-D films made on a single strip of film with either Bolex, Nord or Elgeet camera attachments, and requiring but a single 16mm projector for screening, are being accepted as Festival entries.

When the Festival was first announced in the June issue of *American Cinematographer*, there was immediate response from 16mm film-makers from foreign countries, including England, South Africa, and the Netherlands. Interesting is the fact these inquiries were immediate and preceded those which very soon after began to come in from film-makers in the United States.

No entry blank is being included in this issue by the editors in view of the proximity of the closing date for entries. An official Festival entry blank has appeared in several earlier issues of *American Cinematographer*. It is necessary to fill out and submit an entry blank in advance of sending an entry for the Festival.

Despite the waning interest shown by the public in theatrical films made in 3-D, there is continuing interest among 16mm movie makers for making stereo films. Also, there is increasing use of 16mm 3-D in the production of industrial, promotional and educational films, where depth and full dimension produces a greater impact perhaps than where stereo is used solely as a "gimmick" or novelty for a feature production.

Festival results will appear in the March issue of *American Cinematographer*.

CARE OF FILM

(Continued From Page 89)

and dry it thoroughly by heating it in an oven. When dried sufficiently, pack it loosely in a light-tight box; place the film (wound loosely) in the center of the paper and allow it to remain over night. The paper will absorb any excess moisture from the film; thereafter, it should be packed immediately. The black paper used in dehydrating can be dried again in the oven and re-used.

2) Take a metal container partially filled with calcium chloride and place on the bottom of a large, light-tight and airtight wooden box. Into this box also place a large quantity of black paper and also the exposed film. Allow film and black paper to remain in this desiccating box for at least 24 hours. Then wrap the film in the black paper and seal it in shipping cans. In using this method, care must be taken that neither the black paper nor the film come in contact with the calcium chloride; otherwise the film will show spots that cannot be removed. The calcium Chloride may also be re-used many times before discarding.

After dehydrating by either of the above methods, the film should be wrapped immediately in dry black paper and sealed in a dry film can. Seal the can with tape in the usual manner, then paint the tape and edge of can with hot paraffin to form an air- and moisture-tight seal. The Photo Products Division of the DuPont company offers an excellent black lacquer for this purpose.

It is not advisable to use newspaper or any kind of wrapping paper for packing film, as these generally contain chemicals which can prove injurious to the sensitive emulsion.

A final precaution is always to keep salt air from reaching your film. It has a tendency to fade exposed film and to produce moisture spots. Therefore, when shooting movies at tropic seashores or on board ship in tropic regions, load film indoors, and do it as quickly as possible so that the film will not suffer any adverse effects from exposure to marine air.

The preceding article is condensed from "American Cinematographer Handbook and Reference Guide," published by Jackson J. Rose, ASC, Los Angeles, Calif.—Ed.

Eastman Kodak Company has started moving photo processing equipment from its San Francisco Laboratory to the company's new processing laboratory at Palo Alto.

The new laboratory will serve the Northern California - Oregon - Washington-Idaho-Nevada area.

"Lights"
"Camera"
"Action"

and PROCESSED BY
MOVIELAB

FOR THE FINEST FILM PROCESSING *IN*
THE EAST — FILM MEN WHO KNOW
SAY "IT'S MOVIELAB"

Here—at MOVIELAB . . . efficiency and perfection are the rule. Producers, directors and technicians have at their fingertips the very best in up-to-the-minute equipment necessary to modern FILM PROCESSING techniques.

ROUND THE CLOCK SERVICES

- Negative Developing • First Print Department
- Ultra Violet & Flash Patch Track Printing
- 16mm & 35mm Release Printing
- Quality Control • Title Department
- 22 Cutting & Editing Rooms.

FOR COLOR

it's

Rainbowlab Inc.

MOVIELAB
FILM
LABORATORIES

MOVIELAB FILM LABORATORIES, INC.

619 West 54th Street, New York 19, N. Y. JUDSON 6-0360

mitchell

CAMERA STORES, INC.

T.V. NEWS

We are pleased to announce that in addition to our previously announced complete line of Motion Picture Production equipment with which we are presently serving the motion picture industry, we are expanding to serve the Television Production Field as well.

If your needs are for live TV production equipment or film equipment for television use, Mitchell Camera Stores, Inc., is ready to serve you as follows:

- Professional lenses for all T.V. & M.P. cameras, including Zoom lenses.
- Microphone Booms.
- Camera dollies—tripod or pedestal.
- Friction heads for T.V. cameras.
- Complete line of editing & cutting room equipment.
- Complete line of laboratory equipment including a new "Super Hi-Speed Reversal or Negative-Positive 16mm Developing Machine."
- Tape recorders, synchronous or wild.
- Slide and title making equipment.
- Lighting equipment.
- Mitchell, Bell & Howell, Auricon, Akeley, Arriflex cameras, etc. for rent or sale.
- Complete camera repair service.
- Only authorized Mitchell Camera Repair Service Station on Eastern Seaboard.
- Consultation service to all Television and Motion Picture Producers and studios at no charge. Write Dept. T.C.
- ATT: — SCHOOL AUDIO-VISUAL-AID DEPTS.—A.V. Teachers, we are fully equipped to supply all your needs.— Write for information.



● Phone:
Plaza
7-6812
Circle
5-9372

127 West 50th St. (At Radio City)
New York 19, N. Y.

FINISHING THE PRODUCTION

(Continued From Page 82)

screenings, the director and editor usually discuss which takes and angles should be used in the initial cut of the picture.

The good takes are assembled by the editor into a *rough cut*, while the rejected takes are filed for possible future reference. In this rough cut, the editor works mainly for continuity, assembling the scenes in their proper order. In a later cut he will work for pace, tempo, emphasis and variety in camera angles.

All professional films today are shot "double-system"—that is with the sound recorded simultaneously but with a separate recording instrument. The picture film and sound track film are given "sync" marks at the beginning of each take, either by means of clapsticks or by mechanical devices in the camera and the recorder. Picture and corresponding sound track are edited side by side on a machine called a Moviola (consisting of a picture-viewing scope and a sound speaker) through which picture and track can be run in synchronization.

Each sequence is rough-cut as soon after shooting as possible, so that if any retakes or added scenes are needed, they can be made while the set-up on the sound stage is still intact. The sequences are assembled in order according to the script to form a work-print of the complete film story. This work-print usually runs from ten to fifteen thousand feet in length, and is rather loosely paced. The director and editor then combine their efforts to smooth out and whittle down this footage so that a forceful, coherent motion picture of normal length is achieved.

In this final editing process, some scenes and sequences are shortened to tighten up the tempo, while others may be lengthened to emphasize a particular element. Still others, which prove to be superfluous or which may tend to slow down the story, are eliminated completely.

The work-print is now run and re-run for the producer, director and editor. The last editing process is a tedious one in which a foot of film here and a frame there are carefully pruned to effect the exact match of action, the precise pace of timing. Meanwhile, sound cutting has also progressed. The dialogue, of course, has been edited along with the picture. If necessary, however, dialogue not satisfactorily recorded at the time of photography is re-recorded and dubbed in or "looped." This is often the case in outdoor location se-

quences where traffic noises or other extraneous sounds make it impossible to record a clean track.

From a huge library of recorded sound effects, the effects cutter chooses appropriate background sounds necessary to add further realism to certain sequences. He cuts these in to fit the action. When a continually recurring sound, such as train wheels clicking over tracks, is required over a lengthy sequence, he makes up a "loop" of that sound track, which is played back continuously in the re-recording stage.

If an original music score has been ordered, the composer's task is to time his themes to the finished cut and record them for proper length. If library music is used, the music cutter must tailor the existing themes to coincide with the action.

Dialogue, sound effects and music are assembled in synchronized dubbing units for each reel of picture and sent to the dubbing stage for final re-recording. Here as many as fifteen separate sound tracks may be mixed or blended in a final master recording as a work-print of the picture is run off on a screen. The result is a single track in which all sound elements are balanced in proper relationship.

The advent of stereophonic sound, developed to complement CinemaScope and other wide-screen processes, has added a new dimension to sound, and at the same time has vastly complicated recording and dubbing processes. With the new stereophonic sound systems, three or more microphones are used to match sound perspective to the changing perspective of the visual action. The resultant multiple tracks are recorded side-by-side on magnetic film to be played back in synchronization with the picture. New magnetic oxide coating procedures are presently being developed that will permit the multiple magnetic tracks to be recorded on the release prints.

When all reels of the picture have been dubbed, a preview print is made and a "sneak" preview is generally set up to test average audience reaction. In an effort to get an honest response from a typical audience, the film is usually previewed without fanfare in a suburban or small town movie house. During the running of the film, the producer, director and editor study the reactions of the audience. Do they laugh in the right or the wrong places? Do they become restless during certain sequences and get up to buy popcorn? Do they respond properly to the emotional values of the more dramatic sequences?

The responses of the preview audience may differ greatly from those which studio executives have been receiving in their own projection rooms. These men have "lived with" the picture for months and they tend to lose fresh perspective after a while, whereas a typical audience seeing the picture for the first time will come through with a spontaneous response that is more valid, at least in terms of box-office, than that of the experts.

After the preview, the audience often is invited to fill out cards rating the film, and offering suggestions. On the basis of this criticism, as well as the actual response of the audience observed during the preview screening, certain changes in the film may be indicated. Various sequences may subsequently be tightened up or deleted. Retakes or added scenes may be needed to point up the story or smooth out the continuity. Further "sneak" previews may be held and further refinements made, but inevitably the release date draws near and a final cut of the picture approved.

When this is done, the original negative is cut to match the approved preview print. Dissolves and other optical effects are printed on fine-grain master positive made from the original negative, and these are cut into the positive master from which dupe negatives will be made for release printing.

In the laboratory each scene is given a careful final timing so that the answer print will present the photography and changing visual moods of the story to best advantage. Technicians view the answer print as it is screened and may make further adjustments in the printer light settings. A final sample print called a "studio copy" is struck, and on approval by the production office is considered the standard of technical quality which all subsequent release prints must duplicate as closely as possible.

Actually, few in the lay audience fully realize the great amount of work that is involved in finishing a picture, after the photography is completed. Indeed, it often happens that some who are embarking on a major film production for the first time have any conception of the great amount of work that must be done by relatively obscure but important technicians before the production is completed and ready for exhibition.

The steps that are necessary to make a feature production ready for general release, are also necessary to completing other sound films that are to be given public exhibition, such as industrial, training, promotion and educational films. The procedure is essentially the same for all classes of productions.

hallen
SINCE 1948

PECTACULAR
MAGNETIC *Film* RECORDER

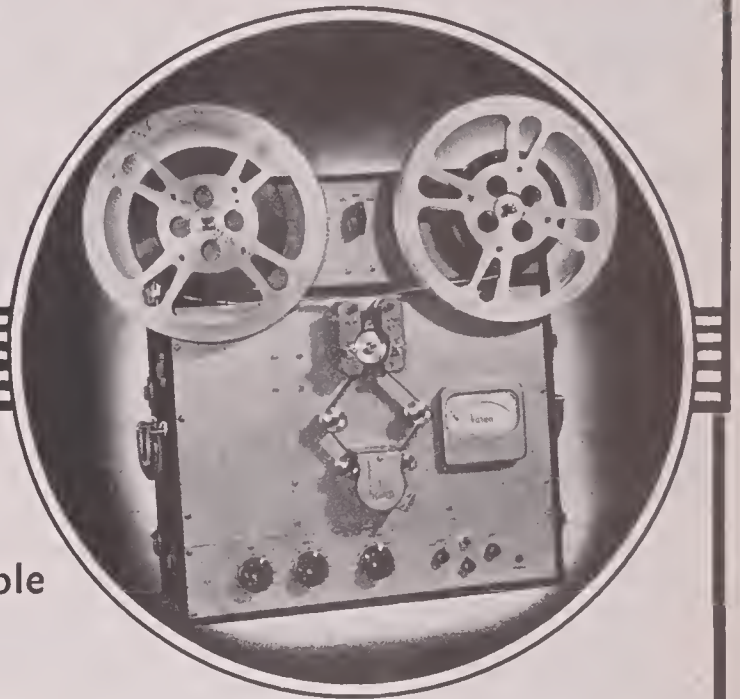

MODEL 25B
'LIP SYNC'
One Case Portable
Unit

Professional SOUND STAGE QUALITY
... At Low Cost

Check these Hallen features:

- Hallen "Drum System," with the Motion Picture Academy award-winning "C. C. Davis Flutter suppressor," results in most stable film motion yet developed.
- Simultaneous monitor of recorded track.
- Three inputs for simultaneous use: two for microphones and one for music or background effects.
- Track placement approved as standard by Motion Picture Research Council for 16mm and 17½mm models.
- High-speed forward and rewind, using separate motors.
- Monitor speakers and power supply are removable from the recorder unit.

\$1495.00 F.O.B.

Immediate Delivery

LICENSED UNDER THE PATENTS OF AMERICAN TELEPHONE AND TELEGRAPH CO., WESTERN ELECTRIC CO., AND HALLEN CORP.

HALLEN CORPORATION

3503 WEST OLIVE, BURBANK, CALIFORNIA

Cable Address "Hallen" • CHarleston 8-6976

WRITE FOR LITERATURE AND PRICE SCHEDULE

Edit Your 16mm Picture In 35mm . . .

35mm Blow-up Work Prints With
Key Numbers Retained

Speed	Service is often a matter of hours.
Protection	A 16mm Dupe Negative is made before the blow-up to afford maximum protection for your valuable original.
Quality	Major studios have found our quality superior by comparison.
Price	Comparable to other methods offering you less.

FILMEFFECTS

OF HOLLYWOOD

SPECIALIZED LABORATORY SERVICES

Dissolves • Fades • Wipes • Zooms
Special Optical Effects

1153 No. Highland • Hollywood 38, Calif.
Phone: HOLLYWOOD 9-5808

C A M A R T Electric Film Timer

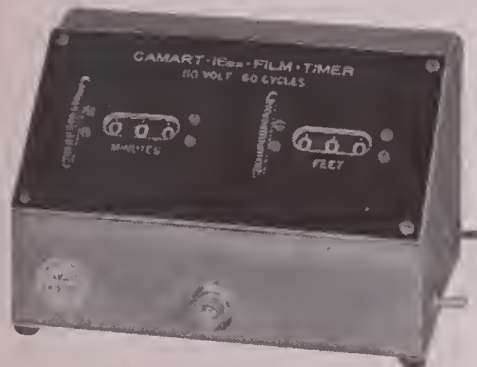

FOR MOTION PICTURE EDITING

Post-Recording Narration
Measures footage in minutes and tenths
Operates on 110 volts 60 cycles
Standard 16mm or 35mm model.....\$125.00
Single Model\$ 65.00

THE CAMERA MART, INC.

1845 Broadway • New York, N.Y.

WORLD FAMOUS

S-5

synchronous
magnetic film
recorder for
motion pictures
and television

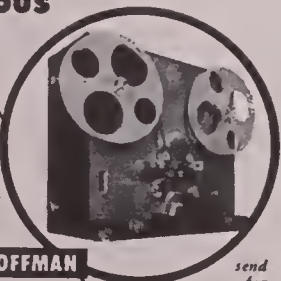

STANCIL-HOFFMAN

921 N. Highland Hollywood 38, Calif.

send
for
particulars

ACCENTING TEMPO WITH LIGHTING

(Continued From Page 87)

ural or artificial illumination were used, the photographic thing to do would be to employ some cross-lighting, creating if possible parallel planes of pronounced light and shade across the line of march. The movement of the actors across this alternate light and shadow pattern accentuates the sense of physical movement, and enhances tempo as a result.

The same lighting principle is often used when photographing actors inside a moving automobile or other vehicle at night. A greater sense of movement is imparted by the changing pattern of light and shade falling on the players in the vehicle's interior, simulating the effect of changing illumination from street lights as the car moves along the thoroughfare.

The greatest application of lighting tempo, perhaps, has been in the photography of musical films. In musical and dance numbers, especially, there is definite physical movement and strong rhythm. Here imaginative lighting can play a big part in enhancing the sense of rhythmic movement, and consequently of tempo of the sequence.

In this respect, there were times in the past when the approach of a producer in staging a musical film was decidedly illogical. The practice was to design and build the sets first, with the musical director tailoring his dance routines and the music to the limits of the set. The director of photography in turn had the task of trying to achieve some reasonable coordination of the two in the lighting and camera work. More recently, the general approach in musical productions is to design the set to conform with the dance routines and the music in order to enhance tempo—a matter which the director of photography complements further in lighting the set.

The matter of dramatic tempo is rather less tangible than physical tempo. A given scene or sequence in a production may achieve a dramatic pace more or less independent of the physical pace of its component movements. It is possible to conceive of a scene in which very little physical action occurs, yet which advances the story at breakneck speed; or of one in which a maximum of physical movement produces the minimum of dramatic advancement. In such cases, it is often the practice to plan the photography and lighting for dramatic tempo rather than to the physical.

This borders very closely upon the subject of mood, although it is by no means an exact parallel. As a general rule, the more somber of dramatic moods suggests action which is slow in

tempo while the lighter and gayer moods are synonymous with brisk tempo.

In much the same way, action which is slow in its dramatic tempo is often best treated with somber, low-key lighting; while a more swiftly-paced narrative tempo is better served by brighter, higher-keyed lighting.

Melodrama and broad comedy, both of which are dramatically exaggerated and therefore maintain an exaggerated dramatic as well as physical tempo, require more or less exaggeration in lighting. Screen melodrama, for example, almost always demands more or less unnatural lighting effects, usually with a definite suppression of the middle range of tonal gradations. Broad comedy frequently impels a reversal of this—greatly exaggerated natural lighting with a minimum of extreme contrasts, and a fairly wide range of intermediate tones.

In general, then, it may be concluded that purely physical tempo in lighting is most frequently expressed through alteration of the visual key of lighting, and by manipulation of the brilliance of the lighting; while the more delicate dramatic tempo is, like mood, revealed more generally through manipulation of the gradational scale, tending to lower tones, with repressed highlights for the slower tempos, and to wider scales for the lighter tempos.

Neither mood or tempo in lighting should be achieved at the expense of the visual coherence of the production as a whole. From the dramatic viewpoint, no individual scene can be considered as independent of the production. Therefore, in normal practice, it is sometimes necessary to sacrifice effects in lighting and composition which would, individually, be effective contributions to visual mood or tempo, but which, viewed in their relation to the greater unity of the production, may prove undesirable. In the same way, it is often necessary to forego effects which would be visually or dramatically potent, in order to maintain some special type of lighting or other treatment necessary to the most favorable presentation of some star or player. In general, however, lighting may not only be closely attuned to the physical and dramatic tempo of a production, but serve as a powerful aid to the direction and acting in creating and maintaining tempo.

Admittedly, this phase of lighting is not so well understood as is lighting for mood or character; but it is one which offers much interest to the analytically-minded cinematographer.



TEWE MOTIVEFINDER

— like a "right arm" for the creative MP and TV Director

TEWE MOTIVEFINDER is a wizard that solves scores of set problems. This Director's Zoom-type Finder reveals the most suitable focal length, the proper camera position, the effects of dolly shots, etc. It is invaluable to a creative Director who likes to plan optical tricks and special effects. Combination Finder zooms from 25mm to 135mm for 35mm Motion Picture and zooms from 28mm to 150mm for TV. Complete with leather carrying case and neck band. **Only \$75**

Other Versatile Viewfinders — each a honey for the money!



ZOOM DIRECTOR'S FINDER for 16mm and 35mm. . . 16mm zooms from 13mm to 75mm, 35mm zooms from 25mm to 6". **\$15.50**



WATSON Director's type finder, pocket size, with mattes from 30mm to 100mm for 35mm cameras. Also for 16mm cameras. **\$35**

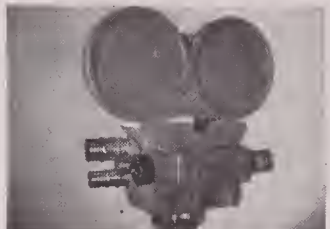

ZOOM Finder for Auricon Cine Voice . . . zooms from 15mm to 12". **\$60**
Available for Filmo and Eyemo. **\$39.50**

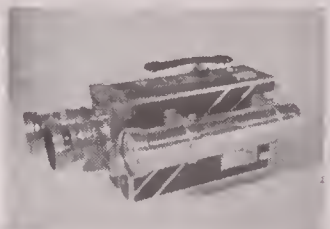

ZOOM Finder for Cine Kodak Special . . . zooms from 15mm to 150mm, with parallax adjustment. **\$75**
Template supplied for mounting Finder on magazine. Additional brackets for magazines available at \$7.50 per set.

FRANK C. ZUCKER

CAMERA EQUIPMENT

1600 BROADWAY NEW YORK CITY

REAR WINDOW

(Continued From Page 78)

screen, it wasn't clear that the object was a wedding ring. It was obvious that it was a ring, but that was all. Then we made the shot over, using different lighting, and it still wasn't what we wanted. So we finally moved out on the boom and put the 6-inch lens on the camera set at f/5.6. The results were sharp as a tack.

"Here was a story point that simply couldn't be done in any other way, without making it look artificial. An insert just wouldn't do, because all action as we put it on the screen was as seen from Stewart's point of view; it had to have the same pictorial and spacial perspective. In this case, Stewart was viewing the scene through his telephoto-equipped camera. Our aim was to match exactly the same visual perspective he obtained when actually viewing the scene with the aid of his camera."

One of the more interesting things about this production perhaps, is the "pre-lighting" phase in which Burks and his gaffers spent the better part of ten days in planning the illumination and rigging the huge complex set prior to starting to shoot. "If this large composite set had been lighted in the conventional manner," said Burks, "we

would have required over a hundred days in which to complete the picture. I went on the sound stage about ten days prior to the starting date. Using a skeleton crew, we pre-lit every one of the 31 apartments for both day and night, as well as lit the exterior of the courtyard for the dual-type illumination required. A remote switch controlled the lights in each apartment. On the stage, we had a switching setup that looked like the console of the biggest organ ever made! Actually, lighting this composite set was the biggest electrical job ever undertaken on the lot by Paramount—not excepting even Cecil B. DeMille's big spectacle sets. Biggest, that is, in terms of number of electrical units used, amps used, and the number of individual light units and amount of cable laid. At one time, we had every switch on the lot in use on the sound stage.

"With a vast setup of this kind, it was a simple matter to light any portion of the set with the mere throw of a switch or two. Thus if Hitchcock decided to start the day's shooting with action in the salesman-murderer's apartment, we'd simply ask the gaffer to "hit number 37!"

A 400-ft. Magazine for Your BOLEX H-16



Complete with Synchronous Motor and Base . . . Includes Installation and Case

Permits continuous run of 400 feet of 16mm film, or—the 200 ft. daylight loading spool may be used in the 400 ft. magazine. The 100 ft. daylight loading spool can be used in the camera without removing the external magazine. In black wrinkle finish to match camera. Fully guaranteed.

See your Bolex dealer or order direct. Immediate delivery.



TOLEDO CINE ENGINEERING
1309 Milburn Ave. Toledo 6, Ohio

C. ROSS

FOR

LIGHTING EQUIPMENT

Inkie and Arc Lamps including Required Accessories
Generators—Cables—Boards—Boxes

Raby Camera Crane—Dollies—Blimps—Geared Heads

GRIP EQUIPMENT

FOR LOCATION AND STUDIO

Parallels—Steps—Platform Ladders
Century Stands—Reflectors—Flags—Scrim

SOLE EASTERN MOLE-RICHARDSON CO. DISTRIBUTOR
RENTALS • SALES • SERVICE

CHARLES ROSS, Inc.

333 WEST 52nd STREET

NEW YORK 19, N.Y.

Circle 6-5470-1

A big chart was prepared, following the pre-lighting activities, which showed graphically the complete set-lighting plan. It indicated what switches controlled what lights, for either the day or night lighting scheme.

This is not to imply that lighting adjustments were not continually being made as the picture progressed; lighting had to be adjusted frequently to fit certain action. But the basic lighting structure was established—the walls, the effect of light coming through the windows and curtains, etc. When the salesman-murderer went over and sat down in his chair and picked up the telephone, for example, an adjustment might be made in the key light for that position. This would take but a few minutes compared to the time that would be required if the action in each apartment was filmed in the conventional manner, where each had to be lighted separately just prior to shooting.

"In the beginning," said Burks, "we attempted to establish three separate lighting schemes—for day, night, and a 'sunset' lighting. But we soon found that in order to do all this would require setting up a complete pattern of lighting units for each scheme. Obviously this would require more lights than the studio had at its disposal; and besides, there wouldn't be room on the scaffolding and stage for them or the attendant equipment.

"So what we did was to set up the day lighting complete, which could be 'put on' the set simply by throwing a few switches. Then we partially set up the night lighting pattern. For the night shots, we then augmented the night lighting setup by robbing the day lighting of some of its units; this also was true when we required the 'sunset' lighting scheme.

"But 'pre-lighting' did pay off, even though we were not able to carry out the plan as extensively as we would like. Ordinarily, to light a set as extensive and complicated as this would entail from a half to a full day's time. We had it down to a routine where we could change the overall lighting from night to day on the entire set, including the apartment interiors, in about 45 minutes."

Some idea of what this means can be gained when it is considered that there were 70 openings—windows, doors, etc.—in the set. Every apartment across the courtyard was loaded with lighting equipment: lamps, spots, photofloods, gauzes, scrims, etc. This was not just effect lighting but carefully worked out set lighting, because action takes place



PRECISION BUILT COMBINATION
16mm AND 35mm

OPTICAL

SOUND READER

FEATURES: Simple threading . . . polished stabilizer drum with needle bearings, with a surface which cannot damage film . . . film rollers machined to conform with SMPTE standards, and equipped with oilless bearings . . . precision ground shafts . . . dimension 6"x6"x7 1/2".

AMPLIFIER: 117 volt - 60 cycle - AC . . . power output - 4 watts . . . heavy duty Alnica V speaker . . . safety fused . . . prefocused socket . . . pilot light . . . 6 ft. heavy duty line card.

NET PRICE \$185.00 F.O.B., FACTORY, NEW YORK

PRECISION LABORATORIES

1139 Utica Avenue

BROOKLYN 3, NEW YORK



FREE! CATALOG

THE BIGGEST OF ITS KIND!!
80 pages, more than 1000
different items with prices
and over 300 illustrations. For
Producers, TV Stations, Film
Labs., Industrial Photography,
Educational Institutions, etc.

MOTION PICTURE PRODUCTION EQUIPMENT

S.O.S. CINEMA SUPPLY CORP., Dept. F, 602 West 52nd St., N. Y. C.

KINEVOX ACCESSORIES

for

Magnetic Recording



MAGNETIC FILM READER

Supplied in 17½mm size, which also accommodates 16mm and ¼-inch tape . . . 35mm model also available . . . Multiple-track readers are available on special order . . . Oilite bearings . . . Platform for easy film marking . . . Operates on 115-v, 50-60 cycles.



MAGNETIC FILM SPLICER

Handles 17½mm and 35mm magnetic film . . . Makes a butt splice, using Minnesota Mining's Mylar perforated joining tape . . . Splices film having any number of tracks, without adding noise . . . Splice area can be erased and re-recorded.

USED BY THE MAJOR STUDIOS IN HOLLYWOOD

Descriptive Catalog of Complete Kinevox Equipment Available On Request.

KINEVOX BUILDING
116 SO. HOLLYWOOD WAY
TELEPHONE: ROckwell 9-3291

KINEVOX

I N C O R P O R A T E D

BURBANK
CALIFORNIA
CABLE: Kinevox, Burbank

ROME • BOMBAY • NEW YORK • RIO DE JANEIRO • CANADA

in almost every apartment or apartment balcony sometime during the story, and in some cases a number of times.

"One of the major problems I encountered," said Burks. "was making the day shots, where action was going on in the apartments. Ordinarily, when one looks at an average apartment window in the daytime, one cannot readily see what is going on inside, even though the room lights are on. When first we lit the apartments for day, they looked 'lighted'—as at night. In other words, when we lit them so you could see action inside, they had the appearance of being over-lighted and thus were unnatural. They looked like shop windows. The problem here was to arrive at a lighting balance where there was enough light inside the apartments to reveal the action, but not enough to make them appear fully lighted as for night. In no case could we use conventional cross-lighting to enhance separation and definition. Moreover, the direction of the lighting within the apartments in the day shots had to look natural—as from daylight coming through the windows.

"There was the additional problems of keeping the light intensity at the

same level no matter how a player moved about in an apartment. Thus if the lighting was set at the right level for a player at the rear of a room, should he walk forward toward the window, he would be 'burned up' by illumination brighter than that outside. We solved this problem by placing graduated scrims just below the light units so that, as the player walked toward the light, the illumination falling on him would be gradually diffused the closer he came to the light."

A glance at the photos of art director Mac Johnson's pre-production sketches of the set will show how the day and night lighting schemes were visualized in advance. They also show the vast scope of the lighting that was necessary in order to give the set the authenticity of a large area of one of New York City's most interesting communities. It required the genius of a man of Burks' extensive photographic experience to impart this authenticity to the sky backings, the distant structures, the facades of the apartments, and to the interesting courtyard where so much of the critical action takes place, and of course, to the apartment interiors themselves.

At the time pre-lighting of the set was taking place, a comprehensive chart of distances and focusing was prepared

New!

*Ultimate in Precision
Equipment & Performance*

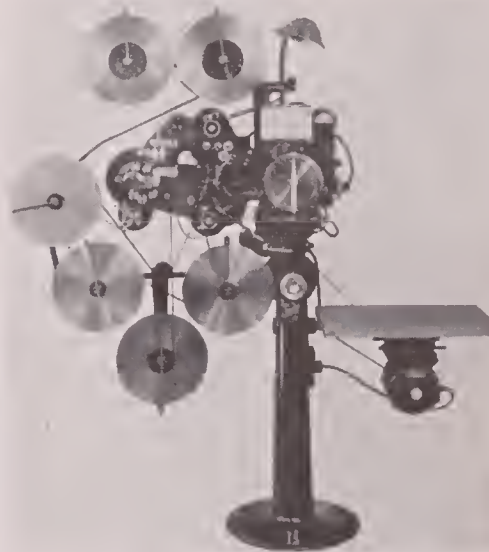

35mm-16mm Sound Printing Head, designed for your model "D" or "J" contact printer. Convert your single-head printer now into a double-head printer for high production output.

Literature On Request

MOTION PICTURE PRINTING EQUIPMENT CO.
Mfrs. of Motion Picture and Micro Film Printers
8136 NORTH LAWDALE AVENUE • SKOKIE, ILLINOIS



GEO. W. COLBURN LABORATORY INC.
 164 NORTH WACKER DRIVE • CHICAGO 6
 TELEPHONE STATE 2-7316

**8 and 16mm
 SERVICES**

for the camera assistants. A study of the illustrations will show that it would have been impractical to run a tape from Stewart's window (the basic camera position) to any one of a number of points where action was to take place across the courtyard, just before starting to shoot. Instead, all measurements were made at one time and noted on the chart. Thus when it came time to shoot the salesman-murderer, say, standing beside his bed, a glance at the chart showed the exact distance from camera to player. This was all the more important when one realizes that, using a telephoto lens on most of the shots, depth of field was extremely shallow.

"I got quite a kick out of Lennie South, my assistant, who has been with me for many years," said Burks. "He was telling me that it was the first time in his career as a camera assistant that he changed focus from 50 to 51 feet!" But in this case, such minute changes in focus were vital, for in some cases if a player, photographed from a distance of 70 feet, was to move back just a half a

step, focus had to be adjusted accordingly—an example of the fine tolerances with which Burks and his crew had to work.

And now we come to what was, perhaps, the most imaginative and meticulous phase of the photography of "Rear Window"—the continuous, non-stop introductory shot, which establishes the locale and identifies the principle characters in the story. Not in the memory of Hollywood's oldest cinematographer was there ever an introduction shot filmed on a sound stage which revealed so much in just 250 feet of film exposed in one continuous take.

In this shot, the camera opens on a closeup of a thermometer near Stewart's open window, which indicates it is a hot summer's day. The camera then moves out through the window and approaches the apartment across the courtyard to introduce all of the interesting characters who live there and who play an important part in the story. The camera continues on its revealing jour-

MOVIOLA

FILM EDITING
 EQUIPMENT
 16MM - 35MM

- PICTURE SOUND
 Photo and
 Magnetic
- SYNCHRO-
 NIZERS
- REWINDERS

One of the new series 20 Moviolas for picture and sound.

*Write for
 Catalogue*



MOVIOLA MANUFACTURING CO.
 1451 Gordon St. • Hollywood 28, Calif.

Photo Research Traveling Field Laboratory



16-FOOT trailer which Photo Research Corp. sends into field to demonstrate products.



INTERIOR view showing some of P-R's products for the film and photo industry.

A SPECIAL mobile laboratory to demonstrate standardized artificial light essential to photographic, manufacturing and farm industries has been put into the field by Photo Research Corporation, Burbank, Calif.

Assembled inside a 16-foot house trailer are representative units of all the light-evaluating equipment which is offered by Photo Research Corp., and the Macbeth Corporation, of New York.

"Function of this traveling laboratory," says Karl Freund, president of Photo Research, "is to enable potential users to see and examine the equipment in the field and put it to practical test."

Equipment of interest to the motion-picture industry and to professional photographers are such PR products as the Spectra color temperature meters;

the Spectra spot meter for evaluating brightness of motion picture screens, Spectra color densitometer, and the Norwood Model A Director exposure meter.

In the industrial and farming field the company supplies lighting equipment and light filters to produce a controlled artificial equivalent of natural daylight. Still other equipment enables textile and canning industries to grade their products according to color in a fraction of the time formerly required by other methods.

Most of the PR products relating to photography are presently in use by Freund in the production of the "I Love Lucy" and "Our Miss Brooks" television film shows, which Freund photographs for Desilu Productions, Hollywood.

**THEATER QUALITY
 16mm SOUND**

The finest equipment plus top technical skill gives you the brilliant, tone-true track that will result in wider distribution and more bookings for your picture. Let us prove Telefilm recording can benefit you.

Write for Information
 Dept. A-11

TELEFILM, INC.
 6039 Hollywood Blvd.
 Hollywood 28, Calif.

ney and finally returns to Stewart's window, where it shows him asleep. Moving in to a big closeup, it shows perspiration trickling down his face. The camera pans down to Stewart's cast-encased leg; it shows the inscription: "Here lie the broken bones of L. B. Jeffries"—thus revealing his name. The camera moves on to show a broken press camera on a nearby table; pans up to a photo which shows two racing cars in a mid-air crash on the Indianapolis speedway—the wheel of one car, torn loose, coming directly at the camera. This explains how Stewart's leg was broken. The camera moves on to a series of still other photos: Korean war scenes, fires, etc., which serve to reveal that the occupant of the apartment is a professional news picture photographer.

The camera continues its probing; it shows a wide assortment of the photographer's equipment. It comes to rest above a light box on which rests a large photo negative of a girl—a cover shot; then it pans to a pile of magazines, and on the cover of the top magazine we see reproduced the photo made from the negative shown earlier.

At this point it is pretty well established that Stewart is a news photographer laid up with a broken leg suffered in line of duty; that it is a very

CAMART PRODUCTS

OPTICAL FX UNIT AND PRISMS

You've got to see it to believe it!

FOR 16mm—35mm—TV CAMERAS
LIVE TV, ANIMATION,
MOTION PICTURES

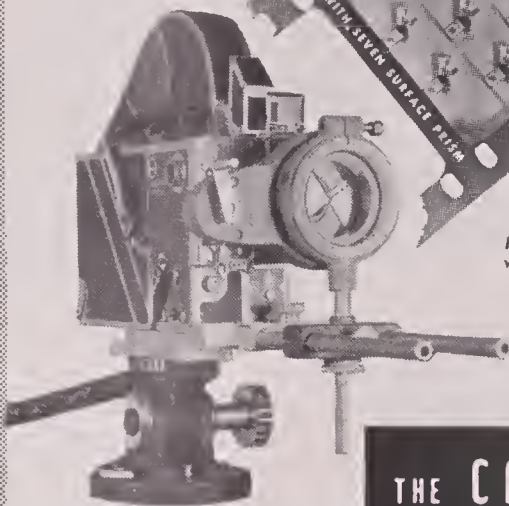

Literature on request.

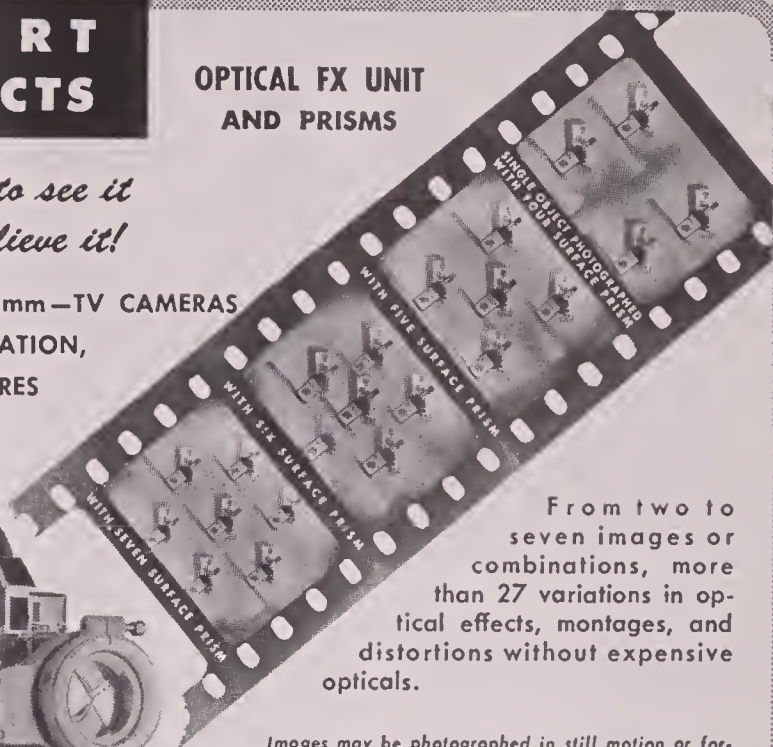

From two to seven images or combinations, more than 27 variations in optical effects, montages, and distortions without expensive opticals.

Images may be photographed in still motion or forward and reverse rotation.

Complete unit consists of a four surface prism, mount, revolving housing, and camera base assembly.

THE CAMERA • MART INC.
1845 BROADWAY at 60th ST. Phone: Circle 6-0930
NEW YORK 23, N. Y. Cable Address CAMERAMART



frost lights the nation!

MOTION PICTURE STUDIO • THEATRICAL • DISPLAY RENTAL EQUIPMENT

WHEREVER YOU ARE—WHATEVER YOU NEED

... in the way of unusual, specialized lighting, call on Jack Frost! For movie-making, stage lighting, feature exhibits, large conventions ... for *any* location that requires exceptional lighting, Jack Frost is ready to serve you! And Jack Frost's unequalled national service includes complete installation and removal *wherever* you are. Rent all your specialized lighting equipment from Jack Frost ... famous for lighting the nation's greatest shows ... most spectacular displays.

FOR FULL INFORMATION ON RENTAL EQUIPMENT MAIL COUPON, OR CALL DETROIT, TRinity 3-8030

**JACK A. FROST, DEPT. J,
234 PIQUETTE AVE.
DETROIT 2, MICHIGAN**

Please send me full information on your rental service.

Name _____
Address _____
City _____ Zone _____ State _____

RUBY CAMERA EXCHANGE

Rents . . . Sells . . . Exchanges

Everything You Need for the

Production & Projection

of Motion Pictures Provided
by a Veteran Organization
of Specialists

35 mm. . . . 16 mm.
Television

IN BUSINESS SINCE 1910

729 Seventh Ave., New York 19, N. Y.

Tel.: Circle 5-5640

Cable address: RUBYCAM

Ready-Eddy

U. S. Registered Trademark

EASY READABLE • ACCURATE
FOR EVERY DAY USE

1001 Ready Sound-Film

Editing Data:

- Footage • Frame Count • Screen Time
- 35mm and 16mm equivalents.

Plastic computer for everyone in movies and TV, from script to screen.

\$2.00 Prepaid

(Delivered in U.S.A.)

ASK FOR REPRINT OF ARTICLE
IN AMERICAN CINEMATOGRAPHER.

Write or ask your dealer

READY-EDDY, Sandy Hook, Conn.

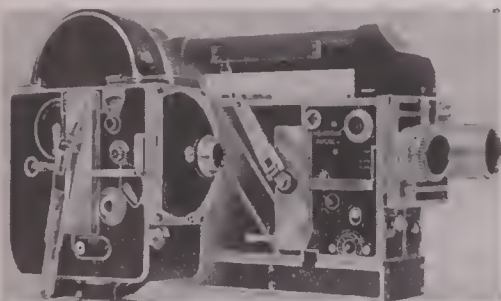

Automatic dissolve attachments for Cine Special and Bolex H-16 (Equipped with Pellegrini Shutter)

JOSEPH YOLO, 1037 N. La Brea
Phone GL. 7103 Hollywood, California

FOR YOUR TV COMMERCIAL

Special optical effects on
35mm or 16mm film. Send
for free optical effects chart.

RAY MERCER & CO.

4241 Normal Ave. • Hollywood 29, Calif.
NOrmandie 3-9331

hot day, and that he lives in an apartment building surrounded by others where some very interesting characters also reside. From this, there is an abrupt dissolve to the editorial offices of the magazine, as the editor picks up the phone and calls Stewart. Until now, not a single word of dialogue has been spoken in the entire shot.

"It was a terrific routine to plan and execute," said Burks. "We mounted the camera on the biggest boom on the Paramount lot, augmented by an extension. The chassis of the crane was moved by grips according to plan. It required a great many rehearsals to enable all concerned to familiarize themselves with the routine, and the cues, etc. We laid out the whole thing one afternoon and completed the rehearsals; then the next day we shot it. We made ten takes before we finally got everything just as we wanted it. We spent half a day shooting. It was well worth all the time and effort. We couldn't have told that much of the story in a whole day's shooting, using conventional methods."

The routine involved a great many, if not almost continuous changes in fo-

cus, said Burks. As a guide for the assistant handling the focusing, a chart was prepared which showed the focal distance from a given point at Stewart's window. We remarked that Burks must have had a pretty sharp crew to handle all the details necessary to executing such a shot so effectively. "I've got the best camera crew in the business," he replied. Burks also mentioned the great cooperation of director Alfred Hitchcock which he credits for making it possible for him to achieve the photographic results he did on "Rear Window."

"I don't think that a picture like this could be done anywhere near as well if it wasn't for 'Hitch' and his complete understanding of technical problems, and his ability and willingness to adjust things within reason to suit any technical problems encountered." Burks added.

"Rear Window" is the fourth film Burks has photographed for Hitchcock. He will shortly go to France to photograph Hitchcock's next picture, "Catch a Thief"—a Paramount production also, starring Cary Grant.

MAGNETIC SOUND FOR ANY PROJECTOR

(Continued From Page 91)

panel were used, employing extended machine screws.

The 8-tooth sprocket gear shaft was lengthened, as previously described, so that it extended through the recording panel as required. On this was mounted the 8-tooth sprocket which pulls the magnetic sound film (double-perforated 16mm oxide coated sound film slit in half). Unlike the previously described combination, here both the projector and playback mechanism are driven by the projector's constant speed motor.

Placement of other components of the playback unit on the panel (Fig. 5) is much the same as in the construction of the recorder unit, and since these details were fully described last month, they will be omitted here. Suffice it to say that the tape proceeds past a tension inducing unit, past the sound head, over a flywheel, and thence over the curved dampener that filters out any vibration in the film movement. From here it proceeds to the drive sprocket and on to the takeup reel, which is driven by spring belt extending from a grooved pulley mounted on the extended drive shaft.

This modification project was based on the assumption that I would be able to play back the recorded signals through the Model UA Ampro projector's sound system. To do this how-

ever, it was necessary to expand the capacity of the projector amplifier by adding another tube to the circuit. The resulting volume and sound quality is satisfactory, even for use in a good-sized auditorium.

Here a word of caution is necessary for others who may wish to adapt a sound projector of this type to magnetic sound, as described above: because the magnetic playback head has a tendency to pick up some noise of the motor, it is important to place the head—when constructing the panel—as far away from the projector motor as feasible. As may be seen in Fig. 5, the head (the square object to left of flywheel) was mounted at the very top of the panel, which was as far from the motor as it was possible to get in order to reduce pickup of motor noise to a minimum.

This outfit was designed to take 800-foot reels of recording film; even larger reels can be accommodated simply by lengthening the reel arms.

Out of all this experimentation, designing, and re-designing has finally evolved my latest adaptation—that of the modern Premiere Model 30 Ampro sound projector, shown in Fig. 3. Here the playback unit for magnetic sound film (circled in photo) was mounted on the projector in a manner similar to that on the earlier Model UA, except

Film Editing Made Easy
with NEW

professional film viewer

for 35mm and 16mm

Every film editor will appreciate a viewer that enables him to view his film from left to right—on a large, brilliantly illuminated screen.

The PROFESSIONAL FILM VIEWER makes film editing a breeze. Easy threading, portable, will not scratch film. Put this viewer between your rewinders and speed up your editing. Size of Viewing Screen 5¾ x 4¾.



35mm Model \$375
16mm Model \$350



that this is a more refined job. Actually, there is no difference in the design of the mechanism used in the modifications pictured in Figs. 3 and 4. The workmanship in the former is perhaps a little better, the finish more professional, and the flywheel has been mounted in back of the panel instead of the front, as in Fig. 5.

The nicest part of the Model 30 installation is that there is sufficient gain in the projector amplifier to play back the magnetic film recordings. The lead from the playback sound head is simply plugged into the microphone input of the projector. Ample volume is provided for average use in the home or small club room; but where the equipment is to be used in large auditoriums, it probably would be necessary to add an extra tube to the amplifier, or perhaps a pre-amplifier to boost the sound volume.

Another good feature is the fact that the motor of the Premier Model 30 is better shielded than that on the Model UA, with the result the magnetic head picks up little if any of the motor noise.

Another adaptation which I have purposely left for description until now, is pictured in Fig. 2. This involved a Bell & Howell 16mm projector instead of an Ampro, and the system of coupling between projector and the playback

Model 35-16C SENSITESTER



★ IMMEDIATE DELIVERY
to the lab owners interested in—

QUALITY
EFFICIENCY
ECONOMY

- DUAL MACHINE
1—Sensitometer
2—Scene Tester
- HIGHLY ACCURATE
Electronic timer unaffected
by climatic changes.
- NEW TYPE LONG-LIFE
Cold Light Exposure Unit
- WITHOUT ADDITIONAL
EXPENSE will match any
printer

Combination 35mm-16mm

ART REEVES MOTION PICTURE EQUIP.

7512 Santa Monica Blvd.

Hollywood 46

California



PELEGRINI
VARIABLE SHUTTER UNITS
FOR THE BOLEX H-16

The real answer to complete FADES and LAP DIS-SOLVES. Faster shutter speeds and many other advantages. Prices within U. S. \$99.60. Cameras with outside frame counter \$109.80. Tax extra. One year guarantee and camera transportation back included. Send for free informative booklet.

Prices subject to change without notice.
TULLIO PELEGRINI
1545 Lombard St.
San Francisco 23, California



AUTOMATIC DAYLIGHT PROCESSING EQUIPMENT



DEVELOPING TANK

- Processes up to 200 Ft.
- 8mm-16mm-35mm
- Movie—X-Ray—Microfilm
- Motor Driven, Portable
- Tough Plastic Tanks
- Uniform Density Assured
- 70mm tank also available

FILM DRYER

- Motor driven—Heated
- Speedy drying
- Automatic shrinkage allowance
- Stainless steel and aluminum construction
- Easily assembled without Tools
- Compact, Portable



Guaranteed. Write for Free Literature

MICRO RECORD CORP.

Dept. AC 225 W. 28th St., N.Y. 1, N.Y.

Color Van
GOBO STAND
That is Really Versatile *It's New!*

THE 12 foot stand may be used with a BOOM ADAPTER or with SCRIMS or with FLAGS

ABSOLUTE LIGHT CONTROL

WRITE FOR FURTHER INFORMATION

NATURAL LIGHTING CORP. GLENDALE 2, CALIFORNIA

Scheibe FILTERS
In World-Wide Use

Produce moonlight and night effects in daytime • fog scenes • diffused focus and many other effects.

Information mailed on request.

SCHIEBE FILTERS COMPANY
ORIGINATORS OF EFFECT FILTERS
P.O. Box 16834, Hollywood 46, Calif.

USED IN EVERY HOLLYWOOD MOTION PICTURE PRODUCTION

TV Film Production is BOOMING

If you have something to sell this growing market, make sure you get your share of sales by advertising in **AMERICAN CINEMATOGRAPHER**—reaches every television film production center.

mechanism is perhaps simple enough for adaptation by those who own projectors of other makes, both 8mm and 16mm. As with the other outfits, this adaptation requires that a typical home tape recorder be employed as the electronic amplifying unit.

As shown in the illustration, the sound film transport mechanism mounted on a panel is placed on top of a box "B" having the same height as the Brush Model 401 tape recorder. Inside the box is a gear arrangement leading to a shaft which extends outside. Coupled to this is a flexible shaft which leads to the projector and which in turn is connected to the threading knob shaft.

Here the complete Brush recorder unit is employed, including the head, with the magnetic film traveling a devious route from the Brush supply spool, to and through my playback mechanism, and thence back to the Brush head and takeup spool. The gear box assembly is driven by the Bell & Howell projector, which thus drives and maintains the speed of both sound and picture film

at 16 fps. This type of adaptation makes unnecessary any alterations to the projector, such as new shafts, drilling holes in the chassis, etc., and is probably one of the simplest methods to employ for either 8mm or 16mm projectors—where the projector owner also has a 1/4-inch tape recorder to provide the electronics component of the outfit.

Perfect synchronization is easily established and maintained by carefully threading both the sound and picture films according to prepared sync marks, so that they start moving in sync right from the start.

The simplicity with which magnetic recording and playback apparatus can be coupled to either camera or projector for the purpose of providing lip-sync sound, is creating widespread interest among enterprising amateur movie makers everywhere. The author will be glad to answer questions and to assist interested readers undertaking similar projects. Queries should be addressed to George W. Cushman in care of **AMERICAN CINEMATOGRAPHER**.

WALT DISNEY'S NATURALIST-CINEMATOGRAPHERS

(Continued From Page 75)

sing, Cecil Rhode, Fred Machetanz, Dick Bird, and Ernst Heiniger.

There are also four man-and-wife teams: Alfred and Elma Milotte, renowned for major contributions to Disney's Academy Award-winning "Seal Island" and "Beaver Valley;" Herb and Lois Crisler, currently filming grizzly bear for "The Northern Tundra;" Dr. Olin Sewall Pettingill, Jr., and his wife Eleanor who are on the Falkland Islands lensing penguins and other bird life; and Herbert and Trudie Knapp whose meticulous 16mm color footage soon will be seen in Disney's "Siam."

Every "True Life Adventure" assignment brings its personal adventures to the Disney wildlife photographers in the field. Encounters with animals and reptiles often pose imminent hazards and hardships inseparable from the self-imposed tasks of this unusual calling.

In Africa the Milottes, Alfred and Elma, Disney's veteran "True Life" camera team, have for two years been facing lions and elephants in their wildest haunts to get the most amazing record of savage beasts yet to be put on movie screens.

Using their specially-constructed camera car, the Milottes stalk their quarry without killing or harming, and when they get within range of their subject, they film it with a 16mm Arriflex camera mounted with a Kilfit 16-inch telephoto lens. Most of the film exposed

by the Milottes is Commercial Kodachrome. The only time they use Kodachrome Type A or Regular is when they encounter some unusual light condition. Their camera car consists of a steel-armored all-purpose cab mounted on a Dodge heavy-duty four-wheel drive chassis. It is complete with living quarters and camera lab. The material they have gathered will soon be seen in Disney's "The Elephant Story," and "The King of Beasts."

Stuart V. Jewell is one of the two noted time-lapse cinematographers contributing rare material in 16mm color for Disney's "Secrets of Life." The camera he uses in getting closeups of high magnification looks something like a mysterious new artillery piece. It is a Cine Kodak Special mounted with a 16-inch telephoto on a unique focusing mount. Long an expert on bee lore, Jewell is now filming the marvels of honey making and pollenization in collaboration with other cameramen. Elsewhere he is pictured beside his camera, wearing the padded suit and glass face mask which protect him from bee stings when working close to his subjects.

John Nash Ott, Jr., whose time-lapse photography laboratory in Winnetka, Ill., is the largest in the world, has provided Disney with many unusual close-range studies for his films. His interval camera exposures in "Nature's Half Acre" were a standout feature.

again available-

OUR FAMOUS
"controlled action"
small **GYRO** tripod

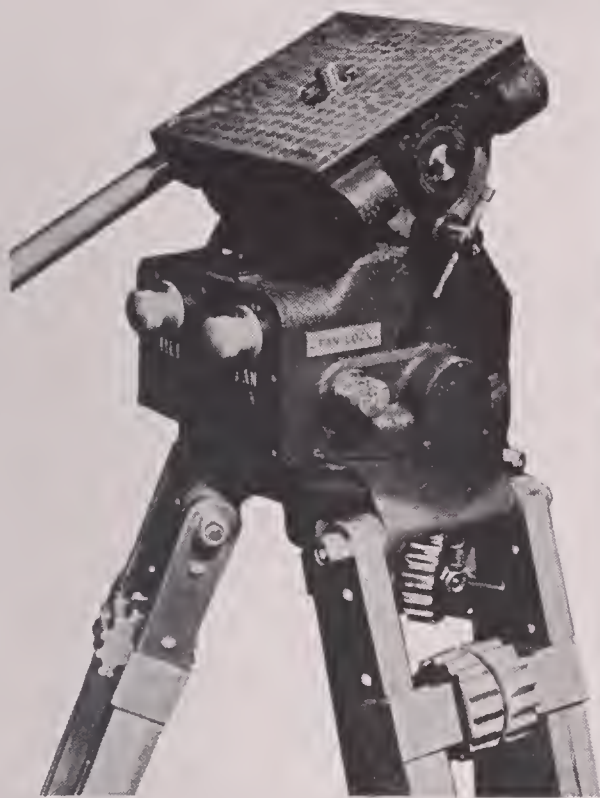

Here is exciting news for many Motion Picture Cameramen. . . . We are happy to announce that we are again in production of our popular Small Gyro Tripod.

If you have used our Gyro, of course no description is necessary. But if you know it only from hearsay, you have an interesting experience ahead of you. You will be delighted with this "Action Controlled" job which is precision-engineered with gears and flywheels like a fine clock.

It has two speeds—slow and fast—for both panning and tilting, and is equipped with a long pan handle which enables you to control the pan and tilt action—helps you capture fine scenic views and fast moving sports events with ease.

Our GYRO is especially recommended for such cameras as the 16mm Mitchell, the 16mm Maurer, the Bell & Howell Eyema with 400 foot magazine and motor and similar cameras.

If you appreciate lightweight convenience in a versatile tripod, lose no time in seeing our Gyro. We predict you will be fascinated by it.

FRANK C. ZUCKER
CAMERA EQUIPMENT ©
1600 BROADWAY NEW YORK CITY

Ott is again at work filming unusual floral and microcosmic scenes for "Secrets of Life."

The other collaborator-cameramen previously named all have similar backgrounds and experiences. One naturally wonders how Walt Disney gathered together such a formidable corps of nature-scientist-cameramen. It began years ago when he was planning to extend his activities to the production of educational films. One of the first 16mm cameramen whose work came to his attention was Alfred Milotte who, together with his wife Elma, had concentrated photographic activities to Alaska and the Canadian Northwest. Disney sent the husband-wife team back to Alaska to gather material for a feature length film. When the Milotte's color footage began to arrive, Disney was so impressed with it he decided that instead of a feature-length production, he would make a series of short subjects on wild life. He turned the rolls of color film over to his staff which ultimately put together "Seal Island," the initial subject in Disney's "True-Life Adventure Series." The film won an Academy Award in 1948.

As Disney's plans for the "True-Life Adventures" began to take more solid form, he saw need for developing a comprehensive source of film ma-

terial, and this culminated in seeking out the nation's leading naturalist and science cinematographers and evaluating their work. Obviously, it would be impractical to put all these men under contract as a staff of cinematographers. Instead, as the Disney staff develops ideas for films, the most suitable cameramen are assigned to bring in the necessary subject matter on 16mm color film.

These men do not work from a script, although there is a general discussion of what the studio wants before the men are sent into the field. Each knows from long study of the subjects completed to date the "slant" desired, and the cameramen must have the editing sense and the imagination to visualize what will make the sort of dramatic or comedy situations which the artful Disney staff weaves, using film, narration, and clever background melody.

While Walt Disney never advertises for cameramen, others having the experience and the imagination required in this specialized field are expected to join in adding luster to "True-Life Adventures," and "People and Places"—newest Disney series.

When the Disney cameramen go afield in search of likely material, they are on their own. Their success depends

(Continued On Page 109)



**Time It!
Test It!**

PRODUCERS, LAB.,
FILM EDITORS:

New electric "butt-weld"
produces miracle-fast splice
for cutting negs (no picture
loss), no flash, eliminating
A and B film editing, for
all types including color.

Presto-Splicer "Pro 3" Splices All
Types Safety, Picture & Magnetic
Film Permanently in 10 Seconds!

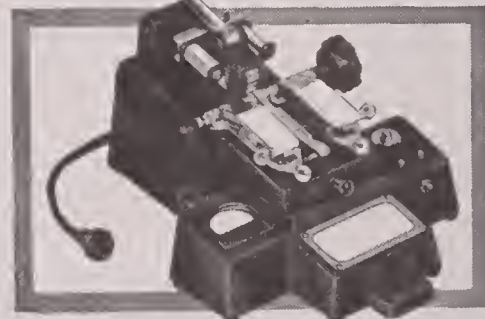

. . . replasticized! Eliminates drying out, no overlap, no cement or scraping, no double thickness or distortion. Guarantees perfect frame alignment. No light required.

Sample splice & brochure on request.
Adaptable to splice Polyester base film.

PRESTOSEAL MFG. CORP.
3727 33rd st., Long Island City 1, N.Y.

Current Assignments of A.S.C. Members



Major film productions on which members of the American Society of Cinematographers were engaged as directors of photography during the past month.

AMERICAN SOCIETY OF CINEMATOGRAPHERS

FOUNDED January 8, 1919, The American Society of Cinematographers is composed of the leading directors of photography in the Hollywood motion picture studios. Its membership also includes non-resident cinematographers and cinematographers in foreign lands. Membership is by invitation only.

•

ARTHUR EDESON, President
 MILTON KRASNER, First Vice-President
 ARTHUR MILLER, Second Vice-President
 HAL MOHR, Third Vice-President
 WILLIAM SKALL, Treasurer
 JOHN W. BOYLE, Secretary
 ROBERT DE GRASSE, Sergeant-At-Arms
 JOHN ARNOLD
 CHARLES G. CLARKE
 LEE GARMES
 ALFRED GILKS
 VICTOR MILNER
 RAY RENNAHAN
 JOSEPH RUTTENBERG
 LEON SHAMROY

Alternate Board Members

JOSEPH BIROC
 WILLIAM DANIELS
 PAUL EAGLER
 SOL HALPRIN
 WINTON HOCH
 CHARLES LANG
 JOSEPH LA SHELLE
 SOL POLITO
 JOHN SEITZ
 JAMES VAN TREES

COLUMBIA

- BURNETT GUFFEY, "The Human Beast," with Glenn Ford, Gloria Grahame, Brod Crawford, Kathleen Case. Fritz Lang, director.
- LESTER WHITE, "The Killer Wore A Badge," with Fred MacMurray, Phil Carey. Richard Quine, director.
- CHARLES LAWTON, JR., "Three Hours To Live," (Technicolor), with Dana Andrews, Donna Reed, Dianne Foster. Al Werker, director.
- HENRY FREULICH, "The Law vs. Billy The Kid," (Technicolor) with Scott Brady, Betta St. John. William Castle, director.

METRO-GOLDWYN-MAYER

- GEORGE FOLSEY, "A Bride For Seven Brothers," (Technicolor. CinemaScope) with Janc Powell, Howard Keel, Jeff Richards, Julie Newmeyer, Tommy Ralls, Russ Tamblyn, Marc Platt. Stanley Donen, director.

- ROBERT SURTEES, "Valley Of The Kings," (Technicolor; wide-screen) with Robert Taylor, Eleanor Parker, Carlos Thompson, Kurt Kasnar. Robert Pirosh, director.

- JOSEPH RUTTENBERG, "Brigadoon," (Technicolor; wide-screen) with Gene Kelly, Van Johnson, Cyd Charisse, Elaine Stewart, Virginia Bosler. Vincente Minnelli, director.

- PAUL C. VOGEL, "The Student Prince," (AnSCO Color; CinemaScope) with Ann Blyth, Edmund Purdom, John Ericson, Louis Calhern, Edmund Gwenn, S. Z. Zakall. Richard Thorpe, director.

- FREDDIE YOUNG, "Betrayed," (Technicolor; wide-screen) with Clark Gable, Lana Turner, Victor Mature, Louis Calhern. Richard Anderson. Gottfried Reinhardt, director.

PARAMOUNT

- ROBERT BURKS, "Rear Window," (Eastman Color; wide-screen) with James Stewart, Grace Kelly, Wendell Corey, Sara Berner, Thelma Ritter, Raymond Burr, Judith Evelyn, Ross Bagdasarian, Marla English. Alfred Hitchcock, producer-director.

- LOYAL GRIGGS, "The Bridges of Toko-Ri," (Eastman Color; wide-screen) with William Holden, Grace Kelly, Mickey Rooney, Fredric March, Robert Strauss. Mark Robson, director.

REPUBLIC

- JACK RUSSELL, "Tobor," (Dudley Prods.; wide-screen) with Charles Drake, Karen Booth. Arthur Shields, Billy Chapin. Lee Scholom, director.

R.K.O.

- HARRY WILD, "The Big Rainbow," (Technicolor) with Jane Russell, Gilbert Roland, Richard Egan, Lori Nelson, Robert Keith, Joseph Calleia. John Sturges, director.
- NICK MUSURACA, "Susan Slept Here," (Technicolor) with Dick Powell, Debbie Reynolds, Anne Francis, Alvy Moore, Glenda Farrell, Les Tremayne, Rita Johnson, Benny Rubin. Frank Tashlin, director.

20th CENTURY-FOX

- LUCIEN BALLARD, "The Raid," (Panoramic Prod.; Technicolor) with Van Heflin, Anne Bancroft, Richard Boone, Tommy Rettig, John Dierkes, Peter Graves, Jimmy Best. Hugo Fregonese, director.
- LLOYD AHERN, "The Gambler From Natchez," (Panoramic Prods.; Technicolor) with Dale Robertson, Debra Paget, Kevin Mc-

Carthy, Thomas Gomez, Lisa Daniels and Douglas Dick. Henry Levin, director.

- MILTON KRASNER, "Garden of Evil," (Technicolor, CinemaScope, shooting in Mexico) with Gary Cooper, Susan Hayward. Henry Hathaway, director.

UNIVERSAL-INTERNATIONAL

- IRVING GLASSBERG, "The Black Shield of Falworth," (Technicolor; CinemaScope) with Tony Curtis, Janet Leigh, David Farrar, Barbara Rush, Herbert Marshall, Ian Keith, Dan O'Herlihy, Craig Hill and Rhys Williams. Rudolph Mate, director.

- RUSSELL METTY, "Sign of the Pagan," (Technicolor; CinemaScope) with Jeff Chandler, Jack Palance, Ludmilla Tcherina, Rita Gam, and Jeff Morrow. Douglas Sirk, director.

- CARL GUTHRIE, "Dawn At Socorro," (Technicolor; wide-screen) with Rory Calhoun, Piper Laurie, David Brian, Kathleen Hughes, Alex Nicol. George Sherman, director.

- CLIFFORD STINE, "This Island Earth," (Technicolor; wide-screen) with Bart Roberts, and Faith Domergue. Joe Newman, director.

- MAURY GERTSMAN, "Bengal Rifles," (Technicolor; wide-screen) with Rock Hudson, Arlene Dahl, Dan O'Herlihy, Torin Thatcher, Michael Ansara. Laslo Benedek, director.

WARNER BROS.

- SAM LEAVITT, "A Star Is Born," (Technicolor; CinemaScope) with Judy Garland, James Mason, Jack Carson, Charles Bickford, Tom Noonan, and Jack Pepper. George Cukor, director.

- WILFRID CLINE, "Lucky Me," (WarnerColor; CinemaScope) with Doris Day, Robert Cummings, Phil Silvers, Eddie Foy, Jr., and Nancy Walker. Jack Donohue, director.

- ARCHIE STOUT, "The High and the Mighty," (Wayne-Fellows Prod.; WarnerColor; CinemaScope) with John Wayne, Claire Trevor, Lorraine Day, Robert Newton, Phil Harris, David Brian, Paul Kelly, Sidney Blackmer. William A. Wellman, director.

- PEVERELL MARLEY, "The Talisman," (WarnerColor; CinemaScope) with Virginia Mayo, Rex Harrison, George Sanders, Laurence Harvey, Robert Douglas. David Butler, director.

INDEPENDENT

- ERNEST LASZLO, "Bronco Apache," (Hecht-Lancaster Prods.; Technicolor; wide-screen) with Burt Lancaster, Jean Peters, John McIntire, Monte Blue, Charles Buchinsky, and Paul Guilfoyle. Robert Aldrich, director.

- JOHN ALTON, "Four Desperate Men," (Bogeaus Prods.; Eastman Color; ScenicScope) with John Payne, Lizabeth Scott, Dan Duryea, Dolores Moran. Allan Dwan, director.

- JACK CARDIFF, "The Barefoot Contessa," (Figaro Prods.; Technicolor; shooting in Italy) with Humphrey Bogart, Ava Gardner, Edmund O'Brien, Valentina Cortessa, Marius Goring, and Bessie Love. Joseph L. Mankiewicz, producer-director.

TELEVISION

(The following directors of photography were active last month in photographing films for television in Hollywood, or were on contract to direct the photography of television films for the producers named.)

• LUCIEN ANDRIOT, "The Life of Riley" series of half-hour comedy-dramas for Hal Roach Studio Prods., starring William Bendix. (NBC.)

• JOSEPH BIROC, "The Lone Wolf" series of half-hour dramas for Gross-Krasne, Inc., California Studios. (UTP).

• NORBERT BRODINE, "Letter To Loretta" series of half-hour dramas for Lewisor Prods.—D.P.I., starring Loretta Young. (Procter & Gamble), RKO-Pathe studio.

• DAN CLARK, "Cisco Kid" series of half-hour western dramas; also "I Led Three Lives" series of half-hour dramas, starring Richard Carlson, for Ziv-TV Corp., California Studio.

• EDWARD COLMAN, "Dragnet" series of half-hour dramas, starring Jack Webb, for Mark VII Prods., Walt Disney Studio. (Chesterfield.)

• ROBERT DEGRASSE, "Make Room For Daddy" series of half-hour comedies starring Danny Thomas for Marterto Prods., Inc., D.P.I., Motion Picture Center. (ABC.)

• GEORGE DISKANT, "Four Star Playhouse" series of half-hour dramas, featuring various stars, for Four Star Productions, RKO-Pathe Studio. (Singer Sewing Machines.)

• KARL FREUND, "I Love Lucy" series of half-hour comedies starring Lucille Ball and Desi Arnaz, for Desilu Productions; (Philip Morris) also "Our Miss Brooks" series of half-hour comedies, starring Eve Arden, also for Desilu Productions, (General Foods) at Motion Picture Center.

• FRED GATELY, "Big Town" series of half-hour mystery-dramas for Gross-Krasne Productions, California Studio. (Lever Bros.)

• JACK GREENHALGH, series of half-hour religious films for Family Films, KTTV studios.

• RUSSELL HARLAN, "Playhouse of Stars" series of half-hour dramas featuring various stars, for Meridian Pictures, Inc., Samuel Goldwyn Studios. (Schlitz).

• BENJAMIN KLINE, "General Electric Theatre" series of half-hour dramas for Bing Crosby Ent., Eagle-Lion Studios. (Gen. Elec.)

• JACK MACKENZIE, "The Hank McCune Show" series for Video Pictures, Inc.

• WILLIAM MELLOR, "Adventures of Ozzie and Harriet" series of half-hour comedy dramas starring Ozzie Nelson and Harriet Hilliard for Stage Five Prods., Inc., General Service Studios. (ABC).

• VIRGIL MILLER, "You Bet Your Life," weekly half-hour audience participation shows, featuring Groucho Marx, for Filmcraft Prods., NBC Studios. (DeSoto-Plymouth).

• HAL MOHR, "The Joan Davis Show" series of half-hour comedy-dramas starring Joan Davis for Joan Davis Enterprises, General Service Studios. (NBC).

• KENNETH PEACH, "Mr. and Mrs. North" series of half-hour dramas starring Barbara Britton and Richard Denning for John W. Loveton Productions, Samuel Goldwyn Studios. (Revlon, and Congoleum-Nairn).

• ROBERT PITTACK, "Private Secretary" series of half-hour comedy dramas starring Ann Sothorn and Don Porter, (Lucky Strike); also "Cavalcade of America" series of half-hour dramas, for Jack Chertok Prods., General Service Studios.

• GUY ROE, alternating with Walter Strenge on the "Rocky Jones, Space Ranger" and "Waterfront" series of half-hour dramas for Roland Reed Productions, Hal Roach Studios.

• MACK STENGLER, "Life With Elizabeth" series of half-hour dramas; also "The Liberace Show," half-hour musical film series for Snader Telescriptions Corp.

• HAROLD STINE, "Cavalcade of America" series of half-hour dramas for Jack Denove Prods., Inc., Samuel Goldwyn Studios. (DuPont).

• WALTER STRENCE, "My Little Margie" series of half-hour comedies, starring Gale Storm and Charles Farrell (Scott Paper Co.); also "Rocky Jones—Space Ranger" series of half-hour science-fiction dramas starring Richard Crane and Sally Mansfield (UTP); also "Waterfront" series of half-hour dramas starring Preston Foster and Lois Moran (UTP) at Hal Roach Studios.

• STUART THOMPSON, "Topper" series of half-hour comedies starring Anne Jeffreys and Robert Sterling for Loveton-Schubert Prods., Goldwyn Studios. (Camels).

• PHIL TANNURA, "The Burns and Allen Show" series of half-hour comedies starring George Burns and Gracie Allen, for McCadden Corp., General Service Studios. (Carnation Milk and Goodrich).

• GILBERT WARRENTON, "Chevron Theatre" series of half-hour dramas featuring various stars, for Revue Productions, Republic Studios.

• HAROLD E. WELLMAN, "Mr. Sun" series of half-hour dramas. (Bell Telephone Co.).

Hal Roach, veteran theatrical film producer who shifted to TV film making, recently told the National Assn. of Radio and Television Broadcasters that all of his TV films are now being shot in color, although they are being released now only in black-and-white.



... has a wide
readership
in the
**16mm Film
Industry**

Yes . . . 16mm cameramen, lab men, sound men, and the 16mm industrial and TV film producers themselves read American Cinematographer regularly for the news it contains about recent developments in things cinematic.

Most readers watch the advertising columns of American Cinematographer for important announcements of new equipment, services and movie-making accessories.

American Cinematographer is the most widely-read billboard in the movie industry. If you have a product to sell, or a service to offer makers of motion picture films, A.C. will get you more results, quicker, than any other publication circulating within the industry.

WRITE FOR OUR ADVERTISING
RATES TODAY

**AMERICAN
CINEMATOGRAPHER**

THE AMERICAN SOCIETY OF CINEMATOGRAPHER'S
MAGAZINE OF MOTION PICTURE PHOTOGRAPHY

NEW ARRIFLEX CAMERAS

(Continued From Page 81)

tical damping techniques have been embodied in its construction. The internal walls are lined with seven layers of foam plastic and sheet lead over which is applied a lining of attractive corduroy velvet. All doors are sealed with foam rubber gaskets, and are secured by means of heavy, "knee-action" clamp locks. Even the camera base within the blimp is cushioned.

The important reflex viewing feature of the camera continues functional after the camera is mounted in the blimp. The regular cover and optical system is removed from the camera, and replaced with a special cover which connects to the unique optical viewing system built into the blimp. Follow-focus is then accomplished by means of either of two controls which are located at the side

Aircraft Analyses Recording with Dual Cameras



WITH THESE two cameras, cinematographer Don King shoots 25,000 feet of film a year.

HOW WOULD YOU like to photograph 10 feature-length motion pictures that nobody looked at?

That, slightly exaggerated, is the plight of Don King, cameraman for Chance Vought Aircraft, who the past year shot enough film on every takeoff and landing of Navy-Vought F7U-3 Cutlass jet at its Dallas, Texas plant to make 10 feature films.

King records the plane action on both 35 mm and 16mm film using two cameras on an ingenious tandem mount atop the 50-foot control tower of the company's landing field. One is a Bell & Howell Eyemo model 71-Q equipped with 12-inch and 20-inch telephoto lenses. Mounted alongside it is a smaller 16mm GSAP gun camera with a 6-inch

telephoto lens, doubling coverage of the event.

Some 25,000 feet of film is shot annually by King in this operation. Pilots may check the footage in studying their technique of handling the speedy fighter plane, while company engineers can analyze it for data on rudder position, angle of speed brakes, wing slats and angle of attack of plane.

The two cameras are mounted on a single swivel base for ease in tracking planes in flight. Instead of a photographic viewfinder, a reflex gunsight is used, affording quicker aiming and tracking. To get sharper pictures, the opening of the shutters in the cameras—normally about 170°—was reduced to 10° and 20°.

and at the rear (D and E in Fig. 3). These are linked directly to the focusing mount of any lens when set in "taking" position. No gears are required around the lens mounts.

A feature which elicited favorable comment from many Hollywood cameramen during the November preview showing, was the oversize focusing scale linked with the taking lens and which may be viewed from a generous-sized window at the side of the blimp. This is a white celluloid band (F in Fig. 3) which covers a rotating, circular mounting in front of the blimp. Prior to filming, it is linked up with the lens and calibrated to correspond with the lens by marking the f/ stops in pencil or ink on the celluloid band. A separate focusing band is calibrated for each lens.

Other observation windows are conveniently located in the blimp to permit viewing the footage counter, and checking the tachometer (B and C in Fig. 2). The lens window on front of the blimp is made of optically flat glass, and shielded by the detachable matte box.

Convenient and easy carrying of the blimp is afforded by two heavy-duty handles. A finger-tip dial (A in Fig. 2) permits the operator to move the camera mechanism (to open the shutter) for preliminary focusing through the lens. A hook is provided at a point corresponding with the film plane for attaching a measuring tape. And a noteworthy feature is a pulsating light at the side of the blimp which indicates when the camera is in operation—a necessary adjunct in view of the great silencing qualities of the blimp. Combined weight of the blimp and camera (with lenses and sync motor unit) is approximately 55 pounds.

As for the Arriflex 16mm camera, already this camera is finding increasing use throughout the motion picture industry. A great deal of the color film which makes up Walt Disney's Academy-Award contender, "The Living Desert," was shot with a 16mm Arriflex. The new, revolutionary Arriflex "16" (Fig. 5) is said to be the only 16mm camera with a mirror reflex shutter. This affords the same continuous through-the-lens focusing and viewing that is an outstanding feature of the Arriflex 35mm camera.

Perhaps the most noteworthy features of the "16," in addition to the reflex shutter are the divergent 3-lens rotary turret, registration pin, and unique motor drive. The turret accommodates lenses from 11.5mm extreme wide angle to the longest telephotos—both of which can be mounted simultaneously without mechanical or optical interference. Lenses are quickly interchangeable.

The registration pin is a feature generally found only in motion picture cameras selling above \$3000. The pin in the 16mm Arriflex automatically engages and locks the film in place during each exposure, and thus insures absolute frame registration and picture steadiness.

With the compact, built-in electric motor drive there is never a need to stop filming to wind a spring. The variable speed 6-volt DC motor operates either forward or in reverse. It is operable from either a portable, rechargeable battery pack; dry cell batteries; or with transformer-rectifier from 115-volt AC. This motor is readily interchangeable with a synchronous motor unit, which will be available as an accessory.

There are still other noteworthy professional features incorporated into the design of the Arriflex "16," which weighs only 7½ pounds, complete with matte box. These include footage and frame counters, which count accurately in both forward and reverse action; a tachometer which indicates speeds from

1 to 50 frames per second; and a contour grip for the camera which provides a natural and firm grip for handheld shooting. Film capacity of the camera ranges from 50 feet to 400 feet; it will take the standard 50-ft. and 100-ft. daylight loading spools. The external film magazine, soon to be made available as an accessory, will accommodate 400-foot rolls of film. The single-sprocket drive permits use of either single or double-perforated film.

The camera boasts as standard equipment one of the most efficient detachable matte box and filter holders yet designed for a 16mm camera. This has both stationary and rotating filter stages for color filters, polarizing filters, and for making fades, dissolves and other matte box effects.

Both the 16mm and the 35mm Arriflex cameras and accessory equipment are now being demonstrated by Kling Photo Corporation at its New York City headquarters, 235 Fourth Avenue, and at its Hollywood office at 7303 Melrose Avenue.

WALT DISNEY'S NATURALIST-CINEMATOGRAPHERS

(Continued From Page 105)

in some measure on luck but more often on patience, the ability to discern a likely subject or a bit of interesting action and get it on film before it escapes; plus the possession of the imagination and continuity-sense that is a must for every good movie maker.

Over a score of communities are on the "People and Places" schedule. The program looks years ahead. The intent is to release at least two subjects annually. Length will depend upon the subject.

The camera visits will report in friendly fashion the intimate home life, the tribal and group activities and picturesque festivities of our global neigh-

bors. These features will go far beyond the conventional travelogue. The cinematographers will be resident, familiar with the region and its citizens, its traditions and history. One of their main concerns will be to accurately trace ancient customs and folk ways forward into the present life and manners of a people. To make certain that their photographers thoroughly understand this viewpoint, Disney representatives recently made a tour of Europe from Stockholm to the Mediterranean, contacting top craftsmen in many areas. Further survey is planned as the itinerary becomes active in other regions around the world.

WHAT'S NEW

(Continued from Page 68)

super-sensitive photoelectric cell. The "pocket-watch" type meter is well-known both for its diminutive size and lightweight (only 3 ozs.) and its quick-reading features. It is calibrated for ASA and Weston film speeds; covers a full range of exposures from 1/1600 sec. to 4 minutes; and diaphragm stops from f/1.5 to f/22. Retail price is \$24.95.

New Projector Data—Readers of *American Cinematographer* interested in securing latest technical data on the new series of Pageant 16mm sound projec-

tors offered by Eastman Kodak Company, are invited to write the company for special descriptive brochure No. 2-11. Address the manufacturer at Rochester 4, New York, mentioning *American Cinematographer*.

Film Trailers and Titles—Filmack Trailer Co., 1327 So. Wabash Ave., Chicago 5, Ill., offers mid-continent film producers prompt service in 16mm and 35mm film trailers, titles, TV spots, and animation.



Endorsed . . .

by the
**WORLD'S LEADING
CAMERAMEN**

Used At All
Hollywood Movie Studios

**New Edition
NOW AVAILABLE**

IMPROVED!

ENLARGED!

REVISED!

with
**TELEVISION
PHOTOGRAPHY DATA**

plus
**NEW CHARTS
and TABLES**

The Book of a Thousand Answers
to Cinematographic Questions

ORDER YOUR COPY TODAY!

PRICE **\$5.00** POSTPAID

Book Department,
American Cinematographer,
1782 No. Orange Dr.,
Hollywood 28, Calif.

Gentlemen: Enclosed please find \$5.00*
for which please send me a copy of
THE AMERICAN CINEMATOGRAPHER HAND-
BOOK AND REFERENCE GUIDE.

Name

Address

City..... Zone..... State.....

*If you live in California, please include 18c
sales tax — total \$5.18.

CLASSIFIED ADVERTISING

RATE: 10c per word—minimum ad \$1.00. Words set in capital letters, 15c per word. Display format 90c per line.

STUDIO & PRODN. EQUIP.

CLEANING HOUSE AFTER INVENTORY

NEW REVERE HI-POWER FLOODLITES, \$150 val. \$ 49.50

SYNCHRONOUS MOTOR for 35mm Mitchell Std. 395.00

DEPUÉ SOUND & PICTURE 16mm Continuous Printer, \$3500 val. 2495.00

DEPUÉ OPTICAL SOUNDTRACK 35 mm Printer. 1995.00

FEARLESS BLIMP for Mitchell NC or Std. 695.00

HEAVY DUTY ESCALATOR TRIPOD with large TV freehead or rolling dolly. \$1250 val. 595.00

ANSCO-SWEET COLOR DENSITOMETERS \$850 val. 367.50

3 DIGIT COUNTERS for printers, etc. 4:95

AMERICAN CINEMATOGRAPHER early 1953 HANDBOOKS. Publ. overstock 2.50

BERNDT-MAURER SINGLE SYSTEM 16mm Sound Camera, turret, 4 lenses, finder, 400' magazine, amplifier, power supply, fair. 1295.00

ELECTRIC FILM FOOTAGE COUNTERS—starts, stops, continues automatically. Comb. 16/35mm, \$119.50; 16 or 35 mm. 67.50

NEW STRIPPING FLANGES, 6" comb. 16/35mm rd. keyway 5.95

HOUSTON 16mm KIA REVERSAL DEVELOPER, recond. 3250.00

HOUSTON 35mm PROCESSOR Model 10 combination, negative/positive. Originally \$13,250.00. Good 4500.00

NEW FILM EDGE NUMBERING MACHINES, 16 or 35mm 2250.00

ARRIFLEX 35mm CAMERA, 3 lenses, tripod, adapter, batteries, etc. 895.00

EYEMO NEWSREEL CAMERAS Model 71 less lens, as is 99.50

EYEMO SPIDER TURRET Newsreel Cameras, Model 71 less lens, as is 295.00

VERTICAL ANIMATION STAND, \$2500 val. 995.00

Trades Taken. Send For Catalog

S. O. S. CINEMA SUPPLY CORPORATION

Dept. fc Cable: SOSOUND
602 W. 52nd Street New York 19, N. Y.

BASS . . . Chicago. Cinema headquarters for 44 years offers money saving buys in quaranteed used equipment. Cine Special 4 lens "C" mt. turret, 1" F:1.9 Super Comat, 0.7" F:2.5 Super Comat., 4" F2.5 Cooke Panchrotal, DeLuxe Comb. Case, \$925.00; Cine Special 1, 1" F:1.9, 15mm F:2.7 W. A., 3" F:4.5, extra 100 ft. chamber, Comb. Case, \$545.00; Bolex H-16 DeLuxe, 1" F:1.5 H. M. Primoplan, 0.7" F:2.5 Super Comat, 3" F:4 C. Z. Sonnar, \$387.50; 16mm. Magazine Movikon, 1" F:1.4 T coated Sonnar, \$137.50; 8mm. Revere 99 Turret, 1/2" F:2.8, 1 1/2" F:3.5 tele, case, \$79.50. Best buys . . . Best trades always. **BASS CAMERA CO.**, Dept. AC. 179 W. Madison St., Chicago 2, Ill.

WALL S. S. 35MM. SOUND CAMERA

COMPLETE with Galvanometer, amplifier, portable power supply, 40-50-75 and 100mm. lenses, erect image viewfinder, complete front attachments, two 1000 ft. magazines, Balanced Tripod, necessary carrying cases. Overhauled. Guaranteed perfect. Reasonable.

CAMERA EQUIPMENT COMPANY
1600 Broadway New York 19, N. Y.

AUDIO AKELEY single system camera complete with Akeley sound head, Gyro tripod, 3 lenses, view finder, Maurer mixing amplifier. Complete with cables, power supply and W. E. microphone. **CAMERA EQUIPMENT CO.**, 1600 Broadway, New York 19, N.Y. Cable Cinequip.

WE BUY, SELL AND RENT PROFESSIONAL AND 16mm. EQUIPMENT, NEW AND USED. WE ARE DISTRIBUTORS FOR ALL LEADING MANUFACTURERS. RUBY CAMERA EXCHANGE, 729 Seventh Ave., New York City Established since 1910.

FOR SALE—Cine Kodak Special, 3 lenses, two 200-ft. magazines, deluxe case, perfect condition, \$1100.00. CHARLES CLARKE, 32B So. Bedford Drive, Beverly Hills, Calif.

BELL & HOWELL 35mm standard camera with high-speed movement, 6 lenses, matt box, viewfinder, 110-volt synchronous motor, two 1000-ft. magazines, two 200-ft. magazines, tachometer, etc., with cases. Excellent condition. \$1950.00 cash. BOX 1182, American Cinematographer.

CECO Professional Junior Maurer type friction head tripod with extra adj. handle, \$130.00. CONTINENTAL INTERNATIONAL PICTURES, 448 Harrison, Greenville, Ohio.

STUDIO & PRODN. EQUIP.

AKELEY 35mm. camera with six matched coated lenses (25mm. to 12-inch) five magazines, gyro tripod, 12-volt motor, cases. Perfect. First \$600.00. HARRY MAMAS, 17 Adams Street, Medfield, Mass.

FREE LIGHT with COLORTRAN converters. Use 750 watts, get over 2,000 watts. Catalogue. KIRK FILMS, 627 St. Philip St., New Orleans 16, La.

COLORTRAN 750 Spot Kit. Like New. \$200.00. EVANS STUDIO, 2132 Sheridan Rd., North Chicago, Illinois.

35MM. CINEPHON Camera, 5 Color Calibrated Coated Lenses, Mitchell type focusing shift, 7 Magazines, electric motor, matte box, cases. Used in theatrical film production. CARL-FREDRIK NELSON, 164-12 110th Road, Jamaica 33, N. Y.

MAURER "D" Recorder, Neg., Pos., 120 omp., NR amp. Cables, mike, accessories, \$1,150.00. H. FULTON, 1839 15th St., Cuyahoga Falls, Ohio.

CAMERA & SOUND MEN

ASSIGNMENTS FOR INDIA or nearby territories for any type of films, 16 or 35mm, B&W or Color, write to KANU PATEL, A.R.P.S., The Clorion Productions, 34, Park Monsions, CALCUTTA-16.

SKILLED CINEMATOGRAPHER available, 16mm.-35mm. Well traveled—has made many 'travellagues'. Work U. S. or anywhere in world. Has 16mm. equipment Passport. EMERSON, 224 Naples Terrace, Bronx 631, New York.

ASSIGNMENTS FOR JAPAN on all subjects, 16 mm. and 35 mm., Color or B & W. Write to AOI-MAJESTIC PRODUCTIONS, 2-Nagatacho, Chiyodaku, Tokyo.

COLOR SLIDES, PHOTOS & FILMS

WANTED GOOD used 16mm. sound films, cartoon, sport, etc. Will pay highest prices. FILM SERVICE, Box 625 Industrial Branch, Hillside, New Jersey.

NATURAL COLOR SLIDES, Scenic, National Parks, Cities, Animals, Flowers, etc. Set of eight \$1.95. Sample and List 25c. SLIDES, P.O. Box 26, Gardena, Calif.

BUGS, SNAIL, LIZARD, etc. Extreme closeups of various insects, 400 ft. MISS UNIVERSE PARADE, 300 ft. All original color film, 24 f.p.s. professionally filmed. Can be made into excellent TV subjects. LEO CALOIA, 10521 Ruthelen St., Los Angeles 47, Calif. PL. 4-5B42 after 6 p.m.

ALASKA WILDLIFE KODACHROME 16mm. — 8mm. 2x2 slides taken by professional photographer and Alaskan Registered Guide. Free Catalog. MAC'S FOTO SERVICE, 315 4th Avenue, Anchorage, Alaska.

Here...

on this page, you'll find

BARGAINS GALORE

in

New and Used Equipment

of all kinds

A Good Place For YOU

to Sell, too!

RATES ARE LOW—ONLY

10c per word

WANTED

IMMEDIATE CASH PAYMENT FOR CAMERAS AND EQUIPMENT

NEED EYEMOS (SINGLE LENS AND TURRET); MITCHELLS, ARRIFLEX, DE BRIES, B&H STANDARDS AND HI-SPEEDS, WALLS, AKELEYS, CINE SPECIALS, AJRCONS, MAURERS, FILMOS. ALSO BALTARS, COOKES AND OTHER LENSES. SOUND STAGE, LABORATORY AND EDITING EQUIPMENT OF ALL TYPES REQUIRED. PLEASE SHIP INSURED OR FORWARD DESCRIPTIONS AIRMAIL. IMMEDIATE PAYMENT.

GORDON ENTERPRISES • 5362 N. Cahuenga
NORTH HOLLYWOOD, CALIFORNIA

WANTED TO BUY FOR CASH

CAMERAS AND ACCESSORIES

MITCHELL, B & H, EYEMO, DEBRIE, AKELEY ALSO

LABORATORY AND CUTTING ROOM EQUIPMENT

CAMERA EQUIPMENT COMPANY
1600 BROADWAY, NEW YORK CITY 19

CABLE: CINEQUIP

WANTED

PRODUCTION EQUIPMENT, LABORATORY EQUIPMENT.

EDITING EQUIPMENT, 16mm. and 35mm. FROM SINGLE ITEMS TO COMPLETE STUDIOS. TRADES ACCEPTED.

THE CAMERA MART, INC.
1845 Broadway Circle 6-0930 New York 23, N.Y.

WANTED

Mitchell — Akeley — B & H — Wall — Eyemo
Cameras — Lenses — Equipment

NATIONAL CINE EQUIPMENT, INC.
209 West 48th St. New York, N.Y.

F & B PAYS MORE

FOR USED 16/35MM EQUIPMENT

WRITE — WIRE — PHONE

FOR OUR CASH OFFER

FLORMAN & BABB MU. 2-292B
70 W. 45TH ST. NEW YORK 36, N.Y.

SOS ARE SPECIALISTS ON SALES

If You Can't Get Your Price We Can Do It For You

Cameras, Dollies, Lenses, Lights,
Moviolas, Printers, Recorders,
Studio or Laboratory Equipment

Western Union Private Wire — WUX New York

S. O. S. CINEMA SUPPLY CORPORATION
Dept. fc Cable: SOSOUND
602 W. 52nd Street New York 19, N. Y.

LABORATORY & SOUND

SOUND RECORDING at a reasonable cost. High Fidelity 16 or 35. Quality guaranteed. Complete studio and laboratory services. Color printing and lacquer coating. ESCAR MOTION PICTURE SERVICE, INC., 7315 Carnegie Avenue, Cleveland 3, Ohio. Phone Endicott 1-2707.

RECORDING and sound editing. 16 or 17 1/2 mm. Magnetic tracks. Music recorded in sync to your work print. L.A. and Harbor area producers call Don Dunn — DAVENPORT 6-4925, EL RANCHO AUDIO, 26236 Fairview Avenue, Lomita, California.

POSITIONS AVAILABLE

PERMANENT POSITION open for versatile 16mm. cameraman familiar with all phases of industrial production.

McLARTY PICTURE PRODUCTIONS
45 Stanley Street
Buffalo 6, New York

IN 16mm. SOUND PROJECTION . . .

Only the Pageant offers all five top-important sound-projection features

. . . and each Pageant model is the lowest-priced projector in its field!

1. *Freedom from lubrication problems.* With the Pageant, lubrication is *never* a problem, for it alone among all 16mm. sound projectors is permanently *pre-lubricated* at the factory. Faulty lubrication—too little oil or too much oil, the prime cause of projector damage—is eliminated. *You can throw away the oil can!*

2. *Permanently quiet.* The show belongs on the screen. There's no place for show-stealing projector noise. Nylon gears, the Pageant's non-skip pull-down mechanism, its minimum of moving parts, with all shafts designed for low-speed operation, combine to keep the Pageant's noise level way down . . . *permanently.*

3. *Provision for optimum sound . . . anywhere.* The highest quality sound . . . in adequate volume . . . properly distributed so everyone can hear . . . is vital to full enjoyment of your shows. In the Pageant the finest type of audio amplifying equipment, an adequate speaker of proper design and capacity—plus the availability of additional *matched* speakers to meet acoustically difficult conditions—give you full assurance of quality sound, whether you show movies in large or small auditoriums or at home.

4. *Sharp, clear pictures.* Screen and film are flat, but conventional lenses have curved fields. As a result, images projected by such lenses can never be *completely* in focus—when the center is sharp, outside edges must be blurred . . . and when you focus for the outside edges of the image, the center area must lose sharpness. But with a Pageant, crisp over-all focus is never a problem! An exclusive field-sharpening element—built into the standard lens—eliminates field curvature to make possible crisp, clear projection over the whole screen area.

5. *Clear-as-a-bell tone quality.* The Pageant's unique Fidelity Control completely does away with fuzzy sound reproduction. It permits exact focusing of the sound scanning beam whether the sound track is threaded toward or away from the lens.

No other 16mm. sound projector offers all these advantages—advantages that result in better performance, freedom from trouble, ease of use, and longer life!

Pageant, Model 1, New Low Price—**\$375**

EASTMAN KODAK COMPANY, Dept. 8-V, Rochester 4, N. Y.

Please send me more information about the Kodoscope Pageant Sound Projectors, Kodoscope Royal, Kodoscope Analyst.

NAME _____ POSITION _____

COMPANY _____

STREET _____

CITY _____ STATE _____

(Zone)



Shown above is the Kodascope Pageant 16mm. Sound Projector, Model 1, sold by thousands of Kodak dealers. Five special-purpose models are available from Kodak Audio-Visual Dealers. And each is the lowest-priced projector in its class!

There are also two 16mm. silent Kodascope Projectors that are built to the same design and incorporate the same optical and mechanical features as the Pageant—the Kodascope Royal Projector for standard projection . . . and the Kodascope Analyst Projector, specially equipped for critical motion-picture analysis.

Price is subject to change without notice.

Kodak
TRADE MARK

ULTRA-SHARP DETAIL

...in



3-D

...in



T-V

...and in

CINEMA SCOPE



*even to the very
EDGE of the picture!*

...with Taylor, Taylor and Hobson Speed Panchro Lenses

T-T-H Speed Panchro lenses again meet the demands of a fast-growing industry — supplying the high degree of sharpness needed for Cinema-Scope, 3-D and television films. A complete set of eight fully color corrected lenses matched for

perfection is now available from Bell & Howell. Each lens is accurately calibrated by scientific measurement of light actually transmitted. Consistent negative densities regardless of which lens is used. For full details, write to Bell & Howell.



100mm T3 (f/2.5)



75mm T2.3 (f/2)



50mm T2.3 (f/2)



40mm T2.3 (f/2)



35mm T2.3 (f/2)



25mm T2.3 (f/2)



32mm T2.3 (f/2)



28mm T2.3 (f/2)

Also 8½", 12½", and 20" F/5.6 T-T-H Telephotos

Look for Bell & Howell's new 35mm anamorphic lens for studio and theater projection.



Bell & Howell

Professional Equipment Department
7148 McCormick Road, Chicago 45, Ill.

Cinematographer

THE MAGAZINE OF MOTION PICTURE PHOTOGRAPHY

THEATRE
TELEVISION
INDUSTRIAL
AMATEUR

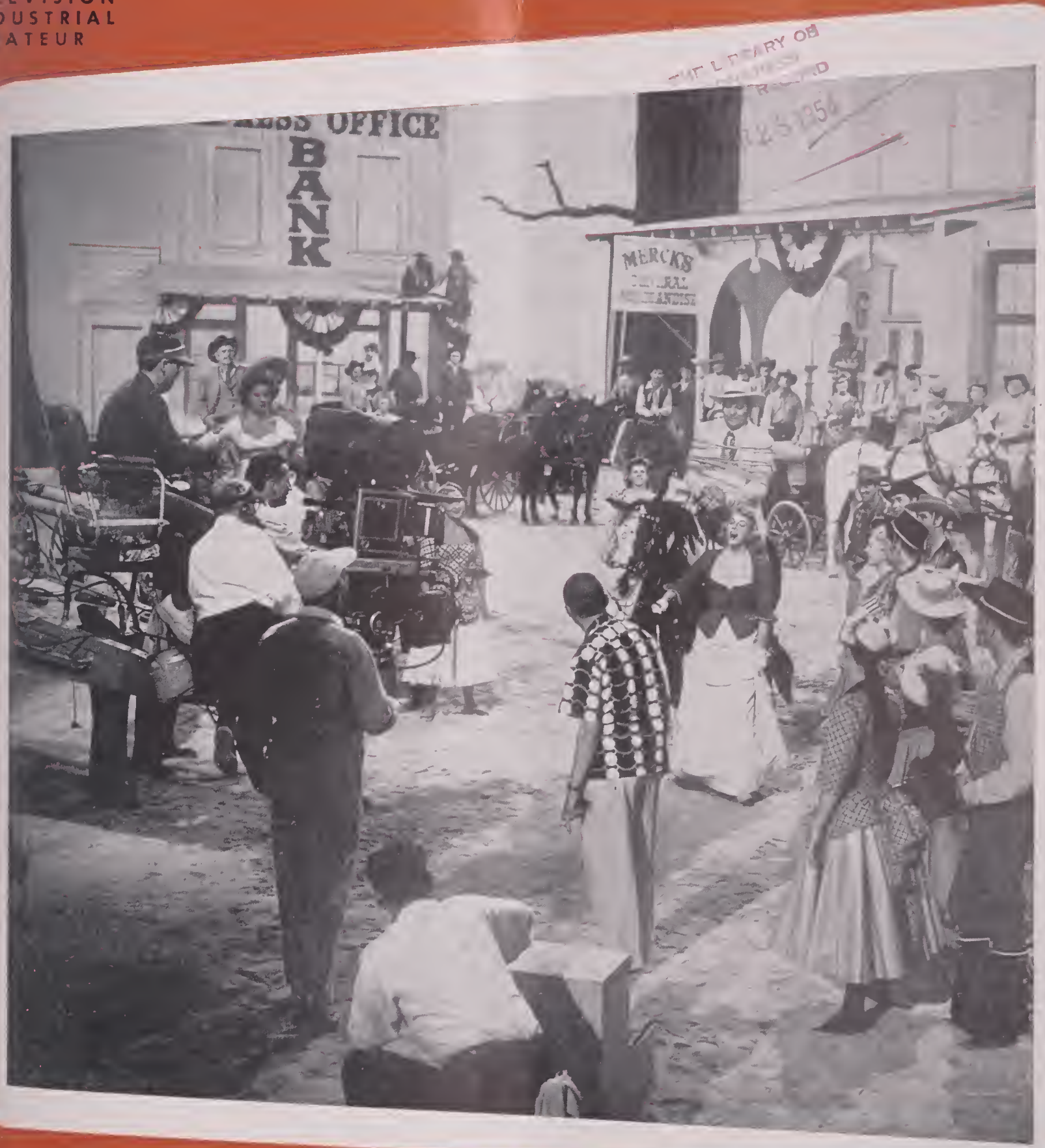

In This Issue . . .

- Filming The Everest Climb
- 3-D Film Festival Screening
- Organizing A TV Film Production Unit

25c
\$3.00 YEARLY

Safety Saves!



How Cowboy Willie learned his lesson

TRAINING FILM ON DU PONT "SUPERIOR" 3 WINS NATIONAL SAFETY COUNCIL AWARD

The National Safety Council has given one of its top honors to the Clark Equipment Co. of Battle Creek, Michigan, for producing a unique, driver-training film entitled "Safety Saves." Designed to explain safe driving practices to operators of fork-lift trucks, the film is based on the dangerous driving habits of a "villain" called Willie the Cowboy. Willie's show-off driving leads him from one narrow escape to another. But he pays no heed, until he finally learns his lesson . . . too late.

Engaged in manufacturing material-handling equipment, the Clark Co. has long recognized the great value of films for explaining the proper operation of this machinery. Clark dealers all over the world can choose from over 15 different titles. Many of these films were made "right on the spot," showing Clark equipment in active use by

Clark's customers. Special lighting was often impossible, so the extreme versatility of a high-speed film, such as Du Pont "Superior" 3, was especially helpful. That's why every foot of "Safety Saves" was shot on this fast film.

Try out the exceptional speed of Du Pont "Superior" 3. Its A.S.A. incandescent rating of 100 permits splendid results under the trickiest conditions of interior lighting . . . captures shots impossible with slower emulsions. It has a daylight rating of 125 . . . wide latitude . . .

longer tonal range . . . pinpoint definition. For more information, write to the nearest District Sales Office listed below. E. I. du Pont de Nemours & Co. (Inc.), Photo Products Department, Wilmington 98, Delaware. *In Canada: Canadian Industries, Ltd., Montreal.*

DISTRICT OFFICES

ATLANTA 5, GA. 805 Peachtree Bldg.
BOSTON 10, MASS. 140 Federal Street
CHICAGO 18, ILL. 3289 N. California Ave.
CLEVELAND 14, OHIO 1033 Union Commerce Bldg.
DALLAS 1, TEXAS 506 Tower Petroleum Bldg.
LOS ANGELES 38, CALIF. 7051 Santa Monica Blvd.
NEW YORK 11, N. Y. 248 West 18th Street
PHILADELPHIA 2, PA. 225 South 15th Street

DU PONT PHOTOGRAPHIC PRODUCTS

FILMS • PAPER • CHEMICALS



BETTER THINGS FOR BETTER LIVING . . . THROUGH CHEMISTRY

SALES • SERVICE • RENTALS

APR -1 1954

THE WORLD'S MOST COMPLETE ASSORTMENT
OF PHOTOGRAPHIC EQUIPMENT FOR



T.V. and Motion Picture Studios

MICROPHONE BOOMS

FOR ALL PURPOSES

SMALL, MEDIUM, LARGE



M-R Microphone Boom with Perambulator. Quiet in operation. Lightweight model Booms — Model C-12 and C-17 and Century Portable Mike Boom. Beautifully engineered for TV and motion pictures.

MOVIOLA FILM EDITING EQUIPMENT

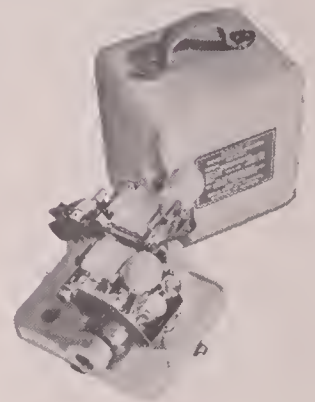
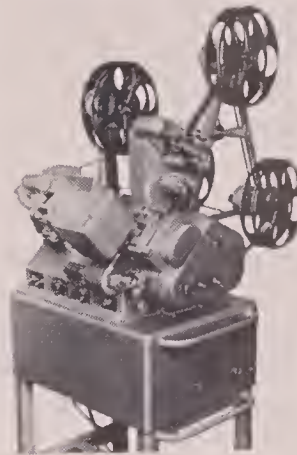

ROBOT AUTOMATIC SPLICER

No heat required. Assures exceptionally strong positive splice. Simple operation. Portable.



AURICON CAMERAS

Illustrated: Cinevoice with 3-lens turret, Zoom Finder and 400 ft. Magazine.

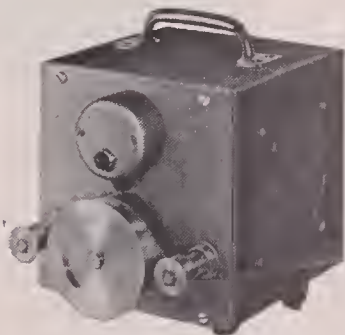

PRECISION SOUND READER

(16-35 COMBINATION)

Simple threading. Polished Stabilizer drum with needle bearings. Surface cannot damage film. Precision ground shafts. Dimensions—6" x 6" x 7 1/2". AMPLIFIER: 117 volt, 60 cycle, AC. Power output 4 Watts. Heavy duty Alnico V. Speaker. Safety fused.

LIGHTWEIGHT ALUMINUM SHOULDER BRACE



... for 16mm and 35mm cameras. Sturdy, yet light enough not to tire user. Easy panning and tilting. For all hand-held cameras.

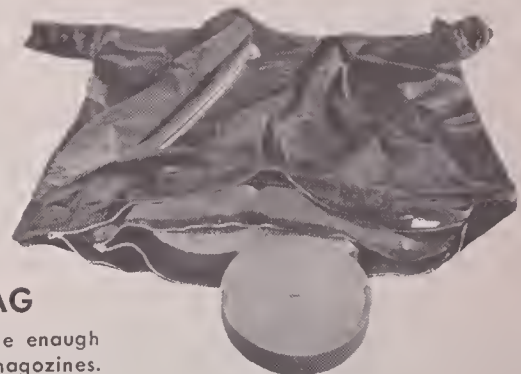

CHANGING BAG

— a portable darkroom. Large enough to take 1000 ft. 35mm magazines. Double zipper. Completely light-proof.

9.5mm Lenses in 16mm C mount. 18.5mm (extreme wide angle-flat field) Lenses available in mounts for all 35 mm Motion Picture Cameras. PHOTO RESEARCH Color Temperature Meters. *Electric Footage Timers Neumade and Hollywood Film Company cutting room equipment. Griswold & B.&H. Hot Splicers. *DOLLIES—Bardwell-McAlister, Mole Richardson, Century and Colortran Lighting Equipment.

Complete line of 16mm and 35mm Cameras

FRANK C. ZUCKER
CAMERA EQUIPMENT CO.
1600 BROADWAY NEW YORK CITY

important news

from the manufacturer of the World's Finest Cameras

NEW PRODUCTION SCHEDULES NOW PERMIT → IMMEDIATE DELIVERIES OF MITCHELL 35mm BNC...35mm NC...16mm PROFESSIONAL CAMERAS

It is impossible to compare a Mitchell with any 35mm or 16mm camera now in existence—for the **history-making Mitchell is the only truly professional motion picture camera.** Exclusive professional operating features plus the smooth trouble-free Mitchell movement, with its .0001 inch tolerances, can insure the success of your film making as can no other single element of production.

Now—on the huge six and one-half acre site of the Mitchell Camera Corporation plant — increasing numbers of 35mm and 16mm cameras are being created to meet the extensive use of professional motion picture equipment in such fields as television, entertainment, business, education, religion and government. Each of these superbly designed cameras possesses the supreme quality craftsmanship rightly due the world's **most used most flexible** professional motion picture camera.

Write today for information and prices of the currently available 35mm BNC, NC and 16mm Professional Mitchell Cameras and accessories.

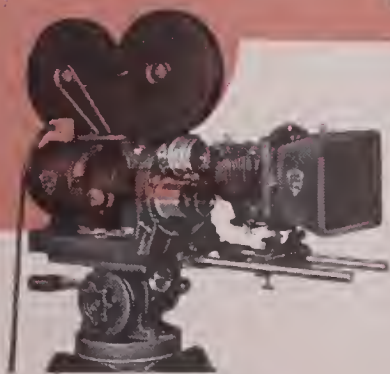

MITCHELL 16mm PROFESSIONAL



MITCHELL 35mm NC CAMERA



MITCHELL 35mm BNC CAMERA

Mitchell Camera CORPORATION

666 West Harvard Street • Glendale 4, Calif. • Cable Address: "MITCAMCO"



85% of the professional motion pictures shown throughout the world are filmed with a Mitchell

AMERICAN

Cinematographer

THE MAGAZINE OF MOTION PICTURE PHOTOGRAPHY
PUBLICATION OF THE AMERICAN SOCIETY OF CINEMATOGRAPHERS

ARTHUR E. GAVIN, *Editor*

EMERY HUSE, *Technical Editor*

GLENN R. KERSHNER, *Art Editor*

Circulation, MARGUERITE DUERR

EDITORIAL ADVISORY BOARD: John Arnold, Arthur Edeson, Lee Garmes, Charles Roshier, Leon Shamroy, Fred Gage, Dr. L. A. Jones

Editorial and Business Office: 1782 N. Orange Dr., Hollywood 28, Calif.
Telephone: HOLLYWOOD 7-2135

VOL. 35

MARCH

• 1954

NO. 3

CONTENTS

ARTICLES

A NEW INSTRUMENT FOR CHECKING THE FOCUS OF CAMERA-MOUNTED LENSES	129
SHOOTING A NEWSREEL-TYPE PRODUCTION IN COLOR—By <i>Ralph W. Luce</i>	130
1953 NOMINEES FOR ACADEMY AWARDS FOR PHOTOGRAPHY	132
ORGANIZING A TV FILM PRODUCTION UNIT—By <i>Merle Agnello</i>	134
FILMING THE EVEREST CLIMB—By <i>Arthur L. Marble</i>	138

AMATEUR CINEMATOGRAPHY

AMERICAN CINEMATOGRAPHER'S 3-D FILM FESTIVAL	140
VIDEO TAPE RECORDING AND HOME MOVIES—By <i>Robert J. Berry</i>	142

FEATURES

WHAT'S NEW IN EQUIPMENT, ACCESSORIES, SERVICE	118
CLOSEUPS—NOTES AND EDITORIAL COMMENT	122
HOLLYWOOD BULLETIN BOARD	126
CURRENT ASSIGNMENTS OF ASC MEMBERS	154

ON THE COVER

COLORFUL SET—The Technicolor camera is trained on the colorful Western Town set for the fadeout scene of Paramount's "Red Garters," photographed by Arthur E. Arling, ASC. At stage center is Rosemary Clooney leading the trussed-up Jack Carson on a horse.—*Paramount photo by Jack Koffman.*

AMERICAN CINEMATOGRAPHER, established 1920, is published monthly by the A. S. C. Agency, Inc., 1782 N. Orange Dr., Hollywood 28, Calif. Entered as second class matter Nov. 18, 1937, at the postoffice at Los Angeles, Calif., under act of March 3, 1879. SUBSCRIPTIONS: United States and Pan-American Union, \$3.00 per year; Canada, \$3.00 per year; Foreign, \$4.00. Single copies, 25 cents; back numbers, 30 cents; foreign single copies, 35 cents; back numbers, 40 cents. Advertising rates on application. Copyright 1954 by A. S. C. Agency, Inc.

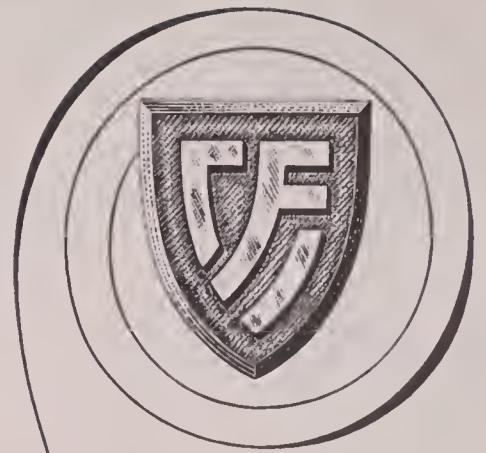

The Seal of Our Pledge to You

... to bring
to the screen
in flawless manner
the artistry
of your
photography

*Hollywood's
only complete*

**LABORATORY
SERVICE**

**CONSOLIDATED
FILM INDUSTRIES**

A DIVISION OF REPUBLIC PICTURES CORPORATION

**959 N. SEWARD ST.
PHONE HO 9-1441**

ONE CAMERA

16mm or 35mm

in 10 SECONDS!

Camerette 16/35

Reflex Motion Picture Camera

The perfect camera for the motion picture film maker working in both 16mm or 35mm color or black and white.

LOOK AT THESE ADVANTAGES—

- The same lenses, same motor drives, same sound blimp and accessory equipment used for both 16mm or 35mm — to convert simply change the magazine.
- Precise rugged movement
- Reflex viewing
- 200 degree adjustable shutter
- Divergent three lens turret
- Automatic film gate 400' magazines 16 or 35mm — the 16mm magazine will accommodate daylight spools as well as standard care load.
- Light weight — only 14 pounds with 3 lenses, 400' magazine, and 6/8 volt motor.

Write for brochure



Camerette

patents coutant-mathot

Manufactured by Ets. Cine. Eclair, Paris



WHAT'S NEW

in equipment, accessories and service



Collapsible Dolly — Camera Equipment Company, 1600 Broadway, New York 19, N. Y., announces a new collapsible 3-wheel camera dolly designed especially for cameramen who want an easily transportable dolly for field and location filming. The new dolly, illustrated above, folds into the compact size of 18" x 12" x 36", and fits into a sturdy carrying case. When fully assembled for use, dolly measures 45" in width by 46" in length.

Dolly is equipped with swivel wheel at rear for easy steering. This may be locked into position for straight forward dollying. Dolly also mounts a "baby" tripod and provides space for both the cameraman and his assistant to ride. Price of the dolly is \$300. Carrying case is \$30.00 additional.

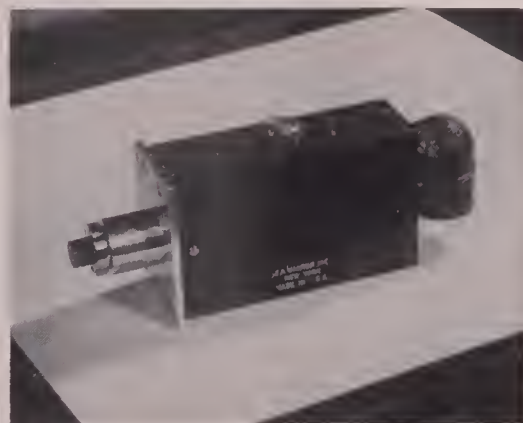

New Recording Unit — J. A. Maurer, Inc., 27-01 Thirty-first Street, Long Island City, New York, announces a new negative-positive dual track Model F prime recording optical system. The new component combines in a single



unit positive or negative recording in a dual bilateral variable area sound track. Variable density is available to meet specific requirements and laboratory facilities. It can be installed in any film recorder or single-system sound camera. Price is \$1,950, including three 90-B pre-focused exposure lamps. The company offers liberal trade-in allowance on earlier Model F prime units.

Split-reels — Florman & Babb, 70 West 45th Street, New York 19, N. Y., offer a complete line of split reels for 16mm motion picture film, which permits projecting film on cores without the necessity of rewinding to reels. You simply open the split reel, insert the film on core, and close the reel. Prices of reels range from \$4.50 for 400-ft. size to \$9.00 for the 1600-ft. size.

Glare Softener — Crescent Portrait & Frame Co., 14068 Euclid Ave., Cleveland 12, Ohio, offers a glare-softening coating material designed to help the TV cameraman and motion picture photographer to get better pictures of bright and shiny objects. The product, known as Crescent Matton, is available in easy-to-use, self-spraying aerosol containers. Formulated from the same acrylic materials used to manufacture many of the modern plastics, Matton is ideal for toning down glossy or bright objects or surfaces of products being photographed for TV film commercials. A 12 oz. container sells for about \$2.25.

(Continued on Page 120)

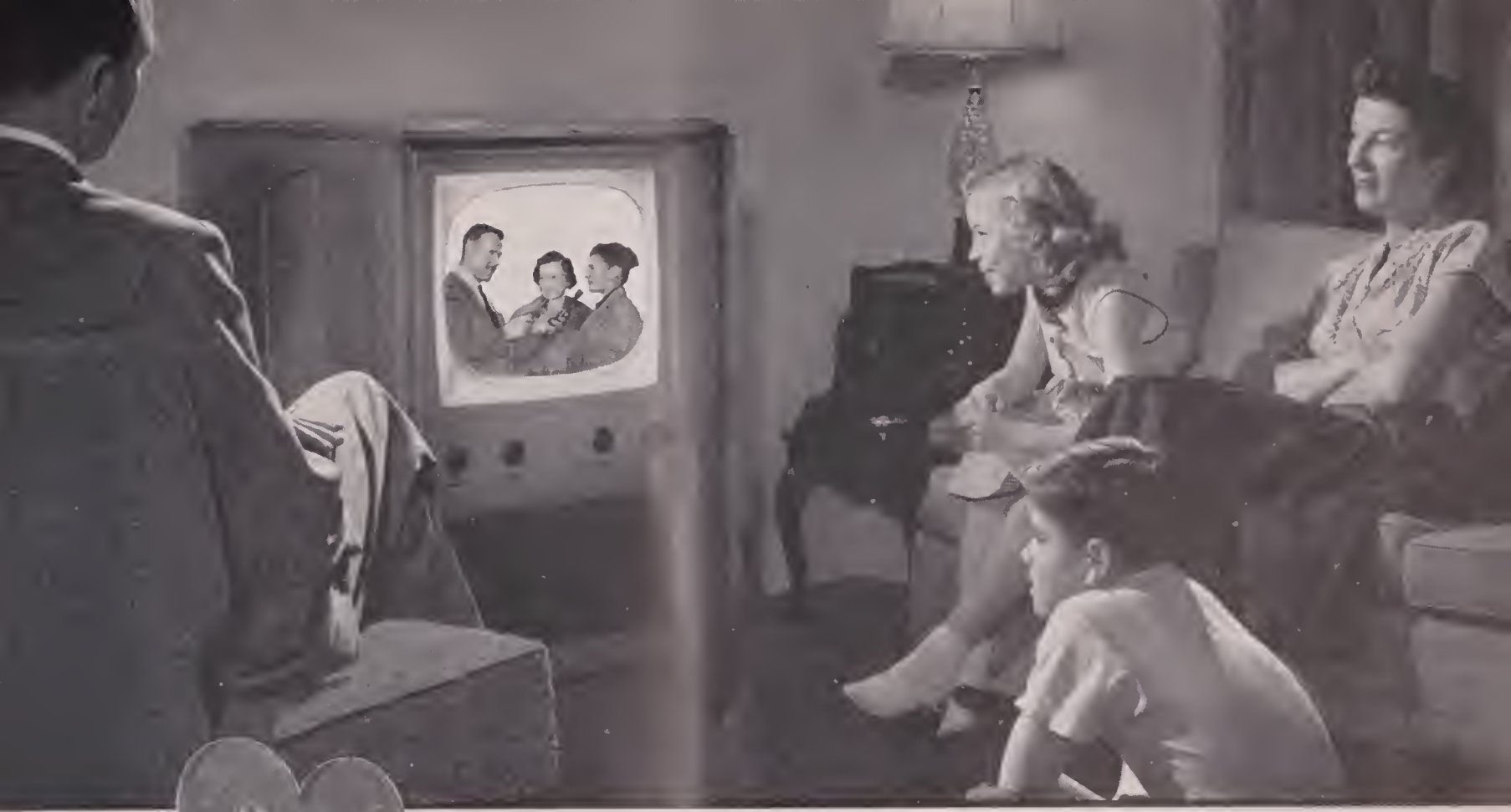

"Street Corner U.S.A." with Clete Roberts



...filmed for Television with the AURICON
"Super 1200" 16mm Sound-On-Film Camera

Again, for the 4th consecutive year, Mr. Clete Roberts uses Auricon 16mm Sound Cameras to shoot his latest national television show "Street Corner U.S.A."

On this National TV Poll, viewers can see and hear public opinion on the most interesting and provocative subjects in America today.

Clete Roberts, Commentator-Reporter, says... "Our Cameramen have shot over one million feet of Auricon 16mm Sound-On-Film and have used virtually every foot of film taken with our Auricon Cameras!"

Write for your Auricon Catalog, describing the "Super 1200"...a superb photographic instrument, sold with a 30 day money-back guarantee. You must be satisfied!

Shown at right of "Super 1200" is Clete Roberts, Commentator-Reporter for "Street Corner U.S.A." Operating the Auricon "Super 1200" 16mm Single System Sound Camera is Charles "Chuck" Short, I.A.T.S.E. Cameraman.

AURICON

BERNDT-BACH, INC.

7381 Beverly Blvd., Los Angeles 36, Calif.

Auricon
Hollywood
Line

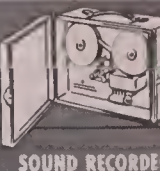
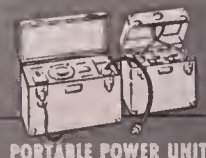
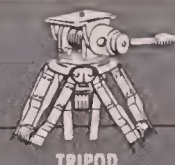
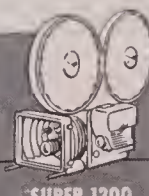

"Lights"
"Camera"
"Action"

and PROCESSED BY
MOVIELAB

FOR THE FINEST FILM PROCESSING **IN
THE EAST** — FILM MEN WHO KNOW
SAY **"IT'S MOVIELAB"**

Here—at MOVIELAB . . . efficiency and perfection are the rule. Producers, directors and technicians have at their fingertips the very best in up-to-the-minute equipment necessary to modern FILM PROCESSING techniques.

ROUND THE CLOCK SERVICES

- Negative Developing • First Print Department
- Ultra Violet & Flash Patch Track Printing
- 16mm & 35mm Release Printing
- Quality Control • Title Department
- 22 Cutting & Editing Rooms.

FOR COLOR

it's

Rainbowlab Inc.



MOVIELAB FILM LABORATORIES, INC.

619 West 54th Street, New York 19, N. Y. JUdson 6-0360

WHAT'S NEW

(Continued from Page 118)

ColorTran Dual Converter—Natural Lighting Corp., 612 West Elk Ave., Glendale, Calif., announces as an addition to its ColorTran Converter line a new unit known as the Dual Converter. This unit handles the input power from two separate 115-volt circuits so that a total wattage of 3000 is available to produce more illumination than a single line allows.

The ColorTran "steps" this quantity



up to produce the equivalent of 7000 watts of photographic color light. The new unit has color temperature adjustments for all types of color film and is equipped with separate ammeters and fuses for each circuit, so the load may be balanced. Price of the Dual Converter is \$197.50. Deliveries begin in April.

Continuous Projector—Triangle Continuous Daylight Motion Picture Projector Company, Skokie, Ill., announces a new portable equipment for the continuous showing of 16mm sound films. The unit, which is both projector and screen, will show up to 1600 feet of film (44 minutes) on a 13 x 18 inch screen by rear projection.

Completely self-contained and similar to a television set in appearance, it will repeat a film continuously for up to 200 hours with no rewinding. Or, by means of an automatic stop at the end of the film, it may be set to run only once and repeated by pushing a button.

Further details and price may be had by writing to the manufacturer and mentioning *American Cinematographer* magazine.

Magnasync Stereo Sound—Concluding several months of engineering and planning, Magnasync Manufacturing Company, North Hollywood, Calif., announces a new series CinemaScope stereophonic sound reproduction equipment in complete theatre packages ranging in price from \$2,757 to \$3,591.50. Accord-

(Continued on Page 156)

PROCESSING
is
PROFITABLE

with
Houston-Fearless
Equipment

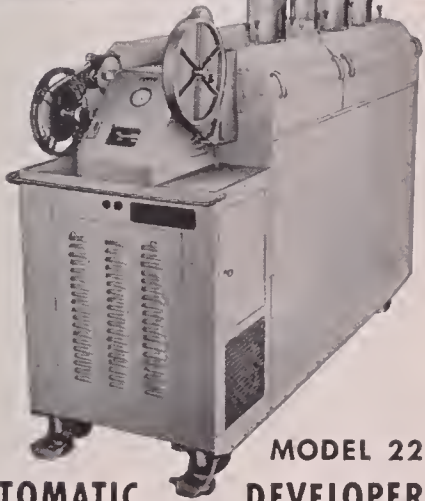

MODEL 22
AUTOMATIC DEVELOPER

Model 22 is a portable developing machine for 16mm black and white, negative, positive or reversal film. Operates in daylight. Capacity up to 60 feet per minute. Self contained, entirely automatic, easy to operate. Complete refrigeration, re-circulating systems, air compressor and positive temperature controls. Moderately priced.

Today's demand for faster, better, more dependable processing presents an excellent opportunity for local laboratories in every community. Houston-Fearless equipment, standard of the motion picture industry in Hollywood and throughout the world for 24 years, makes it possible for you to offer processing service in your locality that is days and weeks ahead of "out of town" schedules. Houston-Fearless processing machines handle the entire job from camera to screen with each step under fully automatic control. Quality of work is unsurpassed. Take advantage of the need for this service in your community. Write for information on your requirements.

- DEVELOPING MACHINES • PRINTERS • COLOR DEVELOPERS
- COLOR PRINTERS • CRANES • DOLLIES • TRIPODS • FRICTION HEADS

The
HOUSTON
FEARLESS
Corporation

11809 W. OLYMPIC BLVD • LOS ANGELES 64, CALIF.

*"World's largest manufacturer of
motion picture processing equipment"*

ARRIFLEX

35mm
Model 11

**A TRULY GREAT
CAMERA**

for TV, Newsreel
and commercial
films

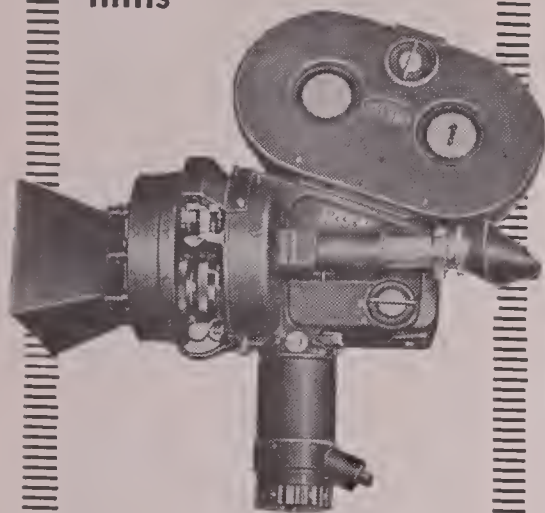

For tough and trying assignments, ARRIFLEX 35 is in a class by itself. Reflex focusing through photographing lens while camera is operating—this is just one outstanding ARRIFLEX feature.

Equipped with bright, right-side-up image finder, $6\frac{1}{2} \times$ magnification. Solves all parallax problems. 3 lens turret. Variable speed motor built into handle operates from lightweight battery. Tachometer registering from 0 to 50 frames per second. Compact, lightweight for either tripod or hand-held filming. Takes 200' or 400' magazine. Write for free folder.

COMPLETE REPAIR FACILITIES

FRANK C. ZUCKER
CAMERA EQUIPMENT CO.
1600 BROADWAY NEW YORK CITY

CLOSEUPS

Notes and
editorial comment

Last month, Paramount Studios officially christened its new compatible system of photography and optical printing, which involves the use of its new "Lazy 8" camera, described in our December, 1953, issue (Pg. 588). The new official name? VistaVision—with a capital "V" in the middle.

With variable expander lenses such as the Tushinsky—which Paramount recommends—VistaVision films can be screened in any theatre of any size in the world. Unlike CinemaScope, with its long, narrow picture format, VistaVision stresses maximum screen height and width. This makes Paramount films adaptable to every theatre in the world, a studio executive has pointed out.

VistaVision begins with the photography by means of the studio's new Lazy-8 camera in which the negative travels horizontally instead of vertically, as with other motion picture cameras. Each frame is twice the area of that of conventional 35mm cameras, i.e., 8 sprocket holes in length. This gives a large negative image which is optically reduced in printing down to the release print, thus reducing grain size—an important factor with color films.

The Lazy-8 cameras, while developed by Paramount, are available to other studios. The company has furnished all major camera manufacturers with complete details, so that any company or individual wishing to acquire one need only place an order, and wait for it to be made up.

The studio stressed that "Paramount has no financial interest, directly or indirectly, in the collection of royalties or in any manufacturing profits that may come from any of the products that may be used by this system."

The studio demonstration, which compared the standard screen size and the standard aspect ratios to the new dimensions, was made on a screen 62 feet long and 35 feet high, said to be the biggest theatre screen in the world.

A sidelight of the demonstration, incidentally, was the new Technicolor process for manufacturing improved release prints which made its bow simultaneously with the screening of scenes from Paramount's first two VistaVision releases—"White Christmas" and "The Big Top." The new dye transfer process was first announced by Technicolor Corporation last October.

During the past ten years, Eastman Kodak Company has been quietly developing a new motion picture negative stock that is faster than any negative yet created.

In recent weeks, five of the major studios in Hollywood have been given a supply of this negative to test. The results have been startling.

Trade-named *Try-X*, the new stock is a successor to *Plus-X*—the film that has given such excellent results in the studios for years. The fastest negative yet made, it requires less light without inducing perceptible grain. Eastman has been exhibiting an 800 foot test reel of the film which was photographed in the New York subway without the aid of supplemental light. The result is one of the most astonishing jobs of black-and-white photography ever seen.

The new film stock will now enable cinematographers to photograph exterior scenes early in the morning or late in the afternoon—in other words, genuine dusk, dawn, and night shots with pictorial realism never before attained with other film stocks and the employment of supplemental lighting and filters.

Perhaps its biggest value will be to producers of television films, where speedy shooting and great economy of production is essential to success. Its use should enable such producers now to include in their TV pictures exteriors they have never before been able to attempt.

At the same time, *Try-X* was introduced, Eastman Kodak Company also introduced its remarkable new fast professional sheet film—Kodak Royal Pan—which is twice as fast as any previous films of this type, and certain to be a boon to press and professional still photographers.

★

New lenses continue to command the attention of studio engineers in Hollywood, while 20th Century-Fox pursues its campaign for extended use of CinemaScope with stereophonic sound.

Several weeks ago, Joseph and Irving Tushinsky, developers of an anamorphic lens system which bears their name, demonstrated the Tushinsky Process of Variable Anamorphic Photography and Projection at the RKO-Radio studios in Hollywood for members of the Society of Motion Picture and Television En-

(Continued on Page 156)

The New
Revolutionary

ARRIFLEX 16

®

The Only 16mm Camera with
MIRROR REFLEX SHUTTER
for Continuous Thru-the-Lens
Focusing and Viewing.

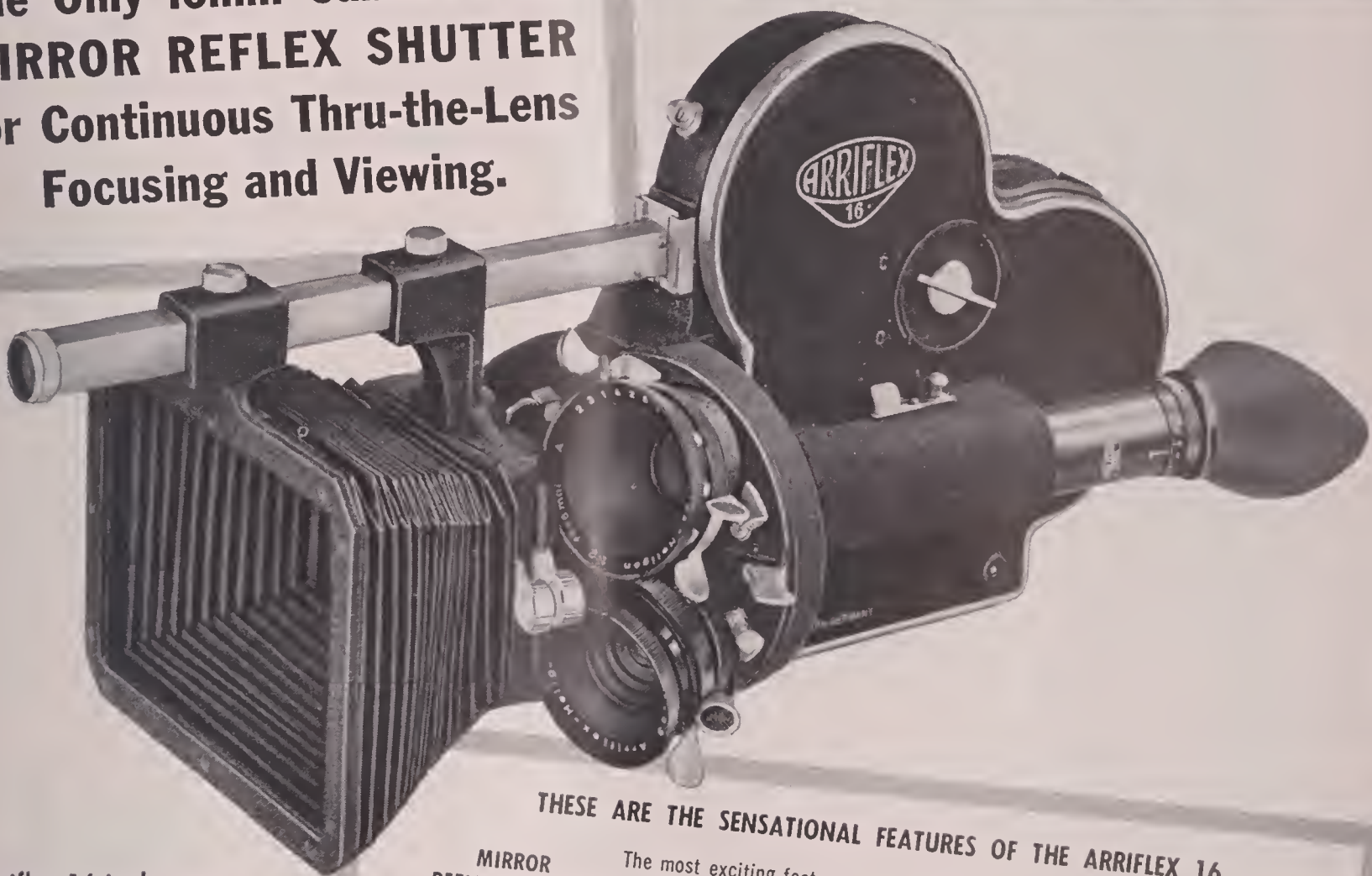

THESE ARE THE SENSATIONAL FEATURES OF THE ARRIFLEX 16

MIRROR REFLEX SHUTTER

The most exciting feature of them all: for accurate framing and critical follow-focus, through the taking lens, even during the actual shooting. Image on ground glass is brilliant, uninverted and right-side-up, magnified 10x through a highly corrected optical system. No parallax, and no need for accessory finders.

REGISTRATION PIN

Found only in cameras selling for \$3000 or more. Automatically engages and locks film during exposure. Assures absolute frame registration, and picture steadiness.

ELECTRIC MOTOR DRIVE

No need to stop a scene to wind a spring. Has variable-speed 6-volt DC motor with rechargeable battery pack, dry cell batteries, or with Transformer-Rectifier Unit on 115 volts AC. Easily interchangeable with Synchronous Motor Unit (available as accessory).

DIVERGENT 3-LENS TURRET

Accommodates lenses from 11.5mm extreme wide angle to longest telephotos. Lenses quickly interchangeable. Wide angle and 300mm telephoto can be mounted simultaneously without mechanical or optical interference.

OTHER ARRIFLEX PROFESSIONAL FEATURES

FOOTAGE & FRAME COUNTERS — for forward and reverse action.

TACHOMETER — indicates speeds from 1 to 50 frames-per-second.

CONTOUR GRIP — provides a natural and firm grip for handheld shooting.

DETACHABLE NECKSTRAP — for handheld filming.

LIGHTWEIGHT — camera with Matte Box weighs only 7½ pounds.

FILM CAPACITY — 50 and 100-foot standard daylight spools.

400-FOOT MAGAZINE — accommodates External Film Magazine. (This accessory will be available at a later date.)

DETACHABLE MATTE BOX-FILTER HOLDER — has stationary and rotating filter stages for color filters, polarizing filters, fades, dissolves, and other effects.

SINGLE SPROCKET DRIVE — for either silent or sound-perforated film.

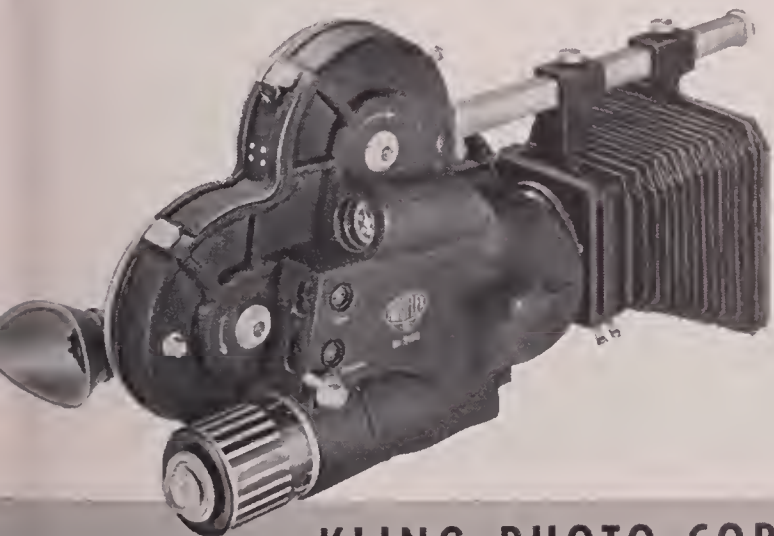

KLING PHOTO CORPORATION

235 Fourth Ave., New York 3, N. Y. • GRamercy 5-1120
7303 Melrose Ave., Hollywood 46, Calif. • WYoming 9026

**SHARPER,
BRIGHTER,
CLEARER
IMAGES**

with...

• **2-D**

• **3-D**

•  **CINEMASCOPE**

• **TV**

BALTAR

Brilliant images, thrillingly detailed—they're yours *for sure* with Bausch & Lomb Baltar lenses on your camera. For finest images on film: complete line of Baltar 35mm and 16mm movie lenses—for 2-D, 3-D and CinemaScope. For finest TV images: Television Baltar lenses, for studio and portable cameras. Order from your professional camera manufacturer.



BAUSCH & LOMB

SINCE



1853

Great equipment makes great cameramen

BALANCED TRIPOD HEAD
and
PROFESSIONAL JUNIOR TRIPOD
are the standbys of the masters



New "BALANCED" TV head — MODEL "C"
 —for the world's smoothest pan and tilt action.

You'll never hear Fritz Kreisler playing on a scratchy fiddle . . . or Louis Armstrong on a \$7 trumpet. Good craftsmen need good tools.

Camera Equipment Company makes, sells, services and rents the world's finest quality TV and Motion Picture Equipment.



SYNCHRONOUS MOTOR DRIVE — 110 Volt AC — Single phase, 60 Cycle. Runs in perfect synchronization with either 16mm or 35mm Sound Recorders. Mounting platform permits removal of magazine while camera remains mounted on motor. Spring steel drive fin coupling prevents damage if film jam occurs.

Knurled knob on armature permits rotating for threading. "On-Off" switch in base. Platform base threaded for 1/4" or 3/8" tripod tie-down screw. Rubber covered power cable with plugs included.

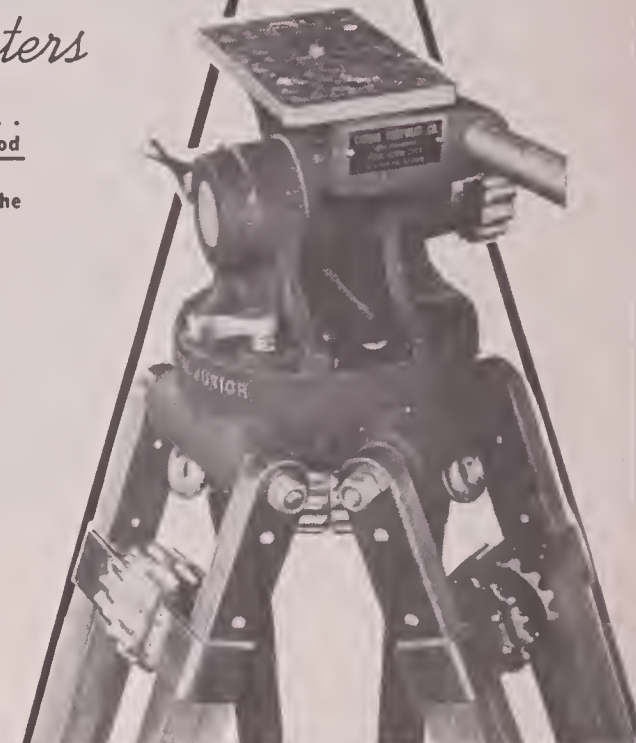

More professional cameramen use The PROFESSIONAL JUNIOR Tripod than any other tripod in the world.

Let's face it. You need a first class tripod to make better pictures. PROFESSIONAL JUNIOR has the rigidity, the range, and the ease of operation that better pictures demand. See it—try this tripod beauty—and you'll never be without it. PROFESSIONAL JUNIOR TRIPOD—Friction Type. Handles all 16mm cameras, with or without motor. Also 35mm DeVry, B & H Eyemo with and without motor, and 400' magazines. Tripod base interchangeable with Professional Junior gear drive head. "Baby" tripod base and "Hi-Hat" base available.

No more groping for center of gravity. The new Model C "Balanced" Tripod Head is equipped with a convenient, accessible positioning handle mounted below the top plate, which allows the operator to reposition the camera to the correct center of gravity. No matter what focal length lens is used on the camera turret, the camera can be balanced on the Model C Head without loosening the camera tie-down screw.

It has all the features which have made the "Balanced" head a gem of engineering ingenuity—quick release pan handle, tilt-tension adjustment to suit your preference. It's a Cameraman's dream!

FRANK C. ZUCKER

CAMERA EQUIPMENT CO.
 1600 BROADWAY NEW YORK CITY

SALES • SERVICE • RENTALS — CAMERAS * MOVIOLAS * DOLLIES

Complete line of 35mm and 16mm equipment available for rental.

MITCHELL: Standard, Hi-Speed, BNC, NC, 16mm

BELL & HOWELL: Standard, Shiftover, Eyemo

ARRIFLEX: 35mm and 16mm

MAURER: 16mm Cameras

MOVIOLA: Editing machines, Synchronizers

We design and manufacture Lens Mounts and camera equipment for 16mm—35mm and TV cameras.



VARIABLE SPEED MOTOR — 110 Volt AC/DC with Tachometer for EK Cine Special Motor drive your Cine Special with confidence! Tachometer is mounted in clear view of operator. Calibrated from 8 to 64 frames per second. Definite RED marking for 24 fps. Electrical governor adjusts speeds. Steady operation at all speeds. No adapters needed. Motor coupling attaches to camera and couples to motor. Spring steel drive arm shears if film jam occurs. Easily replaced.

We calibrate lenses—Precision "T" Stop Calibration of all type lenses, any focal length. Our method is approved by Motion Picture Industry and Standard Committee of SMPTE. For proper exposure density, it is important that you have your lens "T" stop calibrated. Lenses coated for photography. Special TV coating. Rapid service.

Hollywood Bulletin Board



TWO PRESIDENTS AND A VEEP—Following the dinner meeting of the American Society of Cinematographers in Hollywood last month, honored guests of the evening, Earl J. Hudson (L), Vice-president of ABC in charge of West Coast operations and William J. German (R), president of W. J. German, Inc., chat with ASC President Arthur Edeson.

Frank Planer, ASC, is directing the first unit photography of Walt Disney's "20,000 Leagues Under The Sea." The underwater photography is being done by Til Gabbani, the cameraman who also shot the memorable underwater sequences for Fox's "The Frogmen."

Tom Tutwiler, ASC, has been signed by Paramount Studios to shoot the air unit photography for "Strategic Air Command," which sequences are to be directed by veteran airman Paul Mantz.

William Daniels, ASC, will direct the first unit photography on the production, which is to be filmed in Eastman Color with Paramount's new VistaVision cameras.

Harry Stradling, ASC, is enroute to Italy where he will direct the photography of Warner Brothers' "Helen Of Troy."

Harold Wellman, ASC, is photographing a one-hour television film series

in color for the Bell Telephone Company. Title of series is "Mr. Sun," which is being produced and directed by Frank Capra.

Warren Lynch, ASC, is currently shooting a series of television sports films for Sportsvision, Hollywood.

Walter Streng, ASC, one of the first cinematographers in the television film industry, is currently directing the photography of three TV film series at Hal Roach Studios for Roland Reed Productions: "My Little Margie," "Rocky Jones, Space Ranger," and "Waterfront."

Because photography is such an important factor in television films, it is logical that Phil Tannura, ASC, who shoots the "Burns and Allen" TV films, should share in the honor recently bestowed upon the Burns and Allen company by the National Association for Better Radio and Television. The citation, awarded February 8, 1954, states: "We are very happy to inform you that your program has been voted by the members of this Association as the outstanding comedy program on television for the year 1953."

Walt Disney studio engineers have designed a new expander finder lens for use on Mitchell cameras using Cinema-Scope-type lenses. New finder element, which fits on the direct through-the-camera finder, enables the cameraman to see the exact area taken in by the anamorphic lens on the camera.



PHIL TANNURA (R), recently elected to Board of Directors of the American Society of Cinematographers, is briefed on Board procedure by Arthur Miller, ASC 2nd Vice-President.



DONALD E. HYNDMAN, salesmanager of Eastman Kodak Company's motion picture film department in Rochester, and new ASC associate member, chats with John W. Boyle ASC at Society's recent dinner.

Everybody, Everywhere Knows KINEVOX!



THIS LETTER OF INQUIRY from South Africa, with its incomplete address, nevertheless was delivered to us promptly by the U. S. Postoffice Department.

KINEVOX, just as promptly will deliver your order for Magnetic Recording Equipment, no matter where you are located.

Descriptive Catalog of Complete Kinevox Magnetic Recording Equipment Available on Request

Licensed under R.C.A., Western Electric, Armour Research Foundation and Kinevox Patents.

KINEVOX BUILDING
116 SO. HOLLYWOOD WAY
TELEPHONE: ROCKWELL 9-3291
ROME • BOMBAY

KINEVOX

I N C O R P O R A T E D
NEW YORK

BURBANK
CALIFORNIA
CABLE: Kinevox, Burbank
RIO DE JANEIRO • CANADA

SEEING IS BELIEVING!



FAMOUS "FIRSTS"...

50 YEARS AGO, "THE GREAT TRAIN ROBBERY" ATTEMPTED THE FIRST COMPLETE, DRAMATIC FILM STORY. TO THE ENTERTAINMENT WORLD, A FLEDGLING GIANT WAS BORN.

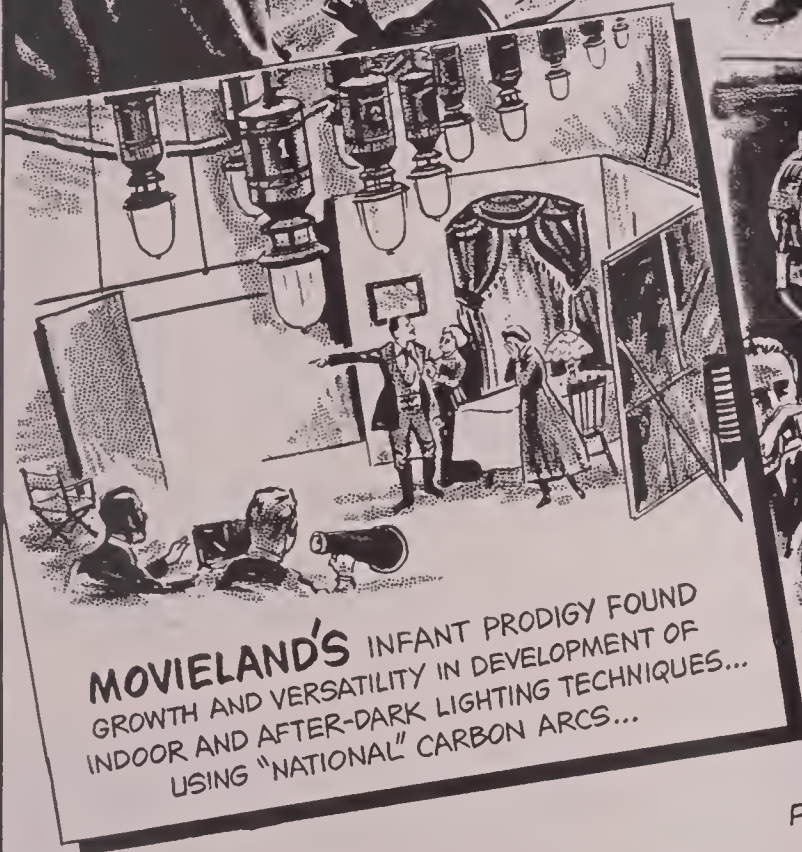

MOVIELAND'S INFANT PRODIGY FOUND GROWTH AND VERSATILITY IN DEVELOPMENT OF INDOOR AND AFTER-DARK LIGHTING TECHNIQUES... USING "NATIONAL" CARBON ARCS...



TODAY...IMPROVED "NATIONAL" CARBONS CONTINUE TO PAY OFF IN DEEP SET PENETRATION, BROAD COVERAGE, SHARP SHADOWS AND COOL BRILLIANCE.

THE "NATIONAL" CARBON ARC...NOTHING BRIGHTER UNDER THE SUN

The term "National" is a registered trade-mark of Union Carbide and Carbon Corporation

NATIONAL CARBON COMPANY

A Division of Union Carbide and Carbon Corporation, 30 East 42nd Street, New York 17, New York

District Sales Offices: Atlanta, Chicago, Dallas, Kansas City, New York, Pittsburgh, San Francisco

IN CANADA: National Carbon Limited, Montreal, Toronto, Winnipeg



FOR ANY SERIOUS cinematography it is highly important to know that the camera lens is accurately focused without having to take a photograph. Exceptionally rough handling or extreme temperature conditions may shift the lens with respect to the film and hence make inaccurate the normal focusing scale.

The Camera Focus Autocollimator enables the camera operator to carry, as an entirely self-contained and self-checking unit, an instrument to set the checking lens in a focus at infinity. The instrument provides an infinitely distant image of an illuminated reticle which can be picked up by the camera and focused on the film plane, thus establishing a true infinity focus. Any error then in the focusing can be eliminated by correcting the fiducial mark.

The whole instrument consists of two systems built in one body, 1) the projector system or collimator and 2) the viewing system or telescope.

Illumination is supplied by a standard-type commercial flashlight mounted adjustably along the body. Light from the bulb is condensed and reflected at right angles to illuminate a reticle. This reticle is in a reflected focal plane of the objective, the reflection being by means of a semi-transparent mirror mounted in the center of the main tube at 45° to its axis. Thus, an image at infinity is formed by the objective, and collimated beams emerge from the instrument. If the camera is now put in front of the instrument, an image of the reticle will be formed in the focal plane of the lens; by moving the lens with respect to the film plane this image can be sharply focused on the film plane.

The objective collects light reflected from the film plane back through the camera lens and forms an image beyond the semi-transparent mirror. This image is seen in the telescope eyepiece, which is focused on a reticle in the focal plane of the objective. When the image from the film plane also appears sharply focused, the film plane is in the focal plane of the camera lens.

The Taylor-Hobson Camera Focus Autocollimator is precisely adjusted in manufacture, and its rigid construction insures that adjustment is maintained permanently. However, if it should be deemed necessary at any time to verify

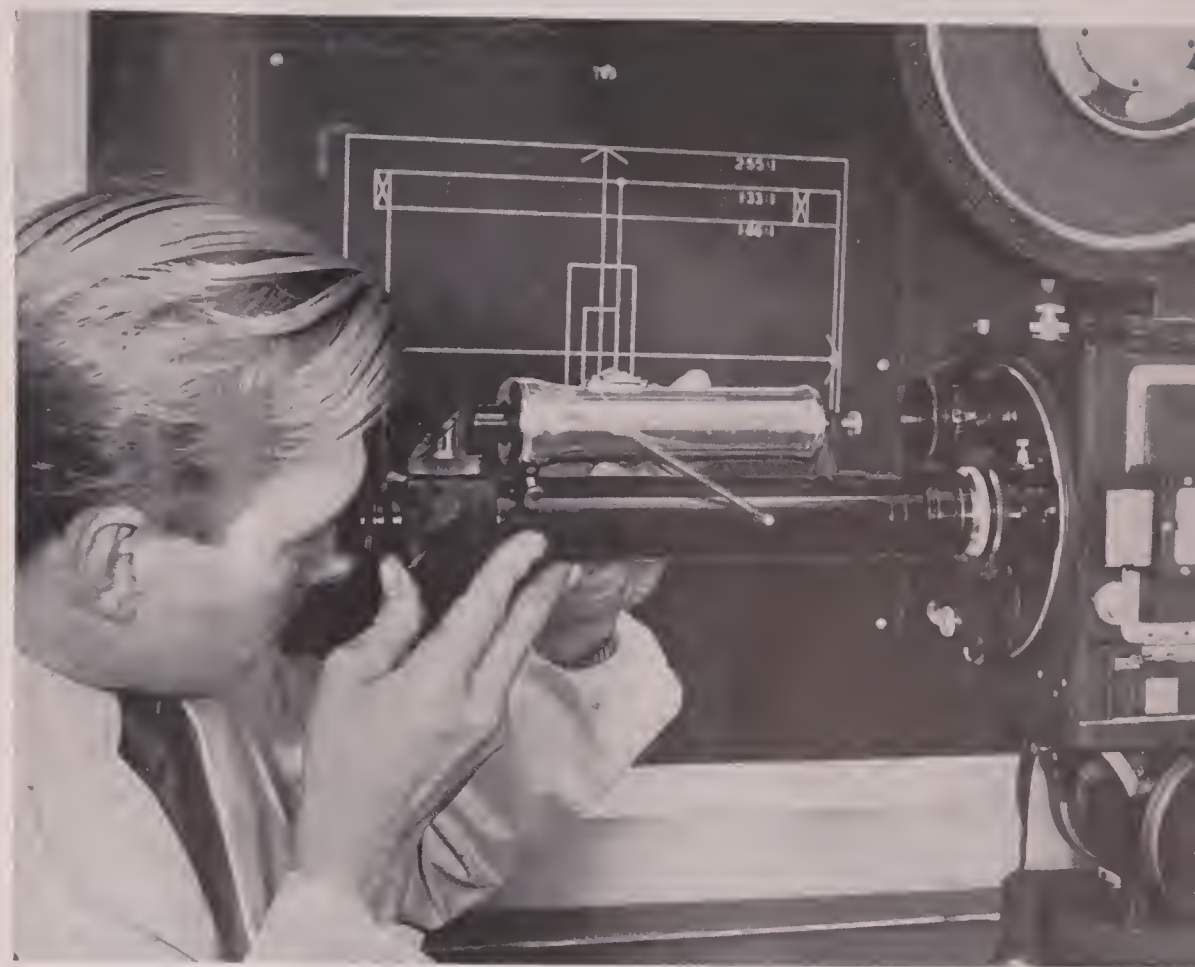

Taylor-Hobson camera focus autocollimator.

A New Instrument For Checking The Focus Of Camera-mounted Lenses

**Taylor-Hobson Camera Focus Autocollimator
enables cameraman to verify focus of lenses
without shooting test strips**

that the adjustment is correct, this can be done easily. The instrument is placed on a convenient support and directed towards a distant object (at least two miles away). The eyepiece is focused on the reticle and it is checked that the plane of the latter coincides with the plane of focus of the distant object. This verifies telescope focus.

The flashlight is now removed, the knurled ring on the side mirror box is unscrewed, and the mirror box also removed. This exposes the side reticle. The eyepiece is unscrewed, placed over

the side reticle and focused on it. It is then checked that the plane of the latter coincides with the reflected plane of focus of the distant object. This verifies collimator focus. No further checks being necessary, the eyepiece is replaced, the mirror box and flashlight re-assembled, and the latter re-adjusted for maximum illumination.

With standard 1/2-inch (X20) eyepiece and the instrument focused on film emulsion, the Camera Focus Autocollimator is suitable for checking

(Continued on Page 153)

Shooting A Newsreel-type Production In Color

There could be no retakes. We had to get the scene right the first time, every time

By RALPH W. LUCE
Pearson & Luce Productions



FOLLOWING the FCC's recent approval of color television, our company, like most other TV and industrial film producers, looks forward with interest to the day when television films and TV commercials are shot entirely in color. We see this transition from black-and-white to color encompassing especially the filming of all news, sports and special events.

We were fortunate recently to undertake our first assignment of this type when we photographed in color for the Berkeley (Calif.) Junior Chamber of Commerce its annual Football Festival. The pattern of photography was essentially newsreel procedure; there could be no retakes and we had to carefully plan our shooting so as to get all the important action on film, and get it right the first time.

The Festival is an annual week-long celebration, beginning with the arrival of girls representing the major universities of the United States and Canada. These girls are Campus Queens of their colleges, and one of them was destined to be chosen "Miss Football of 1953."

As would be expected, there are many interesting events during the Festival, and our problem was to make an entertaining film, showing the highlights of the Festival in color and sound. Since there was only a limited budget available, we continually had to compromise

(Continued on Page 148)

FILMING the "Parade of Lights," a key event in the Berkeley Chamber of Commerce 1953 Football Festival. On parallel is author's cameraman behind the Auricon "1200" camera. Another cameraman below uses hand-held Arriflex 16 camera for closeups and reaction shots. 5KW spots furnished illumination.

COMMERCIAL!

The one that's
never announced---

Always obvious---

“And now---

a word about films---

color or black and white---

negatives and positives---

Best for Television

Best for you

Best for us!

EASTMAN””

W. J. GERMAN, INC.

FORT LEE

CHICAGO

LOS ANGELES



“OSCAR”

Annual achievement award of the Academy of Motion Picture Arts and Sciences

1953 NOMINEES

For Achievement Awards In Cinematography

to all directors of photography in the industry.

In addition to the two pictures of his own filming which he may nominate, each director of photography at his own discretion may also nominate any one eligible black-and-white and one eligible color foreign production which he deems worthy of Academy consideration. Thus, many foreign-made films have a chance to compete with Hollywood productions for the Academy's cinematographic awards. Films are considered eligible for the Academy's consideration when they have been exhibited publicly in Los Angeles in a consecutive run of not less than one week, after an opening prior to midnight December 31st.

On receipt of the preliminary ballot, which contains the names of all the films

entered by the various directors of photography, each man then votes for ten (or less) productions in each classification, in the order of his preference. When the Academy tabulates the votes, the twenty productions receiving the greatest number of votes are then screened by the Academy to give all directors of photography opportunity to evaluate them under uniform screen conditions.

Following these screenings, which are spread over a period of two weeks, a nomination ballot listing the ten black-and-white and ten color productions is mailed to all directors of photography with instructions to vote for five in each class which they consider best, listing them in order of preference. Following

(Continued on Page 145)

TEN HOLLYWOOD directors of photography and one of France are contenders this year to receive the annual awards of the Academy of Motion Picture Arts and Sciences for the best cinematography of 1953. Their names and the titles of the productions they photographed appear at right.

While it is the productions themselves that are voted upon by the Academy members for the cinematographic and other awards, it is the directors of photography to whom the awards for photography are made at the annual presentation ceremonies in Hollywood.

The selection of eligible films for the Academy's annual awards for photography begins with the cinematographers themselves. The first of January, each director of photography in the Hollywood motion picture industry is invited to nominate one black-and-white and one color feature production on which he has received sole or joint screen credit. Titles of these films are then included in a preliminary ballot, which is then sent

Nominees For Best Achievement In Cinematography For 1953

BLACK-AND-WHITE

Joseph C. Brun, A.S.C.
"Martin Luther" (deRochemont)

Burnett Guffey, A.S.C.
"From Here To Eternity" (Col.)

Hal Mohr, A.S.C.
"The Four Poster" (Kramer-Col.)

Frank F. Planer, A.S.C.
Henry Alekan
"Roman Holiday" (Para.)

Joseph Ruttenberg, A.S.C.
"Julius Caesar" (MGM)

COLOR

Edward Cronjager, A.S.C.
"Beneath The Twelve-Mile Reef" (Fox)

George Folsey, A.S.C.
"All The Brothers Were Valiant" (MGM)

Loyal Griggs, A.S.C.
"Shane" (Para.)

Robert Planck, A.S.C.
"Lili" (MGM)

Leon Shamroy, A.S.C.
"The Robe" (Fox)

DEDICATED TO BETTER PERFORMANCE



COLLAPSIBLE 3-WHEEL DOLLY

For motion picture and TV cameras. Sturdy cast aluminum. For standard or baby tripods. Additional baby tripod point holders to control spread of tripod legs. Adjustable spring seat. Extra wide rubber wheels. Bronze tie down clamps and other features.

For studio or location. Folds into one compact unit. Can be used with professional or semi-professional tripods.

'HYDROLLY'

TV OR
CAMERA DOLLY

The advanced dolly for instant moveability — streamlined, lightweight, exceptionally sturdy. Nothing to get out of order. Many new advantages for easy operation. Hydraulic lift type for fast upward and downward motion of TV and motion picture cameras.

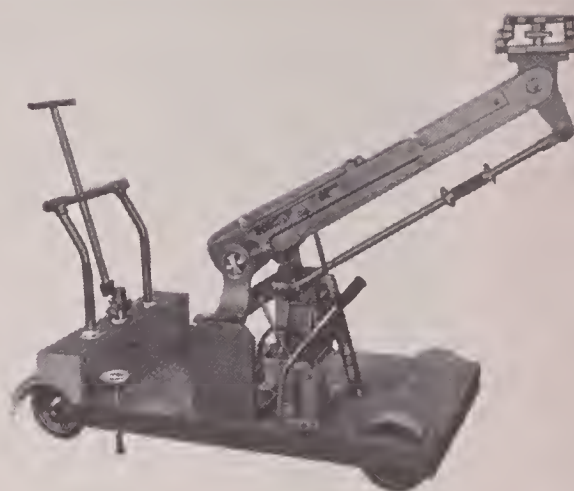

Swivel seat. Adjustable leveling head. Seat for assistant. In-line wheels for track use. Steering wheel, rigid floor locks. Hand pump or combination hand and motor pump. Easily transported in a station wagon. Fits through a 28" door.



Synchro-film-ed Synchronizer

Our Exclusive Distributor
NEUMADE PRODUCTS CORP.

Any combination of 16mm and/or 35mm sprockets assembled to specification. Cast aluminum. Foot linear type, adjustable frame dial. Fast finger roller release. Contact rollers adjusted individually for positive film contact. Sprocket shaft slip lock, foot-age counter, etc.

RENTALS

SALES • REPAIRS • SERVICE

LENS COATING

"T" STOP CALIBRATION

DESIGNING and MANUFACTURING

lens mounts & camera equipt.
for 16mm, 35mm, TV cameras.

BAUSCH & LOMB "BALTAR"
LENSES and others

for motion picture, TV camer-
as. 15mm to 40" focal length.

COMPLETE LINE OF: 16mm, 35mm
cameras, dollies, synchronizers,
animation stands, cutting room
and time lapse equipment.

BELL & HOWELL: Standard, Eye-
mos, Filmos. MITCHELL: Standard,
Hi-speed, BNC, NC, 16mm.

SEND FOR CATALOGUE

Synchro-film- Slate

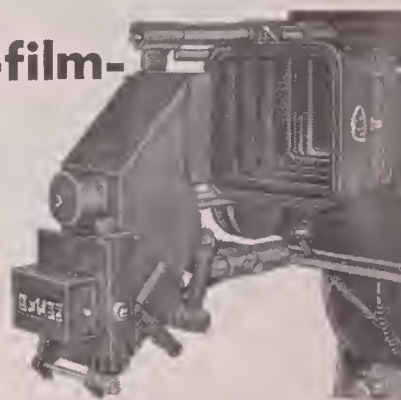

Pays for itself
in production
savings on the
set. A New De-
velopment! Elim-
inates clap stick synch and slate on set. Mounts
on double arm bracket to work with BNC, NC,
Standard, 16mm Mitchell and all types of blimps
and Geared Head. Interlocks with Sound Recorder.



PORTABLE MICROPHONE BOOM

For Studio or on Location. Light-
weight — collapsible — for TV and
motion picture production. Sturdy
construction. Boom telescopes 7 to
17 ft. Rear handle for directional
mike control. A remote control per-
mits 360° rotation of the microphone.
Operator can push the boom and oper-

ate microphone swivel simultaneously. Extension rods make it
simple to operate microphone rotation from floor. Microphone
cable hangs outside of boom, preventing cable from tangling
with the rotation mechanism. Ball bearing casters, rigid foot
locks, pneumatic drop check for lowering the boom, etc.

VARIABLE- SPEED MOTOR with TACHOMETER

for Cine Special or Maurer Cameras

115 V. Universal Motor — AC-DC
Separate Base for Cine Special.
Variable Speed 8-64 frames.
Adapter for Maurer Camera.

INTERCHANGEABLE MOTORS: 12
volt DC Variable Speed 8-64 frames.
115 Volt AC 60 Cycles, Synchron-
ous Motor, Single Phase.

ANIMATION MOTORS: Cine Spe-
cial, Maurer, Mitchell, B & H Motors,
for Bolex and Filmo Cameras.

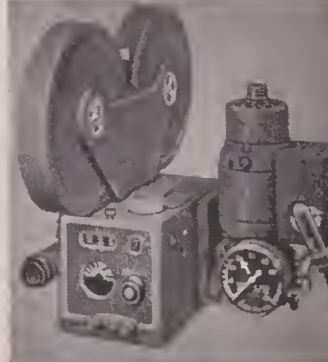



WJAC-TV's compact studio wherein its first studio-produced quiz program is filmed by cameramen Merle Agnello (left) and Andrew J. Racosky (right). In background discussing program are Robert Bo-

linger, radio producer-director; Edward Klym, television director; and quizmaster Paul Flinn. The Auricon Cine-Voice cameras are fitted with 600-ft. magazines, record both sound and picture.

Organizing A TV Film Production Unit

How WJAC-TV launched its own newsreel and special events film production department

By MERLE AGNELLO

Staff Photographer, Johnstown Tribune-Democrat and WJAC-TV

WHEN THE JOHNSTOWN (PENNA.) TRIBUNE reached its 100th year of publication in 1953, the publisher, Walter W. Krebs, decided to print a series of special anniversary editions—one each month throughout the year. He decided also to augment these special editions with a series of TV films covering graphically the same phases of community life as the newspaper series.

That's where we at WJAC-TV got into TV film production. The Tribune Publishing Company owns and operates WJAC-TV.

At first, the company employed a local free-lance cameraman, but for various reasons, this did not work out. An operation of this kind requires first a man having pictorial news-gathering experience, and, if possible, local newspaper experience.

And that's how this writer became the cinematographer for WJAC-TV—after some sixteen years activity as a newspaper and U.S. Army still photographer, and with a limited experience in motion picture photography.

The station decided to purchase its own 16mm camera equipment. The first camera acquired was a Bell & Howell 70-DL with three good lenses on the turret: a B&H 1" f/1.9, a Kern-Paillard 17mm f/2.8, and a 75mm f/2.8. For shooting single-system sound-and-pictures, an Auricon Cine-Voice camera was added with a full complement of lenses. Because newsreel filming often takes the cameramen in areas where power is not readily available, or where use of power packs can be burdensome, a transformer was added to our equipment which makes it possible to operate the Auricon camera from the current supplied by an ordinary automobile storage battery.

A Weston exposure meter, tripod, filters, two light boxes—each equipped with three sockets to take RFL-2's or PH-375 photofloods, and a measuring tape completed the equipment necessary for immediate filming. Later, another Cine-Voice camera was added to permit us more flexibility in filming a studio show requiring two-camera coverage.

In the beginning, the possibility of our doing our own film processing was investigated, but the management of WJAC-TV decided that our film volume did not yet warrant the purchase of such equipment. We located a good laboratory in nearby Pittsburgh, where we have our film processed and returned within 24 hours, and thus solved one of our biggest problems.

Last year, we used both Eastman and DuPont reversal. Because of the high emulsion speed of the DuPont 931 film, and the extraordinary fast service provided by our processing lab in Pittsburgh, we use more of this film than any other. Because of the lab's processing methods, we can expose the film on the basis of an ASA rating of 320 daylight and 250 tungsten, or 250 and 200 respectively on Weston meters.

When Eastman film is used, it is sent to a processing laboratory in Washington, D.C., offering "same day" service. If we get our film in their hands in the morning, it is

processed and mailed out to us the same night. Because of the added distance, however, there is a three-day time lapse between time we ship our film and get it back, which makes it impractical for us to use this film and lab for current news footage.

When the author was assigned to the film production department of WJAC-TV (actually, he is "loaned" to the station by the Tribune-Democrat on "detached" service, to use an Army term), his first move was to write to the various film and lighting manufacturers requesting latest data on use of film and lights in the production of television motion pictures. The most helpful information on lighting for TV films, perhaps, was supplied by a booklet issued by Eastman Kodak Company (1949) entitled "The Use of Motion Picture Film In Television."

Other sources of information were sent requests, including the Society of Motion Picture and Television Engineers, which supplied a number of pamphlets, including one written by Karl Freund, ASC, director of photography for Desilu Productions, Hollywood. In this Mr. Freund explains how he successfully met the photographic challenge of television films. "I familiarized myself with the current television publications of film manufacturers," he states. Then, Mr. Freund, who has been in motion picture photography for more than 20 years, quoted from the very same pamphlet which the author considers the best piece of literature available on lighting for TV films—the Eastman Kodak Company publication which explains why lighting contrast in TV films must not exceed a four-to-one ratio. In essence, the article explains that the iconoscope tube, which is used in telecast-

(Continued on Page 144)



FILMING a documentary on coal mining proved most challenging TV film assignment for cameramen Racosky (L) and Agnello (behind camera) shown here planning a new camera setup.



TO GET thrill shots of a Jaguar racing to and over camera, cinematographer Merle Agnello lowered himself in open manhole, shot the action with a 16mm Bell & Howell camera.



Old style shooting...

new style showing



"Law and lawless meet on the street and shoot it out." Time-honored script . . . new style, wide-angle handling—giant figures, cause-and-effect in action, sense of depth—all in one. Made for today's projection—sound and picture—on today's wider screens. Technical problems, there are . . . problems of film selection, processing and projection . . . problems which Kodak is helping the industry solve through the facilities of the Eastman Technical Service for Motion Picture Film.

Branches are located at strategic centers, inquiries invited.

Address: Motion Picture Film Department, EASTMAN KODAK COMPANY, Rochester 4, N. Y.

East Coast Division
342 Madison Avenue
New York 17, N. Y.

Midwest Division
137 North Wobosh Avenue
Chicago 2, Illinois

West Coast Division
6706 Santa Monica Blvd.
Hollywood 38, California



A 2-B haze filter and a Polaroid filter enabled cameraman Tom Stobart to photograph the rugged mountainous terrain with remarkable clarity.

By ARTHUR L. MARBLE

Filming The Everest Climb

Cameraman Tom Stobart, veteran filmer of mountain climbing expeditions, photographed the conquering of famed Mt. Everest

A COLOR DOCUMENTARY film that has already won world-wide acclaim is "The Conquest of Everest," considered one of the finest adventure films ever made. It is a complete record of events of the English expedition that presented to Queen Elizabeth the most cherished coronation gift of all—news of man's mastery of the highest pinnacle on earth, the apex of northern India's Mount Everest.

Perhaps no subject presents greater filming problems to the cinematographer than high mountain climbing. Most of the Everest photography was the superb work of a professional, Tom Stobart. But the final awe-inspiring climax—the breath-taking panorama from man's topmost natural platform, the 29,002-foot peak—was filmed by an amateur photographer. The story behind this achievement is an epic of man's courage, brains and physical stamina.

During the past thirty years sixteen men have died in heroic attempts to scale Everest, and of the personnel of eleven expeditions that started out hopefully, only six men got within a thousand feet of the last forbidding summit.

The idea for the prize-winning documentary film began in 1951 when Eric Shipton, veteran mountaineer, returned from a scouting climb in the Himalayas. He reported a new Southern route to Everest; all the unsuccessful expeditions had approached from the North Tibetan route. With this valuable information, a new British climbing expedition was formed under the leadership of Colonel John Hunt. Soon after, a film unit was organized to record the proposed adventure.

Heading the cameramen was Tom Stobart, whose skill as a cinematographer was matched by climbing adeptness equal to any of the twelve others on the expedition. In fact, Stobart had

been official cameraman on over thirty other climbing expeditions in all quarters of the globe.

The chief cameras used to film "The Conquest of Everest" were specially-designed eight-pound 16mm units. Significant also were four Bell & Howell lightweight cameras that weighed only two and a half pounds apiece. It was one of these cameras which made possible the thrilling climactic scenes of the expedition that were filmed by an amateur cinematographer.

Special telephoto lenses were fitted to each camera, making possible clear pictures of human figures nearly a mile away.

"There are two ways that an expedition to an out-of-the-way place can be filmed," Mr. Stobart explains. "The first is via the record shot and the second is to capture the effect, both physical and emotional, that the place may

(Continued on Page 152)

MODEL SW-602
PORTABLE RECORDING SYSTEM

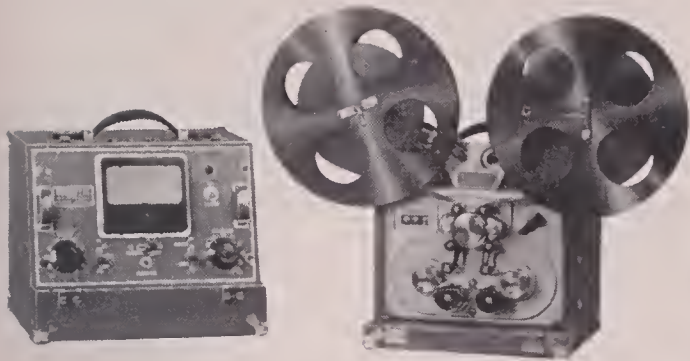

MODEL SW-602-RP
RACK-MOUNT RECORDER
IN PORTABLE CASE



MODEL SW-602-D3
THREE INTERLOCKED DUMMIES
WITH PLAYBACK PRE-AMPLIFIERS

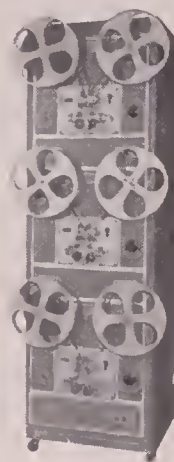

MODEL SW-335
35mm STEREOPHONIC
THEATRE
PLAYBACK SYSTEM

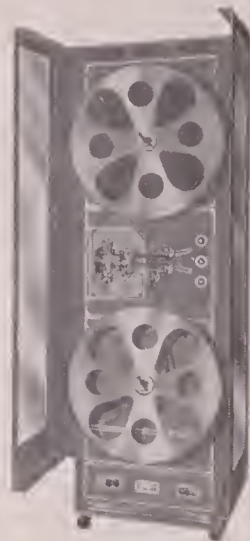

RACK-MOUNT AMPLIFIER WITH SPEAKER



EQUALIZED PLAYBACK PRE-AMPLIFIER



UNITIZED CONSTRUCTION

Designed around this famous "SYNKINETIC" film transport, all MAGNASYNC equipment is built to PERFORM.

You can depend on MAGNASYNC!

16mm CENTER TRACK 16mm EDGE TRACK
17½mm 35mm MULTI-CHANNEL



NORTH HOLLYWOOD, CALIFORNIA

Send for complete technical data

DISTRIBUTORS

MAGNETIC RECORDERS COMPANY
7120 Melrose Ave., Los Angeles 46, Calif.
WEBster 3-5545

CAMERA EQUIPMENT COMPANY
1600 Broadway, New York 19, New York
Judson 6-1420 Cable Address: CINEQUIP

ZENITH CINEMA SERVICE, INC.
3252 Foster Ave., Chicago 25, Illinois
IRving 8-2104

Manufactured by:

MAGNASYNC MFG. CO., Ltd. • P.O. Box 707, North Hollywood, Calif.

MICROPHONE MIXERS • PORTABLE SUPPLIES • SPLIT-APART REELS • BULK ERASERS

Indian Summer

By Mr. Ernst Wildi
New York City, New York

4-D

By Mr. H. G. Hawes
Augusta, Maine

Spring Has Come To He

By Mr. Stig Schubert
Helsinki, Finland

Thorndyke, The Cactus Kid

By Mr. and Mrs. Lloyd N. Sanford
San Diego, California

You And Stone Container

By Academy Film Productions
Inc.
Chicago, Illinois

Zoo Snapshots

By Mr. J. S. Frieze
London, England

S E L E C T E D F O R S C R E E N I N G A T T H E 1 9 5 4 3

Eight 16mm 3-D Films Presented Merit Filming Awards In

AMERICAN CINEMATOGRAPHER'S 3-D FILM

AMERICAN CINEMATOGRAPHER'S first 3-D Film Festival was not the biggest of film festivals, but it was, perhaps, one of the most interesting of recent film exhibitions in that it presented for the first time anywhere a collection of 16mm motion pictures made in the exciting new medium—three-dimension.

The Festival screening was held the evening of March 4th at the Clubhouse of the American Society of Cinematographers, in Hollywood.

The Festival was non-competitive and there were therefore no awards for first, second, and third place, etc.

The eight films, which are listed

above together with the names of their respective producers, represent an interesting crosssection of contemporary 16mm 3-D cinematography. The subjects range from typical short amateur-made home movies to professional productions. Of the eight films, six were photographed with Bolex 3-D camera attachments, one with the Nord stereo attachment, and one with a special twin-camera filming unit.

There are presently three systems commercially available for making 16mm 3-D motion pictures, using one camera and one strip of film. These are Bolex, Elgeet, and Nord. Stereo movies made with any one of these

systems differ in picture format from that of 3-D movies made in 35mm, which are shown in motion picture theatres.

In the Bolex, Elgeet and Nord systems, the twin pictures—that is, the right and left eye images—are on one film, side by side, instead of on two separate films as in most 35mm systems. Because of this physical arrangement, the format of the 16mm 3-D picture on the screen is different than in theatrical films. The picture has a vertical instead of the conventional horizontal rectangular picture.

This is perhaps the greatest shortcoming of the Bolex, Elgeet and Nord

This Is Your Line

By Mr. Joseph D. Price
Bartlesville, Oklahoma

This Is Progress

Raphael G. Wolff Studios
Hollywood, California

M F E S T I V A L

FESTIVAL

stereo systems. Especially today, when we are seeing more and more movies in theatres with larger aspect ratios, including the super aspect ratio of them all—CinemaScope. For many in the Festival audience, the “narrow” picture was an objectional feature.

One thing was clear, however, and that is that 16mm single-film 3-D pictures have none of the uncomfortable eye-irritating distortion inherent in so many 35mm 3-D film presentations in theatres. This is obviously because both of the stereo images are properly located on a single strip of film and therefore are never out of sync. Where two projectors and two films are used,

it is possible for one or the other film to get out of sync during projection unless there is suitable sync-monitor control in the projection system.

Another interesting observation is that 16mm 3-D films made by any of the three systems mentioned cannot be satisfactorily screened in large auditoriums to very large audiences. Here it should be remembered that all three systems were developed primarily to provide 3-D motion pictures (home movies) for essentially small family groups. However, the Festival screening demonstrated that films made with the Bolex system as well as those made with two-camera systems can be shown satisfactorily to audiences numbering up to 100, making either system ideal for production of 16mm stereo motion pictures for advertising, sales promotion, education and training purposes.

As the Festival Committee had pointed out, the films selected for screening were not necessarily extraordinary 16mm motion pictures. Rather, they were selected for their quality of stereo photography—which was, of course, the subject of the Festival.

The eight films, therefore, show typical applications of stereo in amateur movie making, in the production of a serious documentary, and to industrial and business film making.

Indian Summer, photographed in Kodachrome with a Bolex camera by Mr. Ernst Wildi, is a typical personal movie record of a young couple's visit to a popular vacation area in the Smokey Mountain National Park. The film demonstrates masterful handling of the Bolex 3-D camera attachment as well as an unusual flair for pictorial composition. It demonstrates also the full gamut of pictorial possibilities inherent in the stereo attachment, from thrilling, life-like closeups to making objects project through the screen and into the audience. The picture is 300 feet in length and has magnetic sound on film.

Thorndyke, The Cactus Kid, is a short slapstick comedy enacted by a group of movie amateurs under the direction of Mr. and Mrs. Lloyd N. Sanford of San Diego, California, using a Bolex camera and Bolex stereo. One hundred feet in length in 16mm Kodachrome, the story depicts the untimely end of a villain who steals a map from a poor gold miner.

Photographically, the picture is very

good; the stereo effect sparkling. The fact that this was the only entry that was not a dupe, perhaps, made its pictorial quality all the more impressive on the screen. A limited number of titles carefully integrated with the picture aided in the story telling and made sound unnecessary.

Spring Has Come To Helsinki, 300 feet, Kodachrome, was photographed with a Bolex camera by Mr. Stig Schubert of Helsinki, Finland. One of two silent films entered in the festival, it is a typical amateur movie record of people enjoying a Finnish holiday known as the Feast of Spring. According to Mr. Schubert, his is the first 16mm stereo film to be made in his country.

The overall 3-D quality is generally good. As the film was not originally meant for any competition. Mr. Schubert explained, it lacks some of the refinements of a planned film, such as closeups and reaction shots. Nevertheless it holds considerable interest pictorially and technically.

Zoo Snapshots, 295 feet, Kodachrome with narration and sound on film, at once demonstrates the professional skill of its maker, Mr. J. S. Price, director of Peak Film Productions, London, England. Matching the stereo quality is the fine musical score and narrative which accompanies the carefully integrated scenes of a small family's visit to the London Zoo. The camera work is high quality throughout and the stereo effect is emphasized logically in scenes showing an elephant lifting his trunk, which then extends out from the screen, and of a penguin extending his beak for food, etc. The picture was photographed with a Bolex camera and Bolex stereo attachment.

Four-D, 360 feet, Kodachrome, with narration on film, was photographed by Mr. H. G. Hawes, of the Maine Dairy Council, Augusta, Maine, using the Nord stereo system. Unfortunately, because the Nord projection attachment was accidentally damaged just hours before Festival screening time, there was not time to obtain a replacement, and as a consequence this film had to be omitted from the screening.

Sponsored by the Maine Dairy Council, this film sets out to sell the idea of greater participation by teen-agers in sports events for health's sake, and

(Continued on Page 150)

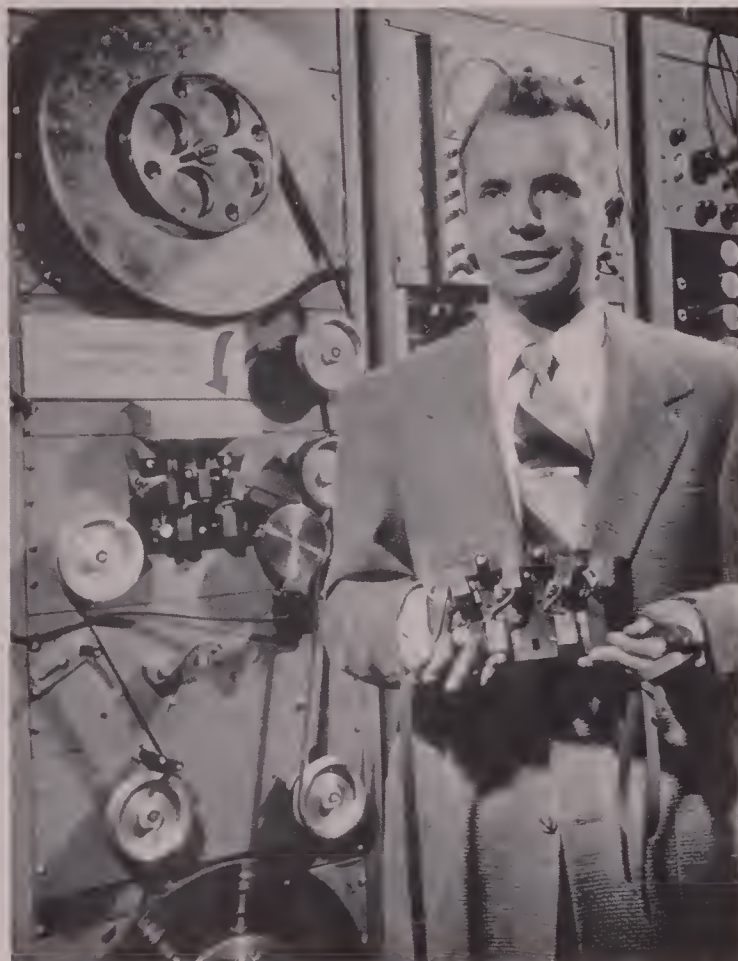

JOSEPH ZENEL, RCA research engineer, shows some of the vast amount of equipment necessary for recording pictures on tape magnetically. Note great size of reels which must store the film as it travels through recorder at speed of 30 feet per second.

Video Tape Recording And Home Movies

Recording home movies on magnetic tape is still a long way off

By ROBERT J. BERRY

Bob Berry Cineventures

NOTE: When the Radio Corporation of America demonstrated publicly for the first time last December its system of video tape recording, Brig. General David Sarnoff, Chairman of the Board of RCA, prophesied that the system would be employed also in fields other than television. He said: "With the further development of video tape techniques, numerous possibilities will open up . . . The all-electronic chain of portable television camera, video tape recorder and standard television receiver, would make a convenient and versatile system for making amateur as well as professional motion pictures . . . In the home, the tape equipment could be used for home movies or connected to the television set to make a personal recording of a favorite television program."—EDITOR.

RECENT ARTICLES on the subject of picture recording on magnetic tape, which have appeared in various publications, have predicted a revolutionary future for the motion picture industry, television film producers, and for amateur movie makers. The nomenclature of video tape recording (VTR) refers to any magnetic tape recording system designed for use at video frequencies. In such systems, electronically dissected images such as are now used in television are stored on tape for future showing.

As a result of receiving inquiries from a number of home movie fans who had read the above-mentioned articles, and who apparently believe that VTR would very soon enable them to record simply and cheaply their own home television shows, the writer wishes to present here some basic facts concerning VTR and the possibilities of its application to home movies. The following views come from a man having many years experience in the radio-electronics field and who's avocation is cinematography.

At the present state of the television art, the standard TV picture in the United States is composed of 525 intensity-modulated horizontal lines regardless of the size of the picture tube. When this standard was chosen it was considered adequate for the prevailing small-size TV sets. Now the picture structure, with its lack of detail, becomes annoyingly conspicuous when viewed on the larger TV screens of today. If this picture is to compete in quality with the projected images of 16mm films, it should have a definition of at least 2,100 lines. A 30 x 40 inch home movie screen has nine times as much area as the screen of a 16-inch rectangular picture tube, which is approximately 10 inches high.

The recently developed VTR system records pictures, having the definition of the present 525 line TV standard, on magnetic tape moving at the rate of 30 feet per second. With the tape traveling at such tremendous speed, it would require approximately 20 miles of tape to record a one-hour TV show, or the equivalent of 2000 feet of 16mm film.

If a suitable picture-integrating projection system were available it would require 640 miles of tape to reproduce a standard 2-hour show equal to that of 16mm film projected on a standard home movie screen—even if we considered the screen to have only four instead of nine times the area of the TV screen. If we consider a standard 35mm picture to have

(Continued on Page 146)



NEW AND USED EQUIPMENT

FOR MOTION PICTURE & TV FILM PRODUCTION

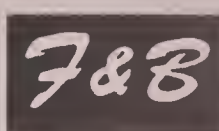

Colortran Converters

High powered studio illumination from ordinary house current.

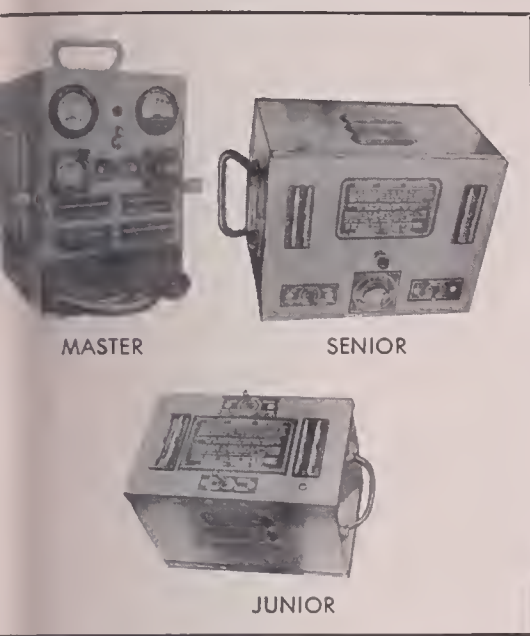

MASTER SENIOR

JUNIOR

WRITE FOR COMPLETE CATALOG

F & B Film Footage Counter

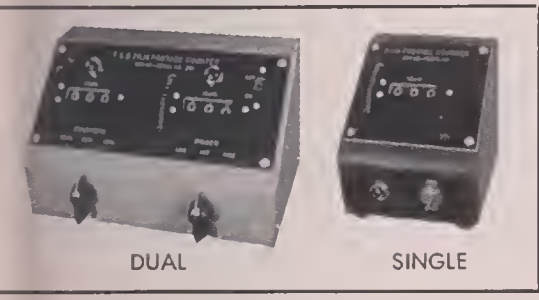

DUAL SINGLE

Write For Brochure

NEW F & B LEG-LOK TRIANGLE

WITH LEG-LOK CLAMPS AND REINFORCED CENTER CASTING

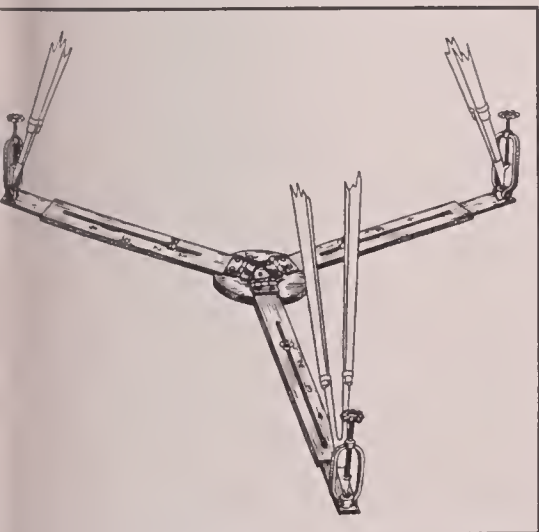

WRITE FOR BROCHURE

F & B 600-Ft. Magazine

for
Auricon
Cinevoice
Camera
At Low Cost

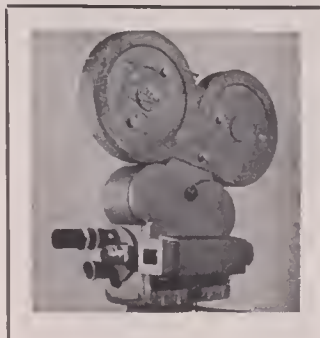

600 Ft. Cinevoice Magazine

NOW IN USE BY: TV STATIONS, TV NEWSREELS, LOCAL NEWSPAPERS, TV FILM PRODUCERS, POLITICAL ORGANIZATIONS, FRATERNAL ORGANIZATIONS, COLLEGES, UNIVERSITIES, SCHOOLS, CHURCHES, RELIGIOUS ORGANIZATIONS, GOVERNMENT AGENCIES, WEDDING AND SOCIAL EVENTS FILM PRODUCERS.

WRITE FOR COMPLETE DETAILS

NEW F & B SPLIT REELS

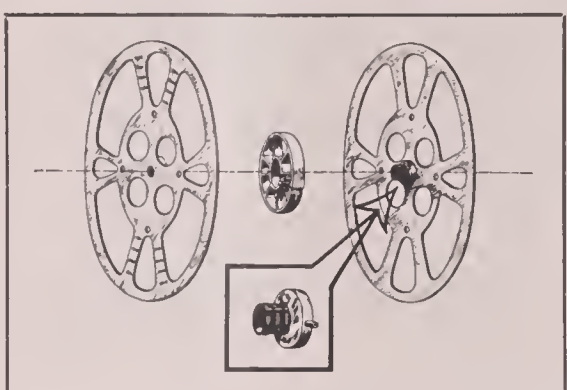

NOW — you can project 16mm film on cores without rewinding. Simply open split reel, slip film in and close reel.

400 ft. split reels — 16mm.....	\$4.50
800 ft. split reel — 16mm.....	\$6.00
1200 ft. split reel — 16mm.....	\$7.50
1600 ft. split reel — 16mm.....	\$9.00

NEW F & B GATOR CLIPLITE WITH BARN DOOR

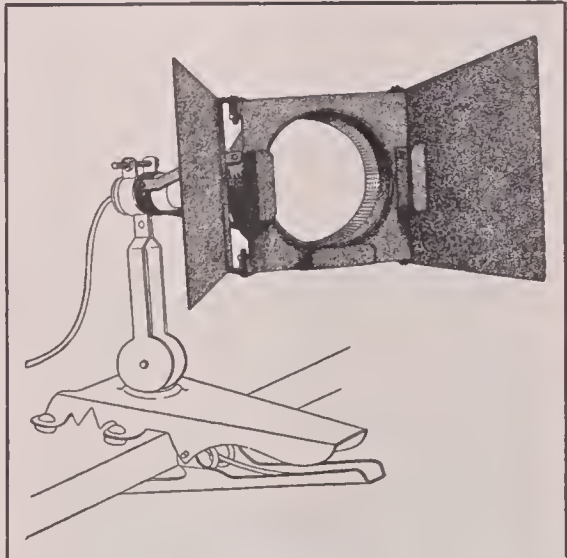

WRITE FOR BROCHURE

SPECIAL ITEMS

**** SPECIAL ****

10" Diameter Flanges (new)
Fits all size rewinds
Round and square holes
Heavy duty aluminum construction
REG. \$10.00 — NOW \$7.45

*** F&B MOVIE STOPWATCH ***
Precision Swiss movement
Calibrated to read seconds, minutes, 16mm & 35mm footage
Starts—Stops—Resets
List Price \$29.50 — Now \$14.75

*** NEW — CRITICAL FOCUSER *
FOR AURICON PRO & CINEVOICE**
Prism reticle, 6x Achromot
Magnifier focuses on groundglass
Only — \$49.50

KELLY CINE CALCULATOR

A Sliderule Disc Computer
Eliminates Bulky Manuals
8-16mm and 35mm models

- ★ 15 USEFUL SCALES
 - ★ Film per second
 - ★ Filters and Factors
 - ★ Aperture Scale
 - ★ Depth of Focus
 - ★ Hyperfocal Distance
 - ★ Field of View
 - ★ Camera Speeds
- Instruction Manual included
\$3.95



F & B USED EQUIPMENT

Always in stock . . . THOUSANDS OF ITEMS . . . cameras, projectors, lenses, accessories, rewinds, splicers, synchronizers, editing, lighting and laboratory equipment . . . ALL AT REASONABLE PRICES. We are always glad to quote lowest prices for specific items. WE WILL BUY . . . FOR CASH . . . all kinds of used items as listed above. F&B is noted for paying FAIR prices. LARGE LOTS OR COMPLETE STUDIOS solicited. We will gladly send our buyer to your studio for accurate appraisals and immediate cash payment. TRADES . . . CONSIGNMENTS ACCEPTED

F & B Rental Equipment

35mm & 16mm

- MITCHELL CAMERAS, 16mm, NC, BNC
- AURICON SUPER 1200 SOUND CAMERA
- AURICON PRO, CINEVOICE, FILMOS
- MAURER 16, ARRIFLEX 16 & 35
- EYEMOS, CINE KODAK SPECIALS
- MOVIOLAS 16 & 35, SYNCHRONIZERS,
- SYNC RECORDERS, SYNC PROJECTORS,
- SOUND READERS, HOT SPLICERS, DOLLIES,
- BLIMPS, MIKE BOOMS, TRIPODS, ZOOM LENSES
- BARDWELL-McALISTER LIGHTS, COLORTRANS

Write For Price Lists

FLORMAN & BABB

70 West 45th Street, New York 19, N. Y.
Phone: Murray Hill 2-2928
Cable Address — FLORBABB, N. Y.

The F & B Guarantee:

All equipment, new or used, guaranteed to your complete satisfaction, or your money returned.

ART FLORMAN

JOHN BABB

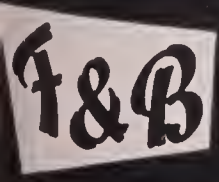

Precision Prints

**YOUR PRODUCTIONS
BEST REPRESENTATIVE**

CLOSE CHECK ON PROCESSING

Picture and sound results are held to the closest limits by automatic temperature regulation, spray development, electronically filtered and humidity controlled air in the drying cabinets, circulating filtered baths, Thymatrol motor drive, film waxing and others. The exacting requirements of sound track development are met in PRECISION'S special developing machinery.

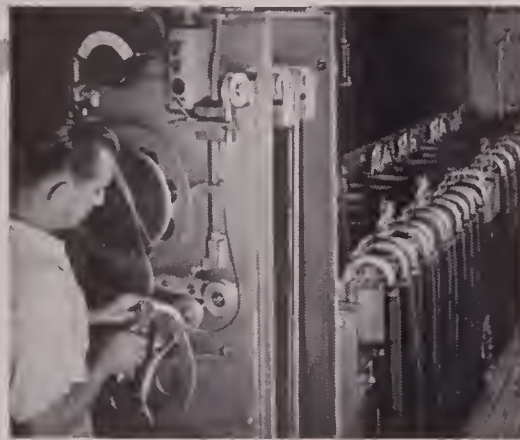

YOUR ASSURANCE OF BETTER 16mm PRINTS

16 Years Research and Specialization in every phase of 16mm processing, visual and aural. So organized and equipped that all Precision jobs are of the highest quality.

Individual Attention is given each film, each reel, each scene, each frame—through every phase of the complex business of processing—assuring you of the very best results.

Our Advanced Methods and our constant checking and adoption of up-to-the-minute techniques, plus new engineering principles and special machinery enable us to offer service unequalled anywhere!

Newest Facilities in the 16mm field are available to customers of Precision, including the most modern applications of electronics, chemistry, physics, optics, sensitometry and densitometry—including exclusive Maurer-designed equipment—your guarantee that only the *best* is yours at Precision!

Precision Film Laboratories—a division of J. A. Maurer, Inc., has 16 years of specialization in the 16mm field, consistently meets the latest demands for higher quality and speed.



ing monochrome film, has certain limitations not yet overcome by the manufacturer, and thus it is necessary to reduce lighting contrast and suppress the brightness range.

All of this information plus that in all the other literature was carefully studied and successfully applied in our initial TV film productions.

Of all the films we produced and televised over WJAC-TV during the past year, the most favorable public reaction came from two: one dealing with the famous Johnstown Flood of 1889, and from another depicting mining operations deep within Pennsylvania coal mines. "Water, Johnstown's Friend and Foe" helped considerably in selling 10,000 extra copies of the Johnstown Tribune-Democrat. Most of these orders were received from persons residing in outlying districts reached by WJAC-TV's television signal, but not reached by the newspaper in ordinary channels of distribution.

The production of the coal mining film presented many photographic problems for the first time. Two days were spent deep inside local coal mines shooting mechanical and hand-loading operations and other activities. We used the Auricon camera here, powered by an automobile storage battery. For illumination, we used two No. 2 photofloods in reflectors. Because the mine power lines were all 250 volts, we wired the two lamps in series and split the line, feeding 125 volts into each lamp.

Still other "first time experience" followed other TV film undertakings for the station. The photographing of a documentary, "Transportation," was anything but a bed of roses for the photographer who had been nearly suffocated in tunnels, made sick on airplanes, and soaked to the skin by rain—all in the pursuit of realism.

Now that the 100th Anniversary series has been completed, we have been kept just as busy shooting news events, commercials and a half-hour quiz show for the station—the latter indoors in a small radio studio which we have fitted out as our TV film production stage. Two Auricon cameras are used in filming this show. Andrew J. Racosky is second cameraman.

For this operation, we found it necessary to have a larger film supply than the original Auricon Cine-Voice cameras provided. The cameras were sent to Hazen Coon of Detroit who installed 600-foot magazines.

Six hundred feet of film is used in each camera. A five-minute break is

taken during filming of the quiz program to permit reloading the magazines with 400 feet of film.

To gain the desired sharpness in focus from any camera position within the small studio, enough lights were hung from the ceiling to enable us to shoot at f/11. The simple lighting units are pictured in an accompanying photograph. They consist of a length of 1" by 6" board. Attached are three lamp sockets that take reflector flood lamps. The units are suspended from the ceiling with the aid of picture hooks and eyescrews, and the power cables run along the ceiling to the junction box.

Both cameramen are in one-way telephone communication with the control room. Wearing headsets, they receive camera directions from Edward Klym.

An added function of our TV film production department is making slides for daily news and sports events. These are made in the photo department of the Johnstown Tribune-Democrat. Copies of Associated Press wirephotos are made on 35mm plus-X film, and transparencies are made on fine grain positive stock, which is then developed in Dektol one-to-one. The wirephotos are taken directly from an AP receiver installed in the newsroom of the newspaper, which is one of 186 member-newspapers in AP's international network. The wirephoto slide reproductions augment WJAC-TV's newscasts and are put on the air via the latest type film and slide pickup equipment.

1953 NOMINEES

(Continued from Page 132)

the final Academy tabulations, the five productions in each class receiving the greatest number of votes become the *official nominees* for the year's Academy Awards for photographic achievement.

Directors of photography are eligible to vote in the preliminary balloting and nomination voting. Only Academy members—and this includes some directors of photography—participate in the final voting, which selects the one best film in each class for the photographic award. In other words, at this time, voting for the photographic achievement awards—as well as the other awards—is participated in by members of all branches of the industry who are also members of the Academy.

Of the eleven cameramen having pictures nominated this year, many have been on the nomination lists in other years, and four have previously won Academy Awards. Leon Shamroy has

IS YOUR PROBLEM

Lip-Sync Sound?
Compare THE HALLEN LINE of
MAGNETIC *Film* RECORDERS

ONLY SOUND RECORDED ON SPROCKET DRIVEN
FILM CAN BE EDITED FRAME FOR FRAME

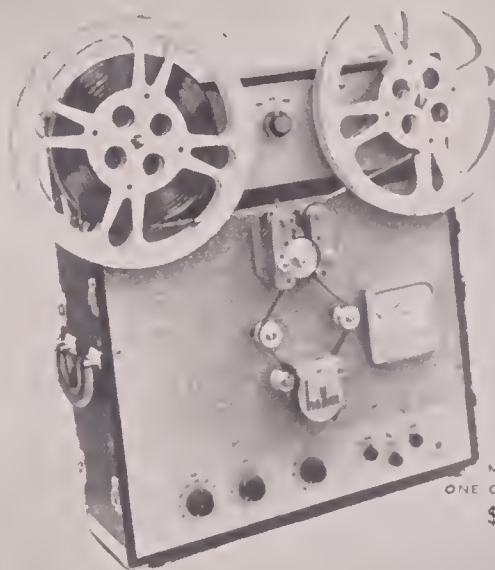

MODEL B-25
ONE CASE PORTABLE
\$1495.00

SOUND STAGE PERFORMANCE AT LOW COST

- Every model specifically designed for the utmost in professional quality and simplicity of operation.
- HalLEN "Drum System," with the Motion Picture Academy award-winning "C. C. Davis Flutter suppressor," results in most stable film motion yet developed.
- Simultaneous monitor of recorded track.
- Three inputs for simultaneous use: two for microphones and one for music or background effects.
- Track placement approved as standard by Motion Picture Research Council for 16mm and 17½mm models.
- High-speed forward and rewind, using separate motors.
- Monitor speakers and power supply are removable from the recorder unit.

Distributors —
Throughout the World
Addresses Upon Request
Licensed under the patents of
American Telephone and Tele-
graph Co., Western Electric
Co., and HalLEN Corp.

halLEN
CORPORATION

3503 WEST OLIVE, BURBANK, CALIF.
CABLE ADDRESS "HALLEN" CHARLESTON 8-6976

DESCRIPTIVE LITERATURE AND PRICE
SCHEDULE AVAILABLE



Primar Reflex Photo
normal 105 mm. lens

"Impossible"
distances
become
close-ups



Primar Reflex Photo
Astro 640 mm. lens
taken simultaneously
by Hans Namuth

with **ASTRO**[®]

LONG DISTANCE LENSES

FOCAL LENGTHS TO 1000 mm.!

Used by the world's foremost explorers, scientists and news services, Astro lenses have been making photographic history all over the globe. Special formulas have produced resolving powers up to 100 lines to the mm.! And these superb lenses are *fast enough for action color work*—focal lengths from 300 to 800 mm. rated at F/5, the giant 1000 mm. (40 in.) at F/6.3.

FOR STILL CAMERAS Leica, Exakta,
Primar Reflex, Master Reflex,
Hasselblad, Praktica, Contax-S

FOR MOVIE CAMERAS 16 & 35 mm.
Bolex, Mitchell, Eyemo, DeBrie,
Askania, E.K., Arriflex, etc.

DUAL PURPOSE

MOUNTS allow
interchanging
movie and
still.

**SUPER SPEED
TELEPHOTOS**

5 in. F/2.3
6 in. F/2.3
6 in. F/1.8



Made by Germany's foremost specialists in long-range optics, Astro lenses are available on order from franchised dealers only.

Write for brochure and prices

ERCONA CAMERA CORP.

DEPT. A-21 527 FIFTH AVE., NEW YORK 17, N.Y.

three "Oscars," for "The Black Swan" (1942), "Wilson" (1944), and "Leave Her To Heaven" (1945). He also holds Nomination Certificates for "The Prince of Foxes" (1949), "David and Bathsheba" (1951), and "Snows of Kilimanjaro" (1952).

Hal Mohr has two "Oscars" gracing the mantle of his home for "Midsummer Night's Dream" (1933) and "Phantom of The Opera" (1943).

Joseph Ruttenberg was presented with an "Oscar" for "The Great Waltz" (1938) and for "Mrs. Miniver" (1942).

In the nominee's circle in recent years have been George Folsey for "Million Dollar Mermaid" (1952); Robert Planck for "The Three Musketeers" (1948) and "Little Women" (1949); and Frank Planer for "Champion" (1949) and "Death of a Salesman" (1951).

As the evening of the Awards presentation ceremonies draws near, speculation as to which productions will win awards rises proportionately. Sometimes a production having a great number of nominations for achievement in various categories stands a better chance in the Awards than a film having but one. Thus, if such pictures also are nominated for best photography, the record shows they stand an even chance of winning an award in this category. In light of this, it may be interesting to review the nominations which have been collected this year by seven of the ten productions also nominated for photographic awards:

Heading the list is "From Here To Eternity," photographed by Burnett Guffey, ASC, with a total of 13 nominations: Best Production, Actor (2 nominations), Supporting Actor, Actress, Supporting Actress, Photography, Costume Design, Directing, Editing, Music Score, Sound Recording and Screenplay.

In second place is "Roman Holiday," photographed in black-and-white jointly by Frank Planer, ASC, and French cameraman Henry Alekan—with a total of 10 nominations: Best Production, Supporting Actor, Actress, Art Direction, Cinematography, Costume Design, Directing, Editing, Story, and Screenplay.

"Lili" and "Shane" are tied for third place with 6 nominations each. "Lili," a color production, was photographed by Robert Planck, ASC. In addition to the nomination for best color photography, the production also has received nominations for best Actress, Art Direction, Directing, Music Score, and Screenplay.

"Shane," also a color production, photographed by Loyal Griggs, ASC, received nominations for best Production, Supporting Actor (2 nominations), Directing, and Screenplay—in addition to Photography.

"Julius Caesar," a black-and-white production photographed by Joseph Rut-

tenberg, ASC, received a total of 5 nominations. In addition to the one for Photography, it also is up for best Production, Actor, Art Direction, and Music Score.

Also winning 5 nominations is "The Robe," only CinemaScope production in the running for a photographic award this year. Photographed in color by Leon Shamroy, ASC, "The Robe" has nominations also for best Production, Actor, Art Direction, and Costume Design.

"Martin Luther" just made the multiple-nominations list with a total of two. Photographed in black-and-white by Joseph Brun, ASC, it has been nominated for Art Direction in addition to Photography.

This year, MGM leads with 3 nominations for photographic awards: "Julius Caesar," "All The Brothers Were Valiant," and "Lili." Columbia, Fox and Paramount each have two: Columbia—"The Four Poster" and "From Here To Eternity"; Fox—"The Robe" and "The Twelve Mile Reef"; Paramount—"Roman Holiday" and "Shane."

No one however (except the auditing firm of Price-Waterhouse) will know who the winners are until the evening of March 25th, when at the RKO-Pantages Theatre in Hollywood the Academy's 1953 Awards presentation ceremonies take place.

Incidentally, if you have a television set, you'll very likely see the whole show from the comfort of your living room. This year, for the first time in Academy history, the Awards presentations will be televised—by the entire NBC-TV network and its affiliates.

VIDEO TAPE RECORDING

(Continued from Page 142)

four times the area of a 16mm picture, it becomes obvious that four times the number of running feet of tape would be necessary to achieve the same quality, or 2,560 miles of tape for a two-hour show. Knock off 90 percent of this and we still have 256 miles of tape that will be required if and when this much improvement is possible. Now that we have dreamed the speed down to where the tape is creeping past the pick-up heads at only 128 miles per hour, can't you hear the projectionist hailing and praising this great boon to the super modern cinema of tomorrow?

After a reasonable amount of improvement, VTR may be expected to have certain advantages over motion picture film for TV use. The picture quality may be improved to a point where it is better than the present kinescope picture on film. Tape would have

again available-

OUR FAMOUS
"controlled action"

small **GYRO** tripod

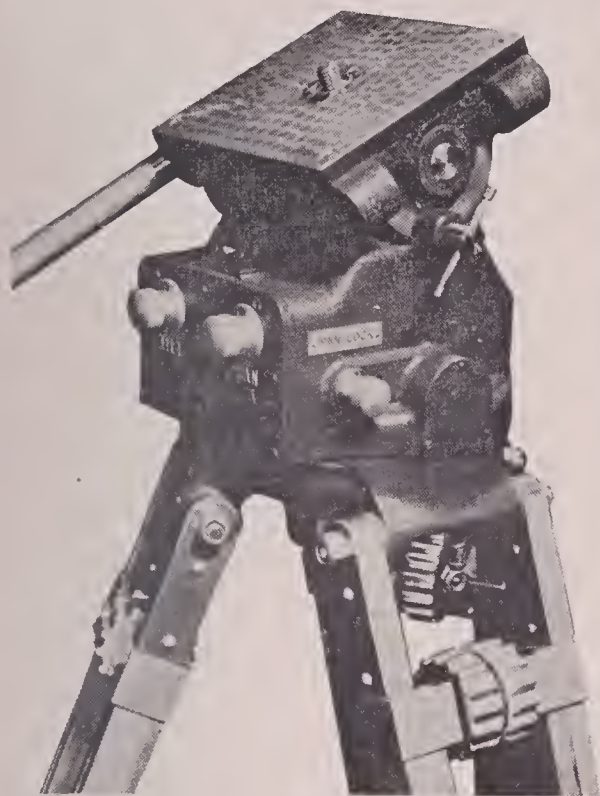

Here is exciting news for many Motion Picture Cameramen. . . . We are happy to announce that we are again in production an our popular Small Gyro Tripod.

If you have used our Gyro, of course no description is necessary. But if you know it only from hearsay, you have an interesting experience ahead of you. You will be delighted with this "Action Controlled" job which is precision-engineered with gears and flywheels like a fine clock.

It has two speeds—slow and fast—for both panning and tilting, and is equipped with a long pan handle which enables you to control the pan and tilt action—helps you capture fine scenic views and fast moving sports events with ease.

Our GYRO is especially recommended for such cameras as the 16mm Mitchell, the 16mm Maurer, the Bell & Howell Eyemo with 400 foot magazine and motor and similar cameras.

If you appreciate lightweight convenience in a versatile tripod, lose no time in seeing our Gyra. We predict you will be fascinated by it.

FRANK C. ZUCKER

CAMERA EQUIPMENT ©

1600 BROADWAY NEW YORK CITY

the advantage of storing the electrical signals directly as they come from the TV camera or off the cable from a distant station, having them ready for immediate playback without the losses presented by the developing processes involved with kinescope films. Another point in favor of VTR is the sound track, which can have a quality that is literally out of this world, and the capability of recording frequencies far beyond those of sound.

Outside of the TV industry the aspects of VTR are quite different. A theater patron would probably be insulted if he were expected to tolerate such picture distortion as he calmly accepts as part of his free home TV entertainment. He expects circles to be round and squares to be square and scenes to be big—at the cinema. Stop motion and slow motion, though possible, would be far too impractical with VTR. Reverse motion would seem impossible. Superimposition and fading would be simple matters of electronic mixing and video gain control. Dial twisting would be the new art.

Finally the complexity, expense, bulk, and lack of portability would seem to eliminate VTR from the home movie field.

Precision Built Combination MAGNETIC FILM AND TAPE SOUND READER

Features: Simple threading . . . polished stabilizer drum with needle bearings . . . combination film rullers for 16mm, 17.5mm, 35mm and 1/4-inch tape, machined to conform with SMPTE standards, and equipped with ailess bearings . . . precision ground shafts . . . Magnetic head mount with adjustments for track locations, azimuth, and magnetic film and tape thickness . . . dimensions 6"x6"x7 1/2".

Amplifier: 117-volt—60-cycle—AC . . . power output—4 watts . . . heavy duty Alnico V speaker . . . safety fused . . . pilot light . . . 6-ft heavy duty line cord

Net Price \$198.00 F.O.B., Factory, N. Y.

PRECISION LABORATORIES
1139 Utica Ave., Brooklyn 3, N. Y.



EVERYTHING PHOTOGRAPHIC AND CINEMATIC FOR PROFESSIONAL AND AMATEUR

The World's Largest Variety of Cameras and Projectors. Studio and Laboratory Equipment with Latest Improvements as used in the Hollywood Studios. New and Used . . . BARGAINS. Established 25 years.

HOLLYWOOD CAMERA EXCHANGE
1600 Cahuenga Boulevard
HO 9-3651 • Hollywood, Calif. • Coble Hocamex



mitchell

CAMERA STORES, INC.

T.V. NEWS

We are pleased to announce that in addition to our previously announced complete line of Motion Picture Production equipment with which we are presently serving the motion picture industry, we are expanding to serve the Television Production Field as well.

If your needs are for live TV production equipment or film equipment for television use, Mitchell Camera Stores, Inc., is ready to serve you as follows:

- Professional lenses for all T.V. & M.P. cameras, including Zoom lenses.
- Microphone Booms.
- Camera dollies—tripod or pedestal.
- Friction heads for T.V. cameras.
- Complete line of editing & cutting room equipment.
- Complete line of laboratory equipment including a new "Super Hi-Speed Reversal or Negative-Positive 16mm Developing Machine."
- Tape recorders, synchronous or wild.
- Slide and title making equipment.
- Lighting equipment.
- Mitchell, Bell & Howell, Auricon, Akeley, Arriflex cameras, etc. for rent or sale.
- Complete camera repair service.
- Only authorized Mitchell Camera Repair Service Station on Eastern Seaboard.
- Consultation service to all Television and Motion Picture Producers and studios of no charge. Write Dept. T.C.
- ATT: — SCHOOL AUDIO-VISUAL-AID DEPTS.—A.V. Teachers, we are fully equipped to supply all your needs.— Write for information.

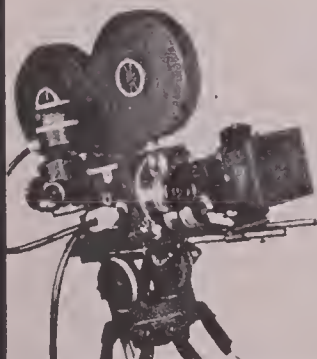

• Phone:
Plaza
7-6812
Circle
5-9372

127 West 50th St. (At Radio City)
New York 19, N. Y.

A NEWSREEL-TYPE PRODUCTION IN COLOR

(Continued from Page 130)

between what we would have liked to do, and what we could do. For one thing, the film was limited to 14 minutes screen time both for economy and with an eye on utilizing it for television.

Six major Festival events were selected for coverage; the arrival of the Campus Queens, a garden party, an air flight Luncheon over Northern California, a night parade, the California-Baylor football game, and finally, the Coronation Ball at the Hotel Claremont. With so many events to be covered within the limited time allotted for the film, there was little opportunity for the development of a story. Hence it was decided to use a short introduction, and then art work in the form of a program as subtitles for the various events.

Commercial Kodachrome was chosen as the film medium. Although its emulsion speed is quite slow, (we used ASA 8 for interiors and ASA 6 for daylight) its latitude proved very useful. The brightness range in daylight is usually too great for regular Kodachrome when it is used as an original for prints, and the same could be said for artificially lighted scenes, where there is insufficient control over lighting balance, as in this project. Besides, the footage numbers on CCO greatly increase the speed and ease of editing.

Since we have had extensive experience in covering news and sports events for television, we decided to apply the techniques we have learned in this type of coverage in photographing the Festival. This decision was necessary because of the nature of the Festival. It contained numerous events scheduled in a close timetable. There was no possibility of re-takes; and we would be lucky to get even a few set-ups, since we were enjoined not to interfere with the events, or the press coverage of them. Also, plans have a habit of going awry, and we could not predict with certainty whether or not an event would happen at the set place and time. Hence, we needed highly flexible and adaptable equipment and crews.

For each event, we used two cameramen, generally equipped with hand cameras. Our "work-horse" was the Arriflex 16. To me this is an ideal camera. It is light, and made to order for handheld shooting. Its motor drive eliminates the embarrassment of spring motor rundowns, or partial winds at crucial moments. Its reflex focusing speeds up shooting, and allows for no parallax and focusing errors. The addition of

400-foot magazines, when they are available, will further increase its usefulness.

As a secondary hand camera, we used a Bolex, which is also an excellent hand camera, especially when fitted with an eye-level focuser, turret lever, filter slot and pistol grip. The filter slot is worth its weight in gold when using CCO in daylight.

Using two cameramen on an event meant that we would have a variety of angles for editing, providing we did not lose an event due to any of those numerous things that so often can go wrong with filming.

In shooting daylight exteriors our greatest problem was varying light conditions. We often had to shoot in heavy overcasts. We used filters to help overcome this handicap—an Eastman 81A or 81B. The problem was to eliminate the excess blueness of cloudy days, without making the scene objectionably warm. People expect an overcast day to be blue, but at the same time, will object to excessive blueness. Our aim was to achieve just that psychological amount of coldness. To do this, we would only partially correct, and this was a matter of judgment. We have not found the average color temperature meter to be dependable outdoors, though quite useful indoors.

Since we could not carry around bulky reflectors, even if we had the time to use them, we relied instead on small hand reflectors, using them especially for closeups. Again, the latitude of CCO helped, allowing us in contrasty scenes to over-expose, yet still retain definition in the highlights.

An interesting problem was the coverage of the flight over Northern California in one of Pan American's Stratoliners. We wanted interiors of the plane, and aerial shots of the terrain. Since there was a great deal of daylight coming into the plane, we used CCO with a Wratten 83 filter to get the desired natural conditions. For the interiors, a couple of blue photofloods run off the plane's 110 line provided fill light. For the aerial shots, we used an Eastman Skylight filter, and made our exposure readings with an SEI meter. We found this meter an extremely useful adjunct to our Norwood, especially for telephoto shots and for determining the brightness range of scenes.

We had two difficult events to cover, which necessitated the use of artificial light; the night parade, and the Coronation Ball. The parade was large and moved down the main street of Berke-

ley. On a limited budget, we had to light an area sufficiently large enough to get a whole band coming in and out of the scene. We decided on 25 kw of lights with power supplied by a DC generator; our light units were 2 Seniors, 6 Juniors, and a Senior Colortran unit.

The lights and fixed camera were mounted on upright aluminum scaffolds. These scaffolds are really a marvel. They are light; one man can erect them, and they will go up to 25 feet without support. They can also be moved around easily. Two scaffolds of lights were placed behind the reviewing stand, and the other was placed facing into the parade area. On this stand was placed an Auricon 1200 as a fixed camera, and 2 Juniors and a movable Senior right above the camera. The Senior followed the subject that the camera shot, giving reasonably flat lighting. The Arriflex 16 was used as a hand camera along the parade route for close-ups and reaction shots. Here the reflex focusing feature of the Arriflex was invaluable, since at F/1.5 and F/1.8 there is little depth of field. The placement of the cameras may be seen in the accompanying photo.

The lighting problem was to achieve a reasonably even light distribution along the parade route, yet have our lights at sufficient height to illuminate the tallest float without having the light

CAMART PRODUCTS

OPTICAL FX UNIT AND PRISMS

You've got to see it to believe it!

FOR 16mm—35mm—TV CAMERAS
LIVE TV, ANIMATION,
MOTION PICTURES

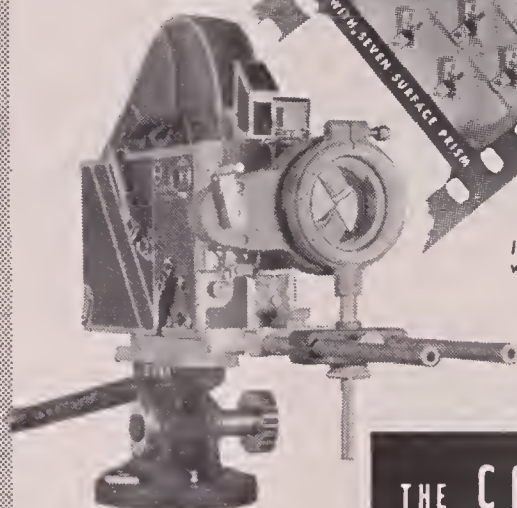

Literature on request.

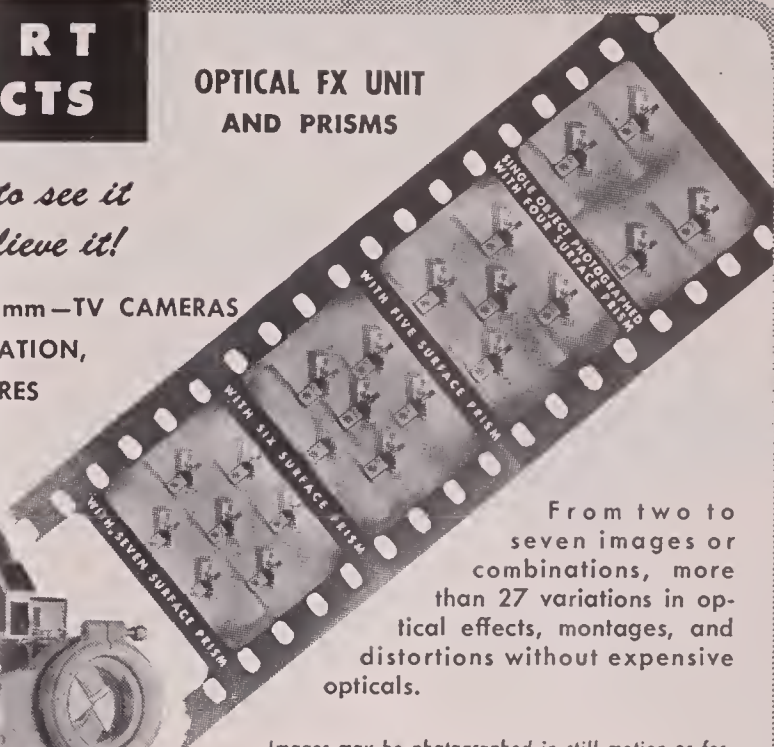

From two to seven images or combinations, more than 27 variations in optical effects, montages, and distortions without expensive opticals.

Images may be photographed in still motion or forward and reverse rotation.

Complete unit consists of a four surface prism, mount, revolving housing, and camera base assembly.

THE CAMERA • MART INC.

1845 BROADWAY at 60th ST.
NEW YORK 23, N. Y.

Phone: Circle 6-0930
Cable Address: CAMERAMART



frost lights the nation!

MOTION PICTURE STUDIO •
THEATRICAL • DISPLAY
RENTAL EQUIPMENT

WHEREVER YOU ARE—WHATEVER YOU NEED

... in the way of unusual, specialized lighting, call on Jack Frost! For movie-making, stage lighting, feature exhibits, large conventions ... for *any* location that requires exceptional lighting, Jack Frost is ready to serve you! And Jack Frost's unequalled national service includes complete installation and removal *wherever* you are. Rent all your specialized lighting equipment from Jack Frost ... famous for lighting the nation's greatest shows ... most spectacular displays.

FOR FULL INFORMATION ON
RENTAL EQUIPMENT
MAIL COUPON, OR CALL
DETROIT, TRinity 3-8030

JACK A. FROST, DEPT. J,
234 PIQUETTE AVE.
DETROIT 2, MICHIGAN

Please send me full information on your rental service.

Name _____
Address _____
City _____ Zone _____ State _____

A CAMART PRODUCT

● CAMART BABY DOLLY

New Model



Send for descriptive literature.

- Advanced glide steering control.
- Adjustable swivel seat.
- Platform for assistant.
- Attractive grey hammertone finish.
- Use with tripod, baby tripod, hi-hat.
- Portable for studio or location.

THE CAMERA MART, INC.

1845 Broadway, near 60th Street
New York 23, N.Y. Circle 6-0930
Cable Address: Cameramart

SPARKLING COLOR FOR YOUR PRINTS

Expert timing by color craftsmen plus the careful attention accorded your film in our famous "personalized service" will give you unsurpassed prints whose brilliance makes them alive on the screen.

Write for Information

Dept. C-11

TELEFILM, INC.

6039 Hollywood Boulevard
Hollywood 28, California

CAMERA CLUB SPECIAL TO EUROPE

Fly New York to London, July 17, 1954; return N. Y. from Paris Aug. 23rd—39 days. See eight countries. Especially arranged for camera enthusiasts—movies, stills or what have you! This is the trip you have been waiting for. A terrific bargain—only taking 30 people. Personally conducted by J. M. Elliott of

ELLIOTT FILM PRODUCTIONS

For Further Information, Write for Brochure to
840 S.W. 7th St. Miami 36, Fla.

shining in the spectators' eyes across the street. Thus, we placed the lights as high as the scaffold would go. On top of this, we had only a few minutes of darkness before the parade started in which to make the final light adjustments. We were able to shoot at F/1.8, and we achieved the correct color temperature by varying the voltage of the generator until the color temperature meter read 3200 Kelvin.

The Coronation Ball posed a similar problem. Here, we had to place the lights on a dance floor without interfering with the dancers. We did this by tying the Juniors to the pillars. Luckily, we didn't need as much light for this event as for the parade. Again we used the Auricon 1200 as the fixed camera, and the Arriflex as a hand camera to shoot the colorful Coronation ceremony.

All together, we shot 2,000 feet of color film, and our batting average was very high. The editing was not too difficult, since we had two camera angles for most shots, and we had shot plenty of reaction and cutaway shots—a definite "must" in this type of shooting,

where you don't have the opportunity to match action.

For the sound, we used narration exclusively, and added sound effects and music. To background the parade shots we used a tape recorder on the spot, to record natural sounds.

The result was a fast paced, entertaining film, which greatly pleased our clients. The film will be used to promote a greater and better Football Festival for 1954.

Although we filmed most of the Festival in much the same way a movie amateur would have done—using hand-held cameras, and with little if any control over what we were shooting—we attained highly professional results. Such results were due to the use of top quality equipment, and to the application of the experience gained from covering innumerable similar events. In addition, we acquired valuable experience in shooting color under newsreel conditions—experience which we believe will come in handy when color television creates a real demand for filmed program material in color.

3-D FILM FESTIVAL

(Continued from Page 141)

points up the importance of the nutritional values of dairy products for greater physical fitness.

The film was well photographed and very professionally put together with the stereo effect giving added luster to the sporting activities.

This Is Your Line, 400 feet, Kodachrome, with narration and music on film, was photographed by Mr. Joseph D. Price, Bartlesville, Oklahoma, using a Bolex camera and Bolex stereo attachment.

Possessing perhaps the finest photography, with respect to pictorial composition, of all the entries, this film gets off to a most impressive start aided by highly interesting narration. The picture suffers somewhat later when the narration is halted and the music allowed to take over. Price's fine photography, however, sustains interest until the final fadeout. Watching the fine camera angles, the unusual compositions, and the way the cameraman evidently kept his continuity in mind as he shot what must have been many thousands of feet of film in some of the roughest terrain imaginable. One almost forgets that it is a picture, it is so realistic.

You And Stone Container, 410 feet, Kodachrome, with narration and music on film, was produced by Academy Films, Chicago, Illinois, for the Stone

Container Corporation, makers of fiberboard and fiberboard cartons.

Photographed with a Bolex camera and stereo attachment, the film is essentially an indoctrination film for showing to prospective employees. Beginning with a shot of the exterior of the Stone plant, the camera moves inside to show the operations that produce the company's products. The story is told by the company's personnel manager as he interviews a prospective employee.

The film is a fine example of how stereo, applied to this type of motion picture, greatly enhances interest.

This Is Progress is the only film not made by one of the three systems previously mentioned. Produced by the Raphael G. Wolff Studios, Hollywood, makers of industrial and training films, *This Is Progress* was photographed with a twin-camera 3-D unit made up of two Maurer 16mm cameras.

Produced for General Motors Corporation, this 400 foot Kodachrome and sound picture depicts the progress of the company in advancing the design and mechanical quality of its motor cars.

The fine quality three-dimension scenes show the company's line of super sports models, its experimental jet automobile, and concludes with scenes showing its latest model Oldsmobiles, Pontiacs and Cadillacs in action.

Film Editing Made Easy
with NEW
**professional
film viewer**

for 35mm and 16mm

Every film editor will appreciate a viewer that enables him to view his film from left to right—on a large, brilliantly illuminated screen.

The PROFESSIONAL FILM VIEWER makes film editing a breeze. Easy threading, portable, will not scratch film. Put this viewer between your rewinders and speed up your editing. Size of Viewing Screen 5¾ x 4¾.



35mm Model \$375
16mm Model \$350



This film, which was tendered a special award, made possible a most comprehensive study of 3-D photography, contrasting the full-frame professional stereo system with that of the equally adaptable twin-image, single frame systems of Bolex, Elgeet and Nord.

It was regretted that no films made with the Elgeet stereo system were available for screening. The two such films for which entry blanks had been received, failed to arrive.

The Festival Committee included Ellis Carter, Charles Lawton, Jr., Peverell Marley, and Lester White—professional cinematographers who themselves have photographed some of Hollywood's best 3-D feature films.

In acknowledgment of their fine photographic work and commemorating the Festival event for which their films were chosen for exhibition, the producer of each film included in the Festival program will receive the American Cinematographer Merit Filming Award.

A light process that projects a picture five times brighter than conventional bulbs has been developed for a new 16mm "shutterless" motion picture projector by the DeVry Corporation.

Model 35-16C

S E N S I T E S T E R

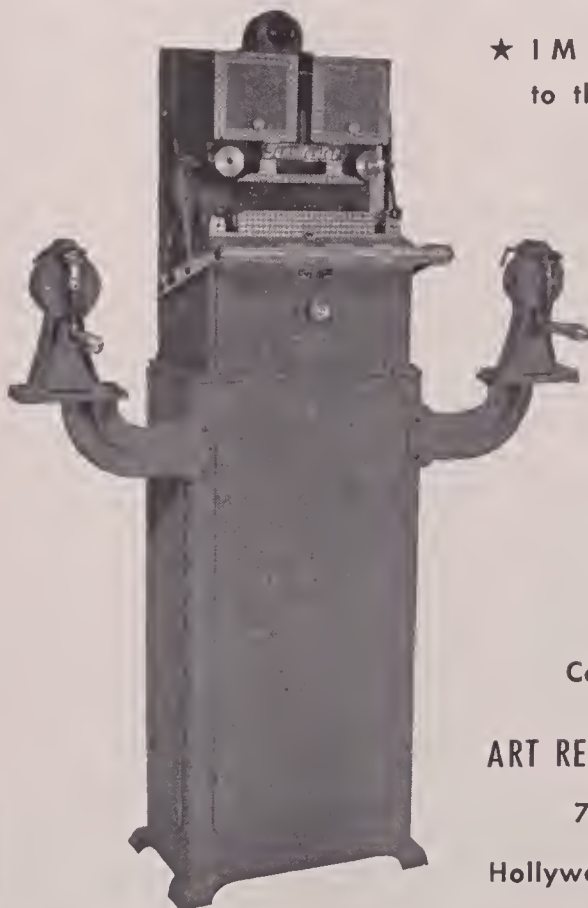

★ IMMEDIATE DELIVERY
to the lab owners interested in—

**QUALITY
EFFICIENCY
ECONOMY**

- DUAL MACHINE
1—Sensitometer
2—Scene Tester
- HIGHLY ACCURATE
Electronic timer unaffected
by climatic changes.
- NEW TYPE LONG-LIFE
Cold Light Exposure Unit
- WITHOUT ADDITIONAL
EXPENSE will match any
printer

Combination 35mm-16mm

ART REEVES MOTION PICTURE EQUIP.

7512 Santa Monica Blvd.

Hollywood 46

California



MOTIVEFINDER

— like a "right arm" for the creative MP and TV Director

TEWE MOTIVEFINDER is a wizard that solves scores of set problems. This Director's Zoom-type Finder reveals the most suitable focal length, the proper camera position, the effects of dolly shots, etc. It is invaluable to a creative Director who likes to plan optical tricks and special effects. Combination Finder zooms from 25mm to 135mm for 35mm Motion Picture and zooms from 28mm to 150mm for TV. Complete with leather carrying case and neck band. **Only \$75**

Other Versatile Viewfinders — each a honey for the money!



ZOOM DIRECTOR'S FINDER for 16mm and 35mm. . . . 16mm zooms from 13mm to 75mm. 35mm zooms from 25mm to 6". **\$15.50**

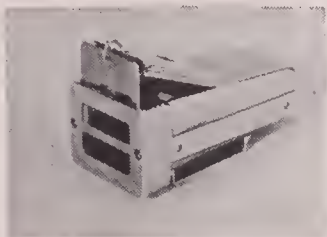

WATSON Director's type finder, pocket size, with mottes from 30mm to 100mm for 35mm cameras. Also for 16mm cameras. **\$35**

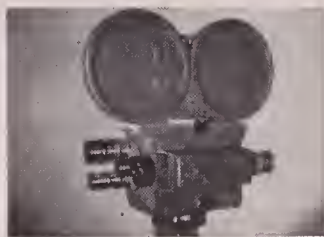

ZOOM Finder for Auricon Cine Voice . . . zooms from 15mm to 12". **\$60**
Available for Filmo and Eyemo. **\$39.50**

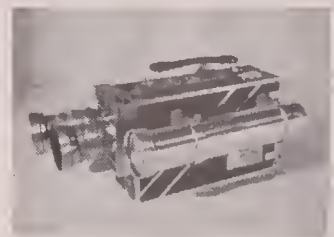

ZOOM Finder for Cine Kodak Special . . . zooms from 15mm to 150mm, with paralox adjustment. **\$75**
Template supplied for mounting Finder on magazine. Additional brackets for magazines available at \$7.50 per set.

FRANK C. ZUCKER
CAMERA EQUIPMENT CO.
 1600 BROADWAY NEW YORK CITY

NEW INSTRUMENT FOR CHECKING FOCUS

(Continued from Page 129)

camera lenses between 1-inch and 8-inch focal length. For camera lenses below 1-inch, which give rise to high magnification of the film emulsion, a lower power eyepiece will be available.

Owing to various factors, such as lens aberrations, magnification of emulsion grain, etc., the accuracy of focusing the camera lens by means of the instrument is not theoretically predictable. Experiments have been made, however, on 1" f/1.4 and 2" f/1.4 lenses at various aperture settings using in their focal plane:—

- a) A mirror
- b) The stationary emulsion surface of exposed and developed 16mm film.
- c) The stationary emulsion surface of undeveloped 16mm film.
- d) The emulsion surface of undeveloped 16mm film passing through a 16mm camera at 16 frames per second.

The results of these experiments can
 (Continued on Page 158)

C. ROSS

FOR

LIGHTING EQUIPMENT

Inkie and Arc Lamps including Required Accessories
 Generators—Cables—Boards—Boxes

Raby Camera Crane—Dollies—Blimps—Geared Heads

GRIP EQUIPMENT

FOR LOCATION AND STUDIO

Parallels—Steps—Platform Ladders
 Century Stands—Reflectors—Flags—Scrim

SOLE EASTERN MOLE-RICHARDSON CO. DISTRIBUTOR

RENTALS • SALES • SERVICE

CHARLES ROSS, Inc.

333 WEST 52nd STREET

NEW YORK 19, N.Y.

Circle 6-5470-1

Now! A 400ft. Magazine For Your BOLEX H-16

Complete
with
Synchronous
Motor
and Base

Includes
Installation
and
Case



Permits continuous run of 400 feet of 16mm film, or—the 200 ft. daylight loading spool may be used in the 400 ft. magazine. The 100 ft. daylight loading spool can be used in the camera without removing the external magazine. In block wrinkle finish to match camera. Fully guaranteed. Write for information on our Rack-Over, Sportsfinder and Camero Base.

See your Bolex dealer or
order direct. Immediate delivery.



TOLEDO CINE ENGINEERING
1309 Milburn Ave. Toledo 6, Ohio

FOR YOUR TV COMMERCIAL

Special optical effects on
35mm or 16mm film. Send
for free optical effects chart.

RAY MERCER & CO.

4241 Normal Ave. • Hollywood 29, Calif.
Normandie 3-9331

AUTOMATIC DAYLIGHT PROCESSING EQUIPMENT

DEVELOPING TANK

- Processes up to 200 Ft.
- 8mm-16mm-35mm
- Movie—X-Ray—Microfilm
- Motor Driven, Portable
- Tough Plastic Tanks
- Uniform Density Assured
- 70mm tank also available

FILM DRYER

- Motor driven—Heated
- Speedy drying
- Automatic shrinkage allowance
- Stainless steel and aluminum construction
- Easily assembled without Tools
- Compact, Portable

Guaranteed. Write for Free Literature

MICRO RECORD CORP.

Dept. AC 225 W. 28th St., N.Y. 1, N.Y.

Scheibe FILTERS

In World-Wide Use

Produce moonlight and night effects in daytime • fog scenes • diffused focus and many other effects.

Information mailed on request.

SCHIEBE FILTERS COMPANY
ORIGINATORS OF EFFECT FILTERS
P. O. Box 16834, Hollywood 46, Calif.

USED IN EVERY HOLLYWOOD MOTION PICTURE PRODUCTION

Current Assignments of A.S.C. Members

Major film productions on which members of the American Society of Cinematographers were engaged as directors of photography during the past month.

AMERICAN SOCIETY OF CINEMATOGRAPHERS

FOUNDED January 8, 1919, The American Society of Cinematographers is composed of the leading directors of photography in the Hollywood motion picture studios. Its membership also includes non-resident cinematographers and cinematographers in foreign lands. Membership is by invitation only.

ARTHUR EDISON, President
MILTON KRASNER, First Vice-President
ARTHUR MILLER, Second Vice-President
HAL MOHR, Third Vice-President
WILLIAM SKALL, Treasurer
JOHN W. BOYLE, Secretary
ROBERT DE GRASSE, Sergeant-At-Arms
JOHN ARNOLD
CHARLES G. CLARKE
LEE GARMES
ALFRED GILKS
VICTOR MILNER
RAY RENNAHAN
JOSEPH RUTTENBERG
LEON SHAMROY

Alternate Board Members

JOSEPH BIROC
WILLIAM DANIELS
PAUL EAGLER
SOL HALPRIN
WINTON HOCH
CHARLES LANG
JOSEPH LA SHELLE
JOHN SEITZ
PHILIP TANNURA
JAMES VAN TREES

COLUMBIA

• **LESTER WHITE**, "The Killer Wore A Badge," with Fred MacMurray, Phil Carey. Richard Quine, director.

• **CHARLES LAWTON, JR.**, "Three Hours To Live," (Technicolor), with Dana Andrews, Donna Reed, Dianne Foster. Al Werker, director.

• **ARTHUR E. ARLING**, "The Pleasure's All Mine," retitled "Three For The Show," (Technicolor; CinemaScope) with Betty Grable, Marge and Gower Champion, Jack Lemmon. H. C. Potter, director.

• **BURNETT GUFFEY**, "Those Reported Missing," with Robert Francis, Diane Foster, Earl Hymann. Lew Seiler, director.

METRO-GOLDWYN-MAYER

• **JOSEPH RUTTENBERG**, "Brigadoon," (Anso Color; CinemaScope) with Gene Kelly, Van Johnson, Cyd Charisse, Elaine Stewart, Virginia Bosler, Hugh Laing, Dodie Heath, Barry Jones, Albert Sharpe, Owne McGivney, Eddie Quillan, and Tudor Owen. Vincente Minnelli, director.

PARAMOUNT

• **LOYAL GRIGGS**, "The Bridges At Toko-Ri," (Eastman Color; Wide Screen) with William Holden, Grace Kelly, Mickey Rooney, Fred-eric March, Charles McGraw, Robert Strauss, Keiko Awaji, Dick Shannon, Bill Bouchey, Mark Robson, director.

• **LOYAL GRIGGS**, "The Big Top," (Hal Wallis Prod.; Eastman Color; Widescreen) with Dean Martin, Jerry Lewis, Joanne Dru, Zsa Zsa Gabor, Wallace Ford, Nick Cravat, and Gene Sheldon. Joseph Pevney, director.

R.K.O.

• **HARRY WILD**, "The Big Rainbow," (Technicolor) with Jane Russell, Gilbert Roland, Richard Egan, Lori Nelson, Robert Keith, Joseph Calleia. John Sturges, director.

UNIVERSAL-INTERNATIONAL

• **RUSSELL METTY**, "Sign of the Pagan," (Technicolor; CinemaScope) with Jeff Chandler, Jack Palance, Ludmilla Tcherina, Rita Gam, and Jeff Morrow. Douglas Sirk, director.

• **CARL GUTHRIE**, "Dawn At Socorro," (Technicolor; wide-screen) with Rory Calhoun, Piper Laurie, David Brian, Kathleen Hughes, Alex Nicol. George Sherman, director.

• **CLIFFORD STINE**, "This Island Earth," (Technicolor; wide-screen) with Bart Roberts, and Faith Domergue. Joe Newman, director.

• **MAURY GERTSMAN**, "Bengal Rifles," (Technicolor; wide-screen) with Rock Hudson, Arlene Dahl, Dan O'Herlihy, Torin Thatcher, Michael Ansara. Laslo Benedek, director.

• **GEORGE ROBINSON**, "The Matchmakers," with Marjorie Main, Chill Wills, Alfonso Bedoya, Pedro Gonzales Gonzales, Rudy Vallee, Ruth Hampton, and Benay Venuta. Charles Lamont, director.

• **IRVING GLASSBERG**, "Francis Joins The WACs," with Donald O'Connor, Julia Adams, Chill Wills, Mamie Van Doren, and Allison Hayes. Arthur Lubin, director.

• **RUSSELL METTY**, "The Tight Squeeze," with Sterling Hayden, Gloria Grahame, and Gene Barry. Jerry Hopper, director.

WARNER BROS.

• **SAM LEAVITT**, "A Star Is Born," (Technicolor; CinemaScope) with Judy Garland, James Mason, Jack Carson, Charles Bickford, Tom Noonan, and Jack Pepper. George Cukor, director.

• **WILFRID CLINE**, "Lucky Me," (Warner-color; CinemaScope) with Doris Day, Robert Cummings, Phil Silvers, Eddie Foy, Jr., and Nancy Walker. Jack Donohue, director.

• **PEVERELL MARLEY**, "The Talisman," (WarnerColor; CinemaScope) with Virginia Mayo, Rex Harrison, George Sanders, Laurence Harvey, Robert Douglas. David Butler, director.

• **SID HICKOX**, "Battle Cry," (WarnerColor; CinemaScope) with Van Heflin, Aldo Ray, James Whitmore, and Tab Hunter. Raoul Walsh, director.

INDEPENDENT

• **JACK CARDIFF**, "The Barefoot Contessa," (Figaro Prods.; Technicolor; shooting in Italy) with Humphrey Bogart, Ava Gardner, Edmund O'Brien, Valentina Cortessa, Marius Goring, and Bessie Love. Joseph L. Mankiewicz, producer-director.

• **FRANK PLANER**, "20,000 Leagues Under The Sea," (Walt Disney Prod.; Technicolor; CinemaScope) with Kirk Douglas, James Mason, and Peter Lorre. Richard Fleischer, director.

• **GIL WARRENTON**, "The White Orchid," (Cosmos Prod. for U-A; Eastman Color; Wide screen) with William Lundigan, Peggie Castle, and Armando Silvestre. Reginald LeBorg, producer-director.

• **HAL ROSSON**, "Mambo," (Ponti-De Laurentiis Prod. for Paramount; shooting in Rome, Italy) with Silvano Mangano, Michael Rennie, Vittorio Gassman, Shelly Winters, and Katharine Dunham. Robert Rossen, director.

• **ERNEST LASZLO**, "Vera Cruz," (Hecht-Lancaster Prod. for U-A; Technicolor; Wide-screen; shooting in Mexico) with Gary Cooper, Burt Lancaster, Mari Blanchard, Cesar Romero, Sarita Montiel, George Macready. Robert Aldrich, director.

TELEVISION

(The following directors of photography were active last month in photographing films for television in Hollywood, or were on contract to direct the photography of television films for the producers named.)

• **LUCIEN ANDRIOT**, "The Life of Riley" series of half-hour comedy-dramas for Hal Roach Studio Prods., starring William Bendix. (NBC.)

• **JOSEPH BIROC**, "The Lone Wolf" series of half-hour dramas for Gross-Krasne, Inc., California Studios; also "The Family Next Door" series of 15-minute films for American National Studios, Inc.

• **NORBERT BRODINE**, "Letter To Loretta" series of half-hour dramas for Lewisor Prods.—D.P.I., starring Loretta Young. (Procter & Gamble), RKO-Pathe studio.

• **DAN CLARK**, "Cisco Kid" series of half-hour western dramas; also "I Led Three Lives" series of half-hour dramas, starring Richard Carlson, for Ziv-TV Corp., California Studio.

• **EDWARD COLMAN**, "Dragnet" series of half-hour dramas, starring Jack Webb, for Mark VII Prods., Walt Disney Studio. (Chesterfield.)

• **ROBERT DEGRASSE**, "Make Room For Daddy" series of half-hour comedies starring Danny Thomas for Marterto Prods., Inc., D.P.I., Motion Picture Center. (ABC.)

• **GEORGE DISKANT**, "Four Star Playhouse" series of half-hour dramas, featuring various stars, for Four Star Productions, RKO-Pathe Studio. (Singer Sewing Machines.)

• **KARL FREUND**, "I Love Lucy" series of half-hour comedies starring Lucille Ball and Desi Arnaz, for Desilu Productions; (Philip Morris) also "Our Miss Brooks" series of half-hour comedies, starring Eve Arden, also for Desilu Productions, (General Foods) at Motion Picture Center.

• **FRED GATELY**, "Big Town" series of half-hour mystery-dramas for Gross-Krasne Productions, California Studio. (Lever Bros.)

• **JACK MACKENZIE**, "Public Defender" series of half-hour films for CBS, starring Reed Hadley. Shooting at Republic Studios.

• **WILLIAM MELLOR**, "Adventures of Ozzie and Harriet" series of half-hour comedy dramas starring Ozzie Nelson and Harriet Hilliard for Stage Five Prods., Inc., General Service Studios. (ABC.)

• **VIRGIL MILLER**, "You Bet Your Life," weekly half-hour audience participation shows, featuring Groucho Marx, for Filmcraft Prods., NBC Studios. (DeSoto-Plymouth).

• **HAL MOHR**, "The Joan Davis Show" series of half-hour comedy-dramas starring Joan Davis for Joan Davis Enterprises, General Service Studios. (NBC.)

• **KENNETH PEACH**, "Mr. and Mrs. North" series of half-hour dramas starring Barbara Britton and Richard Denning for John W. Loveton Productions, Samuel Goldwyn Studios. (Revlon, and Congoleum-Nairn). Also "Topper" series of half-hour films, starring Anne Jeffreys, Robert Sterling, Leo G. Carroll, and Lee Patrick for Loveton-Schubert Prods., at Samuel Goldwyn Studios. (Camel Cigarettes).

• **ROBERT PITTACK**, "Private Secretary" series of half-hour comedy dramas starring Ann Sothern and Don Porter, (Lucky Strike); also "Cavalcade of America" series of half-hour dramas, for Jack Chertok Prods., General Service Studios.

• **GUY ROE**, alternating with Walter Strenge on the "Rocky Jones, Space Ranger" and "Waterfront" series of half-hour dramas for Roland Reed Productions, Hal Roach Studios.

• **MACK STENGLER**, "Life With Elizabeth" series of half-hour dramas; also "The Liberace Show," half-hour musical film series for Snader Telescriptions Corp.

• **HAROLD STINE**, "Cavalcade of America" series of half-hour dramas for Jack Denove Prods., Inc., Samuel Goldwyn Studios. (DuPont).

• **WALTER STRENGE**, "My Little Margie" series of half-hour comedies, starring Gale Storm and Charles Farrell (Scott Paper Co.); also "Rocky Jones—Space Ranger" series of half-hour science-fiction dramas starring Richard Crane and Sally Mansfield (UTP); also "Waterfront" series of half-hour dramas starring Preston Foster and Lois Moran (UTP) at Hal Roach Studios.

• **STUART THOMPSON**, "Topper" series of half-hour comedies starring Anne Jeffreys and Robert Sterling for Loveton-Schubert Prods., Goldwyn Studios. (Camels).

• **PHIL TANNURA**, "The Burns and Allen Show" series of half-hour comedies starring George Burns and Gracie Allen, for McCadden Corp., General Service Studios. (Carnation Milk and Goodrich).

• **GILBERT WARRENTON**, "Chevron Theatre" series of half-hour dramas featuring various stars, for Revue Productions, Republic Studios.

• **HAROLD E. WELLMAN**, "Mr. Sun" series of half-hour dramas. (Bell Telephone Co.).



GEO. W. COLBURN LABORATORY INC.
164 NORTH WACKER DRIVE • CHICAGO 6
TELEPHONE STATE 2-7316

8 and 16mm SERVICES

Color Ray
GOBO STAND
That is Really Versatile *It's New!*



THE 12 foot stand may be used with BOOM ADAPTER or with SCRIMS or with FLAGS

ABSOLUTE LIGHT CONTROL

NATURAL LIGHTING CORP.
GLENDALE 3, CALIFORNIA

EQUIPMENT

FILM ROLLERS

MANY TYPES AND SIZES

Other Processing Machine Parts

Also . . .

COMPLETE FILM DEVELOPING MACHINES
New and Used

METAL MASTERS
(Formerly Wall Laboratories)
5599 University Ave. • San Diego, Calif.



WORLD FAMOUS

S-5
synchronous magnetic film recorder for motion pictures and television



STANCILOFFMAN
921 N. Highland Hollywood 38, Calif.

send for particulars

MOVIOLA

FILM EDITING
EQUIPMENT
16MM - 35MM

- PICTURE SOUND Photo and Mognetic
- SYNCHRONIZERS
- REWINDERS

One of the new series 20 Moviolas for picture and sound.

Write for Catalogue

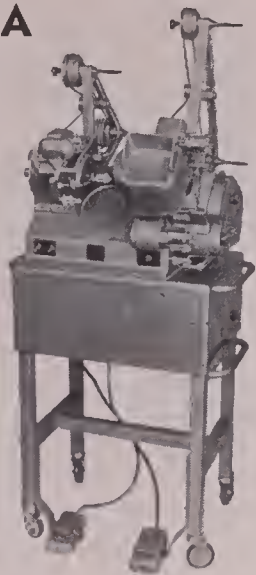

MOVIOLA MANUFACTURING CO.

1451 Gordon St. • Hollywood 28, Calif.

RUBY CAMERA EXCHANGE

Rents . . . Sells . . . Exchanges

Everything You Need for the

Production & Projection

of Motion Pictures Provided
by a Veteran Organization
of Specialists

35 mm. . . . 16 mm.
Television

IN BUSINESS SINCE 1910

729 Seventh Ave., New York 19, N. Y.

Tel.: Circle 5-5640

Cable address: RUBYCAM

Ready-Eddy

U. S. Registered Trademark

EASY READABLE • ACCURATE
FOR EVERY DAY USE

1001 Ready Sound-Film

Editing Data:

- Footage • Frame Count • Screen Time • 35mm and 16mm equivalents.

Plastic computer for everyone in movies and TV, from script to screen.

\$2.00 Prepaid

(Delivered in U.S.A.)

ASK FOR REPRINT OF ARTICLE
IN AMERICAN CINEMATOGRAPHER.

Write or ask your dealer

READY-EDDY, Soudy Hook, Conn.



IF YOU MOVE . . .

. . . remember your monthly copies of American Cinematographer will not be forwarded to you by the Postoffice unless we are given your new address. Change of address should be furnished us promptly, along with your OLD address. A post card will do.
—AMERICAN CINEMATOGRAPHER.

CLOSEUPS

(Continued from Page 122)

gineers. The Tushinsky process involves three separate lenses: variable anamorphic photographic lens; variable anamorphic printing lens; and variable anamorphic projection lens. With these three lenses, it is possible for a studio to provide release prints in a wide range of aspect ratios—up to 3 to 1.

At the demonstration, the Nutcracker Suite from Walt Disney's *Fantasia* was projected from normal to 3 to 1 screen aspect ratio, thus showing how a theatre owner may, by the use of the Tushinsky projection lens, fit any cartoon into any size screen without introducing noticeable distortion.

There were other demonstrations, too, including one of scenes made with a major studio camera with an area of 1.685 x 1.888 converted through the Tushinsky lens to a 2 to 1 print within the standard Academy frame.

Both RKO-Radio and Paramount studios have expressed interest in the lenses.

★

Our apologies to Mr. Hal Pereira, head of Paramount Studio's Art Department, for omitting to credit him last month for his courtesy in loaning us the drawings used in illustrating his department's contribution to the production, "Rear Window," described in our February issue.

WHAT'S NEW

(Continued from Page 120)

ing to D. J. White, president of Magnasync, the new equipment is the answer to the dilemma of the small theatre owner.

Complete descriptive and technical details of the equipment may be had by writing the manufacturer and mentioning *American Cinematographer* magazine.

Title Letters—Clingtite Products, Inc., 4844 S. Ashland Ave., Chicago 9, Ill., offer a new brochure for amateur movie makers describing the company's line of Clingtite titling letters and including samples of the letters for trial. Complete Clingtite letter sets may be purchased at leading camera stores. A set, including 157 letters, numerals, figures, two 8 x 10 titling boards, and a handy carry-all envelope sells for \$2.95.

Copy of brochure and free sample letters may be had by writing the company and mentioning *American Cinematographer* magazine.

Lens Package—Elgeet Optical Co., Inc., 838 Smith Street, Rochester 6, N. Y., offers a complete lens package for the Bell & Howell 172A and 172B mag-



azine cameras and 134V and 134W roll cameras. The package introduces the first inexpensive, fine-quality Rochester-made fixed-focus telephoto lens for these Bell & Howell cameras; it's a 38mm (1½") f/3.5. In the same package are a 7mm f/2.5 wide-angle uni-focus lens, and a set of matching finders for both lenses. List price of the packaged unit is \$80.00.

Voltage Booster—Norpat Sales Inc., 113 West 42nd St., New York 6, N. Y., offers a new 1500-watt line-voltage booster designed for areas where line voltage fluctuates or is below normal. The compact unit provides full-rated 105 to 125 volt 50/60 cycle AC current to any electrical equipment or appliance consuming up to 1500 volts. A meter reads line voltage as well as output from the booster for constant monitoring of voltage applied to device being operated. A switch provides for increasing power five volts per step.

Unit is especially suited for sound motion picture projectors, sound recorders, and for lighting in color photography.

Optical and Filter Glass—Alfa Photo Corp., 303 West 42nd St., N. Y. City, has been appointed American agents for the line of optical and filter glass manufactured by Chance Brothers Ltd., Birmingham, England.

The New York office will function as liaison to the American users of optical glass, answer inquiries, and expedite orders. Catalogs and price information are available on request.

CLASSIFIED ADVERTISING

RATE: 10c per word—minimum ad \$1.00. Words set in capital letters, 15c per word. Display format 90c per line.

STUDIO & PRODN. EQUIP.

OUR 25TH YEAR — SUPPLYING EVERYTHING PHOTOGRAPHIC & CINEMATIC

B&H 25mm EYEMO "Q" CAMERA with 4" f2.9 Cinemat, 2" f2.3 Kinar, 35mm f2 Cooke lenses and viewfinder lenses,, 2-400' mogoazines, freehead tripod, shift over alignment Guage, 12V variable speed motor, 2 carrying cases, excellent condition\$1550.00

35mm DUPLEX CAMERA — Registration pins, lenses: 40mm f2.7 Carl Zeiss, 2" f1.9 Ultra-astigmat, 105mm Schneider f3.5, 3-400' mogoazines, 400' BiPack magazine, viewfinder Motte Box 12V DC motor, battery, Freehead Tripod, 2 carrying cases. A real buy 1125.00

35mm B&H SINGLE SYSTEM SOUND CAMERA, lenses: Cooke, 40mm, 50mm, 75mm, 125mm Modulite Galvanometer, amplifier, motor, Tochrometer, 2-1000' magazines, Tripod with Freehead, quick release legs, carrying cases, guaranteed 3500.00

35mm ARRIFLEX CAMERA, Coated lenses: 35mm f1.2 Carl Zeiss, 50mm f1.5 Carl Zeiss 85mm f2 Carl Zeiss, 125mm f2.3 Astro pan Tachar, variable speed motor, 12V bottery, freehead tripod, 3-2000' magazines, carrying cases, special 1175.00

35mm AKELEY CAMERA, 4 motched Zeiss lenses, 4-200' magazines, slow motion attachment, Akeley friction tripod, quick release legs, carrying cases. Bagain price..... 750.00

16mm B&H 70-H CAMERA, coated lenses, 17mm f2.5 B&H Super Chromat, 25mm f1.9 B&H Lumar, 150mm f4.5 B&H Telate, 4 positive lenses. Parrallax viewfinder, B&H motor, 1-400' magazine, B&H freehead tripod, cases complete, manufacturers guarantee..... 1150.00

35mm DUPLEX PRINTER adapted far sound track, excellent for duping. Academy Aperture. Speed 250 pictures per minute per side, two light change boards, 1B different lights, each side 21 scenes. Motor 110 volts, perfect mechanical condition 875.00

35mm ART REEVES SOUND RECORDER, twin fidelity optical unit, glow lamp type, 1000' B&H mogoazine, complete with cases 997.50

ENLARGERS, excellent condition, Elwood, Auto focus, lens and stand, 5x7 235.00

MOLE RICHARDSON 2000W Spat, rolling stand B&H CAMERA CHECK PAWLS high speed shuttle. List price, new \$1742.00. good cond... 195.00

NEW SCHOEN PRINTER, sound and silent, color, B&W features: 16mm picture alone, 16mm track alone, 16mm picture and sound together, film capacity 1600 feet, 50' per minute, 12 adjustable light changes, AC-DC conversion unit 999.00

HOMRICH COMBINATION COPYING CAMERA and animation table stand, adaptable to 4x5, 5x7, Bx10 holders. Two adjustable light stands with twin reflectors. 11x14, 16x20 copy frames. Built in lamp house, good buy 135.00

HOMRICH ELECTRONIC TIME CONTROL CONTACT PRINTER, timer has full second and split second setting. Handles 4x5, 5x7, Bx10 negatives. Adjustable masking and paper guides. Internal dodging plate glass plate. Four lumps, each controlled by separate toogel switch. A real buy 165.00

Specializing in movie and television supplies, tripods, synchronizers, 16mm sound cameras, lights, lenses, mikes, booms, dollies, motors, etc. New-used reasonable prices. Cash for used equipment. Trades taken.

HOLLYWOOD CAMERA EXCHANGE, LTD.

1600 Cohuengo Boulevard Hollywood, California

WE BUY, SELL AND RENT PROFESSIONAL AND 16mm. EQUIPMENT, NEW AND USED. WE ARE DISTRIBUTORS FOR ALL LEADING MANUFACTURERS. RUBY CAMERA EXCHANGE, 729 Seventh Ave., New York City. Established since 1910.

BALTAR 4" in Eyemo mount \$160.00. 7" F2.5 Ektar in Eyemo or 16mm C mount \$160.00; 2" F1.8 Pan-Tachar in combination 16mm & 35mm C mount \$70.00. SAMUEL KRAVITT, 763 Chapel St., New Haven, Conn.

BELL & HOWELL, 70-H with spider turret 400' magazine, universal motor, three lenses, wide angle, 1" and 2". Camera used only 2,000 feet of film. Like new far \$1,000.00. Write CATHOLIC FILMS, Box 112, Dalhart, Texas.

CINE SPECIAL II, w/200 ft. chamber, Par turret, Maier professional viewfinder, reflex magnifying Par facuser, 1" F1.5 Schneider Xenon, 2" Eastman Ektanon F1.6, 4" Ektanon F3.5, 6" Ektanon F4.0, lenses "T" calibrated, behind-the-lens filter slot, custom built case. In excellent condition. \$1,575.00. 10% with order, balance C.O.D. Box 1184, AMERICAN CINEMATOGRAPHER.

STUDIO & PRODN. EQUIP.

SPRING HOUSE CLEANING SALE

CINE SPECIAL 16MM BLIMP Custom Built. Has follow focus, vertical image 63mm viewfinder, takes 200' mag & syncmotor. \$600 value\$ 350.00

NEW MAURER PROPOD Jr. Professional Tripods 124.95

CAMERETTE 16/35mm REFLEX CAMERA, 4 lenses, 5 magazines, 2 motors, (Sync & 24V DC) batteries, charger, all accessories. \$5,500 value 3950.00

DEBRIE SUPER PARVO 35mm Blimped Camera, 5 lenses, 6-1000' mogoazines, 3 motors (2 sync & 24V DC), 2 tripods, all accessories. \$15,000 value 5995.00

NEW REVERE HI-POWER FLOODLITES, \$150 value 49.50

SYNCHRONOUS MOTOR for 35mm Mitchell Std. 395.00

DEPUE OPTICAL SOUNDTRACK 35mm Printer... 1995.00

FEARLESS BLIMP for Mitchell NC or Std. 695.00

ANSCO-SWEET COLOR DENSITOMETERS \$850 value 367.50

REEVES 35mm MAGICORDER, finest sync outfit built, \$8500 value 3350.00

STANCIL HOFFMAN SYNC MAGNETIC RECORDER S-5, 17 1/2 mm. \$2850 value 1595.00

BERNDT-MAURER SINGLE SYSTEM 16mm Sound Camera, turret, 4 lenses, finder, 400' magazine, amplifier, power supply. Fair... 1295.00

ELECTRIC FILM FOOTAGE COUNTERS—starts, stops, continues automatically. Comb 16/35mm, \$119.50; 16 or 35mm 67.50

HOUSTON 16mm KIA REVERSAL DEVELOPER, reconditioned 3250.00

NEW DIFFERENTIAL REWIND GIMMICKS, match 16mm with 35mm reels. Singly, \$37.50, pair 69.50

NEW FILM EDGE NUMBERING MACHINES, 16 or 35mm 2250.00

ARRIFLEX 35mm CAMERA, 3 lenses, tripod, adapter, batteries, etc. 895.00

EYEMO NEWSREEL CAMERAS Model 71 less lens, as is 99.50

EYEMO SPIDER TURRET Newsreel Cameras, Model 71 less lens, as is 295.00

Trades Taken. Send for 1954 Catalog. Phone PL 7-0440

S. O. S. CINEMA SUPPLY CORPORATION

Dept. fc 602 W. 52nd Stret Coble: SOSOUND New York 19, N. Y.

B&H 70DA 25mm F:1.9, 2" F:1.4, wide angle F:2, with objective viewfinders etc., complete with case\$ 300.00

EK CINE SPECIAL MODEL 2 complete with 25mm F:1.4 Ektar, 15mm F:2.7, 6" F:4.5 telephoto, extra magazine, Zoom Parallax correcting viewfinder, Reflex image magnifier, filter holders, case 1,235.00

BODINE 115V sync motor for Cine Special... 130.00

SET CINE SPECIAL 1 extension tubes and adapter 20.00

1.6 CM F:1.9 SCHNEIDER lens 20.00

MAURER camera blimp — like new 250.00

CRAIG ballhead tripod with leather boot..... 150.00

PROFESSIONAL Junior tripod and case..... 150.00

THALHAMMER tripod 15.00

15MM EKTAR F:2.5 75.00

TURNER electric interlock motor system with master ond two slaves 115 volt AC complete with control box — new 500.00

Phone: HOLLYWOOD 7-1467 or write Arthur Trutler 1714 North Wilton Ploce, Hollywood 28

BASS . . . Chicago. Cinema headquarters for 44 years offers money saving buys in guaranteed used equipment. Cine Special 4 lens "C" mt. turret, 1" F:1.9 Super Comat, 0.7" F:2.5 Super Comat., 4" F2.5 Cooke Panchrotal, DeLux Comb. Case, \$925.00; Cine Special I, 1" F:1.9, 15mm F:2.7 W. A., 3" F:4.5, extra 100 ft. chamber, Comb. Case, \$545.00; Bolex H-16 DeLux, 1" F:1.5 H. M. Primoplant, 0.7" F:2.5 Super Comat, 3" F:4. C. Z. Sonnar, \$387.50; 16mm. Magazine Movikon, 1" F:1.4 T coated Sonnar, \$137.50; Bmm. Revere 99 Turret, 1/2" F:2.8, 1 1/2" F:3.5 tele, case, \$79.50. Best buys . . . Best trades always. BASS CAMERA CO., Dept. AC. 179 W. Madison St., Chicago 2, Ill.

WALL S. S. 35MM. SOUND CAMERA

COMPLETE with Galvanometer, amplifier, portable power supply, 40-50-75 ond 100mm. lenses, erect image viewfinder, complete front attachments, two 1000 ft. mogoazines, Balanced Tripod, necessary carrying cses. Ovehouled. Guaranteed perfect. Reasonable.

CAMERA EQUIPMENT COMPANY 1600 Broadway New York 19, N. Y.

STUDIO & PRODN. EQUIP.

AUDIO AKELEY single system camera complete with Akeley sound head, Gyro tripod, 3 lenses, view finder, Maurer mixing amplifier. Complete with cables, power supply and W. E. microphone. CAMERA EQUIPMENT CO., 1600 Broadway, New York 19, N.Y. Cable Cinequip.

CINE SPECIAL, with Par 4 lens turret, with Par reflex, eye level focusing device. Par-base plate and Yolo fading device, includes case, 100' magazine, and 1" F1.9 T.H.C. lens, uses standard "C" mount lenses, positive type viewfinders, like new. Value \$1,495.00, first \$695.00. POST PHOTO SHOP, 156 N. Illinois St., Indianapolis, Indiana.

HALLEN B-16 16mm synchronous recorder, new demonstrator, \$1,095.00; Cine Special Model 2 with Par 4 lens turret, eye level focuser, Yolo fader, two 200' film chambers, 4 lenses, case, accessories, slightly used, \$2,500.00; Griswold 35mm splicers, \$10.00 each. WEBSTER VISUAL SALES COMPANY, 539 Vine Street, Chattanooga, Tennessee.

CECO Professional Junior Maurer type friction head tripod with extra adj. handle, \$130.00. CONTINENTAL INTERNATIONAL PICTURES, 44B Horrison, Greenville, Ohio.

FREE LIGHT with COLORTRAN converters. Use 750 watts, get over 2,000 watts. Catalogue. KIRK FILMS, 627 St. Philip St., New Orleans 16, La.

16MM. SCENE tester, eleven density, new, satisfaction guaranteed, \$329.00. GREAT LAKES MOTION PICTURE SERVICE, 12037 Grand River, Ave., Detroit 4, Michigan.

ANIMATION Crane 16mm. for Sale or Rental, with or without lights — tables, etc. ACE SCIENTIFIC LABORATORIES, 10364 State Street, Lynwood, Calif. Phone: LOrraine 6-6931.

WANTED

IMMEDIATE CASH PAYMENT FOR CAMERAS AND EQUIPMENT

NEED EYEMOS (SINGLE LENS AND TURRET), MITCHELLS, ARRIFLEX, DE BRIES, B&H STANDARDS AND HI-SPEEDS, WALLS, AKELEYS, CINE SPECIALS, AURICONS, MAURERS, FILMOS. ALSO BALTARS, COOKES AND OTHER LENSES. SOUND STAGE, LABORATORY AND EDITING EQUIPMENT OF ALL TYPES REQUIRED. PLEASE SHIP INSURED OR FORWARD DESCRIPTIONS AIRMAIL. IMMEDIATE PAYMENT.

GORDON ENTERPRISES • 5362 N. Cahuenga NORTH HOLLYWOOD, CALIFORNIA

WANTED TO BUY FOR CASH

CAMERAS AND ACCESSORIES

MITCHELL, B & H, EYEMO, DEBRIE, AKELEY ALSO LABORATORY AND CUTTING ROOM EQUIPMENT

CAMERA EQUIPMENT COMPANY 1600 BROADWAY, NEW YORK CITY 19

CABLE: CINEQUIP

WANTED

PRODUCTION EQUIPMENT, LABORATORY EQUIPMENT, EDITING EQUIPMENT, 16mm. and 35mm. FROM SINGLE ITEMS TO COMPLETE STUDIOS. TRADES ACCEPTED.

THE CAMERA MART, INC. 1845 Broodwoy Circle 6-0930 New York 23, N.Y.

WANTED

Mitchell — Akeley — B & H — Woll — Eyemo Cameras — Lenses — Equipment

NATIONAL CINE EQUIPMENT, INC. 209 West 48th St. New York, N.Y.

(Continued on Next Page)

Classified Ads

(Continued from Preceding Page)

WANTED

F & B PAYS MORE
FOR USED 16/35MM EQUIPMENT

WRITE — WIRE — PHONE
FOR OUR CASH OFFER

FLORMAN & BABB
70 W. 45TH ST.

MU. 2-2928
NEW YORK 36, N.Y.

YE OLDE SOS TRADING POST

Daing Business Since 1928
BUY — SELL — SWAP — CONSIGN

Cameras, Dollies, Lenses, Lights,
Mavialas, Printers, Recorders,
Studio or Laboratory Equipment

S. O. S. CINEMA SUPPLY CORPORATION

Dept. fc
602 W. 52nd Street

Cable: SOSOUND
New York 19, N. Y.

CASH! by immediate Air-Mail Urgently needed now!
Movie cameras. Projectors 8-16mm. Telephoto, wide
angle movie 8-16mm lenses! 8mm 200' cartoons,
16mm Sound Cartoons! Ship your Movie Equipment
today! Immediate Cash by Air Mail! No waiting!
Equipment held 10 days for your approval.
'TRADER' POST PHOTO, 3333 Robson St., Indian-
apolis, Indiana.

CAMERA & SOUND MEN

ASSIGNMENTS FOR INDIA or nearby territories for
any type of films, 16 or 35mm, B&W or Color,
write to KANU PATEL, A.R.P.S., The Clarion
Productions, 34, Park Mansions, CALCUTTA-16.

SKILLED CINEMATOGRAPHER available, 16mm.-35mm.
Well traveled—has made many 'travellagues'. Work
U. S. or anywhere in world. Has 16mm. equipment
Passpart. EMERSON, 224 Naples Terrace, Bronx (63),
New York.

ASSIGNMENTS FOR JAPAN on all subjects, 16 mm.
and 35 mm., Color or B & W. Write to AOI-MAJES-
TIC PRODUCTIONS, 2-Nagatasha, Chiyodaku, Tokyo.

COLOR SLIDES, PHOTOS & FILMS

NATURAL COLOR SLIDES, Scenic, National Parks,
Cities, Animals, Flowers, etc. Set of eight \$1.95
Sample and List 25c. SLIDES, P.O. Box 26,
Gardeno, Calif.

ALASKA WILDLIFE KODACHROME 16mm. — 8mm. 2x2
slides taken by professional photographer and Alas-
kan Registered Guide. Free Catalog. MAC'S FOTO
SERVICE, 315 4th Avenue, Anchorage, Alaska.

LABORATORY & SOUND

SOUND RECORDING at a reasonable cost. High
Fidelity 16 or 35. Quality guaranteed. Complete
studia and laboratory services. Color printing and
lacquer coating. ESCAR MOTION PICTURE SERVICE
INC., 7315 Carnegie Avenue, Cleveland 3, Ohio.
Phone Endicatt 1-2707.

RECORDING and sound editing. 16 or 17½mm. Mag-
netic tracks. Music recorded in sync to your work
print. L.A. and Harbar area producers call Dan
Dunn — DAVenport 6-4925, EL RANCHO AUDIO,
26236 Fairview Avenue, Lomita, California.

SAVE TIME ON 16MM PROCESSING AND PRINTING!
Same day service on 16mm reversal processing. Du-
Pont & EK films in all lengths. Price list available.
WESTERN CINE SERVICE
14 East 8th Avenue Denver 3, Colorado

POSITIONS AVAILABLE

GROWING Chicago Lab wants young man thoroughly
familiar with Bell & Howell Printer for 16mm.
Color and B&W printing and general lab work.
State age, experience and salary. Box 1183,
AMERICAN CINEMATOGRAPHER.

NEW INSTRUMENT FOR CHECKING FOCUS

(Continued from Page 153)

be summarized as follows:—

<i>Focal plane surface</i>	<i>Focusing accuracy</i>	1" f/1.4	2" f/1.4
a. Mirror	$\pm 0.0001''$ up to f/4	$\pm 0.00015''$ up to f/4	
b. Stationary exposed and developed film (emulsion side)	$\pm 0.00025''$ up to f/4	$\pm 0.0003''$ up to f/4	
c. Stationary undeveloped film (emulsion side)	$\pm 0.00025''$ up to f/4	$\pm 0.0003''$ up to f/4	
d. Moving undeveloped film (emulsion side)	$\pm 0.00025''$ up to f/2	$\pm 0.0005''$ up to f/2.8	

CAMERA LENS FOCUS AUTOCOLLIMATOR —REPETITION ACCURACY ON FILM

Speed Ponchros, focal lengths 1" to 4"

Aperture f/2 f/2.8 f/4

Focusing repetition accuracy $\pm .0003''$ $\pm .0004''$ $\pm .0005''$

Telephoto types

6" f/4.5

Aperture f/4.5 f/5.5

Focusing repetition accuracy $\pm .0015''$ $\pm .0020''$

8½" f/5.6

Aperture f/5.6 f/8

Focusing repetition accuracy $\pm .0035''$ $\pm .004''$

The Camera Focus Autocollimator is the product of Taylor-Taylor-Hobson, Ltd., a division of the J. Arthur Rank Organization, London, England.

NEW EDITION

CAMERAMAN'S HANDBOOK

for the

PROFESSIONAL and AMATEUR

by

JACKSON J. ROSE, ASC

New data on Cinerama - Tele-
vision photography - Background
Projection - Zoom Lenses - Un-
derwater Photography - Latensi-
fication - "T" Stops - Ansco
Color - Eastman Color - DuPont
Color - Cameras - Projectors -
Lenses - Filters - Charts - Tables
- Ratings - Diagrams - Systems -
Equalizers - Formulas, Etc.

THE ONLY HAND BOOK
OF ITS KIND

PRICE \$5.00

(California buyers please add sales tax)

Book Department,
American Cinematographer,
1782 No. Orange Dr.,
Hollywood 28, Calif.

Gentlemen: Enclosed please find \$5.00* for
which please send me a copy of
THE AMERICAN CINEMATOGRAPHER HAND-
BOOK AND REFERENCE GUIDE.

Name

Address

City..... Zone..... State.....

*If you live in California, please include
18c sales tax — total \$5.18.



PELEGRINI

VARIABLE SHUTTER UNITS
FOR THE BOLEX H-16

The real answer to complete FADES and LAP DIS-
SOLVES. Faster shutter speeds and many other advantages. Prices within U. S. \$99.60. Cameras with outside frame counter \$109.80. Tax extra. One year guarantee and camera transportation back included. Send for free informative booklet.

Prices subject to change without notice.

TULLIO PELLEGRINI
1545 Lombard St.

San Francisco 23, California

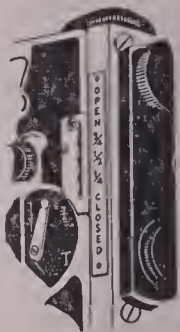

FREE! CATALOG

THE BIGGEST OF ITS KIND!!
80 pages, more than 1000
different items with prices
and over 300 illustrations. For
Producers, TV Stations, Film
Labs., Industrial Photography,
Educational Institutions, etc.

MOTION
PICTURE
PRODUCTION
EQUIPMENT

S.O.S. CINEMA SUPPLY CORP., Dept. F, 602 West 52nd St., N. Y. C.

There's only one

color-correct*

process...



...only

byron

has it!

... and only **byron** can give you all these 16mm production facilities on one order:

script

art

editing

sound effects

animation

recording

complete black-and-white laboratory facilities

music library

sound stage

location photography

titling

Want guaranteed satisfaction for your color films? Demand Byron color-correct* prints, the film industry's highest standard of color duplication. Byron service is dependable — prices are the lowest in the industry — quality the best. Call today for our illustrated brochure and price list.

8-hour service if required

byron Studios and Laboratory

1226 Wisconsin Avenue, N.W., Washington 7, D.C. DUpont 7-1800

550 Fifth Avenue, New York 36, N.Y. Circle 5-8188

*Reg. U.S. Patent Office

PRACTICALLY EVERY 16MM FILM PRODUCER IN THE WESTERN HEMISPHERE IS A CLIENT OF BYRON

ULTRA-SHARP DETAIL

...in



...in



...and in

CINEMA SCOPE



...with Taylor, Taylor and Hobson Speed Panchro Lenses

T-T-H Speed Panchro lenses again meet the demands of a fast-growing industry—supplying the high degree of sharpness needed for CinemaScope, 3-D and television films. A complete set of eight fully color corrected lenses matched for

perfection is now available from Bell & Howell. Each lens is accurately calibrated by scientific measurement of light actually transmitted. Consistent negative densities regardless of which lens is used. For full details, write to Bell & Howell.



100mm T3 (f/2.5)



75mm T2.3 (f/2)



50mm T2.3 (f/2)



40mm T2.3 (f/2)



35mm T2.3 (f/2)



25mm T2.3 (f/2)



32mm T2.3 (f/2)



28mm T2.3 (f/2)

Also 8½", 12½", and 20" F/5.6 T-T-H Telephotos

Look for Bell & Howell's new 35mm anamorphic lens for studio and theater projection.



Bell & Howell

Professional Equipment Department
7148 McCormick Road, Chicago 45, Ill.

Cinematographer

THE MAGAZINE OF MOTION PICTURE PHOTOGRAPHY

THEATRE
TELEVISION
INDUSTRIAL
AMATEUR



COPYRIGHT DEPOSIT

In This Issue . . .

- 1953 Academy Award Winners
 - Tomorrow's Wide-Screen Camera
 - Filming The "Dragnet" TV Show

25c
\$3.00 YEARLY

better pictures

demand the

best equipment!

HOUSTON-FEARLESS PANORAM DOLLY

New life! New action! New drama! New interest! . . . are achieved by pictures made with the Houston-Fearless Panoram Dolly. Gives cameras complete mobility, produces smooth pan effects, angle shots, running shots, dolly shots and countless special effects. Raises camera from low to extreme high position smoothly and silently. Dollies in and out of scenes quietly on rubber-tired ball bearing wheels. Dolly track available. Deluxe model can also be moved sideways. Running board attaches to side, if desired. Very maneuverable. Proved completely dependable by leading studios in Hollywood and throughout the world

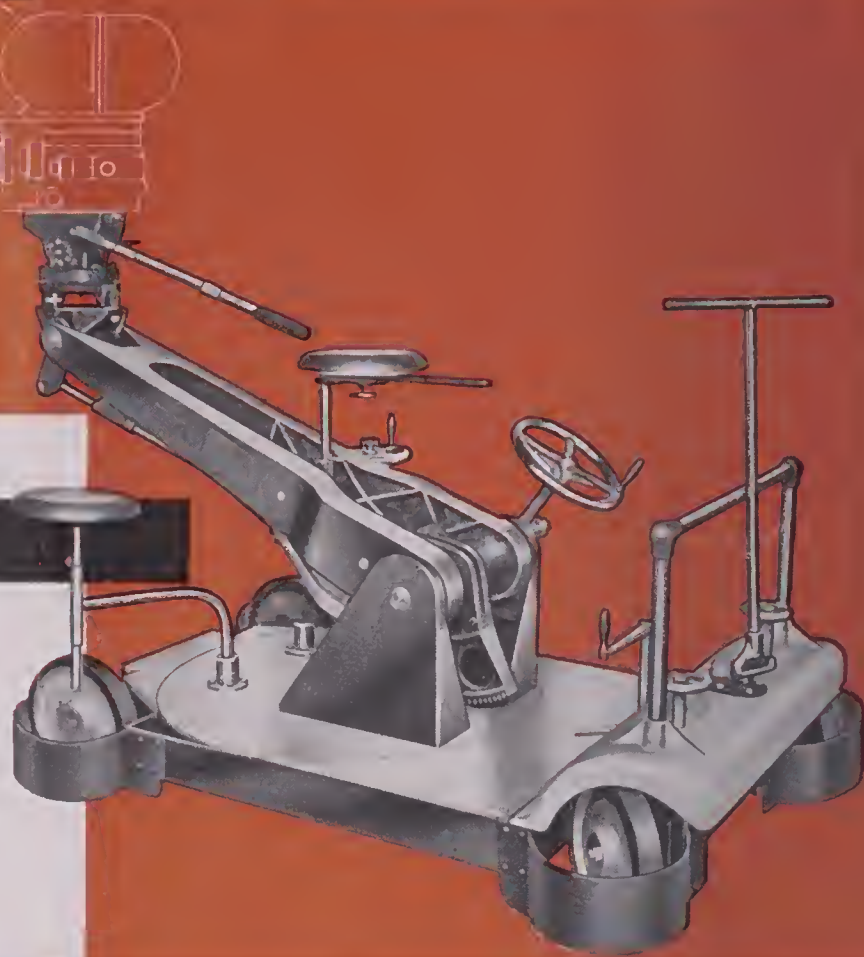

H-F FRICTION HEAD

Provides smooth, easy panning and tilting of cameras. Pans 360° on ball bearings. Tilts 45° up or down with camera counterbalanced at all times. Variable drag and brake are provided on both pan and tilt. Adjustable handle. Fits Houston-Fearless and other standard tripods, pedestals, dollies and cranes.

H-F ALL-METAL TRIPOD

Combines extreme ruggedness, adaptability, rigidity, ease of operation and portability not found in any other tripod. For studio or field use. Levels automatically. Tubular steel legs are easily adjusted for height—lock positively to prevent slipping. Folds compactly. Two sizes: $\frac{3}{4}$ and full length.

H-F TRIPOD DOLLY

Gives convenient mobility to tripod-mounted cameras. In the studio, it offers a rapid means of moving camera. Wheels swivel for maneuverability or can be locked parallel for straight line tracking. In field, provides easy means for positioning camera. Strong, lightweight tubular steel. Folds compactly.



The
**HOUSTON
FEARLESS**
Corporation

MAIL
TODAY!

Write for information on specially-built equipment for your specific needs

THE HOUSTON-FEARLESS CORP.
11809 W. Olympic Blvd., Los Angeles 64, Calif.

Please send catalogs on Friction Head Tripod
 Tripod Dolly Panoram Dolly Film Processors

Name _____

Firm _____

Address _____

City _____ Zone _____ State _____

SALES • SERVICE • RENTALS

APR 27 1954

THE WORLD'S MOST COMPLETE ASSORTMENT
OF PHOTOGRAPHIC EQUIPMENT FOR

T. V. and Motion Picture Studios



New **PROFESSIONAL JUNIOR**

Adjustable wood **BABY TRIPOD**

—for Prof. Jr. friction
and geared heads



Has substantial shoe and spur.

Measures from floor to flange

25" extended —17"

collapsed. **\$75**

FAMOUS
"controlled
action"

**SMALL GYRO
TRIPOD**

Two speeds—slow and fast
—for both panning and tilting.
Helps you capture fine scenic views
and fast-moving sports events. Espe-
cially recommended for 16mm Mitchell,
16mm Maurer, B & H Eyemo
and similar cameras.

\$600

PACKAGED LIGHTING WITH

COLOR-TRAN

—studio lighting in a suitcase

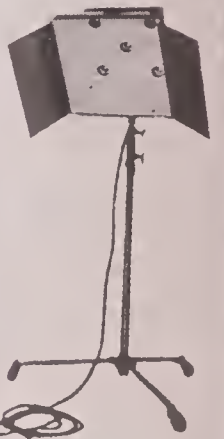

Imagine being able to use two 5000 watt units
on a 30 amp. fuse — **COLOR-TRAN** will do it!
Kit contains 2 light heads, 2 Superior stands and
proper size **COLOR-TRAN** converter to match.
Packed in compact case.

Senior Kit
\$237.50

Other style
kits available.

Write for **COLOR-TRAN** Catalogue.

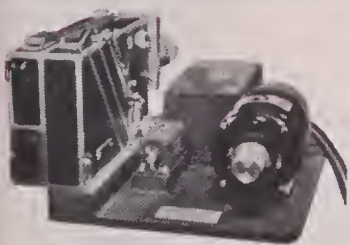

**STOP MOTION MOTOR
FOR CINE KODAK SPECIAL**

Runs forward or reverse, 110
AC synchronous motor with frame
counter. May be run continuously
or for single frames. Camera
mounts without special tools.

\$450

Also available — Stop Motion
Motors for 16mm—35mm B & H,
Mitchell and other professional
cameras.



**ELECTRIC
FOOTAGE TIMER**

Dual model for both 16mm
and 35mm. Large white num-
erals on black background. Accu-
rate reset dial. Switch controlled
by operator, who selects either
16mm operating at 36 feet per
minute—or 35mm operating at
90 feet per minute . . . or both
in synchronization. **\$95**

Single model, either 16mm or
35mm **\$45**

presto-splicer

GIVES PERMANENT SPLICE
IN **10 SECONDS!**

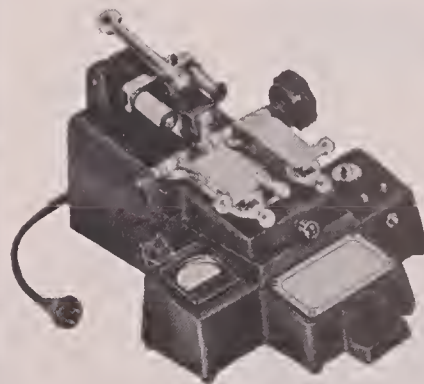

Especially good for splicing magnetic
film. Butt Weld type for non-perforated
or perforated film. 16mm, 35mm or
70mm. **\$547.80**

16mm or 35mm models—
for perforated film.

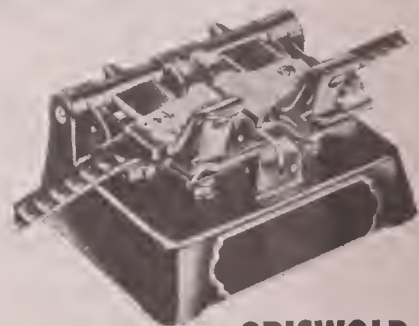

**GRISWOLD
HOT FILM SPLICER**

Model R-2 for 35mm silent and sound
film. Precision construction makes it easy
to get a clean, square splice with accu-
rate hole spacing. Nothing to get out of
order. **\$65**

Also Bell & Howell 8mm, 16mm and
35mm Hot Splicers and B & H Labora-
tory model Foot Splicer.

9.5mm Lenses in 16mm C mount. 18.5mm (extreme wide angle-flat field)
Lenses available in mounts for all 35 mm Motion Picture Cameras.
PHOTO RESEARCH Color Temperature Meters. *Electric Footage Timers
Neumade and Hollywood Film Company cutting room equipment.
Griswold & B.&H. Hot Splicers. *DOLLIES—Bardwell-McAlister, Mole
Richardson, Century and Colortran Lighting Equipment.

Complete line of 16mm and 35mm Cameras

FRANK C. ZUCKER
CAMERA EQUIPMENT CO.
1600 BROADWAY NEW YORK CITY

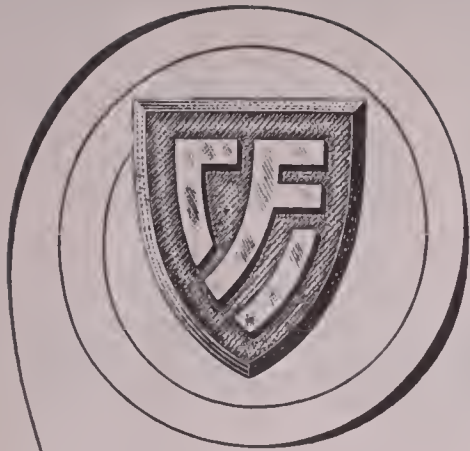

The Seal of Our Pledge to You . . .

... to bring to the screen in flawless manner the artistry of your photography

Hollywood's only complete

LABORATORY SERVICE

CONSOLIDATED FILM INDUSTRIES

A DIVISION OF REPUBLIC PICTURES CORPORATION

**959 N. SEWARD ST.
PHONE HO 9-1441**

AMERICAN

Cinematographer

THE MAGAZINE OF MOTION PICTURE PHOTOGRAPHY
PUBLICATION OF THE AMERICAN SOCIETY OF CINEMATOGRAPHERS

ARTHUR E. GAVIN, *Editor*

EMERY HUSE, *Technical Editor*

GLENN R. KERSHNER, *Art Editor*

Circulation, MARGUERITE DUERR

EDITORIAL ADVISORY BOARD: John Arnold, Arthur Edeson, Lee Garmes, Charles Roshier, Leon Shamroy, Fred Gage, Dr. L. A. Jones

Editorial and Business Office: 1782 N. Orange Dr., Hollywood 28, Calif.
Telephone: HOLLYWOOD 7-2135

VOL. 35

APRIL • 1954

NO. 4

CONTENTS

ARTICLES

TOMORROW'S WIDE SCREEN CAMERA—By Arthur E. Gavin	174
1953 ACADEMY AWARD WINNERS	179
CAMERA MODIFICATIONS	181
FILMING THE "DRAGNET" TV SHOW—By Frederick Foster	188
FILMING HOLLYWOOD'S BIGGEST INDOOR EXTERIOR—By Arthur Rowan	190

AMATEUR CINEMATOGRAPHY

CLUB PROJECT—By George A. Valentine	192
SHAKESPEARE IN 8MM—By Zenda Sanders	194

FEATURES

WHAT'S NEW IN EQUIPMENT, ACCESSORIES, SERVICES	168
HOLLYWOOD BULLETIN BOARD	166
CURRENT ASSIGNMENTS OF A.S.C. MEMBERS	206

ON THE COVER

OSCAR WINNERS—Burnett Guffey, ASC (left), and Loyal Griggs, ASC, smile happily for the camera, following presentation of Academy Awards for achievement in cinematography for 1953. Burnett Guffey won Best Black-and-White Photography Award for "From Here To Eternity"; Loyal Griggs, the Best Color Photography Award for "Shane." Both are Oscar winners for the first time.

AMERICAN CINEMATOGRAPHER, established 1920, is published monthly by the A. S. C. Agency, Inc., 1782 N. Orange Dr., Hollywood 28, Calif. Entered as second class matter Nov. 18, 1937, at the postoffice at Los Angeles, Calif., under act of March 3, 1879. SUBSCRIPTIONS: United States and Canada, \$3.00 per year; Foreign, including Pan-American Union, \$4.00 per year. Single copies, 25 cents; back numbers, 30 cents; foreign single copies, 35 cents; back numbers 40 cents. Advertising rates on application. Copyright 1954 by A. S. C. Agency, Inc.

new! FOLLOW FOCUS ATTACHMENT for Mitchell Cameras one hand control of both Picture Framing and Lens Focusing

Read what cameraman Michael Slifka says about the new Follow Focus Attachment—only mechanism designed for Mitchell Cameras which couples the finder directly to the lens....



Michael Slifka, member of International Photographers of the Motion Picture Industry, Local 644, shown with his Follow Focus equipped Mitchell 35mm NC Camera.

January 5, 1954

Mr. J. D. McCall
Mitchell Camera Corporation
666 West Harvard Street
Glendale 4, Calif.

Dear Mr. McCall:

Enclosed is my check for \$120.25 to cover items listed in Invoice Nos. E4585, E4586, and E4587, all dated December 28, 1953.

We are shooting with parallax follow focus Unit No. 3. Most of the work is play-backs in interiors and exteriors, and this new parallax with an NC camera is paying off in many ways. Production hours are saved because of the rapidity of movement with the light-weight NC, yet there is no fuss or bother when lining up dolly shots. Of particular note is the simplicity and speed with which the lens gear is locked and disengaged to rotate lenses. In rapid dolly shots, while zooming away from an insert, with this NC follow focus unit for the first time we have the proper gear speed ratio with a simple turn of the hand. The follow focus control knob, with its plastic footage dial on which lens footage calibrations can be transferred, is very conveniently located where it can be seen and controlled from any position when following focus on dollies. The dovetail adaptor is an excellent idea as it makes reloading a pleasure but still keeps the finder attached to the camera. The simple design of the unit for mounting and the cam roller releasing knob is first class in that it in no way hampers or interferes with camera operation.

Without a doubt this whole unit puts a new light on the use of an NC camera. You can be sure, Mr. McCall, that the fame of this new follow focus attachment will spread to all producers in New York City and its vicinity.

Sincerely

Michael Slifka
Michael Slifka

345 West 19th Street
New York 11, N. Y.



The Follow Focus Attachment shown assembled here is easily installed and readily removed. Follow focusing control is quickly and smoothly accomplished through the use of the single follow focus control knob.

This long-awaited Follow Focus Attachment permits NC, Standard and 16mm Mitchell Cameras to be used for action shots moving toward or away from the camera. It assures full control of picture framing and lens focusing—particularly at close, critical ranges. Light-weight, the Attachment does not interfere with the use of any standard accessories and is supplied complete with bracket for mounting the matte box. Two models are available: 1, for use with the 16mm Professional, and 2, for use with the 35mm Sound Model (NC) and Standard Cameras. Write today for complete literature and prices.

Mitchell Camera CORPORATION

666 West Harvard Street • Glendale 4, Calif. • Cable Address: "MITCAMCO"



85% of the professional motion pictures shown throughout the world are filmed with a Mitchell

Hollywood Bulletin Board



LOYAL GRIGGS, ASC, Academy Award winner this year for best color photography (for "Shane") won the annual Look Award for the best photography of 1953 for the same picture. Award was presented Griggs in Hollywood latter part of February.

Two New Anamorphic photographic lenses have been developed by 20th Century-Fox, which are said to produce a much sharper and clearer picture and with higher definition in the backgrounds than any lenses used up to now.

"Lucky Me," Warner Brothers' latest CinemaScope production in WarnerColor, is rated by critics one of the best jobs of CinemaScope photography yet. Photographed by Wilfrid Cline, ASC, the picture is marked by sharp definition throughout, and the WarnerColor is the best of that process to come out of the Burbank studio to date.

Walter Griffin, veteran cameraman and a charter member of the American Society of Cinematographers died last month, following a lingering illness. Griffin photographed all of Louis Stone's pictures prior to 1920. On January 8, 1919 he joined fourteen other Hollywood cameramen in organizing the ASC. Following his retirement from cinematography, he became a successful North Hollywood florist.

Ted McCord, ASC, returned from location in Puerto Rico last month,

where he shot 2nd Unit CinemaScope photography on "Battle Cry," for Warner Brothers. Sid Hickox directed 1st Unit photography.

Karl Struss, ASC, will remain in Italy another eight months to complete photography commitments he has there. Thus far, he reports, he has filmed five feature productions in Ferranicolor—three 3-D pictures, and two wide-screen. An inveterate Stereo-Realist fan, Struss spends his spare time shooting 3-D transparencies in Kodachrome. One such picture, incidentally, was selected for exhibition in the 17th International Salon of Photography at Rochester, New York.

Paramount Studios, last month hosted the members of the American Society of Cinematographers at an exclusive demonstration of VistaVision, the studios' new wide-screen filming process. Following the screen demonstration, a technical discussion followed during which Loren Ryder, ASC, Paramount engineering department head, explained the photographic procedure for the system. Story on the new VistaVision camera appears elsewhere in this issue.

James Van Trees, ASC, was signed last month to photograph "For The Defense," new TV film series to be produced by Sam Bischoff and starring Edward G. Robinson.

Don Malkames, ASC, last month completed the photography on the 100th "Man Against Crime" TV film. Series, which stars Ralph Bellamy is produced in New York City by William Esty Co., Inc.

Society of Cinema Collectors and Historians, New York, N. Y., invites applications for membership from those active in preserving the history, material and equipment of the motion picture industry. President is Irving Browning who, incidentally also is president of Camera Mart, Inc., and who has one of the largest and most valuable collections of motion picture memorabilia in America. Secretary is Saul Haber, 4221 Fourth Street, SE, Washington 20, D. C.

ARRIFLEX

35mm
Model 11

**A TRULY GREAT
CAMERA**

for TV, Newsreel
and commercial
films

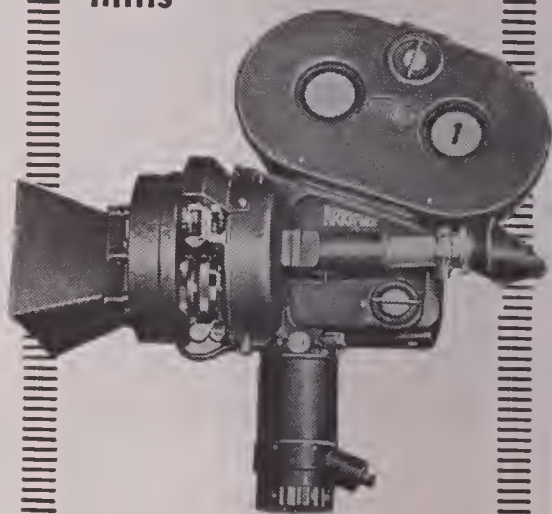

For tough and trying assignments, ARRIFLEX 35 is in a class by itself. Reflex focusing through photographing lens while camera is operating—this is just one outstanding ARRIFLEX feature.

Equipped with bright, right-side-up image finder, 6½ x magnification. Solves all parallax problems. 3 lens turret. Variable speed motor built into handle operates from lightweight battery. Tachometer registering from 0 to 50 frames per second. Compact, lightweight for either tripod or hand-held filming. Takes 200' or 400' magazine. Write for free folder.

COMPLETE REPAIR FACILITIES

FRANK C. ZUCKER
CAMERA EQUIPMENT CO.
1600 BROADWAY NEW YORK CITY

MODEL SW-602
PORTABLE RECORDING SYSTEM

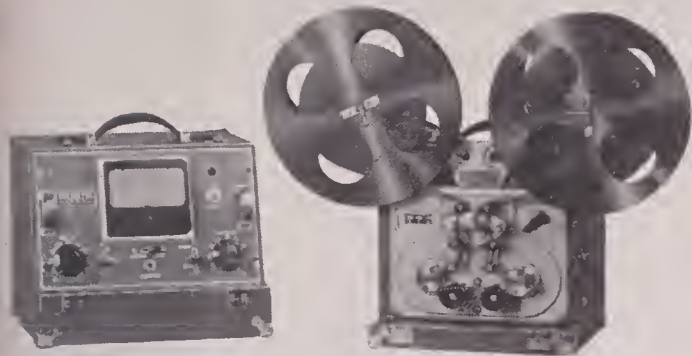

MODEL SW-602-RP
RACK-MOUNT RECORDER
IN PORTABLE CASE



MODEL SW-602-D3
THREE INTERLOCKED DUMMIES
WITH PLAYBACK PRE-AMPLIFIERS



MODEL SW-335
35mm STEREOPHONIC
THEATRE
PLAYBACK SYSTEM

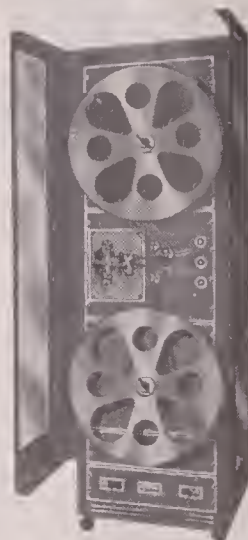

RACK-MOUNT AMPLIFIER WITH SPEAKER



EQUALIZED PLAYBACK PRE-AMPLIFIER

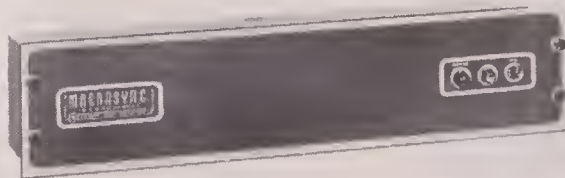

UNITIZED CONSTRUCTION

Designed around this famous "SYNKINETIC" film transport, all MAGNASYNC equipment is built to PERFORM.

You can depend on MAGNASYNC!

16mm CENTER TRACK 16mm EDGE TRACK
17½mm 35mm MULTI-CHANNEL



NORTH HOLLYWOOD, CALIFORNIA

Send for complete technical data

DISTRIBUTORS

MAGNETIC RECORDERS COMPANY **CAMERA EQUIPMENT COMPANY**
7120 Melrose Ave., Los Angeles 46, Calif. 1600 Broadway, New York 19, New York
WEbster 3-5545 Judson 6-1420 Cable Address: CINEQUIP

ZENITH CINEMA SERVICE, INC.

3252 Foster Ave., Chicago 25, Illinois
IRving 8-2104

Manufactured by:

MAGNASYNC MFG. CO., Ltd. • P.O. Box 707, North Hollywood, Calif.

MICROPHONE MIXERS • PORTABLE SUPPLIES • SPLIT-APART REELS • BULK ERASERS

ONE CAMERA

16mm or 35mm

in 10 SECONDS!

Camerette 16/35

Reflex Motion Picture Camera

The perfect camera for the motion picture film maker working in both 16mm or 35mm color or black and white.

LOOK AT THESE ADVANTAGES—

- The same lenses, same motor drives, same sound blimp and accessory equipment used for both 16mm or 35mm — to convert simply change the magazine.
- Precise rugged movement
- Reflex viewing
- 200 degree adjustable shutter
- Divergent three lens turret
- Automatic film gate 400' magazines 16 or 35mm — the 16mm magazine will accommodate daylight spools as well as standard core load.
- Light weight — only 14 pounds with 3 lenses, 400' magazine, and 6/8 volt motor.

Write for brochure



amerette

patents coutant-mathot

Manufactured by Ets. Cine. Eclair, Paris



WHAT'S NEW

in equipment, accessories and service

Multi-Outlet Box—Marcson Products Company, 400 North Wall Street, Chicago 10, Illinois, offer a new portable fused multiple outlet box to quadruple the number of electrical outlets at any place on location or in the studio for lighting motion picture sets. The unit has four receptacles for connecting conventional lighting and equipment plugs.



It is equipped with its own 15 ampere fuse to minimize the possibility of blowing main fuses. In the event of an overload, the unit fuse will blow first, leaving the main line fuse and all circuits intact. Multi-Light is 7" long, 4" wide and 2" deep. It weighs 13¼ pounds and is encased in a durable steel container having a baked-enamel finish. A heavy duty 6-foot service cable is attached, and there is a metal handle to provide easy portability. Retail price is \$4.95.

8MM and 16MM Film Printer—Uhler Cine Machine Company, 1578 Wyoming Avenue, Detroit 38, Michigan, offers a reduction and enlarging printer for 8mm and 16mm films having three special features: it reduces 16mm to 8mm, enlarges 8mm to 16mm, and it is equipped to print color film as well as black and white.

In printing, the film is exposed by a 150 watt lamp on either side of the printer, and there are blowers for cooling. The light range can also be lowered by using a filter and a filter holder.

The printer operates at 25 feet per minute printing speed. The lens is an anastigmat f/3.5. The aperture plate is of a highly polished stainless steel. The printer is equipped with semi-automatic dual light control. One is set in advance the equivalent of one full scene and the light changes automatically as the notched film goes by.

Also announced by the company is its combination continuous printer for

8mm and 16mm film, black and white or color, single or double system sound. The film is run through the machine once only while printing single or double sound system, at the same time the picture is printing. Capacity is 1200 ft. negative, positive, and sound track. The printing speed is up to 16 ft. per hour. The equipment is ideal for professional or amateur movie makers, laboratories, schools, and technicians. For complete technical information and prices, write the manufacturer, mentioning *American Cinematographer Magazine*.

Craig Projecto-Editor — Craig, Inc., division of the Kalart Company, Plainville, Connecticut, announces a new Craig Projecto-Editor for viewing and editing 8mm and 16mm films. The new equipment is literally two units in one—a practical tabletop motion picture viewer, and a complete outfit for film editing and repair. A feature is the built-in frame marker for identifying



the frame selected for cutting. The Craig Projecto-Editor folds neatly into a trim carrying case only 7¼" x 7¾" x 13½" in size. The ground-glass viewing screen is 3¼" by 4¼", said to be larger than any other home movie film viewer. The take-up reel spindle is low geared (1-to-1) for smooth control of film speed. The rewind spindle is high geared (4-to-1) for rapid rewinding. A rotating prism shutter eliminates any mechanical shutter movement and consequently damaged film. Price complete is \$79.50 for either the 8mm or 16mm model.

New Elgeet Lenses — Elgeet Optical Company, Inc., 838 Smith Street,

(Continued on Page 170)

Precision Prints

**YOUR PRODUCTIONS
BEST REPRESENTATIVE**

CLOSE CHECK ON PROCESSING

Picture and sound results are held to the closest limits by automatic temperature regulation, spray development, electronically filtered and humidity controlled air in the drying cabinets, circulating filtered baths, Thymatrol motor drive, film waxing and others. The exacting requirements of sound track development are met in PRECISION'S special developing machinery.

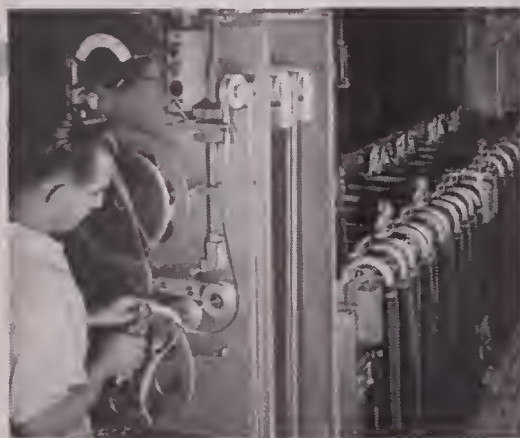

YOUR ASSURANCE OF BETTER 16mm PRINTS

16 Years Research and Specialization in every phase of 16mm processing, visual and aural. So organized and equipped that all Precision jobs are of the highest quality.

Individual Attention is given each film, each reel, each scene, each frame — through every phase of the complex business of processing — assuring you of the very best results.

Our Advanced Methods and our constant checking and adoption of up-to-the-minute techniques, plus new engineering principles and special machinery enable us to offer service unequalled anywhere!

Newest Facilities in the 16mm field are available to customers of Precision, including the most modern applications of electronics, chemistry, physics, optics, sensitometry and densitometry — including exclusive Maurer-designed equipment — your guarantee that only the *best* is yours at Precision!

Precision Film Laboratories — a division of J. A. Maurer, Inc., has 16 years of specialization in the 16mm field, consistently meets the latest demands for higher quality and speed.

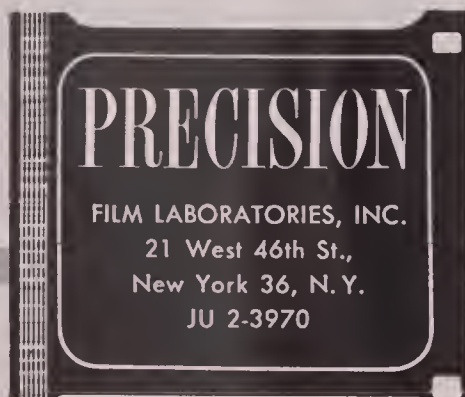

WHAT'S NEW

(Continued from Page 168)

Rochester, New York, announces a new line of Cinematar lenses, a budget-priced companion line to the famous Elgeet Custom lens line.

The first two lenses in the Cinematar line will be: (1) The Elgeet Cinematar 38mm f/3.5 telephoto fixed focus, which lists at \$17.95. This lens fits all "D" mount cameras providing for inter-

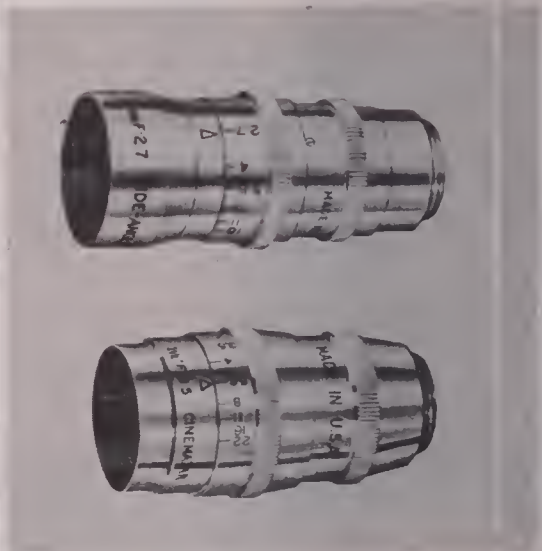

changeable lenses. It is hard coated and provides 3X magnification. (2) The Elgeet Cinematar 7mm f/2.7 wide-angle, which lists at \$29.95 is a high speed true wide-angle lens which covers 4X area of normal lens. This also is for all "D" mount cameras providing for interchangeable lenses. As with the first lens, it is hard coated, distortion free, and provides for the diaphragm setting at the front, for ease of operation. Further information may be had by writing the manufacturer and mentioning *American Cinematographer Magazine*.



New Bell & Howell Camera—Bell & Howell Company, 7100 McCormick Road, Chicago 45, Illinois, announces a new Bell & Howell 16mm magazine load cine camera, having a three-lens turret. Called the 200-TA Automaster, this new camera completes the com-

(Continued on Page 210)

AURICON 16mm Sound-On-Film for Professional Results!



ALL AURICON EQUIPMENT IS SOLD WITH A 30 DAY MONEY-BACK GUARANTEE.

"CINE-VOICE" 16 mm Optical Sound-On-Film Camera. ★ 100 ft. film capacity for 2¾ minutes of recording; 6-Volt DC Converter or 115-Volt AC operation. ★ \$695.00 (and up).



"AURICON-PRO" 16 mm Optical Sound-On-Film Camera. ★ 200 ft. film capacity for 5½ minutes of recording. ★ \$1310.00 (and up) with 30 day money-back guarantee.



"SUPER 1200" 16 mm Optical Sound-On-Film Camera. ★ 1200 ft. film capacity for 33 minutes of recording. ★ \$4652.15 (and up) complete for "High-Fidelity" Talking Pictures.



SOUND RECORDER — Model RT-80...200 foot film capacity, daylight loading, synchronous motor for portable "double-system" 16 mm Optical Sound-On-Film operation. ★ \$862.00 (and up).



PORTABLE POWER SUPPLY UNIT — Model PS-21... Silent in operation, furnishes 115-Volt AC power to drive "Single System" or "Double System" Auricon Equipment from 12 Volt Storage Battery, for remote "location" filming. ★ \$269.50



DUAL PHONO-TURNTABLE — Model DPT-10... Takes up to 16 inch discs with individual Volume Controls for re-recording music and sound effects to 16 mm Sound-On-Film. ★ \$161.15



TRIPOD — Models FT-10 and FT-10S12... Pan-Tilt Head Professional Tripod for velvet-smooth action. Perfectly counter-balanced to prevent Camera "dumping." ★ \$325.00 (and up).

Strictly for Profit CHOOSE AURICON

If it's profit you're after in the production of 16 mm Sound-On-Film Talking Pictures, Auricon Cameras provide ideal working tools for shooting profitable Television Newsreels, film commercials, inserts, and local candid-camera programming. Now you can get Lip-Synchronized Sound WITH your picture at NO additional film cost with Auricon 16 mm "Optical" Sound-On-Film Cameras. Precision designed and built to "take it." Strictly for Profit — Choose Auricon!



BERNDT-BACH, INC.

7381 BEVERLY BLVD., LOS ANGELES 36, CALIF.



Auricon Equipment is sold with a 30-day money-back guarantee. You must be satisfied.

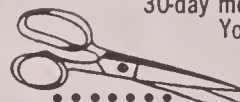

Please send me free Auricon Catalog. 81A

Name.....
(Please write your address in margin)

MANUFACTURERS OF SOUND-ON-FILM RECORDING EQUIPMENT SINCE 1931

Slash your costs with

Ansco *Negative* Color *Positive*



Looking for a way to make important savings in production costs without sacrificing screen quality?

Then standardize on Ansco Negative-Positive Color! It offers a long series of advantages which mean dollars in your pocket and an enhanced reputation as maker of fine motion pictures. Here are just a few of them:

1. No Special Processing Equipment.

Minor modifications adapt standard black and white equipment for rapid, top-quality processing of Ansco Negative-Positive Color.

2. No Costly Waiting To See Results.

With Ansco Negative-Positive Color you don't have to hold expensive casts and sets for days while you wait to see rushes. You can see color rushes within hours—often the same day.

3. No Special Camera.

Any competent cinematographer with standard 35mm equipment can achieve superior results with Ansco Negative-Positive Color.

You Get Better Quality, too:

Finer Grain • Truer Color • Superior Definition

*Higher Emulsion Speed • Greater Latitude • Increased
Production Flexibility*

ANSCO

Binghamton, New York
A Division of General Aniline
& Film Corporation
"From Research to Reality"

Great equipment makes great cameramen . . .

BALANCED TRIPOD HEAD

and

PROFESSIONAL JUNIOR TRIPOD

are the standbys of the masters

You'll never hear Fritz Kreisler playing on a scratchy fiddle . . . or Louis Armstrong on a \$7 trumpet. Good craftsmen need good tools.

Camera Equipment Company makes, sells, services and rents the world's finest quality TV and Motion Picture Equipment.



New "BALANCED" TV head — MODEL "C"
—for the world's smoothest pan and tilt action.



More professional cameramen use The PROFESSIONAL JUNIOR Tripod than any other tripod in the world.

No more groping for center of gravity. The new Model C "Balanced" Tripod Head is equipped with a convenient, accessible positioning handle mounted below the top plate, which allows the operator to reposition the camera to the correct center of gravity. No matter what focal length lens is used on the camera turret, the camera can be balanced on the Model C Head without loosening the camera tie-down screw.

It has all the features which have made the "Balanced" head a gem of engineering ingenuity—quick release pan handle, tilt-tension adjustment to suit your preference. It's a Cameraman's dream!



SYNCHRONOUS MOTOR DRIVE — 110 Volt AC—Single phase, 60 Cycle. Runs in perfect synchronization with either 16mm or 35mm Sound Recorders. Mounting platform permits removal of magazine while camera remains mounted on motor. Spring steel drive fin coupling prevents damage if film jam occurs. Knurled knob on armature permits rotating for threading. "On-Off" switch in base. Platform base threaded for 1/4" or 3/8" tripod tie-down screw. Rubber covered power cable with plugs included.

Let's face it. You need a first class tripod to make better pictures. PROFESSIONAL JUNIOR has the rigidity, the range, and the ease of operation that better pictures demand. See it—try this tripod beauty—and you'll never be without it. PROFESSIONAL JUNIOR TRIPOD—Friction Type. Handles all 16mm cameras, with or without motor. Also 35mm DeVry, B & H Eyemo with and without motor, and 400' magazines. Tripod base interchangeable with Professional Junior gear drive head. "Baby" tripod base and "Hi-Hat" base available.

FRANK C. ZUCKER
CAMERA EQUIPMENT CO.
1600 BROADWAY NEW YORK CITY

SALES • SERVICE • RENTALS — CAMERAS * MOVIOLOS * DOLLIES

Complete line of 35mm and 16mm equipment available for rental.

MITCHELL: Standard, Hi-Speed, BNC, NC, 16mm

BELL & HOWELL: Standard, Shiftover, Eyemo

ARRIFLEX: 35mm and 16mm

MAURER: 16mm Cameras

MOVIOLO: Editing machines, Synchronizers

We design and manufacture Lens Mounts and camera equipment for 16mm—35mm and TV cameras.



VARIABLE SPEED MOTOR — 110 Volt AC/DC with Tachometer for EK Cine Special Motor drive your Cine Special with confidence! Tachometer is mounted in clear view of operator. Calibrated from 8 to 64 frames per second. Definite RED marking for 24 fps. Electrical governor adjusts speeds. Steady operation at all speeds. No adapters needed. Motor coupling attaches to camera and couples to motor. Spring steel drive arm shears if film jam occurs. Easily replaced.

We calibrate lenses—Precision "T" Stop Calibration of all type lenses, any focal length. Our method is approved by Motion Picture Industry and Standard Committee of SMPTE. For proper exposure density, it is important that you have your lens "T" stop calibrated. Lenses coated for photography.



1

1a

2

PICTURED HERE are rough mockups of five tentative VistaVision camera designs. Figs 1 and 1-a above show rear view (left) and front view of a compact model featuring 2000-ft "elephant ear" magazines mounted vertically. Film is turned inside to meet horizontal takeup. Entire movement and sprocket move up and down inside camera box for lineup through taking lens. Finder is on top.

FIG. 2 (above) shows front view and Fig. 2 rear view of a conventional model, which similar to cameras now in use. Film travels into head where it is turned to meet ho

TOMORROW'S WIDE-SCREEN CAMERA . . .

Paramount studio in quest of the most efficient design for its new VistaVision camera.

By ARTHUR E. GAVIN

THE PHOTOGRAPHS shown on these pages are the result of a project undertaken recently by the engineering department of the Paramount studio in Hollywood to design a new VistaVision camera.

Originally dubbed the "Lazy-8" (See American Cinematographer for December, 1953), the present camera is notable as the first to successfully employ horizontal movement of the film. Paramount studio adopted the revolutionary new camera as a means of gaining increased picture width without losing any picture quality. Since its introduction in full-scale studio use last November—it was first used to photograph "White Christmas" in color, using Eastman color negative—the camera has been employed in shooting several other major productions.

In VistaVision photography, the film runs through the camera horizontally; each frame is eight sprocket holes in film length instead of the conventional four. This provides a larger picture area on the negative without involving the use of wider film, such as 65mm and 70mm, which had been

introduced years earlier in some other wide-screen processes.

The VistaVision system of photography utilizes standard 35mm negative. The negative image area, which is 1.472" x .997", is then optically printed in reduced size to standard 35mm positive in an operation which also turns the image 90°. The release print travels through the projector in the conventional vertical manner.

Paramount engineers believe that the VistaVision camera promises to become a major tool in future feature film production, now that public acceptance of wide-screen motion pictures has been established. The studio has invited the major motion picture camera manufacturers to lend their engineering knowhow in the development of a standard VistaVision camera. Because the design and bulk of a studio camera is of prime importance to the men who use it, the engineers of the Studio have invited studio cameramen and technicians to submit any ideas and suggestions which they believe will add to the efficiency and ease of operation of the ultimate VistaVision motion picture camera.



2

3-a

...al film gate. After exposure, film
in turns for takeup in magazine. Assem-
has rack-back for viewfinder to slide
place behind the taking lens.

FIG. 3 (above) and 3-a (at right) is a variation of model shown in Figs. 2 and 2-a, having the motor directly beneath the camera instead of at the side. Both designs offer freedom for any film capacity on top of the camera. Blimping would be an integral part of the camera itself, on the order of the Mitchell model BNC.



4—Cartridge-loader model. This design suggests use of interior magazines for either 1000-ft. or 2000-ft. rolls of film, utilizing a removable compartment to include two stacked magazines in horizontal position. (Housing not shown.) Included is rack-back and finder prism housing mounted to slide vertically behind lens.

FIG. 5—Butterfly type. Where shooting requires minimum height of camera, this design finds immediate acceptance. Separate 2000-ft. magazines mount horizontally on either side of camera. Finder and viewing tube are located on top, center. Camera racks up and down for lineup through taking lens. Viewing tube can be shifted also.

The following tentative specifications have been prepared by Paramount's engineers as a guide in the consideration of a new camera design. It is hoped that the thoughts expressed will bring forth new and better suggestions which can be incorporated in the ultimate specifications for a camera.

1. The film movement shall be horizontal, on edge, and from right to left through the camera as viewed from the rear.
2. The camera pulldown shall be eight sprocket holes.
3. The exact image size and position on the film is still to be defined. Approximately 1.472 x .997 inches.
4. Camera speed shall be a minimum of twenty-four frames

per second. In addition to the production cameras, a special effects camera will be required which can be driven to speeds up to 96 double frames per second.

5. The shutter opening must be at least 170 degrees. It is hoped that eventually cameras will be obtained with a shutter opening of approximately 300 degrees.
6. Acceleration and deceleration characteristics of the movement shall not cause any undue strain on the sprocket holes. The deceleration of the film movement shall be such that the film does not tend to overshoot on some

(Continued on Next Page)

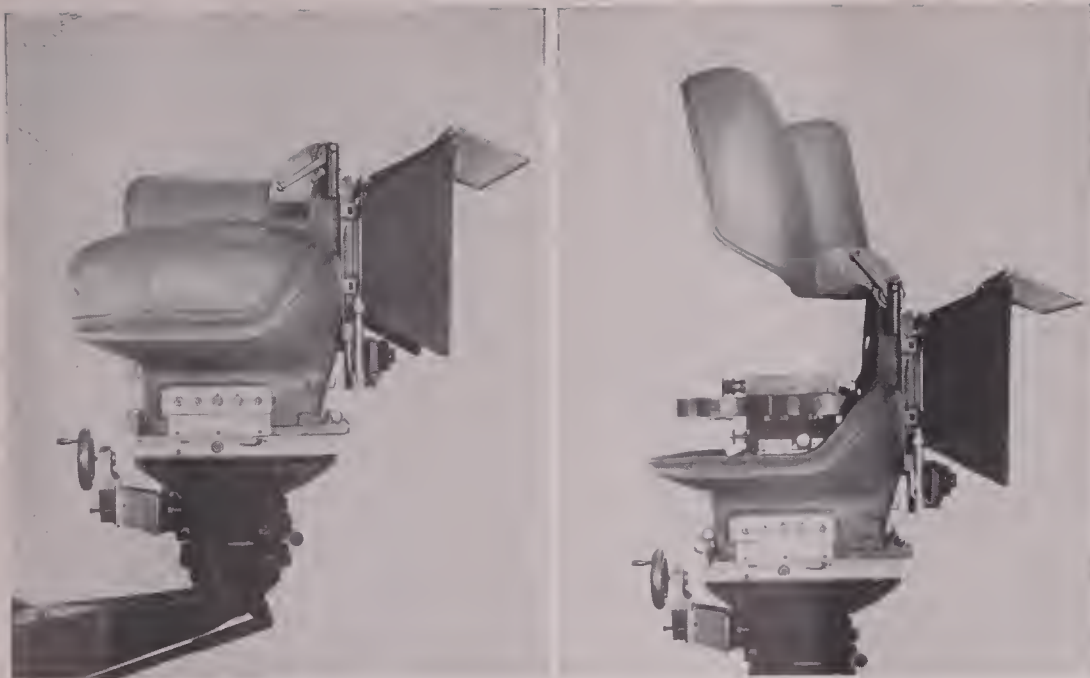

TWO VIEWS of Paramount Studio's first VistaVision camera enclosed in streamlined sponge-rubber blimp. Horizontal position of film magazines and movement can be seen in view at right with blimp opened. Because only a very few of the cameras, which have been modified for VistaVision, are available, the studio plans to build or have built a completely new camera for its VistaVision wide-screen photographic system.

occasions, and undershoot on other occasions with respect to exact registration.

7. This camera shall be designed for standard 35mm Eastman color film negative with Bell & Howell perforations.
8. Camera shall have registration pins. The position of the registration pins shall be upon either side of the film in the first sprocket holes beyond the frame line in the direction of the film pulldown mechanism.
9. Steadiness of ultimate picture and registration must be at least as good as in present production cameras.
10. In this camera the film must lay flat at the aperture plate, not subject to vibration, buckling, and/or the sawing effect from register pins.
11. Minimum threading time is desired. Also threading shall be easily checked for verification of proper threading.
12. Shutters shall be adjustable but without automatic fade. The position of the shutter must be indicated and visible to the camera operator.
13. The camera shall have, or be prepared to accept matte boxes and/or sun shades.
14. Lens mounts shall accept lenses from 28mm to 100mm. If possible, the lens mounts should accept 20mm lenses to meet possible future requirements.
15. Individual lenses shall be separately mounted on camera by bayonet

or similar mounting. No turret will be required.

16. The lens mount shall be positive in position and rapid for lens changing.
17. Lens focusing capability shall include manual and remote control focusing.
18. There seems to be some merit in focusing without lens rotation. This should be studied.
19. The finder shall have adequate light and if possible it shall be free from parallax. There is some objection by photographers to the interrupting shutter-type of parallax-free finders.
20. If necessary, finder shall be coupled to focusing device.
21. If finder parallax cannot be eliminated, the magnitude of parallax shall be held at the minimum. The present experience with the finder placed over the camera indicates that a centrally located finder in this position is very convenient for operation. A design is being prepared so as to establish the position of the central axis of the finder lens between 2 1/2 and 3 inches above the axis of the camera objective lens. If this design is successful, Paramount contemplates locking the finder so that the top frame line of viewing will be 2 1/2 inches above and parallel to the top frame line of photography. This will give effective parallax-free viewing except in very close shots where the cameraman will be

required to learn to allow the 2 1/2 inches.

22. It must be possible to look through the camera lens by lens tube or some convenient method.
23. If required, the rack-over may either be a camera rack-over, or by movement rack-over.
24. A footage counter shall be mounted on the camera or magazines. The counter must be quiet.
25. If dial type footage counters are used, they may indicate both footage of negative consumed and equivalent print footage, also they must be accurate to plus or minus 16 frames.
26. Magazines may be of the split-magazine type and room should be available for magazines of 2000' capacity.
27. Magazine take-up preferably should be a separate motor. This motor must be capable of driving from either DC or AC, or motors should be readily interchangeable.
28. If the magazines are horizontal, they shall have free-running lower flanges (turntables) of very light weight.
29. An effort shall be made to minimize the size of the overall camera. If horizontal type magazines are used, they may be located one above the other, or if vertical magazines are used, it may be possible to locate one unit on each side of the camera.
30. Camera must accept synchronous, interlock and multi-duty motors: however, same may have special housings of new design if desirable. The interlock motor drive must be 1400 rpm and registered for synchronization in background projection.
31. Motors and all shafts operating in a vertical position shall have proper thrust bearings.
32. If feasible, the electrical circuit for the motors shall be made as a part of motor mounting. If motor's electric circuits are carried down inside the camera through the base, it will simplify cabling and camera silencing.
33. The camera motor switch shall also turn the magazine take-up motor on and off.
34. The motor switch must be convenient to the operator. If the motors are not included within an overall blimp, it might be well to have the switch integral to the camera motor. If a single switch unit can be found that will be universal to all motors, such a switch could be mounted integral to the camera. If separate switches are

(Continued on Page 202)

COMMERCIAL!

The one that's
never announced—

Always obvious—

“And now—

a word about films—

color or black and white—

negatives and positives—

Best for Television

Best for you

Best for us!

EASTMAN””

W. J. GERMAN, INC.

FORT LEE

CHICAGO

LOS ANGELES

1953 ACADEMY

Oscars for achievement in cinematography go to Burnett Guffey, ASC, for "From Here To Eternity," best black-and-white



BEST BLACK-AND-WHITE PHOTOGRAPHY award went to Burnett Guffey, ASC, for the photography of Columbia Pictures' "From Here to Eternity." Lana Turner, MGM star, presented the Academy's "Oscar" for this award. At right is a scene from the picture—typical of Guffey's sensitive and artistic camera work and lighting which marked this production.



TWO NEW NAMES have been added to the long list of distinguished cameramen who have won Academy Awards for cinematography. They are Loyal Griggs, ASC, and Burnett Guffey, ASC.

At the 1953 presentation ceremonies of the Academy of Motion Picture Arts and Sciences last month, Loyal Griggs was awarded the Academy's coveted "Oscar" for his magnificent color photography of "Shane," produced by Paramount Pictures, Inc. For his artistic and sensitive photography of Columbia Pictures' "From Here To Eternity," Burnett Guffey won the award for the best black-and-white photography of 1953.

Loyal Griggs' victory is richly deserved, and unquestionably popular with his fellow directors of photography. His achievement in capturing an award this year is unique for the reason that "Shane" is Griggs' first major feature production assignment. For almost 30 years, he had been a cameraman in the transparency or process department at Paramount studios, and he was working in that department when Paramount unexpectedly singled him out to photograph "Shane." That he acquitted himself in his first major feature assign-

ment is evidenced in the award voted him by Academy members.

Camerawork of true Academy calibre demands perfection in not merely one phase of cinematography, but in every one of the many factors which go to make up a well-photographed production. It must begin with outstanding mastery of photographic technique and lighting, and a technical and artistic consistence which is difficult, indeed, to achieve amid the complexities of modern feature film production. Moreover, the players must be presented favorably. Pictorial composition must achieve and maintain outstanding heights of artistry. This Loyal Griggs did with exceptional competence in photographing "Shane."

The achievement of Burnett Guffey in capturing the award for best black-and-white photography is no less singu-

lar. A director of photography with Columbia Pictures since 1946, he has photographed more than 25 major features for this studio. In 1949 he photographed Columbia's "All The King's Men"—which won the Academy's "Best Picture" award for that year. Although the picture was listed on the preliminary ballot for a photography award also, it was nosed out in the final voting. But



SOL HALPRIN, ASC (right) and Darryl Zanuck accepted "Oscars" for 20th Century-Fox's big achievement—CinemaScope. Halprin accepted award in behalf of group honored for creating and developing CinemaScope. Zanuck accepted Honorary Award given to the studio, also for CinemaScope.

AWARD WINNERS

photography; and to Loyal Griggs, ASC, for "Shane," best color photography. Lana Turner makes award presentations.



BEST COLOR PHOTOGRAPHY award went to Loyal Griggs, ASC, for the photography of Paramount Pictures' "Shane." Lana Turner also presented this award to Griggs at the Academy's presentation ceremonies last month. At left is scene from the picture typifying the artful lighting and scene composition which enhanced the prize-winning photography of "Shane."

it did bring Burnett Guffey within hailing distance of his first Academy Award.

Then in 1953, Columbia chose Guffey to direct the photography of its biggest picture of the year—"From Here To Eternity." Almost from the very first day's shooting, an inspired artistic hand was apparent in the daily rushes. Here was a picture with great photographic possibilities, and Guffey's enthusiasm

seemed to mount as shooting progressed. His camerawork and his lighting was beautifully pictorial, even in the grim and brutal scenes of which there are many in the picture. Regardless of the setting or dramatic mood, there seemed scarcely an inch of film in the production which was not marked by flawless composition and pictorial lighting. The award he has received for this outstanding achievement in cinematography is richly deserved.

Several other awards bestowed by the Academy this year are for achievement in fields related to motion picture photography. The category of Best Special Effects embraces visual as well as audible effects. This year, the Academy's award for achievement in this endeavor went to Paramount Pictures, Inc., for "War Of The Worlds," produced by George Pal. Credits for the special effects in this production go to the fol-

lowing *Visual*—Gordon Jennings (deceased), Wallace Kelly, ASC; Paul Lerpae, ASC; Irmin Roberts, ASC; Jan Domela, Chesley Bonestell, Ivyl Burks, George Ulrick, and Lee Vasque. *Audible*—Loren Ryder, ASC, George Dutton, Louis Mesenkop, and William Andrews.

Among the Honorary Award winners this year was the Bell & Howell Company. Mr. H. W. Remerscheid, company vice-president in charge of its Hollywood office, was called to the stage to receive an "Oscar" for the contributions of Bell & Howell to the motion picture industry—contributions which began years ago with the development of the first precision motion picture camera, which was for years the standard of the industry, and which contributions include such precision engineering achievements as the development of the Bell & Howell film printing and laboratory equipment that is pretty generally the standard throughout the Hollywood studios and laboratories, as well as in the motion picture centers throughout the world.

Twentieth Century-Fox studio also was given an Honorary award for the

(Continued on Next Page)



THE BELL & HOWELL COMPANY was honored by the Academy "for its contributions over the years to the Motion Picture industry." Mr. H. W. Remerscheid, company vice-president, accepted the award at the Academy's presentation ceremonies.

**ROSTER OF "OSCAR" WINNERS FOR CINEMATOGRAPHY
1928 to 1953**

Year	Class.	Cameraman	Picture Title	Studio
1953	B&W	Burnett Guffey, A.S.C.	"From Here To Eternity"	Col.
1953	Color	Loyal Griggs, A.S.C.	"Shane"	Para.
1952	B&W	Robert Surtees, A.S.C.	"The Bad and the Beautiful"	MGM
	Color	{ Winton Hoch, A.S.C. } { Archie Stout, A.S.C. }	"The Quiet Man"	Argosy
1951	B&W	William Mellor, A.S.C.	"A Place In The Sun"	Para.
	Color	{ Alfred Gilks, A.S.C. } { John Alton, A.S.C. }	"American In Paris"	MGM
1950	B&W	Robert Krasker	"The Third Man"	British
	Color	Robert Surtees, A.S.C.	"King Solomon's Mines"	MGM
1949	B&W	Paul Vogel, A.S.C.	"Battleground"	MGM
	Color	Winton Hoch, A.S.C.	"She Wore Yellow Ribbon"	R.K.O.
1948	B&W	William Daniels, A.S.C.	"The Naked City"	U-I
	Color	{ Joseph Valentine, A.S.C. } { William V. Skall, A.S.C. } { Winton Hoch, A.S.C. }	"Joan Of Arc"	R.K.O.
1947	B&W	Guy Green	"Great Expectations"	Rank-U-I
	Color	Jack Cardiff, A.S.C.	"Black Narcissus"	Rank-U-I
1946	B&W	Arthur Miller, A.S.C.	"Anna And King Of Siam"	Fox
	Color	{ Charles Rosher, A.S.C. } { Leonard Smith, A.S.C. } { Arthur Arling, A.S.C. }	"The Yearling"	MGM
1945	B&W	Harry Stradling, A.S.C.	"Picture Of Dorian Gray"	MGM
	Color	Leon Shamroy, A.S.C.	"Leave Her To Heaven"	Fox
1944	B&W	Joseph LaSelle, A.S.C.	"Laura"	Fox
	Color	Leon Shamroy, A.S.C.	"Wilson"	Fox
1943	B&W	Arthur Miller, A.S.C.	"Song Of Bernadette"	Fox
	Color	{ Hal Mohr, A.S.C. } { W. Howard Greene }	"Phantom Of The Opera"	Univ.
1942	B&W	Joseph Ruttenberg, A.S.C.	"Mrs. Miniver"	MGM
	Color	Leon Shamroy, A.S.C.	"The Black Swan"	Fox
1941	B&W	Arthur Miller, A.S.C.	"How Green My Valley"	Fox
	Color	{ Ernest Palmer, A.S.C. } { Ray Rennahan, A.S.C. }	"Blood And Sand"	Fox
1940	B&W	George Barnes, A.S.C.	"Rebecca"	Selznick
	Color	George Perrinal	"Thief Of Bagdad"	Korda
1939	B&W	Gregg Toland, A.S.C.	"Wuthering Heights"	Goldwyn
	Color	{ Ernest Haller, A.S.C. } { Ray Rennahan, A.S.C. }	"Gone With The Wind"	Selznick-MGM
1938		Joseph Ruttenebrg, A.S.C.	"The Great Waltz"	MGM
1937		Karl Freund, A.S.C.	"The Good Earth"	MGM
1936		Tony Gaudio, A.S.C.	"Anthony Adverse"	WB
1935		Hal Mohr, A.S.C.	"Midsummer Night's Dream"	WB
1934		Victor Milner, A.S.C.	"Cleopatra"	Para.
1933		Charles B. Lang Jr., A.S.C.	"A Farewell To Arms"	Para.
1932		Lee Garmes, A.S.C.	"Shanghai Express"	Para.
1931		Floyd Crosby, A.S.C.	"Tahu"	Para.
1930		{ William Van Der Veer } { Joseph T. Rucker }	"With Byrd At So. Pole"	Para.
1929		Clyde DeVinna, A.S.C.	"White Shadows In So. Seas"	MGM
1928		{ Charles Rosher, A.S.C. } { Karl Struss, A.S.C. }	"Sunrise"	Fox

development of CinemaScope. Darryl F. Zanuck accepted the award.

CinemaScope brought further acclaim to Twentieth Century-Fox and to its technical staff, when Henry Chretien and five of the studio's technical men were singled out to receive the Academy's statuette—a Class I Technical Award—"for creating, developing and engineering the processes and techniques known as CinemaScope." Besides Mr. Chretien, the group of co-winners of this award include Sol Halprin, ASC; Earl Sponable, Lorin Grignon, Herbert Bragg and Carl Faulkner. Sol Halprin accepted the award in behalf of his associates at the Academy presentation ceremonies.

Sharing awards in the Class I Technical class was another developer of a super widescreen process—Mr. Fred Waller, who was presented a trophy for "designing and developing the multiple photographic and projection systems which culminated in Cinerama."

Reeves Soundcraft Corporation was presented with a Class II Technical Award for the development of a process of applying stripes of magnetic oxide to motion picture film for magnetic sound recording and reproduction.

Westrex Corporation was given a Class III Technical Award for the design and construction of a new film editing machine.

Cinematographers generally were elated when George Stevens, a former director of photography who later became one of Hollywood's top producer-directors, was singled out by the Academy this year to receive the coveted Thalberg Memorial Award. It was Stevens, incidentally, who produced "Shane." His meteoric success has been an inspiration to other directors of photography in Hollywood, many of whom worked on the same sound stages with him in the past.

Photographic achievement again figured in four other awards this year. Breaking all records and precedent, Walt Disney was called to the stage four times to receive "Oscars" for Best Documentary Feature Production ("The Living Desert"), Best Documentary Short ("The Alaskan Eskimo"), Best Cartoon Subject ("Toot, Whistle, Plunk and Boom") and Best Two-Reel Short Subject ("Bear Country"). These four awards bring to 22 the total which the Academy has bestowed on Walt Disney over the years. Unusual photography figured in the production of "The Living Desert," "The Alaskan Eskimo," and "Bear Country"—photography contributed by a staff of roving naturalist-cinematographers to whom Disney paid tribute as a group when accepting the awards.

(Continued on Page 208)

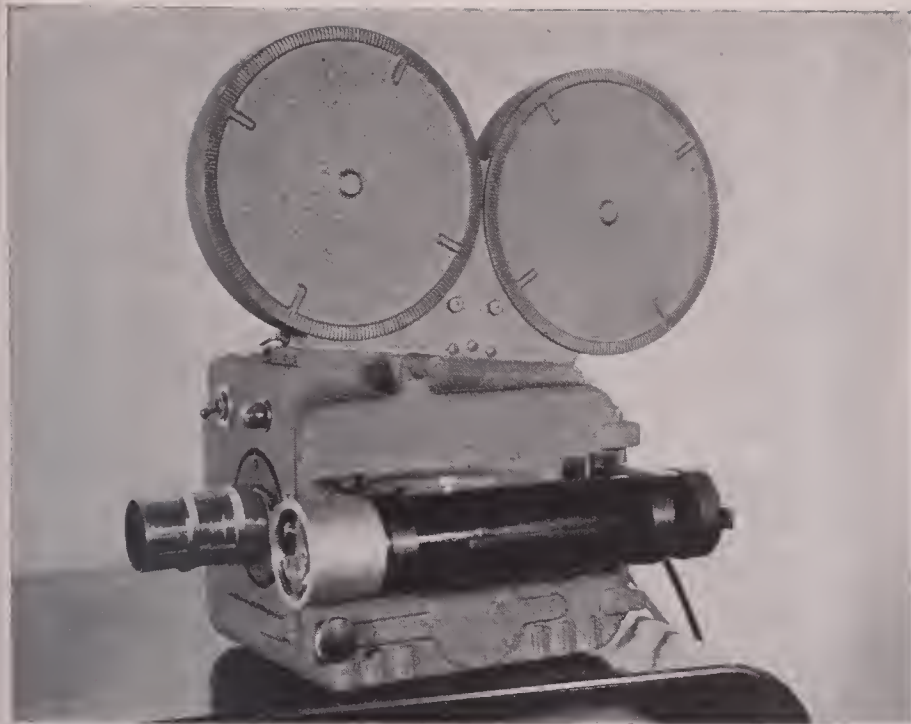

FIG. 1—The Auricon Cine-Voice 16mm single-system sound camera in new dress—an adaptation by Fred Parrish of Culver City. Added is a new and larger soundproofed case, 400-foot interchangeable magazines, a through-the-lens finder system, and an external zoom-type viewfinder.

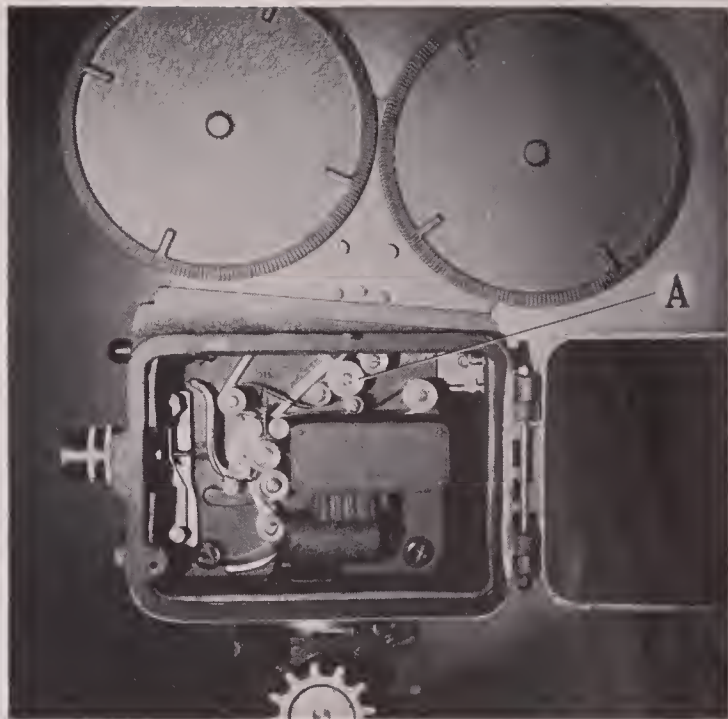

FIG. 2—Same camera with door opened, showing added film drive sprocket (A) with accompanying spindles. This feature smooths flow of film past sound head and on to the larger, external magazine.

Camera Modifications

Fred Parrish has built a business modifying cameras to suit the needs of specialized fields. His modification of the Auricon Cine-Voice makes it ideal for TV film production.

HOPPING UP automobiles is a fad which is spreading in counterpart to other things, including motion picture cameras. Seems that there are a great many people who buy motion picture cameras who want gadgets added which the manufacturer did not include in the basic model. Thus it is that Fred Parrish, of Culver City, California, has built up a thriving business of modifying motion picture cameras to suit the needs or whims of the owners.

The Auricon "Cine-Voice" camera was created originally to fill the need of the advanced amateur movie maker with a desire to make movies with synchronized sound. Because of the high professional quality of sound and picture which this camera turns out, many producers of professional 16mm motion pictures are using it in their work. It has proven especially popular with many producers of television films, and particularly with many independent television stations that have set up their own motion picture production department.

In most 16mm TV film-making operations, including kinescoping, there is need for a camera having a large film capacity, and this is where Fred Parrish has come into the picture. The Auricon "Cine-Voice" camera takes only 100-foot rolls of film, affording but $2\frac{3}{4}$ minutes of recording.

(Continued on Page 204)



FIG. 3—Another Parrish adaptation. Here the Cine-Voice camera has been fitted with the patented Auricon kinescope shutter and Mitchell 1200-foot external film magazine for television film recording—also known as kinescoping.

T W E N T Y - S I X T H A N N U A L A W A R D S

Paramount

Gratefully Acknowledges
the Recognition Given
by the Academy

to

LOYAL GRIGGS, A.S.C.

FOR BEST CINEMATOGRAPHY
(Color)

“SHANE”

A C A D E M Y O F M O T I O N P I C T U R E A R T S A N D S C I E N C E S

T W E N T Y - S I X T H A N N U A L A W A R D S

CONGRATULATIONS

TO

LOYAL GRIGGS, A.S.C.

1953 Academy Award Winner
for Best Color Cinematography

“Shane”

Paramount

Color by **TECHNICOLOR**

TECHNICOLOR IS THE REGISTERED TRADE-MARK OF
TECHNICOLOR MOTION PICTURE CORPORATION

HERBERT T. KALMUS, PRESIDENT AND GENERAL MANAGER

ACADEMY OF MOTION PICTURE ARTS AND SCIENCES

T W E N T Y - S I X T H A N N U A L A W A R D S

The Members of the
AMERICAN SOCIETY OF CINEMATOGRAPHERS
Congratulate

the
1953 ACADEMY AWARD WINNERS

for
ACHIEVEMENT IN CINEMATOGRAPHY

LOYAL GRIGGS, A.S.C.
who photographed "Shane"
BURNETT GUFFEY, A.S.C.
who photographed "From Here To Eternity"

and
Salute the
Directors of Photography

Who Also Were

NOMINATED

for

CINEMATOGRAPHY AWARDS

JOSEPH C. BRUN, A.S.C.
"Martin Luther"
(deRochemont)

ROBERT PLANCK, A.S.C.
"Lili"
(MGM)

EDWARD CRONJAGER, A.S.C.
"Beneath The Twelve-Mile Reef"
(Fox)

FRANK F. PLANER, A.S.C.
HENRY ALEKAN
"Roman Holiday"
(Para.)

GEORGE FOLSEY, A.S.C.
"All The Brothers Were Valiant"
(MGM)

JOSEPH RUTTENBERG, A.S.C.
"Julius Caesar"
(MGM)

HAL MOHR, A.S.C.
"The Four Poster"
(Kramer-Col.)

LEON SHAMROY, A.S.C.
"The Robe"
(Fox)

CONGRATULATIONS
TO
WALT DISNEY PRODUCTIONS
WINNER OF
FOUR ACADEMY AWARDS
FOR 1953

BEST FEATURE DOCUMENTARY

"The Living Desert"



BEST SHORT SUBJECT CARTOON

"Toot, Whistle, Plunk and Boom"

BEST DOCUMENTARY SHORT SUBJECT

"The Alaskan Eskimo"



BEST 2-REEL SHORT SUBJECT

"Bear Country"

ARRIFLEX CAMERAS

ARE NOW PLAYING AN IMPORTANT PART

IN THE PHOTOGRAPHY OF

WALT DISNEY'S "TRUE LIFE ADVENTURE" SERIES



KLING-PHOTO CORPORATION Sole U.S. Distributors of Arri products

235 Fourth Avenue, New York 3, N.Y.



7303 Melrose Avenue, Hollywood 46, Calif.

THE MOST AMAZING

we have for sale

THE FA

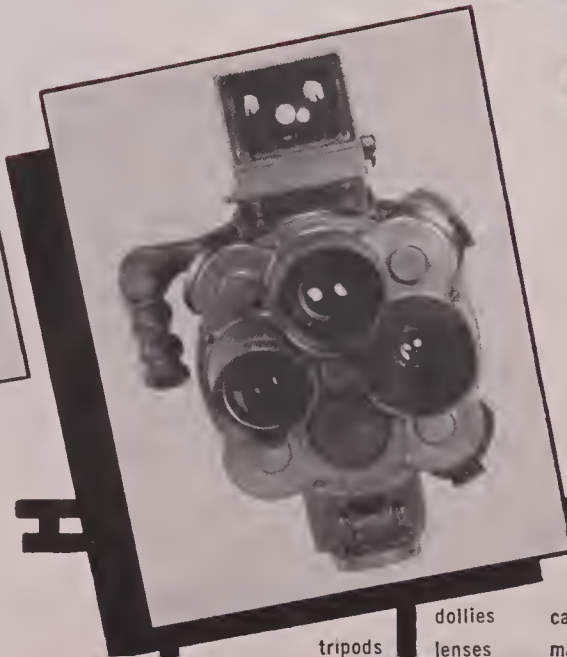
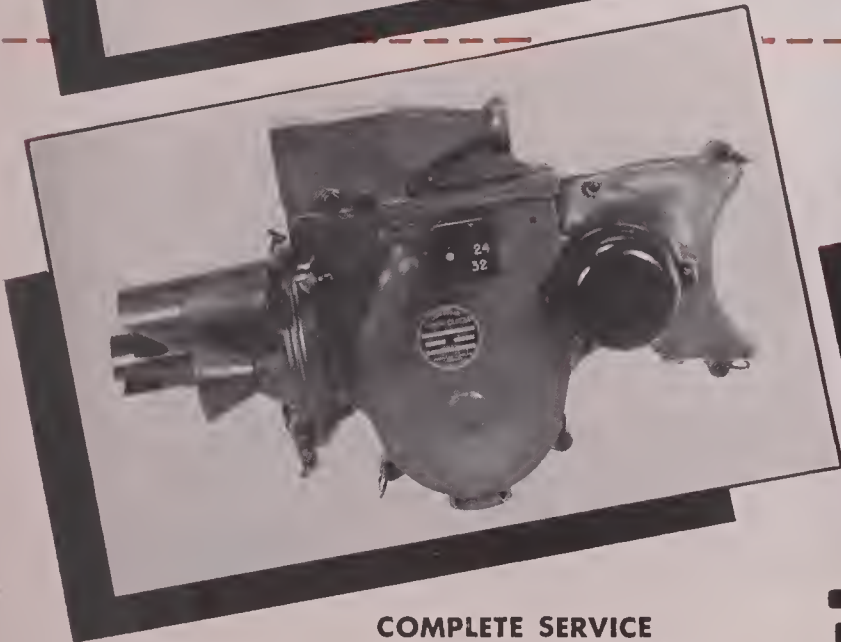
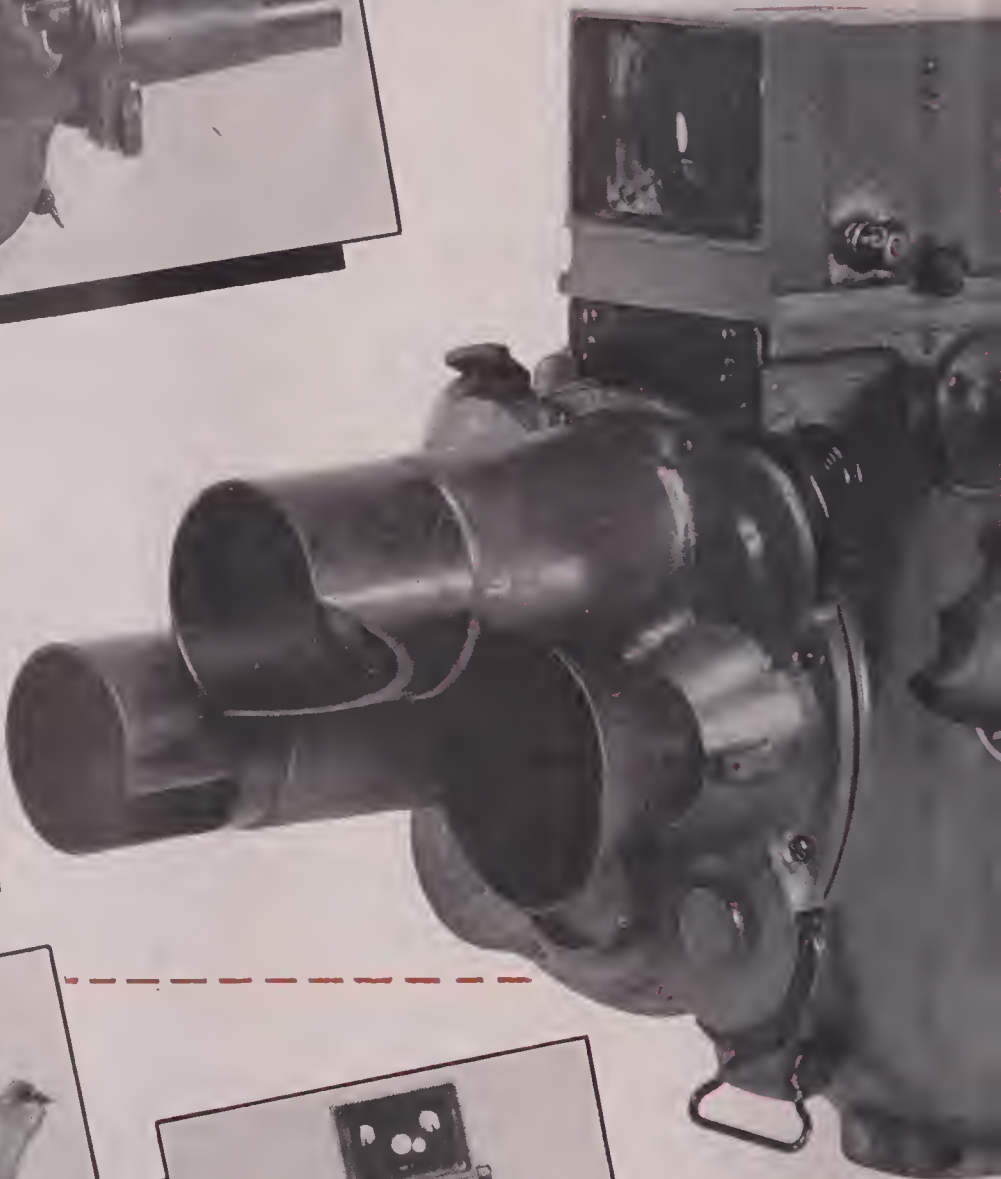
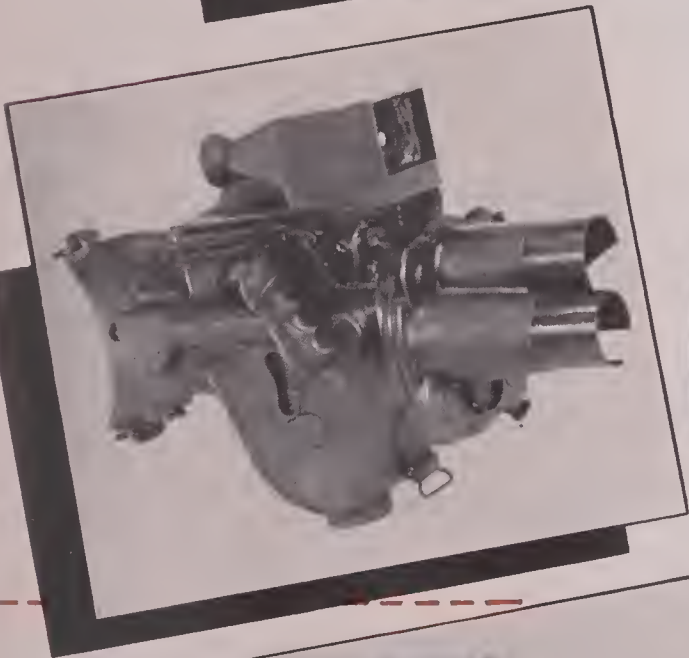
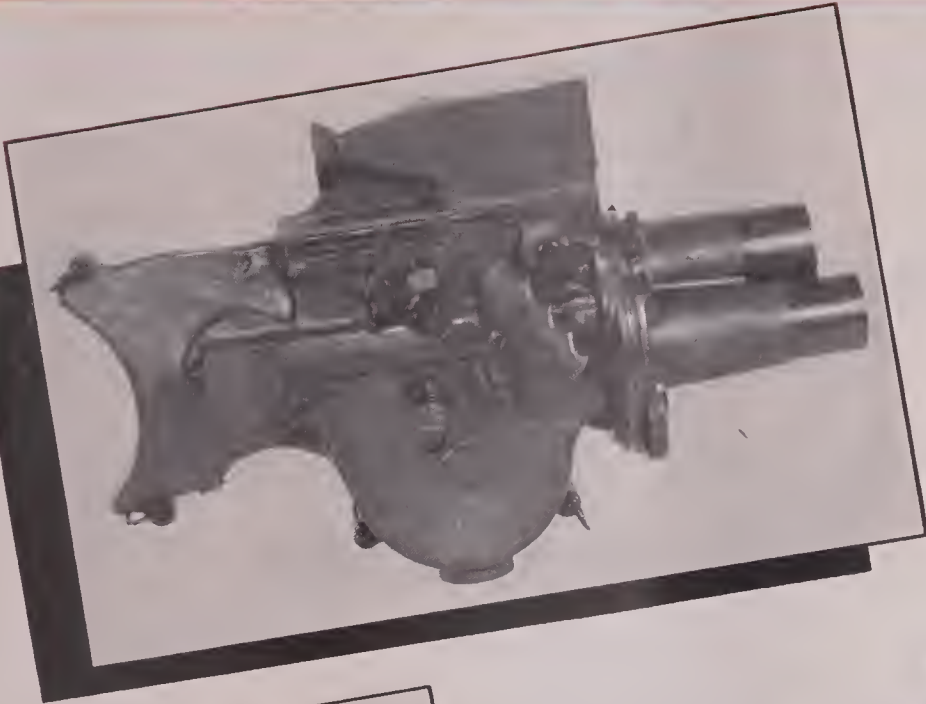

**COMPLETE SERVICE
and PARTS AVAILABLE!**

*Fully guaranteed against defects
in materials and workmanship.*

tripods

dollies
lenses

cameras
magazines



FOR WE'VE EVER MADE

limited number of
CUNNINGHAM 35MM HAND HELD MOTION PICTURE CAMERAS

DESIGNED AND PRODUCED FOR THE O.S.S. (AT AN ORIGINAL COST OF OVER \$7,625 EACH)

ONLY RECENTLY REMOVED FROM THE MILITARY RESTRICTED LIST



The only hand held 35mm cameras produced in the United States with dual pilot pin registration—providing the same accuracy of picture positioning as a studio camera.

Self contained, lightweight magnesium construction, weather-proof and dust-proof, with pistol grip handles and a rifle stock to provide firm support. All controls can be completely set and adjusted while wearing gloves or mittens; and turret rotation, diaphragm setting, focusing, speed changes and on-off switch can be controlled without removing hands from the hand grips.

Camera has a 4 lens self-positioning ball bearing turret with 3 integral lenses and a fourth position for a long focal length telephoto lens. This revolving turret permits the lenses to be completely changed without moving the camera from the shooting position.

Camera is equipped with 1 each 35mm Baltar lens, 1 each 75mm Baltar lens and 1 each 6" telephoto lens and takes standard Mitchell slide filters. An eye level view finder is provided with fields for the three integral lenses.

Camera is driven by a high speed universal electric motor of the governor-controlled type for operation at 16, 24 or 32 frames per second. Shutter is of the 170° rotary type, counter-weighted and dynamically balanced. Camera will operate from any fixed or portable power supply.

The magazine is of the latest displacement type, reducing weight and size. It holds 200 feet of film and contains the complete film movement mechanism with the dual pilot pin registration unit of the Mitchell type.



The fitted carrying case holds the complete unit, camera, magazine, spare lenses, film and accessories.

Orders filled on a first come, first served, basis. Priority will be given only to government contractors, or Military agencies who furnish a Defense Order Rating Number.

Because of the unusual nature of this truly sensational offer our usual open account terms do not apply. Payment for the full amount must accompany order. (California buyers add 3% sales tax.)

PHONE, WIRE OR WRITE TODAY...

NOW YOU CAN BUY ONE OF THESE SENSATIONAL CUNNINGHAM HAND HELD 35MM MOTION PICTURE CAMERAS

consisting of:

1. Camera
2. 3 speed electric motor
3. 35mm Baltar f2.3 lens
4. 75mm Baltar f2.3 lens
5. 6" telephoto f4.5 lens
6. Integral view finder
7. 200' film magazine containing Mitchell type pilot pin registration movement
8. 2 feed spools
9. Carrying case fitted for camera, spare lenses, magazine, film and accessories

\$885
 only

gordon enterprises

Serving the World

5362 North Cahuenga Boulevard
 North Hollywood, California

Cable Address "GORDENT" Teletype "DAC"

Stanley 7-5267

- | | | |
|----------------------|--------------------|---|
| printing equipment | animation stands | PRIME CONTRACTORS
TO THE
UNITED STATES
AIR FORCE
and NAVY |
| processing equipment | lighting equipment | |
| projection equipment | editing equipment | |



SHOOTING A CLOSEUP for "Dragnet," one of the nation's top television programs produced on film in Hollywood by Mark VII Productions. Director of photography is veteran cinematographer Edward Colman, ASC,

(left). Here his camera shoots a closeup of Jack Webb (seated), star of the "Dragnet" series, who is checking police files on a crime suspect. Speed is key to show's production success.

Filming The "Dragnet" TV Show

By FREDERICK FOSTER

IF YOU ARE A "DRAGNET" FAN, very likely you have noticed the many innovations in the photography which mark this top weekly television film program—innovations such as the scene in a recent show where the camera shoots through a telephone booth, catching action far in the background as sharp as that recorded close to the camera where a man is telephoning in the booth—the camera tying the two phases of

action together neatly in a single time-saving take.

Another example was the camera treatment of a sequence in still another picture in which officer Friday and his partner are questioning a drunken housewife suspected of abandoning her children. To point up the locale—a cheap rooming house—the camera shoots through the framework of the old iron bed on which the woman sits; it

never once shows her face, but withholds her identity until the closing scene of the picture.

Such photographic treatment is particularly complementary to the "Dragnet" style of story presentation. Responsible for the camera work on "Dragnet" productions is Edward Colman, ASC, who has directed the photography of the show almost from its inception. At this writing, 100 "Dragnet" shows have been



ANONYMOUS, which dictates procedures in all TV film making, results in many "Dragnet" exteriors being shot on sound stage. Here Webb and Ben Alexander enact scene in front of photo backdrop of an exterior scene, where previously long shots were filmed.



ANOTHER exterior filmed on sound stage. Camera crew at right is photographing Webb and Alexander questioning a suspect as auto he drove off is being recovered.



TYPICAL "Dragnet" treatment where impact of player's identity is to be withheld until final scene. Technique also is used to soften impact of a mutilated body in a murder scene, etc. Here Webb and Alexander question a woman suspected of child abandonment.

filmed, and Colman has photographed 85 of these.

Colman's long career as a process and trick photographer proved helpful in preparing him for the exacting work of photographing television films. He credits a long and successful association with William Cameron Menzies, famous art director and motion picture producer, for equipping him with a valuable fund of knowledge in composition, cinematic effects and the art of improvisation, which has helped him immeasurably in putting the "Dragnet" shows on film.

According to Colman, the photographic technique he now uses evolved through a period of trial and error, and through studying other TV film shows

as well as many of the better feature film productions. "I have adhered closely to standard motion picture production procedures in the photography of 'Dragnet,'" says Colman, "because I feel that it is a proven technique—something we have developed over the years. Now we have successfully transplanted it to television film production."

Scarcely two years ago, films made this way were difficult to transmit successfully over television. At that time, many articles were written emphasizing that only films lit fairly flat were good for television; that extreme dark or white areas in a scene simply failed to reproduce as such on TV receiver screens.

A lot of research and hard work has since changed all this. According to Colman, at least 75% of the quality of all TV film today is due to the processing given it by the laboratory. The labs have learned a lot about making the right kind of prints for television. This has unshackled the photographer and given him more latitude in which to work, insofar as lighting is concerned.

"In major feature production," says Colman, "set lighting is a costly item. We could spend a lot more time on lighting 'Dragnet' than we do, but it would greatly increase our costs. Our problem is to know when to stop lighting—to know when we have enough; to know

(Continued on Page 198)



RUBBER LIFE RAFT, pulled by studio grips, served as camera dolly in shooting scenes for "Casanova's Big Night" on the huge Venice canal set at Paramount studios. Left photo shows camera crew, under direction of Lionel Lindon, ASC, preparing to make shot of



Bob Hope's arrival in gondola. Center photo is what the camera recorded. Photo at right shows lighting setup necessary to illuminate a small portion of the canal set, which began indoors on stage 16 and extended outside for distance of two blocks.



Filming Hollywood's Biggest Indoor Exterior

Lionel Lindon mounted his camera on a rubber life raft to make extensive dolly shots on the two-block long Venetian canal, which Paramount built for "Casanova's Big Night."

By ARTHUR ROWAN

ONE OF THE MOST lavish and expensive productions ever photographed at Paramount studios, "Casanova's Big Night," is a riotous big-scale period comedy co-starring Bob Hope and Joan Fontaine. The photography was directed by Lionel Lindon, ASC, veteran of some forty Hollywood feature productions, most of them photographed for Paramount.

The zany story concerns the exciting and hilarious exploits of a meek tailor's apprentice (Hope) who masquerades as Casanova. Mistaken for history's most notorious libertine, he is hired by a Duchess to "test" the love of her son's fiancée. As proof of his success, he is to bring back a petticoat embroidered with the Duchess' family crest, a gift from the titled lady to the young bride-to-be. What follows promises to set a new high in screen hilarity.

Comedy highlights include a scene in which Hope dresses as a baroness and dances a gavotte with actor Arnold Moss; a sequence in which he is forced to duel the best swordsman of Venice; his arrival in Venice on a gondola; and a hilarious prison sequence involving Hope and several bearded prisoners.

One of the most beautiful and lavish sets of recent years, the studio built an authentic, full-scale replica of a Venice canal for key sequences in the comedy. Perhaps the first time Hollywood has reproduced a canal of this type, it contained 365,000 gallons of water and was more than 400 feet long. Covering two city blocks at the rear of the studio's "New York Street" outdoor set, the canal's width ranged from 30 to 80 feet with a stone bridge crossing it at its narrowest point. Sixteen separate buildings lined both sides of the canal.

all of them accurate replicas of homes and shops of the mid-18th century period. The unusual canal set adjoined the private dock of a huge Italian palace, another of the many luxurious sets used in the picture.

Several scenes, including Hope's arrival in Venice, the comic duel between Hope and Marlow on the gondola, and others were photographed in the canal set. Other key sets included two Italian palaces, an 18th century prison, a tailor shop, Casanova's home and Miss Fontaine's lodgings.

This was one of the last pictures made at Paramount before the studio adopted the VistaVision wide-screen camera. Because the studio had not yet definitely settled on the final dimensions of the aspect ratio for its pictures, Lindon had to compose his scenes in such a manner that they would screen satisfactorily in any ratio from 1.33-to-1 to 1.85-to-1.

It was the Venetian canal set where a substantial part of the picture's action takes place and where some of the most interesting photography of the picture was accomplished. For one important shot early in this sequence, the camera had to travel the full length of the canal to photograph Bob Hope's arrival in Venice. Normally, this type of shot is

(Continued on Page 200)

DEDICATED TO BETTER PERFORMANCE



COLLAPSIBLE 3-WHEEL DOLLY

For motion picture and TV cameras. Sturdy cast aluminum. For standard or baby tripods. Additional baby tripod point holders to control spread of tripod legs. Adjustable spring seat. Extra wide rubber wheels. Bronze tie down clamps and other features.

For studio or location. Folds into one compact unit. Can be used with professional or semi-professional tripods.

'HYDROLLY'

TV OR
CAMERA DOLLY

The advanced dolly for instant moveability — streamlined, lightweight, exceptionally sturdy. Nothing to get out of order. Many new advantages for easy operation. Hydraulic lift type for fast upward and downward motion of TV and motion picture cameras.



Swivel seat. Adjustable leveling head. Seat for assistant. In-line wheels for track use. Steering wheel, rigid floor locks. Hand pump or combination hand and motor pump. Easily transported in a station wagon. Fits through a 28" door.



Synchro-film-ed Synchronizer

Our Exclusive Distributor
NEUMADE PRODUCTS CORP.

Any combination of 16mm and/or 35mm sprockets assembled to specification. Cast aluminum. Foot linear type, adjustable frame dial. Fast finger roller release. Contact rollers adjusted individually for positive film contact. Sprocket shaft slip lock, foot-age counter, etc.

RENTALS

SALES • REPAIRS • SERVICE



LENS COATING

"T" STOP CALIBRATION

DESIGNING and MANUFACTURING

lens mounts & camera equipt.
for 16mm, 35mm, TV cameras.

BAUSCH & LOMB "BALTAR"
LENSES and others

for motion picture, TV cameras.
15mm to 40" focal length.

COMPLETE LINE OF: 16mm, 35mm
cameras, dollies, synchronizers,
animation stands, cutting room
and time lapse equipment.

BELL & HOWELL: Standard, Eye-
mos, Filmos. MITCHELL: Standard,
Hi-speed, BNC, NC, 16mm.

SEND FOR CATALOGUE

Synchro-film- Slate

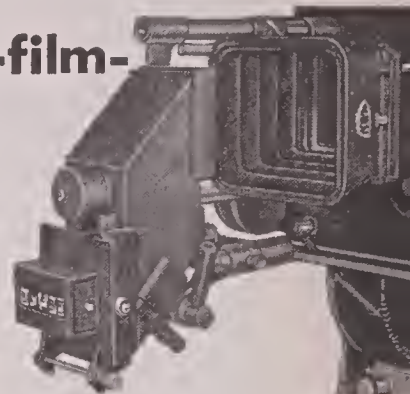

Pays for itself in production savings on the set. A New Development! Eliminates clap stick synch and slate on set. Mounts on double arm bracket to work with BNC, NC, Standard, 16mm Mitchell and all types of blimps and Geared Head. Interlocks with Sound Recorder.



PORTABLE MICROPHONE BOOM

For Studio or on Location. Lightweight — collapsible — for TV and motion picture production. Sturdy construction. Boom telescopes 7 to 17 ft. Rear handle for directional mike control. A remote control permits 360° rotation of the microphone. Operator can push the boom and operate microphone swivel simultaneously.

Extension rods make it simple to operate microphone rotation from floor. Microphone cable hangs outside of boom, preventing cable from tangling with the rotation mechanism. Ball bearing casters, rigid foot locks, pneumatic drop check for lowering the boom, etc.

VARIABLE- SPEED MOTOR with TACHOMETER

for Cine Special or Maurer Cameras

115 V. Universal Motor — AC-DC
Separate Base for Cine Special.
Variable Speed 8-64 frames.
Adapter for Maurer Camera.

INTERCHANGEABLE MOTORS: 12
volt DC Variable Speed 8-64 frames.
115 Volt AC 60 Cycles, Synchron-
ous Motor, Single Phase.

ANIMATION MOTORS: Cine Spe-
cial, Maurer, Mitchell, B & H Motors,
for Bolex and Filmo Cameras.

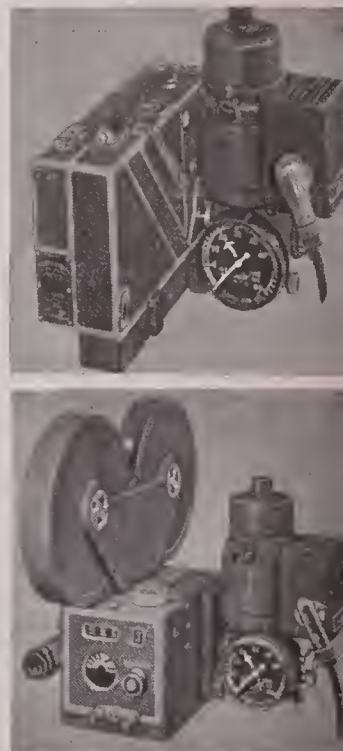



FIG. 1—HOMEMADE TITLER constructed by author was used in photographing the 8mm film leaders which were awarded the winners in the New York City 8mm Club's 1953 film competition. Text on clear celluloid panels was photographed superimposed over decorative revolving background.

HAVING TROUBLE getting prizes to award the winners of your club movie contests? Why not offer film leaders indicative of the awards? That's the way we solved the problem in the New York City 8mm Club.

That hardy perennial of club affairs—the annual club contest—had again come up for consideration. For the 15th time. So we were not altogether unfamiliar with it and its companion problem, "What to give for prizes?". This time our discussion centered on how to make our awards sufficiently interesting to bring out the very best work of our best workers.

In past years the club has donated small cash and merchandise prizes. One year we gave out "Oscars" which bore a striking resemblance to the original Hollywood award except that the latter is gold and ours was brass. We were fortunate then to have a sculptor in our club membership who designed and cast the trophies. He now is no longer a member.

In our quest for a new award, our club committee felt that it should be something tangible and have lasting value. It was then that the film leader was suggested. Here was something that our own club members could produce, thus giving the award increased significance and value.

It was decided then that we should design and produce such a leader, one that would have all the professional quality of the best work turned out by professional title laboratories. It was to be filmed in Kodachrome and get across its message with limited text, attractive design, augmented by smooth fades and dissolves.

CLUB PROJECT

How the New York City 8mm Club solved the problem of contest awards with club-made leaders.

By GEORGE A. VALENTINE

The New York City 8mm Club



FIG. 2—FIRST a plywood turntable was mounted on titler base.



FIG. 5—Glass panel held the various cells.

Since the writer had complete title making equipment plus a camera with the necessary wind-back for the film, he undertook the photography.

Another member, Walter Slovik, an artist, elected to do all the necessary art work. For the leader format, we decided on an attractive circular star-studded background that was to revolve slowly while the text was superimposed over it. Here we followed the best professional procedure to gain the effect. First a turntable base was constructed from a piece of $\frac{3}{8}$ -inch plywood. On the back was mounted a metal pin which set in a socket in the frame at the base of the titler. (See Figs. 1 and 2.) On the opposite side of the turntable (which would face toward the camera) was attached the background panel turned out by Slovik.

The text, which was to be superimposed over this background was then painted by Slovik on transparent celluloid panels, or "cells" as they are known in professional circles. First there was one carrying the club's insignia (Fig. 5); another carried the text: "New York 8mm Club, 1953 award"; and the third (actually a series of three) carried the text that

designated the award, i.e., "First Prize," "Second Prize," etc.

To include these cells in the photography, a panel of clear glass was set on supports about 2 inches above the revolving background (Fig. 4). Each cell then was laid over this glass and properly centered with respect to the camera.

Before the photography began, lights were carefully arranged so that there would be no disturbing reflections from the glass or cells. Meter readings were taken to establish the proper f/stop to use. The titler, as shown in Fig. 1, consists of a sturdy wooden frame 4 feet high and 3 feet square at the base. The camera is mounted in a socket at the top, so that the lens points straight down at the title area. To center the camera on the title text, we line up through the camera finder, correcting for parallax.

This done, we started to shoot. The turntable was rotated by hand as the camera was started—with the lens diaphragm completely closed. To fade in, the diaphragm was slowly opened to the established f/ stop. Three seconds were allowed for this. Then the camera ran another six seconds at full

(Continued on Page 205)



FIG. 3—Decorative background was laid over turntable.



FIG. 4—Clear glass panel was placed above turntable.



FIG. 6—Cell No. 2 was laid over No. 1 in a dissolve.



FIG. 7—The text "First Prize" completes the leader.

Shakespeare In 8mm

With an 8mm camera and \$40.00 to spend, a college group filmed "Hamlet," giving it a comic twist.

By ZENDA SANDERS
OPL Photos By Phil Sanders

AN HILARIOUS parody of the Shakespearean tragedy, "Hamlet," which Jim Blue, speech major at the University of Oregon in Eugene, suddenly dreamed up and then filmed in 8mm, is the talk of the town.

This slapstick amateur movie was produced with the aid of a small group of University students, who really put the "ham" in "Hamlet." Four people handled the major roles, and it took three months of weekend filming for a total cost of approximately \$40. It was shown to an estimated 2,000 people, and aptly described by one teen-ager as "the craziest thing I have ever seen."

The decision to make the parody was the result of one member of the cast having seen Olivier's movie version of

"Hamlet" no less than five times. Why not, Blue thought, substitute comicality for sadness and make a real show?

Four campus comedians who also had seen the tragic version made up the cast. Bob Chambers portrayed ten parts—the ghost of Hamlet's father, Polonius, the King, the grave-digger, Laertes, Horatio, Osric, the Bugler, the Player King, and the Player Queen. Al Barzman took the part of the melancholy Hamlet; Martha Stapleton was Queen Gertrude, Hamlet's mother; while the fair Ophelia was played by Lois Williams. Phil Sanders assisted with the lighting and shot stills for local publicity.

The movie itself was filmed with a Bell & Howell 8mm Sportster camera, having a custom-built back-wind and an f/2.5 fixed-focus lens. A tripod and splicer were borrowed from a camera shop in Eugene. To this equipment, Producer Blue added 13 rolls of Super-X black-and-white film, and three 350-watt medium beam reflector flood-lamps. He was now "in business," and the operation began. With no scenery and no props, Jim put all the materials into three hand satchels and pursued his actors. Photographer Sanders did the same. Scenes were taken on the University Theater stage, in a gravel pit along the Willamette River, and on the campus.

The publicity stills advertised the pro-

duction in Eugene papers, and billboards carried blurbs like, *Stupendous, Colossal, Filmed in Glorious Black-and-White.* Blue's satire was perhaps inspired by the billing of the popular movie, "Quo Vadis," which was playing locally at the time.

For lack of a title, the ingenious Blue made one from a round oatmeal box. It was painted black, with a spindle inserted through the center ends so that the gimmick could be turned by hand. The jerky motions which resulted later delighted the audiences, and put them in the proper spirit for the scenes which followed.

The dramatic opening bore a striking resemblance to the introductions of J.

(Continued on Page 196)



PRODUCER-Director-Cinematographer Jim Blue photographed the comic version of "Hamlet" with a Bell & Howell 8mm Sportster camera.

ONE OF the touching scenes in the production, showing Queen Gertrude imploring with Hamlet. Makeup played an effective part in success of the production.



SEEING IS BELIEVING!

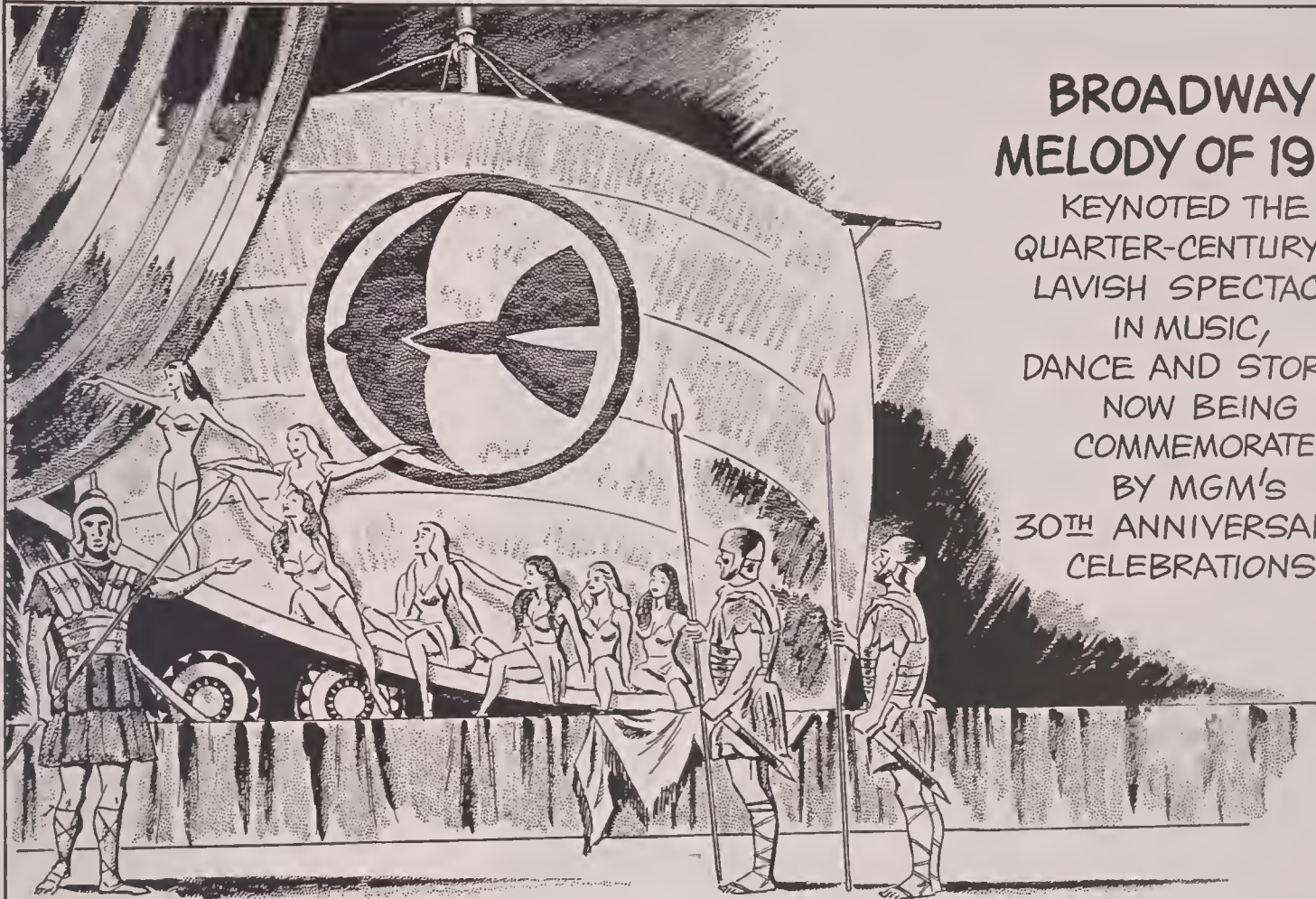

BROADWAY MELODY OF 1929...

KEYNOTED THE
QUARTER-CENTURY OF
LAVISH SPECTACLE
IN MUSIC,
DANCE AND STORY
NOW BEING
COMMEMORATED
BY MGM'S
30TH ANNIVERSARY
CELEBRATIONS.

TODAY... THAT GREAT MGM ENTERTAINMENT TRADITION
CONTINUES IN SUCH SUPERB PRODUCTIONS AS "BRIGADOON,"
UPCOMING CINEMASCOPE TREATMENT OF THE
RECORD-RUN BROADWAY MUSICAL.

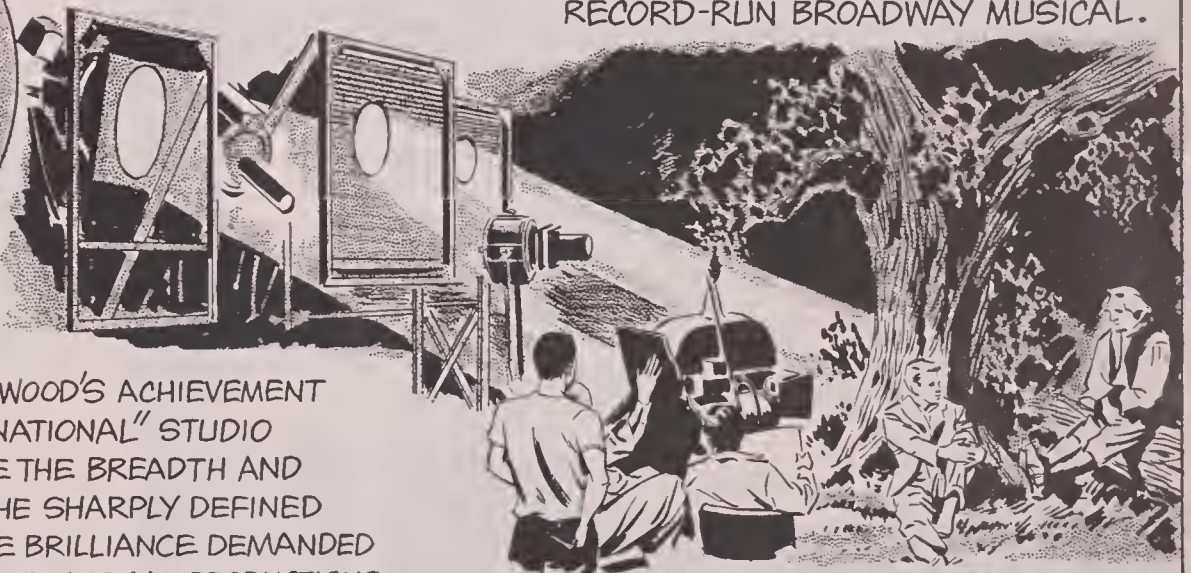

VETERANS IN HOLLYWOOD'S ACHIEVEMENT
OF FILM EXCELLENCE, "NATIONAL" STUDIO
CARBONS STILL PROVIDE THE BREADTH AND
DEPTH OF COVERAGE, THE SHARPLY DEFINED
MODELING AND EXTREME BRILLIANCE DEMANDED
BY MODERN, LARGE-SCALE MUSICAL PRODUCTIONS.

THE "NATIONAL" CARBON ARC... NOTHING BRIGHTER UNDER THE SUN

The term "National" is a registered trade-mark of Union Carbide and Carbon Corporation

NATIONAL CARBON COMPANY

A Division of Union Carbide and Carbon Corporation, 30 East 42nd Street, New York 17, New York

District Sales Offices: Atlanta, Chicago, Dallas, Kansas City, New York, Pittsburgh, San Francisco

IN CANADA: Union Carbide Canada Limited, Toronto



"Lights"
"Camera"
"Action"

and PROCESSED BY
MOVIELAB

FOR THE FINEST FILM PROCESSING *IN*
THE EAST — FILM MEN WHO KNOW
SAY "IT'S MOVIELAB"

Here—at MOVIELAB . . . efficiency and perfection are the rule. Producers, directors and technicians have at their fingertips the very best in up-to-the-minute equipment necessary to modern FILM PROCESSING techniques.

ROUND THE CLOCK SERVICES

- Negative Developing • First Print Department
- Ultra Violet & Flash Patch Track Printing
- 16mm & 35mm Release Printing
- Quality Control • Title Department
- 22 Cutting & Editing Rooms.

FOR COLOR

it's

Rainbowlab Inc.



MOVIELAB FILM LABORATORIES, INC.

619 West 54th Street, New York 19, N. Y. JUdson 6-0360

SHAKESPEARE IN 8MM

(Continued from Page 194)

Arthur Rank. The bronze gong, however, was made of paper, on which was boldly lettered the title, *A Blue Production*.

The role of the slave, who was assigned to strike the gong, was played by Horace Robinson, the University's Director of the Theater. The old trick of pretending to strike was used at first, with the final blow tearing the paper through the middle. The glutinous preparations used in making the gong had so stiffened the paper, however, that when the gong actually struck, the entire hoop burst in the middle. Taken completely unawares by this unexpected occurrence, the actor spontaneously faced the camera, with finger in mouth, to give the movie one of its best humor punches.

Costumes were chosen from the University Wardrobe and players were permitted to use the unfurnished stage at the theater. While the costumes were selected to dress the character for the role intended, they were also picked to make them look ridiculous. For instance, Laertes, appearing in his anachronous attire, also wore a pair of saddle shoes.

While the names of some 23 persons appear under the Dramatis Personae in the original cast of the Tragedy of "Hamlet," Blue's cast numbered only four, which presented some filming problems. This is how he worked out his scenes in proper sequence with his limited talent.

Each of the 135 shots was assigned a number. When Actor Bob Chambers played Laertes, for instance, all scenes were shot at one setting. The same was done when Bob appeared as Polonius, and so on. This was especially important in the scene showing the duel between Laertes and Hamlet. Horatio as a weeping instructor was also Bob's role. When all shooting was finished, the numbers were arranged in progression and the film spliced together.

In the first scenes, Hamlet appears musing over his sordid environment. This is followed closely by the entrance of the ghost of Hamlet's father, and a bit of burlesque is injected in these initial appearances.

Several silly gadgets, symbolic and otherwise, were used in the comic production. In one scene the real King sits munching popcorn, watching the re-enactment of his own foul deed. The Player King pulls the bottle of poison from under his cloak. To achieve this, Blue took a wine bottle and filled it with water and small bits of dry ice. When the actor removes the cork, the carbon dioxide gas escapes, giving the illusion of a deadly poison. The Player

Film Editing Made Easy
with NEW

professional film viewer

for 35mm and 16mm

Every film editor will appreciate a viewer that enables him to view his film from left to right—on a large, brilliantly illuminated screen.

The PROFESSIONAL FILM VIEWER makes film editing a breeze. Easy threading, portable, will not scratch film. Put this viewer between your rewinders and speed up your editing. Size of Viewing Screen 5³/₄ x 4³/₄.



35mm Model \$375
16mm Model \$350



King also takes a funnel from under his clothes, inserts it into the ear of the unsuspecting sleeper, and pours out this violent concoction. Of course, a sealed paper container was fitted into the funnel to prevent any liquid from passing through. Simultaneously, the prone man releases water from his mouth, making it appear that there is no success in the poisoning. After two attempts to poison his victim, the Player King finally produces a cork which he puts into the harassed man, stops the flow, and the murder is committed.

In preparing material for pantomime, these fantastic situations had to be worked out in complete detail. Each subterfuge seemed strangely real, but gloriously funny.

The grave dug for poor Ophelia, who had gone mad, was prepared in a gravel pit on the banks of the Willamette River. The grave-digger, whose business it was to prepare the land, finally begged off, so Producer Blue became even more versatile as Digger Blue, excavating a cavity large enough to hold the twitching corpse of Ophelia, as well as the real grave-digger. Just in case the audience was unaware of Ophelia's drowning, Blue subtly brought it to attention by placing a dried, salted bloater in her hand.

In the final scene, Laertes wounds Hamlet with the fatal foil, made from a

Model 35-16C SENSITESTER

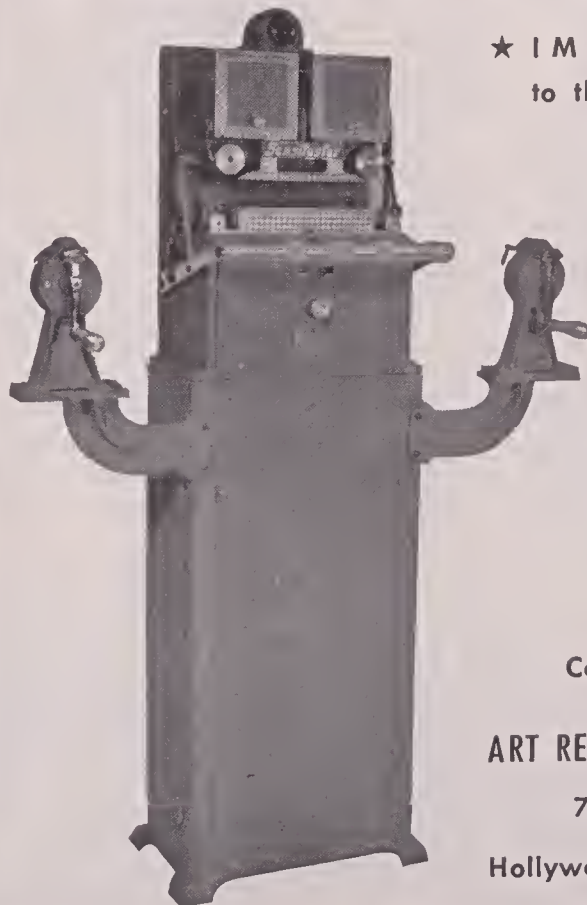

★ IMMEDIATE DELIVERY
to the lab owners interested in—

QUALITY
EFFICIENCY
ECONOMY

- DUAL MACHINE
1—Sensitometer
2—Scene Tester
- HIGHLY ACCURATE
Electronic timer unaffected
by climatic changes.
- NEW TYPE LONG-LIFE
Cold Light Exposure Unit
- WITHOUT ADDITIONAL
EXPENSE will match any
printer

Combination 35mm-16mm

ART REEVES MOTION PICTURE EQUIP.

7512 Santa Monica Blvd.

Hollywood 46

California

Bridgomatic

FILM PROCESSING EQUIPMENT

➔ AWARDED FEDERAL SUPPLY SERVICE CONTRACT 3RD STRAIGHT YEAR FOR ALL U.S. GOV'T. AGENCIES

Producers, TV stations, small labs., colleges, photo finishers, microfilmmers—do it on your own premises—control your production from the start.

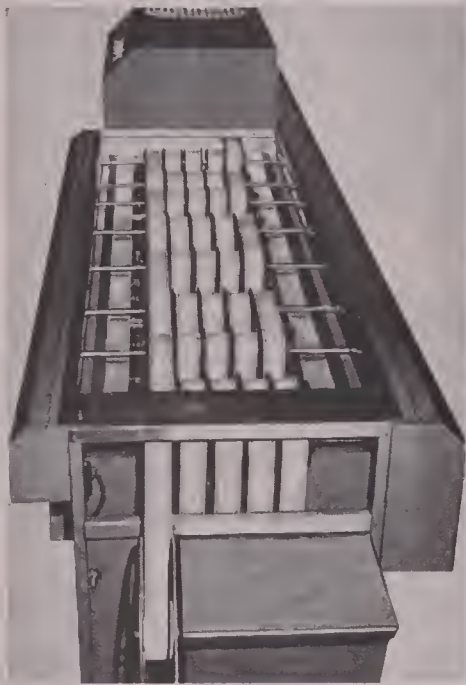

BRIDGAMATIC 216C35 Combination 16/35mm. Positive film speed 900' per hour\$4,495

BRIDGAMATIC JR. \$1095

Good for small labs., pos. speed 600' per hr.

—BRIDGAMATIC straightline "Add-A-Unit" idea lets you buy the basic machine with stainless steel tanks, then add re-circulation, aeration, refrigeration, replenishment, filtration, etc. as needed. Costs little more than old fashioned, cumbersome slow acting rack and tank methods.

Reversal, 16/35mm and 70mm models, black and white or color are available.

The BRIDMATIC Blue Book of users now includes:

- Esso Standard Oil Co.
- International Business Machines Corp.
- The Fox Co. of Louisiana
- Alpho Radio, Indo Chino
- Madison Film Productions, Wisconsin

• Write for illustrated brochure.

S.O.S. CINEMA SUPPLY CORP.

Dept. F, 602 West 52nd St., New York 19
Cable: "SOSOUND"

large tube of toothpaste, labeled poison. As the men struggle, Laertes is knocked down and the tube falls out. Hamlet, realizing the evil doings and the dirty work afoot, seizes the toothpaste poison and squeezes it over the face of the prostrate Laertes. Meanwhile, Queen Gertrude, who has been watching the duel, feels a twinge of thirst, sips the poison wine—which is harmless stage water—and dies. Hamlet then throws the remaining poison into the face of King Claudius.

The movie shows him throughout the duel with the sword of Laertes through his body. Of course, he is mortally wounded and dies. The imaginative

Blue borrowed a broken fencing foil, secured the ragged ends to wooden blocks, then fastened them to Hamlet's body to give the illusion. This presented a realistic, whimsical touch to the death of his characters, and the finish of his parody.

No actual dialog was used, but scattered bits of narration were given during the showing, and the narrator discovered that acceleration of the projection speed added to the entertainment. Musical accompaniment during the screening was furnished by a record turntable playing through speakers located near the screen.

FILMING THE "DRAGNET" TV SHOW

(Continued from Page 189)

how little to light to get the results desired."

As for day-in and day-out set illumination, Colman works at around 200 foot candles at f/4, which enables him to stop down for the added depth he needs in most scenes.

Colman is one of the first TV film cameramen to utilize latensification as a means of circumventing lighting deficiencies in both studio and location shooting. "I am a firm believer in latensification," says Colman. "In fact, I now shoot all my main night exteriors, whether on the sound stage or outdoors, with latensification in mind. The exposed negative is then given this treatment. Thus I am able to get more naturalness in night scenes than I would otherwise get by pouring a lot of light into the set, then stopping down and using filters."

An example how Colman used latensification to advantage is a recent instance where a night scene called for one of the players to carry a lighted flashlight. Instead of shooting the scene with a powerful lamp set in the flashlight reflector, with the attendant need for 110-volt cables dangling after the player as he moved about the set, Colman shot the scene with the player carrying a normal 2-cell flashlight, then had the negative latensified. The result was more natural—more convincing.

"The first time we tried latensification," said Colman, "we had a sequence of scenes to shoot of action staged within the sound stage itself. A crime suspect was being tracked down there; the action involved the suspect dodging in and out between the sets, then scrambling up a ladder and continuing his flight overhead on the catwalks. Because the area of action was vast, there was not enough equipment at the studio to

illuminate it. So we shot with the light we had and ordered the negative latensified to bring it up to normal contrast. We latensified not only all the long shots, but the two-shots and the closeups, so that uniform contrast was maintained from one shot to the next throughout the sequence.

"I also feel we get better TV quality with latensification. Utilizing it is something we dreamed up ourselves. First it was a matter of production economy; finally, it turned out to be a better method photographically."

About the unusual angle shots, which invariably mark every "Dragnet" show. Colman firmly believes this technique greatly enhances the story. Because he is limited in the use of long shots, his technique of shooting through props, such as a chair, a bed frame, etc., gives weight to the scene, otherwise the whole thing appears to be in mid-air. "I feel that by putting a prop before the camera—something to shoot through—it provides a frame for the picture, a sort of setting which ties the locale, the action and the players together, adding interest to the scene and maintaining orientation for the viewer."

With very few exceptions, every shot that Colman makes the Mitchell studio camera is mounted on a mobile crane. While moving camera shots are always held to a minimum, having the camera on the crane not only provides quick mobility between setups, but also quick up or down positioning of the camera when composing the scene prior to shooting. Colman makes a great many high and low shots. Here the crane proves extremely helpful. "With it we can quickly move into position with little trouble and begin shooting."

For low-angle shots Colman uses an Arriflex 35mm camera, hand held or

KINEVOX Portable Field Power Supply For Location Work



115-volt 60 cycle — \$450



115-volt 50 cycle — \$475

Descriptive Catalog of Complete Kinevox Magnetic Recording Equipment Available on Request

KINEVOX BUILDING
116 SO. HOLLYWOOD WAY
TELEPHONE: ROckwell 9-3291

KINEVOX

I N C O R P O R A T E D

ROME • BOMBAY

NEW YORK

RIO DE JANEIRO

BURBANK
CALIFORNIA

CABLE: Kinevox, Burbank

CANADA

mounted on a hi-hat on the floor. Thus he gets a lot of unusual angle shots not possible with the larger camera. To insure uniform photographic results with the two cameras, the Arriflex is fitted with the same type lenses as used on the Mitchell BNC. These are matched Bausch & Lomb Baltars.

An example of the value of the Arriflex is illustrated in one instance where the camera was used to photograph a player who, after being shot, was to fall forward and down on the camera. The Arriflex was placed on the floor on a high-hat. Just above it a panel of plywood was mounted on heavy supports. This had a hole cut for the camera lens. Over the plywood a mattress was laid. As the action was filmed, the actor was "shot" and fell forward over the camera, which was amply protected with the plywood and mattress baffle.

Occasionally officer Friday and his partner encounter a tough suspect and a fist fight ensues. To get vivid action shots of such encounters, the Arriflex is used, hand held, with the players punching directly into the lens. This camera is also used in shooting all inserts, because it enables the operator to see exactly what he is getting while filming, thanks to the camera's through-the-lens finder system.

Colman makes use of wide-angle lenses as much as possible; the forced

F&B

NEW & USED EQUIPMENT

FOR MOTION PICTURE & TV FILM PRODUCTION

F&B

NEW F & B LEG-LOK TRIANGLE

WITH LEG-LOK CLAMPS AND REINFORCED CENTER CASTING

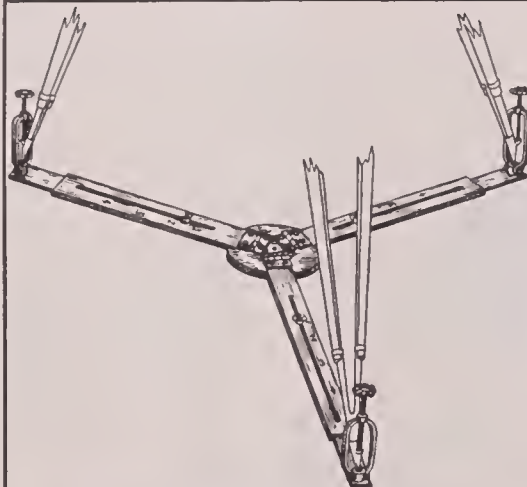

For maximum safety, protection and support, Large Numbers for instant leveling

PRICE
\$26.95

NEW F & B GATOR CLIPLITE

WITH BARN DOOR

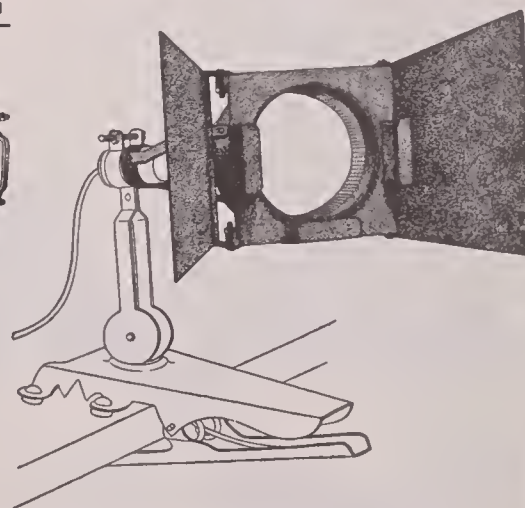

Unit includes — Gator Grip, Parcelain sacket, 15 ft. card & switch Barndoor.

PRICE
\$12.95

F&B

FLORMAN & BABB

70 West 45th Street, New York 19, N. Y.

Phone: Murray Hill 2-2928

Cable Address — FLORBABB, N. Y.



Primar Reflex Photo
normal 105 mm. lens

"Impossible"
distances
become
close-ups



Primar Reflex Photo
Astro 640 mm. lens
taken simultaneously
by Hans Namuth

with **ASTRO**[®]

LONG DISTANCE LENSES FOCAL LENGTHS TO 1000 mm.!

Used by the world's foremost explorers, scientists and news services, Astro lenses have been making photographic history all over the globe. Special formulas have produced resolving powers up to 100 lines to the mm.! And these superb lenses are *fast enough for action color work*—focal lengths from 300 to 800 mm. rated at F/5, the giant 1000 mm. (40 in.) at F/6.3.

FOR STILL CAMERAS Leica, Exakta, Primar-Reflex, Master Reflex, Hasselblad, Praktica, Contax-S

FOR MOVIE CAMERAS 16 & 35 mm. Bolex, Mitchell, Eyemo, Debrise, Askania, E.K., Arriflex, etc.

DUAL PURPOSE MOUNTS allow interchanging movie and still.

SUPER SPEED TELEPHOTOS

5 in. F/2.3
6 in. F/2.3
6 in. F/1.8



Made by Germany's foremost specialists in long-range optics, Astro lenses are available on order from franchised dealers only.

Write for brochure and prices

ERCONA CAMERA CORP.

DEPT. A-22 527 FIFTH AVE., NEW YORK 17, N. Y.

perspective they give enhances the dramatic effect, he says. Long focal length lenses are used in shooting most closeups for the reason that it is necessary to keep the camera as far away from the players as possible. Jack Webb, director and star of "Dragnet," believes that normal tones in speech give scenes realism. Thus players in closeups can scarcely be heard reading their lines ten feet away, as scenes are being photographed. To make such shots with the camera at close range would cause the sound of the mechanism, slight as it is, to intrude.

Mark VII Productions has established a three-day schedule for shooting each film in the "Dragnet" series. Four shows are scheduled and shot in a two-week period. The shooting stops for a week, while the next four films are being prepared and cast.

"When we start production on each four-film series," says Colman, "the first step is to go out and shoot all the exteriors called for in each script. These include the familiar long shots which open each show; cars travelling on a cross-town call, people entering and exiting from buildings, etc. Where extended action is to be staged at close range in exterior settings, that portion of the exterior is erected in duplicate indoors on the sound stage."

Colman is often complimented by fellow craftsmen on the consistency of the

quality of his photography from scene to scene. This, he says, is a matter of remembering and deliberately carrying that quality into the next scene. something he has also learned to do in the long years he spent in process photography.

Colman has the same camera crew on all shows. The advantage in this, he says, is that each man becomes familiar with the routine; he knows instantly what to do, and this saves considerable time. "Time," Colman says, "is our toughest problem—time in which to shoot scenes in the time allotted us in the production schedule. The whole secret is to get everything planned down to the least possible amount of time necessary for each operation."

Jack Webb is an avid student of cinematography. He understands camera technique, lighting, and what is required to get the dramatic effects he wants. After 85 "Dragnet" shows, the pattern of shooting is pretty well established. "Each shot is planned as we go along," Colman says. "When we come on the set, we make a quick appraisal of it, check the action as set down in the script, and then proceed with our camera setup. Webb and I usually talk over the effect he is after, then I figure out the mechanics necessary to getting it on film. His aim is to give 'Dragnet' the same high class photographic treatment found in the better theatrical films. He won't accept anything but the best."

FILMING THE BIGGEST INDOOR EXTERIOR

(Continued from Page 190)

done with the camera on a boom or dolly but it was impossible to use this equipment in the more than three feet of water which filled the canal. Lindon solved this problem by mounting his camera on one of the U. S. Navy's rubber life rafts of World War II. To move the raft through the water, an intricate pulley and cable system was set up. However, there was still the problem of steadying the raft, and here grips wearing rubber hip boots were pressed into service to stand in the water and hold the raft steady. Later, it proved more practical to have them also push or pull the raft through the water in making dolly and travel shots.

The entire canal sequence was photographed with artificial light. Where the canal extended outside the sound stage and into the outdoor set area, framework was built over it and the set entirely blacked-in—covered with black cloth to exclude daylight. This afforded more uniform control of set illumination.

So vast was this set, that Lindon had to light and work on one side of the canal at a time; there was not enough equipment to light the entire set at one time at the level required. Often the camera was called upon to reach into great depths of the scene to pick up people in the distance walking along the canal sides, over the bridge, or coming in and out of buildings. Using Eastman Color negative, Lindon shot all scenes at the normal light level recommended for this film.

Because the water in the canal was so shallow that it was easy to see the bottom, it was tinted blue, which also served a pictorial purpose as well. One of the great responsibilities of the cinematographer when shooting color, is to keep colors consistent from scene to scene—sometimes a problem when shooting a given sequence over a period of days. Imagine Lindon's consternation when he arrived on the set one morning to find that someone had accidentally dumped a quantity of black



TEWE MOTIVEFINDER

—like a "right arm" for the creative MP and TV Director

TEWE MOTIVEFINDER is a wizard that solves scores of set problems. This Director's Zoom-type Finder reveals the most suitable focal length, the proper camera position, the effects of dolly shots, etc. It is invaluable to a creative Director who likes to plan optical tricks and special effects. Combination Finder zooms from 25mm to 135mm for 35mm Motion Picture and zooms from 28mm to 150mm for TV. Complete with leather carrying case and neck band. **Only \$75**

Other Versatile Viewfinders — each a honey for the money!



ZOOM DIRECTOR'S FINDER for 16mm and 35mm. . . . 16mm zooms from 13mm to 75mm. 35mm zooms from 25mm to 6". **\$15.50**

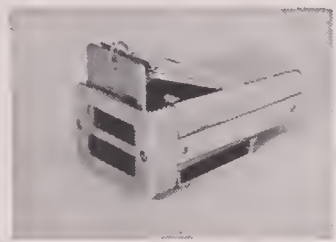

WATSON Director's type finder, pocket size, with mattes from 30mm to 100mm for 35mm cameras. Also for 16mm cameras. **\$35**

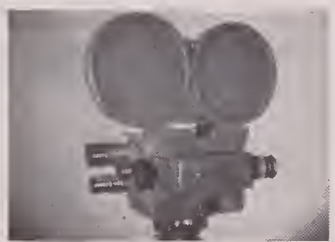

ZOOM Finder for Auricon Cine Voice . . . zooms from 15mm to 12". **\$60**
Available for Filmo and Eyemo. **\$39.50**

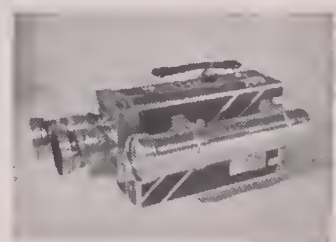

ZOOM Finder for Cine Kodak Special . . . zooms from 15mm to 150mm, with parallax adjustment. **\$75**
Template supplied for mounting Finder on magazine. Additional brackets for magazines available at \$7.50 per set.

FRANK C. ZUCKER
CAMERA EQUIPMENT CO.
 1600 BROADWAY NEW YORK CITY

paint in the canal, darkening the blue-tinted water considerably.

As a result, production on this sequence was held up until the canal had been completely drained, cleaned, and a fresh supply of water—another 365,000 gallons of it — piped into it. Then followed the painstaking job of tinting the new supply of water the same blue color as the original batch, to insure matching the color in the scenes filmed earlier.

Today, cinematographers constantly work against time—the time the production office allows in its schedule for shooting the picture. When an interruption, such as changing the water in the canal, occurs, it sets back the production, creating added problems for the director of photography who usually is expected to accelerate shooting thereafter in order to make up lost time. Sometimes the problem is compounded when added delays occur—such as when the "Casanova" company moved into a large interior set for the picture where hung a number of huge candelabras burning over 500 wax candles.

The larger the set, the greater number of lamps necessary to illuminate it, and consequently the more heat that is generated. And that's what happened on this set. The wax candles, softened by the heat drooped, bent double, and some threatened to fall out of the fix-

TODAY IT IS A MUST! 16mm & 35mm Visible Edge Film Numbering Machine

A necessity in 3D or TV for orderly handling of negatives or prints—where edge numbering is a MUST. Guides projectionist in matching exact frames.

This non-intermittent unit has an automatic metal numbering block, prints black or yellow. Film passes over drying rollers before being rewound — Central lubrication, 2000' capacity, speed 50' per minute.
 16mm machine prints between the perforations only — 35mm model prints between the perforations or on the outside edge as specified. Both negative and positive films can be numbered.

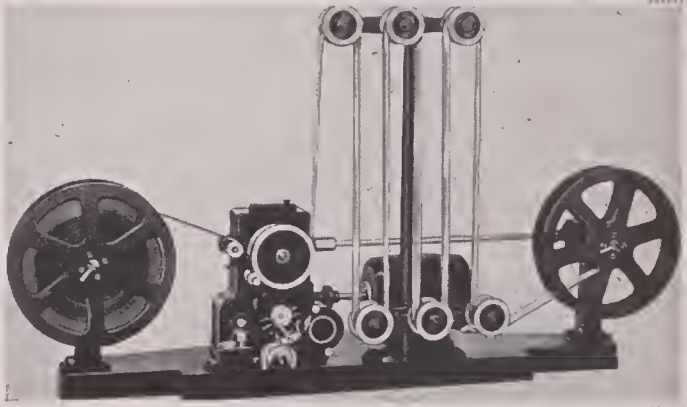

S.O.S. HAS IT!
Film Edge Waxing Machine. Flows liquid wax at 4000' per hour—dries instantly—saves cost many times—prevents damage to new prints—assures perfect recording **\$175**

F.O.B. NEW YORK **\$2250**

AGENTS FOR: Acme Animation, Acmiola Editors, Auricon 1200 Cameras, Bardwell & McAlister Spots, Bell & Howell Printers, Blue Seal Recorders, Bodde Background Screens, Century Lighting, Colortran Lites, Contimotic Printers, Hollen Recorders, Houston-Fearless Cranes & Dollies, Kinevox Synchronous Magnetic Recorders, Mole-Richardson Lights, Moviolas, Precision Sound Readers, Roby Blimps and Gearheads, S.O.S. Edge Numbering Machines, Studio Sound Readers and Synchronizers. Many Available on Time Payments.

S.O.S. CINEMA SUPPLY CORP. DEPT. F.
 602 W. 52nd St., N.Y. 19
 Cable: "SOSOUND"

MOVIOLA

FILM EDITING
EQUIPMENT
16MM - 35MM

- PICTURE SOUND Photo and Magnetic
- SYNCHRONIZERS
- REWINDERS

One of the new series 20 Moviolas for picture and sound.

Write for Catalogue

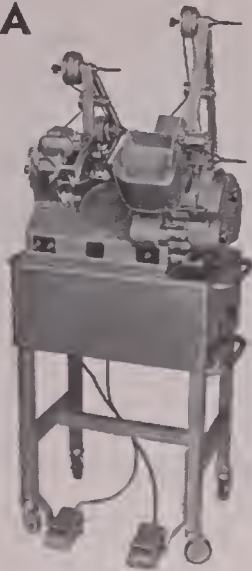

MOVIOLA MANUFACTURING CO.
1451 Gordon St. • Hollywood 28, Calif.

FOR YOUR TV COMMERCIAL

Special optical effects on 35mm or 16mm film. Send for free optical effects chart.

RAY MERCER & CO.
4241 Normal Ave. • Hollywood 29, Calif.
NOrmandie 3-9331

REVERSAL PROCESSING AND DUPLICATING SPECIALISTS FOR OVER A DECADE. MODERN MACHINES, WITH TEMPERATURE CONTROL WITHIN TWO-TENTHS OF ONE DEGREE.

free brochure on request

REVERSAL PROCESSING
E. I. DUPONT BLUE BASE FILM

	PER FT.
16 MM02c
B&W WORK PRINTS05c
B&W FROM KODACHROME ON PAN STOCK06c
TIMED REV. DUPES, SILENT07c
TIMED REV. DUPES, SOUND08c
Edge Numbering005c

NATIONAL CINE LAB

BOX 4425, Washington 17, D. C.



PRECISION BUILT COMBINATION
16mm AND 35mm

OPTICAL

SOUND READER

FEATURES: Simple threading . . . polished stabilizer drum with needle bearings, with a surface which cannot damage film . . . film rollers machined to conform with SMPTE standards, and equipped with oilless bearings . . . precision ground shafts . . . dimension 6"x6"x7 1/2".

AMPLIFIER: 117 volt - 60 cycle - AC . . . power output - 4 watts . . . heavy duty Alnico V speaker . . . safety fused . . . prefocused socket . . . pilot light . . . 6 ft. heavy duty line card.

NET PRICE \$185.00 F.O.B., FACTORY, NEW YORK

PRECISION LABORATORIES
1139 Utico Avenue BROOKLYN 3, NEW YORK

tures. This caused many interruptions in the shooting while grips and prop men scrambled up ladders and replaced the candles.

Despite all these problems and delays, Lindon and his crew brought the picture through on schedule. It was an ideal production for color film, and Lindon—with more than a score of excellent color photography jobs to his credit—had a field day. Several of them, in fact, for Bob Hope wore the gaudiest and most expensive wardrobe

of his career in this picture. It was also the heaviest and most uncomfortable. An impeccable but casual dresser in real life, he had to wear an 18th century white wig and hated every minute of it. His costumes consisted of several fancy tri-cornered hats, multi-colored coats and breeches, and long silk stockings and pumps. "You photograph beautifully," said Lindon one day, trying to cheer him up.

"If Crosby sees this picture, I'll never hear the end of it," Hope moaned.

TOMORROW'S WIDE-SCREEN CAMERA

(Continued from Page 176)

- required for each type of motor, and if the motor housing is included within a blimp, it will probably be necessary to have the switches on a pigtail as at present.
35. Buckle trips should be provided, capable of working on all three types of motors.
 36. If separate type take-up motors are required for each type of power supply, it might be well to consider mounting the respective take-up motors and drive motors as pairs.
 37. A synchronizing bloop light shall be provided. The present preference is to have the bloop light in the sprocket hole area and shielded so it can never ruin the picture.
 38. Consideration shall be given to an automatic slating device, either as a part of, or as an accessory to the camera. There is much merit in the Warner-type slater.
 39. The noise level of the camera shall be as low as possible. The desire is to obtain a silent camera without blimping. However, a blimped camera is acceptable. In any case the noise level should not exceed the noise level of the present BNC Mitchell camera. A new camera de-

sign should have less sound generation and radiation. Possibly the lens mounting and movement should be on a separate mount within the camera housing, said mount to have long leverage legs to minimize angular movement. Possibly the movement should involve counter-balancing. The chambers of noise generation should be isolated and absorbent in the manner of automobile mufflers. With proper design it should not be necessary to blimp the entire camera. If a blimp is required, it should only include blimping of those parts that have large noise level radiation.

40. If a blimp is required, it can be supplied by the studio. However, Paramount would prefer to purchase a silent camera either blimped by the manufacturer, or enclosed in a silent camera housing.
41. As an aid in silencing, it may be desirable to use nylon or similar materials in the fabrication of aperture plates, gears, and other parts where noise is generated.
42. It is hoped that this camera will be sufficiently quiet so as not to require an optical glass in front of the lens.
43. The camera shall be as light-weight as possible. This is very important and should be considered in the same manner that aircraft design has reduced the weight of aircraft parts and equipment.
44. In contemplation of a light-weight camera, a completely new camera mount of lighter weight may be designed to go with these cameras.
45. It is suggested that in considering a camera design, a wooden mock-up should be made and reviewed before undertaking the fabrication of a prototype camera.
46. The overall height should be kept down as much as possible. Paramount's engineering department.

ngallen
CORPORATION
MAKERS OF
SYNCHRONOUS
Magnetic
FILM
RECORDERS

Newest Addition

TO THE *Hallen* LINE OF MAGNETIC *Film* RECORDERS

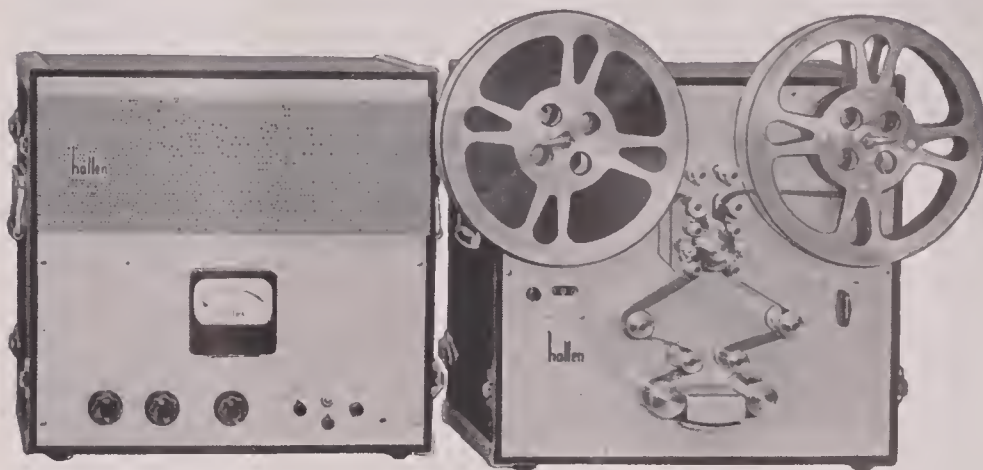

The recorder shown is 35mm using two flywheels, designed to facilitate conversion to multiple track, stereophonic, cinemascope etc.

The two case portable Model 235 magnetic film recording system is also available in both 35mm and 16mm single drum system. Literature available.

3503 WEST OLIVE AVENUE • BURBANK, CALIFORNIA
CABLE ADDRESS "HALLEN" • PHONE THORNWALL 8-6976

under the supervision of Loren L. Ryder, has constructed rough mockups of five different VistaVision cameras, based on the specifications set forth above—each conceived with special emphasis on certain features which careful study and analysis indicate the new camera should have.

Figure 1 and 1-a picture a compact model which features 2000-ft. "elephant ear" magazines mounted vertically on each side. This model—radically different in design than any camera so far—is favored by many in the studio because of its compact design, affording the cameraman greater ease of operation and unobstructed view of the set or scene.

The designs in Figs. 2, 2-a, 3 and 3-a are of a more conventional type camera—much the same as cameras now in use in the studios.

Figure 4 presents another new approach in camera design—one which incorporates the European trend for quick-interchangeable film magazines of the cartridge type.

A design suited for use when minimum height of equipment is a requirement is pictured in Fig 5. The wide span of the horizontal 2000-ft. magazine, however, would appear to be a drawback to this design.

Of the general specifications, those relating to the film transport movement

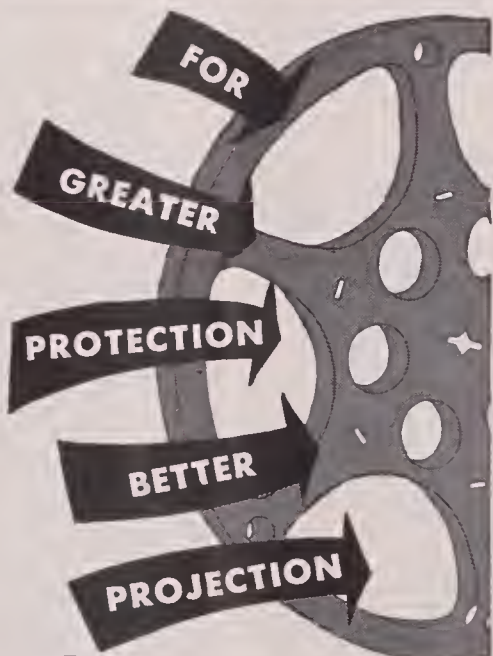

Compc
PROFESSIONAL Reels

For shipping, storing or showing film, precision made Compc Professional Reels are first choice with those who want the finest. Hard, spring type steel construction won't warp or bend . . . eliminates film-wearing rubbing during projection or winding. Your production deserves the finest package—use Compc Professional Reels in 600 ft. to 2,000 ft. sizes.

Write for catalog!

COMPCO CORPORATION
2253 W. ST. PAUL AVENUE, CHICAGO 47, ILL.

F & B SPECIALS

10" Diameter Flanges (new)

Fits all size rewinds
Round and square haes
Heavy duty aluminum construction
REG. \$10.00 — NOW \$7.45

*** F&B MOVIE STOPWATCH ***

Precision Swiss movement
Calibrated to read seconds,
minutes, 16mm & 35mm footage
Starts—Stops—Resets
List Price \$29.50 — Now \$14.75

*** NEW — CRITICAL FOCUSER *
FOR AURICON PRO & CINEVOICE**

Prism reticle, 6x Achromat
Magnifier focuses on groundglass
Only — \$49.50

16MM TEWE VIEWFINDER

POLYFOCUS . . . RANGE 15mm to 150mm
Porollox adjustment . . . can be used
as comero or director's finder.
With leather case.
REG. \$75.00 — NOW \$49.75

COLORTRAN CONVERTERS

FREE for the asking . . .
A complete catalogue
explaining and illustrating
the Colatron hi-intensity,
low voltage lighting system.



FLORMAN & BABB

70 West 45th Street, New York 19, N. Y.
Phone: Murray Hill 2-2928
Cable Address — FLORBABB, N. Y.

F&B USED BARGAINS

KINEVOX SYNCHRONOUS MAGNETIC RECORDER, latest model, used, but perfect cond., PRICE \$1500.00, reduced to only \$ 845.00
MAURER 16mm optical film recorder, mod. D, completely overhauled and NEW "G". PRIME GALVO installed. Complete outfit rock mounted with costers for studio or portable operation. GUARANTEED PERFECT, one only..... 2975.00

CAMERAS — 35mm
WALL, single system, less galvo, with 25mm, 40mm, 50mm, 75mm lenses, rockover, 2-1000 ft. mogs., 12v motor, cuses.....\$2975.00

ARRIFLEX, reflex viewing, with 50mm, 75mm f1.8 lenses, 2-200 ft. mogs., built-in 12v motor, sunshade, filter holder, carrying case..... 595.00

DE VRY, magic eye, 10° shutter, 8 fps, 2" f2.8 in Cmt., like new..... 95.00

EYEMO 71A, 16-24-32 fps, 47mm f2.5.... 165.00

EYEMO 71K, 8-16-24 fps 2" f4.5, pos. turret finder, excellent..... 235.00

EYEMO 71M, compact 3 lens tur. 2" f2.5, behind lens filter slot, like NEW..... 545.00

EYEMO 71Q, spider tur. prism focus, 3 lenses, 7 speeds, motor, just overhauled by B&H..... 895.00

ARRIFLEX, 3 Zeiss lenses, complete..... 875.00

CAMERAS — 16mm

FILMO 70A, 25mm f3.5 lens..... 42.50

FILMO SUPERSPEED, 128 fps, less lens.... 145.00

BOLEX standard, 15mm f2.8, 25mm f1.9, 76mm f4.5, excellent..... 295.00

CINE SPECIAL 1, 4 lenses..... 427.50

AURICON PRO, built-in features incl. focusing device, spider turret, zoom finder, built-up to 360' cop. 1295.00

ALWAYS IN STOCK—
THOUSANDS OF USED ITEMS, ALWAYS AT FAIR AND REASONABLE PRICES

WANTED FOR CASH!

ALL KINDS OF USED EQUIPMENT. SEND YOUR LISTS FOR CASH ESTIMATE.

F&B FLORMAN & BABB
 70 West 45th Street, New York 19, N. Y.
 Phone: Murray Hill 2-2928
 Cable Address—FLORBABB, N. Y.

Ready-Eddy

U. S. Registered Trademark

EASY READABLE • ACCURATE FOR EVERY DAY USE

1001 Ready Sound-Film

Editing Data:

- Footage • Frame Count • Screen Time • 35mm and 16mm equivalents.

Plastic computer for everyone in movies and TV, from script to screen.

\$2.00 Prepaid

(Delivered in U.S.A.)

ASK FOR REPRINT OF ARTICLE IN AMERICAN CINEMATOGRAPHER.

Write or ask your dealer

READY-EDDY, Sandy Hook, Conn.



THEATER QUALITY 16mm SOUND

The finest equipment plus top technical skill gives you the brilliant, tone-true track that will result in wider distribution and more bookings for your picture. Let us prove Telefilm recording can benefit you.

Write for Information

Dept. A-11

TELEFILM, INC.

6039 Hollywood Blvd.
 Hollywood 28, Calif.

and shutter already have been given attention by Mitchell Camera Corporation. This company has designed and built a horizontal movement, and the first to come off the Mitchell assembly line have been installed in Paramount's present VistaVision cameras. Another half-dozen have been supplied Technicolor Corporation for the six VistaVision cameras the company is presently building—actually modifying their present three-strip cameras for single-strip Vista-

Vision color photography.

At Paramount studio, the engineering department is concentrating on assembling and putting into service at least 13 additional VistaVision cameras to meet the needs of the company's 1954 feature film production schedule.

The various camera models now under consideration are to be further evaluated by Paramount, and as soon as the most practical and efficient design is presented, complete new VistaVision cameras will be built, based on this design.

CAMERA MODIFICATIONS

(Continued from Page 181)

Parrish has developed an attractive and practical modification for this camera which permits using either 400-foot or 1200-foot Mitchell magazines. The same modification is applicable also to the "Auricon-Pro" camera.

The complete "Cine-Pro" adaptation is pictured in Figs. 1 and 2. The overall camera case is larger and is self-blinded, assuring quiet operation. A major Parrish innovation is the through-the-lens finder, which permits viewing the scene as it is being photographed and, of course, is ideal for composing and lining up each shot. This innovation, which is based on a patent by Art Reeves, gives a clear, upright image. This viewer involves use of a semi-transparent mirror which is positioned between the rear element of the lens and the film. The resultant light transmission loss is only about 10%, but this is compensated for by re-evaluating the shutter speed. In other words, the regular shutter speed of the camera is 1/50th of a second; with the through-the-lens viewer installed, it becomes 1/45th second.

Another important feature of the Parrish modification is the zoom-type finder which is mounted externally on the left side of the camera. This finder, with its changeable lens field, shows the field area of lenses ranging from 13mm to 6 inches.

Other features include a Veeder footage counter, with knob for turning back to zero; a new and heavier sync motor, which also drives the external magazine takeup; and an additional red indicator lamp on front of the camera, which shows when the camera is running. No less important is the additional film drive sprocket which is added to the camera, plus additional guide rollers. This is shown in Fig. 2 at "A". Its function is to smooth out the travel of film over the sound head and insure more efficient film flow to the takeup reel of the larger, external film magazine.

Another Parrish adaptation of this camera, shown in Fig. 3, is for kinescope recording of television programs directly from a conventional TV receiver. It provides an excellent camera for any television studio for the purpose of making its own air checks or kine recordings.

In addition to all the features enumerated above for the regular Cine-Voice modification, it also incorporates the patented Auricon kinescope shutter, which replaces the regular shutter designed for conventional motion picture photography. Eliminated, however, is the through-the-lens finder, which is unnecessary for this type film recording.

The complete modification, less film magazines, weighs about 26 pounds. The chief advantage it offers is a camera that is more flexible for professional use, whether professional 16mm production, TV film making, or television film recording. In the latter use, the big 1200-foot film magazines, which provide up to 33 minutes of continuous film recording, are an important factor for those who would adapt this moderate-priced sound camera for TV film recording work.

In Hollywood, Fred Parrish's camera work is well known. Readers of *American Cinematographer* will recall the interesting 16mm 3-D filming unit he built, using two Eastman Cine Kodaks—a project which was illustrated and described in our September, 1953, issue. His zoom type finder, originally developed for a cinematographer friend, is now marketed nationally by a prominent equipment distributor.

Twentieth Century-Fox recently announced that Bausch & Lomb Company has developed three new lenses for CinemaScope photography—one for mammoth exteriors or interior sets, the second for group shootings, and the third for intimate closeups. All of the new lenses are reportedly 50% better than the old C-Scope lenses.

CLUB PROJECT

(Continued from Page 193)

stop exposing cell No. 1 over the revolving background. The lens was then capped and the exposed film wound back a total of 48 frames—the equivalent of 3 seconds filming time.

At this point cell No. 2 was laid over cell No. 1 (Fig. 6) and the camera with closed diaphragm started and the diaphragm slowly opened in a time interval of three seconds. At full aperture (ie., the established f/ stop) the camera was run for another 8 seconds, then followed a three-second fadeout. This produced the effect of dissolving cell No. 2 onto cell No. 1 over the revolving background. By repeating these steps with each of the three No. 3 cells (Fig. 7), our leader was complete.

On the screen, the leader appears with a fadein on the club insignia over the revolving background; then the text "New York 8mm Club, 1953 Award" dissolves into view, and then the final text, "First Prize," etc.

This same procedure can be followed to make up leaders, etc., for other club purposes such as identifying leaders to be sold or given to members to attach to their films for the purpose of adver-

(Continued on Page 208)

C. ROSS

FOR

LIGHTING EQUIPMENT

Inkie and Arc Lamps including Required Accessories
Generators—Cables—Boards—Boxes

Raby Camera Crane—Dollies—Blimps—Geared Heads

GRIP EQUIPMENT

FOR LOCATION AND STUDIO

Parallels—Steps—Platform Ladders
Century Stands—Reflectors—Flags—Scrim

SOLE EASTERN MOLE-RICHARDSON CO. DISTRIBUTOR

RENTALS • SALES • SERVICE

CHARLES ROSS, Inc.

333 WEST 52nd STREET

NEW YORK 19, N.Y.

Circle 6-5470-1



frost lights the nation!

MOTION PICTURE STUDIO •
THEATRICAL • DISPLAY
RENTAL EQUIPMENT

WHEREVER YOU ARE—WHATEVER YOU NEED

... in the way of unusual, specialized lighting, call on Jack Frost! For movie-making, stage lighting, feature exhibits, large conventions ... for *any* location that requires exceptional lighting, Jack Frost is ready to serve you! And Jack Frost's unequalled national service includes complete installation and removal *wherever* you are. Rent all your specialized lighting equipment from Jack Frost ... famous for lighting the nation's greatest shows ... most spectacular displays.

FOR FULL INFORMATION ON
RENTAL EQUIPMENT
MAIL COUPON, OR CALL
DETROIT, TRINITY 3-8030

JACK A. FROST, DEPT. J,
234 PIQUETTE AVE.
DETROIT 2, MICHIGAN

Please send me full information on
your rental service.

Name _____

Address _____

City _____ Zone _____ State _____

F & B 600 - Ft. Magazine

for
Auricon
Cinevoice
Camera
At Low Cost

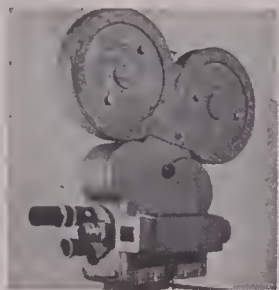

NOW Shoot full 15 minute TV shows without stopping or reloading. The F&B conversion includes 600 ft. magazine, extra silent takeup motor, camera insert plate for stabilization of film movement, and footage counter.

Camera is **not cut down**; can be used without magazine for 100 ft. rolls. Magazine accepts 200 ft. spools as well as 400 ft. and 600 ft. rolls on cores.

NOW IN USE BY: TV STATIONS, TV NEWSREELS, LOCAL NEWSREELS, TV FILM PRODUCERS, POLITICAL ORGANIZATIONS, FRATERNAL ORGANIZATIONS, COLLEGES, UNIVERSITIES, SCHOOLS, CHURCHES, RELIGIOUS ORGANIZATIONS, GOVERNMENT AGENCIES, WEDDING AND SOCIAL EVENTS FILM PRODUCERS.

WRITE FOR COMPLETE DETAILS

TOTAL PRICE: including magazine, motor, insert plate and installation. **\$425.00**

F&B

FLORMAN & BABB

70 West 45th Street, New York 19, N. Y.
Phone: Murray Hill 2-2928
Cable Address - FLORBABB, N. Y.

Blowup Eastman & Ansco Color Negatives

from 16mm Color Originals

HERE

is the most economical
method to obtain 10 to 100
35mm three-color theatre
release prints.

Write For Complete Information

FILMEFFECTS

OF HOLLYWOOD

1153 N. Highland Ave., Hollywood 38, Calif.
Phone Hollywood 9-5808

**SPECIALIZED
LABORATORY SERVICES**

Superimposes - 3D Convergence Correction
Special Optical Effects - Dissolves
Montages - Fades - Wipes - Zooms

Current Assignments of A.S.C. Members



Major film productions on which members of the American Society of Cinematographers were engaged as directors of photography during the past month.

AMERICAN SOCIETY OF CINEMATOGRAPHERS

FOUNDED January 8, 1919, The American Society of Cinematographers is composed of the leading directors of photography in the Hollywood motion picture studios. Its membership also includes non-resident cinematographers and cinematographers in foreign lands. Membership is by invitation only.

ARTHUR EDESON, President
MILTON KRASNER, First Vice-President
ARTHUR MILLER, Second Vice-President
HAL MOHR, Third Vice-President
WILLIAM SKALL, Treasurer
JOHN W. BOYLE, Secretary
ROBERT DE GRASSE, Sergeant-At-Arms
JOHN ARNOLD
CHARLES G. CLARKE
LEE GARMES
ALFRED GILKS
VICTOR MILNER
RAY RENNAHAN
JOSEPH RUTTENBERG
LEON SHAMROY

Alternate Board Members

JOSEPH BIROC
WILLIAM DANIELS
PAUL EAGLER
SOL HALPRIN
WINTON HOCH
CHARLES LANG
JOSEPH LA SHELLE
JOHN SEITZ
PHILIP TANNURA
JAMES VAN TREES

ALLIED ARTISTS

- HARRY NEUMANN, "The Bowery Boys Meet The Monster," with Leo Gorcey, Huntz Hall, Laura Mason, Ellen Corby, Bernard Gorcey, David Condon, and Bennie Bartlett. Edward Bernds, director.
- HARRY NEUMANN, "Sons of the Navy," with Jan Sterling, Neville Brand, Robert Arthur, Alvey Moore, Paul Langton, John Dourcette, Don Haggerty, Lloyd Corrigan, Walter Reed, Ward Wood, Boh Patton, James Best, John Tarrangelo, and Bill Gentry. Lesley Selander, director.

COLUMBIA

- ARTHUR E. ARLING, "Three for the Show," (Technicolor; CinemaScope) with Betty Grable, Marge and Gower Champion, Jack Lemmon, Myron McCormick. H. C. Potter, director.
- BURNETT GUFFEY, "Those Reported Missing," with Robert Francis, Dianne Foster, Brian Keith, Jerome Courtland, E. G. Marshall, Leo Gordon, Jack Kelly, Richard Loo, and Keye Luke. Lew Seiler, director.
- HENRY FREULICH, "Pirates of Tripoli," (Technicolor; Clover Productions) with Paul

Henreid, Patricia Medina, John Miljan, and Maralou Gray. Felix Feist, director.

- CHARLES LAWTON, JR., "The Long Gray Line," (Technicolor; CinemaScope) with Tyrone Power, Maureen O'Hara, Betsy Palmer, Robert Francis, Phil Carey, Bill Leslie, Donald Crisp, Sean McClory, and Harry Carey, Jr. John Ford, director.

- ELLIS CARTER, "The Black Dakotas," (Technicolor) with Gary Merrill, Wanda Hendrix, John Bromfield, Noah Beery, Jr., Richard Webb, James Griffith, Clayton Moore, Howard Wendell, Fay Roope, and Robert Simon. Ray Nazarro, director.

- HENRY FREULICH, "Bat Masterson, Bad Man," (Technicolor) with George Montgomery, Nancy Gates, and James Griffith. William Castle, director.

- CHARLES LANG, JR., "Joseph and His Brethren," (Technicolor; CinemaScope: Shooting in Egypt) William Dieterle, director.

METRO-GOLDWYN-MAYER

- JOSEPH RUTTENBERG, "The Last Time I Saw Paris," (Color; wide-screen; shooting backgrounds temporarily in Paris) with Elizabeth Taylor, Van Johnson, Walter Pidgeon, Donna Reed, Eva Gabor, Kurt Kasznar, Roger Moore, and Sandy Descher. Richard Brooks, director.
- ROBERT PLANCK, "Athena" (Technicolor: wide-screen) with Jane Powell, Edmund Purdom, Debbie Reynolds, Vic Damone, and Louis Calhern, Joe Pasternak, director.

PARAMOUNT

- LOYAL GRIGGS, "The Bridges At Toko-Ri," (Eastman Color; Wide Screen) with William Holden, Grace Kelly, Mickey Rooney, Fredric March, Charles McGraw, Robert Strauss, Keiko Awaji, Dick Shannon, Bill Bouchey. Mark Robson, director.
- WILLIAM DANIELS, "Strategic Air Command," (Technicolor; VistaVision; shooting at Tampa) with Jimmy Stewart, June Allyson, Frank Lovejoy, Barry Sullivan, Bruce Bennett, and Jay C. Flippen. Anthony Mann, director.

20TH CENTURY-FOX

- JOE MACDONALD, "Broken Lance," (Technicolor; CinemaScope) with Spencer Tracy, Katy Jurado, Robert Wagner, Jean Peters, Richard Widmark, Hugh O'Brien, Eduard Franz, E. G. Marshall, Carl Denton Reid, and Earl Holliman. Edward Dmytryk, director.
- LEON SHAMROY, "The Egyptian," (Technicolor; CinemaScope) with Edmund Purdom, Jean Simmons, Victor Mature, Gene Tierney, Bella Darvi, Peter Ustinov, Judith Evelyn. Michael Curtiz, director.
- LEO TOVER, "Untamed," (Technicolor; CinemaScope) shooting backgrounds in South Africa) Henry King, director.

UNIVERSAL-INTERNATIONAL

- MAURY GERTSMAN, "Bengal Rifles," (Technicolor; wide-screen) with Rock Hudson, Arlene Dahl, Dan O'Herlihy, Torin Thatcher, Michael Ansara. Laslo Benedek, director.
- GEORGE ROBINSON, "The Matchmakers," with Marjorie Main, Chill Wills, Alfonso Bedoya, Pedro Gonzales Gonzales, Rudy Vallee, Ruth Hampton, and Benay Venuta. Charles Lamont, director.

● IRVING GLASSBERG, "Francis Joins The WACs," with Donald O'Connor, Julia Adams, Chill Wills, Mamie Van Doren, and Allison Hayes. Arthur Lubin, director.

● RUSSELL METTY, "The Tight Squeeze," with Sterling Hayden, Gloria Grahame, and Gene Barry. Jerry Hopper, director.

● GEORGE ROBINSON, "Nevada Gold," (Technicolor; wide-screen) with Lex Barker, Mala Powers, Howard Duff, John McIntire, and William Demarest. Jesse Hibbs, director.

WARNER BROS.

● SID HICKOX, "Battle Cry," (WarnerColor; CinemaScope) with Van Heflin, Aldo Ray, James Whitmore, Tab Hunter, Dorothy Malone, Allyin McLerie, William Campbell, and Glenn Denning. Raoul Walsh, director.

INDEPENDENT

● FLOYD CROSBY, "The Snow Creature" (Wide-screen) with Paul Langton, Vernon Downing, Bill Phipps, Rollin Moriyama, Constance Weiler, Darwin Greenfield. W. Lee Wilder, producer-director.

● FRED GATELY, "The Bandit," (Josef Shafel Prods.—Eastman color, SuperScope) with Arthur Kennedy, Betta St. John, and Eugene Iglesias. Edgar Ulmer, director.

● RAY JUNE, "Night Music," (Allan Dowling Pictures; RKO release; Eastman color, wide-screen) with Linda Darnell, Rich Jason, Dan Duryea, Faith Domergue, Hal Baylor, Mary Young, Jerry Mathers, and Susie Mathers. Stuart Heisler, director.

● JACK CARDIFF, "The Barefoot Contessa," (Figaro Prods.; Technicolor; shooting in Italy) with Humphrey Bogart, Ava Gardner, Edmund O'Brien, Valentina Cortessa, Marius Goring, and Bessie Love. Joseph L. Mankiewicz, producer-director.

● FRANK PLANER, "20,000 Leagues Under The Sea," (Walt Disney Prod.; Technicolor; CinemaScope) with Kirk Douglas, James Mason, and Peter Lorre. Richard Fleischer, director.

● GIL WARRENTON, "The White Orchid," (Cosmos Prod. for U-A; Eastman Color; Wide screen) with William Lundigan, Peggie Castle, and Armando Silvestre. Reginald LeBorg, producer-director.

● HAL ROSSON, "Mambo," (Ponti-De Laurentiis Prod. for Paramount; shooting in Rome, Italy) with Silvano Mangano, Michael Rennie, Vittorio Gassman, Shelly Winters, and Katherine Dunham. Robert Rossen, director.

● ERNEST LASZLO, "Vera Cruz," (Hecht-Lancaster Prod. for U-A; Technicolor; Wide-screen; shooting in Mexico) with Gary Cooper, Burt Lancaster, Mari Blanchard, Cesar Romero, Sarita Montiel, George Macready. Robert Aldrich, director.

TELEVISION

(The following directors of photography were active last month in photographing films for television in Hollywood, or were on contract to direct the photography of television films for the producers named.)

● LUCIEN ANDRIOT, "The Life of Riley" series of half-hour comedy-dramas for Hal Roach Studio Prods., starring William Bendix. (NBC.)

● JOSEPH BIROC, "The Lone Wolf" series of half-hour dramas for Gross-Krasne, Inc., California Studios; also "The Family Next Door" series of 15-minute films for American National Studios, Inc.

● NORBERT BRODINE, "Letter To Loretta" series of half-hour dramas for Lewisor Prods.

—D.P.I., starring Loretta Young. (Procter & Gamble), RKO-Pathe studio.

● DAN CLARK, "Cisco Kid" series of half-hour western dramas; also "I Led Three Lives" series of half-hour dramas, starring Richard Carlson, for Ziv-TV Corp., California Studio.

● EDWARD COLMAN, "Dragnet" series of half-hour dramas, starring Jack Webb, for Mark VII Prods., Walt Disney Studio. (Chesterfield.)

● ROBERT DEGRASSE, "Make Room For Daddy" series of half-hour comedies starring Danny Thomas for Marterto Prods., Inc., D.P.I., Motion Picture Center. (ABC.)

● GEORGE DISKANT, "Four Star Playhouse" series of half-hour dramas, featuring various stars, for Four Star Productions, RKO-Pathe Studio. (Singer Sewing Machines.)

● BENJAMIN KLINE, "Fireside Theatre" series of half-hour dramas for Frank Wisbar Prods., Inc., at American National Studios (Procter & Gamble).

● JACK MACKENZIE, "Public Defender" series of half-hour films for CBS, starring Reed Hadley. Shooting at Republic Studios.

● WILLIAM MELLOR, "Adventures of Ozzie and Harriet" series of half-hour comedy dramas starring Ozzie Nelson and Harriet Hilliard for Stage Five Prods., Inc., General Service Studios. (ABC.)

● VIRGIL MILLER, "You Bet Your Life," weekly half-hour audience participation shows, featuring Groucho Marx, for Filmcraft Prods., NBC Studios. (DeSoto-Plymouth).

● HAL MOHR, "The Joan Davis Show" series of half-hour comedy-dramas starring Joan Davis for Joan Davis Enterprises, General Service Studios. (NBC.)

● KENNETH PEACH, "Mr. and Mrs. North" series of half-hour dramas starring Barbara Britton and Richard Denning for John W. Loveton Productions, Samuel Goldwyn Studios. (Revlon, and Congoleum-Nairn). Also "Topper" series of half-hour films, starring Anne Jeffreys, Robert Sterling, Leo G. Carroll, and Lee Patrick for Loveton-Schubert Prods., at Samuel Goldwyn Studios. (Camel Cigarettes).

● ROBERT PITTACK, "Private Secretary" series of half-hour comedy dramas starring Ann Sothern and Don Porter, (Lucky Strike); also "Cavalcade of America" series of half-hour dramas, for Jack Chertok Prods., General Service Studios.

● GUY ROE, alternating with Walter Strenge on the "Rocky Jones, Space Ranger" and "Waterfront" series of half-hour dramas for Roland Reed Productions, Hal Roach Studios.

● MACK STENGLER, "Life With Elizabeth" series of half-hour dramas; also "The Liberace Show," half-hour musical film series for Snader Telescriptions Corp.

● HAROLD STINE, "Cavalcade of America" series of half-hour dramas for Jack Denove Prods., Inc., Samuel Goldwyn Studios. (DuPont).

● WALTER STRENGE, "My Little Margie" series of half-hour comedies, starring Gale Storm and Charles Farrell (Scott Paper Co.); also "Rocky Jones—Space Ranger" series of half-hour science-fiction dramas starring Richard Crane and Sally Mansfield (UTP); also "Waterfront" series of half-hour dramas starring Preston Foster and Lois Moran (UTP) at Hal Roach Studios.

● PHIL TANNURA, "The Burns and Allen Show" series of half-hour comedies starring George Burns and Gracie Allen, for McCadden Corp., General Service Studios. (Carnation Milk and Goodrich).

● JAMES VAN TREES, "For The Defense," new series of dramatic films for Sam Bischoff, starring Edward G. Robinson.

Alligator CLAMP
WITH BARN DOOR

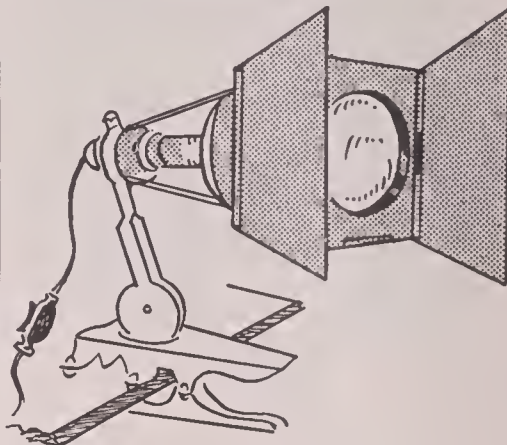

- ★ Hangs from a nail on the wall.
- ★ Clamps to a chair, door, top of set or stand.
- ★ Sets on floor as a foot light.
- ★ Adaptable to almost everywhere.
- ★ Barn door swivels 360°
- ★ For R2 - R40 or Par 38 Bulbs

Price — \$15.00

Clamp without barn door wired with plug and switch — Price—\$5.00
Clamp onlyPrice—\$2.75

Above unit excellent for use with "COLORTANS"

SCHOEN & CROWE

403 WEST 47th STREET
NEW YORK 36, N. Y.
Circle 5-4691

WRITE FOR OUR CATALOG ON LIGHTING EQUIPMENT

Color Tan
GOBO STAND
That is Really Versatile **It's New!**

THE 12 foot stand may be used with a BOOM ADAPTER or with SCRIMS or with FLAGS

ABSOLUTE LIGHT CONTROL

WRITE FOR FURTHER INFORMATION
SCHOEN & CROWE
CALIFORNIA

NATURAL LIGHTING CORP.

WORLD FAMOUS

S-5
synchronous magnetic film recorder for motion pictures and television

STANCIL-HOFFMAN
921 N. Highland Hollywood 38, Calif.

send for particulars

NEW F & B SPLIT REELS

Save

TIME - SPACE
WEAR & TEAR
ON 16mm PRINTS

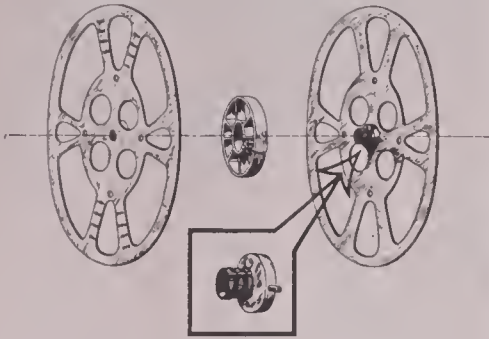

NOW You can project, edit, inspect, synchronize, measure, clean and store 16mm films on cores . . . without rewinding.

You simply open split reel, slip in film on core, and close reel.

400 ft. split reels — 16mm.....	\$4.50
800 ft. split reel — 16mm.....	\$6.00
1200 ft. split reel — 16mm.....	\$7.50
1600 ft. split reel — 16mm.....	\$9.00

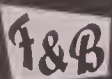

FLORMAN & BABB

70 West 45th Street, New York 19, N. Y.
Phone: Murray Hill 2-2928
Cable Address — FLORBABB, N. Y.



PELLEGRINI

VARIABLE SHUTTER UNITS
FOR THE BOLEX H-16

The real answer to complete FADES and LAP DIS-SOLVES. Faster shutter speeds and many other advantages. Prices within U. S. \$99.60. Cameras with outside frame counter \$109.80. Tax extra. One year guarantee and camera transportation back included. Send for free informative booklet.

Prices subject to change without notice.

TULLIO PELLEGRINI
1545 Lombard St.

San Francisco 23, California

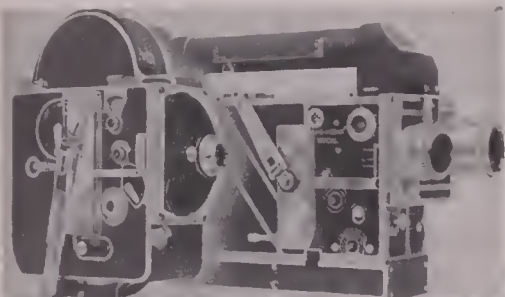

Automatic dissolve attachments for Cine Special and Bolex H-16 (Equipped with Pellegrini Shutter)

JOSEPH YOLO, 1037 N. La Brea
Phone GL. 7103 Hollywood, California

Ads in these columns reach readers in 69 foreign countries.

CLUB PROJECT

(Continued from Page 205)

tising the club: or for making the main and end titles for the various film productions of the club or individual members.

As a club project, title or leader making can be indulged in by several if not all the members, each of whom can take his turn at photographing his own titles or leaders. For clubs faced with the problem of "what to give for prizes" in club film competitions, here is the answer. A prize award in the form of a leader gives a film tremendous prestige as it unfolds on the screen attached to the prize-winning film itself. It reminds the viewer that "here is a prize-winning film"—something that an inarticulate trophy on the mantle cannot do.

ACADEMY AWARDS

(Continued from Page 180)

Other major Academy Awards for 1953 are as follows:

Best Actor: William Holden. "Stalag 17." Paramount Pictures, Inc., photographed by Ernest Laszlo.

Best Actress: Audrey Hepburn. "Roman Holiday." Paramount Pictures, Inc., photographed by Frank Planer, ASC. and Henry Alekan.

Best Supporting Actor: Frank Sinatra. "From Here To Eternity." Stanley Kramer-Columbia Pictures Corp., photographed by Burnett Guffey, ASC.

Best Supporting Actress: Donna Reed. "From Here To Eternity."

Best Direction: Fred Zinneman. "From Here To Eternity."

Best Screenplay: Daniel Taradash. "From Here To Eternity."

Best Motion Picture Story: Ian McLellan Hunter, "Roman Holiday."

Best Story and Screenplay: Charles Brackett, Walter Reisch, and Richard Breen. "Titanic." 20th Century-Fox, photographed by Joseph MacDonald, ASC.

Best Art Direction: (Black and white) Cedric Gibbons and Edward Carfagno, "Julius Caesar," Metro-Goldwyn-Mayer, photographed by Joseph Ruttenberg, ASC. Set decoration: Edwin Willis and Hugh Hunt.

Best Art Direction: (Color) Lyle Wheeler and George W. Davis. "The Robe." 20th Century-Fox, photographed by Leon Shamroy, ASC. Set decoration: Walter M. Scott and Paul S. Fox.

Best Film Editing: William Lyon. "From Here To Eternity."

(Continued on Page 210)

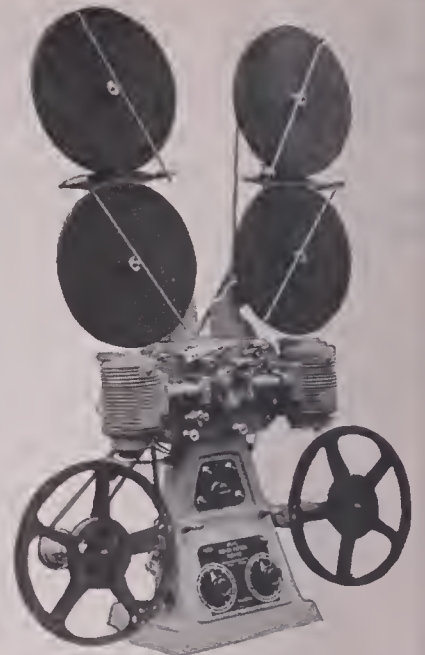

PRINTERS—Combination 16mm and 8mm continuous for color or B&W films. Prints sound and picture simultaneously, either single or double system . . . Reduction and enlarging 16-8mm and 8-16mm . . . Reduction and enlarging 35-16mm and 16-35mm . . . Reduction for sound 35mm to 16mm only . . . Cine 16mm for sound or silent pictures. Machines tested and guaranteed. Write for literature.

UHLER CINE MACHINE CO.

15778 Wyaming Ave Detroit 38, Mich
Phone: UNiversity 1-4663—Cable: "UHLICIMA"

Now! A 400ft. Magazine For Your BOLEX H-16

Complete with
Synchronous
Motor
and Base

Includes
Installation
and
Case



Permits continuous run of 400 feet of 16mm film, or—the 200 ft. daylight loading spool may be used in the 400 ft. magazine. The 100 ft. daylight loading spool can be used in the camera without removing the external magazine. In black wrinkle finish to match camera. Fully guaranteed. Write for information on our Rack-Over, Sportsfinder and Camera Base.

See your Bolex dealer or order direct. Immediate delivery.

TO'EDO CINE ENGINEERING
1309 Milburn Ave. Toledo 6, Ohio



Scheibe FILTERS

In World-Wide Use

Produce moonlight and night effects in daytime • fog scenes • diffused focus and many other effects.

Information mailed on request.

SCHEIBE FILTERS COMPANY
ORIGINATORS OF EFFECT FILTERS
P.O. Box 16834, Hollywood 46, Calif.

USED IN EVERY HOLLYWOOD MOTION PICTURE PRODUCTION

CLASSIFIED ADVERTISING

RATE: 10c per word—minimum ad \$1.00. Words set in capital letters, 15c per word. Display format 90c per line.

STUDIO & PRODN. EQUIP.

OUR 25TH YEAR — SUPPLYING EVERYTHING PHOTOGRAPHIC & CINEMATIC

B&H 25mm EYEMO "Q" CAMERA with 4" f2.9 Cinemat, 2" f2.3 Kinar, 35mm f2 Cooke lenses and viewfinder lenses, 2-400' magazines, freehead tripod, shift over alignment Gauge, 12V variable speed motor, 2 carrying cases, excellent condition\$1550.00

35mm DUPLEX CAMERA — Registration pins, lenses: 40mm f2.7 Carl Zeiss, 2" f1.9 Ultrastigmat, 105mm Schneider f3.5, 3-400' magazines, 400' BiPack magazine, viewfinder Matte Box 12V DC motor, battery, Freehead Tripod, 2 carrying cases. A real buy 1125.00

35mm B&H SINGLE SYSTEM SOUND CAMERA, lenses: Cooke, 40mm, 50mm, 75mm, 125mm Modulite Galvanometer, amplifier, motor, Tachometer, 2-1000' magazines, Tripod with Freehead, quick release legs, carrying cases, guaranteed 3500.00

35mm ARRIFLEX CAMERA, Coated lenses: 35mm f1.2 Carl Zeiss, 50mm f1.5 Carl Zeiss B5mm f2 Carl Zeiss, 125mm f2.3 Astro pan Tachar, variable speed motor, 12V battery, freehead tripod, 3-2000' magazines, carrying cases, special 1175.00

35mm AKELEY CAMERA, 4 matched Zeiss lenses, 4-200' magazines, slow motion attachment, Akeley friction tripod, quick release legs, carrying cases. Bagain price..... 750.00

16mm B&H 70-H CAMERA, coated lenses, 17mm f2.5 B&H Super Chromat, 25mm f1.9 B&H Lumar, 150mm f4.5 B&H Telote, 4 positive lenses. Parallax viewfinder, B&H motor, 1-400' magazine, B&H freehead tripod, cases complete, manufacturers guarantee..... 1150.00

35mm DUPLEX PRINTER adapted for sound track, excellent for duping. Academy Aperture. Speed 250 pictures per minute per side, two light change boards, 1B different lights, each side 21 scenes. Motor 110 volts, perfect mechanical condition 875.00

35mm ART REEVES SOUND RECORDER, twin fidelity optical unit, glow lamp type, 1000' B&H magazine, complete with cases 997.50

ENLARGERS, excellent condition, Elwood, Auto focus, lens and stand, 5x7 235.00
8x10 400.00

MOLE RICHARDSON 2000W Spot, ralling stand B&H CAMERA CHECK PAWLS high speed shuttle. List price, new \$1742.00. good cond... 195.00

NEW SCHOEN PRINTER, sound and silent, color, B&W features: 16mm picture alone, 16mm track alone, 16mm picture and sound together, film capacity 1600 feet, 50' per minute, 12 adjustable light changes, AC-DC conversion unit 999.00

HOMRICH COMBINATION COPYING CAMERA and animation table stand, adaptable to 4x5, 5x7, 8x10 holders. Two adjustable light stands with twin reflectors. 11x14, 16x20 copy frames. Built in lamp house, good buy 135.00

HOMRICH ELECTRONIC TIME CONTROL CONTACT PRINTER, timer has full second and split second setting. Handles 4x5, 5x7, 8x10 negatives. Adjustable masking and paper guides. Internal dodging plate gloss plate. Four lamps, each controlled by separate toggle switch. A real buy 165.00

Specializing in movie and television supplies, tripods, synchronizers, 16mm sound cameras, lights, lenses, mikes, booms, dollies, motors, etc. New-used reasonable prices. Cash for used equipment. Trades taken.

HOLLYWOOD CAMERA EXCHANGE, LTD.
1600 Cohuengo Boulevard Hollywood, California

MAURER 16mm. comero Model 05, viewfinder, 400 ft. magazine, 110 volt sync motor, sunshade filter holder, 25mm. F1.4 Ektor, 40mm. F1.6 Ektor, 15mm. F2.5 Ektor and carrying case. Like new, \$3,800.00; BERNDT-MAURER Mod. H Single System Sound Comero, two 400 ft. magazines, 110 volt sync motor, viewfinder, sound optical system, automatic dissolve, 2" Zeiss Biotar lens F1.4 and carrying case. Like new, \$2,200.00; 2 Berndt-Maurer Film Phonographs. Like new, \$700.00 each. A. F. KLIENDIENST, Beacon Lodge, Webster, Moss.

ZENITH Cinema Service, Inc. . . . Midwest Distributor of the Mognasync Recorder, has for sale:
1 Used Cine Special I with F1.9 lens, Por Reflex focusing magnifier and Kodak variable lens optical viewfinder, excellent candition.....\$625.00
1 Bolex H16 Comero with F1.9 Pizor lens, Stereo lenses, Projection lens, and close up attachment, like new.....\$575.00

ZENITH CINEMA SERVICE, INC., 3252 Foster Avenue, Chicago 25, Illinois.

FLANGES, New Aluminum 16mm., B00 ft. While they last \$5.95 Postpaid. GREAT LAKES MOTION PICTURE SERVICE, 12037 Grand River Ave., Detroit 4, Mich.

STUDIO & PRODN. EQUIP.

SPRING CLEANING SALE CONTINUED

BARDWELL-McALISTER MULTIPLE FLOODLIGHTS, 3 Quadruple heads holding 12 bulbs on rolling tripod stand. Orig. Gov't cost \$180. Surplus\$ 29.50

BM QUADLITE Heads only \$4.95. Stands only 19.95

MR LATEST MIKE BOOM with rolling stand.... 895.00

CINE SPECIAL 16MM BLIMP, Custom built. Has follow focus, vertical image 63mm viewfinder, takes 200' mag. & syncmotor. \$600 value 350.00

NEW MAURER PROPOD Jr. Professional Tripods 124.95

CINEFLEX 35mm REFLEX CAMERAS with lenses, magazines, compl. 595.00

CAMERETTE 16/35mm REFLEX CAMERA, 4 lenses, 5 mgoazines, 2 motors (sync & 24V DC) batteries, chargers, all accessories. \$5500 value 3950.00

CRAB DOLLY, MOVES EVERY WHICH WAY simply, easily. Mount tripod and away you go 650.00

FEARLESS BLIMP for Mitchell NC or Std..... 695.00

ANSCO-SWEET COLOR DENSITOMETERS, \$850 vol. 367.50

REEVES 35mm MAGICORDER, finest sync outfit built \$8500 value..... 3350.00

RCA 4 POSITION CONSOLE, with main amplifier, line omolifier, 4 pre-amps, equalizers, compl. \$3000 val..... 895.00

WESTERN ELECTRIC 35mm OPTICAL RECORDING System comalete..... 4950.00

HOUSTON 16mm KIA REVERSAL DEVELOPER, recond. 3250.00

NEW DIFFERENTIAL REWIND GIMMICKS, match 16mm with 35mm reels. Singly, \$37.50—pair 69.50

NEW FILM EDGE NUMBERING MACHINES, 16 or 35mm..... 2250.00

SOS FILMETER STOP WATCH, \$29.50 list 13.95

TRADES TAKEN. SEND FOR 1954 CATALOG
PHONE PL. 7-0440

S. O. S. CINEMA SUPPLY CORPORATION
Dept. fc Cable SOSOUND
602 W. 52nd Street New York 19 N. Y.

BASS . . . Chicago. Cinema headquarters for 44 years, offers money saving buys in guaranteed used equipment. Cine Special I, 1" F:1.9, 15mm. F:2.7 W.A., 3" F:4.5, 4 1/2" F:4.5, extra 100 ft. chamber, comb. case, \$575.00; B. & H. 3 speed Eyemo, 47mm. F:2.3 Cooke, 2" F:2.8 B. & H., 25mm. F:4.5 Wollensak, case, \$375.00; Bolex H-16, 1" Switar F:1.5, 0.7" F:2.5 Comat, 3" F:3.5 B. & L. Animar, \$365.00; 3 1/2"x1 1/2" Kalart camera, 6 holders, adpoter, fosh gun, \$149.50; 16mm. Ampro Model Y sound projector, \$187.50. Best buys . . . Best trades always.
Boss Comero Co., Dept. AC, 179 W. Madison St., Chicago 2, Ill.

BOLEX H-16 DELUXE Octometer, eye level focuser, Pellegrini variable shutter, sound sprockets, Stevens motor drive, gun handle, prismatic focuser, 25mm. Fktar F1.9, 15mm. Ektor F2.5, 75mm. Berthoit F3.5, custom cose to house all. Excellent shape, \$400.00. BELL & HOWELL FILMOSOUND "202" takes both single and double perforated magnostris. Excellent condition, \$450.00. NICHOLAS A. THERIS, 475 Kimboll Avenue, Yonkers. New York.

7x9cm. AERIAL (German) comero with Schnieder Xenon f:2 125mm. lens, 3 filters, original trunk type case. In excellent condition. Eastman film available. \$125.00. CINE-SPECIAL I with coated 25mm. F/1.9, 15mm. f/2.7 and new Moier-Hancock Finder, \$425.00. SAMUEL KRAVITT, 763 Chapel Street, New Haven, Conn.

ARRIFLEX 35mm. comero, 3 lenses, filters, sunshade, tripod, case. Complete for quick sale . . . \$795.00. Write P.O. Box 312, Ridgewood, N.J., or phone Allendale, N.J. 13046.

WE BUY, SELL AND RENT PROFESSIONAL AND 16mm. EQUIPMENT, NEW AND USED. WE ARE DISTRIBUTORS FOR ALL LEADING MANUFACTURERS. BARRY CAMERA EXCHANGE, 729 Seventh Ave., New York City Established since 1910.

MAKING room for faster machines—will sell one reversal processor and one negative positive, temperature controlled, in excellent condition. CINE-VIDEO PRODUCTIONS, INC., Milford, Conn.

WALL S. S. 35MM. SOUND CAMERA

COMPLETE with Galvanometer, amplifier, portable power supply, 40-50-75 and 100mm. lenses, erect imoge viewfinder, complete front attachments, two 1000 ft. mgoazines, Balanced Tripod, necessary carrying cases. Ovehauled. Guaranteed perfect. Reasonable.

CAMERA EQUIPMENT COMPANY
1600 Broadway New York 19, N. Y.

STUDIO & PRODN. EQUIP.

ALL LIKE NEW:
CINE KODAK SPECIAL II F1.4 EKTAR\$ 695.00
100 FOOT CHAMBER FOR ABOVE, LATEST .. 150.00
16MM GRISWOLD 110V HOT SPLICER 49.50
BOLEX BATTERY DRIVE WITH CASE 59.50
BOLEX TITLER COMPLETE WITH ALL ACCESSORIES 159.00
CINE' KODAK TRIPOD TRUCK 49.50
BOLEX STEREO OUTFIT, WITH CLOSE-UP ATTACHMENT 235.00

CAMERA CRAFT 42ND ST., INC.
18 E. 42nd Street New York 17, N. Y.

AUDIO AKELEY single system camera complete with Akeley sound head, Gyro tripod, 3 lenses, view finder, Mourer mixing omplifier. Complete with cables, power supply and W. E. microphone. CAMERA EQUIPMENT CO., 1600 Broadway, New York 19, N.Y. Cable Cineaup.

HALLEN B-16 16mm synchronous recorder, new demonstrator, \$1,095.00; Cine Special Model 2 with Par 4 lens turret, eye level focuser, Yolo fader, two 200' film chambers, 4 lenses, case, accessories, slightly used, \$2,500.00; Griswold 35mm splicers, \$10.00 each. WEBSTER VISUAL SALES COMPANY, 539 Vine Street, Chattanooga, Tennessee.

16MM. HOUSTON K-1A
Processing machine, like new. List price \$5,500.00. A terrific bargain at \$2,950.00.
AIR PHOTO SUPPLY CORP.
555 East Tremont Avenue
New York 57, New York
Phone: Cypress 9-6400, Mr. Krim.

ELECTRIC GENERATOR. Mobile portable power electric generator plant. Westinghouse 100V., 162 Amp., 1100 r.p.m. 16.2 KW., U.S. Surplus unit on chassis with trailer hitch, 5 good tires, brokes, control panel, etc. \$850.00 F.O.B. ROQUEMORE FILMS, Homburg, N. Y.

WILL TRADE CECO Professional Junior Maurer Type friction head tripod with extra adj. handle for larger, heavier-duty friction head tripod like Auricon, etc. CONTINENTAL INTERNATIONAL PICTURES, 44B Harrison Ave., Greenville, Ohio.

COLORTRAN Grover Kit, used only once, \$140.00; Neumade 2-hub footage counter, brand new, \$95.00. VIC DUNCAN, 4631 Jamison, St. Louis 9, Missouri.

FREE LIGHT with COLORTRAN converters. Use 750 watts, get over 2,000 watts. Catalogue. KIRK FILMS, 627 St. Philip St., New Orleans 16, Lo.

WANTED

IMMEDIATE CASH PAYMENT FOR CAMERAS AND EQUIPMENT

NEED EYEMOS (SINGLE LENS AND TURRET), MITCHELLS, ARRIFLEX, DE BRIES, B&H STANDARDS AND HI-SPEEDS, WALLS, AKELEYS, CINE SPECIALS, AJURICONS, MAURERS FILMOS. ALSO BALTARS, COOKES AND OTHER LENSES. SOUND STAGE, LABORATORY AND EDITING EQUIPMENT OF ALL TYPES REQUIRED PLEASE SHIP INSURED OR FORWARD DESCRIPTIONS AIRMAIL. IMMEDIATE PAYMENT.

GORDON ENTERPRISES • 5362 N. Cohuengo NORTH HOLLYWOOD, CALIFORNIA

YE OLDE SOS TRADING POST

Doing Business Since 1928
BUY — SELL — SWAP — CONSIGN

Cameras, Dollies, Lenses, Lights, Moviolas, Printers, Recorders, Studio or Laboratory Equipment

Western Union-WUX New York
Phone PL. 7-0440

S. O. S. CINEMA SUPPLY CORPORATION
Dept. fc Cable: SOSOUND
602 W. 52nd Street New York 19, N. Y.

WANTED

Mitchell — Akeley — B & H — Woll — Eyemo
Cameras — Lenses — Equipment

NATIONAL CINE EQUIPMENT, INC.
209 West 48th St. New York, N.Y.

(Continued on Next Page)



GEO. W. COLBURN LABORATORY INC.
164 NORTH WACKER DRIVE • CHICAGO 6
TELEPHONE STATE 2-7316

**8 and 16mm
SERVICES**

AUTOMATIC DAYLIGHT PROCESSING



DEVELOPING TANK

- Processes up to 200 Ft.
- 8mm-16mm-35mm
- Movie—X-Ray—Microfilm
- Motor Driven, Portable
- Tough Plastic Tonks
- Uniform Density Assured
- 70mm tank also available

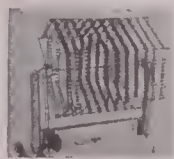

FILM DRYER

- Motor driven—Heated
- Speedy drying
- Automatic shrinkage allowance
- Stainless steel and aluminum construction
- Easily assembled without Tools
- Compact, Portable

Guaranteed. Write for Free Literature
MICRO RECORD CORP.
Dept. AC 225 W. 28th St., N.Y. 1, N.Y.

RUBY CAMERA EXCHANGE

Rents . . . Sells . . . Exchanges

Everything You Need for the

Production & Projection

of Motion Pictures Provided
by a Veteran Organization
of Specialists

35 mm. . . . 16 mm.
Television

IN BUSINESS SINCE 1910

729 Seventh Ave., New York 19, N. Y.
Tel.: Circle 5-5640
Cable address: RUBYCAM

ACADEMY AWARDS

(Continued from Page 208)

Best Sound: "From Here To Eternity,"
John P. Livadary, sound director.

Runners-up in the competition for cinematography awards — i.e., those whose work was nominated in addition to the Award winners—were the following directors of photography: Joseph C. Brun, ASC. ("Martin Luther"), Hal Mohr, ASC. ("The Four Poster"), Frank F. Planer, ASC, and Henry Alekan, ("Roman Holiday"), Joseph Ruttenberg, ASC, ("Caesar"), Edward Cronjager, ASC. ("Beneath The Twelvemile Reef"), George Folsey, ASC, ("All The Brothers Were Valiant"), Robert Planck, ASC. ("Lili"), and Leon Shamroy, ASC. ("The Robe").

WHAT'S NEW

(Continued from Page 170)

pany's line of 16mm magazines, which now includes single lens, two lens, and three lens turret models. Except for the turret, the Automaster has the same body as the 200 Autoload and the 200-T twin Autoload.

The camera features five film speeds—16, 24, 32, 48, and 64, frames per second. Complete winding of the 12½-ft. film run can be accomplished without removing the hand from the key. Exposed footage is read directly from the film magazine dial through a window in center of the exposure guide. Camera has a three-position starting button for normal operation, continuous run, and single frame exposure. With a 1" f/2.5 lens, retail price \$264.95, including federal excise tax. Camera also may be purchased with a standard 1" f/1.9 or 1" f/1.4 lens. Wide-angle and telephoto lenses are also available.

Seamless Plastic Screen—S.O.S Cinema Supply Corporation, 602 West 52nd Street, New York City, announces a new line of metallic-surfaced screens trade named "Mirro-Claric." This screen is available in all sizes. Because sections are invisible-welded, the surface appears free of seams—eliminating distracting vertical or horizontal lines in the picture.

Curved frames of seasoned lumber, which can be selected in either the conventional straight pattern or curved design, can be furnished as a companion piece to the "Mirror-Claric" screen.

Classified Ads

(Continued from Preceding Page)

WANTED

**F & B PAYS MORE
FOR USED 16/35MM EQUIPMENT**

WRITE — WIRE — PHONE
FOR OUR CASH OFFER

FLORMAN & BABB
70 W. 45TH ST.

MU. 2-2928
NEW YORK 36, N.Y.

**WANTED TO BUY FOR CASH
CAMERAS AND ACCESSORIES**

MITCHELL, B & H, EYEMO, DEBRIE, AKELEY ALSO
LABORATORY AND CUTTING ROOM EQUIPMENT

CAMERA EQUIPMENT COMPANY
1600 BROADWAY, NEW YORK CITY 19
CABLE: CINEQUIP

WANTED

PRODUCTION EQUIPMENT, LABORATORY EQUIPMENT,
EDITING EQUIPMENT, 16mm. and 35mm. FROM SINGLE ITEMS TO COMPLETE STUDIOS. TRADES ACCEPTED.

THE CAMERA MART, INC.
1845 Broadway Circle 6-0930 New York 23, N.Y.

1,000 FT., 400 Ft. 35mm. or 16mm. B&H or Mitchell magazines, also BiPack. Quote condition, best price for cash. **HOLLYWOOD CAMERA EXCHANGE**, 1600 Cohuenga Blvd., Hollywood, California.

WANTED: USED 16MM. reversal processing machine and 16mm. single system sound camera. **DON GOODWIN**, 3733 Seventh Ave., Sioux City, Iowa.

CAMERA & SOUND MEN

ASSIGNMENTS FOR INDIA or nearby territories for any type of films, 16 or 35mm, B&W or Color, write to **KANU PATEL, A.R.P.S.**, The Clarion Productions, 34, Park Mansions, CALCUTTA-16.

AFGHANISTAN from the Khyber Pass to Mazar-i-Sharif—Experienced, well-traveled photographer will shoot 16mm movies (Kodak Cine Special II) or B&W (Speed Graphic). Airmail **JIM CUDNEY, c/o American Embassy, Kabul, Afghanistan.**

ASSIGNMENTS FOR JAPAN on all subjects, 16 mm. and 35 mm., Color or B & W. Write to **AOI-MAJESTIC PRODUCTIONS**, 2-Nagatacho, Chiyodaku, Tokyo.

COLOR SLIDES, PHOTOS & FILMS

NATURAL COLOR SLIDES, Scenic, National Parks, Cities, Animals, Flowers, etc. Set of eight \$1.95. Sample and List 25c. **SLIDES, P.O. Box 26, Gardena, Calif.**

ALASKA WILDLIFE KODACHROME 16mm. — 8mm. 2x2 slides taken by professional photographer and Alaskan Registered Guide. Free Catalog. **MAC'S FOTO SERVICE**, 315 4th Avenue, Anchorage, Alaska.

LABORATORY & SOUND

SOUND RECORDING at a reasonable cost. High Fidelity 16 or 35. Quality guaranteed. Complete studio and laboratory services. Color printing and lacquer coating. **ESCAR MOTION PICTURE SERVICE, INC.**, 7315 Carnegie Avenue, Cleveland 3, Ohio. Phone Endicott 1-2707.

SAVE TIME ON 16MM PROCESSING AND PRINTING! Some day service on 16mm reversal processing. Dupont & EK films in all lengths. Price list available.

WESTERN CINE SERVICE
114 East 8th Avenue Denver 3, Colorado

To Classified Advertisers

Copy deadline for classified advertising is the 12th of month preceding publication date. Mail copy and remittance to cover cost to
AMERICAN CINEMATOGRAPHER
1782 No. Orange Dr. Hollywood 28, Calif.

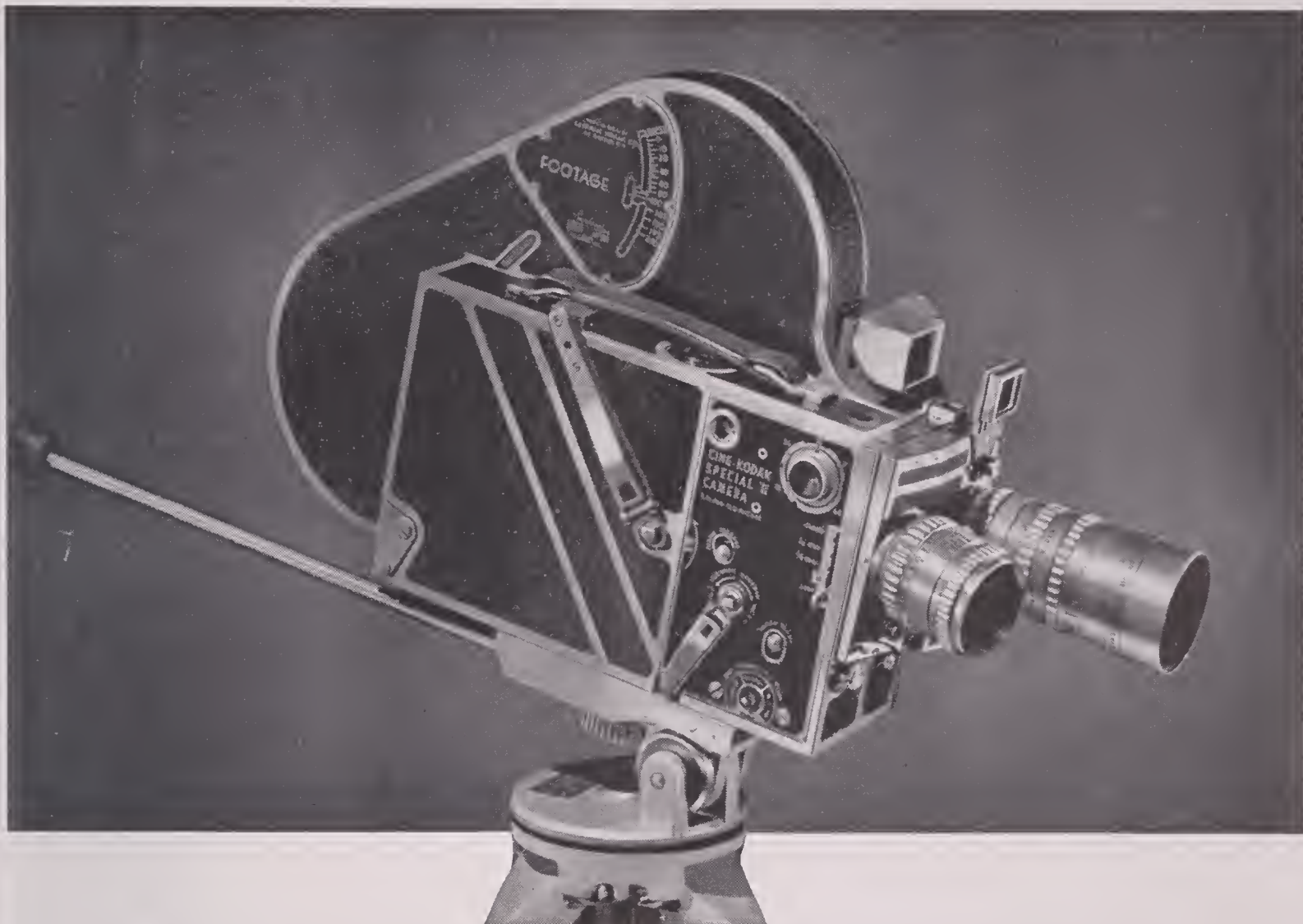

Got an idea for a great movie?

Here's the 16mm. camera to make it click

A wonderful idea for your next movie is born! And now you need the kind of camera equipment that can help you express it on film . . . complete with fades, dissolves, mask shots, double and multiple exposures, montages, animation.

The versatile Cine-Kodak Special II Camera has all the extras you need for *creative* 16mm. movie making . . . built right into a single package.

YOU CAN...

Change lenses instantly with the angled turret which takes any two interchangeable Kodak Cine Lenses, without optical or physical interference.

Make fades and dissolves easily with

the adjustable-opening shutter which can be adjusted from full open, through half-to quarter-open, to closed, even when the camera is running. Also permits precise exposure control under extreme light conditions.

Make double or multiple exposures easily. One- and eight-frame cranks permit precise reverse winding—or can be used for hand operation on extra-long scenes. If electric motor drive is desired, it can be attached to cranking shaft.

Frame your shots . . . get multiple exposures, montages, special effects, with masks which are inserted into a slot between lens and film. Set of six masks comes with the camera.

Keep exact tab on footage, right down to individual frames. Camera has three meters: Film Chamber Meter tells how much film is left on roll. Footage Meter shows exact number of feet already run. Frame Counter records individual frames. The latter two operate either in forward or reverse and provide the precise film control needed for multiple exposures and dissolves.

Focus and frame through the taking lens with the "Special II's" reflex finder. Direct-view eye-level finder permits following fast action.

Shoot entire action on one winding. The powerful spring motor will expose 38 feet of film with a single winding!

Cine-Kodak Special II Camera with Kodak Cine Ektar 25mm. f/1.9 Lens and 100-foot film chamber, \$995. With Ektar f/1.9 Lens and 200-foot film chamber, \$1,215. With Ektar f/1.4 Lens and 100-foot film chamber, \$1,095. With Ektar f/1.4 Lens and 200-foot film chamber, \$1,315. Prices include Federal Tax and are subject to change without notice.

EASTMAN KODAK COMPANY, Dept. 8-V, Rochester 4, N. Y.

Please send me more information about the Cine-Kodak Special II Camera.

4-11

NAME _____ POSITION _____

COMPANY _____

STREET _____

CITY _____ STATE _____
(Zone)

Kodak
TRADE-MARK

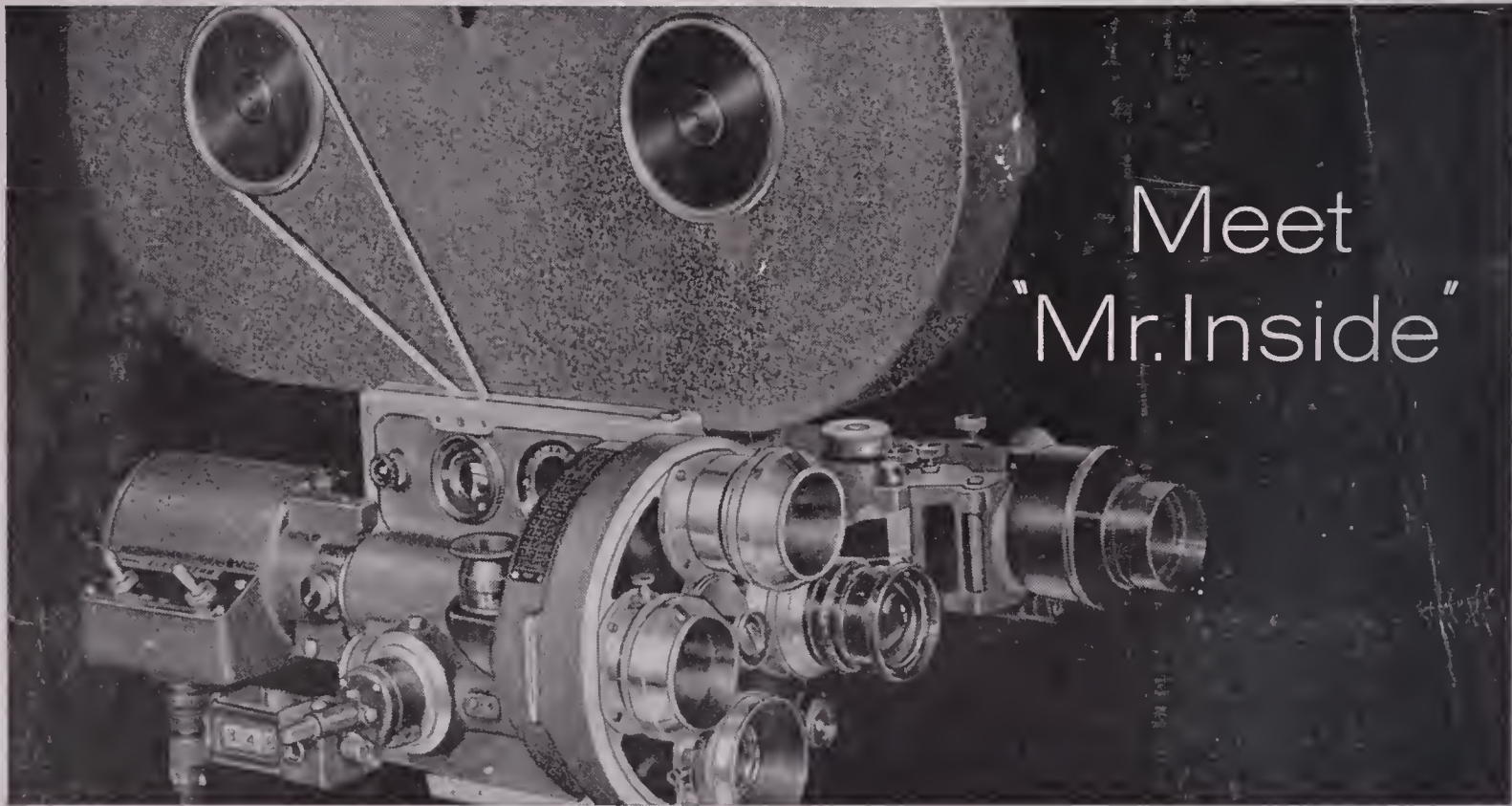

Meet "Mr. Inside"

Since "Birth of a Nation" was a box office favorite, the Bell & Howell 2709 Standard camera has been regarded as the number one "inside" camera for the movie industry . . . assuring perfect registration so vital in animation and rear

process photography. Extreme slow motion has been made possible by a B&H exclusive which permits photographing up to 200 frames per second. No wonder professionals the world over call the famous 2709 "Mr. Inside."



...and "Mr. Outside"

More Eyemos have been sold and are still in use than all other makes of 35mm movie cameras combined! Used under water . . . in searing jungle heat . . . in severest polar cold . . . and even attached to jets travelling faster than

...THE MOST WIDELY USED 35MM MOVIE CAMERAS IN THE WORLD!

the speed of sound, the Bell & Howell Eyemo is unequalled for its superb performance and durability. This is why—on land, sea and in the air—it's the Eyemo which has earned the enviable reputation of "Mr. Outside" of the movie world.

Bell & Howell

Cinematographer

THE MAGAZINE OF MOTION PICTURE PHOTOGRAPHY

THEATRE
TELEVISION
INDUSTRIAL
AMATEUR



In This Issue . . .

- Money-saving Shooting System For TV Films
 - Follow-focus Attachment For Mitchell Cameras
 - The Role Of Light In Creating Mood

25c
\$3.00 YEARLY



Above: Assistant Cameraman Sam Alexander (left) and Operating Cameraman Morris Hartzband chat while threading camera with Du Pont "Superior" 2.

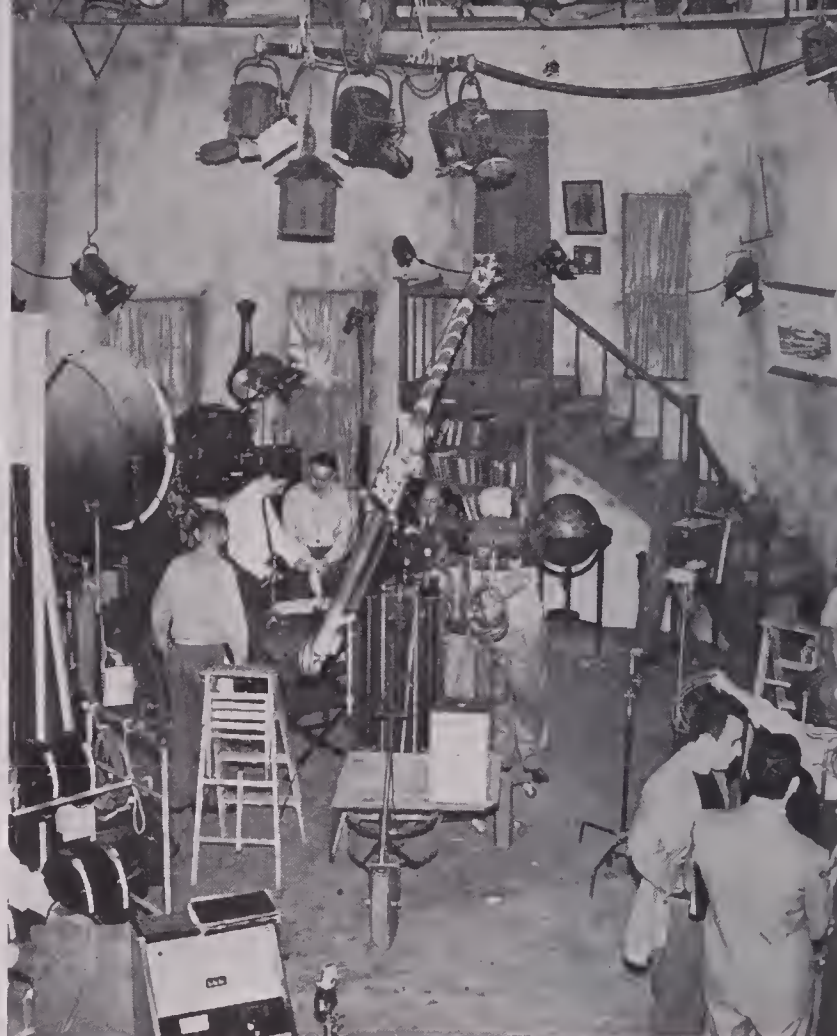

View of lighthouse scene between "takes" on "Inner Sanctum" set.



Left: Director of Photography Zoli Vidor watching the rehearsal.

"'Superior' 2 gives us depth, and gradation that captures the mood"

... states ZOLI VIDOR, Director of Photography for "INNER SANCTUM" — Galahad Productions

"Inner Sanctum," long a radio favorite, is now making its debut on television. The producer, Hi Brown, has made 39 half-hour films—each of which was shot in three 8-hour days! Commenting on the work, Director of Photography Vidor said:

"Meeting tight schedules and getting 'feature' quality proved a real challenge. In choosing a film, speed and good gradation were the prime considerations.

Importance of mood

"Creation of mood in 'Inner Sanctum' depends strongly on set lighting and the ability of the film to retain detail, contrast and depth. We needed a film that is sensitive to minute gradations from highlights to shadows and gives soft reproduction without sacrificing crispness. Du Pont's 'Superior' 2 completely filled the bill."

You too can meet the double problem of tight schedules and "feature" quality by using Du Pont "Superior" 2. You'll keep work moving, and get the soft, de-

tailed images so important in dramatic film presentations. For complete information on Du Pont "Superior" 2 write the nearest District Office or: E. I. du Pont de Nemours & Co. (Inc.), Photo Products Dept., Wilmington 98, Del. *In Canada: Canadian Industries Ltd., Montreal.*

District Offices

- ATLANTA 5, GA.
805 Peachtree Bldg.
- BOSTON 10, MASS.
140 Federal Street
- CHICAGO 18, ILL.
3289 N. California Ave.
- CLEVELAND 14, OHIO
1033 Union Commerce Bldg.
- DALLAS 1, TEXAS
506 Tower Petroleum Bldg.
- LOS ANGELES 38, CALIF.
7051 Santa Monica Blvd.
- NEW YORK 11, N. Y.
248 West 18th Street
- PHILADELPHIA 2, PA.
225 South 15th Street

**DU PONT
MOTION PICTURE
FILM**



BETTER THINGS FOR BETTER LIVING
... THROUGH CHEMISTRY

SALES • SERVICE • RENTALS

NOV 18 1954



THE WORLD'S MOST COMPLETE ASSORTMENT
OF PHOTOGRAPHIC EQUIPMENT FOR

T.V. and Motion Picture Studios



New **PROFESSIONAL JUNIOR**
Adjustable wood **BABY TRIPOD**
—for Prof. Jr. friction
and geared heads



Has substantial shoe and spur.
Measures from floor to flange
25" extended —17"
collapsed. **\$75**

FAMOUS
"controlled
action"
SMALL GYRO
TRIPOD

Two speeds—slow and fast
—for both panning and tilting.
Helps you capture fine scenic views
and fast-moving sports events. Espe-
cially recommended for 16mm Mitchell,
16mm Maurer, B & H Eyemo
and similar cameras. **\$600**

PACKAGED LIGHTING WITH
COLOR-TRAN

—studio lighting in a suitcase



Imagine being able to use two 5000 watt units
on a 30 amp. fuse — **COLOR-TRAN** will do it!
Kit contains 2 light heads, 2 Superlor stands and
proper size **COLOR-TRAN** converter to match.
Packed in compact case.

Senior Kit
\$237.50

Other style
kits available.

Write for **COLOR-TRAN** Catalogue.

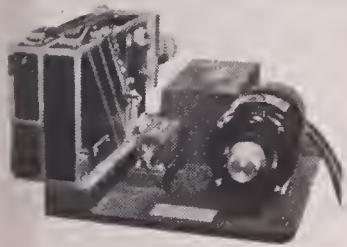

STOP MOTION MOTOR
FOR CINE KODAK SPECIAL

Runs forward or reverse, 110
AC synchronous motor with frame
counter. May be run continuously
or for single frames. Camera
mounts without special tools.

\$450

Also available — Stop Motion
Motors for 16mm—35mm B & H,
Mitchell and other professional
cameras.



ELECTRIC
FOOTAGE TIMER

Dual model for both 16mm
and 35mm. Large white num-
erals on black background. Accu-
rate reset dial. Switch controlled
by operator, who selects either
16mm operating at 36 feet per
minute—or 35mm operating at
90 feet per minute . . . or both
in synchronization. **\$95**

Single model, either 16mm or
35mm **\$45**

presto-splicer

GIVES PERMANENT SPLICE
IN **10** SECONDS!

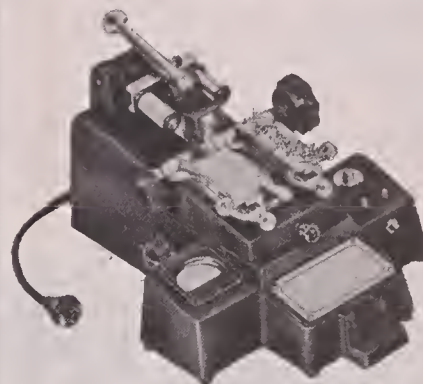

Especially good for splicing magnetic
film. Butt Weld type for non-perforated
or perforated film. 16mm, 35mm or
70mm. **\$547.80**

16mm or 35mm models—
for perforated film.

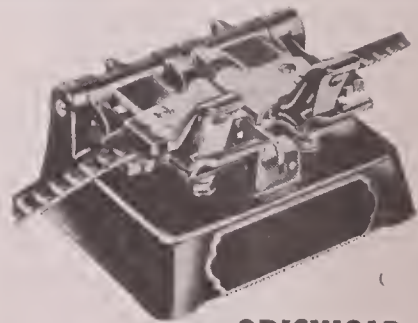

GRISWOLD
HOT FILM SPLICER

Model R-2 for 35mm silent and sound
film. Precision construction makes it easy
to get a clean, square splice with accu-
rate hole spacing. Nothing to get out of
order. **\$65**

Also Bell & Howell 8mm, 16mm and
35mm Hot Splicers and B & H Labora-
tory model Foot Splicer.

9.5mm Lenses in 16mm C mount. 18.5mm (extreme wide angle-flat field)
Lenses available in mounts for all 35 mm Motion Picture Cameras.
PHOTO RESEARCH Color Temperature Meters. *Electric Footage Timers
Neumade and Hollywood Film Company cutting room equipment.
Griswold & B.&H. Hot Splicers. *DOLLIES—Bardwell-McAlister, Mole
Richardson, Century and Colortran Lighting Equipment.

Complete line of 16mm and 35mm Cameras

FRANK C. ZUCKER
CAMERA EQUIPMENT CO.
600 BROADWAY NEW YORK CITY

Important news

from the manufacturer of the World's Finest Cameras

NEW PRODUCTION SCHEDULES NOW PERMIT IMMEDIATE DELIVERIES OF MITCHELL 35mm BNC...35mm NC...16mm PROFESSIONAL CAMERAS

It is impossible to compare a Mitchell with any 35mm or 16mm camera now in existence—for the **history-making Mitchell is the only truly professional motion picture camera.** Exclusive professional operating features plus the smooth trouble-free Mitchell movement, with its .0001 inch tolerances, can insure the success of your film making as can no other single element of production.

Now—on the huge six and one-half acre site of the Mitchell Camera Corporation plant — increasing numbers of 35mm and 16mm cameras are being created to meet the extensive use of professional motion picture equipment in such fields as television, entertainment, business, education, religion and government. Each of these superbly designed cameras possesses the supreme quality craftsmanship rightly due the world's **most used most flexible** professional motion picture cameras.

Write today for information and prices of the currently available 35mm BNC, NC and 16mm Professional Mitchell Cameras and accessories.



MITCHELL 16mm PROFESSIONAL



MITCHELL 35mm NC CAMERA



MITCHELL 35mm BNC CAMERA

Mitchell Camera CORPORATION

666 West Harvard Street • Glendale 4, Calif. • Cable Address: "MITCAMCO"



85% of the professional motion pictures shown throughout the world are filmed with a Mitchell

ONE CAMERA

16mm or 35mm

in 10 SECONDS!

Camerette 16/35

Reflex Motion Picture Camera

The perfect camera for the motion picture film maker working in both 16mm or 35mm color or black and white.

LOOK AT THESE ADVANTAGES—

- The same lenses, same motor drives, same sound blimp and accessory equipment used for both 16mm or 35mm — to convert simply change the magazine.
- Precise rugged movement
- Reflex viewing
- 200 degree adjustable shutter
- Divergent three lens turret
- Automatic film gate 400' magazines 16 or 35mm — the 16mm magazine will accommodate daylight spools as well as standard core load.
- Light weight — only 14 pounds with 3 lenses, 400' magazine, and 6/8 volt motor.

Write for brochure



patents coutant-mathot

Manufactured by Ets. Cine. Eclair, Paris



WHAT'S NEW

in equipment, accessories and service

Shoulder Brace—Kadisch Camera & Sound Engineering Co., 500 W. 52nd St., New York City, offers a sturdy shoulder brace for use with the Arriflex 16mm and 35mm cameras. Brace



eliminates use of tripod when shooting in crowds, and permits smooth panning and tilting of camera. Made of lightweight aluminum, the brace weighs only 8 ozs. It also may be used with other types of hand-held cameras such as Eyemo, Filmo, Cine Special, and Bolex.

Details and prices may be had by writing the manufacturer and mentioning *American Cinematographer*.

Tripod Triangle—The Camera Mart, Inc., 1845 Broadway, New York City, offers a tripod triangle of new and exclusive design. An important feature is the provision for locking tripod legs in place to prevent them jumping out of triangle sockets, should the camera be accidentally bumped while in use. Rigidity of the triangle also permits the unit with camera mounted upon it to be easily moved from place to place while in use. Other features include heavy steel hinge at center which insures rigidity; calibrations on the triangle channels which aid in setting legs equidistant from each other, and the collapsible feature which enables the triangle to be folded compactly for easy carrying or storage. List price is \$29.50.

New Cine Cameras—Wollensak Optical Company, Rochester, N.Y., announces a new line of 16mm and 8mm home movie cameras and projectors. Included are an 8mm magazine cine camera, and 8mm turret model camera, an

8mm spool type camera, an 8mm spool type turret model camera, a 16mm magazine turret model camera, and 8mm projector and a 16mm projector. Both cameras and projectors soon will be available for demonstration in camera stores throughout the country, according to the manufacturer.

Camerette Distributor—Frank Zucker president of Camera Equipment Co., 1600 Bdwy., New York City, announces his company will distribute and service the Eclair Camerette on the east coast.

Lens Attachments—Elgeet Optical Company, 838 Smith Street, Rochester, N. Y., announces production of the Elgeet "Cinematar" wide-angle and telephoto attachments for Bell & Howell 220 and 252. and Kodak Brownie f/1.9 and f/2.7 8mm movie cameras.

Both attachments have full coverage at high aperture, and a 4-element lens system. They are hard-coated and fully color corrected for both color and black-and-white film.

The wide-angle attachment, which doubles the field of view, lists for \$18.90; the telephoto attachment, which provides 2½ times magnification, lists for \$19.90.

Tape Prices Reduced—Orradio Industries, Inc., Opelika, Alabama, announce the following reduced prices on ¼-inch magnetic recording tape: Professional #211, 1200 ft., \$3.30; Brown Band for home recorders, 1200 ft. \$2.50

Three New Projectors—Eastman Kodak Company, Rochester 4, New York, announces three new models of the Kodoscope Pageant sound projector. Model AV-071 features the new Plus-Forty shutter which provides an increase of 43 per cent screen illumination over the former model. It is designed especially for use in hard-to-darken classrooms, halls or auditoriums, or wherever exceptionally long screen throws, extra brilliance, and unusually large projected pictures are required. Its new shutter operates at sound speed only. List price is \$400.00.

Model AV-151 features a 15-watt hi-fidelity amplifier giving true, undistorted output, with the aid of the extra-capacity 12" Kodak deluxe speaker. This machine is said to provide the closest sound control obtainable with a 16mm portable projector. The machine

(Continued on Page 220)

Auricon
"Super 1200"



Auricon
Hollywood

AURICON 16MM SOUND-ON-FILM CAMERAS

des  ned

and

engin  ed

"Auricon-Pro"

FOR PROFESSIONAL RESULTS!

Auricon Cameras are now in use by Television Networks, Film Studios, Newsreels and Educational Producers, for filming quality pictures in natural color or black & white.

Auricon
Hollywood

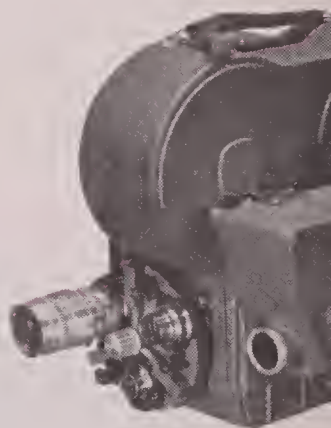

Sold with a 30 day money back guarantee. You must be satisfied!
Write today for free illustrated Auricon Catalog.

Auricon
"Cine-Voice"

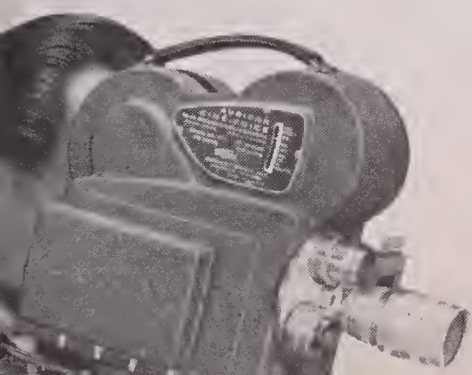

AURICON

BERNDT-BACH, INC.

6902 Romaine Street, Hollywood 38, Calif.

MANUFACTURERS OF SOUND-ON-FILM
RECORDING EQUIPMENT SINCE 1931

Auricon
Hollywood

Faster • Better • Lower Cost

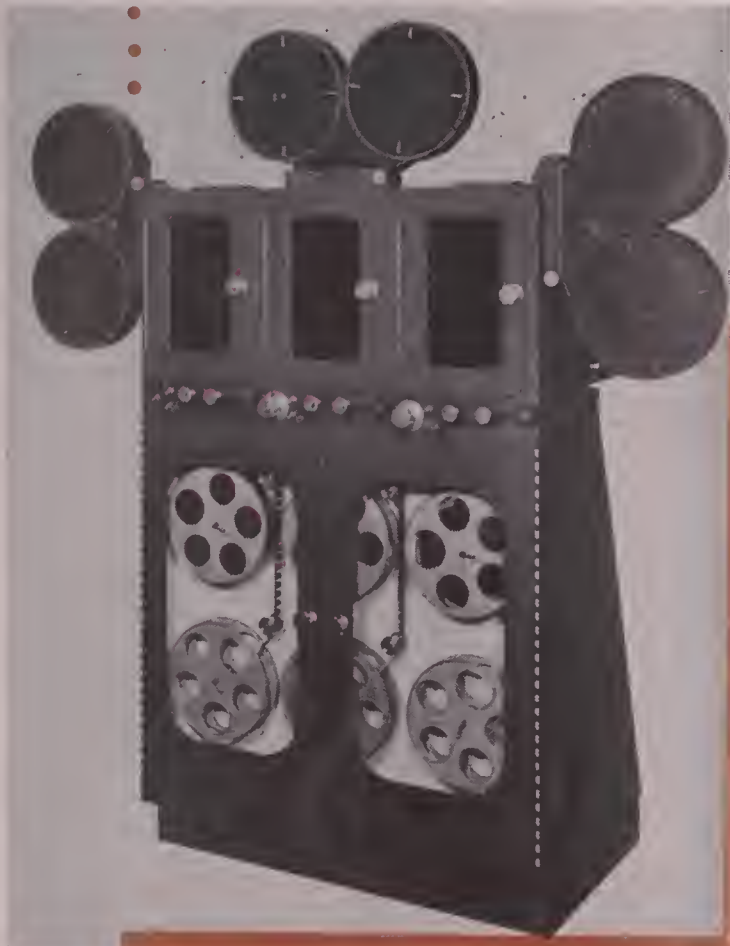

Top quality color
dupe negatives
with effects,
made from
separation
positives,
printed on the
new CIN-TEL
triple-head
precision printer.

EASTMAN and ANSCO COLOR EFFECTS

Specialized Laboratory Services

35mm-3 Color Negatives and Theater Prints
from 16mm Originals
Superimposures • Special Optical Effects
Dissolves • Montages
Fades • Wipes • Zooms

Phone HOLLYWOOD 9-5808

1153 North Highland Avenue • Hollywood 38, California

Complete information available on request.

WHAT'S NEW

(Continued from Page 218)

has sufficient sound capacity to assure successful shows before audiences of several hundreds. List price is \$530.

The third new model AV-151E, features both the new Plus-forty shutter, with its tremendous increase in screen illumination and the new 15-watt amplifier with separate 12" speaker. It is designed for the projection of sound films only and for use under the most demanding projection conditions. It is supplied in two matching cases and lists for \$530.00.

GroverLite—Natural Lighting Corporation, 612 W. Elk Ave., Glendale 4, Calif., announces a new addition to its line of Colortran lighting equipment. Tradenamed the GroverLite Superior, the unit offers many possibilities in motion picture production since it produces, for a current cost of 16 amperes, enough illumination to expose commercial Kodachrome at sound speed at 1/20 of a second, at a distance of 20 ft. with a meter reading of FL.6. The unit weighs less than 8 pounds and is constructed of spun aluminum supported on cast steel brackets. It provides for use of 6 reflector-type lamps which are controlled, on or off, by snap switch at rear of lamp house. Further information and price may be had by writing the manufacturer and mentioning *American Cinematographer*.

Dial Control 8mm Projector—Ampro Corporation, 2835 North Western Avenue, Chicago, Illinois, announces the first dial-control 8mm home movie projector. Trade-named "The Futurist 8," this new light-weight projector features dial-control similar to the channel selector switch on most television sets. Two dials, one on either side of the projector, control all six of the basic steps in motion picture projection. Dial-control provides for forward, reverse, still, and rewind. It provides for variation in film speed for either forward or reverse. It also permits slow motion projection at any desired speed, forward or backward. Maximum illumination is provided by the projector's 750-watt lamp. Continuous projection for 30 full minutes is provided by a 400 ft. reel capacity. Weight of projector is 17 pounds and it comes in a functional, folded Royalite carrying case with a built-in comfort-grip handle for easy portability. Price is \$149.50.



THERE IS A HOUSTON-FEARLESS FILM PROCESSOR FOR EVERY NEED!

Whatever your requirements in motion picture or TV film processing equipment, Houston Fearless has the answer. 16mm, 35mm, 70mm... black and white or color... negative, positive, reversal or positive-negative color film... from 5 to 250 feet per minute... from the smallest, most compact unit to the largest installation, Houston Fearless builds the finest, most dependable, best engineered of all processing equipment. Houston Fearless is a major supplier to the Military and is known and respected throughout the world.

Only a few of the many Houston Fearless models are shown here. For complete information on the type of equipment best suited for your particular needs or for help on your special requirements and problems, send the coupon below. Houston Fearless engineers will recommend what is most appropriate and, if desired, plan your entire film processing lab for maximum efficiency and highest quality results.

The
**HOUSTON
FEARLESS**
Corporation

*"World's Largest Manufacturer of Motion Picture
Film Processing and TV Studio Equipment"*

Houston-Fearless Corporation
11809 W. Olympic Blvd., Los Angeles 64, Calif.
Please send information on film processing equipment
to be used for the following purpose:

NAME _____
FIRM _____
ADDRESS _____
CITY _____ ZONE _____ STATE _____

11809 W. OLYMPIC BLVD. LOS ANGELES 64, CALIF.
BRadshaw 2-4331
620 FIFTH AVE., NEW YORK 20, N.Y. Circle 7-2976

ARRIFLEX

New 35 mm Model 2A
With 180° Shutter

**A TRULY GREAT
CAMERA**

for TV, Newsreel
and commercial
films

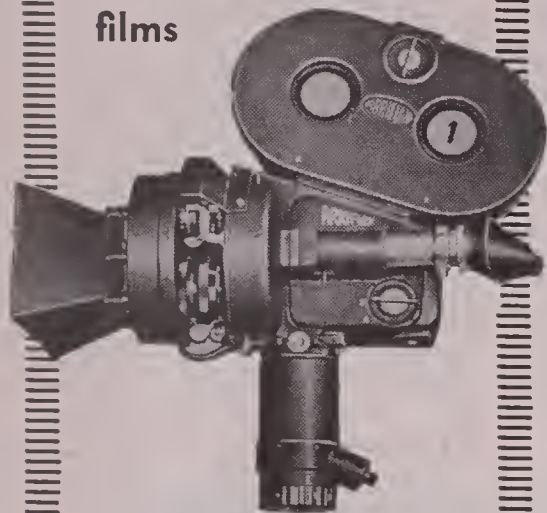

For tough and trying assignments, ARRIFLEX 35 is in a class by itself. Reflex focusing through photographing lens while camera is operating—this is just one outstanding ARRIFLEX feature.

Equipped with bright, right-side-up image finder, 6½ x magnification. Solves all parallax problems. 3 lens turret. Variable speed motor built into handle operates from lightweight battery. Tachometer registering from 0 to 50 frames per second. Compact, lightweight for either tripod or hand-held filming. Takes 200' or 400' magazine. Write for free folder.

Blimp now available.
16mm ARRIFLEX also available.

FRANK C. ZUCKER
CAMERA EQUIPMENT CO.
1600 BROADWAY NEW YORK CITY

Arthur Miller Elected President of A. S. C.



Photo by Croneweth

ARTHUR C. MILLER

ARTHUR C. MILLER, three-time Academy Award winner, last month was elected President of the American Society of Cinematographers. He succeeds Arthur Edeson who was elected to the office last July to serve the balance of the unexpired term of President Charles G. Clarke.

Five new members of the Board of Governors were also elected for three-year terms. They are: George Folsey, Joseph Biroc, Philip Tannura, Walter Strenge, and Sol Halprin.

Alternate board members elected are: John Seitz, Paul Eagler, Robert Pitack, James Van Trees, Farciot Edouart, Paul Vogel, Arthur Arling, Ernest Laszlo, Dan Clark, and Lucien Ballard. Alternate board members will function when various regular board members are absent from the city and unable to attend Society board meetings.

Other officers, in addition to President Miller, selected within the Board of Governors' panel to serve for the coming year are: Sol Halprin, head of the camera department at 20th Century-Fox, First Vice-President; Joseph Rutenberg, director of photography at MGM, 2nd Vice-President; Alfred Gilks, director of photography for Hall Productions, 3rd Vice-President; Walter Strenge, director of photography for Roland Reed Productions, Treasurer; and Philip Tannura, director of photography for McCadden Corp., Secretary. Robert deGrasse, director of photog-

raphy for Marterto Productions, Inc., was re-elected Sergeant-at-arms.

The following incumbent Board members will continue to serve during 1954: John Arnold, Arthur Edeson, Lee Garmes, Victor Milner, and Leon Shamroy.

Although presently retired from actively directing photography in the major studios, President Miller is recognized as one of the industry's ablest cinematographers. Having spent forty-five years as a motion picture cameraman, many of these as one of 20th Century-Fox's top directors of photography. Miller's activities in recent years have been devoted to the personal interests of his fellow directors of photography in the Hollywood studios. In view of his wide experience and extensive acquaintance among both cameramen and studio executives, Miller is well-equipped both in experience and progressive thinking to head the ASC, one of the most important organizations in the motion picture industry.

During his successful career as a director of photography, Miller won prestige and acclaim as a result of his brilliant photography of motion pictures, from the famous "Perils of Pauline" to his most recent pictures. During his years as director of photography at 20th Century-Fox studios, he was honored with seven Academy Award nominations, and received three Academy Awards for achievement in black and white photography. The Academy "Oscars" for outstanding cinematography of "How Green Was My Valley," "The Song of Bernadette," and "Anna and the King of Siam" stand proudly on the mantelpiece in Miller's den.

Beginning with "The Rains Came," produced in 1939, and up until his retirement from the studio in 1950, Arthur Miller photographed the majority of 20th Century-Fox's "blue chip" productions, including "Johnny Apollo," "Tobacco Road," "The Ox Bow Incident," "The Keys of the Kingdom," "Dragonwyck," "The Razor's Edge," "Gentlemen's Agreement," and "A Letter to Three Wives."

Arthur Miller became a member of the ASC in 1927 and during the past 15 years has served almost continuously in some capacity on the Society's board of directors. Early in 1953 he was made an Honorary Member of the Delta Kappa Alpha, national honorary cinema fraternity at the University of Southern California.

The New Revolutionary **ARRIFLEX 16**

The Only 16mm Camera with **MIRROR REFLEX SHUTTER** for Continuous Thru-the-Lens Focusing and Viewing.

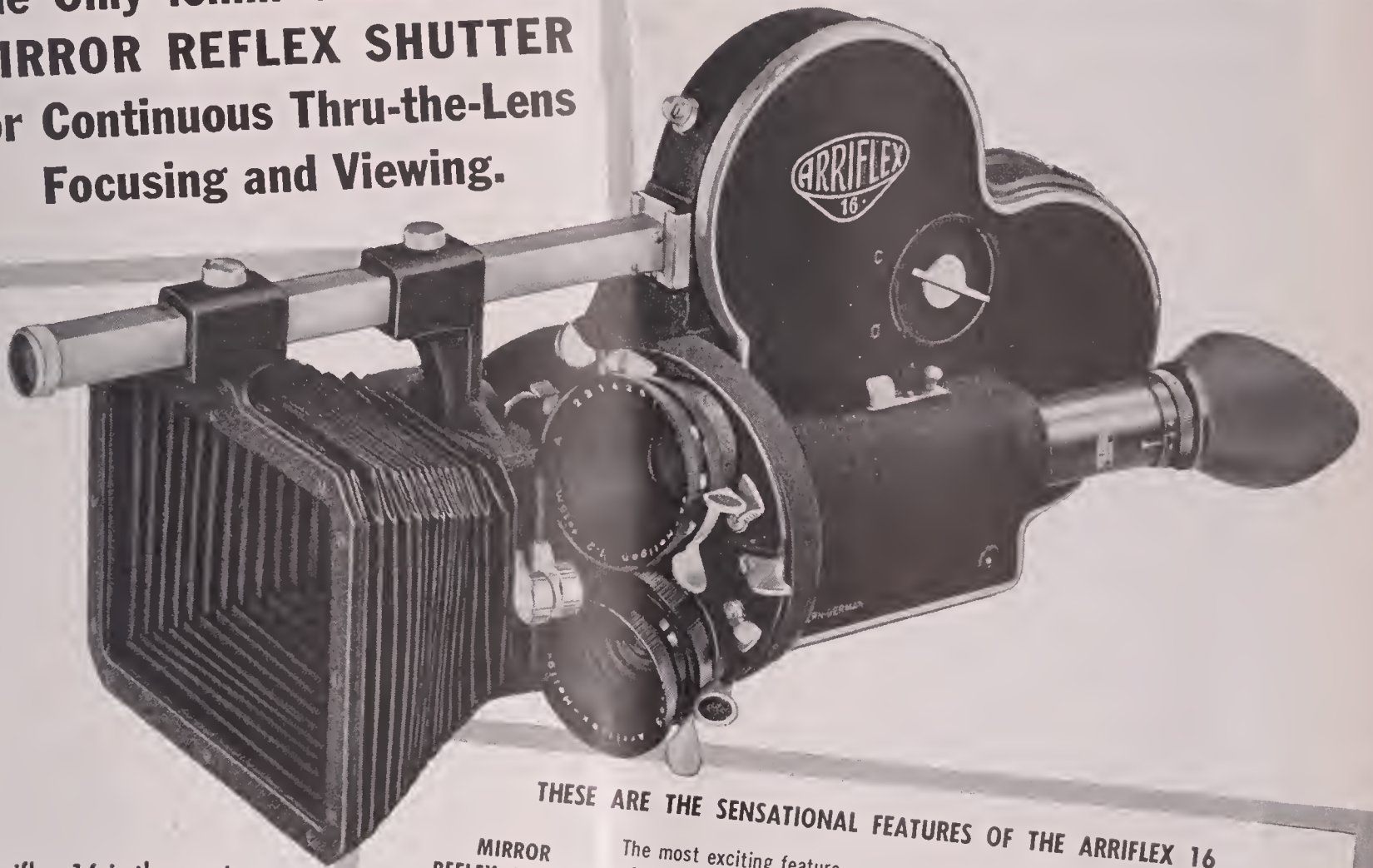

THESE ARE THE SENSATIONAL FEATURES OF THE ARRIFLEX 16

MIRROR REFLEX SHUTTER

The most exciting feature of them all: for accurate framing and critical follow-focus, through the taking lens, even during the actual shooting. Image on ground glass is brilliant, uninverted and right-side-up, magnified 10x through a highly corrected optical system. No parallax, and no need for accessory finders.

REGISTRATION PIN

Found only in cameras selling for \$3000 or more. Automatically engages and locks film during exposure. Assures absolute frame registration, and picture steadiness.

ELECTRIC MOTOR DRIVE

No need to stop a scene to wind a spring. Has variable-speed 6-volt DC motor with rechargeable battery pack, dry cell batteries, or with Transformer-Rectifier Unit on 115 volts AC. Easily interchangeable with Synchronous Motor Unit (available as accessory).

DIVERGENT 3-LENS TURRET

Accommodates lenses from 11.5mm extreme wide angle to longest telephotos. Lenses quickly interchangeable. Wide angle and 300mm telephoto can be mounted simultaneously without mechanical or optical interference.

OTHER ARRIFLEX PROFESSIONAL FEATURES

FOOTAGE & FRAME COUNTERS — for forward and reverse action.

TACHOMETER — indicates speeds from 1 to 50 frames-per-second.

CONTOUR GRIP — provides a natural and firm grip for handheld shooting.

DETACHABLE NECKSTRAP — for handheld filming.

LIGHTWEIGHT — camera with Matte Box weighs only 7½ pounds.

FILM CAPACITY — 50 and 100-foot standard daylight spools.

400-FOOT MAGAZINE — accommodates External Film Magazine. (This accessory will be available at a later date.)

DETACHABLE MATTE BOX-FILTER HOLDER — has stationary and rotating filter stages for color filters, polarizing filters, fades, dissolves, and other effects.

SINGLE SPROCKET DRIVE — for either silent or sound-perforated film.

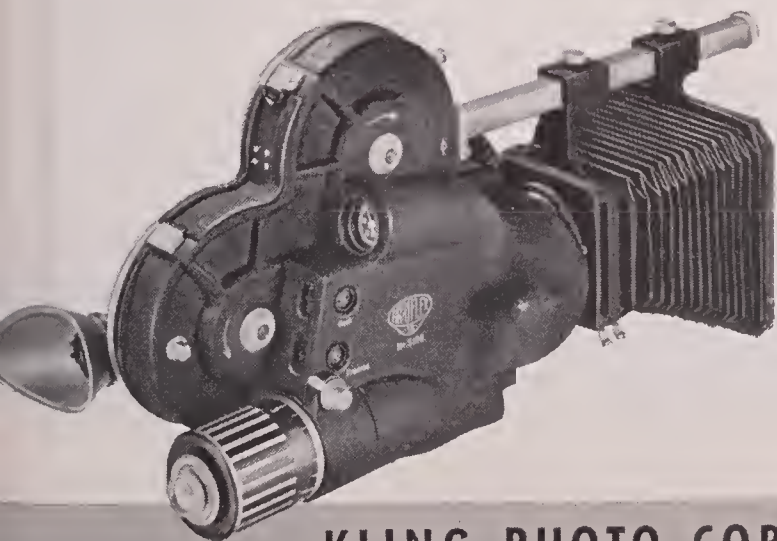

KLING PHOTO CORPORATION

235 Fourth Ave., New York 3, N. Y. • GRamercy 5-1120
7303 Melrose Ave., Hollywood 46, Calif. • WYoming 9026

CLOSEUPS

Notes and
editorial comment



Primar Reflex Photo
normal 105 mm. lens

"Impossible"
distances
become
close-ups



Primar Reflex Photo
Astro 640 mm. lens
taken simultaneously
by Hans Namuth

with **ASTRO**

LONG DISTANCE LENSES

FOCAL LENGTHS TO 1000 mm.!

Used by the world's foremost explorers, scientists and news services, Astro lenses have been making photographic history all over the globe. Special formulas have produced resolving powers up to 100 lines to the mm.! And these superb lenses are fast enough for action color work—focal lengths from 300 to 800 mm. rated at F/5, the giant 1000 mm. (40 in.) at F/6.3.

FOR STILL CAMERAS Leica, Exakta,
Primar-Reflex, Master Reflex,
Hasselblad, Praktica, Contax-S

FOR MOVIE CAMERAS 16 & 35 mm.
Balex, Mitchell, Eyema, Debrie,
Askania, E.K., Arriflex, etc.

**DUAL PURPOSE
MOUNTS** allow
interchanging
movie and
still.

**SUPER SPEED
TELEPHOTOS**

5 in. F/2.3
6 in. F/2.3
6 in. F/1.8



NEW! 12-inch F/3.5 Astro in mounts for all movie and still cameras. **NEW GAUSS TACHARS**—focal lengths 25-32-40-50-75-100 mm.; all F/2, in mounts for practically all 16 and 35 mm. professional and amateur cine cameras.

Write for brochure and prices

ERCONA CAMERA CORP., Dept. A-23,
527 Fifth Ave., New York 17, N.Y.

Color television's impending debut has TV film producers in a dither because as yet no positive and dependable information has developed as to what color films and what color photography procedures render the best results for color TV.

As it was in the beginning with black-and-white films for TV, it is certain that specific lighting and density factors will be established for the TV film producer's guidance as well as for the edification of his cameramen.

This subject is slated to receive special attention at the forthcoming NARTB Broadcast Engineering Conference in Chicago May 23 to 27. Among authorities who will speak on the subject are Ralph Evans and Roland E. O'Connor of Eastman Kodak Company.

The SMPTE and other technical groups are also working on the problem. At the SMPTE's convention in Washington May 3 to 7, E. T. Percy and T. G. Veal of the Research Laboratories of Eastman Kodak Company, are scheduled to present a paper on "Subject Lighting Contrast of Color Motion Pictures for Television."

A study has been made at Eastman Kodak of set lighting in making motion pictures in color for TV. It was found that optimum TV picture quality was obtained when the subject lighting contrast was reduced to correspond more nearly with the range of brightness which can be reproduced over a color TV system.

More detailed information on this subject will be published in *American Cinematographer* in a future issue.

★

The new **Tri-X film**, recently developed by Eastman Kodak Company, is creating considerable interest among studio cinematographers, many of whom personally have made tests with the stock.

The original tests made by Eastman technicians in New York so impressed Hollywood TV film cameramen that further tests were begun at once to determine how to adapt this new fast negative most advantageously to TV film production. Among those making the tests were Walter Streng, ASC, who directs the photography of the "My Little Margie" series of TV films; William Mellor, ASC, who films "Ozzie and Harriett" for TV, and Guy Roe, ASC,

and Phil Tannura, ASC. Some of this test footage was screened for members of the American Society of Cinematographers at a special technical meeting early this month.

Chief attributes of film are its extreme speed, low contrast, and moderate grain. The initial test films revealed it as ideal for newsreel and documentary photography at night, using the normal illumination of the location such as in stores, hotel lobbies, street exteriors, etc.

★

The editorial writer on the *Los Angeles Examiner* is to be commended for taking to task a European technical writer who recently belittled the fame of America's photographers. In a recent editorial the Examiner's writer had this to say:

"Heinrich Stockler, German technical writer on photography, says 'it is just plain astounding' that the United States has 'so few really famous photographers.'

"We're just plain astounded that Mr. Stockler is so badly informed.

"Quite a list could be ticked off of American photographers who may not be 'really famous' in the sense of being intensively publicized, but whose work equals and surpasses that of any European—if that is all that counts.

"Just as a start, there was Matthew B. Brady, whose Civil War pictorial history is still an amazing masterpiece, as art, as technique and as a definitive record of an epic age.

"The trouble is that American photographers have kept their light under a bushel of diffidence. Europeans, on the other hand, have mightily ballyhooed their freakish second-raters.

"Not only in photography, but in painting and literature, they have persuaded Americans to ignore their genuine great talents and beat the drums of imported eccentrics.

"We have left unsung the masters of scientific photography, the triumphs of cinematography, the high quality of the cameraman's daily output, the truly artistic attitude of concentrating on the work and not on what passes for 'fame.'

"Any hasty criticism that overlooks the gold of achievement for the glitter of publicity is in its way also plain astounding."

—A.E.G.

Thank You JOHN CALVERT.....



WE TRAVELED by air, jeep and truck and many miles of foot Safari through the African jungle, where it was necessary to carry equipment on the heads of natives. The remote locations inaccessible by road made us appreciate the portability of the Kinevox recorder.



THE NATIVES referred to the Kinevox as the "Magic Box." With over 80,000 feet of film exposed, we were never a frame out of sync, and no re-recording was necessary for the entire picture.

C. E. H. WOOD-PRIESTER JOHN CALVERT U.S.A. MONOPOLY E. M. LAXTON B. WOOD-PRIESTER (Secret. Secy.)
Asst. Producer E. M. LANTON

EXPEDITION EPICS LIMITED

Motion Picture Production

159 EDGWARE ROAD, LONDON, W.2

Telephone: PADdington 5965 6788
Telegrams: Excepics, Padd., London

London, March 15, 1954

Kinevox, Incorporated
116 S. Hollywood Way
Burbank, Calif.

Gentlemen:

We have just returned from a 20,000 mile motion picture Safari where we made the feature "STRANGE HORIZON", using Eastman color negative and Kinevox recording.

We travelled by air - jeep - truck and many miles of foot Safari through the African jungle, where it was necessary to carry the equipment on the heads of the natives. The remote locations in-accessible by road, made us appreciate the portability of the Kinevox Recorder. This enabled us to record sound that we normally would have had to post-sync back at the studio.

The natives referred to the Kinevox as the "Magic Box". We used it as a means of getting them to work and supply us with native music, chants and drums, as their greatest reward was to hear the immediate playback.

Most important, we returned to London with excellent sound of studio quality. By using a 110 volt synchronous motor on the camera, powered from your Kinevox Portable Power Supply and battery pack, we were able to run all day long, charging our batteries at night. With over 80,000 feet of film exposed, we were never a frame out of sync and no re-recording was necessary for the entire picture.

On all our future productions we plan to use Kinevox exclusively.

With best wishes for your continued success,

Sincerely yours,
John Calvert
John Calvert

JC/vg,

Descriptive Catalog of Complete Kinevox Magnetic

Recording Equipment Available on Request

KINEVOX BUILDING
116 SO. HOLLYWOOD WAY
TELEPHONE: ROckwell 9-3291

KINEVOX

I N C O R P O R A T E D

BURBANK
CALIFORNIA
CABLE: Kinevox, Burbank

ROME • BOMBAY • NEW YORK • RIO DE JANEIRO • CANADA

**SHARPER,
BRIGHTER,
CLEARER
IMAGES**
with...

• 2-D

• 3-D

•  CINEMASCOPE

• TV

BALTAR

Brilliant images, thrillingly detailed—they're yours *for sure* with Bausch & Lomb Baltar lenses on your camera. For finest images on film: complete line of Baltar 35mm and 16mm movie lenses—for 2-D, 3-D and CinemaScope. For finest TV images: Television Baltar lenses, for studio and portable cameras. Order from your professional camera manufacturer.



BAUSCH & LOMB

SINCE



1853

Great equipment makes great cameramen

BALANCED TRIPOD HEAD

and

PROFESSIONAL JUNIOR TRIPOD

are the standbys of the masters

You'll never hear Fritz Kreisler playing on a scratchy fiddle . . . or Louis Armstrong on a \$7 trumpet. Good craftsmen need good tools.

Camera Equipment Company makes, sells, services and rents the world's finest quality TV and Motion Picture Equipment.



New "BALANCED" TV head — MODEL "C"
—for the world's smoothest pan and tilt action.



SYNCHRONOUS MOTOR DRIVE — 110 Volt AC — Single phase, 60 Cycle. Runs in perfect synchronization with either 16mm or 35mm Sound Recorders. Mounting platform permits removal of magazine while camera remains mounted on motor. Spring steel drive fin coupling prevents damage if film jam occurs.

Knurled knob on armature permits rotating for threading. "On-Off" switch in base. Platform base threaded for 1/4" or 3/8" tripod tie-down screw. Rubber covered power cable with plugs included.



More professional cameramen use The PROFESSIONAL JUNIOR Tripod than any other tripod in the world.

Let's face it. You need a first class tripod to make better pictures. PROFESSIONAL JUNIOR has the rigidity, the range, and the ease of operation that better pictures demand. See it—try this tripod beauty—and you'll never be without it. PROFESSIONAL JUNIOR TRIPOD—Friction Type. Handles all 16mm cameras, with or without motor. Also 35mm DeVry, B & H Eyemo with and without motor, and 400' magazines. Tripod base interchangeable with Professional Junior gear drive head. "Baby" tripod base and "Hi-Hat" base available.

No more groping for center of gravity. The new Model C "Balanced" Tripod Head is equipped with a convenient, accessible positioning handle mounted below the top plate, which allows the operator to reposition the camera to the correct center of gravity. No matter what focal length lens is used on the camera turret, the camera can be balanced on the Model C Head without loosening the camera tie-down screw.

It has all the features which have made the "Balanced" head a gem of engineering ingenuity—quick release pan handle, tilt-tension adjustment to suit your preference. It's a Cameraman's dream!

FRANK C. ZUCKER

CAMERA EQUIPMENT CO.
1600 BROADWAY NEW YORK CITY

SALES • SERVICE • RENTALS — CAMERAS * MOVIOLAS * DOLLIES

Complete line of 35mm and 16mm equipment available for rental.

MITCHELL: Standard, Hi-Speed, BNC, NC, 16mm

BELL & HOWELL: Standard, Shiftover, Eyemo

ARRIFLEX: 35mm and 16mm

MAURER: 16mm Cameras

MOVIOLA: Editing machines, Synchronizers

We design and manufacture Lens Mounts and camera equipment for 16mm—35mm and TV cameras.



VARIABLE SPEED MOTOR — 110 Volt AC/DC with Tachometer for EK Cine Special Motor drive your Cine Special with confidence! Tachometer is mounted in clear view of operator. Calibrated from 8 to 64 frames per second. Definite RED marking for 24 fps. Electrical governor adjusts speeds. Steady operation at all speeds. No adapters needed. Motor coupling attaches to camera and couples to motor. Spring steel drive arm shears if film jam occurs. Easily replaced.

We calibrate lenses—Precision "T" Stop Calibration of all type lenses, any focal length. Our method is approved by Motion Picture Industry and Standard Committee of SMPTE. For proper exposure density, it is important that you have your lens "T" stop calibrated. Lenses coated for photography. Special TV coating. Rapid service.

Hollywood Bulletin Board



ASC APRIL MEETING was occasion for installation of newly-elected officers for 1954. Turning over gavel to new president, Arthur Miller (left) is retiring president Arthur Edson. Installation took place at the Society's clubhouse in Hollywood.



GATHERED around president Miller (seated) are newly-elected officers of ASC: (left to right) Walter Strenge, treasurer; Alfred Gilks, 3rd V-p.; Sol Halprin, 1st V-p.; Robert deGrasse, Sgt. at arms; Philip Tannura, secretary; Joseph Rutienberg, 2nd V-p.

Lucien Ballard, ASC, on May 6th, joins the ranks of other studio cinematographers who have gone into television, when he begins shooting the new George Brent TV film series at Roach Studios for Royal Oaks Productions.

Gil Warrenton, ASC, returned from Mexico last month where he completed shooting "White Orchid" in Eastman Color and wide-screen for Cosmos Productions. Entire picture was photo-

graphed, dubbed and edited in Mexico—the interiors being filmed at Churubusco Studios in Mexico City.

Charles Rosher, ASC, returned to Hollywood from his hideaway in Jamaica, and will direct the photography of MGM's "Jupiter's Darling." A great deal of the photography will be under water and Rosher is currently making pre-production photographic tests using some of the latest equipment for underwater color photography.

James Seeley is one of the busiest ASC cameramen on the east coast. Besides doing special events and newsreel items for NBC, Telencws, CBS, Warner Brothers, Pathe, and Universal, he has been increasingly active shooting TV film shows in New York. Recent assignments include "The Big Story," and "Treasury Men In Action." Bernard J. Proctor Prods.; "Industry On Parade." Arthur Lodge Productions, and "You Asked For It." Wayne Steffner Productions.

Among 26 pioneer engineers who have been active in the work of the SMPTE for over thirty years, and who have been singled out by the Society

for special recognition during organization's 75th Semiannual Convention in Washington, D.C., this month are: John G. Capstaff, John I. Crabtree, and C. E. K. Mees, all of Eastman Kodak Co.; William C. Kunzman, of National Carbon Co.; and George A. Mitchell, Mitchell Camera Corp.

Incidentally, some of the most important papers relating to motion picture photography ever presented before the Society will be read at the meeting.



JAMES SEELEY, ASC, who is currently shooting "The Big Story" television film series for Bernard Proctor in New York City.



ASC ceremonies last month included the hanging of photos of this year's "Oscar" winners on ASC's "Wall of Fame" in Society's clubhouse. Left is Burnett Guffey, "Oscar" winner for "From Here To Eternity." Photo of Loyal Griggs, "Oscar" winner for "Shane," is being hung in his absence by Paramount's Farciot Edouart.

A DEPENDABLE NAME IN

CAMART

SALES • SERVICE • RENTALS

16
MM

35
MM

TV

MOTION PICTURE & TV EQUIPMENT

PRODUCTS

STUDIO OR LOCATION

CAMART TV BABY DOLLY

Rigid quick set tripod leg clamps. 8" ball-bearing wheels in alignment for use with or without dolly tracks. Size 35x45 inches, weighs only 75 pounds. Well-balanced to use camera at any height. May be disassembled for transportation in a very few minutes. Immediate delivery.



NEW MODEL

- Four wheel dolly for use with tripod, baby tripod, or hi-hat.
- Improved steering control for greater maneuverability.
- Adjustable swivel seat for camera operator.
- Platform for assistant to ride follow focus.
- Attractive grey hommertone finish.

CAMART ELECTRIC FILM TIMER

For motion pictures, television, sound recording, post-narration, and film editing. Times rehearsals, and measures total film footage or times sequences in minutes and tenths. Synchronous motor operates silently on 110 volts, 60 cycles, finished in attractive grey crackle.

NEW LOW PRICES
Literature on request

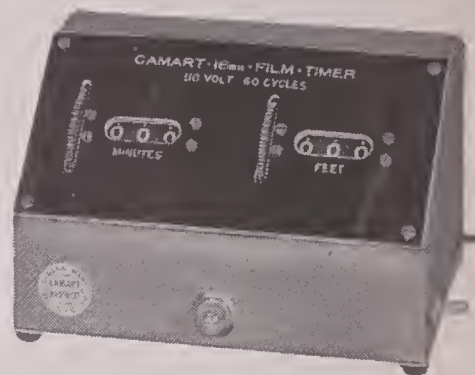

CAMART SLATE and CLAPSTICK

Used in motion picture production where speed is essential for synchronization of sound and picture. Measures 10x12 inches, slate finish with silk-screened letters. Solid construction.

Only \$11.75

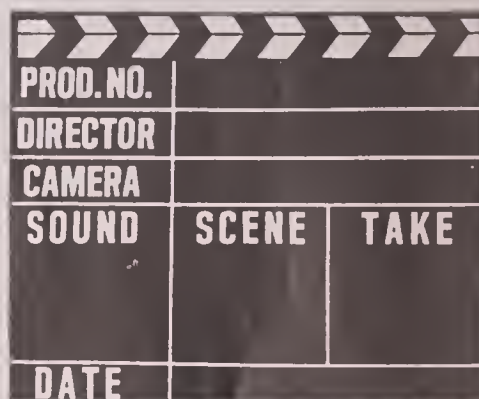

PRODUCTION EQUIPMENT

New and Used

- Mole Richardson telescoping mike boom with perambulator stand, brand new, immediate delivery \$1,920.00
- Blue Seal 35mm optical recorder, two channel amplifier, sync. motor, 100' magazine, cases \$1,695.00
- Moviola 35mm optical reader and speaker, excellent \$95.00
- Moviola 35mm picture head with counter, excellent \$365.00
- Arriflex power supply unit to operate camera from 110 volt current without batteries, new \$110.00
- Filmo DA with Auricon porallax finder, 2" Wollensak f3.5 lens, case, excellent \$295.00
- Cine Special I, chrome, 100' chamber, 15mm f2.7, 1" f-9 lenses, one side c-mount, B&H turret viewfinder with elements, exceptionally fine condition \$450.00
- Mitchell type viewfinder with floating mattes \$150.00
- Precision combination optical-magnetic reader, new \$259.50
- Studio optical-magnetic reader, latest model, new \$169.50
- Bardwell-McAlister four lite bar units made exclusively for the army, sturdy construction, porcelain swivel joint sockets for directional control, neck for stand, ideal for use with Colortran, original cost \$49.50, close out special \$16.95
- Fluorescent lighting units, custom built, takes six 20 watt bulbs, good flat or fill light, original cost \$150.00, now specially priced at \$41.50
- Colortran original movie model converter, excellent condition, was priced at \$235.00, special \$175.00
- Ampro 16mm hi-intensity arc projector, lamphouse, rectifier, amplifier, 12" speaker, stand, like now \$795.00

NOW TAKING ORDERS

NEW CAMERAFLEX 16mm Professional reflex motion picture camera, 400' and 1200' magazines, variable speed and synchronous motors, wide angle lenses from 9.5mm and up. Send for further details.

CAMART SCOUT TRIPOD



THE SCOUT
Includes head
Measures from 42" closed to 72" fully extended. Weighs 9 1/2 pounds.
\$104.50

THE CUB
Baby Tripod
\$35.00

HI-HAT
Ideal for low angle cinematography
\$16.00

Send for descriptive literature

A PROVEN LEADER!

Sturdy tripod for 16mm or 35mm cameras. Well balanced removable friction head for smooth pan and tilt action. Water level. Specially treated wood prevents warping. Fibre boot covers available.

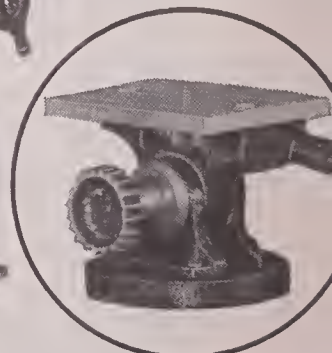

REMOVABLE HEAD
Model A, narrow plate for Cine-Special.
Model B, wide plate for other cameras.

THE CAMERA • MART INC.

MOTION PICTURE AND TV PRODUCTION EQUIPMENT

1845 BROADWAY at 60th St.

Phone: Circle 6-0930

DEDICATED TO BETTER PERFORMANCE



COLLAPSIBLE 3-WHEEL DOLLY

For motion picture and TV cameras. Sturdy cast aluminum. For standard or baby tripods. Additional baby tripod point holders to control spread of tripod legs. Adjustable spring seat. Extra wide rubber wheels. Bronze tie down clamps and other features.

For studio or location. Folds into one compact unit. Can be used with professional or semi-professional tripods.

'HYDROLLY'

TV OR
CAMERA DOLLY

The advanced dolly for instant moveability — streamlined, lightweight, exceptionally sturdy. Nothing to get out of order. Many new advantages for easy operation. Hydraulic lift type for fast upward and downward motion of TV and motion picture cameras.

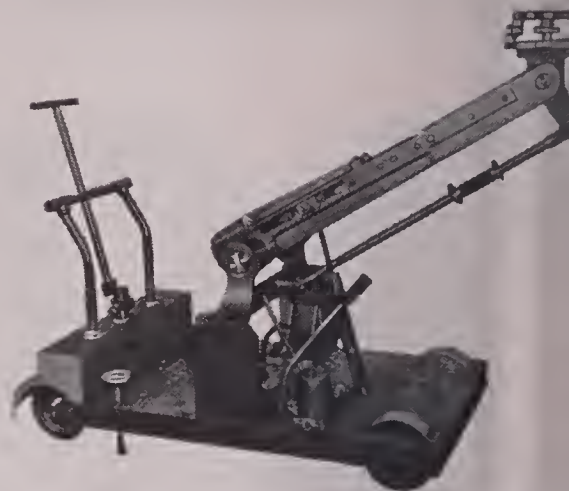

Swivel seat. Adjustable leveling head. Seat for assistant. In-line wheels for track use. Steering wheel, rigid floor locks. Hand pump or combination hand and motor pump. Easily transported in a station wagon. Fits through a 28" door.



Synchro-film-ed Synchronizer

Our Exclusive Distributor
NEUMADE PRODUCTS CORP.

Any combination of 16mm and/or 35mm sprockets assembled to specification. Cast aluminum. Foot linear type, adjustable frame dial. Fast finger roller release. Contact rollers adjusted individually for positive film contact. Sprocket shaft slip lock, footage counter, etc.



PORTABLE MICROPHONE BOOM

For Studio or on Location. Lightweight — collapsible — for TV and motion picture production. Sturdy construction. Boom telescopes 7 to 17 ft. Rear handle for directional mike control. A remote control permits 360° rotation of the microphone. Operator can push the boom and operate microphone swivel simultaneously.

Extension rods make it simple to operate microphone rotation from floor. Microphone cable hangs outside of boom, preventing cable from tangling with the rotation mechanism. Ball bearing casters, rigid foot locks, pneumatic drop check for lowering the boom, etc.

RENTALS

SALES • REPAIRS • SERVICE

LENS COATING

"T" STOP CALIBRATION

DESIGNING and MANUFACTURING

lens mounts & camera equipt.
for 16mm, 35mm, TV cameras.

BAUSCH & LOMB "BALTA"
LENSES and others

for motion picture, TV cameras.
15mm to 40" focal length.

COMPLETE LINE OF: 16mm, 35mm
cameras, dollies, synchronizers,
animation stands, cutting room
and time lapse equipment.

BELL & HOWELL: Standard, Eyemos, Filmos. MITCHELL: Standard, Hi-speed, BNC, NC, 16mm.

SEND FOR CATALOGUE

Synchro-film- Slate

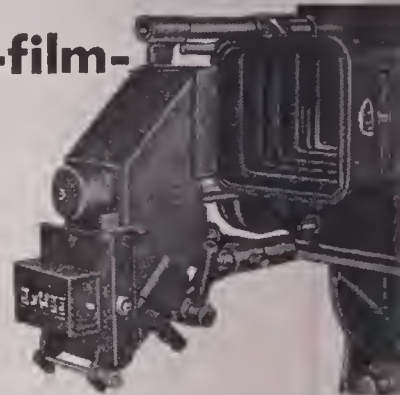

Pays for itself in production savings on the set. A New Development! Eliminates clap stick synch and slate on set. Mounts on double arm bracket to work with BNC, NC, Standard, 16mm Mitchell and all types of blimps and Geared Head. Interlocks with Sound Recorder.

VARIABLE- SPEED MOTOR with TACHOMETER

for Cine Special or Maurer Cameras

115 V. Universal Motor — AC-DC
Separate Base for Cine Special.
Variable Speed 8-64 frames.
Adapter for Maurer Camera.

INTERCHANGEABLE MOTORS: 12
volt DC Variable Speed 8-64 frames.
115 Volt AC 60 Cycles, Synchron-
ous Motor, Single Phase.

ANIMATION MOTORS: Cine Spe-
cial, Maurer, Mitchell, B & H Motors,
for Bolex and Filmo Cameras.

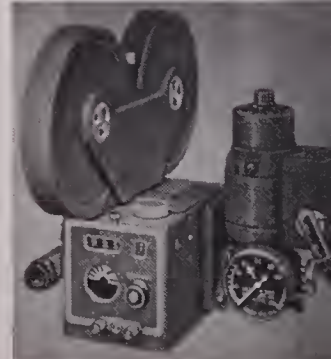
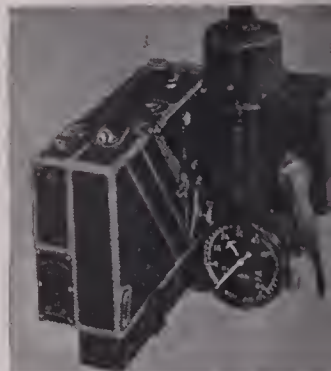



ONE OF THE many outstanding examples of mood lighting which Harry Stradling, ASC, created for "A Streetcar Named Desire." Here the lighting is as near natural in aspect as it is possible to produce artificially on the motion picture sound stage.



A DEATHBED scene in which the poignancy of the situation is greatly enhanced by the mood created by artful lighting and choice of camera angle. The lighting alone, unaided by dialogue or sound, would tell the story adequately.

The Role Of Light In Creating Mood

It is important that the cinematographer carefully plan his lighting to complement the mood, tempo and character of a scene as effectively as do dialogue and action.

BY VICTOR MILNER, A.S.C.

OF ALL THE TOOLS with which the cinematographer works, light—if it may be termed a tool—is the most versatile. With light he can not only make or break a scene composition, display his players to advantage or otherwise, but he can attune the audience-mind to any mood, and key the response to almost any emotional pitch.

It is not enough that a scene be an intrinsically beautiful bit of photography; the cinematographer who strives solely for pictorial effect, or the one who rigidly follows a fixed scheme of lighting for every production often fails to create the desired subconscious, emotional receptiveness in the audience that greatly enhances the dramatic value of the production.

One's lighting technique, therefore, should be flexible—subject to change,

even within a sequence, to harmonize with the mood and tempo of the action.

It is important that the cinematographer of dramatic films train himself to think directly in terms of lighting. Thus, when reading a script, he should be able to visualize each scene not alone in terms of action, or even of camera angles and camera moves, but how it should be lighted to complement the mood which the story or the action demands.

It is easy enough to read in the script the word description of a heavy, dramatic scene, which must necessarily be somber and slow-paced, and understand that it must be photographed in a low key; or to glance over a swift-paced comedy scene and see that it will require high-key lighting. But the really important thing is to be able to form

such a clear mental picture of the set lighting treatment of a scene that the lighting itself expresses the scene's mood, tempo and character as clearly as do dialog and action.

The reader might picture in his mind, for example, this situation: in a bed in a small room, an old man lies dying. Besides him sits his wife who has shared his joys and sorrows over the years tensely watching and waiting for the crisis.

Different cameramen, I suppose, would visualize this scene in different ways. To my mind it conjures up at once a lighting pattern of dramatic light effects. I can see the scene lit in a very low key, with only an extremely repressed scale of gradations. The figure in the bed is limned in grayish

(Continued on Page 256)



LENGTHS OF lightweight channeled iron or aluminum laid on floor provide effective tracks for the new swivel-wheeled camera dollies.



THE CHANNELED rails are generally available from builder's supply houses in either aluminum or iron.



CHANNEL of tracks should accommodate dolly wheels without binding, be deep enough to hold wheels during camera shots.

Low Cost Dolly Tracks

Strips of channeled iron or aluminum provide practical, low-cost tracks for the new lightweight camera dollies.

By JOHN HOKE

DOLLYING "in" or "out" of scenes is a camera technique which often adds an impressive touch to a motion picture production, be it professional or amateur. Without proper equipment, however, dollying becomes difficult to perform smoothly. In the studios, special mobile camera mounts are used on tracks laid on the stage. It is the tracks that guide the camera and enable it to move forward or away from the subject smoothly and without any perceptible wavering.

For the cinematographer who would like to employ dollying in his filming but who does not have the budget to invest in expensive dollies and tracks commercially-made for the pur-

pose, here is a simple method of accomplishing dolly-shots at low cost.

There are a number of moderately priced swivel-wheel camera dollies on the market, like the one illustrated, which can produce smooth directional dolly action on any floor surface with the aid of simple tracks made of readily-available lightweight channel-iron or aluminum. This material is to be had at stores dealing in building supplies and materials. It generally is available in a variety of widths so that it is possible to choose a width to fit the width of the wheels of the particular dolly that is to be used. The inside dimension of the track material should be just wide enough to accommodate the dolly wheels without binding, allowing them to move freely backward and forward in the channels, as pictured here. As shown in the first photo, two wheels of the dolly ride in one track, while the third wheel rides in the second track. Thus the dolly glides smoothly in the direction the tracks are laid. While three tracks can be used—one for each wheel—use of two works quite satisfactory and at the

(Continued on Page 262)

COMMERCIAL!

The one that's
never announced—

Always obvious—

“And now—

a word about films—

color or black and white—

negatives and positives—

Best for Television

Best for you

Best for us!

EASTMAN””

W. J. GERMAN, INC.

FORT LEE

CHICAGO

LOS ANGELES



ALL SETS for the Burns and Allen show are arranged in a straight line to facilitate simplicity in lighting and time-saving operation of cameras on the floor. Note absence of cables on floor which affords unhampered movement of dolly-mounted cameras during shooting.



HERE IS the familiar living room set of the Mortons, next-door neighbors of George and Gracie. Prominent are the two cone lights suspended from ceiling which supply the main fill light. Other units augment the illumination of the cone lights.

Money-Saving Shooting System For TV Films

New, cost-cutting methods of lighting and filming weekly TV shows are essential to profitable production. Here's how the successful Burns and Allen show is photographed today.

By PHILIP TANNURA, A.S.C.
Director of Photography, "The Burns and Allen Show"

THE KEY ECONOMIC FACTOR in the success of any television film production operation today is the photography. If too much time is required in lighting the sets and shooting the picture, high production costs will cause the show to be priced out of the market.

Today, fixed budget limits continue to dictate not only the quality of a show but also the time which can be allotted for putting the show on film. Very early it was seen that the same production methods employed in making feature films could not profitably be followed in making television films; that is, TV film production could not afford the high production costs associated with feature film production. Therefore, new cost-cutting and time-saving procedures have gradually been developed for the production of films for television.

The McCadden Corporation, which produces the Burns and Allen show as well as the Jack Benny and Bing Crosby TV shows on film, has developed a system whereby each half-hour show is completely photographed in one eight-hour day.

To accomplish this it was necessary to do two things: streamline the set arrangement and devise a lighting system that would permit shooting scenes in the absolute minimum of time. The nine different and permanent sets regularly used in the Burns and

Allen show were erected on one sound stage of the General Service Studios. As may be seen in the photographs above, these are arranged in convenient order to expedite fast, assembly-line production. This straight-line arrangement also permitted setting up a pattern of more or less permanent lighting, which requires little if any alteration from show to show — an important cost-saving factor. Occasionally the lighting is altered to produce pictorially a change in mood; in most cases, however, this does not involve moving the lights but merely a re-direction of some lights or an increase or decrease in the

THE LOW, 4-wheeled "crab" dolly which is used in mounting the Mitchell BNC cameras used in filming the Burns and Allen show. Note the small fill lights in front, clamped to base of dolly.

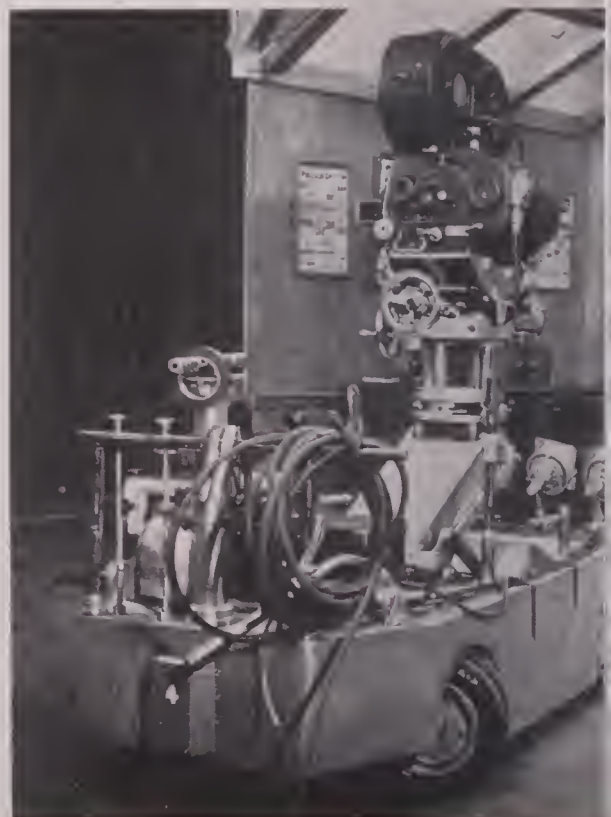



THE FAMILIAR living room of George and Gracie where the action diagrammed below takes place. The lighting units overhead are so arranged to provide uniform illumination on players when moving in any part of the set.—All photos by the author.

illumination volume, achieved by remote control in a simple operation at the switching panel.

In rigging the sets, consideration was given to placing the various light units

so that the players could move freely about in any part of the set and still receive the required illumination for good photography. Also, no power cables for the lights are on the floor at

any time; only those required for the camera. In this way the floor is entirely clear, affording unhampered movement of the dolly-mounted cameras in and before any of the sets.

In lighting the sets for the Burns and Allen show, our aim is to make the show, as seen on home receivers, appear as near a "live show" as is possible. To achieve this we use a preponderance of reflected light supplied by a number of relatively new set lighting units known as "cone lights" and developed by the engineering department of Columbia Studios in Hollywood. (See "Economy Set Lighting With Cone Lights," Pg. 248, June, 1952, *American Cinematographer*.—Ed.)

The unit consists of a cone-shaped housing in which is mounted a 5-KW incandescent lamp behind a baffle which reflects the light back toward the lamphouse interior. The interior surface is painted a soft, matte white. The indirect light reflected by this surface has a peculiar non-shadow-producing

(Continued on Page 254)

DIAGRAM shows a typical photography routine in filming a sequence for the Burns and Allen television show, in which George and Gracie read dialogue and move about the set in a continuous take running up to 4 to 6 minutes, while two cameras (A and B) cover the action in a continuous run and in a number of moves in which the cameras shoot from 7 different setups.

Burns (B) and Allen (A) on stair landing at rear of set, step down and walk forward to coffee table (CT), sit down, and talk. Presently they rise and walk back to divan (D) and sit down, where dialogue is completed.

At start of action both cameras A and B are on the action from position 1. As players move forward to coffee table, camera B moves to position 2 for a two-shot; camera A stays on players until they sit down at table. On cue, camera A moves to position 2 for shot at a different angle. Meantime camera B carries on and covers action from opposite angle.

On dialogue cue, camera A moves to position 3 for straight-on shot of players; meantime, camera B is covering action, favoring Burns. When camera A is set and shooting at position 3, camera B breaks from position 2 and proceeds to position 3. After it is in position, camera A pans to right from position 3 as players rise and walk back to divan.

As they sit down camera B picks them up; camera A moves up to position 4 and gets angle shot of action which is reverse that secured by camera B in position 3. If this action was filmed by a single camera, a total of seven separate setups would be required and entail repeated "stop and go" action for the players.

Both cameras operate continuously. The carefully planned setups and skillful coverage of action by one camera while the other moves into a new position combines to ease the task of the film editor. Thus, most of the picture is "cut while being shot," according to author Tannura.

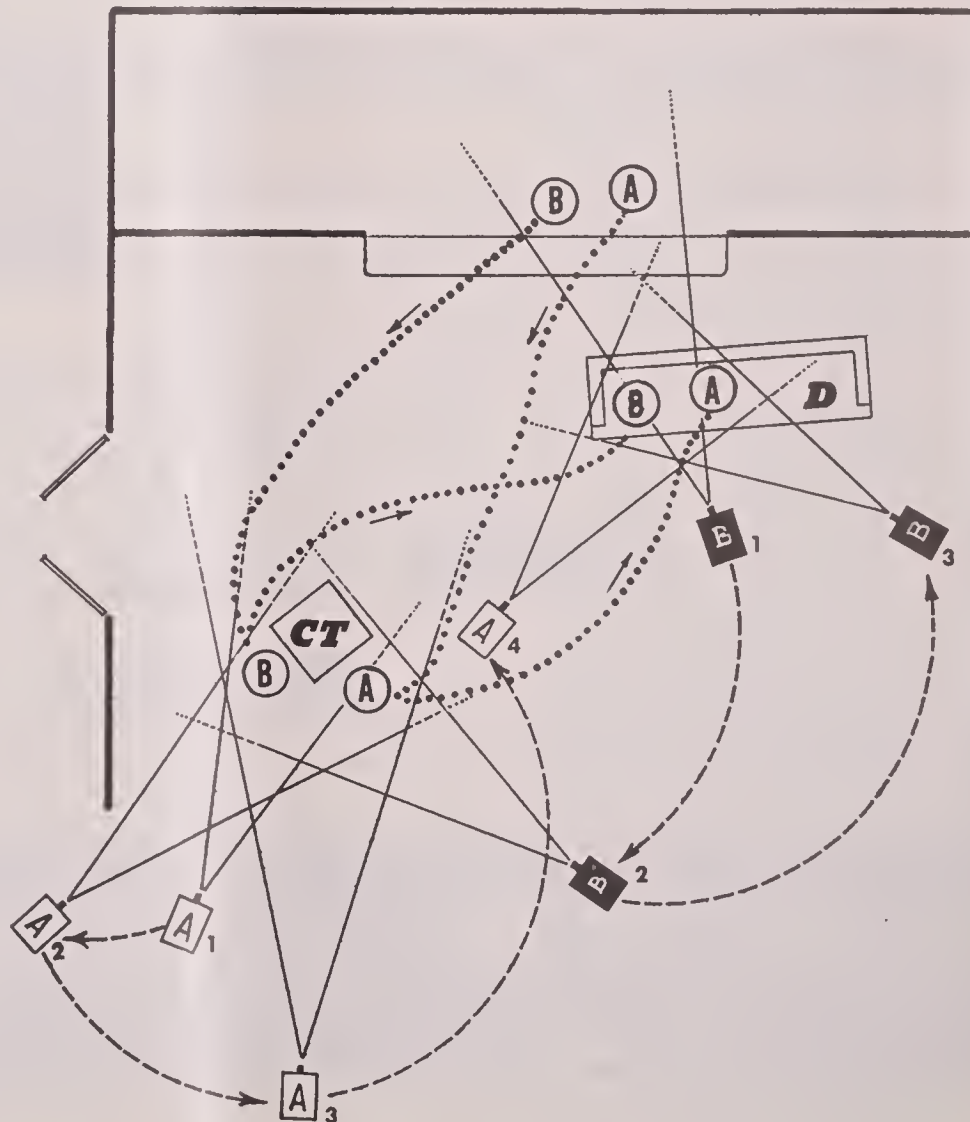



Magnaphonic
SOUND SYSTEM

There's a reason...

why Magnasync enjoys
continued worldwide leadership...

QUALITY...ECONOMY...INTEGRITY

Air S
Univers
Nava
Rad
Protes
Fotovox, Inc. Photographic Technicians Pr
W T S P—Florida Southern Pacific Railroad
Tele-Filmica Maxol, S.A., Havana Southern
Ford Foundation Twentieth Century-Fox, Inc.
University of Wisconsin Gospel Films, In
National Film Board of Canada Cine Associat
R. K. O. Radio Pictures, Inc. Pacific Picture
Gilfillan Bros., Inc. U.S. Air Forces Westingho
Iowa Conservation Commission Providenc
Fairchild Recording Equipment Co. Galbrea
Magnolia Petroleum Co. Kearney & Trecker Co
W K A Q, San Juan, Puerto Rico State Colle
Naval Air Station Beeland-King Film Productions
Columbia Pictures Providence Bible Institu
Television Recording Service, Inc. Iowa Farm Bur
Westinghouse Electric Corp. Sound Recorders, I
Viguie Productions, Inc., Havana U.S. Navy Nort
Paramount Pictures Corp. Baptist Gospel Film
U.S. Department of Agriculture University of Iow
International Productions Goodyear Aircraft Corp
Avalon Pictures, Inc. Reverend D. Kirk Hammond
Southwest Film Laboratory, Inc. Academy Soun
Naval Ordnance Wurtele Film Productions Acade
Bible Institute of Los Angeles University of Tennessee
University of Mississippi Rampart Productions So
Protestant Radio Center, Inc. U.S. Recording Co.
South Dakota State College Aspen Pictures Dallas Jon
Twentieth Century-Fox, Inc. Filmscope
U.S. Air Forces Magnolia Petroleum Co.
Southwest Film Laboratory, Inc. Gilfillan Br
Cine Associates
Kearney & Trecker
University of Iowa
Arcturus Manufacturing
Goodyear Aircraft Corp.
Fairchild Recording Equipment Co.

Select

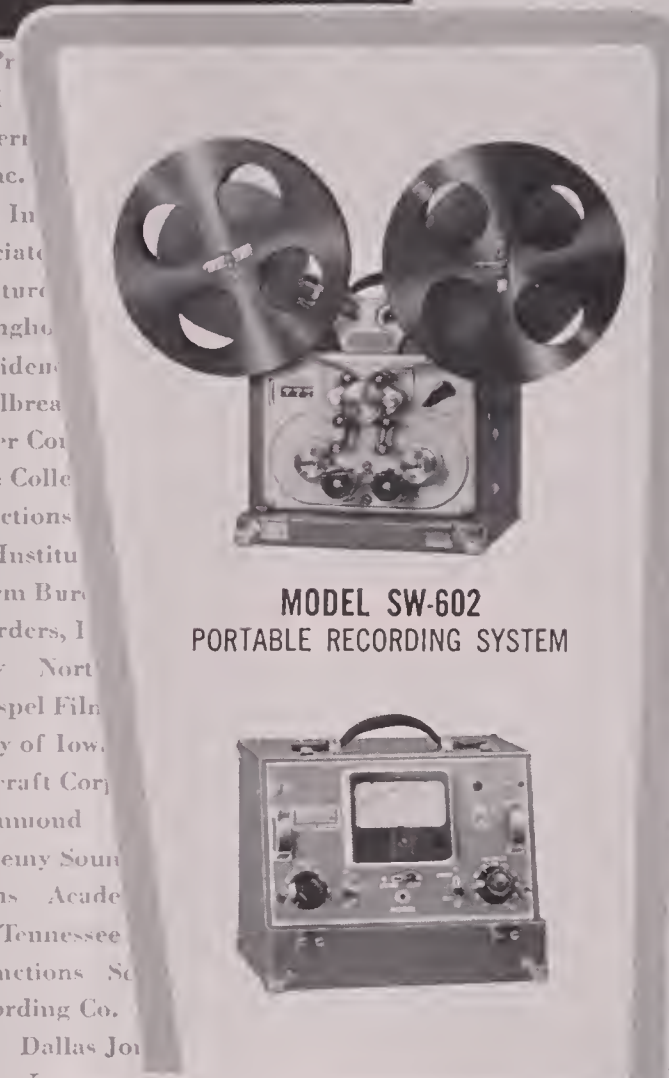

**MODEL SW-602
PORTABLE RECORDING SYSTEM**



DISTRIBUTORS

CAMERA EQUIPMENT COMPANY 1600 Broadway, New York 19, N.Y. Judson 6-1420—Cable: "CINEQUIP"	MAGNETIC RECORDERS COMPANY 7120 Melrose Ave., Los Angeles 46, Calif. WEBster 3-5545	ZENITH CINEMA SERVICE, INC. 3252 Foster Ave., Chicago 25, Illinois IRving 8-2104
--	--	---

AMERICA'S LEADING MANUFACTURER OF MAGNETIC FILM RECORDING AND REPRODUCING DEVICES

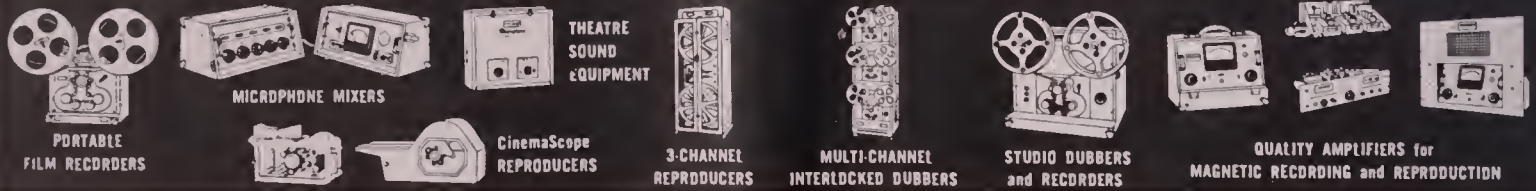

MAGNASYNC MANUFACTURING CO., LTD. • 5521 SATSUMA AVE., NORTH HOLLYWOOD, CALIF. • POplar 6-1692

Northern Pictures
Filmscope, Inc.
Arcturus Manufacturing
South Dakota State College
Galbreath Picture Production
U.S. Recording Co. Aspen Piet
Dallas Jones Productions
Fotovox, Ir
th Dakota
Production
Corp.
of Tennesst
int
Center, Inc.
U.S. Navy
rie Corp.
e., Havana
Baptist C
of Agricultu
Florida
Pacific Pic
Internati
raphic Techn
s, Inc.
rsity of Wisc
ific Railro
I Films
Naval Ordn
Bible Inst
rsity of Missi
Sound Rec
Inc.
Wurtele Fil
ture Prod
U.S. Depat
Viguie Pi
Gospel Films
Beeland-King Film
Ford Foundation
Columbia Pictures
R. K. O. Radio
W K A Q, San Juan, Puerto Rico
Paramount Pictures Corp. Bible Inst
National Film Board of Canada

THE OWNERS OF Mitchell NC, Standard and 16mm cameras now may broaden the scope of their operations to include follow-focus and dolly shots, thanks to a new lightweight, easily operated follow-focus attachment now available from Mitchell Camera Corporation.

The importance of follow-focus control on any motion picture camera cannot be over-emphasized, for without it satisfactory follow-focus shots are difficult to make. In this type shot the camera moves progressively toward or away from the set, or the action itself moves toward or away from the camera. Obviously, sharp focus on the principal subject must be maintained during the full period of the take—a matter that requires the camera lens to be constantly adjusted for focus according to the changing distance between camera and subject while the camera travels.

This is no problem with the Mitchell BNC studio camera, where automatic follow-focus control is an integral part of the camera. The focusing controls are geared to the single camera lens (there is no turret on the BNC) and to the camera viewfinder. As the follow-focus controls are operated, the camera and viewfinder are in identical focus, and the viewfinder is automatically corrected for parallax. Thus, for follow-focus shots, the camera crew has complete focusing control at all times, and the subject is followed perfectly.



FIG. 1—Follow-focus attachment installed on Mitchell NC 35mm camera, which enables it to be used for moving shots at various distances, and gives the cameraman full control of both picture framing and lens focusing through operation of a single follow-focus control knob.



FIG. 2—The attachment for 35mm Mitchell cameras with viewfinder mounted in place. Complete automatic focusing control of viewfinder lens can also be provided at additional cost. Attachment for the Mitchell Professional 16mm camera differs slightly in design.

Follow-focus Attachment For Mitchell Cameras

Mitchell Camera Corporation introduces lightweight, easily-operated attachment for its 35mm NC, Standard and Professional 16mm cameras.

To provide this same convenience for users of the NC, Standard and 16mm models, Mitchell has designed a readily-mounted follow-focus attachment. It is the only mechanism of its kind available, which couples the finder directly to the lens and which is designed for use with Mitchell cameras. It assures full control of picture framing and lens focusing, particularly at close, critical ranges.

It is easy to install and remove. The attachment does not interfere with the use of all standard accessories, and is supplied complete with bracket for attaching matte box. Only in the case of older cameras now in use, is it necessary to drill a small hole in the base of the camera for mounting the follow-focus attachment.

Once it is attached to the camera, all follow-focus control is accomplished

through the use of one knob—the follow-focus control knob, shown in Fig. 1. This results in saving much lost production time on the set normally required for the solving of follow-focus parallax control.

The Mitchell Follow-focus Attachment for the 16mm Mitchell camera differs slightly from that for the 35mm NC and Standard models in that the one lens gear fits all lens ring gears on the 16mm Mitchell camera. The kit includes: 1) Follow-focus Mechanism; 2) The finder harness and individual cams as specified for lenses mounted; and 3) Dovetail bracket unit for older finders. For the 35mm NC model and Standard cameras with original finders, the kit includes: 1) Follow-focus mechanism; 2) Finder Harness and individual cams, as specified for lenses mounted;

(Continued on Page 252)

SEEING IS BELIEVING!

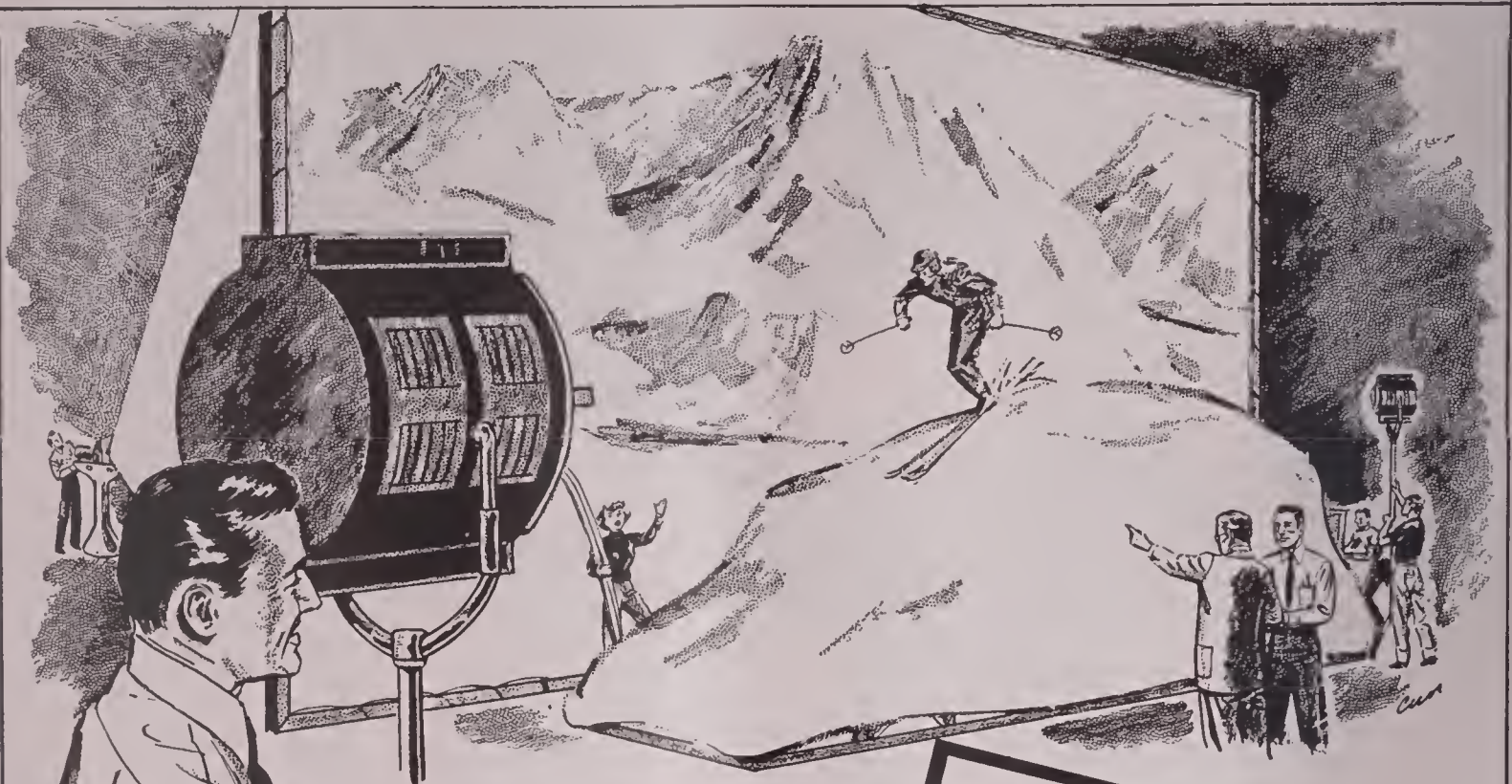

BEHIND THE SCENES...

THE BRILLIANCE AND TRUE COLOR OF "NATIONAL" ARCS IN REAR PROCESS PROJECTION ADJUST PERFECTLY TO FOREGROUND SET LIGHTING...PERMIT AUTHENTIC, FAR-RANGING PRODUCTION LOCALES WITH "STAY-AT-HOME" ECONOMY.



TODAY 1000 FOR PROCESS PROJECTION, BROAD SET COVERAGE, DEEP PENETRATION, CRISP SHADOWS AND HIGH BRILLIANCE WITH LEAST HEAT, IMPROVED "NATIONAL" CARBONS CONTINUE TO LEAD ALL OTHER TYPES OF STUDIO LIGHTING.

FIRST USED IN 1930, EARLY PROCESS PROJECTORS WERE STUDIO CREATIONS...TINY SCREENS, HEAVY "BLIMPS", IMPROVISED MACHINERY AND OPTICS. CURRENT TRIPLE-HEAD MODELS OPERATE WITH SCREENS OVER 20 FEET WIDE AND TOTAL LIGHT OF UP TO 85,000 LUMENS!

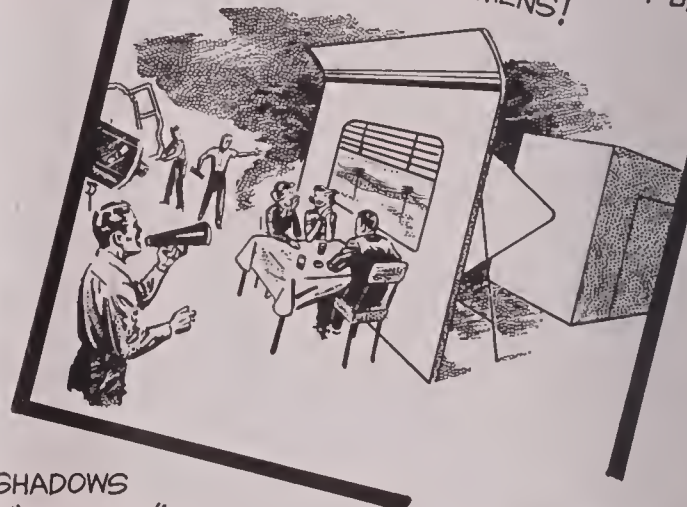

THE "NATIONAL" CARBON ARC...NOTHING BRIGHTER UNDER THE SUN

The term "National" is a registered trade-mark of Union Carbide and Carbon Corporation

NATIONAL CARBON COMPANY

A Division of Union Carbide and Carbon Corporation, 30 East 42nd Street, New York 17, New York

District Sales Offices: Atlanta, Chicago, Dallas, Kansas City, New York, Pittsburgh, San Francisco

IN CANADA: Union Carbide Canada Limited, Toronto





A MAURER 16mm camera was used by Ian Mutsu's cameraman, Tatsuzo Asai, (behind camera) in photographing on 16mm Commercial Kodachrome the scenes for "Queen Silk," designed to promote greater use of Japanese silk.



JAPANESE actress, playing part of silk farm worker, gets some first hand technical advice on handling silk worms, as cameraman gets ready to film a scene for "Queen Silk."

Saga Of The Silk Worm

Moving millions of silk worms from farm to studio was just one of a score of problems encountered in shooting "Queen Silk."

By JACK LEWIS

A 16MM COLOR FILM which took a year to shoot, had a cast of millions, and was climaxed when the heroine of the piece was boiled to death, was recently produced by Ian Mutsu, a leading figure in Japan's still undeveloped industrial film field.

The cast of this production was composed of several million silk worms in various stages of development, plus a few human actors. Shooting the picture required that the cameraman go into the field and film scenes showing the various phases of silk culture from the birth of the worm, follow through on the various stages of its carefully nurtured development, and record the final

processes by which the silk worm's product is made into thread and then into fine fabrics.

Mutsu, who saw the possibilities of industrial and commercial films in post-war Japan, produced this film for the Katakura Silk Mills, Ltd., of Japan through the facilities of International Motion Pictures, which he controls from an office in the Tokyo Correspondent's Club.

Purpose of the film, as explained to me when I was contacted in the beginning to write the script, was to combat the inroads that Nylon and other synthetics had made upon the silk industry

(Continued on Page 246)



THE COLOR FILM was processed in Hollywood. Because "rushes" were a matter of months instead of hours, extreme care was taken in the photography. Here cinematographer's assistant takes a meter reading before starting camera.



AN UNUSUAL camera angle often is an important factor in pictorial composition, and the cameraman who consistently makes the best pictures is the one who takes his camera to any height or locale that will give him the most interesting view of the scene.

I AM OFTEN ASKED by amateur movie makers to give some simple rules for composition in motion picture photography, and I invariably tell of an experience I had years ago which illustrates one very important composition technique—that of concentrating the eyes of the viewer on the principal subject or object in the scene.

While on a visit to Venice, Italy, several years ago, I visited the renowned International Art Galleries where were displayed famous paintings from all over the world. I came upon a large group of people clustered around a single small painting. I elbowed my way through the crowd and was as intrigued with what I saw as were the others.

The painting was a small one—about one-tenth the size of those hung at either side of it. It was the figure of a girl standing in a shaft of light coming from a small window. The girl's hand rested on the foot post of a bed. My eyes quickly followed down her arm to the bed post, thence across the bed to a wash stand on which stood a bowl and pitcher. Then—as though pulled by an irresistible force—my eyes turned to the window and followed the shaft of light back to the lovely figure of the girl.

The artist who painted this picture was a master of composition. He had painted the side of the room opposite the girl in subdued tones, so that the eyes of the beholder would not tarry long there but turn almost immediately back to the girl—the subject of the picture.

We call a composition such as this “non-exit.” because it contains no exit through which one's eyes may escape in viewing the picture; the eyes, or rather the attention of the beholder is unobtrusively “fenced in” and not allowed to escape. It is ideal compositional technique for the motion picture photographer, too.

Pictorial Composition in Cine Photography

By GLENN R. KERSHNER, A.S.C.

Now, of course, composition of this type does not apply to every scene the amateur shoots with his camera. But it can be applied to key scenes in films of a serious type with resulting increase in audience appeal. Thus, for the serious cine filmer, composition is an important subject for study—a study that can give him much pleasure as well as knowledge.

If you would like to spend a profitable outing in the country some week-end, make it a project in the study of pictorial composition. Take along a view camera or a camera of the reflex type and spend an hour or so composing pleasing pictures on the ground glass. This means moving around, studying the various scenes from different camera positions in order to put into the compositions objects of important compositional nature, such as a picturesque tree, an overhanging branch, or clouds. Where there is a great deal of open sky in a scene, it provides an exit for the eye to escape from the frame. Close it up by having a companion hold a tree

(Continued on Page 249)



SCENE FROM a Hollywood production which illustrates the compositional technique of placing the principal subject or actor in the brightest light in the scene. Note how your eyes are immediately drawn to the figure of Louis Calhern, extreme left, as result of skillful lighting.



For a brilliant record of brilliant scenes
use finer ANSCO HYPAN FILM

When your camera is loaded with this modern panchromatic film, you can be sure of getting brighter, more sparkling movie images. That's because Hypan's inherently brilliant gradation imparts a characteristic extra crispness to your black-and-white movie shots.

You'll enjoy working with Hypan because its speed (exposure indexes of 40 daylight, 32 tungsten) makes it an excellent "all around" film for movie-making indoors or outside.

As for price, you'll find that Hypan is easy on your pocketbook. You'll be able to shoot lots of movie footage on even the most modest film budget!

Take the first step toward snappier, brighter movies by asking for Ansco Hypan at your photo dealer's. It comes in 8 and 16mm rolls and magazines.

ANSCO, Binghamton, N. Y. A Division of General Aniline & Film Corporation. "*From Research to Reality.*"

People Who Know Buy Ansco

You'll
get better
color movies with
ANSCO
COLOR FILM

Ask for it in 8 and 16mm
magazines and 16mm rolls.



Judging Amateu

Diehard cinebugs may decry the intrusion of sound in amateur films, but the fact is sound is here to stay. Cine clubs now must co

JUST AS SOUND, in the middle twenties, changed the aspect and destiny of professional motion pictures, so it has today with amateur movies. Sound is now an important adjunct to an increasing number of amateur films.

Now if this sounds like an announcement of a revolutionary new discovery — which it is not — it is simply because it is the only way we might logically preface what we are about to say on a subject which has assumed major importance, especially among amateur movie clubs: *the judging of movies-with-sound submitted in club film contests.*

Amateur movie makers who enter films in club contests now find that sound in some form is almost a "must," for today an ever-increasing number of contest-minded movie makers are utilizing magnetic sound in one form or another.

In the beginning when sound began to augment amateur movie productions, most contest judges allowed a film the same number of points for the commentary of a sound film they allowed a silent film for its titles. That sufficed for the transitional period — a period now past. The amateur sound film has definitely arrived; sound has added a new and valuable technique to the art.

The systems presently in use for evaluating amateur-made motion pictures are numerous, and they must of necessity now be changed and recognition given the film maker for whatever sound he also provides for his picture. Sound adds a new dimension to amateur films; it permits a faster tempo; it keeps the action moving along on the screen — action which in silent films is interrupted incessantly by the subtitles flashing on the screen.

What changes are necessary?

In the judging systems currently in use by most cine clubs and contest committees, the 100 percentage points are allotted solely to the mechanics of producing a silent film. In these systems, titles are generally credited with 10%, if the titling is satisfactory. To allow recorded commentary in a sound film the equivalent percentage of 10 in lieu of titles — as many evaluators have done — is not enough. It is not enough because in most cases the recorded sound accompaniment — whether on the film or on a separate medium played in sync with the picture — improves the presentation of a motion picture far more than do titles. Moreover, when this recording includes good music and a well-written and well-delivered commentary, its value exceeds comparison with titles.

What percentage, then, should be allowed sound?

This becomes more of a problem than determining the per-

AMATEUR MOVIE MAKERS who enter films in club contests now find that sound in some form is almost a "must," for today an ever-increasing number of contest-minded film makers are utilizing relatively inexpensive and easy-to-use magnetic sound.

ound Films...

By GEORGE W. CUSHMAN

er it in judging contest films. Here the author tells how one club evaluates the contribution of sound in contest films.

centage points for titles, because presently the forms of sound employed by amateurs are many and varied. To name a few, we have records — the score of background music played from commercial phonograph records; next comes the special recording on disc, which may include narration, music, sound effects or all three; third, is the recording on magnetic tape, played in sync or semi-sync with the picture as it is being projected; and finally, there is the film with the magnetic sound stripe applied to the edge, or the single-system optical sound film, carrying the sound recording that plays in complete sync with the picture.

In view of this wide diversification of sound as applied to amateur films, I believe that the solution to the present problem of judging the sound film lies in evaluating the sound on its own merits, and separately from the picture — leaving the system of judging the mechanics of producing the picture as it presently is.

One of the first amateur movie clubs to pursue this method is the Long Beach Cinema Club, Long Beach, California. Not only is this club one of the first to recognize the contribution of sound to amateur movies, but it has set out to encourage it by offering a trophy annually for the best sound recording accompanying a picture entered in its club contest. The Southern California Association of Amateur Movie Clubs has fallen in line with the idea and now awards a plaque for the best sound, and a special trophy for the best sound recording for an 8mm film. More recently, the Northern California Council of Amateur Movie Clubs announced a perpetual trophy to be awarded for the best sound recorded for an amateur film produced in its Council group.

The findings of this club, derived in the course of evaluating amateur sound films over a period of three years, merit consideration. The club divides the contribution of sound to amateur films into three classifications: 1) Live or 100% sync sound; 2) dubbed or post-recorded sound; and 3) non-synchronous sound.

The first classification comprises sound recorded in sync with the motion picture as it was photographed, using a single-system optical sound camera, sprocketed tape recorder with sync-motor drive, or a magnetic tape or film recorder interlocked with the camera, such as described by this writer in the January, 1954, issue of *American Cinematographer*.

The second classification, "dubbed or post-recorded sound," means sound that was recorded after the picture was photographed, but synchronized closely with the picture so that on the screen it appears to have been recorded as photographed.

Non-synchronous sound — the third category — is post-recorded sound not necessarily synchronized with the picture or any part thereof, or sound played from records simply as background.

The contest committee of the Long Beach Cinema Club credits the importance of the three sound classifications in the order described above. Sometimes films are entered in a contest in which two or more classifications of sound are employed.

In the beginning it was found that some members of contest committees were inclined to rate sound films mostly on the basis of sound quality and synchronization. Because there are so many variables in amateur recorded sound, the Long Beach judging committee consider these factors, but in their proper relation to the rest. The committee recognizes that sound equipment within the means of the average amateur movie maker cannot deliver the same quality that professional equipment does; moreover, too few amateurs owning or using sound recording equipment know how to properly use a microphone, and a large number who have attempted to record sound for their pictures have made no attempt to acoustically treat the room in which they record sound. Synchronization is another problem which has not been solved by a great many cine filers employing sound. So, with the Long Beach Cinema Club for the present, at least, quality, and synchronization are not considered the most important factors when judging amateur sound films.

What, then, is the basis for judging?

The committee has selected the following three points, which seem to be more pertinent to the strictly amateur-produced sound film. These are:

- 1) Is the sound coordinated to the picture?

(Continued on Page 244)

SOUND FOR AMATEUR movies can be recorded lip-sync by using a magnetic tape recorder coupled to the camera as shown here. The equipment and method of use was described by the author in an article in the January, 1954 issue of *American Cinematographer*.

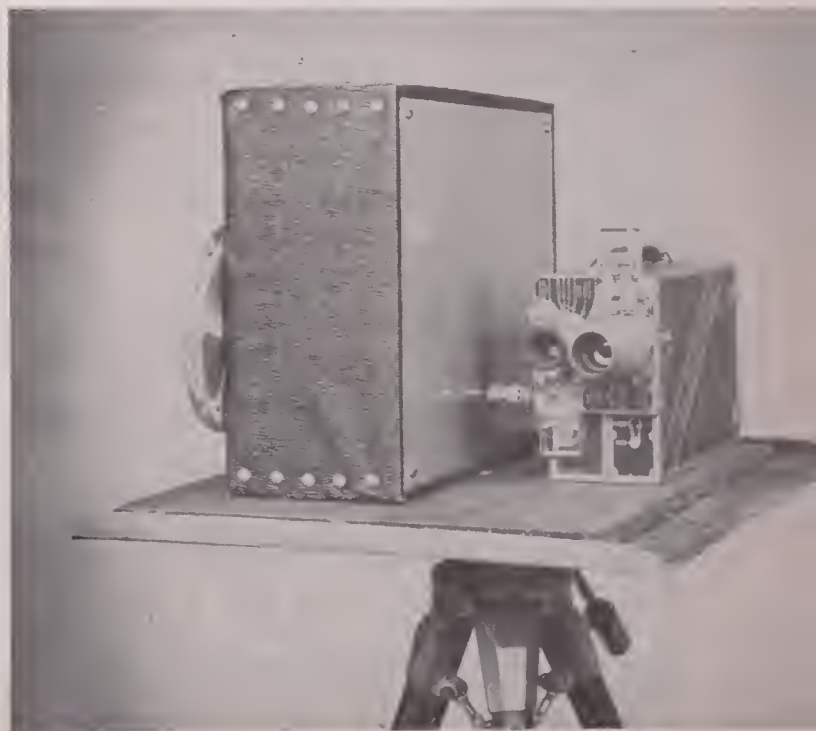

"Lights"
"Camera"
"Action"

and PROCESSED BY
MOVIELAB

FOR THE FINEST FILM PROCESSING IN
THE EAST — FILM MEN WHO KNOW
SAY **"IT'S MOVIELAB"**

Here—at MOVIELAB . . . efficiency and perfection are the rule. Producers, directors and technicians have at their fingertips the very best in up-to-the-minute equipment necessary to modern FILM PROCESSING techniques.

ROUND THE CLOCK SERVICES

- Negative Developing • First Print Department
- Ultra Violet & Flash Patch Track Printing
- 16mm & 35mm Release Printing
- Quality Control • Title Department
- 22 Cutting & Editing Rooms.

FOR COLOR

it's

Rainbowlab Inc.



MOVIELAB FILM LABORATORIES, INC.

619 West 54th Street, New York 19, N. Y. JUdson 6-0360

JUDGING SOUND FILMS

(Continued from Page 243)

- 2) Does the sound add anything to the picture?
- 3) Was a full range of sound used?

Let us consider these points in the order mentioned. First, *is the sound coordinated to the picture?* That is, is it in keeping with the picture subject or theme? For example, if a musical background is used, and the picture is a "cops and robbers" scenario film, is the music slow and "dreamy" or is it of fast, staccato-like tempo — as it should be for such a theme? If it's a travel or vacation picture filmed in Hawaii, has Hawaiian music been used, or music re-recorded from records of an unrelated theme? If the film is narrated, was a narrator having a pleasing voice and forceful delivery chosen for the job? And did he put emphasis in his speech in the right places?

Does the sound add anything to the picture? Would the picture be just as interesting if the sound track had not been added? Did narration add anything material to the picture, or did it merely repeat what was being pictured on the screen?

Was a full range of sound used? In other words, is logical (not necessarily synchronized) sound used in some scenes and absent in others? In scenes where the primary object, such as an automobile, plane, train, etc., appears in action and obviously is making a sound, which is generally familiar in real life, the proper sound or sound effects should accompany the picture.

I have in mind one film submitted in a recent contest which had an excellent dramatic shot of a train emerging from a tunnel and driving directly toward the camera. Pictorially it was an excellent shot, with smoke billowing from the stack and the huge drive wheels revolving, etc. But the sound of the train was lacking; only the musical background was heard. Here the sound of an approaching train, so necessary to the impact of the shot, could easily have been dubbed in from a sound effects record, which is now generally obtainable at moderate cost everywhere.

Offstage sounds, coming from objects not seen in the picture, often can be omitted from a picture without critical results — such as the chirping of crickets in a night scene, etc. But when such sounds are included, they give the scene additional impact and add points to the picture's credits when it comes time for the judges to tally up the total.

Citing again the practice of the sound committee of the Long Beach Cinema

ONE-STOP SOURCE for FILM PRODUCTION EQUIPT.

"The Department Store of the Motion Picture Industry"

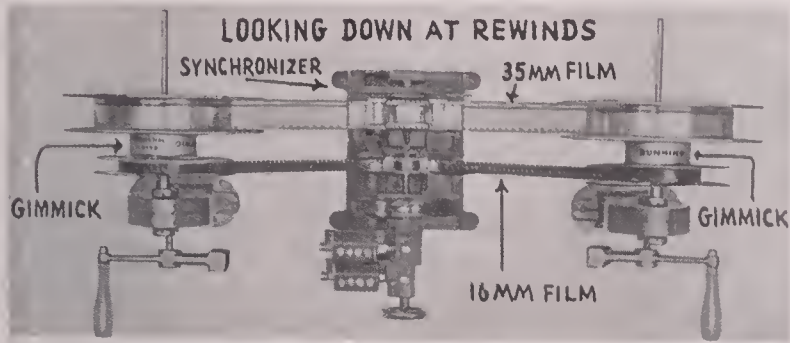

DIFFERENTIAL REWIND GIMMICK —Rewinds 16 & 35mm Reels Simultaneously

Guarantees absolute uniform "take up"

• Simply slide "Gimmick" on any KEY-WAYED rewind spindle. You NEVER throw slack—regardless of varying sizes of rolls or widths of films (16 or 35mm).

• With this clever Differential Rewind Gimmick on each rewind spindle you can go through the synchronizer backward and forward at will.

• Film cutters and editors can save its cost on a single editing job.

Few of the users:

American Broadcasting
Consolidated Films
General Film Lab
Houston Color Lab
Paramount
Pathe Lab
20th Century Fox

\$37.50 EA.

\$69.00 PR.

BARDWELL & McALISTER MULTIPLE FLOODLIGHTS

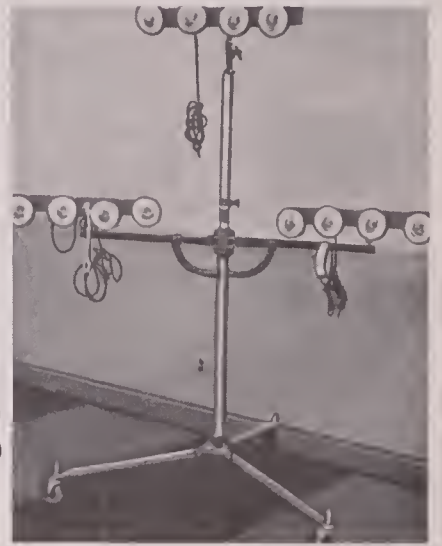

For indoor and outdoor use. 3 BOXES EACH WITH SOCKETS to hold four 150W R40 lamps. Overall size 62"x30"x30". Tripod stand has two folding 1 1/4" tubular steel arms 28" long, to which lamp heads are attached. Detachable head 2" long x 2 1/4" x 3" high. Has 3-4" RUBBER TIED CASTERS.

Government Surplus, New Condition **\$29.50**

SAME with one box to hold 4-150W projector lamps **\$22.50**

Multiple Lamp Heads only **\$ 4.95**

Telescopic Tripod Stand only with 3 brackets **\$19.95**

May be used with Colortran Converters

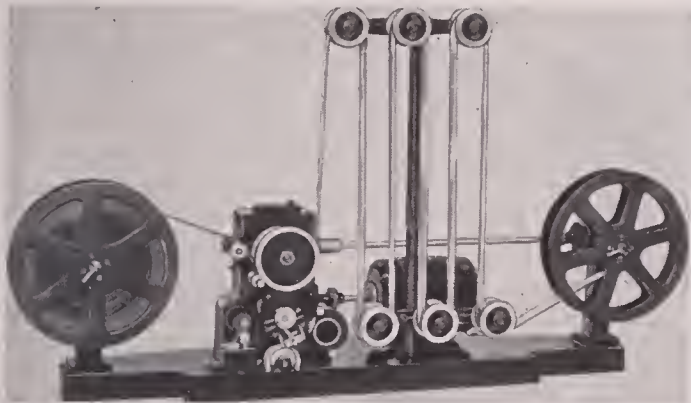

The MOY 16 & 35mm Visible Edge FILM NUMBERING MACHINE

Fills the bill for orderly handling of negatives or prints — where edge numbering is a MUST.
Guides projectionist in matching exact frames.

This non-intermittent unit has automatic metal numbering block, prints block or yellow. Film passes over drying rollers before being rewound—Central lubrication, 2000' capacity, speed 50' per min. 16mm model prints between perforations only—35mm prints between perforations or on outside edge as specified. Both negative and positive films can be numbered.

Most recent Purchasers are:
Maady Bible Institute, Las Angeles
American Optical Co., Buffalo, N. Y.
Cinerama Productions, New York

With new, improved
inking system
\$2,250

Bridgomatic

FILM PROCESSING EQUIPMENT

DEVELOPS FILM in a jiffy

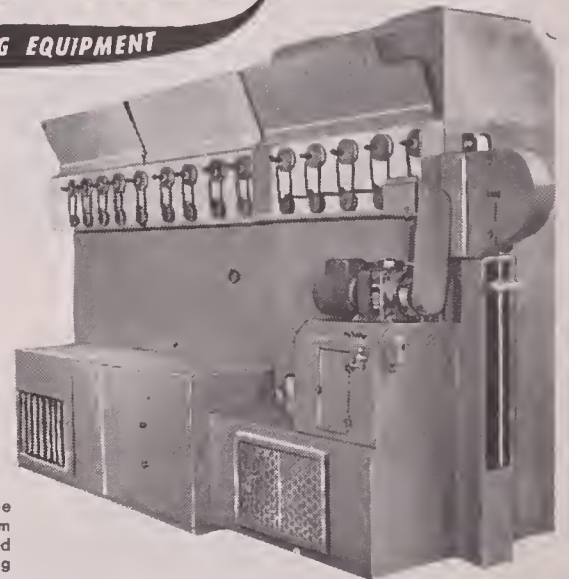

REMOVE THE GUESS—see quickly what's in that film you've sweated and sloved over, instead of killing valuable time waiting for an outside lab. BRIDGOMATIC tells the tale instantly—protects precious negatives and soundtracks.

Producers, TV stations, small labs., colleges, photo finishers, micro-filmers—do the job on your own premises — control your production from the start.

BRIDGOMATIC 470C—one of 12 models, including color machines.

BRIDGOMATIC JR. \$1095

Fine for TV Stations, pos. speed 600' per hr.

COMPACT—occupies little space.
DURABLE—all stainless steel tanks.
ECONOMICAL—costs less than 1/3c per 16mm ft.
LOW UPKEEP—simple design, trouble-free.
PERFORMANCE—proven in hundreds of installations.

S. O. S. CINEMA SUPPLY CORP.

Dept. F, 602 W. 52nd St., N.Y.C.—Cable: SOSOUND

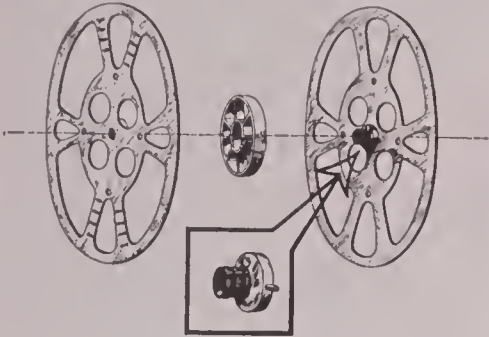
F&B**NEW & USED EQUIPMENT**
FOR MOTION PICTURE & TV FILM PRODUCTION**F&B****NEW F & B SPLIT REELS****Save****TIME - SPACE
WEAR & TEAR
ON 16mm PRINTS**

NOW You can project, edit, inspect, synchronize, measure, clean and store 16mm films on cores . . . without rewinding.

You simply open split reel, slip in film on core, and close reel.

400 ft. split reels — 16mm.....	\$4.50
800 ft. split reel — 16mm.....	\$6.00
1200 ft. split reel — 16mm.....	\$7.50
1600 ft. split reel — 16mm.....	\$9.00

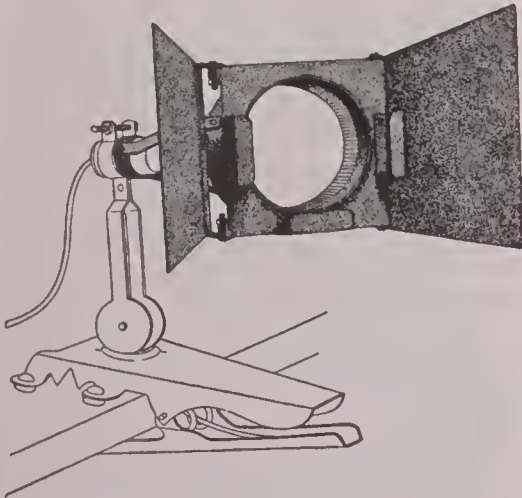
**NEW F & B GATOR
CLIPLITE
WITH BARN DOOR**

Unit Includes — Gator Grip, Porcelain socket, 15 ft. cord & switch Barn door.

PRICE
\$12.95

F & B 600 - Ft. Magazine

for
**Auricon
Cinevoice
Camera
At Low Cost**



NOW Shoot full 15 minute TV shows without stopping or reloading. The F&B conversion includes 600 ft. magazine, extra silent takeup motor, camera insert plate for stabilization of film movement, and footage counter.

Camera is not cut down; can be used without magazine for 100 ft. rolls. Magazine accepts 200 ft. spools as well as 400 ft. and 600 ft. rolls on cores.

NOW IN USE BY: TV STATIONS, TV NEWSREELS, LOCAL NEWSREELS, TV FILM PRODUCERS, POLITICAL ORGANIZATIONS, FRATERNAL ORGANIZATIONS, COLLEGES, UNIVERSITIES, SCHOOLS, CHURCHES, RELIGIOUS ORGANIZATIONS, GOVERNMENT AGENCIES, WEDDING AND SOCIAL EVENTS FILM PRODUCERS.

WRITE FOR COMPLETE DETAILS

TOTAL PRICE: including magazine, motor, insert plate and installation. **\$425.00**

KELLY CINE CALCULATOR

A Sliderule Disc Computer
Eliminates Bulky Manuals
8-16mm and 35mm models

- ★ 15 USEFUL SCALES
- ★ Film per second
- ★ Filters and Factors
- ★ Aperture Scale
- ★ Depth of Focus
- ★ Hyperfocal Distance
- ★ Field of View
- ★ Camera Speeds

Instruction Manual included

\$3.95

*** F&B MOVIE STOPWATCH ***

Precision Swiss movement
Calibrated to read seconds,
minutes, 16mm & 35mm footage
Starts—Stops—Resets

List Price **\$29.50** — Now **\$14.75**

*** NEW — CRITICAL FOCUSER *
FOR AURICON PRO & CINEVOICE**

Prism reticle, 6x Achromat
Magnifier focuses an groundglass

Only — **\$49.50**

WANTED: AURICONS — MITCHELLS — MOVIOLAS — LAB EQUIPMENT — LENSES —
RECORDERS — PROJECTORS — ACCESSORIES

F&B

FLORMAN & BABB
70 West 45th Street, New York 19, N. Y.
Phone: Murray Hill 2-2928
Cable Address — FLORBABB, N. Y.

Club, the committee is most partial to films having tracks of complete synchronized sound all the way through. Where the sound is post-recorded and can hardly be distinguished from sound recorded simultaneously with the picture, the judging committee gives it full value in scoring points. It matters little, they feel, how the sound was created as long as the effect of lip-sync sound is obtained.

One of the most flagrant give-aways of dubbed sound is where only about half the sounds obviously produced in the scene are present on the sound track. An example would be where a woman in high heels walks across a bare hardwood floor as she speaks lines of dialog. In real life, both the dialog and the footsteps can be heard. The same criticism holds where a door is opened or closed or an object is dropped on the floor—yet these sounds are not included in the recording.

As to the points allowed sound films in contest evaluations, the Long Beach club rates the films in Class 1 category 100%; top quality dubbed sound rates 90%; and the best non-synchronous sound 80%. Additional points are given where the sound is coordinated to the picture and thus adds something material to the film; and where the full range of sound is used.

Now, of course, the system which has been outlined here is not offered as the ultimate; but for other cine clubs where the problem of sound credits in contest entries is under discussion, it can be a substantial basis on which to start. Thus far the system has proved quite satisfactory for the Long Beach club. Certainly it can do a great deal toward encouraging a wider use of sound in serious amateur movie films.

SAGA OF THE SILK WORM

(Continued from Page 239)

and its place in world trade. The original version of the film was to include a plug for the sponsors, who wished to preview it in England at an international fabrics fair. Once this had been accomplished, however, the film was to be re-edited and released throughout Japan for use in schools and other educational institutions, and also shown to the silk farmers throughout the country. Still another version was to be edited for American television, along with other films which Mr. Mutsu already had produced or had on his schedule.

Titled "Queen Silk," the film had to be written and filmed from a point of view that would satisfy not only the technically-skilled silk raisers but also entertain public audiences who were to see it later.

Chief cameraman and a permanent member of Mutsu's staff was Tatsuzo Asai. Prior to World War II, he had been a leading cameraman in the Japanese feature film industry. Later he served as a combat photographer with the Imperial Japanese Navy. Much of the footage taken over by Occupation forces and now seen in such filmed series as "Victory at Sea" is said to have been shot by this man during the war. He is said to have far wider experience in the use of American-made and processed color films than any other cameraman in Japan.

A conference between Mutsu, Asai and myself resulted in settling that we were to attack the problem of selling silk worms to the public in a different manner. Thus, the first few minutes of the film showed Japan as it is today, a modern country pulling itself out of the ruins of war and rebuilding an enduring state. The initial scenes covered the reconstruction: new buildings going up, ships being built, and the resurgence of Japan's iron and steel industries. Purpose of all this was to emphasize that Japan is a country "built of silk" that the entire economy of the nation rests upon the welfare of its silk industry.

Asai spoke little English and my Japanese was—and is—highly inferior. Mutsu speaks both well, having been educated in America and England. As I wrote the opening scenes, Mutsu and his clerical staff translated them into Japanese. The non-seasonal scenes were scheduled to be shot "off the cuff." Narration for English versions accompanied my script but was not contained in the Japanese translation. To this day—although I have three copies—I'm not entirely certain what the translations say.

Earlier, Mutsu learned of a Tokyo department store that was going to feature in its window displays silk fashions as designed around the world. The displays included apparel designed and made in the United States, England, France, Italy and several other European fashion centers as well as Japan. Use of this display pointing out the world-wide acceptance of silk was conveniently worked into the script. Asai and his camera crew promptly roped off a section of sidewalk before the store, invited a few select "extras" from the mob of onlookers to "act" in the film, and shot the scene in a single afternoon with the use of arc lights to fill in the autumn shadows.

After that, Asai's problems really began. Kenshi Shimomura, well-known in Japanese movie circles and winner of several awards for filming nature subjects, was employed to direct. He had originally planned to shoot all of the

F&B

NEW & USED EQUIPMENT

FOR MOTION PICTURE & TV FILM PRODUCTION

F&B

Colortran Converters

High powered studio illumination from ordinary house current.

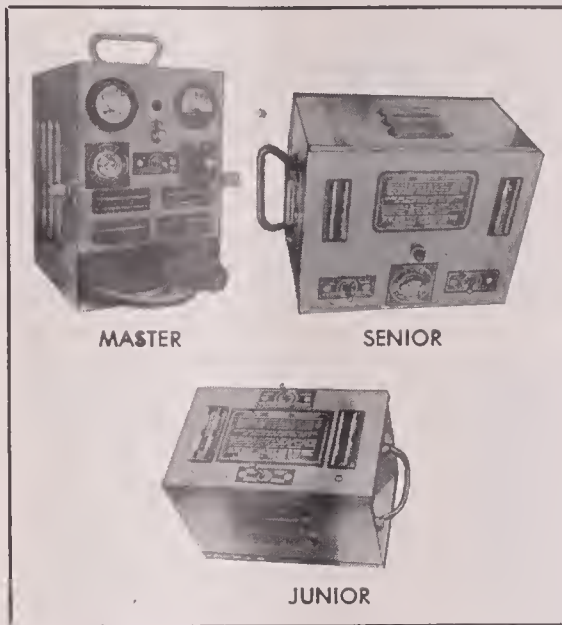

OPERATION: The Colortran is an electrical device which increases the efficiency of ordinary 110-115 volt bulbs by 180%. The PAR 38 150w. bulb, which is recommended here, will give MORE photographic light than a #4 photoflood or TWICE the light of a 500-750 w. spotlight.

CURRENT CONSUMPTION: A #4 photoflood requires 8.7 amperes, whereas a PAR 38 and Colortran needs only 2.5 amperes and gives more light than the photoflood. Three standard 1000w. bulbs will blow a 20 amp house fuse, but the Colortran and SEVEN PAR 38 150w. bulbs will not blow out a 20 amp. fuse. AMAZING BUT TRUE. . . .

COLORTRANS DELIVER 3200° and 3450° KELVIN COLOR-CORRECT LIGHT, JUNIOR CONVERTER, 6 receptacles, 2500w. output . . . \$48.75

SENIOR CONVERTER, 6 receptacles, self-fused, 500w. output . . . \$76.50

MASTER MODEL CONVERTER, 12 receptacles, self-fused, with AMMETER, KELVIN METER, Kelvin control 6 position switch. Remote control switch . . . \$135.00

COMPLETE COLORTRAN KITS

JUNIOR "2000" KIT —
2 - 3 lite units, Jr. Converter,
2 stands, carrying case . . . \$189.75

SENIOR "5000" KIT —
2 - 5 lite units, Sr. Converter,
2 stands, carrying case . . . \$237.50

SLOT KIT —
3 - 1 lite spots, 1 brood, Jr.
Converter, 4 stands, snoots,
diffusers, carrying case . . . \$252.75

ORDER NOW FOR IMMEDIATE DELIVERY

NEW . . . CAMERA SLATE WITH CLAPSTICKS

- ★ Large 11"x14" size overall.
- ★ Your name permanently stencilled on lost line FREE.
- ★ Erosible slate finish.
- ★ Permanent silk-screened letters.
- ★ Sharp-sounding hardwood clapsticks.
- ★ Supply of special, clear dustless chalk.

\$875

F&B HAS A COMPLETE STOCK OF NEW AND USED CAMERAS, PRODUCTION, LIGHTING, EDITING & LABORATORY EQUIPMENT

EVERY ITEM CARRIES ABSOLUTE MONEY-BACK GUARANTEE

NOTE: IMMEDIATE CASH AVAILABLE FOR ALL KINDS OF USED 16-35MM PRODUCTION, LAB. EDITING, LIGHTING EQUIPMENT

BARGAINS IN USED EQUIPMENT

CINE SPECIAL 1, 15mm f2.7, 1" f1.9, 3" f4.5 case, excellent condition . . . \$375.00

CINE SPECIAL 1, 2-1000 ft. mogs. 1-200 ft. mag. 15mm f2.7, 1" f1.9, 3" f4.5, excellent condition . . . 725.00

CINE SPECIAL 200 ft. block magazine . . . 250.00

BOLEX H-16, ext. counter, less lenses . . . \$150.00

BOLEX H-16, built-in counter, 15mm f2.8, 25mm f1.9, leather case . . . 225.00

FILMO 70 A, 1" f3.5 Cooke lens . . . 49.50

FILMO 70 H, beautiful, custom-built PAR accessories incl. 4 lens turret, built-in rockover, focusing thru lens, magnifying facuser, 110v. sync motor, 400 ft. magazine, Veeder counter, deluxe compartment case, all like brand new. Cost over \$2500. SPECIAL, only . . . 950.00

MAURER model D optical film recorder, "G-prime" golv, rock-mounted, perfect cond., can be converted for direct positive recording . . . 2750.00

KINEVOX sync 17 1/2 mm mogn tape recorder . . . 825.00

MAGNECORD sync 1/4" mogn tope recorder . . . 625.00

MACVAN 16mm continuous printer, complete . . . 475.00

DEVRY BANTAM 16mm sound proj., etc. . . 140.00

TRIANGLES, extendable, aluminum used . . . 17.50

COLORTRAN deluxe converters, used . . . 32.50

SCREENS, table model, beaded, 18"x24" . . . 4.50

F&B MOVIE STOPWATCHES, min., sec., 16 and 35 mm Ft. . . 14.75

FLANGES, aluminum, 10" rd. ond sq. shaft . . . 7.95

GATOR GRIPS with borndors . . . 12.95

DOLLY, 3 wheel Ceco model, seat, case, LN . . . 250.00

SUPER XX, 16mm neg. 200 ft. sl, outdated, each . . . 3.45

PRECISION SOUNDREADER, combination optical ond magnet, built-in ompl. & spkr. . . 259.95

ACE 35mm picture viewers with veeder counters ond offset erect. picture screen . . . 250.00

ECCO 1500

NEW ANTI-STATIC FILM CLEANER AND CONDITIONER

Used and highly recommended by leading film studios ond libraries everywhere.

- ★ Stops static attraction of dust ond dirt to film surface.
 - ★ Eliminates waxing
 - ★ Reduces surface friction 80%
 - ★ Mosks film chatter — heat-resistant
 - ★ Conditions green prints — dries foster
 - ★ Lubricates — keeps film non-brittle
 - ★ Does NOT contain carbon tetrachloride
- ECCO 1500 . . . qt. \$2.50 gal. \$9.60
- ECO 1500 Speedral Applicator — Mast practical film cleaning unit. Saves time, fluid, labor, money. Price . . . \$29.50

F&B PORTABLE MIKE BOOM

18-foot boom arm, including 5-foot telescoping section, braced ond strutted to support every weight mike, sturdy 3-wheeled air-cushioned rolling stand, external (no squeak) mike rotating controls. Unit folds to fit in your car.

EXTREME WIDE ANGLE LENSES

New formula Angenieux Retrofocus. For 16mm . . . 9.5mm f2.2 in "C" mt. For 35mm . . . 18.5 mm f2.2, can be mounted for Mitchell, Eyemo, etc. Optical bench tested, guaranteed.

F&B

FLORMAN & BABB

70 West 45th Street, New York 19, N. Y.

Phone: Murray Hill 2-2928

Cable Address — FLORBABB, N. Y.

Alligator CLAMP

WITH BARN DOOR

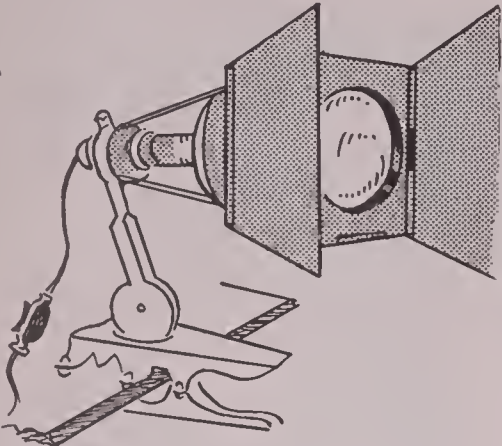

- ★ Hangs from a nail on the wall.
- ★ Clamps to a chair, door, top of set or stand.
- ★ Sets on floor as a foot light.
- ★ Adaptable to almost everywhere.
- ★ Barn door swivels 360°
- ★ For R2 - R40 or Par 38 Bulbs

Price — \$15.00

Clamp without barn door wired
with plug and switch — Price—\$5.00
Clamp onlyPrice—\$2.75

Above unit excellent for use with
"COLORTANS"

SCHOEN & CROWE

403 WEST 47th STREET
NEW YORK 36, N. Y.
Circle 5-4691

WRITE FOR OUR CATALOG
ON LIGHTING EQUIPMENT

SPARKLING COLOR FOR YOUR PRINTS

Expert timing by color craftsmen plus the careful attention accorded your film in our famous "personalized service" will give you unsurpassed prints whose brilliance makes them alive on the screen.

Write for Information

Dept. C-11

TELEFILM, INC.

6039 Hollywood Boulevard
Hollywood 28, California

BACK ISSUES

New subscribers and others often find need to refer to factual or technical information published in earlier issues of *American Cinematographer*. The December issue each year provides a ready index to such information. The issues in which such information appears (when available) may be had direct from the publisher for 30c per copy.

AMERICAN CINEMATOGRAPHER

1782 No. Orange Dr. Hollywood 28, Calif.

picture against authentic backgrounds. It turned out, however, that most of the Japanese silk farms did not boast electricity and generators such as are generally used for motion picture lighting were unavailable. This necessitated shooting the exteriors against the backgrounds of the farm, which was selected in Gumma Prefecture north of Tokyo, then moving into the studio in the city for interiors.

The several million silk worms required were "borrowed" from one of the larger farms and moved into the studio in the city. Here, on a set representing the interior of the farmhouse, the silk worms were shown as they normally are kept on trays and fed mulberry leaves until full grown, at which time they spin their cocoons of silk. While the anxious farmer, who loaned the worms, watched anxiously over his brood from a vantage point in the background, Asai and his camera crew raced against time to accomplish the needed scenes. Afterward, the worms were returned to the native farm to complete their life cycle.

After the harvesting of the cocoons, their movement to the silk mill was filmed. Inside the mill, illumination troubles plagued the camera crew once more. Although excellent working conditions were highlighted in the script, the processing rooms were so large that it required virtually every photo lamp in the Tokyo area to furnish proper illumination for color photography. Asai and his assistants solved some of the problems by cutting down the scope of the shots to include less background, and by shooting high and low angles to take advantage of the shadows and add to the dramatic effect.

Varying weather conditions during the around-the-year shooting schedule added to the difficulties for the crew in the matter of maintaining consistent color temperature. All footage was shot in Commercial Kodachrome and flown to Hollywood where it was processed. A work print was then made and rushed back to International's Tokyo studios where, a scene at a time, the film was pieced together. Once the footage had been assembled, cut and timed, the narration was taped both in English and Japanese. The entire package then was again returned to Hollywood where dubbing of music and narration was accomplished and final prints made.

This 16-millimeter documentary-type film was widely acclaimed in Europe by those who saw its premiere run. Whether it will help to bolster the use of Japanese silk is something that will be answered only over a period of time. Meantime, several American distribution companies have the re-edited version and have expressed interest in this—as well as

other Mutsu productions—for a television package.

Ian Mutsu, in pioneering the documentary and commercial film in the New Japan, has received several commissions from the government. One of his films was produced for the Oriental country's State department for international consumption. Titled "Meet the Watanobes," it deals with a typical Japanese family and their way of life today, showing the effect of American morals and ideas.

One of Mutsu's earliest productions, the film has been well received and has paved the way for other films of its type.

Film viewers throughout the world received a pleasant introduction to Japanese post-war motion pictures a few years ago following the presentation of "Rashomon." This production was highly praised by critics, columnists, reviewers and trade magazines, and it received a whole roomful of awards. What most of those who saw it failed to realize, however, is that this was only one outstanding example of the hundreds of Japanese films turned out each year. Many Japanese pictures still suffer from the lack of technical know-how. Not one studio in the entire country boasts the facilities available to the lowliest of independents in the U.S.

This is one of the factors which Mutsu has had to battle in putting International Motion Pictures, Ltd., in the lead insofar as industrial films are concerned. With inadequate processing and printing facilities, most all lab work as well as dubbing must be done in the United States, and this, of course adds a great deal to the production burden.

Already, however, Ian Mutsu has an eye upon the possibility of expanding his facilities to produce feature films that can be dubbed in both English and Japanese for release in his own country and abroad.

We Invite Your Contributions

Readers who would like to submit articles or papers on subjects relating to cinematography or of interest to motion picture cameramen, or on subjects relating to TV Film Production, Industrial Film Making, Film Laboratory Technique, Special Effects, Amateur Movie Making, etc., are invited to submit such articles to the Editor for consideration.

For all published material we will pay our regular space rates following publication.

Where possible, please accompany material with appropriate photos or drawings for illustration. A stamped, addressed envelope should also accompany contributions for return in the event we are unable to use them.

AMERICAN CINEMATOGRAPHER

PICTORIAL COMPOSITION

(Continued from Page 240)

branch before the camera in the sky area. In this way you stop the eye from turning to the sky in search of something that is evidently missing. If the branch is kept more or less in silhouette it will carry the eye across to the other side of your composition. The angle of a tree, the slant of a roof, or perhaps a shadow, will continue the eye in its circuit. In other words, you so frame your picture with objects, light and shadows, that the frame will be but secondary.

In composition avoid placing a big tree or any other object directly in the center. Also, the horizon should never be in center. The picture should have either a high or low perspective. And never forget that the object of most importance in your composition, whether a still picture, or a motion picture, should be most brilliantly lighted.

This rule is applicable whether you are shooting indoors or out. A good example of this treatment applied in a professional production is shown in one of the two accompanying illustrations.

Out of doors — say, when you are on a vacation trip — there will be many occasions on which you can employ this simple but effective rule. A typical instance would be where you wish to record an especially beautiful scenic panorama and at the same time have one or more persons in the scene. With your camera set up on the most satisfactory composition, start the camera. Have one person come into the scene, *walking toward the sun*, which should be over your shoulder or directly in back of you. This has the effect of directing attention immediately on your subject. If a second person is to be brought into the scene, if possible arrange his entry so that he comes into the scene where the lighting is particularly bright. In a wooded area, where a strong beam of light comes through the trees would be especially appropriate.

There is another important compositional rule to remember, especially when you plan to pan from one object or subject to another: be sure to select in advance an appropriate pictorial composition for the *start* of the pan shot, and an equally picturesque composition on which to end the shot. Here an unusual camera angle can be combined with the pan action to enhance composition.

When panning from right to left, in arranging the compositional pattern for the beginning of the shot, be sure the entire scene area is non-exit, except for

(Continued on Page 251)

Precision Prints

**YOUR PRODUCTIONS
BEST REPRESENTATIVE**

CLOSE CHECK ON PROCESSING

Picture and sound results are held to the closest limits by automatic temperature regulation, spray development, electronically filtered and humidity controlled air in the drying cabinets, circulating filtered baths, Thymatrol motor drive, film waxing and others. The exacting requirements of sound track development are met in PRECISION'S special developing machinery.



YOUR ASSURANCE OF BETTER 16mm PRINTS

16 Years Research and Specialization in every phase of 16mm processing, visual and aural. So organized and equipped that all Precision jobs are of the highest quality.

Individual Attention is given each film, each reel, each scene, each frame — through every phase of the complex business of processing — assuring you of the very best results.

Our Advanced Methods and our constant checking and adoption of up-to-the-minute techniques, plus new engineering principles and special machinery enable us to offer service unequalled anywhere!

Newest Facilities in the 16mm field are available to customers of Precision, including the most modern applications of electronics, chemistry, physics, optics, sensitometry and densitometry — including exclusive Maurer-designed equipment — your guarantee that only the *best* is yours at Precision!

Precision Film Laboratories — a division of J. A. Maurer, Inc., has 16 years of specialization in the 16mm field, consistently meets the latest demands for higher quality and speed.

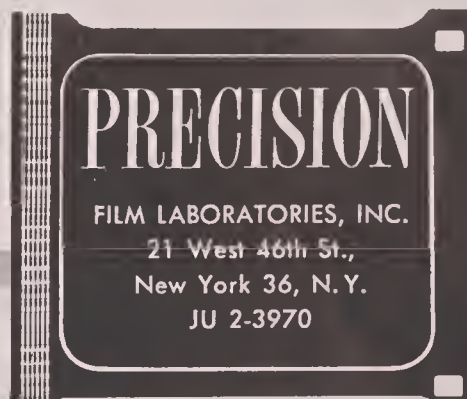

INDUSTRY NEWS



Shoulder Brace for ARRIFLEX

35mm and 16mm Cameras

This scientifically-engineered shoulder brace is made of lightweight aluminum. It can be used to support all 16mm and 35mm hand-held cameras, such as

ARRIFLEX, EYEMO, FILMO,
AURICON, CINE SPECIAL, BOLEX, etc.

This guaranteed-steady brace affords perfect panning and tilting. It eliminates the necessity for a heavy tripod. This new invention brings you a simpler way of shooting. Weighs 8 oz. and is small enough to fit the pocket.

List Price: **\$19.50**

Ten-day Money-back Guarantee!

Adjustable to any arm length. Can be used on either the left or right shoulder. You don't need anymore camera or trigger handle.

Available at leading dealers, or direct.

KADISCH

CAMERA AND SOUND ENGINEERING CO.

500 West 52nd St., New York 19, N.Y.
PLaza 7-3511

DESIGNERS AND MANUFACTURERS OF
MOTION PICTURE—TV EQUIPMENT

PUMPS

for . . .
CHEMICALS
DEVELOPER
HYPO



Centrifugal Pumps for Circulation, Transfer, Mixing, Agitation, Temperature Control. Corrosion-proof pump of plastic & stainless steel. Rotary seal of inert carbon & ceramic. 115 v. 1/4 h.p., pumps up to 20 G.P.M. Inlet 1" hose or 3/4" pipe. Outlet for 3/4" hose. Some type in 1/2, 3/4, and 1 h.p. size. Write for prices. Satisfaction guaranteed.

Also
Complete DEVELOPING MACHINES
with Wall Micro-Tension Drive.

METAL MASTERS

5599 University Ave., San Diego 15, Calif.

Scheibe FILTERS

In World-Wide Use

Produce moonlight and night effects in daytime * fog scenes * diffused focus and many other effects.

Information mailed on request.

SCHIEBE FILTERS COMPANY

ORIGINATORS OF EFFECT FILTERS
P.O. Box 46834, Hollywood 46, Calif.

Water instead of glass is a major component of a new type lens now undergoing test and refinement at 20th Century-Fox studios. Termed a "liquid lens" because it is constructed out of concave and convex glass plates enclosing two quarts of crystal clear water, it has unusual wide focus as compared to the pinpoint focusing of positive lenses. The water lens gives the same optical values as a lens made of glass and eliminates the time and labor necessary to grinding a large segment of perfect optical glass. The lens is being tested in production of "The Egyptian."

Color Corporation of America last month was acquired by Ben B. Smith and Ray C. Wilcox, directors of the Houston Color Film Laboratories and Houston-Fearless Corporation of Los Angeles.

A Dutch invention has recently led to the production of wide-screen motion pictures with a system that does not require the use of any special lenses on the camera or projector.

The Oude Delft Optical Company in Delft, The Netherlands, has developed a system of anamorphic mirrors, which has been given a world-wide patent under the name of Delrama.

The Dutch motion picture company of Polygoon-Profilati, which has applied for a world-wide copyright under the trade name of Largoscoop, will demonstrate sample films in color of this distortion-free, wide-screen system to American studio engineers in the near future.

A revolutionary wide-screen idea for motion pictures has been invented by a University of Illinois professor. Employing standard lenses and conventional film and only one projector, the system permits an audience to sit in a circular theatre and be completely surrounded by the picture.

Prof. Josef Cohen, who conceived and worked out the idea on his own time, has applied for a patent. While the device is capable of producing a picture completely encircling the audience, he envisions actual use involving a half-circle picture, since little demand is expected for the full-circle pictures. Such a half-circle would be twice as wide as that produced by present three-projector wide-screen systems. Picture brilliance and definition both would be greater, according to Prof. Cohen.

Picture height would be increased because the image would be lengthwise on the film, instead of crossways. Two or more soundtracks on the film would provide stereophonic sound.

Two DuPont motion picture films, perforated for high speed camera use, are to be marketed under the Fastex label by Wollensak Optical Company, Rochester, N.Y. The films are DuPont "Superior" 3, type 927, and High Speed Rapid Reversal, type 931—both very fast emulsions widely used in newsreel and TV film production.

"Superior" 3 negative film (125 daylight, 100 tungsten) will be sold in 35mm size only. High Speed Rapid Reversal (160 daylight, 125 tungsten) and negative stock (80 daylight, 64 tungsten) will be available in both 35mm and 16mm sizes.

A Camera Club Special tour to and around Europe is being organized for amateur movie makers and other camera hobbyists by James M. Elliott, head of Elliott Film Productions, 840 S.W. Seventh St., Miami, Florida. The all-expense package tour will leave New York July 17th and return August 22. Travel will be via B.O.A.C. air lines. Tour will cover 8 countries, including England, Belgium, Holland, Austria, Germany, France and Italy. The tour guest list will be limited to thirty people.

Cinerama, which requires three films, cameras and projectors to record and show its super-wide-screen productions, may soon be revolutionized and simplified. Joseph Tushinsky, whose Tushinsky Lens has created much interest in the film industry, recently told S. H. Fabian, head of Cinerama, that his laboratory was working on a method of squeezing the three Cinerama images onto a single 35mm film, so that only one film and one projector would be required for Cinerama exhibition instead of three as at present.

Howard A. Anderson Co., in conjunction with the Hollywood Pathe Laboratories, has revealed a new technique in developing color opticals and dupe negatives which is said to cut cost about 50%. The new system, called a direct color duplicating process, was used for first time on the recent R-K production, "The Golden Mistress." Direct duplication is said to be made right on the original camera film stock with no intermediate step of separations.

PICTORIAL COMPOSITION

(Continued from Page 249)

the left side. Thus your subject can proceed through the scene without having to go around or over some object that was included in the scene to close the left side of the composition. In composing the scene for the terminus of the pan shot, it is important that the left side be completely non-exit. Here it would be advisable also to place a marker on the ground to indicate exactly where subject should come to a stop.

The spot also should be well-considered before shooting, for when you move in at this point to make the necessary closeups, the background will be appropriate and natural—coinciding to that seen in the long shot or pan. Moreover, it will be necessary to consider this location for the prevailing light. To get the proper lighting on your subject in the closeups, reflectors should be used to reflect sunlight upon him. For this reason his position with relation with the position of the sun will be an important factor in the planning both of the composition of the shot as well as the action. It is im-

EVERYTHING PHOTOGRAPHIC AND CINEMATIC

FOR PROFESSIONAL AND AMATEUR

The World's Largest Variety of Cameras and Projectors. Studio and Laboratory Equipment with Latest Improvements as used in the Hollywood Studios. New and Used . . . BARGAINS. Established 25 years.

HOLLYWOOD CAMERA EXCHANGE

1600 Cahuenga Boulevard

HO 9-3651 • Hollywood, Calif. • Cable Hacamex



Precision Built Combination MAGNETIC FILM AND TAPE SOUND READER

Features: Simple threading . . . polished stabilizer drum with needle bearings . . . combination film ralliers for 16mm, 17.5mm, 35mm and 1/4-inch tape, machined to conform with SMPTE standards, and equipped with oilless bearings . . . precision ground shafts . . . Magnetic head mount with adjustments for track locations, azimuth, and magnetic film and tape thickness . . . dimensions 6"x6"x7 1/2".

Amplifier: 117-volt—60-cycle—AC . . . power output—4 watts . . . heavy duty Alnico V speaker . . . safety fused . . . pilot light . . . 6-ft heavy duty line cord

Net Price \$198.00 F.O.B., Factory, N. Y.

PRECISION LABORATORIES
1139 Utica Ave., Brooklyn 3, N. Y.



frost lights the nation!

MOTION PICTURE STUDIO • THEATRICAL • DISPLAY RENTAL EQUIPMENT

WHEREVER YOU ARE—WHATEVER YOU NEED

. . . in the way of unusual, specialized lighting, call on Jack Frost! For movie-making, stage lighting, feature exhibits, large conventions . . . for *any* location that requires exceptional lighting, Jack Frost is ready to serve you! And Jack Frost's unequalled national service includes complete installation and removal *wherever* you are. Rent all your specialized lighting equipment from Jack Frost . . . famous for lighting the nation's greatest shows . . . most spectacular displays.

FOR FULL INFORMATION ON RENTAL EQUIPMENT MAIL COUPON, OR CALL DETROIT, TRINITY 3-8030

JACK A. FROST, DEPT. J,
234 PIQUETTE AVE.
DETROIT 2, MICHIGAN

Please send me full information on your rental service.

Name _____
Address _____
City _____ Zone _____ State _____

**FOR
GREATER
PROTECTION
BETTER
PROJECTION**

Compcoprofessional Reels

For shipping, storing or showing film, precision made Compcoprofessional Reels are first choice with those who want the finest. Hard, spring type steel construction won't warp or bend . . . eliminates film-wearing rubbing during projection or winding. Your production deserves the finest package—use Compcoprofessional Reels in 600 ft. to 2,000 ft. sizes.

Write for catalog!

COMPCO CORPORATION
2253 W. ST. PAUL AVENUE, CHICAGO 47, ILL.

RUBY CAMERA EXCHANGE

Rents . . . Sells . . . Exchanges

Everything You Need for the

Production & Projection

of Motion Pictures Provided
by a Veteran Organization
of Specialists

35 mm. . . . 16 mm.
Television

IN BUSINESS SINCE 1910

729 Seventh Ave., New York 19, N. Y.

Tel.: Circle 5-5640

Cable address: RUBYCAM

WORLD FAMOUS

S-5

synchronous
magnetic film
recorder for
motion pictures
and television

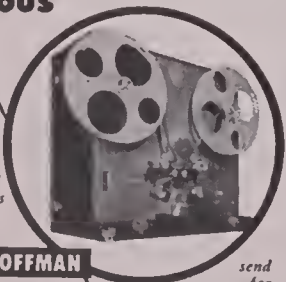

STANCIL-HOFFMAN

921 N. Highland Hollywood 38, Calif.

send
for
particulars

portant, in making a sequence of shots of this kind, that the main or "key" light comes from the same direction in both long shots and closeups. This is common professional cinematographic technique, and it is the responsibility of the professional cameraman to see that all shots in a sequence of this kind match up pictorially as well as technically.

One more important compositional suggestion may be helpful when you are photographing in the field: in shooting toward a stream or a road, always have your subjects exit toward one of the corners of the picture frame. This same rule can be applied also when shooting indoors: have your subject or objects exit from the picture at the corner of a rug, a table, a shelf, etc.—the latter applying to the photography of small, animated objects such as toys, dolls, etc., as in animation.

You can study composition at home, too—in the comfort of your den or living room—without your camera. Gathering a few large pictorial illustrations from some of the popular picture magazines, such as *Life*, *Look*, etc., spread these on a table. Make a mask from a piece of cardboard, with the opening about 2 by 3 inches. Move this across the large pictures so that the mask shows appropriate miniature compositions within the large picture. In this way you can experiment with camera angles, framing scenes with tree boughs, and other similar compositional elements. Then, the next time you go out into the field to make movies, you can apply the same technique with your camera viewfinder—moving it across the scene before you until you find within the finder aperture the most pleasing composition pattern. Actually, that is about all there is to rudimentary pictorial composition.

MITCHELL FOLLOW-FOCUS ATTACHMENT

(Continued from Page 237)

3) Dovetail adaptor; and 4) Set of gears for 35mm NC and Standard camera lenses.

The 35mm attachment also differs from the one for the 16mm camera in that it has a twin gear drive which contacts and drives the lens ring gears. When it is desired to use a short focal length lens and 24mm matte box, the operator merely pulls a knob at front end of the gear and swings the gear unit to right to clear the matte box. To re-engage the gear, the unit is swung left and then rotated until white index lines on both gears line up. When the knob is released, the gears will lock together and turn in unison. The rear gear is used for 24, 25, 30, 32, 35, 40 and 75 millimeter lenses. The front gear is used for 50 and 100 millimeter lenses.

Figure 2 shows the Follow-focus attachment with the viewfinder in place. The attachment does not include the viewfinder, but takes the regular finder which comes as standard equipment with all Mitchell cameras. In other words, purchaser of the attachment uses his own camera finder with it.

In operation, the Follow-focus Attachment works as follows: The follow-focus knob is rotated so that the cam roller moves back to the infinity or extreme rear position. The lens to be used is then set at infinity position. Next, the focusing gear is made to engage the lens gear. When properly engaged, cam roller will be in extreme rear position and the lens will be on infinity mark or slightly beyond.

Next, the lens cam is installed which matches the focal length of the lens to

be used. Then the lens is focused at some near object—for example at a distance of 10 feet—and the vertical center line in camera focus tube is lined up with center of the near object. The cam is then adjusted until the finder vertical center matches that in the focus tube, with both centered on the near object. At this time, the lens calibrations to be used can be marked with pencil on the plastic footage dial on the Follow-focus Attachment. (See Fig. 1). The mechanism is now ready for operation. All follow-focusing control now can be easily and swiftly accomplished through operation of the follow-focus control knob. As the mobile camera moves in toward subject in a dolly shot, the cameraman's assistant—watching the footage dial and indicator—turns the follow-focus control knob progressively as the camera approaches predetermined distances, which are usually indicated by chalk marks placed on the stage floor.

While this attachment is proving of immeasurable value in the production of 35mm motion pictures, it is the 16mm film producer, using the Mitchell "16" camera who, perhaps, will appreciate it most because it now provides for the first time a need long felt—one that enables him to add to his productions one of the most important professional photographic embellishments, available until now only to the producer of 35mm films.

Michael Slifka of New York, one of the first cinematographers to use the attachment, says it saves considerably on production hours because of the rapidity of movement it affords with the light-



TEWE MOTIVEFINDER

— like a "right arm" for the creative MP and TV Director

TEWE MOTIVEFINDER is a wizard that solves scores of set problems. This Director's Zoom-type Finder reveals the most suitable focal length, the proper camera position, the effects of dolly shots, etc. It is invaluable to a creative Director who likes to plan optical tricks and special effects. Combination Finder zooms from 25mm to 135mm for 35mm Motion Picture and zooms from 28mm to 150mm for TV. Complete with leather carrying case and neck band. **Only \$75**

Other Versatile Viewfinders — each a honey for the money!



ZOOM DIRECTOR'S FINDER for 16mm and 35mm. . . . 16mm zooms from 13mm to 75mm. 35mm zooms from 25mm to 6". **\$15.50**



WATSON Director's type finder, pocket size, with mattes from 30mm to 100mm for 35mm cameras. Also for 16mm cameras. **\$35**

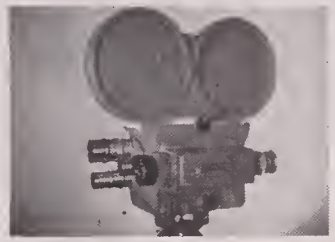

ZOOM Finder for Auricon Cine Voice . . . zooms from 15mm to 12". **\$60**
Available for Filmo and Eyemo. **\$39.50**



ZOOM Finder for Cine Kodak Special . . . zooms from 15mm to 150mm, with parallax adjustment. **\$75**
Template supplied for mounting Finder on magazine. Additional brackets for magazines available at \$7.50 per set.

FRANK C. ZUCKER
CAMERA EQUIPMENT CO.
 1600 BROADWAY NEW YORK CITY

weight NC camera. There is no fuss or bother when lining up dolly shots.

"Of particular note is the simplicity and speed with which the lens gear is locked or disengaged to rotate the lenses," he says. "In rapid dolly shots, while zooming away from an insert, the attachment provides proper gear speed ratio for accurate focusing control through the conveniently located follow-focus control knob."

The Mitchell Follow-focus Attachment is available in two models: 1) for use with the 16mm Professional camera, and 2) for use with the 35mm NC sound model, and the Standard cameras. The price complete is under \$600. For those who want automatic focusing also on the camera viewfinder lens, this feature is available at slight additional cost. Otherwise, the viewfinder lens is focused manually.

Distribution rights to the March of Time stock library, containing between ten and fifteen million feet of film from which the most subjects were made, have been acquired by N.B.C. Film Division. Deal will allow network to release not only to TV film producers but also to motion picture companies. The footage will enlarge the N.B.C. library to more than thirty million feet.

Model 35-16C

SENSITESTER



★ IMMEDIATE DELIVERY
to the lab owners interested in—

**QUALITY
EFFICIENCY
ECONOMY**

- DUAL MACHINE
1—Sensitometer
2—Scene Tester
- HIGHLY ACCURATE
Electronic timer unaffected by climatic changes.
- NEW TYPE LONG-LIFE
Cold Light Exposure Unit
- WITHOUT ADDITIONAL EXPENSE will match any printer

Combination 35mm-16mm

ART REEVES MOTION PICTURE EQUIP.

7512 Santa Monica Blvd.

Hollywood 46 **California**

SHOOTING SYSTEM FOR TV FILMS

(Continued from Page 235)

quality—a quality very similar to natural north light. Because of the diffused quality of illumination produced by the cone light, we use this unit in quantity for our key light, as may be seen in the accompanying photographs. Another important thing that can be said in favor of these lamps is that they ease the way considerably for the sound man, in that the mike often can be extended into the set without producing noticeable shadow.

Because the cone lights carry only a limited distance, we fill in with 2-KW lamps fitted with spun-glass diffusers which give a quality of soft light similar to that of the cone lights.

For an overall fill light, we use a "skylight" dome hung above the set, which is fitted with a number of 500-watt clear bulbs with self-contained reflector bowls that throw an indirect light against the interior of the dome, and thence down upon the set.

This system of lighting, incidentally, has been so carefully planned as to type of lighting units, etc., that when the time comes for us to photograph the Burns and Allen show in color, all we need do

is to replace the present lamps with C-P bulbs designed especially for color photography.

All sets are painted in colors instead of the conventional drab tones of black and white production technique, and are thus compatible with the new Eastman Color negative.

There still is another lighting practice we have adopted in shooting the Burns and Allen show which, perhaps, should also be mentioned here. This is the use of special, filtered fill lights, which are mounted low on the front of each dolly. These are PAR-38 150-watt photolamps mounted in sockets attached to alligator clamps, and may be seen in the photo showing the camera mounted on the crab dolly. Before each lamp is mounted a filter, pinkish in color, which in combination with the lamp produces a fill light that is particularly complimentary to the players when photographed close up.

An important adjunct to obtaining speed in production is a versatile mobile camera mount for each of the two Mitchell BNC cameras we use. We chose the crab dolly, illustrated here,



GEO. W. COLBURN LABORATORY INC.
164 NORTH WACKER DRIVE • CHICAGO 6
TELEPHONE STATE 2-7316

**8 and 16mm
SERVICES**

Color Bar
GOBO STAND
That is Really Versatile *It's New!*



THE 12 foot stand may be used with a BOOM ADAPTER or with SCRIMS or with FLAGS

ABSOLUTE LIGHT CONTROL

WRITE FOR FURTHER INFORMATION
GLENDALE 5, CALIFORNIA

NATURAL LIGHTING CORP.

LIGHTING EQUIPMENT

New Bolex Equipment, Prices Announced



The new Bolex features a turret lever.

trated here) for rapid and accurate turning of turret; plus new built-in filter slot complete with six filter holders and four gelatin filter sheets.

Five additional new Bolex accessories were also introduced. These are: Switar "Visifocus" 2-inch f/1.4 lens for all 16mm cameras; Switar "Visifocus" 16mm f/1.8 wide-angle lens for all 16mm cameras; Switar 5½mm f/1.8 wide-angle lens for 8 mm cameras; new Pan-Cinor zoom-type lens for all 8mm cameras, having a focusing range from 12½mm to 36mm and focuses down to 2½ feet; and the new Bolex Unimotor, a universal electric drive for both the Bolex H-8 and H-16 cameras.

Soon to be announced is a new portable power transformer for use with this equipment.

Interesting price reductions on Bolex cameras and zoom lenses were also announced: The new Pan-Cinor zoom-type lens with new finder now comes complete with case for \$359.50 (formerly \$447.50). The Bolex H-16 Leader camera with one lens is now priced at \$269.50—a reduction of \$30.00. The Bolex H-8 Leader camera with one lens is reduced \$32.00 to a new low price of \$259.50.

Ready-Eddy
U. S. Registered Trademark

**EASY READABLE • ACCURATE
FOR EVERY DAY USE**

1001 Ready Sound-Film Editing Data:
• Footage • Frame Count • Screen Time • 35mm and 16mm equivalents.
Plastic computer for everyone in movies and TV, from script to screen.

\$2.00 Prepaid
(Delivered in U.S.A.)

ASK FOR REPRINT OF ARTICLE
IN AMERICAN CINEMATOGRAPHER.
Write or ask your dealer

READY-EDDY, Sandy Hook, Conn.



YOU WON'T MISS AN ISSUE . . .
of American Cinematographer if you renew your subscription promptly when notice is received. The yearly subscription rate remains the same—\$3.00 (U.S. and Canada) Foreign, \$4.00

"NEW," was the gist of the Bolex news released by Paillard Products, Inc., at the Chicago MPDFA show recently—the new Bolex H-16 "Supreme" camera with new 3-lens turret which locks in three positions for focusing of individual lenses; new built-in turret lever (illus-

ng Allen
CORPORATION
MAKERS OF
SYNCHRONOUS
Magnetic
FILM
RECORDERS

Newest Addition

TO THE *Hallen* LINE OF MAGNETIC *Film* RECORDERS

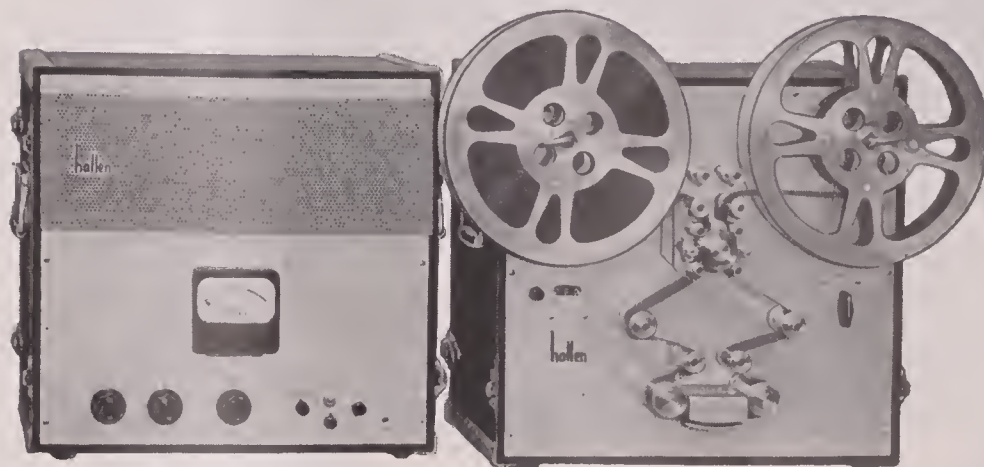

The recorder shown is 35mm using two flywheels, designed to facilitate conversion to multiple track, stereophonic, cinemascope etc.

The two case portable Model 235 magnetic film recording system is also available in both 35mm and 16mm single drum system. Literature available.

3503 WEST OLIVE AVENUE • BURBANK, CALIFORNIA
CABLE ADDRESS "HALLEN" • PHONE THORNWALL 8-6976

which provides smooth action on the floor and rapid directional change. This is important because when shooting the Burns and Allen show, both cameras are "on" all the time. Because a great many scenes run continuously from four to six minutes, we naturally have to provide a number of "cuts" within such periods through several changes in camera setups. These are made as the scene is being shot. While one camera covers the action, the other moves into next position. Because of the limited space in which the cameras must work — often midst the props on the set — a highly maneuverable dolly is essential; the ones we use can virtually "turn on a dime," make sharp right-angle turns, etc. Next to the patent lighting system used, no other factor perhaps contributes so much to the economies of production as the camera operations.

The accompanying diagram illustrates a typical pattern of mobile camera operation in photographing a scene in which George Burns and Gracie Allen begin with dialogue on the stair landing at rear of set, proceed forward to a coffee table at the left, then rise and proceed to a divan at the other side of the room where the dialog is continued. The action, a familiar one in the show, will run several minutes, and may involve as many as ten changes in camera

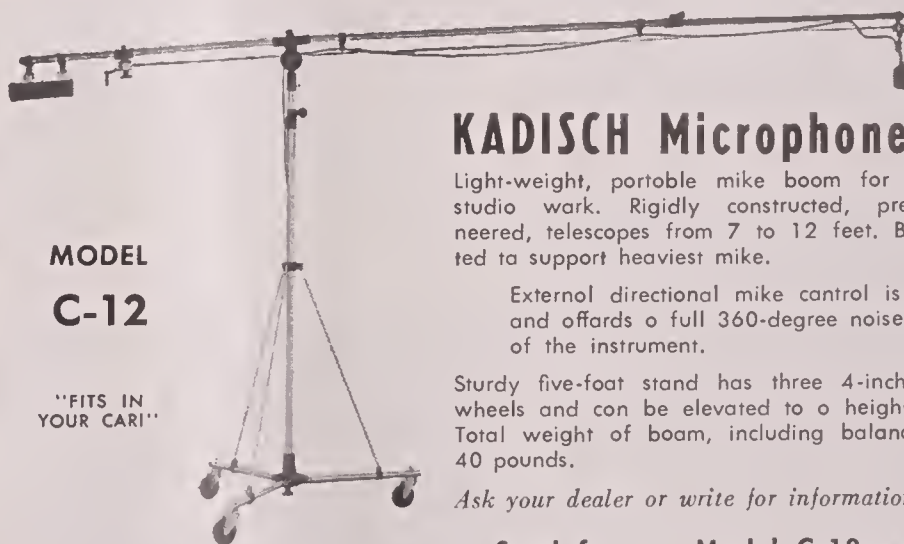

MODEL
C-12

"FITS IN
YOUR CAR!"

KADISCH Microphone Boom

Light-weight, portable mike boom for location and studio work. Rigidly constructed, precision engineered, telescopes from 7 to 12 feet. Boom is strutted to support heaviest mike.

External directional mike control is at rear and affords a full 360-degree noiseless turn of the instrument.

Sturdy five-foot stand has three 4-inch rubber-tired wheels and can be elevated to a height of ten feet. Total weight of boom, including balance weight, is 40 pounds.

Ask your dealer or write for information and prices.

Send for our Model C-18 and C-20
Mike Booms Catalog.

KADISCH CAMERA AND SOUND ENGINEERING CO.

Designers and Manufacturers of Motion Picture and TV Equipment

500 West 52nd Street • New York 19, N. Y. • Phone PLaza 7-3511

Big Future For Cinematographers In TV!

Yes . . . the production of films for television is increasing daily. New shows are going into production; more studio cameramen are filming these shows; more and more new techniques in lighting and filming TV shows are being developed. You can keep abreast of these developments by reading *American Cinematographer* every month. New technical articles are scheduled for future issues!

Subscribe now — **Today**. Only \$3.00 for 12 monthly issues!

AMERICAN CINEMATOGRAPHER • 1782 No. Orange Drive • Hollywood 28, Calif.

SYNCHRONOUS MOTOR with BASE

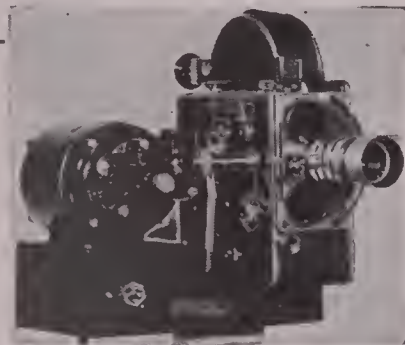

for Your BOLEX H-16

Runs in perfect synchronization with your sound recorder. Spring steel drive will shear if camera jams. Knurled knob on motor permits rotating for threading. Has 'reverse' and 'on and off' switch. Complete with 12 feet of heavy duty cable. No installation necessary. \$165.00 postpaid. Fully guaranteed. Synchronous Motor can be used with our 400 ft. magazine without alteration.

See your Bolex dealer or order direct. Immediate delivery.



TOLEDO CINE ENGINEERING
1309 Milburn Ave. Toledo 6, Ohio

PELEGRINI

VARIABLE SHUTTER UNITS FOR THE BOLEX H-16



The real answer to complete FADES and LAP DIS-SOLVES. Faster shutter speeds and many other advantages. Prices within U. S. \$99.60. Cameras with outside frame counter \$109.80. Tax extra. One year guarantee and camera transportation back included. Send for free informative booklet.



Prices subject to change without notice.

TULLIO PELLEGRINI
1545 Lombard St.
San Francisco 23, California

FOR SALE

AURICON Double System Recorder and N.R. 24 Amplifier—Dual Lateral Variable Area.....	\$500.00
DOUBLE SYSTEM Recorder, made from Auricon Camera movement, and Variable Area Galva. Two motors—one drives take-up only. 200 ft. mogazine. Can be adapted to Mitchell mogazines. Complete with Amplifier	400.00
One Auricon Heavy Duty Pra. Tripod.....	195.00
16mm 3-D CAMERA—Sync. Motor, 2 1/4" to 4 1/2" Interocular. Write for price and photos.	
ONE PAIR 3-D, 16mm PROJECTORS, Mechanical Interlock, Polaroid attachment and blower	150.00
ONE MODEL A Cine Kodak—variable motor drive, 6 volts. 25mm f/1.9 and 78mm f/4.5 lenses. Can be adapted for Mitchell Magazines—extra charge	250.00
ONE CINE SPECIAL MAGAZINE, with Zoom-type Finder attached, 15mm. to 6 inch, with Parallax Adjustment.....	150.00
ONE MODEL Q EYEMO, adopted for Mitchell Mogazines. No lenses.....	500.00
ONE 25mm BALTAR LENS, f/2.3, with Mitchell mount, not calibrated.....	125.00
ONE T. H. COOKE LENS, Ser. O, f/2.35mm focal length, with Eyemo C Mount, not calibrated	100.00
ONE E. CINE LENS, 25mm f/1.9, coated, C mount	30.00
ONE 12-INCH E. K. LENS, f/5, coated.....	100.00
ONE 16mm AMPRO SOUND PROJECTOR, Premier Model 30, demonstrator, late model, slightly used	350.00

FRED. A. PARRISH

10851 Fairbanks Way, Culver City, California.
Phone: VERmont 8-6449.

position. The step-by-step procedure is explained in the text accompanying the illustration.

What we achieve here is a pattern of cutting or "editing-as-we-shoot," a technique that results in far smoother performance by the players than where the conventional feature film production is used, which involves stopping the camera and making a change in setup during a pause in the action. Obviously, it saves time, too. The secret of the success of this system is to move the camera on dialogue cues. A camera is never moved while it is directly on a principal player. The system obviously makes additional demands on members of the camera crews, who must keep a close

check on a copy of the script in order not to miss a camera cue.

At this writing we are photographing the 90th Burns and Allen show, which series has been in regular production now for almost two years. While we are constantly studying our lighting and photographic procedure for opportunity to further improve it, we believe that today the show's photography exemplifies one of the best shooting systems presently in use in television film production. We are naturally elated over the generous favorable comment received from all over the country regarding the show's consistent high transmittal quality as registered on home receivers.

THE ROLE OF LIGHT IN CREATING MOOD

(Continued from Page 231)

light, while the motionless figure of the wife is half-hidden in shadow—ominous, formless shadows, relieved only by the subdued illumination playing on the bed-ridden figure. The lighting alone, unaided by dialogue or action, could tell the story adequately. An atmosphere of such dramatic power could be built up by skillful lighting that the audience would inevitably experience the tense, silent agony of the situation, and sense the breathless emotion of an actual death-bed scene.

Veteran cinematographers understand this technique. Before the advent of

sound, dialogue and mood music, 90 percent of the responsibility for securing the desired emotional effect in a scene such as this lay in the hands of the cinematographer. Today, even with the great advantages of sound, it is still largely up to the man behind the camera whether a given scene shall be merely a well-acted one, or a gripping emotional experience long to be remembered. The true test of good cinematography is its emotional and dramatic impact when viewed without the adjunct of sound.

To a very limited extent, changes in

J. A. Maurer Announces Magnetic Film Splicer

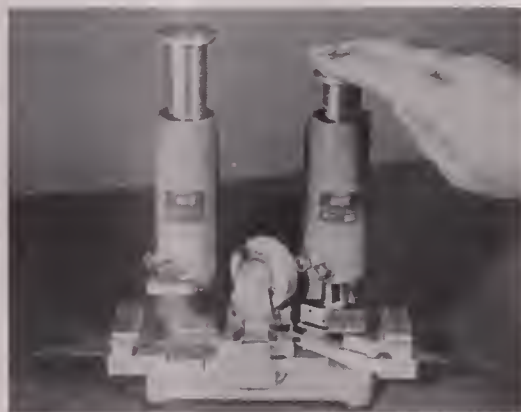

Bob Jones Univ. Magnetic Film Splicer

A NEW MAGNETIC sound film splicer that will permit the cutting and mixing of magnetic sound directly to picture synchronization has been introduced by the J. A. Maurer Company, Long Island City, New York.

Known as the Bob Jones University Splicer, the new device (pictured here)

offers quick and simple bloopless splicing for single—or double—perforated 16mm. or 17 1/2mm single-perforated magnetic sound film. Another model to handle 35mm film will be available soon.

By using this new splicer, sound editors can cut and mix magnetic sound directly to picture synchronization, with only the composite magnetic sound being transferred to optical sound for release printing. By thus avoiding the usual practice of cutting and mixing optical sound (re-recorded from magnetic) greater fidelity of sound results. The spliced perforated magnetic sound tape can be re-used after erasure, so perfect is the splice made with this equipment, according to the Maurer Company.

Splicing consists of three simple operations: mounting and cutting the film; aligning the splicing tape; and the sealing operation.

Film Editing Made Easy
with NEW

professional film viewer

for 35mm and 16mm

Every film editor will appreciate a viewer that enables him to view his film from left to right—on a large, brilliantly illuminated screen.

The PROFESSIONAL FILM VIEWER makes film editing a breeze. Easy threading, portable, will not scratch film. Put this viewer between your rewinders and speed up your editing. Size of Viewing Screen 5¾ x 4¾.



35mm Model \$375
16mm Model \$350



mood and tempo of lighting may be brought about by increasing or decreasing the amount of light used; but the most essential factors in producing such effects are judicious manipulation of the lighting balance, and perhaps the use of diffusion on both camera and lights. Personally, I prefer to minimize the diffusion introduced photographically and to utilize controlled diffusion in illumination. Photographic diffusion is, at best, unnatural and often unsatisfactory and is a practice gradually losing favor in modern cinematography. The trend today is to employ diffusion in lighting to produce the effects desired.

In this, the technique may vary widely among individual cinematographers. Altering the light-diffusion and the beam concentration of the lamps is often preferred to substituting larger, smaller, or optically different units as the camera angle is changed.

A condenser-type spotlight, for example, produces a more intense beam of light than does the average mirror-lamp of comparable wattage; the two, nevertheless, are often used interchangeably for certain effects. I have found, however, that the light from the condenser-type lamp is much whiter, and thus can be cruelly deceptive when one attempts to balance it with other and yellower

(Continued on Page 259)

C. ROSS

FOR

LIGHTING EQUIPMENT

Inkie and Arc Lamps including Required Accessories
Generators—Cables—Boards—Boxes

Raby Camera Crane—Dollies—Blimps—Geared Heads

GRIP EQUIPMENT

FOR LOCATION AND STUDIO

Parallels—Steps—Platform Ladders
Century Stands—Reflectors—Flags—Scrims

SOLE EASTERN MOLE-RICHARDSON CO. DISTRIBUTOR

RENTALS • SALES • SERVICE

CHARLES ROSS, Inc.

333 WEST 52nd STREET

NEW YORK 19, N.Y.

Circle 6-5470-1

Current Assignments of A.S.C. Members

Major film productions on which members of the American Society of Cinematographers were engaged as directors of photography during the past month.

AMERICAN SOCIETY OF CINEMATOGRAPHERS

FOUNDED January 8, 1919, The American Society of Cinematographers is composed of the leading directors of photography in the Hollywood motion picture studios. Its membership also includes non-resident cinematographers and cinematographers in foreign lands. Membership is by invitation only.

BOARD OF GOVERNORS—1954

ARTHUR MILLER, President
SOL HALPRIN, First Vice-President
JOSEPH RUTTENBERG, Second Vice-President
ALFRED GILKS, Third Vice-President
WALTER STRENCE, Treasurer
PHILIP TANNURA, Secretary
ROBERT DE GRASSE, Sergeant-At-Arms
JOHN ARNOLD
JOSEPH BIROC
ARTHUR EDSON
GEORGE FOLSEY
LEE GARMES
VICTOR MILNER
HAL MOHR
LEON SHAMROY

ALTERNATE BOARD MEMBERS

ARTHUR ARLING
LUCIEN BALLARD
DAN CLARK
PAUL EAGLER
FARCIOT EDOUARD
ERNEST LASZLO
ROBERT PITTACK
JOHN SEITZ
JAMES VAN TREES
PAUL VOGEL

ALLIED ARTISTS

● HARRY NEUMANN, "Sons of the Navy," with Jan Sterling, Neville Brand, Robert Arthur, Alvey Moore, Paul Langton, John Dourcette, Don Haggerty, Lloyd Corrigan, Walter Reed, Ward Wood, Bob Patton, James Best, John Tarrangelo, and Bill Gentry. Lesley Selander, director.

● HAROLD LIPSTEIN, "Adventures of Hajji Baba," (Technicolor) with Elaine Stewart, John Derek, Linda Christian, Thomas Gomez, Paul Picerni, Amanda Blake, Rosemarie Bowe, and Peter Mamakos. Don Weis, director.

COLUMBIA

● ARTHUR E. ARLING, "Three for the Show," (Technicolor; CinemaScope) with Betty Grable, Marge and Gower Champion, Jack Lemmon, Myron McCormick. H. C. Potter, director.

● WILFRED CLINE, "Violent Men," (Technicolor) with Randolph Scott, Jocelyn Brando, Alfonso Beyoda, Richard Boone, and Leo Gordon. Bruce Humberstone, director.

● BURNETT GUFFEY, "Rough Company," (Technicolor; CinemaScope) with Glenn Ford, Bar-

bara Stanwyck, Edward G. Robinson, Dianne Foster, May Wynn, Brian Keith, Basil Ruysdael, Warner Anderson, James Westerfield, Richard Jaeckel, Raymond Greenleaf, Jack Kelly, Don Harvey, Carl Andre, Robert Bice, and Peter Hanson. Rudy Mate, director.

● CHARLES B. LANG, JR., "Phffft," with Judy Holliday, Jack Lemmon, Jack Carson, and Luella Gear. Mark Robson, director.

● CHARLES LAWTON, JR., "The Long Gray Line," (Technicolor; CinemaScope) with Tyrone Power, Maureen O'Hara, Betsy Palmer, Robert Francis, Phil Carey, Bill Leslie, Donald Crisp, Sean McClory, and Harry Carey, Jr. John Ford, director.

● HENRY FREULICH, "Bat Masterson, Bad Man," (Technicolor) with George Montgomery, Nancy Gates, and James Griffith. William Castle, director.

● CHARLES LANG, JR., "Joseph and His Brethren," (Technicolor; CinemaScope; Shooting in Egypt) William Dieterle, director.

METRO-GOLDWYN-MAYER

● JOSEPH RUTTENBERG, "The Last Time I Saw Paris," (Color; wide-screen; shooting backgrounds temporarily in Paris) with Elizabeth Taylor, Van Johnson, Walter Pidgeon, Donna Reed, Eva Gabor, Kurt Kasznar, Roger Moore, and Sandy Descher. Richard Brooks, director.

● ROBERT PLANCK, "Athena" (Technicolor; wide-screen) with Jane Powell, Edmund Purdom, Debbie Reynolds, Vic Damone, and Louis Calhern. Joe Pasternak, director.

● PAUL C. VOGEL, "Green Fire," (Eastman color; wide-screen; shooting in Columbia) with Stewart Granger, Grace Kelly, Paul Douglas, John Ericson, Charlita and Murvyn Vye. Andrew Marton, director.

● JOHN SEITZ, "Rogue Cop," (Wide-screen) with Robert Taylor, Janet Leigh, George Raft, Anne Francis, Steve Forrest, Robert Ellinstein, Olive Carey and Alan Hale, Jr. Roy Rowland, director.

PARAMOUNT

● LOYAL GRIGGS, "The Bridges At Toko-Ri," (Eastman Color; Wide Screen) with William Holden, Grace Kelly, Mickey Rooney, Frederic March, Charles McGraw, Robert Strauss, Keiko Awaji, Dick Shannon, Bill Bouche. Mark Robson, director.

● WILLIAM DANIELS, "Strategic Air Command," (Technicolor; VistaVision; shooting at Tampa) with Jimmy Stewart, June Allyson, Frank Lovejoy, Barry Sullivan, Bruce Bennett, and Jay C. Flippen. Anthony Mann, director.

● LOYAL GRIGGS, "The Big Top," (Hal Wallis production-Technicolor; Vista-Vision) with Dean Martin, Jerry Lewis, Joanne Dru, Zsa Zsa Gabor, Wallace Ford, Nick Cravat and Gene Sheldon. Joseph Pevney, director.

R.K.O.

● JOHN ALTON, "Where the Wind Dies," (Technicolor; Superscope) with Cornel Wilde, Yvonne de Carlo, and John Dierkes. Allan Dwan, director.

20TH CENTURY-FOX

● JOE MACDONALD, "Broken Lance," (Technicolor; CinemaScope) with Spencer Tracy, Katy Jurado, Robert Wagner, Jean Peters, Richard Widmark, Hugh O'Brien. Eduard

Franz, E. G. Marshall, Carl Denton Reid, and Earl Holliman. Edward Dmytryk, director.

● LEON SHAMROY, "The Egyptian," (Technicolor; CinemaScope) with Edmund Purdom, Jean Simmons, Victor Mature, Gene Tierney, Bella Darvi, Peter Ustinov, Judith Evelyn. Michael Curtiz, director.

● LEO TOVER, "Untamed," (Technicolor; CinemaScope) shooting backgrounds in South Africa) Henry King, director.

UNIVERSAL-INTERNATIONAL

● IRVING GLASSBERG, "Francis Joins The WACs," with Donald O'Connor, Julia Adams, Chill Wills, Mamie Van Doren, and Allison Hayes. Arthur Lubin, director.

● RUSSELL METTY, "The Tight Squeeze," with Sterling Hayden, Gloria Grahame, and Gene Barry. Jerry Hopper, director.

● GEORGE ROBINSON, "Nevada Gold," (Technicolor; wide-screen) with Lex Barker, Mala Powers, Howard Duff, John McIntire, and William Demarest. Jesse Hibbs, director.

● MAURY GERTSMAN, "So This Is Paris," (Technicolor; wide-screen) with Tony Curtis, Gloria De Haven, Gene Nelson, Paul Gilbert, Mara Corday, Christiane Martel and Myrna Hansen. Richard Quine, director.

● RUSSELL METTY, "Shadow Valley," (Technicolor; wide-screen) with Rory Calhoun, Colleen Miller, Walter Brennan, Nestor Paiva, Richard Carlson, director.

WARNER BROS.

● SID HICKOX, "Battle Cry," (WarnerColor; CinemaScope) with Van Heflin, Aldo Ray, James Whitmore, Tab Hunter, Dorothy Malone, Allyn McLerie, William Campbell, and Glenn Denning. Raoul Walsh, director.

● LEE GARMES and RUSSELL HARLAN, "Land of the Pharaohs," (WarnerColor, CinemaScope; shooting in Egypt) with Jack Hawkins. Howard Hawks, director.

● HARRY STRADLING, "Helen of Troy," (WarnerColor, CinemaScope; shooting in Italy) with Rossana Podesta, Jacques Sernas, Sir Cedric Hardwicke, Torin Thatcher, Robert Douglas, Nora Swinburne and Eduardo Ciannelli. Robert Wise, director.

INDEPENDENT

● FRED GATELY, "The Bandit," (Josef Shaf-tel Prods.—Eastman color, SuperScope) with Arthur Kennedy, Betta St. John, and Eugene Iglesias. Edgar Ulmer, director.

● RAY JUNE, "This Is My Love," (Allan Dowling Pictures: RKO release: Eastman color, wide-screen) with Linda Darnell, Rich Jason, Dan Drury, Faith Domergue, Hal Baylor, Mary Young, Jerry Mathers, and Susie Mathers. Stuart Heisler, director.

● JACK CARDIFF, "The Barefoot Contessa," (Figaro Prods.; Technicolor; shooting in Italy) with Humphrey Bogart, Ava Gardner, Edmund O'Brien, Valentina Cortessa, Marius Goring, and Bessie Love. Joseph L. Mankiewicz, producer-director.

● FRANK PLANER, "20,000 Leagues Under The Sea," (Walt Disney Prod.; Technicolor; CinemaScope) with Kirk Douglas, James Mason, and Peter Lorre. Richard Fleischer, director.

● HAL ROSSON, "Mambo," (Ponti-De Laurentiis Prod. for Paramount; shooting in Rome, Italy) with Silvano Manganò, Michael Rennie, Vittorio Gassman, Shelly Winters, and Katherine Dunham. Robert Rossen, director.

● ERNEST LASZLO, "Vera Cruz," (Hecht-Lancaster Prod. for U-A; Technicolor; Wide-screen; shooting in Mexico) with Gary Cooper, Burt Lancaster, Mari Blanchard, Cesar Romero, Sarita Montiel, George Macready. Robert Aldrich, director.

INDEPENDENT

• **JOE BIROC**, "Case File: F.B.I." (Eclipse Films) with Broderick Crawford, Ruth Roman, Martha Hyer, Marisa Pavan. Arnold Laven, director.

• **CHARLES G. CLARKE**, "Suddenly," (Robt. Bassler Prods., United Artists release) with Frank Sinatra, Sterling Hayden, Nancy Gates, James Gleason and Kim Charney. Lewis Allen, director.

TELEVISION

(The following directors of photography were active last month in photographing films for television in Hollywood, or were on contract to direct the photography of television films for the producers named.)

• **JOSEPH BIROC**, "The Family Next Door" series of 15-minute films for American National Studios, Inc.

• **NORBERT BRODINE**, "Letter To Loretta" series of half-hour dramas for Lewisor Prods.—D.P.I., starring Loretta Young. (Procter & Gamble), RKO-Pathe studio.

• **DAN CLARK**, "Cisco Kid" series of half-hour western dramas; also "I Led Three Lives" series of half-hour dramas, starring Richard Carlson, for Ziv-TV Corp., California Studio.

• **EDWARD COLMAN**, "Dragnet" series of half-hour dramas, starring Jack Webb, for Mark VII Prods., Walt Disney Studio. (Chesterfield.)

• **ROBERT DEGRASSE**, "Make Room For Daddy" series of half-hour comedies starring Danny Thomas for Marterto Prods., Inc., D.P.I., Motion Picture Center. (ABC.)

• **GEORGE DISKANT**, "Four Star Playhouse" series of half-hour dramas, featuring various stars, for Four Star Productions, RKO-Pathe Studio. (Singer Sewing Machines.)

• **KARL FREUND**, "I Love Lucy" series of half-hour comedies starring Lucille Ball and Desi Arnaz, for Desilu Productions; (Philip Morris) also "Our Miss Brooks" series of half-hour comedies, starring Eve Arden, also for Desilu Productions, (General Foods) at Motion Picture Center.

• **BENJAMIN KLINE**, "Fireside Theatre" series of half-hour dramas for Frank Wisbar Prods., Inc., at American National Studios (Procter & Gamble).

• **JACK MACKENZIE**, "Public Defender" series of half-hour films for CBS, starring Reed Hadley. Shooting at Republic Studios.

• **ALFRED L. GILKS**, "Halls of Ivy," series of half-hour dramas starring Ronald Colman and Benita Hume for Hall Prods., Inc., at Motion Picture Center.

• **WILLIAM MELLOR**, "Adventures of Ozzie and Harriet" series of half-hour comedy dramas starring Ozzie Nelson and Harriet Hilliard for Stage Five Prods., Inc., General Service Studios. (ABC.)

• **VIRGIL MILLER**, "You Bet Your Life," weekly half-hour audience participation shows, featuring Groucho Marx, for Filmcraft Prods., NBC Studios. (DeSoto-Plymouth).

• **HAL MOHR**, "The Joan Davis Show" series of half-hour comedy-dramas starring Joan Davis for Joan Davis Enterprises, General Service Studios. (NBC.)

• **NICK MUSURACA**, "The Lone Wolf," series of half-hour dramas for Gross-Krasne, Inc., at California Studios.

• **KENNETH PEACH**, "Mr. and Mrs. North" series of half-hour dramas starring Barbara Britton and Richard Denning for John W.

Loveton Productions, Samuel Goldwyn Studios. (Revlon, and Congoleum-Nairn). Also "Topper" series of half-hour films, starring Anne Jeffreys, Robert Sterling, Leo G. Carroll, and Lee Patrick for Loveton-Schubert Prods., at Samuel Goldwyn Studios. (Camel Cigarettes).

• **ROBERT PITTACK**, "Private Secretary" series of half-hour comedy dramas starring Ann Sothern and Don Porter, (Lucky Strike).

• **JOHN L. RUSSELL, JR.**, "Joe Palooka," series of half-hour comedy-dramas starring Joe Kirkwood and Cathy Downs at Republic.

• **MACK STENGLER**, "Life With Elizabeth" series of half-hour dramas; also "The Liberace Show," half-hour musical film series for Snader Telescriptions Corp.; also "Florian Zabach Show," series of half-hour films.

• **HAROLD STINE**, "Cavalcade of America" series of half-hour dramas for Jack Denove Prods., Inc., Samuel Goldwyn Studios. (DuPont).

• **WALTER STRENCE**, "My Little Margie" series of half-hour comedies, starring Gale Storm and Charles Farrell (Scott Paper Co.); also "Rocky Jones—Space Ranger" series of half-hour science-fiction dramas starring Richard Crane and Sally Mansfield (UTP); also "Waterfront" series of half-hour dramas starring Preston Foster and Lois Moran (UTP) at Hal Roach Studios.

• **PHIL TANNURA**, "The Burns and Allen Show" series of half-hour comedies starring George Burns and Gracie Allen, for McCadden Corp., General Service Studios. (Carnation Milk and Goodrich).

• **JAMES VAN TREES**, "For The Defense," new series of dramatic films for Sam Bischoff, starring Edward G. Robinson.

• **LESTER WHITE**, "Adventures of Rin Tin Tin," series of half-hour dramas starring Lee Aaker, James Brown and Rin Tin Tin for Screen Gems.

THE ROLE OF LIGHT

(Continued from Page 257)

illuminants; so it is better to use the same unit and alter the diffusing media and the beam concentration rather than substitute a light unit of another type. The same applies to the "hard," arc lamps, which are, however, extremely useful in photographing dead, heavy blacks, such as formal evening dress. Here the bluer light of the arc reveals more detail in the black masses than does the more easily absorbed incandescent light.

Similarly, it is by far the best practice, when working on a sequence in which a definite source-lighting has been established, to adhere closely to this source-light pattern throughout, substituting, perhaps, smaller units, greater diffusion, or less concentrated beams of light in the closer shots, rather than altering the source-pattern and considering the close shots as more or less independent of the basic long-shot.

These observations, however, are purely elementary and have only a rudimentary bearing on the discussion. The

(Continued on Page 262)

MOVIOLA

FILM EDITING

EQUIPMENT

16MM - 35MM

• PICTURE SOUND
Photo and
Magnetic

• SYNCHRONIZERS

• REWINDERS

One of the new series 20 Moviolas for picture and sound.

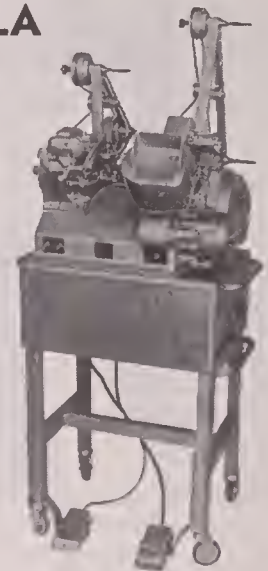

Write for
Catalogue

MOVIOLA MANUFACTURING CO.

1451 Gordon St. • Hollywood 28, Calif.

AUTOMATIC DAYLIGHT PROCESSING



DEVELOPING TANK

- Processes up to 200 Ft.
- 8mm-16mm-35mm
- Movie—X-Ray—Microfilm
- Motor Driven, Portable
- Tough Plastic Tonks
- Uniform Density Assured
- 70mm tonk also available

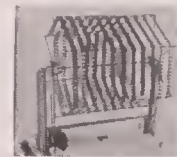

FILM DRYER

- Motor driven—Heated
- Speedy drying
- Automatic shrinkage allowance
- Stainless steel and aluminum construction
- Easily assembled without Tools
- Compact, Portable

Guaranteed. Write for Free Literature

MICRO RECORD CORP.

Dept. AC 225 W. 28th St., N.Y. 1, N.Y.

FOR YOUR TV COMMERCIAL

Special optical effects on 35mm or 16mm film. Send for free optical effects chart.

RAY MERCER & CO.

4241 Normal Ave. • Hollywood 29, Calif.
Normandie 3-9331

REVERSAL PROCESSING AND DUPLICATING SPECIALISTS FOR OVER A DECADE. MODERN MACHINES, WITH TEMPERATURE CONTROL WITHIN TWO-TENTHS OF ONE DEGREE.

free brochure on request

REVERSAL PROCESSING
E. I. DUPONT BLUE BASE FILM

PER FT.
16 MM02c
B&W WORK PRINTS.....05c
B&W FROM KODACHROME ON PAN STOCK06c
TIMED REV. DUPES, SILENT.....07c
TIMED REV. DUPES, SOUND.....08c
Edge Numbering005c

NATIONAL CINE LAB

BOX 443, Washington 11, D. C.



Endorsed...

by the
**WORLD'S LEADING
CAMERAMEN**

Used At All
Hollywood Movie Studios

**New Edition
NOW AVAILABLE**

IMPROVED!

ENLARGED!

REVISED!

with
**TELEVISION
PHOTOGRAPHY DATA**
plus
**NEW CHARTS
and TABLES**

The Book of a Thousand Answers
to Cinematographic Questions

ORDER YOUR COPY TODAY!

PRICE \$5.00 POSTPAID

Book Department,
American Cinematographer,
1782 Na. Orange Dr.,
Hollywood 28, Calif.

Gentlemen: Enclosed please find \$5.00*
for which please send me a copy of
THE AMERICAN CINEMATOGRAPHER HAND-
BOOK AND REFERENCE GUIDE.

Name

Address

City..... Zone.....State.....

*If you live in California, please include 18c
sales tax — total \$5.18.

Booklets Catalogs Brochures

available to readers free on request

Business Film Production

"Proven Formulas for Low-Cost Business Films" is title of booklet available from Telefilm, Inc., 6039 Hollywood Blvd., Hollywood 28, Calif., which outlines the basic production steps in making a business film. All of the services described are available through Telefilm.

Lighting Equipment

A combination equipment catalogue and technical information bulletin is the 30-page booklet, "Lighting Equipment for Motion Pictures and Television" issued by Schoen & Crowe, 403 West 47th St., New York, N.Y. Illustrated and described are most of the principal lighting units used in motion picture set lighting, and which are distributed by the company.

An important feature is the section given over to wiring diagrams for 3 and 4-wire services, with specifications for the required cables and accessories required.

Equipment Catalogue

A 28-page catalogue that makes it easy for anyone to select the right type motion picture lighting and camera equipment, dollies, lenses, etc., has been published by National Cine Equipment, Inc., 209 West 48th St., New York 36, N.Y. Augmenting the pages of equipment descriptions is an extensive price list of equipment rentals, in which the company specializes.

Astro Lenses

For those who want information on the new Astro long distance telephoto lenses for motion picture cameras, Ercona Camera Corporation, 527 Fifth Ave., New York 17, N.Y., has available Astro catalog No. 5-A containing technical data and prices, plus reprints of a comprehensive article describing the lens.

Film Lab Rates

Prices and complete descriptions of all the services offered amateur and professional film producers by the George W. Colburn Laboratory, Inc., 164 No. Wacker Drive, Chicago 6, Ill., is contained in the latest catalog offered by the company. Within its pages also is much valuable information and advice regarding the correct procedures to follow and processes to use, such as

answer and release prints, color masters, dupe negatives, etc. Also quoted are prices for such services as Vacuumating, edge numbering, film cleaning, renovating and lacquering, sound stripping, etc.

Set Lighting Equipment

One of the most complete catalogues of motion picture lighting equipment yet compiled is Catalogue C available from Mole Richardson Company, 937 No. Sycamore Ave., Hollywood 38, Calif.

In addition to illustrating and describing extensively the many items of M-R equipment the company manufactures, catalog contains numerous photos showing actual use of equipment in interesting setups on the sound stages of major motion picture studios, industrial film producers, and TV film makers.

Other sections are devoted to such valuable data as "Power Distribution," "Lighting for Color Photography," and "Illumination Tables" for spot and flood lamps.

Title and Effects Data

Both professional and amateur producers of 16mm films will find much of interest in the booklet "Film Titler and Special Effects Kit" available from Pailard Products, Inc., 100 Sixth Ave., New York 13, N.Y. Illustrated and described is the versatile Bolex Titler and its method of use in the production of professional-like titles and special cinematic effects. A timely feature is the section devoted to making TV spot announcements.

Lighting Equipment

"Let There Be Light With ColorTran" is title of 12-page combination catalog and information booklet offered makers of motion picture films by The Camera Mart, Inc., 1845 Broadway, New York 23, N.Y.

THE LITERATURE described above contains a wealth of valuable data for the cinematographer and others in the film industry. Unless otherwise indicated, copies are free. Requests should be addressed directly to the company named — not to American Cinematographer.

— EDITOR.

CLASSIFIED ADVERTISING

RATE: 10c per word—minimum ad \$1.00. Words set in capital letters, 15c per word. Display format 90c per line.

STUDIO & PRODN. EQUIP.

35mm DeVRY spring driven camera, 100', excellent 39.50
 AMPRO 16mm Arc projector, complete, excellent 495.00
 BELL HOWELL Model 130 silent projector, 2000' capacity, 1200 watt, all gear drive, excellent 195.00
 Brand new 3 inch F3.5 STEINHEIL 16mm telephoto, coated, "C" mount, special 24.50
 1 inch COOKE F1.8, "C" mount, excellent 25.00
 35mm HOLMES sound projector, complete with amplifier, speaker, sound head, very excellent condition. 295.00
 JAP AERIAL CAMERA, 7x5 roll film 400mm. F5.6 lens, excellent condition 69.95
 4x5 COMBAT GRAPHIC, with flash gun. 127mm. F4.7 KODAK anastigmat in supermatic, excellent 69.95
 Brand new BELL & HOWELL 16mm, sprocket defect indicators, original cost \$92.00, special 49.50
 HUGO MEYER F4.5 400 mm telephoto in Compound shutter, mounted for graphic, excellent 85.00
 SCHNEIDER Xenon 125mm F2 in barrel, excellent 69.95
 BAUSCH & LOMB 20 inch F5.6 telephoto in barrel 89.50
 16mm DeVRY sound projector, good condition 75.00
 BELL & HOWELL 202-C 16mm magnetic sound projector, just like new 495.00
 Brand new RCA 16mm Magnetic sound projector 525.00
 4x5 GRAFLEX SUPER "D" F5.6 lens, case, flash, pack adapter, extra holders, just like brand new 175.00
 35mm ZEISS CONTAFLEX, F1.5 lens, excellent 165.00
 Brand new ZEISS 7x50 featherweight coated binoculars, with case, special 139.50
 Brand new 2 inch BELL & HOWELL Eyemax telephoto lens "C" mount, original cost \$49.67, special 19.95
 Brand new BELL & HOWELL 1 inch F2.7 Cooke lens, "C" mount 19.95
 3 1/4 x 4 1/4 ZEISS MIROFLEX, 4.5 Tessar lens, excellent 65.00
 We take old and new Pistols, revolvers, rifles, and shotguns in trade on everything photographic such as Leica, Contax, Graphic, Bell and Howell, etc. Every item listed is offered on a money back if not satisfied basis.

NATIONAL CAMERA EXCHANGE Established in 1914

86 South 6th Street Minneapolis, Minn.

B&H 70DA 25mm. F1.9, 2" F1.4, Wide Angle F:2, with objective viewfinders, etc., Complete with case \$ 300.00
 EK CINE SPECIAL MODEL 2 Complete with 25mm F1.4 Ektar, 15mm. F2.7, 6" F4.5 telephoto, extra magazine, Zoom Parallax Correcting Viewfinder, Reflex image magnifier, Filter holders, case \$1,235.00
 BODINE 115V Sync Motor for Cine Special 130.00
 1.6 CM F1.9 SCHNEIDER Lens 20.00
 CRAIG Ballhead tripod with leather boot 150.00
 PROFESSIONAL junior tripod and case 150.00
 THALHAMMER Tripod 15.00
 15MM. EKTAR F2.5 75.00
 TURNER electric interlock motor system with master and two slaves 115 volt AC complete with control box—New 500.00
 Phone: HOLLYWOOD 7-1467 or write ARTHUR TRUTLER, 1714 North Wilton Place, HOLLYWOOD 2B.

MAURER 16mm. camera Model 05, viewfinder, 400 ft. magazine, 110 volt sync motor, sunshade filter holder, 25mm. F1.4 Ektar, 40mm. F1.6 Ektar, 15mm. F2.5 Ektar and carrying case. Like new, \$3,800.00; BERNDT-MAURER Mod. H Single System Sound Camera, two 400 ft. magazines, 110 volt sync motor, viewfinder, sound optical system, automatic dissolve, 2" Zeiss Biotar lens F1.4 and carrying case. Like new, \$2,200.00; 2 Berndt-Maurer Film Phonographs. Like new, \$700.00 each. A. F. KLIENDIENST, Beacon Lodge, Webster, Mass.

BASS . . . is headquarters for Arriflex 16; the new Zoomar 16; Cine Specials, all models; Bell & Howell 70-DL; Bolex H-16. Used Cine Special I, 1" F:1.9 lens and carrying case \$395.00; Used H-16 Bolex, 1" F:1.5, 0.7" F:2.5 W.A., 3" F:3.5 \$347.50 Used Bell & Howell 70-DA, 1" F:1.9, 4" F:4.5 \$235.00. Used Bell & Howell 70-A, 1" F:3.5 and case \$52.50; Used 200' Chamber Cine Special \$295.00; Used 100' Chamber, Cine Special \$117.50. Best buys . . . Best trades always. BASS CAMERA CO., Dept. AC, 179 W. Madison St., Chicago 2, Ill.

STUDIO & PRODN. EQUIP.

LIKE A BROKEN DRUM—CAN'T BE BEAT
 WALL 35mm MOVIE-TONE Single System Sound Camera \$1995.00
 MAURER 16mm CAMERA w/400' mag; sync-motor; viewfinder; compl. 2750.00
 KODAK HISPEED 16mm Camera w/63mm lens, \$1713 val. 995.00
 PAN CINOR ZOOM LENS for 16mm 229.50
 BARDWELL-MCALISTER MULTIPLE FLOOD-LITES. 3 Quadruple heads holding 12 bulbs on rolling tripod stand. Orig. Gov't Cast \$180. Surplus 29.50
 CINE SPECIAL 16mm BLIMP Custom Built. Has follow focus, vertical image 63mm viewfinder, takes 200' mag & syncmotor. \$600 value 350.00
 CINEFLEX 35mm REFLEX CAMERAS with lenses, magazines, compl. 595.00
 CRAB DOLLY, MOVES EVERY WHICH WAY simply, easily. Mount tripod and away you go 650.00
 ANSCO-SWEET COLOR DENSITOMETERS \$850 val. 367.50
 CINEMAPHONE 35mm DUBBING Heads, less Motor 395.00
 RCA 4 POSITION CONSOLE, with main amplifier, line amplifier, 4 pre-amps, equalizers, compl. \$3000 val. 895.00
 WESTERN ELECTRIC 35mm OPTICAL RECORDING System complete 4950.00
 HOUSTON 16mm KIA REVERSAL DEVELOPER, recond. 3250.00
 NEW DIFFERENTIAL REWIND GIMMICKS, match 16mm with 35mm reels. Singly—\$37.50; Pair 69.50
 NEW FILM EDGE NUMBERING MACHINES, 16 or 35mm 2250.00
 HEAT EXCHANGER, 10 gpm, 1900W, new shopworn 150.00
 SOS FILMETER STOP WATCH \$29.50 list 13.95
 TRADES TAKEN. SEND FOR 1954 CATALOG
 Dept. fc Phone PL. 7-0440 Cable SOSOUND
 S. O. S. CINEMA SUPPLY CORPORATION
 602 W. 52nd Street New York 19, N.Y.

16MM. HOUSTON K-1A
 Processing machine, like new. List price \$5,500.00. A terrific bargain at \$2,950.00.

AIR PHOTO SUPPLY CORP.
 555 East Tremont Avenue
 New York 57, New York
 Phone: Cypress 9-6400, Mr. Krim.

BELL & HOWELL 70-H Camera outfit, 5 lenses, 5 viewfinders, two 400 ft. magazines, 2 matars, batteries, cases. Excellent condition. Complete, only \$1,295.00. H. WILLIAMS, B021 Radford Ave., North Hollywood, Calif.

FLANGES, New Aluminum 16mm., 800 ft. While they last \$5.95 Postpaid. GREAT LAKES MOTION PICTURE SERVICE, 12037 Grand River Ave., Detroit 4, Mich.

WALL S. S. 35MM. SOUND CAMERA

COMPLETE with Galvanometer, amplifier, portable power supply, 40-50-75 and 100mm. lenses, erect image viewfinder, complete front attachments, two 1000 ft. magazines, Balanced Tripod, necessary carrying cases. Overhauled. Guaranteed perfect. Reasonable.

CAMERA EQUIPMENT COMPANY
 1600 Broadway New York 19, N. Y.

AUDIO AKELEY single system camera complete with Akeley sound head, Gyro tripod, 3 lenses, view finder, Maurer mixing amplifier. Complete with cables, power supply and W. E. microphone. CAMERA EQUIPMENT CO., 1600 Broadway, New York 19, N.Y. Cable Cineaudio.

ARRIFLEX 35mm. camera, 3 lenses, filters, sunshade, tripod, case. Complete for quick sale . . . \$795.00. Write P.O. Box 312, Ridgewood, N.J., or phone Allendale, N.J. 13046.

WE BUY, SELL AND RENT PROFESSIONAL AND 16mm. EQUIPMENT, NEW AND USED. WE ARE DISTRIBUTORS FOR ALL LEADING MANUFACTURERS. RUBY CAMERA EXCHANGE, 729 Seventh Ave., New York City. Established since 1910.

WANTED

WANTED

Mitchell — Akeley — B & H — Wall — Eyemo
 Cameras — Lenses — Equipment

NATIONAL CINE EQUIPMENT, INC.
 209 West 48th St. New York, N.Y.

WANTED

IMMEDIATE CASH PAYMENT FOR CAMERAS AND EQUIPMENT

NEED EYEMOS (SINGLE LENS AND TURRET), MITCHELLS, ARRIFLEX, DE BRIES, B&H STANDARDS AND HI-SPEEDS, WALLS, AKELEYS, CINE SPECIALS, AJURICONS, MAURERS, FILMOS, ALSO BALTARS, COOKES AND OTHER LENSES, SOUND STAGE, LABORATORY AND EDITING EQUIPMENT OF ALL TYPES REQUIRED. PLEASE SHIP INSURED OR FORWARD DESCRIPTIONS AIRMAIL. IMMEDIATE PAYMENT.

**GORDON ENTERPRISES • 5362 N. Cahuenga
 NORTH HOLLYWOOD, CALIFORNIA**

YE OLDE SOS TRADING POST

Doing Business Since 1928
 BUY — SELL — SWAP — CONSIGN

Cameras, Dollies, Lenses, Lights, Moviolas, Printers, Recorders, Studio or Laboratory Equipment

Western Union-WUX New York
 Phone PL. 7-0440

S. O. S. CINEMA SUPPLY CORPORATION

Dept. fc Cable: SOSOUND
 602 W. 52nd Street New York 19, N. Y.

WANTED TO BUY FOR CASH

CAMERAS AND ACCESSORIES
 MITCHELL, B & H, EYEMO, DEBRIE, AKELEY ALSO

LABORATORY AND CUTTING ROOM EQUIPMENT

CAMERA EQUIPMENT COMPANY

1600 BROADWAY, NEW YORK CITY 19

CABLE: CINEQUIP

WANTED

PRODUCTION EQUIPMENT, LABORATORY EQUIPMENT, EDITING EQUIPMENT, 16mm. and 35mm. FROM SINGLE ITEMS TO COMPLETE STUDIOS. TRADES ACCEPTED.

THE CAMERA MART, INC.
 1845 Broadway Circle 6-0930 New York 23, N.Y.

F & B PAYS MORE FOR USED 16/35MM EQUIPMENT

WRITE — WIRE — PHONE
 FOR OUR CASH OFFER

**FLORMAN & BABB MU. 2-2928
 70 W. 45TH ST. NEW YORK 36, N.Y.**

200' chamber, leatherette covered, sound film type for Cine Special. BOICE Cine Service, Warsaw, Indiana.

CAMERA & SOUND MEN

ASSIGNMENTS FOR INDIA or nearby territories for any type of films, 16 or 35mm, B&W or Color, write to KANU PATEL, A.R.P.S., The Clarion Productions, 34, Park Mansions, CALCUTTA-16.

AFGHANISTAN from the Khyber Pass to Mazar-i-Sharif—Experienced, well-traveled photographer will shoot 16mm movies (Kodak Cine Special II) or B&W (Speed Graphic). Airmail JIM CUDNEY, c/o American Embassy, Kabul, Afghanistan.

YOUNG qualified photographer, experienced in 16mm documentary production seeks employment that will facilitate immigration from England. Box 1185, AMERICAN CINEMATOGRAPHER.

ASSIGNMENTS FOR JAPAN on all subjects, 16 mm. and 35 mm., Color or B & W. Write to AOI-MAJESTIC PRODUCTIONS, 2-Nogatacho, Chiyodoku, Tokyo.

(Continued on Next Page)

Classified Ads

(Continued from Preceding Page)

FOR SALE

COLLECTOR'S ITEM!

Have all issues of American Cinematographer, beginning with Vol. 1, No. 1, dated 1919, to present. Each in excellent condition. Represents valuable reference library of technical and historical data on cinematography since the founding of the A.S.C. Entire collection must be sold as a whole. Price \$100.00. Address Box 1186, American Cinematographer.

COLOR SLIDES, PHOTOS & FILMS

NATURAL COLOR SLIDES, Scenic, National Parks, Cities, Animals, Flowers, etc. Set of eight \$1.95 Sample and List 25c. SLIDES, P.O. Box 26, Gardena, Calif.

ALASKA WILDLIFE KODACHROME 16mm. — 8mm. 2x2 slides taken by professional photographer and Alaskan Registered Guide. Free Catalog. MAC'S FOTO SERVICE, 315 4th Avenue, Anchorage, Alaska.

LABORATORY & SOUND

SOUND RECORDING at a reasonable cost. High Fidelity 16 or 35. Quality guaranteed. Complete studio and laboratory services. Color printing and lacquer coating. ESCAR MOTION PICTURE SERVICE, INC., 7315 Carnegie Avenue, Cleveland 3, Ohio. Phone Endicott 1-2707.

SAVE TIME ON 16MM PROCESSING AND PRINTING! Same day service on 16mm reversal processing. Dupont & EK films in all lengths. Price list available.

WESTERN CINE SERVICE

114 East 8th Avenue Denver 3, Colorado

POSITIONS AVAILABLE

INTER-AMERICAN EXPEDITION REQUIRES CINEMATOGRAPHER. Departure August for Arctic Circle to Cape Horn 20,000 mile overland Expedition, the first under its own power the length of the Americas. Shooting 16mm Kodachrome and B/W with sync. sound for theatre and TV. Limited cash payment guarantee plus split revenue. INTER-AMERICAN EXPEDITION, 133 East 39 Street, New York 16. MU. 3-4179.

PERMANENT position. Salary up to \$10,000.00 year. 16mm sound color film producing studio, located in Chicago suburb, requires person capable of script writing, film production, and direction to produce training and sales movies for the phenomenally expanding vending machine industry. AUTOMATIC MERCHANDISING CO., 2021 Carroll Avenue, Chicago 12, Illinois.

To Classified Advertisers

Copy deadline for classified advertising is the 12th of month preceding publication date. Mail copy and remittance to cover cost to

AMERICAN CINEMATOGRAPHER

1782 No. Orange Dr. Hollywood 28, Calif.

To Sell

THE MOTION PICTURE INDUSTRY

YOU

NEED

AMERICAN

CINEMATOGRAPHER

AMERICAN CINEMATOGRAPHER reaches all fields of 35mm and 16mm motion picture production—

- Major Hollywood Studios
- Television Film Producers
- Industrial Film Makers
- Educational Film Producers
- Amateur Movie Makers
- Film Laboratories
- Foreign Film Producers (67 countries)

Why be satisfied with anything less?

Write For Advertising Rates

THE ROLE OF LIGHT IN CREATING MOOD

(Continued from Page 269)

real art of set lighting for mood and tempo must depend primarily upon the individual cinematographer's artistic sense, and upon his ability to visualize in terms of lighting.

Since the majority of studio cinematographers have developed this skill to a marked degree, it would, I think, be of incalculable benefit to the industry if more studio directors and producers made it a rule to discuss each production with the cinematographer during its preparatory stages. Having ample time to familiarize himself with the complete script, and a thorough understanding with the producer and director on the lighting and camera problems well in advance of starting actual production results in a better coordinated production. The mechanical details involved in a production—while vastly important—are actually secondary to the importance of visualizing the artistic treatment of the production through proper lighting and photographic approach.

A vital phase of this, incidentally, is the coordination of this treatment with the style concepts of the director. Given the same script and physical production, two directors might easily turn out two radically different versions—each of which would demand basically different photographic treatment.

Cinematographers today try to visualize every angle, every phase of lighting before shooting starts. Thus, just before each scene is actually filmed, they will have a definite mental plan of the technical steps that must be followed so that the lighting will not only be in tune with the dramatic mood and tempo of the action, but will bring out the fundamental traits of each character.

Most of the concepts set forth here can be carried out in the personal lighting of the players, while—like a musical undertone—the lighting of the settings synchronizes with the dramatic tempo of the action. Where the action moves at a dramatically swift pace the set lighting can be of relatively high key; where it grows melodramatic, there can be increased brilliance in the general lighting. Where the action moves at a slower tempo, the lighting can strike a lower key.

Often the spirit of the period can likewise find much expression in the lighting. The buildings of the time may have been built for defense, rather than comfort; accordingly, the only illumination within them was from torches and candles, aided in the day-

light hours by thin shafts of sunlight filtering through tall, narrow windows. To be historically correct in lighting such sets, the illumination must reproduce in a great measure this known condition—and the photographic effects so produced will convey a perfect visual impression of the rough hardihood of the age. With this background as a guide, there would be unusual opportunity for true dramatic cinematography and lighting.

To summarize, the cinematographer—using light artistically and imaginatively—can create and sustain moods in a production that otherwise could not be introduced with the same effectiveness through dialogue, characterization or direction. In the final analysis, the impression of mood is generally more of visual than of aural origin. Here, then, is a vast area in which the cinematographer's artistry and initiative can function to contribute substantially to the success of a motion picture.

DOLLY TRACKS

(Continued from Page 232)

same time leaves more space between the tracks for the operator to walk.

In laying down the tracks, it is important that they be set at the proper distance and uniformly so the full length of the tracks, that the dolly will glide freely up and down the channels without binding. When properly located, the tracks should be firmly attached to the floor at each end with strips of masking tape.

Surprisingly enough, the tracks will have little tendency to shift at the ends if properly placed; hence, the use of masking tape to secure them will prove quite sufficient.

Where it is desired to use the tracks out of doors on rough ground, it is advisable to mount them on lengths of wooden two-by-fours. This will give the tracks sufficient "body" to enable them to support the dolly on uneven ground.

A series of three color films, "The Wealth of Our Nation," has been started by Pat Dowling Pictures, Los Angeles, for which producer's cameramen will travel during this spring and summer in many areas of the United States from coast to coast. The Dowling company, incidentally, has added an additional service to its industrial film production by installing facilities for microscopic photography in color and 16mm.

Check **your color requirements**

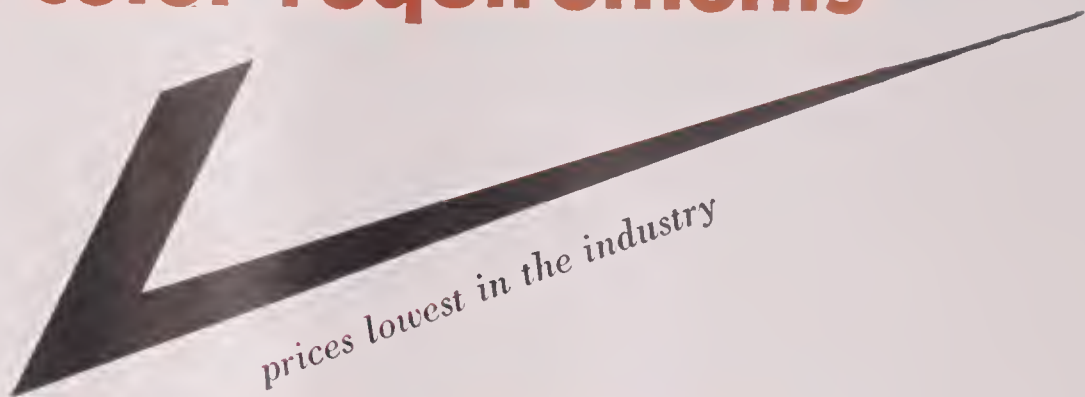

prices lowest in the industry

against the industry standard



best color in the industry

... **color-correct*** **prints**

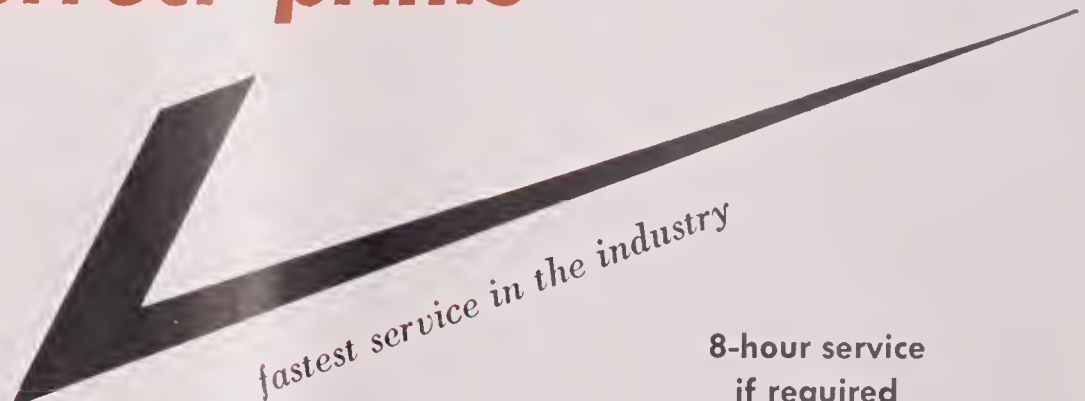

fastest service in the industry

8-hour service
if required

Check these other
byron production facilities
for quality, speed economy:

- ✓ script
- ✓ art
- ✓ editing
- ✓ sound effects
- ✓ animation
- ✓ recording
- ✓ location photography
- ✓ music library
- ✓ sound stage
- ✓ complete black-and-white
laboratory facilities
- ✓ titling

send for the **byron**
price list today

byron Studios and Laboratory

1226 Wisconsin Avenue, N.W., Washington 7, D.C. DUpont 7-1800

550 Fifth Avenue, New York 36, N.Y. Circle 5-8188

*Reg. U.S. Patent Office

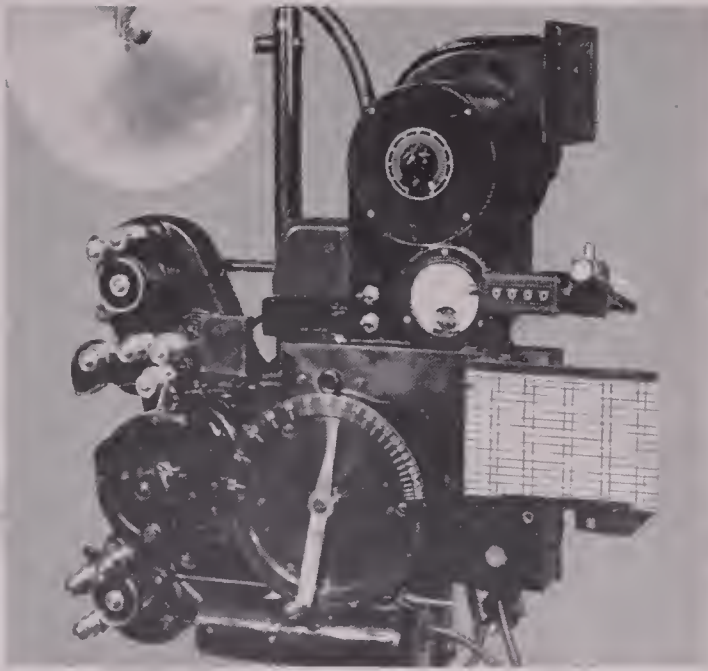

Continuous Printer Model 5205 — adapts for color films, black-and-whites, TV films and for the new 32mm process (printing two 16mm films simultaneously).

Model 5205 from \$3,795



New 300-watt Super-High Intensity Printer Lamp is 194.8 foot-candles brighter than any other 300-watt printer. Included on all new Model 5205 printers, this lamp may be added to B&H printers now in the field. \$595

precision partners

...first in service throughout the world



Professional Portable Splicer for 35mm, 16mm and 8mm films. The Model 198 splicer handles heavy-duty work, yet retains the advantage of portability — sets a new standard of precision and ruggedness. Model 198 from \$185



Automatic Film Splicing Machine Model 5692—famous for fast, easy splicing of both 16mm and 35mm film. Permits scraping of both the emulsion side and the base side of the film — so essential with the new magnetic films and other 35mm developments. Model 5692 from \$975

Bell & Howell

Professional Equipment Department
7148 McCormick Rd., Chicago 45, Ill.

Cinematographer

THE MAGAZINE OF MOTION PICTURE PHOTOGRAPHY

THEATRE
TELEVISION
INDUSTRIAL
AMATEUR



In This Issue . . .

- Hollywood's Greatest Underwater Venture
- Analyzing Documentary Technique
- Lighting Productions for the Business Screen

25c
\$3.00 YEARLY

Here is amazing

MANEUVERABILITY

never before achieved!

NEW!

For Film and TV Cameras

NEW! CIRCULAR STEERING

Entirely new steering mechanism makes possible easy, smooth, sharp turning on own axis or in any desired arc. Wheels can also be locked parallel for straight tracking in any direction.

VERSATILE WHEEL POSITIONS

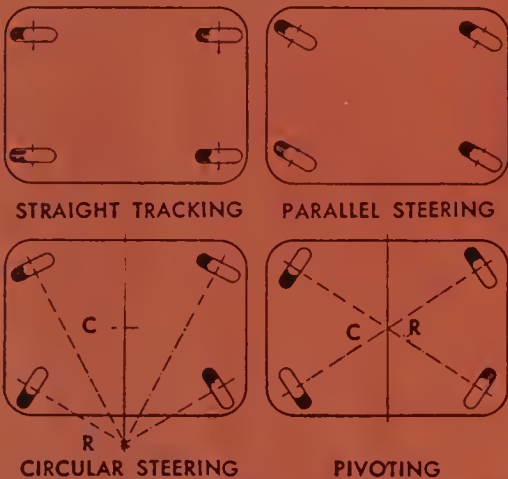

NEW! MANEUVERABILITY

The extreme flexibility of the steering mechanism makes possible fast positioning in small, crowded studios.

NEW! HANDLING EASE

Weighs only 500 pounds. Cameramen and grips appreciate easy dollying, turning, raising and lowering boom.

NEW! LOW SLUNG CHASSIS

Cinemobile is built low down for better balance, greater stability and smoother rolling.

NEW! VERSATILITY

Makes possible a wide range of camera effects formerly achieved only with larger, heavier equipment. Priced to fit the budget of smaller studios.

HOUSTON-FEARLESS CINEMOBILE



NEW! HYDRAULIC BOOM LIFT

Camera boom is raised and lowered smoothly, quietly, effortlessly, automatically by hydraulic system. Extreme high and low lens heights are readily achieved even when dolly is in motion.

SEND FOR FULL INFORMATION NOW!

The
**HOUSTON
 FEARLESS**
Corporation

THE HOUSTON-FEARLESS CORPORATION
 11809 W. Olympic Blvd. • Los Angeles 64, California
 Send information on Cinemobile Film Processors All Metal Tripod
 Ponorom Dolly Camero Crone TV Pedestal

Name _____
 Firm _____
 Address _____
 City _____ Zone _____ State _____

SALES • SERVICE • RENTALS

JUN 14 1954



THE WORLD'S MOST COMPLETE ASSORTMENT
OF PHOTOGRAPHIC EQUIPMENT FOR

T.V. and Motion Picture Studios



New **PROFESSIONAL JUNIOR**

Adjustable wood **BABY TRIPOD**

—for Prof. Jr. friction
and geared heads



Has substantial shoe and spur.
Measures from floor to flange
25" extended —17"
collapsed. **\$75**

FAMOUS
"controlled
action"

SMALL **GYRO**
TRIPOD

Two speeds—slow and fast
—for both panning and tilting.
Helps you capture fine scenic views
and fast-moving sports events. Espe-
cially recommended for 16mm Mitchell,
16mm Maurer, B & H Eyemo
and similar cameras.

\$600

PACKAGED LIGHTING WITH
COLOR-TRAN

—studio lighting in a suitcase



Imagine being able to use two 5000 watt units
on a 30 amp. fuse — COLOR-TRAN will do it!
Kit contains 2 light heads, 2 Superior stands and
proper size COLOR-TRAN converter to match.
Packed in compact case.

Senior Kit
\$237.50

Other style
kits available.

Write for *COLOR-TRAN* Catalogue.

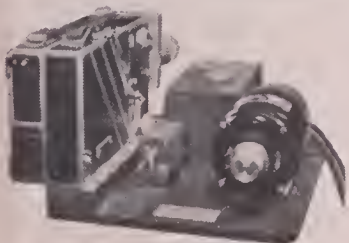

STOP MOTION MOTOR
FOR CINE KODAK SPECIAL

Runs forward or reverse, 110
AC synchronous motor with frame
counter. May be run continuously
or for single frames. Camera
mounts without special tools.

\$450

Also available — Stop Motion
Motors for 16mm—35mm B & H,
Mitchell and other professional
cameras.



ELECTRIC
FOOTAGE TIMER

Dual model for both 16mm
and 35mm. Large white num-
erals on black background. Accu-
rate reset dial. Switch controlled
by operator, who selects either
16mm operating at 36 feet per
minute—or 35mm operating at
90 feet per minute . . . or both
in synchronization.

\$95

Single model, either 16mm or
35mm **\$45**

presto-splicer

GIVES PERMANENT SPLICE
IN **10** SECONDS!

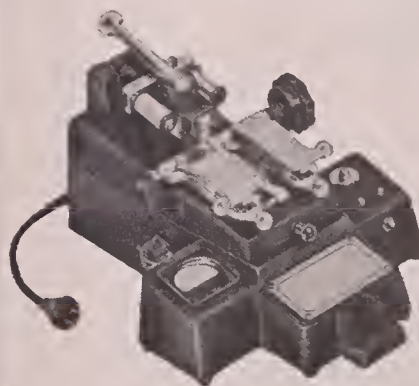

Especially good for splicing magnetic
film. Butt Weld type for non-perforated
or perforated film. 16mm, 35mm or
70mm. **\$547.80**

16mm or 35mm models—
for perforated film.

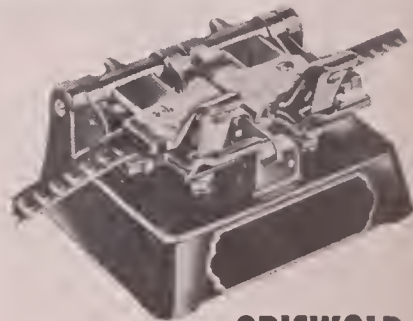

GRISWOLD
HOT FILM SPLICER

Model R-2 for 35mm silent and sound
film. Precision construction makes it easy
to get a clean, square splice with accu-
rate hole spacing. Nothing to get out of
order. **\$65**

Also Bell & Howell 8mm, 16mm and
35mm Hot Splicers and B & H Labora-
tory model Foot Splicer.

9.5mm Lenses in 16mm C mount. 18.5mm (extreme wide angle-flat field)
Lenses available in mounts for all 35 mm Motion Picture Cameras.
PHOTO RESEARCH Color Temperature Meters. *Electric Footage Timers
Neumade and Hollywood Film Company cutting room equipment.
Griswold & B.&H. Hot Splicers. *DOLLIES—Bardwell-McAlister, Mole
Richardson, Century and Colortran Lighting Equipment.

Complete line of 16mm and 35mm Cameras

FRANK C. ZUCKER
CAMERA EQUIPMENT CO.
1600 BROADWAY NEW YORK CITY

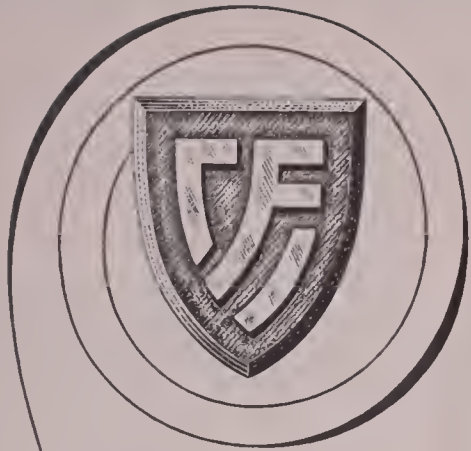

**The Seal of Our
Pledge to You**

**... to bring
to the screen
in flawless manner
the artistry
of your
photography**

*Hollywood's
only complete*

**LABORATORY
SERVICE**

**CONSOLIDATED
FILM INDUSTRIES**

A DIVISION OF REPUBLIC PICTURES CORPORATION

**959 N. SEWARD ST.
PHONE HO 9-1441**

AMERICAN

Cinematographer

THE MAGAZINE OF MOTION PICTURE PHOTOGRAPHY
PUBLICATION OF THE AMERICAN SOCIETY OF CINEMATOGRAPHERS

ARTHUR E. GAVIN, *Editor*

MARION HUTCHINS, *Editorial Assistant*

EMERY HUSE, *Technical Editor*

EDITORIAL ADVISORY BOARD: John Arnold, Arthur Edeson, Lee Garmes, Charles
Rosher, Leon Shamroy, Fred Gage, Glenn R. Kershner

Editorial and Business Office: 1782 N. Orange Dr., Hollywood 28, Calif.
Telephone: HOLlywood 7-2135

VOL. 35

JUNE • 1954

NO. 6

CONTENTS

ARTICLES

HOLLYWOOD'S GREATEST UNDERWATER VENTURE—By <i>Till Gabbani</i>	- - -	282
LIGHTING PRODUCTIONS FOR THE BUSINESS SCREEN— By <i>Frederick Foster</i>	- - -	284
LIGHT PLAYS A PART IN SET DESIGN—By <i>William Bancroft Mellor</i>	- - -	286
THE PRE-EDITING STAGE—By <i>Charles Loring</i>	- - -	288
THE CINERAMA TECHNIQUE—By <i>Joseph Brun, A.S.C.</i>	- - -	290

AMATEUR CINEMATOGRAPHY

ANALYZING DOCUMENTARY TECHNIQUE—By <i>Charles L. Anderson</i>	- - -	292
COMMON SENSE IN CUTTING-IN TITLES—By <i>John Forbes</i>	- - -	294

FEATURES

HOLLYWOOD BULLETIN BOARD	- - -	270
INDUSTRY NEWS	- - -	272
WHAT'S NEW IN EQUIPMENT, ACCESSORIES, SERVICE	- - -	274
CURRENT ASSIGNMENTS OF A.S.C. MEMBERS	- - -	306

ON THE COVER

SPEED MERCHANTS—The cameraman had to look to his safety in this perilous position as the sports cars rocketed past him for scenes in Universal-International's Technicolor production of "Johnny Dark," starring Tony Curtis, Piper Laurie, and Don Taylor, and photographed by Carl Guthrie, A.S.C.—*Photo by Don Christie.*

AMERICAN CINEMATOGRAPHER, established 1920, is published monthly by the A. S. C. Agency, Inc., 1782 N. Orange Dr., Hollywood 28, Calif. Entered as second class matter Nov. 18, 1937, at the postoffice at Los Angeles, Calif., under act of March 3, 1879. SUBSCRIPTIONS: United States and Canada, \$3.00 per year; Foreign, including Pan-American Union, \$4.00 per year. Single copies, 25 cents; back numbers, 30 cents; foreign single copies, 35 cents; back numbers 40 cents. Advertising rates on application. Copyright 1954 by A. S. C. Agency, Inc.



On the set of "I Love Lucy," starring Lucille Ball and Desi Arnaz. The nation's Number 1 TV show for 1951, 1952 and 1953 is a pioneer of the technique of filming its program as a live show with audience. Desilu Productions uses three Mitchell 35mm BNC cameras in filming "I Love Lucy."



Joan Davis on the set of "I Married Joan," produced by P. J. Wolfson and appearing on NBC. Three Mitchell 35mm BNC cameras are used on this top TV show, which is in its 2nd year. Jim Bockus plays the mole lead.



Dennis Day, star of "The Dennis Day Show," a top-rated NBC program. Originally "live," this series is in its second year, and is now produced as a film by Denmac Productions, using a Mitchell 35mm BNC camera.

TO FILM A SUCCESSFUL SHOW...

It takes more than just a good script to insure the success of a top-rated network program. The on-stage performances of the stars and supporting cast must be outstanding, carefully timed, superbly directed. And the camera must perform flawlessly in its vital role of recreating the superior quality of the show for millions of TV viewers.

Mitchell cameras—internationally famous—provide the matchless photographic performances so necessary to the successful making of the finest theater quality films. That is why, wherever top quality filming is the foremost consideration, Mitchell Cameras are to be found... bringing *success* into focus.

MITCHELL *The only truly Professional Motion Picture Camera*

Mitchell Camera CORPORATION

666 West Harvard Street • Glendale 4, Calif. • Cable Address: MITCAMCO



85% of the professional motion pictures shown throughout the world are filmed with a Mitchell

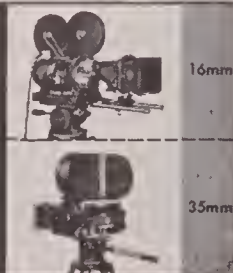

ARRIFLEX

New 35 mm Model 2A
With 180° Shutter

**A TRULY GREAT
CAMERA**

for TV, Newsreel
and commercial
films

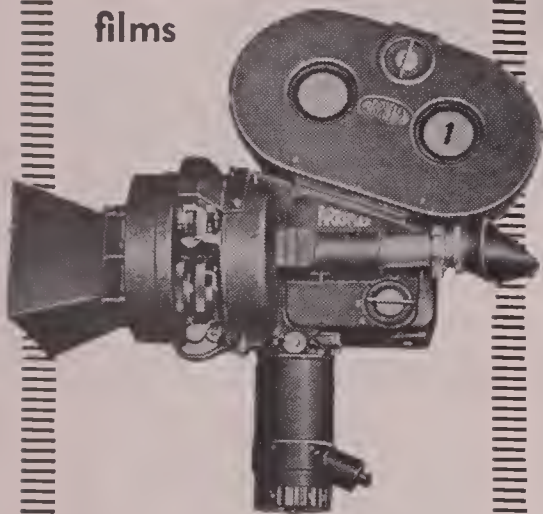

For tough and trying assignments, ARRIFLEX 35 is in a class by itself. Reflex focusing through photographing lens while camera is operating—this is just one outstanding ARRIFLEX feature.

Equipped with bright, right-side-up image finder, 6½ x magnification. Solves all parallax problems. 3 lens turret. Variable speed motor built into handle operates from lightweight battery. Tachometer registering from 0 to 50 frames per second. Compact, lightweight for either tripod or hand-held filming. Takes 200' or 400' magazine. Write for free folder.

Blimp now available.
16mm ARRIFLEX also available.

FRANK C. ZUCKER
CAMERA EQUIPMENT CO.
1600 BROADWAY NEW YORK CITY

Hollywood Bulletin Board



A TRACKING SHOT routine which director of photography Irving Glassberg, ASC, engineered for shooting a scene for Universal-International's "Francis Joins the WACs."



MAURY GERTSMAN, ASC, and his camera crew take to a raft to film scenes for "Tanganyika" on lake on the Universal-International studio backlot. Setting represents British East Africa.

James Wong Howe, ASC, last month was elected an Honorary Member of Delta Kappa Alpha, National Motion Picture Honorary Fraternity at University of Southern California. Howe is second Hollywood cinematographer to be so honored. Previously, Arthur Miller, ASC, had been voted an Honorary membership in the fraternity.

Ted McCord, ASC, following an absence of several months from Warner Brothers Studio where he photographed some of that studio's top productions in recent years, has been signed to a new three-year contract by Jack Warner. His first assignment is "East of Eden," begun May 27th and being filmed in CinemaScope and WarnerColor.

Irving Browning, head of The Camera Mart, Inc., New York City, and founder and first President of the Society of Cinema Collectors and Historians, outlined the aims of the Society in a talk before members of the S.M.P.T.E. at the latter's convention in Washington, D.C. last month.

William German, President of W. J. German, Inc., E-K film distributors, and who also is an Associate Member of the American Society of Cinematographers, last month was presented with the New York Variety Club's first Heart Award in recognition of his work as President of the Variety Club's Foundation to Combat Epilepsy.

Highlight of the evening was a dramatized sketch on the order of "This Is Your Life" covering the illustrious career of German from the time he entered the employ of Eastman Kodak Co. in

Rochester in 1906 to his present status as head of the company which bears his name.

Ralph Staub, ASC, who left Columbia Pictures sometime ago to collaborate with comedian Ken Murray on a new TV film series, has returned to Columbia where he will resume production of the studio's famed "Screen Snapshots" short subjects.

"Elephant Walk," recent Paramount Pictures' Technicolor release, carries credits of six A.S.C. cameramen. In addition to the name of Loyal Griggs, who was Director of Photography on the production, John P. Fulton, Paul Lerpae, Farciot Edouart, Wallace Kelley and Irmin Roberts contributed process and special effects photography to the production.

Edward Cronjager, ASC, flew to Paris early last month to photograph special footage for "Desiree" and "A Man Called Peter." 20th Century-Fox CinemaScope productions. Assignment will keep him overseas about six weeks.

Tom Tutwiler, ASC, who directed 2nd Unit photography on Paramount's "Strategic Air Command," completed the assignment early last month. Raves by studio execs for his exceptional aerial photography greeted him on his return. William Daniels, ASC, directed photography on the first unit at the studio.

Bob Burks, ASC, is in France where he will photograph Alfred Hitchcock's new production for Paramount release, "Catch A Thief."

COLOR

you've been waiting for...

bold, clear, alive!



Henri Toulouse-Lautrec,
pioneer of
commercial color.

"Life-like color," the ultimate in the reproduction of color film, is now available to all producers of 16mm motion pictures. Now you can have your exposed film duplicated with perfect blending and balancing of tones. Your release prints will have a sensitive living quality...surpassing anything you have ever seen in clarity.

This is "Life-Like Color," the result of fifteen years of exhaustive research by the country's outstanding color engineers and technicians. It is now available to you exclusively through the laboratories of Telefilm Studios.

With "Life-Like Color," Telefilm Studios again contributes to its primary objective...to help the 16mm producer make better motion pictures. Telefilm's modern facilities and equipment for color printing...high fidelity sound recording (your choice of optical or electronic sound printing)... editing...titling...special effects...and the skill and the know-how of the finest technicians in the industry are at your command.

*for complete information, visit Telefilm Studios,
or write for a descriptive brochure.*

TELEFILM STUDIOS INC.

estab. 1938

6039 HOLLYWOOD BLVD. • HOLLYWOOD, CALIF.

telephone HOLLYWOOD 9-7205

ONE CAMERA

16mm or 35mm

in 10 SECONDS!

Camerette 16/35

Reflex Motion Picture Camera

The perfect camera for the motion picture film maker working in both 16mm or 35mm color or black and white.

LOOK AT THESE ADVANTAGES—

- The same lenses, same motor drives, same sound blimp and accessory equipment used for both 16mm or 35mm — to convert simply change the magazine.
- Precise rugged movement
- Reflex viewing
- 200 degree adjustable shutter
- Divergent three lens turret
- Automatic film gate 400' magazines 16 or 35mm — the 16mm magazine will accommodate daylight spools as well as standard care load.
- Light weight — only 14 pounds with 3 lenses, 400' magazine, and 6/8 volt motor.

Write for brochure



Camerette

patents coutant-mathot

Manufactured by Ets. Cine. Eclair, Paris



INDUSTRY NEWS



Using the Cunningham camera to shoot a fight scene

WHEN THE GOVERNMENT removed restrictions recently on sale of the famed Cunningham 35mm hand-held motion picture camera, it made available to motion picture studios and others one of the most valuable of cameras for special photographic work.

One of the camera's more interesting uses is pictured above. It shows a Hollywood camera man, reclining on a baggage truck being wheeled by a grip, shooting action closeups of a couple of prizefighters. Because of the camera's extraordinary rugged construction, it is ideal for location work and general studio use wherever a hand-held camera is required.

Designed and produced for the O.S.S. at an original cost said to exceed \$7,000 each, it is reported the only hand-held 35mm camera produced in the U.S. having dual pilot pin registration.

All controls can be set and adjusted by an operator wearing gloves, if necessary, making it ideal for use in extreme cold climes. Turret rotation, diaphragm settings, focusing, speed changes and the on-off switch may be controlled without removing hands from the pistol-grip handles.

The camera features a 4-lens, self-positioning ball-bearing turret with 3 integral lenses. Standard lens equipment includes a 35mm Baltar, a 75mm Baltar and a 6-inch telephoto. An eye-

level finder is provided with field marks for the three integral lenses.

Camera is driven by a high-speed universal electric motor, which is governor-controlled for operation at 16, 24 or 32 fps. Rotary shutter is 170°, counter-weighted and dynamically-balanced.

Film magazine holds 200-ft. loads and contains the complete film movement including the dual register pins.

Gordon Enterprises, 5362 No. Ca-huenga Blvd., North Hollywood, Calif., is exclusive distributor of the Cunningham camera, which is priced under \$900.

TELEFILM STUDIOS in Hollywood have announced the development of a radically new process in the duplicating of 16mm color film. Process, copyrighted as "Life-Like Color," features an electronically-operated color printer that automatically corrects for over and under-exposure in the original shooting of a film.

This new process also insures uniformity of all duplicate prints and accurate blending and balancing of delicate tones. The usual reddish tones and fuzziness of detail on all objects, ranging from closeup to infinity, are absent in the finished product.

"Life-Like Color," through the facilities of Telefilm's laboratories, is now

(Continued on Page 310)



35 and 16/35 mm



reflex viewing



divergent turret



40° to 200° adjustable shutter



lightweight - 14 lbs.



100' to 400' magazine



instantaneous loading

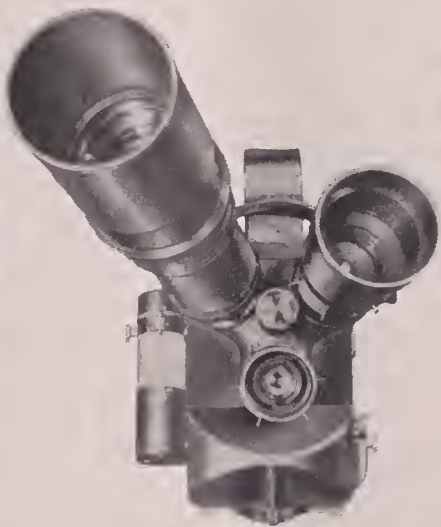

dovetail mounting



camerette

patents Coutant-Mathot
manufactured by Eclair, Paris

for descriptive brochure write U.S. representative

Benjamin Berg Agency, 1410 No. Van Ness Avenue, Hollywood 28, Calif.

in Canada: B.O.P. Co. Ltd., 455 Craig Street West, Montreal, P.Q.

WHAT'S NEW

in equipment, accessories and service



"Impossible" distances become close-ups

Primar Reflex Photo normal 105 mm. lens



Primar Reflex Photo Astro 640 mm. lens taken simultaneously by Hans Namuth

with **ASTRO**[®]

LONG DISTANCE LENSES

FOCAL LENGTHS TO 1000 mm.!

Used by the world's foremost explorers, scientists and news services, Astro lenses have been making photographic history all over the globe. Special formulas have produced resolving powers up to 100 lines to the mm.! And these superb lenses are fast enough for action color work—focal lengths from 300 to 800 mm. rated at F/5, the giant 1000 mm. (40 in.) at F/6.3.

FOR STILL CAMERAS Leica, Exakta, Primar-Reflex, Master Reflex, Hasselblad, Praktica, Contax-S

FOR MOVIE CAMERAS 16 & 35 mm. Bolex, Mitchell, Eyemo, Debrie, Askania, E.K., Arriflex, etc.

DUAL PURPOSE MOUNTS allow interchanging movie and still.

SUPER SPEED TELEPHOTOS

5 in. F/2.3
6 in. F/2.3
6 in. F/1.8

NEW! 12-inch F/3.5 Astro in mounts for all movie and still cameras. **NEW GAUSS TACHARS**—focal lengths 25-32-40-50-75-100 mm.; all F/2, in mounts for practically all 16 and 35 mm. professional and amateur cine cameras.

Write for brochure and prices

ERCONA CAMERA CORP., Dept. A-24,
527 Fifth Ave., New York 17, N.Y.

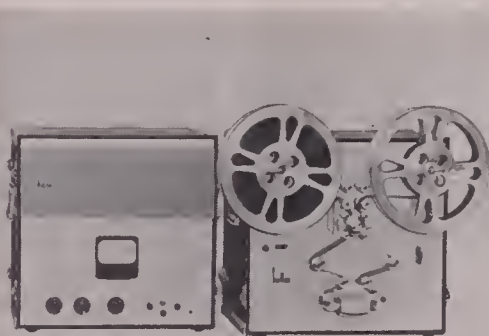

Magnetic Recorders—Hallen Corporation, 3503 W. Olive, Burbank, Calif., announces the addition of two new improved models to its line of professional magnetic film recorders. Model 225 features two sound drums having adequate space between for installation of multiple track, stereophonic or CinemaScope heads.

Model 235 employs a single drum and single track recording system. Otherwise both models are identical and both are available for use with either 35mm, 17½mm or 16mm recording film with standard track placement. Both models come in two units: one containing the electronic section, the other the mechanism. A salient pole synchronous motor, equipped with nylon gears, powers the sprocket. In-sync operation is positive, reverse as well as forward. Other features include smooth and flutter-free film motion, clutch operated take-up, and rewind motors which give fast forward and rewind speed of 1000 ft. per minute, 1200 ft. film capacity, push-button relay operated motor controls, and built-in footage indicator driven from sprocket shaft.

The electronic section consists of record and playback amplifiers, metering and monitor circuits and input and output connections, and one high-level and two low-impedance microphone channels, which can be used simultaneously with abundant gain for use with high quality, low output microphones. Full technical data and price may be had by writing the manufacturer and mentioning *American Cinematographer*.

New Optical Effects System—Consolidated Film Industries, 959 Seward St., Hollywood 38, Calif., announces a new optical effects system particularly adapted to TV production. This new method prints 35mm Eastman color positive from Eastman color negative

without the use of duplicate negatives. The optical effects thus obtained have the same quality as the running footage and there is no extra charge for lap dissolves or fades. The process is in operation and available to customers.

The Rotator Lens is a new and interesting accessory to the well-known Camart Optical FX Unit. With the Rotator Lens attached to the FX Unit it is possible to make such trick effects photographically within the camera as a room revolving, or turned upside down or on its side to photograph people walking on the ceiling, etc. Rotation is possible both clockwise and counter-clockwise.

Still another unusual effect that can be achieved very easily is the creation of the impression subject is getting dizzy

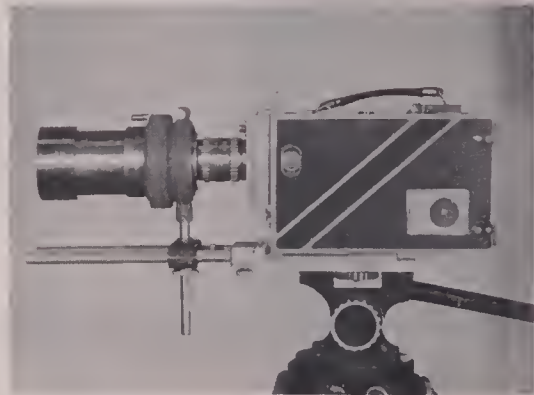

or blacks-out—accomplished simply by revolving the Rotator Lens slowly and gradually increasing rotation speed until scene is whirling rapidly.

By turning the handle back and forth instead of in a full circle a rocking motion is obtained in the scene to give the comedy effect, for instance, of a person seasick.

The Rotator Lens may be used with either 35mm or 16mm cameras, and is just as readily adaptable to television cameras for live action effects.

Present owners of Optical FX Units may attach the Rotator Lens without need for alteration to the FX Unit.

Distributing the Rotator Lens and the Camart FX Unit is Camera Mart, Inc., 1845 Broadway, New York 22, N.Y.

Magnesound Attachment—Victor Animatograph Corp., Davenport, Iowa, announces its new Mixer Magnesound attachment that enables users of either the new 1954 Victor sound projector or any of the company's older model pro-

(Continued on Page 278)

A DEPENDABLE NAME IN
CAMART

SALES • SERVICE • RENTALS

16
MM

35
MM

TV

MOTION PICTURE & TV EQUIPMENT

PRODUCTS
STUDIO OR LOCATION

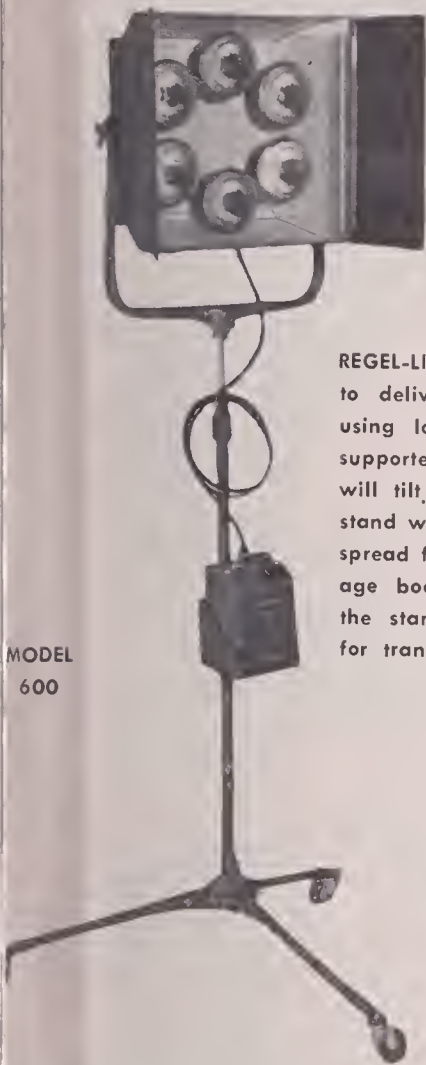

REGEL-LIGHTS

For TRUE COLOR Balance Light for light, you get... MORE light, using LESS current with LONGER bulb life With REGEL-LIGHTS than with any other comparable unit.

REGEL-LIGHTS are specifically designed to deliver correct color temperature using low cost bulbs. The head is supported by a strong cast yoke that will tilt and lock at any angle. The stand with an 8' rise has a wide leg spread for balance. The compact voltage booster is mounted directly on the stand. Entire unit folds readily for transportation to location.

MODEL 600 (illustrated) six bulb unit equivalent to more than 5000 watts, produces 700 foot candles at 12 feet and draws only 16 amps. Complete with head, barndoors, stand, converter\$110.00
MODEL 400, four bulb unit, equivalent to more than 3000 watts, produces 550 foot candles at 12 feet and draws only 10 amps. Complete with head, barndoors, stand, converter\$90.00

Send for descriptive literature.



CAMART TV MIKE BOOM
FOR STUDIO OR LOCATION

Lightweight and practical mike boom for sound production or television studio use. 13' boom arm with counter balance weight and steel stress wire support.

Rear rotating handle for directional mike control. Rugged hinged center joint and lock for folding boom, complete with pan and tilt locks.

Sturdy stand support will rise to 8 feet. Ball-bearing rubber tired wheels for smooth silent movement. Total weight 75 pounds. May be disassembled to fit in your car. Boom arm folds to 6½ feet, stand folds to 4 feet, entire operation requires only a very few minutes for breakdown or set-up on location. Price: \$297.50.

EXCITING NEW EFFECT!
THE ROTATOR LENS



For 16mm - 35mm - TV Cameras

Now you can make your subjects walk on walls and ceilings, create that rocking-the-boat effect, or completely revolve a room 360 degrees in clockwise or counter-clockwise rotation with this new addition to the Camart Optical FX Unit.

Present owners of the Camart Optical FX unit need only the ROTATOR lens in special mount, price.....\$150.00
Revolving housing assembly..... 75.00
Base for most 16mm cameras..... 12.50
Adapter for Mitchell 35mm camera..... 18.50
Camart Optical FX unit motorized, additional..... 125.00
Adapters for TV Cameras, prices on request.

PRODUCTION EQUIPMENT

Developing machine, 16mm positive and negative, film capacity 600' per hour. and new and fully equipped with heavy duty transmission speed control motor, air pump, air squeegees, water spray, drying cabinet, stainless steel tanks. Other comparable units so equipped are more than \$2,100.00. This model is specially priced at.....\$1,795.00
MICHALL Standard 35mm camera, 40mm, 50mm, 75mm Astro Pan Tochar f2.3 lenses, two 1000' magazines, variable speed meter, sunshade and motte box, w/winder, standard friction head tripod with baby, all cases exceptionally in condition\$4,900.00
HILMO 70D, turret, 15mm, 25mm, 50mm lenses, excellent.....\$145.00
HILMO 70DA, turret, 50mm lens, auto-parallax finder, case..... 295.00
Cine-Special 1, black, 15mm, 25mm lenses, excellent..... 395.00
ARRIFLEX Cine-Voice, turret, amplifier, mike, cables, batteries, carrying case, demonstrator, like new..... 625.00
ARRIFLEX RT-70 recorder w/amplifier, mike, cables..... 295.00
ARRIFLEX model L disk playback w/speaker, excellent..... 39.95
ARRIFLEX CINOR Zoom lens, like new..... 295.00
ARRIFLEX DIPLOMAT 16mm projector w/case, excellent..... 115.00
ARRIFLEX Friction head tripod for Eyemo or Filmo 69.50
ARRIFLEX Kodak tripod for Cine-Special, ilke new..... 35.00
ARRIFLEX deluxe bowl type tripod w/boots, demonstrator..... 225.00
ARRIFLEX Jr. three wheel collapsible bicycle seat dolly w/case..... 195.00
ARRIFLEX MACHINE SHOP is completely equipped with the latest and best tools and machinery. Complete stock of spare parts for repair and overhaul of Arriflex, Mitchells, Arriflex, Cine-Special, and Maurer cameras. We are an authorized Bell and Howell Repair and Service Station. We have an optical bench installed for complete lens testing and calibrating service.

THE CAMERA • MART INC.

MOTION PICTURE AND TV PRODUCTION EQUIPMENT

1845 BROADWAY at 60th St.
NEW YORK 23 N. Y.

Phone: Circle 6-0930
Cable Address CAMERAMART

SEEING IS BELIEVING!

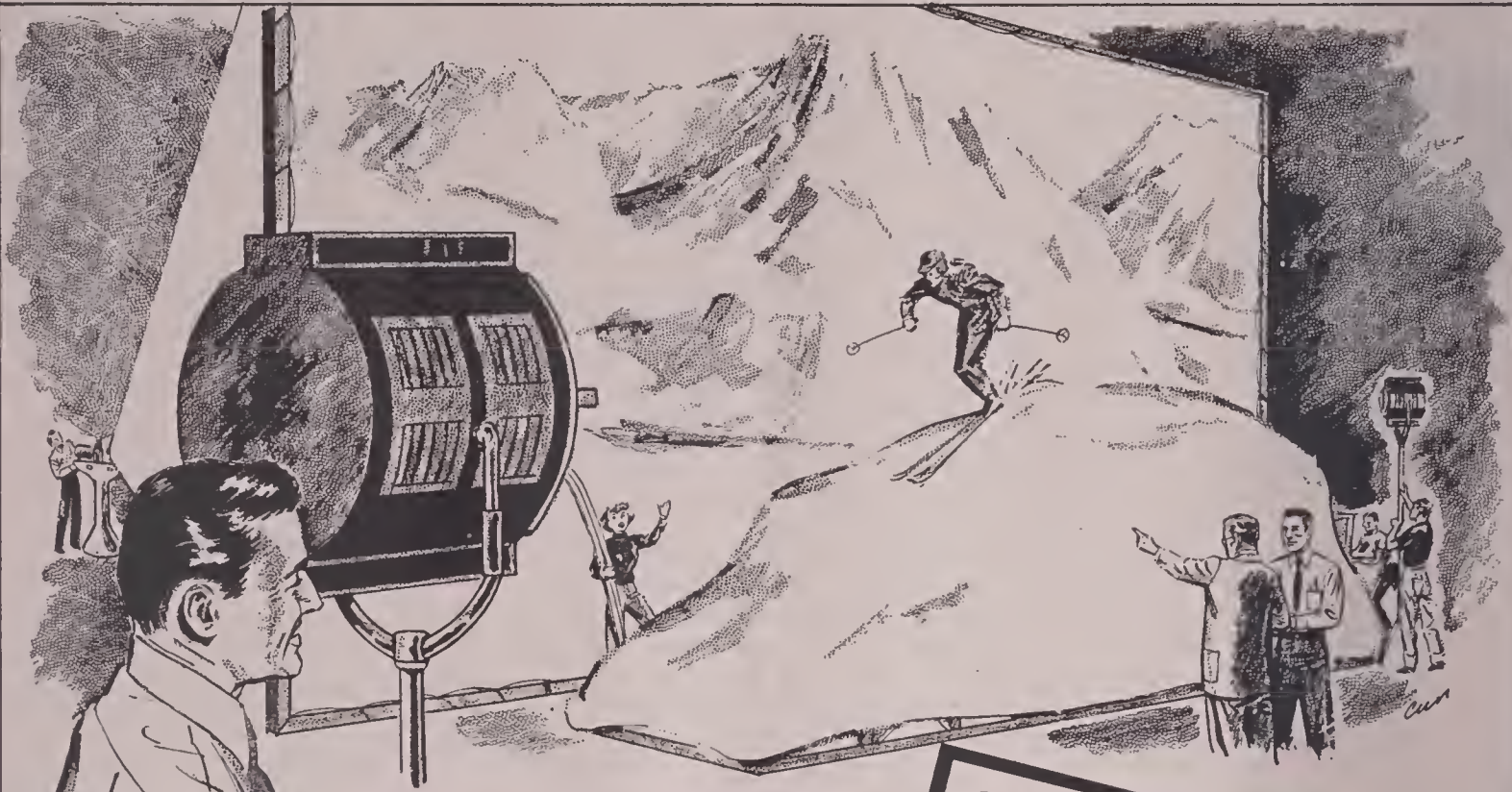

BEHIND THE SCENES...

THE BRILLIANCE AND TRUE COLOR OF "NATIONAL" ARCS IN REAR PROCESS PROJECTION ADJUST PERFECTLY TO FOREGROUND SET LIGHTING...PERMIT AUTHENTIC, FAR-RANGING PRODUCTION LOCALES WITH "STAY-AT-HOME" ECONOMY.

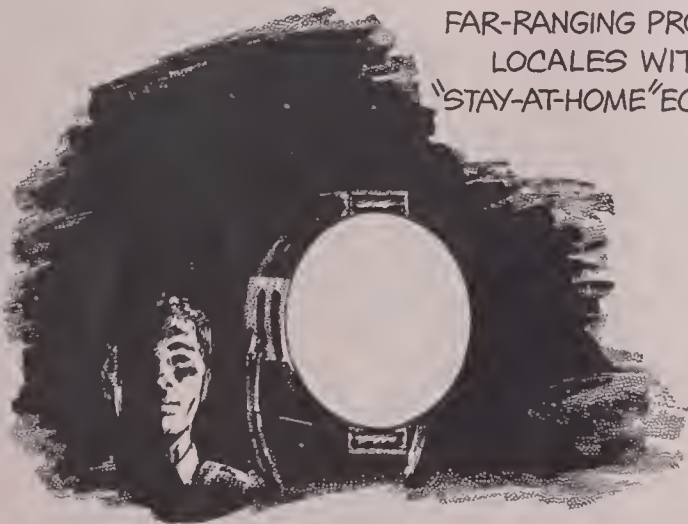

TODAY FOR PROCESS PROJECTION, BROAD SET COVERAGE, DEEP PENETRATION, CRISP SHADOWS AND HIGH BRILLIANCE WITH LEAST HEAT, IMPROVED "NATIONAL" CARBONS CONTINUE TO LEAD ALL OTHER TYPES OF STUDIO LIGHTING.

FIRST USED IN 1930, EARLY PROCESS PROJECTORS WERE STUDIO CREATIONS...TINY SCREENS, HEAVY "BLIMPS", IMPROVISED MACHINERY AND OPTICS. CURRENT TRIPLE-HEAD MODELS OPERATE WITH SCREENS OVER 20 FEET WIDE AND TOTAL LIGHT OF UP TO 85,000 LUMENS!

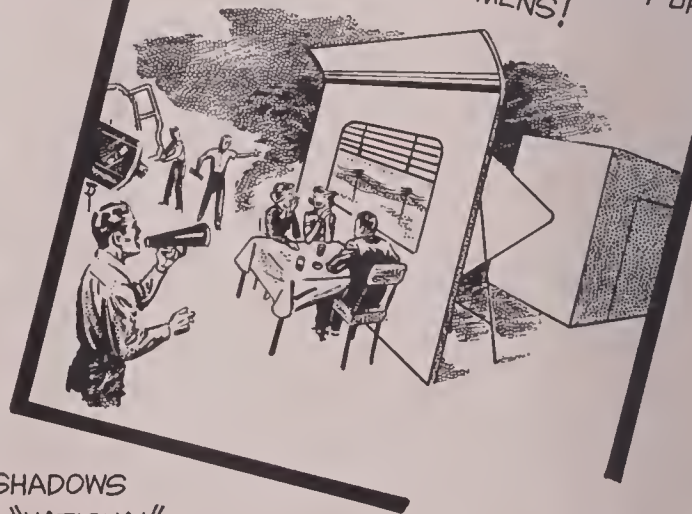

THE "NATIONAL" CARBON ARC... NOTHING BRIGHTER UNDER THE SUN

The term "National" is a registered trade-mark of Union Carbide and Carbon Corporation

NATIONAL CARBON COMPANY

A Division of Union Carbide and Carbon Corporation, 30 East 42nd Street, New York 17, New York

District Sales Offices: Atlanta, Chicago, Dallas, Kansas City, New York, Pittsburgh, San Francisco

IN CANADA: Union Carbide Canada Limited, Toronto



NEW

Modulite Model "S" 16mm variable-area sound-on-film recording Galvanometer with "Shutter" Noise Reduction, now available as optional equipment on the Auricon "Super 1200" and the "Auricon-Pro" Cameras, and the Auricon RT-80 Double-System Recorder.

★ High-fidelity sound-track with 16 DB noise reduction.

★ Sound-track always runs centered on projector photo-cell scanning beam, for crisp and clear sound-track reproduction.

★ Only one audio-modulated sound-track edge, eliminates Gamma (contrast) effects and minimizes "Eberhard Effect" and "Mackie Line" troubles experienced with multiple-track variable-area recording.

★ Audio galvanometer and shutter-noise-reduction galvanometer are independent, preventing noise-reduction-bias cross-talk distortion on sound-track.

★ Rugged. Can be overloaded without danger.

★ Tested and now being used by leading Studios and Television Stations.



OPTICAL SYSTEM DOVE-TAIL CARRIAGE IS ONLY MOVING PART. CAMERA CASING DOES NOT SHIFT TO FOCUS OR SHOOT!

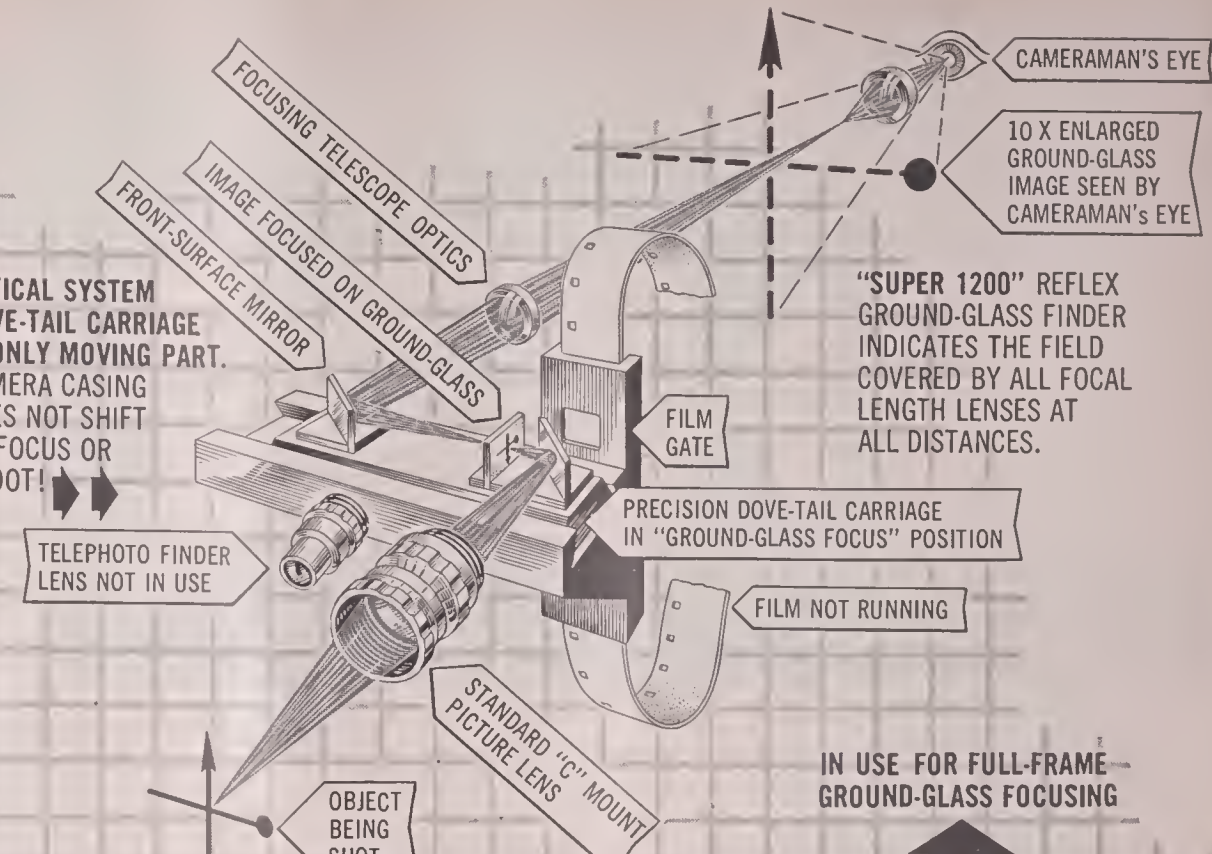

SUPER 1200 CAMERA FOCUSING-OPTICAL-SYSTEM

Precision-Built for Guaranteed Accuracy to .0001 part of an inch

NO CAMERA WEIGHT SHIFT WHEN MOVING FROM FOCUS TO FILM-SHOOTING POSITION.

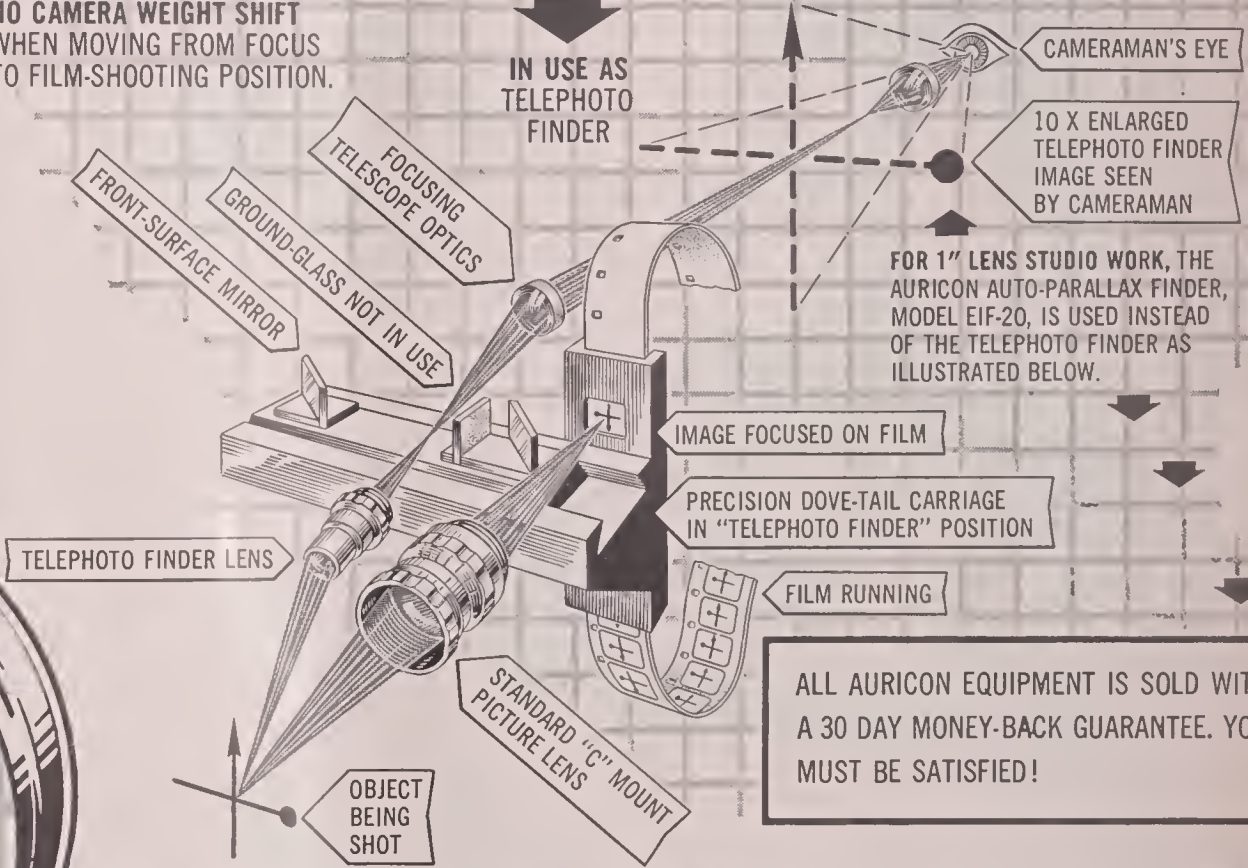

ALL AURICON EQUIPMENT IS SOLD WITH A 30 DAY MONEY-BACK GUARANTEE. YOU MUST BE SATISFIED!

THE CAMERA OF TOMORROW, HERE TODAY. ITS ONLY EQUAL IS ANOTHER AURICON SUPER 1200!

Detailed here are two of the remarkable technical developments built into the new Auricon "Super 1200" Sound-On-Film Recording Camera. The unique Modulite Variable-Area Sound-Track with "Shutter" Noise-Reduction, described at left, and the new Reflex Telephoto-Finder and Focusing-Optical-System shown above, plus "Self-Blimping" for studio work, 33 minutes continuous film capacity, Variable Shutter, and other professional features, have prompted Producers and Cameramen to name the Super 1200... "Finest 16 mm Sound Camera ever built!"

Priced complete for Optical Sound-On-Film Recording, at \$4,315.65 (Lenses additional). Also available without sound. Write for complete Auricon Catalog, free.



AURICON
BERNDT-BACH, INC.
 6902 ROMAINE ST., HOLLYWOOD 38, CALIF.



ANIMATION EQUIPMENT

SPECIAL EFFECTS OPTICAL PRINTERS

- ANIMATION
- TITLES
- STILLS
- CARTOONS
- TRICK PHOTOGRAPHY

For

- INDUSTRIAL MOTION PICTURES
- EDUCATIONAL MOTION PICTURES
- TV MOTION PICTURES
- ENTERTAINMENT MOTION PICTURES

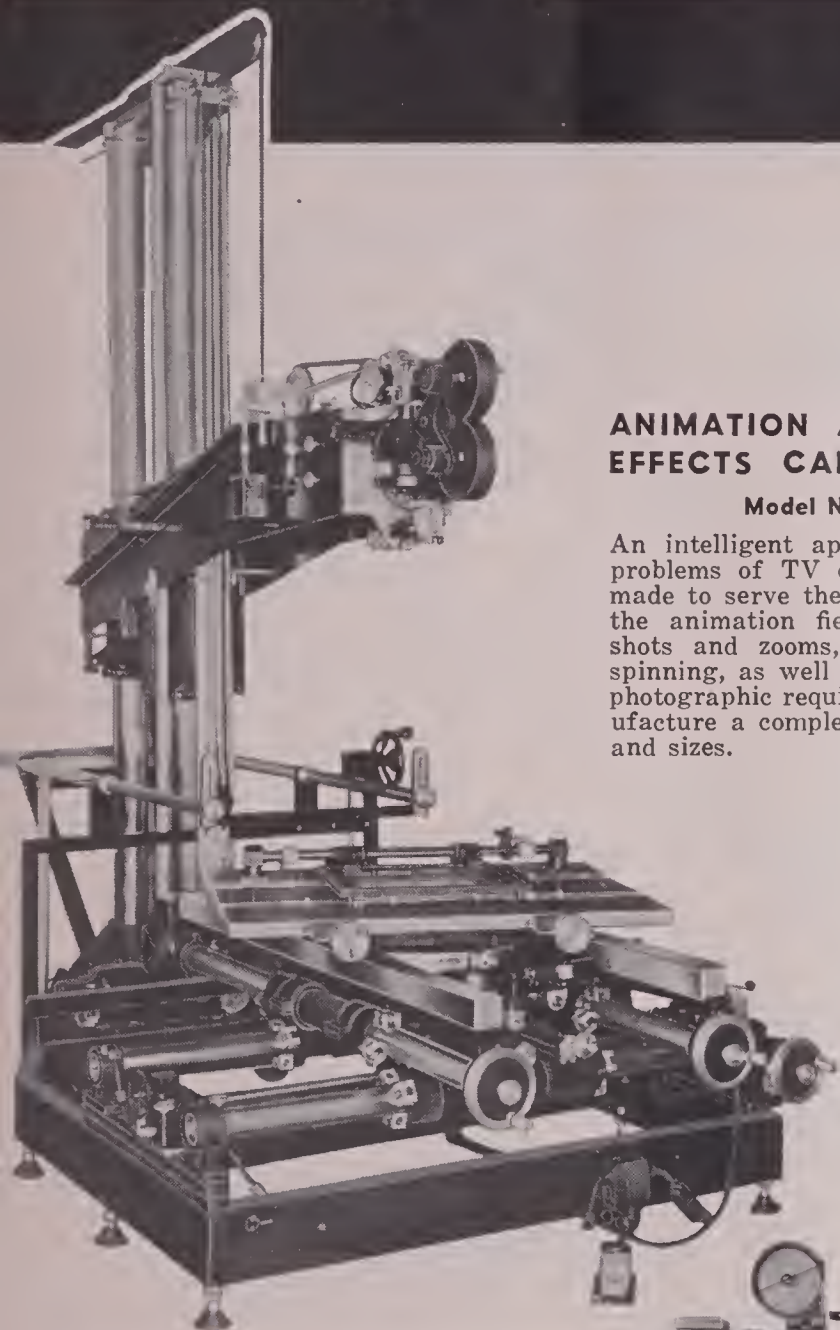

ANIMATION AND SPECIAL EFFECTS CAMERA STAND

Model No. 111-E

An intelligent approach to today's problems of TV commercials. It is made to serve the multiple tasks of the animation field to take angle shots and zooms, matching zooms, spinning, as well as countless other photographic requirements. We manufacture a complete range of styles and sizes.

OPTICAL PRINTER FOR SPECIAL EFFECTS WORK

Prints from one picture to another or one size picture to another. Zoom can be added to the picture without an exposure crew. Foreign titles can be added to bottom of any picture. The machine has a ball bearing mounted zoom for 4 to 1 blow-up or reduction.

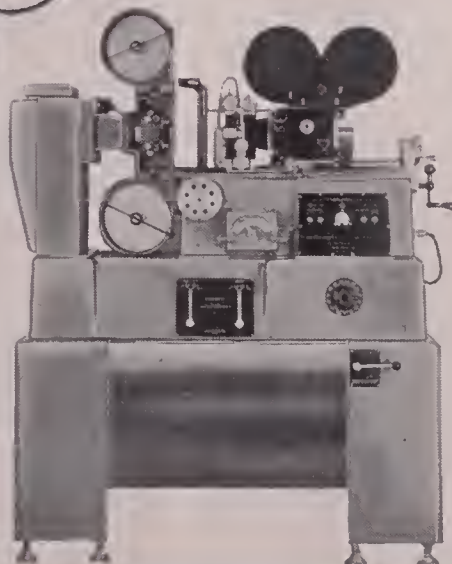

WRITE FOR COMPLETE LITERATURE

Distributed by

J. G. SALTZMAN, INC.
480 Lexington Avenue, New York 17, N. Y.

WHAT'S NEW

(Continued from Page 218)

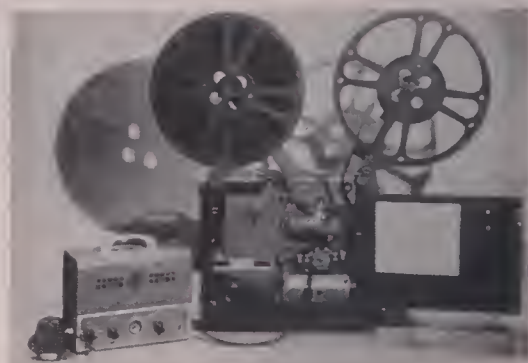

jectors to add sound to either silent or optical sound films. Mixer Magnsound records voice and music simultaneously, plays back immediately, erases and records in one simple operation. Individual inputs for microphone and phonograph have separate controls for coordinating mixing versatility. Price, complete with amplifier, microphone, sound head, and carrying case is \$199.45.

Cam-Stock — Medina Industries, Medina, Texas, announces a gun-stock-type movie camera mount to accommodate any 8mm, 16mm or lightweight 35mm professional type camera. It is adapted for shooting movies of wildlife, hunting, sports action, and shots of children at play and is particularly

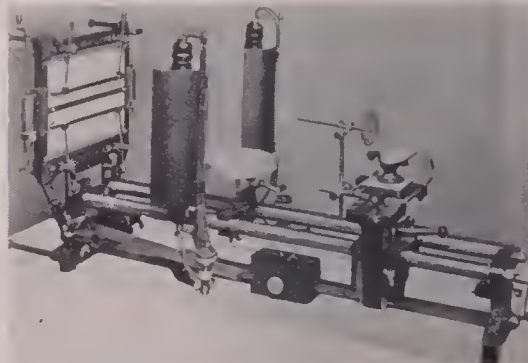

sued to use with a telephoto lens. Made from one piece of redwood it contains a hollow compartment in the shoulder-piece large enough to carry a number of movie-making accessories. Cam-Stock is available only from the manufacturer. Price postpaid is \$9.95.

Foreign Stock Shots — Stock Shots To Order, Inc., 550 5th Ave., New York 36, N. Y., recently organized by R. A. Pheelan, formerly producer-writer with Official Films, announces a special service of supplying European and Asiatic stock shots for TV producers. A crew has recently been sent abroad and will tour for 18 months filming authentic foreign

(Continued on Page 280)

Great equipment makes great cameramen

BALANCED TRIPOD HEAD

and

PROFESSIONAL JUNIOR TRIPOD

are the standbys of the masters

You'll never hear Fritz Kreisler playing on a scratchy fiddle . . . or Louis Armstrong on a \$7 trumpet. Good craftsmen need good tools.

Camera Equipment Company makes, sells, services and rents the world's finest quality TV and Motion Picture Equipment.



New "BALANCED" TV head — MODEL "C"
—for the world's smoothest pan and tilt action.

No more groping for center of gravity. The new Model C "Balanced" Tripod Head is equipped with a convenient, accessible positioning handle mounted below the top plate, which allows the operator to reposition the camera to the correct center of gravity. No matter what focal length lens is used on the camera turret, the camera can be balanced on the Model C Head without loosening the camera tie-down screw.

It has all the features which have made the "Balanced" head a gem of engineering ingenuity—quick release pan handle, tilt-tension adjustment to suit your preference. It's a Cameraman's dream!

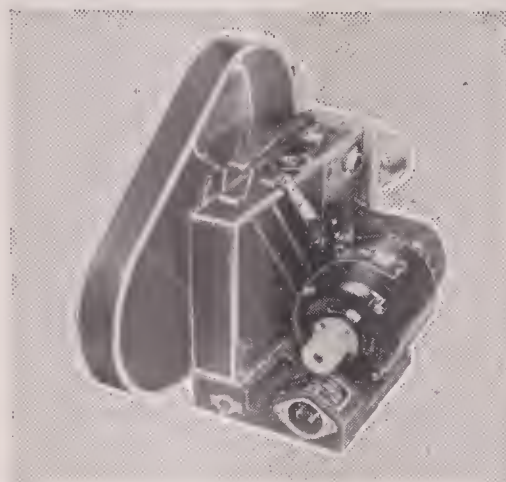

SYNCHRONOUS MOTOR DRIVE—110 Volt AC—Single phase, 60 Cycle. Runs in perfect synchronization with either 16mm or 35mm Sound Recorders. Mounting platform permits removal of magazine while camera remains mounted on motor. Spring steel drive fin coupling prevents damage if film jam occurs.

Knurled knob on armature permits rotating for threading. "On-Off" switch in base. Platform base threaded for 1/4" or 3/8" tripod tie-down screw. Rubber covered power cable with plugs included.



More professional cameramen use The PROFESSIONAL JUNIOR Tripod than any other tripod in the world.

Let's face it. You need a first class tripod to make better pictures. PROFESSIONAL JUNIOR has the rigidity, the range, and the ease of operation that better pictures demand. See it—try this tripod beauty—and you'll never be without it. PROFESSIONAL JUNIOR TRIPOD—Friction Type. Handles all 16mm cameras, with or without motor. Also 35mm DeVry, B & H Eyemo with and without motor, and 400' magazines. Tripod base interchangeable with Professional Junior gear drive head. "Baby" tripod base and "Hi-Hat" base available.

FRANK C. ZUCKER

CAMERA EQUIPMENT CO.
1600 BROADWAY NEW YORK CITY

SALES • SERVICE • RENTALS — CAMERAS * MOVIOLAS * DOLLIES

Complete line of 35mm and 16mm equipment available for rental.

MITCHELL: Standard, Hi-Speed, BNC, NC, 16mm

BELL & HOWELL: Standard, Shiftover, Eyemo

ARRIFLEX: 35mm and 16mm

MAURER: 16mm Cameras

MOVIOLA: Editing machines, Synchronizers

We design and manufacture Lens Mounts and camera equipment for 16mm—35mm and TV cameras.



VARIABLE SPEED MOTOR—110 Volt AC/DC with Tachometer for EK Cine Special Motor drive your Cine Special with confidence! Tachometer is mounted in clear view of operator. Calibrated from 8 to 64 frames per second. Definite RED marking for 24 fps. Electrical governor adjusts speeds. Steady operation at all speeds. No adapters needed. Motor coupling attaches to camera and couples to motor. Spring steel drive arm shears if film jam occurs. Easily replaced.

We calibrate lenses—Precision "T" Stop Calibration of all type lenses, any focal length. Our method is approved by Motion Picture Industry and Standard Committee of SMPTE. For proper exposure density, it is important that you have your lens "T" stop calibrated. Lenses coated for photography. Special TV coating. Rapid service.

(Continued from Page 278)

Precision Prints

**YOUR PRODUCTIONS
BEST REPRESENTATIVE**

CLOSE CHECK ON PROCESSING

Picture and sound results are held to the closest limits by automatic temperature regulation, spray development, electronically filtered and humidity controlled air in the drying cabinets, circulating filtered baths, Thymatrol motor drive, film waxing and others. The exacting requirements of sound track development are met in PRECISION'S special developing machinery.



YOUR ASSURANCE OF BETTER 16mm PRINTS

16 Years Research and Specialization in every phase of 16mm processing, visual and aural. So organized and equipped that all Precision jobs are of the highest quality.

Individual Attention is given each film, each reel, each scene, each frame — through every phase of the complex business of processing — assuring you of the very best results.

Our Advanced Methods and our constant checking and adoption of up-to-the-minute techniques, plus new engineering principles and special machinery enable us to offer service unequalled anywhere!

Newest Facilities in the 16mm field are available to customers of Precision, including the most modern applications of electronics, chemistry, physics, optics, sensitometry and densitometry — including exclusive Maurer-designed equipment — your guarantee that only the *best* is yours at Precision!

Precision Film Laboratories — a division of J. A. Maurer, Inc., has 16 years of specialization in the 16mm field, consistently meets the latest demands for higher quality and speed.

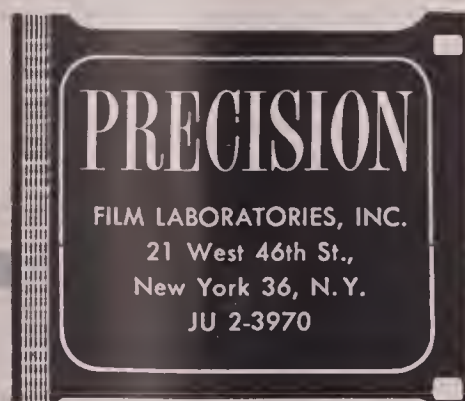

scenes in 16mm and 35mm, color and black-and-white. Footage taken aboard the ocean liner and flown back has already been utilized in TV film production for background projection plates, with dancers and singers performing in front of the rear projection screen.

Telephoto Lens — Camera Specialty Co. Inc., 705 Bronx River Rd., Bronxville 8, N. Y., announces it has been appointed exclusive representative in the U.S. for the new Berthiot 3" f3.5 telephoto lens for all 16mm cameras taking "C" mount lenses. This new lens has a focusing mount, with a range of 31½ ft. to infinity, diaphragm stops from f3.5 to f22, is coated and finished in chrome. Some notable characteristics are high definition, edge-to-edge sharpness and good color rendition. The Berthiot is available for immediate delivery and retails at \$43.50.

8MM and 16MM Film Printer — Uhler Cine Machine Company, 15778 Wyoming Avenue, Detroit 38, Michigan, offers a reduction and enlarging printer for 8mm and 16mm films having three special features: it reduces 16mm to 8mm, enlarges 8 mm to 16mm, and it is equipped to print color film as well as black and white.

In printing, the film is exposed by a 150 watt lamp on either side of the printer, and there are blowers for cooling. The light range can also be lowered by using a filter and a filter holder.

The printer operates at 25 feet per minute printing speed. The lens is an anastigmat f/3.5. The aperture plate is of a highly polished stainless steel. The printer is equipped with semi-automatic dual light control. One is set in advance the equivalent of one full scene and the light changes automatically as the notched film goes by.

Also announced by the company is its combination continuous printer for 8mm and 16mm film, black and white or color, single or double system sound. The film is run through the machine once only while printing single or double sound system, at the same time the picture is printing. Capacity is 1200 ft. negative, positive, and sound track. The printing speed is up to 1600 ft. per hour. The equipment is ideal for professional or amateur movie makers, laboratories, schools, and technicians. For complete technical information and prices, write the manufacturer, mentioning *American Cinematographer Magazine*.

When Time is Money,

You Save With Ansco

Negative
Positive

Color

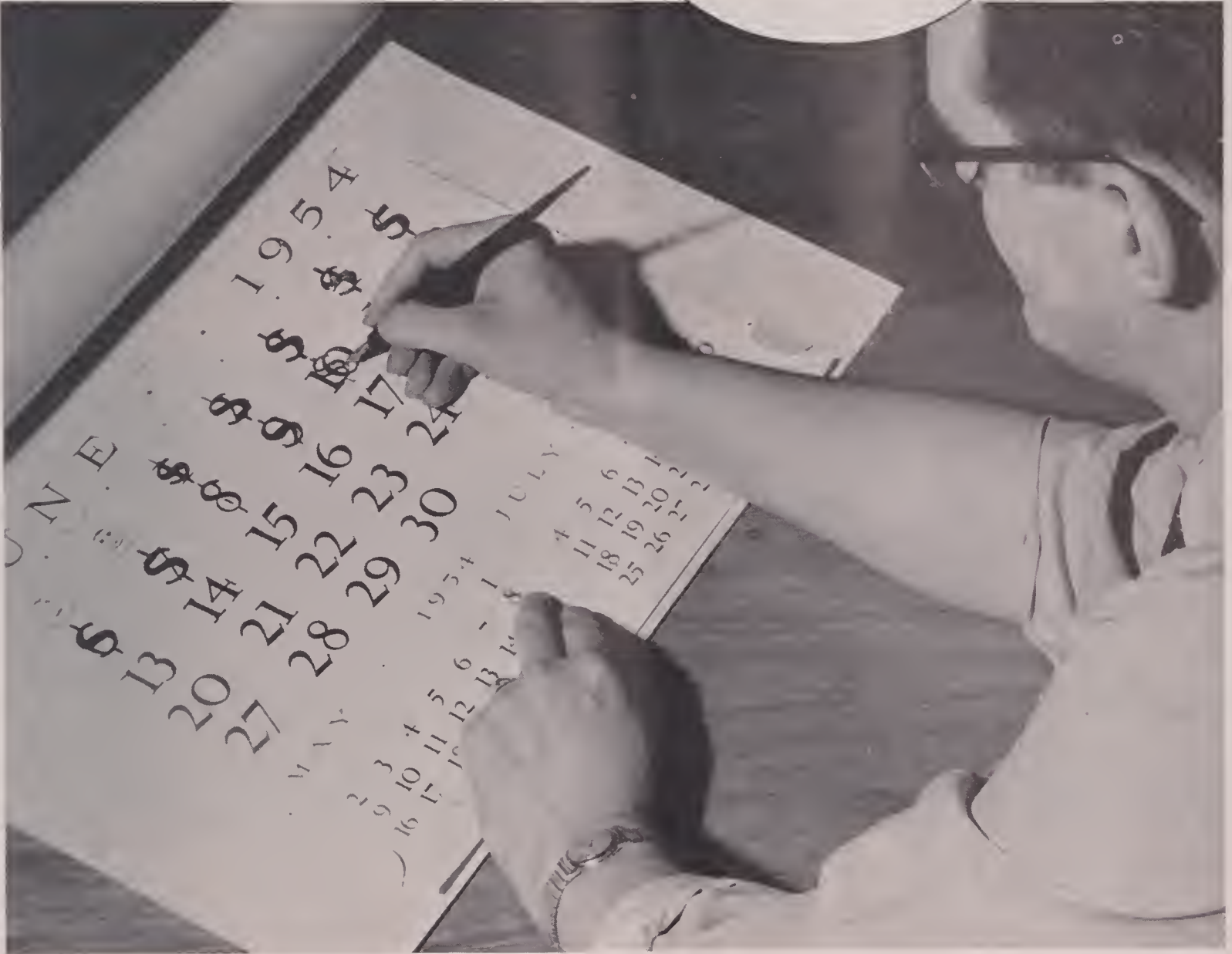

Think how you'd save on production costs if you could eliminate drawn-out waiting to see color rushes. Well, Ansco Negative-Positive Color can do just that for you. It allows you to see the results of your shooting within hours, often the same day. Thus the prolonged holding of costly casts and sets is eliminated.

**YOU MAKE IMPORTANT SAVINGS
IN PRODUCTION, TOO**

No special camera required

Any competent cinematographer can get excellent results with Ansco Negative-Positive Color using standard 35mm black-and-white cameras.

**No special processing equipment
needed**

Minor modifications of standard black-and-white equipment gives superior processing.

**YOU GET ALL THIS PLUS TOP-
NOTCH SCREEN QUALITY!**

Color rendition with Ansco Negative-Positive Color is *truer*. Screen steadiness is excellent. Superior definition. Greater brilliance and depth. Finer grain. Higher emulsion speed. Greater latitude. Increased production flexibility.

Shoot your next production on Ansco Negative-Positive Color. It will mean *much* lower production costs and an enhanced reputation as maker of fine pictures.

Ansco

Binghamton, New York
A Division of General Aniline &
Film Corporation
"From Research to Reality"



1 As when filming on land, a camera parallel is moved into position 30 ft. underwater for a new setup for "20,000 Leagues Under The Sea."



2 Two husky grips wearing Aqua-lung equipment struggle through rocky coral beds with cumbersome tripod, lowered from nearby supply ship.



3 The heavy tripod is carried to top of parallel where it is set up to take the Mitchell Cinema Scope camera mounted in watertight blimp.



7 Grips erect set piece which serves as background for an underwater action scene. Note one diver in regulation Navy diving gear.



8 Prior to starting camera, Till Gabbani takes light reading with meter, which is encased in protective plastic chamber attached to cord.



9 Director Fleischer writes last minute instruction on underwater slate to cameraman before shooting begins on big action scene.

Hollywood's Greatest Underwater Venture

Working 30 feet underwater much the same as on land, a Disney camera crew films thrilling submarine action for "20,000 Leagues Under The Sea."

By TILL GABBANI

PHOTOS BY LT. COMMANDER CHARLES A. HOOPER, USN

THIRTY FEET UNDERWATER in the Caribbean, off Nassau, Bahamas, some eighty motion picture artists and technicians wearing safety diving gear recently completed what unquestionably was the most challenging assignment ever faced by a Hollywood motion picture troupe. Here on the ocean floor was filmed in Eastman Color with a CinemaScope lens the fabulous underwater se-



1 Cameraman Gabbani and Director Richard Fleischer (dark suit) survey scene through special CinemaScope viewfinder before camera is set up.



5 Mitchell camera in pressurized case is carried to parallel by two assistants; 175 pound camera has neutral buoyancy underwater.



6 Heavy hemp mat is placed on ocean floor to reduce amount of sand kicked up by divers, thus increasing production time underwater.



7 Biggest underwater scene ever photographed for a Hollywood production: the burial sequence in "20,000 Leagues Under The Sea."



11 The shooting over, cameraman Gabbani prepares to surface, carrying his exposure meter, underwater slate, and "lily" or color chart.

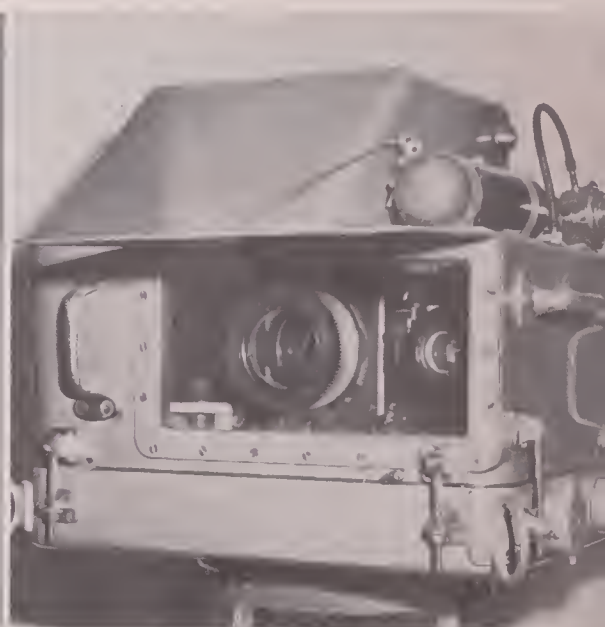

12 Closeup of pressurized, watertight blimp built by Disney engineers for Mitchell camera used in filming underwater scenes in color and C-Scope.

quences for Walt Disney's version of Jules Verne's "20,000 Leagues Under The Sea."

It would require a good size volume to relate in detail everything of interest connected with this unusual undertaking. So this must be but a brief resume which, along with the photos above, I hope will give the reader a comprehensive account of this greatest of underwater filming assignments.

During this assignment there was photographed more underwater footage than for any other motion picture on record. The scenes for the most part were not the familiar undersea swimming shots of

one or two people but embraced carefully-planned and enacted scenes that required painstaking rehearsals, and the use of props and set pieces laboriously brought to the ocean floor and erected by experienced divers trained as grips and prop men for this particular phase of the Disney production.

Of equal interest is the fact that there were more people working underwater at one time in the filming of these scenes than in any other previous attempt at underwater film production. In the key dramatic sequence—the burial under sea of a slain shipmate of the *Nautilus* crew—there was a total of for-

ty-two persons working simultaneously before and behind the camera.

Because most of the undersca action consisted of lengthy routines rather than brief shots of men swimming, etc., our filming operations approximated those of the studio sound stage. We used a standard Mitchell camera for the stationary shots, heavy metal tripod, parallels, etc., and were assisted by the usual crew of camera assistants, prop men, and grips. About the only thing missing was the big studio lights. Here, illumination was supplied by sunlight.

(Continued on Page 308)



SET LIGHTING for business films involves everything from ultra-closeups to full-scale sound stage sets and demands use of just about every type of lighting unit used in major studio production.



Above, left, a group of baby spots concentrate on an arc welding operation. At right, simple reflector-type photofloods mounted on a floor stand supply light for a location interior.



LOCATION INTERIORS in large factories present the greatest problem for the industrial film cameraman. A wide array of lighting units are necessary to cover the vast areas and to spread sufficient



light around the usually dark-painted machinery. Simple, easy-to-light sets such as above require the least lights and special lighting effects. Note cameraman taking light reading.

Lighting Productions For The Business Screen

By FREDERICK FOSTER

TODAY, THE SCIENCE of major studio set lighting is being applied successfully, yet economically, in the production of 16mm industrial and business films. While set lighting in industrial film studios may not be the ambitious project it is in Hollywood major studios, nevertheless it involves considerable planning and skill in execution.

When we speak of sets in commercial film production, we include not only those erected on the sound stage, but also location interiors, which frequently become stages where important scenes are filmed and therefore require special lighting care. The basic techniques of set lighting, which will be analyzed here, will therefore apply both to studio sets

and location interiors. The major difference between the lighting technique for studio sets and location sets is that in the former, lighting can be more precisely controlled. The location set sometimes presents the advantage of offering possibilities for unusual lighting effects characteristic of the locale itself.

(Continued on Page 302)

EASTMAN

PROFESSIONAL

MOTION PICTURE

FILMS

W. J. GERMAN, Inc.

Fort Lee

Chicago

Hollywood



HIGHLY STYLIZED set for "Within Man's Power" in which the scene is suggested rather than depicted in full detail. The photography involved eighteen light changes, required seven hours of lighting

rehearsals, although scene appears on screen only one minute. Room dimensions are defined by white doorway and window frame set against a black velvet drop. Meager props complete the set.

LIGHT PLAYS A PART IN SET DESIGN

"Within Man's Power" employed a series of highly-stylized sets in which major details were suggested rather than depicted.

By WILLIAM BANCROFT MELLOR

MOTION PICTURE PRODUCTION is no novelty on the banks of the Potomac. Washington, D.C., political focal point of the world, for years has been producing newsreel-type films for television—the work of a tight little colony of 16mm cameramen and film technicians. Filmed TV programs, such as those of Drew Pearson, Fulton Lewis, Jr., and Marquis Childs ("M. D.," "Today," and "Washington Newsreel") long have originated in the Nation's capital.

Lately, Washington film production has advanced to the 35mm field. Nicholas Webster, onetime Hollywood actor and cameraman, now a well-known producer-director with a long list of outstanding documentaries to his credit, is undertaking a series of major productions which will include both documentaries and feature films.



ANOTHER scene in which action is played on simple set against black backdrop. Here the pattern of lighting used is clearly shown.

His first film, "Within Man's Power," is at this writing in production on the sound stage of the Capital Film Studio, a converted motion picture theatre operated by National Video Productions, in Southeast Washington.

Webster, whose film "Seizure" won first prize in the documentary class at the 1951 Venice Film Festival, is employing many unusual techniques in the filming of "Within Man's Power." An elaborately-staged costume production, the film has a cast of more than sixty headed by Dorothea Jackson and Joseph Anthony—well-known in television and on the Broadway stage—also John Rodney, who starred in Warner Brothers' "Fighter Squadron" and who has been featured in several other Hollywood productions.

Boris Kauffman is director of photography. Before coming to Washington, he photographed Marlon Brando's most recent picture, "Waterfront," made in New York. Previously, Kauffman had been a cinematographer in the Paris studios. Together with Webster, he has developed many unique innovations both in camera treatment and lighting for "Within Man's Power."

The picture relates, in a series of historical blackouts, the story of man's long and unceasing fight to control tuberculosis. The unusual pictorial effects are achieved by unique use of lights. For instance, instead of fading scenes optically in the conventional manner, fading is accomplished with the use of dimmers to fade out selective parts of a scene individually as a means of directing the audience's attention on a specific prop or person.

To intensify the dramatic sweep of the story, the entire film is played in low key lighting. The lighting effects and composition were carefully planned so as to contribute materially to the basic theme of each scene.

Because all transitions, both physical and psychological, were made with the lights, the lighting chore was an extremely complicated one. Often a single scene involved as many as eighteen light changes. The timing had to be so precise that one scene, which plays on the screen for only one minute, required seven hours of lighting rehearsals.

"Cameraman Kauffman and I, working together, endeavored to build up each individual scene exactly as an artist constructs a painting on canvas," said Webster. "We started from absolute blackness and then, using lights as out

brush strokes, 'painted' in the detail we needed to achieve the desired effect, and no more. Every scene thus was reduced visually to the barest essentials."

That is so not only with regard to lights, but also to the sets themselves.

The opening and closing scenes of "Within Man's Power" are laid against conventional indoor sets, but the rest of the film consists of a series of highly stylized sets in which the scene is suggested rather than depicted in detail by the props.

A room in a victorian home, for instance, appears as a white doorway and window frame against a black velvet curtain, and contains a bed, chair table and an ornate chandelier as the only props. Thus there is nothing superfluous in the set itself to distract audience attention from the central theme of the story.

The black velvet technique also enabled the director to shoot in a single take of continuous action sequences which normally would have required several different sets. One such sequence, for instance, involved a newspaper editor, his managing editor, and a columnist—each of whom had his own office. The "offices" are represented merely by desks set at different levels on black-draped platforms against a black velvet background. On the screen, the desks and the actors seated behind them appear to be floating in air; the position of each editor with relation to the others is clearly symbolized by his "altitude." To bring them in or take them out of the scene required only the use of lights.

Another device employed by the producer was that of using the same actors throughout the film—although the scenes stretch chronologically over a period of 800 years—to accentuate the differences between old and new techniques in the care of tubercular patients, and the public attitudes toward the disease.

One of the big lighting problems was the difficulty of synchronizing the light changes with the continuing action on the stage. This was especially true of the bedroom scene described above. The scene opens in total blackness. The camera then fades in on a mesh curtain (a miniature rigged eighteen inches in front of the lens) which, with the aid of

(Continued on Page 298)



THIS plus one other scene comprise the only conventional ones seen in "Within Man's Power." The others are stylized simplicity.



THE PRODUCTION crew. Producer Webster is seated, 2nd from left; cameraman Boris Kauffman leans against the dolly-mounted camera.



A FILM EDITOR must have patience, a "feel" for pace, an instinct for dramatic emphasis, and the ability to visualize in overall terms the impression separate scenes will convey when cut together according to script.

The Pre-Editing Stage

Like any other phase of film making, editing draws its sureness and creative force from pre-planning.

BY CHARLES LORING

ONE THING the student of motion picture production learns early is that the editing process is more than a mere mechanical procedure. It is a cinematic force. For it is in the cutting room that a mass of incoherent footage gradually evolves into a finished motion picture. The cutting phase, far from being a simple job of assembly, is a creative procedure. It is the final proof of the filmic pudding—for without it, a skillful script, deft direction and brilliant camera work would be just so much wasted effort.

The successful film editor has certain personal attributes that fit him for this most exacting of cinematic techniques. He must have patience, a "feel" for pace, an instinct for dramatic emphasis, and the ability to visualize in overall terms the impression separate scenes will convey when cut together according to a preconceived cutting plan.

Film editing is a task that is at the same time nerve-racking in that it demands absolute precision and timing and matching of action. It is fascinating in that the editor is actually able to see the film story grow bit-by-bit as the various scenes, cut and properly integrated, pass through the scope of his viewer.

Like any other phase of film-making, editing draws its sureness and creative force from pre-planning. The planning begins with the sequences of dramatic climaxes as set down in the master shooting script. It follows through in the direction and staging of the action. Finally, it begins to bear fruit in the series of calculations that immediately precede actual joining together of the separate scenes—the pre-editing stage. It is this very important pre-editing stage that we shall analyse here.

It is of prime importance in film editing, as well as in every other phase of film production, to have a clear-cut system of operation. To many film-makers undertaking editing for the first time, the chore becomes a nightmare simply because they do not know where to begin. Once having begun, they don't know how to control their footage. They are always wondering what became of this scene or that. They get their trims mixed up with the usable footage, and they confuse the good takes with the bad.

The editor should know at all times just where to lay his hands on any scene, once the film has been broken down. He should have an efficient numbering system for identifying each scene; and he should make suitable provision for filing trims instead of discarding them.

Actually, there is no one best system to use in editing film. Every cutter has his own bag of tricks and techniques, which he has found, through long experience, to be most effective. Indeed, if ten first rate film cutters were given identical uncut footage of the same production, the result easily could be ten different versions.

For this reason, it is not to be implied that the following system of editing is the only practical system. Rather, it is offered here as one method that has worked very well in the past and may prove useful to the serious film-maker undertaking editing for the first time. As he goes along, however, he will discover and develop approaches which closely fit his own talents as an editor, and in time will develop an individual editing style distinctly his own.

Let us take the pre-editing principles step by step. Let us suppose that you have just received your processed footage back from the laboratory. If, as is the generally accepted practice, each scene was carefully slated to enable the cutter to identify it and match it with the shooting script, the job of assembling the footage in sequences becomes a simple matter of cutting the scenes apart and reassembling them in numerical order. Where the scenes were not slated, a practical numbering system must then be applied to the footage before it can safely be broken down into separate scenes prior to editing.

First, mount the separate rolls of film on 400 foot reels, clearly marking each reel A, B, C, and so forth. The film you work with may be the original footage or a work print. Today, it is the general practice to have a work print made and edge numbered to match the original negative, whether black-and-white or color. This work print is used for all preliminary editing and makes unneces-

(Continued on Page 299)

DEDICATED TO BETTER PERFORMANCE



COLLAPSIBLE 3-WHEEL DOLLY

For motion picture and TV cameras. Sturdy cast aluminum. For standard or baby tripods. Additional baby tripod point holders to control spread of tripod legs. Adjustable spring seat. Extra wide rubber wheels. Bronze tie down clamps and other features.

For studio or location. Folds into one compact unit. Can be used with professional or semi-professional tripods.

'HYDROLLY'

TV OR
CAMERA DOLLY

The advanced dolly for instant moveability — streamlined, lightweight, exceptionally sturdy. Nothing to get out of order. Many new advantages for easy operation. Hydraulic lift type for fast upward and downward motion of TV and motion picture cameras.

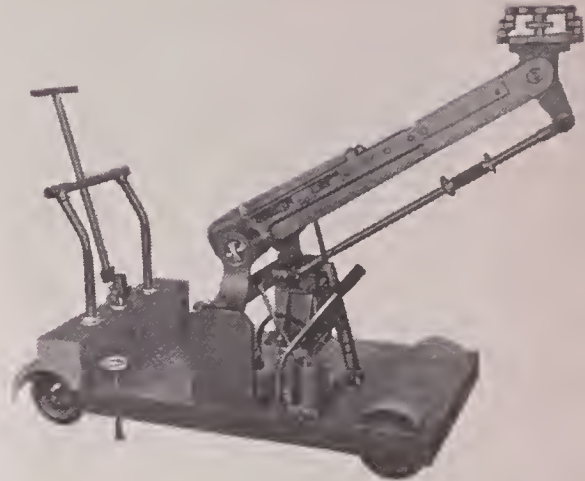

Swivel seat. Adjustable leveling head. Seat for assistant. In-line wheels for track use. Steering wheel, rigid floor locks. Hand pump or combination hand and motor pump. Easily transported in a station wagon. Fits through a 28" door.



Synchro-film-ed Synchronizer

Our Exclusive Distributor
NEUMADE PRODUCTS CORP.

Any combination of 16mm and/or 35mm sprockets assembled to specification. Cast aluminum. Foot linear type, adjustable frame dial. Fast finger roller release. Contact rollers adjusted individually for positive film contact. Sprocket shaft slip lock, foot-age counter, etc.

RENTALS

SALES • REPAIRS • SERVICE

LENS COATING

"T" STOP CALIBRATION

DESIGNING and MANUFACTURING

lens mounts & camera equipt.
for 16mm, 35mm, TV cameras.

BAUSCH & LOMB "BALTA"
LENSES and others

for motion picture, TV cameras.
15mm to 40" focal length.

COMPLETE LINE OF: 16mm, 35mm
cameras, dollies, synchronizers,
animation stands, cutting room
and time lapse equipment.

BELL & HOWELL: Standard, Eye-
mos, Filmos. MITCHELL: Standard,
Hi-speed, BNC, NC, 16mm.

SEND FOR CATALOGUE

Synchro-film- Slate

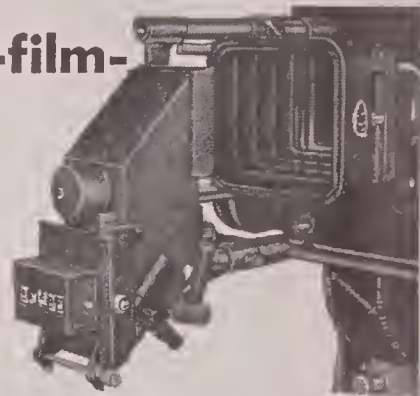

Pays for itself in production savings on the set. A New Development! Eliminates clap stick synch and slate on set. Mounts on double arm bracket to work with BNC, NC, Standard, 16mm Mitchell and all types of blimps and Geared Head. Interlocks with Sound Recorder.



PORTABLE MICROPHONE BOOM

For Studio or on Location. Lightweight — collapsible — for TV and motion picture production. Sturdy construction. Boom telescopes 7 to 17 ft. Rear handle for directional mike control. A remote control permits 360° rotation of the microphone. Operator can push the boom and operate microphone swivel simultaneously.

Extension rods make it simple to operate microphone rotation from floor. Microphone cable hangs outside of boom, preventing cable from tangling with the rotation mechanism. Ball bearing casters, rigid foot locks, pneumatic drop check for lowering the boom, etc.

VARIABLE- SPEED MOTOR with TACHOMETER

for Cine Special or Maurer Cameras

115 V. Universal Motor — AC-DC
Separate Base for Cine Special.
Variable Speed 8-64 frames.
Adapter for Maurer Camera.

INTERCHANGEABLE MOTORS: 12
volt DC Variable Speed 8-64 frames.
115 Volt AC 60 Cycles, Synchron-
ous Motor, Single Phase.

ANIMATION MOTORS: Cine Spe-
cial, Maurer, Mitchell, B & H Motors,
for Bolex and Filmo Cameras.





THE TRI-LENSED Cinerama camera is explained to a bevy of French can-can girls at the famed Lido in Paris by author Joseph Brun, who photographed the girls for "Cinerama Holiday." View of camera is from rear, shows the finder tubes—one for each of the three camera lenses.

WHEN I SAW the picture "This Is Cinerama" for the first time, I was so deeply impressed that, disregarding the limitations of Cinerama, I considered the picture the first real progressive step toward the cinema about which I had been dreaming for years.

And then, six months later, I was asked by Louis de Rochemont to photograph the second Cinerama production, which he had been assigned to produce. As we discussed Cinerama with mutual enthusiasm, I could not help wondering: "What impulse has driven this master of realism into this newest of cinema forms—a medium until now acknowledgedly limited to the presentation of travelogues, operettas, and grand spectacles?"

Had he prophetically sensed that there was a great deal more to it than had thus far been revealed?

Our first experimental tests were discouraging; this medium seemed to be shrinking into a world of physical limitations. The experiences, acquired while shooting for many years what is now so unjustly called "conventional movies," seemed to narrow down now to nothing more than insuring correct exposure.

Were all my illusions to vanish? Could the barriers of physical restrictions be overcome? Would the perception of depth, size, shape and distance; the sensation of presence and participation be limited to a few conditional circumstances, or to stunts and tricks which would unavoidably become

PLANNING a camera setup for filming a sequence on snow sports in Swiss Alps. The Cinerama camera rests on hi-hat in foreground.



The Cinerama Technique

There are no limits to dramatic compositions in Cinerama if the medium is rationally interpreted.

By JOSEPH BRUN, A.S.C.

repetitious? Were we dealing again with a "process"—exploiting the shock effect of novelty?

There is something about Cinerama besides (and maybe in spite of) ratio, size and depth that makes it a definite contribution to the cinema. Cinerama is essentially a subjective medium.

The subjective camera has been, since the birth of motion pictures, the great dream of directors and cameramen. The triple-lensed Cinerama camera recreates a scope of vision comparable to that of human vision through the use of an extremely wide-angle optics combination, which covers a field of 146 degrees—description of which is well known to the reader.* In my opinion, Cinerama is the most perfected instrument for subjective exploration.

The opinion of optical experts may differ about the true scope of human vision. It is said that the total range of visual perception is about 170 degrees. However, the field of relative sharpness is about 140 degrees, and even within this area an angle of about 120 degrees comprises the center of conscious sharpness.

In considering whether subjective or objective Cinerama offers a really new dimension in perception, it should be remembered that the Cinerama camera can "see" not only as the actor does, but can reach total identification with

the spectator, as if he were himself present in the environment of the actor or also involved in the action.

In Cinerama, the objective vision—even if purely descriptive (and therefore not demanding subconscious interpretation)—is physiologically real; for one of the amazing facts about Cinerama is that, as in the physiological retinal process, the area of unconscious sharpness becomes a powerful factor which might be the very key to psychological stereoscopy—the element which creates the perception of presence and participation in direct relation with the audio perception.

An elementary example will illustrate this theory: I screened a scene in which the Cinerama camera had been mounted on a carousel, counter to traffic, facing the children; in the background the parents watching their children could be distinguished quite clearly. The scene was charming, but its value resided in descriptive pictorial quality—color, wide screen, and sound. In the next take, the camera was mounted in the same manner, but this time facing traffic. With the carousel running at the same speed, the background was intolerably blurred. As I am extremely sensitive to motion, I was immediately affected.

The average spectator watching motion pictures accommodates his vision very rapidly to any screen ratio, size or curvature. Once he has admitted a new depth perception he unconsciously starts a critical interpretation of his

sensations; he is either captured by the subject of the picture and falls into an esthetic condition, or is indifferent and consciously rejects the machinery of film making.

Can we create and control new sensations at will and sustain impact of so different a striking power that the audience will sense and admit birth of a new form of cinema?

The challenge and the success lie in the interpretation of the medium, for it calls for a new syntax, a new grammar, a thorough exploration of a new film technology.

Because Cinerama has an explosive quality—a dynamic power of attraction—the maker of films in this medium must analyze each scene for its degree of significance. He must approach the impact of a climax with unusual discretion, dose with humility the beauty of a purely pictorial scene, make tactful use of stereophonic sound, and develop a new sense of space and distance. The rules of motion picture dramatics as we know them, far from being obsolete, are enriched with new harmonics, new shock elements, new editorial juxtapositions.

Our experience in shooting "Cinerama Holiday" the past few months has shown that, contrary to the common belief, this medium is far from being limited to large-scope operations. Most of the shooting in the period referred to took place on location in France and in Switzerland. Here we photographed

(Continued on Page 301)

*See "And Now—Cinerama," Pg. 480, November, 1952, American Cinematographer—EDITOR.

FOLLOW skiers on downgrade flight, camera suspended on framework mounted on sleigh. See it capsized, tossed operator in snowbank.



CAMERA mounted on motor-sled for series of trucking shots. Note 5 microphones overhead for stereophonic sound pickup.



BOOSTER lights were mounted on sleighs to facilitate moving. Note filter gels on lamps to correct light for daylight color film.





WHILE spectacular scenic views are important to travel films, it is the revealing shots of people at work and at play that complete the picture.



SOUND recorded on the spot with tape recorder can give a tremendous lift to the interest of a travel film made in a foreign locale.

Analyzing Documentary Technique

By CHARLES L. ANDERSON

WHAT IS THE DIFFERENCE between a successful and unsuccessful documentary film? After talking to many 16mm movie makers and listening to discussions among students of cinema, this writer must conclude that the answer isn't very well known. The neophyte film maker judging a documentary will invariably speak of the quality of the photography, direction, writing, and the editing. Thinking in terms of "good shots," "well-directed scenes," "interesting narration," and "good cuts" when evaluating a picture. But the technique of organizing a film and its individual sequences is likely to escape notice.

There are several types of documentaries, and in spite of obvious differences they share many techniques. The same methods of presenting subject matter may be found in pictures on, say, airplane design and economics. The use of a picture or its subject matter will be put to doesn't automatically dictate how the material should be handled, as some film makers unfortunately think. There is no need for pictures to be all alike, although many of the best producers

today often draw upon a few time-tested devices and formats.

One useful plan of organizing a film is to tell the story of a complex business in terms of a few people or objects. Audiences prefer information that isn't left in too abstract form. The film "United 6534," previously covered in the American Cinematographer from the production viewpoint, is a fine example of organization. (It is available at several United Airlines offices, making it easy to obtain for study.) An airline's many operations shown in one film could produce a very confusing picture. But the producers have arranged the material in "United 6534" in such a way that no essentials are left out — yet the final result is both entertaining and instructive.

The film succeeded because it had been well organized. The camera follows one particular plane through its overhauling in United's maintenance plant and then on a transcontinental flight. If scenes of the maintenance base, flight control offices, ticket office, airfields, and the flight itself had been included at random without any strong

link, audiences would have been hard put to get a comprehensive view of United's operations. The "gimmick" here, following one plane and the people concerned with it, gives a straight documentary film a plausible story.

Few subjects are so broad that they can't be given this treatment when desirable. Another example is a film on the Western Pacific Railroad which follows one person. A young man interested in working for the line is sent on a trip in a caboose to get a better idea of the company and the jobs available. His freight ride along the main line and his talks with the road's employees bring to audiences a comprehensive picture of the railroad system.

The variations on this "following" theme are limitless. It has made economic ideas palatable by showing how one family may be affected by economic activity. Life and health insurance films demonstrate the statistics of insurance in terms of a few people. Amateur and professional film makers have helped community fund drives with films that specifically show how people benefit from the donations.



SHOTS of native handiwork and skills will need informative narration for maximum effectiveness, and should be filmed with this in mind.

Theatrical short subjects cleverly use this device more often than is realized. A Warner Bros. two-reel Technicolor film on the annual Soap Box Derby frequently cuts to the activities of one boy as he prepares for the race. At the finish, he wins the race. The camera crew probably had him re-enact important pre-race preparations after the event to obtain the necessary continuity footage.

Another familiar format is the "semi-newsreel." The connecting link here is not one person or object but rather a simple continuity in time and action. Cine photographers are more often called upon to record some particular action on film rather than tackle an abstract idea. For want of a better term, we'll call these straightforward films semi-newsreels. These pictures tell what happens. In their simplest form, they offer a clear narrative of events. But plenty of filming skill is needed in shooting first-rate films of this type.

The cine photographer undertaking films of this sort must be able to discern what phases of a given action will look best on the screen. For example, he may be shooting a county fair. Here the exhibitions having the most color and action will probably supply the most interesting footage. Exhibits of handicraft objects, etc., will have to depend on narration to put their importance across, and the filmer must gauge their value in choosing shots unless he has an unlimited supply of film.

A commercial picture made of the California State Fair included many telephoto candid shots of the visitors. A cameraman not alert to the needs of semi-newsreels might have overlooked the importance of such shots, forgetting that a well-rounded film record includes the formal and the informal, the expected and the unexpected.

Knowing how to operate a camera and compose good shots is only half the technique. The other half is being able to spot the really worthwhile scenes. Let's say you have an assignment to film an employees' annual picnic. Sports and games will be worth filming for their action. Some large scenic views will serve the purpose of telling where and what the picnic locale is like. Then shots of small groups meeting for lunch and conversation will introduce the folks participating in the picnic.

Whether a film will be shown silent or with added narration can make a lot of difference in how it is photographed. The silent picture must tell its story and hold interest entirely by what is seen. Subtitles, of course, are necessary here, but too many may prove annoying. Fortunately, sound is an accepted part of nearly all commercial 16mm work today, and you can rely on narration to fill in the continuity. If you're not filming with a prepared script, it's a good idea to imagine what will be discussed at each scene and take any extra shots needed to cover the narration. As an example, an industrial photographer not

long ago filmed a sequence of raw materials being delivered at a paint factory. He hadn't been given specific directions, but he decided to include closeups of the printing on the various shipping cases. Later, narration about the many different chemicals needed for modern paint accompanied these shots for maximum effect.

A common challenge for 16mm film makers is the very technical picture that can easily become dull. Writers and directors have searched for ways of putting some entertainment into such factual films. The trouble here is that clients often expect a picture to serve too many purposes; a technical film on a company's manufacturing process may be designed for both engineers and the general public. Thus, while telling engineers what they want to know, there is also the risk of boring average audiences. You may want to leave the human interest and comic relief to the men who'll prepare the narration, but a better plan is to organize the picture ahead of time to include some changes of pace.

Audience interest in technical pictures increases when viewers understand what the material shown means to them personally. A film on the petroleum industry wisely reminds the audience that the methods and equipment shown are all designed to bring them better petroleum products at lower cost. If it weren't for these references, audiences might overlook the production's significance.

A documentary on the bituminous coal industry begins not with a mine sequence, but with farm scenes. Narration describes the farm's dependance on coal (as a source of electric power at the generating station; tells how coal aids the manufacture of farm implements, etc.), and because everyone knows the importance of farms in the nation's economy, the value of coal is established in the first few seconds.

The organization of travel film production today is pretty well standardized. A good travel film shows the best scenes along the cameraman's route, giving the audience a vicarious tour of days or months in a very short time. The secret here, as revealed in the best films of this type, is in finding plenty of good scenes that typify a country. Spectacular scenic views are missed by no cameramen, but it is the

(Continued on Page 300)

Common Sense In Cutting-in Titles

The skill and care that is put into each step of the mechanical phase of title making goes for naught if the titles are ineptly spliced into the film.

By JOHN FORBES

THE EFFECTIVENESS of a good titling job lies not altogether in colorful backgrounds, ornamentation and trick effects, but also in proper placement of each title in the film. In a great many amateur films descriptive titles are cut in too early or too late, or spoken titles are inserted *after* a person is seen speaking the words. It is a wise and skillful movie maker who knows exactly at what frame to cut in a title—yet this skill is by no means reserved for a few. Any amateur can do it after a little careful study and experimentation.

It is unfortunate that more movie amateurs do not have opportunity to see some of the old silent motion pictures as a means of studying good titling technique. This technique, as applied to amateur movies, is no different than it was in the old days of silent motion pictures, when timing a title properly would step up interest, accent a dramatic effect, or motivate the plot just as it will for the amateur's movie today.

It frequently happens that even after a most thorough analysis of a film, a set of titles are made that, after being spliced into the picture, create a continuity change in the film that wasn't counted on. Sometimes this is due to the tendency of titles to slow down the action caused by the title cutting into the action and momentarily withholding it from the audience.

For example, an untitled roll of film on the subject of deep sea fishing may appear a superb job of filming as it unfolds on the screen—action swift, tense, exciting. To the lay fisherman, the action as pictured needs no explanation. The filmer, however, decides to add titles for the edification of his family and friends. And then what happens?

What was originally a highly interesting picturization of deep sea fishing has become a slower, less interesting series of fishing scenes. The titles, though necessary, have changed tempo of the film—have stolen the tense, exciting atmosphere the film contained before it

was edited. Close analysis shows that the trouble lay in unwise placement of titles. They should not have been cut into the midst of action. And this brings us to three important rules of title cutting and editing:

Don't use a title where it will interrupt interesting action.

Don't allow a title to interfere with the suspense the action is creating.

Don't permit attention of audience to wander because of too many titles, or titles that are too long. Fast action requires the interest of titles.

Often a title which looked good on paper will have to be re-written and refilmed. The message it is to convey must be so written it can be placed before or after peak of an action sequence and lose none of its effect. In spite of the emphasis placed on brief, terse, ti-

tlés, it often becomes expedient to use one lengthy title in place of several short ones in order to avoid cutting frequently into important action. But even in such instances, brevity should invariably be the watchword in title composition.

Again taking the deep-sea fishing film for example, let us assume we have a sequence picturing bringing a marlin swordfish to gaff, consisting of the following scenes: medium shot of fisherman in deck chair fighting the hooked fish; long shot of fish cavorting in water at end of line; telephoto shot of fish fighting line; repeat shot of fisherman reeling in line; medium shot of fish now nearer boat. Another fisherman in foreground with gaff hook, ready to

(Continued on Page 296)



There's more to titling movies than the mere mechanics of printing and photographing them. To be effective, they must be skillfully inserted in the film they are designed to describe. A well-made title, ineptly cut, can hinder rather than improve your picture.

AURICON

Auricon
Hollywood

16mm Sound-On-Film
for Professional Results!

ALL AURICON EQUIPMENT
IS SOLD WITH A 30-DAY
MONEY-BACK GUARANTEE.
YOU MUST BE SATISFIED

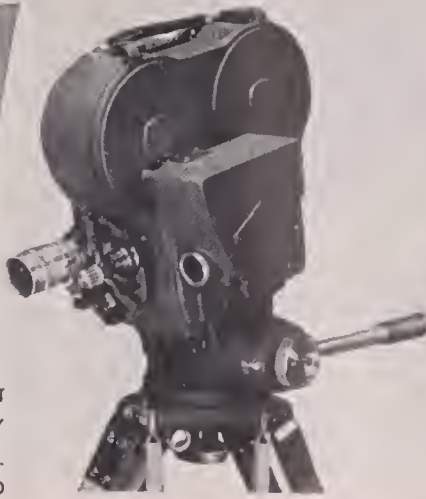

"AURICON-PRO" capacity
for 5½ minutes of recording.
\$1310 and up.



"SUPER 1200" capacity
for 33 minutes of recording.
\$4652.15 and up.



RT-80 SOUND
RECORDER —
200' capacity
"double-system"
optical recorder.
\$862 and up.



"CINE-VOICE"
capacity for
2¾ minutes of
recording. \$695
and up.



TRIPOD—Pan-Tilt Pro-
fessional, velvet-smooth
action. \$325 and up.

● WRITE FOR AURICON CATALOG

**HEADQUARTERS FOR
FILM PRODUCTION EQUIPMENT**

"The Dept. Store of the Motion Picture Industry"

S. O. S. CINEMA SUPPLY CORP.

602 WEST 52nd ST., NEW YORK 19, N.Y. — Cable: SOSOUND

● WRITE FOR M-R CATALOG

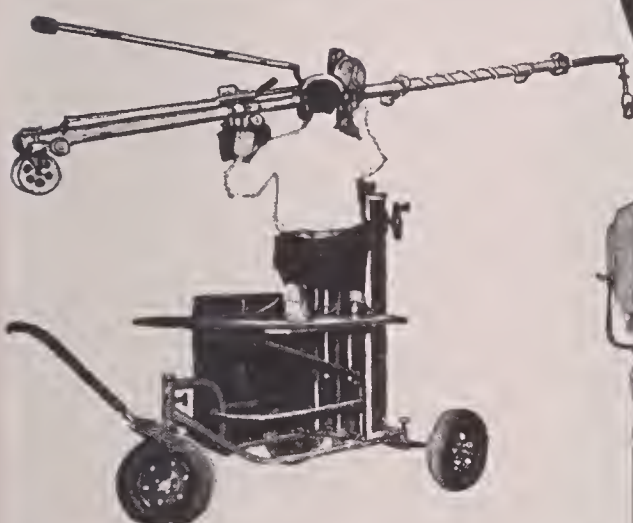

M-R Perambulator for Microphone Boom, \$1080



M-R 22 Single Side Lamp
with Barndoors, \$86.35

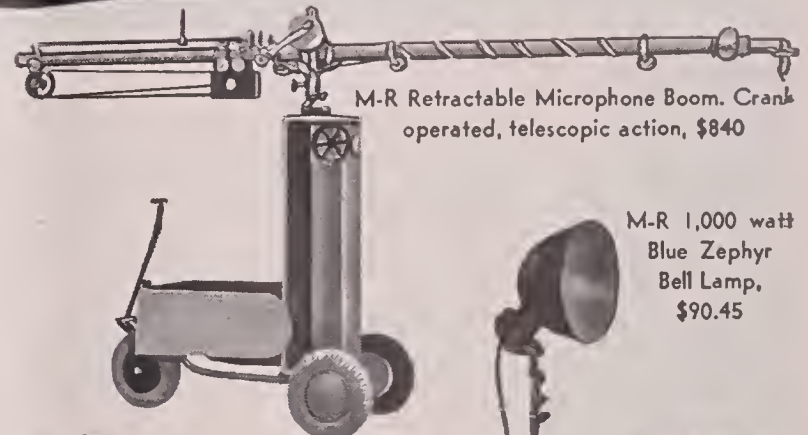

M-R Retractable Microphone Boom. Crank
operated, telescopic action, \$840



M-R 1,000 watt
Blue Zephyr
Bell Lamp,
\$90.45



M-R Blue Zephyr Baby Boom
Light with extra stand, \$203

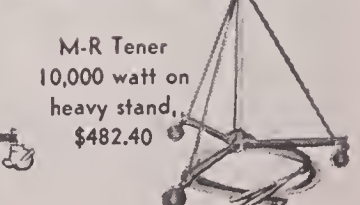

M-R Tener
10,000 watt on
heavy stand,
\$482.40

MOLE-RICHARDSON

The Most Complete Line of
Specialized Lighting Equip.

"Lights"
"Camera"
"Action"

and PROCESSED BY
MOVIELAB

FOR THE FINEST FILM PROCESSING IN
THE EAST — FILM MEN WHO KNOW
SAY "IT'S MOVIELAB"

Here—at MOVIELAB . . . efficiency and perfection are the rule. Producers, directors and technicians have at their fingertips the very best in up-to-the-minute equipment necessary to modern FILM PROCESSING techniques.

ROUND THE CLOCK SERVICES

- Negative Developing • First Print Department
- Ultra Violet & Flash Patch Track Printing
- 16mm & 35mm Release Printing
- Quality Control • Title Department
- 22 Cutting & Editing Rooms.

FOR COLOR
it's

Rainbowlab Inc.



MOVIELAB FILM LABORATORIES, INC.

619 West 54th Street, New York 19, N. Y. JUdson 6-0360

CUTTING-IN TITLES

(Continued from Page 294)

assist with landing of fish. Struggling fish is gaffed and hauled aboard.

Some filmers might insert brief titles between every one of these scenes such as: "Joe hooks a marlin!" "The marlin fights back . . ." "Looks like she's safe!" "Landed at last!"—four annoying interruptions in a highly interesting sequence. How much better to precede the sequence thus: "Third time out Joe hooks and safely lands a fighting marlin!" and then conclude with: "One hundred twenty-five pounds of fighting fish for which Joe gave up five!"

The nature of a film sequence and subject of film itself will dictate where titles should be placed. In most instances, titles will precede scenes or action they describe. Yet there are instances where a descriptive title is better placed after the scene it refers to. This, of course, must be determined before title is written.

In photoplays that build to a heavy action climax, it is best to taper off on titles as much as possible in the closing sequences so that the climax will not be retarded. Then there are pictures in which this rule should be reversed—the climax or high point of interest may be accented by means of titles. An example of this would be in a documentary picture in which some process or operation is being demonstrated. Take for example an Indian forming pottery on a primitive potter's wheel. A sequence of this action would be greatly strengthened by the addition of two or three short titles giving pertinent facts regarding the Indian's pottery making operations, his reputation as a potter, and perhaps the price he may ask for the finished article. The sequence might be considered complete without such titles, but few will deny that titles would add much in interest to the picture as a whole without proving too diverting.

Titles often tend to consume time where a long operation must be shown in almost continuous action. Unlike with the deep sea fishing film, where the camera might run continuously on the interest-absorbing action of the fish-landing incident, continuous camera action on the Indian pottery maker would play far too long on the screen unless otherwise broken up by titles. The skilled filmer, of course, would further diversify this sequence by inter-cutting closeups and angle shots of the action.

Where action in the film is slow, titles should balance the action and remain on the screen longer by virtue of greater wording. In action sequences, the audience, as a rule, becomes alert and capable of reading brief titles quick-



There's a reason...

why Magnasync enjoys
continued worldwide leadership...

QUALITY...ECONOMY...INTEGRITY

Air Force
University
Naval
Radio
Protestant
Fotovox, Inc.
Photographic Technicians
W T S P—Florida
Southern Pacific Railroad
Tele-Filmica Maxol, S.A., Havana
Southern
Ford Foundation
Twentieth Century-Fox, Inc.
University of Wisconsin
Gospel Films, Inc.
National Film Board of Canada
Cine Associates
R.K.O. Radio Pictures, Inc.
Pacific Pictures
Gilfillan Bros., Inc.
U.S. Air Forces
Westinghouse
Iowa Conservation Commission
Providence
Fairchild Recording Equipment Co.
Galbreath
Magnolia Petroleum Co.
Kearney & Trecker Corp.
W K A Q, San Juan, Puerto Rico
State College
Naval Air Station
Beeland-King Film Productions
Columbia Pictures
Providence Bible Institute
Television Recording Service, Inc.
Iowa Farm Bureau
Westinghouse Electric Corp.
Sound Recorders, Inc.
Viguie Productions, Inc.
Havana
U.S. Navy
North
Paramount Pictures Corp.
Baptist Gospel Films
U.S. Department of Agriculture
University of Iowa
International Productions
Goodyear Aircraft Corp.
Avalon Pictures, Inc.
Reverend D. Kirk Hammond
Southwest Film Laboratory, Inc.
Academy Sound
Naval Ordnance
Wurtele Film Productions
Academy
Bible Institute of Los Angeles
University of Tennessee
University of Mississippi
Rampart Productions
South
Protestant Radio Center, Inc.
U.S. Recording Co.
South Dakota State College
Aspen Pictures
Dallas Jones
Twentieth Century-Fox, Inc.
Filmscope
U.S. Air Forces
Magnolia Petroleum Co.
Southwest Film Laboratory, Inc.
Gilfillan Bros.
Cine Associates
Kearney & Trecker
University of Iowa
Arcturus Manufacturing
Goodyear Aircraft Corp.
Fairchild Recording Equipment Co.

Northern Pictures
Filmscope, Inc.
Arcturus Manufacturing
South Dakota State College
Galbreath Picture Production
U.S. Recording Co.
Aspen Pictures
Dallas Jones Productions

Fotovox, Inc.
South Dakota
Production
Corp.
of Tennessee
Int
Center, Inc.
U.S. Navy
Arcturus Corp.
e., Havana
Baptist C
of Agricultu
Florida.
Pacific Pic
Internati
graphic Techn
es, Inc.
University of Wisconsin
Pacific Railroa
l Films
Naval Ordn
Bible Inst
University of Missi
Sound Rec
Inc.
Wurtele Film
ture Prod
U.S. Depart
Viguie Pi
Gospel Films
Beeland-King Film
Ford Foundation
Columbia Pictures
R.K.O. Radio
San Juan, Puerto Rico
Paramount Pictures Corp.
Bible Inst
National Film Board of Canada



MODEL SW-602
PORTABLE RECORDING SYSTEM



Select

DISTRIBUTORS

CAMERA EQUIPMENT COMPANY
1600 Broadway, New York 19, N.Y.
Judson 6-1420—Cable: "CINEQUIP"

MAGNETIC RECORDERS COMPANY
7120 Melrose Ave., Los Angeles 46, Calif.
WEbster 3-5545

ZENITH CINEMA SERVICE, INC.
3252 Foster Ave., Chicago 25, Illinois
IRving 8-2104

AMERICA'S LEADING MANUFACTURER OF MAGNETIC FILM RECORDING AND REPRODUCING DEVICES



MICROPHONE MIXERS



THEATRE SOUND EQUIPMENT



3-CHANNEL REPRODUCERS



MULTI-CHANNEL INTERLOCKED DUBBERS



STUDIO DUBBERS and RECORDERS



QUALITY AMPLIFIERS for MAGNETIC RECORDING and REPRODUCTION



MAGNASYNC MANUFACTURING CO., LTD. • 5521 SATSUMA AVE., NORTH HOLLYWOOD, CALIF. • POplar 6-1692

F&B**NEW & USED EQUIPMENT**

FOR MOTION PICTURE & TV FILM PRODUCTION

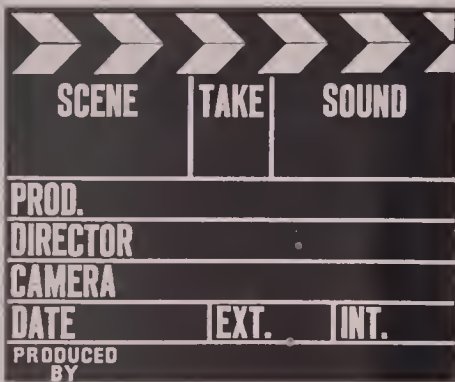
F&B**CAMERA SLATE** with Clapsticks

- * Easily erasable slate finish
 - * Sharp-sounding hardwood clapsticks
 - * Permanent silk-screened letters
 - * Supply of special, dustless chalk
 - * Large 11"x14" size
- Price \$8.75**

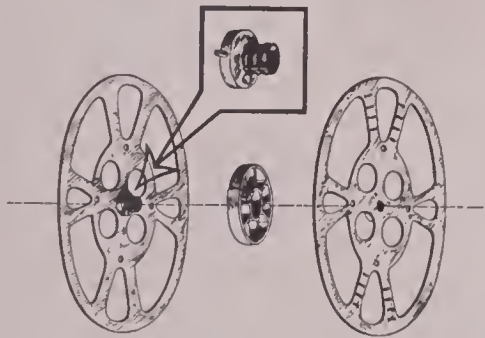
**STOP REWINDING!
USE****F & B Split Reels**

SAVE wear and tear on 16mm prints, time, space, storage.

NOW you can project, edit, inspect, synchronize, clean, measure and store all your films as cares.

No More Rewinding Problems

Now, simply slip film on core into **SPLIT REEL**. Close reel. Use another **SPLIT REEL** for take-up . . . unscrew reel to remove film.

BUY SEVERAL NOW!

400 ft. split reels — 16mm.....	\$4.50
800 ft. split reel — 16mm.....	\$6.00
1200 ft. split reel — 16mm.....	\$7.50
1600 ft. split reel — 16mm.....	\$9.00

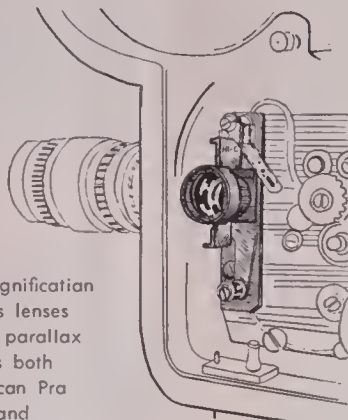
AURICON ACCESSORIES**HI-C CRITICAL FOCUSER**

- 6 X magnification
- Focus lenses
- Check parallax
- Fits both Auricon Pra and Cinevoice

PRICE \$49.50**INCREASE THE VALUE OF YOUR
CINEVOICE CAMERA**

Shoot Complete
15 Minute
Programs

**600 FOOT
MAGAZINE
CONVERSION
FOR 16mm
AURICON
CINEVOICE
CAMERA**



NOW Shoot full 15 minute TV shows without stopping or reloading. The F&B conversion includes 600 ft. magazine, extra silent take-up motor, camera insert plate for stabilization of film movement, and footage counter. Camera is **not cut down**; can be used without magazine for 100 ft. rolls. Magazine accepts 200 ft. spools as well as 400 ft. and 600 ft. rolls on cores.

WRITE FOR COMPLETE DETAILS

**F&B HAS A COMPLETE STOCK OF NEW AND
USED CAMERAS, PRODUCTION, LIGHTING,
EDITING & LABORATORY EQUIPMENT**

EVERY ITEM CARRIES ABSOLUTE MONEY-BACK
GUARANTEE

NOTE: IMMEDIATE CASH AVAILABLE FOR ALL
KINDS OF USED 16-35MM PRODUCTION, LAB.
EDITING, LIGHTING EQUIPMENT

F&B**FLORMAN & BABB****70 West 45th Street, New York 19, N. Y.****Phone: Murray Hill 2-2928****Cable Address — FLORBABB, N. Y.**

ly. A good rule to follow in filming titles is to allow more footage than the established reading time and then cut them into the picture their full length. In this way, it will be much easier to determine how long a title should run on the screen by projecting it along with the picture several times. Where titles are too long in actual screen time, they can be shortened. But those filmed too short, must be remade. In the long run, all titles are better if they are too long than too short in screening time. In every large audience, there is at least one or two spectators whose ability to read is hampered by poor vision, or perhaps because of the small lettering in the title.

Spoken titles are controlled by none of the rules or regulations that apply to the descriptive title except, perhaps, that they should be as brief as possible. The point of insertion in the film for the spoken title is determined by the action; yet many amateur filmers continue to cut in a spoken title before or after the scene showing the person speaking.

For the most natural effect, let the scene run a few frames to show the person starting to speak, then cut in the title, and continue with four or five frames at end of scene showing person completing speech. Where the speech is long, it becomes necessary to delete some of the footage in middle of the pictured action, allowing the title to "do the talking" instead of the person in the picture.

Another technique is to cut directly from the title, not back to the person talking, but to the person spoken to.

So, in the editing phase of your film making, when it comes time to cut in the descriptive—or sub-titles, analyse the scene carefully in order to determine just where the title should be placed. Unless you do, the film will be cut, the title will be spliced, and it will then be too late to move it forward or backward a few frames to gain the intended effect.

LIGHT PLAYS A PART*(Continued from Page 287)*

lights, is made to dissolve as each of the various actors and props are brought in or revealed by means of strong light directed upon them. In contrast with this fading technique, there were very few optical fades or dissolves used in the picture.

Another very tricky photographic problem was posed in a scene in which the script called for an exterior shot sandwiched in among the highly-stylized interiors—something which could easily have provided a jarring note in the predominantly black velvet

sequences already described. The exterior in question was a shot of a group of mourners walking down a cobblestoned path in a cemetery.

The problem was licked by setting the camera right on the ground and shooting through a shadow-box covered with scrim cut into an irregular pattern. The mood of the finished scene was exactly that established in the black velvet interiors—low key and heavy shadows, and including the same effect of rimming the scene with a black border seen in the interiors.

There is nothing unusual or remarkable about the physical equipment used in filming the picture. It was the manner in which the equipment was employed which contributed to the unusual quality of the production. The camera was a standard Mitchell BNC. The lights—controlled by a 9-bank 2-kw and a 6-bank 750-watt dimmer board interlocked—included the usual 750's, 300's and 200's and inkies, plus an occasional 2-kw lamp. The 750 spots were the predominant lights.

"Within Man's Power" is to receive its world premiere in Atlantic City, New Jersey, May 17th, at the 50th annual convention of the National Tuberculosis Association, sponsors of the production. It is scheduled to be released nationally in both 35mm and 16mm.

THE PRE-EDITING STAGE

(Continued from Page 288)

sary the handling of the original film where it might be subject to scratches or other damage. After the work print has been cut and edited the original negative can be cut to match it, using the edge numbers as a guide.

Working with the 400 foot reels of film, the next step is to project them and make a penciled memorandum of each scene as a guide when cutting. The information should include the roll number, a brief description of the contents of the scene, and any additional remarks that might serve as a guide later. Out-of-focus or poorly exposed takes simply may be listed without giving them a roll number. Where there is more than one take of a given scene, this should be identified by a sub-number and a notation indicating which is the best take.

Next, record the data for each good scene on a 3 x 5 file card, including the image size (long shot, closeup, and so forth), the camera angle, and a brief description of the action. Indicate the roll number in the lower right hand corner of the card. Scene B-8, for example would refer to the eighth scene on the B reel of unedited footage.

Next, project the film for the second time. During this screening, try to piece

F&B

NEW & USED EQUIPMENT

FOR MOTION PICTURE & TV FILM PRODUCTION

F&B

Introducing . . . CRESCENT MATTON

. . . an AMAZING, NEW product . . . which removes highlights, hot spots, reflections, etc. from all metal, chrome plating, glass, glassy painted surfaces, etc.

Easy to apply with spray applicator can. Coating hardens in seconds and can be handled safely without removing it. Replaces messy and ineffectual soaps, waxes, etc.

Try one now **PRICE**
\$2.25
PER CAN

A TRIBUTE TO PRECISION SOUND READERS

Our hat's off to Precision Sound Readers—far the utmost in precision manufacture, quality of materials and work and all around excellence and efficiency in use.

Three models available—
Optical—16mm & 35mm \$185.00
Magnetic—1/2", 16mm & 35mm \$197.50
Combination—Optical & Magnetic \$259.50

IMMEDIATE DELIVERY

* F&B MOVIE STOPWATCH *

Precision Swiss movement
Calibrated to read seconds,
minutes, 16mm & 35mm footage
Starts—Stops—Resets

List Price \$29.50 — Now \$14.75

BARGAINS IN USED EQUIPMENT

CINE SPECIAL 1, 15mm f2.7, 1" f1.9, 3" f4.5 case, excellent condition \$ 375.00
FILMO 70 H, beautiful, custom-built PAR accessories incl. 4 lens turret, built-in rackover, focusing thru lens, magnifying facuser, 110v. sync motor, 400 ft. magazine, Veeder counter, deluxe compartment case, all like brand new. Cost over \$2500.
SPECIAL, only 950.00
MAURER model D optical film recorder, "G-prime" galva, rack-mounted, perfect cond., can be converted for direct positive recording 2750.00
KINEVOX sync 17 1/2 mm magn tape recorder 825.00
MAGNECORD sync 1/4" magn tape recorder 625.00
MACVAN 16mm continuous printer, complete 475.00
DEVRY BANTAM 16mm sound proj., etc. 140.00
TRIANGLES, extendable, aluminum used 17.50
COLORTRAN deluxe converters, used 32.50
SCREENS, table model, beaded, 18"x24" 4.50
F&B MOVIE STOPWATCHES, min., sec., 16 and 35 mm Ft. 14.75
FLANGES, aluminum, 10" rd. and sq. shaft 7.95
GATOR GRIPS with barndoors 12.95
DOLLY, 3 wheel Ceca model, seat, case, LN 250.00
SUPER XX, 16mm neg. 200 ft. sl, outdated, each 3.45
BOLEX H-16, built-in counter, 15mm f2.8, 25mm f1.9, leather case 225.00

NEW F & B GATOR CLIPLITE WITH BARN DOOR

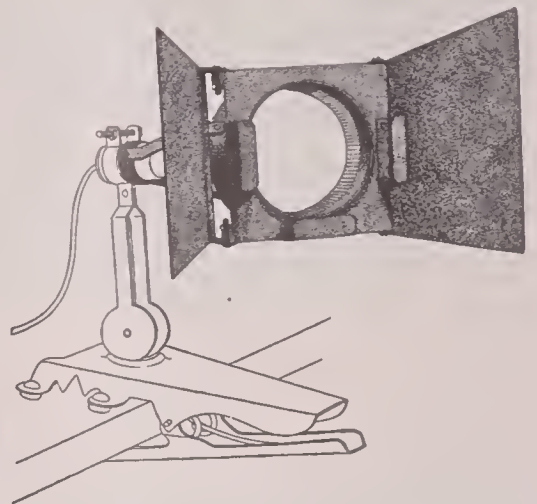

Unit includes — Gator Grip, Porcelain socket, 15 ft. cord & switch Barndoor.

PRICE
\$12.95

NEW F & B LEG-LOK TRIANGLE

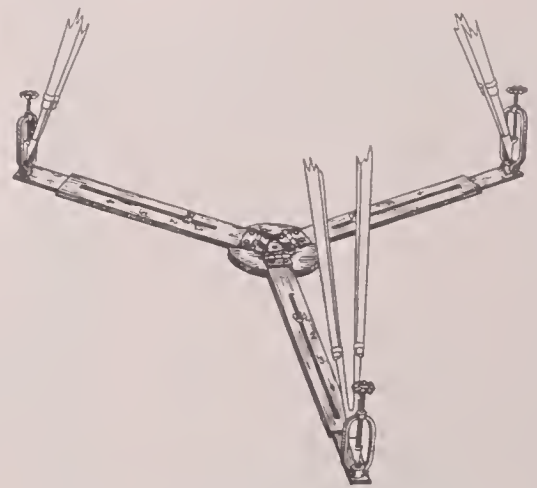

With Leg-Lok Clamps and reinforcing center casting.

PRICE
\$26.95

WANTED: AURICONS — MITCHELLS — MOVIOLAS — LAB EQUIPMENT — LENSES — RECORDERS — PROJECTORS — ACCESSORIES



FLORMAN & BABB

70 West 45th Street, New York 19, N. Y.

Phone: Murray Hill 2-2928

Cable Address — FLORBABB, N. Y.

Make "SOUND MOVIES" Anywhere!



Make your outdoor movies, really complete with on the spot commentary and conversation. Record the story while you shoot the film . . . even in far

away places where electric power is not available. A CARTER CONVERTER and a storage battery supplies 110 v. AC, operates your wire or tape recorder AND electric motor driven movie camera BOTH AT ONCE. Satisfactory "sync" and playback assured. Where synchronization is not vital, it's fun to make RECORDINGS even when using a spring driven camera. Record camera exposure data, remember what happened, when, where, who and how, so you can make better titles and comment when editing your films.



Carter

ORDER THROUGH CARTER DISTRIBUTORS EVERYWHERE. Carter Motor Co., Chicago 47

Carter Motor Company MAIL THIS NOW
2557 N. Moplewood Ave.
Chicago 47, Illinois

Please send illustrated circular and full information on Carter Converters.

Name _____
Address _____
City _____ State _____

RUBY CAMERA EXCHANGE

Rents . . . Sells . . . Exchanges

Everything You Need for the

Production & Projection

of Motion Pictures Provided by a Veteran Organization of Specialists

35 mm. . . . 16 mm.
Television

IN BUSINESS SINCE 1910

729 Seventh Ave., New York 19, N. Y.

Tel.: Circle 5-5640

Cable address: RUBYCAM

WORLD FAMOUS

S-5

synchronous magnetic film recorder for motion pictures and television



STANCIL-HOFFMAN

921 N. Highland Hollywood 38, Calif.

send for particulars

together in your mind as much of the film's sense as possible. Take additional notes on details that may have escaped you during the first screening. Follow your 3 x 5 cards closely as the film unfolds on the screen, and record any additional data alongside its appropriate scene.

During this screening, also watch the footage carefully to note any discrepancies which may exist between continuous action in medium shots and closeups. At this time you may find that although a certain bit of action seemed essential as set down in the shooting script, it is quite meaningless when seen on the screen. Note the scenes that seem to dovetail naturally in content or angle, revealing a relationship that was not evident in the script. Continue to refer to your cards as you view the footage, so that you will mentally associate each scene with the data you have recorded for it.

With your memory thus refreshed from having viewed the film a second time, arrange your 3 x 5 cards in the order in which you feel the scenes should appear in the final cut of the film.

It is quite possible that, having carefully reviewed the footage during screening, you will find that the scenes naturally fall into a cutting sequence that is a bit different from your original concept as set down in the script. In that case juggle the scenes (the 3 x 5 cards) about and make script notations of the proposed changes in scene order. As a final check on continuity, it may be necessary to screen the footage once more before breaking it down in separate scenes. You cannot possibly know your footage too well.

When all the 3 x 5 cards have been arranged in what you think will be the most effective continuity order, number them consecutively, placing the new continuity number in the upper left corner of the card so that it will not be confused with the roll number. The roll number will indicate where a scene of a given description is now located. The continuity number will tell exactly where that particular scene will fit into the cut footage. Afterward, arrange the cards in rotation according to roll number and you will then be ready to break down the footage into separate scenes.

To do this efficiently, a peg-board or a pigeon-hole tray is a necessity. A peg-board is a flat square board with nails or wooden pegs set into it in rows of ten pegs each, and with the rows about four inches apart. The pegs are numbered in rotation from 1 to 100 by means of letters stamped or painted on the board next to each peg. Here the various scenes are filed and held ready for use when it comes time to cut and splice. Each scene is rolled up and held

together with a rubber band and slipped over the peg.

The pigeon-hole tray is an alternative method and is usually about 1 inch deep and divided into squares 2½ x 2½ inches. These trays can be made of cardboard or wood. As with the peg-board, the pigeon holes are arranged ten in a row and are numbered consecutively from left to right with the numbers being stamped or painted in the center of each pigeon-hole. The advantage of the pigeon-hole tray over the peg-board is that it is unnecessary to put rubber bands or adhesive tape on your film clips in order to file them.

To break down your film into separate scenes, use the 3 x 5 file cards as a guide. Start with Roll A and wind off the scenes one by one. Scene A-1, for example, may carry the continuity number of 57 in the upper left corner of the 3 x 5 card. In that case, unwind the scene, write the number of 57 with a grease pencil on the forward end of it, roll it up and place it in pigeon-hole number 57 on the tray or on peg number 57 on the peg-board.

In the same manner, continue on through each scene of each reel of new footage, describing any out-of-focus or poorly exposed takes as they are encountered. The bad takes should be saved and numbered and placed in empty film cans (or typewriter ribbon cans, where 16mm film is being used). You can store up to ten scenes in each can. Be sure to place a label on the can bearing all the numbers of the scenes stored within. These discarded takes have a way of proving useful later.

When all of the film has been completely broken down into individual scenes, the peg-board or pigeon-hole tray will be filled with the separate scene strips, each neatly rolled up and numbered and ready for the next step—which is cutting them into the pattern represented by the 3 x 5 cards.

The basic steps in film cutting will now have been taken care of. The wheat will be separated from the chaff, so to speak. All the extraneous footage will have been discarded and put out of the way so as not to interfere with the orderly process of cutting the selected footage.

The next step is the creative cutting of the film. This is the phase of the job that will be discussed fully in a separate article next month.

DOCUMENTARY TECHNIQUE

(Continued from Page 293)

revealing shots of the people at work and play, little architectural details, market places, private homes, and amusement places that complete the picture. When desired, the regular organizational methods may be applied to travel reels, too.

END

Film Editing Made Easy
with NEW

professional film viewer

for 35mm and 16mm

Every film editor will appreciate a viewer that enables him to view his film from left to right—on a large, brilliantly illuminated screen.

The PROFESSIONAL FILM VIEWER makes film editing a breeze. Easy threading, portable, will not scratch film. Put this viewer between your rewinders and speed up your editing. Size of Viewing Screen 5³/₄ x 4³/₄.



35mm Model \$375

16mm Model \$350



Write Dept. A-6-4

CINERAMA

(Continued from Page 291)

scenes both vast and small in scope. These ranged from the Cathedral of Notre Dame de Paris, and the whole stage of the Opera de Paris to the narrow confines of the tiny Guignol Theatre (a marionette show for children). With the bulky, three-lensed Cinerama camera we shot scenes in two-room apartments and in other similar limited locations, which would be a problem to shoot even with the conventional 35mm camera. But the intimate shots proved to be as desirable and effective as shots of large-scope subjects. This proves there really is no limit to dramatic composition in Cinerama if the medium is rationally interpreted.

It is impossible to say arbitrarily that the closeup is obsolete, that the days of rapid editing are over; this would mean that the wide-angle of human vision does not tolerate selective concentration because "it sees it all." It would be a presumptuous anticipation to narrow down the rules of this medium.

Two - shots, three - shots, over - the - shoulder shots, trucking shots, and

Model 35-16C

SENSITESTER

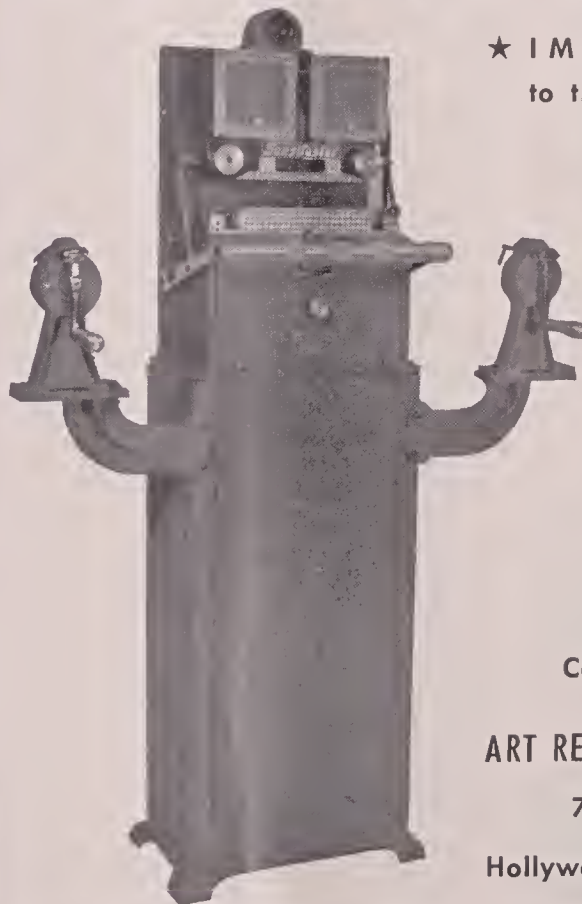

★ IMMEDIATE DELIVERY
to the lab owners interested in—

QUALITY
EFFICIENCY
ECONOMY

- DUAL MACHINE
1—Sensitometer
2—Scene Tester
- HIGHLY ACCURATE
Electronic timer unaffected
by climatic changes.
- NEW TYPE LONG-LIFE
Cold Light Exposure Unit
- WITHOUT ADDITIONAL
EXPENSE will match any
printer

Combination 35mm-16mm

ART REEVES MOTION PICTURE EQUIP.

7512 Santa Monica Blvd.

Hollywood 46

California

Sound Printing Head

for
Greater Output

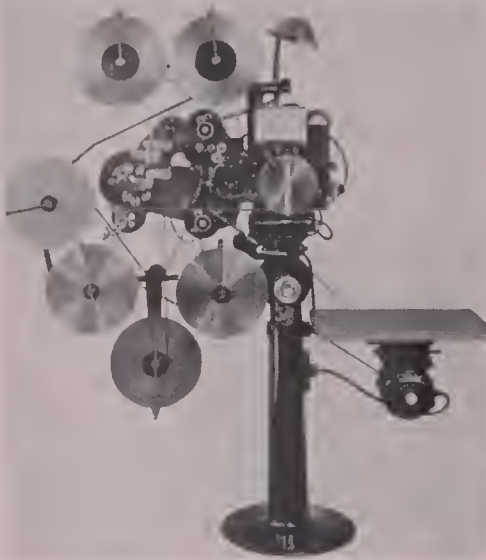

35mm-16mm Sound Printing Head, designed for your model "D" or "J" contact printer. Convert your single-head printer now into a double-head printer for high production output.

Literature On Request

MOTION PICTURE PRINTING EQUIPMENT CO.
Mfrs of Motion Picture and Micro Film Printers
8136 NORTH LAWNDALE AVENUE • SKOKIE, ILLINOIS

MOVIOLA

FILM EDITING
EQUIPMENT
16MM - 35MM

- PICTURE SOUND
Photo and Magnetic
- SYNCHRONIZERS
- REWINDERS

One of the new series 20 Moviolas for picture and sound.

Write for
Catalogue

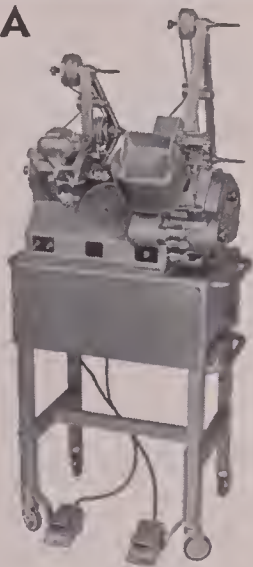

MOVIOLA MANUFACTURING CO.

1451 Gordon St. • Hollywood 28, Calif.

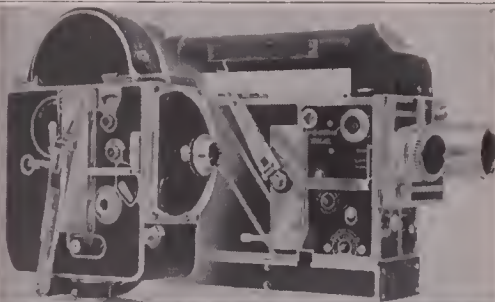

Automatic dissolve attachments for Cine Special and Bolex H-16 (Equipped with Pellegrini Shutter)

JOSEPH YOLO, 1037 N. La Brea
Phone GL. 7103 Hollywood, California

crane shots all have been successfully made with the Cinerama camera; and the resultant footage suggests a new format that opens a still greater field for daring compositions. Cinerama permits interpretive treatment as well as conventional. It is the misuse of the Cinerama format, the lack of understanding of the new medium which could mislead pioneers in striving for the true goal of the medium.

In shooting "Cinerama Holiday," we endeavored to use the subjective approach with our camera, whenever it was justified. The vehicles used to transport the camera in order to create the illusion of audience participation ranged from bobsleigh and skis to a bicycle plus a few extraordinary contraptions specially built for us by ingenious Swiss and French mechanics.

It was for the sake of subjective treatment that would give the audience the sensation of skiing that my operative cameraman, Gayne Resher, risked his life and nearly lost it when the camera, hanging on a special mount designed to keep it vertical, capsized on a steep slope and flipped over twice, throwing him clear and into a snowbank.

The matter of stereophonic sound, which is an important adjunct of Cinerama, must be considered by the cameraman whenever planning a shot with the Cinerama camera. The sound engineer must be consulted, not only because up to seven microphones must be concealed in the field or near the camera, but also because the audio-visual association is so close that the desired composition, camera movement and set illumination can be properly achieved only if the cameraman is conscious of the constant presence of sound whether originating in the field of vision or off-screen.

Here sound perspective is so accurate that the cameraman cannot ignore the rules it automatically presents, rules which influence both composition and set illumination. Thus, the audio impact becomes an inherent part of the photography. Nor can the Cinerama cameraman ignore the rules of editorial progression pertaining to the medium. Upon these rules may depend the choice of camera angle, the visual axis selected and the degree of audience participation to be attained.

More than ever before, the writers, directors, cameramen, sound technicians, editors, set designers, etc., must work in close cooperation in creating a Cinerama production. Any lack of teamwork in the preparation inevitably leads to false depth perception, distorted stereophony, and conflicting audio-visual effects.

These things we are doing with Cinerama: these are only the first steps

toward a great new film technique. There is little doubt that our wide-screen will very soon be perfected to include variable screen ratios. The validity of this technique is borne out by the success of the System Picot in France, where producers of animated cartoons use a variable format, not so much for sake of variety, but to insert into a definite functional frame the dramatic values of a scene.

Whatever will be the technical media in use eventually, the physical difficulties will be overcome. Wide-angle vision, variable screen ratio, stereophonic sound—all are here to stay, whether achieved directly, anamorphically, photographically, electronically, or magnetically. Indeed, the cinematographer can look forward with enthusiasm to fascinating years ahead.

LIGHTING PRODUCTIONS FOR BUSINESS SCREEN

(Continued from Page 284)

In 16mm film production, the cinematographer's major objective—aside from the basic mechanical problem of getting enough light to achieve desirable exposures—is to light the sets so that they will appear natural to the situation, in key with the subject, and visually interesting. To accomplish this, it is necessary for the cameraman to have sufficient set lighting units available to meet adequately all the demands of his set lighting plans.

Almost every shooting script, whether it be for an entertainment feature film or a business, promotion or training film, invariably includes sequences which demand lighting that will accent a specific mood. This calls for special lighting skill. Some sequences, for example, may call for high-key treatment to complement the light, positive, boyant mood indicated in the script. Other sequences, particularly those having a somber, mysterious, primitive, highly dramatic, or nocturnal mood—and you get these in industrial film scripts, too.—will register most effectively where a low-key lighting pattern is employed.

The high-key lighting scheme involves a generally high-level of illumination with relatively light shadow areas and crisp highlights pointing up various elements within the set; the background is invariably brightly lighted, and heavy shadows are avoided.

Low-key lighting, on the other hand, is characterized by general low-level illumination, a softer key-light, less fill light, and greater depth of shadow. The purpose of low-key lighting is not to create mood alone but—in the photography of product advertising films especially—

KINEVOX Synchronous Magnetic Recording Equipment

Everything for Magnetic Recording!

- Synchronous Magnetic Film Recorder
 - Synchronous Magnetic Film Phonograph
 - Remote Amplifier-mixer
 - Magnetic Film Reader
 - Mono-boom for microphone
 - Magnetic Sound Eraser
 - Magnetic Sound Film Splicer



The KINEVOX synchronous magnetic recorder . . . known 'round the world!

Descriptive Catalog of Complete Kinevox Equipment Available On Request

Licensed under R.C.A., Western Electric, Armour Research Foundation and Kinevox Patents.

KINEVOX BUILDING
114-116 SO. HOLLYWOOD WAY
TELEPHONE: VIctoria 9-3291
ROME • BOMBAY

KINEVOX

I N C O R P O R A T E D

BURBANK CALIFORNIA
CABLE: Kinevox, Burbank
NEW YORK • RIO DE JANEIRO • CANADA

to concentrate audience attention on some important function, product, appliance, etc., withholding strong light from all but the most important object or areas within the set.

Once the mood and the lighting key which will best complement it has been decided, there remains one other consideration—that of light source, that is, the element which obviously supplies the natural lighting of the set—i.e., sun coming through a window, an open doorway, a chandelier, fireplace, etc. Whatever is established in the script as the source, the set illumination then should appear as coming naturally from that source. If the setting is a modern office, outside source light may be emphasized by having the pattern of a venetian blind cast upon one wall. If the setting is a modest dining room, the light may appear to be coming from an overhead chandelier. And for a closeup of a man reading in his easy chair, the source light will obviously come from the reading lamp at his side.

In general practice, before the cameraman lights his set, he familiarizes himself with the action pattern of the sequence so that no significant bit of business will be lost through playing it in a dimly-lighted area. Here a run-through of the action by the players or their stand-ins will usually give an idea



PRECISION BUILT COMBINATION
16mm AND 35mm

OPTICAL

SOUND READER

FEATURES: Simple threading . . . polished stabilizer drum with needle bearings, with a surface which cannot damage film . . . film rollers machined to conform with SMPTE standards, and equipped with airtless bearings . . . precision ground shafts . . . dimension 6"x6"x7 1/2".

AMPLIFIER: 117 volt - 60 cycle - AC . . . power output - 4 watts . . . heavy duty Alnica V speaker . . . safety fused . . . prefocused socket . . . pilot light . . . 6 ft. heavy duty line card.

NET PRICE \$185.00 F.O.B., FACTORY, NEW YORK

PRECISION LABORATORIES
1139 Utica Avenue BROOKLYN 3, NEW YORK

FOR YOUR TV COMMERCIALS TITLES and SPECIAL EFFECTS

35mm-16mm Black & White or Color

RAY MERCER & COMPANY

4241 Normal Ave., Hollywood 29, California

NOrmandy 3-9331

30 Years Experience
at Your Service . . .



We Welcome
Your Problems



KADISCH

Synchronous Motor Drive for 16mm Projectors

Especially designed to drive all Bell & Howell and Ampro 16mm projectors at synchronous speed.

The synchronous motor drive can be instantly attached to projector and taken off at any time. No special technical knowledge required for installation and mounting. The synchronous motor drive is complete with base-plate, Cannon plug for cable and power switch, and a set of reduction gears.

Write for more details and prices

NOTE: When ordering please give correct firm and model of projector.

ONE YEAR GUARANTEE!
Immediate Delivery

Available at leading dealers, or direct.

KADISCH
CAMERA AND SOUND ENGINEERING CO.
500 West 52nd St., New York 19, N.Y.
Plaza 7-3511
DESIGNERS AND MANUFACTURERS OF
MOTION PICTURE—TV EQUIPMENT

AUTOMATIC DAYLIGHT PROCESSING



DEVELOPING TANK

- Processes up to 200 Ft.
- 8mm-16mm-35mm
- Movie—X-Ray—Microfilm
- Motor Driven, Portable
- Tough Plastic Tanks
- Uniform Density Assured
- 70mm tank also available



FILM DRYER

- Motor driven—Heated
- Speedy drying
- Automatic shrinkage allowance
- Stainless steel and aluminum construction
- Easily assembled without Tools
- Compact, Portable

Guaranteed. Write for Free Literature
MICRO RECORD CORP.
Dept. AC 225 W. 28th St., N.Y. 1, N.Y.

Color ran

GOBO STAND

That is Really Versatile **It's New!**



THE 12 foot stand may be used with a BOOM ADAPTER or with SCRIMS or with FLAGS



ABSOLUTE LIGHT CONTROL

WRITE FOR FURTHER INFORMATION
GLENNDALE 5, CALIFORNIA

NATURAL LIGHTING CORP.

See the Borgoins this Month
on Page 309 . . .

of the dramatic demands on the lighting.

In arranging actual lighting pattern, the key-light is set up first. Just how large a unit or units to be used here will depend upon such factors as the mood of the sequence, the brightness of the indicated source, the working aperture of the lens favored by the cameraman, and whether the production is to be filmed in black-and-white or color. In black-and-white photography, a single Baby Keg-lite may be sufficient to supply key illumination for a low-key scene or sequence. In color photography, however, a stronger light source will be required.

The fill-light is the next to receive consideration. The amount of fill will depend on the general key lighting of the scene, the mood, and the indicated source. Low-key lighting, of course, requires very little fill light, since shadows are an important adjunct to this type illumination.

A high-key sequence, on the other hand, demands an almost total elimination of shadows in favor of sparkling brilliance. This does not imply that high-key lighting should be flat; it merely calls for less contrast between key-light and fill-light. Color photography, generally speaking, also demands more fill-light than does black-and-white—for sequences of similar mood.

The type of unit to be used for supplying fill-light is usually determined by the sequence to be photographed. For high-key lighting, a lamp as heavy as the standard key-light units may be used; it should be toned down, however, with scrims and diffusers. For low-key lighting, a small spotlight, flooded out for softness but screened down by means of barn doors or a snoot is often used. A single or double "broad" makes a perfect fill-light source for B&W photography, since it produces relatively "shadowless" light. For color photography, the Mole-Richardson Cinelite is a more appropriate unit.

With the key-light and main fill-light set, the cameraman will next consider lighting the background of the set. Here an exposure meter can be used to good advantage in figuring, mathematically, the correct ratios between keylight and background illumination.

The relative brightness of the background will often depend primarily on the mood and general key lighting already established for the scene. In high-key photography, the background is often brighter than the key-light. In low-key lighting there is sometimes virtually no background lighting—or perhaps just enough to accent the contours of selected elements of the background structure or setting.

Background illumination is usually supplied by light units set up out of lens range of the camera in such a manner

that the light falls entirely on the background. Where the light units are mounted overhead and tilted downward, there is less danger of producing conflicting shadows that clutter up a composition. In keeping with the source light pattern, the background illumination should also appear to originate with the established source light object. This may be within the scene itself—a chandelier, a bright table or chair-side lamp, etc. Where such lamps are adjacent to a wall, a spotlight should be used to throw light on the wall back of the lamp to stimulate the natural lighting result.

Back-lighting and top-lighting are essential to produce three-dimensional depth to a scene, and to bring out the contours of furniture, props and texture of various objects of set decor. Like the back-light units, these, too, should be mounted overhead for the most natural lighting effect.

A technique which is valuable from the standpoint of economy and art is that of lighting only certain areas or planes of the set and allowing the rest to fall off into darkness. In such a setting the players move from normal lighting to cross-lighting to silhouette in a manner which can be very dramatic pictorially—not to mention easy on the equipment budget. Such lighting, however, should be logically motivated by mood or story action, and not used too frequently in a single production.

In general, while set lighting for 16mm commercial films need not be elaborate or complicated, it should be kept in mind, however, that the movie-going public has become conditioned to the technical excellence of the entertainment photoplay, and it naturally expects similar quality in any type of motion picture shown publicly.

Carefully chosen lighting units (a wide range of units are now available for rental, relieving the producer of the need to buy), a modicum of originality, and the exercise of moderate care in balancing lights will enable the commercial film photographer to obtain results comparable to the best studio-photographed feature film.

CLARIFICATION on film music copyright laws has been passed along by the Motion Picture Service of the U.S. Department of Agriculture. Information it obtained from the Library of Congress reveals that the nearest thing to a listing of "public domain" music is its "Catalog of Copyright Entries," a yearly listing. Incidentally, music may be protected by copyright for a total of 56 years. If producers have questions about a particular piece of music, the library of Congress will advise on clearance, but cannot furnish a blanket listing of cleared music.

NEW LOOK IN 3-D

A PRIVATE SHOWING of *Naturama*, termed the "New Look" in motion picture presentation, was given last month in Dayton, Ohio, which saw the marriage of super wide-screen and 3-D movies. The picture proportions were the same as CinemaScope and the picture was shown in true 3-D, with both images being projected from a single strip of film. The demonstration film included both black-and-white and color footage from feature-length releases made in Hollywood.

Regular standard projection equipment was used with no change to the projector or booth port, and the installation of the compact *Naturama* superimposing attachment was made in a matter of three minutes. The attachment has the appearance of a simple window through which the beam is projected. Picture brilliance was comparable to that obtained in the past with two projectors interlocked for 3-2.

Naturama is the single-film, wide-screen 3-D system developed by Col. R. V. Bernier, USAF Reserve, and Chief Engineer of Synthetic Vision Corporation.

A trade show for exhibitors, producers and technical representatives of the industry will be presented in Dayton in the near future.

GREATEST NEWS YET IN THEATRE SOUND!

PERSPECTA
STEREOPHONIC SOUND

**Multi-directional sound
on a standard optical track**

This is it! The simple, permanent sound system that solves all the exhibitor's stereophonic sound problems—and it's fully compatible with conventional sound systems. Projection procedures remain the same, too.

Exhibitors with stereophonic sound can switch to Perspecta Stereophonic Sound by installing only an integrator unit, design-engineered by Fairchild. Theatres equipped for conventional sound need only that single miracle unit plus additional power amplifiers, loudspeakers and a multiple gang fader.

REMEMBER! *MGM, Paramount and Warner Bros. are now filming all productions with this new technique.*

See your theatre supply dealer for full information or write:

FAIRCHILD RECORDING EQUIPMENT
MOTION PICTURE SOUND DIVISION • WHITESTONE 57, NEW YORK



frost
lights the nation!

**MOTION PICTURE STUDIO •
THEATRICAL • DISPLAY
RENTAL EQUIPMENT**

WHEREVER YOU ARE—WHATEVER YOU NEED

... in the way of unusual, specialized lighting, call on Jack Frost! For movie-making, stage lighting, feature exhibits, large conventions ... for *any* location that requires exceptional lighting, Jack Frost is ready to serve you! And Jack Frost's unequalled national service includes complete installation and removal *wherever* you are. Rent all your specialized lighting equipment from Jack Frost ... famous for lighting the nation's greatest shows ... most spectacular displays.

**FOR FULL INFORMATION ON
RENTAL EQUIPMENT
MAIL COUPON, OR CALL
DETROIT, TRinity 3-8030**

**JACK A. FROST, DEPT. J,
234 PIQUETTE AVE.
DETROIT 2, MICHIGAN**

Please send me full information on
your rental service.

Name _____
Address _____
City _____ Zone _____ State _____

Now! A 400ft. Magazine For Your BOLEX H-16

Complete
with
Synchronous
Motor
and Base

Includes
Installation
and
Case



Permits continuous run of 400 feet of 16mm film, or—the 200 ft. daylight loading spool may be used in the 400 ft. magazine. The 100 ft. daylight loading spool can be used in the camera without removing the external magazine. In black wrinkle finish to match camera. Fully guaranteed. Write for information on our Rock-Over Sports-finder and Camera Base.

See your Bolex dealer or
order direct. Immediate delivery.

TOLEDO CINE ENGINEERING
1309 Milburn Ave. Toledo 6, Ohio

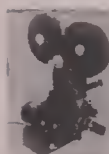

Ready-Eddy

U. S. Registered Trademark
EASY READABLE • ACCURATE
FOR EVERY DAY USE

1001 Ready Sound-Film
Editing Data:
• Footage • Frame
Count • Screen Time
• 35mm and 16mm
equivalents.
Plastic computer for
everyone in movies
and TV, from script to
screen.

\$2.00 Prepaid
(Delivered In U.S.A.)

ASK FOR REPRINT OF ARTICLE
IN AMERICAN CINEMATOGRAPHER.

Write or ask your dealer

READY-EDDY, Sandy Hook, Conn.



REVERSAL PROCESSING AND DUPLICATING
SPECIALISTS FOR OVER A DECADE. MODERN
MACHINES, WITH TEMPERATURE CONTROL WITHIN
TWO-TENTHS OF ONE DEGREE.

free brochure on request

REVERSAL PROCESSING
E. I. DUPONT BLUE BASE FILM

PER FT.
16 MM02c
B&W WORK PRINTS05c
B&W FROM KODACHROME ON PAN STOCK06c
TIMED REV. DUPES, SILENT07c
TIMED REV. DUPES, SOUND08c
Edge Numbering005c

NATIONAL CINE LAB
BOX 1475, Washington 17, D. C.

Scheibe FILTERS
In World-Wide Use

Produce moonlight and night effects
in daytime • fog scenes • diffused focus
and many other effects.

Information mailed on request.

SCHEIBE FILTERS COMPANY

ORIGINATORS OF EFFECT FILTERS
P.O. Box 46834, Hollywood 46, Calif.

Current Assignments of A.S.C. Members

Major film productions on which members of the American Society of Cinematographers were engaged as directors of photography during the past month.

AMERICAN SOCIETY OF CINEMATOGRAPHERS

FOUNDED January 8, 1919, The American Society of Cinematographers is composed of the leading directors of photography in the Hollywood motion picture studios. Its membership also includes non-resident cinematographers and cinematographers in foreign lands. Membership is by invitation only.

BOARD OF GOVERNORS—1954

ARTHUR MILLER, President
SOL HALPRIN, First Vice-President
JOSEPH RUTTENBERG, Second Vice-President
ALFRED GILKS, Third Vice-President
WALTER STRENCE, Treasurer
PHILIP TANNURA, Secretary
ROBERT DE GRASSE, Sergeant-At-Arms
JOHN ARNOLD
JOSEPH BIROC
ARTHUR EDESON
GEORGE FOLSEY
LEE GARMES
VICTOR MILNER
HAL MOHR
LEON SHAMROY

ALTERNATE BOARD MEMBERS

ARTHUR ARLING
LUCIEN BALLARD
DAN CLARK
PAUL EAGLER
FARCIOT EDOUARD
ERNEST LASZLO
ROBERT PITACK
JOHN SEITZ
JAMES VAN TREES
PAUL VOGEL

ALLIED ARTISTS

- HAROLD LIPSTEIN, "Adventures of Hajji Baba," (Technicolor CinemaScope) with Elaine Stewart and John Derek. Don Weis, director.
- HARRY NEUMANN, "Jungle Gents," with Leo Gorcey and Huntz Hall. Edward Bernds, director.

COLUMBIA

- ARTHUR E. ARLING, "Three for the Show," (Technicolor; CinemaScope) with Betty Grable, Marge and Gower Champion. H. C. Potter, director.
- WILFRED CLINE, "Violent Men," (Technicolor) with Randolph Scott and Jocelyn Brando. Bruce Humberstone, director.
- BURNETT GUFFEY, "Rough Company," (Technicolor; CinemaScope) with Glenn Ford and Barbara Stanwyck. Rudy Mate, director.
- CHARLES B. LANG, JR., "Phffft," with Judy Holliday and Jack Lemmon. Mark Robson, director.
- CHARLES LAWTON, JR., "The Long Gray Line," (Technicolor; CinemaScope) with Tyrone Power and Maureen O'Hara. John Ford, director.

- HENRY FREULICH, "The Moon Men," with Johnny Weissmuller and Jean Byron. Charles Gould, director.

METRO-GOLDWYN-MAYER

- JOSEPH RUTTENBERG, "The Last Time I Saw Paris," (Color; wide-screen) with Elizabeth Taylor, Van Johnson. Richard Brooks, director.
- ROBERT PLANCK, "Athena" (Technicolor; wide-screen) with Jane Powell and Edmund Purdom. Joe Pasternak, director.
- PAUL C. VOGEL, "Green Fire," (Eastman color; wide-screen) with Stewart Granger, and Grace Kelly. Andrew Marton, director.
- JOHN SEITZ, "Rogue Cop," (Wide-screen) with Robert Taylor and Janet Leigh. Roy Rowland, director.
- GEORGE FOLSEY, "Deep In My Heart," (Color; CinemaScope) with Jose Ferrer, Donna Reed and Merle Oberon. Stanley Donen, director.
- ARTHUR ARLING, "The Glass Slipper," (Eastman color; wide-screen) with Leslie Caron and Michael Wilding. Charles Walters, director.
- CHARLES ROSHER, "Jupiter's Darling," (Eastman color; CinemaScope) with Esther Williams and Howard Keel. George Sidney, director.

PARAMOUNT

- WILLIAM DANIELS, "Strategic Air Command," (Technicolor; VistaVision) with Jimmy Stewart and June Allyson. Anthony Mann, director.
- DANIEL FAPP, "Run for Cover," (Technicolor; VistaVision) with James Cagney and Viveca Lindfors. Nicholas Ray, director.

R.K.O.

- JOHN ALTON, "Where the Wind Dies," (Technicolor; Superscope) with Cornel Wilde, Yvonne de Carlo, and John Dierkes. Allan Dwan, director.
- WILLIAM SNYDER, "The Conqueror," (Technicolor; wide-screen) with John Wayne and Susan Hayward. Dick Powell, director.

20TH CENTURY-FOX

- JOE MACDONALD, "Woman's World," (Technicolor; CinemaScope) with Clifton Webb and June Allyson. Jean Negulesco, director.
- LEON SHAMROY, "The Egyptian," (Technicolor; CinemaScope) with Edmund Purdom and Jean Simmons. Michael Curtiz, director.
- LEO TOVER, "Untamed," (Technicolor; CinemaScope) shooting backgrounds in Ireland. Henry King, director.

UNIVERSAL-INTERNATIONAL

- MAURY GERTSMAN, "So This Is Paris," (Technicolor; wide-screen) with Tony Curtis, and Gloria De Haven. Richard Quine, director.
- RUSSELL METTY, "Shadow Valley," (Technicolor; wide-screen) with Rory Calhoun and Colleen Miller. Richard Carlson, director.
- GEORGE ROBINSON, "Destry," (Technicolor; wide-screen) with Audie Murphy and Mari Blanchard. George Marshall, director.



TEWE MOTIVEFINDER

— like a "right arm" for the creative MP and TV Director

TEWE MOTIVEFINDER is a wizard that solves scores of set problems. This Director's Zoom-type Finder reveals the most suitable focal length, the proper camera position, the effects of dolly shots, etc. It is invaluable to a creative Director who likes to plan optical tricks and special effects. Combination Finder zooms from 25mm to 135mm for 35mm Motion Picture and zooms from 28mm to 150mm for TV. Complete with leather carrying case and neck band. **Only \$75**

Other Versatile Viewfinders — each a honey for the money!



ZOOM DIRECTOR'S FINDER for 16mm and 35mm. . . . 16mm zooms from 13mm to 75mm. 35mm zooms from 25mm to 6". **\$15.50**

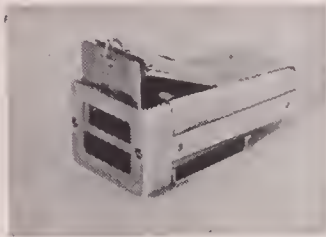

WATSON Director's type finder, pocket size, with mattes from 30mm to 100mm for 35mm cameras. Also for 16mm cameras. **\$35**

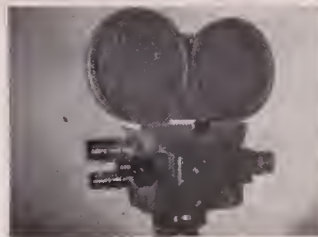

ZOOM Finder for Auricon Cine Voice . . . zooms from 15mm to 12". **\$60**
Available for Filmo and Eyemo. **\$39.50**

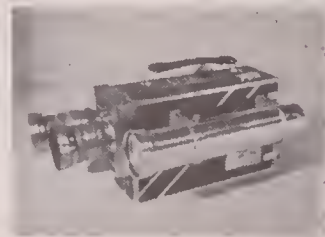

ZOOM Finder for Cine Kodak Special . . . zooms from 15mm to 150mm, with parallax adjustment. **\$75**
Template supplied for mounting Finder on magazine. Additional brackets for magazines available at \$7.50 per set.

FRANK C. ZUCKER
CAMERA EQUIPMENT ©
1600 BROADWAY NEW YORK CITY

WARNER BROS.

- **SID HICKOX**, "Battle Cry," (WarnerColor; CinemaScope) with Van Heflin and Aldo Ray. Raoul Walsh, director.
- **LEE GARMES** and **RUSSELL HARLAN**, "Land of the Pharaohs," (WarnerColor, CinemaScope; shooting in Egypt) with Jack Hawkins and Dewey Martin. Howard Hawks, director.
- **HARRY STRADLING**, "Helen of Troy," (WarnerColor, CinemaScope; shooting in Italy) with Rossana Podesta and Jacques Sernas. Robert Wise, director.
- **EDWARD COLMAN**, "Dragnet," with Jack Webb, Ben Alexander and Ann Robinson. Jack Webb, director.

INDEPENDENT

- **FREDERICK GATELY**, "The Bandit," (Josef Shafitel Prods.—Eastman color, SuperScope) with Arthur Kennedy, Betta St. John, and Eugene Iglesias. Edgar Ulmer, director.
- **RAY JUNE**, "This Is My Love," (Allan Dowling Pictures; RKO release; Eastman color wide-screen) with Linda Darnell and Rich Jason. Stuart Heisler, director.
- **FRANK PLANER**, "20,000 Leagues Under The Sea," (Walt Disney Prod.; Technicolor; CinemaScope) with Kirk Douglas, James Mason, and Peter Lorre. Richard Fleischer, director.
- **ERNEST LASZLO**, "Vera Cruz," (Hecht-Lancaster Prod. for U-A; Technicolor; Wide-screen; shooting in Mexico) with Gary Cooper and Burt Lancaster. Robert Aldrich, director.

(Continued on Page 310)

C. ROSS

FOR

LIGHTING EQUIPMENT

Inkie and Arc Lamps including Required Accessories
Generators—Cables—Boards—Boxes

Raby Camera Crane—Dollies—Blimps—Ceared Heads

GRIP EQUIPMENT

FOR LOCATION AND STUDIO

Parallels—Steps—Platform Ladders
Century Stands—Reflectors—Flags—Scrimms

SOLE EASTERN MOLE-RICHARDSON CO. DISTRIBUTOR

RENTALS • SALES • SERVICE

CHARLES ROSS, Inc.

333 WEST 52nd STREET

NEW YORK 19, N.Y.

Circle 6-5470-1

HOLLYWOOD'S GREATEST UNDERWATER VENTURE

(Continued from Page 283)



Compeco PROFESSIONAL Reels

For shipping, storing or showing film, precision made Compeco Professional Reels are first choice with those who want the finest. Hard, spring type steel construction won't warp or bend . . . eliminates film-wearing rubbing during projection or winding. Your production deserves the finest package—use Compeco Professional Reels in 600 ft. to 2,000 ft. sizes.

Write for catalog!

COMPCO CORPORATION
2253 W. ST. PAUL AVENUE, CHICAGO 47, ILL.



GEO. W. COLBURN LABORATORY INC.
164 NORTH WACKER DRIVE • CHICAGO 6
TELEPHONE STATE 2-7316

**8 and 16mm
SERVICES**

YOU WON'T MISS AN ISSUE . . .
of *American Cinematographer* if you renew your subscription promptly when notice is received. The yearly subscription rate remains the same — \$3.00 (U.S. and Canada) Foreign, \$4.00

Many of the crew, like myself, were experienced in using underwater equipment. Others were readily trained to the equipment that permits normal breathing and moving about underwater with remarkable safety.

For most of the crew, this equipment consisted of the well-known Aqua-lung with air-chambers that strap to the back and permit one to remain submerged for 60 minutes; a pair of swim fins; and a diving mask. Augmenting the crew and cast directly involved in the underwater sequences were a number of expert divers whose duty it was to watch over the neophytes and their equipment and render quick and effective aid in event anything went wrong.

One of these was chief diving expert Fred Zendar. Another was Salvage Man Frank Higgins, the only diver to wear a regulation Navy diver's suit with surface airlines and a built-in telephone. He served as communications link between men and underwater and the crew on deck of the LCT craft, floating base of operations.

Until now, almost all underwater footage for Hollywood feature productions has been shot with portable, lightweight cameras such as the Eclair Camerette or the Arriflex encased in pressurized, water-tight chambers. The limited film capacity of these cameras made them impractical for our work. In their place was provided a standard Mitchell camera mounted within a streamlined, pressurized underwater blimp—a remarkable piece of equipment turned out by Walt Disney studio engineers.

Having a built-in power source for the camera motor, and precise external remote controls for rackover, setting the lens stop and focusing, I was able to do everything underwater with this camera that I am able to do with a Mitchell on the sound stage. The combined camera and blimp, which weighs 175 pounds on land, has neutral buoyancy underwater, making it easy to transport undersea at any depth. For dolly shots and "swim-throughs" we used the Aquaflex (the underwater-blimped Camerette) another highly maneuverable submarine camera.

The Caribbean location site chosen for this production is perhaps the most ideal for underwater cinematography. Nowhere else is there the wide variety of picturesque coral formations, the countless different kinds of fish, ranging from the colorful grouper to barracuda, sharks and sting rays. The crystal-clear water afforded visibility to depths as great as 50 feet. Because there is no direct current running through the waters here, there was not the problem of

mud or silt clouding the water to hamper photography. There was, however, a layer of coral dust or fine sand on the ocean floor which was easily stirred up whenever the divers walked on it. When this happened, operations stopped for about twenty minutes to allow the dust to settle. Later, we eliminated this problem by first laying a heavy hemp mat on the ocean floor, over the area where action was to take place.

The appearance of fish swimming through the water is an accepted component of underwater photography; but we found that this piscatorial prop was not always around when we were ready to start shooting. So here again, ingenuity came to the fore, and fish were gathered up by the prop men and held in wire mesh pens until time came to release them for a "walk through" in the scene.

In gathering the fish, it was learned that if the open end of the net was pointed toward a coral head, the fish would swim into it, rather than away toward the open sea. We thus had excellent luck in always keeping the fish within camera range. Indeed, some of them seemed to like "acting in pictures." Many stuck around after a scene was shot and were re-captured and used again.

Director Richard Fleischer spent as much time underwater as any other man in the troupe, and set an example for the rest of us to follow. Considerable credit is also due Fred Zendar, the production's chief diving expert. So efficiently did Zendar set up the diving operations and his water safety program that there was not a single accident nor any major interruption in shooting during our eight-week stay on location.

Although I had previous experience as an underwater cameraman on 20th Century-Fox's "The Frogmen" and "Beneath The Twelve-Mile Reef," I put in more sub-surface time on this Walt Disney production than on the other two combined. This was certainly a most interesting and challenging job, but I'll be happy to settle for one on a "dull," dry sound stage any time.

Olle Comstedt, ASC, has completed photography of a documentary film on St. John's College in Annapolis, Md., for American Chemical Agricultural Co., and leaves this month for Europe where he will produce a series of documentary films on a number of European countries. His headquarters will be Gothenburg, Sweden.

CLASSIFIED ADVERTISING

RATE: 10c per word—minimum ad \$1.00. Words set in capital letters, 15c per word. Display format 90c per line.

STUDIO & PRODN. EQUIP.

WE'RE NOT SATISFIED UNTIL YOU ARE!
 BERNDT-MAURER 16 mm Single System Sound Camera w/400' mag, 4 lenses, etc. CLOSE OUT \$ 495.00
 CINE SPECIAL MODEL II with 3-200' chambers, Kodak coated lenses, carrying case and Prof. Jr. Tripod. Excellent 2095.00
 MOVIOIA 35mm COMPOSITE Sound/Picture complete 495.00
 WALL 35mm MOVIE-TONE Single System Sound Camera 1995.00
 MAURER 16mm CAMERA w/400' mag; sync-motion viewfinder; compl 2750.00
 KODAK HISPEED 16mm Camera w/63mm lens, \$1713 val. 995.00
 PAN CINOR ZOOM LENS for 16mm 229.50
 BARDWELL-MCALISTER MULTIPLE FLOOD-LITES, 3 Quadruple heads holding 12 bulbs on rolling tripod stand. Orig. Gov't Cost \$180. Surplus 29.50
 BM QUADLITE Heads only \$4.95. Stands only.. 19.95
 CINE SPECIAL 16mm BLIMP Custom Built. Has follow focus, vertical image 63mm viewfinder, takes 200' mag and syncmotor. \$600 value 350.00
 ANSCO-SWEET COLOR DENSITOMETERS \$850 val. 367.50
 CINEMAPHONE 35mm DUBBING Heads, less motor 395.00
 WESTERN ELECTRIC 35mm OPTICAL RECORDING System, complete 4950.00
 HOUSTON 16mm KIA REVERSAL DEVELOPER, Good as is 2495.00
 NEW DIFFERENTIAL REWIND GIMMICKS, match 16mm with 35mm reels. Singly, \$37.50. Pair 69.50
 NEW FILM EDGE NUMBERING MACHINES, 16 or 35 mm 2250.00
 HEAT EXCHANGER, 10 gpm, 1900W, new, shopworn 150.00
 SOS FILMETER STOP WATCH \$29.50 list 13.95
 TRADES TAKEN, SEND FOR 1954 CATALOG
 Phone PL 7-0440

Dept. fc Cable: SOSOUND
S.O.S. CINEMA SUPPLY CORPORATION
 602 W. 52nd Street New York 19

FOR SALE

BOLEX H-16 leader, eye level focuser, Bolex trigger handle filter slot behind lens, filters, case, turret handle. Wollensak F2.5 lens. Excellent condition, \$265.00. PETE C. ZARILLA, 800 Virginia Ave., Rochester, Penno.

AURICON Pro, Cine Voice exposure control, turns on, off with camero — prevents fogging, saves batteries, complete \$40.00. LEE ENGINEERING, 222 Minna St., San Francisco. APPROVED BELL & HOWELL SERVICE. Eyemo parts in stock.

UHLER optical reduction printer 8mm to 16mm, 16mm to 8mm with automatic lite changer, \$200.00 25,000 ft. Eastman 8mm blue base positive film, fresh stock, 1c per foot in 400 ft. rolls plus 50c for postage. Eastman 8mm panchromatic duocating stock 3c per foot. Motor generator set, 110 Volt, AC to DC, 600 watts. \$100.00. ROYAL FILM SERVICE, Box 206, Passaic, N. J.

CINE special, Par 4-lens turret and eye level focus magnifier, Yolo autom. shutter dissolve, filter slot and holders, custom case, 4 "C" mount adapters, Linhof prof. tripod, 1" F1.9 T.T.H. ctd. lens and 2 1/2" E.K. F2.7, 2 objectives, 2 100 ft. chambers. Perf. Cond. First \$895.00 takes all. 1008 Hills Ave., L.A. 24. BR 0-470B.

CINE Special 200 ft. magazine, like new, recently serviced by Eastman \$225.00; Auricon synchronous motor for Cine Special \$95.00. DYNNER, P. O. Box 1072, Youngstown, Ohio.

ALL GUARANTEED LIKE NEW!
 CINE KODAK SPECIAL II F1.9 EKTAR CASE.....\$595.00
 ELGEET STEREO SYSTEM COMPLETE..... 99.50
 BOLEX STEREO SYSTEM COMPLETE..... 250.00
 6" F4 BOLEX YVAR COATED 98.00
 "1 F1.5 BOLEX PIZAR COATED 79.50
 10" F5.6 DALLMEYER COATED 79.50
 WATSON 16MM-35MM DEVELOPING SYSTEM..... 79.50
 NEW 16MM ARRIFLEX IN STOCK
 ALL ORDERS FILLED
CAMERA CRAFT,
 18 East 42nd Street New York 17, N. Y.

ARRIFLEX 35mm. camero, 3 lenses, filters, sunshade, tripod, case. Complete for quick sale . . . \$795.00. Write P.O. Box 312, Ridgewood, N.J., or phone Allendale, N.J. 13046.

FOR SALE

OUR 25TH YEAR — SUPPLYING EVERYTHING PHOTOGRAPHIC & CINEMATIC
 B&H 25 mm EYEMO "Q" CAMERA with 4" f2.9 Cinemat, 2" f2.3 Kinar, 35mm f2 Cooke lenses and viewfinder lenses, 2-400' magazines, freehead tripod, shift-over alignment Gauge, 12V variable speed motor, 2 carrying cases, excellent condition\$1550.00

35mm DUPLEX CAMERA — Registration pins, lenses: 40mm f2.7 Carl Zeiss, 2" f1.9 Ultra-stigmat, 105mm Schneider f3.5, 3-400' magazines, 400' BiPack magazine, viewfinder Matte Box 12V DC motor, battery, Freehead Tripod, 2 carrying cases. A real buy 1125.00

35mm B&H SINGLE SYSTEM SOUND CAMERA, lenses: Cooke, 40mm, 50mm, 75mm, 125mm Modulite Galvanometer, amplifier, motor, Tachometer, 2-1000' magazines, Tripod with Freehead, quick release legs, carrying cases, Guaranteed 3500.00

35mm ARRIFLEX CAMERA, Coated lenses: 35mm f1.2 Carl Zeiss, 50mm f1.5 Carl Zeiss 85mm f2 Carl Zeiss, 135mm f2.3 Astro pan Tachar, variable speed motor, 12V battery, freehad tripod, 3-200' magazines, carrying cases, special 1175.00

35mm AKELEY CAMERA, 4 matched Zeiss lenses, 4-200' magazines, slow motion attachment, Akeley friction tripod, quick release legs, carrying cases. Bargain price 750.00

35mm ART REEVES SOUND RECORDER, twin fidelity optical unit, glow lamp type, 1000' B&H magazine, complete with cases..... 977.50

ENLARGERS, excellent condition, Elwood, Auto focus, lens and stand, 5x7 235.00
 8x10 400.00

MOLE RICHARDSON 2000 Spot, rolling stand.. B&H CAMERA CHECK PAWLS high speed shuttle. List price, new \$1742.00, good cond.... 195.00

NEW SCHOEN PRINTER, sound and silent, color, B&W features: 16mm picture alone, 16mm track alone, 16mm picture and sound together, film capacity 1600 feet, 50' per minute, 12 adjustable light changes, AC-DC conversion unit 999.00

HOMRICH COMBINATION COPYING CAMERA and animation table stand, adaptable to 4x5, 5x7, 8x10 holders. Two adjustable light stands with twin reflectors. 11x14 16x20 copy frames. Built in lamp house, good buy 135.00

HOMRICH ELECTRONIC TIME CONTROL CONTACT PRINTER, timer has full second and split second setting. Handles 4x5, 5x7, 8x10 negatives. Adjustable masking and paper guides. Internal dodging plate glass plate. Four lamps, each controlled by separate toggle switch. A real buy 165.00
 Specializing in movie and television supplies, tripods, synchronizers, 16mm sound cameras, lights, lenses, mikes, booms, dollies, motors, etc. New-used reasonable prices. Cash for used equipment. Trades taken.
HOLLYWOOD CAMERA EXCHANGE, LTD.
 1600 Cohuengo Boulevard Hollywood, California

BASS . . . is headquarters for Arriflex 16; the new Zoomar 16; Cine Specials, all models; Bell & Howell 70-DA; Bolex H-16. Used Cine Special I, 1" F:1.9 lens and carrying case \$395.00; Used H-16 Bolex, 1" F:1.5, 0.7" F:2.5 W.A., 3" F:3.5 \$347.50 Used Bell & Howell 70-DA, 1" F:1.9, 4" F:4.5 \$235.00. Used Bell & Howell 70-A, 1" F:3.5 and case \$52.50; Used 200' Chamber Cine Special \$295.00; Used 100' Chamber, Cine Special \$117.50. Best buys . . . Best trades always. BASS CAMERA CO., Dept. AC, 179 W. Madison St., Chicago 2, Ill.

WALL S. S. 35MM. SOUND CAMERA
 COMPLETE with Galvanometer, amplifier, portable power supply, 40-50-75 and 100mm. lenses, erect image viewfinder, complete front attachments, two 1000 ft. magazines, Balanced Tripod, necessary carrying cases. Overhauled. Guaranteed perfect. Reasonable.
CAMERA EQUIPMENT COMPANY
 1600 Broadway New York 19, N. Y.

16MM. HOUSTON K-1A
 Processing machine, like new. List price \$5,500.00. A terrific bargain at \$2,950.00.
AIR PHOTO SUPPLY CORP.
 555 East Tremont Avenue
 New York 57, New York
 Phone: Cypress 9-6400, Mr. Krim.

AUDIO AKELEY single system camera complete with Akeley sound head, Gyro tripod, 3 lenses, view finder, Maurer mixing amplifier. Complete with cables, power supply and W. E. microphone. CAMERA EQUIPMENT CO., 1600 Broadway, New York 19, N.Y. Cable Cinequip.

FOR SALE

ARRIFLEX II, 3 Schneider lenses, one 400 ft. mag., two 200 ft. mags., batteries, case, filters, etc. Like new \$1,000.00. Cine Special II, Par turret, -200 ft. mag., Maier finder, filter slot, 25mm. Schneider F1.5, good condition \$1,000.00 (no mag. finder tube). BH Recording Proj. like new \$550.00. Will sell lot for \$2,500.00. A good buy for TV station, studio or comeroman. Inspection can be arranged. Write, wire Box 1187, AMERICAN CINEMATOGRAPHER.

WE BUY, SELL AND RENT PROFESSIONAL AND 16mm. EQUIPMENT, NEW AND USED. WE ARE DISTRIBUTORS FOR ALL LEADING MANUFACTURERS. RUBY CAMERA EXCHANGE, 729 Seventh Ave., New York City Established since 1910.

WANTED

IMMEDIATE CASH PAYMENT FOR CAMERAS AND EQUIPMENT
 NEED EYEMOS (SINGLE LENS AND TURRET), MITCHELLS, ARRIFLEX, DE BRIES, B&H STANDARDS AND HI-SPEEDS, WALLS, AKELEYS, CINE SPECIALS, AJURICONS, MAURERS, FILMOS. ALSO BALTARS, COOKES AND OTHER LENSES. SOUND STAGE, LABORATORY AND EDITING EQUIPMENT OF ALL TYPES REQUIRED. PLEASE SHIP INSURFD OR FORWARD DESCRIPTIONS AIRMAIL. IMMEDIATE PAYMENT.

GORDON ENTERPRISES • 5362 N. Cohuengo
 NORTH HOLLYWOOD, CALIFORNIA

YE OLDE SOS TRADING POST
 Doing Business Since 1928
 BUY — SELL — SWAP — CONSIGN
 Cameras, Dollies, Lenses, Lights, Moviolas, Printers, Recorders, Studio or Laboratory Equipment
 Western Union-WUX New York
 Phone PL. 7-0440
S. O. S. CINEMA SUPPLY CORPORATION
 Dept. fc Cable: SOSOUND
 602 W. 52nd Street New York 19, N. Y.

WANTED TO BUY FOR CASH
 CAMERAS AND ACCESSORIES
 MITCHELL, B & H, EYEMO, DEBRIE, AKELEY ALSO
 LABORATORY AND CUTTING ROOM EQUIPMENT
CAMERA EQUIPMENT COMPANY
 1600 BROADWAY, NEW YORK CITY 19
 CABLE: CINEQUIP

WANTED
 PRODUCTION EQUIPMENT, LABORATORY EQUIPMENT, EDITING EQUIPMENT, 16mm. and 35mm. FROM SINGLE ITEMS TO COMPLETE STUDIOS. TRADES ACCEPTED.
THE CAMERA MART, INC.
 1845 Broadway Circle 6-0930 New York 23, N.Y.

F & B PAYS MORE
FOR USED 16/35MM EQUIPMENT
 WRITE — WIRE — PHONE
 FOR OUR CASH OFFER
FLORMAN & BABB MU. 2-2928
 70 W. 45TH ST. NEW YORK 36, N.Y.

WANTED
 Mitchell — Akeley — B & H — Wall — Eyemo
 Cameras — Lenses — Equipment
NATIONAL CINE EQUIPMENT, INC.
 209 West 48th St. New York, N.Y.

1,000 FT., 4000 Ft. 35mm. or 16mm. B&H or Mitchell magazines, also BiPack. Quote condition, best price for cash. HOLLYWOOD CAMERA EXCHANGE, 1600 Cahuenga Blvd., Hollywood, California.

(Continued on Next Page)

Classified Ads

(Continued from Preceding Page)

CAMERA & SOUND MEN

ASSIGNMENTS FOR INDIA or nearby territories for any type of films, 16 or 35mm, B&W or Color, write to KANU PATEL, A.R.P.S., The Clarion Productions, 34, Park Mansions, CALCUTTA-16.

COLOR SLIDES, PHOTOS & FILMS

NATURAL COLOR SLIDES, Scenic, National Parks, Cities, Animals, Flowers, etc. Set of eight \$1.95. Sample and List 25c. SLIDES, P.O. Box 26, Gordena, Calif.

ALASKA WILDLIFE KODACHROME 16mm. — 8mm. 2x2 slides taken by professional photographer and Alaskan Registered Guide. Free Catalog. MAC'S FOTO SERVICE, 315 4th Avenue, Anchorage, Alaska.

ANNIVERSARY DISCOUNTS GALORE. Cameras, Accessories, Old-Time Movies, Slides, etc. Catalog 10 cents. Refunded. VARIETY, 268-14 79th Ave., Floral Park, New York.

LABORATORY & SOUND

SOUND RECORDING at a reasonable cost. High Fidelity 16 or 35. Quality guaranteed. Complete studio and laboratory services. Color printing and lacquer coating. ESCAR MOTION PICTURE SERVICE, INC., 7315 Carnegie Avenue, Cleveland 3, Ohio. Phone Endicott 1-2707.

SAVE TIME ON 16MM PROCESSING AND PRINTING! Same day service on 16mm reversal processing. DuPont & EK films in all lengths. Price list available. WESTERN CINE SERVICE
114 East 8th Avenue Denver 3, Colorado

To Classified Advertisers

Copy deadline for classified advertising is the 12th of month preceding publication date. Mail copy and remittance to cover cost to
AMERICAN CINEMATOGRAPHER
1782 No. Orange Dr. Hollywood 28, Calif.



PELEGRINI VARIABLE SHUTTER UNITS FOR THE BOLEX H-16

The real answer to complete FADES and LAP DIS-
SOLVES. Faster shutter speeds and many other advantages. Prices within U. S. \$99.60. Cameras with outside frame counter \$109.80. Tax extra. One year guarantee and camera transportation back included. Send for free informative booklet.

Prices subject to change without notice.

TULLIO PELEGRINI
1545 Lombard St.
San Francisco 23, California



We Invite Your Contributions

Readers who would like to write articles or papers on subjects relating to cinematography or of interest to motion picture cameramen, or on subjects relating to TV Film Production, Industrial Film Making, Film Laboratory Technique, Special Effects, Amateur Movie Making, etc., are invited to submit such articles to the Editor for consideration.

For all published material we will pay our regular space rates following publication.

AMERICAN CINEMATOGRAPHER
1782 No. Orange Dr., Hollywood 28, Calif.

CURRENT ASSIGNMENTS

(Continued from Page 306)

• CARL GUTHRIE, "Long John Silver," (Joseph Kaufman Prod.—Technicolor; wide-screen—shooting in Australia) with Robert Newton and Connie Gilchrist. Byron Haskin, director.

• FLOYD CROSBY, "Crashout," with John Ireland and Dorothy Malone. Ed Sampson and John Ireland, directors.

• CHARLES G. CLARKE, "Suddenly," (Robt. Bassler Prods., United Artists release) with Frank Sinatra, Sterling Hayden, Nancy Gates. Lewis Allen, director.

TELEVISION

(The following directors of photography were active last month in photographing films for television in Hollywood, or were on contract to direct the photography of television films for the producers named.)

• LUCIEN ANDRIOT, "Where Were You?" series of half-hour shows starring Ken Murray for Bing Crosby Enterprises at Ken Murray Prods.

• NORBERT BRODINE, "Letter To Loretta" series of half-hour dramas—D.P.I., starring Loretta Young. (Procter & Gamble), RKO-Pathe studio and "In Between" series of half-hour dramas for Lewislor Enterprises.

• GEORGE DISKANT, "Four Star Playhouse" series of half-hour dramas, featuring various stars, for Four Star Productions, RKO-Pathe Studio. (Singer Sewing Machines.)

• KARL FREUND, "I Love Lucy" series of half-hour comedies starring Lucille Ball and Desi Arnaz, for Desilu Productions; (Philip Morris).

• ALFRED L. GILKS, "Halls of Ivy," series of half-hour dramas starring Ronald Colman and Benita Hume for Hall Prods., Inc., at Motion Picture Center.

• BENJAMIN KLINE, "Fireside Theatre" series of half-hour dramas for Frank Wisbar Prods., Inc., at American National Studios (Procter & Gamble).

• JACK MACKENZIE, "Public Defender" series of half-hour films for CBS, starring Reed Hadley for Hal Roach Jr. Prods. (Philip Morris).

• WILLIAM MELLOR, "Adventures of Ozzie and Harriet" series of half-hour comedy dramas starring Ozzie Nelson and Harriet Hilliard for Stage Five Prods., Inc., General Service Studios. (ABC).

• VIRGIL MILLER, "You Bet Your Life," weekly half-hour audience participation shows, featuring Groucho Marx, for Filmcraft Prods., NBC Studios. (DeSoto-Plymouth).

• HAL MOHR, "The Joan Davis Show" series of half-hour comedy-dramas starring Joan Davis for Joan Davis Enterprises, General Service Studios. (NBC).

• NICK MUSURACA, "The Lone Wolf," starring Louis Hayward, series of half-hour dramas (UTP) for Gross-Krasne, Inc., at California Studios.

• KENNETH PEACH, "Adventures Of The Falcon" series of half-hour dramas starring Charles McGraw at Federal Telefilm, Inc. (NBC)

• ROBERT PITTAKE, "Private Secretary" series of half-hour comedy dramas starring Ann Sothern and Don Porter, (Lucky Strike) and "The Lone Ranger" series of half-hour dramas starring Clayton Moore and Jay Silverheels for CM-TV Prods. Inc., (General Mills).

• JOHN L. RUSSELL, JR., "Joe Palooka," series of half-hour comedy-dramas starring Joe Kirkwood and Cathy Downs for Guild films at Republic.

• MACK STENGLER, "Life With Elizabeth" series of half-hour dramas; "The Liberace Show," half-hour musical film series and the "Florian Zabach Show," series of half-hour musical films.

• HAROLD STINE, "Cavalcade of America" series of half-hour dramas and "This Is Your Music" for Jack Denove Prods., Inc., Samuel Goldwyn Studios (DuPont).

• WALTER STRENCE, "Waterfront" series of half-hour dramas starring Preston Foster and Lois Moran (UTP) at Hal Roach Studios.

• PHIL TANNURA, "The Burns and Allen Show" series of half-hour comedies starring George Burns and Gracie Allen, for McCadden Corp., General Service Studios. (Carnation Milk and Goodrich).

• LESTER WHITE, "Adventures of Rin Tin Tin," series of half-hour dramas starring Lee Aaker, James Brown and Rin Tin Tin for Screen Gems.

INDUSTRY NEWS

(Continued from Page 272)

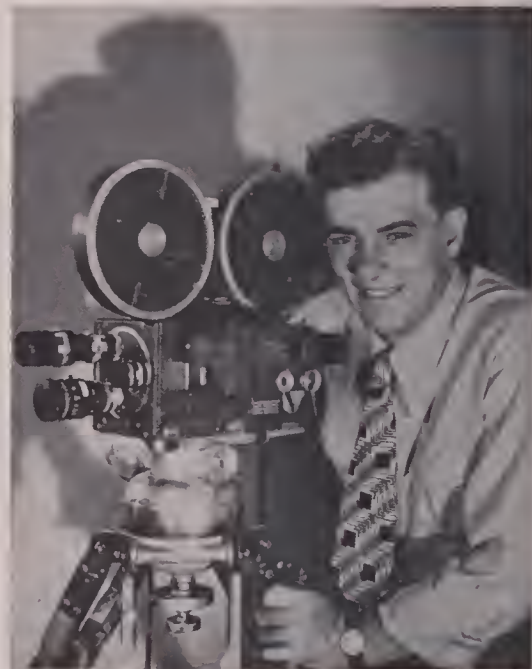

JOE THOMAS
President Telefilm Studios, Hollywood

available to all independent producers.

The technical engineers at Telefilm have spent over fifteen years of exhaustive research in developing this unique printer. Details of its operation are a carefully-guarded secret. However, this much can be said: light changes are controlled through actuated solenoids; notching of film is not required for light control, thus avoiding damage to original prints; after the printer's switches are set, any number of prints can be uniformly printed; it employs an exclusive filter design and application for balancing color; another feature prevents film slippage, thus insuring a top quality sound track.

You've seen
these great
Walt Disney
films ...



PICTURE COURTESY OF WALT DISNEY PRODUCTIONS

Next, see Walt Disney's new feature-length
True-Life Adventure: "The Vanishing Prairie."

Now meet the people who made them!

Here is your index to some of the people who made Walt Disney's famous "True-Life Adventure" series of motion pictures, which have already won six Academy Awards.

The picture above shows: (1) Walt Disney between Mr. and Mrs. Herb Crisler; (2) Karl H. Maslowski; (3) John Nash Ott; (4) Murl Deusing; (5) Tom McHugh; (6) Mr. and Mrs. Alfred G. Milotte; (7)

Lloyd Beebe; (8) Alfred Bailey; (9) Bert Harwell; (10) Mr. and Mrs. Olin Sewall Pettingill, Jr.; (11) John H. Storer.

Note how many of these famous cinematographers, explorers, and naturalists use the Cine-Kodak Special II Camera—the highly precise 16mm. motion-picture camera that's famed the world around for its truly amazing built-in movie versatility.

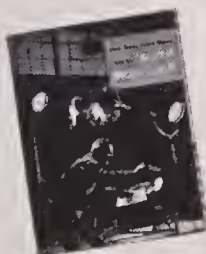

To learn more about this amazing camera, ask your Kodak dealer—or just mail the handy coupon for this free 16-page booklet describing features of Cine-Kodak Special II Camera. Prices start at \$990, including

Federal Tax, subject to change without notice. And most Kodak dealers offer convenient terms.

EASTMAN KODAK COMPANY

6-11

Dept. 8-V, Rochester 4, N. Y.

Please send me a copy of "16mm. Motion Picture Making with the Cine-Kodak Special II Camera."

NAME _____

STREET _____

CITY _____

STATE _____ (Zone)

Kodak
TRADE-MARK

Bell & Howell presents
the world's sharpest
CinemaScope lens



"Best by far!"

—says James E. Coston
Coston Enterprises
Chicago, Illinois

"For sharpness, clarity and brightness right to the edges of the screen, we're convinced there's no finer lens on the market than the Bell & Howell CinemaScope theater projection lens . . . now being used in 14 of our theaters in Illinois, Indiana and Wisconsin.

For all anamorphic type wide screen releases including CinemaScope productions. Designed to fit all theater and studio projection lenses.

sharp focus . . . Six elements provide extreme sharpness. Each individual lens precision collimated for crisp definition to full corners and edges.

resolution . . . modern formula developed by world's foremost lens designers . . . all twelve glass surfaces held to test gauge quality.

brilliance . . . unequalled light transmission . . . all air surfaces magnesium fluoride hard coated—3 doublets butyl methacrylate cemented.

full color . . . color banding and fringing eliminated by full correction of all color aberrations.

For full information see your local theater supply house or write to . . .



Bell & Howell

PROFESSIONAL EQUIPMENT DEPARTMENT • 7148 McCORMICK ROAD • CHICAGO 45, ILL.

Cinematographer

THE MAGAZINE OF MOTION PICTURE PHOTOGRAPHY

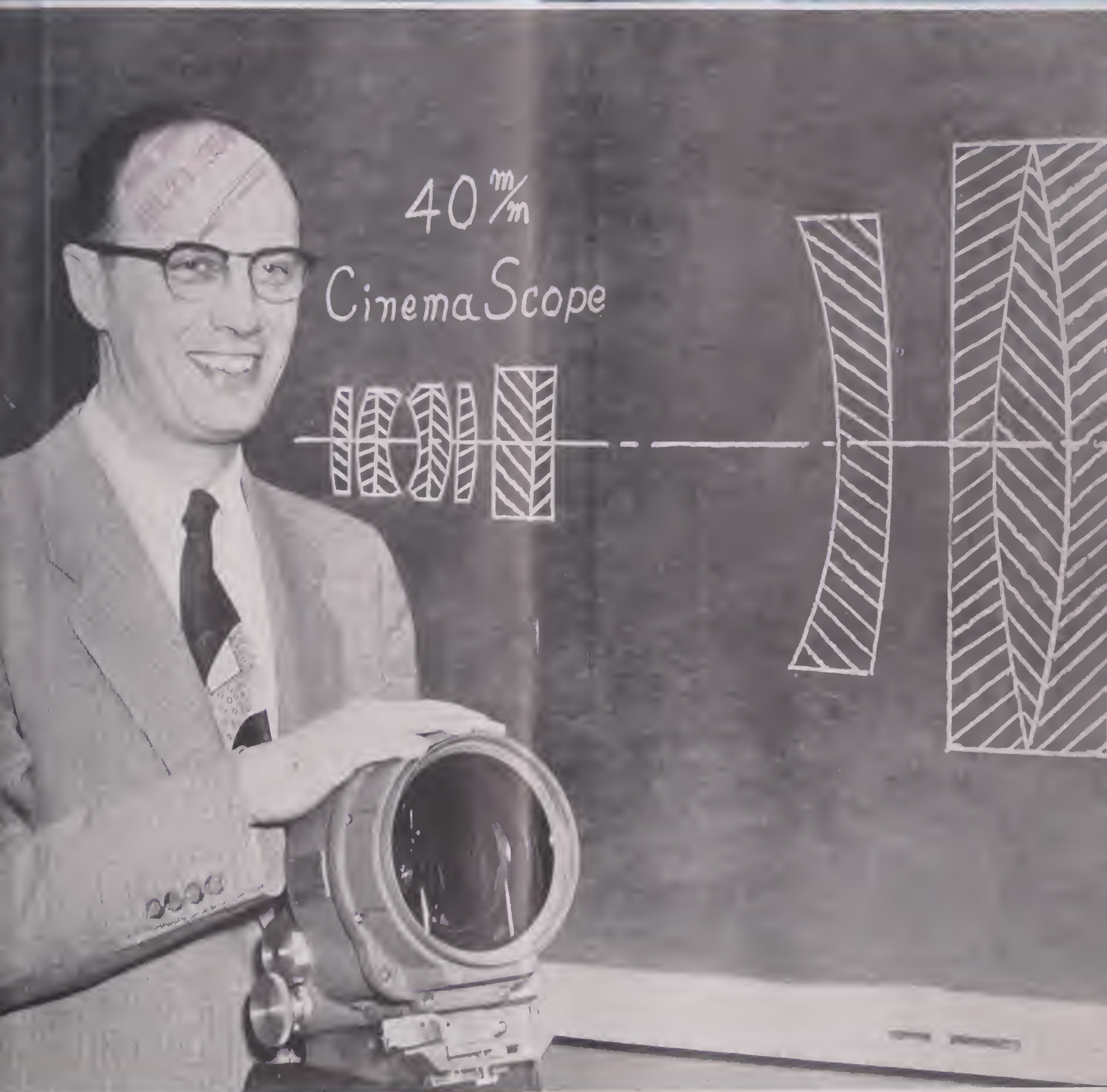

This Issue ...

- Tri-X—New Eastman High-speed Negative Film
- Cukoloris—Most Versatile Set Lighting Tool
- Filming The Ice Show

25c
\$3.00 YEARLY

Mr. McWayne (right) "talking shop" with John B. Phy, Du Pont Technical Representative. "John keeps us up to date on the latest developments... his advice and quick service have helped us many a time."

Another fast, comfortable trip via United—McWayne, (extreme left) grinding out publicity footage on 931A. "We've found its exceptional latitude meets an unusually wide range of lighting conditions."



"With Du Pont 931A, we can handle the toughest jobs—expected or not"

Reports James E. McWayne, Supervisor, United Air Lines' Photo Laboratory, Chicago, Illinois

"In shooting TV newsreel footage and publicity jobs, we often run into fickle lighting and weather. Then, *everything* depends on the film. It has to deliver—even when there's no chance for retakes. That's why we use Du Pont 931A for all black-and-white work. It enables us to handle the toughest jobs—expected or not.

"Like that one last winter, when a VIP was due in on the 7 P.M. flight. Pitch dark . . . so we set up a battery of photofloods to cover the story. The flight was on time and all went well until our celebrity appeared in the doorway. Then—a fuse blew! Out went the floods, leaving us only three 500-watt bulbs—and they were 90 feet away!

"Really tough . . . but there was nothing to do but keep shooting. I opened the lens to F. 1.4, slowed down from 24 to 16 frames and completed the

'take.' In rushing the film to WGN-TV for processing and presentation, I warned 'em that it was underexposed: 'Better overdevelop it!' Certainly felt good when they phoned back and said it was perfect, completely usable. Seemed almost impossible.

"That's why, when conditions are tough, we leave it up to the film. If 931A can't handle the job, we know it can't be handled!"

So test Du Pont 931A Rapid Reversal Pan on *your* next assignment. Check its speed. Note how its rugged emulsion resists reticulation and staining. And how fine grain, long tonal range and sharp gradation combine to produce clean-cut pictures and

crystal-clear sound. For the complete story, contact your Du Pont Technical Representative or nearest district office listed below. E. I. du Pont de Nemours & Co. (Inc.), Photo Products Department, Wilmington 98, Delaware. *In Canada: Du Pont Company of Canada Limited, Montreal.*

District Offices

ATLANTA 5, GA.	805 Peachtree Bldg.
BOSTON 10, MASS.	140 Federal Street
CHICAGO 18, ILL.	3289 N. California Ave.
CLEVELAND 14, OHIO	1033 Union Commerce Bldg.
DALLAS 1, TEXAS	506 Tower Petroleum Bldg.
LOS ANGELES 38, CALIF.	7051 Santa Monica Blvd.
NEW YORK 11, N. Y.	248 West 18th Street
PHILADELPHIA 2, PA.	225 South 15th Street



BETTER THINGS FOR BETTER LIVING . . . THROUGH CHEMISTRY

SPECIFY DU PONT MOTION PICTURE FILM

SALES • SERVICE • RENTALS

JUL 22 1954

THE WORLD'S MOST COMPLETE ASSORTMENT
OF PHOTOGRAPHIC EQUIPMENT FOR

T.V. and Motion Picture Studios



New **PROFESSIONAL JUNIOR**

Adjustable wood **BABY TRIPOD**

—for Prof. Jr. friction
and geared heads



Has substantial shoe and spur.

Measures from floor to flange

25" extended —17"

collapsed. **\$75**

FAMOUS

"controlled
action"

SMALL GYRO
TRIPOD

Two speeds—slow and fast
—for both panning and tilting.
Helps you capture fine scenic views
and fast-moving sports events. Espe-
cially recommended for 16mm Mitchell,
16mm Maurer, B & H Eyemo
and similar cameras.

\$600



PACKAGED LIGHTING WITH

COLOR-TRAN

—studio lighting in a suitcase

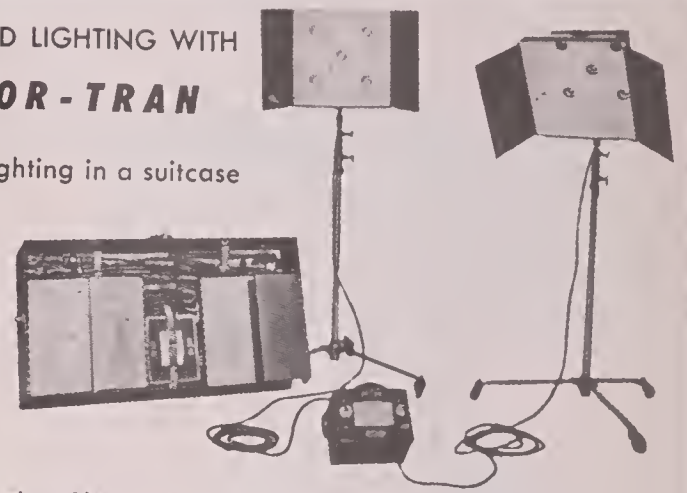

Imagine being able to use two 5000 watt units
on a 30 amp. fuse — **COLOR-TRAN** will do it!
Kit contains 2 light heads, 2 Superior stands and
proper size **COLOR-TRAN** converter to match.
Packed in compact case.

Senior Kit
\$237.50

Other style
kits available.

Write for **COLOR-TRAN** Catalogue.

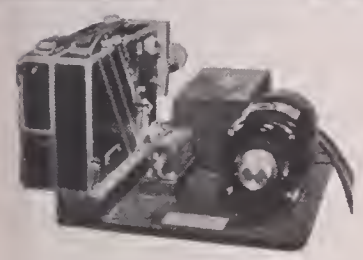

STOP MOTION MOTOR
FOR CINE KODAK SPECIAL

Runs forward or reverse, 110
AC synchronous motor with frame
counter. May be run continuously
or for single frames. Camera
mounts without special tools.

\$450

Also available — Stop Motion
Motors for 16mm—35mm B & H,
Mitchell and other professional
cameras.



ELECTRIC
FOOTAGE TIMER

Dual model for both 16mm
and 35mm. Large white num-
erals on black background. Accu-
rate reset dial. Switch controled
by operator, who selects either
16mm operating at 36 feet per
minute—or 35mm operating at
90 feet per minute . . . or both
in synchronization.

\$95

Single model, either 16mm or
35mm **\$45**

presto-splicer

GIVES PERMANENT SPLICE
IN **10 SECONDS!**



Especially good for splicing magnetic
film. Butt Weld type for non-perforated
or perforated film. 16mm, 35mm or
70mm. **\$547.80**

16mm or 35mm models—
for perforated film.



GRISWOLD
HOT FILM SPLICER

Model R-2 for 35mm silent and sound
film. Precision construction makes it easy
to get a clean, square splice with accu-
rate hole spacing. Nothing to get out of
order. **\$65**

Also Bell & Howell 8mm, 16mm and
35mm Hot Splicers and B & H Labora-
tory model Foot Splicer.

*9.5mm Lenses in 16mm C mount. 18.5mm (extreme wide angle-flat field)
Lenses available in mounts for all 35 mm Motion Picture Cameras.
*PHOTO RESEARCH Color Temperature Meters. *Electric Footage Timers
*Neumade and Hollywood Film Company cutting room equipment.
*Griswold & B.&H. Hot Splicers. *DOLLIES—Bardwell-McAlister, Mole
Richardson, Century and Colortran Lighting Equipment.

Complete line of 16mm and 35mm Cameras

FRANK C. ZUCKER
CAMERA EQUIPMENT CO.
1600 BROADWAY NEW YORK CITY

important news

from the manufacturer of the World's Finest Camera

NEW PRODUCTION SCHEDULES NOW PERMIT → IMMEDIATE DELIVERIES OF MITCHELL 35mm BNC...35mm NC...16mm PROFESSIONAL CAMERAS

It is impossible to compare a Mitchell with any 35mm or 16mm camera now in existence—for the **history-making Mitchell is the only truly professional motion picture camera.** Exclusive professional operating features plus the smooth trouble-free Mitchell movement, with its .0001 inch tolerances, can insure the success of your film making as can no other single element of production.

Now—on the huge six and one-half acre site of the Mitchell Camera Corporation plant — increasing numbers of 35mm and 16mm cameras are being created to meet the extensive use of professional motion picture equipment in such fields as television, entertainment, business, education, religion and government. Each of these superbly designed cameras possesses the supreme quality craftsmanship rightly due the world's **most used most flexible** professional motion picture camera.

Write today for information and prices of the currently available 35mm BNC, NC and 16mm Professional Mitchell Cameras and accessories.



MITCHELL 16mm PROFESSIONAL



MITCHELL 35mm NC CAMERA



MITCHELL 35mm BNC CAMERA

Mitchell Camera CORPORATION

666 West Harvard Street • Glendale 4, Calif. • Cable Address: "MITCAMCO"

 85% of the professional motion pictures shown throughout the world are filmed with a Mitchell

AMERICAN

Cinematographer

THE MAGAZINE OF MOTION PICTURE PHOTOGRAPHY
PUBLICATION OF THE AMERICAN SOCIETY OF CINEMATOGRAPHERS

ARTHUR E. GAVIN, *Editor*

MARION HUTCHINS, *Editorial Assistant*

EMERY HUSE, *Technical Editor*

EDITORIAL ADVISORY BOARD: John Arnold, Arthur Edeson, Lee Garmes, Charles Roshar, Leon Shamroy, Fred Gage, Glenn R. Kershner

Editorial and Business Office: 1782 N. Orange Dr., Hollywood 28, Calif.

Telephone: HOLLYWOOD 7-2135

VOL. 35 JULY • 1954 NO. 7

IN THIS ISSUE

ARTICLES

CUKOLORIS—SET LIGHTING'S MOST VERSATILE TOOL— By Joseph LaShelle, A.S.C.	332
TRI-X—NEW EASTMAN HIGH-SPEED NEGATIVE MOTION PICTURE FILM—By Emery Huse, A.S.C.	335
CREATIVE CUTTING—By Charles Loring	336
SIMULTANEOUS PRODUCTION SHOOTING IN CINEMA SCOPE AND WIDE-SCREEN—By George Folsey, A.S.C.	338
CASE HISTORY OF A NON-THEATRICAL FILM PRODUCTION— By Charles L. Anderson	342
ARRIFLEX CAMERAS ADAPTED FOR CINEMA SCOPE—By Arthur Rowan	344

AMATEUR CINEMATOGRAPHY

FILMING THE ICE SHOW—By Elbert J. Whittington	346
HOT SPLICER CONVERSION—By Hank Stockert	348

FEATURES

BULLETIN BOARD	318
INDUSTRY NEWS	320
WHAT'S NEW IN EQUIPMENT, ACCESSORIES, SERVICE	328
LETTERS	328
WHAT'S NEW IN CINE PHOTOGRAPHY	350
HOLLYWOOD STUDIO PRODUCTION	362

ON THE COVER

SHOWN AGAINST a blackboard diagram of a new 40mm CinemaScope camera lens is John D. Hayes, head of the photographic department of Bausch & Lomb Optical Co. He holds the first of the new CinemaScope lenses, shipped recently to 20th Century-Fox. The complex 12-element lens was developed under Hayes' direction. The 40mm lens is first of a complete range of focal lengths up to 152mm now under development. Its attributes include improved resolving power, much less distortion, enhanced definition and improved color correction.

AMERICAN CINEMATOGRAPHER, established 1920, is published monthly by the A. S. C. Agency, Inc., 1782 N. Orange Dr., Hollywood 28, Calif. Entered as second class matter Nov. 18, 1937, at the postoffice at Los Angeles, Calif., under act of March 3, 1879. SUBSCRIPTIONS: United States and Canada, \$3.00 per year; Foreign, including Pan-American Union, \$4.00 per year. Single copies, 25 cents; back numbers, 30 cents; foreign single copies, 35 cents; back numbers 40 cents. Advertising rates on application. Copyright 1954 by A. S. C. Agency, Inc.

The most important man in our business is
You....

The
Cinematographer



This emblem is your assurance of

CONTINUED FAITHFUL INTEREST

in your work

Consolidated

FILM INDUSTRIES

959 N. SEWARD ST.
PHONE HO 9-1441

HOLLYWOOD'S ONLY COMPLETE

LABORATORY SERVICE

ONE CAMERA

16mm or 35mm

in 10 SECONDS!

Camerette 16/35

Reflex Motion Picture Camera

The perfect camera for the motion picture film maker working in both 16mm or 35mm color or black and white.

LOOK AT THESE ADVANTAGES—

- The same lenses, same motor drives, same sound blimp and accessory equipment used for both 16mm or 35mm — to convert simply change the magazine.
- Precise rugged movement
- Reflex viewing
- 200 degree adjustable shutter
- Divergent three lens turret
- Automatic film gate 400' magazines 16 or 35mm — the 16mm magazine will accommodate daylight spools as well as standard care load.
- Light weight — only 14 pounds with 3 lenses, 400' magazine, and 6/8 volt motor.

Write for brochure



Camerette

patents coutant-mathot

Manufactured by Ets. Cine. Eclair, Paris



Hollywood

Bulletin

Board



ERIC M. BERNDT, president of Berndt-Bach Corp., makers of Auricon cameras, shows some of his vast collection of early-day motion picture cameras. He is a Founder-member of the Society of Cinema Collectors and Historians, Consultant-editor of its Journal.

Earl I. Sponable, Research Director, 20th Century-Fox Studios, was elected to an Associate Member of the American Society of Cinematographers last month.

★

James VanTrees, ASC, has been signed by Volcano Productions to direct the photography of two TV film shows: "The Joan Davis Show," and the new "Mickey Rooney" show. VanTrees formerly directed the photography of "You Bet Your Life" show, featuring Groucho Marx.

★

Frank Zucker, ASC, president of Camera Equipment Co., New York City, was a recent Hollywood visitor. Following his return from a tour of motion picture production centers in Europe. Besides manufacturing and distributing a wide range of camera and motion picture equipment, Zucker's organization also supplies most of the TV and industrial film makers in the New York area with camera and grip equipment, through its rental department.

★

ASC'S June Meeting featured discussions on the Photographic Quality Necessary for Best TV Films. Guests of the Society were prominent engineers and technicians in the television industry, including G. P. Wyland and Ed Miller, CBS-TV; Roy White, KTLA; Philip Caldwell, ABC-TV; Jack Burrell and Oscar Wick, NBC-

TV; Edward Benham and Farrell Quigley, KTTV; and Marvin Wentworth and James Massey of KCOP.

Informal discussions concerned the employment of black and white references in each TV film scene as a contrast key for TV's electronic reproduction system; factors contributing to picture degradation in TV film transmission; and the role of the "knob twister" in the transmission system and his effect on the ultimate picture quality of TV films.

★

In a joint meeting earlier in the month at NBC's El Capitan theatre in Hollywood, ASC members were guests of the SMPTE which held a symposium on the factors necessary to produce motion pictures that render maximum quality in TV transmission.

Brief portions of three popular TV film shows were projected while the same shows were transmitted simultaneously via a duplicate film over closed TV circuit, which afforded a comparison of TV picture with screened picture of same program.

Guest ASC panelists included, Hal Mohr, Walter Streng, and Norbert Brodine.

★

Hal Mohr, ASC, as a representative of the industry's cinematographers, was

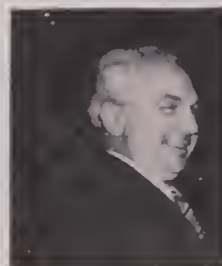

Hal Mohr

elected assistant treasurer of Motion Picture Arts and Sciences last month. Mohr has been directing the photography of the Joan Davis TV film shows, and recently was signed to photograph a new TV film series, "Life With Father," for McCadden Productions.

Continuing on the Board of Governors of the Academy for another term is another member of the ASC—John W. Boyle.

★

Philip Tannura, ASC, who photographs the "Burns and Allen" TV film shows for McCadden Productions, will probably undertake a second show for the same producer. He recently photographed the pilot production of the new Robert Cummings TV film series.



35 and 16/35 mm



reflex viewing



divergent turret



40° to 200° adjustable shutter



lightweight - 14 lbs.



100' to 400' magazine



instantaneous loading



dovetail mounting



camerette

patents Coutant-Mathot
manufactured by Eclair, Paris

for descriptive brochure write U.S. representative

Benjamin Berg Agency, 1410 No. Van Ness Avenue, Hollywood 28, Calif.

in Canada: B.O.P. Co. Ltd., 455 Craig Street West, Montreal, P.Q.

ARRIFLEX

New 35 mm Model 2A
With 180° Shutter

**A TRULY GREAT
CAMERA**

for TV, Newsreel
and commercial
films

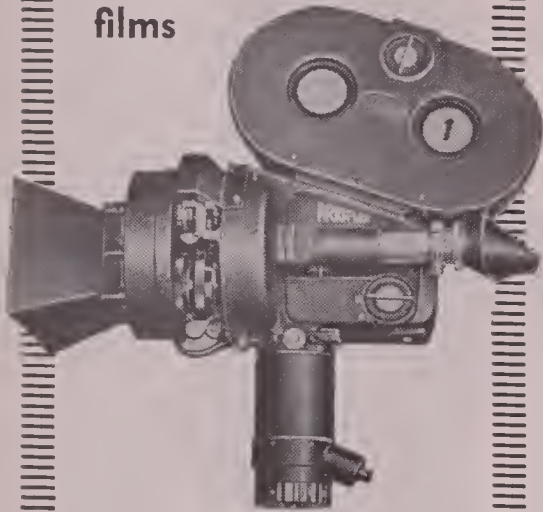

For tough and trying assignments, ARRIFLEX 35 is in a class by itself. Reflex focusing through photographing lens while camera is operating—this is just one outstanding ARRIFLEX feature.

Equipped with bright, right-side-up image finder, $6\frac{1}{2} \times$ magnification. Solves all parallax problems. 3 lens turret. Variable speed motor built into handle operates from lightweight battery. Tachometer registering from 0 to 50 frames per second. Compact, lightweight for either tripod or hand-held filming. Takes 200' or 400' magazine. Write for free folder.

Blimp now available.
16mm ARRIFLEX also available.

FRANK C. ZUCKER
CAMERA EQUIPMENT CO.
1600 BROADWAY NEW YORK CITY

CLOSEUPS

Notes and
editorial comment



AT TODD-AO DEMONSTRATION—Pioneers of new process get together. From left: Fred Zinneman, who will direct "Oklahoma!", Richard Rodgers, Oscar Hammerstein, Michael Todd, and Dr. Brian O'Brien. The Todd-AO camera stands behind Rodgers. (We hope to have a better view of camera plus detailed story for readers next month.)

Super wide-screen processes made news in Hollywood last month when 20th Century-Fox, with its CinemaScope, and Todd-AO, with its single wide-film (65mm) process gave demonstrations before press and industry heads on the same day—June 23rd.

In the morning, at the Chinese Theatre on Hollywood Boulevard, Fox studio had summoned top press representatives and industry engineers and technicians to witness its demonstration of new and improved CinemaScope photography. That it was impressive is an understatement. It was terrific. It was the finest selling job ever undertaken by any motion picture studio.

It demonstrated many things, not the least important the fact that Fox, together with Bauseh & Lomb, has refined the CinemaScope camera lens to a point where now the most superb photographic quality is being obtained by the studio's directors of photography. Today, there is no comparison between the crude results obtained with the first anamorphic lens used in filming "The Robe" and the newer improved CinemaScope lenses, now available in a variety of focal lengths. (See cover photo.)

Twentieth Century-Fox, by this historic demonstration of the process it pioneered and pushed to its present pinnacle of success, left little doubt about the future of CinemaScope as the motion picture medium and format of tomorrow.

The dynamic force behind it all, of course, is the team of Darryl Zanuck and Spyros Skouras. But the real success of the system depended upon a single new piece of equipment—the anamorphic CinemaScope lens. Right from the beginning two men set to work to improve it. They were Sol Halprin, ASC, and Earl Sponable, ASC, photographic department chief and research engineer respectively of 20th Century-Fox. These men, along with John D. Hayes and others at Bauseh & Lomb Optical Company, are due a large measure of credit for the "new look" in CinemaScope.

★

Hollywood had scarcely caught its breath following the CinemaScope demonstration than it was subjected to still another revelation in super-wide-screen processes—Todd-AO. This took place on Stage 2 at MGM studios where the Todd-AO organization is headquartered for the duration of its "Oklahoma" production.

First announced 18 months ago, but seen only by a very few top industry figures, Todd-AO, inspired by Michael Todd, and developed by Dr. Brian O'Brien and the American Optical Company, is a sensational super-wide-screen process on the order of CinemaScope, but without the annoying seams and tri-sectional picture. Only one camera employing 65mm film is used. We hope to bring readers a full report on the system in next issue.—A.E.G.

THERE IS A HOUSTON-FEARLESS FILM PROCESSOR FOR EVERY NEED!

Whatever your requirements in motion picture or TV film processing equipment, Houston Fearless has the answer. 16mm, 35mm, 70mm... black and white or color... negative, positive, reversal or positive-negative color film... from 5 to 250 feet per minute... from the smallest, most compact unit to the largest installation, Houston Fearless builds the finest, most dependable, best engineered of all processing equipment. Houston Fearless is a major supplier to the Military and is known and respected throughout the world.

Only a few of the many Houston Fearless models are shown here. For complete information on the type of equipment best suited for your particular needs or for help on your special requirements and problems, send the coupon below. Houston Fearless engineers will recommend what is most appropriate and, if desired, plan your entire film processing lab for maximum efficiency and highest quality results.

The
**HOUSTON
FEARLESS**
Corporation

*"World's Largest Manufacturer of Motion Picture
Film Processing and TV Studio Equipment"*

Houston-Fearless Corporation
11809 W. Olympic Blvd., Los Angeles 64, Calif.
Please send information on film processing equipment
to be used for the following purpose:

NAME _____
FIRM _____
ADDRESS _____
CITY _____ ZONE _____ STATE _____

11809 W. OLYMPIC BLVD. LOS ANGELES 64, CALIF.
BRadshaw 2-4331
620 FIFTH AVE., NEW YORK 20, N.Y. CIrcle 7-2976

NOW GREATER

THE **NEW** MODEL IIA

ARRIFLEX 35

MIRROR REFLEX CAMERA



With the new Model IIA, the Arriflex 35 attains undisputed first place among all 35mm hand cameras in the professional field. Easily convertible into an efficient studio camera, its versatility is amazing. In addition to the many features which made the earlier model a favorite among top-ranking cameramen, the improvements and engineering advances embodied in the new Model IIA, make the Arriflex 35 greater than ever.



FAMOUS ARRIFLEX FEATURES IN THE NEW MODEL IIA

- Mirror Reflex Shutter for through-the-taking-lens follow-focus and viewing even during actual shooting.
- Bright, uninverted viewing image on ground glass, magnified 6½ times.
- Eliminates parallax and the need for accessory finders.
- Quick-change, geared Film Magazines (200 and 400 feet). No belts used.
- Variable-Speed DC Motor mounted in Grip Handle... operates from 6-8 volts.
- Tachometer — registers from 1 to 50 frames-per-second.
- Matte Box-Filter Holder — quickly and easily detachable.
- Three-lens Revolving Turret.
- Perfect for tripod and handheld filming.



THE NEW ARRI SYNCHRONOUS MOTOR UNIT for ARRIFLEX 35

A smooth-running, constant-speed hysteresis motor for 115-volt, 60-cycle AC operation. Motor is mounted on base-plate housing containing the gear mechanism which connects directly to the main drive-shaft of the camera. Motor Unit has a built-in tripod socket and a built-in footage counter. A safety slip-clutch automatically disengages the motor should the film 'jam'.

The Synchronous Motor Unit is easily and quickly attached to the camera without the need for special tools.



BETTER THAN EVER

The NEW ARRI® Sound-Proof Blimp for ARRIFLEX 35

Designed for the Arriflex 35 with 400-foot Magazine, and Synchronous Motor Unit. Blimp housing is cast magnesium alloy, finished in black crackle.

The most advanced acoustical damping techniques have been employed. Internal walls are lined with corduroy velvet over six alternate layers of foam plastic and lead. For complete soundproofing, all door members are sealed with foam rubber gaskets, and close by means of heavy, 'knee-action' clamp locks. Camera is cushion-mounted.



BLIMP DOORS OPEN

Showing easy access to camera, lenses, and magazine.

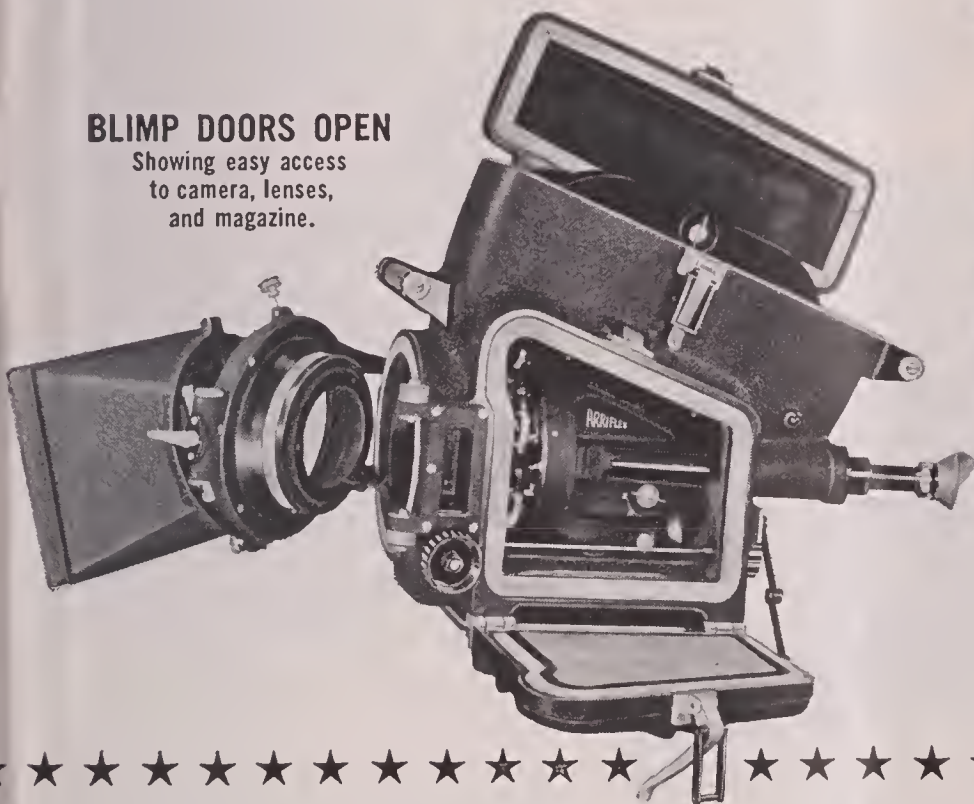

REAR VIEW Showing convenient controls.



The important reflex-viewing feature of the Arriflex 35 is still retained while it is used in the Blimp. The regular cover and optical system is removed from the camera and replaced with a special cover which connects to the optical viewing system built into the Blimp. Follow-focus is then accomplished by means of either of two controls... located at the front side and in the back of the Blimp. These controls connect directly to the focusing mount of any lens in taking position,

equipped with Arri Fallaw-Focus Grips. No gears are required around the lens mounts.

An oversized focusing scale for any lens in use can be set behind, and viewed through the central window located over the focusing knob. Other observation windows are conveniently located to permit viewing the footage counter and checking the tachometer. The lens window is made of optically flat glass, shielded by a detachable matte box.

Two heavy-duty handles facilitate lifting and carrying. A Fingertip Dial permits shutter to be 'turned over' manually for preliminary focusing. A hook is provided in the exact film plane for attaching a measuring tape. A pulsating pilot light indicates that the camera is in operation.

Weight of Blimp with Arriflex 35, lenses, Synchronous Motor Unit, and 400-foot Magazine is approximately 55 pounds.

Write for Complete Details to:

KLING PHOTO CORPORATION

235 Fourth Ave., New York 3, N. Y. • GRamercy 5-1120
7222 Melrose Ave. Hollywood 46, Calif. • WYoming 0026

WHAT'S NEW

... in equipment, accessories, service



Primar Reflex Photo
normal 105 mm. lens

"Impossible"
distances
become
close-ups



Primar Reflex Photo
Astro 640 mm. lens
taken simultaneously
by Hans Namuth

with **ASTRO**[®]

LONG DISTANCE LENSES

FOCAL LENGTHS TO 1000 mm.!

Used by the world's foremost explorers, scientists and news services, Astro lenses have been making photographic history all over the globe. Special formulas have produced resolving powers up to 100 lines to the mm.! And these superb lenses are *fast enough for action color work*—focal lengths from 300 to 800 mm. rated at F/5, the giant 1000 mm. (40 in.) at F/6.3.

FOR STILL CAMERAS Leica, Exakto, Primar-Reflex, Master Reflex, Hosselblad, Praktico, Contox-S

FOR MOVIE CAMERAS 16 & 35 mm. Bolex, Mitchell, Eyemo, Debrie, Askania, E.K., Arriflex, etc.

DUAL PURPOSE MOUNTS allow interchanging movie and still.

SUPER SPEED TELEPHOTOS

5 in. F/2.3
6 in. F/2.3
6 in. F/1.8

NEW! 12-inch F/3.5 Astro in mounts for all movie and still cameras. **NEW GAUSS TACHARS**—focal lengths 25-32-40-50-75-100 mm.; all F/2, in mounts for practically all 16 and 35 mm. professional and amateur cine cameras.

Write for brochure and prices

ERCONA CAMERA CORP., Dept. A-25,
527 Fifth Ave., New York 17, N.Y.

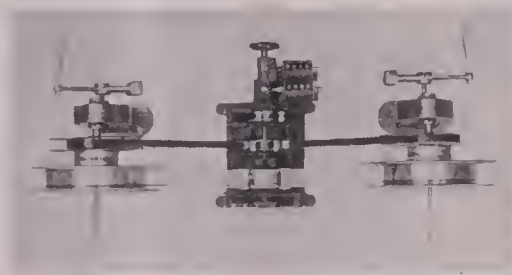

Differential Rewind

S.O.S. Differential Rewind Gimmick is tradename of new device which rewinds 16mm and 35mm reels of film simultaneously, regardless of size of film reels. The Gimmick is placed on any standard keyway rewind spindle and provides a slip-clutch extended spindle for the secondary reels of film, as pictured above. Priced at little more than a pair of film rewinds, device is being marketed by S.O.S. Cinema Supply Corp., 602 West 52nd St., N. Y. City.

Baby Tripod

An adjustable wood Baby Tripod for Professional Jr. friction and gear heads is available from Camera Equipment Co., 1600 Bdwy., New York City. Tripod has sturdy shoe and spur; measures 25" extended, 17" collapsed.

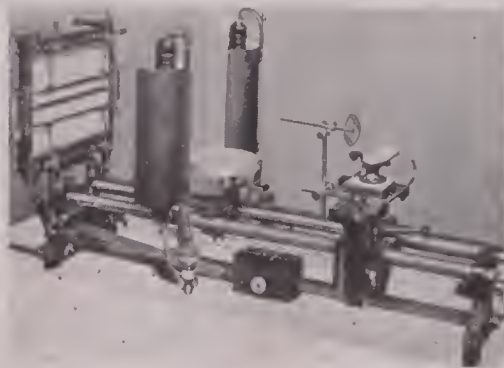

Titler and Effects Kit

Designed for 16mm and 35mm professional use is a new titler and special effects kit capable of producing a wide range of titles, trick films, cartoons, and animation. Equipment provides either horizontal or vertical operation, and has a table adjustable north, south, east or west. Front and rear illumination also is provided.

Three models are available which include complete kits of accessories, offering a choice of title board sizes from 5 1/8" x 7 1/8" to 7 1/8" x 9 1/2".

Prices range from \$159.50 to \$295.00. Distributor is S.O.S. Cinema Supply Corp., 602 West 52nd St., New York City. Descriptive brochure available.

Film Processors

A film processor for every possible type of 16mm or 35mm film production operation, color or black-and-white, is offered by Houston-Fearless Corp., 11809 W. Olympic Blvd., Los Angeles 64, Calif. Complete detailed information on company's many models may be had by writing the manufacturer on your company letterhead.

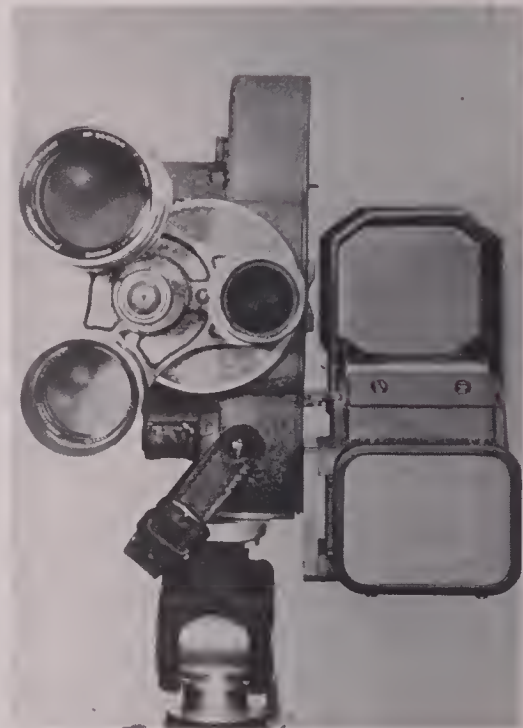

Spider Turret and Finder

Pictured above are two new accessories recently introduced by Bell & Howell Co. for use with the 70-DL camera: 1) a Spider Turret which takes any three lenses from 0.7 to 6 inches in focal length, and 2), the Sports Finder, which was originally developed for the Air Force. Having 1, 2, 3, and 4 inch field clearly marked, finder permits cameraman to see action outside the taking area. Price of turret is \$85.00; the finder is \$125. Both are factory installations.

Stereo Sound Integrators

A new stereophonic sound system for
(Continued on Page 326)



**Auricon
Hollywood**

*You are Invited
to Visit...*

the New Hollywood Home of

AURICON

16mm Sound-On-Film Cameras!

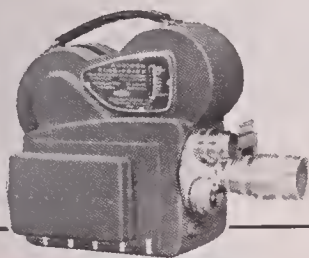

"CINE-VOICE"

16mm Optical Sound-On-Film Camera. 100-ft. film capacity for 2¾ minutes of recording; 6-volt DC Converter or 115-Volt AC operation. \$695 (and up).

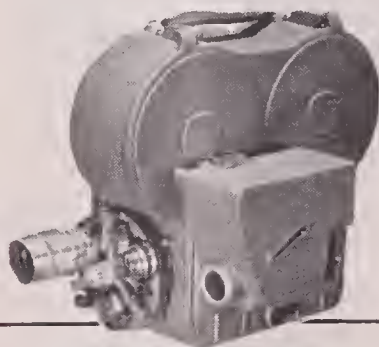

"AURICON-PRO"

16mm Optical Sound-On-Film Camera, for black & white or color filming. 200-ft. film capacity for 5½ minutes of recording. \$1310.00 (and up).

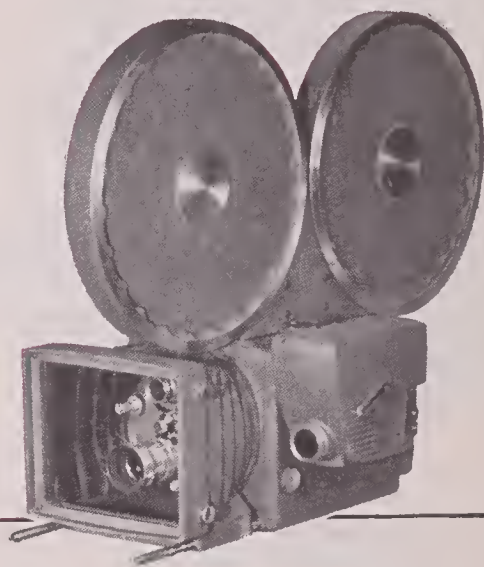

"SUPER 1200"

16mm Sound-On-Film Camera. 1200-ft. film capacity for 33 minutes of recording. \$4652.15 (and up) complete for "High-Fidelity" Talking Pictures.

Auricon Cameras are now in use by Television Networks, Film Studios, Newsreels and Educational Producers, for filming quality pictures in natural color or black & white. Come in for a demonstration or write for free Catalog.

The new Hollywood home of Auricon is a completely modern plant, designed and equipped to serve you better. New engineering, manufacturing and test facilities assure you of the latest and finest in precision 16mm Motion-Picture Cameras. World-wide acceptance and enthusiastic approval of Auricon Equipment makes this new plant possible.

All Auricon equipment is sold with a 30 day money-back guarantee. You must be satisfied! Write today for free illustrated Auricon Catalog.

AURICON
BERNDT-BACH, INC.

6902 Romaine Street, Hollywood 38, Calif.

The Auricon Hollywood Line
SOUND-ON-FILM EQUIPMENT SINCE 1931

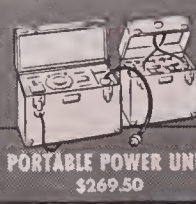
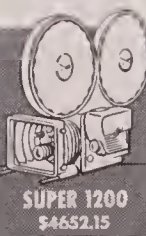

Precision Prints

**YOUR PRODUCTIONS
BEST REPRESENTATIVE**

CLOSE CHECK ON PROCESSING

Picture and sound results are held to the closest limits by automatic temperature regulation, spray development, electronically filtered and humidity controlled air in the drying cabinets, circulating filtered baths, Thymatrol motor drive, film waxing and others. The exacting requirements of sound track development are met in PRECISION'S special developing machinery.

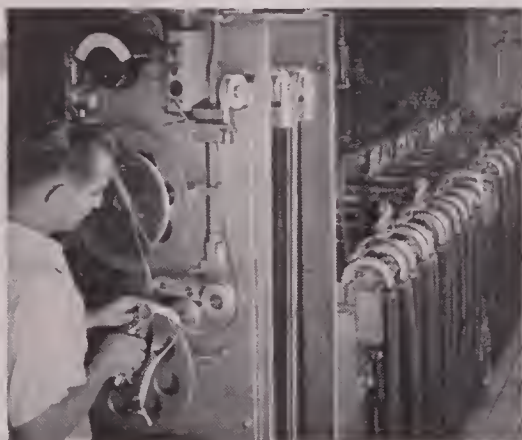

YOUR ASSURANCE OF BETTER 16mm PRINTS

16 Years Research and Specialization in every phase of 16mm processing, visual and aural. So organized and equipped that all Precision jobs are of the highest quality.

Individual Attention is given each film, each reel, each scene, each frame — through every phase of the complex business of processing — assuring you of the very best results.

Our Advanced Methods and our constant checking and adoption of up-to-the-minute techniques, plus new engineering principles and special machinery enable us to offer service unequalled anywhere!

Newest Facilities in the 16mm field are available to customers of Precision, including the most modern applications of electronics, chemistry, physics, optics, sensitometry and densitometry — including exclusive Maurer-designed equipment — your guarantee that only the *best* is yours at Precision!

Precision Film Laboratories — a division of J. A. Maurer, Inc., has 16 years of specialization in the 16mm field, consistently meets the latest demands for higher quality and speed.

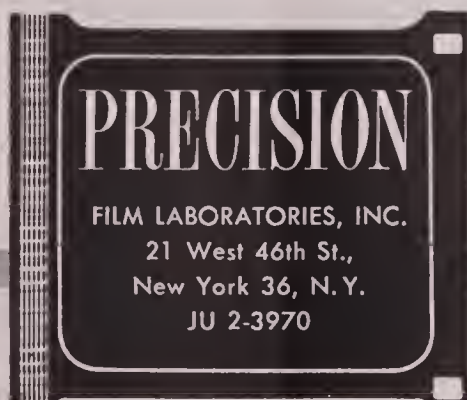

WHAT'S NEW

... in equipment, accessories, service

theatres which produces three-speaker sound from a single, standard optical sound track, has been developed by Fairchild Recording Equip. Co., White-stone, L. I., New York.

The Fairchild integrator first separates the low-frequency tones from speech and music in a track, then modulates the volume of each speaker continuously in relation to the amplitude of each low-frequency tone, producing a true, stereophonic effect.



Tripod Swivel

A swivel ball joint attachment for the Professional Junior and Mitchell "16" motion picture camera tripods is offered by Kadisch Camera & Sound Eng. Co., 500 West 52nd St., New York City. Addition of the swivel converts tripod to all-directional pan and tilt action. As pictured, unit is mounted between head and tripod—a simple matter for anyone; no tools required. Attachment is made of aluminum, weighs approximately 3½ pounds. Further details and prices may be had by writing manufacturer.

Collapsible Dolly

Camera Equipment Company, 1600 Broadway, New York 19, N. Y., announces a new collapsible 3-wheel camera dolly designed especially for cameramen who want an easily transportable dolly for field and location filming. The new dolly folds into the compact size of 18" x 12" x 36", and fits into a sturdy carrying case. When fully assembled for use, dolly measures 45" in width by 46" in length.

Dolly is equipped with swivel wheel at rear for easy steering. This may be locked into position for straight forward dollying. Dolly also mounts a "baby" tripod and provides space for both the cameraman and his assistant to ride. Price of the dolly is \$300.

Great equipment makes great cameramen

BALANCED TRIPOD HEAD

and

PROFESSIONAL JUNIOR TRIPOD

are the standbys of the masters

You'll never hear Fritz Kreisler playing on a scratchy fiddle . . . or Louis Armstrong on a \$7 trumpet. Good craftsmen need good tools.

Camera Equipment Company makes, sells, services and rents the world's finest quality TV and Motion Picture Equipment.



New "BALANCED" TV head — MODEL "C"
—for the world's smoothest pan and tilt action.

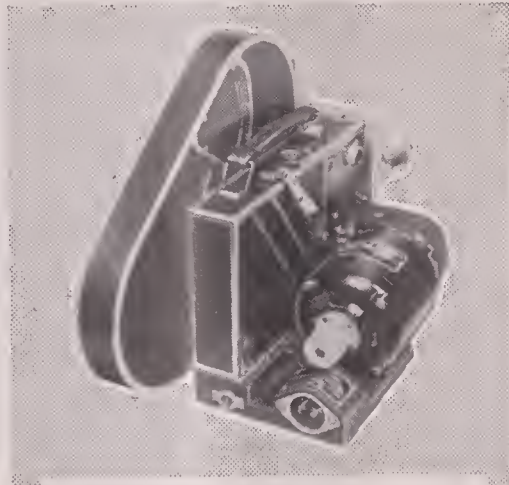

SYNCHRONOUS MOTOR DRIVE — 110 Volt AC — Single phase, 60 Cycle. Runs in perfect synchronization with either 16mm or 35mm Sound Recorders. Mounting platform permits removal of magazine while camera remains mounted on motor. Spring steel drive fin coupling prevents damage if film jam occurs. Knurled knob on armature permits rotating for threading. "On-Off" switch in base. Platform base threaded for 1/4" or 3/8" tripod tie-down screw. Rubber covered power cable with plugs included.

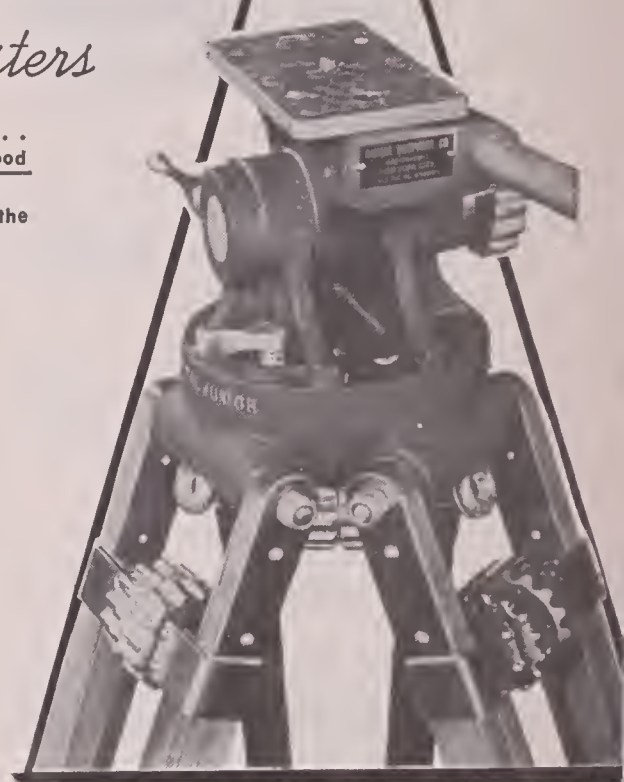

More professional cameramen use The PROFESSIONAL JUNIOR Tripod than any other tripod in the world.

Let's face it. You need a first class tripod to make better pictures. PROFESSIONAL JUNIOR has the rigidity, the range and the ease of operation that better pictures demand. So try it—try this tripod beauty—and you'll never be without it. PROFESSIONAL JUNIOR TRIPOD—Friction Type. Handles a 16mm cameras, with or without motor. Also 35mm DeVriest B & H Eyemo with and without motor, and 400' magazine Tripod base interchangeable with Professional Junior gear drive head. "Baby" tripod base and "Hi-Hat" base available.

No more groping for center of gravity. The new Model C "Balanced" Tripod Head is equipped with a convenient, accessible positioning handle mounted below the top plate, which allows the operator to reposition the camera to the correct center of gravity. No matter what focal length lens is used on the camera turret, the camera can be balanced on the Model C Head without loosening the camera tie-down screw.

It has all the features which have made the "Balanced" head a gem of engineering ingenuity—quick release pan handle, tilt-tension adjustment to suit your preference. It's a Cameraman's dream!

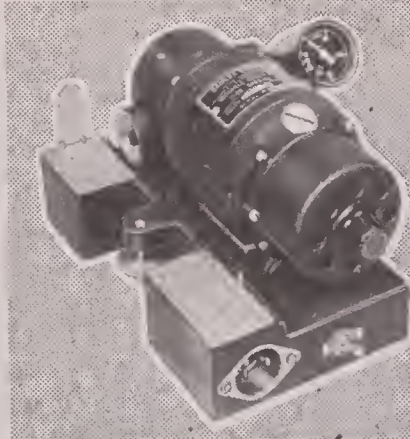

VARIABLE SPEED MOTOR — 110 V AC/DC with Tachometer for Cine Special Motor drive your Cine Special with confidential Tachometer is mounted in clear view of operator. Calibrated from 8 to 64 frames per second. Definite RED mark for 24 fps. Electrical governor controls all speeds. No adapters needed. Motor coupling attaches to camera and couples to motor. Spring steel drive arm shears if film jam occurs. Easily replaced.

We calibrate lenses—Precision "T" Stop Calibration of all type lenses, any focal length. Our method is approved by Motion Picture Industry and Standard Committee of SMPTE. For proper exposure density, it is important that you have your lens "T" stop calibrated. Lenses coated for photography. Special TV coating. Rapid service.

FRANK C. ZUCKER
CAMERA EQUIPMENT CO.
1600 BROADWAY NEW YORK CITY

SALES • SERVICE • RENTALS — CAMERAS * MOVIOLES * DOLLIES

Complete line of 35mm and 16mm equipment available for rental.

MITCHELL: Standard, Hi-Speed, BNC, NC, 16mm

BELL & HOWELL: Standard, Shiftover, Eyemo

ARRIFLEX: 35mm and 16mm

MAURER: 16mm Cameras

MOVIOLE: Editing machines, Synchronizers

We design and manufacture Lens Mounts and camera equipment for 16mm—35mm and TV cameras.



Endorsed...

by the
**WORLD'S LEADING
CAMERAMEN**

Used At All
Hollywood Movie Studios

**New Edition
NOW AVAILABLE**

**IMPROVED!
ENLARGED!
REVISED!**

with
**TELEVISION
PHOTOGRAPHY DATA**
plus
**NEW CHARTS
and TABLES**

The Book of a Thousand Answers
to Cinematographic Questions
ORDER YOUR COPY TODAY!

PRICE **\$5.00** POSTPAID

Book Department,
American Cinematographer,
1782 Na. Orange Dr.,
Hollywood 28, Calif.

Gentlemen: Enclosed please find \$5.00*
for which please send me a copy of
**THE AMERICAN CINEMATOGRAPHER HAND-
BOOK AND REFERENCE GUIDE.**

Name

Address

City..... Zone.....State.....

*if you live in California, please include 18c
sales tax — total \$5.18.

letters

Likes Diagrams

Kudos to Phil Tannura for his very excellent article "Money-saving Shooting System for TV Films" in the May issue. Especially did I like the set diagram showing camera movements. Give us more articles like this—real gutsy how-to-do-it information.

M.H.

Chicago, Ill.

Information Source

I am the NBC Television Newsreel cameraman for Thailand and the adjoining countries of Southeast Asia. Unfortunately I haven't been back to the States for the last six years and I find myself woefully ignorant of the latest equipment, techniques and developments in things cinematic. This, despite the fact I've had more than a hundred TV newsreels and feature stories aired over the NBC network.

It seems to me a good way to catch up would be through back issues of American Cinematographer. Are copies available for, say, the past year? If so, how much would it cost to have them sent to me here?

Jorges Orgibet

Bangkok, Thailand.

• *Foreign rate for back issues is 40c per copy. At this writing, we have all back issues for the months of 1954 to date. Incidentally, a quick reference to subject matter published during the year is the annual index which appears in our December issues.—ED.*

Lazy-10 Preceded Lazy-8!

You may be interested to know that Paramount Pictures was not the first to design a motion picture camera having the negative travel horizontally instead of vertically, as in its "Lazy Eight" camera described in your December, 1953, and April, 1954, issues.

In the late twenties, a Prof. Alberni, in England, designed a wide-screen camera that worked on exactly the same principle as the Paramount "Lazy Eight," except that Prof. Alberni's camera could more properly be termed the "Lazy Ten," having as it did ten sprocket holes to a single frame instead of eight. The negative

was optically printed and rotated 90 degrees to produce a print on conventional 35mm film. London cinematographer George Hill worked with Prof. Alberni on the project.

H. E. Wright

London, England.

Wouldn't Miss A Copy

Having been an amateur motion picture enthusiast for the past twenty years, am beginning now to establish a visual-aid service for our churches in the States (known as "Christian Audio-Visual Pictorial Service"). Your articles and news are very helpful and enlightening. I wouldn't miss a copy of AC. So change my address to Shoals, Indiana, as I shall be returning to the U.S. in three months.

Am presently traveling all over South Korea, and have opportunity to do sound or silent photography in 16mm.

Incidentally, I would like to contact various manufacturers interested in making arrangements for sale and distribution of 16mm projectors, tape recorders, etc., to churches and religious groups.

Chaplin Robt. M. Small

14th Field Hosp.,
c/o P. M., San Francisco.

Re Cinerama

In his article, "The Cinerama Technique," in the June issue, Joseph Brun did not make clear whether or not he used the same Cinerama camera that was used in filming the original production "This Is Cinerama?" I am wondering if the mechanism has since been improved so as to eliminate the lines of demarcation between the three picture sections projected on the screen.

Robert Fallon

Cincinnati, Ohio.

• *Understand the camera used was same type used in making the original film, with three separate films traveling simultaneously past three separate lenses, as described in our November, 1952, issue. Engineering steps have been taken to reduce effect of "seams" between picture segments. —ED.*

**SHARPER,
BRIGHTER,
CLEARER
IMAGES**
with...

• 2-D

• 3-D

•  CINEMASCOPE

• TV

BALTAR

Brilliant images, thrillingly detailed—they're yours *for sure* with Bausch & Lomb Baltar lenses on your camera. For finest images on film: complete line of Baltar 35mm and 16mm movie lenses—for 2-D, 3-D and CinemaScope. For finest TV images: Television Baltar lenses, for studio and portable cameras. Order from your professional camera manufacturer.



BAUSCH & LOMB

SINCE



1853

"Lights"
"Camera"
"Action"

and PROCESSED BY
MOVIELAB

FOR THE FINEST FILM PROCESSING *IN*
THE EAST — FILM MEN WHO KNOW
SAY "IT'S MOVIELAB"

Here—at MOVIELAB . . . efficiency and perfection are the rule. Producers, directors and technicians have at their fingertips the very best in up-to-the-minute equipment necessary to modern FILM PROCESSING techniques.

ROUND THE CLOCK SERVICES

- Negative Developing • First Print Department
- Ultra Violet & Flash Patch Track Printing
- 16mm & 35mm Release Printing
- Quality Control • Title Department
- 22 Cutting & Editing Rooms.

FOR COLOR

it's

Rainbowlab Inc.



MOVIELAB FILM LABORATORIES, INC.

619 West 54th Street, New York 19, N. Y. JUdson 6-0360

CATALOGS & BROCHURES

available to readers

Lighting Equip. Rentals

An attractive leatherette loose-leaf binder containing 53 pages of data and illustrations describing the equipment and scope of service being made available by Jack A. Frost, is available to those in the industry making request on their business letterhead. Some of the equipment is now being made available to west coast producers by a recently appointed Hollywood representative.

Film Processor Equip.

Prices and complete descriptions of the various components for the construction of custom-built film processing equipment is now available in a comprehensive brochure from Metal Masters, 4584 68th Street, San Diego 15, Calif.

Film Treatment

Both professional and amateur producers of motion pictures will find the new price list offered by Peerless Film Processing Corp., of value. The 8-page booklet quotes prices on such services as protective and preservative treatments, restorative and rejuvenation treatments, inspection, cleaning, salvaging; breakdown, packaging and shipping services on TV films and commercials, etc.

Copies are available by writing the company at 165 West 46th St., New York 36, N. Y.

Maurer 16mm Production Equip.

A 24-page illustrated brochure describing the complete range of 16mm professional film production and sound recording equipment manufactured by the company, is available from J. A. Maurer, Inc., 37-01 31st Street, Long Island City 1, N. Y. The brochure is replete with comprehensive illustrations that reveal the many exclusive innovations in film camera and sound recorder design.

1-Track Stereo Sound

How stereophonic sound is obtained from a single optical sound track with the aid of the Fairchild Intergrator is illustrated and described in an interesting new brochure now available from Fairchild Recording and Equipment Co., Motion Picture Sound Division, Whitestone 57, N. Y.

ONE-STOP SOURCE for FILM PRODUCTION EQUIPT.

"The Department Store of the Motion Picture Industry"

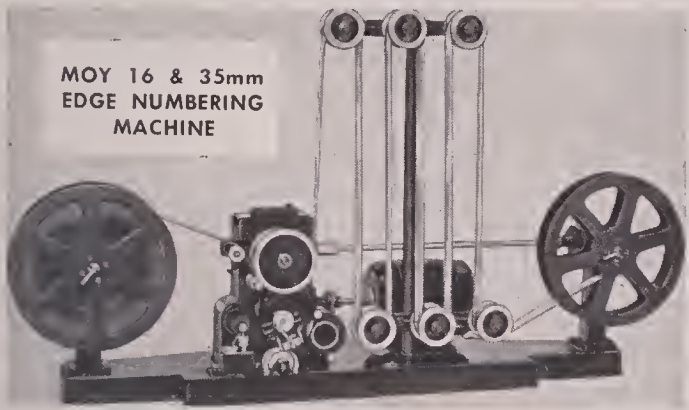

MOY 16 & 35mm
EDGE NUMBERING
MACHINE

IDENTIFY YOUR FILMS INSTANTLY!

Save many man hours now lost classifying films without titles. The Moy edge numbers every foot of film and simplifies the task of checking titles and footage.

Prints black or yellow from automatic metal numbering black on opaque or clear film. 2000' capacity, speed 50' per minute. 16mm model prints between perforations only—35mm prints between perforations or on outside edge as specified.

Recent Purchasers are:

Columbia Broadcasting System, N.Y.
Moody Bible Institute, Los Angeles
American Optical Co., Buffalo, N.Y.
Cinerama Productions, New York

WITH NEW, IMPROVED
INKING SYSTEM

\$2,250



STEPHENS TRU-SONIC WIRELESS MICROPHONE

Fulfills a long
required need!

This miniature F.M. transmitting WIRELESS unit requires no cables, no baams, no hidden mikes to play ta. About the size of a pack of cigarettes, weighs less than 4 ozs. With small battery, shown in photo, it can easily be concealed on the person, enabling performer to wonder about at will and permit shots never before possible. Ideal for TV stations, motion pictures, stage, lectures, industrial applications, etc.

The high fidelity sound pick-up assures utmost tone quality reproduction, surpassing conventional cable-fed microphones in signal to noise ratio as well as frequency response. Includes specially designed, highly sensitive receiver and a power supply with monitor speaker and headphone jack. If desired, the audio output of the receiver can be fed into standard microphone inputs.

COMPLETE \$980

HOLLYWOOD STUDIO SYNCHRONIZERS

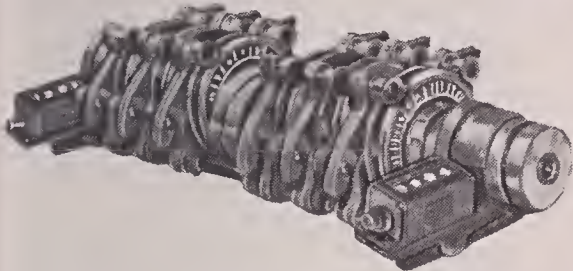

16mm
35mm
16/35mm

Match 16 and 35mm
frame for frame

40 frame rollers (1 linear foot) • Veeder-Root setback counter
• Undercut sound track and picture rollers and guides • Precision needle bearings for free running • Calibrated adjustable frame dial on a stabilized, counterbalanced weighted frame • "Swing-away" guide arms • Fingertip release • Precision machined interchangeable ports allow flexible odd-o-unit feature •

16mm—2 gang \$127; 3 gang \$160; 4 gang \$192.
35mm—2 gang \$145; 3 gang \$177.50; 4 gang \$210.
16/35mm Comb.—1-35 & 1-16 \$185; 1-35 & 3-16 \$240.
Other units available upon request.

HOLLYWOOD JR. 8/16mm Sound/Picture Continuous Printer

Prints from negative, positive, Kodachrome or Ansco color. Exposure meter controls light density; curved printing head—separate apertures for 16mm picture track and bath together or 8mm picture only. Printing lamp apertures from 7 1/2 volt dry cell. Capacity 400' . . . Speed 36 f.p.m.

F.O.B. Hollywood\$167.50

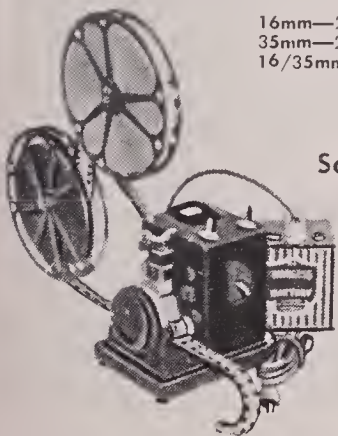

Bridgomatic

FILM PROCESSING EQUIPMENT

PAYS FOR ITSELF!

for TV Stations,
Industrial Pro-
ducers, Photo-
finishers, Micro-
filmers, etc.

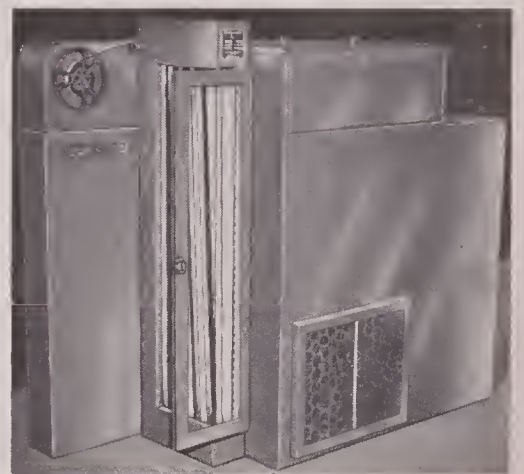

Bridgomatic R-TV, 52" high x 47" long x 30" wide—
one of 12 models, including color machines.

MODEL R-TV for TV stations.....\$5600
(Output 35' per minute at 90°)

MODEL RT-R for racetracks.....\$5995
(Output 82' per minute at 98°)

Other Models for all
purposes,.....\$1095 up

Nothing like it at any-
where near the price!
This new ultra rapid
16mm film developer
assures clear, sharp,
brilliant images. En-
tirely automatic. Will
develop your films with-
in minutes after shaft-
ing. Requires no special
skill. Removes the
guess, protects your
precious negatives—and
clean-dries in minutes.
No darkroom necessary.

S. O. S. CINEMA SUPPLY CORP.

Dept. F, 602 WEST 52nd ST., NEW YORK 19, N.Y.

Phone: PLaza 7-0440

Cable: SOSOUND



THE CUKOLORIS, when interposed between a lighting unit and a wall breaks the light up into interesting patterns of light and shadow. Here both lamp and "cookie" are placed much closer to wall than in normal use, in order to more graphically demonstrate the effect obtained.

Cukoloris—Set Lighting's Most Versatile Tool

"Cookies" placed before set lights enable the cinematographer to give individuality to his lighting; they create interesting patterns of light and shadow that complement dramatic action and enhance effect lighting.

By JOSEPH LASHELLE, A.S.C.

ONE OF THE MOST important accessories used in set lighting carries the strangest of names. It is the cukoloris, or "cookie," as it is termed in the parlance of the gaffer. Its origin is probably as strange as its name, and its originator's identity has long since become

lost among the scores of studio technicians who have come and gone over the years. But the cukoloris remains and is to be found in the grip equipment of every production company at work on Hollywood studio sets today.

Briefly, a cukoloris is a perforated

screen which is placed before a lamp on the set, where it is desired to break up into varied patterns of light and shadow the lighting on a wall or a certain portion of a scene. This is illustrated in photo at left; here the lamp and cukoloris are set up close to a wall in order to demonstrate the immediate effect of the cukoloris when it is interposed between a light source and a wall or object. In normal use, both the lamp and the cukoloris is set up some distance from the wall, and the pattern of the "cookie" on the wall is less defined, as will be described more fully later.

Long before the advent of the cukoloris, cameramen with a talent for painting with light employed the basic fundamental of the cukoloris in lighting certain sets. The late George Barnes was one of these. When I was an operative cameraman, quite a number of years ago, I worked with Barnes on many pictures. One of the first things I noticed about his lighting technique was the way he often placed odd objects between the set lights and the walls in order to break up the light and cast a subtle shadow pattern on them. Sometimes it was a vase of flowers he used, or perhaps a step ladder—anything that would produce the irregular shadows he



CUKOLORIS patterns follow no set rule. Usually they are turned out by the studios themselves and cut from panels of cardboard, plywood, cellophane, or cellophane, as is the one shown above.

felt would enhance the lighting pattern. I soon realized that here was a highly effective technique having many possibilities. Later I observed Arthur Miller, ASC, using the same technique—employing various objects before certain set lamps to break up flat lighting on vast wall expanses.

It was about this time that the cukoloris as we know it today made its appearance on studio sets. I have come to be one of the more ardent users of the device, indeed to the extent that one joker on the Fox studio lot coined the phrase, "Queer for cukoloris!" which is still heard to this day.

The cukoloris is one item used by studios that, as far as I know, has never been manufactured commercially outside the studios and marketed, as are other lighting accessories and equipment. Today, just as years ago when the "cookies" first made their appearance, they are invariably turned out in the workshops of the studios.

A cukoloris can be made of almost any material, opaque or semi-opaque. In the beginning, most were cut from cardboard or wallboard. Lately, semi-opaque materials such as celloglass have been employed. As may be seen in the photos on opposite page, "cookies" made of such material produce a softer pattern, with the shadow areas less defined.

While a cukoloris may be of any size and not necessarily rectangular in shape, the average size of those used in the studios is about 18" by 24". Those made of celloglass are usually mounted on a sturdy wire frame having a vertical pin at the bottom that permits mounting the device on an adjustable floor stand. (See photos). The perforations or cutout areas follow no established pattern; rather this follows the whim and fancy of the maker as he starts at one edge of the material and, with a sharp knife or other tool, cuts out the irregular pieces that permit the light to pass through. For obvious reasons, the cutouts always follow a rolling, uneven pattern; they are never straight nor square, except where a distinct angular pattern is required for an unusual lighting effect.

Just as an artist uses paint to express a mood or create a certain atmosphere on canvas, so a director of photography uses controlled light to express a mood or to establish an atmosphere complimentary to the period in which the play takes place or which is most compatible to the story. Today, the cukoloris is regularly employed in this control of light.

I have used "cookies" in almost every production that I have filmed; but increasingly in highly dramatic productions such as "Les Miserables" (1952), "My Cousin Rachel" (1952) and "River of No Return" (1954)—all 20th Century-Fox productions.

On this page are stills from two dramatic scenes from "My Cousin Rachel," which show graphically the use of cukoloris in the lighting. The story, as most readers will remember, was laid in England about a hundred years ago, in the candle light era. One of the strong pictorial points made in most of the interiors was the effect of candle light, and for this I used cukoloris most effectively.

In such somber settings as those in which the action for "Rachel" took place, it would be unthinkable to light the interiors either brightly or flat. Consequently we concentrated on a pattern of semi-low-key illumination with the ceilings and upper reaches of the walls greatly subdued and all large surfaces splashed with a mixture of light and shadow. Obviously, the cukoloris was the ideal tool for creating these lighting patterns.

Because there is a considerable difference between the pattern projected by the "cookie" on the wall in the round photo on the opposite page and that produced by "cookies" in the two scenes from "Rachel," it should be explained here that the projected shadow pattern of the cukoloris is greatly altered in density and form as it is moved toward or away from the light source, and again as it is moved toward or away from



SCENE FROM "My Cousin Rachel," 20th Century-Fox production photographed by the author, which demonstrates subtle use of cukoloris in the background lighting. "Cookies" were used widely throughout the production.

the set walls. Also, the type of light unit used will affect the result; a spot will produce a cukoloris pattern more sharply defined than a flood lamp. Also, the farther the cukoloris is set from the wall on which its pattern is to be thrown, the softer will be the pattern of shadows.

Note the very subtleness of the shadow pattern on the upper areas of the walls in the top photo on this page; yet how much more dramatic is the effect than would be the case where the walls were simply left in a dark uniform tone.

(Continued on Page 365)



ANOTHER scene from "My Cousin Rachel" in which the cukoloris was used most effectively in lighting the background walls and arches. Note how much larger are the shadow patterns than those in the circled photo on the opposite page.

DEDICATED TO BETTER PERFORMANCE



COLLAPSIBLE 3-WHEEL DOLLY

For motion picture and TV cameras. Sturdy cast aluminum. For standard or baby tripods. Additional baby tripod point holders to control spread of tripod legs. Adjustable spring seat. Extra wide rubber wheels. Bronze tie down clamps and other features.

For studio or location. Folds into one compact unit. Can be used with professional or semi-professional tripods.

'HYDROLLY'

TV OR
CAMERA DOLLY

The advanced dolly for instant moveability — streamlined, lightweight, exceptionally sturdy. Nothing to get out of order. Many new advantages for easy operation. Hydraulic lift type for fast upward and downward motion of TV and motion picture cameras.

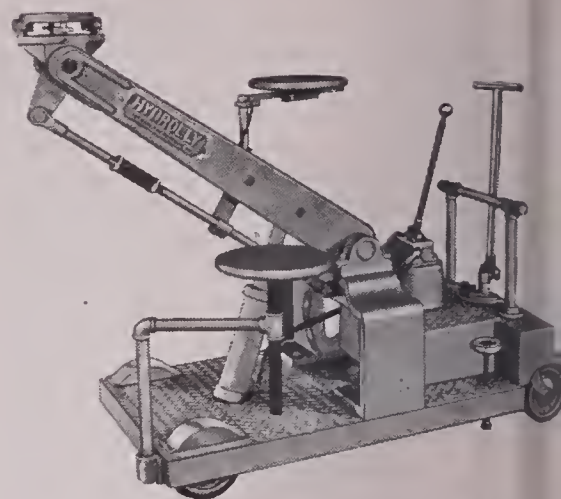

Swivel seat. Adjustable leveling head. Seat for assistant. In-line wheels for track use. Steering wheel, rigid floor locks. Hand pump or combination hand and motor pump. Easily transported in a station wagon. Fits through a 28" door.

SYNCHROMASTER SYNCHRONIZER

Our Exclusive Distributor
Neumade

Any combination of 16mm and/or 35mm sprockets assembled to specification. Cast aluminum. Foot linear type, adjustable frame dial. Fast finger roller release. Contact rollers adjusted individually for positive film contact. Sprocket shaft slip lock, footage counter, etc.



RENTALS

SALES · REPAIRS · SERVICE

LENS COATING

"T" STOP CALIBRATION

DESIGNING and MANUFACTURING

lens mounts & camera equipt.
for 16mm, 35mm, TV cameras.

BAUSCH & LOMB "BALTAR"
LENSES and others

for motion picture, TV cameras.
15mm to 40" focal length.

COMPLETE LINE of 16mm, 35mm
cameras, dollies, synchronizers,
animation equipment, cutting room
and time lapse equipment.

BELL & HOWELL: Standard, Eyemos, Filmos. MITCHELL: Standard, Hi-speed, BNC, NC, 16mm.

SEND FOR CATALOGUE

ColorTran Groverlite

SENIOR & JUNIOR KITS

"A STUDIO IN A SUITCASE"

ColorTran replaces heavy and expensive equipment... gives you illumination up to 5000w. from an ordinary 20 amp. house current. Equipped with barndoors, diffuser slots for silks, snoots and other accessories. Ideal for studio or location shots.

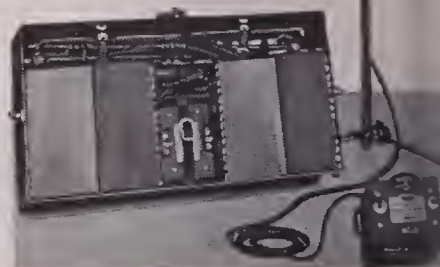

PORTABLE MICROPHONE BOOM

For Studio or on Location. Lightweight — collapsible — for TV and motion picture production. Sturdy construction. Boom telescopes 7 to 17 ft. Rear handle for directional mike control. A remote control permits 360° rotation of the microphone. Operator can push the boom and operate microphone swivel simultaneously.

Extension rods make it simple to operate microphone rotation from floor. Microphone cable hangs outside of boom, preventing cable from tangling with the rotation mechanism. Ball bearing casters, rigid foot locks, pneumatic drop check for lowering the boom, etc.



VARIABLE- SPEED MOTOR with TACHOMETER

for Cine Special or Maurer Cameras

115 V. Universal Motor — AC-DC
Separate Base for Cine Special.
Variable Speed 8-64 frames.
Adapter for Maurer Camera.

INTERCHANGEABLE MOTORS: 12
volt DC Variable Speed 8-64 frames.
115 Volt AC 60 Cycles, Synchronous
Motor, Single Phase.

ANIMATION MOTORS: Cine Special,
Maurer, Mitchell, B & H Motors,
for Bolex and Filmo Cameras.

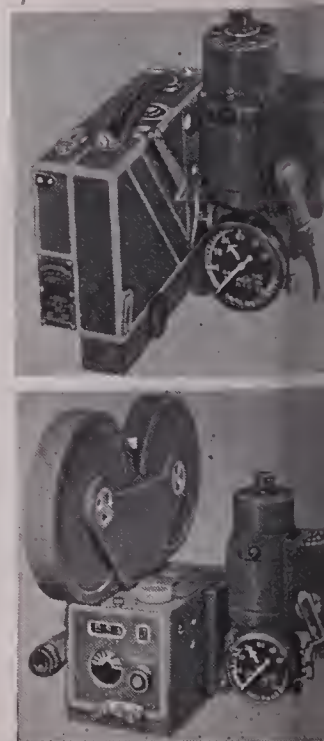

NATIONAL CINE EQUIPMENT, Inc.

JOHN CLEMENS

ERWIN HARWOOD

209 W. 48th ST., NEW YORK 36, N.Y. — Circle 6-034

THE EASTMAN KODAK COMPANY has recently placed on the market a new high speed negative motion picture film under the name Eastman Tri-X Panchromatic Negative Film, Type 5233 (35mm) and Type 7233 (16mm). This is a new material incorporating the most advanced techniques in film manufacture. In the past, higher emulsion speed has always been a desirable goal for the film manufacturer, but high speed has inevitably been accompanied by an increase in the granularity of the developed negative image. A print made therefrom consequently showed greater graininess in the projected screen image. While notable advances have been made over the years in improving the so-called "speed graininess" ratio of various Eastman motion picture films, this new product represents a most remarkable achievement in this respect. For example, while it is fully twice the speed of Eastman Super-XX Negative Film, Type 5232, its granularity is actually less, even approaching that of Eastman Plus-X Negative Film, Type 5231.

As is true with other negative films, however, granularity increases with density of the negative and it is therefore important to avoid overexposure. This precaution is even more important with this film because of its extremely high speed and the greater danger of overexposure.

As indicated by the exposure index and the illumination values given in Table I, the speed of the film is exceptionally high for use under either daylight or tungsten illumination conditions. This high speed is mainly the result of higher inherent emulsion sensitivity, but another characteristic is worthy of note and one which has led many people to consider this film as actually faster than the exposure index values alone would indicate. Because of the fact that the negative contrast or gradient is maintained at extremely low densities, it is possible to obtain satisfactory tonal relationships in the print even when the negative is very thin—actually thinner than what one is accustomed to regard as satisfactory for obtaining acceptable quality prints.

This high effective speed is an important consideration when pictures must be made under extremely poor lighting conditions, such as are frequently en-

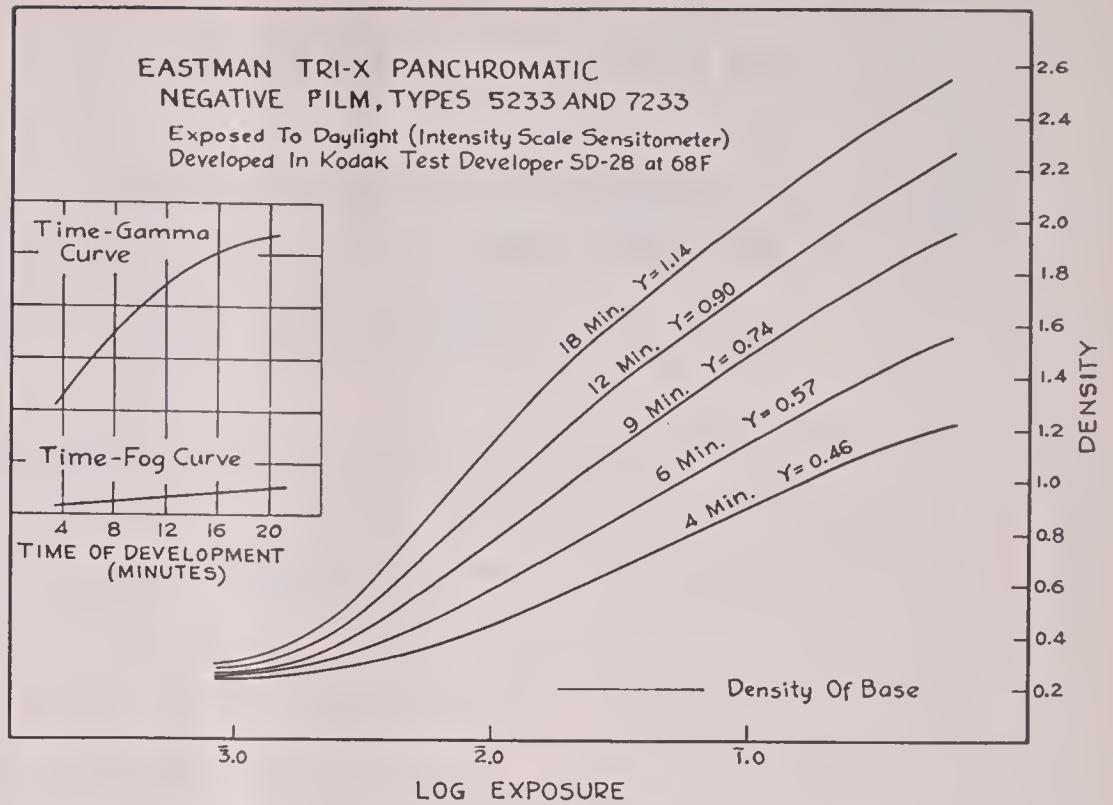

FIG. 1—The development time for Eastman Tri-X Panchromatic Negative film (Types 5233 and 7233) is about the same as that for Plus-X film, Type 5231, resulting in a gamma of 0.65 to 0.70. The film is not intended for processing at high temperatures.

Tri-X—New Eastman High-speed Negative Motion Picture Film

A remarkable fast negative, ideal for dark days or night exteriors, it can be used for shooting at night with existing light.

By EMERY HUSE, A. S. C.

countered in newsreel photography. The film should find extensive use in photographing scenes on dark days or night exteriors. It should also find wide application in photographing factory interiors, hotel lobbies and the like, under existing lighting conditions, where it might be difficult or impossible to set up auxiliary lighting units.

Like other Eastman picture negative films, Tri-X Film is intended for processing by the user. It is developed in a normal motion picture negative developer such as Kodak D-76 or some

modification thereof. The development time is about the same as that for Plus-X Film, Type 5231, resulting in a gamma of 0.65 to 0.70. Fixing, washing, and drying operations are also similar to those used for other picture negative films. The film is not intended for processing at high temperatures.

The same precautions regarding keeping of raw stock and exposed film should be observed as have been recommended for other black and white picture films.

(Continued on Page 364)



FIG. 2—Type 5233, sunlight exposure.

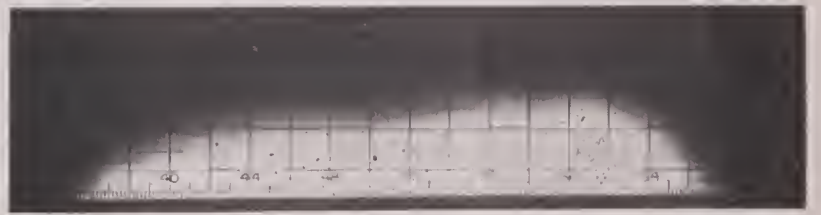

FIG. 3—Type 5233, Tungsten exposure.

Creative Cutting

If it was thoughtfully photographed, methodical cutting will invariably produce a successful film.

By CHARLES LORING

LAST MONTH we discussed the preliminary steps necessary to the process of editing a motion picture film. In this article, we shall take up the actual mechanics of editing as well as the subtleties of creative cutting, which invariably spell the difference between a well-edited and poorly-edited film.

Continuing with the hypothetical example described last month, let us assume that the unedited film received from the laboratory has been completely broken down in the primary step of editing. The various scenes, which were separated from the various rolls of film, are now arranged in consecutive order on a peg-board, scene-strip rack, or pigeon-hole tray. It has been decided, after reference to the script and the descriptive 3 x 5 file cards, that this consecutive order is actually the order in which the various scenes are to be cut together—or as you want them to appear in your tentative plan for the final cut.

The next step is to *rough cut* the footage, one sequence at a time. Starting with the first or "A" sequence, cut the

slate frames off of Scene 1 and hang it on peg No. 1 on the editing-bin rack. These pegs are actually small nails with the heads cut off, mounted along a horizontal rack suspended over a rectangular bin lined with soft white muslin. The pegs are designed by painted numbers running consecutively from 1 to 50, or 100, depending upon the size of the bin—as described last month.

Proceed now to mount each scene of the sequence on its respectively numbered peg. When you reach the end of Sequence "A," splice all of the scenes together in order. Now you can either rough-cut the rest of the sequences, or screen Sequence "A" preliminary to final cutting of that sequence. Many editors prefer to join all of the rough-cut sequences together before doing any final cutting, so that they can get an idea of the flow of the entire production.

The rough-cut sequence will include *over-lap* action to bridge continuity from one scene to another; this will be eliminated in the final cutting. Also, the action in these scenes will probably run

over-long because it is unrelieved by the variety of scenes which will later be *inter-cut* to speed up the pace.

In screening the rough-cut sequence, there are a few basic editing axioms to be considered. Firstly, your main objective in cutting is to create a smoothly flowing story that will hold the audience's attention by virtue of having its dramatic emphasis in the right places. Secondly, two scenes taken separately will have two separate meanings—but when they are joined together consecutively an entirely new meaning rises out of the relationship. For example, you may have a shot of an airplane flying and another shot of a man looking up at the sky. If the two scenes are joined together, your audience will quite naturally assume that the man is looking up at the airplane.

Thirdly, in final cutting you will be concerned with three important elements: *continuity*, *tempo*, and *dramatic punch*. It is these factors which you will want to keep firmly in mind when screening the rough-cut of your sequences. First, determine how you must cut your footage so that each scene will flow smoothly into the next. If there is a jump in continuity, decide which type of optical transition will best bridge the gap.

Next, notice the pace of the action in individual scenes and decide where you will want the general tempo speeded up or slowed down in the final cutting.

Then notice which scenes contain your climatic action, the situations which must be built up to give your scene story *dramatic punch*.

In simplest terms, continuity in cutting means a smooth flow of story action from scene to scene and sequence to sequence. Actually, as we have pointed out before, continuity originates in the script and is enhanced by proper direction of the action. With this firm basis, it is a simple matter for the cutter to put together a smoothly-flowing screen story from the footage at hand. But, it is a mistake to believe that good continuity can be *manufactured* in the cutting room from poorly matched, disjointed scenes.

Good continuity implies that cutting should be so smooth that the audience will not be immediately conscious of changes of angle or image size as the camera changes point-of-view. Thus, in cutting continuous action, the *overlap* (or repetition of action at the beginning of a new scene) must be cut at a point where the action will continue to flow uninterrupted. Sometimes it is a simple matter to locate this point; at other times you will have to experiment.

(Continued on Page 352)

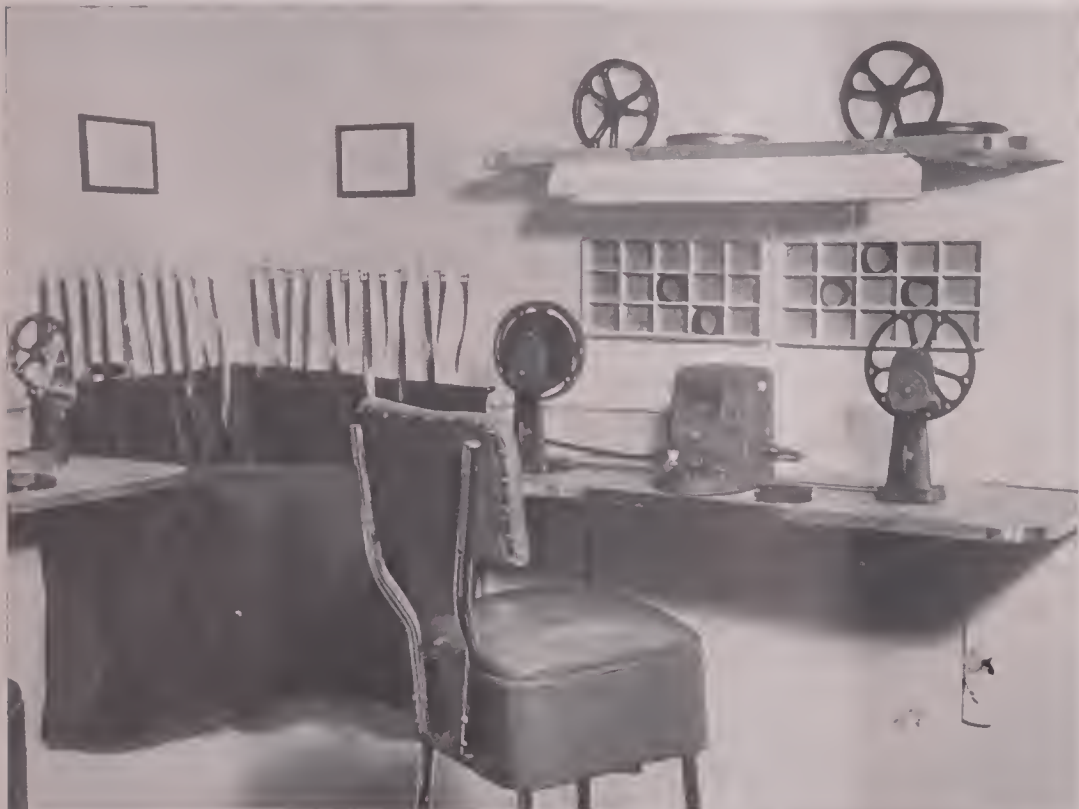

YOU'VE GOT TO have the right tools to do any job well, and this applies equally to film editing. Here is a simple, but well-arranged editing table for 16mm film, with scene-strip rack in the corner which utilizes numbered plastic clothespins to hold the strips.

EASTMAN

PROFESSIONAL

MOTION PICTURE

FILMS

W. J. GERMAN, INC.

Fort Lee

Chicago

Hollywood



TWO CAMERAS—one for CinemaScope and one for wide-screen—were used in photographing in color most of the scenes for MGM's "Seven Brides for Seven Brothers." Here director of photography George Folsey's dual camera crews photograph a scene on an

exterior set erected indoors on one of MGM's sound stages. The studio's recently developed "skylights" supplied the diffused lighting necessary to simulate daylight.—All MGM photographs by Frank Shugrue.

Simultaneous Production Shooting In CinemaScope And Wide-screen

There's always something new being tried in the making of MGM productions, and this was no less true during the shooting of "Seven Brides for Seven Brothers" when two cameras were used for every shot and gaffers communicated via short wave radio.

By GEORGE FOLSEY, A.S.C.



BACK IN 1922 I had the pleasure of being associated with director Chester Franklin at the old Long Island studios, working mostly with Bebe Daniels on such memorabilia as "Nancy From Nowhere" and "Rum Runners."

I mentioned this biographical fact, not to establish how long I have labored in the celluloid vineyards, but to bring up an interesting discovery made at that time, viz.: that fog—the variety that creeps up New York's East River—is one of the greatest aids in light dispersal, producing soft values in illumination which, I have also discovered, are ideal for CinemaScope photography.

So, when I was assigned recently to photograph M-G-M's CinemaScope musical, "Seven Brides for Seven Brothers," produced by Jack Cummings, my earlier experience with fog stood me in good stead. In starting to shoot this production, certain problems in set lighting soon made themselves apparent—namely, that created by the much larger CinemaScope aspect ratio and the unusually large cast of principals, fourteen in all. At times more than twenty featured players were on stage at the same time—a matter that posed a problem of lighting them all adequately and uniformly.

By contrast, for the intimate love scenes in which were paired Howard Keel and Jane Powell, Jeff Richards and Julie Newmeyer and all the rest of the newly-wedded couples—all prominent in the picture—the CinemaScope area in the camera finder loomed as empty as the Rose Bowl on January 2nd when setting up for closeups or medium shots of the individual couples. Here the compositional and lighting problems were to make unobtrusive, without being obvious about it, those parts of the wide CinemaScope picture area left open when action was concentrated in the middle of the screen.

The solution was in strategic placement of kickers and sidelights, all rigged to produce reflected or diffused light—similar to the soft quality of fog-diffused light I had discovered years earlier. Actually, this lighting technique, now widely used by many cinematographers, is the single innovation of no one man. If any credit is due anyone for this pictorial innovation, it should go to Leonardi Da Vinci (see his Mona Lisa) and others of the Old Masters; for although it may not be apparent at first glance, such artists virtually swept their entire canvas with diffused light.

I once used this technique of diffused light during the entire production of "If Winter Comes," and for many sequences in "Green Dolphin Street," lighting through silks.

Problems on "Seven Brides for Seven Brothers" began with the word go. The picture was being shot in two aspect ratios: CinemaScope and Wide-screen, which required shooting about 90 percent of the scenes simultaneously with two cameras—one for each format.

The opening sequence encompassed almost continuous action on a set three blocks in extent erected on M-G-M's back lot. Howard Keel, singing one of the hit tunes of the picture, strides up and down the sidewalk in search of a girl—"any girl!" This vast set was successfully lighted for wide-screen photography by mounting arc lamps high on parallels erected

(Continued on Page 369)

EXAMPLES of some of the artful lighting which marks the photography of "Seven Brides for Seven Brothers" is evidenced in the three scenes pictured at right. Contrasting the interesting lighting scheme of the interior (top photo) is the illumination treatment given the next two scenes—both indoor "exteriors" employing painted backdrops very effectively, and a lighting technique that lent the utmost realism to the settings.

LEFT—For big fight scene (for which there could be no re-takes) four cameras were used: two CinemaScope and two wide-screen. Cinematographer George Folsey, ASC, is second from right. Others are Andy McIntyre, Bob Tobey, George Hollister, Wm. Spencer, Robt. Brunner, director Stanley Donen, and actor Howard Keel.





Out of this world . . .

New, exciting wide-screen entertainment! Thrills! Thrills! Large things made even larger! The barely visible made man-size and more! Entertainment that fills eye and mind. That's today's motion picture—a new world of advanced production, processing and projection with a world of new problems. Today many of these problems are being solved in co-operation with the Eastman Technical Service for Motion Picture Film. Branches located at strategic centers. Inquiries are invited.



Address: Motion Picture Film Department
EASTMAN KODAK COMPANY, Rochester 4, N.Y.

East Coast Division

342 Madison Avenue, New York 17, N. Y.

Midwest Division

137 North Wabash Avenue, Chicago 2, Illinois

West Coast Division

6706 Santa Monica Blvd., Hollywood 38, California



GOSPEL FILMS' Ken Anderson runs a tape prior to setting focus for a closeup for "The Great Light." Sets were erected in rented garage which served as company's first studio.



TALKING over a shot for sequence filmed in Nuremberg, Germany, where company went on location, are Ken Anderson, writer; Ralph Papin, cameraman and actor Hans Hillerbrand. Here a Cine Special was used to film scene.

Case History of a Non-theatrical Film Production

How Gospel Films, Muskegon, Michigan's bustling two-man film producing company, turned out a 60-minute religious feature on a \$15,000 budget.

By CHARLES L. ANDERSON

GOSPEL FILMS is typical of so many of the energetic young film production enterprises which are springing up regularly throughout the country to supply a need for motion picture productions in specific non-theatrical fields. Ralph Papin and Ken Anderson, who head the company, and with considerable practical film making experience behind them, began as have so many of our successful young non-theatrical film producers — with very modest resources and equipment.

As production profits accumulated, they plowed them back into the business, purchasing new and better equipment. Recently Gospel Films acquired a Magna-sync sound recorder, a Micro daylight film developer for special photographic work, a Hollywood "Jr." printer, and Bardwell-McAlister and ColorTran lighting equipment. More recently the company has relinquished its original rented-garage "studio" and purchased more commodious quarters for its studio in Muskegon, Michigan.—*Editor.*

A SERIES OF 16mm religious films that combine entertainment and spiritual quality in their dramatic stories have earned Gospel Films of Muskegon, Michigan, a growing prestige in the religious motion picture field. What surprises those acquainted with the company only through its pictures is that, as far as production is concerned, it's a "two-man outfit." Ralph Papin serves as cameraman, editor, and direct-

or, while Ken Anderson is writer and producer.

Only the cast and occasional filming assistants are added to this crew for actual production. But following the standard business practice of most successful companies, Gospel Films has a small board of directors that meets to supervise general policies and make recommendations on stories. This board consists of local business men with a back-

ground of participation in church activities. They offer guidance which insures that the films will meet current needs of religious motion picture users. Papin and Anderson, therefore, may concentrate more thoroughly on the complex details of production. Business responsibilities are assumed by Jack Sonneveldt, president, and Charles Peterman, business manager.

The current Gospel Films release is "The Great Light," a 60-minute 16mm feature filmed in Germany and the United States. It tells of a young German war veteran who finds religion an answer to the unsettled times about him. Total budget for "The Great Light" was only \$15,000 — proof that feature-length pictures can be economically made for markets not as large, or demanding, as the theatrical one. This total includes a location trip to Germany for Papin, Anderson, and for Hans Hillerbrand, a German exchange student who plays the lead role.

Exteriors for "The Great Light" were filmed in Germany, while interiors were shot in a rented building in Muskegon. The little company was six weeks on the European location trip. Here scenes were filmed at an old castle, in the courtyard of a medieval school, and on the streets of Nuremberg. Interested people walking by during the shooting of street scenes gave the crew quite a bit of trouble. No sooner would the Cine Special camera be set up, then a crowd would gather to see what was being



REALISTIC castle interior constructed of wallboard panels finished with stucco paint, and expertly painted to create illusion of ancient German castle, interiors for which were shot on locale in Germany.

done. Just the camera itself attracted attention before Hillerbrand entered the scene. It was noticed that the Germans dress very conservatively, and as a method of getting their attention away from the camera and action for one shot, Papin wore a bright yellow sweater and a red cap. He locked the camera starting button in "on" position and ran from the doorway where the camera was stationed and pointed excitedly down the street to distract the onlookers. Hillerbrand, meantime, played the scene without interference by the distracting visitors.

The most important setting for action in the picture called for an old castle. The crew did quite a bit of scouting around until they found the most suitable one. They chose a castle on the out-

skirts of Nuremberg, one that wasn't so well-kept that it looked like a modern country home, as some did, or so much in ruin that it was hard to recognize. Papin and Anderson were disappointed to find that real castles didn't have the immense courtyards which Hollywood tradition attributes them, so the courtyard of a medieval school was substituted for exteriors for this sequence. Castle interiors were constructed later in Muskegon and filmed in what was then Gospel Films' studio—a rented garage. The company has since purchased an old dance hall, 40 by 50 feet in size, and converted it to a studio.

Because "The Great Light" deals unsympathetically with political extremists of all sorts, the crew visiting Germany made every effort to keep its work

unpublicized. Cameraman Ralph Papin took the leading villain role himself rather than possibly reveal the nature of the filming project by hiring a professional actor. In addition, the cost of another ship fare was thus saved, too, because the big chase with Hillerbrand and the villain was continued in Michigan, staged against the ersatz castle interiors. In Germany, most of the footage was filmed unobtrusively in the guise of amateur travel pictures to avoid declaring the exact nature of the work. By the time the company returned to the United States, Hans Hillerbrand's student visa had expired, and Gospel Films had to enlist the aid of the State Department to enable him to remain in the U.S. long enough to complete balance of the interior scenes.

Six weeks in Europe, two months constructing sets, and six weeks filming interiors were included in the production schedule, with some remaining time spent in post-recording, editing, and lab work. The entire production was shot "wild," and dialogue and effects were dubbed in later. Sync-sound would have complicated the German location work too much; also, the studio set-up for interiors was located near a noisy engine testing plant, making sync recording impractical. Therefore, dialogue was post-recorded on tape and the good takes were later transferred to film. Gospel Films has since purchased a Magnasync magnetic film recorder which will afford lip-sync recording on all picture productions.

The major interior sequence of "The Great Light" is a chase in which Hans Hillerbrand is pursued by the "heavy," portrayed by Ralph Papin. Clever rearrangement of a few castle set pieces simulated many castle rooms and pas-

(Continued on Page 363)



THREE PHOTOS above show ingenious set construction detail for German castle interiors. Basic facade above was given new look by addition . . .



. . . of door, and change of camera angle and lighting for still another sequence. "Stone" is wallboard panels cemented to flats and painted.



MASONRY detail also constructed in "garage" studio by Gospel Film's ingenious craftsmen, again using wallboard paste, paint and plaster.



FIG. 1—CinemaScope lens swings readily out of way to permit setting stop and focus of camera lens. Pictured is the first Arriflex Cinema-Scope camera adapted for Astra Pictures, Italy, used by cameraman Mario Gaveri in making helicopter shots for "Lost Continent" in Indonesia.

Arriflex Cameras Adapted For CinemaScope

Latest anamorphic lens adaption makes the portable Arriflex 35mm camera ideal for short subject and newsreel photography in CinemaScope

By ARTHUR ROWAN

THE TREMENDOUS SUCCESS of CinemaScope, which is evidenced by the steadily growing number of feature productions being made in this format by major studios, and the increasing number of theatres fitted or being fitted to show CinemaScope films (There will be 10,411 in the U.S. on August 1st, says the *Hollywood Reporter* in its June 17, 1954, issue.) has given impetus to still another phase of the motion picture industry—the production of short subjects in CinemaScope.

Short subject production very often is carried on by small producing units employing light, mobile equipment—especially so the cameras. One of the most

popular cameras for this work is the 35 mm. Arriflex, a popularity attained because of its many exclusive features.

Shortly after the introduction of CinemaScope by Twentieth Century-Fox studios, the Arnold & Richter Company in Germany, manufacturer of the Arriflex camera, was urged to adapt an anamorphic lens to this camera for CinemaScope work. Now CinemaScope and Arriflex have finally been "wedded" and two very successful methods of anamorphic lens adaptation have been worked out, both of which have proved highly successful in actual production work. In one adaptation, a new single-lens turret plate is substituted for the conventional 3-lens turret, permitting the CinemaScope lens to be mounted as an integral part of the camera. The other adaptation is suitable for use with standard Arriflex cameras having a 3-lens turret, enabling present owners of Arriflex 35mm. cameras to readily adapt them for CinemaScope filming.

Adapting the Arriflex for CinemaScope was not without its problems, and in order that the reader may under-

stand something of the problems involved, they will be explained briefly here.

The shutter of the Arriflex, as many readers know, is a glass disk which rotates at a 45° angle between the optical axis of the taking lens and the center of the film plane. Its front surface is mirrored and intermittently reflects the lens image through a separate optical system to a ground-glass lens in the camera finder, enabling the operator to view the scene exactly as it is recorded by the camera.

The film gate of this camera normally has the standard sound aperture. The lens sockets in the 3-lens turret are so designed that the optical axis of the taking lens is exactly in the center of the picture negative area. For CinemaScope photography, however, it becomes necessary to enlarge the film gate from standard "sound" aperture to the new standard CinemaScope aperture, which is 23.79mm by 18.67mm in size. This is accomplished by milling out the standard sound aperture as shown in Fig. 4

(Continued on Page 354)

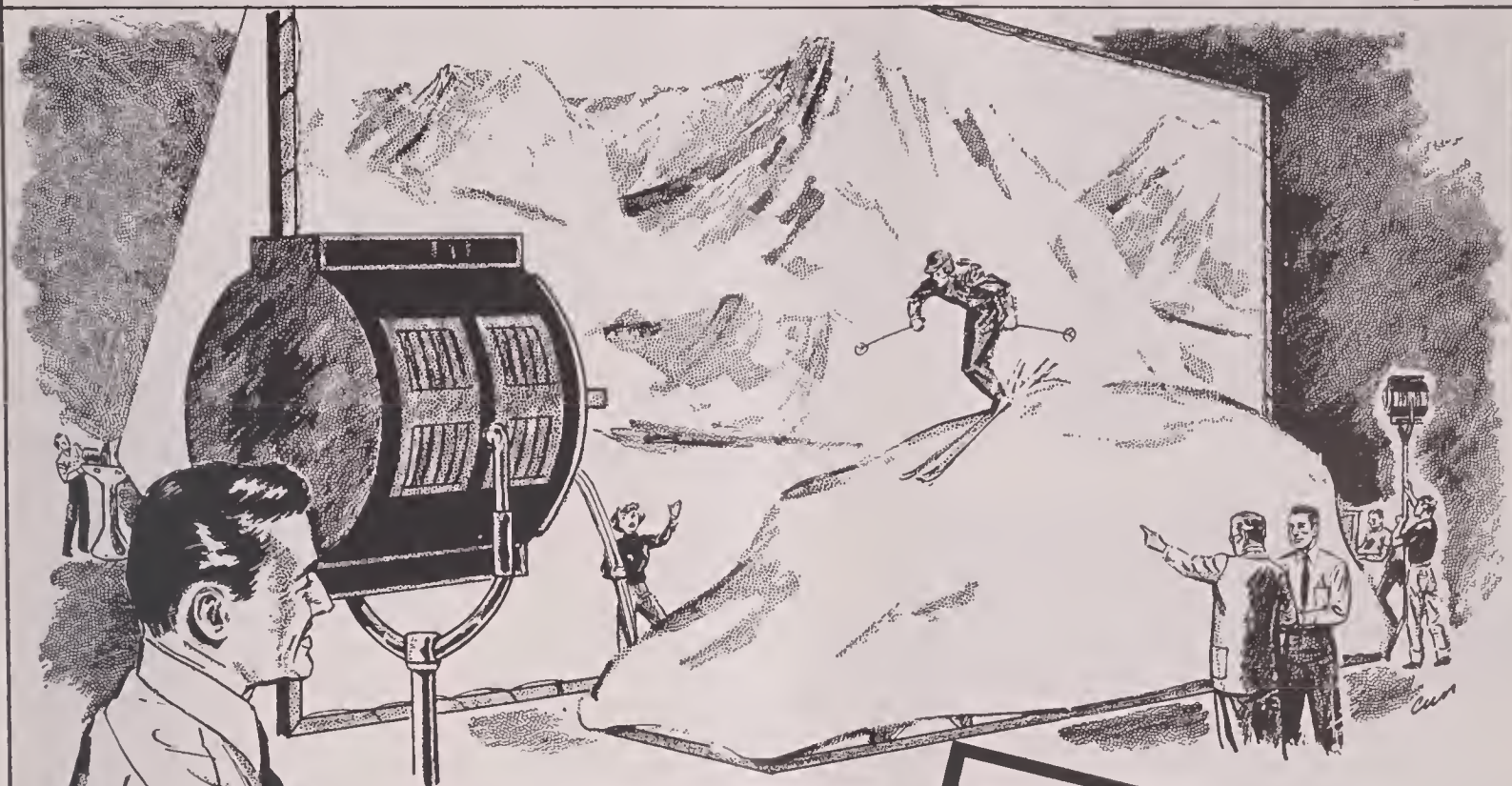

FIG. 2—In this adaptation, regular 3-lens turret is replaced by single-lens turret plate which also provides swing-mount for the CinemaScope lens. Note special finder on bracket.



FIG. 3—Adaptation of CinemaScope lens to present 3-lens Arriflex 35mm cameras. C-lens is mounted on special cradle which slides before camera lens on rails.

SEEING IS BELIEVING!



BEHIND THE SCENES...

THE BRILLIANCE AND TRUE COLOR OF "NATIONAL" ARCS IN REAR PROCESS PROJECTION ADJUST PERFECTLY TO FOREGROUND SET LIGHTING...PERMIT AUTHENTIC, FAR-RANGING PRODUCTION LOCALES WITH "STAY-AT-HOME" ECONOMY.

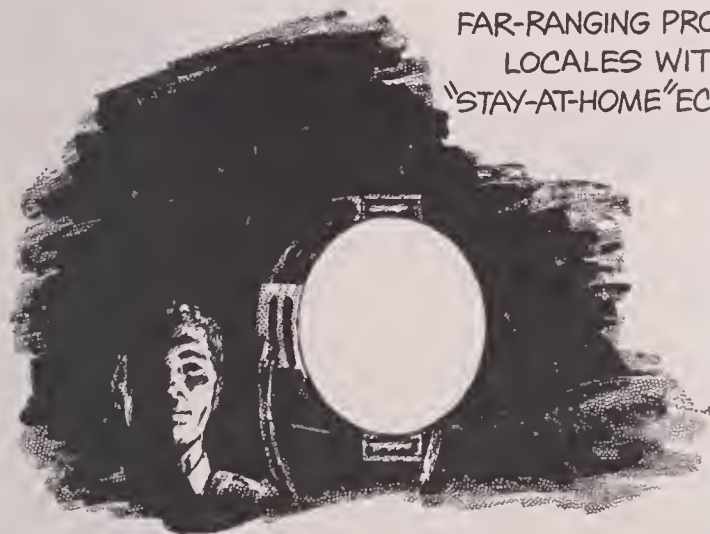

TODAY FOR PROCESS PROJECTION, BROAD SET COVERAGE, DEEP PENETRATION, CRISP SHADOWS AND HIGH BRILLIANCE WITH LEAST HEAT, IMPROVED "NATIONAL" CARBONS CONTINUE TO LEAD ALL OTHER TYPES OF STUDIO LIGHTING.

FIRST USED IN 1930, EARLY PROCESS PROJECTORS WERE STUDIO CREATIONS...TINY SCREENS, HEAVY "BLIMPS", IMPROVISED MACHINERY AND OPTICS. CURRENT TRIPLE-HEAD MODELS OPERATE WITH SCREENS OVER 20 FEET WIDE AND TOTAL LIGHT OF UP TO 85,000 LUMENS!

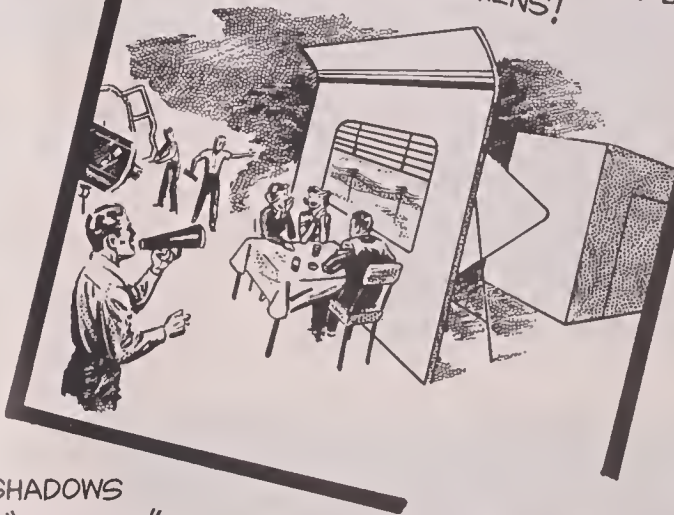

THE "NATIONAL" CARBON ARC... NOTHING BRIGHTER UNDER THE SUN

The term "National" is a registered trade-mark of Union Carbide and Carbon Corporation

NATIONAL CARBON COMPANY

A Division of Union Carbide and Carbon Corporation, 30 East 42nd Street, New York 17, New York

District Sales Offices: Atlanta, Chicago, Dallas, Kansas City, New York, Pittsburgh, San Francisco

IN CANADA: Union Carbide Canada Limited, Toronto





FILMING THE ICE SHOW

One of the most colorful and exciting subjects for cine cameras, it also presents hazards created by the ever-changing lighting and action of players.

By ELBERT J. WHITTINGTON
Washington Society of Cinematographers

NO OTHER SUBJECT, perhaps, poses such a challenge for the movie maker as ice shows. When the "Ice Capades," the "Ice Follies" or any of the other big time skating spectacles come to town, there is created among most cine cameraists the desire to get the show — the whole show — on color film. The challenge presented by the difficulty in obtaining desired pictorial results is hard to resist, and seems only to spur the cinebug onward to the task. The first problem faced by the amateur movie maker is that of adequate light; thus only those cine cameras with fast lenses will be capable of getting good pictures in the subdued light in which most ice show routines are performed.

One of the difficulties often encountered by cine filmers is the ban against use of cameras by some ice show managements. Fortunately, such bans are imposed with less frequency and today we find most of the shows eager to encourage amateur photographers and even cooperating with them to insure the best picture results.

Good ice show movies may be filmed with either an 8mm or 16mm camera, providing it has a good, fast lens. Ideal lenses for this work are the standard one-inch f/1.4 and two-inch f/1.6 for 16mm cameras, and 1/2-inch and one-inch lenses with similar apertures for 8mm cameras. This is not to say that f/1.9 or f/2.5 lenses will not get results; a great deal depends upon the volume of lighting used for the show.

More than one lens, of course, is a must if you are to get variety into your ice show record. In addition to a lens for general scenes, a telephoto lens is necessary in order to get the occasional closeups that should be intercut with your film to give it variety and increased interest. The longer focal length "speed" lenses, such as used on many 35mm still cameras, may also be used on cine cameras for closeups. One such lens, which gives excellent results, is the 85mm f/1.5 Leitz. This lens is rather bulky when used on a cine camera,
(Continued on Page 355)

FRAME ENLARGEMENTS from author's 16mm Kodachrome film of an ice show, which illustrates the quality of shots that can be obtained where an adequate lens is used plus good judgment of exposure. The latter is a vital factor because an exposure meter is almost useless in evaluating light conditions for ice show numbers.



Get more crispness in your movies ...
shoot on **ANSCO HYPAN FILM**

The added brightness and sharpness you'll get into your home movies by using Hypan will give you a new, exciting experience in black-and-white picture taking.

This modern, high-speed panchromatic film possesses an inherently brilliant gradation which lends to screen images the kind of sparkle and snap seldom seen in home movies. And Hypan's speed (exposure indexes of 40 for daylight, 32 for tungsten) allows you to shoot high-quality footage of just about any kind of subject you can name, in-

doors with floods or outside in sunlight.

You'll like the way Hypan film renders tone and texture, and you'll be pleasantly surprised to learn that it's low-priced, too. With Hypan you can shoot plenty of high-quality footage on even the most modest budget. Ansco Hypan Film is available at photo dealers everywhere in 8 and 16mm magazines and rolls.

ANSCO, Binghamton, N. Y. A Division of General Aniline & Film Corporation. *"From Research to Reality."*

For
superior
color movies
use
**ANSCO
COLOR FILM**

Ask for it in
8 and 16mm magazines
and 16mm rolls.

People Who Know Buy Ansco

Hot Splicer Conversion

Adding a heating unit to your film splicer will increase its efficiency and speed.

By HANK STOCKERT



FIG. 1—Converted Griswold Splicer



FIG. 2—Base plate removed, showing heater.

HOT SPLICERS have several advantages over the conventional type film splicer. Among these are increased splicing speed, initially stronger splices, and splices which last longer when subjected to repeated flexing in such machines as printers and projectors.

Many small desk-type splicers can be converted to hot splicers simply by adding a small heating unit beneath the base plate. The writer recently converted a Griswold 16mm film splicer to a hot splicer with excellent results. For the benefit of others who may wish to make a similar conversion the basic steps in the procedure are set down here.

The first step in the modification is the only operation requiring the use of machine tools. A good amateur machinist with a metal lathe, or a regular machine shop may do the job. Tolerances are not critical.

The basic Griswold splicer has a round hole underneath the pressure bar to allow film clips to fall out of the way. Since these clips should not contact the heating unit, this hole must be covered.

In so doing an additional feature is gained for the splicer. I used a disc of ground glass to cover the opening, and mounted a small light underneath. This light is of great assistance in checking the film base for complete emulsion removal and for active application of the film cement.

The next step is to mount the splicer base casting upon a base plate. Then center up the hole in casting, making sure that the inner surface of the casting runs true. Begin by cleaning off the edge of the hole already present, and widen it to a uniform $1\frac{7}{8}$ " diameter. If the base has been properly aligned when it is mounted, the hole will clear the two lugs cast upon the outer surface of the base. Remove sufficient metal from the inner face of the casting to give a smooth surface $1\frac{7}{8}$ " diameter. This will remove a slight amount of the small retaining wall. As indicated in figure 5, it will not prove a disadvantage. From this smooth surface remove metal to form a wall of $1\frac{3}{4}$ " inner diameter and $\frac{3}{32}$ " deep. This completes the turning of the base casting.

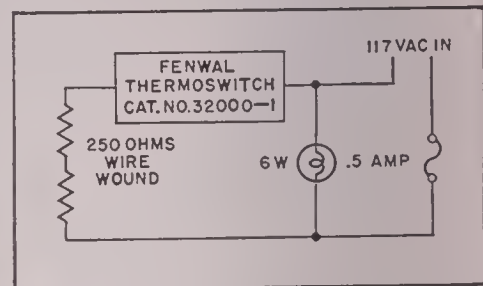
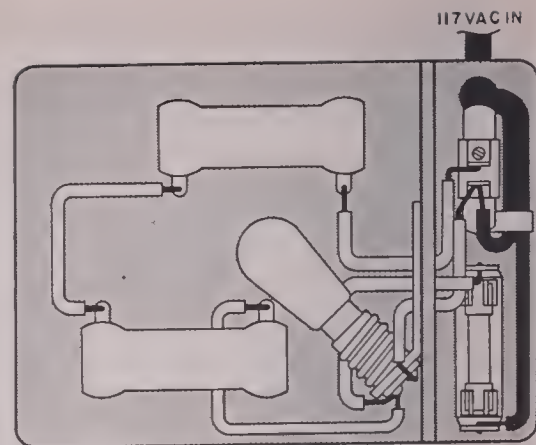

FIG. 3—Plan and wire diagram of base plate.

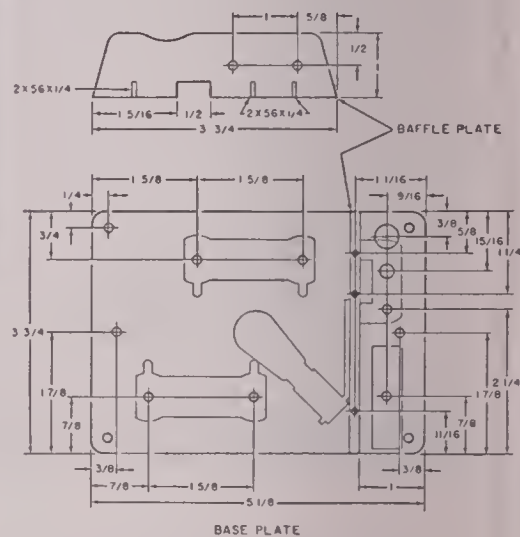

FIG. 4—Base plate dimensions

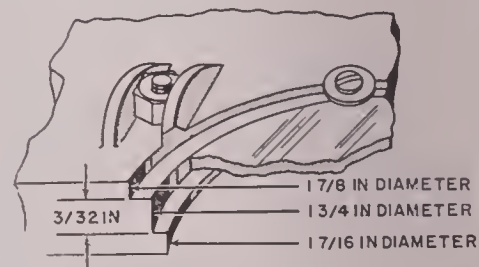

FIG. 5—Detail of glass port in base.

Your local glass shop can provide the single-weight ground glass disc $1\text{-}23/32$ " diameter for little cost. This disc should drop easily into the relief provided, almost flush with the surface, but not tightly in contact with the wall. For ease in cleaning, insert the glass disc with

(Continued on Page 350)

A DEPENDABLE NAME IN

CAMART

SALES • SERVICE • RENTALS

16
MM

35
MM

TV

MOTION PICTURE & TV EQUIPMENT

PRODUCTS

STUDIO OR LOCATION

CAMART TV CAMERA DOLLY

NEW IMPROVED MODEL II

Professional four wheel camera dolly for motion picture and TV cameras. Smooth geared mechanical principle raises and lowers boom quickly, quietly, and efficiently. Reinforced boom arm will support a professional camera with blimp and operator. Operator's seat mounted directly on the boom arm.

Easily handled by crew in studio or on location. Weighs less than 400 pounds, 28" width will clear standard door. Approved by leading film studios.

FOR PROFESSIONAL RESULTS

CAMART ELECTRIC FILM TIMER

For motion pictures, television, sound recording, post-narration, and film editing. Times rehearsals, and measures total film footage or times sequences in minutes and tenths. Synchronous motor operates silently on 110 volts, 60 cycles, finished in attractive grey crackle.

NEW LOW PRICES
Literature on request

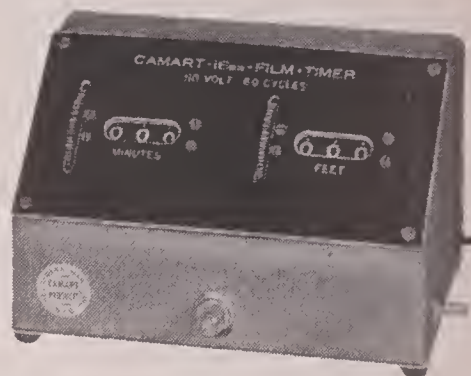

CAMART SLATE & CLAPSTICK

Used in motion picture production where speed is essential for synchronization of sound and picture. Measures 10x12 inches, slate finish with silk-screened letters. Solid construction.

Only \$11.75

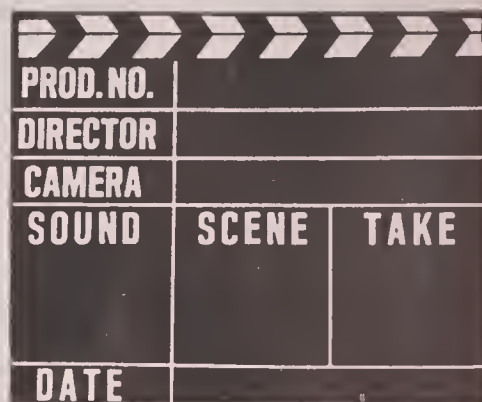

EXCITING NEW EFFECT! THE ROTATOR LENS



For 16mm - 35mm - TV Cameras

Now you can make your subjects walk on walls and ceilings, create that rocking-the-boat effect, or completely revolve a room 360 degrees in clockwise or counter-clockwise rotation with this new addition to the Camart Optical FX Unit.

- Present owners of the Camart FX unit need only the ROTATOR lens in special mount, price.....\$150.00
- Revolving housing assembly..... 75.00
- Base for most 16mm cameras..... 12.50
- Adapter for Mitchell 35mm camera..... 18.50
- Camart Optical FX unit motorized, additional..... 125.00

Adapters for TV Cameras, prices on request

ATTENTION!

ALL FILM STUDIOS, TELEVISION STATIONS,
UNIVERSITY FILM DEPARTMENTS, STATE
AND GOVERNMENT AGENCIES

Our 1954-55 SUPER Catalogue will be ready for distribution shortly after the Labor Day weekend. We're checking our mailing list now for additions and corrections. If your address has changed or if you have just gone into production within the last two years, please let us know. Be sure that you are included by clipping or copying the form below, fill it out and send it in without delay!

Name of organization

Address

City..... Zone..... State.....

Production Manager

Studio Manager

Purchasing Agent

Specific needs at present

THE CAMERA • MART INC.

MOTION PICTURE AND TV PRODUCTION EQUIPMENT

1845 BROADWAY at 60th St.
NEW YORK 23, N. Y.

Phone: Circle 6-0930
Cable Address CAMERAMART

what's new in

Cine Photography

Tips On Vacation Movie Making is title of latest "Tips" booklet published for amateur movie makers by Bell & Howell Company. There's plenty of interest for the seasoned movie maker, too, things you know but have probably forgotten about. At any rate, booklet is chock full of ideas on "what" and "how" to make vacation movies more professional and interesting. Copies are available for a dime at most camera stores, or direct from Bell & Howell Co., 7100 McCormick Rd., Chicago 45, Ill.

★

To tell the story of quality in photographic lenses, the Eastman Kodak Company has produced a 16mm Kodachrome motion picture titled "Quality In Photographic Lenses." The film won a Golden Reel Award in the first annual selection of 16mm films by the Film Council of America.

The film follows a lens through production, shows all the intricate steps a lens goes through until it is mounted in a camera.

The subject is ideal for showing on Cine Club programs. Club secretaries may get more information about availability of prints from Informational Films Division, Eastman Kodak Co., Rochester 1, N. Y.

★

A new list of Free Loan 16mm sound films, which make ideal program material for Cine Club meetings has been compiled by Princeton Film Center, Inc., Princeton, N. J. Program chairmen are invited to write for copies of list and inquire about use of films for movie club programs.

★

West Coast cine film users are now able to get stepped up service in the processing of Cine Kodak 8mm and 16mm films. Eastman's new processing lab at Palo Alto, California, was opened last month, just in time to care for the summer rush of color film shooting. Lab is Eastman's eighth in the U. S. and was built to take care of increasing business from northern California, Oregon, Washington, Idaho, and Nevada.

HOT SPLICER CONVERSION

(Continued from Page 348)

smooth side up. Allow a slight amount of space for any expansion that may be created by the heating unit. Next drill and tap the three holes for the 2 x 56 retaining screws, but before placing the screws, bend three 1/4" washers into a very shallow "V" shape. These washers will place a slight tension on the disc and permit expansion without shattering.

Cut the base plate, which will serve both as bottom cover plate and as a support for the various components of the heating unit, from 24 ST aluminum alloy 1/8" in thickness. Since the splicer base is an unfinished casting and therefore may vary from normal dimensions, it will pay first to cut a template from a piece of stiff cardboard to the dimensions shown in figure 4, and try it for size. The base plate should fit flush with the bottom of the casting, with the corner "feet" extending.

After cutting the base plate to size, level the edges with a file to mate with the slope of the inner walls of the splicer base. Finish the base plate by drilling all holes indicated in figure 4.

Next, cut and fit the baffle plate shown in figure 4. The concave cutout area is to match one of the small outer retaining walls in the bottom of the casting. Clamping baffle and base plate together, drill the three holes indicated. Cut the holes in the baffle, and countersink the holes in the new base plate. Assemble the two parts with three 2 x 56 x 1/8" flathead screws. When proper fit with the casting is obtained, mount thermostat (a Fenwal 32,000 miniature rectangular thermoswitch) upon the small angle brackets, using solder. Make sure that the flat, heat-sensitive surface of the thermostat is flush with the top of the baffle, so that it will rest in contact with the inner surface of the casting when assembled. For insulation, place a short length of electrician's rubber tape between the baffle plate and the miniature angle brackets.

The heating elements are two conventional wire-wound electronic resistors. They come complete with mounting brackets, and these should be bent to shape as shown in the sketch of the completed base plate. With 6 x 32 flathead screws, mount the resistors, pilotlight socket, fuse block and rubber legs as indicated. Soldering is simplified if all lugs on the resistors and other parts are in the positions shown. Place a rubber grommet in the 3/8" hole, and insert the lamp cord, securing it with a small cable clamp and a 6 x 32 nut and bolt, as illustrated.

The unit is now ready for wiring. For

this use heat-resistant wire. If no suitable wire is available, use a length of insulated wire commonly used in electric iron cords. But first remove the outer braid. Cut and bend all wires as shown in the wiring diagram, and scrape all ends to assure a good solder joint. Bend each end tightly around the indicated lug. When all wiring is in place and checked, solder the connections. Then add the fuse and pilot bulb. To assist the baffle in shielding the thermostat from direct heat, add two pieces of fiber glass insulation material, cut 1" x 1" x 4" in size. Insert one piece between the heating elements and baffle plate, and use the other to fill the thermostat compartment as shown in Fig. 2.

Two 6 x 32 x 1 3/8" flathead screws will hold the completed heating unit in place. Use a pair of nuts upon each screw to set the depth of the base plate. Now carefully insert the assembled unit into the splicer base, making sure no solder lugs or exposed wire touches any part of the base or base plate. Add a nut to each of the two retaining screws and the job is finished.

To enable more heat to reach the lugs which support the splice bar, it may be necessary to add the two small blocks of aluminum shown on top of the resistors in the drawing. For this drill a hole 3/8" of an inch in diameter through the center of an inch-long piece of 3/4" square aluminum, and saw into two parts. You may have to file the top surface to allow the base plate unit to fit into the splicer.

To adjust the thermostat to proper temperature, set it about one third of a turn clockwise from its stop. From this initial setting make slight adjustments at about half-hour intervals until the correct temperature is established. This

(Continued on Page 352)

We Invite Your Contributions

Readers who would like to write articles or papers on subjects relating to cinematography or of interest to motion picture cameramen, or on subjects relating to TV Film Production, Industrial Film Making, Film Laboratory Technique, Special Effects, Amateur Movie Making, etc., are invited to submit such articles to the Editor for consideration.

For all published material we will pay our regular space rates following publication.

AMERICAN CINEMATOGRAPHER

1782 No. Orange Dr., Hollywood 28, Calif.



Magnaphonic
SOUND SYSTEM

There's a reason...

why Magnasync enjoys
continued worldwide leadership...

QUALITY...ECONOMY...INTEGRITY

Air S
Univers
Nava
Rad
Protes
Fotovox, Inc. Photographic Technicians Pr
W T S P—Florida Southern Pacific Railroad
Tele-Filmica Maxol, S.A., Havana Southern
Ford Foundation Twentieth Century-Fox, Inc.
University of Wisconsin Gospel Films, In
National Film Board of Canada Cine Associat
R.K.O. Radio Pictures, Inc. Pacific Picture
Gilfillan Bros., Inc. U.S. Air Forces Westingho
Iowa Conservation Commission Providenc
Fairchild Recording Equipment Co. Galbrea
Magnolia Petroleum Co. Kearney & Trecker Cor
W K A Q, San Juan, Puerto Rico State Colle
Naval Air Station Beeland-King Film Productions
Columbia Pictures Providence Bible Institu
Television Recording Service, Inc. Iowa Farm Bur
Westinghouse Electric Corp. Sound Recorders, I
Vignie Productions, Inc., Havana U.S. Navy Nort
Paramount Pictures Corp. Baptist Gospel Film
U.S. Department of Agriculture University of Iow
International Productions Goodyear Aircraft Corp
Avalon Pictures, Inc. Reverend D. Kirk Hammond
Southwest Film Laboratory, Inc. Academy Soun
Naval Ordnance Wurtele Film Productions Acade
Bible Institute of Los Angeles University of Tennessee
University of Mississippi Rampart Productions Sc
Protestant Radio Center, Inc., U.S. Recording Co.
South Dakota State College Aspen Pictures Dallas Jo
Twentieth Century-Fox, Inc. Filmscope
U.S. Air Forces Magnolia Petroleum Co.
Southwest Film Laboratory, Inc. Gilfillan Br
Cine Associates
Kearney & Trecker
University of Iowa
Arcturus Manufacturing
Goodyear Aircraft Corp.
Fairchild Recording Equipment Co.

Select



MODEL SW-602
PORTABLE RECORDING SYSTEM



DISTRIBUTORS

CAMERA EQUIPMENT COMPANY
1600 Broadway, New York 19, N.Y.
Judson 6-1420—Cable: "CINEQUIP"

MAGNETIC RECORDERS COMPANY
7120 Melrose Ave., Los Angeles 46, Calif.
WEBster 3-5545

ZENITH CINEMA SERVICE, INC.
3252 Foster Ave., Chicago 25, Illinois
IRving 8-2104

AMERICA'S LEADING MANUFACTURER OF MAGNETIC FILM RECORDING AND REPRODUCING DEVICES



PORTABLE
FILM RECORDERS



MICROPHONE MIXERS



THEATRE
SOUND
EQUIPMENT



3-CHANNEL
REPRODUCERS



MULTI-CHANNEL
INTERLOCKED DUBBERS



STUDIO DUBBERS
and RECORDERS



QUALITY AMPLIFIERS for
MAGNETIC RECORDING and REPRODUCTION



F&B

NEW & USED EQUIPMENT

FOR MOTION PICTURE & TV FILM PRODUCTION

F&B

MATTON

**REMOVES HOTSPOTS . . .
SUBDUES HIGHLIGHTS . . .
REDUCES REFLECTION
AND GLARE . . .**

Just spray instont MATTON an all chrame, plated, shiny, metollic, glassy ar gloss surfaces.

- Easy to apply with spray applicator con.
- Instont MATTON coating hardens instontly.
- Can be handled without fear of mess ar of removing hard MATTON coating.

DON'T USE MESSY, INEFFECTIVE SOAPS OR WAXES . . .

DO USE MATTON

Large Spray Can \$2.25 ea.
NOW . . . ORDER 6 for \$12.00

*** F&B MOVIE STOPWATCH ***

Precision Swiss movement
Colibroted to read seconds,
minutes, 16mm & 35mm footage
Starts—Staps—Resets

List Price \$29.50 — Now \$14.75

BARGAINS IN USED EQUIPMENT

- CINE SPECIAL 1, 15mm f2.7, 1" fl.9, 3" f4.5 cose, excellent condition.....\$ 375.00
- FILMO 70 H, beautiful, custom-built PAR accessories incl. 4 lens turret, built-in rockover, focusing thru lens, mognifying focuser, 110v. sync motor, 400 ft. mogozine, Veeder counter, deluxe compartment cose, oll like brand new. Cost over \$2500. SPECIAL, only 950.00
- MAURER model D optical film recorder, "G-prime" golvo, rock-mounted, perfect cond., con be converted for direct positive recording...2750.00
- KINEVOX sync 17 1/2 mm mogn tope recorder 825.00
- MAGNECORD sync 1/4" mogn tope recarder 625.00
- MACVAN 16mm continuous printer, complete 475.00
- DEVRY BANTAM 16mm sound proj., etc. 140.00
- TRIANGLES, extendable, aluminum used 17.50
- COLORTRAN deluxe converters, used... 32.50
- SCREENS, toble model, beoded, 18"x24" 4.50
- F&B MOVIE STOPWATCHES, min., sec., 16 ond 35 mm Ft. 14.75
- FLANGES, oluminum, 10" rd. ond sq. shaft 7.95
- GATOR GRIPS with barndoors 12.95
- DOLLY, 3 wheel Ceco model, seat, case, LN 250.00
- SUPER XX, 16mm neg. 200 ft. sl, outdoted, each 3.45
- BOLEX H-16, built-in counter, 15mm f2.8, 25mm fl.9, leather case..... 225.00

**NEW F&B GATOR
CLIPLITE**

WITH BARN DOOR

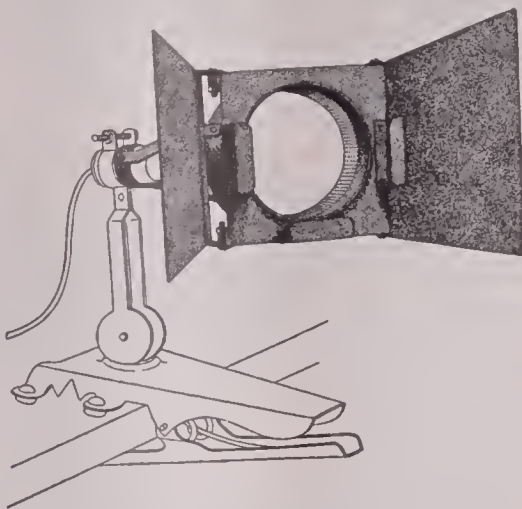

Unit includes — Gator Grip, Porcelain socket. 15 ft. cord & switch Barndoor.

PRICE
\$12.95

**NEW F&B LEG-LOK
TRIANGLE**

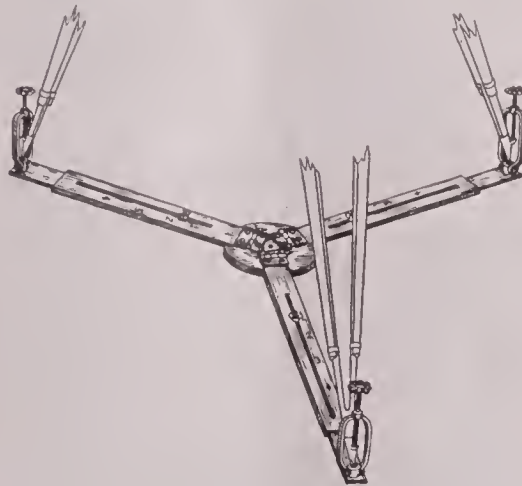

With Leg-Lok Clamps and reinforcing center casting.

PRICE
\$26.95

WANTED: AURICONS — MITCHELLS — MOVIOLAS — LAB EQUIPMENT — LENSES — RECORDERS — PROJECTORS — ACCESSORIES

F&B

FLORMAN & BABB

70 West 45th Street, New York 19, N. Y.

Phone: Murray Hill 2-2928

Cable Address — FLORBABB, N. Y.

splice bar when fully heated should be about 105°F., a temperature which feels slightly warm to the touch.

Following is a list of parts that will be required in making this conversion.

- 1 Fenwal 32000 rectangular miniature thermoswitch control unit.
 - 2 250 ohm, 25 watt, wire wound resistors with mounting brackets.
 - 1 6 watt, 15v candclabra bulb, frosted (Note: this is the same bulb as used in Bell & Howell sound projector pilot lights.)
 - 1 Buss type 4405 fuse block.
 - 1 Buss type MDL 1/2 Amp Fusetron Fuse.
 - 1 115v candelabra socket, long screw slot mounting type.
 - 2 ft. high-temperature hookup wire. (See text for substitute.)
 - 8 ft. lamp cord, complete with male plug.
- Total cost for these parts in radio supply stores is estimated at about \$7.80. You may have to order the Fenwal switch from a Fenwal branch office.

CREATIVE CUTTING

(Continued from Page 336)

A natural pause in the action is usually a good place to cut, picking up the movement at the same spot in the following scene. It is especially important to match the action closely when a long shot and closeup of continuous movement are both shot from the same angle. In a case such as this, if there is more than a slight discrepancy in the action patterns of the two scenes, a *jump-cut* will result.

If, on the other hand, the shift from long shot to closeup involves a considerable change of angle, you can jump the action ahead several feet without the gap being noticed. Where an awkward gap is unavoidable, lessen the impact by a *cut-in*, a *cut-away shot*, an *optical transition*, or in the case of a silent film, a *sub-title*.

A *cut-in* or *insert*, is a closeup of a segment of the main action. It is one of the best and most natural devices to use in bridging a gap between two scenes because it focuses audience attention closely upon the action of the story.

The *cut-away* is a shot which, as the term implies, literally cuts away from the main action to another segment of the same situation. For example, in a film showing a football game, *cut-aways* would include shots of the crowd, the score board, the band, cheer leaders, etc. Lapses in time can also be covered by effective *cut-aways*.

Optical transitions include *dissolves*, *wipes*, *jades*, etc., which, in professional

F&B**NEW & USED EQUIPMENT**

FOR MOTION PICTURE & TV FILM PRODUCTION

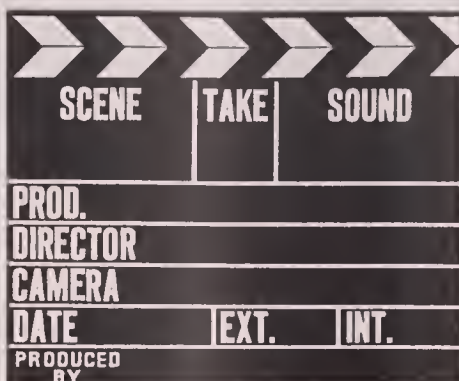
F&B**CAMERA SLATE** with Clapsticks

- * Easily erasable slate finish
 - * Sharp-sounding hardwood clapsticks
 - * Permanent silk-screened letters
 - * Supply of special, dustless chalk
 - * Large 11"x14" size
- Price \$8.75**

STOP REWINDING!

USE

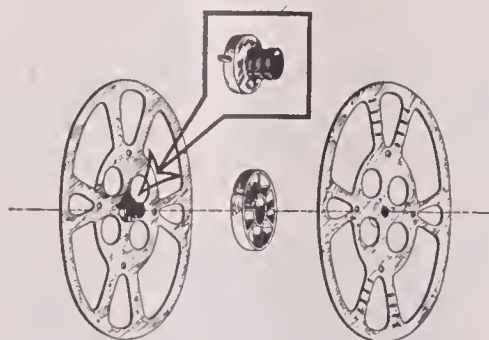
F & B Split Reels

SAVE wear and tear on 16mm prints, time, space, storage.

NOW you can project, edit, inspect, synchronize, clean, measure and store all your films on cores.

No More Rewinding Problems

Now, simply slip film on core into SPLIT REEL. Close reel. Use another SPLIT REEL for take-up . . . unscrew reel to remove film.

BUY SEVERAL NOW!

400 ft. split reels — 16mm.....	\$4.50
800 ft. split reel — 16mm.....	\$6.00
1200 ft. split reel — 16mm.....	\$7.50
1600 ft. split reel — 16mm.....	\$9.00

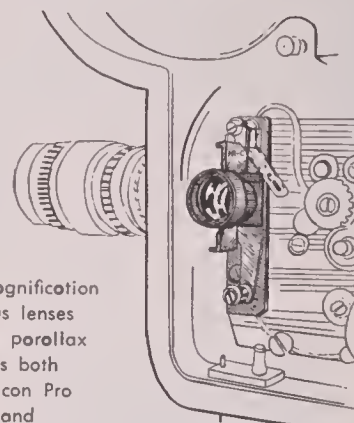
AURICON ACCESSORIES**HI-C CRITICAL FOCUSER**

- 6 X magnification
- Focus lenses
- Check parallax
- Fits both Auricon Pro and Cinevoice

PRICE \$49.50**INCREASE THE VALUE OF YOUR CINEVOICE CAMERA**

Shoot Complete
15 Minute
Programs

600 FOOT
MAGAZINE
CONVERSION
FOR 16mm
AURICON
CINEVOICE
CAMERA

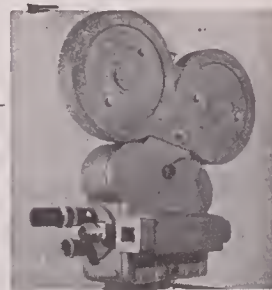

NOW Shoot full 15 minute TV shows without stopping or reloading. The F&B conversion includes 600 ft. magazine, extra silent take-up motor, camera insert plate for stabilization of film movement, and footage counter. Camera is **not cut down**; can be used without magazine for 100 ft. rolls. Magazine accepts 200 ft. spools as well as 400 ft. and 600 ft. rolls on cores.

WRITE FOR COMPLETE DETAILS

F&B HAS A COMPLETE STOCK OF NEW AND USED CAMERAS, PRODUCTION, LIGHTING, EDITING & LABORATORY EQUIPMENT

EVERY ITEM CARRIES ABSOLUTE MONEY-BACK GUARANTEE

NOTE: IMMEDIATE CASH AVAILABLE FOR ALL KINDS OF USED 16-35MM PRODUCTION, LAB. EDITING, LIGHTING EQUIPMENT

F&B**FLORMAN & BABB**

70 West 45th Street, New York 19, N. Y.

Phone: Murray Hill 2-2928

Cable Address — FLORBABB, N. Y.

the audience sit up and take notice at the right times?

Dramatic punch is achieved by placing the emphasis of the situation at the proper point in the sequence. While this is primarily a problem of direction, it is even more definitely a matter of deft cutting. All of the tricks of the editor's trade must sometimes be brought into play to insure a definite result.

Generally speaking, the closer we get to a subject, the more emphatic the impression of that subject becomes. For this reason, *image size* has a good deal to do with *dramatic punch*. The closeup is the most emphatic of all angles because it brings the audience face to face with the subject. Use closeups where *punch* is needed in the film narrative. Don't waste them on unimportant details or you will have nothing forceful left to use when you want to make an important statement.

Build up to your climactic scenes by making sure that the scenes which go before lead directly to that climax. It is sometimes effective to begin a sequence with slowly-paced cutting, gradually quickening the tempo and cutting in closer and closer shots until the action develops in the climactic scene. Hit your audience with the important idea; hold the shot just long enough for it to register; then go on to the next sequence.

Avoid forcing *dramatic punch* into your film by means of chopped up *montages* or the kind of radical cutting which highbrows like to call "impressionism." Such vague symbolism may be all right in experimental films made for the chosen few, but it has proved to be merely confusing to the mass audience.

Boiling the whole problem down to its basic essentials, let us say that the real secret of cutting for dramatic punch is to include in a particular scene only as much of the action as can best be portrayed by that particular angle. If you planned your shots carefully before shooting, you will be sure to have enough shots made at different angles to cover your subject in the most emphatic manner.

While good editing cannot in itself *make* a picture, poor editing can very definitely *unmake* it. The surest mark of the rank amateur (next to poor photography and direction) is sloppy, undramatic cutting. On the other hand—deft, forceful cutting can sometimes breathe into prosaic footage a vitality which was not apparent in the rough cut.

Take your time making the final cut. Make sure that you know your footage and the effect you want to place on the screen. Although you are cutting for three separate elements — continuity,

tempo and punch—you cannot arbitrarily separate them, because each is very closely related to the other.

Remember that you are not working with separate, unrelated strips of film; you are working with scenes that should fit together like the stones of a mosaic to produce a dramatic overall pattern. In this process, *association of ideas* plays a vital part. Be on the alert to tie your scenes together by means of the elements they have in common.

In making your final cut, screen your footage again and again, each time concentrating on one of the three important cutting factors. Remember that the smoothest jobs of cutting are the result of gradually whittling down the footage, not haphazard slashing. **END.**

ARRIFLEX CAMERAS

(Continued from Page 344)

on this page. In this operation, it will be noted, the center of the negative no longer intersects with the lens axis—the difference being 0.48mm.

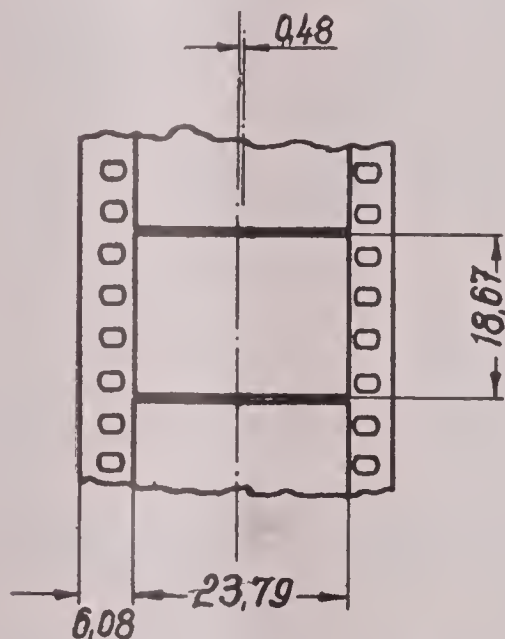

FIG. 4—In adapting the 35mm Arriflex for CinemaScope photography, it is necessary to enlarge film gate aperture as shown here.

To solve this problem, the new single-lens turret plate previously mentioned was engineered. This centers the lens accurately over the enlarged negative area. This new turret plate also incorporates a sturdy cylindrical bracket which holds the CinemaScope lens, and at the same time permits it to be swung out of the way (as shown in Fig. 1) in order to adjust the regular camera lens, with which the CinemaScope is used. This feature may be seen extending out from the camera and adjacent to the CinemaScope lens and matt box in Fig. 2, on page 344.

It is not feasible to modify other optical components of the camera and as a result, the picture area seen in the finder appears slightly smaller than that recorded on the film. The slight difference between the margins of the negative and finder picture areas amounts to 1.08mm on top and bottom, and 0.6mm on both sides. Practical use of the equipment has shown that this difference induces no problem for the cameraman in framing or composing his pictures; he very soon learns to get the "feel" of it.

For those who need to see the picture exactly as it is recorded by the CinemaScope lens, a special finder is available. This may also be seen in Fig. 2, mounted on the square rail extending out from left side of the camera.

The adaptation described above is not offered for conversion of existing cameras. It can be obtained only when ordering a new camera.

The alternative adaptation, which will be of interest to those who already own Arriflex 35mm cameras, is pictured in Fig. 3, and is the result of a request received very early in the CinemaScope planning from the German Fox Movietone Newsreel organization. In this adaptation, the film aperture plate is enlarged as in the adaptation described above; but otherwise, no other changes are made in the camera. The CinemaScope lens is held in place before the camera lens by means of a specially designed adapter cradle, which is bolted securely to the tripod socket of the Arriflex camera. The combined unit then is readily mounted on the Arri tripod head. In this adaptation, access to the camera lens for setting and focusing is obtained by sliding the CinemaScope lens forward on the twin rails. Focusing of the CinemaScope lens, of course, is accomplished by moving the lever bar, which may be seen extending upward from the lens in both Figs. 2 and 3.

Besides being a much less expensive installation, this method offers the advantage of using the conventional Arriflex with its three-lens turret for normal filming by simply removing the CinemaScope attachment.

Both the adaptation for standard 35mm Arriflex cameras and the special CinemaScope integrated job are available from Kling Photo Corporation, New York City—sole U.S. distributors of Arriflex cameras and Arri products.

Most of the 16mm color films produced during the past 10 years will be suitable for color television, thanks to a new electronic masking amplifier unit developed by the Allen B. DuMont Laboratories. New device was described in a paper read before recent convention of Institute of Radio Engineers in N. Y.



TEWE MOTIVEFINDER

— like a "right arm" for the creative MP and TV Director

TEWE MOTIVEFINDER is a wizard that solves scores of set problems. This Director's Zoom-type Finder reveals the most suitable focal length, the proper camera position, the effects of dolly shots, etc. It is invaluable to a creative Director who likes to plan optical tricks and special effects. Combination Finder zooms from 25mm to 135mm for 35mm Motion Picture and zooms from 28mm to 150mm for TV. Complete with leather carrying case and neck band. **Only \$75**

Other Versatile Viewfinders — each a honey for the money!



ZOOM DIRECTOR'S FINDER for 16mm and 35mm. . . . 16mm zooms from 13mm to 75mm. 35mm zooms from 25mm to 6". **\$15.50**



WATSON Director's type finder, pocket size, with mattes from 30mm to 100mm for 35mm cameras. Also for 16mm cameras. **\$35**



ZOOM Finder for Auricon Cine Voice . . . zooms from 15mm to 12". **\$60**
Available for Filmo and Eyemo. **\$39.50**



ZOOM Finder for Cine Kodak Special . . . zooms from 15mm to 150mm, with parallax adjustment. **\$75**
Template supplied for mounting Finder on magazine. Additional brackets for magazines available at \$7.50 per set.

FRANK C. ZUCKER
CAMERA EQUIPMENT CO.
1600 BROADWAY NEW YORK CITY

FILMING ICE SHOWS

(Continued from Page 346)

and when used on a turret, may often preclude use of other lenses.

One way to get around this is to bring along two cameras — one may be borrowed from a brother cinebug, or rented from your local camera store — and mount a long focal length lens on one and the short focal length lens or lenses on the other. In addition to providing two cameras for a wider range of coverage, it also insures against running out of film at a critical moment. One camera can be loaded while the other is being used, provided of course, two people are filming the show as a team.

When a three- or four-power lens is used, the subject matter should be at the far end of the arena or stage, unless it is possible to change the focusing distance of the lens frequently. This is somewhat impractical, and often difficult to do without inducing a chopping-up of the scene as well as making errors in focusing. Here a penlight flashlight is a necessity in checking lens settings in the subdued lighting of the theatre or auditorium.

The location which the cameraman

C. ROSS

FOR

LIGHTING EQUIPMENT

Inkie and Arc Lamps including Required Accessories
Generators—Cables—Boards—Boxes

Raby Camera Crane—Dollies—Blimps—Geared Heads

GRIP EQUIPMENT

FOR LOCATION AND STUDIO

Parallels—Steps—Platform Ladders
Century Stands—Reflectors—Flags—Scrims

SOLE EASTERN MOLE-RICHARDSON CO. DISTRIBUTOR

RENTALS • SALES • SERVICE

CHARLES ROSS, Inc.

333 WEST 52nd STREET

NEW YORK 19, N.Y.

Circle 6-5470-1

PETERSON Automatic Fade

An Attachment For Your
Bell & Howell Model J.
Printer

FOR DEPENDABLE
FADES & DISSOLVES
IN COLOR & BLACK & WHITE

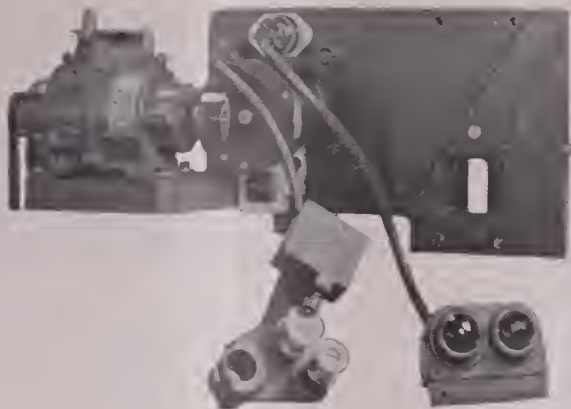

Some advantages of installing a Peterson Automatic Fade Attachment:

1. Fade lengths from 20 to 180 frames, or any intermediate number of frames.
2. Pilot light for indicating open or closed position.
3. Furnished with micro-switch breaker box mounted on bracket. Additional film rollers for proper film path.
4. Removable filter pack holder mounted in unit.
5. Can be furnished for use with magnetic "cueing" on special order.
6. Simple installation, easily done in your laboratory.

PLEASE WRITE FOR OUR LITERATURE

MOTION PICTURE PRINTING EQUIPMENT CO.

Mfrs. of Motion Picture and Micro Film Printers

8136 NORTH LAWNDALE AVENUE • SKOKIE, ILLINOIS

EVERYTHING PHOTOGRAPHIC

AND CINEMATIC

FOR PROFESSIONAL AND AMATEUR

The World's Largest Variety of Cameras and Projectors. Studio and Laboratory Equipment with Latest Improvements as used in the Hollywood Studios. New and Used . . . BARGAINS. Established 25 years.

HOLLYWOOD CAMERA EXCHANGE

1600 Cahuenga Boulevard

HO 9-3651 • Hollywood, Calif. • Coble Hocomex



BACK ISSUES

30^c

While Supply Lasts
(Foreign, 40c)

Complete your files of American Cinematographer with issues you have missed or lost. Valuable technical data in every issue for future reference for both amateur and professional cinematographers.

AMERICAN CINEMATOGRAPHER

1782 No. Orange Dr., Hollywood 28, Calif.

chooses for his shooting is very important. In a theatre where the seating completely surrounds the ice rink, the first choice should be high up on one side, in the center of the top row of seats. In this location, the cameraman usually can stand as he uses his camera, thus eliminating the bobbing of spectator's heads in front of his camera. There may be occasions when another spectator may rise and obstruct the lens, but the alert cameraman will stop his camera at this point and start a new take after the obstruction passes. Any frames or footage showing a bobbing head or the momentary obstruction of view by a moving spectator should be deleted in the editing.

Second choice for a camera setup is at one end of the theatre or auditorium, and the third choice right down in front, on the ice. The flashing of lights from the spots which are used to light the show invariably rule out the possibility of shooting from a front row position; the light reflections from the ice are not only hard on the cameraman's eyes but on any audience who sees your film. I have seen many films of ice shows shot from such locations that were almost a total loss, as far as interest was concerned. This does not mean that there are no good front row positions from which satisfactory photography can be done. Here again the conditions that prevail in a particular ice rink, auditorium or theatre may differ and camera position will be a matter of discretion on the part of the filmer.

Choice of location also will depend upon the filmer's lens equipment; where he is using a one-inch or one-power lens exclusively on his 16mm camera, then insofar as depth of field of his lens is concerned, the location makes no difference. But it should be remembered that the back row at the far end of an auditorium will not enable such a lens to give much in the way of magnification. Here, use of a two-inch lens would give better results, even though the depth of field would be rather shallow to cover the entire floor.

For the top, back-row position mentioned earlier as first choice, a one- or two-inch lens should give good results; both have good depth of field at the largest stop.

The use of a hyperfocal distance setting is a necessity, particularly when the two-inch lens is used. The one-inch lens may be set on the 50-foot mark, or if the lens has a depth of field scale it can be set at 25 or 50 feet on the near side and at infinity on the far side. When the two-inch lens is used, the setting should be at 75 feet hyperfocal, which would be at 50 feet near side and 100 feet far side. This is my practice when using a two-inch Eastman f/1.6 lens.

Where adaptors are used in fitting a

lens to a cine camera, one must be certain that the adaptors are of the correct size. It is an easy matter to check adaptors where the camera affords through-the-lens focusing, as does the Bolex. This is done by making visual checks through the lens of objects at various distances, say, 50, 75, and 100 feet from the camera. The need for such checking I learned the hard way, when I once wasted a 400 foot roll of film on a show because my lens was not properly adjusted.

Choosing the right f/ stop for filming an ice show is very important both for black-and-white and color films. While the exposure settings for color film exposed at 16 fps will be discussed here, the lens stops to be used with black-and-white film can readily be determined by comparing the ASA tungsten rating of the B&W film with that for Type A Kodachrome shown below.

Obviously theatres and auditoriums in which ice shows are staged will vary considerably in the number of lights available for the shows, and there is the additional factor of distances of lights to the ice surface or point of the show, which invariably change from auditorium to auditorium and thus alter the intensity of the light falling on the performers.

When I have filmed local ice shows, I invariably found a stop of f/1.4 to

NOW HIGH-SPEED PROCESSING

The **HILLS** Filmatic High temperature 16mm film processor

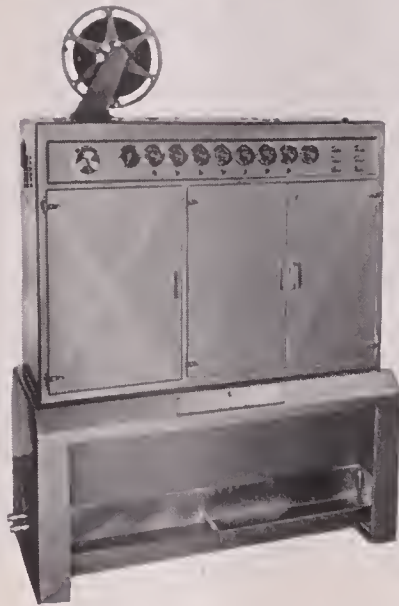

The Filmatic Model 16 HT is a completely automatic high-speed, high temperature processing machine. The thermostatically controlled operating temperatures up to 125°F. is designed to process 16mm sound or silent film at the rate of 115 feet per minute. No permanent installation necessary.

- Reversal, negative or positive at speeds up to 115 ft. per minute
- First scenes are processed, dried and rewinding in 2½ minutes.
- Full load of 1200 ft. completely processed in approximately 13 minutes
- Compact unit, 72" high, 51" long, and 24" wide.
- Built-in replenishing system
- Daylight operation
- Economical processing
- Sprcket film drive
- Automatic temperature controls
- No permanent installation
- Nothing else to buy

By utilizing the latest fast-processing emulsions (DuPont 930-931 types) the Filmatic Model 16 HT will continuously deliver exceptionally high-quality processing at maximum speeds. For illustrated folder and additional information write to William Halpern, Sales Representative, 8240 Fayette St., Phila. 19, Pa.



MANUFACTURING CO., LANSDALE, PA.



Jack Frost lights the nation!

MOTION PICTURE STUDIO • THEATRICAL • DISPLAY RENTAL EQUIPMENT

WHEREVER YOU ARE—WHATEVER YOU NEED

... in the way of unusual, specialized lighting, call on Jack Frost! For movie-making, stage lighting, feature exhibits, large conventions ... for *any* location that requires exceptional lighting, Jack Frost is ready to serve you! And Jack Frost's unequalled national service includes complete installation and removal *wherever* you are. Rent all your specialized lighting equipment from Jack Frost ... famous for lighting the nation's greatest shows ... most spectacular displays.

FOR FULL INFORMATION ON RENTAL EQUIPMENT MAIL COUPON, OR CALL DETROIT, TRINITY 3-8030

JACK A. FROST, DEPT. J,
234 PIQUETTE AVE.
DETROIT 2, MICHIGAN

Please send me full information on your rental service.

Name _____
Address _____
City _____ Zone _____ State _____



Synchronous Motor Drive for 16mm Projectors

Especially designed to drive all Bell & Howell and Ampro 16mm projectors at synchronous speed.

The synchronous motor drive can be instantly attached to projector and taken off at any time. No special technical knowledge required for installation and mounting.

The synchronous motor drive is complete with base-plate, Cannon plug for cable and power switch, and a set of reduction gears.

Write for more details and prices

NOTE: When ordering please give correct firm and model of projector.

ONE YEAR GUARANTEE!

Immediate Delivery

Available at leading dealers, or direct.

KADISCH

CAMERA AND SOUND ENGINEERING CO.
500 West 52nd St., New York 19, N.Y.
Plaza 7-3511

DESIGNERS AND MANUFACTURERS OF
MOTION PICTURE—TV EQUIPMENT

f/1.9 gave good results with Type A Kodachrome. Sometimes it was possible to shoot at f/2.5, but there was always the danger of underexposure.

Still other factors that govern photographic results are the color of the lights and the color of the costumes used. If spotlights are used predominantly instead of floodlights, there will be greater light intensity, and the filmer must consider this in setting his exposures.

The tables given below are based on the use of white light for auditorium illumination and dark costumes of average color density. Thus, white is intended to be white. The "light" category includes colors such as light blue, grey, tan, pink, bright red, etc. In the "dark" column we consider black, oxford or charcoal grey, deep blue, dark brown, etc. The figures in each column indicate the f/stops for use with Type A Kodachrome at 16 fps.:

Lighting	Average Costumes		
	White	Light	Dark
White spots	2.5	1.9	1.5
Lt. colored spots	1.9	1.5	—
Dk. colored spots	1.5	—	—
White flood	1.9	1.5	—
Colored flood	1.5	—	—

Some, of course, may wish to shoot ice show scenes at 24 fps instead of sixteen. Obviously, this will place further limitation on the exposure latitude for color film and could result in some underexposure. The exposures for shooting Type A Kodachrome at 24 fps are indicated in the table below, and can be compared with the figures in the preceding table:

Lighting	Average Costumes		
	White	Light	Dark
White spots	2	1.6	1.3
Lt. colored spots	1.6	1.3	—
Dk. colored spots	1.3	—	—
White flood lights	1.6	1.3	—
Colored flood lights	1.3	—	—

The above figures are based on the average lighting of a theatre or auditorium stage which is considered well-lighted, although not necessarily adequately lighted. There have been instances where film has been exposed in one ice show location at f/2.5 with good results, yet to get comparable results filming the same scenes of the show in another auditorium would require an exposure of f/1.9.

Actually, the successful filming of an ice show will depend a great deal on the photographer's ability to judge the quality and volume of the light, and to expose accordingly. Some theatres as well as some shows will be better lighted than others. Even where an ice show returns to the same theatre each year with a new show, there is every chance that the lighting will be different. So the amateur filming an ice show for the first time can do one of two things: he can get first hand exposure information from more experienced cine cameraists, or he can start off slowly, filming a little carefully, and not try to get the whole show the first time.

One of the best scenes in an ice show that I ever photographed, and in 8mm color, too, was of a stilts skater wearing a red and white "Johnny Walker" cos-



Reversal PROCESSING

Reversal specialists for over a decade. Our long experience insures superior quality. Electronically controlled machines keep temperature constant within .2 of one degree. National "Brilliantone" Cine prints are the finest available. Write for free catalogue.

CONTACT PRINTING B & W DUPLICATING
WORK PRINTS KODACHROME DUPLICATING
EDGE NUMBERING VACUUMATING

All work veporeted at no extra charge

NATIONAL CINE LAB

Box 4425 Washington 17, D. C.

"The Finest Cameras
Deserve the Finest Care"



AUTHORIZED

Service To All Fine Cameras
ROMLE-WAHL & CO.
520 W. 7th ST.
LOS ANGELES 14, CAL.

Scheibe FILTERS

EST. 1916
In World-Wide Use

Produce moonlight and night effects in daytime - fog scenes - diffused focus and many other effects.

Information mailed on request.

SCHEIBE FILTERS COMPANY
ORIGINATORS OF EFFECT FILTERS

P.O. Box 46B34, Hollywood 46, Calif.



"Look, fellows—the movie I photographed in 1910 starring John Bunny. Doesn't that make me the first TV film cameraman?"

Film Editing Made Easy
with NEW

professional film viewer

for 35mm and 16mm

Every film editor will appreciate a viewer that enables him to view his film from left to right—on a large, brilliantly illuminated screen.

The PROFESSIONAL FILM VIEWER makes film editing a breeze. Easy threading, portable, will not scratch film. Put this viewer between your rewinders and speed up your editing. Size of Viewing Screen 5¾ x 4¾.



35mm Model \$375
16mm Model \$350



Write Dept. A-7-4

tume. Very early I learned what colors in ice show lighting and costumes photograph best. Blue and dark brown are very misleading and quite difficult to photograph with any success. Black is not too difficult if properly backgrounded with a lighter color and illuminated by spots or concentrated beams of light.

The filmer with a questionable lens or shooting under questionable light conditions would do well to skip the dark-costumed scenes and those not fully illuminated, and concentrate on filming only the brightly-lit show numbers. Usually there are enough numbers of this kind to provide footage for a subject of interesting length. He will leave the really tough scenes go until he has gained more experience in filming the subject.

The use of a meter to determine proper exposure for filming ice shows is just about out of the question. This is because the lighting changes frequently and varies between a wide range of levels. Obviously this poses a serious exposure problem. But if the exposure tables above are used as a point to start from, the ice show filmer will be on safe ground. It should be emphasized here again, that these exposures are only tentative. Because light conditions prevailing in the Ice Capades show in Los An-

FOR YOUR TV COMMERCIALS TITLES and SPECIAL EFFECTS

35mm-16mm Black & White or Color

RAY MERCER & COMPANY

4241 Normal Ave., Hollywood 29, California

NOrmandy 3-9331

30 Years Experience
at Your Service . . .



We Welcome
Your Problems

Precision Built Combination MAGNETIC FILM AND TAPE SOUND READER

Features: Simple threading . . . polished stabilizer drum with needle bearings . . . combination film rollers for 16mm, 17.5mm, 35mm and ¼-inch tape, machined to conform with SMPTE standards, and equipped with oilless bearings . . . precision ground shafts . . . Magnetic head mount with adjustments for track locations, azimuth, and magnetic film and tape thickness . . . dimensions 6" x 6" x 7½".

Amplifier: 117-volt—60-cycle—AC . . . power output—4 watts . . . heavy duty Alnico V speaker . . . safety fused . . . pilot light . . . 6-ft heavy duty line cord

Net Price \$198.00 F.O.B., Factory, N. Y.

PRECISION LABORATORIES
1139 Utica Ave., Brooklyn 3, N. Y.

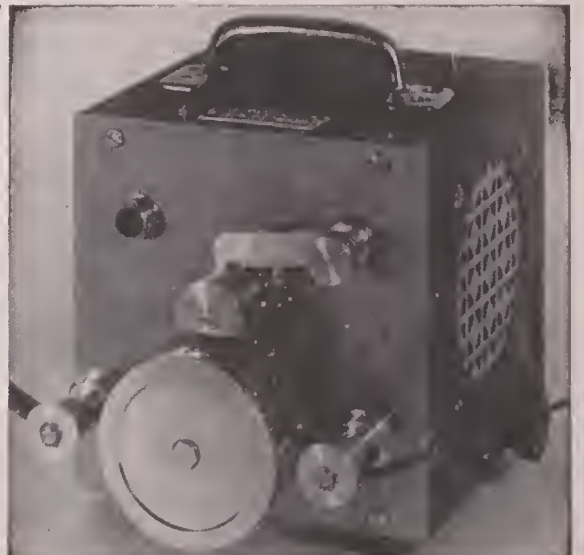

Simple Addition of
Sound Printing Head
 Increases Output Over 30%

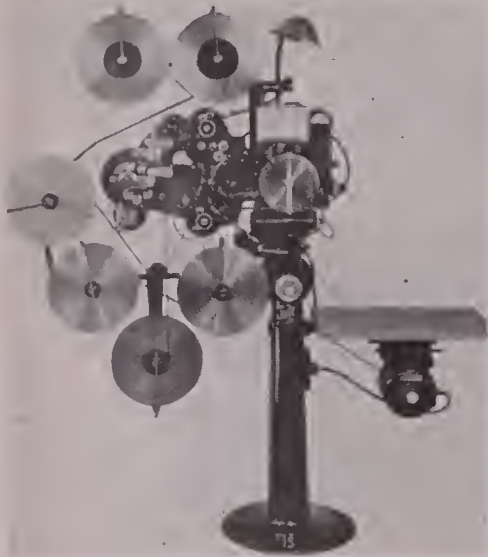

35mm-16mm Sound Printing Head, designed for your model "D" or "J" contact printer. Convert your single-head printer now into a double-head printer for high production output.

Literature On Request

MOTION PICTURE PRINTING EQUIPMENT CO.
 Mfrs. of Motion Picture and Micro Film Printers
 6136 NORTH LAWNDALE AVENUE • SKOKIE, ILLINOIS

RUBY CAMERA EXCHANGE

Rents . . . Sells . . . Exchanges

Everything You Need for the

Production & Projection

of Motion Pictures Provided
 by a Veteran Organization
 of Specialists

35 mm. . . . 16 mm.
 Television

IN BUSINESS SINCE 1910

729 Seventh Ave., New York 19, N. Y.
 Tel.: Circle 5-5640
 Cable address: RUBYCAM

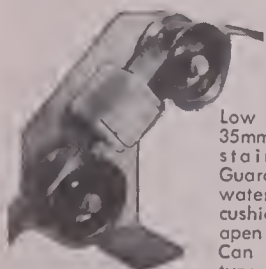

AIR SQUEEGEE

Low pressure. For 16 and 35mm. Nylon case. Hollow stainless steel rollers. Guaranteed to remove all water spots. Film rides on cushion of air. Rollers open to let splices through. Can be operated with tank type vacuum cleaner used as blower. Satisfaction guaranteed.

Send 25c for our new illustrated catalog of processing machines and parts.

METAL MASTERS

5599 University Ave. San Diego 15, Calif.

geles probably differ widely say, from those which prevail when the show is put on in Chicago, it would be misleading to say that a given exposure figure would be valid for scenes filmed in both locations.

As may be seen from the above tables, there will be times when the photographer will find it impractical to film certain acts of a show, unless, of course he can afford to gamble a little film on experimental exposures.

Because pre-planning will pay off in a much better film, the same as when

filming other subjects, it is advisable that the cine filmer attend the show more than once—first, without his camera, at which time he will analyze the show for its lighting and spot his camera setups or positions; the second time to actually film the show, based on plans made on the first visit. Where possible, he should make arrangements in advance with the management for certain privileges that will enable him to shoot from the most desirable seat or vantage point, or to move about with his camera at will.

SHOOTING IN CINEMASCOPE AND WIDE-SCREEN

(Continued from Page 339)

on the opposite side of the street. Key lights were mounted on the camera car that moved along the street and followed the singing Keel.

Some indication of the production scope of "Seven Brides for Seven Brothers" may be seen in two vastly differing sets used in the picture. One took up the entire 23,000 square feet of M-G-M's Stage 29. Dressing rooms, makeup tables and mirrors, and all spare equipment normally fringing the sets on a sound stage, had to be parked outdoors. In the corridor between the stages special "big top" tents were erected to house the makeup and wardrobe facilities, and trailers were parked nearby to provide accommodations for the cast.

This huge set, erected for the "Barn Raising" sequence of the picture—actually a combination of old-fashioned hoe-down, barn raising, and a spectacular free-for-all brawl—called for nearly a quarter of a million watts in lighting, more than used on any previous M-G-M film. Twelve overhead batteries of sky lights, each holding in its aluminum reflector ten 1,000-watt photolamps, were augmented by 85 K-10 lamps of 10,000 watts each plus 47 K-5's.

The tremendous heat generated by this great volume of light units kept the studio air-conditioning plant working overtime in an effort to keep the stage temperature at a workable level. Even so, readings of 98 degrees F were common, but not popular, center stage.

Such an array of overhead lighting equipment naturally posed a communications problem for gaffer Fenton Hamilton and his assistants and the electrical crew working on the catwalks overhead. This was met easily by Hamilton who employed a relatively new innovation of the sound stage—a compact miniature two-way radio system.

The transmitter, virtually a miniature radio station, consisted of a microphone,

transmitter and batteries—the unit weighing around six ounces. Resembling a hearing aid case, it is worn around the neck. Speaking through the microphone, gaffer Hamilton's instructions were broadcast and picked up by a series of thirty-five 4-inch speakers spaced at intervals around the catwalks. The little broadcasting set has a carrying range of 600 to 800 feet—ample for use within the largest sound stage. The system was used earlier during the filming of "The Student Prince" and "Brigadoon," shooting on adjacent sound stages. The transmitters on each production were set to operate at different frequencies to prevent one interfering with the other.

So sensitive are these tiny transmitters that the user need only speak in a whisper. An uninitiated extra unaware of this, stopped me one day with the observation: "The gaffer has blown his top. Been talking to himself for the past hour!"

In shooting the big "Barn raising" sequence, our only problem camerawise arose from the spectacular dance routines created by choreographer Michael Kidd—dances that were basically violent ballet. In a nutshell our problem involved keeping the dancers within camera range both vertically and horizontally. Much of this was accomplished by shooting from a very high angle or from ground level—especially when we had to capture the high leaps and acrobatics of some of the dancers.

The big dance number ran for twelve minutes and was climaxed by the "big brawl." Because any retakes would have been long and costly and especially because they would have necessitated the complete rebuilding of the barn (which was demolished in the brawl), we used four cameras simultaneously in shooting the long and medium shots—two CinemaScope and two wide-screen. Another consideration, I understand, was the

ngallen
CORPORATION
MAKERS OF
SYNCHRONOUS
Magnetic
FILM
RECORDERS

Newest Addition

TO THE *Hallen* LINE OF MAGNETIC *Film* RECORDERS

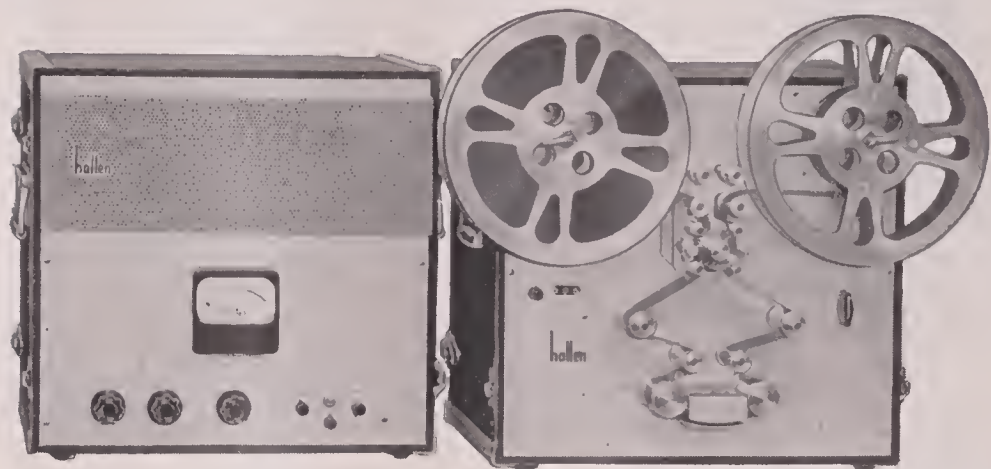

The recorder shown is 35mm using two flywheels, designed to facilitate conversion to multiple track, stereophonic, cinemascope etc.

The two case portable Model 235 magnetic film recording system is also available in both 35mm and 16mm single drum system. Literature available.

3503 WEST OLIVE AVENUE • BURBANK, CALIFORNIA
CABLE ADDRESS "HALLEN" • PHONE THORNWALL 8-6976

possibility of injury to members of the cast, especially because all the principals were performing their own stunts.

By contrast, Stage 25—where we filmed the mood number "Lament"—called for many controlled gradations of light. The setting was a snow-covered meadow on a dreary winter day—the number beginning in a gray overcast and gradually achieving full sunlight. Director Stanley Donen, in a last minute decision, decided that we should film the entire number without a cut. This we did. The operation involved 17 camera moves, 80 feet of dolly track, and use of the studio's large RO boom.

It worked beautifully, gave an uninterrupted "flow" to the number, nervous prostration to the operators, and called for a series of backstage signals rivalling anything ever dreamed up by Knute Rockne. Large shutters, resembling giant venetian blinds, were hung from the catwalks in front of the set lighting units. Operated on cue, these provided a simple yet effective method of varying the light. On the screen this is a simple scene, apparently effortless, yet all six principals involved moved constantly to and fro over the entire set.

Shooting with two cameras — one CinemaScope and one wide-screen—

(Continued on Page 363)

Model 35-16C

S E N S I T E S T E R

★ IMMEDIATE DELIVERY
to the lab owners interested in—

**QUALITY
EFFICIENCY
ECONOMY**

- DUAL MACHINE
1—Sensitometer
2—Scene Tester
- HIGHLY ACCURATE
Electronic timer unaffected
by climatic changes.
- NEW TYPE LONG-LIFE
Cold Light Exposure Unit
- WITHOUT ADDITIONAL
EXPENSE will match any
printer

Combination 35mm-16mm

ART REEVES MOTION PICTURE EQUIP.

7512 Santa Monica Blvd.

Hollywood 46

California

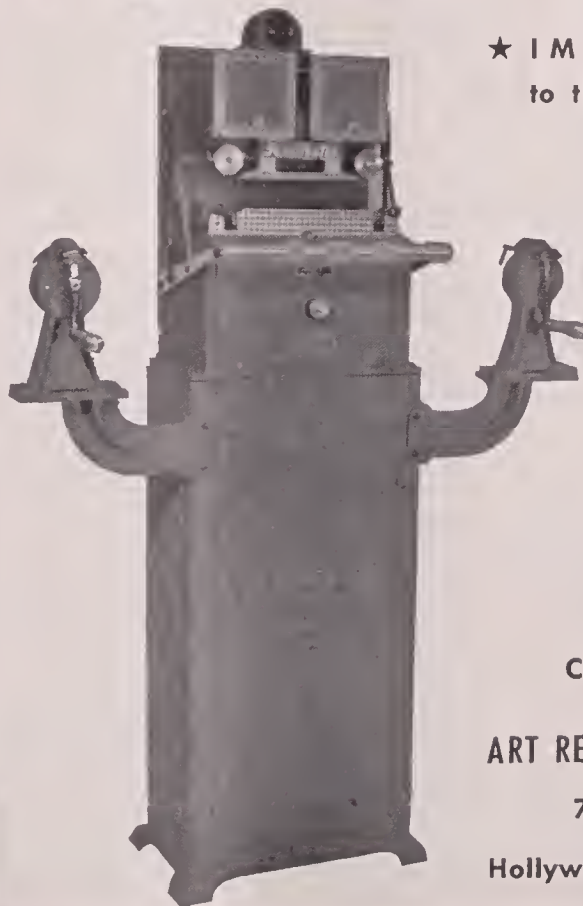

HOLLYWOOD STUDIO PRODUCTION

Feature and television film productions for which members of the American Society of Cinematographers were engaged as Directors of Photography during the past month.

AMERICAN SOCIETY OF CINEMATOGRAPHERS

FOUNDED January 8, 1919, The American Society of Cinematographers is composed of the leading directors of photography in the Hollywood motion picture studios. Its membership also includes non-resident cinematographers and cinematographers in foreign lands. Membership is by invitation only.

BOARD OF GOVERNORS—1954

ARTHUR MILLER, President
 SOL HALPRIN, First Vice-President
 JOSEPH RUTTENBERG, Second Vice-President
 ALFRED GILKS, Third Vice-President
 WALTER STRENCE, Treasurer
 PHILIP TANNURA, Secretary
 ROBERT DE GRASSE, Sergeant-At-Arms
 JOHN ARNOLD
 JOSEPH BIROC
 ARTHUR EDESON
 GEORGE FOLSEY
 LEE GARMES
 VICTOR MILNER
 HAL MOHR
 LEON SHAMROY

ALTERNATE BOARD MEMBERS

ARTHUR ARLING
 LUCIEN BALLARD
 DAN CLARK
 PAUL EAGLER
 FARCIOT EDOUARD
 ERNEST LASZLO
 ROBERT PITTACK
 JOHN SEITZ
 JAMES VAN TREES
 PAUL VOGEL

ALLIED ARTISTS

● ELLIS CARTER, "The Police Story," with Gary Merrill and Jan Sterling. Joe Neuman, director.

COLUMBIA

● LESTER WHITE, "Wyoming Outlaws," with Phil Carey and Gene Evans. Fred F. Sears, director.

METRO-GOLDWYN-MAYER

● JOHN SEITZ, "Many Rivers To Cross," (Eastman Color; CinemaScope) with Robert Taylor and Eleanor Parker. Roy Rowland, director.

● ARTHUR E. ARLING, "The Glass Slipper," (Eastman color; wide-screen) with Leslie Caron and Michael Wilding. Charles Walters, director.

● GEORGE FOLSEY, "Deep In My Heart," (Color; CinemaScope) with Jose Ferrer, Donna Reed and Merle Oberon. Stanley Donen, director.

● PAUL VOGEL, "Jupiter's Darling," (Eastman color; CinemaScope) with Esther Williams and Howard Keel, George Sidney, director.

PARAMOUNT

● LIONEL LINDON, "Love Is A Weapon." (Technicolor; VistaVision) with John Payne and Mary Murphy.

● LOYAL GRIGGS, "We're No Angels," (Technicolor; VistaVision) with Humphrey Bogart and Joan Bennett.

● ROBERT BURKS, "To Catch A Thief," Technicolor; VistaVision; shooting in France) with Cary Grant and Grace Kelly. Alfred Hitchcock, director.

● DANIEL FAPP, "Run for Cover," (Technicolor; VistaVision) with James Cagney and Viveca Lindfors. Nicholas Ray, director.

REPUBLIC

● JOHN L. RUSSELL, JR., "The Atomic Kid," with Mickey Rooney and Elaine Davis. Leslie Martinson, director.

R.K.O.

● JOSEPH LA SHELLE, "The Conqueror" (Color; CinemaScope) with John Wayne and Susan Hayward. Dick Powell, director.

● WILLIAM SNYDER, "The Americano" (Technicolor) with Glenn Ford and Ursula Thiess. William Castle, director.

20TH CENTURY-FOX

● LEON SHAMROY, "There's No Business Like Show Business," (Color CinemaScope) with Ethel Merman and Donald O'Connor. Walter Lang, director.

● CHARLES G. CLARKE, "Black Widow," (Color; CinemaScope) with Ginger Rogers and Van Heflin. Nunally Johnson.

● MILTON KRASNER, "Desiree," (Color; CinemaScope) with Marlon Brando and Jean Simmons. Henry Koster, director.

UNIVERSAL-INTERNATIONAL

● WILLIAM DANIELS, "Five Bridges To Cross," with Tony Curtis and Julia Adams. Joseph Pevney, director.

● CLIFFORD STINE, "Smoke Signal" (Technicolor; wide-screen) with Dana Andrews and Piper Laurie. Jerry Hopper, director.

● IRVING GLASSBERG, "Captain Lightfoot," (shooting in Ireland), with Barbara Rush and Jeff Morrow. Douglas Sirk, director.

● HAROLD LIPSTEIN, "Chief Crazy Horse," (Technicolor; CinemaScope) with Victor Mature and Suzan Ball. George Sherman, director.

● R. L. METTY, "Man Without A Star," (Technicolor; wide-screen) with Kirk Douglas and Jeanne Crain. King Vidor, director.

WARNER BROS.

● LEE GARMES and RUSSELL HARLAN, "Land of the Pharaohs," (WarnerColor), CinemaScope; shooting in Egypt) with Jack Hawkins and Dewey Martin. Howard Hawks, director.

● HARRY STRADLING, "Helen of Troy," (WarnerColor, CinemaScope; shooting in Italy) with Rossana Podesta and Jacques Sernas. Robert Wise, director.

● TED McCORD, "East of Eden," (WarnerColor; CinemaScope) with Julie Harris and Raymond Massey. Elia Kazan, director.

● WILLIAM SKALL, "The Silver Chalice," (WarnerColor; CinemaScope) with Virginia Mayo and Jack Palance. Victor Saville, director.

● J. PEVERELL MARLEY, "Drum Beat," (WarnerColor; CinemaScope) with Alan Ladd and Audrey Dalton. Delmer Daves, director.

● SID HICKOX, "Drum Beat," second unit.

● WILFRED CLINE, "Tall Man Riding," (WarnerColor) with Randolph Scott and Paul Richards. Lesley Selander, director.

INDEPENDENT

● CARL GUTHRIE, "Long John Silver," (Joseph Kaufman Prod.—Technicolor; wide-screen—shooting in Australia) with Robert Newton and Connie Gilchrist. Byron Haskin, director.

● BURNETT GUFFEY, "Private Hell 36" with Ida Lupino and Steve Cochran. Don Siegel, director.

● RAY JUNE, "Day of Triumph," (Eastman color, wide screen) with Lee J. Cobb and Joanne Dru. Irving Pichel and John T. Coyle, director.

● GILBERT WARRENTON, "The Black Pirates," (AnSCO color; wide-screen) with Anthony Dexter and Lon Chaney. Allen Miner, director.

● HAROLD WELLMAN, "The Long Chance," with Paul Langton and Barbara Peyton. Edgar Ulmer, director.

TELEVISION

(The following directors of photography were active last month in photographing films on television in Hollywood, or were on contract to direct the photography of television films for the producers named.)

● LUCIEN ANDRIOT, "Public Defender," series of half-hour films for CBS, starring Reed Hadley for Hal Roach Jr. Prods. (Philip Morris) and "Meet the O'Briens," series of half-hour films, Roland Reed Prods. at Hal Roach Studios.

● JOSEPH BIROC, "T-Men In Action" series half-hour dramas starring John Stephens for Prockter Tele Ents. (ABC)

● NORBERT BRODINE, "Letter To Loretta" series of half-hour dramas—D.P.I., starring Loretta Young. (Procter & Gamble), RKO-Pathe studio, "In Between" series of half-hour dramas for Lewislor Enterprises and "Life of Riley" series half hour films, Roland Reed Prods., at Hal Roach Studios.

● GEORGE DISKANT, "Four Star Playhouse" series of half-hour dramas, featuring various stars, for Four Star Productions, RKO-Pathe Studio. (Singer Sewing Machines.)

● E. B. DUPAR, "Fresh From Paris," for Mercury International.

● KARL FREUND, "I Love Lucy" series of half-hour comedies starring Lucille Ball and Desi Arnaz, for Desilu Productions; (Philip Morris).

● ALFRED L. GILKS, "Halls of Ivy," series of half-hour dramas starring Ronald Colman and Benita Hume for Hall Prods., Inc., at Motion Picture Center.

● BENJAMIN KLINE, "Fireside Theatre" series of half-hour dramas for Frank Wisbar Prods., Inc., at American National Studios (Procter & Gamble).

● WILLIAM MELLOR, "Adventures of Ozzie and Harriet" series of half-hour comedy dramas starring Ozzie Nelson and Harriet Hilliard for Stage Five Prods., Inc., General Service Studios. (ABC).

• VIRGIL MILLER, "You Bet Your Life," weekly half-hour audience participation shows, featuring Groucho Marx, for Filmcraft Prods., NBC Studios. (DeSoto-Plymouth).

• HAL MOHR, "The Joan Davis Show" series of half-hour comedy-dramas starring Joan Davis for Joan Davis Enterprises, General Service Studios. (NBC).

• NICK MUSURACA, "The Lone Wolf," starring Louis Hayward, series of half-hour dramas (UTP) for Gross-Krasne, Inc., at California Studios.

• KENNETH PEACH, "Adventures Of The Falcon" series of half-hour dramas starring Charles McGraw at Federal Telefilm, Inc. (NBC)

• ROBERT PITTAKE, "Private Secretary" series of half-hour comedy dramas starring Ann Sothern and Don Porter, (Lucky Strike) and "The Lone Ranger" series of half-hour dramas starring Clayton Moore and Jay Silverheels for CM-TV Prods. Inc., (General Mills).

• JOHN L. RUSSELL, JR., "Joe Palooka," series of half-hour comedy-dramas starring Joe Kirkwood and Cathy Downs for Guild films.

• WILLIAM SICKNER, "The Whistler," with Paul Kelly and Ann Doran. (Pilot) Lindsley Parsons Prods.

• MACK STENGLER, "Life With Elizabeth" series of half-hour dramas; "The Liberace Show," half-hour musical film series; "Florian Zabach Show," series of half-hour musical films and "The Frankie Laine" show, series of half-hour musicals starring Frankie Lane for Guild Films.

• HAROLD STINE, "Cavalcade of America" series of half-hour dramas and "This Is Your Music" for Jack Denove Prods., Inc., Samuel Goldwyn Studios (DuPont).

• WALTER STRENCE, "Waterfront" series of half-hour dramas starring Preston Foster and Lois Moran (UTP) at Hal Roach Studios.

• PHIL TANNURA, "The Burns and Allen Show" series of half-hour comedies starring George Burns and Gracie Allen, for McCadden Corp., General Service Studios. (Carnation Milk and Goodrich and "The Jack Benny Show," starring Jack Benny. Al Simon Prods.

• STUART THOMPSON, "Lassie," series half-hour dramas (color) for Maxwell Prods. (Campbell Soups).

CINEMASCOPE AND WIDE-SCREEN

(Continued from Page 361)

simultaneously on the same set involved little or no additional problems, except when shooting closeups, and then we would shoot with one camera, move out, and move in with the other for a duplicate shot. Setting up two cameras side-by-side takes a few additional minutes time, but the overall benefits are well worth the effort. Where it was physically impossible to muscle in with the second camera, the "Old Pros," as the CinemaScope crew dubbed themselves, would get their shot then back out quickly with the cheerful call for the wide-screen boys, "Time for Beany!"

This happy spirit of competition and cameraderie that prevailed at all times

during production of "Seven Brides for Seven Brothers" is to me convincing proof of the theory that the easiest and most efficient method of working on a sound stage is to harness the collective intelligence of everyone on the stage, blend it, and channel it into one stream. That is the kind of teamwork we had on this picture, with everybody—grips, electricians, props, and others—all apparently inspired by the rollicking spirit of the story.

CASE HISTORY OF A FILM PRODUCTION

(Continued from Page 343)

sageways. Stone construction was imitated by use of squares of wallboard and other materials. Walls, columns, and an archway were first put together from large sheets of wallboard. Next, squares of corrugated cardboard and scrap wallboard were cut to shape and glued to the flats to represent stone construction. Above this was fastened a layer of newspapers soaked in wheat paste. In experimenting, Papin found that gray Bondex (a water-soluble powdered paint) mixed in a thick paste with some lampblack gave a realistic stone gray finish to the castle pieces.

A suit of armor, seen but not worn, was constructed from wire screen, papier maché, and metallic paint. Low-key sidelighting in the photography disguises its plebian origin. Castle set pieces were shifted and interchanged about between takes to reproduce a variety of settings. For instance, the same archway was seen once with a door, again as a small wall recess with another wall flat behind it, and later with a stairway leading through it. Changes in lighting patterns and camera angles helped disguise the repetitious use of set components.

Papin shoots his black and white pictures (which include "The Great Light") on Eastman 16mm Plus-X blue-base reversal film. The original is cut to A-B rolls, from which a dupe release negative is made, incorporating fades and dissolves. A commercial lab handles this work, although Papin does develop short lengths of film himself when special effects are involved. For effects work, he has a Micro daylight film developer and a Hollywood Jr. printer. Lighting equipment includes B. & M. junior spots and Colortan sets. When occasion demands, other camera and grip equipment is rented to augment the work of the company's Cine Special.

"The Great Light" is Gospel Films' eighth release. The company's first two productions, "Forgotten Valley" and

(Continued on Next Page)

Advantage Never Before Offered!



SWIVEL BALL JOINT ATTACHMENT FOR

PROFESSIONAL JUNIOR and MITCHELL 16 TRIPODS

Swivel Ball Joint Attachment can be mounted between head and tripod body in a few seconds and without any technical knowledge. Swivel Ball has enough tightening strength to hold the largest and heaviest movie cameras, permits leveling camera quickly when tripod is set up on uneven ground. Ball Attachment is made of lightweight aluminum, weighs approximately 3 1/2 pounds.

Ten Day Money-back Guarantee
Ask Your Dealer or Write for Catalog and Prices

KADISCH

CAMERA AND SOUND ENGINEERING CO.
500 WEST 52ND ST., NEW YORK 19, N.Y.

PLoZo 7-3511
DESIGNERS AND MANUFACTURERS OF
MOTION PICTURE—TV EQUIPMENT

MOVIOLA

FILM EDITING
EQUIPMENT
16MM - 35MM

- PICTURE SOUND Photo and Magnetic
- SYNCHRONIZERS
- REWINDERS

One of the new series 20 Moviolas for picture and sound.

Write for Catalogue

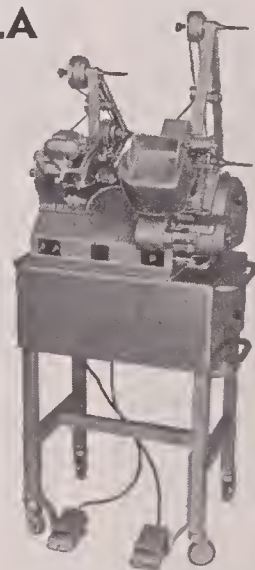

MOVIOLA MANUFACTURING CO.

1451 Gordon St. • Hollywood 28, Calif.

WORLD FAMOUS

S-5

synchronous magnetic film recorder for motion pictures and television

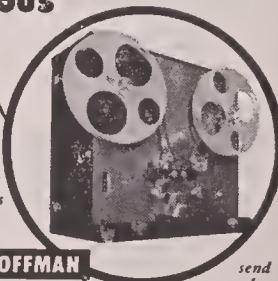

STANCIL-HOFFMAN

921 N. Highland Hollywood 38, Calif.

send for particulars

Now! A 400ft. Magazine For Your BOLEX H-16

Complete
with
Synchronous
Motor
and Base

•
Includes
Installation
and
Case



Permits continuous run of 400 feet of 16mm film, or—the 200 ft. daylight loading spool may be used in the 400 ft. magazine. The 100 ft. daylight loading spool can be used in the camera without removing the external magazine. In block wrinkle finish to match camera. Fully guaranteed. Write for information on our Rock-Over Sports-finder and Camera Base.

See your Bolex dealer or
order direct. Immediate delivery.

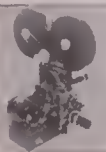

TOLEDO CINE ENGINEERING
1309 Milburn Ave. Toledo 6, Ohio

CASE HISTORY OF A FILM PRODUCTION

(Continued from Page 363)

"Regions Beyond," made about three years ago by Stan Taylor and Ken Anderson, are still in active demand. Taylor left the organization to produce independently, and his "Call of the Navajo" is distributed to church groups by Gospel Films. Ralph Papin joined the firm to continue the work with Anderson. This team's first production, "Counter Attack," dealt with juvenile delinquency. Then followed "Betrayed," a 45-minute dramatic story about youth in some difficult situations. "Call of the East" and "Korea," while carrying the company's name, were shot outside the country by missionaries and released by the firm. As a change of pace, an industrial picture for a toolmaking company, "Tools for Living," was produced before work on "The Great Light" began.

Gospel Films also distributes its own pictures, and the returns from film rentals and print sales underwrite the cost of new productions. An office in Belfast,

North Ireland, has been established for European evangelists using the company's films. An unusual sidelight to the rental activities is the distribution for regular projection of kinescopes of "Youth on the March" television programs. These are probably the only kinescopes in the country being rented as motion picture shorts.

Before establishing Gospel Films, Ken Anderson wrote many popular Christian adventure books for children, was managing editor of the "Youth for Christ" magazine, and worked on a film at the Youth Haven camp ground in Michigan. Ralph Papin has received an M. A. degree from the University of Southern California's Cinema Dept. Before this graduate college study, he was a still and movie aerial photographer in Alaska, and a U. S. Air Force cameraman. He photographed documentary footage for inclusion in the Protestant Film Commission's "Again Pioneers" while attending U.S.C.

TRI-X, NEW EASTMAN HIGH SPEED FILM

(Continued from Page 335)

TABLE I

General Specifications

Exposure Index: Daylight 250 Tungsten 200
Development in Kodak Test Developer SD-28 to gamma of 0.65

These values are suitable for use with Weston, General Electric and similar exposure meters with or without the calculators for ASA Exposure Indexes. The exposure required will depend upon the processing techniques used and the values and data given should be considered as a preliminary guide, subject to revision on the basis of tests processed with the actual formulas to be used.

Because of the high speed of this material and the limited sensitivity of some meters, it should be noted that adequate exposure may often be obtained even when the illumination is so low that a reading cannot be obtained with the meter, especially when reflected light measurements are made. Under such circumstances, proper exposure must be determined on the basis of actual tests.

Illumination (Incident Light) Table For Tungsten Light: Shutter speed approximately 1/50 second — 24 frames per second.

Lens Apertures	f/1.4	f/2.0	f/2.8	f/4.0	f/5.6	f/8.0
Number of foot candles required	13	25	50	100	200	400

Filter Factors:

Kodak Wratten Filter	#3	#8	#12	#15	#21	#23A	#8N5	#25	#29
Filter Factor for Sunlight	1.5	2.0	2.5	3	3.5	5	5	8	25

Recommended IIb Control Gamma: 0.60 to 0.70

Base: Gray safety

Safelight: Total darkness. After development is one-half complete, a Kodak Safelight Filter, Wratten Series 3, can be used with a 15-watt bulb at not less than 4 feet. The total exposure should

not exceed the equivalent of a few seconds at 4 feet.

Identification: The letter C is printed just before the footage number on on 35mm only.

Ready-Eddy

U. S. Registered Trademark

EASY READABLE • ACCURATE
FOR EVERY DAY USE

1001 Ready Sound-Film

Editing Data:

• Footage • Frame

Count • Screen Time

• 35mm and 16mm

equivalents.

Plastic computer for

everyone in movies

and TV, from script to

screen.

\$2.00 Prepaid

(Delivered in U.S.A.)

ASK FOR REPRINT OF ARTICLE

IN AMERICAN CINEMATOGRAPHER.

Write or ask your dealer

READY-EDDY, Sandy Hook, Conn.



AUTOMATIC DAYLIGHT PROCESSING

DEVELOPING TANK

- Processes up to 200 Ft.
- 8mm-16mm-35mm
- Movie—X-Ray—Microfilm
- Motor Driven, Portable
- Tough Plastic Tonks
- Uniform Density Assured
- 70mm tonk also available

FILM DRYER

- Motor driven—Heated
- Speedy drying
- Automatic shrinkage allowance
- Stainless steel and aluminum construction
- Easily assembled without Tools
- Compact, Portable

Guaranteed. Write for Free Literature

MICRO RECORD CORP.

Dept. AC 225 W. 28th St., N.Y. 1, N.Y.

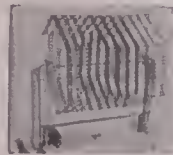

YOU WON'T MISS AN ISSUE . . .

of American Cinematographer if you renew your subscription promptly when notice is received. The yearly subscription rate remains the same — \$3.00 (U.S. and Canada) Foreign, \$4.00

16mm Film Production Is Now Big Business



TELEFILMS STUDIOS' production crew is shown here shooting a scene for one of company's earlier 16mm color productions for Catalina Swim Suits. Recognize the blonde model? It's none other than Marilyn Monroe—before she became a popular Fox star.

IN HOLLYWOOD, "The Battle of the Dimensions" continues among the major motion picture studios with flamboyant claims being made to the press and exhibitors. But while the "scopes," trick cameras, lenses and sound systems vie for top position, another phase of filmmaking—the industrial side—rolls serenely on its way, turning out thousands of 16mm pictures every year for big business.

The boom has its roots in the widespread use of government training films during World War II. Industry quickly adopted the idea as an aid to training salesmen or familiarizing dealers and consumers with new models and products.

Today, these films, telling the story of American business, have an audience numbering in the millions. They are shown before conventions, industrial audiences, business groups, social clubs, on television and in schools and colleges. In some rural theaters, they are booked as regular features.

James Kemper, President of Lumberman's Mutual Insurance Company, revealed that a film made for his firm has been viewed by more people than have seen "Gone With The Wind," Hollywood's all-time top entertainment grosser!

All this, of course, has sparked a new and still growing industry in its own right. In 1946, fewer than 150 such movies were ground out by 10 or 12 struggling companies. This year, over 200 companies—most of them fat and thriving—will turn out over 4,000 films.

Not bad when you consider the cost of one 30 minute 16mm film in black and white costs anywhere from \$3,000 to \$60,000. Color runs about 25% more.

Financial health of these studios, however, isn't all due to industrial pictures.

Joe Thomas, president of Telefilm Studios Inc. (one of the nation's four largest producers and processors of industrial films), points out that being small, they are versatile. A Telefilm Studio sideline, for example, is making screen tests for major studios. Probably their most well-known test was of Jane Russell for "The Outlaw" over twelve years ago.

Thomas, who helped pioneer the industry in 1938, says technical improvements have kept costs at about where they were at the beginning. His own firm takes credit for first utilizing twin-camera filming, now standard in television, and for perfecting a commercially acceptable method for putting sound on 16mm film.

And Thomas's diversified clients show that "Everybody's getting into the act." The Telefilm lab processes, edits and applies sound tracks to films for a missionary in Australia, a coffee grower in Brazil, a white hunter in South Africa and an Indian prince as well as countless business, large and small, throughout the United States.

CUKOLORIS

(Continued from Page 333)

Again in the lower photo on the same page, the cukoloris lighting effect can be seen splotching the area above the arches in the background, lending a most dramatic effect pictorially. It is an effect, perhaps, which does as much to lend an aura of naturalness to a set lighting scheme as any factor, indeed any other tool, in the technique of set lighting.

It is possible, of course, for a director of photography to go overboard in the use of the cukoloris; restraint must be exercised both to gain the most subtle effects and in order not to exhaust the possibilities of the device through overuse.

In this respect I am reminded of a grip—the studio's term for a stagehand—I once knew who was the most confirmed disciple of the cukoloris technique I had ever met. His proficiency in cutting out cukoloris matched his enthusiasm for their use, and ultimately those he turned out assumed weird and sometimes almost frightening shapes. Thus he came to expect his "cookies" to be used in every production and on every set, and would sulk openly if they were not.

Which is what can happen to a guy who goes "queer for cukoloris" after awhile!

GEO. W. COLBURN LABORATORY INC.
164 NORTH WACKER DRIVE • CHICAGO 6
TELEPHONE STATE 2-7316

8 and 16mm SERVICES

PELEGRINI
VARIABLE SHUTTER UNITS
FOR THE BOLEX H-16

The real answer to complete FADES and LAP DIS-SOLVES. Faster shutter speeds and many other advantages. Prices within U. S. \$99.60. Cameras with outside frame counter \$109.80. Tax extra. One year guarantee and camera transportation book included. Send for free informative booklet.

Prices subject to change without notice.
TULLIO PELLEGRINI
1545 Lombard St.
San Francisco 23, California

COLOR TALK

GOBO STAND
That is Really Versatile *It's New!*

NATURAL LIGHTING CORP.
GLENDALE 5, CALIFORNIA

BACK ISSUES

New subscribers and others often find need to refer to factual or technical information published in earlier issues of American Cinematographer. The December issue each year provides a ready index to such information. The issues in which such information appears (when available) may be had direct from the publisher for 30c per copy.

AMERICAN CINEMATOGRAHER
1782 No. Orange Dr. Hollywood 28, Calif.

CLASSIFIED ADVERTISING

10c per word, minimum ad \$1.00. Words set in capital letters except 1st word and advertiser's name, 15c per word. Modified display format 90c per line. No discount on classified advertising. Send copy with remittance to editorial office, 1782 No. Orange Drive, Hollywood 28, Calif. Deadline 15th of month preceding date of issue.

STUDIO & PRODN. EQUIP.

SPECIALS FROM THE ONE STOP STORE

MOTORIZED DOLLY with 2 seats. Takes heaviest cameras \$ 295.00

H'WOOD ESCALATOR TRIPOD, freehead for heaviest TV or Movie Cameras, on 3 wheel dolly. \$1250 originally..... 395.00

BERNDT-MAURER 16mm Single System Sound camera w/400' mag, 4 lenses, etc. CLOSE OUT 495.00

CINE SPECIAL MODEL II with 3-200' chambers; 5 Kodak coated lenses, carrying case and Prof. Jr. Tripod. Excellent 2095.00

KODAK HISPEED 16mm CAMERA w/63mm lens, \$1713 val. 995.00

MOVIOLA 35mm PREVIEW UDPVCS. Sound one side, composite sound/picture, other side. Beautifully rebuilt..... 1695.00

MOVIOLA 35mm COMPOSITE Sound/Picture complete 495.00

WALL 35mm MOVIE TONE Single System Sound Camera 1995.00

MAURER 16mm CAMERA w/400' mag; syncmotor; viewfinder; blimp 3100.00

PAN CINOR ZOOM LENS for 16mm..... 229.50

BARDWELL-McALISTER MULTIPLE FLOODLIGHTS. 3 quadruple heads holding 12 bulbs on rolling tripod stand. Orig. Gov't cost \$180. Surplus 29.50

BM QUADLITE Heads only \$4.95. Stands only.. 19.95

CENTURY 750W LEKO TV framing spotlights, \$63 value 29.50

CINE SPECIAL 16MM BLIMP Custom Built. Has follow focus, vertical image 63mm viewfinder, takes 200' mag & syncmotor. \$600 value 350.00

CINEMAPHONE 35mm DUBBING Heads, less motor 395.00

WESTERN ELECTRIC 35mm OPTICAL RECORDING System complete 4950.00

NEW FILM EDGE NUMBERING MACHINES, 16 or 35mm 2250.00

HEAT EXCHANGER, 10 gpm, 1900W, new shopworn 150.00

SOS FILMETER STOP WATCH \$29.50 value..... 13.95

GIANT METAL FILM CABINETS, hold 120 assorted 16mm reels. \$240 value. New..... 190.00

TRADES TAKEN SEND FOR 1954 CATALOG

Dept fc Cable: SOSOUND
S.O.S. CINEMA SUPPLY CORPORATION
602 W. 52nd Street New York 19, N. Y.

FOR SALE

ALL GUARANTEED LIKE NEW

AURICON CINE' VOICE SOUND CAMERA WITH THREE LENS TURRET..... \$ 419.50

DUAL-TRACK CONCERTONE TAPE RECORDER WITH CASE 269.50

CINE' SPECIAL II F1.9 EKTAR AND CASE..... 595.00

KODASCOPE PAGEANT SOUND PROJECTOR..... 279.50

PATHE' CINE' CAMERA, LATEST MODEL..... 329.50

CAMERA CRAFT
18 East 52nd Street New York 17, N. Y.

LATE Arriflex 35mm model 11 with fine 2B, 50, 75 Schneiders; coated, tested, calibrated and T-stopped. Wild 12 v motor, 3 400 ft. magazines with machined covers to eliminate film jams, sun shade, etc. and fitted aluminum case for above. Arri tripod and follow focus blimp with lens rings, sync motor, etc. Entire outfit has had little use and in excellent condition as result of good maintenance.
Ideal for TV, documentary, industrial or feature. A superb professional unit and a bargain at \$2,465.00 F.O.B. New York. CAGLE FILMS, 14 East 64th Street, New York 21. Telephone TEmpleton B-2035.

AURICON Pro, Cine Voice exposure control, turns on, off with camera — prevents fogging, saves batteries, complete \$40.00. LEE ENGINEERING, 222 Minna St., San Francisco. APPROVED BELL & HOWELL SERVICE. Eyemo parts in stock.

ARRIFLEX 35mm. camera, 3 lenses, filters, sunshade, tripod, case. Complete for quick sale . . . \$795.00. Write P.O. Box 312, Ridgewood, N.J., or phone Allendale, N.J. 13046.

BACK issues, American Cinematographer — 90 copies 1942 to 1952 \$22.50 postpaid. BOX 1189, American Cinematographer.

SOUND and picture continuous bench printer, \$125; Morse G-3 tank and spin dryer, \$45; 4 wheel dolly, \$35; VIDEO FILMS, 1004 E. Jefferson, Detroit 7, Michigan.

FOR SALE

3-D OUTFIT FOR SALE

Equipment engineered by top Hollywood Physicists. Ideal For Feature Prod. & Commercials. Fortune Spent In Engineering. Can Be Bought At Reasonable Figure. Outfit Consists of Two-Bell-Howell Cameras completely silenced and overhauled. Each with Fearless or Mitchell Type Shuttle. Both Cameras parallel to each other facing same direction when shooting. With Finest optical system in U.S. Three of the Latest Bell-Howell Micrometer 50MM Lens and Mitchell finder. Completely blimped. Base for entire equipment 21 x 27 inches. Drive for cameras consists of quarter horsepower Mitchell Motor, 220 Volts AC, 60 Cycle. Has Finest automatic convergence system in world. No measuring or slide rules necessary. Automatic focus. Calibrated to the lenses. For Information Write or Wire **TRINITY PICTURES, INC.** 729 7th Ave., N.Y.C.

BASS . . . is headquarters for Arriflex 16; the new Zoomar 16; Cine Specials, all models; Bell & Howell 70-DL; Bolex H-16. Used Cine Special I, 1" F:1.9 lens and carrying case \$395.00; Used H-16 Bolex, 1" F:1.5, 0.7" F:2.5 W.A., 3" F:3.5 \$347.50 Used Bell & Howell 70-DA, 1" F:1.9, 4" F:4.5 \$235.00. Used Bell & Howell 70-A, 1" F:3.5 and case \$52.50; Used 200' Chamber Cine Special \$295.00; Used 100' Chamber, Cine Special \$117.50. Best buys . . . Best trades always. BASS CAMERA CO., Dept. AC, 179 W. Madison St., Chicago 2, Ill.

WALL S. S. 35MM. SOUND CAMERA

COMPLETE with Galvanometer, amplifier, portable power supply, 40-50-75 and 100mm. lenses, erect image viewfinder, complete front attachments, two 1000 ft. magazines, Balanced Tripod, necessary carrying cases. Overhauled. Guaranteed perfect. Reasonable.

CAMERA EQUIPMENT COMPANY
1600 Broadway New York 19, N. Y.

ARRIFLEX II, 3 Schneider lenses, one 400 ft. mag., two 200 ft. mags., batteries, case, filters, etc. Like new \$1,000.00. Cine Special II, Par turret, 200 ft. mag., Maier finder, filter slot, 25mm. Schneider F1.5, good condition \$1,000.00 (no mag. finder tube). BH Recording Proj. like new \$550.00. Will sell lot for \$2,500.00. A good buy for TV station, studio or cameraman. Inspection can be arranged. Write, wire Box 1187, AMERICAN CINEMATOGRAPHER.

AUDIO AKELEY single system camera complete with Akeley sound head, Gyra tripod, 3 lenses, view finder, Maurer mixing amplifier. Complete with cables, power supply and W. E. microphone. CAMERA EQUIPMENT CO., 1600 Broadway, New York 19, N.Y. Cable Cinequip.

WE BUY, SELL AND RENT PROFESSIONAL AND 16mm. EQUIPMENT, NEW AND USED. WE ARE DISTRIBUTORS FOR ALL LEADING MANUFACTURERS. RUBY CAMERA EXCHANGE, 729 Seventh Ave., New York City. Established since 1910.

AURICON Pro silent with Wollensak 25mm F1.5 Auto-Parallax View-Range Finder, Follow-Focus coupled to finder. Like new \$995. SAMUEL KRAVITT, 763 Chapel St., New Haven, Conn.

WANTED

IMMEDIATE CASH PAYMENT FOR CAMERAS AND EQUIPMENT

NEED EYEMOS (SINGLE LENS AND TURRET), MITCHELLS, ARRIFLEX, DE BRIES, B&H STANDARDS AND HI-SPEEDS, WALLS, AKELEYS, CINE SPECIALS, AURICONS, MAURERS, FILMOS. ALSO BALTARS, COOKES AND OTHER LENSES. SOUND STAGE, LABORATORY AND EDITING EQUIPMENT OF ALL TYPES REQUIRED. PLEASE SHIP INSURED OR FORWARD DESCRIPTIONS AIRMAIL. IMMEDIATE PAYMENT.

GORDON ENTERPRISES • 5362 N. Cohuenga
NORTH HOLLYWOOD, CALIFORNIA

WANTED

Mitchell — Akeley — B & H — Wall — Eyemo
Cameras — Lenses — Equipment
NATIONAL CINE EQUIPMENT, INC.
209 West 48th St. New York, N.Y.

WANTED

**OUR SHINGLE STILL HANGS
YE OLDE SOS TRADING POST**
BUY — SELL — SWAP — CONSIGN

Cameras, Dollies, Lenses, Lights, Moviolas, Printers, Recorders, Studio or Laboratory Equipment

Western Union-WUX New York
Phone PL. 7-0440

S. O. S. CINEMA SUPPLY CORPORATION

Dept. fc Cable: SOSOUND
602 W. 52nd Street New York 19, N. Y.

WANTED TO BUY FOR CASH

CAMERAS AND ACCESSORIES

MITCHELL, B & H, EYEMO, DEBRIE, AKELEY ALSO

LABORATORY AND CUTTING ROOM EQUIPMENT

CAMERA EQUIPMENT COMPANY

1600 BROADWAY, NEW YORK CITY 19

CABLE: CINEQUIP

WANTED

PRODUCTION EQUIPMENT, LABORATORY EQUIPMENT, EDITING EQUIPMENT, 16mm. and 35mm. FROM SINGLE ITEMS TO COMPLETE STUDIOS. TRADES ACCEPTED.

THE CAMERA MART, INC.

1845 Broadway Circle 6-0930 New York 23, N.Y.

F & B PAYS MORE FOR USED 16/35MM EQUIPMENT

WRITE — WIRE — PHONE

FOR OUR CASH OFFER

FLORMAN & BABB MU. 2-2928
70 W. 45TH ST. NEW YORK 36, N.Y.

WANTED: Used 16mm reversal processing machine and 16mm single system sound camera. DON GOODWIN, 3833 7th Ave., Sioux City 6, Iowa.

CAMERA & SOUND MEN

JAMES JEWELL, Detroit cinematographer, 12 years. 35mm, 16mm. B & W, Color Negative, Kodachrome. Camera, A&B rolls, magnetic sync sound and music, mixed and cut, only optical on composite answer print, from dependable Lab by air express. Also National Newsreel assignments. IATSE Local 666. JEWELL PRODUCTIONS, 2560 Woodward, Detroit 1, Mich., Phone WOODWARD 5-6299.

ASSIGNMENTS FOR INDIA or nearby territories for any type of films, 16 or 35mm, B&W or Color, write to KANU PATEL, A.R.P.S., The Clarion Productions, 34, Park Mansions, CALCUTTA-16.

COLOR SLIDES, PHOTOS & FILMS

NATURAL COLOR SLIDES, Scenic, National Parks, Cities, Animals, Flowers, etc. Set of eight \$1.95. Sample and List 25c. SLIDES, P.O. Box 26, Gardena, Calif.

ALASKA WILDLIFE KODACHROME 16mm. — Bmm. 2x2 slides taken by professional photographer and Alaskan Registered Guide. Free Catalog. MAC'S FOTO SERVICE, 315 4th Avenue, Anchorage, Alaska.

LABORATORY & SOUND

SOUND RECORDING at a reasonable cost. High Fidelity 16 or 35. Quality guaranteed. Complete studio and laboratory services. Color printing and lacquer coating. ESCAR MOTION PICTURE SERVICE, INC., 7315 Carnegie Avenue, Cleveland 3, Ohio. Phone Endicott 1-2707.

KODACHROME duplicates: 16mm 10c per foot, mail orders accepted, satisfaction guaranteed. COLOR-VISION FILMS, 122 N. Maclay Ave., San Fernando, California.

LOW cost 16mm sound recording—picture and magnetic sound editing. EL RANCHO AUDIO, 26236 Fairview Ave., Lomita, California. Davenport 6-4925.



NOW

COLOR-CORRECT*
RELEASE
PRINTING from separate

track and picture masters incorporating
“A” and “B” effects

1¢ per foot

- Color Duplicating Stock furnished at cost if payment accompanies order — \$.058 per foot.
- We will mount all prints on your reels and cans at no extra charge — and pack for shipping anywhere in the world.
- Delivery to meet your schedules.

**Reg. U.S. Patent Office*

byron *Studios and Laboratory*

1226 Wisconsin Avenue, N.W., Washington 7, D.C. DUpont 7-1800

550 Fifth Avenue, New York 36, N.Y. Circle 5-8188

PRACTICALLY EVERY 16MM FILM PRODUCER IN THE WESTERN HEMISPHERE IS A CLIENT OF BYRON

Color

you've been waiting for

bold, clear, alive!

"Life-like color," the ultimate in the reproduction of color film, is now available to all producers of 16mm motion pictures. Now you can have your exposed film duplicated with perfect blending and balancing of tones. Your release prints will have a sensitive living quality...surpassing anything you have ever seen in clarity.

This is "Life-Like Color," the result of fifteen years of exhaustive research by the country's outstanding color engineers and technicians. It is now available to you exclusively through the laboratories of Telefilm Studios.

With "Life-Like Color," Telefilm Studios again contributes to its primary objective...to help the 16mm producer make better motion pictures. Telefilm's modern facilities and equipment for color printing...high fidelity sound recording (your choice of optical or electronic sound printing)... editing...titling...special effects...and the skill and the know-how of the finest technicians in the industry are at your command.

*for complete information, visit Telefilm Studios,
or write for a descriptive brochure.*

TELEFILM STUDIOS INC.

estab. 1938

6039 HOLLYWOOD BLVD. • HOLLYWOOD, CALIF.

telephone HOLLYWOOD 9-7205



Henri Toulouse-Lautrec,
pioneer of commercial color.

AMERICAN

AUGUST • 1954

Cinematographer

THE MAGAZINE OF MOTION PICTURE PHOTOGRAPHY



This Issue ...

- SHORT CUTS CUT COSTS IN TV FILM PRODUCTION
- PUTTING A CHAMPIONSHIP BOUT ON FILM
- SHOOTING A BIG GAME FISHING FILM

25c
\$3.00 YEARLY

Perfect Balance!



**SMOOTHER, EASIER
TV CAMERA CONTROL**

NEW
HOUSTON- FEARLESS
**CRADLE
HEADS**

Perfect balance makes the big difference in the terrific new Houston-Fearless Cradle Heads! No matter how the camera is tilted, it is always in absolute balance... resulting in wonderful new ease of operation and remarkable new smoothness never before achieved.

This perfect balance is made possible by the cradle action of the head. When the camera is tilted up or down, the cradle rotates around a constant center of gravity, maintaining positive balance at all times. Added weight, such as long lenses and camera accessories, is easily compensated for by simply moving the camera and the top plate of the head forward or back by means of a lead screw. This adjustment does not require loosening the camera hold-down screws.

The Cradle Head rides on four phenolic-covered ball bearing rollers for smooth, quiet, easy tilting. Panning is also smooth and easy, accomplished by two precision ball bearings in the base. Drag adjustments and brakes are provided on both pan and tilt.

FOR MONOCHROME AND COLOR TV CAMERAS

The new Houston-Fearless Cradle Heads are available in two types: Model MCH for standard black and white cameras, Model CH-1 for the RCA Color TV camera.

Like all Houston-Fearless products, these new Cradle Heads are soundly engineered and precision built of the finest materials to give a maximum of dependable service. Send the coupon below for complete information today.

The
**HOUSTON
FEARLESS**
Corporation

THE HOUSTON- FEARLESS CORP.
11809 W. Olympic Blvd., Los Angeles 64, Calif.

Send information on Cradle Heads Friction Heads
 Remote Control Heads Tripods Dollies
 Camera Cranes TV Pedestals Film Processors

Name _____ Title _____

Firm _____

Address _____

City _____ Zone _____ State _____

*"World's Largest Manufacturer of TV Studio
and Motion Picture Film Processing Equipment"*

11809 W. OLYMPIC BLVD., LOS ANGELES 64, CALIF.
620 FIFTH AVE., NEW YORK 20, N. Y.

AUG 17 1954



THE WORLD'S MOST COMPLETE ASSORTMENT
OF PHOTOGRAPHIC EQUIPMENT FOR

T. V. and Motion Picture Studios



New **PROFESSIONAL JUNIOR**
Adjustable wood **BABY TRIPOD**
—for Prof. Jr. friction
and geared heads



Has substantial shoe and spur.
Measures from floor to flange
25" extended —17"
collapsed. **\$75**

FAMOUS
"controlled
action"
SMALL GYRO
TRIPOD

Two speeds—slow and fast
—for both panning and tilting.
Helps you capture fine scenic views
and fast-moving sports events. Espe-
cially recommended for 16mm Mitchell,
16mm Maurer, B & H Eyemo
and similar cameras. **\$600**

PACKAGED LIGHTING WITH
COLOR-TRAN

—studio lighting in a suitcase

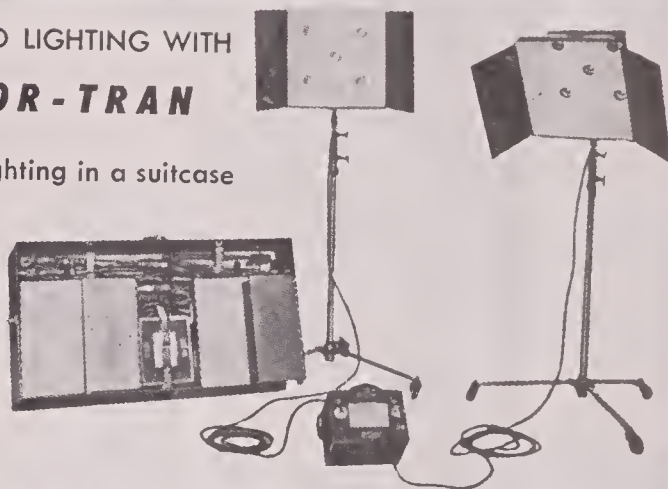

Imagine being able to use two 5000 watt units
on a 30 amp. fuse — **COLOR-TRAN** will do it!
Kit contains 2 light heads, 2 Superior stands and
proper size **COLOR-TRAN** converter to match.
Packed in compact case.

Senior Kit
\$237.50

Other style
kits available.

Write for **COLOR-TRAN** Catalogue.

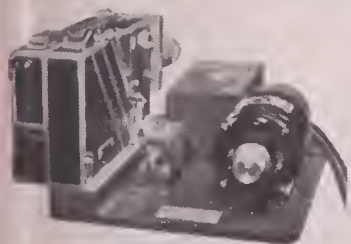

STOP MOTION MOTOR
FOR CINE KODAK SPECIAL

Runs forward or reverse, 110
AC synchronous motor with frame
counter. May be run continuously
or for single frames. Camera
mounts without special tools.

\$450

Also available — Stop Motion
Motors for 16mm—35mm B & H,
Mitchell and other professional
cameras.



ELECTRIC
FOOTAGE TIMER

Dual model for both 16mm
and 35mm. Large white num-
erals on black background. Accu-
rate reset dial. Switch controlled
by operator, who selects either
16mm operating at 36 feet per
minute—or 35mm operating at
90 feet per minute . . . or both
in synchronization. **\$95**

Single model, either 16mm or
35mm **\$45**

presto-splicer

GIVES PERMANENT SPLICE
IN **10** SECONDS!

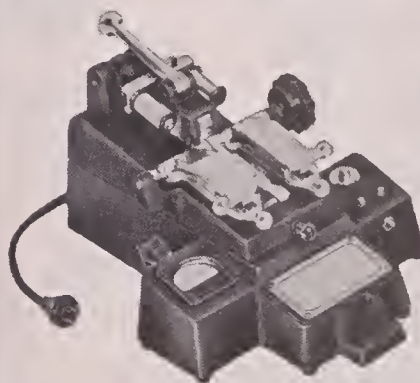

Especially good for splicing magnetic
film. Butt Weld type for non-perforated
or perforated film. 16mm, 35mm or
70mm. **\$547.80**

16mm or 35mm models—
for perforated film.

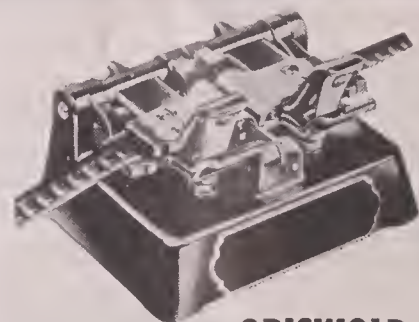

GRISWOLD
HOT FILM SPLICER

Model R-2 for 35mm silent and sound
film. Precision construction makes it easy
to get a clean, square splice with accu-
rate hole spacing. Nothing to get out of
order. **\$65**

Also Bell & Howell 8mm, 16mm and
35mm Hot Splicers and B & H Labora-
tory model Foot Splicer.

9.5mm Lenses in 16mm C mount. 18.5mm (extreme wide angle-flat field)
Lenses available in mounts for all 35 mm Motion Picture Cameras.
PHOTO RESEARCH Color Temperature Meters. *Electric Footage Timers
Neumade and Hollywood Film Company cutting room equipment.
Griswold & B.&H. Hot Splicers. *DOLLIES—Bardwell-McAlister, Mole
Richardson, Century and Colortran Lighting Equipment.

Complete line of 16mm and 35mm Cameras

FRANK C. ZUCKER
CAMERA EQUIPMENT CO.
1600 BROADWAY NEW YORK CITY



This emblem is
your assurance

of

Courteous
Faithful
Intelligent

**LABORATORY
SERVICE**

OUR GOAL:
To bring to the
screen in flaw-
less manner,
the skill and
artistry of the
cinematographer

Consolidated
FILM INDUSTRIES
959 N. SEWARD ST.
PHONE HO 9-1441

AMERICAN

Cinematographer

THE MAGAZINE OF MOTION PICTURE PHOTOGRAPHY
PUBLICATION OF THE AMERICAN SOCIETY OF CINEMATOGRAPHERS

ARTHUR E. GAVIN, *Editor*

MARION HUTCHINS, *Editorial Assistant*

EMERY HUSE, *Technical Editor*

EDITORIAL ADVISORY BOARD: John Arnold, Arthur Edeson, Lee Garmes, Charles
Roshier, Leon Shamroy, Fred Gage, Glenn R. Kershner

Editorial and Business Office: 1782 N. Orange Dr., Hollywood 28, Calif.

Telephone: HOLLYWOOD 7-2135

VOL. 35

AUGUST

• 1954

NO. 8

In This Issue

ARTICLES

- PUTTING A CHAMPIONSHIP BOUT ON FILM—*By Chuck Austin* 388
- INDIA'S FIRST FEATURE IN GEVACOLOR—*By Frederick Foster* 390
- THE FILM LABORATORY—YOUR PARTNER IN PRODUCTION—
By Charles L. Anderson 392
- HIGH-SPEED NEGATIVE SPEEDS PRODUCTION—*By Andrew M. Costikyan* 394
- SENSITOFLEX—NEW PHOTOMETRIC EXPOSURE MEASURING DEVICE—
By John Forbes 396
- SHORT CUTS CUT COSTS IN TV AD FILM PRODUCTION—
By Arthur Rowan 397

AMATEUR CINEMATOGRAPHY

- SHOOT A BIG GAME FISHING FILM—*By Charles W. Herbert. A.S.C.* 398
- CINE HOBBYIST WITH A FUTURE—*By Harold Benson* 400

FEATURES

- HOLLYWOOD BULLETIN BOARD 374
- WHAT'S NEW IN EQUIPMENT, ACCESSORIES, SERVICES 376
- BOOKLETS, CATALOGS, BROCHURES 378
- LETTERS 380
- INDUSTRY NEWS 384
- HOLLYWOOD STUDIO PRODUCTION 402

ON THE COVER

A BEHIND-THE-CAMERA-GLIMPSE during the location filming of Universal-International's "Magnificent Obsession" co-starring Jane Wyman, Rock Hudson and Barbara Rush. Russell Metty, A.S.C., directed the photography of the picture. Shown here is some of the equipment normally used in shooting on an outdoor location: the muffled mike on a boom extended above the players, and the big arc lamps used to supply fill light.—*Universal-International photo by Sherman Clark.*

AMERICAN CINEMATOGRAPHER, established 1920, is published monthly by the A. S. C. Agency, Inc., 1782 N. Orange Dr., Hollywood 28, Calif. Entered as second class matter Nov. 18, 1937, at the postoffice at Los Angeles, Calif., under act of March 3, 1879. SUBSCRIPTIONS: United States and Canada, \$3.00 per year; Foreign, including Pan-American Union, \$4.00 per year. Single copies, 25 cents; back numbers, 30 cents; foreign single copies, 35 cents; back numbers 40 cents. Advertising rates on application. Copyright 1954 by A. S. C. Agency, Inc.

new! FOLLOW FOCUS ATTACHMENT for Mitchell Cameras

one hand control of both Picture Framing and Lens Focusing

Read what cameraman Michael Slifka says about the new Follow Focus Attachment—only mechanism designed for Mitchell Cameras which couples the finder directly to the lens....



Michael Slifka, member of International Photographers of the Motion Picture Industry, Local 644, shown with his Follow Focus equipped Mitchell 35mm NC Camera.

January 5, 1954

Mr. J. D. McCall
Mitchell Camera Corporation
866 West Harvard Street
Glendale 4, Calif.

Dear Mr. McCall:

Enclosed is my check for \$120.25 to cover items listed in Invoice Nos. E4586, E4586, and E4587, all dated December 28, 1953.

We are shooting with parallax follow focus Unit No. 3. Most of the work is play-backs in interiors and exteriors, and this new parallax with an NC camera is paying off in many ways. Production hours are saved because of the rapidity of movement with the light-weight NC, yet there is no fuss or bother when lining up dolly shots. Of particular note is the simplicity and speed with which the lens gear is locked and disengaged to rotate lenses. In rapid dolly shots, while zooming away from an insert, with this NC follow focus unit for the first time we have the proper gear speed ratio with a simple turn of the hand. The follow focus control knob, with its plastic footage dial on which lens footage calibrations can be transferred, is very conveniently located where it can be seen and controlled from any position when following focus on dollies. The dovetail adaptor is an excellent idea as it makes reloading a pleasure but still keeps the finder attached to the camera. The simple design of the unit for mounting and the cam roller releasing knob is first class in that it in no way hampers or interferes with camera operation.

Without a doubt this whole unit puts a new light on the use of an NC camera. You can be sure, Mr. McCall, that the fame of this new follow focus attachment will spread to all producers in New York City and its vicinity.

Sincerely

Michael Slifka
Michael Slifka

345 West 19th Street
New York 11, N. Y.



The Follow Focus Attachment shown assembled here is easily installed and readily removed. Follow focusing control is quickly and smoothly accomplished through the use of the single follow focus control knob.

This long-awaited Follow Focus Attachment permits NC, Standard and 16mm Mitchell Cameras to be used for action shots moving toward or away from the camera. It assures full control of picture framing and lens focusing—particularly at close, critical ranges. Lightweight, the Attachment does not interfere with the use of any standard accessories and is supplied complete with bracket for mounting the matte box. Two models are available: 1, for use with the 16mm Professional, and 2, for use with the 35mm Sound Model (NC) and Standard Cameras. Write today for complete literature and prices.

Mitchell Camera CORPORATION

666 West Harvard Street • Glendale 4, Calif. • Cable Address: "MITCAMCO"

 85% of the professional motion pictures shown throughout the world are filmed with a Mitchell

Hollywood

Bulletin

Board



Primar Reflex Photo normal 105 mm. lens

"Impossible" distances become close-ups



with **ASTRO**®

Primar Reflex Photo Astro 640 mm. lens taken simultaneously by Hans Namuth

LONG DISTANCE LENSES
FOCAL LENGTHS TO 1000 mm.!

Used by the world's foremost explorers, scientists and news services, Astro lenses have been making photographic history all over the globe. Special formulas have produced resolving powers up to 100 lines to the mm. And these superb lenses are fast enough for action color work—focal lengths from 300 to 800 mm. rated at F/5, the giant 1000 mm. (40 in.) at F/6.3.

FOR STILL CAMERAS Leica, Exokto, Primar-Reflex, Master Reflex, Hasselblad, Praktica, Contax-S

FOR MOVIE CAMERAS 16 & 35 mm. Bolex, Mitchell, Eyemo, Debrie, Askania, E.K., Arriflex, etc.

DUAL PURPOSE MOUNTS allow interchanging movie and still.

SUPER SPEED TELEPHOTOS

5 in. F/2.3
6 in. F/2.3
6 in. F/1.8

NEW! 12-inch F/3.5 Astro in mounts for all movie and still cameras. **NEW GAUSS TACHARS**—focal lengths 25-32-40-50-75-100 mm.; all F/2, in mounts for practically all 16 and 35 mm. professional and amateur cine cameras.

Write for brochure and prices

ERCONA CAMERA CORP.

DEPT. A-26 527 FIFTH AVE., NEW YORK 17, N. Y.

Arthur C. Miller, American Society of Cinematographers' president, who long has been active in the welfare of cameramen members of Local 659, I.A.T.S.E., on the west coast, will attend the I.A.T.S.E. convention this month in Cincinnati, Ohio, as an official Union representative.



Arthur Miller

Prior to his departure he will meet with an A.S.C. committee to formulate plans for the Society's forthcoming fall function—the Annual Ladies' Night Dinner and Dance, to be held in Hollywood in September.

American Society of Cinematographers' members were hosted by the Society of Television Engineers at CBS' new studio in Hollywood last month where discussion on the lighting quality of TV films necessary for good transmission was continued from a previous SMPTE meeting held the month before.

Here, with the aid of slides, film and TV screens, the engineers showed the results that come through on home receivers with films of various densities and contrast.

The meeting was the third in a continuing study, by cinematographers engaged in TV film production, of the methods for lighting and photographing TV films that will produce prints most compatible with TV's existing transmission systems.

Nick Musuraca, ASC, is again behind the camera shooting Gross-Krasne's "The Lone Wolf" series of TV films at California studios in Hollywood. He had been bedded for four weeks with a virus infection.

Ellsworth Fredericks, who directs the photography of "The Dennis Day Show" series of TV films for Denmac Productions in Hollywood, has been admitted to membership in the American Society of Cinematographers.

Ellis Carter, ASC, arrived in Germany late last month where he now is directing the photography of "The River

Changes" for Warner Brothers. Previously, he completed shooting "Police Story" for Allied Artists.

Hal Mohr, ASC, following a brief vacation in Hawaii, will direct the photography of the new Donald O'Connor TV film show. Present schedule calls for production of 19 half-hour shows at General Service studios.

Virgil Miller, ASC, who directed the photography of Hall Bartlett's "Nava-jo" and "Crazylegs," is currently filming a third for Bartlett, a prison story at Chino, Calif., titled "Unchained."

Jack Russell, ASC, has been borrowed from Republic Pictures by Guild Films to shoot the new series of "Joe Palooka" TV films starring Joe Kirkwood and Kathy Downs.

Robert Surtees, ASC, is probably thankful to MGM for those many assignments in Africa ("King Solomon's Mines," "Mogambo.") because of the climatic conditioning they gave him.



Robert Surtees

Now he's in Nogales, Arizona, shooting Rodgers & Hammerstein's "Oklahoma," first Todd-AO production, in a climate far hotter than Africa's—reportedly 115 degrees daily daytime temperatures.

Surtees recently completed extensive pre-production tests at MGM with the company's Todd-AO wide-film cameras. Location shooting will include large scale dance numbers staged out-of-doors in fields that were specially planted in wheat and corn early this year. Far in the background, of course, are beautiful scenic vistas appropriate to the story.

George Sidney, MGM director and president of the Screen Directors Guild, has been awarded the honorary degree of Doctor of Science by Hahnemann Medical College and Hospital of Philadelphia in recognition of his technical

(Continued on Page 418)

Color

you've been waiting for

bold, clear, alive!

"Life-like color," the ultimate in the reproduction of color film, is now available to all producers of 16mm motion pictures. Now you can have your exposed film duplicated with perfect blending and balancing of tones. Your release prints will have a sensitive living quality...surpassing anything you have ever seen in clarity.

This is "Life-Like Color," the result of fifteen years of exhaustive research by the country's outstanding color engineers and technicians. It is now available to you exclusively through the laboratories of Telefilm Studios.

With "Life-Like Color," Telefilm Studios again contributes to its primary objective...to help the 16mm producer make better motion pictures. Telefilm's modern facilities and equipment for color printing...high fidelity sound recording (your choice of optical or electronic sound printing)... editing...titling...special effects...and the skill and the know-how of the finest technicians in the industry are at your command.

for complete information, visit Telefilm Studios, or write for a descriptive brochure.

TELEFILM STUDIOS INC.

estab. 1938

6039 HOLLYWOOD BLVD. • HOLLYWOOD, CALIF.
telephone HOLLYwood 9-7205



Henri Toulouse-Lautrec,
pioneer of commercial color.

WHAT'S NEW

... in equipment, accessories, service



CAMERA CRADLE HEADS

Easier, smoother panning and tilting of television cameras is made possible with two new cradle heads introduced recently by Houston-Fearless Corp., 11809 W. Olympic Blvd., Los Angeles 64, Calif.

Positive balance of camera in every position is achieved; cradle rotates around center of gravity, maintaining absolute balance at all times. In tilting, cradle head rides on 4 phenolic-covered ball bearings in base, giving unusually smooth, steady and silent movement. Degree of tilt ranges from 30° down to 30° up. Adjustable tilt drag is provided. Panning is equally smooth; vertical load is carried on ball bearings. Drag adjustment is provided. Brakes on both pan and tilt action lock camera in fixed position.

Balancing camera, when extra long lenses and other accessories are added, is accomplished simply by moving top camera plate forward or back with lead screw.

One model is designed for monochrome TV cameras; the other for RCA color TV cameras. Both heads will fit all standard tripods, pedestals, dollies, cranes or hi-hats.

ZEISS LENS SERVICE

Offering service to all Zeiss lens owners on West Coast is Romle-Walsh Co., 520 W. 7th St., Los Angeles. Fac-

tory-trained personnel are able to instrument check lenses, flashguns, shutter timing, etc.

TRIPOD DOLLY

A collapsible, three-wheel tripod dolly designed especially for easy mobility of cameras on location or in the studio is offered by Kadisch Camera and Sound Engineering Co., 500 W. 52nd St., New York 19, N. Y.

Special features include unique caster locking system that permits setting two or all three wheels in a parallel position for straight line dolly shots; screw-clamps for securing tripod leg



tips to dolly; and ability to fold into a compact, easy-to-carry unit 23 inches in length. Net weight is only 14 lbs.

For literature and prices, write manufacturer and mention American Cinematographer.

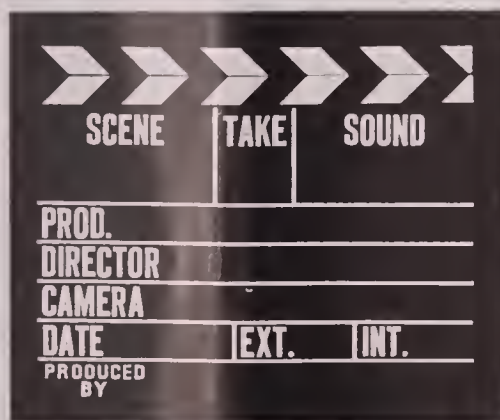

SLATE AND CLAPSTICKS

Priced below \$10.00 is a new and efficient slate and clapsticks combination for film producers which is available from Florman & Babb, 70 W. 45th St., New York 36, N. Y.

Featuring a special finish, lettering is permanently silk-screened on durable

Masonite. Overall size is 11" x 14". Supply of chalk is included with slate.

GUNSTOCK CAMERA MOUNT

Designed for steadier operation of hand-held 8mm and 16mm cameras in shooting rapidly moving subjects is the Cam-Stock camera mount pictured



above. Made from a single piece of hardwood, it features a hollow compartment for film and accessories storage. Price is \$9.95 postpaid. Manufacturer is Medina Industries, Medina, Texas.

HIGH-SPEED PROCESSOR

A portable, high-speed, high temperature 16mm film processor for reversal, negative or positive with a speed capacity up to 115 ft. per minute is announced by Hills Mfg. Co., Lansdale, Pa.

Pictured is company's Filmatic Mod-



el 16-HT which, where films such as DuPont's 930 or 931 are used, will effect processing and drying of first scenes and have them rewinding in a period of 2½ minutes.

Features include 1200 ft. capacity, built-in replenishing system, daylight operation, sprocket film drive and automatic temperature controls. **END**



NOW

COLOR-CORRECT*
RELEASE
PRINTING from separate

track and picture masters incorporating
"A" and "B" effects

1¢ per foot

- Color Duplicating Stock furnished at cost if payment accompanies order — \$.058 per foot.
- We will mount all prints on your reels and cans at no extra charge — and pack for shipping anywhere in the world.
- Delivery to meet your schedules.

**Reg. U.S. Patent Office*

byron *Studios and Laboratory*

1226 Wisconsin Avenue, N.W., Washington 7, D.C. DU pont 7-1800

550 Fifth Avenue, New York 36, N.Y. Circle 5-8188

PRACTICALLY EVERY 16MM FILM PRODUCER IN THE WESTERN HEMISPHERE IS A CLIENT OF BYRON

ONE CAMERA

16mm or 35mm

in 10 SECONDS!

Camerette 16/35

Reflex Motion Picture Camera

The perfect camera for the motion picture film maker working in both 16mm or 35mm color or black and white.

LOOK AT THESE ADVANTAGES—

- The same lenses, some motor drives, some sound blimp and accessory equipment used for both 16mm or 35mm — to convert simply change the magazine.
- Precise rugged movement
- Reflex viewing
- 200 degree adjustable shutter
- Divergent three lens turret
- Automotic film gate 400' magazines 16 or 35mm — the 16mm magazine will accommodate daylight spools as well as standard core load.
- Light weight — only 14 pounds with 3 lenses, 400' magazine, and 6/8 volt motor.

Write for brochure



Camerette

patents coutant-mathot

Manufactured by Ets. Cine. Eclair, Paris



Booklets Catalogs Brochures

available from equipment manufacturers

Film Lab Rates

A 16-page illustrated brochure illustrating and describing the company's complete 16mm motion picture laboratory and its many varied services, and a file folder containing price lists of all services offered are available to those in the 16mm motion picture industry from Byron Studios and Laboratory, 1226 Wisconsin Ave., Washington 7, D. C.

G-E Photolamp Data

Users of photoflood lamps will want a copy of the informative booklet titled "G-E" Photolamp Data" issued by General Electric Company, Lamp Division, Nela Park, Cleveland 12, Ohio.

In addition to the descriptive data on G-E photolamps, exposure figures and movie making tips, the booklet also includes information and technical data on photoflash lamps and other types of lamps for motion picture illumination.

Editing and Film Equip. Catalog

A 36-page illustrated catalog of all the film editing, storage and shipping equipment and accessories manufactured or distributed by Neumade Products Corp., may be had by writing the company at 330 West 42nd St., New York 36, N. Y.

Company is said to be largest manufacturer of equipment of this kind.

Photography Study

"Photography for a Profitable Career" is title of new 36 page illustrated booklet available from New York Institute of Photography, which offers students of photography interesting resident or home study courses in both still and motion picture photography. Supplementary data which is included with booklet gives full information on the courses offered, costs of same, and terms on which they may be had. Write the company at 10 West 33rd St., New York 1, N. Y.

Projection Data

"Secrets of Good Color Projection" is title of interesting 12-page booklet published by Radiant Manufacturing Company. It explains the importance

of proper exposure in filming in order to obtain color pictures which will screen well. It explains the importance of a top quality screen in order to secure the maximum results in color film projection.

There are several charts which will aid the film-maker-projectionist in determining quickly the proper screen width for movies or slides for a given distance and other information.

Copies may be had free by writing to the company at 1201 S. Talman Ave., Chicago 1, Ill., Att'n: Public Relations Dept.

Arri Equipment

The complete Arri line of photographic and laboratory equipment manufactured by Arnold & Richter, Germany, and distributed in U.S. by Kling Photo Corp., is illustrated and described in a comprehensive 84 page brochure now available from Kling.

Equipment includes film developing machines, film printers, tape recorders, set lighting equipment, film editing equipment, and the Arriflex cameras.

Copies are available to those in the industry making request on their business letterhead to Kling Photo Corp., 235 Fourth Ave., New York 3, N. Y.

Color Photography

"Color Photography Made Easy" is title of 96 page booklet published by Ansco, Binghamton, New York. It deals with the use and processing of Ansco Color film and Ansco Color Printon, and the exposure of Ansco color in motion picture photography. Price of booklet is 50 cents. Copies may be had from most camera stores or direct from Ansco.

Trick Filming

"Tips on Movie Making Tricks" is title of one of the newest "Tips" booklets published by Bell & Howell Company, 7100 McCormick Road, Chicago 45, Ill.

Written for the amateur movie maker, it illustrates and describes how to make reverse motion trick shots, stop motion magic, ghost effects, distortion shots and time lapse photography. Every cine filmer can learn a lot from its 24 pages. Copies, which sell for 5¢, are available at camera stores or from Bell & Howell Co. direct.



35 and 16/35 mm



reflex viewing



divergent turret



40° to 200° adjustable shutter



lightweight - 14 lbs.



100' to 400' magazine



instantaneous loading



dovetail mounting



camérette

patents Coutant-Mathot
manufactured by Eclair, Paris

for descriptive brochure write U.S. representative

Benjamin Berg Agency, 1410 No. Van Ness Avenue, Hollywood 28, Calif.

in Canada: B.O.P. Co. Ltd., 455 Craig Street West, Montreal, P.Q.

ARRIFLEX

New 35 mm Model 2A
With 180° Shutter

**A TRULY GREAT
CAMERA**

for TV, Newsreel
and commercial
films



For tough and trying assignments, ARRIFLEX 35 is in a class by itself. Reflex focusing through photographing lens while camera is operating—this is just one outstanding ARRIFLEX feature.

Equipped with bright, right-side-up image finder, 6½ x magnification. Solves all parallax problems. 3 lens turret. Variable speed motor built into handle operates from lightweight battery. Tachometer registering from 0 to 50 frames per second. Compact, lightweight for either tripod or hand-held filming. Takes 200' or 400' magazine. Write for free folder.

Blimp now available.
16mm ARRIFLEX also available.

FRANK C. ZUCKER
CAMERA EQUIPMENT CO.
1600 BROADWAY NEW YORK CITY

letters

Paging Jim Blue

Would you please assist me in contacting Jim Blue, whose achievement in producing "Hamlet" in 8mm was described in your April, 1954, issue.

In the article, it was stated that Blue's B&H 8mm "Sportster" camera was equipped with a built-in backwind.

I have a Keystone A-12 16mm camera that I would like fitted with a similar attachment; thought Mr. Blue could tell me where I could have it done.

Richard De Muyack,
Rock Island, Ill.

• *Mr. Blue's address is going to you by letter.—ED.*

Reprint Request

In the June issue of your interesting magazine we have seen with much interest the pictures accompanying the article entitled "Hollywood's Greatest Underwater Venture." We would like to reprint this article together with the photos, giving your publication due credit, of course.

Raymond A. Bech,
L'Illustre,
Lausanne, Switzerland.

• *We are glad to grant you permission to reprint the article. The original photos, however, are unavailable. We believe duplicates may be had from Walt Disney Productions and are referring your request to them.—ED.*

Please rush to me (if available) the 12 cuts used in illustrating the yarn "Hollywood's Greatest Underwater Venture." Nice graphic splash, beaucoup dress-up—just with captions and even without copy!

Jim Finn,
International Projectionist,
New York, N. Y.

Song From Singer

I work with a 70-DL and a tape recorder plus a Bell & Howell "202" magnetic recorder-projector. Here's hoping I can find a little more in American Cinematographer from now

on about 16mm sound film making to help me along.

Joseph Singer,
Milwaukee, Wisc.

• *We hope to have a very interesting article for you in our September issue.—ED.*

Article Suggestions

Any chance of a series of articles on the amateur level abridged from the text of 'Principles of Color Photography'? Articles emphasizing the basic differences between Eastman, Ansco, and Agfa color film processes? Also an article on amateur processing of color film?

Hope to see more in future issues of AC on 3-D. Warner Brothers' latest (and last?) was technically perfect but Universal's "Creature From the Black Lagoon" in 3-D was not so good. Shown here in single-strip 3-D system called Pola-Lite, it was hard to view; the right and left images were far from steady. So I ask, "What is Pola Lite? Did I miss your article on it? And last: I hope to see more on R. V. Bernier's 'Naturama.'

Jack Kane,
Pittsburgh, Penna.

• *We're giving your suggestion for article series to our Editorial Board for consideration. The poor showing made by the Pola-Lite process which you saw was probably due to poor projection, which is usually at the root of most of the unsatisfactory screenings in 3-D. No, we did not publish an article on this system.—ED.*

Wants Interlock Plans

I have a problem. I would like to interlock a 16mm projector with an 8mm projector to make an optical printer. Do you know of an article or any book on this subject which would give me instructions on how to make the necessary mechanical interlock between the projectors?

Sam Sancenito,
Passaic, New Jersey.

• *With the hope that one of our readers may be able to supply the information you want, we are publishing your letter herewith.—ED.*

The New
Revolutionary

ARRIFLEX 16

®

The Only 16mm Camera with
MIRROR REFLEX SHUTTER
for Continuous Thru-the-Lens
Focusing and Viewing.

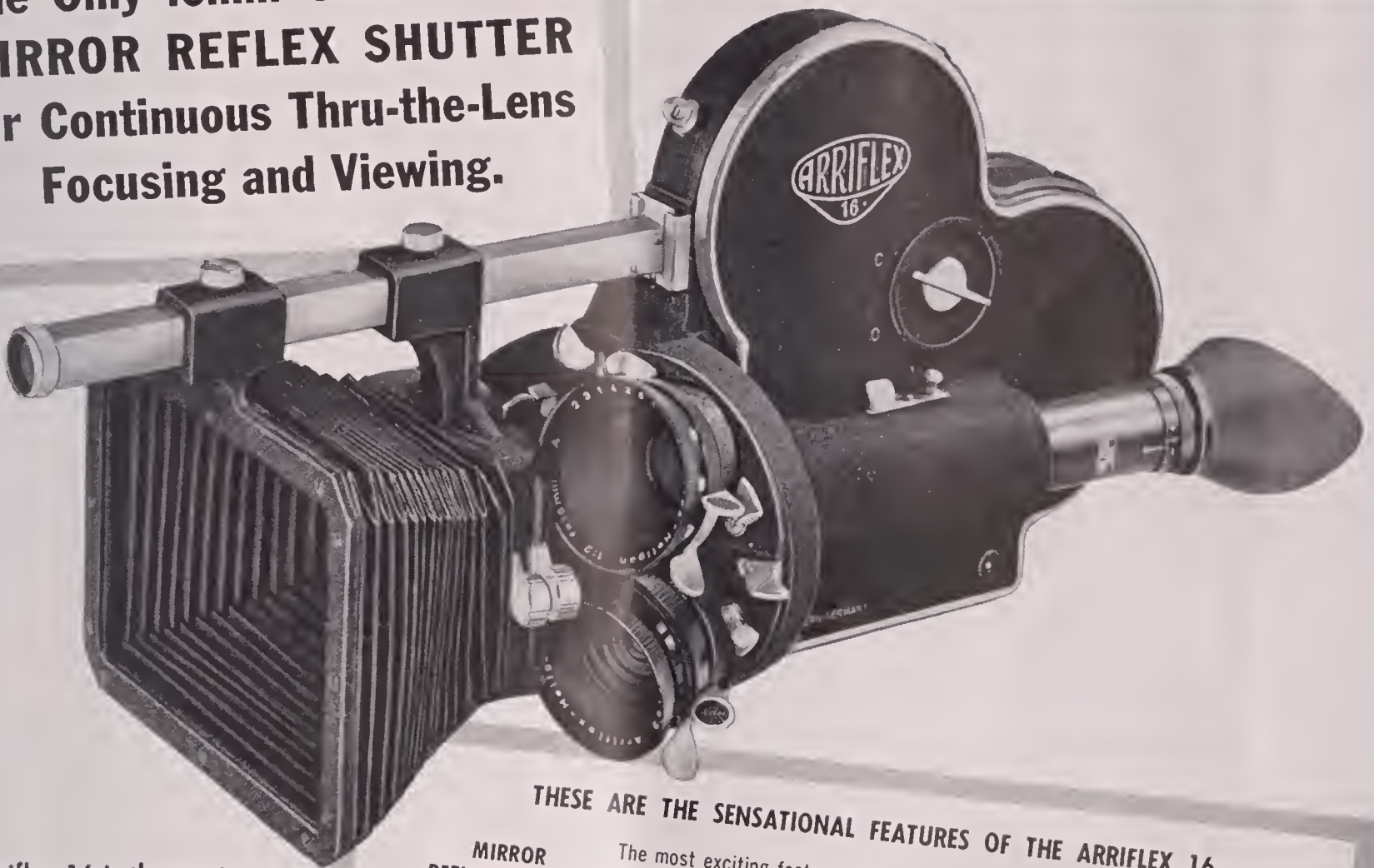

The Arriflex 16 is the most advanced camera in the 16mm field. No comparison can be made with any existing equipment. It is in a class by itself... unique for its features, and outstanding for its workmanship.

THESE ARE THE SENSATIONAL FEATURES OF THE ARRIFLEX 16

MIRROR REFLEX SHUTTER

The most exciting feature of them all: for accurate framing and critical follow-focus, through the taking lens, even during the actual shooting. Image on ground glass is brilliant, uninverted and right-side-up, magnified 10x through a highly corrected optical system. No parallax, and no need for accessory finders.

REGISTRATION PIN

Found only in cameras selling for \$3000 or more. Automatically engages and locks film during exposure. Assures absolute frame registration, and picture steadiness.

ELECTRIC MOTOR DRIVE

No need to stop a scene to wind a spring. Has variable-speed 6-volt DC motor with forward and reverse switch. Operates from portable, rechargeable battery pack, dry cell batteries, or with Transformer-Rectifier Unit on 115 volts AC. Easily interchangeable with Synchronous Motor Unit (available as accessory).

DIVERGENT 3-LENS TURRET

Accommodates lenses from 11.5mm extreme wide angle to longest telephotos. Lenses quickly interchangeable. Wide angle and 300mm telephoto can be mounted simultaneously without mechanical or optical interference.

OTHER ARRIFLEX PROFESSIONAL FEATURES

FOOTAGE & FRAME COUNTERS — for forward and reverse action.

TACHOMETER — indicates speeds from 1 to 50 frames-per-second.

CONTOUR GRIP — provides a natural and firm grip for handheld shooting.

DETACHABLE NECKSTRAP — for handheld filming.

LIGHTWEIGHT — camera with Matte Box weighs only 7½ pounds.

FILM CAPACITY — 50 and 100-foot standard daylight spools.

400-FOOT MAGAZINE — accommodates External Film Magazine. (This accessory will be available at a later date.)

DETACHABLE MATTE BOX-FILTER HOLDER — has stationary and rotating filter stages for color filters, polarizing filters, fades, dissolves, and other effects.

SINGLE SPROCKET DRIVE — for either silent or sound-perforated film.

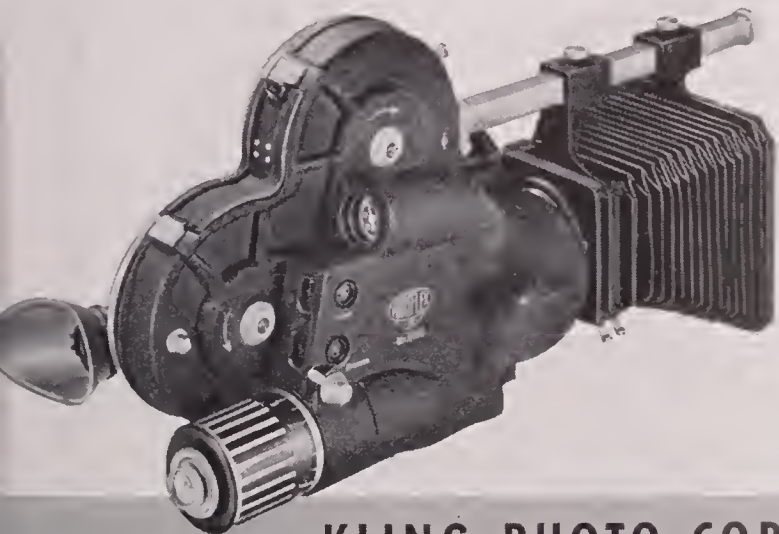

KLING PHOTO CORPORATION

235 Fourth Ave., New York 3, N. Y. • GRamercy 5-1120
7303 Melrose Ave., Hollywood 46, Calif. • WYoming 9026

SEEING IS BELIEVING!

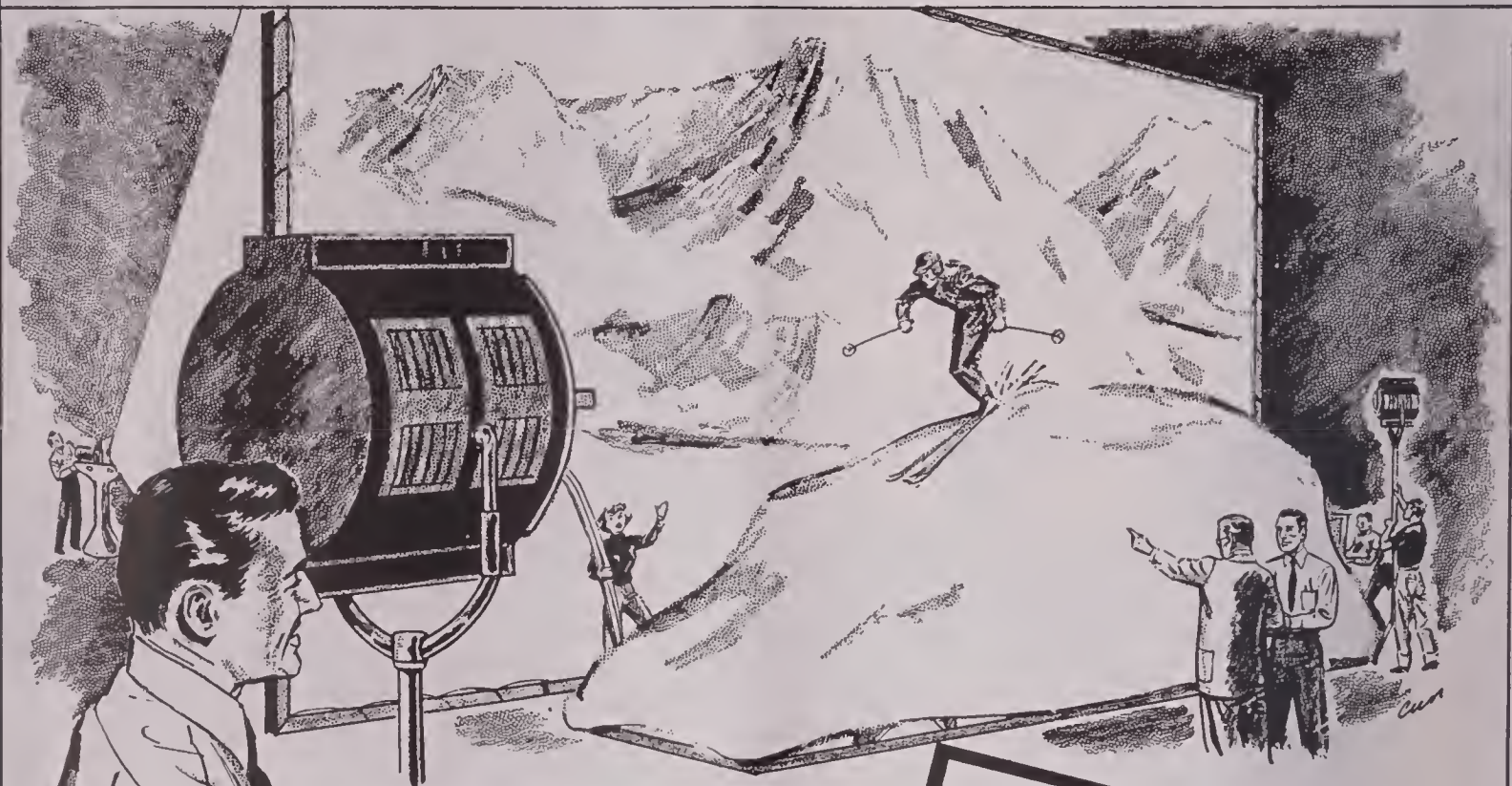

BEHIND THE SCENES...

THE BRILLIANCE AND TRUE COLOR OF "NATIONAL" ARCS IN REAR PROCESS PROJECTION ADJUST PERFECTLY TO FOREGROUND SET LIGHTING...PERMIT AUTHENTIC, FAR-RANGING PRODUCTION LOCALES WITH "STAY-AT-HOME" ECONOMY.



TODAY FOR PROCESS PROJECTION, BROAD SET COVERAGE, DEEP PENETRATION, CRISP SHADOWS AND HIGH BRILLIANCE WITH LEAST HEAT, IMPROVED "NATIONAL" CARBONS CONTINUE TO LEAD ALL OTHER TYPES OF STUDIO LIGHTING.

FIRST USED IN 1930, EARLY PROCESS PROJECTORS WERE STUDIO CREATIONS...TINY SCREENS, HEAVY "BLIMPS", IMPROVISED MACHINERY AND OPTICS. CURRENT TRIPLE-HEAD MODELS OPERATE WITH SCREENS OVER 20 FEET WIDE AND TOTAL LIGHT OF UP TO 85,000 LUMENS!



THE "NATIONAL" CARBON ARC...NOTHING BRIGHTER UNDER THE SUN

The term "National" is a registered trade-mark of Union Carbide and Carbon Corporation

NATIONAL CARBON COMPANY

A Division of Union Carbide and Carbon Corporation, 30 East 42nd Street, New York 17, New York

District Sales Offices: Atlanta, Chicago, Dallas, Kansas City, New York, Pittsburgh, San Francisco

IN CANADA: Union Carbide Canada Limited, Toronto



INDUSTRY NEWS

Simple Addition of Sound Printing Head Increases Output Over 30%

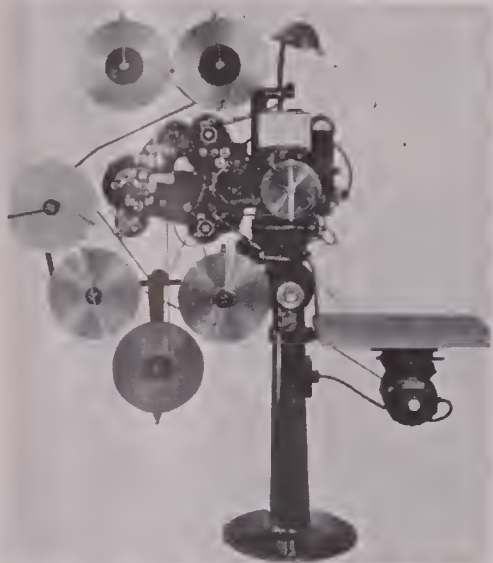

35mm-16mm Sound Printing Head, designed for your model "D" or "J" contact printer. Convert your single-head printer now into a double-head printer for high production output.

Literature On Request

MOTION PICTURE PRINTING EQUIPMENT CO.
Mfrs. of Motion Picture and Micro Film Printers
8136 NORTH LAWNDALE AVENUE • SKOKIE, ILLINOIS



Synchronous Motor Drive for 16mm Projectors

Especially designed to drive all Bell & Howell and Ampro 16mm projectors at synchronous speed.

The synchronous motor drive can be instantly attached to projector and taken off at any time. No special technical knowledge required for installation and mounting.

The synchronous motor drive is complete with base-plate, Cannon plug for cable and power switch, and a set of reduction gears.

Write for more details and prices

NOTE: When ordering please give correct firm and model of projector.

ONE YEAR GUARANTEE!

Immediate Delivery

Available at leading dealers, or direct.

KADISCH

CAMERA AND SOUND ENGINEERING CO.
500 West 52nd St., New York 19, N.Y.
Plaza 7-3511

DESIGNERS AND MANUFACTURERS OF
MOTION PICTURE—TV EQUIPMENT

The Technicolor selsyn-motor-driven follow-focus device has been adapted to the new Bausch & Lomb CinemaScope lens by J. P. Van Wormer of 20th Century-Fox camera department.

The simplicity and improved results achieved by selsyn systems have been proved by Technicolor and the system is now standard equipment on all of their cameras. Now the focusing problems which arose because of the revolutions necessary to change focus with a CinemaScope lens, have been overcome by Fox engineers through the adaptation of the selsyn device.

★

"TV Handbook For Motor Clubs" is title of an interesting publication recently issued by the American Automobile Association which contains a great deal of helpful information for the independent producer of television films.

Written primarily as an aid to the small and independent automobile club or association as a guide in producing and using TV films for promotion, the text describes how such films can be put to work to benefit the clubs, and there are detailed explanations of the various types of promotional and advertising TV films such as spot announcements, participation programs, etc.

For the small group with limited resources, it tells what equipment is necessary to make TV spot films and then outlines simple film making procedures.

According to American Automobile Assn., copies of the handbook are available to readers of American Cinematographer without cost. "With an increasing number of AAA motor clubs making their own motion pictures for television use," the company says, "the handbook suggests certain standards and procedures which we hope will be helpful."

For your copy, write Mr. Edgar Parsons, Dept. of Public Relations, American Automobile Assn., 1712 G Street, N. W., Washington 6, D. C.

★

John G. Capstaff, the Eastman Kodak scientist who in 1914 improved the photographic reversal process and made possible inexpensive home movies, retired July 1st after 42 years with the company.

A prolific inventor, with more than sixty-odd patents to his credit, Capstaff worked on optical filters, photographic solutions, special instruments and equipment, processing systems, and color photography.

His research played an important part in the development of the lenticular process of color photography on 16mm film placed on the market in 1928 by Eastman. This was the original Kodacolor film which brought color to amateur motion pictures for the first time.

For his key inventions, which formed the basis of amateur movies, Capstaff received a Modern Pioneers Award of the National Association of Mfrs. in 1940. He was a familiar figure at meetings of the American Society of Cinematographers where he was a frequent honored guest.

★

Three of the first Bell & Howell 16mm CinemaScope lenses to come off the assembly line were delivered to Walt Disney Studios in Burbank. They were mounted on 16mm Arriflex cameras for use by cameramen in the field shooting footage for forthcoming Walt Disney short subjects to be released in 35mm CinemaScope.

One of the C-Scope-lensed cameras was used by a Disney cameraman, during the shooting of "20,000 Leagues Under the Sea," to make a complete record in 16mm color and CinemaScope of the shooting of the Jules Verne story. The film is to be used in exploiting "20,000 Leagues" on TV and also in schools and colleges.

★

A ten-fold increase in the light output of Bell & Howell's Design 5205 film printer will speed the production of 16mm and 35mm prints. It will also afford more uniform light.

A new super high-intensity lamp is responsible for increasing the light at the printing aperture from 20.2 to 215 foot candles. The company claims this is ten times as much light as is provided by any other existing 300-watt printer.

Other improvements in the printer include a new dowser shutter, which allows lamp to be preheated to the desired color temperature, and an air duct frame to hold filters in slots surrounded by air streams.



Indispensable
for production
control in
motion picture
studios and
processing
laboratories

PHOTOVOLT SOUND-TRACK DENSITOMETER

For the accurate measuring of sound-track density on 35mm or 16mm and evolving sensitometric step-tablets. Suitable for general block-&-white, also color densitometry. Built-in electronic spot-photometer can be used separately for light measurements of high sensitivity in motion picture work. Remarkably versatile, does many other jobs. No particular skill required. Sturdily built, compact, lightweight and portable.

Sound-Track Densitometer comprising Track Density Unit and Spot-Photometer for 100-125V, 60 cycle AC.....\$445

Sound-Track Density Unit only, including aperture slide and film guide, for 100-125V, 60 cycle AC.....\$225

Electronic Spot-Photometer only, for 100-125V, 60 cycle AC.....\$220

Kinevox

PORTABLE SYNC MAGNETIC RECORDER



Takes 17 1/2 mm Film

Used by major studios in Hollywood, New York, Europe. Main sprocket driven by synchronous motor at 90' per min. Silent tight-winds for smooth delivery and take-up. Instant "Start", "Stop" and "Reverse" with film threaded. 4" VU meter. High and Low pass filters. Has pre-amplifier; amplifies for recording; bias and erase; playback; and monitoring. Power supply; 8" PM monitor speaker. Response: $\pm 1\frac{1}{2}$ db. 50 to 10 kc. 3 heads with azimuth adjustment, special erase, record and playback mounted on one shielded plate. Complete in one 50 lb. case, 60 cycle 110V single phase.\$1,550

50 cycle 110V single phase, \$1575. 50 cycle 220V single or 3 phase, \$1600
S.O.S. carries a complete line of Kinevox Products.

The One-Stop Source Of Supply

Here, under one roof, an entire building devoted to practically every conceivable need of film production equipment . . . including processing, recording and editing of motion picture films—a stock more varied, more complete than any in the industry.

28 YEARS OF PROGRESS

S.O.S. CINEMA SUPPLY CORP.

602 WEST 52nd ST., NEW YORK 19, N.Y. Phone: PLaza 7-0440 Cable: SOSOUND



A.C.E. 35mm ROTARY VIEWER

with New Image Erector

Famous for its performance and durability!

Acclaimed by directors, editors, animators, cutters, lab. technicians, inspectors, spotters, etc. Films clearly viewed while in motion, forward or backward. No pads, gates or other pressure mediums to cause scratches or abrasions. Single frames may be inspected without heating the film. Optically perfect magnifier assures sharp, undistorted view of entire picture area. No intermittent or oscillating ports—no film slap or mechanical noise—no complicated film threading—no snapping or breaking of film—nothing to wear out or cause trouble.\$159.50

A.C.E. Footage and Frame Counter.....\$64.90

A.C.E. Image Erector..... 27.00

TELEFUNKEN Mighty Midget Model 201M CONDENSER MICROPHONE



Nothing like it on the market!

Ideal for TV, broadcasting, film recording, etc. Takes place of 5 or 6 ordinary microphones. Easily switched from non-directional to cardioid. Extremely smooth response and wide range in the cardioid pattern. This, plus its slight rise in upper range when used as non-directional, make Telefunken the world's most advanced transducer. Immune to temperature or humidity changes. Response: ± 4 db 30-16,000 cps. Output: 30/50; 200/250 ohms, balanced. Size 7 3/8" x 7/8". Weighs only 4 ozs. Includes portable power supply unit, cable and plugs.....\$490

These users prove Telefunken's ultra-fine quality:

RCA Victor
Reeves Sound Studios
Capitol Records
Columbia Records
Decca Recording

Cinerama, Inc.
Gatham Recording Corp.
Warner Bros., Hollywood
Metro Goldwyn Mayer,
Hollywood
Hotel Statler

WMGM Recording
Studio
Bob Fine Recording
J. A. Maurer
20th Century-Fox
Ampeg Corp.



Magnaphonic
SOUND SYSTEM

There's a reason...

why Magnasync enjoys
continued worldwide leadership...

QUALITY...ECONOMY...INTEGRITY

Air S
Univer
Nava
Rad
Protes
Fotovox, Inc. Photographic Technicians Pr
W T S P—Florida Southern Pacific Railroad
Tele-Filmica Maxol, S.A., Havana Southern
Ford Foundation Twentieth Century-Fox, Inc.
University of Wisconsin Gospel Films, In
National Film Board of Canada Cine Associat
R.K.O. Radio Pictures, Inc. Pacific Picture
Gilfillan Bros., Inc. U.S. Air Forces Westingho
Iowa Conservation Commission Providenc
Fairchild Recording Equipment Co. Gallbrea
Magnolia Petroleum Co. Kearney & Trecker Co
W K A Q, San Juan, Puerto Rico State Colle
Naval Air Station Beeland-King Film Productions
Columbia Pictures Providence Bible Institu
Television Recording Service, Inc. Iowa Farm Bur
Westinghouse Electric Corp. Sound Recorders, I
Viguie Productions, Inc., Havana U.S. Navy Nort
Paramount Pictures Corp. Baptist Gospel Film
U.S. Department of Agriculture University of Iowa
International Productions Goodyear Aircraft Corp
Avalon Pictures, Inc. Reverend D. Kirk Hammond
Southwest Film Laboratory, Inc. Academy Soun
Naval Ordnance Wurtele Film Productions Acade
Bible Institute of Los Angeles University of Tennessee
University of Mississippi Rampart Productions Sc
Protestant Radio Center, Inc., U.S. Recording Co.
South Dakota State College Aspen Pictures Dallas Jo
Twentieth Century-Fox, Inc. Filmscope
U.S. Air Forces Magnolia Petroleum Co.
Southwest Film Laboratory, Inc. Gilfillan B
Cine Associates
Kearney & Trecker
University of Iowa
Arcturus Manufacturing
Goodyear Aircraft Corp.
Fairchild Recording Equipment Co.

Northern Pictures
Filmscope, Inc.
Arcturus Manufacturing
South Dakota State College
Gallbreath Picture Production
U.S. Recording Co. Aspen Pict
Dallas Jones Productions

Fotovox, Ir
th Dakot
Production
Corp.
of Tennesse
nt
Center, Inc.
U.S. Navy
ric Corp.
e., Havana
Baptist C
of Agricult
Florida
Pacific Pic
Internati
graphic Techn
es, Inc.
rsity of Wise
ific Railro
l Films
Naval Ordn
Bible Inst
rsity of Missi
Sound Rec
Inc.
Wurtele Fil
ture Prod
U.S. Depar
Viguie Pi
Gospel Films
Beeland-King Film
Ford Foundation
Columbia Pictures
R.K.O. Radio
W K A Q, San Juan, Puerto Rico
Paramount Pictures Corp. Bible Inst
National Film Board of Canada



MODEL SW-602
PORTABLE RECORDING SYSTEM

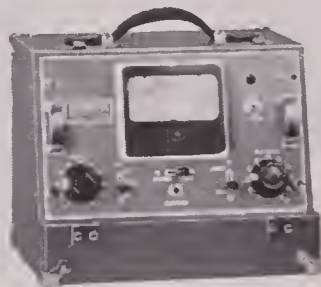

Select



DISTRIBUTORS

CAMERA EQUIPMENT COMPANY
1600 Broadway, New York 19, N.Y.
Judson 6-1420—Cable: "CINEQUIP"

MAGNETIC RECORDERS COMPANY
7120 Melrose Ave., Los Angeles 46, Calif.
WEbster 3-5545

ZENITH CINEMA SERVICE, INC.
3252 Foster Ave., Chicago 25, Illinois
IRving 8-2104

AMERICA'S LEADING MANUFACTURER OF MAGNETIC FILM RECORDING AND REPRODUCING DEVICES



PORTABLE
FILM RECORDERS



MICROPHONE MIXERS



CinemaScope
REPRODUCERS



THEATRE
SOUND
EQUIPMENT



3-CHANNEL
REPRODUCERS



MULTI-CHANNEL
INTERLOCKED DUBBERS

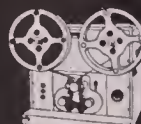

STUDIO DUBBERS
and RECORDERS



QUALITY AMPLIFIERS for
MAGNETIC RECORDING and REPRODUCTION



QUALITY AMPLIFIERS for
MAGNETIC RECORDING and REPRODUCTION



QUALITY AMPLIFIERS for
MAGNETIC RECORDING and REPRODUCTION

MAGNASYNC MANUFACTURING CO., LTD. • 5521 SATSUMA AVE., NORTH HOLLYWOOD, CALIF. • POplar 6-1692

The HANK McCUNE TV Show

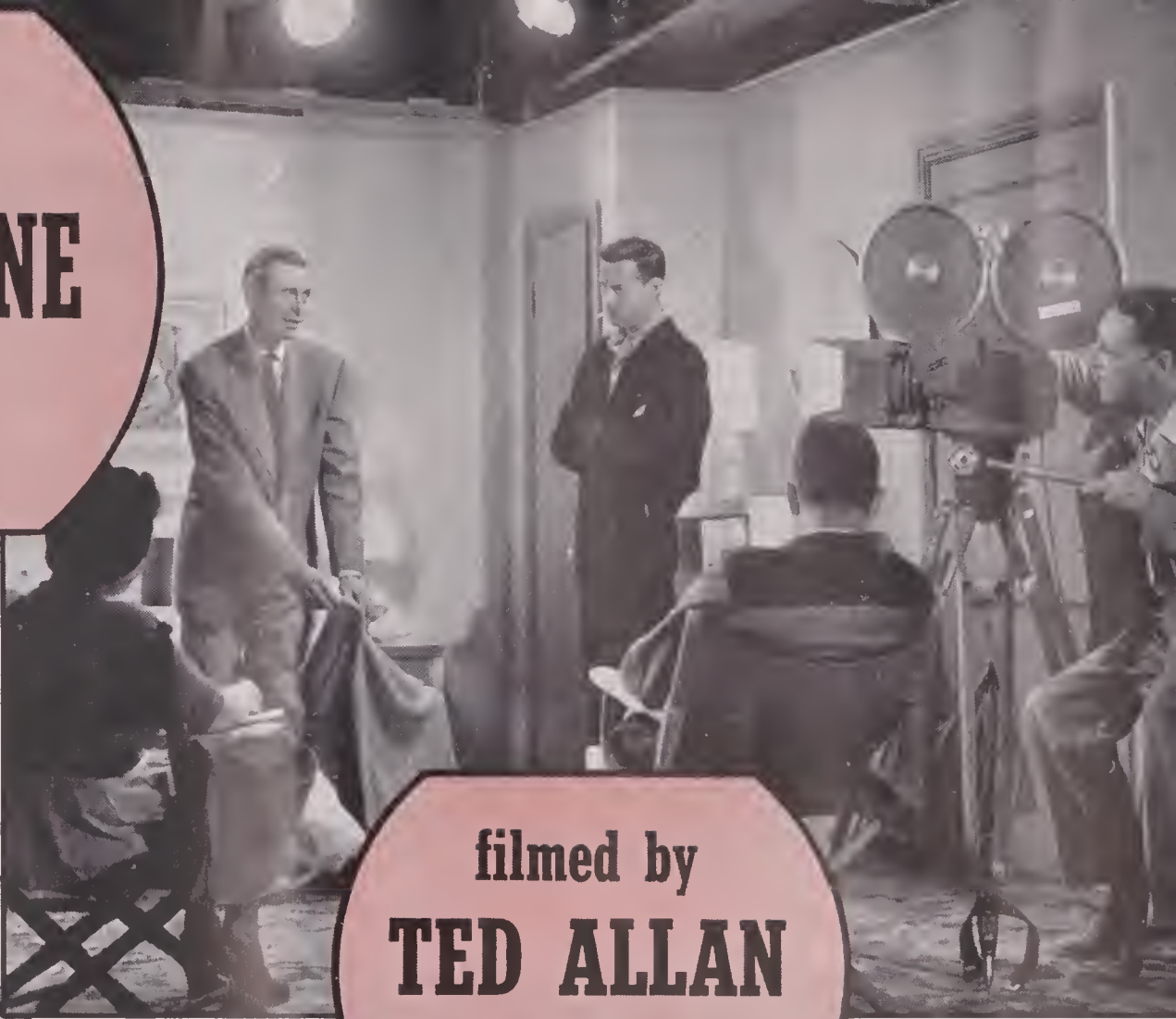
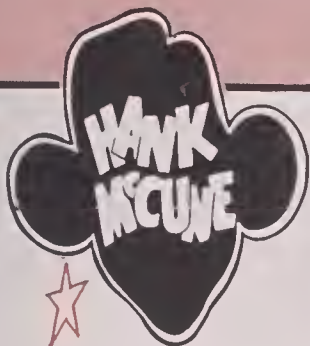

filmed by
TED ALLAN
Studios



... in **COLOR** with the
AURICON "SUPER 1200"

16mm Sound-on-Film Camera!

NAVY STORY

Filmed at Destroyer Base Reception Center, San Diego, California, with cooperation of the United States Navy.

Ted Allan, veteran Hollywood Photographer of the Stars, is one of the many professional film producers whose first choice for dependable television filming of the highest quality, is an Auricon 16mm Camera.

The "Hank McCune Show," a comedy series soon to be seen by millions over national TV networks, is being filmed in natural color with the "Super 1200" Camera. Ted Allan says, "45,000 feet of film have been run through the Auricon Camera without a film-scratch or loss of a foot of film!"

Write for your free copy of the complete Auricon Catalog, which includes the "Super 1200" Camera, a superb photographic instrument. Sold with a 30 day money-back guarantee, you must be satisfied!

FANTASY

Dream scene from "Aladdin and the Magic Lamp" story in the Hank McCune TV Show Series.



AURICON
BERNDT-BACH, INC.

6902 Romaine Street, Hollywood 38, Calif.

The **Auricon Hollywood** Line
SOUND-ON-FILM EQUIPMENT SINCE 1931



CINE-VOICE
\$485.00

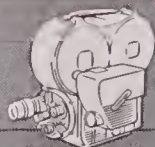

AURICON-PRO
\$930.00

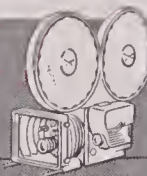

SUPER 1200
\$4652.35



TRIPOD
\$325.00



PORTABLE POWER UNIT
\$269.50

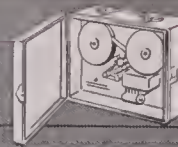

SOUND RECORDER
\$1149.50



1 FIRST STEP in preparation for shooting movies of recent Marciano-Charles title bout was erection of huge camera parallel in Yankee Stadium. Camera crews were hoisting cameras, tripods and film cases to top of parallel even before erection was completed.



2 TO PROVIDE adequate light for film and TV coverage of bout, thirty-four No. 4 Photofloods mounted in reflectors were installed in framework above the ring. Lamps, which were good for six hours of continuous burning, provided over 600 foot-candles of illumination.



5 DIRECTOR of Photography Freddy Fordham takes a final light reading at ringside before start of bout, relayed information to cameramen on parallel. Cameras, using 10" tele lenses, were set at f/8. DuPont No. 2 film was used and developed by Deluxe in New York.



6 THREE MITCHELL hi-speed cameras (in rear) recorded action at 72 frames per second for slow-motion analysis shots; three Mitchell standard cameras, one with a 17 inch lens and two with 10 inch lenses, shot entire fight at 24 frames per second.

Putting A Championship Bout On Film

Organization and pre-planning paid off handsomely in well-rounded film coverage of the recent Marciano-Charles title bout. Eight cameramen using six Mitchells and two Arriflex cameras covered fight from every angle, at 24 and 72 fps.

By CHUCK AUSTIN
Photos by the Author

PICTURES OF THE recent Marciano-Charles title bout were viewed in the nation's theatres by millions of fans via two mediums—films and television. The latter method brought the event to fight fans as it occurred via closed circuit TV. The film presentation of the fight was the result of smooth organizational work on the part of Leslie Winik, head of Winik Films, New York City,



3 CAREFUL pre-planning before start of bout insured top camera coverage of action. Producer Leslie Winik surveyed ring, using Mitchell finder to determine best camera angles, also positions for cameramen who were to shoot at ringside with hand-held cameras.



4 DUSK—with only minutes to go before start of bout. Six Mitchell 35mm cameras are set up and checked, ready to roll. Three TV cameras on adjacent parallel covered fight for the DuMont network for closed-circuit televising of event to theatres.

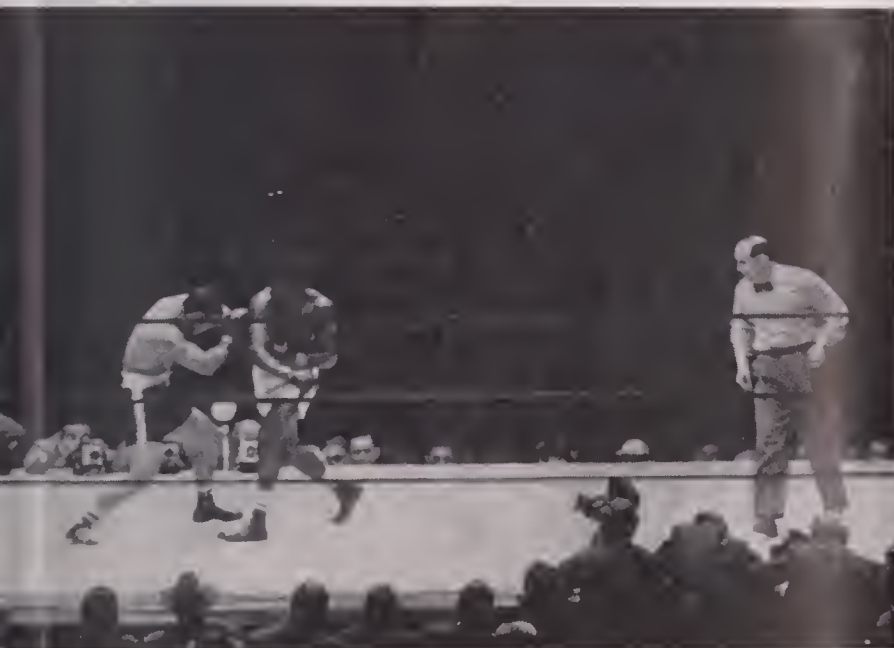

7 FIGHT ACTION as seen by cameramen on parallel. In right foreground, at edge of ring, can be seen cameraman Charles Downs, Sr., covering action closeup with an Arriflex 35mm camera while cameraman Doug Downs on opposite side of ring covered action from that point.

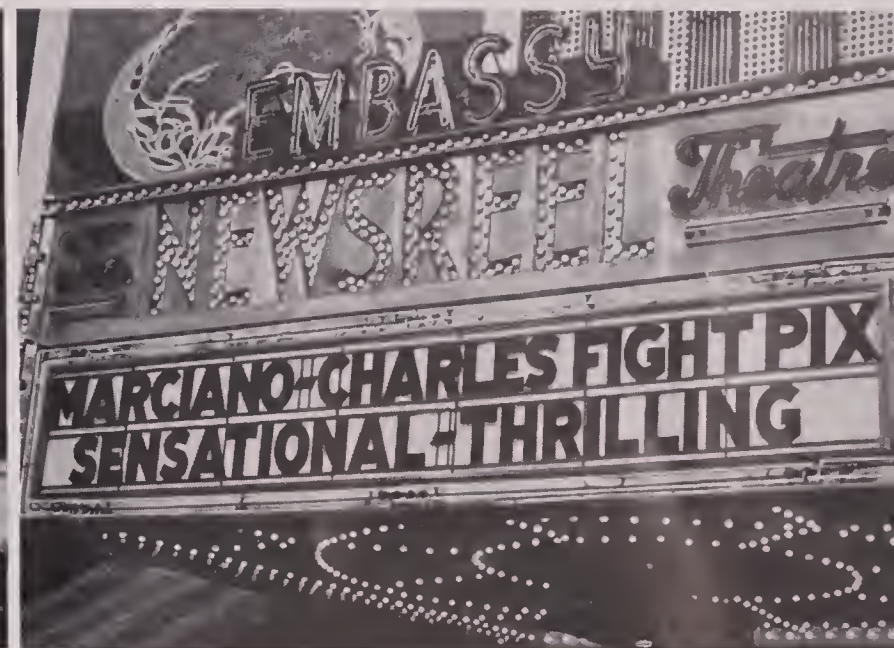

8 THE RESULT: only a few hours later, thanks to carefully-planned camera work and fast, efficient processing of negative and prints, the Marciano-Charles fight pictures were exhibited as a major attraction on many of the nation's theatre screens.

and a staff of eight top-flight cinematographers who recorded the entire match in both standard and slow-motion speeds to produce one of the most dramatic fight films ever brought to theatre screens.

It was Winik who produced the first fight film in 3-D when he and his camera crew recorded the Marciano-Walcott championship bout in Chicago last year with stereo filming units made up of both Mitchell and Camerette cameras.

This year's Marciano-Charles bout was filmed in black-and-white in 35mm with six Mitchell cameras, plus smaller

Arriflex hand-held cameras picking up closeups of critical action at the ringside.

After the ring had been built inside the Yankee Stadium, the rows of seats set in place, and a framework built over the ring for the photo lamps, two giant parallels were erected for the TV and motion picture cameras. Early in the afternoon preceding the fight, camera crews began hoisting the six Mitchell cameras along with their tripods and other equipment to the top of the parallel. The cameras were quickly set up, power lines were run up to supply cur-

rent for the camera motors, and a period of alignment and testing was begun.

At the same time, electricians were mounting thirty-four huge metal reflectors above the ring and fitting them with No. 4 Photofloods. These were to furnish illumination of a volume of 600 foot candles, which would provide a wide exposure range for both the film and TV cameras. The cameras fitted with 10-inch telephoto lenses, for example, were able to operate at a stop of f/8.

Of the six Mitchell cameras mounted high on the parallel, the three at the

(Continued on Page 418)

India's First Feature In Gevacolor

"Pamposh," 70-minute Gevacolor feature is first all-color film to be produced, processed and printed entirely in India.

By FREDERICK FOSTER



THE CAMERA as well as reflectors were mounted on flat-bottomed boats in filming most of the picture. Here it was set up on shore for one of the few scenes photographed on land.

A NOVEL camera boom was made from a telegraph pole. Cameraman Marconi sits precariously on the far end to make a vital crane shot, while group of assistants lend balance at the other end.



THE "BIG THREE" of "Pamposh" whose enterprise, initiative and courage made possible this fine color film. From left: Ezra Mir, writer-director; Carlos Marconi, cinematographer; and leaning against the Eclair Camerette, Ambalal J. Patel who financed, produced and processed it.

NOT ALL THE explorations of color film processes are conducted in Rochester and Hollywood. In addition to Technicolor, Cinecolor, Pathecolor, Eastman Color and Ansco Color, to name the most prominent of American origin, elsewhere in the world color films such as Agfa, Ferrania, and Gevacolor are finding their niche in feature film production.

The last named is a product of Belgium, yet perhaps one of its most zealous proponents is Ambalal J. Patel, of Bombay, India, who also is exclusive distributor of Gaevart motion picture films in India. Patel, in addition to his wide and varied enterprises, also operates the only complete color film laboratory in the far east. He built it especially for the processing of Gevacolor, for without adequate processing facilities, the use of Gevacolor among India's vast motion picture industry would necessarily be limited; processing then would have to be done in some distant country.

More recently, the use of Gevacolor film for feature productions was given further impetus when Patel personally produced India's finest feature-length color production, "Pamposh," in 35mm Gevacolor, filmed entirely out of doors.

Inspired partly by the desire to vindicate the new Gevacolor process, and partly by a long-repressed ambition to make a feature film, Patel conceived the idea of shooting a picture in the Kashmir province of India, where the riotous profusion of colors in the world's most beautiful springtime combines with ideal sunlight to provide the perfect testing ground for any color film.

The mere concatenation of color sequences was not the film pattern sought by Patel; there had to be a story which, as it unfolded on the screen, would distill something of the

(Continued on Page 414)

MOST of the action takes place on a dillapidated houseboat on Lake Dal. Here cameraman Marconi has set up his 35mm Camerette low on the boat deck for a series of closeups for "Pamposh."



DEDICATED TO BETTER PERFORMANCE



COLLAPSIBLE 3-WHEEL DOLLY

For motion picture and TV cameras. Sturdy cast aluminum. For standard or baby tripods. Additional baby tripod point holders to control spread of tripod legs. Adjustable spring seat. Extra wide rubber wheels. Bronze tie down clamps and other features.

For studio or location. Folds into one compact unit. Can be used with professional or semi-professional tripods.

'HYDROLLY'

TV OR CAMERA DOLLY

The advanced dolly for instant moveability — streamlined, lightweight, exceptionally sturdy. Nothing to get out of order. Many new advantages for easy operation. Hydraulic lift type for fast upward and downward motion of TV and motion picture cameras.

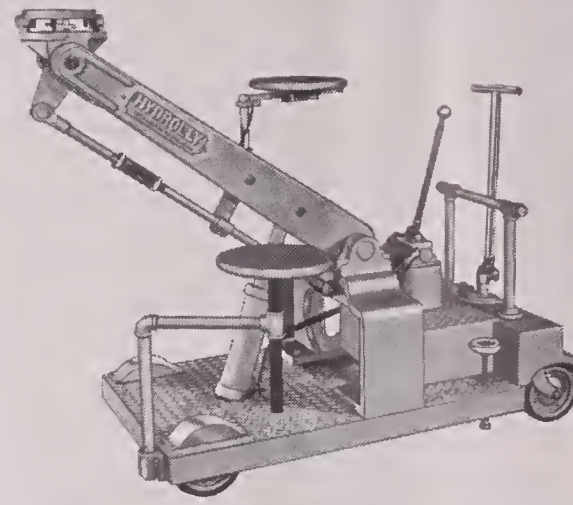

Swivel seat. Adjustable leveling head. Seat for assistant. In-line wheels for track use. Steering wheel, rigid floor locks. Hand pump or combination hand and motor pump. Easily transported in a station wagon. Fits through a 28" door.



SYNCHROMASTER SYNCHRONIZER

Our Exclusive Distributor
Neumade

Any combination of 16mm and/or 35mm sprockets assembled to specification. Cast aluminum. Foot linear type, adjustable frame dial. Fast finger roller release. Contact rollers adjusted individually for positive film contact. Sprocket shaft slip lock, footage counter, etc.

RENTALS

SALES • REPAIRS • SERVICE

LENS COATING

"T" STOP CALIBRATION

DESIGNING and MANUFACTURING

lens mounts & camera equipt. for 16mm, 35mm, TV cameras.

BAUSCH & LOMB "BALTAR" LENSES and others

for motion picture, TV cameras. 15mm to 40" focal length.

COMPLETE LINE of 16mm, 35mm cameras, dollies, synchronizers, animation equipment, cutting room and time lapse equipment.

BELL & HOWELL: Standard, Eyemos, Filmos. MITCHELL: Standard, Hi-speed, BNC, NC, 16mm.

SEND FOR CATALOGUE

ColorTran Groverlite SENIOR & JUNIOR KITS

"A STUDIO IN A SUITCASE"

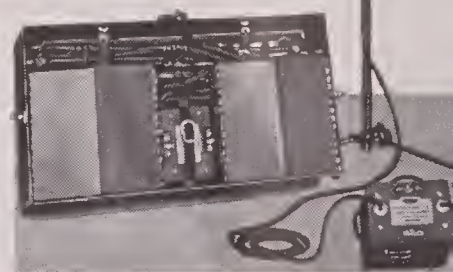

ColorTran replaces heavy and expensive equipment... gives you illumination up to 5000w. from an ordinary 20 amp. house current. Equipped with barndoors, diffuser slots for silks, snoots and other accessories. Ideal for studio or location shots.



PORTABLE MICROPHONE BOOM

For Studio or on Location. Lightweight — collapsible — for TV and motion picture production. Sturdy construction. Boom telescopes 7 to 17 ft. Rear handle for directional mike control. A remote control permits 360° rotation of the microphone. Operator can push the boom and operate

microphone swivel simultaneously. Extension rods make it simple to operate microphone rotation from floor. Microphone cable hangs outside of boom, preventing cable from tangling with the rotation mechanism. Ball bearing casters, rigid foot locks, pneumatic drop check for lowering the boom, etc.

VARIABLE-SPEED MOTOR with TACHOMETER

for Cine Special or Maurer Cameras

115 V. Universal Motor — AC-DC Separate Base for Cine Special. Variable Speed 8-64 frames. Adapter for Maurer Camera.

INTERCHANGEABLE MOTORS: 12 volt DC Variable Speed 8-64 frames. 115 Volt AC 60 Cycles, Synchronous Motor, Single Phase.

ANIMATION MOTORS: Cine Special, Maurer, Mitchell, B & H Motors, for Bolex and Filmo Cameras.

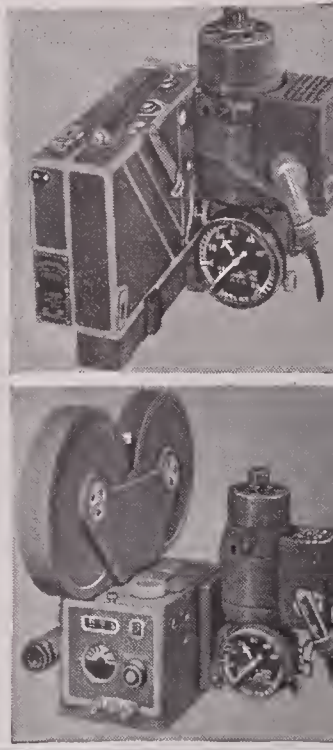



PRODUCERS of industrial, educational and training films would not be able to turn out the professional jobs they do without the independent film, sound and title labs. Facilities and experience of the latter now equal the best to be found in the major studios.

The Film Laboratory— Your Partner In Production

Independent film laboratories give the non-theatrical film producer all the production advantages of a major Hollywood studio.

By CHARLES L. ANDERSON

INDEPENDENT LABORATORIES in the United States servicing independent film producers now number over a hundred. The independent lab is not only essential to the fast growing non-theatrical film production field, but without it, few motion pictures produced outside Hollywood would have the professional embellishments that have come to be associated with professional productions.

When a major Hollywood studio plans a production, there are no limiting factors to contend with with regard to film developing, special effects, titles, or sound recording. Most of the majors have their own labs which provide these services right on the lot.

The growth of independent film production in recent years in both 16mm and 35mm has seen a comparable growth

in laboratories equipped to render the finest professional services to the independent producer. The old established industrial film producers, a great many government film production centers, and the majority of the big industrial firms who maintain movie making departments long have been steady patrons of these labs; indeed, with the extensive service which the independent labs now offer, such film producers probably could not have attained the important positions they now hold.

Every day, of course, hundreds of new 16mm and 35mm motion picture projects are started outside of the theatrical film field, and in some cases by film makers not entirely familiar with the scope of the services offered by the nation's film. special effects, title and sound recording laboratories. To familiarize the independent film producer with the services available to him to the end that such knowledge will make it possible for him to greatly enhance the professional quality of his films, is the purpose of this article.

The first time you read a film lab's price list you'll probably wonder why such a wide array of different services are catalogued. All you really want, it seems to you, is to have your film developed and printed. But professional film production requires more than just this. Invariably there are special photographic effects, fades and lap-dissolves required that will give your film the necessary smooth, professional "look" on the screen. And then there are titles to be made, sound to be recorded, and editing and cutting to be done. Shooting the picture is just the beginning.

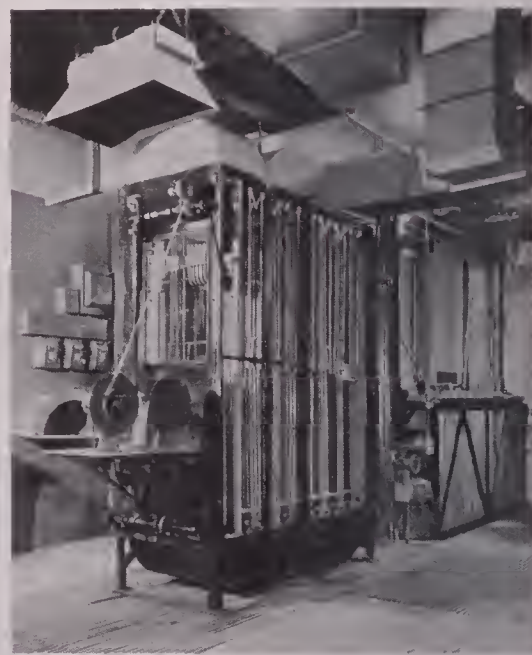

CAREFULLY controlled processing is offered independent producers of 16mm and 35mm films by film labs coast to coast, enabling them to achieve the same print quality that is found in the best theatrical films.

Let me say that the average laboratory makes it a point to be as helpful as possible to the neophyte embarking on his first professional production. Sometimes, of course, it appears to the lab man that the movie business consists of two types of film makers: former 35mm producers who are switching to 16mm, and former 16mm movie makers graduating to 35mm and producing TV or industrial films. Sometimes, also, it seems the latter have an advantage over the old experienced film producer who often has to learn entirely new procedures for setting up his films for release printing.

The two basic laboratory processes for commercial motion pictures, as most readers probably know, are the negative and reversal methods. Negative-positive, the standard in 35mm, is directly comparable to still photography, where the negatives from a camera are used to make positive prints. In the reversal process, film exposed in a camera is developed to a positive image with tonal qualities similar to the original subject. Color film transparencies and amateur motion picture film are familiar examples of reversal.

In the negative-positive process, a production unit sends exposed but undeveloped negative to the lab and receives back a positive print of the developed negative. The editor uses these positive prints, or "dailies," in putting together his work print of the picture. When the work print has been approved, either the studio or laboratory edits the original negative in conformance with it. Prints



A PRODUCER and lab representative watch an announcer record narration for picture being flashed on screen above in a laboratory which specializes on comprehensive sound service for the independent film producer. In background are sound mixer and music operator cueing records.

for showings may be made directly from this edited negative.

With the reversal process, there is no original negative but rather a "master positive." A work print of this film is made on reversal stock. Some producers project the original film when selecting the best takes before ordering work prints; and a few do part of their editing with the original. Release prints are

made either by the reversal process or by a duplicate negative for printing in the negative-positive fashion.

Most color release footage is made directly from the color reversal original. Black-and-white prints, in orders of 3 or more, are generally more economical in the dupe negative method. Dupe negatives give a better quality, too. B&W prints from color originals offer the same two optional methods.

The lab situation gets a bit more complicated when you need fades and dissolves. The standard method for producing these effects in 35mm is to print special low-contrast positives, known as "fine grains," for each scene affected. The lab effects-man rephotographs the positives in an optical printer, incorporating the desired fades, dissolves, and wipes.

When making release prints or dupe negatives from 16mm color or B&W reversal originals, fades may be added by merely dimming the printer light source. Lap-dissolves require double-printing, and therefore the picture is set up in A—B rolls. (See "How To Edit A and B Rolls", *Amer. Cinematographer*, April, 1950.—Ed.) The outgoing scene is on one reel and the incoming one on another. The laboratory prints the A roll first, which includes all footage up to the first dissolve. At this first dissolve, the printer light fades out and only leader stock runs through until the light fades on for the incoming scene of the second dissolve. Then the B roll is print-

(Continued on Page 408)

COLOR RELEASE prints and B&W dupe negatives are made with traveling matte effects transitions in this step printer. Matte reel at left controls light reaching color original and raw stock at right. Photo by Calvin Company.

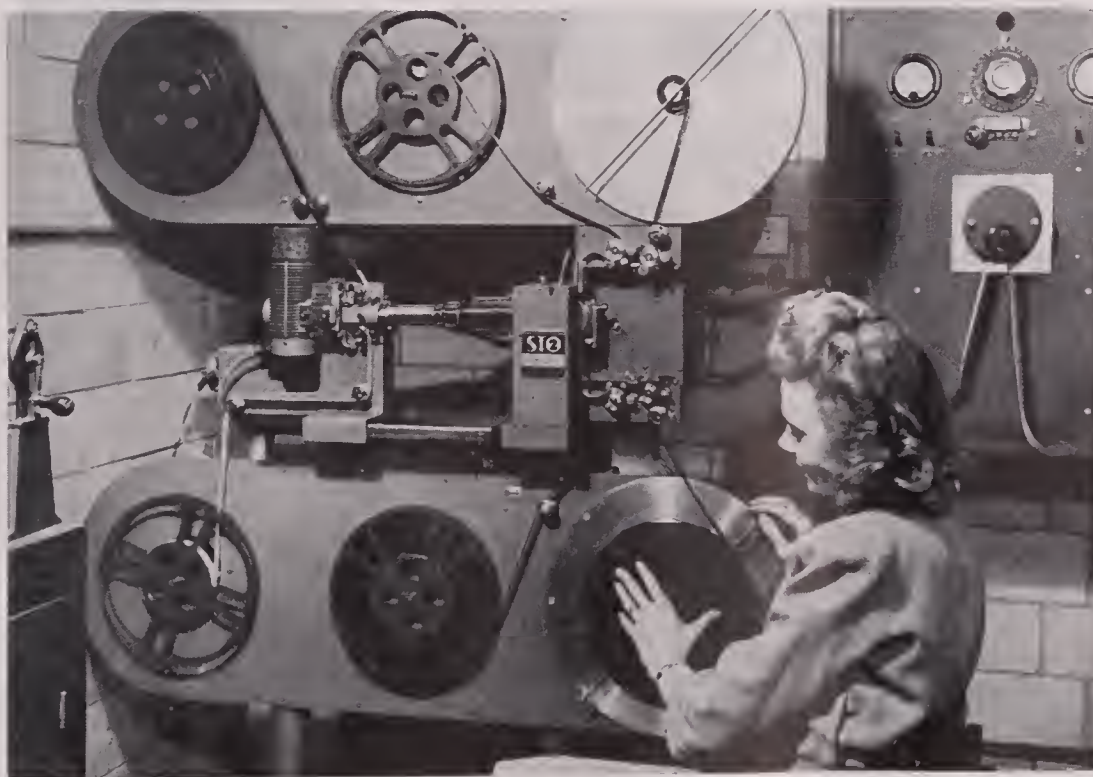

High-speed Negative Speeds Production

Encyclopaedia Britannica Films, Inc., one of first to use the new Eastman Tri-X high-speed negative in production of classroom films.

By ANDREW M. COSTIKYAN

Director of Photography, Encyclopaedia Britannica Films, Inc.

EVEN BEFORE THE call sheet was posted our crew had heard rumors about our next job. Destination: Washington, D.C. Personnel: full camera crew, plus cameraman, unit manager, the director-producer. Assignment: authentic background shots in every corner of the nation's capital. Later these would be cut into the series of educational government films we'd return to stage at our home studio. Altogether, the amount of work equalled that on a feature picture.

For an assignment like this in an earlier day, the crew would have worked far into the night loading two trucks and the carry-all to be ready for the early start. Now, all that has changed. In no time at all a single one-ton truck had been loaded. That was it. We were set. And we felt like pioneers in the movie business, because a new film emulsion had forever changed the method of production.

As movie history goes, it hasn't been too long in coming. A steady progression

from various wet plate techniques to dry plates; flexible film supports; improved color sensitivity; most recently, integral color emulsions—paralleling these, great advances in emulsion speeds, sensitivities undreamed of a few decades ago. High speed film has been the bluebird chased by the producer of educational, documentary and industrial pictures alike. In these fields mobility, photographic agility, spatial limitations, and pictorial ex-

cellence place severe demands on the producer; but the addition of these elements frequently builds the cost-limited production to major stature. Yet, until this year, countless dynamic, story-telling scenes have been struck from scripts because they'd require complex electrical rigging and hundreds of man-hours in preparation—far too costly for the small producer's budget.

Now we have new ultra-high-speed

USING AN Eclair Camerette and Tri-X negative, E-B's camera crew was able to shoot scenes such as this on the rostrum of the House of Representatives in Washington, D. C., without the need for cumbersome lights. From left are author Costikyan, Producer John T. Bobbitt, and Assistant Cameraman Michael A. Carlo.

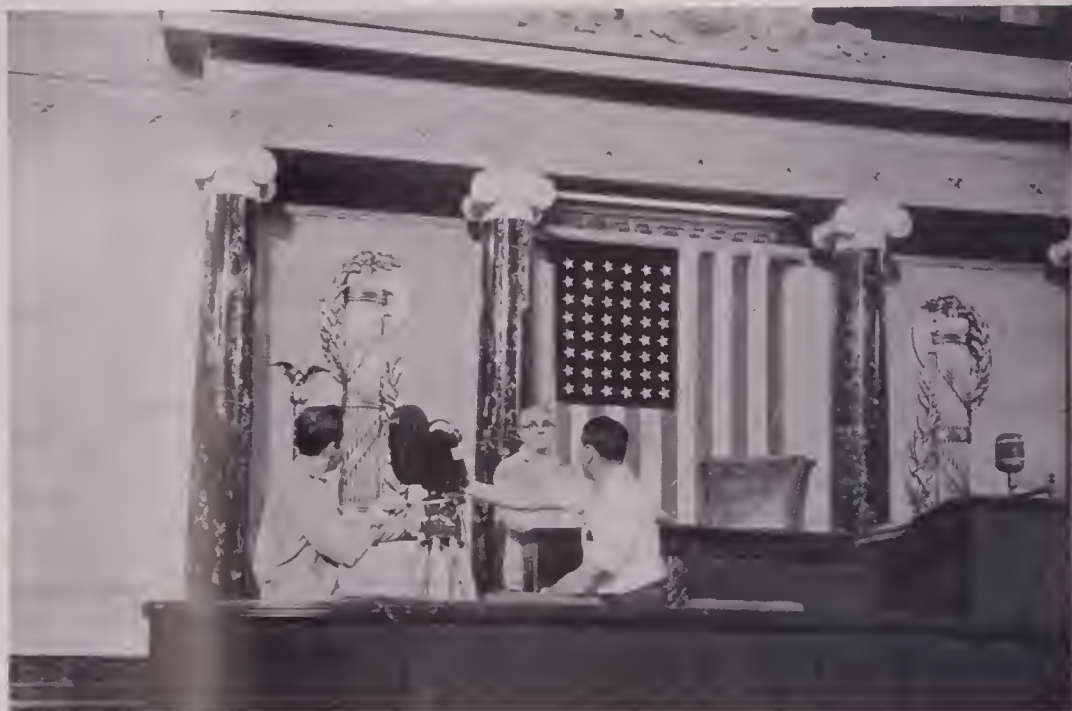

emulsions. Several are available or imminent but the experiences here noted are based on our use of the new Eastman Tri-X pan negative film, Type 5233. Films for classroom use, as produced by Encyclopaedia Britannica Films, are released in 16mm. Those in which the medium is most effectively and economically used in black-and-white are shot in 35mm, whereas most color subjects are filmed directly in 16mm. For this reason our use of Tri-X has been in 35mm, though we understand that equally good results are being obtained by producers using the 16mm Tri-X negative.

(Continued on Page 412)

FRAME ENLARGEMENT from film clip of Eastman 35mm Tri-X negative of scene for E-B's classroom film "The Congress," showing Armed Services Committee in session. Note "candid" quality obtained, thanks to absence of studio lights.

EASTMAN

PROFESSIONAL

MOTION PICTURE

FILMS

W. J. GERMAN, INC.

Fort Lee

Chicago

Hollywood

Sensitoflex—New Photometric Exposure Measuring Device

by JOHN FORBES



WHEN MOUNTED in the Eclair Camerette, the Sensitoflex is known as the Came-Radar. Here operator is shown moving the finger-tip control that moves the tiny photocell over the groundglass within the finder—an operation the cameraman observes through the finder eyepiece. Attached to tripod (lower right) is the photometer which records the light response of the Came-Radar.

CONSIDERED ONE OF the more promising of inventions for calculating exposures for cinematography is the recent development of French engineer, A. C. Coutant. It is a tiny light-measuring device known as the Came-Radar, which is built into motion picture cameras and which is capable of measuring exactly the luminosity of all points in a scene to be photographed—this, by exploring selectively with a small sensitometric probe 1mm by 3mm in size, the whole image at a point within the camera's optical system. (See "A Built-in Exposure Calculator for Motion Picture Cameras," American Cinematographer, February, 1953, Pg. 68.—ED.)

Until recently, about all that was known of this device was what had been set down in the technical publications of the industry. Today, the Eclair Camerette is available in the United States, as well as in France, with this built-in exposure-measuring device, according to Benjamin Berg, U. S. distributor.

What this photometric measuring instrument does is permit the cinematographer to obtain selective sectional readings of the overall scene as viewed through the Camerette reflex finder. In the late model Camerette having the measuring device built in, the operator may observe the probing of the picture area with the tiny photo-cell through the finder eyepiece.

Fig. 1 shows the Camerette (with film magazine removed) having the Came-Radar device built in. With his finger on the probe control, the operator observes the tiny measuring cell move across the picture area defined in the finder. At bottom right is the sensitometer to which wires leading from

(Continued on Page 416)

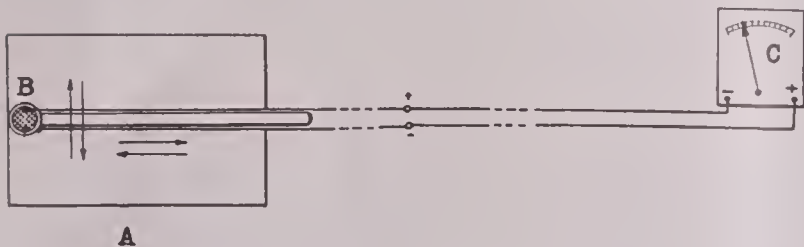
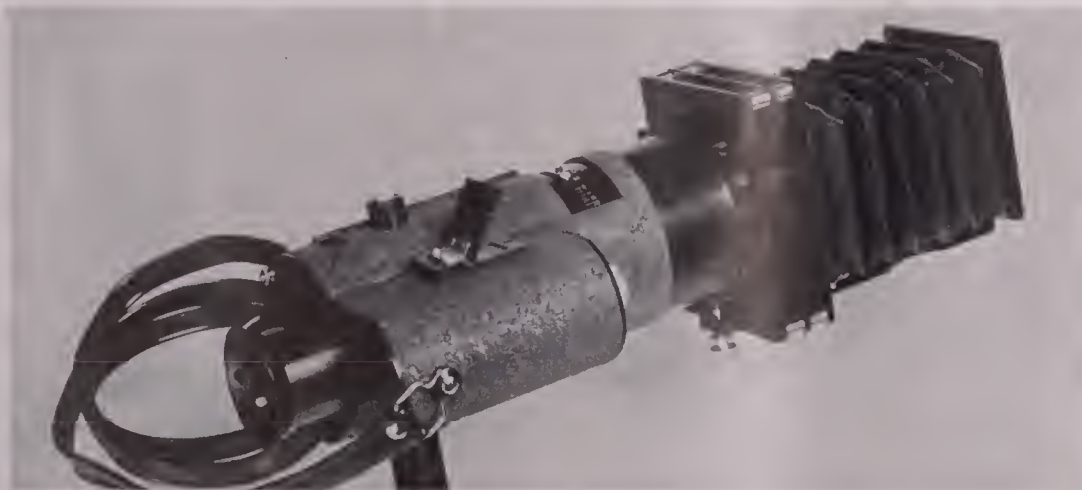

DIAGRAM of the Came-Radar. The ground glass is indicated at A, while the tiny photocell is indicated at B. As arrows indicate, this may be moved vertically and horizontally so that every point within the scene area may be read by the cell. The meter readings appear on the photometer at C.

Fig. 1 shows the Camerette (with film magazine removed) having the Came-Radar device built in. With his finger on the probe control, the operator observes the tiny measuring cell move across the picture area defined in the finder. At bottom right is the sensitometer to which wires leading from

(Continued on Page 416)



THE SENSITOFLEX (above left) functions same as the Came-Radar, but affords cameraman means of reading scene brightness selec-

tively without carrying camera around the set. Typical use of the Sensitoflex is shown at right. The instrument weighs but 25 ounces.

HOW TO PRODUCE top quality industrial TV films in sound and color at a price local advertisers and sponsors could pay, was the dilemma faced by Robert Young Studios, Indianapolis. "With new television stations coming into Indianapolis, we decided to venture into this motion picture field after many years in the industrial and commercial still picture business," said Mr. Young of the Indianapolis studio. "Through the usual trial-and-error method we started about two years ago with an Auricon Cine-Voice 16mm. single-system sound camera. Progressing steadily, we soon found it necessary to compete, quality wise, with some large national firms, but the high cost of necessary equipment would have priced our work out of the local-market."

Now the Indianapolis firm has hit on a plan that gives local sponsors the quality they desire at a very economical price. Working with Indianapolis agencies to prepare the material, the Young Studio now uses two Cine Voice cameras—shooting all film on regular daylight Kodachrome instead of the commercial Kodachrome in order to get a sound track right on location. All film is shot on location with full sound—including background noises, for a totally natural effect. Then a black and white work print is made and each scene given a number. A description of each scene is made and numbered on a file card. After reviewing the work print sufficiently to become familiar with each scene, the studio cuts the rough story by juggling the file cards. Each scene is then picked up by number according to the card and spliced together, leaving the full length of the scene including the number.

This can then be reviewed and changed to suit everyone, including the sponsor, by eliminating undesired scenes and cutting to length necessary for com-



A BLACK-AND-WHITE work print is made from the Kodachrome reversal original and each scene is given a number. Description of scenes is written on numbered 3x5 index cards and the film then cut according to the order of the cards following a pre-editing arrangement.

Short Cuts Cut Costs In TV Ad Film Production

By ARTHUR ROWAN

mentary to be written later. A record is made of the number of the scenes to be used and their sequence. The work print is then cut further, each scene shortened to its desired length and the action

matched. Upon approval of the sponsor or advertiser, each scene of the color original is then cut and spliced together in proper sequence. Color original scenes, however, are still left longer than the work print by at least twenty-six frames.

The next step is to re-record a sound effects track from the original sound track on the color film. This re-recorded sound track and the original film is recut and synchronized according to the work print. The work print is cued for the narrator by punching. Then a magnetic

(Continued on Page 418)



TELEVISION advertisement and spot films are shot on 16mm daylight type Kodachrome with an Auricon Cine-Voice single-system sound camera, which provides a fully-synchronized sound track with picture. Later, track is re-recorded with sponsor's narration mixed in.



THE PRIZE: A climactic shot to highlight a film on big game fishing. Here the composition and framing is perfect and produces a punchy pictorial effect bound to excite any audience.

If you want to demonstrate your professional movie making ability; if you want to film a subject that will sell,

SHOOT A BIG GAME FISHING FILM

BY CHARLES W. HERBERT, A.S.C.
Western Ways Photos by Tommy Lark.

NEARLY EVERY SERIOUS amateur movie maker at some time or another has dreamed of making a film that would sell, or at least one that would earn for him recognition in the professional field.

Such filming accomplishments have been realized by a few who happened to be in just the right place at the right

time, when some event of importance was taking place. They had their cameras loaded, were alert to the subject possibilities, were steady under the excitement, and came up with an important document, which sold. Others have found an unusual subject, stayed with it, and eventually produced a worthwhile film.

Film subjects which have the greatest chance of sale are those which carry the greatest general interest, contain spectacular or dramatic action. Take big game hunting or sports fishing for example. Here are two subjects replete with thrills, drama and pictorial interest for just about everyone. Out of casual fishing trips to out-of-the-way spots have



AFTER THE introductory sequence, your fishing film should jump immediately to the meat of the subject—catching the big fish. Here one prize has already been brought to gaff and a lookout is busy atop the cabin of the boat searching the sea surface for the telltale fin that indicates another potential prize lurking near.



THE STRIKE! Now the big fight to land the fighting monster begins, while the cameraman records the action over the shoulder of the fisherman.

come some exceptionally pictorial and interest-packed films, made by cine cameraists who had the imagination and took the pains to produce story-telling movies.

In this article I shall cover the making of a film on big game fishing. The general pattern, however, may also be applied to a film on hunting. A film on either subject should consist of the following four essential parts:

- 1—Preparation or introduction.
- 2—The quest.
- 3—The battle and the victory.
- 4—The celebration.

Big game fishing naturally offers more opportunity for spectacular action and a wider variety of scenes and camera angles—so that's our subject.

There is one fundamental requirement that must be considered and arranged before you even dream about doing a film on big game fishing. Unless you own your own boat and thus are able to dictate its operation on the water, you must be sure to arrange for unlimited cooperation from the owner or operator of any rented or borrowed boat you may use. It is important that you merge your talent with that of the boat operator to the end that your united objective is to catch and play big fish where and when your camera will have the best chance of recording perfectly-framed and properly exposed scenes—in

TIRING, but game! A closeup of the big, game, fighter of the deep made with a telephoto lens and with camera on tripod.

short, good usable footage which will fit together into a smooth continuity when edited.

The areas for big game fishing are numerous, but none, perhaps, surpass Guaymas, on the west coast of Mexico. Guaymas is just 260 miles south of Nogales, Arizona. It is easily reached by rail or by automobile over the new West Coast of Mexico Highway that begins at Nogales and continues to Mexico City.

(Continued on Page 403)



HAPPY MOMENT COMES when the hard-fought-for prize is safely landed aboard the boat. Where you fail to get this shot while at sea, you can re-stage and shoot it later.



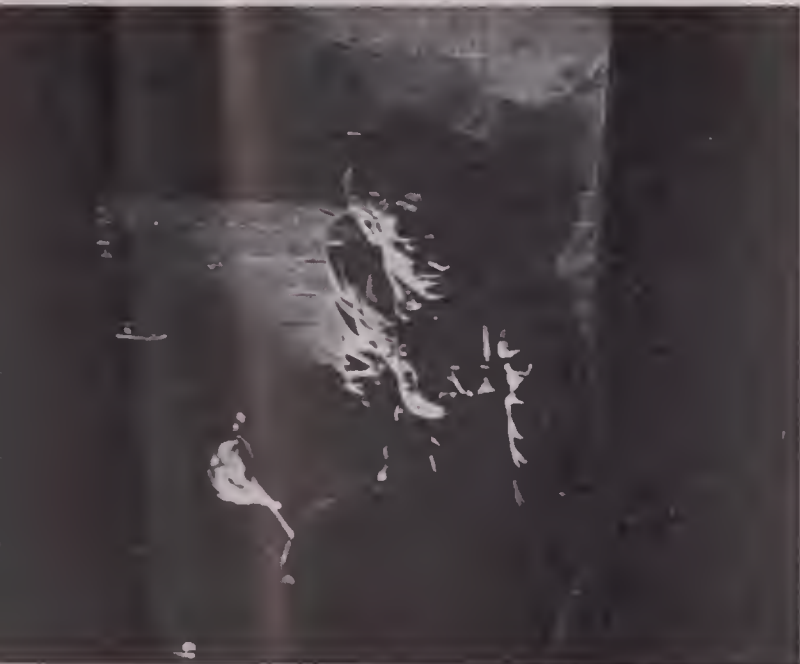

CINE HOBBYIST WITH A FUTURE

How intensive study of professional films influenced one London amateur's movie-making technique.

By HAROLD BENSON

RECENTLY I witnessed the screening of 170 feet of the most astonishing motion pictures I have ever seen. The "cinema" was a small projection room in a North London suburb. The film was all the footage so far shot for "Les Prisonniers," an adaptation of Guy de Maupassant's famous short story. The projectionist was also the script writer, director, producer, cameraman, and editor of the film, which is his first serious production. His name? Kevin Brownlow. His age? Sixteen.

There have been teenage producers before, of course. But I doubt if any of them have shown as much promise in all their work as is apparent in the truly remarkable seven minutes of "Les Prisonniers." The control and the understanding shown by this youngster would do credit to a hardened pro.

A feeling for filmic expression usually comes with years of experience. How, then, has young Brownlow managed to handle his ambitious subject with such fluency?

His intense study of film technique and history provides the answer. Fascinated by film ever since he can remember, Brownlow has built up a library of 142 films, all unobtainable from commercial libraries and almost all valuable rarities.

As he bought each film, so he hunted out all the information he could find about it. Credit lists, production details, contemporary comments and reviews were read and copied until he felt confident he had exhausted every possible source. He spent—and still does spend—hour after hour in the information department of the British Film Institute, the British equivalent of the Museum of Modern Art Film Library.

The result is that he has absorbed the finer points of technique from the old masters of the cinema. His repeated screenings of the lesser-known works of Griffith and von Stroheim have helped him to think visually, and have also made him unusually appreciative of the merits and defects of current releases. Pride of place in his collection at present belongs to the Abel Gance classic, "Napoleon," a rarity among rarities.

All Brownlow's work is done on 9.5mm., a gauge still very popular in Europe, though it enjoyed only a brief spell of life in America about twenty-five years ago. Apart from its size, the most obvious difference between it and 16mm. is the single row of sprocket holes which runs down the centre of the film. 9.5mm. equipment is con-

(Continued on Page 410)

PRODUCTION STILLS from 16-year-old Kevin Brownlow's 9.5mm monochrome film, "Les Prisonniers," showing results of his low-key lighting technique, using a single photoflood lamp without reflector.

LOWEST PRICES IN YEARS

OR GUARANTEED NEW AND USED EQUIPMENT

16mm CAMERAS:

WALL Single system camera, less galva, 25, 40, 50, 75mm lenses, rackover focusing, 2-1000 ft. mags., 12v. motor, cases.....	\$2375.00
EYEMO 71C, compact three lens turret, 7 speeds, 2" f2.8 lens, drum viewfinder, case, like new.....	545.00
EYEMO 71Q, spider 3 lens turret, prismatic focusing, 7 speeds, turret viewfinder, 12v. or 110v. motor, 400 ft. mag., 2" f2.5 lens, case.....	675.00
DE VRY Magic Eye, 10" shutter, 8fps. adapted with Eyemo C lens mount, 2" f4.5, 6" tubular viewfinder, case, like new.....	137.50
ARRIFLEX, 35mm Biatar f2, 50mm. f1.8, 75mm f1.8 (all coated lenses), 2-200 ft. mags., case, complete.....	745.00
SERVICE . . . Repairs . . . PARTS FOR EYEMOS . . .	
LENSES FOR EYEMO . . . "C" mount.	
75mm Zeiss Tessar f2.8.....	67.50
2" Eymax f4.5, fixed focus.....	27.50
2" Eymax f2.8.....	65.00
6" Cooke Telekinic f4.5.....	122.50
6" Eymax f4.5.....	54.50
47mm Cooke f2.5.....	49.50
42mm Kina Plasmat f1.5.....	29.50
25mm Eymax f4.5, fixed focus.....	29.50
16mm CAMERAS:	
FILMO 70A, 1" f3.5 Cooke.....	47.50
BOLEX H-16, ext. fr. ctr., 15mm f2.8, 1" f1.9, 3" f3.5, case, exc.....	269.75
FILMO 70D, 3 lens turret, 1" f1.8, 15mm. f2.7, 3" f4.5, drum viewfinder, completely overhauled.....	289.50
CINE SPECIAL 1, 1" f1.9, 15mm f2.7, 100 ft. mag., complete.....	377.50
CINE SPECIAL 200 ft. magazine.....	224.75
CINE SPECIAL synchronous motor.....	104.50
CINE SPECIAL var. speed motor, tachometer Reg. \$350.....	244.50
CINE SPECIAL optical zoom viewfinder.....	74.50
CINE SPECIAL magnifying reflex focuser.....	73.40

BUY NOW AND SAVE!

FILMO PAR DELUXE, with beautiful 4 lens turret, built-in rackover, focusing and viewing thru lenses, image magnifier, pas. obj. finders, 110v. sync. motor, 400 ft. mag, Veeder counter, large deluxe compartment case. LIKE NEW, value over \$2000.00.....	895.00
AURICON PRO with special features, 3 lens spider turret, side zoom viewfinder, 360 ft. capacity, prism focuser, ampl. case, etc.....	1395.00
MAURER camera complete, 2 Batar lenses, motor, 400 ft. magazine, case.....	3875.00
ARRIFLEX 16, 180° shutter, reflex focusing, lenses interchangeable with 35 Arri available NOW . . . write for lists.	
CAMERETTE, 35-16mm camera, motor, 18.5, 25, 50, 75mm lenses, 3-35mm mags., 2-16mm mags., case, extras.....	3595.00
EDITING EQUIPMENT:	
MOVIOLA 35mm pic, takeups.....	349.75
MOVIOLA 35mm comp. 3 sound heads, preview screen, ampl. cabinet etc., (FOR SALE OR LONG TERM RENTAL)	
MOVIOLA 16mm pic, takeups.....	354.50
MOVIOLA type 16mm sound head, takeups, less ampl and motor.....	224.50
ALL MOVIOLA SYNCHRONIZERS & REWINDS IN STOCK AND FOR SALE.	
ACE 35mm viewer, like new.....	125.00
ACE offset erect image adapter.....	29.50
BAIA 16mm viewer, head only.....	29.75
CRAIG 16mm editor—new model.....	36.75
FILMO-PRO 16mm viewer, head.....	78.50
FRANKLIN 16mm editor, rewinds and splicer mtd. on board.....	49.75
PRECISION 35-16mm optical sd. reader.....	185.00
GRISWOLD splicers R2 or R3.....	21.75
SYNCHRONIZER 4 gang 35mm ctr., NEW.....	169.50
SYNCHRONIZER 2 gang 35mm ctr., NEW.....	111.50
SYNCHRONIZER 1 gang 35mm, 1 gang 16mm ctrs., NEW.....	161.50
STUDIO apt-magn. sound reader.....	79.50
NEUMAIDE 4 gang 35mm synchronizer, ctrs., mtd. on parc. black.....	110.00
NEUMAIDE 35mm meas. machine.....	54.50
NEUMAIDE 16mm meas. machine.....	62.50
NEUMAIDE 2 gong 35mm sync. NEW.....	132.50

TRADES ACCEPTED

F & B 16mm SPLIT REELS			
400 ft.....	4.50	1200 ft.....	7.50
800 ft.....	6.00	1600 ft.....	9.00
KELLY cine calculator, sliderule.....			3.95
F & B 1200' heavy duty alum. flange.....			7.45
COTTON editing gloves. dox. pr.....			2.75
MOVIETONE blaaoping ink.....			1.20
SCOTCH 1/4" magn. tape, 1200'.....			3.30
F & B ELECTRIC film footage counter, comb. 16 and 35 mm, sync motors, NEW 35mm single model.....			87.50
			43.75
MISCELLANEOUS:			
BARDWELL 12 ft. heavy duty lights stands, holds 3 lights.....			37.50
BARDWELL QUAD striplite.....			7.95
MORSELITE 22" floodlite, magul base, hi-la switch, rolling stand.....			23.50
COLORTRAN deluxe converters, used.....			32.50
F & B GATOR GRIPLITES, heavy duty parc. socket, 25 ft. card and switch, rotatable lightweight barndaars.....			12.95
COLORTRAN JR. KIT, used.....			110.00
KLEIGEL TV scooplites, 18", clampon.....			24.50

NEW: Pro-Cine Tripod

for Auricon-Pro . . . Maurer . . . Cinevoice . . . Cine Special . . . Filmo . . . Bolex . . . Eyemo with motor and magazine . . . Arriflex 35 & 16 . . . Camerette . . . all still cameras . . . view cameras.



The F&B PRO-CINE is a brand-new, modern medium weight tripod; precision engineered and designed by cameramen for cameramen; constructed with emphasis on smooth controlled friction pan and tilt movements, ruggedly built for the utmost in rigidity and for long, satisfactory service.

FEATURING . . .

- Super-smooth friction head, unconditionally guaranteed for five years of the ultimate in pan and tilt performance.
- Telescoping two-position offset panhandle for easy adjustment to your length requirements . . . can be quickly changed to left or right position . . . offset for added comfort and convenience.
- Knurled camera-tightening knob, externally operated by angle gears for maximum, fumble-free tightening.
- Precision engineered positive pan and tilt lacks for utmost rigidity and safety.
- Superb, seasoned, solid hardwood legs, beautifully finished for smooth, non-sticking telescoping action.
- All metal fittings precision machined
- One piece leg-tightening knurled knobs for quick, easy leg adjustments.



REMOVABLE FRICTION HEAD MOUNTS EASILY ON BABY TRIPOD OR HI-HAT.

Weight: 14 lbs.
Height: 41" low spread
75" high spread
Pan: 360°
Tilt: 90°

FINEST MATERIALS AND WORKMANSHIP THROUGHOUT

Friction head unconditionally guaranteed for 5 years

FREE: Fibre carrying case (value \$20.00) to first 100 buyers. LIST PRICE **\$135.00**

NOTE: Spring balanced head, adjusted to your camera, available at extra cost.

Agencies and territories now available for all F&B products for dealers and distributors.

F&B
FLORMAN & BABB
70 West 45th Street, New York 19, N. Y.
Phone: Murray Hill 2-2928
Cable Address — FLORBABB, N. Y.

F&B HAS A COMPLETE STOCK OF NEW AND USED CAMERAS, PRODUCTION, LIGHTING, EDITING & LABORATORY EQUIPMENT
Visit our new, larger showroom or WRITE—WIRE—PHONE
EVERY ITEM SOLD IS MONEYBACK GUARANTEED
WE BUY — SELL — RENT

HOLLYWOOD STUDIO PRODUCTION

Feature and television film productions for which members of the American Society of Cinematographers were engaged as Directors of Photography during the past month.

AMERICAN SOCIETY OF CINEMATOGRAPHERS

FOUNDED January 8, 1919, The American Society of Cinematographers is composed of the leading directors of photography in the Hollywood motion picture studios. Its membership also includes non-resident cinematographers and cinematographers in foreign lands. Membership is by invitation only.

BOARD OF GOVERNORS—1954

ARTHUR MILLER, President
 SOL HALPRIN, First Vice-President
 JOSEPH RUTTENBERG, Second Vice-President
 ALFRED GILKS, Third Vice-President
 WALTER STRENCE, Treasurer
 PHILIP TANNURA, Secretary
 ROBERT DE GRASSE, Sergeant-At-Arms
 JOHN ARNOLD
 JOSEPH BIROC
 ARTHUR EDSON
 GEORGE FOLSEY
 LEE GARMES
 VICTOR MILNER
 HAL MOHR
 LEON SHAMROY

ALTERNATE BOARD MEMBERS

ARTHUR ARLING
 LUCIEN BALLARD
 DAN CLARK
 PAUL EAGLER
 FARCIOT EDOUARD
 ERNEST LASZLO
 ROBERT PITTACK
 JOHN SEITZ
 JAMES VAN TREES
 PAUL VOGEL

ALLIED ARTISTS

HARRY NEUMANN, "Bowery to Bagdad."

COLUMBIA

HENRY FREULICH, "Bugle's Wake," Technicolor.

METRO-GOLDWYN-MAYER

ARTHUR E. ARLING, "The Glass Slipper," Eastman color, wide-screen.

WILLIAM MELLOR, "Bad Day at Black Rock," Technicolor, wide-screen.

JOHN SEITZ, "Many Rivers To Cross," Eastman color, CinemaScope.

PAUL VOGEL, "Jupiter's Darling," Eastman color, CinemaScope.

PARAMOUNT

ROBERT BURKS, "To Catch A Thief," Technicolor, VistaVision.

DANIEL L. FAPP, "Blue Horizons," Technicolor, VistaVision.

LOYAL GRIGGS, "We're No Angels," Technicolor, VistaVision.

REPUBLIC

JOHN L. RUSSELL, JR., "The Atomic Kid."

R.K.O.

JOSEPH LA SHELLE, "The Conqueror," Color, CinemaScope.

20TH CENTURY-FOX

LUCIEN BALLARD, "White Feather," Technicolor, CinemaScope.

CHARLES G. CLARKE, "Black Widow," Color, CinemaScope.

MILTON KRASNER, "Desiree," color, CinemaScope.

JOE MACDONALD, "The Racers," color, CinemaScope.

LEO TOVER, "Untamed," Technicolor, CinemaScope.

LEON SHAMROY, "There's No Business Like Show Business," color, CinemaScope.

UNIVERSAL-INTERNATIONAL

WILLIAM DANIELS, "Foxfire," Technicolor, wide-screen.

HAROLD LIPSTEIN, "Chief Crazy Horse," Technicolor, CinemaScope.

R. L. METTY, "Man Without A Star," Technicolor, wide-screen.

CLIFFORD STINE, "Smoke Signal," Technicolor, wide-screen.

WARNER BROS.

ELLIS CARTER, "The River Changes," Warner Color, CinemaScope.

LEE GARMES and RUSSELL HARLAN, "Land of the Pharaohs," Warner-Color, CinemaScope.

CHARLES LANG, "Young at Heart," Warner Color.

J. PEVERELL MARLEY, "Drum Beat," WarnerColor, CinemaScope.

TED MCCORD, "East of Eden," Warner-Color, CinemaScope.

WILLIAM SKALL, "The Silver Chalice," WarnerColor, CinemaScope.

HARRY STRADLING, "Helen Of Troy," WarnerColor, CinemaScope.

INDEPENDENT

STANLEY CORTEZ, "Black Tuesday."

BURNETT GUFFEY, "Private Hell 36."

CARL GUTHRIE, "Long John Silver," Technicolor, CinemaScope.

RAY JUNE, "Day of Triumph," Eastman color, wide-screen.

VIRGIL E. MILLER, "Unchained," wide-screen.

RAY RENNAHAN, "Stranger On Horseback," Technicolor.

ROBERT SURTEES, "Oklahoma," Eastman-color, Todd-AO, CinemaScope.

GILBERT WARRENTON, "The Black Pirates," Ansco Color, wide-screen.

TELEVISION

(The following directors of photography were active last month in photographing films for television in Hollywood, or were on contract to direct the photography of television films for the producers named.)

LUCIEN ANDRIOT, "Where Were You?," Ken Murray Productions; "It's a Great Life," Raydic Corp'n; "The Life of Riley," Hal Roach Studios.

JOSEPH BIROC, "Treasury Men in Action," American National Studios, Inc.

WILLIAM BRADFORD, "Gene Autry," Flying A Productions.

FLOYD CROSBY, "Royal Canadian Mounted Police," S & S Films, Ltd.

GEORGE DISKANT, "Four Star Theatre," Four Star Productions, Inc.

ELLSWORTH FREDERICKS, "The Dennis Day Show," Denmac Productions.

HENRY FREULICH, "Captain Midnight," Screen Gems.

FREDERICK GATELY, "Mayor of the Town," Rawlins-Grant, Inc.

AL GILKS, "The Halls of Ivy," Television Programs of America, Inc.

BEN KLINE, "Fireside Theatre," "An Argument With Death," Frank Wisbar Prods.

JACK MACKENZIE, "Public Defender," Hal Roach, Jr., Productions.

ERNEST W. MILLER, "Rocky Jones, Space Ranger," Roland Reed Productions.

NICK MUSURACA, "The Lone Wolf," Gross-Krasne, Inc.

KENNETH PEACH, "Adventures of the Falcon," Federal Telefilm, Inc.

ROBERT PITTACK, "The Lone Ranger," CM TV Productions, Inc.

JOHN L. RUSSELL, JR., "Joe Palooka," Guild Films.

WILLIAM SICKNER, "The Whistler," Lindsay Parsons Productions.

MACK STENGLER, "Liberace," "Life With Elizabeth," "Florian Zabach Show," and "Frankie Laine Show," Guild Films.

WALTER STRENCE, "Waterfront," Roland Reed Productions.

STUART THOMPSON, "Lassie," Robert Maxwell Associates.

JAMES VAN TREES, "I Married Joan," Joan Davis Enterprises and "Hey, Mulligan," Mickey Rooney Enterprises.

Santa Fe Film Award

"Arts and Crafts of the Southwest Indians," a 22-minute color film produced for Santa Fe Railway by Ernest Kleinberg of Los Angeles, received an "outstanding sponsored film" award in the 5th annual presentation made at Town Hall Club, New York, by Scholastic Teacher Magazine.

In April, the film was also awarded a certificate of merit from the Film Council of Greater Columbus (Ohio).

The film features today's Indian artisans among members of the Navajo and Pueblo tribes.

SHOOT A BIG GAME FISHING FILM

(Continued from Page 399)

Another reason for selecting Guaymas is Tommy Jamison, who operates a big game fishing fleet of boats there and is always ready and willing to cooperate with photographers who wish to make a picture of "fishing for the big ones" in the bay of Guaymas. Tommy maintains offices at both the major hotels there—the luxurious Hotel Playa de Cortes and the well-appointed popular Hotel Miramar.

Best time for fishing at Guaymas is during the summer months when the marlin, sailfish and dolphin are running in the clear, warm waters of the Gulf of California. Tommy's boat captains know the fishing waters like a Manhattan cop knows his city beat. To enable fishermen to promptly reach areas where the big fish are running, and with a minimum loss of time, Tommy uses a seaplane to search for and spot the big runs of game fish. An alert ship-to-plane-to-shore radio network relays information to the boat captains and guides them to the day's fishing grounds.

But before you start out for a day's fishing and filming, you'll have important preparations to make such as checking your camera, deciding which accessories and spare parts to take along, etc. Be sure to allow an extra amount of film, because you will be working on a subject where you cannot control the essen-

tial action; you will probably expend a lot more film than you planned just in getting those important and spectacular shots of game fish jumps. Be sure to bring along a good steady tripod and provide a method of anchoring it securely to the boat in case you encounter rough water; here a lightweight tripod triangle with clamps will prove a big help.

It will prove beneficial, too, to practice beforehand removing the camera from the tripod quickly so that you won't miss important action shots that require holding the camera by hand. Being able to dismount the camera quickly in such instances may provide some of your most thrilling action shots. Here it is important to hold the camera firm and steady, and this should be part of your beforehand training.

Where you want to capture wild, uncontrolled action at great distances from your camera, it's a must to have one or two good telephoto lenses with matching finders, and it's well worth the time and effort to practice quick changing of lenses before going into action with a fighting marlin doing its stuff. Naturally, a camera with lenses already in position on a turret speeds up this changeover.

A small "raincoat" for your camera
(Continued on Page 404)

Berndt-Bach Opens New Auricon Plant



Auricon Cameras' new modern home in Hollywood

BERNDT-BACH, INC., manufacturers and world-wide distributor of Auricon 16mm sound-on-film cameras and equipment since 1931 opened its new and modern plant at 6900 Romaine Street, in Hollywood, last month.

The new office and plant facilities were especially planned by Berndt-Bach engineers for the highest efficiency in the

design, development and production of high-quality, precision motion picture cameras and Kinescope recording equipment for the film and television industries.

Special facilities have been provided for research and development of natural-color film equipment for television, major studio and educational use.

F&B

GUARANTEED
PRODUCTS
FOR
PROFESSIONALS

CAMERA SLATE with Clapsticks

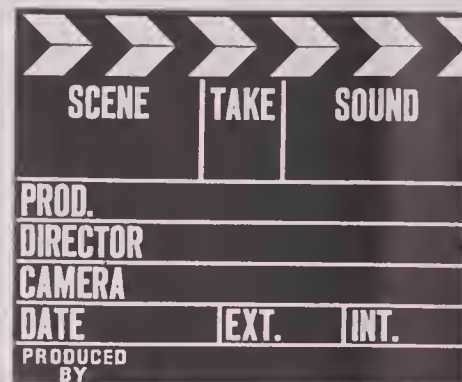

- * Easily eroseable slate finish
- * Sharp-sounding hardwood clapsticks
- * Permanent silk-screened letters
- * Supply of special, dustless chalk
- * Large 11"x14" size **Price \$8.75**
- * Medium 9"x11" size **Price \$5.00**
(Illustrated)

F & B Split Reels

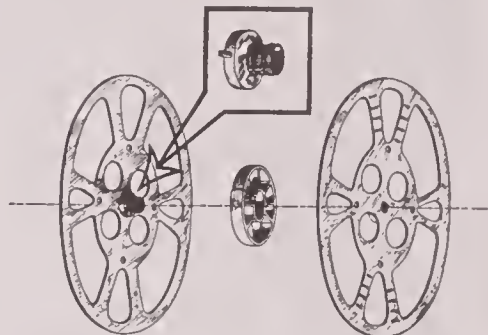

SAVE wear and tear on 16mm prints, time, space, storage.

NOW you can project, edit, inspect, synchronize, clean, measure and store all your films on cores.

No More Rewinding Problems

Now, simply slip film on core into SPLIT REEL. Close reel. Use another SPLIT REEL for take-up . . . unscrew reel to remove film.

BUY SEVERAL NOW!

400 ft. split reels — 16mm.....	\$4.50
800 ft. split reel — 16mm.....	\$6.00
1200 ft. split reel — 16mm.....	\$7.50
1600 ft. split reel — 16mm.....	\$9.00

Shoot Complete
15 Minute
Programs

600 FOOT
MAGAZINE
CONVERSION
FOR 16mm
AURICON
CINEVOICE
CAMERA

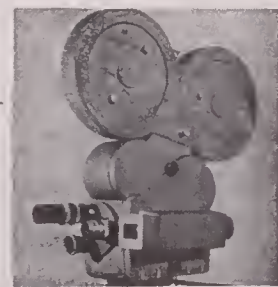

NOW Shoot full 15 minute TV shows without stopping or reloading. The F&B conversion includes 600 ft. magazine, extra silent take-up motor, camera insert plate for stabilization of film movement, and footage counter. Camera is **not cut down**; can be used without magazine for 100 ft. rolls.

F&B

FLORMAN & BABB
70 West 45th Street, New York 19, N. Y.
Phone: Murray Hill 2-2928
Cable Address — FLORBABB, N. Y.



PRECISION BUILT COMBINATION
16mm AND 35mm

OPTICAL SOUND READER

FEATURES: Simple threading . . . polished stabilizer drum with needle bearings, with a surface which cannot damage film . . . film rollers machined to conform with SMPTE standards, and equipped with ailess bearings . . . precision ground shafts . . . dimension 6"x6"x7 1/2".

AMPLIFIER: 117 volt - 60 cycle - AC . . . power output - 4 watts . . . heavy duty Alnico V speaker . . . safety fused . . . prefocused socket . . . pilot light . . . 6 ft. heavy duty line cord.

NET PRICE \$185.00 F.O.B., FACTORY, NEW YORK

PRECISION LABORATORIES
1139 Utica Avenue BROOKLYN 3, NEW YORK

FOR YOUR TV COMMERCIALS TITLES and SPECIAL EFFECTS

35mm-16mm Black & White or Color

RAY MERCER & COMPANY

4241 Normal Ave., Hollywood 29, California

NOrmandy 3-9331

We Welcome
Your Problems

RAY MERCER, A.S.C.

30 Years Experience
at Your Service . . .

We'll Send This Issue To Your Friends **WITHOUT CHARGE**

Know someone interested in motion picture photography you think would like **American Cinematographer**? We'll gladly send them a free sample copy if you'll send us their name and address on form below:

AMERICAN CINEMATOGRAPHER
1782 No. Orange Drive
Hollywood 28, California

Please send a free copy of "American Cinematographer"
with my compliments to: —

To

Address

City..... Z..... State.....

★ ★ ★

To

Address

City..... Z..... State.....

Sender

Address

City..... Zone..... State.....

is a handy accessory that keeps the salt spray from clouding up the lenses while waiting for something to shoot. It surely invites failure to pack your camera away to protect it when you are waiting for a good shot to show up. On this job you have to be ever-ready to shoot when the action happens. Provide yourself with a suitable case for your accessories and film, which will enable you to remove any article without searching around or taking out something else first. Keep this close by your shooting position.

Work out a system best suited to your own habits, a system that will insure quick and plain marking and storing away of exposed rolls of film so that during the excitement of changing film in the middle of good action there is no chance for you to pick up an exposed roll thinking it is unexposed.

Other accessories which will prove helpful are filters, lens-cleaning solution and tissue, oil and an exposure meter. And if you can afford it, an extra camera might save the day for you.

If you can team up with another cameraman on a joint venture, one of you can shoot the general views while the other makes the matching closeups.

The preparation sequence can be built up in many different ways: stage and shoot a conference with your fishing cronies, studying maps brochures and timetables. The den of a seasoned fisherman, with hunting and fishing trophies in the background is an interesting setting. Still other shots of your companions checking fishing tackle, buying new tackle, making reservations by phone, telegram or letter will make good tie-in sequences. A cut-in closeup of a letter or telegram or a map with a finger tracing the route and coming to rest on the destination works nicely too. By breaking this scene into two parts you can show your first stop at Nogales, Arizona, right on the Mexican border. Then by going into live action bring in scenes of local Mexican atmosphere, to get closer to your location.

Or to speed up action, go direct to recording the formality of obtaining a Mexican tourist permit and clearing the Mexican customs office. Whether you go by automobile, train, bus or plane, you still have to go through the same formalities which do provide some directly-connected and interesting action for your story.

If you go by automobile there will be opportunities to pick up typical local shots, and you will be thrilled with the possibilities offered by the new modern aspects in the capital city of Hermosillo.

Going by plane you can pick up shots of boarding a modern air liner and then an air view of the countryside and the fine city of Hermosillo, and wind up

with imposing air views of Miramar Bay and the hotels and beach homes there.

Guaymas, the Hotel Playa de Cortes and the sights along the shore of the bay are so picturesque that you could make a film on this subject alone. But that would be a travelogue and you are out to do an action Big Game Fishing reel, so better get going. Besides you will probably need all your film for those fishing scenes that only come once and don't wait for any cameraman.

You can bring in local atmosphere as you check into Tommy Jamison's fishing office for your boat reservation. Here there are usually marlin and sailfish from the previous day's catch hanging up for display. In making a shot here, be sure to have the fish in the background, then move in for a closeup as your fishermen examine the demons of the deep. Good action comes when you have a hand stretch out the huge sail on the back of the fish.

Filming The Quest sequence comes next. Shoot the fishing party going aboard; cut in the name of the boat in a closeup; show the deck boy casting off the line; a closeup of a finger pressing the starter button on the boat; tilt down to the water as it churns up from the propeller; bring in a closeup of the captain at the wheel and of your party getting set in the special revolving chairs in the stern of the boat.

Try to arrange your departure so that other boats will be going out at the same time. Use them for the general views of the boat under way. As you go along there will be opportunities to pick up shots of pelicans diving in the water and large flocks of gulls following the boat, hoping for a handout. Make shots of fishing tackle being readied and be sure to feature the special bait which the boat brings along, and include a detailed closeup of how it is set on the hook. As you approach the fishing grounds you can make some different "on board" shots that give the feeling of going fishing; but don't spend too much time now; shoot up the roll of film you started out with and get a fresh roll in the camera so that you can stand by for a strike and real fishing action.

You can include a nice sequence of the seaplane spotting the fish and sending word back to your boat. Of course, you can't be in two places at the same time, so concentrate on fishing and plan to get the seaplane cut-ins another day.

The Battle and Victory segment is next on your shooting plans. While you are waiting you can practice picking up imaginary fish jumps in your finder and so develop a definite plan on what angles you will use when you are shooting the fish . . . on the line. . . . It may take hours for the first strike and it might come any moment; whoever is fishing will certainly help you and warn you as

"Lights"
"Camera"
"Action"

and PROCESSED BY
MOVIELAB

FOR THE FINEST FILM PROCESSING *IN THE EAST* — FILM MEN WHO KNOW SAY "IT'S MOVIELAB"

Here—at MOVIELAB . . . efficiency and perfection are the rule. Producers, directors and technicians have at their fingertips the very best in up-to-the-minute equipment necessary to modern FILM PROCESSING techniques.

ROUND THE CLOCK SERVICES

- Negative Developing • First Print Department
- Ultra Violet & Flash Patch Track Printing
- 16mm & 35mm Release Printing
- Quality Control • Title Department
- 22 Cutting & Editing Rooms.

FOR COLOR

it's

Rainbowlab Inc.



MOVIELAB FILM LABORATORIES, INC.

619 West 54th Street, New York 19, N. Y. JUdson 6-0360

NEW
600ft.
REEL

16 mm



WITH EXCLUSIVE COMPCO CLIP

HOLDS COMPLETE 15-MINUTE SOUND PROGRAM!

This Model 119 Compcop reel in the new 600 ft. (16mm.) size holds a complete 15-minute sound or

25-minute silent program. It is clearly marked with scales for footage and for running time in minutes... is durably made of high grade tempered steel, finished in scratch-resistant, baked-on hammertone gray enamel... and has the exclusive "Compcop Clip" that makes threading fast and easy, even in the dark! Model 120 Film Can fits this reel. Fibre Shipping Cases also available. Write for catalog.

Compcop
CORPORATION
2251 W. St. Paul Ave
Chicago 47

RUBY CAMERA EXCHANGE

Rents . . . Sells . . . Exchanges

Everything You Need for the

Production & Projection

of Motion Pictures Provided by a Veteran Organization of Specialists

35 mm. . . . 16 mm.
Television

IN BUSINESS SINCE 1910

729 Seventh Ave., New York 19, N. Y.

Tel.: Circle 5-5640

Cable address: RUBYCAM



Reversal PROCESSING

Reversal specialists for over a decade. Our long experience insures superior quality. Electronically controlled machines keep temperature constant within .2 of one degree. National "Brilliantone" Cine prints are the finest available. Write for free catalogue.

CONTACT PRINTING B & W DUPLICATING
WORK PRINTS KODACHROME DUPLICATING
EDGE NUMBERING VACUUMATING

All work vaporated at no extra charge

NATIONAL CINE LAB

Box 4425 Washington 17, D. C.

soon as they feel a bite. Since the bait is trailing far behind the boat and since the first jumps will be far away, your telephoto lens should be in position and focused on infinity, properly stopped down. When you are on the open sea the light is usually brighter; so be sure to stop down proportionately. Be sure you have a comfortable shooting position and when the real strike comes, get your camera rolling and keep it pointed right where you see the bait breaking the water. When the fish jumps he will jump again right away and perhaps many times at first. This will be your best chance to get the best action shots. Scenes will be much more interesting if you show the entire action of the fish leaving the water, shaking itself and falling back into the water.

Both marlin and sailfish are great fighters and will put on a real show of jumping clear of the water, trying to get rid of the hook. Here the fisherman must keep a tight line and gradually bring the fish closer to the boat as it tires out.

Big game fishing takes skill, patience and endurance because the battle might well last five hours or more. So you will have many chances to shoot jumps. As the fisherman brings the fish in closer you can then switch to a shorter focal length lens to take in more territory and at the same time keep the fish large enough to be effective. As soon as you feel that you have shot enough jumps you can then start shots of the fisherman

handling the rod and reel. Here big closeups of the fisherman, his hands winding in the line, are mighty effective; but cutin shots of other people on the boat watching and the skipper handling the boat will fit in well too.

When it looks like the fish is going to be brought in close enough for final capture then you should again concentrate on the fish. Sometimes its last jumps made right close to the boat are very spectacular and easy to shoot; one usually can tell when it is going to break water. Here it might be advisable to take your camera off the tripod and hold it to make the shots of the fish being brought aboard. As soon as the men begin to bring the fish on the deck, move back again to take in more picture area.

With the prize safe on board you can stage shots of examining the catch so as to have a good effective scene of the fish itself. For action, show hands opening the mouth and raising up the sail.

If you have been lucky so far and if there are others fishing nearby, try for shots of the fishermen in other boats as they hook, play and land a fish. Then, after you return to the boat dock, you can stage a number of closeups that were not possible to get while you were out on the water—closeups of the fish being brought to gaff, of the fisherman fighting and reeling in his line, etc. Here it is important that you carefully exclude from your finder frame anything that would indicate the shot was made anywhere

C. P. Goerz Moves To Larger Plant



The new, modern Goerz plant in Inwood, Long Island, N. Y.

C. P. GOERZ AMERICAN OPTICAL COMPANY, one of America's oldest lens makers has moved to its new, modern scientifically-equipped factory which was recently completed in Inwood, Long Island, New York.

The company has been manufacturing lenses in the United States since 1899, under the management of Fred Schmid. From its very beginning, the primary object of the company was to follow the same superior design and quality of craftsmanship used in the company's Berlin plant.

During World War II, the C. P. Goerz company was a leading supplier to the government of high-grade motion picture and still camera lenses. For years, of course, Goerz lenses have been among the most popular in Hollywood's motion picture industry.

The new plant is operated under the management of company president Dr. C. P. Goerz and sales manager P. Goerz Langfeld, son and grandson respectively of the original founder of the Berlin company.

else but at sea. Obviously it would be alright to include portions of the boat in such scenes.

With luck, it should be quite possible to photograph the whole foundation of your fishing film in one day. However, you should be prepared to go out again with the boat in case you failed to get the breaks the first time. There is one great advantage of making a second trip: you have had the chance to think over how you covered the story on the first trip, and to figure out better shots or to pick up shots which you missed on the earlier trip.

A smart cameraman will keep a record of every scene he makes, or better still have another person do this for him. In making a picture of this kind, the experienced cinematographer works from a scene list or shooting script, which has been carefully prepared before shooting begins. While such a method is not absolutely necessary, still it is just another one of the things a cameraman can do that will tend toward professional perfection.

At the close of this second trip, as the boat is headed back to the hotel dock, watch out for opportunities to pick up some "artistic" shots of the play of the light on the water, interesting or colorful cloud formations, the turbulent wake of the boat, or the bow cutting the water.

For the closing, "Celebration" sequence, your best shooting opportunities will come if your boat docks while there still is light enough to make shots of the inevitable ceremony of hanging up the catch, and of the proud angler having his picture taken as he stands alongside his prize. An interesting touch would be an insert shot of the usual signboard, with data written on it about the size, weight and kind of fish, the date caught, etc.

If you wish to add still further to this closing sequence, you can make shots of a group of fishermen sitting around the hotel cocktail lounge, at Tommy Jamison's office, or at the side of the swimming pool as they swap yarns about the day's fishing trip. Their happy, satisfied experiences can best be reflected in a series of brief closeups, with a slow fade closing the last scene in the sequence.

No C-Scope Newsreels?

The move by 20th Century-Fox to interest exhibitors in the possibility of a color CinemaScope newsreel has met with an initial rebuff, due to the inevitable higher rentals, according to a recent report in *Daily Variety*.

Fox has long wanted to convert its newsreel to the CinemaScope format plus color, same as is being done with its short subjects.

Precision Prints

**YOUR PRODUCTIONS
BEST REPRESENTATIVE**

CLOSE CHECK ON PROCESSING

Picture and sound results are held to the closest limits by automatic temperature regulation, spray development, electronically filtered and humidity controlled air in the drying cabinets, circulating filtered baths, Thymatrol motor drive, film waxing and others. The exacting requirements of sound track development are met in PRECISION'S special developing machinery.

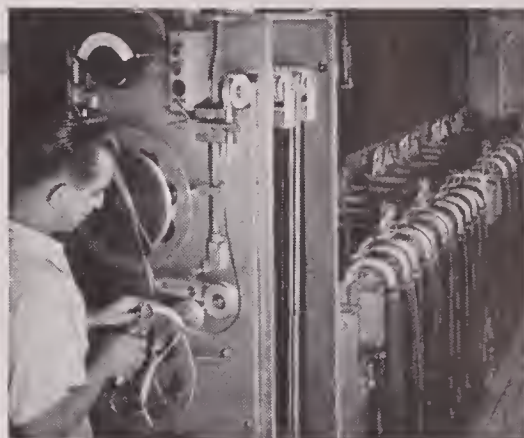

YOUR ASSURANCE OF BETTER 16mm PRINTS

16 Years Research and Specialization in every phase of 16mm processing, visual and aural. So organized and equipped that all Precision jobs are of the highest quality.

Individual Attention is given each film, each reel, each scene, each frame — through every phase of the complex business of processing — assuring you of the very best results.

Our Advanced Methods and our constant checking and adoption of up-to-the-minute techniques, plus new engineering principles and special machinery enable us to offer service unequalled anywhere!

Newest Facilities in the 16mm field are available to customers of Precision, including the most modern applications of electronics, chemistry, physics, optics, sensitometry and densitometry — including exclusive Maurer-designed equipment — your guarantee that only the *best* is yours at Precision!

Precision Film Laboratories — a division of J. A. Maurer, Inc., has 16 years of specialization in the 16mm field, consistently meets the latest demands for higher quality and speed.

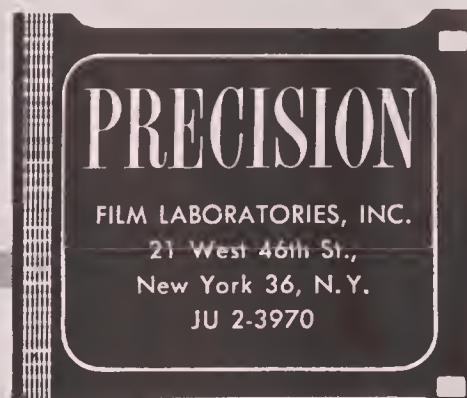

Now! A 400ft. Magazine For Your BOLEX H-16

Complete
with
Synchronous
Motor
and Base

Includes
Installation
and
Case



Permits continuous run of 400 feet of 16mm film, or—the 200 ft. daylight loading spool may be used in the 400 ft. magazine. The 100 ft. daylight loading spool can be used in the camera without removing the external magazine. In black wrinkle finish to match camera. Fully guaranteed. Write for information on our Rock-Over Sports-finder and Camero Base.

See your Bolex dealer or
order direct. Immediate delivery.



TOLEDO CINE ENGINEERING
1309 Milburn Ave. Toledo 6, Ohio

MOVIOLA

FILM EDITING
EQUIPMENT
16MM - 35MM

- PICTURE
SOUND
Photo and
Magnetic
- SYNCHRO-
NIZERS
- REWINDERS

One of the
new series 20
Moviolas for
picture and
sound.

Write for
Catalogue

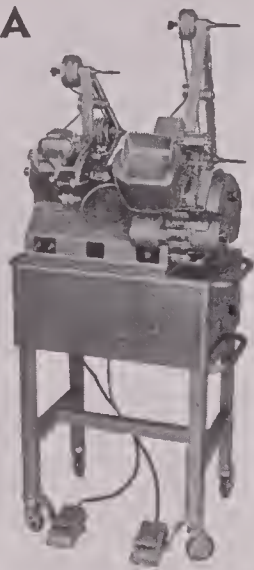

MOVIOLA MANUFACTURING CO.

1451 Gordon St. • Hollywood 28, Calif.



PELLEGRINI

VARIABLE SHUTTER UNITS
FOR THE BOLEX H-16

The real answer to complete FADES and LAP DIS-

SOLVES. Faster shutter speeds and many other advantages. Prices within U. S. \$99.60. Cameras with outside frame counter \$109.80. Tax extra. One year guarantee and camera transportation back included. Send for free informative booklet.

Prices subject to change
without notice.

TULLIO PELLEGRINI
1545 Lombard St.
San Francisco 23, California



FILM LABORATORY—PARTNER IN PRODUCTION

(Continued from Page 393)

ed onto the same raw stock. This time, the printer light remains out while the previously-exposed footage runs in contact with first part of the B roll. The light fades on while the incoming scene of the dissolve moves across the printing gate. Because the fadeout of one scene is printed over the fadein of another, the final effect is a smooth lap-dissolve.

Thirty-five millimeter B&W and color motion pictures are invariably a product of the negative-positive process. In the beginning, 35mm Ansco Color was a reversal process, but it has since been converted to neg.-pos.

Most of the 16mm color originals are photographed on reversal film such as Kodachrome and Ansco Color, and it will probably be some time before a 16mm color negative is on the market. Of course, color prints from these originals are also reversal. Labs are just now beginning to make a few 16mm prints on color positive stock from 35mm color negatives.

More B&W 16mm productions utilize reversal than negative film. Most labs outside Hollywood and New York encourage their customers to photograph on reversal. This procedure is generally accepted for 16mm industrial and educational work beyond those cities. In one lab's brochure the customer is cautioned that, "Negative film tends to pick up scratches, dirt, abrasions, etc., more readily than the 'tougher' reversal types. With 16mm's smaller size, the defects show up prominently on the screen . . . Camera negative splices print through to the positive prints, and show on the screen as white flashes." Other statements in the brochure maintain that the original isn't protected in printing, as when dupe negs are made from reversals, and that release printing requires printer-light changes.

However, several laboratories in Hollywood and New York turn out excellent prints of pictures shot on camera negative. Apparently, it's all a matter of what you prefer. If negatives are carefully handled in dust-free labs and cutting rooms and given the care they deserve, they are not going to show dirt and scratches. Negative splices will show up when they're not made on a professional splicer with narrow overlap. Many producers assemble their negatives and leave the final splicing to the lab.

A laboratory can print directly from camera negative, or from a dupe negative. This latter method is preferred when many fades and dissolves are involved. For fades only, a producer orders (1) a master positive from his nega-

tive and (2) a dupe negative printed with fades from the positive. For both fades and dissolves, he puts the master positive on A—B rolls and makes his dupe negative from them. But when only a few effects are wanted and the picture will not have a large print order, the takes involved are generally duped and cut into the original negative.

It is easier for a lab to err in making dupe negatives than in most any other function of its service. When you get poor dupes, the best advice is to either switch to reversal or find another lab. Master positives should be made on special fine grain, high-resolving power duplicating positive film rather than regular release positive stock. Quite often, excellent negative-positive work is found at labs also handling 35mm film.

Motion picture laboratories may be divided roughly into two classes: 1) straight labs and 2) service companies. The first specializes in film developing and printing, with perhaps titling and splicing services included. Those in the second class are usually complete organizations offering just about any film service a producer may need. Many are film producers themselves with an imposing roster of clients. Service labs are especially helpful for those film makers who do not wish to invest heavily in equipment or to have to go to more than one company for processing, sound recording, art work, music clearances, etc. The more complete service laboratory offers the handy "one-stop" service.

On the other hand, the average lab which confines its service to processing and printing only, often will rent you a cutting room and a Moviola. You may find their rates, especially in B&W, a little lower than some of the other companies charge. A general organization's most helpful service is probably their flat-rate sound recording. For definite prices per reel, a producer receives sound recording, studio use, a narrator to read his script, background music, sound film, and processing. He may also receive supervisory help.

One good way of becoming acquainted with the services a lab offers is to carefully study its price list. First item is usually *Negative Developing*. Note here whether they develop negative, reversal, or both. Reversal labs customarily develop sound negative, though. The next item is *Daily Work Prints*. This is the price you pay for prints to use in editing the picture. If both negative and reversal are handled, the latter dailies might be included in a separate reversal section.

Fine Grain Prints, sometimes also called *Masters*, are low contrast positive

Film Editing Made Easy
with NEW

professional film viewer

for 35mm and 16mm

Every film editor will appreciate a viewer that enables him to view his film from left to right—on a large, brilliantly illuminated screen.

The PROFESSIONAL FILM VIEWER makes film editing a breeze. Easy threading, portable, will not scratch film. Put this viewer between your rewinders and speed up your editing. Size of Viewing Screen 5¾ x 4¾.



35mm Model \$375
16mm Model \$350



Write Dept. A-7-4

prints on special stock. They are used to print dupe negatives. Fine grains may be considered equivalent to reversal originals, except that their emulsion position is different due to their being prints.

Dupe Negatives can be classified under a few subheadings: *Picture* refers to straight prints from fine grains or reversals; *Sound* refers to prints from sound track positive; *Composite* refers to a negative with sound and picture together for convenience in release printing; *A—B* refers to prints made from fine grains or reversal film in A—B rolls; and *Temp Dupe* is a cheap negative printed from a work print to get duplicate copies of the work print for the sound department and others.

Release Printing begins with the *First Trial Composite*, or *Answer Print*. This shows you what a print from your edited negative and sound track looks like. Following approval of the answer print, *Subsequent Prints* are ordered, and their price often depends upon the size of the order. *Replacements* are sections of print less than a reel in length made for replacing damaged film.

Color or Kodchrome Printing may refer to both work prints and release printing. The latter is done *Sound* or *Silent* and *straight* or *A—B* effects. This gives four different prices for color release work in each quantity classification.

NOW HIGH-SPEED PROCESSING

The **HILLS** Filmatic
High temperature 16mm film processor

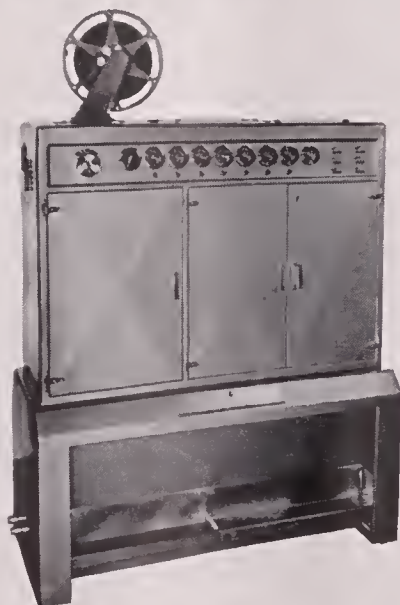

The Filmatic Model 16 HT is a completely automatic high-speed, high temperature processing machine. The thermostatically controlled operating temperatures up to 125°F. is designed to process any 16mm sound or silent film at rates up to 115 feet per minute.

- Reversal, negative or positive at speeds up to 115 ft. per minute
- First scenes are processed, dried and rewinding in 2½ minutes.
- Full load of 1200 ft. completely processed in approximately 13 minutes
- Compact unit, 72" high, 51" long, and 24" wide.
- Built-in replenishing system
- Daylight operation
- Economical processing
- Automatic temperature controls
- No permanent installation
- Nothing else to buy

By utilizing the latest fast-processing emulsions (DuPont 930-931 types) the Filmatic Model 16 HT will continuously deliver exceptionally high-quality processing at maximum speeds. For illustrated folder and additional information write to William Halpern, Sales Representative, 8240 Fayette St., Philadelphia 19, Pennsylvania.

HILLS MANUFACTURING CO., LANSDALE, PA.



GEO. W. COLBURN LABORATORY INC.
164 NORTH WACKER DRIVE • CHICAGO 6
TELEPHONE STATE 2-7316

**8 and 16mm
SERVICES**

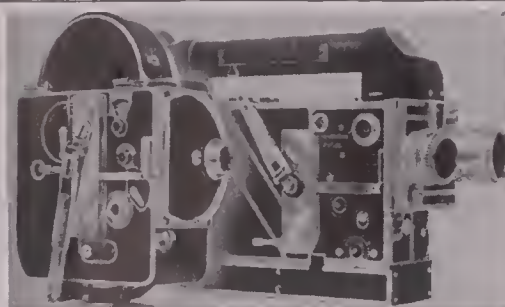

Automatic dissolve attachments for Cine Special and Bolex H-16 (Equipped with Pellegrini Shutter)

JOSEPH YOLO, 1037 N. La Brea
Phone GL. 7103 Hollywood, California

Ready-Eddy

U. S. Registered Trademark
**USEFULNESS GUARANTEED
FOR EVERY DAY USE**

1001 Ready Sound-Film
Editing Data:
• Footage • Frame
Count • Screen Time
• 35mm and 16mm
equivalents.
Plastic computer for
everyone in movies
and TV, from script to
screen.

\$2.00 Prepaid
(Delivered in U.S.A.)

ASK FOR REPRINT OF ARTICLE
IN AMERICAN CINEMATOGRAPHER.
Write or ask your dealer
READY-EDDY, Sandy Hook, Conn.



Scheibe FILTERS
In World-Wide Use

Produce moonlight and night effects
in daytime • fog scenes • diffused focus
and many other effects.

Information mailed on request.

SCHIEBE FILTERS COMPANY
ORIGINATORS OF EFFECT FILTERS
P.O. Box 46834, Hollywood 46, Calif.

USED
IN EVERY
HOLLYWOOD
MOVIE PICTURE
PRODUCTION

The various labs have slightly different working methods. Some will notch your film to control the printer light and fading device, while others, such as Telefilm Studios in Hollywood, put a magnetic cueing mark on the film edge or notch a separate control film instead.

The film printers used by professional labs are equipped with a device that controls the brightness of the printing light. Thus, the light intensity may be adjusted manually or automatically to conform with each scene in the reel as it passes through the printer. (Sometimes there is a small additional charge for printer light changes on small orders.) Printing light control is very important in color film printing as a means of modulating both the scene brightness and color saturation.

The maximum length of each printing reel is usually 400 feet, 300 feet, or 1200 feet, including leaders, depending on the individual lab. A few laboratories print from dupe negatives only and do not accept original camera negatives for printing purposes.

The length of fades and dissolves varies with some companies. It's necessary that you know how many frames in length your lab has established for this procedure when editing the work print for effects. Some labs offer a choice.

Many labs offer certain specialty services in addition to their standard laboratory work. Telefilm, in Hollywood, can vary the color quality as well as the brightness of the printing light in scene-to-scene control. The George W. Colburn Laboratory in Chicago offers low contrast color prints from originals having too much contrast. Both Telefilm, and William A. Palmer of San Francisco have facilities for electronic sound track printing. Moviellab in New York is geared for large quantity Kodachrome printing at minimum prices.

The Calvin Company, Kansas City, Missouri, has facilities for release color printing with traveling mattes. The latter control light reaching the printing gate and allow wipes to be made in addition to the usual fades and dissolves. Calvin is probably the only independent lab which develops its own Kodachrome print stock.

For more comprehensive details of the services offered by laboratories, the reader is urged to phone or write the one he contemplates dealing with and request a copy of the company's catalogue and price list. Among the "service" laboratories are Byron, Inc., Washington, D.C., Telefilm Studios, Hollywood; George W. Colburn Laboratory, Chicago; and The Calvin Company, Kansas City, Mo.

Labs offering fine film processing service only in B&W and color include

Consolidated Film Industries, Hollywood; Precision Film Laboratories, Inc., New York; Moviellab Film Laboratories, Inc., New York; and Pathe, Hollywood Film Enterprises, and General Film Laboratories Corp., all of Hollywood; and National Cine Lab., Washington, D.C.

Laboratories which offer special effects services are Ray Mercer & Company, Filmeffects of Hollywood, and Cinema Research—all located in Hollywood.

More complete details and the addresses of most of these companies are to be found in their advertisements which appear regularly in American Cinematographer.

HOBBYIST WITH A FUTURE

(Continued from Page 400)

siderably cheaper than 8mm., but film stock is more expensive.

Brownlow works entirely in monochrome. The slimmest of shoe-string budgets would look absurdly extravagant beside his expense sheet. With pocket money the controlling factor, he has to save for film stock over a period of months. Already more than a year has passed since he shot the first scene. He anticipates a final footage of about 300 ft. (The running time of 9.5mm. is the same as that of 16mm.)

To see Brownlow directing his cast is an engrossing sight. Small for his age, he is literally dwarfed by his actors, most of whom are many years his senior. Yet he is not flustered by the age gap. He knows the result he wants, and he rehearses and rehearses until he gets it. The players may not exactly cower before this pint-sized prodigy, but they obviously respect his air of authority.

This in itself is no mean feat on Brownlow's part, for he picked up most of his cast in restaurants and in the street. He has adapted Maupassant's story to a modern setting, but one of his biggest problems remained the uniforms of the German soldiers. With some trepidation he approached a costumier just off Piccadilly. He explained his needs and his restricted resources to such effect that the costumier not only let him hire the uniforms at fantastically reduced rates, but volunteered his own services for the part of one of the soldiers. Needless to say, his offer was immediately accepted, and he is now one of Brownlow's most enthusiastic players.

Prominent among the striking qualities apparent in the footage-to-date of "Les Prisonniers" is the dramatic inte-

rior lighting. It is so expressive, so exactly right for its purpose, that it conjures up visions of great banks of photofloods and armies of lighting technicians.

In actual fact the players hold the light (repeat light) in position for each other's shots, and Brownlow comments that he merely "puts it where it looks as if it ought to go." Incredible as it sounds, he uses just one photoflood, without even a reflector.

Attention to detail is another of this youngster's flairs. The hut interior needed for most of the action required only a large fireplace as an essential item. Brownlow was offered the use of premises with a fireplace which looked as if it had been built for the purpose. But when he saw the first few shots he knew at once that on film the set-up looked artificial.

He decided to build an artificial fireplace in the hope it would look more like the real thing. One of the cast constructed an impressive looking affair in an ancient garage from a piece of planking, old newspapers and cardboard, and the whole thing was painted and smothered in soot. A string of onions, a pot of soup, and the result satisfied even Brownlow's scrutiny.

Another production story of this one-man, or rather one-boy, film unit indicates the hazards he is prepared to undergo to insure the correctness of

C. ROSS

FOR

LIGHTING EQUIPMENT

Inkie and Arc Lamps including Required Accessories
Generators—Cables—Boards—Boxes

Raby Camera Crane—Dollies—Blimps—Geared Heads

GRIP EQUIPMENT

FOR LOCATION AND STUDIO

Parallels—Steps—Platform Ladders
Century Stands—Reflectors—Flags—Scrim

SOLE EASTERN MOLE-RICHARDSON CO. DISTRIBUTOR
RENTALS • SALES • SERVICE

CHARLES ROSS, Inc.

333 WEST 52nd STREET

NEW YORK 19, N.Y.

Circle 6-5470-1



frost lights the nation!

MOTION PICTURE STUDIO •
THEATRICAL • DISPLAY
RENTAL EQUIPMENT

WHEREVER YOU ARE—WHATEVER YOU NEED

... in the way of unusual, specialized lighting, call on Jack Frost! For movie-making, stage lighting, feature exhibits, large conventions ... for *any* location that requires exceptional lighting, Jack Frost is ready to serve you! And Jack Frost's unequalled national service includes complete installation and removal *wherever* you are. Rent all your specialized lighting equipment from Jack Frost ... famous for lighting the nation's greatest shows ... most spectacular displays.

FOR FULL INFORMATION ON
RENTAL EQUIPMENT
MAIL COUPON, OR CALL
DETROIT, TRinity 3-8030

JACK A. FROST, DEPT. J,
234 PIQUETTE AVE.
DETROIT 2, MICHIGAN

Please send me full information on
your rental service.

Name _____
Address _____
City _____ Zone _____ State _____



Endorsed...

by the
**WORLD'S LEADING
CAMERAMEN**

Used At All
Hollywood Movie Studios

**New Edition
NOW AVAILABLE**

IMPROVED!

ENLARGED!

REVISED!

with
**TELEVISION
PHOTOGRAPHY DATA**
plus
**NEW CHARTS
and TABLES**

The Book of a Thousand Answers
to Cinematographic Questions

ORDER YOUR COPY TODAY!

PRICE \$5.00 POSTPAID

Book Department,
American Cinematographer,
1782 No. Orange Dr.,
Hollywood 28, Calif.

Gentlemen: Enclosed please find \$5.00*
for which please send me a copy of
THE AMERICAN CINEMATOGRAPHER HAND-
BOOK AND REFERENCE GUIDE.

Name

Address

City..... Zone..... State.....

*If you live in California, please include 18c
sales tax — total \$5.18.

every detail. He wanted to tilt up from a plate to a girl serving soup. As he rehearsed he noticed with horror that the girl's blonde hair was blazing with highlights. A visit to her hairdresser's had spoiled the resemblance to a lusty forester's daughter which had first made Brownlow approach her in a local milk bar.

"Yes," he told me, "we had quite a time trying to get her hair back to what it ought to have been. We damped it down, and finally soaked it, but it was no good. With all those shining highlights stealing the scene we had to re-take the shot a few weeks later."

I can think of few amateurs twice Brownlow's age who'd risk spoiling

their leading lady's hair-do for the sake of realism; but then Brownlow's enthusiasm is so infectious that it carries all before it.

I had another look at "Les Prisonniers" before I left to confirm my first impressions. If anything it strengthened them. Camerawork, lighting, composition, direction and cutting are among the most accomplished amateur work I've seen. Kevin Brownlow obviously has quite a future in cinematography.

At least, so I thought until I questioned him further. Then, "Become a professional?" he echoed with surprise. "Oh, no! Cine work's all right as a hobby—but I want to go in the Navy!"

HIGH-SPEED NEGATIVE SPEEDS PRODUCTION

(Continued from Page 394)

The series of classroom films designed to describe the workings of our government, called for a fairly large amount of on-the-spot coverage in our National Capitol. Planned to illustrate the complex, yet fundamental facts of our political heritage, they needed the authenticity that good educational principles require, the real life situations as they occurred on the political scene. So we were on our way to spend some time in Washington "peeking in" as it were on the activities of various government agencies; in committee rooms of the

Senate and the House, in the corridors of the Capitol, in some of the thousands of government offices that form a part of our government structure.

We needed to photograph the interior of the Supreme Court itself, see the bench from which the greatest judicial decisions have been read. Our "one-liners" called for scenes of the President's office, his desk, the atmospheric touches that are part of the daily activities surrounding the biggest job in the world. We would look into the President's Cabinet room, where many of the nation's

Movielab Brings Hollywood To East Coast



Movielab's theatre brings to the East the ultimate in theatre projection, where the producer can preview films in all the most modern techniques including 3-D.

ONE OF THE MORE important customer services available at Movielab Film Laboratories, 619 West 54th St., New York, is a modern preview theatre.

In operation for more than a year, the Movielab Theatre is more than an ordinary projection room. One of its more important features is its triple interlock, which producers have found to be tremendously advantageous; it enables them to pre-preview a client's film before it is finished by running the music, dialogue, and effects tracks simultaneously but

separately with the picture. In this way, if any changes are to be made, they can be done at the nominal projection room rate instead of the more expensive studio time rate.

Some other features of the projection room are the combination 17½mm and 35mm tape interlock, 16mm interlock, and a variety of aspect ratios or screen sizes—anything a film producer needs from a television aperture to normal screen or wide-screen aperture.

KINEVOX Remote Amplifier-Mixer

for any sound application



New **LOW** Price—\$425.00

The **BEST VALUE** in
Amplifier-Mixers available today!

FEATURES:

- Hi-level mixing
- 4 input channels
- AC operated
- Sloping Panel
- Cannon receptacles
- Complete in one case
- Meter reference point adjustment
- Monitor volume adjustment
- Inter-communication system
- DC heater supply
- 2-way buzzer system
- Shock-mounted pre-amplifier tubes
- Dialogue equalizer (4-position)

Write for Performance Data

A product of the manufacturers of KINEVOX PORTABLE SYNCHRONOUS MAGNETIC RECORDERS and associated equipment

Licensed under RCA, Western Electric, Armour Research Foundation and Kinevox patents

KINEVOX BUILDING
114-116 SO. HOLLYWOOD WAY
TELEPHONE: Victoria 9-3291
ROME • BOMBAY

KINEVOX

I N C O R P O R A T E D
NEW YORK

BURBANK
CALIFORNIA
CABLE: Kinevox, Burbank
RIO DE JANEIRO • CANADA

great policies are shaped. We might ride with the Senators on the little subway that connects the Senate office building with the Capitol itself. And we should be able to put our audience so fully into the whispering gallery of Statuary Hall that perhaps they might feel the presence of the giants who helped build the mighty structure of our nation.

Our early tests with the new film indicated that shooting at a speed of ASA 400 produced a full, rich negative; that even at a speed of 650 there was no serious loss of shadow detail in average subjects. Pushing our developments a bit, we produced satisfactory images shooting at ASA 1000, though grain size under these conditions began to prove a problem. At normal development we found grain appreciably no greater than in medium speed emulsions, with good scale and contrast. We plunged into the Washington job with only one previous experience of using this film in production, and we still felt rather nervous and unbelieving of our new baby.

Our camera selection was an Eclair Camerette, which we felt would provide good maneuverability, light weight, and, of course, speed. Its 200° shutter added a small margin of exposure which no cameraman can ignore; its range of lenses, from an Angenieux 18.5mm to a Kinoptik 100mm was adequate for any situation. The 18.5mm, by the way,

PETERSON Automatic Fade

An Attachment For Your
Bell & Howell Model J.
Printer

FOR DEPENDABLE
FADES & DISSOLVES
IN COLOR & BLACK & WHITE

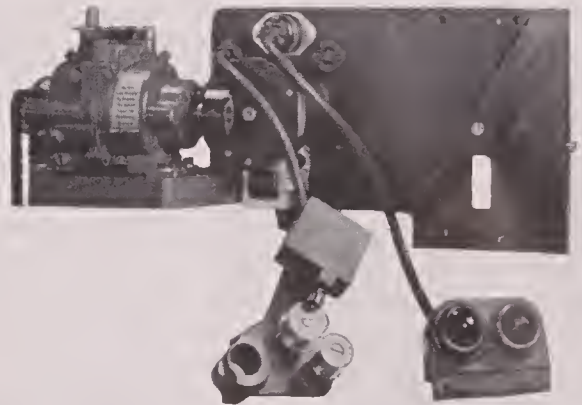

Some advantages of installing a Peterson Automatic Fade Attachment:

1. Fade lengths from 20 to 180 frames, or any intermediate number of frames.
2. Pilot light for indicating open or closed position.
3. Furnished with micro-switch breaker box mounted on bracket. Additional film rollers for proper film path.
4. Removable filter pack holder mounted in unit.
5. Can be furnished for use with magnetic "cueing" on special order.
6. Simple installation, easily done in your laboratory.

PLEASE WRITE FOR OUR LITERATURE

MOTION PICTURE PRINTING EQUIPMENT CO.

Mfrs. of Motion Picture and Micro Film Printers

8136 NORTH LAWNDALE AVENUE • SKOKIE, ILLINOIS

proved the work-horse in the tight locations we found ourselves in so often. The quick-change magazines were a boon when it became necessary to switch from our Tri-X back to conventional emulsions for exterior use. And this is a camera that could be used when necessary for hand-held pickups without the limitations of spring-wound cameras.

Lighting equipment, like our camera, was designed for great maneuverability . . . heavy enough to carry maximum loads, yet compact enough to be picked up and moved in a hurry. A new, special wiring system was devised for this job, making it possible to spread small light units around large areas at as many different points as required. The largest lamps we carried were 750-watt spots and "Colortran" Seniors, and the bulk of our lighting load was to be borne by reflector floods and spots of the "Birds-eye" type. We planned on using many photoflood lamps, as we would be running into a lot of direct current where our "Colortran" transformers could not be used.

Prior to the arrival in Washington of our major equipment and the balance of our crew, test shots were made at primary locations to determine just to what extent we could rely on the natural light present, and where and in what way we would call on auxiliary lighting units. For this purpose a hand-held Eyemo was used, shooting approximately five feet on each camera angle. These test rolls were airmailed to the laboratory in California, since strips were returned to us within a couple of days for our examination. On the basis of these preliminary tests we were able to proceed on the main job for the following week.

Advance top-level arrangements had been made, of course, for our crew to photograph the specific operations in which our director was interested. Some of the more important of these involved several of the best-known and most active congressional committees. Our assignment called for footage of these committees at work. Thanks to our new fast film, it was actually possible for us to move into the committee rooms and, with little more than two or three accent lights placed in corners or behind tables, to photograph scenes during actual committee meetings. In most rooms we were working at levels of from 10 to 40 foot candles, with our lenses set somewhere between $f/2.0$ and $f/3.5$. Where there were large windows or fluorescent lighting, we occasionally found levels as high as 64 foot candles, but in nearly all cases we were shooting scenes which, before the day of Tri-X, could not be shot at all.

One of the most challenging photographic problems met was filming Statu-

ary Hall in the Capitol. This is a large, semi-circular hall, with a radius of more than 100 feet, surrounded on the perimeter by statues of American statesmen. Until 1852, the members of our House of Representatives had met in this room. Shooting between the hundreds of tourists who were sightseeing through the hall, listening to the guides as they whispered their messages across the "whispering gallery," it was our job to make dramatic scenes showing the partial silhouettes of these statues, whose ghost voices would later be heard on the sound track delivering their deathless lines. Behind the statues we placed strings of small lights, mostly reflector floods, and we did the same with the entire diameter of the front of the hall, and half the arc of the remaining semi-circle. A few 750-watt spots were used from the front for accent fill. With only an occasional interruption to the normal stream of tourist traffic, we were able to shoot these scenes and the associated closeups of the statues. With a back-to-front light ratio of about 8 to 1, we could expose for this dramatic sequence at about $f/4.0$.

The Supreme Court is perhaps the most impressive of all our government buildings. The most impressive part of the building is inside in the main courtroom. Here we spent the better part of a day trying to capture on film the momentous role our Supreme Court has played as a vital branch of our democracy. We were photographing a room in a building, and through the use of dramatic light, camera movement, creative angles, we aimed to recreate in the minds of our audiences some of the real-life situations that have come to pass here.

We worked at a time when the court was not in session. This enabled us to achieve certain artistic effects that would be otherwise impossible. We were able to place lights at the base of the marble pillars behind the bench, between the pillars along the sides, and high in the rear of the courtroom. Our lighting was planned so that we would be able later to match to smaller-scale reproductions of the court to be erected in our main studio for certain lip-sync sequences that would become part of the finished films. Here, again, through the use of our high speed Tri-X film we could photograph artistically what would have been difficult to do even reportorially before.

One of the most important in this series of teaching films is "The Presidency." The script writers called for shots inside the White House itself, the center of the executive branch of the government. Our interest was not the personal side of the President's life, but the symbolism of his functions as head

of the government. It was most gratifying to us when we were granted limited permission to photograph in the press wing of the White House which includes the President's study as well as the Cabinet room.

Our time here was extremely limited, and with but three light units we made our scenes with exposure to spare. In the Cabinet room we were shooting a dark mahogany table flanked by dark leather-covered, high-backed chairs, yet we found good exposure at $f/3.5$ using two 750-watt spots, and a "Colortran" head bounced off the ceiling for general indirect fill. The President's office presented a similar situation, and we were helped there by more natural daylight filtering through the large French windows. The President's horn-rimmed glasses lay in the center of the desk just as he'd left them a few minutes before. It's hardly necessary to say, that we outdid ourselves framing them into meaningful shots. The main entrance to the building we shot with no extra lights at all, utilizing only the practical lights as we found them, and getting a beautiful negative at $f/2.8$. In less than an hour and a half we covered four rooms of this building, exposing some 700 feet of Tri-X.

There were many more interesting, challenging locations. But without this amazing new film we could not have done this series one quarter as successfully as we did. To be sure, there are lots of ways to skin a cat, and no doubt substitute footage could have been devised as in the past; yet here has been provided for us a new emulsion which has eliminated, to a large extent, one of our greatest limitations of the past—having *enough* light on remote locations. With the help of Tri-X Pan, we were able to bring to the classrooms of America a *real* slice of reality as we found it at the heart of our government.

INDIA'S FIRST FEATURE IN GEVACOLOR

(Continued from Page 390)

romance, the glamour, the beauty and charm of Kashmir. As it all had to be authentic, it naturally had to be enacted in the actual locales. And so it was that Ambalal J. Patel's "Pamposh" became a celluloid feature of more than passing merit.

The story, written by Ezra Mir, who also directed it, concerns a little mute orphan befriended by an old man and his wife who dwell with two daughters in a dilapidated houseboat on Lake Dal. The wife at once takes a dislike to the child and makes her the household drudge. One day while her adopted

hallen
CORPORATION
MAKERS OF
SYNCHRONOUS
Magnetic
FILM
RECORDERS

Degausser

FOR MAGNETIC FILM AND TAPE



Complete Erasure of Noise and Program Material Can Be Yours In A Matter of Seconds With the HALLEN Model 5500 Bulk Eraser.

NET PRICE **\$69.50** F. O. B.

3503 WEST OLIVE AVENUE • BURBANK, CALIFORNIA
CABLE ADDRESS "HALLEN" • PHONE THORNWALL 8-6976

parents arc away, the child accidentally sets fire to the houseboat and is herself seriously burned. She is chastised by her foster mother and subsequently disappears. Only the Old Man of The Lake, to whom she had often turned for solace, knew that the child had set out in a canoe on the lake, where often great storms suddenly arose, and would never return.

While this may not seem the sort of plot that would justify a feature-length production by Hollywood standards, it should be remembered that Indian pictures are made essentially for exhibition in India; they follow a much different format and, as in the case of "Pamposh," invariably they are fantasy—pictorial poems—and therefore unfold at a much slower pace than pictures made here.

Both producer Patel and Director-writer Mir were resolved that the keynote of the picture should be authenticity in the utmost degree and to the last detail. The story had to fit the locale and atmosphere. It also had to achieve the inspired level of fantasy in keeping with the extraordinary beauty of the setting and with sufficient substance to engage the interest of a world to which Kashmir and Dal Lake are only names.

Mr. Mir wandered around the lake for weeks for atmosphere and inspiration, while he built up the fictitious

Model 35-16C

SENSITESTER

★ IMMEDIATE DELIVERY
to the lab owners interested in—

QUALITY
EFFICIENCY
ECONOMY

- DUAL MACHINE
1—Sensitometer
2—Scene Tester
- HIGHLY ACCURATE
Electronic timer unaffected
by climatic changes.
- NEW TYPE LONG-LIFE
Cold Light Exposure Unit
- WITHOUT ADDITIONAL
EXPENSE will match any
printer

Combination 35mm-16mm

ART REEVES MOTION PICTURE EQUIP.

7512 Santa Monica Blvd.

Hollywood 46

California

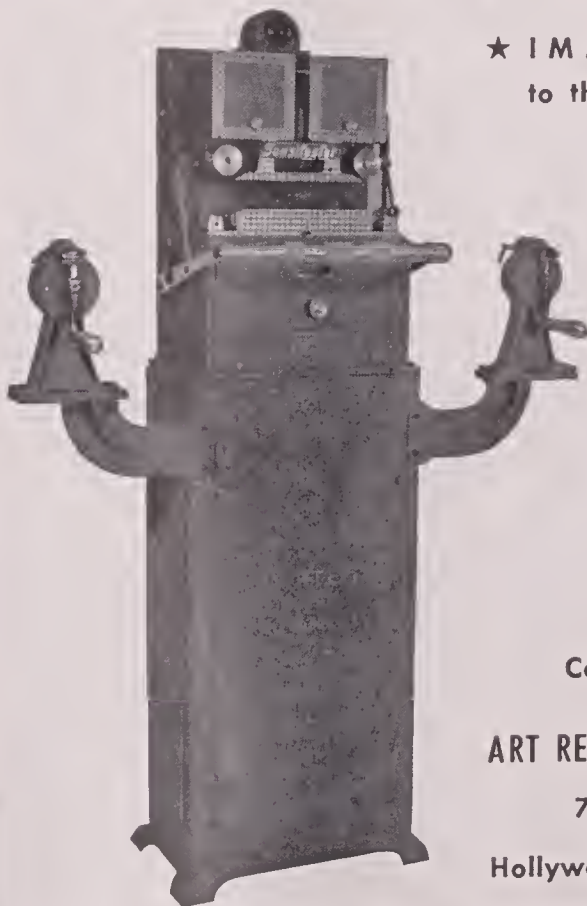

legend bit by bit out of the things he saw and people he met.

Thus, every foot of the film was shot on the spot for authenticity. This gives to "Pamposh" a documentary character of unique and inestimable value. Every bit of costume, every action, every spectacle—marriage, dance, race and revel—the whole business of life upon the lake, are genuinely presented exactly as they happened, and have happened for countless generations.

Despite the paradisiacal environment in which it was produced, photographing "Pamposh" was not entirely a picnic. Shooting the picture on the treacherous waters of Dal Lake with cameras balanced delicately on flat-bottomed boats rocked by the slightest movement of the water or from squalls that spring up without a second's warning, was a difficult as well as a dangerous business.

In the beginning, Patel himself did the photography—the whole project started originally as a holiday filming venture—then he engaged cinematographer Carlos F. Marconi to take over the camera, after plans for the production had been enlarged to feature-length.

An Eclair 35mm Camerette was used throughout the production. Heavier camera equipment could not be used because of the narrow streams and lake channels, and the rugged terrain the little company had to traverse.

Sometimes the crudest but non-the-less ingenious innovations were used in the filming. For a boom shot, a long timber, similar to a tall telegraph pole, was mounted in a crude cradle atop a lake houseboat and extended out over the water. In a hastily constructed seat nailed to the far end of the pole, cameraman Marconi sat and filmed boom and crane shots, while four natives, seated on the other end of the pole provided the necessary balancing weight and maneuvering. This interesting rig may be seen in one of the photos on page 390.

Patel held his shooting activities to within an eight-hour day, and the picture was completed in four weeks. It was photographed "wild," and lip-sync sound was dubbed-in later at a Bombay studio. Today, prints of "Pamposh," running 7000 feet in Gevacolor, are available in a number of languages, including English, French, German, Spanish and three Indian dialects. At the present time a version is also being dubbed in Japanese.

In 1945 Mr. Patel started Flm Center, his film process laboratory at Taredo, Bombay—the only color laboratory outside of Europe and the U.S.; subsequently, in 1946, he launched the now internationally-known concern, Patel-India. Incidentally, he should not be confused

with still another well-known Patel, a Bombay publisher.

When A. J. Patel started his color lab, many were skeptical about his ability to process color film. Today Film Center has an impressive record of having successfully processed 7 color features and 80 short subjects, totalling in all ten million feet of Gevacolor 35mm film.

Patel's equipment purchases are phenomenal, mostly from the U.S., information about which he gleans from American technical journals. (Patel was one of the very first in India to subscribe to American Cinematographer.—Editor)

In addition to the Eclair Camerette, he owns several Mitchell cameras, Mole-Richardson lighting equipment, a unique giant camera crane which his own technicians designed and constructed, and countless other equipment, all of which enables him to produce motion pictures having all the technical quality of the best American product. "Pamposh," incidentally, is the first all-color film to be produced, processed and printed entirely in India.

SENSITOFLEX

(Continued from Page 396)

the photo-cell are connected and which indicates the brightness of the picture area read by the cell.

With a scene brightness measuring device such as this, it is possible for the cinematographer to hold his lighting range down to fine tolerances, where the photography demands such critical sensitometric control. A typical application is TV film photography where it becomes necessary to hold exposures within a very narrow range of scene brightness.

But more important, perhaps, for this field of motion picture photography is the new hand-held selective light-measuring device also developed by M. Coutant. Tradenamed the Sensitoflex, the device, pictured in Fig. 3, is an accurately-operating photometrical remote measuring instrument which affords instantaneous evaluation of the brightness of the several characteristic points within the scene.

The Sensitoflex is calibrated in accordance with the 21 steps of standard sensitometry. Thus with TV film transmission demanding prints of limited contrast range, it is a simple matter for the TV film cameraman to light his scenes to more closely accommodate the requirements of the TV film transmission system.

In use, the Sensitoflex is held up to the eye by the cameraman, who scans the scene and takes readings of the various light and dark areas. What he sees in the eyepiece of the Sensitoflex

is a ground glass image of the scene reflected through the instrument's three-inch lens. In the center of the ground glass is the tiny photo-cell 1mm by 3mm in size. To read the brightness of a selected point within the scene, the Sensitoflex is aimed at the scene and moved until the photo-cell covers the point to be read. The brightness response is recorded on the dial which is also observable in the finder eyepiece.

Thus, let us say it has been established that a given television film must be photographed with a brightness range between 10 and 14 (on the Sensitoflex dial). The operator simply checks all the various highlight and lowlight areas within the scene with the Sensitoflex to determine if the various points fall within this range. If they do not—say, for example, where a certain brightness area is above point 14, the set illumination is diminished at this point until it is brought down to the desired level. Obviously, the instrument is ideal for insuring correct lighting of faces and other bright areas of importance within the scene.

The Sensitoflex weighs only 25 ounces and is customarily worn around the neck by the camera operator or director of photography. Two types are presently available: 1) Model B designed for black-and-white cinematography, which may be equipped with special attachment for color photography; and 2) the TV Model which is supplied on special order and is fitted with a microphotocell whose scale of sensitivity more closely approximates the lighting range demanded by TV's iconoscope tube.

This interesting new light measuring device, whether used with the Camerette (built-in as described above) or as the hand-held Sensitoflex, has great possibilities in the field of scientific photography, and for photography of very small objects as in microphotography; and again, for the photography of distant scenes or objects where the cinematographer is unable to approach the area to obtain a light reading in any other way.

For studio use, the director of photography working on a very large set is able to stand at the camera position and evaluate the light at any point within the set.

Both the Camerette with the built-in Came-Radar and the separate Sensitoflex instrument are soon to be demonstrated before industry cinematographers in Hollywood and New York by Benjamin Berg.

Use of industrial films has grown to where at least seventy-five big companies such as Santa Fe Railroad and Standard Oil, now have their own film studios.

CLASSIFIED ADVERTISING

10c per word, minimum ad \$1.00. Words set in capital letters except 1st word and advertiser's name, 15c per word. Modified display format 90c per line. No discount on classified advertising. Send copy with remittance to editorial office, 1782 No. Orange Drive, Hollywood 28, Calif. Deadline 15th of month preceding date of issue.

STUDIO & PRODN. EQUIP.

SHOP AT THE ONE STOP SHOP

B & H AUTOMATIC FOOT SPLICERS, 35mm \$595.00, combination 16/35mm\$ 695.00
 NEW OLESEN CHROMOSPOTS, SR. 5KW \$1B4.BB; JR 2KW 92.6B
 H'WOOD ESCALATOR TRIPOD, freehead for heaviest TV or Movie Cameras, on 3 wheel dolly. \$1250 originally. CLOSE OUT..... 295.00
 CINE SPECIAL MODEL II with 1-200' chamber, 5 Kodak coated lenses, carrying case. Excellent 1275.00
 NEW MICROPHONE BOOMS with pan/tilt head, remote control, counterweight. 12' model \$195.00; 13' BOOM with guy wire for added strength 229.50
 NEW STEPHENS WIRELESS MIKE with FM Transmittina Unit. Concealed on performer, operates 200' from camera 980.00
 B&H FILM SPROCKET DEFECT INDICATORS, 16mm, new 79.50
 MOTORIZED DOLLY with 2 seats. Takes heaviest cameras. CLOSE OUT 195.00
 KODAK HISPEED 16mm CAMERA w/63mm lens, \$1713 val. 995.00
 MOVIOIA 35mm PREVIEW UDPVCS. Sound one side, composite sound/picture other side. Beautifully rebuilt 1695.00
 MOVIOIA 35mm COMPOSITE Sound/Picture complete 495.00
 MAURER 16mm CAMERA w/400' mag.; syncmotor; viewfinder; blimp 3100.00
 BARDWELL-McALISTER MULTIPLE FLOODLITES. 3 Quadruple heads holding 12 bulbs on rolling tripod stand. Orig. Gov't cost \$180. Surplus 29.50
 BM QUADLITE Heads only \$4.95; Stands only 19.95
 CENTURY 750W LEKO TV framing spotlights, \$63 value 29.50
 CINE SPECIAL 16mm BLIMP Custom Built. Has follow focus, vertical image 63mm viewfinder, takes 200' mag. & syncmotor. \$600 value 350.00
 CINEMAPHONE 35mm DUBBING Heads, less motor 395.00
 NEW FILM EDGE NUMBERING MACHINES, 16 or 35mm 2250.00
 SOS FILMETER STOP WATCH \$29.50 value..... 13.95
 GIANT METAL FILM CABINETS, hold 120 assorted 16mm reels. \$240 value. New.... 171.00
 TRADES TAKEN SEND FOR 1954 CATALOG
 Phone PL 7-0440

Dept. fc Cable: SOSOUND
S.O.S. CINEMA SUPPLY CORPORATION
 602 W. 52nd Street New York 19

FOR SALE

GUARANTEED LIKE NEW!

CINE KODAK "K" F1.9, 3" F4.5 TELEPHOTO..\$ 98.00
 B&H 70DL F1.5 COOKE and 2" F3.5 WOLLEN-SACK 299.50
 CONCERTONE TAPE RECORDER WITH CASE..... 275.00
 1" F1.5 BAUSCH & LOMB ANIMAR..... 114.50
 5" F4.0 BOLEX YVAR IN "C" MOUNT..... 98.00
 ELGEET STEREO SYSTEM..... 99.50
 BOLEX PAN-CINOR ZOOM LENS..... 198.00

MAIL ORDERS FILLED

CAMERA CRAFT, 18 East 42nd Stret, New York 17, N.Y.

BERNDT-MAURER, 16mm SINGLE SYSTEM CAMERA, MODEL H Three lens turret, dissolving shutter, bilateral VA galv., 115V sync and 12V DC motor, matte box, camera case, Bell & Howell tripod, two 400 ft. magazines, magazine case, two-channel amplifier and case, AC supply and case, AGN amplifier and case, 12V portable supply with dynamotor and case, blimp, W.E. mike, all accessories. Perfect condition. Price: \$2950.00. BYRON INC., 1226 Wisconsin Avenue, Washington 7, D. C.

CINE SPECIAL 16mm Blimp Auricon, with Auricon parallax viewfinder and syncmotor, new condition \$500. W. MAHONEY, 1730 Kleemeier St., Cincinnati 5, Ohio.

AURICON Pro, Cine Voice exposure control, turns on, off with camera — prevents fogging, saves batteries, complete \$40.00. LEE ENGINEERING, 222 Minna St., San Francisco. APPROVED BELL & HOWELL SERVICE. Eyemo parts in stock.

ARRIFLEX 35mm. camera, 3 lenses, filters, sunshade, tripod, case. Complete for quick sale . . . \$795.00. Write P.O. Box 312, Ridgewood, N.J., or phone Allendale, N.J. 13046.

FOR SALE

OUR 25TH YEAR — SUPPLYING EVERYTHING PHOTOGRAPHIC & CINEMATIC

B&H 25mm EYEMO "Q" CAMERA with 4" f2.9 Cinemat, 2" f2.3 Kinar, 35mm f2 Cooke lenses and viewfinder lenses, 2-400' magazines, freehead tripod, shift-over alignment Gauge, 12V variable speed motor, 2 carrying cases, excellent condition\$1550.00
 35mm DUPLEX CAMERA — Registration pins, lenses: 40mm f2.7 Carl Zeiss, 2" f1.9 Ultrastigmat, 105mm Schneider f3.5, 3-400' magazines, 400' BiPack magazine, viewfinder Matte Box, 12V DC motor, battery, Freehead Tripod, 2 carrying cases. A real buy 1125.00
 35mm B&H SINGLE SYSTEM SOUND CAMERA, lenses: Cooke, 40mm, 50mm, 75mm, 125mm Modulite Galvanometer, amplifier, motor, Tachometer, 2-1000' magazines, Tripod with Freehead, quick release legs, carrying cases, Guaranteed 3500.00
 35mm ARRIFLEX CAMERA, Coated lenses: 35mm f1.2 Carl Zeiss, 50mm f1.5 Carl Zeiss, B5mm f2 Carl Zeiss, 135mm f2.3 Astro pan Tachar, variable speed motor, 12V battery, freehead tripod, 3-200' magazines, carrying cases, special 1175.00
 35mm AKELEY CAMERA, 4 matched Zeiss lenses, 4-200' magazines, slow motion attachment, Akeley friction tripod, quick release legs, carrying cases. Bargain price 750.00
 35mm ART REEVES SOUND RECORDER, twin fidelity optical unit, glow lamp type, 1000' B&H magazine, complete with cases..... 977.50
 ENLARGERS, excellent condition, Elwood, Auto focus, lens and stand, 5x7 235.00
 Bx10 400.00
 MOLE RICHARDSON 2000 Spot, rolling stand.. 110.00
 B&H CAMERA CHECK PAWLS high speed shuttle. List price, new \$1742.00, good cond... 195.00
 NEW SCHOEN PRINTER, sound and silent, color, B&W features: 16mm picture alone, 16mm track alone, 16mm picture and sound together, film capacity 1600 feet, 50' per minute, 12 adjustable light changes, AC-DC conversion unit 999.00
 HOMRICH COMBINATION COPYING CAMERA and animation table stand, adaptable to 4x5, 5x7, Bx10 holders. Two adjustable light stands with twin reflectors. 11x14 16x20 copy frames. Built in lamp house, good buy 135.00
 HOMRICH ELECTRONIC TIME CONTROL CONTACT PRINTER, timer has full second and split second setting. Handles 4x5, 5x7, Bx10 negatives. Adjustable masking and paper guides. Internal dodging plate glass plate. Four lamps, each controlled by separate toggle switch. A real buy 165.00
 Specializing in movie and television supplies, tripods, synchronizers, 16mm sound cameras, lights, lenses, mikes, booms, dallies, motors, etc. New-used reasonable prices. Cash for used equipment. Trades taken.
HOLLYWOOD CAMERA EXCHANGE, LTD.
 1600 Cahuenga Boulevard Hollywood, California

BASS . . . is headquarters for Arriflex 16; the new Zoomar 16; Cine Specials, all models; Bell & Howell 70-DL; Bolex H-16. Used Cine Special 1, 1" F:1.9 lens and carrying case \$395.00; Used H-16 Bolex, 1" F:1.5, 0.7" F:2.5 W.A., 3" F:3.5 \$347.50 Used Bell & Howell 70-DA, 1" F:1.9, 4" F:4.5 \$235.00. Used Bell & Howell 70-A, 1" F:3.5 and case \$52.50; Used 200' Chamber Cine Special \$295.00; Used 100' Chamber, Cine Special \$117.50. Best buys . . . Best trades always. BASS CAMERA CO., Dept. AC, 179 W. Madison St., Chicago 2, Ill.

WALL S. S. 35MM. SOUND CAMERA

COMPLETE with Galvanometer, amplifier, portable power supply, 40-50-75 and 100mm. lenses, erect image viewfinder, complete front attachments, two 1000 ft. magazines, Balanced Tripod, necessary carrying cases. Overhauled. Guaranteed perfect. Reasonable.

CAMERA EQUIPMENT COMPANY

1600 Broadway New York 19, N. Y.

AUDIO AKELEY single system camera complete with Akeley sound head, Gyro tripod, 3 lenses, view finder, Maurer mixing amplifier. Complete with cables, power supply and W. E. microphone. CAMERA EQUIPMENT CO., 1600 Broadway, New York 19, N.Y. Cable Cinequip.

WE BUY, SELL AND RENT PROFESSIONAL AND 16mm. EQUIPMENT, NEW AND USED. WE ARE DISTRIBUTORS FOR ALL LEADING MANUFACTURERS. RUBY CAMERA EXCHANGE, 729 Seventh Ave., New York City. Established since 1910.

FOR SALE

PRINTER, two headed 16mm duplex step printer, with opening for color printing. Variable aperture for masking out frame lines. \$795.00. BYRON, INC., 1226 Wisconsin Avenue, Washington 7, D. C.

WANTED

IMMEDIATE CASH PAYMENT FOR CAMERAS AND EQUIPMENT

NEED EYEMOS (SINGLE LENS AND TURRET), MITCHELLS, ARRIFLEX, DE BRIES, B&H STANDARDS AND HI-SPEEDS, WALLS, AKELEYS, CINE SPECIALS, AUJRICONS, MAURERS, FILMOS. ALSO BALTARS, COOKES AND OTHER LENSES. SOUND STAGE, LABORATORY AND EDITING EQUIPMENT OF ALL TYPES REQUIRED. PLEASE SHIP INSURED OR FORWARD DESCRIPTIONS AIRMAIL. IMMEDIATE PAYMENT.

GORDON ENTERPRISES • 5362 N. Cahuenga
 NORTH HOLLYWOOD, CALIFORNIA

WANTED

Mitchell — Akeley — B & H — Wall — Eyemo
 Cameras — Lenses — Equipment
NATIONAL CINE EQUIPMENT, INC.
 209 West 48th St. New York, N.Y.

OUR SHINGLE STILL HANGS YE OLDE SOS TRADING POST BUY — SELL — SWAP — CONSIGN

Cameras, Dollies, Lenses, Lights, Moviolas, Printers, Recorders, Studia or Laboratory Equipment
Western Union-WUX New York
 Phone PL. 7-0440

S. O. S. CINEMA SUPPLY CORPORATION

Dept. fc Cable: SOSOUND
 602 W. 52nd Street New York 19, N. Y.

WANTED TO BUY FOR CASH CAMERAS AND ACCESSORIES

MITCHELL, B & H, EYEMO, DEBRIE, AKELEY ALSO
 LABORATORY AND CUTTING ROOM EQUIPMENT
CAMERA EQUIPMENT COMPANY
 1600 BROADWAY, NEW YORK CITY 19
 CABLE: CINEQUIP

WANTED

PRODUCTION EQUIPMENT, LABORATORY EQUIPMENT, EDITING EQUIPMENT, 16mm. and 35mm. FROM SINGLE ITEMS TO COMPLETE STUDIOS. TRADES ACCEPTED.

THE CAMERA MART, INC.

1845 Broadway Circle 6-0930 New York 23, N.Y.

F & B PAYS MORE FOR USED 16/35MM EQUIPMENT WRITE — WIRE — PHONE FOR OUR CASH OFFER

FLORMAN & BABB MU. 2-2928
 70 W. 45TH ST. NEW YORK 36, N.Y.

1,000 FT., 4,000 Ft. 35mm. or 16mm. B&H or Mitchell magazines, also BiPack. Quote condition, best price far cash. HOLLYWOOD CAMERA EXCHANGE, 1600 Cahuenga Blvd., Hollywood, California.

CAMERA & SOUND MEN

ASSIGNMENTS FOR INDIA or nearby territories for any type of films, 16 or 35mm, B&W or Color, write to KANU PATEL, A.R.P.S., The Clarion Productions, 34, Park Mansions, CALCUTTA-16.

(Continued on Next Page)

Classified Ads

(Continued from Page

COLOR SLIDES, PHOTOS & FILMS

"PERILS OF PAULINE" WITH PEARL WHITE, NOW AVAILABLE 16MM SOUND AND SILENT. OTHER COLLECTORS ITEMS BOUGHT, SOLD, TRADES ACCEPTED. LISTS FREE. JOHNNY ALLEN, PARK RIDGE, NEW JERSEY.

LABORATORY & SOUND

SOUND RECORDING at a reasonable cost. High Fidelity 16 or 35. Quality guaranteed. Complete studio and laboratory services. Color printing and lacquer coating. ESCAR MOTION PICTURE SERVICE, INC., 7315 Carnegie Avenue, Cleveland 3, Ohio. Phone Endicott 1-2707.

KODACHROME duplicates: 16mm 10c per foot, mail orders accepted, satisfaction guaranteed. COLOR-VISION FILMS, 122 N. Mociay Ave., San Fernando, California.

LOW cost 16mm sound recording—picture and magnetic sound editing. EL RANCHO AUDIO, 26236 Fairview Ave., Lomita, California. Davenport 6-4925.

PRODUCTION SERVICES

STUDIOS AVAILABLE for independent, low budget 16mm productions. Specializing in sound track recordings for industrial and educational films. Original musical scores provided on the Hollywood Organ. See us about your production problems or write us for free literature. RAMPART PRODUCTIONS, 2356 Doris Place, Los Angeles 31, CAPitol 8138.

AUTOMATIC DAYLIGHT PROCESSING



DEVELOPING TANK

- Processes up to 200 Ft.
- 8mm-16mm-35mm
- Movie—X-Ray—Microfilm
- Motor Driven, Portable
- Tough Plastic Tanks
- Uniform Density Assured
- 70mm tank also available



FILM DRYER

- Motor driven—Heated
- Speedy drying
- Automatic shrinkage allowance
- Stainless steel and aluminum construction
- Easily assembled without Tools
- Compact, Portable

Guaranteed. Write for Free Literature

MICRO RECORD CORP.

Dept. AC, 487 South Ave., Beacon, N. Y.

"The Finest Cameras
Deserve the Finest Care"



AUTHORIZED

Service To All Fine Cameras

ROMLE-WAHL & CO.

520 W. 7th ST.
LOS ANGELES 14, CAL.

WORLD FAMOUS

S-5

synchronous
magnetic film
recorder for
motion pictures
and television



STANCIL-HOFFMAN

921 N. Highland Hollywood 38, Calif.

send
for
particulars

BOUT ON FILM

(Continued from Page 388)

rear were set to photograph slow-motion action at 72 frames per second. The other three shot at 24 frames per second. The high speed cameras were each fitted with 12-inch telephoto lenses. Two of those operating at 24 f.p.s. used 10-inch lenses, and the third a 17-inch lens.

DuPont Superior No. 2. Type 901, negative was used in the high-speed cameras, and DuPont No. 3 was used in the Mitchells shooting at sound speed.

Director of photography Freddy Fordham maintained an accurate check on the volume of illumination at the ring by taking frequent meter readings and relaying the result to his staff of cameramen high on the parallel. Here manning the Mitchell cameras were cinematographers Bill Kelly, George Hinners, John Garvey, Sid Zucker, and Irving Smith. Picking up the closeup action at ringside with hand-held cameras were Charles Downs, Sr., and Doug Downs.

As fast as the cameras were reloaded, the exposed film magazines were sent off to DeLuxe Laboratories for processing. Before the last of the footage reached the lab, indeed, while the final moments of the fight were being filmed, the footage of rounds 1, 2, and 3 already was in the cutter's hands and going through the editing process.

Less than fifteen hours after the title bout ended in a decision for Marciano, the film record of the event was being exhibited as a major attraction in Gotham theatres. Meantime, prints were being dispatched by air to theatres in major cities throughout the U.S. Theatregoers who had missed the special closed-circuit TV showing of the fight, were thus able to see the complete championship bout at their convenience and in the comfort of their favorite local theatre.

SHORT CUTS CUT COSTS

(Continued from Page 397)

track of the narrator's voice is made in sync with the work print. These two sound tracks are then mixed, with the narrator's voice and the natural background sounds combined and re-recorded to a positive optical track suitable for printing on Kodachrome duplicating stock.

The Young Studio worked closely with Film Associates, a Dayton, Ohio Laboratory, whose experience and know-how has added considerably to the success of the films. While the Young firm makes its film on regular Kodachrome, the quality of the duplicate prints is well

above average. In fact, they are considered better than many prints made from a commercial Kodachrome original. Young's Studio films have won numerous awards. One, made for the Indiana Farm Bureau Co-op, was entered in National competition and awarded first prize.

"We think our technique of combining the sound track with all the natural, on-location sounds and disturbances, together with the voice of the narrator gives more striking realism than is usually found in industrial films where the background noises are missing," says Robert Young of the Young firm. "We have also found," said Mr. Young, "that our system of editing with file-cards, with each scene numbered and described, cuts our editing time and cost virtually in half. It gives us a finishing technique that affords more control, simplifies the writer's job and permits us to do much of our editing on paper, rather than actually cutting the film. This also keeps the laboratory time cost to a minimum—reduces the actual film cutting—and gives the advertiser or sponsor the top-quality he wants, at a price he is glad to pay."

BULLETIN BOARD

(Continued from Page 374)

contributions toward the conquering of hitherto impossible phases of heart surgery.

He was specifically cited for his highly technical assistance and advice rendered in the making of special films relating to heart surgery.

★

Lucien Andriot, ASC, and Mack Stengler, ASC, are tied for number of TV film shows they photograph weekly. Andriot, one of the first cinematographers in TV film production, is currently shooting "Where Were You?" for Ken Murray; "It's a Great Life" for Raydic Corp.; and "Life of Riley" for Hal Roach.

Mack Stengler is filming three shows for Guild Films: "Liberace," "Life With Elizabeth," and the "Frankie Laine Show."

★

Sidney Solow, head of Consolidated Film Industries' Hollywood plant and an Associate Member of the A.S.C., was named Vice-president of Republic Pictures, last month. Solow will remain as head of Consolidated, where he has been for 22 years.

★

Lloyd Ahern, ASC, returned from Nicaragua last month where he shot footage in color for 20th Century-Fox's forthcoming CinemaScope short, "Tuna Clipper Ship."

Check these features of the versatile
Cine-Kodak Special II Camera
against your 16mm. movie-making needs

Aim, frame, and focus through the taking lens. A built-in reflex finder does away with problems of parallax, gives critical hairline focusing on close-ups. For finding and following fast action, the camera has a direct-view finder with parallax adjustment for distances from two feet to infinity.

Masks for double exposures and special effects. A standard set of masks which fit the integral mask slot is supplied with the camera. Set includes a circle, an oval, and two vertical and two horizontal matched half-masks for making double exposures.

Make fades and dissolves. The adjustable-opening shutter can be changed during operation to provide smooth fades and dissolves and also to provide, when desired, a useful means of controlling exposure. Hand-cranking shafts provide one or eight frames per turn, forward or reverse.

Get more run per winding. One winding of the powerful spring-driven motor is sufficient for the exposure of 38 feet of film. Camera has provision for attaching auxiliary motor drive.

Shift from one film to another. Camera comes with either 100- or 200-foot film chamber. Extra chambers may be purchased separately. Easily removable for rapid shift from one type of film to another.

Make speeded-up or slow-motion pictures. Any desired speed, governor-controlled from 8 to 64 frames per second, including 24-frames-per-second sound speed, can be obtained. Single-frame release provides for animations and special title effects.

Switch from telephoto to normal shooting distance instantly. Two-lens turret permits quick shift from one lens to another. Angle mounting prevents physical or optical interference, regardless of lens barrel length or design. Camera comes with either $f/1.4$ or $f/1.9$ Kodak Cine Ektar Lens. Other Kodak Cine Ektar Lenses, from 15mm. wide-angle to 152mm. telephoto, available.

Know your exact footage at all times. Three film meters show footage exposed or rewound. One, on the film chamber, shows amount of unexposed film. A mechanical footage meter on the camera indicates amount of film run or being rewound. And a frame counter registers individual frames run forward or reverse to make possible exact control for special effects.

For further details and prices, see your Kodak dealer or mail coupon below.
Most Kodak dealers offer convenient terms.

EASTMAN KODAK COMPANY, Dept. 8-V, Rochester 4, N. Y.

Please send me more information about the Cine-Kodak Special II Camera.

NAME _____ POSITION _____

COMPANY _____

STREET _____

CITY _____ STATE _____

(Zone)

8-11

Kodak
TRADE-MARK

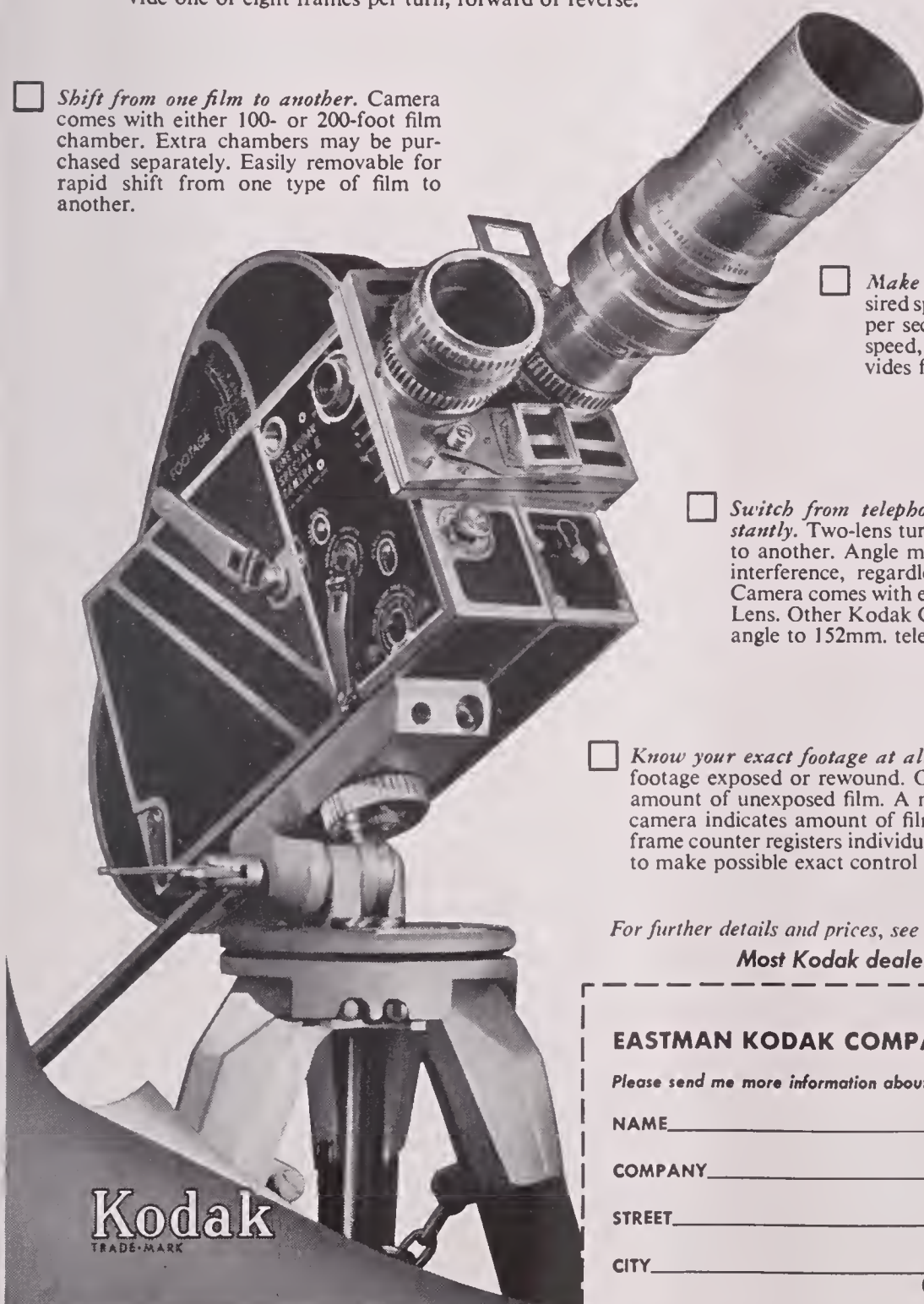

ULTRA-SHARP DETAIL

...in ↓

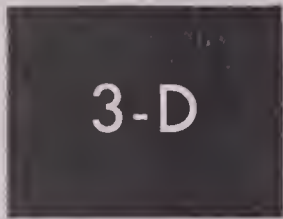

...in ↓



...and in ↓

CINEMA SCOPE



...with Taylor, Taylor and Hobson Speed Panchro Lenses

T-T-H Speed Panchro lenses again meet the demands of a fast-growing industry—supplying the high degree of sharpness needed for Cinema-Scope, 3-D and television films. A complete set of eight fully color corrected lenses matched for

perfection is now available from Bell & Howell. Each lens is accurately calibrated by scientific measurement of light actually transmitted. Consistent negative densities regardless of which lens is used. For full details, write to Bell & Howell.



100mm T3 (f/2.5)



75mm T2.3 (f/2)



50mm T2.3 (f/2)



40mm T2.3 (f/2)



35mm T2.3 (f/2)



25mm T2.3 (f/2)



32mm T2.3 (f/2)



28mm T2.3 (f/2)

Also 8½", 12½", and 20" F/5.6 T-T-H Telephotos

Look for Bell & Howell's new 35mm anamorphic lens for studio and theater projection.



Bell & Howell

Professional Equipment Department
7148 McCormick Road, Chicago 45, Ill.

AMERICAN

SEPTEMBER • 1954

Cinematographer

THE MAGAZINE OF MOTION PICTURE PHOTOGRAPHY



This Issue ...

- MGM'S NEW UNDERWATER CAMERA BLIMP
- TV SERIES FILMED IN 16MM COLOR
- SYNC SOUND WITHOUT INTERLOCK

25c
\$3.00 YEARLY



Shooting that helps save lives

DALLAS POLICE REPORT EXCELLENT RESULTS WITH DU PONT FILMS DESPITE UNPREDICTABLE LIGHTING AND WEATHER

Plagued by a high accident rate, the Dallas Police Department made a series of safety movies on the importance of careful driving. For the most part, shots of actual traffic accidents were used. The movies were made on Du Pont Motion Picture Film.

Taking this real-life footage is seldom easy. Day or night, the police photographer must be prepared for cloudy weather, heavy fog . . . even driving rain. And regardless of time of day, there's always the problem of lighting. That's why the versatility of Du Pont Film is so important for these operations. It's proved ideal for television broadcasting of these safety films, too.

No Chance for Retakes

Many of these motion pictures are designed to train rookies. One that shows the rights and wrongs of directing traffic, for example, has been so successful that other police departments have copied it. However, in making these films there's often no opportunity for reshooting scenes and the consistency of Du Pont Film from reel to reel naturally proves valuable.

Used Normal Indoor Lighting

Another film made by the Department teaches merchants and salespeople how to apprehend swindlers and shoplifters. It was shot under normal retail-store lighting without a single auxiliary light. Yet every frame was bright and clear, thanks to the high speed of Du Pont Motion Picture Film.

Both Du Pont 930A and 931A offer wide latitude, excellent definition. And their high speed plus longer tonal range make them ideal for semi-professional motion pictures and TV news releases. For more information,

write your nearest District Office or: E. I. du Pont de Nemours & Co. (Inc.), Photo Products Department, Wilmington 98, Delaware. *In Canada: Du Pont Company of Canada Limited, Montreal.*

District Offices

ATLANTA 5, GA.	805 Peachtree Bldg.
BOSTON 10, MASS.	140 Federal Street
CHICAGO 18, ILL.	3289 N. California Ave.
CLEVELAND 14, OHIO	1033 Union Commerce Bldg.
DALLAS 1, TEXAS	506 Tower Petroleum Bldg.
LOS ANGELES 38, CALIF.	
	7051 Sonto Monico Blvd.
NEW YORK 11, N. Y.	248 West 18th Street
PHILADELPHIA 2, PA.	225 South 15th Street

DU PONT MOTION PICTURE FILM



REG. U. S. PAT. OFF.

BETTER THINGS FOR BETTER LIVING . . . THROUGH CHEMISTRY

Great equipment makes great cameramen

OCT 25 1954

BALANCED TRIPOD HEAD
and
PROFESSIONAL JUNIOR TRIPOD
are the standbys of the masters



New "BALANCED" TV head — MODEL "C"
 —for the world's smoothest pan and tilt action.

You'll never hear Fritz Kreisler playing on a scratchy fiddle . . . or Louis Armstrong on a \$7 trumpet. Good craftsmen need good tools.

Camera Equipment Company makes, sells, services and rents the world's finest quality TV and Motion Picture Equipment.

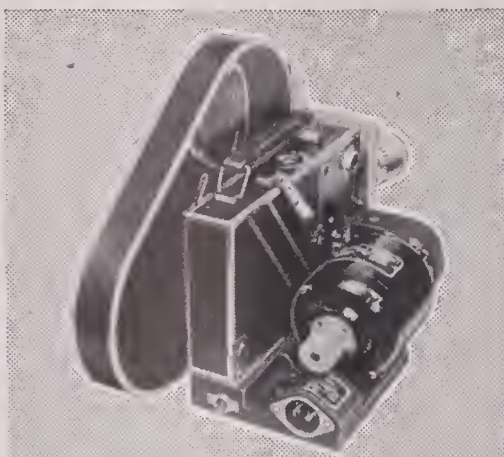

SYNCHRONOUS MOTOR DRIVE — 110 Volt AC — Single phase, 60 Cycle. Runs in perfect synchronization with either 16mm or 35mm Sound Recorders. Mounting platform permits removal of magazine while camera remains mounted on motor. Spring steel drive fin coupling prevents damage if film jam occurs.

Knurled knob on armature permits rotating for threading. "On-Off" switch in base. Platform base threaded for 1/4" or 3/8" tripod tie-down screw. Rubber covered power cable with plugs included.



More professional cameramen use The PROFESSIONAL JUNIOR Tripod than any other tripod in the world.

Let's face it. You need a first class tripod to make better pictures. PROFESSIONAL JUNIOR has the rigidity, the range, and the ease of operation that better pictures demand. See it—try this tripod beauty—and you'll never be without it. PROFESSIONAL JUNIOR TRIPOD—Friction Type. Handles all 16mm cameras, with or without motor. Also 35mm DeVry, B & H Eyemo with and without motor, and 400' magazines. Tripod base interchangeable with Professional Junior gear drive head. "Baby" tripod base and "Hi-Hat" base available.

No more groping for center of gravity. The new Model C "Balanced" Tripod Head is equipped with a convenient, accessible positioning handle mounted below the top plate, which allows the operator to reposition the camera to the correct center of gravity. No matter what focal length lens is used on the camera turret, the camera can be balanced on the Model C Head without loosening the camera tie-down screw.

It has all the features which have made the "Balanced" head the gem of engineering ingenuity—quick release pan handle, tilt-tension adjustment to suit your preference. It's a Cameraman's dream!

FRANK C. ZUCKER

CAMERA EQUIPMENT CO.
 1600 BROADWAY NEW YORK CITY

SALES • SERVICE • RENTALS — CAMERAS * MOVIOLES * DOLLIES

Complete line of 35mm and 16mm equipment available for rental.

MITCHELL: Standard, Hi-Speed, BNC, NC, 16mm

BELL & HOWELL: Standard, Shiftover, Eyemo

ARRIFLEX: 35mm and 16mm

MAURER: 16mm Cameras

MOVIOLA: Editing machines, Synchronizers

Design and manufacture Lens Mounts and camera equipment for 16mm—35mm and TV cameras.



VARIABLE SPEED MOTOR — 110 Volt AC/DC with Tachometer for EK Cine Special Motor drive your Cine Special with confidence! Tachometer is mounted in clear view of operator. Calibrated from 8 to 64 frames per second. Definite RED marking for 24 fps. Electrical governor adjusts speeds. Steady operation at all speeds. No adapters needed. Motor coupling attaches to camera and couples to motor. Spring steel drive arm shears if film jam occurs. Easily replaced.

We calibrate lenses—Precision "T" Stop Calibration of all type lenses, any focal length. Our method is approved by Motion Picture Industry and Standard Committee of SMPTE. For proper exposure density, it is important that you have your lens "T" stop calibrated. Lenses coated for photography. Special TV coating. Rapid service.



**The Seal of Our
Pledge to You**

**... to bring
to the screen
in flawless manner
the artistry
of your
photography**

*Hollywood's
only complete*

**LABORATORY
SERVICE**

**CONSOLIDATED
FILM INDUSTRIES**

A DIVISION OF REPUBLIC PICTURES CORPORATION

**959 N. SEWARD ST.
PHONE HO 9-1441**

AMERICAN

Cinematographer

THE MAGAZINE OF MOTION PICTURE PHOTOGRAPHY
PUBLICATION OF THE AMERICAN SOCIETY OF CINEMATOGRAPHERS

ARTHUR E. GAVIN, *Editor*

MARION HUTCHINS, *Editorial Assistant*

EMERY HUSE, *Technical Editor*

EDITORIAL ADVISORY BOARD: John Arnold, Arthur Edeson, Lee Garmes, Charles Roshier, Leon Shamroy, Fred Gage, Glenn R. Kershner

Editorial and Business Office: 1782 N. Orange Dr., Hollywood 28, Calif.

Telephone: HOLLYWOOD 7-2135

VOL. 35

SEPTEMBER • 1954

NO. 9

In This Issue

ARTICLES

MGM'S NEW UNDERWATER CAMERA BLIMP—By Arthur Rowan	440
HE MAKES NEWS LIVE—By Jim F. Palmer	442
SYNC SOUND WITHOUT INTERLOCK—By Frank Harris	445
HANK McCUNE TV SERIES FILMED IN 16MM COLOR—By Frederick Foster	446
HIGH-SPEED FILMING OF INSTRUMENT ACTION—By Alvin D. Roe	448
RADIO CONTROLLED CINEMATOGRAPHY—By J. W. Bakke	450
HIGH-SPEED FILM PROCESSOR	450
IS YOUR 16-MILLIMETER CAMERA SHOWING ITS AGE?—By Hank Stockert	452
YOU CAN MAKE DOLLY SHOTS, TOO—By John Forbes	454

FEATURES

INDUSTRY NEWS	426
WHAT'S NEW IN EQUIPMENT ACCESSORIES, SERVICES	428
LETTERS	432
HOLLYWOOD BULLETIN BOARD	434
HOLLYWOOD STUDIO PRODUCTION	468

ON THE COVER

PHOTOGRAPHING underwater scenes for MGM's "Jupiter's Darling" at Silver Springs, Florida. Camera operators Dale Deverman and John Nickolaus make last-minute check of blimped cameras before giving "ready" signal to director of photography Paul Vogel, A.S.C. Production, which stars Esther Williams, was directed by George Sidney. (See story on Page 40).—Photo courtesy Florida's Silver Springs.

AMERICAN CINEMATOGRAPHER, established 1920, is published monthly by the A. S. C. Agency, Inc., 1782 N. Orange Dr., Hollywood 28, Calif. Entered as second class matter Nov. 18, 1937, at the postoffice at Los Angeles, Calif., under act of March 3, 1879. SUBSCRIPTIONS: United States and Canada, \$3.00 per year; Foreign, including Pan-American Union, \$4.00 per year. Single copies, 25 cents; back numbers, 30 cents; foreign single copies, 35 cents; back numbers 40 cents. Advertising rates on application. Copyright 1954 by A. S. C. Agency, Inc.

"I feel I owe you this letter..."

DON MALKAMES

Cinematography- Mitchell Cameras

7 PLYMOUTH AVENUE
TUCKAHOE 7, N. Y.

June 11, 1954

Mitchell Camera Corp.,
666 West Harvard St.,
Glendale 4, Calif.

Gentlemen:-

I feel that I owe you this letter.
Since purchasing my Mitchell BNC camera
from you in January 1951, more than two million
feet of film has been exposed in it, in the
production of over two hundred television shows.

During the entire photographing of this
footage, we have never had a buckle, a scratch
or an abrasion mark on the film. We have never
experienced the slightest mechanical trouble
and not a single screw has been adjusted since
the camera left your hands, at the factory.
The only times that even a screwdriver has
touched the camera have been when I personally
removed the movement, once each month, cleaned
it in benzine, and replaced in camera.

My experience with the above camera upholds
the reputation of the original Standard Mitchell
Camera which I purchased from you more than
twenty eight years ago and which is still in
use, along side of the BNC, making 'wild' shots.

Sincerely,

Don Malkames

Mitchell Camera CORPORATION

66 WEST HARVARD STREET · GLENDALE 4, CALIFORNIA · CABLE ADDRESS: (MITCAMCO)

85% of the motion pictures shown in theatres throughout the world are filmed with a Mitchell

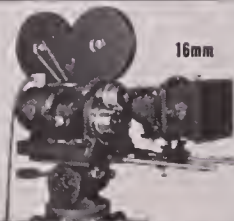

16mm



35mm

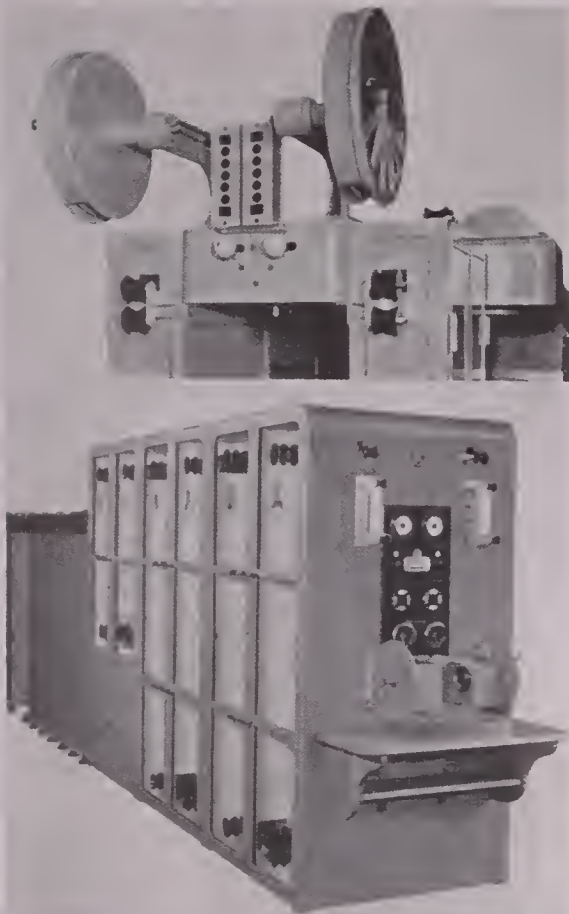

FILM LABORATORIES AND PRODUCERS THE WORLD OVER ARE CHANGING TO UNION EQUIPMENT!

Highest workmanship, famous machine-building tradition, favorable cost schedules, and profitable exchange rates between American and German currencies offer you top quality color developing machines at really *spectacular prices*.

Pictured is UNION'S Model 351/V, a sprocket driven machine, for \$20,763

THE UNION COLORA DEVELOPING MACHINE . . .

Duplex type, each side with its own tanks, motor and speed control, 35/16mm combination rollers and combination sound track applicators. Speed 100 ft. per minute per side, based on maximum developing time of 14 minutes, (higher speeds with shorter development time). This means a capacity of at least 200 ft. per minute!

Other features of this machine include a bottom friction drive, air recirculation with refrigeration type dehumidifier, and automatic temperature control. **\$43,522**

f.o.b. Hamburg, Germany

Add approximately \$10,000 for import duties and freight, and the price is still far below competitive offers.



UNITED MOVIE TECHNICIANS, INC.

324 Union Street, Hackensack, N. J.

Diamond 2-0597

For complete, detailed information, write, wire, phone:

HERE'S SOUND ADVICE!

If the confusion that surrounds the various sound systems being offered today has delayed your decision on just what you should install in your theatre, consider these facts:

Three of the majors — M-G-M, Paramount and Warner Brothers — have already announced that all future productions will have Perspecta Stereophonic Sound. Other studios are following their example.

Why has Perspecta Stereophonic Sound been chosen as standard — a standard certain to remain for years to come? For three very good reasons:

1. *The movie industry wants to make money. To do this they know they must keep your box-office busy. Perspecta Stereophonic Sound will do just that by giving the movie-going public the dramatic realism they want.*

2. *Perspecta Stereophonic Sound is a system every movie exhibitor can afford to install.*

3. *Perspecta Stereophonic Sound Track operates identically with the optical sound track you've been using for years except for the inclusion of three low-level, low-frequency tones "heard" only by the Integrator, which automatically controls volume and direction for true stereophonic effect.*

The Perspecta Stereophonic Sound Integrator, design-engineered by Fairchild, makes this system available to you at a price you can afford. Only one Fairchild Integrator serves all projectors in the booth — controls Perspecta Stereophonic Sound through any 3-channel sound system of standard make. And projector modifications are not required.

Call, wire or write now for full information on your specific theatre sound problem.

FAIRCHILD RECORDING EQUIPMENT
MOTION PICTURE SOUND DIVISION • WHITESTONE 57, NEW YORK

The New Vista-Vision camera, designed and manufactured by the Mitchell Camera Corporation, Glendale, Calif., is in production and deliveries are scheduled to start in the near future. First deliveries will be made to Paramount Studios in Hollywood, where Vista-Vision had its inception. The new camera is expected to be used by a number of other major studios.

★

Nippon Kogaku, Japanese manufacturers of the Nikon line of cameras and optical goods, is now supplying theatres in this country with Cinema-Scope projection lenses.

★

D. J. White, President of Magnasync Mfg. Co., Ltd., recently concluded a franchise agreement with Henri A. Lube, President of Cuauhtemoc Studios in Mexico City whereby latter will handle distribution of Magnasync equipment in Mexico.

★

Technicolor Motion Picture Corp. has developed a modified process for shooting TV films and has demonstrated it to a number of video film producers. The corporation reportedly will soon announce a new low-cost camera and a single-strip color film for TV film production.

★

W. J. German, Inc., agent and distributor for Eastman motion picture films, last month moved to new quarters at 6677 Santa Monica Blvd., Hollywood. William J. German, president, flew in from New York to be on hand for the opening ceremonies.

★

Technical Services, Inc., Livonia, Michigan, manufacturers of continuous projectors and special devices, has purchased all tools, spare parts and completed inventories of the DeVrylite 16mm sound motion picture projector.

★

Ralph Chapman, who built the largest camera crane used in Hollywood, has built a new and even larger mobile electric crane. It was given its initial big production tests by RKO in location shooting in Utah for "The Conqueror."

Crane has two motors: gasoline for highway travel and exterior shots, and electric for sound stage use.

Perfect Balance!



**SMOOTHER, EASIER
TV CAMERA CONTROL**

NEW
HOUSTON- FEARLESS
CRADLE
HEADS

Perfect balance makes the big difference in the terrific new Houston-Fearless Cradle Heads! No matter how the camera is tilted, it is always in absolute balance... resulting in wonderful new ease of operation and remarkable new smoothness never before achieved.

This perfect balance is made possible by the cradle action of the head. When the camera is tilted up or down, the cradle rotates around a constant center of gravity, maintaining positive balance at all times. Added weight, such as long lenses and camera accessories, is easily compensated for by simply moving the camera and the top plate of the head forward or back by means of a lead screw. This adjustment does not require loosening the camera hold-down screws.

The Cradle Head rides on four phenolic-covered ball bearing rollers for smooth, quiet, easy tilting. Panning is also smooth and easy, accomplished by two precision ball bearings in the base. Drag adjustments and brakes are provided on both pan and tilt.

FOR MONOCHROME AND COLOR TV CAMERAS

The new Houston-Fearless Cradle Heads are available in two types: Model MCH for standard black and white cameras, Model CH-1 for the RCA Color TV camera.

Like all Houston-Fearless products, these new Cradle Heads are soundly engineered and precision built of the finest materials to give a maximum of dependable service. Send the coupon below for complete information today.

The
**HOUSTON
FEARLESS**
Corporation

THE HOUSTON- FEARLESS CORP.
11809 W. Olympic Blvd., Los Angeles 64, Calif.

Send information on Cradle Heads Friction Heads
 Remote Control Heads Tripods Dollies
 Camera Cranes TV Pedestals Film Processors

Name _____ Title _____
Firm _____
Address _____
City _____ Zone _____ State _____

*"World's Largest Manufacturer of TV Studio
and Motion Picture Film Processing Equipment"*

11809 W. OLYMPIC BLVD., LOS ANGELES 64, CALIF.
620 FIFTH AVE., NEW YORK 20, N. Y.

Another triumph for Kinevox, too!

VARIETY DAILY

Fri., Aug. 6, 1954

er
Roles

Holly-
here
made
y of
Mel

ed by
an of
onth.
ven-
er is
sion
The

Up

atfit
has
ilman,
and
bjects
ature

rnace
on is
next
n was
stand

t. 9

pre-
has
au-
an-
eat
and
eart
ren.
ar-
and
ity

ase

The
start
will
g in
s an
will

by
as-
ng-
ase.

ut-
the
with
do-
gle

OPEN LETTER TO LOUIS HAYWARD

Mr. Louis Hayward
c/o California Studios
570 No. Bronson Ave.,
Hollywood 4, California

Dear Louis:

Remember a very short time ago, when we went into partnership with you in a business called television? Remember the many hours spent processing material? Remember selecting the Louis Vance "Lone Wolf" character as your vehicle? Of course you do. We even remember your words, "I hope we've made the right decision."

Well, today, the jury brought in its verdict and our decisions were proved correct. In a phenomenally short period of time audiences have taken to their hearts our series, and your portrayal of Michael Lanyard. In the recent poll conducted by Billboard many honors were accorded you and the show, notably:

"WOLF" PLACED SECOND FOR THE BEST NEW SERIES REGARDLESS OF PROGRAM TYPE OR HOW SOLD.

And, as for yourself, the audiences, who for so long bought tickets to see your pictures, are now turning a dial and watching you in their homes. In just 10 weekly television shows, Louis, you accomplished the following:

WRAPPED UP SECOND PLACE LAURELS AS THE BEST ACTOR APPEARING REGULARLY IN A NON-NETWORK MYSTERY FILM SERIES.

We offer to you, our producer Donald Hyde, and to all the others who have contributed to the "Lone Wolf" success, our sincere and heartfelt congratulations.

Cordially,

Jack Gross Phil Krasne

P. S. Also, Partner, Billboard had this to say: "'Lone Wolf' the show which stars Louis Hayward, is a dark horse because it has only been on the market for a few months and is rated one of the best."

*P.P.S. - The Sound was recorded with
Kinevox equipment, of course!*

KINEVOX, INC.
Burbank, Calif.

WHAT'S NEW

... in equipment, accessories, service



Tightwind Adapter

Camera Mart, Inc., 1845 Broadway, New York 23, N. Y., announces a new device which aids in rewinding 16mm or 35mm film on cores and without using reels or flanges. Tradenamed the Camart Tightwind Adapter, it fits over most standard rewinds and is complete with core adapter.

Adapter permits winding short lengths of film quickly, tightly and evenly; need for separate tightwinders is eliminated.

As pictured here, adapter fits over any Neumade or Moviola rewind. No machining or other alterations to rewind are necessary. Unit may be readily detached. Price is \$24.00.



Hi-Hat For Arriflex

Kadisch Camera & Sound Engr. Co., 500 West 52nd St., New York 19, N. Y., offer a lightweight hi-hat for the Arriflex 35mm camera. It can be used on any tripod or mounted on any other support. The hi-hat features a special dovetail for attaching accessories such as sunshade, TV effects

(Continued on Page 430)



NOW

COLOR-CORRECT*
RELEASE
PRINTING

from separate
track and picture masters incorporating
“A” and “B” effects

1¢ per foot

- Color Duplicating Stock furnished at cost if payment accompanies order — \$.058 per foot.
- We will mount all prints on your reels and cans at no extra charge — and pack for shipping anywhere in the world.
- Delivery to meet your schedules.

**Reg. U.S. Patent Office*

byron *Studios and Laboratory*

1226 Wisconsin Avenue, N.W., Washington 7, D.C. DUpont 7-1800

PRACTICALLY EVERY 16MM FILM PRODUCER IN THE WESTERN HEMISPHERE IS A CLIENT OF BYRON

NOW, more than ever... QUALITY COUNTS

in the
East...

... it's

MOVIELAB

The superior
QUALITY CONTROL consistently maintained
by MOVIELAB on all film processing assignments has earned
it the jealously-guarded reputation of being the "QUALITY
LABORATORY" in the east.

More producers, cameramen and technicians throughout
the east put their trust into Movielab's "KNOW-HOW" and
"personalized service" than any other.

Get to know Movielab—for this is the standard by which
all film processing is judged.

ROUND THE CLOCK SERVICES

Negative Developing
Ultra Violet and Flash Patch Printing
Quality Control
16 mm and 35 mm Release Printing
Title Department
25 Cutting and Editing Rooms
First Print Department

for color it's...

Rainbowlab Inc.

MOVIELAB FILM LABORATORIES, INC.
619 West 54th Street, New York 19, N. Y. JUdson 6-0360

WHAT'S NEW

(Continued from Page 428)

unit, telephoto lens bed, or cradle for
a CinemaScope lens. For price and
further details, write manufacturer
direct.

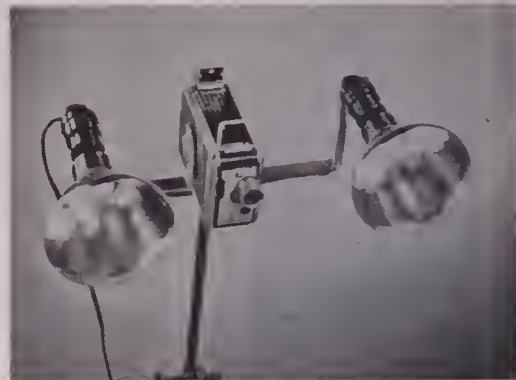

Brownie Movie Light

Eastman Kodak Company, through
its many retail distributors offers a
new, inexpensive light bar for use in
shooting indoor or after-dark movies.
Fixture which is readily attachable to
any cine camera by means of a tripod
socket screw, accommodates two 375-
watt reflector flood lamps. With the
light source thus attached to the cam-
era, the photographer can then follow
subject action, through the finder, in
the normal way. There is no problem
of changing exposure because the light
follows the action. The Movie Lite re-
tails for \$5.55; the lamps, \$1.35 each.

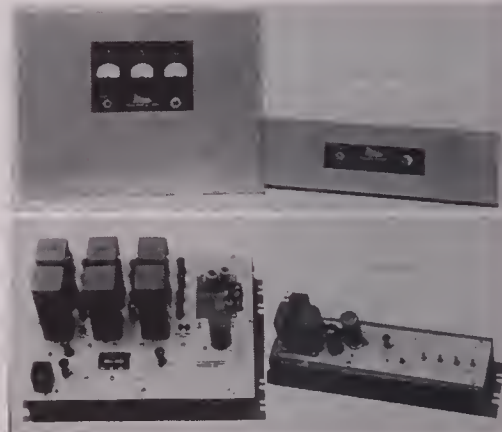

Stereo Sound Integrator

Fairchild Recording Equip. Co.,
Whitestone, L. I., New York, an-
nounces a new model of its Perspecta
Stereophonic Sound Integrator, pre-
viously announced here in our July is-
sue. Designated as Model 315C, new
version consists of standard Perspecta
Integrator and Power Supply mounted
on vertical chassis of the recessed
type, said to be ideal for mounting in
theatre installations where space is at a
premium.

The HANK McCUNE TV Show

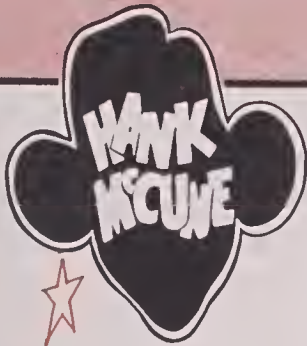

filmed by
TED ALLAN
Studios

... in **COLOR** with the
AURICON "SUPER 1200"

16mm Sound-on-Film Camera!

NAVY STORY

Filmed at Destroyer Base Reception Center, San Diego, California, with cooperation of the United States Navy.

Ted Allan, veteran Hollywood Photographer of the Stars, is one of the many professional film producers whose first choice for dependable television filming of the highest quality, is an Auricon 16mm Camera.

The "Hank McCune Show," a comedy series soon to be seen by millions over national TV networks, is being filmed in natural color with the "Super 1200" Camera. Ted Allan says, "45,000 feet of film have been run through the Auricon Camera without a film-scratch or loss of a foot of film!"

Write for your free copy of the complete Auricon Catalog, which includes the "Super 1200" Camera, a superb photographic instrument. Sold with a 30 day money-back guarantee, you must be satisfied!

AURICON
BERNDT-BACH, INC.

6902 Romaine Street, Hollywood 38, Calif.



FANTASY

Dream scene from "Aladdin and the Magic Lamp" story in the Hank McCune TV Show Series.



The **Auricon Hollywood** Line
SOUND-ON-FILM EQUIPMENT SINCE 1931

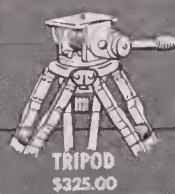
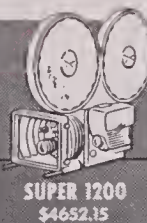

ARRIFLEX

New 35 mm Model 2A
With 180° Shutter

**A TRULY GREAT
CAMERA**

for TV, Newsreel
and commercial
films



For tough and trying assignments, ARRIFLEX 35 is in a class by itself. Reflex focusing through photographing lens while camera is operating—this is just one outstanding ARRIFLEX feature.

Equipped with bright, right-side-up image finder, $6\frac{1}{2}$ x magnification. Solves all parallax problems. 3 lens turret. Variable speed motor built into handle operates from lightweight battery. Tachometer registering from 0 to 50 frames per second. Compact, lightweight for either tripod or hand-held filming. Takes 200' or 400' magazine. Write for free folder.

Blimp now available.
16mm ARRIFLEX also available.

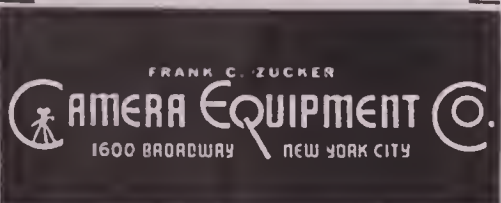

letters

Cover Clicks

That was a swell cover photo you had on the August issue—lots of details for readers to study which show just how professional movies are made. One thing I noticed particularly was the microphone extended out over the players. With the sun directly overhead, it must have cast a mike shadow in the scene. Wouldn't the camera pick this up?

Ray Harris,
Chicago, Ill.

Look at position of camera in the photo and you'll note it is shooting a closeup, therefore would miss any shadows on ground. Also, mike is not directly over heads of players, so no shadow fell on them.—ED.

In the cover photo, your August issue, it shows booster lights used to supply fill light on what appears to be a very bright and sunny day. Why didn't cameraman Metty use sunlight reflectors instead?

J. H. Ballinger,
Harrisburg, Penna.

The booster lights give much better results than reflectors—more even light, better quality. They are used on location whenever power is available to light them; otherwise, reflectors are used.—ED.

Hot Splicer

Relative to Hank Stockert's article, "Hot Splicer Conversion," on page 348 of your July issue, I want to say that Mr. Stockert went far afield to accomplish his purpose and I doubt very much whether his idea will work satisfactorily. The simplest method for accomplishing the same result involves nothing more than installing a 7- or 12-watt miniature lamp and socket in the base of the splicer, plus a toggle switch to turn off the juice when the base becomes warm enough.

It is not wise to keep the heat on any splicer continuously because the latest film cements set too quickly. My experience has shown that the only time a heated splicer is needed is in winter months or in very humid atmospheres. This is especially true when working with 35mm film.

I hesitate to break into anything

like this, but I feel that I was the originator of heating the Griswold splicer, both 16mm and 35mm, and I should therefore bring this to your attention.

L. H. Georger,
Buffalo, New York.

Answer to a Letter

Sam Sancenito, whose letter requesting interlock plans appeared in this column in your August issue, may be interested in the book "Photographic Amusements" by Frank R. Fraprie. The book deals with trick photography and one chapter in the edition which I read gives instructions, but no illustrations, for building and using a 16mm optical printer. By the way, your August issue is the most informative I can remember seeing.

Chuck Anderson,
Burlingame, Calif.

Kudos from an Amateur

I am an amateur movie maker who reads American Cinematographer regularly for the instructional material it contains for the non-professional as well as the professional.

That was a very inspirational article in the last issue by Charles W. Herbert on the subject of big game fishing. Please give us more like it!

Hal Sterling,
Seattle, Washn.

A and B Rolls

In Charles L. Anderson's article in your August issue, he refers to an article "How to Edit A and B Rolls," which appeared in an earlier issue of your publication. Can you supply extra copies of this issue?

Gus T. Hansen,
Milwaukee, Wisc.

Hope you can air mail a copy of the April, 1950 issue of American Cinematographer to me, which contains the instructional article on editing A and B rolls. Do you also have reprints of this article available?

Dave Jennings,
Denver, Colorado.

No reprints are available, but back numbers of the April, 1950, issue of AC, are available at 30 cents per copy.—ED.



FILM LAB EQUIPMENT

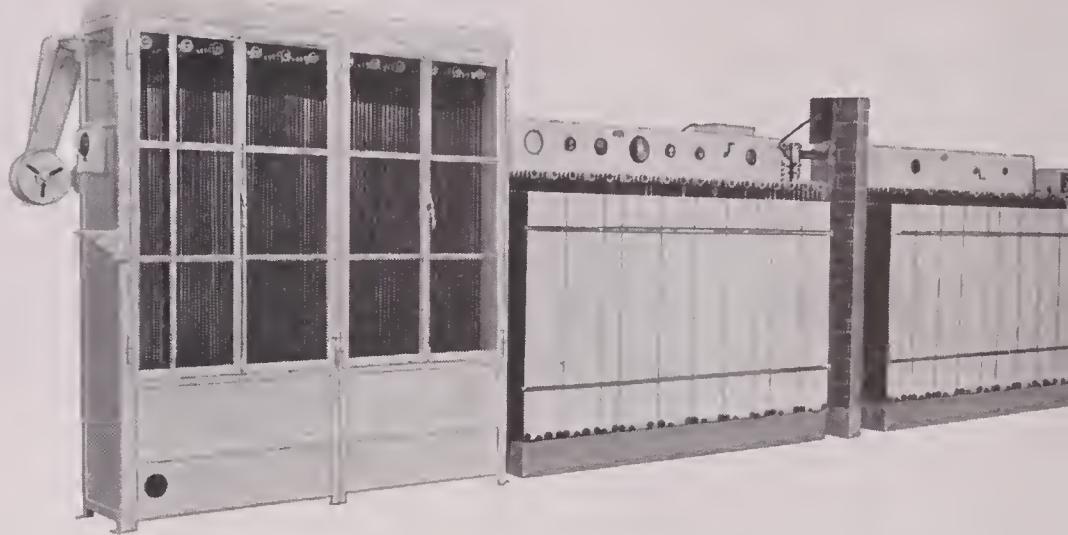
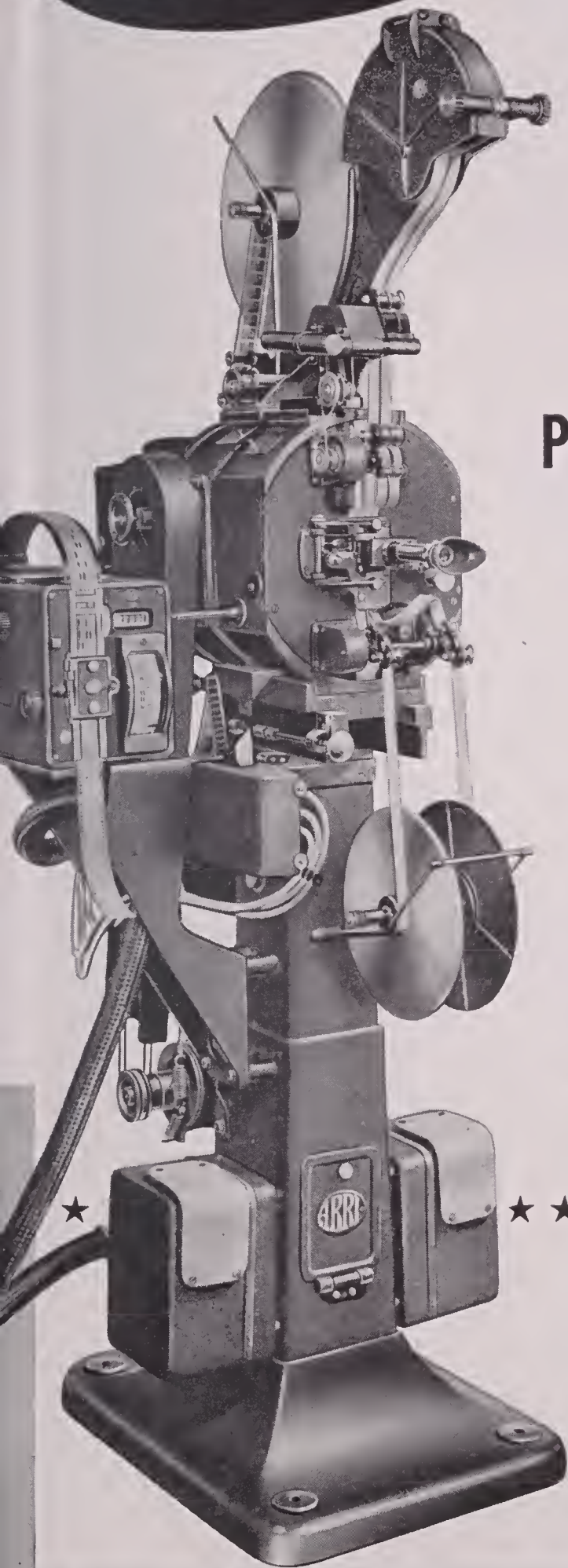

Printers and Developing Machines

Arnold & Richter, established in 1919, is West Germany's leading manufacturer of professional motion picture equipment. In addition to the Arriflex 16 and Arriflex 35 cameras, this firm is known throughout the world for high quality printers and developing machines.

Arnold & Richter also operates a large film processing laboratory which serves as a proving ground for its own products. Here, each design and development is rigidly tested under actual working conditions before it is approved and released for the general market.

MOTION PICTURE PRINTERS

Available for 35mm and 16mm film . . . sound and silent . . . black-and-white or color. Also optical printers and sound reduction printers, 35mm to 16mm.

MOTION PICTURE PROCESSING MACHINES

Available in all sizes and capacities, for 16mm and 35mm film . . . black-and-white or color. Installations planned to suit space conditions

Complete data on request.

NEW SERVICE FACILITIES for ARRI PRODUCTS

Complete facilities have been created for factory-approved service and maintenance of Arriflex 16 and Arriflex 35 cameras, Arri printers, and other Arri products. These facilities, located at our New York headquarters, are staffed by factory trained personnel. Special tools have been installed, and are now in use in this expanded service department.

Owners of Arriflex cameras and other Arri products are urged to avail themselves of our specialized services to insure proper maintenance of their equipment.

ONE CAMERA

16mm or 35mm

in 10 SECONDS!

Camerette 16/35

Reflex Motion Picture Camera

The perfect camera for the motion picture film maker working in both 16mm or 35mm color or black and white.

LOOK AT THESE ADVANTAGES—

- The same lenses, same motor drives, same sound blimp and accessory equipment used for both 16mm or 35mm — to convert simply change the magazine.
- Precise rugged movement
- Reflex viewing
- 200 degree adjustable shutter
- Divergent three lens turret
- Automatic film gate 400' magazines 16 or 35mm — the 16mm magazine will accommodate daylight spools as well as standard care load.
- Light weight — only 14 pounds with 3 lenses, 400' magazine, and 6/8 volt motor.

Write for brochure



Camerette

patents coutant-mathot

Manufactured by Ets. Cine. Eclair, Paris



Hollywood

Bulletin

Board



MANY YEARS AGO, two Miller brothers, William (left) and Arthur became cinematographers in New York. One, Arthur, went west to Hollywood, won three Academy Awards, is now President of the American Society of Cinematographers. William is active in east coast film production. Both are active in affairs of the I.A.T.S.E. and last month attended the Union's convention in Cincinnati, Ohio.

Winton Hoch, ASC, who has photographed many of director John Ford's pictures, has been chosen by Ford again to direct the CinemaScope photography of "Mr. Roberts." Hoch left for Midway Island August 20th, where much of the picture will be shot in natural locations.

Phil Tannura, ASC, resumed shooting the Burns and Allen TV show last month. First picture in the new series was shot in Eastman color to give crew and cast experience in color filming, looking toward the day when color will be the thing in TV.

Joseph Galea, a non-professional photographer of Malta and a visitor at the American Society of Cinematographer's clubhouse last month, told members that Hollywood cinematographers are regarded as absolute tops in his country. In Malta, people go to theatres to study the photography of the pictures as well as to be entertained, Galea stated.

Paul Vogel, ASC, who recently completed the photography of MGM's "Jupiter's Darling" follows right up with another assignment at the Culver City lot—this time "Interrupted Melody," starring Eleanor Parker and Glenn Ford.

Lloyd Knechtel, ASC, optical effects cameraman, is now affiliated with Jack Rabin and Louis DeWitt of Studio Film Service at American National Studios, formerly Eagle-Lion.

Charles Clarke, ASC, has been signed by Twentieth Century-Fox to direct the photography of "Prince of Players" in CinemaScope.

Virgil Miller, ASC, who recently completed the photography of "Unchained" for Hal Bartlett, has resumed shooting the Groucho Marx TV show. It's Miller's second season with Groucho.

Sol Halprin, ASC, head of Twentieth Century-Fox camera department, and who figured prominently in the development of CinemaScope, has been signed to a new term contract by the studio.

Ernie Haller, ASC, who lately has been shooting more pictures on foreign soil than in California for Hollywood producers, has taken off again—this time for Germany, where he will direct the photography of "The Magic Fire" which Wm. Dieterle will produce and direct for Republic release. Picture will be photographed in True-Color and wide-screen.

American Society of Cinematographers' August membership meeting featured a screening of "Hell's Gate," Japanese production photographed in Eastman Color and processed in Japan, which won a top award in recent Tokyo Film Festival. The picture has won wide acclaim for its fine color photography and art direction.

Floyd Crosby, ASC, who directed second unit photography on the Todd-AO production, "Oklahoma," returned to Hollywood last month from the company's location near Nogales, Arizona. Robert Surtees, ASC, is directing photography on the 1st unit.



35 and 16/35 mm



reflex viewing



divergent turret



40° to 200° adjustable shutter



lightweight - 14 lbs.



100' to 400' magazine



instantaneous loading



dovetail mounting



camerette

patents Coutant-Mathot
manufactured by Eclair, Paris

for descriptive brochure write U.S. representative

Benjamin Berg Agency, 1410 No. Van Ness Avenue, Hollywood 28, Calif.

in Canada: B.O.P. Co. Ltd., 455 Craig Street West, Montreal, P.Q.

SEEING IS BELIEVING!

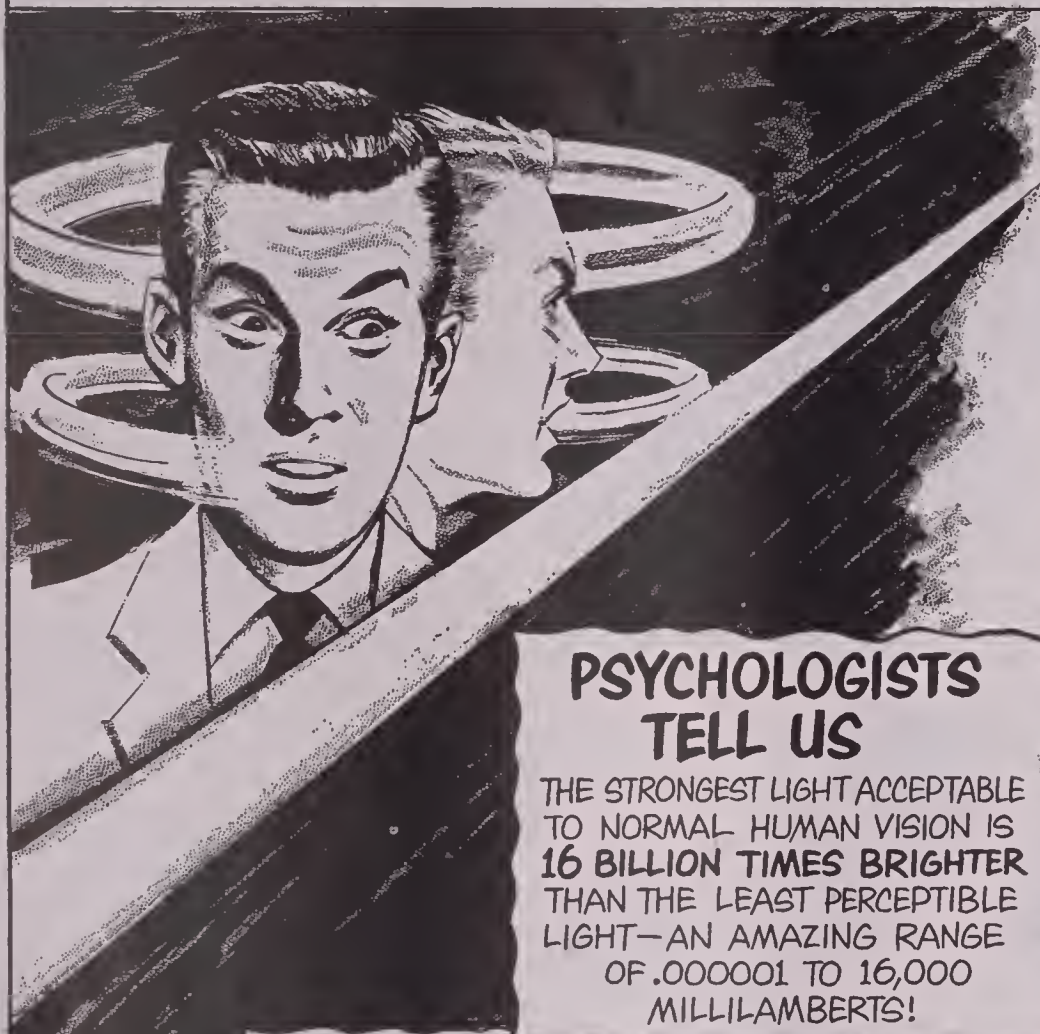

SCIENTISTS CAN MEASURE

THE SPEED OF LIGHT WITH GREATER ACCURACY THAN THAT OF ALMOST ANY OTHER PHYSICAL CONSTANT—DESPITE ITS INCREDIBLE VELOCITY OF 2.99776×10^{10} CENTIMETERS PER SECOND.

PSYCHOLOGISTS TELL US

THE STRONGEST LIGHT ACCEPTABLE TO NORMAL HUMAN VISION IS 16 BILLION TIMES BRIGHTER THAN THE LEAST PERCEPTIBLE LIGHT—AN AMAZING RANGE OF .000001 TO 16,000 MILLILAMBERTS!



"NATIONAL" STUDIO ARC-CARBONS ARE COOLER, MORE POWERFUL, MORE PENETRATING...WITH BROADER COVERAGE AND SHARPER DEFINITION THAN ANY OTHER SOURCE OF SET-LIGHTING.

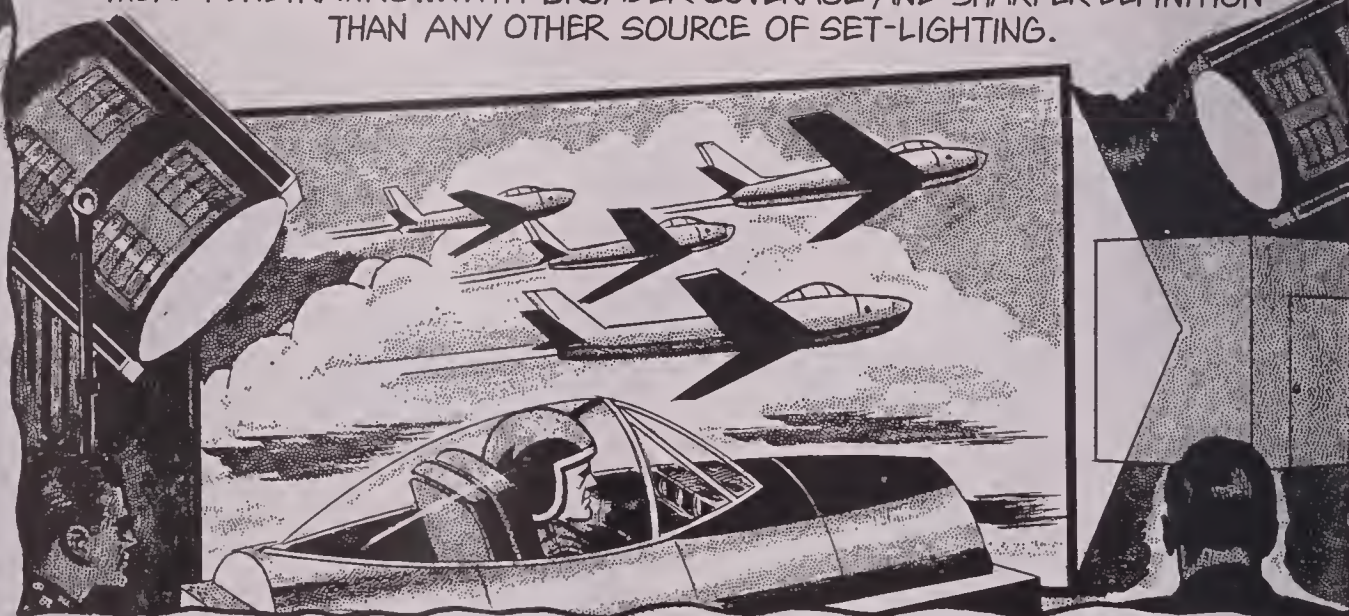

THE "NATIONAL" CARBON ARC...NOTHING BRIGHTER UNDER THE SUN

The term "National" is a registered trade-mark of Union Carbide and Carbon Corporation

NATIONAL CARBON COMPANY

A Division of Union Carbide and Carbon Corporation, 30 East 42nd Street, New York 17, New York

District Sales Offices: Atlanta, Chicago, Dallas, Kansas City, New York, Pittsburgh, San Francisco

IN CANADA: Union Carbide Canada Limited, Toronto



You'll have fewer budget worries

with Ansco

*Negative
Positive*

Color!



THIS 35mm *truer color* film offers three distinct advantages which cut production costs many percent. At the same time it assures you of nothing less than the finest screen qualities!

NO SPECIAL CAMERAS REQUIRED Give any competent cinematographer a standard 35mm black-and-white camera and he'll get excellent results with Ansco Neg-

ative-Positive Color.

NO SPECIAL PROCESSING EQUIPMENT Minor modifications in regular black-and-white equipment give excellent, rapid processing.

NO COSTLY, DRAWN-OUT WAITING Within hours—often the same day—you see the results of your shooting. Thus there's no prolonged holding of costly casts and sets.

• UNEXCELLED SCREEN QUALITY

• TRUER COLOR

• FINER GRAIN

• EXCELLENT SCREEN STEADINESS

• SUPERIOR DEFINITION

• MORE PRODUCTION FLEXIBILITY

• GREATER BRILLIANCE AND DEPTH

New York • Hollywood **Ansco** Chicago • Binghamton

A Division of General Aniline & Film Corp. "From Research to Reality."



Magnaphonic SOUND SYSTEM

There's a reason...

why Magnasync enjoys continued worldwide leadership...

QUALITY...ECONOMY...INTEGRITY

Air Force
 University
 Naval
 Radio
 Protest
 Fotovox, Inc. Photographic Technicians Pro
 W T S P—Florida Southern Pacific Railroad
 Tele-Filmica Maxol, S.A., Havana Southern
 Ford Foundation Twentieth Century-Fox, Inc.
 University of Wisconsin Gospel Films, Inc.
 National Film Board of Canada Cine Associate
 R.K.O. Radio Pictures, Inc. Pacific Picture
 Gilfillan Bros., Inc. U.S. Air Forces Westingho
 Iowa Conservation Commission Providence
 Fairchild Recording Equipment Co. Galbrea
 Magnolia Petroleum Co. Kearney & Trecker Cor
 W K A Q, San Juan, Puerto Rico State Colle
 Naval Air Station Beeland-King Film Productions
 Columbia Pictures Providence Bible Institu
 Television Recording Service, Inc. Iowa Farm Bur
 Westinghouse Electric Corp. Sound Recorders, I
 Viguie Productions, Inc., Havana U.S. Navy Nort
 Paramount Pictures Corp. Baptist Gospel Film
 U.S. Department of Agriculture University of Iowa
 International Productions Goodyear Aircraft Corp
 Avalon Pictures, Inc. Reverend D. Kirk Hammond
 Southwest Film Laboratory, Inc. Academy Soun
 Naval Ordnance Wurtele Film Productions Acade
 Bible Institute of Los Angeles University of Tennessee
 University of Mississippi Rampart Productions Se
 Protestant Radio Center, Inc., U.S. Recording Co.
 South Dakota State College Aspen Pictures Dallas Jo
 Twentieth Century-Fox, Inc. Filmscope
 U.S. Air Forces Magnolia Petroleum Co.
 Southwest Film Laboratory, Inc. Gilfillan Br
 Cine Associates
 Kearney & Trecker
 University of Iowa
 Arcturus Manufacturing
 Goodyear Aircraft Corp.
 Fairchild Recording Equipment Co.

Select



MODEL SW-602 PORTABLE RECORDING SYSTEM

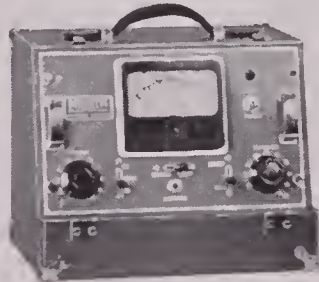

DISTRIBUTORS

CAMERA EQUIPMENT COMPANY
 1600 Broadway, New York 19, N.Y.
 Judson 6-1420—Cable: "CINEQUIP"

MAGNETIC RECORDERS COMPANY
 7120 Melrose Ave., Los Angeles 46, Calif.
 WEBster 3-5545

ZENITH CINEMA SERVICE, INC.
 3252 Foster Ave., Chicago 25, Illinois
 IRving 8-2104

AMERICA'S LEADING MANUFACTURER OF MAGNETIC FILM RECORDING AND REPRODUCING DEVICES



PORTABLE FILM RECORDERS



MICROPHONE MIXERS



THEATRE SOUND EQUIPMENT



3-CHANNEL REPRODUCERS



MULTI-CHANNEL INTERLOCKED DUBBERS

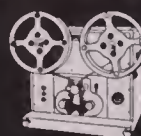

STUDIO DUBBERS and RECORDERS



QUALITY AMPLIFIERS for MAGNETIC RECORDING and REPRODUCTION



MAGNASYNC MANUFACTURING CO., LTD. • 5521 SATSUMA AVE., NORTH HOLLYWOOD, CALIF. • POplar 6-1692

DEDICATED TO BETTER PERFORMANCE



COLLAPSIBLE 3-WHEEL DOLLY

For motion picture and TV cameras. Sturdy cast aluminum. For standard or baby tripods. Additional baby tripod point holders to control spread of tripod legs. Adjustable spring seat. Extra wide rubber wheels. Bronze tie down clamps and other features.

For studio or location. Folds into one compact unit. Can be used with professional or semi-professional tripods.

'HYDROLLY'

TV OR
CAMERA DOLLY

The advanced dolly for instant moveability — streamlined, lightweight, exceptionally sturdy. Nothing to get out of order. Many new advantages for easy operation. Hydraulic lift type for fast upward and downward motion of TV and motion picture cameras.

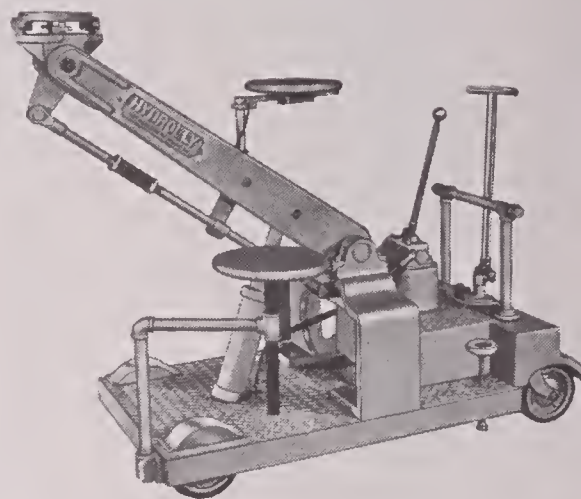

Swivel seat. Adjustable leveling head. Seat for assistant. In-line wheels for track use. Steering wheel, rigid floor locks. Hand pump or combination hand and motor pump. Easily transported in a station wagon. Fits through a 28" door.

SYNCHROMASTER SYNCHRONIZER

Our Exclusive Distributor
Neumade

Any combination of 16mm and/or 35mm sprockets assembled to specification. Cast aluminum. Foot linear type, adjustable frame dial. Fast finger roller release. Contact rollers adjusted individually for positive film contact. Sprocket shaft slip lock, foot-age counter, etc.

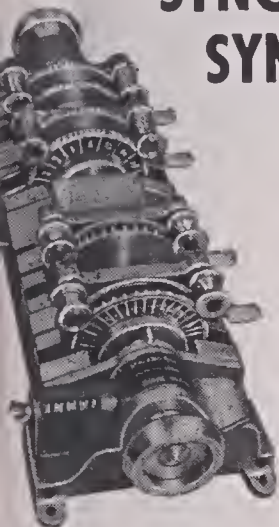

RENTALS

SALES • REPAIRS • SERVICE

LENS COATING

"T" STOP CALIBRATION

DESIGNING and MANUFACTURING

lens mounts & camera equipt.
for 16mm, 35mm, TV cameras.

BAUSCH & LOMB "BALTA"
LENSES and others

for motion picture, TV cameras.
15mm to 40" focal length.

COMPLETE LINE of 16mm, 35mm
cameras, dollies, synchronizers,
animation equipment, cutting room
and time lapse equipment.

BELL & HOWELL: Standard, Eyemos, Filmos. MITCHELL: Standard, Hi-speed, BNC, NC, 16mm.

SEND FOR CATALOGUE

ColorTran Groverlite SENIOR & JUNIOR KITS

"A STUDIO IN A SUITCASE"

ColorTran replaces heavy and expensive equipment... gives you illumination up to 5000w. from an ordinary 20 amp. house current. Equipped with barndoors, diffuser slots for silks, snoots and other accessories. Ideal for studio or location shots.



PORTABLE MICROPHONE BOOM

For Studio or on Location. Lightweight — collapsible — for TV and motion picture production. Sturdy construction. Boom telescopes 7 to 17 ft. Rear handle for directional mike control. A remote control permits 360° rotation of the microphone. Operator can push the boom and operate microphone swivel simultaneously.

Extension rods make it simple to operate microphone rotation from floor. Microphone cable hangs outside of boom, preventing cable from tangling with the rotation mechanism. Ball bearing casters, rigid foot locks, pneumatic drop check for lowering the boom, etc.



VARIABLE- SPEED MOTOR with TACHOMETER

for Cine Special or Maurer Cameras

115 V. Universal Motor — AC-DC
Separate Base for Cine Special.
Variable Speed 8-64 frames.
Adapter for Maurer Camera.

INTERCHANGEABLE MOTORS: 12
volt DC Variable Speed 8-64 frames.
115 Volt AC 60 Cycles, Synchron-
ous Motor, Single Phase.

ANIMATION MOTORS: Cine Spe-
cial, Maurer, Mitchell, B & H Motors,
for Bolex and Filmo Cameras.

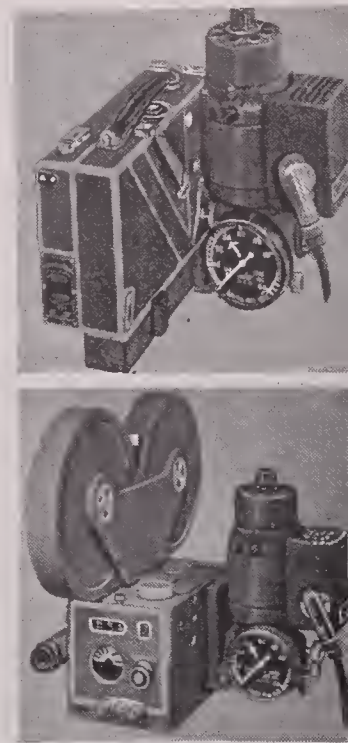



RUNNING A TAPE before starting to shoot a scene for MGM's "Jupiter's Darling" at Silver Springs, Florida. The two underwater blimps house Mitchell cameras with 1,000-foot magazines. One camera shoots CinemaScope, the other wide-screen. Camera oper-

ators are Dale Deverman and John Nicholas. Both wear regulation Aqualungs which enables them to work underwater with the cameras with almost the same ease as when above surface. —Photo courtesy Florida's Silver Springs.

MGM's New Underwater Camera Blimp

Said to be most advanced of any yet designed for a 35mm camera, this blimp requires no tripod or other support under water, takes Mitchell cameras having 1,000-foot film magazines.

By ARTHUR ROWAN

PRODUCTIONS requiring underwater sets and photography are being made with increasing regularity by Hollywood studios. To facilitate the underwater shots, most of the studios have constructed their own underwater camera blimps. Perhaps the most interesting of these was the blimp which John Arnold, A.S.C., head of the camera department at MGM studio, designed for the Mitchell cameras that were used in filming underwater scenes for the studio's recent

production, "Jupiter's Darling," starring Esther Williams.

This production included, perhaps, the greatest amount of underwater footage of any yet filmed by the studio. Underwater scenes were photographed in the huge tank on the studio lot, and at Silver Springs and Weeki Wachee, Florida.

At Silver Springs, MGM erected what was probably the world's largest and most costly underwater set. The set was

assembled at the studio, then dismantled and shipped to Silver Springs where it was re-assembled beneath 30 feet of water. The set consisted of a wreck of an ancient Roman Galley, and was complete in detail, including artificial studio-made moss, seaweed and rubber barnacles. On the floor of the set were treasure chests and ancient urns. Here Esther Williams was pursued by three husky Roman soldiers as two cameras—one with a CinemaScope lens and the other shooting wide-screen—recorded the action on Eastman Color negative. Each camera was protected by a monstrous and formidable-looking all-metal blimp which you see pictured on these pages. Paul Vogel, A.S.C., directed the photography, aided by operators Dale Deverman and John Nickolaus.

John Arnold's original design for the camera blimp included a motor driven propeller and a rudder intended to fa-

facilitate mobility of the blimp underwater. However, in actual use, it was found unnecessary to add these features, for when the blimp attained neutral buoyancy, thanks to automatically regulated air pressure, it is as easy to maneuver as though it weighed but one pound instead of the several hundred pounds that it does.

The blimp is said by studio engineers to be the most advanced of any yet designed for use with 35mm cameras. For one thing, it is the only blimp so far designed and built that permits use of cameras with 1000-foot film magazines. This feature alone proved a tremendous time-saver when filming at Silver Springs, where the camera was often used at a depth of fifty feet. There were days when it was never necessary to re-surface in order to reload the cameras with film; the single thousand-foot load took care of the entire day's shooting.

Although we have mentioned here only one blimp, actually two were constructed and used for this picture—one for the camera having a CinemaScope lens, and the other which encased the camera shooting wide-screen. The last-named blimp with camera and batteries weighs 472 pounds; the one for CinemaScope, which requires additional mechanical controls and other features, weighs 510 pounds with camera and batteries. Buoyancy of the blimps has been so engineered that these great weights are neutralized once the blimps are submerged.

The main body segments of each blimp are of cast aluminum. These are bolted together and have rubber gaskets protecting the seams. At the front is a large door supported on heavy brass hinges with a window of heavy optical glass through which the camera shoots the scene.

Remote controls for all necessary camera and lens adjustments are located on side of the blimp so that the operator can do all the things with the camera underwater that is possible when it is on the sound stage: i.e., change lens stop, change focus, adjust the CinemaScope lens, alter shutter opening, change motor speed and control lens on follow focus shots.

The blimp is equipped with a complete Aqualung unit—the same as worn by divers and operators using the camera when submerged—and this supplies the compressed air to the blimp chamber that provides air pressure for buoyancy and protection of the blimp against the external water pressure. In addition to a pressure gauge there is an automatic pressure regulator which allows air to escape through a pop-off valve whenever the blimp moves upward toward the surface in water of diminishing pressure, or it directs additional



STANDING BESIDE huge underwater camera blimps is John Arnold, ASC, head of the camera department at MGM Studio, who designed them and supervised their construction. One at left is for CinemaScope, the other for wide-screen.

air into the blimp when it submerges. Thus, pressure inside the blimp compensates for the change in water pressure externally at all times; it is done automatically without the need of attention of the cameraman or operator. Incidentally, there is no limitation in the depth which the blimped camera can operate. In the Florida springs, MGM worked the cameras in depths exceeding 50 feet.

A feature which makes the blimp so easy to work with is that it is entirely self-contained. That is, there are no air lines or power cables attached to it and leading to the surface overhead. As already indicated, all necessary power for operating camera motor is supplied by

a number of 45-volt Burgess B-batteries having a total output of 145 volts.

The most interesting feature of the MGM blimp, however is the tubular, water-tight stabilizers mounted on top of the blimps. As may be seen from the accompanying photos, one blimp—that housing the heavier CinemaScope camera—has four stabilizing tubes, while the other has but two. These are so mounted that they can be shifted forward or backward or sideways in order to position the camera at an angle or to level it when underwater.

Through the buoyancy controls, it is possible to submerge the blimped camera to a depth, say for example, of 15

(Continued on Page 458)

REAR VIEW of blimps is shown, below left. Here may be seen the small glassed portholes through which operators observe footage counter, shutter indicator and other controls. At right is view of the unique tubular stabilizers by which blimps are set on an angle underwater when required.

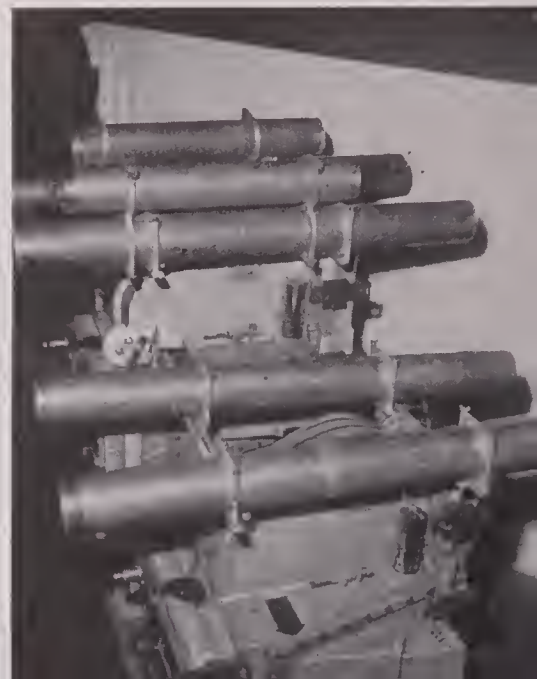

He Makes News Live

TV film reporter Bob Gray has worked out a way to give the viewer a seat at exciting news events.

By JIM F. PALMER

Photos Courtesy of KPRC-TV



DU PONT'S fast film lets him use natural light to give his news shots added impact, says TV newsreel photographer Bob Gray.

HAVE YOU EVER been fascinated by the plight of a perspiring, blinking city councilman on a TV film news show? It's probably not his constituents that upset him. It's that bustling TV cameraman with his battery of glaring lights and maze of wires.

Or take that gambling raid you expected to see on television. The only footage the TV newsman managed to bring back showed one last diceplayer being hustled into the police van. By the time the cameraman could set up and plug in his lights, the raid was over.

Most television news is brought to you via the motion picture camera, and until recently the need for extensive artificial light frequently made news shots stilted and unnatural. Many were impossible, because the time required to set

up bulky equipment allowed vital scenes to escape.

Now fast and complete news is being photographed daily by Bob Gray, chief film reporter for KPRC-TV in Houston, Texas. When news develops, Gray just aims his 16mm camera and shoots. Often he uses no artificial lights at all.

Gray's secret is a very fast motion picture film, Du Pont High Speed Rapid Reversal Pan (Type 931). It's so sensitive that almost any amount of light—from an open window or an ordinary light bulb—will do the trick. The photographer then overdevelops the film to reinforce the image. The result is casual, natural photography that makes for effective reporting.

More important, the new technique also lets KPRC-TV cover stories it was never allowed to touch before.

The Houston City Council, for instance, was leery when radio and TV newsmen first began taping and filming council sessions. The councilmen were afraid the meetings might take on a sideshow aspect. But when Gray began filming council sessions without elaborate preparation, using only existing window and overhead ceiling lights, the council soon accepted the camera as a reporting tool right along with a reporter's pencil. On occasions since, artificial light has been used in council sessions, but sparingly.

Until recently, TV film coverage of certain Houston courtrooms also was banned. Officials thought it marred the dignity of the court and disrupted the air of concentration necessary to legal proceedings. Now, working unobtrusively with existing light, Gray operates in the criminal courts of all three local district judges, with their blessing.

Gray hasn't abandoned artificial light entirely, of course. His basic idea is to

(Continued on Page 462)

THREE CLIPS from typical candid newsreel films photographed by Bob Gray of KPRC-TV: 1) Gray used light from an unshaded window in this filmed interview with Bob Tucker, Democratic Party chairman; 2) Ordinary room lights allowed Gray to film school board hearing; 3) Existing light was used in covering this courtroom scene for TV.

1



2



3



to put *Life* on film...



**Scene from "The Egyptian," 20th Century-Fox CinemaScope Epic.*

BALTAR



Thrilling realism . . . vivid detail . . . brilliant images in 2D, 3D or CinemaScope—that's what Bausch & Lomb Baltar Lenses mean to the professional cinematographer. For your finest work in movies and TV, specify B&L Baltar Lenses.

ORDER from your professional camera manufacturer or **WRITE** to Bausch & Lomb Optical Co.,
30033 Martin St., Rochester 2, N. Y.

**To film "The Egyptian," 20th Century-Fox chose the new B&L 40mm Baltar CinemaScope Lenses—cine and anamorphic lens elements in a unified mount operated by a single control.*

BAUSCH & LOMB





Each frame – each scene in the print must be perfectly matched to assure an outstanding film production. Leading producers, directors and cameramen know that Precision processing guarantees that individual attention.

Skilled hands and exclusive Maurer-designed equipment are teamed to bring these perfect results to each Precision print. Even more important, continuing research constantly improves techniques that are already accepted as unequalled in the field.

In everything there is one best...in film processing, it's **Precision.**



F I L M L A B O R A T O R I E S , I N C .
21 WEST 46TH STREET, NEW YORK 36, N. Y.

A division of J. A. Maurer, Inc.



FOR THE PUB scenes we used a lighting load of about 12-kw. which allowed us to work at around f/2.4. In order to simulate the essentially "warm" atmosphere of the English pub, we shot everything through a Wratten 81-B filter.



THE RATHER SIMPLE set on which the scene at left was photographed. Here may be seen how the various light units were placed to achieve the quality of flat lighting we desired for Kodachrome.

THE INSTRUCTIONAL film has long since found an honored place in British industry and the list of commercial and other organizations using the medium is lengthening every year. There are many regular film producing companies who specialize in this type of film and even more privately-operated units who work exclusively to satisfy their own film requirements.

Naturally, the quality and scope of the end-product turned out by this latter class is found to vary considerably and ranges from the fine major productions of the famous Shell Petroleum Film Unit to the frankly unambitious record pictures made by the plant photographers of smaller concerns.

The privately-sponsored film may be purely instructional, designed to help the user of a given product to get the best from it. Or it may be straightforward publicity when it will probably contain a good deal of "human interest" or "entertainment value." The films for which the writer and his associates are largely responsible employ, as a rule, a combination of both techniques. for we believe that just as a good lecturer will lighten his teaching with the occasional touch of humor, so an effective instructional film is all the better if it can mix business with a little pleasure.

We are always careful never to let

Sync Sound Without Interlock

How one British producer of instructional films records sound on discs and integrates sound with the picture with the aid of a click-track.

By FRANK HARRIS, A.I.B.P., A.R.P.C., M.B.K.S.

a gag obtrude and detract from the main purpose of the film. If it does not help the picture along, no matter how tempting, we let it pass unused. For the foregoing and other reasons we work almost entirely in Kodachrome, and since our audiences include large numbers of apprentices and junior trainees—the buyers of the future!—our not-too-serious approach seems to work pretty successfully.

At this writing we are in the final stages of just such a film. Its subject—the sharpening of edge tools—is cer-

tainly of interest to nearly everybody at some time or other but, admittedly, it is hardly of spectacular appeal. And to be anything like complete in its teaching, the film has to cover a lot of

(Continued on Page 464)

HOMEMADE CAMERA BLIMP used with the Cine Kodak Special. It is made of wood and lined with thick felt, enabling camera to be used within four feet of the mike.





BIGGEST ECONOMY factor, perhaps, in shooting the Hank McCune Show lies in the photography. Producer Ted Allan uses an Auricon 16mm "Super 1200" camera, Commercial Kodachrome film and

economical incandescent lighting. Here Allan and camera operator Brydon Baker line up camera for a "dream" scene for a recent film in the Hank McCune TV series.

Hank McCune TV Series Filmed In 16mm Color

Ted Allan, veteran Hollywood photographer, points up trend to all-color for TV films.

By FREDERICK FOSTER

JUST ABOUT EVERY PRODUCER of television films is gearing for production in color and many have already photographed one or more shows using color film. A few have decided to go all out for color now and are so shooting their entire series. At present these films are televised in black-and-white, but they are planned for the time when color telecasting will become general.

The added cost entailed in 35mm color

film production is a big factor retarding an immediate general-swing to color for TV films. Color film costs more than black-and-white; it costs more to light sets for color film; and, finally, color prints are more expensive than black-and-white. Where sponsors of TV film shows have been very reluctant to accept any kind of price increase for black-and-white films, it is obvious what their reaction might be to the much

higher price tag that TV films in color will carry. So any production of TV films in color today, if it is to pay off, must be done at lowest possible cost.

One way in which this is being done is by shooting the shows on 16mm color film instead of 35mm. One producer who is doing this successfully is Ted Allan of Hollywood, who films the Hank McCune Show, a popular half-hour series starring McCune supported by well-known Hollywood film players.

The economy Allan effects by using the narrower color film is not all in the reduced film size; Allan is able to shoot 16mm Kodachrome a great deal more economically than 35mm color film for a number of reasons. For one thing, he



LIGHT, portable 16mm camera equipment makes it easy for the Ted Allan company to work fast on location. Here the company prepares to shoot a scene aboard a Navy destroyer on maneuvers off San Diego, Calif.—just one of the many locations used for action scenes for recent films in the Hank McCune series.

TED ALLAN, behind the Auricon "Super 1200" camera, directs the photography of the Hank McCune Show. At one time a cameraman for a west coast TV broadcasting company, Allan resigned to start his own TV film producing company.

can and does use more economical lighting than is required for 35mm.

The Hank McCune show sets are lit entirely with incandescent lamps—10-Ks for key lights, plus a number of spots and floor lamps for fill. But the big "Economy" factor, perhaps, lies in the photography. Allan, who personally directs the photography of the Hank McCune Show, uses an Auricon 16mm "Super 1200" camera. This marks the first time, perhaps, this camera has been selected for photographing a major TV film series in color.

Its many exclusive features contribute to the economies which Allan has found so advantageous in his TV film production operations.

"With its giant magazines providing a maximum film supply of 1200 feet of Kodachrome at one loading," says Allan, "the frequency of reloading is greatly reduced, thus saving time and operational expense. The camera produces a rock-steady picture. I like the three separate finder systems, which are combined in this self-blipped camera that runs so quietly no external blimp is



required, even for sound stage operation. Its precision mechanism is another big reason I favor the "Super 1200." Recently we exposed in the camera a total of 45,000 feet of color film that came through without a single scratch. For this we credit the camera's unique sapphire film gate."

No less important is the light weight of the camera making for unusual portability; it is often used on a comparative-

(Continued on Page 463)



TYPICAL lighting of an "indoor exterior" for the Hank McCune Show. Allan Studio uses local power lines and incandescent lamps for all set-lighting. Pictured are Hank McCune (left) and Tommy Rettig rehearsing lines prior to a take.

High-Speed Filming Of Instrument Action

The technique and equipment used by National Bureau of Standards to investigate cutting action of dental burs.

By ALVIN D. ROE

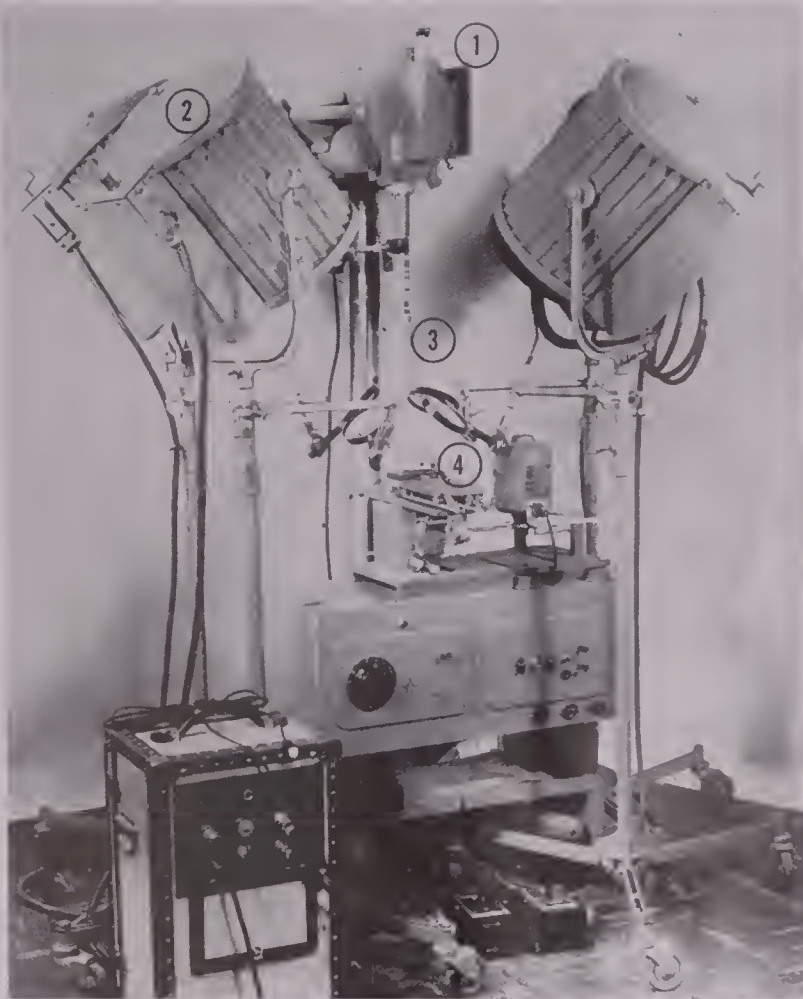

FIG. 1—EQUIPMENT used at the National Bureau of Standards for slow-motion photography of rotating dental burs: (1) High-speed motion picture camera; (2) four 1000-watt spotlights with condensing lenses; (3) extension tube containing lenses for magnification; and (4) bur test machine. The camera control unit is at lower left.

SIGNIFICANT information on the cutting action of rotating dental instruments has been provided by a cinematographic technique recently developed at the National Bureau of Standards. In this technique, a high-speed motion picture camera is used in combination with an optical magnification system to make a greatly enlarged, slow-motion record of the action of each blade of a dental bur throughout the cutting cycle. It has thus been possible to obtain dynamic observations of clogging, intermittent cutting, eccentric rotation, and other hitherto unsuspected details of the passage of the bur blades through the tooth structure. Used in combination with conventional test procedures, the photographic method should prove of considerable value for experimental study of new types of dental burs since it will permit rapid evaluation of new designs prior to extended laboratory investigation.

The photographic method was devised and applied by Major Jack L. Hartley and Colonel Donald C. Hudson (both NBS guest workers from the U. S. Air Force Dental Service), and W. T. Sweeney and W. P. Richardson of the NBS staff. The project was part of a program of dental research which the Bureau is conducting in cooperation with the American Dental Association and the dental services of the Air Force, the Army, the Navy, and the Veterans' Administration.

Until now little has been known regarding the cutting action of dental burs in the cavity preparation of human teeth. Although considerable information is available on the cutting mechanism of industrial abrasive wheels and milling cutters, this information is not directly applicable to dental instruments because the properties of human tooth enamel and

dentin differ so greatly from those of other materials and because dental instruments are so much smaller than the industrial cutters. Also, the patient's sensitivity to pain, frictional heat, and vibration is an important additional factor which must be taken into account in the design of dental burs. The high-speed photomicrography program was undertaken to provide basic information that might lead to improvement in the design and use of rotating dental cutting instruments.

In preliminary investigations a conventional laboratory camera was used with a 2-microsecond light source to produce still photomicrographs of dental burs cutting glass and resin specimens in a standard bur testing machine. While these still photographs were of some value, they did not permit sequential studies of the cutting action of any particular blade under dynamic conditions. It was therefore decided to make continuous observations using motion picture techniques.

Three 16mm high-speed motion picture cameras were used to study the cutting action of a large number of types of dental burs on mounted specimens of human dentin and enamel. The three cameras operated at speeds of 3,000, 7,000, and 14,000 frames per second; they thus effectively slowed the action of burs rotating at 2,500, 5,000 and 10,000 rpm, respectively, so that all phases of the rotation cycle could be readily studied. These speeds of rotation correspond approxi-

(Continued on Page 466)

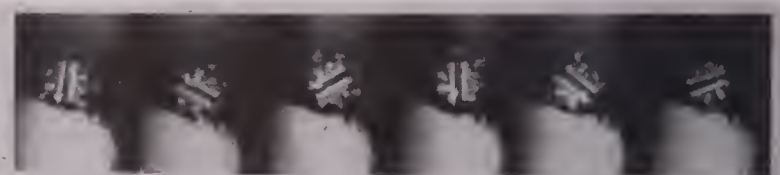

559 CARBIDE BUR CUTTING HUMAN ENAMEL

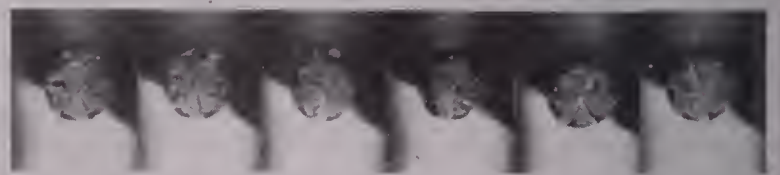

559 STEEL BUR CUTTING HUMAN DENTIN

THE INSTRUMENTS ABOVE WERE ROTATING AT A SPEED OF 2,500 RPM AT A LOAD OF 300 GRAMS

FIG. 2—High-speed motion picture frames enlarged to show stages in the rotation cycle of typical dental burs.

EASTMAN

PROFESSIONAL

MOTION PICTURE

FILMS

W. J. GERMAN, INC.

Fort Lee

Chicago

Hollywood

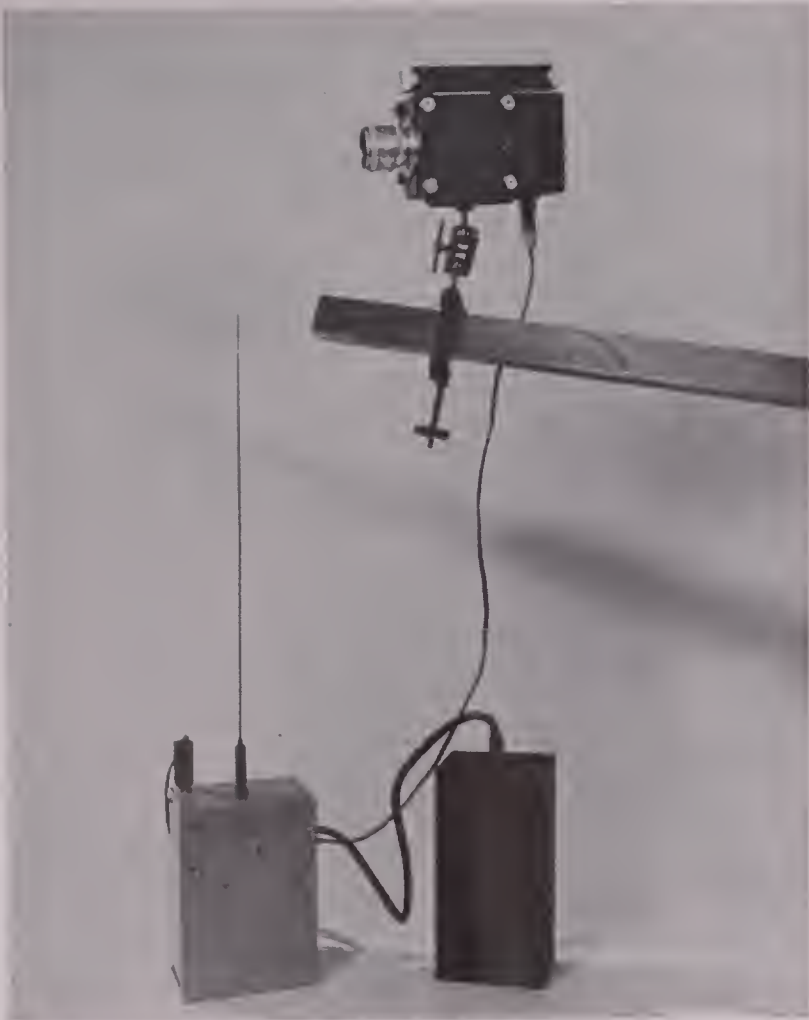

RADIO CONTROL unit for camera. Receiver with antenna is shown at lower left; battery box for camera motor power at right. Camera is started and stopped by transmitted radio impulse.



REMOTE CONTROL transmitter in hands of author. Pushing a button creates radio impulse which is picked up by receiver connected to camera control unit. Transmission range is 1 mile.

Radio Controlled Cinematography

Tiny radio transmitter used to control model planes may be used to operate 16mm cameras from remote locations.

By J. W. BAKKE

SMALL RADIO TRANSMITTERS, which model plane builders are using so successfully to control model aircraft in flight, now offer a practical means of remote wireless control of motion picture cameras used in specialized filming jobs.

The industrial and scientific cinematographer is often faced with the problem of photographing a non-repetitive event, such as that which may involve an element of personal danger, making it desirable to operate the camera by remote control from a safe distance. Other photographers are often faced with a similar problem when they wish to employ their artistic ability to the fullest and get an unusual high-angle

shot from an overhead crane hook, from the front bumper of a moving automobile, or the wing of an airplane.

Such shots have always been possible, of course, using a lightweight electric motor-driven camera, a length of cable and a remote control switch. In most instances, this method has proven quite satisfactory; the objections are the need for stringing the cable and the possibility of electrical connections separating, or power failure. Also, where such wire-controlled shots are to be made from a great height, the control cable may be unhandy, hazardous or impossible to string. Here the radio control proves ideal.

The main control unit, which is es-

essentially a small, compact radio transmitter on the order of the war-time "Walky-Talky," is relatively inexpensive and has but a single control switch. The receiving unit, which is used to stop and start the camera, consists of one or two small tubes and a relay in a tiny housing. Weighing but a few ounces, it can be mounted on the camera battery pack or on the camera itself. This miniature receiver can be operated if necessary from a line-of-sight distance of one mile. Pressing a button on the transmitter operates the receiver relay which controls the camera starting switch.

In specialized filming operations, where more than one camera may be required to record an operation from

High-Speed Film Processor

The Bridgamatic processor may be operated in daylight and is entirely automatic.

One of the popular film processors designed specifically for high-speed processing is the Bridgamatic, distributed by S.O.S. Cinema Supply Corporation, New York City. Several models are available, each designed for a specific need. One model, which was designed especially for processing films having pre-hardened emulsions, such as DuPont's 930A and 931A, utilizes but 100 feet of leader, thus cutting 2/3 of the time-lag due to leader travel. In the Bridgamatic Model RT-R (designed for film patrol systems), 16mm reversal film is in the first developer but 12 seconds and dries in less than 30 seconds.

Filmline Corporation, builders of the Bridgamatic, put to good use the experience gained from the development of the Model RT-R processor. With only slight modifications the company produced Model R-TV for the specific needs of television stations producing their own motion picture films. Available as a standard daylight operating model, the R-TV is capable of producing a posi-

tive reversal film ready for telecasting in about three minutes.

The operational routine for this model is as follows: Using DuPont 16mm reversal film No. 931A, first developer time is 36 seconds; shortstop bath 6.4 seconds; bleach 20 seconds; clearing bath 20 seconds; second developer 20 seconds; hypo 6.4 seconds; spray wash 12 seconds; drybox 39 seconds. The total elapsed time is a trifle over 2 1/2 minutes. Other reversal films, and negative and positive films may also be processed with this same machine with comparable savings in time.

Utilizing all the advantages that the high-energy processing solutions afford has been a big factor in the success of both Bridgamatic models. The Model RT-R machine operates at about 100° F. with the film traveling at speeds up to 85 feet per minute. The Model R-TV operates at 90° with the film traveling 35 feet per minute and more.

Both models are water-jacketed
(Continued on Page 466)



TRANSMITTER, which operates on frequency of 27.255 mc., relays radio signal to remote receiver which actuates camera mechanism.

various distances or angles. the one transmitter can be used to control all cameras, as long as their operation (starting and stopping) is uniform.

As with all radio transmitting equipment, a simple permit for operation is required by the Federal Communications Commission. However, no technical knowledge of radio is necessary nor is an examination required. Anyone can use the equipment; complete instructions for its operation are furnished at the time of purchase.

Originally designed for use with model planes and target drone planes used in anti-aircraft gunnery, the equipment is quite rugged and capable of withstanding heavy shocks. Simplicity of operation, low cost and lightweight make these units worthy of consideration for operating 16mm cameras in the recording of many subjects and technical and mechanical operations that heretofore have presented unsurmountable photographic problems.

Radio control is most effective when used with electric motor-driven cameras. Battery-operated motors are now available for just about every 16mm camera on the market. The author used a con-

(Continued on Page 462)

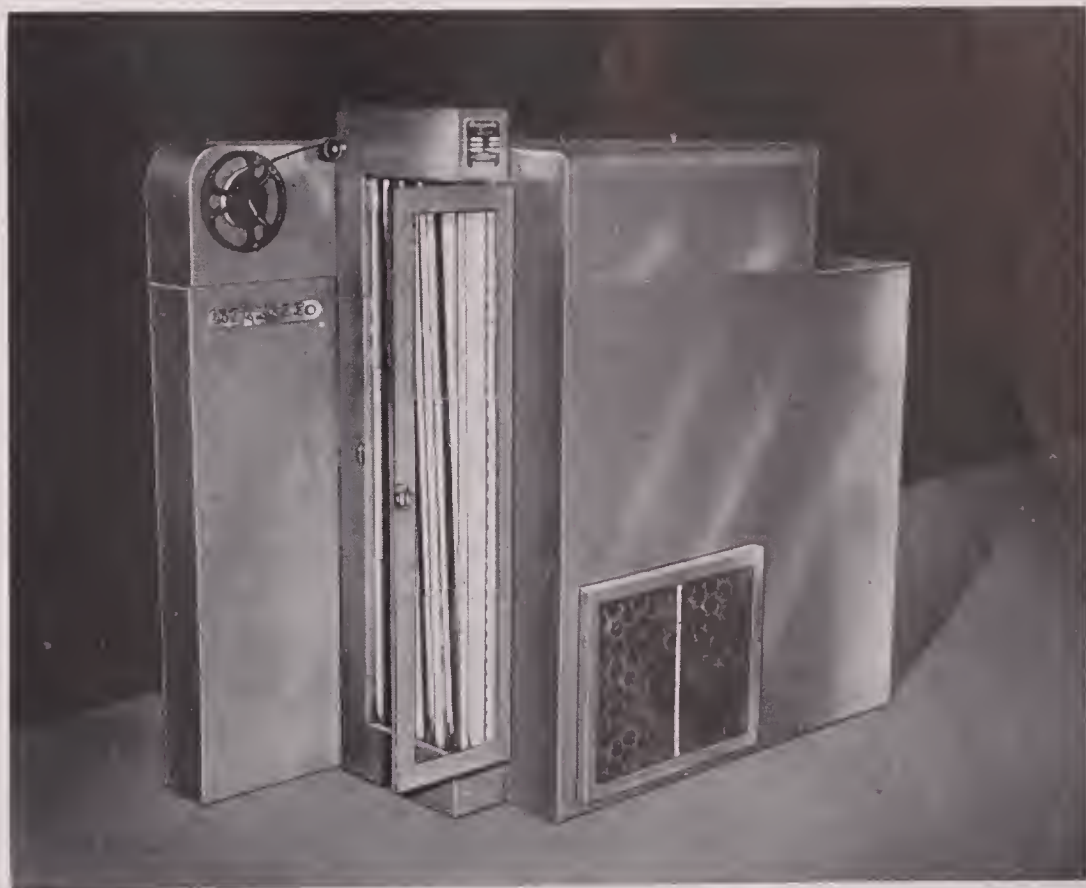

ONE OF THE AUTOMATIC developing machines designed especially for fast processing of 16mm film is the ultra-high-speed Bridgamatic, above, originally created for race tracks. It is now used by many TV stations. Thanks to the new, fast negative emulsions now available, the Bridgamatic, using high-energy solutions, can process a hundred feet of film and have it ready for projection within three minutes.

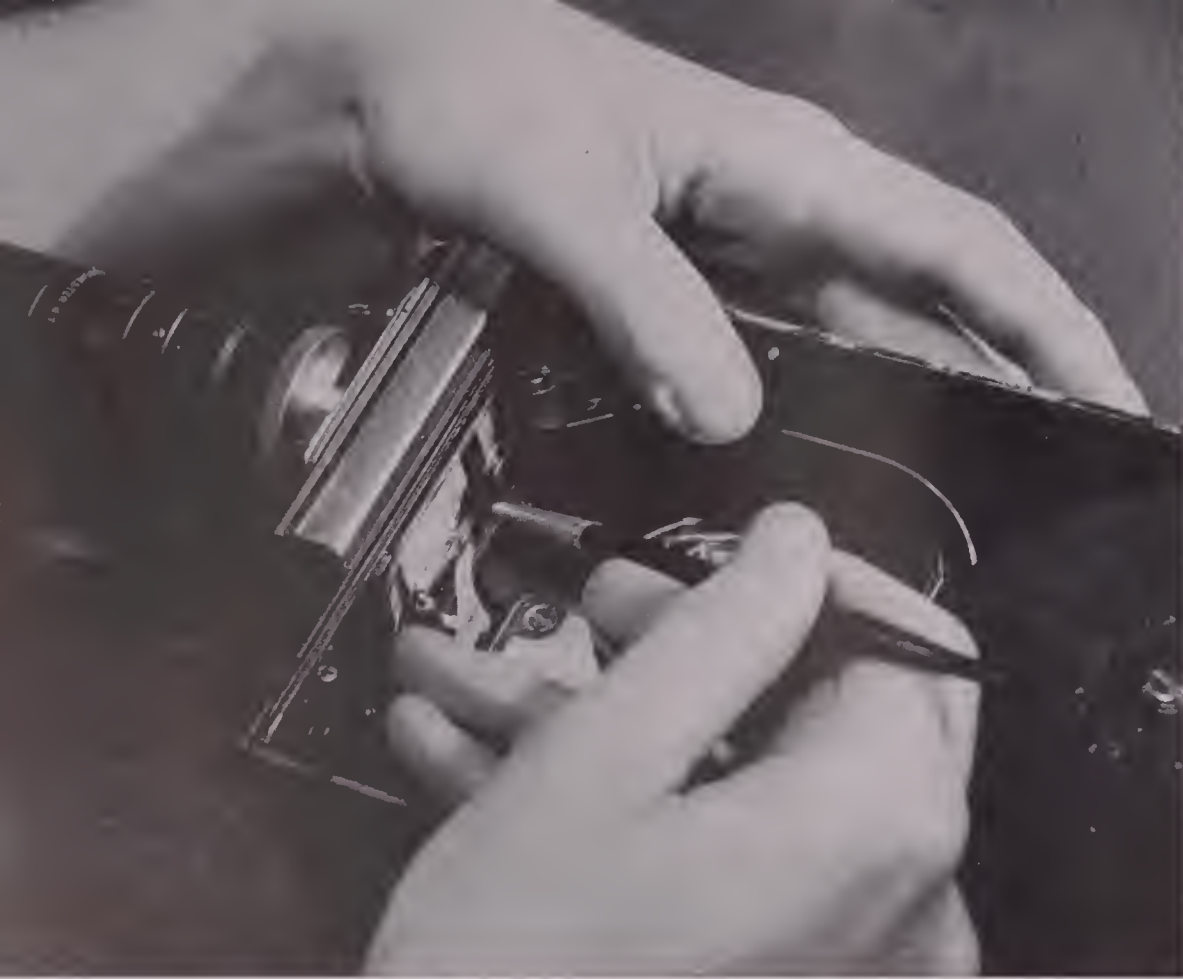

OFF-CENTER framing can result from a bent pull-down claw. So when cleaning the camera film gate, use care and avoid bending any delicate parts.

Is Your 16-millimeter Camera Showing Its Age

Some simple tests you can make to check accuracy and performance of your camera.

By HANK STOCKERT
Illustrations by the Author

THE PHOTOGRAPHIC QUALITY obtained with a motion picture camera can only be as good as the camera itself. If the mechanism is worn out or out of adjustment, the results will show prominently on the screen. Although many of the components of a motion picture camera are similar to the related components of a still camera, which may be easily tested and adjusted following well-established procedures, the procedures for correcting faults in motion picture camera mechanisms are not as generally understood.

A movie camera has many parts which move during its operation, and some of these move extremely rapid. Eventual wear must be expected. The important point is to know how to test your camera so that it may be given due attention before wear increases to the point where it causes additional damage to the parts, or even ruins film. The frequency of such testing should depend upon the use the camera is given. A cine camera allowed long rests, for example, with its drive spring un tensioned and well protected from dust

will need less checking than a similar camera which does daily professional duty.

The amount of "play" tolerated in a camera is dependent not only upon the standards set by the owner but also by the service to which the camera is put. A camera used for television newsreel work may have more unsteadiness in the film movement than a camera used upon a title stand. Any scene shot with a firmly anchored camera, including motionless objects crossing the frame line, will show the effects of picture unsteadiness more readily than a scene not meeting either or both of these conditions.

Your projector must be eliminated as the source of unsteadiness before you can correctly blame this trouble on the camera. Although a rough indication of projector condition can be obtained by projecting a relatively new print known to be steady, there is a better test. The best method for checking 16mm projector unsteadiness is to use the special test film prepared for the purpose by the Society of Motion Picture and Television Engineers. This film, Code Number ST16, has holes punched in the picture area at the same time that the sprocket holes were punched. By following the SMPTE's directions this film may be used to obtain a quantitative measure of projector unsteadiness.

The camera test for unsteadiness may be so planned that you may also check several other details without influencing the results of the steadiness check. For example, if an accurate record is made of the framing of the test subject in the viewfinder, the accuracy of the viewfinder frame may also be established. Some manufacturers design their viewfinders to cover a slightly smaller field than that of the lens, as a preventive measure against parallax errors, should the cameraman forget to make proper allowances. Where the camera operator is not aware of this it can result in scenes ruined from shooting beyond the edge of sets or by including lights which have been located close to the set line. Reflex-type viewfinders should also be checked at this time if the camera is so equipped.

The actual subject matter for the camera test is limited only by the imagination of the photographer. In shooting out-of-doors, you can find no better test subject than the time-honored brick wall. This will also allow you to judge lens sharpness by examination of the rendering of the minute texture of the bricks and mortar. Make sure that the camera is mounted upon a rock-steady support. By photographing the wall head-on, you will avoid perspective troubles when evaluating viewfinder accuracy in the screened result.

For testing your camera indoors you can prepare a chart similar to the one

illustrated below. This chart offers an advantage over most outdoor testing targets since a special technique will make the steadiness test completely independent of any other influencing factors such as film shrinkage, perforation inaccuracy, projector unsteadiness, etc.

All of the precautions mentioned in the outdoor test should be observed indoors. A firm table for mounting your camera is better than a questionable tripod, unless the special technique is utilized. The test chart, with the "X"s crossing the frame line will accurately locate your original framing during projection. Since you will probably be working close to the chart, viewfinder parallax will be so great that the framing can only be checked upon cameras which allow viewing the image through the lens, or with cameras that can be used with a rackover device that places the viewfinder in the same position that the lens will occupy during the filming.

Where you can backwind the film in your camera between takes, or can rewind the take in a darkroom, you may use a method which will eliminate all causes of unsteadiness other than the camera. This technique calls for shooting from five to ten feet of film of a test chart similar to the one illustrated. After the first take has been backwound to the beginning, shift the camera by a very small amount, both horizontally and vertically. If you reduce the exposure of the second take by about one stop, evaluation of screened image will be greatly simplified. After this double-exposed footage is processed, make a loop of the film and project it. *Any inter-movement of the pairs of lines from the two takes will be due to camera unsteadiness alone.*

In screening the test film and evaluating any errors, it isn't the average difference in the location of the lines you will be interested in, for this difference will represent the shifting of the camera between takes. The movement *relative* to each other will represent *double* the amount of camera unsteadiness. Examination of the film may give a clue as to whether the trouble, if any, is due to edge guide (horizontal image movement) or pull-down trouble (vertical image movement.) Although this isn't sufficient information to enable you to pinpoint the cause, you can aid the factory to whom you send the camera for adjustment by sending along the test films for their inspection and study.

Many 16mm films have been ruined for audience enjoyment because of another possible camera defect. Even among professionally-produced films this defect may be detected all too often. I refer to those films that must be re-framed frequently as they are screened. In most instances, this fault



STEADINESS of intermittent movement and viewfinder accuracy may be checked at the same time, by photographing a chart such as shown here. The procedure is described by author in the text.

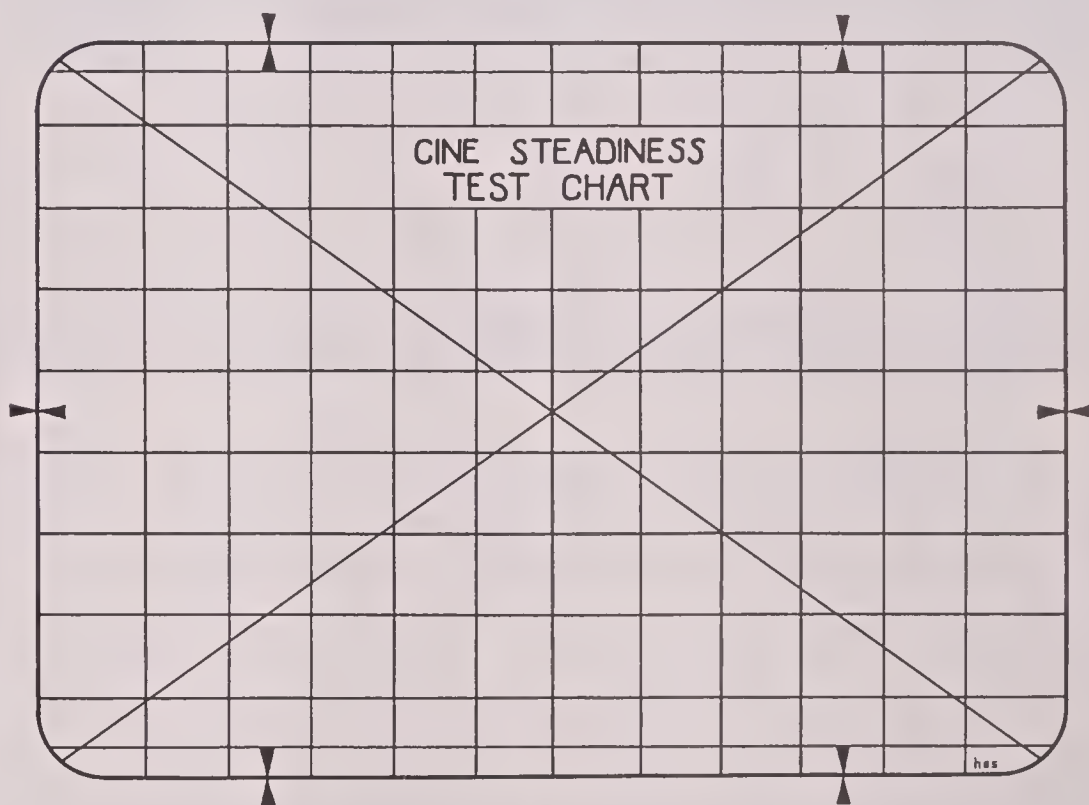

TEST CHART for checking intermittent steadiness and viewfinder accuracy. Photograph and enlarge this drawing to approximately 14-inches in width or have a photostat made; then photograph it with your 16mm camera as outlined by author.

lies with the use of two different 16mm cameras in the photography which were not first checked to insure that aperture plates of both were properly aligned.

Sometimes this defect is caused more through careless camera handling than by camera wear. It sometimes can be blamed upon a pull-down claw which

has been bent during film loading, or during an extremely bad film jam. Since the error is liable to be in the range of ten-thousands of an inch, it doesn't take much to bend the claw sufficiently to change the frame line location. It is evident that remedy of such a

(Continued on Page 456)



DOLLY SHOTS can enhance family movies—give them a professional touch. Here a tripod-mounted camera rides a simple dolly that is equally-adaptable to professional filming.



TRACKS for the dolly wheels make for smoother dolly travel. Here a commercial-type dolly designed for both amateur and professional cameras, riding a channel track made of light-weight metal that is generally available in heavy hardware stores.

You Can Make Dolly Shots, Too

Whether you buy a camera dolly or build one, or use the baby's toy wagon, you'll find dolly shots add a lot of class to your movies.

By JOHN FORBES

IF A DOLLY SHOT can enhance the storytelling of a feature film, it can contribute similarly to an amateur film, as has been proved so often in well photographed 8mm and 16mm movies. It is surprising, therefore, that so few cine photographers use the device; for effective dolly shots can be made with the aid of a great many mobile supports other than specially constructed camera dollies.

By employing a dolly in shooting certain action, you not only give your film an added professional embellishment, but, when properly used, the dolly shot

can enhance the flow of a film story, and even improve the pictorial effect of an unpretentious family record film.

For filming indoors, a dolly like the one pictured above, is available from better-stocked camera stores at fairly reasonable cost. But for those who delight in building their own photographic equipment, a dolly capable of producing comparable results can be built in the home workshop, using scrap lumber and three furniture casters or roller skate wheels. Of course, for a more professional job, one can purchase rubber-tired wheels—even balloon-tired wheels—from

hardware stores that will provide smoother travel of the dolly when used outdoors as well as indoors.

The first step is to make a T-shaped frame work of pieces of wood 2"x2" by 30" in length. At either end of the member representing the top of the "T" a fixed or non-swiveling wheel is attached—both fixed to travel parallel in the same direction. At the end of the other member a swiveling castor is mounted. This permits steering the dolly by the camera operator. The "free-wheeling" of the castor will provide all the free movement of the dolly necessary.

Certain filming situations preclude the use of a camera dolly unless a track is provided for it to run upon. Such a track may be constructed from two-by-fours of the required length and laid flat. A trough for the wheels to follow may be

(Continued from Page 460)



Catch more *snap* and *sparkle* in your movies by using Ansco Hypan Film

You'll enjoy a new movie-making thrill when you shoot with Ansco Hypan Film because this modern panchromatic emulsion has inherently brilliant gradation that gives greater crispness to your screen images.

Its high speed (exposure indexes of 40 daylight, 32 tungsten) permits the use of Hypan under all good filming conditions, indoors and out, making it an excellent "all around" movie-making film.

Hypan's low price is another important attraction. With Hypan in your camera you can shoot plenty of high-quality footage on even the most modest budget. Your photo dealer stocks this finer movie film in 8 and 16mm rolls and magazines. Try it!

People Who Know Buy Ansco

You'll
get better
color with
ANSCO
COLOR FILM

In 8 and 16mm magazines,
and 16mm rolls.

Ask for it at your dealer's!

FOR BETTER

Projection AND GREATER PROTECTION

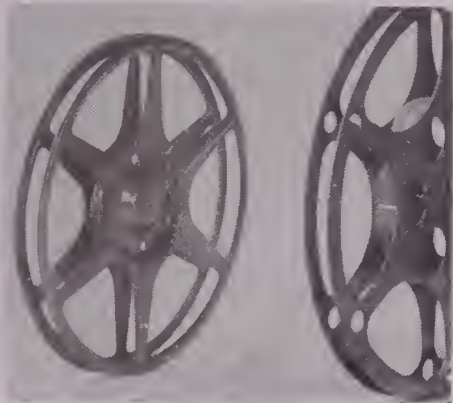

Compcoprofessional Reels

For shipping, storing or showing film, precision made Compcoprofessional Reels are first choice with those who want the finest. Hard, spring type steel construction won't warp or bend... eliminates film-wearing rubbing during projection or winding. Your production deserves the finest package—use Compcoprofessional Reels in 600 ft. to 2,000 ft. sizes.

Write for catalog!

COMPCO CORPORATION
2253 W. St. Paul Avenue, Chicago 47, Ill.

CAMERA SHOWING AGE?

(Continued from Page 453)

minute but important error should be placed in the hands of the manufacturer rather than to attempt any amateur cures. Often, efforts by inexperienced camera mechanics to adjust or repair such cameras results in more trouble such as side-effects, overcorrections, binding of the associated pivot points, sidewise maladjustment, punching of the film, etc.

A suitable test for proper framing is one of the simpler tests the average cine camera owner can perform himself. You don't even have to shoot special footage. All that is necessary is a decent length of original camera film. (Prints, which may exhibit faults of the printer, should not be used.) Original negative is as suitable as reversal original. One important requirement is that the film be perforated on both edges. If your's is a single-system sound camera, you have the choice between shooting a length of double perforated film (if your camera will accept it), or shooting a second piece of single perforated film of clear or blue base stock, through the back. The resulting out-of-focus image will not matter. Blue Base film will require additional exposure; common

positive print stock may also be used and will serve perfectly.

To make the test for improper camera frame line location, make a test loop by splicing two sections of the camera original together so that one is backwards. Thread up this loop and project it. Shift the projector framing lever so that either the top or bottom frame line is visible. Going to the screen, place a piece of dark tape on the screen at the location of the frame line for one of the film sections. The shift from this location for the frame line of the other film section represents double the frame line error.

You may carry this test one step further by computing the magnification ratio of your projection setup. Measure the amount of frame line shift and divide this by the magnification to determine how large the camera error is.

One note of caution regarding frame line troubles: Some cameras give different framing at ultra-fast or ultra-slow filming speeds. If you use more than one speed, check the framing in similar manner for original films shot at the limits of your shooting range.

There is one more trouble item which may creep into your footage. This is the possibility of uneven density from frame to frame, due to an erratic shutter or some other moving part of the camera. Where the camera is electric

Precision Built Combination Sound Readers

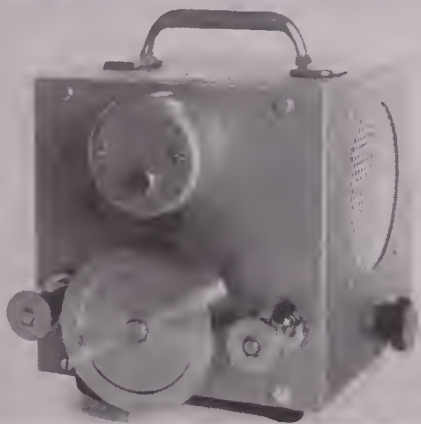

OPTICAL

Model 600.....16mm and 35mm
NET PRICE \$185.00



OPTICAL-MAGNETIC

Model 800.....16mm, 35mm & 1/4 inch
NET PRICE \$259.50



MAGNETIC

Model 700....16mm, 17.5mm, 35mm
and 1/4 inch
NET PRICE \$198.00

FEATURES: Simple threading . . . polished stabilizer drum with needle bearings, with a surface which cannot damage film . . . film ralliers machined to conform with SMPTE standards, and equipped with oilless bearings . . . precision ground shafts . . . dimension 6x6x7 1/2 inches.

AMPLIFIER: 117 volt — 60 cycle — AC . . . power output — 4 watts . . . heavy duty Alnica V speaker . . . safety fused . . . prefocused socket . . . pilot light . . . 6 ft. heavy duty cord.

All Prices F. O. B. Factory, Brooklyn, New York

PRECISION LABORATORIES

1139 UTICA AVENUE

BROOKLYN 3, NEW YORK

AURICON Auricon Hollywood

16mm Sound-On-Film for Professional Results!

ALL AURICON EQUIPMENT IS SOLD WITH A 30-DAY MONEY-BACK GUARANTEE. YOU MUST BE SATISFIED

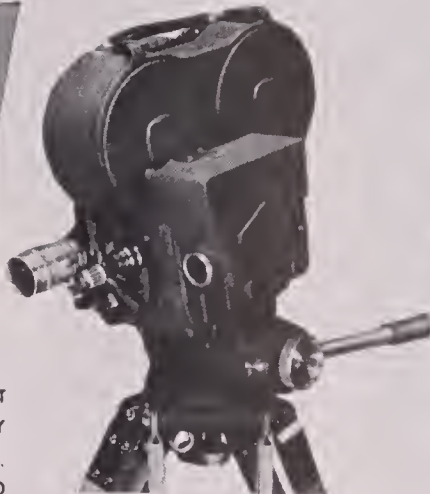

"AURICON-PRO" capacity for 5½ minutes of recording. \$1310 and up.



"SUPER 1200" capacity for 33 minutes of recording. \$4652.15 and up.

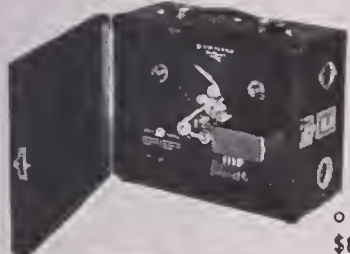

RT-80 SOUND RECORDER — 200' capacity "double-system" optical recorder. \$862 and up.



"CINE-VOICE" capacity for 2¾ minutes of recording. \$695 and up.



TRIPOD—Pan-Tilt Professional, velvet-smooth action. \$325 and up.

● WRITE FOR AURICON CATALOG

HEADQUARTERS FOR FILM PRODUCTION EQUIPMENT

"The Dept. Store of the Motion Picture Industry"

S. O. S. CINEMA SUPPLY CORP.

602 WEST 52nd ST., NEW YORK 19, N.Y. — Cable: SOSOUND

Bridgomatic

FILM PROCESSING EQUIPMENT

Develop Your Own Films and Save!

PAYS FOR ITSELF!

for TV Stations, Industrial Producers, Photo-finishers, Microfilmers, Colleges, Small Labs, etc.

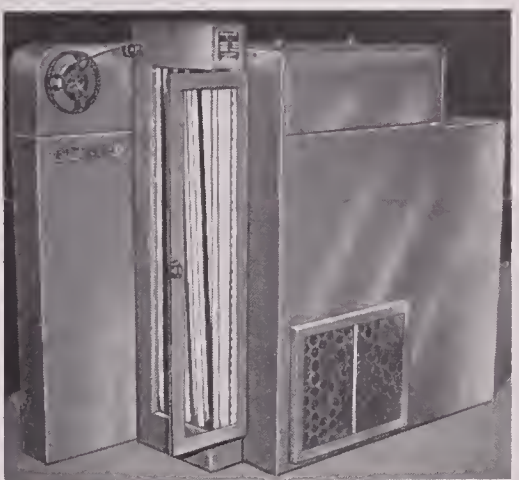

Bridgomatic R-TV, 52" high x 47" long x 30" wide—one of 12 models, including calar machines.

MODEL R-TV for TV stations....\$5600 (Output 35' per minute at 90°)

MODEL RT-R for racetracks....\$5995 (Output 82' per minute at 98°)

OTHER MODELS for all purposes\$1095 up

Nothing like it at anywhere near the price! This new ultra rapid 16mm film developer assures clear, sharp, permanent images. Entirely automatic. Will develop your films within a few seconds after shooting. Requires no special skill. Removes the guess, protects your precious negatives and soundtracks—and clean-dries in minutes. No darkroom necessary.

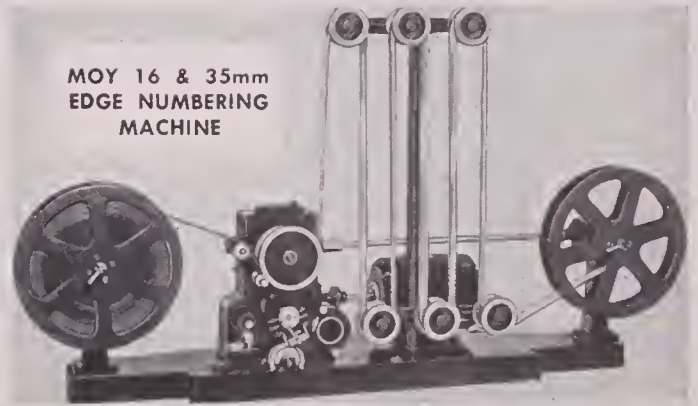

MOY 16 & 35mm EDGE NUMBERING MACHINE

IDENTIFY YOUR FILMS INSTANTLY

Save many man hours now lost classifying films without titles. The Moy edge numbers every foot of film and simplifies the task of checking titles and footage.

Prints block or yellow from automatic metal numbering block on opaque or clear film. 2000' capacity, speed 50' per minute. 16mm model prints between perforations only—35mm prints between perforations or on outside edge as specified.

Recent Purchasers are:
Columbia Broadcasting System, N.Y.
Moody Bible Institute, Los Angeles
American Optical Co., Buffalo, N.Y.
Cinerama Productions, New York

WITH NEW, IMPROVED INKING SYSTEM
\$2,250

ngallen
CORPORATION
MAKERS OF
SYNCHRONOUS
Magnetic
FILM
RECORDERS

Newest Addition

TO THE *Hallen* LINE OF MAGNETIC *Film* RECORDERS

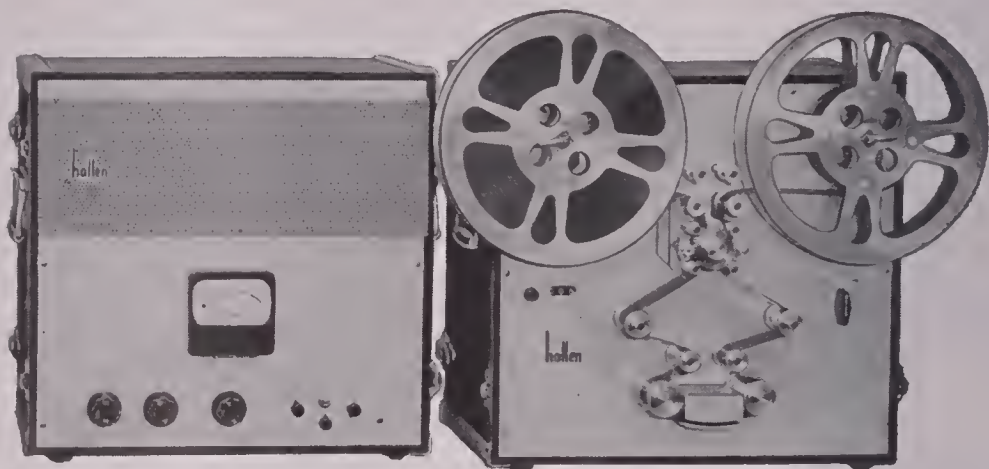

The recorder shown is 35mm using two flywheels, designed to facilitate conversion to multiple track, stereophonic, cinemascope etc.

The two case portable Model 235 magnetic film recording system is also available in both 35mm and 16mm single drum system. Literature available.

3503 WEST OLIVE AVENUE • BURBANK, CALIFORNIA

CABLE ADDRESS "HALLEN" • PHONE THORNWALL 8-6976

Model 35-16C

S E N S I T E S T E R

★ IMMEDIATE DELIVERY
to the lab owners interested in—

QUALITY
EFFICIENCY
ECONOMY

- DUAL MACHINE
1—Sensitometer
2—Scene Tester
- HIGHLY ACCURATE
Electronic timer unaffected
by climatic changes.
- NEW TYPE LONG-LIFE
Cold Light Exposure Unit
- WITHOUT ADDITIONAL
EXPENSE will match any
printer

Combination 35mm-16mm

ART REEVES MOTION PICTURE EQUIP.

7512 Santa Monica Blvd.

Hollywood 46

California



motor-driven the trouble might be due to a defect common with some synchronous motors called "hunting." If you suspect your camera is giving flicker trouble, shoot a test strip of some neutral gray object full frame, a gray wall, cardboard, etc., or underexpose a section of clear northern sky. Projection of this test strip may not tell you much, but measuring the density of the varying frames of the test strip should give the answer. **END**

UNDERWATER BLIMP

(Continued from Page 441)

feet and keep it at that level indefinitely. Now if the shot calls for the camera to shoot down from this height at an angle, the stabilizing tubes are shifted toward the back the distance required to lift back of the camera above the level of the front. For an up-angle shot, the tubes are pushed forward and locked in place. With other underwater cameras, it has been necessary to mount them on a tripod or parallel to make shots of this type, with consequent added loss of production time required to erect the camera support, and to move and set the camera upon it. Lateral shifting of the tubes is employed to level the camera from left to right.

The photo on the cover shows one of

HIGH-SPEED

PROCESSING

The **HILLS** Filmatic

High Temperature 16mm
Film Processor

- REVERSAL
- NEGATIVE
- POSITIVE

SPEEDS UP TO 115 FT. PER MIN.
BUILT IN REPLENISHING SYSTEM
DAYLITE OPERATION
COMPACT — SELF-CONTAINED
NOTHING ELSE TO BUY
ECONOMICAL PROCESSING
NO INSTALLATION



The Filmatic Model 16 HT is a completely automatic high-speed, high temperature processing machine. Thermostatically controlled operating temperatures at every step. Designed to process any 16mm sound or silent film at speeds up to 115 feet per minute. For illustrated folder and additional information write to William Halpern, Sales Representative, 8240 Fayette St., Philadelphia 19, Penn.

HILLS

MANUFACTURING CO.,
LANSDALE, PA.

the few instances when it became necessary to tie down the blimped cameras with cables leading to anchors on floor of the springs. This was because there were underwater currents which would manifest themselves so suddenly the operators could not hold the cameras rigid against them. "Otherwise, the cameras were as easy to manage or maneuver as a feather," said operator Dale Deverman.

When making purely static shots, the cameramen would deliberately move the cameras ever so slightly in order to enhance the realism of having actually photographed the scenes underwater.

It is to the great credit of John Arnold, his engineers and to the cameramen who photographed "Jupiter's Darling" that not a single camera failure was experienced during the entire period of location filming in Florida. The two blimps, imposing in their stature and looking not unlike some strange new lethal weapon of war, rest for the moment in a corner of the camera department at MGM studios. But each day, as more and more of the spectacular color footage they made possible is viewed in the projection room by studio executives, the enthusiasm engendered brings nearer a new production which will again see these monsters of the deep in action.

DOLLY SHOTS

(Continued from Page 454)

formed by nailing strips of wood 1-inch square on the two-by-fours.

In use, care should be taken to insure that the tracks lie solidly on the ground, and level—except where the dolly travel is purposely planned on an incline or otherwise. Where wooden tracks of any great length are laid over uneven ground, wooden wedges should be inserted beneath the tracks in the low spots to support them as the dolly passes over.

Follow shots with a dolly-mounted camera can be made in a number of ways—that is, the camera can follow the players or the action from the side or rear, or the camera may precede the players who follow some distance behind the retreating camera. The method selected, of course, will depend upon the situation, the location and the terrain on which the action takes place.

Let us take, for example, a familiar bit of action often recorded by home movie cameras—that of a child riding a tricycle. Where such action is filmed on a sidewalk in front of the home, the camera and dolly follow the child from any of the angles previously mentioned, and—if the sidewalk is smooth—without the need for a track.

On the other hand, suppose the sub-

ject for filming is a hiker on a country lane, or two people walking along a path in a thicket. This might involve shooting from a track laid parallel to the action, which would permit the camera to move along smoothly during the entire length of the shot.

Dolly shots reach their height of effectiveness when made out of doors of action such as this, where objects such as trees or shrubbery momentarily come between camera and players during progress of the shot. It is the type of dolly shot familiar in professional motion pictures, yet one which many cine photographers have yet to try.

Quick dolly action, forward or backward, is particularly adaptable to fast movement of subject when a "zooming" of the camera toward or away from the subject will effectively heighten interest. This effect can be utilized for ordinary home movie subjects, too.

A problem that arises when making dolly shots is that of keeping subject in sharp focus throughout the cycle of camera travel, especially where subject moves progressively toward or away from the camera, or where the dolly-mounted camera moves toward or away from a stationary subject. The best answer to the problem is to provide sufficient light in the scene to enable stopping down the lens to gain maximum depth of field.

As an example, suppose a certain bit of action calls for the camera to start filming at a distance of ten feet, then move progressively forward to a distance of 3½ feet. Here we have a problem of keeping subject in sharp focus during the entire time camera is traveling from the ten-foot mark.

If there is insufficient light and the lens has to be opened to f/1.5, depth of field will be very limited. The only way the shot can be made so that subject will be in focus at all times is to gradually change focus of the lens as the camera moves toward subject—obviously a chore requiring a capable camera assistant.

On the other hand, if light is sufficient to permit shooting the same action at f/8, depth of field will be considerably greater. By setting focus at ten feet at the beginning of the shot, it can be left at that mark for the entire shot, because of the increased depth of field created by the smaller lens stop.

Here a depth of field chart is a handy thing to have for reference. Several are to be found in the American Cinematographer Hand Book, published by Jackson J. Rose A.S.C. Lacking these, it is well to remember that depth of field is increased as the size of the lens stop is reduced.

For those who are not prepared to buy a small light-weight dolly or to build one along the lines suggested earlier,

MATTON

REMOVES HOTSPOTS . . .
SUBDUES HIGHLIGHTS . . .
REDUCES REFLECTION
AND GLARE . . .

CHROME
SURFACE

SPRAYED
WITH MATTON



Large Spray Can \$2.25 ea.
NOW . . . ORDER 6 for \$12.00

Just spray instant MATTON on all chrome, plated, shiny, metallic, glossy or glass surfaces.
• Easy to apply with spray applicator can.
• Instant MATTON coating hardens instantly.
• Can be handled without fear of mess or of removing hard MATTON coating.
DON'T USE MESSY, INEFFECTIVE CAPS OR WAXES . . . DO USE MATTON

F & B Split Reels

Prevent wear and tear on 16mm prints, film, splice, storage.
Now you can project, edit, inspect, synchronize, clean, measure and store all your films on cores.
No More Rewinding Problems
Now, simply slip film on core into SPLIT REEL. Close reel. Use another SPLIT REEL for take-up . . . unscrew to remove film.
BUY SEVERAL NOW!
100 ft. split reels — 16mm.....\$4.50
100 ft. split reel — 16mm.....\$6.00
100 ft. split reel — 16mm.....\$7.50
100 ft. split reel — 16mm.....\$9.00

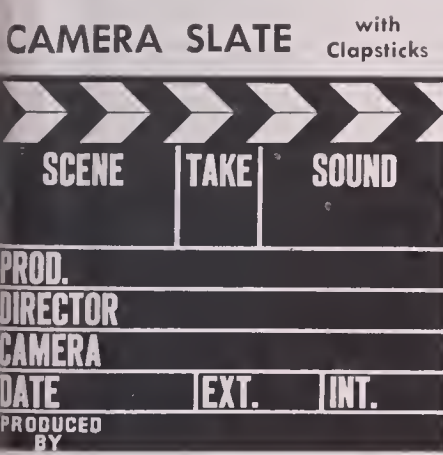
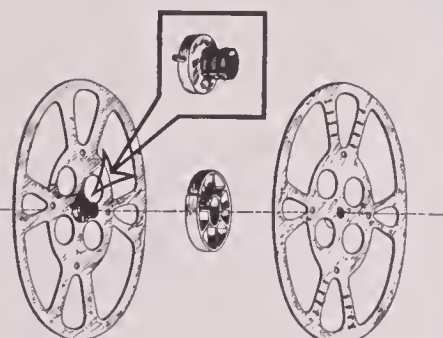

- * Easily erasable slate finish
 - * Sharp-sounding hardwood clapsticks
 - * Permanent silk-screened letters
 - * Supply of special, dustless chalk
 - * Large 11"x14" size Price \$8.75
 - * Medium 9"x11" size Price \$5.00
- (Illustrated)

Now Shoot full 15 minute TV shows without stopping or reloading. The F&B conversion includes 100 ft. magazine, extra silent take-up motor, camera insert plate for stabilization of film movement, and footage counter. Camera is not cut down; can be used with magazine for 100 ft. rolls.
Write for Brochure

Shoot Complete
15 Minute
Programs
**600 FOOT
MAGAZINE
CONVERSION
FOR 16mm
AURICON
CINEVOICE
CAMERA**

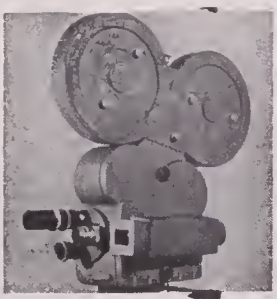

ANNOUNCING THE NEW PRECISION MAGNETIC SOUND READER ATTACHMENT FOR YOUR SYNCHRONIZER

Converts your 16/35mm synchronizer into a double-duty machine for synchronizing picture with magnetic tape in a single operation.
Write for full details.

NEW: Pro-Cine Tripod

for Auricon-Pro . . . Maurer . . . Cinevoice . . . Cine Special . . . Filmo . . . Bolex . . . Eyemo with motor and magazine . . . Arriflex 35 & 16 . . . Camerette . . . all still cameras . . . view cameras.

The F&B PRO-CINE is a brand-new, modern medium weight tripod; precision engineered and designed by cameramen for cameramen; constructed with emphasis on smooth controlled friction pan and tilt movements, ruggedly built for the utmost in rigidity and for long, satisfactory service.



FEATURING . . .

- Super-smooth friction head, unconditionally guaranteed for five years of the ultimate in pan and tilt performance.
- Telescoping two-position offset panhandle for easy adjustment to your length requirements . . . can be quickly changed to left or right position . . . offset for added comfort and convenience.
- Knurled camera-tightening knob, externally operated by angle gears for maximum, fumble-free tightening.
- Precision engineered positive pan and tilt locks for utmost rigidity and safety.
- Superb, seasoned, solid hardwood legs, beautifully finished for smooth, non-sticking telescoping action.
- All metal fittings precision machined
- One piece leg-tightening knurled knobs for quick, easy leg adjustments.

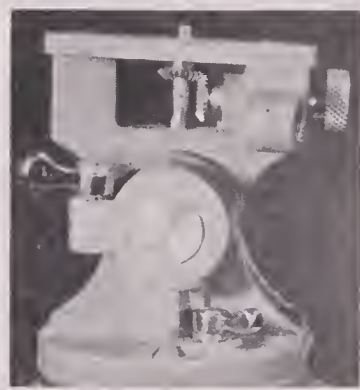

REMOVABLE FRICTION HEAD MOUNTS EASILY ON BABY TRIPOD OR HI-HAT.

Weight: 14 lbs.
Height: 41" low spread
75" high spread
Pan: 360°
Tilt: 90°

FINEST MATERIALS AND WORKMANSHIP THROUGHOUT
Friction head unconditionally guaranteed for 5 years

FREE: Fibre carrying case (value \$20.00) to first 100 buyers. LIST PRICE **\$135.00**

NOTE: Spring balanced head, adjusted to your camera, available at extra cost.

Agencies and territories now available for all F&B products for dealers and distributors.

F&B
FLORMAN & BABB
70 West 45th Street, New York 19, N. Y.
Phone: Murray Hill 2-2928
Cable Address — FLORBABB, N. Y.

F&B HAS A COMPLETE STOCK OF NEW AND USED CAMERAS, PRODUCTION, LIGHTING, EDITING & LABORATORY EQUIPMENT
Used equipment always accepted as trade-in.
EVERY ITEM SOLD IS MONEYBACK GUARANTEED
WE BUY — SELL — RENT

Simple Addition of
Sound Printing Head
Increases Output Over 30%

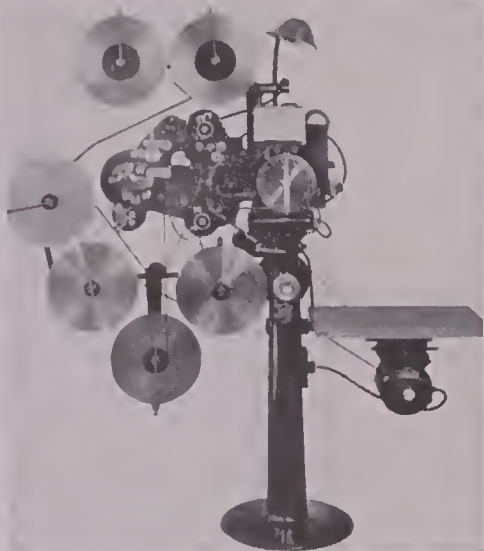

35mm-16mm Sound Printing Head, designed for your model "D" or "J" contact printer. Convert your single-head printer now into a double-head printer for high production output.

Literature On Request

MOTION PICTURE PRINTING EQUIPMENT CO.
Mfrs. of Motion Picture and Micro Film Printers
8136 NORTH LAWDALE AVENUE • SKOKIE, ILLINOIS

RUBY CAMERA EXCHANGE
Rents . . . Sells . . . Exchanges

Everything You Need for the
Production & Projection

of Motion Pictures Provided
by a Veteran Organization
of Specialists

35 mm. . . . 16 mm.
Television

IN BUSINESS SINCE 1910

729 Seventh Ave., New York 19, N. Y.
Tel.: Circle 5-5640
Cable address: RUBYCAM

SURPLUS AIR BLOWERS
SUTORBILT 2M STYLE



Impellers 2" wide. 1" pipe size inlet and outlet. Approximately 20 cu. ft. per minute at 2, 3, 4 or 5 lbs. pressure. 1/2 h.p. required at 4 lbs.

Not \$150.00
ONLY \$40.00

Send 25c for our new 24-page catalog of processing machines and parts.

METAL MASTERS

5599 University Ave., San Diego 15, Calif.

dolly shots can be made simply and easily by employing any one of a number of vehicles such as a child's express wagon, a tricycle, or other four-wheeled toy. Some very successful dolly shots have been made by movie amateurs who mounted the camera on a carpet sweeper for a low-angle travel shot. Still other methods include holding the camera while sitting astride the hood of the family car, as it is driven in the desired direction, or setting up the camera in a rowboat for a smooth shot on water.

Remember, just about everything mechanical and solid that moves may be used for a moving camera shot in some way. So if you want to try a shot or two just to see what a difference moving camera shots make on the screen, follow one of these suggestions. Later, you are sure to buy or build a dolly. Your local camera store can probably supply one to suit your needs, or get it for you.

MAKES NEWS LIVE

(Continued from Page 442)

use natural lighting whenever it helps him get action he couldn't capture otherwise. Often he's willing to sacrifice detail for the over-all impression.

"It's the news we're after," he says. "In this business, that comes ahead of technical perfection."

Gray cites the coverage of a beauty contest as an example. All eyes are on the winner as she walks across the platform to receive the prize. All eyes except the photographer's. He sees the adoration on the face of a young girl spectator as she gazes up at the new queen. He swings his camera around almost automatically, switches focus in an instant, and captures the kind of human interest shot that can't be posed. He does, that is, if his camera is loaded with

New Accessories For Film Printers

SPECIAL EQUIPMENT designed to increase production and improve the quality of prints, particularly in color productions, for users of Bell & Howell motion picture printers is now being marketed by the Motion Picture Printing Equipment Company, Skokie, Ill.

The company offers a Sound Printing Head which, when added to Models J and D Bell & Howell contact printers, permits printing both picture and sound track simultaneously in one operation, using separate picture and sound negative. Quality prints are insured by printing the sound track on a precision sound drum.

The Peterson Automatic Fade attachment is another accessory which the company offers for use on the B & H Model J printer. It is easily installed. Fades are made by a shutter mechanism which permits increasing or decreasing light at a uniform rate. Fade length can be varied from 20 to 180 frames.

A third accessory offered by the company eliminates the need to edgenotch film for changing the printer light control. New device provides electronic control of the printer light and is actuated by magnetic cueing spots applied to edge of film. The unit has two independent channels that permit dual control of printer light and filters by placing cue marks on both sides of film. An actuating head (2 in photo below) having proper rollers has been designed especially for Bell & Howell printers.

The company has also developed an Automatic Light Control Shutter for installation in a Bell & Howell printer, which permits changing the light intensity by a shutter instead of through altering the electrical resistance.

Descriptive literature on all of the above named accessories may be had by writing the company at 8136 North Lawndale Avenue, Skokie, Illinois.



FILM PRINTING equipment developed and manufactured by Motion Picture Printing Equipment Co.; 1) Electronic independent 2-channel relay; 2) Actuating head for B&H printer where electronic cueing of light changes replaces old notching method; 3) iron oxide paint used to spot films scenes to effect electronic cueing; 4) arrows point to cueing spots applied to edge of film for printer light cues; 5) arrows point to old method of notching film for activating printer light changes.

a film that can penetrate the shadows.

For inside work, Gray prefers day light from a window. He uses Type 931 film with a large stop opening, careful focusing and controlled long development. In the absence of a window, fluorescent lighting is the next best source. On occasion, ordinary light bulbs must be used.

The Texas photographer has obtained excellent closeups with a 75-watt bulb as much as five feet away from the subject. He has taken what he considers acceptable shots with only a 60-watt bulb six feet overhead. And he takes long shots as well as close-ups in a crowded courtroom where there are only a dozen 100-watt bulbs 12 feet overhead.

Even with overdevelopment, however, Gray finds some existing light scenes that come up without enough contrast. But if there's a sharp enough image—and the film is newsworthy enough to be used—television engineers can adjust electronic contrast controls to make the picture appear more contrasty on home TV receivers.

The natural lighting technique is not new. It has been used in still photography from the earliest days. But there time exposures made it possible. Now, thanks to the speed of films like Du Pont Type 931, the technique can also be applied to motion pictures.

Through proper use of fast film and a willingness to tread fresh paths in news photography, Bob Gray and KPRC-TV are doing their part to create a better informed community.

Reprinted from Du Pont Magazine, August-September, 1954.

HANK McCUNE TV SERIES

(Continued from Page 447)

ly light tripod instead of a dolly or other type of mobile support commonly used on the sound stage. Quick shifts of camera and tripod to a new setup are thus effected without the need for more than one camera crewman. With the production company thus streamlined, it can wrap up a single show in 3 days, or two in a week.

Power for set illumination for color productions is always a big cost factor. But by using incandescent lamps exclusively, Allan is able to use current supplied by the local power and light company, thus dispensing with the need for a generator and a crew to operate it.

Where a strong light is required to produce sharply defined shadows, as for a venetian-blind effect on walls, etc., Allan simply removes the Fresnel lens from a 10-K lamp and directs the strong light beam on the blind or wall. Or-

PETERSON OPTICAL PRINTER

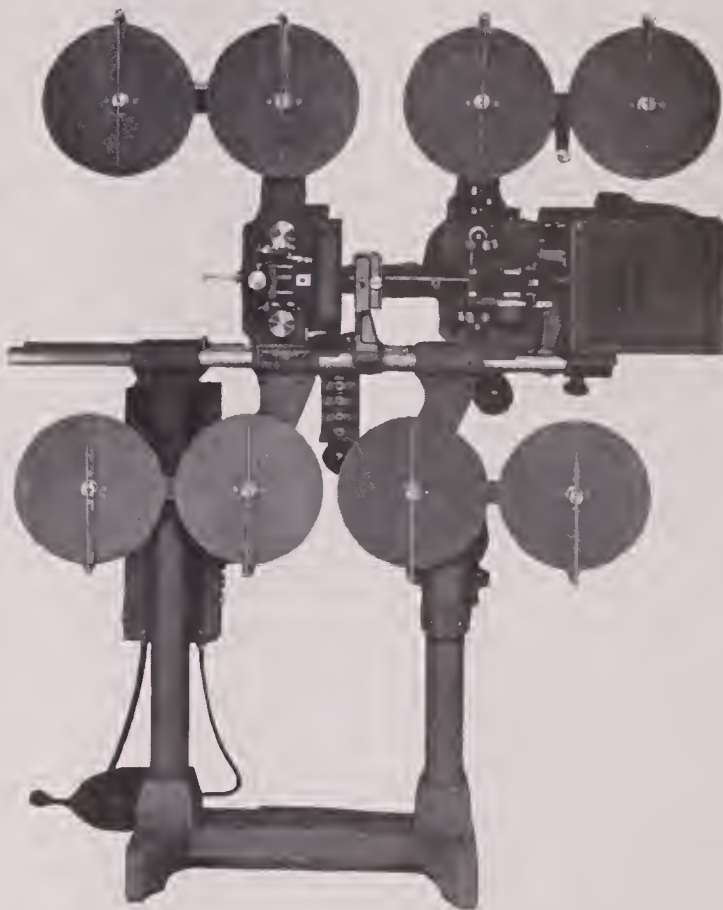

MODEL 300

FOR HIGHEST QUALITY PICTURE REDUCTION PRINTING

- Reduction Printing from 35mm to 16mm
- Enlarging from 16mm to 35mm
- Contact Printing 16mm to 16mm
- Contact Printing 35mm to 35mm
- Fully Automatic Fade can be provided

LITERATURE SENT ON REQUEST

MOTION PICTURE PRINTING EQUIPMENT CO.

Mfrs. of Motion Picture and Micro Film Printers

8136 NORTH LAWNDALE AVENUE • SKOKIE, ILLINOIS

EVERYTHING PHOTOGRAPHIC

AND CINEMATIC

FOR PROFESSIONAL AND AMATEUR

The World's Largest Variety of Cameras and Projectors. Studio and Laboratory Equipment with Latest Improvements as used in the Hollywood Studios. New and Used . . . BARGAINS. Established 25 years.

HOLLYWOOD CAMERA EXCHANGE

1600 Cahuenga Boulevard

HO 9-3651 • Hollywood, Calif. • Cable Hocamex



Now! A 400ft. Magazine For Your BOLEX H-16

Complete
with
Synchronous
Motor
and Base

•
Includes
Installation
and
Case



Permits continuous run of 400 feet of 16mm film, or—the 200 ft. daylight loading spool may be used in the 400 ft. magazine. The 100 ft. daylight loading spool can be used in the camera without removing the external magazine. In black wrinkle finish to match camera. Fully guaranteed. Write for information on our Rack-Over Sparts-finder and Camera Base.

Ask your dealer to show you the demonstration sound picture showing our 400 ft. magazine in action. An interesting, informative picture.

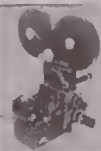

TOLEDO CINE ENGINEERING
1309 Milburn Ave. Toledo 6, Ohio



Reversal PROCESSING

Reversal specialists for over a decade. Our long experience insures superior quality. Electronically controlled machines keep temperature constant within .2 of one degree. National "Brilliantone" Cine prints are the finest available. Write for free catalogue.

CONTACT PRINTING B & W DUPLICATING
WORK PRINTS KODACHROME DUPLICATING
EDGE NUMBERING VACUUMATING

All work veporated at no extra charge

NATIONAL CINE LAB
Box 4425 Washington 17, D. C.

FREE! 55th ANNUAL BURKE & JAMES CAMERA, LENS AND EQUIPMENT CATALOGUE

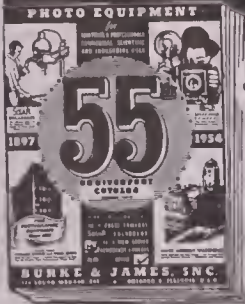

96 Pages crammed with THOUSANDS of Newest PHOTO TOOLS, CAMERAS (Press, Studio, Candid, Special Purpose, etc.), LENSES, PROJECTORS, Lighting Equipment, Developing Equip., Enlargers, etc., for Amateur — Professional in daily Scientific or Industrial work.

Write for Catalog No. 154, Mr. White, Dept.
BURKE & JAMES, Inc., 321 S. Wabash, Chicago 4, Ill

"The Finest Cameras
Deserve the Finest Care"



AUTHORIZED

Service To All Fine Cameras
ROMLE-WAHL & CO.
520 W. 7th ST.
LOS ANGELES 14, CAL.

dinarily, a powerful arc lamp would be used for this purpose.

A compromise is made between low and high key lighting in order to complement both the color film and the television black-and-white reproducing system, by employing 10,000-watt key lights and 5,000-watt skyspans, plus snoots and diffusion for fill lights. Seniors are used for back light, and "kickers" are employed in order to keep the illumination at a uniform level at all times, permitting use of the same lens stop for all shots.

Unlike so many TV film producers who confine shooting to the sound stage for economy reasons, the Hank McCune troupe shoots a great many scenes out of doors in natural locations. Here the portability of the Auricon camera and the ability to dispense with booster lights in favor of reflectors make exterior filming as economical as that indoors at the studio. To shoot shipboard scenes for a recent film, the Ted Allan company recently went aboard a Navy destroyer on maneuvers off the coast of San Diego. The small technical crew required along with the compactness of the camera and grip equipment made this assignment an easy one.

In addition to the Hank McCune series, the Ted Allan Studio has several other television productions, including two unique puppet shows, slated for filming in 16mm color. Included in this schedule also is a dramatic series to be produced at the rate of six 15-minute shows a day.

The use of the Auricon 16mm "Super 1200" camera for filming the Hank McCune TV films in color, highlights the strong trend toward all-color 16mm film production for the fast-growing demands of the television industry.

SYNC SOUND

(Continued from Page 445)

ground. Its message is directed at what over here we call "the man in the street," and our problem is to keep the thing interesting and alive throughout its forty minutes' running time.

We felt that our story had to be carried by five or six stock characters—typical workmen who could be taken as representative of the principal trades using our product. In addition to putting over convincingly the instruction peculiar to his own trade, each character had also to be dramatically interesting. For continuity's sake there had to be a reasonable link between the workmen and this was achieved by bringing them together in that typically British rendezvous, the "local," or as it was better known to many thousands of our G.I. friends, the "pub." As they begin to

MOVIOLA

FILM EDITING
EQUIPMENT
16MM - 35MM

- PICTURE SOUND Photo and Magnetic
- SYNCHRONIZERS
- REWINDERS

One of the new series 20 Moviolas for picture and sound.

Write for
Catalogue

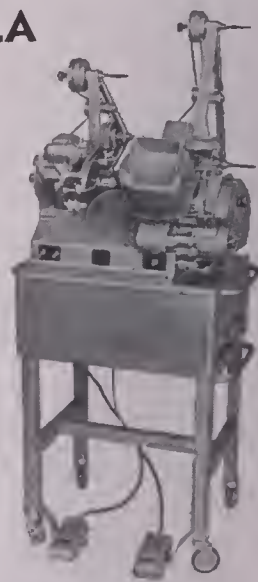

MOVIOLA MANUFACTURING CO.

1451 Gordan St. • Hollywood 28, Calif.

AUTOMATIC DAYLIGHT PROCESSING

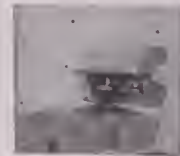

DEVELOPING TANK

- Processes up to 200 Ft.
- 8mm-16mm-35mm
- Movie—X-Ray—Microfilm
- Motor Driven, Portable
- Tough Plastic Tanks
- Uniform Density Assured
- 70mm tank also available



FILM DRYER

- Motor driven—Heated
- Speedy drying
- Automatic shrinkage allowance
- Stainless steel and aluminum construction
- Easily assembled without Tools
- Compact, Portable

Guaranteed. Write for Free Literature

MICRO RECORD CORP.

Dept. AC, 487 South Ave., Beacon, N. Y.

WORLD FAMOUS

S-5

synchronous
magnetic film
recorder for
motion pictures
and television



STANCIL-HOFFMAN

921 N. Highland Hollywood 38, Calif.

send
for
particulars

To Sell

THE MOTION PICTURE INDUSTRY

YOU

NEED

AMERICAN

CINEMATOGRAPHER

AMERICAN CINEMATOGRAPHER reaches all fields of 35mm and 16mm motion picture production—

- Major Hollywood Studios
- Television Film Producers
- Industrial Film Makers
- Educational Film Producers
- Amateur Movie Makers
- Film Laboratories
- Foreign Film Producers (67 countries)

Why be satisfied with anything less?

Write For Advertising Rates

talk of their own particular interest in the art of sharpening we dissolve to the workshop or the farm and illustrate the dialogue with instructional scenes. After each instructional sequence we cut back, of course, to the pub for a little light relief—by no means a new device but still a good one for preventing pictures like this from becoming static.

The building of the pub set was no embarrassment to us for we have an excellent studio with adequate lighting gear and most of the equipment necessary to the kind of film we normally produce. But we could hardly justify the heavy capital expenditure for synchronous recording apparatus, which would only be used once in a blue moon, anyway. For the instructional sequences there was no recording problem since these required nothing more than the addition of the usual "wild" commentary. The pub was a different matter for there we had to have live dialogue, a new experience for our small unit. We owned, however, a first-rate disc recorder capable of really good sound quality and this was pressed into service. In trying to run the discs in sync with our Cine Kodak Special cameras we encountered all the anticipated difficulties—and several new ones! But as so often is the case we finally found that the simplest method was the best.

Believe it or not, we dispensed with all forms of interlock and operated disc recorder and spring-driven camera independently of each other. Here is what actually happens on the set: With the scene rehearsed and everyone ready for a take, the sound-man starts his recorder and when satisfied that he is cutting properly, calls, "Sound OK!" This is for the cue for the camera to start and for the clapper-boy to announce and mark the scene. Action then begins and at the end of each take the clapper-boy again steps in to mark its conclusion.

Once a sequence is shot and recorded the discs are sent away for dubbing on to film and here, of course, is the problem of tight synchronization. Our own solution involves the careful use of a "click-track" which is made immediately before shooting begins. We take a roll of spoiled but unprocessed film and mark every twenty-fourth frame with an easily-seen cross, then load it into the camera. The camera itself is set to run as close as possible at twenty-four frames per second although, in fact, this need not be anything like accurate. Constant speed is the important thing here and in this respect we find the Special is excellent.

With the lens removed and the recording microphone placed close at hand we start camera and recorder, closely watching the gate. As each cross flashes into view, we tap out a sharp signal—



Illuminate all important sets and stages
Lighting STANDARD BEARERS of Photography

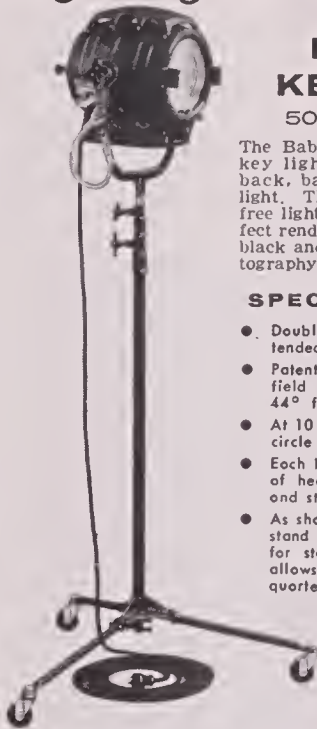

BABY KEG-LITE
 500-750 Watt

The Baby Keg is ideal as a key light, modeling light, back, background, and fill light. The intense filament free light delivered gives perfect rendition of tone in either black and white or color photography.

SPECIFICATIONS

- Double riser stand can be extended from 4 ft. to 9 ft.
- Patented device focuses light field from a 4° spot to a 44° flood.
- At 10 feet on full flood, light circle is 9 ft.
- Each light equipped with 25' of heavy duty rubber cable and standard house plug.
- As shown below, structure of stand permits folding of legs for storage. Angular design allows clearance for close-quarter grouping.

\$81.00

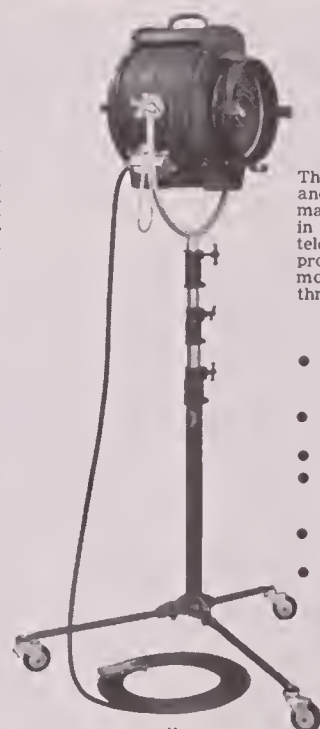

JUNIOR SPOT
 1000-1200 Watt

The high intensity, even light field and ample coverage of this unit make it a superior light for use in all types of photographic or television work. Its popularity has proven its value among still and motion picture photographers throughout the world.

SPECIFICATIONS

- Half turn of focusing knob changes light from 4° spot to 44° flood.
- At 12 ft. on full flood, light circle is 10 ft. in diameter.
- Stand extends from 5 ft. to 9 ft.
- Supplied with 25 ft. No. 14 rubber cable with shock-proof stage plug.
- Folding legs on stand with 3" casters.
- Angular structure of stand legs permits close grouping.

\$178.60



Write for catalog "PAINT WITH LIGHT" describing our complete line and price list.

BARDWELL & McALISTER, INC. BURBANK, CALIFORNIA

TITLES and SPECIAL EFFECTS

Motion Picture or Television, 35mm-16mm, Black & White or Color

RAY MERCER & COMPANY

4241 Normal Ave., Hollywood 29, California

NOrmandy 3-9331

We Welcome
Your Problems

RAY MERCER, A.S.C.

30 Years Experience
at Your Service . . .



GEO. W. COLBURN LABORATORY INC.
164 NORTH WACKER DRIVE • CHICAGO 6
TELEPHONE STATE 2-7316

**8 and 16mm
SERVICES**

Ready-Eddy
U. S. Registered Trademark
**USEFULNESS GUARANTEED
FOR EVERY DAY USE**

1001 Ready Sound-Film
Editing Data:
• Footage • Frame
Count • Screen Time
• 35mm and 16mm
equivalents.
Plastic computer for
everyone in movies
and TV, from script to
screen.



\$2.00 Prepaid
(Delivered in U.S.A.)
**ASK FOR REPRINT OF ARTICLE
IN AMERICAN CINEMATOGRAPHER.**
Write or ask your dealer
READY-EDDY, Sandy Hook, Conn.

PELLEGRINI
**VARIABLE SHUTTER UNITS
FOR THE BOLEX H-16**



The real answer to complete Fades and LAP DIS-
SOVLES. Faster shutter speeds
and many other advantages.
Prices within U. S. \$99.60.
Cameras with outside frame
counter \$109.80. Tax extra.
One year guarantee and cam-
era transportation back in-
cluded. Send for free infor-
mative booklet.
Prices subject to change
without notice.
TULLIO PELLEGRINI
1545 Lombard St.
San Francisco 23, California

Scheibe FILTERS
In World-Wide Use

Produce moonlight and night effects
in daytime • fog scenes • diffused focus
and many other effects.
Information mailed on request.

SCHEIBE FILTERS COMPANY
ORIGINATORS OF EFFECT FILTERS
P.O. Box 46834, Hollywood 46, Calif.

USED IN EVERY
HOLLYWOOD
MOVIE PICTURE
PRODUCTION

using, in our own case, a metal pencil tapped on a slate—which is picked up and recorded on disc. It follows that so long as the resulting disc is played back on a turntable running at the same speed as the recorder, we shall have an audible and reasonably accurate record of the camera speed. This “click-track” can also be readily matched to the speed of the sound-camera used for dubbing. A little thought will show that it is not even important that the picture-camera and sound-camera are running at the same speed nor that the recording table and the dubbing-playback-table should do so. So long as the click-track is brought into line with the sound-camera, all recordings made at the original speed (of the click-track) will be in reasonably close sync with the picture.

In practice, we found the maximum error between picture and sound-track was about eight frames in a twenty-foot shot. Our method of correcting this is to locate and mark four fairly equally-spaced silent points on the track and at each point to cut out two frames or add two frames of buzz-track, according to whether the track is longer or shorter than the picture film. Obviously, there are serious disadvantages in the method and that even lacking regular equipment vast improvements could be made using synchronous motors and/or the more modern and flexible tape. But that was a case where the normal run of our present work would not justify the installation of costly recording equipment and we were anxious to make the best of what we had.

As a matter of fact, the only additional piece of apparatus we couldn't do without was a blimp for the Special, and as there was great difficulty in importing one, we made our own. On the credit side we managed to get excellent sound quality. Lip-synchronization is close enough—certainly closer than could have been expected from the players post-synchronizing the lines against their own lip movements on the screen.

I mentioned that practically all our work is on Kodachrome. For the pub scenes we used a lighting load of about 12-kw., which allowed us to work around f2.4. In order to simulate the essentially “warm” atmosphere of the English pub, we shot everything through a Wratten 81B filter which, without increasing exposure, effectively lowered the color-temperature of the lighting to give us what we needed.

Naturally, we had our difficulties. The cast of six, headed by a well-known British screen actor, were only jointly available over one particular week-end, which meant shooting 120 scenes including closeups and cover shots (about thirteen minutes' screen time) in something like twenty-two working hours. We

can think of quieter ways of spending a week-end but — so what? There's still a lot of fun to be had making pictures. Especially when your sound equipment can't possibly work — and does!

HIGH-SPEED PROCESSOR

(Continued from Page 451)

throughout and all solutions are automatically temperature-controlled.

The dry-box, of unusual design, holds only 33 feet of film, which is rapidly dried after leaving the final wash, in a turbulence of air heated to a temperature of 140° F. The unique design of this segment of the processor imparts a swirling motion of air at the point of entry in the drying compartment and all moisture-laden air is forced out.

Model R-TV has seven tanks; a 1200-foot film magazine which takes loading spools of the film 50, 100, 200, 400 or 1200 feet in length, just as they come from the camera; a re-circulating pump for the first developer; and agitation for bleach, clearing bath, and second developer. A quiet, rotary-type air compressor supplies filtered air for the squeegee and solution agitation. Day-light operation is entirely automatic and requires only limited supervisory attention by one employee.

HIGH-SPEED FILMING

(Continued from Page 448)

mately to low, average, and high dental operating speeds. One-hundred-foot rolls of 16mm black-and-white reversal film traveled through the camera in from 0.8 to 1.25 seconds. About one-third of this period was utilized by the camera in building up to top speed. The action recorded on the film was extended for study to approximately three minutes by projection at 24 frames per second.

Adequate magnification was obtained by attaching to the camera an 8-inch extension tube containing an f/4.0 6-inch telephoto lens and a 2-diopter supplementary lens. The extension tube reduced the indicated f/ stop of the lens to an effective aperture of f 9.2. A high-intensity light source of eleven 750-watt pre-focused floodlamps was required for the 3,000-fps camera because of this small aperture and an exposure time of 1/15,000th second per frame. Additional illumination was needed for the faster cameras, since the exposure was only 1/35,000 second for the 7,000-fps camera and 1/70,000 second for the 14,000-fps camera. This illumination was provided by four 1000-watt photo spotlights with parabolic reflectors. Their light was further concentrated by means of 2-diopter condensing lenses four inches in dia-

Film Editing Made Easy
with NEW
**professional
film viewer**

for 35mm and 16mm

Every film editor will appreciate a viewer that enables him to view his film from left to right—on a large, brilliantly illuminated screen.

The PROFESSIONAL FILM VIEWER makes film editing a breeze. Easy threading, portable, will not scratch film. Put this viewer between your rewinders and speed up your editing. Size of Viewing Screen 5¾ x 4¾.



35mm Model \$375
16mm Model \$350



Write Dept. A-9-4

meter. Thus, over 300,000 foot candles of light was focused on an area of two square inches. The short interval of time involved in turning on the lights, energizing the camera, and turning off the lights prevented any damage to the specimen or equipment from heat.

Much can be learned regarding the operation of the bur blades through observation of the slow-motion films projected on a screen. For more detailed study of individual frames, enlargements are made either from the 16mm film on direct-positive paper or from negative film, which is used in the cameras when print studies are desired.

The photographic evidence shows that, with very few exceptions, all burs studied were intermittent cutters because of eccentricity and irregularities in blade formation. Chip formation is revealed in detail as the individual bur blades pass through the excavation in the tooth material. A chip that is formed by one type of blade may break away from the parent substance and strike the blade ahead, thus causing clogging. Fine, pulverized chips, produced by a bur which is cutting ineffectively or which is rotating at too low a speed, are seen to follow the vortex of air created by the revolving bur until they are carried back into the excavation. However, the slow-motion

(Continued on Page 469)

C. ROSS

FOR

LIGHTING EQUIPMENT

**Inkie and Arc Lamps including Required Accessories
Generators—Cables—Boards—Boxes**

Raby Camera Crane—Dollies—Blimps—Geared Heads

GRIP EQUIPMENT

FOR LOCATION AND STUDIO

**Parallels—Steps—Platform Ladders
Century Stands—Reflectors—Flags—Scrims**

SOLE EASTERN MOLE-RICHARDSON CO. DISTRIBUTOR

RENTALS • SALES • SERVICE

CHARLES ROSS, Inc.

333 WEST 52nd STREET

NEW YORK 19, N.Y.

Circle 6-5470-1

HOLLYWOOD STUDIO PRODUCTION

Feature and television film productions for which members of the American Society of Cinematographers were engaged as Directors of Photography during the past month.

AMERICAN SOCIETY OF CINEMATOGRAPHERS

FOUNDED January 8, 1919, The American Society of Cinematographers is composed of the leading directors of photography in the Hollywood motion picture studios. Its membership also includes non-resident cinematographers and cinematographers in foreign lands. Membership is by invitation only.

BOARD OF GOVERNORS—1954

ARTHUR MILLER, President
SOL HALPRIN, First Vice-President
JOSEPH RUTTENBERG, Second Vice-President
ALFRED GILKS, Third Vice-President
WALTER STRENCE, Treasurer
PHILIP TANNURA, Secretary
ROBERT DE GRASSE, Sergeant-At-Arms
JOHN ARNOLD
JOSEPH BIROC
ARTHUR EDESON
GEORGE FOLSEY
LEE GARMES
VICTOR MILNER
HAL MOHR
LEON SHAMROY

ALTERNATE BOARD MEMBERS

ARTHUR ARLING
LUCIEN BALLARD
DAN CLARK
PAUL EAGLER
FARCIOT EDOUART
ERNEST LASZLO
ROBERT PITTACK
JOHN SEITZ
JAMES VAN TREES
PAUL VOGEL

ALLIED ARTISTS

SAM LEAVITT, "Annapolis Story," Technicolor.

WILLIAM SICKNER, "Ketchikan."

ELLSWORTH FREDERICKS, "Shotgun."

COLUMBIA

LESTER WHITE, "Women's Prison."

METRO-GOLDWYN-MAYER

ARTHUR E. ARLING, "The Glass Slipper," Eastman color, wide-screen.

WILLIAM MELLOR, "Bad Day at Black Rock," Technicolor, wide-screen.

PAUL VOGEL, "Jupiter's Darling," Eastman color, CinemaScope.

JOSEPH RUTTENBERG, "The Prodigal," Eastman color, CinemaScope.

ROBERT PLANCK, "Moonfleet," color, CinemaScope.

PARAMOUNT

ROBERT BURKS, "To Catch A Thief," Technicolor, VistaVision.

DANIEL L. FAPP, "Blue Horizons," Technicolor, VistaVision.

LIONEL LINDON, "Lucy Gallant," Technicolor, VistaVision.

R.K.O.

JOSEPH LA SHELLE, "The Conqueror," Color, CinemaScope.

20TH CENTURY-FOX

LUCIEN BALLARD, "White Feather," Technicolor, CinemaScope.

MILTON KRASNER, "Desiree," color, CinemaScope.

JOE MACDONALD, "The Racers," color, CinemaScope.

LEO TOVER, "Untamed," Technicolor, CinemaScope.

LEON SHAMROY, "There's No Business Like Show Business," color, CinemaScope.

CHARLES G. CLARKE, "Prince of Players," color, CinemaScope.

UNIVERSAL-INTERNATIONAL

WILLIAM DANIELS, "Foxfire," Technicolor, wide-screen.

IRVING GLASSBERG, "Captain Lightfoot," Technicolor, CinemaScope.

GEORGE ROBINSON, "The Looters."

WARNER BROS.

ELLIS CARTER, "The River Changes," Warner Color, CinemaScope.

LEE GARMES and RUSSELL HARLAN, "Land of the Pharaohs," Warner-Color, CinemaScope.

TED MCCORD, "East of Eden," Warner-Color, CinemaScope.

WILLIAM SKALL, "The Silver Chalice," WarnerColor, CinemaScope.

HARRY STRADLING, "Helen Of Troy," WarnerColor, CinemaScope.

CHARLES LANG, "Young At Heart," Warner-Color.

HAL ROSSON, "Strange Lady In Town," Warner-Color, CinemaScope.

INDEPENDENT

ROBERT SURTEES, "Oklahoma," Eastman-color, Todd-AO, CinemaScope, R & H Pictures.

WILLIAM SNYDER, "Mad At The World," shooting at Republic Studios.

RUSSELL METTY, "Crashout," Hal Chester Productions.

SAM LEAVITT, "Carmen Jones," Carlyle Productions.

STANLEY CORTEZ, "Night Of The Hunter," Gregory Productions.

ERNEST LASZLO, "The Gabriel Horn," Technicolor, Cinemascope, Hecht-Lancaster Productions.

TELEVISION

(The following directors of photography were active last month in photographing films for television in Hollywood, or were on contract to direct the photography of television films for the producers named.)

LUCIEN ANDRIOT, "Where Were You?," Ken Murray Productions; "It's a Great Life," Raydic Corp'n; "The Life of Riley," Hal Roach Studios.

JOSEPH BIROC, "Treasury Men in Action," American National Studios, Inc., and "Dear Phoebe," Dear Phoebe Productions.

WILLIAM BRADFORD, "Gene Autry," Flying A Productions.

NORBERT BRODINE, "The Loretta Young Show," Lewislor Ent.

FLOYD CROSBY, "Royal Canadian Mounted Police," S & S Films, Ltd.

ROBERT DE GRASSE, "Make Room For Daddy," Marterto Prods., Inc., and "The Ray Bolger Show," B & R Ent.

GEORGE DISKANT, "Four Star Theatre," Four Star Productions, Inc.

E. B. DUPAR, "Tim McCoy Show," Mercury-Int'l Pictures.

ELLSWORTH FREDERICKS, "The Dennis Day Show," Denmac Productions.

HENRY FREULICH, "Captain Midnight," Screen Gems.

KARL FREUND, "Willy" and "December Bride," Desilu Productions, Inc.

FREDERICK GATELY, "Mayor of the Town," Rawlins-Grant, Inc., and "Big Town," Gross-Krasne, Inc.

AL GILKS, "The Halls of Ivy," Television Programs of America, Inc.

BEN KLINE, "Fireside Theatre," "An Argument With Death," Frank Wisbar Prods.

JACK MACKENZIE, "Public Defender," Hal Roach, Jr., Productions.

ERNEST W. MILLER, "Rocky Jones, Space Ranger," Roland Reed Productions, and "Stu Erwin Show," Roland Reed Productions.

NICK MUSURACA, "The Lone Wolf," Gross-Krasne, Inc., and "Lineup," Desilu Prods., Inc.

KENNETH PEACH, "Adventures of the Falcon," Federal Telefilm, Inc.

ROBERT PITTACK, "The Lone Ranger," CM TV Productions, Inc.

JOHN L. RUSSELL, JR., "Joe Palooka," Guild Films.

WILLIAM SICKNER, "The Whistler," Lindsay Parsons Productions.

MACK STENGLER, "Liberace," "Life With Elizabeth," "Florian Zabach Show," and "Frankie Laine Show," Guild Films.

WALTER STRENCE, "Waterfront," Roland Reed Productions, and "My Little Margie," Roach, Jr.-Reed Productions.

PHILIP TANNURA, "Burns And Allen Show," McCadden Corporation.

STUART THOMPSON, "Lassie," Robert Maxwell Associates.

JAMES VAN TREES, "I Married Joan," Joan Davis Enterprises and "Hey, Mulligan," Mickey Rooney Enterprises.

HIGH-SPEED FILMING

(Continued from Page 467)

studies show a definite improvement in clearance of debris when the speed of rotation is increased from 5,000 to 10,000 rpm.

Eccentricity, evident in all but a few of the burs, causes a definite bounce as the bur cuts tooth structure. As a result, only three or four blades of an eight-bladed bur actually cut; the remaining blades are not in contact with the specimen when they pass through the excavation. Ineffective cutting is observed when a steel bur is used on human enamel; the bur rapidly dulls

and then chatters uselessly. A carbide bur is seen to cut more enamel effectively. The effect of improper design is readily observed in some carbide burs which perform very poorly even though they do not dull.

The photographic studies were combined with conventional laboratory test methods based on the weight loss of test materials when cut under controlled speeds and pressures. This combination provides a more complete approach to the study of design improvement of rotating dental cutting instruments.

RADIO CONTROLLED CINEMATOGRAPHY

(Continued from Page 451)

verted "GSAP" camera obtained from a war surplus outlet. The low cost of this magazine-load camera makes it easily "expendable" in the event it is lost or badly damaged in use. Where Commercial Kodachrome film is to be used, it becomes necessary for the user to load the magazines himself, as this film is not presently supplied in magazines.

The complete radio control unit, which includes transmitter and receiver, can be purchased from any hobby shop

or model supply dealer, and there are a number of makes to choose from. The one used by the writer is manufactured by Babcock Radio Engineering Company, Van Nuys, Calif., which company originally developed the equipment for the government as a means of controlling target drones used in anti-aircraft practice. It sells for under fifty dollars.

The equipment is also available in kits for assembly by the user, making the overall cost considerably less.

Now ready for Immediate Delivery
THE NEW PLUG-IN "MIRACLE
BUTT-WELD PRESTO-SPLICER"

Producers, Labs., Film Editors:—

New electric "butt-weld" produces miracle-fast splice for cutting negs (no picture loss), no floss, eliminating A and B film editing, for all types including color.

Presto-Splicer "Pro 3" Splices All Types Safety, Picture & Magnetic Film Permanently in 10 Seconds!

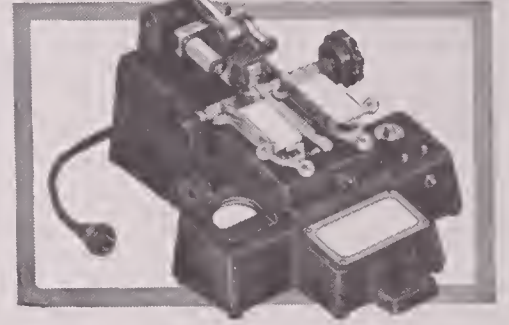

... with new
PLUG-IN HEATER BLOCK
Eliminates Down Time!

... replasticized! Eliminates drying out, no overlap, no cement or scraping, no double thickness or distortion. Guarantees perfect frame alignment. No light required.

Sample splice & brochure on request.
Adaptable to splice DuPont Cronar film.

PRESTOSEAL MFG. CORP.

3727 33rd st., Long Island City 1, N.Y.



Jack Frost lights the nation!

**MOTION PICTURE STUDIO •
THEATRICAL • DISPLAY
RENTAL EQUIPMENT**

WHEREVER YOU ARE—WHATEVER YOU NEED

... in the way of unusual, specialized lighting, call on Jack Frost! For movie-making, stage lighting, feature exhibits, large conventions ... for *any* location that requires exceptional lighting, Jack Frost is ready to serve you! And Jack Frost's unequalled national service includes complete installation and removal *wherever* you are. Rent all your specialized lighting equipment from Jack Frost ... famous for lighting the nation's greatest shows ... most spectacular displays.

**FOR FULL INFORMATION ON
RENTAL EQUIPMENT
MAIL COUPON, OR CALL
DETROIT, TRinity 3-8030**

**JACK A. FROST, DEPT. J,
234 PIQUETTE AVE.
DETROIT 2, MICHIGAN**

Please send me full information on
your rental service.

Name _____
Address _____
City _____ Zone _____ State _____

CLASSIFIED ADVERTISING

10c per word, minimum ad \$1.00. Words set in capital letters except 1st word and advertiser's name, 15c per word. Modified display format 90c per line. No discount on classified advertising. Send copy with remittance to editorial office, 1782 No. Orange Drive, Hollywood 28, Calif. Deadline 15th of month preceding date of issue.

STUDIO & PRODN. EQUIP.

SHOP AT THE ONE STOP SHOP
 SENSATIONAL KENSOL HOT LETTERING PRESS, prints dry. Complete.....\$ 681.00
 B & H AUTOMATIC FOOT SPLICERS, 35mm \$595.00, combination 16/35mm..... 695.00
 NEW OLESEN CHROMOSPOTS, SR. 5KW.....\$184.88; JR 2KW..... 92.68
 CINE SPECIAL BLIMP, custom built w/follow focus, 63mm upright image viewfinder, takes 200' magazine & syncmotor. Close Out
 MOTORIZED DOLLY with 2 seats. Takes heaviest cameras. Close Out..... 195.00
 H'WOOD ESCALATOR TRIPOD, freehead for heaviest TV or Movie Cameras, on 3 wheel dolly. \$1250 originally. Close Out..... 295.00
 CINE SPECIAL MODEL II with 1-200' chamber, 5 Kodak coated lenses, carrying case. Excellent 1275.00
 NEW MH MITCHELL type Viewfinders..... 139.50
 MOVIOLA 35mm COMPOSITE Sound/Picture complete 495.00
 MAURER 16mm NEGATIVE/DIRECT POSITIVE Recording System, Rebuilt..... 2995.00
 NEW STEPHENS WIRELESS MIKE with FM Transmitting Unit. Concealed on performer, operates 200' from camera..... 980.00
 MAURER 16mm CAMERA w/400' mag; syncmotor; viewfinder; blimp..... 3100.00
 BARDWELL-McALISTER MULTIPLE FLOODLITES, 3 Quadruple heads holding 12 bulbs on rolling tripod stand. Orig. Gov't Cost \$180.00. Surplus 29.50
 BM QUADLITE Heads only \$4.95. Stands only CENTURY 750W LEKO TV framing spotlights, \$63 value 29.50
 CINEMAPHONE 35mm DUBBING Heads, less motor 395.00
 SOS FILMETER STOP WATCH, \$29.50 value.... 13.95
 GIANT METAL FILM CABINETS, hold 120 assorted 16mm reels. \$240 value. New..... 171.00
 EASTMAN AUTOMATIC FILM WAXER, \$1200 value, Rebuilt 795.00
 DUPLEX 16mm STEP PRINTER, pilot pins, automatic light changer. Recond..... 1995.00
Trades Taken. Phone PL 7-0440 Dept. Fc
S.O.S. CINEMA SUPPLY CORPORATION
 602 W. 52nd Street, New York 19.

FOR SALE

ALL GUARANTEED LIKE NEW!
 2" TAYLOR HOBSON F1.4.....\$ 95.00
 4" T.H. COOKE T2.5 125.00
 6" COOKE TELEKINIC F4.5..... 79.50
 BOLEX PAN CINOR ZOOM LENS..... 198.00
 BOLEX GUIDE 1.75
 BAIA 16MM EDITOR COMPLETE..... 39.50
 CRAIG BMM ACTION VIEWER..... 37.95
 (MAIL ORDERS FILLED PROMPTLY)
CAMERA CRAFT
 18 East 42nd Street New York 17, N.Y.

35MM STANDARD BELL AND HOWELL STUDIO CAMERA, silenced shuttle, four 400-foot magazines, Bi-Pack magazine, and Bi-Pack shuttle silenced. Bell and Howell shift-over tripod gear operated, good home-made blimp, B & L lenses: 32mm, 40mm, 50mm, 75mm and a 100mm Zeiss. Also frame counter, matte box, and finder. A good used outfit. Well worth \$1250.00. Write C. L. VENARD, Peoria 2, Illinois.

WALL S. S. 35MM. SOUND CAMERA

COMPLETE with Galvanometer, amplifier, portable power supply, 40-50-75 and 100mm. lenses, erect image viewfinder, complete front attachments, two 1000 ft. magazines, Balanced Tripod, necessary carrying cases. Overhauled. Guaranteed perfect. Reasonable.

CAMERA EQUIPMENT COMPANY
 1600 Broadway New York 19, N. Y.

CINE SPECIAL with four-lens turret. 15, 25, 50 and 150mm lenses. Par magnifying focuser, special Meier-Handcock finder with turret, 400-foot magazine and 200-foot magazine, Jr. Professional tripod. Excellent condition. \$1150.00. Write C. L. VENARD, Peoria 2, Illinois.

LATEST model 1200' Auricon complete with amplifier, tripod and two matched Baltar lenses, perfect condition, list \$5,724.00, available immediately at 20% off. NATIONAL VIDEO PRODUCTIONS, INC., 105 11th Street, S.E., Washington, D.C.

BOLEX STEREO H-16 DeLuxe 16mm camera, close-up device, projector lens, screen, case, 25 viewing glasses. Excellent. Lists- \$783.00. Sale: \$530.00. WOLFE STUDIO, Box 332, Butler, Pa.

FOR SALE

BASS . . . is headquarters for Arriflex 16; the new Zoomar 16; Cine Specials, all models; Bell & Howell 70-DL; Bolex H-16. Used Cine Special I, 1" F:1.9 lens and carrying case \$395.00; Used H-16 Bolex, 1" F:1.5, 0.7" F:2.5 W.A., 3" F:3.5 \$347.50 Used Bell & Howell 70-DA, 1" F:1.9, 4" F:4.5 \$235.00. Used Bell & Howell 70-A, 1" F:3.5 and case \$52.50; Used 200' Chamber Cine Special \$295.00; Used 100' Chamber, Cine Special \$117.50. Best buys . . . Best trades always. BASS CAMERA CO., Dept. AC, 179 W. Madison St., Chicago 2, Ill.

AUDIO AKELEY single system camera complete with Akeley sound head, Gyra tripod, 3 lenses, view finder, Maurer mixing amplifier. Complete with cables, power supply and W. E. microphone. CAMERA EQUIPMENT CO., 1600 Broadway, New York 19, N.Y. Cable Cinequip.

WE BUY, SELL AND RENT PROFESSIONAL AND 16mm. EQUIPMENT, NEW AND USED. WE ARE DISTRIBUTORS FOR ALL LEADING MANUFACTURERS. RUBY CAMERA EXCHANGE, 729 Seventh Ave., New York City. Established since 1910.

ARRIFLEX 35mm. camera, 3 lenses, filters, sunshade, tripod, case. Complete for quick sale . . . \$795.00. Write P.O. Box 312, Ridgewood, N.J., or phone Allendale, N.J. 13046.

COMPLETE 35mm Reeves Recorder, 100-foot B and H magazine, with interlocking motors, microphones, amplifier, trunks, cables, and all accessories. Capable of making excellent sound. Write C. L. VENARD, Peoria 2, Illinois.

MAGNECORDER, Rangertone Sync Head, Pt-6 Amplifier and Recorder with 3-pot mixer. Excellent condition. Includes cables and mike. \$550.00. TV COMMERCIAL FILMS, 1215 N. Copia, El Paso, Texas.

CINE SPECIAL Model 1, complete with lens and 100-foot magazine. Perfect. First \$200. ARTHUR GASKILL, 179 East Emerson Street, Melrose, Mass.

WANTED

IMMEDIATE CASH PAYMENT FOR CAMERAS AND EQUIPMENT

NEED EYEMOS (SINGLE LENS AND TURRET), MITCHELLS, ARRIFLEX, DE BRIES, B&H STANDARDS AND HI-SPEEDS, WALLS, AKELEYS, CINE SPECIALS, AURICONS, MAURERS, FILMOS. ALSO BALTARS, COOKES AND OTHER LENSES. SOUND STAGE, LABORATORY AND EDITING EQUIPMENT OF ALL TYPES REQUIRED. PLEASE SHIP INSURED OR FORWARD DESCRIPTIONS AIRMAIL. IMMEDIATE PAYMENT.

GORDON ENTERPRISES • 5362 N. Cahuenga
 NORTH HOLLYWOOD, CALIFORNIA

JUST KEEPS ROLLING ALONG YE OLDE SOS TRADING POST

BUY — SELL — SWAP — CONSIGN

Cameras, Dollies, Lenses, Lights, Moviolas, Printers, Recorders, Studio or Laboratory Equipment

Western Union-WUX New York
 Phone PL. 7-0440

S. O. S. CINEMA SUPPLY CORPORATION

Dept. Fc Cable: SOSOUND
 602 W. 52nd Street New York 19, N. Y.

WANTED

Mitchell — Akeley — B & H — Wall — Eyemo
 Cameras — Lenses — Equipment
NATIONAL CINE EQUIPMENT, INC.
 209 West 48th St. New York, N.Y.

HOUSTON Fearless 16mm continuous film processor for black-and-white negative and print stock, not reversible. UNIVERSITY OF CALIFORNIA, Reference 1J 46, Box 5190, Metropolitan Station, Los Angeles 55, California.

WANTED—A good used 35mm outfit, Akeley or Bell & Howell standard camera. State condition and price. P.O. BOX 121, Niles, Ohio.

WANTED

WANTED TO BUY FOR CASH

CAMERAS AND ACCESSORIES

MITCHELL, B & H, EYEMO, DEBRIE, AKELEY ALSO

LABORATORY AND CUTTING ROOM EQUIPMENT

CAMERA EQUIPMENT COMPANY

1600 BROADWAY, NEW YORK CITY 19

CABLE: CINEQUIP

WANTED

PRODUCTION EQUIPMENT, LABORATORY EQUIPMENT, EDITING EQUIPMENT, 16mm. and 35mm. FROM SINGLE ITEMS TO COMPLETE STUDIOS. TRADES ACCEPTED.

THE CAMERA MART, INC.

1845 Broadway Circle 6-0930 New York 23, N.Y.

F & B PAYS MORE FOR USED 16/35MM EQUIPMENT

WRITE — WIRE — PHONE

FOR OUR CASH OFFER

FLORMAN & BABB MU. 2-2928
 70 W. 45TH ST. NEW YORK 36, N.Y.

CAMERA & SOUND MEN

ASSIGNMENTS FOR INDIA or nearby territories for any type of films, 16 or 35mm, B&W or Color, write to KANU PATEL, A.R.P.S., The Clarion Productions, 34, Park Mansions, CALCUTTA-16.

WANTED ASSIGNMENTS in Japan Production or Background Footage Contact. TOM MATSUMOTO, IATSE 665, #1 Hiroo-Cho, Azabu, Minato-Ku, Tokyo, Japan.

COLOR SLIDES, PHOTOS & FILM

PREPARED MOVIES OF HAWAII, 16mm-8mm Kodachrome. Write for free literature. HAWAIIAN FILMS, LTD., 226-A Lewers Road, Honolulu, Hawaii.

LABORATORY & SOUND

SOUND RECORDING at a reasonable cost. High Fidelity 16 or 35. Quality guaranteed. Complete studio and laboratory services. Color printing and lacquer coating. ESCAR MOTION PICTURE SERVICE, INC., 7315 Carnegie Avenue, Cleveland 3, Ohio. Phone ENdicort 1-2707.

KODACHROME duplicates: 16mm 10c per foot, mail orders accepted, satisfaction guaranteed. COLOR-VISION FILMS, 122 N. Macray Ave., San Fernando, California.

LOW cost 16mm sound recording—picture and magnetic sound editing. EL RANCHO AUDIO, 26236 Fairview Ave., Lomita, California. Davenport 6-4925.

POSITIONS AVAILABLE

OPENING for man fully experienced in assembly and servicing of European high precision motion picture printing and developing machines. Must be able to weld Vinidur, Box 1190, AMERICAN CINEMATOGRAPHER.

To Classified Advertisers

Copy deadline for classified advertising is the 15th of month preceding publication date. Mail copy and remittance to cover cost to

AMERICAN CINEMATOGRAPHER

1782 No. Orange Dr.
 Hollywood 28, Calif.

The letters "A.S.C." are rendered in a large, bold, black serif font. Each letter is separated by a small black dot. The entire logo is enclosed within a thick, black, rounded rectangular border.

A.S.C.

Hallmark Of Superior Cinematography . . .

Since 1919, the initials "A.S.C." after the names of cinematographers in credit titles have identified the men who have photographed Hollywood's best motion pictures. Today, as they have for over thirty years, discerning producers in every field of film production demand the experience and artistry of members of the American Society of Cinematographers—the "A.S.C."

you've been waiting for

bold, clear, alive!



Henri Toulouse-Lautrec,
pioneer of commercial color.

"Life-like color," the ultimate in the reproduction of color film, is now available to all producers of 16mm motion pictures. Now you can have your exposed film duplicated with perfect blending and balancing of tones. Your release prints will have a sensitive living quality...surpassing anything you have ever seen in clarity.

This is "Life-Like Color," the result of fifteen years of exhaustive research by the country's outstanding color engineers and technicians. It is now available to you exclusively through the laboratories of Telefilm Studios.

With "Life-Like Color," Telefilm Studios again contributes to its primary objective...to help the 16mm producer make better motion pictures. Telefilm's modern facilities and equipment for color printing...high fidelity sound recording (your choice of optical or electronic sound printing)... editing...titling...special effects...and the skill and the know-how of the finest technicians in the industry are at your command.

*for complete information, visit Telefilm Studios,
or write for a descriptive brochure.*

TELEFILM STUDIOS INC.

estab. 1938

6039 HOLLYWOOD BLVD. • HOLLYWOOD, CALIF.
telephone HOLLYWOOD 9-7205

AMERICAN

OCTOBER • 1954

Cinematographer

THE MAGAZINE OF MOTION PICTURE PHOTOGRAPHY



This Issue ...

- FILMORAMA—CINEMASCOPE IN 16MM
- TODD-AO—NEWEST WIDE-SCREEN SYSTEM
- IMPORTANCE OF VARIABLE CAMERA SPEEDS

25c
\$3.00 YEARLY

THERE IS A HOUSTON-FEARLESS FILM PROCESSOR FOR EVERY NEED!

Whatever your requirements in motion picture or TV film processing equipment, Houston Fearless has the answer. 16mm, 35mm, 70mm... black and white or color... negative, positive, reversal or positive-negative color film... from 5 to 250 feet per minute... from the smallest, most compact unit to the largest installation, Houston Fearless builds the finest, most dependable, best engineered of all processing equipment. Houston Fearless is a major supplier to the Military and is known and respected throughout the world.

Only a few of the many Houston Fearless models are shown here. For complete information on the type of equipment best suited for your particular needs or for help on your special requirements and problems, send the coupon below. Houston Fearless engineers will recommend what is most appropriate and, if desired, plan your entire film processing lab for maximum efficiency and highest quality results.

The
**HOUSTON
FEARLESS**
Corporation

*"World's Largest Manufacturer of Motion Picture
Film Processing and TV Studio Equipment"*

11809 W. OLYMPIC BLVD. LOS ANGELES 64, CALIF.
BRadshaw 2-4331
620 FIFTH AVE., NEW YORK 20, N.Y. Circle 7-2976

Houston-Fearless Corporation
11809 W. Olympic Blvd., Los Angeles 64, Calif.
Please send information on film processing equipment
to be used for the following purpose:

NAME _____
FIRM _____
ADDRESS _____
CITY _____ ZONE _____ STATE _____

SALES • SERVICE • RENTALS

OCT 12 1954

B 499203



THE WORLD'S MOST COMPLETE ASSORTMENT
OF PHOTOGRAPHIC EQUIPMENT FOR

T.V. and Motion Picture Studios

New PROFESSIONAL JUNIOR

Adjustable wood BABY TRIPOD
—for Prof. Jr. friction
and geared heads



Has substantial shoe and spur.
Measures from floor to flange
25" extended —17"
collapsed. **\$75**

FAMOUS
"controlled
action"
SMALL **GYRO**
TRIPOD

Two speeds—slow and fast
—for both panning and tilting.
Helps you capture fine scenic views
and fast-moving sports events. Espe-
cially recommended for 16mm Mitchell,
16mm Maurer, B & H Eyemo
and similar cameras. **\$600**



PACKAGED LIGHTING WITH **COLOR-TRAN**

—studio lighting in a suitcase

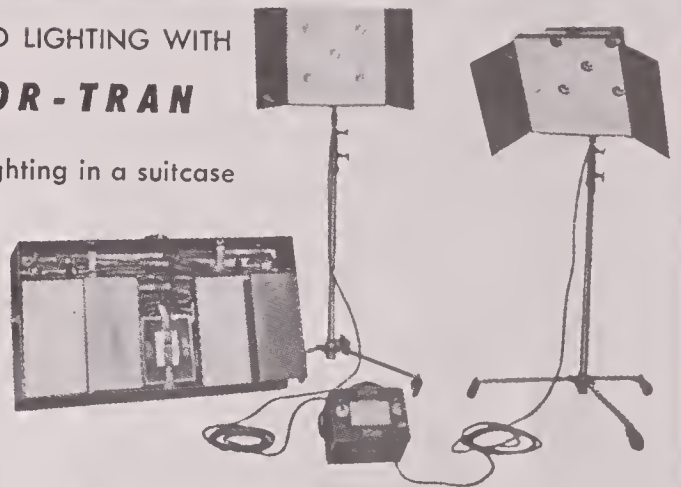

Imagine being able to use two 5000 watt units
on a 30 amp. fuse — COLOR-TRAN will do it!
Kit contains 2 light heads, 2 Superior stands and
proper size COLOR-TRAN converter to match.
Packed in compact case.

Senior Kit
\$237.50

Other style
kits available.

Write for *COLOR-TRAN* Catalogue.

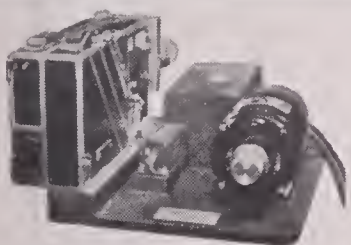

STOP MOTION MOTOR FOR CINE KODAK SPECIAL

Runs forward or reverse, 110
AC synchronous motor with frame
counter. May be run continuously
or for single frames. Camera
mounts without special tools.

\$550

Also available — Stop Motion
Motors for 16mm—35mm B & H,
Mitchell and other professional
cameras.



ELECTRIC FOOTAGE TIMER

Dual model for both 16mm
and 35mm. Large white num-
erals on black background. Accu-
rate reset dial. Switch controlled
by operator, who selects either
16mm operating at 36 feet per
minute—or 35mm operating at
90 feet per minute . . . or both
in synchronization. **\$95**

Single model, either 16mm or
35mm **\$45**

presto-splicer

GIVES PERMANENT SPLICE
IN **10** SECONDS!

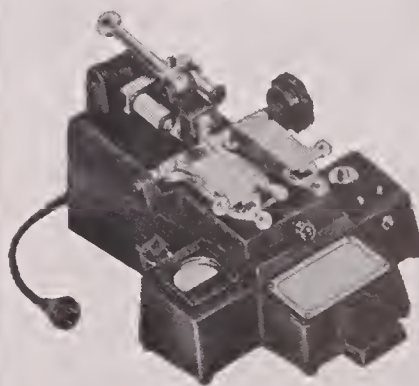

Especially good for splicing magnetic
film. Butt Weld type for non-perforated
or perforated film. 16mm, 35mm or
70mm. **\$547.80**

16mm or 35mm models—
for perforated film.

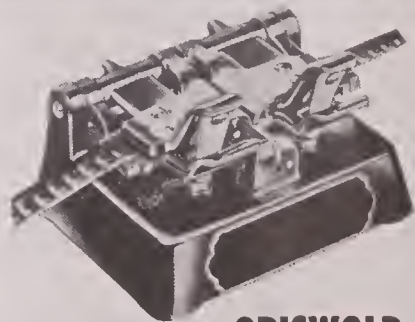

GRISWOLD HOT FILM SPLICER

Model R-2 for 35mm silent and sound
film. Precision construction makes it easy
to get a clean, square splice with accu-
rate hole spacing. Nothing to get out of
order. **\$65**

Also Bell & Howell 8mm, 16mm and
35mm Hot Splicers and B & H Labora-
tory model Foot Splicer.

9.5mm Lenses in 16mm C mount. 18.5mm (extreme wide angle-flat field)
Lenses available in mounts for all 35 mm Motion Picture Cameras.
PHOTO RESEARCH Color Temperature Meters. *Electric Footage Timers
*Neumade and Hollywood Film Company cutting room equipment.
*Griswold & B.&H. Hot Splicers. *DOLLIES—Bardwell-McAlister, Mole
Richardson, Century and Colortran Lighting Equipment.

FRANK C. ZUCKER
CAMERA EQUIPMENT CO.
1600 BROADWAY NEW YORK CITY

**YOUR FILM
GOES THROUGH
EXPERIENCED
HANDS**

**CONSOLIDATED
FILM INDUSTRIES**
Hollywood's only complete film lab

**35 MM
16 MM
B & W
EASTMAN
COLOR**

959 SEWARD ST., HOLLYWOOD 38, CALIF. • HOLLYWOOD 9-1441
1740 BROADWAY, NEW YORK 19, NEW YORK • JUDSON 6-1700

AMERICAN

Cinematographer

THE MAGAZINE OF MOTION PICTURE PHOTOGRAPHY
PUBLICATION OF THE AMERICAN SOCIETY OF CINEMATOGRAPHERS

ARTHUR E. GAVIN, *Editor*

MARION HUTCHINS, *Editorial Assistant*

EMERY HUSE, *Technical Editor*

EDITORIAL ADVISORY BOARD: John Arnold, Arthur Edeson, Lee Garmes, Charles Roshier, Leon Shamroy, Fred Gage, Glenn R. Kershner

Editorial and Business Office: 1782 N. Orange Dr., Hollywood 28, Calif.

Telephone: HOLLYWOOD 7-2135

VOL. 35

OCTOBER • 1954

NO. 10

In This Issue

ARTICLES

S.M.P.T.E. TO CONVENE IN HOLLYWOOD	482
TODD-AO—NEWEST WIDE-SCREEN SYSTEM—By Arthur Rowan	494
HOW TO EDIT "A" AND "B" ROLLS—By John Forbes	498
A REMOTE CONTROL FOR STOP-MOTION PHOTOGRAPHY—By John Hoke	500
EQUIPMENT SOURCE FOR FILM PRODUCERS—By Frederick Foster	502
CAMERAMEN ARE A BREED APART—By Earl L. Clark	503
FILMORAMA—CINEMASCOPE IN 16MM—By Leigh Allen	504

AMATEUR CINEMATOGRAPHY

THE IMPORTANCE OF VARIABLE CAMERA SPEEDS—By Alvin D. Roe	506
THE PLACE OF THE CLOSEUP IN YOUR MOVIES—By John Forbes	508
A FILM RULE FOR FILM MAKERS	509

FEATURES

HOLLYWOOD BULLETIN BOARD	478
WHAT'S NEW IN EQUIPMENT, ACCESSORIES, SERVICE	480
LETTERS	484
INDUSTRY NEWS	488
CATALOGS & BROCHURES	490

ON THE COVER

ROBERT L. SURTEES, first cinematographer to shoot a major production in Todd-AO, is shown with the camera which he is using in photographing the Rodgers & Hammerstein production, "Oklahoma." Camera takes 65mm negative, records picture 3½ times larger than that on standard 35mm film. Note grotesque size of the 128-degree "bugeye" lens—widest of the Todd-AO wide-angle lenses. See story beginning on page 494.—Photo by Schuyler Crail.

AMERICAN CINEMATOGRAPHER, established 1920, is published monthly by the A. S. C. Agency, Inc., 1782 N. Orange Dr., Hollywood 28, Calif. Entered as second class matter Nov. 18, 1937, at the postoffice at Los Angeles, Calif., under act of March 3, 1879. SUBSCRIPTIONS: United States and Canada, \$3.00 per year; Foreign, including Pan-American Union, \$4.00 per year. Single copies, 25 cents; back numbers, 30 cents; foreign single copies, 35 cents; back numbers 40 cents. Advertising rates on application. Copyright 1954 by A. S. C. Agency, Inc.



On the set of "I Love Lucy," starring Lucille Ball and Desi Arnaz. The nation's Number 1 TV show for 1951, 1952 and 1953 is a pioneer of the technique of filming its program as a live show with audience. Desilu Productions uses three Mitchell 35mm BNC cameras in filming "I Love Lucy."



Jean Davis on the set of "I Married Joan," produced by P. J. Wolfson and appearing on NBC. Three Mitchell 35mm BNC cameras are used on this top TV show, which is in its 2nd year. Jim Backus plays the male lead.

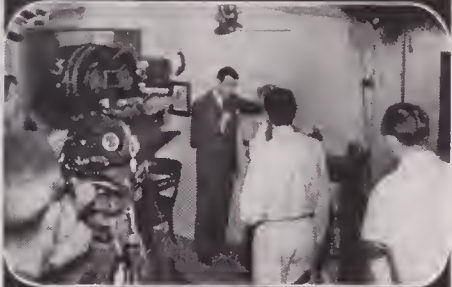

Dennis Day, star of "The Dennis Day Show," a top-rated NBC program. Originally "live," this series is in its second year, and is now produced on film by Denmac Productions, using a Mitchell 35mm BNC camera.

TO FILM A SUCCESSFUL SHOW...

It takes more than just a good script to insure the success of a top-rated network program. The on-stage performances of the stars and supporting cast must be outstanding, carefully timed, superbly directed. And the camera must perform flawlessly in its vital role of recreating the superior quality of the show for millions of TV viewers.

Mitchell cameras—internationally famous—provide the matchless photographic performances so necessary to the successful making of the finest theater quality films. That is why, wherever top quality filming is the foremost consideration, Mitchell Cameras are to be found... bringing *success* into focus.

MITCHELL *The only truly Professional Motion Picture Camera*

Mitchell Camera CORPORATION

666 West Harvard Street • Glendale 4, Calif. • Cable Address: MITCAMCO



85% of the professional motion pictures shown throughout the world are filmed with a Mitchell

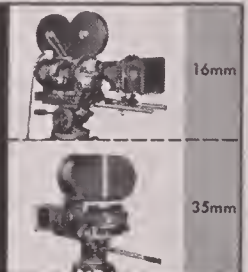

16mm

35mm

Hollywood Bulletin Board



LADIES' NIGHT at the American Society of Cinematographer's clubhouse in Hollywood last month saw a gay gathering of members and wives enjoying the lawn party and dance which featured the French theme, "A Night in the Monmartre." Among those snapped by the candid camera were: (1) Mrs. Norbert Brodine receives gift from host Philip Tannura upon arrival with her popular cameraman husband, while ASC president Arthur Miller and Society VP Arthur Edeson look on. (2) Mr. and Mrs. William Mellor stop to chat with Arthur Edeson at the Cafe de Cinema champagne bar. (3) A happy foursome were (l. to r.) Philip Tannura, Mrs. Tannura, Mrs. Arthur

Miller, and Mr. Miller. (4) Another party which arrived early and stayed late were (l. to r.) Len Roos, Mrs. Roos, Dan Clarke, Mrs. Clyde deVinna, Mr. Charles Handley of National Carbon, and Mrs. Handley. (5) A general view of the canopied area on lawn in front of the ASC clubhouse. (6) John Boyle looks on while Mrs. Boyle opens her lovely gift. (7) Arthur Edeson, who chairmanned the entertainment committee, takes a turn at the mike. (8) Peter Mole of Mole-Richardson Company listens to director Rudolph Mate discuss his latest assignment. (9) The camera-shy turned to avoid the flashbulbs of the cameraman.

Dave Savitt, who is associated with the Kling Film Enterprises, Inc., Chicago, is a new Associate Member of the American Society of Cinematographers.



Thomas Tutwiler, ASC, is in Caracas, Venezuela, shooting a 35mm production in Eastman Color for the President

of that South American country. Tutwiler brought along a Mitchell and an Arriflex camera and a carload of Eastman Color negative.



Bob Roberts, ASC, brother of ASC member Irmin Roberts at Paramount studios, passed away last month in Buenos Aires where he had gone re-

cently to resume his career as director of photography.



Arthur Arling, ASC, flew to India September 12 with a production department group from MGM for purpose of making exploratory survey of location sites for studio's forthcoming

(Continued on Page 486)

Color

you've been waiting for

bold, clear, alive!

"Life-like color," the ultimate in the reproduction of color film, is now available to all producers of 16mm motion pictures. Now you can have your exposed film duplicated with perfect blending and balancing of tones. Your release prints will have a sensitive living quality...surpassing anything you have ever seen in clarity.

This is "Life-Like Color," the result of fifteen years of exhaustive research by the country's outstanding color engineers and technicians. It is now available to you exclusively through the laboratories of Telefilm Studios.

With "Life-Like Color," Telefilm Studios again contributes to its primary objective...to help the 16mm producer make better motion pictures. Telefilm's modern facilities and equipment for color printing...high fidelity sound recording (your choice of optical or electronic sound printing)... editing...titling...special effects...and the skill and the know-how of the finest technicians in the industry are at your command.

*for complete information, visit Telefilm Studios,
or write for a descriptive brochure.*

TELEFILM STUDIOS INC.

estab. 1938

6039 HOLLYWOOD BLVD. • HOLLYWOOD, CALIF.

telephone HOLLYwood 9-7205



Henri Toulouse-Lautrec,
pioneer of commercial color.

WHAT'S NEW

... in equipment, accessories, service



Pro-Cine Tripod

Florman & Babb, 70 West 45th St., New York 36, N. Y., announce a new, medium-weight tripod which incorporates many unique features, most important of which is the extremely smooth controlled pan and tilt movement of friction head. Weighing 14 lbs., tripod will accommodate following cameras: Auricon-Pro, Maurer, Cine Voice, Cine Special, Eyemo, Filmo, Arriflex, Camerette, and Bolex. List price of tripod is \$135.00. Carrying case is \$20.00 extra.

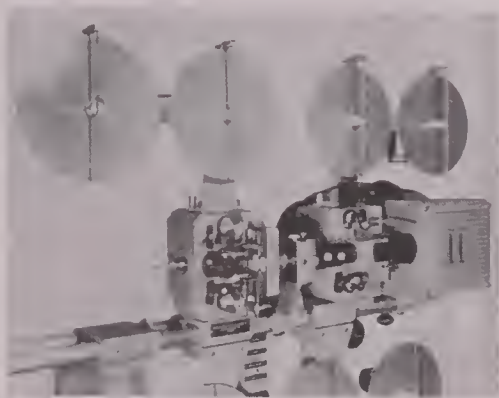

Optical Printer

Motion Picture Printing Equipment Co., 8136 No. Lawndale Ave., Skokie, Ill., announces a new optical reduction printer. This Model 300 printer can be used for picture reduction printing from 35mm negative to 16mm positive, enlarging from 16mm negative to 35mm positive, and contact printing 16mm to 35mm films. Features include constant takeup, large lamphouse for 1000-w lamps, and provision for installation of automatic fade.

Mercer Film Patch

Ray Mercer & Co., 4241 Normal Ave., Hollywood 29, Calif., has stepped up production of the famous Mercer Film Patch, a valuable temporary film-joining clip used in the processing and editing of motion picture film. In use in Hollywood studios and film labs for over 25 years, Mercer Film Patch is now available for CinemaScope film. Product is available in stainless steel, celluloid, and durable white paper.



Extension Tube for Arriflex

A new extension tube for Arriflex 16mm and 35mm cameras is offered by Kadisch Camera & Sound Engr. Co., 500 West 52nd St., New York. Use of tube is recommended for ultra-closeup work such as micro and surgical photography. It is precision machined with tooled interior to prevent reflection. For further details and prices, write manufacturer direct.

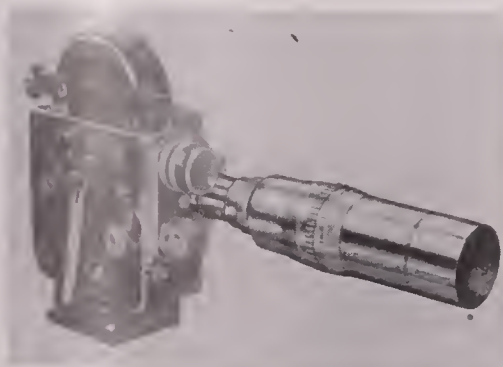

9-Inch Telephoto Lens

Century Photographic Equipment Co., 10427 Burbank Blvd., No. Hollywood, Calif., offers a new telephoto lens for 16mm cameras which is particularly adaptable to shooting scien-

tific and wild-life movies. Tradenamed the Tele-Athenar, it has a focal length of 9", (230mm) and a rated speed of f/3.8. Light in weight, it requires no support. It may be focused as close as 15 feet, its iris stops down to f/22, it is coated and color-corrected.

Made in the U. S., the lens is supplied in standard "C" focusing mount. Price is \$99.50.



Hi-Fidelity Mike

Shure Brothers, Inc., 225 West Huron, Chicago 10, Ill., announce their new Model 333 high fidelity studio microphone, a uni-directional microphone with the following features: extended frequency response (30-15,000 cps, plus or minus 2 1/2 db; patented "Uniphase" system; small size and slim design. Complete technical data and price may be had by writing manufacturer direct.



Tape Comes on New Reel

Orradio Industries, Inc., Opelika, Alabama, announce that its Irish Green-Band professional magnetic recording tape is now being mounted on new-type 7-inch reels having a new, improved hub 2 1/4-inches in diameter.



NOW

COLOR-CORRECT*
RELEASE
PRINTING from separate

track and picture masters incorporating
"A" and "B" effects

1¢ per foot

- Color Duplicating Stock furnished at cost if payment accompanies order — \$.058 per foot.
- We will mount all prints on your reels and cans at no extra charge — and pack for shipping anywhere in the world.
- Delivery to meet your schedules.

**Reg. U.S. Patent Office*

byron *Studios and Laboratory*

1226 Wisconsin Avenue, N.W., Washington 7, D.C. DUpont 7-1800

PRACTICALLY EVERY 16MM FILM PRODUCER IN THE WESTERN HEMISPHERE IS A CLIENT OF BYRON

SMPTE To Convene In Hollywood

Society's 76th semi-annual convention opens in Los Angeles on October 18th.

RECENT TECHNICAL advances in the motion picture and television fields, which have greatly stimulated these industries during the year, are destined to make the forthcoming get-together of the Society of Motion Picture and Television Engineers one of the largest in the Society's history.

The S.M.P.T.E.'s 76 semi-annual convention will open at the Ambassador Hotel in Los Angeles on October 18th and will continue through October 24th.

Indicative of the increased activity is the sponsoring of an exhibit of manufacturers television and motion picture equipment.

Technical sessions will be held morning, afternoon and evening each day and several concurrent sessions have been scheduled to accommodate the many papers planned for delivery.

A luncheon get-together on Monday, October 18th, will serve to open the convention. The semi-annual banquet and dance will be held Wednesday evening, October 20th, at the Ambassador Hotel. Field trips to the color TV studios of CBS and NBC, and to the Moody Institute of Science, and the Paramount Studio theatre are scheduled.

Five awards for outstanding technical achievement by individuals are to be presented. They include the Samuel L. Warner Memorial Award, the David Sarnoff Gold Medal Award, the SMPTE Journal Award, the SMPTE Progress Medal, and the Society's Fellow Awards.

An extensive program of papers, discussions, and field trips is in preparation. Of these, the following subjects will be of interest to those in the motion picture industry:

PROGRAM—MOTION PICTURE SUBJECTS

Monday, October 18

9:30 A.M. Registration, Ambassador Hotel lobby. 12:30 P.M. Get-together luncheon, Coconut Grove. 3:00 P.M. Business meeting: 3:30 P.M. Color television. Ambassador Theatre.

Tuesday, October 19

9:30 A.M. Field Trip to NBC television studios. 3:00 P.M., Color Television-Session, Academy Award Theatre. Sidney P. Solow and Edward H. Reichard of Consolidated Film Laboratories will deliver a paper on subject of "Some Laboratory Procedures in Preparing Television Prints in Black-and-white and Color from Eastman Color Negative."

Wednesday, October 20

10:00 A.M., Ambassador Theatre, discussion of the factors pertinent to obtaining magnetic-stripe sound tracks on 16mm and 35mm TV films.

Thursday, October 21

9:30 A.M. Field trip to Moody Institute of Science for study of high-speed cinematography.

10:00 A.M., Motion Picture Equipment session. Frank G. Back will present paper on "New Studio Zoomar Lens for 35mm Motion Picture Work. John D. Hayes, of Bausch & Lomb, will read paper on "CinemaScope Camera Lenses." D. C. Chambers and W. R. Holm of DuPont will present paper on "An Exploration of New Methods for Splicing Film."

2:00 P.M. High speed photography session. Also discussion of modern motion picture screens as applied to the new aspect ratios of film exhibition.

2:00 P.M.—Mr. R. Clark Jones of Polaroid Corp., will present paper on "A New Method of Describing and Measuring the Granularity of Photographic Materials."

8:00 P.M. Wide Screen Processes. An analysis of factors controlling image quality. Paramount Studio Theatre.

Friday, October 22

Webster Blake of Douglas Aircraft Corp. will present paper on "Simple Electronic Timing Device for High Speed Photography."

10:00 A.M. A general discussion of amateur motion picture photography at the Ambassador Theatre. Glenn E. Matthews and Raife G. Tarkington will present paper on "Early History of Motion Picture Film." C. R. Fordyce, J. M. Calloun, and E. E. Moyer, of Eastman Kodak Co., Rochester, will present paper on "Shrinkage Behavior of Motion Picture Film."

A. J. Sant, M. C. Goddard, and O. E. Miller, of Eastman Kodak Co., will present paper on "A Light Meter for Printer Control."

Frank P. Hernfeld, Culver City, Calif., will present paper on "A System for Automatic Additive Printing and Scene Testing of Color Film."



The greatest advance in motion picture camera design in the past decade—Reflex Viewing... seeing through the taking lens at all times... in the CAMERETTE 35 and 16/35. 3-D, Anamorphoscope, Wide Aspect Ratio—the more critical requirements of the new techniques for accurate framing and focusing DEMAND this modern motion picture camera.

look at these advantages:

- Reflex Viewing
- Precise, rugged movement
- 200 degree adjustable shutter
- Divergent 3-lens turret
- Automatic film gate 400' magazines,
- Light weight: Only 14 pounds with 3 lenses, 400' magazine and 6/8 volt motor.
- Patents Coutant-Mathot manufactured by Eclair, Paris
- for descriptive brochure write U.S. representative Benjamin Berg Agency 1410 No. Van Ness Avenue Hollywood 28, California

35mm and 16/35 **camerette**



**anamorphoscope
wide aspect ratio**

Once in a decade
a basic tool is so improved
as to add a new dimension
to its use. The world's most modern
motion picture camera — Camerette
35mm and 16/35 — patents Coutant-Mathot
manufactured by Eclair, Paris

for descriptive brochure write U. S. representative

Benjamin Berg Agency, No. Van Ness Avenue, Hollywood 28, Calif.

ONE CAMERA

16mm or 35mm

in 10 SECONDS!

Camerette 16/35

Reflex Motion Picture Camera

The perfect camera for the motion picture film maker working in both 16mm or 35mm color or black and white.

LOOK AT THESE ADVANTAGES—

- The same lenses, same motor drives, same sound blimp and accessory equipment used for both 16mm or 35mm — to convert simply change the magazine.
- Precise rugged movement
- Reflex viewing
- 200 degree adjustable shutter
- Divergent three lens turret
- Automatic film gate 400' magazines 16 or 35mm — the 16mm magazine will accommodate daylight spools as well as standard core load.
- Light weight — only 14 pounds with 3 lenses, 400' magazine, and 6/8 volt motor.

Write for brochure



Camerette

patents coutant-mathot

Manufactured by Ets. Cine. Eclair, Paris



letters

A.C. At Top of List

I am gathering a collection of photographs (stereo), descriptive brochures, and advertising material on motion picture cameras. I have quite a few such items to date, though there are still some I need.

Glad to see a "Letters" column in *American Cinematographer*. Besides being an amateur cinematographer, I am a magazine collector (I subscribe to 41 at present), and am familiar with everything from *Dick Tracy* to the *Proceedings of the (British) Society for Physical Research*. The one I value highest is the *American Cinematographer*!

Walter A Carrithers, Jr.
463 North Second St.,
Fresno 2, Calif.

Reads the Ads, Too!

Enclosed is my check for \$3.00 for renewal of my subscription.

I want to tell you that all the material that your publication contains is always very important to me and the knowledge that I get from all the articles is a very good help to me. Also the information contained in the advertisements is of great importance to those of us who live south of the Border.

Vincente De Benedictis,
San Jose,
Costa Rica.

• *Mucho gracias, Senor De Benedictis!*
—ED.

Tradelast For Loyal Griggs

I would like to take this opportunity of expressing to you the very great pleasure and enjoyment received from the reading of your publication. For many years it was my ambition to enter the film industry here and train to become a professional cinematographer, but it was not to be, although never for an instant has my sincere interest in this subject been relaxed: I have now to be content with sub-standard filming on 9.5mm stock.

I have the greatest admiration for the work of members of the A.S.C., and although he already will have received many congratulations from fellow workers, would you be kind enough to extend to director of photography Loyal Griggs my very greatest admiration for his work in the pro-

duction "Shane"? Never can I recall such exquisite photography, so technically excellent and so full of atmosphere in the very real sense. I was very greatly impressed and look forward with enthusiasm to his work on the new technique of VistaVision.

C. H. Couzens,
Sheffield,
England.

Seconds The Motion

In the letters column of your August issue, I noted request of Jack Kane of Pittsburgh, Pa., for information on processing of amateur color film.

I stand with Jack on his request, but would like to expand it by requesting the names and addresses of all the manufacturers of the equipment necessary for this work as well as full data on the technique.

I would also request a series of articles describing the various color films presently available to the amateur.

Walter J. Young,
Syracuse University,
Syracuse, N. Y.

Film Lab Information

I should remain very thankful to you if you would send me the addresses of all the film laboratories which were mentioned in the recent article entitled "The Film Laboratory—Your Partner In Production." by Charles L. Anderson, which incidentally I found very interesting.

Dr. J. de Los Santos,
Vedado,
Havana, Cuba.

• *The addresses requested are being mailed to you.*—ED.

Pleased

I was very pleased to read "India's First Feature in Gevacolor" by Frederick Foster. This is the first time that I have read about an Indian film in an American magazine. I hope the film will be distributed in the U.S.A.

I am an artist from India and at present am carrying on some experiments in animation techniques at A.V. Center, Syracuse University.

I have always enjoyed reading *American Cinematographer*.

Kantilal Rathod,
Syracuse,
New York.

NAIDICH

COMPLETE 16mm and 35mm SERVICES...including STRIPING



GENERAL FILM LABORATORIES CORP.

1546 NO. ARGYLE • HOLLYWOOD 28, CALIF. • HO 9-6391

16mm color division: ASSOCIATED FILM LABORATORIES

Carl Hunt Hans de Schulthess Bob Goodwin Alton Brody John Aitkens Bill Gephart Harlan Baumbach Stacy O'Brien Paul Schwegler Bob Creamer
president vice president vice president sales director comptroller processing director technical director prod. superintendent sales sales

ANIMATION EQUIPMENT

SPECIAL EFFECTS OPTICAL PRINTERS

- ANIMATION
- TITLES
- STILLS
- CARTOONS
- TRICK PHOTOGRAPHY

For

- INDUSTRIAL MOTION PICTURES
- EDUCATIONAL MOTION PICTURES
- TV MOTION PICTURES
- ENTERTAINMENT MOTION PICTURES

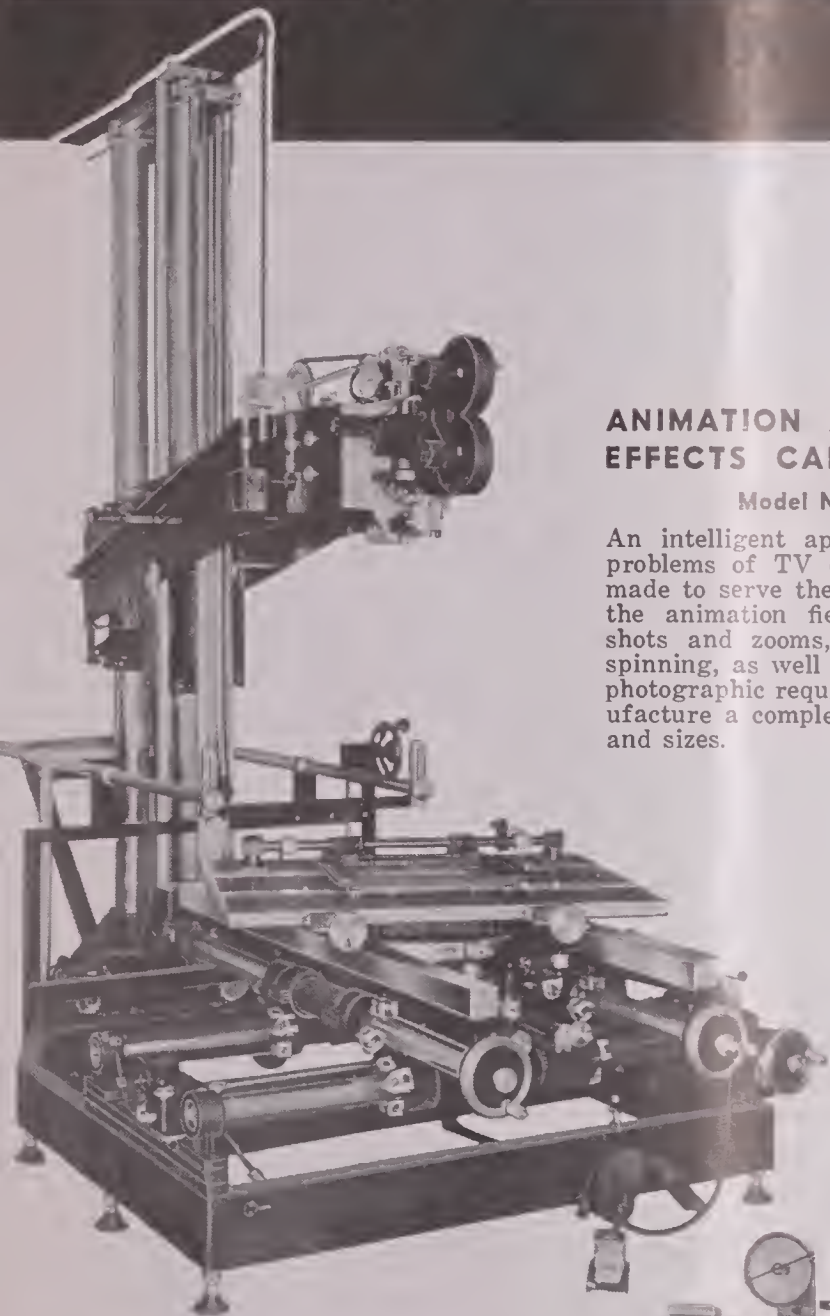

ANIMATION AND SPECIAL EFFECTS CAMERA STAND

Model No. 111-E

An intelligent approach to today's problems of TV commercials. It is made to serve the multiple tasks of the animation field to take angle shots and zooms, matching zooms, spinning, as well as countless other photographic requirements. We manufacture a complete range of styles and sizes.

OPTICAL PRINTER FOR SPECIAL EFFECTS WORK

Prints from one picture to another or one size picture to another. Zoom can be added to the picture without an exposure crew. Foreign titles can be added to bottom of any picture. The machine has a ball bearing mounted zoom for 4 to 1 blow-up or reduction.

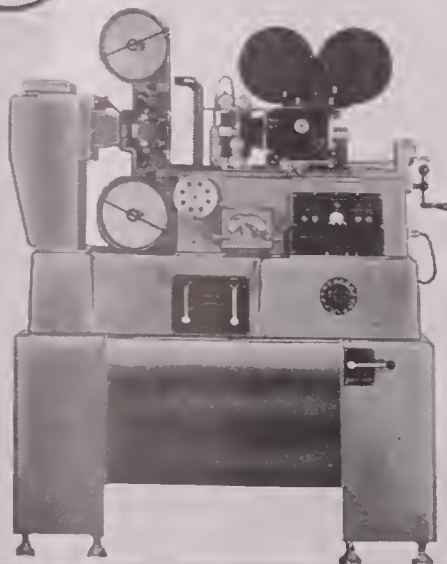

WRITE FOR COMPLETE LITERATURE

Distributed by

J. G. SALTZMAN, INC.
480 Lexington Avenue, New York 17, N. Y.

BULLETIN BOARD

(Continued from Page 478)

production to be filmed entirely in India. Assignment will take 8 weeks.

★

Hal Mohr, ASC, who directs the photography of the TV film series, "Life With Father," will be subject of full-page photo layout in October 18th issue of LIFE magazine.

★

Mr. P. Chandr, head of Eastern Movies in New Delhi, India, was an ASC visitor last month. His company is leading film production company in New Delhi, turning out educational, documentary, and newsreel films for world consumption. The small-scale studio employs a staff of five cameramen.

★

Harry Squire, ASC, the original Cinarama cameraman, has begun a 'round-the-world tour with the tri-lensed Cinarama camera for the purpose of making another new feature titled "The Seven Wonders of the World. Teddy Tetzlaff will direct, and Lowell Thomas will produce and narrate the picture for Stanley Warner. Assignment will take six months.

★



Len Roos, ASC, when not developing new magnetic sound equipment, devotes his spare time to his one and only hobby, the restoration of ancient automobiles. Recently his 1910 vintage Stearns, which he entered in recent Reno get-together of the Horseless Carriage Club of Nevada, won for him the First Place trophy awarded for the best restoration of a vintage car originally costing over \$2,000.

In photo above, Roos (left) is receiving trophy from William Harrah, secretary of the H.C.C. of Nevada.

★

Jack Bishop, ASC, head of the camera department at Paramount's Hollywood studios, took delivery of the first completely new Vista-Vision camera turned

(Continued on Page 524)

FAIRCHILD ANSWERS

6
Pointed
Questions About
**PERSPECTA
STEREOPHONIC
SOUND**

A FRANK DISCUSSION OF THE FACTS!

Q. *Is Perspecta Stereophonic Sound really here?*

A. It sure is! M-G-M, Paramount and Warners are releasing all future productions with Perspecta Sound. Other studios are following.

Q. *Will it be the industry standard for years to come?*

A. Yes, it will — because, from the producers' viewpoint, it's the *compatible* system — yet offers exhibitors the finest stereophonic sound at the lowest installation and operating cost.

Q. *How soon should theatre owners install it?*

A. The sooner, the better. All Loew's theatres are being equipped now and hundreds of others here and abroad have ordered! Be first in *your* community. Order now!

Q. *How many Fairchild Perspecta Integrators does a theatre need?*

A. Only *one!* A single Fairchild Perspecta Integrator serves *all* projectors in a booth and controls the sound through any three-channel sound system of standard-make.

Q. *What about costs and installation time?*

A. The Fairchild Perspecta Integrator costs \$990. A complete installation can be made in less than a day — without loss of showing time and, incidentally, without continued maintenance and replacement of magnetic heads!

Q. *Where do I go to find out more?*

A. See your dealer or — call — write — or wire Fairchild. We understand exhibitors' problems—can answer your questions immediately.

**FAIRCHILD RECORDING
EQUIPMENT**
THEATRE EQUIPMENT DIVISION • WHITESTONE 57, NEW YORK

ARRIFLEX

New 35 mm Model 2A
With 180° Shutter

**A TRULY GREAT
CAMERA**

for TV, Newsreel
and commercial
films



For tough and trying assignments, ARRIFLEX 35 is in a class by itself. Reflex focusing through photographing lens while camera is operating—this is just one outstanding ARRIFLEX feature.

Equipped with bright, right-side-up image finder, $6\frac{1}{2}$ x magnification. Solves all parallax problems. 3 lens turret. Variable speed motor built into handle operates from lightweight battery. Tachometer registering from 0 to 50 frames per second. Compact, lightweight for either tripod or hand-held filming. Takes 200' or 400' magazine. Write for free folder.

Blimp now available.
16mm ARRIFLEX also available.

FRANK C. ZUCKER
CAMERA EQUIPMENT CO.
1600 BROADWAY NEW YORK CITY

INDUSTRY NEWS

Technicolor Credits, such as "Color by Technicolor" and "Print by Technicolor" are explained in a leaflet released last month by Technicolor Motion Picture Corp.

According to this informative announcement, "the credit phrase 'Color by Technicolor' is used for motion pictures in color which have been controlled from the developing of the original negative or taking film to the manufacture of the positive release prints by a Technicolor company.

"In brief, the credit is 'Color by Technicolor' if the original negative is developed, and the release prints made by Technicolor, regardless of the type of original negative used or the method of making the release prints.

"The credit phrase 'Print by Technicolor' is used for motion pictures in color which are photographed on negative or taking film other than that developed by Technicolor but which are, however, controlled by Technicolor through some of the stages subsequent to photography, *always* including manufacture of the positive release prints.

"The credit is 'Print by Technicolor' if the original is not developed by Technicolor, but the release prints are made by Technicolor."

"Use of proper Technicolor credits," the company emphasizes, "is solicited not only on theatre marquees, but in all forms of publicity and advertising, including newspapers, magazines, posters, radio and television."

Anti-mildew compounds are harmful to color films, according to Eastman Kodak Company, which recently cautioned that a number of color films have been processed which had been spoiled by exposure to paraformaldehyde, an ingredient in most anti-mildew preparations.

The first effect on Kodachrome film is a color shift toward green, with increased graininess. In later stages, the film becomes very dense, often with a dark red appearance. Kodacolor negatives so affected have a milky translucent appearance. When printable, the prints are off color. Paraformaldehyde works in from the edges of the film and has the effect of hardening the gelatine of the film emulsion, therefore interfering seriously with the processing.

Typical exposure to this chemical

occurs when a loaded cine or still camera is put in a clothes closet in which a bag of anti-mildew compound has been hung. Even when an empty camera has been exposed to this vapor, enough of the vapor can stay in the camera to affect the film.

Unopened packages of color film, says Eastman Kodak Company, are sufficiently vapor-tight so that such precautions are unnecessary in ordinary circumstances.

★

Rochester, New York, observed the 100th Anniversary of the birth of one of its foremost inventors on September 26th.

He is Edward Bausch, who 80 years ago pioneered in the manufacture of low-cost microscopes for scientists and medical students throughout the world. The company since has become one of the leading suppliers of lenses and optical elements used in the motion picture industry. The company's most recent noteworthy achievement was the re-engineering of the CinemaScope lens, aided by 20th Century-Fox engineers.

★

Invitations have been extended by the Screen Producers Guild to 104 American colleges and universities to participate in the Guild's Second Annual Intercollegiate Awards. The competition is for the best amateur motion picture conceived and created in the colleges and universities of America.

Any student film produced or completed during the year of 1954 is eligible for entry. November 30, 1954, has been set for the submission of the application, and December 31, 1954, for the film itself.

A special viewing committee composed of members of the SPG will select and nominate films for the awards.

Last year the SPG Gold Award Medallion was presented to the University of Southern California, honoring Herbert Skoble, student director, who produced "Let Me See."

The Guild's Silver Award was presented to University of California at Los Angeles for "Treasure in a Garbage Can." and its Bronze Award to University of Minnesota for "Art of Seeing."

END

the ARRIFLEX 16[®]

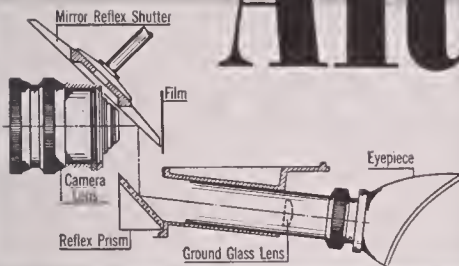

... ONLY 16mm Camera with a
Mirror-Reflex Focusing-Finder

The advantages of continuous thru-the-lens focusing and viewing... even during actual shooting... are well understood and recognized. The important thing is that these advantages are available only in the Arriflex 16.

HOW THE MIRROR REFLEX SHUTTER WORKS:

The Arriflex 16 shutter rotates at a 45° angle between the lens axis and film plane. The front of the shutter is an optically flat, surface-coated mirror. When in 'closed' position, it reflects the lens image into the optical system of the finder. In 'open' position, the image is projected directly onto the film for the exposure.

In this way, the Arriflex 16 Mirror-Reflex system makes all of the light transmitted by the lens available to both the finder and the film, intermittently. The image viewed is brilliant, uninverted and right-side-

up. It is seen, magnified 10 times, through a highly corrected, adjustable eyepiece. There is no parallax... and no need for special finders.

OTHER FEATURES INCLUDE:

- Registration Pin for absolute frame registration and picture steadiness
- Electric Motor Drive for uninterrupted filming without the need to stop and wind a spring
- Divergent 3-Lens Turret accommodates extreme wide-angle to 300mm telephoto lenses, simultaneously, without physical or optical interference
- Footage and Frame Counters
- Tachometer
- Hand-Contour Grip
- Single Sprocket Sound Film Drive
- Detachable Matte Box-Filter Holder
- Detachable Neckstrap
- Weighs only 7½ lbs. including Matte Box
- Accommodates 400-foot Magazine.

The **ARRIFLEX 16** is the world's finest 16mm motion picture camera.

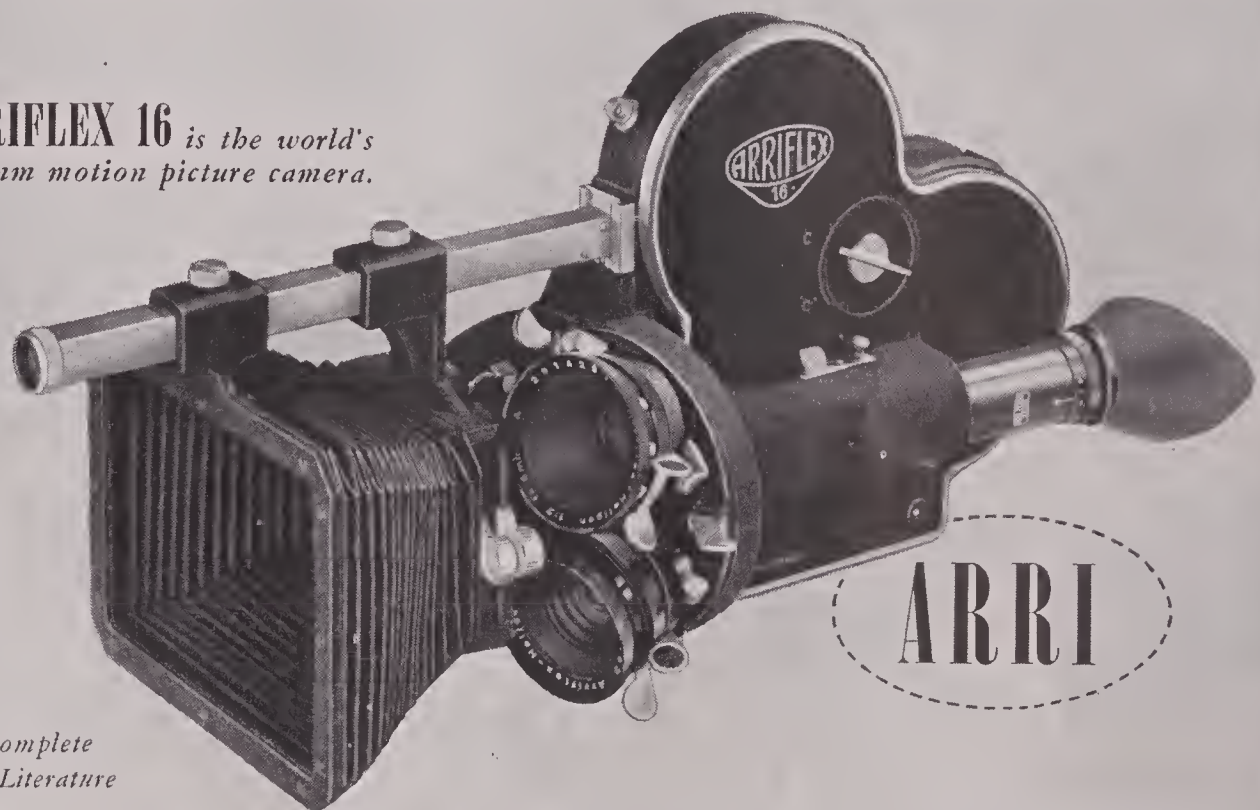

Write for Complete
Descriptive Literature

KLING PHOTO CORP., 235 Fourth Ave., New York 3, N. Y. • 7303 Melrose Ave., Hollywood 46, Calif.

NOW, more than ever...QUALITY COUNTS

in the
East...

... it's

MOVIELAB

The superior
QUALITY CONTROL consistently maintained
by MOVIELAB on all film processing assignments has earned
it the jealously-guarded reputation of being the "QUALITY
LABORATORY" in the east.

More producers, cameramen and technicians throughout
the east put their trust into Moviellab's "KNOW-HOW" and
"personalized service" than any other.

Get to know Moviellab—for this is the standard by which
all film processing is judged.

ROUND THE CLOCK SERVICES

Negative Developing

Ultra Violet and Flash Patch Printing

Quality Control

16 mm and 35 mm Release Printing

Title Department

25 Cutting and Editing Rooms

First Print Department

for color it's...

Rainbowlab Inc.

MOVIELAB FILM LABORATORIES, INC.
619 West 54th Street, New York 19, N. Y. JUDSON 6-0360

CATALOGS & BROCHURES available to readers

DuPont Film Data

A handy reference folder of technical data on DuPont professional motion picture films is available from the company's Photo Products Department, Wilmington 98, Delaware, and from its eight district offices.

Attractively printed in red and black, the folder contains sensitometric and processing data for DuPont's negative, soundrecording, release positive, duplicating, and special purpose cine films.

The data sheets are punched for use in standard three-ring notebooks.

District offices are located in Boston, New York, Philadelphia, Atlanta, Dallas, Cleveland, Chicago, and Hollywood.

Light on Indoor Filming

A new booklet of interest to the amateur cine photographer titled "Indoor Photos Made Easy." has been published by the Smith-Victor Corp., Griffith, Indiana, makers of portable lighting equipment utilizing photoflood lamps.

A companion booklet to "Indoor Movies Made Easy," which was issued earlier by the company, newest volume describes in detail the procedure and equipment required by the beginner as well as advanced amateur.

Various lighting systems are discussed and tips given on how to achieve various lighting effects. Copies are free for the asking from dealers or from the company direct.

Film Processing

A booklet describing the full scope of services offered by Precision Film Laboratories, Inc., 21 West 46th St., New York 36, N. Y., is available from the company to those making request on their business letterhead.

For Magnetic Recorders

A booklet explaining the use of sound striping of motion picture films and describing the Magna-Striping service offered by the company, is offered by Reeves Soundcraft Corp., 10 East 52nd St., New York 22, N. Y.

Booklet is a primer for those who are interested in recording magnetic sound on their own 16mm films, and gives detailed information on step by step procedure. Copies are free on request.

For Motion Pictures with

IMPACT

International Film Associates

uses the

AURICON "Cine-Voice" 16mm Sound-On-Film Camera!



Roy Zeper, Director of Photography for International Film Associates, P.O. Box 9434, Philadelphia 39, Pa., uses the Auricon "Cine-Voice" 16mm Sound-On-Film Camera for motion pictures with **IMPACT!**

International Film Associates travel the world with Auricon producing unusual films of travel, wildlife, archaeology, natural resources conservation, civic promotions and public relations.

INTERNATIONAL FILM ASSOCIATES

Motion Picture Producers

TELEPHONE
GREENWOOD 3-4486

P. O. BOX 9434 PHILADELPHIA 39, PENNA.



Berndt-Bach, Incorporated
6900 Romaine Street
Hollywood 38, California

Gentlemen:

The operation of a good camera in the studio can be taken for granted. But when our camera crew is on location, and that location is deep within the humid jungles of Yucatan, or high upon some frigid mountain peaks; - that is the true test of camera equipment. When we find our Auricon to continue to operate efficiently and with dependability -- no film jams, no lost loops, no mechanism failures -- we know this is THE camera.

And for lip sync in the field, only the Auricon can faithfully record an animal's snarl or a native's dialect in stark realism and vivid impact.

When our very pictures are at stake, we shoot with our Auricon.

Sincerely yours,
INTERNATIONAL FILM ASSOCIATES

Roy Zeper
Roy Zeper
Director of Photography



Auricon Cameras are sold with a 30-day money-back guarantee. You must be satisfied! Write today for free illustrated Auricon Catalog.

AURICON BERNDT-BACH, INC.

6902 Romaine Street, Hollywood 38, Calif.

The **Auricon Hollywood** Line
SOUND ON FILM EQUIPMENT SINCE 1931



CINE-VOICE

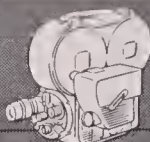

AURICON-PRO

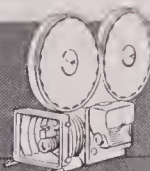

SUPER 1200



TRIPOD



PORTABLE POWER UNIT

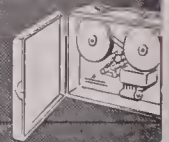

SOUND RECORD

SEEING IS BELIEVING!

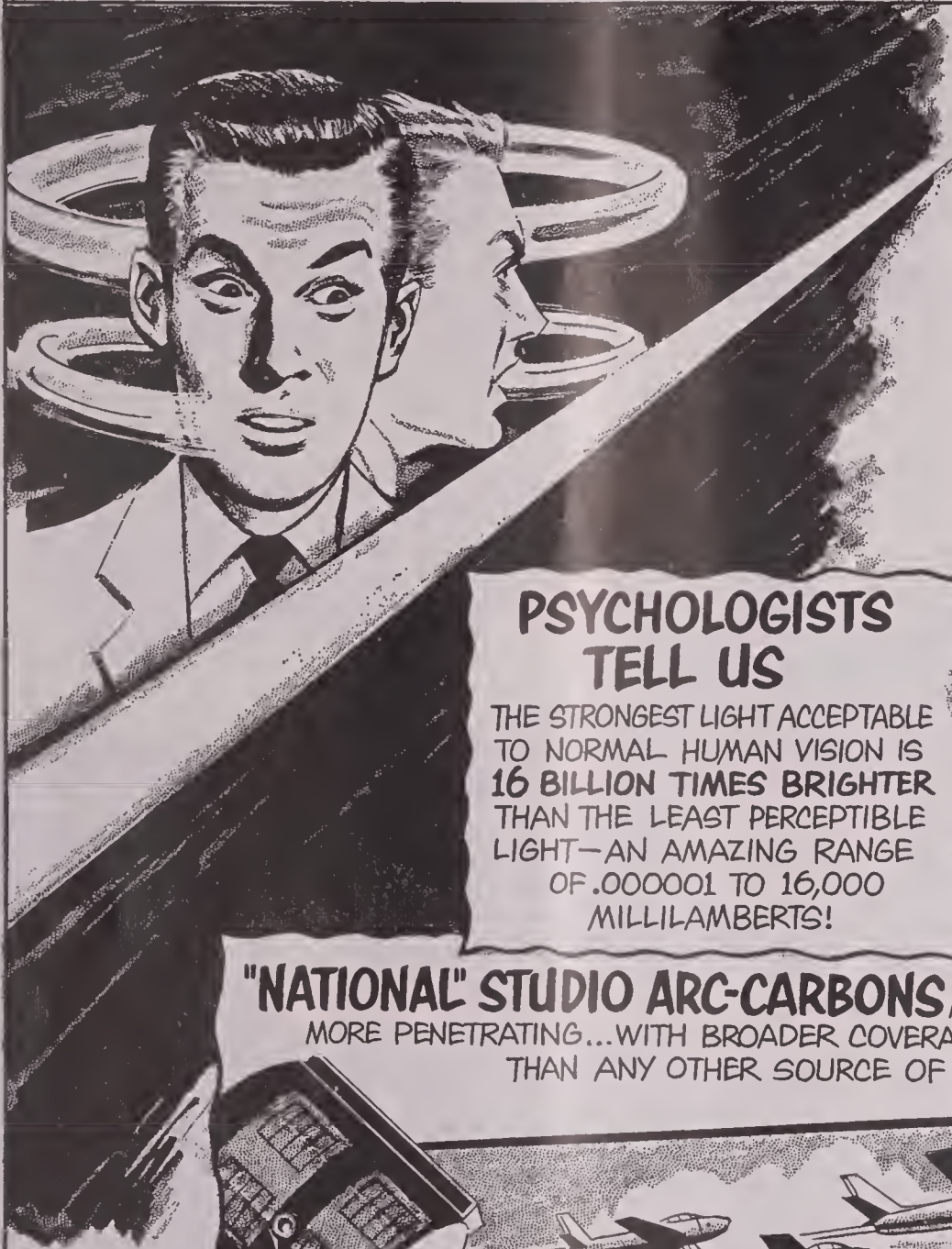

SCIENTISTS CAN MEASURE

THE SPEED OF LIGHT WITH GREATER ACCURACY THAN THAT OF ALMOST ANY OTHER PHYSICAL CONSTANT—DESPITE ITS INCREDIBLE VELOCITY OF 2.99776×10^{10} CENTIMETERS PER SECOND.

PSYCHOLOGISTS TELL US

THE STRONGEST LIGHT ACCEPTABLE TO NORMAL HUMAN VISION IS 16 BILLION TIMES BRIGHTER THAN THE LEAST PERCEPTIBLE LIGHT—AN AMAZING RANGE OF .000001 TO 16,000 MILLILAMBERTS!



"NATIONAL" STUDIO ARC-CARBONS ARE COOLER, MORE POWERFUL, MORE PENETRATING...WITH BROADER COVERAGE AND SHARPER DEFINITION THAN ANY OTHER SOURCE OF SET-LIGHTING.

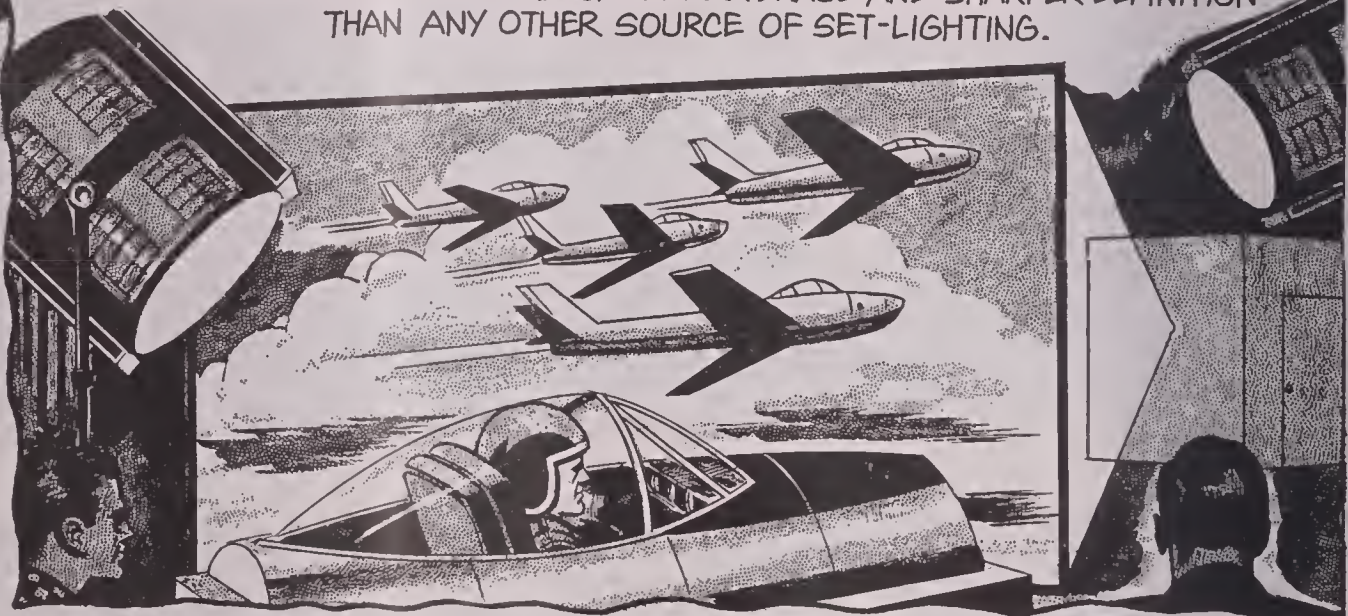

THE "NATIONAL" CARBON ARC... NOTHING BRIGHTER UNDER THE SUN

The term "National" is a registered trade-mark of Union Carbide and Carbon Corporation

NATIONAL CARBON COMPANY

A Division of Union Carbide and Carbon Corporation, 30 East 42nd Street, New York 17, New York

District Sales Offices: Atlanta, Chicago, Dallas, Kansas City, New York, Pittsburgh, San Francisco

IN CANADA: Union Carbide Canada Limited, Toronto



● THE ROTATOR LENS



Now for television and motion picture trick effects, turn your subjects upside down or revolve your scenes 360°, many other effects with this addition to the Camart Optical FX unit. Fully illustrated literature and sound film available.

● TIGHTWIND ADAPTER



DISCARDS SPLIT REELS AND FLANGES because the Camart tightwind adapter outdates them. Easily fitted to your rewind, save time and money using one rewind for 16mm and 35mm.

Price: **\$24.00**

● SLATE and CLAPSTICK

Cameramen prefer the large professional 10"x12" slate for sound production. Constructed of the highest grade materials available, special slate finish for easier removal of chalk marks.

New low price: **\$7.50**

PRODUCTION CLAPSLATE		
PROD. NO.		
DIRECTOR		
CAMERA		
SOUND	SCENE	TAKE
DATE		

● REGEL-LIGHTS

High intensity color corrected light on low voltage with REGEL LIGHTS. Rugged construction withstands hard wear. Six 150 watt bulbs converted to more than 5000 watts. Four 150 watt bulbs converted to more than 3000 watts. Literature and sound film available.

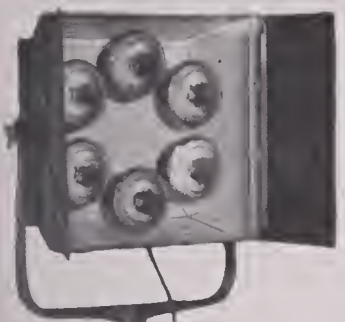

Model 600



3-D camera

Specially designed three dimension system and constructed by one of the country's leading experts in 3-D. Ideal for production of industrial and educational films. Unit includes two interlocked 35mm cameras, special optical 3-D system, sync motor drive and base. Write for further details.

CAMART TRIANGLE

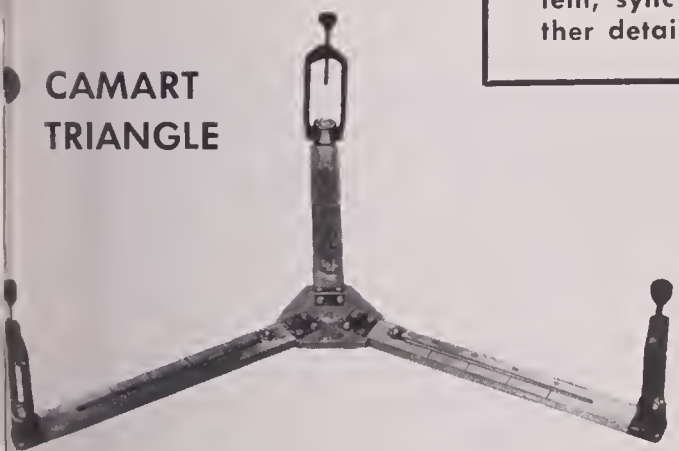

Our own exclusive heavy duty triangle which features new shoe with deep wells, center keystone casting locks the triangle legs and sturdy clamps assures a solid tripod support. Calibrated legs permit equidistant setting. Price: **\$29.50**

SPECIAL SERVICES

- AUTHORIZED BAUSCH & LOMB
- BALTAR LENS AGENCY
- FACTORY APPROVED SERVICE & REPAIR OF BELL & HOWELL EQUIPMENT.
- BALTAR LENSES MOUNTED FOR ALL 16-35mm CAMERAS.
- WORN and DAMAGED MOVIOLAS FULLY RECONDITIONED IN OUR SHOP.

Todd-AO—Newest Wide-screen System

“Oklahoma,” now nearing completion, marks the debut of this super-wide-screen system that employs completely new cameras that were engineered especially to take the wide-angle Todd-AO lenses and 65mm negative.

By ARTHUR ROWAN



TODD-AO camera, showing the 128 degree “bugeye” lens and the companion wide-angle viewfinder. Camera is not much larger than a Mitchell and is about the same weight, due to use of new type fiberglass insulation in blimp. Camera uses 65mm negative.

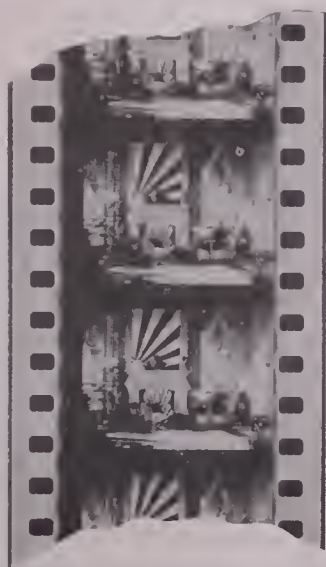

ABOVE is clip of Todd-AO 65mm film, and below, a clip of standard 35mm film for comparison. The Todd-AO film picture area is 3½ times that of the 35mm film. The projected Todd-AO picture has an aspect ratio of 2 to 1. Regular release prints are made on 70mm film to accommodate the seven sound tracks.

TODD-AO is a term being heard and seen with increasing frequency. It stands for the newest of wide-screen motion picture processes. The term is a combination of the name of Michael Todd, whose vision inspired the development of the process, and the initials of the American Optical Company whose research staff of more than 100 of the nation’s top engineers and scientists developed it.

Todd-AO is not merely wide-screen. It is *large* screen and it is wide angle. Todd-AO motion pictures are photographed on film that is 65mm in width—wider than the conventional 35mm film used in all other wide-film processes. Both negative and prints are made on Eastman Color film, which is processed by Consolidated Film Laboratories at Fort Lee, N.J.

On the same order as Cinerama, but vastly superior, since it is photographed with only one camera and projected with only one machine instead of three, Todd-AO gives the spectator a terrific sense of audience participation.

Aspect ratio of Todd-AO is 2-1, and projection is on a curved screen with a high-reflectance surface. A typical size would be 51 feet across by 25 feet in height, with a curve 13 feet deep at the center. Actual screen length along the curve would be 65 feet.

A new high-fidelity stereophonic sound system is employed that involves seven tracks—six sound tracks plus one control track.

Completely new cameras had to be built for the system. They are approximately the size of a Mitchell, but have a slightly larger head and wider film magazines to accommodate

the larger 65mm negative. The wider film allows greater flexibility and degree of clarity. The 65mm picture frame is $3\frac{1}{2}$ times the area of the standard 35mm frame. Where there are four sprocket holes on either side of the conventional 35mm film frame, the 65mm Todd-AO frame has five sprocket holes. Another feature is the higher speed of film travel. Camera speed has been stepped up from the conventional 24 frames per second to thirty, which tends to smooth out action on the larger screen.

As with conventional motion picture cameras, the Todd-AO takes a range of lenses of different sizes; but unlike the lenses used on 35mm motion picture cameras, which vary in focal length, the Todd-AO lenses are classified according to the angle of coverage. Thus the Todd-AO have a selection of four lenses that cover everything from a closeup to distant scenic shots. These range from the huge 128-degree "bugeye" wide-angle lens—so-called because of its enormous front element—down through the 64, 48, and 37 degree (angle of coverage) lenses.

At present two cameras are required in shooting Todd-AO productions—one having the 128 degree "bugeye" lens permanently attached, and the other designed to take the 64, 48, and 37 degree lenses interchangeably. The company presently is building cameras that will take all the Todd-AO lenses interchangeably, including the "bugeye," thus eliminating the need for two or more cameras for each setup.

Recently, the Todd-AO process was



ONE OF THE unique camera mountings employed by Floyd Crosby, ASC, who directed photography of the second unit of the initial Todd-AO production, "Oklahoma." Here "bugeye" lens was used on camera to make a running shot from a moving locomotive on a rail line near Nogales, Arizona.

demonstrated for the industry and press at Metro-Goldwyn-Mayer studios in Culver City, where are quartered the Rodgers & Hammerstein company, producers of "Oklahoma"—initial production in the Todd-AO process. Test footage photographed by Robert Surtees, ASC, and Harry Stradling, ASC, was screened which demonstrated the results

obtained with the four different Todd-AO lenses. Of particular interest was the way both cameramen had adapted the 48-degree lens for closeups in dramatic scenes. The same was true in the use of the 128 degree "bugeye" lens for exteriors. The scope of coverage of this lens, incidentally, is so great that cameraman and assistants must stand well back of the front plane of the camera when shooting in order not to be included in the scene.

All the lenses have a short, sharp vanishing point, and the depth of field is very shallow. This means that the assistant cameraman really has to be on his toes when moving crane and dolly shots are being made with Todd-AO cameras.

According to Surtees, who is directing the photography of "Oklahoma," Todd-AO is a much better approach to wide-screen film production and exhibition than any other large scope process, because of the overall larger negative area of the Todd-AO 65mm film. Moreover, he says, that by projecting prints made on 65mm film a far superior picture quality results on the screen.

"From the standpoint of optics alone," Surtees said. "Todd-AO is a superior picture process. The proportion of the screened image is better, too. In short, Todd-AO is the epitome of perfection for the director of photography. From the point of composition Todd-AO presents a much better format—one that affords greater compositional latitude for the cameraman and enables him to

(Continued On Next Page)



TODD-AO camera on location at Nogales, Arizona, where much of "Oklahoma" was shot. Director of Photography Robert Surtees, ASC, at left of camera and wearing wide-brimmed hat, spent many months in testing the Todd-AO equipment and making pre-production camera tests.



LOCATION filming for "Oklahoma" involved use of Todd-AO cameras on a wide array of vehicles for moving camera shots. Here camera, mounted on a helicopter, is being given final check by operator Robert Moreno.

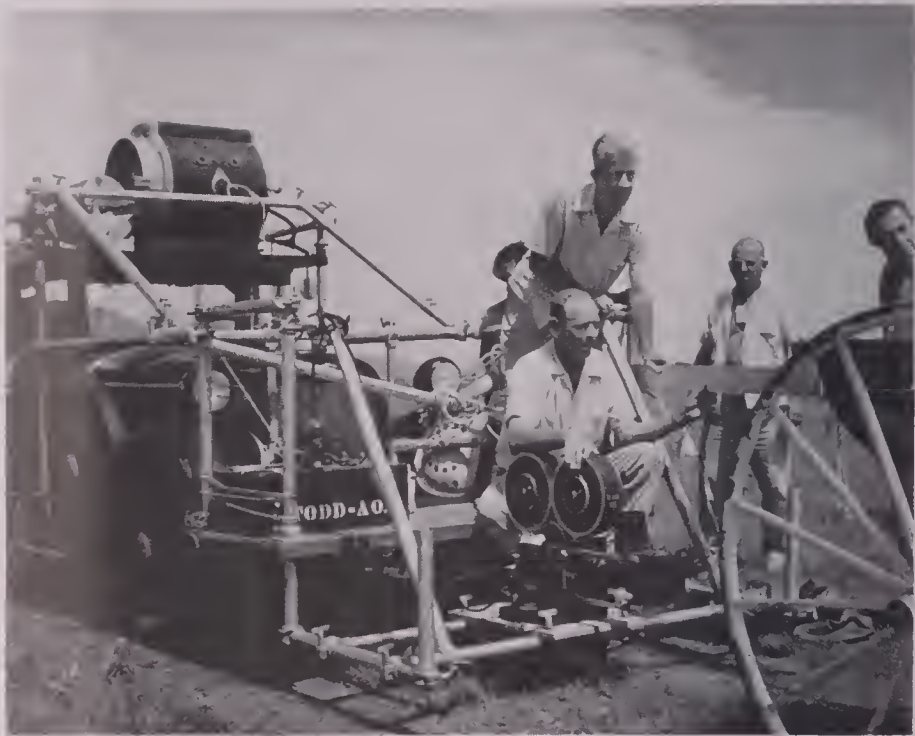

FOR A LOW angle running shot, the Todd-AO camera was mounted as shown here on a location camera car. Camera was focused beneath horse-drawn carriage at right to gain special effect shot through legs of the running horses. Floyd Crosby, ASC, directed the 2nd Unit photography.

do a great many things pictorially that he has never been able to do in 35mm with the 3 by 4 format."

"With Todd-AO," Surtees continued, "we don't have to work so close to the players as when shooting with 35mm cameras. We have to be especially careful how players will look on the screen with relation to the larger screen size, however, keeping the 'giant' effect to a minimum. Big closeups are better in Todd-AO; we don't have to worry about space at the sides as in the case with CinemaScope. In closeup and medium shot compositions, we never put a person dead-center in the scene. Also, we avoid panning with the movement of the play-

ers, but allow the players to move instead."

Todd-AO gives the spectator more of the feeling of participation—of actually being on the scene—perhaps, than any other wide-screen process. The objectional feature of the three panels that exists in Cinerama, which cannot be exactly synchronized (or at least not to date) and therefore results in jumping action and distortion, is naturally not present in Todd-AO. The picture is one single unit, as the reader may observe from the reproduction of the clip of Todd-AO film on page 494.

Except for one or two things, Todd-AO photographic technique is little dif-

ferent from conventional 35mm. The differences lie mainly in the technical operations of the assistant cameraman and the operator. For obvious reasons, panning must be held to a minimum. The cameraman must know precisely the optical limits of each of the four Todd-AO lenses—know what they can and cannot do.

Any "across-the-screen" action must be photographed very carefully if not avoided entirely, because of the rapidly changing speed of travel which moving objects or players seem to assume in cross-screen action when filmed with the wide-angle Todd-AO lenses. A running

(Continued on Page 526)

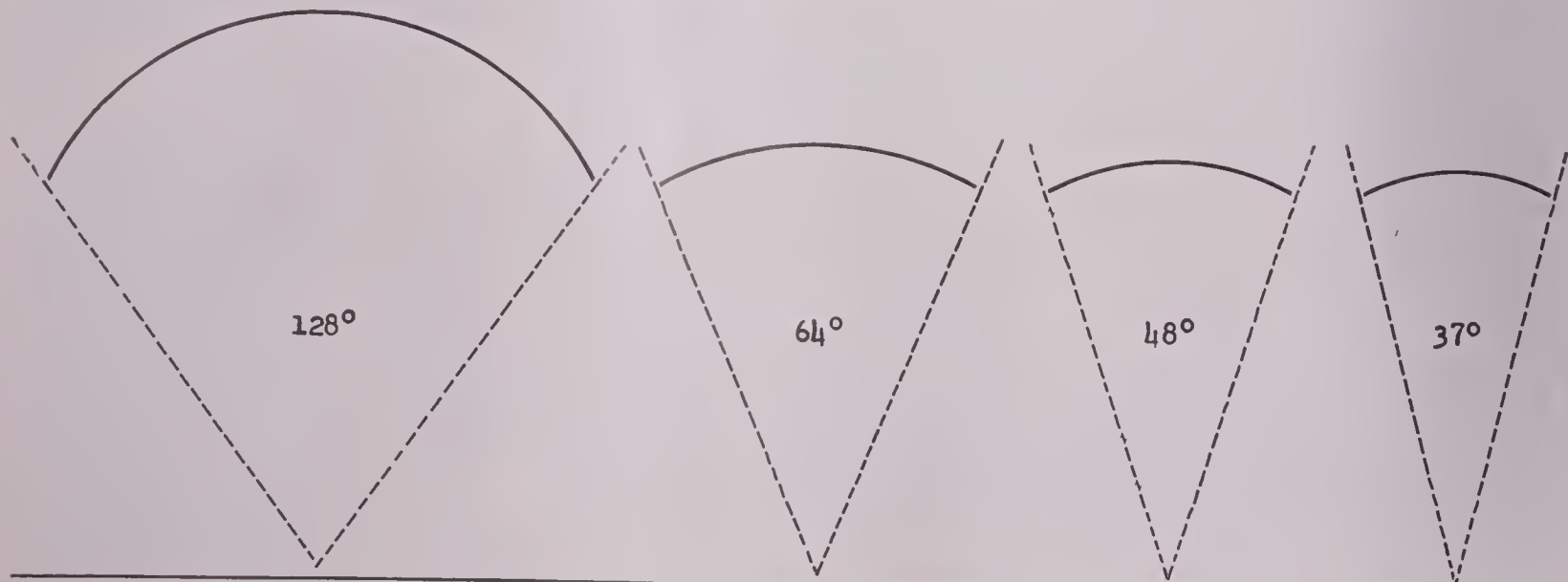

ABOVE DIAGRAMS illustrate the angle of coverage of the four Todd-AO lenses. Unlike the lenses used on standard 35mm cameras,

which vary in focal length, the Todd-AO lenses are classified according to angle of coverage. Depth of field is very shallow.

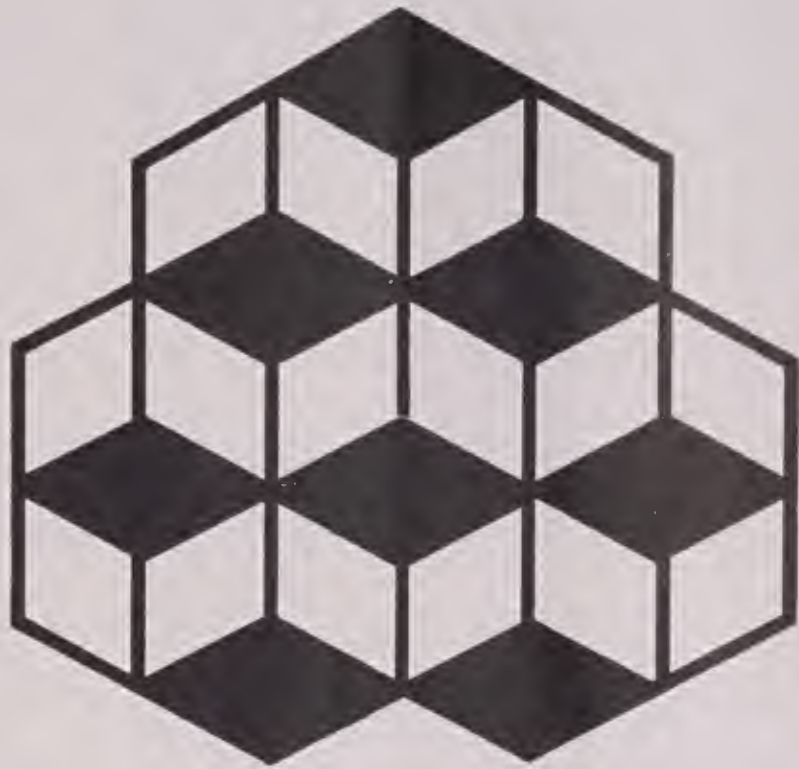

How many blocks? 6 or 7? *Appearances can be deceiving, but the good appearance of a Precision print is not an optical illusion. Immediately apparent are the results of Precision-quality processing.*

The individual attention given to each original through the entire operation has earned Precision its top spot in the film processing field. Leaders in the photographic profession know they can depend on Precision for accurate, intelligent handling of their material. And constant research continues for even better ways to serve your requirements.

*In everything there is one best...in film processing, it's **Precision.***



A division of J. A. Maurer, Inc.

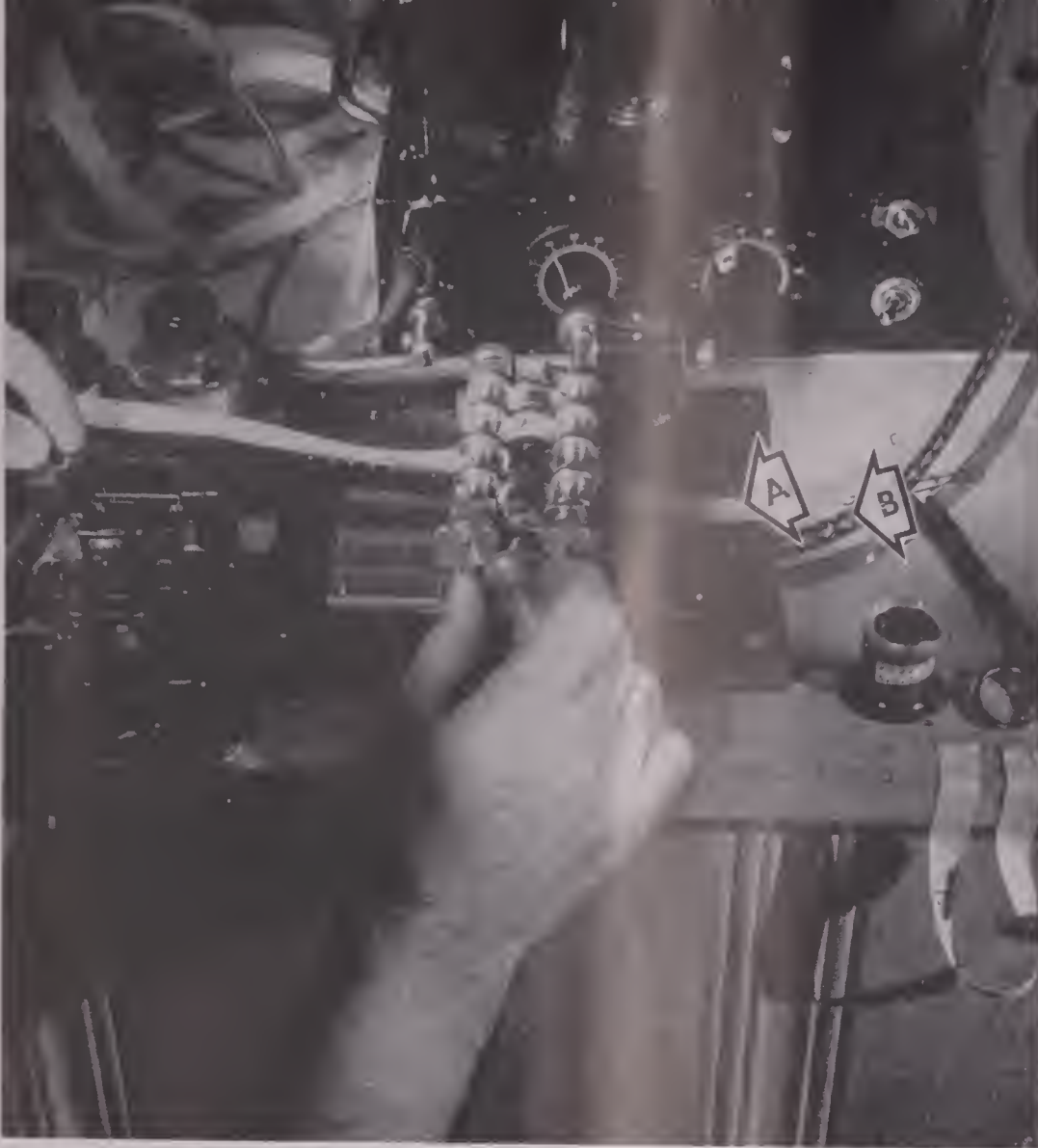

THE MULTIPLE OR "GANG" synchronizer is an essential tool in the process of editing "A" and "B" rolls. As shown here, the "A" and "B" film strips enter the synchronizer from the right, are locked in sync and remain so until editing is completed.

However, most 16mm release prints, particularly those in Kodachrome, are made directly from the camera "original" with a continuous contact printer. This direct printing procedure, involving only one transfer step or "generation," results in release prints having better characteristics than prints made from an intermediate "master." Where dissolves and other effects are desired in these prints, they are printed in during the printing process from the original scenes assembled for "A and B" handling.

In typical 16mm editing procedure, a work print usually is marked with a grease pencil at the points where effects are desired. Sometimes little markers made of heavy white paper known as Mercer Film Patches are employed. These have tabs which fit into the sprocket holes of the film, and are removed easily during the printing process. A crayon or grease pencil is used when certain symbols are to be marked on the film, indicating the type of effect that is to be inserted at a given point. This is indicated on line 1 in the charts shown in Figs. 1 and 2.

When matching the original scenes to the edited work print, the "A and B"

How To Edit 16mm "A" and "B" Rolls

The procedure for preparing 16mm films for the addition of fades, dissolves, and other optical effects.

By JOHN FORBES

IN PROFESSIONAL 16MM production, as with 35mm, optical effects are invariably made by the laboratory at the time of making the release prints. To facilitate this, film editors employ what is known as the "A and B rolls" procedure. This is a system of cutting in which the edited material is assembled on two or more "rolls" or reels instead of one, and enables the laboratory to add to the release print or duplicate negative such effects as fades, lap-dissolves, superimposures, etc. How this is done will be explained here.

The 35mm special effects editor uses a similar method when preparing scenes for optical effects. Common 35mm practice is to select two scenes between which an effect is desired, prepare these "A and B," and by the use of an optical single-frame printer, a new negative is made with the desired effect printed in.

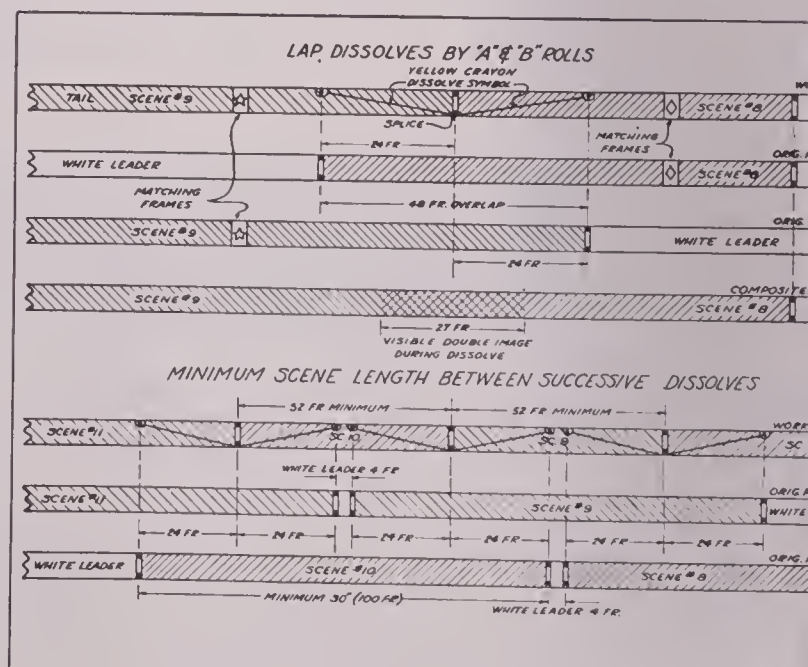

FIG. 1—This chart shows method of marking and identifying "A" and "B" films where lap-dissolves are to be made.

roll method requires the use of a multi-channel or "gang" synchronizer, such as that shown in the photo. Three channels are employed. With the work print head sync mark established in one channel of the synchronizer, the leaders of rolls "A" and "B" with corresponding sync marks are locked in place directly opposite in the two adjoining channels.

From this point, you proceed as follows: Attach the first original scene, or title, to the leader on the "A" roll, so that its action and edge numbers, if any, match the work print scene while passing through the synchronizer. (See lines 1, 2 and 3, Fig. 1). Using three take-up reels, with white leader only on the "B" roll at first, roll through the synchronizer, matching and attaching each successive scene to the "A" roll, until a crayon symbol appears on the work print indicating an effect, such as a dissolve for instance, is to be processed and inserted. (See line 1, Fig. 1).

Where the two work print scenes are spliced, do *not* cut off the outgoing original scene. Allow it to extend 24 frames beyond the work print splice (Line 2, Fig. 1). Now, match the incoming original scene to the work print, but instead of cutting it off opposite the work print splice, extend it 24 frames to precede the work print splice, cutting off the leader accordingly. (Line 3, Fig. 1).

This brings up the important point of making sure to *cut out of the work print*, when editing, the 48 frames for each dissolve, thus insuring that the original is long enough to extend the required 24 frames *each way* from the work print splice. This dissolve "switch-over" "A" roll to "B" roll results in a

48 frame overlap of the two scenes, opposite the work print symbol. (Lines 1, 2, and 3—Fig. 1).

Now proceed to match and attach successive scenes to the "B" roll with the white leader now continuing on the "A" roll. When the next dissolve symbol appears on the work-print, switch-over again to the "A" roll with the same overlap of 48 frames as before. Continue this procedure for the entire reel, so that some original scenes are on the "A" roll, others on the "B" roll, with white leader filling out the opposite roll. Hence a 400 foot reel of work print will be "matched" with two rolls ("A" and "B") of original scenes.

In making the release print, first the "A" roll is printed the full length, but the printer light is cued so that exposure is made only in the sections where the scenes are assembled, the light source fading out where leader is in the roll. Then the roll of partially exposed duplicating film is rewound, and threaded up again to the same punched starting sync mark as used when printing the "A" roll scenes. Then, the "B" roll is threaded into the printer, in contact with the roll of duplicating film, and the "B" roll scenes are printed. This time, the printer light fades on in order to print the "B" roll scenes in those areas of the roll of duplicating film where no exposure was made over the leader portions when previously printing from the "A" roll. Where the 48-frame dissolve overlaps occur, one scene fades out while the next scene is appearing. This coming and going double exposure, achieved by overlapping two fades, results in the dissolve effect planned.

Fades between scenes can be printed in two ways: first, by switching over

from "A" roll to "B" roll. (Lines 2 and 3, Fig. 2). This assembly method is advisable, as it clearly indicates to the printer that a fade is planned, and also, it enables a variable length of all-black in the print, between the fade-out and fade-in. (Lines 5 to 8, Fig. 2). With the second fade method (Lines 1 and 2, Fig. 3), scenes on the same roll can be cued to fade without switching over "A" to "B." This requires advising the laboratory that a fade is desired, usually indicated by temporarily attaching a piece of tape across the splice between the two original scenes, with the word "fade" on the tape. The first method is simple and variable.

Several "tricks" are possible when using the "A" and "B" roll method. So that a title can be printed or super-imposed over an action background, for instance, a title with white letters over a black background can be cut into the leader in the roll opposite the scene over which the title is to be printed. White lettered titles are desirable, but the letters should be positioned to occur over a darker part of the scene, for proper contrast or legibility. Brilliant colored letters can be used, depending upon the additive effect when combined with whatever color is predominant in the section of the scene over which the title is to be printed. Other superimposures are possible, such as arrows appearing to emphasize a situation within a scene in instruction or training films, etc.

Another alternative in the superimposing title procedure is to splice about 30 frames of black leader to the head of the title so that the printer can fade-in over the black leader, thus causing the title to cut-in instead of fade-in. With a little

(Continued on Page 524)

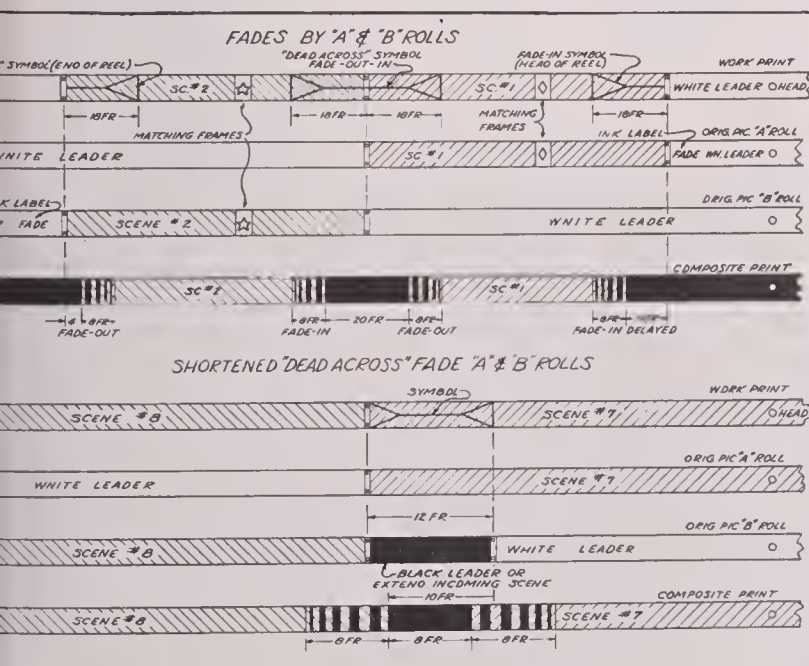

FIG. 2—Symbols and marking procedure for editing "A" and "B" film rolls for fades, using work print and original "A" and "B" rolls.

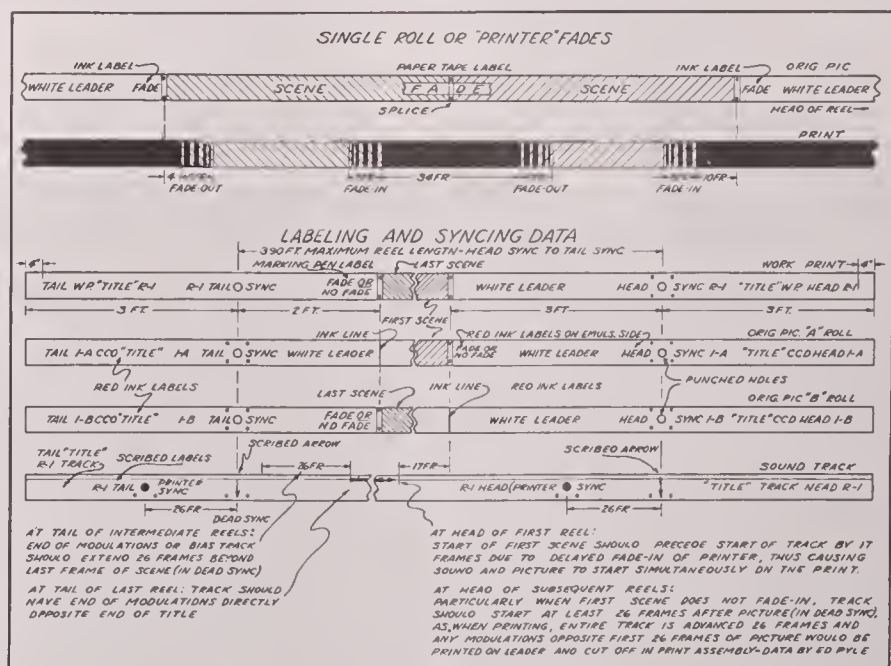
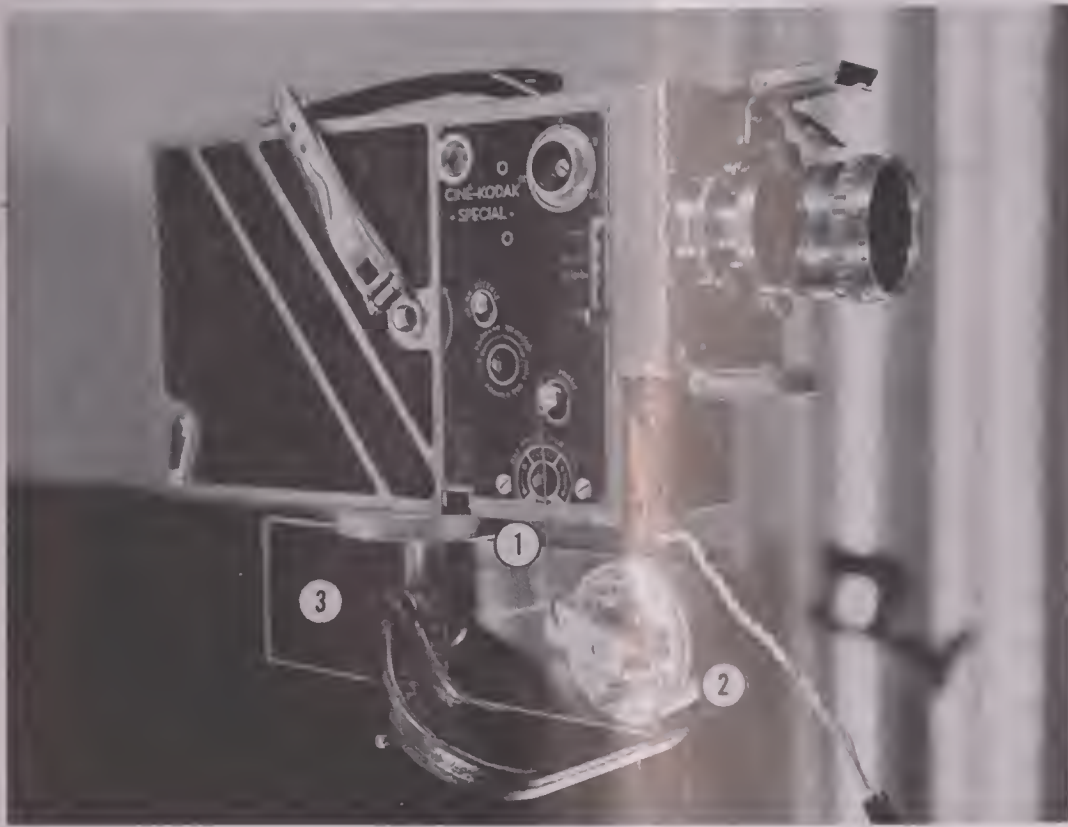

FIG. 3—Guide to editing 16mm negative for printer fades, with labeling and syncing data.—Charts courtesy Telefilm Studios, Inc.



CINE SPECIAL camera equipped with author's remote control for use in stop-motion photography. Shown is hookup wire (1) leading from single-frame release button on camera to lever of solenoid (2) which is mounted on plastic panel (3) attached to camera mount. Solenoid is powered by 6-volt lantern battery (not shown).

A Remote Control For 16mm Stop-motion Photography

By JOHN HOKE

IN SINGLE-FRAME cinematography with a 16mm camera, one important precaution that must be observed is that the camera must never move in its fixed position during the cycle of photography. If it is inadvertently moved the slightest amount, there will be a noticeable jump on the screen at that point in the sequence of action. And despite all the precautions that one can take in the way of locking the camera securely on a rigid tripod or other support, a 16mm camera used in this type of work sometimes is easily moved when it is operated by hand. The answer to this problem, of course, is to start and stop the camera by some method of remote control.

Many of the 16mm cameras now available provide for single-frame exposure, and therefore simplify the installation of a remote-control device. One of these is the Cine Kodak-Special. The control which the author devised for this camera is shown in the photo at the top of this page. Here, tripping the single-frame exposure button is accomplished by use of a lever solenoid (2) connected to the camera starting button by a length of wire (1).

In this application, the solenoid unit is mounted on a rectangular piece of clear plastic $\frac{1}{8}$ th inch in thickness (3). It is held in place by means of a C-clamp, which secures it firmly to the camera mount—in this case a metal tripod. Power to operate the solenoid is furnished by a 6-volt lantern battery. Extending from the camera is a generous length of cord having a push button at the end. This is shown in the left hand of the girl in the photograph at right, below.

While the photo above shows the use of a rectangular piece of plastic for the solenoid mount, the needs of individual

(Continued on Page 520)

AUTHOR adjusts camera for position, focus, etc., before starting to shoot. Here camera is mounted overhead on Graflarger stand.



PRODUCTION staff at work photographing stop-motion sequence. Subject is map on floor. Girl at left operates camera remote control.



CAMERA control button in hand, operator moves "line" on map fraction of an inch before exposing next frame of film in sequence.



EASTMAN

PROFESSIONAL

MOTION PICTURE

FILMS

W. J. GERMAN, INC.

Fort Lee

Chicago

Hollywood



CORNER in Camera Equipment Company's rental department showing range of editing equipment available on rental, lease or sale.

EVERY CAMERA that goes out on rental is given a thorough checking and, where necessary, overhauling upon its return to Camera Equipment Co.

CAMERA Equipment Co. maintains a constant service and engineering staff to serve patrons need of special equipment.

Equipment Source For Film Producers

Camera Equipment Company's rental service makes it unnecessary for independent film producers to maintain large inventories of equipment.

By FREDERICK FOSTER

THE PRODUCTION of motion pictures involves the use of equipment that is as varied as it is voluminous. In Hollywood, each studio is fairly independent of the equipment renter, owning outright equipment valued in the millions of dollars. Elsewhere, however, most film producers rely on suppliers of motion picture equipment to provide their day-to-day needs in everything from splicers to Mitchell cameras. One of these is Camera Equipment Company, New York City.

"Sales-Service-Rentals" is the laconic three-point statement which Camera Equipment Company carries in all its advertising and promotion. It may not have much significance to the mythical Martian, but it speaks volumes to practically every professional producer, director and cameraman engaged in the production of theatrical television, commercial, industrial, educational and documentary films.

Under the heading of "Sales" Camera Equipment is known far and wide as both distributor and manufacturer of perhaps the world's largest and most comprehensive assortment of motion picture equipment. The professional knows that whatever his requirements—a tripod, dolly, mike boom, editing machine, geared or friction heads, viewfinder, film viewer or the thousand and one other devices indigenous to his craft—Camera Equipment either has it in stock or will get it promptly.

Under the heading of "Service and Rentals" Camera Equipment offers such unique dependability—day and night—that many professionals regard it as an indispensable adjunct to their own operations. What in many enterprises would be regarded as "emergency" is taken in



FRANK ZUCKER (right), head of Camera Equipment Co., and son Burton look on as cameramen (not shown) make ready to film a recent Marciano-Charles title bout, for which filming assignment C. E. Co. furnished Mitchell cameras and other equipment.



THE COMPANY has available set lighting equipment every available type and make. Each piece is rigidly inspected before rented or sold.

routine stride by Camera Equipment Company.

For example, a producer gets a rush assignment to photograph in color the tribal ceremonies of Crow Indians as they induct an important business executive into the tribe. A vast amount of equipment, plus cameras, have to be in Billings, Montana, in two days. Notwithstanding that this is the day before Christmas, Camera Equipment assembles an emergency crew and airships the material in time.

A Hollywood production company making a film on the Brooklyn and New Jersey waterfront rents an enormous amount of equipment. The uninitiated sometimes asks why a large motion picture studio, with ample equipment of its own, resorts to renting from Camera Equipment Company when it is on a remote location. The answer lies in the magic word "service." When hundreds of thousands of dollars are on the line, producers find it false economy to risk taking pictures with inaccurate cameras. Every camera which goes out on rental—for either a single day or months at a time—is given a thorough shakedown and overhauling to make sure its calibration and working parts are 100% efficient before it is rented out again to the next user.

But Camera Equipment's daily routine is far from routine. For instance, the Glenn L. Martin aircraft company recently was engaged in a top secret assignment for the Government. Photography connected with the project called for very high magnification in both lenses and viewfinders. The Martin Company tried everywhere, but such equipment was nowhere available. Camera Equipment Company didn't have it

(Continued on Page 518)

Cameramen Are A Breed Apart

By EARL L. CLARK

Director, Associated Screen Studios, Montreal, Canada

SCRATCH A CINEMATOGRAPHER and invariably you will find a creature of odd habit and uncertain habitat—an extrovert when grinding out film and an introvert when without a camera; an individual with the soul of a poet and the mien of a slave driver. Yes, cameramen are a breed apart—particularly those lens artisans of the newsreel, the documentary and the special subject film.

This contrary by-product of man's need to see accepts his bizarre assignments with a stoical calm that belies any semblance of emotion. Yet the true camera fiend will go into ecstasies over the sight of sunlight pearly early morning beads of dew.

He will remember a depth-of-focus chart to the last inch and forget to remove his lens cap for the millenium. He will race traffic lights for fractional seconds to sit all day in a tree for bird pictures. Although he abhors such simple labors as camera reports, he will climb mountains, ascend towers and perch on precarious vantage points for a better angle. Normally law-abiding, he can invent the most ingenious reasons for entering prohibited areas.

In his contact with fellow men, the cinematographer retains his contradictory characteristics. He will loan valuable equipment to a needy competitor and steal his ideas with the same dispatch. He will spend patient hours wooing the confidence of little children and use his press pass to push, scrounge and intimidate—although he considers assault and battery unbecoming to men of distinction!

This, then, is the *unpredictable* tribe of lensmen. It is not certain whether the profession created them or whether their idiosyncrasies are of their own making; but whatever the school of thought, the problems, exploits and humor of the brotherhood recounted below probably will touch a nostalgic note in the hearts of veteran cinematographers. The identities will remain anonymous, but their brand of humor may offer a clue to some readers. Some of this humor is as objective as an exploding flashbulb.

Before filming a sequence at a Quebec asylum, the camera crew was lectured on the treatment of inmates. It was emphasized that many patients were suffering from fixation of mind; they understood little outside of one fixed orbit. Since the best curative was contentment, these people were humored

and allowed to do only that work which they liked. One man swept floors day after day. Another washed automobiles from morning until night. The doctors and nurses would line up their cars, bumper to bumper, for his benefit.

The camera crew was impressed by the lecture—but hardly as expected! One member decided that, when he became eligible for entry to the institution, he was going to have a phobia for filming nudes. Another was going to have a penchant for rocking-chairs. But the cameraman was the one most impressed. Each day thereafter he placed his car in line for the free auto wash!

This "fixed idea" ailment was responsible for a remarkable scene—an incongruous picture that bespoke both humor and tragedy. It was desired to illustrate the healthy outdoor activities of mental patients. Twelve inmates were to be filmed at their normal work in a hay field. Since the regular haymakers were miles away in another field, a dozen gardeners were substituted and sent to get the necessary pitchforks.

But pitchforks were unknown implements to these men of the garden. They selected, instead, tools familiar to their hands. The effect in the field was startling. One man chopped at the hay with an axe. Another sprinkled it with a watering can. A third swept up the hay with a broom. A hoe—a spade—garden clippers—twelve men working with familiar tools at an unfamiliar job.

There was genuine pathos in the scene. But it took the cameraman of the crew to recapture normal perspective with the crack:

"What's the matter with you guys? You nuts—or something?"

And so, when the camera crew left the asylum, there may have been more truth than was intended in their parting remark, "Guess the inmates can get back to normal now. The crazy cameramen have left."

Sometimes, the rapier thrust of photographic humor is parried and returned with interest. Halifax citizens are notoriously sensitive to adverse criticism of their home town. They look upon their cobble-stone streets, antique landmarks and iron-gated parks as century-old evidence of the important role their city plays as Canada's eastern doorstep. This nostalgic pride is nowhere more evident than in the old salts who frequent the waterfront to reminisce about

(Continued on Page 512)



SHOOTING wide-screen scenic film of Chattanooga, Tenn., with the new Bell & Howell FilmoRama CinemaScope-type lens is James E. Webster (left) and Gene A. Carr of Continental Productions. The same FilmoRama lens is also used for projection.



THE FILMORAMA lens mounted on a Bell & Howell "70" camera. It may also be mounted on other makes of 16mm cameras. For Filmo cameras, a special companion wide-angle viewfinder is available.

FilmoRama—CinemaScope In 16mm

Bell & Howell Co. introduces new 16mm anamorphic lens.

By LEIGH ALLEN

IT IS NOW POSSIBLE to shoot CinemaScope movies in 16mm. A new, wide-screen system for 16mm film producers has been developed by Bell & Howell Company, Chicago. Trade-named FilmoRama, it is patterned after 20th Century-Fox's 35mm CinemaScope and now makes possible the production of 16mm films in the CinemaScope format by makers of amateur, industrial and educational motion pictures. It consists of a single anamorphic or "squeeze" lens attachment, which is used for both photography and projection.

The FilmoRama lens attachment, pictured above, can be used on all existing 16mm cameras; its use is not confined to the Filmo camera alone. A universal bracket, also shown in the photograph, makes it easy to mount the lens before the camera. For use with the Bell & Howell "70" model cameras,

a special wide-screen viewfinder is available as extra equipment.

The FilmoRama lens has six elements which provide extreme sharpness. Each individual lens is precision collimated for crisp definition to full corners and edges, according to Bell & Howell. The company claims it is unequalled for light transmission: all air surfaces are magnesium fluoride hard coated. Color banding and fringing is said to be entirely eliminated by full correction of all color aberrations.

When FilmoRama was first introduced, it was expected that its chief use would be in the production of sales and industrial films, and that its use in projection would find a ready market among many foreign theatrical film exhibitors who screen

(Continued on Page 521)



Magnaphonic
SOUND SYSTEM

There's a reason...

why Magnasync enjoys
continued worldwide leadership...

QUALITY...ECONOMY...INTEGRITY

Air S
Univers
Nava
Rad
Protes
Fotovox, Inc. Photographic Technicians Pr
W T S P--Florida Southern Pacific Railroad
Tele-Filmica Maxol, S.A., Havana Southern
Ford Foundation Twentieth Century-Fox, Inc.
University of Wisconsin Gospel Films, In
National Film Board of Canada Cine Associat
R.K.O. Radio Pictures, Inc. Pacific Picture
Gilfillan Bros., Inc. U.S. Air Forces Westingho
Iowa Conservation Commission Providen
Fairchild Recording Equipment Co. Galbrea
Magnolia Petroleum Co. Kearney & Trecker Cor
W K A Q, San Juan, Puerto Rico State Colle
Naval Air Station Beeland-King Film Productions
Columbia Pictures Providence Bible Institu
Television Recording Service, Inc. Iowa Farm Bur
Westinghouse Electric Corp. Sound Recorders, L
Viguie Productions, Inc., Havana U.S. Navy Nort
Paramount Pictures Corp. Baptist Gospel Film
U.S. Department of Agriculture University of Iowa
International Productions Goodyear Aircraft Corp
Avalon Pictures, Inc. Reverend D. Kirk Hammond
Southwest Film Laboratory, Inc. Academy Soun
Naval Ordnance Wurtele Film Productions Acade
Bible Institute of Los Angeles University of Tennessee
University of Mississippi Rampart Productions Sc
Protestant Radio Center, Inc. U.S. Recording Co.
South Dakota State College Aspen Pictures Dallas Jo
Twentieth Century-Fox, Inc. Filmscope
U.S. Air Forces Magnolia Petroleum Co.
Southwest Film Laboratory, Inc. Gilfillan Br
Cine Associates
Kearney & Trecker
University of Iowa
Arcturus Manufacturing
Goodyear Aircraft Corp.
Fairchild Recording Equipment Co.

Select

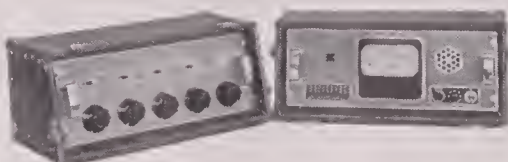

CONSOLE SETUP

Revolutionary New

MIXER Model G-924

for Motion Picture Sound Recording
and Broadcast Remote Transmission



CONVENTIONAL SETUP



DISTRIBUTORS

CAMERA EQUIPMENT COMPANY
1600 Broadway, New York 19, N.Y.
Judson 6-1420—Cable: "CINEQUIP"

MAGNETIC RECORDERS COMPANY
7120 Melrose Ave., Los Angeles 46, Calif.
WEbster 3-5545

ZENITH CINEMA SERVICE, INC.
3252 Foster Ave., Chicago 25, Illinois
IRving 8-2104

AMERICA'S LEADING MANUFACTURER OF MAGNETIC FILM RECORDING AND REPRODUCING DEVICES



THEATRE
SOUND
EQUIPMENT



3-CHANNEL
REPRODUCERS



MULTI-CHANNEL
INTERLOCKED
DUBBERS

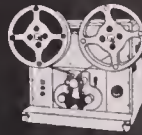

STUDIO DUBBERS
and RECORDERS



QUALITY AMPLIFIERS for
MAGNETIC RECORDING and REPRODUCTION

MAGNASYNC MANUFACTURING CO., LTD. • 5521 SATSUMA AVE., NORTH HOLLYWOOD, CALIF. • POplar 6-1692

The Importance Of Variable Camera Speeds

Knowing how to use them to advantage
will make you a better cine photographer.

By ALVIN D. ROE

UNLIKE the professional cinematographer whose daily work is pretty much confined to the routine of sound stage shooting, the amateur cine photographer works in a more versatile field. His is more of a creative camera work. Like some musicians, he "makes it up as he goes along." Naturally, the amateur must be versatile, must be able to improvise, and to cope with a wide range of conditions and situations. This requires a wide knowledge of cinematographic technique.

One of the important things he should know is the value of using, when the occasion demands, the range of camera speeds which his camera provides—and most cine cameras do provide two or more, as a rule. Yet, many owners of cine cameras have yet to explore the interesting if not amusing effects to be

achieved by shooting pictures at 8, 32, or 64 frames per second, instead of the normal 16 or 24.

For example, a speed of eight frames per second—half normal speed—will compress the time required for a given action by making the motion appear twice as fast as normal. On the other hand, a higher speed, such as thirty-two frames per second, slows movement in the scene and makes the time element twice as long.

The speed at which the camera is operating not only affects the time element on the screen, but also affects the exposure time for each frame of film passing through the camera. The eight frames per second half-speed is more often used to gain exposure time than for some special effect in the action. For example, take a filmer's camera that

DIAPHRAGM COMPENSATOR						
Lens Stop Conversion						
For Various Camera Speeds						
16 mm. AND 8 mm. CAMERAS						
8	12	16	24	32	48	64
Pictures per Second	Pictures per Second	Pictures per Second	Pictures per Second	Pictures per Second	Pictures per Second	Pictures per Second
LENS STOPS COMPENSATED FOR SPEEDS ABOVE						
F. Value	F. Value	F. Value	F. Value	F. Value	F. Value	F. Value
2.8	2.3	2.	1.8	1.4		
3.2	2.8	2.3	2.	1.8	1.4	
4.	3.2	2.8	2.3	2.	1.8	1.4
4.5	4.	3.2	2.8	2.3	2.	1.8
5.6	4.5	4.	3.2	2.8	2.3	2.
6.3	5.6	4.5	4.	3.2	2.8	2.3
8.	6.3	5.6	4.5	4.	3.2	2.8
9.1	8.	6.3	5.6	4.5	4.	3.2
11.3	9.1	8.	6.3	5.6	4.5	4.
12.5	11.3	9.1	8.	6.3	5.6	4.5
16.	12.5	11.3	9.1	8.	6.3	5.6
18.	16.	12.5	11.3	9.1	8.	6.3
22.	18.	16.	12.5	11.3	9.1	8.
25.	22.	18.	16.	12.5	11.3	9.1
32.	25.	22.	18.	16.	12.5	11.3
36.	32.	25.	22.	18.	16.	12.5
45.	36.	32.	25.	22.	18.	16.
64.	45.	36.	32.	25.	22.	18.

EXAMPLE: With a light value of F.8 at 16 pictures per second which is normal to shoot at a speed of 32 pictures per second, lens is opened to F.5.6; to shoot at a speed of 8 pictures per second, lens is closed to F.11.3. SHUTTER OPENING IS CONSTANT.

ABOVE CHART will enable you to determine quickly at what stop to set lens, when changing camera speed from normal 16fps. (Chart reproduced courtesy Jackson Rose.)

exposes film at normal speed at 1/30th of a second. His lens is f/2.9 and he wants to shoot a well-lighted street at night using Kodachrome. By setting camera speed at 8 frames, he will gain increased exposure equivalent to approximately f/1.9. Of course, any movement within the scene will be speeded up and

(Continued on Page 516)



SCENES of waterfalls and rolling surf become more impressive on the screen in the languid, slower motion provided by 24 or 32 fps.



FAST ACTION, such as this, can be shot straight-on at 24 or 32 fps. At 16 fps., a slight blurring will occur.

ONE-STOP SOURCE for FILM PRODUCTION EQUIPMENT

"The Department Store of the Motion Picture Industry"

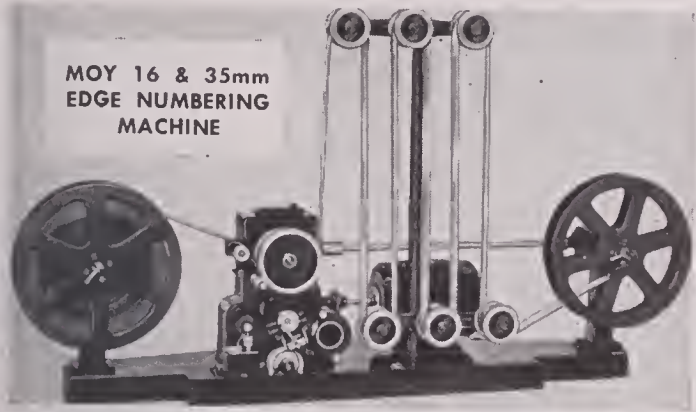

MOY 16 & 35mm
EDGE NUMBERING
MACHINE

VISIBLE EDGE FILM NUMBERING Identifies Your Films Instantly

Save many man hours now lost classifying films without titles. The Moy edge numbers every foot of film and simplifies the task of checking titles and footage.

Prints black or yellow from automatic metal numbering black on opaque or clear film. 2000' capacity, speed 50' per minute. 16mm model print between perforations only—35mm prints between perforations or on outside edge as specified.

Recent Purchasers are

Columbia Broadcasting System, N.Y.
American Optical Co., Buffalo, N.Y.
Cinerama Productions, New York
Reeves Soundcraft Corp., Springdale, Conn.

WITH NEW, IMPROVED
INKING SYSTEM

\$2,250

Bridgomatic

FILM PROCESSING EQUIPMENT

DEVELOPS

16/35/70mm

FILMS in Seconds

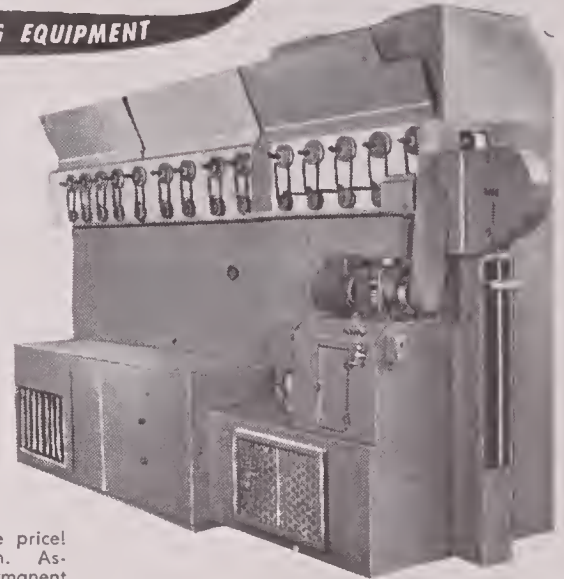

BRIDGAMATIC 470C — one of 12 models,
16/35/70mm, including color machines.

Nothing like it near the price! Requires little attention. Assures sharp, clear, permanent images. BRIDGAMATIC removes the guess—controls production from the start. BRIDGAMATIC tells the tale instantly—no time lost waiting for outside jobs. Protects precious negatives and soundtracks—and clean-dries in minutes. Ideal for TV stations, Industrial Producers, Photo-finishers, Microfilmmers, Colleges, etc.

Price range \$1095 to \$4945
for most popular models

A PRODUCT OF FILMLINE CORPORATION

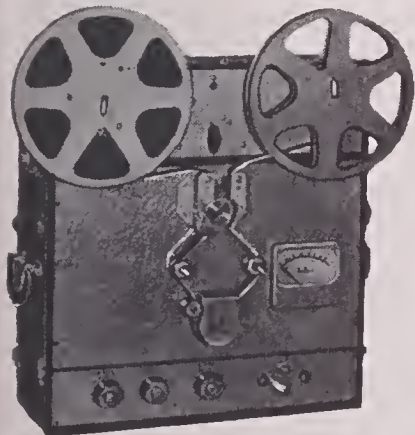

The Spectacular HALLEN MAGNETIC FILM RECORDERS

Model 25B—Complete "Lip-Sync" Recording System

- The utmost in professional sound stage quality and simplicity of operation. Weighs only 73 lbs.; one case, easily portable.
- Hallen "Drum System" has the Academy Award winning "C. C. Davis Filter suppressor", the most stable film motion yet developed.
- Simultaneous monitor of recorded track • Three simultaneous inputs—two for microphones and one for music and background effects.
- 16mm and 17 1/2 mm track placement approved as standard by Motion Picture Research Council.
- High-speed forward and rewind, using three separate motors, assure smooth take-up • Monitor Speaker and power supply are removable from the recorder unit.
- Licensed under A.T.&T. and W.E. patents. F.O.B. West Coast...\$1495
Complete line 16, 17 1/2, 35 and 17 1/2 /35mm Recorders

NEW!

COLORTRAN COMBINATION KIT

All Hollywood Type
Controls Included
in this Newest Kit
of ColorTran's
Famous

"Packaged Lighting"

"A STUDIO IN A SUITCASE"

ColorTran puts that "Hollywood Touch" into your pictures. Replaces heavy, cumbersome and expensive equipment. Ideal for studio and location shots. Imagine being able to use 5000 watts of light from ordinary house current. This New Combination Kit includes Senior ColorTran Converter, Senior Gravelite with Senior Stand, Junior Gravelite with Junior Stand, "750" Spot with two diffusors, gator grip spot clamp, Gobo stand with Flag and Net. Compactly packaged in two fibre cases, easily portable. Complete.....\$293.75



Other ColorTran Kits available. Write for Catalog

S. O. S. CINEMA SUPPLY CORP.

Dept. F, 602 WEST 52nd St., NEW YORK 19, N. Y.

Phone: PLaza 7-0440 Cable: SOSOUND



TWO PHOTOS on this page show a typical professional treatment of a dramatic scene in which the long shot (above left) is followed by a detail-revealing closeup that tells what the safecracker is doing.

MOVING IN closer, the camera reveals that the man is rigging wires in a gang's safecracking preparation. The closeup gets the point across at once and with less footage than a long shot would require.

The Place Of The Closeup In Your Movies

The closeup is one of the most important elements in story-telling films. It belongs in amateur films, too. Knowing how and where to use it is a trick every filmer should know.

By JOHN FORBES

THE CLOSEUP, perhaps, is responsible as much as anything else for the triumph of the motion picture over the theatrical stage as a source of entertainment. This is because movies, through the medium of the closeup, bring the story closer to the spectator.

Here, then, is a clue for the amateur movie maker who would pursue the professional manner of styling his movies. The closeup is the easiest and the best method of injecting maximum interest in the pictorial account of almost any subject that can come before the lens of an 8mm or 16mm camera.

The thing that should be remembered

is that it is just as easy to shoot a closeup as a long shot; but a closeup requires less film because it takes the spectator less time to observe details in the more vivid, closer shot. An example of this is the situation pictured above in the first two photos. The first shows a safe-cracking operation filmed from a medium distance. Just exactly what the man in the background is doing cannot be clearly seen at that distance; moreover, if the shot was held until the action was completed, it would be overly tedious. So what did the professional do here? Moved in for a closeup of the vital ac-

tion—the safecracker wiring the safe for the blast, as shown in next photo.

Now the reader may never be called upon to shoot action of this kind, perhaps, but this example of professional treatment will serve to guide him in executing the photography and subsequent editing of some similar situation, i.e., action introduced from a medium or long shot.

If for no other reason than to conserve film by the increased number of scenes he thus can get on a roll, the cine amateur should think more and more in terms of closeups when shooting.

We are often asked to define a closeup—its proportion with relation to the scenes and precede and follow it.

This depends a great deal upon the subject. Where the subject is a person, then the type of closeup will depend upon the theme of the story, the action at hand, and the emphasis or the effect one wishes to create at this point in the production. Therefore we have a fairly wide range of closeup formats to choose from. A "tight" closeup consists of fram-



ARTFUL composition of a closeup can point up with considerable emphasis important story-telling dialogue between two people.

ing the subject's head tightly against the frame of the picture—sometimes cutting into the forehead. Where subject is to move about slightly, the camera will shoot the closeup a little farther back, so that as subject moves he does not go outside the frame line.

Closeups, of course, are not always confined to persons or players in a film story. There are hands in interesting or story-telling action, and feet; and then there are any number of small objects which require closeup filming in order that they may be seen in greater detail on the screen. Where the subject is a flower or some other inanimate thing, a closeup will consist of showing the subject full screen size.

Smart cine filmers given to traveling and recording the interesting detail of places they visit will invariably include closeups of intricate designs in architecture, such as is to be found in Taxco, Mexico, or in India. A Taxco cathedral, for instance, is an enthralling sight when viewed from any distance, but its real beauty is revealed in closeups of architectural detail.

When filming photoplays or continuity films in which people appear, the real importance of closeups presents itself. Here the closeup singles out the leading

(Continued on Page 510)

A Film Rule For Film Makers

A novel tool for the serious cinefilmer that will aid him in cutting and editing films.

DO YOU KNOW how many frames you should allow for a fade? For a lap-dissolve? Or how long an 8mm or 16mm title should be? This information is set down in a unique film ruler designed by Ray Mercer, A.S.C., head of one of Hollywood's oldest independent title making and special effects laboratories. With the Mercer film rule as a guide, the amateur can quickly arrive at the answer to a number of problems in film making. Made of metal, the rule—pictured at right—provides a wealth of vital data for both amateur and professional, for the making of 35mm, 16mm, and 8mm films.

Ray Mercer, in discussing use of the rule, reveals pertinent information relative to film making and editing for amateurs in a leaflet his company offers entitled "Professional Hints on Cutting and Editing Your Own 16mm Film."

"In telling a story cinematically, always remember that if your subject or scenes are entertaining, then and only then does your picture justify existence," says Mercer.

"Every scene must have significance and must sustain interest. Therefore judicious care and thought must be given to the footage of each scene. If a scene is too long, it drags and thus dampens interest. If it is too short, its point may be lost. Unfortunately, no rule or formula is applicable to this important phase of film editing. But with the above thoughts in mind, plus some imagination and a little experience resulting from the "trial and error" method, you should achieve a fair amount of success.

"Film editing is basically an art. True that definite mechanics are involved which should be performed almost instinctively. But, one artist is only better than the other artist (both possessing comparable technique) because the former possesses more imagination. Therefore, strive for the mechanics first.

"Since the average amateur shoots his own film, he is in a position to control the editing to a great extent

(Continued on Page 510)

THE MERCER Film Rule designed for movie makers, film editors and others as an aid to quickly determining such information as how many frames in a foot of film; how many frames per word should be allowed for a title; the average length of a fade; of a dissolve, etc.

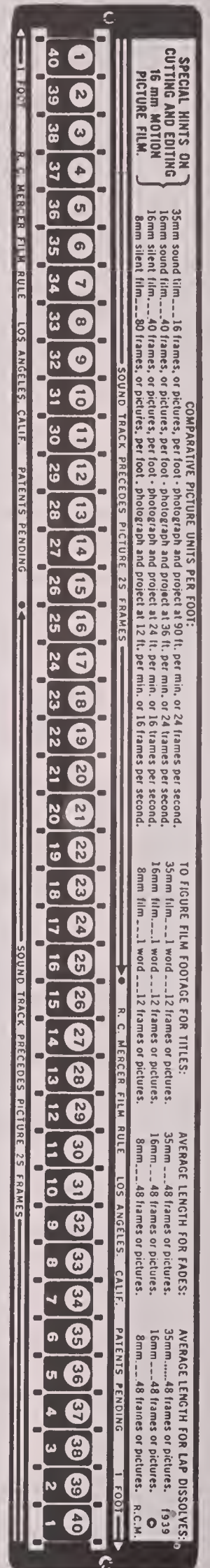

HIGH-SPEED

PROCESSING

The **HILLS** Filmatic

High Temperature 16mm
Film Processor

- REVERSAL
- NEGATIVE
- POSITIVE

SPEEDS UP TO 115 FT. PER MIN.
BUILT IN REPLENISHING SYSTEM
DAYLITE OPERATION
COMPACT — SELF-CONTAINED
NOTHING ELSE TO BUY
ECONOMICAL PROCESSING
NO INSTALLATION



The Filmatic Model 16 HT is a completely automatic high-speed, high temperature processing machine. Thermostatically controlled operating temperatures at every step. Designed to process any 16mm sound or silent film at speeds up to 115 feet per minute. For illustrated folder and additional information write to William Halpern, Sales Representative, 8240 Fayette St., Philadelphia 19, Penn.

HILLS

MANUFACTURING CO.,
LANSDALE, PA.

A FILM RULE FOR FILM MAKERS

(Continued from Page 509)

by shooting with forethought. For instance, he can first establish locale with a long shot. In order to permit the audience to become a little more intimate with the subject, cut next to a medium shot which is considerably closer than the first long shot. The long shot and medium shot are left on the screen for sufficient time to familiarize the audience with generalities. Now punctuate definite points of interest by cutting to a closeup. The closeup scene may be compared to an underlined word—it concentrates attention on just one point, eliminating any distracting influence. Therefore, this closeup scene need not be on the screen quite as long as the long shot or medium shot. In other words, less film footage need be devoted to the closeup. In shooting closeups, however, bear in mind that the action of players must be slower than in the long shot or medium shot, to prevent blurring of the image.

“The artistry of the film editor is determined by his ability to properly intercut the various long shots, coordinated pattern so that the story is told without straining the audience’s attention.

“The next important step is to establish proper cinematic timing between the various episodes or sequences in your film. In this important procedure the Mercer film rule is a necessary adjunct to insure ease of operation and accuracy of results. By this time you have acquainted yourself with the significance of the fadein and fadeout. The former is comparable to the rising of the curtain in the legitimate theatre, and the fadeout represents the lowering of the cur-

tain on one of the acts. Thus with the fadeout you have a definite cessation of time, and you will use this cinematic device to signify the ending of an episode and the beginning of another sequence. The Mercer film rule will quickly determine for you the length of the fade and the method for marking it to enable the laboratory to carry out your requirements, where these effects are to be laboratory-made.

“On the other hand, should you desire a quick transition from one locale to another, use the device known as the dissolve. Here the Mercer film rule will facilitate the accuracy of marking one’s film for the laboratory where such an effect is to be added. Thus, through the judicious use of fade or dissolves, real professional embellishment is given amateur films.

“Most 8mm and 16mm home movies require titles. Here again the Mercer film rule can be of immense value in aiding the amateur to determine the number of frames that he should allow any given title composition. The ideal allowance for a subtitle for an 8mm film, for example, is 12 frames per word. If the title consists, say, of 25 words, reference to the Mercer film rule will show that such a title should be 600 frames or 7½ feet in length and will be on the screen a little over a half a minute (projected at 16 f.p.s.).”

It goes without saying that any tool or gadget that will ease the task of shooting, editing or titling movies deserves a place in the movie amateur’s kit of tools.

THE CLOSEUP IN YOUR MOVIES

(Continued from Page 509)

characters and shows them more intimately on the screen. Any heavy emoting of characters in a play should be photographed in closeup; this adds the necessary emphasis to the action.

In the professional Hollywood films, closeups are utilized to emphasize bits of action important to the story because such action is usually only vaguely discernible in medium or long shots—as in the scene of the safecrackers pictured here. For this reason, a shot of a person writing should be followed immediately by a closeup of what he is writing—a shot, which in Hollywood parlance is more properly termed an “insert.” Similarly, a scene showing a man reaching into a desk drawer should be followed up by a closeup of what he found there—unless the story demands a different treatment. A person shown in a medium shot operating a machine can be made

more interesting if a closeup of what he is doing with the machine immediately follows.

Closeups serve as reaction shots, too. These show the audience the human reaction of one or more persons in a scene to some action or sound, startling or otherwise, taking place as the story unfolds. A simple example of a reaction shot would be cutting quickly to a closeup of a man’s face as he observes a pretty bathing girl pass by at the beach. The essence of the reaction shot is brevity; to let it linger on the screen too long, kills or at least greatly reduces its impact.

The best of the documentary film makers utilize closeups a great deal to reveal new and interesting things close up on the screen—to reveal important details at close range. An unusually well-made amateur film on the subject of pot-

DEDICATED TO BETTER PERFORMANCE



COLLAPSIBLE 3-WHEEL DOLLY

For motion picture and TV cameras. Sturdy cast aluminum. For standard or baby tripods. Additional baby tripod point holders to control spread of tripod legs. Adjustable spring seat. Extra wide rubber wheels. Bronze tie down clamps and other features.

For studio or location. Folds into one compact unit. Can be used with professional or semi-professional tripods.

'HYDROLLY'

TV OR
CAMERA DOLLY

The advanced dolly for instant moveability — streamlined, lightweight, exceptionally sturdy. Nothing to get out of order. Many new advantages for easy operation. Hydraulic lift type for fast upward and downward motion of TV and motion picture cameras.

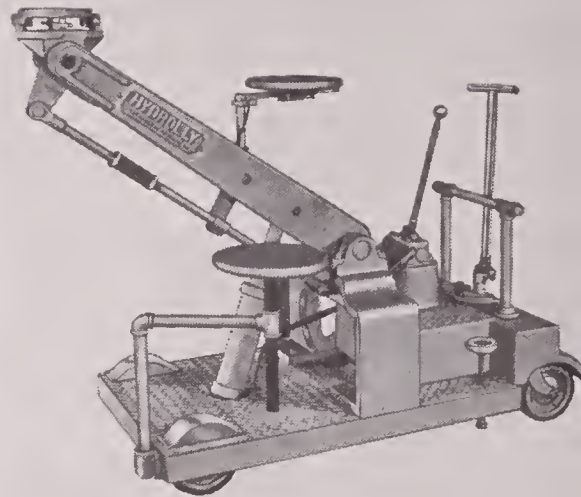

Swivel seat. Adjustable leveling head. Seat for assistant. In-line wheels for track use. Steering wheel, rigid floor locks. Hand pump or combination hand and motor pump. Easily transported in a station wagon. Fits through a 28" door.

SYNCHROMASTER SYNCHRONIZER

Our Exclusive Distributor
Neumade

Any combination of 16mm and/or 35mm sprockets assembled to specification. Cast aluminum. Foot linear type, adjustable frame dial. Fast finger roller release. Contact rollers adjusted individually for positive film contact. Sprocket shaft slip lock, foot-age counter, etc.



RENTALS

SALES • REPAIRS • SERVICE

LENS COATING

"T" STOP CALIBRATION

DESIGNING and MANUFACTURING

lens mounts & camera equipt.
for 16mm, 35mm, TV cameras.

BAUSCH & LOMB "BALTAR"
LENSES and others

for motion picture, TV camer-
as. 15mm to 40" focal length.

COMPLETE LINE of 16mm, 35mm
cameras, dollies, synchronizers,
animation equipment, cutting room
and time lapse equipment.

BELL & HOWELL: Standard, Eye-
mos, Filmos. MITCHELL: Standard,
Hi-speed, BNC, NC, 16mm.

SEND FOR CATALOGUE

ColorTran Groverlite

SENIOR & JUNIOR KITS

"A STUDIO IN A SUITCASE"

ColorTran re-
places heavy
and expensive
equip-
ment... gives
you illumina-
tion up to
5000w. from
an ordinary 20 amp. house current. Equipped with
barndoors, diffuser slots for silks, snoots and other
accessories. Ideal for studio or location shots.



PORTABLE MICROPHONE BOOM

For Studio or on Location. Light-weight — collapsible — for TV and motion picture production. Sturdy construction. Boom telescopes 7 to 17 ft. Rear handle for directional mike control. A remote control permits 360° rotation of the microphone. Operator can push the boom and operate

microphone swivel simultaneously. Extension rods make it simple to operate microphone rotation from floor. Microphone cable hangs outside of boom, preventing cable from tangling with the rotation mechanism. Ball bearing casters, rigid foot locks, pneumatic drop check for lowering the boom, etc.



VARIABLE- SPEED MOTOR with TACHOMETER

for Cine Special or Maurer Cameras

115 V. Universal Motor — AC-DC
Separate Base for Cine Special.
Variable Speed 8-64 frames.
Adapter for Maurer Camera.

INTERCHANGEABLE MOTORS: 12
volt DC Variable Speed 8-64 frames.
115 Volt AC 60 Cycles, Synchron-
ous Motor, Single Phase.

ANIMATION MOTORS: Cine Spe-
cial, Maurer, Mitchell, B & H Motors,
for Bolex and Filmo Cameras.

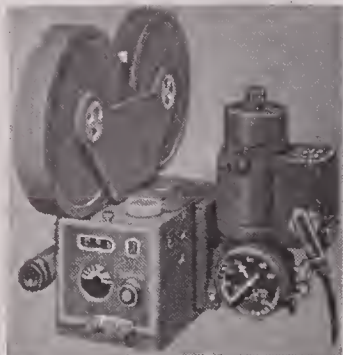
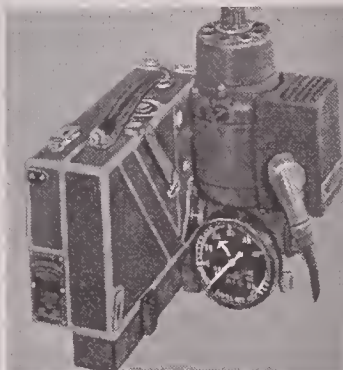

Now ready for Immediate Delivery
**THE NEW PLUG-IN "MIRACLE
 BUTT -WELD PRESTO-SPLICER"**

Producers, Labs., Film Editors:—

New electric "butt-weld" produces miracle-fast splice for cutting negs (no picture loss), no floss, eliminating A and B film editing, for all types including color.

Presto-Splicer "Pro 3" Splices All Types Safety, Picture & Magnetic Film Permanently in 10 Seconds!

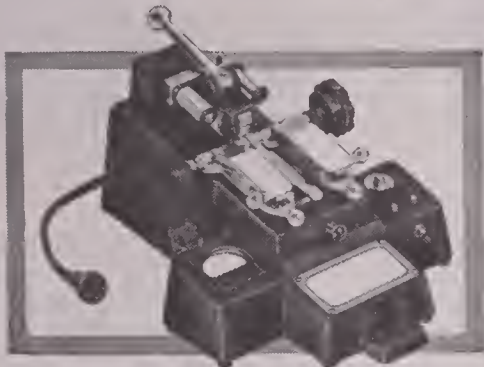

... with new
PLUG-IN HEATER BLOCK
Eliminates Down Time!

... reproticized! Eliminates drying out, no overlap, no cement or scraping, no double thickness or distortion. Guarantees perfect frame alignment. No light required.

Sample splice & brochure on request.
 Adaptable to splice DuPont Cronar film.

PRESTOSEAL MFG. CORP.
 3727 33rd St., Long Island City 1, N.Y.

**FOR BETTER
 Projection AND
 GREATER PROTECTION**

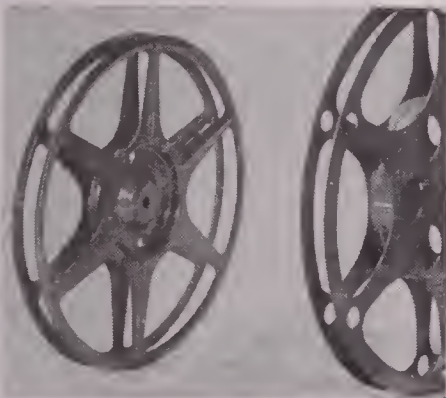

Compcor Reels
PROFESSIONAL

For shipping, storing or showing film, precision made Compcor Professional Reels are first choice with those who want the finest. Hard, spring type steel construction won't warp or bend... eliminates film-wearing rubbing during projection or winding. Your production deserves the finest package—use Compcor Professional Reels in 600 ft. to 2,000 ft. sizes.

Write for catalog!

COMPCOR CORPORATION
 2253 W. St. Paul Avenue, Chicago 47, Ill.

tery making which this writer saw recently, was remarkable for its abundance of carefully detailed closeup shots—many of them actually ultra-closeups—which showed every particular and device of the potter's technique.

In professional film making, the script writers understand the function of various type shots and know what effect they can produce on the screen. For this reason, each scene is carefully detailed in the script as to the kind of shot, medium, long, closeup, two-shot, etc. The shots are thus planned far in advance of the actual shooting.

When amateur movie makers undertake a continuity film, it should likewise be carefully visualized in advance, then laid out on paper in the form of a shooting script, so that the cameraman will know immediately what type shot to set up for when it comes time to film the various scenes. It is possible, of course—following a great deal of experience of shooting and "editing your film as you shoot"—to shoot continuity films "off the cuff." But much better results will follow where the script is prepared in advance.

Thus, in preparing a shooting script, the following rules can be helpful:

In most cases, the action to be pictured in a closeup should first be introduced in one or more medium or long shots immediately preceding it. These establish the locale, the mood, or the reason for the existence of the subject or action to be shown in closeup. The closeup emphasizes and brings the action to a climax.

Sometimes this technique is reversed for special reasons; a sequence will begin with a closeup, with the camera moving progressively farther away, either in a dolly shot, or in a succession of cuts until the setting of the action is revealed fully in a long shot. This technique is often employed where it is desired to inject an air of mystery or

suspense into the story at the very beginning.

A typical example would be this sequence, seen recently in an amateur film: The picture opens with the camera close up on a partially opened door. A hand clasping a revolver is suddenly thrust through the opening and pulls the trigger. The door slowly closes and there is an immediate cut to a closeup of the assassin's feet walking quickly along a corridor. The setting of the action is never revealed until the next scene—a medium shot of an office in which the victim of the gunman is shown slumped across a desk.

Closeups of such action as a hand ringing a doorbell, the posting of a letter, the writing of a note, etc., are all too familiar. Yet few amateur film makers photograph such closeups with the imagination and artistry necessary to make them fully effective, just a little different. There's a knack in choosing the right camera angle and the most intriguing lighting to achieve a closeup that carries the maximum impact.

So, no matter what the subject of your filming, closeups will make your picture more interesting. Movies of the family, of your vacation, the company's annual picnic, etc., all will be more professional if you include closeups.

And if you don't mind this oft-repeated admonition: study the professional film maker's technique at your local theatre. Note how skillfully closeups are used in theatrical film dramas to build climaxes, to reveal startling facts, to build interest in a love scene; how the same medium is used in a documentary short subject to acquaint the audience with some important detail; how even the animated cartoon producer uses it skillfully to point up some humorous action. Your theatre screen is a powerful teacher. Employ it frequently to aid you in your closeup filming technique.

CAMERAMEN ARE A BREED APART

(Continued from Page 503)

the great battle wagons and liners which have anchored in the Basin.

A cameraman, unimpressed with his first view of the great port and understanding nothing of Haligonian pride, sought to open a conversation with an ancient sea-dog.

"This is certainly the garbage can of the world, isn't it?"

The ancient mariner caught the cameraman in his sights, elevated for range, and fired a broadside aimed at reducing the offending lensman to ignominy.

"It sure is, son, judging by the trash

that keeps dropping in!"

The relationship of cameramen to work is open to controversy. A director and cameraman were scouting Vancouver Island for possible scenics. The job involved considerable legwork. After a very rugged piece of climbing, the director looked around to discover his cameraman relaxing comfortably in the car far below. The cameraman's explanation was a model of logic. "No sense both of us getting tired. I knew you'd yell if you found something." Two weeks later, the same director and cameraman were resting on a ship's

F&B

NEW AND USED EQUIPMENT

FOR MOTION PICTURE & TV FILM PRODUCTION

F&B

MATTON

REMOVES HOTSPOTS . . .
SUBDUES HIGHLIGHTS . . .
REDUCES REFLECTION
AND GLARE . . .

CHROME
SURFACE

SPRAYED
WITH MATTON

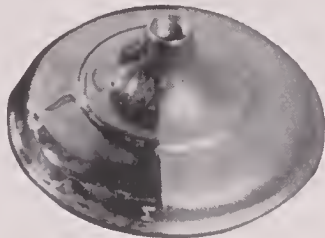

Large Spray Can \$2.25 ea.
NOW . . . ORDER 6 for \$12.00

Just spray Instant MATTON on all chrome, plated, shiny, metallic, glossy or glass surfaces.

- Easy to apply with spray applicator can.
- Instant MATTON coating hardens instantly.
- Can be handled without fear of mess or of removing hard MATTON coating.

DON'T USE MESSY, INEFFECTIVE SOAPS OR WAXES . . . DO USE MATTON

SAVE wear and tear on 16mm prints, time, space, storage.

NOW you can project, edit, inspect, synchronize, clean, measure and store all your films on cores.

No More Rewinding Problems

Now, simply slip film on core into SPLIT REEL. Close reel. Use another SPLIT REEL for take-up . . . unscrew reel to remove film.

BUY SEVERAL NOW!

- 400 ft. split reels — 16mm.....\$4.50
- 800 ft. split reel — 16mm.....\$6.00
- 1200 ft. split reel — 16mm.....\$7.50
- 1600 ft. split reel — 16mm.....\$9.00

F & B Split Reels

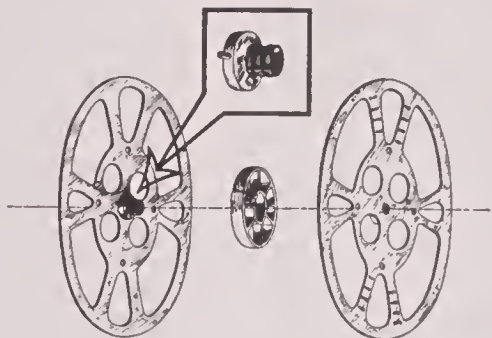

CAMERA SLATE

with Clapsticks



- * Easily eraseable slate finish
- * Sharp-sounding hardwood clapsticks
- * Permanent silk-screened letters
- * Supply of special, dustless chalk
- * Large 11"x14" size Price \$8.75
- * Medium 9"x11" size Price \$5.00

(Illustrated)

NOW Shoot full 15 minute TV shows without stopping or reloading. The F&B conversion includes 600 ft. magazine, extra silent take-up motor, camera insert plate for stabilization of film movement, and footage counter. Camera is not cut down; can be used without magazine for 100 ft. rolls.
Write for Brochure

Shoot Complete
15 Minute
Programs

600 FOOT
MAGAZINE
CONVERSION
FOR 16mm
AURICON
CINEVOICE
CAMERA

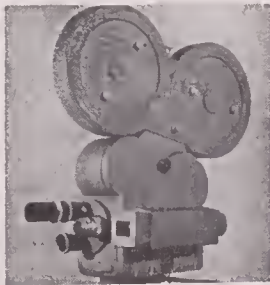

ANNOUNCING THE NEW PRECISION MAGNETIC SOUND READER ATTACHMENT FOR YOUR SYNCHRONIZER

Converts your 16/35mm synchronizer into a double-duty machine for synchronizing picture with magnetic tape in a single operation.

Write for full details.

NEW: Pro-Cine Tripod

for Auricon-Pro . . . Maurer . . . Cinevoice . . . Cine Special . . . Filmo . . . Bolex . . . Eyemo with motor and magazine . . . Arriflex 35 & 16 . . . Camerette . . . all still cameras . . . view cameras.

The F&B PRO-CINE is a brand-new, modern medium weight tripod; precision engineered and designed by cameramen for cameramen; constructed with emphasis on smooth controlled friction pan and tilt movements, ruggedly built for the utmost in rigidity and for long, satisfactory service.



Made In U.S.A.

FEATURING . . .

- Super-smooth friction head, unconditionally guaranteed for five years of the ultimate in pan and tilt performance.
- Telescoping two-position offset panhandle for easy adjustment to your length requirements . . . can be quickly changed to left or right position . . . offset for added comfort and convenience.

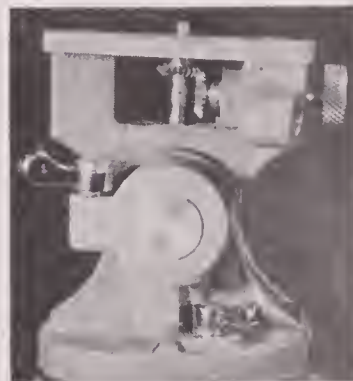

- Knurled camera-tightening knob, externally operated by angle gears for maximum fumble-free tightening.
- Precision engineered positive pan and tilt locks for utmost rigidity and safety.
- Superb, seasoned, solid hardwood legs, beautifully finished for smooth, non-sticking telescoping action.
- All metal fittings precision machined
- One piece leg-tightening knurled knobs for quick, easy leg adjustments.

REMOVABLE FRICTION HEAD MOUNTS EASILY ON BABY TRIPOD OR HI-HAT.

Weight: 14 lbs.
Height: 41" low spread
75" high spread
Pan: 360°
Tilt: 90°

FINEST MATERIALS AND WORKMANSHIP THROUGHOUT
Friction head unconditionally guaranteed for 5 years

List Price **\$135⁰⁰**

Heavy Duty Fibre Carrying Case — \$20.00

NOTE: Spring balanced head, adjusted to your camera, available at extra cost.

Agencies and territories now available for all F&B products for dealers and distributors.

F&B HAS A COMPLETE STOCK OF NEW AND USED CAMERAS, PRODUCTION, LIGHTING, EDITING & LABORATORY EQUIPMENT

Used equipment always accepted as trade-in.
EVERY ITEM SOLD IS MONEYBACK GUARANTEED

WE BUY — SELL — RENT

FLORMAN & BABB

70 West 45th Street, New York 19, N. Y.

Phone: Murray Hill 2-2928

Cable Address — FLORBABB, N. Y.

F&B



FISHER FILM CLEANER

for Clear Pictures,
Faultless
Sound!

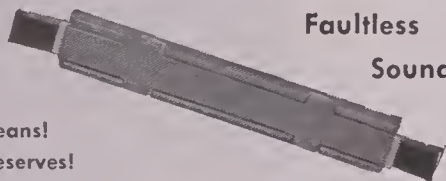

Cleans!
Preserves!
8 and 16mm Films!

Save your precious films. Show them at their best, free from dirt, dust, specks and spots. Eliminate annoying magnified fuzz and lint from your screened picture.

With sound film you get undistorted, smooth reproduction without disturbing noises due to dirt on the sound track.

Dry chemicals on soft, replaceable cleaner pads assure brilliant highlights and sparkling color. Easy, simple to use!

Send **ONLY \$2.95** direct. (Former advertised price, \$3.95.) Postage paid. Satisfaction guaranteed or money refunded.

FISHER MFG. CO.,

1185 MT. READ BLVD., ROCHESTER 6, N. Y.

Advantage Never Before Offered!



SWIVEL BALL JOINT ATTACHMENT

for
PROFESSIONAL JUNIOR TRIPODS

Swivel Ball Joint Attachment can be mounted between head and tripod body in a few seconds and without any technical knowledge. Swivel Ball has enough tightening strength to hold the largest and heaviest movie cameras, permits leveling camera quickly when tripod is set up on uneven ground. Ball Attachment is made of lightweight aluminum, weighs approx. 3 1/2 lbs.

Ten Day Money-Back Guarantee
Write for Catalog and Prices

KADISCH

CAMERA AND SOUND ENGINEERING CO.

500 West 52nd St., New York 19, N.Y.
Plaza 7-3511

DESIGNERS AND MANUFACTURERS OF
MOTION PICTURE—TV EQUIPMENT

deck after a hard day's filming. The director became interested in the photographic possibilities of the gulls following the ship. But he hadn't the courage to request more of his weary cameraman. So he dismissed the idea.

Some months later, in the screening room, the director was amazed to see his gull shots. The tired photographer had, without request, spent a tedious hour trying to recapture scenes of gulls in flight. The problem had intrigued him.

Sometimes, in the mortal conflict between director and cameraman, the lensman is the plaintiff. A director once condoned his choice of a jet-black horse for a whitewashed stable scene with the inconsiderate remark, "Don't let the contrast worry you. Black is black and white is white. Just expose properly and the scene will be okay."

To the conscientious color cameraman who spends his precarious existence trying to balance all color elements within the narrow, two-stop limitations of color film, such misunderstandings of his problems smacks of an outright conspiracy to sabotage his work. But it is probably in the realm of ingenuity that the cameraman exhibits his true genius.

A fishing film had as its theme the thought that a small boy and his pet bear might be better fishermen than their professional elders. The key scene was to show the little bear waddling down a forest trail behind his young companion. Over the boy's shoulder hung his homemade line with a fish dangling at the end.

Little trouble was anticipated in putting the scene on film. But Bruin had a mind of his own. Maybe he was allergic to having his picture taken. Whatever the reason, at every camera start, the frolicsome bear would dodge off the path into the bushes. Even the sight and smell of the fish proved no incentive to keep him on the trail.

After several unsuccessful attempts, it was decided that several men should lie down on either side of the path out of camera range. The theory was that, by hoarse shouting from both sides, the men could scare the uncooperative mammal into a reasonably center course. But Bruin Junior had never been to college, and didn't understand theories. Was it his fault if he thought that the men wanted to play?

The next inspiration was to tie an invisible thread from the boy's leg to the wanderer. But such coupling can be a double-edged weapon. The young denizen of the forest reversed his field, and the boy, fish and bear were soon wound in a tangle of fishing line.

Enter our genius! With a sudden flash of understanding, he remembered that, sometimes, that which cannot be

led or pushed can be coaxed. A courier was hastily despatched to camp. On his return, a thick, creamy substance was smeared around the cuffs of the boy's trousers.

Take twelve coming up! Master Bruin followed the boy down the path as meekly as a sixteen-year-old bride. It is your privilege to estimate, in the long anthology of Bruin history, the number of wilful bears who have been seduced by a little bit of honey!

Sometimes the production mountain labors and brings forth an extra small mouse. On a boat trip up the Yukon, it was necessary to secure long shots of the ancient paddlewheeler as it clip-clopped its shallow passage upstream. But wilderness being noted for its lack of civilization, the territory offered no locations or other means of transportation from which such scenes might be filmed.

The captain offered a solution. The boat had to travel around a long neck of land to reach a certain port. The trip required several hours. But a camera crew could reach the port by an overland hike in two hours. They could then film the wood-burner from a high hill as it approached the settlement. The idea sounded excellent.

At zero hour—ten in the morning—the ambitious crew set out for the port of their dreams. The trail proved rough, multi-directional, and ankle-deep in dust. The hot Yukon sun turned the camera equipment into lead. The two hours stretched into five.

But, finally, a grim, dog-tired crew dragged into port—a crew painfully educated in the rigors of wilderness travel. The weary innocents were greeted by the entire population—one white family and twelve Indians. All that remained was to climb the hill for proper elevation.

Yes, the hill! But the absent-minded captain had forgotten to mention that, between the settlement and the hill, there lay a little matter of a muskeg swamp of unknown trustworthiness. So, with outraged bone and muscle, the pilgrims spent another two hours of prospective circling and climbing, with frequent losses of direction, until the hill finally was won.

Won—but of little use until a large patch of virgin timber had been cleared to permit an unrestricted view of the settlement and river below. As the heroes draped their limp bodies over the handiest supports to await the long-overdue boat, there was little effort to resist the swarms of angry, black gnats and mosquitoes that so violently objected to this intrusion into their sanctuary.

With the scene on film, a major decision had to be made. Which way back—the two-hour circuit or the steep, 200-

ATTENTION ALL TV STATIONS, STUDIOS, PRODUCERS!

PRODUCTION EQUIPMENT REDUCED

FOR YOUR FALL NEEDS!

35mm PRODUCTION CAMERAS

MITCHELL 35mm camera, 2-1000' mags, motor, 40mm, 50mm, 75mm Astro f2.3 lenses, sunshade, viewfinder, tripod, cases, first class\$4,900.00
MITCHELL 35mm camera, 2-1000' mags, sync motor, wild motor, 40mm, 50mm, 75mm, 100mm Baltar f2.3 lenses, sunshade, viewfinder, tripod, cases, reconditioned like new\$6,500.00
CINEPHON newsreel camera, rackover, 4 mags, motor, dissolving shutter, 32mm, 50mm, 75mm Astro lenses, perfect.....\$1,350.00
CINEPHON newsreel camera, reflex, 2 mags, motor, 32mm, 50mm, 75mm lenses, very fine condition\$750.00
ARRIFLEX, 2 mags, motor, sunshade, 32mm, 50mm, 75mm lenses, excellent.....\$595.00
ARRIFLEX, late model, 4 mags, motor, sunshade, case, 35mm, 50mm, 85mm lenses, tripod, battery, exceptionally fine production unit\$1,295.00
EYEMO 71K, 2" f4.5 lens.....\$285.00
EYEMO 71K, 2" f2.8 lens.....\$325.00
EYEMO 71K, filter slot, open back with 400' mag, motor, 2" f2.8 lens, drum finder, like new condition, special.....\$595.00
EYEMO compact turret, filter slot, 25mm, 2", 4" lenses, completely reconditioned.....\$895.00
EYEMO 71Q, 35mm, 50mm, 4" lenses, positive elements, 2 mags, motor, case, tripod, almost brand new condition.....\$1,595.00
DEVRY, 2" and 6" lenses, very fine..\$115.00

ARRIFLEX ACCESSORIES

SYNC motor 110/60c, new.....\$295.00
ARRIFLEX 12 volt motor, excellent.....\$125.00
CAMART hi-hat for Arriflex, new.....\$ 24.50
CAMART lens extension tubes, new....\$ 14.50
12VOLT battery w/case and fittings..\$ 49.50
16 VOLT battery w/case and fittings..\$ 55.00
200' Cineflex converted mags, new....\$ 39.50
200' Arriflex mags, used.....\$ 75.00
400' Arriflex mags, new.....\$160.00
6" Kilar f3.5 telephoto lens, new.....\$136.45
12" Kilar f5.6 telephoto lens, new.....\$166.45
ARRIFLEX shoulder pod, new.....\$ 30.00
CAMERA shoulder brace.....\$ 15.00
ARRIFLEX power supply unit, converts 110 volts AC to 12 volts DC for 16mm or 35mm Arriflex, also battery charger, case, new.....\$110.00

RECORDING EQUIPMENT

HALLEN B-22 for 17.5mm magnetic, two channel mixer, playback, erase, counter, demonstrator\$1,250.00
HALLEN 25B for 16mm magnetic, two channel mixer, playback, erase, counter, like new\$1,450.00
CAMART for 17.5mm magnetic, 90' per minute sync speed, three channel mixer, Magne-cord heads, playback, erase, counter, exceptionally fine quality reproduction..\$1,495.00
BELL & HOWELL type 35mm optical recorder, two channel mixer, 400' mag, sync motor, cables, cases, completely reconditioned \$995.00
PRESTO K-8 recorder, mike, amplifier, speaker, like new\$225.00
PRESTO model L playback unit, two speeds, amplifier, speaker, good for PA system \$39.95

BRUSH 1/4" tape recorder, table model \$125.00
BRUSH 1/4" tape recorder portable, like new\$195.00

16mm PRODUCTION CAMERAS

MAURER 05 camera, rackover, 2-400' mags, sync motor, sunshade, finder, case, tripod, 12 volt motor, 15mm, 25mm, 50mm lenses, factory checked, perfect condition....\$4,450.00
BERNDT-Maurer, prismatic focusing, registration pins, 400' mag, sync motor, sunshade, finder, case, 15mm, 25mm, 50mm lenses, first class\$2,150.00
BLIMP, lightweight metal for Maurer 05 camera, geared follow focus, soundproof, excellent\$495.00
AURICON Super-1200, 2-1200' mags, auto-parallax finder, best model NRS galvo and matching amplifier for v.a. sound track, mike, cables, batteries, tripod, demonstrator, like new\$4,450.00
As above, variable density sound....\$4,350.00
AURICON PRO 200' capacity, auto-parallax finder, galvo, no amplifier, like new..\$995.00
CINE VOICE, turret, amplifier, mike, cables, case, like brand new condition.....\$625.00
CINE SPECIAL I, black, 15mm, 25mm lenses, 100' chamber, excellent.....\$395.00
CINE SPECIAL II, 25mm Ektar f1.4, like new\$825.00
CINE SPECIAL 100' chambers, black, excellent\$125.00
CINE SPECIAL 200' chambers, excellent, black —\$245.00, chrome\$325.00
CINE SPECIAL side viewfinder, like new \$74.50
CONVERTER, 25mm Ektar f1.4 to 15mm \$69.50
AURICON sync motor for Cine Special \$159.50
CECO variable speed motor, tachometer, cable, case, like new, for Cine Special.....\$295.00
FILMO 70DL, demonstrator, 0.7" f2.5 and 1" f1.4 lenses, case, elements.....\$475.00
FILMO 70DA, parallax finder, 2" lens, case, very fine condition.....\$295.00
FILMO 70A, 1" f3.5 lens, excellent....\$49.50
FILMO Super Speed, 128 fps only, 1" f1.5 lens\$245.00
EASTMAN model A camera, motor, lens, suitable for animation work or printer.....\$95.00

LIGHTING EQUIPMENT

COLORTRAN 750 kit used\$175.00
COLORTRAN 2000 kit used.....\$125.00
COLORTRAN 5000 kit used.....\$165.00
DELUXE converters, previous model\$39.50
MOVIE model converter, original list \$235.00, excellent condition\$165.00
FREZZO-LITE, portable newsreel light, power pack, battery charger, new.....\$195.00
FLUORESCENT lighting units, takes six 20 watt tubes, excellent overhead flat or fill light, new, original cost \$150.00, special.....\$29.50
DIMMERS, 1000 watts to 750.....\$52.50
DIMMERS, 2000 watts to 1650.....\$75.00
CONE LIGHTS, 24" diameter, 160 degree smooth, even shadow-less light, uses 1000 watt or 2000 watt G-48 bulbs, less stands\$150.00

EDITING EQUIPMENT

MOVIOLA 16mm picture only w/counter, new\$595.00
used\$365.00

MOVIOLA 35mm picture only w/counter, new—\$465, used\$365.00
MOVIOLA 35mm sound reader w/speaker\$95.00
MOVIOLA synchronizers, immediate delivery.
SYNCHRO-Reader, w/speaker, attaches directly to your Moviola synchronizer for magnetic film, list \$129.50, special\$109.50
B&H 8/16mm hot splicers, new.....\$185.00
B&H 16/35mm hot splicers, new.....\$299.00
B&H Exchange model 35mm splicers..\$725.00
NEUMADE 16mm Junior splicers, used..\$12.50
NEUMADE Senior splicers, used.....\$19.50
35mm x 1000' flanges, per set, used.....\$7.95
Precision optical and magnetic sound readers in stock available for immediate delivery.
MICRO 2/35mm synchronizers, l.n. ..\$89.50
ACE 35mm Rotary viewer w/counter, used\$175.00
Image erectors for above, new.....\$27.00
CRAIG latest model 16mm viewers....\$49.50
BAIA 16mm viewers, new.....\$34.65
BAIA 16mm editor, splicer, rewinds, l.n.\$45.00

MOTORS

MITCHELL 110v wild motor.....\$250.00
BELL & HOWELL 110v wild motor.....\$245.00
MITCHELL motor adapter for B&H camera with tachometer\$95.00
less tachometer\$75.00
EYEMO DC motors, like new.....\$95.00
BERNDT-Maurer 12 volt DC motor.....\$95.00

MISCELLANEOUS

BODDE background projector, 4x5 slides, latest model, stand, 9' x 12' screen, frame, new\$1,275.00
AMPRO 16mm hi-intensity arc projector, amplifier, 12" speaker, rectifier, stand, like new\$795.00
MITCHELL insert matte viewfinder, excellent\$250.00
AURICON auto-parallax finder.....\$125.00
BOLEX sunshade & filter holder.....\$35.00
PORTABLE 8'x10' screen, stand, case \$125.00
SCENE identification titler unit for Eyemo camera\$8.95
ANIMATION peg bars, each.....\$10.00
1/4" TAPE splicers, new.....\$4.95
POLAROID series VIII yellow polarizing filter\$8.95
POLAROID series VII polarizing filters..\$4.95
PAN Cinor zoom lens, like new.....\$295.00
BOLEX Stereo unit complete, demonstrator\$319.50
MOLE RICHARDSON perambulator mike boom, new immediate delivery.....\$1,920.00
TELESCOPING mike boom, custom built, geared operation from 13' to 19', excellent \$795.00
MAURER film phono, sync motor, power supply unit, case, factory checked.....\$1,850.00
DUPLEX 35mm to 16mm optical reduction printer, second head for further modifications, good condition, special sale.....\$495.00
THREE wheel bicycle seat dolly w/case\$195.00
B&H Filmsound projector, 12" speaker, demonstrator, like new.....\$425.00

SALES

RENTALS - REPAIRS

Baltar lenses mounted for all 16-35mm cameras.

THE CAMERA • MART INC.
MOTION PICTURE AND TV PRODUCTION EQUIPMENT
1845 BROADWAY at 60th ST. Phone: Circle 6-0930
NEW YORK 23, N. Y. Cable Address CAMERAMART

LIBERAL TRADE-IN

ALLOWANCE FOR YOUR USED EQUIPMENT.

SEND YOUR LISTING NOW!

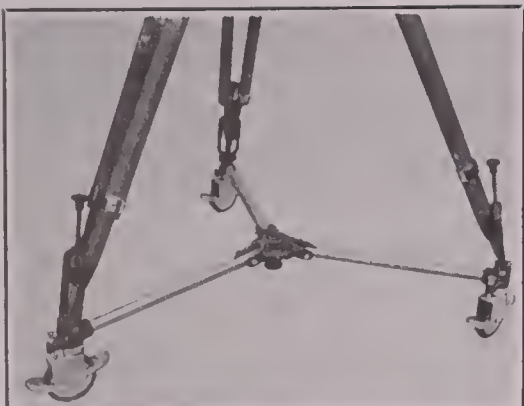

KADISCH JUNIOR TRIPOD DOLLY

This collapsible three-wheel tripod dolly is especially designed to meet the demand for convenient mobility of cameras on location or in the studio.

Dolly can be used with any professional or semi-pro tripod.

The tripod is fastened firmly to the dolly by a clamp at each leg tip.

The special individual caster locking system makes it possible to lock either two or three wheels in a parallel position, enabling the dolly to track in a straight line for rolling dolly shots.

Dolly folds quickly into a single compact, easy-to-carry unit, 23 inches in length, weighing 14 lbs.

For Prices and Literature,

Ask Your Dealer or Write

KADISCH

CAMERA AND SOUND ENGINEERING CO.
500 WEST 52ND ST., NEW YORK 19, N.Y.

PLaza 7-3511

DESIGNERS AND MANUFACTURERS OF
MOTION PICTURES AND TV EQUIPMENT

RUBY CAMERA EXCHANGE

Rents . . . Sells . . . Exchanges

Everything You Need for the

Production & Projection

of Motion Pictures Provided
by a Veteran Organization
of Specialists

35 mm. . . . 16 mm.
Television

IN BUSINESS SINCE 1910

729 Seventh Ave., New York 19, N. Y.

Tel.: Circle 5-5640

Cable address: RUBYCAM

"The Finest Cameras
Deserve the Finest Care"



AUTHORIZED

Service To All Fine Cameras

ROMLE-WAHL & CO.

520 W. 7th ST.
LOS ANGELES 14, CAL.

ft. hill and the swamp? Bruised bodies and over-taxed endurance supplied the answer.

And so, the valiants slid, tripped and fell down the steep slope into the swamp. The forbidding journey across the bog was accomplished with apprehensive eyes and flailing arms as the reckless crew with uncertainty jumped from hummock to hummock. Sometimes, the hummock was solid ground. Often it proved false and lowered the unfortunate into two or three feet of quagmire—the refuse of the years.

At zero plus eight, the men, now looking like scarecrows, arrived at boat-side with torn clothing, lacerated faces and bodies caked with trail dust and swamp water. They had worked eight strenuous hours without food.

And what was the product of this labor—what great accomplishment of this mortification of flesh and spirit?

Two six foot scenes of Yukon wilderness!

Three months later, the scenes found their way into that cemetery of all rejects—the cutting room scrap basket. And who can say that, as the film fluttered to its last resting place, certain cameramen didn't feel a little of their blood sacrificed?

By the fairest of judgments—the most impartial of trials—such motion picture cameramen stand convicted of using pressure and opportunism for photographic considerations. On the credit side, stands the heart which recognizes no obstacles in the work of placing before men's eyes the visions which guide their knowledge and understanding.

In the final analysis, the cinematographer has no defense for his art. He stands naked before a critical audience. But he need have no fear. For the phantasies of light and shadow which he created have clothed his person in an aura of worshipful light—a light reflected from the eyes of movie fans of all ages around the world.

IMPORTANCE OF VARIABLE CAMERA SPEEDS

(Continued from Page 506)

for this reason shots of this kind should not include vehicles or people.

Two very important things must be remembered when shooting in normal light at half speed: (1) be sure to decrease exposure by stopping down lens (because of the lengthened exposure time allowed by slower movement of the shutter) and, (2) camera must be held as steadily as possible—preferably on a substantial tripod. The first may be taken care of by closing down the lens one full stop when changing camera speed indicator. The second is equally important, for when speed of subject is increased, any jiggling or sideway in the camera is likewise increased and shows up painfully on the screen. Panning, for example, should never be done at 8 frames per second.

Some makes of cine cameras provide for speeds of 8, 16, 24, 32, 48, and 64 frames per second. Others include only the 8, 16, and 32, providing for half and double speed in addition to the normal speed of 16 f. p. s. There is probably no reason for this other than the fact that mechanical design precluded the possibility of providing all five speeds, not that the average amateur ever has use for all of them.

Twenty-four frames per second is the established speed for sound film. All sound motion pictures or silent movies filmed with the object of dubbing in sound later are filmed at this speed and, of course, are projected at the same speed. Many amateurs, who have no thought of using sound, frequently shoot

at 24 frames because it smooths action when the film is screened at 16 f. p. s.

Twenty-four frames represents a fifty per cent increase in camera speed and means that each frame is exposed for only 1/45th of a second, in the case of cameras giving a normal 1/30th second exposure. This also means the lens must be opened up 1/2 stop to compensate for the decreased shutter exposure.

Here a diaphragm compensator or lens stop conversion chart is a handy thing to have around. One is included in the wealth of charts and tables that appear in the American Cinematographer Handbook, edited and published by Jackson Rose, A.S.C. The chart, which is reproduced here, has been prepared especially for users of 8mm and 16mm cameras.

Take for example a scene which would normally be shot at f/6 (at 16 fps). Should you wish to shoot the same scene at 48 fps, a glance at the lens stop conversion chart would show that your lens should be opened up to f/3.2. You get an immediate answer without the need to figure it out in your head or with pencil and paper.

Following are some examples of how and when to use camera speeds faster or slower than normal:

Shooting from moving vehicles: If the ride is rough and you are shooting from the conveyance, shoot at 24 fps instead of 16 to smooth out any extraneous camera movement caused by the vehicle.

To slow action: Scenes of waterfalls, rolling surf, high waves, etc., will appear more breathtaking on the screen if the

(Continued on Page 518)

BOOKS

you'll want to read

Theory of Photography Process—
By Dr. C. E. Kenneth Mees. Published
by Eastman Kodak Co., Rochester,
N. Y.; 1124 pages. \$21.50.

The availability of a new, revised,
second edition of this famous book is
announced by Eastman Kodak Com-
pany.

Book deals with the composition and
properties of photographic light-sensi-
tive materials, factors controlling their
sensitivity to light, changes induced by
light action, the development process,
properties of the final image, and the
measurement of its tonal values. Its
list of contents include: Photographic
material, Action of Radiation, Optical
Sensitizing, Development and After-
Process, and Physics of Photographic
Process.

Home Movies Scripts — Edited by
Henry Provisor. Publisher: VerHalen
Publications, 6327 Santa Monica Blvd.,
Hollywood, Calif. 96 pages; \$1.50.

Here is a collection of short movie
scripts prepared especially for makers
of 8mm and 16mm amateur movies.

The advanced amateur will also find
much of interest in this collection, too.
In addition to the four longer profes-
sional-type scripts, many of the short
skits may, with the exercise of a little
imagination, be expanded into longer,
more complex narratives. As such, the
book is a veritable source book of story
ideas for the cine filmer.

Optical Image Evaluation—Proceed-
ings of the symposium held October
18-20, 1951, National Bureau of Stand-
ards Circular 526, 212 figures, 289
pages, \$2.25. Order from Government
Printing Office, Washington 25, D.C.

The National Bureau of Standards has
been active in the field of optical image
evaluation for many years. In the field
of applied optics it has been usual to
evaluate optical design by taking meas-
urements of the system's geometric
abberations. However, because of newer,
more modern procedures which have
been developed, it seems desirable to re-
examine the older methods of image
evaluation as well as the newer pro-
cedures in order to place image evalua-
tion upon a more sound engineering
basis. For this purpose the symposium
mentioned above was held. The full
papers of this symposium are presented
in this book, including the discussions.

IS YOUR PROBLEM

Lip-Sync Sound?
Compare THE HALLEN LINE of
MAGNETIC Film RECORDERS

ONLY SOUND RECORDED ON SPROCKET DRIVEN
FILM CAN BE EDITED FRAME FOR FRAME.

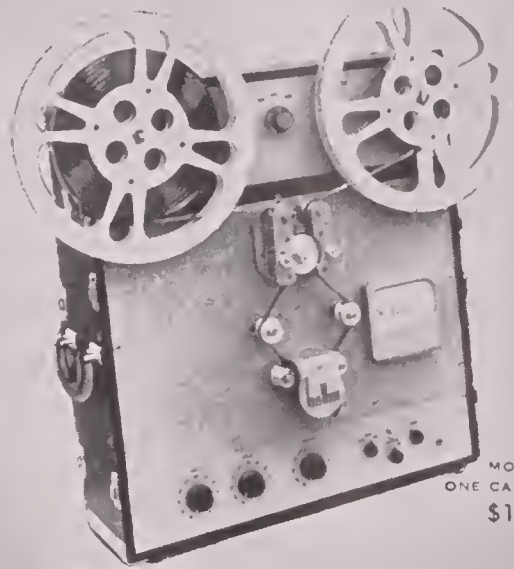

MODEL B-25
ONE CASE PORTABLE
\$1495.00

SOUND STAGE PERFORMANCE AT LOW COST

- Every model specifically designed for the utmost in professional quality and simplicity of operation.
- HalLEN "Drum System," with the Motion Picture Academy award-winning "C. C. Davis Flutter suppressor," results in most stable film motion yet developed.
- Simultaneous monitor of recorded track.
- Three inputs for simultaneous use: two for microphones and one for music or background effects.
- Track placement approved as standard by Motion Picture Research Council for 16mm and 17½mm models.
- High-speed forward and rewind, using separate motors.
- Monitor speakers and power supply are removable from the recorder unit.

Distributors —
Throughout the World
Addresses Upon Request
Licensed under the patents of
American Telephone and Tele-
graph Co., Western Electric
Co., and HalLEN Corp.

halLEN
CORPORATION

3503 WEST OLIVE, BURBANK, CALIF.
CABLE ADDRESS "HALLEN" CHARLESTON 8-6976

DESCRIPTIVE LITERATURE AND PRICE
SCHEDULE AVAILABLE.



AND NOW . . .

A VARIABLE SHUTTER FOR THE BOLEX H-8

A PROUD TWIN OF THE H-16

The **UTMOST** for the 8mm cinematographer

The **FIRST** and **ONLY** 8mm camera in the world to become equipped with a **VARIABLE SHUTTER**, the real answer to complete **FADES** and **LAP DISSOLVES**. Faster shutter speeds and many other advantages. Prices for both H-8 or H-16 within the U.S. \$99.60. Cameras with outside frame counter, \$109.80, tax extra. One-year guarantee and camera transportation back included. Send for free informative booklet.



PRICES SUBJECT TO CHANGE WITHOUT NOTICE

TULLIO PELLEGRINI 1545 LOMBARD ST., SAN FRANCISCO 23, CALIFORNIA

SPECIALIZED TITLES and SPECIAL EFFECTS

Motion Picture or Television, 35mm-16mm, Black & White or Color

RAY MERCER & COMPANY

4241 Normal Ave., Hollywood 29, California

NOrmandy 3-9331

We Welcome
Your Problems

RAY MERCER, A.S.C.

30 Years Experience
at Your Service . . .

Southeastern

Film Processing Company

1305 Geiger Ave., Columbia 2, S.C.

SPECIALIST IN

DuPont 930-931 B & W
REVERSAL 16mm FILM

Industrial

Television

Training

24 hour service

FILM IN STOCK

To Sell

THE MOTION PICTURE INDUSTRY

YOU

NEED

AMERICAN

CINEMATOGRAPHER

AMERICAN CINEMATOGRAPHER reaches all fields of 35mm and 16mm motion picture production—

- Major Hollywood Studios
- Television Film Producers
- Industrial Film Makers
- Educational Film Producers
- Amateur Movie Makers
- Film Laboratories
- Foreign Film Producers (67 countries)

Why be satisfied with anything less?
Write For Advertising Rates

VARIABLE CAMERA SPEEDS

(Continued from Page 516)

action is reduced slightly by shooting at 32 fps. Also scenes of boxing, rodeo and other fast-action athletic events will be easier to watch on the screen if filmed at 32 fps.

Where fast motion amplifies movement of an unsteady camera, slow motion minimizes it. For this reason 32 fps speed is often used in making telephoto shots.

Ultra-Slow Motion Protography is accomplished by shooting at 48 or 64 frames per second. At such speeds, film passes the lens at a terrific rate—a hundred-foot roll being consumed by the camera in surprisingly fast time. The screening time, however, remains the same as with film exposed at normal speed.

One use to which high and low camera speeds are put in the Hollywood studios is the filming of miniatures. In feature films, all action on miniature sets is shot at 48 or 64 frames per second. This effects a more natural aspect to the movement of objects within the scene, such as miniature ships, trains, the movement of water, etc.

So take a tip from the professional and use the range of speeds your camera provides whenever they can enhance the result in a scene or sequence.

EQUIPMENT SOURCE

(Continued from Page 503)

either—but it could be made right out of rental stock. It designed and built special telescope finders and cradle-mounted telephoto lenses, which permitted the Glenn L. Martin Company to complete its assignment with complete success, and without the added expense of purchasing the special equipment.

This reputation for ingenious solution of difficult engineering problems, for doing things that were never done before, has won for Camera Equipment Company an enviable reputation in the professional film world. Because of its large storehouse of experience, Camera Equipment maintains a consulting service on production and engineering, helping producers hurdle what appear to be insurmountable obstacles.

The advent of CinemaScope and other sensational projection methods found Camera Equipment abreast of all the new techniques, offering production companies important advice in adapting themselves to these new arts. Nor does the company limit itself to developments in the United States. Periodically Frank C. Zucker, head of the organization, makes quick continental tours to check up on foreign developments and to keep in close touch with the producers shooting on European soil.

Another instance of the company's resourcefulness occurred when CBS was conducting its color tests. The TV cameraman requested a tripod head, and the company sent its famous "Balanced" model C. TV head. But the cameraman was having trouble with the frontal adjustment. Since the changeover from long to short lens required split-second timing, the cameraman found the front wrench adjustment inconvenient.

C-E technicians took back the "Balanced" head, eliminated the wrench entirely, and attached a knob at the rear, permitting the cameraman to "shift gears" easily and almost effortlessly.

Recently Senator Kefauver and his famous investigating committee were looking into the matter of comic books. Hearings were held in the Federal Courthouse, New York. One day an agitated telephone call came to Camera Equipment Company. The committee was having trouble in projecting the evidence on a large screen. Would C-E send a qualified man to correct the difficulty? The representative quickly found that the powerful lights used by the TV and newsreel camera crews washed out the picture on the screen. A projector having a more powerful lamp was brought in, thereby winning the personal thanks of Senator Kefauver.

If institutions reflect individuals, Camera Equipment Company is the brain-

Film Editing Made Easy
with NEW
**professional
film viewer**

for 35mm and 16mm

Every film editor will appreciate a viewer that enables him to view his film from left to right—on a large, brilliantly illuminated screen.

The PROFESSIONAL FILM VIEWER makes film editing a breeze. Easy threading, portable, will not scratch film. Put this viewer between your rewinders and speed up your editing. Size of Viewing Screen 5¾ x 4¾.



35mm Model \$375
16mm Model \$350



Write Dept. A-10-4

child and the embodiment of Frank Zucker, one of the outstanding motion picture pioneers in America. A topnotch cameraman who started 'way back in the days of D. W. Griffith, Frank was a contemporary of Billy Bitzer and other lens immortals. When Flo Ziegfield took his European tour after World War I, Frank went along to record it on film. When talking pictures were in their nebulous stage, Frank experimented with sound for RCA, Warner Brothers and Dr. Lee DeForest. Because Frank was a great cameraman and knew the problems of his profession, he exerted all the skill and creative thinking at his command in manufacturing equipment that enables the man behind the shutter to achieve outstanding results.

At the executive level, Frank Zucker is aided by Gene Levy, who came up from the working cameraman ranks to become associated with the company at its inception, some 18 years ago, and Burton Zucker, a son, who has inherited his father's celluloid blood.

It was typical of Zucker thinking that, when the company entered the micro-relay equipment field, existing standards served only as a jumping-off place for C-E designers and technicians. The result is that Camera Equipment micro-relay line has been certified by equipment manufacturers to exceed all standards for efficiency and strength of cur-

Model 35-16C

S E N S I T E S T E R

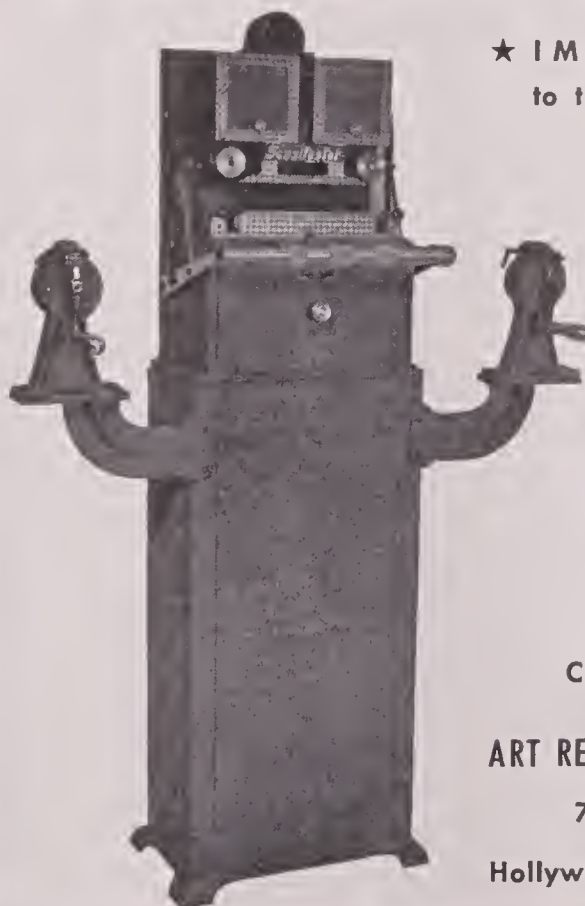

★ IMMEDIATE DELIVERY
to the lab owners interested in—

**QUALITY
EFFICIENCY
ECONOMY**

- DUAL MACHINE
1—Sensitometer
2—Scene Tester
- HIGHLY ACCURATE
Electronic timer unaffected
by climatic changes.
- NEW TYPE LONG-LIFE
Cold Light Exposure Unit
- WITHOUT ADDITIONAL
EXPENSE will match any
printer

Combination 35mm-16mm

ART REEVES MOTION PICTURE EQUIP.

7512 Santa Monica Blvd.

Hollywood 46

California

1
2
3
4
5
5SS
6
6SS
7
8
8F
8P
9
9P
9F
10
12
12F



It's easy with the
MERCER FILM PATCH
 Descriptive Chart & Price List
 Mailed on Request
R. C. MERCER & COMPANY
 4241 Normol Ave., Hollywood 29, Calif.
 NOrmondY 3-9331

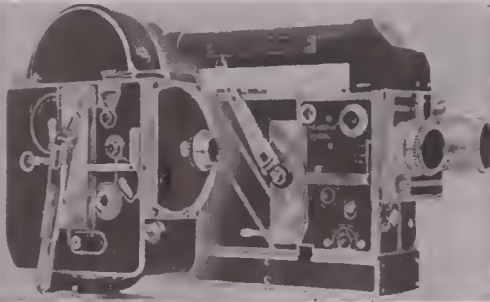

Automatic dissolve attachments for Cine Special and Bolex H-16 (Equipped with Pellegrini Shutter)
JOSEPH YOLO, 1037 N. La Brea
 Phone GL. 7103 Hollywood, California

SURPLUS AIR BLOWERS
SUTORBILT 2M STYLE



Impellers 2" wide. 1" pipe size inlet and outlet. Approximately 20 cu. ft. per minute at 2, 3, 4 or 5 lbs. pressure. 1/2 h.p. required at 4 lbs.
 Not \$150.00
ONLY \$40.00

Send 25c for our new 24-page catalog of processing machines and parts.
METAL MASTERS
 5599 University Ave., San Diego 15, Calif.

WORLD FAMOUS

S-5
 synchronous magnetic film recorder for motion pictures and television

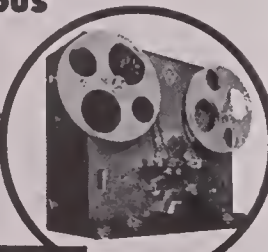

STANCIL-HOFFMAN
 921 N. Highland Hollywood 38, Calif. send for particulars

rent products on the market.

Like most people who are engaged in this absorbing business, the practitioners are too busy to see the romance. Once an employe kept a log of a Mitchell Camera, beginning with the day it received its shakedown test for accuracy and efficiency prior to being placed in Camera Equipment's extensive rental department.

The Mitchell went to a TV producer to make a commercial. Another TV producer rented it to make a half-hour short. Then a call came from the Ford Motor Company—they needed it for special photography on their proving grounds. Rome, Munich and Canada were next on the itinerary. Then came a series of sport events, football and boxing—then South America.

After each trip the camera went into the C-E maintenance shop for thorough testing and overhauling by experienced technicians. This devotion to quality and accuracy is one of the many reasons why Camera Equipment Company is a by-word in the industry, the standby for so many cameramen, directors, producers and executives whose job it is to make the film chronicles of the nation.

REMOTE CONTROL FOR 16mm STOP MOTION PHOTOGRAPHY

(Continued from Page 500)

cameras will perhaps suggest different shapes for this component of the device. There is nothing critical about it; it need only be strong enough to insure that action of the solenoid lever will be firm and not likely to jar loose during use.

The solenoid illustrated comes equipped with two mooring bolts, located directly opposite each other. The lever operates between them. Three holes must be drilled in the plastic mount—two for the mounting bolts and one for the shaft of the solenoid on which is mounted the lever. The latter is readily removed from the shaft by means of an Allen wrench. Care must be taken, after the solenoid is bolted in place and the lever re-mounted, that the lever does not bind on the plastic mount, but works as freely as it did before mounting.

The two wires which supply the battery current lead from the solenoid terminals to the battery. At a convenient point, the cable having the push button at one end is cut in—joined in "series" with one of the two battery wires. Thus, the push-button operated at a remote distance serves to activate the solenoid whenever a single-frame exposure is to be made.

Obviously, the hookup for the various

makes of cameras will differ somewhat, but none pose difficult problems. Observing the hookup of the Cine Kodak-Special pictured here will suggest how it may be applied to other cameras. Here an ordinary paper clip, straightened out, provided a suitable linkage between the solenoid and the camera starting button. In arriving at this step of the installation, one should make sure that the solenoid is so mounted that its action corresponds with the direction in which the starting button operates. In other words, if the button must be pulled down to operate the camera, then the solenoid lever must also operate in this direction—elementary, but nevertheless a matter than can easily be overlooked.

The action or "stroke" of the solenoid is usually much greater than that of the camera starting button. This is not likely to result in camera damage, however, for the solenoid does not have to complete its maximum stroke in order to be effective. It will pull the wire link sufficiently to trip the shutter, and when the remote control button is released the solenoid and shutter release will return to normal position.

The three photos at bottom of page 500 show use of the solenoid-equipped Cine Kodak-Special in photographing an animation sequence depicting the route of travel on a topography map. In the first photo, the author is shown adjusting the camera for position, focus and lens stop before starting to shoot the sequence. Here the camera is mounted on a Graflarger stand, available in camera stores. The stand is inexpensive and is ideally suited for the purpose described.

The center photo shows the production staff at work. The camera is overhead, focused down on the map on the floor. The girl at the left holds the remote control button in her hand, the cord of which is seen leading to the camera. In the left photo the same girl is shown moving the "line," which is the animation subject, a fraction of an inch, following which she pressed the control button momentarily to effect the camera exposure.

A remote control such as this virtually puts the camera release button in your hand, so that you have it with you at all times when working on an animation project of this type. It makes the operation of tripping the shutter and advancing the action of the animation much easier, and there is less wasted motion. After the necessary change has been made in the subject being photographed, the operator need only lean back out of range of the camera, then push the button, and repeat the animation step again.

FILMORAMA

(Continued from Page 504)

16mm films exclusively. Not only has it made it possible for these exhibitors to screen the latest CinemaScope releases in 16mm, but many areas of film production hitherto unconsidered have adopted the 16mm wide-screen camera lens. Walt Disney, for one, is providing many of his field cameramen with the Bell & Howell anamorphic lens, enabling them to shoot 16mm color footage that may be blown up to standard 35mm CinemaScope.

In the independent field, an interesting 15-minute scenic film of Chattanooga, Tennessee, titled "Backgrounds To Beauty," has been filmed by Continental Productions Corporation of that city. James E. Webster, head of the producing company, says that when he started the production, there were only four FilmoRama lenses in existence. Disney Studios got the first three, and Webster's organization was lucky to get the fourth.

A 16mm motion picture in color, "Niagara Holidays," is now being produced by Roquemore Films of Buffalo, N. Y., using the new anamorphic lens. According to Everett Roquemore, head of the company, many producers of professional business films are adjusting

16mm CONTINUOUS COLOR PRINTER THAT OUT-PERFORMS THEM ALL!

We guarantee that no other printer can match its speed and convenience . . . no other continuous printer can give you better quality!



**MODEL 16-C-60
DOUBLE HEAD -
CONTINUOUS
16mm CONTACT PRINTER**

- Designed for color . . .** has automatic shutter for full range exposure control, and automatic fade and dissolve.
- No more edge notching . . .** has two channel Electronic Cuing System for control of exposure and filters or fade.
- Faster . . .** speeds up to 100 ft. per minute.
- Saves time . . .** prints sound and picture from separate negatives in one operation. Also prints from composite negative.
- Prevents film damage . . .** take-up flanges have individual torque mats! Absolutely prevents cinching, scratching, and other film damage.

For complete information and prices write:

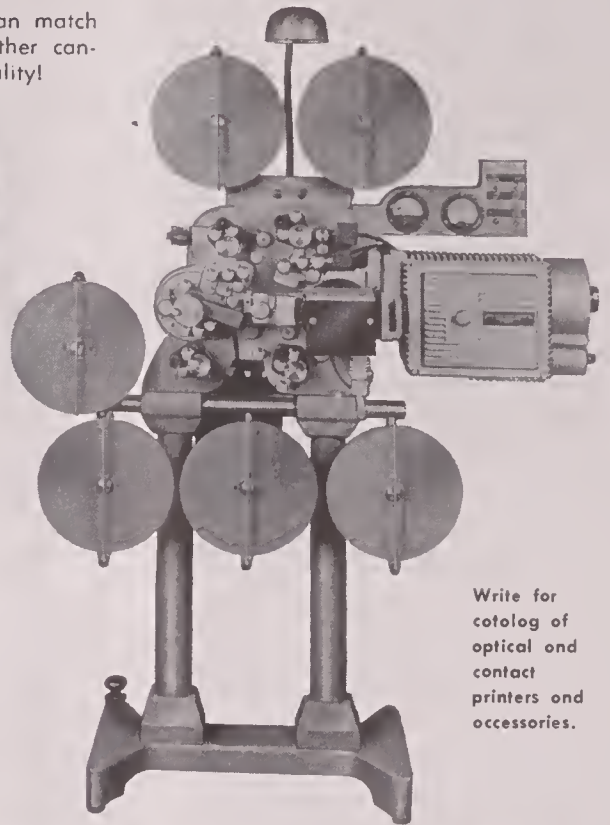

Write for catalog of optical and contact printers and accessories.

MOTION PICTURE PRINTING EQUIPMENT CO.

Mfrs. of Motion Picture and Micro Film Printers

8136 NORTH LAWNDALE AVENUE • SKOKIE, ILLINOIS



**Jack Frost
lights the nation!**

**MOTION PICTURE STUDIO •
THEATRICAL • DISPLAY
RENTAL EQUIPMENT**

WHEREVER YOU ARE—WHATEVER YOU NEED

. . . in the way of unusual, specialized lighting, call on Jack Frost! For movie-making, stage lighting, feature exhibits, large conventions . . . for *any* location that requires exceptional lighting, Jack Frost is ready to serve you! And Jack Frost's unequalled national service includes complete installation and removal *wherever* you are. Rent all your specialized lighting equipment from Jack Frost . . . famous for lighting the nation's greatest shows . . . most spectacular displays.

**FOR FULL INFORMATION ON
RENTAL EQUIPMENT
MAIL COUPON, OR CALL
DETROIT, TRinity 3-8030**

**JACK A. FROST, DEPT. J,
234 PIQUETTE AVE.
DETROIT 2, MICHIGAN**

Please send me full information on your rental service.

Name _____
Address _____
City _____ Zone _____ State _____

HOLLYWOOD STUDIO PRODUCTION

Feature and television film productions for which members of the American Society of Cinematographers were engaged as Directors of Photography during the past month.

AMERICAN SOCIETY OF CINEMATOGRAPHERS

FOUNDED January 8, 1919, The American Society of Cinematographers is composed of the leading directors of photography in the Hollywood motion picture studios. Its membership also includes non-resident cinematographers and cinematographers in foreign lands. Membership is by invitation only.

BOARD OF GOVERNORS—1954

ARTHUR MILLER, President
SOL HALPRIN, First Vice-President
JOSEPH RUTTENBERG, Second Vice-President
ALFRED GILKS, Third Vice-President
WALTER STRENCE, Treasurer
PHILIP TANNURA, Secretary
ROBERT DE GRASSE, Sergeant-At-Arms
JOHN ARNOLD
JOSEPH BIROC
ARTHUR EDESON
GEORGE FOLSEY
LEE GARMES
VICTOR MILNER
HAL MOHR
LEON SHAMROY

ALTERNATE BOARD MEMBERS

ARTHUR ARLING
LUCIEN BALLARD
DAN CLARK
PAUL EAGLER
FARCIOT EDOUART
ERNEST LASZLO
ROBERT PITTACK
JOHN SEITZ
JAMES VAN TREES
PAUL VOGEL

ALLIED ARTISTS

SAM LEAVITT, "Annapolis Story," Technicolor.
WILLIAM SICKNER, "Ketchikan."
ELLSWORTH FREDERICKS, "Shotgun."

COLUMBIA

CHARLES LAWTON, "My Sister Eileen," Technicolor, CinemaScope.
BURNETT GUFFEY, "Tight Spot."

METRO-GOLDWYN-MAYER

JOSEPH RUTTENBERG, "The Prodigal," Eastman color, CinemaScope.
ROBERT PLANCK, "Moonfleet," color, CinemaScope.
GEORGE FOLSEY, "Hit The Deck," CinemaScope, Eastman color.
PAUL C. VOGEL, "Interrupted Melody," color, CinemaScope.

PARAMOUNT

ROBERT BURKS, "To Catch A Thief," Technicolor, VistaVision.
ROBERT BURKS, "The Trouble With Harry," Technicolor, VistaVision.

LIONEL LINDON, "Lucy Gallant," Technicolor, VistaVision.

20TH CENTURY-FOX

LUCIEN BALLARD, "White Feather," Technicolor, CinemaScope.
JOE MACDONALD, "The Racers," color, CinemaScope.
LEO TOVER, "Untamed," Technicolor, CinemaScope.
LEON SHAMROY, "There's No Business Like Show Business," color, CinemaScope.
CHARLES G. CLARKE, "Prince of Players," color, CinemaScope.
MILTON KRASNER, "The Seven Year Itch," color, CinemaScope.

UNIVERSAL-INTERNATIONAL

WILLIAM DANIELS, "Foxfire," Technicolor, wide-screen.
CARL GUTHRIE, "Lady Godiva of Coventry," Technicolor.
LLOYD AHERN, "The Looters."
MAURY GERTSMAN, "To Hell and Back," Technicolor, CinemaScope.
RUSSELL METTY, "Justice Comes to Tomahawk."

WARNER BROS.

ELLIS CARTER, "The River Changes," Warner Color, CinemaScope.
LEE GARMES and RUSSELL HARLAN, "Land of the Pharaohs," Warner-Color, CinemaScope.
WILLIAM SKALL, "The Silver Chalice," WarnerColor, CinemaScope.
HARRY STRADLING, "Helen Of Troy," WarnerColor, CinemaScope.
HAL ROSSON, "Strange Lady In Town," Warner-Color, CinemaScope.
TED McCORD, "Young At Heart," Arwin Prods., WarnerColor.
WINTON HOCH, "Mister Roberts," CinemaScope, WarnerColor.
HAROLD ROSSON, "Strange Lady In Town," WarnerColor, CinemaScope.

INDEPENDENT

ROBERT SURTEES, "Oklahoma," Eastman-color, Todd-AO, CinemaScope, R & H Pictures.
STANLEY CORTEZ, "Night Of The Hunter," Gregory Productions.
ERNEST LASZLO, "The Kentuckian," Hecht-Lancaster Prods., Technicolor, CinemaScope.
FRANK PLANER, "Not As a Stranger," Stanler Kramer Prods., Widescreen.

TELEVISION

(The following directors of photography were active last month in photographing films for television in Hollywood, or were on contract to direct the photography of television films for the producers named.)

LUCIEN ANDRIOT, "Where Were You?," Ken Murray Productions; "It's a Great Life," Raydic Corp'n; "The Life of Riley," Hal Roach Studios.

JOSEPH BIROC, "Treasury Men in Action," American National Studios, Inc., and "Dear Phoebe," Dear Phoebe Productions.

WILLIAM BRADFORD, "Gene Autry," Flying A Productions.

NORBERT BRODINE, "The Loretta Young Show," Lewislor Ent.

EDWARD COLEMAN, "Dragnet," Sherry TV, Inc.

FLOYD CROSBY, "Authors Playhouse," Authors Playhouse Prods.

ROBERT DE GRASSE, "Make Room For Daddy," Marterto Prods., Inc., and "The Ray Bolger Show," B & R Ent.

GEORGE DISKANT, "Four Star Theatre," Four Star Productions, Inc.

E. B. DUPAR, "Tim McCoy Show," Mercury-Int'l Pictures.

ELLSWORTH FREDERICKS, "The Dennis Day Show," Denmac Productions.

HENRY FREULICH, "Captain Midnight," Screen Gems.

KARL FREUND, "Willy" and "December Bride," Desilu Productions, Inc.

FREDERICK GATELY, "Mayor of the Town," Rawlins-Grant, Inc., and "Big Town," Gross-Krasne, Inc.

AL GILKS, "The Halls of Ivy," Television Programs of America, Inc.

BEN KLINE, "Fireside Theatre," "An Argument With Death," Frank Wisbar Prods.

JACK MACKENZIE, "Public Defender," Hal Roach, Jr., Productions.

ERNEST W. MILLER, "Rocky Jones, Space Ranger," and "Stu Erwin Show," Roland Reed Productions.

VIRGIL MILLER, "You Bet Your Life," Filmcraft Prods.

HAL MOHR, "That's My Boy," McCadden Corp'n.

NICK MUSURACA, "The Lone Wolf," Gross-Krasne, Inc., and "Lineup," Desilu Prods., Inc.

KENNETH PEACH, "Here Comes Donald," O'Connor Prods.

ROBERT PITTACK, "The Lone Ranger," CM TV Productions, Inc.

JOHN L. RUSSELL, JR., "Joe Palooka," Guild Films.

WILLIAM SICKNER, "The Whistler," Lindsay Parsons Productions.

MACK STENGLER, "Liberace," "Life With Elizabeth," "Florian Zabach Show," and "Frankie Laine Show," Guild Films.

HAROLD STINE, "Cavalcade of America," "This is Your Music," Jack Denove Prods., and "Corla Pandit," Snader Prods.

WALTER STRENCE, "Waterfront," Roland Reed Productions, and "My Little Margie," Roach, Jr.-Reed Productions.

PHILIP TANNURA, "Burns And Allen Show" and "The Jack Benny Show," McCadden Corp'n.

STUART THOMPSON, "Lassie," Robert Maxwell Associates.

JAMES VAN TREES, "I Married Joan," Joan Davis Enterprises and "Hey, Mulligan," Mickey Rooney Enterprises.

Precision Built Combination Sound Readers



OPTICAL

Model 600.....16mm and 35mm
NET PRICE \$185.00



OPTICAL-MAGNETIC

Model 800.....16mm, 35mm & 1/4 inch
NET PRICE \$259.50



MAGNETIC

Model 700....16mm, 17.5mm, 35mm
and 1/4 inch
NET PRICE \$198.00

FEATURES: Simple threading . . . polished stabilizer drum with needle bearings, with a surface which cannot damage film . . . film rollers machined to conform with SMPTE standards, and equipped with ailess bearings . . . precision ground shafts . . . dimension 6x6x7 1/2 inches.

AMPLIFIER: 117 volt — 60 cycle — AC . . . power output — 4 watts . . . heavy duty Alnico V speaker . . . safety fused . . . prefocused socket . . . pilot light . . . 6 ft. heavy duty cord.

All Prices F. O. B. Factory, Brooklyn, New York

PRECISION LABORATORIES

1139 UTICA AVENUE

BROOKLYN 3, NEW YORK

FILMORAMA

(Continued from Page 521)

their sights to include the new Cinema-Scope type of 16mm pictures in the belief that added realism and greater interest will make these films more effective in the fields of selling, advertising, and mass education. "I'm sure that we can look forward to many more 16mm non-theatrical films, photographed and projected with anamorphic lenses, which will be shown on wide screens in meeting rooms, schools, churches, clubs, etc.," Roquemore said.

The FilmoRama picture when projected is of normal brilliance and fills a screen 2.68 times as wide as it is high. To enable the same lens to be used for photography in projection, a special bracket is provided to fit the lens to the projector.

The new FilmoRama system will not obsolete existing 16mm motion picture equipment, according to the Bell & Howell Company. Instead, it is destined to breathe new life into the production and exhibition of 16mm films.

The FilmoRama wide-screen lens retails for \$596.00. View-finder attachments for cameras and brackets for projectors of other than Bell & Howell manufacture are promised by the respective equipment manufacturers.

C. ROSS

FOR

LIGHTING EQUIPMENT

Inkie and Arc Lamps including Required Accessories
Generators—Cables—Boards—Boxes

Raby Camera Crane—Dollies—Blimps—Geared Heads

GRIP EQUIPMENT

FOR LOCATION AND STUDIO

Parallels—Steps—Platform Ladders
Century Stands—Reflectors—Flags—Scrims

SOLE EASTERN MOLE-RICHARDSON CO. DISTRIBUTOR

RENTALS • SALES • SERVICE

CHARLES ROSS, Inc.

333 WEST 52nd STREET

NEW YORK 19, N.Y.

Circle 6-5470-1

Now! A 400ft. Magazine For Your BOLEX H-16

Complete with Synchronous Motor and Base

Includes Installation and Case



Permits continuous run of 400 feet of 16mm film, or—the 200 ft. daylight loading spool may be used in the 400 ft. magazine. The 100 ft. daylight loading spool can be used in the camera without removing the external magazine. In black wrinkle finish to match camera. Fully guaranteed. Write for information on our Rack-Over Sports-finder and Camera Base.

See your Bolex dealer or order direct. Immediate delivery.



TOLEDO CINE ENGINEERING
1309 Milburn Ave. Toledo 6, Ohio

MOVIOLA

FILM EDITING EQUIPMENT
16MM - 35MM

- PICTURE SOUND Photo and Magnetic
- SYNCHRONIZERS
- REWINDERS

One of the new series 20 Moviolas for picture and sound.

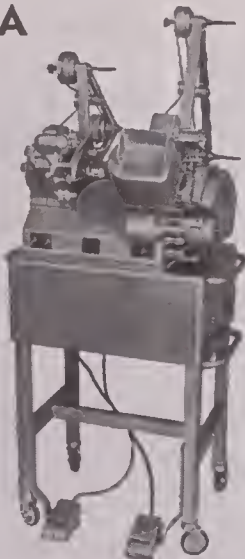

Write for Catalogue

MOVIOLA MANUFACTURING CO.
1451 Gordon St. • Hollywood 28, Calif.

AUTOMATIC DAYLIGHT PROCESSING

DEVELOPING TANK

- Processes up to 200 Ft.
- 8mm-16mm-35mm
- Movie—X-Ray—Microfilm
- Motor Driven, Portable
- Tough Plastic Tanks
- Uniform Density Assured
- 70mm tank also available

FILM DRYER

- Motor driven—Heated
- Speedy drying
- Automatic shrinkage allowance
- Stainless steel and aluminum construction
- Easily assembled without Tools
- Compact, Portable

Guaranteed. Write for Free Literature

MICRO RECORD CORP.
Dept. AC, 487 South Ave., Beacon, N. Y.

"A" AND "B" ROLLS

(Continued from Page 499)

practice and ingenuity, the 16mm film editor can "A" and "B" many clever effects. Sometimes "C," "D" and "E" rolls are also assembled to achieve almost unlimited multiple exposures or "montage" sequences. Opening titles, for instance, can each be dissolved "A" to "B" while action background scenes are simultaneously dissolving on "C and D" rolls.

Recently, a unique editing and printing procedure has been developed that, for the first time, permits camera negative 16mm scenes to be printed with dissolves, fades and superimposed titles. With this ingenious method, black and white release prints from camera negatives can be dressed up with effects previously only possible by first filming on reversal original film, then printing the effects into a duplicate negative from which the second generation release prints were made.

A clear understanding of the various "A and B roll" procedures enables the 16mm editor and producer to avoid the limiting camera-dissolves and camera fades, thus assuring the uniformity and versatility of scene transitions.

Figure 3 also illustrates standardized procedure of labeling and preparing 16mm film leaders, locating sync marks, etc.

Abridged from "How To Edit 16mm 'A' and 'B' Rolls," by Edward Pyle, Jr., April, 1950, American Cinematographer.

BULLETIN BOARD

(Continued from Page 486)

out for them by Mitchell Camera Corp., Glendale, Calif.



Metro-Goldwyn-Mayer, studios, incidentally, has its own Vista-Vision type camera, which it is keeping under wraps. Developed by John Arnold, ASC, head of the studio's camera department, camera has lateral film movement instead of vertical, as does Vista-Vision, but a curved film plane in the gate. Also, intermittent is interchangeable with others to provide aspect ratios of different sizes, ranging from six to ten sprocket holes in film length.



Mack Stengler, ASC, has been shooting the "Life With Elizabeth" TV film shows on an average of one a day—approximately 65 camera setups in an 8-hour period.



GEO. W. COLBURN LABORATORY INC.

164 NORTH WACKER DRIVE • CHICAGO 6
TELEPHONE STATE 2-7316

8 and 16mm SERVICES

Ready-Eddy

U. S. Registered Trademark
USEFULNESS GUARANTEED FOR EVERY DAY USE

1001 Ready Sound-Film

Editing Data:

- Footage • Frame Count • Screen Time
- 35mm and 16mm equivalents.

Plastic computer for everyone in movies and TV, from script to screen.

\$2.00 Prepaid

(Delivered in U.S.A.)

ASK FOR REPRINT OF ARTICLE IN AMERICAN CINEMATOGRAPHER.

Write or ask your dealer

READY-EDDY, Sandy Hook, Conn.



Reversal PROCESSING

Reversal specialists for over a decade. Our long experience insures superior quality. Electronically controlled machines keep temperature constant within .2 of one degree. National "Brilliantone" Cine prints are the finest available. Write for free catalogue.

CONTACT PRINTING B & W DUPLICATING
WORK PRINTS KODACHROME DUPLICATING
EDGE NUMBERING VACUUMATING

All work repeated at no extra charge

NATIONAL CINE LAB

Box 4425 Washington 17, D. C.

Scheibe FILTERS

In World-Wide Use

Produce moonlight and night effects in daytime • fog scenes • diffused focus and many other effects.

Information mailed on request.

SCHIEBE FILTERS COMPANY
ORIGINATORS OF EFFECT FILTERS

P.O. Box 46834, Hollywood 46, Calif.

USED IN EVERY HOLLYWOOD MOTION PICTURE PRODUCTION

CLASSIFIED ADVERTISING

10c per word, minimum ad \$1.00. Words set in capital letters except 1st word and advertiser's name, 15c per word. Modified display format 90c per line. No discount on classified advertising. Send copy with remittance to editorial office, 1782 No. Orange Drive, Hollywood 28, Calif. Deadline 15th of month preceding date of issue.

STUDIO & PRODN. EQUIP.

DEPT. STORE OF THE INDUSTRY
PRICE REDUCTION! Crab Dally, moves every which way. New stock \$ 495.00
 35MM REWIND SETS, geared & dummy ends, good 6.95
 B & H AUTOMATIC FOOT SPLICERS, 35mm \$595.00, combination 16/35mm..... 695.00
 CLOSING OUT 2000W Creco Fresnel Spots, good as is 39.50
 Creca Rolling Spatlite Stands..... 17.95
 NEW MH MITCHELL type Viewfinders..... 139.50
 MOVIOIA 35mm COMPOSITE Sound/Picture complete 495.00
 MAURER 16mm NEGATIVE/DIRECT POSITIVE Recording System, Rebuilt..... 2995.00
 NEW CINEFLEX 35mm REFLEX CAMERA, 2 mags, 3 lenses, 24V motor, case. \$1500 value 695.00
 MAURER 16mm CAMERA w/400' mag; sync-motor; viewfinder. Very clean..... 2295.00
 KINEVOX SYNCHRONOUS MAGNETIC RECORDER. Guaranteed 895.00
 CINEMAPHONE 35mm DUBBING Heads, less motor 395.00
 GIANT METAL FILM CABINETS, hold 120 assorted 16mm reels, \$240 value. New..... 171.00
 EASTMAN AUTOMATIC FILM WAXER, \$1200 value. Rebuilt 795.00
 LATEST HOLMES 25W Soundfilm amplifiers, \$250 val. Rebuilt 95.00

REAL LOW PRICES ON 16MM REELS & CANS

	12 or less	12-49	50 up
200'	\$.72	\$.60	\$.54
400'	.78	.70	.64
800'	2.84	2.70	1.90
1200'	3.24	3.04	2.30
1600'	3.60	3.30	3.00
2000'	6.50	6.10	5.50

TRADES TAKEN Phone PL 7-0440
 Dept. fc Cable: SOSOUND

S. O. S. CINEMA SUPPLY CORPORATION
 602 W. 52nd Street, New York 19.

OPERATION CINEMA

Owner-Producer, with \$80,000 package of professional 16mm equipment, seeks partnership or corporate union for production of non-theatrical films in sound market area. A desirable opportunity for outstanding management, sales, and creative talent to join with owner's skill and facilities in the establishment of a profitable operation. For particulars or conference appointment write Box 1193, American Cinematographer, 1782 North Orange Drive, Hollywood 28, California.

FOR SALE

BASS . . . is headquarters for Arriflex 16; the new Zoomar 16; Cine Specials, all models; Bell & Howell 70-DL; Bolex H-16. Used Cine Special I, 1" F:1.9 lens and carrying case \$395.00; Used H-16 Bolex, 1" F:1.5, 0.7" F:2.5 W.A., 3" F:3.5 \$347.50 Used Bell & Howell 70-DA, 1" F:1.9, 4" F:4.5 \$235.00. Used Bell & Howell 70-A, 1" F:3.5 and case \$52.50; Used 200' Chamber Cine Special \$295.00; Used 100' Chamber, Cine Special \$117.50. Best buys . . . Best trades always. BASS CAMERA CO., Dept. AC, 179 W. Madison St., Chicago 2, Ill.

BELL AND HOWELL 70 DL with 1" F1.9 Lens.....\$249.50
 CINE KODAK TRIPOD TRUCK..... 49.50
 MINIFON POCKET RECORDER..... 219.50
 KEYSTONE K160 16MM PROJECTOR, 750 watts 95.00
 BOLEX DELUXE TRIPOD..... 57.50
 16MM KODACHROME SINGLE PERF. 100' [out-door] Sept. dating..... 7.75
 (MAIL ORDERS FILLED PROMPTLY)

CAMERA CRAFT

18 East 42nd Street New York 17, N.Y.

WE BUY, SELL AND RENT PROFESSIONAL AND 16mm. EQUIPMENT, NEW AND USED. WE ARE DISTRIBUTORS FOR ALL LEADING MANUFACTURERS. RUBY CAMERA EXCHANGE, 729 Seventh Ave., New York City. Established since 1910.

ARRIFLEX 35mm. camera, 3 lenses, filters, sunshade, tripod, case. Complete for quick sale . . . \$795.00. Write P.O. Box 312, Ridgewood, N.J., or phone Allendale, N.J. 13046.

CINE SPECIAL II, 4-lens Par turret, 200-foot chamber, Meyer prof. viewfinder, 25mm F1.5 Schneider lens, value \$1800. Will sacrifice for immediate sale, \$900. Box 1191, AMERICAN CINEMATOGRAPHER.

FOR SALE

FOR SALE
OUR 25TH YEAR — SUPPLYING EVERYTHING PHOTOGRAPHIC & CINEMATIC

B&H 25mm EYEMO "Q" CAMERA with 4" f2.9 Cinemat, 2" f2.3 Kinar, 35mm f2 Cooke lenses and viewfinder lenses, 2-400' magazines, freehead tripod, shift-over alignment Gauge, 12V variable speed motor, 2 carrying cases, excellent condition.....\$1550.00
 35mm DUPLEX CAMERA — Registration pins, lenses: 40mm f2.7 Carl Zeiss, 2" f1.9 Ultrastigmat, 105mm Schneider f3.5, 3-400' magazines, 400' BiPack magazine, viewfinder Matte Box, 12V DC motor, battery, Freehead Tripod, 2 carrying cases. A real buy 1125.00
 35mm B&H SINGLE SYSTEM SOUND CAMERA, lenses: Cooke, 40mm, 50mm, 75mm, 125mm Modulite Galvanometer, amplifier, motor, Tachometer, 2-1000' magazines, Tripod with Frehead, quick release legs, carrying cases, Guaranteed 3500.00
 35mm ARRIFLEX CAMERA, Coated lenses: 35mm f1.2 Carl Zeiss, 50mm f1.5 Carl Zeiss, 85mm f2 Carl Zeiss, 135mm f2.3 Astro pan Tachar, variable speed motor, 12V battery, freehead tripod, 3-200' magazines, carrying cases, special 1175.00
 35mm AKELEY CAMERA, 4 matched Zeiss lenses, 4-200' magazines, slow motion attachment, Akeley friction tripod, quick release legs, carrying cases. Bargain price.... 750.00
 35mm ART REEVES SOUND RECORDER, twin fidelity optical unit, glow lamp type, 1000' B&H magazine, complete with cases..... 977.50
 ENLARGERS, excellent condition, Elwood, Auto focus, lens and stand, 5x7..... 235.00
 8x10 400.00
 MOLE RICHARDSON 2000 Spot, rolling stand.. 110.00
 B&H CAMERA CHECK PAWLS high sped shuttle. List price, new \$1742.00, good cond.... 195.00
 NEW SCHOEN PRINTER, sound and silent, color, B&W features: 16mm picture alone, 16mm track alone, 16mm picture and sound together, film capacity 1600 feet, 50' per minute, 12 adjustable light changes, AC-DC conversion unit 999.00
 HOMRICH COMBINATION COPYING CAMERA and animation table stand, adaptable to 4x5, 5x7, 8x10 holders. Two adjustable light stands with twin reflectors. 11x14 16x20 copy frames. Built in lamp house, good buy 135.00
 HOMRICH ELECTRONIC TIME CONTROL CONTACT PRINTER, timer has full second and split second setting. Handles 4x5, 5x7, 8x10 negatives. Adjustable masking and paper guides. Internal dodging plate glass plate. Four lamps, each controlled by separate toggle switch. A real buy..... 165.00
 Specializing in movie and television supplies, tripods, synchronizers, 16mm sound cameras, lights, lenses, mikes, booms, dollies, motors, etc. New-used reasonable prices. Cash for used equipment. Trades taken.
HOLLYWOOD CAMERA EXCHANGE, LTD.
 1600 Cahuenga Boulevard Hollywood, California

WALL S. S. 35MM. SOUND CAMERA

COMPLETE with Galvanometer, amplifier, portable power supply, 40-50-75 and 100mm. lenses, erect image viewfinder, complete front attachments, two 1000 ft. magazines, Balanced Tripod, necessary carrying cases. Overhauled. Guaranteed perfect. Reasonable.

CAMERA EQUIPMENT COMPANY
 1600 Broadway New York 19, N. Y.

AUDIO AKELEY single system camera complete with Akeley sound head, Gyro tripod, 3 lenses, view finder, Maurer mixing amplifier. Complete with cables, power supply and W. E. microphone. CAMERA EQUIPMENT CO., 1600 Broadway, New York 19, N.Y. Cable Cinequip.

AURICON R.T.-80 Recorder and N.R.S.-24 amplifier modified for negative or direct positive recordings. Price \$495.00. SOOJIAN'S, 4175 S. Cherry Ave., Fresno, Calif.

LATEST model Hallen 16mm synchronous tape recorder. \$975.00 or will trade for animation stand or hydro-dolly. Write G. A. CARR, 539 Vine Street, Chattanooga, Tennessee.

MAURER Model 25, dissolving shutter, viewfinder, sunshade filter halder, 400' magazine, electric motor, 8 frame crank, carrying case.. Best offer. Write BOX 385, Waukesha, Wisconsin.

WANTED

IMMEDIATE CASH PAYMENT FOR CAMERAS AND EQUIPMENT

NEED EYEMOS (SINGLE LENS AND TURRET), MITCHELLS, ARRIFLEX, DE BRIES, B&H STANDARDS AND HI-SPEEDS, WALLS, AKELEYS, CINE SPECIALS, AJURICONS, MAURERS, FILMOS. ALSO BALTARS, COOKES AND OTHER LENSES. SOUND STAGE, LABORATORY AND EDITING EQUIPMENT OF ALL TYPES REQUIRED. PLEASE SHIP INSURED OR FORWARD DESCRIPTIONS AIRMAIL. IMMEDIATE PAYMENT.

GORDON ENTERPRISES • 5362 N. Cahuenga
 NORTH HOLLYWOOD, CALIFORNIA

WE'RE ALWAYS IN THE MOOD FOR EQUIPMENT THAT IS GOOD BUY — SELL — SWAP — CONSIGN

Cameras, Dollies, Lenses, Lights, Moviolas, Printers, Recorders, Studio or Laboratory Equipment

Western Union-WUX New York
 Phone PL. 7-0440

S. O. S. CINEMA SUPPLY CORPORATION
 Dept. fc Cable: SOSOUND
 602 W. 52nd Street New York 19, N. Y.

WANTED

Mitchell — Akeley — B & H — Wall — Eyemo
 Cameras — Lenses — Equipment
NATIONAL CINE EQUIPMENT, INC.
 209 West 48th St. New York, N.Y.

WANTED TO BUY FOR CASH

CAMERAS AND ACCESSORIES
 MITCHELL, B & H, EYEMO, DEBRIE, AKELEY ALSO
 LABORATORY AND CUTTING ROOM EQUIPMENT
CAMERA EQUIPMENT COMPANY
 1600 BROADWAY, NEW YORK CITY 19
 CABLE: CINEQUIP

WANTED

PRODUCTION EQUIPMENT, LABORATORY EQUIPMENT, EDITING EQUIPMENT, 16mm. and 35mm. FROM SINGLE ITEMS TO COMPLETE STUDIOS. TRADES ACCEPTED.

THE CAMERA MART, INC.
 1845 Broadway Circle 6-0930 New York 23, N.Y.

F & B PAYS MORE FOR USED 16/35MM EQUIPMENT WRITE — WIRE — PHONE FOR OUR CASH OFFER

FLORMAN & BABB MU. 2-2928
 70 W. 45TH ST. NEW YORK 36, N.Y.

CAMERA & SOUND MEN

ASSIGNMENTS FOR INDIA or nearby territories for any type of films, 16 or 35mm, B&W or Color, write to KANU PATEL, A.R.P.S., The Clarion Productions, 34, Park Mansions, CALCUTTA-16.

COLOR SLIDES, PHOTOS & FILM

PREPARED MOVIES OF HAWAII, 16mm-8mm Kodachrome. Write for free literature. HAWAIIAN FILMS, LTD., 226-A Lewers Raad, Honolulu, Hawaii.

LABORATORY & SOUND

SOUND RECORDING at a reasonable cost. High Fidelity 16 or 35. Quality guaranteed. Complete studio and laboratory services. Color printing and lacquer coating. ESCAR MOTION PICTURE SERVICE, INC., 7315 Carnegie Avenue, Cleveland 3, Ohio. Phone Endicott 1-2707.

(Continued On Next Page)

Classified Ads

(Continued from Page 525)

LABORATORY & SOUND

KODACHROME duplicates: 16mm 10c per foot, mail orders accepted, satisfaction guaranteed. COLOR-VISION FILMS, 122 N. Mo clay Ave., San Fernando, California.

POSITIONS AVAILABLE

EXPERIENCED 16mm Cameraman wanted by growing producer in South. Give experience and references in first letter. Write Box 1192, AMERICAN CINEMATOGRAPHER.

PRODUCTION SERVICE

TECHNICAL, scientific, high speed and macro motion picture photography at low budget for production companies, industry, etc. All motion picture services. GOLDEN KEY PRODUCTIONS, INC., 1921 Hillhurst Ave., Hollywood 27, NOrmandy 3-9421.

To Classified Advertisers

Copy deadline for classified advertising is the 15th of month preceding publication date. Mail copy and remittance to cover cost to

AMERICAN CINEMATOGRAPHER

1782 No. Orange Dr.
Hollywood 28, Calif.

AMERICAN CINEMATOGRAPHER HANDBOOK

for the

PROFESSIONAL and AMATEUR

by

JACKSON J. ROSE, ASC

New data on Cinerama - Television photography - Background Projection - Zoom Lenses - Underwater Photography - Latensification - "T" Stops - Ansco Color - Eastman Color - DuPont Color - Cameras - Projectors - Lenses - Filters - Charts - Tables - Ratings - Diagrams - Systems - Equalizers - Formulas, Etc.

THE ONLY HAND BOOK
OF ITS KIND

PRICE **\$5.00**

(California buyers please add 18c sales tax)

Book Department,
American Cinematographer,
1782 No. Orange Dr.,
Hollywood 28, Calif.

Gentlemen: Enclosed please find \$5.00* for which please send me a copy of THE AMERICAN CINEMATOGRAPHER HANDBOOK AND REFERENCE GUIDE.

Name

Address

City..... Zone..... State.....

*If you live in California, please include 18c sales tax — total \$5.18.

TODD-AO NEWEST WIDE-SCREEN SYSTEM

(Continued from Page 496)

horse, or a train in motion—entering the scene from one corner and traveling across diagonally—would appear on the screen to pick up speed as it neared the center, then sharply diminish in speed as it proceeded toward the opposite side of the screen.

Makeup is another important factor, according to Surtees. When not exactly right, it shows up glaringly on the screen. "One thing we learned early," said Surtees, "is that Todd-AO is not kind to the aging. Middle-aged or elderly players really look their age when photographed in color with Todd-AO, even with the benefit of the most expert makeup."

In the beginning, the origination and development of Todd-AO called for a complete revolution in equipment design—from the camera down to the splicers—even sound recording equipment interlocks had to be revamped because recording equipment for Todd-AO runs at the same conventional speed as 35mm, 90 feet per minute, against the speed of 140 feet per minute for the picture.

While the Todd-AO picture negative is 65mm in width, the release prints are on 70mm film—the extra width accommodating the extra tracks for stereophonic sound.

The well-known Phillips Electric Company of Holland designed and is constructing the Todd-AO 70mm projectors which are to be used in exhibiting "Oklahoma" and other productions yet to be made in the Todd-AO process. The Phillips company presently is at work on a revolutionary new "universal" projector for theatres that will take both 35mm and 70mm films interchangeably, enabling an exhibitor to screen motion pictures in every format that is presently available without the need for investing in dual projection equipment. The changeover from 35mm to 70mm, for instance, will be accomplished simply by flicking a switch and twisting one or two dials; it will be unnecessary to interchange film movements, gates, etc.

When the Rodgers and Hammerstein Company prepared to shoot on the Nogales, Arizona, location, they set up there in advance a complete machine shop staffed with expert technicians from Mitchell Camera Corp., American Optical Company, and others. This enabled the company to promptly make any changes or repairs on the cameras on location without the delays that otherwise would be encountered were it necessary to ship the cameras back to the studio.

When the company began the first

day's shooting, it had but two Todd-AO cameras. Additional cameras were shipped as they were completed by the factory. Ultimately there were six cameras on the location, plus a spare head designed to take all the Todd-AO lenses previously described.

Naturally enthusiastic about Todd-AO, Robert Surtees is firm in the belief that the system is the true showman's medium. Todd, Rodgers and Hammerstein all are sagacious showmen, each with many outstanding successes to their credit. They recognized immediately the great possibilities presented by the Todd-AO system in bringing to the motion picture screen their many valuable stage properties, without losing any of their spectacular value. The first, "Oklahoma," is rapidly nearing completion. Final scenes are now being shot on the sound stages at MGM studios.

Here Surtees has developed further new approaches in the photography of the picture. He employs additional contrast, which he believes is vital in the Todd-AO system because otherwise the picture would flatten out on the enormous screen. As an example, when shooting interiors, he lights them entirely with arcs. All interiors are so vast, that it takes a tremendous volume of illumination to bring the lighting level up to that encountered in shooting exteriors, which most of the interior sets must match. The key Surtees employs in matching color temperature on these "indoor exteriors" is the chart of color temperature readings, which he made for each scene photographed on location, scenes that had to be matched later at the studio on the sound stages.

The introduction of Todd-AO has also been an interesting experience for Floyd Crosby, ASC, who directed the photography on the second unit, also on location in Arizona. One of the big challenges for Crosby was the problem of working out methods of mounting the Todd-AO camera on a number of vehicles ranging from locomotives to conventional camera cars—all of which Crosby had to use in filming the scenes that were part of his assignment. Here again, the problems of the extreme wide angle of the lenses and the "cross-screen" movement of players, etc., had to be taken into account, more than elsewhere, perhaps.

As more Todd-AO cameras are manufactured, they are to be made available to other studios and independent film producers by the Todd-AO company. In the meantime, Rodgers & Hammerstein are preparing another production to follow completion of "Oklahoma."

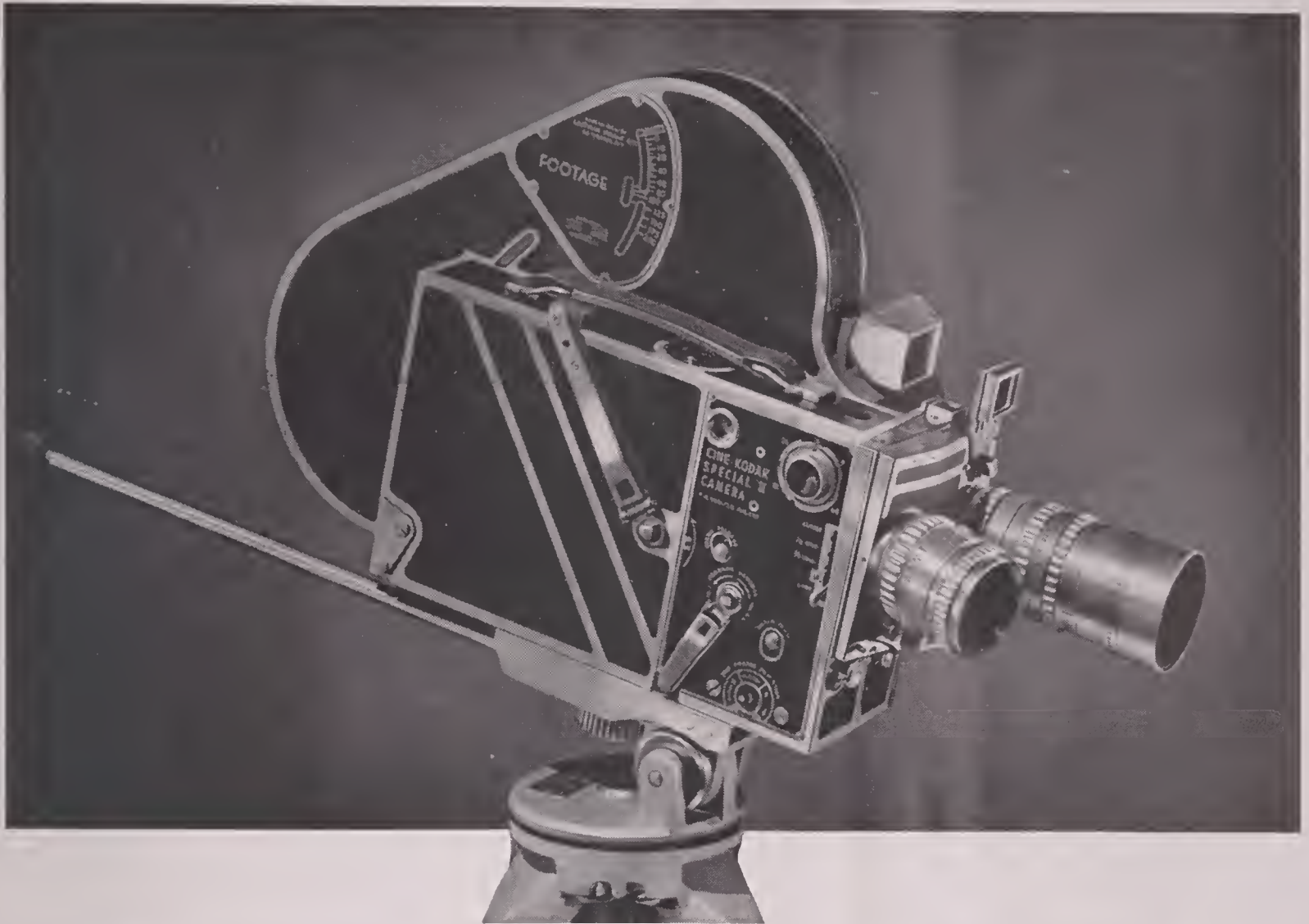

Got an idea for a great movie?

Here's the 16mm. camera to make it click

A wonderful idea for your next movie is born! And now you need the kind of camera equipment that can help you express it on film . . . complete with fades, dissolves, mask shots, double and multiple exposures, montages, animation.

The versatile Cine-Kodak Special II Camera has all the extras you need for *creative* 16mm. movie making . . . built right into a single package.

YOU CAN...

Change lenses instantly with the angled turret which takes any two interchangeable Kodak Cine Lenses, without optical or physical interference.

Make fades and dissolves easily with

the adjustable-opening shutter which can be adjusted from full open, through half-to quarter-open, to closed, even when the camera is running. Also permits precise exposure control under extreme light conditions.

Make double or multiple exposures easily. One- and eight-frame cranks permit precise reverse winding—or can be used for hand operation on extra-long scenes. If electric motor drive is desired, it can be attached to cranking shaft.

Frame your shots . . . get multiple exposures, montages, special effects, with masks which are inserted into a slot between lens and film. Set of six masks comes with the camera.

Keep exact tab on footage, right down to individual frames. Camera has three meters: Film Chamber Meter tells how much film is left on roll. Footage Meter shows exact number of feet already run. Frame Counter records individual frames. The latter two operate either in forward or reverse and provide the precise film control needed for multiple exposures and dissolves.

Focus and frame through the taking lens with the "Special II's" reflex finder. Direct-view eye-level finder permits following fast action.

Shoot entire action on one winding. The powerful spring motor will expose 38 feet of film with a single winding!

Cine-Kodak Special II Camera with Kodak Cine Ektar 25mm. f/1.9 Lens and 100-foot film chamber, \$995. With Ektar f/1.9 Lens and 200-foot film chamber, \$1,215. With Ektar f/1.4 Lens and 100-foot film chamber, \$1,095. With Ektar f/1.4 Lens and 200-foot film chamber, \$1,315. Prices include Federal Tax and are subject to change without notice.

EASTMAN KODAK COMPANY, Dept. 8-V, Rochester 4, N. Y.

Please send me more information about the Cine-Kodak Special II Camera.

10-11

NAME _____ POSITION _____

COMPANY _____

STREET _____

CITY _____ STATE _____
(Zone)

Kodak
TRADE-MARK

Bell & Howell presents
the world's sharpest
CinemaScope lens

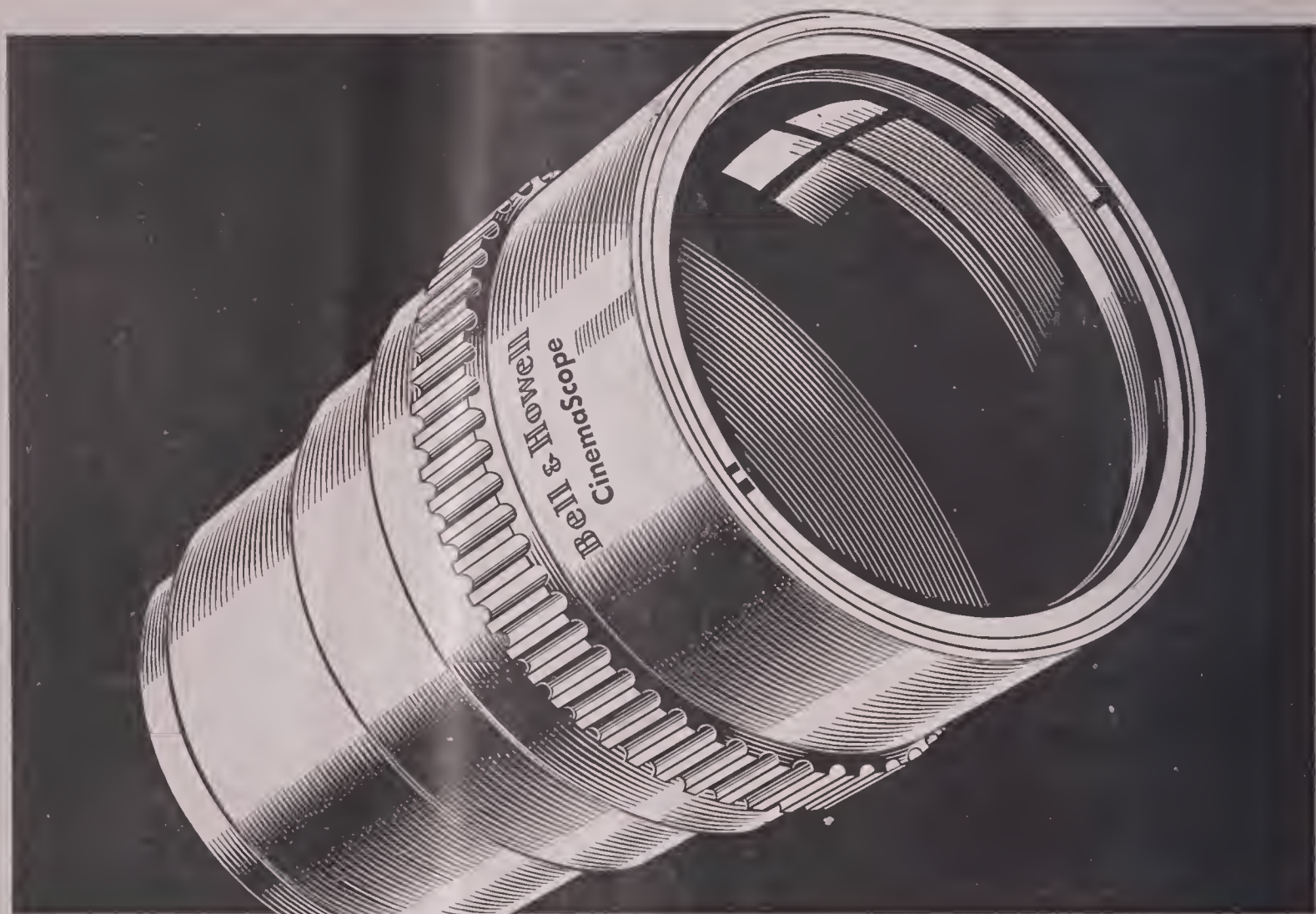

"Best by far!"

— says James E. Coston
Coston Enterprises
Chicago, Illinois

"For sharpness, clarity and brightness right to the edges of the screen, we're convinced there's no finer lens on the market than the Bell & Howell CinemaScope theater projection lens . . . now being used in 14 of our theaters in Illinois, Indiana and Wisconsin.

For all anamorphic type wide screen releases including CinemaScope productions. Designed to fit all theater and studio projection lenses.

sharp focus . . . Six elements provide extreme sharpness. Each individual lens precision collimated for crisp definition to full corners and edges.

resolution . . . modern formula developed by world's foremost lens designers . . . all twelve glass surfaces held to test gauge quality.

brilliance . . . unequalled light transmission . . . all air surfaces magnesium fluoride hard coated—3 doublets butyl methacrylate cemented.

full color . . . color banding and fringing eliminated by full correction of all color aberrations.



Bell & Howell

For full information see your local theater supply house or write to . . .

PROFESSIONAL EQUIPMENT DEPARTMENT • 7148 McCORMICK ROAD • CHICAGO 45, ILL.

AMERICAN

NOVEMBER • 1954

Cinematographer

THE MAGAZINE OF MOTION PICTURE PHOTOGRAPHY



This Issue ...

- VISTAVISION MOVES FORWARD
- WANT TO SHOOT FOR THE TV NEWSREELS?
- SPEED IN SMALL STUDIO TV FILM PRODUCTION

25c
\$3.00 YEARLY



Bad-weather scenes in "On the Waterfront" are authentic! Location shooting an Type 926 "Superior" 2 during night snowstorms was tough on cameramen — great for atmosphere.



Boris Kaufman, Director of Photography, is the man responsible for the outstanding cinematography in "On the Waterfront."



Director Elia Kazan and Director of Photography Boris Kaufman work under cover of a dock on the Hoboken, N. J., waterfront.

Realism stars in "ON THE WATERFRONT"

Du Pont "Superior" 2 captures low lighting, rough weather in dockside drama

Midwinter location shooting *could* have made Columbia's picture "On the Waterfront" (produced by Sam Spiegel) a cameraman's nightmare. But Boris Kaufman, the film's Director of Photography, decided to take advantage of this wintry atmosphere in portraying the waterfront's docks and slums. Mr. Kaufman chose Du Pont Type 926 "Superior" 2 motion-picture film to shoot under these dramatic but difficult conditions.

Here's what Mr. Kaufman says about Du Pont "Superior" 2: "Maintaining consistency through-

out sequences with changing weather conditions was one of my toughest problems. To capture the mood in sun, snow, rain, fog and at night, I had to rely on my own judgment for exposures and balance. The response of Du Pont Type 926 'Superior' 2 gave me exactly what I wanted."

That's real praise from an expert! And you'll agree with Mr. Kaufman when you see the results that you get on "Superior" 2. Use it on your next assignment—it's a film to match the finest camera technique. E. I. du Pont de Nemours & Co. (Inc.), Photo Products

Department, Wilmington 98, Delaware. *In Canada: Du Pont Company of Canada Limited, Montreal.*

District Offices

ATLANTA 5, GA.	805 Peachtree Bldg.
BOSTON 10, MASS.	140 Federal Street
CHICAGO 18, ILL.	3289 N. Colifornia Ave.
CLEVELAND 14, OHIO	1033 Union Commerce Bldg.
DALLAS 1, TEXAS	506 Tower Petroleum Bldg.
LOS ANGELES 38, CALIF.	7051 Sonto Monico Blvd.
NEW YORK 11, N. Y.	248 West 18th Street
PHILADELPHIA 2, PA.	225 South 15th Street



BETTER THINGS FOR BETTER LIVING
... THROUGH CHEMISTRY

SPECIFY **DU PONT** MOTION-PICTURE **FILM**

NOV 17 1954

Great equipment makes great cameramen

BALANCED TRIPOD HEAD and PROFESSIONAL JUNIOR TRIPOD

are the standbys of the masters



New "BALANCED" TV head — MODEL "C"
—for the world's smoothest pan and tilt action.

You'll never hear Fritz Kreisler playing on a scratchy fiddle . . . or Louis Armstrong on a \$7 trumpet. Good craftsmen need good tools.
Camera Equipment Company makes, sells, services and rents the world's finest quality TV and Motion Picture Equipment.

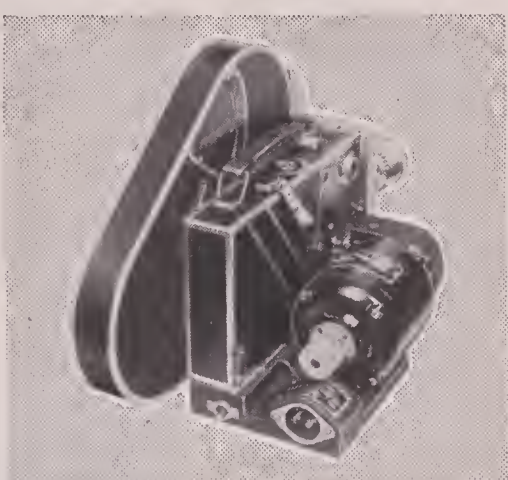

SYNCHRONOUS MOTOR DRIVE — 110 Volt AC—Single phase, 60 Cycle. Runs in perfect synchronization with either 16mm or 35mm Sound Recorders. Mounting platform permits removal of magazine while camera remains mounted on motor. Spring steel drive fin coupling prevents damage if film jam occurs.
Knurled knob on armature permits rotating for threading. "On-Off" switch in base. Platform base threaded for 1/4" or 3/8" tripod tie-down screw. Rubber covered power cable with plugs included.

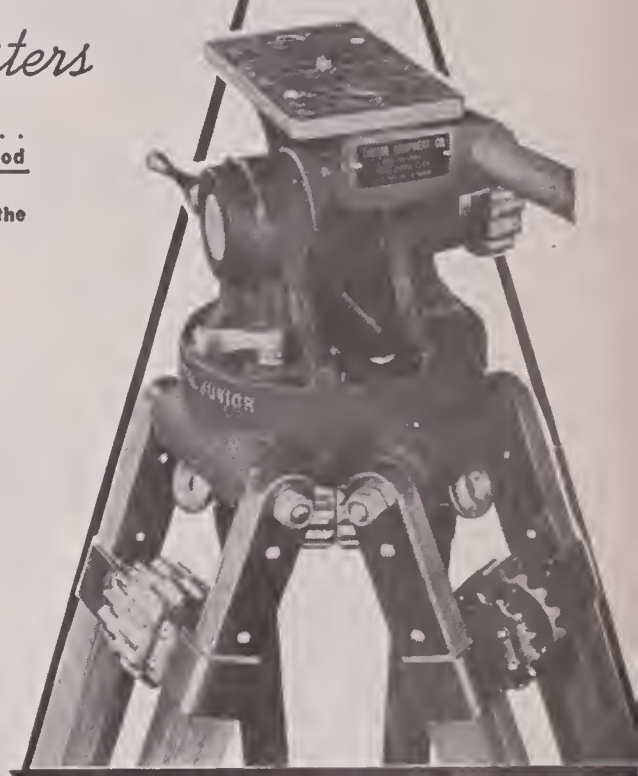

More professional cameramen use The PROFESSIONAL JUNIOR Tripod than any other tripod in the world.

No more groping for center of gravity. The new Model C "Balanced" Tripod Head is equipped with a convenient, accessible positioning handle mounted below the top plate, which allows the operator to reposition the camera to the correct center of gravity. No matter what focal length lens is used on the camera turret, the camera can be balanced on the Model C head without loosening the camera tie-down screw.

It has all the features which have made the "Balanced" head a gem of engineering ingenuity—quick release pan handle, tilt-tension adjustment to suit your preference. It's a Cameraman's dream!

Let's face it. You need a first class tripod to make better pictures. PROFESSIONAL JUNIOR has the rigidity, the range, and the ease of operation that better pictures demand. See it—try this tripod beauty—and you'll never be without it.
PROFESSIONAL JUNIOR TRIPOD—Friction Type. Handles all 16mm cameras, with or without motor. Also 35mm DeVry B & H Eyemo with and without motor, and 400' magazines. Tripod base interchangeable with Professional Junior gear drive head. "Baby" tripod base and "Hi-Hat" base available.

FRANK C. ZUCKER

CAMERA EQUIPMENT CO.

1600 BROADWAY NEW YORK CITY

SALES • SERVICE • RENTALS — CAMERAS * MOVIOLAS * DOLLIES

Complete line of 35mm and 16mm equipment available for rental.
MITCHELL: Standard, Hi-Speed, BNC, NC, 16mm
BELL & HOWELL: Standard, Shiftover, Eyemo
ARRIFLEX: 35mm and 16mm
MAURER: 16mm Cameras
MOVIOLA: Editing machines, Synchronizers
We design and manufacture Lens Mounts and camera equipment for 16mm—35mm and TV cameras.

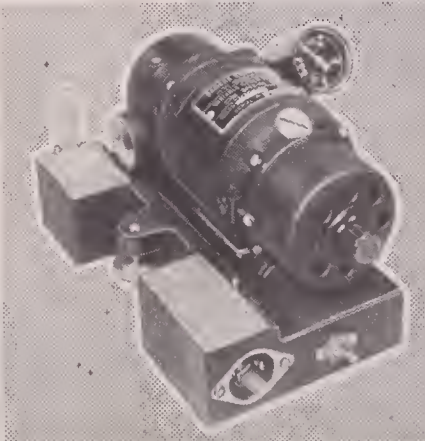

VARIABLE SPEED MOTOR — 110 Volt AC/DC with Tachometer for EK Cine Special Motor drive your Cine Special with confidential Tachometer is mounted in clear view of operator. Calibrated from 8 to 64 frames per second. Definite RED marking for 24 fps. Electrical governor adjusts speeds. Steady operation at all speeds. No adapters needed. Motor coupling attaches to camera and couples to motor. Spring steel drive arm shears if film jam occurs. Easily replaced.

We calibrate lenses—Precision "T" Stop Calibration of all type lenses, any focal length. Our method is approved by Motion Picture Industry and Standard Committee of SMPTE. For proper exposure density, it is important that you have your lens "T" stop calibrated. Lenses coated for photography. Special TV coating. Rapid service.

**YOUR FILM
GOES THROUGH
EXPERIENCED
HANDS**

**CONSOLIDATED
FILM INDUSTRIES**
Hollywood's only complete film lab

**35 MM
16 MM
B & W
EASTMAN
COLOR**

959 SEWARD ST., HOLLYWOOD 38 CALIF. • HOLLYWOOD 9-1441
1740 BROADWAY, NEW YORK 19, NEW YORK • JUDSON 6-1700

AMERICAN

Cinematographer

THE MAGAZINE OF MOTION PICTURE PHOTOGRAPHY
PUBLICATION OF THE AMERICAN SOCIETY OF CINEMATOGRAPHERS

ARTHUR E. GAVIN, *Editor*

MARION HUTCHINS, *Editorial Assistant*

EMERY HUSE, *Technical Editor*

EDITORIAL ADVISORY BOARD: John Arnold, Arthur Edeson, Lee Garmes, Charles Roshier, Leon Shamroy, Fred Gage, Glenn R. Kershner

Editorial and Business Office: 1782 N. Orange Dr., Hollywood 28, Calif.

Telephone: HOLLYWOOD 7-2135

VOL. 35

NOVEMBER • 1954

NO. 11

In This Issue

ARTICLES

A.S.C. FETES CHARLES ROSHER	538
VISTAVISION MOVES FORWARD—By Loren L. Ryder, ASC, and Jack Bishop, ASC	552
DO-IT-YOURSELF SOUND RECORDING ADDS CLASS TO 16MM FILMS	554
560 PHOTOFLOODS—280,000 WATTS!—By Leigh Allen	556
SPEED IN SMALL STUDIO TV FILM PRODUCTION—By Wm. Bancroft Mellor	561
EFFECTING ECONOMIES IN THE EDITING OF TV FILMS—By Hyman R. Cohen	562
SLOW SPEED CAMERA MOTOR—By John W. Bakke	563
MAKING THE MOST OF LABORATORY SERVICES—By Charles L. Anderson	564

AMATEUR CINEMATOGRAPHY

WANT TO SHOOT FOR THE TV NEWSREELS?—By Arthur Marble	566
'PIXILATION'—NEW IDEA IN MOVIE MAKING—By Harold Benson	568

FEATURES

HOLLYWOOD BULLETIN BOARD	534
WHAT'S NEW IN EQUIPMENT, ACCESSORIES, SERVICE	536
INDUSTRY NEWS	542
BOOKLETS, CATALOGS AND BROCHURES	544
HOLLYWOOD STUDIO PRODUCTION	582

ON THE COVER

PARAMOUNT'S first new VistaVision camera. Engineered and built by Mitchell Camera Corp., following suggestions supplied by Paramount engineers, the camera is of radical design and completely new in every respect. Most notable exterior feature is the vertical 2,000-ft. magazines. At the gearhead controls is Jack Bishop, ASC, head of Paramount's camera department. More details of the camera appear in the article which begins on page 552 in this issue.—*Photo courtesy Paramount Pictures Corp.*

AMERICAN CINEMATOGRAPHER, established 1920, is published monthly by the A. S. C. Agency, Inc., 1782 N. Orange Dr., Hollywood 28, Calif. Entered as second class matter Nov. 18, 1937, at the postoffice at Los Angeles, Calif., under act of March 3, 1879. SUBSCRIPTIONS: United States and Canada, \$3.00 per year; Foreign, including Pan-American Union, \$4.00 per year. Single copies, 25 cents; back numbers, 30 cents; foreign single copies, 35 cents; back numbers 40 cents. Advertising rates on application. Copyright 1954 by A. S. C. Agency, Inc.

IMPORTANT ANNOUNCEMENT

re: the *Mitchell*
16mm Professional Camera

IMMEDIATE SHIPMENTS

are currently
being made

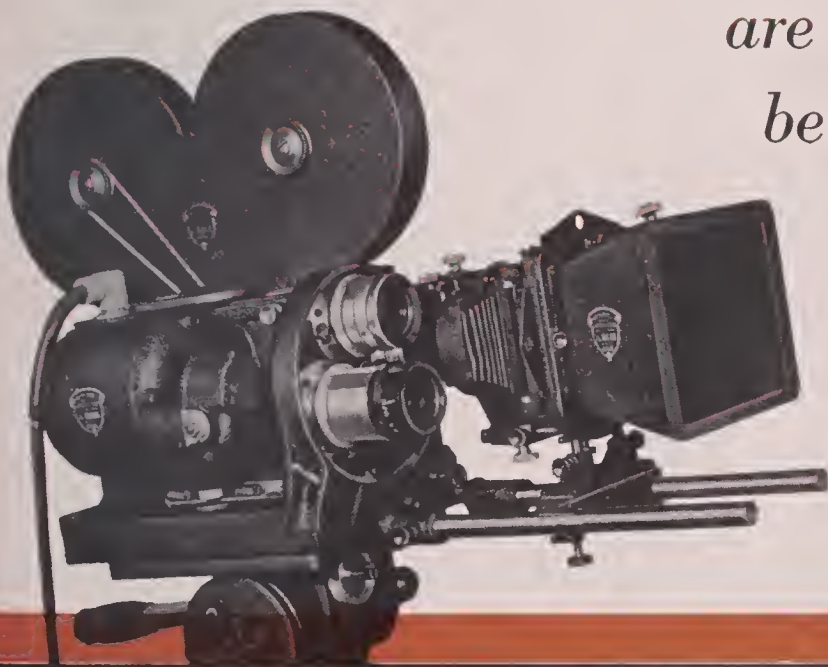

...with this announcement
the Mitchell
Camera Corporation,
for the first time
in history,
now offers you
shipment of the
famed Mitchell 16mm
Professional Camera
on receipt
of your order.



THE CAMERA WITH A HERITAGE

There is no substitute for a heritage
of GREAT ENGINEERING. No 16mm motion picture camera
made anywhere in the world can match
the technical perfection which a Mitchell 16
brings to your film. Each 16mm camera has the same
supreme custom workmanship and Mitchell's
exclusive, positive operation that is today world-famous
... wherever truly professional films are made.

Mitchell Camera CORPORATION

666 West Harvard Street • Glendale 4, Calif. • Cable Address: "MITCAMCO"



85% of the professional motion pictures shown throughout the world are filmed with a Mitchell



This is TOPS!

This issue of

AMERICAN
CINEMATOGRAPHER
is the BIGGEST YET!

- More pages
- More advertising
- More circulation

Than Any Previous Issue!

No wonder more and more advertisers are swinging to American Cinematographer, the one publication in the motion picture field that delivers more sales per unit of circulation than any other, and at a cost far less than that of any of the others.

If you have a product or service to sell those in the business of producing motion pictures, if you want your message to reach more of the men who buy, include American Cinematographer in your 1955 Advertising Schedule.

WRITE FOR ADVERTISING
RATE CARD TODAY

Rates Remain Unchanged for 1955

AMERICAN
CINEMATOGRAPHER

THE AMERICAN SOCIETY OF CINEMATOGRAPHER'S
MAGAZINE OF MOTION PICTURE PHOTOGRAPHY

Hollywood Bulletin Board



THE SOCIETY of Motion Picture and Television Engineers made its annual technical awards at the Society's 76th semi-annual convention in Los Angeles last month. Herbert Barnett, SMPTE president (R.) is shown making presentations. (L. to R.) Ray D. Kell, David Sarnoff Award; Lorin D. Grignon, Samuel L. Warner Award; and Armin J. Hill, SMPTE Journal Award.

A new book on cinematography, authored by four of Hollywood's foremost directors of photography, is soon to make its appearance.

Lee Garmes, ASC, has joined with cinematographers Joseph Ruttenberg, ASC, Charles Rosher, ASC, and Victor Milner, ASC, in publishing "The Academy Award Winners' School of Photography." Volume will reveal the real inside of cinematography. Each of the co-authors is an Academy Award winner, each having won one or more "Oscars."

Visitors in Hollywood last month attending the S.M.P.T.E. convention, who dropped in to the American Society of Cinematographers clubhouse for a visit, included Joseph A. Tanney (S.O.S. Cinema Supply Corp.), George Kadisch (Cinekad Eng. Co.), Frank Zucker, ASC (Camera Equip. Co.), and Charles Herbert, ASC, of Tucson, Ariz.

Harold Stine, ASC, is now shooting three TV film shows weekly: "This Is Your Music," "Corla Pandit," and "Cavalcade of America."

Arthur E. Reeves, who headed Art Reeves Motion Picture Equipment Co., in Hollywood, died October 8th following a brief illness. A veteran cameraman and motion picture engineer, Reeves is credited with having deve-

loped many valuable equipment and camera innovations. One of his foremost industry contributions was the "Sensitester," a dual sensitometer and scene testing device which today is found in most of the major film laboratories.

Surviving are his wife Grayce and two daughters, Mrs. Grace Reeves Nichols and Mrs. Barbara Hite. Bob Nichols, son-in-law, will assume management of the Art Reeves Motion Picture Equipment Co.

Gil Warrenton, ASC, left Hollywood for the Philippines last month, where he will shoot "No Place To Hide," in Eastman Color. Picture features Marsha Hunt and David Brian. Assignment marks the third one on foreign soil this year for Warrenton.

Alan Stensvold, veteran Hollywood cinematographer, was elected to membership in The American Society of Cinematographers last month. At one time Hollywood's leading professional 16mm cameraman, Stensvold later organized the Society of 16mm Cinematographers. His most recent feature film assignment was for Cy Roth Productions in Hollywood, for whom he photographed "Air Strike" for Lippert release.

George T. Clemens, former member of the A.S.C., has renewed his membership in the Society.

Stereocolor Corp., of Davenport, Ia., last month demonstrated to Hollywood technical men its new three-dimensional wide-screen photography and projection process. System requires but one camera and one projector and a single strip of film on which the right and left eye images are both placed horizontally. Synchronization problems are said to be eliminated by the single film. In projection, non-anamorphic aspect ratios of up to 1 to 2.44 are claimed.

Harold J. Marzorati, ASC, until recently a cinematographer in the Process Department at MGM, is currently directing the photography of Metro's "The Marauders" in color and wide-screen.



PANORAM DOLLY gives camera complete mobility; smooth panning, dolly shots, running shots, special effects. Two man crew.

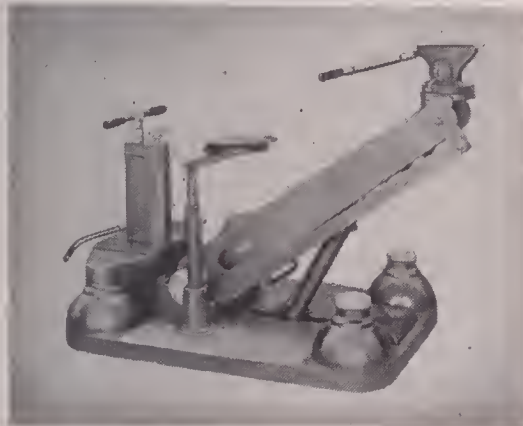

CINEMOBILE offers extreme maneuverability. Camera boom raises hydraulically. Ideal for smooth dollying, panning, etc. Two man crew.



HOUSTON-FEARLESS TC-1 CRANE raises camera to extremely high and low positions. Permits "fluid motion" shots. Foot-operated panning.



HOUSTON-FEARLESS All-Metal Tripod on Tripod Dolly gives mobility to cameras at low cost. Completely portable. Ideal for remotes.

CAMERA is counterbalanced in Model PD-3 TV Pedestal by Houston-Fearless, enabling cameraman to raise or lower with ease.



WHICH TYPE OF CAMERA MOUNT SHOULD YOU BUY?

Proper mounting of television and motion picture cameras is essential for efficient operation, smooth production and good showmanship. Choice of mobile equipment should be determined by the size of your studio, types of shows, size of camera crew, camera equipment used, budget and many other factors.

Each piece of Houston-Fearless equipment shown here has been designed

for a specific purpose. Each is the finest of its type, the standard of the industry.

A Houston-Fearless representative will be happy to analyze your requirements and recommend the equipment that will serve you best. Write or phone: The Houston-Fearless Corp., 11801 West Olympic Boulevard, Los Angeles 64, California. BRadshaw 2-4331. 620 Fifth Avenue, New York 20, N. Y. Circle 7-2976.



MODEL BT-1 CRANE has power drive, hydraulic lift. Provides lens height from 2' to 10'. Developed for Motion Picture Research Council.



TV PEDESTAL MODEL PD-1 by Houston-Fearless is operated by cameraman. Rolls smoothly, raises, lowers, turns on own radius.

WHAT'S NEW

... in equipment, accessories, service



Film Editing Machine

Resultant Engineering, Inc., announces its line of new editing equipment which includes a Standard model for 35mm picture film with 17½mm or 35mm magnetic or optical track, and the Combination model that takes both 16mm and 35mm picture film with 17½mm or 35 mm sound tracks.

Features include 9" Jensen speaker and hi-fidelity amplifier, rugged Geneva theatre-projector type intermittent, electrical hand brake, large picture for easy viewing, optical unit which springs away from film exposing entire frame for easy marking, tone control, light well, and extra large film bag.

Price of Standard model is \$1,050. Combination model is \$1,375. A 60 day delivery schedule is now in effect.

Lab Equipment Sale

One of the largest sales of motion picture film laboratory equipment ever held is being conducted by the Houston Fearless Corporation. The extensive selection of equipment is from the laboratories of Color Corporation of America.

Included are processing and printing machines, chemical mixing and control equipment, projectors, editing equipment, cameras, tripods, lenses and a wide variety of other equipment.

This unusual sale makes it possible

to purchase many types of lab equipment for immediate delivery. Further information can be obtained from The Houston Fearless Corp., 11809 West Olympic Blvd., Los Angeles 64, Calif.

Electronic Power Supply

A multi-purpose 500-watt electronic power supply has been announced by Stencil-Hoffman Corp., 921 No. Highland, Hollywood 38, Calif. Unit furnishes 117volts 60 cycles AC with sufficient capacity to handle recorders, turntables and other synchronously driven pieces of equipment that require constant speed.

For data sheet and price, write the manufacturer direct.

Film Measurer

Neumade Products Corp., 330 West 42nd St., New York 36, N. Y., announce its new Showtimer film measuring machine for 16mm sound film. Instead of measuring in terms of feet and/or frames, Showtimer records the



hours, minutes, seconds and split-seconds of projection time. For price and descriptive literature, write to the manufacturer and mention *American Cinematographer*.

New Firm Name

Kadisch Camera and Sound Engineering Co., 500 West 52nd St., N. Y. 19, N. Y., has changed the firm name to Cinekad Engineering Co., simultaneously with the establishment of an expansion program which will see the company expanding its sales outlets in a number of key cities throughout the U. S. George Kadisch continues to

head the organization which manufactures and distributes a fast growing line of professional motion picture and TV film production equipment. A comprehensive equipment catalog is available from the company to those making request on their business letterhead.

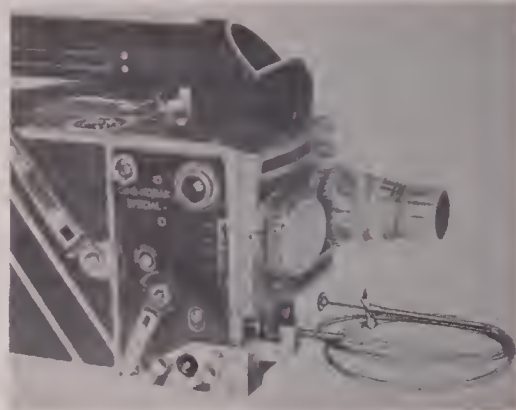

Cable Release for Cine Special

PAR Products Corp., 926 No. Citrus Ave., Hollywood 38, Calif., announces a new cable release for the Cine Special Kodak. Use of release permits remote operation of shutter release. Release is all metal, 3-feet in length, with an adapter for use on either Cine Special I or II. Unit is complete, ready for easy attachment by user without need for special tools or camera modification. List price is \$24.00.

The company also offers a cable release for use on Cine Specials equipped with Par 4-lens turrets. This must be installed by the manufacturer and lists for \$18.50.

Camera Brace

S.O.S. Cinema Supply Corp., 602 West 52nd St., New York 19, N. Y., offers a new type camera support for hand-held motion picture cameras. Tradenamed the Body-Brace Camera Pod, it provides extra camera steadiness and greater comfort for the cameraman. Made of lightweight aluminum, it weighs but 3½ lbs., is priced at \$24.95. For descriptive literature, write the company direct, mentioning *American Cinematographer*.

High Speed Movie Films

Eastman Kodak Co., Rochester, N. Y., announces development of two new high-speed 16mm designed for use under extremely poor lighting conditions, such as those frequently encountered by newsreel, sports, and industrial cinematographers.

They are Tri-X Panchromatic negative and Cine-Kodak TriX CP reversal film. Both films must be processed by the user or by a commercial laboratory.

TriX negative has twice the speed

(Continued on Page 548)

practically
every film producer
in the western
hemisphere is **a client**
of
byron



byron production services

- | | |
|------------------------------|---|
| <i>script</i> | <i>titling</i> |
| <i>animation</i> | <i>location photography</i> |
| <i>sound stage</i> | <i>music library</i> |
| <i>editing</i> | <i>recording</i> |
| <i>color-correct* prints</i> | <i>complete black-and-white laboratory facilities</i> |
| <i>art</i> | <i>sound effects</i> |

When you want the best quality and service —
use swift, economical Byron production facilities!
Visit our studios, discuss your plans with us,
or ask for our illustrated brochure and price list.

*Reg. U.S. Patent Office

byron *Studios and Laboratory*

1226 Wisconsin Avenue, N.W., Washington 7, D.C. DUpont 7-1800

550 Fifth Avenue, New York 36, N.Y. Circle 5-8188

ONE CAMERA

16mm or 35mm

in 10 SECONDS!

Camerette 16/35

Reflex Motion Picture Camera

The perfect camera for the motion picture film maker working in both 16mm or 35mm color or black and white.

LOOK AT THESE ADVANTAGES—

- The same lenses, same motor drives, same sound blimp and accessory equipment used for both 16mm or 35mm — to convert simply change the magazine.
- Precise rugged movement
- Reflex viewing
- 200 degree adjustable shutter
- Divergent three lens turret
- Automatic film gate 400' magazines 16 or 35mm — the 16mm magazine will accommodate daylight spools as well as standard core load.
- Light weight — only 14 pounds with 3 lenses, 400' magazine, and 6/8 volt motor.

Write for brochure



Camerette

patents coutant-mathot

Manufactured by Ets. Cine. Eclair, Paris



A. S. C. Fetes Charles Rosher



CLIMAX of testimonial dinner tendered Charles Rosher last month by members of the A.S.C. Hal Mohr (left) presents Rosher with commemorative plaque and replica of A.S.C. Charter.



ROSDER reads score of telegrams sent him on the occasion by old friends and well-wishers while screen director George Sidney (L.) and George A. Mitchell, ASC, look on.

DIRECTOR OF PHOTOGRAPHY Charles Rosher ASC, veteran of 45 years in Hollywood motion picture industry, was feted last month on the eve of his retirement to Jamaica, where he has a large estate. Occasion was the Testimonial Dinner tendered him by fellow members of the American Society of Cinematographers.

Nearly a hundred fellow-craftsmen and guests were present at the Society's clubhouse in Hollywood to pay tribute to one of the founders of the Society and to his achievements as a director of photography.

Special guests of honor who attended and who have been associated with Rosher over the years, included George Mitchell, developer of the famous Mitchell camera; Robert Z. Leonard, famed motion picture director; and George Sidney, for whom Rosher has photographed most of his pictures at Metro Goldwyn Mayer studios.

Hal Mohr, A.S.C. vice-president, who presided in the absence of president Arthur Miller, introduced the honored guests after reading a score of telegrams from well-wishers and a letter from Mary Pickford, for whom Rosher was at one time chief cinematographer.

Director Robert Z. Leonard praised Rosher's sensitive camera artistry as he recalled an association with the cinematographer that embraced a period of 40 years.

George Mitchell recalled a close friendship with Charles Rosher of over forty years and told how the two had worked together to make the debut of the first Mitchell studio camera a success. This was in 1920, Mitchell recalled, when Rosher used the camera to photograph Mary Pickford in "The Lovelight." This was the great test that was to lead Mitchell to supremacy in the manufacture of motion picture cameras.

Edward O. Blackburn, head of the Hollywood office of Wm. J. German,

Inc., paid tribute to Rosher's integrity and his great accomplishments in color cinematography.

George Sidney, M-G-M director, with whom Rosher has worked longer and more closely than any other person in the industry, likened Rosher's proposed retirement to that of the famous Harry Lauder, and said that, like Lauder, "each time he returns, he is even greater!"

"It is Rosher's great integrity that has made him the great camera artist he is," Sidney said. "No matter how trivial the scene, Rosher always gave it the same attention he would the big climactic one."

"It might be a brief four-foot insert," Sidney added, "but Rosher insisted it be lighted and photographed as carefully and as artistically as any other shot in the story."

Hal Mohr then presented to Rosher, in behalf of the members of the American Society of Cinematographers, a mounted miniaturized replica of the original charter of the American Society of Cinematographers, which he helped organize.

He also presented him with a Citation of Merit plaque on behalf of the A.S.C., which was inscribed as follows:

"The American Society of Cinematographers, in recognition of his outstanding contribution to the art of cinematography, presents to *Charles Rosher* this Citation of Merit in commemoration of his long and brilliant career as a fellow craftsman and one who has brought high honor to our profession, and as one of the founders of the American Society of Cinematographers.—October 18, 1954.

A highlight of the evening was the screening of two reels of "Sunrise," which Rosher photographed in company with Karl Struss, A.S.C., and which was the first motion picture to win an Academy Award for photography. The "Os-

(Continued on Page 586)



THE



FASTEST



WAY

is this:

to this:

to this

FULL COATED 3 CHANNEL RECORDING

MAGNA-STRIPE® FOR EDITING

OPTICAL SOUND RELEASE PRINTS

LET SOUNDCRAFT MAGNETIC FILMS

● SPEED YOUR SOUND PRODUCTION

● BETTER YOUR SOUND QUALITY

● SAVE YOU MONEY

DO as progressive film producers do. Make virtually distortion-free, full fidelity sound tracks—*fast* . . . with Hollywood-accepted, time-proved Soundcraft Magnetic Recording Films.

Soundcraft coated films are made with the same superior magnetic coating used on Magna-Stripe, the development that won Soundcraft the coveted "Oscar" of the Academy of Motion Picture Arts and Sciences in 1953.

When you use *both* Soundcraft full-width film for original recording and Soundcraft Magna-Striped Film for editing and mixing, you are assured of maximum fidelity release prints without

time-consuming, intermediate photographic-track processing.

Both the 35-mm and 17.5-mm Soundcraft full-coated stock come with or without footage marks. The 35-mm stock is also available coated between sprocket holes only, where a clear edge is desired. Full-coated 16-mm is available with either single or double perforations.

For full details on how Soundcraft Full Coated and "Oscar"-winning Magna-Striped Films can improve your original and edited sound tracks, speed your work, and open new business frontiers, write Dept. AE11.

All Soundcraft magnetic films use a 5-mil tri-acetate safety backing. They are extremely compliant for intimate head contact. Full-width film is Micro-Polished® to remove minute surface defects, and assure perfect frequency response right from the start. Output variation is $\pm\frac{1}{2}$ db. within a reel, ± 1 db. reel-to-reel.

REEVES **SOUNDCRAFT** CORP.
10 East 52nd St., New York 22, N. Y.

SEEING IS BELIEVING!

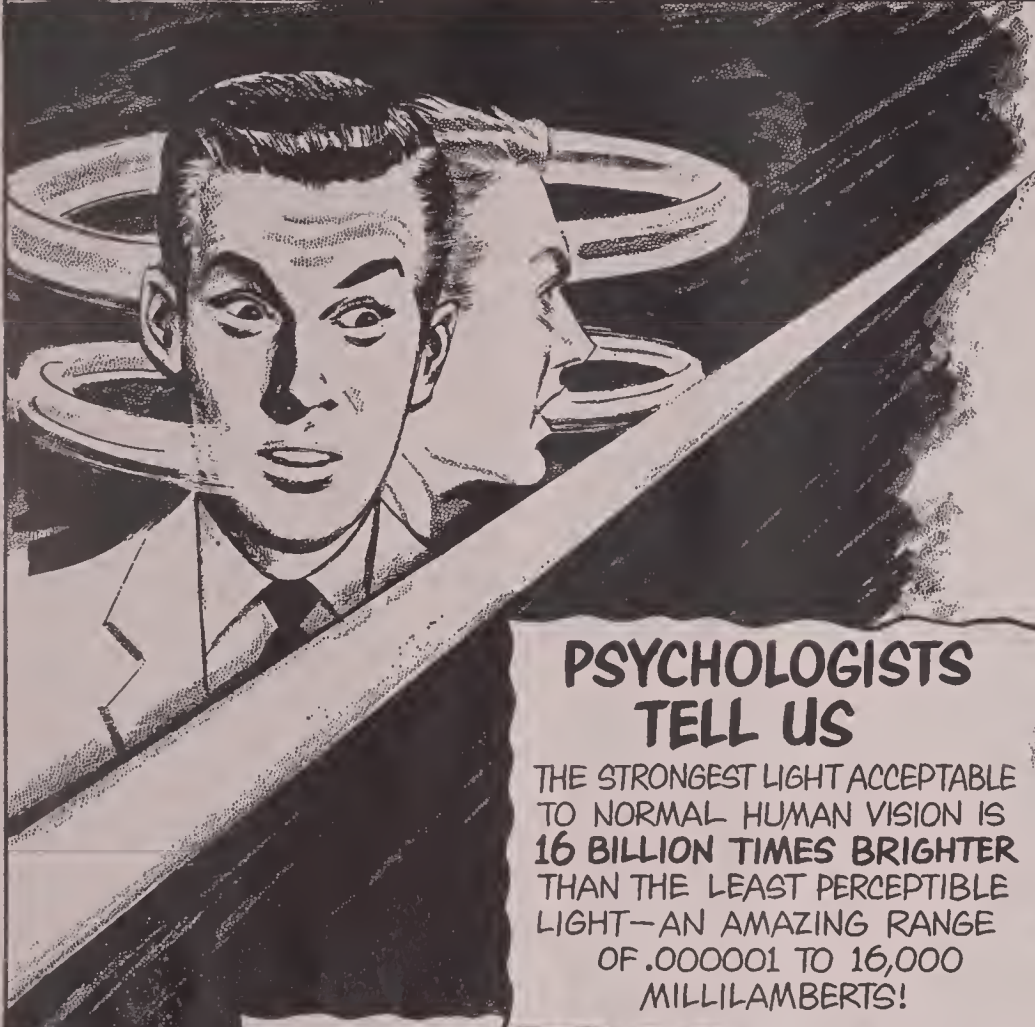

SCIENTISTS CAN MEASURE

THE SPEED OF LIGHT WITH GREATER ACCURACY THAN THAT OF ALMOST ANY OTHER PHYSICAL CONSTANT—DESPITE ITS INCREDIBLE VELOCITY OF 2.99776×10^{10} CENTIMETERS PER SECOND.

PSYCHOLOGISTS TELL US

THE STRONGEST LIGHT ACCEPTABLE TO NORMAL HUMAN VISION IS 16 BILLION TIMES BRIGHTER THAN THE LEAST PERCEPTIBLE LIGHT—AN AMAZING RANGE OF .000001 TO 16,000 MILLILAMBERTS!



"NATIONAL" STUDIO ARC-CARBONS ARE COOLER, MORE POWERFUL, MORE PENETRATING...WITH BROADER COVERAGE AND SHARPER DEFINITION THAN ANY OTHER SOURCE OF SET-LIGHTING.

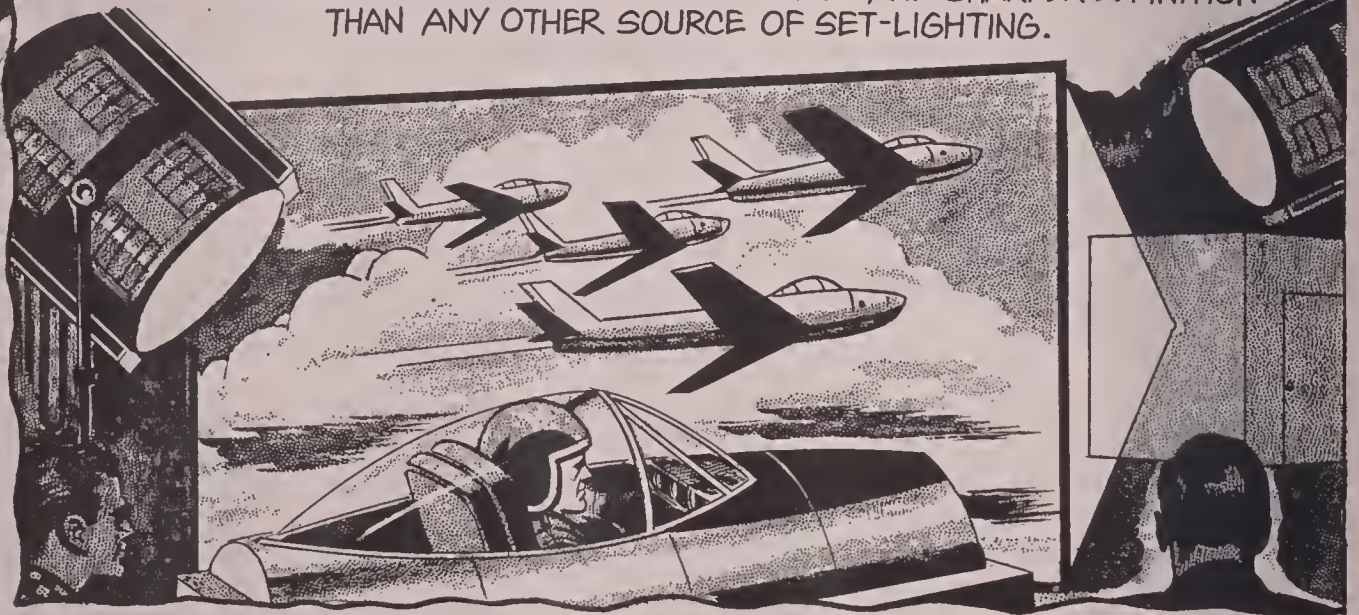

THE "NATIONAL" CARBON ARC...NOTHING BRIGHTER UNDER THE SUN

The term "National" is a registered trade-mark of Union Carbide and Carbon Corporation

NATIONAL CARBON COMPANY

A Division of Union Carbide and Carbon Corporation, 30 East 42nd Street, New York 17, New York

District Sales Offices: Atlanta, Chicago, Dallas, Kansas City, New York, Pittsburgh, San Francisco

IN CANADA: Union Carbide Canada Limited, Toronto



DEDICATED TO BETTER PERFORMANCE



COLLAPSIBLE 3-WHEEL DOLLY

For motion picture and TV cameras. Sturdy cast aluminum. For standard or baby tripods. Additional baby tripod point holders to control spread of tripod legs. Adjustable spring seat. Extra wide rubber wheels. Bronze tie down clamps and other features.

For studio or location. Folds into one compact unit. Can be used with professional or semi-professional tripods.

'HYDROLLY'

TV OR
CAMERA DOLLY

The advanced dolly for instant moveability — streamlined, lightweight, exceptionally sturdy. Nothing to get out of order. Many new advantages for easy operation. Hydraulic lift type for fast upward and downward motion of TV and motion picture cameras.

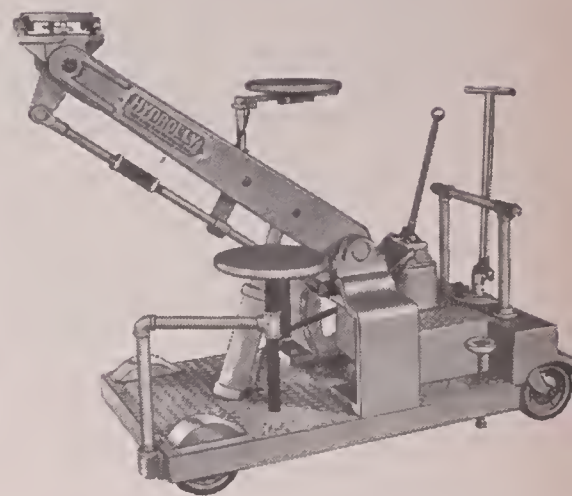

Swivel seat. Adjustable leveling head. Seat for assistant. In-line wheels for track use. Steering wheel, rigid floor locks. Hand pump or combination hand and motor pump. Easily transported in a station wagon. Fits through a 28" door.



SYNCHROMASTER SYNCHRONIZER

Our Exclusive Distributor
Neumade

Any combination of 16mm and/or 35mm sprockets assembled to specification. Cast aluminum. Foot linear type, adjustable frame dial. Fast finger roller release. Contact rollers adjusted individually for positive film contact. Sprocket shaft slip lock, footage counter, etc.

RENTALS

SALES • REPAIRS • SERVICE

LENS COATING

"T" STOP CALIBRATION

DESIGNING and MANUFACTURING

lens mounts & camera equipt.
for 16mm, 35mm, TV cameras.

BAUSCH & LOMB "BALTAR"
LENSES and others

for motion picture, TV cameras.
15mm to 40" focal length.

COMPLETE LINE of 16mm, 35mm
cameras, dollies, synchronizers,
animation equipment, cutting room
and time lapse equipment.

BELL & HOWELL: Standard, Eyemos, Filmos. MITCHELL: Standard, Hi-speed, BNC, NC, 16mm.

SEND FOR CATALOGUE

ColorTran Groverlite SENIOR & JUNIOR KITS

"A STUDIO IN A SUITCASE"

ColorTran replaces heavy and expensive equipment... gives you illumination up to 5000w. from an ordinary 20 amp. house current. Equipped with barndoors, diffuser slots for silks, snoots and other accessories. Ideal for studio or location shots.



PORTABLE MICROPHONE BOOM

For Studio or on Location. Lightweight — collapsible — for TV and motion picture production. Sturdy construction. Boom telescopes 7 to 17 ft. Rear handle for directional mike control. A remote control permits 360° rotation of the microphone. Operator can push the boom and operate microphone swivel simultaneously.

Extension rods make it simple to operate microphone rotation from floor. Microphone cable hangs outside of boom, preventing cable from tangling with the rotation mechanism. Ball bearing casters, rigid foot locks, pneumatic drop check for lowering the boom, etc.

VARIABLE- SPEED MOTOR with TACHOMETER

for Cine Special or Maurer Cameras

115 V. Universal Motor — AC-DC
Separate Base for Cine Special.
Variable Speed 8-64 frames.
Adapter for Maurer Camera.

INTERCHANGEABLE MOTORS: 12
volt DC Variable Speed 8-64 frames.
115 Volt AC 60 Cycles, Synchronous
Motor, Single Phase.

ANIMATION MOTORS: Cine Special,
Maurer, Mitchell, B & H Motors,
for Bolex and Filmo Cameras.

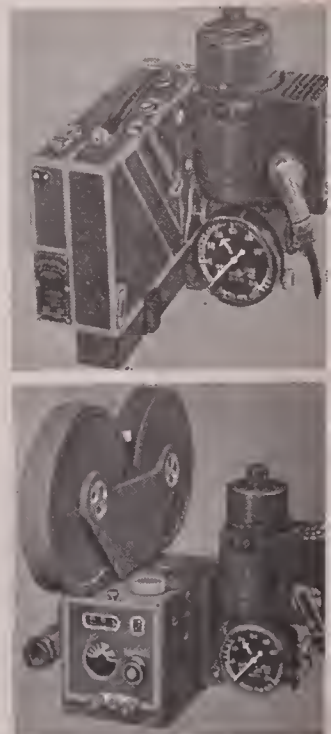

ARRIFLEX

New 35 mm Model 2A
With 180° Shutter

**A TRULY GREAT
CAMERA**

for TV, Newsreel
and commercial
films

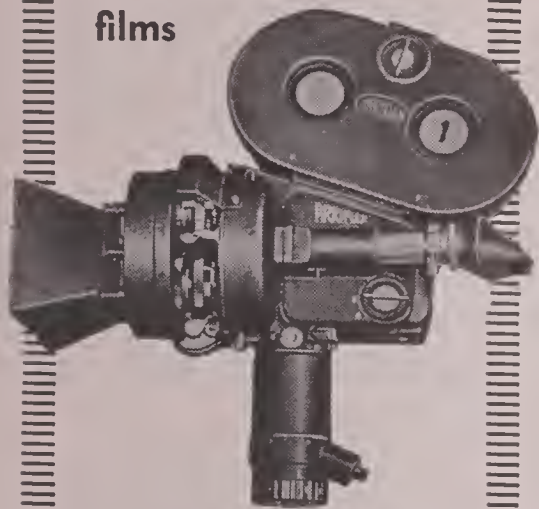

For tough and trying assignments, ARRIFLEX 35 is in a class by itself. Reflex focusing through photographing lens while camera is operating—this is just one outstanding ARRIFLEX feature.

Equipped with bright, right-side-up image finder, $6\frac{1}{2}x$ magnification. Solves all parallax problems. 3 lens turret. Variable speed motor built into handle operates from lightweight battery. Tachometer registering from 0 to 50 frames per second. Compact, lightweight for either tripod or hand-held filming. Takes 200' or 400' magazine. Write for free folder.

Blimp now available.
16mm ARRIFLEX also available.

FRANK C. ZUCKER
CAMERA EQUIPMENT CO.
1600 BROADWAY NEW YORK CITY

INDUSTRY NEWS

SMPTE Convention

The 76th semi-annual convention of the Society of Motion Picture and Television Engineers, which was held last month in Los Angeles, was probably one of the Society's most successful both from point of interesting papers presented and the attendance.

John G. Frayne, director of research for the Westrex Corp., Hollywood, was elected president to succeed retiring Herbert Barnett.

Other officers include: Barton Kreuzer, of RCA, executive vice-president; Norwood L. Simmons, Eastman Kodak, editorial VP.; Byron Roudabush, Byron, Inc., convention VP.; and Edward S. Seeley, Altec Service, secretary.

Election of regional governors resulted as follows: East Coast, Gordon A. Chambers and George Lewin; Central area, M. G. Townsley and W. W. Lozier; West Coast, L. T. Goldsmith and John W. DuVal.

Awards of Fellowship in the Society were presented to 16 members: Philip G. Caldwell, John R. Clark, Jr., Albert A. Duryea, Ralph H. Heacock, Armin J. Hill, Lester Isaac, U. B. Iwerks, and George Lewin.

Also, Everett Miller, Harry F. Olson, Richard H. Ranger, Reid H. Ray, Hazard E. Reeves, Ralph A. Teare, R. Edw. Warn, and James L. Wassell.

Among the important papers read was that presented by Edward Schmidt of Reeves Soundcraft, Inc., New York, which described the development of a 16mm magnastriper which makes possible magnetic sound for color TV films. Equipment is a 16mm version of the company's 35mm equipment which produces the magnetic stereophonic sound on CinemaScope motion pictures.

To aid TV broadcasters get the utmost quality of color TV films on the air, the SMPTE has arranged to provide the first color test films. Test films will be produced by Eastman Kodak, Ansco, and Technicolor according to standards set up by the SMPTE's television committee. The Society will make quantity prints and furnish them to broadcasters as a service to the industry. They are expected to be available early in 1955. Films will be available in both 16mm and 35mm.

★

In 16mm CinemaScope

The first experimental 16mm CinemaScope-type motion picture designed for behind-the-wheel driver training

has been produced by Aetna Casualty and Surety Co., Hartford, Conn.

Providing a panoramic picture similar to the view through the windshield of a real car, the 16mm wide-screen movies were produced especially for use with the Aetna Drivotrainer, a device for giving students driving lessons in small model cars right in the classroom.

Use of CinemaScope-type films in driver training is expected to heighten the sensation of actual driving in the Drivotrainer.

★

TV in 3-D

The American Public will soon be able to view three-dimensional pictures on their present television sets without need for any attachment and by wearing special 3-D viewing glasses, according to National Films-Television, New York. Without the glasses, a regular two-dimensional TV picture can be viewed sharper and clearer than the present two-dimensional TV pictures, according to the company.

The revolutionary 3-D system was invented by Leslie P. Dudley of England. A series of half-hour 3-D TV films are currently being produced. First public showing of the films over TV is scheduled on or about December 20th.

★

Technicolor In France

Technicolor Motion Picture Corporation has completed arrangements for the establishment of a complete color film processing laboratory in Paris, according to Herbert T. Kalmus, President and General Manager of Technicolor.

Name of the Paris company is to be Societe Technicolor. Move is a continuation of the policy of Technicolor to expand its laboratories over the world.

★

Films In Industry

How industry uses motion pictures is one of several discussion sessions planned for the Time & Motion Study and Management Clinic meeting to be held in Chicago November 10-11-12 at the Sherman Hotel.

★

Studio In Texas

A brand new, completely equipped photographic studio is being built for Photographic Laboratories, Houston, Texas. The \$60,000 plant is to be completed in January.

the ARRIFLEX 16

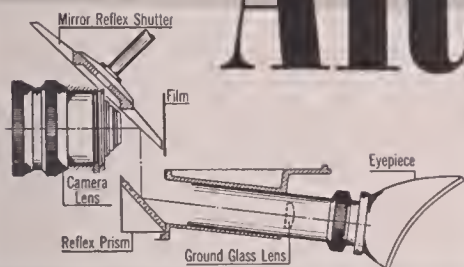

... ONLY 16mm Camera with a
Mirror-Reflex Focusing-Finder

The advantages of continuous thru-the-lens focusing and viewing... even during actual shooting... are well understood and recognized. The important thing is that these advantages are available only in the Arriflex 16.

HOW THE MIRROR REFLEX SHUTTER WORKS:

The Arriflex 16 shutter rotates at a 45° angle between the lens axis and film plane. The front of the shutter is an optically flat, surface-coated mirror. When in 'closed' position, it reflects the lens image into the optical system of the finder. In 'open' position, the image is projected directly onto the film for the exposure.

In this way, the Arriflex 16 Mirror-Reflex system makes all of the light transmitted by the lens available to both the finder and the film, intermittently. The image viewed is brilliant, uninverted and right-side-

up. It is seen, magnified 10 times, through a highly corrected, adjustable eyepiece. There is no parallax... and no need for special finders.

OTHER FEATURES INCLUDE:

- Registration Pin for absolute frame registration and picture steadiness
- Electric Motor Drive for uninterrupted filming without the need to stop and wind a spring
- Divergent 3-Lens Turret accommodates extreme wide-angle to 300mm telephoto lenses, simultaneously, without physical or optical interference
- Footage and Frame Counters
- Tachometer
- Hand-Contour Grip
- Single Sprocket Sound Film Drive
- Detachable Matte Box-Filter Holder
- Detachable Neckstrap
- Weighs only 7½ lbs. including Matte Box
- Accommodates 400-foot Magazine.

The **ARRIFLEX 16** is the world's finest 16mm motion picture camera.

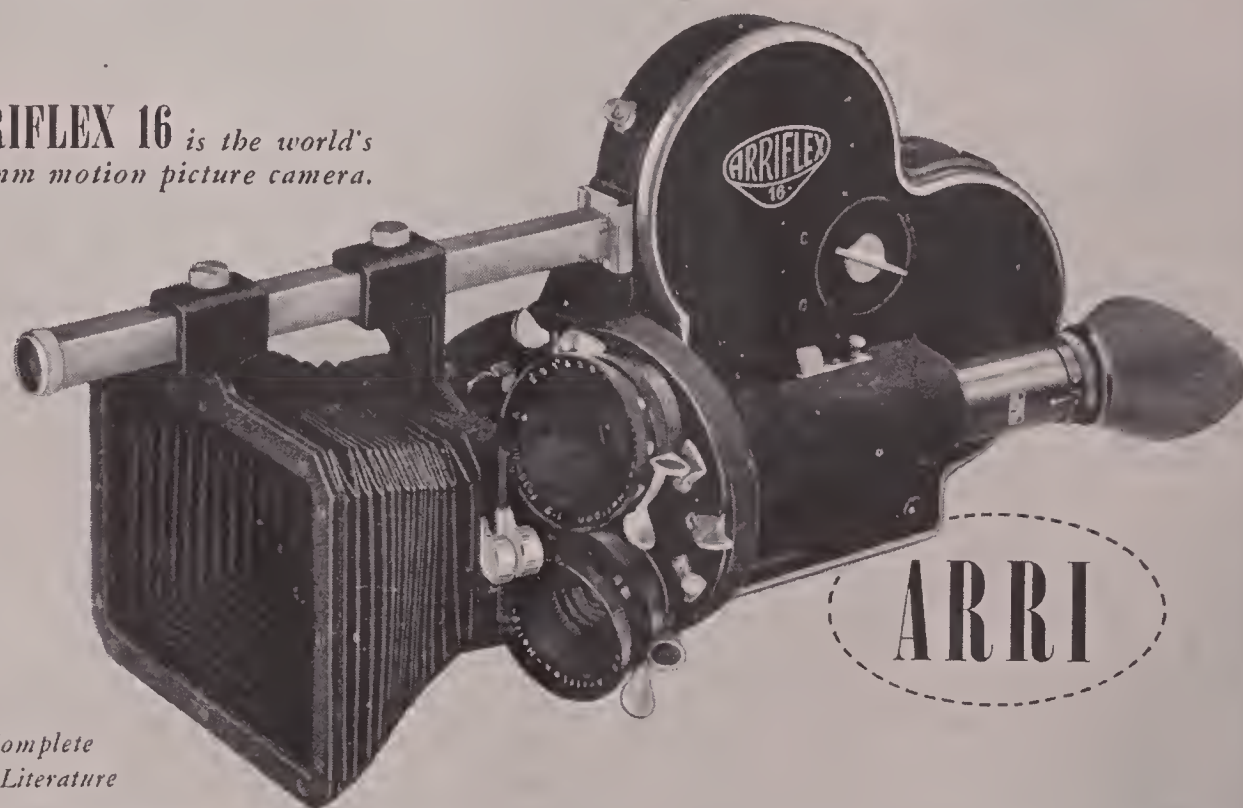

Write for Complete
Descriptive Literature

KLING PHOTO CORP., 235 Fourth Ave., New York 3, N. Y. • 7303 Melrose Ave., Hollywood 46, Calif.

Booklets Catalogs Brochures

available from equipment manufacturers



The greatest advance in motion picture camera design in the past decade—Reflex Viewing... seeing through the taking lens at all times... in the CAMERETTE 35 and 16/35.

3-D, Anamorphoscope, Wide Aspect Ratio—the more critical requirements of the new techniques for accurate framing and focusing DEMAND this modern motion picture camera.

look at these advantages:

- Reflex Viewing
- Precise, rugged movement
- 200 degree adjustable shutter
- Divergent 3-lens turret
- Automatic film gate 400' magazines,
- Light weight: Only 14 pounds with 3 lenses, 400' magazine and 6/8 volt motor.
- Patents Coutant-Mathot manufactured by Eclair, Paris

for descriptive brochure write U.S. representative Benjamin Berg Agency 1410 No. Van Ness Avenue Hollywood 28, California

Equipment Data

A folder of illustrated data sheets on all motion picture equipment presently available from the company is offered by Cinekad Engineering Co., formerly the Kadisch Camera and Sound Engineering Co., New York City.

Illustrated and described are such items as Swivel Ball tripod attachment, tripod dollies, tripod triangles, camera shoulder brace, microphone booms, sync motor for 16mm projectors, sync motor drive for Arriflex cameras, camera blimps, and other kindred equipment.

Copies are available free by writing the company at 500 West 52nd St., New York 19, N. Y.

Film Lab Equipment Catalog

Motion picture film laboratories will be interested in the new illustrated catalog just released by Motion Picture Printing Equipment Co., 8136 No. Lawndale Ave., Skokie, Ill., which brings complete information on all the varied equipment offered by this 30-year-old organization. When writing, ask for catalog M-1.

High-speed Equipment

Traid Corporation, 4515 Sepulveda Blvd., Sherman Oaks, Calif., has released a new 36 page catalog of all its high-speed and data-recording cameras and accessories. Company makes custom built motion picture equipment for industrial and military use, such as 16mm and 35mm high-speed motion picture cameras, 35mm data recording cameras, pilot pin registration cameras, motor-driven magazine cameras, 16mm and 35mm time and motion cameras, and others for flight testing, rocket and missile tracking, missile testing, etc.

Depth of Field Data

Technical and semi-technical terms which have passed along from photographer to photographer, have acquired meanings only remotely related to their true concepts. Two of the terms, which have perhaps been confused and misused more than any others, are depth of focus and depth of field.

To set photographers straight, Bausch & Lomb Optical Co., Rochester, N. Y.,

has issued an informative booklet "Depth of Focus—Depth of Field," which explains these two terms and illustrates what they mean in easy-to-understand illustrations.

Densitometer Bulletin

Details and specifications of the Photovolt soundtrack densitometer are contained in Bulletin No. 245 recently issued by Photovolt Corporation, 95 Madison Ave., New York 16, N. Y. Also included in the six-page Bulletin is an explanation of densitometry for both color and black-and-white films, and instructions for operating Photovolt equipment.

Kodak Booklets

A new listing of authoritative sources of information on all phases of photography, amateur and professional, has just been published by the Eastman Kodak Co. under the title "Kodak Books and Guides." All the publications described therein have been prepared by experts in their respective fields; more than 58 books, booklets and data guides are illustrated and described.

"Kodak Books and Guides" is available free from the Sales and Service Division, Eastman Kodak Co., Rochester 4, N. Y.

Tele Lens Data

An interesting booklet descriptive of the line of "Reflectar" lightweight super-telephoto lenses distributed by Zoomar, Inc., is offered free by the company. Booklet is replete with valuable information and data on telephoto lens construction, functions and use. Copies may be had by writing the company at 55 Seacliff Avenue, Glen Cove, Long Island, N. Y.

Cine Equipment

A new catalog "of a thousand-and-one ideas to enhance your enjoyment of home movies" is offered by Eso-s Pictures, 47th and Holly Sts., Kansas City 2, Mo., one of the largest of mail order houses dealing in cine equipment. The 60-page catalog illustrates hundreds of items of interest to pro-16 movie makers as well as amateurs.



35mm and 16/35 **camerette**



**anamorphoscope
wide aspect ratio**

Once in a decade
a basic tool is so improved
as to add a new dimension
to its use. The world's most modern
motion picture camera — Camerette
35mm and 16/35 — patents Coutant-Mathot
manufactured by Eclair, Paris

for descriptive brochure write U. S. representative

Benjamin Berg Agency, 1410 No. Van Ness Avenue, Hollywood 28, Calif.



There's a reason...

why Magnasync enjoys continued worldwide leadership...

QUALITY...ECONOMY...INTEGRITY

Air Force
 University
 Naval
 Radio
 Protes
 Fotovox, Inc. Photographic Technicians Pr
 W T S P—Florida Southern Pacific Railroad
 Tele-Filmica Maxol, S.A. Havana Southern
 Ford Foundation Twentieth Century-Fox, Inc.
 University of Wisconsin Gospel Films, In
 National Film Board of Canada Cine Associat
 R.K.O. Radio Pictures, Inc. Pacific Picture
 Gilfillan Bros., Inc. U.S. Air Forces Westingho
 Iowa Conservation Commission Providenc
 Fairchild Recording Equipment Co. Galbrea
 Magnolia Petroleum Co. Kearney & Trecker Cor
 W K A Q, San Juan, Puerto Rico State Colle
 Naval Air Station Becland-King Film Productions
 Columbia Pictures Providence Bible Institu
 Television Recording Service, Inc. Iowa Farm Bur
 Westinghouse Electric Corp. Sound Recorders, I
 Viguie Productions, Inc., Havana U.S. Navy Nort
 Paramount Pictures Corp. Baptist Gospel Film
 U.S. Department of Agriculture University of Iow
 International Productions Goodyear Aircraft Corp
 Avalon Pictures, Inc. Reverend D. Kirk Hammond
 Southwest Film Laboratory, Inc. Academy Soun
 Naval Ordnance Wurtele Film Productions Acade
 Bible Institute of Los Angeles University of Tennessee
 University of Mississippi Rampart Productions Sc
 Protestant Radio Center, Inc., U.S. Recording Co.
 South Dakota State College Aspen Pictures Dallas Jon
 Twentieth Century-Fox, Inc. Filmscope
 U.S. Air Forces Magnolia Petroleum Co.
 Southwest Film Laboratory, Inc. Gilfillan Br
 Cine Associates
 Kearney & Trecker
 University of Iow
 Arcturus Manufacturing
 Goodyear Aircraft Corp.
 Fairchild Recording Equipment Co.

Northern Pictures
 Filmscope, Inc.
 Arcturus Manufacturing
 South Dakota State College
 Galbreath Picture Production
 U.S. Recording Co. Aspen Pict
 Dallas Jones Productions

Fotovox, Ir
 th Dakot
 Production
 Corp.
 of Tennesse
 int
 Center, Inc.
 U.S. Navy
 ric Corp.
 e., Havana
 Baptist C
 of Agricult
 Florida
 Pacific Pic
 Internati
 raphic Techn
 s, Inc.
 rsity of Wisc
 ific Railroa
 l Films
 Naval Ordn
 Bible Inst
 rsity of Missi
 Sound Rec
 Inc.
 Wurtele Fil
 ture Prod
 U.S. Depar
 Viguie Pi
 Gospel Films
 Becland-King Film
 Ford Foundation
 Columbia Pictures
 R.K.O. Radio
 W K A Q, San Juan, Puerto Rico
 Paramount Pictures Corp. Bible Inst
 National Film Board of Canada



**MODEL SW-602
PORTABLE RECORDING SYSTEM**



Select



DISTRIBUTORS

CAMERA EQUIPMENT COMPANY
 1600 Broadway, New York 19, N.Y.
 Judson 6-1420—Cable: "CINEQUIP"

MAGNETIC RECORDERS COMPANY
 7120 Melrose Ave., Los Angeles 46, Calif.
 WEBster 3-5545

ZENITH CINEMA SERVICE, INC.
 3252 Foster Ave., Chicago 25, Illinois
 IRving 8-2104

AMERICA'S LEADING MANUFACTURER OF MAGNETIC FILM RECORDING AND REPRODUCING DEVICES

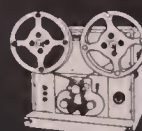

PORTABLE FILM RECORDERS



CinemaScope REPRODUCERS

3-CHANNEL REPRODUCERS

MULTI-CHANNEL INTERLOCKED DOUBBERS

STUDIO DOUBBERS and RECORDERS

QUALITY AMPLIFIERS for MAGNETIC RECORDING and REPRODUCTION

MAGNASYNC MANUFACTURING CO., LTD. • 5521 SATSUMA AVE., NORTH HOLLYWOOD, CALIF. • POplar 6-1692

ONE-STOP SOURCE for FILM PRODUCTION EQUIPMENT

"The Department Store of the Motion Picture Industry"

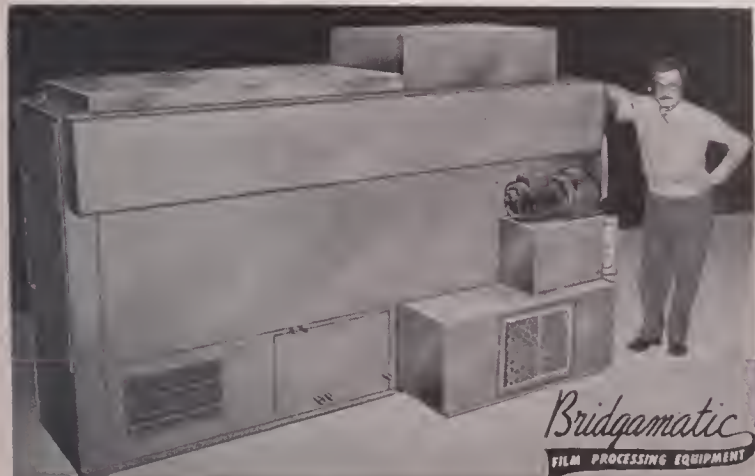

BRIDGAMATIC 416D35, combination 16/35mm high speed automatic film developing machine, totally enclosed for daylight operation—one of 12 standard models.

A TRUE ONE-MAN LAB

Entirely automatic! Capable of speeds up to 3000' per hr. positive, 1200' per hr. negative, depending on developing times. Standard design has open tanks, outside feed-in and take-up reels. Variable speed transmission gives graduated control from zero to infinity. Built-in drybox allows 15 to 30 minutes drying time. Write for illustrated brochure.

Among recent BRIDGAMATIC purchasers are:

U.S. Army, Frankford Arsenal, Philadelphia, Pa.
A.I. Dupont Inst. (The Nemours Foundation), Wilmington, Del.
U.S. Naval Microfilm Laboratory, Washington, D. C.

A PRODUCT OF FILMLINE CORP.

Kinevox PORTABLE SYNC MAGNETIC RECORDER



Takes 17 1/2 mm Film

Used by major studios in Hollywood, New York, Europe

Main sprocket driven by synchronous motor at 90' per min. Silent tight-winds for smooth delivery and take-up. Instant "Start", "Stop" and "Reverse" with film threaded. 4" VU meter. High and low pass filters. Has pre-amplifier; amplifiers for recording; bias and erase; playback; and monitoring. Power supply; 8" PM monitor speaker. Response: ± 1 1/2 db. 50 to 10 kc. 3 heads with azimuth adjustment, special erase, record and playback mounted on one shielded plate. Complete in one 50 lb. case, 60 cycle, 110V single phase.\$1,550

50 cycle 110V single phase.....\$1575
50 cycle 220V single or 3 phase.....\$1600

Complete line of Kinevox Products in Stock

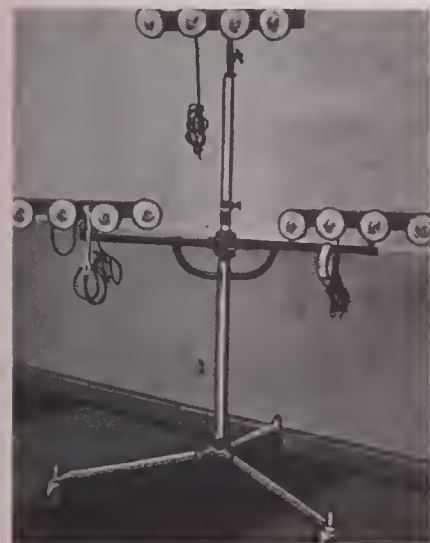

BARDWELL & McALISTER MULTIPLE STRIPLITES

for Spot or Flood

Extends 4 to 15ft. high

For indoors and outdoors. Three Striplites, each with four swivel sockets and switch, holds twelve 150-watt R40 lamps—totaling 1800-watts illumination. Folds compactly into portable size. Tripod stand has two folding 1 1/4" tubular steel arms 28" long, to which striplite lamp heads are attached. Each head measures 2" long x 2 1/4" x 3" high; includes weather-proof cable and plug. Rolling stand has three 4" rubber tired casters. Can also be used with ColorTran converters. Excellent condition. Original U.S. Government Cast \$180; Now priced at a fraction of its original cost...only \$29.50

Some with One Striplite, holds four 150W projector lamps, \$22.50
Multiple Striplite Lamp Heads Only.....\$ 4.95
Telescopic Tripod Stand Only with 3 brackets.....\$19.95

The NEW REVOLUTIONARY Prof. 16mm Mirror Reflex Shutter ARRIFLEX CAMERA

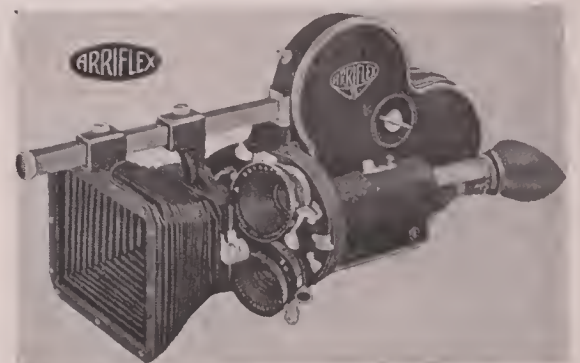

The Only
16 mm
Camera
of its kind

View and focus thru taking lens during actual shooting. Bright, big, clear, superbly-defined vertical finder image, magnified 10X. No parallax; no need for accessory finders. 100' loading spool. 400' magazines available. Pilot Pin Registration gives absolute picture steadiness. 6V motor slides into housing, permits use of standard tripods. Synchronous motor available. Complete with Reflex Shutter, turret, motor, tachometer, 0/50 fps, matte box, frame/footage counter, cable

Acclaimed the most advanced 16mm camera in the field—unique for its many features and outstanding for its workmanship.

Forward and reverse switch. Complete with Reflex Shutter, turret, motor, tachometer, 0/50 fps, matte box, frame/footage counter, cable

\$1475

Complete line of Arriflex Products in Stock

S. O. S. CINEMA SUPPLY CORP.

Dept. F, 602 WEST 52nd St., NEW YORK 19, N. Y.

Phone: PLaza 7-0440

Cable: SOSOUND

NOW, more than ever... QUALITY COUNTS

in the East...

... it's

MOVIELAB

The superior QUALITY CONTROL consistently maintained by MOVIELAB on all film processing assignments has earned it the jealously-guarded reputation of being the "QUALITY LABORATORY" in the east.

More producers, cameramen and technicians throughout the east put their trust into Movielab's "KNOW-HOW" and "personalized service" than any other.

Get to know Movielab—for this is the standard by which all film processing is judged.

ROUND THE CLOCK SERVICES

Negative Developing
 Ultra Violet and Flash Patch Printing
 Quality Control
 16 mm and 35 mm Release Printing
 Title Department
 25 Cutting and Editing Rooms
 First Print Department

for color it's...

Rainbowlab Inc.



MOVIELAB FILM LABORATORIES, INC.
 619 West 54th Street, New York 19, N. Y. JUdson 6-0360

WHAT'S NEW

(Continued from Page 536)

of Super-XX negative and about the same granularity. The Tri-X C-P reversal film is ideal where situations require multiple prints and in which extremely rapid processing at high temperatures is desirable. While not as fast as the negative film, it has 50% greater speed than CineKodak Super-XX.

Tri-X Pan nexative in 100-ft. rolls is priced at \$3.80; 200-ft. rolls, \$6.35. The C-P reversal is \$4.85 for 100-ft. and \$8.25 for 200-ft. on camera spools; 400-ft. darkroom loads are \$15.45.



3-Way Sixtomat Meter

Photoptic Corp., 235 Fourth Ave., N. Y., announces a new 3-Way Sixtomat exposure meter that gives critical exposure readings for reflected and incident light and color temperature readings. Built-in diffuser instantly converts meter from reflected light to incident readings. It also reads color temperatures from 2,600 to 10,000 Kelvin. Finished in Ivory and gold, list price is \$29.95.

Pro-Cine Tripod

Florman & Babb, 70 West 54th St., New York 36, N. Y., announce a new, medium-weight tripod which incorporates many unique features, most important of which is the extremely smooth controlled pan and tilt movement of friction head. Weighing 14 lbs., tripod will accommodate following cameras: Auricon-Pro, Maurer, Cine Voice, Cine Special, Eyemo, Filmo, Arriflex, Camerette, and Bolex. List price of tripod is \$135.00. Carrying case is \$20.00 extra.

AURICON 16mm Sound-On-Film for Professional Results!



ALL AURICON EQUIPMENT IS SOLD WITH A 30 DAY MONEY-BACK GUARANTEE.

"CINE-VOICE" 16 mm Optical Sound-On-Film Camera.
 ★ 100 ft. film capacity for 2¾ minutes of recording; 6-Volt DC Converter or 115-Volt AC operation. ★ \$695.00 (and up).

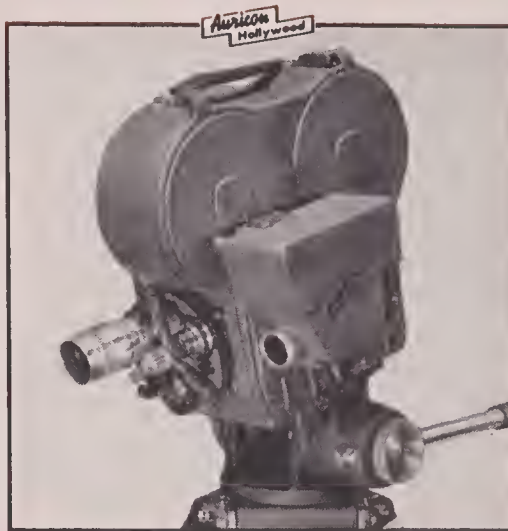

"AURICON-PRD" 16 mm Optical Sound-On-Film Camera.
 ★ 200 ft. film capacity for 5½ minutes of recording. ★ \$1310.00 (and up) with 30 day money-back guarantee.



"SUPER 1200" 16 mm Optical Sound-On-Film Camera.
 ★ 1200 ft. film capacity for 33 minutes of recording. ★ \$4652.15 (and up) complete for "High-Fidelity" Talking Pictures.



SOUND RECORDER — Model RT-80... 200 foot film capacity, daylight loading, synchronous motor for portable "double-system" 16 mm Optical Sound-On-Film operation. ★ \$862.00 (and up).



PORTABLE POWER SUPPLY UNIT — Model PS-21... Silent in operation, furnishes 115-Volt AC power to drive "Single System" or "Double System" Auricon Equipment from 12 Volt Storage Battery, for remote "location" filming. ★ \$269.50



DUAL PRONO-TURNTABLE — Model DPT-10... Takes up to 16 inch discs with individual Volume Controls for re-recording music and sound effects to 16mm Sound-On-Film. ★ \$161.15



TRIPOD — Models FT-10 and FT-10S12... Pan-Tilt Head Professional Tripod for velvet-smooth action. Perfectly counter-balanced to prevent Camera "dumping." ★ \$325.00 (and up).

Strictly for Profit CHOOSE AURICON

If it's profit you're after in the production of 16 mm Sound-On-Film Talking Pictures, Auricon Cameras provide ideal working tools for shooting profitable Television Newsreels, film commercials, inserts, and local candid-camera programming. Now you can get Lip-Synchronized Sound WITH your picture at NO additional film cost with Auricon 16 mm "Optical" Sound-On-Film Cameras. Precision designed and built to "take it." Strictly for Profit — Choose Auricon!

AURICON
BERNDT-BACH, INC.

6902 ROMAINE STREET, HOLLYWOOD 38, CALIF.



Auricon Equipment is sold with a 30-day money-back guarantee. You must be satisfied.



Please send me free Auricon Catalog. 6902A

Name.....
 (Please write your address in margin)

MANUFACTURERS OF SOUND-ON-FILM RECORDING EQUIPMENT SINCE 1931

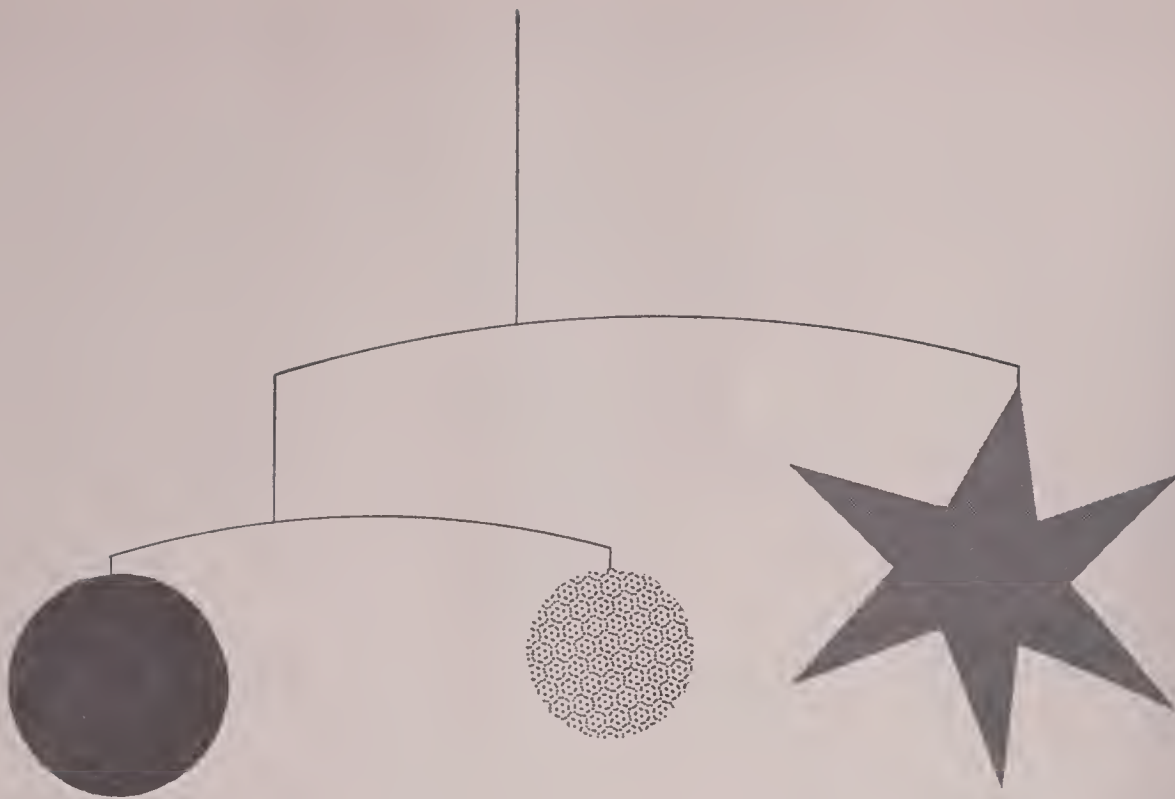

Perfect balance...of skilled operating technicians, specially designed equipment, and constant laboratory research maintains Precision leadership in the field of film processing.

Electronic Printing, for example, illustrates the results of Precision's continuing search for improved ways to serve leading producers, directors, and cameramen. This important Maurer development in the printing of optical sound from magnetic original is installed at Precision for kinescope and other recording direct to the optical track.

*In everything there is one best...in film processing, it's **Precision.***



A division of J. A. Maurer, Inc.

They choose Ansco **Negative Positive** Color to make their work easier

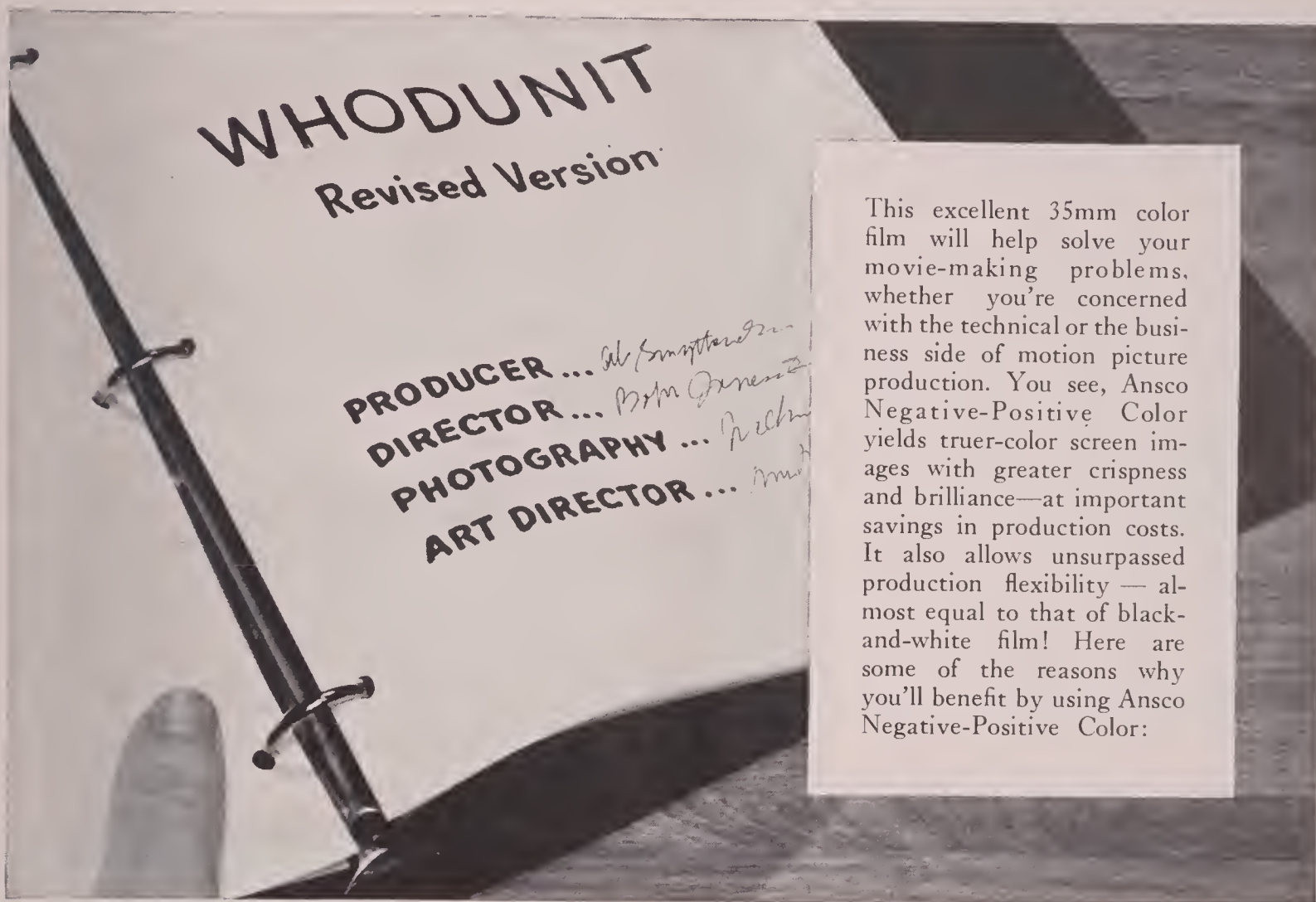

This excellent 35mm color film will help solve your movie-making problems, whether you're concerned with the technical or the business side of motion picture production. You see, Ansco Negative-Positive Color yields truer-color screen images with greater crispness and brilliance—at important savings in production costs. It also allows unsurpassed production flexibility — almost equal to that of black-and-white film! Here are some of the reasons why you'll benefit by using Ansco Negative-Positive Color:

FINER SCREEN QUALITIES

- ★ Truer color
- ★ Excellent screen steadiness
- ★ Finer grain
- ★ Sharper definition
- ★ More brilliance and depth

LOWER COSTS

★ *No special camera required*

Any competent cinematographer can get excellent results using Ansco Negative-Positive Color with standard 35mm cameras.

★ *No special processing equipment*

Minor modifications adapt your regular black-and-white equipment to fast, easy processing of Ansco Negative-Positive Color.

★ *No costly, drawn-out waiting*

You can see your color rushes within hours—often the same day. Thus you don't have to hold expensive casts and sets for days while you wait to see the results of your shooting.

Ask your Ansco representative for full details, then shoot some test footage on Ansco Negative-Positive Color. You'll decide to standardize on it!

Ansco

BINGHAMTON • NEW YORK
HOLLYWOOD • CHICAGO

A Division of General Aniline &
Film Corporation

"From Research to Reality."

VISTAVISION MOVES FORWARD

Advent of the new VistaVision cameras and a new method of full double-frame projection of VistaVision prints marks progress of Paramount's new wide-screen system.

By LOREN L. RYDER, A.S.C., and JACK BISHOP, A.S.C.



FIG. 1—Exterior side view of the new VistaVision camera, showing 2000 ft. vertical film magazine (with cover removed). After exposure, film is taken up in separate magazine on the other side of the camera. Note tilt mechanism as integral part of the camera base unit. Camera was built by Mitchell, gearhead by Paramount.

ITS NEW SYSTEM of full double-frame projection of VistaVision prints was introduced last month by Paramount Pictures Corporation in Hollywood. Following the initial technical demonstrations at the Paramount Studios, the system was demonstrated publicly in New York simultaneously with the world premiere at the Music Hall Theatre of "White Christmas," Paramount's first VistaVision production.

In this improved VistaVision system, the full area of the double-frame negative is transferred to the release print, and by means of a projector in which the film travels horizontally instead of vertically (see illustrations on page 574)—the same as it does in the VistaVision camera—it is projected with resultant improved picture quality.

This step marks a new era in the progress of VistaVision at Paramount. The initial introduction of VistaVision was in itself a tremendous step forward in improving the quality of motion picture exhibition. The original VistaVision system, as explained in the December, 1953, issue of *American Cinematographer*, involved a radically new camera that utilized standard 35mm negative, but recorded the scene image on a larger frame area, 1.485" by .991" in size as

compared to the .868" by .631" picture area of standard 35mm negatives. This, then, was optically printed in reduced size to standard 35mm positive in an operation which also turned the image 90° so that the VistaVision print could be screened with conventional 35mm theatre projectors.

All the progress in VistaVision has not been confined to projection and exhibition. The VistaVision camera has received due attention, also; and almost simultaneously with the unveiling of its advanced method of full double-frame projection of VistaVision prints, the studio took delivery of the first of the new VistaVision cameras manufactured by Mitchell Camera Corporation. This new camera will be described in detail later.

With the introduction of a new double-frame print, Paramount solidifies its program of release which now includes:

1. Standard VistaVision prints for theatre screens ranging from small to 50' and even 60' in width.
2. The squeezed print which will be available for exhibitors who have variable anamorphic lenses and, for reasons of light conservation, wish to use the squeezed print.
3. The new double-frame print, which will meet both present and future requirements in screen width from 50' to 100'.

With the double-frame VistaVision release film Paramount demonstrates the full quality achieved by the new process.

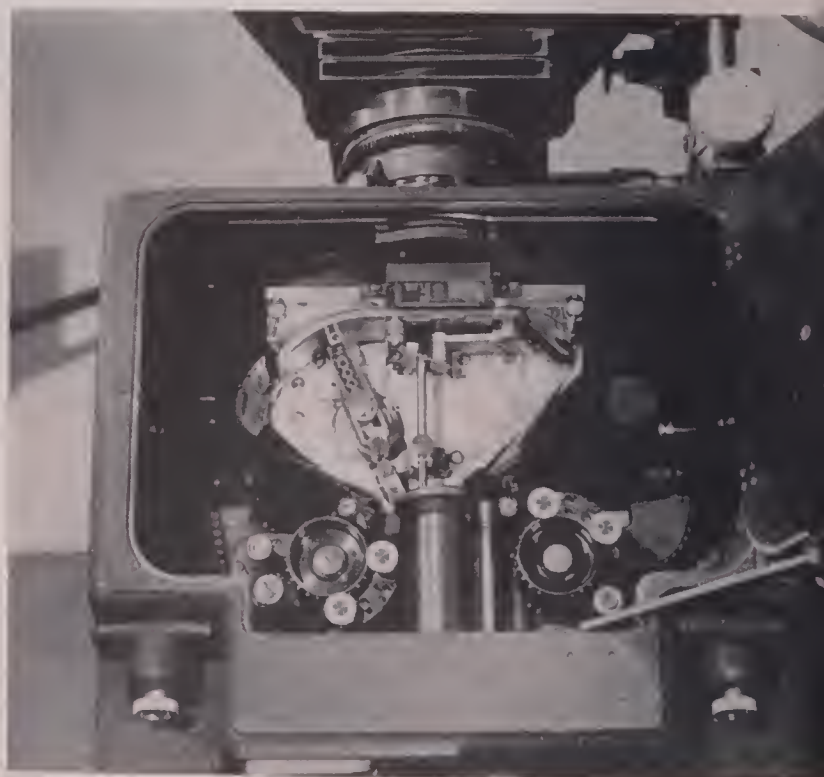

FIG. 2—View looking down into top of new VistaVision camera, showing movement that advances film horizontally. The frame area exposed is 8 sprocket holes in length instead of the conventional 4. Film is twisted before and after entering gate.

It is, of course, a natural evolution from the previously announced VistaVision horizontal negative. It was introduced so as to complement the standard and squeezed prints.

In introducing this latest member of the VistaVision family, it does not change Paramount's policy as already announced; namely, that standard VistaVision prints will be available to play in any theatre anywhere in the world with no requirement that the exhibitor alter his equipment in order to play a VistaVision picture. From the outset, Paramount stated that the flexibility and compatibility of VistaVision which includes wide screen presentation may be taken advantage of if the exhibitor wishes to install a new larger screen and has adequate projection equipment; the exhibition with anamorphic lenses if the theatre has this type of equipment; the exhibition with stereophonic sound if the exhibitor has a stereophonic sound integrator; and now the exhibition of the new large, double-frame image if the necessary projection equipment is installed.

It is the opinion of technical people at Paramount that the greatest shortcoming in present motion picture presentation is in the projector and the lenses used. This is not in condemnation of present projection equipment but a statement in recognition of a problem which has now become a bottleneck by the industry's rapid conversion to large screens. Most of the difficulty is due to a varied amount of bowing that takes place in the film as it is subjected to the light. Here, the large VistaVision frame has the advantage over all other current systems in that the amount of light per unit area of film is actually less than that required under the standard system with the old "Postage Stamp" screen. Furthermore, Paramount technicians have worked with both 65mm and 35mm film and it is their declaration that much of the improved quality apparent from the new horizontal projector is the result of the 35mm film support as compared with the lack of support existent in the 65mm experiments previously conducted by Paramount.

Paramount's double-frame VistaVision projection uses the largest picture image now being projected on any motion picture screen anywhere in the world. The gain in light from this very large area has not been accurately determined,

(Continued on Page 573)

FIG. 3—Diagram of VistaVision double-frame print showing placement of picture image on regular 35mm film stock, and the recommended aperture dimensions for best screen presentation.

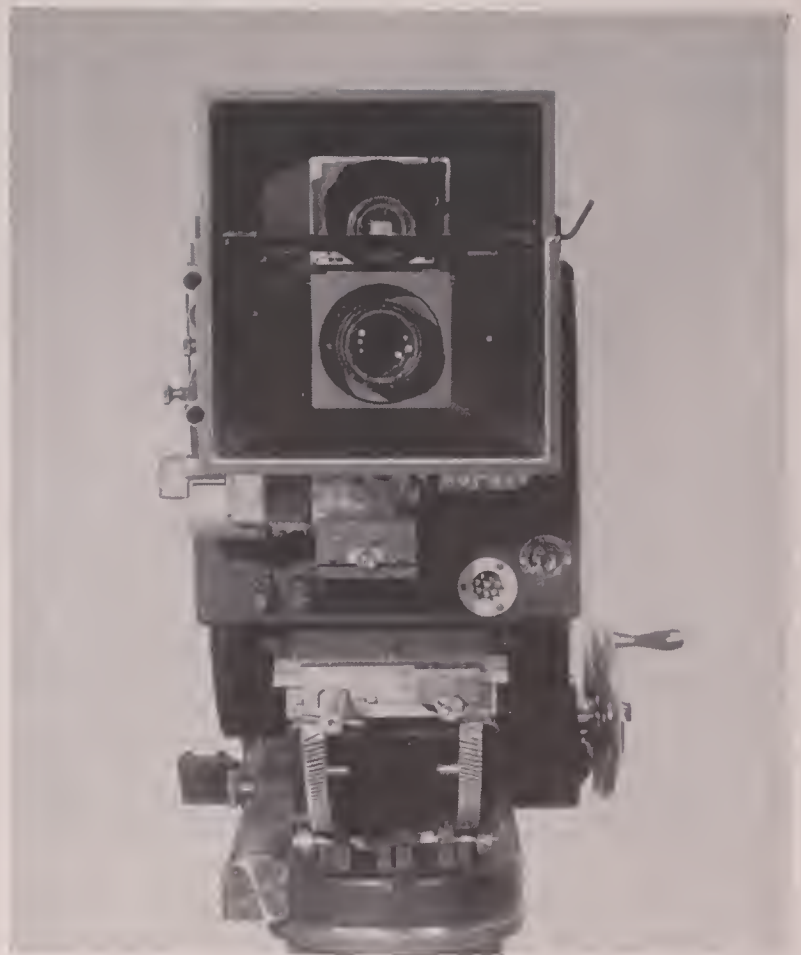
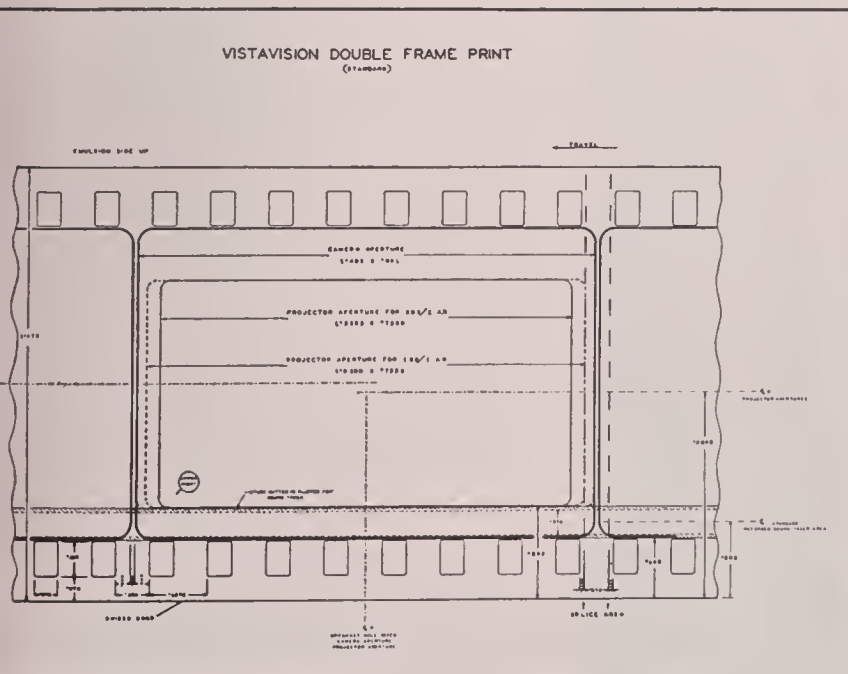

FIG. 4—Front view of new VistaVision camera. Note its unusual narrow width—approximately 13 inches. Length is 25 3/8 inches; height, including finder, is 20 3/4 inches. Approximate gross weight, with 2000 ft. film load, is 105 lbs.

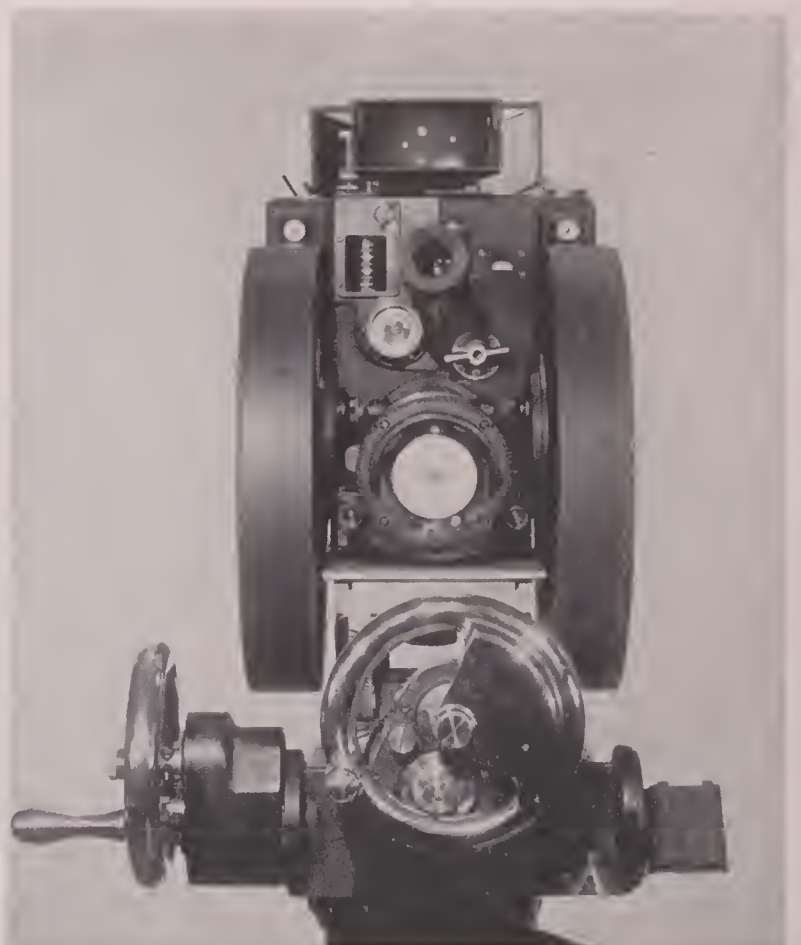

FIG. 5—Rear view of camera, as seen from operator's position. Vertical film magazines may be seen on either side. On top is Mitchell-type finder. At rear are optical viewing tube, shutter position indicator, veeder footage counter, rackover lever, and motor with threading knob at rear.



THE PROCEDURE for adding a sound track to a 16mm film with a magnetic recorder-projector is illustrated here; as the picture is projected, the narrator records commentary with aid of the Bell & Howell Model 202 projector. Actually, the arrangement is a little different in practice: the projector is placed in a room separated from the microphone so that no extraneous noise is picked up.

Do-it-yourself Sound Recording Adds Class To 16mm Films

Magnetic sound boon to non-commercial film maker

A "ONE-WOMAN" production company is Mrs. Andrew Winton ("Dicky") Roth of Harrison, N. Y., who single-handedly mixes tape-recorded sound with narration and records it via a Bell & Howell 202 projector on her soundstriped Norwegian travelog films.



THE DO-IT-YOURSELF movement in recent years has been rolling up like a tidal wave. People who keep statistics on such things report that the public is investing in hobbies and home workshops at the rate of several billion dollars annually.

This do-it-yourself trend has spread to the motion picture field, too. For years amateur movie makers have been turning out films complete with plot, titles and sound. Now the idea is no longer confined to family films or vacation records. In business, science and education people with various degrees of skill are making their own 16mm sound films, and doing the whole job themselves.

Making these low-cost sound movies possible is a new method of soundstripping 16mm films to take magnetic recording, and the development by Bell & Howell Company of a new optical-magnetic 16mm projector enabling anyone to record sound on a 16mm film, then play it back as it is projected. Known as the model 202 Filmosound, it and other similar machines have done more than any other single recent development in the motion picture field to make possible the production of low cost 16mm sound films by those who heretofore were unable to afford them. Also, it has made possible the conversion of many silent films to sound, thus extending their period of useful service.

Recently a teacher was ready to scrap an ancient silent film dealing with history; the kids no longer would hold still for it. But the film had some basic value as a teaching tool. So the teacher had it soundstriped, then added music and narration with the aid of the Filmosound 202 recorder-projector. This was a solo week-end project for the man, and his very first try; but the results were good enough and the students now take genuine interest in the picture.

The real activity with the 202 Filmosound, however, is in the fields of industry, science and selling. Here, in the hands of a capable employee, the 202 is creating sound films having all the appeal and selling potential of films made by the professional 16mm studios.

The American Automobile Association has been active in the film field for many years. Because of the necessity of having films produced by outside studios, cost always had been a limiting factor in determining the number of films released by AAA.

Then, with the expansion of its Public Relations department a few years ago, the company considered ways and means of producing its own motion pictures. Along with the necessary cameras and associated equipment, it acquired a Bell & Howell 202 projector,



AMERICAN Automobile Assn. produces its own 16mm sound films, using Filmosound 202 projector to record the narration and background music. Edgar Parsons reads the script while his assistant Eleanor Kelly relays cues to sound crew in recording booth. Hearing aid is used for monitoring the track.



MIXING multiple sound channels during a recording session. June Halvorsen moves the dials on cue from her father, Roy, during the recording of magnetic sound for a film depicting the operation of Halvorson Trees, Inc.

dual variable-speed turntables, tape recording equipment, and the necessary amplifiers and mixing apparatus.

Production procedure is comparatively simple. Up to the point of sound recording, the process is standard. The original Kodachrome is rough-cut, a black-and-white work print is made, edited and cut. The original color film is matched to the work print, frame for frame, and the optical effects such as fades and dissolves added.

The next step is adding sound. At this point the procedure departs from the usual. An inexpensive monochrome work print is run off from the completed color picture and sent to Bell & Howell to be magnetically striped. When the film comes back it is placed on the 202 Filmosound and made ready for the recording session.

This takes place in the recording studio, which is a converted office, having only the most elementary sound proofing. An adjoining room serves as a projection booth, with space for turntables and other recording equipment. The picture for which sound is to be recorded is projected through a glass panel between the two rooms, to eliminate unwanted noise. A signal system between members of the team keeps everybody on the beam with split-second cues. The team consists of Edgar Parsons, who reads the script while assistant Eleanor Kelly watches the screen and directs the recording. John Hoke handles the projector and

recording controls, and Russ Bradley watches a duplicate copy of the script and has sound effects and music records ready to spin on cue.

The thing that makes production of sound tracks with the Filmosound so simple is the way errors can be quickly

corrected without the cost of recording a complete new track. In case of a "fluff" or a missed cue, the magnetic track or any portion of it can be erased and recorded again.

In another instance, Doughboy In-
(Continued on Page 584)

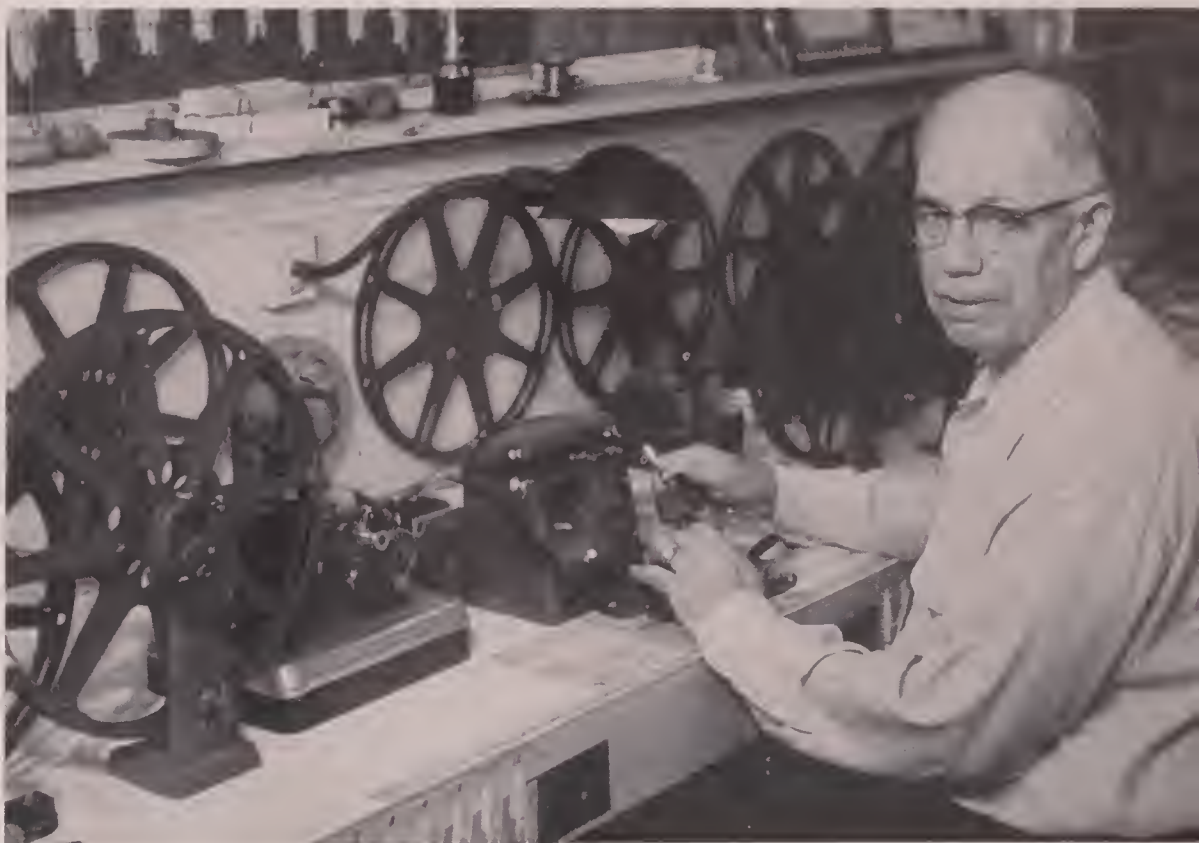

CAREFUL editing is a must procedure prior to soundstripping and recording of a picture. Here C. J. Tinker of Michigan Conservation Dept's., film division puts final editorial touches on a film in readying it for recording.



THIS TREMENDOUS bank of 560 photoflood lamps was the source of illumination for the huge vinyl resinite backing of a church window seen in photo at right.



SCENE from recent 20th Century-Fox short subject in CinemaScope and color of the famous Roger Wagner Choral group. The unique lighting arrangement for the backing, shown at right, provided the desired even illumination simulating daylight.

560 Photofloods—280,000 Watts!

How Twentieth Century-Fox illuminating engineers solved an unusual set lighting problem.

By LEIGH ALLEN

HOW 20TH CENTURY-FOX electrical engineers solved a knotty lighting problem is illustrated in the photos above. A recent short subject production of the famous Roger Wagner Choral group involved a setting having a replica of a massive stained glass window in the background. The problem was to light this window so it would appear illuminated by soft, natural daylight.

Obviously no standard set lighting units available could be used immediately behind the backing to provide the desired quality of illumination, and deliver it evenly over the entire surface of the huge vinyl resinite backing. The solution, Fox engineers saw, was to use a mass of small photo lamps evenly distributed behind the backing.

First, two large vertical frameworks were constructed and mounted on

casters for easy mobility on the sound stage. Mounted horizontally across each framework and spaced at intervals of about 18 inches were seven wooden strips. Mounted on each strip were nine standard light sockets complete with wiring and fitted with reflector photoflood lamps.

The two units, when placed side by side behind the backing, provided uniform illumination for the lower half of it. To illuminate the upper half, two frameworks of similar size and design were built and suspended from the catwalks overhead.

This unique lighting bank, holding a total of 560 photoflood lamps and generating 280,000 watts of illumination, provided the sole source of lighting for the stained window backdrop. The huge multi-colored plastic backing, incidentally, was designed by studio art

(Continued on Page 580)

Unusual Opportunity!

LAB EQUIPMENT

of the Color Corporation of America

available for

IMMEDIATE SALE!

and delivery

PRINTING EQUIPMENT

11 Houston Fearless step printers with automatic Iris-type light changers and resistance type light changers, with perforator, punch for light control tapes.

6 Twin Movement step printers, adaptable for use as direct color printers, with Iris punch for light control tapes. Output, 112 ft. per min. each.

11 Hughes step printers, 6 are equipped with 35mm apertures and 5 with double 16mm apertures.

10 Bell & Howell Model "D" 35mm printers, 4 adapted for direct color printing.

2 Duplex printers adapted for registration printing, one to allow for 1, 2, or 3 frame negative pull-downs.

1 35mm daylight contact printer. Double camera type movement, automatic dissolve shutters.

1 Cinex light tester.

3 Bell & Howell foot pedal splicers.

2 Bell & Howell Filmo-Pro 16mm splicers.

8 Dupue Resistance type light change boards.

2 Densichron printing control meters.

Miscellaneous film racks, rewind tables, reels, synchronizers, etc.

PROCESSING EQUIPMENT

(COLOR NEGATIVE-POSITIVE)

2 Complete Eastmancolor processing machines, sprocket drive, each complete with 32 tanks, dry box, tank and dry box drives, tank drive hoist (electric), feed table, take up table with standard 35mm sprocket and adapted for negative and positive Eastmancolor film.

1 Eastmancolor developing machine in process of assembly. Designed to operate at 150 ft. per minute for the processing of EK positive film.

Sound track developer applicators for each of the above color film processing machines.

NEGATIVE DEVELOPING EQUIPMENT

2 Negative Developing Machines, tendency drive, complete with stainless steel tanks, dry box, tank and dry box drives, tank drive hoist (manual), feed and take up tables, adapted for either standard 35mm or double 16mm negative or positive film.

1 Herrnfeld Sensitometer (Model 1201) with power regulator unit.

2 ERPI Densitometers (Model RA 1100 B).

Miscellaneous makeup and rewind tables, footage counters, etc.

PROJECTION EQUIPMENT

2 Complete Simplex Model E-7 Projection Machines with Peerless Magna-arc high intensity lamps and extra RCA dummyheads for projection of picture and sound track synchronously from two separate films.

2 Super Simplex high intensity Arc Projection Machines with double drive motors for 50 ft. per minute or 90 ft. per minute projection speed, with forward or reverse movement.

Complete RCA Sound Installation.

2 Power Rewind Cabinets.

2 Ampro 16mm Sound Projectors, Speakers.

1 DeVry 16mm Projector, with speaker.

5 Simplex Mazda lamp Projection Machines with high speed movement for inspection projection.

Rewind tables, chairs, stools, etc.

Misc. film storage Cabinets, film racks.

EDITING EQUIPMENT

3 Bell & Howell 35mm foot pedal type splicing machines.

1 Eastman Model B-35 Edge numbering machine.

1 Negative cleaning machine.

1 Bell & Howell 35mm film perforator, adapted for double 16mm perforating.

2 Film slitting machines for separating double 16mm prints.

Miscellaneous editing tables, complete with light boxes and synchronizing film counters, rewinds, film bins, etc. Misc. film storage cabinets, racks, etc.

CHEMICAL CONTROL AND CHEMICAL MIXING EQUIPMENT

Complete analytical and control equipment including sensitometers, spectro-photometers, electrometers, scales and balances, tool makers microscope, densitometers, colorimeters, etc.

1 RCA sound analyzer complete with Western Electric intermodulation analyzer and monitor system.

Complete chemical mixing and storage facilities, including water softeners, water filters, tanks, stainless steel pumps, motors, automatic mixers, flowmeters, recording temperature controllers, etc.

2 York (Freon) Refrigeration Compressor units complete with compressors, motors, valves, gauges, controls and bronze pumps.

2 Worthington (Freon) Refrigeration Compressor units, complete with compressors, motors, condensers, valves, gauges, controls, and bronze pumps.

MACHINE SHOP EQUIPMENT

1 Van Norman #12 Universal milling machine, complete.

1 Elgin Universal milling machine.

1 Regal 13 inch lathe, complete.

1 Logan 10 inch lathe, complete.

1 Buffalo 18 inch floor model drill press, complete.

1 Delta 16 inch floor model drill press, complete.

1 Lee surface grinder Model B-600.

1 Walker-Turner 16 inch metal-cutting bandsaw, complete.

Miscellaneous workbenches with vises, drills, grinders, plates, etc.

Miscellaneous electrical testing eqpt.

CAMERA EQUIPMENT

2 Mitchell-N.C. cameras complete with finders, matte boxes, tripods, friction tiltheads, motors, and 30mm, 40mm, and 75mm Baltar lenses—F2.3, magazines, carrying cases, etc.

Miscellaneous extra equipment including 25mm, 35mm, 100mm and 150mm lenses, baby tripods, Bipack magazines and adaptors.

All equipment for sale as is, or can be reconditioned and guaranteed.

Write, wire or phone

THE HOUSTON FEARLESS CORPORATION

11801 W. Olympic Blvd., Los Angeles 64, Calif.

BRadshaw 2-4331



Hearts are always young

Oldsters come—and recall, tearfully, the days of their youth. Youngsters come and find themselves heart and soul in the good old days when bicycles were built for two—and more. That's today's wide-screen entertainment as it thrills the audience—entertainment based on new technics in production, processing, projection. The Eastman Technical Service for Motion Picture Film is helping the industry master these technics. Branches at strategic centers. Inquiries invited.



and gay—on the new, wide, wide screen

Address: Motion Picture Film Department

EASTMAN KODAK COMPANY, Rochester 4, N. Y.

East Coast Division
342 Madison Avenue
New York 17, N. Y.

Midwest Division
137 North Wabash Avenue
Chicago 2, Illinois

West Coast Division
6706 Santa Monica Blvd.
Hollywood 38, California

to put *Life* on film...



**Scene from "The Egyptian," 20th Century-Fox CinemaScope Epic.*

BALTAR



Thrilling realism . . . vivid detail . . . brilliant images in 2D, 3D or CinemaScope—that's what Bausch & Lomb Baltar Lenses mean to the professional cinematographer. For your finest work in movies and TV, specify B&L Baltar Lenses.

ORDER from your professional camera manufacturer or **WRITE** to Bausch & Lomb Optical Co., 30035 Martin St., Rochester 2, N. Y.

**To film "The Egyptian," 20th Century-Fox chose the new B&L 40mm Baltar CinemaScope Lenses—cine and anamorphic lens elements in a unified mount operated by a single control.*

BAUSCH & LOMB





ANKERS
WASHINGTON, D.C.

SHOOTING a choral scene in Capital Film Studios for the "Hand to Heaven" evangelistic series of TV films. A great variety of special

effects in the lighting were obtained through use of the 14-bank dimmer board, shown in left foreground.

Speed In Small Studio TV Film Production

Drum-tight production schedule enables Capital Film Studio's crew to complete six half-hour TV films in two days shooting time.

By WILLIAM BANCROFT MELLOR

RECENTLY a record of some sort was established on the sound stage of the Capital Film Studios, Washington, D.C., when six 30-minute television films were wrapped up in two hectic days of shooting.

The films were the first in the series of the "Hand to Heaven" evangelistic program of the Rev. Joe Uhrig, widely-known Washington divine. They are now running coast-to-coast on TV, being shown Sunday afternoons on WTC, Washington; KTLA, Los Angeles;

WLWA, Atlanta; KFEL-TV, Denver, and other stations.

During those mad 48 hours of production, the hard-pressed crew filmed and tape-recorded a dozen hymns rendered by a 12-voice choir; also six quartets, six duets, a dozen solos, a number of incidental organ numbers, and six sermons by the Rev. Mr. Uhrig.

The drum-tight shooting schedule worked out by Production Supervisor F. William Hart threw all the work of filming and recording the choir and

smaller vocal units in the first day of shooting, while the sermons and solos rounded out the two-day race. The speed was necessitated by commitments made by the evangelist prior to the letting of the filming contract.

Because of the low-budget limitation, only one camera could be used—a Mitchell BNC on a Fearless dolly. Close-ups, reverse angles and other devices usually employed to lend variety to a film were out of the question because

(Continued on Page 580)

Effecting Economies In The Editing of TV Films

Some ideas for cutting costs and saving time in the editing phase of TV film production.

By HYMAN R. COHEN



THE ROUGH cut of a TV film is reviewed in the Moviola by the editing staff.

TELEVISION FILM producers, large and small, are necessarily preoccupied with two common problems: 1) keeping costs within the limits of established budgets, and 2) meeting deadlines. The solution to the first problem is also the solution to the second, and has its beginning in systematic planning and economical operation of all the intermediate

steps in the physical production of TV films.

It is the writer's aim to explain here how good production planning practice, with special emphasis on the editing phase, can make a major contribution toward the successful solution of the two problems. In particular, a close examination of the working relationship between the unit production manager and the editor or his assistant in conduct of the editing rooms is the main theme.

Inevitably producers find that every step in TV film production requires more time to complete than originally estimated. The first step in the solution to this problem lies in strict adherence to a script breakdown, and a shooting schedule should be standard procedure. A certain period of the working day should be set aside to enable the director, director of photography, film editor, and others to view the daily rushes. Thus, where retakes are necessary, decisions can be made before sets are struck or returns to location are out of the question.

So much for the shooting phase of production.

For this discussion, we shall assume

this phase has proceeded quite normally, and concern ourselves primarily with the organized handling of work print and original material, so that the editing and final assembly of the film can be done at least cost and expenditure of time.

The following observations and recommendations are based on experience with a series of twenty-six 12-minute "Junior Science" TV films made by a small producer. Some of the elements that make this a unique operation are the following: low unit cost; meeting deadlines; the variety of operations involved in the production i.e., "wild" narration for the most part; "lip sync" narration sequences; animation sequences; sound effects; music; working in 16mm color; the severely limited time the narrator was available; emphasis on high quality.

The producer who thinks that once shooting is done, the rest of his operating costs are fixed, is operating on a false premise. There is plenty of room for flexibility in costs all along the way. It is true that lab costs are fixed, more or less, at so much per foot, recording sessions at so much per session, animation costs are fixed by the nature and quantity of the animation shot. But it



THE DESIRED scene is quickly located by referring to a copy of the script and to the cameraman's report sheet.



PROJECTING a rough cut work print from a soundproof booth while recording sound effects in sync with the picture.

is precisely in the working out of the details of these operations and their fitting into the assembly process that costs can mount or be kept down, depending on how one operates.

Wasteful costs can result from a number of sources: 1) extending the time of operation beyond the planned period 2) having to repeat processes because of undetected (until too late) errors or faulty planning, 3) paying for work done but not really needed, such as the printing of "N.G." takes, 4) paying penalties for not meeting deadlines, 5) unwise policy in paying for use of equipment, 6) uneconomical use of stock. Some of these losses can be trimmed by more careful attention to the problem in the beginning.

The secret behind the smooth operation of the editing department lies in establishing a good working relationship between the unit manager and the assistant editor. The unit manager should be able to analyze clearly the editing and assembly problems peculiar to his production. He should plan to bring together the various elements that make up the film, at the right time and at the right place. He has to create a flow of material from one "technician" to the next with a minimum waste of time. Specifically, this will mean receiving requests for material from the various technicians, placing orders with labs, handling all the business that will produce the needed filmic elements. He must have a facility for persistent attention to detail, an ability to "follow up" until a job is done, a faculty for keeping in mind a clear picture of the moving process at all stages. He should keep clear and simple records of the movement of all materials in and out of the editing rooms. He must have a general idea as to where material is and when it

(Continued on Page 570)



SOUND tape is quickly spliced by editor using Bob Jones University magnetic film splicer.



USING ultra-slow-speed motor on Filmo "70" camera, author prepares to film raising of a silo in exposures of one frame per second.



Actual raising of structure, which took several minutes, was recorded on film which screened for five seconds.



VIEW of the Bell & Howell "70" camera showing installation of the Bodine gear-reduction motor, which made photography possible.



THE unmounted motor, showing (in foreground) the additional parts that had to be added to permit mounting on the B&H "70" camera.

Slow Speed Camera Motor

Solves the problem of shooting 16mm industrial films under adverse light conditions or where hand cranking would be required.

By JOHN W. BAKKE

Motion Picture Dept., A. O. Smith Corporation

THE INDUSTRIAL FILM photographer, having few if any of the advantages of the motion picture studio, often encounters unusual demands on his ingenuity than does his studio contemporary. The photographic problems that arise in the studio and are quickly solved by the special photographic effects department are nothing compared to the problems that the industrial cinematographer invariably encounters, and rather suddenly too, in his routine work. Like photographing a large, cavernous interior for which he couldn't possibly assemble enough lighting equipment.

Such a situation can often be met by using the available light and ultra-fast

lenses; or if its a black-and-white job, the new Tri-X film will usually save the day. Where there is no movement of persons in the scene, some cameramen will tie down the camera and tripod securely and shoot the scene in a double or triple exposure, which doubles or trebles the amount of light reaching the film to produce a normal image on the negative.

There is still another way in which to shoot scenes of this type and that is by driving the camera with a special slow-speed motor. We had a problem similar to the above in filming a recent production—one which could not be

(Continued on Page 578)

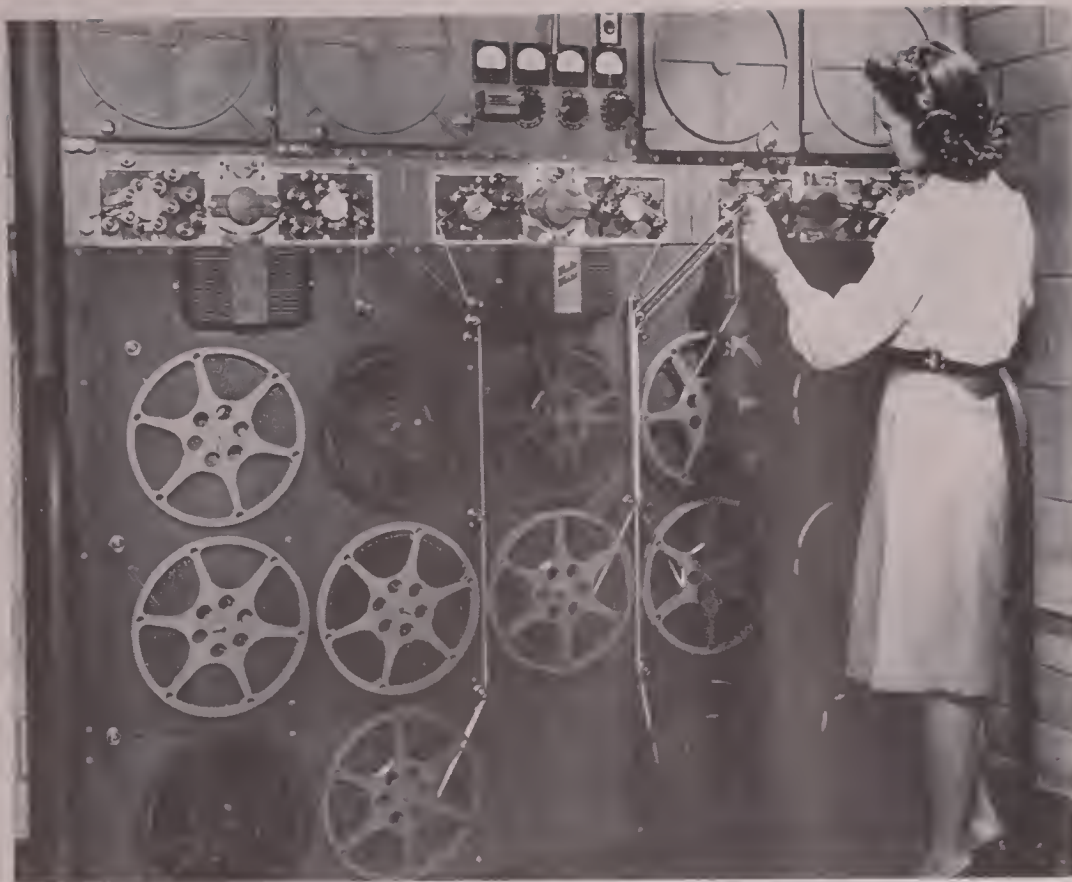

EQUIPMENT for handling A—B roll printing in the laboratory of the Calvin Company, Kansas City, Mo. Reels holding traveling matte, sound track and raw stock feed the films into the printer heads above in an automatic operation that produces fully corrected prints.

which calls for an overlap of two scenes, certain prescribed areas of the raw print stock receive exposure in printing runs with both the A and B rolls.

Producers using the A—B system can deliver Kodachrome originals to the lab properly prepared for A—B handling; or, if the lab offers an editing service, they may bring an edited workprint and original footage to be conformed to it. However, the charge for this work is often rather high, and it generally pays the semi-professional or small industrial producer to do it himself. Because good splices are important in a well-prepared film, a compromise solution is for the producer to cut his scenes himself and place them in order on reels, unspliced, along with the required leader stock, and leave the final splicing to the lab.

Though A—B printing is most commonly applied to straight dissolves, it offers other possibilities, too. Titles superimposed over live background follow as the second most popular use. Once a picture is assembled in A—B rolls, it is not a very difficult matter to include a set of main titles in white letters in front of a real scene. This requires: (a) Color footage suitable in length and subject matter to be used with the titles, and (b) a high-contrast title film, white letters against black background, with the main titles in a series of dissolves. Title cam-

(Continued on Page 576)

Making The Most Of Laboratory Services

Today, thanks to the independent film service laboratory, the 16mm film producer lacks nothing to make his films a success.

By CHARLES L. ANDERSON

TODAY, thanks to the many laboratory services available to him, the industrial, educational or training film producer has all the advantages of the major studio for the production of top quality films. In my article which appeared in the August issue, I gave a general outline of the services available from these laboratories, which are now to be found in most of the large cities coast to coast.

Here, I will attempt to describe more fully some of the specific services the laboratories offer and what the services mean in terms of "professional finish"

for the film product of the independent producer.

A—B roll effects, once the special luxury of a few producers having their own film printing equipment, now are available to all. The A—B roll method (described in detail by John Forbes in last month's issue) makes it possible to put dissolves in Kodachrome release prints without resorting to the use of dupes or making dissolves in the camera. In the A—B roll method, the film to be printed is put through the printer two or more times. To make a dissolve,

PRINTING COST CALCULATOR

Price per foot	per 36'	per 100'	Per 400'
.005	.18	.50	2.
.02	.72	2.	8.
.03	1.08	3.	12.
.04	1.44	4.	16.
.05	1.80	5.	20.
.06	2.16	6.	24.
.07	2.52	7.	28.
.08	2.88	8.	32.
.09	3.24	9.	36.
.10	3.60	10.	40.
.11	3.96	11.	44.
.12	4.32	12.	48.
.13	4.68	13.	52.
.14	5.04	14.	56.
.15	5.40	15.	60.
.16	5.76	16.	64.
.16	5.76	16.	64.
.17	6.12	17.	68.
.18	6.48	18.	72.

ABOVE CHART will enable readers to estimate cost of printing films of various lengths and at varying costs. The 36-ft. column is the most useful inasmuch as this represents 1-minute screen units. Thus if your picture is to screen for 15 minutes, its printing cost can be estimated accordingly by multiplying cost of a 36-ft. segment by the number of minutes screen time.

EASTMAN
PROFESSIONAL
MOTION PICTURE
FILMS

W. J. GERMAN, INC.

Fort Lee

Chicago

Hollywood



SKILLED free lance cameramen are supplying more and more news footage for television newsreels. Accuracy, speed and reliability are qualities necessary to success in this field.



FOR THE AGGRESSIVE cameraman, good news items are to be found everywhere. The sailing of an important new liner can have tremendous pictorial news value when handled imaginatively.

Want To Shoot For The TV Newsreels?

Free lance news cinematography opens new vistas for the 16mm movie amateur.

By ARTHUR MARBLE

ALTHOUGH the large TV newsreel services have staff cinematographers spotted throughout the world, many still depend upon alert non-professional 16mm cameramen to supply spot news that can only be covered by capable filmers who are lucky enough to have a motion picture camera handy when the news breaks.

But there is more than luck involved for an amateur to photograph acceptable newsreels. Added to his camera skill and nose for news must be a knowledge of what the big newsreel companies are looking for and how to submit the mater-

ial so it has a good chance for use on the air.

Because the United Press Movietone Service supplies most of the news-film to TV stations throughout the world, let's review some of the experiences that 16mm non-professionals have had in supplying news film for United Press TV broadcasting.

Throughout the world amateur cine photographers have had interesting news-gathering experiences. Dr. M. Rafique Chaudhri of Nairobi, Africa felt he was qualified to shoot news pictures, so he wrote United Press explaining his quali-

fications. When the Mau Mau revolts began in Kenya Colony, the Doctor was there shooting the historic making scenes that appeared late on TV screen everywhere.

Beginning with a seemingly insignificant news sequence in his home city, Hong Kong, Wong Keung is now earning money filming spot news in such hot spots as Siam, Burma and Indo-China.

An American movie maker whose experience is typical of many others is Dr. Walter Hodson of Cincinnati. Dr. Hodson was aboard the Isle de France

(Continued on Page 583)



WHEN OLD CHIEFS get together at Oregon's Pendleton Roundup each September, it's a pow-wow for sure and a natural for the TV newsreel cameraman. Festivals, fairs and pageants make excellent newsreel subjects.



Brighten up your movies with *AnSCO Hypan Film*

You literally wash away dullness from your home movie screen images when you shoot with AnSCO Hypan Film.

That's because Hypan is an extremely fine-grain panchromatic film of inherently brilliant gradation. These qualities put more snap and sparkle into movie shots than you'd ever have dreamed possible.

What's more, the high exposure indexes of Hypan (40 daylight, 32 tungsten) make it ideal for all-around movie-making, outdoors or inside.

You'll really get far better screen images by taking your movies on AnSCO Hypan Film. And you save, too, because its moderate price lets you make more movies for your money. Leading dealers everywhere have AnSCO Hypan in 8 and 16mm rolls and magazines.

Ask for
**ANSCO
HYPAN**
and
SAVE!

	Rolls	Magazines
8mm x 25'	\$2.85	\$3.75
16mm x 50'	4.20	5.40
16mm x 100'	7.25

AnSCO

Binghamton, New York.

A Division of General Aniline & Film Corporation. "From Research to Reality."



A WHOLE RANGE of techniques are allied to the pixilation method. Stop-motion has often been employed for the appearance or disappearance of characters and objects, but used in conjunction with real-life single-frame animation, it has greater possibilities.

'Pixilation'—New Idea In Movie Making

Animating real life characters and objects by cartoon methods gives every movie maker a chance to produce films with new and lasting interest.

By HAROLD BENSON

what would happen if, instead of putting our subject in these walking positions, we asked him to stand a little further forward for each frame, but always with his feet together. Now picture the screened result. The man would appear to glide smoothly along the street without moving his legs or feet.

Imagine a shot of a girl at the bottom of a flight of stairs. By pixilation she could glide up with her feet together, bounce from step to step on one leg, or swoop upwards laying flat on her face. She could even squat on the bottom step and float to the top in a sitting position.

There are unlimited chances for characters to perform the most spectacular and unlikely of feats. And think of some of the less obvious possibilities. New ways of walking, running, swimming and riding can be devised. Facial expressions taken in a series of single frames can add up to apparently impossible contortions. A grotesque new style of caricature-like acting can be evolved.

A whole range of techniques are allied to the pixilation method. Stop-motion has often been employed for the appearance and disappearance of characters and objects, but used in conjunction with real-life single-frame animation it has greater possibilities. Actors can bound from place to place, continuing with their natural actions all the while.

For example, a wife searching a bar for her husband might look from corner to corner of the room. As she peers from one direction to another, the husband appears in the opposite corner unhurriedly downing his drink.

Yet another series of effects can be obtained by shooting at, say, half the normal camera speed and getting the actor to perform at half *his* usual speed. The projected film would look perfectly normal for most shots, but there are many instances where startling results can be effected.

Imagine a waiter scurrying along at tremendous speed, almost hidden behind a huge pile of plates. Someone sticks a foot out to trip him; he stops dead, and the plates, instead of swaying forward and crashing to the ground, remain perfectly vertical. Filmed in a straightforward manner it would be virtually impossible to manage the trick unless the waiter

(Continued on Page 579)

IT IS IMPOSSIBLE to overrate the importance of originality. A film with new ideas and a new technique starts off with an immeasurable advantage over the hackneyed routine stuff that so many amateurs seem content to churn out week after week. But new ideas are rare, and new techniques can be costly and cumbersome.

Yet there is one original technique which has only just begun to be explored. Its potentialities are enormous and its cost is nil. Only one professional and one amateur producer have so far investigated its possibilities, and both the resulting films have indicated the tremendous scope open to anyone who cares to explore further.

The new idea is called "pixilation." Briefly, it consists of animating real-life characters and objects by cartoon methods, and it gives every movie maker the chance of breaking almost every natural law from gravity to momentum.

Visualize a length of film which shows a man walking. Each frame shows him a fraction further forward in his movement. When the film is screened, persistence of vision interprets the series of still pictures as a single moving image. Now suppose for a moment that instead of shooting the man as he actually walked, we placed him in a series of walking poses and took a single frame picture of each. Providing that we had worked out details of speed and movement correctly, the effect on the screen would be exactly the same.

So what, you're probably saying. It might be clever, but it's very longwinded and utterly pointless. True; but imagine

**CAMART TV
CAMERA DOLLY**



CAMART dollies have been tested and proven for motion picture and television production. Designed for studio and location, the boom arm model operates quickly and evenly on a new geared principle. The baby model for tripod use enables the assistant to ride the platform for follow focus. Dolly tracks available, descriptive literature on request.

A DEPENDABLE NAME IN
CAMART
SALES • SERVICE • RENTALS

16
MM
35
MM
TV

MOTION PICTURE & TV EQUIPMENT
PRODUCTS
STUDIO OR LOCATION

**CAMART
BABY DOLLY**



**CAMART
TRIANGLE**

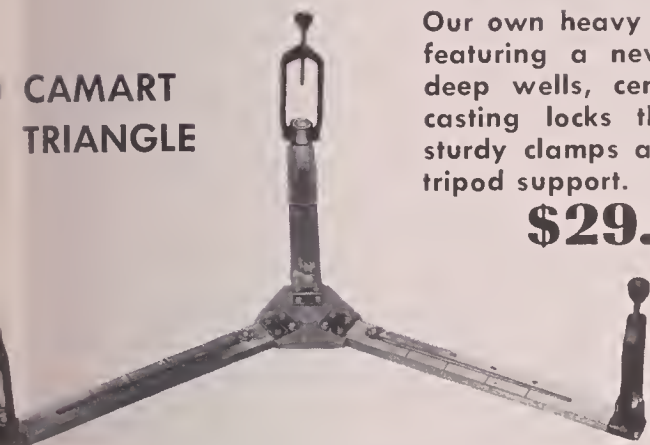

Our own heavy duty triangle featuring a new shoe with deep wells, center keystone casting locks the legs and sturdy clamps assure a solid tripod support.

\$29.50

TIGHTWIND ADAPTER

DISCARD your SPLIT REELS and RANGES by fitting this adapter to your rewind to wind film evenly on cores faster and smoother than ever before. Save time and money by using the same rewind and adapter for 16mm and 35mm film. Model 1 for Neumade and model 2 for Moviola rewinds.

Price: **\$24.00**



CLAPSTICK		
REEL NO.		
DIRECTOR		
CAMERA		
REEL	SCENE	TAKE
DATE		

SLATE and CLAPSTICK

Cameramen prefer this large 10" x 12" slate for sound production. Contains all essential information, well constructed for professional use. Increased production makes this new low price possible.

\$7.50

SPECIAL SERVICES
 AUTHORIZED BAUSCH & LOMB
 BALTAR LENS AGENCY
 FACTORY APPROVED SERVICE & REPAIR
 OF BELL & HOWELL EQUIPMENT.
 BALTAR LENSES MOUNTED FOR ALL
 16-35mm CAMERAS.
 WORN and DAMAGED MOVIOLAS FULLY
 RECONDITIONED IN OUR SHOP.

CAMART SCOUT TRIPOD



**A PROVEN
LEADER!**

Sturdy tripod for 16mm or 35mm cameras. Well balanced removable friction head for smooth pan and tilt action. Water level. Specially treated wood prevents warping. Fibre boot covers available.

THE SCOUT
Includes head
Measures from
42" closed to
72" fully ex-
tended. Weighs
9 1/2 pounds.
\$104.50

THE CUB
Baby Tripod
\$35.00

HI-HAT
Ideal for
low angle
cinematography
\$16.00

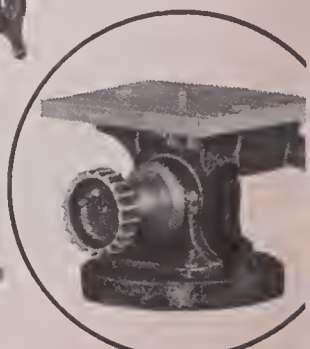

REMOVABLE HEAD
Model A, narrow plate
for Cine-Special.
Model B, wide plate

THE CAMERA • MART INC.

MOTION PICTURE AND TV PRODUCTION EQUIPMENT

15 BROADWAY at 60th ST.

Phone: Circle 6-0930

C. No. Address CAMERAMART

Send for

EFFECTING ECONOMIES IN EDITING TV FILMS

(Continued from Page 563)

"The Finest Cameras
Deserve the Finest Care"



AUTHORIZED

Service To All Fine Cameras

ROMLE-WAHL & CO.

520 W. 7th ST.
LOS ANGELES 14, CAL.



PELEGRINI

**VARIABLE SHUTTER UNITS
FOR THE BOLEX H-16
AND H-8**

The real answer to complete FADES and LAP DIS-SOVLES. Faster shutter speeds and many other advantages. Prices for both the H-8 or H-16 within U. S. \$99.60. Cameras with outside frame counter \$109.80. Tax extra. One year guarantee and camera transportation lock included. Send for free informative booklet. Prices subject to change without notice.



TULLIO PELEGRINI
1545 Lombard St.
San Francisco 23, California



Reversal PROCESSING

Reversal specialists for over a decade. Our long experience insures superior quality. Electronically controlled machines keep temperature constant within .2 of one degree. National "Brilliantone" Cine prints are the finest available. Write for free catalogue.

CONTACT PRINTING B & W DUPLICATING
WORK PRINTS KODACHROME DUPLICATING
EDGE NUMBERING VACUUMATING

All work vaporated at no extra charge

NATIONAL CINE LAB

Box 4425 Washington 17, D. C.

SURPLUS AIR BLOWERS SUTORBILT 2M STYLE



Impellers 2" wide. 1" tube size inlet and outlet. Approximately 20 cu. ft. per minute at 2, 3, 4 or 5 lbs. pressure. 1/2 h.p. required at 2 lbs.

Not \$150.00

NOW ONLY \$35.00

Send 25c for our new 24-page catalog of processing machines and parts.

METAL MASTERS

5599 University Ave., San Diego 15, Calif.

will be available for any particular part of the assembly process.

The unit manager enjoys a unique position. Almost by definition, and by the very nature of the complexity of picture production, the unit manager must be in complete control. Having the overall picture in view, he must be the one to make many, if not most, decisions; but precisely because he has the overall picture, the unit manager is in the best position to set up a system of priorities among competing operations and, in extreme cases, to modify this system, when necessary. His is a full time job.

Working closely with the unit manager, the assistant editor will be in "physical" contact, as it were, with the material. He must know specifically where all material is or have such records as will enable him to locate quickly any desired piece of film material. If it is a general practice that all material passes through his hands, responsibility can be fixed and no confusion will ensue.

Here are some practical rules that can bring order to any editing room:

1. Keep simple but adequate records of the movement of all pieces of film, tapes, etc., in and out of the editing rooms. Label every length of film or roll of tape, etc., to provide a concise and ready description of it, preferably by "show number or name," scene number and "take" number. Shipping memos and purchase orders (dated!) should be scrupulously and carefully filed. Reliance on memory alone, where a large volume of film is handled and operated on, is bound to be fatal.

2. If your lab processing requirements are different from the lab norm in any way, be precise in your instructions. Do not trust the lab to figure out what you want or expect. Learn the preparatory procedures that your lab has established for every type of operation and set up your work in accordance with their standard procedure.

3. "Check in" original material and work print against the camera report as soon as they are received from the lab. Needed retakes and shots that were not work-printed should be taken care of before they are critically needed.

4. Assemble work print in order and check against script for missing scenes. Follow up on missing or needed scenes.

5. Make a record of "N.G." takes that were printed (for refund).

6. Record the first and last edge numbers of each roll of film on the camera report. Store rolls in convenient, well labeled containers in a vault. Number each report, each can and each core-mounted roll with the same identifying number or letter. Systematize their order and location. Your camera report is a ready guide to locating any desired piece of original film. The final "original" may very easily be assembled by locating the required sections of film recorded on a "shot list" obtained from the work print.

Now let us see how these ideas were put into practice in the production of the Junior Science series.

Our "sound" problem consisted of the following elements: "wild" narration which ultimately had to be fitted to an edited picture work print; interspersed shots of the narrator in "lip sync": sound effects; an introductory "leader" narrated to a picture sequence by a second narrator. The films were assembled in two batches. For each batch, the following recording sessions were scheduled: 1) a sufficient number of sessions to record the narration of 13 films; 2) a sufficient number of sessions to shoot and record the "lip sync" sequences; 3) at a later date, after picture "leader" material had been chosen and partially edited, one session with the second narrator was scheduled; 4) at a convenient time, two sound effects recording sessions were held, after the work prints were rough cut, during which "effects" were recorded to the projected print.

It was decided to edit the sound in the following way. All recording was done on 1/4-inch tape with a synchronous recorder. A transfer was made to a 16mm master magnetic tape and from this an optical transfer was made for work print. A tone signal was put into the beginning of each 16mm tape, when re-recording, and the optical duplication of this was used as the "registration" mark for edge-numbering tape and optical in synchronization. After editing the sound work print, the master tape was matched to it by edge-number in a synchronizer and spliced (bloopless) with a Bob Jones University splicer.

EVERYTHING PHOTOGRAPHIC

AND CINEMATIC

FOR PROFESSIONAL AND AMATEUR

The World's Largest Variety of Cameras and Projectors. Studio and Laboratory Equipment with Latest Improvements as used in the Hollywood Studios. New and Used . . . BARGAINS. Established 25 years.

HOLLYWOOD CAMERA EXCHANGE

1600 Cahuenga Boulevard

HO 9-3651 • Hollywood, Calif. • Cable Hocamex



F&B

NEW — EQUIPMENT — USED

FOR MOTION PICTURE & TV FILM PRODUCTION

F&B

F & B Split Reels

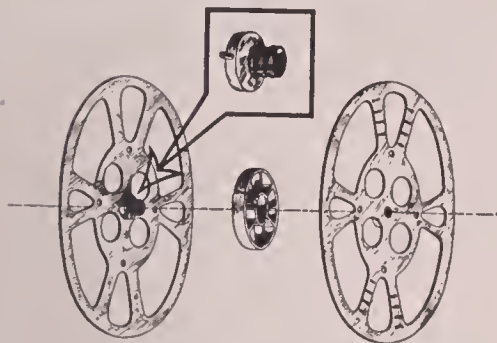

SAVE wear and tear on 16mm prints, time, space, storage.

NOW you can project, edit, inspect, synchronize, clean, measure and store all your films on cassettes.

No More Rewinding Problems.

ELIMINATES EXPENSIVE TITELANDS

400 ft. 16mm	\$4.50
800 ft. 16mm	\$6.00
1200 ft. 16mm	\$7.50
1600 ft. 16mm	\$9.00

Professional and Educational Discounts

CAMERA SLATE with Clapsticks



BETTER DESIGN . . . LOWER PRICE

Materials & Workmanship
Guaranteed Top Quality

*Medium 9"x11" size
(Illustrated) Price \$5.00

*Large 11"x14" size Price \$8.75

KINEVOX MAGNETIC SYNCHRONOUS 17½mm TAPE RECORDER

Excellent Condition Guaranteed.

One Only

Current List Price.....\$1500.00

Closeout Price\$ 845.00

600 FT. CONVERSION

NOW Shoot full 15 minute TV shows without stopping or reloading. The F&B conversion includes 600 ft. magazine, extra silent take-up motor, camera insert plate for stabilization of film movement, and footage counter. Camera is not cut down; can be used without magazine for 100 ft. rolls.

Write for Brochure

Shoot Complete
15 Minute
Programs

600 FOOT
MAGAZINE
CONVERSION
FOR 16mm
AURICON
CINEVOICE
CAMERA

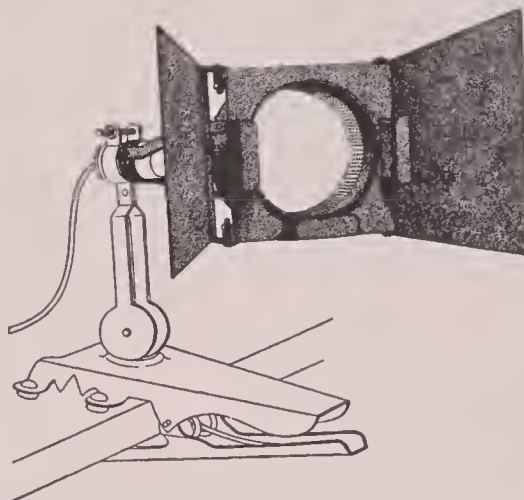
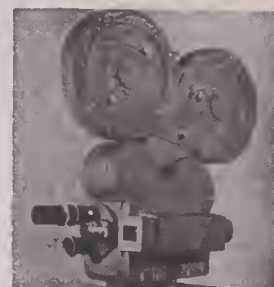

F & B GATOR CLIPLITE

The cameraman's favorite . . . invaluable accessory light for location work . . . Clips anywhere . . . Great with Color-tran converters.

WITH BARN DOOR, \$12.95

Gator Grip only...\$2.50
Gator, Splicer, 25 ft. Cord...\$4.95

NEW F&B Pro-Cine 14lb. TRIPOD

— for all cameras —
Auricon-Pro . . . Mower . . .
Cinevoice . . . Cine Special . . .
Filmo . . . Bolex . . . Eyemo . . . with
magazine & motor . . . Arriflex 16 . . .
Arriflex 35 . . . comerette . . . view cameras

A BRAND-NEW, MODERN TRIPOD . . . precision engineered and designed, ruggedly constructed for long and satisfactory service.

- ★ SUPER-SMOOTH, fluid friction pan and tilt head.
- ★ TELESCOPING, two position, offset panhandle, for adjustability to your length requirements, left or right hand use; offset for greatest comfort and convenience.
- ★ KNURLED camera-tightening knob, externally operated by angle gears for fumble-free, maximum tightening.
- ★ PRECISION ENGINEERED positive pan & tilt locks for utmost in rigidity and safety.
- ★ SUPERB, SEASONED, solid hardwood legs, finished for smooth, non-sticking telescoping action.
- ★ REMOVABLE friction head for easy mounting on baby tripod or hi-hat.
- ★ SPRING-BALANCED HEAD, adjusted to your camera, available at extra cost.

HEIGHT: 41" to 75" . . . 360° pan; 90° tilt.
FINEST WORKMANSHIP AND MATERIALS
5 YEAR UNCONDITIONAL GUARANTEE . . .



LIST PRICE: \$135.00

Heavy Duty Fibre
Carrying Case, \$20.00

MADE IN U.S.A.

DEALERS & AGENTS
WANTED

ALL F&B PRODUCTS NOW
AVAILABLE FOR MOST
TERRITORIES

F&B

FLORMAN & BABB

70 West 45th Street, New York 19, N. Y.

Phone: Murray Hill 2-2928

Cable Address — FLORBABB, N. Y.



FISHER FILM CLEANER

for Clear Pictures,
Faultless
Sound!



Cleans!
Preserves!
8 and 16mm Films!

Save your precious films. Show them at their best, free from dirt, dust, specks and spots. Eliminate annoying magnified fuzz and lint from your screened picture.

With sound film you get undistorted, smooth reproduction without disturbing noises due to dirt on the sound track.

Dry chemicals on soft, replaceable cleaner pads assure brilliant highlights and sparkling color. Easy, simple to use!

Send ONLY \$2.95 direct. (Former advertised price, \$3.95.) Postage paid. Satisfaction guaranteed or money refunded.

FISHER MFG. CO.,

1185 MT. READ BLVD., ROCHESTER 6, N. Y.

RUBY CAMERA EXCHANGE

Rents . . . Sells . . . Exchanges

Everything You Need for the

Production & Projection

of Motion Pictures Provided
by a Veteran Organization
of Specialists

35 mm. . . . 16 mm.
Television

IN BUSINESS SINCE 1910

729 Seventh Ave., New York 19, N. Y.

Tel.: Circle 5-5640

Cable address: RUBYCAM

Southeastern

Film Processing Company
1305 Geiger Ave., Columbia 2, S.C.

SPECIALIST IN

DuPont 930-931 B & W
REVERSAL 16mm FILM

- Industrial
- Television
- Training

24 hour service

FILM IN STOCK

The following flow system was set up for the smooth and economical handling of editing and assembly:

1. Assistants assembled the picture work print in sequential order from the supply of "breakdown rolls" and spliced these together. A completed reel was passed to Editor No. 1.

2. Editor No. 1 "picked the takes" and made the first rough cut. He then roughly "cued" scenes that called for animation, against the script as he read it. The necessary leader was "laid in" temporarily, in place of animation scenes, and "cues" were made on it. Animation was ordered somewhat "long" since it was necessary to order animation early in the editing process in order to have it available when the fine cutting was to take place and to have plenty of time for retakes.

3. The work print was then passed to Editor No. 2 who "laid in" the wild narration, roughly, to correspond to picture and script. He would then either pass the reel to an assistant to lay in the "lip sync" narration shots in their proper sequence or do it himself if he had time.

4. By this time the animation had come in and could be roughly laid in to replace the leader, this step being done by Editor No. 1. He then made the first fine cut of the whole picture.

5. Editor No. 1 then passed the reel to Editor No. 3 who "fine cut" it to its final form. By working on two films at a time, three editors were kept busy.

6. After the work prints were fine cut, the sound print was passed to an assistant who matched the 16mm master tape to it. At the same time, Editor No. 2 used the picture work print to lay in the sound effects and the music. This editor also specialized in preparing all elements for the "mix" of two pictures, which he attended.

7. Meanwhile a "matcher" (assistant editor) was roughly assembling the original, using a script and the camera reports to locate the needed scenes. When the picture work print was next available, it was used by the negative cutter to set up the A and B rolls.

8. The No. 2 Editor received all elements (after the mix) for checking and for preparation of mixed track plus A and B rolls for making an answer print.

This was the "flow schedule" that we followed and while it worked out reasonably well, some unforeseen problems did come up. A glance at some of the major ones and the ways we handled them might be of help.

It was found that prolonged handling of the sound work print in the Moviola had caused the edge numbers of one or two reels to rub off (the ink may not have been just right) so that matching to the tape was impossible. As soon as this was noticed, the master tape of all material in that work print was re-

recorded as a fine grain optical. This optical was matched to the work print by eye. Of course, this required blooming of the optical and the setting up of an optical channel in the mix instead of a magnetic channel. This whole problem might be avoided if edge numbers were printed down the middle of the film instead of at the perforation edge where the rubbing occurs.

Another sound problem was introduced by the difference in levels between the wild narration and the lip sync narration, each of which was recorded at a different time and under different acoustic conditions. Some advance thinking about preparation of the recording studio, placement of the narrator, checking of levels, etc., should reduce this problem to a minimum.

In the preparation of A and B rolls, additional frames beyond the change-over point are required, especially where there are dissolves and "insert" or "cut-back" scenes. The best way to handle this problem is in the shooting stage, when plenty of footage at the beginning and end of each important scene or action should be shot. Otherwise, the setting up of A and B rolls can become a very difficult process.

It is hoped that this account of the specific problems involved in a particular production will pinpoint the principles mentioned above. To conclude on a general note, especially important when working on a series of pictures for television, permit me to summarize:

1. First, examine the operation as a whole. Then set up a "flow schedule" which will guarantee a continuous and smooth flow of finished work. This will eliminate the tendency to work on a "crisis" basis, trying to meet each picture deadline as a separate problem.

2. Next, break down the operation into its unit processes, examining closely the detailed physical techniques involved.

3. Make certain every worker and technician understands his job and his relation to the other staff members.

4. Do not hesitate to take time out for staff meetings to clear up problems—especially when apparently pressed for time.

5. Be conservative in estimating the time needed for each operation, especially those over which you have no direct control.

6. Last, but not least, always plan well ahead. Have material on hand that will enable you to shift to other profitable operations, whenever an emergency impasse arises in the production that is current.

Film Editing Made Easy
with NEW
**professional
film viewer**

for 35mm and 16mm

Every film editor will appreciate a viewer that enables him to view his film from left to right—on a large, brilliantly illuminated screen.

The PROFESSIONAL FILM VIEWER makes film editing a breeze. Easy threading, portable, will not scratch film. Put this viewer between your rewinders and speed up your editing. Size of Viewing Screen 5¾ x 4¾.



**35mm Model \$375
16mm Model \$350**



Write Dept. A-11-4

VISTAVISION MOVES FORWARD

(Continued from Page 553)

but is probably in the ratio of 2 to 1 as compared to the standard film.

There has been considerable information published pro and con on light illumination of the motion picture screen between standard pictures as compared to anamorphic pictures with respect to "cropping." A study made by Paramount shows that the number of theatres that are now "cropping" pictures are about the same for the two processes. Figures also show that if the lamps are adjusted for standard Academy presentation, the resulting comparative light levels are close enough not to be distinguished by the audience.

Along with the use of VistaVision for color pictures, Paramount will be shooting black-and-white VistaVision. In black-and-white, especially with the double-frame projection, there is more apparent improvement even than in color films. This again is probably due to the fact that grain size has been very much reduced and the resolution improved with respect to the seeing capability of the eye.

In the VistaVision camera, with the larger horizontal negative, standard

focal length lenses of 50mm and 35mm can be used to gain wider angle photography than with the normal camera. A 50mm lens gives 39 degrees in VistaVision as compared to 24 degrees in standard photography. A 35mm lens with VistaVision gives 54 degrees as compared to 33 degrees in standard photography. These sizes incidentally are in the range of best known lens design.

With respect to aspect ratios, the studies made by Paramount indicate that by far the majority of theatres can best accommodate pictures in the aspect ratio of 1.85/1. However, the VistaVision standard positive will play on any projector anywhere in the world; and while the original photography is in the aspect ratio of 1.85/1 and 1.66/1 for best composition, it will play well up to a ratio of 2/1 and down to a ratio of 1.33/1.

In this connection it might be well to review this subject starting with the original photographic negative. Tests made at Paramount indicate that we have the ideal ratio of negative to positive in standard VistaVision. The negative is wider than the standard

AT LAST! ONE

EDITING
MACHINE

for
16mm and 35mm

60 DAY
DELIVERY

COMBINATION

16/35mm

\$1375.00

STANDARD

35mm

\$1050.00



- Rugged Geneva movement
- 9" Jensen speaker
- 10-watt hi-fidelity amplifier
- Bath magnetic and optical heads at no extra cost
- Sound head accepts 16mm, 17½mm, 35mm
- Picture head accepts 16mm or 35mm
- 16mm picture with 17½mm, or 35mm track possible with this machine
- Electric hand brake
- Large picture for easy viewing

**RESULTANT
ENGINEERING, INC.,**

7424 Santa Monica Blvd.,
Hollywood 46, California
Write For Brochure

FOR BETTER
Projection AND
GREATER PROTECTION



Compco Reels
PROFESSIONAL

For shipping, storing or showing film, precision made Compco Professional Reels are first choice with those who want the finest. Hard, spring type steel construction won't warp or bend... eliminates film-wearing rubbing during projection or winding. Your production deserves the finest package—use Compco Professional Reels in 600 ft. to 2,000 ft. sizes.

Write for catalog!

COMPACO CORPORATION
2253 W. St. Paul Avenue, Chicago 47, Ill.

MOVIOLA

**FILM EDITING
EQUIPMENT
16MM - 35MM**

- PICTURE SOUND
Photo and
Magnetic
- SYNCHRO-
NIZERS
- REWINDERS

One of the new series 20 Moviolas for picture and sound.

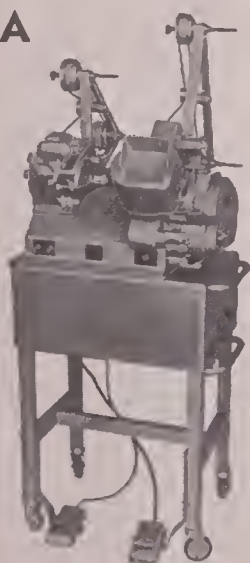

*Write for
Catalogue*

MOVIOLA MANUFACTURING CO.

1451 Gordon St. • Hollywood 28, Calif.

WORLD FAMOUS

S-5

synchronous
magnetic film
recorder for
motion pictures
and television

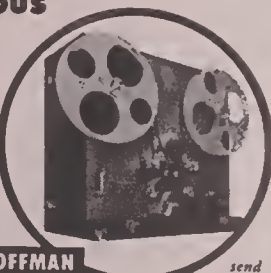

STANCIL-HOFFMAN

921 N. Highland Hollywood 38, Calif.

*send
for
particulars*

negative by a figure of 1.62. It is also 2.76 times larger in area than the standard negative. This differential of area of negative is based upon the theoretical ideal ratio of negative to positive size for best image resolution as determined by both Eastman and Paramount. If we use a negative that



THEATRE PROJECTOR with horizontal film movement head installed for screening VistaVision double-frame prints at Music Hall Theatre in N.Y.

is either larger or smaller, we lose the quality of the ultimate picture. Our desire is to take full advantage of the film print stock under conditions of normal 35mm projection. As it happens, the 35mm standard image has the pictorial resolution capability of adequately filling a screen of 50 to 60 feet in width. Thus by increasing the negative size as exhibited in standard VistaVision, we have increased the resolution and reduced the grain to an optimum. At the same time, if we continue to increase the width of the picture, we will lose depth of field and produce an inferior picture. These are the reasons why Paramount has selected the above stated ratio of negative-to-positive size.

The improvement in picture quality from the large frame projector is greater than that which would normally be expected. It seems that when the reproduced grain size is reduced, as compared to the eye-seeing capability, there is an apparent improvement in resolution beyond that which would be expected on any computations based on the normal laws of resolution and circle of confusion. This experience further shows that the VistaVision process gives an improved depth of field as compared with normal photography.

The sound on all Paramount pictures, including the double-frame release, will be optical in the standard sound track

position and standard in every respect, except that on full double-frame prints, the film will be made to run twice as fast. Here, all sound will be single track and carry stereophonic sound control.

The first VistaVision camera, then known as the "Lazy-8," was a converted Natural Color system camera built in the late 20's by William P. Stein of New York. This camera was used in photographing "White Christmas." Results achieved with it were so satisfactory. Paramount very soon decided on the new double-frame system as its standard and trade-named it VistaVision.

Following this, the studio engineering department studied a number of proposed designs and ultimately choose the compact model having vertical film magazines (Originally designed several years ago by Jack Bishop, A.S.C., head of Paramount's camera department.—ED.) and engaged Mitchell Camera Corp. to further engineer the design and produce the new model VistaVision camera. Four have been delivered to the studio to date and have been shipped to the Cecil B. DeMille Company in Egypt for use in photographing "The Ten Commandments."

On pages 552 and 553 are four views of the new camera. Fig. 1 is a side



LOOKING DOWN on the conversion head. Here may be seen how VistaVision film is twisted as it enters and leaves the horizontal movement.

view with the cover of one film magazine removed, revealing the 2000 ft. film load. Fig. 2 is a view looking down into the top of the camera. The door is open, showing the film transport mechanism and gate, and shows how the film is twisted as it enters and leaves the horizontal film gate. Fig. 4 is a front view of the camera, revealing the slimmer, more compact design. Fig. 5 is rear view of camera, and shows the controls of the specially-designed gear-



**INCREASE YOUR OUTPUT
30% to 100% WITH A**



SOUND PRINTING HEAD

For Model "J" & "D" Contact Printers

Now you can print both sound and picture from separate negatives in one operation. The Peterson Sound Head mounts right on your Model "J" or "D" . . . converts it to a double-head printer . . . enables you to increase your output 30% to 100%!

Easy to install—mounts in place of gear-housing cover—no drilling or machining needed! The sound track is printed on a precision stainless steel drum for perfect contact. All film path parts are polished stainless steel . . . precision ball bearings are used throughout. Take-up flange has torque motor that prevents cinching and scratching and other film damage.

Send for Catalog
of Motion Picture
Printing Equipment
and Accessories



MOTION PICTURE PRINTING EQUIPMENT CO.
Mfrs. of Optical and Continuous Printers and Accessories.
8136 NORTH LAWNDALE AVENUE • SKOKIE, ILLINOIS

Write today
for prices
and complete
literature.

head engineered by Paramount's mechanical department.

The film moves from right to left a distance of 8 perforations per frame. The movement is a modification of the well-known Mitchell NC link movement. The pull-down period has been shortened to provide a 190° exposure time. The movement racks up and down for alternate viewing of the scene through the lens and photographing. Racking is controlled by the operator through a lever at rear of the camera.

The optical viewing tube, which sights through the lens, provides for precise alignment of camera with the scene, and has the conventional Mitchell magnifying device for critical focusing.

There are keeper rollers of the quick-release type on all sprockets. Buckle trips are provided on both sides of the film movement that assure positive safeguard to the film in event a buckle develops at either side of the movement.

The vertical film magazines are a new departure in design, hold 2,000 ft. of negative, and are power driven (instead of by belts) through a friction-slip-clutch mechanism, which provides constant and uniform takeup tension on the film at all times. The camera may be driven either forward or reverse and a simple clutch disengages the takeup

Model 35-16C

S E N S I T E S T E R



★ IMMEDIATE DELIVERY
to the lab owners interested in—

**QUALITY
EFFICIENCY
ECONOMY**

- DUAL MACHINE
1—Sensitometer
2—Scene Tester
- HIGHLY ACCURATE
Electronic timer unaffected
by climatic changes.
- NEW TYPE LONG-LIFE
Cold Light Exposure Unit
- WITHOUT ADDITIONAL
EXPENSE will match a y
printer

Combination 35mm-16mm

ART REEVES MOTION PICTURE EQUIP.

7512 Santa Monica Blvd.

Hollywood 46

California

Now! A 400ft. Magazine For Your BOLEX H-16

Complete with Synchronous Motor and Base

Includes Installation and Case



Permits continuous run of 400 feet of 16mm film, or—the 200 ft. daylight loading spool may be used in the 400 ft. magazine. The 100 ft. daylight loading spool can be used in the camera without removing the external magazine. In block wrinkle finish to match camera. Fully guaranteed. Write for information on our Rack-Over Sports-finder and Camera Base.

See your Bolex dealer or order direct. Immediate delivery.

TOLEDO CINE ENGINEERING
1309 Milburn Ave. Toledo 6, Ohio

Inquiries Invited

Opportunity for Dealers and Distributors

for

CINEKAD

line of motion picture and TV equipment

in

the United States and Foreign Countries

All items in constant demand, attractively priced, with generous profit-making discounts.

Write For Details to
CINEKAD

ENGINEERING COMPANY
(Formerly Kadish Engr. Co.)

500 WEST 52ND ST., NEW YORK 19, N.Y.
Plaza 7-3511

DESIGNERS AND MANUFACTURERS OF
MOTION PICTURES AND TV EQUIPMENT

AUTOMATIC DAYLIGHT PROCESSING



DEVELOPING TANK

- Processes up to 200 Ft.
- 8mm-16mm-35mm
- Movie—X-Ray—Microfilm
- Motor Driven, Portable
- Tough Plastic Tanks
- Uniform Density Assured
- 70mm tank also available



FILM DRYER

- Motor driven—Heated
- Speedy drying
- Automatic shrinkage allowance
- Stainless steel and aluminum construction
- Easily assembled without Tools
- Compact, Portable

Guaranteed. Write for Free Literature

MICRO RECORD CORP.

Dept. AC, 487 South Ave., Beacon, N. Y.

drive and re-directs it to the magazine on the opposite side.

The 96-220 volt motor, which is situated at rear of camera in horizontal position, is a multi-duty, reversible, synchronous job that drives directly from end of motor shaft. It is mounted in rubber to minimize noise and vibration.

A miniature shutter dial at rear of camera shows operator the position of the camera shutter at all times. A Veeder footage counter, also at the rear, indicates the exposed footage.

The monitoring finder is a modified Mitchell and is mounted on top of the camera, directly above the photographing objective. Thus there is no lateral parallax, and only a small vertical parallax of about 3 inches. Correction of vertical parallax is accomplished by shifting the prism in a vertical direction, but without varying the parallel line sight of the taking lens.

Follow-focus shots are accomplished by remote Selsyn control of the camera lens, similar to that in Technicolor cameras.

All lenses used on VistaVision cameras have been specially designed to cover the double-frame area of the negative. All are mounted in rotating focusing barrels, are in ball-bearing

mounts, and are calibrated for T-stops. Range of the lenses consists of: 21mm, 28mm, 35mm, 44mm, 50mm, 75mm, 85mm, 100mm, and 152mm. Lenses of longer focal length will be added as the need develops.

A special gearhead has been engineered and built by the Paramount Studio mechanical department. A unique feature is the provision made for balancing the camera on the cradle base, by moving the camera forward or back by a simple lead screw. The gearhead provides for panning through a full 360°, and a maximum tilt of 45° down and 30° up—said to be greater than that permitted by available gearheads for conventional 35mm studio cameras. A choice of two speeds are provided for both pan and tilt movements. Two handwheels at rear of gearhead provide operator with velvet-smooth control of both actions during a take.

Incidentally, for the record, Loyal Griggs, A.S.C., and Wallace Kelly, A.S.C., have the distinction of being the first cinematographers to shoot a production with the new VistaVision cameras. They are presently directing the photography of Cecil B. DeMille's "The Ten Commandments" in Egypt.

MAKING THE MOST OF LABORATORY SERVICES

(Continued from Page 564)

eras are equipped with dissolving shutters, and so it is no problem to have the titles photographed with dissolves.

The background scene is placed at the beginning of one printing reel and the title footage at the start of the other. When both reels have been exposed onto the raw stock, the result is a fine-looking superimposed title scene. You have a choice of processes in shooting the title letters. Reversal film may be employed to photograph white letters on black title cards, or positive printing stock may be used to film black lettering on white cards. Black-and-white film is called for in either case.

Other optional title arrangements are: (a) Background scene and opening title fade in at the same time; (b) Background scene fades in first, then followed by title; and (c) producer's regular color trademark title fades in, dissolves to background scene, and opening title fades in over it. A few producers have tried for an especially dramatic effect by fading from one set of titles to another instead of dissolving. They keep the background scene on screen in the meanwhile.

It is also possible to dissolve to a new scene at each title dissolve, if A, B, and C rolls are furnished the lab.

Another handy application of A—B rolls, though not so well known, is in superimposing words or diagrams over scenes in the picture. As an example, a film tracing one company's history included scenes of past events. Each scene began with the date superimposed for a few seconds at the bottom of the frame by the A—B roll method.

An entertaining way to present statistical information is to print it over normal shots. Data on steel production, for example, may be appropriately exposed over a scene of pouring the molten metal. Or a rising sales graph may be animated over a view of the client's products moving along the assembly line.

"Zero cuts" are a specialized use of A—B rolls. Some labs have printers with instantaneous shutters to cut off the light, and thus can offer A—B cuts as well as dissolves. You may ask, "Why make cuts this way? Isn't it enough just to splice one shot to another?" Well, suppose you have only one take of an important scene you want to include in two separate color pictures. And imagine that different lengths of the scene are needed for each picture. Zero cutting is the answer. The scene is spliced into the A roll, full length. The shots before

Hal len
CORPORATION
MAKERS OF
SYNCHRONOUS
Magnetic
FILM
RECORDERS

Newest Addition

TO THE *Hallen* LINE OF MAGNETIC *Film* RECORDERS

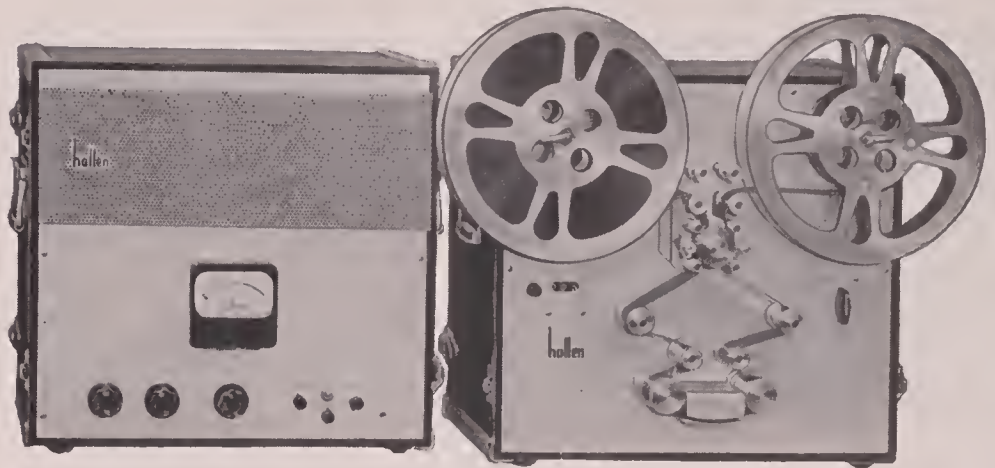

The recorder shown is 35mm using two flywheels, designed to facilitate conversion to multiple track, stereophonic, cinemascope etc.

The two case portable Model 235 magnetic film recording system is also available in both 35mm and 16mm single drum system. Literature available.

3503 WEST OLIVE AVENUE • BURBANK, CALIFORNIA
CABLE ADDRESS "HALLEN" • PHONE THORNWALL 8-6976

and after it are spliced into the B roll. Both cuts are formed by closing and opening the printer shutter at the right times.

In addition, zero cuts are favored by meticulous producers who object to any evidence of splices on the screen.

And now we come to—montages. Complex montages occasionally appear in color industrial films, and they reflect A—B printing developed to the highest degree. A sequence in a railroad film comes to mind. Here, views of the scenery along the right of way quickly dissolved from one shot to another, with the railroad's trademark continuously superimposed over it all. This footage employed A, B, and C rolls to produce three separate pictures on the screen at one time. Usually, there were two shots visible, trademark and scenery; but during dissolve, three scenes filled the screen.

A four-way run, or A, B, C, D, printing, takes place for even more involved effects. Naturally, the cost is greater for this work. Your lab may charge about 2c a foot per print for each extra run. To avoid having an entire picture charged for at this higher rate, a producer will set a special sequence on a different group of reels and order it printed separately. Later, the lab cuts these sequences into the regular prints.

By patronizing service laboratories and equipment rental agencies, the small producer is able to offer specialized and large-scale work when the occasion demands. Their assistance ranges from lettering and shooting titles to supplying cameraman, director, crew, and camera and sound equipment for whole sequences. Most of these companies also offer sound recording service and are able to exactly match their recording and release printing facilities.

Because they naturally desire to see their customers prospering, managers of service labs generally offer a good deal of friendly advice to newcomers who want it. They either are currently commercial producers themselves, or have been, and can therefore speak from experience. But when you take your printing to a straight film lab, your recording to a regular sound studio, etc., you're more on your own. The extra help from these latter concerns applies to just their specialties.

A few service companies offer "package rates" on sound recording. One is Telefilm in Hollywood, which, for \$212 a reel for black and white pictures, or \$220 for color, agrees to supply "recording, narrator, music over main and end titles, sound recording film, and developing." For \$125 more per reel, their complete music service adds "selection, cue-

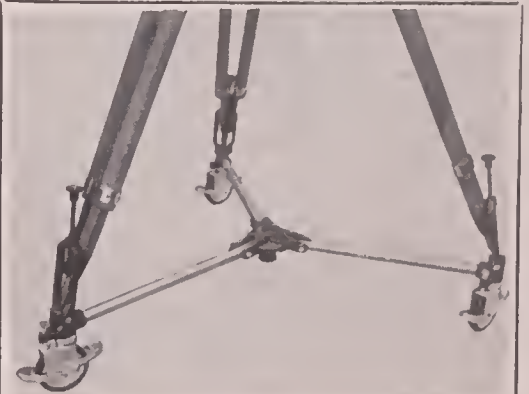

**CINEKAD
JUNIOR TRIPOD DOLLY**

This collapsible three-wheel tripod dolly is especially designed to meet the demand for convenient mobility of cameras on location or in the studio.

Dolly can be used with any professional or semi-pro tripod.

The tripod is fastened firmly to the dolly by a clamp on each leg tip.

The special individual coaster locking system makes it possible to lock either two or three wheels in a parallel position, enabling the dolly to track in a straight line for rolling dolly shots.

Dolly folds quickly into a single compact, easy-to-carry unit, 23 inches in length, weighing 14 lbs.

Write for Prices and Literature

CINEKAD

ENGINEERING COMPANY

(Formerly Kadish Engr. Co.)

500 WEST 52ND ST., NEW YORK 19, N.Y.
PLaza 7-3511

DESIGNERS AND MANUFACTURERS OF
MOTION PICTURES AND TV EQUIPMENT



1
2
3
4
5
5SS
6
6SS
7
8
8F
8P
9
9P
9F
10
12
12F
13

It's easy with the
MERCER FILM PATCH
Descriptive Chart & Price List
Mailed on Request

R. C. MERCER & COMPANY
4241 Normal Ave., Hollywood 29, Calif.
NOrmandy 3-9331

ADD 100% VALUE TO YOUR MOVIE CAMERA



As You Achieve Sensational New Picture Taking Success With These **EXTRA LENSES**

B&L F/3, 1 3/8 in. TELE-type Lens, focus Inf. standard screw thread for 8mm Camera. Triple magnification of normal lens.....\$24.50
Wray Semi-WIDE ANGLE F/3.5, 20mm fixed focus Lens, standard screw thread, for 16mm Camera. 20% MORE coverage than normal lens.....\$14.50
Schneider Xenon F/2, 50mm TELE-type Lens in Focus mt. (coated) standard screw thread for 16mm Camera. Double magnification of normal lens\$52.50

Fully GUARANTEED—15 Day Trial Offer. Write Mr. H. Hill for FREE Lens Catalog #154.

BURKE & JAMES, INC. 321 So. Wabash, Chicago 4.

It's Film Industries
for
PROCESSING PRO'S PREFER

Last month's installation of several Filmline negative-positive and reversal processors, plus new Bell & Howell printers and new German editing equipment, gives us a daily capacity of 300,000 feet of critical duplication and processing.

We are now the world's largest and finest-equipped mail order film laboratory. Send for free catalog covering 16mm laboratory services as well as DuPont bulk film.

FILM INDUSTRIES, INC.
Dept. A, P.O. Box 938 • Bridgeport, Conn.

ing, copyright clearance, and use of recordings from our library." For a small fraction of his total budget, the educational or industrial producer may have all his sound track problems taken care of. He only needs to supply the script, and service companies will help with writing it—for a fee.

But on the other hand, an enterprising film maker renting facilities on a per-hour rather than per-reel basis, buying his own recording stock, hiring a narrator, and arranging for the processing himself, could bring down the quoted figures to half or less. If he's able to do his own narrating, the saving is even more. Savings on licensed library music are possible when you make the selections yourself. In deciding between facilities, a producer should weigh the quality of the service lab's work against what he can reasonably expect of his own efforts. And it's wise to give a service lab the benefit of the doubt.

Having access to a good tape recorder can help you obtain the lowest sound costs. Only the good recording takes are sent to a sound service for straight transferring onto film.

Color pictures that will have a very large print order are sometimes duplicated onto Kodachrome printing masters. This is especially true of educational films, in which a slight loss in color quality is not so important. A master is an intermediate film used in release printing, allowing the valuable original to escape the rigors of repeated handling. Since they are correctly balanced for scene-to-scene brightness, and may already contain dissolves and other effects from A-B originals, labs will do release printing from them at their minimum prices.

Another valuable service available to film makers is the conditioning of prints against damage by scratching or abrasion, humidity, etc. Four protective services generally available are: the Peerless treatment, Vaporating, lacquering, and waxing.

Peerless and Vaporate are trade names for patented processes which many independent labs are equipped for. In both, film is placed in a vacuum tank and then film-protecting chemicals replace the atmosphere in the tank. They guard film against changes in humidity, and against scratches by their lubricating qualities. Wax is applied at some labs in a solvent which evaporates, leaving an even coating on the footage. Lacquering is the ideal, though most expensive, method of protecting original Kodachrome intended for projection.

Thus, with all the varied services available, the independent film producer lacks nothing to make his film technically a success. Indeed, what often pleasantly surprises many purchasing such

services for the first time is how much careful attention is given even the smallest order. Most laboratories, considerable of their reputations, are as eager to produce the best possible prints as the customer is to obtain them.

CAMERA MOTOR

(Continued from Page 563)

solved satisfactorily by the multiple-exposure method. We purchased a slow-speed standard Bodine gear-reduction motor and adapted it to our Bell & Howell model 70 16mm camera, as pictured above.

This motor readily fits the standard motor mounting bracket and hand crank sockets of the camera. The mounting bracket and universal drive arm were obtained directly from the Bell & Howell factory in Chicago and mounted on the motor by a local machine shop.

The gear ratio of the motor is such that it operated the 70 camera at an even speed of 1 frame per second, providing an effective exposure of slightly more than 1/2 second per frame. We thus increased the exposure potential of the camera 24 times.

After mounting the camera, we made tests which revealed that we could produce satisfactory pictures on Commercial Kodachrome using even ordinary incandescent room illumination.

Obviously, when shooting at a speed of 1 frame per second, there can be no action in the scene that would appear accelerated to a ridiculous degree on the screen. Since the film runs through the camera at only 11 1/2 feet per minute, from three to five minutes running time (camera) are necessary for the average scene.

With the Bodine motor in use, exposure is very even, frame to frame, and there is no flicker nor backlash as is so often evident when hand-cranking a camera at slow speeds.

Where scenes filmed in this way require some evidence of people, we have found the best method is to intercut closeups of individuals which have been filmed in the customary manner.

This ultra-slow-motion method can also be used advantageously in photographing some exterior scenes. The two photos shown at the top of page 563 show one instance in which the camera and motor described here were used to record the gradual raising of a glass-lined silo by means of mechanical jacks. In the first picture the author is shown behind the camera ready to begin the series of exposures.

The next photo (a composite still shot) shows the progressive raising of the silo—an operation which required several minutes, but screened for an interval of only five seconds.

Just below these photos of the filming operation are a closeup of the Bell & Howell 70 camera with the Bodine motor mounted thereon, and at right, a view of the unmounted motor showing the parts that had to be added to facilitate mounting on the camera. The motor, which is available in a number of drive ratios and voltages, readily converts a 16mm camera for time-lapse or low-level illumination photography with color film.

"PIXILATION"

(Continued from Page 568)

was an accomplished juggler. Taken at half speed with the actor walking at a comfortable pace instead of running, the effect presents no problems.

Objects have often been animated by single-frame methods for trick effects, of course, and several avant-garde producers have approached the idea of pixilation for a brief sequence or two. But the first film-maker to use pixilation and its allied techniques for a complete film was Norman McLaren of the National Film Board of Canada.

The film was *Neighbors*, and it became a celebrated award-winner at the Edinburgh Festival. Pixilation is so obviously suited to comedy that it is rather remarkable that this first experiment in the technique should be a dramatic and sometimes savage short concluding with a plea to "love thy neighbour."

Yet *Neighbors* gave more indications of the scope of pixilation than any light-hearted fantasy could have done. The absurd and extravagant movement offered by the technique is shown in the opening sequences, when two men sniff at a tiny flower and spin and glide around the garden with delight. Later, when they fight, their grimaces gradually become more and more distorted, until great blotches of color appear across the twisted faces.

So far only one amateur seems to have followed McLaren's lead. John Daborn, the 24-year-old British cine enthusiast whose cartoon, *History of Walton*, was acclaimed the best amateur film of the year at two European festivals, experimented with pixilation and produced *Two's Company*. This 16mm monochrome comedy was subsequently awarded a trophy as one of the ten best films of the year in a British competition, and is proving immensely popular with audiences during its current tour of Britain's cine clubs.

Daborn used a simple story—the rivalry of two men for the same girl—but his use of single-frame animation and stop motion has given the comedy a terrific pace. One man eyes the girl



Illuminate all important sets and stages
Lighting **STANDARD BEARERS** of Photography

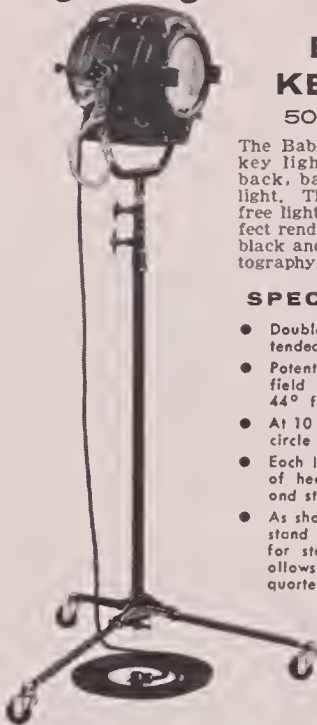

BABY KEG-LITE 500-750 Watt

The Baby Keg is ideal as a key light, modeling light, back, background, and fill light. The intense filament free light delivered gives perfect rendition of tone in either black and white or color photography.

SPECIFICATIONS

- Double riser stand can be extended from 4 ft. to 9 ft.
- Patented device focuses light field from a 4° spot to a 44° flood.
- At 10 feet on full flood, light circle is 9 ft.
- Each light equipped with 25' of heavy duty rubber cable and standard house plug.
- As shown below, structure of stand permits folding of legs for storage. Angular design allows clearance for close-quarter grouping.

\$81.00

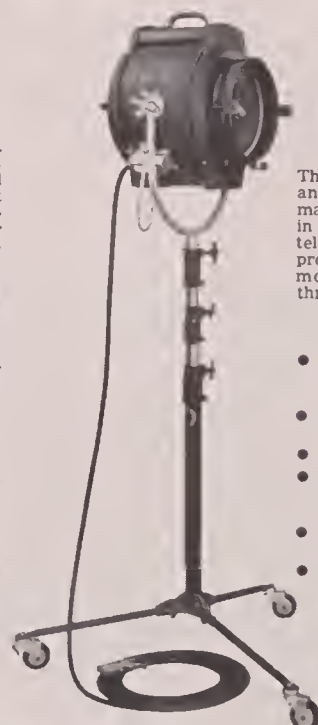

JUNIOR SPOT 1000-1200 Watt

The high intensity, even light field and ample coverage of this unit make it a superior light for use in all types of photographic or television work. Its popularity has proven its value among still and motion picture photographers throughout the world.

SPECIFICATIONS

- Half turn of focusing knob changes light from 4° spot to 44° flood.
- At 12 ft. on full flood, light circle is 10 ft. in diameter.
- Stand extends from 5 ft. to 9 ft.
- Supplied with 25 ft. No. 14 rubber cable with shock-proof stage plug.
- Folding legs on stand with 3" casters.
- Angular structure of stand legs permits close grouping.

\$178.60



Write for catalog "PAINT WITH LIGHT" describing our complete line and price list.

BARDWELL & McALISTER, INC. BURBANK, CALIFORNIA

SPECIALIZED TITLES and SPECIAL EFFECTS

Motion Picture or Television, 35mm-16mm, Black & White or Color

RAY MERCER & COMPANY

4241 Normal Ave., Hollywood 29, California

NOrmandy 3-9331

We Welcome
Your Problems

RAY MERCER, A.S.C.

30 Years Experience
at Your Service . . .



GEO. W. COLBURN LABORATORY INC.
 164 NORTH WACKER DRIVE • CHICAGO 6
 TELEPHONE STATE 2-7316

**8 and 16mm
 SERVICES**

16mm LABORATORY SERVICES

Controlled machine processing. Rapid service. In today—out tomorrow.

Reversal Processing—E.K. Super XX, Plus X, DuPont 931, 930, 914, 901, \$2.50 per 100'.

Negative Processing—\$2.50 per 100'.

Positive or Reversal Work Prints.....5c ft.
 B&W work prints from Kodachrome.....6c ft.
 Timed duplicotes B&W.....7c ft.
 Kodachrome copies.....12c ft.
 B&H printers. 15 yrs. exp. Write for circular.

ILLINOIS-WELLS FILM LAB.
 450 N. Wells St., Chicago 10, Ill.

Ready-Eddy

U. S. Registered Trademark
**USEFULNESS GUARANTEED
 FOR EVERY DAY USE**

1001 Ready Sound-Film
 Editing Data:
 • Footage • Frome
 Count • Screen Time
 • 35mm and 16mm
 equivalents.
 Plastic computer for
 everyone in movies
 and TV, from script to
 screen.

\$2.00 Prepaid
 (Delivered in U.S.A.)
 ASK FOR REPRINT OF ARTICLE
 IN AMERICAN CINEMATOGRAPHER.
 Write or ask your dealer
READY-EDDY, Sandy Hook, Conn.



Scheibe FILTERS
 In World-Wide Use

Produce moonlight and night effects
 in daytime • fog scenes • diffused focus
 and many other effects.

Information mailed on request.

SCHEIBE FILTERS COMPANY
 ORIGINATORS OF EFFECT FILTERS
 P.O. Box 46834, Hollywood 46, Calif.

USED IN EVERY
 HOLLYWOOD
 MOTION PICTURE
 PRODUCTION

on a park bench and glides across the grass until he is alongside. His rival leers from behind a tree-trunk, his eyes popping and hat spinning with excitement.

One man grabs at the other, who instantly disappears and re-appears behind him. During a chase round a tree, the pursued one appears in a series of absurd poses in the branches while his rival continues dashing round the trunk. Finally, an incredible fencing duel sends the two combatants scuttling across country at an impossible rate.

McLaren believes pixilation offers scope for a new genre of film ballet and mime; Daborn feels it is limited to fantastic comedy. But one thing is certain. The potentialities offered by the technique should be of fascinating interest to every amateur, for the scope of experiment in this field is practically unlimited.

560 PHOTOFLOODS

(Continued from Page 556)

director John De Cuir. The electrical production, art, drapery, grip, prop and paint departments all had a hand in readying it.

Because, for most of the shots, the camera would be facing the lighted backdrop, there was posed for director of photography Milton Krasner, ASC, a problem of balancing the overall set lighting to provide adequate illumination on the two groups of choristers. How well this was achieved is revealed in the photo at the right on page 556.

SPEED IN TV FILM PRODUCTION

(Continued from Page 561)

the master scene involved the direct recording of music, and there wasn't time for playbacks and matching of scenes.

The static effect inherent in a long take on a single lens, therefore, created a considerable problem.

The production crew licked it by resorting to live TV techniques, with dolly-ing in and out frequently to pre-determined positions. A great variety of special effects was obtained through the use of a 14-bank dimmer board.

The choir and other musical groups were well rehearsed before the shooting marathon, and re-takes were held down to almost zero. Teleprompters were used to help the vocalists through the long verses. To eliminate any possibility of eye movements during the frequent dolly shots, a stand unit was used in place of a camera mount.

Another problem was posed by the

background organ music which was used throughout each of the six films, and the necessity for bridging underscore dissolves without an expensive mixing session later. A solution was found in the use of chords of a common key to open and close all sequences, so that transitions would be virtually unnoticed despite necessary minor cuts.

All sound was recorded on 1/4-inch tape on a Rangertone-equipped Ampex. It was transferred to 17 1/2 mm magnetic tape on RCA equipment at Capital Film Laboratories, Inc. The 17 1/2 mm magnetic tape was used for editing before transfer to the 35mm optical track.

The choir and other vocal numbers were filmed during an 11-hour schedule on the first day. All choir numbers were photographed on the same basic set, but a variety of backgrounds was used for the other numbers.

Much time was saved by placing emphasis on variety within each of the six films, rather than giving any consideration to the group of films as a whole. As an example, Bob Daniels, the featured soloist, did two solos in each program. A different set-up, with special lighting effects, was necessary for each program. Once a set-up was lit for the first program, however, the same one was used to film sequences for the five following programs, with a considerable saving in production time. The same technique was used on mix-duets and quartets.

As a result of this device, although each program has a wide range of varying set-ups, total production was accomplished in a fraction of the time it would have taken had each program been staged and filmed as a unit.

Despite the pressure, Robert Nordbye, director of photography, placed great emphasis on lighting, and carefully avoided the washed-out, flat techniques common to live TV productions. Cukolorises were employed extensively for subdued background lighting effects. A dimmer-controlled obie light on the camera was used as a fill, and the usual deuces, 750's, 300's and single broads constituted the main battery of lights.

The second day's shooting was begun with playback of four solos, which Daniels previously had recorded at Sacred Records of Hollywood on hi-fidelity LP disks. These were transferred to 1/4-inch tape for the playback. The balance of the final day was devoted to scenes in which Mr. Uhrig appeared.

Introductions by the evangelist for each of the six films were shot in sequence, followed by the sermons and other scenes in which he appeared alone.

All of Mr. Uhrig's appearances were ad lib, to time cues. His sermons were filmed last, since the timing of each

Precision Built Combination Sound Readers



OPTICAL

Model 600.....16mm and 35mm
NET PRICE \$185.00



OPTICAL-MAGNETIC

Model 800.....16mm, 35mm & 1/4 inch
NET PRICE \$259.50



MAGNETIC

Model 700....16mm, 17.5mm, 35mm
and 1/4 inch
NET PRICE \$198.00

FEATURES: Simple threading . . . polished stabilizer drum with needle bearings, with a surface which cannot damage film . . . film rollers machined to conform with SMPTE standards, and equipped with oilless bearings . . . precision ground shafts . . . dimension 6x6x7 1/2 inches.

AMPLIFIER: 117 volt — 60 cycle — AC . . . power output — 4 watts . . . heavy duty Alnico V speaker . . . safety fused . . . prefocused socket . . . pilot light . . . 6 ft. heavy duty cord.

All Prices F. O. B. Factory, Brooklyn, New York

Write for Literature

PRECISION LABORATORIES

• 1139 UTICA AVENUE

• BROOKLYN 3, NEW YORK

program had to be exact—28 minutes and 30 seconds—and the “inspirational messages” of about 6 minutes each offered the best opportunity to make necessary compensations to bring each program out on time.

During the filming, every scene was played against the stopwatch. After all the sequences except sermons had been filmed, the time was added up and the required length of each sermon established. Mr. Uhrig then had to condense or expand his messages, which varied from just under five minutes to almost eight.

Although there were no lens changes in some of the sermon sequences for as long as five minutes, the tendency for such scenes to become static was overcome by having the minister move constantly about his “study” as he spoke extemporaneously. A 35mm lens provided a depth-of-field safety factor. About two minutes before the end of the sermon, the camera began a slow dolly-in—a cue to the minister to begin a transition from pulpit oratory to the intimacy of person-to-person contact. The sermons all closed on tight-closeups.

The series of six films was photographed with a total of only seven hours of overtime required. Careful planning made the marathon possible—but the exhausted Capital crew probably isn't looking for another like it for quite a spell.

C. ROSS

FOR

LIGHTING EQUIPMENT

Inkie and Arc Lamps including Required Accessories
Generators—Cables—Boards—Boxes

•
Raby Camera Crane—Dollies—Blimps—Geared Heads

•
GRIP EQUIPMENT

FOR LOCATION AND STUDIO

Parallels—Steps—Platform Ladders
Century Stands—Reflectors—Flags—Scrims

•
SOLE EASTERN MOLE-RICHARDSON CO. DISTRIBUTOR

RENTALS • SALES • SERVICE

•
CHARLES ROSS, Inc.

333 WEST 52nd STREET

NEW YORK 19, N.Y.

Circle 6-5470-1

HOLLYWOOD STUDIO PRODUCTION

Feature and television film productions for which members of the American Society of Cinematographers were engaged as Directors of Photography during the past month.

AMERICAN SOCIETY OF CINEMATOGRAPHERS

BOARD OF GOVERNORS—1954

ARTHUR MILLER, President
SOL HALPRIN, First Vice-President
JOSEPH RUTTENBERG, Second Vice-President
ALFRED GILKS, Third Vice-President
WALTER STRENCE, Treasurer
PHILIP TANNURA, Secretary
ROBERT DE GRASSE, Sergeant-At-Arms
JOHN ARNOLD
JOSEPH BIROC
ARTHUR EDISON
GEORGE FOLSEY
LEE GARMES
VICTOR MILNER
HAL MOHR
LEON SHAMROY

ALTERNATE BOARD MEMBERS

ARTHUR ARLING
LUCIEN BALLARD
DAN CLARK
PAUL EAGLER
FARCIOT EDOUARD
ERNEST LASZLO
ROBERT PITTACK
JOHN SEITZ
JAMES VAN TREES
PAUL VOGEL

ALLIED ARTISTS

ELLSWORTH FREDERICKS, "John Brown's Raider's."

HARRY NEUMANN, "High Society."

COLUMBIA

CHARLES LAWTON, "My Sister Eileen," Technicolor, CinemaScope.

BURNETT GUFFEY, "Tight Spot."

HENRY FREULICH, "The Monster Beneath The Sea."

CHARLES LANG, "The Man From Laramie," Wm. Goetz Prods. Technicolor: CinemaScope.

HENRY FREULICH, "Gun That won The West."

METRO-GOLDWYN-MAYER

ROBERT PLANCK, "Moonfleet," color, CinemaScope.

GEORGE FOLSEY, "Hit The Deck," CinemaScope, Eastman color.

PAUL C. VOGEL, "Interrupted Melody," color, CinemaScope.

HAROLD MARZARATI, "The Marauders," Wide-screen: color.

PAUL C. VOGEL, "The Scarlet Coat," Color: CinemaScope.

PARAMOUNT

ROBERT BURKS, "The Trouble With Harry," Technicolor, VistaVision.

LIONEL LINDON, "Lucy Gallant," Technicolor, VistaVision.

DANIEL FAPP, "You're Never Too Young," Technicolor: VistaVision.

LEE GARMES, "The Desperate Hours," VistaVision.

LOYAL GRIGGS, and WALLACE KELLEY, "The Ten Commandments," Technicolor; VistaVision.

REPUBLIC

JOHN L. RUSSELL, JR., "The Admiral Hoskins Story," wide-screen.

R.K.O.

RAY RENNAHAN, "Seven Bad Men," Technicolor; Superscope.

20TH CENTURY-FOX

JOE MACDONALD, "The Racers," color, CinemaScope.

LEO TOVER, "Untamed," Technicolor, CinemaScope.

CHARLES G. CLARKE, "Prince of Players," color, CinemaScope.

MILTON KRASNER, "The Seven Year Itch," color, CinemaScope.

HAROLD LIPSTEIN, "A Man Called Peter," color; CinemaScope.

UNIVERSAL-INTERNATIONAL

CARL GUTHRIE, "Lady Godiva of Coventry," Technicolor.

MAURY GERTSMAN, "To Hell and Back," Technicolor, CinemaScope.

RUSSELL METTY, "Justice Comes to Tomahawk."

WILLIAM DANIELS, "The Shrike."

IRVING GLASSBERG, "The Purple Mask," Technicolor; CinemaScope.

WARNER BROS.

ELLIS CARTER, "The River Changes," Warner Color, CinemaScope.

WINTON HOCH, "Mister Roberts," CinemaScope, WarnerColor.

HAROLD ROSSON, "Strange Lady In Town," WarnerColor, CinemaScope.

EDWIN DUPAR, "Target Zero."

J. PEVERELL MARLEY, "Jump Into Hell."

INDEPENDENT

ROBERT SURTEES, "Oklahoma," Eastman-color, Todd-AO, CinemaScope, R & H Pictures.

STANLEY CORTEZ, "Night Of The Hunter," Gregory Productions.

ERNEST LASZLO, "The Kentuckian," Hecht-Lancaster Prods., Technicolor, CinemaScope.

FRANK PLANER, "Not As a Stranger," Stanler Kramer Prods., Widescreen.

ALAN STENSVOID, "Air Strike," Cy Roth Prods.

TELEVISION

(The following directors of photography were active last month in photographing films for television in Hollywood, or were on contract to direct the photography of television films for the producers named.)

LUCIEN ANDRIOT, "Where Were You?," Ken Murray Productions; "It's a Great Life,"

Raydic Corp'n; "The Life of Riley," Hal Roach Studios.

JOSEPH BIROC, "Treasury Men in Action," American National Studios, Inc., and "Dear Phoebe," Dear Phoebe Productions.

WILLIAM BRADFORD, "Gene Autry," Flying A Productions.

NORBERT BRODINE, "The Loretta Young Show," Lewislors Ent.

EDWARD COLMAN, "Dragnet," Sherry TV Inc.

FLOYD CROSBY, "Authors Playhouse," Authors Playhouse Prods.

ROBERT DE GRASSE, "Make Room For Daddy," Marterto Prods., Inc., and "The Ray Bolger Show," B & R Ent.

GEORGE DISKANT, "Four Star Theatre," Four Star Productions, Inc.

E. B. DUPAR, "Tim McCoy Show," Mercury-Int'l Pictures.

HENRY FREULICH, "Captain Midnight," Screen Gems.

KARL FREUND, "I Love Lucy," "Willy" and "December Bride," Desilu Productions, Inc.

FREDERICK GATELY, "Mayor of the Town," Rawlins-Grant, Inc., and "Big Town," Gross-Krasne, Inc.

AL GILKS, "The Halls of Ivy," Television Programs of America, Inc.

SID HICKOX, "Holiday In Rhythm," Mercury Int'l Inc.

BEN KLINE, "Fireside Theatre," "An Argument With Death," Frank Wisbar Prods.

JACK MACKENZIE, "Public Defender," and "Passport To Danger," Hal Roach, Jr., Productions.

ERNEST W. MILLER, "Rocky Jones, Space Ranger," and "Stu Erwin Show," Roland Reed Productions.

VIRGIL MILLER, "You Bet Your Life," Filmcraft Prods.

HAL MOHR, "That's My Boy," McCadden Corp'n.

NICK MUSURACA, "The Lone Wolf," Gross-Krasne, Inc., and "Lineup," Desilu Prods., Inc.

KENNETH PEACH, "Here Comes Donald," O'Connor Prods.

ROBERT PITTACK, "The Lone Ranger," CM TV Productions, Inc.

JOHN L. RUSSELL, JR., "Joe Palooka," Guild Films.

WILLIAM SICKNER, "The Whistler," Lindsay Parsons Productions.

MACK STENGLER, "Liberace," "Life With Elizabeth," "Florian Zabach Show," "Frankie Laine Show," and the "Connie Haines Show," Guild Films.

HAROLD STINE, "Cavalcade of America," "This is Your Music," Jack Denove Prods., and "Corla Pandit," Snader Prods.

WALTER STRENCE, "Waterfront," Roland Reed Productions, and "My Little Margie," Roach, Jr.-Reed Productions.

PHILIP TANNURA, "Burns And Allen Show" and "The Jack Benny Show," McCadden Corp'n.

STUART THOMPSON, "Lassie," Robert Maxwell Associates.

JAMES VAN TREES, "I Married Joan," Joan Davis Enterprises and "Hey, Mulligan," Mickey Rooney Enterprises.

WANT TO SHOOT FOR TV NEWSREELS?

(Continued from Page 566)

returning from a medical convention in France. When Hodson found the ship's radio operator answering a S.O.S. from the Danish freighter *Greenville*, he lost no time in getting busy with his camera. When he went on deck he found many others ready with still and motion picture cameras, yet Dr. Hodson was not at all discouraged by possible competition. He knew how to shoot and market the material.

Strong winds, heavy sea and rolling deck made steady filming from the deck almost impossible. Looking for the best viewpoint, Dr. Hodson mounted the small platform by the funnel. Bracing the camera against himself and the funnel, he used the swing of his arms and head to try to compensate for the heaving deck.

"Because the *Greenville* was so far away, my first shot was through a three-inch telephoto to bring the stricken vessel closer," Dr. Hodson relates. "Then as the *Isle de France* circled closer, I changed to a one-inch lens to get the broad, general view of the scene. I used a wide-angle lens first and then other lenses to show the faces of the passengers of the *Isle de France* standing at

the rail with the sinking ship in the background. Through the entire day of rescue operations, I shot 200 feet of film—all I had with me—carefully metered out, scene by scene, to assure complete pictorial coverage of the entire rescue."

On arriving in New York, the purser told all 16mm camera owners who had filmed the rescue that the various newsreel companies were very anxious to get footage of the *Greenville* disaster. Dr. Hodson immediately got in touch with the agent of United Press Movietone News who made a commitment for his film.

At the request of U. P. Movietone editors, the rescue films were given emergency attention by the Eastman Kodak Laboratory in Flushing, New York. Within six hours black-and-white prints were on their way to television stations. Added to Dr. Hodson's substantial check from Movietone News was the pleasure of having friends tell him that they had seen his films on television.

Bert L. Coleman, Associate Editor of United Press Movietone News, is in an excellent position to advise amateurs who are hopeful of hitting the newsreels. Now employed as supervisor of

Advantage Never Before Offered!



SWIVEL BALL JOINT ATTACHMENT

for

PROFESSIONAL JUNIOR TRIPODS

Swivel Ball Joint Attachment can be mounted between head and tripod body in a few seconds and without any technical knowledge. Swivel Ball has enough tightening strength to hold the largest and heaviest movie cameras, permits leveling camera quickly when tripod is set up on uneven ground. Ball Attachment is made of lightweight aluminum, weighs approx. 3½ lbs.

Ten Day Money-Back Guarantee

Write for Catalog and Prices

CINEKAD

ENGINEERING COMPANY

(Formerly Kadish Engr. Co.)

500 West 52nd St., New York 19, N.Y.

PLaza 7-3511

DESIGNERS AND MANUFACTURERS OF
MOTION PICTURE—TV EQUIPMENT



frost lights the nation!

MOTION PICTURE STUDIO •
THEATRICAL • DISPLAY
RENTAL EQUIPMENT

WHEREVER YOU ARE—WHATEVER YOU NEED

... in the way of unusual, specialized lighting, call on Jack Frost! For movie-making, stage lighting, feature exhibits, large conventions ... for *any* location that requires exceptional lighting, Jack Frost is ready to serve you! And Jack Frost's unequalled national service includes complete installation and removal *wherever* you are. Rent all your specialized lighting equipment from Jack Frost ... famous for lighting the nation's greatest shows ... most spectacular displays.

FOR FULL INFORMATION ON
RENTAL EQUIPMENT
MAIL COUPON, OR CALL
DETROIT, TRinity 3-8030

JACK A. FROST, DEPT. J,
234 PIQUETTE AVE.
DETROIT 2, MICHIGAN

Please send me full information on
your rental service.

Name _____
Address _____
City _____ Zone _____ State _____

production, Coleman is a professional photographer and has been for many years a 16mm fan.

First of all, according to Coleman. *keep your camera with you all the time.* This makes it possible to be ready for the unexpected story when it breaks.

Second: be sure to keep supplied with black-and-white film, a reserve of at least 200 feet. Preferred for TV use is a blue base stock such as Dupont 930 or Eastman Plus X.

Third: Aim always for good, steady pictures. A tripod is the best guarantee of this.

Fourth: Shoot at 24 frames per second. Footage shot at 16 frames per second cannot be televised satisfactorily.

Fifth: If your camera is fitted with a turret or you otherwise have a range of lenses of varying focal lengths at your disposal, be sure to use them judiciously for wide-angle and telephoto shots. Where only one lens is available, change camera setup and angle frequently to give variety to your coverage.

Sixth: Avoid making pan shots unless absolutely necessary to follow the action. Run the film for a few feet before beginning a pan and keep it running for another few feet after the pan.

Seventh: Include inserts or cut-in shots of supporting material that helps to explain the main scenes. When filming a flood, for example, show closeups of the effect of the flood on people and animals.

Eighth: Plan the story sequence with great care as you go along. Steer a middle course between being stingy and wasteful with film. Remember that all your exposed film will cost time and money to process.

Ninth: make a written "dope sheet" describing each scene and listing all important people and places that will make it possible for the newsreel editors to narrate your scenes. When possible, send along a newspaper story of your subject if it is available.

Tenth: Get acquainted with your local United Press representative. He may help you locate stories and can give you much valuable advice. However, if your subject is an immediate and important one the Movietone editors suggest shooting first and asking questions afterward. After shooting the story, immediately contact the local newsreel office or write, telegraph or telephone United Press Movietone News, 460 W. 54th Street, New York.

Eleventh: In shipping news films, remember that speed is vitally important. Ship the undeveloped film by air express. Then telegraph shipping information to New York or wherever the film is sent. The telegram should include the following information: name of airline, waybill number of shipment, flight number and time of arrival.

For useable footage the TV newsreel companies pay regular rates on acceptance. Shipping and telegraph charges are refunded.

Anyone hoping to make regular sales to the TV newsreels should try to develop as much knowledge of pictorial news values as possible. Study newspaper and magazine headlines and the theatrical and TV newsreels to learn what subjects are most generally used and how they are handled. Go to your public library and seek out books on pictorial journalism to learn some of the shortcuts in finding and treating news subjects. Remember, you will learn to do by doing, by shooting news films and trying to improve on each subject that you handle.

In closing, let us review some of the qualities required of those who would seek success in free lance newsreel photography. First requirement, perhaps, is *accuracy*. Here the reliable news cameraman will be accurate in setting down data, facts and figures as an accompanying description of his submitted footage.

Speed is vital in getting any type of news before the people. Therefore, your newsfilm demands the fastest possible transportation to the buyer. This might entail a midnight automobile ride to the nearest postoffice or express office, but the resultant remuneration will be worth it.

The third most important quality perhaps is *reliability*. A free lance cameraman who can develop a nose for news and consistently produce quality footage will find a steadily expanding demand for his services, if not a permanent assignment on a newsreel staff.

Next to newspaper reporting, no other calling perhaps holds the thrills and excitement—the chance for the "scoop" or "newsbeat"—that is everpresent in newsreel filming.

DO-IT-YOURSELF

SOUND RECORDING

(Continued from Page 555)

dustries of Minneapolis, Minnesota, put its own personnel to work with a Bell & Howell 70-DA camera and a 202 projector to show farmers what scientific feeds and feeding can do for stock and poultry. The resulting color soundfilm, "Life With Doughboy," proved to be the hit of a series of Good Neighbor parties put on by the company and its feed dealers in Minnesota, Wisconsin and Iowa.

Filming of the production was done by John Whaley of the company staff. Most of the scenes were filmed inside the Doughboy feed mill and factory. A Minneapolis radio station organist re-

corded the background music and narration. The music was used largely for musical bridges where the action carries the story.

Most of the footage was shot with a THC 1-inch f/1.5 lens. Cameraman Whaley shot at 24 fps, except for an aerial view of the plant which was filmed at 48 fps to smooth out bumps and vibration.

After finishing his original film with sound track, Whaley made a duplicate magnetic film. Both 202 Filmosounds (one threaded with the soundtrack original, the other with a striped duplicate print) were placed in one room. Then the speaker from one and the microphone plugged into the other were led to an adjacent room to eliminate any projector noise. Whaley succeeded in starting both projectors simultaneously, and they stayed in sync throughout the 900 feet of film. To permit full use of the film anywhere, an optical sound print was made from the original, with very good results.

Mrs. Andrew Winton ("Dieky") Roth of Harrison, New York, has proved emphatically that an amateur single-handedly can produce a big-league color travelogue with little more than a knapsack of equipment plus a magnetic reorder-projector after shooting's done. Her enthusiasm for Norway's scenic quality and an avid yen to make 16mm color movies of professional quality got Mrs. Roth into the lecture film business before she knew it.

She spent five months traveling many thousand miles in Norway with two 16mm cameras and a tape recorder. Sound, except for narration, was recorded on the spot as scenes were filmed, thus providing unusual realism. She simply turned the recorder on and let it run while she was busy with her camera. Later, narration was dubbed in over this location recording to make a composite magnetic track which was applied to her finished film with the aid of a Filmosound 202.

Mrs. Roth's ingenuity enabled her to arrange and record a fairly complicated soundtrack with very little assistance. She devised a system of foot-pedal controls (shown in accompanying photo)—one for the Filmosound 202 record switch, another for the tape recorder motor. Her hands thus were free to operate the projector motor switch and the volume control.

Following the success of her first travel-lecture film, Mrs. Roth's accomplishment as a "one-woman" film producer received national acclaim in the press. Ambitious 16mm film makers are still writing her for her secrets of putting films together and recording sound for them entirely unaided except for the

(Continued on Page 586)

CLASSIFIED ADVERTISING

10c per word, minimum ad \$1.00. Words set in capital letters except 1st word and advertiser's name, 15c per word. Modified display format 90c per line. No discount on classified advertising. Send copy with remittance to editorial office, 1782 No. Orange Drive, Hollywood 28, Calif. Deadline 15th of month preceding date of issue.

STUDIO & PRODN. EQUIP.

SPECIALS FROM OUR \$250,000 STOCK
 300 Watt Neck SILVERED REFLECTOR SPOTS...\$.89
PRICE REDUCTION! Crab Dolly, moves every which way. New Stock..... 495.00
 35MM REWIND SETS, geared & dummy ends, good 6.95
 MAGNETIC SOUND READER for MOVIOLA SYNCHRONIZERS w/amplifier & speaker... 127.50
 B & H AUTOMATIC FOOT SPlicERS, 35mm \$595.00, combination 16/35mm..... 695.00
 CINE SPECIAL 16MM CAMERA with PAR 4 lens turret, 400' magazine and reflex finder; spring motor; 3 lenses w/objectives and case. \$2250 value..... 1195.00
 MOVIOLA 35MM UDS, separate Sound and Picture. Rebuilt 1250.00
 MAURER 16mm NEGATIVE/DIRECT POSITIVE Recording System. Rebuilt..... 2995.00
 NEW CINEFLEX 35MM REFLEX CAMERA, 2 mags, 3 lenses, 24V motor, case. \$1500 value 695.00
 MAURER 16mm CAMERA w/400' mag; sync-motor; viewfinder. Very clean 2295.00
 KINEVOX SYNCHRONOUS MAGNETIC RECORDER. Guaranteed 895.00
 GIANT METAL FILM CABINETS, hold 120 assorted 16mm reels, \$240 value. New..... 171.00
 EASTMAN AUTOMATIC FILM WAXER, \$1200 value. Rebuilt 795.00
 BRIDGAMATIC 16mm FILM DEVELOPER, Positive 1800', Negative 510' per hour. Reconditioned 1795.00
 EASTMAN AIRGRAPH FILM DEVELOPING MACHINES. Takes 100' 16mm or 50' 35mm film, fixes, washes and dries. Stainless steel tank and drum, drive motor, heater and blower. \$1800 originally, Gov't Surplus. New, \$295.00; Good used condition.... 225.00
REAL LOW PRICES ON 16MM REELS & CANS

	12 or less	12-49	50 up
200'	\$.72	\$.60	\$.54
400'	.78	.70	.64
800'	2.84	2.70	1.90
1200'	3.24	3.04	2.30
1600'	3.60	3.30	3.00
2000'	6.50	6.10	5.50

TRADES TAKEN. Phone PL 7-0440, Dept. fc. Cable: SOSOUND.
S.O.S. CINEMA SUPPLY CORPORATION
 602 W. 52nd Street, New York 19.

ANIMATION STAND including 16mm BELL & HOWELL 2709 CAMERA WITH SHIFT OVER FOCUSING, 3 Taylor Hobson lenses, 2 motors, 2 magazines, MITCHELL viewfinder and sunshade and Acme cell punch. Full specifications and photo of equipment available to prospective purchaser.....\$8,600.00
 BELL & HOWELL MODEL 70 SPECIALIST CAMERA WITH SHIFT OVER FOCUSING including 1-2-2-B-4 inch TAYLOR HOBSON matched lenses, three motors, three 400-foot magazines, case and viewfinder. Mechanically perfect.....\$2,000.00
 MAURER MODEL E 16mm Sound on Film Recording System, variable density complete including extra WESTERN ELECTRIC four channel mixing console and monitor amplifier.....\$6,000.00
 BELL & HOWELL MODEL 5692 Professional Splicer combination 16/35mm\$700.00
 2-BELL & HOWELL MODEL 140R Arc Projectors complete less speaker\$1,000.00 each.
PICTOSOUND PRODUCTIONS
 4010 Lindell Blvd., St. Louis 8, Missouri.

FOR SALE

BASS . . . is headquarters for Arriflex 16; the new Zoomar 16; Cine Specials, all models; Bell & Howell 70-DA; Bolex H-16. Used Cine Special I, 1" F:1.9 lens and carrying case \$395.00; Used H-16 Bolex, 1" F:1.5, 0.7" F:2.5 W.A., 3" F:3.5 \$347.50
 Used Bell & Howell 70-DA, 1" F:1.9, 4" F:4.5 \$235.00. Used Bell & Howell 70-A, 1" F:3.5 and case \$52.50; Used 200' Chamber Cine Special \$295.00; Used 100' Chamber, Cine Special \$117.50. Best buys . . . Best trades always. BASS CAMERA CO., Dept. AC, 179 W. Madison St., Chicago 2, Ill.

WE BUY, SELL AND RENT PROFESSIONAL AND 16mm. EQUIPMENT, NEW AND USED. WE ARE DISTRIBUTORS FOR ALL LEADING MANUFACTURERS. RUBY CAMERA EXCHANGE, 729 Seventh Ave., New York City. Established since 1910.

AUDIO AKELEY single system camera complete with Akeley sound head, Gyro tripod, 3 lenses, view finder, Maurer mixing amplifier. Complete with cables, power supply and W. E. microphone. CAMERA EQUIPMENT CO., 1600 Broadway, New York 19, N.Y. Cable Cinequip.

FOR SALE

35MM slightly used Aeroflex turret camera, magazine, motor, \$529. 50mm lens, \$55; wide angle, \$65. Extra magazines, \$39. Shoulderpod, \$13.75; new extra Tachometers, Waltham for Cineflex, Aeroflex, \$19.75; wild motors, \$36.50. 35mm precision sound film Edetola #67 series 6, like new, complete, original price \$4,765, with table, twin speakers, large screen, \$1,575. B-16 sound, silent, 1200' capacity table model printer, complete, slightly used, \$195. Cine-special chrome like new, F1.9 camera, \$425. Auricon synchronous motor for Cine special, \$119.50. New 400' double film magazines, 16mm for Bell & Howell, etc. cameras, \$79.50. House of Bargains. MOGULL'S, 112 W. 48th, New York.

FEARLESS dolly with track \$1600; PR22 RCA license free recorder only \$3000; 16mm Hallen recorder \$1000; one Moviola \$595; Western Electric distributor \$975; Mitchell combination matte box and sunshade \$150; Mitchell hi-hat \$10; Mitchell 24 volt DC wild motor \$490; Bell & Howell variable cine motor AC-DC \$395; MR mike boom \$450; Eastman film waxer \$600. BOX 1195, American Cinematographer.

WALL S. S. 35MM. SOUND CAMERA

COMPLETE with Galvanometer, amplifier, portable power supply, 40-50-75 and 100mm. lenses, erect image viewfinder, complete front attachments, two 1000 ft. magazines, Balanced Tripod, necessary carrying cases. Overhauled. Guaranteed perfect. Reasonable.

CAMERA EQUIPMENT COMPANY
 1600 Broadway New York 19, N. Y.

NEW 35mm sound-on-film recorders. With or without Galvanometers. Fearless blimp for Mitchell camera. 220 volt 3 phase Interlock motors and distributor. BLUE SEAL SOUND DEVICES, P.O. Box 100B, New Canaan, Conn.

ARRIFLEX 35mm, 3 lenses Astro (Berlin) 32mm F/2, 50mm F/1.8, 75mm F/1.8, 3 magazines, metalcase, \$580.00. R. BUGNO, 689 W. Ferry, Detroit 2, Michigan.

FOR IMMEDIATE SALE

LAB EQUIPMENT of the Color Corporation of America. Printers, Processing Eqt., Projectors, Editing Eqt., Cameras, etc. See ad on Page 557, HOUSTON FEARLESS CORP., 11801 W. Olympic Blvd., Los Angeles 64. BR 2-4331.

CINE SPECIAL II, 4-lens Par turret, 200-foot chamber, Meyer prof. viewfinder, 25mm F1.5 Schneider lens, value \$1800. Will sacrifice for immediate sale, \$900. Box 1191, AMERICAN CINEMATOGRAPHER.

ONE rackover Bell & Howell with Fearless movement, 3 lenses. Has cutout for Galvanometer with 12v loader and tachometer, excellent condition, \$2250.00. Box 1196, American Cinematographer.

MOTOR generator sets mounted on trailer 2400-4400 volts AC, 120-240 volts DC, 1200 amps—1800 amps. BOX 1197, American Cinematographer.

WANTED

IMMEDIATE CASH PAYMENT FOR CAMERAS AND EQUIPMENT

NEED EYEMOS (SINGLE LENS AND TURRET), MITCHELLS, ARRIFLEX, DE BRIES, B&H STANDARDS AND HI-SPEEDS, WALLS, AKELEYS, CINE SPECIALS, AURICONS, MAURERS, FILMOS. ALSO BALTARS, COOKES AND OTHER LENSES. SOUND STAGE, LABORATORY AND EDITING EQUIPMENT OF ALL TYPES REQUIRED. PLEASE SHIP INSURED OR FORWARD DESCRIPTIONS AIRMAIL. IMMEDIATE PAYMENT.

GORDON ENTERPRISES • 5362 N. Cohuengo
 NORTH HOLLYWOOD, CALIFORNIA

WE'RE ALWAYS IN THE MOOD FOR EQUIPMENT THAT IS GOOD

BUY — SELL — SWAP — CONSIGN

Cameras, Dollies, Lenses, Lights, Maviolas, Printers, Recorders, Studio or Laboratory Equipment

Western Union-WUX New York
 Phone PL 7-0440

S. O. S. CINEMA SUPPLY CORPORATION

Dept. fc 602 W. 52nd Street
 Cable: SOSOUND New York 19, N. Y.

WANTED TO BUY FOR CASH

CAMERAS AND ACCESSORIES

MITCHELL, B & H, EYEMO, DEBRIE, AKELEY ALSO

LABORATORY AND CUTTING ROOM EQUIPMENT

CAMERA EQUIPMENT COMPANY

1600 BROADWAY, NEW YORK CITY 19

CABLE: CINEQUIP

WANTED

PRODUCTION EQUIPMENT, LABORATORY EQUIPMENT, EDITING EQUIPMENT, 16mm. and 35mm. FROM SINGLE ITEMS TO COMPLETE STUDIOS. TRADES ACCEPTED.

THE CAMERA MART, INC.

1845 Broadway Circle 6-0930 New York 23, N.Y.

F & B PAYS MORE FOR USED 16/35MM EQUIPMENT

WRITE — WIRE — PHONE

FOR OUR CASH OFFER

FLORMAN & BABB MU. 2-2928
 70 W. 45TH ST. NEW YORK 36, N.Y.

WANTED

Mitchell — Akeley — B & H — Wall — Eyemo
 Cameras — Lenses — Equipment

NATIONAL CINE EQUIPMENT, INC.

209 West 48th St. New York, N.Y.

CAMERA & SOUND MEN

WANTED ASSIGNMENTS in Japan Production or Background Footage Contact. TOM MATSUMOTO, IATSE 665, #1 Hiroo-Cho, Azazu, Minato-Ku, Tokyo, Japan.

ASSIGNMENTS in Florida and Bahama Islands in 16mm news, special features, etc. Portable sound equipment, many years experience in color photography. TROPICAL FILMS, 291B Hillsboro Road, West Palm Beach, Florida.

COLOR SLIDES, PHOTOS & FILM

MARILYN MONROE—Third dimension in colors, 2 art nude poses and 3 more beautiful French models, also art nude poses in colors with 3-D viewer and mount to project, \$2.50 check or stamps. Shipped prepaid. PRODUCCIONES ARTISTICAS, Constantinopla, 6-6, Mexico City, Mexico.

(Continued on Next Page)

To Classified Advertisers

Copy deadline for classified advertising is the 15th of month preceding publication date. Mail copy and remittance to cover cost to

AMERICAN CINEMATOGRAPHER

1782 No. Orange Dr.

Hollywood 28, Calif.

Classified Ads

(Continued from Preceding Page)

PRODUCTION SERVICE

TECHNICAL, scientific, high speed and macro motion picture photography at low budget for production companies, industry, etc. All motion picture services. GOLDEN KEY PRODUCTIONS, INC., 1921 Hillhurst Ave., Hollywood 27, NORMANDY 3-9421.

LABORATORY & SOUND

SOUND RECORDING at a reasonable cost. High Fidelity 16 or 35. Quality guaranteed. Complete studio and laboratory services. Color printing and lacquer coating. ESCAR MOTION PICTURE SERVICE, INC., 7315 Carnegie Avenue, Cleveland 3, Ohio. Phone Endicott 1-2707.

LOWER cost 16mm editing and sound recording—only 22 miles from Hollywood. EL RANCHO AUDIO, 26236 Fairview Avenue, Lomita, California. Davenport 6-4925.

KODACHROME duplicates: 16mm 10c per foot, mail orders accepted, satisfaction guaranteed. COLOR-VISION FILMS, 122 N. Maclay Ave., San Fernando, California.

POSITIONS AVAILABLE

RESPONSIBLE person with background to manage both motion picture production and laboratory in growing southwest concern. Bright future for the right person. Reply Box 1194, % AMERICAN CINEMATOGRAPHER.

STATEMENT REQUIRED BY THE ACT OF AUGUST 24, 1912, AS AMENDED BY THE ACTS OF MARCH 3, 1933, AND JULY 2, 1946 (Title 39, United States Code, Section 233) SHOWING THE OWNERSHIP, MANAGEMENT, AND CIRCULATION OF AMERICAN CINEMATOGRAPHER, published monthly at Los Angeles, California, for October 1, 1954.

1. The names and addresses of the publisher, editor, managing editor, and business managers are: Publisher, A.S.C. Agency, Inc., 1782 N. Orange Drive, Hollywood 28, Calif.; Editor, Arthur E. Gavin, 1782 N. Orange Drive, Hollywood 28, Calif.; Managing Editor, Arthur E. Gavin, 1782 N. Orange Drive, Hollywood 28, Calif.

2. The owner is: (If owned by a corporation, its name and address must be stated and also immediately thereunder the names and addresses of stockholders owning or holding 1 percent or more of total amount of stock. If not owned by a corporation, the names and addresses of the individual owners must be given. If owned by a partnership or other unincorporated firm, its name and address, as well as that of each individual member, must be given.) A.S.C. Agency, Inc., 1782 N. Orange Dr., Hollywood, Calif., wholly owned by the American Society of Cinematographers, Inc., a non-profit corporation whose address is 1782 N. Orange Dr., Hollywood, Calif. Officers of the American Society of Cinematographers, Inc., are: President, Arthur Miller, 1782 N. Orange Dr., Hollywood, Calif.; 1st Vice-President, Sol Halprin, 1782 N. Orange Dr., Hollywood, Calif.; 2nd Vice-President, Joseph Ruttenberg, 1782 N. Orange Dr., Hollywood, Calif.; 3rd Vice-President, Alfred Gilks, 1782 N. Orange Dr., Hollywood, Calif.; Treasurer, Walter Strenge, 1782 N. Orange Dr., Hollywood, Calif.; Secretary, Philip Tannura, 1782 N. Orange Dr., Hollywood, Calif.; Sergeant-At-Arms, Robert de Grasse, 1782 N. Orange Dr., Hollywood, Calif.

3. The known bondholders, mortgagees, and other security holders owning or holding 1 percent or more of total amount of bonds, mortgages, or other securities are: (If there are none, so state.) None.

4. Paragraphs 2 and 3 include, in cases where the stockholder or security holder appears upon the books of the company as trustee or in any other fiduciary relation, the name of the person or corporation for whom such trustee is acting; also the statements in the two paragraphs show the affiant's full knowledge and belief as to the circumstances and conditions under which stockholders and security holders who do not appear upon the books of the company as trustees, hold stock and securities in a capacity other than that of a bona fide owner.

5. The average number of copies of each issue of this publication sold or distributed, through the mails or otherwise, to paid subscribers during the 12 months preceding the date shown above was: (This information is required from daily, weekly, semiweekly, and triweekly newspapers only.)

ARTHUR E. GAVIN,
Editor.

Sworn to and subscribed before me this 30th day of September, 1954.

(Seal) G. Bargerstock,
Notary Public.

(My commission expires July 31, 1957).

DO-IT-YOURSELF SOUND RECORDING

(Continued from Page 584)

well-chosen array of equipment which cuts corners in her work.

The world's Christmas tree king, Roy Halvorsen of Minnesota, has employed the Bell & Howell magnetic recorder-projector in turning out his own personally-produced films that tell the story of Halvorsen Trees. Halvorsen's forestry operations are highly scientific. With 11,000 acres of his own and many thousands more under lease, he cooperates with rangers in prevention of forest fires, and avidly follows a reforestation program that insures perpetual coverage of his acreage in trees.

Besides his movie equipment, Halvorsen owns a Navion plane. He and daughter June are accomplished pilots, and besides, June also assists her dad at the mixer panel when there's sound recording to do.

Recently Halvorsen shot 4500 feet of Commercial Kodachrome for a promotional film on his operations. The film was edited, then soundstriped. In Halvorsen's "studio" are two soundproof rooms—one for the mike and the other for the Filmosound 202 and other sound recording equipment. What emerged from the father-daughter sound recording sessions was an expertly-narrated film that pictured Halvorsen Christmas trees in progressive stages

from forest to gift-package merchandise.

To administer and publicize the state of Michigan's natural resources to best advantage, the department of conservation enlisted the aid of sound motion pictures as far back as 1937. Today, the department has more than thirty 16mm sound projectors regularly screening its films. Recently, it added a Filmosound 202, and this led Clarence J. Tinker, of the department's motion picture section, to produce its first sound and color film.

Thus far, says Mr. Tinker, the conservation department is using the 202 and magnetic film largely as a flexible and inexpensive procedure in producing optical prints for statewide release.

These are but a few examples of how use of recording-projectors, such as the Filmosound 202, is putting new emphasis on the do-it-yourself type of 16mm production as a means of informing, selling, teaching and training. Not only are many audio-visual-minded business and industrial firms thus able to turn out more and less-costly films for these purposes, but more and more 16mm movie makers are employing soundstripping and recording-projectors to give their films, old and new, real professional class.

A.S.C. FETES CHARLES ROSHER

(Continued from Page 538)

car" which Rosher received for this fine black-and-white photographic job was his first.

Rosher told the gathering he was approaching his 70th birthday, had been in cinematography for 45 years. He lauded Cecil B. De Mille for having given him the greatest encouragement in his early days as a Hollywood cameraman and said De Mille was the first director to permit him to use a spot light. By the time color motion picture film had been perfected, Rosher already had begun to think of retirement; but color movies renewed his interest in cinematography and delayed his thoughts of giving up Hollywood and his colorful career.

And it has been colorful, indeed. Helping to found the A.S.C. was but the beginning of Rosher's dedicated aim to help his fellow craftsmen and lift up the cinematographic art to the highest pinnacle of perfection. He has been an officer or a member of the Board of Directors of the A.S.C. almost continuously from its inception.

Few of his close associates believe that Charles Rosher is really retiring. Not that they doubt his intentions. It's just that there's too much celluloid in his system to permit him to rest long before yearning to be back again behind a camera. So it's likely that after a brief visit to his Jamaica estate, he'll likely be back in Hollywood plotting the photography of another MGM feature. For his old and dear friend, George Sidney, of course.

Believing that a picture is worth a thousand words and a movie at least a million, Bell & Howell Co. sends along with each of its magnetic recording projectors, a short sound movie on how to operate the unit. The purchaser watches the movie and listens to the sound track, which tells him how to flip the right switches to record his own voice magnetically on the same film. The recording is made on a magnetic track next to the optical track.

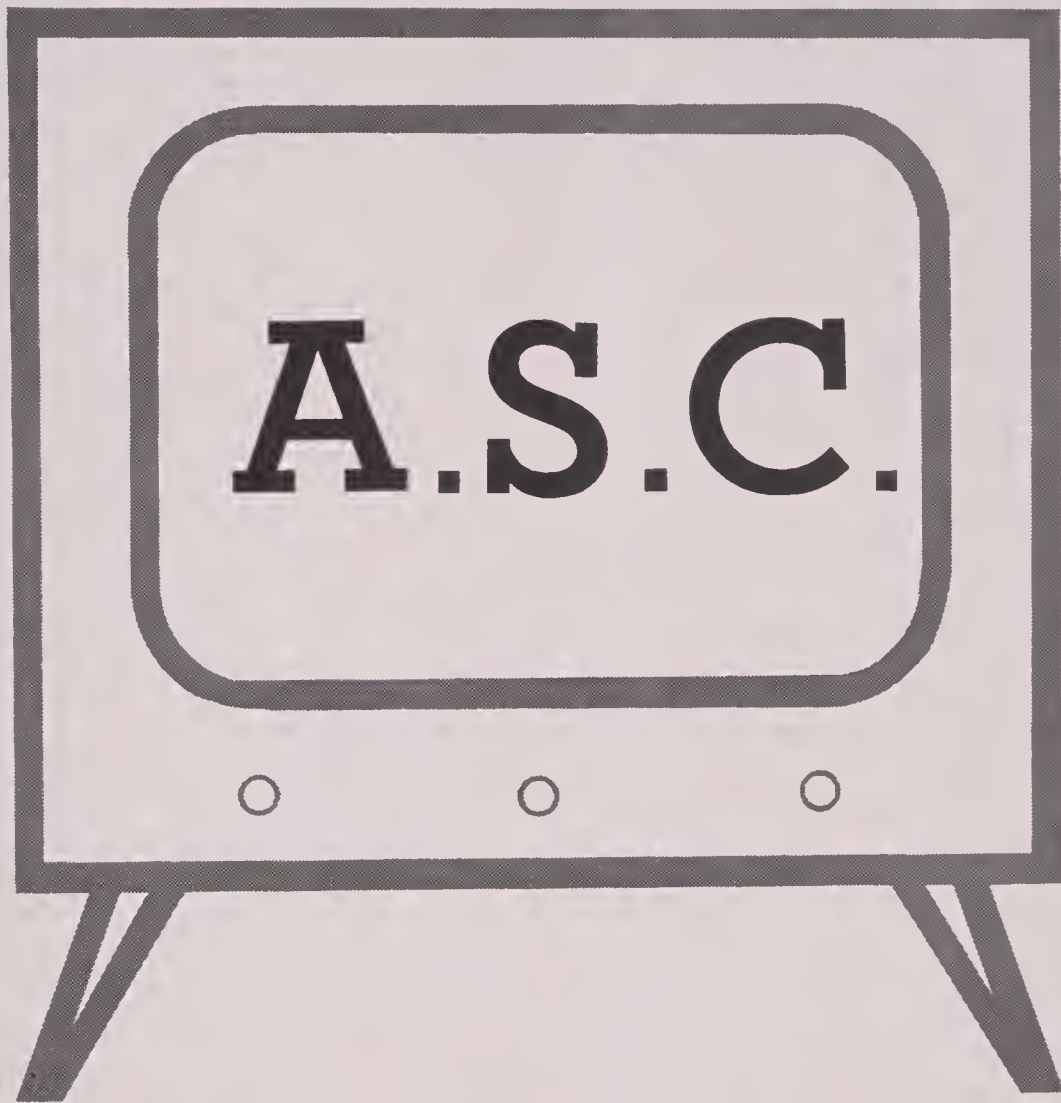

In Television, too...

Good cinematography has contributed as much to the advancement of television as any other factor. Today, the bulk of the important TV programming is on film, with more to come. For this reason discriminating producers of TV films choose members of the American Society of Cinematographers to direct the photography of their pictures . . . More and more, you see "ASC" after the names of the cinematographers who shoot the industry's best television films.



A.S.C.

Hallmark
of Superior
Cinematography . . .

you've been waiting for

bold, clear, alive!

"Life-like color," the ultimate in the reproduction of color film, is now available to all producers of 16mm motion pictures. Now you can have your exposed film duplicated with perfect blending and balancing of tones. Your release prints will have a sensitive living quality...surpassing anything you have ever seen in clarity.

This is "Life-Like Color," the result of fifteen years of exhaustive research by the country's outstanding color engineers and technicians. It is now available to you exclusively through the laboratories of Telefilm Studios.

With "Life-Like Color," Telefilm Studios again contributes to its primary objective...to help the 16mm producer make better motion pictures. Telefilm's modern facilities and equipment for color printing...high fidelity sound recording (your choice of optical or electronic sound printing)... editing...titling...special effects...and the skill and the know-how of the finest technicians in the industry are at your command.

for complete information, visit Telefilm Studios, or write for a descriptive brochure.

TELEFILM STUDIOS INC.

estab. 1938

telephone HOLLYWOOD 9-7205

6039 HOLLYWOOD BLVD. • HOLLYWOOD, CALIF.

Henri Toulouse-Lautrec,
pioneer of commercial color



Pen

Cinematographer

THE MAGAZINE OF MOTION PICTURE PHOTOGRAPHY



ONE COPY SENT TO L.C. 17

This Issue ...

- So You Want To Photograph Birds!
- Radio Communication In Film Production
- Photographing "Carmen Jones" In CinemaScope

25c
\$3.00 YEARLY



HOW TO GET A HEAD IN MOTION PICTURES

Selection of the proper camera head is important for smooth television and motion picture production. With the many types of heads available, it is often a problem to know which one will best serve the purpose.

Shown here are the various types of camera heads made by Houston Fear-

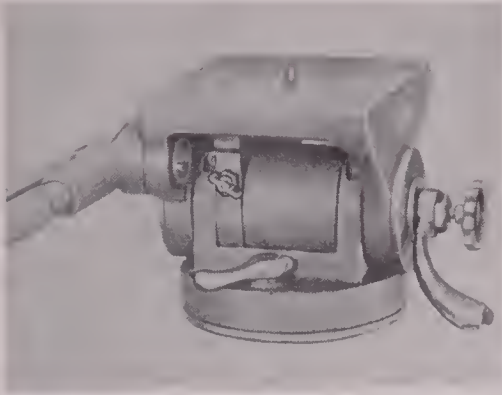

FRICTION HEAD. The most practical head for monochrome TV cameras and motion picture cameras weighing between 80 and 150 lbs. Provides smooth, easy panning and tilting. Pans full 360°. Tilts 45° up and 45° down. Adjustable drag and brakes provided on both actions. Camera is accurately counterbalanced. Adjustable to compensate for extra lenses, etc.



TILT HEAD. For fixed-position TV cameras or microwave parabolas. Friction-type action, but without drag adjustment. Camera or parabola may easily be positioned and locked in place. Calibration scales on both azimuth and tilt allow for quick re-setting of fixed points.

less. Each has been designed to fill a specific need. Each has its particular characteristics, features and advantages. The proper choice can be determined by the type, size and weight of the camera to be mounted, the camera accessories to be attached, and the types of shows on which it will be used.

Working closely with the motion picture and television industries over a period of many years, Houston Fearless has engineered this equipment for maximum ease of operation, smooth performance and complete dependability. Exhaustive tests have proved the metals and other materials best suited for the purpose. Precision workmanship assures years of satisfactory service.

Before deciding on a camera head, camera mount, or film processing equipment, consult your Houston Fearless representative. He will be pleased to analyze your requirements



MONOCHROME CRADLE HEAD. Remarkable smoothness and ease of operation for black and white TV cameras are made possible by the perfect balance of the monochrome cradle head. The camera rotates around a constant center of gravity, always in absolute balance. Tilts down 38° and up 30° on ball bearing rollers. Tilt drag is adjustable. In panning, also rides on ball bearings. Brakes on both pan and tilt.

and recommend the equipment that will serve you best. Write or phone: Houston Fearless, 11801 W. Olympic Blvd., Los Angeles 64, Calif., BRadshaw 2-4331. 620 Fifth Ave., New York 20, N. Y., Circle 7-2976.



GEARED HEAD. Provides exceptionally smooth, constant-speed panning and tilting for television and 35mm motion picture cameras. Two geared speeds on both the pan and tilt. Gearing can be quickly disengaged so unit operates as a free head. In tilting, the head rotates camera about its center of gravity, maintaining absolute balance at all times. Full 360° panning is smooth and steady.



REMOTE CONTROL HEAD. Makes possible the operation of a TV camera from a remote point several hundred feet away. Panning, tilting, focusing and lens changing are accomplished with small electric motors operated from a portable control panel. Operation is smooth and steady. Speed is variable. Camera can be mounted in extremely high or low positions on stage, in auditoriums, stadiums, on rooftops and other inaccessible places.



COLOR CRADLE HEAD. Specifically designed for RCA color television cameras. Action is similar to monochrome cradle head. On both models, camera, with all accessories attached, can be balanced perfectly when mounted on the head simply by moving the top plate on the head forward or back with a lead screw. Adapted to fit all recommended tripods, pedestals or dollies.

DEC 17 1954

B 509741

THE WORLD'S MOST COMPLETE ASSORTMENT
OF PHOTOGRAPHIC EQUIPMENT FOR

T. V. and Motion Picture Studios



New **PROFESSIONAL JUNIOR**

Adjustable wood **BABY TRIPOD**

—for Prof. Jr. friction

and geared heads

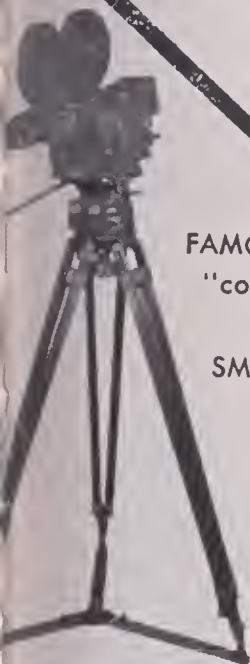

FAMOUS

"controlled
action"

SMALL GYRO
TRIPOD

Two speeds—slow and fast
—for both panning and tilting.
Helps you capture fine scenic views
and fast-moving sports events. Espe-
cially recommended for 16mm Mitchell,
16mm Murer, B & H Eyemo
and similar cameras.

\$600



Has substantial shoe and spur.

Measures from floor to flange

25" extended —17"

collapsed. **\$75**

PACKAGED LIGHTING WITH

COLOR-TRAN

—studio lighting in a suitcase

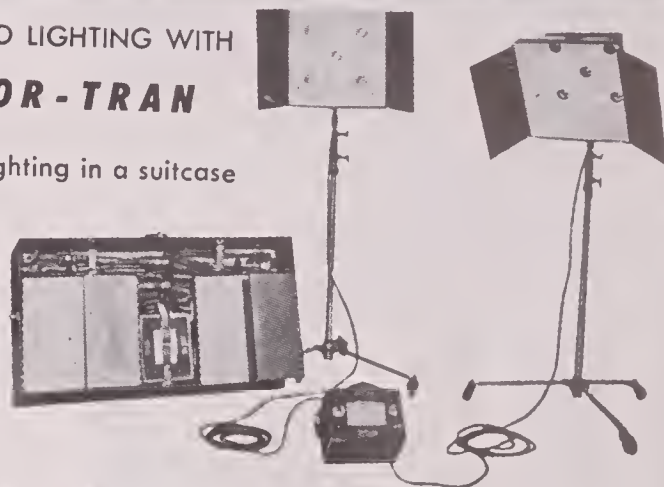

Imagine being able to use two 5000 watt units
on a 30 amp. fuse — COLOR-TRAN will do it!
Kit contains 2 light heads, 2 Superior stands and
proper size COLOR-TRAN converter to match.
Packed in compact case.

Senior Kit
\$237.50

Other style
kits available.

Write for *COLOR-TRAN* Catalogue.

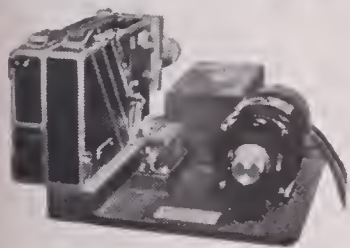

STOP MOTION MOTOR
FOR CINE KODAK SPECIAL

Runs forward or reverse, 110
AC synchronous motor with frame
counter. May be run continuously
or for single frames. Camera
mounts without special tools.

\$550

Also available — Stop Motion
Motors for 16mm—35mm B & H,
Mitchell and other professional
cameras.



ELECTRIC
FOOTAGE TIMER

Dual model for both 16mm
and 35mm. Large white num-
erals on black background. Accu-
rate reset dial. Switch controlled
by operator, who selects either
16mm operating at 36 feet per
minute—or 35mm operating at
90 feet per minute . . . or both
in synchronization. **\$95**

Single model, either 16mm or
35mm **\$45**

presto-splicer

GIVES PERMANENT SPLICE
IN **10 SECONDS!**

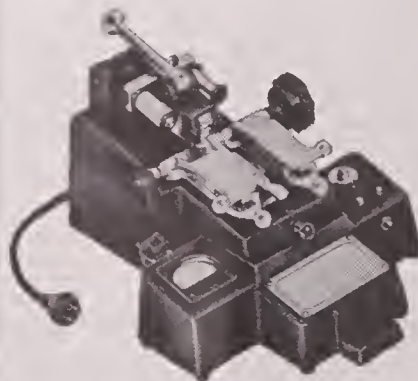

Especially good for splicing magnetic
film. Butt Weld type for non-perforated
or perforated film. 16mm, 35mm or
70mm. **\$547.80**

16mm or 35mm models—
for perforated film.

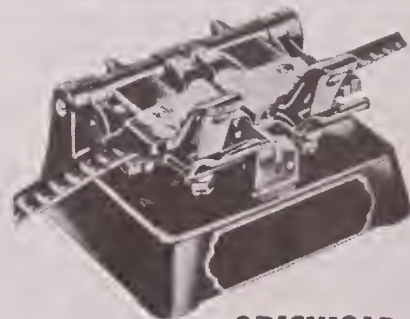

GRISWOLD
HOT FILM SPLICER

Model R-2 for 35mm silent and sound
film. Precision construction makes it easy
to get a clean, square splice with accu-
rate hole spacing. Nothing to get out of
order. **\$65**

Also Bell & Howell 8mm, 16mm and
35mm Hot Splicers and B & H Labora-
tory model Foot Splicer.

9.5mm Lenses in 16mm C mount. 18.5mm (extreme wide angle-flat field)
lenses available in mounts for all 35 mm Motion Picture Cameras.
PHOTO RESEARCH Color Temperature Meters. *Electric Footage Timers
Neumade and Hollywood Film Company cutting room equipment.
*Griswold & B.&H. Hot Splicers. *DOLLIES—Bardwell-McAlister, Mole
Richardson, Century and Colortran Lighting Equipment.

Complete line of 16mm and 35mm Cameras

FRANK C. ZUCKER
CAMERA EQUIPMENT CO.
1600 BROADWAY NEW YORK CITY

**YOUR FILM
GOES THROUGH
EXPERIENCED
HANDS**

**CONSOLIDATED
FILM INDUSTRIES**
Hollywood's only complete film lab

**35 MM
16 MM
B & W
EASTMAN
COLOR**

959 SEWARD ST., HOLLYWOOD 38, CALIF. • HOLLYWOOD 9-1441
1740 BROADWAY, NEW YORK 19, NEW YORK • JUDSDN 6-1700

AMERICAN

Cinematographer

THE MAGAZINE OF MOTION PICTURE PHOTOGRAPHY
PUBLICATION OF THE AMERICAN SOCIETY OF CINEMATOGRAPHERS

ARTHUR E. GAVIN, *Editor*

MARION HUTCHINS, *Editorial Assistant*

EMERY HUSE, *Technical Editor*

EDITORIAL ADVISORY BOARD: John Arnold, Arthur Edeson, Lee Garmes, Charles Rosher, Leon Shamroy, Fred Gage, Glenn R. Kershner

Editorial and Business Office: 1782 N. Orange Dr., Hollywood 28, Calif.

Telephone: HOLLYWOOD 7-2135

VOL. 35

DECEMBER • 1954

NO. 12

In This Issue

ARTICLES

RADIO COMMUNICATION IN FILM PRODUCTION—By Leigh Allen	609
'CARMEN JONES'—CINEMA SCOPE PHOTOGRAPHY AT ITS BEST—By Arthur Rowan	610
BIG-SCALE UNIVERSITY FILM PRODUCTION	612
BIRDS OF A FEATHER—By Harris B. Tuttle and Glenn B. Matthews	614
SHOOTING A TV FILM SERIES IN 16MM—By Dudley M. Whittelsey	617
DOLLARS AND SENSE OF BUSINESS FILMS	622

AMATEUR CINEMATOGRAPHY

MODELS AND MINIATURES—By Harold Benson	618
SO YOU WANT TO PHOTOGRAPH BIRDS!—By Herbert D. Shumway	620

FEATURES

HOLLYWOOD BULLETIN BOARD	594
WHAT'S NEW IN EQUIPMENT, ACCESSORIES, SERVICES	598
INDUSTRY NEWS	606
HOLLYWOOD STUDIO PRODUCTION	634
ANNUAL INDEX TO AMERICAN CINEMATOGRAPHER	641

ON THE COVER

SID HICKOX, A.S.C., and his camera crew photograph a closeup with the CinemaScope camera for the Warner Brothers color production, "Battle Cry," starring Van Heflin, Aldo Ray, Mona Freeman and Nancy Olson.

AMERICAN CINEMATOGRAPHER, established 1920, is published monthly by the A. S. C. Agency, Inc., 1782 N. Orange Dr., Hollywood 28, Calif. Entered as second class matter Nov. 18, 1937, at the postoffice at Los Angeles, Calif., under act of March 3, 1879. SUBSCRIPTIONS: United States and Canada, \$3.00 per year; Foreign, including Pan-American Union, \$4.00 per year. Single copies, 25 cents; back numbers, 30 cents; foreign single copies, 35 cents; back numbers 40 cents. Advertising rates on application. Copyright 1954 by A. S. C. Agency, Inc.

IMPORTANT ANNOUNCEMENT

re: the *Mitchell*
16mm Professional Camera

IMMEDIATE SHIPMENTS

are currently
being made



...with this announcement
the Mitchell
Camera Corporation,
for the first time
in history,
now offers you
shipment of the
famed Mitchell 16mm
Professional Camera
on receipt
of your order.

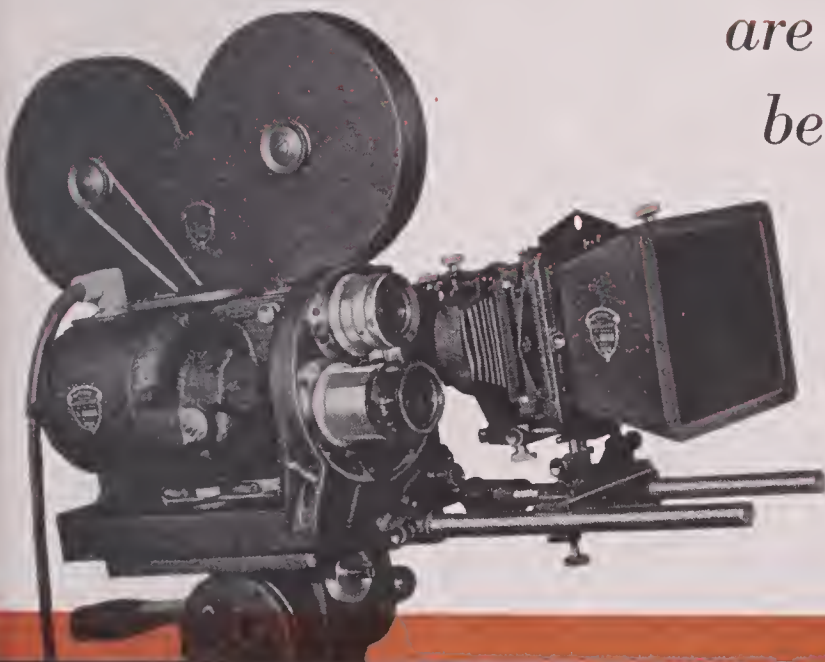

THE CAMERA WITH A HERITAGE

There is no substitute for a heritage of GREAT ENGINEERING. No 16mm motion picture camera made anywhere in the world can match the technical perfection which a Mitchell 16 brings to your film. Each 16mm camera has the same supreme custom workmanship and Mitchell's exclusive, positive operation that is today world-famous ... wherever truly professional films are made.

Mitchell Camera CORPORATION

666 West Harvard Street • Glendale 4, Calif. • Cable Address: "MITCAMCO"



85% of the professional motion pictures shown throughout the world are filmed with a Mitchell

Hollywood Bulletin Board



LEN ROOS (2nd from left), president of Kinevox, Inc., and Richard T. Silberman, president of Kay Lab, demonstrate for members of the ASC the new Kinevox-Kay Lab electronic viewfinder for motion picture cameras. Others (from L. to R.) are: John Arnold, Joe Biroc, Art Arling, Sam DeGrasse, John Day and Hal Helms.



ALSO demonstrated for first time before members of the ASC at the Society's November meeting was the new method for splicing motion picture film developed by DuPont. Making splice is DuPont's Bill Holm. Watching demonstration (from L. to R.) are Harold Wellman, Paul Eagler, and Edward Colman.

An electronic viewfinder for motion picture cameras was demonstrated before members of the A.S.C. at the Society's November meeting by Len Roos, ASC, president of Kinevox, Inc., whose company engineered the finder in association with the Kay Lab of San Diego, Calif.

Virtually a miniature TV camera, the finder mounts on regular Mitchell finder bracket, replacing the optical finder. The pickup, which is in parallax with the camera lens, is viewed on separate monitors.

★

RKO-Pathé studios, later in the month, also demonstrated its version of an electronic finder for studio cameras. This method combines the Dumont Teleye, a miniature television camera, with a standard 35mm Mitchell film camera. The image is then viewed from adjoining monitors.

★

Russell T. Ervin, cameraman for Grantland Rice "Sportlight" films, has been admitted to membership in the American Society of Cinematographers.

★

Back from Italy is Harry Stradling, ASC, who has been shooting "Helen of Troy" in and near Rome for Warner

Brothers. One of the industry's biggest productions to date, more than 200 persons were injured and 3 reportedly killed during the filming.

★

Arthur Lloyd, ASC, veteran director of photography who photographed many of the old Harold Lloyd, Snub Pollard and Our Gang Comedies, and who has been retired from active cinematography for several years, passed away unexpectedly last month. Lloyd also had served in World War II as Captain in the Signal Corps.

★

Wilton Holm, ASC, DuPont photo products representative, demonstrated a new method of film splicing before members of the A.S.C. at the Society's November meeting. The splicing operation involves a radically new type splicer, developed by Du Pont, which uses thin transparent tape, gummed on one side and perforated to match standard film perforations, in making splices. Splicer is especially adaptable to lab and process department uses.

★

Karl Struss, ASC, returned to Hollywood last month after an absence of two years. He had been in Italy where he directed the photography of seven feature films—

two of them in 3-D and all in Ferrania Color. A rabid stereo fan, Struss shot over 3500 3-D slides in color while there. It was Struss' first trip to Italy since he photographed MGM's "Ben Hur" there about 30 years ago.

★

J. Burgi Contner, ASC, reports that as of November 1st, he directed the photography of 39 "Janet Dean, Registered Nurse" half-hour TV film productions in New York for Cornwall Productions. Series features Ella Raines. He has since signed with Information Productions, Inc., to photograph 26 "You Are There" half-hour TV film shows.

★

Ernest Haller, ASC, returned from Germany the latter part of November, where he had been directing the photography on William Dieterle's production of "Magic Fire" for Republic. Assignment included shooting backgrounds of many of the famous castles throughout Germany.

★

Sid Hickox, ASC, is being applauded by contemporaries for his photography of "Battle Cry" in CinemaScope and color for Warner Brothers. The battle scenes reportedly are some of the best photographed yet to be seen in any production.

Check **your color requirements**



prices lowest in the industry

against the industry standard

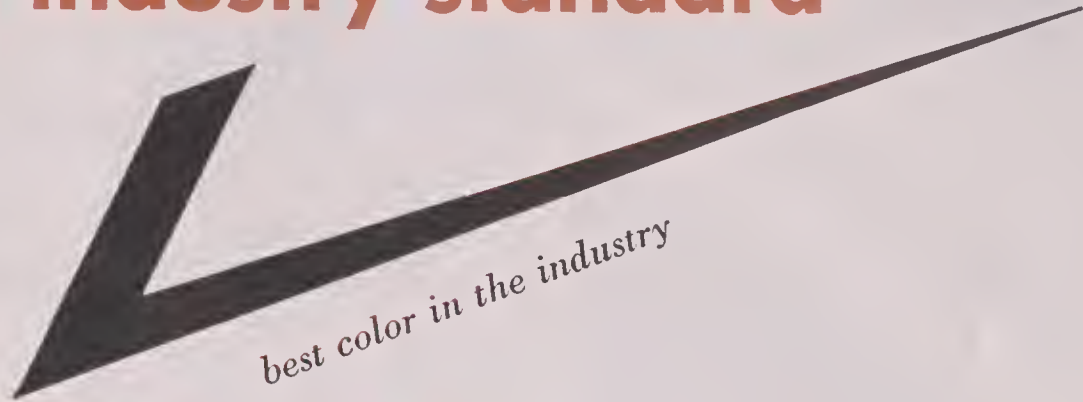

best color in the industry

... **color-correct** * **prints**

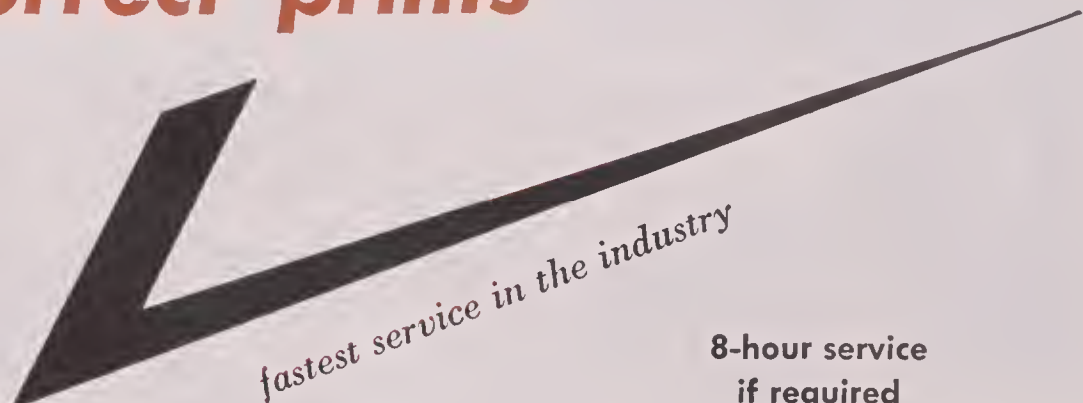

fastest service in the industry

**8-hour service
if required**

Check these other
byron production facilities
for quality, speed economy:

- ✓ *script*
- ✓ *art*
- ✓ *editing*
- ✓ *sound effects*
- ✓ *animation*
- ✓ *recording*
- ✓ *location photography*
- ✓ *music library*
- ✓ *sound stage*
- ✓ *complete black-and-white
laboratory facilities*
- ✓ *titling*

send for the **byron**
price list today

byron Studios and Laboratory

1226 Wisconsin Avenue, N.W., Washington 7, D.C. DU pont 7-1800

*Reg. U.S. Patent Office

SEEING IS BELIEVING!

SCIENTISTS CAN MEASURE

THE SPEED OF LIGHT WITH GREATER ACCURACY THAN THAT OF ALMOST ANY OTHER PHYSICAL CONSTANT—DESPITE ITS INCREDIBLE VELOCITY OF 2.99776×10^{10} CENTIMETERS PER SECOND.

PSYCHOLOGISTS TELL US

THE STRONGEST LIGHT ACCEPTABLE TO NORMAL HUMAN VISION IS 16 BILLION TIMES BRIGHTER THAN THE LEAST PERCEPTIBLE LIGHT—AN AMAZING RANGE OF .000001 TO 16,000 MILLILAMBERTS!



"NATIONAL" STUDIO ARC-CARBONS ARE COOLER, MORE POWERFUL, MORE PENETRATING...WITH BROADER COVERAGE AND SHARPER DEFINITION THAN ANY OTHER SOURCE OF SET-LIGHTING.

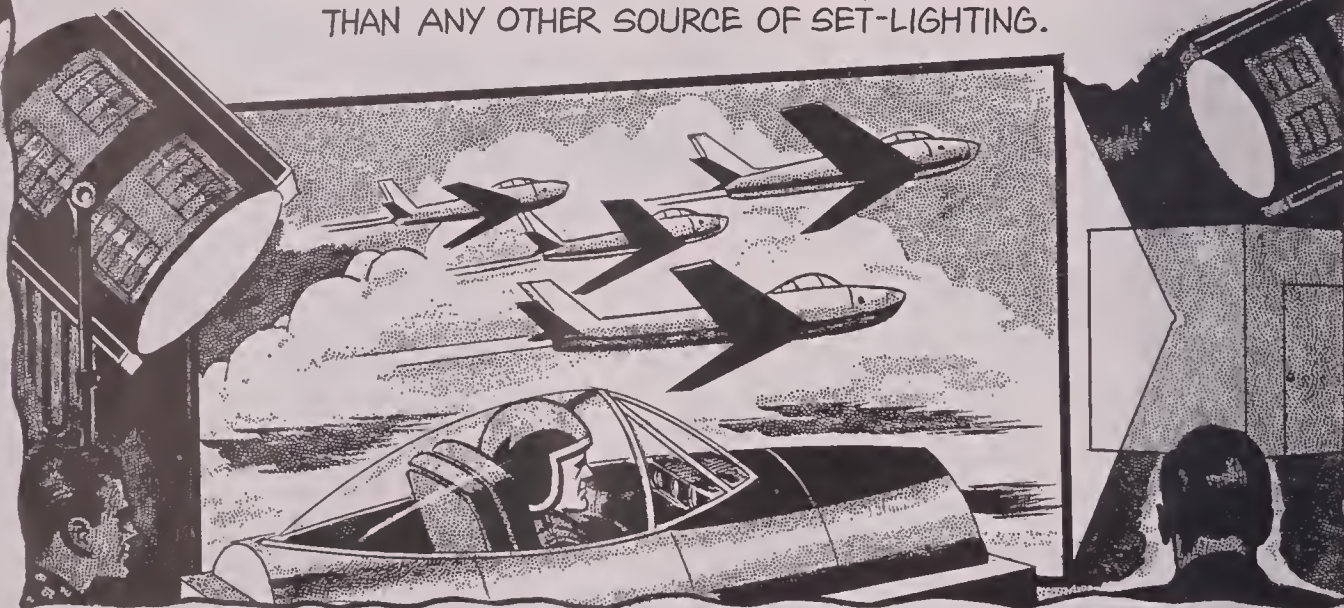

THE "NATIONAL" CARBON ARC... NOTHING BRIGHTER UNDER THE SUN

The term "National" is a registered trade-mark of Union Carbide and Carbon Corporation

NATIONAL CARBON COMPANY

A Division of Union Carbide and Carbon Corporation, 30 East 42nd Street, New York 17, New York

District Sales Offices: Atlanta, Chicago, Dallas, Kansas City, New York, Pittsburgh, San Francisco

IN CANADA: Union Carbide Canada Limited, Toronto



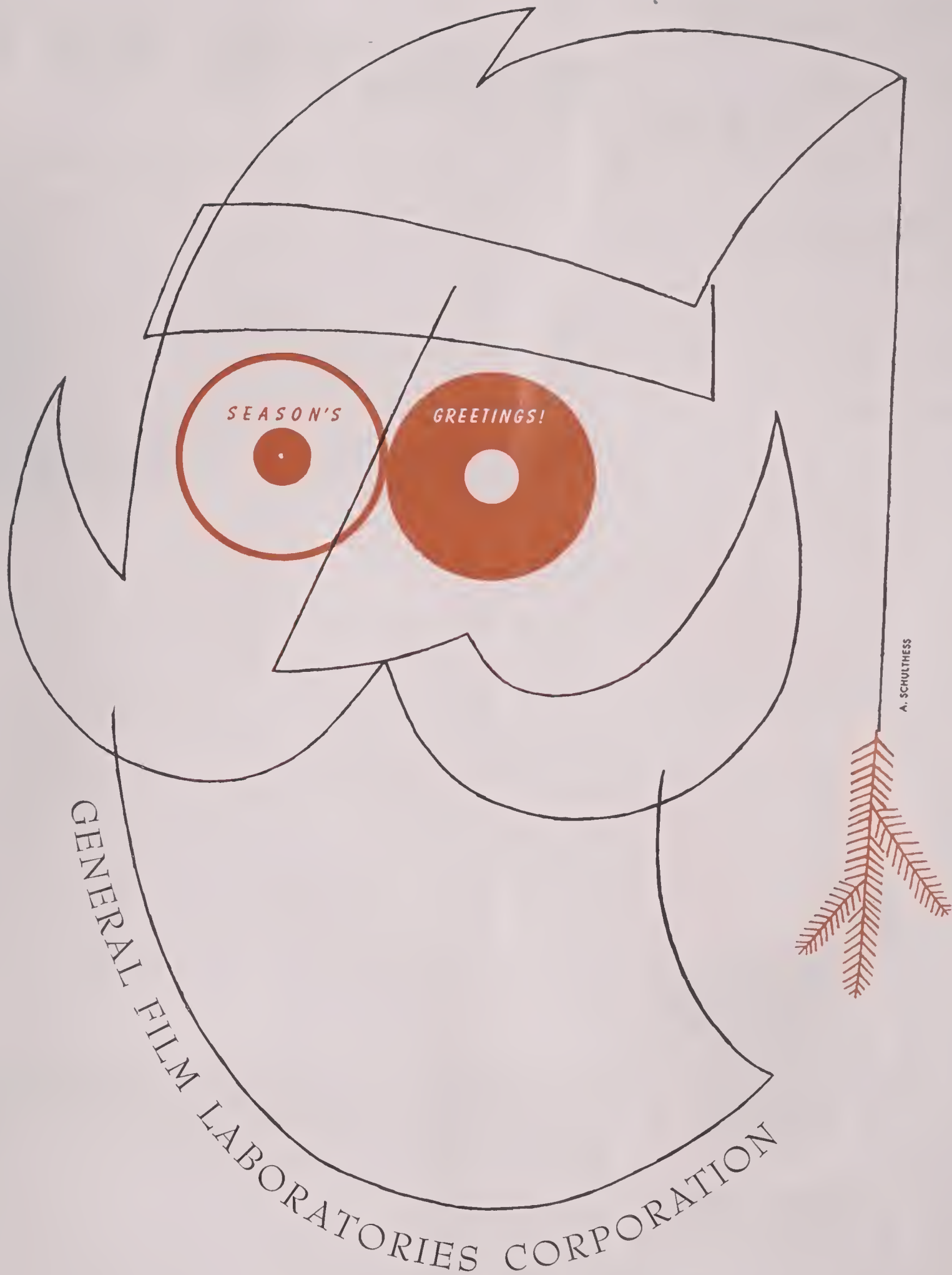

A. SCRULTHES

1546 NORTH ARGYLE AVENUE • HOLLYWOOD 28, CALIFORNIA

HOLLYWOOD 9-6391

ONE CAMERA

16mm or 35mm

in 10 SECONDS!

Camerette 16/35

Reflex Motion Picture Camera

The perfect camera for the motion picture film maker working in both 16mm or 35mm color or black and white.

LOOK AT THESE ADVANTAGES—

- The same lenses, same motor drives, same sound blimp and accessory equipment used for both 16mm or 35mm — to convert simply change the magazine.
- Precise rugged movement
- Reflex viewing
- 200 degree adjustable shutter
- Divergent three lens turret
- Automatic film gate 400' magazines 16 or 35mm — the 16mm magazine will accommodate daylight spools as well as standard care load.
- Light weight — only 14 pounds with 3 lenses, 400' magazine, and 6/8 volt motor.

Write for brochure



C

amerette

patents coutant-mathot

Manufactured by Ets. Cine. Eclair, Paris



WHAT'S NEW

... in equipment, accessories, service

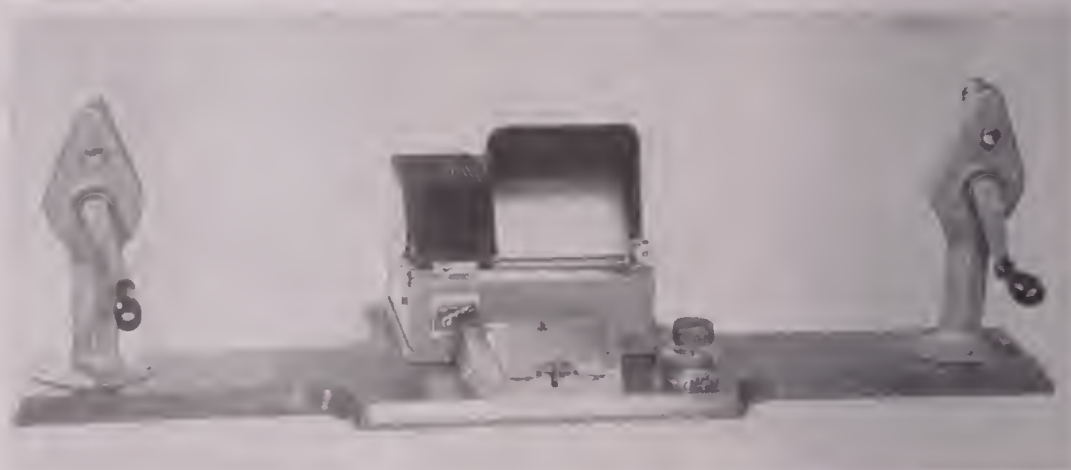

New Craig Professional Editor

Pro Film Editor

Craig, Inc., division of Kalart, Plainville, Conn., announces a new professional model of the Craig Projecto-Editor for 8mm and 16mm films. New model is aimed at needs of the advanced amateur and professional, supplying a large screen viewer. Complete unit pictured above, includes rewinds to take 2000-ft. reels. List price is \$79.50.

Wide Screen for 16mm

Radiant Mfg. Corp., 2627 W. Roosevelt Rd., Chicago 8, Ill., announces a new semi-portable aluminum frame and projection screen in 6 by 16 ft. and 8 by 21 ft. sizes for use in 16mm CinemaScope and wide-screen projection. Screen is made of mildew-resistant beaded fabric, which is also flame

resistant. Screen is mounted on frame by means of self-adjusting tension hooks, assuring a taut surface.

Telephoto Lens

A new Angenieux 3-inch f/2.5 telephoto lens for 16mm cine cameras has been announced by Bell & Howell Co., Chicago. New lens replaces the company's 3-inch f/3.5 lens, and is made exclusively for Bell & Howell.

New lens is a 5-element true telephoto with the distance from film plane to front of lens only 2.4 inches. Because of its compact size, it can be used on camera turrets without optical or physical interference in combination with most other lenses.

Iris click-stops range from f/2.5 to f/32 with a focusing scale from 4'

(Continued on Page 602)

New Radiant Wide Screen for 16mm Projection



NOW BETTER THAN EVER!

New Sound Blimp adds a new dimension to the Camerette—the world's most versatile motion picture camera.

ONLY THE CAMERETTE HAS

- 1-Ability to use both 16mm and 35mm film in one camera.
- 2-Reflex viewing through the taking lens at all times for both film sizes.

AND NOW . . .

A Sound Blimp with reflex viewing, making a fully-blimped 16mm or 35mm camera.

Synchronous motors — 110-volt single-phase or 220-volt three-phase.

Write For Details



Magnaphonic SOUND SYSTEM

There's a reason...

why Magnasync enjoys continued worldwide leadership...

QUALITY...ECONOMY...INTEGRITY

Air S
Univers
Nava
Rac
Protes
Fotovox, Inc. Photographie Technicians Pr
W T S P—Florida Southern Pacific Railroad
Tele-Filmica Maxol, S. A., Havana Southern
Ford Foundation Twentieth Century-Fox, Inc.
University of Wisconsin Gospel Films, In
National Film Board of Canada Cine Associat
R.K.O. Radio Pictures, Inc. Pacific Picture
Gilfillan Bros., Inc. U.S. Air Forces Westingho
Iowa Conservation Commission Providenc
Fairchild Recording Equipment Co. Galbrea
Magnolia Petroleum Co. Kearney & Trecker Cor
W K A Q, San Juan, Puerto Rico State Colle
Naval Air Station Beeland-King Film Productions
Columbia Pictures Providence Bible Institu
Television Recording Service, Inc. Iowa Farm Bur
Westinghouse Electric Corp. Sound Recorders, I
Vignie Productions, Inc., Havana U.S. Navy Nort
Paramount Pictures Corp. Baptist Gospel Film
U.S. Department of Agriculture University of Iowa
International Productions Goodyear Aircraft Corp
Avalon Pictures, Inc. Reverend D. Kirk Hammond
Southwest Film Laboratory, Inc. Academy Soun
Naval Ordnance Wurtele Film Productions Acade
Bible Institute of Los Angeles University of Tennessee
University of Mississippi Rampart Productions Sc
Protestant Radio Center, Inc., U.S. Recording Co.
South Dakota State College Aspen Pictures Dallas Jo
Twentieth Century-Fox, Inc. Filmscope
U.S. Air Forces Magnolia Petroleum Co.
Southwest Film Laboratory, Inc. Gilfillan Br
Cine Associates
Kearney & Trecker
University of Iowa
Arcturus Manufacturing
Goodyear Aircraft Corp.
Fairchild Recording Equipment Co.

Select



MODEL SW-602
PORTABLE RECORDING SYSTEM



DISTRIBUTORS

CAMERA EQUIPMENT COMPANY
1600 Broadway, New York 19, N.Y.
Judson 6-1420—Cable: "CINEQUIP"

MAGNETIC RECORDERS COMPANY
7120 Melrose Ave., Los Angeles 46, Calif.
Webster 3-5545

ZENITH CINEMA SERVICE, INC.
3252 Foster Ave., Chicago 25, Illinois
IRving 8-2104

AMERICA'S LEADING MANUFACTURER OF MAGNETIC FILM RECORDING AND REPRODUCING DEVICES

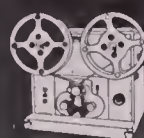

PORTABLE
FILM RECORDERS



CinemaScope
REPRODUCERS

3-CHANNEL
REPRODUCERS

MULTI-CHANNEL
INTERLOCKED DOUBBERS

STUDIO DOUBBERS
and RECORDERS

QUALITY AMPLIFIERS for
MAGNETIC RECORDING and REPRODUCTION

MAGNASYNC MANUFACTURING CO., LTD. • 5521 SATSUMA AVE., NORTH HOLLYWOOD, CALIF. • POplar 6-1692

introducing... **CAPITAL**
FILM LABORATORIES'

SCOTCH TRACK^{*}

BRAND

Magnetic  Laminate

Capital Film Laboratories, in cooperation with the Minnesota Mining and Manufacturing Company, offers the finest magnetic sound track on motion picture film!

SCOTCH TRACK BRAND Magnetic  Laminating Process by **CAPITAL**

The only low cost magnetic process with High Quality Reproduction — (10 to 12 decibel higher gain).

Has uniform quality — The magnetic track is uniform and precise in thickness, placement and width — micrometer controlled!

It's different! — A non-liquid process, coated by Minnesota Mining, laminated by Capital, to your film absolutely flat and smooth.

No crowning, no spreading, no crinkling or cracking.

Gives you a choice —

16mm or 8 mm striping
30, 50, or 100 mil track width

placement on the base or emulsion side of the film

Fast, dependable delivery in days — not weeks!

Scotch Track Brand Magnetic  Laminating Process is Capital's newest addition to its long list of its quality services for the creative producer.

write or call today for details....

CAPITAL



FILM LABORATORIES, INC.

Formerly McGeary-Smith Laboratories, Incorporated

1905 Fairview Ave., N.E., Washington 2, D.C.

Telephone Lawrence 6-4634

Editing • Processing • Printing • RCA Sound Recording • Capital Film Studios

* Scotch Track Brand Magnetic Laminate and the accompanying process are the registered and copyrighted brand names of the 3 M Company

WHAT'S NEW

(Continued from Page 598)

inches to infinity. The depth of field scale is clear and easy to read. Lens has a C-mount and rotating back for setting iris and focusing marks at the most convenient point. It retails for \$99.50.

New Zoomar Offices

Zoomar, manufacturers of high precision lenses, has opened a West Coast branch office at 1586 Cross Roads of The World, Hollywood 28, Calif. Here a complete line of Zoomar products will be represented, including the new 8mm, 16mm and 35mm Zoomar lenses. Literature on Zoomar products is available from this new office.

Interval Timer

Anson Research Co., 4337 Clybourn Ave., North Hollywood, announces a new electronic interval timer for time lapse photography with 16mm cameras. The unit, which was demonstrated at the SMPTE convention in Hollywood in October, received wide acclaim. For literature and further particulars, write manufacturer and mention *American Cinematographer* magazine.

Animation Stand

Animation Equipment Inc., 38 Hudson St., New Rochelle, N. Y., announce the new Oxberry stand and compound for animation of films and slides. It features the exclusive Tri-motion which gives live motion effects for pictures by combining a number of image movements in the animation procedure.

Illustrated brochure and full particulars may be had by writing the manufacturer and mentioning *American Cinematographer* magazine.

Variable Shutter for Bolex

Tullio Pellegrini, 1545 Lombard St., San Francisco 23, Calif., announces a variable shutter for the Bolex H-8 cine camera. Installation of shutter enables H-8 owners to make fades and lap-dissolves in the camera, same as with the Bolex H-16 and Cine Special, etc. Cost installed is \$99.60; on cameras having outside frame counter, cost is \$109.80.

Magnetic Tape Splicer

F. Reiter Co., 3340 Bonnie Hill Drive, Hollywood 28, Calif., announces a 1/4-inch magnetic tape splicer which automatically ejects, applies, cuts off, and presses into place the correct mount of splicing tape. Only three operations are required to complete a splice. Base size is 4 3/4" by 5 1/4". Finish is grey wrinkle enamel. List price is \$69.75.

16 mm
Kodachrome enlarged
to 35 mm
Anso direct
positive
color release
prints

35 mm
Color blow-ups on
Eastman Color Negative
and Anso Color
Negative and
release prints

Unsurpassed separation
positives and color inter-negatives,
with special effects, made on our new
precision triple-head
reel-to-reel printer

Specialists
in

specialized laboratory services

FILM EFFECTS
of hollywood

1153 North Highland Avenue
Hollywood 38, California
Hollywood 9-5808

zooms
montages
dissolves
superimposes
frame sequence
alteration
special effects
wipes



THE

is this:

FULL COATED 3 CHANNEL RECORDING



FASTEST

to this:

MAGNA-STRIPE® FOR EDITING



WAY

to this

OPTICAL SOUND RELEASE PRINTS

LET SOUNDCRAFT MAGNETIC FILMS

● SPEED YOUR SOUND PRODUCTION

● BETTER YOUR SOUND QUALITY

● SAVE YOU MONEY

Do as progressive film producers do. Make virtually distortion-free, full fidelity sound tracks—fast . . . with Hollywood-accepted, time-proved Soundcraft Magnetic Recording Films.

Soundcraft coated films are made with the same superior magnetic coating used on Magna-Stripe, the development that won Soundcraft the coveted "Oscar" of the Academy of Motion Picture Arts and Sciences in 1953.

When you use *both* Soundcraft full-width film for original recording and Soundcraft Magna-Striped Film for editing and mixing, you are assured of maximum fidelity release prints without

time-consuming, intermediate photographic-track processing.

Both the 35-mm and 17.5-mm Soundcraft full-coated stock come with or without footage marks. The 35-mm stock is also available coated between sprocket holes only, where a clear edge is desired. Full-coated 16-mm is available with either single or double perforations.

For full details on how Soundcraft Full Coated and "Oscar"-winning Magna-Striped Films can improve your original and edited sound tracks, speed your work, and open new business frontiers, write Dept. AE12.

All Soundcraft magnetic films use a 5-mil tri-acetate safety backing. They are extremely compliant for intimate head contact. Full-width film is Micro-Polished® to remove minute surface defects, and assure perfect frequency response right from the start. Output variation is $\pm\frac{1}{2}$ db. within a reel, ± 1 db. reel-to-reel.

REEVES **SOUNDCRAFT** CORP.
10 East 52nd St., New York 22, N. Y.



Better movies begin with

AnSCO

*Negative
Positive*

Color!

From the time your cameras roll at Scene 1, Take 1, to the final fade-out, AnSCO Negative-Positive Color gives you finer screen qualities and faster, more economical production.

Here are the ways AnSCO Negative-Positive Color helps you cut costs and make superior color motion pictures:

TOP SCREEN QUALITY

- Truer color • Excellent screen steadiness • Finer grain • Superior definition • Greater brilliance and depth.

NO SPECIAL CAMERA IS REQUIRED to get excellent results with AnSCO Negative-Positive Color. Just give any competent cine-

matographer standard 35mm cameras and he'll do a top-quality job.

NO SPECIAL PROCESSING EQUIPMENT IS NEEDED because minor modifications adapt standard black-and-white equipment for speedy, dependable processing of AnSCO Negative-Positive Color.

NO COSTLY, DRAWN-OUT WAITING for color rushes because AnSCO Negative-Positive Color lets you see the results of your shooting within hours—often the same day. Thus you don't need to hold casts and sets for long periods.

Ask your ANSCO representative for full details.

NEW YORK • HOLLYWOOD

AnSCO

CHICAGO • BINGHAMTON

A DIVISION OF GENERAL ANILINE & FILM CORPORATION. "FROM RESEARCH TO REALITY."

For Motion Pictures with

IMPACT

International Film Associates

uses the

AURICON "Cine-Voice" 16mm Sound-On-Film Camera!



Roy Zeper, Director of Photography for International Film Associates, P.O. Box 9434, Philadelphia 39, Pa., uses the Auricon "Cine-Voice" 16mm Sound-On-Film Camera for motion pictures with **IMPACT!**

International Film Associates travel the world with Auricon producing unusual films of travel, wildlife, archaeology, natural resources conservation, civic promotions and public relations.

INTERNATIONAL FILM ASSOCIATES

Motion Picture Producers

TELEPHONE
GREENWOOD 3-4486

P. O. BOX 9434 PHILADELPHIA 39, PENNA.



Berndt-Bach, Incorporated
6900 Romaine Street
Hollywood 38, California

Gentlemen:

The operation of a good camera in the studio can be taken for granted. But when our camera crew is on location, and that location is deep within the humid jungles of Yucatan, or high upon some frigid mountain peaks; - that is the true test of camera equipment. When we find our Auricon to continue to operate efficiently and with dependability -- no film jams, no lost loops, no mechanism failures -- we know this is THE camera.

And for lip sync in the field, only the Auricon can faithfully record an animal's snarl or a native's dialect in stark realism and vivid impact.

When our very pictures are at stake, we shoot with our Auricon.

Sincerely yours,
INTERNATIONAL FILM ASSOCIATES

Roy Zeper
Roy Zeper
Director of Photography



Auricon Cameras are sold with a 30-day money-back guarantee. You must be satisfied! Write today for free illustrated Auricon Catalog.

BERNDT-BACH, INC.

6902 Romaine Street, Hollywood 38, Calif.

The **Auricon** Hollywood Line

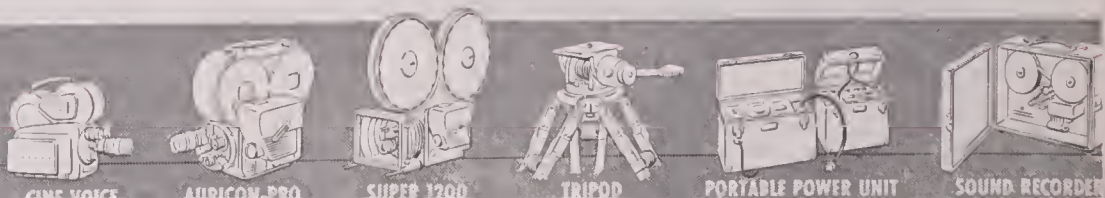

ARRIFLEX

New 35 mm Model 2A
With 180° Shutter

**A TRULY GREAT
CAMERA**

for TV, Newsreel
and commercial
films



For tough and trying assignments, ARRIFLEX 35 is in a class by itself. Reflex focusing through photographing lens while camera is operating—this is just one outstanding ARRIFLEX feature.

Equipped with bright, right-side-up image finder, 6½ x magnification. Solves all parallax problems. 3 lens turret. Variable speed motor built into handle operates from lightweight battery. Tachometer registering from 0 to 50 frames per second. Compact, lightweight for either tripod or hand-held filming. Takes 200' or 400' magazine. Write for free folder.

Blimp now available.
16mm ARRIFLEX also available.

FRANK C. ZUCKER
CAMERA EQUIPMENT CO.
1600 BROADWAY NEW YORK CITY

INDUSTRY NEWS

Edwin Gillette, Hollywood cinematographer, has developed a method of producing composite shots and special effects particularly adaptable to 16mm color photography.

Tradenamed "Color-Mat" the method consists of an attachment which fits in front of the camera lens and features a unique method of making mattes and accurately positioning them to create the desired effects.

With the "Color-Mat" attachment, Gillette can combine live action with a still photograph, miniature, or scene from another location with no apparent line of demarkation between them. In this way it is possible to make so-called location shots without leaving the studio and without need for building elaborate sets, using process screens or optical printing.

According to Gillette, with this method it is possible to delete from scenes such unwanted features as waterfalls, buildings, telephone poles, trees, etc.

Although adaptable also to 35mm cameras, Gillette says the "Color-Mat" method is suited primarily to the independent, low-budget production shot in 16mm color, since this field does not share all the advantages of special effects departments, optical printing and process photography available to the major studios.

Development of "noise-free" light bulbs for use in motion picture studios has been announced by General Electric Company's lamp division in Nela Park.

To solve the problem of noise which was attendant to some incandescent photo lamps, rendering them unusable on the sound stage, G-E engineers first conducted a series of studies to discover the source of the noise. Then they devised methods of constructing the large lamps in such a way that the noise was reduced to a point where it could not be detected by sensitive instruments even in a quiet studio.

Lamps which have been sound-treated include a 1000-watt general service lamp for TV, a 1000-watt 3200° K lamp for photography, and a 2000-watt spotlight also for photographic use.

Metro-Goldwyn-Mayer studios, until recently, had been using a regularly-fitted 35mm camera alongside the CinemaScope camera on its produc-

tions in order to obtain standard prints of the same production, if needed.

Last month, the studio abandoned this practice. Following successful experiments by studio engineers, a method was devised for "de-anamorphosing" CinemaScope negatives to obtain standard 35mm prints.

Experiments in the studio laboratory with the recently installed Micro-Panatar printing lens, developed by Panavision Corp., showed that it was possible to obtain a "flat" internegative from the anamorphic negative and from this make standard prints.

National Carbon Co. reportedly is working on a new carbon for use in motion picture set lighting which is designed to balance lighting to 3200 K for color photography, when used in conjunction with incandescent lamps. Further tests are necessary, according to engineers, before the carbon goes into regular manufacture and distribution.

The Screen Producers Guild, Hollywood, last month announced the second annual Intercollegiate Awards competition for the best amateur motion pictures conceived and created in the colleges and universities in the United States.

In a letter of invitation mailed to 104 educational institutions, Arthur Freed, Guild president stated, "This is the first realistic and tangible contact that has been extended between professional film producers and students seeking to enter the motion picture field."

Any student-made film produced or completed during 1954 is eligible for entry. November 30 was deadline for applications; and December 31 is deadline for films.

Readers who are interested in the competition may write Arthur P. Jacobs, 360 No. Bedford Drive, Beverly Hills, Calif.

The new DuPont photographic film base, which the company has tradenamed "Cronar," will go into production in commercial quantities by the middle of 1955, following completion of a plant now under construction at Parlin, N. J. Limited quantities of Cronar have been made available for use as leader for motion picture processing.

CATALOGS & BROCHURES

available to readers

Lighting Control

A new "Handbook on Modern Stage Lighting Control" is available from Lumi-Tron Division, Metropolitan Electric Mfg. Co., Long Island 5, New York.

For Better Color Pictures

A new Kodak booklet for the still photographer who wants to steer away from deep technical waters and simply produce better Kodachrome pictures is now available through Kodak dealers. Titled "How To Take Better Kodachrome Pictures," it is priced at 35¢ a copy.

Color TV Films

"Color Television Film Shooting Practices" is title of 14-page handbook prepared by CBS engineers and available to cinematographers in the industry through CBS Television Engineering Department, New York City.

Chapters deal with staging, lighting, cameras, film, and sound recording in color TV film production.

DuPont Film Data

A handy reference folder of technical data on DuPont professional motion picture films is available from the company's Photo Products Department, Wilmington 98, Delaware, and from its eight district offices.

Attractively printed in red and black, the folder contains sensitometric and processing data for DuPont's negative, sound recording, release positive, duplicating, and special purpose films.

The data sheets are punched for use in standard three-ring notebooks.

Set Lighting Catalog

One of the most attractive and informative catalogs on motion picture set lighting equipment has been issued by J. G. McAlister, Inc., 1117 North McCadden Place, Hollywood 38, Calif. Illustrated and described are all of the lamps and equipment manufactured by the company with a detailed analysis of the proper uses and the specifications of each unit.

Kilfitt KILAR

TELE-LENSES & ACCESSORIES



400mm (16") f5.6 Fern-Kilar
Shown with ARRIFLEX 35

For the BEST in Movie Tele-Photography

Cinematography demands the best in optical performance. Long shots, medium shots, close-ups . . . each must be equally sharp and clear as if taken with one lens. One scene marred by poor quality daams an entire sequence. That is why so many of the leading professional cinematographers rely on Kilar lenses.

Kilar lenses are highly color corrected. They are entirely free from haze or flare, even at widest apertures, and they are unsurpassed for critical sharpness and definition. Extremely lightweight, they are ideal for portable equipment, and are easy to handle and interchange.

Kilar lenses have the added advantage of flexibility and economy. By means of simple screw-on adapters, one lens may be used on several movie cameras, 16mm and 35mm, and on 35mm still cameras. Adapters are available for standard 'C' mounts and for the Arriflex. Custom-built adapters and mounts are also available for others. Information and prices on request.

BASIC KILAR LENSES (Complete with Lens Shade-Filter Holder):

90mm (3 1/4") f3.5 Kilar.....	\$ 74.95*
135mm (5 1/4") f3.8 Kilar.....	89.95*
150mm (6") f3.5 Kilar.....	119.95*
300mm (12") f5.6 Tele-Kilar.....	149.95*
400mm (16") f5.6 Fern-Kilar with Filter Slot and one Gelatine Filter Holder.....	239.95*
'C' Mount Adapters.....each	16.50
Arriflex Adapters.....each	16.50

*Less Adapters

KILFITT Products are made in Western Germany



300 mm

150 mm

135 mm

90 mm

At Leading Dealers, or Write: **KLING PHOTO CORPORATION**
235 Fourth Avenue, New York 3, N. Y. • 7303 Melrose Avenue, Los Angeles 46, Calif.

A Merry Christmas and A Happy New Year
 to our friends all over the world



● **CAMART TV and CAMERA DOLLY**

MORE AND MORE

motion picture and television producers are learning that they can turn out fine professional films with our dolly, involving less time and effort for the camera crew, in studio or on location.

Write for Prices and Descriptive Literature.



PATENT PENDING

\$29

8 REASONS . . .
 Why You Need The **CAMART TIGHTWIND ADAP**

- JUNKS SPLIT REELS & FLANGES!
- Designed to fit all rewinds.
- Chrome plated ball-bearing roller guide.
- For left and right hand rewinds.
- Core adapter fits 16mm and 35mm and female plastic cores.
- Saves storing of film on reels.
- Eliminates cinching and film abrasion.
- Does not interfere with normal operation of the rewind.

● **ROTATOR LENS**



Sensational and exciting effects are made right in your own motion picture or television camera with this addition to the Camart Optical FX Unit. Revolve your scenes 360°, simulate ship-board action, many unlimited applications. Adapters available for television cameras. Send for descriptive literature. Sound film also available.



● **TV MIKE BOOM**

FOR STUDIO OR LOCATION

- For a lightweight and practical overhead boom, this model will suit your needs. 13' boom arm, rugged construction, directional mike control, can be disassembled in a few minutes to fit in your car. Rugged center lock for folding boom, convenient pan and tilt control. \$297.50.

★ ★ ★ **SPECIAL SERVICES** ★ ★ ★

AUTHORIZED BAUSCH & LOMB BALTAR LENS AGENCY
 FACTORY APPROVED SERVICE & REPAIR OF
 BELL & HOWELL EQUIPMENT
 BALTAR LENSES MOUNTED FOR ALL 16-35mm CAMERAS
 WORN and DAMAGED MOVIOLAS FULLY RECONDITIONED
 IN OUR SHOP

THE **CAMERA • MART** INC

1845 BROADWAY AT 60TH ST.

NEW YORK 23, N.Y.

CI. 6-0930

WITH THE DEVELOPMENT of the small, wireless microphone, Hollywood studios have been quick to adapt it to film production. One of the most interesting applications perhaps is the use of the wireless mike and short-wave radio as a means of communication between gaffer and electricians on the set.

The photos at the bottom of this page show the equipment in use by gaffers at Twentieth Century-Fox and Metro-Goldyn-Mayer studios. Other studios also using the equipment at this time are Universal-International, Paramount, and Columbia.

In nearly every case, the equipment used is that pictured in photo at right—the Stephens Tru-Sonic wireless microphone—manufactured by Stephens Manufacturing Corporation, Culver City, Calif. Crux of the system is the miniature combination mike and transmitter shown in right foreground. The similarly designed unit at left is a small battery which powers the mike and transmitter. Transmission range is approximately 500 to 800 feet.

In use on the sound stage, in a typical application, the mike is suspended from a neckstrap, and the battery pack is hung from the gaffer's belt, as shown in the photos. Here, it will be noted, a larger battery is used than that pictured in the photo at right. The small unit provides power for up to 4 hours continuous use; the larger pack, up to 30 hours.

The gaffer (or other user) thus becomes a walking radio transmitter, able to broadcast messages to members of his crew located anywhere within the sound stage where signals are reproduced by remote speakers. Set up on the floor—usually as near the center of the sound stage as is practical—is a ver-

(Continued on Page 638)



STUDIOS are using this wireless microphone equipment for sound stage communication between technicians, also to eliminate the mike boom in certain types of shots. System includes power supply and monitor speaker in one unit, receiver, combination mike and transmitter, and small battery to power transmitter. Also included but not shown here is a vertical receiving antenna mounted on floor stand.

Radio Communication In Film Production

The gaffer's chore is eased through use of wireless mike and short wave radio.

By LEIGH ALLEN



KENNETH LANG, chief set electrician at 20th Century-Fox studios uses wireless mike to give instructions to electricians on catwalks above.



WITHOUT raising his voice above normal, Lang gives orders which are heard through speakers placed near workers on the catwalks.



CHESTER DAVIS, gaffer at MGM studios, Hollywood, also uses equipment. He shows small speaker through which orders are transmitted.



CAMERA ASSISTANT runs a tape measure to Dorothy Dandridge (Carmen) as director of photography Sam Leavitt, ASC (left), prepares to shoot scene on location for "Carmen Jones." At extreme right is director Otto Preminger; in background, Harry Belafonte.



WITH CINEMASCOPE camera on boom, Sam Leavitt's camera crew shoots a scene on location. As Jeep approaches camera, assistants on either side of camera move the boom, enabling operator to follow the action.

'Carmen Jones'—CinemaScope Photography At Its Best

The pictorial and dramatic highlights of this picture are enhanced by a fine combination of skillful lighting and camera handling.

By ARTHUR ROWAN

PERHAPS NO PICTURE filmed in recent months so aptly demonstrates, as does "Carmen Jones," the ability of the CinemaScope lens to put on film with great dynamic flow and scope a story that is not necessarily a spectacle. Produced and directed by Otto Preminger for release by 20th Century-Fox, it was photographed in Eastman Color by Sam Leavitt, A.S.C., who previously had directed the photography of "A Star Is Born."

In this contemporary version of the famous opera "Carmen" told with Negro characters, the range, realism and intimacy of the CinemaScope lens presents the story on the screen as it never could have been done in the old "3 by 4" format. Not all the credit for the production's great pictorial success is due to CinemaScope, but thanks to this wide-screen lens, both Preminger and Leavitt were able to undertake more daring treatment of the picture photo-

graphically and accomplish it with notable results.

The screen version of the famed Broadway musical, with its story in modern dress, follows that of the opera. Carmen (Dorothy Dandridge), elemental, passionate and selfish, is employed in a parachute factory; she seduces Joe (Harry Belafonte), a soldier on training duty there. To satisfy her desire to see Chicago, Joe goes AWOL and with her to the big city. But she quickly casts him aside in favor of a boxing champ riding the wave of success, who lavishes on her money and clothes in exchange for her company. Joe, with the MPs hot on his trail, follows Carmen to the fight arena the night of the championship bout, and after making a final plea for her return to him, strangles her to death.

A great deal of the story is told in the lyrics of the songs sung by Dandridge, Belafonte and others, and it is to the great credit of director Preminger that this was achieved so successfully. For he saw to it that the lyrics were so precisely sung that no one in the audience could fail to understand them and follow the story line.

The fact this was an independent production, perhaps, made it possible for the photography to reach the artistic heights that it did. Unhampered by the strict supervision of budget-minded unit managers which often hampers artistic endeavor on major studio productions, director of photography Leavitt found more freedom to pursue his photographic and lighting inspirations in working with Preminger—the only man on the production to whom he had to answer.

This freedom obviously paid off handsomely for Preminger, also, for "Carmen Jones" is replete with many beautiful lighting compositions, not to mention skillfully engineered boom and dolly shots which enabled the director to stage a musical number, a dance or a lengthy dramatic action in a continuous take running into minutes without a single cut. There are at least two that run 500 feet in length after editing.

It is perhaps these lengthy, continuous shots that highlight much of the picture and which demonstrate most effectively the true worth of the intimate, wide-screen CinemaScope lens in the hands of an able craftsman; and it is due to these continuous shots, which eliminated the need for so many intermediate camera setups, that the company was able to save much time and bring the picture in one day under schedule at a considerable saving in production costs.

One of the most impressive of these continuous shots occurs early in the picture when Carmen sings a tantalizing melody to Joe as he lunches with his small-town sweetheart. The setting is a large dining hall in the parachute factory. The scene, which plays for several minutes without a stop, begins with Carmen making a play for attrac-



VIEWING a scene from behind camera as it records a musical number being sung by group at bar, which includes Pearl Bailey and Dorothy Dandridge. Sam Leavitt is silhouetted at right of camera; director Preminger may be seen crouching in front of bright light at left.

tive Joe. As Carmen sings, she moves about the hall, stopping momentarily here and there, with the camera always upon her in medium or closeup format. A two-inch lens was used throughout the number with the camera mounted on a small crane. Leavitt and his crew panned, dollied, zoomed and followed Carmen, often moving in at a reverse angle to get an over-the-shoulder shot. A study of this shot on the screen also shows the painstaking artistry in the overall lighting which produced a fine, even level of illumination on all players no matter what the camera position.

One of the most dramatic follow shots to be seen in a long time takes place when Carmen and Joe are together in her mother's shack. As she is about to embrace Joe, she snatches a peach he has been eating and flings it over her shoulder. The camera follows it in a rapid pan to show it splattering on a large Zodiac map hanging on the opposite wall—an effect device to suggest Carmen's disdain for her superstitious mother's earlier admonition that trouble was brewing for her according to the stars. It is the dramatic suddenness of

(Continued on Page 625)



TWO SCENES from "Carmen Jones" notable for their lighting. Night exterior at left is courtyard in front of cafe where boxer Husky Miller sees Carmen for first time. The effect lighting here is most natural. Scene at right is interior of boxing arena where



spectators are gathered to see Husky Miller defend his title. Belafonte, behind column, is searching crowd for Carmen. This shot in picture is notable for the way lighting contributes to the scope and depth of the scene.

Big-scale University Film Production

Bob Jones University's Unusual Films studio is not only one of the best-equipped college film production units but its staff is one of the most versatile.

ONE OF THE MOST ambitious feature-length motion pictures ever undertaken by a university is *Wine of Morning*, the latest production of Unusual Films, motion picture division of Bob Jones University, Greenville, South Carolina. The story itself has all the essentials—suspense, intrigue, shipwreck, murder, love and redemption. It ties together many characters and incidents that are mentioned in the Bible—men like Barabbas, Paul, Manean, Barnabas, Pilate, Herod, Steven, and Joseph; also events such as the calling of Levi, the marriage at Cana of Galilee, and the Crucifixion.

The production involved 35 sound stage sets, an exterior construction providing nine different sets, and a number of location shots which were done in the surrounding countryside; also involved was a cast of 75 speaking parts and 800 extras.

The production posed all the problems usually encountered in making a top Hollywood Technicolor feature plus a few more which one would naturally expect for a production unit not having the unlimited facilities of a major studio. Yet it

is surprising how shortcomings were so quickly remedied through the ingenuity and imagination of the remarkable group of people behind Unusual Films.

First there is Dr. Bob Jones, Jr., president of the university. For years he had wanted to write a novel based on many of the characters and incidents of Biblical times. Not until he began a slow recovery from a bout with pleurisy in 1950 did he find time to write his story, *Wine of Morning*. The year the book was published the university's Unusual Films studio was opened. One of Dr. Jones' most cherished dreams, the studio was established for the purpose of producing Christian and educational films of top quality.

Katherine Stenholm, who has been with the university for nineteen years, was appointed director. She had received considerable practical training in motion picture production from Rudolph Sternad, production designer for Stanley Kramer in Hollywood. She also took graduate cinema courses at the University of Southern California.

Bob Craig is chief cinematographer. Originally a member of the university staff, he gained considerable experience in



KATHERINE STENHOLM, Unusual Films' dynamic and versatile woman director, gives last minute instructions before a take for *Wine of Morning*. Others, from left to right, are George Jensen on mike boom; Tom Woodward, script clerk; Robert Craig, cinematographer;

and George Hess, assistant. The players are Al Carter (Barabbas) and David Yearick (Prince Manaen). The finely detailed set was designed and constructed by staff members of the university's film production unit under the guidance of director Stenholm.

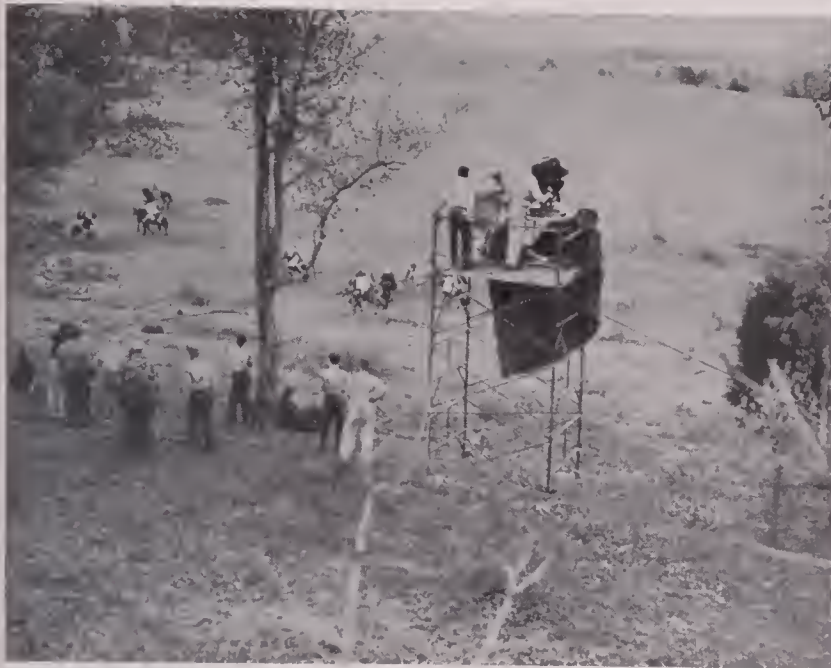

ON LOCATION. The Mitchell 16mm camera is mounted on a parallel for a series of panoramic shots of Roman soldiers in action in a chase sequence for "Wine of Morning."



SOME IDEA of the excellent period detail of the massive sets erected by Unusual Films technical staff is shown in photo above. Note the professional lighting and camera equipment being used.



ANOTHER EXAMPLE of meticulous set construction. After studying Hollywood set construction methods, Unusual Films studios technicians utilized them to reproduce this set of a Roman castle.



IN AN UNDERGROUND tavern set made of plaster and sawdust, Barabbas overhears his capture being plotted by talkative Roman soldiers. Note the excellent lighting achieved here.

photography during World War II, and subsequently trained in Hollywood.

George Jensen, another Bob Jones graduate, is film editor; his assistant is Thomas Woodward. Sound engineer is Rodger Groff; Lois Nichterlein is make-up supervisor; and Murray Havens is art director. Production manager is Melvin Stratton. Others on the production staff include Alice Gromley, script; Margaret Hurlston, secretary; and Marilyn Jensen, Laura Fleming and Verle Kippenham. In addition to the regular staff members, there are hundred of students who volunteered to work in the film department.

From the very founding of Unusual Films, several events have come to pass that justify the studio's very unusual name. Unusual Films is reported to be the very first to start production of films employing magnetic sound, and to continue with it until the production is ready for the final transfer to optical. One of the big handicaps recognized early in an

operation of this kind was the absence of a satisfactory magnetic tape splicer. Members of the film production staff set about to solve the problem. The result is the now famous Bob Jones University Splicer. This is being marketed internationally by J. A. Maurer, Inc., New York.

Still another staff accomplishment was the building of a satisfactory magnetic sound reader. The readers that were then available were found to build up a static "hiss" during cutting operations.

While the bulk of the university's film production equipment was purchased in Hollywood or directly from manufacturers, still a great deal was built by the staff. One unique piece was a 12-KW skylight which was patterned after those built by MGM and described in the December, 1952, issue of *American Cinematographer*. In another instance, the staff acquired a surplus government generator truck, installed in

(Continued on Page 624)



ADA AND DICK BIRD in quest of bird-life shots for a nature film. Once a professional 35mm cameraman, Dick Bird switched to 16mm photography, is presently shooting for Walt Disney.

DICK BIRD studies a subject for one of his films at close range—a young double-crested cormorant.



Birds Of A Feather

Dick and Ada Bird's unusual nature films of birds won them assignments to film wild-life for Walt Disney.

By HARRIS B. TUTTLE
and
GLENN E. MATTHEWS*

OF ALL THE 16MM cameramen who are contributing unusual color footage for Walt Disney's series of True Life Adventures films, none, perhaps, is more unusual than Dick Bird. There are numerous instances where 16mm cameramen have graduated to 35mm, but Dick Bird is one of the very few 35mm professionals who gave up the old standard in favor of professional 16mm cinematography. Today, aided by his naturalist photographer-wife, Ada, Dick is gathering color footage in Northern Canada for future Disney short subjects.

During his youth Bird worked as assistant cameraman, as cameraman, then assistant director. For a number of years he was a photographer for Universal, Biograph, Mutual, Selig, Lubin, Thanhouser, and Essanay—which indicates how early he got his start. Later, he became a newsreel cameraman, working for Fox, Hearst-Tribune, Screen News, Pathe and others. Subsequently, he spent a lot of time shooting animated cartoon films, which were used chiefly for advertising.

Dick Bird became interested in photographing nature subjects just prior to World War II. A friend who was curator in the Provincial Museum in Regina, Canada—his home town—suggested that with all his professional experience he was ideally equipped to photograph nature subjects. Dick liked the idea but kept putting it off, believing that nature photography was easy—something he could turn to when he was old and retired from the strenuous work of globe-trotting with a newsreel camera.

He soon learned differently. On his first trip out on the prairie with his camera, he spied a chestnut-colored Longspur carrying food to her young. He decided to film a story sequence on the behavior of the parents, feeding their offspring, what they ate and how much. The bird led Dick Bird around in circles for hours without disclosing the location of her nest. He cursed himself for his incompetence in permitting another bird to outsmart him. Later, quite by accident, he did locate the nest and spent the rest of the day trying to get satisfactory shots of the offspring, but without success. Right there he lost some of his egotism and all feeling of superiority as a human Bird over birds of the field.

Since then, Dick Bird has not only exposed countless thousands of feet of 16mm color film on nature and wildlife subjects, but he has gained considerable knowledge of the habits and habitat of his camera subjects. Nevertheless, he often encounters disappointment.

Today, his wife, Ada, is his inseparable companion on wild life filming expeditions. And a nice thing it is, too. For often it is necessary to wait long periods at a time and in all kinds

(Continued on Page 638)

*Based on the article, "Birds of A Feather" by same authors, *PSA Journal*, February, 1953.

EASTMAN

PROFESSIONAL

MOTION PICTURE

FILMS

W. J. GERMAN, Inc.

Fort Lee

Chicago

Hollywood



The maze—of details involved in expert film processing presents no problem at Precision. Skilled technicians, exclusive equipment, and expert research groups team up constantly to keep performance at the highest possible level. Precision-processed film is recognized by industry leaders—producers, directors, cameramen—as the finest in the field.

Just one example of advanced film printing methods is the individual Printing Control Strip technique—available only at Precision. This Strip permits complete printing control without notching or altering the original film in any way—and may be filed for later precise duplication.

In everything there is one best...in film processing, it's **Precision.**



A division of J. A. Maurer, Inc.



SHOOTING A TV film series in 16mm. Featured is the venerable Model T Ford which serves as a vehicle to carry the personalities to interesting scenic spots which the film illustrates and describes.

Behind the cameras are the author (far right) and Larry Washburn. Each film in series is 13 minutes in length and photographed on regular Kodachrome.

THEODORE LINCOLN JONES, a pioneer American name if there ever was one, happens in this instance to belong to a spry and adventuresome 1915 Model T Ford car. I say adventuresome because the Ford is starring in a new series of 13-minute TV films being produced in New York by Club Productions.

The photography of the first episode of the series posed something of a challenge. We worked from a shooting script, but many sequences were born on the spot when they were introduced as spontaneous suggestions. We kept two cameras "hot" at all times, for time was of the essence if we were to take ad-

Shooting A TV Film Series In 16mm

By DUDLEY M. WHITTELEY

vantage of the good weather that prevailed during the major portion of the filming.

Camera equipment consisted of a Cine Kodak Special, with 15mm and 25mm Ektar lenses on the turret, and a Bolex H-16 with a 15mm f/2.8, a 25mm f/1.5, and a 63mm f/2.7 lenses on the turret. Since the Bolex afforded a wider range of lenses on the turret, this camera

was used mainly for medium and close-up shots, with the Special being used almost exclusively for establishing shots and long running scenes.

An interesting innovation we employed may be of interest to other 16mm cameramen. To give added rigidity to the tripod on which the Bolex was mounted, it was weighted down by

(Continued on Page 637)



HOW TRACKING shots were photographed. The camera was mounted on tripod securely tied down to floor of car trunk compartment and focused on the Model T, which followed.



SHOT SHOWING the car occupants pushing vehicle out of sand. Car was pulled by cable by another car, while occupants went through motion of pushing. The tow-line was omitted in the camera framing.



LINING UP his 9.5mm Pathe cine camera for a shot for his all-model-and-miniature film, "Victory Convoy," is Aivar Kaulins of London, England.

THE LIMITATIONS of the amateur make it almost impossible for him to shoot and intercut model scenes with real-life action so that his audiences are unaware of the transition. Aivar Kaulins, an eighteen-year-old Latvian now living in London, had always wanted to make a short war film, and he knew it would probably necessitate the use of models for a large proportion of shots. But then he had also always wanted to make a model film.

He decided to combine the two ambitions in one production by making an all-model film which looked deliberately artificial. By making a virtue of the difficulties of getting a model to look exactly like its actual counterpart, Kaulins is now nearing completion of a 300 ft. story with a style all its own. From the first shot to the last there is no attempt to cover up the fact that models are being used.

The cut-out characters have no form of separate limb animation. A simple gliding motion is effected by the usual single-frame technique, with the result that the whole production has a deliberate lack of realism as pronounced as that of some cartoon and puppet films.

The story of *Victory Convoy* suits the style of the film. Apparently an action-filled drama, its final shots turn the tables on the audience and provide the justification of its artificial technique. The opening titles are superimposed over a shot of an approaching train. A German fighter swoops low over the train and returns to report to base.

Meanwhile a number of large crates are taken from the train and loaded by Allied troops into a lorry. Each crate is labeled "Urgent," "Top Secret," "Allied H.Q.," etc. The lorry sets off, guarded by a tank and an armored car. Suddenly the shadow of a bomber crosses the convoy's path: scores of paratroopers leap from the plane. The Germans

Models And Miniatures In Movie Making

By HAROLD BENSON

take over a house and erect a road block as the convoy approaches.

During the battle that follows, the lorry crashes into a ditch, but the tank and armored car prove too much for the Germans, who surrender. The tank pulls the lorry from the ditch, and as it does so one of the crates falls from the back and bursts open—to disclose hundreds upon hundreds of glamour photos! "And thus," says a concluding title, "the precious cargo was saved and victory assured."

Originally Kaulins intended to shoot the whole film out of doors, but the notorious English weather—which makes the completion of any film involving exteriors something of a miracle—finally beat him. However, after carrying over a dozen buckets of sand up into the loft of the house (with noticeable effect on the ceiling below), Kaulins prepared an interior miniature road and railway track. Bushes and trees were added with the aid of a few tiny plants.

The first snag arose in trying to get the electric train to run smoothly over the rails on their uneven surface of sand. Luckily Kaulins has infinite reserves of patience—essential to any amateur who embarks on a production involving single frame animation—and he soon solved the difficulty.

Working in the cramped loft meant that practically every shot had to be a closeup. However, Kaulins did manage to

(Continued on Page 640)



MINIATURIZED set constructed by Kaulins for "Victory Convoy" utilized model trains and track, as well as automobile, tractor and tank models. Photo flood lamps furnished the lighting.

F&BRentals
Sales

Motion Picture & TV Film Production

EQUIPMENT!Service
Repair**F&B**

TRADE - IN!

MODERNIZE YOUR EQUIPMENT!

Get rid of old, depreciated equipment . . . realize a generous cash value towards new.

TRADE IN YOUR OLD TRIPOD FOR . . .

NEW **F&B Pro-Cine** 14lb. TRIPOD

— for all cameras —
Auricon-Pro . . . Maurer . . .
Cinevoice . . . Cine Special . . .
Filmo . . . Bolex . . . Eyemo . . . with
mogozine & motor . . . Arriflex 16 . . .
Arriflex 35 . . . All still cameras . . . view cameras

A BRAND- NEW, MODERN TRIPOD . . . precision engineered and designed, ruggedly constructed for long and satisfactory service.

- ★ SUPER-SMOOTH, fluid friction pan and tilt head.
- ★ TELESCOPING, two position, offset panhandle, for adjustability to your length requirements, left or right hand use; offset for greatest comfort and convenience.
- ★ KNURLED camera-tightening knob, externally operated by angle gears for fumble-free, maximum tightening.
- ★ PRECISION ENGINEERED positive pan & tilt locks for utmost in rigidity and safety.
- ★ SUPERB, SEASONED, solid hardwood legs, finished for smooth, non-sticking telescoping action.
- ★ REMOVABLE friction head for easy mounting on boby tripod or hi-hat.
- ★ SPRING-BALANCED HEAD, adjusted to your camera, available at extra cost.

HEIGHT: 41" to 75" . . . 360° pan; 90° tilt.
FINEST WORKMANSHIP AND MATERIALS
5 YEAR UNCONDITIONAL GUARANTEE . . .

Shoot Complete
15 Minute
Programs

600 FOOT
MAGAZINE
CONVERSION
FOR 16mm
AURICON
CINEVOICE
CAMERA

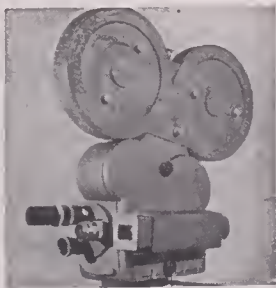

WRITE FOR
COMPLETE DETAILS



MADE IN U.S.A.

List Price.....\$135.00

Fibre Carrying Case.....\$20.00

Available Direct or at Your Dealer

FACTS ABOUT F & B

- F&B cannot be undersold . . . F&B prices are always the lowest in the industry. Maximum discounts cheerfully granted whenever possible.
- F&B carries a Complete Stock . . . Everything in new and used equipment for production, projection, processing, recording, editing, distribution, etc. F&B is agent for all major manufacturers.
- F&B offers an Ironclad Guarantee . . . Nothing sold "as is". Every item sold carries a 100% money back guarantee.
- F&B wants your Account . . . Your credit is good at F&B. You will receive top service, courtesy and reliability when you deal with F&B.

WRITE FOR NEW, FREE CATALOG NOW . . .

FLORMAN & BABB

70 West 45th Street, New York 19, N. Y.

Phone: Murray Hill 2-2928

Cable Address — FLORBABB, N. Y.

TRADE IN Your Old Camera For . . .

AURICON

Cinevoice
Pro
Super 1200

NEW ARRIFLEX . . . 16mm or 35mm
BELL & HOWELL . . . 16mm or 35mm
CINE KODAK SPECIAL II

TRADE IN Your Old Lenses For . . .

BALTAR . . . EKTAR
ASTRO . . . ANIMAR
ANGENIEUX . . . COOKE
BERTHIOT PAN CINOR

TRADE IN Your Old Lights For . . .

BARDWELL-McALISTER
COLORTRAN

TRADE IN for . . .

PROJECTORS, B&H, Ampro, RCA, Devry
EDITORS . . . MOVIOLA, B&H, Croig, Ace
RECORDERS . . . MAGNASYNC, HALLEN, KINEVOX
PRECISION SOUND READERS
SYNCHRONIZERS . . . Moviola, Neumade

OR ANY OF
THE THOUSAND
ITEMS
in

EDITING EQUIPMENT
LIGHTING EQUIPMENT
LAB EQUIPMENT

in F&B's tremendous stock

LET'S TRADE

I want to trade the following: _____

For: _____

Send generous offer by return mail

Name _____

Address _____



WITH YOUR cine camera set up close to a nest and controlled remotely from a distance, it is possible to get interesting candid shots of birds such as this.

SO YOU WANT TO PHOTOGRAPH BIRDS!

You've got to outsmart 'em, and the best way to do it is to shoot from a blind or at a distance, operating your camera by remote control.

By HERBERT D. SHUMWAY

Photographs by the author.

FEW FIELDS of nature photography offer greater challenges to the outdoor-minded camera fan than does the provocative pastime of bird filming. There's a fascination about this pursuit with camera and color film that's enticing an

evergrowing number of cine photographers to pit their skill and equipment against the behavior of the wary denizens of the bird world. Bluebirds and robins, bluejays and cardinals, flickers and warblers—there are just a sam-

pling of the many brilliant birds near at hand in America to make bird photography the colorful, exciting, and rewarding hobby that it is.

To those who have never filmed birds, the question always arises as to how



FIG. 1—Filming from a blind will net good pictures, too. One pictured here is constructed of burlap stretched over simple wooden frame. Camera is set up inside and focused on birds or nest.



FIG. 2—To shoot bird life with camera operated by remote control, operator observes birds through binoculars and when action is just right, presses control that starts camera.

closeup shots of birds are obtained. All too often the general impression seems to be that super powerful telephoto lenses do the entire job. Actually, helpful as telephoto lenses may be, they alone seldom are responsible for intimate views of birdlife. In order to film a sizable image, even the use of a telephoto lens requires that the camera be relatively close to such a tiny creature as a bird. For instance, when a cine camera is fitted with a three-power telephoto lens, it must still be placed within five feet of a nest in order to get a screen-filling image of birds as small as sparrows, chickadees, and warblers.

Needless to say, it just isn't possible for the photographer to approach that

close to any bird and photograph it. There's much more to it than that. There are, in fact, two methods in widespread use by which closeup bird photographs are obtained. One method relies on the construction very close to the nest of a cloth-covered structure, a "blind," to conceal both the camera and its operator during filming sessions. The other method depends upon remote control operation of a camera which has been tripod-mounted near a nest, and with its lens prefocused upon a point on which the bird regularly perches. Then, whenever the bird returns to that particular spot, the camera shutter is operated by remote control from a distant viewing point.

Filming birds from the concealment of a blind is a method regularly used by many professional wildlife photographers, and amateur bird filers have been quick to adopt the use of blinds for their own filming. Basically, blinds are constructed of cloth or burlap fastened to a frame of lightweight wood or metal. A blind must be designed for easy portability. This means it must be assembled and disassembled easily and quickly, because often the blind must be hauled through fields, woods, and swamps to be erected at each new nesting site. Anyone handy with ordinary tools can quickly build a suitable blind such as the one pictured in Figure 1.

(Continued on Page 630)

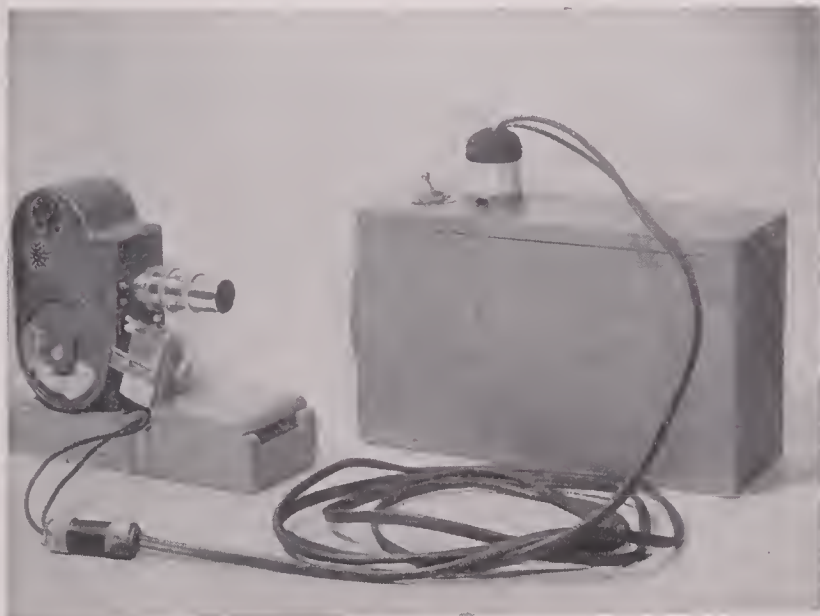

FIG. 3—A remote control and camera for filming birdlife at close range. Camera-operating solenoid is activated by toggle switch on the battery box. Note that a telephoto lens is mounted on camera.



FIG. 4—The remote controlled camera must be pre-focused and framed so the desired bird action takes place where camera will record it. Here a ruler is used to determine correct focusing distance.

HIGH-SPEED

PROCESSING

The **HILLS** Filmatic

High Temperature 16mm
Film Processor

- REVERSAL
- NEGATIVE
- POSITIVE

SPEEDS UP TO 115 FT. PER MIN.
BUILT IN REPLENISHING SYSTEM
DAYLITE OPERATION
COMPACT — SELF-CONTAINED
NOTHING ELSE TO BUY
ECONOMICAL PROCESSING
NO INSTALLATION



The Filmatic Model 16 HT is a completely automatic high-speed, high temperature processing machine. Thermostatically controlled operating temperatures at every step. Designed to process any 16mm sound or silent film at speeds up to 115 feet per minute. For illustrated folder and additional information write to William Halpern, Sales Representative, 8240 Fayette St., Philadelphia 19, Penn.

HILLS

MANUFACTURING CO.,
LANSDALE, PA.

Dollars And Sense Of Business Films

Survey is first to provide cost and distribution data. Work based on films costing \$12 million.



JOHN FLORY, chairman of the A.N.A. Films Steering Committee which produced the new report "The Dollars and Sense of Business Films," is shown here with copy of book.

WHAT DOES IT cost to produce and distribute a movie for advertising or public relations purposes?

That's a question on which accurate, documented information has never been available.

Now, however, the Association of National Advertisers has published a new book, "The Dollars and Sense of Business Films," which for the first time provides heretofore confidential data on actual production, print, distribution costs and methods for advertising and public relations films by 67 of the nation's leading companies.

Based on a survey of 157 non-theatrical films representing a total investment of \$12,000,000, this 128-page book is going to make businessmen sit up and take notice. It will have its effect on film producers, too. Among eye-opening points are these:

The typical company spends only 4.6 cents to obtain an average of 26 minutes of a viewer's time to tell the company's story.

The cost per viewer can drop to as low as 3-mils over the life of the film if a good film is made for a broad, general purpose audience.

The average film has a long useful life—usually five years, often more.

When films are in circulation for over 10 years, the cost-per-viewer may drop to as low as 1/2-cent.

It is possible to produce successful non-theatrical films for \$25,800, the median cost in this study.

The study shows a film can be expected to reach an audience of 276,036 in a year, although audiences of up to 4,548,000 have been booked, all depending upon the nature of the film story and the target audiences.

Based on the work of the A.N.A. Films Steering Committee, chaired by John Flory of the Eastman Kodak Company, the book is the result of more than two years' efforts aimed at putting pertinent data in the hands of those people who are investigating the possibilities of non-theatrical films as a solution to their communications problems.

The book reveals a number of important findings. Of the films surveyed, color films are favored nearly four to one. The median running-time of the picture is 26 minutes. While 91% of all films surveyed are circulated in part or entirely by the sponsoring company, one-third are also handled by commercial distributors.

A typical sponsor spends 55% of his budget for the production itself; release prints account for 25%; and the final 19% is located for distribution. Considering that this survey includes a number of specialized films intended for distribution to selected audiences, the over-all average cost-per-viewer of 4.6 cents is equally interesting. This figure includes production, prints and distribution costs, and represents normal circulation—not including television.

The study also reveals that most sponsors design their films so that they will have a long life—at least five years. In this way, the pre-viewer cost of the film attains a maximum economy. For example, the figures given, though they represent a fairly small sample of the various types of distribution and target audiences, show that for those films in circulation up to one year, the cost-per-viewer amounts to 97 cents. For those circulated from 1 to 2 years, the cost-per-viewer is less than 7 cents.

Additional detailed information is offered in the book's summary of findings. Among these are: 99.4% of films surveyed are released in sound; 95% are 16mm prints; total production cost of 116 of the films is \$4,514,477; production costs ranged from a low of \$1,732 to a high of \$426,600, with a medium cost of \$25,800.



DEDICATED TO BETTER PERFORMANCE



COLLAPSIBLE 3-WHEEL DOLLY

For motion picture and TV cameras. Sturdy cast aluminum. For standard or baby tripods. Additional baby tripod point holders to control spread of tripod legs. Adjustable spring seat. Extra wide rubber wheels. Bronze tie down clamps and other features.

For studio or location. Folds into one compact unit. Can be used with professional or semi-professional tripods.

'HYDROLLY'

TV OR
CAMERA DOLLY

The advanced dolly for instant moveability — streamlined, lightweight, exceptionally sturdy. Nothing to get out of order. Many new advantages for easy operation. Hydraulic lift type for fast upward and downward motion of TV and motion picture cameras.

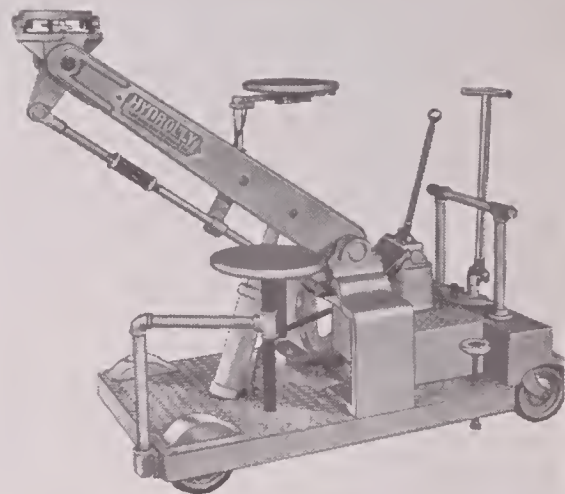

Swivel seat. Adjustable leveling head. Seat for assistant. In-line wheels for track use. Steering wheel, rigid floor locks. Hand pump or combination hand and motor pump. Easily transported in a station wagon. Fits through a 28" door.



SYNCHROMASTER SYNCHRONIZER

Our Exclusive Distributor
Neumade

Any combination of 16mm and/or 35mm sprockets assembled to specification. Cast aluminum. Foot linear type, adjustable frame dial. Fast finger roller release. Contact rollers adjusted individually for positive film contact. Sprocket shaft slip lock, footage counter, etc.

RENTALS

SALES • REPAIRS • SERVICE

LENS COATING

"T" STOP CALIBRATION

DESIGNING and MANUFACTURING

lens mounts & camera equipt.
for 16mm, 35mm, TV cameras.

BAUSCH & LOMB "BALTA"
LENSES and others

for motion picture, TV camer-
as. 15mm to 40" focal length.

COMPLETE LINE of 16mm, 35mm
cameras, dollies, synchronizers,
animation equipment, cutting room
and time lapse equipment.

BELL & HOWELL: Standard, Eye-
mos, Filmos. MITCHELL: Standard,
Hi-speed, BNC, NC, 16mm.

SEND FOR CATALOGUE

ColorTran Groverlite SENIOR & JUNIOR KITS

"A STUDIO IN A SUITCASE"

ColorTran re-
places heavy
and expens-
ive equip-
ment...gives
you illumina-
tion up to
5000w. from

an ordinary 20 amp. house current. Equipped with
barndoors, diffuser slots for silks, snoots and other
accessories. Ideal for studio or location shots.



PORTABLE MICROPHONE BOOM

For Studio or on Location. Light-
weight — collapsible — for TV and
motion picture production. Sturdy
construction. Boom telescopes 7 to
17 ft. Rear handle for directional
mike control. A remote control per-
mits 360° rotation of the microphone.
Operator can push the boom and oper-
ate microphone swivel simultaneously.

Extension rods make it
simple to operate microphone rotation from floor. Microphone
cable hangs outside of boom, preventing cable from tangling
with the rotation mechanism. Ball bearing casters, rigid foot
locks, pneumatic drop check for lowering the boom, etc.

VARIABLE- SPEED MOTOR with TACHOMETER

for Cine Special or Maurer Cameras

115 V. Universal Motor — AC-DC
Separate Base for Cine Special.
Variable Speed 8-64 frames.
Adapter for Maurer Camera.

INTERCHANGEABLE MOTORS: 12
volt DC Variable Speed 8-64 frames.
115 Volt AC 60 Cycles, Synchron-
ous Motor, Single Phase.

ANIMATION MOTORS: Cine Spe-
cial, Maurer, Mitchell, B & H Motors,
for Bolex and Filmo Cameras.



BIG SCALE UNIVERSITY FILM PRODUCTION

(Continued from Page 613)

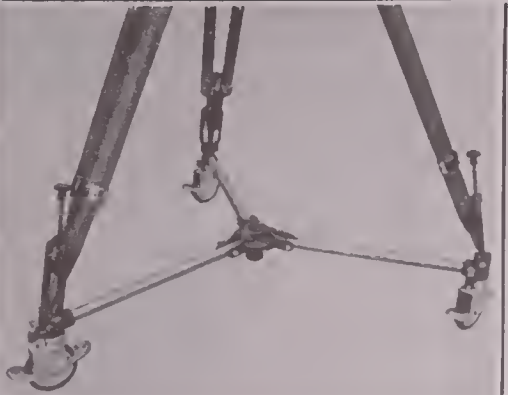

CINEKAD JUNIOR TRIPOD DOLLY

This collapsible three-wheel tripod dolly is especially designed to meet the demand for convenient mobility of cameras on location or in the studio.

Dolly can be used with any professional or semi-pro tripod.

The tripod is fastened firmly to the dolly by a clamp at each leg tip.

The special individual caster locking system makes it possible to lock either two or three wheels in a parallel position, enabling the dolly to track in a straight line for rolling dolly shots.

Dolly folds quickly into a single compact, easy-to-carry unit, 23 inches in length, weighing 14 lbs.

Write for Prices and Literature

CINEKAD

ENGINEERING COMPANY
(Formerly Kadish Engr. Co.)

500 WEST 52ND ST., NEW YORK 19, N.Y.
PLaza 7-3511

DESIGNERS AND MANUFACTURERS OF
MOTION PICTURES AND TV EQUIPMENT

RUBY CAMERA EXCHANGE

Rents . . . Sells . . . Exchanges

Everything You Need for the

Production & Projection

of Motion Pictures Provided
by a Veteran Organization
of Specialists

35 mm. . . . 16 mm.
Television

IN BUSINESS SINCE 1910

729 Seventh Ave., New York 19, N. Y.

Tel.: Circle 5-5640

Cable address: RUBYCAM

it a 25-KW A.C. gasoline generator and two diesel generators of 30-KW each to supply power for location shooting.

The staff then tackled the construction of a multi-directional dolly, similar to Rosie's Dolly described in another issue of *American Cinematographer*. They also fabricated 200 feet of track for same, built four set jacks for moving flats, and constructed a four-blade wind machine patterned after those used in major studios.

In a far corner of the scene storage shed, a D.C. motor generator was set up to provide power for set lighting. Although it was mounted on cork slabs, it was necessary also to construct a fiberglass blimp to minimize operational sounds.

A problem in sound occurred whenever an arc was struck: the burning carbon produced a high-frequency squeal. Staff members came up with a remedy. A filter made from an old line transformer and some condensers successfully eliminated the unwanted noise.

The studio's inventory of equipment also includes a camera crane, a 16mm Mitchell, 16mm Maurer, and Bell & Howel 16mm cameras; five Stancil-Hoffman 16mm double-sprocketed magnetic film recorders and playbacks; a Western Electric recording console; Eastman Model 25 and Holmes arc projectors; plus the necessary interlock systems. Other lighting units, not already mentioned, include 52 pieces of assorted Mole-Richardson equipment.

Two years before actual shooting began on *Wine of Morning*, the original screen play and all drawings for the exterior sets had been completed. A great deal of research went into the planning of costumes, all of which were made by staff members especially for the production. Basic scenery pieces were constructed so they could be used in different combinations. Since many of the sets called for stone walls, special attention was given to casting the

replica material. A framework of 2 by 4's was covered with plaster which was molded in the shape of limestone blocks. From this mold, a genuine effect of a massive limestone wall could be obtained, and inexpensively, too. The wall segments were made by using old burlap bags soaked in molding plaster. These were spread over the negative mold and allowed to set. Actually, two molds were used; they were so designed that the finished castings could be used alternately and upside down in order to provide an un-repetitious effect in the stone pattern. The castings, which incidentally cost about 30 cents each to make, were then nailed to frames and painted.

Squares of Masonite wallboard, 4 by 4 feet in size, were marbelized in lacquer in two basic color combinations to provide tiles for a variety of floor designs.

There were many times when shooting could not be done according to standard procedures — if, indeed, there be such a thing. During the filming of the crucifixion scene, for example, the greatest problem encountered was how to produce the earthquake effect. Here again, reference to a back issue of *American Cinematographer* provided the answer; a camera-vibrating gadget was built—similar to the one MGM constructed for "Battleground" and which was illustrated and described in the January, 1949, issue of this publication. By carefully synchronizing the vibrations with the reactions of the characters in the scene, a tremendously realistic effect was produced.

Near the end of the picture there is a scene in which a ship hits a reef during a storm. This called for the employment of special devices to produce the desired realism. A steel fulcrum was fabricated so that the 12 by 10 foot platform on which the ship's cabin was built could be rocked. The entire cabin was lifted onto the fulcrum with a highlift and adjusted to the approximate center of gravity. Stops were nailed in place to keep it from slipping, and a large coil spring was mounted on each end of the platform to serve as a limit. Two long timbers were extended from each end of the platform to increase the leverage.

During filming of the scene, when the ship hit the reef the cabin was tipped to its limit. The character Barabbas in this scene was hurled against a break-away table. He scrambled to his feet and started up the ship's ladder. Then, as if the wreck had been hit by a huge wave, 200 gallons of water cascaded

SPECIALIZED TITLES and SPECIAL EFFECTS

Motion Picture or Television, 35mm-16mm, Black & White or Color

RAY MERCER & COMPANY

4241 Normal Ave., Hollywood 29, California

NOrmandy 3-9331

We Welcome
Your Problems

RAY MERCER, A.S.C.

30 Years Experience
at Your Service . . .

down the narrow passageway hurling Barabbas back into the cabin.

There are some intricate crane shots in the picture which compare in technique to the best seen in Hollywood productions. Several involved lengthy, sustained action and careful cueing.

In any modern film production, of course, music is of prime importance. The task of preparing this fell to Dr. Joseph Schmoll of the university music faculty. After composing the score, Dr. Schmoll selected and rehearsed forty members of the university orchestra and a choir of fifty voices, after which the score was recorded.

And so the many problems involved in shooting *Wine of Morning* were met and solved one by one. Almost every staff member doubled or trebled in brass at least once during the production. Keen satisfaction was derived by all in the knowledge that their work will be used in Christian service—the purpose and reason behind Unusual Films.

CARMEN JONES

(Continued from Page 611)

this camera action and the abrupt revelation at its conclusion that gives great impact to the scene.

The location of this shack, incidentally, was the scene of another photographic highlight. Actually situated in a shanty-town street in a small town east of Los Angeles, the Preminger company had arrived there late in the afternoon. By the time camera and other equipment had been unloaded and set up, the sun was well below the accepted meridian for good color photography.

Director Preminger decided to make the shot anyway and rehearsed Carmen and Joe in the important scene showing the couple arriving in Carmen's home town. As the couple trudge down the road toward the mother's shack, Carmen is greeted by old friends and presented with gifts of food. By the time the scene was ready to be shot, it was already 7 p.m. The sun was low, decidedly on the red side, and not too many booster lights were available.

Still, Preminger decided to risk the take and told Leavitt to do his best. The resultant shot proved a tremendous delight to both of them, for it had just the right feel of dusk—a pictorial and lighting quality that could not have been duplicated with tricky artificial illumination. It was just another instance where the company dared try, and was well rewarded.

Because the production from start to finish is especially notable for its interesting lighting and camera technique, these two facets of the picture deserve

NOW, more than ever...QUALITY COUNTS

in the East...

... it's

MOVIELAB

The superior QUALITY CONTROL consistently maintained by MOVIELAB on all film processing assignments has earned it the jealously-guarded reputation of being the "QUALITY LABORATORY" in the east.

More producers, cameramen and technicians throughout the east put their trust into Moviellab's "KNOW-HOW" and "personalized service" than any other.

Get to know Moviellab—for this is the standard by which all film processing is judged.

ROUND THE CLOCK SERVICES

Negative Developing
Ultra Violet and Flash Patch Printing
Quality Control
16 mm and 35 mm Release Printing
Title Department
25 Cutting and Editing Rooms
First Print Department

for color it's...

Rainbowlab Inc.

MOVIELAB FILM LABORATORIES, INC.
619 West 54th Street, New York 19, N. Y. JUdson 6-0360

1
2
3
4
5
5SS
6
6SS
7
8
8F
8P
9
9P
9F
12
12F



It's easy with the
MERCER FILM PATCH
 Descriptive Chart & Price List
 Mailed on Request
R. C. MERCER & COMPANY
 4241 Normal Ave., Hollywood 29, Calif.
 NOrmondY 3-9331

**Now! A 400ft. Magazine
 For Your BOLEX H-16**

Complete
 with
 Synchronous
 Motor
 and Base



Includes
 Installation
 and
 Case

Permits continuous run of 400 feet of 16mm film, or—the 200 ft. daylight loading spool may be used in the 400 ft. magazine. The 100 ft. daylight loading spool can be used in the camera without removing the external magazine. In black wrinkle finish to match camera. Fully guaranteed. Write for information on our Rack-Over Sportsfinder and Camera Base.

See your Bolex dealer or
 order direct. Immediate delivery.



TOLEDO CINE ENGINEERING
 1309 Milburn Ave. Toledo 6, Ohio

WORLD FAMOUS

S-5

synchronous
 magnetic film
 recorder for
 motion pictures
 and television



STANCIL-HOFFMAN

921 N. Highland Hollywood 38, Calif.

send
 for
 particulars

additional analysis. Students of cinematography will especially like the unique follow action of the camera in the scene where Carmen, now living with Joe in a third-rate Chicago flophouse, flounces out of the room after an argument with him and runs down the stairs to a telephone on the landing below.

Here the camera, close upon her at the start of this action, moves briskly through the door as she exits and follows her in the flight down the stairs and continues to zoom further as she starts to dial the telephone. The impact of this camera treatment here is terrific and greatly heightens the dramatic effect of the action at this point.

Another unusual camera manipulation occurs when the group of girls, visiting the fighter, Husky Miller, in his lavish hotel room are telling fortunes with cards. Suddenly, Carmen, who until now has been a disinterested spectator, suddenly moves to the table, sits down and picks up the deck of cards. As she does so, the camera simultaneously

zooms in and lowers to a new level to frame a dramatic closeup that starts a new song by Carmen.

While a great deal of the picture calls for nothing more than routine standard lighting, there are instances where imaginative set illumination is employed to build or sustain a mood. An outstanding example is the exterior setting where Husky Miller makes his initial entrance in the picture. In the background is the cafe where Carmen and Joe have met, loved and quarrelled. As Miller enters the scene in his expensive foreign sports car, a crowd of admiring fans gathers around him. The camera moves from a medium shot of Carmen on the cafe veranda and works its way eventually to a closeup of Miller. What Leavitt accomplished here was a genuine feeling of night time, yet all the Negro players are so subtly lit that each face is easily distinguishable; there is none of the forced illumination nor any of the spurious night effect lighting that so often characterizes a color production. *(Continued on next page)*

Quad-life—Economy Set Lighting Tool



AL LANE, set electrician at MGM studios in Hollywood, points out rugged quad-lite which that studio engineered and built for standard set lighting use. Quads have sockets for four photoflood lamps, switches to control lamps in pairs. Housing is all aluminum and has regulation tilting and swivel fitting for use on regular lamp standards. Heavy wire brackets at either side of lamps protect them from damage.

Film Editing Made Easy
with NEW
**professional
film viewer**

for 35mm and 16mm

Every film editor will appreciate a viewer that enables him to view his film from left to right—on a large, brilliantly illuminated screen.

The PROFESSIONAL FILM VIEWER makes film editing a breeze. Easy threading, portable, will not scratch film. Put this viewer between your rewinders and speed up your editing. Size of Viewing Screen 5¾ x 4¾.



35mm Model \$375
16mm Model \$350



Write Dept. A-12-4

Because director Preminger had chosen to shoot so much of the picture in natural locales, lighting became an even greater challenge when working in these setups. A great deal of the closing action takes place in a boxing arena frequented by colored people. These scenes were staged inside the Olympic Auditorium in Los Angeles. One of the impressive things the photographic-minded reader will note when seeing this picture is the great depth of perception that was achieved in the mob scenes of the spectators seated in the auditorium. Very few scenes of this kind filmed in black-and-white have ever shown such vast crowds; the camera never seemed to reach back into the dark recesses as did Leavitt's Cinema-Scope camera in these scenes. The result is that one appreciates more what can be done today with color film and moderate lighting in recording difficult scenes of this kind.

A discussion of this phase of the photography would not be complete without dwelling a moment on the lighting of the arena between rounds of the climactic championship bout. As most readers are aware, fight arena house lights are all but extinguished between rounds of a bout, with only the lights above the ring left on; at the end of each round the house lights are turned on.

(Continued on next page)

C. ROSS

FOR

LIGHTING EQUIPMENT

**Inkie and Arc Lamps including Required Accessories
Generators—Cables—Boards—Boxes**

Raby Camera Crane—Dollies—Blimps—Geared Heads

GRIP EQUIPMENT

FOR LOCATION AND STUDIO

**Parallels—Steps—Platform Ladders
Century Stands—Reflectors—Flags—Scrims**

SOLE EASTERN MOLE-RICHARDSON CO. DISTRIBUTOR

RENTALS • SALES • SERVICE

CHARLES ROSS, Inc.

333 WEST 52nd STREET

NEW YORK 19, N.Y.

Circle 6-5470-1



GEO. W. COLBURN LABORATORY INC.

164 NORTH WACKER DRIVE • CHICAGO 6
TELEPHONE STATE 2-7316

**8 and 16mm
SERVICES**



PELEGRINI

**VARIABLE SHUTTER UNITS
FOR THE BOLEX H-8
AND H-16**

The real answer to complete FADES and LAP DIS-

SOVLES. Faster shutter speeds and many other advantages. Prices for both the H-8 or H-16 within U. S. \$99.60. Cameras with outside frame counter \$109.80. Tax extra. One year guarantee and camera transportation back included. Send for free informative booklet.

Prices subject to change without notice.

TULLIO PELLEGRINI
1545 Lombard St.
San Francisco 23, California



Ready-Eddy

U. S. Registered Trademark
**USEFULNESS GUARANTEED
FOR EVERY DAY USE**

1001 Ready Sound-Film

Editing Data:
• Footage • Frame
Count • Screen Time
• 35mm and 16mm
equivalents.

Plastic computer for everyone in movies and TV, from script to screen.

\$2.00 Prepaid

(Delivered in U.S.A.)

ASK FOR REPRINT OF ARTICLE
IN AMERICAN CINEMATOGRAPHER.

Write or ask your dealer

READY-EDDY, Sandy Hook, Conn.



16mm SCENE TESTER

11 densities. Tests track and picture. Also used to check developer.

\$395.00

GREAT LAKES MOTION PICTURE SERVICE
12037 Grand River Ave. • Detroit 4, Mich.

Leavitt achieved this effect very successfully by having his lighting circuits divided so that the audience section of the background could be dimmed at the sound of the judges' gong. At no time, of course, is the lighting entirely extinguished, and it is possible to distinguish spectators not only at ringside but in the row of seats far at the rear. This enabled Preminger to get from his spectators the audience reaction so necessary to building suspense at this point.

The recording of the fight action between Husky Miller and his challenger is a terrific bit of photography, and yet it was quite simply achieved. Here, by virtue of the CinemaScope lens, it was possible to shoot the entire action from a single vantage point, without need for moving the camera at any time. So intimate and revealing is the scope of the wide-screen lens that you see every bit of the action without the need for cuts to closeups. Perhaps the most distinguished thing about the photography of the fight scenes is that hand-held camera shots were studiously avoided. As a result, the scene is as dynamic as it is different.

Probably the most challenging se-

quence to be filmed was the group of scenes which became the climax of the story—the meeting of Joe and Carmen at the fight arena and the strangulation that follows. Director Preminger chose a vacant refreshment stand in the arena auditorium as the locale for this action. The stand, a niche in the massive concrete structure barely 8 by 12 feet in size, had a narrow door opening on the main corridor and a window above a counter through which drinks and sandwiches normally are dispensed. For the scenes, the window was shuttered and the door unlocked. As Carmen is descending the stairs after the fight, Joe confronts her suddenly and pushes her through the door and into the small room, and begins his plea for Carmen not to forsake him.

Here the photography followed a carefully planned pattern—a continuous shot; no cuts. The camera was mounted on the small boom, with the boom raised and extended through the window. The lighting, keyed perfectly to the somber mood of the action, was accomplished with only six small lamps.

It was in the closing part of the scene played here that the ingenuity of the camera crew was taxed to the limit to

Uses Bucket For Underwater Shots



BUCKET FISHING with a camera is one of the ways in which travel film producer-photographer Julian Gromer captured the submarine beauty of the Florida Keys on film. With his cine camera secured inside the glass-bottomed bucket, Gromer gets undersea shots without getting wet. He recently completed "Keys To Adventure" for makers of Mercury outboard motors; the film contains one of the finest tarpon fishing sequences ever recorded.

achieve the type shot desired—a follow shot of Joe in a rage strangling Carmen, then as the two sink to the floor, of Joe rising slowly as the MPs arrive to take him away, and of Joe as he sadly walks out and down the corridor. Here the camera had to perform a “snake” shot—that is, on the boom, it was extended far inside the stand; then as Joe rises and exits, it moves forward to the very limit, then twists sharply to the left to catch him exiting the door.

There are more, many more instances, of course, of brilliant camera handling in this production; but those described here should prove sufficiently intriguing and suggest such educational possibilities for the student of cinematography as to warrant a special study of the entire production on the screen. It is easily one of the year's better films.

A new tool has been created for the amateur movie maker interested in producing 8mm and 16mm movies with sound as well as magnetic soundfilms. On one long-playing, pure vinylite, hi-fidelity record the Audio-Master Corp., 17 East 45th St., New York 17, provides a group of 16 musical selections composed of openings, closings, bridges, fanfares and a variety of mood music, ranging in time from 23 seconds to 3 minutes.

Model 35-16C
S E N S I T E S T E R

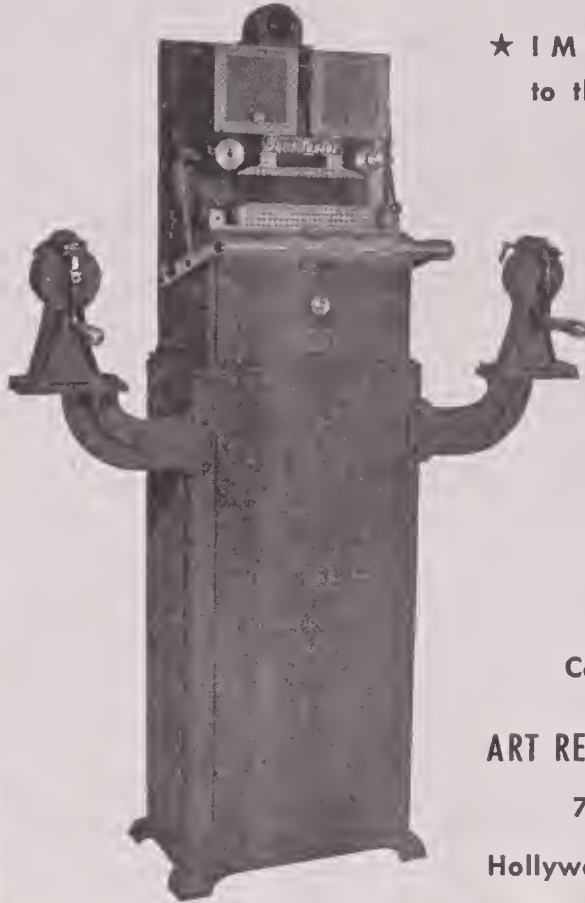

★ IMMEDIATE DELIVERY
to the lab owners interested in—

**QUALITY
EFFICIENCY
ECONOMY**

- DUAL MACHINE
1—Sensitometer
2—Scene Tester
- HIGHLY ACCURATE
Electronic timer unaffected
by climatic changes.
- NEW TYPE LONG-LIFE
Cold Light Exposure Unit
- WITHOUT ADDITIONAL
EXPENSE will match any
printer

Combination 35mm-16mm

ART REEVES MOTION PICTURE EQUIP.

7512 Santa Monica Blvd.

Hollywood 46

California



frost
lights the nation!

**MOTION PICTURE STUDIO •
THEATRICAL • DISPLAY
RENTAL EQUIPMENT**

WHEREVER YOU ARE—WHATEVER YOU NEED

... in the way of unusual, specialized lighting, call on Jack Frost! For movie-making, stage lighting, feature exhibits, large conventions ... for *any* location that requires exceptional lighting, Jack Frost is ready to serve you! And Jack Frost's unequalled national service includes complete installation and removal *wherever* you are. Rent all your specialized lighting equipment from Jack Frost ... famous for lighting the nation's greatest shows ... most spectacular displays.

**FOR FULL INFORMATION ON
RENTAL EQUIPMENT
MAIL COUPON, OR CALL
DETROIT, TRinity 3-8030**

**JACK A. FROST, DEPT. J,
234 PIQUETTE AVE.
DETROIT 2, MICHIGAN**

Please send me full information on
your rental service.

Name _____
Address _____
City _____ Zone _____ State _____

ADD 100% VALUE TO YOUR MOVIE CAMERA



As You Achieve Sensational New Picture Taking Success With These **EXTRA LENSES**

B&L F/3, 1 3/4 in. TELE-type Lens, focus Inf. standard screw thread for 8mm Camera. Triple magnification of normal lens.....\$24.50
 Wray Semi-WIDE ANGLE F/3.5, 20mm fixed focus Lens, standard screw thread, for 16mm Camera. 20% MORE coverage than normal lens.....\$14.50
 Schneider Xenon F/2, 50mm TELE-type Lens in Focus mt. (coated) standard screw thread for 16mm Camera. Double magnification of normal lens.....\$52.50
 Fully GUARANTEED—15 Day Trial Offer. Write Mr. H. Hill for FREE Lens Catalog #154.

BURKE & JAMES, INC. 321 So. Wabash, Chicago 4.

Inquiries Invited

Opportunity for Dealers and Distributors for **CINEKAD** line of motion picture and TV equipment in the United States and Foreign Countries

All items in constant demand, attractively priced, with generous profit-making discounts.

Write For Details to **CINEKAD**

ENGINEERING COMPANY
 (Formerly Kadish Engr. Co.)
 500 WEST 52ND ST., NEW YORK 19, N.Y.
 PLaza 7-3511
 DESIGNERS AND MANUFACTURERS OF MOTION PICTURES AND TV EQUIPMENT

It's Film Industries

for

PROCESSING PRO'S PREFER

Recent installation of several Filmline negative-positive and reversal processors, plus new Bell & Howell printers and new German editing equipment, gives us a daily capacity of 300,000 feet of critical duplication and processing.

We are now the world's largest and finest-equipped mail order film laboratory. Send for free catalog covering 16mm laboratory services as well as DuPont bulk film.

REVERSAL - NEGATIVE - POSITIVE - COLOR
FILM INDUSTRIES, INC.

Dept. A, P.O. Box 938 • Bridgeport, Conn.

Scheibe FILTERS

In World-Wide Use

Produce moonlight and night effects in daytime • fog scenes • diffused focus and many other effects.
 Information mailed on request.

SCHEIBE FILTERS COMPANY
 ORIGINATORS OF EFFECT FILTERS

P.O. Box 46834, Hollywood 46, Calif.

SO YOU WANT TO PHOTOGRAPH BIRDS!

(Continued from Page 621)

Once the blind has been erected, there is often a long waiting period before the birds become accustomed to it and return to their normal activity. Sometimes it is necessary to erect the blind several days in advance of its use in order to allow the more timid birds time to accept it as harmless. Once the birds do return to their nest, however, the cameraman seated inside the blind has an unexcelled view of everything that is taking place before the lens of his camera. It is this opportunity to film in detailed closeup all the beauty of birdlife that makes bird photography so exciting, so much fun, and so well worth the time and patience it requires.

In many locations, however, the use of a blind is impractical. Such is the case when the nest is high in a tree or bush. In other instances the nest may be located so far off the beaten path that it will be both difficult and time consuming to set up a blind. Under such conditions bird filming by remote control is the logical solution.

With a simple remote control device

almost any movie camera may be operated at distances of fifty to one hundred feet. No blind is needed for concealment of the camera as long as the operator remains reasonably quiet and motionless. It is surprising how quickly most birds recover their confidence after a small, motionless object such as a tripod-mounted camera has been placed near the nest. Usually within twenty or thirty minutes they have lost all fear of it and are again feeding their young. Because the camera can be placed very near the nest without alarming the birds, remote-controlled filming enables extreme close-up bird photos to be taken with the use of relatively inexpensive low-power telephoto lenses.

Now, how does one adapt a camera for remote control operation? One very dependable method relies upon electromagnetic tripping of the shutter. In its simplest form this is accomplished by mounting an electromagnet (or solenoid) on the camera in such a position that it will trip the shutter release lever whenever current is sent through the coils of the magnet. Thus the camera may be operated from quite a distance merely by running wire from the shutter-operating magnet to a combined battery box and control switch.

Mobile Camera Shots With Fork Lift Truck



PART OF the success of any newsreel or documentary film photography can be credited to the use of varied camera angles. The Yale & Towne Mfg. Co., Philadelphia, demonstrated this recently when one of the company's fork lift trucks with special platform was pressed into use by a cameraman covering a big outdoor get-together for employees at the Y & T plant. The camera was raised or lowered smoothly and with ease, and dollyed back and forth, giving the cameraman all the maneuverability achieved in major studio sound stages.

nglen
CORPORATION
MAKERS OF
SYNCHRONOUS
Magnetic
FILM
RECORDERS

Degausser

FOR MAGNETIC FILM AND TAPE



The only full size Degausser that can be carried with one hand.

NET PRICE **\$69.50** F. O. B.

3503 WEST OLIVE AVENUE • BURBANK, CALIFORNIA
CABLE ADDRESS "HALLEN" • PHONE THORNWALL 8-6976

The details of adapting any particular motion picture camera for remote control operation will vary from camera to camera. Those cameras having release levers which require but little pressure to trip are best suited for remote control filming. In most cases an arrangement whereby a solenoid pulls down a lever which, in its downward thrust, trips the camera release lever will be best. The lever must be spring-mounted so that it will spring upward when current is no longer applied to the solenoid. Such a simple arrangement, illustrated in Figs. 2 and 3, permits the camera to be started and stopped at any instant from any distance. Both the camera and the solenoid are mounted in alignment upon a common base of wood or metal into which a 1/4-20 hole has been tapped so that the whole unit may be threaded onto a tripod.

Since remote control operation often demands long distances between battery control box and the camera operating solenoid, the voltage supplied must be great enough to insure precise and consistent operation of the unit. Various combinations of solenoids and camera release lever resistances may require more or less voltage for best operation. If a stronger "pull" by the solenoid is needed to start the camera, it may be obtained by increasing the voltage sup-

ply. Too great a voltage, however, may cause the solenoid to overheat. Test any arrangement thoroughly before taking it into the field for actual bird filming.

Pondered by many who have a yearning to photograph birds is the all-important question of the equipment required. Happily such equipment doesn't have to be elaborate and it doesn't have to be expensive. Often the 8mm or 16mm camera one already uses can be readily adapted for a wide variety of bird filming, so let's consider the basic equipment necessary to enjoy this fascinating pastime.

Cine filmers will find that a telephoto lens of moderate power will be required for bird photography, for the camera must be placed far enough from the nest to prevent the whir of its motor from alarming the birds. At this distance the lens must possess sufficient magnification to record a large, detailed image of the bird. For most bird movies a three-power telephoto lens (1 1/2-inch focal length for 8mm cameras, 3-inch for 16mm cameras) will be entirely adequate.

Telephoto lenses for motion picture filming of birds should be as "fast" as one can afford. This is true because all filming of birds must be done by natural light. Often birds build nests in locations where the light is poor; in

Advantage Never Before Offered!



SWIVEL BALL JOINT ATTACHMENT

for
PROFESSIONAL JUNIOR TRIPODS

Swivel Ball Joint Attachment can be mounted between head and tripod body in a few seconds and without any technical knowledge. Swivel Ball has enough tightening strength to hold the largest and heaviest movie cameras, permits leveling camera quickly when tripod is set up on uneven ground. Ball Attachment is made of lightweight aluminum, weighs approx. 3 1/2 lbs.

Ten Day Money-Back Guarantee
Write for Catalog and Prices

CINEKAD

ENGINEERING COMPANY
(Formerly Kadish Engr. Co.)

500 West 52nd St., New York 19, N.Y.
PLaza 7-3511

DESIGNERS AND MANUFACTURERS OF
MOTION PICTURE—TV EQUIPMENT

MOVIOLA

FILM EDITING
EQUIPMENT
16MM - 35MM

- PICTURE SOUND Photo and Mognetic
- SYNCHRONIZERS
- REWINDERS

One of the new series 20 Moviolas for picture and sound.

Write for Catalogue

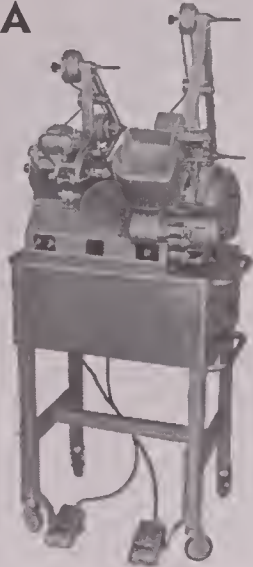

MOVIOLA MANUFACTURING CO.

1451 Gordon St. • Hollywood 28, Calif.

Automatic Daylight Processing



DEVELOPING TANK

- Processes up to 200 Ft.
- 8mm-16mm-35mm
- Movie—X-Ray—Microfilm
- Motor driven portable
- Tough plastic tanks
- Uniform Density Assured
- 70mm tank also available

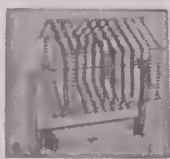

FILM DRYER

- Motor driven—Heated
- Speedy drying
- Automatic shrinkage allowance
- Stainless steel and aluminum construction
- Easily assembled without tools
- Compact, Portable

Guaranteed. Write for Free Literature.

Micro Record Corp. Dept. AC
487 South Ave.
Beacon, N. Y.



Reversal PROCESSING

Reversal specialists for over a decade. Our long experience insures superior quality. Electronically controlled machines keep temperature constant within .2 of one degree. National "Brilliantone" Cine prints are the finest available. Write for free catalogue.

CONTACT PRINTING B & W DUPLICATING
WORK PRINTS KODACHROME DUPLICATING
EDGE NUMBERING VACUUMATING

All work vaporated at no extra charge

NATIONAL CINE LAB

Box 4425 Washington 17, D. C.

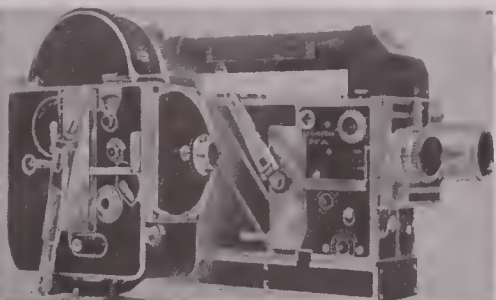

Automatic dissolve attachments for Cine Special and Bolex H-16 (Equipped with Pellegrini Shutter)

JOSEPH YOLO, 1037 N. La Brea
Phone GL. 7103 Hollywood, California

other cases filming must be done on overcast days. Consequently lenses possessing maximum apertures of f/2.8 or larger are most desirable. Choose all telephoto lenses with a focusing mount to permit filming as close as five feet to the subject. In general, fixed-focus telephoto lenses are of little use for bird filming.

In addition to camera, lenses, tripod, and remote control equipment, every bird photographer should have a pair of good binoculars; those having a magnification of six to eight power are ideal. Not only are binoculars helpful in locating birds, but they are indispensable for observing the birds at their nests during the actual filming. Since the location chosen from which to operate a camera by remote control must be some distance from the nest in order to avoid alarming the birds, binoculars make it easy to see every movement of the birds. It's then a simple matter to determine the instant of the bird's best pose as the moment for tripping the shutter.

To many, bird nest hunting in itself is an absorbing pastime. To a bird photographer it becomes a necessity, for birds are most easily and most naturally filmed at their nest. Skillful as birds are in concealing their nests, they do furnish clues which ultimately re-

veal their hidden location.

These clues are easily detected when the parent birds are building their nests. With the aid of binoculars, look for a bird gathering bits of grass, sticks, leaves, and other nest building material. Then watch the bird closely as it comes and goes in order to pinpoint the exact location of its nest. Approach the nest slowly and quietly, for at this stage of nest construction many birds will desert a partially-built nest if they become alarmed.

A similar nest hunting system works equally well for the location of nests after the young have hatched. At this time the parent birds are observed as they carry insects to their young. A few birds fly directly to their young—their nests are relatively easy to find. Others approach their nesting sites only in an indirect fashion, landing first in one place, then flitting nervously to another, finally going to the nest itself by stalking through concealed pathways in the grass or by flying through nearby dense thickets. To uncover the nesting site of such wary, secretive birds demands the keenest and most patient observation.

Success with common birds provides excellent experience with which to tackle later the shyer, more secluded birds. For that reason beginning bird filmers will do well to confine their first film-

World's Largest Pola Screen

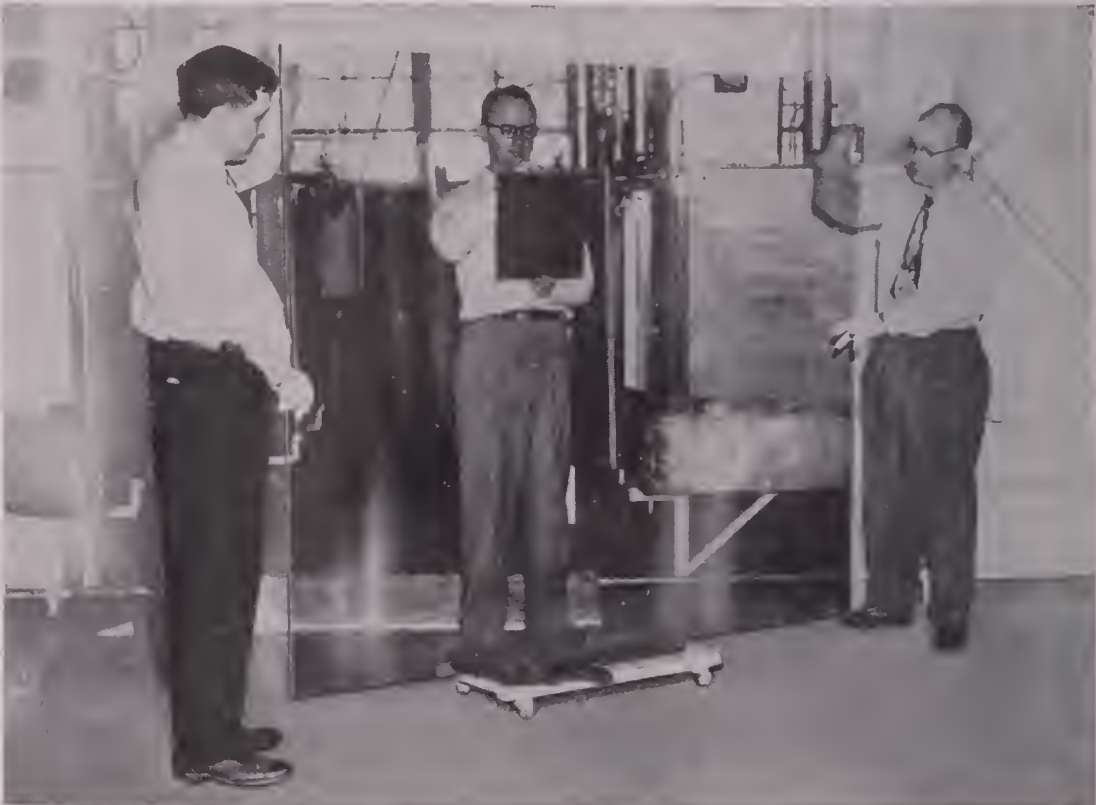

WHAT is believed to be the world's largest continuous polarized glass sheet was manufactured recently by Polacoat Incorporated, Cincinnati, Ohio, and was processed into a polarized daytime screen for rear projection of movies. Measuring 70" by 80", the polarizing coating is on quarter-inch polished plate glass. The man in the background is holding another glass polarizer turned at opposite axis, which appears to be black.



INCREASE YOUR OUTPUT 30% to 100% WITH A



SOUND PRINTING HEAD

- Converts your model "J" or "D" into a double head printer without machining.
- Print both sound and picture from separate negatives in one operation with this conversion.
The following three models are available:
- For printing 16mm negative to 16mm positive.
- For printing 35mm negative to 35mm positive.
- For printing 16mm negative to 32mm positive and 32mm negative to 35mm perforated 32mm positive.

Send for Catalog
of Motion Picture
Printing Equipment
and Accessories



MOTION PICTURE PRINTING EQUIPMENT CO.
Mfrs. of Optical and Continuous Printers and Accessories.
8136 NORTH LAWNDALE AVENUE • SKOKIE, ILLINOIS

Write today
for prices
and complete
literature.

ing sessions to the more familiar birds. Robins, bluebirds, bluejays, flickers, and sparrows are just a few of the birds well-suited for beginning bird photographers. Not only are these birds colorful objects, but their nests are also easily found and filmed. Frequently their nests may be placed at low elevations. Bluebirds and flickers, for instance, often nest in holes only six to twelve feet above ground level. Many other species build nests low in bushes and thickets. Some birds, such as meadowlarks, towhees, bobolinks, and several of the sparrows construct their nests directly upon the ground.

Once a nest has been located, devote some time to observing the habits of the birds before actually setting up the photo equipment. Determine what branches and which sides of the nest are favorite perches. Then place the movie camera so that it is focused upon one of these favorite perches. Success with remote control bird filming especially depends upon correct anticipation of the exact spot upon which the bird will consistently alight.

Success, too, depends upon flawless camera technique. Closeup bird photography demands precise focusing. Many movie cameras lack the accuracy and convenience of through-the-lens focusing. With such cameras always measure the

exact camera-to-subject distance with a ruler or tape measure and set the focusing scale accordingly. Only accurate measurements will insure crisp focus. Never estimate subject distances—an error of just a few inches may be enough to throw the resulting bird picture badly out of focus.

Fine bird movies demand that the camera position be changed often during the filming session, usually each time the camera spring is rewind. Such change injects a variety of viewpoints into the film. For example, shoot opening scenes from a distance of ten or fifteen feet to picture both the bird and its surroundings. Such a scene constitutes a "long shot" when applied to bird filming. Then move the camera closer for succeeding views, climaxing the series with screen-filming closeup of the bird itself. Try especially for a few extreme closeups of the wide-open mouths of the young. Cut to a closeup of the parent, revealing in detail its bill full of worms and insects. Then photograph in medium shots the actual feeding sequence.

Such action-packed movie sequences demand time and patience to film. All are within the capability of remote control photography. To produce such a sequence necessitates shifting the camera

(Continued on Page 636)



FISHER FILM CLEANER

for Clear Pictures,
Faultless
Sound!

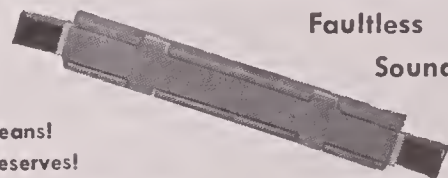

Cleans!
Preserves!
8 and 16mm Films!

Save your precious films. Show them at their best, free from dirt, dust, specks and spots. Eliminate annoying magnified fuzz and lint from your screened picture. With sound film you get undisturbed, smooth reproduction without disturbing noises due to dirt on the sound track. Dry chemicals on soft, replaceable cleaner pads assure brilliant highlights and sparkling color. Easy, simple to use!

Send ONLY \$2.95 direct. (Former advertised price, \$3.95.) Postage paid. Satisfaction guaranteed or money refunded.

FISHER MFG. CO.,
1185 MT. READ BLVD., ROCHESTER 6, N. Y.

HOLLYWOOD STUDIO PRODUCTION

Feature and television film productions for which members of the American Society of Cinematographers were engaged as Directors of Photography during the past month.

AMERICAN SOCIETY OF CINEMATOGRAPHERS

BOARD OF GOVERNORS—1954

ARTHUR MILLER, President
SOL HALPRIN, First Vice-President
JOSEPH RUTTENBERG, Second Vice-President
ALFRED GILKS, Third Vice-President
WALTER STRENCE, Treasurer
PHILIP TANNURA, Secretary
ROBERT DE GRASSE, Sergeant-At-Arms
JOHN ARNOLD
JOSEPH BIROC
ARTHUR EDSON
GEORGE FOLSEY
LEE GARMES
VICTOR MILNER
HAL MOHR
LEON SHAMROY

ALTERNATE BOARD MEMBERS

ARTHUR ARLING
LUCIEN BALLARD
DAN CLARK
PAUL EAGLER
FARCIOT EDOUART
ERNEST LASZLO
ROBERT PITTACK
JOHN SEITZ
JAMES VAN TREES
PAUL VOGEL

ALLIED ARTISTS

HARRY NEUMANN, "High Society."
ELLSWORTH FREDERICKS, "Code Three."

COLUMBIA

CHARLES LAWTON, "My Sister Eileen,"
Technicolor, CinemaScope.
HENRY FREULICH, "The Monster Beneath
The Sea."
CHARLES LANG, "The Man From Laramie,"
Wm. Goetz Prods. Technicolor; CinemaScope.
LESTER WHITE, "Five Against The House."
HENRY FREULICH, "Chicago Syndicate."

METRO-GOLDWYN-MAYER

GEORGE FOLSEY, "Hit The Deck," Cinema-
Scope, Eastman color.
PAUL C. VOGEL, "Interrupted Melody,"
color, CinemaScope.
HAROLD MARZARATI, "The Marauders,"
Wide-screen; color.
PAUL C. VOGEL, "The Scarlet Coat," Color;
CinemaScope.
RUSSELL HARLAN, "Blackboard Jungle,"
wide-screen.

PARAMOUNT

ROBERT BURKS, "The Trouble With
Harry," Technicolor, VistaVision.
DANIEL FAPP, "You're Never Too Young,"
Technicolor; VistaVision.
LEE GARMES, "The Desperate Hours,"
VistaVision.

LOYAL GRIGGS, and WALLACE KELLEY,
"The Ten Commandments," Technicolor;
VistaVision.

JAMES WONG HOWE, "The Rose Tattoo,"
VistaVision.

RAY RENNAHAN, "The Court Jester," Dena
Prods.—Technicolor; VistaVision.

20TH CENTURY-FOX

MILTON KRASNER, "The Seven Year Itch,"
color, CinemaScope.

HAROLD LIPSTEIN, "A Man Called Peter,"
color; CinemaScope.

LEON SHAMROY, "Daddy Long Legs,"
Color; CinemaScope.

LEO TOVER, "Soldier Of Fortune," Color;
CinemaScope.

UNIVERSAL-INTERNATIONAL

WILLIAM DANIELS, "The Shrike."

IRVING GLASSBERG, "The Purple Mask,"
Technicolor; CinemaScope.

GEORGE ROBINSON, "Abbott And Costello
In The Mummy."

RUSSELL METTY, "Cult Of The Cobra."

WILFRID CLINE, "Third Girl From The
Right," Technicolor.

CARL GUTHRIE, "Kiss Of Fire," Techni-
color; wide-screen.

MAURY GERTSMAN, "Tacey," Technicolor.

WARNER BROS.

ELLIS CARTER, "The River Changes,"
Warner Color, CinemaScope.

WINTON HOCH, "Mister Roberts," Cinema-
Scope, WarnerColor.

HAROLD ROSSON, "Strange Lady In Town,"
WarnerColor, CinemaScope.

J. PEVERELL MARLEY, "Jump Into Hell."

INDEPENDENT

ROBERT SURTEES, "Oklahoma," Eastman-
color, Todd-AO, CinemaScope, R & H
Pictures.

FRANK PLANER, "Not As a Stranger,"
Stanler Kramer Prods., Widescreen.

HARRY WILD, "Top Of The World," Land-
mark Prods., Wide-screen.

JOSEPH LASHELLE, "Marty," Hecht-Lan-
caster Prods.

GILBERT WARRENTON, "No Place To
Hide." Jos. Shiftel Prods. EastmanColor;
Wide-screen.

LUCIEN BALLARD, "Magnificent Matador,"
EastmanColor; CinemaScope. Nat'l Pics.
Primero production for 20th-Fox release.

JOHN L. RUSSELL, "The Indestructible
Man." J. Pollexfen Prods.

TELEVISION

(The following directors of photography were active last month in photographing films for television in Hollywood, or were on contract to direct the photography of television films for the producers named.)

LUCIEN ANDRIOT, "Where Were You?,"
Ken Murray Productions; "It's a Great Life,"

Raydic Corp'n; "The Life of Riley," Hal
Roach Studios.

JOSEPH BIROC, "Treasury Men in Action,"
American National Studios, Inc., and "Dear
Phoebe," Dear Phoebe Productions.

WILLIAM BRADFORD, "Gene Autry," Fly-
ing A Productions.

NORBERT BRODINE, "The Loretta Young
Show," Lewislors Ent.

EDWARD COLMAN, "Dragnet," Sherry TV
Inc.

FLOYD CROSBY, "Authors Playhouse,"
Authors Playhouse Prods.

ROBERT DE GRASSE, "Make Room For
Daddy," Marterto Prods., Inc., and "The
Ray Bolger Show," B & R Ent.

GEORGE DISKANT, "Four Star Theatre,"
Four Star Productions, Inc.

E. B. DUPAR, "Tim McCoy Show," Mercury-
Int'l Pictures.

HENRY FREULICH, "Captain Midnight,"
Screen Gems.

KARL FREUND, "I Love Lucy," "Willy" and
"December Bride," and "Our Miss Brooks,"
Desilu Productions, Inc.

FREDERICK GATELY, "Mayor of the
Town," Rawlins-Grant, Inc.

AL GILKS, "The Halls of Ivy," Television
Programs of America, Inc.

SID HICKOX, "Holiday In Rhythm," Mercury
Int'l Inc.

BEN KLINE, "Fireside Theatre," "An Argu-
ment With Death," Frank Wisbar Prods.

JACK MACKENZIE, "Public Defender," and
"Passport To Danger," Hal Roach, Jr., Pro-
ductions.

WILLIAM C. MELLOR, "The Adventures of
Ozzie And Harriet," Stage Five Prods., Inc.

ERNEST W. MILLER, "Rocky Jones, Space
Ranger," and "Stu Erwin Show," Roland
Reed Productions.

VIRGIL MILLER, "You Bet Your Life,"
Filmcraft Prods.

HAL MOHR, "That's My Boy," McCadden
Corp'n.

NICK MUSURACA, "Lineup," Desilu Prods,
Inc.

KENNETH PEACH, "Here Comes Donald,"
O'Connor Prods.

ROBERT PITTACK, "The Lone Ranger,"
CM TV Productions, Inc.

JOHN L. RUSSELL, JR., "Joe Palooka,"
Guild Films.

WILLIAM SICKNER, "The Whistler," Linds-
lay Parsons Productions.

MACK STENGLER, "Liberace," "Life With
Elizabeth," "Florian Zabach Show," and the
"Frankie Lane Show," Guild Films.

HAROLD STINE, "Superman," Superman,
Inc., "Cavalcade of America," "This is Your
Music," Jack Denove Prods., and "Korla
Pandit," Snader Prods.

ALAN STENSVOLD, "Andy's Gang," Frank
Ferrin Prods.

WALTER STRENCE, "Waterfront," Roland
Reed Productions, and "My Little Margie,"
Roach, Jr.-Reed Productions.

PHILIP TANNURA, "Burns And Allen
Show" and "The Jack Benny Show," McCad-
den Corp'n.

STUART THOMPSON, "Lassie," Robert Max-
well Associates.

JAMES VAN TREES, "I Married Joan," Joan
Davis Enterprises and "Hey, Mulligan,"
Mickey Rooney Enterprises.



In Television, too...

Good cinematography has contributed as much to the advancement of television as any other factor. Today, the bulk of the important TV programming is on film, with more to come. For this reason discriminating producers of TV films choose members of the American Society of Cinematographers to direct the photography of their pictures . . . More and more, you see "ASC" after the names of the cinematographers who shoot the industry's best television films.

The logo consists of the letters 'A.S.C.' in a bold, serif font, enclosed within a rounded rectangular border.

A.S.C.

Hallmark
of Superior
Cinematography . . .

UHLER PRINTERS



Combination 16mm continuous for color or B and W films. Prints sound and picture simultaneously, either single or double system.

Other printers for:

Reduction and enlarging 16-8mm and 8-16mm.
Reduction and enlarging 35-16mm and 16-35mm.
Sound reduction for 35 to 16mm only.
Cine 16mm for sound or silent pictures.

Machines are tested and guaranteed.

Write for literature.

UHLER CINE MACHINE CO.

15778 Wyoming Ave., Detroit 38, Mich.
Ph.: UNiversity 1-4663 Cable: "UHLICIMA"

SO YOU WANT TO PHOTOGRAPH BIRDS!

(Continued from Page 633)

position for each scene, then waiting for the adult bird to return. Often the various scenes cannot be filmed in their proper sequence, but must be obtained whenever the desired action occurs. Subsequent editing of these scenes permits their rearrangement to create a smooth, coherent feeding sequence. Other aspects of bird life may be treated in a similar manner to vastly improve the final bird movie as it appears on the screen.

Remember that no bird picture is worth taking if its filming means the death of the nestlings. Yet unless precautions are taken to protect the young, both during and after the filming session, death may overtake them. Careless destruction of the protective nest cover will reveal the young birds to predators. Merciless exposure to the hot summer sun will also cause death. Whenever it becomes necessary to remove branches or grass in order to photograph a nest, do it with care. Tie branches out of view—do not break them. When a nest is on the ground, carefully part the grasses and weeds about it. Avoid

trampling the grasses so that they will not return to their original protective position. Finally, confine prolonged filming sessions to overcast days so that the young will not become sun-scorched. Fortunately the soft lighting so characteristic of overcast days creates bird movies possessing a softness and delicateness of color that is impossible to obtain beneath the harsh, contrasty light of the noonday sun.

There's action ahead when you focus your movie camera on the amazing wonders of birdlife. Every photographer who loves the out-of-doors, who delights in tramping the woods and fields with his camera, will discover in bird filming a hobby never lacking in thrills and excitement.

The U. S. Information Agency has issued its 5000th certificate as part of a program which helps American educational motion pictures get certain privileges, including customs facilitation and duty-free entry into a number of foreign countries. Certificate No. 5000 was recently issued to Walt Disney Productions for "Beaver Valley." The Agency certificates are issued on the basis of carefully developed and internationally accepted criteria.

Precision Built Combination Sound Readers



OPTICAL

Model 600.....16mm and 35mm
NET PRICE \$185.00

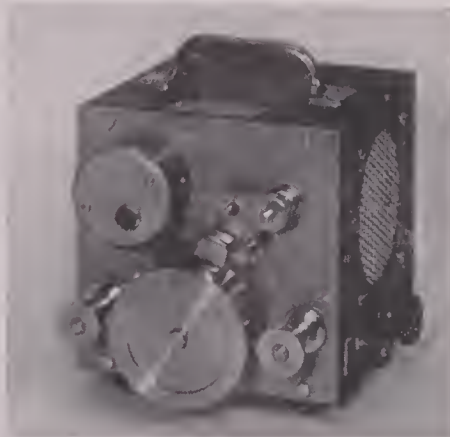

OPTICAL-MAGNETIC

Model 800.....16mm, 35mm & 1/4 inch
NET PRICE \$259.50



MAGNETIC

Model 700.....16mm, 17.5mm, 35mm
and 1/4 inch
NET PRICE \$198.00

FEATURES: Simple threading . . . polished stabilizer drum with needle bearings, with a surface which cannot damage film . . . film rollers machined to conform with SMPTE standards, and equipped with oilless bearings . . . precision ground shafts . . . dimension 6x6x7 1/2 inches.

AMPLIFIER: 117 volt — 60 cycle — AC . . . power output — 4 watts . . . heavy duty Alnico V speaker . . . safety fused . . . prefocused socket . . . pilot light . . . 6 ft. heavy duty cord.

All Prices F. O. B. Factory, Brooklyn, New York

Write for Literature

PRECISION LABORATORIES

• 1139 UTICA AVENUE

• BROOKLYN 3, NEW YORK

KINEVOX Synchronous Magnetic Recording Equipment

Everything for Magnetic Recording!

- Synchronous Magnetic Film Recorder
- Synchronous Magnetic Film Phonograph
 - Remote Amplifier-mixer
 - Magnetic Film Reader
 - Mono-boom for microphone
 - Magnetic Sound Eraser
 - Magnetic Sound Film Splicer



KINEVOX 17 1/2 mm Synchronous Magnetic Recorder . . . Known 'round the World!

Descriptive Catalog of Complete Kinevox Equipment Available On Request

Licensed under R.C.A., Western Electric, Armour Research Foundation and Kinevox Patents.

KINEVOX BUILDING
114-116 SO. HOLLYWOOD WAY
TELEPHONE: Victoria 9-3291
ROME • BOMBAY

KINEVOX

I N C O R P O R A T E D

• NEW YORK

• RIO DE JANEIRO

BURBANK
CALIFORNIA

CABLE: Kinevox, Burbank

• CANADA

TV FILM SERIES IN 16MM

(Continued from Page 617)

means of a brick enclosed in a canvas bag, which was suspended between the tripod legs. Resultant shots were smooth and steady.

We used regular Kodachrome film exclusively. We found that Precision Film Laboratories, Inc., in New York, give us excellent low-contrast prints from this stock. The ratio of 3-to-1 which we established for filming gave adequate footage and at the same time kept expenses down.

In order to provide fill light in shadow areas, we employed reflectors instead of booster lights. Two distinct types were used: when a "hot" fill-light was needed and could be used unobtrusively, we employed two 18 by 24 inch polished chrome ferrotype tins, such as photo finishers use in drying glossy prints. When a softer light was required, we used conventional reflectors with painted aluminum surfaces. These worked especially satisfactory whenever we were filming closeups, and particularly when we made shots of the black Model T Ford.

To make a series of tracking shots showing the Model T being driven along various roads, we mounted the Bolex

camera in the open trunk compartment of a 1951 Pontiac, which served as our camera car. This was equipped with soft, over-sized tires and loaded with sand bags weighing a total of 300 pounds for ballast. Here the tripod was chained down securely to prevent undue camera motion. To further minimize any motion induced by movement of the car, the tracking shots were first made on an extremely smooth section of pavement. But as it turned out, the results were not too good; we needed more "bounce" in the motion of the Model T. It just didn't appear natural moving along the highway so smoothly. So to inject just the needed amount of motion to the car, we had an assistant run along behind the Model T—out of camera range, of course—and shake the car as it moved along during retakes. The effect was further enhanced by shooting these scenes at 16 instead of 24 frames per second.

All action in the picture was carefully planned to fit the needs and restrictions of television. Long shots were restricted to establishing shots only, and were especially conceived to establish direction of movement. We then concentrated on medium and closeup shots to carry the meat of the story.

Since the cast included principals with

considerable television experience, the number of scenes for which it was necessary to do "dry runs" were reduced to a minimum. Lenka Peterson, who appears frequently in dramatic TV presentations played the leading role of the surprised Miss who finds the Model T Ford introducing himself to her. Co-starring with her was Jim Moran, as the bearded wandering ant hunter—who added humor as well as interest to the picture by relating interesting historical facts considered important in a TV film series designed for juvenile audiences.

It seems appropriate at this point to list some important credits: Henry Austin Clark, Jr., owner of the Long Island Automotive Museum, provided the venerable Model T. Co-producers of the film series and partners in Club Productions are E. Powis Jones, renowned artist, and John L. (Larry) Washburn, one-time summer stock company owner and lately a television writer and production supervisor. The author, with a background of television and business film photography, is chief cinematographer. Washburn also doubled as 2nd cameraman.

Our experience so far has shown that the key to success in filming this type production lies in careful pre-planning, coupled with plenty of on-the-spot creativeness.

END

RADIO IN FILM PRODUCTION

(Continued from Page 609)

tical receiving antenna, which picks up the voice broadcast of the gaffer. The antenna line feeds into the receiver amplifier from which leads run to any number of speakers located around the stage.

Because the system is mainly used by gaffers to transmit instructions to electricians working on the catwalks overhead, the speakers usually are placed on the catwalks close to the workers. Thus, on large sets, it is possible for the gaffer to order changes made in light units without calling to his men above the din of other sounds being made on the stage or set. This is particularly advantageous also to the director and his cast, because he can carry on with rehearsals without the interference that otherwise would prevail where workers must call out to one another in a loud voice.

In the third photo at bottom of page 609, gaffer Chester Davis of Metro-Goldwyn-Mayer studios holds one of the speakers which is used at that studio to amplify messages relayed through the miniature wireless mike. Also shown is the wire brace which Davis designed to hold the mike away from his body and in a better position for pickup of sound. Here a simple antenna is used consisting of a short length of wire, which extends from the mike, up over Davis' left shoulder and down to his belt in back.

In the adjoining photos Kenneth Lang, chief set electrician at Twentieth Century-Fox, is shown using the equipment. In photo at extreme left he is shown standing by the vertical receiver antenna. On this head he wears an extension of the transmitter antenna—a length of strong wire bent in a zig-zag design and connected to the regular antenna wire to improve transmission over long distances. In the center photo, Lang is giving instructions to electricians high above the stage floor without raising his voice above normal.

The equipment has other applications in film production also. Many of the studios already named have or are

using the wireless mike in recording sound or dialog in filming scenes where use of a conventional microphone would not be practical, or for picking up sounds at distant points for stereophonic sound recording.

William Boyd (Hopalong Cassidy) uses the tiny mike-transmitter concealed on his person to record his words when being filmed in many action scenes, thus obtaining a realism in dialogue that could not be otherwise obtained.

The wireless mike illustrated here gives the utmost in studio quality of reproduction for regular sound recording, equaling and often surpassing conventional cable-fed microphones in signal-to-noise ratio as well as fidelity of response. The audio output of the receiver may be fed into standard microphone inputs; the Stephens mike is interchangeable with equipment presently in use.

The equipment was originally conceived for motion picture use when engineers at MGM came to Stephens Manufacturing Corp. technical men to solve a recording problem. Today, the studio has six of the units in use for both sound recording and as a means of communication by crew or production staffs on the sound stage or on location.

A complete unit of Stephens wireless microphone equipment consists of the four pieces pictured at the top of page 609. These are: combination power supply and monitor speaker, receiver, transmitter battery, and combination microphone-transmitter. Also included is the receiving antenna with floor stand, not shown.

The microphone is actually a miniature FM transmitting unit and is designed for high-fidelity sound pickup in stage, radio, television, motion picture and industrial applications. Frequency response is 30 to 12,000 cps. \pm 3db. Power requirement ranges from 1.1 to 1.5 volts, 0.1 amperes; or 35-60 volts, 0.01 amperes. Physical size of the microphone-transmitter is $3\frac{5}{8}$ in. high, 2 in. wide, depth 1 in.; weight is 4 ounces. Price of the complete 5-piece combination transmitting and receiving system is around \$980.00.

BIRDS OF A FEATHER

(Continued from Page 614)

of weather just to get a shot or two of wildlife that may be only a flash—but a vital one—on the screen. Like the time Dick and Ada squatted on a small rickety wooden platform built out on a lake, for eight to ten hours a day for ten days in a continuous drizzle—just to photograph a phase of bird life.

As Dick describes the incident, "It was a cold spring day in North Dakota. We had heard about the strange nuptial dance of the western grebes, and had journeyed to a remote lake for the purpose of recording the event on film. We set up our camera on the flimsy platform out on the lake and prepared to shoot whenever the birds went into action. But the weather immediately took a turn for the worse and during the next ten days it rained continuously; heavy black clouds hung low over the whole area. However, the grebes went about building their nests, courting, strutting, dancing and the business of raising their families—entirely unperturbed by the inclement weather. It was hopeless to waste film on the action for the light was insufficient for color photography. By the tenth day we hadn't exposed a single frame of film, so we gave up and drove back home to Regina—a distance of 200 miles."

The Birds no sooner arrived home than they received a telephone call that the weather at the lake had cleared and the sun was shining brightly. So they packed up their gear and retraced the arduous 200 miles back to the habitat of the grebes.

Before they could set up the camera, it had begun to cloud up again and it very quickly started to rain. During the ensuing 72 hours, $7\frac{1}{2}$ inches of rain fell, raising the lake level way above the platform of the Bird's filming site.

Having come so far and believing that such weather could not last indefinitely, Dick and Ada stuck it out for another six days. The sun came out just as they decided to leave again. So they

(Continued on Page 640)

Process Your Own Films and Save with BRIDGAMATIC

The self-contained automatic film processor that will solve your developing problems. It pays for itself! A true one-man lab—anyone can operate it. 16mm or 16/35mm for TV stations, Film Producers, Small Labs., Microfilers, Churches, Schools, etc. Reversal and Color models, standard or custom built. From \$1095 up. Write for brochure.

S. O. S. CINEMA SUPPLY CORP. Dept. F
602 W 52nd St., New York 19, Cable: SOSOUND

"The Finest Cameras
Deserve the Finest Care"



AUTHORIZED

Service To All Fine Cameras

ROMLE-WAHL & CO.

520 W. 7th ST.
LOS ANGELES 14, CAL.

Southeastern

Film Processing Company
1305 Geiger Ave., Columbia 2, S.C.

SPECIALIST IN

DuPont 930-931 B & W
REVERSAL 16mm FILM

- Industrial
- Television
- Training

24 hour service
FILM IN STOCK

CLASSIFIED ADVERTISING

10c per word, minimum ad \$1.00. Words set in capital letters except 1st word and advertiser's name, 15c per word. Modified display format 90c per line. No discount on classified advertising. Send copy with remittance to editorial office, 1782 No. Orange Drive, Hollywood 28, Calif. Deadline 15th of month preceding date of issue.

STUDIO & PROD. EQUIP.

SPECIALS FROM OUR \$250,000 STOCK

BARDWELL-McALISTER MULTIPLE FLOODLITES.
3 Quadruple heads holding 12 bulbs on rolling tripod stand. Orig. Gov't cost \$180.00. Surplus\$ 29.50
BM QUADLITE Heads only \$4.95. Stands only 19.95
300 Watt Neck SILVERED REFLECTOR SPOTS .89
PRICE REDUCTION! Crab Dolly, moves every which way. New stock..... 495.00
35MM REWIND SETS, geared & dummy ends, good for 16mm 6.95
MAGNET SOUND READER for MOVIOLA SYNCHRONIZERS w/amplifier & speaker..... 127.50
B & H AUTOMATIC FOOT SPICERS, 35mm \$595.00, combination 16/35mm..... 695.00
CINE SPECIAL 16MM CAMERA with PAR 4 lens turret, 400' magazine and reflex finder; spring motor; 3 lenses w/objectives and case. \$2250 value..... 1195.00
MOVIOLA 35MM UDS, separate Sound and Picture. Rebuilt 1250.00
DUPLIX PICTURE REDUCTION PRINTER 35/16mm, ready to go..... 2995.00
NEW CINEFLEX 35MM REFLEX CAMERA, 2 mags, 3 lenses, 24V motor, case. \$1500 value 695.00
MAURER 16mm CAMERA w/400' mag; sync motor; viewfinder. Very clean..... 2295.00
EASTMAN AUTOMATIC FILM WAXER, \$1200 value. Rebuilt 795.00
BRIDGMATIC 16mm FILM DEVELOPE, Positive 900', Negative 300' per hour. Reconditioned 1795.00
EASTMAN AIRGRAPH 16/35mm FILM DEVELOPING MACHINES. Fixes, washes and dries. Stainless steel tank and drum, drive motor, heater, blower. \$1800 value, Gov't Surplus. New 295.00
Good used condition 225.00

REAL LOW PRICES ON 16MM REELS & CANS

	12 or less	12-49	50 up
200'	\$.72	\$.60	\$.54
400'	.78	.70	.64
800'	2.84	2.70	1.90
1200'	3.24	3.04	2.30
1600'	3.60	3.30	3.00
2000'	6.50	6.10	5.50

TRADES TAKEN Phone PL 7-0440 Dept. fc
Cable: SOSOUND
S.O.S. CINEMA SUPPLY CORPORATION
602 W. 52nd Street. New York 19.

FOR SALE

BASS . . . is headquarters for Arriflex 16; the new Zaomar 16; Cine Specials, all models; Bell & Howell 70-DL; Bolex H-16. Used Cine Special I, 1" F:1.9 lens and carrying case \$395.00; Used H-16 Bolex, 1" F:1.5, 0.7" F:2.5 W.A., 3" F:3.5 \$347.50
Used Bell & Howell 70-DA, 1" F:1.9, 4" F:4.5 \$235.00. Used Bell & Howell 70-A, 1" F:3.5 and case \$52.50; Used 200' Chamber Cine Special \$295.00; Used 100' Chamber, Cine Special \$117.50. Best buys . . . Best trades always. BASS CAMERA CO., Dept. AC, 179 W. Madison St., Chicago 2, Ill.

WALL S. S. 35MM. SOUND CAMERA

COMPLETE with Galvanometer, amplifier, portable power supply, 40-50-75 and 100mm. lenses, erect image viewfinder, complete front attachments, two 1000 ft. magazines, Balanced Tripod, necessary carrying cases. Overhauled. Guaranteed perfect. Reasonable.

CAMERA EQUIPMENT COMPANY

1600 Broadway New York 19, N. Y.

WE BUY, SELL AND RENT PROFESSIONAL AND 16mm. EQUIPMENT, NEW AND USED. WE ARE DISTRIBUTORS FOR ALL LEADING MANUFACTURERS. RUBY CAMERA EXCHANGE, 729 Seventh Ave., New York City. Established since 1910.

AUDIO AKELEY single system camera complete with Akeley sound head, Gyro tripod, 3 lenses, view finder, Maurer mixing amplifier. Complete with cables, power supply and W. E. microphone. CAMERA EQUIPMENT CO., 1600 Broadway, New York 19, N.Y. Cable Cinequip.

PRECISION Magnetic Heads for Engineers - Industry Erase - Record - Playback

STANCIL-HOFFMAN CORPORATION
921 North Highland Avenue
Hollywood 38, California

SOUND-mirror tape recorder Model B-K-414. Like new, \$100.00. J. GROSS, 2424 S. 2nd St., Philadelphia 48, Penna.

FOR SALE

OUR 25TH YEAR—SUPPLYING EVERYTHING PHOTOGRAPHIC & CINEMATIC

B&H 25mm EYEMO "Q" CAMERA with 4" f2.9 Cinemat, 2" f2.3 Kinar, 35mm f2 Cooke lenses and viewfinder lenses, 2-400' magazines, freehead tripod, shift-over alignment Gauge, 12V variable speed motor, 2 carrying cases, excellent condition.....\$1550.00
35mm DUPLIX CAMERA—Registration pins, lenses: 40mm f2.7 Carl Zeiss, 2" f1.9 Ul-trastigmat, 105mm Schneider f3.5, 3-400' magazines, 400' BiPack magazine, viewfinder Matte Box, 12V DC motor, battery, Freehead Tripod, 2 carrying cases. A real buy 1125.00
35mm B&H SINGLE SYSTEM SOUND CAMERA, lenses: Cooke, 40mm, 50mm, 75mm, 125mm Modulite Galvanometer, amplifier, motor, Tachometer, 2-1000' magazines, Tripod with Freehead, quick release legs, carrying cases, Guaranteed 3500.00
35mm ARRIFLEX CAMERA, Coated lenses: 35mm f1.2 Carl Zeiss, 50mm f1.5 Carl Zeiss, B5mm f2 Carl Zeiss, 135mm f2.3 Astro pan Tachar, variable speed motor, 12V battery, freehead tripod, 3-200' magazines, carrying cases, special 1175.00
35mm AKELEY CAMERA, 4 matched Zeiss lenses, 4-200' magazines, slow motion attachment, Akeley friction tripod, quick release legs, carrying cases. Bargain price.... 750.00
35mm ART REEVES SOUND RECORDER, twin fidelity optical unit, glow lamp type, 1000' B&H magazine, complete with cases..... 977.50
ENLARGERS, excellent condition, Elwood, Auto focus, lens and stand, 5x7..... 235.00
Bx10 400.00
MOLE RICHARDSON 2000 Spot, rolling stand.. 110.00
B&H CAMERA CHECK PAWLS high speed shutter. List price, new \$1742.00, good cond..... 195.00
NEW SCHOEN PRINTER, sound and silent, color, B&W features: 16mm picture alone, 16mm track alone, 16mm picture and sound together, film capacity 1600 feet, 50' per minute, 12 adjustable light changes, AC-DC conversion unit 999.00
HOMRICH COMBINATION COPYING CAMERA and animation table stand, adaptable to 4x5, 5x7, Bx10 holders. Two adjustable light stands with twin reflectors. 11x14, 16x20 copy frames. Built in lamp house, good buy 135.00
HOMRICH ELECTRONIC TIME CONTROL CONTACT PRINTER, timer has full second and split second setting. Handles 4x5, 5x7, Bx10 negatives. Adjustable masking and paper guides. Internal dodging plate glass plate. Four lamps, each controlled by separate toggle switch. A real buy..... 165.00
Specializing in movie and television supplies, tripods, synchronizers, 16mm sound cameras, lights, lenses, mikes, booms, dollies, motors, etc. New-used, reasonable prices. Cash for used equipment. Trades taken.

HOLLYWOOD CAMERA EXCHANGE, LTD.

1600 Cahuenga Boulevard Hollywood, California

FOR SALE

RACKOVER 35mm Bell & Howell Standard Camera, custom case, 3 lenses, Mitchell finder, 2—1,000 ft. magazines, sunshade and matte box complete. Excellent condition, \$4,200.00. Motor driven Bell & Howell Turret Eyemo custom case, 2—200 ft. magazines, counter, 3 lenses, extended finder, 115 volt AC-DC motor, \$1,475.00. 35mm Single System Sound Camera complete for AC or DC work, 5 lenses, amplifier, power packs, mike, counter, tach, 2—1,000 ft. magazines, tripod, cables, all in custom cases, \$9,950.00. 35mm recording head, excellent condition, custom case, 1,000 ft. magazine, \$975.00. 35mm rerecorder heads, used, \$375.00 each. Galvanometer, 35mm, Maurer, Model F-Prime used, \$950.00. BOX 1200, American Cinematographer.

BELL AND HOWELL 70-H, like new. Has three lenses, 400 ft. magazine, 110 volt electric motor, Matte Box and rods, Meier Handcock viewfinder, husky tripod—all for only \$800.00. Used six months, owner sick. Inquire Box 112, Dalhart, Texas. (Ardux Films). Also have a special Auricon Viewfinder and door to fit camera for \$200.00 additional.

16MM PRODUCTION BUSINESS

Selling out all equipment. Everything needed to put you in business anywhere. Fine, clean, well cared for equipment—no cats and dogs. \$6000.00 will handle, needn't buy another item. Sell as complete lot only. T-V COMMERCIAL FILM CO., 1215 N. Copia St., El Paso, Texas.

CINE-SPECIAL II outfit, one year old, exactly like new: Ektar 25mm f/1.4, 63mm f/2, 15mm converter; Reflex Magnifier; custom leather case; C.E. matte box, filters; cost \$1,500, will sell for \$985. Also offer Prof. Jr. Tripod and carrying case \$95; EK Cine-Special Tripod with case \$25. DYNNER, P.O. Box 1072, Youngstown, Ohio.

MAURER Model 25, dissolving shutter, viewfinder, sunshade, filter holder, 400-foot magazine, electric motor, B frame crank, carrying case. Best offer. Also—1 Cine Special with Par 4 lens turret—1 Cine Special II with full set Ektar lenses. Write BOX 385, Waukesha, Wisconsin.

MITCHELL NC #473. Two years old. Guaranteed perfect condition. Six Baltar lenses from 25mm to 100mm with focus rings. 110 sync motor. Four 1000-foot magazines. Complete accessories including tripod, head, matte boxes. \$9,500. BOX 1199, American Cinematographer.

NEW 35mm sound-on-film recorders. With or without Galvanometers. Fearless blimp for Mitchell camera. 220 volt 3 phase Interlock motors and distributor. BLUE SEAL SOUND DEVICES, P.O. Box 100B, New Canaan, Conn.

CINE SPECIAL II, 4-lens Par turret, 200-foot chamber, Meyer prof. viewfinder, 25mm F1.5 Schneider lens, value \$1800. Will sacrifice for immediate sale, \$900. Box 1191, AMERICAN CINEMATOGRAPHER.

WANTED

IMMEDIATE CASH PAYMENT FOR CAMERAS AND EQUIPMENT

NEED EYEMOS (SINGLE LENS AND TURRET), MITCHELLS, ARRIFLEX, DE BRIES, B&H STANDARDS AND HI-SPEEDS, WALLS, AKELEYS, CINE SPECIALS, AURICONS, MAURERS, FILMOS. ALSO BALTARS, COOKES AND OTHER LENSES. SOUND STAGE, LABORATORY AND EDITING EQUIPMENT OF ALL TYPES REQUIRED. PLEASE SHIP INSURED OR FORWARD DESCRIPTIONS AIRMAIL. IMMEDIATE PAYMENT.

GORDON ENTERPRISES • 5362 N. Cahuenga NORTH HOLLYWOOD, CALIFORNIA

YOU MOST ALWAYS GET THE MOST AT THE S.O.S. TRADING POST BUY — SELL — SWAP — CONSIGN

Cameras, Dollies, Lenses, Lights, Moviolas, Printers, Recorders, Studio or Laboratory Equipment

Western Union-WUX New York Phone PL. 7-0440

S. O. S. CINEMA SUPPLY CORPORATION

Dept. fc Cable: SOSOUND
602 W. 52nd Street New York 19, N. Y.

(Continued on Next Page)

To Classified Advertisers

Copy deadline for classified advertising is the 15th of month preceding publication date. Mail copy and remittance to cover cost to

AMERICAN CINEMATOGRAPHER

1782 No. Orange Dr.
Hollywood 28, Calif.

Classified Ads

(Continued from Preceding Page)

WANTED TO BUY FOR CASH

CAMERAS AND ACCESSORIES

MITCHELL, B & H, EYEMO, DEBRIE, AKELEY ALSO

LABORATORY AND CUTTING ROOM EQUIPMENT

CAMERA EQUIPMENT COMPANY

1600 BROADWAY, NEW YORK CITY 19

CABLE: CINEQUIP

WANTED

PRODUCTION EQUIPMENT, LABORATORY EQUIPMENT, EDITING EQUIPMENT, 16mm. and 35mm. FROM SINGLE ITEMS TO COMPLETE STUDIOS. TRADES ACCEPTED.

THE CAMERA MART, INC.

1845 Broadway Circle 6-0930 New York 23, N.Y.

F & B PAYS MORE
FOR USED 16/35MM EQUIPMENT

WRITE — WIRE — PHONE

FOR OUR CASH OFFER

FLORMAN & BABB

MU. 2-2928

70 W. 45TH ST.

NEW YORK 36, N.Y.

WANTED

Mitchell — Akeley — B & H — Wall — Eyemo

Cameras — Lenses — Equipment

NATIONAL CINE EQUIPMENT, INC.

209 West 48th St.

New York, N.Y.

CAMERA & SOUND MEN

WANTED ASSIGNMENTS in Japan Production or Background Footage Contact. TOM MATSUMOTO, IATSE 665, #1 Hiroo-Cho, Azozu, Minato-Ku, Tokyo, Japon.

CANADA! What do you need in Canada? Background plates? TV film bridges? Establishing shots? For any shooting in 35 or 16mm, colour or B&W, write FELIX LAZARUS, York Film Productions, 344 Jarvis Street, Toronto, Ontario.

FAST, imaginative cameraman desires assignments, color or B&W, in south, east or west. Available December. STILES, 4520 Frankfort Ave., Louisville, Ky.

LABORATORY & SOUND

SOUND RECORDING at a reasonable cost. High Fidelity 16 or 35. Quality guaranteed. Complete studio and laboratory services. Color printing and lacquer coating. ESCAR MOTION PICTURE SERVICE, INC., 7315 Carnegie Avenue, Cleveland 3, Ohio. Phone Endicott 1-2707.

LOWER cost 16mm editing and sound recording—only 22 miles from Hollywood. EL RANCHO AUDIO, 26236 Fairview Avenue, Lomita, California. Davenport 6-4925.

KODACHROME duplicates: 16mm 10c per foot, all orders accepted, satisfaction guaranteed. COLOR-VISION FILMS, 122 N. Moday Ave., San Fernando, California.

POSITIONS AVAILABLE

MOTION PICTURE CAMERAMAN: Studio in midwestern city, producing commercials for television has unusually good opportunity for man thoroughly experienced in camera, sound, lighting and editing. Permanent position. Stote experience, age, past positions and earnings. Reply to Box No. 1198, % AMERICAN CINEMATOGRAPHER.

FILM EDITOR

Man experienced in editing and cutting mostly 16mm color motion picture film. Know-how to put together script and coach staff in field motion picture work for nationally known educational organization. Must be fully experienced in running motion picture shows and handling sound equipment. In confidential resume, give education, positions held and salary requirements. Age to 32. American Cinematographer. BOX 1201

BIRDS OF A FEATHER

(Continued from Page 638)

hurriedly set up the camera, made a few "sighting" or test shots, just to get the "feel" of the situation, then returned to their hotel with plans to get in a full day's shooting the next day.

"The weather prospects for the next few days seemed good," said Dick, "so we drove back to our hotel in good spirits. During the night we were awakened by a terrific thunderstorm but thought nothing of it, for such storms were common and usually of short duration. The next morning, with hopes high, we made our way to the lake to reap the rewards of our patience.

"We arrived at the nesting site, and a devastating spectacle greeted our eyes. There were no birds—no nests—nothing but our sagging, storm-wrecked camera platform standing as a grim reminder of the fruitless hours and days we had spent waiting to get the rare sequence of shots of the dancing grebes."

The wonder is that Dick and Ada Bird still pursue this field of cinematography, considering the many such experiences they have encountered during their photographic careers. The answer must lie, of course, in their innate patience—a quality which, next to basic photographic skill, is essential to successful nature and wildlife cinematography.

Where the studio cameraman has only the vagaries of crew and production staff to try his patience, the wildlife photographer inevitably has to contend with the capriciousness of the weather and the inability to direct his inarticulate subjects. Dick and Ada Bird's success in this field, therefore, points unmistakably to the importance unrelenting patience holds for any cinematographer electing to follow wildlife photography as a career.

MODELS AND MINIATURES

(Continued from Page 618)

edge himself far enough into a corner to obtain some apparent long shots of the train. To minimize the problems of the train's comparative screen speeds, he took the long shots at 16 f.p.s. and the close-ups at 24 f.p.s.

A 1500-watt lamp proved insufficient for the 20mm f/1.9 lens and the 2 in. telephoto in the dark loft, and Kaulins supplemented it with a 500-watt photoflood. Much as he would like to work on 16mm neg-pos., financial considerations—in other words pocket-money—mean that he has to be content with 9.5mm reversal. Though the American life of this gauge was brief, it is still very popular in Europe.

One advantage of Kaulins' interior set-up is that it can be left exactly as required for as long as necessary between shooting sessions without fear of wind or rain causing havoc. Some scenes, though, were decidedly best shot out of doors. The shots of the planes and the paratroopers needed a background of clouds, so Kaulins hung his models from a wire running the length of the garden and shot them against the sky from a low angle.

He used paper cut-out figures for closeups of the paratroopers and diminutive blobs on tiny paper parachutes for the long shots, which were actually taken from the same distance, of course. But he had reckoned without the wind. After several hours trying to get the few shots he needed he was left with several tangled lengths of cotton and a number of tattered paper figures.

He remade the figures, this time in cardboard, and again tried to shoot. The breeze still did its best to frustrate his attempts at filming the dangling paratroopers, but eventually his efforts were rewarded and he obtained all the material he required without a single twisting figure among the lot.

Scenes of the aircraft were easier. Kaulins had already taken a shot in the loft from the pilot's viewpoint as he swooped over the train. Now he wanted a shot showing the plane passing overhead. Efforts at bringing the model over the camera failed because of the side-to-side sway on the plane. Kaulins tried fixing the camera to the front of his bicycle and wheeling the machine towards the plane. This time the camera wobbled. Finally he broke every rule in the book by shuffling towards the model with the camera in his hands—and the results were perfect!

Another unorthodox idea came about as the result of Kaulin's need for a shot showing an aerial view of fields and hedges. After some thought he decided to try shooting directly down onto some crazy paving. Again the results exceeded his most optimistic expectations. The thin lines of cement between the stones look exactly like divisions between cultivated fields.

The success of *Victory Convoy* seems assured. Kaulin's work as an amateur since the age of fourteen has resulted in his election as Secretary of Focus Film Unit, one of the best-known of Britain's numerous cine clubs. The Unit's production *Judgement in White* was recently awarded coveted prizes by both the Federation of Cine Societies and the Scottish Film Council. Kaulins was assistant cameraman on this 16mm drama.

At present Kaulins is studying to enter the film industry professionally.

INDEX BY TOPICS

A

"A" and "8" roll editing: 498.
 Academy Award winners: 178.
 "Accenting Tempo With Lighting": 87.
 Accuracy check for 16mm camera: 452.
 Ad film production, TV: 397.
 "A Film Rule for Film Makers": 509.
 "Aircraft Analyses Recording With Dual Cameras": 108.
 "American Cinematographer's 3-D Film Festival": 140.
 Analyzing Documentary Technique": 292.
 "A New Instrument for Checking the Focus of Camera-Mounted Lenses": 129.
 Animation: 568.
 "A Remote Control for Stop-Motion Photography": 500.
 Arriflex cameras: 80; 344; 388.
 "Arriflex Cameras Adapted for CinemaScope": 344.
 "Arthur Miller Elected President of A.S.C.": 222.
 "ASC Fetes Charles Posher": 538.
 Assignments for ASC Cameramen, (Box Score for 1953): 20.
 Auricon camera modification: 181.
 Autocollimator to verify lens focus: 129.

B

Big game fishing, filming: 398.
 Big-Scale University Film Production: 612.
 Birds of a Feather: 614.
 Blimp underwater camera: 440.
 Book Reviews:—"Theory of Photography Process"—Mes: 517;
 —"Home Movies Scripts"—Provisor: 517;
 —"Optical Image Evaluation": Nat'l Bureau of Standards: 517.
 "Booklets, Catalogs, Brochures": 378; 490; 544.
 "Bulletin Board": 12; 72; 126; 206; 228; 270; 318; 374; 343; 478; 534; 594.
 "Burns and Allen Show," filming: 234.

C

"Camera Crews Go to College to Get Material for New TV Film Series": 32.
 "Camera Modifications": 181.
 Camera motor, slow speed: 563.
 Camera movement for pictorial continuity: 30.
 Camera speeds: 506.
 "Cameramen Are a Breed Apart": 503.
 Cameras, 35mm: 80; 174; 272; 344.
 Cameras, 16mm: 80; 181.
 "Care and Handling of Film in the Tropics": 89.
 "Carmen Jones"—CinemaScope Photography at Its Best: 610.
 "Case History of a Non-Theatrical Film Production": 342.
 "Cine Hobbyist With a Future": 400.
 CinemaScope in 16mm: 504.
 CinemaScope photography: 338; 344.
 CinemaScope photography underwater: 440.
 Cinerama photography: 290.
 Closeups: 122; 224; 508.
 "Club Project": 192.
 Color-film process (16mm), new professional: 272.
 "Color-Matic" control meter: 44.
 Color TV filming: 446.
 Common sense in cutting-in titles: 294.
 Composition, pictorial: 240.
 Continuity: 30.
 Continuity, pictorial: 30.
 Continuous optical projection editor without intermittent: 23.
 Cost-cutting methods for TV films: 234.
 Creative cutting: 336.
 "Cukoloris—Set Lighting's Most Versatile Tool": 332.
 Cukoloris, use in lighting of: 332.
 Cunningham camera: 272.
 Cutting: 336.

D

"Dioptr" lenses: 36.
 Distortion lens, homemade: 36.
 Documentary technique, successful: 292.
 "Do-It-Yourself Sound Recording Adds Class to 16mm Films": 554.
 Dollars and Sense of Business Films: 622.
 Dolly shots: 454.
 Dolly tracks, low-cost: 232.
 "Dragnet", filming: 188.

E

Editor (Westrex) projection viewing: 23.
 Editing: 82; 498.
 Editing, TV: 562.
 Editor for new CinemaScope-Stereophonic film as well as standard: 23.
 Educational research achievements for TV series: 32.
 Effect lighting: 332.
 "Effecting Economies in the Editing of TV Films": 562.
 "Equipment Source for Film Producers": 502.
 Everest climb, photographing: 138.
 Exposure meter: 44.

F

Fights, photographing: 388.
 Film editor: 23.
 Film in tropics, care of: 89.
 Film processor, high-speed: 451.

Film, Tri-X negative: 335; 394.
 "Filming a Water Ski Ballet": 19.
 "Filming Hollywood's Biggest Indoor Exterior": 190.
 "Filming the 'Dragnet' TV show": 188.
 "Filming the Ice Show": 346.
 "Filming the Everest Climb": 138.
 "FilmoRama-CinemaScope in 16mm": 504.
 "Finishing the Production": 82.
 Fishing, photographing big game: 398.
 "560 Photofloods—280,000 watts": 556.
 Focus checking with autocollimator: 129.
 "Follow-Focus Attachment for Mitchell Cameras": 237.
 Free lance news cinematography, 16mm: 566.

G

Gevalcolor: 390.

H

"Hank McCune TV Series Filmed in 16mm Color": 446.
 "He Makes News Live": 442.
 "High-Speed Film Processor": 450.
 "High-Speed Filming of Instrument Action": 448.
 High-speed filming, 16mm: 448.
 "High-Speed Negative Speeds Production": 394.
 "Hollywood Studio Production" (See also "Current Assignments ASC Members"): 362; 402; 468; 522; 582; 634.
 "Hollywood's Greatest Underwater Venture": 282.
 "Hot splicer conversion": 348.
 "How to Edit 'A' and '8' Rolls": 498.

I

Ice show filming: 346.
 "India's First Feature in Gevalcolor": 390.
 Indoor exterior studio shooting: 190.
 Industrial 16mm filming: 239; 563.
 "Industry News": 6; 62; 250; 272; 320; 384; 426; 488; 542; 606.
 Instrument action, 16mm filming of: 448.
 "Is Your 16-Millimeter Camera Showing Its Age?": 452.

J

"Judging Amateur Sound Films": 243.

K

Kinescope recording, TV-T Auricon shutter for: 48.

L

Laboratories: 100; 392; 451; 564.
 Laboratory, traveling field: 100.
 Lens, distortion: 36.
 Lens focus verification with autocollimator: 129.
 Lenses: 27; 36.
 "Letters": 328; 380; 432; 484.
 "Light Plays a Part in Set Design": 286.
 Lighting: 87; 231; 284; 286; 332; 456; 556.
 "Lighting Productions for the Business Screen": 284.
 Lighting, TV: 456.
 "Literature, Booklets, Etc.": 260.
 "Low-Cost Dolly Tracks": 232.

M

Magnetic sound: 34; 90; 142; 554.
 "Magnetic Sound for Any Projector": 90.
 "Making the Most of Laboratory Services": 564.
 "Maurer, J. A. Announces Magnetic Film Splicer": 256.
 Measuring exposure, device for: 396.
 Mercer film rule: 509.
 Meter, "Color-Matic" control: 44.
 "MGM's New Underwater Camera 8limp": 440.
 Models and Miniatures in Movie Making: 618.
 "Money-Saving Shooting System for TV Films": 234.
 Mood created by light: 231.

N

Naturama: 305.
 Negative film, Tri-X: 335; 394.
 "New Arriflex Cameras Feature Many Improvements": 80.
 "New Bolex Equipment, Prices Announced": 254.
 "New Norwood Meter Features 'Color-Matic' Control": 44.
 "New Shutter Converts Auricons for TV Recording": 48.
 Newsreel-type production: 130.
 Newsreels, TV: 442; 566.
 "1953 Academy Award Winners": 178.
 "1953 Nominees for Academy Awards for Photography": 132.

O

"Organizing a TV Film Production Unit": 134.

P

"Photo Research Traveling Field Laboratory": 100.
 Photography, business: 284.
 Photography, 8mm: 194.
 Photography, 9 1/2 mm: 400.
 Photography, 16mm: 74; 130; 138; 239; 292; 342; 346; 398; 445; 446; 448; 450; 563.
 Photography, 16mm documentary: 292.
 Photography, studio: 19; 76; 190; 282; 338; 388; 494.
 Photography, TV: 32; 134; 188; 234; 397; 442; 446.
 Photographing Cinerama: 290.
 Photographing CinemaScope: 338; 344.

Photographing VistaVision: 552.
 "Pictorial Composition in Cine Photography": 240.
 "Pictorial Continuity": 30.
 "Pixilation": 568.
 "Pixilation"—New Idea in Movie Making": 568.
 Pre-editing: 288.
 "Projection Viewing With the Westrex Editor": 23.
 "Putting a Championship Bout on Film": 388.

R

Radio Communication in Film Production: 609.
 "Radio Controlled Cinematography": 450.
 "Rear Window": 76.
 "Record Sound as You Shoot": 34.
 Remote controlled cameras, 16mm: 450; 500.
 Rental service for producers: 502.
 "Roster of American Society of Cinematographers": 53.

S

"Saga of the Silk Worm": 239.
 Schedule for speed in TV filming: 561.
 Sensitoflex: 396.
 "Sensitoflex—New Photometric Exposure Measuring Device": 396.
 Services offered by laboratories: 392; 564.
 "Shakespeare in 8mm": 194.
 "Shoot a Big Game Fishing Film": 398.
 "Shooting a Newsreel-type Production in Color": 130.
 Shooting a TV Film Series in 16mm: 617.
 "Short Cuts Cut Costs in TV Ad Film Production": 397.
 "Simple Lens Assembly for Making Special Effects": 36.
 "Simultaneous Production Shooting in CinemaScope and Wide-Screen": 338.
 "Slow Speed Camera Motor": 563.
 So You Want to Photograph Birds!: 620.
 "S.M.P.T.E. to Convene in Hollywood": 482.
 Sound: 34; 90; 142; 445; 554.
 Sound synchronized (amateur): 34; 90; 142.
 Special effects lens: 36.
 "Speed in Small Studio TV Film Production": 561.
 Splicer conversion, 16mm: 348.
 Stop-motion: 568.
 Stop-motion photography, remote controlled: 500.
 Studio photography: 19; 76; 190; 282; 338; 388; 494.
 "Swap Your Odd Shots": 40; 92.
 Sync Sound Without Interlock": 445.

T

Tempo through lighting: 87.
 "The Cinerama Technique": 290.
 "The Film Laboratory—Your Partner in Production": 392.
 "The Importance of Variable Camera Speeds": 506.
 "The Place of the Closeup in Your Movies": 508.
 "The Pre-Editing Stage": 288.
 "The Role of Light in Creating Mood": 231.
 "3-D Film Festival": 92; 140.
 "3-D Film Festival to Be Held at ASC Clubhouse in Hollywood": 92.
 Titles: 192.
 Titles, cutting-in: 294.
 Titling: 294.
 "Todd-AO—Newest Wide-Screen System": 494.
 "Tomorrow's Wide-Screen Camera": 174.
 Tri-X film: 335; 394.
 "Tri-X—New Eastman High-Speed Negative Motion Picture Film": 335.
 TV Editing: 562.
 TV filming: 32; 134; 188; 234; 397; 442; 556; 561.
 TV filming in color: 446.
 TV lighting: 556.
 TV news filming: 442; 566.
 TV production speed: 561.
 TV production unit, organizing: 134.
 TV-T shutter for kinescope recordings: 48.

U

Underwater camera blimp: 440.
 Underwater 35mm photography: 282; 440.

V

Variable camera speeds: 506.
 Varifocal Lens for 16mm cameras, Zoomar: 27.
 "Video Tape Recording and Home Movies": 142.
 VistaVision: 174; 552.
 VistaVision camera: 174; 552.
 "VistaVision Moves Forward": 552.

W

"Walt Disney's Naturalist-Cinematographers": 74.
 "Want to Shoot for the TV Newsreels?": 566.
 Water Skiing ballet filmed from plane and boat: 18.
 Westrex editor, latest: 23.
 "What's New in Cine Photography": 350.
 "What's New in Equipment, Accessories, Services": 3; 66; 118; 168; 218; 274; 328; 376; 428; 480; 536; 598.
 Wide-Screen photography: 174; 338 440; 494; 552.
 Wide-Screen photography underwater: 440.

Y

"You Can Make Dolly Shots, Too": 454.

Z

"Zoomar varifocal lens for 16mm cameras": 27.

ANNUAL INDEX . . . Continued

INDEX BY AUTHORS

A

Agnello, Merle—"Organizing a TV Film Production Unit": 134.
 Allen, Leigh—"Projection Viewing With the Westrex Editor": 23;
 —Radio Communication in Film Production: 609;
 —"FilmoRama—CinemaScope in 16mm": 504.
 Anderson, Charles L.—"Analyzing Documentary Technique": 292;
 —"Case History of a Non-Theatrical Film Production": 342;
 —"Making the Most of Laboratory Services": 564.
 Austin, Chuck—"Putting a Championship Bout on Film": 388.

B

Bakke, J. W.—"Radio Controlled Cinematography": 450;
 —"Slow Speed Camera Motor": 563.
 Benson, Harold—"Cine Hobbyist With a Future": 400;
 —"Pixilation—New Idea in Movie Making": 56B.
 —Models and Miniatures in Movie Making: 61B.
 Berry, Robert J.—"Video Tape Recording and Home Movies": 142.
 Bishop, Jack, and Loren L. Ryder—"VistaVision Moves Forward": 552.
 Brun, Joseph—"The Cineroma Technique": 290.

C

Clark, Earl L.—"Cameramen Are a Breed Apart": 503.
 Cohen, Hyman R.—"Effecting Economies in the Editing of TV Films": 562.
 Costikyan, Andrew M.—"High-Speed Negative Speeds Production": 394.
 Cushman, George—"Record Sound as You Shoot": 34;
 —"Magnetic Sound for Any Projector": 90;
 —"Judging Amateur Sound Films": 243.

F

 Folsiey, George—"Simultaneous Production in CinemaScope and Wide-Screen": 33B.
 Forbes, John—"Care and Handling of Film in the Tropics": 89;
 —"Common Sense in Cutting-In Titles": 294;
 —"Sensitoflex—New Photometric Exposure Measuring Device": 396;
 —"You Can Make Dolly Shots, Too": 454;
 —"How to Edit 'A' and 'B' Rolls": 49B;
 —"The Place of the Closeup in Your Movies": 50B.
 Foster, Frederick—"Walt Disney's Naturalist-Cinematographers": 74;
 —"Filming the 'Dragnet' TV show": 18B;
 —"Lighting Productions for the Business Screen": 284;
 —"India's First Feature in Gevacolor": 390;
 —"Hank McCune TV Series Filmed in 16mm Color": 446;
 —"Equipment Source for Film Producers": 502.

G

Gabbani, Till—"Hollywood's Greatest Underwater Venture": 282.
 Gavin, Arthur—"Rear Window": 76;
 —"Tomorrow's Wide-Screen Camera": 174.

H

Harris, Frank—"Sync Sound Without Interlock": 442.
 Herbert, Charles W.—"Shoot a Big Game Fishing Film": 39B.
 Hake, John—"Low-Cost Dolly Tracks": 232;
 —"A Remote Control for Stop-Motion Photography": 500.
 Huse, Emery—"Tri-X—New Eastman High-Speed Negative Motion Picture Film": 335.

K

Kershner, Glenn R.—"Pictorial Composition in Cine Photography": 240.

L

LaSelle, Joseph—"Set Lighting's Most Versatile Tool": 332.
 Lewis, Jack—"Saga of the Silk Worm": 239.
 Lightman, Herb. A.—"Finishing the Production": 82.
 Loring, Charles—"Pictorial Continuity": 30;
 —"The Pre-Editing Stage": 28B;
 —"Creative Cutting": 366.
 Luce, Ralph W.—"Shooting a Newsreel-Type Production in Color": 130.

M

MacDonald, Joseph W.—"Camera Crews Go to College to Get Material for New TV Film Series": 32.
 Marble, Arthur L.—"Filming the Everest Climb": 13B;
 —"Want to Shoot for the TV Newsreels?": 566.
 Mellor, William Bancroft—"Light Plays a Part in Set Design": 286;
 —"Speed in Small Studio TV Film Production": 561.
 Milner, Victor—"The Role of Light in Creating Mood": 231.

R

Roe, Alvin D.—"The Zoomar Varifocal Lens for 16mm Cameras": 27;
 —"Rear Window": 76;

—"High-Speed Filming of Instrument Action": 44B;
 —"The Importance of Variable Camera Speeds": 506.
 Rawan, Arthur—"Filming a Water Ski Ballet": 1B;
 —"New Arriflex Cameras Feature Many Improvements": 80;
 —"Filming Hollywood's Biggest Indoor Exterior": 190;
 —"Arriflex Cameras Adapted for CinemaScope": 344;
 —"Short Cuts Cut Costs in TV Ad Film Production": 397;
 —"MGM's New Underwater Camera Blimp": 440;
 —"Todd-AD—Newest Wide-Screen System": 494;
 —"Carmen Jones—CinemaScope Photography at Its Best": 610.
 Ryder, Loren L. (and Jack Bishop)—"VistaVision Moves Forward": 552.

S

Sanders, Zenda—"Shakespeare in 8mm": 194.
 Stockert, Honk—"Hot Splicer Conversion": 34B;
 —"Is Your 16-Millimeter Camera Showing Its Age?": 452.

T

Tannura, Philip—"Money-Saving Shooting System for TV Films": 234.

V

Valentine, George A.—"Club Project": 192.

W

Whittington, Elbert J.—"Filming the Ice Show": 346.

INDEX BY PAGE NUMBERS

Page
 3—What's New in Equipment, Accessories, Service
 6—Industry News
 12—Hollywood Bulletin Board
 18—Filming a Water-Ski Ballet
 20—1953 Box Score (Year's Assignments for ASC Cameramen)
 23—Projection Viewing With the Westrex Editor
 27—The Zoomar Varifocal Lens for 16mm Cameras
 30—Pictorial Continuity
 32—Camera Crews Go to College to Get Material for New TV Film Series
 34—Record Sound as You Shoot
 36—Simple Lens Assembly for Making Special Effects
 40—Swap Your Odd Shots
 52—Current Assignments of ASC Members
 53—Poster of American Society of Cinematographers
 62—Industry News
 66—What's New in Equipment, Accessories, Services
 72—Bulletin Board
 74—Walt Disney's Naturalist-Cinematographers
 76—Rear Window
 80—New Arriflex Cameras Feature Many Improvements
 82—Finishing the Production
 87—Accenting Tempo With Lighting
 89—Care and Handling of Film in the Tropics
 90—Magnetic Sound for Any Projector
 92—3-D Film Festival
 92—Swap Your Odd Shots
 106—Current Assignments of ASC Members
 11B—What's New in Equipment, Accessories, Services
 122—Closeups—Notes and Editorial Comment
 126—Hollywood Bulletin Board
 129—A New Instrument for Checking the Focus of Camera-Mounted Lenses
 130—Shooting a Newsreel-Type Production in Color
 132—1953 Nominees for Academy Awards for Photography
 134—Organizing a TV Film Production Unit
 138—Filming the Everest Climb
 140—American Cinematographer's 3-D Film Festival
 142—Video Tape Recording and Home Movies
 154—Current Assignments of ASC Members
 168—What's New in Equipment, Accessories, Services
 166—Hollywood Bulletin Board
 174—Tomorrow's Wide-Screen Camera
 179—1953 Academy Award Winners
 181—Camera Modifications
 18B—Filming the "Dragnet" TV Show
 190—Filming Hollywood's Biggest Indoor Exterior
 192—Club Project
 194—Shakespeare in Bmm
 206—Current Assignments of ASC Members
 21B—What's New in Equipment, Accessories, Services

224—Closeups—Notes and Editorial Comment
 22B—Hollywood Bulletin Board
 231—The Role of Light in Creating Mood
 232—Low-Cost Dolly Tracks
 234—Money-Saving Shooting System for TV Films
 237—Follow-Focus Attachment for Mitchell Cameras
 239—Saga of the Silk Worm
 240—Pictorial Composition in Cine Photography
 243—Judging Amateur Sound Films
 250—Industry News
 254—New Bolex Equipment, Prices Announced
 256—J. A. Mourer Announces Magnetic Film Splicer
 258—Current Assignments of ASC Members
 260—Literature, Booklets, etc.
 270—Hollywood Bulletin Board
 272—Industry News
 274—What's New in Equipment, Accessories, Service
 282—Hollywood's Greatest Underwater Venture
 284—Lighting Productions for the Business Screen
 286—Light Plays a Part in Set Design
 288—The Pre-Editing Stage
 290—The Cinerama Technique
 292—Analyzing Documentary Technique
 294—Common Sense in Cutting-In Titles
 306—Current Assignments of ASC Members
 31B—Bulletin Board
 320—Industry News
 32B—What's New in Equipment, Accessories, Services
 328—Letters
 332—Cukoloris—Set Lighting's Most Versatile Tool
 335—Tri-X—New Eastman High-Speed Negative Motion Picture Film
 336—Creative Cutting
 33B—Simultaneous Production Shooting in CinemaScope and Wide-Screen
 342—Case History of a Non-Theatrical Film Production
 344—Arriflex Cameras Adapted for CinemaScope
 346—Filming the Ice Show
 34B—Hot Splicer Conversion
 350—What's New in Cine Photography
 362—Hollywood Studio Production
 374—Hollywood Bulletin Board
 376—What's New in Equipment, Accessories, Services
 37B—Booklets, Catalogs, Brochures
 380—Letters
 384—Industry News
 388—Putting a Championship Bout on Film
 390—India's First Feature in Gevacolor
 392—The Film Laboratory—Your Partner in Production
 394—High-Speed Negative Speeds Production
 396—Sensitoflex—New Photometric Exposure Measuring Device
 397—Short Cuts Cut Costs in TV Ad Film Production
 39B—Shoot a Big Game Fishing Film
 400—Cine Hobbyist With a Future
 402—Hollywood Studio Production
 426—Industry News
 42B—What's New in Equipment, Accessories, Services
 432—Letters
 434—Hollywood Bulletin Board
 440—MGM's New Underwater Camera Blimp
 442—He Makes News Live
 445—Sync Sound Without Interlock
 446—Hank McCune TV Series Filmed in 16mm Color
 448—High-Speed Filming of Instrument Action
 450—Radio Controlled Cinematography
 450—High-Speed Film Processor
 452—Is Your 16-Millimeter Camera Showing Its Age?
 454—You Can Make Dolly Shots, Too
 46B—Hollywood Studio Production
 478—Hollywood Bulletin Board
 480—What's New in Equipment, Accessories, Services
 482—S.M.P.T.E. to Convené in Hollywood
 484—Letters
 48B—Industry News
 490—Catalogs & Brochures
 494—Todd-AD—Newest Wide-Screen System
 49B—How to Edit "A" and "B" Rolls
 500—A Remote Control for Stop-Motion Photography
 502—Equipment Source for Film Producers
 503—Cameramen Are a Breed Apart
 504—FilmoRama—CinemaScope in 16mm
 506—The Importance of Variable Camera Speeds
 50B—The Place of the Closeup in Your Movies
 509—A Film Role for Film Makers
 534—Hollywood Bulletin Board
 536—What's New in Equipment, Accessories, Services
 538—ASC Fetes Charles Rosher
 542—Industry
 544—Booklets, Catalogs and Brochures
 552—VistaVision Moves Forward
 554—Do-It-Yourself Sound Recording Adds Class to 16mm Films
 556—560 Photofloods—280,000 Watts
 561—Speed in Small Studio TV Film Production
 562—Effecting Economies in the Editing of TV Films
 563—Slow Speed Camera Motor
 564—Making the Most of Laboratory Services
 566—Want to Shoot for the TV Newsreels
 56B—"Pixilation"—New Idea in Movie Making
 582—Hollywood Studio Production
 594—Hollywood Bulletin Board
 598—What's New in Equipment, Accessories, Services
 606—Industry News
 609—Radio Communication in Film Production
 610—"Carmen Jones"—CinemaScope Photography at Its Best
 612—Big-Scale University Film Production
 614—Birds of a Feather
 617—Shooting a TV Film Series in 16mm
 61B—Models and Miniatures in Movie Making
 620—So You Want to Photograph Birds!
 622—Dollars and Sense of Business Films
 634—Hollywood Studio Production

INDEX GUIDE

To locate the issue in which an article appears, find the month in which the page number appears below:

January	1 to 56
February	57 to 112
March	113 to 160
April	161 to 212
May	213 to 264
June	265 to 312
July	313 to 368
August	369 to 420
September	421 to 472
October	473 to 528
November	529 to 588
December	589 to 642



How Herbert Knapp captured a kingdom for Walt Disney's movie "Siam"



FOR Walt Disney's new "People and Places" series, Herbert Knapp, well-known cinematographer, explorer, scientist, and lecturer, took a fast plane to Siam. There, on square-cut emerald rice paddies . . . in the heart of lush jungles . . . in the royal court . . . and amidst river sampan traffic as jumbled as Fifth Avenue during the rush hour, he set up his Cine-Kodak Special II Camera and recorded life as he found it.

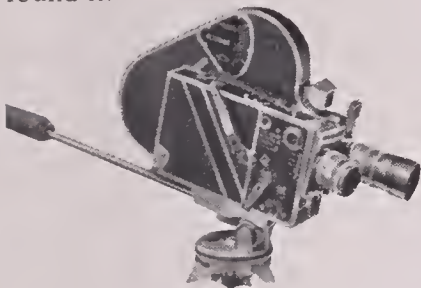

Cine-Kodak Special II Camera can be obtained with either a 25mm. *f*/1.9 or *f*/1.4 lens . . . and with either a 100-foot or 200-foot interchangeable film chamber. Prices start at \$990 . . . and no other camera in its price range offers such great precision or so many built-in features.

Without the convenience of studio lighting and accessories, Knapp and his Special II shot color movies with all the quality and special effects of a studio-made film.

When you see Walt Disney's film, "SIAM," consider why—when theater-quality films were the chief object—Knapp chose the Cine-Kodak Special II for this difficult expedition.

The Cine-Kodak Special II Camera

The Cine-Kodak Special II is the favorite not only of the world's top professional cinematographers like Herbert

Knapp, but of expert amateur cameramen, too. No wonder. It has all the versatility you need for making the finest 16mm. movies . . . built right into a single, compact unit. You can quickly and easily make fades, dissolves, and multiple exposures . . . change from one film to another . . . shift from normal shooting to telephoto lens . . . make speeded-up or slow-motion movies, masked shots, and many other cinematic effects.

Ask your Kodak dealer—or mail the handy coupon—for a free 16-page booklet describing this amazing camera.

Most Kodak dealers offer convenient terms. Price includes Federal Tax and is subject to change without notice.

EASTMAN KODAK COMPANY

12-11

Dept. 8-V, Rochester 4, N. Y.

Please send me more information about the Cine-Kodak Special II Camera.

NAME _____

POSITION _____

COMPANY _____

STREET _____

CITY _____ STATE _____
(Zone)



Kodak
TRADE-MARK

ULTRA-SHARP DETAIL

...in

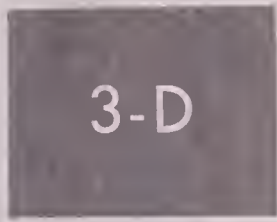

...in



...and in



CINEMA SCOPE



*even to the very
EDGE of the picture!*

...with Taylor, Taylor and Hobson Speed Panchro Lenses

T-T-H Speed Panchro lenses again meet the demands of a fast-growing industry —supplying the high degree of sharpness needed for CinemaScope, 3-D and television films. A complete set of eight fully color corrected lenses matched for

perfection is now available from Bell & Howell. Each lens is accurately calibrated by scientific measurement of light actually transmitted. Consistent negative densities regardless of which lens is used. For full details, write to Bell & Howell.



100mm T3 (f/2.5)



75mm T2.3 (f/2)



50mm T2.3 (f/2)



40mm T2.3 (f/2)



35mm T2.3 (f/2)



25mm T2.3 (f/2)



32mm T2.3 (f/2)



28mm T2.3 (f/2)

Also 8½", 12½", and 20" F/5.6 T-T-H Telephotos

Look for Bell & Howell's new 35mm anamorphic lens for studio and theater projection.



Bell & Howell

Professional Equipment Department
7148 McCormick Road, Chicago 45, Ill.



LIBRARY OF CONGRESS



0 007 552 315 4