

3 1430 02616403 0

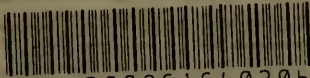

a31430026164030b

UNIV. OF MD. COLLEGE PARK

*National Trust
for
Historic Preservation*



NTHP. HQ - LIBRARY.

Date Due

0 8 2 8

Date Due			
0 8 2 8			



1000





National Trust for
Historic Preservation
Library
of the
University of Maryland,
College Park



31

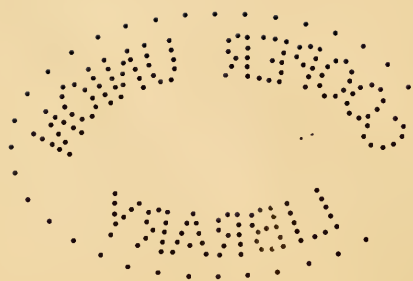

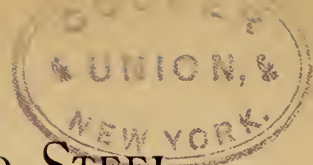

✓ ARCHITECTURAL IRON AND STEEL,

AND ITS APPLICATION

IN THE

CONSTRUCTION OF BUILDINGS.

INCLUDING BEAMS AND GIRDERS IN FLOOR CONSTRUCTION, ROLLED IRON STRUTS, WROUGHT AND CAST-IRON COLUMNS, FIRE-PROOF COLUMNS, COLUMN CONNECTIONS, CAST-IRON LINTELS, ROOF TRUSSES, STAIRWAYS, ELEVATOR ENCLOSURES, ORNAMENTAL IRON, FLOOR LIGHTS AND SKYLIGHTS, VAULT LIGHTS, DOORS AND SHUTTERS, WINDOW GUARDS AND GRILLES, ETC., ETC., WITH

SPECIFICATION OF IRONWORK.

AND SELECTED PAPERS IN RELATION TO IRONWORK, FROM A REVISION OF THE PRESENT LAW BEFORE THE LEGISLATURE AFFECTING PUBLIC INTERESTS IN THE CITY OF NEW YORK, IN SO FAR AS THE SAME REGULATES THE CONSTRUCTION OF BUILDINGS IN SAID CITY.

TABLES,

SELECTED EXPRESSLY FOR THIS WORK,

OF THE PROPERTIES OF BEAMS, CHANNELS, TEES AND ANGLES, USED AS BEAMS, STRUTS AND COLUMNS, WEIGHTS OF IRON AND STEEL BARS, CAPACITY OF TANKS, AREAS OF CIRCLES, WEIGHTS OF CIRCULAR AND SQUARE CAST-IRON COLUMNS, WEIGHTS OF SUBSTANCES, TABLES OF SQUARES, CUBES, ETC., WEIGHTS OF SHEET COPPER, BRASS AND IRON, ETC.

BY

WM. H. BIRKMIRE.

Fully Illustrated.

THIRD EDITION.

NEW YORK :

JOHN WILEY, & SONS,

LONDON : CHAPMAN & HALL, LIMITED.

1905

S.

30836

COPYRIGHT, 1897,
BY
WM. H. BIRKIRE,

5691.7

~~721.9~~

B619

WITHDRAWN FROM
COOPER UNION LIBRARY

NTHP, HQ - LIBRARY

ROBERT DRUMMOND, ELECTROTYPHER AND PRINTER, NEW YORK.

PREFACE.

THIS work is intended for Architects, Architectural Students and Builders.

The Author has been induced to prepare it because of his inability to find, among the many excellent works on the Mathematics of Construction, one that could be readily adapted as a reference book, treating of the various details of Iron and Steel as applied in the construction and finishing of buildings.

It was considered advisable to give but general information on the manufacture of Iron in the first chapter, to serve as an introduction to the chapters on Construction which immediately follow, and to give in these chapters such simple formulas and complete tables as would readily enable one to calculate the strength of beams, girders, etc., subject to a transverse strain, and of vertical supports subject to compression.

Desiring to give as much information as possible in relation to the construction and practical description of the miscellaneous details, especial attention has been given to their illustration.

WM. H. BIRKMIRE.

NEW YORK, March, 1891.



Digitized by the Internet Archive
in 2011 with funding from
LYRASIS members and Sloan Foundation

CONTENTS.

CHAPTER I.

THE MANUFACTURE OF IRON.

ARTICLE	PAGE
1. Iron,	1
2. Smelting,	1
3. Pig Iron,	1

WROUGHT IRON.

4. Puddling,	2
5. Piling,	2
6. Rolling,	3
7. Channels,	3
8. Quality of Wrought Iron,	3
9. Testing Wrought Iron,	4
10. Cold Bend Test,	4
11. Modulus of Elasticity,	5
12. Wrought Iron in Compression,	5
13. Weight of Wrought Iron,	5

STEEL.

14. Steel,	5
15. Mild or Soft Steel,	5
16. Rolling Steel,	6
17. Billets,	6
18. Weight of Steel,	7

CAST IRON.

19. Cast Iron,	7
20. Castings,	8
21. Cores,	8
22. Crushing Strength of Cast Iron,	8
23. Tenacity of Cast Iron,	8
24. Weight of Cast Iron,	8

CHAPTER II.

FLOORS.

ARTICLE	PAGE
25. Dead Load,	9
26. Live Load,	9
27. Method of determining Rolled-iron Beams by Diagram,	9
28. Beams as Girders,	11
29. To determine Coefficient for Beams,	11
30. Properties of Wrought-iron I Beams,	12
31. Deflection,	12
32. Coefficients for Steel Beams,	13
33. Properties of Steel I Beams,	13
34. Channels,	14
35. Properties of Wrought-iron Channels,	14
36. Properties of Steel Channels,	15
37. Zee Bars,	15
38. Floors should be Rigid,	15
39. Elastic Limit,	15
40. Maximum Deflection,	16
41. Framed Beams,	16
42. Tie Rods,	16
43. Beam Connections,	18
44. Bearing for Beams,	18
45. Pressure on Brick and Stone Work,	18
46. Keys for Beam Connections,	18
47. Bolts and Rivets for Beam Connections,	19
48. Tee Irons as Beams,	19
49. Angle Irons as Beams (Even Legs),	20
50. Angle Irons as Beams (Uneven Legs),	20
51. Beams not uniformly loaded, and Beams not supported at both Ends,	20

CHAPTER III.

GIRDERS.

52. Compound Girders,	22
53. Webs,	22
54. Buckling,	22
55. Flanges,	22
56. Deflection,	22
57. Rivets in Girders,	22
58. Strain on Flanges of Girders,	23
59. Shearing,	24
60. Flanges reduced in Thickness near Ends,	24
61. Weight of Brickwork,	26
62. Separators,	27

CONTENTS.

vii

ARTICLE	PAGE
63. Cast-iron Plates on Girders for Walls,	28
64. Bolts and Rivets,	28
65. Shearing and Bearing of Rivets,	28
66. Pins,	29

CHAPTER IV.

CAST-IRON LINTELS.

67. Cast-iron Lintels,	30
68. Skew-back Lintels,	31
69. Lintels for Iron Fronts,	31
70. Sidewalk Lintels,	32
71. Window-head Lintels,	32
72. Double-web Lintels,	32
73. Window Sills,	32
74. Rule for Breaking Weight at Middle,	32
75. Webs,	33
76. Tests of Cast-iron Lintels,	33

CHAPTER V.

TRUSSES.

77. Roof Trusses,	35
78. Loads on Trusses,	35
79. Snow and Wind Pressure,	36
80. Ceiling Weight,	36
81. The Graphic Method,	36
82. King-post Truss,	36
83. Truss No. 2,	38
84. Truss No. 3,	38
85. Truss No. 4,	39
86. Truss No. 5,	40
87. Details of Iron Trusses,	42
88. Ties and Struts,	42
89. Wooden Purlins,	42
90. Connections,	42

CHAPTER VI.

STRUTS.

91. Rolled-iron Struts,	44
92. End Connections,	44
93. Factors of Safety,	46

ARTICLE	PAGE
94. Greatest Safe Load on Struts,	47
95. Channel Struts,	48
96. Angles as Struts,	48
97. Tees as Struts,	49
98. Properties of Beams for Struts,	50
99. Properties of Channels for Struts,	51
100. Properties of Angles for Struts,	52
101. Properties of Tees for Struts,	54

CHAPTER VII.

CAST-IRON COLUMNS.

102. Columns, Shafts Ornamented,	55
103. Capitals,	55
104. Cast-iron Column Connection,	56
105. Holes Drilled,	58
106. Column Flanges,	58
107. Fire-proof Column,	58
108. Dowel Columns,	59
109. Strength of Cast-iron Columns,	60
110. Weight to be Estimated for any Use,	62
111. Strength of Hollow Cast-iron Columns,	62
112. Factors of Safety for Cast-iron Columns,	63
113. Ribbed Base Plates,	64
114. Flat Base Plates,	65
115. Grouting,	65
116. Bedding,	66
117. Cast-iron Dowels for Wooden Columns,	66
118. Wrought-iron Pins and Cast-iron Star-shaped Dowels,	66

CHAPTER VIII.

WROUGHT-IRON COLUMNS.

119. Wrought-iron Column Sections,	67
120. Zee-bar Columns,	68
121. Strength of Wrought-iron Columns,	68
122. Safe Load on Wrought-iron Columns,	69
123. Radii of Gyration for Round Column,	70
124. Radii of Gyration for Square Column,	70

CHAPTER IX.

STAIRWAYS.

125. Close-string Stairs,	71
126. Height and Breadth of Steps,	71
127. Cast-iron Stairs,	71

ARTICLE	PAGE
128. To Measure Height of Railing,	72
129. Number of Strings regulated by Width,	74
130. Wrought-iron Stairs,	74
131. Circular Stairs,	76
132. Deck-beam Strings,	77
133. Channel Strings,	77
134. Plate and Angle Strings,	77
135. Treads and Risers,	78
136. Fascias,	79
137. Posts or Newels,	79
138. Brackets for Stair Handrail,	79
139. Stairs to be carefully constructed,	79

CHAPTER X.

ORNAMENTAL IRONWORK.

140. Ornamental Design,	80
141. Hammered Wrought Iron,	80
142. Method of Hammering Leaves, etc.,	83
143. Hammered Wrought-iron Grilles,	83
144. Cast-iron Ornamented,	83
145. Modelling for Ornamental Castings,	84
146. Finish of Ornamental Iron,	86

CHAPTER XI.

ELEVATOR ENCLOSURES.

147. Passenger-elevator Enclosure,	88
148. Freight-elevator Enclosure,	90
149. Double Sliding Doors for Passenger-elevator Fronts,	92
150. Elevator Guide Supports,	94

CHAPTER XII.

DOORS AND SHUTTERS.

151. Circular-head Door and Frame,	95
152. Sidewalk Door,	95
153. Outside Folding Shutters,	98
154. Shutter Hinges,	99
155. Storm Hooks,	99
156. Shutter Eyes,	99
157. Shutter Rings,	99
158. Cast-iron Brick,	99
159. Rolling Steel Shutters,	100
160. The Noiseless Shutter,	100

CHAPTER XIII.

FLOOR LIGHTS AND SKYLIGHTS.

ARTICLE	PAGE
161. Cast-iron Floor Lights for Iron Beams,	102
162. Cast-iron Floor Lights for Wooden Beams,	102
163. Wrought-iron Floor Lights for Wooden Beams,	102
164. Skylights,	106
165. Hip-Skylight,	109

CHAPTER XIV.

HOLLOW BURNT CLAY.

166. Hollow Blocks for Arches,	110
167. Porous Terra Cotta,	110

CHAPTER XV.

ANCHORS.

168. Ashler Anchors,	113
169. Side Anchors,	113
170. Wall Anchors,	114
171. Hook Anchors,	114
172. Drive Anchors,	114
173. Wedge Anchors,	115
174. Coping Anchors,	116
175. Government or V Anchors,	116
176. Girder Straps,	116
177. Beam Straps,	116

CHAPTER XVI.

BOLTS.

178. Square-head Bolts,	117
179. Hexagon-head Bolts,	117
180. Button-head or Carriage Bolts,	117
181. Countersunk-head Bolts,	117
182. Screw-head Bolts,	117
183. Tap Bolts,	117
184. Counter-sunk Tap Bolts,	118
185. Double and Single Expansion Bolts,	118
186. Lag Screws,	119
187. Upset Ends,	119
188. Open-drop Forged Turn-buckles, Pipe Swivel and Arm Swivel,	119

CHAPTER XVII.

MISCELLANEOUS DETAILS.

189. Mail Chutes,	120
190. Folding Gates,	122

ARTICLE	PAGE
191. Box Slides,	123
192. Hanging Ceilings,	124
193. Flich-plate Girders,	125
194. Sidewalk Elevator,	127
195. Wrought-iron Gratings,	129
196. Cast-iron Perforated Plates,	130
197. Knee Gratings,	130
198. Galvanized Iron Cornices,	130
199. Scuttle,	131
200. Scuttle Ladder,	131
201. Iron Fronts,	132
202. Plain Fire Escapes,	134
203. Brackets on New Buildings,	135
204. Top Rails,	136
205. Bottom Rails,	136
206. Filling-in Bars,	136
207. Stairs,	136
208. Floors,	136
209. Drop Ladders,	136
210. Height of Railing,	137
211. Ornamental Fire Escapes,	137
212. Fire Escapes for Schools, Factories, etc.,	137
213. Vault Cover and Frame,	137
214. Cast-iron Grating,	138
215. Strainers,	138
216. Plain Wrought-iron Bar Window Guards,	138
217. Bridle or Stirrup Irons,	139
218. Chimney Cap,	142
219. Cast-iron Flue Door and Frame,	142
220. Wrought-iron Flue Door,	142
221. Flue Ring and Cover,	142
222. Chimney Ladder,	143
223. Corrugated Iron,	143
224. Galvanized and Black Iron,	144
225. Finial and Crestings,	145
226. Vault Lights,	146
227. Wrought-iron Guard,	147
228. Dwarf Doors,	148
229. Cast-iron Wheel Guards,	148
230. Fire Pipes,	148
231. Mansard Roof,	148
232. Railings for Roof Protection,	148
233. Pipe Railing,	149
234. Corrugated Flooring,	149
235. Tanks,	150
236. Chains and Cables,	152

ARTICLE	PAGE
237. Wire Work,	154
238. Cast-iron Boiler Flues,	155
239. Wrought-iron Boiler Flues,	155

CHAPTER XVIII.

FINISHING IRON AND STEEL.

240. Bronzing,	156
241. Enamelling Cast and Wrought iron,	156
242. Electro-plating,	156
243. Galvanizing Sheet Iron,	157
244. Painting of Iron,	157
245. Malleable Castings,	158
246. Lacquer for Iron,	158

CHAPTER XIX.

SPECIFICATION.

General Conditions,	159
Time of Completion,	160
Payments,	160
Constructive Work,	161
Wrought Iron,	161
Wrought Steel,	161
Cast Iron,	162
Painting,	162
Anchors, Clamps, Dowels, etc.,	162
Columns,	162
Girders,	163
Cast-iron Lintels,	164
Stairs,	164
Bulkheads on roof,	165
Miscellaneous,	165
Setting,	165

CHAPTER XX.

TABLES.

Average Weight in Pounds of a Cubic Foot of Various Substances,	166, 167 168
Squares and Cubes, of Numbers from 1 to 440,	169, 170, 171, 172
The Circumference and Areas of Circles from 1 to 50,	173, 174, 175
Weight per Foot of Flat Iron,	176, 177
Number of U. S. Gallons (231 Cubic Inches) Contained in Circular Tanks,	178

	PAGE
Decimal Equivalents for Fractions of an Inch,	178
Decimal Equivalents for Fractions of a Foot,	179
Weight of 100 Bolts with Square Heads and Nuts,	180
Weights of Nuts and Bolt-heads in Pounds,	180
Weight of Sheets of Wrought Iron, Steel, Copper, and Brass,	181
Weight of Square Cast-iron Columns in Pounds per Lineal Foot,	182
Weight per Lineal Foot of Circular Cast-iron Columns,	183

CHAPTER XXI.

NEW YORK BUILDING LAW.

Vault Lights and Areas Protected,	184
Buildings Increased in Size by Use of Columns and Girders,	185
Anchors,	185
Floors, Stairs and Ceilings of Iron,	185
Weight on Floors,	186
Framing of Beams,	187
Cast-iron Templates,	188
Iron Lintels,	188
Fire-proof Columns,	189
Iron Fronts Backed with Brick,	190
Thickness of Cast-iron Posts,	190
Curtain-wall Girders,	190
Rolled Iron and Steel Beams and Factors of Safety,	191
Girders to be Tested,	192
Beams, Lintels and Girders to be Inspected,	192
Stirrup Irons,	193
Beam Anchors,	193
Fitch-plates for Girders,	193
Smoke Flues Lined with Cast Iron,	194
Iron Shutters,	194
Railings around Well-holes,	195
Elevator Wells Inclosed with Brick or Iron,	196
Dumb-waiters, Skylights over Elevators,	196
Screen of Iron under Elevator Machinery,	196
Mansard Roof,	196
Bulkheads,	197
Cornices and Gutters,	197
Dormer Windows, Scuttles and Skylights,	197
Iron Ladders to Scuttles,	198
Fire Escapes,	198
Roof Gardens on Theatres,	198
Proscenium Wall Girder, etc.,	199
Skylights and Doorways to Theatres,	199

	PAGE
Doorways through Proscenium Wall, Doors of Iron and Wood,	199
Roof of Auditorium, Main Floor of Auditorium and Vestibule, Floor of Second Story over Entrance, Lobby and Corridors of Iron and Fire- proof Materials,	200
The Fronts of Galleries, Ceiling of Auditorium, Partitions in Auditorium, Entrance Vestibule, Partitions of Dressing-rooms and Doors in same to be Fire-proof,	200
Actors' Dressing-rooms and Fly Galleries,	201
Stage and Fly Galleries Fire-proof,	201
Proscenium Opening and Curtain,	201

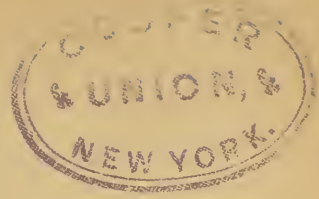

ARCHITECTURAL IRON AND STEEL.

CHAPTER I.

THE MANUFACTURE OF IRON.

1. Iron—is obtained from its ores, in which it generally exists in the state of an oxide, combined with earthy or rocky matters, and frequently with *carbon, sulphur, silica, manganese,* etc.

The foreign substances which iron is found to contain modify in a marked manner its essential properties. *Carbon* adds to its hardness, but destroys some of its characteristic qualities, and produces cast iron or steel according to the proportion of carbon it contains.

2. Smelting—is the process by which iron is separated from foreign substances with which it is combined in the ore.

It consists in raising the ore to a high heat, in contact with carbon and a suitable flux, in the blast or smelting furnace. The flux unites with the earthy matter of the ore, forming a glassy substance called *slag* or cinder, and the carbon unites with the oxygen of the ore, setting the iron free, which in turn unites with a portion of the carbon and forms a fusible compound, *carburet of iron* or cast iron. The furnace is tapped from time to time. The metal is run out and formed into bars called *pigs*.

3. Pig Iron—according to the proportion of carbon which it contains, is divided into different grades, No. 1, 2, 3, 4, etc. The lower numbers are the more expensive to produce; they

are used for foundry purposes, and are called "*foundry pig*"; the high numbers are converted into wrought iron by the puddling furnace, and are termed "*forge pig*."

WROUGHT IRON.

4. **Puddling.**—After the proper melting of the pig iron in the puddling furnace, and stirring the mass until it loses its fluidity, it is formed into balls weighing from 100 to 200 pounds, and the liquid cinder being pressed out in the squeezer, it is then passed through the *puddle rolls*, making a rough bar several feet in length.

5. **Piling.**—To prepare rough bars for this operation, they are cut, hot or cold, by a pair of shears, into such lengths as may be best adapted to the finished bar, then placed in the heating furnace, heated to a welding heat, and passed back and forth through the finishing rolls, from which their commercial shape is derived.

The piles used in making beams are numerous, the following sketches giving a few :

FIG. 1.

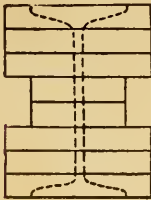

FIG. 2.

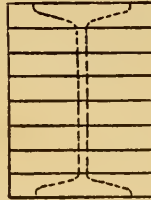

FIG. 3.

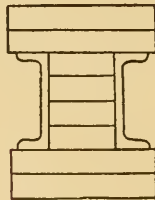
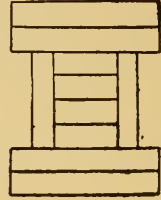

FIG. 4.

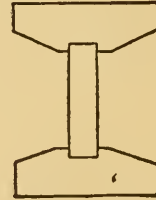

FIG. 5.

In Fig. 1 the large plates are placed on top of each other for the flange of the I beam, with the smaller plates between for the web; the dotted lines showing the form of beam when in its finished state.

In Fig. 2 the pile is made entirely of one size plates.

Fig. 3 shows a common arrangement of piles for 7 to 10 inch beams.

The piles for 10 to 20 inch beams are built up as in Fig. 4. It will be noticed that in this form channels are used, the flanges of which are worked into the flanges of the beam.

Some piles for 12 to 20 inch beams are made with three pieces only, one for each flange, with a groove to receive the web piece, as in Fig. 5.

Iron channel piles are formed similarly to the above.

6. Rolling.—Iron beams from 6 to 12 inches can be rolled 60 feet long as easily as 30 feet, providing the entire weight of beam is not over 2500 pounds. For deeper beams than 12 inches the length is limited by the length of pile and size of furnace; 15 feet being an extra-long furnace.

The quality of a beam is often governed by the manner of rolling. The webs being strained and worked more than the flanges, will cause wavy or buckled webs; or an unequal working on the web and flange will cause broken flanges; or the flanges do not always fill the passes of the rolls, causing wavy flanges, which are then called *wire-drawn*.

7. Channels (C's), angles (L's), tees (T's), and various shapes are rolled similar to I beams.

8. Quality of Wrought Iron.—The ultimate tensile strength of prepared test bars having a sectional area of about one square inch for a length of 10 inches should not be less than 50,000 pounds. The elastic limit should be regarded as the measure of quality, and should not be less than 25,000 pounds per square inch of section, the working loads proportioned with reference to the elastic limit.

The shape of the bar has much to do with determining the breaking strain.

A round bar one inch in diameter should bend double, cold, without sign of fracture, while a square bar of the same quality may show cracks on the edges under such a test.

9. Testing Wrought Iron.—By taking a number of bars of best commercial iron and fracturing them off short, some specimens will present coarse crystals whitish in color, others very fine ones of a dark gray appearance, and in others the fracture will be lustrous like satin. The coarse crystals indicate an iron poor in quality, being hard and brittle; the fine ones an iron the reverse of this, but one on which dependence can be placed for all purposes where strength is required. The fracture exposing a soft and silky fibre indicates a high grade of iron,—the finer the fibre the better the quality.

All iron is built up, as it were, of crystals having different degrees of fineness, depending upon impurities and the manipulation.

Rolling develops fibre by elongating these crystals.

When the bar is broken off short, the ends of the elongated crystals are seen to be formed like threads.

10. Cold Bend Test.—A simple method of determining the quality is by the *cold bend test*, and is readily understood. It consists in bending by blows of a sledge-hammer, until the two sides approach each other to within a distance equal to the thickness of the bar.

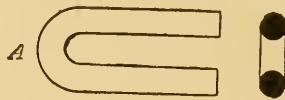

If the iron endures this treatment without showing signs of fracture on the back of the bend at *A*, it can be rated as of the very best quality. The test is more severe on a square than a

round bar, the fibres becoming very much strained at the corners.

The basis of strength is made on small bars of about one inch or less in diameter, while large bars will not show the same ultimate strength per square inch.

11. Modulus of Elasticity—is a term used to designate such a *weight* as would extend a bar through a space equal to its original length, supposing the elasticity of the bar to be perfect.

Then if one ton extends an inch bar of wrought iron one ten-thousandth of its length, it is evident that, upon the supposition that the bar is perfectly elastic, 10,000 tons would produce an extension equal to double the length of the bar. Hence on this assumption 10,000 tons, or 20,000,000 pounds, will be the *modulus of elasticity* of the wrought iron stated in *weight*.

The modulus of elasticity is found to vary from 25,000,000 to 29,000,000 pounds, and will of course vary according to the character of the material tested, being greater in higher than in lower grades of iron. Careful and repeated rolling improves the quality of iron, the best being that which has been re-worked.

12. Wrought Iron in Compression.—To resist *compression*, wrought iron is usually taken equal to its tensile strength.

13. Weight of Wrought Iron.—The average weight of wrought iron is 480 lbs. per cubic foot. A bar one inch square, three feet long, weighs therefore exactly ten pounds.

STEEL.

14. Steel—is a compound principally of iron, in the proportion of one tenth (0.1) of one per cent to two (2.0) per cent of *carbon*, with a very low percentage of *phosphorus*, *silica*, *manganese*, etc. Steel above three tenths (0.3) of one per cent of

carbon is used for "Tool Steel"; below fifteen hundredths (0.15) of one per cent it is called "Mild Steel."

The greater the percentage of *carbon* the higher will be the tensile strength.

Steel is distinguished from iron by its fine grain; it can be made more uniform, varies more in quality and has greater power of hardening.

15. Mild or Soft Steel.—Of the many processes by which *mild or soft steel* is manufactured, one of the latest is that in which the air is forced at high pressure through the metallic iron, the *silicon* first burned out, and then the carbon contained in the pig iron consumed; the length of time required being about 20 minutes to each charge. The color of the flame determines the instant at which the pressure of air shall cease. This is when the *carbon* has been entirely consumed, at which time the metallic iron is ready for conversion to steel.

Then recarbonizing material, *ferro-manganese*, is put in, either molten or in lumps, the exact quantity being carefully weighed, in order that the steel may be of such quality as the purpose for which it is to be used requires. The molten metal is then formed into ingot moulds, and transferred to the blooming mill. The result has been to change *cast iron* into a material as soft as the best quality of *wrought iron*, capable of being forged to shapes, bent cold, punched, drilled, or welded.

16. Rolling.—What has been said in regard to the rolling of iron also applies to steel; being rolled at a lower heat, it is denser, and therefore stiffer and stronger.

17. Billets.—Steel beams are rolled from a *billet*.

To make a 6-inch beam 35 pounds per yard, a billet 7 by $5\frac{1}{2}$ inches is used, and it requires eleven passes in the rolls to finish it. For 7, 8, and 9 inch beams billets 9 by $7\frac{1}{2}$ inches are taken, and fifteen passes are necessary to finish them. A 10-inch beam requires a 9 by $9\frac{1}{2}$ inch billet and needs seventeen passes; a 12-inch beam, a billet 10 by 10 inches, and the beam is finished in seventeen passes.

For steel beams above these sizes the billets are shaped in a blooming mill in the following form :



The remarks concerning the superiority of steel I beams over wrought iron can also be applied to channels and other shapes.

18. Weight of Steel.—Steel has a weight two (2.0) per cent greater than that of wrought iron ; and an *ultimate* tensile strength in the “mild steels” of 70,000 lbs. per square inch with an elastic limit of 36,000 pounds.

CAST IRON.

19. Cast Iron—for building purposes, possesses many advantages for strength, economy and adaptability to ornament and decoration. Unlike wrought iron and steel, it is not subject to rapid oxidation, and whatever tendency it may have in that direction, paint properly applied is a great preventive. In preparing iron for castings, the “foundry pig” is remelted in the “cupola,” the bed of which is covered with shavings, then from 1600 to 1800 pounds of hard coal are added, then a “draft” consisting of from 1000 to 1100 pounds of *pig iron* and scrap ; when several draughts have been fed, coke is added at regular intervals.

In charging iron, wood and coal all together, the iron when melted, being the heaviest, works through to the bottom, the purest iron being at the lowest point.

The metal for the finer castings, such as leaves for capitals, fascias, cornices, stair risers and ornamental stair strings, is poured first. Then metal for the heavy castings, such as columns, lintels, etc.

20. Castings—for architectural work are mainly done in what is called *green sand*, which contains a small percentage of clay and oxide of iron and is more or less porous.

21. Cores—are used for forming vacancies in castings where the pattern cannot be formed to draw from sand, and are made of white sand from the seashore, commonly called *dry sand*, being mixed with flour, sour beer, etc., forming a paste, and baked hard in the oven.

22. Crushing Strength of Cast Iron.—Cast iron is crushed by a force of 90,000 pounds per square inch, and will bear without permanent alteration 18,000 pounds per square inch, with an ultimate tensile strength of from 15,000 to 20,000 pounds; but it has an irregular elasticity, and castings may have initial strains through unequal cooling, or they may be thinner on one side than the other, or they may be weak through concealed holes, “cold shuts” or cinder. Therefore castings should be thoroughly tested with the hammer, and columns supporting heavy weights should be drilled (for inspection) on four sides if square, and two places if round.

23. Tenacity of Cast Iron.—The tenacity of cast iron being about one third ($\frac{1}{3}$) that of wrought iron, should not be subjected to more than one sixth ($\frac{1}{6}$) of the breaking strain, or say 3000 pounds per square inch.

24. Weight of Cast Iron.—The weight of cast iron per cubic foot averages 450 pounds.

CHAPTER II.

FLOORS.

25. Dead Load.—In arranging the beams upon the floor plan of a building, the first point to consider is the maximum load that will probably be placed upon the floor. The weight of the material comprising the floor—that is, the floor beams, girders, arches, flooring, timbers for nailing the flooring upon, the filling between timbers, partitions, and plastering on the ceiling and on partitions—is usually called the “*dead load*.”

For the weight of a cubic foot of any of the materials likely to be used, refer to Table of Weight of Various Substances, and chapter on “Hollow Burnt Clay.”

26. Live Load.—The weight of persons, or of stores of any kind, which may be placed upon the floor is called the “*live load*.”

This load for dwellings or offices may be assumed at 75 pounds per square foot of floor surface; for places of public assembly, 120 pounds; for stores, factories, or for any manufacturing or commercial purpose, from 150 pounds upwards; for warehouses, 200 to 250 pounds; and for heavy machinery, 250 to 400 pounds.

27. Method of Determining Rolled Iron Beams by Diagram.—Having determined the load per square foot to be sustained, by referring to the following diagram showing the proper distances in feet between centres of beams for different

spans and different uniform loads per square foot, proper rolled iron beams of 12,000 pounds strain may be found.

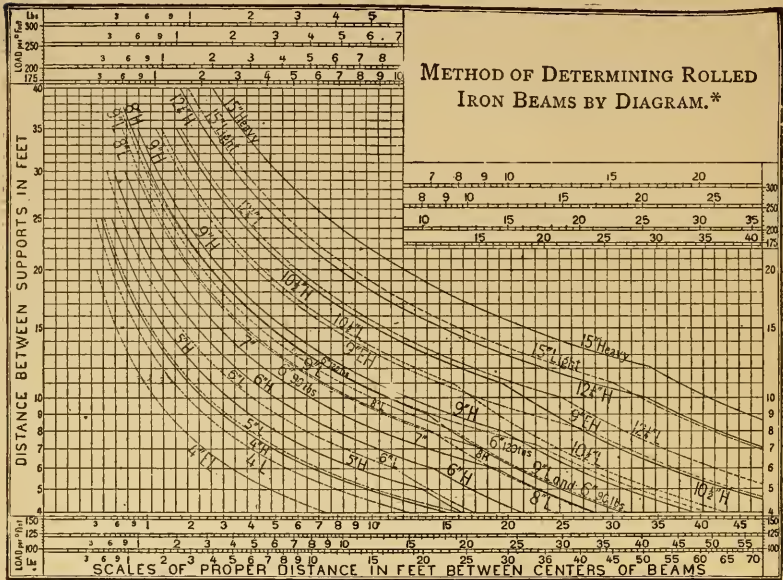

EXAMPLE 1. At what distance between centres must 9-inch heavy beams be set when the span is 15 feet and the entire load is 200 pounds per square foot? *Ans.* Follow the horizontal line from 15, on scale of distances between supports, to where it intersects the curve for 9-inch heavy beams, thence follow on line at right angles to scale of 200 pounds, and find the distance—4 feet.

EXAMPLE 2. A floor of 30 feet span is to carry 300 pounds per square foot on beams 2 feet apart: what size beam should be used? *Ans.* The horizontal line for 30 feet and the vertical line from 2 feet on 300 pounds scale intersect near curves of 15-inch light and 12½-inch heavy beams, either of which may be used.

* Diagram arranged by A. Faber du Faur, M.E.

EXAMPLE 3. What weight per square foot will a 12 $\frac{1}{4}$ -inch heavy beam carry, at 25 feet span and 3 feet between centres?
Ans. Follow up from intersection of the horizontal line for 25 feet span and the curve for 12 $\frac{1}{4}$ -inch heavy beam, and 250 pounds to the square foot is found to be the nearest to 3 feet span. The beam will carry a little more.

28. Beams deeper than those drawn on the diagram are principally used for girders. For the strength and dimensions of most of the numerous sizes rolled, and for steel beams, etc., see the following tables of coefficients.

29. To Determine Coefficient for Beams.—The following formula for uniform weights gives coefficient for 12,000 pounds strain:

$$\frac{1}{8}WL = 12,000 \frac{I}{e},$$

where W = weight in pounds uniformly distributed;

L = length in inches;

I = moment of inertia;

e = distance of extreme lamina from neutral axis (half the depth of I beam);

C = coefficient.

$$WL = 96,000 \frac{I}{e};$$

or if L be given in feet as is usual, then

$$WL = 8000 \frac{I}{e} = C.$$

EXAMPLE. The moment of inertia of a 15-inch beam 50 pounds per foot = 522.6. Distance of extreme lamina, 7".5.

$$\text{Coefficient} = 8000 \times \frac{522.6}{7.5} = 557,500.$$

30. PROPERTIES OF WROUGHT-IRON I BEAMS.

Depth of Beam.	Weight per ft.	Area of Section.	Thickness of Web.	Width of Flange.	Moment of Inertia, axis perpendicular to web at centre.	Coefficient, 12,000 lbs. strain.
inches.	lbs.	inches.	inches.	inches.		
20	90.7	27.2	.69	6.75	1650.3	1,320,000
20	66.7	20.0	.50	6.00	1238.0	990,000
15	80.0	24.0	.76	6.08	813.7	868,000
15	66.7	20.02	.50	6.00	707.0	743,000
15	60.0	18.0	.57	5.45	625.5	667,200
15	50.0	15.0	.49	5.05	522.6	557,500
* 12½ H.	56.7	16.77	.60	5.50	391.2	511,000
12	56.5	17.0	.78	5.16	348.5	464,800
12	42.0	12.6	.51	4.63	274.8	366,400
12½ L.	41.7	12.33	.47	4.79	288.0	377,000
10½ H.	45.0	13.36	.47	5.00	233.7	356,000
10½	40.0	12.0	.55	4.80	201.7	307,200
10½ L.	35.0	10.44	.38	4.50	185.6	283,000
10½	31.5	9.5	.41	4.53	165.0	251,200
10½ EX. L.	30.0	8.90	.31	4.50	164.0	250,000
10	42.0	12.6	.50	4.75	198.8	318,100
10	36.0	10.8	.44	4.50	170.6	273,000
-10	30.0	9.0	.37	4.31	145.8	233,300
9	38.5	11.6	.46	4.71	150.1	266,900
9	28.5	9.6	.40	4.16	110.3	196,000
9	23.5	7.1	.34	3.96	92.3	164,000
8	34.0	10.2	.50	4.50	102.0	203,900
8	27.0	8.1	.41	4.09	82.5	165,100
8	21.5	6.5	.33	3.71	66.2	132,300
7	22.0	6.6	.38	3.82	51.9	118,500
7	18.0	5.4	.26	3.52	44.2	101,100
6	16.0	4.8	.25	3.44	29.0	77,400
6	13.5	4.1	.24	3.24	24.4	65,100
5	12.0	3.6	.28	2.96	14.4	46,000
5	10.0	3.0	.23	2.85	12.5	40,000
4	7.0	2.1	.18	2.50	5.7	22,800
4	6.0	1.8	.18	2.18	4.6	18,300
3	9.0	2.7	.40	2.58	3.5	18,900
3	5.5	1.7	.16	2.22	2.5	13,400

To find the safe load in pounds equally distributed, divide the coefficient by the span in feet. To find the safe load in pounds, weight in centre of span, divide the coefficient by the span in feet, and take one half the quotient.

31. Deflection.—To find the deflections of beams for the above distributed loads, divide the square of the span in feet by 70 times the depth of beam in inches.

* Letters designate Heavy and Light sections.

32. **Coefficients for Steel Beams.**—If L be given in feet, as before for iron beams, but using 16,000 pounds strain, then

$$WL = 10,666 \frac{I}{e} = C.$$

EXAMPLE. The moment of inertia of a 9-inch beam 27 pounds per yard is 110.6. Distance of extreme lamina, 4.5.

$$\text{Coefficient} = 10,666 \times \frac{110.6}{4.5} = 262,200.$$

33.

PROPERTIES OF STEEL I BEAMS.

Depth of Beam.	Weight per ft.	Area of Section.	Thickness of Web.	Width of Flange.	Moment of Inertia, axis perpendicular to web at centre.	Coefficient, 16,000 lbs. strain.
inches.	lbs.	inches.	inches.	inches.		
24	100	30.0	.75	7.20	2322.3	2,064,000
24	80	23.2	.50	6.95	2059.3	1,830,500
20	80	23.5	.60	7.00	1449.2	1,545,600
20	64	18.8	.50	6.25	1146.0	1,222,400
15	75	22.1	.67	6.31	757.7	1,077,300
15	60	17.6	.54	6.04	644.0	916,300
15	50	14.7	.45	5.75	529.7	753,300
15	41	12.0	.40	5.50	424.1	603,200
12	40	11.7	.39	5.50	281.3	500,100
12	32	9.4	.35	5.25	222.3	395,200
10	32	9.7	.37	5.00	161.3	344,000
10	25.5	7.5	.32	4.75	123.7	263,800
9	27	7.9	.31	4.75	110.6	262,200
9	21	6.2	.27	4.50	84.3	199,900
8	22	6.5	.27	4.50	71.9	191,600
8	18	5.3	.25	4.25	57.8	154,000
7	20	5.9	.27	4.25	49.7	151,400
7	15.5	4.6	.23	4.00	38.6	117,600
6	16	4.7	.26	3.63	28.6	101,800
6	13	3.8	.23	3.50	23.5	83,500
5	13	3.8	.26	3.13	15.7	67,000
5	10	3.0	.22	3.00	12.4	52,900
4	10	2.9	.24	2.75	7.7	41,200
4	7.5	2.0	.20	2.63	5.9	31,400

To find the safe load in pounds equally distributed, divide the coefficient by the span in feet. To find the safe load in pounds, with weight in centre of span, divide the coefficient by the span in feet, and take one half the quotient.

34. Channels—are placed against walls in place of I beams to receive the wall arches.

35. PROPERTIES OF WROUGHT-IRON CHANNELS.

Depth of Channel.	Weight per ft.	Area of Section.	Thickness of Web.	Width of Flange.	Moment of Inertia, axis perpendicular to web.	Coefficient, 12,000 lbs. strain.
inches.	lbs.	inches.	inches.	inches.		
15	63.3	18.85	.75	4.75	586.0	625,000
15	60	18.00	.93	3.93	473.1	502,000
15	40	12.00	.50	4.00	376.0	401,000
12 $\frac{1}{4}$	46.6	14.10	.68	4.00	291.6	381,000
12 $\frac{1}{4}$	23.3	7.00	.33	3.00	153.2	201,100
12	50	15.00	.97	3.23	247.3	329,600
12	30	9.00	.47	2.73	175.3	233,600
12	20	6.00	.32	3.01	120.2	159,100
10 $\frac{1}{2}$	20	6.00	.375	2.75	88.4	134,750
10	35	10.50	.75	2.95	126.3	202,400
10	20	6.00	.30	2.50	88.8	142,400
10	16	4.80	.32	2.51	62.8	100,800
9	23.3	7.02	.43	3.125	82.1	146,000
9	30	9.00	.71	2.83	87.8	156,800
9	18	5.40	.31	2.43	63.5	113,600
9	16.6	5.08	.33	2.5	58.8	104,000
8	28	8.40	.76	2.80	63.9	128,000
8	15	4.48	.26	2.5	44.5	88,950
8	11	3.30	.20	2.2	32.9	65,800
7	20	8.40	.76	2.8	63.9	128,000
7	12	3.60	.25	2.5	27.1	62,000
6	16	4.80	.52	2.34	22.3	59,600
6	11	3.20	.28	2.25	17.2	45,700
5	14	4.20	.56	2.24	13.10	41,900
5	6	1.80	.15	1.65	7.16	22,900
4	9	2.70	.39	1.89	5.75	23,100
4	5	1.50	.17	1.49	3.69	14,800
3	6	1.80	.33	1.65	2.22	11,800
3	5	1.45	.20	1.50	2.0	10,500

To find the safe load equally distributed, divide the coefficient by the span in feet. For a safe centre load take one half the quotient.

NOTE.—Inasmuch as there is a great diversity in published tables of safe load for beams, etc., every one must judge for himself what proportion of the elastic strength of the beam will best suit his purpose.

36.

STEEL CHANNELS.

Depth of Channel.	Weight per ft.	Area of Section.	Thickness of Web.	Width of Flange.	Moment of Inertia, axis perpendicular to web.	Coefficient, 16,000 lbs. strain.
inches.	lbs.	inches.	inches.	inches.		
15	32.00	9.4	.40	3.40	284.5	404,700
15	51.00	15.0	.775	3.76	390.0	554,700
12	20.00	5.9	.30	2.90	117.9	209,600
12	30.25	8.9	.55	3.15	153.9	273,600
10	15.25	4.5	.26	2.66	63.8	136,100
10	23.75	7.0	.51	2.91	84.6	180,500
9	12.75	3.7	.24	2.44	43.3	102,700
9	20.50	6.0	.49	2.69	58.5	138,700
8	10.50	3.0	.22	2.22	28.2	75,300
8	17.25	5.0	.47	2.47	38.9	103,700
7	8.50	2.5	.20	2.00	17.4	53,100
7	14.50	4.3	.45	2.25	24.6	75,000
6	7.00	2.1	.19	1.89	11.1	39,400
6	12.00	3.6	.44	2.14	15.6	55,400
5	6.00	1.7	.18	1.78	6.5	27,900
5	10.25	3.0	.43	2.03	9.1	39,000
4	5.00	1.4	.17	1.67	3.5	18,700
4	8.25	2.4	.42	1.92	4.8	25,700

To find the safe load equally distributed, divide the coefficient by the span in feet. For a safe centre load take one half the quotient.

37. Zee Bars—are used in a similar manner, but prove more suitable than channels in many cases, as the one leg of the *zee bar* is built in with the wall, preventing any passage of fire from one story to another. See list of zee bars in common use, under chapter on Wrought-iron Columns.

38. Floors should be Rigid.—The strength of a beam may be sufficient to carry the imposed load, but the risk of vibration is also to be considered. Since repeated vibrations may injure the connections with columns and masonry, the floor should be *rigid*, as rigidity prevents vibration.

In certain circumstances it is advisable to consider whether it may not be more economical to use deep beams placed well apart than a greater number of light ones set at shorter intervals.

39. Elastic Limit.—Under no circumstances should a beam

be strained beyond the *limits of elasticity*; in other words, deflected so much that after the removal of the load it will not return to its former position before being loaded.

40. Maximum Deflection.—A beam that may be quite strong enough to carry a given load may deflect under this load more than is desirable, and stiffness being a different quality from strength, about one thirtieth ($\frac{1}{30}$) of an inch per foot of clear span is the usual *maximum* of deflection that is permissible: under ordinary loads this is attained when the clear span is about twenty-six times the depth of the beam.

The deflection of iron is somewhat greater than that of steel, experiments having proved that a steel beam will deflect slightly less than an iron beam of the same section under the same load.

41. Framed Beams.—Care should be exercised, in placing and spacing the beams, to see that there is not an excess of strength or too little used, and that beams are placed for support of partitions, framing of stair wells, floor lights, and to observe proper spacing and levels for arches. In the annexed plan the beams are shown as drawn on floor plans of buildings.

Fig. 2 is an elevation of beam *K*, with the header or cross-beam *L* framed, or coped, into it at *A* (see also connection *A*, Fig. 3). The distance *F* should be given on plan between centres of beams, unless there are special reasons for making a fixed distance between flanges of *K* beam at *M*.

The distance *E* on elevation of beam *K* is generally three inches, with $\frac{1}{16}$ -inch holes for $\frac{3}{4}$ -inch-diameter tie rods, $\frac{1}{8}$ -inch for $\frac{7}{8}$ -inch rods, and $1\frac{1}{16}$ -inch for one-inch rods.

42. Tie Rods—may be placed from four to six times the depth of beam apart, and holes are usually punched in the centre of web; but they should be placed as low as possible, so as not to be seen, and not injure under side of arch. Fig. 4 at *B* shows a smaller framed into a larger beam, and flush on bottom, with the angle-iron knees on the web close in between the flanges. Fig. 5 is the opposite view of Fig. 3, and shows

two knees attached to the framed beam, the centre of holes regulated by the size of angles to be used. The rivets or

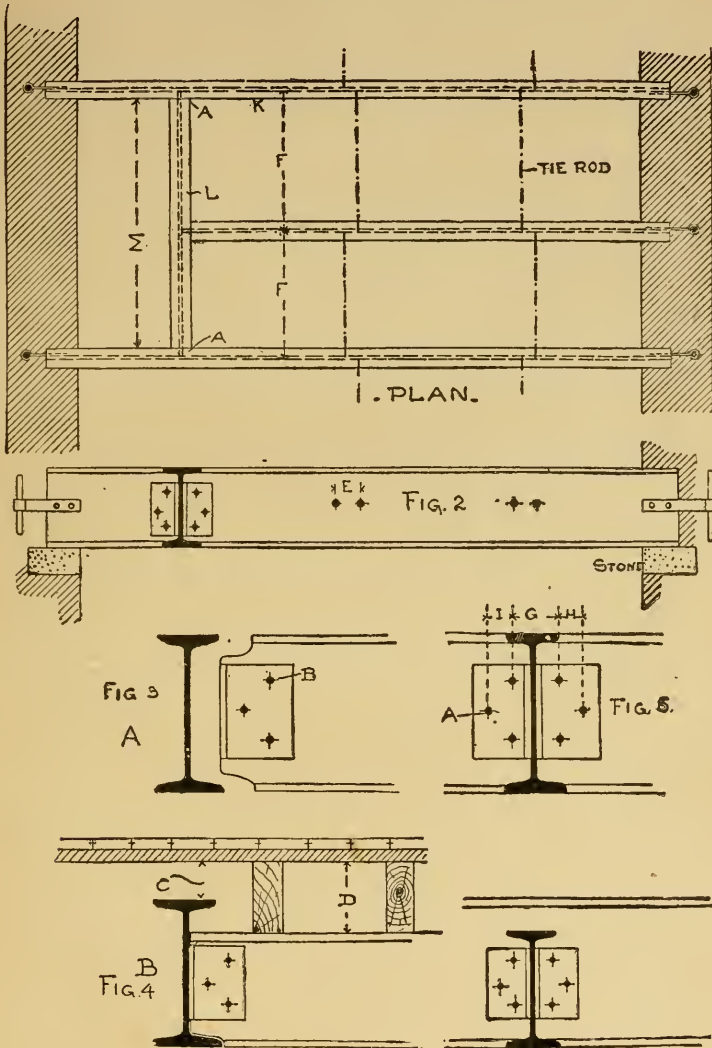

bolts, Figs. 4 and 5, should be proportioned to resist the shearing moment; that is, the strain at the joint multiplied by the

leverage or average distance of the bolt or rivet B from the face of joint.

43. Beam Connections.—It is not an uncommon thing to make the connection by resting the cross-beam on the flange of its supporter. As the fitting is not accurately done, it is not customary to depend on the lower flange taking the load, for the reason that if the beam is to resist bending strains symmetrically, these strains should be transmitted through axis of beam, which would not occur if the cross-beam rested on one flange of its supporter. It would not be felt injuriously, however, if the connection did not occur at middle of beam, or if a corresponding beam occurred directly opposite.

In Fig. 4 a section of portion of floor is shown. C distance is allowed for the passing of pipes, and is generally two inches; D distance is filled with a light fire-proof material, such as ashes, etc.

44. Bearing for Beams.—When the ends of beams rest upon walls, cast or wrought iron bed plates should be used to distribute the pressure over a greater surface. For buildings stone beds are generally used, but when the pressure is great both plates and stone. Beams have seldom less than 8 inches bearing or more than 12 inches; if less than 8 feet long, 6 inches will be sufficient.

45. Pressure on Brick and Stone Work.—The pressure per square foot for brickwork should not exceed six tons, and for stone twelve to twenty tons, according to its character.

46. Knees for Beam Connections.—The following sizes of knees are commonly used for beam connections:

24'' into 24'' beam	=	6 × 4 × $\frac{1}{2}$ ''	angles, 20'' long;
20'' " 20'' "	=	6 × 4 × $\frac{1}{2}$ ''	" 16'' "
15'' " 15'' "	=	6 × 4 × $\frac{1}{2}$ ''	" 11'' "
12'' " 12'' "	=	6 × 4 × $\frac{1}{2}$ ''	" 8'' "
10 $\frac{1}{2}$ '' " 10 $\frac{1}{2}$ '' "	=	6 × 4 × $\frac{7}{16}$ ''	" 6 $\frac{1}{2}$ '' "

10''	into	10''	beam	=	6	×	4	×	$\frac{7}{16}$ ''	angles,	6''	long;
9''	"	9''	"	=	6	×	4	×	$\frac{7}{16}$ ''	"	5''	"
8''	"	8''	"	=	5	×	$3\frac{1}{2}$	×	$\frac{3}{8}$ ''	"	$4\frac{1}{2}$ ''	"
7''	"	7''	"	=	5	×	$3\frac{1}{2}$	×	$\frac{3}{8}$ ''	"	$3\frac{1}{2}$ ''	"
6''	"	6''	"	=	5	×	$3\frac{1}{2}$	×	$\frac{3}{8}$ ''	"	3''	"
5''	"	5''	"	=	5	×	$3\frac{1}{2}$	×	$\frac{3}{8}$ ''	"	$2\frac{1}{2}$ ''	"
4''	"	4''	"	=	$3\frac{1}{2}$	×	$3\frac{1}{2}$	×	$\frac{3}{8}$ ''	"	$2\frac{1}{4}$ ''	"

47. Bolts and Rivets for Beam Connections.—The number of bolts and rivets is determined by shearing and bearing strain. See article on "Bolts and Rivets."

48. Tee Irons as Beams.—The following table gives

SAFE LOAD, IN POUNDS, UNIFORMLY DISTRIBUTED, FOR T IRONS, INCLUDING WEIGHT OF T.

MAXIMUM STRAIN 12,000 POUNDS PER SQUARE INCH.

Size of T.			Weight per yard.	Coefficient for Transverse Strain.	Distance between Supports, in feet.														
					4	5	6	7	8	9	10	11	12						
flange	stem	th'kness	lbs.																
5''	× 3''	× $\frac{1}{2}$ ''	38.1	7480	1870	1500	1250	1070	940	830	750	680	620						
4 $\frac{1}{2}$ ''	× 3 $\frac{1}{2}$ ''	× $\frac{1}{8}$ ''	46.5	6010	1502	1200	1000	860	750	670	600	550	500						
4	× 5	× $\frac{1}{2}$ ''	45.6	24,800	6200	4960	4130	3540	3100	2770	2480	2250	2070						
4	× 4 $\frac{1}{2}$ ''	× $\frac{1}{2}$ ''	42.9	20,400	5100	4080	3400	2910	2550	2270	2040	1860	1700						
4	× 4	× $\frac{1}{2}$ ''	37.5	15,800	3950	3160	2633	2257	1975	1755	1580	1435	1325						
4	× 3	× $\frac{3}{8}$ ''	27.3	7070	1765	1414	1178	1010	884	785	707	634	589						
3 $\frac{1}{2}$ ''	× 3 $\frac{1}{2}$ ''	× $\frac{1}{2}$ ''	27.0	9530	2382	1900	1590	1360	1190	1060	950	870	790						
3 $\frac{1}{2}$ ''	× 4	× $\frac{1}{2}$ ''	29.1	12,380	3095	2476	2064	1770	1550	1380	1240	1130	1030						
3 $\frac{1}{2}$ ''	× 3	× $\frac{1}{2}$ ''	22.5	5790	1418	1160	970	830	720	640	580	530	480						
3	× 4	× $\frac{1}{2}$ ''	34.8	15,480	3870	3100	2580	2210	1940	1720	1550	1410	1290						
3	× 3 $\frac{1}{2}$ ''	× $\frac{1}{2}$ ''	32.1	11,910	2975	2380	1990	1700	1490	1320	1190	1080	990						
3	× 3	× $\frac{5}{16}$ ''	19.5	5900	1475	1180	980	840	740	650	590	540	490						
3	× 2 $\frac{1}{2}$ ''	× $\frac{1}{2}$ ''	18.0	4100	1025	820	680	590	510	460	410	370	340						
3	× 2	× $\frac{1}{2}$ ''	14.6	2540	637	508	423	363	317	283	254	231	212						
2 $\frac{1}{2}$ ''	× 2 $\frac{1}{2}$ ''	× $\frac{1}{2}$ ''	16.2	4000	1000	800	670	570	500	440	400	360	330						
2 $\frac{1}{2}$ ''	× 3	× $\frac{1}{2}$ ''	18.0	6110	1527	1220	1020	870	760	680	610	560	510						
2 $\frac{1}{4}$ ''	× 2 $\frac{1}{4}$ ''	× $\frac{3}{8}$ ''	11.90	2811	703	560	460	402	352	312	281	254	234						
2	× 2	× $\frac{1}{2}$ ''	9.4	1970	493	394	328	282	246	218	197	179	164						
1 $\frac{3}{4}$ ''	× 1 $\frac{3}{4}$ ''	× $\frac{1}{4}$ ''	9.0	1550	390	310	260	220	190	170	155	140	130						
1 $\frac{1}{2}$ ''	× 1 $\frac{1}{2}$ ''	× $\frac{1}{4}$ ''	6.68	1033	258	207	172	147	129	115	103	94	86						
1 $\frac{1}{2}$ ''	× 1 $\frac{1}{2}$ ''	× $\frac{3}{8}$ ''	4.87	596	149	119	98	85	75	66	59	54	49						
1	× 1	× $\frac{3}{8}$ ''	2.80	268	67	53	45	38	36	29	26	24	22						

49. Angle Irons as Beams.—The following table gives

SAFE LOAD, IN POUNDS, UNIFORMLY DISTRIBUTED, FOR EQUAL-LEG ANGLES, INCLUDING WEIGHT OF ANGLES.

MAXIMUM STRAIN 12,000 POUNDS PER SQUARE INCH.

Size of Angle.	Weight per yard.	Coefficient for Transverse Strength.	Distance between Supports, in feet.											
			4	5	6	7	8	9	10	11	12			
inches.	lbs.													
6 × 6 × $\frac{7}{16}$	50.6	32,560	8140	6510	5430	4650	4070	3620	3260	2960	2715			
6 × 6 × $\frac{5}{8}$	57.5	36,900	9225	7400	6150	5270	4612	4100	3690	3354	3075			
5 × 5 × $\frac{3}{8}$	36.0	19,360	4840	3870	3230	2770	2420	2150	1940	1760	1618			
4½ × 4½ × $\frac{3}{16}$	37.5	18,000	4500	3600	3000	2571	2250	2000	1800	1633	1500			
4 × 4 × $\frac{3}{8}$	28.6	12,184	3046	2437	2031	1740	1523	1354	1218	1107	1015			
3½ × 3½ × $\frac{1}{4}$	24.8	9200	2300	1840	1530	1310	1150	1020	920	840	770			
3 × 3 × $\frac{1}{4}$	14.4	4611	1153	922	767	658	576	512	461	419	384			
2½ × 2½ × $\frac{5}{16}$	16.2	4710	1177	942	785	672	589	522	471	428	393			
2½ × 2½ × $\frac{1}{4}$	11.9	3156	789	631	526	451	394	344	317	287	263			
2½ × 2½ × $\frac{1}{8}$	10.6	2530	633	506	422	362	316	281	253	230	211			
2 × 2 × $\frac{7}{8}$	8.3	1752	438	350	292	250	219	195	175	159	146			
1½ × 1½ × $\frac{3}{16}$	6.21	1150	287	230	192	164	144	128	115	104	96			
1½ × 1½ × $\frac{1}{4}$	5.27	832	208	164	139	119	104	92	83	76	69			
1½ × 1½ × $\frac{1}{8}$	2.97	393	98	78	65	56	49	44	39	36	33			

50. SAFE LOAD FOR UNEQUAL-LEG ANGLES, THE LONGER LEG VERTICAL.

MAXIMUM STRAIN 12,000 POUNDS PER SQUARE INCH.

Size of Angle.	Weight per yard.	Coefficient for Transverse Strength.	Distance between Supports, in feet.											
			4	5	6	7	8	9	10	11	12			
inches.	lbs.													
6 × 4 × $\frac{7}{16}$	41.8	30,680	7670	6136	5113	4383	3834	3409	3068	2789	2556			
6 × 4 × $\frac{5}{8}$	36.1	26,560	6640	5310	4430	3790	3320	2950	2660	2410	2210			
6 × 3½ × $\frac{3}{8}$	34.2	26,000	6500	5200	4330	3710	3250	2890	2600	2360	2170			
5 × 4 × $\frac{3}{8}$	32.3	18,720	4680	3740	3120	2670	2340	2080	1870	1700	1560			
5 × 3½ × $\frac{3}{8}$	30.5	18,353	4590	3671	3059	2622	2294	2038	1835	1668	1528			
5 × 3 × $\frac{3}{8}$	28.6	17,840	4460	3570	2970	2550	2230	1980	1784	1620	1490			
4½ × 3 × $\frac{3}{8}$	26.7	14,580	3645	2916	2430	2083	1823	1620	1458	1325	1217			
4 × 3½ × $\frac{3}{8}$	26.7	12,000	3000	2400	2000	1710	1500	1330	1200	1090	1000			
4 × 3 × $\frac{5}{16}$	20.9	9850	2462	1970	1641	1407	1231	1094	985	895	821			
3½ × 3 × $\frac{5}{16}$	19.3	7680	1920	1540	1280	1100	960	850	770	700	640			
3½ × 2½ × $\frac{1}{4}$	14.4	6000	1500	1200	1000	860	750	670	600	540	500			
3 × 2½ × $\frac{1}{4}$	13.1	4480	1120	900	750	640	560	500	450	410	370			
3 × 2 × $\frac{1}{4}$	11.9	4320	1080	860	720	620	540	480	430	390	360			
2½ × 2 × $\frac{3}{16}$	8.1	2320	580	460	390	330	290	260	230	210	190			

51. Beams not Uniformly Loaded and Beams not Supported at Both Ends.

(a) For a beam fixed at one end and loaded at the other as a *cantilever*,

$$\text{Safe load in lbs.} = \frac{\text{coefficient}}{8L}.$$

(b) For a beam fixed at one end and uniformly loaded,

$$\text{Safe load in lbs.} = \frac{\text{coefficient}}{4L}.$$

(c) For a beam supported at both ends, load concentrated at any point,

$$\text{Safe load in lbs.} = \frac{\text{coefficient}}{L} \times \frac{L^2}{8A \times B}.$$

A = distance from load to one support; B = distance from load to the other support.

NOTE.—The beams, channels and other shapes treated of in this chapter are selected from the hand-books of the Passaic Rolling Mill Co., Phoenix Iron Co., Columbia Iron and Steel Co., and Pottsville Iron and Steel Co.

CHAPTER III.

GIRDERS.

52. Compound Girders.—Where spans occur too great to admit the use of rolled beams, *compound girders* are employed, made up of plates and angle irons.

The single web or "*plate girder*" is the most economical, the most accessible for painting, for inspection, and for connecting the floor beams. But where a thick wall is to be supported and lateral stiffness is required, the double web or "*box girder*" is used.

If girders have no lateral bracing, the flanges should not be less than one twentieth the span.

53. Webs.—The *webs* should be of such thickness that there shall be no tendency to buckle and the vertical shearing stress per square inch shall not exceed 6000 pounds. This stress is greatest near the bearings, and is obtained by dividing one half the load upon the girder by the web section.

54. Buckling.—Vertical angle irons are riveted to webs to prevent *buckling*, at intervals of not more than the depth of the web, and should always be used at the bearings and where concentrated loads occur; it is good practice to use stiffeners when the thickness of web is less than one sixtieth ($\frac{1}{60}$) the depth.

55. Flanges.—The *flange* embraces all the metal in top and bottom of girder, exclusive of web plates.

56. Deflection.—For *deflection* the depth of girder should be about one twentieth ($\frac{1}{20}$) the span.

57. Rivets in Girders—should not be spaced closer than two and one half ($2\frac{1}{2}$) inches between centres or three times

the diameter, nor farther apart than sixteen times the thickness of plate connected, and should be closer near bearings.

Rivets five eighths ($\frac{5}{8}$), three quarters ($\frac{3}{4}$), and seven eighths ($\frac{7}{8}$) of an inch in diameter are commonly used.

If the webs are connected to the flanges by single angles as in box girders, the rivets will be in single shear; but if a pair of angles are placed each side of the web as in a plate girder, the rivets will be in double shear.

In long girders it is often necessary to increase the thickness of webs near ends, to give a greater bearing surface for the rivets.

58. Strain on Flanges of Girders.—To calculate a girder accurately we should allow for the rivet holes; but by taking the safe strength of the iron at 14,000 pounds per square inch strain on the flanges, and using a formula for 12,000 pounds, and disregarding the rivet holes, we can compute it with sufficient accuracy for all practical purposes in buildings.

If 12,000 pounds strain per square inch is desired, add one sixth ($\frac{1}{6}$) to the total area of flanges for loss by rivet holes.

Proceeding on the first assumption, we have the following rule for the strength:

Safe loads in tons =

$$\frac{12 \times \text{area of one flange} \times \text{height of web in inches}}{3 \times \text{span in feet}}$$

To find area of one flange in inches, divide ($3 \times \text{weight in tons} \times \text{span in feet}$) by ($12 \times \text{height of web in inches}$).

EXAMPLE. Given a brick wall 12 inches wide, 29 feet $1\frac{1}{2}$ inches high, the span 24 feet, and girder 20 inches in height: what should be the area of each flange, the load being 40.2 tons, at 115 pounds per square foot of 12-inch wall?

Ans. Area of one flange = $\frac{3 \times 40.2 \times 24}{12 \times 20} = 12.06$ square inches.

To divide the area of 12.06 square inches into a proper working flange, we should require a

$$\text{Plate } 10 \times \frac{3}{4} \text{ in.} \quad = 7.5 \text{ inches}$$

$$\text{Two angles } 4 \times 3 \times \frac{3}{8} \text{ in.} = 4.96 \quad "$$

Total, 12.46 inches—an excess of 0.4 in.

59. Shearing.—A sufficient area having been provided in the top and bottom flanges to resist the compressive and tensile strains, there will be needed in the web sufficient metal to resist the *shearing* strain. This strain is, theoretically, nothing at the middle of a girder uniformly loaded, but from thence increases by equal increments to each support, where it is equal to one half of the whole load.

For example: In the case considered, the girder of 24 feet span carries 80,400 pounds uniformly distributed over its whole length. Taking half of the load over half the beam, at the centre the shearing strain is nothing; at 4 feet from the centre it is equal to $\frac{1}{3}$ of half the load, or 13,400 pounds; at 8 feet it is 26,800 pounds; at 12 feet, or at the supports, it is 40,200 pounds, or half the whole load.

The thickness of web may be determined as follows:

Let G = shearing stress;

A = area of web in inches at point of stress;

k = effective resistance of wrought iron to shearing;

t = thickness of web;

d = height of web.

Then $A = td$, and $G = ktd$, or

$$t = \frac{G}{dk}, \text{ or } t = \frac{40,200}{20 \times 6000} = .335, \text{ or nearly } \frac{3}{8} \text{ inch.}$$

As the least practicable thickness of plates is $\frac{1}{4}$ inch, it is not worth while to compute that of the web at the 4 and 8 feet stations.

60. Flanges Reduced in Thickness near Ends.—In heavy girders a saving of iron may often be made by reducing

the thickness of the flanges towards the ends of the girder, where the strain is less. Then for the area of bottom flange at any point in its length, taking the stations as above, 4 feet and 8 feet, for a load uniformly distributed we have the following formula :

$$A = W \frac{xy}{2dkl}.$$

Let d = depth in feet ;

W = weight distributed over entire girder in pounds ;

x = short lever arm in feet ;

y = long lever arm in feet ;

l = span in feet ;

k = taken at 12,000 pounds.

We have

$$A = \frac{80,400xy}{2 \times 1.66 \times 12,000 \times 24} = .084xy.$$

When $x = y = 12$, then $A = .084 \times 12 \times 12 =$ say 12 inches,
or the area required in the bottom flange at the middle.

When $x = 8$, then $y = 16$, and $A = .084 \times 8 \times 16 = 11$ inches,
or the area required at 4 feet from the middle either way.

When $x = 4$, then $y = 20$, and $A = .084 \times 4 \times 20 = 7$ ins.,
or the area required at 8 feet from the middle either way.

In the results just given, the area required in the flanges increases gradually from the points of support each way to the middle of the girder. Then by making the chord or flange angles uniform throughout, and dividing the sum by the width of girder, being 10 inches in this case, the results are :

At the middle three quarters ($\frac{3}{4}$) of an inch thick.

At four feet from middle five eighths ($\frac{5}{8}$) " "

At eight feet from middle one quarter ($\frac{1}{4}$) " "

Or, at middle 7''.5 plate area + 4''.96 angle area = 12''.46 ;

4 ft. from " 6''.25 " " + 4''.96 " " = 11''.21 ;

8 ft. from " 2''.5 " " + 4''.96 " " = 7''.46.

An excess of metal will have to be placed in the plates at eight (8) feet from middle to make up the area, as it requires a one-quarter ($\frac{1}{4}$) inch plate the entire length, and within four (4) feet of each end a one-half ($\frac{1}{2}$) inch plate to make up the three quarters ($\frac{3}{4}$) of an inch section; or use a one-half ($\frac{1}{2}$) inch plate the entire length, and a one-quarter ($\frac{1}{4}$) inch plate eight (8) feet each way from middle.

Most girders will work to better advantage in the plates than this example; always remembering that it is not practicable to make the plates for webs and flanges less than one quarter ($\frac{1}{4}$) of an inch thick.

61. Weight of Brickwork.—In calculating the weight of brick walls, the following weights per square foot of surface are generally adopted:

8 inches thick = 77 pounds;	20 inches thick = 192 pounds;
12 “ “ = 115 “	24 “ “ = 230 “
16 “ “ = 153 “	28 “ “ = 268 “

The *box girder*, as shown in the plate, is connected to a column by the bolts *A* extending through to a girder on the opposite side. The rivets are countersunk on the bottom at each end *D*, to allow an even surface for the bearing of heel of girder on bracket and on stone templet.

Secured to the girder is a floor beam, which can be set at any height to accommodate the finished floor of building. The knees should be riveted to girders before being finished, providing the beam can be pushed into knees at right angles to girder; otherwise one knee should be riveted and the other placed on the beam and holes tapped into girder.

At section of box girder, *F* is the width of top flange, *E* is the height of webs, *B* and *C* are stiffeners, with fillers at the back extending under the same between the chord angles.

Fig. 1 is a single beam with a wrought-iron plate to increase flange area, riveted to flanges with four lines of rivets.

Fig. 2 is a double beam girder, used similarly to Fig. 1.

Fig. 3 is a double channel girder, used similarly to Figs. 1 and 2.

The same formula to be used for these sections as for plate girders; the flange section being taken equal to the area of plate and flange of beam.

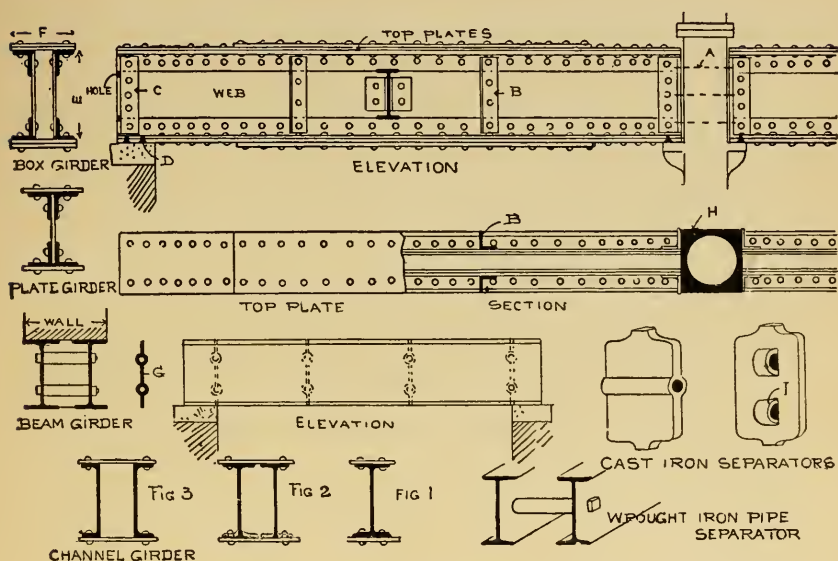

The simplest support for a brick wall is two I beams side by side, or any number placed to suit size of wall and weight to be sustained. (See elevation and section of beam girder.)

62. Separators.—To accommodate the thickness of wall cast-iron separators are placed between webs; for 10½-inch beams and under one bolt is used; for 12-inch beams and over, two bolts.

The *separators* for beam girders are generally $\frac{3}{4}$ of an inch thick, with $\frac{3}{4}$ -inch-diameter bolts, and made to fit accurately the form of beams. (See section at G for one with two bolts.)

Wrought-iron pipe separators are frequently used in the smaller beams with $\frac{3}{4}$ -inch-diameter bolts, but give very little stiffness to the girder.

63. Cast-iron Plates on Girders for Walls.—If large and thick walls are to be supported, and several inches intervene between flanges of beams, cast-iron plates are placed on top, providing a good bearing for masonry.

The strength of the girder in this form is generally taken as equal to the sum of two beams used singly.

64. Bolts and Rivets—as used for beams and girders must be proportioned to resist shearing, and the area of their bearing must be such that the metal against which they bear shall not be crushed. The strains allowed per square inch on these members are: shearing, 7500 pounds; crushing, 12,500 pounds. The shearing strain is measured on the area of the cross-section of the bolt or rivet; the crushing strain, on the area obtained by the product of the diameter of the rivet by the thickness of the plate or web on which it bears. It is customary to disregard the friction between the parts joined, as being too uncertain an element to be relied on to any great extent.

65. Shearing and Bearing of Rivets.—Take, for example, two plates of wrought iron 8 inches wide by $\frac{1}{2}$ inch thick which overlap each other for a joint, with 45,000 pounds strain on the plates. What number of rivets will be required to resist the strain on the joint?

The area of a rivet $\frac{3}{4}$ of an inch in diameter is 0.4417 square inch; this multiplied by 7500 pounds, the safe shearing, = 3312.75 pounds, the safe amount of strain each rivet can sustain without shearing. Dividing 45,000 by this, we get 13.6,—say 14 rivets.

The bearing area of each rivet is $\frac{3}{4}$ inch by $\frac{1}{2}$ inch = $\frac{3}{8}$ square inch; this multiplied by 12,500 pounds for crushing would equal 4688 pounds, the safe compression for each rivet. $45,000 \div 4688 = 9.6$,—say 10 rivets.

This latter condition is very often overlooked in riveted work. Its observance in most cases of riveted girders with single webs gives the size and number of rivets to be used, and in thin webs the bearing value may be small, necessitating a thicker web than would otherwise be required.

For the above calculation the plates as overlapped would be in single shear. If the plates butted and a small plate were placed each side of the joint, or as an angle knee each side of a framed or coped beam, the rivets would be in double shear and have twice the value. If there are two cover plates, experience shows that each had better be equal to two thirds the thickness of the butted plates, although theory requires each to be but *half* their thickness. Plates butting require twice as many rivets as laps, because in the lap each rivet passes through both joined plates; and in the butt through only one, in case one cover plate is used. If the plates joined are sufficiently wide, the rivets should be placed *zigzag*, this being a much better system of riveting than the *chain*, that is, rivets following each other in one or more parallel lines.

66. Pins—must be calculated for shearing, bending and bearing strains, but one of the latter two in almost every case determines the size to be used.

The pressure on the *pins*, multiplied by the leverage with which it acts on the pin supports, is the *bending moment*. The strain allowed per square inch of the cross-section is 15,000 pounds for iron and 20,000 pounds for steel.

CHAPTER IV.

CAST-IRON LINTELS.

67. **Cast-iron Lintels.**—When the fracture of an iron lintel is produced by vertical pressure, the fibres or molecules of the lower section are separated by extension; consequently a lintel of the section shown in Fig. 1, when the weight is imposed, will have the bottom flange *C* in a state of tension and the top rib *D* in a state of compression, and the parts of the section generally will be extended or compressed according to their distance from the neutral axis *A --- B*.

If cast-iron lintels were required to serve to the full extent of the power of the metal to resist *rupture*, the base or bed should be five times the top flange, cast iron in compression being 5 to 1 in tension.* On the other hand, they are seldom subjected in practice to the ultimate load, and when the flanges are as 1 to 4 the proportion meets the requirements of practice.

Allowance of an excess of strength should be made where a lintel is loaded more on one side than on the other, as it always has a tendency to twist and thus produce fracture.

In the *plain cast-iron lintel*, Fig. 2, the weakest part is the top of the vertical part *C*. It cannot resist compression in a degree corresponding to its tenacity, and by many experiments made as to its strength it is found that fracture is produced by the crushing of the vertical part *C*; by stiffening the web, as shown in Fig. 5, the strength is somewhat increased (see test, lintel *B*). This also occurs when the lintel is built in with the wall, being thus braced by the surrounding masonry.

* In first-class foundries a high average is 20,000 pounds per square inch in tension. This gives $4\frac{1}{2}$ to 1.

68. **Skew-back Lintels**—are placed over openings to receive the thrust of the arch, and to make a square-finished opening for windows or doors. The bed of lintel acts as a tie bar between the *skew-backs*.

69. **Lintels for Iron Fronts**—are placed between upright and continuous columns of fronts, or a continuous line of

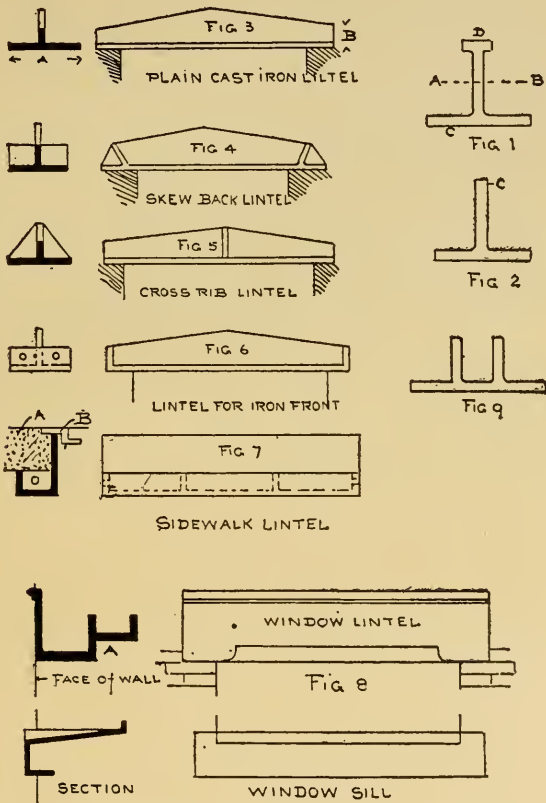

lintels is placed on top of the columns to receive the cornice and masonry. The ribs with holes in the ends are for bolting the lintels to each other and to columns. (See article Iron Fronts.)

70. Sidewalk Lintels—as shown by Fig. 7, are made to receive the granite sidewalk *A* and vault lights *B*. The lintel should be one inch lower than the granite, to form a rebate for the vault-light frame. Where several lintels are in one line, they are connected and bolted together similarly to lintels for fronts, Fig. 6.

71. Window-head Lintel.—This acts as a finished window head and lintel at the same time. It is set flush with wall outside, the section at *A* being formed for the head of window frame.

72. Double-web Lintels.—Where lintel beds are required to be over 16 inches wide more than one web is used. For handling and moulding it is best to make the beds not more than 24 inches wide; if wider than this, several lintels with double webs should be placed side by side.

73. Window Sills.—For openings where the *window-head lintels* are used the sills are made of cast iron $\frac{3}{8}$ of an inch thick, with a wash on top and lip on back to receive the sill of window frame.

74. Rule for Breaking Weight at Middle.—Mr. Hodgkinson gives for *breaking weight* *W*, when the bottom flange is four times the top flange,

$$W = \frac{ca'd}{l},$$

in which *W* = breaking weight at middle;

l = span in inches;

d = extreme depth in inches;

a' = area of bottom flange;

c = 26, a constant derived from experiment where the weight was in tons of 2240 pounds and the dimensions all in inches;—

and therefore
$$W = \frac{26a'd}{l},$$

where a is a factor of safety equal to 5,

$$W = \frac{26a'd}{al},$$

$$\text{or } a' = \frac{Wal}{26d}.$$

EXAMPLE. What should be the area of the bottom flange of a lintel to sustain safely a load at middle of 10 tons, span 12 feet, height of lintel at centre 12 inches? By formula,

$$a' = \frac{10 \times 5 \times 144}{26 \times 12} = 23.1 \text{ inches.}$$

75. **Web.**—The *web* at end need only be thick enough to resist the shearing strain upon the metal. Owing to the tendency to fracture when the casting is cooling, the thickness of web should not be less than the flange.

76. **Tests of Cast-iron Lintels.**—The results of some tests on cast iron, among which were two cast-iron lintels, by Geo. A. Just, C.E., for the Jackson Architectural Iron Works, illustrated in vol. XXII (Feb. 1890), Transactions of the Am.



Soc. C. E., gave results corresponding nearly with those of the above formula for W , when the lower flange was four times the top flange.

The lintels here illustrated were proportioned as follows :

LINTEL A.		LINTEL B.	
Weight.....	306 pounds.	Weight.....	275½ pounds.
Length.....	.6 feet 3½ inches.	Length.....	.7 feet 4 inches.
Width of bottom flange.....	12 "	Width of bottom flange	12 "
Depth at centre.....	12 "	Depth at centre.....	8 "
" " ends.....	4 "	" " ends.....	4 "
Average thickness of flange.....	1⅜ "	Average thickness of flange.....	⅝ "
" " " web.....	⅞ "	" " " web.....	¾ "
Clear span.....	.5 feet 6 "	Clear span.....	.6 feet.
Ultimate strength.....	98,450 pounds.	Ultimate strength.....	40,030 pounds.

Both lintels were subjected to a centre load. When 81,700 pounds had been applied to lintel A, its deflection was approximately $\frac{5}{8}$ inch. Upon releasing the load an approximate set of $\frac{1}{8}$ inch was found, and the lintel broke in the centre, its load being applied practically at one point.

In the case of lintel B, failure took place by tearing of the lower flange, the web having been stiffened by triangular brackets, and the lintel broke at the flaw about 6 inches from the centre, its load being distributed over the web for a length of 8 inches.

By formula,
$$W = \frac{26a'd}{l}.$$

Then for lintel A,

$$W = \frac{26 \times 9.75 \times 12}{66} = 46 \text{ tons (2240 lbs.) or } 103,040 \text{ lbs. ;}$$

and for lintel B,

$$W = \frac{26 \times 7.5 \times 8}{72} = 22 \text{ tons, or } 49,280 \text{ lbs.}$$

From the above formula and tests, lintels in ordinary use, as Figs. 3 and 5, may be employed,—the circumstances of the case regulating their proper use;—a factor of safety of 5 being adopted.

CHAPTER V.

TRUSSES.

77. Roof Trusses.—There are several important points to be considered in planning a roof for a building. The trusses should be so placed as to be central over piers; consequently the number of trusses will be governed by the number of piers and the distance between centres, which should be from eight to sixteen feet; twelve feet being a suitable proportionate distance. The closer the trusses the less the proportion of the load each will have to sustain, and the lighter may be the rafters to support the roof surface.

In all calculations for roofs, the exact load should be found which will come upon each truss—the weight of the truss itself, the roof, ceiling, snow and wind. The rafters will be required to support the roofing timbers, the boarding, covering, snow and wind. The tie beam will have to support the weight of ceiling.

78. Loads on Trusses.—According to Mr. Trautwine, for spans not exceeding seventy-five feet, and with trusses seven feet apart, the total *dead load* per square foot, including the truss itself, purlins, etc., complete, may be safely taken as follows :

	Pounds.
Roof covered with corrugated iron, unboarded.....	8
If plastered below rafters.....	18
Roof covered with corrugated iron on boards.....	11
If plastered below rafters.....	18

	Pounds.
Roof covered with slate, unboarded as on laths.....	13
“ “ “ “ on boards $1\frac{1}{4}$ inches thick....	16
If plastered below rafters.....	26
Roof covered with shingles or laths.....	10
If plastered below the rafters or tie beam.....	20
Roof covered with shingles on $\frac{7}{8}$ -inch boards.....	13

For spans of from seventy-five to one hundred and fifty feet it will suffice to add four pounds to each of these totals.

79. Snow and Wind Pressure.—For wind pressure taken at an angle of $22\frac{1}{2}$ degrees add 10 pounds per square foot; at an angle of 45 degrees, 20 pounds. For snow reverse these figures, adding for pressure at $22\frac{1}{2}$ degrees 20 pounds, and at 45 degrees 10 pounds per square foot.

80. Ceiling Weight.—If a ceiling composed of wooden timbers with lathing and plastering is to be included, 10 to 12 pounds per square foot should be added. If the ceiling rafters are to be of iron, their size and thickness may readily be calculated. Then take 7 to 9 pounds per square foot for plastering, 11 pounds for two-inch porous terra-cotta blocks: if metallic or wire lath is used instead of porous blocks, only slight allowance need be made therefor.

81. The Graphic Method—consists of representing loads and strains by lines drawn to a scale of pounds to the fraction of an inch, being the simplest and readiest way of computing strains in trusses. Only a few examples will be given, a treatise on roofs not being within the scope of this volume.

82. King-post Truss.—No. 1 is a simple *king-post truss* with braces for supporting centre of the rafters. For finding the strains it is best to represent each member by a single line, being a diagram of the truss. Having found the correct weight to be supported, it should be divided into four parts; the point between *D* and *F* taking one half of *F* and *D*, the point between *B* and *D* one half of each, and each abutment one half of *B* and one half of *H*. The fine lines represent tension, the heavy lines compression.

With any convenient scale, as Fig. 1A, lay off the spaces representing the vertical load supported at each point of the roof respectively.

As the reactions will be each one half the load, we locate k half way between the abutments.

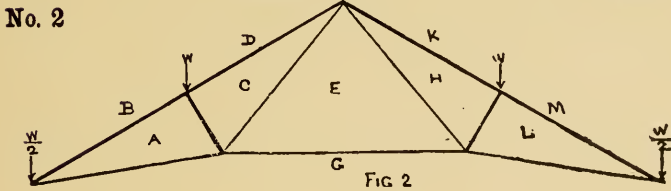
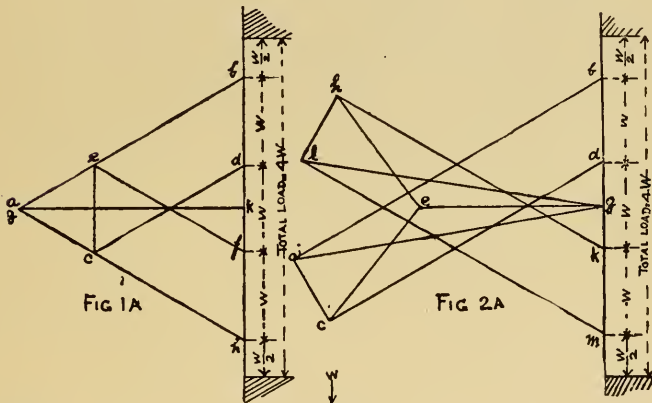
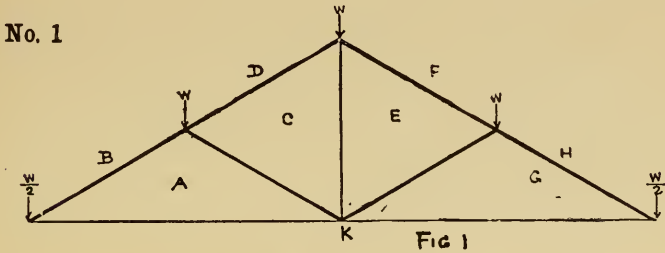

Begin with the joint at foot of rafter and draw ab parallel to AB , and ak parallel to AK until it meets ab at a ; draw cd parallel to CD ; draw ac parallel to AC , and ce parallel to CE .

The joints to the right will be similar to those on the left, the truss being uniformly loaded.

The strains may be then scaled off, on which the total load = L as follows :

The length of	<i>ab</i>	<i>ak</i>	<i>cd</i>	<i>ac</i>	<i>ce</i>
= strain on	<i>AB</i>	<i>AK</i>	<i>CD</i>	<i>AC</i>	<i>CE</i>

83. Truss No. 2 (Fig. 2).—Draw a strain diagram, Fig. 2A, as before.

Draw *ab* parallel to *AB*, *ag* parallel to *AG*, *cd* parallel to *CD*, *ac* parallel to *AC*, *ce* parallel to *CE*, *eg* parallel to *EG*.

The strains may be then scaled off, on which the total load = L as follows :

The length of	<i>ab</i>	<i>ag</i>	<i>cd</i>	<i>ac</i>	<i>ce</i>	<i>eg</i>
= strain on	<i>AB</i>	<i>AG</i>	<i>CD</i>	<i>AC</i>	<i>CE</i>	<i>EG</i>

By continuing the strain diagram it will be noticed that the other side is similar; it is therefore unnecessary to continue the other half.

84. Truss No. 3 (Fig. 1)—is divided into eight parts, continuing the strain sheet as before, but using half of diagram Fig. 1A, which would give *bo*. Draw *ab* parallel to *AB*, *ao* to *AO*, *cd* to *CD*, *ac* to *AC*, *ck* to *CK*; then draw *ef* parallel to *EF*, and *gh* to *GH*; then draw *eg* in line with *ac*, and draw *kl* parallel to *KL*, and *cl* to *EL*. Then draw *gm* parallel to *GM*; it will pass through *l*. Draw *om* intersecting *gm* at *m*. *lm* lies over *gm* and is taken as two lines. *MM* is a light rod preventing the main tie from sagging. The strain may then be scaled off, on which the total load = L as follows :

The length of	<i>ab</i>	<i>ao</i>	<i>cd</i>	<i>ac</i>	<i>ck</i>	<i>ef</i>	<i>gh</i>	<i>kl</i>	<i>el</i>	<i>gm</i>	<i>om</i>	<i>lm</i>
= strain on	<i>AB</i>	<i>AO</i>	<i>CD</i>	<i>AC</i>	<i>CK</i>	<i>EF</i>	<i>GH</i>	<i>KL</i>	<i>EL</i>	<i>GM</i>	<i>OM</i>	<i>LM</i>

85. **Truss No. 4** (Fig. 2)—has horizontal top and bottom chords. One half of truss being drawn, the centre line of truss is at tie *N*.

To draw the strain diagram Fig. 2A, lay off the loads as

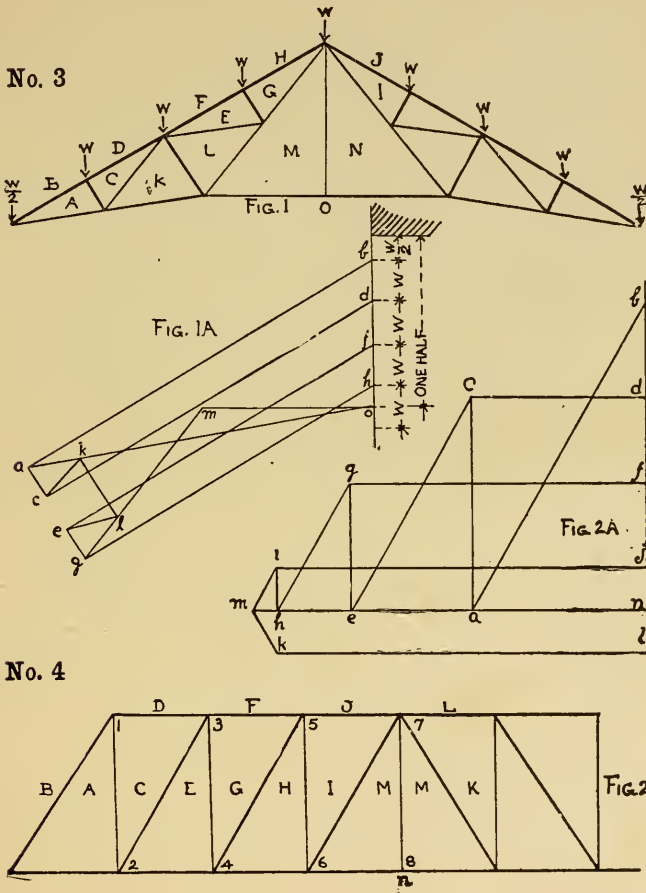

heretofore, commencing with the joints nearest the support. Thus *bd* = joints 1 and 2, *df* = joints 3 and 4, *fg* = joints 5 and 6, and *nj* and *nl* each equal one half of loads at 7 and 8. One half of the total load on the truss being sustained by each

support and commencing at one support we have the force bn , the stress in rafters ba and in tie na , closing the figure. At joint 1 we know ba and bd ; draw dc and ac , closing the figure. At joint 2 we know na and ac ; draw ce and ne . At joint 3 we know dc , ce and df ; draw eg and fg . At joint 4 we know eg , ne ; draw gh and nh . At joint 5 we know gh , fg and ff ; draw hi and ji . At joint 6 we know hi , nh ; draw im and nm . At joint 7 we know im , ji and jl ; draw lk and mk .

The centre rod has no strain excepting the holding up of lower chord from sagging.

The length of	ba	na	ac	dc	ce	ne	eg
= strain on	BA	NA	AC	DC	CE	NE	EG
The length of	fg	gh	nh	hi	ji	im	nm
= strain on	FG	GH	NH	HI	JI	IM	NM

86. Truss No. 5 (Fig. 1).—Draw strain diagram Fig. 2 as before. Draw ab parallel to AB , ak to AK , cd to CD , ac to AC , cl to CL , ef to EF , le to LE , eg to EG . The dotted lines indicate the other half of truss. The strain scaled off will be:

The length of	ab	ak	ac	cd	cl	lk	ef	le	eg
= strain on	AB	AK	AC	CD	CL	LK	EF	LE	EG

If the principal chord supports a ceiling, the weight is divided similarly to that on the rafters, supported by the rods CL and EG and carried to the points of support BD , DF and FH .

The sum of the ceiling and roof loads is then taken, proceeding with the strain diagram as before.

The weight of ceiling, in addition to that scaled from the strain diagram, is the strain on ties CL and EG . For example:

the point at joint *CLEFD* supports 10,000 pounds of roof, the point at joint *CLK* 5000 pounds of ceiling, which weight is carried to the first joint by rod *CL*. Then, line *df* on strain dia-

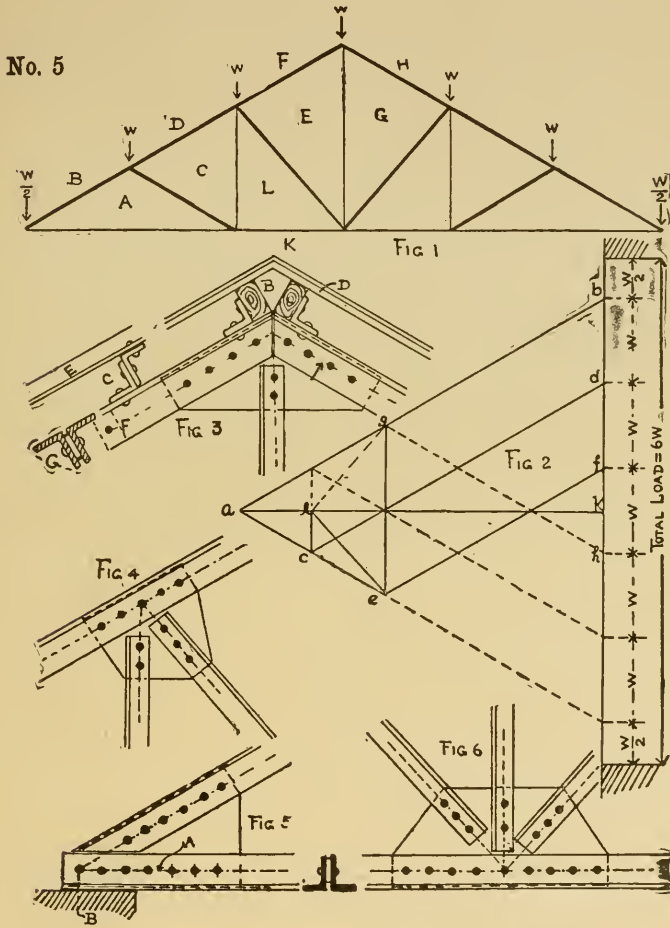

gram being completed, the 5000 pounds is to be added to the scaled distance on *cl*, for the reason that by carrying 5000 pounds to point *DF*, *CL* is required to perform its portion of

the complete truss, and the weight of ceiling is still to be supported directly by *CL*.

87. Details of Iron Trusses.—Iron trusses are far superior to wooden trusses, in that they may be built stronger and lighter, and are more durable. The sections used in the different members are to be considered when the truss is designed. The forms in common use are I beams, deck beams, channel bars, T and angle bars.

88. Ties and Struts.—Flat bars are more suitable for *ties*. For *struts* it is necessary to use some form of section offering resistance to bending, such as T irons, two angles riveted back to back, or four angles in the shape of a star. The fewer the members in compression the more economical will be the truss. For rafters of trusses on large spans channel irons are used placed back to back, also with plates riveted top and bottom to make up any section required, the struts and ties being connected to the webs of channels by pins. (See chapter on “Rolled Iron Struts.”)

For simple and economical trusses angle irons and plates are used, as shown by the details in plate of truss No. 5, Fig. 3 being the apex of roof, Fig. 4 the point between *D* and *E*, Fig. 5 the heel of truss, Fig. 6 the centre of bottom chord. The dotted line *A* represents the neutral axis of each member, or the line of the diagram of strains which should be the centre of the bearing of truss on the wall at *B*.

89. Wooden Purlins—are connected and secured by knees to the main rafters, as shown at *B*, Fig. 3, the covering in this case being boarding and slate. For an iron or fire-proof covering purlins of angle iron at *C*, and T's or L's at rafters *E*, should be used. The angles of the main rafter *G* are separated by the plates at the connections. To keep these angles in a straight line, filling pieces as shown by the dotted line are placed between and riveted through hole *F*.

90. Connections.—After the proper struts and ties have been calculated and arranged, the *connections* are the important

part of the truss. It may have more than is necessary in its struts and ties; but if the connections have not the proper proportion of pins and rivets, the truss is proportionately weak. For shearing, bending and crushing strains on rivets and pins, see article on "Bolts and Rivets" and table of Rivets and Pins.

When two or more plates are to be riveted, they are held together by temporary bolts inserted through some of the holes.

The rivets, heated red hot, are then inserted into the holes up to the head and hammered by hand, or pressed as in machine riveting.

In a good joint, especially when newly riveted, the friction of the plates is very great.

In calculating the strength of the frame, the strength due to friction is not considered, as it cannot be relied on in cases where the frame is subjected to shocks and vibrations.

NOTE.—For spans of 30 feet to 45 feet use truss No. 1;
 " " " 40 " " 60 " " " " 2;
 " " " 60 " " 100 " " " " 3, 4 and 5.

CHAPTER VI.

STRUTS.

91. Rolled Iron Struts.—In the following consideration of *rolled struts* of various shapes, the *least* radius of gyration of the cross-section taken around an axis through the centre of gravity is assumed as the effective radius of the strut. The resistance of any section per unit of area will in general terms vary directly as the square of the least radius of gyration, and inversely as the square of the length of the strut.* The shape of the section, and the distribution of the metal to resist local crippling strains, must also be considered. As a rule, that shape will be strongest which presents the least extent of flat unbraced surface. For instance, two I sections of unequal web widths may have the same web thickness, the same flange area, and the same least radius of gyration, but the wider-webbed section will be the weaker per unit of area, on account of the greater extent of unbraced web surface it contains. For the same reason a hollow rectangular section composed of thin plates will be to some extent weaker than a circular section of the same length having the same area and radius of gyration.

92. End Connections.—As is well known, the method of securing the ends of the struts exercises an important influence on their resistance to bending, as the member is held more or less rigidly in the direct line of thrust.

In the table, page 46, struts are classified in four divisions,

* This applies only to long struts with free ends.

viz. : "Fixed-ended," "Flat-ended," "Hinged-ended," and "Round-ended."

In the class of "fixed ends" the struts are supposed to be so rigidly attached at both ends to the contiguous parts of the structure that the attachment would not be severed if the member were subjected to the ultimate load. "Flat-ended" struts are supposed to have their ends flat and square with the axis of length but not rigidly attached to the adjoining parts. "Hinged ends" embrace the class which have both ends properly fitted with pins, or ball-and-socket joints, of substantial dimensions as compared with the section of the strut; the centres of these end joints being practically coincident with an axis passing through the centre of gravity of the section of the strut. "Round-ended" struts are those which have only central points of contact, such as balls or pins resting on flat plates, but still the centres of the balls or pins coincident with the proper axis of the strut.

If in hinged-ended struts the balls or pins are of comparatively insignificant diameter, it will be safest in such cases to consider the struts as round-ended.

When the pins of hinged-ended struts are of substantial diameter, well fitted and exactly centred, experiment shows that the hinged-ended will be equally as strong as flat-ended struts.

But a very slight inaccuracy of the centring rapidly reduces the resistance to lateral bending; and as it is almost impossible in practice to uniformly maintain the rigid accuracy required, it is considered best to allow for such inaccuracies to the extent given in the table.

In the table, the first column gives the effective length of the strut divided by the least radius of gyration of its cross-section, and the successive columns give the safe load per square inch of sectional area for each of the four classes aforesaid. By *ultimate load* is meant that pressure under which the strut fails. For hinged-ended struts the figures apply to those

cases in which the axis of the pin is at right angles to the least radius of gyration, or in which the strut is free to rotate on the pin in its weakest direction.

93. Factors of Safety.—It is good practice to increase the factor of safety as the length of the strut is increased, owing to the greater inability of the long struts to resist cross-strains, etc. For similar reasons it is advisable to increase the factor of safety for hinged and round ends in a greater ratio than for fixed or flat ends. Upon this consideration the table is arranged, with the factor of safety of 3 for the short to 6 for the long struts. The loads to be applied only under the most favorable circumstances, such as an invariable condition of the load, little or no vibration, etc.

Length Least Radius of Gyration.	Flat Ends.	Fixed Ends.	Hinged Ends.	Round Ends.
20	14,380	14,380	13,940	13,330
30	13,030	13,030	12,460	11,670
40	11,760	11,760	11,110	10,140
50	10,860	10,860	10,130	8,930
60	10,000	10,000	9,230	7,820
70	9,190	9,190	8,330	6,850
80	8,420	8,420	7,500	5,950
90	7,920	7,950	6,840	5,230
100	7,450	7,500	6,220	4,560
110	6,840	7,070	5,620	3,980
120	6,260	6,670	5,060	3,440
130	5,790	6,220	4,580	2,960
140	5,340	5,800	4,120	2,510
150	4,830	5,390	3,570	2,120
160	4,350	5,000	3,060	1,760
170	3,920	4,570	2,640	1,530
180	3,500	4,170	2,250	1,310
190	3,190	3,830	2,020	1,150
200	2,900	3,500	1,800	1,000
210	2,670	3,190	1,590	890
220	2,440	2,880	1,400	790
230	2,250	2,640	1,260	720
240	2,070	2,410	1,140	650
250	1,910	2,180	1,040	600
260	1,750	1,960	940	550
270	1,610	1,840	870	500
280	1,460	1,720	790	440
290	1,330	1,610	730	410
300	1,200	1,500	670	370

94. **Greatest Safe Load on Struts.**—If the strut is hinged by an uncertain method so that the centres of pins and axis of strut may not coincide, or the pins may be relatively small and loosely fitted, it is best in such cases to consider the strut as “round-ended.”

In all cases the strut is supposed to stand vertical. In short struts this is immaterial; but when the length becomes considerable the deflection resulting from its own weight, if horizontal, would seriously affect the stability of the strut.

EXAMPLE. (a) An 8'' I beam 65 pounds per yard, 18 feet long, is used as a strut having pins at both ends at right angles to the web. It would then be flat-ended in the direction of the flanges. By the table, page 50, for the radius of gyration of an 8'' I beam, 65 lbs., $r = .88$. Then

$$\frac{l}{r} = \frac{216}{.88} = 245.$$

In the column $\frac{l}{r}$ taking the greatest number nearest 245 (being 250), we find 1910 = *greatest* safe load in pounds per square inch of section.

(b) If braced in the direction of the flanges at two points 6 feet apart, it should then be considered as a series of *flat-ended* struts 6 feet long, whose safe load would be

$$\frac{l}{r} = \frac{72}{.88} = \text{say } 80.$$

Opposite this number is 8420 = greatest safe load per square inch of section.

(c) When braced in the direction of its web it remains a *hinged-ended* strut 18 feet long; the radius of gyration is 3.25. Then

$$\frac{l}{r} = \frac{216}{3.25} = 67.$$

Opposite this, taking the greatest number nearest 67 (i.e. 70), we have 9190 as the *greatest* safe load per square inch of section.

95. Channel Struts.—The foregoing remarks apply also to channels, which are seldom used singly as struts, but frequently in pairs. When so used, if the methods of connection are not of such a nature as to insure the unity of action of the pair, they should be treated as an assemblage of separate struts.

But if connected by a proper system of triangular latticing, the pair can be considered as a unit, and each channel treated as a series of short struts whose length is the distance between centres of latticing.

96. Angles as Struts.—As described by diagram of angle in table for even legs, the angle is considered free to yield in its weakest direction, that is, in the direction of the *least* radius of gyration.

If the angle is prevented from failing in this direction by bracing or otherwise, its resistance will be increased to some extent, and a correction can be made by taking the *greatest* instead of the *least* radius of gyration into calculation.

EXAMPLE. An angle strut with flat ends, whose dimensions are $4 \times 4 \times \frac{3}{8}$ inches and 12 feet long, has a least radius of gyration of .81 inch and greatest radius of gyration 1.24.

When the strut has no lateral support the value of $\frac{l}{r}$ will be

$\frac{144}{.81} = 178$. By table, the nearest equals 3500 pounds per square inch.

If this strut is now braced so that it cannot fail in the weakest direction, that is, in the line of a diagonal from the corner of the angle, but is free to fail in the direction of its legs, then the value of $\frac{l}{r}$ becomes $\frac{144}{1.24} = 116$, and the safe load, by the table, becomes 6260 pounds per square inch.

97. Tees as Struts.—For single uneven tees, find the least radius of gyration from table of Tees, and proceed as described for angle struts. This also applies to even-legged tees.

When a pair of uneven tees are braced together in the direction of the shorter leg, they form a single strut, whose *least* radius of gyration is the same as the *greatest* radius of gyration for a single tee.

Therefore when determining the resistance of the combined strut, take the *greatest* radius of gyration from the table of uneven-leg tees, and the least radius of gyration when determining the distance between centres of lateral bracing.

EXAMPLE. A pair of uneven tees $5 \times 2\frac{1}{2}$ inches, whose total area is 6.14 square inches, are braced together in the direction of the shorter leg, forming a single *hinged-ended* strut 15 feet long.

What is the greatest safe load, and what the greatest distance between centres of lateral bracing?

By the table of tees, the greatest radius of gyration = 1.14 inches; $\frac{l}{r} = 158$, which gives, by table, 3060 pounds per square inch, or 18,788 pounds as the total greatest safe load.

Least radius of gyration = .72, which multiplied by 158 gives 113 inches as the greatest distance between centres of lateral bracing.

Experiments thus far made upon *steel struts* indicate that for lengths up to 90 radii of gyration their ultimate strength is about 20% higher than for iron. Beyond this point the excess of strength diminishes until it becomes zero at about 200 radii. After passing this limit the compressive resistance of steel and iron seems to become practically equal.

98. Properties of Beams for Struts.

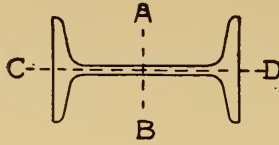

Size in inches.	Weight per yard.	AREAS IN SQUARE INCHES.			RADIUS OF GYRATION.	
		Flanges.	Web.	Total.	Axis AB.	Axis CD.
15	200	11.86	8.04	19.90	5.86	1.20
15	145	8.97	5.58	14.55	5.98	1.08
12	168	10.66	6.23	16.89	4.69	1.17
12	120	7.42	4.53	11.95	4.78	1.01
10½	134	9.57	3.87	13.44	4.24	1.19
10½	108	7.33	3.50	10.83	4.25	1.07
10½	89	5.91	3.03	8.94	4.26	.97
10	112	7.23	3.94	11.17	3.94	.98
10	90	6.29	2.75	9.04	4.05	.95
9	90	6.15	2.92	9.07	3.62	.96
9	70	4.77	2.21	6.98	3.68	.89
8	81	5.58	2.56	8.14	3.21	.94
8	65	4.50	2.03	6.53	3.25	.88
7	65	4.17	2.41	6.58	2.75	.79
7	52	3.84	1.30	5.14	2.89	.82
6	50	3.16	1.88	5.04	2.31	.65
6	40	2.91	1.17	4.08	2.43	.66
5	34	2.13	1.25	3.38	1.99	.60
5	30	2.06	.88	2.94	2.06	.60
4	28	2.15	.75	2.90	1.63	.63
4	18.5	1.34	.56	1.90	1.65	.51
3	23	1.72	.53	2.25	1.21	.59

Articles 98 and 99 give the radii of gyration for many of the sections in ordinary use. For any other section desired, refer to "Properties of Beams and Channels," in Chapter II, which gives the moment of inertia of a greater variety of sections. The greatest radius of gyration can be found by the following formula:

$$R = \sqrt{\frac{I}{A}}$$

The least radius of gyration of I beams = $\frac{\text{width of flange}}{4.58}$;

" " " " " " channels = $\frac{\text{width of flange}}{3.54}$.

99. Properties of Channels for Struts.

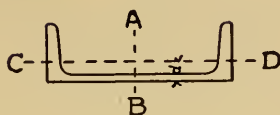
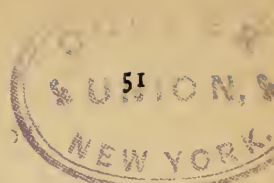

Size in inches.	Weight per yard.	AREAS IN SQUARE INCHES.			RADI OF GYRATION.		Distance, d , from Base to Neutral Axis.
		Flanges.	Web.	Total.	Axis AB .	Axis CD .	
15	148	6.50	8.36	14.86	5.51	1.13	.95
12	88.5	4.59	4.24	8.83	4.55	.92	.71
12	60	2.87	3.07	5.94	4.56	.74	.62
10	60	3.56	2.43	5.99	3.92	.84	.75
10	49	2.67	2.22	4.89	3.89	.69	.64
9	54	2.97	2.43	5.40	3.45	.68	.67
9	37	1.81	1.91	3.72	3.43	.59	.55
8	43	2.28	1.97	4.25	3.06	.71	.60
8	30	1.34	1.62	2.96	3.09	.60	.50
7	41	2.30	1.80	4.10	2.68	.65	.65
7	26	1.38	1.26	2.64	2.64	.58	.48
6	33	2.04	1.25	3.29	2.36	.67	.66
6	23	1.09	1.18	2.27	2.27	.51	.46
5	27.3	1.69	1.04	2.73	1.93	.56	.61
5	19	.91	.97	1.88	1.88	.45	.42
4	21.5	1.34	.81	2.15	1.55	.50	.53
4	17.5	1.02	.73	1.75	1.54	.48	.45
3	15	.86	.66	1.52	1.16	.46	.51
2½	11.3	.69	.44	1.13	.85	.43	.46
2	8.75	.55	.33	.88	.74	.31	.37

NOTE.—This chapter on struts is based upon the results of several hundred experiments conducted at the Pencoyd Iron Works.

The quality of the wrought iron was about as follows: elastic limit, 32,000 pounds per square inch; ultimate tensile strength, 49,600 pounds per square inch; ultimate elongation, 18 per cent in 8 inches.

The length of the specimens varied from 6 inches to 16 feet, and the ratio of length to least radius of gyration varied from 20 to 480.

For more detailed information, refer to articles by Mr. James Christie published in the Transactions of the Am. Soc. of Civil Engineers, entitled "Experiments on the Strength of Wrought-iron Struts."

100. Properties of Angles for Struts.

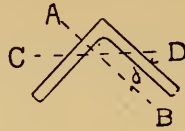

EVEN LEGS

Size in inches.	Weight per yard.	RADIUS OF GYRATION.		Distance, <i>d</i> , from Base to Neutral Axis.
		Axis <i>AB</i> .	Axis <i>CD</i> .	
6 × 6 × $\frac{7}{16}$	50.6	1.87	1.19	1.66
6 × 6 × 1	110.0	1.80	1.17	1.86
5 × 5 × $\frac{7}{16}$	41.8	1.55	1.00	1.41
5 × 5 × 1	90.0	1.48	.98	1.61
4 × 4 × $\frac{3}{8}$	28.6	1.24	.81	1.14
4 × 4 × $\frac{1}{2}$	54.4	1.19	.80	1.27
3 $\frac{1}{2}$ × 3 $\frac{1}{2}$ × $\frac{1}{2}$	24.8	1.07	.70	1.01
3 $\frac{1}{2}$ × 3 $\frac{1}{2}$ × $\frac{3}{8}$	39.8	1.04	.69	1.10
3 × 3 × $\frac{1}{4}$	14.4	.93	.60	.84
3 × 3 × $\frac{3}{8}$	33.6	.88	.59	.98
2 $\frac{3}{4}$ × 2 $\frac{3}{4}$ × $\frac{1}{4}$	13.1	.85	.55	.78
2 $\frac{3}{4}$ × 2 $\frac{3}{4}$ × $\frac{1}{2}$	25.0	.82	.54	.87
2 $\frac{1}{2}$ × 2 $\frac{1}{2}$ × $\frac{1}{4}$	11.9	.77	.50	.72
2 $\frac{1}{2}$ × 2 $\frac{1}{2}$ × $\frac{1}{2}$	22.5	.74	.49	.81
2 $\frac{1}{4}$ × 2 $\frac{1}{4}$ × $\frac{1}{4}$	10.6	.69	.45	.65
2 $\frac{1}{4}$ × 2 $\frac{1}{4}$ × $\frac{3}{16}$	17.8	.67	.44	.72
2 × 2 × $\frac{3}{16}$	7.1	.62	.40	.57
2 × 2 × $\frac{1}{8}$	13.6	.61	.39	.64
1 $\frac{3}{4}$ × 1 $\frac{3}{4}$ × $\frac{3}{16}$	6.2	.53	.36	.51
1 $\frac{3}{4}$ × 1 $\frac{3}{4}$ × $\frac{1}{8}$	11.7	.51	.35	.57
1 $\frac{1}{2}$ × 1 $\frac{1}{2}$ × $\frac{3}{16}$	5.3	.46	.31	.44
1 $\frac{1}{2}$ × 1 $\frac{1}{2}$ × $\frac{1}{8}$	9.8	.44	.31	.51
1 $\frac{1}{4}$ × 1 $\frac{1}{4}$ × $\frac{1}{4}$	3.0	.41	.26	.36
1 $\frac{1}{4}$ × 1 $\frac{1}{4}$ × $\frac{1}{8}$	5.6	.38	.26	.40
1 × 1 × $\frac{1}{8}$	2.3	.29	.20	.30
1 × 1 × $\frac{1}{4}$	4.4	.29	.20	.35

When struts of any section are hinged in order to utilize the maximum efficiency of the strut, it is of the utmost importance to keep the centre of the pin with the *centre of gravity* of the strut.

In the tables of channels, angles and tees this is defined by the distance *a* and *l* from base to neutral axes.

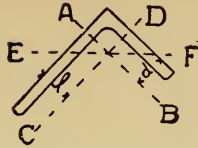

UNEVEN LEGS.

Size in inches.	Weight per yard.	RADI OF GYRATION.			DISTANCE FROM BASE TO NEUTRAL AXES.	
		Axis AB.	Axis CD.	Axis EF.	d.	l.
6 × 4 × $\frac{7}{16}$	41.8	1.92	1.16	.92	1.96	.96
6 × 4 × 1	90.0	1.85	1.09	.91	2.17	1.17
5 × 4 × 1	32.3	1.59	1.20	.87	1.53	1.03
5 × 4 × 1	80.0	1.51	1.13	.86	1.75	1.25
5 × 3 $\frac{1}{2}$ × 1	30.5	1.60	1.03	.80	1.61	.86
5 × 3 $\frac{1}{2}$ × 1	58.1	1.55	.98	.79	1.75	1.00
5 × 3 × 1	28.6	1.61	.85	.70	1.70	.70
5 × 3 × 1	54.4	1.55	.80	.69	1.84	.84
4 $\frac{1}{2}$ × 3 × 1	26.7	1.44	.86	.69	1.49	.74
4 $\frac{1}{2}$ × 3 × 1	43.0	1.40	.83	.68	1.58	.83
4 × 3 $\frac{1}{2}$ × 1	26.7	1.25	1.06	.74	1.20	.95
4 × 3 $\frac{1}{2}$ × 1	43.0	1.22	1.03	.73	1.29	1.04
4 × 3 × 1	24.8	1.26	.88	.67	1.28	.78
4 × 3 × 1	39.8	1.23	.85	.65	1.37	.87
3 $\frac{1}{2}$ × 3 × 1	21.2	1.09	.90	.64	1.07	.82
3 $\frac{1}{2}$ × 3 × 1	36.7	1.06	.87	.64	1.17	.92
3 × 2 $\frac{1}{2}$ × 1	16.2	.94	.74	.54	.93	.68
3 × 2 $\frac{1}{2}$ × 1	25.0	.91	.72	.54	1.00	.75
3 × 2 × 1	11.9	.96	.58	.46	.99	.49
3 × 2 × 1	22.5	.92	.55	.46	1.08	.58
3 $\frac{1}{2}$ × 2 × 1	17.8	1.11	.73	.56	1.14	.64
3 $\frac{1}{2}$ × 2 × 1	27.5	1.08	.70	.56	1.20	.70
6 × 3 $\frac{1}{2}$ × 1	39.6	1.93	.98	.82	2.06	.81
6 × 3 $\frac{1}{2}$ × 1	85.0	1.86	.92	.81	2.26	1.01
6 $\frac{1}{2}$ × 4 × 1	44.0	2.09	1.14	.94	2.18	.93
6 $\frac{1}{2}$ × 4 × 1	95.0	2.02	1.08	.93	2.38	1.13
5 $\frac{1}{2}$ × 3 $\frac{1}{2}$ × 1	32.3	1.77	1.05	.81	1.82	.82
5 $\frac{1}{2}$ × 3 $\frac{1}{2}$ × 1	52.3	1.73	.97	.80	1.91	.91
7 × 3 $\frac{1}{2}$ × 1	61.7	2.21	.92	.85	2.57	.82
7 × 3 $\frac{1}{2}$ × 1	95.0	2.19	.88	.84	2.71	.96
2 $\frac{1}{2}$ × 2 × 1	10.6	.81	.59	.43	.78	.54
2 $\frac{1}{2}$ × 2 × 1	20.0	.74	.56	.43	.87	.62
2 $\frac{1}{4}$ × 1 $\frac{1}{2}$ × 1	6.7	.71	.43	.34	.76	.38
2 $\frac{1}{4}$ × 1 $\frac{1}{2}$ × 1	12.6	.63	.40	.34	.82	.44
2 × 1 $\frac{1}{4}$ × 1	5.7	.63	.35	.31	.68	.31
2 × 1 $\frac{1}{4}$ × 1	9.2	.59	.33	.29	.70	.32

Articles 100 and 101 embrace all the angles and tees in common use.

101. Properties of Tees for Struts.

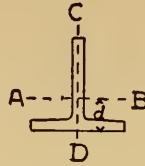

EVEN LEGS.

Size in inches.	Weight per yard.	RADIUS OF GYRATION.		Distance, <i>d</i> , from Base to Neutral Axis.	Size in inches.	Weight per yard.	RADIUS OF GYRATION.		Distance, <i>d</i> , from Base to Neutral Axis.
		Axis <i>AB</i> .	Axis <i>CD</i> .				Axis <i>AB</i> .	Axis <i>CD</i> .	
4 × 4 × 1/2	36.5	1.20	.84	1.14	2 × 2 × 9/8	10.5	.60	.43	.60
3 1/2 × 3 1/2 × 1/2	31	1.06	.74	1.00	1 3/4 × 1 3/4 × 7/8	7.1	.54	.37	.50
3 × 3 × 1/2	26	.90	.62	.90	1 1/2 × 1 1/2 × 3/4	6	.46	.32	.45
2 1/2 × 2 1/2 × 1/4	19.5	.78	.55	.75	1 1/4 × 1 1/4 × 3/8	4.5	.37	.27	.37
2 1/2 × 2 1/2 × 3/8	17.52	.75	.53	.75	1 × 1 × 3/8	3.0	.30	.26	.30
2 1/4 × 2 1/4 × 1/4	11.75	.65	.50	.61	3 × 3 × 1/8	19.3	.91	.62	.84
2 1/4 × 2 1/4 × 3/8	12	.67	.47	.65	3 × 3 × 3/8	22.6	.90	.63	.86

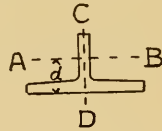

UNEVEN LEGS.

Size in inches.	Weight per yard.	RADIUS OF GYRATION.		Distance, <i>d</i> , from Base to Neutral Axis.	Size in inches.	Weight per yard.	RADIUS OF GYRATION.		Distance, <i>d</i> , from Base to Neutral Axis.
		Axis <i>AB</i> .	Axis <i>CD</i> .				Axis <i>AB</i> .	Axis <i>CD</i> .	
4 1/2 × 3 1/2	44.5	1.09	.91	1.16	2 × 1 1/2	8.75	.43	.45	.43
4 × 3 1/2	41.8	1.05	.88	1.09	2 × 1	7	.26	.49	.27
5 × 2 1/2	30.7	.72	1.14	.67	2 × 9/16	5.88	.13	.54	.17
5 × 2 1/2	33.0	.70	1.17	.64	2 1/4 × 1 1/4	18.75	.55	.58	.66
4 × 3	25.9	.86	.92	.77	2 1/4 × 2	21	.63	.55	.75
4 × 3	25.25	.91	.82	.84	5 × 3 1/2	48.44	1.05	1.04	1.05
4 × 2	20.4	.58	.91	.54	5 × 4	44.1	1.19	1.09	1.08
3 × 3 1/2	28.25	1.05	.61	1.10	2 1/4 × 3/8	6.5	.12	.61	.18
3 × 2 1/2	23.8	.76	.63	.82	4 × 4 1/2	38.5	1.37	.84	1.32
3 × 1 1/2	11.2	.41	.71	.37	3 × 2 1/2	17.6	.73	.65	.69
2 1/2 × 1 1/4	9.1	.33	.60	.32	3 × 2 1/2	20.6	.72	.66	.70

CHAPTER VII.

CAST-IRON COLUMNS.

102. Column Shafts Ornamented.—In almost all modern buildings *cast-iron columns* are used, not only for their strength in the support of the superstructure, but as a means of decoration, being ornamented to suit the style of the building and the taste of the architect.

The shaft of the column is cast without capitals, bases and other ornaments, these being cast separately and fitted to the shaft when the column is turned off, or fitted to the column when placed in the building. The plain and moulded bands if not undercut are frequently cast with the shaft, serving as a good guide and rest for the other ornamental parts.

103. Capitals.—The *capital* of column if ornamented with leaves, etc., as Fig. 2, is constructed of a $\frac{3}{16}$ -inch-thick shell bell; the leaves are cast singly and screwed to the bell.

The abacus *B* is cast in two pieces or halves $\frac{3}{16}$ inch thick. The entire capital is fitted up completely at the works and taken apart in halves, and placed over and secured to column when this has been set in place.

The shaft of column above neck moulding *C*, Fig. 3, should be from $\frac{3}{8}$ to $\frac{1}{2}$ inch less than the diameter of body, to admit of the bell being placed on it without showing any bulging of the bottom of capital.

To give a rich bold relief to the ornamentation on Fig. 1, the work will require to be well undercut.

104. Cast iron Column Connection.—For connecting with the floor beams and with each other cast-iron columns make

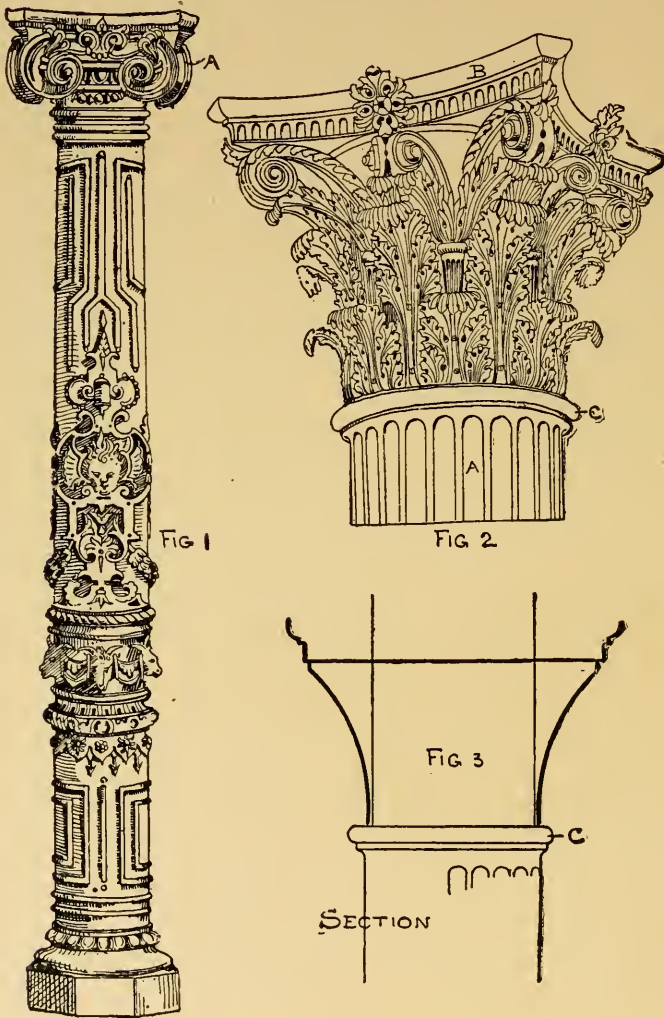

the simplest, cheapest and best finished connections for buildings. The single beam has for its bearing a small bracket

at *D*, and for connection a lug at *C*, with a stiffening web (*E*) at side.

For the double-beam girder a lug separator is cast on the column, fitting closely to the webs and flanges of same.

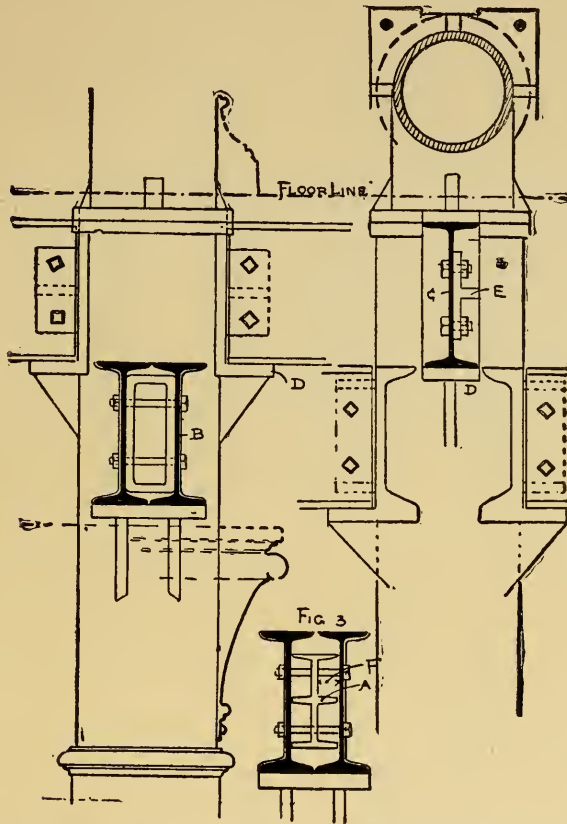

Fig. 3 shows another kind of lug, but one not so good as the former, for the reason that if there is any tendency to pull the girder from column, the bolts will be apt to bend at distance *F*.

The lugs and brackets should not be less in thickness than the body of column; and allow 5 to 6 inches projection for brackets and 4 inches for lugs, with not less than two bolts in each lug.

105. Holes Drilled.—It is better practice to drill all holes in flanges and lugs. Oval holes in lugs are of no use when a good tight connection is required.

In connecting the columns of a story with those of the one below, the floor line should be considered; otherwise the bolt heads would appear above the floor, unless a large shell base be required. In that case it would be well to make the joint of columns at the finished floor level, especially if floor beams are connected to the columns on all sides; otherwise there would be little flange left for bolts.

As shown in plate, the upper column has brackets to reinforce the flange; the lower column is made thicker on the inside, to bring the body of metal in the column below under that of the column above. But plates between flanges serve a better purpose. The flanges and plates should be planed true and columns set plumb, as shimming (by placing small thin plates to make up difference) or wedging (by driving wedges under flange) may cause a rupture in column by the concentrated weight which would naturally pass to the point of column bearing.

106. Column Flanges.—Circular and square flanges are used for connecting columns together. The diameter of bolts and heads often determines the projection of flange. If square-head bolts are used, the flanges should project not less than three inches from shaft.

If hexagon-head bolts are used, the flanges may project a trifle less than three inches.

107. Fire-proof Column—is a supporting column of cast iron, with a cast-iron shell covering, and an air space of one to three inches, sometimes filled with some incombustible material, but more frequently left entirely clear.

The inner column should be of sufficient strength to alone sustain the weight to be imposed.

In connecting and resting an upper on a lower column, a plate should be placed between the two as shown at Fig. 2; a

floor beam or girder also being shown below the connection, secured to a lug and resting on a bracket cast on the column.

If a small beam, with a light load, is to be connected, a bracket cast on the outer shell will be sufficient for its support,

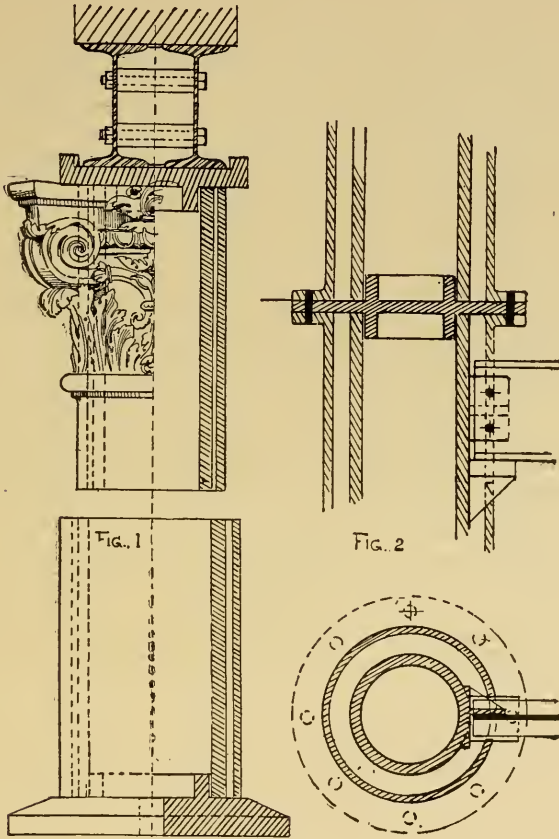

a $\frac{3}{4}$ -inch-thick shell being as light a column (over 9 inches in diameter) that should be cast for supporting any weight.

108. Dowel Columns.—For buildings where the floor beams and girders are of wood, the columns for their support are cast as shown. The portion of column at girder is cast similar to

the dowel *A*; the girder being cut to this shape with 2 inches at least on each side of the flat portion of dowel, and resting on a cast-iron plate made the full width of girder, with additional lips on each side for holding the girder in place.

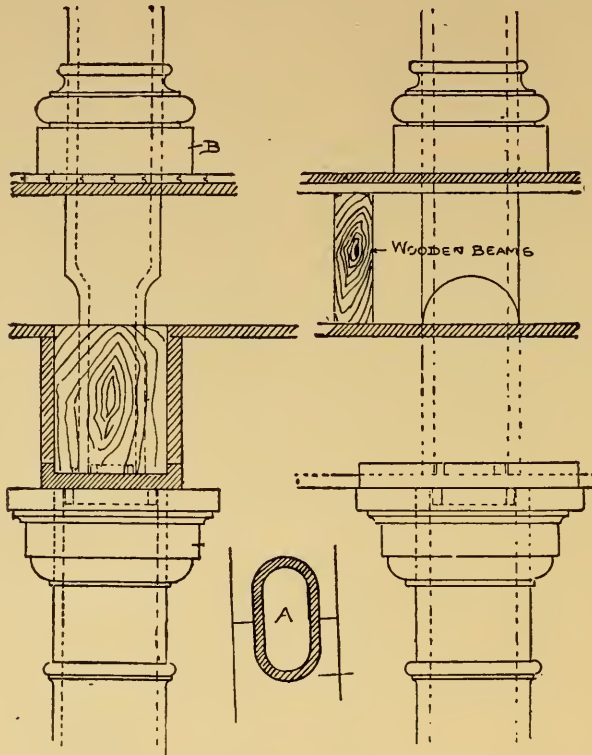

This manner of connecting columns is not an example of good construction, as the upper column is prevented from moving from its position only by the wooden girder and the raised socket cast on the plate and entering the dowel. For a better and safer connection with wooden girders, see "Fitch-plate Girders."

109. Strength of Cast-iron Columns.—We owe our knowledge of the *strength of cast-iron columns* chiefly to the experiments of Mr. Eaton Hodgkinson in the year 1840.

These were very numerous, and to a certain degree comprehensive, embracing over two hundred examples.

As deduced from these experiments it was found that where cylindrical cast-iron columns were shorter than thirty external diameters, the weight required to break them by bending is so great that the crushing force becomes sensible, and the column yields to the combined effect of the forces. But in a long column (where the length exceeds thirty external diameters), although the pressure contributes to break it by crushing as well as by flexure or bending, yet the column yields from bending with a weight which is insufficient to sensibly affect it by crushing alone. It was found that when the pressure on the column exceeded *one fourth* of the *breaking weight*, a change or derangement of the metal took place. Therefore *one fifth* the crushing weight is as great a pressure as can be put upon cast-iron columns without having their *ultimate* strength decreased by incipient crushing: provided the thickness of metal in column is uniform, with turned ends, secured top and bottom and bolted through flanges.

If the column is secured by an uncertain method, it is safer to use *one sixth* the crushing weight.

It is obvious, therefore, that it will not do to take the table on page 62 as a guide unless the columns are of uniform thickness throughout, of good metal, with cores made in one piece, castings reasonably perfect and straight, the ends turned off true in a lathe in planes at right angles with their axis, and set up perpendicularly in the building.

Mr. Hodgkinson, in his experiments, found that columns with rounded ends can sustain only about *one third* the weight of those with flat ends carefully fitted, with the ends at right angles to the axis of the column. In the ordinary mode of chipping off (cutting with a chisel) the ends of a column in an unfinished state, the inequalities of the bearing surfaces cause the weight to rest on a few points on the ends, and it is almost impossible that the ends shall be at right angles with

the axis. The safe weight a column can sustain in such cases is considered to be about *two thirds* that of one turned true.

110. Weight to be Estimated for any Use.—In computing the weight to be sustained by a column, it is not sufficient to consider only the weight appropriate to that particular use for which it is intended; but the weight should be estimated for any use to which the building may be applied, with full allowance for floors and the weights to be placed thereon. It is not safe to take the average weight sustained on each column, as some columns will have more or less on them than the average, and will be loaded more on one side than the other; besides, they are subject to concussions from bodies falling on a floor above, or may receive a lateral blow from goods falling against them in transmission.

Great allowance should also be made for columns that are subject to vibrations caused by machinery, etc.

111. Strength of Hollow Cast-iron Columns.—The following table gives the *ultimate* strength of round and square cast-iron columns, in pounds per square inch of sectional area.

The numbers in column $\frac{l}{r} =$ the length divided by the *least* diameter, each taken in inches.

$\frac{l}{r}$	Round.	Square.	$\frac{l}{r}$	Round.	Square.
5	75,300	76,200	17	46,444	50,700
6	73,400	74,630	18	44,200	48,540
7	71,270	72,860	19	42,100	46,460
8	68,970	70,920	20	40,000	44,450
9	66,530	68,850	21	38,100	42,510
10	64,000	66,670	22	36,200	40,650
11	61,420	64,410	23	34,460	38,870
12	58,820	62,110	24	32,790	37,175
13	56,240	59,890	25	31,220	35,560
14	53,860	57,470	26	29,740	34,010
15	51,200	55,170	27	28,340	32,550
16	48,780	52,910	28	27,030	31,150

112. Factors of Safety for Cast-iron Columns.

(a) If column is accurately turned to a true plane and its bearing surfaces are perfectly true, take *one fifth* of ultimate strength.

(b) If column has turned ends and is set with the usual care as in ordinary buildings, take *one sixth* of ultimate strength.

(c) If the ordinary mode of chipping off ends as with a chisel is employed, take *one eighth* of ultimate strength.

EXAMPLE 1. What safe load will a 12-inch-diameter column 1 inch thick, 15 feet long, support with a safety factor of 5 or one fifth the ultimate strength?

$$\frac{l}{r} = \frac{180}{12} = 15.$$

Opposite this number for round columns is 51,200 pounds, and dividing this by 5 we get 10,240 pounds, safe load per square inch of sectional area. For the exact area in square inches, refer to the table of "Areas of Circles."

A 12" dia. area = 113.10 sq. in.

" 10" " " = 78.54 " "

34.56 = area of a 12" dia. column 1" thick.

Then 34.56 inches \times 10,240 = 353,894 pounds or 177 tons, total safe load the column will support.

EXAMPLE 2. What safe load will a 10-inch-square column 1 inch thick, 10 feet long, support, with a safety factor of 6 or one sixth the ultimate strength?

$$\frac{l}{r} = \frac{120}{10} = 12.$$

Opposite this number for square columns is 62,110, which divided by 6 gives 10,352 pounds, safe load per square inch of sectional area.

Area of column = 36 inches \times 10,352 = 372,672 pounds or 186 tons, the total safe load the column will support.

113. Ribbed Base Plates—are used where large columns and heavy weights are carried to the base stone on these bases. The plate is ribbed to distribute the load over a greater area on the granite,—generally 1000 pounds per square inch safe load on granite, 200 pounds per square inch on brickwork, 150 pounds per square inch on concrete, 60 pounds per square inch on earth.

The ribs (*D*) should be the thickness of the body of base, or they may disconnect (after casting) with the body of column in cooling. The *A* in section is a flange which will be found

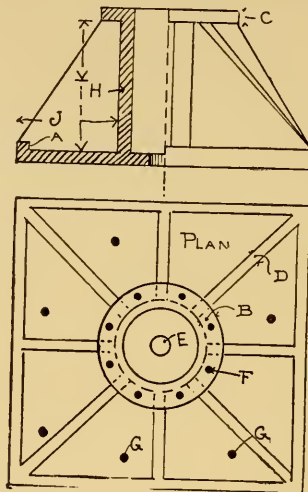

very useful in keeping the outer edge of plate straight in cooling, and will also give considerable strength to the plate. *E* is a large hole 2 inches diameter in centre of plate; *G* are small holes 1 inch in diameter in bottom plate (for explanation see "Grouting"). *C* is the flange, 3 inches wide, as at *B*, with holes (*F*) for connecting with column flange.

The body of base (*H*) and flange (*C*) should be the thickness of column above; the bottom the same. The flanges (*A*) should be the thickness of bottom by $1\frac{1}{2}$ inches high on inside.

The distance from top of base stone to finished floor is to

be taken into consideration when designing these bases. It is a good plan to make the height of the rib equal to its base; that is, K equal to J , as J will be found when the number of square inches required on granite is established and bottom made into a rectangular base.

The height of rib (K) may be two thirds the projection of J , and be found to be a good angle to resist bending.

114. Flat Base Plates—are used in most cases for small columns, or columns with light loads, also plain plates without the bevel A . The ring is used for fitting in the column in each case. This plate is also used for heavy loads; it may be strong enough, but the deflection is so great as to throw load on centre of cap, instead of distributing the weight over entire area of base stone.

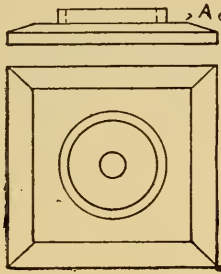

115. Grouting.—To grout a base plate properly, allow one half to three quarters of an inch space between base stone and plate, with the base stone trimmed off true and level; set plate in its proper place (also level); make a bed of cement on all sides of bottom, to prevent mixture from spreading outside. Mix Portland cement with water until it runs smoothly (not like paste); then fill the body of the ribbed base plate until it is about half full. If the mixture is properly made, it will begin to ooze up at small holes in the bottom of plate. (These holes are necessary in every plate grouted, as they show that the mixture has filled under thoroughly.)

If cement is used entirely, being quick-setting (except in

freezing weather), grouting is found to be practically sufficient for base plates.

116. Bedding.—After the base stone is trimmed off level and true, make the mixture the consistency of paste, spread it equally over the stone from one to two inches in thickness. Set the base plate in its proper place, ramming it down solid, true and level.

117. Cast-iron Dowels for Wooden Columns.—Wooden columns connected by iron dowels are equally as objectionable as dowelled iron columns. The *dowels* for the former are made in two shapes, square and circular ended as shown, of $\frac{3}{4}$ -inch metal 5" \times 10" by the height of the girder, with raised sockets for inserting the top and bottom of posts, and a lip on each top and bottom plate.

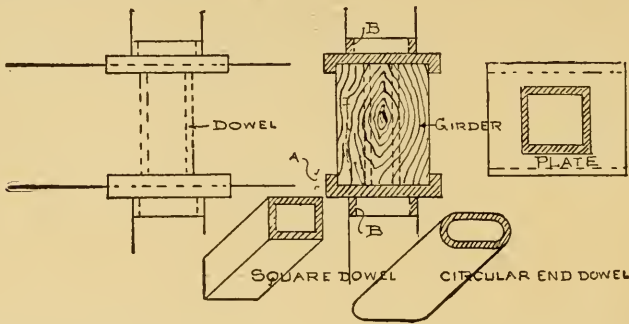

The lip on plate at *A* is usually $1\frac{1}{2}$ inches, and the lower lip (*B*) 2 inches by $\frac{3}{4}$ of an inch thick.

118. Wrought-iron Pins and Cast-iron Star-shaped Dowels—are also used similarly to the above.

In each case the holes for inserting the dowels are first bored through the wooden girder before setting same on the columns.

CHAPTER VIII.

WROUGHT-IRON COLUMNS.

119. Wrought-iron Column Sections.—What has been said in regard to “Rolled Iron Struts” in Chapter VI applies also to *wrought-iron columns*.

The following compound sections of I beams, channels, angles, tees, and zec bars are frequently used.



FIG. 1.



FIG. 2.

The section Fig. 1 of columns is composed of three I beams ; the inner beam is riveted through its flanges to the webs of the outer beams by four lines of rivets.

In Fig. 2 channels are used on the outside in place of I beams ; the flanges being turned inward gives the column a better finished appearance than Fig. 1.



FIG. 3.



FIG. 4.

The section Fig. 3 is composed of two channels with latticing, or of two channels and plates riveted to the flanges of channels with four lines of rivets.

In Fig. 4 the section is composed of four corner angles with four plates, and joined together with eight lines of rivets.



FIG. 5.



FIG. 6.

The section Fig. 5 is formed in the same manner as Fig. 4, latticing being used in place of plates.

The rolled-segment or "Phoenix" column, as Fig. 6, is composed of from four to eight segments riveted together through the projecting flanges, and made from 4 to $17\frac{1}{8}$ inches outside diameter and $6\frac{1}{8}$ to 21 inches outside of flanges. Fillers of flat iron can be placed between these flanges to make up any required sectional area.

120. Zee-bar Columns—represent types of columns with open sections, in common with I beam and channel columns, which readily admit of repainting and are therefore suitable for out-door work.

The standard sections of zee-bar columns, as shown on page 69, at Fig. 3, may be re-enforced to the required strength by using either three plates, as in Fig. 2, or making a square closed column, as in Fig. 1.

121. Strength of Wrought-iron Columns.—Wrought-iron columns fail either by deflecting bodily out of a straight line, or by buckling of the metal between rivets or other points of support. Both actions may take place at the same time; but if buckling occurs alone, it may be an indication that the rivet spacing or the thickness of the metal is insufficient.

The rule has been deduced from actual experiments upon columns, as in girders, that the distance between centres of rivets should not exceed, in the line of strain, sixteen times the thickness of metal of the parts joined, and the distance between rivets or other points of support, at right angles to

the line of strain, should not exceed thirty-two times the thickness.

122. Safe Load on Wrought-iron Columns.—On account of the perfect symmetry of form possessed by round and square sections, as compared with the shapes for which the

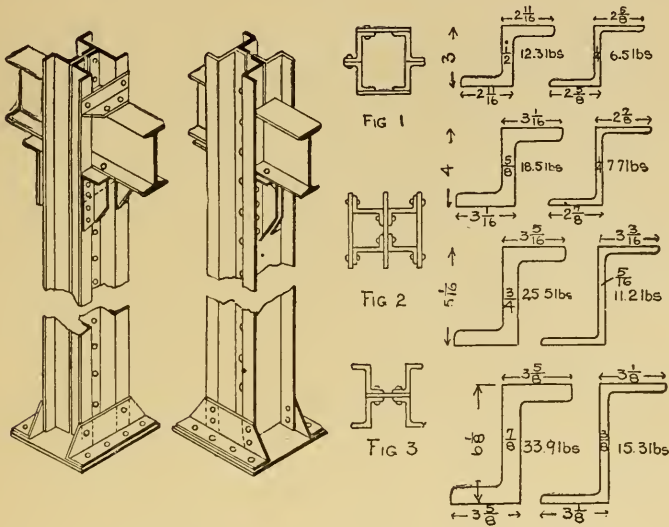

table of "Safe Load on Struts" was especially calculated, the *safe loads* per square inch of section are increased ten (10) per cent for round columns and five (5) per cent for square columns. That is, the factors of safety previously given remaining the same, the ultimate strength is supposed to be 10 and 5 per cent, respectively, greater than the rolled struts.

The following tables give the values of the radius of gyration for round and square columns from 4 to 12 inches diameter and from $\frac{1}{10}$ of an inch to 1 inch thick.

NOTE.—The weights given in the section of zee bars are pounds per foot in length.

123. RADII OF GYRATION FOR ROUND COLUMNS.

Outside Diameter of Column in inches.	Thickness in inches, varying by Tenths.									
	.1	.2	.3	.4	.5	.6	.7	.8	.9	1.0
	Corresponding Radius of Gyration in inches.									
4	1.38	1.35	1.31	1.28	1.25	1.22	1.19	1.16	1.14	1.12
5	1.73	1.70	1.66	1.63	1.60	1.57	1.54	1.51	1.48	1.46
6	2.08	2.05	2.02	1.98	1.95	1.92	1.89	1.86	1.83	1.80
7	2.43	2.40	2.36	2.33	2.30	2.27	2.24	2.21	2.18	2.15
8	2.79	2.76	2.72	2.69	2.66	2.62	2.59	2.56	2.53	2.50
9	3.15	3.11	3.08	3.04	3.01	2.97	2.94	2.91	2.88	2.85
10	3.51	3.47	3.44	3.40	3.37	3.33	3.30	3.27	3.23	3.20
11	3.86	3.82	3.79	3.75	3.72	3.68	3.65	3.62	3.58	3.55
12	4.21	4.18	4.15	4.11	4.08	4.04	4.01	3.97	3.94	3.90

124. RADII OF GYRATION FOR SQUARE COLUMNS.

Outer Diameter across Flats in inches.	Thickness in inches, varying by Tenths.									
	.1	.2	.3	.4	.5	.6	.7	.8	.9	1.0
	Corresponding Radius of Gyration in inches.									
4	1.59	1.55	1.51	1.47	1.44	1.41	1.38	1.35	1.32	1.2
5	2.00	1.96	1.92	1.89	1.85	1.81	1.78	1.75	1.71	1.68
6	2.41	2.37	2.33	2.29	2.25	2.21	2.18	2.15	2.11	2.08
7	2.82	2.78	2.74	2.70	2.66	2.62	2.58	2.55	2.51	2.48
8	3.23	3.19	3.15	3.11	3.07	3.03	2.99	2.96	2.92	2.89
9	3.63	3.59	3.55	3.51	3.48	3.44	3.40	3.36	3.32	3.29
10	4.04	4.00	3.96	3.92	3.88	3.84	3.80	3.77	3.73	3.70
11	4.45	4.41	4.37	4.33	4.29	4.25	4.21	4.17	4.13	4.10
12	4.86	4.82	4.78	4.74	4.70	4.66	4.62	4.58	4.54	4.51

EXAMPLE. What is the greatest safe load for a flat-ended round column 6 inches outer diameter, $\frac{1}{2}$ inch thick, 8.64 square inches area, and 18 feet long?

$$r = 1.95, \quad \frac{l}{r} = 111. \quad \text{By table of "Safe Load on Struts,"}$$

Chapter VI, the corresponding safe load = 6780 + 10 per cent = 7460 lbs. per square inch of section, or 64,440 lbs. for the column.

For a square column add 5 per cent to the table instead of 10 per cent as above.

CHAPTER IX.

STAIRWAYS.

125. Close-string Stairs.—There is no part of a building which furnishes a better opportunity for ornamentation than the stairway. It is generally a continuation of the entrance-hall, and is the means of communication between the several stories. The design page 72 shows a cast-iron string and cast-iron railing and what are commonly called *close-string stairs*, the ends of treads and risers not being visible from outside the string.

126. Height and Breadth of Steps.—In straight staircases the *height* and *breadth* of steps are very variable quantities, generally subject to the exigencies of the space reserved. As a rule, the broader the tread at the line of traffic, the less should be the riser or height of step. The breadth varies from 9 to 12 inches (not considering the nosing), and the height of riser from 6 to 8 inches—a minimum and maximum that should never be exceeded. It is always a safe rule to make twice the rise plus the tread equal to 25. Within these limits stairs are easy of ascent and not tiring.

An ordinary staircase to be convenient should be pitched at an angle ranging from 24 to 30 degrees. It should consist of steps uniform in height in each flight between the stories as measured from flooring to flooring.

127. Cast-iron Stairs.—The plan, section, and details, page 73, show stairs of *cast-iron* with slate treads. The connections of strings are covered entirely by the posts, thus giving them a finished appearance.

The face string extends to the wall for support and forms a riser. (See detail *B.*) It is seldom made less than twelve inches or required more than sixteen inches wide.

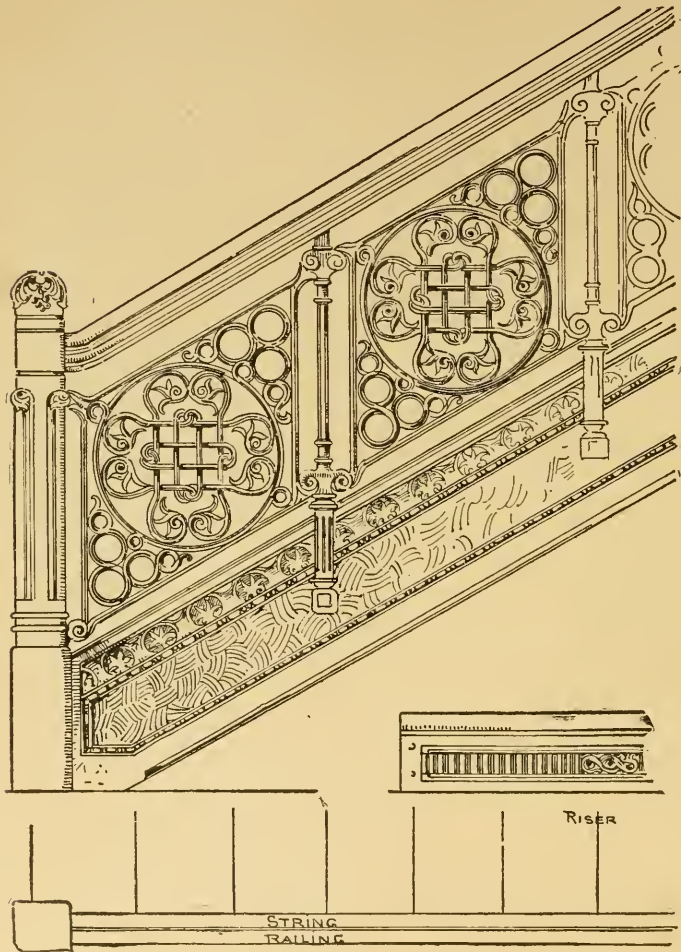

128. To Measure Height of Railing.—The railing height is measured from a point on the tread directly above the face of riser (not the moulding under the nosing of tread), and should be from 2 feet 8 inches to 3 feet. Fig. 2 is the string

connection at the top of stairs. The wall string is set 2 to 2½ inches from face of wall to receive the plastering at top and bottom, and is frequently made with a wider top and bottom

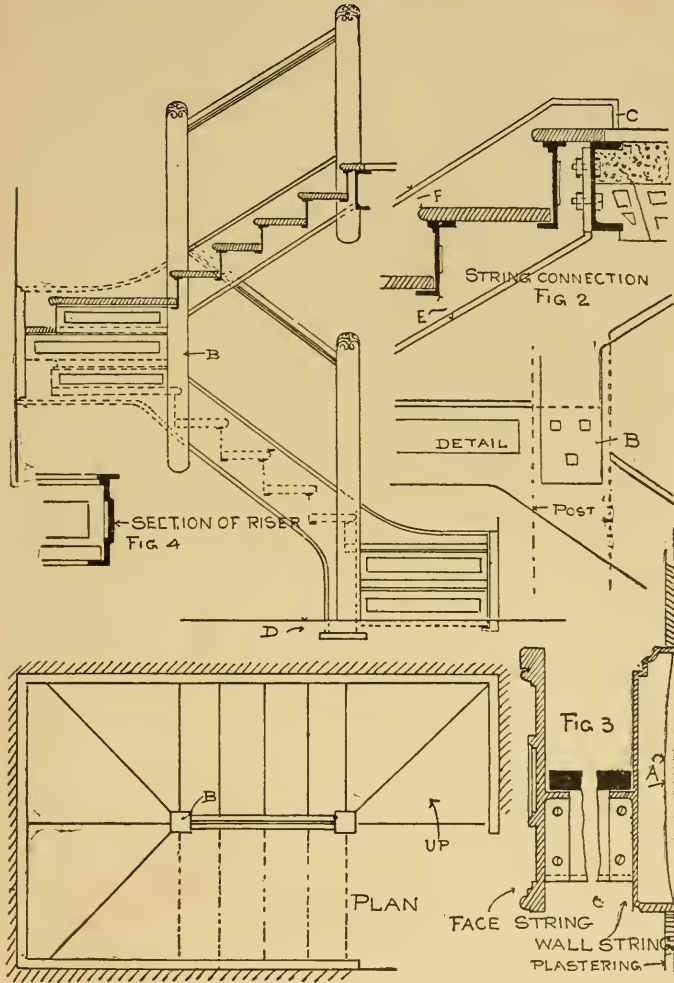

flange to receive any furring placed on wall. The section of wall string at Fig. 3 shows clearly the manner of receiving the plastering.

To arrange the treads and risers upon the strings, the F distance on Fig. 2 should not be less than 2 inches above nosing of tread, and from 4 to 8 inches at E below riser, depending at this point upon the size of treads, height of risers, and length of string. The F distance need seldom be changed. To have the string show a proper finish at top of stairs, the top moulding should return downward to flooring as shown at C , Fig. 2.

A continuous vertical and horizontal flange, $\frac{3}{8}$ by $1\frac{1}{4}$ inches thick, is cast on the string to secure the risers.

The wall string, if of considerable length, can be secured to the wall by *lag* screws or *expansion* bolts (see plate of Bolts), and cast with ribs as shown at A , Fig. 3. These ribs perform an important part when the casting is cooling, keeping it straight, also forming separators when the string is drawn up close to wall.

129. Number of Strings Regulated by Width.—Stairs over four feet in width should have three strings—that is, an outside or face string, a middle string to follow the shape of riser and tread, and a wall string. If less are used for stairs over four feet in width, the risers should be increased in thickness. The average thickness for an ordinary riser is one fourth ($\frac{1}{4}$) of an inch.

130. Wrought-iron Stairs.—For area stairs, or stairs to be used for light traffic in any locality, those of *wrought iron* are the lightest and simplest constructed. The strings are made of flat iron, welded and made the shape of treads and risers, riveted to a plain bar as shown at B . The portion of string at F has angle knee clips for fastening the treads upon. The treads are $\frac{3}{4}$ of an inch thick; to give them stiffness a vertical flange is cast on the back. The railing is constructed as shown by the connection D , with the baluster curved to clear the tread at C .

The top rail is composed of a flat bar with a half-round bar of wrought iron riveted on top. These stairs can be adapted

for spans from 4 feet to 12 feet long by 3 feet wide. The straight bar *G* may be from $1\frac{1}{4} \times \frac{3}{8}$ inch to $2\frac{1}{2} \times \frac{1}{2}$ inch, the bar *F* $1\frac{1}{8} \times \frac{5}{16}$ inch to $1\frac{1}{2} \times \frac{1}{2}$ inch, the balusters *H* $\frac{3}{4}$ inch square.

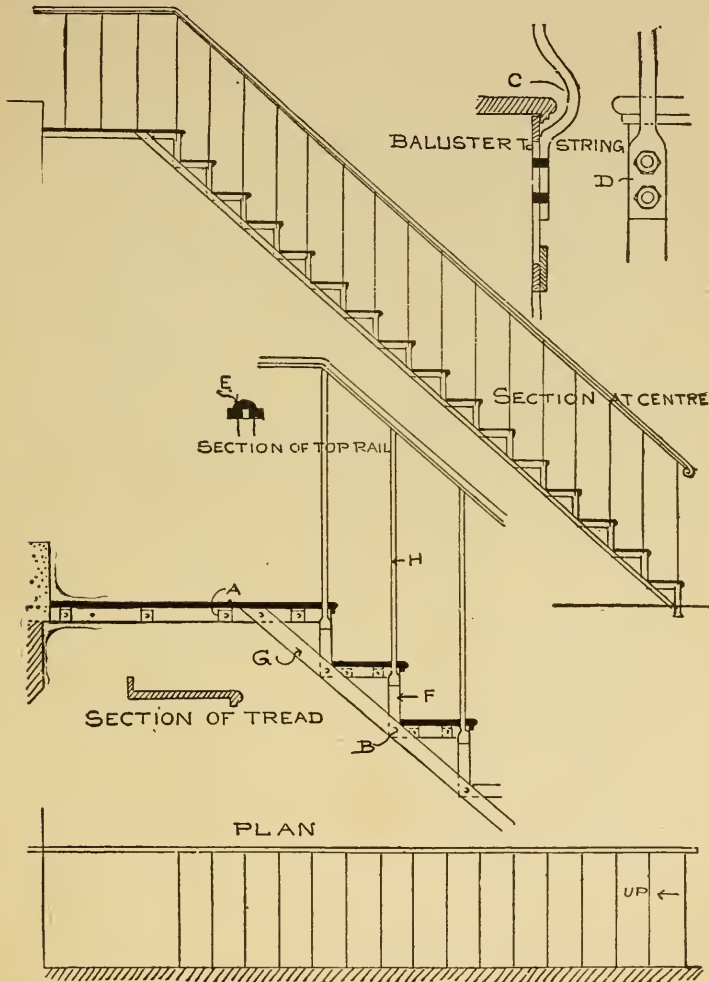

The treads to be cast iron, open-diamond pattern. Wooden treads are often used by securing them to the angle knee clippings (*A*) with carriage bolts.

131. Circular Stairs—are used where circumstances prevent the construction of a straight staircase. The treads and risers, as shown in the detail, are cast in one piece, placed over

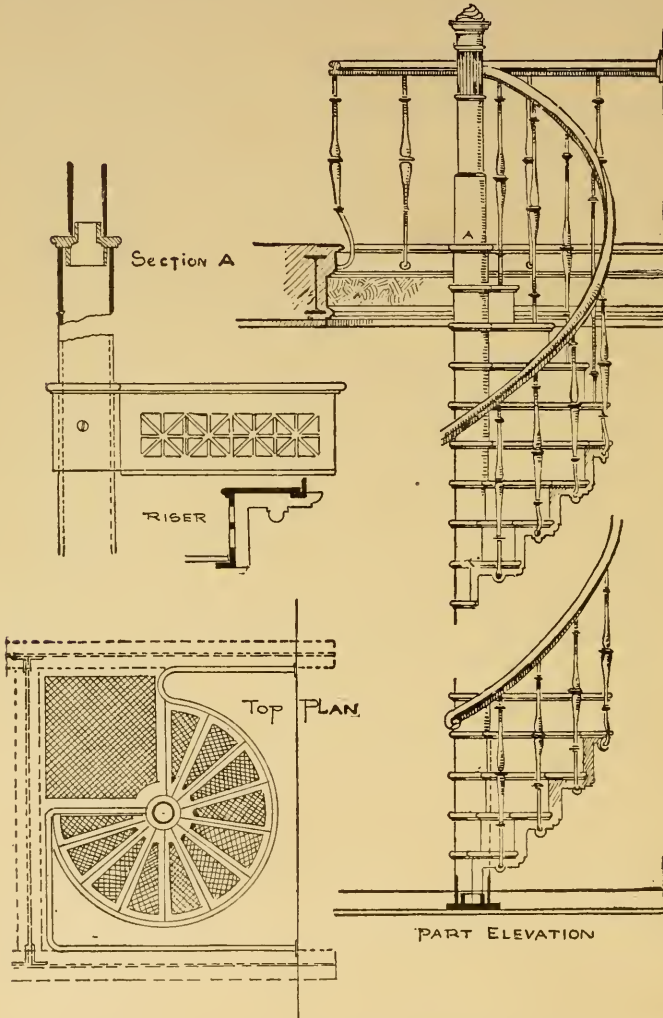

and secured to a 4 or 6 inch diameter wrought-iron pipe extending the full height of stairs.

In adjusting the plan, it is important that the head-room

be sufficiently large to allow passage up and down: it should not be less than 7 feet from top to bottom of treads. The landing, as shown in top plan, has a square platform, well-hole, railing, and cast-iron fascia.

The treads may be of slate or marble, or of cast iron, solid or open pattern.

A cast-iron post, as shown at section *A*, is set into a socket, on the top of pipe, giving it a finished appearance.

132. Deck-beam Strings.—In Fig. 1 of the following plate of details the string is composed of a deck-beam and cast-iron stepping-blocks (*A*). The apron (*F*) on stepping-blocks extends over outer edge of beam flange.

The angle knee *H* is for connecting the deck beam to floor beams of stair well.

The post *G* is made to cover the connection of string. The risers are secured to the face of blocking pieces on face string, and to the projecting flange *E* on wall string. The wall string projects from the wall line and receives the plastering as shown at *C*. The railing bars *D* are bent over the treads and secured to the blocking pieces.

133. Channel Strings—as shown at Fig. 2, are constructed as close strings, the treads and risers being secured to the channels by cast-iron or wrought-iron angles formed to the shape of the treads and risers.

The face of channel at flanges can be filled with cast-iron mouldings, and webs ornamented with rosettes.

134. Plate and Angle Strings—are constructed similarly to “channel strings.” Cast-iron mouldings and rosettes may be applied in the same manner.

This is a more expensive stairway than any of the others previously described, and is used only in cases of long flights and heavy traffic. The wall strings can be constructed of cast iron for any length of span if placed directly against walls, for the reason that dowels or expansion bolts are used to tie the string to wall for support. It will also be found to give a

better finish and connection with base moulding, which is generally continued around landings and platforms.

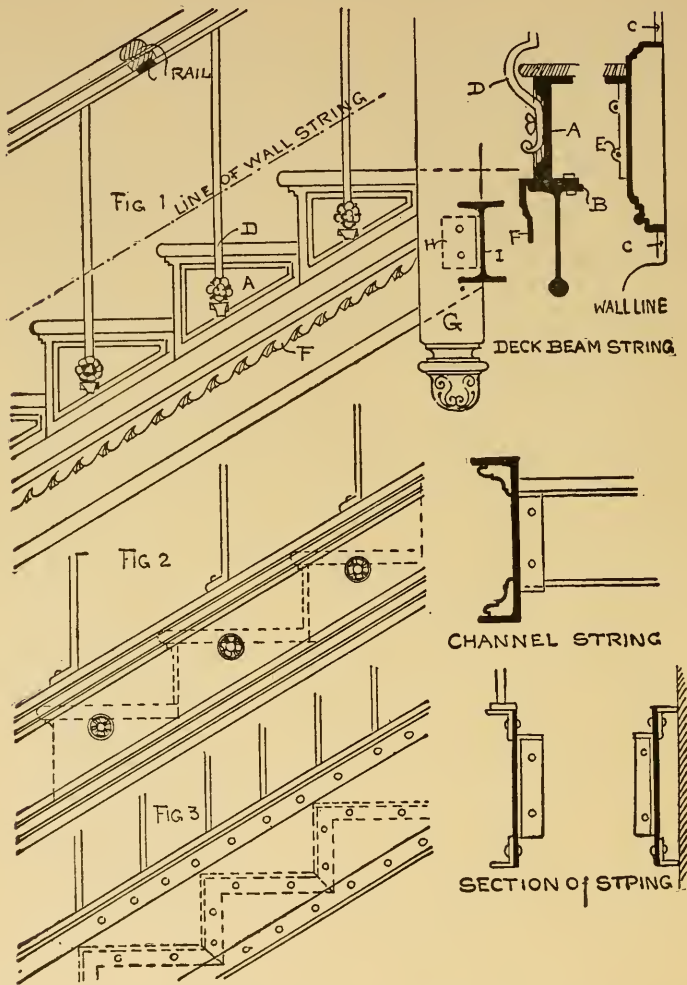

135. Treads and Risers.—Treads are generally made of slate, $1\frac{1}{4}$, $1\frac{1}{2}$, $1\frac{3}{4}$, and 2 inches thick, and risers of iron, $\frac{1}{4}$ and $\frac{3}{8}$ inch thick. Where stairs have little light and dependence is placed upon skylights, the treads and risers are frequently

made of cast iron perforated. Where a first-class finished staircase is adopted, the treads are made of white Italian marble, and the cast-iron riser is faced with marble.

Tiling can also be applied to the risers and treads by making the outer border and body of riser and tread solid iron and setting the tiling in recess.

136. Fascias.—The landings and platforms of all stairways should have *fascias* the size of outer strings, and should project a few inches below ceiling line to receive plastering, and a few inches above to receive finished floor. The casting can be made as thin as $\frac{3}{16}$ of an inch.

137. Posts or Newels—are to be placed in all corners where necessary, extending above and receiving the rail, and to have a finished “drop” below ceiling at *G*.

138. Brackets for Stair Handrail.—These brackets are used on landings, corridors, and wall side of stairway, for the hand rail to rest in, and made of a $\frac{3}{4}$ -inch-diameter brass or wrought-iron bar. The distance of pipe from wall at *A* is generally 2 inches.

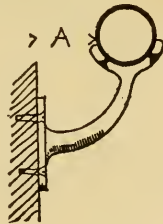

139. Stairs to be Carefully Constructed.—To give the staircase a finished appearance in every respect, it is very important that the work should be *carefully constructed*. The wall strings should extend along all landings and finish with some post or door trim.

The slate and marble for the treads and platform should not be too large (not over 4×5 feet), with small beams, tees, or cast-iron bridge pieces for their support.

CHAPTER X.

ORNAMENTAL IRON WORK.

140. Ornamental Design.—The art of *ornamental design* is appreciated both by the public and by the manufacturer, by the consumer as well as the producer of all the innumerable appliances of modern life.

Every style contends for the mastery, and in our manufactories every variety is encouraged; nor can we identify any one as national. The ornamental sculptor, the wood carver, the house decorator, the glass painter, and the designer for iron and brass,—all these are called upon to assist in the production of articles from every variety of design.

The architectural-iron worker is called upon not only to prepare and erect the iron employed in the building, but to supply a considerable portion of the decoration, generally from designs furnished by the architect to be worked in cast and wrought iron.

We frequently observe how beautifully these designs have been reproduced.

141. Hammered Wrought Iron—as a means of decoration, is an established feature of architectural work. Although expensive for good work, the results attained are very satisfactory for workmanship and beauty.

Flowers, vines and leaves, fantastic iron work for hinges and door latches, are worked in particular excellence; in fact, all manner of design known to decoration can be reached by the artisan in this style of work.

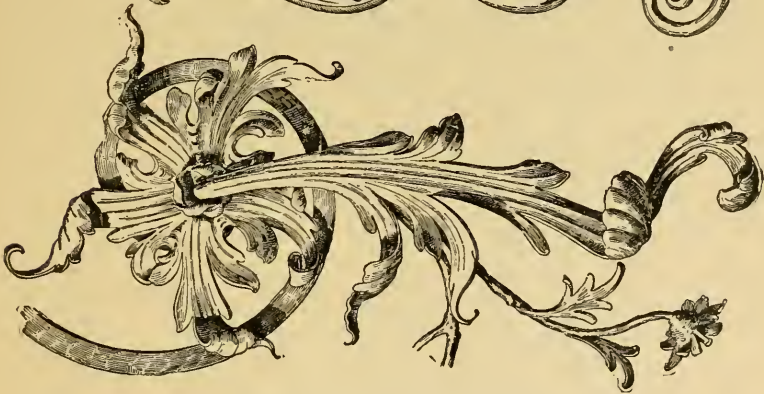
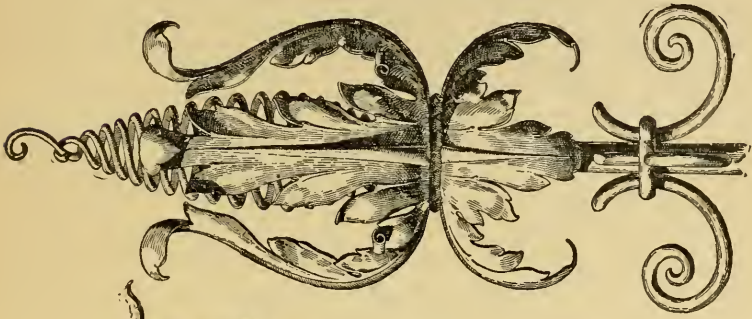

ORNAMENTAL WROUGHT-IRON LEAVES.



WROUGHT-IRON GRILLE.

142. Method of Hammering Leaves, etc.—For a correct and intelligent manner of producing the best results in *hammered leaves*, etc., the designs should be drawn full size and correctly shaded to show their proper forms and inclinations, with a sketch showing the complete outlines of the figure. If this is not sufficiently clear to the artisan, a model should be made, in clay or wax, which gives a true and perfectly clear representation of the design in its finished state.

To facilitate the production of many forms for similar designs, the model is reproduced in cast iron and the casting used as a pattern, upon which the leaves are more readily hammered into shape.

143. Hammered Wrought-iron Grilles.—Window, door and panel grilles give the best opportunity for design in hammered wrought iron. Of the two designs herein shown, the first can be made of square or round bars, curved to the proper shape and placed inside the frame; then heads, face and leaves hammered separately and welded or riveted to the curved bars.

In the second design, the inside open panel is formed of leaves, vines, etc., and the outside border may be closed or open. To give an effective and well-relieved appearance, the leaves, grapes and vines can be hammered work, and the body made of a plain casting, to which the relieved work is secured.

144. Cast Iron Ornamented.—We seldom think of comparing ornamental cast iron with hammered wrought iron to its disadvantage; both are excellent; whereas modern castings *do* invite comparison, as by an infinitely careful ingenuity of pattern-making the very best results are obtained.

Ornamented cast iron is largely used in railings, balconies and verandas, with graceful posts and panels of delicate lattice; or inside the house—the grates, stairs and stair railings.

Even the ordinary area railing of straight bars has cast knobs, rosettes, etc., very good in their way, and everything so compact that one never sees parts fractured. The grates found in the best houses are for the most part of excellent de-

sign, and remarkable examples of careful castings; some are quite plain, with just a moulding or two, and others are fluted and beaded all over with tiny ornaments on flat surfaces. Repetition is the very nature of cast work, and hence the same

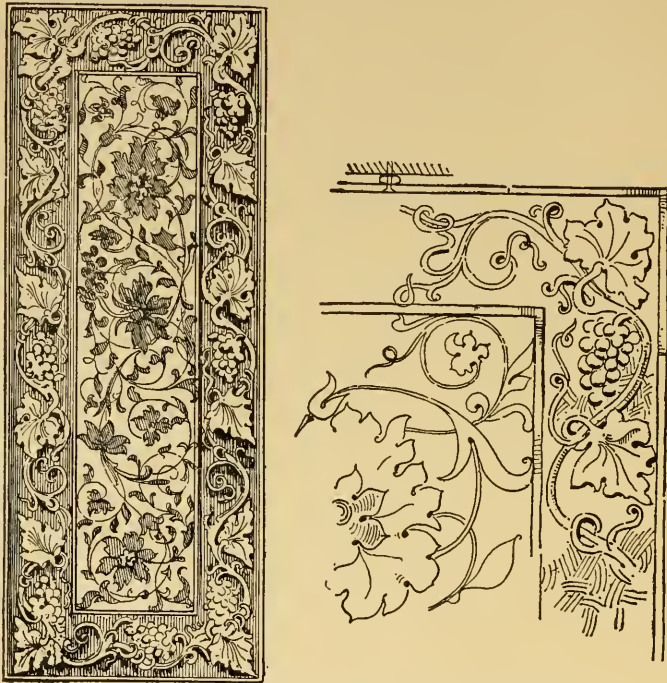

WROUGHT-IRON GRILLE WITH CAST-IRON BORDER.

form, as we have often seen, is many times impressed from the same pattern. Repetition of a few simple elements in different combinations makes great actual variety possible, as in fire-backs of grates, etc.

145. Modelling for Ornamental Castings.—The very old method of *modelling* the ornament in wax is also applied to the finer class of castings at the present time. Where frequent repetition of the ornament is necessary, a casting

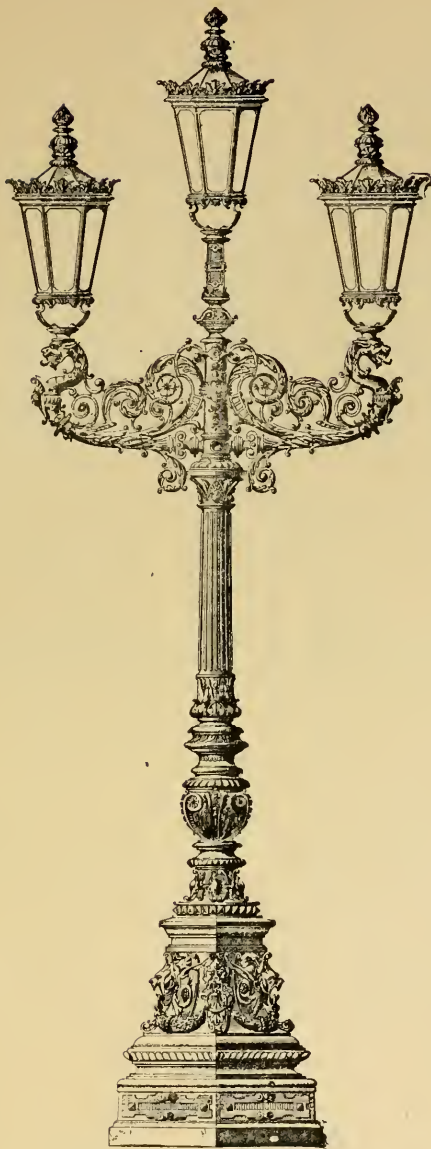

GAS-LIGHT POST OF CAST IRON.

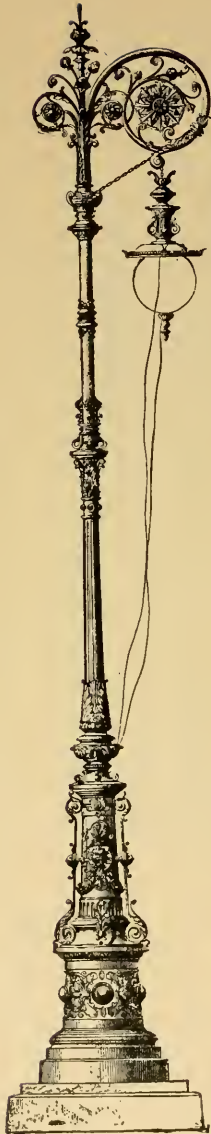

ELECTRIC-LIGHT POST
OF CAST IRON.

is made from the model, in lead, brass or bronze, and used as a pattern.

If the model is not finished in wax, recourse can be had to carving the pattern in wood.

146. Finish of Ornamental Iron.—In many cases of finishing ornamental iron painting is generally adopted.

For the best class of work various other means are used, as the "Barff" process, so called from the name of its discoverer. Its purpose is to render the surface of metallic articles treated resistant to acids and impervious to humid oxidation. Iron that has been properly barffed will not rust. The process belongs in no sense to the chemical laboratory, and requires no particular scientific knowledge or technical skill for its success. The iron to be treated is made perfectly clean, free from oil and dust, and placed in a *muffle*—an air-tight oven into which is led a steam-pipe from a boiler that carries steam at a pressure of from 60 to 100 pounds to the inch. The effect of this steam on the iron exposed to its action is to convert its surface into magnetic oxide of iron.

Galvanizing, the modern version of tinning applied to iron, is a valuable process. Galvanizing and good oil gilding right over the surface would probably be a perfect protection from rust, or the galvanized portion might be lacquered and

varnished in one or many lustrous tints, or in black, gold and silver patterns.

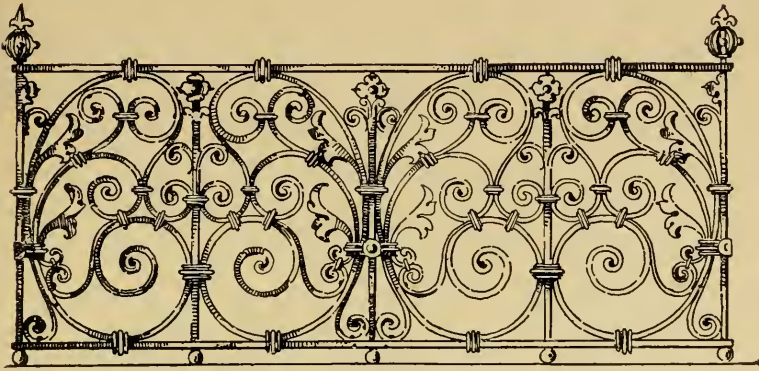

WROUGHT-IRON BALCONY RAILING.

For some work, oiling or varnishing, or an application of thin "Berlin black," may be sufficient.

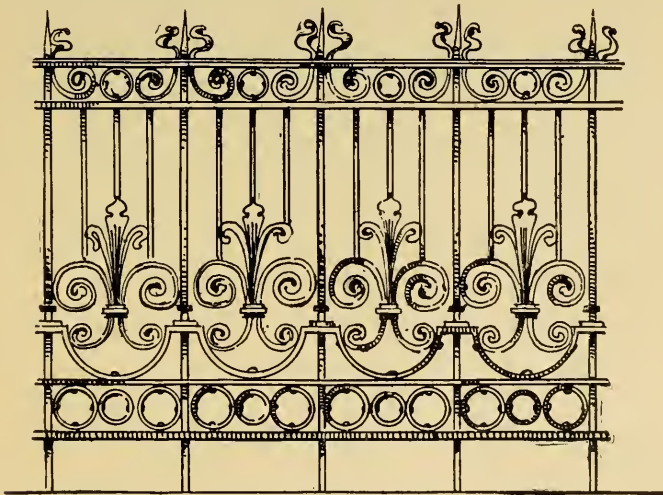

WROUGHT-IRON STREET RAILING.'

Electro-plating in copper, silver, nickel, bronze, and very often in gold, is a favorite method and universally adopted.

CHAPTER XI.

ELEVATOR ENCLOSURES.

147. Passenger-elevator Enclosure.—The enclosure front represented in the annexed engraving is not a design of any particular merit, but is given here to illustrate the combination and construction.

The transom rail over the doors is made of a wrought-iron angle (*I*) and faced with a cast-iron moulding. A smaller wrought-iron angle (*F*) is secured on the larger, with one leg planed to serve as a track for the sheaves of sliding door, and extends across the entire front. The sheaves are anti-friction and arranged into a hanger or welded bar, formed with an open groove as shown at *H*; the pin in the sheave runs back and forth, travelling the full length each time the door is opened or shut.

The hangers are secured to top of door as shown in section of track.

The bottom of door is prevented from falling out by the pin *A* projecting into the grooved saddle.

The saddle extends across the entire front and down over the channel on inside of enclosure as shown at *B*.

To give a neat appearance to the face of channel, rosettes (*E*) or mouldings are generally employed. The moulding *C* is made to extend below ceiling to receive the plastering.

These fronts are often used as entrance doors to shafts where it is desired to carry goods from one story to another,

some passenger elevators having an auxiliary compartment for freight. The entire front is hung on heavy pin hinges, in such a manner that when the sliding door is back of the stationary panel, and bolts loosened from end of transom, the front may be swung out.

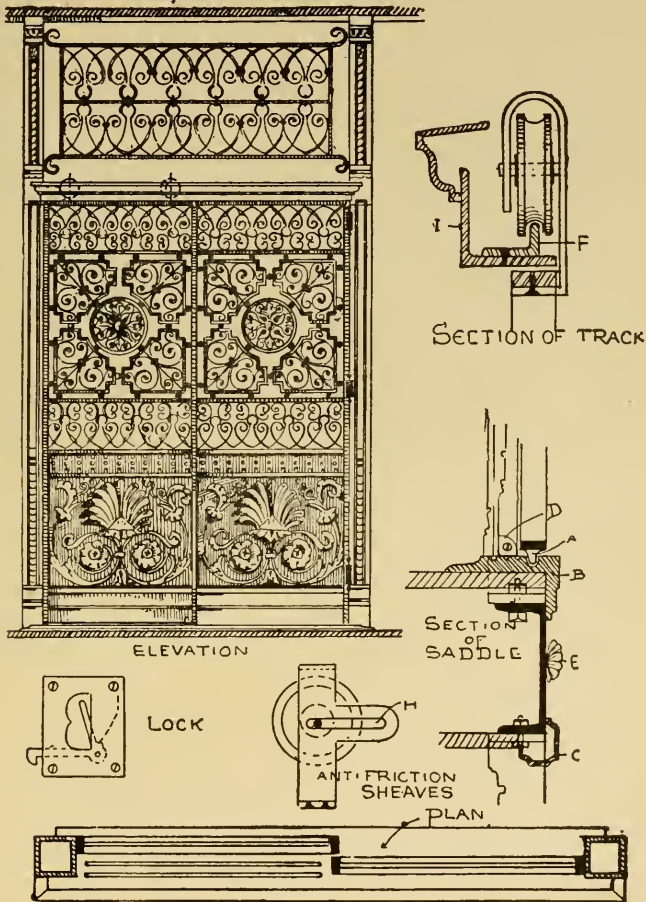

To secure the sliding door when closed, brass or bronze locks $3'' \times 4'' \times \frac{3}{4}''$ are placed upon the inside, with a rubber buffer, against which the door strikes, attached to post.

The doors of front should be set plumb over each other in the different stories, as the door in elevator car takes the same position at each story as it rises and falls.

148. Freight-elevator Enclosure.—Of the many methods of constructing an enclosure for elevators, that of the angle-iron frame requires the least room and is the simplest in erection. The frame is filled in with porous terra-cotta blocks 4 inches thick. The corner angles, of $3'' \times 4'' \times \frac{3}{8}''$, extend to the lower floor level, resting on a base plate of cast iron, a small foundation being prepared for the same. If the stories are not too high, a connection need only be made at every other story. For these connections wrought-iron plates $\frac{1}{4}$ inch to $\frac{3}{8}$ inch thick are used. (See connection *C*. For connection above roof where upright angles discontinue, see connection *B, G*.) At each floor level a horizontal angle is placed which receives the uprights of door and also the cast-iron saddle. The uprights or jambs should be $3'' \times 3'' \times \frac{3}{8}''$ angle, with $3'' \times 4'' \times \frac{3}{8}''$ at head: the head angle to have the 4-inch leg down to receive the 4-inch block. The distance between head of door and the next story will require a good-sized panel of terra-cotta blocks; therefore a larger angle is needed.

The connections of door jambs should have counter-sunk bolt heads on door side as shown at detail *D*, that door opening may be perfectly free.

To prepare the jambs for the door a wrought-iron eye is riveted as shown in plan, with proper projection for the wooden casing. The pin or strap hinge is secured to door and works in this eye. To stiffen the jambs and prevent any vibration caused by the continual closing and swinging of doors, a flat bar $2\frac{1}{2}'' \times \frac{1}{2}''$ is placed between jamb and corner angle, half way in height (see connection *E*). The doors are made of wood and covered with sheet iron No. 16 to No. 20 gauge. The strength of the angles to support the superstructure need not be taken into consideration: those adopted will be found sufficiently strong for the requirements. Angles of $3'' \times 4''$

were selected for practical reasons; the fire-proof blocks being 4 inches thick, a 4-inch angle is required.

By reference to side elevation it will be seen that an angle extends vertically against wall. The terra-cotta blocks require

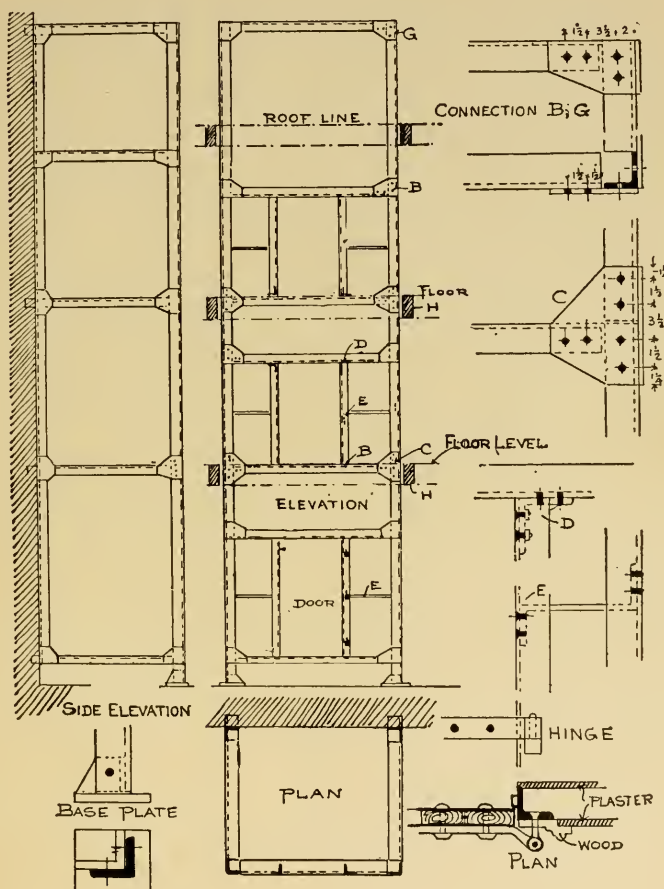

side supports on each story at that point; out these are frequently omitted when the mason leaves vertical openings, the width of terra-cotta blocks by 18 inches in height, every 4 or 5 feet apart in the height of enclosure.

The cross-pieces on side elevation extend into and bear on the wall, to carry each panel as shown.

Most if not all enclosures extend several feet above the roof, with a large skylight for ventilation and light. Although the car seldom extends to roof, the sheaves for the gearing of car should extend above the roof line to give ample height for the proper working of the car at top story.

The sides of the enclosure above the roof should be covered with crimped or plain sheet iron No. 16 gauge.

When the iron frame of enclosure extends above level of roof it is called a *bulkhead*. Similar bulkheads are placed over stairs, dumb-waiters, and light-shafts.

149. Double Sliding Doors for Passenger-elevator Fronts.—Buildings not fire-proof having passenger-elevator shafts enclosed in a frame of iron filled with porous terra-cotta blocks, or enclosed in brickwork, have double doors arranged as shown by the following details.

The outer door is constructed of iron, and used at night to prevent the passage of fire from one story to another. The inner door is constructed of wood with glass or grille work, and used during the day.

The jambs for the doors are made of channel iron. In the plan view opposite, *C* is 6 inches and *B* 4 inches wide. *D* is a continuation of saddle (see section, Fig. 2).

In Fig. 1 the 6-inch jamb is continued over the top of door. *A* is a small channel with one leg planed for the sheave *E* to run upon. *D* is the hanger secured to frame of door. *B* is a cast-iron moulding which extends overhead and down the 6-inch jamb, acting as a guide for the outer door.

The section of saddle and bottom of both doors is shown in Fig. 2. *A* is a section through frame of inner door, with a projecting pin *H* acting as a guide in the groove *G*. *B* is a section through frame of outside door, which is made of plain sheet iron (*F*) and cast-iron moulding (*E*). The frame can be made into as many panels as desired. The sheave *C* is

secured to the frame by the hanger *D* (see Fig. 4) and runs upon the projecting lip cast with the saddle.

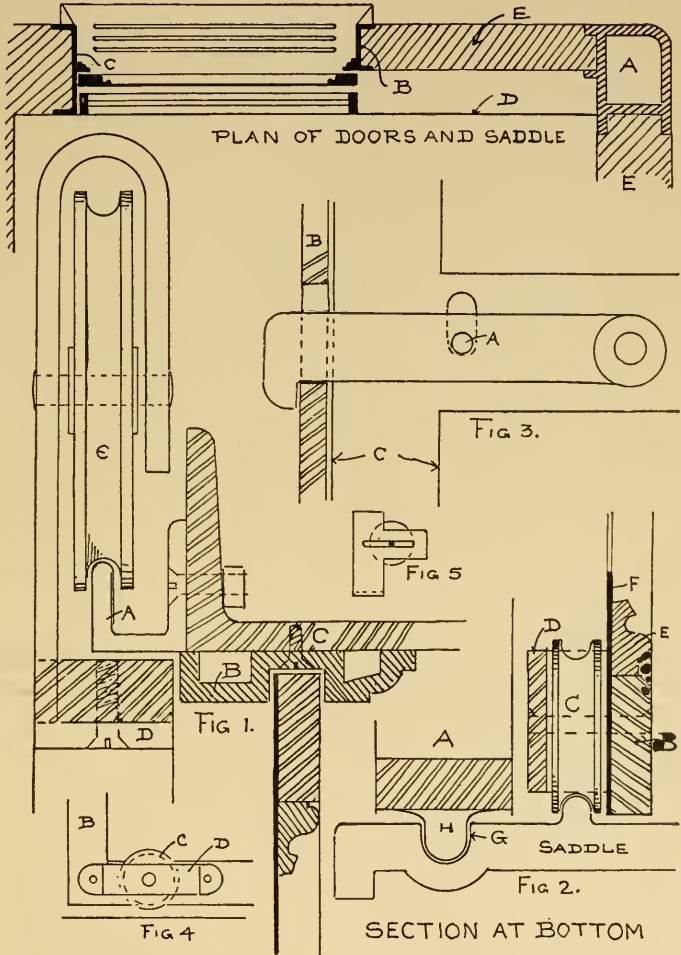

To secure the outer door when closed, a slot is cut into the channel jamb as shown in Fig. 3. *B* is the channel, *C* the door frame, and *A* a pin for raising the latch.

To secure the inner door, the same lock and buffer are used as explained for passenger-elevator enclosure.

150. Elevator-car Guide Supports—are generally constructed of 6-inch channels if placed on sides of shaft, or of 5 × 5-inch angles if placed in corners, and are continuous from cellar or basement to top of upper story. The wooden guides are secured to the channels and angles by heavy screws placed 2 to 3 feet apart.

When two elevator shafts adjoin each other and the guides are placed on the sides, the supports should be of two channels placed back to back, with the wooden guides between, and then bolted together by $\frac{5}{8}$ -inch-diameter bolts three or four feet between centres. To stiffen and support this combination they should rest and be secured to I beams placed in the shaft at each floor level.

CHAPTER XII.

DOORS AND SHUTTERS.

151. Circular-head Door and Frame.—This door is made double, as shown in the plan (page 96). The frame is of $3 \times \frac{3}{8}$ -inch flat iron on both sides of a sheet-iron plate of from No. 16 to No. 20 gauge. The panels are formed by bars running horizontally as well as vertically, the moulded-panel effect being given by a cast-iron moulding $\frac{3}{8}$ of an inch deep by one inch long. The entire work is riveted with $\frac{5}{16}$ -inch-diameter rivets, with heads smoothed off.

The frame upon which the door hangs is made of cast-iron $\frac{3}{8}$ of an inch thick, and secured to the masonry with lag screws.

The cast-iron saddle is $\frac{3}{4}$ of an inch thick, extends across the entire opening, and is secured to the cast-iron frame.

Bolts are placed top and bottom of door as shown in the elevation and section.

152. Sidewalk Door.—These doors are set level with the sidewalk into a cast-iron frame or a stone coping. The section (see page 97) as shown at *A-B* is a cast-iron frame, with a raised lip cast on to prevent surface water from entering the opening.

The door frame is made of $2 \times \frac{1}{2}$ -inch flat wrought-iron bars, and covered with sheet iron of No. 12 to No. 14 gauge (No. 12 being the heaviest), with rivet-heads, 4 to 6 inches between centres, projecting above the surface.

The doors are secured to the cast-iron frame by wrought-iron, brass, or bronze hinges $\frac{1}{2}$ inch thick.

At the centre of each door a rebate is formed by riveting to it a $3 \times 3 \times \frac{3}{8}$ -inch angle iron, which also adds considerable

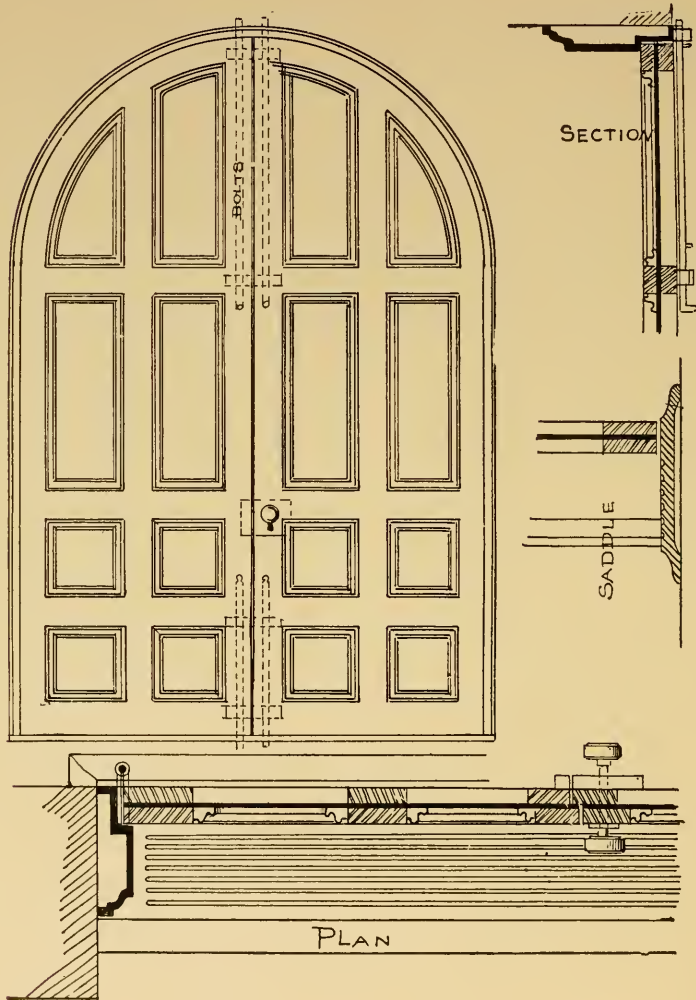

stiffness to the doors when closed. To secure them when shut, a padlock is placed in centre, with bolts at each end.

A 4-inch-diameter ring $\frac{1}{2}$ inch thick is placed on the outside, by which to raise the doors when required to be opened.

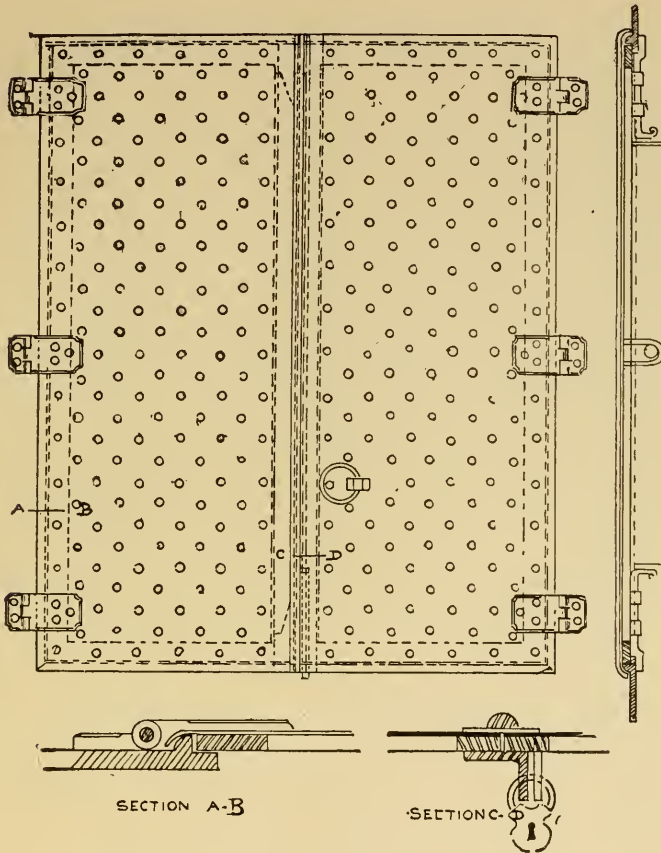

A resting block in the shape of a triangle is secured to the sidewalk, for each door to rest against when open; and a $\frac{7}{8}$ -inch-diameter bar, turned down at each end, resting in an eye riveted to the frame, holds the door open at an angle of 75 degrees.

153. **Outside Folding Shutters**—are constructed of flat iron frames, and covered with crimped or plain sheet iron of

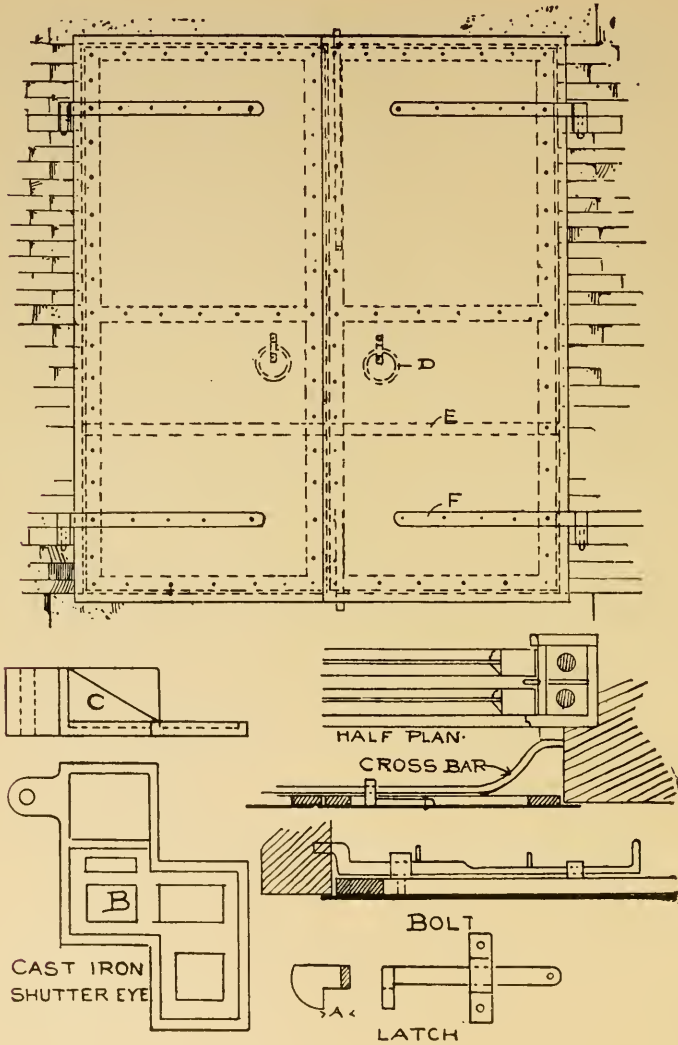

No. 16 to No. 20 gauge (No. 16 being the heaviest), and riveted to the frames with $\frac{5}{16}$ -inch-diameter rivets, placed at

four to six inches (between centres) apart. The heads on inside of frame are flattened and filed off smooth.

If the opening is flush on four sides, the sheet iron should project $1\frac{1}{2}$ inches all around; if the sills are not flush with masonry, but project two inches or more, the sheet iron will not project beyond bottom of frame.

The shutters are supported by strap hinges, the size of which is proportioned to the size and weight of shutter. For an ordinary-sized opening, from 4 to 7 feet, the shutters are made in twofold, with the frame $2'' \times \frac{3}{8}$ of an inch thick; if very stiff frames are required, $1\frac{1}{2} \times 1\frac{1}{2} \times \frac{3}{8}$ -inch angle iron should be used.

154. Shutter Hinges.—For shutters to openings 5 feet and less in width the *hinges* are made of $2 \times \frac{3}{8}$ -inch flat bars as shown at *F*, with a $\frac{3}{4}$ -inch-diameter pin working in a cast-iron shutter eye built in with the wall.

The shutters are secured, when shut, by a latch hooking over the cross-bar *E*, as shown in sketch of latch at *A*, and further secured by bolts top and bottom. (See sketch of bolt, also showing flush sill and window head.)

155. Storm Hooks—are used for securing the shutters when open, made of a $\frac{3}{4}$ -inch-diameter bar with end turned down 2 inches, connected to eyes riveted to bottom of frame, and bracing the shutters by setting the turned-down end into a hole drilled into stone sill.

156. Shutter Eyes—are made of $\frac{1}{4}$ -inch-thick cast iron in the shape as shown, cast the size of, and made to work in as, a brick, with an eye for the pin of hinge. The border is $\frac{3}{8}$ of an inch thick, the web *C* is $\frac{1}{4}$ of an inch. The open holes *B* are for bedding in cement or mortar.

157. Shutter Rings—are used for attaching a hook on end of pole to open and close the shutters.

158. Cast-iron Brick—are made similar to shutter eyes, but cast without an eye, and are built in with masonry, for secur-

ing all manner of iron work to jambs, where drilling or hammering might cause injury to the masonry.

Frames of doors, guards, and grilles are often secured to the bricks by first drilling, then tapping the holes and using *tap bolts*.

159. Rolling Steel Shutters—are suitable for closing store fronts, warehouses, goods sheds, staircase openings, elevator openings, and in many cases where protection from fire and thieves is desired. The shutters are made of steel, corrugated and riveted together, forming a firm and unbroken surface. They can be made self-coiling up to twenty feet in width; and require no winding apparatus, being pushed up and down with a rod. They are also fitted with winding gear, and protected by metal shields which prevent the edges from being worn by

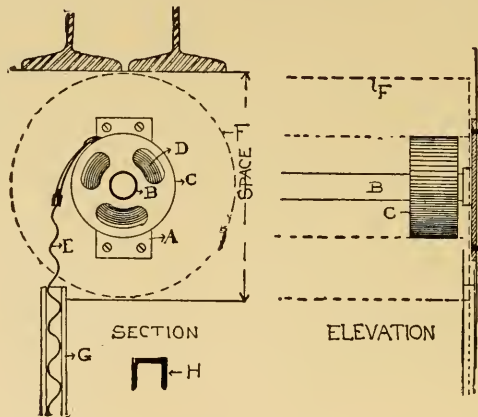

friction in the iron grooves. These grooves are made of iron channel bars $1\frac{1}{2}'' \times 1\frac{1}{2}'' \times \frac{1}{4}''$ thick.

160. The Noiseless Shutter—consists in the application of strips of leather to the edge, which are woven through mortises in the steel, forming a protection to the parts that work in the grooves, and a cushion for the coils when rolled up. The effect of this leather is to reduce the vibration of the steel and cause the shutter to work easily and *noiselessly* in the



grooves; also to vastly increase the wearing qualities and general usefulness.

The shutters are lubricated with "graphite axle grease" thinned down with oil, which gives a metallic polished surface to the leather edging, fills up any inequalities in the grooves and improves the working.

By referring to the elevation and section on page 100, it will be noticed that when the drum *C* receives the shutter when rolled up, a certain size space is required. This is governed by the size of opening or length of shutter.

The dotted line *F* represents the space when the drum *C* receives the entire shutter. *B* is a wrought-iron shaft on which the drum is secured. *A* is a plate with socket to support the shaft. *D* is the spring, *I* the corrugated shutter, and *G* the channel groove.

The following are the sizes of spaces required for different-sized openings:

PLAIN-EDGE STEEL SHUTTER.

NOISELESS OR LEATHERED.

Height of Opening, feet.	Size of Space, inches.
4	8
6	9
8	10
10	12
12	13
14	13
16	14
18	15
20	16
24	18

Height of Opening, feet.	Size of Space, inches.
4	9
6	10
8	11
10	13
12	14
14	14
16	15
18	16
20	17
24	19

NOTE.—The author's attention has been called to a valuable device, patented by the Cornell Iron Works, for securing folding shutters when open, and closed.

CHAPTER XIII.

FLOOR LIGHTS AND SKYLIGHTS.

161. Cast-iron Floor Lights for Iron Beams—in the form as shown in the plate opposite, are cast in one piece. The glass is 6 inches square by $\frac{3}{4}$ inch thick. The section of rib *A—B* is 2 inches by $\frac{1}{2}$ inch thick, the section *C—D* is 3 inches by $\frac{1}{2}$ inch thick, and frames are usually made from 2 feet square to 4 × 6 feet. The frames may be made longer than 6 feet, but should never be over 4 feet 6 inches wide: the deepest rib in all cases to extend the 4 feet 6 inch way.

The border shown at *C* is made $2\frac{1}{2}$ to 3 inches wide, with reeds continuous on four sides. If the border is not required, the frame need only extend to floor to receive the glass.

The rebate *E* which receives the glass requires to be $\frac{1}{8}$ inch deeper than the thickness of glass to receive the putty, and $\frac{1}{2}$ to $\frac{3}{4}$ inch wide. The section of rib *A—B* is made deeper on the ends as shown at *B*. The outside frame is stiffened by the ribs *E* and secured to the beams by the bolt *D*.

162. Cast-iron Floor Lights for Wooden Beams—are made similar to the cast-iron floor lights for iron beams, but the frame is arranged somewhat differently (see illustration on page 104), and the ribs section *C—D* are 3 inches deep.

The particulars concerning rebates, glass and putty described in the preceding article apply also to this floor light.

163. Wrought-iron Floor Light for Wooden Beams.—This floor light (see page 105) has the same cast-iron frame as the cast-iron floor light, but the frame is slotted as shown at section *E—F*, to receive the principal bearing bars, which are of wrought iron.

Riveted to each side of these bearing bars, for a rebate, are $1'' \times \frac{1}{2}''$ strips, as section *C—D*, with $\frac{5}{16}$ -inch-diameter rivets

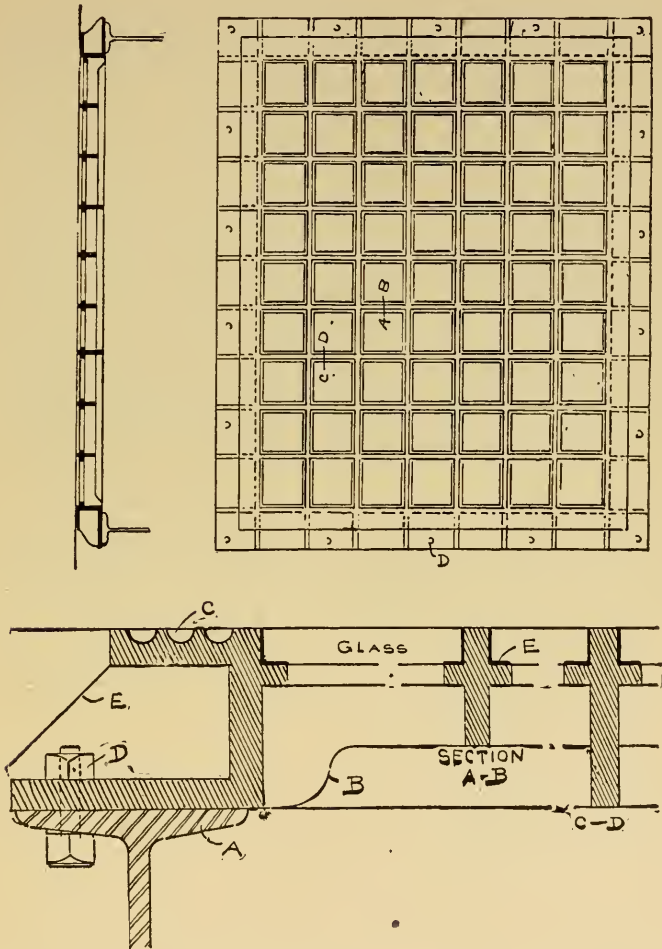

placed 6 inches apart between centres, and sunk the thickness of glass and putty below the top. The one-inch-square cross-

bars, section *A—B*, also receive the glass, and extend in one piece through the bearing bars, the number varying to suit the length of glass and width of span. The glass is rough plate,

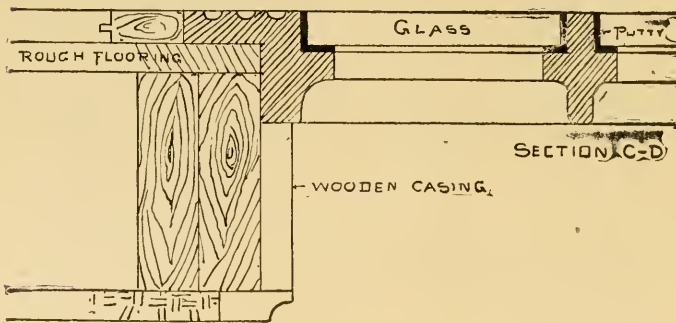
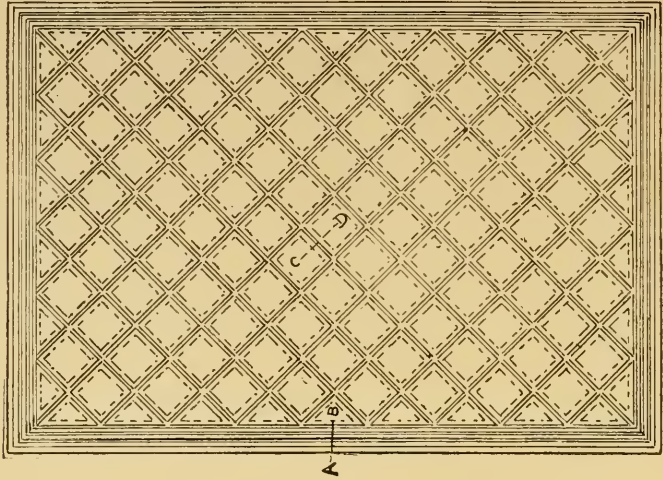

SECTION A-B

three quarters of an inch to one inch thick, from 12 to 16 inches wide, with $\frac{1}{8}$ inch clearance on each side for putty; the length should not be over 30 inches. But as the glass is liable to break unless it be perfectly flat, it is preferable to have

it square: the smaller the square the more easily is it replaced when broken.

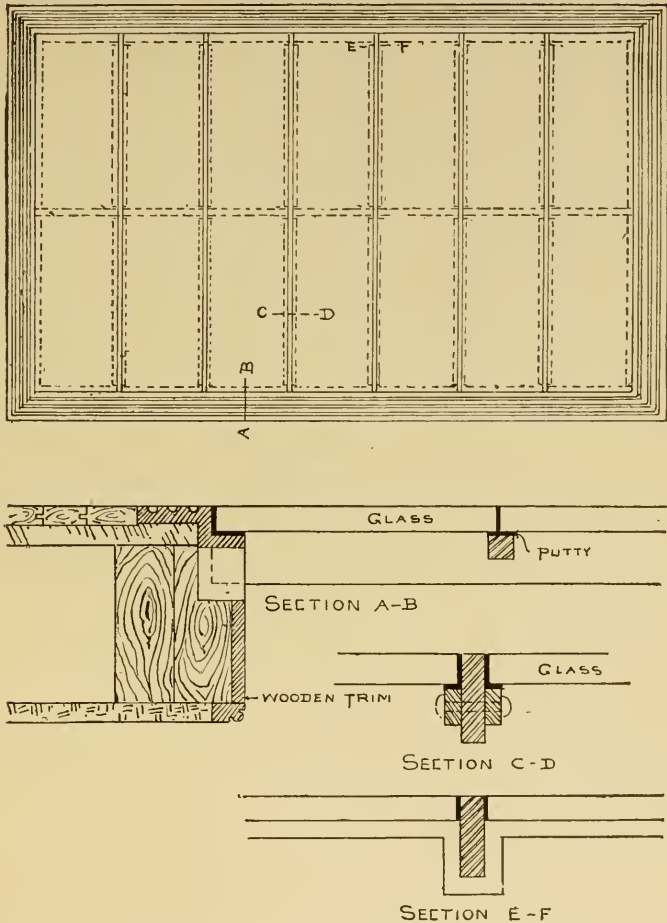

In calculating the strength of bearing bars, deduct the area of hole punched out for the one-inch-square bars. Then for safe load uniformly distributed use the following formula :

$$\text{Safe load in tons} = \frac{2.6AD}{3L},$$

where A = area of section ;

D = depth of bar ;

L = span in feet.

EXAMPLE. To find the uniformly distributed load of a 6" \times 1" flat bar used for a floor light with a span of 6 feet.

Deduct one square inch of area for loss of section by the one-inch cross-bar. The bar loses in area by the holes punched for the rebate bars, but gains again by the addition of the bars. Then by formula,

$$\text{Safe load} = \frac{2.6 \times 5 \times 6}{3 \times 6} = 4.3 \text{ tons.}$$

To find the deflection for the above bar under the same load uniformly distributed :

$$\text{Deflection} = \frac{WL^3}{48AD^2} = \frac{4.3 \times 216}{48 \times 5 \times 36} = 0.107 \text{ of an inch.}$$

To prevent the glass from being broken, the deflection should not be over .33 of an inch in centre of span.

164. Skylights.—In nearly every building a skylight in one shape or another is required, and almost invariably it is inserted for ventilation as well as light.

Single-pitch skylights should not have less pitch than two inches to the foot. In double-pitch hipped skylights the angle should be 33 degrees or 8 inches to the foot ; for instance, a skylight with a span of 12 feet should have the ridge 4 feet high. The curb should be from 4 to 6 inches above the roof : if ventilators are placed in the curb, it should be from 12 to 16 inches high. For ornamentation various kinds of glass may be used—opalescent, crown disks, pressed, fancy, fluted, etc. The best glass for skylight purposes is rough plate or fluted, and the following thicknesses are proportionate to the

sizes: 15'' × 40'' × $\frac{3}{16}$ '' thick; 16'' × 60'' × $\frac{1}{4}$ '' thick; 20'' × 100'' × $\frac{3}{8}$ '' thick. Rough plate is to be preferred to fluted; it will admit more light, while it is equally translucent. The flutes often become filled with dust and dirt, which will accumulate and be held in the recesses of the fluting.

WEIGHT OF ROUGH GLASS PER SQUARE FOOT.

Thickness.	Weight.	Thickness.	Weight.
$\frac{1}{8}$ inch.	2 lbs.	$\frac{1}{2}$ inch.	7 lbs.
$\frac{3}{16}$ "	2 $\frac{1}{2}$ "	$\frac{5}{8}$ "	8 $\frac{1}{2}$ "
$\frac{1}{4}$ "	3 $\frac{1}{2}$ "	$\frac{3}{4}$ "	10 "
$\frac{3}{8}$ "	5 "	1 "	12 $\frac{1}{2}$ "

For covering bars, ridges and curbs, galvanized iron is often used, and sometimes brass and copper. See section of flat sky-

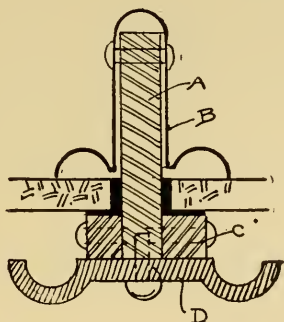

light bar. *B* is the covering; *A* is the main supporting bar, of wrought iron, $\frac{1}{2}$ inch thick by the height to suit the span; *C* are small bars riveted to side, serving as a rebate for the glass. If the main bars are long and several layers of glass are required, the *C* bars should be made as steps following the different layers of glass. *D* is a cast-iron condensation bar, $\frac{1}{4}$ of an inch thick, riveted to main bar.

It is a mistaken idea that galvanized iron does not require painting. It should always receive at least two coats of paint—applied one or two months after it has been exposed, as the

paint adheres much better after the gloss is off, in the same manner as with tin roofs. The best kind of paint to use is the oxide of zinc or of lead.

Condensation caused by the heat within and the chilling influence of the cold atmosphere without, and also any leakage which might occur between the bars and glass, is taken up by a small condensation gutter.

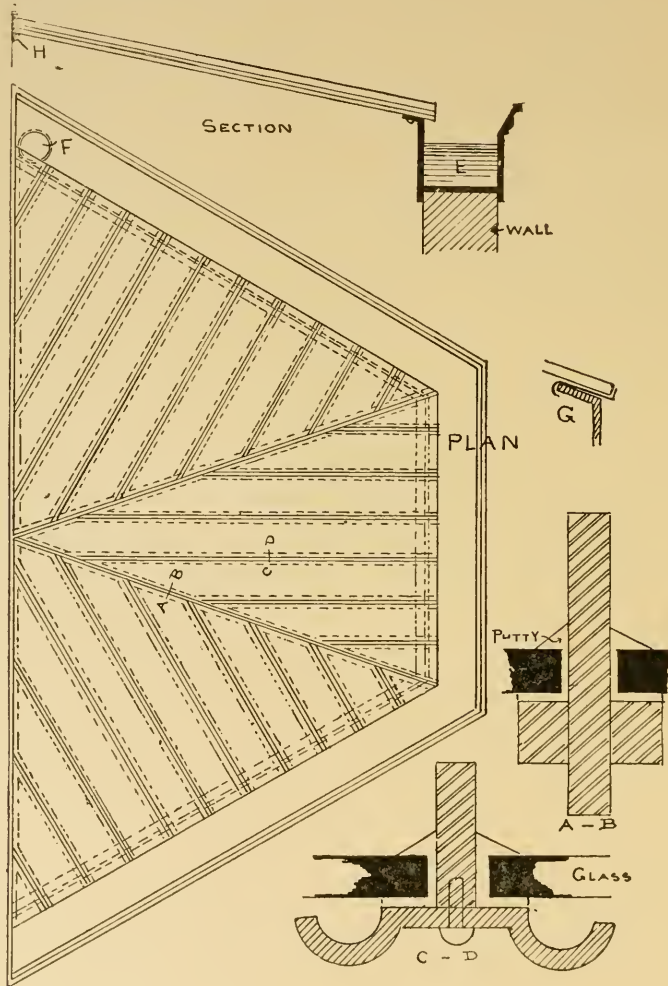

165. Hip Skylight—is made of wrought-iron bars for rafters (section *C—D* in plate opposite), with cast-iron condensation gutter riveted to bottom for support of glass. In this case the glass is $\frac{1}{2}$ inch thick by 12 inches wide by 60 inches long. In considering the width and length of glass, it is best to use what is generally called stock glass; otherwise it may be difficult to get when needed. The shorter the lengths, the more easily they are handled and the less liable to break. If the span is long, several lengths may be necessary; these can be overlapped at each joint. The rebates should then be raised on the condensation gutter by strips of iron of different thicknesses under each plate of glass, to keep them in one pitch as steps. This will be found best for the glass, as the putty may shrink and become dislodged by the action of the atmosphere, leaving a wedge-shaped opening under each sheet.

Section *A—B* is the ridge bar having $1'' \times \frac{1}{2}''$ strips riveted to sides. The filling-in bars are tenoned and mortised into this ridge, while some are mortised into the bar *H*, which is secured to wall with expansion bolts or lag screws.

The section of wall shows a cast-iron gutter $\frac{1}{2}$ inch thick, with a false bottom *E*. This bottom is cast with the gutter near the top of moulding on one end, pitching down to the opening *F* in bottom of gutter where the leader connects.

This gutter is cast in several lengths, and is accurately fitted and water-tight. On the inside where the bars rest the glass is secured by galvanized or copper strips to prevent the plates from sliding out (see section *G*).

The weight to be calculated, in addition to iron and glass, is that of snow at 40 pounds per square foot; and use the formula as adopted for wrought-iron floor lights.

CHAPTER XIV.

HOLLOW BURNT CLAY.

166. Hollow Blocks for Arches.—These blocks are made of hard-burned fire-clay, hollow, of equal vertical thicknesses. The number of blocks varies according to size and distance between the iron beams. The two outer blocks are called *skew-backs*, and are made with a shoulder formed to fit the flange (Fig. 6, opposite), and extend three quarters to one inch below, completely covering the beam. The centre block is the key, and the intermediate blocks are so placed, when laid with cement, as to form a self-supporting arch. All are dovetailed, as shown in Fig. 5, when burnt, to receive the plastering.

Width of Span.	Depth of Arch.	Weight per square foot.	Safe Load in pounds per square foot.
3 ft. 6 in. to 4 ft.	6"	29 lbs.	1,000
4 ft. to 4 ft. 6 in.	7"	33 "	1,200
4 ft. 6 in. to 5 ft.	8"	37 "	1,400
5 ft. 6 in. to 6 ft.	9"	40 "	1,500
6 ft. 0 in. to 6 ft. 6 in.	10"	43 "	1,500
6 ft. 6 in. to 7 ft.	12"	48 "	1,800

167. Porous Terra Cotta—is a mixture of clay and saw-dust; or any other combustible matter may be substituted, such as shavings, tanbark, and charcoal. After the compound is properly mixed the blocks are moulded and, when sufficiently dry, placed in a kiln prepared for the purpose, and subjected to an intense heat adequate to consume all the combustible matter, leaving the blocks porous. For hanging

ceilings, etc., these blocks are made in different sizes: 25 inches between centres is a good spacing of T irons, the blocks being 24 inches wide and allowance being made for cement.

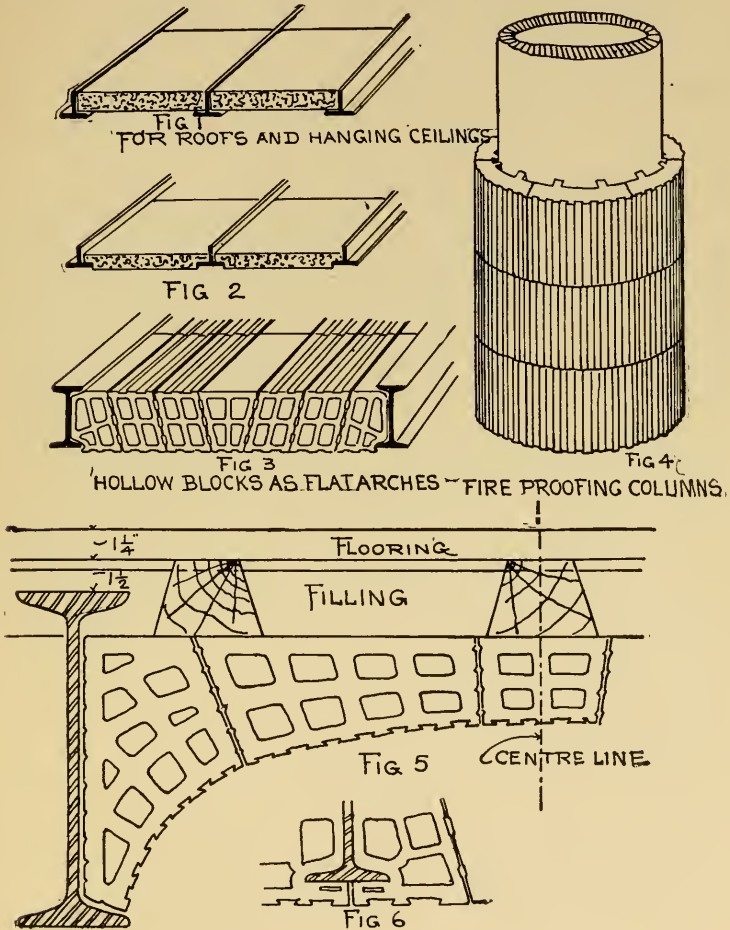

Blocks 2 inches thick weigh 11 pounds per square foot; 3 inches thick, 15 pounds. Fig. 3 shows blocks as flat arches. Fig. 5 is a segment arch with a space allowed for filling of con-

crete or other incombustible material, and timbers to which flooring is to be nailed.

Fig. 4 is a column protected by a casing of ribbed blocks, with an air space between. The blocks are dovetailed on the outside for holding the plastering, and set with cement and firmly secured with copper wire bound on the outside.

Partitions of hollow clay	3''	thick,	14 lbs.	per sq. ft.			
" " "	4''	"	18½	"	"	"	"
" " "	5''	"	23	"	"	"	"
" " "	6''	"	25	"	"	"	"
" " "	7''	"	31	"	"	"	"
" " "	8''	"	34	"	"	"	"
Partitions of porous terra cotta	3''	"	12	"	"	"	"
" " " "	4''	"	17	"	"	"	"
" " " "	5''	"	23	"	"	"	"
" " " "	6''	"	27	"	"	"	"
" " " "	7''	"	31	"	"	"	"
" " " "	8''	"	36	"	"	"	"

FURRING, ROOFING AND CEILING.

Hollow clay furring	2''	thick,	12 lbs.	per sq. ft.			
Porous terra-cotta furring	2''	"	8	"	"	"	"
" " " roofing	2''	"	12	"	"	"	"
" " " "	3''	"	16	"	"	"	"
" " " ceiling	2''	"	11	"	"	"	"
" " " "	3''	"	15	"	"	"	"

CHAPTER XV.

ANCHORS.

168. Ashler Anchors.—Where brick or stone walls are faced with stone ashler from 4 to 12 inches thick, and it is necessary to tie the outer surfaces to the body of the wall, *ashler anchors* are used. One end is let into the stone, the other end resting on and built in with the wall. Where an exceptionally large wall is lined with ashler, the anchors should be made heavier in proportion. This anchor forms a good tie for an air-space lining wall; that is, where a stone wall is built under sidewalk with an air space, then a brick wall from 4 to 8 inches thick; the anchors being built into the stone wall, projecting through the air space and tying the brick wall, and placed from 4 to 5 feet between centres in all directions.

The sizes commonly used are $\frac{3}{16}'' \times \frac{3}{4}'' \times 12''$ long; $\frac{1}{4}'' \times \frac{3}{4}'' \times 12''$ long; $\frac{1}{4}'' \times 1'' \times 14''$ long; $\frac{3}{8}'' \times 1\frac{1}{4}'' \times 12''$ long; $\frac{1}{2}'' \times 1\frac{1}{2}'' \times 16''$ long.

Ashler anchor *A* in plate (page 115) is similar, with the exception that the end let into stone is round, the hole in stone being drilled round instead of cut square.

169. Side Anchors.—The side anchor *B* is for iron beams, to be bolted to the webs with two $\frac{3}{4}$ -inch-diameter bolts, and placed on all beams resting on walls. These following lengths are for beams with 8 inches bearing on a 16-inch wall and over: $\frac{3}{8}'' \times 1\frac{1}{2}'' \times 16''$ long; $\frac{3}{8}'' \times 1\frac{3}{4}'' \times 16''$ long; $\frac{3}{8}'' \times 2'' \times 16''$ long. For a 12-inch wall the anchor should be two angle knees bolted or riveted to web.

Side anchor *A* is used for wooden beams, and nailed to the side of about every fifth beam with two or three $\frac{5}{16}$ " nails. If the walls are less than 16 inches and more than 12 feet high, the anchors should be nailed to every fourth beam. The following lengths will do for any thickness of wall, as they can be nailed at any point near the end of beam: $\frac{1}{4}$ " \times $1\frac{1}{4}$ " \times 12" long; $\frac{3}{8}$ " \times $1\frac{1}{2}$ " \times 16" long; $\frac{3}{8}$ " \times $1\frac{1}{4}$ " \times 16" long.

170. Wall Anchors.—These anchors are used for tying the front, side and interior walls together when the side walls are carried up ahead of the front walls. They are placed about 4 feet apart in height, single for a 20-inch wall and less, and double for 24-inch wall and over. The hook end, being turned down or up 2 inches, is built in side walls, and the spear end projecting sufficiently to take the centre of front wall. Sizes are from two to three feet in length, of $1\frac{1}{2}$ " \times $\frac{3}{8}$ ", $1\frac{1}{2}$ " \times $\frac{1}{2}$ ", and $1\frac{3}{4}$ " \times $\frac{1}{2}$ " flat iron, with $\frac{3}{4}$ " diameter rod 12 inches long for a spear.

171. Hook Anchors.—This anchor is made similar to the wall anchor, but used to tie a front or rear wall to the cross-beams which run parallel with front and rear walls, and sometimes made to extend over three or four beams, but generally only two.

The hook end rests on and is turned down over beam and nailed. The iron beam girders supporting the upper stories over a front, at second-story level, are connected to interior beams by these anchors; the end in wall and over girder is hooked over flange of outer beam, or middle one if girder is of three beams. Sizes commonly used: $1\frac{1}{4}$ " \times $\frac{3}{8}$ ", $1\frac{1}{2}$ " \times $\frac{3}{8}$ ", and $1\frac{1}{2}$ " \times $\frac{1}{2}$ ", the length varying to suit the centres of beams.

172. Drive Anchors.—When an old wall is to be lined with a small one from 8 to 16 inches thick, these anchors are used, being driven into the old work with the hook end projecting from 4 to 8 inches. The new wall is then tied with the

old, and the hook is turned up. The anchors are made $1'' \times \frac{3}{8}'' \times 8''$ long and $1\frac{1}{2}'' \times \frac{3}{8}'' \times 12''$ long.

173. **Wedge Anchors.**—Before the wooden shores and needles used in supporting a wall that has been undermined

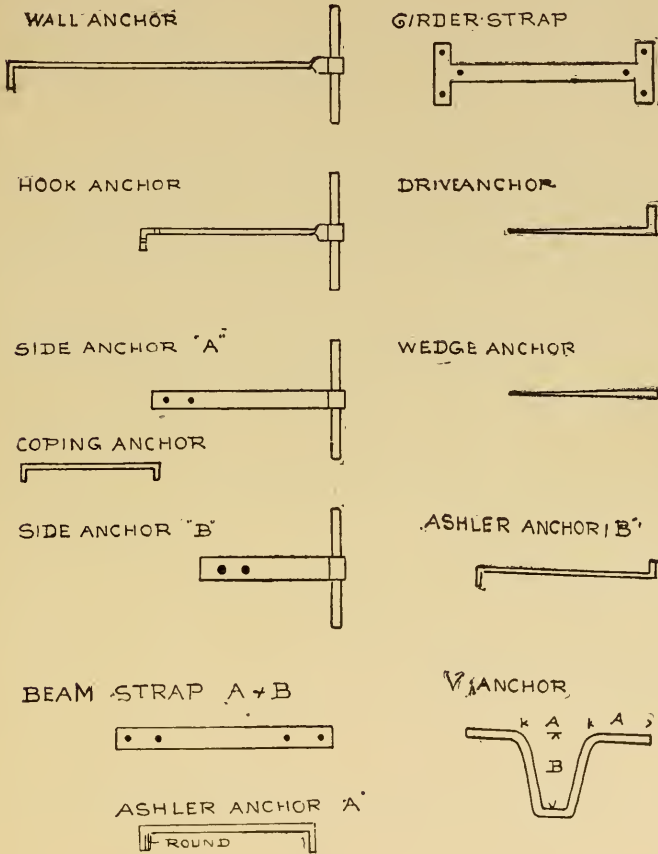

for the purpose of extending the foundation of an adjoining building deeper are removed, the new foundation and wall are rebuilt as near as possible to the old work, leaving an open joint. These anchors are then driven into this joint with a

sledge-hammer, making both the new and the old wall perfectly tight and secure. The shoring can then be removed without any settlement of the old wall. The anchors are made of flat iron $1\frac{1}{2}'' \times \frac{3}{8}''$, $2'' \times \frac{1}{2}''$, and flattened as shown in plate. The length varies with the thickness of wall.

174. Coping Anchors—are used for stone coping. Where the coping is 4 to 6 inches thick, each end to be leaded into stone $2\frac{1}{2}''$ to $3''$ from joint. If exposed to the action of the atmosphere, as is generally the case, they should be galvanized. Size, $1\frac{1}{4}'' \times 1'' \times 6\frac{1}{2}''$ long.

175. Government or V-shaped Anchors.—These anchors are extensively used in government work, and are made of a $\frac{3}{4}''$ diameter bar, bent to the form as shown, 8 inches at each letter. They do away with any bolts, and can be slipped through $\frac{1}{16}''$ holes in end of iron beams.

176. Girder Straps—are employed for connecting wooden girders to each other on either side of column. (See illustration of *fitch-plate girder*.) Size, $1\frac{1}{4}'' \times \frac{1}{4}''$ (or $1\frac{1}{2}'' \times \frac{3}{8}''$) $\times 20''$ long.

177. Beam Straps.—*A* is used for connecting iron beams together end to end, and is bolted with two $\frac{3}{4}''$ diameter bolts on each beam joined. Size, $1\frac{1}{2}'' \times \frac{3}{8}''$ by $12''$ long.

B is for wooden beams, and is used in the same manner as strap *A*, with the exception that $\frac{5}{16}''$ diameter anchor nails are used instead of bolts, and it is made $1\frac{1}{4}'' \times \frac{1}{4}'' \times 20''$ long and $1\frac{1}{2}'' \times \frac{3}{8}'' \times 20''$ long.

CHAPTER XVI.

BOLTS.

178. Square-head Bolts—are used for all common connections, such as column flanges, beam connections, separator bolts, tie-rod bolts, etc. For lengths, sizes, and weights see table of Bolts.

179. Hexagon-head Bolts—are needed where the conditions will not allow of the turning of the square nut, especially when the flanges of column connections are small and holes in knees of beam connections are close; they are also used for surfaces where the square-head bolts are an objection to the finish of the work.

180. Button-head or Carriage Bolts—are principally adapted to bolting wooden treads to wrought-iron strings; the circular or flat head making a smooth surface on top of tread, and the square portion of bolt giving a shoulder for tightening the nut.

181. Countersunk-head Bolts—are used for all work requiring a smooth surface.

182. Screw-head Bolts—are employed for a similar purpose, the slot in head being afterwards filled with putty and painted.

183. Tap Bolts—are required for all connections where it is impossible to get a nut on the end. The hole to receive this bolt requires to be tapped, that is, a thread cut in the drilled hole where the bolt is to be screwed.

184. Counter-sunk Tap Bolts.—These are for heavy work, to make a finished surface, and where screw-head bolts are too

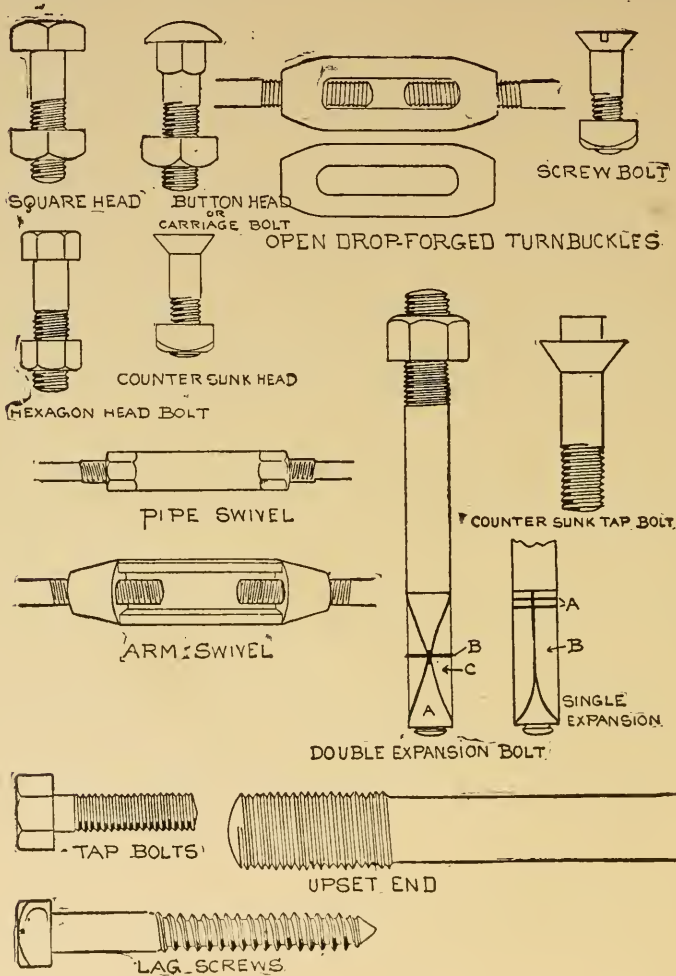

light. The square end can be taken hold of by the wrench and tightened up, and the end projecting then cut off.

185. Double and Single Expansion Bolts—are for fastening all manner of work to smooth surfaces. All that is required to secure them is a hole of sufficient size and depth,

from one to four inches, to insert the bolt expansion; then by turning the head, as with a common bolt, the expansions are drawn toward each other, thus causing them to bind in the strongest manner. These bolts have an advantage over other fastenings in that they can be removed with ease without injuring the surface of the work to which the bolt is fastened.

The double expansion is used where great strength is required, and is made in all sizes and lengths.

186. Lag Screws—are used in the same manner as expansion bolts, but a plug of metal or wood is required to be driven in the hole before inserting the screw.

187. Upset Ends.—To get the full value of the diameter of a tie rod or bolt, the ends on which the nut is screwed are heated and forged thicker; the thread is then cut on the increased diameter.

188. Open-drop Forged Turn-buckles, Pipe Swivel and Arm Swivel—are used for tie bars in trusses, etc., with a right and left thread cut in each open end to draw together or extend the length of tie.

CHAPTER XVII.

MISCELLANEOUS DETAILS.

189. Mail Chutes.—Office buildings, apartment houses and hotels are now so generally provided with the U. S. Mail

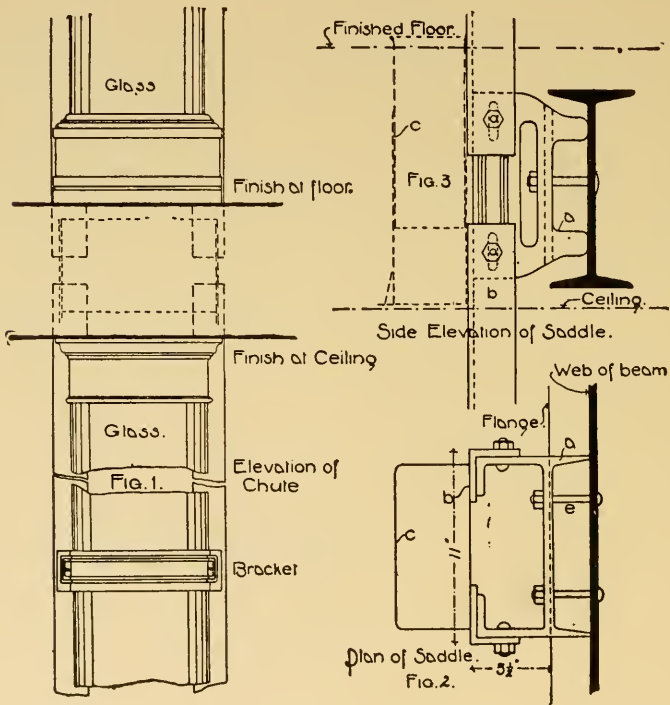

chutes, that some reference seems to be required to the limitations under which these modern conveniences may be obtained. A vertical fall is absolutely necessary, and the restrictions of the Post-Office Department require that the chute shall be

accessible throughout its entire length, and under no circumstances run behind a partition or wall, or through any room or part of the building which is not accessible to the general public. Where the construction of the building is to be entirely fire-proof, angle irons are usually erected to support the chute, which being made in removable sections, to comply with the Post-Office regulation, requires this or equivalent support.

In the accompanying plate, Fig. 1 shows a front elevation of the chute, with a base at floor level, and a cap at ceiling for a finish with the surrounding work, and a bracket for support of chute between floors. Fig. 2 is a plan of the saddle, which is of cast iron and secured to the beams with two bolts at *e*. The chipping pieces on saddle at *a* may be trimmed off to suit any flange width. To this saddle are secured the continuous wrought-iron or steel angles *b*, as shown in Fig. 3 and previously mentioned, and which must be perfectly true and straight. To these angles the chute is secured, *c* being the line of chute in Fig. 2.

190. Folding Gates.—These gates are constructed of channel iron or steel upon the principle of the well-known “lazy-tongs” pattern, and may be made as light as $\frac{1}{2}$ -inch channel, or as heavy and strong as desired. Their chief advantage being that they fold close, and may be turned out of the way, occupying but little space in their working.

Elevation, Fig. 1, in the plate on page 122, is the gate across the opening or entrance; also the gate closed.

The two channels *A* are placed as shown, and joined at top with an ornamental cast-iron tip *E*. When the gate is opened, the channels slide on the bar *C* which is at top and bottom of gate, and the pins at *G* move down and up in the channels (see pin *B*); with a stationary pin joining the channels together. When the gate is folded the channels are close together on the cross-bar *C*, which bar then drops against the folded gate. The gate is then swung round out of the way on the eye *D* which is secured to the wall.

Fig. 2 is a simple gate of the "lazy-tongs" pattern. The cross-bars are of flat iron, and work on the pins at *F* and close into the channel, and are then swung around against jamb.

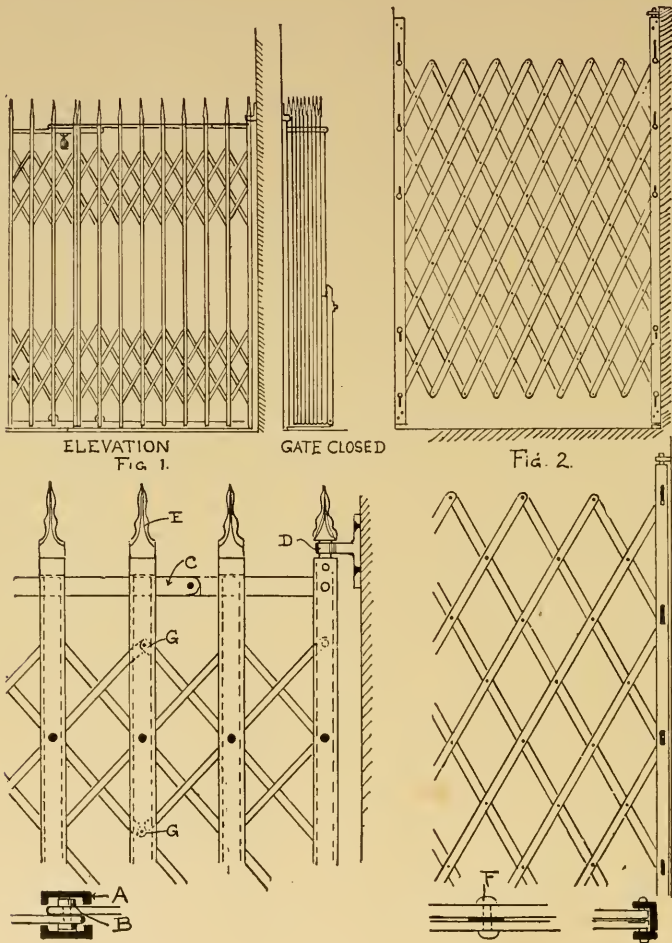

The slots in channel are required for the rising and falling of the pins as the gate opens and closes. The diagonal bars in large gates of this pattern may be of channel or small angle bars placed back to back.

191. Box Slides—are used for sliding boxed goods from sidewalk to lower floors in warehouses and stores. The principal supporting bars, composing the outside frame, are made of

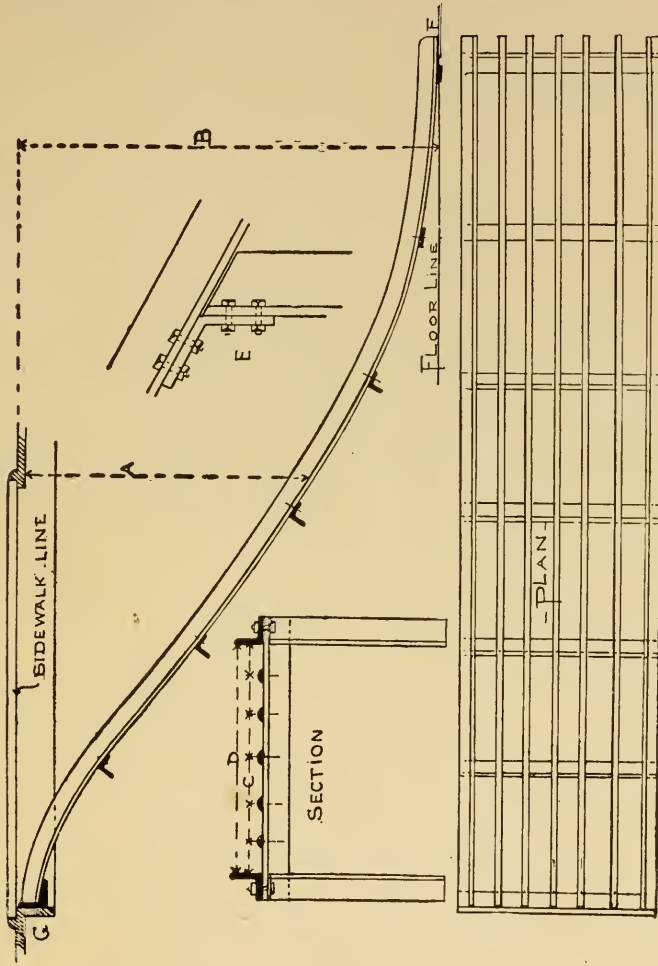

$3 \times 3 \times \frac{3}{8}$ -inch angle irons. The distance D between these angles, as shown in the section in plate, being the effective width of the slide, can be made any width to accommodate opening on sidewalk and size of boxes requiring handling. At

right angles to this frame, and riveted or bolted underneath it, are cross-pieces of the same size angle irons, for the support of the half-oval strips which extend parallel with the outside frame. These strips are secured to the cross-pieces by counter-sunk rivets which are smoothed off for the free sliding of boxes. They should be placed from 4 to 6 inches apart between centres, depending somewhat on the size of boxes. The smaller the boxes the closer the bars should be set. At foot of slide (see side view at *F*) a plate of black sheet iron (No. 12 gauge), about 4 feet long by the width of the slide, should be secured, to prevent the wearing of the floor by the constant sliding of boxes. Sometimes the slide extends to a cellar under basement; in that case uprights of $3 \times 3 \times \frac{3}{8}$ -inch angle iron should be placed for the support of frame near the middle of length, as shown in section under frame.

Care should be taken in laying off the pitch of slide that the distance *A* is sufficient to clear any size of box. *G* is a section of vault-light frame on which frame of slide is secured. *B* represents the height of basement.

The half-round bars have a radius of three quarters of an inch.

192. Hanging Ceilings—are used in all fire-proof buildings under roofs of iron. To make the ceilings level in upper story, they are suspended from the roof beams by hangers of wrought iron. As the weight to be borne is simply that of iron plastering and lathing, the hangers are made as small as will practically stand a hole being punched through. Generally $\frac{1}{2}$ -inch-diameter bolts are used, with hangers of $1\frac{1}{4} \times \frac{1}{4}$ -inch flat iron, bent as shown in sketch, to take the flange of roof beams. In the detail, the main bars of ceiling run parallel with the roof beams; the hangers supporting them are then placed about 5 feet apart, while the small T iron *D* rests on and is secured to the main bars. Section *A* gives the hanger double, with a T iron for a main supporting bar; section *B* is a single hanger for a double angle bar. If porous terra-cotta blocks

are used, the small T irons *B* are generally placed 25 inches apart between centres. If wire cloth or wire lathing is used, they may be much lighter and be four feet apart. The T-iron and double angle-iron principal supporting bars are usually made of $3 \times 2 \times \frac{5}{16}$ inch angles, and are placed about 4 feet 6 inches apart between centres. The bolts in hangers are $\frac{1}{2}$ inch in diameter.

If the ceiling area is of considerable dimensions, the principal bars may be punched out the shape as shown at *E*, the

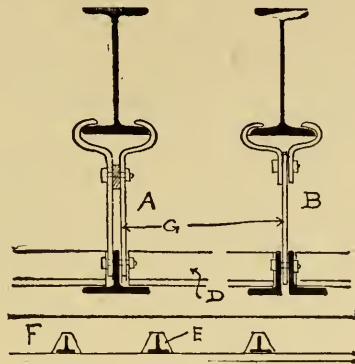

smaller T irons passing through them and secured on every third bar with $\frac{5}{16}$ -inch-diameter bolts.

A simpler and more economical manner of arranging the principal supporting bars, if wire lathing is required, is to secure the hanger to a single angle iron and bolt to this, and flat under it, another angle extending at right angles, then secure the wire lathing by wire clips over the lower angle.

193. Flitch-plate Girders.—In the floor framing of heavy buildings not fire-proof and where wooden girders occur resting on columns as shown in plate, the columns are sometimes placed farther apart than would be safe if wooden girders alone were used. In such cases the *flitch-plate* girder is sometimes adopted (see plan and section). It is composed of two wooden beams connected by an iron plate with $\frac{3}{4}$ -inch bolts placed about two feet apart.

It has been found in practice that the thickness of the plate should be about one twelfth of the whole thickness of the beams. The elasticity of iron being so much greater than that of wood, the beams should be proportioned so that they will bend at the same time as the iron, otherwise the whole strain

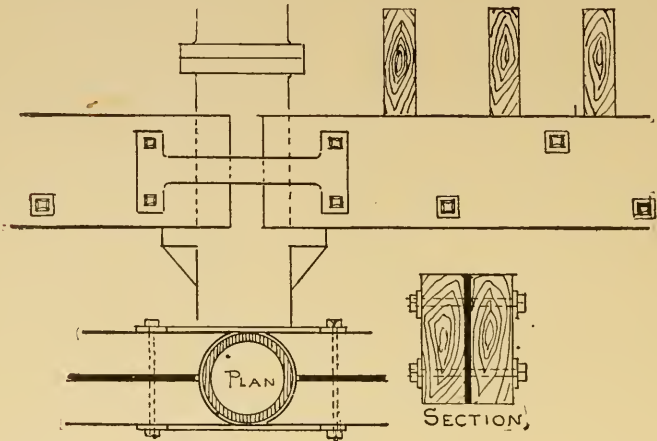

might be thrown on the plate. The modulus of elasticity of wrought iron is about thirteen times that of hard pine; or a beam of hard pine one inch wide would bend thirteen times as much as a plate of iron of the same size under the same load.

- Let D = depth of beam ;
 B = thickness of wood ;
 L = clear span in feet ;
 t = thickness of iron plate ;
 f = 100 pounds for pine ;
 W = total load on girder.

Then for a distributed load, girder supported both ends,

$$D = \sqrt{\frac{WL}{2fB + 1500t}}$$

For a load in centre take one half, or

$$D = \sqrt{\frac{WL}{fB + 1500t}}$$

For example, what should be the depth of a girder composed of two 6'' timbers supporting 26.16 tons or 52,320 pounds, span 20 feet, load equally distributed, the thickness of the iron plate being $1\frac{1}{8}$ inches, or one twelfth the thickness of the entire girder?

$$D = \sqrt{\frac{52,320 \times 20}{2 \times 100 \times 12 + 1500 \times 1\frac{1}{8}}} = \sqrt{256}, \text{ or } 16 \text{ inches.}$$

For a safe load in pounds equally distributed

$$= \frac{2D^2}{L} (fB + 750t), \text{ or}$$

$$\text{Safe load} = \frac{2 \times 16 \times 16}{20} (100 \times 12 + 750 \times 1\frac{1}{8}) = 52,320 \text{ lbs.}$$

$$\text{For a safe load in pounds loaded at centre} = \frac{D^2}{L} (fB + 750t).$$

194. Sidewalk Elevator.—These hand elevators are used to hoist from 500 to 3000 pounds, and extend from lower floors under store floor to sidewalk. The platform is of wood, with an iron- or wooden-frame hoisting apparatus, securely and firmly braced. The plan is shown with square iron guides at *N* and platform *M*. Extending from the pillow block *P* and under the platform is a $2\frac{1}{2}$ -inch-diameter shaft connected with the iron-frame hoisting apparatus. This is composed of two 30-inch-diameter wheels *H* and *C* arranged on the cast-iron frame *D*, and worked by the crank *I* and 6-inch-diameter pinion wheel *E*, as shown in plan and elevation.

A heavy chain is used for raising the platform. It is connected to the four corners, and extends over the three wheels in each cross-head *O* and down each side of the platform to the drum wheels *A*.

To lower a weight from the sidewalk, the pinion wheel *E*

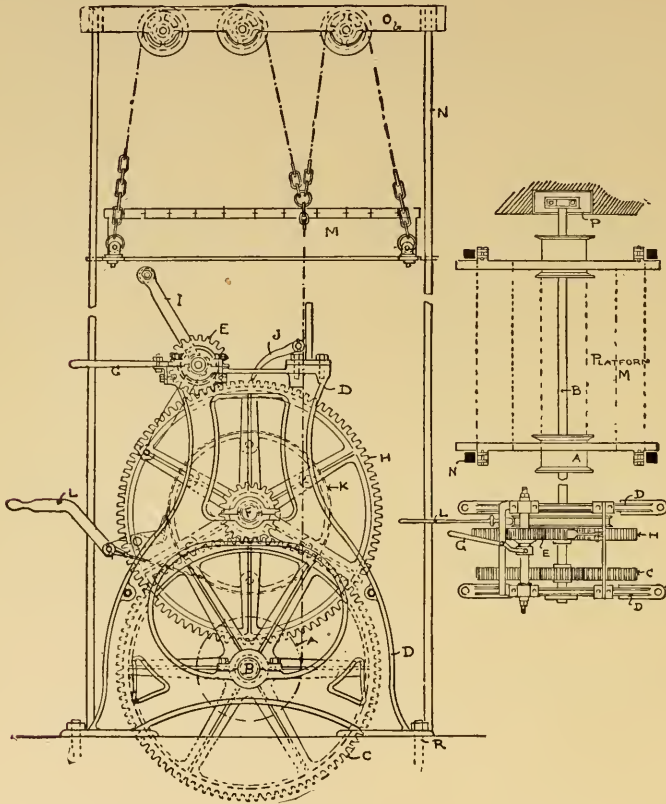

is thrown off the small shaft by the arm *G*; then a brake on wheel *K* worked by the lever arm *L* prevents any sudden falling of the platform. The framework is 4 feet high by 3 feet long by 22 inches wide. The crank arms extend 14 inches on each side, beyond the width of frame.

In setting the framework care should be taken that the

platform lowers to the level of the floor; this is accomplished by building a ditch a trifle larger than the car, and placing the shaft *B* below floor level.

195. Wrought-iron Gratings—are generally used for base-

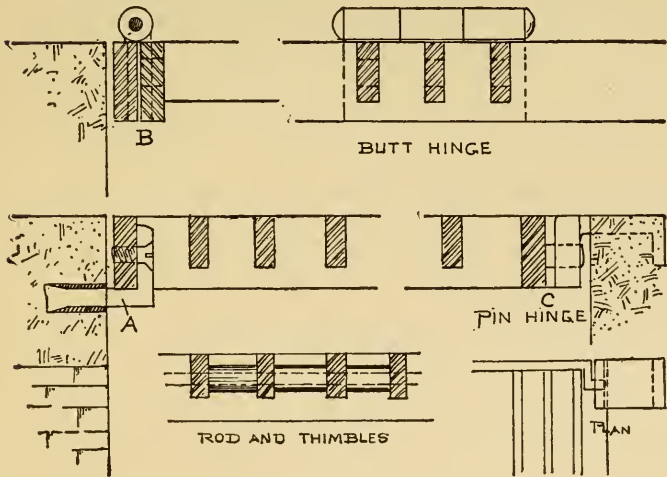
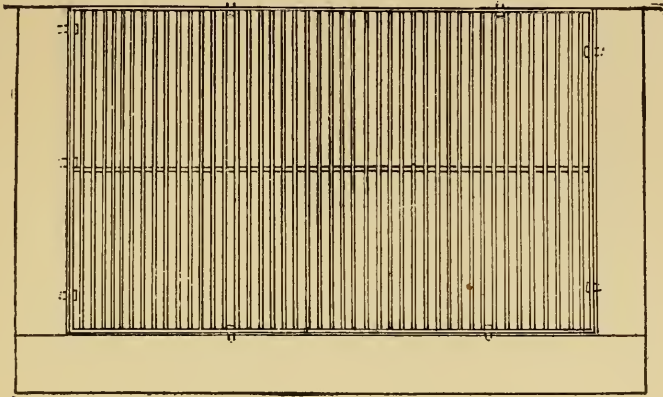

ment areas, and are made of $2\frac{1}{2} \times \frac{1}{2}$ -inch frames, with $\frac{1}{2} \times \frac{3}{8}$ -inch filling bars placed $1\frac{1}{2}$ inches apart between centres, and

secured to the frame by a tenon cut on each end, mortised into the frame and riveted cold.

Thimbles are placed on a $\frac{3}{8}$ -inch-diameter rod which passes through and stiffens the bars. The outside frame is set flush with top of coping, and dowelled with $1\frac{1}{2} \times \frac{1}{2}$ -inch flat dowels as at *A*.

The gratings are also made to open in sections as a door, working on butt or pin hinges as shown at *B* and *C*.

Spans.	Filing Bars.	Frames.
3 ft. and less	$1\frac{1}{4}'' \times \frac{3}{8}''$	$1\frac{3}{4}'' \times \frac{1}{2}''$; one row of thimbles.
3 ft. to 5 ft.	$1\frac{1}{2}'' \times \frac{3}{8}''$	$2'' \times \frac{1}{2}''$ " " " "
5 ft. to 8 ft.	$1\frac{3}{4}'' \times \frac{3}{8}''$	$2'' \times \frac{1}{2}''$; two rows of thimbles.
8 ft. to 10 ft.	$2'' \times \frac{3}{8}''$	$2\frac{1}{4}'' \times \frac{1}{2}''$ " " " "

196. Cast-iron Perforated Plates—are used in front of doorways in connection with the above gratings cast from $\frac{1}{2}$ to $\frac{3}{4}$ of an inch thick, and of various designs.

197. Knee Gratings—are frequently employed for forming platforms, treads and risers in connection with the cast perforated plates, and made of the same iron as that used for plain gratings.

198. Galvanized Iron Cornices—are made of No. 22 to No. 28 gauge galvanized sheet iron, 22 being the heaviest. Mouldings of all sizes and shapes are soldered together, the ornamental work made of zinc, either cast or pressed in various designs. When a large cornice is placed on a front extending above the roof, the framework is made of wrought iron, usually constructed as shown, the framework to take the heaviest portion of cornice. The section at *C* is the wall of a front; *A* is a 3×3 -inch angle-iron frame secured to roof.

B is the same covering as applied to roof surface of building. If the wall is built before the cornice is ready, a recess should be left in brickwork across front, 3 inches deep by $\frac{3}{4}$ of an inch high. But a more satisfactory method, and one insur-

ing greater rigidity, is to set the lower portion of cornice on wall at the proper height and build in the anchor straps, filling the masonry in and around the anchorage as much as possible.

In regard to painting galvanized cornices, see article on Skylights.

199. Scuttle.—The scuttle opening on roof is formed by a cast-iron curb at *A* (see plate, page 132), $\frac{1}{2}$ inch thick, and secured to beams with $\frac{1}{2}$ -inch bolts, the curb to be at least 8

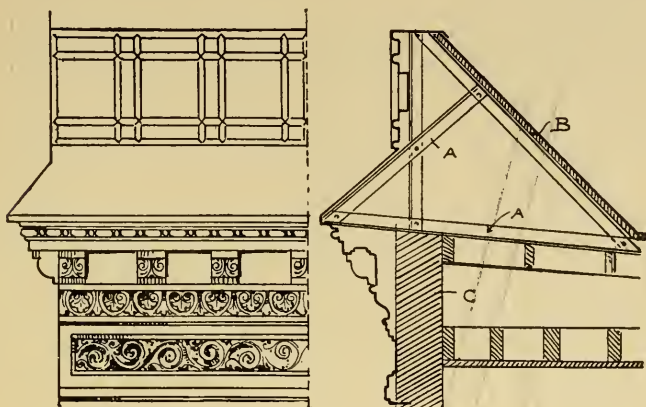

inches above roof and from 2 by 2 feet to 3 by 4 feet in size. It should be covered with a sheet-iron door of No. 16 gauge, with $1\frac{1}{4} \times \frac{3}{8}$ -inch frames, hinged and bolted on inside.

The lattice door at bottom of curb is made of $1 \times \frac{1}{4}$ -inch flats resting on top of each other and riveted. If made of $\frac{1}{16}$ or $\frac{1}{8}$ inch flats they can be interlaced. This door folds outwards into curb, serving as a protection against ingress to building when outer door is open for ventilation, etc. The doors are secured on the inside to ladder by a padlock or chain and padlock.

200. Scuttle Ladder—is placed at the entrance to scuttle, and is made of $3 \times \frac{1}{4}$ -inch flat iron, for the sides, and $\frac{1}{2}$ -inch double rungs, 12 inches in rise. The width of ladder 20 inches from outside to outside of sides. To be secured to floor, and beams above, by $3 \times 2 \times \frac{1}{4}$ -inch knees.

In buildings where wooden beams are used, the scuttle doors and curbs are also made of wood, and covered with No.

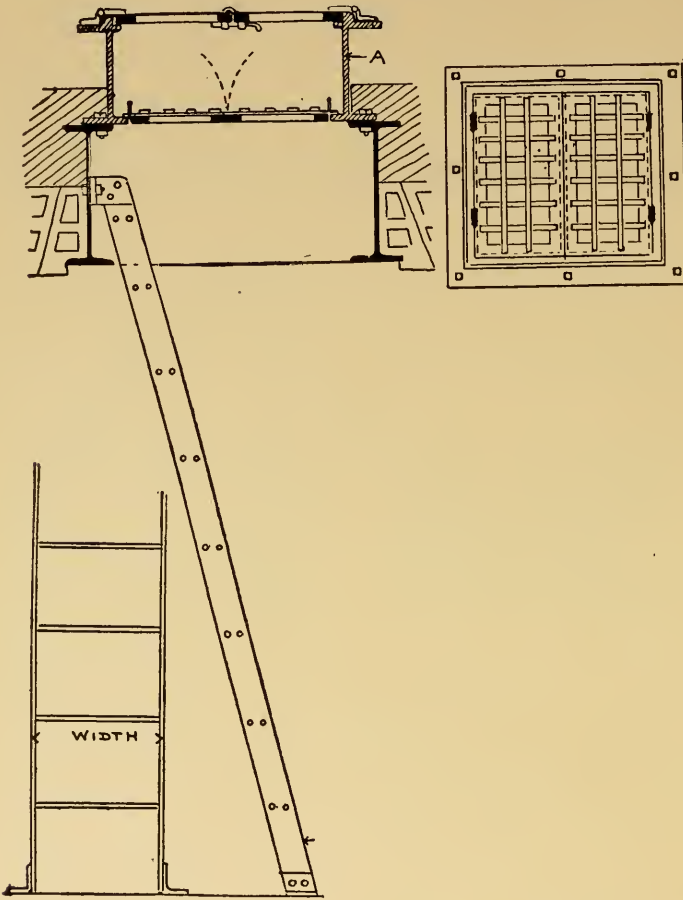

16 sheet iron. The lower door is fastened to curb by an angle-iron frame $1\frac{1}{4} \times 1\frac{1}{4} \times \frac{1}{4}$ inch thick.

201. Iron Fronts.—Cast-iron for fronts has many advantages in its favor—strength, lightness of structure, facility of erection, durability, economy and incombustibility. Previous to their erection in the building for which they are intended, the columns, mullions, sills, soffits and fascias are fitted together complete at the works.

Iron is cheaper and more durable than any other material for fronts; and whatever mouldings, carvings, etc., are appropriate for stone, brick and terra cotta, are also suitable for iron. In business quarters blocks of stores are built up solid with iron fronts.

Light being one of the principal requirements, a front of

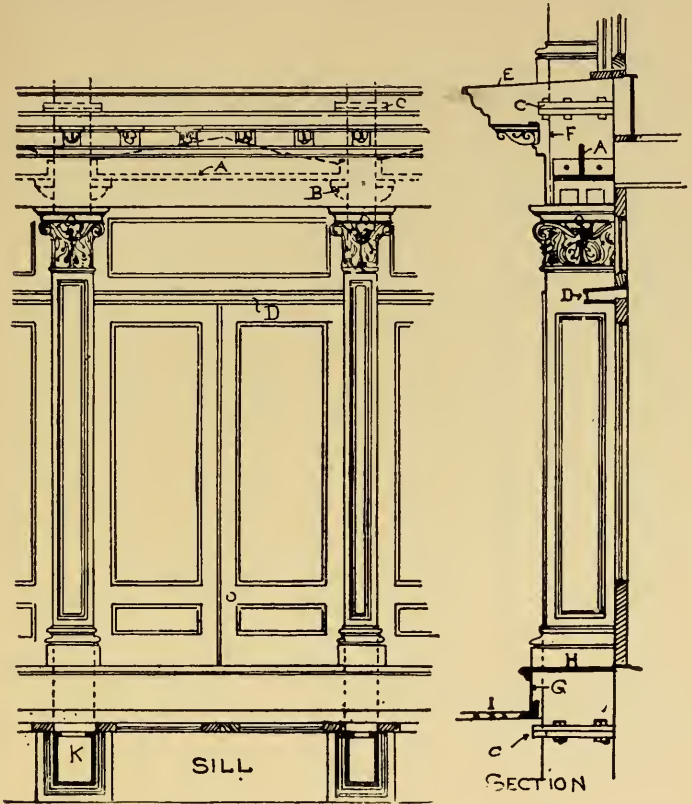

iron may be safely used in place of the bulkier constructions of other material; as, while ample strength is secured, it allows freer admission of light.

In the most costly buildings erected at the present day cast iron is largely used for enclosing the fronts between piers, for mullions and fascias in bay-windows, fascias under windows, and

for ornamentation where richness of design is desired. For the latter it serves a valuable purpose, as ornate effects may be produced whose cost in stone or other material would prove prohibitive.

The space in this volume not admitting of the full details for an entire front, only a portion of an ordinary front is shown.

The principal bearing columns must first be taken into consideration. These generally carry the girders, which extend at right angles to the front by brackets cast on the back.

The bearing columns should be continuous from foundation stone or piers to top of front, and connected at each story level by flanges as shown at *C*. To brace the columns on sides, cast-iron lintels (*A*) or beam girders are used, bolted to column and resting on bracket *B*. The cornice, sill *E*, soffit above door, and fascia cover the above connecting flanges.

The cast-iron lintel is also used to support a brick wall 12 inches thick which should be built to fill in cornice.

Many fronts have the columns sufficiently large to allow the backs open, with bridge pieces across, and the column filled with brickwork.

The section of front herein shown is taken through the doorway. *D* is the cast-iron transom, *H* the sill, with riser *G* and patent light sidewalk.

In the plan *K* represents an open-back column. The cornice work and fascias should be cast $\frac{1}{4}$ of an inch thick, and supported by cast-iron brackets resting on and secured to lintels.

202. Plain Fire Escapes.—Outside fire escapes should be placed on all dwelling houses over two stories in height, occupied or intended to be occupied by two or more families on any floor above the first; on dwellings more than four stories in height, occupied by three or more families above the first floor; and on office buildings, hotels and lodging houses, factories, mills, workshops, hospitals, asylums and schools. They are constructed as follows:

Brackets should be not less than $\frac{1}{2} \times 1\frac{3}{4}$ -inch wrought iron,

placed edgewise, or $1\frac{3}{4}$ -inch angle iron $\frac{1}{4}$ inch thick, well braced, and not more than 3 feet apart, and the braces to brackets not less than $\frac{3}{4}$ -inch square wrought iron, and should extend two thirds of the width of the respective brackets or balconies. In all cases the upper bar of brackets should go through the wall and be turned down 3 inches.

203. Brackets on New Buildings—should be set as the

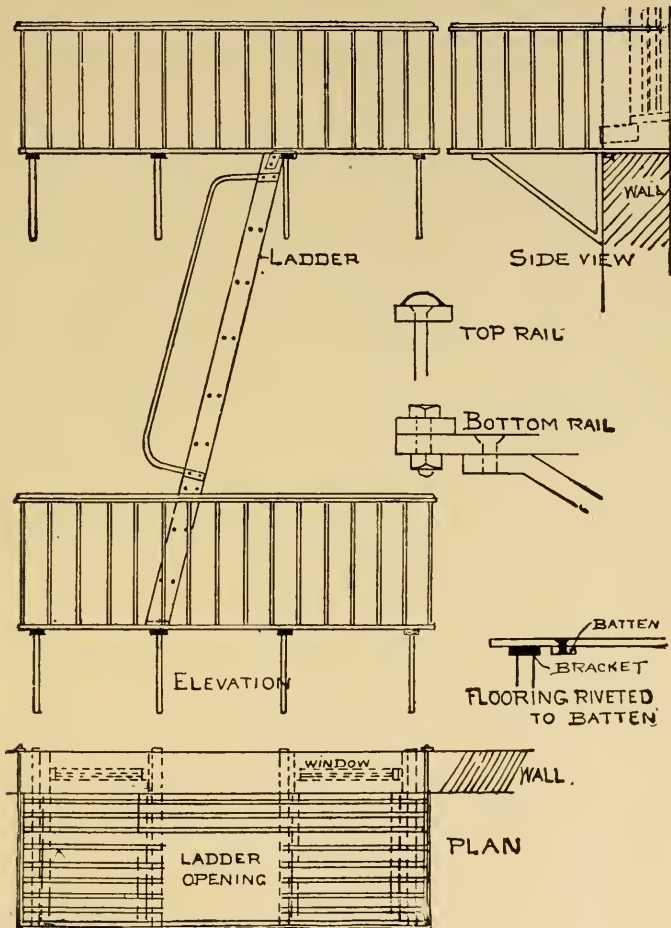

walls are being built. When brackets are to be put on old houses, the part going through the wall should be not less than

one inch diameter, with screw nuts and washers not less than 5 inches square and $\frac{1}{2}$ inch thick.

204. Top Rails.—The top rail of balcony must be $1\frac{3}{4}$ \times $\frac{1}{2}$ -inch wrought iron, or $1\frac{1}{2}$ -inch angle iron $\frac{1}{4}$ inch thick, and in all cases must go through the walls and be secured by nuts, and 4-inch-square washers at least $\frac{3}{8}$ inch thick; and no top rail should be connected at angles by means of cast iron.

205. Bottom Rails.—Bottom rails must be $1\frac{1}{4}$ \times $\frac{3}{8}$ -inch wrought iron, or $1\frac{1}{2}$ -inch angle iron $\frac{3}{4}$ inch thick, well led into the wall. In frame buildings the top rails should go through the studding, and be secured on the inside by washers and nuts as above.

206. Filling-in Bars.—The filling-in bars to be not less than $\frac{1}{2}$ -inch round or square wrought iron, placed not more than 6 inches apart between centres, and well riveted to the top and bottom rails.

207. Stairs.—The stairs in all cases must be not less than 18 inches wide, and constructed of $\frac{1}{4}$ \times $3\frac{1}{2}$ -inch wrought-iron sides or strings. Steps may be of cast iron of the same width as strings, or $\frac{5}{8}$ -inch round iron, double rungs, and well riveted to the strings. The stairs to be secured to a bracket on top, and to rest on and be secured to a bracket or extra cross-bar at bottom. All stairs must have a $\frac{3}{4}$ -inch handrail of wrought iron, well braced.

208. Floors.—The flooring of balconies must be of $1\frac{1}{2}$ \times $\frac{3}{8}$ -inch wrought-iron slats placed not over $1\frac{1}{4}$ inches apart, and secured to iron battens, $1\frac{1}{2}$ \times $\frac{3}{8}$ inch, not over 3 feet apart and riveted at the intersection. The openings for stairways in all balconies should be not less than 20 inches wide and 36 inches long, and have no covers.

209. Drop Ladders.—Drop ladders from lower balconies, where required, should be not less than 14 inches wide, and be made of $1\frac{1}{2}$ \times $\frac{3}{8}$ -inch sides and $\frac{5}{8}$ -inch rungs of wrought iron. In no case should a drop ladder be more than 12 feet in length,

nor should the ends of balconies extend more than 9 inches beyond the brackets.

210. **The Height of Railing**—around balconies should be not less than 2 feet 9 inches.

211. **Ornamental Fire Escapes**—very seldom become an ornament to a building unless ornamental balconies are provided as a feature in the design. The brackets are generally made of cast iron with heavy ornamentation, or wrought iron brackets of scroll designs, and should not be placed farther apart than 3 feet, unless the floor is increased in proportion.

212. **Fire Escapes for Schools, Factories, etc.**—should have the balcony extend across several windows; the stairs constructed of cast-iron treads and wrought-iron strings, and arranged outside of balconies.

213. **Vault Cover and Frame.**—This is principally used for openings into coal vault under sidewalk. The frame is set upon arches or iron beams, and placed level on top with finished sidewalk, the height at *A* varying with the thickness of concrete filling of sidewalk. The frame to be cast $\frac{1}{2}$ inch

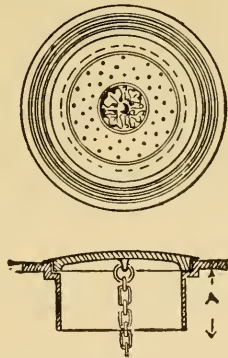

thick with $\frac{3}{4}$ of an inch rebate for the cover. The cover has a roughened surface to prevent pedestrians from slipping. It is cast $\frac{1}{2}$ inch thick in centre to $\frac{3}{4}$ of an inch at rebate, and made from 16 to 24 inches in diameter. Almost any size can be made

for special purposes. For sidewalks made of granite only the cover is necessary, a rebate being cut in the stone.

214. Cast-iron Grating—for ventilating areas under sidewalk. This is from 4 to 8 inches wide by 8 to 12 inches long, with a border about 2 inches wide, and secured to stone with counter-sunk expansion bolts or screws. These gratings are

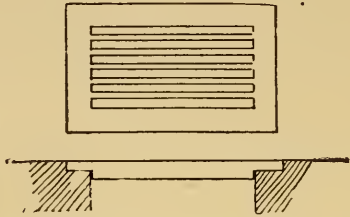

galvanized, and when from 12 to 14 inches square they have a movable slat register and iron drawer to prevent the dirt from falling through.

215. Strainers—are made of cast iron $\frac{3}{8}$ of an inch thick, and perforated with $\frac{1}{4}$ -inch holes as shown. They are used



principally in areas at the entrance of area drain pipe, to protect it from being clogged with refuse, and are made from 6 to 12 inches square.

216. Plain Wrought-iron Bar Window Guards—are made of $\frac{5}{8}$ or $\frac{3}{4}$ inch diameter bars, 4 or 5 inches apart between centres, secured to and extending through $1\frac{1}{2} \times \frac{3}{8}$ -inch or $1\frac{1}{2} \times \frac{1}{2}$ -inch cross-bars. These bars are let into the stone or brick reveals, as plan *B*, and halved on one side so the guards

can be set after openings are built. They are also secured by screws to the window box, as shown at plan A. The vertical

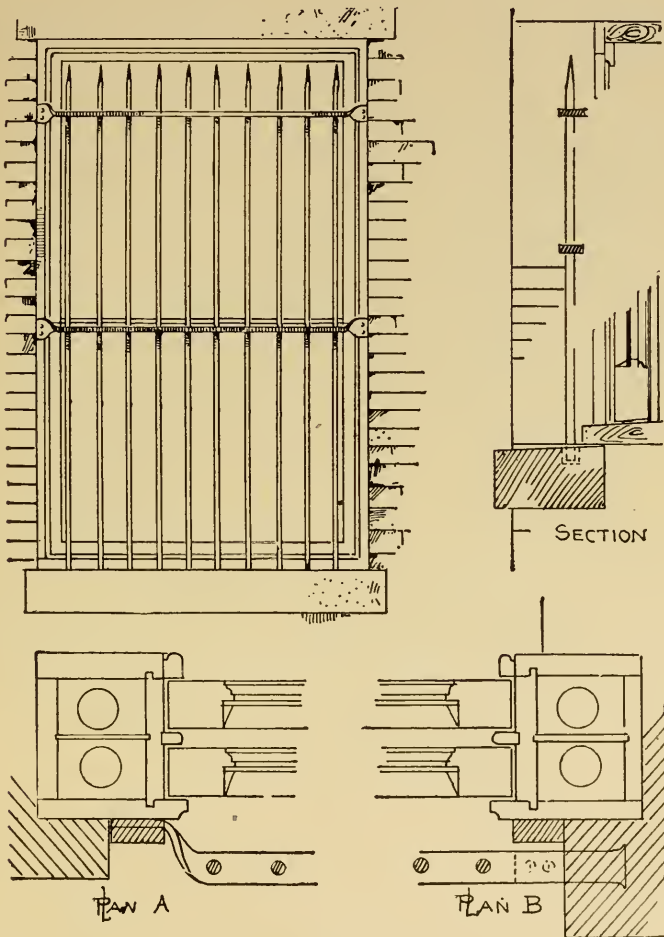

bars are further secured at the bottom by drilling holes into sill and leading in the bars.

217. Bridle or Stirrup Irons—are used for wooden headers and trimmers to stairways, hoistways, floor lights, fireplaces

and flues in all first-class buildings where the floors are supported by wooden beams.

In Fig. 1, W represents the width of iron, X the depth of header or supported beam, and Z the width of the same beam. The two views A show the twist as commonly used.

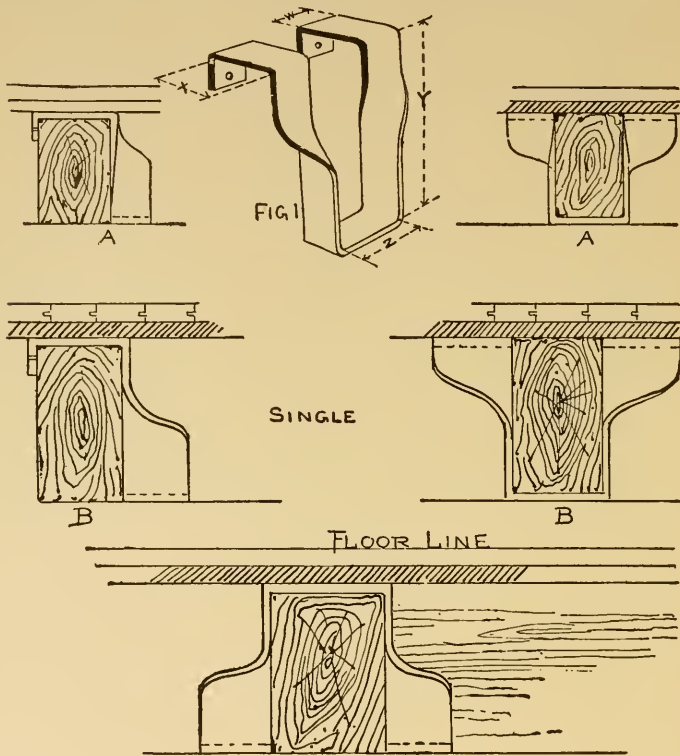

Section C is a double bridle for carrying opposite headers on one trimmer. Section B is the twist in opposite direction to that shown at A . The iron used for bridles is a medium grade cut to proper lengths; these are heated in a large furnace, bent and twisted in a machine, and completed in about fifteen seconds, in one heat, without hammering. They are of uniform strength and fitted to beams. The following sizes are commonly used:

Size of Beam.	Size of Iron.	Size of Beam.	Size of Iron.
4" × 10" × 4" 2" × $\frac{3}{8}$ "		6" × 12" × 6" 2½" × $\frac{1}{2}$ "	
4" × 12" × 4" 2" × $\frac{3}{8}$ "		6" × 14" × 4" 2½" × $\frac{1}{2}$ "	
4" × 14" × 4" 2" × $\frac{3}{8}$ "		6" × 16" × 6" 3" × $\frac{1}{2}$ "	
6" × 10" × 4" 2½" × $\frac{3}{8}$ "		8" × 10" × 8" 3" × $\frac{1}{2}$ "	
6" × 10" × 6" 2½" × $\frac{3}{8}$ "		8" × 12" × 6" 3" × $\frac{5}{8}$ "	
6" × 12" × 4" 2½" × $\frac{3}{8}$ "		8" × 12" × 8" 3½" × $\frac{5}{8}$ "	

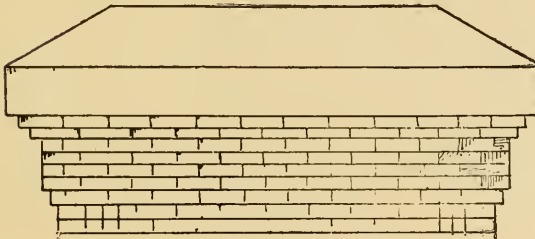
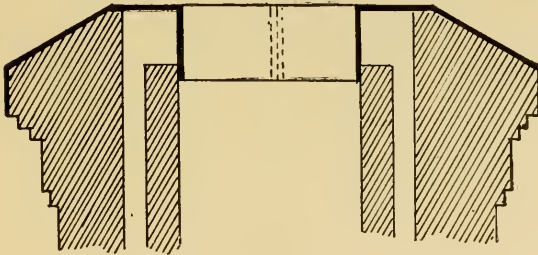
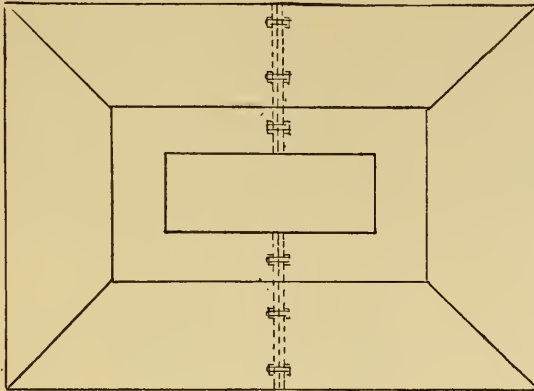

218. Chimney Cap.—This cap is made of cast iron, $\frac{1}{4}$ inch thick if small and $\frac{3}{8}$ inch thick if the chimney is larger than 4 feet square. The outer lip of cap projects down, completely covering the upper layers of brickwork and protecting the mortar joints from the action of the weather.

The inside lip of the cap covers in the same manner the inside wall of air chamber, and extends down in flue from 8 to 12 inches.

The cap herein shown is made of two pieces; more will be needed if a top larger than 6 feet long is required.

219. Cast-iron Flue Door and Frame—are used to enclose an entrance for cleaning boiler flues, and are built in with the brickwork. The frame is $\frac{3}{8}$ of an inch thick, and cast with eyes for the pins of door hinge. The door is also $\frac{3}{8}$ of an inch thick.

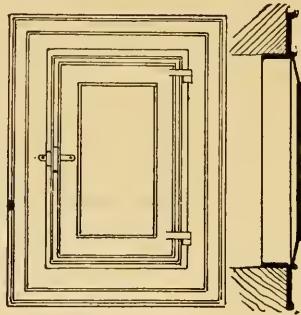

220. Wrought-iron Flue Door—is for a similar purpose as a cast-iron flue door, made of $1\frac{1}{4} \times \frac{3}{8}$ -inch flat iron covered with No. 16 gauge sheet iron, and hung to shutter eyes built in jamb. If no shutter eyes are used, the door frame is made of angle iron with hinges, and secured to the brick jamb.

221. Flue Ring and Cover—are used to enclose openings into flues when the stove pipe is not inserted. The size in general use is a 6-inch-diameter ring.

The ventilator is made similar in thickness, but square as shown in plate.



222. Chimney Ladder—is made of $\frac{3}{4}$ -inch-diameter bars bent the shape as shown, and placed in the wall of chimney when built. For easy climbing the rungs should be placed 12 inches apart between centres and about 18 inches wide, and project 6 inches from chimney. Where large chimneys are concerned they become useful at times, as the action of the weather often displaces the cap on chimney, and the ladder serves as a ready means of reaching the top.

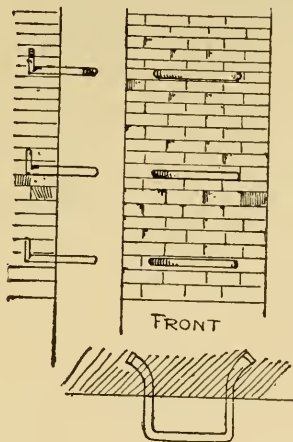

223. Corrugated Iron—is used for roofs, sides of bulkheads, sides of buildings and sheds; also for arches in floors of buildings.

For roofs it is usually laid directly upon the purlins, and held in position by clips of hoop iron, which encircle the purlins and are placed about 12 inches apart.

For bulkheads, etc., the angle and tee iron uprights have $\frac{5}{16}$ -inch-diameter holes drilled about 12 inches apart between centres; the corrugation is then overlapped and riveted with $\frac{1}{4}$ -inch-diameter rivets through these holes.

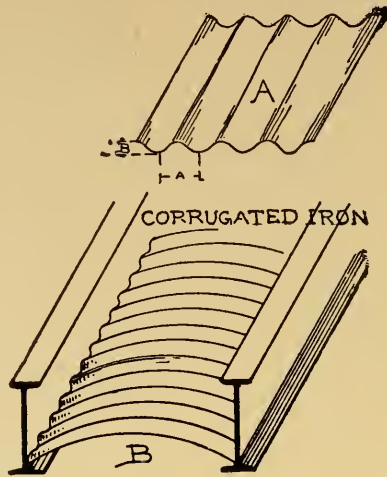

As shown in Fig. *A*, *B* is the depth of corrugation, and *A* is the width, which varies from 2 to 5 inches. Fig. *B* illustrates the manner of application as arches between I beams.

In securing the corrugated iron to purlins on roofs, the bolts, screws and rivets must be in the ridges and not in the valleys of the corrugation.

224. Galvanized and Black Iron.—The table opposite gives the weight in pounds per square foot of galvanized sheet iron, both flat and corrugated. The numbers and thicknesses are those of the iron before it is galvanized. When a flat sheet (the ordinary size of which is from 2 to $2\frac{1}{2}$ feet in width by 6 to 8 feet in length) is converted into a corrugated one, with corrugations 5 inches wide from centre to centre, and about an inch deep (the common sizes), its width is thereby reduced about $\frac{1}{10}$ part, or from 30 to 27 inches; and consequently the weight per square foot of area covered

is increased about $\frac{1}{3}$ part. When the corrugated sheets are laid upon a roof, the overlapping of about $2\frac{1}{2}$ inches along their sides, and of 4 inches along their ends, diminishes the covered area about $\frac{1}{4}$ part more; making their weight per square foot of roof about $\frac{1}{3}$ part greater than before. Or the weight of corrugated iron per square foot, in place on a roof, is about $\frac{1}{3}$ greater than that of the flat sheets of above sizes of which it is made.

Number by Birmingham Wire Gauge.	BLACK.		GALVANIZED.		
	Thickness in inches.	Flat. lbs.	Flat. lbs.	Corrugated. lbs.	Cor. on Roof. lbs.
30	.012	.485	.806	.896	1.08
29	.013	.526	.857	.952	1.14
28	.014	.565	.897	.997	1.20
27	.016	.646	.978	1.09	1.30
26	.018	.722	1.06	1.18	1.41
25	.020	.808	1.14	1.27	1.52
24	.022	.889	1.22	1.36	1.62
23	.025	1.01	1.34	1.49	1.79
22	.028	1.13	1.46	1.62	1.95
21	.032	1.29	1.63	1.81	2.17
20	.035	1.41	1.75	1.94	2.33
19	.042	1.60	2.03	2.26	2.71
18	.049	1.98	2.32	2.58	3.09
17	.058	2.34	2.68	2.98	3.57
16	.065	2.63	2.96	3.29	3.95
15	.072	2.91	3.25	3.61	4.33
14	.083	3.36	3.69	4.10	4.92
13	.095	3.84	4.18	4.64	5.57

NOTE.—The galvanizing of sheet iron adds about one third of a pound to its weight per square foot.

225. Finial and Cresting.—Of the various means of finishing towers, spires, ridges, etc., the *finial* and *cresting* are valuable as ornaments, and give a light appearance to the top of heavy and plain roofs.

In the following illustration both are shown. The design can be accommodated either to wrought iron, cast iron, or copper.

226. **Vault Lights.**—One of the important improvements in *vault lights*, and one now generally adopted, is filling concrete around the glass, which, while giving an even, non-slippery and durable surface, is also strong and perfectly water-tight.

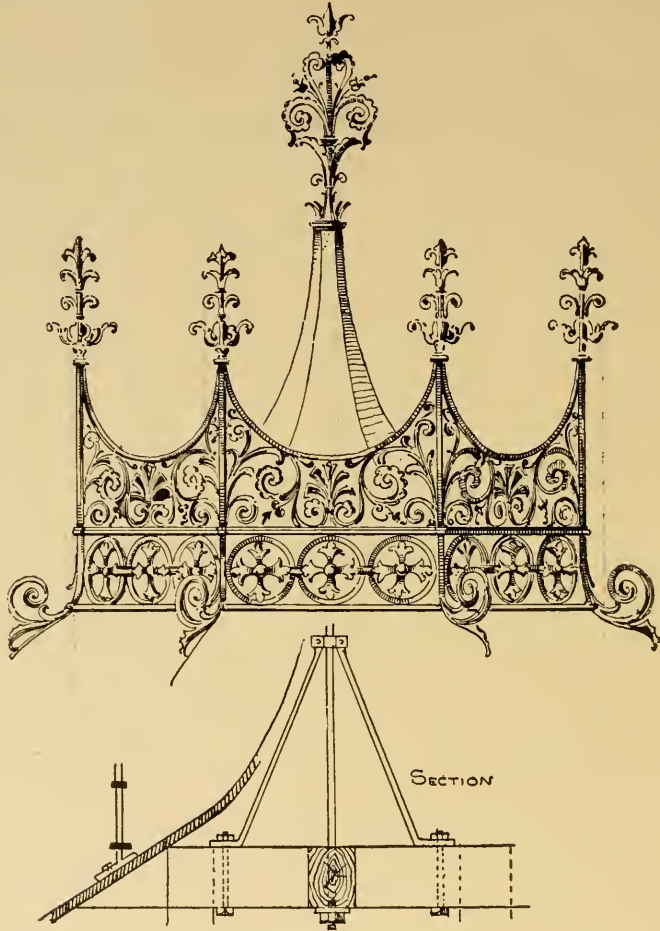

The metal being covered by a non-conducting material, the rooms over which the light is laid are warmer in winter and cooler in summer than those over which the old-style lights are placed. The round and elongated knob-protected bullseye

lights are known as *iron vault lights*. There is very little cement used, only enough to bed the lens. The diameter of the lens in both concrete and iron lights is from $1\frac{1}{2}$ to 2 inches.

Wrought-iron illuminating doors are frequently used, in combination with the above lights, for entrances to sidewalk elevators, area steps and hatchways. The doors are made of galvanized sheet iron, with bronze or wrought-iron hinges similar to those for sheet-iron sidewalk doors. Illuminating vault covers with and without frames, from 12 to 36 inches in diameter, are frequently used. The glass is round or square, and set either in plain iron lights or concrete illuminating lights. The concrete light is an inch and the iron light $\frac{7}{8}$ inch thick. All the above lights are employed principally for areas, vaults, roofs, floors, skylights, vault covers, etc.

227. **Wrought-iron Guard.**—The following illustration is a simple and neat design of guard. The rings are made of

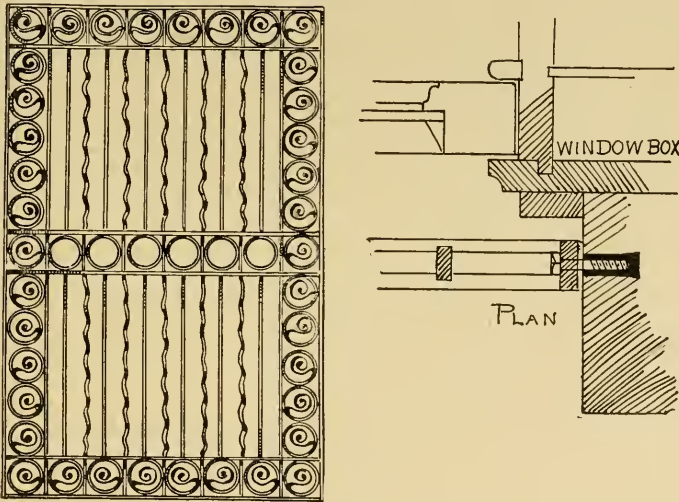

$\frac{3}{16} \times \frac{3}{4}$ -inch flat iron, the frame on outside $\frac{1}{2} \times 1\frac{1}{2}$ inches, the wavy bars $\frac{3}{4} \times \frac{2}{3}$ inch, and the cross-bars $\frac{2}{3} \times 1\frac{1}{2}$ inches. To secure the frame to jamb, expansion bolts or lag screws may be used as shown in the plan.

228. Dwarf Doors—are generally placed below the rolling shutters of store or warehouse entrances. They are from 2 feet 6 inches to 3 feet high, in two, three and four folds, and made of a $3 \times \frac{3}{8}$ -inch flat iron welded frame, covered with No. 16 gauge black sheet iron. Flat cast-iron mouldings are set against the sheet iron to form panels, showing from outside as a finished door. Dwarf doors are sometimes made of wood two inches thick, and covered with sheet iron similar to that used in the iron door.

229. Cast-iron Wheel Guards—are used to protect the jambs of vehicle-entrances, and made of $\frac{1}{2}$ -inch-thick metal, by the height of wheel hub. Wrought-iron guards are simply three $\frac{7}{8}$ -inch-diameter bars bent outward, and leaded into flagging and jamb base-stone.

230. Fire Pipes—are generally required in all warehouses, stores and factories, and are made of 4-inch-diameter wrought-iron pipe, built in with the wall, with a hose connection at each floor level, and extending through outer wall a foot or two above the sidewalk.

231. Mansard Roof.—The best-constructed mansard roofs have a continuous bed plate and top plate of channel iron or angle iron, with uprights of angles 25 inches apart between centres, all bolted together, thus forming a rigid framework of iron, which is then filled in with porous terra-cotta blocks and covered with slate or metal. The uprights may also be made of 6-inch beams 4 feet apart between centres, and purlins of small tees or angles $1\frac{1}{2}'' \times 1\frac{1}{2}'' \times \frac{3}{16}''$ placed on outside; the slate on the iron purlins to be hung with suitable copper wire carefully twisted, two wires to each slate, and the slate made to lie flat.

The sides and roofs of dormers are similarly constructed, the covering being galvanized iron or copper.

232. Railings for Roof Protection.—In cities, where houses adjoin each other and have their roofs on the same level, the roofs are protected from thieves by wrought-iron

picket railings made of $\frac{1}{2}$ -inch to $\frac{3}{4}$ -inch diameter bars, from 3 to 5 inches apart between centres and from 5 to 7 feet in height, extending in a quarter circle over front of cornice. The longitudinal bars are $1\frac{1}{2} \times \frac{1}{2}$ -inch flat iron. The pickets are single or double pointed, in fact made as jagged as possible.

233. Pipe Railing.—For neat, inexpensive and substantial railings, pipes connected and screwed into couplings are the simplest. The rails can be bent to any desired pitch and angle. The standards or posts are also of pipe, and are set into and secured to cast-iron sockets, and further secured to the coping or base upon which they set by expansion bolts.

234. Corrugated Flooring.*—The trough-shaped sections as shown are now successfully used in the floors of buildings

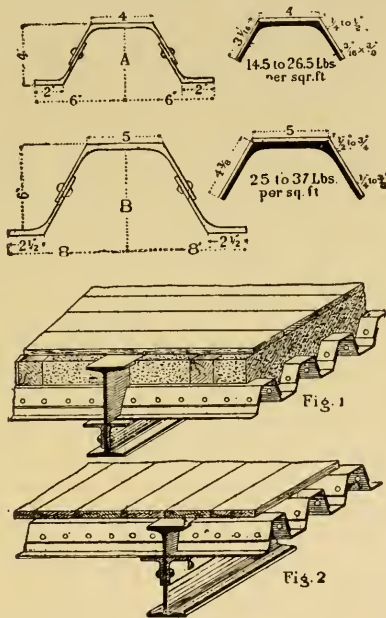

as well as bridges. The smaller section, *A*, is generally applied to buildings as shown at Fig. 1, while the larger section, *B*, is better adapted for bridges, as Fig. 2.

* Taken from Pencoyd Iron Works Handbook,

The following table gives weight per square foot of floor surface for different thicknesses of the section ; also the moments of resistance for one foot in width.

Section.	A	A	A	A	A	B	B	B	B	B
Weight per square foot in pounds.	14.5	17.5	20.5	23.5	26.5	24.5	27.5	30.5	33.5	36.5
Moment of resistance for 1 foot in width.	4.41	5.50	6.61	7.74	8.89	11.56	13.06	14.57	16.12	17.67

235. Tanks.—An ordinary tank, open to the atmosphere, will have no other strain to withstand beyond that which is due to the weight of water in it ; hence the maximum strain on the plates will be reached when the tank is full of water. The tank made of wrought-iron plates should, if of any considerable depth, be strengthened at intervals by angles or tee irons, in order to prevent the sides bulging out ; and this being the case, the proper thickness of plate at any depth can be found from the following

RULE. To find the thickness in inches of any plate necessary to resist the pressure of the water, divide the distance in feet between the strengthening ribs by 20, and multiply the quotient by the square root of the depth in feet from the surface of the water to the plate under consideration.

For example: Let a tank be 10 feet deep, the distance between ribs 3 feet ; then the depth of the bottom plates will be 10 feet. Hence, as 3.16 is the square root of 10, we proceed thus :

$$20)3 \text{ feet} = \text{distance between ribs.}$$

$$\underline{\quad\quad\quad}$$

$$0.15$$

$$3.16 = \text{square root of depth.}$$

$$\underline{\quad\quad\quad}$$

$$90$$

$$15$$

$$\underline{\quad\quad\quad}$$

$$45$$

$$.4740 \text{ inch} = \text{thickness of bottom plate.}$$

Or the thickness of bottom plate should be not less than $\frac{1}{2}$ inch.

Having found the thickness of bottom plate, the next step is to determine that of the side plates. The thickness must be calculated for the depth of the lower edges of each tier of plates where the maximum strain will come. A tank of the dimensions assumed would be made with three tiers of plates, forming the sides, each tier being 3 feet 4 inches deep, so as to make up a total length of 10 feet of the tank, and upon these depths we may base our calculations.

The bottom tier of plates should be of the same thickness as the bottom plates of the tank, that is $\frac{1}{2}$ inch, as their lower edges are the same distance below the surface as the bottom plates. The lower edge of the second or middle tier of plates will be 6 feet 8 inches (6.67 feet) below the top of the tank.

20)3 feet = distance between ribs.

0.15

2.58 = square root of depth in feet.

120

75

30

.3870 inch = thickness of middle tier of plates.

The middle tier should therefore be $\frac{7}{16}$ inch thick.

The lower edge of the top row of plates will be 3 feet 4 inches (3.34 feet) below the top of tank.

20)3 feet = distance between ribs.

0.15

1.82 = square root of depth.

30

120

15

.2730 inch = the thickness of top row.

So the top row should be $\frac{5}{16}$ inch thick.

The angle irons, tee irons and cover strips should be proportionate to the thicknesses of the plates. The $\frac{1}{2}$ -inch plate should be fastened with $\frac{3}{4}$ -inch rivets, the cover strips 4 inches wide. The angle iron for joining the bottom of tank to the sides should be $2\frac{1}{2}'' \times 2\frac{1}{2}'' \times \frac{1}{2}''$, thus allowing 2 inches width of plate for each rivet, which may be 2 inches pitch. Vertical tee irons should be $4'' \times 3'' \times \frac{1}{2}''$. The $\frac{5}{16}$ -inch plates should have $\frac{5}{8}$ -inch rivets, with cover strips $3\frac{1}{2}$ inches wide, and stiffening tee irons $4'' \times 3'' \times \frac{1}{2}''$ —the $\frac{5}{16}$ -inch plates to be jointed the same as the $\frac{7}{16}$ -inch. The vertical stiffeners should be bent across the top of the tank so as to form frames; and the edges of the tank may be stiffened by angle irons $3 \times 3 \times \frac{3}{8}$ inch.

236. Chains and Cables.—Every link of a chain has to transmit the whole strain to which the chain is subject, so that one faulty link renders the chain useless.

To have a perfect chain, its strength should be equal to that of two rods of iron from which the links are made; that is to say, a chain made of iron one inch in diameter should bear in tension a load equal to that which two one-inch rods would be capable of sustaining. To resist shearing, wrought iron is safe at 7500 pounds per square inch of sectional area.

Chains should be tested, as one imperfect link or pin will injure the whole.

Fig. 1 in the accompanying plate shows elevation and plan of a portion of a flat-link chain; it consists of a series of short bars fastened together by pins or rivets.

It will be observed that the links are arranged alternately in twos and threes; hence, to keep the strength uniform throughout, those links which occur in twos should be thicker than those where there are three together. Thus we might have alternately two links $\frac{3}{4}$ of an inch thick and three links $\frac{1}{2}$ inch thick.

The requisite size of the pin is determined by considering the strain on the chain and the number of places where the

pins must be sheared, together with the mode in which such strain is distributed through the links.

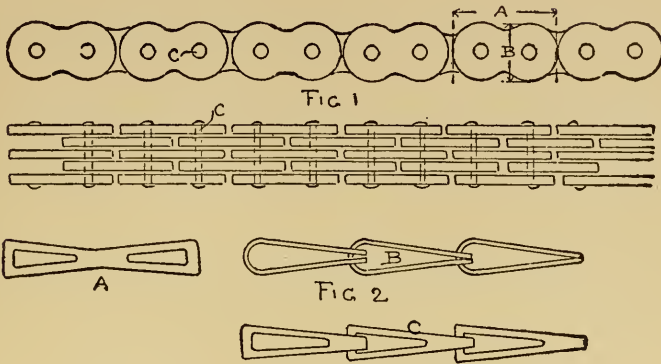

Where the three links occur, it may be assumed that the load is equally distributed throughout, or that there is one third of the load on each of the three links; then it is evident that in the case of the outside link the pin requires to be sheared in one place only for rupture to ensue; therefore we have the following simple

RULE. To find the greatest strain on one section of a pin in a flat-link chain, divide the total load on the chain by the greatest number of links placed together.

It is common practice to test chains up to two thirds the breaking weight; but a lower limit should be set, as in many cases failure is due to overstraining the material in the process of testing.

An ordinary chain will give way at the weld. To ascertain that the welds are perfect in every link, the chain is passed through a smith's fire and heated to redness, after which cold water is poured on each link: if the shut be imperfect it will open and thus exhibit the defect.

In Fig. 1 the links are in one piece and punched from steel

or iron plates, *A* being the length and *B* the width of each link. *C* is the pin.

Fig. 2 is punched in a similar manner, as shown at *A*, and linked together as shown in elevation *B* and plan *C*. There being no pins, the tensile strain of the iron or steel is alone considered.

237. Wirework.—Of the various ways in which *wirework* is employed in building construction, the following are particularly notable:

(*a*) For the protection of glass over skylights, and where glass is to be protected from being broken by falling objects.

1" diam. mesh No. 13 wire, round frame (Fig. 2), $\frac{3}{4}$ lb. per sq. ft.
 1" " " " " " grooved " 1 " " " "

(*b*) For window guards, bank and office railings and elevator enclosures.

$1\frac{1}{4}$ " mesh, No. 10 and 11 wire, round frame, $1\frac{1}{4}$ lbs. per sq. ft.
 $1\frac{1}{4}$ " " " " " " " grooved " $1\frac{1}{2}$ " " " "



FIG. 1.

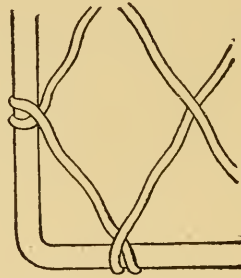

FIG. 2.

The following sizes are also used to enclose well-holes of elevators, guard windows, etc. They make the cheapest guard that can be produced consistent with strength.

$1\frac{1}{2}$ " mesh, No. 9 or 10 wire, round frame, 1 lb. per sq. ft.

$1\frac{1}{2}$ " " " " " " " grooved " $1\frac{1}{2}$ " " " "

(c) For guards requiring rough usage, such as window guards for factories or warehouses.

$1\frac{1}{2}$ " mesh, No. 8 wire, $\frac{3}{4}$ " grooved frame, $1\frac{3}{4}$ lbs. per sq. ft.

(d) Where light is not considered, but glass is to be protected.

$1\frac{1}{2}$ " mesh, No. 7 wire, $\frac{7}{8}$ " grooved frame, 2 lbs. per sq. ft.

(e) For railings, partitions and guards requiring strength.

2" mesh, No. 7 wire, $\frac{7}{8}$ " grooved frame, 2 lbs. per sq. foot.

$2\frac{1}{2}$ " " No. 5 or 6 wire, 1" " " $2\frac{1}{2}$ " " " "

(f) To screen pipes and machinery when situated in recesses.

1" square mesh (Fig. 1), flat wire $\frac{5}{16}$ " wide, $2\frac{1}{4}$ lbs. per sq. ft.

The flat wire can also be applied as railings, partitions and enclosures. Then use the following sizes :

$1\frac{1}{4}$ " and $1\frac{1}{2}$ " mesh, $\frac{3}{4}$ " grooved frame, $1\frac{1}{4}$ lbs. per sq. ft.

(g) In fire-proof buildings wire is extensively used in place of wooden lath.

238. Cast-iron Boiler Flues—are cast in sections from 5 to 8 feet in length and $\frac{1}{2}$ inch thick, enclosed in brickwork, with an air-space between the flue and the brick enclosure. Expansion and contraction are to be considered when joining the sections. The *maximum* distance that the flue will expand or contract nearest the boiler is $\frac{1}{8}$ inch per foot; therefore for a section 8 feet long 1 inch should be allowed in the overlapped joint, and proportionately less at a greater distance from boiler.

239. Wrought-iron Boiler Flues—are made of $\frac{1}{4}$ -inch plate, constructed similarly to cast-iron flues, with wrought-iron angles for the overlapped joints.

CHAPTER XVIII.

FINISHING IRON AND STEEL.

240. Bronzing.—Metals are bronzed by chemical agents or by the application of bronze powders. The latter are principally applied upon metals to imitate bronze. To give the object a *gold bronze*, ochre is triturated with linseed oil and red lead, and some blue or black mixed with it, so that a dirty green color results. Two or three layers of this color are applied. The last coating should not be allowed to become entirely dry. The bronze powder is laid upon this layer with a badger brush or otherwise, and adheres strongly. After drying and dusting off the superfluous bronze powder with a stiff brush, the whole is covered with a coat of transparent and colorless varnish.

Silver bronze, copper bronze, red bronze, and green bronze are frequently used for finishing iron work.

241. Enamelling Cast and Wrought Iron.—An enamel for cast and wrought iron is obtained by fusing together finely pulverized crystal glass, calcined soda and boric acid. This enamel is glass-like, transparent, and lasts well upon sheet iron.

242. Electro-plating—in gold, silver, nickel, copper and brass is a favorite method of finishing iron. The articles should first be ground or polished to free them of grease and make their surfaces purely metallic.

They are then dipped in dilute sulphuric acid and water, and pickled in nitric acid, sulphuric acid and common salt. After being thoroughly rinsed they are brought without delay into the bath, which is connected to a dynamo-electric machine.

243. Galvanizing Sheet Iron.—The metal to be coated requires to be freed of oxide and impurities of every description before it will take a proper coating of zinc.

The first step in the process is to pickle the sheets in a tank containing sulphuric acid diluted with water. In from one to two hours the scaling of the iron is effected; the sheets are then withdrawn and transferred to large, shallow washing vats of wood, in which they are washed in a stream of fresh water. They are next subjected to an inspection, and such patches and scales as may yet adhere in spots to the pickled sheet are scraped and brushed with a stiff brush; they are then passed into a second tank filled with clean water and allowed to remain for 12 to 24 hours, which removes all traces of sulphuric acid and basic sulphate of iron. From the clearing tank the sheets are arranged on edge in a rack which is mounted on a truck and rolled into a drying chamber. In about 20 minutes they are removed and are then ready for dipping.

The galvanizing pot is a rectangular vessel of heavy boiler plate, riveted in the most substantial manner, about 4 feet deep, 12 feet long, and 15 to 24 inches wide, and capable of containing 20 to 30 tons of zinc. A fire space is kept around the tank, and the heat of the bath is about 1000° F. The sheets are passed one by one into the melted zinc on a pair of rollers, and as they emerge on the other side are seized at one end by an iron gripper and drawn through a layer of sand strewn on the surface of the melted zinc, the object of which is to remove all the superfluous metal.

In the setting of the zinc coating, which takes place almost instantly after the withdrawal from the bath, the beautiful crystallization of the metal ensues which is so much admired.

244. Painting of Iron.—On exposure to the atmosphere all metals soon lose their metallic lustre. They oxidize by absorbing oxygen from the air. Iron becomes coated with a layer of rust. Every drop of rain causes a rust stain, and hence only iron perfectly free from rust can be successfully painted.

When the oxidizing process has once commenced, its progress may for a time be interrupted by painting, but it progresses slowly even under the paint, the latter finally peeling off together with the layer of rust.

The principal point in painting iron is the priming color. If this is defective or applied incorrectly, the efficacy of the entire work is doubtful, even if the succeeding coats are properly laid on. In order that the priming color shall adhere firmly to the iron, three conditions are required: (1) it must be capable of drying quickly and thoroughly; (2) it must be thinly fluid; and (3) it must be applied in a thin layer only. The priming color is linseed oil with red lead. For painting use 1 part of verdigris, 1 of white lead and 3 of linseed oil; or $\frac{1}{2}$ of verdigris, $1\frac{1}{2}$ of white lead, and $2\frac{1}{2}$ of linseed oil; the iron to receive three coats, the first before the iron is used, the second after the first is thoroughly dry, and the third three days later.

245. Malleable Castings—are formed by subjecting the castings to a process of annealing in boxes with hematite iron ore or black oxide of iron. The boxes are kept in an annealing oven under an equable heat, the duration of the process depending on the form and size of castings.

246. Lacquer for Iron.—A lacquer protecting the iron from rust and presenting a beautiful black appearance is composed of asphalt, pine oil and colophony. For coating iron on a large scale asphalt tar is used, first freeing the scales from the iron by immersion in diluted hydrochloric acid.

CHAPTER XIX.
SPECIFICATION.

For the IRONWORK of.....
.....
To be erected.....
.....
.....
For.....
In accordance with the drawings prepared by.....
.....

.....
Architect.

General Condition.—The drawings and specifications are intended to co-operate ; but any work shown on the drawings and not particularly described in the specifications, and any work necessary to the complete finish of the building as specified or shown, is to be done by the Contractor without extra charge, the same as if it were both specified or shown.

The Contractor is to comply with corporation ordinances, the State and other laws, and to be liable for all penalties and all damages to life and limb that may occur owing to his negligence, or that of his employees, during the erection of the building.

No extra work will be allowed unless ordered by the Architect *in writing*.

All work not made in strict conformity to the drawings and specifications will be rejected and must be removed, and all

other work injured or destroyed by such rejected work must be made good at Contractor's expense.

Figured dimensions on the drawings are to be followed in all cases in preference to scale measurements.

The Contractor must secure all necessary permits in connection with his work, and pay all fees for the same.

The Architect, as the representative of the Owners,, reserves the right to annul and cancel the contract in case the Contractor neglects or refuses to remove rejected work, and replace as specified and according to the instruction of the Architect, within a reasonable time after being notified.

A schedule, or detail, of the prices on which the Contract is based is to be furnished to the Architect, which schedule shall be the basis for all payments on account of Contract.

The Contractor must properly protect his work from injury, until the final completion and acceptance of the building. Any damage done to work of other contractors by the Contractor and employees will be made good at the Contractor's expense.

Time of Completion.—The entire building is to be completely finished and must be delivered ready for occupancy on or before the The Contractor is to provide all necessary night and overtime work without extra charge. Should any delay occur in the progress of the work included in these specifications, or should the other contractors be delayed on account of the Iron Work or on account of replacing or altering defective work, the Contractor is to pay to the sum of as liquidated damages for each and every day that the work is delayed, and for each and every day that the Iron Work may be unfinished and uncompleted after the

Payments.—On the first day of each month a certificate will be given by the Architect for a payment on account of the Contract of eighty-five per cent (85%) of the value of the

work furnished and put up at the building, providing a schedule has been furnished as before specified.

A certificate for the balance will be given by the Architect upon the completion of the Contract in conformity with the drawings and the specifications.

No certificate will be given, in case any work is furnished not in strict conformity with the drawings and specifications, nor until the defective work has been removed, and replaced to the satisfaction of the Architect.

Any certificate given or any payment made on account of the Contract for work furnished and erected at the building, or for materials furnished and set aside, does not act as an acceptance of any materials or work which may subsequently be found to be defective, by reason of existing defects at the time such certificate is given, or payment made, or defects arising from accidental injury or otherwise until the completion of the Contract.

The Contractor must replace all such defective work in which payments have been made before another certificate will be issued.

Constructive Work.—The minimum weight and sizes of all constructive work are shown on the drawings and given in these specifications. Any deviation from their sizes and weights will be rejected by the Architect, to whom every facility is to be afforded for inspection at the shop and building.

Wrought Iron.—Wrought iron to be ductile and of good fibre throughout, to have an ultimate resistance to tension of 50,000 pounds to the square inch; the elastic limit to be at least 26,000 pounds to the square inch, and stretch 18% in 8 inches.

Wrought Steel.—All steel to be mild steel having an ultimate tensile strength of 65,000 lbs. to the square inch and an elastic limit not less than 36,000 lbs., and stretch 22% in 8 inches.

Cast Iron.—All heavy cast iron to be of good gray iron, smooth, free from air holes, cinders and other defects.

Ornamental cast iron to be of fine stove castings; mouldings and decorations to be clean, sharp and well relieved.

Painting.—All ironwork cleaned of scales and dirt, and to receive one coat of best oxide of iron and pure linseed oil, and all pins, pin holes and machined surfaces to be coated with pure white lead and tallow before leaving the shop, and after erection to receive one additional coat of paint.

All holes in cast iron to be drilled; rivet holes to be drilled or punched.

All wrought-iron angle knees connecting the beams to be as long as the web of the framed beam, and wide enough on the web to contain as many bolts or rivets to resist shearing and bending strains, equal to one half the safe strength of framed beam.

The floors are figured for lbs. per square foot, including the weight of materials. The weights on columns and beams to be verified by Contractor.

Anchors, Clamps, Dowels, etc.—Supply all necessary anchors, clamps and dowels for the stonework. Each piece of stone ashler to be anchored, and all pieces of coping clamped with galvanized iron clamps.

Furnish for mason all necessary anchors for brickwork.

Furnish all necessary galvanized anchors, rods, bolts and clamps for terra-cotta work.

Furnish all bridle irons, anchors and straps for carpenter, and do all drilling and tapping into ironwork necessary to secure the woodwork.

All iron beams and girders resting on walls to have necessary anchors.

All light castings anchored and bracketed for a stiff and substantial support.

Columns.—Furnish and set for the support of floors and roof girders, columns of the following dimensions:

Columns in cellar,	Diameter.....	Metal.....
“ “ basement,	“	“
“ “ first story,	“	“
etc. etc.	etc.	etc.

The first-story columns to have ornamental capitals, moulded bands and bases. Columns for the other stories to have moulded caps and bases. All according to sectional and detail drawings.

The lowest columns to have base plates of sufficient bearing area to distribute the load, at 1000 lbs. per square inch, on the granite base stones, and to be the thickness of the columns, the ribs not less than an angle of 45° , with flanges the thickness of column, and a rim on the outside of bottom of plate $1\frac{1}{2}$ " above the thickness of the plate.

The base plates to be bedded or grouted in solid with pure Portland cement.

Columns of cast iron to have brackets, flanges and lugs the thickness of metal in shaft, but none less than $\frac{3}{4}$ " thick, and connected through the flanges with not less than four heavy bolts.

If cast columns are connected with girders and beams, acting as struts or ties, angle knees are to be used in place of cast lugs, and bolted to column with tight-fitting bolts.

Columns of wrought iron to have wrought-iron brackets, flanges and knees for beams and girders, of the proper thickness and stiffness as specified for framed connections.

All columns to be turned off true and at right angles to their axis, as no shimming or wedging will be allowed.

The ends of all columns, where necessary, are to be cast with an additional thickness so that the inside diameters are of uniform sizes at the connections, with a plate, planed on both sides and the full size of the column flanges, to be placed between and bolted through plates and flanges.

Girders.—Girders formed of two or more beams to have inserted between the webs, not more than five feet apart, cast iron separators to fit accurately the form of the beams, with

two bolts for 12-inch beams and over, and one bolt for 10½-inch beams and under.

The bearings of all beams, girders and lintels must be not less than 6 inches at each end. Spans of 20 feet and over to have bearings on the walls of not less than 10 inches; lintels over openings more than 5 feet wide to have one inch additional bearing for each additional foot of span.

Cast-iron Lintels.—Furnish and set over all windows in bearing walls and others, as shown, cast-iron lintels the full bed of wall to be supported. The webs at ends to be 4 inches high, and to have a rise of 1½ inches to every foot of span; all over 16 inches bed to have two webs, or two or more lintels placed side by side.

All lintels (not carrying floor beams) not over 6 feet span to have 1-inch-thick flanges and webs, and over 6 feet to 8 feet 1¼ inches thick, and over 8 feet 1½ inches thick.

All lintels in special cases to be good and sufficient.

Stairs.—The stairways are to be built of iron, with slate treads and platforms 1¼ inches thick from basement floor to top story, and with iron treads below basement and from top story to roof.

Outside strings to be of deck or I beams, with ornamental cast-iron step blocks.

If outside strings are cast iron, to be not less than ¾ of an inch at thinnest part and ornamented.

The risers to be of cast iron, ornamented both sides unless otherwise specified.

The wall strings to be of cast iron, with moulded edges top and bottom, and project from wall sufficient to receive any furring, plastering or wainscoting.

The railings to be made of wrought and cast iron, the level railings similar; the top bar prepared to receive wooden hand-rail under another contract.

All the stair work to be made according to detail drawings furnished by Architect.

Bulkheads on Roofs.—The stairs which extend to roof to have a bulkhead made of $3\frac{1}{2}'' \times 3\frac{1}{2}''$ tee and angle iron, covered with galvanized crimped iron No. 16 gauge.

All other bulkheads as shown to be of the same material.

Where roofs of bulkheads are not enclosed with glass, rafters to be provided of tee or angle iron, placed twenty-five inches between centres, to receive the fire-proof blocks. A galvanized gutter and leader to be provided for carrying water from bulkhead roof to main roof.

Miscellaneous.

[NOTE.—Under this heading give an accurate description of all work required, according to the previous plates and descriptions, which will give the Iron Contractor all that is required for the completion of the work at shop and building.]

Setting.—All the ironwork throughout to be set and connected in the very best manner. Furnish all scaffolding, all fascias, railings and other light work.

CHAPTER XX.

TABLES.

AVERAGE WEIGHT, IN POUNDS, OF A CUBIC FOOT OF VARIOUS SUBSTANCES

Aluminum,	162
Anthracite, solid, of Pennsylvania,	93
" broken, loose,	54
" heaped bushel, loose,	(80)
Ash, American white, dry,	38
Asphaltum,	87
Brass, (Copper and Zinc,) cast,	504
" rolled,	524
Brick, best pressed,	150
" common hard,	125
" soft, inferior,	100
Brickwork, pressed brick,	140
" ordinary,	112
Cement, hydraulic, ground, loose, American, Rosendale,	56
" " " " " Louisville,	50
" " " " English, Portland,	90
Cherry, dry,	42
Chestnut, dry,	41
Clay, potter's, dry,	119
" in lump, loose,	63
Coal, bituminous, solid,	84
" " broken, loose,	49
" " heaped bushel, loose,	(74)
Coke, loose, of good coal,	62
" " heaped bushel,	(40)
Copper, cast,	542
" rolled,	548
Earth, common loam, dry, loose,	76
" " " " moderately rammed,	95
" as a soft flowing mud,	108
Ebony, dry,	76
Elm, dry,	35
Flint,	162
Glass, common window,	157
Gneiss, common,	168

WEIGHT OF A CUBIC FOOT OF VARIOUS SUBSTANCES. 167

Gold, cast, pure, or 24 carat,	1204
“ pure, hammered,	1217
Granite,	170
Gravel, about the same as sand, which see.	
Gypsum (plaster of paris),	142
Hemlock dry,	25
Hickory, dry,	53
Hornblende, black,	203
Ice,	58.7
Iron, cast,	450
“ wrought, purest,	485
“ “ average,	480
Ivory,	114
Lead,	711
Lignum Vitæ, dry,	83
Lime, quick, ground, loose, or in small lumps,	53
“ “ “ “ thoroughly shaken,	75
“ “ “ “ per struck bushel,	(66)
Limestones and Marbles,	168
“ “ “ loose, in irregular fragments,	96
Magnesium,	109
Mahogany, Spanish, dry,	53
“ Honduras, dry,	35
Maple, dry,	49
Marbles, see Limestones.	
Masonry, of granite or limestone, well dressed,	165
“ “ mortar rubble,	154
“ “ dry “ (well scabbled,)	138
“ “ sandstone, well dressed,	144
Mercury, at 32° Fahrenheit,	849
Mica,	183
Mortar, hardened,	103
Mud, dry, close,	80 to 110
“ wet, fluid, maximum,	120
Oak, live, dry,	59
“ white, dry,	50
“ other kinds,	32 to 45
Petroleum,	55
Pine, white, dry,	25
“ yellow, Northern,	34
“ “ Southern,	45
Platinum,	1342
Quartz, common, pure,	165
Rosin,	69
Salt, coarse, Syracuse, N. Y.,	45
“ Liverpool, fine, for table use,	49

168 *WEIGHT OF A CUBIC FOOT OF VARIOUS SUBSTANCES.*

Sand, of pure quartz, dry, loose,	90 to 106
“ well shaken,	99 to 117
“ perfectly wet,	120 to 140
Sandstones, fit for building,	151
Shales, red or black,	162
Silver,	655
Slate,	175
Snow, freshly fallen,	5 to 12
“ moistened and compacted by rain,	15 to 50
Spruce, dry,	25
Steel,	490
Sulphur,	125
Sycamore, dry,	37
Tar,	62
Tin, cast,	459
Turf or Peat, dry, unpressed,	20 to 30
Walnut, black, dry,	38
Water, pure rain or distilled, at 60° Fahrenheit,	62 $\frac{1}{3}$
“ sea,	64
Wax, bees,	60.5
Zinc or Spelter,	437

SQUARES AND CUBES, OF NUMBERS FROM 1 TO 440.

No.	Squares.	Cubes.	No.	Squares.	Cubes.
1	1	1	56	31 36	175 616
2	4	8	57	32 49	185 193
3	9	27	58	33 64	195 112
4	16	64	59	34 81	205 379
5	25	125	60	36 00	216 000
6	36	216	61	37 21	226 981
7	49	343	62	38 44	238 328
8	64	512	63	39 69	250 047
9	81	729	64	40 96	262 144
10	1 00	1 000	65	42 25	274 626
11	1 21	1 331	66	43 56	287 496
12	1 44	1 728	67	44 89	300 763
13	1 69	2 197	68	46 24	314 432
14	1 96	2 744	69	47 61	328 509
15	2 25	3 375	70	49 00	343 000
16	2 56	4 096	71	50 41	357 911
17	2 89	4 913	72	51 84	373 248
18	3 24	5 832	73	53 29	389 017
19	3 61	6 859	74	54 76	405 224
20	4 00	8 000	75	56 25	421 875
21	4 41	9 261	76	57 76	438 976
22	4 84	10 648	77	59 29	456 533
23	5 29	12 167	78	60 84	474 552
24	5 76	13 824	79	62 41	493 039
25	6 25	15 625	80	64 00	512 000
26	6 76	17 576	81	65 81	531 441
27	7 29	19 683	82	67 24	551 368
28	7 84	21 952	83	68 89	571 787
29	8 41	24 389	84	70 56	592 704
30	9 00	27 000	85	72 25	614 125
31	9 61	29 791	86	73 96	636 056
32	10 24	32 768	87	75 69	658 503
33	10 89	35 937	88	77 44	681 472
34	11 56	39 304	89	79 21	704 969
35	12 25	42 875	90	81 00	729 000
36	12 96	46 656	91	82 81	753 571
37	13 69	50 653	92	84 64	778 688
38	14 44	54 872	93	86 49	804 357
39	15 21	59 319	94	88 36	830 584
40	16 00	64 000	95	90 25	857 375
41	16 81	68 921	96	92 16	884 736
42	17 64	74 088	97	94 09	912 673
43	18 49	79 507	98	96 04	941 192
44	19 36	85 184	99	98 01	970 299
45	20 25	91 125	100	1 00 00	1 000 000
46	21 16	97 336	101	1 02 01	1 030 301
47	22 09	103 823	102	1 04 04	1 061 268
48	23 04	110 592	103	1 06 09	1 092 727
49	24 01	117 649	104	1 08 16	1 124 864
50	25 00	125 000	105	1 10 25	1 157 625
51	26 01	132 651	106	1 12 36	1 191 016
52	27 04	140 608	107	1 14 49	1 225 043
53	28 09	148 877	108	1 16 64	1 259 712
54	29 16	157 464	109	1 18 81	1 295 029
55	30 25	166 375	110	1 21 00	1 331 000

SQUARES AND CUBES—Continued.

No.	Squares.	Cubes.	No.	Squares.	Cubes.
111	1 23 21	1 367 631	166	2 75 56	4 574 296
112	1 25 44	1 404 928	167	2 78 89	4 657 463
113	1 27 69	1 442 897	168	2 82 24	4 741 632
114	1 29 96	1 481 544	169	2 85 61	4 826 809
115	1 32 25	1 520 875	170	2 89 00	4 913 000
116	1 34 56	1 560 896	171	2 92 41	5 000 211
117	1 36 89	1 601 613	172	2 95 84	5 088 448
118	1 39 24	1 643 032	173	2 99 29	5 177 717
119	1 41 61	1 685 159	174	3 02 76	5 268 024
120	1 44 00	1 728 000	175	3 06 25	5 359 375
121	1 46 41	1 771 561	176	3 09 76	5 451 776
122	1 48 84	1 815 848	177	3 13 29	5 545 233
123	1 51 29	1 860 867	178	3 16 84	5 639 752
124	1 53 76	1 906 624	179	3 20 41	5 735 339
125	1 56 25	1 953 125	180	3 24 00	5 832 000
126	1 58 76	2 000 376	181	3 27 61	5 929 741
127	1 61 29	2 048 383	182	3 31 24	6 028 568
128	1 63 84	2 097 152	183	3 34 89	6 128 487
129	1 66 41	2 146 689	184	3 38 56	6 229 504
130	1 69 00	2 197 000	185	3 42 25	6 331 625
131	1 71 61	2 248 091	186	3 45 96	6 434 856
132	1 74 24	2 299 968	187	3 49 69	6 539 203
133	1 76 89	2 352 637	188	3 53 44	6 644 672
134	1 79 56	2 406 104	189	3 57 21	6 751 269
135	1 82 25	2 460 375	190	3 61 00	6 859 000
136	1 84 96	2 515 456	191	3 64 81	6 967 871
137	1 87 69	2 571 353	192	3 68 64	7 077 888
138	1 90 44	2 628 072	193	3 72 49	7 189 057
139	1 93 21	2 685 619	194	3 76 36	7 301 384
140	1 96 00	2 744 000	195	3 80 25	7 414 875
141	1 98 81	2 803 221	196	3 84 16	7 529 536
142	2 01 64	2 863 288	197	3 88 09	7 645 373
143	2 04 49	2 924 207	198	3 92 04	7 762 392
144	2 07 36	2 985 984	199	3 96 01	7 880 599
145	2 10 25	3 048 625	200	4 00 00	8 000 000
146	2 13 16	3 112 136	201	4 04 01	8 120 601
147	2 16 09	3 176 523	202	4 08 04	8 242 408
148	2 19 04	3 241 792	203	4 12 09	8 365 427
149	2 22 01	3 307 949	204	4 16 16	8 489 664
150	2 25 00	3 375 000	205	4 20 25	8 615 125
151	2 28 01	3 442 951	206	4 24 36	8 741 816
152	2 31 04	3 511 808	207	4 28 49	8 869 743
153	2 34 09	3 581 577	208	4 32 64	8 998 912
154	2 37 16	3 652 264	209	4 36 81	9 129 329
155	2 40 25	3 723 875	210	4 41 00	9 261 000
156	2 43 36	3 796 416	211	4 45 21	9 393 931
157	2 46 49	3 869 893	212	4 49 44	9 528 128
158	2 49 64	3 944 312	213	4 53 69	9 663 597
159	2 52 81	4 019 679	214	4 57 96	9 800 344
160	2 56 00	4 096 000	215	4 62 25	9 938 375
161	2 59 21	4 173 281	216	4 66 56	10 077 646
162	2 62 44	4 251 528	217	4 70 89	10 218 313
163	2 65 69	4 330 747	218	4 75 24	10 360 232
164	2 68 96	4 410 944	219	4 79 61	10 503 459
165	2 72 25	4 492 125	220	4 84 00	10 648 000

SQUARES AND CUBES—Continued.

No.	Squares.	Cubes.	No.	Squares.	Cubes.
221	4 88 41	10 793 861	276	7 61 76	21 024 576
222	4 92 84	10 941 048	277	7 67 29	21 253 933
223	4 97 29	11 089 567	278	7 72 84	21 484 952
224	5 01 76	11 239 424	279	7 78 41	21 717 639
225	5 06 25	11 390 625	280	7 84 00	21 952 000
226	5 10 76	11 543 176	281	7 89 61	22 188 041
227	5 15 29	11 697 083	282	7 95 24	22 425 768
228	5 19 84	11 852 352	283	8 00 89	22 665 187
229	5 24 41	12 008 989	284	8 06 56	22 906 304
230	5 29 00	12 167 000	285	8 12 25	23 149 125
231	5 33 61	12 326 391	286	8 17 96	23 393 656
232	5 38 24	12 487 168	287	8 23 69	23 639 903
233	5 42 89	12 649 337	288	8 29 44	23 887 872
234	5 47 56	12 812 904	289	8 35 21	24 137 569
235	5 52 25	12 977 875	290	8 41 00	24 389 000
236	5 56 96	13 144 256	291	8 46 81	24 642 171
237	5 61 69	13 312 053	292	8 52 64	24 897 088
238	5 66 44	13 481 272	293	8 58 49	25 153 757
239	5 71 21	13 651 919	294	8 64 36	25 412 184
240	5 76 00	13 824 000	295	8 70 25	25 672 375
241	5 80 81	13 997 521	296	8 76 16	25 934 336
242	5 85 64	14 172 488	297	8 82 09	26 198 073
243	5 90 49	14 348 907	298	8 88 04	26 463 592
244	5 95 36	14 526 784	299	8 94 01	26 730 899
245	6 00 25	14 706 125	300	9 00 00	27 000 000
246	6 05 16	14 886 936	301	9 06 01	27 270 901
247	6 10 09	15 069 223	302	9 12 04	27 543 608
248	6 15 04	15 252 992	303	9 18 09	27 818 127
249	6 20 01	15 438 249	304	9 24 16	28 094 464
250	6 25 00	15 625 000	305	9 30 25	28 372 625
251	6 30 01	15 813 251	306	9 36 36	28 652 616
252	6 35 04	16 003 008	307	9 42 49	28 934 443
253	6 40 09	16 194 277	308	9 48 64	29 218 112
254	6 45 16	16 387 064	309	9 54 81	29 503 629
255	6 50 25	16 581 375	310	9 61 00	29 791 000
256	6 55 36	16 777 216	311	9 67 21	30 080 231
257	6 60 49	16 974 593	312	9 73 44	30 371 328
258	6 65 64	17 173 512	313	9 79 69	30 664 297
259	6 70 81	17 373 979	314	9 85 96	30 959 144
260	6 76 00	17 576 000	315	9 92 25	31 255 875
261	6 81 21	17 779 581	316	9 98 56	31 554 496
262	6 86 44	17 984 728	317	10 04 89	31 855 013
263	6 91 69	18 191 447	318	10 11 24	32 157 432
264	6 96 96	18 399 744	319	10 17 61	32 461 759
265	7 02 25	18 609 625	320	10 24 00	32 768 000
266	7 06 56	18 821 096	321	10 30 41	33 076 161
267	7 12 89	19 034 163	322	10 36 84	33 386 248
268	7 18 24	19 248 832	323	10 43 29	33 698 267
269	7 23 61	19 465 109	324	10 49 76	34 012 224
270	7 29 00	19 683 000	325	10 56 25	34 328 125
271	7 34 41	19 902 511	326	10 62 76	34 645 976
272	7 39 84	20 123 648	327	10 69 29	34 965 783
273	7 45 29	20 346 417	328	10 75 84	35 287 552
274	7 50 76	20 570 824	329	10 82 41	35 611 289
275	7 56 25	20 796 875	330	10 89 00	35 937 000

SQUARES AND CUBES—Continued.

No.	Squares.	Cubes.	No.	Squares.	Cubes.
331	10 95 61	36 264 691	386	14 89 96	57 512 456
332	11 02 24	36 594 368	387	14 97 69	57 960 603
333	11 08 89	36 926 037	388	15 05 44	58 411 072
334	11 15 56	37 250 704	389	15 13 21	58 863 869
335	11 22 25	37 595 375	390	15 21 00	59 319 000
336	11 28 96	37 933 056	391	15 28 81	59 776 471
337	11 35 69	38 272 753	392	15 36 64	60 236 288
338	11 42 44	38 614 472	393	15 44 49	60 698 457
339	11 49 21	38 958 219	394	15 52 36	61 162 984
340	11 56 00	39 304 000	395	15 60 25	61 629 875
341	11 62 81	39 651 821	396	15 68 16	62 099 136
342	11 69 64	40 001 688	397	15 76 09	62 570 773
343	11 76 49	40 353 607	398	15 84 04	63 044 792
344	11 83 36	40 707 584	399	15 92 01	63 521 199
345	11 90 25	41 063 625	400	16 00 00	64 000 000
346	11 97 16	41 421 736	401	16 08 01	64 481 201
347	12 04 09	41 781 923	402	16 16 04	64 964 808
348	12 11 04	42 144 192	403	16 24 09	65 450 827
349	12 18 01	42 508 549	404	16 32 16	65 939 264
350	12 25 00	42 875 000	405	16 40 25	66 430 125
351	12 32 01	43 243 551	406	16 48 36	66 923 416
352	12 39 04	43 614 208	407	16 56 49	67 419 143
353	12 46 09	43 986 977	408	16 64 64	67 917 312
354	12 53 16	44 361 864	409	16 72 81	68 417 929
355	12 60 25	44 738 875	410	16 81 00	68 921 000
356	12 67 36	45 118 016	411	16 89 21	69 426 531
357	12 74 49	45 499 293	412	16 97 44	69 934 528
358	12 81 64	45 882 712	413	17 05 69	70 444 997
359	12 88 81	46 268 279	414	17 13 96	70 957 944
360	12 96 00	46 656 000	415	17 22 25	71 473 375
361	13 03 21	47 045 881	416	17 30 56	71 991 296
362	13 10 44	47 437 928	417	17 38 89	72 511 713
363	13 17 69	47 832 147	418	17 47 24	73 034 632
364	13 24 96	48 228 544	419	17 55 61	73 560 059
365	13 32 25	48 627 125	420	17 64 00	74 088 000
366	13 39 56	49 027 896	421	17 72 41	74 618 461
367	13 46 89	49 430 863	422	17 80 84	75 151 448
368	13 54 24	49 836 032	423	17 89 29	75 686 967
369	13 61 61	50 243 409	424	17 97 76	76 225 024
370	13 69 00	50 653 000	425	18 06 25	76 765 625
371	13 76 41	51 064 811	426	18 14 76	77 308 776
372	13 83 84	51 478 848	427	18 23 29	77 854 483
373	13 91 29	51 895 117	428	18 31 84	78 402 752
374	13 98 76	52 313 624	429	18 40 41	78 953 589
375	14 06 25	52 734 375	430	18 49 00	79 507 000
376	14 13 76	53 157 376	431	18 57 61	80 062 991
377	14 21 29	53 582 633	432	18 66 24	80 621 568
378	14 28 84	54 010 152	433	18 74 89	81 182 737
379	14 36 41	54 439 939	434	18 83 56	81 746 504
380	14 44 00	54 872 000	435	18 92 25	82 312 875
381	14 51 61	55 306 341	436	19 00 96	82 881 856
382	14 59 24	55 742 968	437	19 09 69	83 453 453
383	14 66 89	56 181 887	438	19 18 44	84 027 672
384	14 74 56	56 623 104	439	19 27 21	84 604 519
385	14 82 25	56 066 625	440	19 36 00	85 184 000

THE CIRCUMFERENCE AND AREAS OF CIRCLES FROM 1 TO 50.

Diam.	Circumf.	Area.	Diam.	Circumf.	Area.	Diam.	Circumf.	Area.
1-64	.049087	.00019	2. 1-16	6.47953	3.3410	5. 3-16	16.2970	21.135
1-32	.098175	.00077	1-8	6.67588	3.5466	1-4	16.4934	21.648
3-64	.147262	.00173	3-16	6.87223	3.7583	5-16	16.6897	22.166
1-16	.196350	.00307	1-4	7.06858	3.9761	3-8	16.8861	22.691
3-32	.294524	.00690	5-16	7.26493	4.2000	7-16	17.0824	23.221
1-8	.392699	.01227	3-8	7.46128	4.4301	1-2	17.2788	23.758
5-32	.490874	.01917	7-16	7.65763	4.6664	9-16	17.4751	24.301
3-16	.589049	.02761	1-2	7.85398	4.9087	5-8	17.6715	24.850
7-32	.687223	.03758	9-16	8.05033	5.1572	11-16	17.8678	25.406
1-4	.785398	.04909	5-8	8.24668	5.4119	3-4	18.0642	25.967
9-32	.883573	.06213	11-16	8.44303	5.6727	13-16	18.2605	26.535
5-16	.981748	.07670	3-4	8.63938	5.9396	7-8	18.4569	27.109
11-32	1.07992	.09281	13-16	8.83573	6.2126	15-16	18.6532	27.688
3-8	1.17810	.11045	7-8	9.03208	6.4918	6. 1-8	18.8496	28.274
13-32	1.27627	.12962	15-16	9.22843	6.7771	1-8	19.2423	29.465
7-16	1.37445	.15033	3. 1-16	9.42478	7.0686	1-4	19.6350	30.680
15-32	1.47262	.17257	1-16	9.62113	7.3662	3-8	20.0277	31.919
1-2	1.57080	.19635	1-8	9.81748	7.6609	1-2	20.4204	33.183
17-32	1.66897	.22166	3-16	10.0138	7.9798	5-8	20.8131	34.472
9-16	1.76715	.24850	1-4	10.2102	8.2958	3-4	21.2058	35.785
19-32	1.86532	.27688	5-16	10.4065	8.6179	7-8	21.5984	37.122
5-8	1.96350	.30680	3-8	10.6029	8.9462	7. 1-8	21.9911	38.485
21-32	2.06167	.33824	7-16	10.7992	9.2806	1-8	22.3838	39.871
11-16	2.15984	.37122	1-2	10.9956	9.6211	1-4	22.7765	41.282
23-32	2.25802	.40574	9-16	11.1919	9.9678	3-8	23.1692	42.718
3-4	2.35619	.44179	5-8	11.3883	10.321	1-2	23.5619	44.179
25-32	2.45437	.47937	11-16	11.5846	10.680	5-8	23.9546	45.664
13-16	2.55254	.51849	3-4	11.7810	11.045	3-4	24.3473	47.173
27-32	2.65072	.55914	13-16	11.9773	11.416	7-8	24.7400	48.707
7-8	2.74889	.60132	7-8	12.1737	11.793	8. 1-8	25.1327	50.265
29-32	2.84707	.64504	15-16	12.3700	12.177	1-4	25.5254	51.849
15-16	2.94524	.69029	4. 1-16	12.5664	12.566	1-4	25.9181	53.456
31-32	3.04342	.73708	1-16	12.7627	12.962	3-8	26.3108	55.088
1. 3-16	3.14159	.78540	1-8	12.9591	13.364	1-2	26.7035	56.745
1-16	3.33794	.88664	3-16	13.1554	13.772	5-8	27.0962	58.426
1-8	3.53429	.99402	1-4	13.3518	14.186	3-4	27.4889	60.132
3-16	3.73064	1.1075	5-16	13.5481	14.607	7-8	27.8816	61.862
1-4	3.92699	1.2272	3-8	13.7445	15.033	9. 1-8	28.2743	63.617
5-16	4.12334	1.3530	7-16	13.9408	15.466	1-8	28.6670	65.397
3-8	4.31969	1.4849	1-2	14.1372	15.904	1-4	29.0597	67.201
7-16	4.51604	1.6230	9-16	14.3335	16.349	3-8	29.4524	69.029
1-2	4.71239	1.7671	5-8	14.5299	16.800	1-2	29.8451	70.882
9-16	4.90874	1.9175	11-16	14.7262	17.257	5-8	30.2378	72.760
5-8	5.10509	2.0739	3-4	14.9226	17.721	3-4	30.6305	74.662
11-16	5.30144	2.2365	13-16	15.1189	18.190	7-8	31.0232	76.589
3-4	5.49779	2.4053	7-8	15.3153	18.665	10. 1-8	31.4159	78.540
13-16	5.69414	2.5802	15-16	15.5116	19.147	1-4	31.8086	80.516
7-8	5.89049	2.7612	5. 1-16	15.7080	19.635	1-4	32.2013	82.516
15-16	6.08684	2.9483	1-16	15.9043	20.129	3-8	32.5940	84.541
2. 1-16	6.28319	3.1416	1-8	16.1007	20.629	1-2	32.9867	86.590

CIRCUMFERENCE AND AREAS OF CIRCLES—Continued.

Diam.	Circumf.	Area.	Diam.	Circumf.	Area.	Diam.	Circumf.	Area.
10. 5-8	33.3794	88.664	17. 1-4	54.1925	233.71	23. 7-8	75.0055	447.69
3-4	33.7721	90.763	3-8	54.5852	237.10	24.	75.3982	452.39
7-8	34.1648	92.886	1-2	54.9779	240.53	1-8	75.7909	457.11
11.	34.5575	95.033	5-8	55.3706	243.98	1-4	76.1836	461.86
1-8	34.9502	97.205	3-4	55.7633	247.45	3-8	76.5763	466.64
1-4	35.3429	99.402	7-8	56.1560	250.95	1-2	76.9690	471.44
3-8	35.7356	101.62	18.	56.5487	254.47	5-8	77.3617	476.26
1-2	36.1283	103.87	1-8	56.9414	258.02	3-4	77.7544	481.11
5-8	36.5210	106.14	1-4	57.3341	261.59	7-8	78.1471	485.98
3-4	36.9137	108.43	3-8	57.7268	265.18	25.	78.5398	490.87
7-8	37.3064	110.75	1-2	58.1195	268.80	1-8	78.9325	495.79
12.	37.6991	113.10	5-8	58.5122	272.45	1-4	79.3252	500.74
1-8	38.0918	115.47	3-4	58.9049	276.12	3-8	79.7179	505.71
1-4	38.4845	117.86	7-8	59.2976	279.81	1-2	80.1106	510.71
3-8	38.8772	120.28	19.	59.6903	283.53	5-8	80.5033	515.72
1-2	39.2699	122.72	1-8	60.0830	287.27	3-4	80.8960	520.77
5-8	39.6626	125.19	1-4	60.4757	291.04	7-8	81.2887	525.84
3-4	40.0553	127.68	3-8	60.8684	294.83	26.	81.6814	530.93
7-8	40.4480	130.19	1-2	61.2611	298.65	1-8	82.0741	536.05
13.	40.8407	132.73	5-8	61.6538	302.49	1-4	82.4668	541.19
1-8	41.2334	135.30	3-4	62.0465	306.35	3-8	82.8595	546.35
1-4	41.6261	137.89	7-8	62.4392	310.24	1-2	83.2522	551.55
3-8	42.0188	140.50	20.	62.8319	314.16	5-8	83.6449	556.76
1-2	42.4115	143.14	1-8	63.2246	318.10	3-4	84.0376	562.00
5-8	42.8042	145.80	1-4	63.6173	322.06	7-8	84.4303	567.27
3-4	43.1969	148.49	3-8	64.0100	326.05	27.	84.8230	572.56
7-8	43.5896	151.20	1-2	64.4026	330.06	1-8	85.2157	577.87
14.	43.9823	153.94	5-8	64.7953	334.10	1-4	85.6084	583.21
1-8	44.3750	156.70	3-4	65.1880	338.16	3-8	86.0011	588.57
1-4	44.7677	159.48	7-8	65.5807	342.25	1-2	86.3938	593.96
3-8	45.1604	162.30	21.	65.9734	346.36	5-8	86.7865	599.37
1-2	45.5531	165.13	1-8	66.3661	350.50	3-4	87.1792	604.81
5-8	45.9458	167.99	1-4	66.7588	354.66	7-8	87.5719	610.27
3-4	46.3385	170.87	3-8	67.1515	358.84	28.	87.9646	615.75
7-8	46.7312	173.78	1-2	67.5442	363.05	1-8	88.3573	621.26
15.	47.1239	176.71	5-8	67.9369	367.28	1-4	88.7500	626.80
1-8	47.5166	179.67	3-4	68.3296	371.54	3-8	89.1427	632.36
1-4	47.9093	182.65	7-8	68.7223	375.83	1-2	89.5354	637.94
3-8	48.3020	185.66	22.	69.1150	380.13	5-8	89.9281	643.55
1-2	48.6947	188.69	1-8	69.5077	384.46	3-4	90.3208	649.18
5-8	49.0874	191.75	1-4	69.9004	388.82	7-8	90.7135	654.84
3-4	49.4801	194.83	3-8	70.2931	393.20	29.	91.1062	660.52
7-8	49.8728	197.93	1-2	70.6858	397.61	1-8	91.4989	666.23
16.	50.2655	201.06	5-8	71.0785	402.04	1-4	91.8916	671.96
1-8	50.6582	204.22	3-4	71.4712	406.49	3-8	92.2843	677.71
1-4	51.0509	207.39	7-8	71.8639	410.97	1-2	92.6770	683.49
3-8	51.4436	210.60	23.	72.2566	415.48	5-8	93.0697	689.30
1-2	51.8363	213.82	1-8	72.6493	420.00	3-4	93.4624	695.13
5-8	52.2290	217.08	1-4	73.0420	424.56	7-8	93.8551	700.98
3-4	52.6217	220.35	3-8	73.4347	429.13	1-8	94.2478	706.86
7-8	53.0144	223.65	1-2	73.8274	433.74	1-4	94.6405	712.76
17.	53.4071	226.98	5-8	74.2201	438.36	3-8	95.0332	718.69
1-8	53.7998	230.33	3-4	74.6128	443.01		95.4259	724.64

CIRCUMFERENCE AND AREAS OF CIRCLES—Continued.

Diam.	Circumf.	Area.	Diam.	Circumf.	Area.	Diam.	Circumf.	Area.
30. 1-2	95.8186	730.62	37.	116.239	1075.2	43. 1-2	136.659	1486.2
5-8	96.2113	736.62	1-8	116.632	1082.5	5-8	137.052	1494.7
3-4	96.6040	742.64	1-4	117.024	1089.8	3-4	137.445	1503.3
7-8	96.9967	748.69	3-8	117.417	1097.1	7-8	137.837	1511.9
31. 1-8	97.3894	754.77	1-2	117.810	1104.5	44.	138.230	1520.5
1-4	97.7821	760.87	5-8	118.202	1111.8	1-8	138.623	1529.2
3-8	98.1748	766.99	3-4	118.596	1119.2	1-4	139.015	1537.9
3-8	98.5675	773.14	7-8	118.988	1126.7	3-8	139.408	1546.6
1-2	98.9602	779.31	38.	119.381	1134.1	1-2	139.801	1555.3
5-8	99.3529	785.51	1-8	119.773	1141.6	5-8	140.194	1564.0
3-4	99.7456	791.73	1-4	120.166	1149.1	3-4	140.586	1572.8
7-8	100.138	797.98	3-8	120.559	1156.6	7-8	140.979	1581.6
32.	100.531	804.25	1-2	120.951	1164.2	45.	141.372	1590.4
1-8	100.924	810.54	5-8	121.344	1171.7	1-8	141.764	1599.3
1-4	101.316	816.86	3-4	121.737	1179.3	1-4	142.157	1608.2
3-8	101.709	823.21	7-8	122.129	1186.9	3-8	142.550	1617.0
1-2	102.102	829.58	39.	122.522	1194.6	1-2	142.942	1626.0
5-8	102.494	835.97	1-8	122.915	1202.3	5-8	143.335	1634.9
3-4	102.887	842.39	1-4	123.308	1210.0	3-4	143.728	1643.9
7-8	103.280	848.83	3-8	123.700	1217.7	7-8	144.121	1652.9
33.	103.673	855.30	1-2	124.093	1225.4	46.	144.513	1661.9
1-8	104.065	861.79	5-8	124.486	1233.2	1-8	144.906	1670.9
1-4	104.458	868.31	3-4	124.878	1241.0	1-4	145.299	1680.0
3-8	104.851	874.85	7-8	125.271	1248.8	3-8	145.691	1689.1
1-2	105.243	881.41	40.	125.664	1256.6	1-2	146.084	1698.2
5-8	105.636	888.00	1-8	126.056	1264.5	5-8	146.477	1707.4
3-4	106.029	894.62	1-4	126.449	1272.4	3-4	146.869	1716.5
7-8	106.421	901.26	3-8	126.842	1280.3	7-8	147.262	1725.7
34.	106.814	907.92	1-2	127.235	1288.2	47.	147.655	1734.9
1-8	107.207	914.61	5-8	127.627	1296.2	1-8	148.048	1744.2
1-4	107.600	921.32	3-4	128.020	1304.2	1-4	148.440	1753.5
3-8	107.992	928.06	7-8	128.413	1312.2	3-8	148.833	1762.7
1-2	108.385	934.82	41.	128.805	1320.3	1-2	149.226	1772.1
5-8	108.778	941.61	1-8	129.198	1328.3	5-8	149.618	1781.4
3-4	109.170	948.42	1-4	129.591	1336.4	3-4	150.011	1790.8
7-8	109.563	955.25	3-8	129.993	1344.5	7-8	150.404	1800.1
35.	109.956	962.11	1-2	130.376	1352.7	48.	150.796	1809.6
1-8	110.348	969.00	5-8	130.769	1360.8	1-8	151.189	1819.0
1-4	110.741	975.91	3-4	131.161	1369.0	1-4	151.582	1828.5
3-8	111.134	982.84	7-8	131.554	1377.2	3-8	151.975	1837.9
1-2	111.527	989.80	42.	131.947	1385.4	1-2	152.367	1847.5
5-8	111.919	996.78	1-8	132.340	1393.7	5-8	152.760	1857.0
3-4	112.312	1003.8	1-4	132.732	1402.0	3-4	153.153	1866.5
7-8	112.705	1010.8	3-8	133.125	1410.3	7-8	153.545	1876.1
36.	113.097	1017.9	1-2	133.518	1418.6	49.	153.938	1885.7
1-8	113.490	1025.0	5-8	133.910	1427.0	1-8	154.331	1895.4
1-4	113.883	1032.1	3-4	134.303	1435.4	1-4	154.723	1905.0
3-8	114.275	1039.2	7 8	134.696	1443.8	3-8	155.116	1914.7
1-2	114.668	1046.3	43.	135.088	1452.2	1-2	155.509	1924.4
5-8	115.061	1053.5	1-8	135.481	1460.7	5-8	155.902	1934.2
3-4	115.454	1060.7	1-4	135.874	1469.1	3-4	156.294	1943.9
7-8	115.846	1068.0	3-8	136.267	1477.6	7-8	156.687	1953.7

TABLE OF WEIGHT OF FLAT IRON.

WEIGHT PER FOOT OF FLAT IRON.

(For weight per foot of steel add 2 per cent.)

Breadth in inches.	THICKNESS IN FRACTIONS OF INCHES.										
	$\frac{1}{16}$	$\frac{1}{8}$	$\frac{3}{16}$	$\frac{1}{4}$	$\frac{5}{16}$	$\frac{3}{8}$	$\frac{7}{16}$	$\frac{1}{2}$	$\frac{9}{16}$	$\frac{5}{8}$	$\frac{11}{16}$
1	.208	.417	.625	.833	1.04	1.25	1.46	1.67	1.88	2.08	2.29
1 $\frac{1}{16}$.234	.469	.703	.938	1.17	1.41	1.64	1.87	2.11	2.34	2.58
1 $\frac{1}{8}$.260	.521	.781	1.04	1.30	1.56	1.82	2.08	2.34	2.60	2.86
1 $\frac{1}{4}$.286	.573	.859	1.15	1.43	1.72	2.01	2.29	2.58	2.86	3.15
1 $\frac{1}{2}$.313	.625	.938	1.25	1.56	1.88	2.19	2.50	2.81	3.13	3.44
1 $\frac{3}{8}$.339	.677	1.02	1.36	1.69	2.03	2.37	2.71	3.05	3.39	3.73
1 $\frac{1}{2}$.365	.729	1.09	1.46	1.82	2.19	2.55	2.92	3.28	3.65	4.01
1 $\frac{3}{4}$.391	.781	1.17	1.56	1.95	2.34	2.73	3.12	3.51	3.91	4.30
2	.417	.833	1.25	1.67	2.08	2.50	2.92	3.33	3.75	4.17	4.58
2 $\frac{1}{16}$.443	.886	1.33	1.77	2.21	2.65	3.10	3.54	3.98	4.43	4.87
2 $\frac{1}{8}$.469	.938	1.41	1.88	2.34	2.81	3.28	3.75	4.22	4.69	5.16
2 $\frac{1}{4}$.495	.990	1.48	1.98	2.47	2.97	3.46	3.96	4.46	4.95	5.44
2 $\frac{1}{2}$.521	1.04	1.56	2.08	2.60	3.13	3.65	4.17	4.69	5.21	5.73
2 $\frac{3}{8}$.547	1.09	1.64	2.19	2.73	3.28	3.83	4.38	4.92	5.47	6.02
2 $\frac{1}{2}$.573	1.15	1.72	2.29	2.86	3.44	4.01	4.58	5.16	5.73	6.30
2 $\frac{3}{4}$.599	1.20	1.80	2.40	3.00	3.60	4.20	4.79	5.39	5.99	6.59
3	.625	1.25	1.88	2.50	3.13	3.75	4.38	5.00	5.63	6.25	6.88
3 $\frac{1}{16}$.677	1.35	2.03	2.71	3.39	4.06	4.74	5.42	6.09	6.77	7.45
3 $\frac{1}{8}$.729	1.46	2.19	2.92	3.65	4.38	5.10	5.83	6.56	7.29	8.02
3 $\frac{1}{4}$.781	1.56	2.34	3.13	3.91	4.69	5.47	6.25	7.03	7.81	8.59
4	.833	1.67	2.50	3.33	4.17	5.00	5.83	6.67	7.50	8.33	9.17
4 $\frac{1}{16}$.885	1.77	2.66	3.54	4.43	5.31	6.20	7.08	7.97	8.85	9.74
4 $\frac{1}{8}$.938	1.88	2.81	3.75	4.69	5.63	6.56	7.50	8.44	9.38	10.31
4 $\frac{1}{4}$.990	1.98	2.97	3.96	4.95	5.94	6.93	7.92	8.91	9.90	10.89
5	1.042	2.08	3.13	4.17	5.21	6.25	7.29	8.33	9.38	10.42	11.46
5 $\frac{1}{16}$	1.09	2.19	3.28	4.38	5.47	6.56	7.66	8.75	9.84	10.94	11.03
5 $\frac{1}{8}$	1.15	2.29	3.44	4.58	5.73	6.88	8.02	9.17	10.31	11.46	12.60
5 $\frac{1}{4}$	1.20	2.40	3.59	4.79	5.99	7.19	8.39	9.58	10.78	11.98	13.18
6	1.25	2.50	3.75	5.00	6.25	7.50	8.75	10.00	11.25	12.50	13.75
6 $\frac{1}{16}$	1.30	2.60	3.91	5.21	6.51	7.81	9.11	10.42	11.72	13.02	14.32
6 $\frac{1}{8}$	1.35	2.71	4.06	5.42	6.77	8.13	9.48	10.83	12.19	13.54	14.90
6 $\frac{1}{4}$	1.41	2.81	4.22	5.63	7.03	8.44	9.84	11.25	12.66	14.06	15.47
7	1.46	2.92	4.38	5.83	7.29	8.75	10.21	11.67	13.13	14.58	16.04
7 $\frac{1}{16}$	1.51	3.02	4.53	6.04	7.55	9.06	10.57	12.08	13.59	15.10	16.61
7 $\frac{1}{8}$	1.56	3.13	4.69	6.25	7.81	9.38	10.94	12.50	14.06	15.63	17.19
7 $\frac{1}{4}$	1.61	3.23	4.84	6.46	8.07	9.69	11.30	12.92	14.53	16.15	17.76
8	1.67	3.33	5.00	6.67	8.33	10.00	11.67	13.33	15.00	16.67	18.33
8 $\frac{1}{16}$	1.72	3.44	5.16	6.88	8.59	10.31	12.03	13.75	15.47	17.19	18.91
8 $\frac{1}{8}$	1.77	3.54	5.31	7.08	8.85	10.63	12.46	14.17	15.94	17.71	19.48
8 $\frac{1}{4}$	1.82	3.65	5.47	7.29	9.11	10.94	12.76	14.58	16.41	18.23	20.05
9	1.88	3.75	5.63	7.50	9.38	11.25	13.13	15.00	16.88	18.75	20.63
9 $\frac{1}{16}$	1.93	3.85	5.78	7.71	9.64	11.56	13.49	15.42	17.14	19.27	21.20
9 $\frac{1}{8}$	1.98	3.96	5.94	7.92	9.90	11.88	13.85	15.83	17.81	19.79	21.77
9 $\frac{1}{4}$	2.03	4.06	6.09	8.13	10.16	12.19	14.22	16.25	18.28	20.31	22.34
10	2.08	4.17	6.25	8.33	10.42	12.50	14.58	16.67	18.75	20.83	22.92
10 $\frac{1}{16}$	2.14	4.27	6.41	8.54	10.68	12.81	14.95	17.08	19.22	21.35	23.49
10 $\frac{1}{8}$	2.19	4.38	6.56	8.75	10.94	13.13	15.31	17.50	19.69	21.88	24.06
10 $\frac{1}{4}$	2.24	4.48	6.72	8.96	11.20	13.44	15.68	17.92	20.16	22.40	24.64
11	2.29	4.58	6.88	9.17	11.46	13.75	16.04	18.33	20.63	22.92	25.21
11 $\frac{1}{16}$	2.34	4.69	7.03	9.38	11.72	14.06	16.41	18.75	21.09	23.44	25.78
11 $\frac{1}{8}$	2.40	4.79	7.19	9.58	11.98	14.38	16.77	19.17	21.56	23.96	26.35
11 $\frac{1}{4}$	2.45	4.90	7.34	9.79	12.24	14.70	17.14	19.58	22.03	24.48	26.93
12	2.50	5.00	7.50	10.00	12.50	15.00	17.50	20.00	22.50	25.00	27.50

WEIGHT PER FOOT OF FLAT IRON—Continued.

(For weight per foot of steel add 2 per cent.)

Breadth in inches.	THICKNESS IN FRACTIONS OF INCHES.										
	$\frac{1}{8}$	$\frac{13}{128}$	$\frac{1}{4}$	$\frac{15}{128}$	$\frac{1}{2}$	$\frac{17}{128}$	$\frac{3}{8}$	$\frac{19}{128}$	$\frac{1}{2}$	$\frac{21}{128}$	
1	2.50	2.71	2.92	3.13	3.33	3.54	3.75	3.96	4.17	4.37	4.58
1 $\frac{1}{8}$	2.81	3.05	3.28	3.52	3.75	3.98	4.22	4.45	4.69	4.92	5.16
1 $\frac{1}{4}$	3.13	3.39	3.65	3.91	4.17	4.43	4.69	4.95	5.21	5.47	5.73
1 $\frac{3}{8}$	3.44	3.72	4.01	4.30	4.58	4.87	5.16	5.44	5.73	6.02	6.30
1 $\frac{1}{2}$	3.75	4.06	4.38	4.69	5.00	5.31	5.63	5.94	6.25	6.56	6.88
1 $\frac{5}{8}$	4.06	4.40	4.74	5.08	5.42	5.75	6.09	6.43	6.77	7.11	7.45
1 $\frac{3}{4}$	4.38	4.74	5.10	5.47	5.83	6.20	6.56	6.93	7.29	7.66	8.02
1 $\frac{7}{8}$	4.69	5.08	5.47	5.86	6.25	6.64	7.03	7.42	7.81	8.20	8.59
2	5.00	5.42	5.83	6.25	6.67	7.08	7.50	7.92	8.33	8.75	9.17
2 $\frac{1}{8}$	5.31	5.75	6.20	6.64	7.08	7.52	7.97	8.41	8.85	9.30	9.74
2 $\frac{1}{4}$	5.63	6.09	6.56	7.03	7.50	7.97	8.44	8.91	9.38	9.84	10.31
2 $\frac{3}{8}$	5.94	6.43	6.93	7.42	7.92	8.41	8.91	9.40	9.90	10.39	10.89
2 $\frac{1}{2}$	6.25	6.77	7.29	7.81	8.33	8.85	9.38	9.90	10.42	10.94	11.46
2 $\frac{5}{8}$	6.56	7.11	7.66	8.20	8.75	9.30	9.84	10.39	10.94	11.48	12.03
2 $\frac{3}{4}$	6.88	7.45	8.02	8.59	9.17	9.74	10.31	10.89	11.46	12.03	12.60
2 $\frac{7}{8}$	7.19	7.79	8.39	8.98	9.58	10.18	10.78	11.38	11.98	12.58	13.18
3	7.50	8.13	8.75	9.38	10.00	10.63	11.25	11.88	12.50	13.13	13.75
3 $\frac{1}{8}$	8.13	8.80	9.48	10.16	10.83	11.51	12.19	12.86	13.54	14.22	14.90
3 $\frac{1}{4}$	8.75	9.48	10.21	10.94	11.67	12.40	13.13	13.85	14.58	15.31	16.04
3 $\frac{3}{8}$	9.38	10.16	10.94	11.72	12.50	13.28	14.06	14.84	15.63	16.41	17.19
4	10.00	10.83	11.67	12.50	13.33	14.17	15.00	15.83	16.67	17.50	18.33
4 $\frac{1}{8}$	10.63	11.51	12.40	13.28	14.17	15.05	15.94	16.82	17.71	18.59	19.48
4 $\frac{1}{4}$	11.25	12.19	13.13	14.06	15.00	15.94	16.88	17.81	18.75	19.69	20.63
4 $\frac{3}{8}$	11.88	12.86	13.85	14.84	15.83	16.82	17.81	18.80	19.79	20.78	21.77
5	12.50	13.54	14.58	15.63	16.67	17.71	18.75	19.79	20.83	21.88	22.92
5 $\frac{1}{8}$	13.13	14.22	15.31	16.41	17.50	18.59	19.69	20.78	21.88	22.97	24.06
5 $\frac{1}{4}$	13.75	14.90	16.04	17.19	18.33	19.48	20.63	21.77	22.92	24.06	25.21
5 $\frac{3}{8}$	14.38	15.57	16.77	17.97	19.17	20.36	21.56	22.76	23.96	25.16	26.35
6	15.00	16.25	17.50	18.75	20.00	21.25	22.50	23.75	25.00	26.25	27.50
6 $\frac{1}{8}$	15.63	16.93	18.23	19.53	20.83	22.14	23.44	24.74	26.04	27.34	28.65
6 $\frac{1}{4}$	16.25	17.60	18.96	20.31	21.67	23.02	24.38	25.73	27.08	28.44	29.79
6 $\frac{3}{8}$	16.88	18.28	19.69	21.09	22.50	23.91	25.31	26.72	28.13	29.53	30.94
7	17.50	18.96	20.42	21.88	23.33	24.79	26.25	27.71	29.17	30.62	32.08
7 $\frac{1}{8}$	18.13	19.64	21.15	22.66	24.17	25.68	27.19	28.70	30.21	31.72	33.23
7 $\frac{1}{4}$	18.75	20.31	21.88	23.44	25.00	26.56	28.13	29.69	31.25	32.81	34.38
7 $\frac{3}{8}$	19.38	20.99	22.60	24.22	25.83	27.45	29.06	30.68	32.29	33.91	35.52
8	20.00	21.67	23.33	25.00	26.67	28.33	30.00	31.67	33.33	35.00	36.67
8 $\frac{1}{8}$	20.63	22.34	24.06	25.78	27.50	29.22	30.94	32.66	34.38	36.09	37.81
8 $\frac{1}{4}$	21.25	23.02	24.79	26.56	28.33	30.10	31.88	33.65	35.42	37.19	38.96
8 $\frac{3}{8}$	21.88	23.70	25.52	27.34	29.17	30.99	32.81	34.64	36.46	38.28	40.10
9	22.50	24.38	26.25	28.13	30.00	31.88	33.75	35.63	37.50	39.38	41.25
9 $\frac{1}{8}$	23.13	25.05	26.98	28.91	30.83	32.76	34.69	36.61	38.54	40.47	42.40
9 $\frac{1}{4}$	23.75	25.73	27.71	29.69	31.67	33.65	35.63	37.60	39.53	41.56	43.54
9 $\frac{3}{8}$	24.38	26.41	28.44	30.47	32.50	34.53	36.56	38.59	40.63	42.66	44.69
10	25.00	27.08	29.17	31.25	33.33	35.42	37.50	39.58	41.67	43.75	45.83
10 $\frac{1}{8}$	25.62	27.76	29.90	32.03	34.17	36.30	38.44	40.57	42.71	44.84	46.98
10 $\frac{1}{4}$	26.25	28.44	30.63	32.81	35.00	37.19	39.38	41.56	43.75	45.94	48.13
10 $\frac{3}{8}$	26.88	29.11	31.35	33.59	35.83	38.07	40.31	42.55	44.79	47.03	49.27
11	27.50	29.79	32.08	34.38	36.67	38.96	41.25	43.54	45.83	48.13	50.42
11 $\frac{1}{8}$	28.13	30.47	32.81	35.16	37.50	39.84	42.19	44.53	46.88	49.22	51.56
11 $\frac{1}{4}$	28.75	31.15	33.54	35.94	38.33	40.73	43.13	45.52	47.92	50.31	52.71
11 $\frac{3}{8}$	29.38	31.82	34.27	36.72	39.17	41.61	44.06	46.51	48.96	51.41	53.85
12	30.00	32.50	35.00	37.50	40.00	42.50	45.00	47.50	50.00	52.50	55.00

178 DECIMAL EQUIVALENTS FOR FRACTIONS OF AN INCH.

NUMBER OF U. S. GALLONS (231 CUBIC INCHES) CONTAINED IN CIRCULAR TANKS.

Depth in feet.										
	1	2	3	4	5	6	7	8	9	10
Dia.	Gals.	Gals.	Gals.	Gals.	Gals.	Gals.	Gals.	Gals.	Gals.	Gals.
In.										
20	16.32	32.64	48.96	65.28	81.60	97.92	114.24	130.56	146.88	163.20
24	23.50	47.00	70.50	94.00	117.50	141.00	164.50	188.00	211.50	235.00
26	27.58	55.16	82.74	110.32	137.90	165.48	193.06	220.64	248.22	275.80
28	31.99	63.98	95.97	127.96	159.95	191.94	223.93	255.92	288.91	319.90
30	36.72	73.44	110.16	146.88	183.60	220.32	257.04	293.76	330.48	367.20
36	52.88	105.76	158.64	211.52	264.40	317.28	370.16	423.04	475.92	528.80
42	71.96	143.92	215.88	287.84	359.80	431.76	503.72	575.68	647.64	719.60
45	82.62	165.24	247.86	330.48	413.10	495.72	578.34	660.96	743.58	826.20
48	94.02	188.04	282.06	376.08	470.10	564.12	658.14	752.16	846.18	940.20
50	102.00	204.00	306.00	408.00	510.00	612.00	714.00	816.00	918.00	1020.00
54	119.00	238.00	357.00	476.00	595.00	714.00	833.00	952.00	1071.00	1190.00
60	146.90	293.80	440.70	587.60	734.50	881.40	1028.30	1175.20	1322.10	1469.00
66	177.70	355.40	533.10	710.80	888.50	1066.20	1243.90	1421.60	1599.20	1777.00
72	211.50	423.00	634.50	846.00	1057.50	1269.00	1480.50	1692.00	1903.50	2115.00
84	287.80	575.60	863.40	1151.20	1439.00	1726.80	2014.60	2302.40	2590.20	2878.00

DECIMAL EQUIVALENTS FOR FRACTIONS OF AN INCH.

Fraction.	Decimal.	Fraction.	Decimal.	Fraction.	Decimal.	Fraction.	Decimal.
$\frac{1}{64}$.015625	$\frac{17}{64}$.265625	$\frac{33}{64}$.515625	$\frac{49}{64}$.765625
$\frac{1}{32}$.03125	$\frac{9}{32}$.28125	$\frac{17}{32}$.53125	$\frac{25}{32}$.78125
$\frac{3}{64}$.046875	$\frac{19}{64}$.296875	$\frac{35}{64}$.546875	$\frac{51}{64}$.796875
$\frac{1}{8}$.0625	$\frac{5}{8}$.3125	$\frac{9}{16}$.5625	$\frac{13}{16}$.8125
$\frac{5}{64}$.078125	$\frac{21}{64}$.328125	$\frac{37}{64}$.578125	$\frac{53}{64}$.828125
$\frac{3}{32}$.09375	$\frac{11}{32}$.34375	$\frac{19}{32}$.59375	$\frac{27}{32}$.84375
$\frac{7}{64}$.109375	$\frac{23}{64}$.359375	$\frac{39}{64}$.609375	$\frac{55}{64}$.859375
$\frac{1}{8}$.125	$\frac{5}{8}$.375	$\frac{7}{8}$.625	$\frac{3}{4}$.875
$\frac{9}{64}$.140625	$\frac{25}{64}$.390625	$\frac{41}{64}$.640625	$\frac{57}{64}$.890625
$\frac{5}{32}$.15625	$\frac{13}{32}$.40625	$\frac{21}{32}$.65625	$\frac{29}{32}$.90625
$\frac{11}{64}$.171875	$\frac{21}{64}$.421875	$\frac{33}{64}$.671875	$\frac{41}{64}$.921875
$\frac{3}{16}$.1875	$\frac{7}{16}$.4375	$\frac{11}{16}$.6875	$\frac{15}{16}$.9375
$\frac{13}{64}$.203125	$\frac{29}{64}$.453125	$\frac{45}{64}$.703125	$\frac{61}{64}$.953125
$\frac{7}{32}$.21875	$\frac{15}{32}$.46875	$\frac{23}{32}$.71875	$\frac{31}{32}$.96875
$\frac{15}{64}$.234375	$\frac{31}{64}$.484375	$\frac{47}{64}$.734375	$\frac{63}{64}$.984375
$\frac{1}{4}$.25	$\frac{1}{2}$.5	$\frac{3}{4}$.75		

DECIMAL EQUIVALENTS FOR FRACTIONS OF A FOOT.

$\frac{1}{16}$.0052	$3\frac{1}{16}$.2552	$6\frac{1}{16}$.5052	$9\frac{1}{16}$.7552
$\frac{2}{16}$.0104	$3\frac{2}{16}$.2604	$6\frac{2}{16}$.5104	$9\frac{2}{16}$.7604
$\frac{3}{16}$.0156	$3\frac{3}{16}$.2656	$6\frac{3}{16}$.5156	$9\frac{3}{16}$.7656
$\frac{1}{8}$.0208	$3\frac{4}{16}$.2708	$6\frac{4}{16}$.5208	$9\frac{4}{16}$.7708
$\frac{2}{8}$.0260	$3\frac{5}{16}$.2760	$6\frac{5}{16}$.5260	$9\frac{5}{16}$.7760
$\frac{3}{8}$.0312	$3\frac{6}{16}$.2812	$6\frac{6}{16}$.5312	$9\frac{6}{16}$.7812
$\frac{7}{16}$.0364	$3\frac{7}{16}$.2865	$6\frac{7}{16}$.5364	$9\frac{7}{16}$.7865
$\frac{1}{2}$.0417	$3\frac{8}{16}$.2917	$6\frac{8}{16}$.5411	$9\frac{8}{16}$.7917
$\frac{9}{16}$.0469	$3\frac{9}{16}$.2969	$6\frac{9}{16}$.5469	$9\frac{9}{16}$.7969
$\frac{5}{8}$.0521	$3\frac{10}{16}$.3021	$6\frac{10}{16}$.5521	$9\frac{10}{16}$.8021
$\frac{11}{16}$.0573	$3\frac{11}{16}$.3073	$6\frac{11}{16}$.5573	$9\frac{11}{16}$.8073
$\frac{3}{4}$.0625	$3\frac{12}{16}$.3125	$6\frac{12}{16}$.5625	$9\frac{12}{16}$.8125
$1\frac{1}{16}$.0677	$3\frac{13}{16}$.3177	$6\frac{13}{16}$.5677	$9\frac{13}{16}$.8177
$\frac{5}{8}$.0729	$3\frac{14}{16}$.3229	$6\frac{14}{16}$.5729	$9\frac{14}{16}$.8229
$1\frac{1}{8}$.0781	$3\frac{15}{16}$.3281	$6\frac{15}{16}$.5781	$9\frac{15}{16}$.8281
1	.0833	4	.3333	7	.5833	10	.8333
$1\frac{1}{8}$.0885	$4\frac{1}{16}$.3385	$7\frac{1}{16}$.5885	$10\frac{1}{16}$.8385
$1\frac{1}{4}$.0937	$4\frac{2}{16}$.3437	$7\frac{2}{16}$.5937	$10\frac{2}{16}$.8437
$1\frac{3}{8}$.0990	$4\frac{3}{16}$.3490	$7\frac{3}{16}$.5990	$10\frac{3}{16}$.8490
$1\frac{1}{2}$.1042	$4\frac{4}{16}$.3542	$7\frac{4}{16}$.6042	$10\frac{4}{16}$.8542
$1\frac{5}{8}$.1094	$4\frac{5}{16}$.3594	$7\frac{5}{16}$.6094	$10\frac{5}{16}$.8594
$1\frac{3}{4}$.1146	$4\frac{6}{16}$.3646	$7\frac{6}{16}$.6146	$10\frac{6}{16}$.8646
$1\frac{7}{8}$.1198	$4\frac{7}{16}$.3698	$7\frac{7}{16}$.6198	$10\frac{7}{16}$.8698
$1\frac{1}{2}$.1250	$4\frac{8}{16}$.3750	$7\frac{8}{16}$.6250	$10\frac{8}{16}$.8750
$1\frac{9}{16}$.1302	$4\frac{9}{16}$.3802	$7\frac{9}{16}$.6302	$10\frac{9}{16}$.8802
$1\frac{5}{8}$.1354	$4\frac{10}{16}$.3854	$7\frac{10}{16}$.6354	$10\frac{10}{16}$.8854
$1\frac{11}{16}$.1406	$4\frac{11}{16}$.3906	$7\frac{11}{16}$.6406	$10\frac{11}{16}$.8906
$1\frac{3}{4}$.1458	$4\frac{12}{16}$.3958	$7\frac{12}{16}$.6458	$10\frac{12}{16}$.8958
$1\frac{13}{16}$.1510	$4\frac{13}{16}$.4010	$7\frac{13}{16}$.6510	$10\frac{13}{16}$.9010
$1\frac{3}{8}$.1562	$4\frac{14}{16}$.4062	$7\frac{14}{16}$.6562	$10\frac{14}{16}$.9062
$1\frac{5}{8}$.1615	$4\frac{15}{16}$.4114	$7\frac{15}{16}$.6615	$10\frac{15}{16}$.9115
2	.1667	5	.4167	8	.6667	11	.9167
$2\frac{1}{16}$.1719	$5\frac{1}{16}$.4219	$8\frac{1}{16}$.6719	$11\frac{1}{16}$.9219
$2\frac{1}{8}$.1771	$5\frac{2}{16}$.4271	$8\frac{2}{16}$.6771	$11\frac{2}{16}$.9271
$2\frac{3}{16}$.1823	$5\frac{3}{16}$.4323	$8\frac{3}{16}$.6823	$11\frac{3}{16}$.9323
$2\frac{1}{4}$.1875	$5\frac{4}{16}$.4375	$8\frac{4}{16}$.6875	$11\frac{4}{16}$.9375
$2\frac{5}{16}$.1927	$5\frac{5}{16}$.4427	$8\frac{5}{16}$.6927	$11\frac{5}{16}$.9427
$2\frac{3}{8}$.1979	$5\frac{6}{16}$.4479	$8\frac{6}{16}$.6979	$11\frac{6}{16}$.9479
$2\frac{7}{16}$.2031	$5\frac{7}{16}$.4531	$8\frac{7}{16}$.7031	$11\frac{7}{16}$.9531
$2\frac{1}{2}$.2083	$5\frac{8}{16}$.4583	$8\frac{8}{16}$.7083	$11\frac{8}{16}$.9583
$2\frac{9}{16}$.2135	$5\frac{9}{16}$.4635	$8\frac{9}{16}$.7135	$11\frac{9}{16}$.9635
$2\frac{5}{8}$.2187	$5\frac{10}{16}$.4688	$8\frac{10}{16}$.7187	$11\frac{10}{16}$.9687
$2\frac{11}{16}$.2240	$5\frac{11}{16}$.4740	$8\frac{11}{16}$.7240	$11\frac{11}{16}$.9740
$2\frac{3}{4}$.2292	$5\frac{12}{16}$.4792	$8\frac{12}{16}$.7292	$11\frac{12}{16}$.9792
$2\frac{13}{16}$.2344	$5\frac{13}{16}$.4844	$8\frac{13}{16}$.7344	$11\frac{13}{16}$.9844
$2\frac{7}{8}$.2395	$5\frac{14}{16}$.4896	$8\frac{14}{16}$.7396	$11\frac{14}{16}$.9896
$2\frac{15}{16}$.2448	$5\frac{15}{16}$.4948	$8\frac{15}{16}$.7448	$11\frac{15}{16}$.9948
3	.2500	6	.5000	9	.7500	12	1.000

WEIGHT OF 100 BOLTS WITH SQUARE HEADS AND NUTS.
(HOOPES & TOWNSEND'S LIST.)

Length under head to point.	Diameter of Bolts.								
	$\frac{1}{4}$ in.	$\frac{3}{8}$ in.	$\frac{1}{2}$ in.	$\frac{7}{8}$ in.	1 in.	$\frac{5}{8}$ in.	$\frac{3}{4}$ in.	$\frac{7}{8}$ in.	1 in.
	lbs.	lbs.	lbs.	lbs.	lbs.	lbs.	lbs.	lbs.	lbs.
1½	4.00	7.00	10.50	15.20	22.50	39.50	63.00
1¾	4.35	7.50	11.25	16.30	23.82	41.62	66.00
2	4.75	8.00	12.00	17.40	25.15	43.75	69.00	109.00	163
2¼	5.15	8.50	12.75	18.50	26.47	45.88	72.00	113.25	169
2½	5.50	9.00	13.50	19.60	27.80	48.00	75.00	117.50	174
2¾	5.75	9.50	14.25	20.70	29.12	50.12	78.00	121.75	180
3	6.25	10.00	15.00	21.80	30.45	52.25	81.00	126.00	185
3½	7.00	11.00	16.50	24.00	33.10	56.50	87.00	134.25	196
4	7.75	12.00	18.00	26.20	35.75	60.75	93.10	142.50	207
4½	8.50	13.00	19.50	28.40	38.40	65.00	99.05	151.00	218
5	9.25	14.00	21.00	30.60	41.05	69.25	105.20	159.55	229
5½	10.00	15.00	22.50	32.80	43.70	73.50	111.25	168.00	240
6	10.75	16.00	24.00	35.00	46.35	77.75	117.30	176.60	251
6½	25.50	37.20	49.00	82.00	123.35	185.00	262
7	27.00	39.40	51.65	86.25	129.40	193.65	273
7½	28.50	41.60	54.30	90.50	135.00	202.00	284
8	30.00	43.80	56.90	94.75	141.50	210.70	295
9	46.00	64.90	103.25	153.60	227.75	317
10	48.20	70.20	111.75	165.70	244.80	339
11	50.40	75.50	120.25	177.80	261.85	360
12	52.60	80.80	128.75	189.90	278.90	382
13	86.10	137.25	202.00	295.95	404
14	91.40	145.75	214.10	313.00	426
15	96.70	154.25	226.20	330.05	448
16	102.00	162.75	238.30	347.10	470
17	107.30	171.00	250.40	364.15	492
18	112.60	179.50	262.60	381.20	514
19	117.90	188.00	274.70	398.25	536
20	123.20	206.50	286.80	415.30	558
Per inch additional	1.37	2.13	3.07	4.18	5.45	8.52	12.27	16.70	21.82

WEIGHTS OF NUTS AND BOLT-HEADS IN POUNDS.

FOR CALCULATING THE WEIGHT OF LONGER BOLTS.

Diameter of Bolt in inches.		$\frac{1}{4}$	$\frac{3}{8}$	$\frac{1}{2}$	$\frac{5}{8}$	$\frac{3}{4}$	$\frac{7}{8}$
Weight of Hexagon Nut and Head..017	.057	.128	.267	.43	.73
Weight of Square Nut and Head....021	.069	.164	.320	.55	.88

Diameter of Bolt in inches.	1	1¼	1½	1¾	2	2½	3
Weight of Hexagon Nut and Head..	1.10	2.14	3.78	5.6	8.75	17	28.8
Weight of Square Nut and Head....	1.31	2.56	4.42	7.0	10.5	21	36.4

WEIGHT OF SHEETS OF WROUGHT IRON, STEEL, COPPER,
AND BRASS.

(HASWELL.)

Weights per square foot. Thickness by Birmingham Gauge.

No. of Gauge.	Thickness in inches.	Iron.	Steel.	Copper.	Brass.
0000	.454	18.22	18.46	20.57	19.43
000	.425	17.05	17.28	19.25	18.19
00	.38	15.25	15.45	17.21	16.26
0	.34	13.64	13.82	15.40	14.55
1	.3	12.04	12.20	13.59	12.84
2	.284	11.40	11.55	12.87	12.16
3	.259	10.39	10.53	11.73	11.09
4	.238	9.55	9.68	10.78	10.19
5	.22	8.83	8.95	9.97	9.42
6	.203	8.15	8.25	9.20	8.69
7	.18	7.22	7.32	8.15	7.70
8	.165	6.62	6.71	7.47	7.06
9	.148	5.94	6.02	6.70	6.33
10	.134	5.38	5.45	6.07	5.74
11	.12	4.82	4.88	5.44	5.14
12	.109	4.37	4.43	4.94	4.67
13	.095	3.81	3.86	4.30	4.07
14	.083	3.33	3.37	3.76	3.55
15	.072	2.89	2.93	3.26	3.08
16	.065	2.61	2.64	2.94	2.78
17	.058	2.33	2.36	2.63	2.48
18	.049	1.97	1.99	2.22	2.10
19	.042	1.69	1.71	1.90	1.80
20	.035	1.40	1.42	1.59	1.50
21	.032	1.28	1.30	1.45	1.37
22	.028	1.12	1.14	1.27	1.20
23	.025	1.00	1.02	1.13	1.07
24	.022	.883	.895	1.00	.942
25	.02	.803	.813	.906	.856
26	.018	.722	.732	.815	.770
27	.016	.642	.651	.725	.685
28	.014	.562	.569	.634	.599
29	.013	.522	.529	.589	.556
30	.012	.482	.488	.544	.514
31	.01	.401	.407	.453	.428
32	.009	.361	.366	.408	.385
33	.008	.321	.325	.362	.342
34	.007	.281	.285	.317	.300
35	.005	.201	.203	.227	.214
Specific Gravity, Weight cubic foot, Weight cubic inch,		7.704 481.25 .2787	7.806 487.75 .2823	8.698 543.6 .3146	8.218 513.6 .2972

WEIGHT OF SQUARE CAST-IRON COLUMNS IN POUNDS PER LINEAL FOOT.

<div style="border: 1px solid black; width: 20px; height: 20px; display: inline-block; vertical-align: middle;"></div> a b $2a + 2b$	Thickness of Metal in inches.								
	$\frac{5}{8}$	$\frac{3}{4}$	$\frac{7}{8}$	1	$1\frac{1}{8}$	$1\frac{1}{4}$	$1\frac{1}{2}$	$1\frac{3}{4}$	2
*									
12	18.6	21.1	23.3	25.0	26.4	27.3	28.1
14	22.5	25.8	28.7	31.3	33.4	35.1	37.5
16	26.4	30.5	34.2	37.5	40.4	43.0	46.9	49.2	50.0
18	30.3	35.2	39.7	43.8	47.4	50.8	56.3	60.2	62.5
20	34.2	39.8	45.1	50.0	54.5	58.6	65.6	71.1	75.0
22	38.1	44.5	50.6	56.3	61.5	66.4	75.0	82.0	87.5
24	42.0	49.2	56.1	62.5	68.5	74.2	84.4	93.0	100.0
26	45.9	53.9	61.5	68.8	75.6	82.0	93.8	103.9	112.5
28	49.8	58.6	67.0	75.0	82.6	89.8	103.1	114.8	125.0
30	53.7	63.3	72.5	81.3	89.6	97.7	112.5	125.8	137.5
32	57.6	68.0	77.9	87.5	96.7	105.5	121.9	136.7	150.0
34	61.5	72.7	83.4	93.8	103.7	113.3	131.3	147.7	162.5
36	65.4	77.3	88.9	100.0	110.7	121.1	140.6	158.6	175.0
38	69.3	82.0	94.3	106.3	117.8	128.9	150.0	169.5	187.5
40	73.2	86.7	99.8	112.5	124.8	136.7	159.4	180.5	200.0
42	77.1	91.4	105.3	118.8	131.8	144.5	168.8	191.4	212.5
44	81.0	96.1	110.8	125.0	138.8	152.3	178.1	202.3	225.0
46	84.9	100.8	116.2	131.3	145.9	160.2	187.5	213.3	237.5
48	88.8	105.5	121.7	137.5	152.9	168.0	196.9	224.2	250.0
50	92.8	110.2	127.2	143.8	159.9	175.8	206.3	235.2	262.5
52	96.7	114.8	132.6	150.0	167.0	183.6	215.6	246.1	275.0
54	100.6	119.5	138.1	156.3	174.0	191.4	225.0	257.0	287.5
56	104.5	124.2	143.6	162.5	181.0	199.2	234.4	268.0	300.0
58	108.4	128.9	149.0	168.8	188.1	207.0	243.8	278.9	312.5
60	112.3	133.6	154.5	175.0	195.1	214.9	253.2	289.8	325.0
62	116.2	138.3	160.0	181.3	202.1	222.7	262.5	300.8	337.5
64	120.1	143.0	165.4	187.5	209.2	230.5	271.9	311.7	350.0
66	124.0	147.7	170.9	193.8	216.2	238.3	281.3	322.7	362.5
68	127.9	152.3	176.4	200.0	223.2	246.1	290.6	333.6	375.0
70	131.8	157.0	181.8	206.3	230.3	253.9	300.0	344.5	387.5
72	135.7	161.7	187.3	212.5	237.3	261.7	309.4	355.5	400.0
74	139.6	166.4	192.8	218.8	244.3	269.5	318.8	366.4	412.5
76	143.5	171.1	198.3	225.0	251.3	277.3	328.1	377.3	425.0
78	147.4	175.8	203.7	231.3	258.4	285.2	337.5	388.3	437.5
80	151.3	180.5	207.2	237.5	265.4	293.0	346.9	399.2	450.0

* a and b = either side. $2a + 2b$ = number.

EXAMPLE. What is the weight per lineal foot of a $12'' \times 16'' \times 1''$ thick column?

Ans. $2a + 2b = 24 + 36 = 56$. Opposite this number, under 1-inch thick metal, we find 162 5, or weight per lineal foot of a $12'' \times 16'' \times 1''$ thick column.

NOTE.—For flanges, brackets, etc., calculate the cubical contents of same and multiply by .26; cast iron averaging 450 pounds per cubic foot.

WEIGHT PER LINEAL FOOT OF CIRCULAR CAST-IRON COLUMNS.

Out- side Diam. in inches.	Thickness of Metal in inches.													
	1/2	3/8	1/2	5/8	1	1 1/8	1 1/4	1 1/2	1 3/4	1 7/8	2	2 1/4	2 1/2	2 3/4
3	12.3	14.6	16.6	18.3	19.6	21.1	22.6	24.1	25.6	27.1	28.6	30.1	31.6	33.1
4	17.2	21.0	24.0	27.0	29.5	32.1	34.6	37.1	39.6	42.1	44.6	47.1	49.6	52.1
5	22.1	27.0	31.3	35.5	39.3	43.0	46.0	49.0	51.5	54.1	56.6	59.1	61.6	64.1
6	27.0	33.0	39.0	44.0	49.1	54.1	58.3	62.4	66.3	69.9	73.0	76.0	78.6	81.1
7	32.0	39.1	46.0	53.0	59.0	65.1	70.6	76.1	81.0	85.8	90.2	94.3	98.2	101.7
8	36.8	45.3	53.4	61.2	69.1	76.1	83.1	89.5	95.8	101.8	107.4	112.8	117.8	122.6
9	41.7	51.4	61.1	70.0	78.6	87.1	95.1	103.1	110.5	117.7	124.6	131.2	137.5	143.4
10	46.6	57.5	75.5	87.1	88.4	98.0	107.4	116.4	125.2	133.7	142.0	149.6	157.1	164.3
11	51.6	64.0	83.0	96.1	98.2	109.1	120.1	130.1	140.0	149.6	159.0	168.0	176.8	185.2
12	56.5	70.0	90.0	104.2	108.0	120.0	132.1	143.5	154.7	165.6	176.0	186.4	196.4	206.0
13	61.4	76.0	98.1	113.1	118.1	131.2	144.2	157.1	169.4	181.5	193.3	204.8	216.0	226.9
14	66.3	82.1	105.1	121.4	128.1	142.0	156.5	170.4	184.1	197.4	210.5	223.3	235.7	247.7
15	71.2	88.2	112.3	130.1	137.5	153.3	169.4	184.1	198.9	213.4	227.7	241.6	255.3	268.6
16	76.1	94.4	119.7	138.6	147.3	164.3	181.0	197.4	213.5	229.4	244.9	260.0	274.9	289.5
17	81.0	100.5	120.1	139.1	157.1	175.4	193.3	211.0	228.3	245.3	262.0	278.4	294.5	310.3
18	86.0	107.0	127.0	147.0	167.0	186.4	206.0	224.4	243.0	261.3	279.2	296.8	314.2	331.5
19	91.0	113.0	134.4	156.0	177.1	197.5	218.1	238.0	257.7	277.2	296.4	315.2	333.8	352.1
20	96.0	119.0	142.1	164.3	186.6	208.8	230.1	251.5	272.5	293.2	313.6	333.6	353.4	372.9
21	100.6	125.0	149.1	173.1	196.6	219.6	242.4	265.0	287.3	309.0	330.8	352.1	373.1	393.8
22	105.6	131.2	156.5	181.5	206.2	230.6	254.2	278.0	302.0	325.1	348.0	370.5	392.0	414.0
23	110.5	137.3	164.1	190.1	216.1	242.0	267.0	292.0	316.7	341.0	365.1	388.9	412.3	435.5
24	115.4	143.5	171.2	199.1	226.0	253.0	279.2	305.4	331.4	357.0	382.3	407.3	432.0	456.4

(NOTE.—The table is arranged for the weight of plain shaft. For brackets, flanges, etc., calculate the cubical contents and multiply by .26.)

CHAPTER XXI.

NEW YORK BUILDING LAW.

AN ACT

To consolidate into one act and declare the special and local laws affecting public interests in the city of New York in so far as the same regulates the construction of buildings in said city.

SECTION 475. Vault Lights and Areas Protected.—In buildings where the space under the sidewalk is utilized, a sufficient stone or brick wall shall be built to retain the roadways of the street, and the side, end or party walls of such building shall extend under the sidewalk to such wall. The roofs of all vaults shall be of incombustible material. No roof of a vault under a sidewalk shall be higher than the established grade of the street. Openings in the roofs of vaults, for the admission of coal or light, shall be covered with lens lights in iron frames, or with iron covers having a rough surface and rabbeted flush with the sidewalk; the bearing in such rabbet shall not be less than one and one-quarter inch. Open areas shall be properly protected with suitable railings. When areas are covered over with iron, or with iron and glass combined, or with stone or other materials, sufficient strength in such covering shall be provided to insure safety to persons walking on the same, and to carry the loads which may be placed thereon.

SEC. 477. Buildings Increased in Size by Use of Columns and Girders.—In all stores, warehouses and factories over twenty-five feet in width between walls, in which there shall be brick partition walls, or girders supported on iron or wooden columns, or piers of masonry, the partition walls, or girders, shall be so placed that the space between any two partitions or girders shall not exceed twenty-five feet, and the iron or wooden columns, or piers of masonry, and girders, shall be made of sufficient strength and diameter to bear safely the weight and any lateral strain to be imposed upon them. In case iron or wooden girders, supported by iron or wooden columns, or piers of masonry, are substituted in place of brick partition walls, the building may be seventy-five feet wide and two hundred and ten feet deep, and when the building is located on a corner, may be one hundred feet wide and one hundred and five feet deep, but not wider nor deeper, except in case of fire-proof buildings.

SEC. 478. Anchors.—The front, rear, side and party walls shall be properly bonded together, or shall be anchored to each other every six feet in their height by wrought-iron tie anchors, not less than one and a half inches by three eighths of an inch. The side anchors shall be built into the side or party walls not less than sixteen inches and into the front and rear walls, so as to secure the front and rear walls to the side, or party walls, when not built and bonded together.

SEC. 480. Floors, Stairs and Ceilings of Iron.—Every building hereafter erected or altered to be occupied as a hotel, and every dwelling-house exceeding five stories in height hereafter erected or altered to be occupied by one or more families on any floor above the first, shall have the halls and stairs inclosed with twelve-inch brick walls. But eight-inch walls, not exceeding fifty feet in their vertical measurement, may inclose said halls and stairs, and be used as bearing walls where the distance between the outside bearing walls does not exceed thirty-three feet, and the area between said brick inclosure

walls does not exceed one hundred and eighty superficial feet. The floors, stairs and ceilings in said halls and stairways shall be made of iron, brick, stone or other hard incombustible materials, excepting that the flooring and sleepers underneath the same may be of wood and the treads and handrails of stairs may be of hard wood, provided that where wooden treads are used the underside of the stairs shall be entirely lathed with iron and plastered, and at least one flight of such stairs in each of said buildings shall extend to the roof, and be inclosed in a bulkhead built of fire-proof materials.

SEC. 483. **Weight on Floors.**—In every building used as dwelling-house, tenement-house, apartment-house, or hotel, every floor shall be of sufficient strength in all its parts to bear safely upon every superficial foot of its surface seventy pounds; and if to be used for office purposes not less than one hundred pounds upon every superficial foot; if to be used as a place of public assembly, one hundred and twenty pounds; and if to be used as a store, factory, warehouse, or for any other manufacturing or commercial purpose, from one hundred and fifty pounds and upwards upon every superficial foot, and every floor shall be of sufficient strength to bear safely the weights to be imposed thereon in addition to the weight of the materials of which the floor is composed. The roof of all buildings shall be proportioned to bear safely fifty pounds upon every superficial foot of their surface, in addition to the weight of materials composing the same. Every column, post or other vertical support shall be of sufficient strength to bear safely the weight of the portion of each and every floor depending upon it for support, in addition to the weight required as before stated to be safely supported upon said portions of said floors. The dimensions of each piece or combination of materials required shall be ascertained by computation, according to the rules given in Trautwine's Civil Engineer's Pocket-book, except as may be otherwise provided for in this title. The strength of all columns and posts shall be computed according

to Gordon's formula, and the crushing weights in pounds per square inch of section for the following-named materials shall be taken as the coefficients in said formula, viz.: cast iron, 80,000; wrought or rolled iron, 40,000; rolled steel, 48,000.

SEC. 484. **Framing of Beams.**—All cast-iron, wrought-iron, or wrought-steel columns shall be made true and smooth at both ends, and shall rest on iron bed-plates, and have iron cap-plates, which shall also be made true. All iron or steel trimmer beams, headers and tail beams shall be suitably framed and connected together, and the iron girders, columns, beams, trusses and all other ironwork of all floors and roofs shall be strapped, bolted, anchored and connected together, and to the walls, in a strong and substantial manner. Where beams are framed into headers, the angle irons which are bolted to the tail beams shall have at least two bolts for all beams over seven inches in depth, and three bolts for all beams over twelve inches in depth, and these bolts shall not be less than three quarters of an inch in diameter. Each one of such angles or knees, when bolted to girders, shall have the same number of bolts as stated for the other leg. The angle iron in no case shall be less in thickness than the header or trimmer to which it is bolted; and the width of angle in no case shall be less than one third the depth of beam, excepting that no angle knee shall be less than two and a half inches wide, nor required to be more than six inches wide. All wrought-iron or wrought-steel beams ten and a half inches deep and under shall have bearings equal to their depth, if resting on a wall; twelve-inch beams may have a bearing of ten inches, and all beams more than twelve inches in depth must have bearings not less than twelve inches if resting on a wall. Where beams rest on iron supports, and are properly ties to the same, no greater bearings shall be required than one third of the depth of beams. Iron or steel floor beams shall be so arranged as to spacing and length of beams that the load to be supported by them together with the weights of materials used in the construction of the

floors shall not cause a deflection of the said beams of more than one thirtieth of an inch per linear foot of span; and if said beams are unsupported laterally by floor arches between them, or otherwise, they shall be tied together at intervals of not more than eight times the depth of the beam.

Cast-iron Templates.—Under the ends of all iron or steel beams where they rest on the walls, a stone or cast-iron template must be built into the walls, said templates to be eight inches wide in twelve-inch walls, and in all walls of greater thickness to be twelve inches wide, and such templates, if of stone, shall not be in any case less than two and one-half inches in thickness and no template shall be less than twelve inches long.

SEC. 485. Iron Lintels.—All iron lintels shall have bearings proportionate to the weight to be imposed thereon, but no lintel used to span any opening more than ten feet in width shall have a bearing less than twelve inches at each end, if resting on a wall, but if resting on an iron post, such lintel shall have a bearing of at least six inches at each end by the thickness of the wall to be supported. If the posts are to be party posts in front of a party wall and are to be used for two buildings, then the said posts shall not be less than sixteen inches on the face by the thickness of the wall above, and if the party wall be more than sixteen inches thick, then the posts shall be the thickness of the wall on the face. Intermediate posts may be used, which shall be sufficiently strong, and the lintels thereon shall have sufficient bearing to carry the weight above with safety, as in this title provided. When the lintels or girders are supported at the ends by brick walls or piers they shall rest upon cut granite or bluestone blocks at least twelve inches thick, or upon cast-iron plates of equal strength by the full size of the bearings. In case the opening is less than twelve feet, the stone blocks may be six inches in thickness, or cast-iron plates of equal strength by the full size of the bearings may be used. In all cases where the girder carries a wall and rests on

brick piers of walls, the bearing shall be sufficient to support the weight above with safety. No cast-iron lintel or beam shall be less than three quarters of an inch in thickness in any of its parts. Iron beams or girders used to span openings more than sixteen feet in width, upon which walls rest, or on which floor beams are carried, shall be of wrought iron and of sufficient strength; or cast-iron arch girders may be used having a rise of not less than one inch to each foot of span between the bearings, with one or more wrought-iron tie rods of sufficient strength to resist the thrusts, well fastened at each end of the girder. All lintels or girders placed over any opening in the front, rear or side of a building, or returned over a corner opening, when supported by brick or stone piers or iron columns, shall be of iron and of the full breadth of the wall supported.

Fire-proof Columns.—In all buildings hereafter erected or altered, where any iron or steel column or columns are used to support a wall or part thereof, whether the same be an exterior or interior wall, excepting a wall fronting on a street, and columns located below the level of the sidewalk, which are used to support exterior walls or arches over vaults, the said column or columns either constructed double, that is, an outer and inner column, the inner column alone to be of sufficient strength to sustain safely the weight to be imposed thereon; or such other iron or steel column of sufficient strength and so constructed as to secure resistance to fire, may be used as approved by the superintendent of buildings. Iron posts in front of party walls shall be filled up solid with masonry and made perfectly tight between the posts and walls, to effectually prevent the passage of smoke or fire. Cast-iron posts or columns which are to be used for the support of wooden or iron girders or brick walls, not cast with one open side or back, before being set up in place, shall have a three-eighths of an inch hole drilled in the shaft of each post or column, by the manufacturer or contractor furnishing the same, to exhibit the thick-

ness of the castings, and any other similar-sized hole or holes which the superintendent of buildings, or his duly authorized representative, may require, shall be drilled in the said posts or columns by the said manufacturer or contractor at his own expense. Iron posts or columns cast with one or more open sides and backs shall have solid iron plates on top of each to prevent the passage of smoke or fire through them from one story to another, excepting where pierced for the passage of pipes, and at the bottoms and tops of all iron posts and columns, caps and bases shall be made true.

Iron Fronts Backed with Brick.—The iron arches, or the usual light castings connecting the columns of an iron front of a building, shall be filled in from the soffits to the sills on each upper story with brickwork not less than eight inches thick, or hollow fire-proof blocks not less than eight inches thick, and carried through on the same upper level, the brickwork or blocks to rest on the plates within the columns.

Thickness of Cast-iron Posts.—No cast-iron posts or columns shall be used in any building of a less average thickness of shaft than three quarters of an inch, nor shall have an unsupported length of more than twenty times its least lateral dimension or diameter, nor have a thickness of metal less than three quarters of an inch. No wrought-iron or rolled-steel column shall have an unsupported length of more than thirty times its least lateral dimension or diameter, nor shall its metal be less than one fourth of an inch in thickness. All cast-iron, wrought-iron, and steel columns shall have their bearings faced smooth, and at right angles to the axis of the column; and when one column rests upon another column, they shall be securely bolted together.

Curtain-wall Girders.—Where columns are used to support iron or steel girders carrying curtain walls, the said columns shall be of cast iron, wrought iron or rolled steel, and on their exposed surfaces be constructed to resist fire, by having an outer shell of iron, with an air space between, or by having

a casing of brickwork or burnt-clay blocks, not less than four inches in thickness and bonded into the brickwork of the curtain walls; and the exposed sides of the iron or steel girders shall also be similarly covered in, and tied and bonded.

SEC. 486. Rolled Iron and Steel Beams and Factors of Safety.—The factors of safety shall be as one to four for all beams, girders and other pieces subject to a transverse strain; and as one to five for all posts, columns and other vertical supports subject to a compressive strain; and as one to six for tie rods, tie beams and other pieces subject to a tensile strain.

Rolled iron or steel beam girders, or riveted iron or steel plate girders, used as lintels, or as girders, carrying a wall or floor, or both, shall be so proportioned that the loads which may come upon them shall not produce strains in tension or compression upon the flanges of more than twelve thousand pounds for iron nor more than fifteen thousand pounds for steel per square inch of the cross-section of each of such flanges, nor a shearing strain upon the web plate of more than six thousand pounds per square inch of section of such web plate, if of iron, nor more than seven thousand pounds if of steel; but no web plate shall be less than one quarter of an inch in thickness. Rivets in plate girders shall not be less than five eighths of an inch in diameter, and shall not be spaced more than six inches apart in any case. They shall be so spaced that their shearing strains shall not exceed nine thousand pounds per square inch of section, nor their bearing exceed fifteen thousand pounds per square inch on their diameter, multiplied by the thickness of the plates through which they pass. The riveted plate girders shall be proportioned upon the supposition that the bending or chord strains are resisted entirely by the upper and lower flanges, and that the shearing strains are resisted entirely by the web plate. No part of the web shall be estimated as flange area, nor more than one half of that portion of the angle iron which rests against the web. The distance between the centres of gravity of the flange areas will be considered as the effective depth of the girder.

Girders to be Tested.—Before any girder, as before mentioned, to be used in any building shall be so used, the architect or the manufacturer of or contractor for it shall, if required so to do by the superintendent of buildings, submit for his examination and approval a diagram showing the loads to be carried by said girder, and the strains produced by such load, and also showing the dimensions of the materials of which said girder is to be constructed, to provide for the said strains; and the manufacturer or contractor shall cause to be marked upon said girder, in a conspicuous place, the weight said girder will sustain, and no greater weight than that marked on such girder shall be placed thereon.

SEC. 487. Beams, Lintels and Girders to be Inspected.—Before any beam, lintel or girder intended to span an opening over ten feet in length, in any building, shall be used for supporting a wall, the manufacturer or founder thereof, or the owner, shall have the said beam, lintel or girder inspected, and if required by the superintendent of buildings shall have the same tested by actual weight or pressure thereon, under the direction and supervision of an inspector authorized by the superintendent of buildings. Said manufacturer, founder or owner shall notify the superintendent of buildings, in writing, of the time when, and the place where, said inspection and test may be made, and said inspector shall cause the weight which each of said beams, lintels, or girders will safely sustain, to be properly stamped or marked in a conspicuous place thereon, and no greater weight shall be put or placed upon any beam, lintel or girder than that stamped or marked thereon by said inspector. In case any beam, girder or lintel, or any iron column shall be rejected by said inspector as unfit or insufficient to be used for the purpose proposed, the same shall not be used for such purpose, in or upon, or about any building or part thereof. All iron and steel work used in any building shall be of the best material and made in the best manner, properly painted with oxide of iron and linseed-oil paint before being placed in posi-

tion, or coated with some other equally good preparation or suitably treated for preservation against rust.

SEC. 488. Stirrup Irons.—Every beam, except header and tail beams, shall rest at one end four inches in the wall, or upon a girder as authorized by this title. And every header or trimmer more than four feet long used in any building, shall be hung in stirrup irons of suitable thickness for the size of timbers.

Anchors.—Each tier of beams shall be anchored to the side, front, rear or party walls at intervals of not more than six feet apart, with good, strong wrought-iron anchors not less than one and a half inches by three eighths of an inch, well fastened to the side of the beams by two or more nails made of wrought iron at least one fourth of an inch in diameter. Where the beams are supported by girders, the girders shall be anchored to walls and fastened to each other by suitable iron straps. The ends of beams resting upon girders shall be butted together end to end and strapped by wrought-iron straps of the same size and distance apart, and in the same beam as the wall anchors, and shall be fastened in the same manner as said wall anchors, or they may lap each other at least twelve inches and be well spiked or bolted together where lapped. Every pier and wall, front or rear, shall be well anchored to the beams of each story, with the same size anchors as are required for the side walls, which anchors shall hook over the second beam. Each tier of beams, front and rear, opposite each pier shall have hard wood or Georgia pine anchor strips dovetailed into the beams diagonally, which strips shall cover at least four beams, and be one inch thick and four inches wide, but no such anchor strips shall be let in within four feet of the centre line of the beams; or wooden strips may be nailed on the top of the beams and kept in place until the floors are being laid.

Flitch-plates for Girders.—No wooden floor beams nor wooden roof beams used in any building other than a frame building, hereafter erected, shall be of a less thickness than

three inches. All trimmer and header beams shall not be less than one inch thicker than the floor or roof beams on the same tier, where the header is four feet or less in length; and where the header is more than four feet and not more than fifteen feet in length the trimmer and header beams shall be at least double the thickness of the floor or roof beams, or shall each be made of two iron beams forming such thickness properly spiked or bolted together, and when the header is more than fifteen feet in length wrought-iron fitch-plates of proper thickness and depth shall be placed between two wooden beams suitably bolted together to and through the iron plates in constructing the trimmer and header beams; or wrought-iron or wrought-steel beams of sufficient strength may be used.

SEC. 489. Smoke Flues Lined with Cast Iron.—In all buildings hereafter erected every smoke flue shall be lined on the inside with cast iron or well-burnt clay or fire-proof terracotta pipe from the bottom of the flue, or from the throat of the fireplace, if the flue starts from the latter, and carried up continuously to the extreme height of the flue. The ends of all such lining pipes shall be made to fit close together, and the pipes shall be built in as the flue or flues are carried up. Each smoke pipe shall be inclosed on all sides with not less than four inches of brickwork properly bonded together.

SEC. 491. Iron Shutters.—Every building which is more than two stories in height above the curb level, except dwelling-houses, hotels, school-houses and churches, shall have doors, blinds or shutters made of iron hung to iron hanging frames or to iron eyes built into the wall, and on every window and opening above the first story thereof, excepting on the front openings of buildings fronting on streets which are more than thirty feet in width; or the said doors, blinds or shutters may be constructed of pine or other soft wood of two thicknesses of matched boards at right angles with each other, and securely covered with tin, on both sides and edges, with folded lapped joints, the nails for fastening the same being driven inside the

lap. The hinges and bolt, or latches, shall be secured or fastened to the door or shutter after the same has been covered with the tin, and such doors or shutters shall be hung upon an iron frame, independent of the woodwork of the windows or doors, or to iron hinges securely fastened in the masonry; or such frames, if of wood, shall be covered with tin in the same manner as the doors and shutters. All occupants of buildings shall close the shutters, doors and blinds of the rear and side windows and openings; and where front shutters are provided, shall also close such shutters at the close of business. All shutters opening on fire escapes, and at least one row, vertically, in every three rows on the front window openings above the first story of any building, shall be so arranged that they can be readily opened from the outside by the firemen. All rolling iron or steel shutters hereafter placed in the first story of any building shall be counterbalanced, so that said rolling shutters may be readily opened by the firemen. No building hereafter erected, other than a dwelling-house or fire-proof building, shall have inside iron shutters to windows above the first story. All windows and openings above the first story may be exempted from having shutters by the board of examiners.

Railings around Well-holes.—In any building in which there shall be any hoistway or freight elevator or well-hole not inclosed in walls constructed of brick or other fire-proof material, and provided with fire-proof doors, the openings thereof, through and upon each floor of said building, shall be provided with and protected by a substantial railing, or with such good and sufficient trap-doors with which to close the same, or both, as may be directed and approved by the superintendent of buildings; and such railings and trap-doors shall be kept closed at all times, except when in actual use by the occupant or occupants of the building having the use or control of same. And in all buildings hereafter erected the roof immediately over the said hoistway, elevator or well-hole shall be covered with a skylight of suitable size.

Elevator Wells Inclosed with Brick or Iron.—All elevators hereafter placed in any building, except such fire-proof buildings as have been or may be erected in accordance with section four hundred and eighty-four of this title, shall be inclosed in suitable walls of brick, or with a suitable framework of iron and burnt-clay filling, or of such other fire-proof material and form of construction as may be approved by the superintendent of buildings. Said walls or construction shall extend through and at least three feet above the roof, and shall have suitable openings in the same, to be provided with fire-proof doors, made solid for three feet above the floor level and with grille openings above. Elevators may be put in the well-hole of stairs, in buildings, without such brick or fire-proof inclosures, where the stairs are inclosed in brick or stone walls, and the stairs are constructed as specified in section four hundred and seventy-nine of this title. Elevators may also be placed in any stair-well or open court of any building erected prior to the passage of this act, under a permit therefor from the superintendent of buildings, who may grant such permit upon the approval of the board of examiners hereinafter provided, but the framework and inclosure of any such elevator shall be constructed of fireproof materials.

Dumb-waiters, Skylights over Elevators.—The foregoing requirement as to brick or fire-proof shafts shall include dumb-waiters which extend through more than three stories in dwelling-houses. The roofs over all elevators shall be made of fire-proof materials, with a skylight at least three fourths the area of the shaft, made of glass, set in iron frames.

Screen of Iron under Elevator Machinery.—Immediately under the machinery at the top of every elevator shaft hereafter placed in any building in said city, there shall be provided and placed a substantial grating or screen of iron, of such construction as shall be approved by the superintendent of buildings.

SEC. 493. Mansard Roof.—If a mansard or any other

roof having a pitch of over sixty degrees be placed on any building, except a wooden building, or a dwelling-house not exceeding thirty-three feet in height, it shall be constructed of iron rafters, and lathed with iron on the inside and plastered, or filled in with fire-proof material not less than three inches thick, and covered with metal, slate, or tile.

Bulkheads—used as inclosures for tanks and elevators, and coverings for the machinery of elevators and all other bulkheads, including the bulkheads of all dwelling-houses hereafter erected or altered, may be constructed of hollow fire-proof blocks or of wood, covered with not less than two inches of fire-proof material, or filled in the thickness of the studding with such material, and covered on all sides with metal, including sides and edges of doors.

Cornices and Gutters.—All exterior cornices and gutters of all buildings hereafter erected shall be of some fire-proof material. All fire proof cornices shall be well secured to the walls with iron anchors.

SEC. 494. **Dormer Windows, Scuttles and Skylights.**—The planking and sheathing of the roof of every building erected or built as aforesaid shall in no case be extended across the front, rear, side, end or party wall thereof, and every such building and the tops and sides of every dormer window thereon shall be covered and roofed with slate, tin, zinc, copper or iron, or such other quality of fire-proof roofing as the superintendent of buildings, under his certificate, may authorize, and the outside of the frames of every dormer window hereafter placed upon any building as aforesaid shall be made of some fire-proof material. And no wooden building in any part of the said city, more than two stories or above twenty feet in height above the curb level to the highest part thereof, which shall require roofing, shall be roofed with any other roofing or covered except as aforesaid. Nothing in this section shall be construed to prohibit the repairing of any shingle roof, provided the building is not altered in height. All buildings shall have

scuttles or bulkheads, covered with some fire-proof materials, with ladders or stairs leading thereto. No scuttle shall be less in size than two by three feet. All skylights having a superficial area of more than nine square feet, placed in any building, shall have the sashes and frames thereof constructed of iron and glass. Every fire-proof roof hereafter placed on any building shall have, besides the usual scuttle or bulkhead, a skylight or skylights of a superficial area equal to not less than one fiftieth the superficial area of such fire-proof roof.

Iron Ladders to Scuttles.—All buildings shall have scuttles or bulkheads, covered with some fire-proof materials, with ladders or stairs leading thereto.

Fire Escapes.—Every dwelling-house occupied by or built to be occupied by three or more families above the first story, and every building already erected, or that may hereafter be erected, more than three stories in height, occupied or used as a hotel or lodging-house, and every boarding-house having more than fifteen sleeping-rooms above the basement story, and every factory, mill, manufactory or workshop, hospital, asylum or institution for the care or treatment of individuals, and every building in whole or in part occupied or used as a school or place of instruction, or assembly, and every office building five stories or more in height, shall be provided with such good and sufficient fire escapes or other means of egress in case of fire as shall be directed by the superintendent of buildings, and said superintendent shall direct such fire escapes and means of egress to be provided in all cases where he shall deem the same necessary.

Roof Gardens on Theatres.—Nothing herein contained shall prevent a roof garden, art gallery or rooms for similar purposes being placed above a theatre or public building, provided the floor of same forming the roof over such theatre or building shall be constructed of iron or steel and fire-proof materials, and that said floor shall have no covering boards or sleepers of wood, but be of tile or cement. Every roof over

said garden or rooms shall have all supports and rafters of iron or steel, and shall be covered with glass or fire-proof materials or both.

Proscenium Wall Girder, etc.—Above the proscenium opening there shall be an iron girder covered with fire-proof materials to protect it from the heat. There shall also be constructed a relieving arch over the same, the intervening space being filled in with hollow or other brick of the full thickness of the proscenium wall. Should there be constructed an orchestra over the stage, above the proscenium opening, the said orchestra shall be placed on the auditorium side of the proscenium fire-wall, and shall be entered only from the auditorium side of said wall. The moulded frame around the proscenium opening shall be formed entirely of fire-proof materials. If metal be used, the metal shall be filled in solid with non-combustible material and securely anchored to the wall with iron.

Skylights and Doorways to Theatres.—There shall be provided over the stage metal skylights of an area or combined area of at least one eighth the area of said stage, fitted up with sliding sash and glazed with double-thick sheet glass, not exceeding one eighth of an inch thick, and each pane thereof measuring not less than three hundred square inches, and the whole of which skylights shall be so constructed as to open instantly on the cutting or burning of a hempen cord which shall be arranged to hold said skylights closed, or some other equally simple approved device for opening them may be provided.

Doorways through Proscenium Wall, Doors of Iron and Wood.—All doorways or openings through the proscenium wall, in every tier, shall have doors of iron or wood on each face of the wall; if of wood, the doors shall be constructed as hereinbefore described, and the doors hung so as to be opened from either side at all times. There shall be no openings in the proscenium fire-wall above the level of the auditorium

ceiling. Direct access to these doors shall be provided on both sides, and the same shall always be kept free from any incumbrance. Iron ladders or stairs securely fixed to the wall on the stage side shall be provided to overcome any difference of level existing between the floor or galleries on the stage side of the fire-wall and those on the side of the auditorium.

Roof of Auditorium, Main Floor of Auditorium and Vestibule, Floor of Second Story over Entrance, Lobby and Corridors of Iron and Fire-proof Materials.—The roof over the auditorium and the entire main floor of the auditorium and vestibule, also the entire floor of the second story of the front superstructure over the entrance, lobby and corridors, and all galleries in the auditorium shall be constructed of iron and fire-proof materials, not excluding the use of wooden floor boards and necessary sleepers to fasten the same to, but such sleepers shall not mean timbers of support.

The Fronts of Galleries, Ceiling of Auditorium, Partitions in Auditorium, Entrance Vestibule, Partitions of Dressing-rooms and Doors in same to be Fire-proof.—The fronts and ceilings of each gallery shall be formed of fire-proof material excepting the capping, which may be made of wood. The ceiling of auditorium shall be formed of fire-proof materials. All lathing wherever used must be of metal. The partitions in that portion of the building which contains the auditorium, the entrance vestibule and every room and passage devoted to the use of the audience, shall be constructed of fire-proof materials, including the furring of outside or other walls, and none of the walls or ceilings shall be covered with wood sheathing, canvas, or any combustible material, but this shall not exclude the use of wood wainscoting to a height not to exceed six feet, which shall be filled in solid between the wainscoting and the wall with fire-proof materials. The walls separating the actors' dressing-rooms from the stage, and the partitions dividing the dressing-rooms, together with the partitions of any passage from the same to the stage, and all other

partitions on or about the stage shall be constructed of fire-proof material approved by the superintendent of buildings. All doors in any of said partitions shall be of iron or of wood, constructed as hereinbefore described. All the shelving and cupboards in each and every dressing-room, property-room or other storage rooms shall be constructed of metal, slate or some fire-proof material.

Actors' Dressing-rooms and Fly Galleries.—Dressing-rooms may be placed in the fly galleries, provided that proper exits are secured therefrom to the fire-escapes in the open court, and the partitions and other matters pertaining to dressing-rooms to conform to the requirements herein contained, but the stairs leading to the same must be fire-proof.

Stage and Fly Galleries Fire-proof.—All that portion of the stage not comprised in the working of scenery, traps and other mechanical apparatus for the presentation of a scene, usually equal to the width of the proscenium opening, shall be built of iron beams filled in between with fire-proof material, and all girders for the support of said beams shall be of wrought iron. The fly galleries entire, including pin rails, shall be constructed of iron, and the floor of said galleries shall be composed of iron beams, filled in with fire-proof materials, and no wood boards or sleepers shall be used as a covering over beams, but the said floor shall be entirely fire-proof. The rigging loft shall be fire-proof, except the floor covering of same.

Proscenium Opening and Curtain.—The proscenium opening shall be provided with a fire-proof metal curtain or a curtain of asbestos or similar fire-proof material approved by the superintendent of buildings, sliding at each end into iron grooves, securely fastened to the brick wall, and extending into such grooves not less than six inches on each side.

The proscenium curtains shall be placed at least three feet distant from the footlights at the nearest point.

SHORT-TITLE CATALOGUE

OF THE

PUBLICATIONS

OF

JOHN WILEY & SONS,

NEW YORK.

LONDON: CHAPMAN & HALL, LIMITED.

ARRANGED UNDER SUBJECTS.

Descriptive circulars sent on application. Books marked with an asterisk (*) are sold at *net* prices only, a double asterisk (**) books sold under the rules of the American Publishers' Association at *net* prices subject to an extra charge for postage. All books are bound in cloth unless otherwise stated.

AGRICULTURE.

Armsby's Manual of Cattle-feeding.	12mo,	\$1 75
Principles of Animal Nutrition.	8vo,	4 00
Budd and Hansen's American Horticultural Manual:		
Part I. Propagation, Culture, and Improvement.	12mo,	1 50
Part II. Systematic Pomology.	12mo,	1 50
Downing's Fruits and Fruit-trees of America	8vo,	5 00
Elliott's Engineering for Land Drainage.	12mo,	1 50
Practical Farm Drainage.	12mo,	1 00
Green's Principles of American Forestry.	12mo,	1 50
Grotenfelt's Principles of Modern Dairy Practice. (Woll.)	12mo,	2 00
Kemp's Landscape Gardening.	12mo,	2 50
Maynard's Landscape Gardening as Applied to Home Decoration.	12mo,	1 50
* McKay and Larsen's Principles and Practice of Butter-making	8vo,	1 50
Sanderson's Insects Injurious to Staple Crops.	12mo,	1 50
Insects Injurious to Garden Crops. (In preparation.)		
Insects Injuring Fruits. (In preparation.)		
Stockbridge's Rocks and Soils.	8vo,	2 50
Winton's Microscopy of Vegetable Foods.	8vo,	7 50
Woll's Handbook for Farmers and Dairymen.	16mo,	1 50

ARCHITECTURE.

Baldwin's Steam Heating for Buildings.	12mo,	2 50
Bashore's Sanitation of a Country House.	12mo,	1 00
Berg's Buildings and Structures of American Railroads.	4to,	5 00
Birkmire's Planning and Construction of American Theatres.	8vo,	3 00
Architectural Iron and Steel.	8vo,	3 50
Compound Riveted Girders as Applied in Buildings.	8vo,	2 00
Planning and Construction of High Office Buildings.	8vo,	3 50
Skeleton Construction in Buildings.	8vo,	3 00
Brigg's Modern American School Buildings.	8vo,	4 00
Carpenter's Heating and Ventilating of Buildings.	8vo,	4 00
Freitag's Architectural Engineering.	8vo,	3 50
Fireproofing of Steel Buildings.	8vo,	2 50
French and Ives's Stereotomy.	8vo,	2 50

Gerhard's Guide to Sanitary House-inspection.	16mo,	1 00
Theatre Fires and Panics.	12mo,	1 50
*Greene's Structural Mechanics	8vo,	2 50
Holly's Carpenters' and Joiners' Handbook.	18mo,	75
Johnson's Statics by Algebraic and Graphic Methods.	8vo,	2 00
Kidder's Architects' and Builders' Pocket-book. Rewritten Edition.	16mo, mor.,	5 00
Merrill's Stones for Building and Decoration.	8vo,	5 00
Non-metallic Minerals: Their Occurrence and Uses.	8vo,	4 00
Monckton's Stair-building.	4to,	4 00
Patton's Practical Treatise on Foundations.	8vo,	5 00
Peabody's Naval Architecture.	8vo,	7 50
Richey's Handbook for Superintendents of Construction	16mo, mor.,	4 00
Sabin's Industrial and Artistic Technology of Paints and Varnish.	8vo,	3 00
Siebert and Biggin's Modern Stone-cutting and Masonry.	8vo,	1 50
Snow's Principal Species of Wood.	8vo,	3 50
Sondericker's Graphic Statics with Applications to Trusses, Beams, and Arches.	8vo,	2 00
Towne's Locks and Builders' Hardware.	18mo, morocco,	3 00
Wait's Engineering and Architectural Jurisprudence	8vo,	6 00
Sheep,		6 50
Law of Operations Preliminary to Construction in Engineering and Architecture.	8vo,	5 00
Sheep,		5 50
Law of Contracts.	8vo,	3 00
Wood's Rustless Coatings: Corrosion and Electrolysis of Iron and Steel.	8vo,	4 00
Worcester and Atkinson's Small Hospitals, Establishment and Maintenance, Suggestions for Hospital Architecture, with Plans for a Small Hospital.	12mo,	1 25
The World's Columbian Exposition of 1893.	Large 4to,	1 00

ARMY AND NAVY.

Bernadou's Smokeless Powder, Nitro-cellulose, and the Theory of the Cellulose Molecule.	12mo,	2 50
* Bruff's Text-book Ordnance and Gunnery	8vo,	6 00
Chase's Screw Propellers and Marine Propulsion.	8vo,	3 00
Cloke's Gunner's Examiner.	8vo,	1 50
Craig's Azimuth.	4to,	3 50
Crehore and Squier's Polarizing Photo-chronograph.	8vo,	3 00
* Davis's Elements of Law.	8vo,	2 50
* Treatise on the Military Law of United States.	8vo,	7 00
Sheep,		7 50
De Brack's Cavalry Outposts Duties. (Carr.)	24mo, morocco,	2 00
Dietz's Soldier's First Aid Handbook	16mo, morocco,	1 25
* Dredge's Modern French Artillery.	4to, half morocco,	15 00
Durand's Resistance and Propulsion of Ships.	8vo,	5 00
* Dyer's Handbook of Light Artillery.	12mo,	3 00
Eissler's Modern High Explosives.	8vo,	4 00
* Fieberger's Text-book on Field Fortification.	Small 8vo,	2 00
Hamilton's The Gunner's Catechism	18mo,	1 00
* Hoff's Elementary Naval Tactics.	8vo,	1 50
Ingalls's Handbook of Problems in Direct Fire.	8vo,	4 00
* Ballistic Tables.	8vo,	1 50
* Lyons's Treatise on Electromagnetic Phenomena. Vols. I. and II.	8vo, each,	6 00
* Mahan's Permanent Fortifications. (Mercur.)	8vo, half morocco,	7 50
Manual for Courts-martial.	16mo, morocco,	1 50
* Mercur's Attack of Fortified Places.	12mo,	2 00
* Elements of the Art of War.	8vo,	4 00

Metcalf's Cost of Manufactures—And the Administration of Workshops. .8vo,	5 00
* Ordnance and Gunnery. 2 vols.	12mo, 5 00
Murray's Infantry Drill Regulations.	18mo, paper, 10
Nixon's Adjutants' Manual.	24mo, 1 00
Peabody's Naval Architecture.	8vo, 7 50
* Phelps's Practical Marine Surveying.	8vo, 2 50
Powell's Army Officer's Examiner.	12mo, 4 00
Sharpe's Art of Subsisting Armies in War.	18mo, morocco, 1 50
* Walke's Lectures on Explosives.	8vo, 4 00
* Wheeler's Siege Operations and Military Mining.	8vo, 2 00
Winthrop's Abridgment of Military Law.	12mo, 2 50
Woodhull's Notes on Military Hygiene.	16mo, 1 50
Young's Simple Elements of Navigation.	16mo, morocco, 2 00

ASSAYING.

Fletcher's Practical Instructions in Quantitative Assaying with the Blowpipe.	12mo, morocco, 1 50
Furman's Manual of Practical Assaying.	8vo, 3 00
Lodge's Notes on Assaying and Metallurgical Laboratory Experiments.	8vo, 3 00
Low's Technical Methods of Ore Analysis.	8vo, 3 00
Miller's Manual of Assaying.	12mo, 1 00
Minet's Production of Aluminum and its Industrial Use. (Waldo.)	12mo, 2 50
O'Driscoll's Notes on the Treatment of Gold Ores.	8vo, 2 00
Ricketts and Miller's Notes on Assaying.	8vo, 3 00
Robine and Lenglen's Cyanide Industry. (Le Clerc.)	8vo, 3 00
Ulke's Modern Electrolytic Copper Refining.	8vo, 3 00
Wilson's Cyanide Processes.	12mo, 1 50
Chlorination Process.	12mo, 1 50

ASTRONOMY.

Comstock's Field Astronomy for Engineers.	8vo, 2 50
Craig's Azimuth.	4to, 3 90
Doolittle's Treatise on Practical Astronomy.	8vo, 4 00
Gore's Elements of Geodesy.	8vo, 2 50
Hayford's Text-book of Geodetic Astronomy.	8vo, 3 00
Merriman's Elements of Precise Surveying and Geodesy.	8vo, 2 50
* Michie and Harlow's Practical Astronomy.	8vo, 3 00
* White's Elements of Theoretical and Descriptive Astronomy.	12mo, 2 00

BOTANY.

Davenport's Statistical Methods, with Special Reference to Biological Variation.	16mo, morocco, 1 25
Thomé and Bennett's Structural and Physiological Botany.	16mo, 2 25
Westermaier's Compendium of General Botany. (Schneider.)	8vo, 2 00

CHEMISTRY.

Adriance's Laboratory Calculations and Specific Gravity Tables.	12mo, 1 25
Allen's Tables for Iron Analysis.	8vo, 3 00
Arnold's Compendium of Chemistry. (Mandel.)	Small 8vo, 3 50
Austen's Notes for Chemical Students	12mo, 1 50
Bernadou's Smokeless Powder.—Nitro-cellulose, and Theory of the Cellulose Molecule.	12mo, 2 50
* Browning's Introduction to the Rarer Elements.	8vo, 1 50

Brush and Penfield's Manual of Determinative Mineralogy.	8vo,	4 00
Classen's Quantitative Chemical Analysis by Electrolysis. (Eoltwood.)	8vo,	3 00
Cohn's Indicators and Test-papers.	12mo,	2 00
Tests and Reagents.	8vo,	3 00
Crafts's Short Course in Qualitative Chemical Analysis. (Schaeffer.)	12mo,	1 50
Dolezalek's Theory of the Lead Accumulator (Storage Battery). (Von Ende.)	12mo,	2 50
Drechsel's Chemical Reactions. (Merrill.)	12mo,	1 25
Duhem's Thermodynamics and Chemistry. (Burgess.)	8vo,	4 00
Eissler's Modern High Explosives.	8vo,	4 00
Effront's Enzymes and their Applications. (Prescott.)	8vo,	3 00
Erdmann's Introduction to Chemical Preparations. (Dunlap.)	12mo,	1 25
Fletcher's Practical Instructions in Quantitative Assaying with the Blowpipe.	12mo, morocco,	1 50
Fowler's Sewage Works Analyses.	12mo,	2 00
Fresenius's Manual of Qualitative Chemical Analysis. (Wells.)	8vo,	5 00
Manual of Qualitative Chemical Analysis. Part I. Descriptive. (Wells.)	8vo,	3 00
System of Instruction in Quantitative Chemical Analysis. (Cohn.)	8vo,	12 50
2 vols.		
Fuertes's Water and Public Health.	12mo,	1 50
Furman's Manual of Practical Assaying.	8vo,	3 00
* Getman's Exercises in Physical Chemistry	12mo,	2 00
Gill's Gas and Fuel Analysis for Engineers.	12mo,	1 25
Grotenfelt's Principles of Modern Dairy Practice. (Woll.)	12mo,	2 00
Hammarsten's Text-book of Physiological Chemistry. (Mandel.)	8vo,	4 00
Helm's Principles of Mathematical Chemistry. (Morgan.)	12mo,	1 50
Hering's Ready Reference Tables (Conversion Factors).	16mo, morocco,	2 50
Hind's Inorganic Chemistry.	8vo,	3 00
* Laboratory Manual for Students	12mo,	1 00
Holleman's Text-book of Inorganic Chemistry. (Cooper.)	8vo,	2 50
Text-book of Organic Chemistry. (Walker and Mott.)	8vo,	2 50
* Laboratory Manual of Organic Chemistry. (Walker.)	12mo,	1 00
Hopkins's Oil-chemists' Handbook.	8vo,	3 00
Jackson's Directions for Laboratory Work in Physiological Chemistry	8vo,	1 25
Keep's Cast Iron.	8vo,	2 50
Ladd's Manual of Quantitative Chemical Analysis.	12mo,	1 00
Landauer's Spectrum Analysis. (Tingle.)	8vo,	3 00
* Langworthy and Austen. The Occurrence of Aluminium in Vegetable Products, Animal Products, and Natural Waters.	8vo,	2 00
Lassar-Cohn's Practical Urinary Analysis. (Lorenz.)	12mo,	1 00
Application of Some General Reactions to Investigations in Organic Chemistry. (Tingle.)	12mo,	1 00
Leach's The Inspection and Analysis of Food with Special Reference to State Control.	8vo,	7 50
Löb's Electrochemistry of Organic Compounds. (Lorenz.)	8vo,	3 00
Lodge's Notes on Assaying and Metallurgical Laboratory Experiments.	8vo,	3 00
Low's Technical Method of Ore Analysis.	8vo,	3 00
Lunge's Techno-chemical Analysis. (Cohn.)	12mo,	1 00
Mandel's Handbook for Bio-chemical Laboratory	12mo,	1 50
* Martin's Laboratory Guide to Qualitative Analysis with the Blowpipe.	12mo,	60
Mason's Water-supply. (Considered Principally from a Sanitary Standpoint.) 3d Edition, Rewritten.	8vo,	4 00
Examination of Water. (Chemical and Bacteriological.)	12mo,	1 25
Matthew's The Textile Fibres.	8vo,	3 50
Meyer's Determination of Radicles in Carbon Compounds. (Tingle.)	12mo,	1 00
Miller's Manual of Assaying.	12mo,	1 00
Minet's Production of Aluminum and its Industrial Use. (Waldo.)	12mo,	2 50
Mixer's Elementary Text-book of Chemistry.	12mo,	1 50
Morgan's Elements of Physical Chemistry.	12mo,	3 00
* Physical Chemistry for Electrical Engineers.	12mo,	1 50

Morse's Calculations used in Cane-sugar Factories.	16mo, morocco,	1 50
Mulliken's General Method for the Identification of Pure Organic Compounds. Vol. I.	Large 8vo,	5 00
O'Brine's Laboratory Guide in Chemical Analysis.	8vo,	2 00
O'Driscoll's Notes on the Treatment of Gold Ores.	8vo,	2 00
Ostwald's Conversations on Chemistry. Part One. (Ramsey.)	12mo,	1 50
" " " " Part Two. (Turnbull.)	12mo,	2 00
* Penfield's Notes on Determinative Mineralogy and Record of Mineral Tests. 8vo, paper,		50
Pictet's The Alkaloids and their Chemical Constitution. (Biddle.)	8vo,	5 00
Pinner's Introduction to Organic Chemistry. (Austen.)	12mo,	1 50
Poole's Calorific Power of Fuels.	8vo,	3 00
Prescott and Winslow's Elements of Water Bacteriology, with Special Refer- ence to Sanitary Water Analysis.	12mo,	1 25
* Reising's Guide to Piece-dyeing.	8vo,	25 00
Richards and Woodman's Air, Water, and Food from a Sanitary Stand- point.	8vo,	2 00
Richards's Cost of Living as Modified by Sanitary Science.	12mo,	1 00
Cost of Food, a Study in Diets	12mo,	1 00
* Richards and Williams's The Dietary Computer.	8vo,	1 50
Ricketts and Russell's Skeleton Notes upon Inorganic Chemistry. (Part I. Non-metallic Elements.)	8vo, morocco,	75
Ricketts and Miller's Notes on Assaying.	8vo,	3 00
Rideal's Sewage and the Bacterial Purification of Sewage.	8vo,	3 50
Disinfection and the Preservation of Food.	8vo,	4 00
Rigg's Elementary Manual for the Chemical Laboratory.	8vo,	1 25
Robine and Lenglen's Cyanide Industry. (Le Clerc.)	8vo,	
Rostoski's Serum Diagnosis. (Bolduan.)	12mo,	1 00
Ruddiman's Incompatibilities in Prescriptions.	8vo,	2 00
* Why in Pharmacy	12mo,	1 00
Sabin's Industrial and Artistic Technology of Paints and Varnish.	8vo,	3 00
Salkowski's Physiological and Pathological Chemistry. (Orndorff.)	8vo,	2 50
Schimpf's Text-book of Volumetric Analysis.	12mo,	2 50
Essentials of Volumetric Analysis.	12mo,	1 25
* Qualitative Chemical Analysis.	8vo,	1 25
Spencer's Handbook for Chemists of Beet-sugar Houses.	16mo, morocco,	3 00
Handbook for Cane Sugar Manufacturers.	16mo, morocco,	3 00
Stockbridge's Rocks and Soils.	8vo,	2 50
* Tillman's Elementary Lessons in Heat.	8vo,	1 50
* Descriptive General Chemistry.	8vo,	3 00
Treadwell's Qualitative Analysis. (Hall.)	8vo,	3 00
Quantitative Analysis. (Hall.)	8vo,	4 00
Turneure and Russell's Public Water-supplies.	8vo,	5 00
Van Deventer's Physical Chemistry for Beginners. (Boltwood.)	12mo,	1 50
* Walke's Lectures on Explosives.	8vo,	4 00
Ware's Beet-sugar Manufacture and Refining	Small 8vo, cloth,	4 00
Washington's Manual of the Chemical Analysis of Rocks.	8vo,	2 00
Wassermann's Immune Sera: Hæmolysins, Cytotoxins, and Precipitins. (Bol- duan.)	12mo,	1 00
Well's Laboratory Guide in Qualitative Chemical Analysis.	8vo,	1 50
Short Course in Inorganic Qualitative Chemical Analysis for Engineering Students.	12mo,	1 50
Text-book of Chemical Arithmetic	12mo,	1 25
Whipple's Microscopy of Drinking-water.	8vo,	3 50
Wilson's Cyanide Processes	12mo,	1 50
Chlorination Process.	12mo,	1 50
Winton's Microscopy of Vegetable Foods.	8vo,	7 50
Wulling's Elementary Course in Inorganic, Pharmaceutical, and Medical Chemistry.	12mo,	2 00

CIVIL ENGINEERING.

BRIDGES AND ROOFS. HYDRAULICS. MATERIALS OF ENGINEERING. RAILWAY ENGINEERING.

Baker's Engineers' Surveying Instruments.	12mo,	3 00
Bixby's Graphical Computing Table.	Paper 19 $\frac{1}{2}$ × 24 $\frac{1}{2}$ inches.	25
** Burr's Ancient and Modern Engineering and the Isthmian Canal. (Postage, 27 cents additional.)	8vo,	3 50
Comstock's Field Astronomy for Engineers.	8vo,	2 50
Davis's Elevation and Stadia Tables.	8vo,	1 00
Elliott's Engineering for Land Drainage.	12mo,	1 50
Practical Farm Drainage.	12mo,	1 00
* Fiebegeer's Treatise on Civil Engineering.	8vo,	5 00
Folwell's Sewerage. (Designing and Maintenance.)	8vo,	3 00
Freitag's Architectural Engineering. 2d Edition, Rewritten.	8vo,	3 50
French and Ives's Stereotomy.	8vo,	2 50
Goodhue's Municipal Improvements.	12mo,	1 75
Goodrich's Economic Disposal of Towns' Refuse.	8vo,	3 50
Gore's Elements of Geodesy.	8vo,	2 50
Hayford's Text-book of Geodetic Astronomy.	8vo,	3 00
Hering's Ready Reference Tables (Conversion Factors).	16mo, morocco,	2 50
Howe's Retaining Walls for Earth.	12mo,	1 25
Johnson's (J. B.) Theory and Practice of Surveying.	Small 8vo,	4 00
Johnson's (L. J.) Statics by Algebraic and Graphic Methods.	8vo,	2 00
Laplace's Philosophical Essay on Probabilities. (Truscott and Emory.)	12mo,	2 00
Mahan's Treatise on Civil Engineering. (1873.) (Wood.)	8vo,	5 00
* Descriptive Geometry.	8vo,	1 50
Merriman's Elements of Precise Surveying and Geodesy.	8vo,	2 50
Merriman and Brooks's Handbook for Surveyors.	16mo, morocco,	5 00
Nugent's Plane Surveying.	8vo,	3 50
Ogden's Sewer Design.	12mo,	2 00
Patton's Treatise on Civil Engineering.	8vo half leather,	7 50
Reed's Topographical Drawing and Sketching	4to,	5 00
Rideal's Sewage and the Bacterial Purification of Sewage.	8vo,	3 50
Siebert and Biggin's Modern Stone-cutting and Masonry.	8vo,	1 50
Smith's Manual of Topographical Drawing. (McMillan.)	8vo,	2 50
Sondericker's Graphic Statics, with Applications to Trusses, Beams, and Arches.	8vo,	2 00
Taylor and Thompson's Treatise on Concrete, Plain and Reinforced.	8vo,	5 00
* Trautwine's Civil Engineer's Pocket-book.	16mo, morocco,	5 00
Wait's Engineering and Architectural Jurisprudence.	8vo,	6 00
Sheep,		6 50
Law of Operations Preliminary to Construction in Engineering and Architecture.	8vo,	5 00
Sheep,		5 50
Law of Contracts.	8vo,	3 00
Warren's Stereotomy—Problems in Stone-cutting.	8vo,	2 50
Webb's Problems in the Use and Adjustment of Engineering Instruments.	16mo, morocco,	1 25
Wilson's Topographic Surveying.	8vo,	3 50

BRIDGES AND ROOFS.

Boller's Practical Treatise on the Construction of Iron Highway Bridges.	8vo,	2 00
* Thames River Bridge.	4to, paper,	5 00
Burr's Course on the Stresses in Bridges and Roof Trusses, Arched Ribs, and Suspension Bridges.	8vo,	3 50

Burr and Falk's Influence Lines for Bridge and Roof Computations.....	8vo,	3 00
Design and Construction of Metallic Bridges.....	8vo,	5 00
Du Bois's Mechanics of Engineering. Vol. II.....	Small 4to,	10 00
Foster's Treatise on Wooden Trestle Bridges.....	4to,	5 00
Fowler's Ordinary Foundations.....	8vo,	3 50
Greene's Roof Trusses.....	8vo,	1 25
Bridge Trusses.....	8vo,	2 50
Arches in Wood, Iron, and Stone.....	8vo,	2 50
Howe's Treatise on Arches.....	8vo,	4 00
Design of Simple Roof-trusses in Wood and Steel.....	8vo,	2 00
Johnson, Bryan, and Turneure's Theory and Practice in the Designing of Modern Framed Structures.....	Small 4to,	10 00
Merriman and Jacoby's Text-book on Roofs and Bridges:		
Part I. Stresses in Simple Trusses.....	8vo,	2 50
Part II. Graphic Statics.....	8vo,	2 50
Part III. Bridge Design.....	8vo,	2 50
Part IV. Higher Structures.....	8vo,	2 50
Morison's Memphis Bridge.....	4to,	10 00
Waddell's De Pontibus, a Pocket-book for Bridge Engineers.....	16mo, morocco,	2 00
Specifications for Steel Bridges.....	12mo,	1 25
Wright's Designing of Draw-spans. Two parts in one volume.....	8vo,	3 50

HYDRAULICS.

Bazin's Experiments upon the Contraction of the Liquid Vein Issuing from an Orifice. (Trautwine.).....	8vo,	2 00
Bovey's Treatise on Hydraulics.....	8vo,	5 00
Church's Mechanics of Engineering.....	8vo,	6 00
Diagrams of Mean Velocity of Water in Open Channels.....	paper,	1 50
Hydraulic Motors.....	8vo,	2 00
Coffin's Graphical Solution of Hydraulic Problems.....	16mo, morocco,	2 50
Fletcher's Dynamometers, and the Measurement of Power.....	12mo,	3 00
Folwell's Water-supply Engineering.....	8vo,	4 00
Frizell's Water-power.....	8vo,	5 00
Fuertes's Water and Public Health.....	12mo,	1 50
Water-filtration Works.....	12mo,	2 50
Ganguillet and Kutter's General Formula for the Uniform Flow of Water in Rivers and Other Channels. (Hering and Trautwine.).....	8vo,	4 00
Hazen's Filtration of Public Water-supply.....	8vo,	3 00
Hazlehurst's Towers and Tanks for Water-works.....	8vo,	2 50
Herschel's 115 Experiments on the Carrying Capacity of Large, Riveted, Metal Conduits.....	8vo,	2 00
Mason's Water-supply. (Considered Principally from a Sanitary Standpoint.)	8vo,	4 00
Merriman's Treatise on Hydraulics.....	8vo,	5 00
* Michie's Elements of Analytical Mechanics.....	8vo,	4 00
Schuyler's Reservoirs for Irrigation, Water-power, and Domestic Water- supply.....	Large 8vo,	5 00
** Thomas and Watt's Improvement of Rivers. (Post., 44c. additional).)	4to,	6 00
Turneure and Russell's Public Water-supplies.....	8vo,	5 00
Wegmann's Design and Construction of Dams.....	4to,	5 00
Water-supply of the City of New York from 1658 to 1895.....	4to,	10 00
Williams and Hazen's Hydraulic Tables.....	8vo,	1 50
Wilson's Irrigation Engineering.....	Small 8vo,	4 00
Wolff's Windmill as a Prime Mover.....	8vo,	3 00
Wood's Turbines.....	8vo,	2 50
Elements of Analytical Mechanics.....	8vo,	3 00

MATERIALS OF ENGINEERING.

Baker's Treatise on Masonry Construction.....	8vo,	5 00
Roads and Pavements.....	8vo,	5 00
Black's United States Public Works.....	Oblong 4to,	5 00
* Bovey's Strength of Materials and Theory of Structures.....	8vo,	7 50
Burr's Elasticity and Resistance of the Materials of Engineering.....	8vo,	7 50
Byrne's Highway Construction.....	8vo,	5 00
Inspection of the Materials and Workmanship Employed in Construction.....	16mo,	3 00
Church's Mechanics of Engineering.....	8vo,	6 00
Du Bois's Mechanics of Engineering. Vol. I.....	Small 4to,	7 50
*Eckel's Cements, Limes, and Plasters.....	8vo,	6 00
Johnson's Materials of Construction.....	Large 8vo,	6 00
Fowler's Ordinary Foundations.....	8vo,	3 50
* Greene's Structural Mechanics.....	8vo,	2 50
Keep's Cast Iron.....	8vo,	2 50
Lanza's Applied Mechanics.....	8vo,	7 50
Marten's Handbook on Testing Materials. (Henning.) 2 vols.....	8vo,	7 50
Maurer's Technical Mechanics.....	8vo,	4 00
Merrill's Stones for Building and Decoration.....	8vo,	5 00
Merriman's Mechanics of Materials.....	8vo,	5 00
Strength of Materials.....	12mo,	1 00
Metcalf's Steel. A Manual for Steel-users.....	12mo,	2 00
Patton's Practical Treatise on Foundations.....	8vo,	5 00
Richardson's Modern Asphalt Pavements.....	8vo,	3 00
Richey's Handbook for Superintendents of Construction.....	16mo, mor.,	4 00
Rockwell's Roads and Pavements in France.....	12mo,	1 25
Sabin's Industrial and Artistic Technology of Paints and Varnish.....	8vo,	3 00
Smith's Materials of Machines.....	12mo,	1 00
Snow's Principal Species of Wood.....	8vo,	3 50
Spalding's Hydraulic Cement.....	12mo,	2 00
Text-book on Roads and Pavements.....	12mo,	2 00
Taylor and Thompson's Treatise on Concrete, Plain and Reinforced.....	8vo,	5 00
Thurston's Materials of Engineering. 3 Parts.....	8vo,	8 00
Part I. Non-metallic Materials of Engineering and Metallurgy.....	8vo,	2 00
Part II. Iron and Steel.....	8vo,	3 50
Part III. A Treatise on Brasses, Bronzes, and Other Alloys and their Constituents.....	8vo,	2 50
Thurston's Text-book of the Materials of Construction.....	8vo,	5 00
Tillson's Street Pavements and Paving Materials.....	8vo,	4 00
Waddell's De Pontibus. (A Pocket-book for Bridge Engineers.).....	16mo, mor.,	2 00
Specifications for Steel Bridges.....	12mo,	1 25
Wood's (De V.) Treatise on the Resistance of Materials, and an Appendix on the Preservation of Timber.....	8vo,	2 00
Wood's (De V.) Elements of Analytical Mechanics.....	8vo,	3 00
Wood's (M. P.) Rustless Coatings: Corrosion and Electrolysis of Iron and Steel.....	8vo,	4 00

RAILWAY ENGINEERING.

Andrew's Handbook for Street Railway Engineers.....	3x5 inches, morocco,	1 25
Berg's Buildings and Structures of American Railroads.....	4to,	5 00
Brook's Handbook of Street Railroad Location.....	16mo, morocco,	1 50
Butt's Civil Engineer's Field-book.....	16mo, morocco,	2 50
Crandall's Transition Curve.....	16mo, morocco,	1 50
Railway and Other Earthwork Tables.....	8vo,	1 50
Dawson's "Engineering" and Electric Traction Pocket-book.....	16mo, morocco,	5 00

Dredge's History of the Pennsylvania Railroad: (1879).....	Paper,	5 00
* Drinker's Tunnelling, Explosive Compounds, and Rock Drills.....	4to, half mor.,	25 00
Fisher's Table of Cubic Yards.....	Cardboard,	25
Godwin's Railroad Engineers' Field-book and Explorers' Guide.....	16mo, mor.,	2 50
Howard's Transition Curve Field-book.....	16mo, morocco,	1 50
Hudson's Tables for Calculating the Cubic Contents of Excavations and Embankments.....	8vo,	1 00
Molitor and Beard's Manual for Resident Engineers.....	16mo,	1 00
Nagle's Field Manual for Railroad Engineers.....	16mo, morocco,	3 00
Philbrick's Field Manual for Engineers.....	16mo, morocco,	3 00
Searles's Field Engineering.....	16mo, morocco,	3 00
Railroad Spiral.....	16mo, morocco,	1 50
Taylor's Prismoïdal Formulæ and Earthwork.....	8vo,	1 50
* Trautwine's Method of Calculating the Cube Contents of Excavations and Embankments by the Aid of Diagrams.....	8vo,	2 00
The Field Practice of Laying Out Circular Curves for Railroads.....	12mo, morocco,	2 50
Cross-section Sheet.....	Paper,	25
Webb's Railroad Construction.....	16mo, morocco,	5 00
Wellington's Economic Theory of the Location of Railways.....	Small 8vo,	5 00

DRAWING.

Barr's Kinematics of Machinery.....	8vo,	2 50
* Bartlett's Mechanical Drawing.....	8vo,	3 00
* " " " " Abridged Ed.....	8vo,	1 50
Coolidge's Manual of Drawing.....	8vo, paper	1 00
Coolidge and Freeman's Elements of General Drafting for Mechanical Engineers.....	Oblong 4to,	2 50
Durley's Kinematics of Machines.....	8vo,	4 00
Emch's Introduction to Projective Geometry and its Applications.....	8vo,	2 50
Hill's Text-book on Shades and Shadows, and Perspective.....	8vo,	2 00
Jamison's Elements of Mechanical Drawing.....	8vo,	2 50
Advanced Mechanical Drawing.....	8vo,	2 00
Jones's Machine Design:		
Part I. Kinematics of Machinery.....	8vo,	1 50
Part II. Form, Strength, and Proportions of Parts.....	8vo,	3 00
MacCord's Elements of Descriptive Geometry.....	8vo,	3 00
Kinematics; or, Practical Mechanism.....	8vo,	5 00
Mechanical Drawing.....	4to,	4 00
Velocity Diagrams.....	8vo,	1 50
MacLeod's Descriptive Geometry.....	Small 8vo,	1 50
* Mahan's Descriptive Geometry and Stone-cutting.....	8vo,	1 50
Industrial Drawing. (Thompson.).....	8vo,	3 50
Moyer's Descriptive Geometry.....	8vo,	2 00
Reed's Topographical Drawing and Sketching.....	4to,	5 00
Reid's Course in Mechanical Drawing.....	8vo,	2 00
Text-book of Mechanical Drawing and Elementary Machine Design.....	8vo,	3 00
Robinson's Principles of Mechanism.....	8vo,	3 00
Schwamb and Merrill's Elements of Mechanism.....	8vo,	3 00
Smith's (R. S.) Manual of Topographical Drawing. (McMillan.).....	8vo,	2 50
Smith (A. W.) and Marx's Machine Design.....	8vo,	3 00
Warren's Elements of Plane and Solid Free-hand Geometrical Drawing.....	12mo,	1 00
Drafting Instruments and Operations.....	12mo,	1 25
Manual of Elementary Projection Drawing.....	12mo,	1 50
Manual of Elementary Problems in the Linear Perspective of Form and Shadow.....	12mo,	1 00
Plane Problems in Elementary Geometry.....	12mo,	1 25

Warren's Primary Geometry.....	12mo,	75
Elements of Descriptive Geometry, Shadows, and Perspective.....	8vo,	3 50
General Problems of Shades and Shadows.....	8vo,	3 00
Elements of Machine Construction and Drawing.....	8vo,	7 50
Problems, Theorems, and Examples in Descriptive Geometry.....	8vo,	2 50
Weisbach's Kinematics and Power of Transmission. (Hermann and Klein.).....	8vo,	5 00
Whelpley's Practical Instruction in the Art of Letter Engraving.....	12mo,	2 00
Wilson's (H. M.) Topographic Surveying.....	8vo,	3 50
Wilson's (V. T.) Free-hand Perspective.....	8vo,	2 50
Wilson's (V. T.) Free-hand Lettering.....	8vo,	1 00
Woolf's Elementary Course in Descriptive Geometry.....	Large 8vo,	3 00

ELECTRICITY AND PHYSICS.

Anthony and Brackett's Text-book of Physics. (Magie.).....	Small 8vo,	3 00
Anthony's Lecture-notes on the Theory of Electrical Measurements.....	12mo,	1 00
Benjamin's History of Electricity.....	8vo,	3 00
Voltaic Cell.....	8vo,	3 00
Classen's Quantitative Chemical Analysis by Electrolysis. (Boltwood.).....	8vo,	3 00
Crehore and Squier's Polarizing Photo-chronograph.....	8vo,	3 00
Dawson's "Engineering" and Electric Traction Pocket-book.....	16mo, morocco,	5 00
Dolezalek's Theory of the Lead Accumulator (Storage Battery). (Von Ende.).....	12mo,	2 50
Duhem's Thermodynamics and Chemistry. (Burgess.).....	8vo,	4 00
Flather's Dynamometers, and the Measurement of Power.....	12mo,	3 00
Gilbert's De Magnete. (Mottelay.).....	8vo,	2 50
Hanchett's Alternating Currents Explained.....	12mo,	1 00
Hering's Ready Reference Tables (Conversion Factors).....	16mo, morocco,	2 50
Holman's Precision of Measurements.....	8vo,	2 00
Telescopic Mirror-scale Method, Adjustments, and Tests.....	Large 8vo,	75
Kinzbrunner's Testing of Continuous-current Machines.....	8vo,	2 00
Landauer's Spectrum Analysis. (Tingle.).....	8vo,	3 00
Le Chatelier's High-temperature Measurements. (Boudouard—Burgess.).....	12mo,	3 00
Löb's Electrochemistry of Organic Compounds. (Lorenz.).....	8vo,	3 00
* Lyons's Treatise on Electromagnetic Phenomena. Vols. I. and II. 8vo, each.....		6 00
* Michie's Elements of Wave Motion Relating to Sound and Light.....	8vo,	4 00
Niaudet's Elementary Treatise on Electric Batteries. (Fishback.).....	12mo,	2 50
* Rosenberg's Electrical Engineering. (Haldane Gee—Kinzbrunner.).....	8vo,	1 50
Ryan, Norris, and Hoxie's Electrical Machinery. Vol. I.....	8vo,	2 50
Thurston's Stationary Steam-engines.....	8vo,	2 50
* Tillman's Elementary Lessons in Heat.....	8vo,	1 50
Tory and Pitcher's Manual of Laboratory Physics.....	Small 8vo,	2 00
Ulke's Modern Electrolytic Copper Refining.....	8vo,	3 00

LAW.

* Davis's Elements of Law.....	8vo,	2 50
* Treatise on the Military Law of United States.....	8vo,	7 00
*	Sheep,	7 50
Manual for Courts-martial.....	16mo, morocco,	1 50
Wait's Engineering and Architectural Jurisprudence.....	8vo,	6 00
	Sheep,	6 50
Law of Operations Preliminary to Construction in Engineering and Architecture.....	8vo	5 00
	Sheep,	5 50
Law of Contracts.....	8vo,	3 00
Winthrop's Abridgment of Military Law.....	12mo,	2 50

MANUFACTURES.

Bernadou's Smokeless Powder—Nitro-cellulose and Theory of the Cellulose Molecule.....	12mo,	2 50
Bolland's Iron Founder.....	12mo,	2 50
"The Iron Founder," Supplement.....	12mo,	2 50
Encyclopedia of Founding and Dictionary of Foundry Terms Used in the Practice of Moulding.....	12mo,	3 00
Eissler's Modern High Explosives.....	8vo,	4 00
Effront's Enzymes and their Applications. (Prescott.).....	8vo,	3 00
Fitzgerald's Boston Machinist.....	12mo,	1 00
Ford's Boiler Making for Boiler Makers.....	18mo,	1 00
Hopkin's Oil-chemists' Handbook.....	8vo,	3 00
Keep's Cast Iron.....	8vo,	2 50
Leach's The Inspection and Analysis of Food with Special Reference to State Control.....	Large 8vo,	7 50
Matthews's The Textile Fibres.....	8vo,	3 50
Metcalf's Steel. A Manual for Steel-users.....	12mo,	2 00
Metcalf's Cost of Manufactures—And the Administration of Workshops.....	8vo,	5 00
Meyer's Modern Locomotive Construction.....	4to,	10 00
Morse's Calculations used in Cane-sugar Factories.....	16mo, morocco,	1 50
* Reising's Guide to Piece-dyeing.....	8vo,	25 00
Sabin's Industrial and Artistic Technology of Paints and Varnish.....	8vo,	3 00
Smith's Press-working of Metals.....	8vo,	3 00
Spalding's Hydraulic Cement.....	12mo,	2 00
Spencer's Handbook for Chemists of Beet-sugar Houses.....	16mo, morocco,	3 00
Handbook for Cane Sugar Manufacturers.....	16mo, morocco,	3 00
Taylor and Thompson's Treatise on Concrete, Plain and Reinforced.....	8vo,	5 00
Thurston's Manual of Steam-boilers, their Designs, Construction and Operation.....	8vo,	5 00
* Walke's Lectures on Explosives.....	8vo,	4 00
Ware's Beet-sugar Manufacture and Refining.....	Small 8vo,	4 00
West's American Foundry Practice.....	12mo,	2 50
Moulder's Text-book.....	12mo,	2 50
Wolff's Windmill as a Prime Mover.....	8vo,	3 00
Wood's Rustless Coatings: Corrosion and Electrolysis of Iron and Steel.....	8vo,	4 00

MATHEMATICS.

Baker's Elliptic Functions.....	8vo,	1 50
* Bass's Elements of Differential Calculus.....	12mo,	4 00
Briggs's Elements of Plane Analytic Geometry.....	12mo,	1 00
Compton's Manual of Logarithmic Computations.....	12mo,	1 50
Davis's Introduction to the Logic of Algebra.....	8vo,	1 50
* Dickson's College Algebra.....	Large 12mo,	1 50
* Introduction to the Theory of Algebraic Equations.....	Large 12mo,	1 25
Emch's Introduction to Projective Geometry and its Applications.....	8vo,	2 50
Halsted's Elements of Geometry.....	8vo,	1 75
Elementary Synthetic Geometry.....	8vo,	1 50
Rational Geometry.....	12mo,	1 75
* Johnson's (J. B.) Three-place Logarithmic Tables: Vest-pocket size, paper.....	15	
100 copies for.....	5 00	
* Mounted on heavy cardboard, 8×10 inches.....	25	
100 copies for.....	2 00	
Johnson's (W. W.) Elementary Treatise on Differential Calculus. Small 8vo.....	3 00	
Johnson's (W. W.) Elementary Treatise on the Integral Calculus. Small 8vo.....	1 50	

Johnson's (W. W.) Curve Tracing in Cartesian Co-ordinates.	12mo,	1 00
Johnson's (W. W.) Treatise on Ordinary and Partial Differential Equations.		
	Small 8vo,	3 50
Johnson's (W. W.) Theory of Errors and the Method of Least Squares.	12mo,	1 50
* Johnson's (W. W.) Theoretical Mechanics.	12mo,	3 00
Laplace's Philosophical Essay on Probabilities. (Truscott and Emory.)	12mo,	2 00
* Ludlow and Bass. Elements of Trigonometry and Logarithmic and Other		
Tables.	8vo,	3 00
Trigonometry and Tables published separately.	Each,	2 00
* Ludlow's Logarithmic and Trigonometric Tables.	8vo,	1 00
Mathematical Monographs. Edited by Mansfield Merriman and Robert		
S. Woodward.	Octavo, each	1 00
No. 1. History of Modern Mathematics, by David Eugene Smith.		
No. 2. Synthetic Projective Geometry, by George Bruce Halsted.		
No. 3. Determinants, by Laenas Gifford Weld. No. 4. Hyper-		
bolic Functions, by James McMahon. No. 5. Harmonic Func-		
tions, by William E. Byerly. No. 6. Grassmann's Space Analysis,		
by Edward W. Hyde. No. 7. Probability and Theory of Errors,		
by Robert S. Woodward. No. 8. Vector Analysis and Quaternions,		
by Alexander Macfarlane. No. 9. Differential Equations, by		
William Woolsey Johnson. No. 10. The Solution of Equations,		
by Mansfield Merriman. No. 11. Functions of a Complex Variable,		
by Thomas S. Fiske.		
Maurer's Technical Mechanics.	8vo,	4 00
Merriman and Woodward's Higher Mathematics.	8vo,	5 00
Merriman's Method of Least Squares.	8vo,	2 00
Rice and Johnson's Elementary Treatise on the Differential Calculus. Sm.	8vo,	3 00
Differential and Integral Calculus. 2 vols. in one.	Small 8vo,	2 50
Wood's Elements of Co-ordinate Geometry.	8vo,	2 00
Trigonometry: Analytical, Plane, and Spherical	12mo,	1 00

MECHANICAL ENGINEERING.

MATERIALS OF ENGINEERING, STEAM-ENGINES AND BOILERS.

Bacon's Forge Practice.	12mo,	1 50
Baldwin's Steam Heating for Buildings.	12mo,	2 50
Barr's Kinematics of Machinery.	8vo,	2 50
* Bartlett's Mechanical Drawing.	8vo,	3 00
* " " " " Abridged Ed.	8vo,	1 50
Benjamin's Wrinkles and Recipes.	12mo,	2 00
Carpenter's Experimental Engineering.	8vo,	6 00
Heating and Ventilating Buildings.	8vo,	4 00
Cary's Smoke Suppression in Plants using Bituminous Coal. (In Prepara-		
tion.)		
Clerk's Gas and Oil Engine.	Small 8vo,	4 00
Coolidge's Manual of Drawing.	8vo, paper,	1 00
Coolidge and Freeman's Elements of General Drafting for Mechanical En-		
gineers.	Oblong 4to,	2 50
Cromwell's Treatise on Toothed Gearing.	12mo,	1 50
Treatise on Belts and Pulleys.	12mo,	1 50
Durley's Kinematics of Machines.	8vo,	4 00
Flather's Dynamometers and the Measurement of Power.	12mo,	3 00
Rope Driving.	12mo,	2 00
Gill's Gas and Fuel Analysis for Engineers.	12mo,	1 25
Hall's Car Lubrication.	12mo,	1 00
Hering's Ready Reference Tables (Conversion Factors).	16mo, morocco,	2 50

Hutton's The Gas Engine.	8vo,	5 00
Jamison's Mechanical Drawing.	8vo,	2 50
Jones's Machine Design:		
Part I. Kinematics of Machinery.	8vo,	1 50
Part II. Form, Strength, and Proportions of Parts.	8vo,	3 00
Kent's Mechanical Engineers' Pocket-book.	16mo, morocco,	5 00
Kerr's Power and Power Transmission.	8vo,	2 00
Leonard's Machine Shop, Tools, and Methods.	8vo,	4 00
* Lorenz's Modern Refrigerating Machinery. (Pope, Haven, and Dean.)	8vo,	4 00
MacCord's Kinematics; or, Practical Mechanism.	8vo,	5 00
Mechanical Drawing.	4to,	4 00
Velocity Diagrams.	8vo,	1 50
MacFarland's Standard Reduction Factors for Gases.	8vo,	1 50
Mahan's Industrial Drawing. (Thompson.)	8vo,	3 50
Poole's Calorific Power of Fuels.	8vo,	3 00
Reid's Course in Mechanical Drawing.	8vo,	2 00
Text-book of Mechanical Drawing and Elementary Machine Design.	8vo,	3 00
Richard's Compressed Air.	12mo,	1 50
Robinson's Principles of Mechanism.	8vo,	3 00
Schwamb and Merrill's Elements of Mechanism.	8vo,	3 00
Smith's (O.) Press-working of Metals.	8vo,	3 00
Smith (A. W.) and Marx's Machine Design.	8vo,	3 00
Thurston's Treatise on Friction and Lost Work in Machinery and Mill Work.	8vo,	3 00
Animal as a Machine and Prime Motor, and the Laws of Energetics.	12mo,	1 00
Warren's Elements of Machine Construction and Drawing.	8vo,	7 50
Weisbach's Kinematics and the Power of Transmission. (Herrmann—Klein.)	8vo,	5 00
Machinery of Transmission and Governors. (Herrmann—Klein.)	8vo,	5 00
Wolff's Windmill as a Prime Mover.	8vo,	3 00
Wood's Turbines.	8vo,	2 50

MATERIALS OF ENGINEERING.

* Bovey's Strength of Materials and Theory of Structures.	8vo,	7 50
Burr's Elasticity and Resistance of the Materials of Engineering. 6th Edition.	8vo,	7 50
Reset.	8vo,	7 50
Church's Mechanics of Engineering.	8vo,	6 00
* Greene's Structural Mechanics.	8vo,	2 50
Johnson's Materials of Construction.	8vo,	6 00
Keep's Cast Iron.	8vo,	2 50
Lanza's Applied Mechanics.	8vo,	7 50
Martens's Handbook on Testing Materials. (Henning.)	8vo,	7 50
Maurer's Technical Mechanics.	8vo,	4 00
Merriman's Mechanics of Materials.	8vo,	5 00
Strength of Materials.	12mo,	1 00
Metcalf's Steel. A manual for Steel-users.	12mo,	2 00
Sabin's Industrial and Artistic Technology of Paints and Varnish.	8vo,	3 00
Smith's Materials of Machines.	12mo,	1 00
Thurston's Materials of Engineering.	3 vols., 8vo,	8 00
Part II. Iron and Steel.	8vo,	3 50
Part III. A Treatise on Brasses, Bronzes, and Other Alloys and their Constituents.	8vo,	2 50
Text-book of the Materials of Construction.	8vo,	5 00
Wood's (De V.) Treatise on the Resistance of Materials and an Appendix on the Preservation of Timber.	8vo,	2 00

Wood's (De V.) Elements of Analytical Mechanics.	8vo.	3 00
Wood's (M. P.) Rustless Coatings: Corrosion and Electrolysis of Iron and Steel.	8vo.	4 00

STEAM-ENGINES AND BOILERS.

Berry's Temperature-entropy Diagram.	12mo.	1 25
Carnot's Reflections on the Motive Power of Heat. (Thurston.)	12mo.	1 50
Dawson's "Engineering" and Electric Traction Pocket-book.	16mo, mor.	5 00
Ford's Boiler Making for Boiler Makers.	18mo.	1 00
Goss's Locomotive Sparks.	8vo.	2 00
Hemenway's Indicator Practice and Steam-engine Economy.	12mo.	2 00
Hutton's Mechanical Engineering of Power Plants.	8vo.	5 00
Heat and Heat-engines.	8vo.	5 00
Kent's Steam boiler Economy.	8vo.	4 00
Kneass's Practice and Theory of the Injector.	8vo.	1 50
MacCord's Slide-valves.	8vo.	2 00
Meyer's Modern Locomotive Construction.	4to.	10 00
Peabody's Manual of the Steam-engine Indicator.	12mo.	1 50
Tables of the Properties of Saturated Steam and Other Vapors	8vo.	1 00
Thermodynamics of the Steam-engine and Other Heat-engines.	8vo.	5 00
Valve-gears for Steam-engines.	8vo.	2 50
Peabody and Miller's Steam-boilers.	8vo.	4 00
Pray's Twenty Years with the Indicator.	Large 8vo.	2 50
Pupin's Thermodynamics of Reversible Cycles in Gases and Saturated Vapors. (Osterberg.)	12mo.	1 25
Reagan's Locomotives: Simple Compound, and Electric.	12mo.	2 50
Rontgen's Principles of Thermodynamics. (Du Bois.)	8vo.	5 00
Sinclair's Locomotive Engine Running and Management.	12mo.	2 00
Smart's Handbook of Engineering Laboratory Practice.	12mo.	2 50
Snow's Steam-boiler Practice.	8vo.	3 00
Spangler's Valve-gears.	8vo.	2 50
Notes on Thermodynamics.	12mo.	1 00
Spangler, Greene, and Marshall's Elements of Steam-engineing	8vo.	3 00
Thurston's Handy Tables.	8vo.	1 50
Manual of the Steam-engine.	2 vols., 8vo.	10 00
Part I. History, Structure, and Theory.	8vo.	6 00
Part II. Design, Construction, and Operation.	8vo.	6 00
Handbook of Engine and Boiler Trials, and the Use of the Indicator and the Prony Brake.	8vo.	5 00
Stationary Steam-engines.	8vo.	2 50
Steam-boiler Explosions in Theory and in Practice	12mo.	1 50
Manual of Steam-boilers, their Designs, Construction, and Operation.	8vo.	5 00
Weisbach's Heat, Steam, and Steam-engines. (Du Bois.)	8vo.	5 00
Whitham's Steam-engine Design.	8vo.	5 00
Wilson's Treatise on Steam-boilers. (Flather.)	16mo.	2 50
Wood's Thermodynamics, Heat Motors, and Refrigerating Machines.	8vo.	4 00

MECHANICS AND MACHINERY.

Barr's Kinematics of Machinery.	8vo.	2 50
* Bovey's Strength of Materials and Theory of Structures	8vo.	7 50
Chase's The Art of Pattern-making.	12mo.	2 50
Church's Mechanics of Engineering.	8vo.	6 00
Notes and Examples in Mechanics.	8vo.	2 00
Compton's First Lessons in Metal-working.	12mo.	1 50
Compton and De Groodt's The Speed Lathe.	12mo.	1 50

Cromwell's Treatise on Toothed Gearing.....	12mo,	1 50
Treatise on Belts and Pulleys.....	12mo,	1 50
Dana's Text-book of Elementary Mechanics for Colleges and Schools.....	12mo,	1 50
Dingey's Machinery Pattern Making.....	12mo,	2 00
Dredge's Record of the Transportation Exhibits Building of the World's Columbian Exposition of 1893.....	4to half morocco,	5 00
Du Bois's Elementary Principles of Mechanics:		
Vol. I. Kinematics.....	8vo,	3 50
Vol. II. Statics.....	8vo,	4 00
Mechanics of Engineering. Vol. I.....	Small 4to,	7 50
Vol. II.....	Small 4to,	10 00
Durley's Kinematics of Machines.....	8vo,	4 00
Fitzgerald's Boston Machinist.....	16mo,	1 00
Flather's Dynamometers, and the Measurement of Power.....	12mo,	3 00
Rope Driving.....	12mo,	2 00
Goss's Locomotive Sparks.....	8vo,	2 00
* Green's Structural Mechanics.....	8vo,	2 50
Hall's Car Lubrication.....	12mo,	1 00
Holly's Art of Saw Filing.....	18mo,	75
James's Kinematics of a Point and the Rational Mechanics of a Particle.....	Small 8vo,	2 00
* Johnson's (W. W.) Theoretical Mechanics.....	12mo,	3 00
Johnson's (L. J.) Statics by Graphic and Algebraic Methods.....	8vo,	2 00
Jones's Machine Design:		
Part I. Kinematics of Machinery.....	8vo,	1 50
Part II. Form, Strength, and Proportions of Parts.....	8vo,	3 00
Kerr's Power and Power Transmission.....	8vo,	2 00
Lanza's Applied Mechanics.....	8vo,	7 50
Leonard's Machine Shop, Tools, and Methods.....	8vo,	4 00
* Lorenz's Modern Refrigerating Machinery. (Pope, Haven, and Dean.).....	8vo,	4 00
MacCord's Kinematics; or, Practical Mechanism.....	8vo,	5 00
Velocity Diagrams.....	8vo,	1 50
Maurer's Technical Mechanics.....	8vo,	4 00
Merriman's Mechanics of Materials.....	8vo,	5 00
* Elements of Mechanics.....	12mo,	1 00
* Michie's Elements of Analytical Mechanics.....	8vo,	4 00
Reagan's Locomotives: Simple, Compound, and Electric.....	12mo,	2 50
Reid's Course in Mechanical Drawing.....	8vo,	2 00
Text-book of Mechanical Drawing and Elementary Machine Design.....	8vo,	3 00
Richards's Compressed Air.....	12mo,	1 50
Robinson's Principles of Mechanism.....	8vo,	3 00
Ryan, Norris, and Hoxie's Electrical Machinery. Vol. I.....	8vo,	2 50
Schwamb and Merrill's Elements of Mechanism.....	8vo,	3 00
Sinclair's Locomotive-engine Running and Management.....	12mo,	2 00
Smith's (O.) Press-working of Metals.....	8vo,	3 00
Smith's (A. W.) Materials of Machines.....	12mo,	1 00
Smith (A. W.) and Marx's Machine Design.....	8vo,	3 00
Spangler, Greene, and Marshall's Elements of Steam-engineering.....	8vo,	3 00
Thurston's Treatise on Friction and Lost Work in Machinery and Mill Work.....	8vo,	3 00
Animal as a Machine and Prime Motor, and the Laws of Energetics.....	12mo,	1 00
Warren's Elements of Machine Construction and Drawing.....	8vo,	7 50
Weisbach's Kinematics and Power of Transmission. (Herrmann—Klein.).....	8vo,	5 00
Machinery of Transmission and Governors. (Herrmann—Klein.).....	8vo,	5 00
Wood's Elements of Analytical Mechanics.....	8vo,	3 00
Principles of Elementary Mechanics.....	12mo,	1 25
Turbines.....	8vo,	2 50
The World's Columbian Exposition of 1893.....	4to,	1 00

METALLURGY.

Egleston's Metallurgy of Silver, Gold, and Mercury:

Vol. I. Silver.....	8vo,	7 50
Vol. II. Gold and Mercury.....	8vo,	7 50
** Iles's Lead-smelting. (Postage 0 cents additional.).....	12mo,	2 50
Keep's Cast Iron.....	8vo,	2 50
Kunhardt's Practice of Ore Dressing in Europe.....	8vo,	1 50
Le Chatelier's High-temperature Measurements. (Boudouard—Burgess.).....	12mo,	3 00
Metcalf's Steel. A Manual for Steel-users.....	12mo,	2 00
Minet's Production of Aluminum and its Industrial Use. (Waldo.).....	12mo,	2 50
Robine and Lenglen's Cyanide Industry. (Le Clerc.).....	8vo,	
Smith's Materials of Machines.....	12mo,	1 00
Thurston's Materials of Engineering. In Three Parts.....	8vo,	8 00
Part II. Iron and Steel.....	8vo,	3 50
Part III. A Treatise on Brasses, Bronzes, and Other Alloys and their Constituents.....	8vo,	2 50
Ulke's Modern Electrolytic Copper Refining.....	8vo,	3 00

MINERALOGY.

Barringer's Description of Minerals of Commercial Value. Oblong, morocco.....	2 50
Boyd's Resources of Southwest Virginia.....	8vo, 3 00
Map of Southwest Virginia.....	Pocket-book form, 2 00
Brush's Manual of Determinative Mineralogy. (Penfield.).....	8vo, 4 00
Chester's Catalogue of Minerals.....	8vo, paper, 1 00
Dictionary of the Names of Minerals.....	Cloth, 1 25
Dictionary of the Names of Minerals.....	8vo, 3 50
Dana's System of Mineralogy.....	Large 8vo, half leather, 12 50
First Appendix to Dana's New "System of Mineralogy.".....	Large 8vo, 1 00
Text-book of Mineralogy.....	8vo, 4 00
Minerals and How to Study Them.....	12mo, 1 50
Catalogue of American Localities of Minerals.....	Large 8vo, 1 00
Manual of Mineralogy and Petrography.....	12mo, 2 00
Douglas's Untechnical Addresses on Technical Subjects.....	12mo, 1 00
Eakle's Mineral Tables.....	8vo, 1 25
Egleston's Catalogue of Minerals and Synonyms.....	8vo, 2 50
Hussak's The Determination of Rock-forming Minerals. (Smith.).....	Small 8vo, 2 00
Merrill's Non-metallic Minerals: Their Occurrence and Uses.....	8vo, 4 00
* Penfield's Notes on Determinative Mineralogy and Record of Mineral Tests.....	8vo, paper, 50
Rosenbusch's Microscopical Physiography of the Rock-making Minerals. (Iddings.).....	8vo, 5 00
* Tillman's Text-book of Important Minerals and Rocks.....	8vo, 2 00

MINING.

Beard's Ventilation of Mines.....	12mo,	2 50
Boyd's Resources of Southwest Virginia.....	8vo,	3 00
Map of Southwest Virginia.....	Pocket-book form	2 00
Douglas's Untechnical Addresses on Technical Subjects.....	12mo,	1 00
* Drinker's Tunneling, Explosive Compounds, and Rock Drills.....	4to, hf. mor.,	25 00
Eissler's Modern High Explosives.....	8vo	4 00

Fowler's Sewage Works Analyses.....	12mo,	2 00
Goodyear's Coal-mines of the Western Coast of the United States.....	12mo,	2 50
Ihlseng's Manual of Mining.....	8vo,	5 00
**Jiles's Lead-smelting. (Postage 9c. additional.).....	12mo,	2 50
Kunhardt's Practice of Ore Dressing in Europe.....	8vo,	1 50
O'Driscoll's Notes on the Treatment of Gold Ores.....	8vo,	2 00
Robine and Lenglen's Cyanide Industry. (Le Clerc.).....	8vo,	
* Walke's Lectures on Explosives.....	8vo,	4 00
Wilson's Cyanide Processes.....	12mo,	1 50
Chlorination Process.....	12mo,	1 50
Hydraulic and Placer Mining.....	12mo,	2 00
Treatise on Practical and Theoretical Mine Ventilation.....	12mo,	1 25

SANITARY SCIENCE.

Bashore's Sanitation of a Country House.....	12mo,	1 00
Folwell's Sewerage. (Designing, Construction, and Maintenance.)....	8vo,	3 00
Water-supply Engineering.....	8vo,	4 00
Fuertes's Water and Public Health.....	12mo,	1 50
Water-filtration Works.....	12mo,	2 50
Gerhard's Guide to Sanitary House-inspection.....	16mo,	1 00
Goodrich's Economic Disposal of Town's Refuse.....	Demy 8vo,	3 50
Hazen's Filtration of Public Water-supplies.....	8vo,	3 00
Leach's The Inspection and Analysis of Food with Special Reference to State Control.....	8vo,	7 50
Mason's Water-supply. (Considered principally from a Sanitary Standpoint) 8vo,		4 00
Examination of Water. (Chemical and Bacteriological.).....	12mo,	1 25
Ogden's Sewer Design.....	12mo,	2 00
Prescott and Winslow's Elements of Water Bacteriology, with Special Reference to Sanitary Water Analysis.....	12mo,	1 25
* Price's Handbook on Sanitation.....	12mo,	1 50
Richards's Cost of Food. A Study in Dieteries.....	12mo,	1 00
Cost of Living as Modified by Sanitary Science.....	12mo,	1 00
Richards and Woodman's Air, Water, and Food from a Sanitary Standpoint.....	8vo,	2 00
* Richards and Williams's The Dietary Computer.....	8vo,	1 50
Rideal's Sewage and Bacterial Purification of Sewage.....	8vo,	3 50
Turneure and Russell's Public Water-supplies.....	8vo,	5 00
Von Behring's Suppression of Tuberculosis. (Bolduan.).....	12mo,	1 00
Whipple's Microscopy of Drinking-water.....	8vo,	3 50
Winton's Microscopy of Vegetable Foods.....	8vo,	7 50
Woodhull's Notes on Military Hygiene.....	16mo,	1 50

MISCELLANEOUS.

De Fursac's Manual of Psychiatry. (Rosanoff and Collins.)... Large	12mo,	2 50
Emmons's Geological Guide-book of the Rocky Mountain Excursion of the International Congress of Geologists..... Large	8vo,	1 50
Ferrel's Popular Treatise on the Winds.....	8vo,	4 00
Haines's American Railway Management.....	12mo,	2 50
Mott's Fallacy of the Present Theory of Sound.....	16mo,	1 00
Ricketts's History of Rensselaer Polytechnic Institute, 1824-1894.. Small	8vo,	3 00
Rostoski's Serum Diagnosis. (Bolduan.).....	12mo,	1 00
Rotherham's Emphasized New Testament..... Large	8vo,	2 00

Steel's Treatise on the Diseases of the Dog.....	.8vo,	3	50
The World's Columbian Exposition of 1893.....	.4to,	1	00
Von Behring's Suppression of Tuberculosis. (Bolduan.).....	.12mo,	1	00
Winslow's Elements of Applied Microscopy.....	.12mo,	1	50
Worcester and Atkinson. Small Hospitals, Establishment and Maintenance; Suggestions for Hospital Architecture: Plans for Small Hospital. .12mo,		1	25

HEBREW AND CHALDEE TEXT-BOOKS.

Green's Elementary Hebrew Grammar.....	.12mo,	1	25
Hebrew Chrestomathy.....	.8vo,	2	00
Gesenius's Hebrew and Chaldee Lexicon to the Old Testament Scriptures. (Tregelles.).....	Small 4to, half morocco,	5	00
Letteris's Hebrew Bible.....	.8vo,	2	25



1177 abt
2,80

